

# THE MANY USES OF LYE



MAKING  
LYE

wish, you can add **10ml** (2 teaspoons) of wintergreen, lemon, or other oil at this stage for perfume. Pour into a mold box, let stand **48** hours, and follow the procedure below.

Empty the soap from **the** box and cut it into bars with a string or **wire** (see Figure 2). Place the bars in an open stack so that air can circulate around and through them (see Figure 3). Leave them in a warm, dry place for 2 to 4 weeks.

References:

**Bramson**, Ann, *Soap*. New York.: Workman Publishing Co., 1975

Donkor, Peter, *Small-Scale Soapmaking*. London: **Intermediate** Technology Development Group, 1986

Francioni, **J.B.** and **Collings**, M.L. *Soap Making*. Extension circular 246. Baton Rouge, **Louisiana**: Louisiana State University, 1943

*Making Soaps and Candles*. Pownal, Vermont: P.H. Storey Communications Inc., 1973.

## SOFT SOAP WITH LYE LEACHED FROM ASHES

This method, patterned after one used by the early settlers of North America, produces soft soap by combining fat and potash (lye obtained by leaching wood or plant ashes.) The recipe has been tried successfully with waste cooking grease, olive oil, peanut oil, and cocoa butter.

### Leaching the Lye

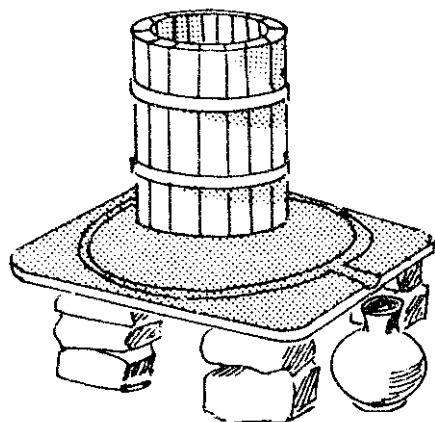

FIGURE 5. ROCKS ARE PILED TO FORM A BASE FOR THE FLAT, GROOVED STONE ON WHICH THE BUCKET IS PLACED.

### Tools and Ingredients

Several medium sized rocks

A flat stone with a groove and a run-off lip chipped into it.

**19-liter** (5-gallon) wooden bucket with several small holes in the bottom. A hollowed log with the same capacity can be used.

Collection vessels for the lye. These should be made of iron, steel, enamel, or clay. An **aluminum** vessel should not be used, since lye would corrode it.

Small twigs, straw

19 liters (5 gallons) of wood ashes. The ashes may be from all types of woods. Ashes from hardwoods yield the best lye, but ashes from the burning of plants and leaves of trees may be used (see Table 1). Ashes of burnt seaweed are **particularly** useful as **these** produce a sodium-based lye from which hard soap can be made. Lye hacked from the ashes of plant life (excepting seaweed) is **potash** or potassium carbonate ( $K_2CO_3$ ), an alkali. This alkali reacts with fat to form soft soap. **Ashes** from other materials such as paper, cloth, or garbage cannot be used.

7.6 liters (2 gallons) of soft or medium-hard water.

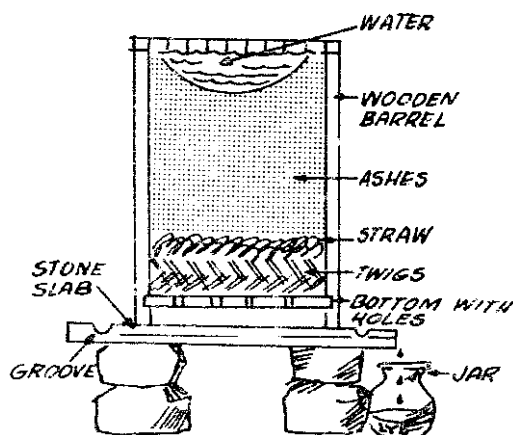

FIGURE 6. TWO LAYERS OF SMALL TWIGS ARE CRISS-CROSSED TO FORM A FILTER IN THE BOTTOM OF THE BUCKET. WHEN THE BUCKET IS FILLED WITH ASHES, WATER IS POURED IN AND THE LYE SOLUTION, A BROWN LIQUID, SLOWLY DRIPS INTO A CONTAINER.

Pile the rocks so that the **flat**, grooved stone rests evenly on top (see Figure 5). Set the wooden bucket on this stone.

In the bottom of the bucket, make a filter to trap the ashes by criss-crossing two layers of small twigs and placing a layer of straw on top (see Figure 6).

Fill the bucket with dry ashes. To keep the lye from being **leached** accidentally, the **ashes** must be kept dry before **they** are used.

Pour warm water into the bucket, making the ashes moist and sticky. To make sure that the water passes through the ashes at the correct rate for leaching the lye, move the ashes up at the sides of the bucket to form a depression in the center.

Add **all** the remaining water in small amounts in the following manner: Fill the center depression **with** water; let the water be absorbed, till the depression again. When about two-thirds of the water has been added, the lye or potash, a brown liquid, **will start** to flow from the bottom of the bucket. Use more water, if necessary, to start this **flow**. The lye flows over the flat stone into the groove and then into the collection vessel below **the** run-off lip. It takes about an hour to start the Row of lye.

The **yield** from the **amounts** given here is about 1.8 liter (7  $\frac{3}{4}$  cups) lye. The **results** vary according to the amount of water loss from evaporation and the kind of ashes used.

If the lye is of the correct strength, an egg or potato should float in it. A chicken feather **dipped** in the solution should be coated, but not eaten away. If

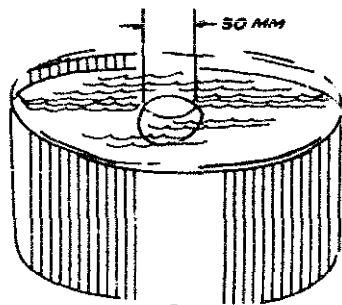

FIGURE 7. THE STRENGTH OF A LYE SOLUTION CAN BE TESTED BY FLOATING AN EGG IN IT. A SOLUTION OF THE CORRECT STRENGTH WILL RAISE PART OF THE EGG OUT OF THE WATER, FORMING AN OVAL ABOUT 30 MM LONG AT THE WATER'S SURFACE.

the solution is weak, pour it through the barrel **again**, or through a new barrel of ashes, or concentrate it by boiling. **Thirty-five** liters of ashes is about **the right** amount for 2 kilograms of fat (a bushel of ashes for 4 pounds of fat). This proportion is cited in soap-making recipes of the **colonial** period in the United States, but many of the recipes of that era differ on the proportion of ashes to fat.

Here is a list of tropical plants whose leaf ashes **yield** lye for soap making:

Scientific Name	Common Name	Prominent location
<i>Arthrocnemum indicum</i>	mangrove	Indian coast
<i>Atriplex repens</i>	salt bush	Indian coast
<i>Avicennia nitida</i>	mangrove	<b>Philippino</b> swamps
<i>Cocos nucifera</i>	coconut palm	Coasts of <b>all</b> tropical regions
<i>Halocharis violacea</i>		Indian coast
<i>Haloxylon recurvum</i>	camel food	Indian coast
<i>Haloxylon multiflorum</i>		Indian coast
<i>Haloxylon salicornicum</i>		Indian coast
<i>Kochia indica</i>		<b>India</b> coast
<i>Salicornia brachiata</i>		Indian coast
<i>Salsola foetida</i>	<b>Aden</b> balsam	Indian coast
<i>Suaeda fruticosa</i>		Indian coast
<i>Suaeda monoica</i>		Indian coast
<i>Suaeda maritima</i>		Indian coast
<i>Suaeda nudiflora</i>		Indian coast

## Making the Soap

### Equipment and Materials

Iron kettle  
 Wooden spoon or stick for stirring  
 Measuring vessels  
 Wooden, steel, iron, glass, or clay vessels for storing the soap

Clarified fat (see the entry on Soap Making with Commercial Lye for **cleaning process**)

Lye that floats an egg or potato (see Figure 7)

Put **115ml (1/2 cup)** of lye in the kettle for every **230ml (1 cup)** of fats or oils.

Add the measured amount of fat.

Boil the lye and fat together until the mixture becomes thick, rubbery, and foamy.

Remove ~~the~~ kettle from the fire and let it cool.

The soap is a thick jelly substance that ranges in color from tan to dark brown depending on the fats or oils used and the length of **boiling** time.

Upon strong mixing in water, the soap will lather up into **white suds** and serve as an effective cleaning agent. This soap greatly improves with age. Store it in a container for at least a month before using it.

**230ml (1 cup)** of fat yields **230ml (1 cup)** of soft soap.

Sources:

Marietta Ellis, VITA Volunteer, Bedford, Massachusetts  
Dr. S. K. **Barat**, VITA Volunteer, Adyar, Madras, India

Earl, Alice Morse. *Home Life in Colonial Days*. New York: MacMillan Company.

*Make Your Own Soap*. Washington, D.C: Federal Extension Service, U.S. Department of Agriculture.

## LARGER-SCALE SOAP PRODUCTION

In many areas in developing countries soap-making can be an important small business, providing a needed product and earning income with minimal investment. The Intermediate Technology Development Group, for example, has worked **with** the University of Science and Technology in Ghana to develop equipment for **small** manufacturing operations. One such set up uses specially made tanks heated by wood **fires**. The diagrams below show the parts for the tank. Soap-making processes are the same as those described above. Recipe quantities change according to the amount of soap produced. For example, **one small** manufacturer **in** Brazil supplied the following recipe for 45 kgs (**100 lbs**):

10 kgs tallow  
2 kgs lye  
2 kgs rosin  
36 liters water