

AT MICROFICHE
REFERENCE
LIBRARY

A project of Volunteers in Asia

Manual of Information: RIFE Hydraulic Rams

Published by:

Rife Hydraulic Engine Manufacturing Co.
P.O. Box 790
Norristown, Pennsylvania 19401
USA

Available from:

same as above

Reproduced by permission.

Reproduction of this microfiche document in any form is subject to the same restrictions as those of the original document.

MANUAL OF INFORMATION

RIFE HYDRAULIC WATER SINCE 1884 **RAMS**

“WATER PUMPS WATER”

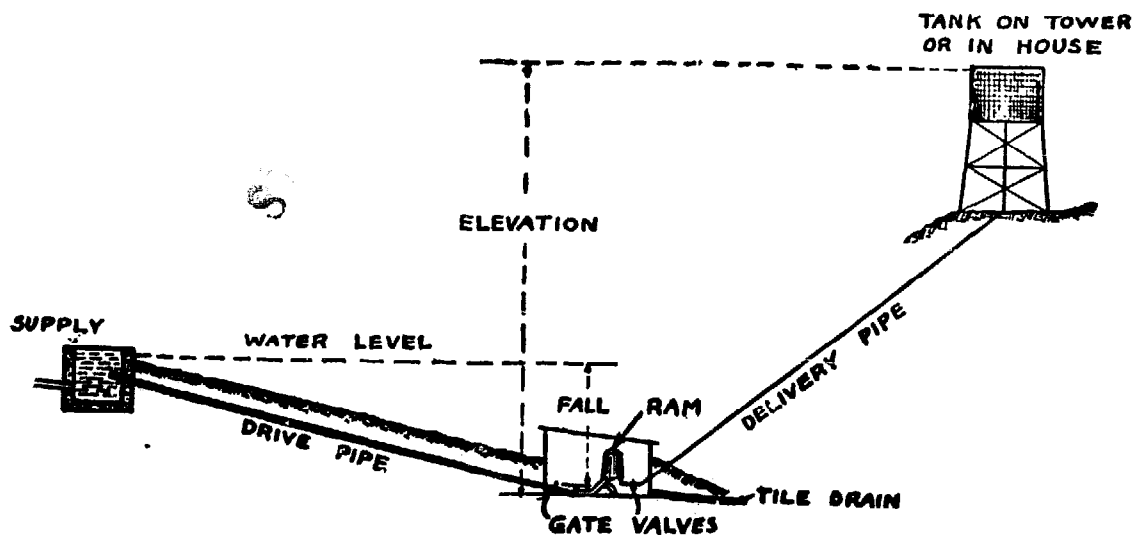

Manufactured By
Rife Hydraulic Engine Manufacturing Co.
Rife Ram and Pump Works
316 W. Poplar Street
Norristown, PA 19401
(215) 279-2997

RIFE RAMS

What They Are and What They Will Do

A RIFE HYDRAULIC RAM is a device for pumping water by means of water-power, connected with a Spring, Creek, or Artesian Well, with a flow of 1½ gallons per minute or more. It is necessary to have a Fall or "Head" of 20 inches or more. When so located, it will automatically pump a good volume of the water to a height of 25 feet for each one-foot of Fall available. (For example, if there is a Fall of 3 feet, the Ram will pump a good volume of water 75 feet high.)

RIFE HYDRAULIC RAMS are built on the "HIGH BASE" principle, embracing a Positive and Automatic Air Feed which maintains indefinitely the all-important "Air Cushion" in the Air Chamber,

preventing the Air Chamber filling up with water. They are the last word from the standpoint of efficiency and freedom from service interruptions. They use NO GASOLINE, NO ELECTRICITY, NO POWER BILL. A RIFE RAM will pump a continuous flow of water day in and day out, year in and year out, without one cent operating cost. THE FLOW AND FALL OF YOUR OWN WATER DOES THE PUMPING.

RIFE RAMS have been manufactured continuously since 1884 and since that time more than 50,000 have been sold in every State of the Union and in many foreign countries.

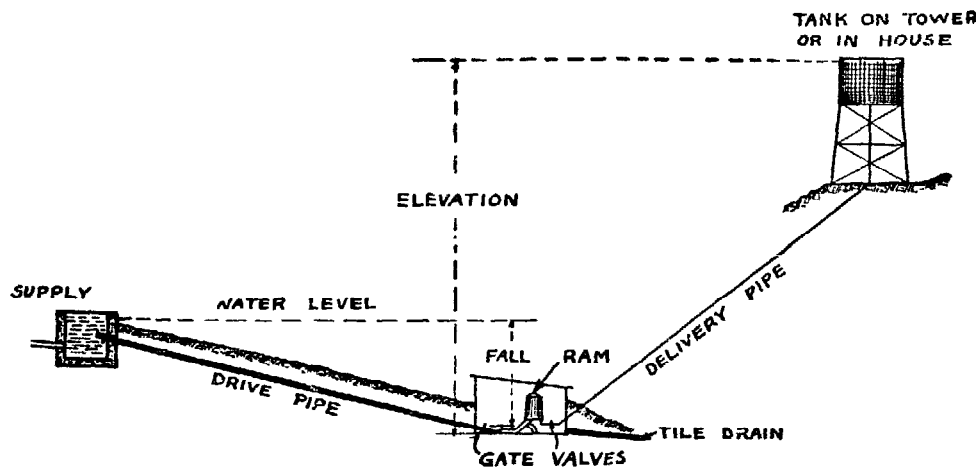

USUAL METHOD OF INSTALLING A RIFE HYDRAULIC RAM. THIS MAY BE VARIED, DEPENDING ON LOCAL CONDITIONS. SEE FOLLOWING PARAGRAPHS.

HOW A RIFE HYDRAULIC RAM WORKS

The operation of a Rife Hydraulic Ram may be briefly expressed as follows: Water flows down the Drive Pipe to the Ram and develops a certain power due to its weight and velocity. It flows through the Outside Valve until it reaches a certain velocity, then the Valve closes suddenly. The column of water continues on through the Inside Rubber Valve into the Air Chamber. When the pressure in the Air Chamber equalizes and overcomes the Driving Force behind it, a rebound takes place. This operation is repeated from 25 to 100 times per minute working on a Hydraulic principle, building up pressure in the Air Chamber, which in turn forces water

through the Delivery Pipe up to where it is desired.

With each stroke of the Ram the water in the Drive Pipe rebounds or backs up, which causes a partial vacuum under the Outside Valve, allowing it to drop away from its seat. Momentarily the water again begins to flow down the Drive Pipe and the action is repeated. When the rebound takes place a small amount of air is sucked through the Air Feed Valve and lodges in the upper portion of the Base and is forced into the Air Chamber when the next blow takes place; this prevents the Air Chamber from filling up with water.

INFORMATION REQUIRED

For each prospective installation it is necessary to have the following information—

1. Flow of Supply Water $\left\{ \begin{array}{l} \text{Spring} \\ \text{Creek} \\ \text{Artesian Well} \end{array} \right.$ in Gallons per minute.
2. The Vertical Fall in feet from the Source of Supply to Location of Ram.
3. Distance between Point of Supply and where Ram is to be located.
4. Vertical Height above Ram the water is to be raised.
5. Pipe Line distance water is to be delivered.
6. Number of Gallons required per day of 24 hours.

FLOW OF SUPPLY WATER AVAILABLE IN GALLONS PER MINUTE

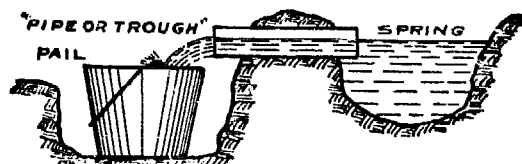

DETERMINE HOW MANY SECONDS ARE REQUIRED
TO FILL A BUCKET OF KNOWN CAPACITY.

Do not guess at this: Be sure to measure it! If the supply is small, run the water into a bucket or tub of known capacity, using the second hand of a watch to figure how

much supply water is available in gallons per minute. This should be figured on basis of flow at dryest season of the year.

MEASURING LARGE QUANTITIES OF WATER

Where the flow of water is large and therefore not practical for measuring by means of a bucket or tub, make use of a notch in a board, known as a "Weir."

Measure the width of the notch "W" and the height of the water in the notch "H". The height should be measured on a level 2 feet up from stream from the notch.

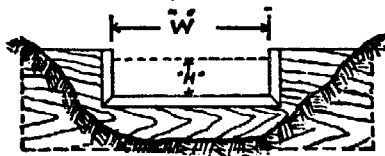

THE RATE OF FLOW
CAN BE QUICKLY
DETERMINED BY
REFERRING TO THE
"WEIR TABLE"
BELOW.

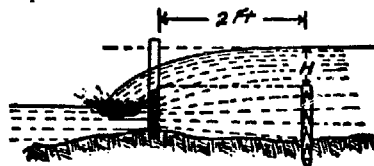

WEIR TABLE FOR DETERMINING THE FLOW OF STREAM

INCHES	0	$\frac{1}{8}$	$\frac{1}{4}$	$\frac{3}{8}$	$\frac{1}{2}$	$\frac{5}{8}$	$\frac{3}{4}$	$\frac{7}{8}$
0.....	0.00	0.01	0.05	0.09	0.14	0.19	0.26	0.32
1.....	0.40	0.47	0.55	0.64	0.73	0.82	0.92	1.02
2.....	1.13	1.23	1.35	1.46	1.58	1.70	1.82	1.95
3.....	2.07	2.21	2.34	2.48	2.61	2.76	2.90	3.05
4.....	3.20	3.35	3.50	3.66	3.81	3.97	4.14	4.30
5.....	4.47	4.64	4.81	4.98	5.15	5.33	5.51	5.69
6.....	5.87	6.06	6.25	6.44	6.62	6.82	7.01	7.21
7.....	7.40	7.60	7.80	8.01	8.21	8.42	8.63	8.83
8.....	9.05	9.26	9.47	9.69	9.91	10.13	10.35	10.57
9.....	10.80	11.03	11.25	11.48	11.71	11.94	12.17	12.41
10.....	12.64	12.88	13.12	13.36	13.60	13.85	14.09	14.34

This table gives the number of cubic feet of water that will pass over a weir 1 inch wide and from $\frac{1}{8}$ to $10\frac{7}{8}$ inches in depth. The figures in the first upright column represent whole inches and those in the top horizontal line represent fractional parts of an inch of depth over the weir. The figures in the second upright column indicate the number of cubic feet of water that will flow per minute over the weir for whole inches in depth, and in the succeeding columns, whole inches and the fractions under which they occur. Then the number of cubic feet thus found multiplied by the width of the weir in inches will give the capacity of a stream.

Example: To find the required number of cubic feet of water that will flow over a weir $4\frac{1}{4}$ inches in depth and 30 inches in width, follow down the left-hand column of figures in the table to 4, then across until directly under the $\frac{1}{4}$ in the top line, where will be found 4.14; this, multiplied by 30 (width of notch in weir) will give 124, the number of cubic feet of water that passes over the whole weir per minute. To reduce to gallons per minute multiply by $7\frac{1}{2}$ which equals 930 gallons per minute.

DETERMINING THE VERTICAL FALL

The Fall or difference in the Vertical elevation between the level of the water at the source of supply and where the Ram will be located is known as the Fall. This can be easily and quickly measured by the

use of an ordinary carpenter's level on a stick, starting at where the Ram will be located and going upwards, as shown in the following illustration.

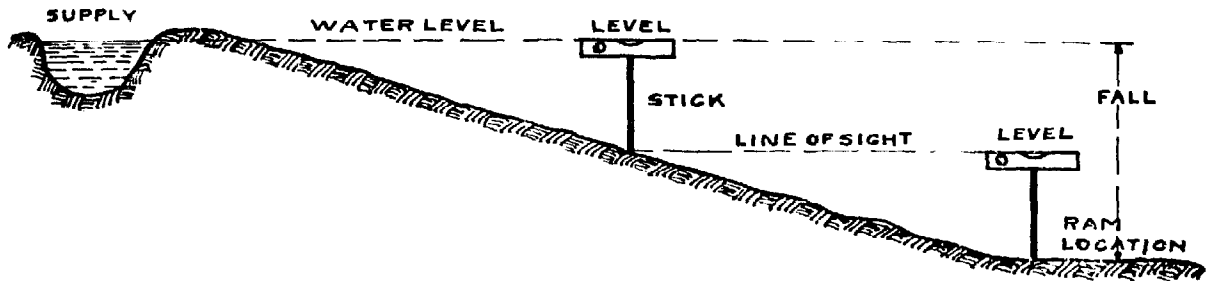

METHOD OF USING CARPENTER'S LEVEL TO DETERMINE THE FALL OR HEAD.

Bear in mind that the more Fall available, the more water the Ram pump—all other conditions being the same. For example: With a Fall of 8 feet the Ram will pump exactly twice as much water as

with a Fall of 4 feet. Therefore it is advisable to take advantage of all the Fall available. In most instances, to get more Fall, it is merely a matter of locating the Ram further downstream.

VERTICAL ELEVATION

The VERTICAL ELEVATION—that is the height which the water is to be pumped above the Ram location—can easily be determined by use of an ordinary carpenter's level on a stick as illustrated,

see page 4, for determining the amount of Fall. Start measurements at Ram location and work upward to the highest point at which water is to be delivered.

DISTANCE WATER IS TO BE DELIVERED

This is the Pipe Line distance from the the Ram Location to the farthest point water is to be delivered.

RULE FOR CALCULATING THE NUMBER OF GALLONS OF WATER RIFE RAMS WILL PUMP

As soon as you have the "Information Required," as listed on page 3, you can easily figure the amount of water a Ram could deliver for you. Multiply the available flow in gallons per minute (V) by the vertical fall in feet (F), divide by the vertical elevation (E), and multiply the result by % (60%), the normal efficiency

of a Ram installation:

$$V \times F / E \times \% = D$$

This will give you the delivery (D) in gals. per min. using all the available water supply. To obtain gals. per hr., multiply this amount by 60 and to gals. per day, multiply by 1440.

CHOICE OF MODEL AND SIZE OF RAM

Consult the Specification Sheet. Select first the model designed to handle your vertical fall and lift; then, in that model, the smallest size which will handle the available flow of water in gals. per min. which you have. You can confirm your

calculation from the chart on page 5, which gives the percentage of the water used (V) a RIFE Ram will deliver under various conditions of vertical fall and vertical lift.

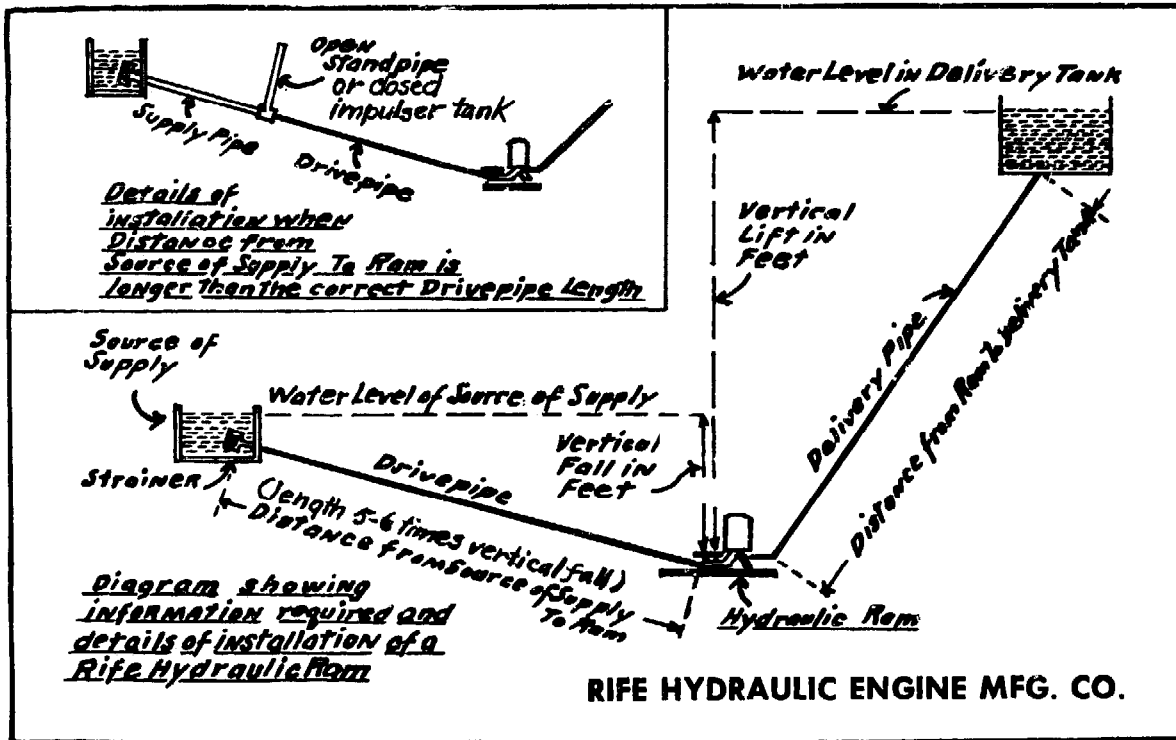

PERFORMANCE CHART FOR RIFE HYDRAULIC RAMS
 SHOWING THE PERCENTAGE OF THE WATER USED WHICH THE RAM WILL DELIVER
 UNDER VARIOUS CONDITIONS OF VERTICAL FALL AND LIFT

	8	16	25	50	75	100	125	150	200	250	400	500		
4	22.5%	12.5%	8.0%	3.6%	1.0%								4	
5		22.5%	16.0%	9.6%	6.4%	4.8%	3.5%	2.7%	2.0%				5	
12			21.5%	13.2%	9.6%	7.2%	5.7%	4.8%	3.3%	2.4%	2.0%		12	
16				16.0%	11.7%	9.6%	7.7%	6.4%	4.8%	3.8%	2.9%	2.0%	16	
30				18.0%	14.7%	12.0%	9.6%	8.0%	6.0%	4.8%	4.0%	2.5%	2.0%	30
25				22.5%	16.7%	13.8%	12.0%	10.0%	7.7%	6.0%	5.0%	3.8%	2.5%	25
30					18.0%	15.0%	13.2%	12.0%	9.0%	7.2%	6.0%	4.5%	3.3%	30
35					21.0%	17.5%	15.2%	14.0%	10.3%	8.4%	7.0%	5.4%	4.2%	35
40						18.0%	16.0%	14.7%	12.0%	9.6%	8.0%	6.0%	4.8%	40
50						22.5%	18.0%	16.7%	13.8%	12.0%	10.0%	7.5%	6.0%	50

Vertical Lift in Feet Including Delivery Pipe Friction

NOTE: The amount of water used and pumped by RIFE Hydraulic Rams increases with increase in the vertical fall from the source of supply to the Ram, and with increased lift of the lever arm above the lever rest during the stroke. This lift determines the opening of the outside valve and is adjustable. The range of intake capacity of each model and size of the new RIFE High Capacity Models is listed on the sheet, "Specifications of RIFE Rams". The "Normal Intake Capacity" listed in gals. per min. corresponds to operation with vertical fall of half the maximum permissible for that model, and with half the possible lift of the lever.

EXAMPLE TAKEN FROM THE ABOVE CHART: A RIFE Ram, using vertical fall of 12 ft., will deliver to elevation of 125 ft. 5.7% of the water used. For a No. 30BU Ram using 40 gpm, this would be about 2 1/4 gpm. One gpm = 60 gal. per hr., or 1440 gals. per day.

RIFE HYDRAULIC ENGINE MFG. CO.

DRIVE PIPES

THE DRIVE PIPE SHOULD BE METAL, (usually galvanized steel), unless encased in concrete. It should be straight as possible without elbows, and normally the same pipe size as intake end of the Ram. It should be watertight and rigidly anchored, with strainer in source of supply to keep refuse out of Ram. THE DRIVE PIPE

ITSELF MUST BE OF CORRECT LENGTH. For Rife rams with vertical fall of up to 15 ft. this length is about 6 times the vertical fall; for 25 ft. fall 4 times, and for 50 ft. 3 times. With special conditions ask us for correct length and diameter of drivepipe to assure maximum delivery.

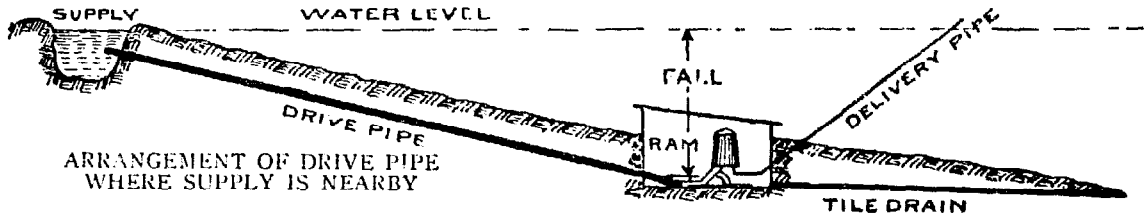

Where you have to go down-stream some distance to obtain MORE Fall, it is necessary to use a Standpipe and use a combination of Drive Pipe and Supply Pipe. When practical to run both Supply

Pipe and Drive Pipe straight through from the source of supply to where the Ram is located on a straight incline, this can be done by the use of an open Steel Standpipe as illustrated below.

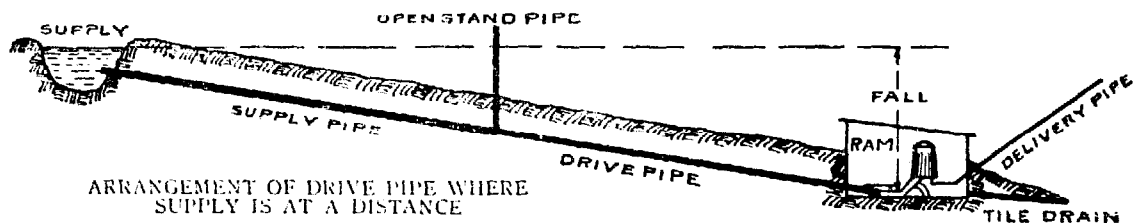

The Supply Pipe must be ONE SIZE LARGER THAN THE DRIVE PIPE. Where the two pipes come together, use a "T" pipe fitting into which is fitted the Open Steel Standpipe, which should be two

sizes larger than the Supply Pipe. The top of the Standpipe should be a few inches ABOVE the level of the water at Source of Supply.

In cases where the Supply Pipe and Drive cannot be carried through on a straight incline, or where the Supply Pipe and Drive Pipes come together at different angles, it is necessary to install a Concrete Pit, the top of which should be several

inches above the level of the water at the Source of Supply. Water can be conveyed as much as One Mile through a Supply Pipe when necessary, to get the Fall required to pump the amount of water needed.

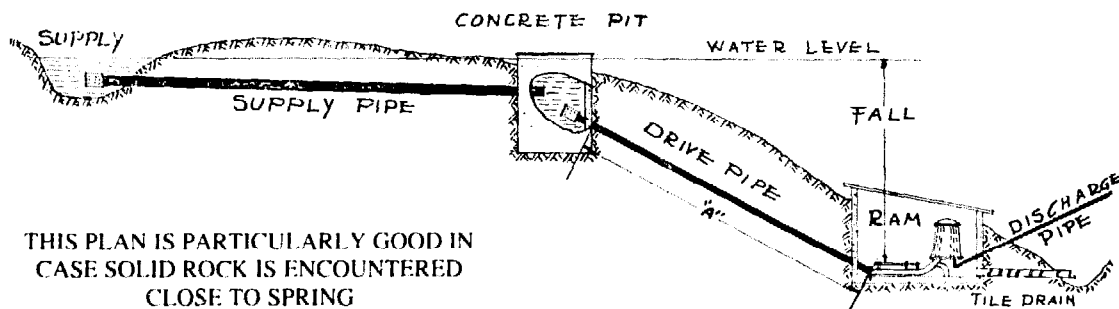

The upper end of the Drive Pipe should be so installed so that it will be at least 1 foot under water at all times in order to avoid whirlpools forming and sucking air into the Drive Pipe.

Where economy is a matter of consideration or where it is impractical to use a Concrete Pit, a joint of large Terra Cotta Tile can be installed as a substitute.

GENERAL INSTRUCTIONS FOR INSTALLING RIFE RAMS

Rife Rams are easy to install when instructions are followed. There are many different ways Rams can be installed, depending mainly on lay and character of ground and other local conditions. If your conditions are different from those described elsewhere in this Manual, write us, giving full details and we will advise you explicitly regarding the proper method of installing the Ram.

THE BEST LOCATION FOR THE RAM

Always locate the Ram as near the source of supply and the delivery point as is possible while maintaining the lowest elevation. This will insure the minimum expense for pipe. Sinking a deeper ram pit and digging out for drive pipe and waste line might improve the installation at a saving.

FOUNDATION AND RAM PIT

A concrete slab or a large flat rock provides a good solid foundation on which to set the Ram. The best procedure is to put in a concrete slab as a foundation, slightly sloping towards the rear where the waste water will be carried off. After the Drive Pipe and Delivery Pipe are installed and the Ram is in operation, the Ram should be enclosed in a concrete pit. The Ram pit should be large enough to give a clearance of 18" from Ram on all sides in order to expedite removal of bolts should occasion necessitate. The pit should be high enough to prevent normal flood water getting in. Sloping shed roof of boards provides a good cover or protection. However, in colder climates it is well to cover with a concrete slab in order to prevent freezing.

A manhole or metal cistern cover can be used to provide an opening to get into the Ram pit. This metal manhole covering can be provided with a lock if desired.

DELIVERY PIPE

Correct size Delivery Pipe should be the dimensions given for each particular size Ram. Do not install Delivery Pipe smaller than that specified, because to do so increases the amount of friction loss and a consequent reduction in the amount of water delivered. Avoid right angle elbows wherever possible to reduce friction loss. Use a good grade of red or white lead on the joints and screw up good and tight. **DO NOT FILL UP THE DITCH UNTIL THE RAM IS STARTED AND IN OPERATION SO THAT IN CASE LEAKS DEVELOP THEY CAN BE EASILY LOCATED AND STOPPED BEFORE COVERING THE DELIVERY PIPE.**

The installation of a Gate Valve (D) in the Delivery Pipe at the Ram is a great convenience for cutting off water when it is necessary to adjust or repair Ram. The ditch for the Delivery Pipe should be sufficiently deep to be below the frost line.

In case Delivery Line goes over the top of a hill and down into a valley on its way from the Ram to the house, a small Air Release Valve or Pet Cock should be installed in the Delivery Pipe at the highest point to release accumulations of air from time to time. Otherwise air will collect in such volume it will retard the free flow of the water.

In connecting up to a reservoir, the Delivery Pipe should enter the *bottom* and when being laid "T" pipe fittings should be installed at convenient points to take off service connections wherever desired.

The overflow pipe should also enter the *bottom* of the reservoir and terminate with a sleeve joint connection. Into this sleeve joint is screwed a piece of pipe the length of which determines the height of the water in the reservoir. An emergency overflow should be provided in the side of the reservoir at the top a few inches above the level of the regular overflow.

DRAIN TILE

The Ram pit should be provided with drain tile to carry off the waste water. In many cases the total amount of Fall available can be materially increased by sinking the Ram pit deep into the ground and carrying off the waste water through a long line of drain tile on a Fall of 1½ to

2 inches per 100 feet and of sufficient length to bring it out at water level down stream. In many cases it is a choice between increasing the length of the Supply Pipe or running a line of drain tile. In most cases it is cheaper to use more tile and less length of steel Supply Pipe.

OPERATION

SECTION DRAWING OF
"NEW MODEL" SERIES BU RAM

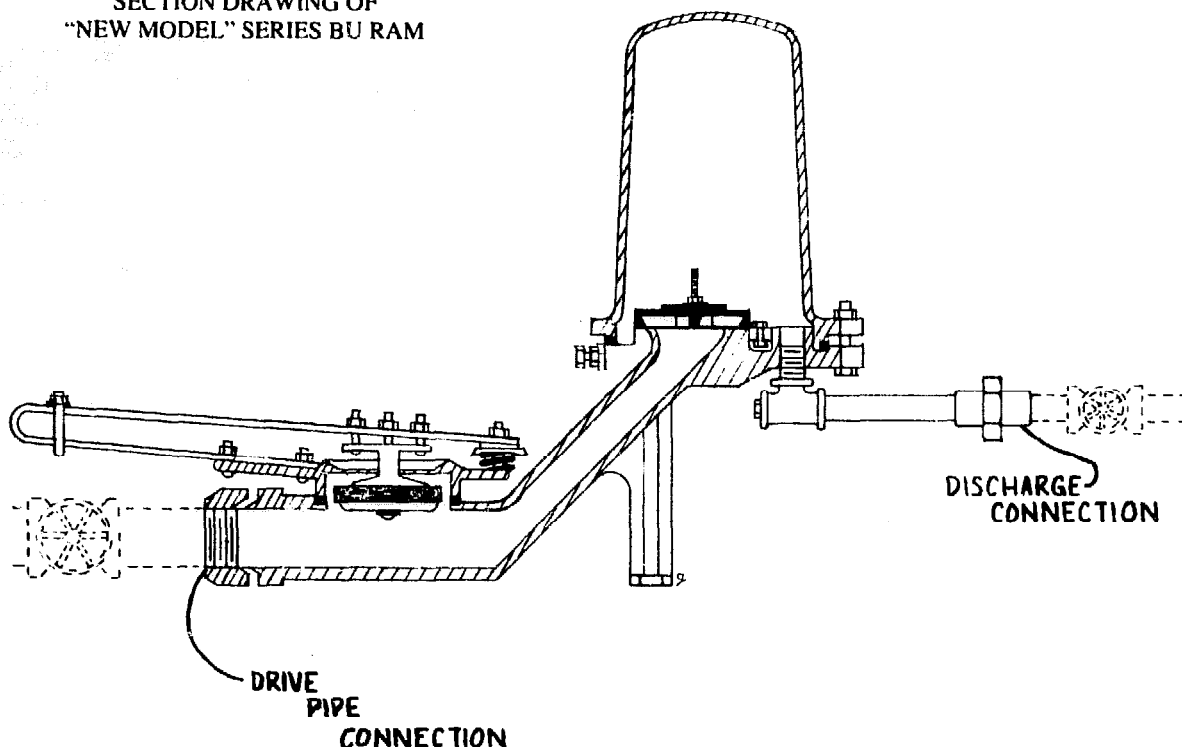

HOW TO START A RIFE HYDRAULIC RAM

The Drive Pipe must be full of water. If there is a valve between the RAM and the Drive Pipe, this must be open. If there is a valve between the RAM and the delivery pipe, this should be closed.

Then open the waste (outside) valve by pushing the valve down for about 2 seconds allowing the waste from the drive pipe to escape through the valve. Release the valve which will then close from the pressure of the water below. The water in motion will then drive forward entering the air chamber through the inside valve. The inside valve will close, the waste valve will re-open, and the RAM should begin to operate automatically forcing water continuously into the air chamber. If the RAM does not begin to work automatically at once, repeat the opening of the waste valve several times.

If there is a valve between the RAM and the delivery pipe this should be opened after the RAM has made 10 to 15 strokes.

As soon as the delivery pipe is full,

water will begin to flow from its upper end.

If the pressure on the waste valve is too great to allow it to be opened (depressed) by hand the same result can be obtained by alternately opening and closing the valve between the drive pipe and the RAM.

The RAM is started by the same process and operates in the same manner whether or not there are valves at each or either end of the Ram.

The air feeder valve should be set so that it gives a small spurt of water with each stroke. If the valve is too far open, the air chamber will fill with air and the RAM, while continuing to operate, will pump only air. If valve is not sufficiently open, the water going through the RAM will absorb all the air in the air chamber and the RAM will begin to pound with a metallic sound at every stroke. This condition should be immediately corrected by increasing the opening of the air feeder valve as it might result in breakage of some part of the RAM.

ADJUSTMENT:

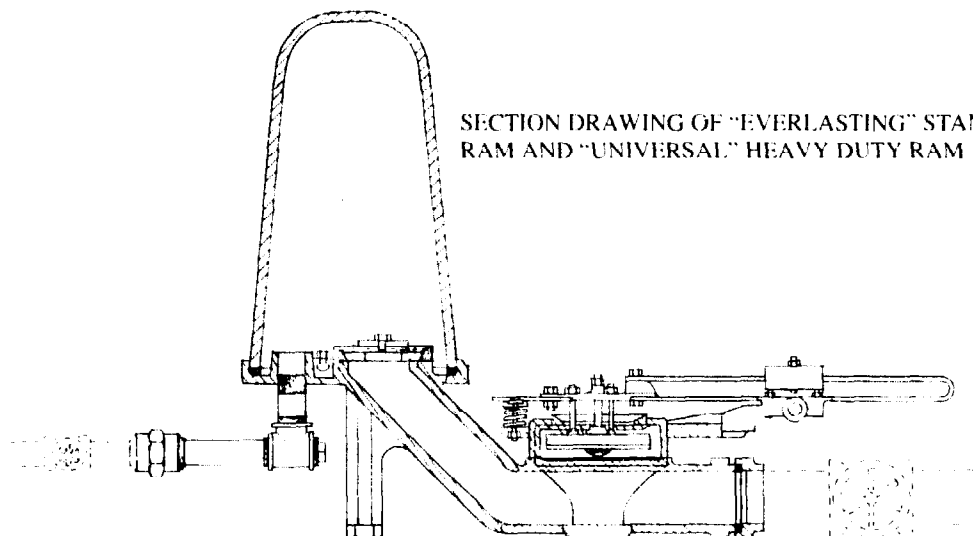

SECTION DRAWING OF "EVERLASTING" STANDARD RAM AND "UNIVERSAL" HEAVY DUTY RAM

REGULATING AIR SUPPLY

The air feeder valve should be set so that it gives a small spurt of water with each stroke. If the valve is too far open, the air chamber will fill with air and the RAM, while continuing to operate, will pump only air. If valve is not sufficiently open, the water going through the RAM will

absorb all the air in the air chamber and the RAM will begin to pound with a metallic sound at every stroke. This condition should be immediately corrected by increasing the opening of the air feeder valve as it might result in breakage of some part of the RAM.

SETTING AT MAXIMUM CAPACITY

To regulate the Ram to operate at *maximum* capacity under average conditions, the Outside Valve should operate at 20 to 40 strokes per minute.

SETTING AT MINIMUM CAPACITY

To regulate the Ram to operate at *minimum* capacity under average conditions, the Outside Valve should operate at 60 to 100 strokes per minute.

Each larger size Ram has slower max. and min. strokes.

USING MORE OR LESS WATER

The *slower* the strokes per minute of the Outside Valve the more water the Ram uses and the more water it pumps. The *faster* the strokes per minute of the Outside Valve the less water the Ram uses and the less water it pumps.

To slow down the strokes per minute at which the Outside Valve operates, lower the Lever Rest by screwing down the nuts on bolts that hold it in place.

To increase the number of strokes per minute of the Outside Valve raise the Lever Rest by unscrewing the nuts on bolts that hold it in place.

Each Rifle Ram will regulate with a *minimum* and *maximum* amount of water,

which provides for variation in flow of supply water during droughts and wet seasons. Regulation to vary the amount of water used by the Ram would, therefore, be accomplished by raising and lowering the Lever Rest.

A careful study and observance of the above instructions will soon enable any one to properly regulate the stroke of the Ram to any number per minute from full capacity down to a minimum supply of water in dry season.

Carefully check over Ram once a week for several months to make certain no bolts have worked loose.

MAINTENANCE and REPAIRS:

We endeavor to maintain at all times a complete supply of replacement parts for our RAMS in all sizes for immediate shipment. Parts list and assembly diagram

will be mailed upon request.

In ordering parts please specify Model size and serial number of RAM.

DOUBLE ACTING RAM

RIFE'S DOUBLE ACTING RAM is used where there is not sufficient Pure Spring Water available to operate a Ram, but where there is a nearby creek with sufficient water and Fall to operate the Ram. In this instance the creek water is used to furnish the power to operate the

Ram, and pump the Pure Spring Water. It is possible for a RIFE RAM to pump two-thirds of the Pure Uncontaminated Spring Water. The other one-third mixes with the creek water and is wasted through the Outside Valve.

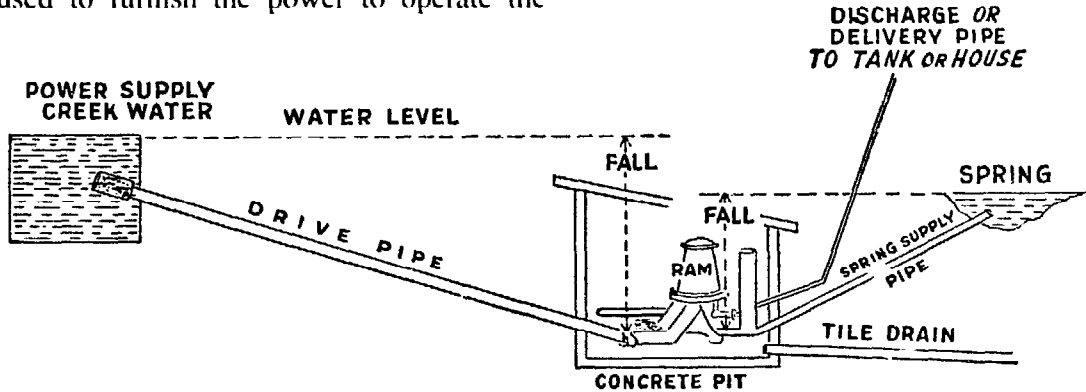

Layout of Double Acting Ram Installation. Spring Water connections can be brought into Ram from any direction. Delivery Pipe can likewise be led away from RAM at any desired angle. A minimum fall of 18 inches is required from Spring to Ram location. Take advantage of all Fall possible of Creek Water.

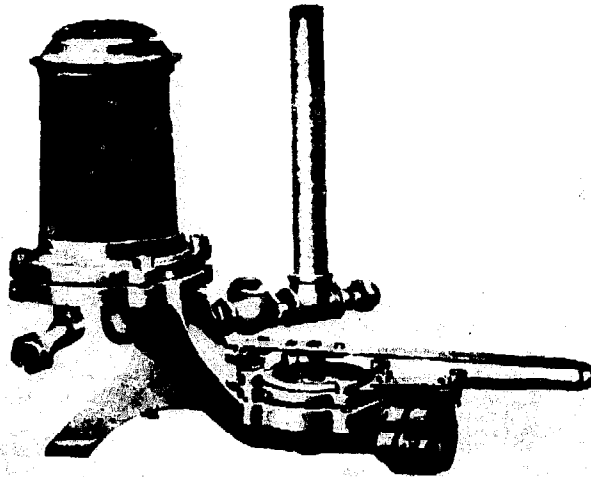

RIFE #20BU DOUBLE ACTING RAM

Showing impure water intake at right, pure water intake with check valve and open standpipe at upper centre, and pure water discharge at left.

SPRING SUPPLY PIPE

The size of the Spring Supply Pipe for each Double Acting Ram is the *same size* as its Delivery Pipe and therefore proper size Spring Supply Pipe for each size Ram.

It is necessary to install a Gate Valve (B) in the Spring Supply Pipe in order to

regulate the flow of the Spring Water and to avoid overflowing the Steel Standpipe of the Double Acting Connection, in cases where the Fall from Spring to Ram exceeds 2 feet.

A minimum Fall of 18 inches is required from Spring to Ram Location.

HOW DOUBLE ACTING RAM WORKS

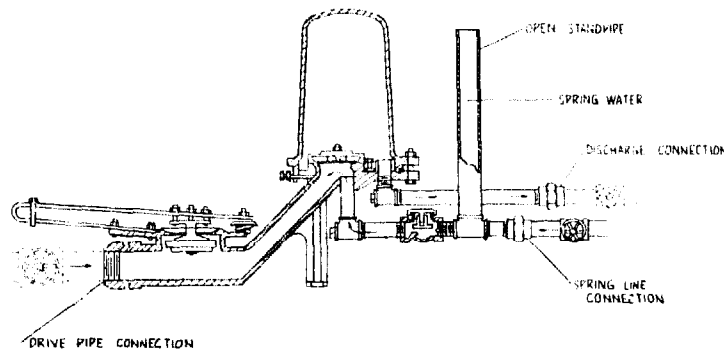

Creek Water provides the Source of Power through Drive Pipe and operates Ram.

At end of each stroke the rebound creates a vacuum beneath Inside Valve which draws pure spring water through Spring Supply Pipe and fills up the area in the base between the Outside Valve and Inside Valve. This action is assisted by

reservoir of water in Open Standpipe. A small part of the spring water comes in contact with creek water and is wasted through Outside Valve. The remaining pure, clean uncontaminated spring water is rammed into the Air Chamber through Inside Rubber Valve and delivered through Discharge Pipe to where desired.

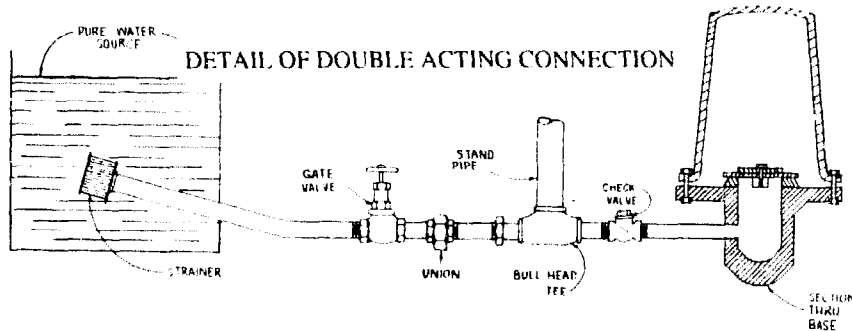

PNEUMATIC PRESSURE TANK WATER SYSTEM

A PNEUMATIC PRESSURE TANK WATER SYSTEM consists of an air-tight steel tank into which water is pumped by the Ram. This tank can be located in the cellar of the house, in the Ram Pit, or any other convenient place. Its location depends upon whether or not use of the waste water is desired. If the overflow or

waste water is to be used in a Watering Trough, Dairy, Rock Garden, etc., the Pneumatic Pressure Tank should be installed in the basement or some other location near the house. If no use is to be made of the overflow or waste water, the Pneumatic Tank can be installed in Ram Pit.

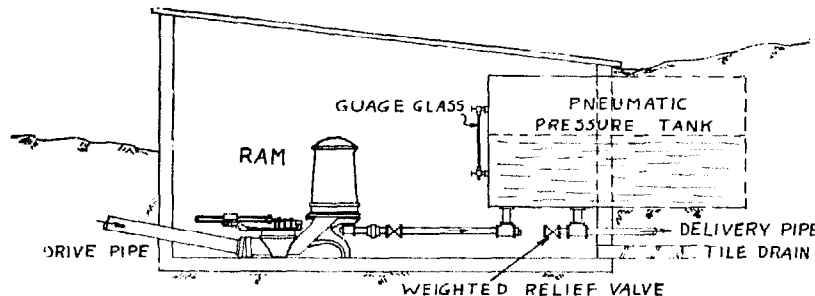

A Relief Valve is installed in the Delivery Pipe. When the pressure in the Tank, corresponding to the setting of the Relief Valve is reached, the water by-passes through the Relief Valve. The location of the Relief Valve should be such that this waste water flows in a downward direction from the Relief Valve to where it

is desired. A setting of 20 lbs. on Relief Valve will force water approximately 45 feet above the Tank. A setting of 30 lbs. will force the water approximately 75 feet above the Tank. To lower or raise water level in pressure tank, feed more or less air through Air Feed Valve on Ram.

RIFE RAM—ARTESIAN WELL INSTALLATION

An Artesian (flowing) Well provides an ideal source of Supply Water for operating a Rife Ram. Because the constantly flowing sand in the water from Artesian Wells rapidly wears Bronze or other metal valves, Special Composition Rubber

Valves are used in Rife Rams, thus eliminating damage from this source.

There are various methods of connecting a Ram to an Artesian Well, as illustrated.

ARTESIAN WELL CASING

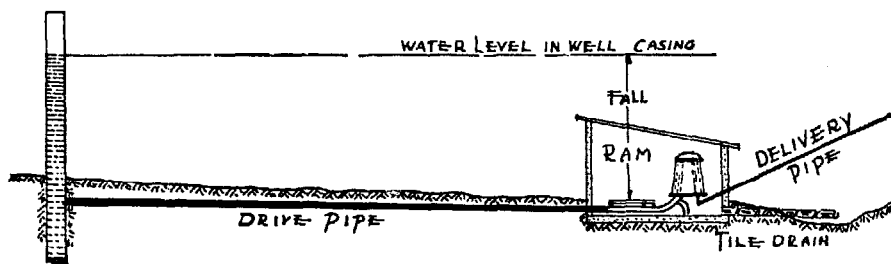

Drive Pipe is connected directly to Well-casing slightly below the level of the ground. Give Drive Pipe as much Slope or Fall to where it connects on to the Ram as the lay of the ground will permit. This method is ideal for small domestic installations.

Where necessary to install a smaller well-casing inside a larger one, and therefore impractical to connect the Drive Pipe directly to the Well-casing below the level of the ground, the installation illustrated below is ideal and inexpensive.

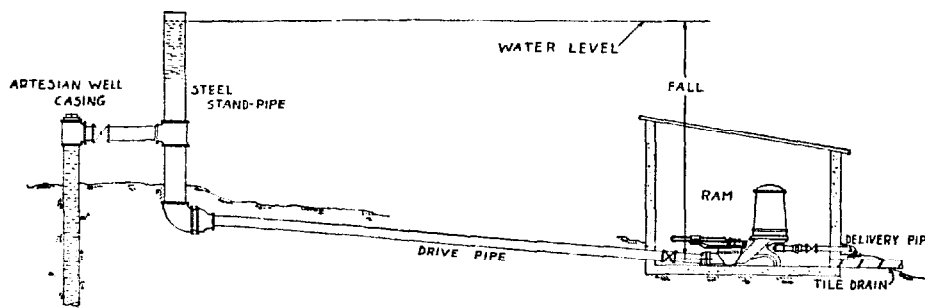

A "T" Pipe-fitting is installed on top of the casing with a Gate or Cut-off Valve controlling the flow of water into the Steel Stand-pipe, the latter being high enough to

prevent overflowing. This type of installation is particularly well adapted to Medium-sized jobs.

LARGE ARTESIAN WELL—RAM INSTALLATION

For Irrigation, Municipal Water Supply and other large installations, this illustration shows a most effective manner of installing the Rife Ram to be operated from Artesian Well. It is particularly well adapted where Two or more Rams are

installed in a battery. A Gate or Cut-off Valve controls the flow of water from the well-casing into the Concrete Pit—the Pit being high enough to prevent over-flowing. Note the Drain at the bottom of Concrete Pit for removal of sand accumulation.

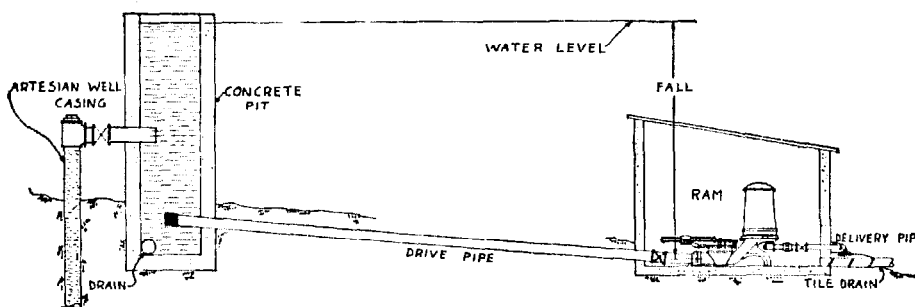

The Correct Length of Drive Pipe for Artesian Well is determined in the same manner as for Spring or Creek.

INSTALLATION OF TWO OR MORE RAMS

In case two or more Rams are installed one common Delivery Pipe of sufficient size to carry the water pumped by the Rams. In case two or more Rams are installed along side of each other, it is necessary for each Ram to have its own individual Drive Pipe, but both or all of them can pump into

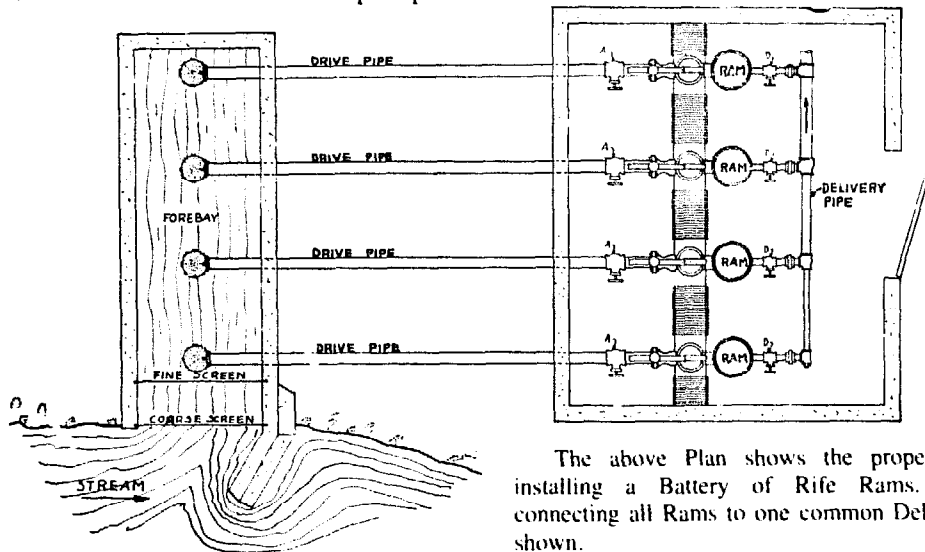

The above Plan shows the proper method of installing a Battery of Rife Rams. Method of connecting all Rams to one common Delivery Pipe is shown.

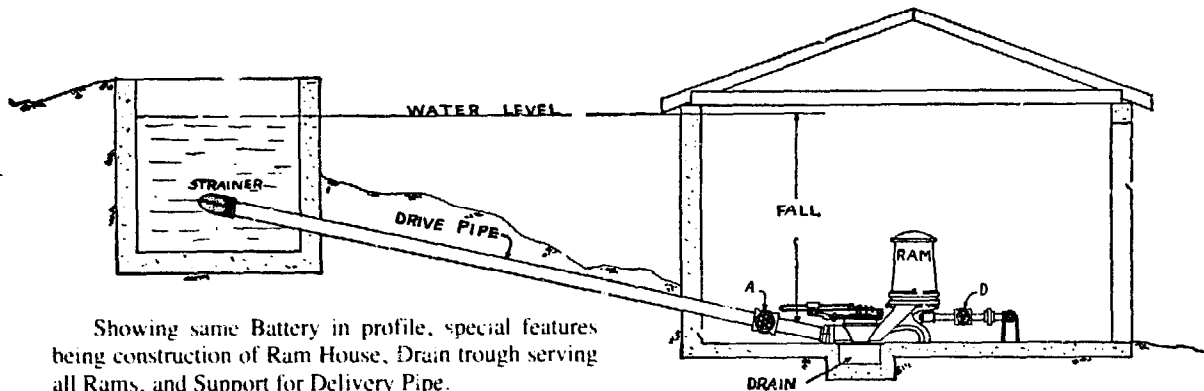

Showing same Battery in profile, special features being construction of Ram House, Drain trough serving all Rams, and Support for Delivery Pipe.

On Irrigation, Municipal Water Supply or other large projects a Battery of 2 or more Rife Rams offers unlimited possibilities for an efficient and economical water system. It is often desirable to install 2 medium sized Rams to pump the same amount of water that could be pumped by

one larger sized Ram. For instance, a Golf Course requires much more water in Summer than in Winter. With a Battery Installation the number of Rams kept in operation can be governed by the amount of water required.

We have a number of installations in which a battery of up to six Rams are placed together drawing water from the same source through individual Drive Pipes but pumping through a common Delivery Pipe. This arrangement will deliver a correspondingly larger amount of water than could be obtained with a single Ram.

STORAGE OF WATER

It is often advisable to pump the water into a Storage Tank of some kind so as to have available at all times a large supply for ready use. The storage can either be an outside overhead tank, a concrete pit in the side of a hill, a steel or wooden tank in the attic or a Pneumatic Pressure Tank in the basement. In case the amount of water being pumped exceeds one gallon per

minute, a Storage Tank, in most cases, is unnecessary, except for fire protection.

The flow of water from a Rife Ram is continuous 24 hours per day WITHOUT ATTENTION. The water that is not used at the house or the overflow water can be piped to any convenient place such as a Watering Trough, Spring House, Dairy, Pool, Rock Garden, etc.

THE NEW HIGH CAPACITY MODELS OF RIFE AND DAVEY
HYDRAULIC RAM PUMPS

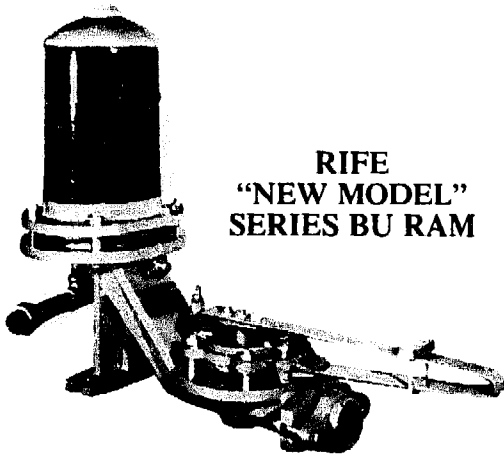

RIFE
"NEW MODEL"
SERIES BU RAM

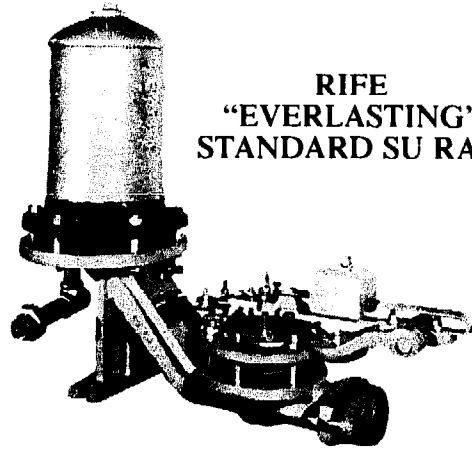

RIFE
"EVERLASTING"
STANDARD SU RAM

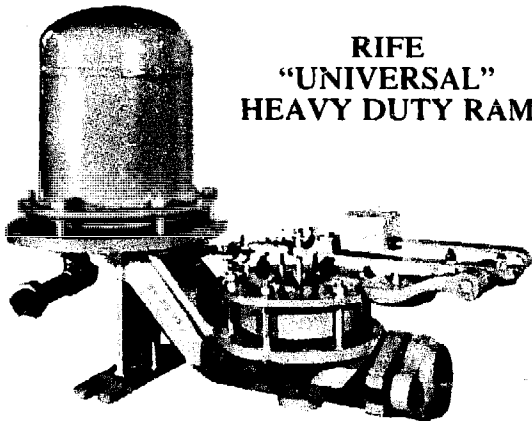

RIFE
"UNIVERSAL"
HEAVY DUTY RAM

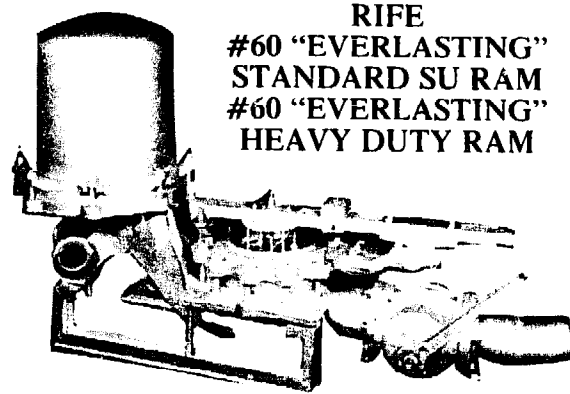

RIFE
#60 "EVERLASTING"
STANDARD SU RAM
#60 "EVERLASTING"
HEAVY DUTY RAM

DAVEY RAM

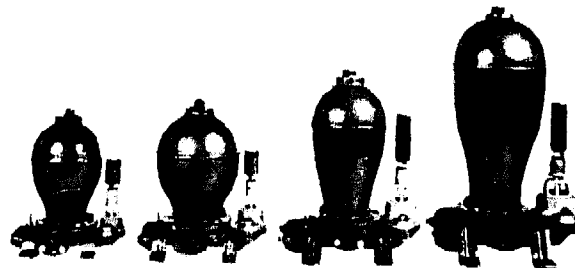

Information Sheet

For

Proposed Rife Hydraulic Ram Installation

- 1. Available supply of water in gallons per minute _____
- 2. Vertical fall in feet _____
(Measure the amount of vertical fall in feet from the water level of the source of supply down to the level of the foundation on which the Ram will rest.)
- 3. Distance from source of supply to Ram _____
- 4. Vertical lift in feet _____
(Measure the vertical lift in feet from the level of the foundation on which the Ram will rest up to the elevation of the highest point to which the water is delivered.)
- 5. Distance in feet from Ram to delivery tank. _____
- 6. Number of gallons required to be delivered per day. _____

NAME _____

ADDRESS _____

PHONE _____

If you will fill out this sheet and send it to us, we will send you, without obligation, our recommendation of the size of RAM required and our estimate of the number of gallons per water which it will deliver per day. The diagram on the reverse side of this sheet illustrates a typical RAM installation.

NOTE — The usual hydraulic RAM installation consists of supply basin or reservoir, an inclined drive pipe leading down to the hydraulic RAM, which operates without power, and a delivery pipe and tank located at higher elevation than the supply basin. The amount of the vertical fall to the RAM can be between four and thirty feet and the amount of lift from the RAM to the delivery tank must be at least twice but not more than twenty times the amount of vertical fall.

RETURN TO

RIFE HYDRAULIC ENGINE MFG. CO.

316 W. Popular Street, P. O. Box 790

Norristown, Pennsylvania 19401

(215) 279-2997

RIFE HYDRAULIC ENGINE MANUFACTURING CO.

Rife Ram & Pump Works

P.O. Box 790

Norristown, PA 19404

U.S.A.

JUN
198



RIFE
SINCE 1884

KEN DARROW

APPROPRIATE TECHNOLOGY PROJECT

P O BOX 4543

STANFORD CA 94305

DAVEY FIGURE 84 HYDRAULIC RAM

RIFE
SINCE 1884

RIFE HYDRAULIC ENGINE MANUFACTURING CO.

Rife Ram & Pump Works
316 W. Poplar St./P.O. Box 790
Norristown, PA 19401
U.S.A.

Nov. 1985

**WATER
PUMPING
EQUIPMENT
WORLDWIDE**

(215) 279-2997

CONDITIONS FOR A SATISFACTORY DAVEY HYDRAULIC RAM INSTALLATION

There must be three or more feet of fall from spring or pond to Ram. There must be some fall away from Ram so that water discharged from Impetus Valve can drain away from Ram.

The length of Intake or Drive Pipe should be no less than five times and no greater than ten times the height of fall.

Intake and discharge Pipe should be the same size their entire length as their respective tappings in Ram.

Gate Valves should be installed close to Inlet and Outlet of Ram so that by closing these Valves adjustment or servicing of Ram can be done without draining the water from supply or discharge Pipes.

Ram and Gate Valves should be installed in a frost proof pit and the supply and discharge Pipes buried below the frost line.

Air or snifter Valve must have cap removed when Ram is operating and must at no time be immersed in the waste water from Impetus Valve.

Entrance to intake or Drive Pipe in spring or pond must be fitted with a strainer to keep out sticks, etc.

The Davey Ram is designed to use a supply head of 3 - 20 ft. and deliver to elevation of 5 - 10 times the supply head, maximum 100 ft.

SIZE OF RAM No.	QUANTITY OF WATER FURNISHED PER MIN. BY SPRING OR BROOK TO WHICH RAM IS ADAPTED	SIZE OF PIPE DRIVE DISCHARGE		PRICE	VALVE KIT	WT
2	3 Quarts to 2 Gallons	3/4"	1/2"	\$ 264.00	\$ 34.00	16
3	1 1/2" Gallons to 4 Gallons	1"	1/2"	\$ 308.00	\$ 37.00	25
4	3 Gallons to 7 Gallons	1 1/2"	3/4"	\$ 358.00	\$ 58.00	30
5	6 Gallons to 14 Gallons	2"	1"	\$ 429.00	\$ 77.00	51

****NOTE:** We recommend that plug type Valves be installed at both ends of the Davey figure 84 Ram. We can ship the proper Valves with each Ram at the cost listed above.

***PRICES AND SPECIFICATIONS SUBJECT TO CHANGE WITHOUT NOTICE.**

SPECIFICATION AND PRICES OF RIFE HYDRAULIC RAMS
New High Capacity Models

RIFE
SINCE 1884

RIFE HYDRAULIC ENGINE MANUFACTURING CO.
Rife Ram & Pump Works
316 W. Poplar St./P.O. Box 790
Norristown, PA 19401
U.S.A.

Nov. 1985

**WATER
PUMPING
EQUIPMENT
WORLDWIDE**

(215) 279-2997

RAM MODEL #	INTAKE DRIVE PIPE	DISCHARGE DELIVERY PIPE SIZE	INTAKE CAP GPM USED MIN. MAX.	MIN, VERT FALL REQ (IN feet)	SHIP & WT IN Lb. APPROX.	PRICE SINGLE ACTING F.O.B. NORRISTOWN, PA
-------------	-------------------	------------------------------	-------------------------------	------------------------------	--------------------------	---

RIFE "NEW MODEL" SERIES BU RAMS (4-BOLTS DESIGN)
Maximum vertical fall 15 ft. Maximum vertical lift 150 ft.

						RAM	VALVE KIT
10BU	1½"	¾"	2 - 7	3	120	\$ 549.00	\$ 51.00
15BU	1½"	¾"	5 - 13	3	120	\$ 561.00	\$ 51.00
20BU	2"	1"	8 - 20	3	120	\$ 633.00	\$ 75.00

RIFE "EVERLASTING" STANDARD RAMS

A more rugged development of the previous series "A" (6-Bolts Design)
Maximum vertical fall 25 ft. Maximum vertical lift 250 ft.

10SU	1½"	¾"	3 - 10	3	125	\$ 706.00	\$ 51.00
15SU	1½"	¾"	5 - 14	3	125	\$ 726.00	\$ 51.00
20SU	2"	1"	10 - 22	4	125	\$ 825.00	\$ 75.00
20SUL	2"	1"	12 - 30	4	270	\$1056.00	\$ 75.00
25SU	2½"	1"	15 - 45	4	270	\$1072.00	\$174.00
30SU	3"	1½"	20 - 70	4	270	\$1210.00	\$221.00
40SU	4"	2"	35 - 125	4	565	\$2013.00	\$319.00
60SU	6"	3"	75 - 350	4	1325	\$4395.00	\$495.00

RIFE "UNIVERSAL" HEAVY DUTY RAMS (6-BOLTS DESIGN)

Maximum vertical fall 50 ft. Maximum vertical lift 500 ft.

10HDU	1½"	¾"	3 - 10	3	170	\$ 853.00	\$ 51.00
15HDU	1½"	¾"	5 - 15	3	170	\$ 877.00	\$ 51.00
20HDU	2"	1"	10 - 25	4	170	\$ 963.00	\$ 75.00
20HDUL	2"	1"	12 - 33	4	310	\$1183.00	\$ 75.00
25HDU	2½"	1"	15 - 45	4	310	\$1265.00	\$174.00
30HDU	3"	1½"	25 - 75	4	310	\$1375.00	\$221.00
40HDU	4"	2"	35 - 150	5	565	\$2475.00	\$319.00
60HDU	6"	3"	75 - 400	5	1325	\$5247.00	\$495.00

Note: BU, SU, AND HDU shipped with strainer for intake end of drive pipe.

We recommend taht valves be installed at both intake and discharge ends of Rife Hydraulic Rams. We can ship the proper valves with each Ram at the cost listed above. We can also furnish Double Acting Attachments.

*PRICES AND SPECIFICATIONS SUBJECT TO CHANGE WITHOUT NOTICE