

WIND ENERGY SYSTEMS

Electronic Edition

by

Gary L. Johnson

Manhattan, KS

TABLE OF CONTENTS

1 Introduction.....	1-1
1.1 Historical Uses of Wind.....	1-2
1.2 History of Wind Electric Generation.....	1-3
1.3 Horizontal Axis Wind Turbine Research.....	1-5
1.4 Darrieus Wind Turbines.....	1-13
1.5 Innovative Wind Turbines.....	1-16
1.6 California Wind farms.....	1-21
2 Wind Characteristics.....	2-1
2.1 Meteorology of Wind.....	2-1
2.2 World Distribution of Wind.....	2-7
2.3 Wind Speed Distribution in the United States.....	2-8
2.4 Atmospheric Stability.....	2-14
2.5 Wind Speed Variation With Height.....	2-23
2.6 Wind Speed Statistics.....	2-26
2.7 Weibull Statistics.....	2-30
2.8 Determining the Weibull Parameters.....	2-38
2.9 Rayleigh and Normal Distributions.....	2-44
2.10 Distribution of Extreme Winds.....	2-55
2.11 Problems.....	2-62
3 Wind Measurements.....	3-1
3.1 Eolian Features.....	3-1
3.2 Biological Indicators.....	3-2
3.3 Rotational Anemometers.....	3-5
3.4 Other Anemometers.....	3-14
3.5 Wind Direction.....	3-17
3.6 Wind Measurements with Balloons.....	3-28
3.7 Problems.....	3-34

4 Wind Turbine Power, Energy, and Torque.....	4-1
4.1 Power Output from an Ideal Turbine.....	4-1
4.2 Aerodynamics.....	4-4
4.3 Power Output from Practical Turbines.....	4-7
4.4 Transmission and Generator Efficiencies.....	4-13
4.5 Energy Production and Capacity Factor.....	4-21
4.6 Torque at Constant Speeds.....	4-29
4.7 Drive Train Oscillations.....	4-33
4.8 Starting a Darrieus Turbine.....	4-39
4.9 Turbine Shaft Power and Torque at Variable Speeds.....	4-43
4.10 Problems.....	4-49
5 Wind Turbine on the Electrical Network.....	5-1
5.1 Methods of Generating Synchronous Power.....	5-1
5.2 AC Circuits.....	5-4
5.3 The Synchronous Generator.....	5-14
5.4 Per Unit Calculations.....	5-22
5.5 The Induction Machine.....	5-27
5.6 Motor Starting.....	5-37
5.7 Capacity Credit.....	5-40
5.8 Features of the Electrical Network.....	5-48
5.9 Problems.....	5-58
6 Asynchronous Electrical Generators.....	6-1
6.1 Asynchronous Systems.....	6-2
6.2 DC Shunt Generator with Battery Load.....	6-5
6.3 Permanent Magnet Generators.....	6-11
6.4 AC Generators.....	6-18
6.5 Self-Excitation of the Induction Generator.....	6-20
6.6 Single-Phase Operation of the Induction Generator.....	6-32

6.7 Field Modulated Generator.....	6-37
6.8 Roesel Generator.....	6-39
6.9 Problems.....	6-42
7 Asynchronous Loads.....	7-1
7.1 Piston Water Pumps.....	7-2
7.2 Centrifugal Pumps.....	7-10
7.3 Paddle Wheel Water Heaters.....	7-21
7.4 Batteries.....	7-23
7.5 Hydrogen Economy.....	7-33
7.6 Electrolysis Cells.....	7-40
7.7 Problems.....	7-47
8 Economics of Wind Systems.....	8-1
8.1 Capital Costs.....	8-1
8.2 Economic Concepts.....	8-9
8.3 Revenue Requirements.....	8-15
8.4 Value of Wind Generated Electricity.....	8-20
8.5 Hidden Costs in Industrialized Nations.....	8-23
8.6 Economic Factors in Developing Countries.....	8-24
8.7 Problems.....	8-26
9 Wind Power Plants.....	9-1
9.1 Turbine Placement.....	9-1
9.2 Site Preparation.....	9-2
9.3 Electrical Network.....	9-4
9.4 Selection of Sizes, Low Voltage Equipment.....	9-7
9.5 Selection of Sizes, Distribution Voltage Equipment.....	9-14
9.6 Voltage Drop.....	9-22
9.7 Losses.....	9-24
9.8 Protective Relays.....	9-28

9.9 Wind farm Costs.....	9-30
9.10 Problems.....	9-34
Appendix A: Conversion Factors.....	9-36
Appendix B: Answers To Selected Problems.....	9-37
Appendix C: Wire Sizes.....	9-39
Appendix D: Streams and Waterways.....	9-45

PREFACE TO FIRST EDITION

Wind energy systems draw on a wide range of disciplines. Any prospective user, regardless of his background, will feel large gaps in his knowledge, areas where he does not even know what the question is, let alone where to go look for the answer. This book is written to help people identify the proper question to ask.

There are several groups of potential users of a book on wind energy systems. There are those with non technical backgrounds who want a readable introduction. There are graduate engineers who need a detailed treatment of some aspect of wind power systems. And there are undergraduate engineering students who need a formal course in the subject. We have chosen the undergraduate engineering student as the primary audience, but have tried to consider the needs of other users. Many of the key concepts should be readily understood by those with a good high school education. Those sections which demand a more technical treatment, however, assume a background in chemistry, physics, calculus, circuit theory, and dynamics. Rather detailed treatments of meteorology, statistics, electrical machines, and engineering economics are given, but since these subjects are not studied by all engineers, no background is assumed for these areas. Enough detail is included so that a technically trained person can evaluate a given system for a proposed application and also learn enough of the specific language that he can look elsewhere for more information in an efficient manner.

This book will be of interest to those students who are interested in energy sources besides coal and nuclear. Oil and natural gas are obviously not suitable long term solutions to our energy requirements, and coal and nuclear energy face severe environmental obstacles. This means that the so-called alternative energy sources may well become primary sources over the next few decades. At the present time wind, solar photovoltaic, and solar thermal systems appear to be the main contenders for supplying a substantial fraction of the energy requirements of the United States and much of the remainder of the world as well.

A number of books about wind power have been written in the last decade by those working in the field. These books generally have no problems at the end of the chapters, and hence are difficult to use in a formal course. The author believes that significant numbers of students in engineering or technology would be interested in a course on wind energy systems

if an appropriate textbook were available. It is hoped that this book will fill such a need.

An attempt has been made to pull together information from many sources and present it in a clear, consistent fashion in this text. Most of the material is available in the open literature, but some that has been developed from research at Kansas State University has not been published elsewhere. This includes some wind speed data and much of the material on induction generators.

Both large and small wind turbines are discussed. The person designing a wind farm of multi-megawatt machines connected to the utility grid should find the necessary background material here, as well as the person desiring to install a small battery charging system in a remote location. Information is included on piston pumps, centrifugal pumps, batteries, electrolysis cells, and other topics that may be important in certain wind power applications. Much of this information is difficult to find in a concise form elsewhere, so this should increase the usefulness of the book.

The field is evolving rapidly, so some specific examples will become obsolete quickly. An effort has been made, however, to present the basic information that is not likely to change, so the book will be useful for a number of years.

It has been the author's experience that the quantity of material is ample for a three hour course. The instructor may need to be selective about sections to be covered. Chapters 2,4,5, and 8 are viewed as the heart of the course, and the other chapters can be omitted, if necessary, with little loss of continuity. The book has been classroom tested over a five year period and much of it has been rewritten to include improvements suggested by the students.

SI units have been used extensively throughout the book, with English units used as necessary to bridge the gap between present practice and the anticipated total conversion to SI units. A list of conversion factors is given at the end of the book.

A good selection of problems is given at the end of each chapter. Some problems require the use of a programmable hand calculator or a digital computer. These can be used where all the students have access to such equipment to give additional practice in computational techniques.

The author wishes to express appreciation to Theresa Shipley and Teresa Gallup for typing various versions of the manuscript. He also wishes to thank the many students who offered suggestions and criticisms. Finally, he wishes to thank his wife Jolene, and his children, Kirk and Janel, for their patience during the writing of the book.

PREFACE TO SECOND EDITION

A ninth chapter, on wind farm layout, has been added to the second edition. This discusses topics like wire and transformer selection. We actually start the semester with this chapter

and Chapter 8, so we can give a wind farm design project early in the semester. Each student is asked to do a paper design of a wind farm, including layout, sizing of components, and economic analysis. This design has worked very well, helping to make the course one of the most popular elective courses in the department. There were 46 in the course Fall 1993, which was the largest enrollment of any elective course in the department. The chapter has enough tables on wire sizes, wire costs, transformer sizes and costs, and other costs that the student can feel confident of doing a respectable design without seeking other sources of information. Each student is given a topographical map and an aerial photo of a particular square mile at one of five sites, and performance data for a particular turbine or two at that site. One student may have a flat site while another may have one with hills and sharp ravines. Some sites have railroads or pipelines. Each student has a different design to do, which greatly reduces concern about copying, but still the difficulty of each design is approximately the same. The deadline for designs is about two-thirds of the way through the semester, so there is ample time to grade them.

Once the designs are given, we go back to the start of the book and see how far we can get. We usually skip Chapter 3, and the portions of Chapter 5 that are covered in an earlier required course on Energy Conversion.

After Prentice-Hall let the First Edition go out of print, the copyright was returned to the author. This Second Edition is copyrighted, however, it is planned to grant a broad authorization to copy and/or edit any or all of this material to a school or other organization upon the payment of a one time fee. Any reader who is not already covered by an existing authorization should contact the author for details.

Gary L. Johnson

Manhattan, KS

January 1994

PREFACE TO ELECTRONIC EDITION

The author took early retirement in May, 1994 and spent the next two years working as a consultant to a wind farm developer that was interested in establishing a wind farm in Kansas. A large ranch in southern Kansas was selected and three towers were instrumented, two at 40 m and one at 60 m. At the end of two years it was obvious that it would be several more years before wind farms were established in Kansas, so the developer walked away from the lease. The rancher and the author have continued to collect data since that time, confirming that the ranch is indeed a premium site. A number of developers and utilities have considered the possibilities, but as of this writing, the ranch is still available.

A number of copies of this book were photocopied and sold since 1994, and several organizations opted to buy the permission to edit and photocopy at will, as mentioned in the previous preface. But things have slowed down such that economically there is no point in continuing this process. While some of the prices are outdated, the author believes there is considerable basic information in this book that is still quite valid. Therefore the decision was made to scan in some of the figures and photographs and prepare these files in PDF format. The only change made was to put references at the end of each chapter rather than at the end of the book. Except for the photographs copyrighted by others, this material should be considered as in the public domain. May it yet serve a role in establishing wind power as a significant source of electrical energy throughout the world.

November, 2001

INTRODUCTION

Look at the ships also:, though they are so great and are driven by strong winds, they are guided by a very small rudder wherever the will of the pilot directs. James 3:4

The wind is a free, clean, and inexhaustible energy source. It has served mankind well for many centuries by propelling ships and driving wind turbines to grind grain and pump water. Interest in wind power lagged, however, when cheap and plentiful petroleum products became available after World War II. The high capital costs and the uncertainty of the wind placed wind power at an economic disadvantage. Then in 1973, the Arab nations placed an embargo on petroleum. The days of cheap and plentiful petroleum were drawing to an end. People began to realize that the world's oil supplies would not last forever and that remaining supplies should be conserved for the petrochemical industry. The use of oil as a boiler fuel, for example, would have to be eliminated. Other energy sources besides oil and natural gas must be developed.

The two energy sources besides petroleum which have been assumed able to supply the long term energy needs of the United States are coal and nuclear energy. Many people think there is enough coal for several centuries at present rates of consumption, and likewise for nuclear energy after the breeder reactor is fully developed. These are proven resources in the sense that the technology is highly developed, and large coal and nuclear powered electrical generating plants are in operation and are delivering substantial blocks of energy to the consumer. Unfortunately, both coal and nuclear present serious environmental problems. Coal requires large scale mining operations, leaving land that is difficult or impossible to restore to usefulness in many cases. The combustion of coal may upset the planet's heat balance. The production of carbon dioxide and sulfur dioxide may affect the atmosphere and the ability of the planet to produce food for its people. Coal is also a valuable petrochemical feedstock and many consider the burning of it as a boiler fuel to be foolish.

Nuclear energy has several advantages over coal in that no carbon dioxide or sulfur dioxide are produced, mining operations are smaller scale, and it has no other major use besides supplying heat. The major difficulty is the problem of waste disposal, which, because of the fears of many, will probably never have a truly satisfying solution.

Because of these problems, wind power and other forms of solar power are being strongly encouraged. Wind power may become a major source of energy in spite of slightly higher costs than coal or nuclear power because of the basically non-economic or political problems of coal and nuclear power. This is not to say that wind power will always be more expensive than coal or nuclear power, because considerable progress is being made in making wind power less expensive. But even without a clear cost advantage, wind power may become truly important in the world energy picture.

1 HISTORICAL USES OF WIND

The wind has been used to power sailing ships for many centuries. Many countries owed their prosperity to their skill in sailing. The New World was explored by wind powered ships. Indeed, wind was almost the only source of power for ships until Watt invented the steam engine in the 18th Century.

On land, wind turbines date back many centuries. It has been reported that the Babylonian emperor Hammurabi planned to use wind turbines for irrigation in the seventeenth century B.C. [3]. Hero of Alexandria, who lived in the third century B.C., described a simple horizontal axis wind turbine with four sails which was used to blow an organ [3].

The Persians were using wind turbines extensively by the middle of the seventh century A.D. Theirs was a vertical axis machine with a number of radially-mounted sails [3].

These early machines were undoubtedly crude and mechanically inefficient, but they served their purpose well for many centuries. They were made from local materials by cheap labor. Maintenance was probably a problem which served to keep many people at work. Their size was probably determined by the materials available. A need for more power was met by building more wind turbines rather than larger ones. There are many of the lesser developed countries of the world today which could profitably use such low technology machines because of the large amounts of cheap, unskilled labor available. Such countries often have difficulty acquiring the foreign exchange necessary to purchase high technology machines, and then have difficulty maintaining them.

The earliest recorded English wind turbine is dated at 1191. The first corn-grinding wind turbine was built in Holland in 1439. There were a number of technological developments through the centuries, and by 1600 the most common wind turbine was the tower mill. The word mill refers to the operation of grinding or milling grain. This application was so common that all wind turbines were often called windmills even when they actually pumped water or performed some other function. We will usually use the more general terms wind turbine or wind machine rather than windmill, unless the application is actually that of grinding grain.

The tower mill had a fixed supporting tower with a rotatable cap which carried the wind rotor. The tower was usually built of brick in a cylindrical shape, but was sometimes built of wood, and polygonal in cross section. In one style, the cap had a support or tail extending out and down to ground level. A circle of posts surrounded the tower where the support touched the ground. The miller would check the direction of the prevailing wind and rotate the cap and rotor into the wind with a winch attached between the tail and one of the posts. The tail would then be tied to a post to hold the rotor in the proper direction. This process would be repeated when the wind direction changed. Protection from high winds was accomplished by turning the rotor out of the wind or by removing the canvas covering the rotor latticework.

The optimization of the rotor shape probably took a long time to accomplish. It is interesting to note that the rotors on many of the Dutch mills are twisted and tapered in the

same way as modern rotors and appear to have nearly optimized the aerodynamic parameters necessary for maximum efficiency. The rotors presently on the tower mills probably do not date back to the original construction of the tower, but still indicate high quality aerodynamic engineering of a period much earlier than the present.

Dutch settlers brought this type of wind turbine to America in the mid-1700's. A number were built but not in the quantity seen in Europe.

Then in the mid-1800's a need developed for a smaller wind turbine for pumping water. The American West was being settled and there were wide areas of good grazing lands with no surface water but with ample ground water only a few meters under the surface. With this in mind, a distinctive wind turbine was developed, called the American Multibladed wind turbine. It had high starting torque and adequate efficiency, and suited the desired water pumping objective very well. If the wind did not blow for several days, the pump would be operated by hand. Since this is a reasonably good wind regime, hand pumping was a relatively rare occurrence.

An estimated 6.5 million units were built in the United States between 1880 and 1930 by a variety of companies. Many of these are still operating satisfactorily. By providing water for livestock, these machines played an important role in settling the American West.

2 HISTORY OF WIND ELECTRIC GENERATION

Denmark was the first country to use the wind for generation of electricity. The Danes were using a 23 m diameter wind turbine in 1890 to generate electricity. By 1910, several hundred units with capacities of 5 to 25 kW were in operation in Denmark.

About 1925, commercial wind-electric plants using two- and three-bladed propellers appeared on the American market. The most common brands were Wincharger (200 to 1200 W) and Jacobs (1.5 to 3 kW). These were used on farms to charge storage batteries which were then used to operate radios, lights, and small appliances with voltage ratings of 12, 32, or 110 volts. A good selection of 32 Vdc appliances was developed by industry to meet this demand. Then the Rural Electric Administration (REA) was established by Congress in 1936. Low interest loans were provided so the necessary transmission and distribution lines could be constructed to supply farmers with electricity. In the early days of the REA, around 1940, electricity could be supplied to the rural customer at a cost of 3 to 6 cents per kWh. The corresponding cost of wind generated electricity was 12 to 30 cents per kWh when interest, depreciation, and maintenance were included [6]. The lower cost of electricity produced by a central utility plus the greater reliability led to the rapid demise of the home wind electric generator.

After 1940, the cost of utility generated electricity continued a slow decline, dipping under 3 cents per kWh in the early 1970's. This was accomplished by their using larger and more efficient generating plants. A trend of decreasing cost for electricity while other costs are

increasing could not be continued forever, and utility generated electricity started increasing in cost in the early 1970's reaching the 1940 cost level around 1976. This was accompanied by many consumer complaints, of course, which were largely unjustified when the long term performance of the utilities in providing low cost, reliable electricity is considered.

In addition to home wind electric generation, a number of utilities around the world have built larger wind turbines to supply power to their customers. The largest wind turbine built before the late 1970's was a 1250 kW machine built on Grandpa's Knob, near Rutland, Vermont, in 1941. The concept for this started in 1934 when an engineer, Palmer C. Putnam, began to look at wind electric generators to reduce the cost of electricity to his Cape Cod home [8]. In 1939, Putnam presented his ideas and the results of his preliminary work to the S. Morgan Smith Company of York, Pennsylvania. They agreed to fund a wind-energy project and the Smith-Putnam wind turbine experiment was born. The wind machine was to be connected into the Central Vermont Public Service Corporation's network. This utility had some hydro-electric capacity, which makes a good combination with wind generation in that water can be saved when the wind is blowing and used later when the wind is not blowing.

The Smith-Putnam machine had a tower which was 34 m high and a rotor 53 m in diameter. The rotor had a chord (the distance from the leading to the trailing edge) of 3.45 m. Each of the two blades was made with stainless steel ribs covered by a stainless steel skin and weighed 7300 kg. The blade pitch (the angle at which the blade passes through the air) was adjustable to maintain a constant rotor speed of 28.7 r/min. This rotational speed was maintained in wind speeds as high as 32 m/s. At higher wind speeds, the blades were feathered and the machine stopped. The rotor turned an ac synchronous generator that produced 1250 kW of electrical power at wind speeds above 13 m/s.

Between 1941 and 1945 the Smith-Putnam machine accumulated about 1100 hours of operation. More would have been accumulated except for the problem of getting critical repair parts during the war. In 1945 one of the blades failed, due more to inadequate design than to technological limitations. The project was reviewed and was determined to be a technical success. The economics did not justify building more machines at that time, however. It appeared that additional Smith-Putnam machines could be built for about \$190/installed kW. Oil and coal fired generation could be bought in 1945 for \$125/installed kW. This was too large a difference to justify to the stock-holders, so the project was stopped and the wind machine was dismantled.

The technical results of the Smith-Putnam wind turbine caused Percy H. Thomas, an engineer with the Federal Power Commission, to spend approximately 10 years in a detailed analysis of Wind Power Electric Generation [14]. Thomas used economic data from the Smith-Putnam machine and concluded that even larger machines were necessary for economic viability. He designed two large machines in the size range he felt to be best. One was 6500 kW and the other was 7500 kW in size. The tower height of the 6500 kW machine was to be 145 m with two rotors each 61 m in diameter. Each rotor was to drive a dc generator. The dc power was used to drive a dc to ac synchronous converter which was connected to the power grid.

Thomas estimated the capital costs for his machine at \$75 per installed kW. This was low enough to be of interest so the Federal Power Commission approached Congress for funding a prototype of this machine. It was in 1951 when the Korean War was starting, and Congress chose not to fund the prototype. The project was later canceled. This basically marked the end of American wind power research for over twenty years until fuel supplies became a problem.

Other countries continued wind research for a longer period of time. Denmark built their Gedser wind turbine in 1957. This machine produced 200 kW in a 15 m/s wind. It was connected to the Danish public power system and produced approximately 400,000 kWh per year. The tower was 26 m high and the rotor was 24 m in diameter. The generator was located in the housing on the top of the tower. The installation cost of this system was approximately \$250/kW. This wind turbine ran until 1968 when it was stopped [14].

Dr. Ulrich Hutter of Germany built a 100 kW machine in 1957. It reached its rated power output at a wind speed of 8 m/s, which is substantially lower than the machines mentioned earlier. This machine used lightweight, 35 m diameter fiberglass blades with a simple hollow pipe tower supported by guy wires. The blade pitch would change at higher wind speeds to keep the propeller angular velocity constant. Dr. Hutter obtained over 4000 hours of full rated power operation over the next 11 years, a substantial amount for an experimental machine. This allowed important contributions to the design of larger wind turbines to be made.

3 HORIZONTAL AXIS WIND TURBINE RESEARCH IN THE UNITED STATES

The Federal Wind Energy Program had its beginning in 1972 when a joint Solar Energy Panel of the National Science Foundation (NSF) and the National Aeronautics and Space Administration (NASA) recommended that wind energy be developed to broaden the Nation's energy options for new energy sources.[9] In 1973, NSF was given the responsibility for the Federal Solar Energy Program, of which wind energy was a part. The Lewis Research Center, a Federal Laboratory controlled by NASA, was selected to manage the technology development and initial deployment of large wind turbines. Early in 1974, NASA was funded by NSF to (1) design, build, and operate a wind turbine for research purposes, designated the MOD-0, (2) initiate studies of wind turbines for utility application, and (3) undertake a program of supporting research and technology development for wind turbines.

In 1975, the responsibility within the Federal government for wind turbine development was assigned to the newly created Energy Research and Development Administration (ERDA). ERDA was then absorbed by the Department of Energy (DOE) in 1977. The NASA Lewis Research Center continued to direct the technology development of large turbines during this period.

During the period following 1973, other Federal Laboratories became involved with other

aspects of Wind Energy Collection Systems (WECS). Sandia Laboratories, a DOE Laboratory located at Albuquerque, New Mexico, became responsible for federally sponsored research on Darrieus wind turbines. Battelle Pacific Northwest Laboratories, Richland, Washington, became responsible for wind resource assessments. Solar Energy Research Institute, (now the National Renewable Energy Laboratory) Golden, Colorado, became responsible for innovative wind turbines. Small wind turbine research was handled by Rockwell, International at their Rocky Flats plant near Golden, Colorado. Agricultural applications were handled by the U. S. Department of Agriculture from facilities at Beltsville, Maryland, and Bushland, Texas. This division of effort allowed existing personnel and facilities to be shifted over to wind power research so that results could be obtained in a relatively short time.

It was decided very early in the program that the MOD-0 would be rated at 100 kW and have a 38-m-diameter rotor with two blades[12]. This machine would incorporate the many advances in aerodynamics, materials, controls, and data handling made since the days of the Smith-Putnam machine. The choice of the two bladed propeller over some more unusual wind turbines was made on the basis of technology development. The two bladed machines had been built in larger sizes and had been operated more hours than any other type, hence had the highest probability of working reasonably well from the start. For political reasons it was important to get something working as soon as possible. This machine became operational in September, 1975, at the NASA Plumbrook facility near Sandusky, Ohio.

A diagram of the turbine and the contents of the nacelle (the structure or housing on top of the tower which contains the gearbox, generator, and controls) is shown in Fig. 1. The rotor and nacelle sit on top of a 4-legged steel truss tower about 30 m high. The rotor is downwind of the tower, so the wind strikes the tower before striking the rotor. Each rotor blade thus sees a change in wind speed once per revolution when it passes through the tower shadow. This introduces vibration to the blades, which has to be carefully considered in blade design. An upwind design tends to introduce vibration in the tower because of blade shadowing so neither design has strong advantages over the other. In fact, the MOD-0 was operated for brief periods as an upwind machine to assess some of the effects of upwind operation on structural loads and machine control requirements.

The MOD-0 was designed so the rotor would turn at a constant 40 r/min except when starting up or shutting down. A gear box increases the rotational speed to 1800 r/min to drive a synchronous generator which is connected to the utility network. Startup is accomplished by activating a control which aligns the wind turbine with the wind. The blades are then pitched by a hydraulic control at a programmed rate and the rotor speed is brought to about 40 r/min. At this time an automatic synchronizer is activated and the wind turbine is synchronized with the utility network. If the wind speed drops below the value necessary to get power from the rotor at 40 r/min, the generator is disconnected from the utility grid, the blades are feathered (pitched so no power output is possible) and the rotor is allowed to coast to a stop. All the steps of startup, synchronization, power control, and shutdown are automatically controlled by a microprocessor.

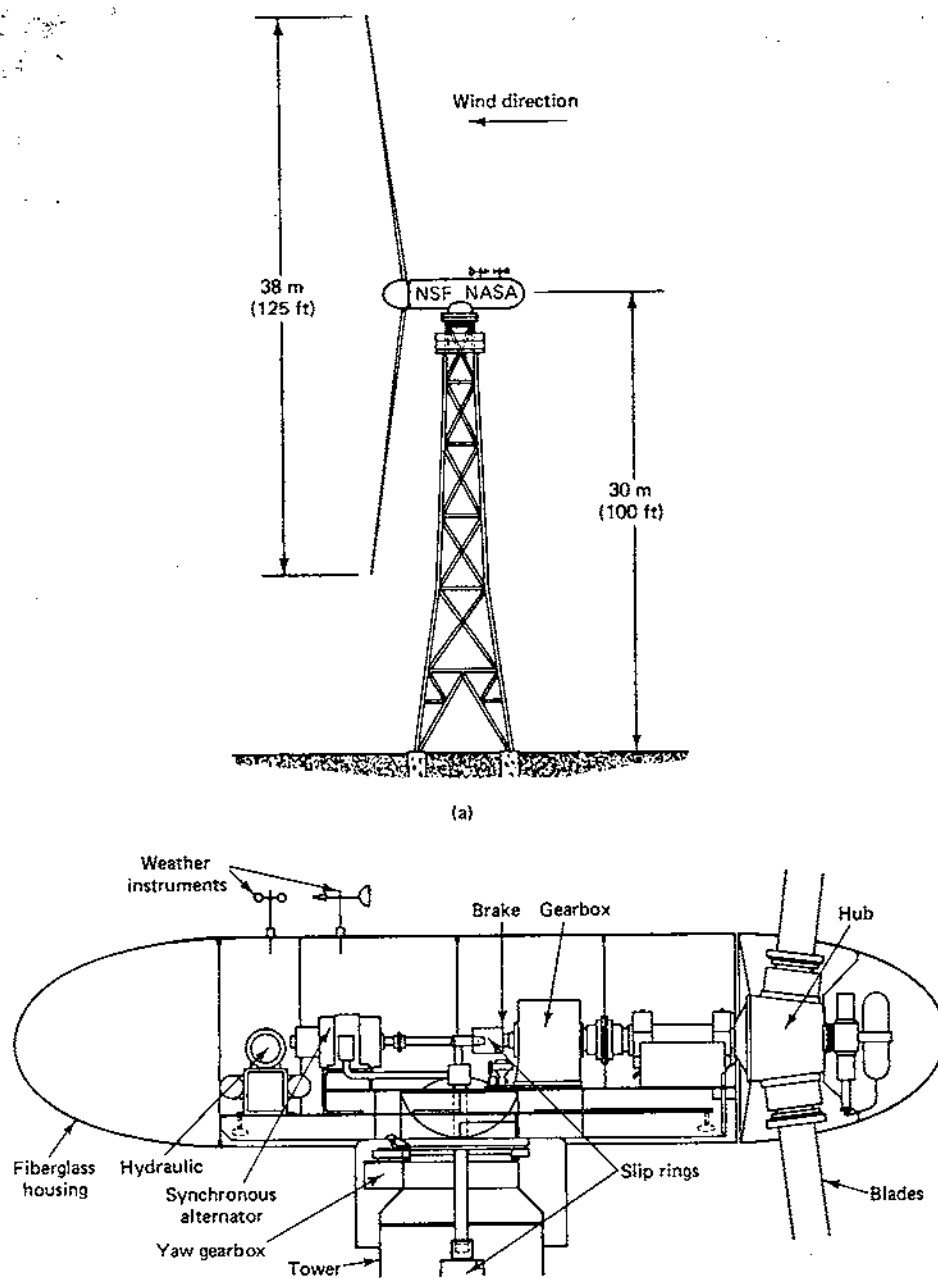

Figure 1: NSF-NASA MOD-0 wind power system: (a) general view; (b) superstructure and equipment. Rated power output, 100 kW; rated wind speed, 8 m/s (18 mi/h). (Courtesy of DOE.)

The stresses in the aluminum blades were too high when the unit was first placed into operation, and it was determined that the tower shadow was excessive. The tower was blocking the airflow much more than had been expected. A stairway inside the tower which had been added late in the design was removed and this solved the problem.

Except for this tower blockage problem, the MOD-0 performed reasonably well, and provided a good base of experience for designing larger and better turbines. The decision was made in 1975 to build several of these turbines, designated as the MOD-0A. The size of tower and rotor remained the same, but the generator size was doubled from 100 to 200 kW. The extra power would be produced in somewhat higher wind speeds than the rated wind speed of the MOD-0. The Westinghouse Electric Corporation of Pittsburgh, Pennsylvania was the prime contractor responsible for assembly and installation. The blades were built by the Lockheed California Company of Burbank, California. The first MOD-0A was installed at Clayton, New Mexico in late 1977, the second at Culebra, Puerto Rico in mid 1978, the third at Block Island, Rhode Island in early 1979, and the fourth at Kahuku Point, Oahu, Hawaii in early 1980. The first three machines used aluminum blades while the Kahuku MOD-0A used wood composite blades. The wooden blades weighed 1360 kg each, 320 kg more than the aluminum blades, but the expected life was longer than their aluminum counterparts. A MOD-0A is shown in Fig. 2.

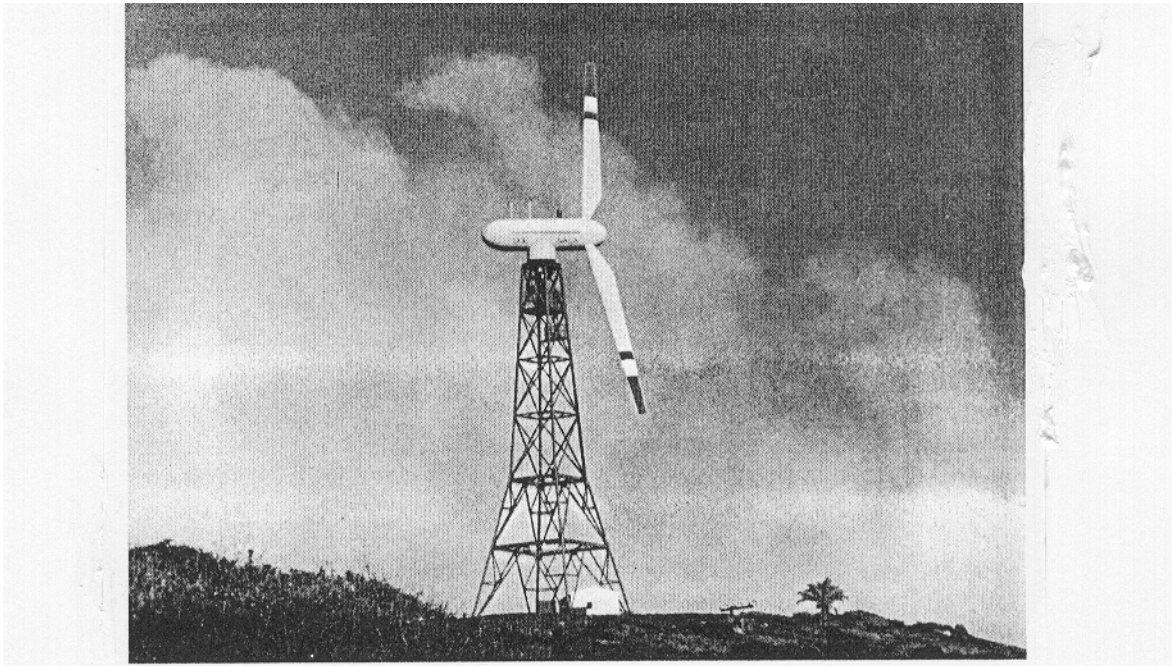

Figure 2: MOD-0A located at Kahuku Point, Oahu, Hawaii. (Courtesy of DOE.)

The Kahuku machine is located in a trade wind environment where relatively steady, high speed winds are experienced for long periods of time. The machine produced an average

power output of 178 kW for the first 573 hours of operation. This was an outstanding record compared with the output of the other MOD-0A machines of 117 kW at Culebra, 89 kW at Clayton, and only 52 kW at Block Island during the first few months of operation for these machines. This shows the importance of good site selection in the economical application of large wind turbines.

Following the MOD-0 and MOD-0A was a series of other machines, the MOD-1, MOD-2, etc. Design parameters for several of these machines are shown in Table 1.1. The MOD-1 was built as a 2000-kW machine with a rotor diameter of 61 m. It is pictured in Fig. 3. Full span pitch control was used to control the rotor speed at a constant 35 r/min. It was built at Howard's Knob, near Boone, North Carolina in late 1978. It may be noticed from Table 1.1 that the rated windspeed for the MOD-1 was 14.6 m/s at hub height, significantly higher than the others. This allowed the MOD-1 to have a rated power of 10 times that of the MOD-0A with a swept area only 2.65 times as large.



Figure 3: MOD-1 located at Boone, North Carolina. (Courtesy of DOE.)

TABLE 1.1 Specifications of ERDA and DOE
Two-Bladed Horizontal-Axis Wind Turbines

	MOD-0	MOD-0A	MOD-1	MOD-2
Rotor r/min	40	40	34.7	17.5
Generator output power (kW)	100	200	2000	2500
Rotor coefficient of performance, $C_{p,max}$	0.375	0.375	0.375	0.382
Cut-in wind speed at hub height (m/s)	4.3	5.4	7.0	6.3
Rated wind speed at hub height (m/s)	7.7	9.7	14.6	12.4
Shutdown wind speed at hub height (m/s)	17.9	17.9	19.0	20.1
Maximum wind speed (m/s)	66	67	66	66
Rotor diameter (m)	37.5	37.5	61	91.5
Hub height (m)	30	30	46	61
Coning angle	7°	7°	12°	0°
Effective swept area (m ²)	1072	1140	2920	6560
Airfoil section, NACA-	23,000	23,000	44XX	230 XX
Weight of two blades (kg)	2090	2090	16,400	33,200
Generator voltage, line to line	480	480	4160	4160

The gearbox and generator were similar in design to those of the MOD-0A, except larger. The tower was a steel, tubular truss design. The General Electric Company, Space Division, of Philadelphia, Pennsylvania was the prime contractor for designing, fabricating, and installing the MOD-1. The Boeing Engineering and Construction Company of Seattle, Washington, manufactured the two steel blades.

As the MOD-1 design effort progressed, it became clear that the MOD-1 would be relatively heavy and costly and could not lead to a cost competitive production unit. Weight and cost were being determined by a number of factors, the most significant of which were the stiff tower design criteria, the full span pitch control which required complicated, heavy mechanisms and excessive space in the hub area, and a heavy bedplate supporting the weight on top of the tower. A number of possible improvements in the design became evident too late to be included in the actual construction. Only one machine was built because of the predicted production costs. Like the MOD-0, it was operated as a test unit to help the designs of later generation turbines.

One early problem with the MOD-1 was the production of subaudible vibrations which would rattle the windows of nearby houses. The rotor would interact with the tower to produce two pulses per revolution, which resulted in a vibration frequency of about 1.2 Hz. Techniques used to reduce the annoyance included reducing the speed of rotation and replacing the steel blades with fiberglass blades. Other operational problems, including a broken low speed shaft, plus a reduction in federal funding, caused the MOD-1 to be disassembled in 1982.

The next machine in the series, the MOD-2, represented an effort to build a truly cost competitive machine, incorporating all the information gained from the earlier machines. It was a second generation machine with the Boeing Engineering and Construction Company

servicing as the prime contractor. The rotor had two blades, was 91.5 m in diameter, and was upwind of the tower. Rotor speed was controlled at a constant 17.5 r/min. Rated power was 2500 kW (2.5 MW) at a wind speed of 12.4 m/s measured at the hub height of 61 m. In order to simplify the configuration and achieve a lower weight and cost, partial span pitch control was used rather than full span pitch control. That is, only the outer 30 percent of the span was rotated or pitched to control rotor speed and power. This construction feature can be seen in Fig. 4. To reduce the loads on the system caused by wind gusts and wind shear, the rotor was designed to allow teeter of up to 5 degrees in and out of the plane of rotation. These load reductions saved weight and therefore cost in the rotor, nacelle, and tower. The word *teeter* is also used for the motion of a plank balanced in the middle and ridden by children so one end of the plank goes up while the other end goes down. This described the same type of motion in the rotor except that motion was around a horizontal pivot point rather than the vertical one used on the playground.

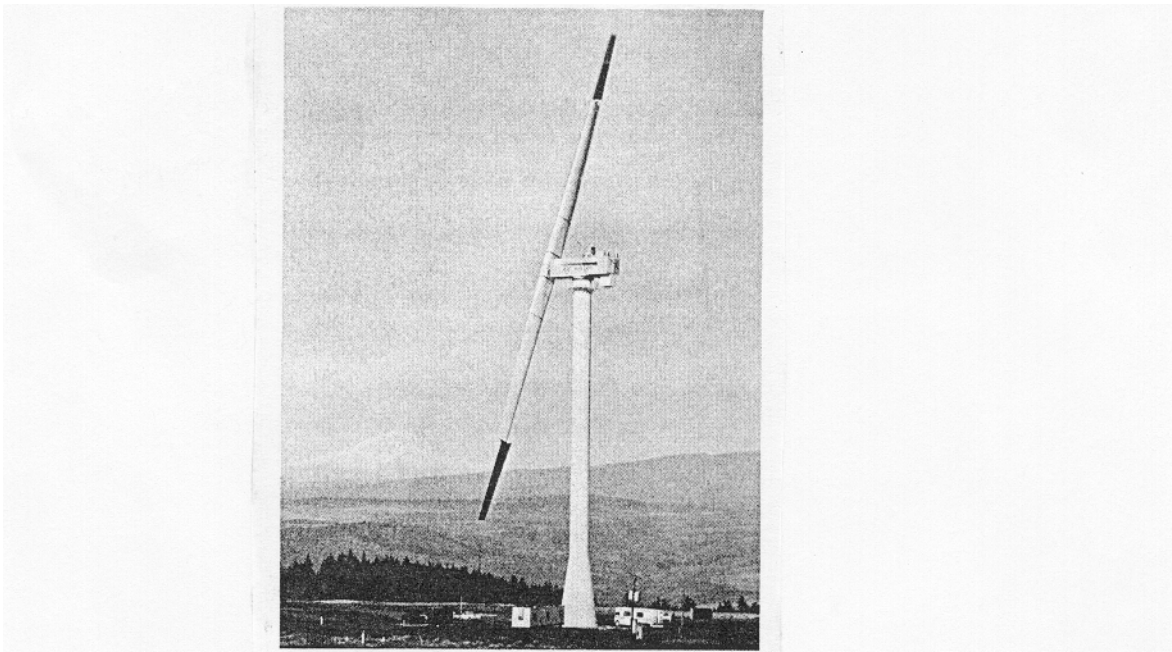

Figure 4: MOD-2 located at the Goodnoe Hills site near Goldendale, Washington. (Courtesy of DOE.)

The MOD-2 tower was designed to be soft or flexible rather than stiff or rigid. The softness of the tower refers to the first mode natural frequency of the tower in bending relative to the operating frequency of the system. For a two-bladed rotor, the tower is excited (receives a pulse) twice per revolution of the rotor. If the resonant frequency of the tower is greater than the exciting frequency, the tower is considered stiff. A tower is considered soft if the resonant frequency is less than the exciting frequency, and very soft if the resonant frequency is less than half the exciting frequency. The tower of the MOD-2 was excited at its resonant

frequency for short time periods during startup and shutdown, so extreme care had to be taken during these times so the oscillations did not build up enough to damage the tower.

The MOD-2 tower was a welded steel cylindrical shell design. This design was more cost effective than the stiff, open-truss tower of the first generation machines. The MOD-2 was significantly larger than the MOD-1, yet the above ground mass was less, 273,000 kg as compared with 290,000 kg.

The first installation of the MOD-2 was a three machine cluster at the Goodnoe Hills site near Goldendale, Washington, built in early 1981. Two additional units were built, one in Wyoming and one in California.

The numbering system hit some difficulties at this point, since the next machine after the MOD-2 was the MOD-5. Actually, this third generation machine was designed by two different companies, with the General Electric version being named the MOD-5A while the Boeing version was named the MOD-5B. Objectives of the MOD-2 and MOD-5 programs were essentially identical except that the target price of electricity was reduced by 25 percent, to 3.75 cents per kWh in 1980 dollars.

The General Electric MOD-5A design called for a rotor diameter of 122 m (400 ft) and a rated power of 6.2 MW. Rated power would be reached in wind speeds of 13 m/s (29 mi/h) at the hub height of 76 m (250 ft). The wood rotor would turn at two rotational speeds, 13 or 17 r/min, depending on wind conditions.

The Boeing MOD-5B was designed to be an even larger machine, 7.2 MW with a rotor diameter of 128 m (420 ft). The rotor was designed to be built of steel with wood tips. A variable speed generator was selected as opposed to the fixed speed generator used on the MOD-2.

Federal research on the MOD series of turbines was terminated in the mid 1980s, and all the turbines have been scraped. One reason was that smaller turbines (in the 100-kW range) could be built at lower costs and with better performance than the large turbines. Many of us underestimated the difficulty of building large reliable wind turbines. The technology step was just too large.

A second reason was that the American aerospace industry did not have a desire to produce a cost effective commercial product. Wind turbine research was viewed as just another government contract. A given company would build a turbine on a cost plus basis. When it broke, it would be repaired on a cost plus basis. When the federal money ran out, the company's interest in wind power vanished. Hindsight indicates it would have been far better to have spent the federal money on the small, mostly undercapitalized, companies that were dedicated to producing a quality wind turbine.

A third reason for the lack of interest in wind was the abundance and depressed costs of petroleum products throughout the 1980s and into the 1990s. In the mid-1970s, it was standard wisdom that we were running out of natural gas. Many utilities converted from burning natural gas as a boiler fuel, instead using coal or nuclear energy. The price of natural gas

increased substantially from its artificially low values. But by the mid-1980s, it was discovered that we had substantial reserves of natural gas (at this higher price), and utilities started converting back to natural gas as a fuel, especially for peaking gas turbines. The development of wind power has certainly been delayed by these various actions of the government, aerospace, and oil industries.

4 DARRIEUS WIND TURBINES

Most wind turbines designed for the production of electricity have consisted of a two or three bladed propeller rotating around a horizontal axis. These blades tend to be expensive, high technology items, and the turbine has to be oriented into the wind, another expensive task for the larger machines. These problems have led many researchers in search of simpler and less expensive machines. The variety of such machines seems endless. One that has seen considerable development is the Darrieus wind turbine. The Darrieus was patented in the United States by G. J. M. Darrieus in 1931[9]. It was reinvented by engineers with the National Research Council of Canada in the early 1970's. Sandia Laboratories built a 5 m diameter Darrieus in 1974, and has been strongly involved with further research on the Darrieus turbine since that time[11].

Fig. 5 shows a 17 meter Darrieus built at Sandia. The diameter of the blades is the same as the height, 17 m. The extruded aluminum blades were made by Alcoa (Aluminum Company of America, Alcoa Center, Pennsylvania). This machine is rated at 60 kW in a 12.5 m/s wind. Fig. 6 shows one of the blades during fabrication. Several models of this basic machine were built during 1980.

The Darrieus has several attractive features. One is that the machine rotates about a vertical axis, hence does not need to be turned into the wind. Another is that the blades take the shape of a jumping rope experiencing high centrifugal forces. This shape is called *troposkein*, from the Greek for turning rope. Since the blade operates in almost pure tension, a relatively light, inexpensive blade is sufficient. Another advantage is that the power train, generator, and controls are all located near ground level, hence are easier to construct and maintain. The efficiency is nearly as good as that of the horizontal axis propeller turbine, so the Darrieus holds considerable promise as a cost effective turbine.

One disadvantage of the Darrieus is that it is not normally self starting. That is, if the turbine has stopped during a period of low wind speeds, it will not usually start when the wind speed increases. Starting is usually accomplished by an induction motor connected to the local utility network. This is not necessarily a major disadvantage because the same induction motor can be used as an induction generator to supply power to the utility network when the turbine is at operating speed. Induction machines are simple, rugged, and inexpensive, requiring essentially no controls other than a contactor to connect the machine to the utility network. For these reasons, they are seeing wide use as wind turbine generators.

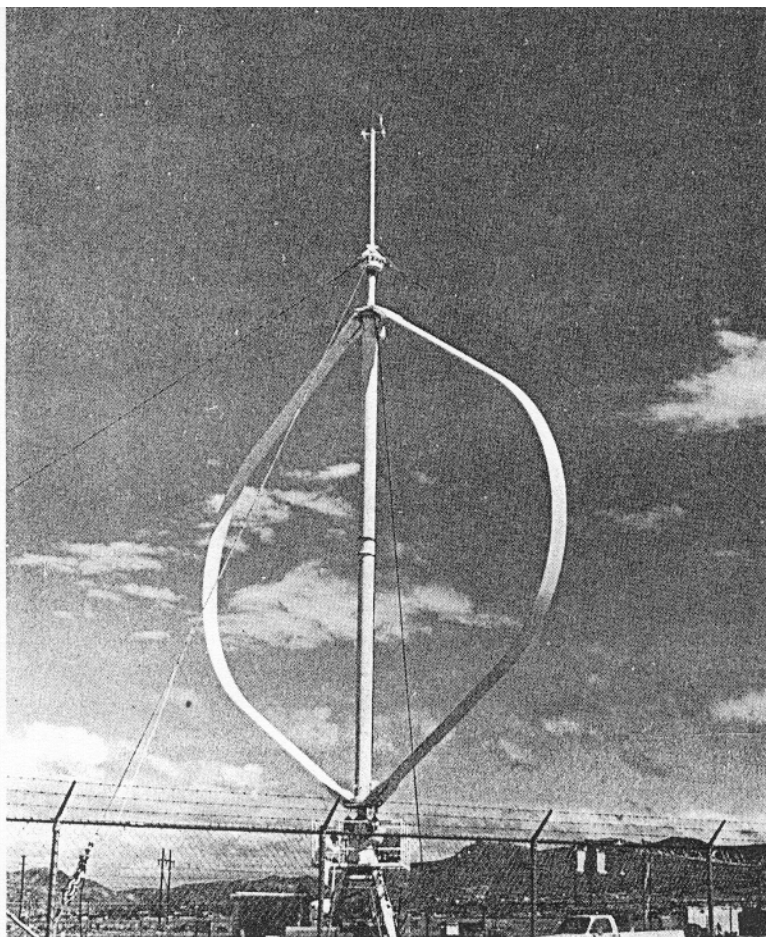

Figure 5: Sandia Laboratories 17-m Darrieus, rated at 60 kW in a 12.5-m/s wind. (Courtesy of Aluminum Company of America.)

The first large Darrieus constructed was a 230-kW machine on Magdalen Island, Quebec, Canada in May, 1977 by Dominion Aluminium Fabricators, Limited of Ontario, Canada. The average power output of this machine was 100 kW over the first year of operation, which is quite good. Then a noise was observed in the gearbox so the machine was stopped for inspection and repairs. During the inspection process, the brakes were removed, which should have been safe because the turbine was not supposed to be able to self start. Unfortunately, on July 6, 1978, the turbine started, and without a load or any way of stopping it, went well over the design speed of 38 r/min. The spoilers did not activate properly, and when the turbine reached 68 r/min a guy wire broke, letting the turbine crash to the ground. Perhaps the main lesson learned from this accident was that the Darrieus will sometimes start under unusual gust conditions and that braking systems need to be designed with this fact in mind.

A major design effort on Darrieus turbines has been made by Alcoa. They first designed

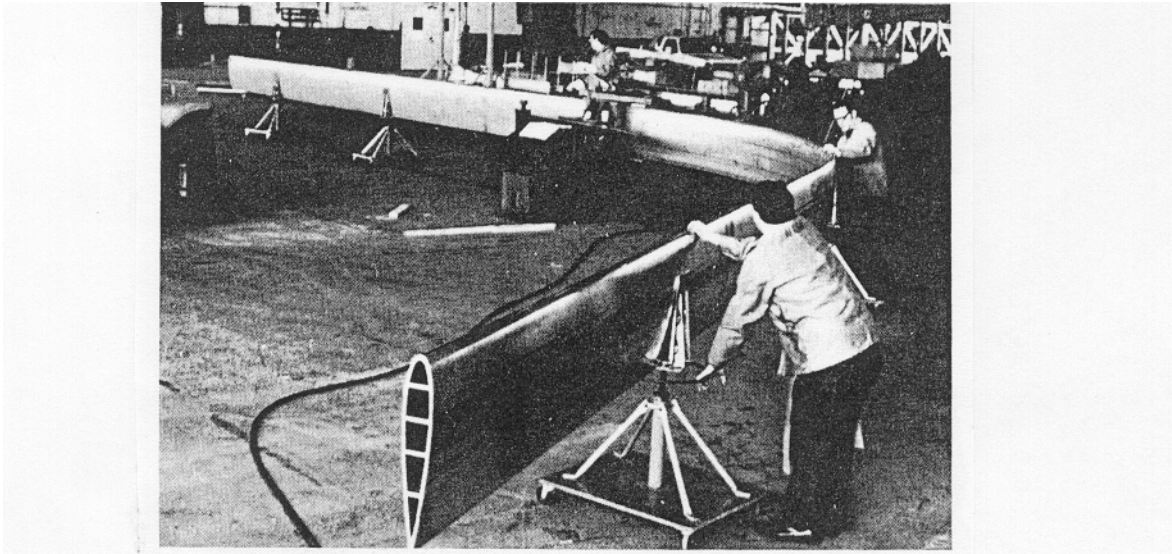

Figure 6: Extruded aluminum blade of 17-m Darrieus during fabrication. (Courtesy of Aluminum Company of America.)

a 5.5 m diameter machine which would produce about 8 kW of power, but dropped that size in favor of more economical larger machines. Other sizes developed by Alcoa include a 12.8 m diameter (30 to 60 kW), 17 m diameter (60 to 100 kW), and a 25 m diameter (300 or 500 kW depending on the gear ratio).

The Alcoa effort has been plagued by a number of accidents. A 12.8 m diameter machine collapsed at their Pennsylvania facility on March 21, 1980, when its central torque tube started vibrating and eventually buckled when the machine was running above rated speed. Then in April, 1981, a 25 m machine crashed in the San Geronio Pass east of Los Angeles[17]. The machine itself worked properly to a speed well above rated speed, but a software error in the microcomputer controller prevented proper brake application in high winds. When the machine rotational speed reached 60 r/min, well above the rated speed of 41 r/min, a bolt broke and allowed a blade to flare outward and cut one of the guy wires. The machine then crashed to the ground.

Accidents like these are not uncommon in new technology areas, but they are certainly frustrating to the people involved. It appears that the various problems are all solvable, but the string of accidents certainly slowed the deployment of Darrieus turbines as compared with the horizontal axis turbines.

Sandia continued work on the theory of the Darrieus turbine during the 1980s, with the result that the turbine is well understood today. It appears that there is no reason the Darrieus could not be an important contributor to the production of power from the wind. It just needs a large aluminum company that is willing and able to do the aluminum extrusions and possibly wait for several years before seeing a significant return on investment.

5 INNOVATIVE WIND TURBINES

Another type of turbine developed at about the same time as the Darrieus was the Savonius turbine, developed in Finland by S. J. Savonius[10]. This is another vertical axis machine which needs no orientation into the wind. Alternative energy enthusiasts often build this turbine from used oil barrels by cutting the barrels in half lengthwise and welding the two halves back together offset from one another to catch the wind. A picture of a somewhat more advanced unit developed at Kansas State University, Manhattan, Kansas, is shown in Fig. 7.

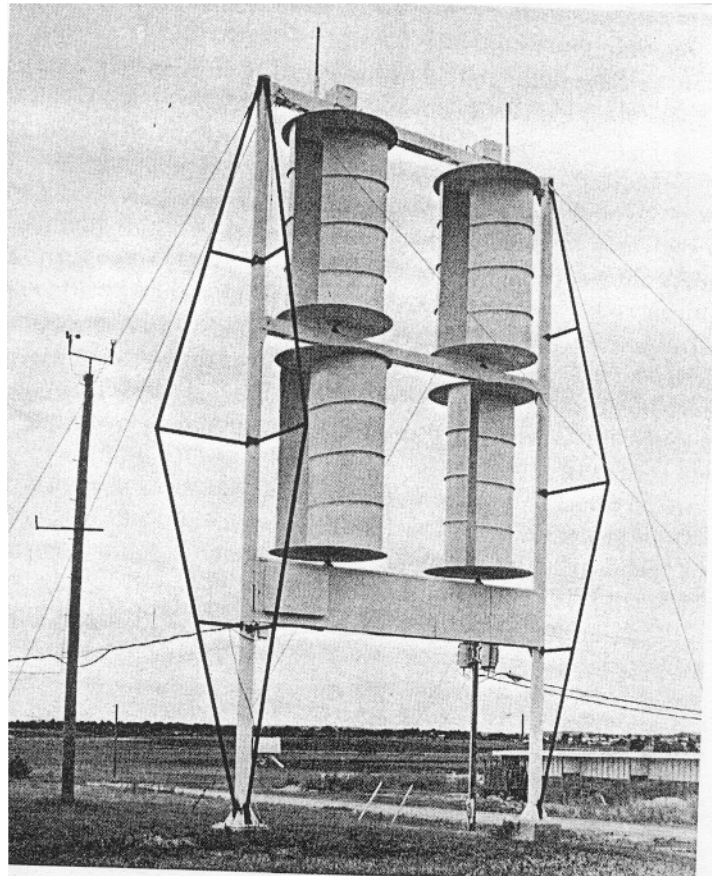

Figure 7: Kansas State University Savonius, rated at 5 kW in a 12-m/s wind.

The tower of the KSU Savonius was 11 m high and 6 m wide. Each rotor was 3 m high by 1.75 m in diameter. The rotors were connected together and drove a single 5 kW, three-phase, permanent magnet generator. At the rated wind speed of 12 m/s, the rotor speed was 103 r/min, the generator speed was 1800 r/min, and the frequency was 60 Hz. Output voltage and frequency varied with wind speed and load, which meant that this particular turbine could not be directly paralleled with the utility grid. Applications for this *asynchronous* (not synchronized with the utility grid) electricity are limited to electric heating and driving

three-phase induction motors in situations which can tolerate variable speed operation. These include heat pumps, some water pumps, and fans. Such applications consume large quantities of electrical energy, so variable frequency operation is not as restrictive as it might appear. Asynchronous systems do not require complex blade pitch, voltage, and frequency controls, hence should be less expensive.

The main advantages of the Savonius are a very high starting torque and simple construction. The disadvantages are weight of materials and the difficulty of designing the rotor to withstand high wind speeds. These disadvantages could perhaps be overcome by good engineering if the turbine efficiency were high enough to justify the engineering effort required.

Agreement on the efficiency of the Savonius turbine apparently has finally been reached a half century after its development. Savonius claimed an efficiency of 31 per cent in the wind tunnel and 37 per cent in free air. However, he commented:[10] “The calculations of Professor Betz gave 20 % as the highest theoretical maximum for vertical airwheels, which under the best of circumstances could not produce more than 10 % in practical output.” The theoretical and experimental results failed to agree. Unfortunately, Savonius did not specify the shape and size of his turbine well enough for others to try to duplicate his results.

A small unit of approximately 2 m high by 1 m diameter was built and tested at Kansas State University during the period 1932-1938[6]. This unit was destroyed by a high wind, but efficiencies of 35 to 40 % were claimed by the researchers. Wind tunnel tests were performed by Sandia on 1.5 m high by 1 m diameter Savonius turbines, with a maximum efficiency measured of 25 % for semicircular blades[1]. Different blade shapes which were tested at the University of Illinois showed a maximum efficiency of about 35 %[5]. More Savonius turbines were tested at Kansas State University, with efficiencies reported of about 25 %[13, 4]. It thus appears that the Savonius, if properly designed, has an efficiency nearly as good as the horizontal axis propeller turbine or the Darrieus turbine. The Savonius turbine therefore holds promise in applications where low to medium technology is required or where the high starting torque is important.

A chart of efficiency of five different turbine types is shown in Fig. 8. The efficiency or power coefficient varies with the ratio of blade tip speed to wind speed, with the peak value being the number quoted for a comparison of turbines. This will be discussed in more detail in Chapter 4. It may be noticed that the peak efficiencies of the two bladed propeller, the Darrieus, and the Savonius are all above 30 %, while the American Multiblade and the Dutch windmills peak at about 15 %. These efficiencies indicate that the American Multiblade is not competitive for generating electricity, even though it is almost ideally suited and very competitive for pumping water.

The efficiency curves for the Savonius and the American Multiblade have been known for a long time[6, 10]. Unfortunately, the labels on the two curves were accidentally interchanged in some key publication in recent years, with the result that many authors have used an erroneous set of curves in their writing. This historical accident will probably take years to correct.

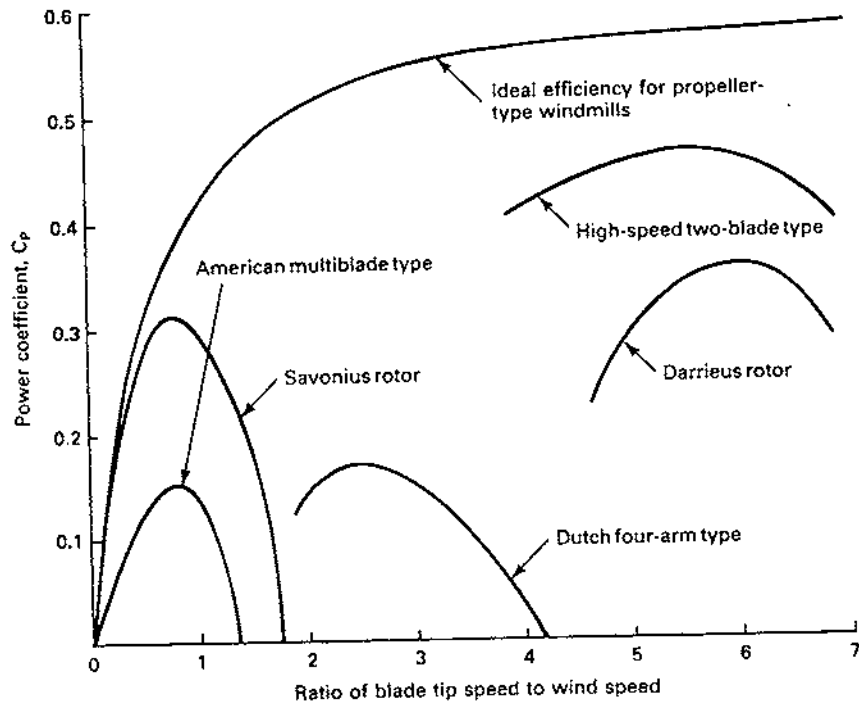

Figure 8: Typical performances of wind machines.

Another vertical axis machine which has interested people for many years is the Madaras rotor. This system was invented by Julius D. Madaras, who conducted considerable tests on his idea between 1929 and 1934. This concept uses the *Magnus effect*, which refers to the force produced on a spinning cylinder or sphere in a stream of air. The most familiar example of this effect is the curve ball thrown by a baseball pitcher. The Madaras rotor is a large cylinder which is spun in the wind by an electric motor. When the wind is from the left and the cylinder is spinning counterclockwise as shown in Fig. 9, the cylinder will experience a lift force in the direction shown. There will also be a drag force in the direction of the wind flow.

If the cylinder is mounted on a special type of railroad car and if the wind speed component perpendicular to the railroad tracks is sufficiently strong, the lift force will be adequate to move the car along the tracks. The basic idea is shown in Fig. 10. The railroad car or tracked carriage must be heavy enough that it will not overturn due to the drag forces. Power can be extracted from the system by electrical generators connected to the wheels of the tracked carriage. The cars roll around a circular or racetrack shaped track. Twice during each orbit of a rotor car around the track (when the wind is parallel to the track), each spinning rotor in turn must be de-spun to a stop, and then spun-up in the opposite direction. This cycle is necessary in order to assure that the propulsive force changes direction so that all rotors are propelling the train in the same angular direction.

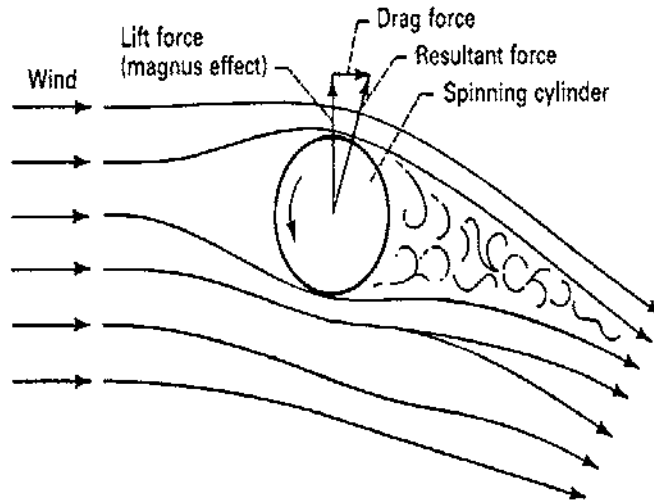

Figure 9: Magnus force on a spinning cylinder.

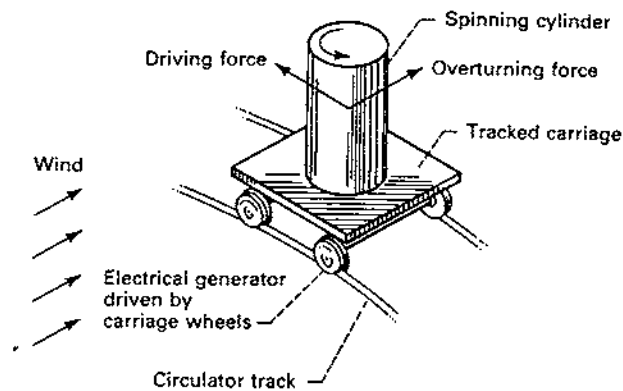

Figure 10: Madaras concept for generating electricity.

The original system proposed by Madaras consisted of 27 m high by 6.8 m diameter cylinders which were vertically mounted on flat cars and rotated by electric motors to convert wind energy to Magnus-effect forces. The forces would propel an endless train of 18 cars around a 460 m diameter closed track. Generators geared to the car axles were calculated to produce up to 18 MW of electric power at a track speed of 8.9 m/s in a wind speed of 13 m/s.

More recent studies[15, 16] have shown that energy production is greater with a racetrack shaped plant perhaps 3 km wide by 18 km long which is oriented perpendicular to the prevailing winds. This modern design includes cylinders 4.9 m in diameter by 38.1 m tall, cars with a length of 19.2 m and a width of 17.4 m, and a track with 11 m between rails. Individual

cars would have a mass of 328,000 kg. Each rotor would be spun with a 450 kW, 500 volt dc motor. Each of the four wheels would drive a 250 kW induction generator. There would be about 200 cars on the track with a total rating of about 200 MW. Power would be extracted from the system by a 4160 V, three-phase, 500 A overhead trolley bus.

Cost estimates for the electricity costs from this large system were comparable to those from the MOD-1. Wind tunnel tests and field tests on a rotating cylinder on a fixed platform indicate that the concept will work. The questions remain whether the aerodynamic, mechanical, and electrical losses will be acceptable and whether the reliability will be adequate. Only a major development effort can answer these questions and there will probably not be sufficient interest in such a development if the horizontal axis wind turbines meet the basic requirements for cost and reliability.

All the wind turbines discussed thus far have a problem with capital costs. Although these machines work satisfactorily, capital costs are large. The Darrieus may become more cost effective than the two-bladed propeller turbine, but neither is likely to produce really inexpensive electricity. There is a desire for a breakthrough, whereby some new and different concept would result in substantial cost reductions. One candidate for such a wind machine is the augmented vortex turbine studied by James Yen at Grumman Aerospace Corporation[18]. An artist's concept of the machine is shown in Fig. 11.

The turbine tower has vertical vanes which direct the wind into a circular path around the inside of the tower. Wind blowing across the top of the tower tends to pull the air inside in an upward direction, causing the entering air to flow in a spiral path. This spiral is a vortex, which is characterized by a high speed, low pressure core. The vortex is basically that of a confined tornado. The pressure difference between the vortex core and outside ambient air is then used to drive a relatively small, high speed turbine at the base of the tower. The vortex machine is extracting power from pressure differences or the potential energy in the air, rather than directly from the kinetic energy of the moving air. The potential energy in the air due to pressure is vastly more than the kinetic energy of the air in moderate wind speeds, so there is a possibility of large energy outputs for a given tower size which could result in very inexpensive electricity.

One problem with the vortex machine is the potential for spawning tornadoes. If the vortex extending out of the top of the tower should become separated from the tower, grow a tail, and become an actual tornado, a permanent shutdown would be highly probable. In fact, based on the experience of the nuclear industry, fear of such an occurrence may prevent the implementation of such a wind machine.

Many other wind machines have been invented over the last few hundred years. The propeller type and the Darrieus have emerged as reasonably reliable, cost competitive machines which can provide a significant amount of electrical energy. Barring a major breakthrough with another type of wind machine, we can expect to see a wide deployment of these machines over the next few decades.

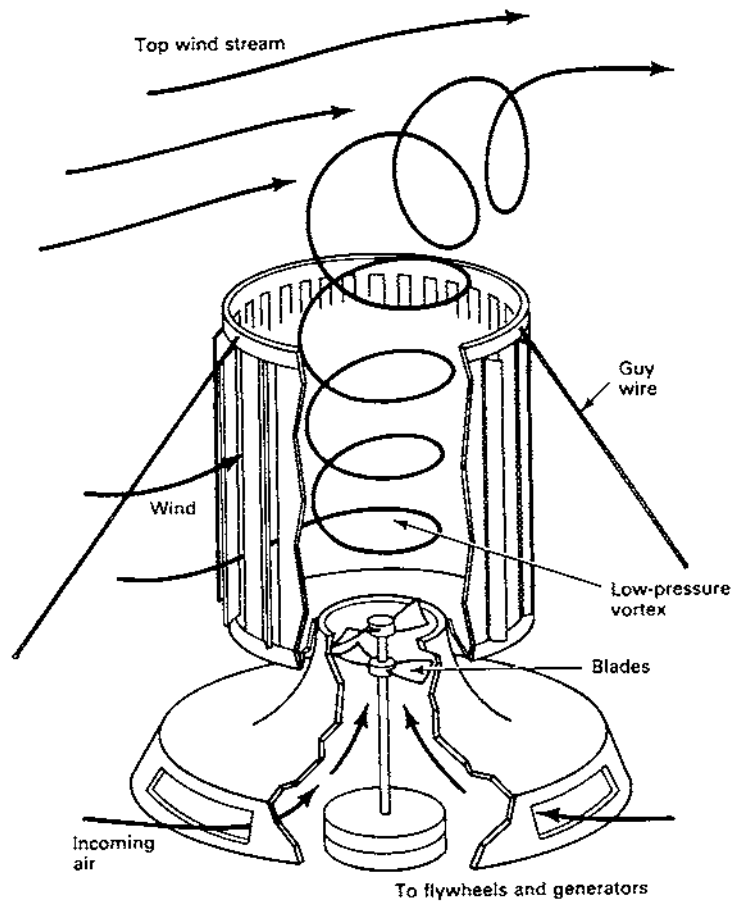

Figure 11: Augmented vortex turbine. (Reprinted from *Popular Science* with permission. ©1977 Times Mirror Magazines, Inc.)

6 CALIFORNIA WINDFARMS

Over 1500 MW of wind turbines have been installed in California, starting about 1980. On average, wind energy supplies around 1 % of California's electricity demand. Among electric utilities, Pacific Gas & Electric (PG&E), one of the largest in the country, uses the most wind power. At peak times during the summer, as much as 7 % of its demand is supplied by wind[2].

These are primarily horizontal-axis turbines, with two- or three-bladed rotors. Power ratings are in the range of 100 to 250 kW, with some smaller older units and a few larger new units. These turbines are deployed in large arrays known as windfarms. In addition to tower foundations and interconnecting cables, windfarms require construction and maintenance roads, a central control station, a distribution substation, and transmission lines. Some

of the costs are fixed, so the larger the windfarm the lower the overall cost of electricity produced. The rule of thumb is that a windfarm must have at least 100 machines, corresponding to a peak output of at least 20 MW, to hope to be economical. We shall see details of some of these costs in Chapter 9.

Cost of energy from these windfarms is approximately \$0.07–\$0.09 per kWh[7]. These costs can be reduced by at least 40%, and perhaps 60% by the use of innovative, light-weight designs and improved operating efficiencies. If the cost can be reduced below \$0.05/kWh, and this figure appears well within reach, wind-generated electricity will be very competitive with other types of generation.

Lynette[7] indicates that new airfoils can increase energy capture by 25–30%, variable-speed generators can increase production by 5–15%, advances in control strategies by 3–5%, and taller towers by 10–20% (and sometimes more as we shall see in Chapter 2). The corresponding increase in turbine costs will be about 15–20%. Costs have been reduced dramatically since the early 1980s and should continue the trend for some time.

References

- [1] Blackwell, B. F., R. E. Sheldahl, and L. V. Feltz: *Wind Tunnel Performance Data for Two- and Three-Bucket Savonius Rotors*, Sandia Laboratories Report SAND 76-0131, July 1977.
- [2] Brower, Michael C., Michael W. Tennis, Eric W. Denzler, Kaplan, Mark M.: *Powering the Midwest—Renewable Electricity for the Economy and the Environment*, A Report by the Union of Concerned Scientists, 1993.
- [3] Golding, E.: *The Generation of Electricity by Wind Power*, Halsted Press, New York, 1976.
- [4] Johnson, G. L.: “Preliminary Results of a 5-kW Savonius Wind Turbine Test,” USDA-DOE Workshop on Wind Energy Application in Agriculture, Ames, Iowa, May 15-17, 1979.
- [5] Khan, M. H.: “Model and Prototype Performance Characteristics of Savonius Rotor Windmill,” *Wind Engineering*, Vol. 2, No. 2, 1978, pp. 75-85.
- [6] Kloeffler, R. G. and E. L. Sitz: *Electric Energy from Winds*, Kansas State College of Engineering Experiment Station Bulletin 52, Manhattan, Kans., September 1, 1946.
- [7] Lynette, Robert: “Status and Potential of Wind Energy Technology,” Windpower ‘90 Proceedings, American Wind Energy Association Conference, Washington, D. C., September 24–28, 1990.
- [8] Putnam, P.C.: *Power from the Wind*, Van Nostrand, New York, 1948.

- [9] Ramler, J. R. and R. M. Donovan: *Wind Turbines for Electric Utilities: Development Status and Economics*, Report DOE/NASA/1028-79/23, NASA TM-79170, AIAA-79-0965, June 1979.
- [10] Savonius, S. J.: “The S-Rotor and Its Applications,” *Mechanical Engineering*, Vol. 53, No. 5, May 1931, pp. 333-338.
- [11] Sheldahl, R. E. and B. F. Blackwell: *Free-Air Performance Tests of a 5-Meter-Diameter Darrieus Turbine*, Sandia Laboratories Report SAND 77-1063, December, 1977.
- [12] *Third Wind Energy Workshop*, Washington, D. C., September, 1977, CONF 770921 D.C.
- [13] Turnquist, R. O. and F. C. Appl: “Design and Testing of a Prototype Savonius Wind Machine,” *Frontiers of Power Technology Conference*, Oklahoma State University, Stillwater, Okla., October 27-28, 1976.
- [14] Vargo, D. J.: *Wind Energy Development in the 20th Century*, NASA Technical Memorandum NASA TM X-71634, September, 1974.
- [15] Whitford, D. H., J. E. Minardi, B. S. West, and R. J. Dominic: *An Analysis of the Madaras Rotor Power Plant: An Alternative Method for Extracting Large Amounts of Power from the Wind*, DOE Report DSE-2554-78/2, Vol. 2, June 1978.
- [16] Whitford, D. H. and J. E. Minardi: “Utility-Sized Wind-Powered Electric Plants Based on the Madaras Rotor Concept,” *Wind Energy Innovative Systems Conference Proceedings*, SERI/TP-245-184, May 23-25, 1979, pp. 71-81.
- [17] *Wind Energy Report*, April 1981.
- [18] Yen, J. T.: “Summary of Recent Progress on Tornado-Type Wind Energy System,” *Third Wind Energy Workshop Proceedings*, Washington, D.C., September 1977, CONF 770921, pp. 808-818.

WIND CHARACTERISTICS

The wind blows to the south and goes round to the north.; round and round goes the wind, and on its circuits the wind returns. Ecclesiastes 1:6

The earth's atmosphere can be modeled as a gigantic heat engine. It extracts energy from one reservoir (the sun) and delivers heat to another reservoir at a lower temperature (space). In the process, work is done on the gases in the atmosphere and upon the earth-atmosphere boundary. There will be regions where the air pressure is temporarily higher or lower than average. This difference in air pressure causes atmospheric gases or wind to flow from the region of higher pressure to that of lower pressure. These regions are typically hundreds of kilometers in diameter.

Solar radiation, evaporation of water, cloud cover, and surface roughness all play important roles in determining the conditions of the atmosphere. The study of the interactions between these effects is a complex subject called meteorology, which is covered by many excellent textbooks.[4, 8, 20] Therefore only a brief introduction to that part of meteorology concerning the flow of wind will be given in this text.

1 METEOROLOGY OF WIND

The basic driving force of air movement is a difference in air pressure between two regions. This air pressure is described by several physical laws. One of these is Boyle's law, which states that the product of pressure and volume of a gas at a constant temperature must be a constant, or

$$p_1V_1 = p_2V_2 \quad (1)$$

Another law is Charles' law, which states that, for constant pressure, the volume of a gas varies directly with absolute temperature.

$$\frac{V_1}{T_1} = \frac{V_2}{T_2} \quad (2)$$

If a graph of volume versus temperature is made from measurements, it will be noticed that a zero volume state is predicted at -273.15°C or 0 K.

The laws of Charles and Boyle can be combined into the *ideal gas law*

$$pV = nRT \quad (3)$$

In this equation, R is the universal gas constant, T is the temperature in kelvins, V is the volume of gas in m^3 , n is the number of kilomoles of gas, and p is the pressure in pascals (N/m^2). At standard conditions, 0°C and one atmosphere, one kilomole of gas occupies 22.414 m^3 and the universal gas constant is $8314.5 \text{ J}/(\text{kmol}\cdot\text{K})$ where J represents a joule or a newton meter of energy. The pressure of one atmosphere at 0°C is then

$$\frac{(8314.5\text{J}/(\text{kmol}\cdot\text{K}))(273.15\text{ K})}{22.414\text{ m}^3} = 101,325\text{ Pa} \quad (4)$$

One kilomole is the amount of substance containing the same number of molecules as there are atoms in 12 kg of the pure carbon nuclide ^{12}C . In dry air, 78.09% of the molecules are nitrogen, 20.95% are oxygen, 0.93% are argon, and the other 0.03% are a mixture of CO_2 , Ne , Kr , Xe , He , and H_2 . This composition gives an average molecular mass of 28.97 , so the mass of one kilomole of dry air is 28.97 kg . For all ordinary purposes, dry air behaves like an ideal gas.

The density ρ of a gas is the mass m of one kilomole divided by the volume V of that kilomole.

$$\rho = \frac{m}{V} \quad (5)$$

The volume of one kilomole varies with pressure and temperature as specified by Eq. 3. When we insert Eq. 3 into Eq. 5, the density is given by

$$\rho = \frac{mp}{RT} = \frac{3.484p}{T} \quad \text{kg}/\text{m}^3 \quad (6)$$

where p is in kPa and T is in kelvins. This expression yields a density for dry air at standard conditions of $1.293 \text{ kg}/\text{m}^3$.

The common unit of pressure used in the past for meteorological work has been the *bar* (100 kPa) and the *millibar* (100 Pa). In this notation a standard atmosphere was referred to as 1.01325 bar or 1013.25 millibar .

Atmospheric pressure has also been given by the height of mercury in an evacuated tube. This height is 29.92 inches or 760 millimeters of mercury for a standard atmosphere. These numbers may be useful in using instruments or reading literature of the pre-SI era. It may be worth noting here that several definitions of *standard conditions* are in use. The chemist uses 0°C as standard temperature while engineers have often used 68°F (20°C) or 77°F (25°C) as standard temperature. We shall not debate the respective merits of the various choices, but note that some physical constants depend on the definition chosen, so that one must exercise care in looking for numbers in published tables. In this text, standard conditions will always be 0°C and 101.3 kPa .

Within the atmosphere, there will be large regions of alternately high and low pressure.

These regions are formed by complex mechanisms, which are still not fully understood. Solar radiation, surface cooling, humidity, and the rotation of the earth all play important roles.

In order for a high pressure region to be maintained while air is *leaving* it at ground level, there must be air *entering* the region at the same time. The only source for this air is *above* the high pressure region. That is, air will flow *down* inside a high pressure region (and *up* inside a low pressure region) to maintain the pressure. This descending air will be warmed *adiabatically* (i.e. without heat or mass transfer to its surroundings) and will tend to become dry and clear. Inside the low pressure region, the rising air is cooled adiabatically, which may result in clouds and precipitation. This is why high pressure regions are usually associated with good weather and low pressure regions with bad weather.

A line drawn through points of equal pressure on a weather map is called an *isobar*. These pressures are corrected to a common elevation such as sea level. For ease of plotting, the intervals between the isobars are usually 300, 400, or 500 Pa. Thus, successive isobars would be drawn through points having readings of 100.0, 100.4, 100.8 kPa, etc. Such a map is shown in Fig. 1. This particular map of North America shows a low pressure region over the Great Lakes and a high pressure region over the Southwestern United States. There are two frontal systems, one in the Eastern United States and one in the Pacific Northwest. The map shows a range of pressures between 992 millibars (99.2 kPa) and 1036 millibars (103.6 kPa). These pressures are all corrected to sea level to allow a common basis for comparison. This means there are substantial areas of the Western United States where the actual measured station pressure is well below the value shown because of the station elevation above sea level.

The horizontal pressure difference provides the horizontal force or *pressure gradient* which determines the speed and initial direction of wind motion. In describing the direction of the wind, we always refer to the direction of origin of the wind. That is, a north wind is blowing on us *from* the north and is going *toward* the south.

The greater the pressure gradient, the greater is the force on the air, and the higher is the wind speed. Since the direction of the force is from higher to lower pressure, and perpendicular to the isobars, the initial tendency of the wind is to blow parallel to the horizontal pressure gradient and perpendicular to the isobars. However, as soon as wind motion is established, a deflective force is produced which alters the direction of motion. This force is called the *Coriolis force*.

The Coriolis force is due to the earth's rotation under a moving particle of air. From a fixed observation point in space air would appear to travel in a straight line, but from our vantage point on earth it appears to curve. To describe this change in observed direction, an equivalent force is postulated.

The basic effect is shown in Fig. 2. The two curved lines are lines of constant latitude, with point *B* located directly south of point *A*. A parcel of air (or some projectile like a cannon ball) is moving south at point *A*. If we can imagine our parcel of air or our cannon ball to have zero air friction, then the speed of the parcel of air will remain constant with respect to the ground. The direction will change, however, because of the earth's rotation under the parcel.

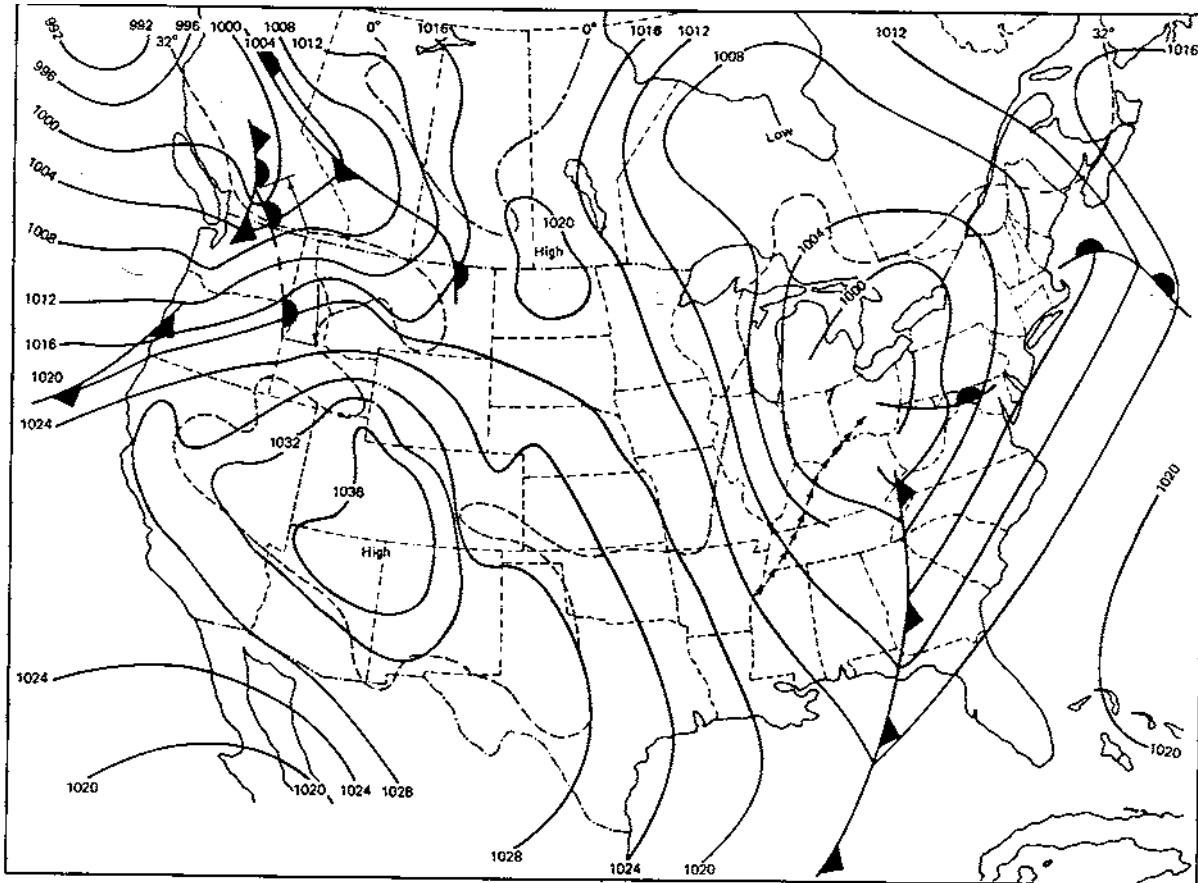

Figure 1: Weather map showing isobars

At point *A*, the parcel has the same eastward speed as the earth. Because of the assumed lack of friction, it will maintain this same eastward speed as it moves south. The eastward speed of the earth increases, however, as we move south (in the Northern Hemisphere). Therefore, the parcel will appear to have a westward component of velocity on the latitude line passing through point *B*. During the time required for the parcel to move from the first latitude line to the second, point *A* has moved eastward to point *A'* and point *B* has moved eastward to point *B'*. The path of the parcel is given by the dashed line. Instead of passing directly over point *B'* which is directly south of point *A'*, the parcel has been deflected to the right and crosses the second latitude line to the west of *B'*. The total speed relative to the earth's surface remains the same, so the southward moving component has decreased to allow the westward moving component of speed to increase.

It can be shown that a parcel of air will deflect to its right in the Northern Hemisphere, regardless of the direction of travel. This is not an obvious truth, but the spherical geometry necessary to prove the statement is beyond the scope of this text. We shall therefore accept

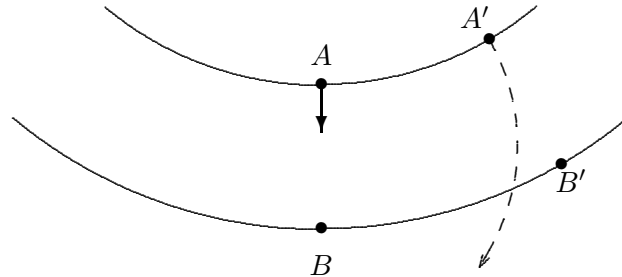

Figure 2: Coriolis force

it on faith.

Another statement we shall accept on faith is that the deflection of the parcel of air must cease when the wind direction becomes parallel to the isobars. Otherwise the wind would be blowing in the direction of increasing pressure, which would be like water running uphill. Since the Coriolis force acts in a direction 90 degrees to the right of the wind, it must act in a direction opposite to the pressure gradient at the time of maximum deflection. If there are no other forces present, this Coriolis force will exactly balance the pressure gradient force and the wind will flow parallel to the isobars, with higher pressure to the right of the wind direction. For straight or slightly curved isobars this resultant wind is called the *geostrophic wind*.

When strongly curved isobars are found, a *centrifugal force* must also be considered. Fig. 3 shows one isobar around a *cyclone*, which is a low pressure area rotating counterclockwise (Northern Hemisphere). Fig. 4 shows an isobar around a high pressure area which is rotating clockwise (Northern Hemisphere). This region is called an *anticyclone*. As mentioned earlier, the low pressure area is usually associated with bad weather, but does not imply anything about the magnitude of the wind speeds. A cyclone normally covers a major part of a state or several states and has rather gentle winds. It should not be confused with a tornado, which covers a very small region and has very destructive winds.

The wind moving counterclockwise in the cyclone experiences a pressure gradient force f_p inward, a Coriolis force f_c outward, and a centrifugal force f_g outward. For wind to continue moving in a counterclockwise direction parallel to the isobars, the forces must be balanced, so the pressure gradient force for a cyclone is

$$f_p = f_c + f_g \quad (7)$$

The pressure force inward is balanced by the sum of the Coriolis and centrifugal forces. The wind that flows in such a system is called the *gradient wind*. The term “geostrophic

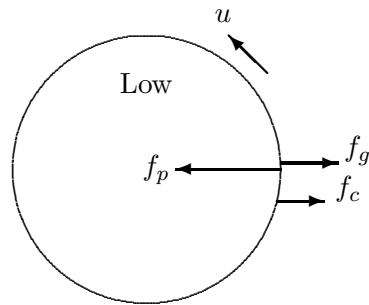

Figure 3: Wind forces in a low-pressure area

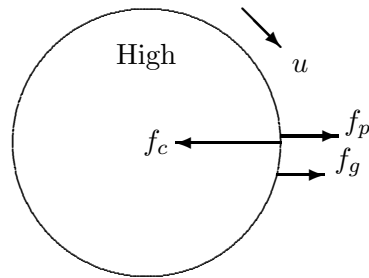

Figure 4: Wind forces in a high-pressure area

wind” applies only to a wind flowing in the vicinity of nearly straight isobars.

For the high pressure area of Fig. 4, the pressure and Coriolis forces reverse in direction. The pressure gradient force for an anticyclone is therefore

$$f_p = f_c - f_g \quad (8)$$

The difference between Eqs. 7 and 8 means that cyclones and anticyclones tend to stabilize at somewhat different relative pressures and wind speeds. Since the atmosphere is never completely stable, these differences are not usually of major concern.

2 WORLD DISTRIBUTION OF WIND

Ever since the days of sailing ships, it has been recognized that some areas of the earth's surface have higher wind speeds than others. Terms like *doldrums*, *horse latitudes*, and *trade winds* are well established in literature. A very general picture of prevailing winds over the surface of the earth is shown in Fig. 5. In some large areas or at some seasons, the actual pattern differs strongly from this idealized picture. These variations are due primarily to the irregular heating of the earth's surface in both time and position.

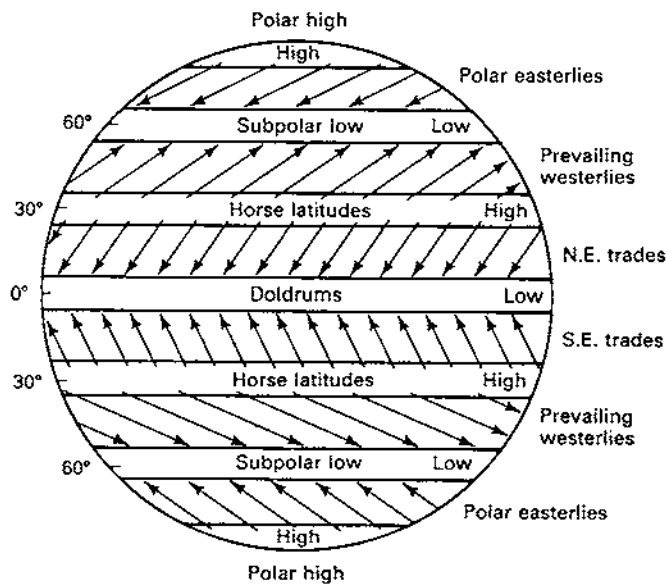

Figure 5: Ideal terrestrial pressure and wind systems

The *equatorial calms* or *doldrums* are due to a belt of low pressure which surrounds the earth in the equatorial zone as a result of the average overheating of the earth in this region. The warm air here rises in a strong convection flow. Late afternoon showers are common from the resulting adiabatic cooling which is most pronounced at the time of highest *diurnal* (daily) temperature. These showers keep the humidity very high without providing much surface cooling. The atmosphere tends to be oppressive, hot, and sticky with calm winds and slick glassy seas. Unless prominent land features change the weather patterns, regions near the equator will not be very good for wind power applications.

Ideally, there are two belts of high pressure and relatively light winds which occur symmetrically around the equator at 30° N and 30° S latitude. These are called the *subtropical calms* or *subtropical highs* or *horse latitudes*. The latter name apparently dates back to the sailing vessel days when horses were thrown overboard from becalmed ships to lighten the load and conserve water. The high pressure pattern is maintained by vertically descending air inside the pattern. This air is warmed adiabatically and therefore develops a low relative

humidity with clear skies. The dryness of this descending air is responsible for the bulk of the world's great deserts which lie in the horse latitudes.

There are then two more belts of low pressure which occur at perhaps 60° S latitude and 60° N latitude, the *subpolar lows*. In the Southern Hemisphere, this low is fairly stable and does not change much from summer to winter. This would be expected because of the global encirclement by the southern oceans at these latitudes. In the Northern Hemisphere, however, there are large land masses and strong temperature differences between land and water. These cause the lows to reverse and become highs over land in the winter (the *Canadian* and *Siberian highs*). At the same time the lows over the oceans, called the *Iceland low* and the *Aleutian low*, become especially intense and stormy low pressure areas over the relatively warm North Atlantic and North Pacific Oceans.

Finally, the polar regions tend to be high pressure areas more than low pressure. The intensities and locations of these highs may vary widely, with the center of the high only rarely located at the geographic pole.

The combination of these high and low pressure areas with the Coriolis force produces the prevailing winds shown in Fig. 5. The *northeast* and *southeast trade winds* are among the most constant winds on earth, at least over the oceans. This causes some islands, such as Hawaii (20° N. Latitude) and Puerto Rico (18° N. Latitude), to have excellent wind resources. The westerlies are well defined over the Southern Hemisphere because of lack of land masses. Wind speeds are quite steady and strong during the year, with an average speed of 8 to 14 m/s. The wind speeds tend to increase with increasing southerly latitude, leading to the descriptive terms *roaring forties*, *furious fifties*, and *screaming sixties*. This means that islands in these latitudes, such as New Zealand, should be prime candidates for wind power sites.

In the Northern Hemisphere, the westerlies are quite variable and may be masked or completely reversed by more prominent circulation about moving low and high pressure areas. This is particularly true over the large land masses.

3 WIND SPEED DISTRIBUTION IN THE UNITED STATES

There are over 700 stations in the United States where meteorological data are recorded at regular intervals. Records at some stations go back over a century. Wind speeds are measured at these stations by devices called *anemometers*. Until recently, wind speed data were primarily recorded in either *knots* or *miles per hour* (mi/h), and any study of the old records will have to be done in these old units. A knot, short for nautical mile per hour, is equal to 0.5144 m/s. A mi/h is equal to 0.4470 m/s, which makes a knot equal to 1.15 mi/h.

Wind speed data are affected by the anemometer height, the exposure of the anemometer as regards the surrounding buildings, hills, and trees, the human factor in reading the wind speed, as well as the quality and maintenance of the anemometer. The standardization of

these factors has not been well enforced over the years. For example, the standard anemometer height is 10 m but other heights are often found. In one study [16], six Kansas stations with data available from 1948 to 1976 had 21 different anemometer heights, none of which was 10 m. The only station which did not change anemometer height during this period was Russell, at a 9 m height. Heights ranged from 6 m to 22 m. The anemometer height at Topeka changed five times, with heights of 17.7, 22.3, 17.7, 22.0, and 7.6 m.

Reported wind data therefore need to be viewed with some caution. Only when anemometer heights and surrounding obstructions are the same can two sites be fairly compared for wind power potential. Reported data can be used, of course, to give an indication of the best regions of the country, with local site surveys being desirable to determine the quality of a potential wind power site.

Table 2.1 shows wind data for several stations in the United States. Similar data are available for most other U. S. stations. The percentage of time that the wind speed was recorded in a given speed range is given, as well as the mean speed and the peak speed[3]. Each range of wind speed is referred to as a *speed group*. Wind speeds were always recorded in integer knots or integer mi/h, hence the integer nature of the speed groups. If wind speeds were recorded in knots instead of the mi/h shown, the size of the speed groups would be adjusted so the percentage in each group remains the same. The speed groups for wind speeds in knots are 1-3, 4-6, 7-10, 11-16, 17-21, 22-27, 28-33, 34-40, and 41-47 knots. When converting wind data to mi/h speed groups, a 6 knot (6.91 mi/h) wind is assigned to the speed group containing 7 mi/h, while a 7 knot (8.06 mi/h) wind is assigned to the 8-12 mi/h speed group. Having the same percentages for two different unit systems is a help for some computations.

This table was prepared for the ten year period of 1951-60. No such tabulation was prepared by the U. S. Environmental Data and Information Service for 1961-70 or 1971-80, and no further tabulation is planned until it appears that the long term climate has changed enough to warrant the expense of such a compilation.

It may be seen that the mean wind speed varies by over a factor of two, from 3.0 m/s in Los Angeles to 7.8 m/s in Cold Bay, Alaska. The power in the wind is proportional to the cube of the wind speed, as we shall see in Chapter 4, so a wind of 7.8 m/s has 17.6 times the available power as a 3.0 m/s wind. This does not mean that Cold Bay is exactly 17.6 times as good as Los Angeles as a wind power site because of other factors to be considered later, but it does indicate a substantial difference.

The peak speed shown in Table 2.1 is the average speed of the fastest mile of air (1.6 km) to pass through a *run of wind* anemometer and is not the instantaneous peak speed of the peak gust, which will be higher. This type of anemometer will be discussed in Chapter 3.

The Environmental Data and Information Service also has wind speed data available on magnetic tape for many recording stations. This magnetic tape contains the complete record of a station over a period of up to ten years, including such items as temperature, air pressure, and humidity in addition to wind speed and direction. These data are typically recorded once

TABLE 2.1 Annual Percentage Frequency of Wind by Speed Groups and the Mean Speed^a

Station								Mean	Peak
	0-3	4-7	8-12	13-18	19-24	25-31	32-38	Speed	Speed ^b
	mi/h	mi/h	mi/h	mi/h	mi/h	mi/h	mi/h	(mi/h)	(m/s)
Albuquerque	17	36	26	13	5	2		8.6	40.2
Amarillo	5	15	32	32	12	4	1	12.9	37.5
Boise	15	30	32	18	4	1		8.9	27.3
Boston	3	12	33	35	12	4	1	13.3	38.9
Buffalo	5	17	34	27	13	3	1	12.4	40.7
Casper	8	16	27	27	13	7	2	13.3	NA
Chicago(O'Hare)	8	22	33	27	8	2		11.2	38.9
Cleveland	7	18	35	29	9	2		11.6	34.9
Cold Bay	4	9	18	27	21	14	5	17.4	NA
Denver	11	27	34	22	5	2		10.0	29.0
Des Moines	3	17	38	29	10	3	1	12.1	34.0
Fargo	4	13	28	31	15	7	2	14.4	51.4
Ft. Worth	4	14	34	34	10	3		12.5	30.4
Great Falls	7	19	24	24	15	9	3	13.9	36.6
Honolulu	9	17	27	32	12	2		12.1	30.0
Kansas City	9	29	35	23	5	1		9.8	32.2
Los Angeles	28	33	27	11	1			6.8	21.9
Miami	14	20	34	20	2			8.8	59.0
Minneapolis	8	21	34	28	9	2		11.2	41.1
Oklahoma City	2	11	34	34	13	6	1	14.0	38.9
Topeka	11	19	30	27	10	2		11.2	36.2
Wake Island	1	6	27	48	17	2		14.6	NA
Wichita	4	12	30	31	16	5	1	13.7	44.7

^aSource: *Climatology of the United States, Series 82: Decennial Census of the United State Climate, "Summary of Hourly Observations, 1951-1960"* (Table B).

^bNA, not available

an hour but the magnetic tape only has data for every third hour, so there are eight wind speeds and eight wind directions per day available on the magnetic tape.

The available data can be summarized in other forms besides that of Table 2.1. One form is the *speed-duration curve* as shown in Fig. 6. The horizontal axis is in hours per year, with a maximum value of 8760 for a year with 365 days. The vertical axis gives the wind speed that is exceeded for the number of hours per year on the horizontal axis. For Dodge City, Kansas, for example, a wind speed of 4 m/s is exceeded 6500 hours per year while 10 m/s is exceeded 700 hours per year. For Kansas City, 4 m/s is exceeded 4460 hours and 10 m/s is exceeded only 35 hours a year. Dodge City is seen to be a better location for a wind turbine

than Kansas City. Dodge City had a mean wind speed for this year of 5.68 m/s while Kansas City had a mean wind speed of 3.82 m/s. The anemometer height for both stations was 7 m above the ground.

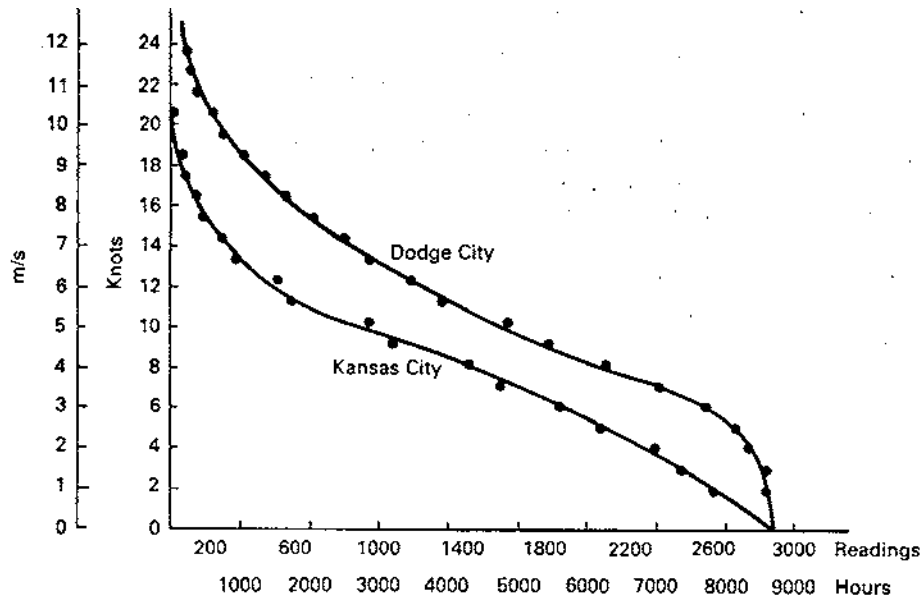

Figure 6: Speed-duration curves, 1970

Speed duration curves can be used to determine the number of hours of operation of a specific wind turbine. A wind turbine that starts producing power at 4 m/s and reaches rated power at 10 m/s would be operating 6500 hours per year at Dodge City (for the data shown in Fig. 6 and would be producing rated output for 700 of these hours. The output would be less than rated for the intermediate 5800 hours.

Speed duration curves do not lend themselves to many features of wind turbine design or selection. It is difficult to determine the optimum rated wind speed or the average power output from a speed duration curve, for example. For this reason, another type of curve has been developed, the *speed-frequency curve*. The two speed-frequency curves corresponding to the data of Fig. 6 are given in Fig. 7. These curves show the number of hours per year that the wind speed is in a given 1 m/s interval. At Dodge City the wind speed of 4 m/s is seen to occur 1240 hours per year. This actually means that we would expect wind speeds between 3.5 and 4.5 m/s for 1240 hours per year. The summation of the number of hours at each wind speed over all the wind speed intervals should be the total number of hours in the year.

Speed-frequency curves have several important features. One is that the intercept on the vertical axis is always greater than zero, due to the existence of calm spells at any site. Another feature is that the *most frequent speed* (the wind speed at the peak of this curve) is lower than the mean speed and varies with it. Still another feature is that the duration of the most frequent speed decreases as the mean speed increases[10].

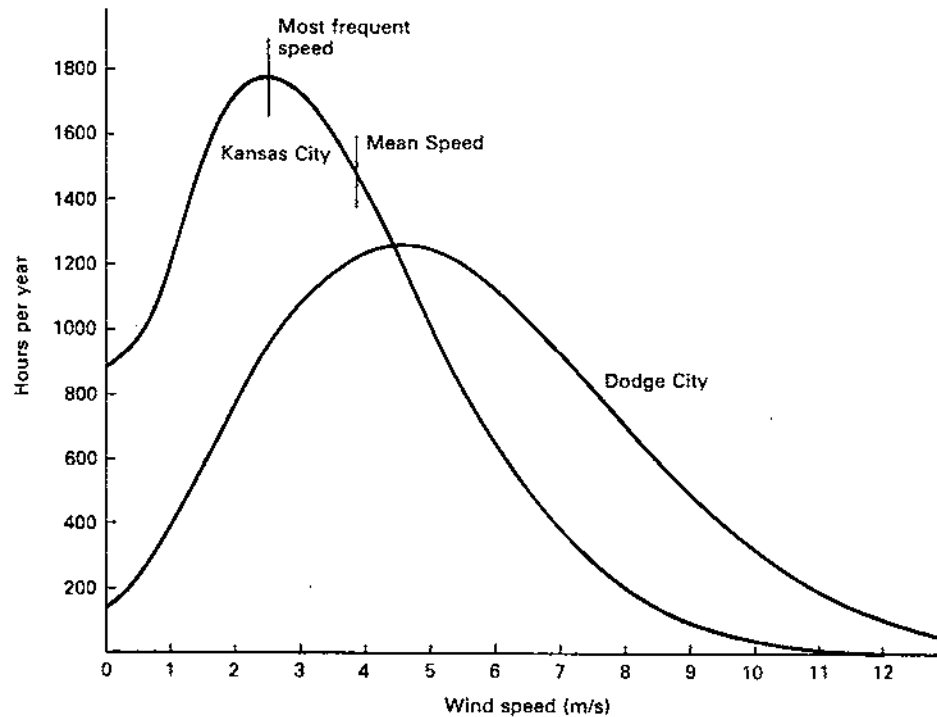

Figure 7: Speed-frequency curves, 1970

Speed frequency curves, or similar mathematical functions, can be used in studies to develop estimates of the seasonal and annual available wind power density in the United States and elsewhere. This is the power density in the wind in W/m^2 of area perpendicular to the flow of air. It is always substantially more than the power density that can actually be extracted from the wind, as we shall see in Chapter 4. The result of one such study[9] is shown in Fig. 8. This shows the estimated annual average power density available in the wind in W/m^2 at an elevation of 50 m above ground. Few wind data are recorded at that height, so the wind speeds at the actual anemometer heights have been extrapolated to 50 m by using the one-seventh power law, which will be discussed later in this chapter.

The shaded areas indicate mountainous terrain in which the wind power density estimates represent lower limits for exposed ridges and mountain tops. (From [9])

The map shows that the good wind regions are the *High Plains* (a north-south strip about 500 km wide on the east side of the Rocky Mountains), and mountain tops and exposed ridges throughout the country. The coastal regions in both the northeastern and northwestern United States are also good. There is a definite trend toward higher wind power densities at higher latitudes, as would be expected from Fig. 5. The southeastern United States is seen to be quite low compared with the remainder of the country.

There are selected sites, of course, which cannot be shown on this map scale, but which

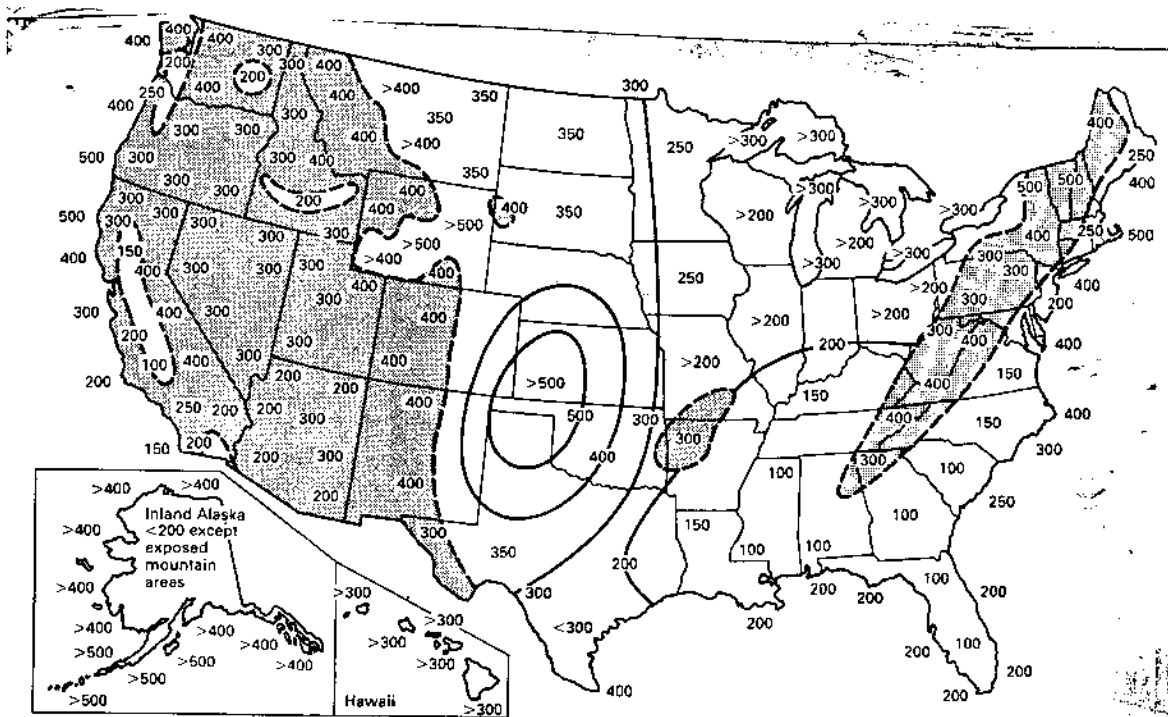

Figure 8: Annual mean wind power density W/m^2 estimated at 50 m above exposed areas.

have much higher wind power densities. Mt. Washington in New Hampshire has an average wind speed of over 15 m/s, twice that of the best site in Table 2.1. The annual average wind power density there would be over $3000 W/m^2$. Mt. Washington also has the distinction of having experienced the highest wind speed recorded at a regular weather data station, 105 m/s (234 mi/h). Extreme winds plus severe icing conditions make this particular site a real challenge for the wind turbine designer. Other less severe sites are being developed first for these reasons.

Superior sites include mountain passes as well as mountain peaks. When a high or low pressure air mass arrives at a mountain barrier, the air is forced to flow either over the mountain tops or through the passes. A substantial portion flows through the passes, with resulting high speed winds. The mountain passes are also usually more accessible than mountain peaks for construction and maintenance of wind turbines. One should examine each potential site carefully in order to assure that it has good wind characteristics before installing any wind turbines. Several sites should be investigated if possible and both hills and valleys should be considered.

4 ATMOSPHERIC STABILITY

As we have mentioned, most wind speed measurements are made about 10 m above the ground. Small wind turbines are typically mounted 20 to 30 m above ground level, while the propeller tip may reach a height of more than 100 m on the large turbines, so an estimate of wind speed variation with height is needed. The mathematical form of this variation will be considered in the next section, but first we need to examine a property of the atmosphere which controls this vertical variation of wind speed. This property is called *atmospheric stability*, which refers to the amount of mixing present in the atmosphere. We start this discussion by examining the pressure variation with height in the lower atmosphere

A given parcel of air has mass and is attracted to the earth by the force of gravity. For the parcel not to fall to the earth's surface, there must be an equal and opposite force directed away from the earth. This force comes from the decrease in air pressure with increasing height. The greater the density of air, the more rapidly must pressure decrease upward to hold the air at constant height against the force of gravity. Therefore, pressure decreases quickly with height at low altitudes, where density is high, and slowly at high altitudes where density is low. This balanced force condition is called *hydrostatic balance* or *hydrostatic equilibrium*.

The average atmospheric pressure as a function of elevation above sea level for middle latitudes is shown in Fig. 9. This curve is part of the model for the U.S. Standard Atmosphere. At sea level and a temperature of 273 K, the average pressure is 101.3 kPa, as mentioned earlier. A pressure of half this value is reached at about 5500 m. This pressure change with elevation is especially noticeable when flying in an airplane, when one's ears tend to 'pop' as the airplane changes altitude.

It should be noticed that the independent variable z is plotted on the vertical axis in this figure, while the dependent variable is plotted along the horizontal axis. It is plotted this way because elevation is intuitively up. To read the graph when the average pressure at a given height is desired, just enter the graph at the specified height, proceed horizontally until you hit the curve, and then go vertically downward to read the value of pressure.

The pressure in Fig. 9 is assumed to not vary with local temperature. That is, it is assumed that the column of air directly above the point of interest maintains the same mass throughout any temperature cycle. A given mass of air above some point will produce a constant pressure regardless of the temperature. The volume of gas in the column will change with temperature but not the pressure exerted by the column. This is not a perfect assumption because, while the mass of the entire atmosphere does not vary with temperature, the mass directly overhead will vary somewhat with temperature. A temperature decrease of 30°C will often be associated with a pressure increase of 2 to 3 kPa. The atmospheric pressure tends to be a little higher in the early morning than in the middle of the afternoon. Winter pressures tend to be higher than summer pressures. This effect is smaller than the pressure variation due to movement of weather patterns, hence will be ignored in this text.

It will be seen later that the power output of a wind turbine is proportional to air density,

which in turn is proportional to air pressure. A given wind speed therefore produces less power from a particular turbine at higher elevations, because the air pressure is less. A wind turbine located at an elevation of 1000 m above sea level will produce only about 90 % of the power it would produce at sea level, for the same wind speed and air temperature. There are many good wind sites in the United States at elevations above 1000 m, as can be seen by comparing Fig. 8 with a topographical map of the United States. Therefore this pressure variation with elevation must be considered in both technical and economic studies of wind power.

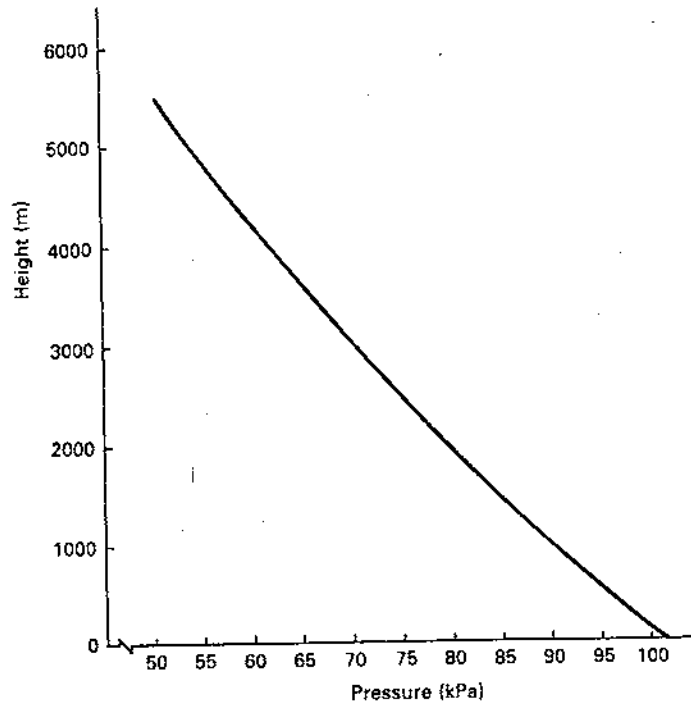

Figure 9: Pressure variation with altitude for U.S. Standard Atmosphere

The air density at a proposed wind turbine site is estimated by finding the average pressure at that elevation from Fig. 9 and then using Eq. 6 to find density. The ambient temperature must be used in this equation.

Example

A wind turbine is rated at 100 kW in a 10 m/s wind speed in air at standard conditions. If power output is directly proportional to air density, what is the power output of the turbine in a 10 m/s wind speed at Medicine Bow, Wyoming (elevation 2000 m above sea level) at a temperature of 20°C?

From Fig. 9, we read an average pressure of 79.4 kPa. The density at 20°C = 293 K is then

$$\rho = \frac{3.484(79.4)}{293} = 0.944$$

The power output at these conditions is just the ratio of this density to the density at standard conditions times the power at standard conditions.

$$P_{\text{new}} = P_{\text{old}} \frac{\rho_{\text{new}}}{\rho_{\text{old}}} = 100 \left(\frac{0.944}{1.293} \right) = 73 \text{ kW}$$

The power output has dropped from 100 kW to 73 kW at the same wind speed, just because we have a smaller air density.

We have seen that the average pressure at a given site is a function of elevation above sea level. Ground level temperatures vary in a minor way with elevation, but are dominated by latitude and topographic features. Denver, Colorado, with an elevation of 1610 m above sea level has a slightly higher winter temperature average than Topeka, Kansas with an elevation of 275 m, for example. We must be cautious, therefore, about estimating ground level temperatures based on elevation above sea level.

Once we leave the ground, however, and enter the first few thousand meters of the atmosphere, we find a more predictable temperature decrease with altitude. We shall use the word *altitude* to refer to the height of an object above ground level, and *elevation* to refer to the height above sea level. With these definitions, a pilot flying in the mountains is much more concerned about his altitude than his elevation.

This temperature variation with altitude is very important to the character of the winds in the first 200 m above the earth's surface, so we shall examine it in some detail. We observe that Eq. 3 (the ideal gas law or the *equation of state*) can be satisfied by pressure and temperature decreasing with altitude while the volume of one kmol (the *specific volume*) is increasing. Pressure and temperature are easily measured while specific volume is not. It is therefore common to use the *first law of thermodynamics* (which states that energy is conserved) and eliminate the volume term from Eq. 3. When this is done for an adiabatic process, the result is

$$\frac{T_1}{T_o} = \left(\frac{p_1}{p_o} \right)^{R/c_p} \quad (9)$$

where T_1 and p_1 are the temperature and pressure at state 1, T_o and p_o are the temperature and pressure at state 0, R is the universal gas constant, and c_p is the *constant-pressure specific heat* of air. The derivation of this equation may be found in most introductory thermodynamics books. The average value for the ratio R/c_p in the lower atmosphere is 0.286.

Eq. 9, sometimes called *Poisson's equation*, relates adiabatic temperature changes experienced by a parcel of air undergoing vertical displacement to the pressure field through which it moves. If we know the initial conditions T_o and p_o , we can calculate the temperature T_1 at any pressure p_1 as long as the process is adiabatic and involves only ideal gases.

Ideal gases can contain no liquid or solid material and still be ideal. Air behaves like an ideal gas as long as the water vapor in it is not saturated. When saturation occurs, water

starts to condense, and in condensing gives up its *latent heat of vaporization*. This heat energy input violates the adiabatic constraint, while the presence of liquid water keeps air from being an ideal gas.

Example

A parcel of air at sea level undergoes an upward displacement of 2 km. The initial temperature is 20°C. For the standard atmosphere of Fig. 9 and an adiabatic process, what is the temperature of the parcel at 2 km?

From Fig. 9 the pressure at 2 km is $p_1 = 79.4$ kPa. The temperature is, from Eq. 9,

$$T_1 = T_o \left(\frac{p_1}{p_o} \right)^{0.286} = 293 \left(\frac{79.4}{101.3} \right)^{0.286} = 273.3\text{K}$$

We see from this example that a parcel of air which undergoes an upward displacement experiences a temperature decrease of about 1°C/100 m in an adiabatic process. This quantity is referred to as the *adiabatic lapse rate*, the *dry- adiabatic lapse rate*, or the *temperature gradient*. It is an ideal quantity, and does not vary with actual atmospheric parameters.

This ideal temperature decrease is reasonably linear up to several kilometers above the earth's surface and can be approximated by

$$T_a(z) = T_g - R_a(z - z_g) \quad (10)$$

where $T_a(z)$ is the temperature at elevation z m above sea level if all processes are adiabatic, T_g is the temperature at ground level z_g , and R_a is the adiabatic lapse rate, 0.01°C/m. The quantity $z - z_g$ is the altitude above ground level.

The actual temperature decrease with height will normally be different from the adiabatic prediction, due to mechanical mixing of the atmosphere. The actual temperature may decrease more rapidly or less rapidly than the adiabatic decrease. In fact, the actual temperature can even increase for some vertical intervals. A plot of some commonly observed temperature variations with height is shown in Fig. 10. We shall start the explanation at 3 p.m., at which time the earth has normally reached its maximum temperature and the first 1000 m or so above the earth's surface is well mixed. This means that the curve of actual temperature will follow the theoretical adiabatic curve rather closely.

By 6 p.m. the ground temperature has normally dropped slightly. The earth is much more effective at receiving energy from the sun and reradiating it into space than is the air above the earth. This means that the air above the earth is cooled and heated by conduction and convection from the earth, hence the air temperature tends to lag behind the ground temperature. This is shown in Fig. 10b, where at 6 p.m. the air temperature is slightly above the adiabatic line starting from the current ground temperature. As ground temperature continues to drop during the night, the difference between the actual or prevailing temperature and the adiabatic curve becomes even more pronounced. There may even be a *temperature*

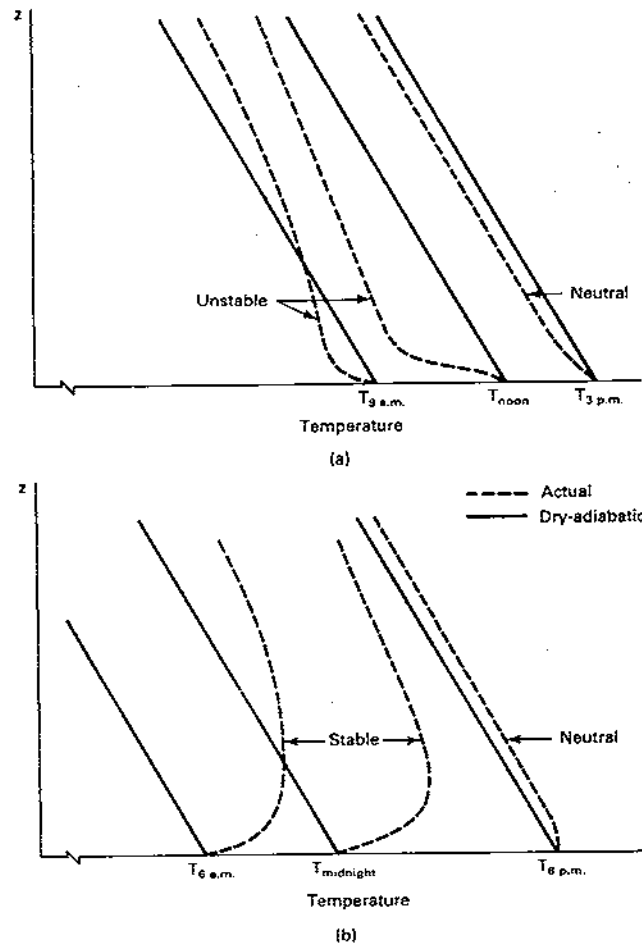

Figure 10: Dry-adiabatic and actual temperature variations with height as a function of time of day, for clear skies.

inversion near the ground. This usually occurs only with clear skies, which allow the earth to radiate its energy into space effectively.

When sunlight strikes the earth in the morning, the earth's surface temperature rises rapidly, producing the air temperature variations shown in Fig. 10a. The difference between the actual air temperature and the adiabatic curve would normally reach its maximum before noon, causing a relatively rapid heating of the air. There will be a strong convective flow of air during this time because a parcel of air that is displaced upward will find itself warmer and hence lighter than its surroundings. It is then accelerated upwards under hydrostatic pressure. It will continue to rise until its temperature is the same as that of the adiabatic curve. Another parcel has to move down to take the first parcel's place, perhaps coming down where the earth is not as effective as a collector of solar energy, and hence causes the atmosphere to be well mixed under these conditions. This condition is referred to as an *unstable atmosphere*.

On clear nights, however, the earth will be colder than the air above it, so a parcel at the temperature of the earth that is displaced upward will find itself colder than the surrounding air. This makes it more dense than its surroundings so that it tends to sink back down to its original position. This condition is referred to as a *stable atmosphere*. Atmospheres which have temperature profiles between those for unstable and stable atmospheres are referred to as *neutral atmospheres*. The daily variation in atmospheric stability and surface wind speeds is called the *diurnal cycle*.

It is occasionally convenient to express the actual temperature variation in an equation similar to Eq. 10. Over at least a narrow range of heights, the prevailing temperature $T_p(z)$ can be written as

$$T_p(z) = T_g - R_p(z - z_g) \quad (11)$$

where R_p is the slope of a straight line approximation to the actual temperature curve called the *prevailing lapse rate*. T_g is the temperature at ground level, z_g m above mean sea level, and z is the elevation of the observation point above sea level. We can force this equation to fit one of the dashed curves of Fig. 10 by using a *least squares* technique, and determine an approximate *lapse rate* for that particular time. If we do this for all times of the day and all seasons of the year, we find that the average prevailing lapse rate R_p is $0.0065^\circ\text{C}/\text{m}$.

Suppose that a parcel of air is heated above the temperature of the neighboring air so it is now buoyant and will start to rise. If the prevailing lapse rate is less than adiabatic, the parcel will rise until its temperature is the same as the surrounding air. The pressure force and hence the acceleration of the parcel is zero at the point where the two lapse rate lines intersect. The upward velocity, however, produced by acceleration from the ground to the height at which the buoyancy vanishes, is greatest at that point. Hence the air will continue upward, now colder and more dense than its surroundings, and decelerate. Soon the upward motion will cease and the parcel will start to sink. After a few oscillations about that level the parcel will settle near that height as it is slowed down by friction with the surrounding air.

Example

Suppose that the prevailing lapse rate is $0.0065^\circ\text{C}/\text{m}$ and that a parcel of air is heated to 25°C while the surrounding air at ground level is at 24°C . Ground level is at an elevation 300 m above sea level. What will be the final altitude of the heated parcel after oscillations cease, assuming an adiabatic process?

The temperature variation with height for the linear adiabatic lapse rate is, from Eq. 10,

$$T_a = 25 - 0.01(z - 300)$$

Similarly, the temperature variation for the prevailing lapse rate is, from Eq. 11,

$$T_p = 24 - 0.0065(z - 300)$$

The two temperatures are the same at the point of equal buoyancy. Setting T_a equal to T_p and solving for z yields an intersection height of about 585 m above sea level or 285 m above ground level. This is illustrated in Fig. 11.

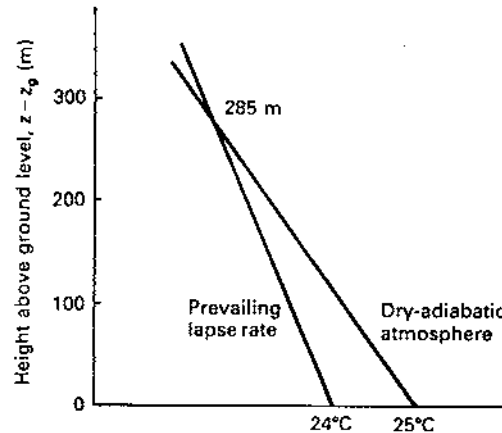

Figure 11: Buoyancy of air in a stable atmosphere

Atmospheric mixing may be limited to a relatively shallow layer if there is a temperature inversion at the top of the layer. This situation is illustrated in Fig. 12. Heated parcels rise until their temperature is the same as that of the ambient air, as before. Now, however, a doubling of the initial temperature difference does not result in a doubling of the height of the intersection, but rather yields a minor increase. Temperature inversions act as very strong lids against penetration of air from below, trapping the surface air layer underneath the inversion base. Such a situation is responsible for the maintenance of smog in the Los Angeles basin.

A more detailed system of defining stability is especially important in atmospheric pollution studies. Various stability parameters or categories have been defined and are available in the literature[18].

A stable atmosphere may have abrupt changes in wind speed at a boundary layer. The winds may be nearly calm up to an elevation of 50 or 100 m, and may be 20 m/s above that boundary. A horizontal axis wind turbine which happened to have its hub at this boundary would experience very strong *bending moments* on its blades and may have to be shut down in such an environment. An unstable atmosphere will be better mixed and will not evidence such sharp boundaries.

The wind associated with an unstable atmosphere will tend to be gusty, because of thermal mixing. Wind speeds will be quite small near the ground because of ground friction, increasing upward for perhaps several hundred meters over flat terrain. A parcel of heated air therefore leaves the ground with a low horizontal wind speed. As it travels upward, the surrounding air exerts drag forces on the parcel, tending to speed it up. The parcel will still maintain its identity for some time, traveling slower than the surrounding air.

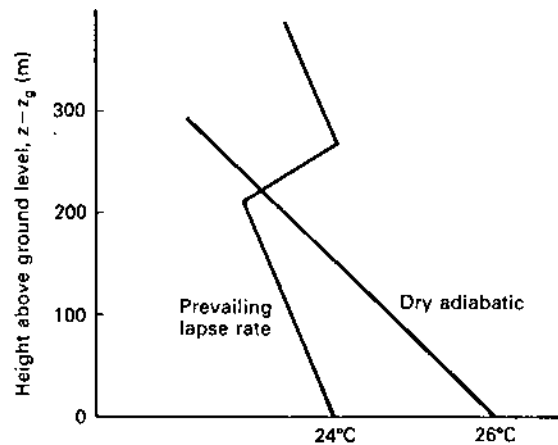

Figure 12: Deep buoyant layer topped by temperature inversion.

Parcels of air descending from above have higher horizontal speeds. They mix with the ascending parcels, causing an observer near the ground to sense wind speeds both below and above the mean wind speed. A parcel with higher velocity is called a *gust*, while a parcel with lower velocity is sometimes called a *negative gust* or a *lull*. These parcels vary widely in size and will hit a particular point in a random fashion. They are easily observed in the wave structure of a lake or in a field of tall wheat.

Gusts pose a hazard to large wind turbines because of the sudden change in wind speed and direction experienced by the turbine during a gust. Vibrations may be established or structural damage done. The wind turbine must be designed to withstand the peak gust that it is likely to experience during its projected lifetime.

Gusts also pose a problem in the adjusting of the turbine blades during operation in that the sensing anemometer will experience a different wind speed from that experienced by the blades. A gust may hit the anemometer and cause the blade *angle of attack* (the angle at which the blade passes through the air) to be adjusted for a higher wind speed than the blades are actually experiencing. This will generally cause the power output to drop below the optimum amount. Conversely, when the sensing anemometer experiences a lull, the turbine may be *trimmed* (adjusted) to produce more than rated output because of the higher wind speed it is experiencing. These undesirable situations require the turbine control system to be rather complex, and to have long time constants. This means that the turbine will be aimed slightly off the instantaneous wind direction and not be optimally adjusted for the instantaneous wind speed a large fraction of the time. The power production of the turbine will therefore be somewhat lower than would be predicted for an optimally adjusted and aimed wind turbine in a steady wind. The amount of this reduction is difficult to measure or even to estimate, but could easily be on the order of a 10 % reduction. This makes the simpler vertical axis machines more competitive than they might appear from wind tunnel tests since they require

no aiming or blade control.

Thus far, we have talked only about gusts due to *thermal turbulence*, which has a very strong diurnal cycle. Gusts are also produced by *mechanical turbulence*, caused by higher speed winds flowing over rough surfaces. When strong frontal systems pass through a region, the atmosphere will be mechanically mixed and little or no diurnal variation of wind speed will be observed. When there is no significant mixing of the atmosphere due to either thermal or mechanical turbulence, a boundary layer may develop with relatively high speed laminar flow of air above the boundary and essentially calm conditions below it. Without the effects of mixing, upper level wind speeds tend to be higher than when mixed with lower level winds. Thus it is quite possible for nighttime wind speeds to decrease near the ground and increase a few hundred meters above the ground. This phenomenon is called the *nocturnal jet*. As mentioned earlier, most National Weather Service (NWS) anemometers have been located about 10 m above the ground, so the height and frequency of occurrence of this nocturnal jet have not been well documented at many sites. Investigation of nocturnal jets is done either with very tall towers (e.g. 200 m) or with meteorological balloons. Balloon data are not very precise, as we shall see in more detail in the next chapter, but rather long term records are available of National Weather Service balloon launchings. When used with appropriate caution, these data can show some very interesting variations of wind speed with height and time of day.

Fig. 13 shows the diurnal wind speed pattern at Dodge City, Kansas for the four year period, 1970-73, as recorded by the National Weather Service with an anemometer at 7 m above the ground. The average windspeed for this period was 5.66 m/s at this height. The spring season (March, April, and May) is seen to have the highest winds, with the summer slightly lower than the fall and winter seasons. The wind speed at 7 m is seen to have its peak during the middle of the day for all seasons.

Also shown in Fig. 13 are the results from two balloon launchings per day for the same period for three Kansas locations, Dodge City, Goodland, and Wichita. The terrain and wind characteristics are quite similar at each location, and averaging reduces the concern about missing data or local anomalies. The surface wind speed is measured at the time of the launch. These values lie very close to the Dodge City curves, indicating reasonable consistency of data. The wind speed pattern indicated by the balloons at 216 m is then seen to be much different from the surface speeds. The diurnal cycle at 216 m is opposite that at the surface. The lowest readings occur at noon and the highest readings occur at midnight. The lowest readings at 216 m are higher than the highest surface winds by perhaps 10-20 %, while the midnight wind speeds at 216 m are double those on the surface. This means that a wind turbine located in the nocturnal jet will have good winds in the middle of the day and even better winds at night. The average wind speed at 216 m for this period was 9.22 m/s, a very respectable value for wind turbine operation.

Measurements at intermediate heights will indicate some height where there is no diurnal cycle. A site at which the wind speed averages 7 or 8 m/s is a good site, especially if it is relatively steady. This again indicates the importance of detailed wind measurements at any

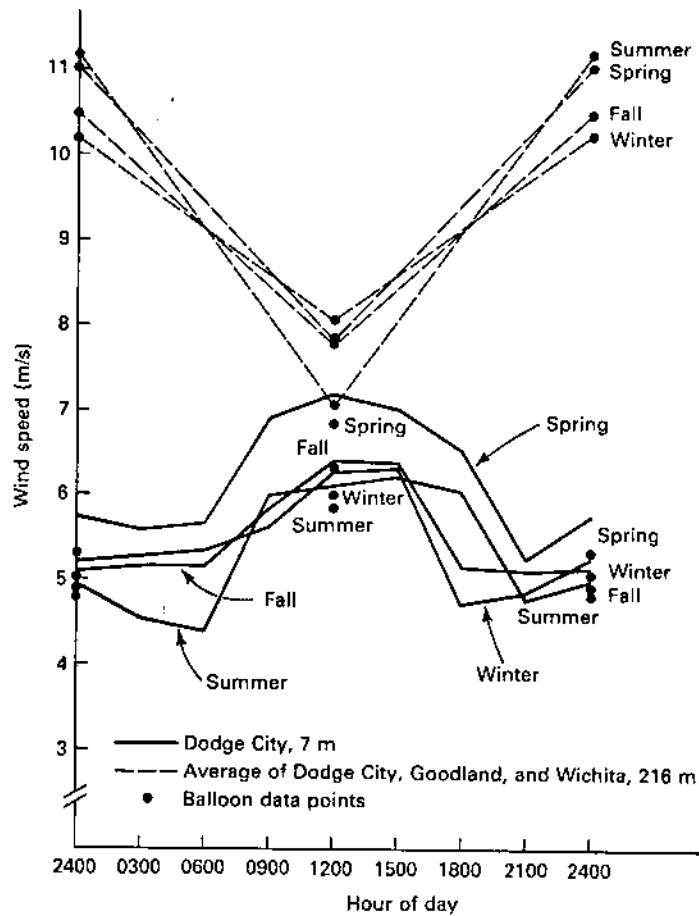

Figure 13: Western Kansas wind data, 1970-1973.

proposed site. Two very similar sites may have the same surface winds, but one may have a well developed nocturnal jet at 20 m while the other may never have a nocturnal jet below 200 m. The energy production of a wind turbine on a tall tower at the first site may be nearly double that at the second site, with a corresponding decrease in the cost of electricity. We see that measurements really need to be taken at heights up to the hub height plus blade radius over a period of at least a year to clearly indicate the actual available wind.

5 WIND SPEED VARIATION WITH HEIGHT

As we have seen, a knowledge of wind speeds at heights of 20 to 120 m above ground is very desirable in any decision about location and type of wind turbine to be installed. Many times, these data are not available and some estimate must be made from wind speeds measured at

about 10 m. This requires an equation which predicts the wind speed at one height in terms of the measured speed at another, lower, height. Such equations are developed in texts on fluid mechanics. The derivations are beyond the scope of this text so we shall just use the results. One possible form for the variation of wind speed $u(z)$ with height z is

$$u(z) = \frac{u_f}{K} \left[\ln \frac{z}{z_o} - \xi \left(\frac{z}{L} \right) \right] \quad (12)$$

Here u_f is the *friction velocity*, K is the *von Kármán's constant* (normally assumed to be 0.4), z_o is the surface roughness length, and L is a scale factor called the *Monin Obukov length*[17, 13]. The function $\xi(z/L)$ is determined by the net solar radiation at the site. This equation applies to short term (e.g. 1 minute) average wind speeds, but not to monthly or yearly averages.

The surface roughness length z_o will depend on both the size and the spacing of roughness elements such as grass, crops, buildings, etc. Typical values of z_o are about 0.01 cm for water or snow surfaces, 1 cm for short grass, 25 cm for tall grass or crops, and 1 to 4 m for forest and city[19]. In practice, z_o cannot be determined precisely from the appearance of a site but is determined from measurements of the wind. The same is true for the friction velocity u_f , which is a function of surface friction and the air density, and $\xi(z/L)$. The parameters are found by measuring the wind at three heights, writing Eq. 12 as three equations (one for each height), and solving for the three unknowns u_f , z_o , and $\xi(z/L)$. This is not a linear equation so nonlinear analysis must be used. The results must be classified by the direction of the wind and the time of year because z_o varies with the upwind surface roughness and the condition of the vegetation. Results must also be classified by the amount of net radiation so the appropriate functional form of $\xi(z/L)$ can be used.

All of this is quite satisfying for detailed studies on certain critical sites, but is too difficult to use for general engineering studies. This has led many people to look for simpler expressions which will yield satisfactory results even if they are not theoretically exact. The most common of these simpler expressions is the power law, expressed as

$$\frac{u(z_2)}{u(z_1)} = \left(\frac{z_2}{z_1} \right)^\alpha \quad (13)$$

In this equation z_1 is usually taken as the height of measurement, approximately 10 m, and z_2 is the height at which a wind speed estimate is desired. The parameter α is determined empirically. The equation can be made to fit observed wind data reasonably well over the range of 10 to perhaps 100 or 150 m if there are no sharp boundaries in the flow.

The exponent α varies with height, time of day, season of the year, nature of the terrain, wind speeds, and temperature[10]. A number of models have been proposed for the variation of α with these variables[22]. We shall use the *linear logarithmic plot* shown in Fig. 14. This figure shows one plot for day and another plot for night, each varying with wind speed

according to the equation

$$\alpha = a - b \log_{10} u(z_1) \quad (14)$$

The coefficients a and b can be determined by a *linear regression* program. Typical values of a and b are 0.11 and 0.061 in the daytime and 0.38 and 0.209 at night.

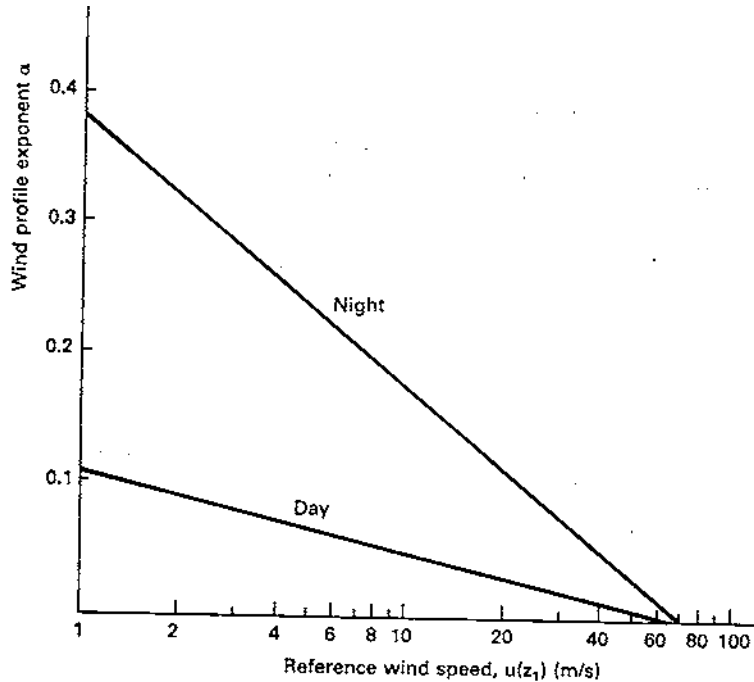

Figure 14: Variation of wind profile exponent α with reference wind speed $u(z_1)$.

Several sets of this figure can be generated at each site if necessary. One figure can be developed for each season of the year, for example. Temperature, wind direction, and height effects can also be accommodated by separate figures. Such figures would be valid at only the site where they were measured. They could be used at other sites with similar terrain with some caution, of course.

The average value of α has been determined by many measurements around the world to be about one-seventh. This has led to the common reference to Eq. 13 as the *one-seventh power law equation*. This average value should be used only if site specific data is not available, because of the wide range of values that α can assume.

6 WIND-SPEED STATISTICS

The speed of the wind is continuously changing, making it desirable to describe the wind by statistical methods. We shall pause here to examine a few of the basic concepts of probability and statistics, leaving a more detailed treatment to the many books written on the subject.

One statistical quantity which we have mentioned earlier is the average or arithmetic mean. If we have a set of numbers u_i , such as a set of measured wind speeds, the mean of the set is defined as

$$\bar{u} = \frac{1}{n} \sum_{i=1}^n u_i \quad (15)$$

The sample size or the number of measured values is n .

Another quantity seen occasionally in the literature is the *median*. If n is odd, the median is the middle number after all the numbers have been arranged in order of size. As many numbers lie below the median as above it. If n is even the median is halfway between the two middle numbers when we rank the numbers.

In addition to the mean, we are interested in the variability of the set of numbers. We want to find the discrepancy or deviation of each number from the mean and then find some sort of average of these deviations. The mean of the deviations $u_i - \bar{u}$ is zero, which does not tell us much. We therefore square each deviation to get all positive quantities. The *variance* σ^2 of the data is then defined as

$$\sigma^2 = \frac{1}{n-1} \sum_{i=1}^n (u_i - \bar{u})^2 \quad (16)$$

The term $n - 1$ is used rather than n for theoretical reasons we shall not discuss here[2].

The *standard deviation* σ is then defined as the square root of the variance.

$$\text{standard deviation} = \sqrt{\text{variance}} \quad (17)$$

Example

Five measured wind speeds are 2,4,7,8, and 9 m/s. Find the mean, the variance, and the standard deviation.

$$\bar{u} = \frac{1}{5}(2 + 4 + 7 + 8 + 9) = 6.00 \text{ m/s}$$

$$\begin{aligned}
 \sigma^2 &= \frac{1}{4}[(2-6)^2 + (4-6)^2 + (7-6)^2 + (8-6)^2 + (9-6)^2] \\
 &= \frac{1}{4}(34) = 8.5 \text{ m}^2/\text{s}^2 \\
 \sigma &= \sqrt{8.5} = 2.92 \text{ m/s}
 \end{aligned}$$

Wind speeds are normally measured in integer values, so that each integer value is observed many times during a year of observations. The numbers of observations of a specific wind speed u_i will be defined as m_i . The mean is then

$$\bar{u} = \frac{1}{n} \sum_{i=1}^w m_i u_i \quad (18)$$

where w is the number of different values of wind speed observed and n is still the total number of observations.

It can be shown[2] that the variance is given by

$$\sigma^2 = \frac{1}{n-1} \left[\sum_{i=1}^w m_i u_i^2 - \frac{1}{n} \left(\sum_{i=1}^w m_i u_i \right)^2 \right] \quad (19)$$

The two terms inside the brackets are nearly equal to each other so full precision needs to be maintained during the computation. This is not difficult with most of the hand calculators that are available.

Example

A wind data acquisition system located in the tradewinds on the northeast coast of Puerto Rico measures 6 m/s 19 times, 7 m/s 54 times, and 8 m/s 42 times during a given period. Find the mean, variance, and standard deviation.

$$\begin{aligned}
 \bar{u} &= \frac{1}{115}[19(6) + 54(7) + 42(8)] = 7.20 \text{ m/s} \\
 \sigma^2 &= \left\{ \frac{1}{114}[19(6)^2 + 54(7)^2 + 42(8)^2] - \frac{1}{115}[19(6) + 54(7) + 42(8)]^2 \right\} \\
 &= \frac{1}{114}(6018 - 5961.600) = 0.495 \text{ m}^2/\text{s}^2 \\
 \sigma &= 0.703 \text{ m/s}
 \end{aligned}$$

Many hand calculators have a built-in routine for computing mean and standard deviation. The answers of the previous example can be checked on such a machine by anyone willing to punch in 115 numbers. In other words, Eq. 19 provides a convenient shortcut to finding the variance as compared with the method indicated by Eq. 16, or even by direct computation on a hand calculator.

Both the mean and the standard deviation will vary from one period to another or from one location to another. It may be of interest to some people to arrange these values in *rank order* from smallest to largest. We can then immediately pick out the smallest, the median, and the largest value. The terms *smallest* and *largest* are not used much in statistics because of the possibility that one value may be widely separated from the rest. The fact that the highest recorded surface wind speed is 105 m/s at Mt. Washington is not very helpful in estimating peak speeds at other sites, because of the large gap between this speed and the peak speed at the next site in the rank order. The usual practice is to talk about *percentiles*, where the 90 percentile mean wind would refer to that mean wind speed which is exceeded by only 10 % of the measured means. Likewise, if we had 100 recording stations, the 90 percentile standard deviation would be the standard deviation of station number 90 when numbered in ascending rank order from the station with the smallest standard deviation. Only 10 stations would have a larger standard deviation (or more variable winds) than the 90 percentile value. This practice of using percentiles allows us to consider cases away from the median without being too concerned about an occasional extreme value.

We shall now define the *probability* p of the discrete wind speed u_i being observed as

$$p(u_i) = \frac{m_i}{n} \quad (20)$$

By this definition, the probability of an 8 m/s wind speed being observed in the previous example would be $42/115 = 0.365$. With this definition, the sum of all probabilities will be unity.

$$\sum_{i=1}^w p(u_i) = 1 \quad (21)$$

Note that we are using the same symbol p for both pressure and probability. Hopefully, the context will be clear enough that this will not be too confusing.

We shall also define a cumulative distribution function $F(u_i)$ as the probability that a measured wind speed will be less than or equal to u_i .

$$F(u_i) = \sum_{j=1}^i p(u_j) \quad (22)$$

The cumulative distribution function has the properties

$$F(-\infty) = 0, \quad F(\infty) = 1 \quad (23)$$

Example

A set of measured wind speeds is given in Table 2.2. Find $p(u_i)$ and $F(u_i)$ for each speed. The total number of observations is $n = 211$.

Table 2.2. Wind speed histogram

i	u_i	m_i	$p(u_i)$	$F(u_i)$
1	0	0	0	0
2	1	0	0	0
3	2	15	0.071	0.071
4	3	42	0.199	0.270
5	4	76	0.360	0.630
6	5	51	0.242	0.872
7	6	27	0.128	1.000

The values of $p(u_i)$ and $F(u_i)$ are computed from Eqs. 20 and 22 and tabulated in the table.

We also occasionally need a probability that the wind speed is between certain values or above a certain value. We shall name this probability $P(u_a \leq u \leq u_b)$ where u_b may be a very large number. It is defined as

$$P(u_a \leq u \leq u_b) = \sum_{i=a}^b p(u_i) \quad (24)$$

For example, the probability $P(5 \leq u \leq \infty)$ that the wind speed is 5 m/s or greater in the previous example is $0.242 + 0.128 = 0.370$.

It is convenient for a number of theoretical reasons to model the wind speed frequency curve by a continuous mathematical function rather than a table of discrete values. When we do this, the probability values $p(u_i)$ become a density function $f(u)$. The density function $f(u)$ represents the probability that the wind speed is in a 1 m/s interval centered on u . The discrete probabilities $p(u_i)$ have the same meaning if they were computed from data collected at 1 m/s intervals. The area under the density function is unity, which is shown by the integral equivalent of Eq. 21.

$$\int_0^{\infty} f(u) du = 1 \quad (25)$$

The *cumulative distribution function* $F(u)$ is given by

$$F(u) = \int_0^u f(x) dx \quad (26)$$

The variable x inside the integral is just a dummy variable representing wind speed for the purpose of integration.

Both of the above integrations start at zero because the wind speed cannot be negative. When the wind speed is considered as a continuous random variable, the cumulative distribution function has the properties $F(0) = 0$ and $F(\infty) = 1$. The quantity $F(0)$ will not necessarily be zero in the discrete case because there will normally be some zero wind speeds measured which are included in $F(0)$. In the continuous case, however, $F(0)$ is the integral of Eq. 26 with integration limits both starting and ending at zero. Since $f(u)$ is a well behaved function at $u = 0$, the integration has to yield a result of zero. This is a minor technical point which should not cause any difficulties later.

We will sometimes need the inverse of Eq. 26 for computational purposes. This is given by

$$f(u) = \frac{dF(u)}{du} \quad (27)$$

The general relationship between $f(u)$ and $F(u)$ is sketched in Fig. 15. $F(u)$ starts at 0, changes most rapidly at the peak of $f(u)$, and approaches 1 asymptotically.

The mean value of the density function $f(u)$ is given by

$$\bar{u} = \int_0^{\infty} u f(u) du \quad (28)$$

The variance is given by

$$\sigma^2 = \int_0^{\infty} (u - \bar{u})^2 f(u) du \quad (29)$$

These equations are used to compute theoretical values of mean and variance for a wide variety of statistical functions that are used in various applications.

7 WEIBULL STATISTICS

There are several density functions which can be used to describe the wind speed frequency curve. The two most common are the *Weibull* and the *Rayleigh* functions. For the statistically inclined reader, the Weibull is a special case of the Pearson Type III or generalized gamma distribution, while the Rayleigh [or *chi with two degrees of freedom*(chi-2)] distribution is a subset of the Weibull. The Weibull is a *two parameter* distribution while the Rayleigh has only *one parameter*. This makes the Weibull somewhat more versatile and the Rayleigh somewhat simpler to use. We shall present the Weibull distribution first.

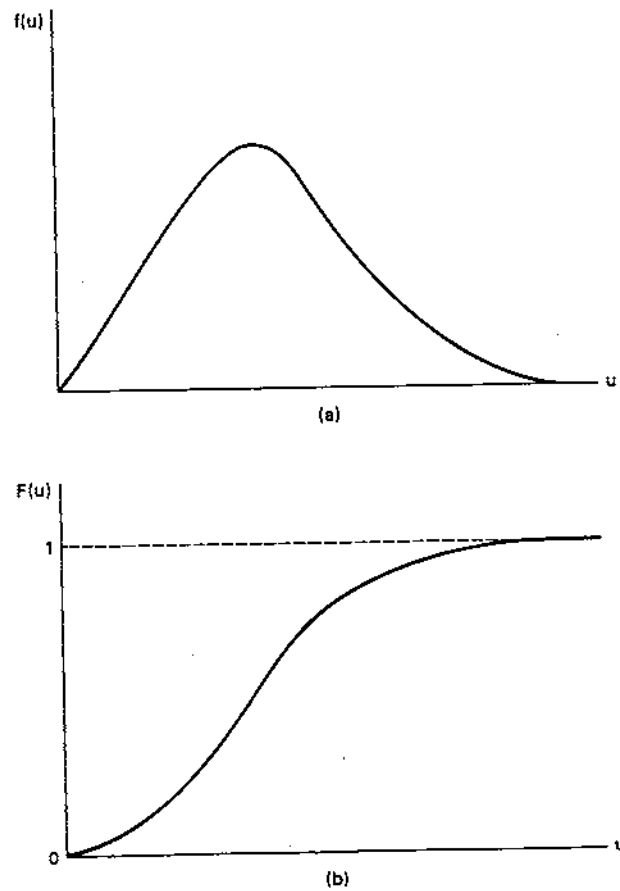

Figure 15: General relationship between (a) a density function $f(u)$ and (b) a distribution function $F(u)$

The wind speed u is distributed as the Weibull distribution if its probability density function is

$$f(u) = \frac{k}{c} \left(\frac{u}{c}\right)^{k-1} \exp \left[-\left(\frac{u}{c}\right)^k \right] \quad (k > 0, u > 0, c > 1) \quad (30)$$

We are using the expression $\exp(x)$ to represent e^x .

This is a two parameter distribution where c and k are the *scale parameter* and the *shape parameter*, respectively. Curves of $f(u)$ are given in Fig. 16, for the scale parameter $c = 1$. It can be seen that the Weibull density function gets relatively more narrow and more peaked as k gets larger. The peak also moves in the direction of higher wind speeds as k increases. A comparison of Figs. 16 and 7 shows that the Weibull has generally the right shape to fit

wind speed frequency curves, at least for these two locations. Actually, data collected at many locations around the world can be reasonably well described by the Weibull density function if the time period is not too short. Periods of an hour or two or even a day or two may have wind data which are not well fitted by a Weibull or any other statistical function, but for periods of several weeks to a year or more, the Weibull usually fits the observed data reasonably well.

It may have been noticed in Fig. 16 that the wind speed only varies between 0 and 2.4 m/s, a range with little interest from a wind power viewpoint. This is not really a problem because the scale parameter c can scale the curves to fit different wind speed regimes.

If c is different from unity, the values of the vertical axis have to be divided by c , as seen by Eq. 30. Since one of the properties of a probability density function is that the area under the curve has to be unity, then as the curve is compressed vertically, it has to expand horizontally. For $c = 10$, the peak value of the $k = 2.0$ curve is only 0.0858 but this occurs at a speed u of 7 rather than 0.7. If the new curve were graphed with vertical increments of 1/10 those of Fig. 16 and horizontal increments of 10 times, the new curve would have the same appearance as the one in Fig. 16. Therefore this figure may be used for any value of c with the appropriate scaling.

For k greater than unity, $f(u)$ becomes zero at zero wind speed. The Weibull density function thus cannot fit a wind speed frequency curve at zero speed because the frequency of calms is always greater than zero. This is not a serious problem because a wind turbine's output would be zero below some cut-in speed anyway. What is needed is a curve which will fit the observed data above some minimum speed. The Weibull density function is a suitable curve for this task.

A possible problem in fitting data is that the Weibull density function is defined for all values of u for $0 \leq u \leq \infty$ whereas the actual number of observations will be zero above some maximum wind speed. Fitting a nonzero function to zero data can be difficult. Again, this is not normally a serious problem because $f(u)$ goes to zero for all practical purposes for u/c greater than 2 or 3, depending on the value of k . Both ends of the curve have to receive special attention because of these possible problems, as will be seen later.

The mean wind speed \bar{u} computed from Eq. 28 is

$$\bar{u} = \int_0^{\infty} \frac{uk}{c} \left(\frac{u}{c}\right)^{k-1} \exp\left[-\left(\frac{u}{c}\right)^k\right] du \quad (31)$$

If we make the change of variable

$$x = \left(\frac{u}{c}\right)^k \quad (32)$$

then the mean wind speed can be written

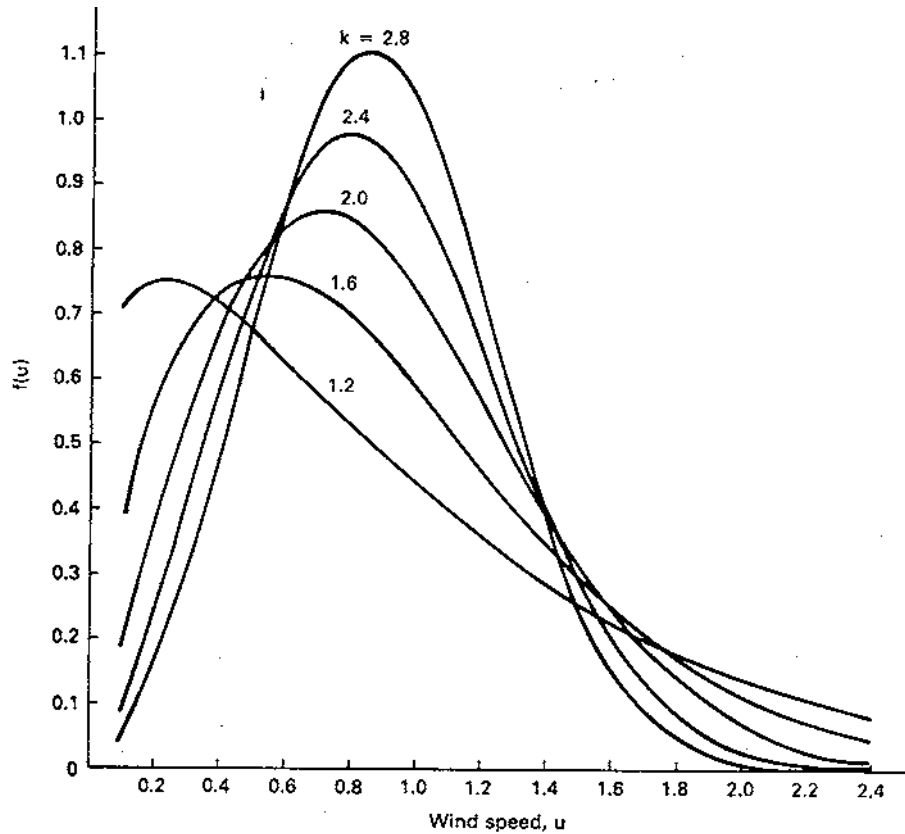

Figure 16: Weibull density function $f(u)$ for scale parameter $c = 1$.

$$\bar{u} = c \int_0^{\infty} x^{1/k} e^{-x} dx \quad (33)$$

This is a complicated expression which may not look very familiar to us. However, it is basically in the form of another mathematical function, the *gamma function*. Tables of values exist for the gamma function and it is also implemented in the large mathematical software packages just like trigonometric and exponential functions. The gamma function, $\Gamma(y)$, is usually written in the form

$$\Gamma(y) = \int_0^{\infty} e^{-x} x^{y-1} dx \quad (34)$$

Equations 33 and 34 have the same integrand if $y = 1 + 1/k$. Therefore the mean wind speed is

$$\bar{u} = c\Gamma\left(1 + \frac{1}{k}\right) \quad (35)$$

Published tables that are available for the gamma function $\Gamma(y)$ are only given for $1 \leq y \leq 2$. If an argument y lies outside this range, the recursive relation

$$\Gamma(y + 1) = y\Gamma(y) \quad (36)$$

must be used. If y is an integer,

$$\Gamma(y + 1) = y! = y(y - 1)(y - 2) \cdots (1) \quad (37)$$

The factorial $y!$ is implemented on the more powerful hand calculators. The argument y is not restricted to an integer, so the quantity computed is actually $\Gamma(y + 1)$. This may be the most convenient way of calculating the gamma function in many situations.

Normally, the wind data collected at a site will be used to directly calculate the mean speed \bar{u} . We then want to find c and k from the data. A good estimate for c can be obtained quickly from Eq. 35 by considering the function c/\bar{u} as a function of k which is given in Fig. 17. For values of k below unity, the ratio c/\bar{u} decreases rapidly. For k above 1.5 and less than 3 or 4, however, the ratio c/\bar{u} is essentially a constant, with a value of about 1.12. This means that the scale parameter is directly proportional to the mean wind speed for this range of k .

$$c = 1.12\bar{u} \quad (1.5 \leq k \leq 3.0) \quad (38)$$

Most good wind regimes will have the shape parameter k in this range, so this estimate of c in terms of u will have wide application.

It can be shown by substitution that the Weibull distribution function $F(u)$ which satisfies Eq. 27, and also meets the other requirements of a distribution function, i.e. $F(0) = 0$ and $F(\infty) = 1$, is

$$F(u) = 1 - \exp\left[-\left(\frac{u}{c}\right)^k\right] \quad (39)$$

The variance of the Weibull density function can be shown to be

$$\sigma^2 = c^2 \left[\Gamma\left(1 + \frac{2}{k}\right) - \Gamma^2\left(1 + \frac{1}{k}\right) \right] = (\bar{u})^2 \left[\frac{\Gamma(1 + 2/k)}{\Gamma^2(1 + 1/k)} - 1 \right] \quad (40)$$

The probability of the wind speed u being equal to or greater than u_a is

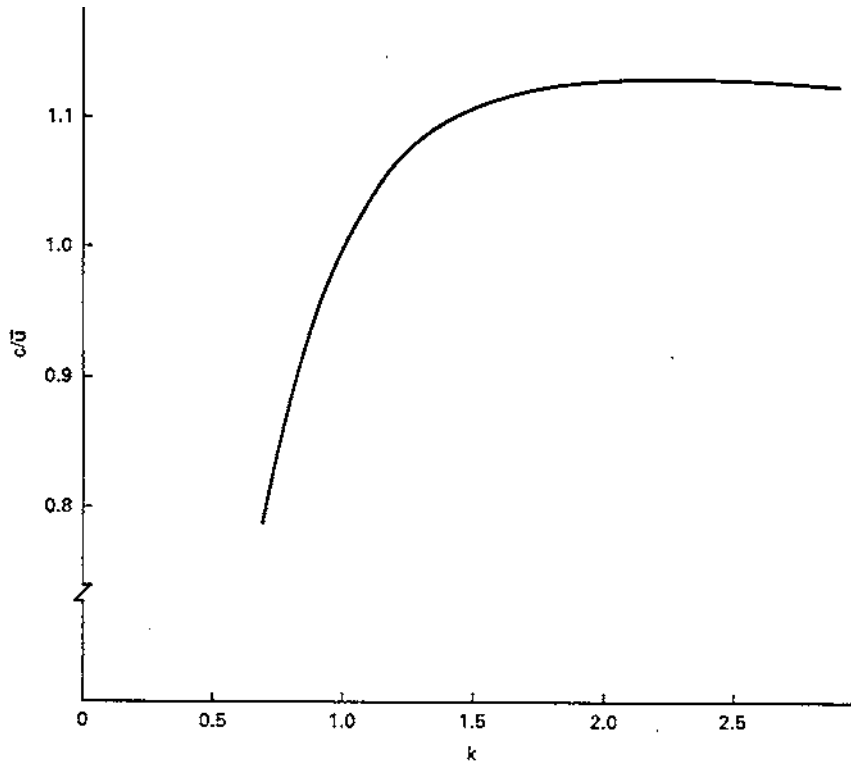

Figure 17: Weibull scale parameter c divided by mean wind speed u versus Weibull shape parameter k

$$P(u \geq u_a) = \int_{u_a}^{\infty} f(u) du = \exp \left[- \left(\frac{u_a}{c} \right)^k \right] \quad (41)$$

The probability of the wind speed being within a 1 m/s interval centered on the wind speed u_a is

$$\begin{aligned} P(u_a - 0.5 \leq u \leq u_a + 0.5) &= \int_{u_a - 0.5}^{u_a + 0.5} f(u) du \\ &= \exp \left[- \left(\frac{u_a - 0.5}{c} \right)^k \right] - \exp \left[- \left(\frac{u_a + 0.5}{c} \right)^k \right] \end{aligned}$$

$$\simeq f(u_a)\Delta u = f(u_a) \quad (42)$$

Example

The Weibull parameters at a given site are $c = 6$ m/s and $k = 1.8$. Estimate the number of hours per year that the wind speed will be between 6.5 and 7.5 m/s. Estimate the number of hours per year that the wind speed is greater than or equal to 15 m/s.

From Eq. 42, the probability that the wind is between 6.5 and 7.5 m/s is just $f(7)$, which can be evaluated from Eq. 30 as

$$f(7) = \frac{1.8}{6} \left(\frac{7}{6}\right)^{1.8-1} \exp\left[-\left(\frac{7}{6}\right)^{1.8}\right] = 0.0907$$

This means that the wind speed will be in this interval 9.07 % of the time, so the number of hours per year with wind speeds in this interval would be

$$(0.0907)(8760) = 794 \text{ h/year}$$

From Eq. 41, the probability that the wind speed is greater than or equal to 15 m/s is

$$P(u \geq 15) = \exp\left[-\left(\frac{15}{6}\right)^{1.8}\right] = 0.0055$$

which represents

$$(0.0055)(8760) = 48 \text{ h/year}$$

If a particular wind turbine had to be shut down in wind speeds above 15 m/s, about 2 days per year of operating time would be lost.

We shall see in Chapter 4 that the power in the wind passing through an area A perpendicular to the wind is given by

$$P_w = \frac{1}{2}\rho A u^3 \quad \text{W} \quad (43)$$

The average power in the wind is then

$$\bar{P}_w = \frac{1}{2}\rho A \sum_{i=1}^w p(u_i) u_i^3 \quad \text{W} \quad (44)$$

We may think of this value as the true or actual power in the wind if the probabilities $p(u_i)$ are determined from the actual wind speed data.

If we model the actual wind data by a probability density function $f(u)$, then the average power in the wind is

$$\bar{P}_w = \frac{1}{2}\rho A \int_0^{\infty} u^3 f(u) du \quad \text{W} \quad (45)$$

It can be shown[13] that when $f(u)$ is the Weibull density function, the average power is

$$\bar{P}_w = \frac{\rho A \bar{u}^3 \Gamma(1 + 3/k)}{2[\Gamma(1 + 1/k)]^3} \quad \text{W} \quad (46)$$

If the Weibull density function fits the actual wind data exactly, then the power in the wind predicted by Eq. 46 will be the same as that predicted by Eq. 44. The greater the difference between the values obtained from these two equations, the poorer is the fit of the Weibull density function to the actual data.

Actually, wind speeds outside some range are of little use to a practical wind turbine. There is inadequate power to spin the turbine below perhaps 5 or 6 m/s and the turbine may reach its rated power at 12 m/s. Excess wind power is spilled or wasted above this speed so the turbine output power can be maintained at a constant value. Therefore, the quality of fit between the actual data and the Weibull model is more important within this range than over all wind speeds. We shall consider some numerical examples of these fits later in the chapter.

The function $u^3 f(u)$ starts at zero at $u = 0$, reaches a peak value at some wind speed u_{me} , and finally returns to zero at large values of u . The yearly energy production at wind speed u_i is the power in the wind times the fraction of time that power is observed times the number of hours in the year. The wind speed u_{me} is the speed which produces more energy (the product of power and time) than any other wind speed. Therefore, the maximum energy obtained from any one wind speed is

$$W_{\max} = \frac{1}{2}\rho A u_{me}^3 f(u_{me})(8760) \quad (47)$$

The turbine should be designed so this wind speed with maximum energy content is included in its best operating wind speed range. Some applications will even require the turbine to be designed with a rated wind speed equal to this maximum energy wind speed. We therefore want to find the wind speed u_{me} . This can be found by multiplying Eq. eq:2.30 by u^3 , setting the derivative equal to zero, and solving for u . After a moderate amount of algebra the result can be shown to be

$$u_{me} = c \left(\frac{k+2}{k} \right)^{1/k} \quad \text{m/s} \quad (48)$$

We see that u_{me} is greater than c so it will therefore be greater than the mean speed \bar{u} . If the mean speed is 6 m/s, then u_{me} will typically be about 8 or 9 m/s.

We see that a number of interesting results can be obtained by modeling the wind speed histogram by a Weibull density function. Other results applicable to the power output of wind turbines are developed in Chapter 4.

8 DETERMINING THE WEIBULL PARAMETERS

There are several methods available for determining the Weibull parameters c and k [13]. If the mean and variance of the wind speed are known, then Eqs. 35 and 40 can be solved for c and k directly. At first glance, this would seem impossible because k is buried in the argument of a gamma function. However, Justus[13] has determined that an acceptable approximation for k from Eq. 40 is

$$k = \left(\frac{\sigma}{\bar{u}} \right)^{-1.086} \quad (49)$$

This is a reasonably good approximation over the range $1 \leq k \leq 10$. Once k has been determined, Eq. 35 can be solved for c .

$$c = \frac{\bar{u}}{\Gamma(1 + 1/k)} \quad (50)$$

The variance of a histogram of wind speeds is not difficult to find from Eq. 19, so this method yields the parameters c and k rather easily. The method can even be used when the variance is not known, by simply estimating k . Justus[13] examined the wind speed distributions at 140 sites across the continental United States measured at heights near 10 m, and found that k appears to be proportional to the square root of the mean wind speed.

$$k = d_1 \sqrt{\bar{u}} \quad (51)$$

The proportionality constant d_1 is a site specific constant with an average value of 0.94 when the mean wind speed \bar{u} is given in meters per second. The constant d_1 is between 0.73 and 1.05 for 80 % of the sites. The average value of d_1 is normally adequate for wind power calculations, but if more accuracy is desired, several months of wind data can be collected and analyzed in more detail to compute c and k . These values of k can be plotted versus $\sqrt{\bar{u}}$ on log-log paper, a line drawn through the points, and d_1 determined from the slope of the line.

Another method of determining c and k which lends itself to computer analysis, is the least squares approximation to a straight line. That is, we perform the necessary mathematical operations on Eq. 30 to linearize it and then determine c and k to minimize the least squared

error between the linearized ideal curve and the actual data points of $p(u_i)$. The process is somewhat of an art and there may be more than one procedure which will yield a satisfactory result. Whether the result is satisfactory or not has to be judged by the agreement between the Weibull curve and the raw data, particularly as it is used in wind power computations.

The first step of linearization is to integrate Eq. 27. This yields the distribution function $F(u)$ which is given by Eq. 39. As can be seen in Fig. 15, $F(u)$ is more nearly describable by a straight line than $f(u)$, but is still quite nonlinear. We note that $F(u)$ contains an exponential and that, in general, exponentials are linearized by taking the logarithm. In this case, because the exponent is itself raised to a power, we must take logarithms twice.

$$\ln[-\ln(1 - F(u))] = k \ln u - k \ln c \quad (52)$$

This is in the form of an equation of a straight line

$$y = ax + b \quad (53)$$

where x and y are variables, a is the slope, and b is the intercept of the line on the y axis. In particular,

$$\begin{aligned} y &= \ln[-\ln(1 - F(u))] \\ a &= k \\ x &= \ln u \\ b &= -k \ln c \end{aligned} \quad (54)$$

Data will be expressed in the form of pairs of values of u_i and $F(u_i)$. For each wind speed u_i there is a corresponding value of the cumulative distribution function $F(u_i)$. When given values for $u = u_i$ and $F(u) = F(u_i)$ we can find values for $x = x_i$ and $y = y_i$ in Eqs. 55. Being actual data, these pairs of values do not fall exactly on a straight line, of course. The idea is to determine the values of a and b in Eq. 53 such that a straight line drawn through these points has the best possible fit. It can be shown that the proper values for a and b are

$$a = \frac{\sum_{i=1}^w x_i y_i - \frac{\sum_{i=1}^w x_i \sum_{i=1}^w y_i}{w}}{\sum_{i=1}^w x_i^2 - \frac{\left(\sum_{i=1}^w x_i\right)^2}{w}} = \frac{\sum_{i=1}^w (x_i - \bar{x})(y_i - \bar{y})}{\sum_{i=1}^w (x_i - \bar{x})^2} \quad (55)$$

$$b = \bar{y}_i - a\bar{x}_i = \frac{1}{w} \sum_{i=1}^w y_i - \frac{a}{w} \sum_{i=1}^w x_i \quad (56)$$

In these equations \bar{x} and \bar{y} are the mean values of x_i and y_i , and w is the total number of pairs of values available. The final results for the Weibull parameters are

$$\begin{aligned} k &= a \\ c &= \exp\left(-\frac{b}{k}\right) \end{aligned} \quad (57)$$

One of the implied assumptions of the above process is that each pair of data points is equally likely to occur and therefore would have the same weight in determining the equation of the line. For typical wind data, this means that one reading per year at 20 m/s has the same weight as 100 readings per year at 5 m/s. To remedy this situation and assure that we have the best possible fit through the range of most common wind speeds, it is possible to redefine a weighted coefficient a in place of Eq. 55 as

$$a = \frac{\sum_{i=1}^w p^2(u_i)(x_i - \bar{x})(y_i - \bar{y})}{\sum_{i=1}^w p^2(u_i)(x_i - \bar{x})^2} \quad (58)$$

This equation effectively multiplies each x_i and each y_i by the probability of that x_i and that y_i occurring. It usually gives a better fit than the unweighted a of Eq. 55.

Eqs. 55, 56, and 58 can be evaluated conveniently on a programmable hand held calculator. Some of the more expensive versions contain a built-in linear regression function so Eqs. 55 and 56 are handled internally. All that needs to be entered are the pairs of data points. This linear regression function can be combined with the programming capability to evaluate Eq. 58 more conveniently than by separately entering each of the repeating data points m_i times.

Example

The actual wind data for Kansas City and Dodge City for the year 1970 are given in Table 2.3. The wind speed u_i is given in knots. Calm includes 0 and 1 knot because 2 knots are required to spin the anemometer enough to give a non zero reading. The parameter x_i is $\ln(u_i)$ as given in Eq. 55. The number m_i is the number of readings taken during that year at each wind speed. The total number of readings n at each site was 2912 because readings were taken every three hours. The function $p(u_i)$ is the measured probability of each wind speed at each site as given by Eq. 20. Compute the Weibull parameters c and k using the linearization method.

Table 2.3. 1970 Wind Data

		Kansas City				Dodge City			
u_i	x_i	m_i	$p(u_i)$	$F(u)$	y_i	m_i	$p(u_i)$	$F(u)$	y_i
1	0	300	0.103	0.103	-2.22	47	0.016	0.016	-4.12
2	0.69	161	0.055	0.158	-1.765	0.002	0.018	-4.02	
3	1.10	127	0.044	0.202	-1.49	82	0.028	0.046	-3.05
4	1.39	261	0.090	0.292	-1.06	65	0.022	0.068	-2.65
5	1.61	188	0.065	0.356	-0.82	140	0.048	0.116	-2.09
6	1.79	294	0.101	0.457	-0.49	219	0.075	0.92	-1.55
7	1.95	151	0.052	0.509	-0.34	266	0.091	0.283	-1.10
8	2.08	347	0.119	0.628	-0.01	276	0.095	0.378	-0.75
9	2.20	125	0.043	0.671	0.11	198	0.068	0.446	-0.53
10	2.30	376	0.129	0.800	0.48	314	0.108	0.554	-0.22
11	2.40	67	0.023	0.823	0.55	155	0.053	0.607	-0.07
12	2.48	207	0.071	0.894	0.81	177	0.061	0.668	0.10
13	2.56	67	0.023	0.917	0.91	141	0.048	0.716	0.23
14	2.64	91	0.031	0.948	1.09	142	0.049	0.765	0.37
15	2.71	29	0.010	0.958	1.16	133	0.046	0.810	0.51
16	2.77	51	0.017	0.976	1.32	96	0.033	0.843	0.62
17	2.83	19	0.006	0.982	1.40	102	0.035	0.878	0.75
18	2.89	39	0.013	0.996	1.70	101	0.035	0.913	0.89
19	2.94	1	0	0.996	1.72	48	0.016	0.930	0.98
20	3.00	7	0.002	0.999	1.89	78	0.027	0.956	1.14
21	3.05	0	0	0.999	1.89	28	0.010	0.966	1.22
22	3.09	2	0.001	0.999	1.97	21	0.007	0.973	1.29
23	3.13	0	0	0.999	1.97	23	0.008	0.981	1.38
24	3.18	1	0	1.000	2.08	12	0.004	0.985	1.44
25	3.22	1	0	1.000	-	19	0.006	0.992	1.57
26	3.26	0	0			8	0.003	0.995	1.65
27	3.30	0	0			2	0.001	0.995	1.67
28	3.33	0	0			9	0.003	0.998	1.85
>28		0	0			5			
		2912				2912			

We first use Eq. 22 to compute $F(u_i)$ for each u_i and Eqs 55 to compute y_i for each $F(u_i)$. These are listed in Table 2.3 as well as the original data.

We are now ready to use Eqs. 58 and 56 to find a and b . First, however, we plot the point pairs (x_i, y_i) for each u_i as shown in Fig. 18 for both sites. The readings for calm (0 and 1 knot) are assumed to be at 1 knot so that $x_i = \ln u_i$ is zero rather than negative infinity.

Placing a straight edge along the sets of points shows the points to be in reasonable alignment except for calm and 2 knots for Kansas City, and calm for Dodge City. As mentioned earlier, the goal is to describe the data mathematically over the most common wind speeds. The Weibull function is zero for wind speed u equal to zero (if $k > 1$) so the Weibull cannot describe calms. Therefore, it is desirable to ignore calms and perhaps 2 knots in order to get the best fit over the wind speeds of greater interest.

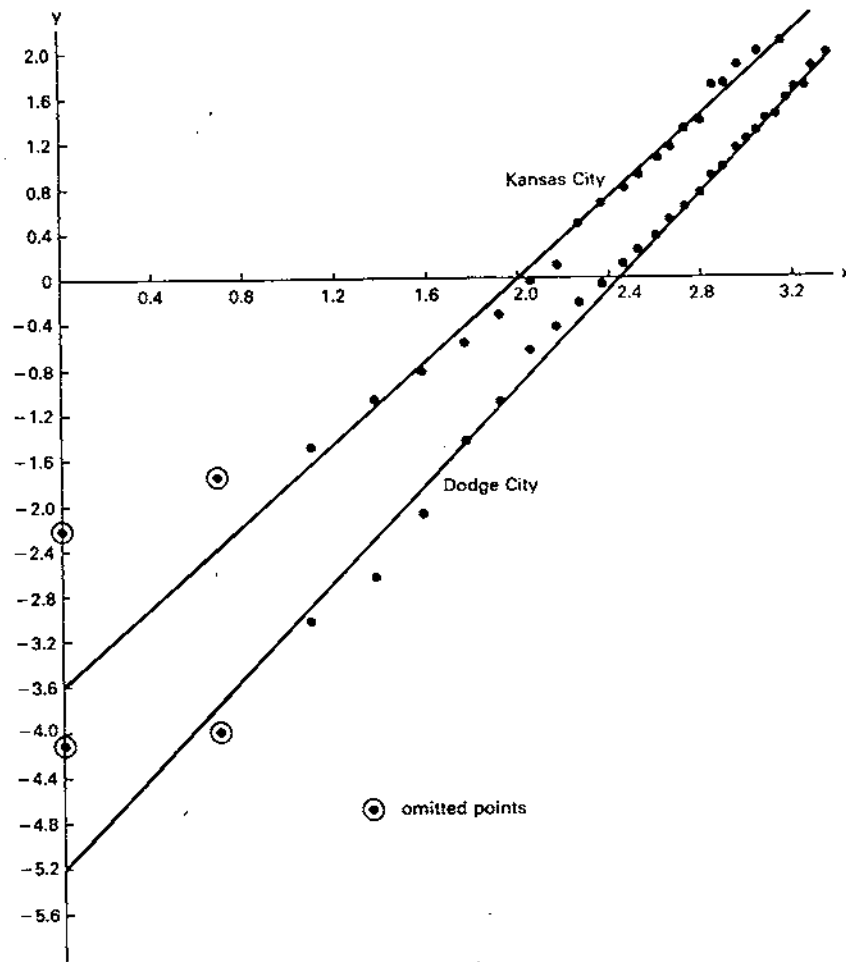

Figure 18: y versus x for Kansas City and Dodge City, 1970

A word of caution is appropriate about ignoring data points. Note that we do not want to change the location of any of the points on Fig. 18. We therefore compute $F(u_i)$, x_i , and y_i from the original data set and do not adjust or renormalize any of these values. The summations of Eqs. 55, 56, and 58 are corrected by running the summation from $i = 3$ to w rather than $i = 1$ to w , if $u_i = 1$ and $u_i = 2$ are ignored. The corrected values for \bar{x} and \bar{y} as computed from the summations in Eq. 56 are then used in Eqs. 55 or 58. If there are no readings at a particular u_i , then the summations should just skip this value of i .

The data for Kansas City were processed for $i = 3$ to 20 and for Dodge City for $i = 3$ to 28. These upper limits include about 99.8 % of the data points and should therefore give adequate results. The expression for y in Eqs. 55 becomes undefined for $F(u)$ equal to unity so the last data point cannot be included unless $F(u)$ for this last point is arbitrarily set to something less than unity, say 0.998. The results for Kansas City are $c = 7.65$ knots and $k = 1.776$, and $c = 11.96$ knots and $k = 2.110$ for Dodge City. The corresponding best fit lines are shown in Fig. 18. It is evident that these lines fit the plotted points rather well.

There may be some who are curious about the fit of the Weibull density function to the original wind speed histogram with the c and k computed in this example. The values for $p(u_i)$ for Dodge City are shown in Fig. 19 as well as the curve of $f(u)$ computed from Eq. 30. It can be seen that the data points are rather scattered but the Weibull density function does a reasonable job of fitting the scattered points.

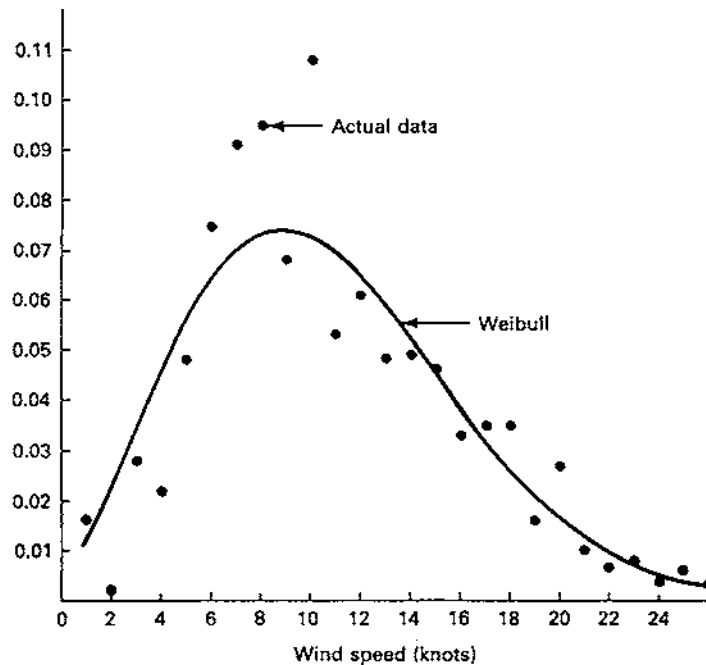

Figure 19: Actual wind data and weighted Weibull density function for Dodge City, 1970. (Data from National Weather Service.)

The data in Fig. 19 were recorded by human observation of a wind speed indicator which is continuously changing[25]. There is a human tendency to favor even integers and multiples of five when reading such an indicator. For this data set, a speed of 8 knots was recorded 276 times during the year, 9 knots 198 times, 10 knots 314 times, and 11 knots 155 times. It can be safely assumed that several readings of 8 and 10 knots should have actually been 9 or 11 knots. An automatic recording system without human bias should give a smoother set of data. The system with a human observer has excellent reliability, however, and a smoother data set really makes little difference in wind power calculations. The existing system should therefore not be changed just to get smoother data.

9 RAYLEIGH AND NORMAL DISTRIBUTIONS

We now return to a discussion of the other popular probability density function in wind power studies, the *Rayleigh* or *chi-2*. The Rayleigh probability density function is given by

$$f(u) = \frac{\pi u}{2\bar{u}^2} \exp \left[-\frac{\pi}{4} \left(\frac{u}{\bar{u}} \right)^2 \right] \quad (59)$$

The Rayleigh cumulative distribution function is

$$F(u) = 1 - \exp \left[-\frac{\pi}{4} \left(\frac{u}{\bar{u}} \right)^2 \right] \quad (60)$$

The probability that the wind speed u is greater than or equal to u_a is just

$$P(u \geq u_a) = 1 - F(u_a) = \exp \left[-\frac{\pi}{4} \left(\frac{u}{\bar{u}} \right)^2 \right] \quad (61)$$

The variance of this density function is

$$\sigma^2 = \left(\frac{4}{\pi} - 1 \right) \bar{u}^2 \quad (62)$$

It may be noted that the variance is only a function of the mean wind speed. This means that one important statistical parameter is completely described in terms of a second quantity, the mean wind speed. Since the mean wind speed is always computed at any measurement site, all the statistics of the Rayleigh density function used to describe that site are immediately available without massive amounts of additional computation. As mentioned earlier, this makes the Rayleigh density function very easy to use. The only question is the quality of results. It appears from some studies[5, 6], that the Rayleigh will yield acceptable results in most cases. The natural variability in the wind from year to year tends to limit the need for the greater sophistication of the Weibull density function.

It should be emphasized that actual histograms of wind speeds may be difficult to fit by any mathematical function, especially if the period of time is short. This is illustrated by Fig. 20, which shows actual data for a site and the Weibull and Rayleigh models of the data. The wind speed was automatically measured about 245,000 times over a 29 day period in July, 1980, between 7:00 and 8:00 p.m. to form the histogram. A bimodal (two-humped) characteristic is observed, since 3 m/s and 9 m/s are observed more often than 5 m/s. This is evidently due to the wind speed being high for a number of days and relatively low the other days, with few days actually having average wind speeds.

The Weibull is seen to be higher than the Rayleigh between 5 and 12 m/s and lower outside this range. Both functions are much higher than the actual data above 12 m/s. The actual

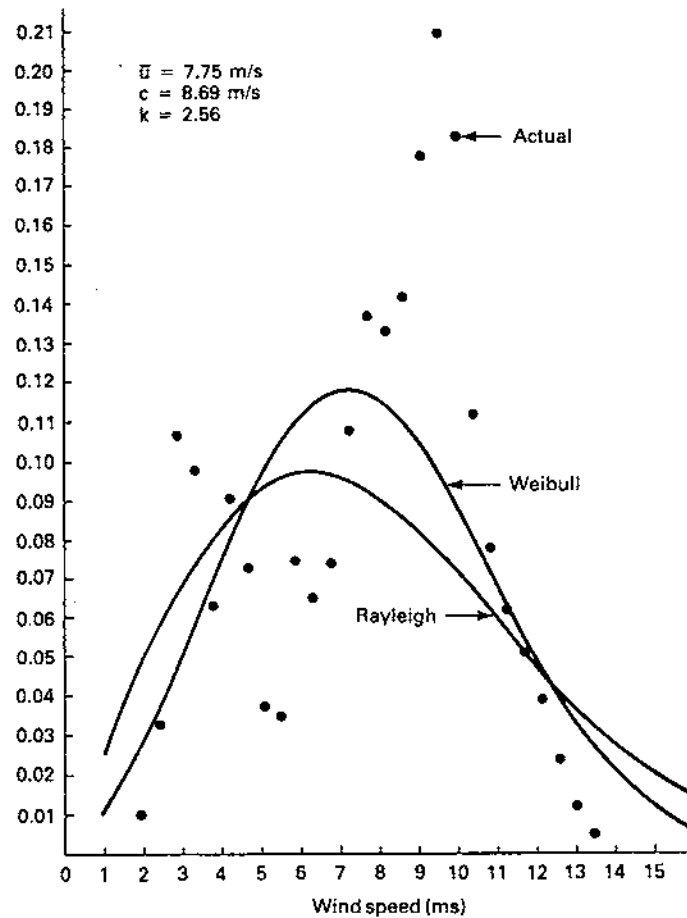

Figure 20: Actual wind data, and Weibull and Rayleigh density functions for Tuttle Creek, 7:00–8:00 p.m., July 1980, 50 m.

wind power density as computed from Eq. 44 for standard conditions is $\bar{P}_w/A = 396 \text{ W/m}^2$. The power density computed from the Weibull model, Eq. 46, is 467 W/m^2 , while the power density computed from the Rayleigh density function by a process similar to Eq. 44 is 565 W/m^2 . The Weibull is 18 % high while the Rayleigh is 43 % high.

If we examine just the wind speed range of 5–12 m/s, we get an entirely different picture. The actual wind power density in this range is $\bar{P}_w/A = 362 \text{ W/m}^2$, while the Weibull predicts a density of 308 W/m^2 , 15 % low, and the Rayleigh predicts 262 W/m^2 , 28 % low. This shows that neither model is perfect and that results from such models need to be used with caution. However, the Weibull prediction is within 20 % of the actual value for either wind speed range, which is not bad for a data set that is so difficult to mathematically describe.

Another example of the ability of the Weibull and Rayleigh density functions to fit actual data is shown in Fig. 21. The mean speed is 4.66 m/s as compared with 7.75 m/s in Fig. 20

and k is 1.61 as compared with 2.56. This decrease in k to a value below 2 causes the Weibull density function to be below the Rayleigh function over a central range of wind speeds, in this case 2–8 m/s. The actual data are concentrated between 2 and 4 m/s and neither function is able to follow this wide variation. The actual wind power density in this case is 168 W/m^2 , while the Weibull prediction is 161 W/m^2 , 4 % low, and the Rayleigh prediction is 124 W/m^2 , 26 % low. Considering only the 5–12 m/s range, the actual power density is 89 W/m^2 , the Weibull prediction is 133 W/m^2 , 49 % high, and the Rayleigh prediction is 109 W/m^2 , 22 % high.

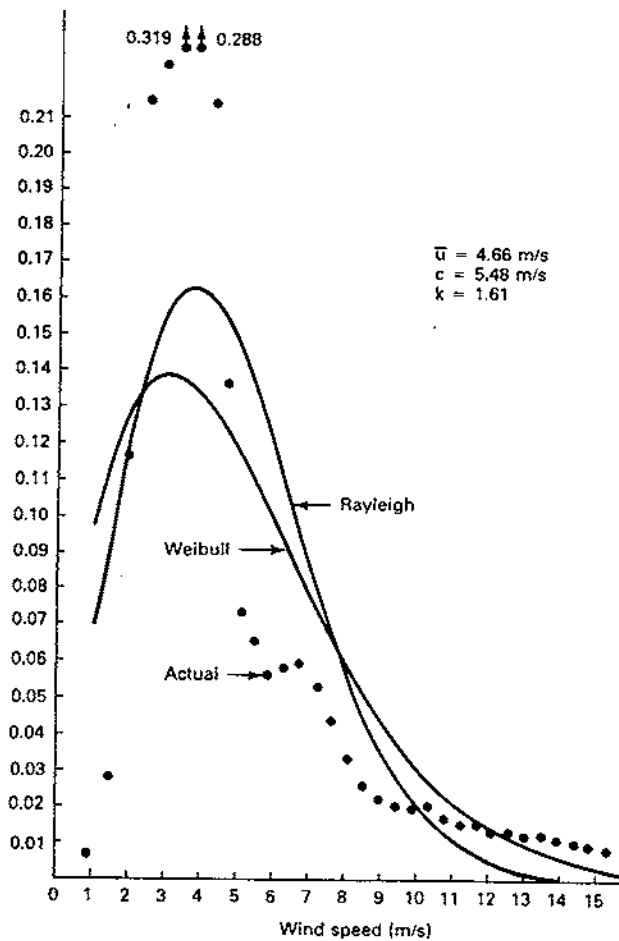

Figure 21: Actual wind data, and Weibull and Rayleigh density functions for Tuttle Creek, 7:00–8:00 a.m., August 1980, 10 m.

We see from these two figures that it is difficult to make broad generalizations about the ability of the Weibull and Rayleigh density functions to fit actual data. Either one may be either high or low in a particular range. The final test or proof of the usefulness of these functions will be in their ability to predict the power output of actual wind turbines. In the

meantime it appears that either function may yield acceptable results, with the Weibull being more accurate and the Rayleigh easier to use.

Although the actual wind speed distribution can be described by either a Weibull or a Rayleigh density function, there are other quantities which are better described by a *normal distribution*. The distribution of monthly or yearly mean speeds is likely to be normally distributed around a long-term mean wind speed, for example. The normal curve is certainly the best known and most widely used distribution for a continuous random variable, so we shall mention a few of its properties.

The density function $f(u)$ of a normal distribution is

$$f(u) = \frac{1}{\sigma\sqrt{2\pi}} \exp \left[-\frac{(u - \bar{u})^2}{2\sigma^2} \right] \quad (63)$$

where \bar{u} is the mean and σ is the standard deviation. In this expression, the variable u is allowed to vary from $-\infty$ to $+\infty$. It is physically impossible for a wind speed to be negative, of course, so we cannot forget the reality of the observed quantity and follow the mathematical model past this point. This will not usually present any difficulty in examining mean wind speeds.

The cumulative distribution function $F(u)$ is given by

$$F(u) = \int_{-\infty}^u f(x)dx \quad (64)$$

This integral does not have a simple closed form solution, so tables of values are determined from approximate integration methods. The variable in this table is usually defined as

$$q = \frac{u - \bar{u}}{\sigma} \quad \text{or} \quad u = \bar{u} + q\sigma \quad (65)$$

Thus q is the number of standard deviations that u is away from \bar{u} . A brief version of this table is shown in Table 2.4. We see from the table, for example, that $F(u)$ for a wind speed one standard deviation below the mean is 0.159. This means there is a 15.9 % probability that the mean speed for any period of interest will be more than one standard deviation below the long term mean. Since the normal density function is symmetrical, there is also a 15.9 % probability that the mean speed for some period will be more than one standard deviation above the long term mean.

Table 2.4. Normal Cumulative Distribution Function

q	$F(u)$	q	$F(u)$
-3.090	0.001	+0.43	0.666
-2.326	0.01	+0.675	0.75
-2.054	0.02	+0.842	0.8
-2.00	0.023	+1.0	0.841
-1.645	0.05	+1.281	0.9
-1.281	0.1	+1.645	0.95
-1.0	0.159	+2.0	0.977
-0.842	0.2	+2.054	0.98
-0.675	0.25	+2.326	0.99
-0.43	0.334	+3.090	0.999
0	0.5		

As we move further away from the mean, the probability decreases rapidly. There is a 2.3 % probability that the mean speed will be smaller than a value two standard deviations below the long term mean, and only 0.1 % probability that it will be smaller than a value three standard deviations below the long term mean. This gives us a measure of the width of a normal distribution.

It is also of interest to know the probability of a given data point being within a certain distance of the mean. A few of these probabilities are shown in Table 2.5. For example, the fraction 0.6827 of all measured values fall within one standard deviation of the mean if they are normally distributed. Also, 95 % of all measured values fall within 1.96 standard deviations of the mean.

We can define the 90 percent confidence interval as the range within ± 1.645 standard deviations of the mean. If the mean is 10 m/s and the standard deviation happens to be 1 m/s, then the 90 % confidence interval will be between 8.355 and 11.645 m/s. That is, 90 % of individual values would be expected to lie in this interval.

Table 2.5. Probability of finding the variable within q standard deviations of \bar{u} .

q	$P(u - \bar{u} \leq q\sigma)$
1.0	0.6827
1.645	0.9000
1.960	0.9500
2.0	0.9545
2.576	0.9900
3.0	0.9973

Example

The monthly mean wind speeds at Dodge City for 1958 were 11.78, 13.66, 11.16, 12.94, 12.10, 13.47, 12.56, 10.86, 13.77, 11.76, 12.44, and 12.55 knots. Find the yearly mean (assuming all months have the same number of days), the standard deviation, and the wind speeds one and two standard deviations from the mean. What monthly mean will be exceeded 95 % of the time? What is the 90 % confidence interval?

By a hand held calculator, we find

$$\bar{u} = 12.42$$

$$\sigma = 0.94$$

The wind speeds one standard deviation from the mean are 11.48 and 13.36 knots, while the speeds two standard deviations from the mean are 10.54 and 14.30 knots. From Table 2.4 we see that $F(u) = 0.05$ (indicating 95 % of the values are larger) for $q = -1.645$. From Eq. 65 we find

$$u = 12.42 + (-1.645)(0.94) = 10.87 \text{ knots}$$

Based on this one year's data we can say that the monthly mean wind speed at Dodge City should exceed 10.87 knots (5.59 m/s) for 95 % of all months.

The 90 % confidence interval is given by the interval $12.42 \pm 1.645(0.94)$ or between 10.87 and 13.97 knots. We would expect from this analysis that 9 out of 10 monthly means would be in this interval. In examining the original data set, we find that only one month out of 12 is outside the interval, and it is just barely outside. This type of result is rather typical with such small data sets. If we considered a much larger data set such as a 40 year period with 480 monthly means, then we could expect approximately 48 months to actually fall outside this 90 % confidence interval.

We might now ask ourselves how confident we are in the results of this example. After all, only one year's wind data were examined. Perhaps we picked an unusual year with mean and standard deviation far removed from their long term averages. We need to somehow specify the confidence we have in such a result.

Justus, Mani and Mikhail examined long term wind data[14] for 40 locations in the United States, including Alaska, Hawaii, and Wake Island. All sites had ten or more years of data from a fixed anemometer location and a long term mean wind speed of 5 m/s or greater. They found that monthly and yearly mean speeds are distributed very closely to a normal or Gaussian distribution, as was mentioned earlier.

The monthly means were distributed around the long term measured monthly mean \bar{u}_m with an average standard deviation of $0.098\bar{u}_m$ where \bar{u}_m is the mean wind speed for a given month of the year, e.g. all the April average wind speeds are averaged over the entire period of observation to get a long term average for that month. For a normal distribution the 90 % confidence interval would be, using Table 2.5, $\bar{u}_m \pm 1.645(0.098)\bar{u}_m$ or the interval between $0.84\bar{u}_m$ and $1.16\bar{u}_m$. We can therefore say that we have 90 % confidence that a measured monthly mean speed will fall in the interval $0.84\bar{u}_m$ to $1.16\bar{u}_m$. If we say that each measured

monthly mean lies in this interval, we will be correct 90 times out of 100, and wrong 10 times

The above argument applies *on the average*. That is, it is valid for sites with an average standard deviation. We cannot be as confident of sites with more variable winds and hence higher standard deviations. Since we do not know the standard deviation of the wind speed at the candidate site, we have to allow for the possibility of it being a larger number. According to Justus[14], 90 % of all observed monthly standard deviations were less than $0.145\bar{u}_m$. This is the *90 percentile level*. The appropriate interval is now $\bar{u}_m \pm 1.645(0.145)\bar{u}_m$ or the interval between $0.76\bar{u}_m$ and $1.24\bar{u}_m$. That is, any single monthly mean speed at this highly variable site will fall within the interval $0.76\bar{u}_m$ and $1.24\bar{u}_m$ with 90 % confidence. The converse is also true. That is, if we designate the mean for one month as \bar{u}_{m1} , the unknown long term monthly mean \bar{u}_m will fall within the interval $0.76\bar{u}_{m1}$ and $1.24\bar{u}_{m1}$ with 90 % confidence. We shall try to clarify this statement with Fig. 22.

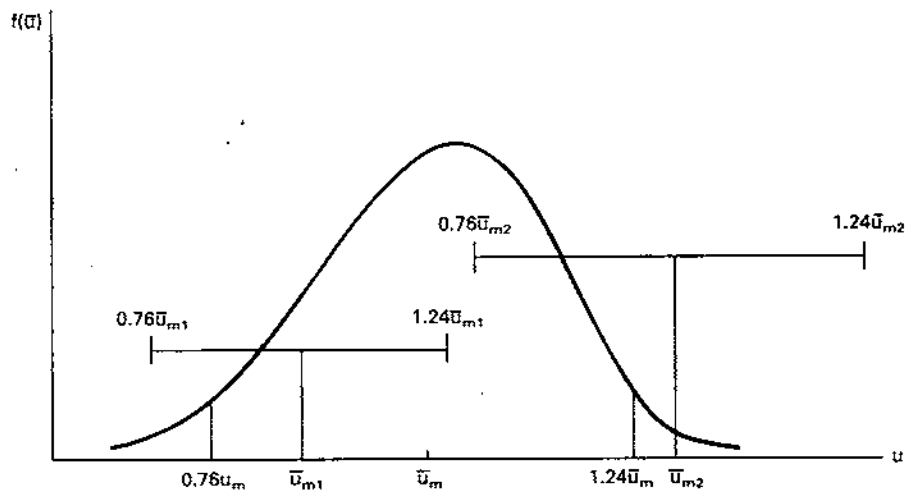

Figure 22: Confidence intervals for two measured monthly means, \bar{u}_{m1} and \bar{u}_{m2} .

Suppose that we measure the average monthly wind speed for April during two successive years and call these values \bar{u}_{m1} and \bar{u}_{m2} . These are shown in Fig. 22 along with the intervals $0.76\bar{u}_{m1}$ to $1.24\bar{u}_{m1}$, $0.76\bar{u}_{m2}$ to $1.24\bar{u}_{m2}$, and $0.76\bar{u}_m$ to $1.24\bar{u}_m$. The confidence interval centered on \bar{u}_m contains 90 % of measured means for individual months. The mean speed \bar{u}_{m1} is below \bar{u}_m but its confidence interval includes \bar{u}_m . The mean speed \bar{u}_{m2} is outside the confidence interval for \bar{u}_m and the reverse is also true. If we say that the true mean \bar{u}_m is between $0.76\bar{u}_{m2}$ and $1.24\bar{u}_{m2}$, we will be wrong. But since only 10 % of the individual monthly means are outside the confidence interval for \bar{u}_m , we will be wrong only 10 % of the time. Therefore we can say with 90 % confidence that \bar{u}_m lies in the range of $0.76\bar{u}_{mi}$ to $1.24\bar{u}_{mi}$ where \bar{u}_{mi} is some measured monthly mean.

Example

The monthly mean speeds for April in Dodge City for the years 1948 through 1973 are: 15.95, 12.88, 13.15, 14.10, 13.31, 15.14, 14.82, 15.58, 13.95, 14.76, 12.94, 15.03, 16.57, 13.88, 10.49, 11.30, 13.80, 10.99, 12.47, 14.40, 13.18, 12.04, 12.52, 12.05, 12.62, and 13.15 knots. Find the mean \bar{u}_m and the normalized standard deviation σ_m/\bar{u}_m . Find the 90 % confidence intervals for \bar{u}_m , using the 50 percentile standard deviation ($\sigma_m/\bar{u}_m = 0.098$), the 90 percentile standard deviation ($\sigma_m/\bar{u}_m = 0.145$), and the actual σ_m/\bar{u}_m . How many years fall outside each of these confidence intervals? Also find the confidence intervals for the best and worst months using $\sigma_m/\bar{u}_m = 0.145$.

From a hand held calculator, the mean speed $\bar{u}_m = 13.50$ knots and the standard deviation $\sigma_m = 1.52$ knots are calculated. The normalized standard deviation is then

$$\frac{\sigma_m}{\bar{u}_m} = 0.113$$

This is above the average, indicating that Dodge City has rather variable winds.

The 90 % confidence interval using the 50 percentile standard deviation is between $0.84\bar{u}_m$ and $1.16\bar{u}_m$, or between 11.34 and 15.66 knots. Of the actual data, 2 months have means above this interval, with 21 or 81 % of the monthly means inside the interval.

The 90 % confidence interval using the nationwide 90 percentile standard deviation is between $0.76\bar{u}_m$ and $1.24\bar{u}_m$, or between 10.26 and 16.74 knots. All the monthly means fall within this interval.

The 90 % confidence interval using the actual standard deviation of the site is between the limits $\bar{u}_m \pm 1.645(0.113)\bar{u}_m$ or between 10.99 and 16.01 knots. Of the actual data, 24 months or 92 % of the data points fall within this interval.

If only the best month was measured, the 90 % confidence interval using the 90 percentile standard deviation would be $16.57 \pm (0.24)16.57$ or between 12.59 and 20.55 knots. The corresponding interval for the worst month would be $10.49 \pm (0.24)10.49$ or between 7.97 and 13.01 knots. The latter case is the only monthly confidence interval which does not contain the long term mean of 13.5 knots. This shows that we can make confident estimates of the possible range of wind speeds from one month's data without undue concern about the possibility of that one month being an extreme value.

The 90 % confidence interval for monthly means is rather wide. Knowing that the monthly mean speed will be between 11 and 16 knots (5.7 and 8.2 m/s), as in the previous example, may not be of much help in making economic decisions. We will see in Chapter 4 that the energy output of a given turbine will increase by a factor of two as the monthly mean speed increases from 5.7 to 8.2 m/s. This means that a turbine which is a good economic choice in a 8.2 m/s wind regime may not be a good choice in a 5.7 m/s regime. Therefore, one month of wind speed measurements at a candidate site will not be enough, in many cases. The confidence interval becomes smaller as the number of measurements grows.

The wind speed at a given site will vary seasonally because of differences in large scale weather patterns and also because of the local terrain at the site. Winds from one direction may experience an increase in speed because of the shape of the hills nearby, and may experience a decrease from another direction. It is therefore advisable to make measurements of speed over a full yearly cycle. We then get a *yearly mean speed* \bar{u}_y . Each yearly mean speed \bar{u}_y will be approximately normally distributed around the long term mean speed \bar{u} . Justus[14] found that the 90 % confidence interval for the yearly means was between $0.9\bar{u}$ and

$1.1\bar{u}$ for the median (50 percentile) standard deviation and between $0.85\bar{u}$ and $1.15\bar{u}$ for the 90 percentile standard deviation. As expected, these are narrower confidence intervals than were observed for the single monthly mean.

Example

The yearly mean speed at Dodge City was 11.44 knots at 7 m above the ground level in 1973. Assume a 50 percentile standard deviation and determine the 90 % confidence interval for the true long term mean speed.

The confidence interval extends from $11.44/1.1 = 10.40$ to $11.44/0.9 = 12.71$ knots. We can therefore say that the long term mean speed lies between 10.40 and 12.71 knots with 90 % confidence.

Our estimate of the long term mean speed by one year's data can conceivably be improved by comparing our one year mean speed to that of a nearby National Weather Service station. If the yearly mean speed at the NWS station was higher than the long term mean speed there, the measured mean speed at the candidate site can be adjusted upward by the same factor. This assumes that all the winds within a geographical region of similar topography and a diameter up to a few hundred kilometers will have similar year to year variations. If the long term mean speed at the NWS station is \bar{u} , the mean for one year is \bar{u}_a , and the mean for the same year at the candidate site is \bar{u}_b , then the corrected or estimated long term mean speed \bar{u}_c at the candidate site is

$$\bar{u}_c = \bar{u}_b \frac{\bar{u}}{\bar{u}_a} \quad (66)$$

Note that we do not know how to assign a confidence interval to this estimate. It is a single number whose accuracy depends on both the accuracy of \bar{u} and the correlation between \bar{u}_a and \bar{u}_b . The accuracy of \bar{u} should be reasonably good after 30 or more years of measurements, as is common in many NWS stations. However, the assumed correlation between \bar{u}_a and \bar{u}_b may not be very good. Justus[14] found that the correlation was poor enough that the estimate of long term means was not improved by using data from nearby stations. Equally good results would be obtained by applying the 90 % confidence interval approach as compared to using Eq. 66. The reason for this phenomenon was not determined. One possibility is that the type of anemometer used by the National Weather Service can easily get dirty and yield results that are low by 10 to 20 % until the next maintenance period. One NWS station may have a few months of low readings one year while another NWS station may have a few months of low readings the next year, due to the measuring equipment rather than the wind. This would make a correction like Eq. 66 very difficult to use. If this is the problem, it can be reduced by using an average of several NWS stations and, of course, by more frequent maintenance. Other studies are necessary to clarify this situation.

The actual correlation between two sites can be defined in terms of a *correlation coefficient* r , where

$$r = \frac{\sum_{i=1}^w (\bar{u}_{ai} - \bar{u}_a)(\bar{u}_{bi} - \bar{u}_b)}{\sqrt{\sum_{i=1}^w (\bar{u}_{ai} - \bar{u}_a)^2 \sum_{i=1}^w (\bar{u}_{bi} - \bar{u}_b)^2}} \quad (67)$$

In this expression, \bar{u}_a is the long term mean speed at site a , \bar{u}_b is the long term mean speed at site b , \bar{u}_{bi} is the observed monthly or yearly mean at site b , and w is the number of months or years being examined. We assume that the wind speed at site b is linearly related to the speed at site a . We can then plot each mean speed \bar{u}_{bi} versus the corresponding \bar{u}_{ai} . We then find the best straight line through this cluster of points by a least squares or linear regression process. The correlation coefficient then describes how closely our data fits this straight line. Its value can range from $r = +1$ to $r = -1$. At $r = +1$, the data falls exactly onto a straight line with positive slope, while at $r = -1$, the data falls exactly onto a straight line with negative slope. At $r = 0$, the data cannot be approximated at all by a straight line.

Example

The yearly mean wind speeds for Dodge City, Wichita, and Russell, Kansas are given in Table 2.6. These three stations form a triangle in central Kansas with sides between 150 and 220 km in length. Dodge City is west of Wichita, and Russell is northwest of Wichita and northeast of Dodge City. The triangle includes some of the best land in the world for growing hard red winter wheat. There are few trees outside of the towns and the land is flat to gently rolling in character. Elevation changes of 10 to 20 m/km are rather typical. We would expect a high correlation between the sites, based on climate and topography.

There were several anemometer height changes over the 26 year period, so in an attempt to eliminate this bias in the data, all yearly means were extrapolated to a 30 m height using the power law and an average exponent of 0.143. As mentioned earlier in this chapter, this assumption should be acceptable for these long term means.

A plot of Russell wind speeds versus Dodge City speeds is given in Fig. 23, and a similar plot for Russell versus Wichita is given in Fig. 24. A least squares fit to the data was computed using a hand held calculator with linear regression and correlation coefficient capability. The equation of the straight line through the points in Fig. 23 is $\bar{u}_b = 0.729\bar{u}_a + 3.59$ with $r = 0.596$. The corresponding equation for Fig. 24 is $\bar{u}_b = 0.181\bar{u}_a + 11.74$ with $r = 0.115$. Straight lines are drawn on these figures for these equations.

It can be seen from both the figures and the correlation coefficients that Russell winds are poorly predicted by Dodge City winds and are hardly predicted at all by Wichita winds. Years with mean speeds around 14 knots at Wichita display mean speeds between 12.3 and 16 knots at Russell. This gives further support to the conclusion made by Justus that one year's data with a 90 % confidence interval at a candidate site is just as good as extrapolating from adjacent sites.

In examining the data in Table 2.6, one notices some clusters of low wind speed years and high wind speed years. That is, it appears that a low annual mean wind may persist through the following year, and likewise for a high annual mean wind. If this is really the case, we may select a site for a wind turbine in spite of a poor wind year, and then find the performance of

Table 2.6 Average yearly speeds corrected to 30 m (100 ft)

Year	Dodge City	Wichita	Russell
1948	14.98	14.09	14.14 ^a
1949	13.53	13.35	13.08 ^b
1950	12.89	12.77	14.11
1951	13.83	13.47	13.07
1952	14.22	13.97	12.31
1953	15.57	14.45 ^c	13.37
1954	15.20	14.98	12.83
1955	14.83	15.22	14.89
1956	14.60	14.86	14.85
1957	14.71	13.60	15.38
1958	13.85	13.74	13.63
1959	14.91	15.21	14.88
1960	15.23	14.55	13.67
1961	12.37	13.29	12.45
1962	13.53	13.18	12.99
1963	14.90	12.74	15.20
1964	16.32	13.95	16.04
1965	15.17	13.46	14.71
1966	15.37	13.40	15.17
1967	15.26	13.78	15.20
1968	15.25	14.51	15.70 ^d
1969	14.19	13.33	14.52 ^e
1970	14.85	14.11	15.66
1971	15.04	13.97	15.01
1972	14.40	13.84	13.39
1973	15.35	13.87	14.41

^aEstimated from 50, 51, 52 data by method of ratios.

^bEstimated from 50, 51, 52 data by method of ratios.

^cEstimated from 50, 51, 52 data by method of ratios.

^dEstimated from 66, 67, 70, 71 data by method of ratios.

^eEstimated from 66, 67, 70, 71 data by method of ratios.

the wind turbine to be poor in the first year after installation. This has economic implications because the cash flow requirements will usually be most critical the first year after installation. The turbine may go ahead and deliver the expected amount of energy over its lifetime, but this does not help the economic situation immediately after installation. Justus[14] examined this question also, for 40 sites in the United States, and concluded that there is about a 60 % probability that one low wind speed month or year will be followed by a similar one. If wind speeds were totally random, then this probability would be 50 %, the same as for two heads in a row when flipping a coin. The probability of an additional low speed month or

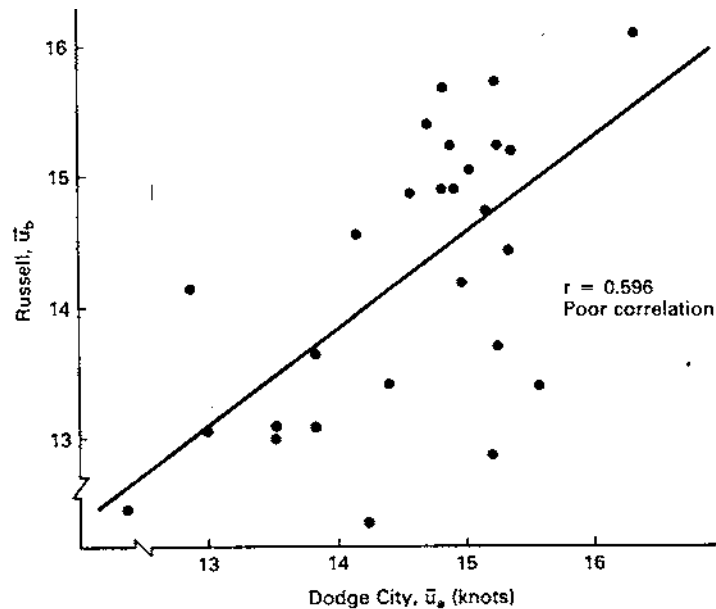

Figure 23: Yearly mean wind speeds (knots) at Russell, Kansas, versus simultaneous speeds at Dodge City, Kansas.

year following the first two is totally random. Based on these results, Justus concluded that clusters of bad wind months or years are not highly probable. In fact, the variation of speed from one period to the next is almost totally random, and therefore such clusters should not be of major concern.

We have seen that the 90 % confidence interval for the long term annual mean speed at a site is between $0.9\bar{u}$ and $1.1\bar{u}$ when only one year's data is collected. If this is not adequate, then additional data need to be collected. Corotis[7] reports that the 90 % confidence interval is between $0.93\bar{u}$ and $1.07\bar{u}$ for two year's data, and between $0.94\bar{u}$ and $1.06\bar{u}$ for three year's data. The confidence interval is basically inversely proportional to the square root of the time period, so additional years of data reduce the confidence interval at a slower and slower rate.

10 DISTRIBUTION OF EXTREME WINDS

Two important wind speeds which affect turbine cost are the design wind speed which the rotor can withstand in a parked rotor configuration, and the maximum operating wind speed. A typical wind turbine may start producing power at 5 to 7 m/s (11 to 16 mi/h), reach rated power at 12 to 16 m/s (27 to 36 mi/h), and be shut down at a maximum operating speed of 20 to 25 m/s (45 to 56 mi/h).

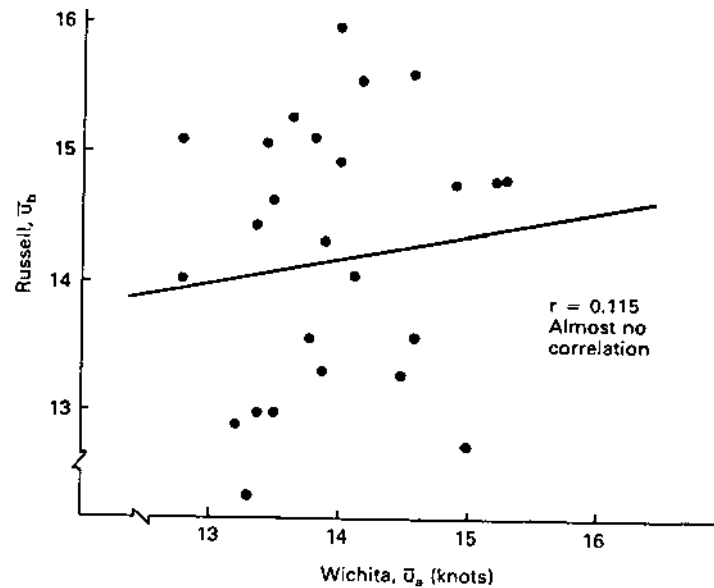

Figure 24: Yearly mean wind speeds (knots) at Russell, Kansas, versus simultaneous speeds at Wichita, Kansas.

The design wind speed is prescribed in a ANSI Standard[1], as modified by height and exposure. This varies from 31 m/s (70 mi/h) to 49 m/s (110 mi/h) in various parts of the United States. It is not uncommon for wind turbines to be designed for 55 m/s (125 mi/h) or more. This high design speed may be necessary at mountainous or coastal sites, but may be unnecessary and uneconomical in several Great Plains states where the highest wind speed ever measured by the National Weather Service is less than 45 m/s (100 mi/h).

Also of interest is the number of times during a year that the wind reaches the maximum turbine operating wind speed so the turbine must be shut down. This affects the turbine design and has an impact on the utility when the power output suddenly drops from rated to zero. For example, if a wind farm had to be shut down during the morning load pickup, other generators on the utility system must ramp up at a greater rate, perhaps causing operational problems.

Wind turbine designers and electric utility operators therefore need accurate models of extreme winds, especially the number of times per year the maximum operating speed is exceeded. Variation of extreme winds with height is also needed. The ANSI Standard[1] gives the extreme wind that can be expected once in 50 years, but daily and monthly extremes are also of interest.

The extreme wind data which are available in the United States are the monthly or yearly fastest mile of wind at a standard anemometer height. Anemometers will be discussed in detail in the next chapter, but the electrical contact type used by the National Weather

Service stations will be mentioned briefly here. Its three-cup rotor drives a gear train which momentarily closes a switch after a fixed number of revolutions. The cup speed is proportional to the wind speed so contact is made with the passage of a fixed amount of air by or through the anemometer. The anemometer can be calibrated so the switch makes contact once with every mile of wind that passes it. If the wind is blowing at 60 mi/h, then a mile of wind will pass the anemometer in one minute.

The contact anemometer is obviously an averaging device. It gives the average speed of the fastest mile, which will be smaller than the average speed of the fastest 1/10th mile, or any other fraction of a mile, because of the fluctuation of wind speed with time. But one has to stop refining data at some point, and the fastest mile seems to have been that point for structural studies.

The procedure is to fit a probability distribution function to the observed high wind speed data. The Weibull distribution function of Eq. 30 could probably be used for this function, except that it tends to zero somewhat too fast. It is convenient to define a new distribution function $F_e(u)$ just for the extreme winds.

Weather related extreme events, such as floods or extreme winds[11], are usually described in terms of one of two Fisher-Tippett distributions, the Type I or Type II. Thom[23, 24] used the Type II to describe extreme winds in the United States. He prepared a series of maps based on annual extremes, showing the fastest mile for recurrence intervals of 2, 50, and 100 years. Height corrections were made by applying the one-seventh power law. National Weather Service data were used.

The ANSI Standard[1] is based on examination of a longer period of record by Simiu[21] and uses the Type I distribution. Only a single map is given, for a recurrence interval of 50 years. Other recurrence intervals are obtained from this map by a multiplying factor. Tables are given for the variation of wind speed with height.

Careful study of a large data set collected by Johnson and analyzed by Henry[12] showed that the Type I distribution is superior to the Type II, so the mathematical description for only the Type I will be discussed here. The Fisher-Tippett Type I distribution has the form

$$F_e(u) = \exp(-\exp(-\alpha(x - \beta))) \quad (68)$$

where $F_e(u)$ is the probability of the annual fastest mile of wind speed being less than u . The parameters α and β are characteristics of the site that must be estimated from the observed data. If n period extremes are available, the maximum likelihood estimate of α may be obtained by choosing an initial guess and iterating

$$\alpha_{i+1} = \frac{1}{\bar{x} - \frac{\sum_{j=1}^n x_j \exp(-\alpha_i x_j)}{\sum_{j=1}^n \exp(-\alpha_i x_j)}} \quad (69)$$

until convergence to some value $\tilde{\alpha}$. The maximum likelihood estimate of β is

$$\beta = \bar{x} - \frac{0.5772}{\tilde{\alpha}} \quad (70)$$

If $F_e(u) = 0.5$, then u is the median annual fastest mile. Half the years will have a faster annual extreme mile and half the years will have a slower one. Statistically, the average time of recurrence of speeds greater than this median value will be two years. Similar arguments can be made to develop a general relationship for the *mean recurrence interval* M_r , which is

$$M_r = \frac{1}{1 - F_e(u)} \quad (71)$$

which yields

$$u = -\frac{1}{\alpha} \ln \left(-\ln \left(1 - \frac{1}{M_r} \right) \right) + \beta \quad (72)$$

A mean recurrence interval of 50 years would require $F_e(u) = 0.98$, for example.

Example

At a given location, the parameters of Eq. 68 are determined to be $\gamma = 4$ and $\beta = 20$ m/s. What is the mean recurrence interval of a 40 m/s extreme wind speed?

From Eq. 68 we find that

$$F_e(40) = \exp \left[- \left(\frac{40}{20} \right)^{-4} \right] = 0.939$$

From Eq. 67, the mean recurrence interval is

$$M_r = \frac{1}{1 - 0.939} = 16.4$$

At this location, a windspeed of 40 m/s would be expected about once every 16 years, on the average.

If we have 20 years or more of data, then it is most appropriate to find the distribution of yearly extremes. We use one value for each year and calculate α and β . If we have only

a few years of data, then we might want to find the distribution of monthly extremes. The procedure is the same, but we now have 12 values for each year instead of one. If we have only a few months to a year of wind data, then we can find the distribution of daily extremes.

When modeling is conducted using one period length and it is desired to express the results in terms of a larger period, the parameters of the distribution must be altered. If there are n of the smaller periods within each larger unit, the distribution function for the larger period is

$$F_L = [F_s]^n \quad (73)$$

where F_s is the distribution function for the smaller period. The relationship between parameters is then

$$\alpha_L = \alpha_s \quad \text{and} \quad \beta_L = \beta_s + \frac{\ln n}{\alpha_s} \quad (74)$$

For example, the relationship between monthly and yearly extremes is

$$\alpha_a = \alpha_m, \quad \beta_a = \beta_m + \frac{2.485}{\alpha_m} \quad (75)$$

An example of values of α and β for daily extremes is shown in Table 2.7. These are calculated from a large data set collected by Kansas State University for the period October, 1983 through September, 1984 at 7 Kansas locations, using the daily fastest minute.

Table 2.7 α and β for seven Kansas sites, daily fastest minute in mi/h

	50 m		30 m		10 m	
	α	β	α	β	α	β
Tuttle Creek Lake	0.1305	23.47	0.1298	22.25	0.1414	20.76
Plainville	0.1410	26.04	0.1474	23.63	0.1660	19.57
Beaumont	0.1441	26.14	0.1522	24.71	0.1620	21.74
Lyndon	0.1582	23.00	0.1547	21.24	0.1648	18.21
Dodge City	0.1448	25.86	0.1483	23.92	0.1552	20.83
Lyons	0.1537	23.55	0.1594	21.75	0.1689	19.49
Oakley	0.1435	26.89	0.1457	24.51	0.1556	20.72
mean	0.1451	24.24	0.1482	23.14	0.1591	20.19
std. dev.	0.0089	2.16	0.0094	1.39	0.0094	1.17

Differences among sites are relatively small, as seen by the standard deviations. There is a tendency for α to get smaller and β to get larger with height.

Similar data for 5 Kansas National Weather Service Stations for the same time period is shown in Table 2.8. The fastest mile is used rather than the fastest minute, which theoretically makes only a small difference.

Table 2.8 α and β for five Kansas NWS Stations, daily fastest mile.

	α	β	Height in ft
Wichita	0.2051	17.01	25
Topeka	0.2068	14.89	20
Concordia	0.2149	17.45	33
Goodland	0.2272	18.20	20
Dodge City	0.2060	19.46	20
mean	0.2120	17.40	
std. dev.	0.0094	1.68	

Differences among the NWS sites are also relatively small. However, the NWS sites have a consistently larger α and smaller β than the KSU sites in Table 2.7. Both differences cause the predicted extreme wind to be smaller at the NWS sites than at the KSU sites. In making a detailed comparison of the Dodge City NWS and the Dodge City KSU sites, which are about 5 miles apart in similar terrain, it appears that the difference was caused by the type of anemometer used. The KSU study used the Maximum anemometer, a small, light, and inexpensive device, while the National Weather Service used the Electric Speed Indicator anemometer, a much larger and heavier device. The 10 m mean speed with the KSU equipment was 12.8 mi/h for the year, while the NWS mean was 14.1 mi/h, so the Maximum anemometer indicated a mean speed 9 % below the NWS mean. On the other hand, the extreme winds measured by the Maximum anemometer averaged 18 % higher than the NWS extremes. The Maximum anemometer indication for the extreme winds varied from about the same as the NWS measurement to as much as 15 mi/h faster. It is evident that the type of measurement equipment can make a significant difference in the results.

A longer period of time was then analyzed for two of the NWS Stations, using monthly extremes rather than daily extremes. The results of this study are shown in Table 2.9.

Table 2.9. α and β for Topeka and Dodge City, using monthly fastest mile for 1949–1968.

	α	β
Topeka	0.1420	34.38
Dodge City	0.1397	41.94

The fastest mile observed at Dodge City for this period was 77 mi/h, while at Topeka it was 74 mi/h. The α values are much closer to the KSU values than to the NWS values for the one year study. The β values are larger as required by Eq. 74. From these values

for Dodge City, the extreme wind expected once every 3.3 months (approximately 100 days) would be 49.23 mi/h, a value surprisingly close to the prediction using the KSU data and daily extremes.

As mentioned earlier, it is important to have an estimate of the number of days during a year in which the wind speed should equal or exceed a given value. This is done by inserting values of α , β , and the given wind speed in Eq. 68, then using Eq. 69 to find M_r , and finally taking the reciprocal of the interval M_r to find the frequency. Values are given in Table 2.10 for the mean KSU parameters, the mean NWS parameters from Table 2.8, and the mean NWS parameters for monthly extremes from Table 2.9, all expressed in days per year for a wind speed in mi/h.

Table 2.10. Days per year a given wind speed or greater is observed.

speed	50 m	30 m	10 m	NWS	Topeka	Dodge City
30	128.4	110.8	69.1	39.3		
35	69.1	57.8	33.0	14.6		
40	35.3	28.8	15.3	5.3	4.4	8.8
45	17.5	14.0	7.0	1.9	2.4	5.8
50	8.6	6.8	3.2	0.7	1.2	3.3
55	4.2	3.2	1.4	0.2	0.6	1.8
60	2.0	1.6	0.6	0.1	0.3	0.9

There is some scatter in the results, as has been previously discussed, but the results are still quite acceptable for many purposes. For example, a wind turbine with a maximum operating speed of 45 mi/h and a height of 10 m or less would be expected to be shut down between 2 and 7 times per year. If the turbine height were increased to 30 m, the number of shutdowns would approximately double, from 7 to 14. Increasing the maximum operating speed by 5 mi/h will cut the number of shutdowns in half. These rules of thumb may be quite useful to system designers.

As mentioned earlier, Thom[23] has analyzed 141 open-country stations averaging about 15 years of data per station and has published results for $F_e(u) = 0.5, 0.98, \text{ and } 0.99$ which correspond to mean times between occurrences of 2, 50, and 100 years, respectively. These curves are given in Figs. 25–27. Since he used the Type II distribution, the absolute values are not as accurate as we get from the Type I. However, the trends are the same with either distribution and illustrate some very interesting facts about the geographical variation of extreme winds.

The curve for the 2 year mean recurrence interval gives results which might be anticipated from information on average winds presented earlier in the chapter. The High Plains have the highest extreme wind speeds and the southeastern and southwestern United States have the lowest. This relationship is basically the same as that for the average wind speeds. The 50

year and 100 year curves are distinctly different, however. The *once a century* extreme wind in Western Kansas, Oklahoma, and Texas is about 40 m/s, a figure exceeded in large areas of the coastal regions. The Gulf Coast and Atlantic Coast, as far north as Southern Maine, have experienced extreme winds from tropical cyclones, or hurricanes. The effect of these storms often extends inland from 100 to 200 miles. The remainder of the United States experiences extreme winds largely from thunderstorms. This type of storm accounts for over one third of the extreme-wind situations in the contiguous United States.

Water areas have a marked effect on extreme wind speeds. Where a location has unobstructed access to a large body of water, extreme winds may be 15 m/s or more greater than a short distance inland. High winds in cyclones and near water tend to remain steady over longer periods than for thunderstorms. They also tend to be much more widespread in a given situation and hence cause widespread damage, although damage to individual structures may not be greater than from thunderstorm winds.

The speed of the greatest gust experienced by a wind turbine will be somewhat greater than the speed of the fastest mile because of the averaging which occurs during the period of measurement. This will vary with the period chosen for the gust measurement and on the speed of the fastest mile. It appears that a good estimate of a three second gust speed is 1.25 times the speed of the fastest mile[15]. That is, if the fastest mile is measured at 40 m/s, the fastest gust will probably be about $1.25(40) = 50$ m/s. This is the speed which should be used in talking about survivability of wind turbines.

Standard civil engineering practice calls for ordinary buildings to be designed for a 50 year recurrence interval, and for structures whose collapse do not threaten human safety to be designed for a 25 year recurrence interval. The civil engineers then typically add safety factors to their designs which cause the structures to actually withstand higher winds. A similar approach would seem appropriate for wind turbines[15]. A 50 year recurrence interval would imply that a design for a maximum gust speed of 50 m/s would be adequate over most of the United States, with perhaps 65 m/s being desirable in hurricane prone areas. Wind turbine costs tend to increase rapidly as the design speed is increased, so rather careful cost studies are required to insure that the turbine is not over designed. Wind turbines are different from public buildings and bridges in that they would normally fail in high winds without people getting hurt. It may be less expensive to replace an occasional wind turbine with a design speed of 50 m/s than to build all wind turbines to withstand 65 m/s.

11 PROBLEMS

1. What is the density of dry air in kg/m^3 at standard pressure (101.3 kPa) and
 - (a) $T = 35^\circ\text{C}$
 - (b) $T = -25^\circ\text{C}$?

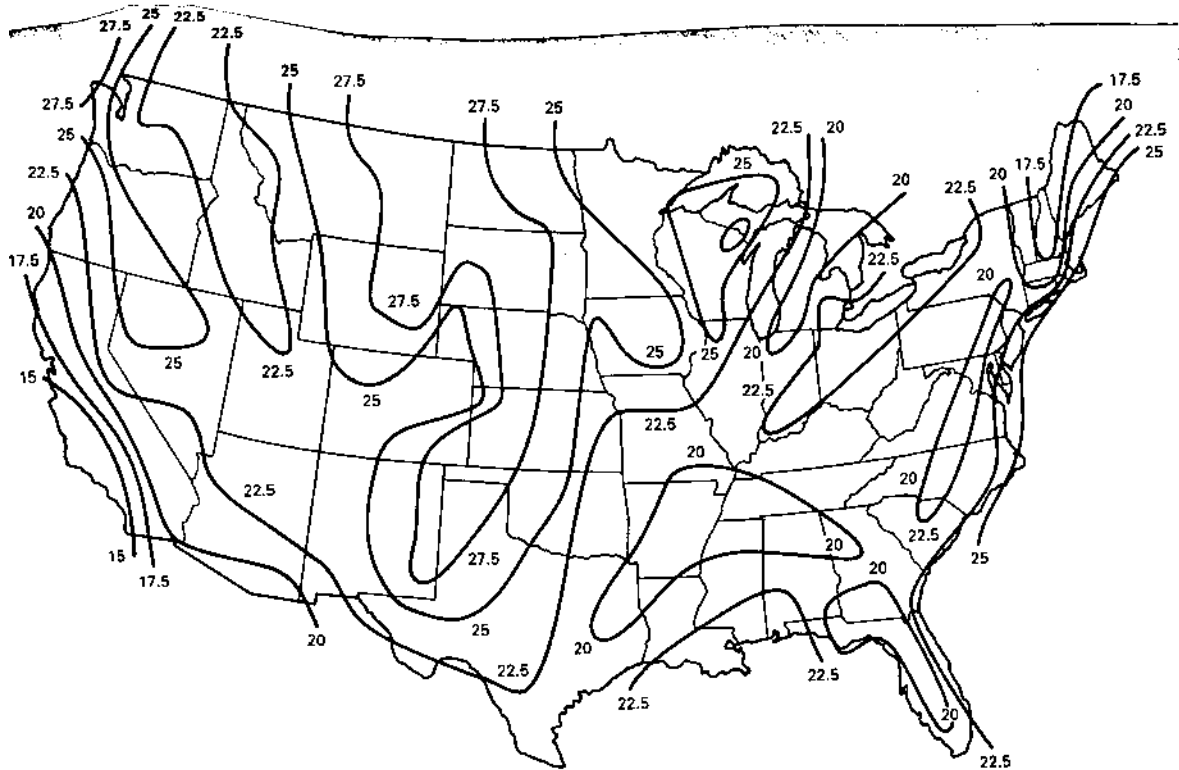

Figure 25: Isotach 0.50 quantiles in meters per second. Annual extreme mile (1.6km) 10 m above ground; 2-year mean recurrence interval. (After [23].)

2. Locate several of the world's major deserts on a map. List at least five of these deserts with an estimate of the range of latitude. (For example, the American Southwest extends from about 25°N Latitude to about 37°N Latitude.) Compare with Fig. 5.
3. What is the nominal air pressure in kPa as predicted by the U. S. Standard Atmosphere curve at
 - (a) Dodge City, elevation 760 m.
 - (b) Denver, elevation 1600 m.
 - (c) Pike's Peak, elevation 4300 m.
4. If the temperature at ground level is 30°C , at what altitude would you reach the freezing point of water in an atmosphere where the lapse rate is adiabatic?
5. Dodge City is at an elevation of 760 m above sea level. A parcel of air 1500 m above Dodge City (2260 m above sea level) descends adiabatically to ground level. If its initial temperature is 0°C , what is its final temperature?

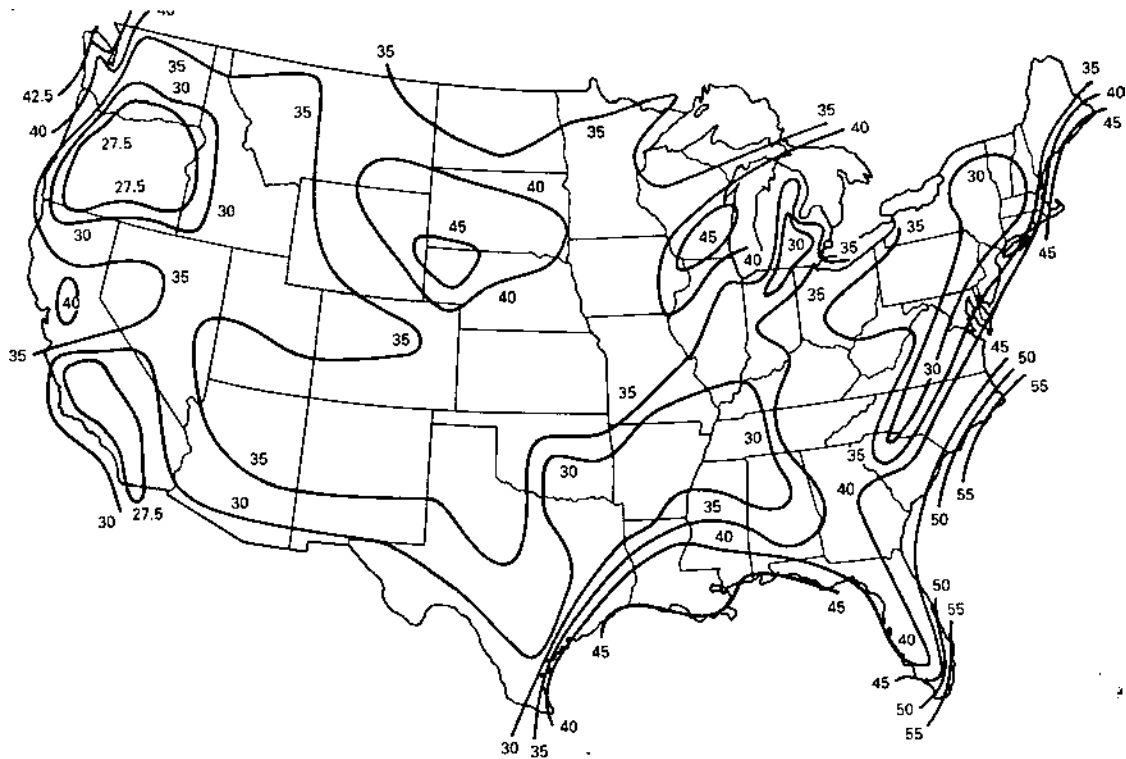

Figure 26: Isotach 0.02 quantiles in meters per second. Annual extreme mile (1.6 km) 10 m above ground; 50-year mean recurrence interval. (After [23].)

6. Ten measured wind speeds are 5, 9, 6, 8, 12, 7, 8, 5, 11, and 10 m/s. Find the mean, the variance, the standard deviation, and the median speed.
7. A wind data acquisition system located at Kahuku Point, Hawaii, measures 7 m/s 24 times, 8 m/s 72 times, 9 m/s 85 times, 10 m/s 48 times, and 11 m/s 9 times during a given period. Find the mean, variance, and standard deviation.
8. For the data of the previous problem, find the probability of each wind speed being observed. Compute the cumulative distribution function $F(u_i)$ for each wind speed. What is the probability that the wind speed will be 10 m/s or greater?
9. Evaluate $f(u)$ of Eq. 30 for $c = 1$ for $u = 0.1, 0.2, 0.4, 0.6, 0.8, 1.0, 1.2, 1.4, 1.6,$ and 1.8 if
 - (a) $k = 3.2$
 - (b) $k = 0.8$
 - (c) Plot $f(u)$ versus u in a plot similar to Fig. 16.
10. Evaluate the gamma function of Eq. 35 to five significant places for

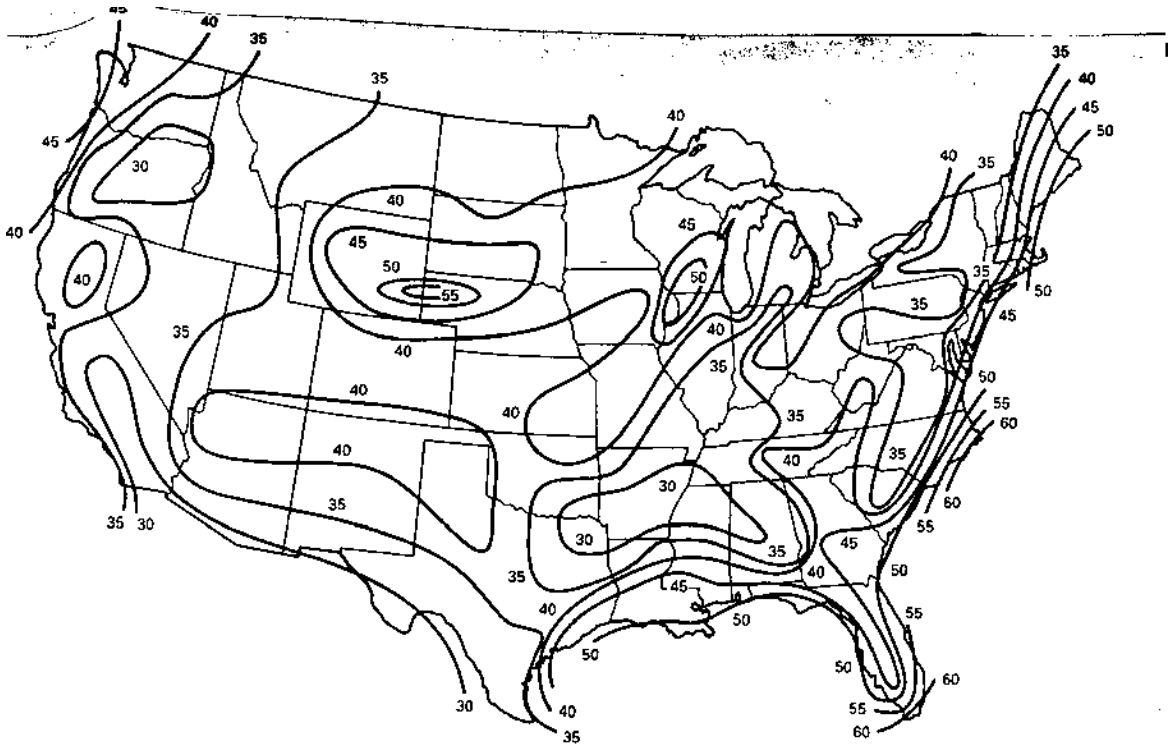

Figure 27: Isotach 0.01 quantiles in meters per second. Annual extreme mile (1.6 km) 10 m above ground; 100-year mean recurrence intervals. (After [23].)

- (a) $k = 1.2$
- (b) $k = 2.8$

Note: If you use the math tables, you will need to use linear interpolation to get five significant places.

11. Values of wind speed u_i in knots and numbers of readings per year m_i at each speed u_i are given below for Dodge City in 1971. Note that there are 2920 readings for that year.
 - (a) Compute the mean wind speed in knots. Express it in m/s.
 - (b) Prepare a table of u_i , x_i , m_i , $f(u_i)$, $F(u_i)$, and y similar to Table 2.3.
 - (c) Plot the data points of y versus x similar to Fig. 18.
 - (d) Ignore wind speeds below 3 knots and above 31 knots and compute \bar{x} , \bar{y} , a , b , k , and c using Eqs. 55–56.

u_i	1	2	3	4	5	6	7	8	9	10
m_i	82	5	69	81	137	199	240	274	157	291
u_i	11	12	13	14	15	16	17	18	19	20
m_i	134	186	167	140	159	110	124	141	38	67
u_i	21	22	23	24	25	26	27	28	29	30
m_i	16	21	21	17	12	7	5	5	0	7
u_i	31	32	33	34	35	36	37	38	39	40
m_i	0	3	1	1	3	0	0	0	0	0

12. At a given site, the mean wind speed for a month is 6 m/s with a standard deviation of 2.68 m/s. Estimate the Weibull parameters k and c using the Justus approximation of Eq. 49.
13. Weibull parameters at a given site are $c = 7$ m/s and $k = 2.6$. About how many hours per year will the wind speed be between 8.5 and 9.5 m/s? About how many hours per year will the wind speed be greater than 10 m/s? About how many hours per year will the wind speed be greater than 20 m/s?
14. The Dodge City anemometer was located 17.7 m above the ground for the 14 year period 1948-61. The location was at the Dodge City airport, on top of a gentle hill, and with excellent exposure in all directions. The average Weibull parameters for this period were $c = 14.87$ knots and $k = 2.42$. The mean speed was 12.91 knots.
 - (a) Plot both the Weibull and Rayleigh probability density functions $f(u)$ on the same sheet of graph paper.
 - (b) Find the probability $P(u \geq u_a)$ of the wind speed being greater than or equal to 10, 15, and 20 knots for both distributions.
 - (c) How does the Rayleigh density function compare with the Weibull over the ranges 0-10, 11-20, and over 20 knots?
15. The monthly mean speeds for July in Dodge City for the years 1948 through 1973 are 12.82, 10.14, 10.49, 10.86, 14.30, 13.13, 12.13, 13.38, 11.29, 12.10, 12.56, 9.03, 12.20, 9.18, 9.29, 12.02, 12.01, 10.21, 11.64, 9.56, 10.10, 10.06, 11.38, 10.19, 10.14, and 10.50 knots.
 - (a) Find the mean \bar{u}_m and the normalized standard deviation σ_m/\bar{u}_m .
 - (b) Find the 90% confidence interval for \bar{u}_m , using the actual standard deviation. How many months are outside this interval?
 - (c) Find the 90% confidence interval for the best and worst months, using the 90 percentile standard deviation for all U. S. sites. Do these intervals include the long term monthly mean?

16. The yearly mean speeds for Dodge City for the years 1948 through 1973 are 13.50, 12.15, 11.54, 12.41, 12.77, 14.04, 13.68, 13.34, 13.12, 13.23, 12.42, 13.41, 13.71, 11.05, 9.93, 11.06, 12.29, 11.31, 11.48, 11.40, 11.37, 10.48, 11.04, 11.22, 10.65, and 11.44 knots.
- Find the mean \bar{u} and the standard deviation σ .
 - Find the 90 % confidence interval for \bar{u} , using the actual standard deviation. How many years are outside this confidence interval?
 - Discuss the accuracy of using just the last year and a 50 percentile standard deviation to estimate the long term mean.
17. Find the equation for Wichita wind speeds versus Dodge City wind speeds for the data in Table 2.6. What is the correlation coefficient r ? (Note: This requires a hand calculator with linear regression capability or access to a computer.)

References

- [1] ANSI Standard A58.1-1982, *Minimum Design Loads for Buildings and other Structures*, American National Standards Institute, Inc., 1982.
- [2] Burr, I. W.: *Applied Statistical Methods*, Academic Press, New York, 1974.
- [3] Climatology of the United States, Series 82: Decennial Census of the United States Climate, "Summary of Hourly Observations, 1951-1960" (Table B).
- [4] Cole, F. W.: *Introduction to Meteorology*, Wiley, New York, 1970.
- [5] Corotis, R. B.: *Stochastic Modeling of Site Wind Characteristics*, ERDA Report RLO/2342-77/2, September 1977.
- [6] Corotis, R. B., A. B. Sigl, and J. Klein: "Probability Models of Wind Velocity Magnitude and Persistence," *Solar Energy*, Vol. 20, No. 6, 1978, pp. 483-493.
- [7] Corotis, R. B.: *Statistic Models for Wind Characteristics at Potential Wind Energy Conversion Sites*, DOE Report DOE/ET/20283-1, January 1979.
- [8] Donn, W. L.: *Meteorology*, McGraw-Hill, New York, 1965.
- [9] Elliott, D. L.: *Synthesis of National Wind Energy Assessments*, Pacific Northwest Laboratory, Richland, Wash., Report NTIS BNWL-2220 WIND-5, 1977.
- [10] Golding, E.: *The Generation of Electricity by Wind Power*, Halsted Press, New York, 1976.
- [11] Gumbel, E. J., *Statistics of Extremes*, Columbia University Press, New York, 1958.

- [12] Henry, David H. and Gary L. Johnson: "Distributions of Daily Extreme Winds and Wind Turbine Operation," *IEEE Transactions on Power Apparatus and Systems*, Vol. EC-1, No. 2, June, 1986, pp. 125-130.
- [13] Justus, C. G.: *Winds and Wind System Performance*, Franklin Institute Press, Philadelphia, 1978.
- [14] Justus, C. G., K. Mani, and A. Mikhail: *Interannual and Month-to-Month Variations of Wind Speed*, DOE Report RLO-2439-78/2, April 1978.
- [15] Liu, H.: "Matching WECS Survivability with Severe Wind Characteristics: A Rational Approach," Wind and Solar Energy Conference, Kansas City, Mo., April 5-7, 1982.
- [16] Odette, D. R.: *A Survey of the Wind Energy Potential of Kansas*, M.S. thesis, Electrical Engineering Department, Kansas State University, Manhattan, Kans., 1976.
- [17] Panofsky, H. A.: "Wind Structure in Strong Winds below 150 m," *Wind Engineering*, Vol. 1, No. 2, 1977, pp. 91-103.
- [18] Pasquill, F.: *Atmospheric Diffusion*, 2nd ed., Halsted Press, New York, 1974.
- [19] Putnam, P.C.: *Power from the Wind*, Van Nostrand, New York, 1948.
- [20] Riehl, H.: *Introduction to the Atmosphere*, McGraw- Hill, New York, 1965.
- [21] Simiu, E., M. J. Changery, and J. J. Filliben, *Extreme Wind Speeds at 129 Stations in the Contiguous United States*, NBS Building Science Series 118, National Bureau of Standards, Washington, D. C., March, 1979.
- [22] Spera, D. A., and T. R. Richards: "Modified Power Law Equations for Vertical Wind Profiles," Conference and Workshop on Wind Energy Characteristics and Wind Energy Siting 1979, Portland, Oreg., June 1979, Pacific Northwest Laboratory, Battelle Memorial Institute, Report PNL-3214.
- [23] Thom, H. C. S.: "Distributions of Extreme Winds in the United States," *Journal of the Structural Division, Proceedings of the ASCE*, Vol. 86, No. ST4, April 1960, pp. 11-24.
- [24] Thom, H. C. S.: "New Distributions of Extreme Winds in the United States," *Journal of the Structural Division, Proceedings of the ASCE*, Vol. 94, No. ST7, Proc. Paper 6038, July 1968, pp. 1787-1801.
- [25] WMO: World Meteorological Organization Guide to Meteorological Instrumentation and Observing Practices, WMO-No. 8TP3, 4th ed., WHO, Geneva, 1971.

WIND MEASUREMENTS

God made a wind blow over the earth. Genesis 8:1

Measurement of wind speed is very important to people such as pilots, sailors, and farmers. Accurate information about wind speed is important in determining the best sites for wind turbines. Wind speeds must also be measured by those concerned about dispersion of airborne pollutants.

Wind speeds are measured in a wide variety of ways, ranging from simple go-no go tests to the most sophisticated electronic systems. The variability of the wind makes accurate measurements difficult, so rather expensive equipment is often required.

Wind direction is also an important item of information, as well as the correlation between speed and direction. In the good wind regime of the western Great Plains, prevailing winds are from the north and south. Winds from east and west are less frequent and also have lower average speeds than the winds from north and south. In mountain passes, the prevailing wind direction will be oriented with the pass. It is conceivable that the most economical wind turbine for some locations will be one that is fixed in direction so that it does not need to turn into the wind. If energy output is not substantially reduced by eliminating changes in turbine orientation, then the economic viability of that wind turbine has been improved. But we must have good data on wind direction before such a choice can be made.

We shall examine several of the methods of measuring both wind speed and direction in this chapter.

1 EOLIAN FEATURES

The most obvious way of measuring the wind is to install appropriate instruments and collect data for a period of time. This requires both money and time, which makes it desirable to use any information which may already be available in the surface of the earth, at least for preliminary investigations. The surface of the earth itself will be shaped by persistent strong winds, with the results called *eolian features* or *eolian landforms*[5]. These eolian landforms are present over much of the world. They form on any land surface where the climate is windy. The effects are most pronounced where the climate is most severe and the winds are the strongest. An important use of eolian features will be to pinpoint the very best wind energy sites, as based on very long term data.

Sand dunes are the best known eolian feature. Dunes tend to be elongated parallel to the dominant wind flow. The wind tends to pick up the finer materials where the wind speed is higher and deposit them where the wind speed is lower. The size distribution of sand at a

given site thus gives an indication of average wind speed, with the coarser sands indicating higher wind speeds.

The movement of a sand dune over a period of several years is proportional to the average wind speed. This movement is easily recorded by satellite or aerial photographs.

Another eolian feature is the *playa lake*. The wind scours out a depression in the ground which fills with water after a rain. When the water evaporates, the wind will scour out any sediment in the bottom. These lakes go through a maturing process and their stage of maturity gives a relative measure of the strength of the wind.

Other eolian features include *sediment plumes* from dry lakes and streams, and *wind scour*, where airborne materials gouge out streaks in exposed rock surfaces.

Eolian features do not give precise estimates for the average wind speed at a given site, but can identify the best site in a given region for further study. They show that moving a few hundred meters can make a substantial difference in a wind turbine output where one would normally think one spot was as good as another. We can expect to see substantial development of this measurement method over the next few decades.

2 BIOLOGICAL INDICATORS

Living plants will indicate the effects of strong winds as well as eolian features on the earth itself. Eolian features are most obvious where there is little plant cover, so the plants which hide eolian features may be used for wind information instead. Strong winds deform trees and shrubs so that they indicate an integrated record of the local wind speeds during their lives. The effect shows up best on coniferous evergreens because their appearance to the wind remains relatively constant during the year. Deciduous trees shed their leaves in the winter and thus change the exposed area tremendously. If the average wind speed is high but still below some critical value, above which deciduous trees cannot survive, they will not indicate relative differences in wind speeds very well, although they do show distinctive wind damage.

Putnam lists five types of deformation in trees: *brushing*, *flagging*, *throwing*, *wind clipping*, and *tree carpets*[8]. A tree is said to be *brushed* when the branches are bent to *leeward* (downwind) like the hair in an animal pelt which has been brushed one way. Brushing is usually observable only on deciduous trees and then only when the leaves are off. It will occur with light prevailing winds, and is therefore of little use as a wind prospecting tool.

A tree is said to be *flagged* when the wind has caused its branches to stretch out to leeward, perhaps leaving the windward side bare, so the tree appears like a flagpole carrying a banner in the breeze. This is an easily observed and measured effect which occurs over a range of wind speeds important to wind power applications.

A tree is said to be *windthrown* when the main trunk, as well as the branches, is deformed so as to lean away from the prevailing wind. This effect is produced by the same mechanism

which causes flagging, except that the wind is now strong enough to modify the growth of the upright leaders of the tree as well as the branches.

Trees are said to be *wind clipped* when the wind has been sufficiently severe to suppress the leaders and hold the tree tops to a common, abnormally low level. Every twig which rises above that level is promptly killed, so that the upper surface is as smooth as a well-kept hedge.

Tree carpets are the extreme case of clipping in that a tree may grow only a few centimeters tall before being clipped. The branches will grow out along the surface of the ground, appearing like carpet because of the clipping action. The result may be a tree 10 cm tall but extending 30 m to leeward of the sheltering rock where the tree sprouted.

Hewson and Wade have proposed a rating scale[2] for tree deformation which is shown in Fig. 1. In this scale 0 corresponds to no wind damage, I, II, III, and IV to various degrees of flagging, V to flagging plus clipping, and VI to throwing. Class VII is a flagged tree with the flagging caused by other factors besides a strong prevailing wind, such as salt spray from the ocean or mechanical damage from a short, intense storm.

The average wind speed at which these effects occur will vary from one species to another so calibration is necessary. This is a long, laborious process so refinements can be expected for a number of years as new data are reported. Putnam has reported calibration data for balsam trees in New England[8], which are given in Table 3.1. The wind velocity at the top of the specimen is given. This must be translated to wind speed at wind turbine hub height by the shear equations found in the previous chapter, when wind turbine power estimates are required.

It can be seen in Table 3.1 that the full range of observed deformations occur over the speed range of 7 to 12 m/s, which is an important range of interest to wind turbines. The balsam trees can be used to effectively rank various sites and to eliminate many marginal locations.

Deformations also show the location of high wind speed zones produced by *standing waves* or *gravity waves* in the air flow over rough surfaces. A high wind striking a mountain top may be deflected downward and hit in the valley or on the side of a hill with much greater force than the expected prevailing wind at that altitude. Putnam mentions the Wamsutta Ridge of Mt. Washington as a good example of this effect. Along most of the crest of the ridge the trees grow between 5 and 10 m high. But in one patch, a hundred meters wide, the high speed upper level winds have been deflected downward and sear the ridge. Here balsam grows only in the lee of rocks and only to a height of 0.3 m. The transition from the high wind zone to the normal wind zone occurs in a matter of meters. Finding such a zone is to the wind prospector what finding gold is to the miner.

Once such zones have been identified, it is still important to place wind instrumentation at those sites. The eolian and biological indicators help identify the very best sites and eliminate the poor sites without giving the precise wind data needed for wind turbine deployment.

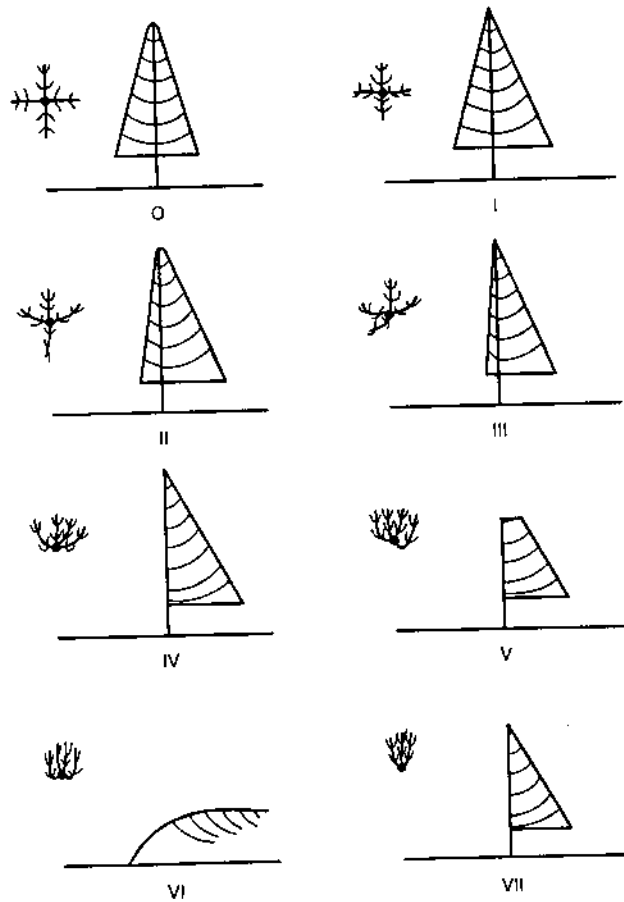

Figure 1: Representation of the rating scale based on the shape of the crown and degree of bending of twigs, branches, and the trunk. Class VII is pure mechanical damage. (From Ref. 3.)

Table 3.1 Putnam's Calibration of Balsam Deformation versus Average Wind Speed in New England

Deformation	Wind Speed u_x at Height x (m) at
	Top of Specimen above Ground (m/s)
Balsam held to 0.3 m	$u_{0.3} = 12$ m/s
Balsam held to 1.2 m	$u_{1.2} = 9.6$ m/s
Balsam thrown	$u_8 = 8.6$ m/s
Balsam strongly flagged	$u_9 = 8.3$ m/s
Balsam flagged	$u_9 = 8.0$ m/s
Balsam minimally flagged	$u_{12} = 7.7$ m/s
Balsam unflagged	$u_{12} = 6.9$ m/s

3 ROTATIONAL ANEMOMETERS

Anemometers, instruments that measure wind speed, have been designed in great variety[6, 1]. Each type has advantages and disadvantages, as we shall see. Anemometer types include the *propeller*, *cup*, *pressure plate*, *pressure tube*, *hot wire*, *Doppler acoustic radar*, and *laser*. The propeller and cup anemometers depend on rotation of a small turbine for their output, while the others basically have no moving parts.

Figure 2 shows a propeller type anemometer made by Weathertronics. This particular model includes both speed and direction in the same sensor. The propeller is made of aluminum and the tail is made of fiberglass. The sensor is able to withstand wind speeds of 90 m/s.

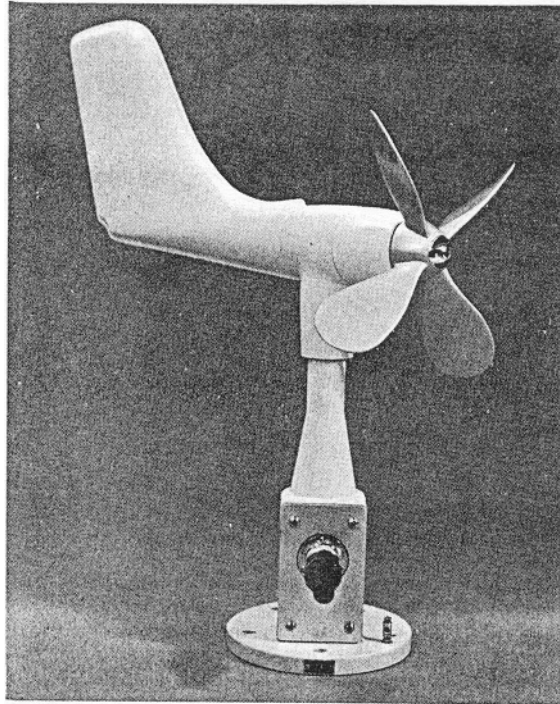

Figure 2: Propeller-type wind-speed sensor. (Courtesy of Weathertronics, a Division of Qualimetrics, Inc., P.O. Box 41039, Sacramento, CA 95841.)

Anemometers may have an output voltage, either *dc* or *ac*, or a string of pulses whose frequency is proportional to anemometer speed. The *dc generator* is perhaps the oldest type and is still widely used. It requires no external power source and is conveniently coupled to a simple dc voltmeter for visual readout or to an analog-to-digital converter for digital use. The major disadvantages are the brushes required on the generator, which must be periodically maintained, and the susceptibility to noise in a recording system dependent on voltage level. The long runs of cable from an anemometer to a recording station make electromagnetic

interference a real possibility also. Anemometers with *permanent magnet ac generators* in them do not require brushes. However, the ac voltage normally needs to be rectified and filtered before being used. This is difficult to accomplish accurately at the low voltages and frequencies associated with low wind speeds. This type of anemometer would not be used, therefore, where wind speeds of below 5 m/s are of primary interest.

The *digital anemometer* uses a slotted disk, a light emitting diode (LED), and a photo-transistor to obtain a pulse train of constant amplitude pulses with frequency proportional to anemometer angular velocity. Wind speed can be determined either by counting pulses in a fixed time period to get frequency, or by measuring the duration of a single pulse. In either case, the noise immunity of the digital system is much better than the analog system. The major disadvantages of the digital anemometer would be the complexity, and the power consumption of the LED in battery powered applications. One LED may easily draw more current than the remainder of a data acquisition system. This would not be a consideration where commercial power is available, of course.

Fig. 3 shows a cup type anemometer made by Electric Speed Indicator Company. This is the type used by most National Weather Service stations and airports. The cups are somewhat cone shaped rather than hemispherical and are about 11 cm in diameter. The turning radius of the tip of the cup assembly is about 22 cm. The cups turn a small dc generator which has a voltage output proportional to wind speed. The proportionality constant is such that for every 11.2 m/s increase in wind speed, the voltage increases by 1 volt. Wind speeds below 1 m/s do not turn the cups so there is an offset in the curve of voltage versus wind speed, as shown in Fig. 4. Since the straight line intercepts the abscissa at 1 m/s, an output voltage of 1 V is actually reached at 12.2 m/s.

In equation form, the wind speed u is given by

$$u = 11.2V + 1 \quad \text{m/s} \quad (1)$$

where V is the output voltage.

A visual indication of wind speed is obtained by connecting this dc generator to a dc voltmeter with an appropriately calibrated scale. The scale needs to be arranged such that the pointer indicates a speed of 1 m/s when the generator is stalled and the voltage is zero. Then any wind speeds above 1 m/s will be correctly displayed if the scale is calibrated according to Fig. 4.

Many applications of anemometers today require a digital output for data collection. This is usually accomplished by an *analog-to-digital (A/D) converter*. This is an electronic device which converts an analog voltage into a digital number. This digital number may be eight bits long, which gives a maximum range of 2^8 or 256 different values. It may also be twelve or sixteen bits long which gives more resolution. The cost of this greater resolution may not be justified because of the variability of the wind and the difficulty in measuring it.

The output of a typical 8-bit A/D converter is shown in Fig. 5. The rated voltage V_R is

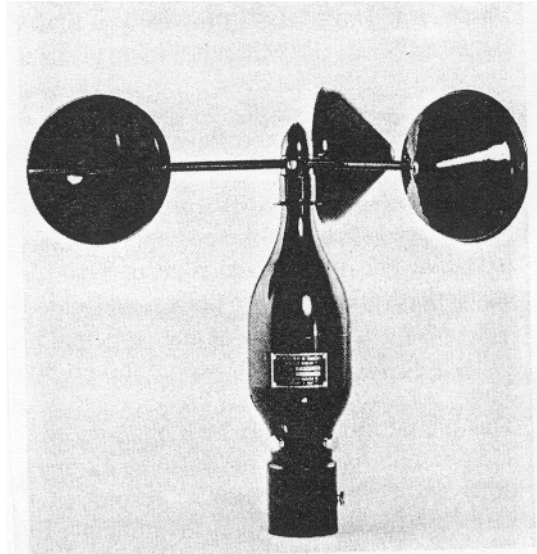

Figure 3: Cup-type wind-speed sensor. (Courtesy of Electric Speed Indicator Company, 12234 Triskett Rd., Cleveland, OH 44111.)

divided into 256 increments of ΔV volts each. The analog voltage appears along the horizontal axis, and the corresponding digital numbers, ranging from 0 to 255, appear along the vertical axis. In this figure, digital 0 represents the first half increment of voltage or from 0 to $\Delta V/2$ volts. The digital 1 then is centered at ΔV volts and represents the analog voltages between $\Delta V/2$ and $3\Delta V/2$ volts. The digital number 255 represents the voltages between $254.5 \Delta V$ and $256 \Delta V = V_R$. If the input voltage is above the rated voltage, the A/D converter will put out a signal indicating that the output is not valid. If V_R is 5 volts, which is a typical value, the A/D converter will not have its rating exceeded for wind speeds below 57 m/s for the anemometer of Fig. 3, which is quite adequate for most sites.

Since each digital number represents a range of voltage, it also represents a range of wind speed. This range would be about 0.22 m/s for an 8-bit, 5 volt A/D converter attached to the anemometer of Fig. 3. Wind power computations performed on a digital computer require a single wind speed to represent this range, which is usually selected at the midpoint. This introduces an error because of the cubic variation of wind power with wind speed and because the wind does not usually blow equally at speeds above and below the midpoint, but rather according to some probability density function. This error becomes smaller as the range of speeds represented by a single number becomes smaller. The magnitude of the error is somewhat difficult to determine, but would be well within acceptable limits for a range of 0.22 m/s.

Example

An 8-bit A/D converter with the characteristics shown in Fig. 5 is connected to an anemometer with an output voltage characteristic like Fig. 4. The A/D converter has an output digital number

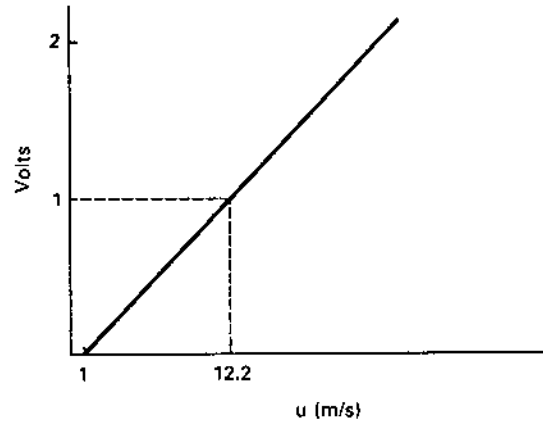

Figure 4: Output voltage of Electric Speed Indicator anemometer versus wind speed.

of 47 for a given wind speed. What is the possible range of wind speeds that this digital number represents?

From Fig. 5 we see that a digital value of 47 corresponds to an analog voltage of $47 \Delta V = 47(5/256) = 0.9180$ V. We get the same digital value over a voltage range of $\pm \Delta V/2$, so the voltage range is 0.9180 ± 0.0098 or from 0.9082 to 0.9278 V. From Eq. 1 we find that the wind speed at the low end of this range is

$$u = 11.2(0.9082) + 1 = 11.17 \quad \text{m/s}$$

while at the upper end of this range it is

$$u = 11.2(0.9278) + 1 = 11.39 \quad \text{m/s}$$

Therefore, the digital value 47 represents a wind speed of 11.28 ± 0.11 m/s.

Both cup and propeller anemometers have inertia and require a certain amount of time to accelerate to the new angular velocity when the wind speed increases. This time can be determined by solving the equation of motion for the anemometer. This equation is found by setting the product of the *moment of inertia* I in $\text{kg} \cdot \text{m}^2$ and the *angular acceleration* α in rad/rms^2 equal to the sum of the *moments* or *torques* around the anemometer shaft.

$$I\alpha = I \frac{d\omega}{dt} = T_u - T_{bf} - T_{af} \quad \text{N} \cdot \text{m} \quad (2)$$

These torques are illustrated in Fig. 6. T_u is the torque due to the wind speed u , and is the driving or forcing function. T_{bf} is the countertorque due to bearing friction. T_{af} is the torque due to air drag or air friction, and ω is the mechanical angular velocity in radians per second.

If the torques can be written as linear functions of ω , then we have a first order linear

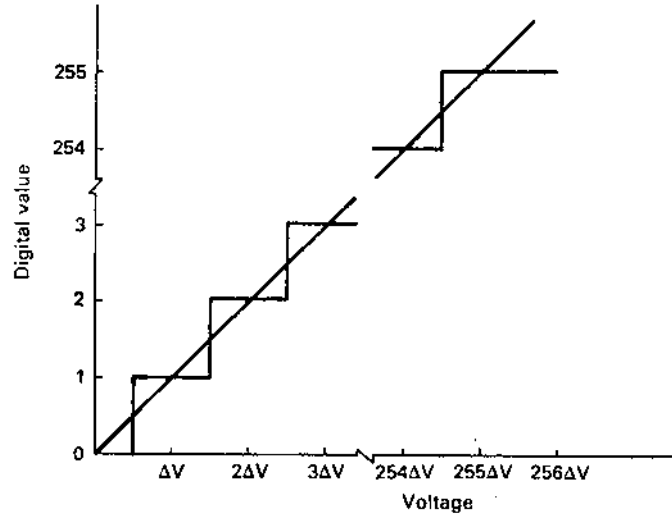

Figure 5: Digital representation of analog voltages.

differential equation which is solved easily. Unfortunately the air friction torque is a nonlinear function of ω , being described by[4]

$$T_{af} = a_o\omega^2 + a_1\omega + a_2 \quad (3)$$

where a_o , a_1 , and a_2 are constants determined from wind tunnel tests. The driving torque T_u is a nonlinear function of wind speed and also varies with ω . This makes Eq. 2 very difficult to solve exactly. Instead of this exact solution we shall seek analytic insights which might be available from a simpler and less precise solution.

A linearized equation of motion which is approximately valid for small variations in u and ω about some equilibrium values u_o and ω_o is given by[4]

$$I\frac{d\omega}{dt} + (K_{bf} + K_1u_o)\omega = K_1\omega_o u \quad (4)$$

In this equation, the torques of Eq. 2 have been assumed to be represented by

$$\begin{aligned} T_u &= K_1\omega_o u \\ T_{af} &= K_1u_o\omega \\ T_{bf} &= K_{bf}\omega \end{aligned} \quad (5)$$

If the torque due to the bearing friction is small, then at equilibrium T_u and T_{af} have to be numerically equal, as is evident from Eqs. 2 and 6.

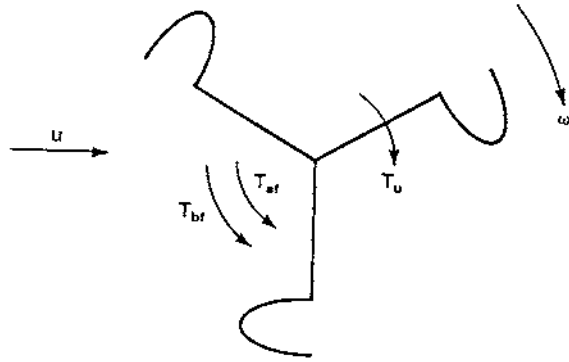

Figure 6: Torques or moments existing on a cup-type anemometer.

The solution to Eq. 4 for a step change in wind speed from u_o to u_1 is

$$\omega = \frac{\omega_o}{K_{bf} + K_1 u_o} \left(K_1 u_1 + [K_{bf} + K_1 (u_o - u_1)] e^{-t/\tau} \right) \quad \text{rad/s} \quad (6)$$

The time constant τ is given by

$$\tau = \frac{I}{K_{bf} + K_1 u_o} \quad \text{s} \quad (7)$$

For good bearings, the bearing friction torque is small compared with the aerodynamic torques and can be neglected. This simplifies the last two equations to the forms

$$\omega = \omega_o \frac{u_1}{u_o} + (u_o - u_1) \frac{\omega_o}{u_o} e^{-t/\tau} \quad \text{rad/s} \quad (8)$$

$$\tau = \frac{I}{K_1 u_o} \quad \text{s} \quad (9)$$

Equation 8 shows that the angular velocity of a linearized anemometer is directly proportional to the wind speed when transients have disappeared. Actual commercial anemometers satisfy this condition quite well. The transient term shows an exponential change in angular velocity from the equilibrium to the final value. This also describes actual instrumentation rather well, so Eqs. 8 and 9 are considered acceptable descriptors of anemometer performance even though several approximations are involved.

A plot of ω following a step change in wind speed is given in Fig. 7. The angular velocity increases by a factor of $1 - 1/e$ or 0.63 of the total increase in one time constant τ . In the

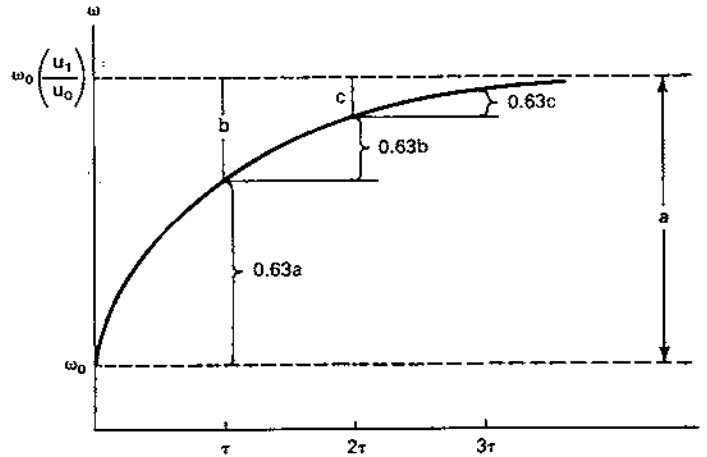

Figure 7: Anemometer response to a step function change in wind speed.

next time constant, τ increases by 0.63 of the amount remaining, and so on until it ultimately reaches its final value.

During the transient period the anemometer will indicate a wind speed u_i different from the actual ambient wind speed u . This indicated wind speed will be proportional to the anemometer angular velocity ω .

$$u_i = K_i \omega \quad (10)$$

For a cup-type anemometer, the tip speed of the cups will be approximately equal to the wind speed, which means that K_i would be approximately the radius of rotation of the cup assembly. Propeller type anemometers will have a higher tip speed to wind speed ratio, perhaps up to a factor of five or six, which means that K_i would be proportionately smaller for this type of anemometer.

At equilibrium, $u_i = u_o$ and $\omega = \omega_o$, so

$$u_o = K_i \omega_o \quad (11)$$

When Eqs. 10 and 11 are substituted into Eq. 8 we get an expression for the indicated wind speed u_i :

$$u_i = K_i \omega = K_i \left[\frac{\omega_o u_i}{K_i \omega_o} + (u_o - u_1) \frac{\omega_o}{K_i \omega_o} e^{-t/\tau} \right]$$

$$= u_1 + (u_o - u_1)e^{-t/\tau} \quad (12)$$

If the indicated wind speed would happen not to be linearly proportional to ω , then a more complicated expression would result.

The time constant of Eq. 9 is inversely proportional to the equilibrium wind speed. That is, when the equilibrium speed increases, the anemometer will make the transition to its final speed more rapidly for a given difference between equilibrium and final speeds. This means that what we have called a time constant is not really a constant at all. It is convenient to multiply τ by u_o in order to get a true constant. The product of time and speed is distance, so we define a distance constant as

$$d_m = u_o\tau = \frac{I}{K_1} \quad \text{m} \quad (13)$$

The distance constant is 7.9 m for the Electric Speed Indicator anemometer shown in Fig. 3. This means that 7.9 m of air must pass by the anemometer before its speed will change by 63 per cent of the difference in the old and new wind speeds. Most commercially available anemometers have distance constants in the range of 1 to 8 m, with the smaller numbers associated with smaller, lighter anemometers[7]. The smaller anemometers are better able to follow the high frequency variations in wind speed in the form of small gusts. A gust of 1 m diameter can easily be observed with an anemometer whose $d_m = 1$ m, but would hardly be noticed by one whose $d_m = 8$ m. Wind turbines will have a slower response to changes in wind speed than even the slowest anemometer, so knowledge of the higher frequency components of wind speed is not of critical importance in wind power studies. The smaller anemometers are more commonly used in studies on evaporation and air pollution where the smaller gusts are important and the wind speeds of interest are less than perhaps 8 m/s.

Example

An Electric Speed Indicator anemometer is connected to a data acquisition system which samples the wind speed each 0.2 s. The distance constant is 7.9 m. Equilibrium has been reached at a wind speed of 5 m/s when the wind speed increases suddenly to 8 m/s. Make a table of wind speeds which would be recorded by the data acquisition system during the first second after the step increase of wind speed.

From Eq. 13, the time constant for an initial wind speed of 5 m/s is

$$\tau = \frac{d_m}{u_o} = \frac{7.9}{5} = 1.58 \quad \text{s}$$

From Eq. 12 the indicated wind speed is

$$u_i = 8 - 3e^{-t/1.58} \quad \text{m/s}$$

The following table for indicated wind speed is obtained by substituting $t = 0, 0.2, 0.4, \dots$ in the above equation.

t	0	0.2	0.4	0.6	0.8	1.0
u_i	5	5.36	5.67	5.95	6.19	6.41

Several observations can be made from these results. One is that the indicated wind speed does not change substantially between successive readings. This would imply that the data rate is ample, so that the period between recordings could be increased to perhaps 0.5 or 1.0 s without a serious reduction in data quality.

Another observation is that the mechanical time constant τ is rather large compared with most electrical time constants of a data collection system. As long as the electrical time constant of an input filter circuit is less than τ , the data system response is limited by the mechanical rather than the electrical filtering. Since τ decreases with increasing wind speed, it is important to keep the electrical time constant less than the minimum τ of interest. A value of 0.2 s would probably be acceptable for this type of anemometer.

It can be seen by extending the above table that about 5 mechanical time constants, or about 8 s in this case, are required for the anemometer to reach its new equilibrium angular velocity. If this time is too long for some application, then a smaller anemometer with faster response would need to be used.

Rotating anemometers tend to accelerate faster in a positive gust than they decelerate in a negative gust, making their average output somewhat high in gusty winds. This is one of the effects not correctly represented by Eq. 4. This error is difficult to measure but could be as much as 10 per cent in very gusty winds.

Another type of rotational anemometer is the contact anemometer. Instead of an electrical generator or a slotted disk on the rotating shaft, there is an input to a gear-reduction transmission. The transmission output makes one revolution for a fixed number of revolutions of the cup wheel or propeller, which is correlated to the amount of air passing the anemometer. A contact is operated once per revolution, which when supplied from a voltage source will cause a short pulse to be delivered to a recording device, typically a strip chart recorder or a totaling counter. If a contact closure occurs for every mile of wind passing the cups, the number of pulses in one hour will give the average wind speed for that hour. If a strip chart traveling at constant speed is used, higher wind speeds are represented by pulses with closer spacing. The two pulses which have the smallest spacing in any time interval can be used to determine the fastest mile for that interval. If pulses are 2 minutes apart for a 1 mile contact anemometer, the average wind speed during that interval was 1 mile per 2 minutes or 30 miles per hour. The instantaneous wind speed would be higher than 30 mph during a portion of the interval, of course, but such fluctuation could not be displayed by a contact anemometer since it is basically an averaging instrument. The fastest mile during a day or a month is one of the items recorded by the National Weather Service, as mentioned in the previous chapter.

A wide variety of gear ratios between the cup wheel or propeller and the contact are used for various applications. The gear ratio is usually expressed as the amount of wind required to pass the anemometer to produce one pulse, e.g. a 1/15 mile contact anemometer produces one pulse for every 1/15 mile of air passing by, or 15 pulses per mile of air passing by.

Contact anemometers connected to battery operated electromechanical counters are able

to rank prospective wind sites with minimum cost and excellent reliability. The site with the highest count at the end of the time period of observation would have the highest average wind speed, and would be expected to be the best site for wind power production. If more detailed information about diurnal and directional variation of wind speed is needed, a more sophisticated data acquisition system can be placed at each site which appeared promising in the initial screening.

4 OTHER ANEMOMETERS

Pressure Plate Anemometer

Another type of anemometer is known as the *pressure plate* or *normal plate anemometer*[6]. This is the oldest anemometer known, having been developed by Robert Hooke in 1667. It uses the fact that the force of moving air on a plate held normal to the wind is

$$F_w = cA\rho\frac{u^2}{2} \quad \text{N} \quad (14)$$

where A is the area of the plate, ρ is the density of air, u is the wind speed, and c is a constant depending on the size and shape of the plate but not greatly different from unity. This force can be used to drive a recording device directly or as input to a mechanical to electrical transducer. The main application of this type of anemometer has been in gust studies because of its very short response time. Gusts of duration 0.01 s can be examined with this anemometer.

This type of anemometer may become a serious competitor of the rotating anemometer if an inexpensive, reliable mechanical to electrical transducer is developed. If a cylinder is used instead of a flat plate it would be possible to have an anemometer with no moving parts. This would eliminate many maintenance problems and sources of error. Experimental anemometers like this have been built using strain gauges but have not performed satisfactorily. A mechanically stiff cylinder has been used which tends to vibrate or oscillate in the wind and make measuring the wind speed difficult. Strain gauges require power to operate, which is a disadvantage in remote sites, and also present problems in building and installing so that good results over the full range of wind speeds are obtained. Until some sort of breakthrough is made in the technology, this type of anemometer will see relatively little use.

Pressure Tube Anemometer

Yet another type of anemometer is the *pressure tube anemometer*. It is not used much in the field because of difficulties with ice, snow, rain, and the sealing of rotating joints. However, it is often used as the standard in a wind tunnel where these difficulties are not present. It has been known for almost two centuries that the wind blowing into the mouth of a tube causes

an increase of pressure in the tube, and that an air flow across the mouth causes a suction. The pressure in a thin tube facing the wind is

$$p_1 = p_s + \frac{1}{2}\rho u^2 \quad \text{Pa} \quad (15)$$

where p_s is the atmosphere pressure. The pressure in a tube perpendicular to the wind is

$$p_2 = p_s - \frac{1}{2}c_1\rho u^2 \quad \text{Pa} \quad (16)$$

where c_1 is a constant less than unity. The total difference of pressure will then be

$$\Delta p = p_1 - p_2 = \frac{1}{2}\rho u^2(1 + c_1) \quad \text{Pa} \quad (17)$$

The combination of parallel and perpendicular tubes is preferred because the atmospheric pressure term can be eliminated. The pressure difference can be measured with a *manometer* or with a solid state pressure-to-voltage transducer. Air density needs to be measured also, in order to make an accurate computation of u in Eq. 17.

This technique of measuring wind speed also lends itself to a fully solid state measurement system with no moving parts. A number of perpendicular pairs of pressure tubes would be required, each with its own differential pressure transducer feeding into a microprocessor. The microprocessor would select the transducer with the largest value, perhaps correct for pointing error, compute air density from atmospheric pressure and temperature measurements, and compute the wind speed. The major difficulty would be keeping the pressure tubes free of moisture, dirt, and insects so that readings would be accurate.

Hot Wire Anemometers

The *hot wire anemometer* depends on the ability of the air to carry away heat. The resistance of a wire varies with temperature, so as the wind blows across a hot wire the wire tends to cool off with a corresponding decrease in resistance. If the hot wire is placed in one leg of a bridge circuit and the bridge balance is maintained by increasing the current so the temperature remains constant, the current will be related to the wind speed by

$$i^2 = i_o^2 + K\sqrt{u} \quad \text{A}^2 \quad (18)$$

where i_o is the current flow with no wind and K is an experimentally determined constant. The wire, made of fine platinum, is usually heated to about 1000°C to make the anemometer output reasonably independent of air temperature. This anemometer is especially useful in measuring very low wind speeds, from about 0.05 to 10 m/s.

Rather sophisticated equipment is required to make the hot wire anemometer convenient to use. Rain drops striking the wire may cause it to break, making it difficult to use outdoors on a continuous basis. The power consumption may also be significant. The hot wire anemometer will probably not be important to wind power studies because of these difficulties.

Doppler Acoustic Radar

Sonic anemometers, or *Doppler acoustic radars*, as they are often called, use sound waves reflecting off small blobs or parcels of air to determine wind speed. A vertical profile of wind speed is typically determined from one receiving antenna and three transmitting antennas, located at ground level and arranged as in Fig. 8. The receiving antenna is pointed straight up. The transmit antennas are aimed toward the vertical line above the receiving antenna. They need to have rather narrow beamwidths so they do not illuminate the receiving antenna directly but just the space above it. Transmit beamwidths of about 50 degrees in the vertical and 35 degrees in the horizontal can be obtained from commercially available high frequency driver and spectral horn speaker combinations. The receiving antenna may consist of another high frequency driver coupled to a parabolic dish, with the entire antenna inside an acoustic enclosure which serves to suppress the side lobes of the receive antenna pattern. The receive antenna beamwidth may be around 15 degrees with a good enclosure.

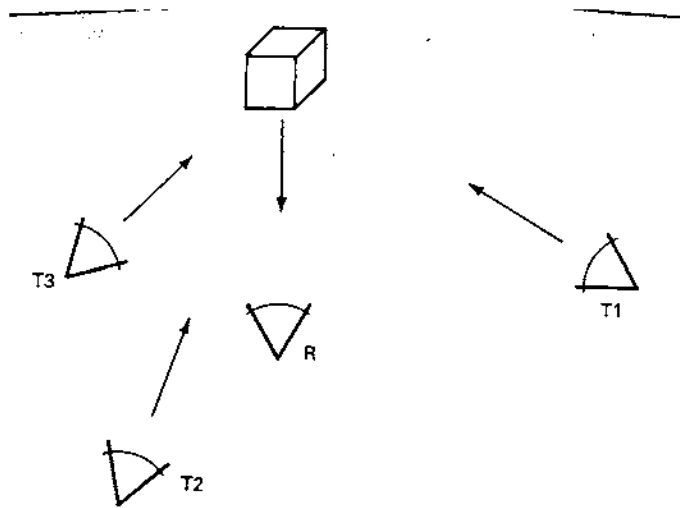

Figure 8: Doppler acoustic radar configuration.

Each transmit antenna in sequence broadcasts an audio pulse in the frequency range of 2000 to 3000 Hz. Some of these signals are reflected by *atmospheric scatterers* (small regions of slightly different density or pressure in the air stream) into the receiving antenna. The frequency and phase of the received signal are analyzed to determine the horizontal and vertical velocities of the atmospheric scatterers. Time delays are used to map the velocities

at different heights.

The advantages of such a system are many:

1. No tower is needed.
2. The anemometer has no moving parts.
3. No physical devices interfere with the flow of air being measured.
4. The instrument is best suited for examining heights between 30 and 100 m.
5. Measurements can be made over the entire projected area of a wind turbine.
6. Complex volume measurements can be made.

Disadvantages include the large size and complexity of the antennas and the relatively high cost. There are also problems with reflections from the ground or from nearby towers, especially in complex terrain. If these disadvantages can be overcome in a reliable system, Doppler acoustic radar will be a widely used tool in wind measurements.

The same Doppler effect can be used with *microwave radar* or with *lasers*. These systems have the same advantages over conventional anemometers as the acoustic radar, but tend to be even more complex and expensive. The beamwidths are much smaller so a rather small volume can be examined. Mechanical movement of the antennas is then required to examine a larger region, which increases the cost significantly. Unless these problems are solved, the microwave and laser systems will see only limited use.

5 WIND DIRECTION

The *wind vane* used for indicating wind direction is one of the oldest meteorological instruments. Basically, a wind vane is a body mounted unsymmetrically about a vertical axis, on which it turns freely. The end offering the greatest resistance to the wind goes downwind or to the leeward. The wind vane requires a minimum normal or perpendicular wind speed to initiate a turn. This minimum is called the starting threshold, and is typically between 0.5 and 1 m/s. A wind vane and direction transmitter made by Electric Speed Indicator Company is shown in Fig. 9.

Wind direction is usually measured at some distance from where the information is needed. The most convenient way of transmitting direction information is by electric cable so a mechanical position to electrical output transducer is required. One type of wind direction transmitter which works well for digital data systems is a potentiometer (a three terminal variable resistor), a voltage source V_B , and an analog to digital converter, as shown in Fig. 10. The potentiometer is oriented so the output voltage V_d is zero when the wind is from the

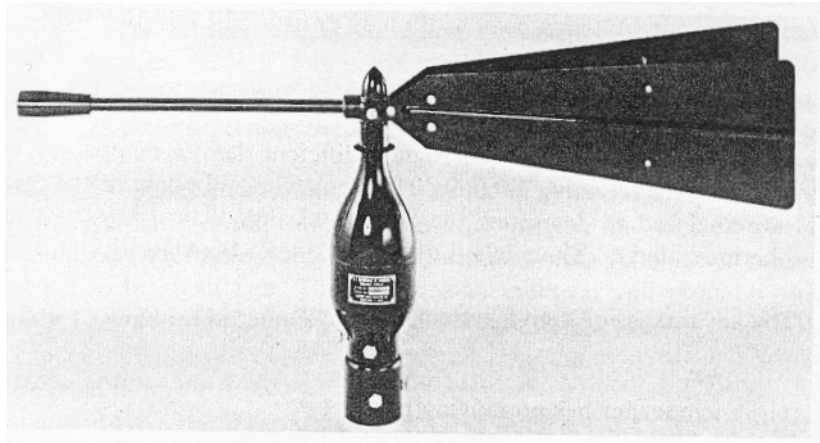

Figure 9: Wind direction vane and transmitter. (Courtesy of Electric Speed Indicator Company, 12234 Triskett Rd., Cleveland, OH 44111.)

north, $V_B/4$ when the wind is from the east, $V_B/2$ when the wind is from the south, etc. The A/D converter filters noise and converts V_d to a digital form for recording. The potentiometer is usually wire-wound so V_d changes in small discrete steps as the wiper arm rotates. The A/D output always changes in discrete steps even for a smoothly varying input. These two effects make direction output resolutions of less than 3 degrees rather impractical, but such a resolution is usually quite adequate.

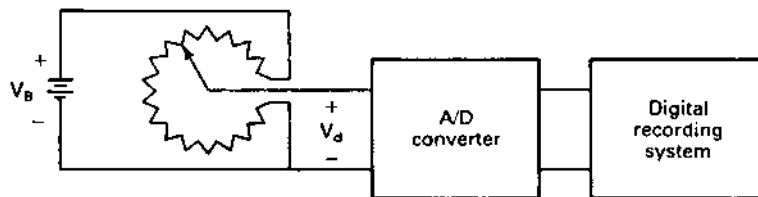

Figure 10: Potentiometer-type wind direction transmitter.

Each digital number represents a range of wind direction, in a similar manner to the wind speed ranges discussed earlier. This range can be changed by adjusting the voltage V_B . Suppose that we have a 7 bit A/D converter, which will have 128 different digital numbers if the input voltage varies from zero all the way to rated voltage. V_B can be adjusted to a value less than the rated voltage of the A/D converter so the A/D output just reaches 120 at the maximum setting of the potentiometer, which makes each digital number, or bin, represent a range of 3 degrees. Each of the eight cardinal directions then can easily be determined by adding 15 adjacent bins to get a total of 45 degrees. This increment size does not work as well for a 16 direction system since this would require splitting a bin. If 16 directions are required, an 8 bit A/D converter with 1.5 degree bins may be desirable.

When the wind is from the north and is varying slightly in direction, the potentiometer output will jump back and forth between 0 and V_B . This is not a problem to the A/D or the recording system, although any computer analysis program will have to be able to detect and accommodate this variation. If a mechanical output is desired, such as an analog voltmeter or a strip chart recorder, this oscillation from maximum to minimum and back make the instruments very difficult to read. It is possible to overcome this with a potentiometer system, but other techniques are more commonly used.

If only a mechanical or visual output is required, perhaps the most satisfactory method of indicating angular position at a distance is by the use of *self-synchronous motors*, or *synchros*. A synchro consists of a stator with a balanced three-phase winding and a rotor of dumbbell construction with many turns of wire wrapped around the stem. The rotor leads are brought out of the machine by slip rings. The connection diagram is shown in Fig. 11. The transmitter T is mechanically connected to a wind vane while the receiver R is connected to a pointer on an indicating instrument. Both rotors are connected to the same source of ac. Voltages are then induced in the stator windings due to transformer action, with amplitudes that depend on the reluctance of the flux path, which depends on the position of the rotors. When both rotors are in the same angular position, the voltages in the corresponding windings of the stators will be the same. The phase angle of each winding voltage has to be the same because of the common single-phase source. When the induced voltages are the same, and opposing each other, there will be no current flow and no rotor torque. When the transmitter rotor is moved, voltage magnitudes become unbalanced, causing currents to flow and a torque to be produced on the receiver rotor. This causes the receiver rotor to turn until it again is in alignment with the transmitter rotor.

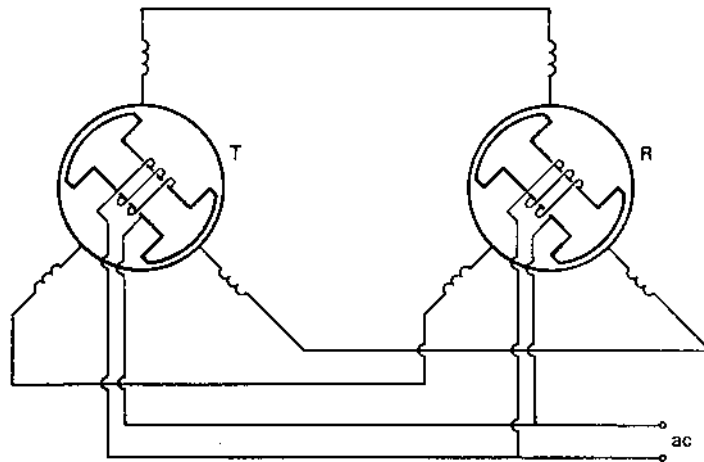

Figure 11: Synchro wind direction transmitter and receiver.

Synchros are widely used for controlling angular position as well as in indicating instruments. They may have static or dynamic errors in some applications. The receiver often has

a mechanical viscous damper on its shaft to prevent excessive overshoots. Perhaps the major disadvantage is that a synchro operated direction system may cost 50-100 % more than a wind speed system of equal quality. For this reason, other remote direction indicating instruments are often used on wind systems.

The direction system used by Electric Speed Indicator Company to give a visual meter reading is shown in Fig. 12. The wind direction transmitter contains a continuous resistance coil in toroid form, around the edge of which move two brushes spaced 180 degrees apart. The brushes are attached to the wind vane shaft and turn with the shaft. A dc voltage of perhaps 12 V is applied to the two brushes. This causes three voltages between 0 and 12 volts to appear at the three equally spaced taps of the resistance coil. These three voltages are then connected to three taps on a toroidal coil located on a circular iron core. A small permanent magnet located at the center of the iron core, and supporting the indicator pointer shaft, follows the magnetic field resulting from the currents through the three sections of the coil, causing the pointer to indicate the direction of the wind. This system performs the desired task quite well, at somewhat less cost than a synchro system.

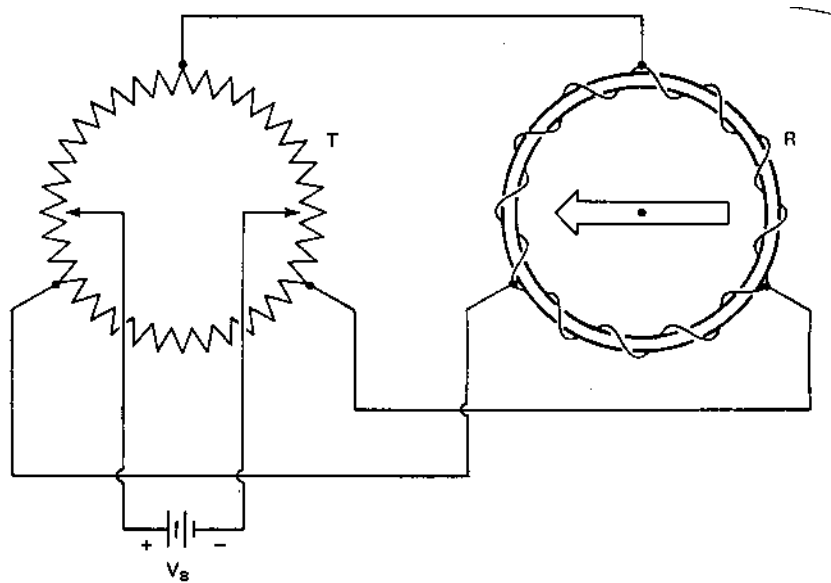

Figure 12: Resistance coil wind direction transmitter and magnetic receiver.

A sudden change in wind direction will cause the vane to move to a new direction in a fashion described by an equation of motion. There will be some time delay in reaching the new direction and there may be some overshoot and oscillation about this point. These effects need to be understood before a direction vane can be properly specified for a given application[4].

A simple wind vane is shown in Fig. 13. The vane is oriented at an angle θ with respect to a fixed reference, while the wind is at an angle γ with respect to the same reference. The vane is

free to rotate about the origin and the bearing friction is assumed to be negligible. The positive direction for all angles, as well as $d\theta/dt$ and $d^2\theta/dt^2$, is taken to be the counterclockwise direction. The torque T is in the clockwise direction so the equation of motion can be written as

$$I \frac{d^2\theta}{dt^2} = -T = -Fr \quad (19)$$

where I is the moment of inertia, r is the distance from the pivot point to the centroid of the tail and F is the equivalent force of the wind acting at the centroid.

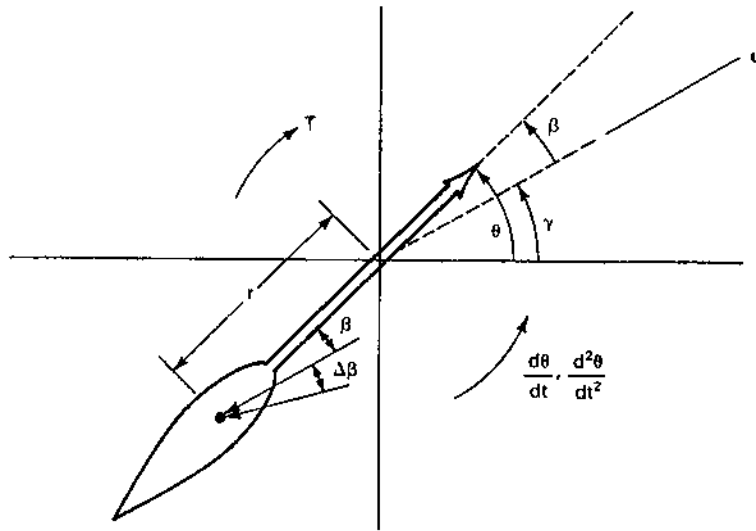

Figure 13: Wind vane angles

The force F on the tail is assumed to be an extension of Eq. 14 for the case of the wind not perpendicular to the plate. The force is assumed to be proportional to the angle between the vane and the apparent local wind, or $\beta + \Delta\beta$.

$$F \doteq cA\rho \frac{u^2}{2} (\beta + \Delta\beta) \quad (20)$$

where c is a constant depending on the aerodynamics of the vane, A is the area, ρ is the air density, and u is the wind speed. The $\Delta\beta$ term is necessary because of the motion of the vane. If $d\theta/dt$ is positive so the vane is rotating in a counterclockwise direction, the relative motion of the vane with respect to the wind makes the wind appear to strike the vane at an angle $\beta + \Delta\beta$. This is illustrated in Fig. 14 for the case $\beta = 0$. The vane centroid is rotating in the counterclockwise direction at a speed $r\omega$, which when combined with the wind velocity \mathbf{u} yields an apparent wind velocity \mathbf{u}' at an angle $\Delta\beta$ with respect to \mathbf{u} . The velocity \mathbf{u} is a vector that shows both the speed and the direction of the wind. If $r\omega$ is small compared with u , as will normally be the case, then $\Delta\beta$ can be approximated by

$$\Delta\beta \doteq \frac{r\omega}{u} \quad (21)$$

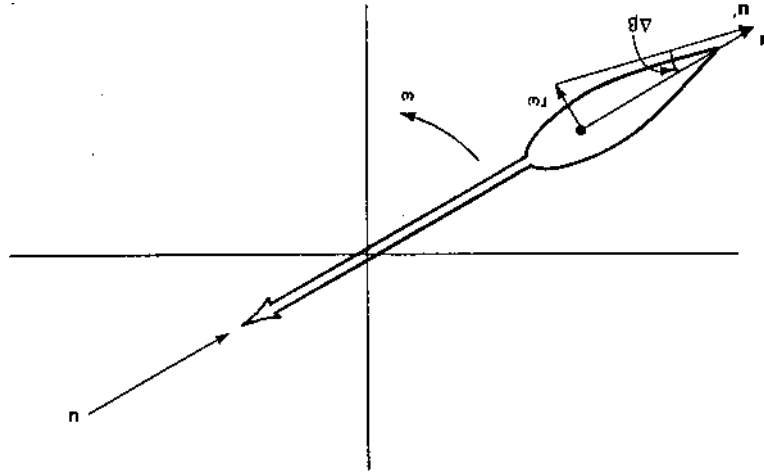

Figure 14: Effective direction of wind due to vane rotation.

We now use the fact that $\omega = d\theta/dt$ and $\beta = \theta - \gamma$ to write Eq. 19 in an expanded form:

$$\frac{d^2\theta}{dt^2} + \frac{cA\rho ur^2}{2I} \frac{d\theta}{dt} + \frac{cA\rho u^2 r}{2I} \theta = \frac{cA\rho u^2 r}{2I} \gamma \quad (22)$$

This is a second-order differential equation which is normally rewritten as

$$\frac{d^2\theta}{dt^2} + 2\xi\omega_n \frac{d\theta}{dt} + \omega_n^2 \theta = f(t) \quad (23)$$

where the parameters ω_n and ξ are given by

$$\omega_n = u \sqrt{\frac{cA\rho r}{2I}} \quad \text{rad/s} \quad (24)$$

$$\xi = \sqrt{\frac{cA\rho r^3}{8I}} \quad (25)$$

The general solution to the homogeneous differential equation $f(t) = 0$ is assumed to be

$$\theta = A_1 e^{s_1 t} + A_2 e^{s_2 t} \quad (26)$$

where s_1 and s_2 are the roots of the characteristic equation

$$s_2 + 2\xi\omega_n s + \omega_n^2 = 0 \quad (27)$$

These roots are

$$\begin{aligned} s_1 &= -\omega_n\xi + \omega_n\sqrt{\xi^2 - 1} \\ s_2 &= -\omega_n\xi - \omega_n\sqrt{\xi^2 - 1} \end{aligned} \quad (28)$$

We see that the character of the solution changes as ξ passes through unity. For ξ greater than unity, the roots are real and distinct, but when ξ is less than unity, the roots are complex conjugates. We shall first consider the solution for real and distinct roots.

Suppose that the vane is at rest with both θ and γ equal to zero, when the wind direction changes suddenly to some angle γ_1 . We want to find an expression for θ which describes the motion of the vane. Our initial conditions just after the initial change in wind direction are $\theta(0+) = 0$ and $\omega(0+) = 0$, because of the inertia of the vane. Since $\omega = d\theta/dt$, we see that $d\theta/dt$ is zero just after the wind direction change. After a sufficiently long period of time the vane will again be aligned with the wind, or $\theta(\infty) = \gamma_1$. The latter value would be the particular solution for this case and would have to be added to Eq. 26 to get the general solution for the inhomogeneous differential equation, Eq. 23.

$$\theta = A_1 e^{s_1 t} + A_2 e^{s_2 t} + \gamma_1 \quad (29)$$

Substituting the initial conditions for θ and $d\theta/dt$ in this equation yields

$$\begin{aligned} 0 &= A_1 + A_2 + \gamma_1 \\ 0 &= A_1 s_1 + A_2 s_2 \end{aligned} \quad (30)$$

Solving these two equations for the coefficients A_1 and A_2 yields

$$\begin{aligned} A_1 &= \frac{\gamma_1}{s_1/s_2 - 1} \\ A_2 &= \frac{\gamma_1}{s_2/s_1 - 1} \end{aligned} \quad (31)$$

These coefficients can be evaluated for given vane parameters and a particular wind speed and inserted in Eq. 29 to give an expression for θ as a function of time.

When the roots are complex conjugates a slightly different general solution is normally used. Equation 29 is valid whether the roots are real or not, but another form of the solution yields more insight into the physical phenomena being observed. This alternative form is

$$\theta = \gamma_1 + B e^{-\omega_n \xi t} \sin(\omega_d t + \sigma) \quad \text{rad} \quad (32)$$

where

$$\omega_d = \omega_n \sqrt{1 - \xi^2} \quad \text{rad/s} \quad (33)$$

This form of the solution is a sinusoidal function of time with a phase angle σ and an exponentially decaying amplitude, a so-called *damped sinusoid*. When the initial conditions for θ and $d\theta/dt$ are substituted into this expression, we get two equations involving the unknown quantities B and σ .

$$\begin{aligned} 0 &= \gamma_1 + B \sin \sigma \\ 0 &= B \omega_d \cos \sigma - B \omega_n \xi \sin \sigma \end{aligned} \quad (34)$$

Solving for B and σ yields

$$\begin{aligned} B &= -\frac{\gamma_1}{\sin \sigma} \\ \sigma &= \tan^{-1} \frac{\omega_d}{\omega_n \xi} = \tan^{-1} \frac{\sqrt{1 - \xi^2}}{\xi} \end{aligned} \quad (35)$$

When ξ is zero, the sinusoid of Eq. 32 is not damped but oscillates at a frequency $\omega_d = \omega_n$. We therefore call ω_n the *natural frequency* of the system. The quantity ξ is called the *damping ratio* since it contributes to the decay or damping of the sinusoid. When ξ is less than unity, we have oscillation, and this is referred to as the *underdamped case*. When ξ is greater than unity, we no longer have oscillation but rather a monotonic change of angle from the initial to the final position. This is called the *overdamped case*. *Critical damping* occurs for $\xi = 1$. For most direction vanes used in meteorological applications, ξ is well below 1, giving a damped oscillatory response.

B and γ_1 can be expressed in either degrees or radians as convenient. However, since ω_n and ω_d are both computed in units of rad/s, σ must be in radians for Eq. 32 to be evaluated properly.

Figure 15 gives plots of θ/γ_1 for various values of ξ . As ξ increases, the amount of overshoot decreases, and the distance between zero crossings increases. This means that the damped frequency ω_d is decreasing as ξ is increasing.

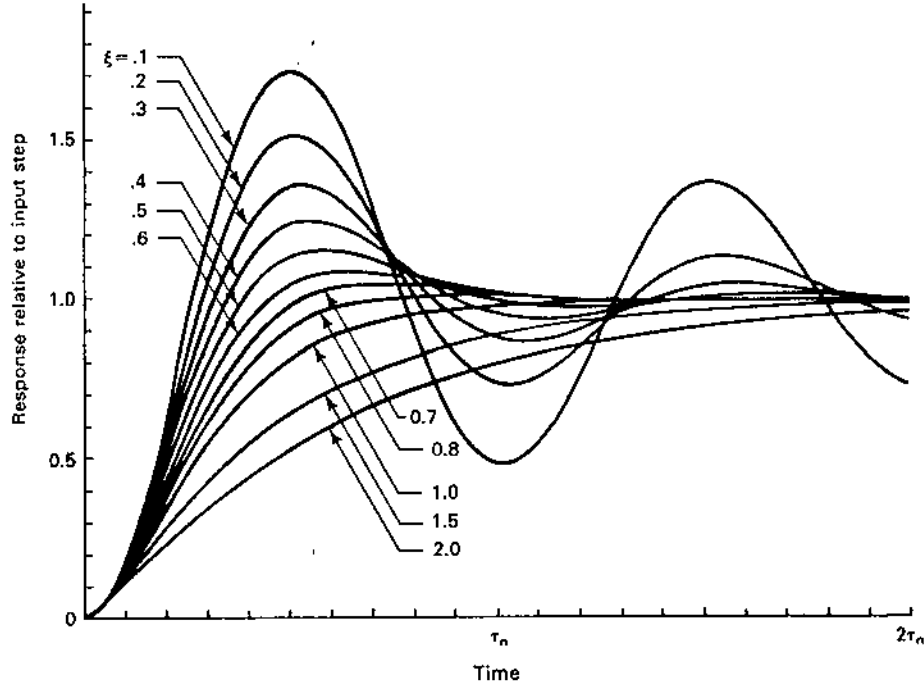

Figure 15: Second-order system response to a step input

It is common to define a *natural period* τ_n and a *damped period* τ_d from the corresponding radian frequencies.

$$\tau_n = \frac{2\pi}{\omega_n}$$

$$\tau_d = \frac{2\pi}{\omega_d} = \frac{2\pi}{\omega_n \sqrt{1-\gamma^2}} = \frac{\tau_n}{\sqrt{1-\gamma^2}} \quad (36)$$

The damped period is the time required to go from one peak to the next, or twice the time required to go from one zero crossing to the next.

It is sometimes necessary to determine the damping ratio and the natural period from wind tunnel tests on a particular vane. From a strip chart recording we can easily determine the overshoot h and the damped period τ_d , as shown in Fig. 16. The time at which the maximum occurs can be estimated from the strip chart and can also be computed from Eq. 32 by taking the time derivative, setting it equal to zero, and solving for t_{max} . It can be shown that

$$t_{max} = \frac{\tau_d}{2} \quad (37)$$

When this value of t is substituted into Eq. 32 we have

$$\begin{aligned} \frac{\theta}{\gamma_1} &= 1 - e^{-\omega_n \xi t_{max}} \frac{\sin(\pi + \sigma)}{\sin \sigma} \\ &= 1 + \exp\left(\frac{-\pi \xi}{\sqrt{1 - \xi^2}}\right) \end{aligned} \quad (38)$$

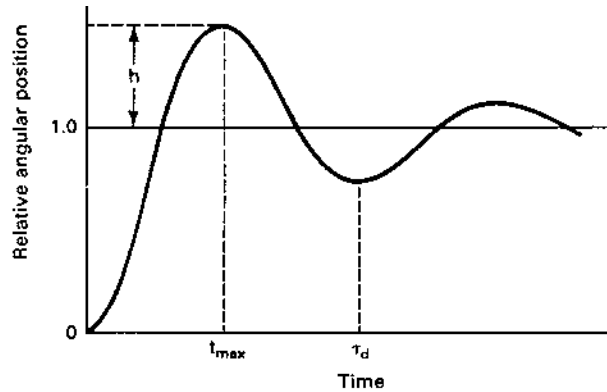

Figure 16: Overshoot h and damped period τ_d of direction vane tested in a wind tunnel.

By comparing Fig. 16 and Eq. 38, we recognize that

$$h = \exp\left(\frac{-\pi \xi}{\sqrt{1 - \xi^2}}\right) \quad (39)$$

which yields the following expression for ξ .

$$\xi = \frac{-\ln h}{\sqrt{\pi^2 + (\ln h)^2}} \quad (40)$$

We then use Eq. 36 and the measured damped period to solve for the natural period.

$$\tau_n = \tau_d \sqrt{1 - \xi^2} \quad (41)$$

We can see from Eqs. 24 and 36 that this period, measured in seconds, is inversely proportional to the wind speed. This is somewhat inconvenient in specifying instruments, so a *gust wavelength* λ_g is defined in a manner similar to the distance constant d_m in the previous section. We multiply the natural period in seconds by the wind speed in m/s to get a gust wavelength λ_g that is expressed in meters and is independent of the wind speed. That is,

$$\lambda_g = u\tau_n \quad \text{m} \quad (42)$$

Example

A Weather Measure Corporation Model W101-P-AC wind vane is placed in a wind tunnel with $u = 7$ m/s. The damped period is measured to be 2.62 s and the measured overshoot h is 0.53. Find the damping ratio ξ , the natural period τ_n , and the gust wavelength λ_g . Also estimate the time required for the output to reach and remain within five percent of the final value.

From Eq. 40 we find the damping ratio:

$$\xi = \frac{-\ln 0.53}{\pi^2 + (\ln 0.53)^2} = 0.20$$

From Eq. 41 the natural period is

$$\tau_n = 2.62 \sqrt{1 - (0.2)^2} = 2.57 \text{ s}$$

The gust wavelength is then

$$\lambda_g = u\tau_n = 7(2.57) = 18.0 \text{ m}$$

The time required to reach and remain within five percent of the final value can be estimated from the exponential factor in Eq. 32. When this term, which forms the envelope of the damped sinusoid, reaches a value of 0.05, the sinusoid is guaranteed to be this value or less. Depending on the location of the peaks, the sinusoid may dip below 0.05 sooner than the envelope, but certainly not later. From the above argument we set

$$e^{-\omega_n \xi t} = 0.05$$

and find

$$t = \frac{-\tau_n \ln(0.05)}{2\pi\xi} = 6.1 \text{ s}$$

This value of t is sometimes called the *response time*.

The damping ratio of commercially available wind vanes is typically within the range of 0.14 to 0.6 while the gust wavelength is normally between 1 and 18 m. The larger, heavier, and more durable wind vanes have longer gust wavelengths and do not respond fully to rapid changes in wind direction. The smaller, lighter, and more delicate wind vanes have shorter gust wavelengths and respond more accurately to rapid changes in wind direction. The most desirable instrument for turbulence and air pollution dispersion studies is one with a damping ratio close to 0.6 and a short gust wavelength. Measurements made at potential wind power sites normally do not require this sort of detail and a heavier, more rugged instrument can be used.

6 WIND MEASUREMENTS WITH BALLOONS

Economic and technical studies of large wind turbines require a knowledge of wind speed and direction throughout at least the first 100 m above the earth's surface. The possible existence of *nocturnal jets* makes wind data desirable at even greater heights, up to several hundred meters. Meteorological towers of these heights are very expensive, so alternative methods of measuring wind data at these heights are used whenever possible. One such method which has been widely used is the release and tracking of *meteorological balloons*. This method allows the relatively fast and inexpensive screening of a number of sites so a meteorological tower can be properly located if one is found to be necessary.

About 600,000 meteorological balloons are released annually at various National Weather Service stations throughout the United States. The majority of these are relatively small and are released without load. They are visually tracked and the wind speed computed from trigonometric relationships. Larger balloons carry payloads of electronic instrumentation which telemeter information back to earth. These can be used in inclement weather where visual tracking is impossible, and also can provide data from much greater heights. The nocturnal jet is primarily a fair weather phenomenon so the smaller balloons are quite adequate for these lower level wind measurements.

A widely used meteorological balloon is the Kaysam 35P, made by the Kaysam Corporation, Paterson, New Jersey. This balloon has a mass of 30 grams and is normally inflated with hydrogen gas, until it just lifts an attached 140 gm mass. The balloon is then said to have a free lift of 140 gm when this mass is removed. The diameter at launch is about 0.66 m with a volume of about 0.15 m³. The balloon expands as it rises, finally bursting at a diameter of about 1.2 m at a height of over 10,000 m. These balloons are available in three colors: white for blue skies, red for broken skies, and black for overcast skies. At night, a candle or a small electric light can be attached to the balloon to aid the visual tracking process.

When the balloon is released, it will accelerate to its terminal vertical velocity in about five seconds. This terminal velocity depends somewhat on the temperature and pressure of the atmosphere but is usually assumed to be the long term average value. Perhaps the major source of error in measuring wind speeds with balloons is an ascent rate different from the

assumed average. This can be caused by turbulent air which contains significant vertical wind speeds. Mountain valleys or hillsides with strong vertical updrafts or downdrafts should be avoided for this reason.

The National Weather Service forms used for recording the 30 gm balloon data indicate a slightly greater ascent rate during the first five minutes of flight than that assumed later in the flight. They show an average rise of 216 m during the first minute, 198 m the second and third minutes, 189 m the fourth and fifth minutes, and 180 m each minute thereafter. The average rate of ascent therefore decreases from about 3.6 m/s near the ground to about 3 m/s at levels above 1000 m.

The instrument used in tracking the balloon after launch is the *theodolite*, a rather expensive instrument used in surveying work. The theodolite is mounted on a three-legged support called a *tripod*. The balloon is observed through a telescope and angles of elevation and azimuth are read from dials at prescribed intervals; usually one minute. The observer must stop at the prescribed time, read two angles, and then find the balloon in the telescope again before the time for the next reading. The number of possible observations per minute is limited to perhaps three or four by the speed of the human operator. This yields average windspeeds over rather large vertical increments: about 200 m with the standard procedure down to about 50 m at the limit of the operator's ability. Even smaller vertical increments are desirable, however, when the height of the lower level of a nocturnal jet is being sought. These can be obtained by attaching a data collection system to a tracker containing two potentiometers mounted at right angles to each other. The basic concept is shown in Fig. 17.

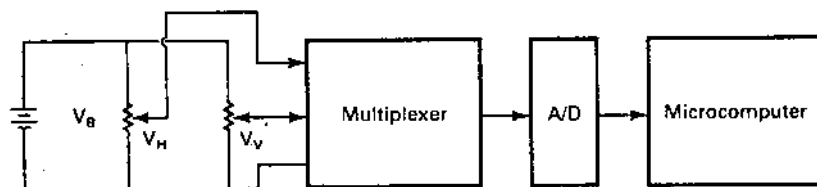

Figure 17: Block diagram of a simple balloon tracking system

In this system the horizontal potentiometer produces a voltage V_H proportional to azimuth while the vertical potentiometer produces a voltage V_V proportional to elevation. These voltages are *multiplexed* into an analog-to-digital converter and recorded in the memory of a microcomputer. A *multiplexer* is an electronic switching device which connects one input line at a time to the single output line. These values can then be manually recorded on paper after the launch is complete, if a very simple system is desired. More sophisticated electronics are possible, but one needs to remember that portability, ruggedness, and insensitivity to weather extremes are very desirable features of such a system. It should be mentioned that theodolites can be purchased with these potentiometers, but acceptable results can be obtained with a simple rifle scope connected to two potentiometers, at a small fraction of the cost of a theodolite[3].

The voltages V_H and V_V produce integer numbers N_H and N_V at the output of the A/D converter. The actual angles being measured are proportional to these numbers. That is, the azimuth angle α is given by

$$\alpha = kN_H \quad (43)$$

where k is a constant depending on the construction of the potentiometer and the applied battery voltage. A similar equation is valid for the elevation angle β .

The basic geometry of the balloon flight is shown in Fig. 18. At some time t_i the balloon is at point P , at an azimuth angle α_i with respect to the reference direction (the x axis) and an elevation angle β_i as seen by the balloon tracker located at the origin. The balloon is at a height z_i above the horizontal plane extending through the balloon tracker. The vertical projection on this plane is the point P' . At some later time t_j the balloon has moved to point Q , at angles α_j and β_j , and with projection Q' on the horizontal plane. The length $P'Q'$ represents the horizontal distance traveled during time $\Delta t = t_j - t_i$. The average wind speed during the time Δt is

$$u_{ij} = \frac{P'Q'}{\Delta t} \quad (44)$$

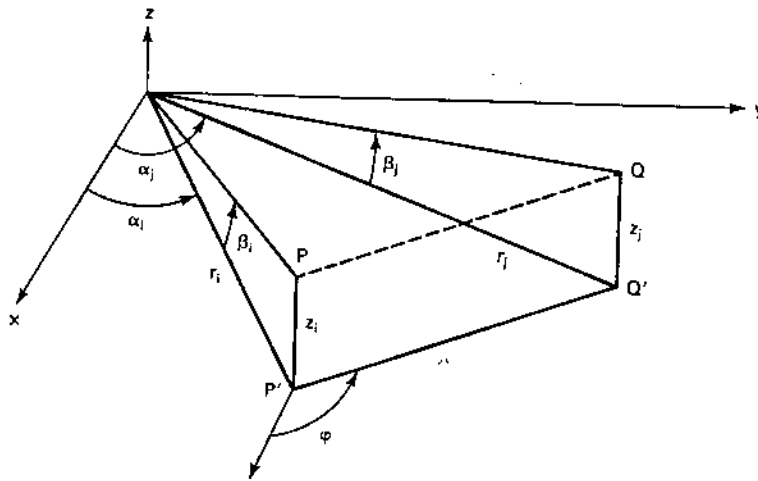

Figure 18: Geometry of balloon flight

If the vertical distance z_i is known from the balloon ascent rate and the time elapsed since launch, the distance r_i can be computed from

$$r_i = z_i \cot \beta_i \quad (45)$$

The projection of the balloon flight on the horizontal plane is shown in Fig. 19. The distance A_i is given by

$$A_i = r_i \cos \alpha_i = z_i \cot \beta_i \cos \alpha_i \quad (46)$$

The distance B_i is given by a similar expression:

$$B_i = r_i \sin \alpha_i = z_i \cot \beta_i \sin \alpha_i \quad (47)$$

The projections of $P'Q'$ on the x and y axes are given by

$$\Delta A = A_j - A_i = z_j \cot \beta_j \cos \alpha_j - z_i \cot \beta_i \cos \alpha_i \quad (48)$$

$$\Delta B = B_j - B_i = z_j \cot \beta_j \sin \alpha_j - z_i \cot \beta_i \sin \alpha_i \quad (49)$$

The length $P'Q'$ is then given by

$$P'Q' = \sqrt{(\Delta A)^2 + (\Delta B)^2} \quad (50)$$

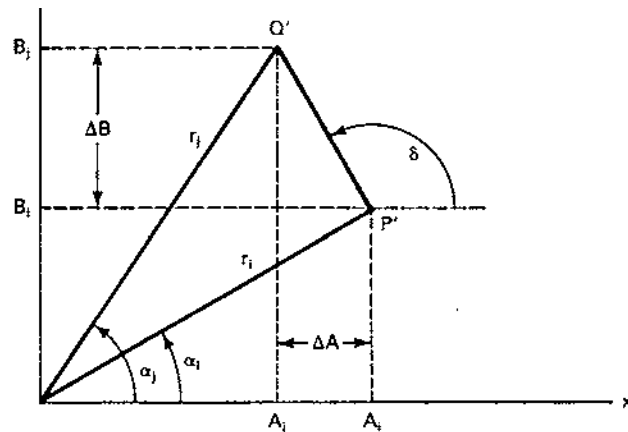

Figure 19: Projection of balloon flight on a horizontal plane.

The angle δ , showing direction of balloon travel with respect to the x axis, is given by

$$\delta = \tan^{-1} \frac{\Delta B}{\Delta A} \quad (51)$$

An alternative approach is to combine the length and direction into a vector quantity $\mathbf{P'Q'}$, where, by using complex arithmetic, we have

$$\mathbf{P}'\mathbf{Q}' = \Delta A + j\Delta B = P'Q' \angle \delta \quad (52)$$

In general, ΔA may be either positive or negative, and the same is true for ΔB . Some care needs to be exercised if δ is to be computed from Eq. 51 using a hand calculator because the inverse tangent function normally gives a result between -90° and $+90^\circ$. This does not cover the full 360° required in this application so a sketch must be drawn of the actual setting each time, and the correct angle determined. Those hand calculators which have a rectangular to polar conversion will normally give both $P'Q'$ and δ correctly from Eq. 52 under all circumstances without additional computations.

The balloon tracker needs to be located so the wind is blowing at nearly a right angle across the launch point, for maximum accuracy. The balloon tracker then needs to be oriented on the tripod so the azimuth potentiometer will stay in its linear region during the balloon flight. This means that the x axis of Figs. 18 and 19 is arbitrarily oriented at some angle α_a with respect to north. This is shown in Fig. 20. The angle δ shows the direction of balloon flight with respect to the x axis. What is really needed, however, is the direction θ the wind is coming from, with respect to north. As implied in the previous section, a wind from the north is characterized by $\theta = 0^\circ$ or 360° , a wind from the east by $\theta = 90^\circ$, etc. The final result for wind direction, after δ is computed and α_a is measured at a particular site, is

$$\theta = 180 - (\delta - \alpha_a) \quad (53)$$

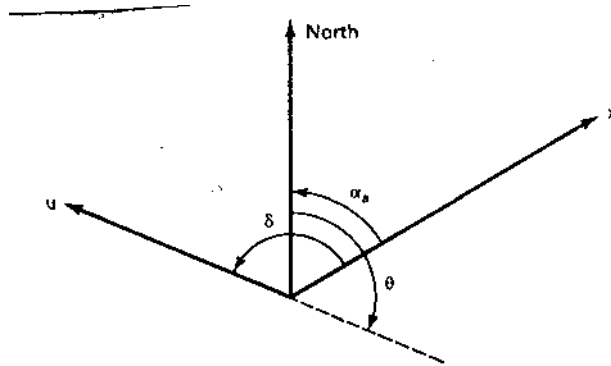

Figure 20: Geometry for computing wind direction.

Example

A balloon launched at Manhattan, Kansas yielded the following values of N_H and N_V from a simple balloon tracker at 10-s intervals:

	Time (s)					
	0	10	20	30	40	50
N_V	6	47	53	50	47	44
N_H	2	58	125	156	170	178

The horizontal distance between the balloon tracker and the launch point was 90 m. The constant k was 0.48 for both elevation and azimuth angles. The angle α_a was determined to be 140° . The average ascent rate for the first minute may be assumed to be 3.6 m/s. Prepare a table showing wind speed and direction as a function of time.

The elevation angle to the launch point is given by

$$\beta_o = kN_V = (0.48)(6) = 2.88^\circ$$

We then find the initial height from Eq. 45.

$$z_o = \frac{r_o}{\cot \beta_o} = \frac{90}{\cot 2.88^\circ} = 4.5 \text{ m}$$

The initial azimuth angle is

$$\alpha_o = kN_H = (0.48)(2) = 0.96^\circ$$

The height of the balloon after the first 10 s of travel will be

$$z_1 = 4.5 + 10(3.6) = 40.5 \text{ m}$$

The other desired quantities are

$$A_o = r_o \cos \alpha_o = 90 \cos 0.96^\circ = 90 \text{ m}$$

$$B_o = r_o \sin \alpha_o = 90 \sin 0.96^\circ = 1.5 \text{ m}$$

$$\alpha_1 = (0.48)(58) = 27.84^\circ$$

$$\beta_1 = (0.48)(47) = 22.56^\circ$$

$$A_1 = z_1 \cot \beta_1 \cos \alpha = 40.5(2.41)(0.88) = 86.2 \text{ m}$$

$$B_1 = 40.5(2.41)(.47) = 45.6 \text{ m}$$

$$\Delta A = A_1 - A_o = 86.2 - 90 = -3.8 \text{ m}$$

$$\Delta B = B_1 - B_o = 45.6 - 1.5 = 44.1 \text{ m}$$

$$\mathbf{P}'\mathbf{Q}' = \Delta A + j\Delta B = -3.8 + j44.1 = 44.3\angle 95^\circ$$

$$u_{01} = \frac{P'Q'}{\Delta t} = \frac{44.3}{10} = 4.43 \text{ m/s}$$

$$\theta = 180 - (\delta - \alpha_a) = 180 - (95 - 140) = 225^\circ$$

Proceeding in a similar manner for the other heights yields the following table:

Time	i	α_i	β_i	z_i	A_i	B_i	u_{ij}	θ_{ij} (deg)
0	0	0.96	2.88	4.5	90	1.5		
10	1	27.84	22.56	40.5	86.2	45.6	4.43	225
20	2	60.0	25.44	76.5	80.4	139.3	9.39	226
30	3	74.88	24.0	112.5	65.9	243.9	10.56	222
40	4	81.60	22.56	148.5	52.2	353.6	11.06	223
50	5	85.44	21.12	184.5	38.8	476.1	12.32	224

We see that in the first interval that the average wind speed was 4.43 m/s while the second interval showed an average speed of 9.39 m/s, with the speeds building to 12.32 m/s in the fifth interval. It would appear from these data that a nocturnal jet was starting at about 40 or 50 m above the balloon tracker. A large wind turbine with hub height of perhaps 80 m would be operating at near capacity conditions, even though the winds predicted by an anemometer at 10 m elevation would perhaps not be adequate to even start the turbine.

It should be mentioned that balloon data normally give more erratic wind speeds than those shown in this example. After the first few intervals, the angular change is rather small, and the discrete nature of the A/D output will tend to make uniform wind speeds appear larger in one interval and smaller in the next. A limited amount of empirical averaging or smoothing of the calculated wind speeds may therefore be necessary if a monotonic curve is desired.

7 PROBLEMS

1. An eight bit A/D converter which reaches maximum output for an input of 5 V is connected to the anemometer of Fig. 4. Specify the range of wind speeds represented by the four digital outputs 0, 1, 2, and 255. Show wind speeds to at least two decimal places, in m/s.

2. The distance constant for the Climet Instruments Model WS- 011 anemometer is 1.5 m. Equilibrium has been reached at a wind speed of 4 m/s when the wind speed suddenly increases to 7 m/s. How long does it take for the indicated wind speed to reach 6.9 m/s?
3. The distance constant for the Climatronics Model WM-III anemometer is 2.5 m. Equilibrium has been reached at 5 m/s when the wind speed suddenly increases to 9 m/s, remains there for one second, and then decreases suddenly to 6 m/s, as shown in Fig. 21. Assume that the indicated wind speed after one second, u'_o , is the new equilibrium speed for the time period denoted by t' . Assume that the anemometer has the voltage output of Fig. 4, and that the A/D converter of Problem 1 is connected to the anemometer and is sampling the voltage every 0.2 s starting at $t = 0$. Make a table of the expected digital output of the A/D converter (in decimal form) from time $t = 0$ to $t = 2$ s. Sketch the indicated wind speed for this time range. Does this sampling rate appear adequate to detect and represent gusts of this height and duration? Discuss.

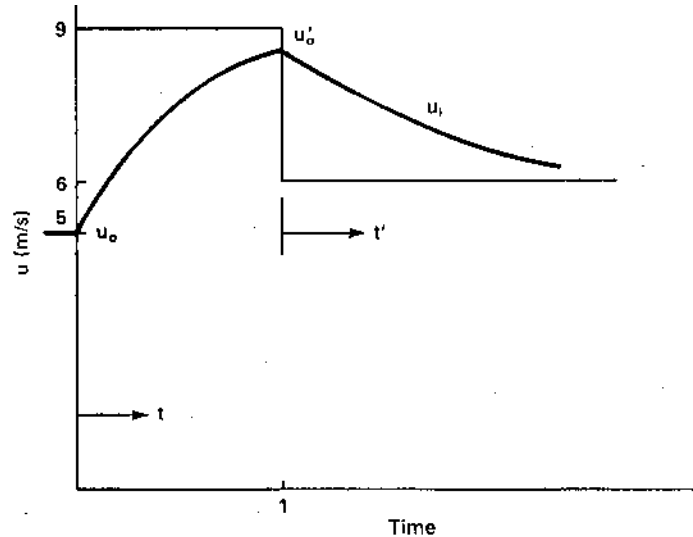

Figure 21: Applied wind speed u and indicated wind speed u_i for Problem 3.

4. The U.S. Corps of Engineers has recorded a considerable amount of wind speed data using a 1/15 mile contact anemometer and a summation period of 5 minutes. What is the average wind speed in m/s during a 5 minute period for which the count was 18?
5. A pressure plate anemometer has a plate 0.1 m on a side. The constant c may be taken as unity and the atmosphere is at standard conditions (0°C and 101.325 kPa).
 - (a) What is the force on the plate at wind speeds of 2, 5, 10, 20, and 40 m/s? If the output signal is proportional to force, comment on the difficulty of building a meter which will accept all speeds up to 40 m/s and still read accurately in the 2 - 6 m/s range.

- (b) (optional - extra credit) The ideal transducer would be one with a mechanical or electrical output proportional to the square root of force so the scale of wind speed would be linear on an indicating meter. How might this be accomplished?
6. An Electric Speed Indicator Company direction vane Model F420C has a damping ratio $\xi = 0.14$ and a gust wavelength $\lambda_g = 17.7$ m. The wind speed is 8 m/s and equilibrium has been reached when the wind direction suddenly changes by 30° . Evaluate the coefficients of Eq. 32. Plot θ on a sheet of graph paper for the time period $t = 0$ to $t = 4$ s assuming that $\theta = 0$ at $t = 0$.
 7. Repeat Problem 6 for the R.M. Young Company Gill Anemometer - Bivane which has damping ratio $\xi = 0.60$ and a gust wavelength $\lambda_g = 4.4$ m. Plot on the same graph.
 8. You develop a new wind vane for which the damping ratio ξ is 1.3 and the gust wavelength λ_g is 4.4 m. Repeat Problem 6 for this vane, noting that the appropriate solution is Eq. 29. Plot the result on the same graph as Problems 6 and 7.
 9. A balloon launched at Manhattan, Kansas yielded the following values of N_H and N_V at 10 s intervals:

	Time (s)					
	0	10	20	30	40	50
N_V	9	46	85	94	91	86
N_H	236	218	156	81	41	18

The horizontal distance between the balloon tracker and the launch point was 122 m. The constant k was 0.48 for both elevation and azimuth angles. The angle α_a was determined to be 335° . The average ascent rate for the first minute may be assumed to be 3.6 m/s. Prepare a table showing wind speed and direction as a function of time.

References

- [1] Golding, E.: *The Generation of Electricity by Wind Power*, Halsted Press, New York, 1976.
- [2] Hewson, E.W. and J.W. Wade: "Biological Wind Prospecting", *Third Wind Energy Workshop Proceedings*, Washington, D.C., September 1977, CONF 770921, pp. 335-348.
- [3] Johnson, G.L.: "Measuring Wind Speed Profiles with Balloons", *Wind Energy Technology Conference*, Kansas City, Missouri, March 16, 17, 1981.
- [4] MacCready, P.B., Jr. and H.R. Jex: "Response Characteristics and Meteorological Utilization of Propeller and Vane Wind Sensors," *Journal of Applied Meteorology*, Vol. 3, No. 2, April, 1964, pp. 182-193.

- [5] Marrs, R.W. and J. Marwitz: “Locating Areas of High Wind Energy Potential by Remote Observation of Eolian Geomorphology and Topography,” *Third Wind Energy Workshop Proceedings*, Washington, D.C., September, 1977, CONF 770921, pp. 307-320.
- [6] Middleton, W., E. Knowles, and A.F. Spilhaus: *Meteorological Instruments*, 3rd. ed., University of Toronto Press, Toronto, 1953.
- [7] Noll, K.E. and T.L. Miller: *Air Monitoring Survey Design*, Ann Arbor Science Publishers, Ann Arbor, 1977, pp. 215-237.
- [8] Putnam, P.C.: *Power from the Wind*, Van Nostrand, New York, 1948.

WIND TURBINE POWER, ENERGY, AND TORQUE

Who has gathered the wind in his fists? Proverbs 30:4

Gathering or harvesting the wind has been of concern to man for a long time. As mentioned earlier, wind turbines have been used for several centuries and literally millions of units have been put into service. For the most part, these machines performed their intended purpose well, and in many cases were still being used with minimum maintenance after half a century of service. Operational machines four centuries old are not unheard of, pointing out the fact that planned obsolescence does not have to be a part of engineering work. A major reason for their success was the lack of competition, of course. There was a choice of using the wind to perform some task or doing it by hand, and doing it by hand is last choice for most people.

Today, wind turbines have to compete with many other energy sources. It is therefore important that they be cost effective. They need to meet any load requirements and produce energy at a minimum cost per dollar of investment. Performance characteristics such as power output versus wind speed or versus rotor angular velocity must be optimized in order to compete with other energy sources. Yearly energy production and its variation with annual wind statistics must be well known. The shaft torque must be known so the shaft can be built with adequate strength and the turbine load properly sized. We shall examine such performance characteristics in this chapter.

1 POWER OUTPUT FROM AN IDEAL TURBINE

The kinetic energy in a parcel of air of mass m , flowing at speed u in the x direction is

$$U = \frac{1}{2}mu^2 = \frac{1}{2}(\rho Ax)u^2 \quad \text{Joules} \quad (1)$$

where A is the cross-sectional area in m^2 , ρ is the air density in kg/m^3 , and x is the thickness of the parcel in m. If we visualize the parcel as in Fig. 1 with side x moving with speed u and the opposite side fixed at the origin, we see the kinetic energy increasing uniformly with x , because the mass is increasing uniformly.

The power in the wind, P_w , is the time derivative of the kinetic energy:

$$P_w = \frac{dU}{dt} = \frac{1}{2}\rho Au^2 \frac{dx}{dt} = \frac{1}{2}\rho Au^3 \quad \text{W} \quad (2)$$

This can be viewed as the power being supplied at the origin to cause the energy of the parcel to increase according to Eq. 1. A wind turbine will extract power from side x , with Eq. 2 representing the total power available at this surface for possible extraction.

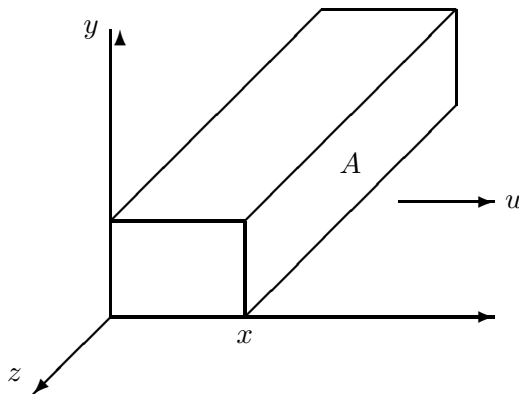
Figure 1: Packet of air moving with speed u

An expression for air density is given in Chapter 2 and is repeated here for convenience:

$$\rho = 3.485 \frac{p}{T} \quad \text{kg/m}^3 \quad (3)$$

In this equation, p is the pressure in kPa and T is the temperature in kelvin. The power in the wind is then

$$P_w = \frac{1}{2} \rho A u^3 = \frac{1.742 p A u^3}{T} \quad \text{W} \quad (4)$$

where A is area in square meters and u is wind speed in meters per second. For air at standard conditions, 101.3 kPa and 273 K, this reduces to

$$P_w = 0.647 A u^3 \quad \text{W} \quad (5)$$

The more general Eq. 4 should be used whenever the wind turbine elevation is more than a few hundred meters above sea level or the temperature is significantly above 0°C .

At standard conditions, the power in 1 m^2 of wind with a speed of 5 m/s is $0.647(5)^3 = 81 \text{ W}$. The power in the same 1 m^2 of area when the wind speed is 10 m/s is 647 W. This illustrates two basic features of wind power. One is that wind power is rather diffuse. It requires a substantial area of wind turbine to capture a significant amount of power. The other feature is that wind power varies rapidly with wind speed. Overspeed protection devices are therefore required to protect both the turbine and the load at high wind speeds.

The physical presence of a wind turbine in a large moving air mass modifies the local air speed and pressure as shown in Fig. 2. The picture is drawn for a conventional horizontal axis propeller type turbine.

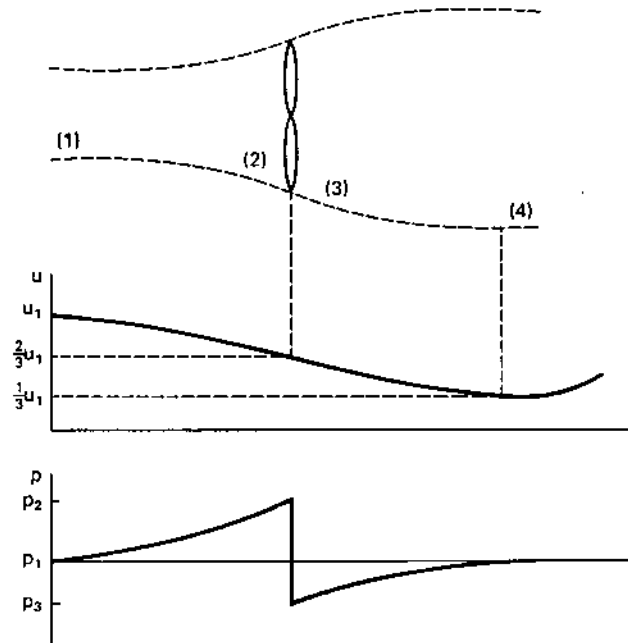

Figure 2: Circular tube of air flowing through ideal wind turbine.

Consider a tube of moving air with initial or undisturbed diameter d_1 , speed u_1 , and pressure p_1 as it approaches the turbine. The speed of the air decreases as the turbine is approached, causing the tube of air to enlarge to the turbine diameter d_2 . The air pressure will rise to a maximum just in front of the turbine and will drop below atmospheric pressure behind the turbine. Part of the kinetic energy in the air is converted to potential energy in order to produce this increase in pressure. Still more kinetic energy will be converted to potential energy after the turbine, in order to raise the air pressure back to atmospheric. This causes the wind speed to continue to decrease until the pressure is in equilibrium. Once the low point of wind speed is reached, the speed of the tube of air will increase back to $u_4 = u_1$ as it receives kinetic energy from the surrounding air[3].

It can be shown[2] that under optimum conditions, when maximum power is being transferred from the tube of air to the turbine, the following relationships hold:

$$\begin{aligned}
 u_2 &= u_3 = \frac{2}{3}u_1 \\
 u_4 &= \frac{1}{3}u_1 \\
 A_2 &= A_3 = \frac{3}{2}A_1 \\
 A_4 &= 3A_1
 \end{aligned} \tag{6}$$

The mechanical power extracted is then the difference between the input and output power in the wind:

$$P_{m,\text{ideal}} = P_1 - P_4 = \frac{1}{2}\rho(A_1u_1^3 - A_4u_4^3) = \frac{1}{2}\rho\left(\frac{8}{9}A_1u_1^3\right) \quad \text{W} \quad (7)$$

This states that 8/9 of the power in the original tube of air is extracted by an *ideal turbine*. This tube is smaller than the turbine, however, and this can lead to confusing results. The normal method of expressing this extracted power is in terms of the undisturbed wind speed u_1 and the turbine area A_2 . This method yields

$$P_{m,\text{ideal}} = \frac{1}{2}\rho\left[\frac{8}{9}\left(\frac{2}{3}A_2\right)u_1^3\right] = \frac{1}{2}\rho\left(\frac{16}{27}A_2u_1^3\right) \quad \text{W} \quad (8)$$

The factor $16/27 = 0.593$ is sometimes called the *Betz coefficient*. It shows that an actual turbine cannot extract more than 59.3 percent of the power in an undisturbed tube of air of the same area. In practice, the fraction of power extracted will always be less because of mechanical imperfections. A good fraction is 35-40 percent of the power in the wind under optimum conditions, although fractions as high as 50 percent have been claimed. A turbine which extracts 40 percent of the power in the wind is extracting about two-thirds of the amount that would be extracted by an ideal turbine. This is rather good, considering the aerodynamic problems of constantly changing wind speed and direction as well as the frictional loss due to blade surface roughness.

It is interesting to note that the total pressure difference across the turbine is rather small. For a 6 m/s wind speed, p_2 will be about 12.6 Pa greater than p_1 , while p_3 will be about 7.6 Pa less. The pressure difference is then about 0.02 percent of the ambient pressure. Small pressure differences are therefore able to provide rather substantial turbine power outputs.

2 AERODYNAMICS

Air flow over a stationary airfoil produces two forces, a *lift* force perpendicular to the air flow and a *drag* force in the direction of air flow, as shown in Fig. 3. The existence of the lift force depends upon *laminar* flow over the airfoil, which means that the air flows smoothly over both sides of the airfoil. If turbulent flow exists rather than laminar flow, there will be little or no lift force. The air flowing over the top of the airfoil has to speed up because of a greater distance to travel, and this increase in speed causes a slight decrease in pressure. This pressure difference across the airfoil yields the lift force, which is perpendicular to the direction of air flow.

The air moving over the airfoil also produces a drag force in the direction of the air flow. This is a loss term and is minimized as much as possible in high performance wind turbines.

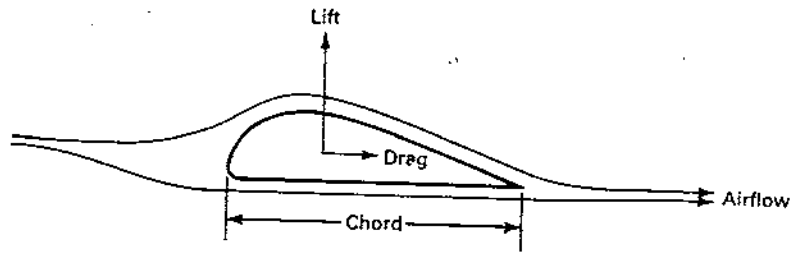

Figure 3: Lift and drag on a stationary airfoil.

Both the lift and the drag are proportional to the air density, the area of the airfoil, and the square of the wind speed.

Suppose now that we allow the airfoil to move in the direction of the lift force. This motion or translation will combine with the motion of the air to produce a relative wind direction shown in Fig. 4. The airfoil has been reoriented to maintain a good lift to drag ratio. The lift is perpendicular to the relative wind but is not in the direction of airfoil translation.

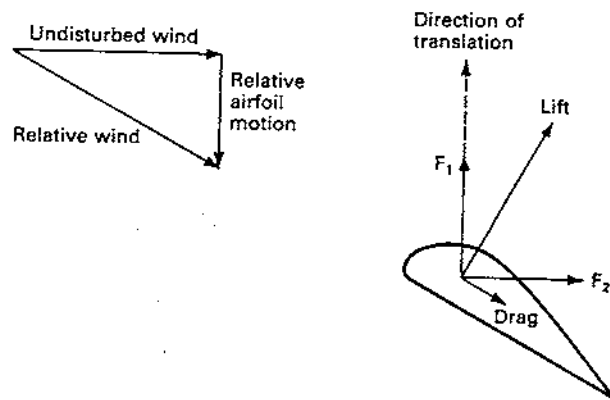

Figure 4: Lift and drag on a translating airfoil.

The lift and drag forces can be split into components parallel and perpendicular to the direction of the undisturbed wind, and these components combined to form the net force F_1 in the direction of translation and the net force F_2 in the direction of the undisturbed wind. The force F_1 is available to do useful work. The force F_2 must be used in the design of the airfoil supports to assure structural integrity.

A practical way of using F_1 is to connect two such airfoils or blades to a central hub and allow them to rotate around a horizontal axis, as shown in Fig. 5. The force F_1 causes a torque which drives some load connected to the propeller. The tower must be strong enough to withstand the force F_2 .

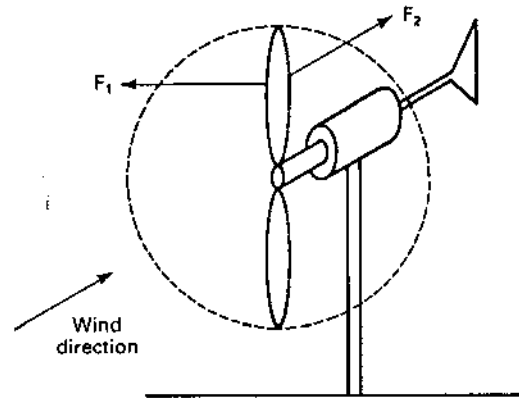
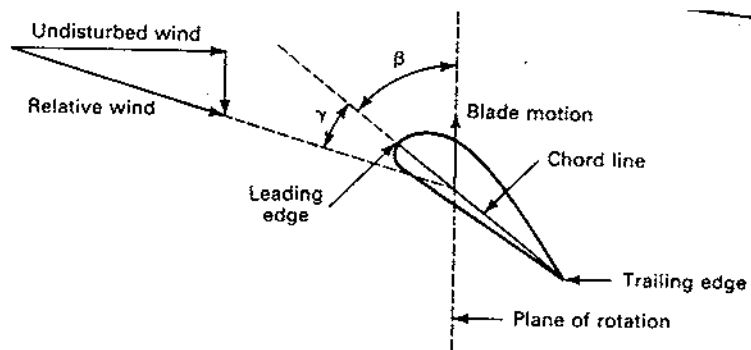

Figure 5: Aerodynamic forces on a turbine blade.

These forces and the overall performance of a wind turbine depend on the construction and orientation of the blades. One important parameter of a blade is the *pitch angle*, which is the angle between the chord line of the blade and the plane of rotation, as shown in Fig. 6. The *chord line* is the straight line connecting the leading and trailing edges of an airfoil. The *plane of rotation* is the plane in which the blade tips lie as they rotate. The blade tips actually trace out a circle which lies on the plane of rotation. Full power output would normally be obtained when the wind direction is perpendicular to the plane of rotation. The pitch angle is a static angle, depending only on the orientation of the blade.

Figure 6: Definition of pitch angle β and angle of attack γ .

Another important blade parameter is the *angle of attack*, which is the angle γ between the chord line of the blade and the relative wind or the effective direction of air flow. It is a dynamic angle, depending on both the speed of the blade and the speed of the wind. The blade speed at a distance r from the hub and an angular velocity ω_m is $r\omega_m$.

A blade with twist will have a variation in angle of attack from hub to tip because of the

variation of $r\omega_m$ with distance from the hub. The lift and drag have optimum values for a single angle of attack so a blade without twist is less efficient than a blade with the proper twist to maintain a nearly constant angle of attack from hub to tip. Even the blades of the old Dutch windmills were twisted to improve the efficiency. Most modern blades are twisted, but some are not for cost reasons. A straight blade is easier and cheaper to build and the cost reduction may more than offset the loss in performance.

When the blade is twisted, the pitch angle will change from hub to tip. In this situation, the pitch angle measured three fourths of the distance out from the hub is selected as the reference.

3 POWER OUTPUT FROM PRACTICAL TURBINES

The fraction of power extracted from the power in the wind by a practical wind turbine is usually given the symbol C_p , standing for the coefficient of performance. Using this notation and dropping the subscripts of Eq. 8 the actual mechanical power output can be written as

$$P_m = C_p \left(\frac{1}{2} \rho A u^3 \right) = C_p P_w \quad \text{W} \quad (9)$$

The coefficient of performance is not a constant, but varies with the wind speed, the rotational speed of the turbine, and turbine blade parameters like angle of attack and pitch angle.

The Darrieus turbines operate with fixed pitch while the large horizontal axis turbines normally have variable pitch. The pitch is varied to hold C_p at its largest possible value up to the rated speed u_R of the turbine, and then is varied to reduce C_p while P_w continues to increase with wind speed, in order to maintain the output power at its rated value, P_{mR} . This is shown in Fig. 7.

It is not practical to hold C_p constant with pitch control because of manufacturing and control limitations, so it will vary with wind speed even for a fixed rotational speed, variable pitch blade. A variation of C_p versus u is shown in Fig. 8 for the MOD-2 wind turbine[1, 8]. The turbine starts producing power at a hub height wind speed of 6.3 m/s (14 mi/h) and a C_p of about 0.28. A maximum C_p of 0.41, defined as C_{pm} , occurs at 9 m/s (20 mi/h). Designing the blades to have a maximum coefficient of performance below the rated wind speed helps to maximize the energy production of the turbine.

The rated wind speed for the MOD-2 is 12.3 m/s (27.5 mi/h) at hub height. C_p has dropped to about 0.36 at this wind speed. The coefficient of performance at rated wind speed can be defined as C_{pR} . Two curves for C_p are shown in Fig. 8 for wind speeds above the rated wind speed, the upper curve showing the capability of the rotor and the lower curve showing C_p under actual operating conditions. The turbine is shut down at 20 m/s (45 mi/h) to prevent damage from such high winds, and the actual C_p is well under 0.1 when this wind

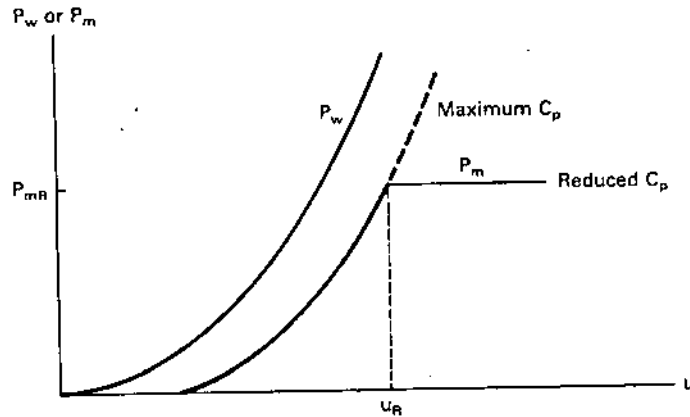

Figure 7: Shaft power output of a variable-pitch turbine.

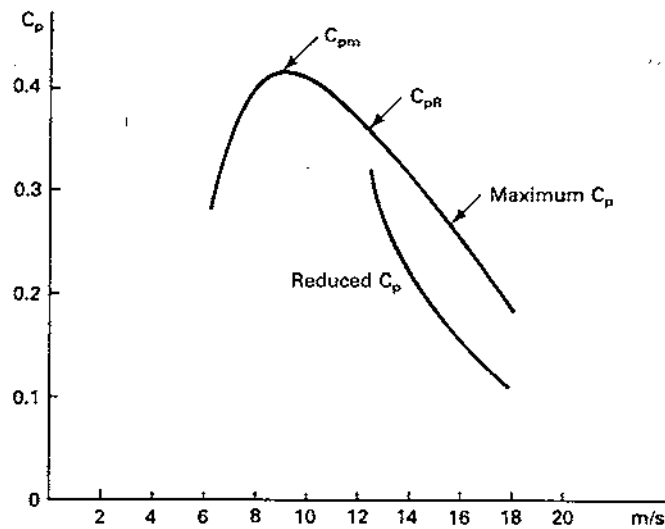

Figure 8: Coefficient of performance versus wind speed for MOD-2.

speed is reached.

The curve shown in Fig. 8 is only valid for one rotational speed, in this case 17.5 revolutions per minute (r/min). When the rotational speed is changed, $r\omega_m$ changes and causes the angle of attack to change. This in turn changes C_p at a given wind speed. It is often convenient for design purposes to have a single curve for C_p , from which the effects of changing either rotational speed or wind speed can be determined. This means that the rotational speed and the wind speed must somehow be combined into a single variable before such a single curve can be drawn. Experiments show that this single variable is the ratio of the turbine *tip speed*

$r_m\omega_m$ to the wind speed u . This *tip speed ratio* is defined as

$$\lambda = \frac{r_m\omega_m}{u} \quad (10)$$

where r_m is the maximum radius of the rotating turbine in m, ω_m is the *mechanical angular velocity* of the turbine in rad/s, and u is the undisturbed wind speed in m/s.

The angular velocity ω_m is determined from the *rotational speed* n (r/min) by the equation

$$\omega_m = \frac{2\pi n}{60} \quad \text{rad/s} \quad (11)$$

The variation of C_p with λ for the Sandia 17-m Darrieus[10] is shown in Fig. 9. This particular machine will be used for illustration purposes in this chapter. All horizontal axis propeller turbines and other Darrieus machines will have generally similar curves. This curve is for a machine similar to the one shown in Fig. 1.5 with the difference being that each blade has two struts extending from the blade to the center of the vertical shaft. Performance is somewhat better without the aerodynamic losses introduced by the struts, but this will not affect our discussion. This particular machine has a rotor diameter of 16.7 m, a rotor height of 17 m, and a rotor swept area of 187 m².

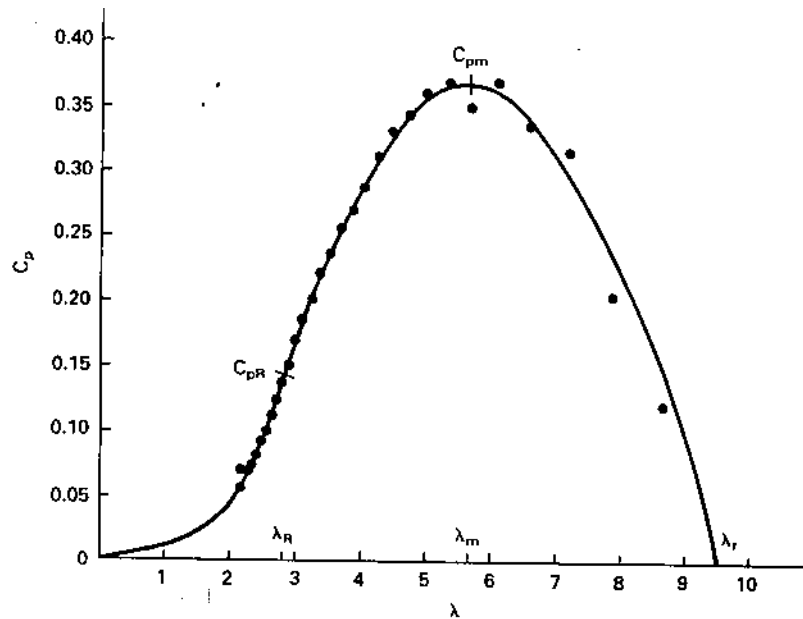

Figure 9: Coefficient of performance C_p versus tip-speed ratio λ for Sandia 17-m Darrieus turbine. Two blades; 42 r/min.

The size of this machine was chosen on the basis of available aluminum forming equipment

and other hardware and may not be an optimum size. A good design procedure is to select several sizes, perhaps arbitrarily, and then determine manufacturing costs, energy production, and unit energy costs for each size. The detailed designs for each size reveal possible difficulties that do not appear in the conceptual design stage. The fact that no one builds a satisfactory gearbox, or that no one can extrude the aluminum blade in the desired size, would probably not be discovered until the detailed design stage. Such designs, with certain sizes and operating conditions arbitrarily selected to allow a detailed design to continue, are often called *point designs*. Other Darrieus point designs will be mentioned later in the chapter.

The Darrieus is operated as a fixed pitch turbine since there is no convenient way of varying the pitch. The blade motion causes the relative direction of the air seen by the blade to change continuously during a revolution. This means that the angle of attack is continuously changing during rotation. The coefficient of performance shown in Fig. 9 is therefore an average value for one complete revolution.

As mentioned earlier, the Darrieus turbine is normally not self starting. Fig. 9 indicates that C_p is very low for a Darrieus turbine operating at tip speed ratios below about two. The correspondingly low shaft power is insufficient to overcome friction so the Darrieus turbine needs a mechanical assist to get its tip speed up to at least twice the wind speed. At tip speed ratios above two, the Darrieus is able to extract enough power from the wind to accelerate itself up to the desired operating angular velocity. As it accelerates, it passes through the rated coefficient of performance C_{pR} at λ_R , reaching the maximum coefficient of performance C_{pm} at λ_m . If there is no load on the turbine it will continue to accelerate until the *runaway* tip speed ratio λ_r is reached. In high winds, the turbine angular velocity may easily exceed design limits at λ_r , hence the turbine should not be operated without a load.

The normal operating mode of a large wind turbine will have the turbine rotating at fixed rotational speed (e.g. 42 r/min for the data of Fig. 9). For fixed $r_m\omega_m$, the tip speed ratio will be large for a low wind speed and get smaller as the wind speed increases. As the wind speed increases from a small value the mechanical power output increases due to both the greater power in the wind and the larger values of C_p . This variation is shown in Fig. 10. Eventually C_p reaches its maximum C_{pm} at the tip speed ratio λ_m . For higher wind speeds (lower tip speed ratios) the power in the wind continues to increase while C_p starts to decrease. The product of $C_p P_w$ continues to increase until the rated mechanical power output P_{mR} is reached at C_{pR} and λ_R . After that point, C_p decreases at an even greater rate than before, so P_m starts a slow decrease.

It should be mentioned that the rated power can be selected at a value below the maximum possible power. In fact, this may be a common practice for purposes of guarantees. A Darrieus turbine which can produce 30 kW at a wind speed of 12 m/s may be rated at 25 kW at a wind speed of 10 m/s, for example. A customer testing a machine would find power flows equal to and slightly above the nameplate rating and would conclude that the machine was performing as advertised. If the actual power never reached the advertised rating, due perhaps to manufacturing tolerances or installation errors, the customer may become angry and initiate legal action against the manufacturer.

We could therefore distinguish between the coefficient of performance and tip speed ratio at rated wind speed and at the wind speed where maximum power is actually obtained. This may be necessary in some situations, but normally is not required. We shall therefore use C_{pR} and λ_R to refer to both the rated power and the maximum power cases.

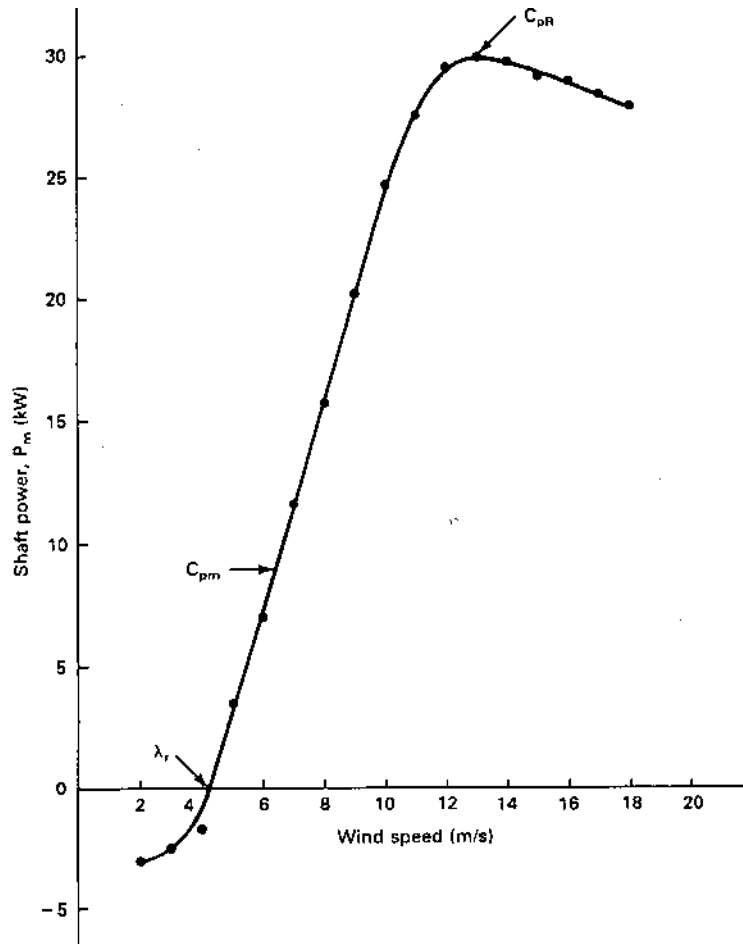

Figure 10: Shaft power output of Sandia 17-m Darrieus turbine at 42 r/min in an average pressure of 83 kPa and an average temperature of 15°C.

Figure 10 shows experimental data recorded at an average temperature of 15°C and an average pressure of 83 kPa. The power output of the same turbine in air at standard conditions would be nearly 30 percent greater at the same wind speeds.

The lack of a convenient means for changing the pitch of the Darrieus blades is seen to not be a serious disadvantage because of this self limiting characteristic of power output. If the fixed speed load is able to accept the maximum possible mechanical power, no additional braking or loading is necessary as the wind speed increases above its rated value.

Let us now consider the effect of changing the rated rotational speed on the operation of the turbine. A higher rotational speed means that a given value of λ will occur at a higher wind speed. If the turbine characteristic does not change with rotational speed, then the same C_{pR} applies at the same λ_R , which is at a higher wind speed than before. The higher wind speed means that a larger shaft power will be delivered. A 25 percent increase in wind speed means the power in the wind has increased by $(1.25)^3 = 1.95$. Therefore, if we operate the turbine of Figs. 9 and 10 at a 25 percent higher rotational speed [$42(1.25) = 52.5$ r/min], we would expect approximately twice the peak shaft power output observed at 42 r/min. This indeed is the case, as shown by Fig. 11. In fact, C_{pR} has increased slightly so our 30-kW (mechanical power) machine at 42 r/min has become a 67-kW machine at 52.5 r/min.

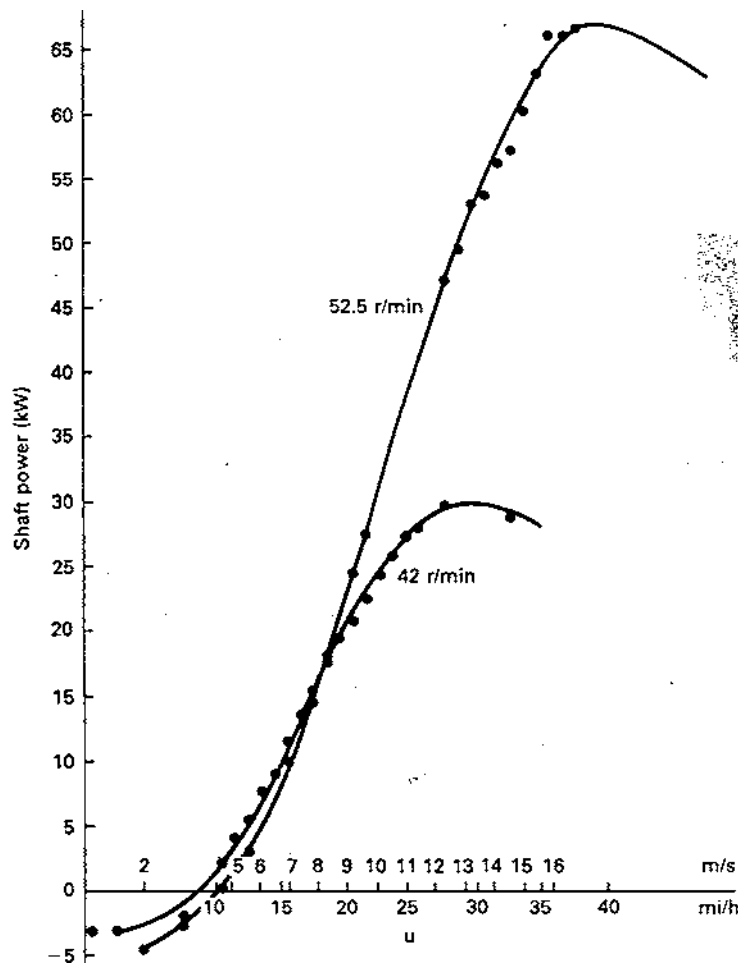

Figure 11: Shaft power output of Sandia 17-m Darrieus at two angular velocities in an ambient pressure of 83 kPa and an ambient temperature of 15°C.

At first glance, it would appear that 52.5 r/min would be a superior choice over 42 r/min. This may not be the case, however, because the extra power is available only at the higher

wind speeds, above about 9 m/s. Below 9 m/s the power output at 52.5 r/min is actually less than for 42 r/min. Wind speeds below 9 m/s are usually more common than speeds above 9 m/s, so additional power output at higher wind speeds may be more than offset by reduced power output at lower wind speeds. The choice of rated rotational speed therefore depends on the wind regime of a given site. A site with a mean wind speed of 9 m/s could probably justify the 52.5-r/min machine while a site with a mean speed of 6 m/s could not. We shall consider a more detailed analysis of this choice later in the chapter.

4 TRANSMISSION AND GENERATOR EFFICIENCIES

The shaft power output that we have been discussing is not normally used directly, but is usually coupled to a load through a transmission or gear box. The load may be a pump, compressor, grinder, electrical generator, and so on. For purposes of illustration, we will consider the load to be an electrical generator. The basic system is then as shown in Fig. 12. We start with the power in the wind, P_w . After this power passes through the turbine, we have a mechanical power P_m at the turbine angular velocity ω_m , which is then supplied to the transmission. The *transmission output power* P_t is given by the product of the turbine output power P_m and the *transmission efficiency* η_m :

$$P_t = \eta_m P_m \quad \text{W} \quad (12)$$

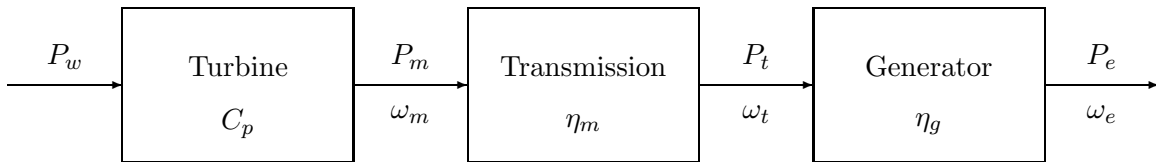

Figure 12: Wind electric system

Similarly, the generator output power P_e is given by the product of the transmission output power and the generator efficiency η_g :

$$P_e = \eta_g P_t \quad \text{W} \quad (13)$$

Equations 9, 12, and 13 can be condensed to a single equation relating electrical power output to wind power input:

$$P_e = C_p \eta_m \eta_g P_w \quad \text{W} \quad (14)$$

At rated wind speed, the rated electrical power output can be expressed as

$$P_{eR} = C_{pR}\eta_{mR}\eta_{gR}\frac{\rho}{2}Au_R^3 \quad \text{W} \quad (15)$$

where C_{pR} is the coefficient of performance at the rated wind speed u_R , η_{mR} is the transmission efficiency at rated power, η_{gR} is the generator efficiency at rated power, ρ is the air density, and A is the turbine area.

The quantity $C_{pR}\eta_{mR}\eta_{gR}$ is the *rated overall efficiency* of the turbine. We shall give this quantity a symbol of its own, η_o :

$$\eta_o = C_{pR}\eta_{mR}\eta_{gR} \quad (16)$$

It should be mentioned that the American Wind Energy Association is trying to avoid the use of the term *rated power* in favor of *maximum power*. Many wind turbine distributors will also refuse to use the term *rated power*. The reason for this is the tendency for the uninformed to attach more significance to this quantity than it deserves. With conventional generators, a 60-kW generator priced at \$1000 per kilowatt is almost always a better buy than a 25-kW generator priced at \$2000 per kilowatt. This does not necessarily hold true for wind turbines since the 60-kW and the 25-kW wind turbine systems may be the same turbine with a larger transmission and synchronous generator in the 60-kW version. One salesman is asking \$60,000 for almost the same machine being offered by someone else for \$50,000. The higher price is being disguised by quoting the price in dollars per unit rating. This situation can lead to much confusion as well as some unethical behavior.

With this cautionary note, we shall retain the use of the term *rated power*, but we shall try not to give it more significance than it deserves. We shall restrict its use to theoretical models where the rated power occurs at the rated wind speed u_R at a sharp corner of the power output versus wind speed curve. We shall then use the *maximum power* to refer to the peak value seen on the experimental power output curve.

We shall see a better way of describing the performance of a given wind turbine in the next section. Rather than either rated or maximum power, it is the energy production that one could expect from a given turbine in a given wind regime.

Example

The Sandia 17-m Darrieus is rated at 60 kW at 15.5 m/s and 52.5 r/min, and at 25 kW at 11 m/s and 42 r/min. The area A is 187 m². Compute the rated overall efficiency at each rating and standard conditions.

At standard conditions, $\rho/2 = 0.647$. Inserting this value in Eqs. 15 and 16 we get

$$\eta_{0,25} = \frac{25,000}{0.647(187)(11)^3} = 0.155$$

$$\eta_{0,60} = \frac{60,000}{0.647(187)(15.5)^3} = 0.133$$

These results illustrate the fact that the rated overall efficiency may be significantly lower than the maximum coefficient of performance of the turbine itself. This is not a major problem if the various efficiencies are high below the rated wind speed. For wind speeds at or above rated, the power in the wind is large enough that somewhat lower efficiencies do not prevent rated power from being reached.

The rated overall efficiency just defined is only valid at rated wind speed. We need to know the overall efficiency at lower wind speeds to determine the energy production of the turbine, so we need to determine the individual efficiencies. We have already examined the variation of C_p , so we shall now consider η_m and η_g .

Transmission losses are primarily due to viscous friction of the gears and bearings turning in oil. At fixed rotational speed, the losses do not vary strongly with transmitted torque. It is therefore reasonable to assume that the transmission loss is a fixed percentage of the low speed shaft rated power. The actual percentage will vary with the quality of the transmission, but a reasonable value seems to be 2 percent of rated power per stage of gears. The maximum practical gear ratio per stage is approximately 6:1, so two or three stages of gears are typically required. Two stages would have a maximum allowable gear ratio of $(6)^2:1 = 36:1$ so any design requiring a larger gear ratio than this would use three stages.

Suppose that q is the number of gear stages. The transmission efficiency is then

$$\eta_m = \frac{P_t}{P_m} = \frac{P_m - (0.02)qP_{mR}}{P_m} \quad (17)$$

where P_{mR} is the rated turbine shaft power.

This equation is plotted in Fig. 13 for one, two, and three stages. It can be seen that the transmission efficiency is not very good for low power inputs. It is therefore desirable to choose ratings such that the transmission is operating above the knee of the curve in Fig. 13 as much as possible.

Example

How many gear stages are required in the transmission for the Sandia 17-m Darrieus to drive a 1800 r/min generator for each of the proposed speeds of 42 and 52.5 r/min? Assume the maximum gear ratio for a single stage is 6:1.

The overall gear ratio at 42 r/min is $1800/42 = 42.86:1$, while at 52.5 r/min it is $1800/52.5 = 34.29:1$. Operating at 42 r/min requires a 3 stage transmission while a 2 stage transmission would be adequate at 52.5 r/min. The transmission for the 52.5 r/min system will therefore be more efficient and probably less expensive than the corresponding transmission for the 42 r/min system. This would encourage us to use the higher speed system, if possible.

It should be mentioned that synchronous generators are also made to operate at 1200 r/min for only a small increase in cost over the 1800 r/min version. Therefore, the possibility of using a 1200 r/min generator should be examined if the 42 r/min mode is selected. This would present an overall gear ratio of $1200/42 = 28.57:1$, which could be accomplished with a two stage transmission.

The generator losses may be considered in three categories: hysteresis and eddy current

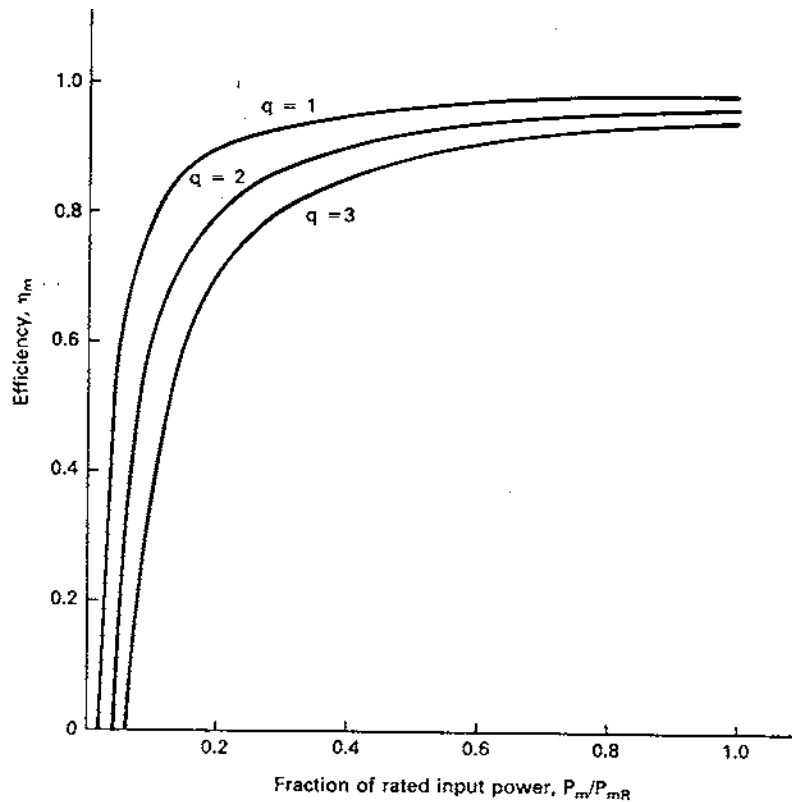

Figure 13: Transmission efficiency for one, two, and three stages, with 2 percent loss per stage.

losses, which are functions of the operating voltage and frequency, windage and bearing friction losses, which vary with rotational speed, and copper losses, which vary as the square of the load or output current. Normal operation with the generator connected to the utility grid will be with fixed voltage and frequency, and either fixed or almost fixed angular velocity depending on whether the generator is of the synchronous or induction type. These generators will be discussed in more detail in the next chapter.

It is appropriate to group the losses into two categories: fixed and variable, with hysteresis, eddy currents, windage, and bearing friction considered fixed, and copper losses being variable. The relative magnitudes of these losses will vary with the design of the generator. It is considered good design to have the two categories approximately equal to each other when the generator is delivering rated power, and we will assume this for discussion purposes.

Larger generators are inherently more efficient than smaller generators. Some losses are proportional to the surface area of the rotor while the rated electrical power is proportional to the volume. The ratio of volume to area increases with increased physical size, hence the efficiency goes up. Good quality generators may have full load efficiencies of 0.85 for a 2-kW

rating, 0.9 for a 20-kW rating, 0.93 for a 200-kW rating, and 0.96 for a 2-MW rating. The efficiency continues to climb with size, exceeding 0.98 for the very large generators in coal and nuclear power plants. This variation in efficiency with rating is different from the efficiencies of the turbine and transmission, which were assumed to not vary with size. The differences between very small and large generators are significant, and should be included in any detailed economic study.

The effects of rated power and actual power on generator efficiency can all be combined in an empirical equation[10]. When expressed in terms of the input shaft power to the generator, this expression is

$$\eta_g = \frac{X - (0.5)Y(1 - Y)(X^2 + 1)}{X} \quad (18)$$

where the parameters X and Y are given by

$$X = \frac{P_t}{P_{tR}} \quad (19)$$

$$Y = 0.05 \left(\frac{10^6}{P_{eR}} \right)^{0.215} \quad (20)$$

In these equations, P_{tR} and P_{eR} are the *rated mechanical power input* and the *rated electrical power output* in watts of the generator. Equation eq:4.18 is plotted in Fig. 14 for three rated generator sizes: 20 kW (20×10^3 W), 200 kW, and 2000 kW. The curves are seen to be very similar in shape to the transmission efficiency curves of Fig. 13.

The power output of the electrical generator can now be determined, conceptually at least, by finding C_p , η_m and η_g for a given turbine and wind speed, multiplying them together to find the overall efficiency, and then multiplying that by the power in the wind. This can be done by reading values from graphs or by analytical techniques if the appropriate mathematical models have been defined. Design values of turbine rated rotational speed and rated sizes of the transmission and generator can be varied, and the process repeated. Optimum values can be determined which will maximize the energy production per dollar of investment.

The selection of ratings is somewhat of an art, partly because commercial products are made in discrete size increments. A company which manufactured a 25-kW and a 30-kW generator would probably not manufacture a 27-kW generator. We are therefore forced to choose a size which is not exactly equal to the theoretically desired value. Consider, for example, the Sandia 17-m Darrieus turbine with shaft power production shown in Fig. 10. The peak shaft power is 30 kW. We would want to select a transmission of at least this input rating. If there is a 30-kW transmission built for this class of service, it would be selected. Otherwise, a 35- or 40-kW transmission would probably be chosen. This would allow a safety factor and perhaps increase the operational life of the transmission.

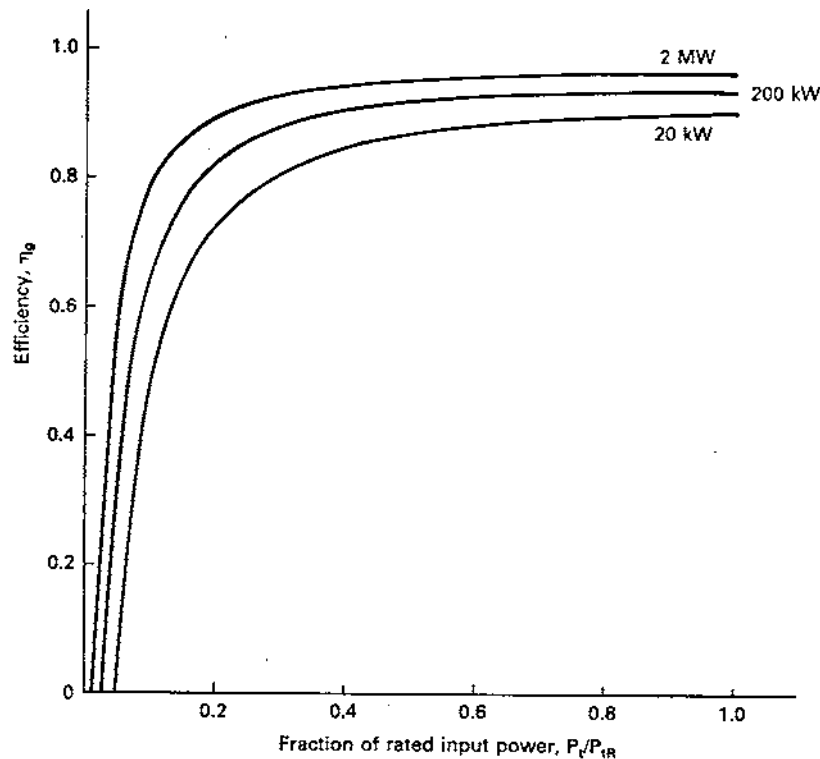

Figure 14: Generator efficiency for three generator sizes.

If a two stage, 30-kW transmission with an efficiency curve such as Fig. 13 is selected, the rated output power is $(0.96)(30) = 28.8$ kW. Generators are always rated in terms of output power, so a 25-kW generator with efficiency of 0.9 has a rated input power $25/0.9 = 27.8$ kW. The next size up, say 30 kW, would have a rated input power of $30/0.9 = 33.3$ kW. Should we select the generator that is slightly undersized, or should we choose the next larger unit? In this particular situation, a good case can be made for choosing the smaller generator. There will be some slight savings in cost and weight, and some increase in average system efficiency because the generator will be operated at a higher fraction of its rating. The slight overload is acceptable because it is not present all the time. Any generator can supply 10 or 20 percent greater power than its rating for periods up to an hour if it is allowed to cool after that period. The wind is variable enough that periods of slight overload will be compensated by other periods of lighter load, so the average power delivered in a period of perhaps one hour would not be above the rated power.

It should be remembered that the heat conduction away from the generator is greater in higher winds, and that the generator rating is determined for indoor or calm conditions. This effect may increase the practical rating of the generator by 5 percent or so. These factors of variable power operation and increased air cooling make it permissible to size the generator

by as much as 10 percent under the predicted steady state requirement.

If we choose the 25-kW generator and connect it to the turbine whose shaft power is shown in Fig. 10, and if a two-stage transmission is assumed, the electrical power output as a function of wind speed will be as shown in Fig. 15. The shaft power input is also shown for comparison purposes. It is seen that both the shaft power and the electrical power output increase nearly linearly with wind speed up to their maximum values. This may seem somewhat surprising since the power in the wind increases as the cube of the wind speed. It is correct, however, since the low efficiencies at low wind speeds are responsible for linearizing the power output curve.

We note in Fig. 15 that the electrical power output rises above zero at a wind speed of about 5 m/s. This wind speed at which electrical power production starts is called the *cut-in speed* u_c . The turbine will develop enough mechanical power to rotate itself at slightly lower speeds, but this wind speed will actually supply all the generator and transmission losses so useful electrical power can be produced.

Fig. 15 has been developed from actual turbine data and from reasonably complete models of the transmission and generator. Other turbines, transmissions, and generators will produce somewhat different curves with approximately the same shape.

It is convenient to define a model for P_e that can be used in discussing any wind system. The simplest model would use a straight line to describe the variation in output power between cut-in and rated wind speeds. A straight line describes the output of the Sandia 17-m Darrieus rather well. We must remember, of course, that other monotonic functions will fit the observed data nearly as good as a straight line, or perhaps even better for some machines, and may yield more accurate energy estimates or more convenient analytic results. It will be seen later that a closed form expression for energy production can be obtained if P_e is assumed to vary as u^k between cut-in and rated wind speeds, where k is the Weibull shape parameter. Numerical integration is required if P_e is assumed to vary as u , or in a linear fashion. Therefore, our choice of a somewhat complicated model will make later computations easier, and perhaps more accurate, than the choice of the simplest possible model. We therefore define the following equations for the electrical power output of a model wind turbine[9]:

$$\begin{aligned}
 P_e &= 0 & (u < u_c) \\
 P_e &= a + bu^k & (u_c \leq u \leq u_R) \\
 P_e &= P_{eR} & (u_R < u \leq u_F) \\
 P_e &= 0 & (u > u_F)
 \end{aligned} \tag{21}$$

In the expression, P_{eR} is the *rated electrical power*, u_c is the *cut-in* wind speed, u_R is the *rated* wind speed, u_F is the *furling* wind speed, and k is the Weibull shape parameter. Furling

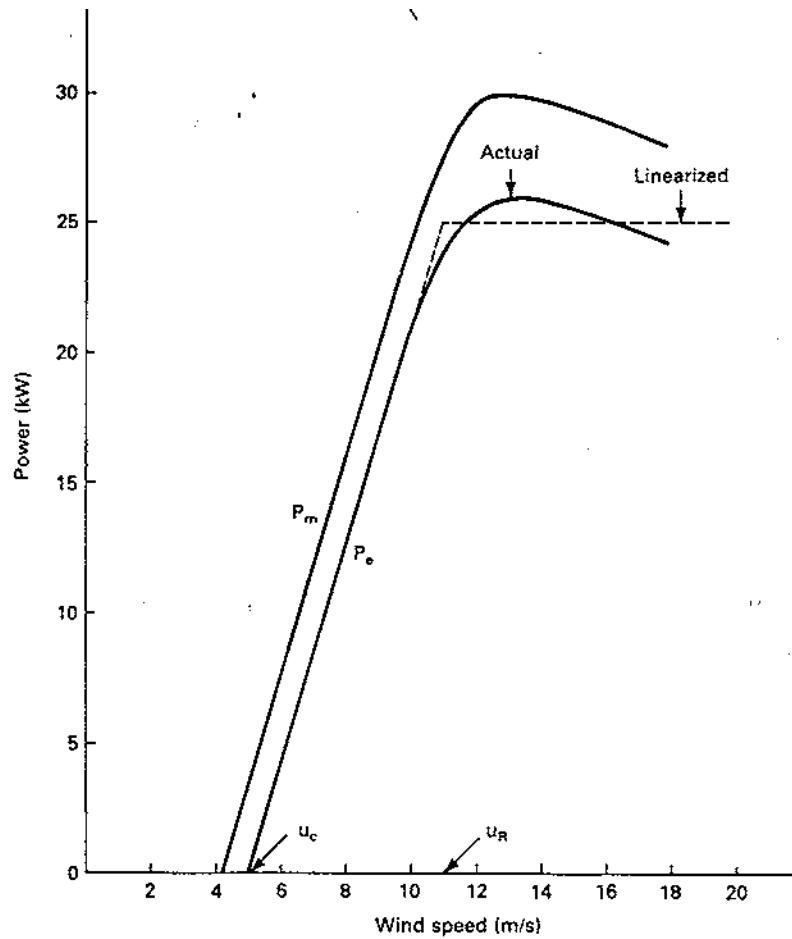

Figure 15: Electrical power output compared with shaft power of Sandia 17-m Darrieus turbine operating at 42 r/min.

is an old sailing term which refers to the process of rolling up the canvas sails in anticipation of high winds. It therefore is used to refer to the wind speed at which the turbine is shut down to prevent structural damage. This condition normally occurs only a few hours during the year, and therefore does not have a large influence on energy production.

The coefficients a and b are given by

$$a = \frac{P_{eR} u_c^k}{u_c^k - u_R^k}$$

$$b = \frac{P_{eR}}{u_R^k - u_c^k} \quad (22)$$

As mentioned in Chapter 2, the Rayleigh distribution is a special case of the Weibull distribution with $k = 2$ and is often sufficiently accurate for analysis of wind power systems. This value of k should be used if the wind statistics at a given site are not well known.

A plot of P_e versus u is shown in Fig. 16, for $k = 2$. P_e varies as u^k between the cut-in and rated wind speeds. It is then assumed to be a constant value between the rated and furling wind speeds. At the furling wind speed u_F the turbine is shut down to protect it from high winds.

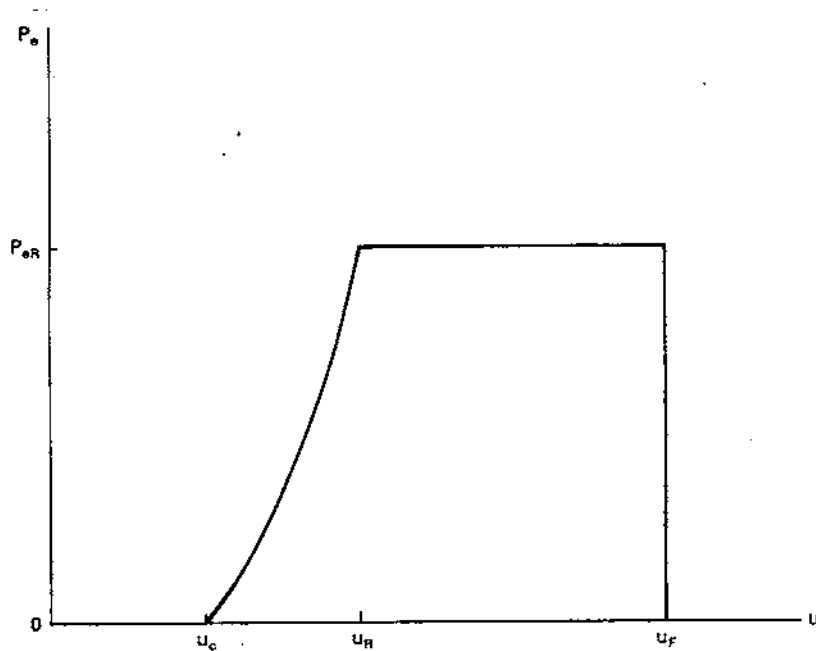

Figure 16: Model wind turbine output versus wind speed.

5 ENERGY PRODUCTION AND CAPACITY FACTOR

We have seen that the electrical power output of a wind turbine is a function of the wind speed, the turbine angular velocity, and the efficiencies of each component in the drive train. It is also a function of the type of turbine (propeller, Darrieus, etc.), the inertia of the system,

and the gustiness of the wind. We will assume that the power output can be adequately described by the model of Eqs. 21, although more sophisticated models might be necessary in rare cases. We now want to combine the variation in output power with wind speed with the variation in wind speed at a site to find the *average power* $P_{e,ave}$ that would be expected from a given turbine at a given site. The average power output of a turbine is a very important parameter of a wind energy system since it determines the total energy production and the total income. It is a much better indicator of economics than the rated power, which can easily be chosen at too large a value.

The average power output from a wind turbine is the power produced at each wind speed times the fraction of the time that wind speed is experienced, integrated over all possible wind speeds.

In integral form, this is

$$P_{e,ave} = \int_0^{\infty} P_e f(u) du \quad \text{W} \quad (23)$$

where $f(u)$ is a probability density function of wind speeds. We shall use the Weibull distribution

$$f(u) = \frac{k}{c} \left(\frac{u}{c}\right)^{k-1} \exp \left[- \left(\frac{u}{c}\right)^k \right] \quad (24)$$

as described in Chapter 2.

Substituting Eqs. 21 and 24 into Eq. 23 yields

$$P_{e,ave} = \int_{u_c}^{u_R} (a + bu^k) f(u) du + P_{eR} \int_{u_R}^{u_F} f(u) du \quad \text{W} \quad (25)$$

There are two distinct integrals in Eq. 25 which need to be integrated. One has the integrand $u^k f(u)$ and the other has the integrand $f(u)$. The integration can be accomplished best by making the change in variable

$$x = \left(\frac{u}{c}\right)^k \quad (26)$$

The differential dx is then given by

$$dx = k \left(\frac{u}{c}\right)^{k-1} d\left(\frac{u}{c}\right) \quad (27)$$

The two distinct integrals of Eq. 25 can therefore be written as

$$\int f(u)du = \int e^{-x}dx = -e^{-x} \quad (28)$$

$$\begin{aligned} \int u^k f(u)du &= \int c^k \left(\frac{u^k}{c^k} \right) f(u)du \\ &= c^k \int x e^{-x} dx = -c^k (x+1)e^{-x} \end{aligned} \quad (29)$$

When we substitute the limits of integration into Eq. 25, and reduce to the minimum number of terms, the result is

$$P_{e,ave} = P_{eR} \left\{ \frac{\exp[-(u_c/c)^k] - \exp[-(u_R/c)^k]}{(u_R/c)^k - (u_c/c)^k} - \exp \left[- \left(\frac{u_F}{c} \right)^k \right] \right\} W \quad (30)$$

We now have an equation which shows the effects of cut-in, rated, and furling speeds on the average power production of a turbine. For a given wind regime with known c and k parameters, we can select u_c , u_R , and u_F to maximize the average power, and thereby maximize the total energy production. There are relationships among u_c , u_R , and u_F which must be considered, however, if realistic results are to be expected. The wind must contain enough power at the cut-in speed to overcome all the system losses. A cut-in speed of $0.5u_R$ would imply that the gearbox and generator losses at cut-in are the fraction $(0.5)^3 = 0.125$ of rated power. A cut-in speed of $0.4u_R$ implies that the losses in that case are the fraction $(0.4)^3 = 0.064$ of rated power. It would take a rather efficient generator and gearbox combination to have losses less than 6.4 percent of rated power while losses of 12.5 percent would indicate a rather mediocre design. We would expect then that u_c would almost always lie in the range between 0.4 and $0.5u_R$.

Commercial wind turbines typically have furling speeds between 20 and 25 m/s and rated wind speeds between 10 and 15 m/s. A furling speed of twice the rated speed means that the turbine control system is able to maintain a constant power output over an eight to one range of wind power input. This is quite an engineering challenge. This design difficulty plus the difficulty of building wind turbines which can survive operation in wind speeds greater than perhaps 25 m/s means that the furling speed will not normally be above $2u_R$, unless u_R happens to be chosen unusually low for a special application.

We can see from this discussion that selecting a rated wind speed u_R is an important part of wind turbine design. This selection basically determines the cut-in speed and also imposes certain constraints on the furling speed. As stated earlier, we want to select u_R so

the average power will be as large as possible for a given turbine area. The capital investment in the turbine will be proportional to the turbine area so maximizing the average power will minimize the cost per unit of energy produced. If the rated speed is chosen too low, we will lose too much of the energy in the higher speed winds. If the rated speed is too high, the turbine will seldom operate at capacity and will lose too much of the energy in the lower speed winds. This means that the average power output will reach a maximum at a specific value of rated wind speed. We can determine this value by evaluating Eq. 30 for various values of u_R and P_{eR} .

We can gain some insight into this design step by normalizing Eq. 30. We first observe that the quantity inside the brackets of Eq. 30 is called the *capacity factor* CF. Also called the *plant factor*, it is an important design item in addition to the average power.

When we combine Eqs. 15, 16, and 30 we get

$$P_{e,ave} = P_{eR}(\text{CF}) = \eta_o \frac{\rho}{2} A u_R^3 (\text{CF}) \quad \text{W} \quad (31)$$

The choice of rated wind speed will not depend on the rated overall efficiency, the air density, or the turbine area, so these quantities can be normalized out. Also, since the capacity factor is expressed entirely in normalized wind speeds, it is convenient to do likewise in normalizing Eq. 31 by dividing the expression by c^3 to get the term $(u_R/c)^3$. We therefore define a normalized average power P_N as

$$P_N = \frac{P_{e,ave}}{\eta_o(\rho/2)Ac^3} = (\text{CF}) \left(\frac{u_R}{c} \right)^3 \quad (32)$$

Plots of P_N are given in Fig. 17 for various values of the Weibull shape parameter k and for two ratios of cut-in to rated speed. As argued earlier, most turbines will have cut-in speeds between 0.4 and 0.5 of the rated wind speed, so these plots should bracket the designs of practical interest.

We see that maximum power is reached at different values of u_R/c for different values of k . For $u_c = 0.5u_R$, the maximum power point varies from $u_R/c = 1.5$ to 2.5 as k decreases from 2.6 to 1.4. As the cut-in speed is lowered to $0.4u_R$, the maximum power point varies from $u_R/c = 1.6$ to 3.0 . If $k = 2$ at a particular site, the optimum value of u_R/c is between 1.8 and 2.0. We saw in Chapter 2 that c is usually about 12 percent larger than the mean wind speed, so the optimum design for energy production is a rated speed of about twice the mean speed. If the mean wind speed at a site is 6 m/s, then the rated speed of the turbine should be about 12 m/s.

This design choice only holds for wind regimes where k is about 2. In a trade wind regime, k will be significantly larger than 2, so a rated speed perhaps 1.3 times the mean speed may be a better choice in such locations.

We see that the curves for P_N are gently rounded near their maximum values so small

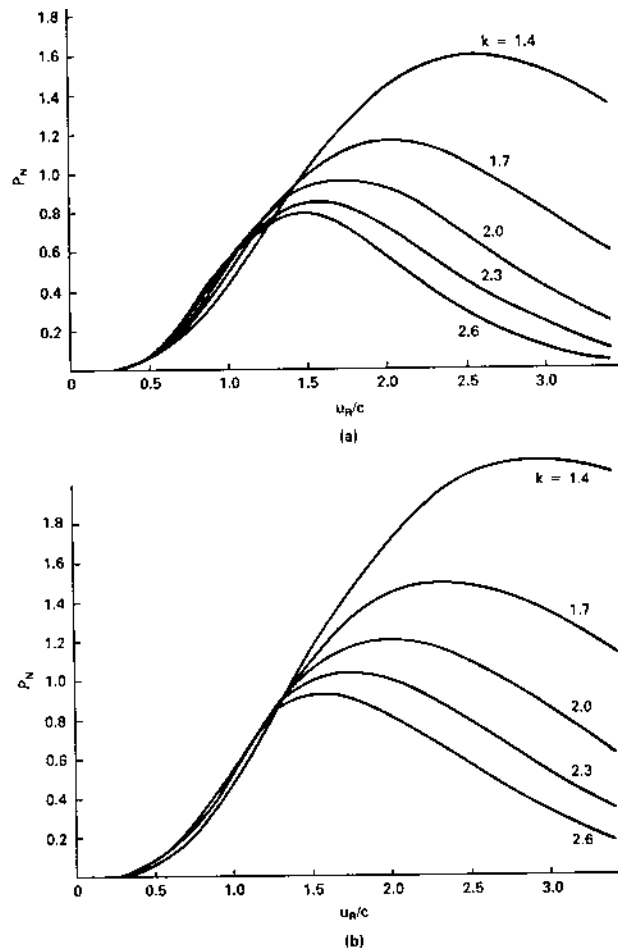

Figure 17: Normalized power versus normalized rated speed: (a) $u_c = 0.5u_R$, $u_F = 2u_R$; (b) $u_c = 0.4u_R$, $u_F = 2u_R$.

errors in selecting a rated speed are not critical. In fact, a manufacturer could cover most of the potential market by having only two rated speeds for a given size of turbine. A rated speed of 11 m/s would be adequate for most sites with mean wind speeds up to 6 m/s, and a rated speed of 13 or 14 m/s would be appropriate for sites with greater wind speeds. This is a big help to the mass production of turbines in that it is not essential to have a turbine specifically designed for each site. Only when a wind turbine factory is dedicated to producing turbines for a specific wind regime, such as a large wind farm, would a more detailed design be advisable.

It would appear from Fig. 17 that sites with lower k are superior to those with larger k . This is true only if the mean wind speed is the same at each site. As was mentioned in Chapter 2, sites with low mean wind speeds tend to have lower values of k than sites with greater mean wind speeds. These lower wind speeds will usually reduce the average power

more than the increase due to lower values of k . However, if two sites have the same mean wind speed, the site with the lower k will have the larger energy production.

Once we select u_R/c to maximize the average power, we can find the rated power for a turbine with a given area and rated overall efficiency located at an elevation with a known average air density. We know that

$$\text{energy} = (\text{average power})(\text{time}) \quad (33)$$

Therefore, the yearly energy production of such a turbine is

$$W = P_{e,\text{ave}}(\text{time}) = (\text{CF})P_{eR}(8760) \quad \text{kWh} \quad (34)$$

where 8760 is the number of hours in a year of 365 days and P_{eR} is expressed in kilowatts.

We note that when we select a larger value of u_R for a turbine that the rated power P_{eR} will increase. This is accompanied by a decrease in capacity factor CF. This decrease has economic implications which may force us to select a smaller rated speed than that which produces maximum energy. What we really want is the maximum energy production per dollar of investment, which may yield a different design than the one which strictly maximizes total energy. As we increase P_{eR} for a given turbine, the costs of the necessary generator, transformer, switches, circuit breakers, and distribution lines all increase. However, the decrease in capacity factor means that these items are being used proportionately less of the time. Equipment costs will increase more rapidly than energy output as we approach the peak of the curves in Fig. 17 so the actual economic optimum will be at a rated wind speed slightly below that which yields maximum yearly energy.

These economic considerations may extend well beyond the equipment immediately attached to the wind turbine. Wind turbines with low capacity factors supply power to the utility grid in an intermittent fashion, which forces conventional generating plants to cycle more than they otherwise would. This cycling of conventional generating plants causes them to operate at lower efficiencies than if operated at more constant power levels, so the economic optimum when the entire power network is considered may be at an even lower rated wind speed and higher capacity factor. A proper determination of the rated wind speed for this overall economic optimum may require a very detailed study of the power system. Lacking such a detailed study, a reasonable design procedure would be to use the u_R/c ratio at which the normalized power is perhaps 90 percent of the peak normalized power for a given wind regime. This will yield a total energy production close to the maximum, at a much better capacity factor.

It is of some interest to actually examine the variation in capacity factor with u_R/c . A plot of capacity factor versus u_R/c for $u_c = 0.5u_R$ and $k = 2$ is given in Fig. 18. The curve of practical interest is for $u_F = 2u_R$, but the curve for $u_F = 5u_R$ is also shown. There is essentially no difference between the curves for $u_R/c \geq 1$ but significant differences appear for very low values of rated wind speed. It is seen that the capacity factor does not exceed 0.6

for the curve of $u_F = 2u_R$. There is no combination of practical values for cut-in, rated, and furling speeds which will yield a capacity factor greater than 0.6 in a wind regime described by the Weibull shape parameter $k = 2$. The average power will never be more than 0.6 of the rated power in such a wind regime. Only if impractical values of rated and cut-in speeds are selected can the capacity factor be raised above 0.6. For example, if we have a good wind regime described by $c = 10$ m/s (mean speed $\bar{u} = 9$ m/s) we could have a capacity factor approaching 0.9 if we pick a rated wind speed of 4 m/s ($u_R/c = 0.4$) and if the turbine could deliver rated power up to $u_F = 50$ m/s. Even if this were technically possible, it would not be economically practical. We shall see that economics will normally force us to a rated wind speed greater than c , in which case a furling speed of approximately twice the value of c will produce the same capacity factor as a larger furling speed. This is true because the wind rarely blows at speeds greater than $2c$, so wind speeds above $2c$ do not significantly affect the average power.

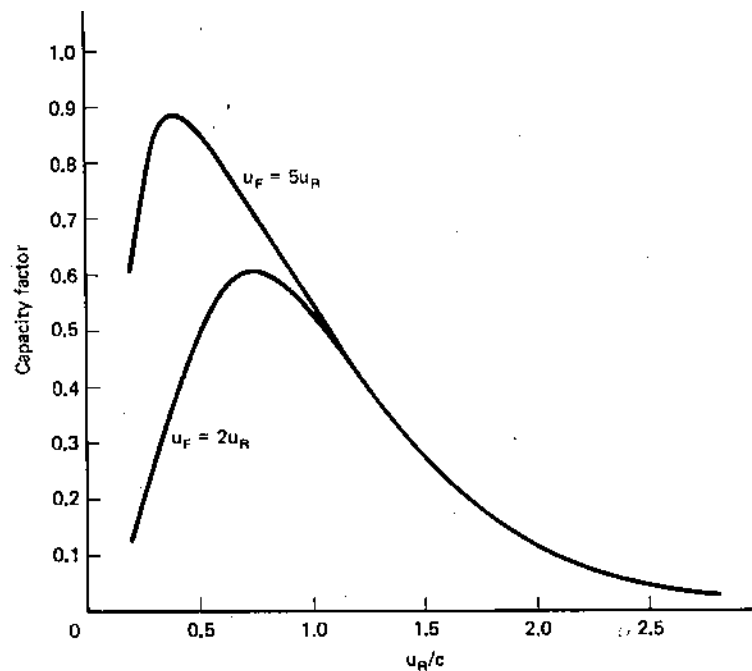

Figure 18: Wind turbine capacity factor as a function of rated speed. $u_c = 0.5u_R$ and $k = 2$.

The important point is that the capacity factor decreases rapidly with increasing values of rated wind speed for practical values of u_R . As the rated wind speed is increased, the turbine will operate fewer hours at rated power and more hours at partial power or below cut-in. This decrease in capacity factor must be balanced against an increase in total energy production to obtain the desired economic optimum.

Example

Preliminary data suggest that the 50 m wind speeds at a potential wind farm site are characterized

by the Weibull parameters $c = 9$ m/s and $k = 2.3$. You work for a wind farm company that plans to build wind machines of the same size as the MOD-2 (rotor diameter 91.5 m) but optimized for this site, if necessary. You know that the MOD-2 has a rated power of 2500 kW at a rated wind speed of 12.4 m/s at hub height. You conservatively estimate that $u_c = 0.5u_R$ and $u_F = 2u_R$.

- a) What is the optimum rated wind speed?
- b) What is the capacity factor of your optimized turbine?
- c) What are the average power and yearly energy production values for your optimized turbine?
- d) What would be the capacity factor, average power, and yearly energy production of the MOD-2 turbine used in that wind regime without modification?
- e) Should you recommend building the MOD-2 on this site without modification?

From Fig. 17 we see that the normalized power is greatest at $u_R/c = 1.6$ for $k = 2.3$ and $u_c = 0.5u_R$. The optimum rated wind speed is then

$$u_R = 1.6(9) = 14.4 \text{ m/s}$$

The capacity factor is, from Eq. 30,

$$\begin{aligned} \text{CF} &= \frac{\exp[-(1.6/2)^{2.3}] - \exp(-1.6)^{2.3}}{(1.6)^{2.3} - (1.6/2)^{2.3}} - \exp\{-[2(1.6)]^{2.3}\} \\ &= \frac{0.550 - 0.052}{2.948 - 0.599} - 5 \times 10^{-7} \\ &= 0.212 \end{aligned}$$

The rated power, assuming all efficiencies remain the same, will just be in the ratio of the cube of the wind speeds.

$$P_{eR} = 2500 \left(\frac{14.4}{12.4} \right)^3 = 3900 \text{ kW}$$

The average power is

$$P_{e,ave} = (\text{CF})P_{eR} = (0.212)(3900) = 830 \text{ kW}$$

The yearly energy production is then

$$W = 830(8760) = 7,270,000 \text{ kWh}$$

The same computations for the unmodified MOD-2 in that wind regime yield the following results:

$$\begin{aligned}
 \text{CF} &= 0.319 \\
 P_{e,\text{ave}} &= 800 \text{ kW} \\
 W &= 7,000,000 \text{ kWh}
 \end{aligned}$$

Optimizing the MOD-2 for this site has increased our total energy production about 4 percent while increasing the rated power by 56 percent. The increase in total energy is desirable, but only if it can be accomplished in a cost effective manner. If the basic MOD-2 structure is adequate to handle the larger power rating without structural changes, then we can get 4 percent more energy for perhaps 1 percent greater investment in the electrical system. If the structure needs to be changed, however, the additional cost could easily exceed the additional benefit.

Another difficulty seen in this example is the difference between the capacity factors. The capacity factor for the standard MOD-2 is 0.319 while that for the optimized system is only 0.212. This lower capacity factor means that the machine will be operating in a more intermittent fashion and this poses additional operating difficulties for the other generating plants on the system, as mentioned earlier. It may well be that the best decision is to use the standard MOD-2 without any effort to optimize it.

It should now be evident that rated power is not a totally satisfactory parameter for distinguishing between wind turbines. We can put a larger generator on a given set of blades and actually reduce the yearly energy production. We also reduce the capacity factor, which may be an important factor in some situations. Several pieces of information are needed to properly specify a wind turbine, including average power and capacity factor in a variety of wind regimes. Specifying only the rated power makes it difficult to properly compare competing turbines.

6 TORQUE AT CONSTANT SPEEDS

Most wind turbines extract power from the wind in mechanical form and transmit it to the load by rotating shafts. These shafts must be properly designed to transmit this power. When power is being transmitted through a shaft, a *torque* T will be present. This torque is given by

$$T = \frac{P}{\omega} \quad \text{N} \cdot \text{m}/\text{rad} \quad (35)$$

where P is mechanical power in watts and ω is angular velocity in rad/sec. The torque in the low speed shaft of Fig. 12 is $T_m = P_m/\omega_m$ while the torque in the high speed shaft is $T_t = P_t/\omega_t$. The units may be expressed as either N·m/rad or N·m, depending on one's preference. We shall express torque in rotating shafts in N·m/rad and torque on a stationary structure such as a tower in N·m. This will hopefully clarify the application and make the necessary analysis more obvious.

The application of torque to a shaft causes internal forces or pressures on the shaft material. Such a pressure is called the *stress* f_s with units Pa or N/m². Since this pressure is trying

to *shear* the shaft, as opposed to compress or stretch, it is referred to as the *shearing stress*. The shearing stress varies with the distance from the shaft axis, having the largest value at the surface of the shaft. It is shown in textbooks on Mechanics of Materials that the shearing stress in a solid shaft is given by

$$f_s = \frac{Tr}{J} \quad \text{N/m}^2 \quad (36)$$

where r is the distance from the axis of the shaft to where the stress is to be determined, and J is the *polar moment of inertia* of the shaft. It is given by

$$J = \frac{\pi r_o^4}{2} \quad \text{m}^4 \quad (37)$$

where r_o is the shaft radius.

It should be mentioned that there are two distinct but closely related quantities which are both called the moment of inertia. One is the *area* moment of inertia, with units m^4 , and the other is the *mass* moment of inertia, with units $\text{kg}\cdot\text{m}^2$. The area moment of inertia is used in studying the mechanics of materials, normally in a static or stationary mode, while the mass moment of inertia is used in determining the dynamics of rotating structures. These topics are usually covered in separate textbooks, so the prefixes *area* or *mass* are usually omitted, with the reader expected to know which one is meant by the context. We shall sometimes omit the prefixes also, but we shall use the symbol J for the polar area moment of inertia and the symbol I for the polar mass moment of inertia. We have no need for the rectangular moment of inertia in this text, so we can also drop the word polar from the terminology.

The mass moment of inertia is found from the area moment of inertia by multiplying by the area density ρ_a in kg/m^2 . The area density is measured across the area perpendicular to the axis of rotation.

Example

A solid steel shaft has a radius of 0.1 m and a length of 0.8 m. Find the area moment of inertia J and the mass moment of inertia I if the volume density of steel is $7800 \text{ kg}/\text{m}^3$.

The area moment of inertia is given by Eq. 37 as

$$J = \frac{\pi(0.1)^4}{2} = 1.57 \times 10^{-4} \text{ m}^4$$

The area density of the shaft would simply be the length times the volume density.

$$\rho_a = 0.8\rho = 0.8(7800) = 6240 \text{ kg}/\text{m}^2$$

The mass moment of inertia is then

$$I = J\rho_a = 1.57 \times 10^{-4}(6240) = 0.980 \text{ kg}\cdot\text{m}^2$$

One way of designing shafts to carry a given torque is to select a maximum shearing stress which will be allowed for a given shaft material. This stress occurs at $r = r_o$, so Eqs. 36 and 37 can be solved for the shaft radius. The shaft diameter which will have this maximum stress is

$$D = 2r_o = 2\sqrt[3]{\frac{2T}{\pi f_s}} \quad \text{m} \quad (38)$$

The maximum stress in Eq. 38 is usually selected with a significant safety factor. Recommended maximum stresses for various shaft materials can be found in machine design books.

Example

You are designing a wind turbine with an electrical generator rated at 200 kW output. The low speed shaft rotates at 40 r/min and the high speed shaft rotates at 1800 r/min. Solid steel shafts are available with recommended maximum stresses of 55 MPa. The gearbox efficiency at rated conditions is 0.94 and the generator efficiency is 0.93. Determine the necessary shaft diameters.

From Eq. 11, the angular velocities for the low and high speed shafts are

$$\omega_m = \frac{2\pi(40)}{60} = 4.19 \text{ rad/s}$$

$$\omega_t = \frac{2\pi(1800)}{60} = 188.5 \text{ rad/s}$$

The power in the high speed shaft is

$$P_t = \frac{200,000}{0.93} = 215,000 \text{ W}$$

The power in the low speed shaft is

$$P_m = \frac{215,000}{0.94} = 229,000 \text{ W}$$

The torques are then

$$T_m = \frac{229,000}{4.19} = 54,650 \text{ N} \cdot \text{m/rad}$$

$$T_t = \frac{215,000}{188.5} = 1140 \text{ N} \cdot \text{m/rad}$$

The shaft diameters are then computed from Eq. 37.

$$D_L = 2 \sqrt[3]{\frac{2(54,650)}{\pi(55 \times 10^6)}} = 0.172 \text{ m}$$

$$D_H = 2 \sqrt[3]{\frac{2(1140)}{\pi(55 \times 10^6)}} = 0.0473 \text{ m}$$

It can be seen that the low speed shaft is rather substantial in size. This adds to the mass and cost of the turbine and should be held to a minimum length for this reason.

Torque at the rotor shaft will vary significantly as the rotor goes by the tower. This will be smoothed out somewhat by the inertia and damping of the system but will still appear in the electrical power output curve. Fig. 19 illustrates this situation for the MOD-0 wind turbine in a 15 m/s wind[7]. The system losses have been subtracted from the power input curve, so the areas under the input and output curves are the same. The actual aerodynamic rotor input power is rather difficult to measure, so its curve is theoretically developed. It shows the input power decreasing to 40 kW as a blade goes by the tower and increasing to 120 kW as the blade clears the tower. The torque will follow the same pattern since the rotor rotational speed is fixed. The output power is considerably damped, but still shows a variation of about 18 kW for a stiff steel shaft, 16 kW for a flexible elastomeric shaft and 14 kW for a fluid coupling. The system lag is such that the output power is at a peak when the rotor power is at a minimum.

A power variation of this magnitude can be a major problem to a utility. It can affect voltage levels, causing lights to flicker. It can cause utility control equipment such as voltage regulators to cycle excessively. Careful attention must be given to the design of the drive train in order to hold this variation to a minimum.

This power flow variation can also be minimized by placing several wind turbines in a wind farm in parallel operation. The larger wind turbines normally use synchronous generators, to be discussed in the next chapter. One feature of synchronous generators in parallel is that they all turn at exactly the same speed, and the angular positions of their shafts vary only slightly with individual power flows. If fixed gearing is used, and there are no drive train components like vee-belts or fluid couplings which allow slip, each rotor in the wind farm can be at a different angular position. A collection of 18 turbines with a 10° angular position difference between individual rotors would be expected to have a much smoother net output than the output of any one turbine.

The torque and power variation for a Darrieus turbine is even more pronounced than that for a horizontal axis turbine. Figure 20 shows the aerodynamic torque for the Sandia 17-m

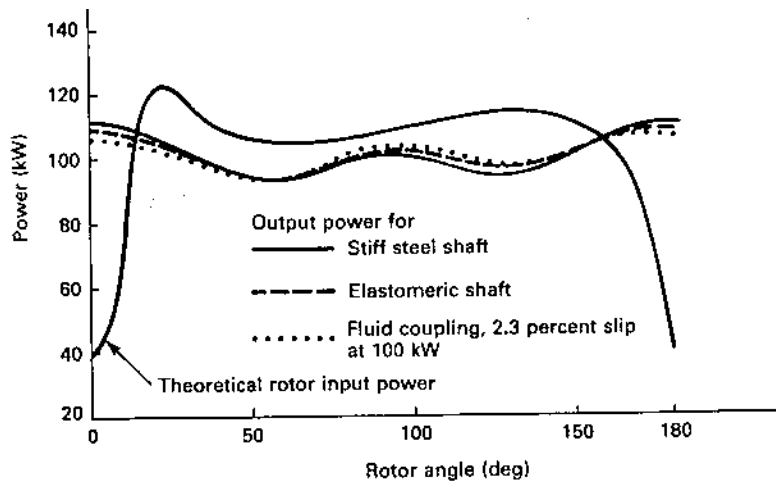

Figure 19: MOD-0 power output for three high-speed shaft configurations.

Darrieus at a rotational speed of 50.6 r/min and at wind speeds of 9.8, 15.2, and 19.7 m/s. These are measurements of the actual torque caused by the wind, obtained by a clever use of accelerometers on the blades[6]. The shaft torque measured by torque sensors is much smoother. As expected, the two bladed machine has two distinct torque cycles per rotor revolution. At a wind speed of 9.8 m/s, the aerodynamic torque peaks at a rotor angle just below 90° , as defined in Fig. 21, at which point the plane of the rotor is parallel to the wind. The torque variation at this wind speed is nearly symmetric with changes in angular position and goes slightly negative when the plane of the rotor is perpendicular to the direction of the wind.

As the wind speed increases the torque pattern becomes more complex. We saw in Fig. 15 that the power output of this Darrieus does not increase above a certain point, even though the power in the wind continues to increase with wind speed. We now see in Fig. 20 that the average torque at two wind speeds may be about the same, but that the instantaneous torque of the higher wind speed may oscillate more widely. This is due to complex interactions between the blades, the supporting tower, and the air flow, which we shall not try to explain. The important point to note is that there is a cyclic torque variation in both the horizontal and vertical axis turbines and that the drive train needs to be designed with this torque variation in mind.

7 DRIVE TRAIN OSCILLATIONS

When torque is applied to a shaft, it will twist. This is illustrated in Fig. 22 where the line AB on a shaft of length L has been twisted to position AC . The total twist is the angle θ . The twist will be directly proportional to the torque as long as the material remains in its

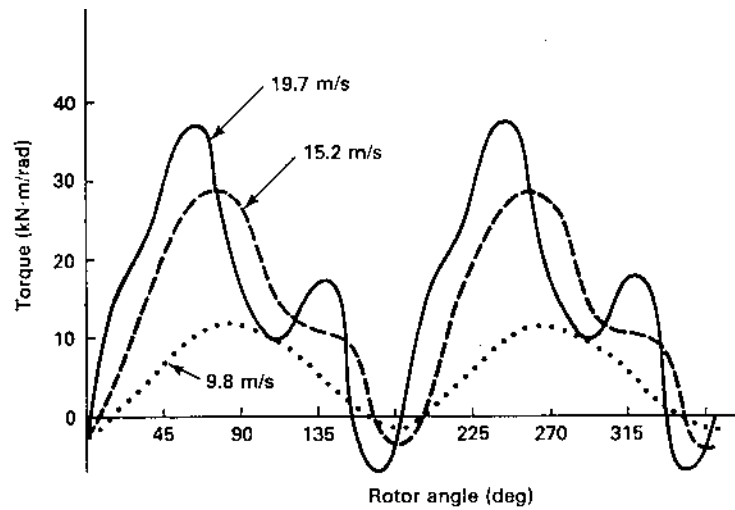

Figure 20: Aerodynamic torque variation for Sandia 17-m Darrieus at 50.6 r/min.

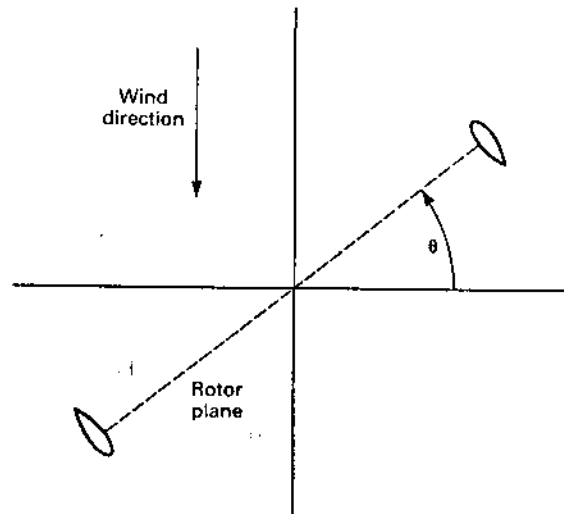

Figure 21: Definition of rotor angle for Sandia 17-m Darrieus.

elastic range. Permanent deformation occurs when a material exceeds its elastic range.

The shaft can be thought of as a spring with a *torsional spring constant* k_T where

$$k_T = \frac{T}{\theta} \quad (39)$$

The angle θ has to be expressed in radians, of course. A large value of k_T represents a

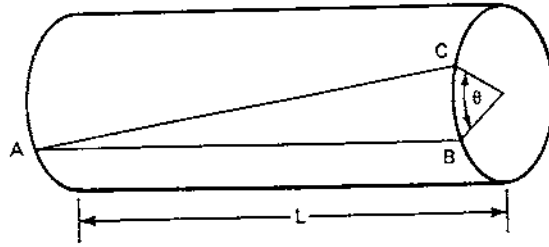

Figure 22: Shaft twisted under an applied torque.

stiff shaft, while a small value represents a soft or flexible shaft.

The torsional spring constant is also given by

$$k_T = \frac{JG}{L} \quad (40)$$

where J is the polar area moment of inertia, G is the *shear modulus*, and L is the length of the shaft. The shear modulus is the proportionality constant between a shear stress and the resulting deflection or *strain*. A typical value for the shear modulus for steel is 83 GPa (83×10^9 Pa).

A twisted shaft contains potential energy, just like a compressed spring. The amount of this potential energy is given by

$$U = \frac{k_T \theta^2}{2} \quad \text{J} \quad (41)$$

This potential energy has to be supplied to the shaft during system start-up and will be delivered back to the system during shut-down. Also, when a wind gust strikes the turbine, part of the extra power will go into shaft potential energy rather than instantly appearing in the electrical output. This stored energy will then go from the shaft into the electrical system during a wind lull. We see then that a shaft helps to smooth out the power fluctuations in the wind.

Example

Assume that the high speed shaft of a wind turbine has a torque of 1140 N·m/rad, an angular velocity of 188.5 rad/s, a diameter of 0.0473 m, and a shear modulus of 83 GPa. The length is 2 m. Find the rotation angle θ and the energy stored in the shaft.

From Eq. 37 the moment of inertia is

$$J = \frac{\pi(0.0473/2)^4}{2} = 4.914 \times 10^{-7} \text{ m}^4$$

From Eq. 40, the torsional spring constant is

$$k_T = \frac{(4.914 \times 10^{-7})(83 \times 10^9)}{2} = 20,400$$

From Eq. 39, the angle is

$$\theta = \frac{T}{k_T} = \frac{1140}{20,400} = 0.0559 \text{ rad} = 3.20^\circ$$

The potential energy is then given by

$$U = \frac{(20,400)(0.0559)^2}{2} = 31.9 \text{ J}$$

The amounts of twist and stored potential energy in this example are not large and will cause no problems in steady state operation. Operation is never quite steady state, however, because of variations in wind speed and direction, and the tower shadow experienced by each blade once per revolution. The shaft acts as a spring connecting two rotating masses (the blades on one end and the generator on the other end) and this system can oscillate in a torsional mode. If the oscillation frequency happens to be the same as that of the pulse from the tower shadow, the system will oscillate with ever increasing amplitude until the shaft breaks or some protective circuit shuts the turbine down. This means that a shaft which is conservatively designed for steady state operation may fail catastrophically as soon as it is placed in operation. We therefore need to know the frequency of oscillation to make sure this does not happen.

A simple model for a torsional oscillator[5] is shown in Fig. 23. One end of the shaft is attached to a rigid support and the other end is attached to a disk with a mass moment of inertia I . If the disk is displaced through an angle θ , a restoring torque T is exerted on the disk by the shaft, of magnitude $T = k_T\theta$. If the disk is released, the restoring torque T results in angular acceleration of the disk, which causes rotation of the disk back toward the equilibrium position. In this process, the potential energy stored in the shaft is transformed to rotational kinetic energy of the disk. As the disk reaches its equilibrium position, the kinetic energy acquired causes the disk to overshoot the equilibrium position, and the process of energy transformation reverses, creating oscillations of the disk.

The basic equation relating torque to angular acceleration α for this simple torsional oscillator is

$$-k_T\theta = I\alpha \quad (42)$$

The minus sign is necessary because the restoring torque is opposite to the angular displacement. We can now replace α by $d^2\theta/dt^2$ to get the second order differential equation

$$\frac{d^2\theta}{dt^2} + \left(\frac{k_T}{I}\right)\theta = 0 \quad (43)$$

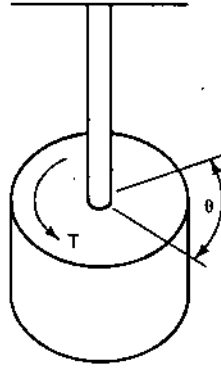

Figure 23: Simple torsional oscillator.

The solution to this equation is

$$\theta(t) = A \sin \omega t + B \cos \omega t \quad (44)$$

where A and B are constants to be determined from the initial conditions. The radian frequency of oscillation is given by

$$\omega = \sqrt{\frac{k_T}{I}} \quad \text{rad/s} \quad (45)$$

We see that the frequency of oscillation is directly proportional to the torsional spring constant and inversely proportional to the inertia of the disk. If the shaft is rotating rather than fixed, then ω of Eq. 45 is the frequency of oscillation about the mean shaft speed.

Example

The turbine in the previous example suddenly loses the interconnection to the electrical grid, thus allowing the high speed shaft to unwind. The inertia of the generator is $10.8 \text{ kg}\cdot\text{m}^2$, which is so much smaller than the inertia of the turbine blades and gearbox that the generator acts like a torsional oscillator with the other end of the high speed shaft fixed. Find an expression for θ as a function of time.

From the previous example we can take $\theta(0+) = 0.0559 \text{ rad}$. The relative angular velocity $d\theta/dt$ can not change instantaneously, so

$$\frac{d\theta(0+)}{dt} = \frac{d\theta(0-)}{dt} = 0.$$

We can then insert these two initial conditions into Eq. 44 and evaluate the constants.

$$\theta(0+) = 0.0559 = A \sin 0 + B \cos 0$$

$$\frac{d\theta(0+)}{dt} = 0 = A\omega \cos 0 + B\omega(-\sin 0)$$

From these two equations we observe that $B = 0.0559$ and $A = 0$.

The relative angular velocity about the mean angular velocity is given by Eq. 45.

$$\omega = \sqrt{\frac{20,400}{10.8}} = 43.46 \text{ rad/s}$$

The expression for θ is then

$$\theta = 0.0559 \cos 43.46t \text{ rad}$$

The generator will oscillate with respect to the gearbox at the rate of 43.46 rad/s or 6.92 Hz. The amplitude is not large but the torque reversal twice per cycle would probably produce audible noise.

An actual wind turbine drive train is quite complicated[7]. The rotor itself is not a perfect rigid body, but is able to flex back and forth in the plane of rotation. The rotor can therefore be modeled as a stiff shaft supplying power to the rotor hub. We have the various inertias of the rotor blades, hub, gearbox, generator, and shafts. There is *damping* caused by the wind, the oil in the gearbox, and various nonlinear elements. This damping causes any oscillations to die out if they are not being continually reinforced. A reasonably complete model[7] may have six inertial masses separated by five shafts and described by five second order differential equations. These equations are all coupled so the solution process requires a computer program. The full solution contains a number of oscillation frequencies, some of which may be heavily damped and others rather lightly damped. If the system is pulsed at the lightly damped oscillation frequencies, serious damage can occur.

The most important source of a pulsation in the driving function is that of the rotor blades passing by the tower each revolution. If we had only one blade on the rotor, we would have one pulse per revolution. If the rotor were spinning at 40 r/min, the pulsation frequency seen by the shaft would be 40 pulses per minute, or 40/60 pulses per second, 0.667 Hz. A rotor with two perfectly identical blades will have the lowest pulsation frequency equal to two pulses per revolution, or 1.33 Hz for a 40 r/min rotor. In practice, the two blades are not identical, so both 0.667 and 1.33 Hz would be available to drive oscillations near those frequencies. These driving frequencies are normally referred to as 1P and 2P. Oscillation frequencies near a multiple of the driving frequencies can also be excited, especially 4P, 6P, 8P, and so on.

Example

The original low speed steel shaft for the MOD-0 wind turbine had a torsional spring constant $k_T = 2.4 \times 10^6$ N·m/rad. The inertia of the rotor and hub is 130,000 kg·m². What is the frequency of oscillation, assuming the generator connected to the electrical grid causes a high effective inertia at the gearbox end of the low speed shaft, so the torsional oscillator model applies?

From Eq. 45 we find

$$\omega = \sqrt{\frac{2.4 \times 10^6}{130,000}} = 4.297 \text{ rad/s}$$

The frequency is then

$$f = \frac{\omega}{2\pi} = 0.684 \text{ Hz}$$

Reducing the actual system to a single inertia and a single torsional spring is a rather extreme approximation, so any results need to be viewed with caution. The actual system will have many modes of oscillation which can be determined by a computer analysis, only one of which can be found by this approximation.

The oscillation frequency found in the above example would appear to be rather close to the pulsation frequency of 0.667 Hz. In fact, when the MOD-0 was first put into service, oscillations at this frequency were rather severe. It was discovered that the two blades were pitched differently by 1.7 degrees. Even with this asymmetry corrected, turbulent winds would still cause oscillations. It was therefore decided to consider two other shaft combinations. One of these was an elastomeric shaft on the high speed side of the gearbox with a torsion spring constant of about 3000 N·m/rad. The other was a fluid coupling set to slip 2.3 percent when the transmitted power is 100 kW. The fluid coupling dissipates 2.3 percent of the power delivered to it, but adds sufficient damping to prevent most drive train oscillations that would otherwise be present. It was determined that both modifications would reduce the oscillations to acceptable levels.

This type of problem is typical with new pieces of equipment. We have excellent hindsight but our foresight is not as good. The only way we can be positive we have correctly considered all the vibration modes is to build a turbine and test it. This was one of the advantages of the MOD-0, in that it served as a test bed which permitted a number of such problems to be discovered and corrected.

8 STARTING A DARRIEUS TURBINE

A Darrieus wind turbine is not normally self starting, so some mechanism for starting must be used. This mechanism may be direct mechanical, hydraulic, or electrical, with electrical being preferred when utility power is available. As will be discussed in the next chapter, the induction machine will work as a motor for starting purposes, and then automatically change role and become a generator as the Darrieus accelerates. This is a convenient and economical method of starting the turbine.

Starting a high inertia load such as a large Darrieus turbine requires careful design to assure that adequate but not excessive torque is available for a sufficient time to start the turbine without damaging the electrical equipment. This design requires that we know the acceptable turbine acceleration and the required energy to get the turbine to its operating speed.

A rotating mass with a moment of inertia I has a stored energy

$$U = \frac{I\omega^2}{2} \quad \text{J} \quad (46)$$

where ω is the angular velocity in rad/s and I has units kg·m². The motor must supply this amount of energy to the rotor without exceeding the rated torque of the drive train.

The acceleration of the rotor when a torque T is applied is

$$\alpha = \frac{T}{I} \quad \text{rad/s}^2 \quad (47)$$

The time t_s required for starting the turbine and accelerating it to rated angular velocity ω_R with rated torque T_R would be

$$t_s = \frac{\omega_R}{\alpha} = \frac{\omega_R I}{T_R} \quad \text{s} \quad (48)$$

Example

A point design[4] for a 120-kW Darrieus has a moment of inertia $I = 51,800$ kg·m² and rated torque of 23,900 N·m/rad. Rated rotor speed is 52 r/min. How much time is required to accelerate the rotor to rated speed, assuming rated torque is applied and that there is no help from the wind?

From Eq. 48, the time required is

$$t_s = \frac{\omega_R I}{T_R} = \frac{2\pi(52/60)(51,800)}{23,900} = 11.8 \text{ s}$$

If the turbine geometry, tip speed ratio, and mass of the blades per unit length are all fixed, then the inertia and the rated torque increase in direct proportion to each other as the turbine size is increased. When these conditions hold, the starting time is the same for a larger turbine as it is for a smaller one. Actually, the blade mass per unit length increases with turbine size, so larger turbines take somewhat longer to start than smaller ones. A 1600-kW Darrieus point design[4] would take 18 seconds to start, as compared with 11.8 s for a 120-kW system that we saw in the previous example.

These starting times are quite long when compared with normal motor starting times, and it is not desirable to start such heavy loads with a directly coupled induction motor. The preferred design is to start the motor while unloaded and then start the Darrieus with a

controlled torque clutch, as shown in Fig. 24. The motor can deliver rated torque at its rated speed and current during any required starting time with no hazard to the motor.

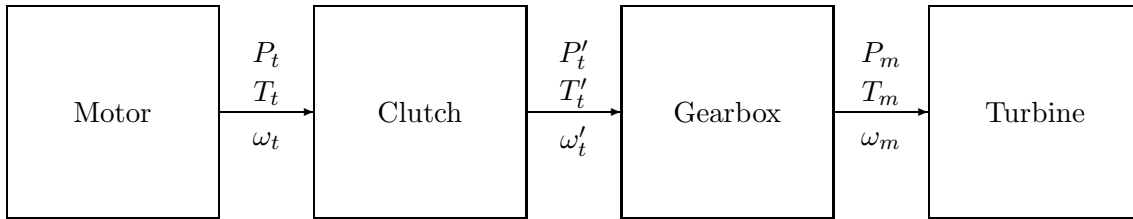

Figure 24: Electric motor and clutch for starting a Darrieus turbine.

The clutch normally is operated with the output torque T'_t equal to the input torque T_t . When the clutch is first engaged, the output angular velocity ω'_t will be zero while the input angular velocity is the rated angular velocity of the motor.

A constant torque applied to the turbine will result in a constant acceleration, as seen from Eq. 48. Since the acceleration is $\alpha = d\omega/dt$, we can determine that the angular velocity of the turbine must increase linearly with time until the turbine reaches its rated angular velocity ω_{mR} . This is shown in Fig. 25.

The power input to the turbine, $P_m = T_m\omega_m$, will also increase linearly with time. The clutch power output P'_t will increase in the same fashion if the gearbox is lossless or if the losses increase linearly with speed. For the purposes of determining clutch sizes, an assumption of a lossless gearbox is usually acceptable. The clutch would normally be placed on the high speed side of the gearbox to minimize the torque which it must transmit.

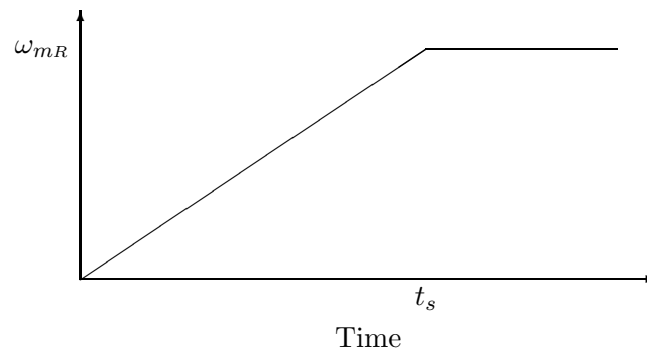

Figure 25: Angular velocity of a turbine with constant torque applied during start.

The energy supplied to the turbine during start is the integral of power, $T\omega$, through time.

$$U = \int_0^{t_s} T_m \omega_m dt = \int_0^{t_s} T_m \omega_{mR} \frac{t}{t_s} dt = \frac{T_m \omega_m t_s}{2} \quad (49)$$

The power input to the clutch is a constant, $P_t = P_{mR} = T_m \omega_{mR}$, during start, so the total energy delivered to the clutch during start is $T_m \omega_{mR} t_s$, or twice the energy delivered to the turbine. This means that the clutch must absorb the same amount of energy during start as the final rotational energy of the turbine. It must do this without mechanical damage due to overheating, hence must be properly sized. Overheating may result in a lowered clutch friction as well as mechanical damage, so the allowable temperature rise in a clutch may be restricted to a rather moderate amount, like 100°C , to assure proper operation.

The temperature rise in the clutch is inversely proportional to the *specific heat capacity* c_p of the clutch plate material. This is the amount of energy required to raise the temperature of 1 kg of material 1°C . A typical value for the c_p of steel is $527 \text{ J/kg}\cdot^\circ\text{C}$. The required mass of a given clutch is then given by

$$m = \frac{U}{c_p \Delta T} \quad \text{kg} \quad (50)$$

where U is the energy the clutch must dissipate, c_p is the specific heat capacity of the clutch material, and ΔT is the allowable temperature increase.

Example

A steel clutch plate is to be used for starting the Darrieus in the previous example. The specific heat capacity is $527 \text{ J/kg}\cdot^\circ\text{C}$ and the allowable temperature rise is 100°C . The density of steel is $\rho = 7800 \text{ kg/m}^3$. The clutch plate is to be circular with a thickness $L = 1 \text{ inch}$ (2.54 cm). What is the minimum radius of the plate?

The energy to be absorbed by the clutch is

$$U = \frac{I\omega^2}{2} = \frac{51,800[(2\pi)(52/60)]^2}{2} = 768,000 \text{ J}$$

The mass is

$$m = \frac{U}{c_p \Delta T} = \frac{768,000}{527(100)} = 14.57 \text{ kg}$$

The volume V is

$$V = \frac{m}{\rho} = \frac{14.57}{7800} = 1.868 \times 10^{-3} \text{ m}^3$$

The radius r_o is then given by

$$r_o = \sqrt{\frac{V}{\pi L}} = \sqrt{\frac{1.868 \times 10^{-3}}{\pi(0.0254)}} = 0.153 \text{ m}$$

This is obviously not excessively large. In fact, since the cost of such a clutch would be a very small fraction of the total turbine cost, it would normally be built larger than this minimum size to allow a greater safety factor and to permit more frequent starts. A larger clutch plate will not get as hot during start and will radiate this heat to the surroundings more rapidly because of a larger surface area.

A clutch guarantees a smooth start on power lines of any capacity with minimum voltage fluctuations and power flow transients. This allows considerable flexibility in the location of the turbine as far as power line availability is concerned.

Each size of turbine needs careful study to determine the most economical and reliable starting technique. In one study of several point designs¹⁰, Darrieus turbines of 10- and 30-kW ratings were found to have sufficiently low inertias that it would be quite practical to start these turbines without a clutch and with full voltage applied to the induction machine. Sizes of 120 kW or more were found to require a clutch, and sizes of 200 kW or more were found to require reduced voltage starting (discussed in the next chapter) for the induction machine even with the clutch disengaged. Once the motor is running at rated speed and rated voltage, the clutch is engaged and the turbine is started.

We see that starting a Darrieus turbine requires careful design of the starting system. Smaller turbines can be started easily, but larger machines require a clutch and perhaps reduced voltage starting for the motor.

9 TURBINE SHAFT POWER AND TORQUE AT VARIABLE SPEEDS

Most wind turbines operate at fixed rotational speeds except when starting and stopping. This simplifies system operation when using synchronous generators paralleled with the utility grid. It also helps to prevent the turbine from being operated at a speed which will excite a mechanical resonance that might destroy the turbine. However, fixed speed operation means that the maximum coefficient of performance C_{pm} is available only at one particular wind speed. A lower coefficient of performance is observed for all other wind speeds, which reduces the energy output below that which might be expected from variable speed operation. That is, if the turbine speed could be adjusted in relation to the wind speed, a higher average coefficient of performance and a higher average power output could be realized. Variable pitch operation at a fixed speed also helps improve the average coefficient of performance, but this is not feasible for turbines such as the Darrieus. Variable pitch operation also increases complexity and cost, hence may not be the most economical solution for all applications. It is therefore interesting to explore variable speed turbine operation. We shall now examine the variation of shaft power and torque with turbine angular velocity, leaving the discussion of specific methods of generating synchronous power from variable speed turbines to Chapter 6.

We shall proceed by examining the variation of P_m as a function of ω_m , with the wind speed

u as a parameter. We shall use the Sandia 17-m Darrieus turbine for discussion purposes. The shaft power P_m for this turbine as a function of shaft rotational speed n is shown in Fig. 26. P_m is seen to rise to a maximum for each wind speed for a particular value of rotational speed. Higher wind speeds have more power in the wind, and the change in tip speed ratio with increasing wind speed causes the maximum to shift to a higher rotational speed. Maximum power is reached at 38 r/min in a 6 m/s wind and at 76 r/min in a 12 m/s wind. The maximum possible shaft power in a 12 m/s wind is eight times that in a 6 m/s wind, as would be expected from the cubic variation of power with wind speed.

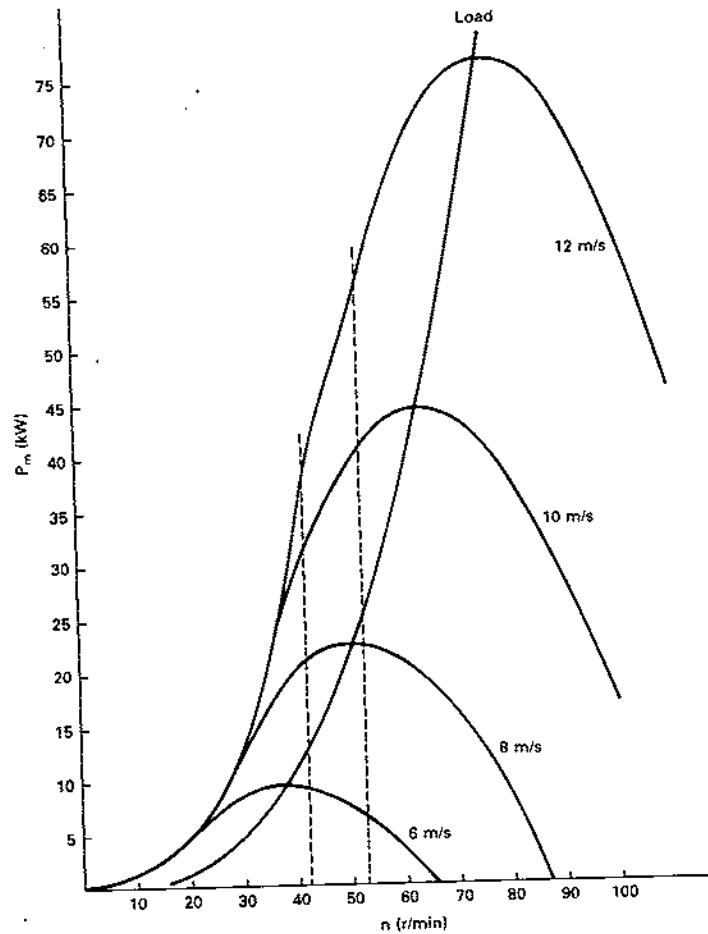

Figure 26: Shaft power output of Sandia 17-m Darrieus in variable-speed operation.

Also shown in Fig. 26 are two vertical dashed lines at 42 and 52.5 r/min. We see that at 42 r/min we are close to the maximum shaft power for $u = 6$ m/s but are below the maximum for higher wind speeds. In fact, no additional shaft power can be obtained for winds above about 12 m/s because curves for higher wind speeds all follow the same line at this rotational speed. At 52.5 r/min we are close to the maximum shaft power at $u = 8$ m/s, and are able to

extract significantly more power from the wind for wind speeds above 8 m/s than was possible at 42 r/min. It would appear that if fixed speed operation is required, that 52.5 r/min is a good choice for sites with a high percentage of winds between 6 and 10 m/s since the turbine can deliver nearly the maximum possible shaft power over this wind speed range. A higher fixed shaft speed would be justified only if there were a significant fraction of wind speeds above 10 m/s. Increasing the shaft speed above 52.5 r/min would decrease the power output for wind speeds below 8 m/s, and this would be a significant penalty at many sites.

Suppose now that the load can accept shaft power according to the curve marked *Load* in Fig. 26 and that the turbine is free to operate at any speed. The turbine will then operate at maximum power for any wind speed, so the energy output will be maximized. If this maximum energy output can be obtained without increasing losses or costs, then we have developed a system which extracts more energy from the wind at a lower cost per unit of energy.

Variable speed operation requires a load which has a suitable curve of power input versus rotational speed. The optimum load will have a cubic variation of input power versus rotational speed. In examining various types of loads, we notice that the input power to pumps and fans often has a cubic variation with rotational speed. The power input to an electrical generator connected to a fixed resistance will vary as the square of the rotational speed. The power input to a generator used to charge batteries will vary even more rapidly than cubic, as we shall see in Chapter 6. Load curves like the one shown in Fig. 26 are therefore quite possible, so variable speed operation is possible with several applications.

In addition to the variation of shaft power with rotational speed, we must also examine the variation of torque with rotational speed. If we take the shaft power curves in Fig. 26 and divide by the angular velocity at each point, we obtain the torque curves shown in Fig. 27. One important feature of these curves is that the torque is zero for $n = 0$, which means that the Darrieus turbine can not be expected to start without help. The friction in the transmission and generator produces an opposing torque, and the torque T_m must exceed this opposing or *tare* torque before the turbine can be accelerated by the power in the wind. The turbine must be accelerated to some minimum rotational speed by an external power source so that T_m will reach a sufficient value to accelerate the turbine up to operating speed. This particular machine would need to be accelerated up to perhaps 10 r/min before the wind would be able to accelerate it to higher speeds.

This external power source is required for reliable starting of any Darrieus turbine. However, there have been cases where a combination of very low tare torques and strong, gusty winds allowed a Darrieus turbine to start on its own, sometimes with disastrous consequences. A Darrieus turbine should have a brake engaged when repairs are being made or at other times when rotation is not desirable.

The torque rises to a maximum at a particular rotational speed for each wind speed, in the same manner as the shaft power. The peak torque is reached at a lower rotational speed than the peak shaft power, as can be seen by a careful comparison of Figs. 26 and 27. From Eq. 35 and the fact that maximum shaft power varies as the cube of the rotational speed,

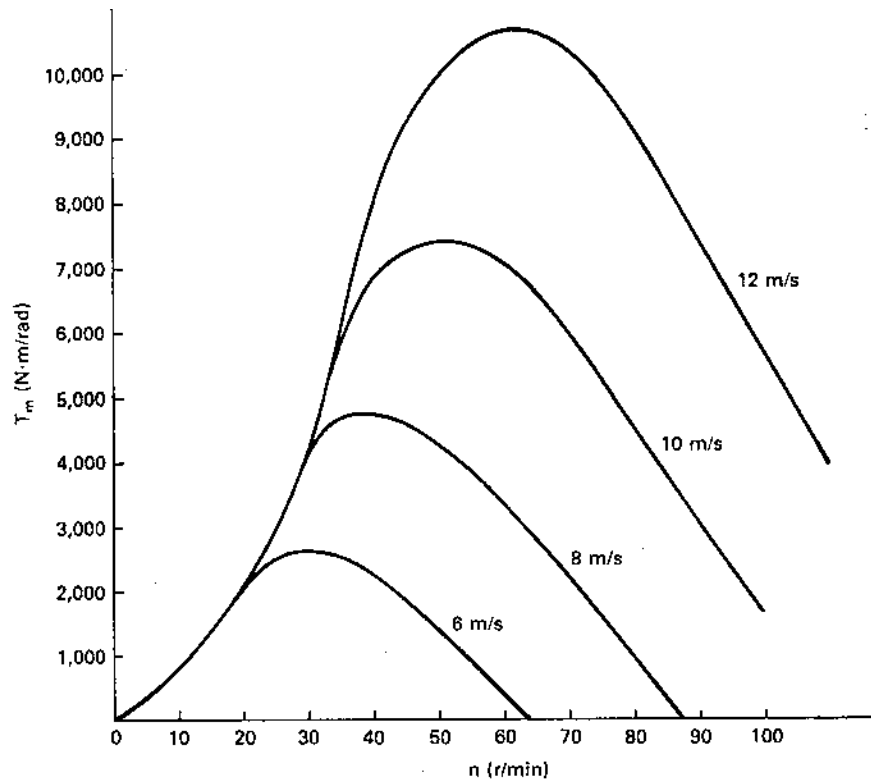

Figure 27: Shaft torque output of Sandia 17-m Darrieus in variable-speed operation.

we can argue that the maximum shaft torque varies as the square of the rotational speed. In Fig. 27, for example, the peak torque in a 12 m/s wind is 10,600 N·m/rad at 60 r/min. The peak torque in a 6 m/s wind is 2650 N·m/rad at 30 r/min. The peak torque has changed by a factor of four while the rotational speed has changed by a factor of two.

The turbine torque T_m must be opposed by an equal and opposite load torque T_L for the turbine to operate at a steady rotational speed. If T_m is greater than T_L , the turbine will accelerate, while if T_m is less than T_L the turbine will decelerate. The mathematical relationship describing this is

$$T_m = T_L + I \frac{d\omega_m}{dt} \quad \text{N} \cdot \text{m/rad} \quad (51)$$

where I is the moment of inertia of the turbine, transmission, and generator, all referred to the turbine shaft.

The relationship between shaft torque and an optimum load torque for the Sandia 17-m Darrieus turbine is illustrated in Fig. 28. We have assumed a load torque with the optimum variation

$$T_L = Kn^2 \quad \text{N} \cdot \text{m}/\text{rad} \quad (52)$$

The constant K is selected so the load torque curve passes through the peaks of the curves for turbine torque at each wind speed.

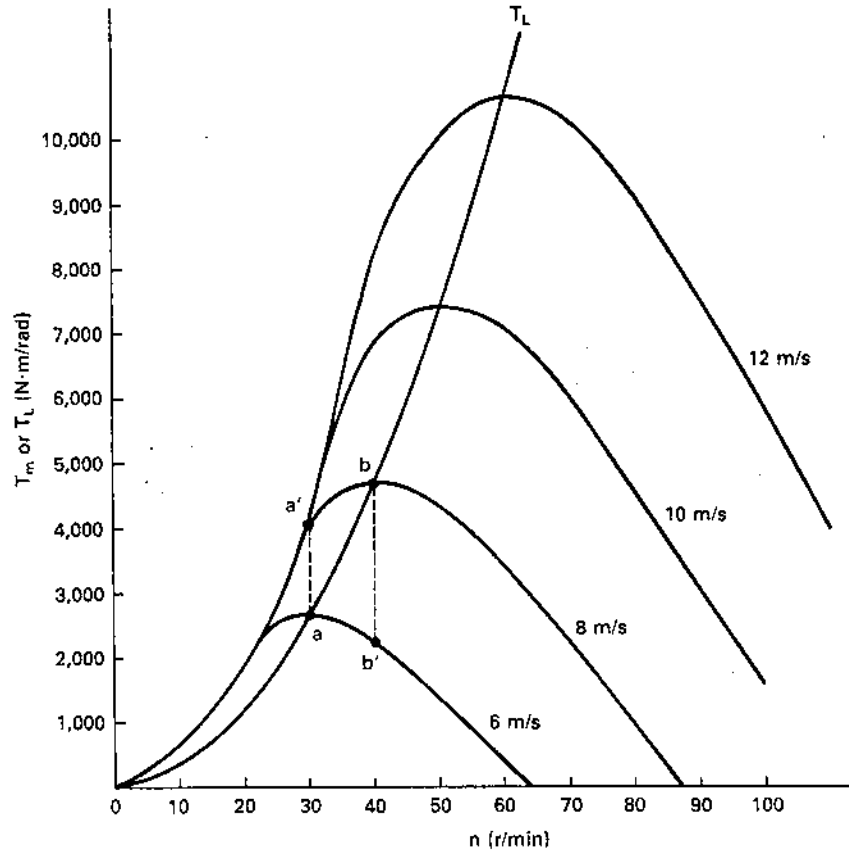

Figure 28: Load with square-law torque variation connected to Sandia 17-m turbine.

In order for the turbine to operate at steady state or at a constant speed, the $d\omega_m/dt$ term of Eq. 51 must be zero, and the load torque must be equal to the shaft torque. Suppose that we have a steady wind of 6 m/s and that the shaft torque and load torque have reached equilibrium at point a in Fig. 28. Now suppose that the wind speed suddenly increases to 8 m/s and remains constant at that speed. The shaft torque T_m increases to the value at a' before the rotational speed has time to change. The load is still requiring the torque at point a . Since the shaft torque is larger than the load torque, the turbine rotational speed will increase until point b is reached, at which time the two torques are equal and steady state has again been reached.

If the turbine is operating at point b and the wind speed suddenly decreases to 6 m/s,

the turbine torque will drop to the value at b' . Since the turbine torque is less than the load torque at this point, the turbine will slow down until the turbine and load torques are again equal at point a .

The constant K of Eq. 52 must be carefully selected for the variable speed system to operate properly. Figure 29 shows the optimum load torque curve for the Sandia 17-m turbine and also shows torque curves for two other loads where the load torque at a given speed has been either doubled or halved. A problem is immediately evident for the load curve described by $2Kn^2$ in that the load torque exceeds the turbine torque above a rotational speed of about 16 r/min. The turbine will not accelerate past this point and the system will be characterized by a rather steady but very low output. A load, such as a pump, with this torque curve would have to be replaced with a load with a smaller rating. Load torque specifications, as well as turbine specifications, are often not precisely known and would be expected to vary slightly between two apparently identical systems, so an adequate margin of safety needs to be applied when selecting load sizes. It is better to slightly undersize a load than to get it so large that the turbine cannot accelerate to rated speed.

The load specified as $Kn^2/2$ requires torques that are just slightly down the turbine torque curve from the maximum torques. The total energy production may be only 10 or 15 percent less for this load than that for the optimum load. This reduction from the optimum output may be acceptable in many applications, except for one major difficulty. The turbine rotational speed in a 12 m/s wind is 80 r/min for the smaller load and 60 r/min for the optimum load. This greater speed may exceed the turbine speed rating and cause some speed limiting system to be activated. We therefore need to have a load with a torque curve that falls between rather narrow limits, perhaps within ten or twenty percent of the optimum torque curve. We shall examine torque curves of specific loads in greater detail later in the text.

Turbines that are self-starting must have greater wind produced torques at low rotational speeds than the Darrieus turbine. The torque at low rotational speeds will be proportional to the *solidity* of the turbine, which is basically the fraction of the projected swept area that is actually covered by the rotor blades. The Savonius turbine would have a solidity of 1.0, for example, with the American Multiblade turbine approaching that value. Two-bladed horizontal axis turbines may have solidities closer to 0.1 at the other extreme. The variation of torque with rotational speed for a low solidity, 10 m diameter, two bladed propeller is given in Fig. 30. It may be noticed that the torque is greater than zero at zero rotational speed, so the machine will start by itself. Once the machine is started, the torque curve looks much like the torque curve for the Darrieus in that the torque increases with increasing rotational speed until a peak torque is reached. The torque decreases rapidly past the peak until it reaches zero at the run away or free wheeling rotational speed.

A high solidity machine may have its maximum torque at zero speed. This is the case for the torque of the Savonius turbine shown in Fig. 31. This is the experimental torque curve for the machine shown in Fig. 1.4. The high torque at low speeds may be essential for some applications: for example, starting a larger Darrieus or operating a positive displacement pump.

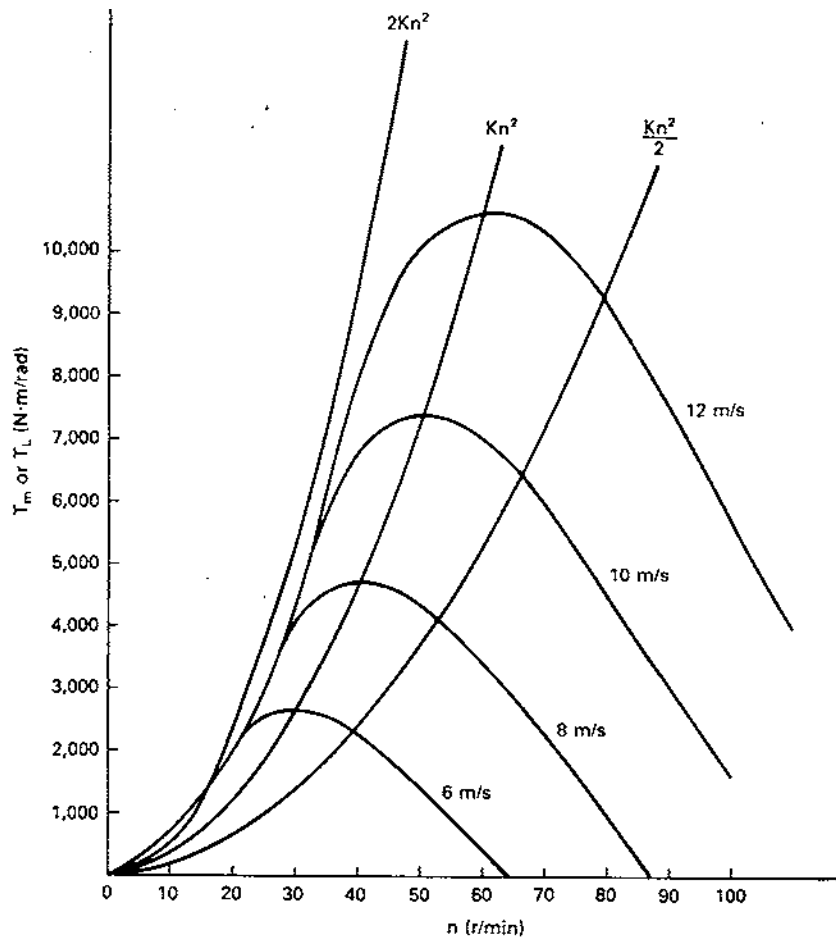

Figure 29: Three loads attached to Sandia 17-m turbine.

We have shown that variable speed turbine operation is technically possible. There is a possibility of simplified construction and lower costs and also a possibility of greater energy production from a given rotor. Fixed speed systems will probably dominate where induction or synchronous generators are used to supply power to a grid, but variable speed systems may find a role in stand alone situations as well as those situations where mechanical power is needed rather than electrical power.

10 PROBLEMS

1. A large turbine is rated at 2500 kW at standard conditions (0° and 101.3 kPa). What would be its rated power at the same rated wind speed if the temperature were 20°C and the turbine was located at 1500 m above sea level? Use the U. S. Standard Atmosphere

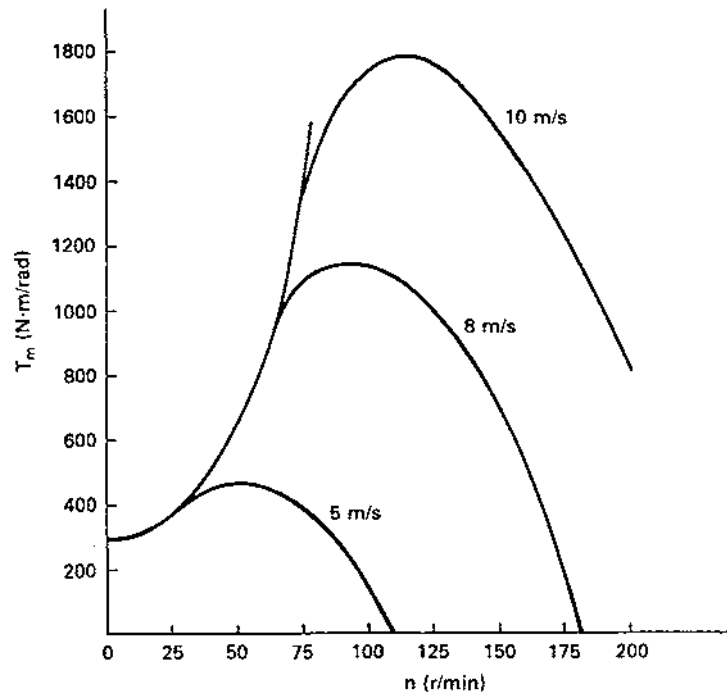

Figure 30: Torque versus rotational speed for low-solidity 10-m-diameter two-bladed propeller.

model discussed in Chapter 2 to find the average pressure.

2. An anemometer mounted on the nacelle of an operating downwind propeller type turbine measures an average wind speed of 10 m/s. Estimate the undisturbed wind speed, assuming this anemometer measures the same wind speed as seen by the propeller.
3. The Sandia 17-m turbine has a diameter of 16.7 m, an area of 187 m^2 , and is spinning at 42 r/min. The ambient temperature is 15°C and the pressure is 83 kPa. For each of the wind speeds 5, 7, 12, and 16 m/s,
 - (a) Find the tip speed ratio.
 - (b) Find the coefficient of performance from Fig. 9.
 - (c) Find the predicted mechanical power output. Compare these values with those given on Fig. 10.
4. An electric utility decides to add 50 MW of wind generation to its system. If the individual units are to be rated at 2 MW in a 13-m/s wind at standard conditions and have efficiencies $C_{pR} = 0.32$, $\eta_{mR} = 0.94$, and $\eta_{gR} = 0.96$, what is the required swept area A of each rotor? What is the rotor diameter, if the rotor is a two bladed horizontal axis propeller?

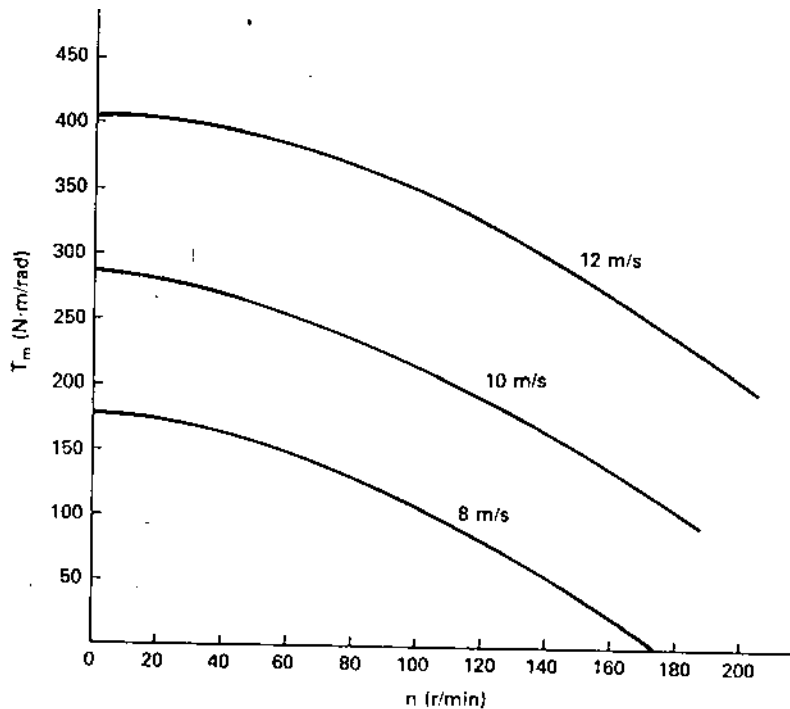

Figure 31: Torque versus rotational speed for Savonius turbine: radius 0.88 m; area 22 m².

5. The MOD-2 wind turbine is rated at 2500 kW at standard conditions in a 12.3 m/s wind speed. Assume a three stage gearbox with rated efficiency of 0.94 and a generator with rated efficiency 0.95, and estimate the output power in a 8 m/s wind speed. Include the effects of lowered efficiency due to lowered power transfer.
6. The NASA-DOE MOD-0 has a rated electrical output of 100 kW, a cut-in wind speed of 3.5 m/s, a rated wind speed of 8 m/s, a rotor diameter of 37.5 m, a fixed rotor rotational speed of 40 r/min, and a generator rotational speed of 1800 r/min.
 - (a) What is the tip speed ratio at rated wind speed?
 - (b) What is the tip speed ratio at cut-in?
 - (c) What is the overall efficiency of the turbine, drive train, and generator if $P_e = 100$ kW when the wind speed is 8 m/s? Assume standard conditions.
7. A MOD-2 wind turbine is delivering a mechanical power $P_m = 2000$ kW at 17.5 r/min to a gearbox with an output speed of 1800 r/min. The gearbox is 92 percent efficient at this power level.
 - (a) What is the average torque in the low speed shaft?

- (b) What is the average torque in the high speed shaft?
8. Assume that a wind turbine rated at 100 kW can be adequately modeled by the model turbine of Fig. 16, a rated wind speed of 7.7 m/s, a cut-in speed of 4.3 m/s, and a furling speed of 17.9 m/s. Determine the capacity factor and the monthly energy production in kWh (in a 30 day month) for sites where:
- (a) $c = 5.0$ and $k = 1.6$
 - (b) $c = 6.5$ and $k = 2.0$
 - (c) $c = 8.0$ and $k = 2.4$
9. A Sandia 17-m Darrieus is located at a site with wind characteristics $c = 7$ m/s and $k = 2.6$. Which configuration produces more energy each year, the 42 r/min machine rated at 25 kW in an 11 m/s wind speed, or the 52.5 r/min machine rated at 60 kW in a 15.5 m/s wind speed? Assume $u_c = 5$ m/s and 6.5 m/s respectively and that the furling speed is 20 m/s.
10. You are designing a wind turbine for which the cut-in wind speed is one-half the rated wind speed. What is the rated wind speed for which yearly energy production is maximized for
- (a) $c = 6$ m/s and $k = 1.4$
 - (b) $c = 6$ m/s and $k = 2.0$
 - (c) $c = 8$ m/s and $k = 2.6$
11. You are designing the low speed shaft for a horizontal axis turbine which has to transmit 50 kW of mechanical power at a rotational speed of 95 r/min. Solid steel shafts are available in half-inch increments starting at 2 inches outside diameter. The recommended maximum stress is 55 MPa. What size shaft should you specify?
12. An elastomeric shaft 2 m in length is used to deliver 100 kW of mechanical power to a generator at 1800 r/min. The shaft diameter is 0.05 m and the shear modulus G is 0.9 GPa.
- (a) What is the total twist θ in the shaft?
 - (b) What is the total energy stored in the shaft?
13. The generator of the previous problem is receiving 100 kW of mechanical power when it suddenly loses electrical load at time $t = 0$. The inertia I of the generator can be assumed to be $3.6 \text{ kg}\cdot\text{m}^2$.
- (a) Find an expression for θ as a function of time.
 - (b) How long does it take for θ to change $\pi/2$ radians?

- (c) A four pole synchronous generator changes the output electrical phase by π radians or 180° when the input mechanical position is changed by $\pi/2$ radians 90° . Is there any problem in reconnecting the generator to the electrical grid when it is in this position?
14. The Sandia 17-m Darrieus is to be operated at 52.5 r/min with the low speed shaft delivering an average power of 65 kW mechanical in winds of 15 m/s or more. The shaft is to be of solid steel with a recommended maximum stress of 55 MPa.
- (a) What approximate size of shaft is needed to transmit the average torque?
- (b) What approximate size shaft is needed to accept the peak torque at wind speeds up to about 20 m/s? You can estimate the peak torque from Fig. 20.
15. A wind turbine is being operated in a variable speed mode with an optimum load. If the wind speed doubles, what is the change in
- (a) output power?
- (b) torque?
- (c) rotor speed?
16. A Darrieus turbine produces a low-speed-shaft power of 531 kW at the rated speed of 30.8 r/min. It is started by applying rated torque of 164,500 N·m/rad for 13 seconds.
- (a) What is the moment of inertia?
- (b) If a constant torque clutch is used, how much energy does the clutch absorb during the start cycle?
- (c) If the steel used in the clutch plate has a specific heat capacity of 527 J/kg·°C and the average temperature rise in the plate can be no more than 100°C, what is the minimum mass of steel required in the plate?
17. A Darrieus turbine produces a low speed shaft power of 1650 kW at the rated speed of 22.1 r/min in a 14.3 m/s wind speed.
- (a) Determine rated rotor torque from the values given for measured power and rated rotor speed.
- (b) If the rotor is started at this rated torque in 18 seconds, determine the rotor inertia.
- (c) If a constant torque clutch is used, how much energy is absorbed during the start cycle?
- (d) If the generator is rated at 1800 r/min, what is the input torque to the generator, assuming no losses in the gearbox?

References

- [1] Boeing Engineering and Construction: *MOD-2 Wind Turbine System Concept and Preliminary Design Report, Vol. II, Detailed Report*, DOE/NASA 0002-80/2, NASA CR-159609, July 1979.
- [2] Dwinnell, J. H.: *Principles of Aerodynamics*, McGraw- Hill, New York, 1949.
- [3] Eldridge, F. R.: *Wind Machines*, 2nd ed., Van Nostrand Reinhold, New York, 1980.
- [4] Grover, R. D. and E. G. Kadlec: *Economic Analysis of Darrieus Vertical Axis Wind Turbine Systems for the Generation of Utility Grid Electrical Power. Vol. III: Point Designs*, Sandia Laboratories Report SAND78-0962, August 1979.
- [5] Hutton, D. V.: *Applied Mechanical Vibrations*, McGraw- Hill, New York, 1981.
- [6] McNERNEY, G. M.: *Accelerometer Measurements of Aerodynamic Torque on the DOE/Sandia 17-m Vertical Axis Wind Turbine*, Sandia Laboratories Report SAND80-2776, April 1981.
- [7] Seidel, R. C., H. Gold, and L. M. Wenzel: *Power Train Analysis for the DOE/NASA 100-kW Wind Turbine Generator*, DOE/NASA/1028-78/19, NASA TM-78997, October 1978.
- [8] Linscott, B. S., J. T. Dennett, and L. H. Gordon: *The MOD-2 Wind Turbine Development Project*, DOE/NASA/20305-5, NASA TM-82681, July 1981.
- [9] Powell, W. R.: "An Analytical Expression for the Average Output Power of a Wind Machine," *Solar Energy*, Vol. 26, No. 1, 1981, pp. 77-80.
- [10] Worstell, M. H.: *Aerodynamic Performance of the 17- Metre-Diameter Darrieus Wind Turbine*, Sandia Laboratories Report SAND78-1737, January 1979.

WIND TURBINE CONNECTED TO THE ELECTRICAL NETWORK

He brings forth the wind from His storehouses. Psalms 135:7

Only a few hardy people in the United States live where 60 Hz utility power is not readily available. The rest of us have grown accustomed to this type of power. The utility supplies us reliable power when we need it, and also maintains the transmission and distribution lines and the other equipment necessary to supply us power. The economies of scale, diversity of loads, and other advantages make it most desirable for us to remain connected to the utility lines. The utility is expected to provide high quality electrical power, with the frequency at 60 Hz and the harmonics held to a low level. If the utility uses wind turbines for a part of its generation, the output power of these turbines must have the same high quality when it enters the utility lines. There are a number of methods of producing this synchronous power from a wind turbine and coupling it into the power network. Several of these will be considered in this chapter.

Many applications do not require such high quality electricity. Space heating, water heating, and many motor loads can be operated quite satisfactorily from dc or variable frequency ac. Such lower quality power may be produced with a less expensive wind turbine so that the unit cost of electrical energy may be lower. The features of such machines will be examined in the next chapter.

1 METHODS OF GENERATING SYNCHRONOUS POWER

There are a number of ways to get a constant frequency, constant voltage output from a wind electric system. Each has its advantages and disadvantages and each should be considered in the design stage of a new wind turbine system. Some methods can be eliminated quickly for economic reasons, but there may be several that would be competitive for a given application. The fact that one or two methods are most commonly used does not mean that the others are uncompetitive in all situations. We shall, therefore, look at several of the methods of producing a constant voltage, constant frequency electrical output from a wind turbine.

Eight methods of generating synchronous power are shown in Table 5.1. The table applies specifically to a two or three bladed horizontal axis propeller type turbine, and not all the methods would apply to other types of turbines[4]. In each case the output of the wind energy collection system is in parallel or in synchronism with the utility system. The ac or synchronous generator, commonly used on larger wind turbines, may be replaced with an induction generator in most cases. The features of both the ac and induction generators will

be considered later in this chapter.

Systems 1,2, and 3 are all constant speed systems, which differ only in pitch control and gearbox details. A variable pitch turbine is able to operate at a good coefficient of performance over a range of wind speeds when turbine angular velocity is fixed. This means that the average power density output will be higher for a variable pitch turbine than for a fixed pitch machine. The main problem is that a variable pitch turbine is more expensive than a fixed pitch turbine, so a careful study needs to be made to determine if the cost per unit of energy is lower with the more expensive system. The variable pitch turbine with a two speed gearbox is able to operate at a high coefficient of performance over an even wider range of wind speeds than system 1. Again, the average power density will be higher at the expense of a more expensive system.

TABLE 5.1 Eight methods of generating synchronous electrical power.

Rotor	Transmission	Generator
1. Variable pitch, constant speed	Fixed-ratio gear	ac generator
2. Variable pitch, constant speed	Two-speed-ratio gear	ac generator
3. Fixed pitch, constant speed	Fixed-ratio-gear	ac generator
4. Fixed pitch, variable speed	Fixed-ratio gear	dc generator/ dc motor/ac generator
5. Fixed pitch, variable speed	Fixed-ratio gear	ac generator/rectifier/ dc motor/ac generator
6. Fixed pitch, variable speed	Fixed-ratio gear	ac generator/rectifier/inverter
7. Fixed pitch, variable speed	Fixed-ratio gear	field-modulated generator
8. Fixed pitch,	Variable-ratio	ac generator

Systems 4 through 8 of Table 5.1 are all variable speed systems and accomplish fixed frequency output by one of five methods. In system 4, the turbine drives a dc generator which drives a dc motor at synchronous speed by adjusting the field current of the motor. The dc motor is mechanically coupled to an ac generator which supplies 60 Hz power to the line. The fixed pitch turbine can be operated at its maximum coefficient of performance over the entire wind speed range between cut-in and rated because of the variable turbine speed. The average power output of the turbine is high for relatively inexpensive fixed pitch blades.

The disadvantage of system 4 over system 3 is the requirement of two additional electrical machines, which increases the cost. A dc machine of a given power rating is larger and more complicated than an ac machine of the same rating, hence costs approximately twice as much. A dc machine also requires more maintenance because of the brushes and commutator. Wind turbines tend to be located in relatively hostile environments with blowing sand or salt

spray so any machine with such a potential weakness needs to be evaluated carefully before installation.

Efficiency and cost considerations make system 4 rather uncompetitive for turbine ratings below about 100 kW. Above the 100-kW rating, however, the two dc machines have reasonably good efficiency (about 0.92 each) and may add only ten or fifteen percent to the overall cost of the wind electric system. A careful analysis may show it to be quite competitive with the constant speed systems in the larger sizes.

System 5 is very similar to system 4 except that an ac generator and a three-phase rectifier is used to produce direct current. The ac generator-rectifier combination may be less expensive than the dc generator it replaces and may also be more reliable. This is very important on all equipment located on top of the tower because maintenance can be very difficult there. The dc motor and ac generator can be located at ground level in a more sheltered environment, so the single dc machine is not quite so critical.

System 6 converts the wind turbine output into direct current by an ac generator and a solid state rectifier. A dc generator could also be used. The direct current is then converted to 60 Hz alternating current by an inverter. Modern solid state inverters which became available in the mid 1970's allowed this system to be one of the first to supply synchronous power from the wind to the utility grid. The wind turbine generator typically used was an old dc system such as the Jacobs or Wincharger. Sophisticated inverters can supply 120 volt, 60 Hz electricity for a wide range of input dc voltages. The frequency of inverter operation is normally determined by the power line frequency, so when the power line is disconnected from the utility, the inverter does not operate. More expensive inverters capable of independent operation are also used in some applications.

System 7 uses a special electrical generator which delivers a fixed frequency output for variable shaft speed by modulating the field of the generator. One such machine of this type is the field modulated generator developed at Oklahoma State University[7]. The electronics necessary to accomplish this task are rather expensive, so this system is not necessarily less expensive than system 4, 5, or 6. The field modulated generator will be discussed in the next chapter.

System 8 produces 60 Hz electricity from a standard ac generator by using a variable speed transmission. Variable speed can be accomplished by a hydraulic pump driving a hydraulic motor, by a variable pulley vee-belt drive, or by other techniques. Both cost and efficiency tend to be problems on variable ratio transmissions.

Over the years, system 1 has been the preferred technique for large systems. The Smith-Putnam machine, rated at 1250 kW, was of this type. The NASA-DOE horizontal axis propeller machines are of this type, except for the MOD-5A, which is a type 2 machine. This system is reasonably simple and enjoys largely proven technology. Another modern exception to this trend of using system 1 machines is the 2000 kW machine built at Tvind, Denmark, and completed in 1978. It is basically a system 6 machine except that variable pitch is used above the rated wind speed to keep the maximum rotational speed at a safe value.

The list in Table 5.1 illustrates one difficulty in designing a wind electric system in that many options are available. Some components represent a very mature technology and well defined prices. Others are still in an early stage of development with poorly defined prices. It is conceivable that any of the eight systems could prove to be superior to the others with the right development effort. An open mind and a willingness to examine new alternatives is an important attribute here.

2 AC CIRCUITS

It is presumed that readers of this text have had at least one course in electrical theory, including the topics of electrical circuits and electrical machines. Experience has shown, however, that even students with excellent backgrounds need a review in the subject of ac circuits. Those with a good background can read quickly through this section, while those with a poorer background will hopefully find enough basic concepts to be able to cope with the remaining material in this chapter and the next.

Except for dc machines, the person involved with wind electric generators will almost always be dealing with sinusoidal voltages and currents. The frequency will usually be 60 Hz and operation will usually be in steady state rather than in a transient condition. The analysis of electrical circuits for voltages, currents, and powers in the steady state mode is very commonly required. In this analysis, time varying voltages and currents are typically represented by equivalent complex numbers, called phasors, which do not vary with time. This reduces the problem solving difficulty from that of solving differential equations to that of solving algebraic equations. Such solutions are easier to obtain, but we need to remember that they apply only in the steady state condition. Transients still need to be analyzed in terms of the circuit differential equation.

A complex number z is represented in *rectangular form* as

$$z = x + jy \quad (1)$$

where x is the real part of z , y is the imaginary part of z , and $j = \sqrt{-1}$. We do not normally give a complex number any special notation to distinguish it from a real number so the reader will have to decide from the context which it is. The complex number can be represented by a point on the complex plane, with x measured parallel to the real axis and y to the imaginary axis, as shown in Fig. 1.

The complex number can also be represented in *polar form* as

$$z = |z|\angle\theta \quad (2)$$

where the magnitude of z is

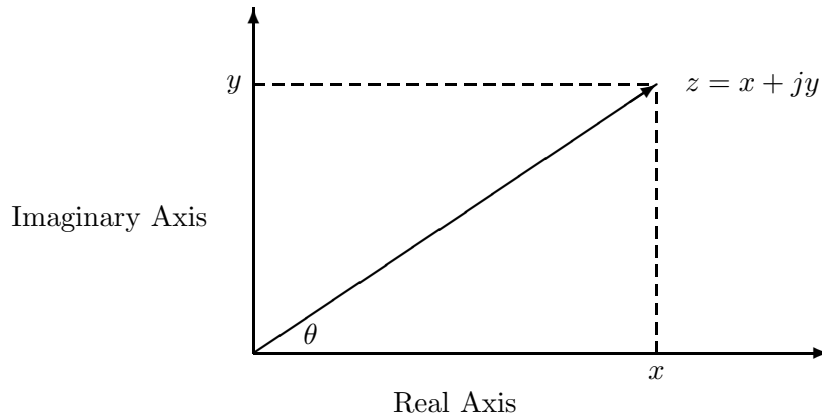

Figure 1: Complex number on the complex plane.

$$|z| = \sqrt{x^2 + y^2} \quad (3)$$

and the angle is

$$\theta = \tan^{-1} \frac{y}{x} \quad (4)$$

The angle is measured counterclockwise from the positive real axis, being 90° on the positive imaginary axis, 180° on the negative real axis, 270° on the negative imaginary axis, and so on. The arctan function covers only 180° so a sketch needs to be made of x and y in each case and 180° added to or subtracted from the value of θ determined in Eq. 4 as necessary to get the correct angle.

We might also note that a complex number located on a complex plane is different from a *vector* which shows direction in real space. Balloon flight in Chapter 3 was described by a vector, with no complex numbers involved. Impedance will be described by a complex number, with no direction in space involved. The distinction becomes important when a given quantity has both properties. It is shown in books on electromagnetic theory that a time varying electric field is a phasor-vector. That is, it has three vector components showing direction in space, with each component being written as a complex number. Fortunately, we will not need to examine any phasor-vectors in this text.

A number of hand calculators have the capability to go directly between Eqs. 1 and 2 by pushing only one or two buttons. These calculators will normally display the full 360° variation in θ directly, saving the need to make a sketch. Such a calculator will be an important asset in these two chapters. Calculations are much easier, and far fewer errors are made.

Addition and subtraction of complex numbers are performed in the rectangular form.

$$z_1 + z_2 = x_1 + jy_1 + x_2 + jy_2 = (x_1 + x_2) + j(y_1 + y_2) \quad (5)$$

Multiplication and division of complex numbers are performed in the polar form:

$$z_1 z_2 = |z_1| |z_2| / \underline{\theta_1 + \theta_2} \quad (6)$$

$$\frac{z_1}{z_2} = \frac{|z_1|}{|z_2|} / \underline{\theta_1 - \theta_2} \quad (7)$$

The impedance of the series RLC circuit shown in Fig. 2 is the complex number

$$Z = R + j\omega L - \frac{j}{\omega C} = |Z| \angle \theta \quad \Omega \quad (8)$$

where $\omega = 2\pi f$ is the angular frequency in rad/s, R is the resistance in ohms, L is the inductance in henrys, and C is the capacitance in farads.

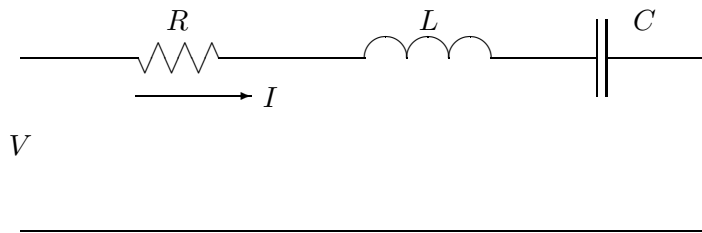

Figure 2: Series RLC circuit.

We define the reactances of the inductance and capacitance as

$$X_L = \omega L \quad \Omega \quad (9)$$

$$X_C = \frac{1}{\omega C} \quad \Omega \quad (10)$$

Reactances are always real numbers. The impedance of an inductor, $Z = jX_L$, is imaginary, but X_L itself (and X_C) is real and positive.

When a phasor root-mean-square voltage (rms) $V = |V| \angle \theta$ is applied to an impedance, the resulting phasor rms current is

$$I = \frac{V}{Z} = \frac{|V|}{|Z|} / \underline{-\theta} \quad \text{A} \quad (11)$$

Example

The RL circuit shown in Fig. 3 has $R = 6 \Omega$, $X_L = 8 \Omega$, and $V = 200\angle 0^\circ$. What is the current?

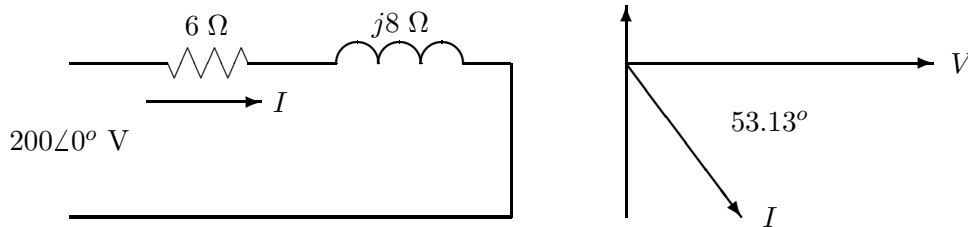

Figure 3: Series RL Circuit.

First we find the impedance Z .

$$Z = R + jX_L = 6 + j8 = 10\angle 53.13^\circ$$

The current is then

$$I = \frac{200\angle 0^\circ}{10\angle 53.13^\circ} = 20\angle -53.13^\circ$$

A sketch of V and I on the complex plane for this example is also shown in Fig. 3. This sketch is called a *phasor diagram*. The current in this inductive circuit is said to *lag* V . In a capacitive circuit the current will *lead* V . The words “lead” and “lag” always apply to the relationship of the current to the voltage. The phrase “ELI the ICE man” is sometimes used to help beginning students remember these fundamental relationships. The word ELI has the middle letter L (inductance) with E (voltage) before, and I (current) after or lagging the voltage. The word ICE has the middle letter C (capacitance) with E after, and I before or leading the voltage in a capacitive circuit.

In addition to the voltage, current, and impedance of a circuit, we are also interested in the power. There are three types of power which are considered in ac circuits, the complex power S , the real power P , and the reactive power Q . The relationship among these quantities is

$$S = P + jQ = |S|\angle\theta \quad \text{VA} \quad (12)$$

The magnitude of the complex power, called the *volt-amperes* or the *apparent* power of the circuit is defined as

$$|S| = |V||I| \quad \text{VA} \quad (13)$$

The *real* power is defined as

$$P = |V||I| \cos \theta \quad \text{W} \quad (14)$$

The *reactive* power is defined as

$$Q = |V||I| \sin \theta \quad \text{var} \quad (15)$$

The angle θ is the difference between the angle of voltage and the angle of current.

$$\theta = \underline{\angle V} - \underline{\angle I} \quad \text{rad} \quad (16)$$

The power factor is defined as

$$pf = \cos \theta = \cos \left(\tan^{-1} \frac{Q}{P} \right) \quad (17)$$

The real power supplied to a resistor is

$$P = VI = I^2 R = \frac{V^2}{R} \quad \text{W} \quad (18)$$

where V and I are the voltage across and the current through the resistor.

The magnitude of the reactive power supplied to a reactance is

$$|Q| = VI = I^2 X = \frac{V^2}{X} \quad \text{var} \quad (19)$$

where V and I are the voltage across and the current through the reactance. Q will be positive to an inductor and negative to a capacitor. The units of reactive power are volt-amperes reactive or vars.

Example

A series RLC circuit, shown in Fig. 4, has $R = 4 \Omega$, $X_L = 8 \Omega$, and $X_C = 11 \Omega$. Find the current, complex power, real power, and reactive power delivered to the circuit for an applied voltage of $100 \angle 0^\circ$ V. What is the power factor?

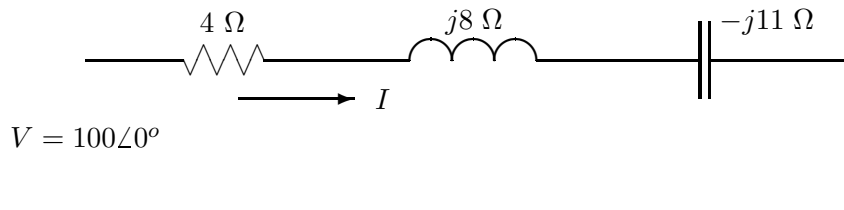

Figure 4: Series RLC circuit.

The impedance is

$$Z = R + jX_L - jX_C = 4 + j8 - j11 = 4 - j3 = 5/\underline{-36.87^\circ} \ \Omega$$

Assuming $V = |V|/0^\circ$ is the reference voltage, the current is

$$I = \frac{V}{Z} = \frac{100/0^\circ}{5/\underline{-36.87^\circ}} = 20/\underline{36.87^\circ} \ \text{A}$$

The complex power is

$$S = |V||I|\angle\theta = (100)(20)/\underline{-36.87^\circ} = 2000/\underline{-36.87^\circ} \ \text{VA}$$

The real power supplied to the circuit is just the real power absorbed by the resistor, since reactances do not absorb real power.

$$P = I^2R = (20)^2(4) = 1600 \ \text{W}$$

It is also given by

$$P = |V||I| \cos\theta = 100(20) \cos /36.87^\circ = 1600 \ \text{W}$$

The reactive power supplied to the inductor is

$$Q_L = I^2X_L = (20)^2(8) = 3200 \ \text{var}$$

The reactive power supplied to the capacitor is

$$Q_C = -I^2X_C = -(20)^2(11) = -4400 \ \text{var}$$

The net reactive power supplied to the circuit is

$$Q = Q_L + Q_C = 3200 - 4400 = -1200 \ \text{var}$$

It is also given by

$$Q = |V||I| \sin\theta = 100(20) \sin(-36.87^\circ) = -1200 \ \text{var}$$

The power factor is

$$\text{pf} = \cos\theta = \cos(-36.87^\circ) = 0.8 \ \text{lead}$$

The word “lead” indicates that θ is negative, or that the current is leading the voltage.

We see that the real and reactive powers can be found either from the input voltage and current or from the summation of the component real and reactive powers within the circuit.

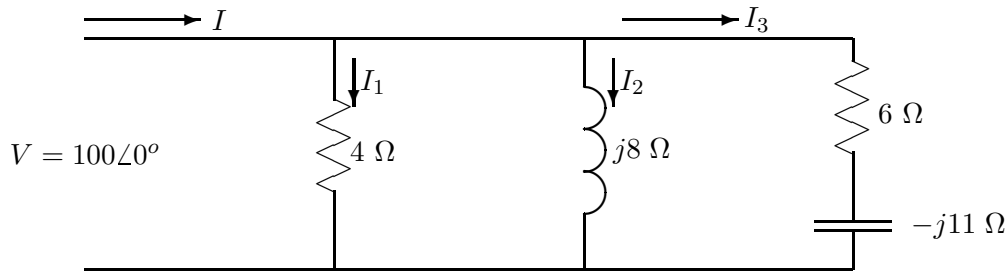
Figure 5: Parallel RLC circuit.

The effort required may be smaller or greater for one approach as compared to the other, depending on the structure of the circuit. The student should consider the relative difficulty of both techniques before solving the problem, to minimize the total effort.

Example

Find the apparent power and power factor of the circuit in Fig. 5.

One solution technique is to first find the input impedance.

$$\begin{aligned} Z &= \frac{1}{1/4 + 1/j8 + 1/(6 - j11)} = \frac{1}{0.25 - j0.125 + 1/(12.53/\underline{-61.39^\circ})} \\ &= \frac{1}{0.25 - j0.125 + 0.080/\underline{61.39^\circ}} = \frac{1}{0.25 - j0.125 + 0.038 + j0.070} \\ &= \frac{1}{0.288 - j0.055} = \frac{1}{0.293/\underline{-10.79^\circ}} = 3.41/\underline{10.79^\circ} \Omega \end{aligned}$$

The input current is then

$$I = \frac{V}{Z} = \frac{100/\underline{0^\circ}}{3.41/\underline{10.79^\circ}} = 29.33/\underline{-10.79^\circ} \text{ A}$$

The apparent power is

$$|S| = |V||I| = 100(29.33) = 2933 \text{ VA}$$

The power factor is

$$\text{pf} = \cos \theta = \cos 10.79^\circ = 0.982 \text{ lag}$$

Another solution technique is to find the individual component powers. We have to find the current I_3 to find the real and reactive powers supplied to that branch.

$$I_3 = \frac{V}{6 - j11} = \frac{100/0^\circ}{12.53/\underline{-61.39^\circ}} = 7.98/\underline{61.39^\circ}$$

The capacitive reactive power is then

$$Q_C = -|I_3|^2 X_C = -(7.98)^2(11) = -700 \text{ var}$$

The inductive reactive power is

$$Q_L = \frac{V^2}{X_L} = \frac{(100)^2}{8} = 1250 \text{ var}$$

The real power supplied to the circuit is

$$P = \frac{V^2}{4} + |I_3|^2(6) = \frac{(100)^2}{4} + (7.98)^2(6) = 2500 + 382 = 2882 \text{ W}$$

The complex power is then

$$S = P + jQ = 2882 + j1250 - j700 = 2882 + j550 = 2934/\underline{10.80^\circ} \text{ var}$$

so the apparent power is 2934 var and the power factor is

$$\text{pf} = \cos \underline{10.80^\circ} = 0.982 \text{ lag}$$

The total effort by a person proficient in complex arithmetic may be about the same for either approach. A beginner is more likely to get the correct result from the second approach, however, because it reduces the required complex arithmetic by not requiring the determination of the input impedance.

We now turn our attention to three-phase circuits. We are normally interested in a balanced set of voltages connected in wye as shown in Fig. 6. If we select E_a , the voltage of point a with respect to the neutral point n , as the reference, then

$$\begin{aligned} E_a &= |E_a|/\underline{0^\circ} & \text{V} \\ E_b &= |E_a|/\underline{-120^\circ} & \text{V} \\ E_c &= |E_a|/\underline{-240^\circ} & \text{V} \end{aligned} \tag{20}$$

This set of voltages is said to form an *abc sequence*, since E_b lags E_a by 120° , and E_c lags E_b by 120° . We use the symbol E rather than V to indicate that we have a source voltage.

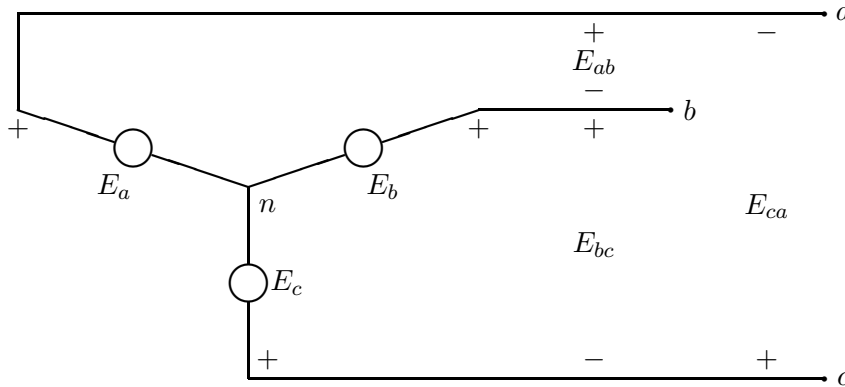

Figure 6: Balanced three-phase source.

The symbol V will be used for other types of voltages in the circuit. This will become more evident after a few examples.

The line to line voltage E_{ab} is given by

$$\begin{aligned}
 E_{ab} &= E_a - E_b = |E_a|(1/\underline{0^\circ} - 1/\underline{-120^\circ}) \\
 &= |E_a|[1 - (-0.5 - j0.866)] = |E_a|(1.5 + j0.866) \\
 &= |E_a|\sqrt{3}/\underline{30^\circ} \quad \text{V}
 \end{aligned} \tag{21}$$

In a similar fashion,

$$\begin{aligned}
 E_{bc} &= \sqrt{3}|E_a|/\underline{-90^\circ} \quad \text{V} \\
 E_{ca} &= \sqrt{3}|E_a|/\underline{-210^\circ} \quad \text{V}
 \end{aligned} \tag{22}$$

These voltages are shown in the phasor diagram of Fig. 7.

When this three-phase source is connected to a balanced three-phase wye-connected load, we have the circuit shown in Fig. 8.

The current I_a is given by

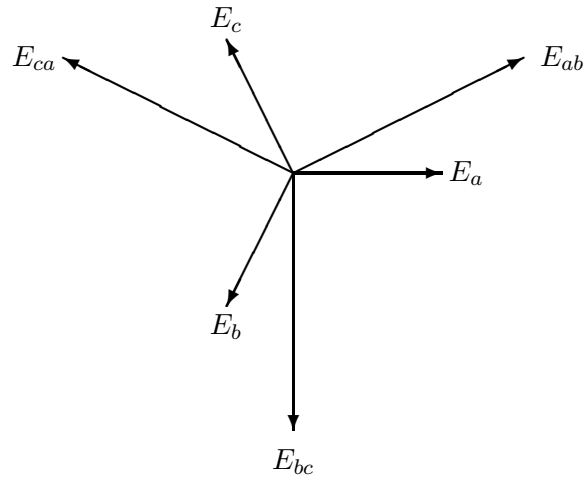

Figure 7: Balanced three-phase voltages for circuit in Fig. 5.6.

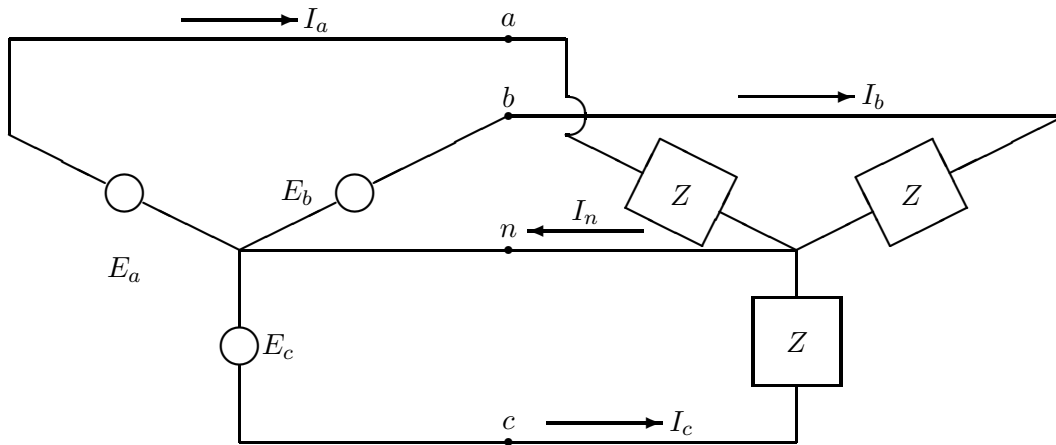

Figure 8: Balanced three-phase wye-connected source and load.

$$I_a = \frac{E_a}{Z} = \frac{|E_a|}{|Z|} \angle -\theta = |I_a| \angle -\theta \quad \text{A} \quad (23)$$

The other two currents are given by

$$\begin{aligned} I_b &= |I_a| \angle -\theta - 120^\circ \quad \text{A} \\ I_c &= |I_a| \angle -\theta - 240^\circ \quad \text{A} \end{aligned} \quad (24)$$

The sum of the three currents is the current I_n flowing in the neutral connection, which can

easily be shown to be zero in the balanced case.

$$I_n = I_a + I_b + I_c = 0 \text{ A} \quad (25)$$

The total power supplied to the load is three times the power supplied to each phase.

$$\begin{aligned} |S_{\text{tot}}| &= 3|E_a||I_a| && \text{VA} \\ P_{\text{tot}} &= 3|E_a||I_a| \cos \theta && \text{W} \\ Q_{\text{tot}} &= 3|E_a||I_a| \sin \theta && \text{var} \end{aligned} \quad (26)$$

The total power can also be expressed in terms of the line-to-line voltage E_{ab} .

$$\begin{aligned} |S_{\text{tot}}| &= \sqrt{3}|E_{ab}||I_a| && \text{VA} \\ P_{\text{tot}} &= \sqrt{3}|E_{ab}||I_a| \cos \theta && \text{W} \\ Q_{\text{tot}} &= \sqrt{3}|E_{ab}||I_a| \sin \theta && \text{var} \end{aligned} \quad (27)$$

We shall illustrate the use of these equations in the discussion on synchronous generators in the next section.

3 THE SYNCHRONOUS GENERATOR

Almost all electrical power is generated by three-phase ac generators which are synchronized with the utility grid. Engine driven single-phase generators are used sometimes, primarily for emergency purposes in sizes up to about 50 kW. Single-phase generators would be used for wind turbines only when power requirements are small (less than perhaps 20 kW) and when utility service is only single-phase. A three-phase machine would normally be used whenever the wind turbine is adjacent to a three-phase transmission or distribution line. Three-phase machines tend to be smaller, less expensive, and more efficient than single-phase machines of the same power rating, which explains their use whenever possible.

It is beyond the scope of this text to present a complete treatment of three-phase synchronous generators. This is done by many texts on electrical machines. A brief overview is necessary, however, before some of the important features of ac generators connected to wind turbines can be properly discussed.

A construction diagram of a three-phase ac generator is shown in Fig. 9. There is a rotor which is supplied a direct current I_f through slip rings. The current I_f produces a flux Φ . This flux couples into three identical coils, marked aa' , bb' , and cc' , spaced 120° apart, and produces three voltage waveforms of the same magnitude but 120° electrical degrees apart.

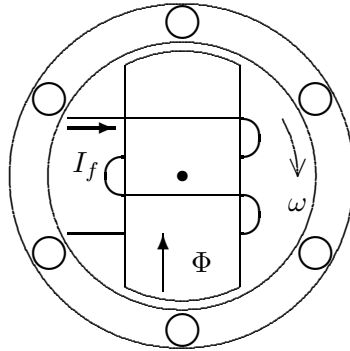

Figure 9: Three-phase generator

The equivalent circuit for one phase of this ac generator is shown in Fig. 10. It is shown in electrical machinery texts that the magnitude of the generated rms *electromotive force* (emf) E is given by

$$|E| = k_1 \omega \Phi \quad (28)$$

where $\omega = 2\pi f$ is the electrical radian frequency, Φ is the flux per pole, and k_1 is a constant which includes the number of poles and the number of turns in each winding. The reactance X_s is the *synchronous reactance* of the generator in ohms/phase. The generator reactance changes from steady-state to transient operation, and X_s is the steady-state value. The resistance R_s represents the resistance of the conductors in the generator windings. It is normally much smaller than X_s , so is normally neglected except in efficiency calculations. The synchronous impedance of the winding is given the symbol $Z_s = R_s + jX_s$.

The voltage E is the open circuit voltage and is sometimes called the voltage behind synchronous reactance. It is the same as the voltage E_a of Fig. 8.

The three coils of the generator can be connected together in either wye or delta, although the wye connection shown in Fig. 8 is much more common. When connected in wye, E is the line to neutral voltage and one has to multiply it by $\sqrt{3}$ to get the magnitude of the line-to-line voltage.

The frequency f of the generated emf is given by

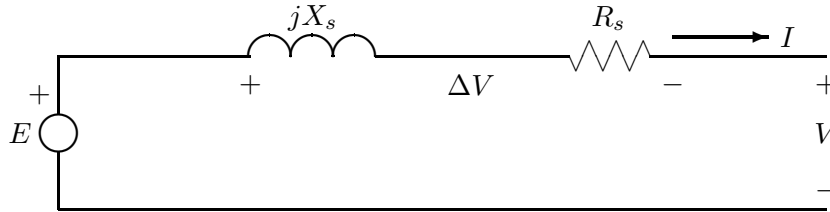

Figure 10: Equivalent circuit for one phase of a synchronous three-phase generator.

$$f = \frac{p}{2} \frac{n}{60} \quad \text{Hz} \quad (29)$$

where p is the number of poles and n is the rotational speed in r/min. The speed required to produce 60 Hz is 3600 r/min for a two pole machine, 1800 r/min for a four pole machine, 1200 r/min for a six pole machine, and so on. It is possible to build generators with large numbers of poles where slow speed operation is desired. A hydroelectric plant might use a 72 pole generator, for example, which would rotate at 100 r/min to produce 60 Hz power. A slow speed generator could be connected directly to a wind turbine, eliminating the need for an intermediate gearbox. The propellers of the larger wind turbines turn at 40 r/min or less, so a rather large number of poles would be required in the generator for a gearbox to be completely eliminated. Both cost and size of the generator increase with the number of poles, so the system cost with a very low speed generator and no gearbox may be greater than the cost for a higher speed generator and a gearbox.

When the generator is connected to a utility grid, both the grid or terminal voltage V and the frequency f are fixed. The machine emf E may differ from V in both magnitude and phase, so there exists a difference voltage

$$\Delta V = E - V \quad \text{V/phase} \quad (30)$$

This difference voltage will yield a line current I (defined positive away from the machine) of value

$$I = \frac{\Delta V}{Z_s} \quad \text{A} \quad (31)$$

The relationship among E , V , and I is shown in the phasor diagram of Fig. 11. E is proportional to the rotor flux Φ which in turn is proportional to the field current flowing in the rotor. When the field current is relatively small, E will be less than V . This is called the *underexcitation* case. The case where E is greater than V is called *overexcitation*. E will lead V by an angle δ while I will lag or lead V by an angle θ .

The conventions for the angles θ and δ are

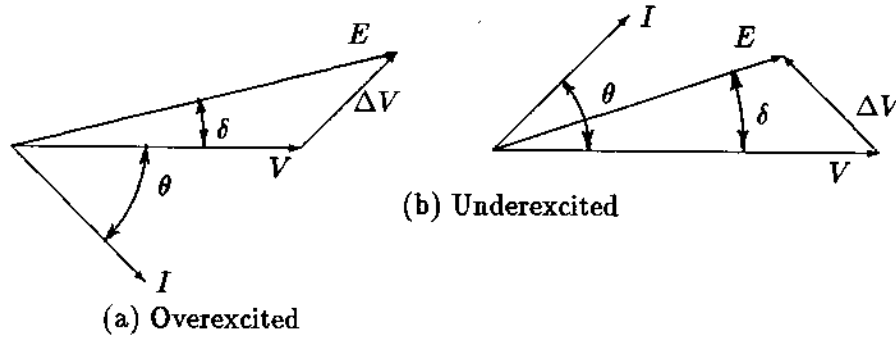

Figure 11: Phasor diagram of one phase of a synchronous three-phase generator: (a) overexcited; (b) underexcited.

$$\begin{aligned}\theta &= \underline{V} - \underline{I} \\ \delta &= \underline{E} - \underline{V}\end{aligned}\quad (32)$$

Phasors in the first quadrant have positive angles while phasors in the fourth quadrant have negative angles. Therefore, both θ and δ are positive in the overexcited case, while δ is positive and θ is negative in the underexcited case.

Expressions for the real and reactive powers supplied by each phase were given in Eqs. 14 and 15 in terms of the terminal voltage V and the angle θ . We can apply some trigonometric identities to the phasor diagrams of Fig. 11 and arrive at alternative expressions for P and Q in terms of E , V , and the angle δ .

$$\begin{aligned}P &= \frac{|E||V|}{X_s} \sin \delta \quad \text{W/phase} \\ Q &= \frac{|E||V| \cos \delta - |V|^2}{X_s} \quad \text{var/phase}\end{aligned}\quad (33)$$

A plot of P versus δ is shown in Fig. 12. This illustrates two important points about the use of an ac generator. One is that as the input mechanical power increases, the output electrical power will increase, reaching a maximum at $\delta = 90^\circ$. This maximum electrical power, occurring at $\sin \delta = 1$, is called the *pullout* power. If the input mechanical power is increased still more, the output power will begin to decrease, causing a rapid increase in δ and a loss of synchronism. If a turbine is operating near rated power, and a sharp gust

of wind causes the input power to exceed the pullout power from the generator, the rotor will accelerate above rated speed. Large generator currents will flow and the generator will have to be switched off the power line. Then the rotor will have to be slowed down and the generator resynchronized with the grid. Rapid pitch control of the rotor can prevent this, but the control system will have to be well designed.

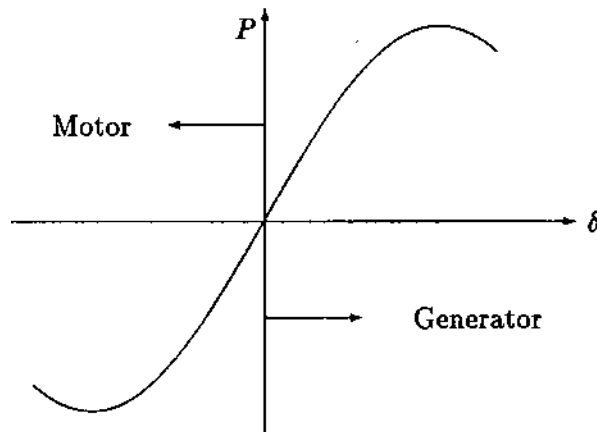

Figure 12: Power flow from an ac generator as a function of power angle.

The other feature illustrated by this power plot is that the power becomes negative for negative δ . This means the generator is now acting as a motor. Power is being taken from the electric utility to operate a giant fan and speed up the air passing through the turbine. This is not the purpose of the system, so when the wind speed drops below some critical value, the generator must be disconnected from the utility line to prevent motoring.

Before working an example, we need to discuss generator rating. Generators are often rated in terms of apparent power rather than real power. The reason for this is the fact that generator losses and the need for generator cooling are not directly proportional to the real power. The generator will have hysteresis and eddy current losses which are determined by the voltage, and ohmic losses which are determined by the current. The generator can be operated at rated voltage and rated current, and therefore with rated losses, even when the real power is zero because $\theta = 90$ degrees. A generator may be operated at power factors between 1.0 and 0.7 or even lower depending on the requirements of the grid, so the product of rated voltage and rated current (the rated apparent power) is a better measure of generator capability than real power. The same argument is true for transformers, which always have their ratings specified in kVA or MVA rather than kW or MW.

A generator may also have a real power rating which is determined by the allowable torque in the generator shaft. A rating of 2500 kVA and 2000 kW, or 2500 kVA at 0.8 power factor, would imply that the machine is designed for continuous operation at 2500 kVA output, with 2000 kW plus losses being delivered to the generator through its shaft. There are always safety

factors built into the design for short term overloads, but one should not plan to operate a generator above its rated apparent power or above its rated real power for long periods of time.

We should also note that generators are rarely operated at exactly rated values. A generator rated at 220 V and 30 A may be operated at 240 V and 20 A, for example. The power in the wind is continuously varying, so a generator rated at 2500 kVA and 2000 kW may be delivering 300 kW to the grid one minute and 600 kW the next minute. Even when the source is controllable, as in a coal-fired generating plant, a 700-MW generator may be operated at 400 MW because of low demand. It is therefore important to distinguish between *rated* conditions and *operating* conditions in any calculations.

Rated conditions may not be completely specified on the equipment nameplate, in which case some computation is required. If a generator has a per phase rated apparent power S_R and a rated line to neutral voltage V_R , the rated current is

$$I_R = \frac{S_R}{V_R} \quad (34)$$

Example

The MOD-0 wind turbine has an 1800 r/min synchronous generator rated at 125 kVA at 0.8 pf and 480 volts line to line[8]. The generator parameters are $R_s = 0.033 \Omega/\text{phase}$ and $X_s = 4.073 \Omega/\text{phase}$. The generator is delivering 75 kW to the grid at rated voltage and 0.85 power factor lagging. Find the rated current, the phasor operating current, the total reactive power, the line to neutral phasor generated voltage E , the power angle *delta*, the three-phase ohmic losses in the stator, and the pullout power.

The first step in the solution is to determine the per phase value of terminal voltage, which is

$$|V| = \frac{480}{\sqrt{3}} = 277 \text{ V/phase}$$

The rated apparent power per phase is

$$S_R = \frac{125}{3} = 41.67 \text{ kVA/phase} = 41,670 \text{ VA/phase}$$

The rated current is then

$$I_R = \frac{S_R}{V_R} = \frac{41,670}{277} = 150.4 \text{ A}$$

The real power being supplied to the grid per phase is

$$P = \frac{75}{3} = 25 \text{ kW/phase} = 25 \times 10^3 \text{ W/phase}$$

From Eq. 14 we can find the magnitude of the phasor operating current to be

$$|I| = \frac{P}{|V| \cos \theta} = \frac{25 \times 10^3}{277(0.85)} = 106.2 \text{ A}$$

The angle θ is

$$\theta = \cos^{-1}(0.85) = +31.79^\circ$$

The phasor operating current is then

$$I = |I| \angle -\theta = 106.2 \angle -31.79^\circ = 90.3 - j55.9 \text{ A}$$

The reactive power supplied per phase is

$$Q = (277)(106.2) \sin 31.79^\circ = 15,500 \text{ var/phase}$$

The generator is then supplying a total reactive power of 46.5 kvar to the grid in addition to the total real power of 75 kW.

The voltage E is given by Kirchhoff's voltage law.

$$\begin{aligned} E = V + IZ_s &= 277 \angle 0^\circ + 106.2 \angle -31.79^\circ (0.033 + j4.073) \\ &= 508 + j366 = 626 \angle 35.77^\circ \text{ V/phase} \end{aligned}$$

Since the terminal voltage V has been taken as the reference ($V = |V| \angle 0^\circ$), the power angle is just the angle of E , or 35.77° . The total stator ohmic loss is

$$P_{\text{loss}} = 3I^2 R_s = 3(106.2)^2 (0.033) = 1.117 \text{ kW}$$

This is a small fraction of the total power being delivered to the utility, but still represents a significant amount of heat which must be transferred to the atmosphere by the generator cooling system.

The pullout power, given by Eq. 33 with $\sin \delta = 1$ is

$$P = \frac{|E||V|}{X_s} = \frac{626(277)}{4.073} = 42.6 \text{ kW/phase}$$

or a total of 128 kW for the total machine. As mentioned earlier, if the input shaft power would rise above the pullout power from a wind gust, the generator would lose synchronism with the power grid. In most systems, the pullout power will be at least twice the rated power of the generator to prevent this possibility. This larger pullout power represents a somewhat better safety margin than is available in the MOD-0 system.

One advantage of the synchronous generator is its ability to supply either inductive or capacitive reactive power to a load. The generated voltage $|E|$ is produced by a current

flowing in the field winding, which is controlled by a control system. If the field current is increased, then $|E|$ must increase. If the real power is fixed by the prime mover, then from Eq. 33 we see that $\sin \delta$ must decrease by a proportional amount as $|E|$ increases. This causes the reactive power flow to increase. A decrease in $|E|$ will cause Q to decrease, eventually becoming negative. A synchronous generator rated at 125 kVA and 0.8 power factor can supply its rated real power of 100 kW and at the same time can supply any value of reactive power between +75 kvar and -75 kvar to the grid. Most loads require some reactive power for operation, so the synchronous generator can meet all the requirements of a load while requiring nothing from the load. It can operate in an independent mode as well as intertied with a utility grid.

The major disadvantage of a synchronous generator is its complexity and cost, as well as the cost of the required control systems. Some of the complexity is shown by the synchronization process, as illustrated in Fig. 13. From a complete stop, the first step is to start the rotor. The sensors will measure wind direction and actuate the direction controls so the turbine is properly directed into the wind. If the wind speed is above the cut-in value, the pitch controls will change the propeller pitch so rotation can occur. The generator field control is activated so a predetermined current is sent through the field of the generator. A fixed field current fixes the flux Φ , so that E is proportional to the rotational speed n . The turbine accelerates until it almost reaches rated angular velocity. At this point the frequency of E will be about the same as that of the power grid. The amplitude of E will be about the same as V if the generator field current is correct. Slightly different frequencies will cause the phase difference between E and V to change slowly over the range of 0 to 360° . The voltage difference V_d is sensed so the relay can be closed when V_d is a minimum. This limits the transient current through the relay contacts, thus prolonging their lives, and also minimizes the shock to both the generator and the power grid. If the relay is closed when V_d is not close to its minimum, very high currents will flow until the generator is accelerated or decelerated to the rotational position where E and V are in phase.

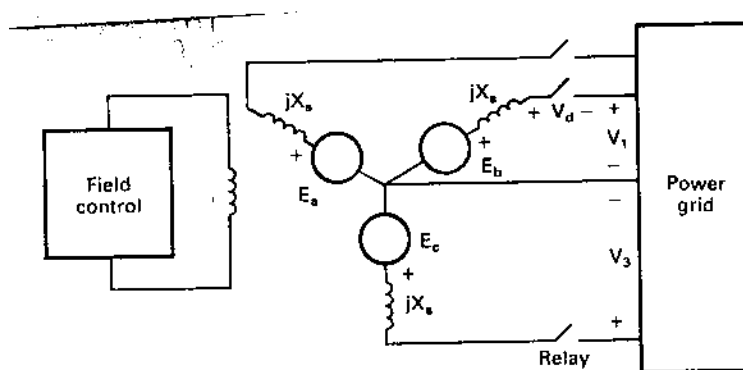

Figure 13: AC generator being synchronized with the power grid.

Once the relay is closed, there will still be no power flow as long as E and V have the same

magnitude and phase. Generator action is obtained by increasing the magnitude of E with the field control. The pitch controller sets the blade pitch at the optimum point if the blades are not already at this point. The blade torque will attempt to accelerate the generator, but this is impossible because the generator and the power grid are in synchronism. The torque will advance the relative position of the generator rotor with respect to the power grid voltage, however, so E will lead V by the power angle δ . The input mechanical power to the generator is fixed for a given wind speed and blade pitch, which also fixes the output power. If $|E|$ is changed by the generator field control, then the power angle will change automatically to maintain this fixed output power.

This synchronization process may sound very difficult, but is accomplished routinely by automatic equipment. If the wind speed and blade pitch are such that the turbine and generator are slowly accelerating through synchronous speed, the relay can usually be closed just as synchronous speed is reached. The microprocessor control would then adjust the field current and the blade pitch for proper operating conditions. An observer would see a smooth operation lasting only a minute or so.

The control systems necessary for synchronization and the generator field supply are not cheap. On the other hand, their costs are not strongly dependent on system size over the normal range of wind turbine sizes. This means that the control systems would form a small fraction of the total turbine cost for a 1000-kW turbine, but a substantial fraction for a 5-kW turbine. For this reason, the synchronous generator will be more common in sizes of 100 kW and up, and not so common in the smaller sizes.

4 PER UNIT CALCULATIONS

Problems such as those in the previous section can always be worked using the actual circuit values. There is an alternative, however, to the use of actual circuit values which has several advantages and which is widely used in the electric power industry. This is the *per unit* system, in which voltages, currents, powers, and impedances are all expressed as a percent or per unit of a base or reference value. For example, if a base voltage of 120 V is chosen, voltages of 108, 120, and 126 V become 0.90, 1.00, and 1.05 per unit, or 90, 100, and 105 percent, respectively. The per unit value of any quantity is defined as the ratio of the quantity to its base value, expressed as a decimal.

One advantage of the per unit system is that the product of two quantities expressed in per unit is also in per unit. Another advantage is that the per unit impedance of an ac generator is essentially a constant for a wide range of actual sizes. This means that a problem like the preceding example needs to be worked only once in per unit, with the results converted to actual values for each particular size of machine for which results are needed.

We shall choose the base or reference as the per phase quantities of a three-phase system.

The base radian frequency $\omega_{\text{base}} = \omega_o$ is the rated radian frequency of the system, normally

$$2\pi(60) = 377 \text{ rad/s.}$$

Given the base apparent power per phase S_{base} and base line to neutral voltage V_{base} , the following relationships are valid:

$$I_{\text{base}} = \frac{S_{\text{base}}}{V_{\text{base}}} \quad \text{A} \quad (35)$$

$$Z_{\text{base}} = R_{\text{base}} = X_{\text{base}} = \frac{V_{\text{base}}}{I_{\text{base}}} \quad \Omega \quad (36)$$

$$P_{\text{base}} = Q_{\text{base}} = S_{\text{base}} \quad \text{VA} \quad (37)$$

We may even define a base inductance and a base capacitance.

$$L_{\text{base}} = \frac{X_{\text{base}}}{\omega_o} \quad (38)$$

$$C_{\text{base}} = \frac{1}{X_{\text{base}}\omega_o} \quad (39)$$

The per unit values are then the actual values divided by the base values.

$$V_{\text{pu}} = \frac{V}{V_{\text{base}}} \quad (40)$$

$$I_{\text{pu}} = \frac{I}{I_{\text{base}}} \quad (41)$$

$$Z_{\text{pu}} = \frac{Z}{Z_{\text{base}}} \quad (42)$$

$$\omega_{\text{pu}} = \frac{\omega}{\omega_{\text{base}}} = \frac{\omega}{\omega_o} \quad (43)$$

$$L_{\text{pu}} = \frac{L}{L_{\text{base}}} \quad (44)$$

$$C_{\text{pu}} = \frac{C}{C_{\text{base}}} \quad (45)$$

Example

The MOD-2 generator is rated at 3125 kVA, 0.8 pf, and 4160 V line to line. The typical per phase synchronous reactance for the four-pole, conventionally cooled generator is 1.38 pu. The generator is supplying power at rated voltage and frequency to an isolated load with a per phase impedance of $1.2 - j0.8$ pu as shown in Fig. 14. Find the base, actual, and per unit values of terminal voltage V , generated voltage E , apparent power, real power, reactive power, current, generator inductance, and load capacitance.

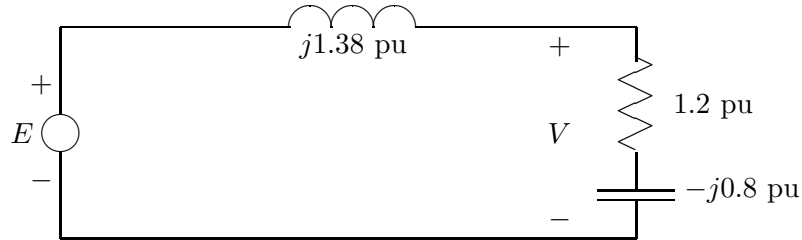

Figure 14: Per phase diagram for example problem.

First we determine the base values, which do not depend on actual operating conditions but on nameplate ratings.

$$V_{\text{base}} = \frac{4160}{\sqrt{3}} = 2400 \text{ V}$$

$$E_{\text{base}} = V_{\text{base}} = 2400 \text{ V}$$

$$S_{\text{base}} = \frac{3125}{3} = 1042 \text{ kVA}$$

$$P_{\text{base}} = Q_{\text{base}} = S_{\text{base}} = 1042 \text{ kVA}$$

$$I_{\text{base}} = \frac{S_{\text{base}}}{V_{\text{base}}} = \frac{1,042,000 \text{ VA}}{2400 \text{ V}} = 434 \text{ A}$$

$$Z_{\text{base}} = \frac{V_{\text{base}}}{I_{\text{base}}} = \frac{2400}{434} = 5.53 \text{ } \Omega$$

$$L_{\text{base}} = \frac{X_{\text{base}}}{\omega_o} = \frac{Z_{\text{base}}}{\omega_o} = \frac{5.53}{377} = 14.7 \text{ mH}$$

$$C_{\text{base}} = \frac{1}{X_{\text{base}}\omega_o} = \frac{1}{5.53(377)} = 480 \text{ } \mu\text{F}$$

The actual voltage is given in the problem as the rated or base voltage, so

$$V = 2400 \text{ V}$$

The per unit terminal voltage is then

$$V_{\text{pu}} = \frac{V}{V_{\text{base}}} = \frac{2400}{2400} = 1$$

We now have to solve for the per unit current.

$$\begin{aligned} I_{\text{pu}} &= \frac{V_{\text{pu}}}{Z_{\text{pu}}} = \frac{1/0^\circ}{1.2 - j0.8} = \frac{1/0^\circ}{1.44 / -33.69^\circ} = 0.693 / 33.69^\circ \\ &= 0.577 + j0.384 \end{aligned}$$

The actual current is

$$I = I_{\text{pu}} I_{\text{base}} = (0.693 / 33.69^\circ)(434) = 300 / 33.69^\circ \text{ A}$$

The per unit apparent power is

$$S_{\text{pu}} = |V_{\text{pu}}| |I_{\text{pu}}| = (1)(0.693) = 0.693$$

The per unit real power is

$$P_{\text{pu}} = |V_{\text{pu}}| |I_{\text{pu}}| \cos \theta = (1)(0.693) \cos(-33.69^\circ) = 0.577$$

The per unit reactive power is

$$Q_{\text{pu}} = |V_{\text{pu}}| |I_{\text{pu}}| \sin \theta = (1)(0.693) \sin(-33.69^\circ) = -0.384$$

The actual powers per phase are

$$S = (0.693)(1042) = 722 \text{ kVA/phase}$$

$$P = (0.577)(1042) = 600 \text{ kW/phase}$$

$$Q = (-0.384)(1042) = -400 \text{ kvar/phase}$$

The total power delivered to the three-phase load would then be 2166 kVA, 1800 kW, and -1200 kvar.

The generated voltage E in per unit is

$$\begin{aligned}
 E_{\text{pu}} &= V_{\text{pu}} + I_{\text{pu}}(jX_{s,\text{pu}}) = 1 + 0.693/\underline{33.69^\circ}(1.38)/\underline{90^\circ} \\
 &= 1 + 0.956/\underline{123.69^\circ} = 1 - 0.530 + j0.796 \\
 &= 0.470 + j0.796 = 0.924/\underline{59.46^\circ}
 \end{aligned}$$

The per unit generator inductance per phase is

$$L_{\text{pu}} = \frac{X_{s,\text{pu}}}{\omega_{\text{pu}}} = \frac{1.38}{1} = 1.38$$

The actual generator inductance per phase is

$$L = L_{\text{pu}}L_{\text{base}} = 1.38(14.7) = 20.3 \text{ mH}$$

The per unit load capacitance per phase is

$$C_{\text{pu}} = \frac{1}{X_{C,\text{pu}}\omega_{\text{pu}}} = \frac{1}{0.8(1)} = 1.25$$

The actual load capacitance per phase is

$$C = C_{\text{pu}}C_{\text{base}} = 1.25(480) = 600 \text{ } \mu\text{F}$$

The base of any device such as an electrical generator, motor, or transformer is always understood to be the nameplate rating of the device. The per unit impedance is usually available from the manufacturer.

Sometimes the base values need to be changed to a common base when several devices are connected together. Solving an electrical circuit requires either the actual impedances or the per unit impedances referred to a common base. The per unit impedance on the old base can be converted to the per unit impedance for the new base by

$$Z_{\text{pu,new}} = Z_{\text{pu,old}} \left(\frac{V_{\text{base,old}}}{V_{\text{base,new}}} \right)^2 \frac{S_{\text{base,new}}}{S_{\text{base,old}}} \quad (46)$$

Example

A single-phase distribution transformer secondary is rated at 60 Hz, 10 kVA, and 240 V. The open circuit voltage V_{oc} is 240 V. The per unit series impedance of the transformer is $Z = 0.005 + j0.03$. Two electric heaters, one rated 1500 W and 230 V, and the other rated at 1000 W and 220 V, are connected to the transformer. Find the per unit transformer current I_{pu} and the magnitude of the actual load voltage V_1 , as shown in Fig. 15.

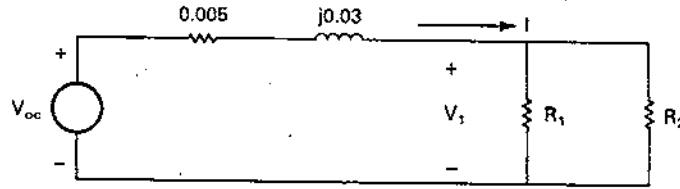

Figure 15: Single-phase transformer connected to two resistive loads.

The first step is to get all impedance values computed on the same base. Any choice of base will work, but minimum effort will be exerted if we choose the transformer base as the reference base. This yields $V_{\text{base}} = 240$ V and $S_{\text{base}} = 10$ kVA. The per unit values of the electric heater resistances would be unity on their nameplate ratings. The per unit values referred to the transformer rating would be

$$R_{1,\text{pu}} = (1) \left(\frac{230}{240} \right)^2 \frac{10}{1.5} = 6.12$$

$$R_{2,\text{pu}} = (1) \left(\frac{220}{240} \right)^2 \frac{10}{1} = 8.40$$

The equivalent impedance of these heaters in parallel would be

$$R_{\text{pu}} = \frac{6.12(8.40)}{6.12 + 8.40} = 3.54$$

The per unit current is then

$$I_{\text{pu}} = \frac{V_{\text{oc,pu}}}{Z_{\text{pu}} + R_{\text{pu}}} = \frac{1}{0.005 + j0.03 + 3.54} = 0.282 / \underline{-0.48^\circ}$$

The load voltage magnitude is

$$|V_1| = I_{\text{pu}} R_{\text{pu}} V_{\text{base}} = 0.282(3.54)(240) = 239.6 \text{ V}$$

The voltage V_1 has decreased only 0.4 V from the open circuit value for a current of 28.2 percent of rated. This indicates the voltage varies very little with load changes, which is quite desirable for transformer outputs.

5 THE INDUCTION MACHINE

A large fraction of all electrical power is consumed by induction motors. For power inputs of less than 5 kW, these may be either single-phase or three-phase, while the larger machines are

almost invariably designed for three-phase operation. Three-phase machines produce a constant torque, as opposed to the pulsating torque of a single-phase machine. They also produce more power per unit mass of materials than the single-phase machine. The three-phase motor is a very rugged piece of equipment, often lasting for 50 years with only an occasional change of bearings. It is simple to construct, and with mass production is relatively inexpensive. The same machine will operate as either a motor or a generator with no modifications, which allows us to have a rugged, inexpensive generator on a wind turbine with rather simple control systems.

The basic wiring diagram for a three-phase induction motor is shown in Fig. 16. The motor consists of two main parts, the *stator* or stationary part and the *rotor*. The most common type of rotor is the *squirrel cage*, where aluminum or copper bars are formed in longitudinal slots in the iron rotor and are short circuited by a conducting ring at each end of the rotor. The construction is very similar to a three-phase transformer with the secondary shorted, and the same circuit models apply. In operation, the currents flowing in the three stator windings produce a rotating flux. This flux induces voltages and currents in the rotor windings. The flux then interacts with the rotor currents to produce a torque in the direction of flux rotation.

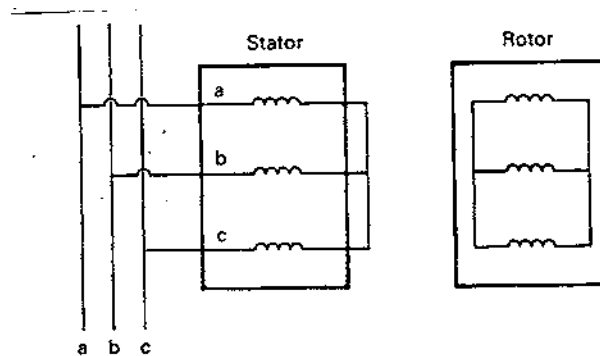

Figure 16: Wiring diagram for a three-phase induction motor.

The equivalent circuit of one phase of an induction motor is given in Fig. 17. In this circuit, R_m is an equivalent resistance which represents the losses due to eddy currents, hysteresis, windage, and friction, X_m is the magnetizing reactance, R_1 is the stator resistance, R_2 is the rotor resistance, X_1 is the leakage reactance of the stator, X_2 is the leakage reactance of the rotor, and s is the slip. All resistance and reactance values are referred to the stator. The reactances X_1 and X_2 are difficult to separate experimentally and are normally assumed equal to each other. The *slip* may be defined as

$$s = \frac{n_s - n}{n_s} \quad (47)$$

where n_s is the synchronous rotational speed and n is the actual rotational speed. If the synchronous frequency is 60 Hz, then from Eq. 29 the synchronous rotational speed will be

$$n_s = \frac{7200}{p} \quad \text{r/min} \quad (48)$$

where p is the number of poles.

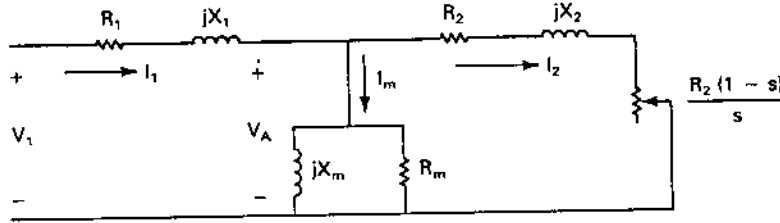

Figure 17: Equivalent circuit for one phase of a three-phase induction motor

The total losses in the motor are given by

$$P_{\text{loss}} = \frac{3|V_A|^2}{R_m} + 3|I_1|^2 R_1 + 3|I_2|^2 R_2 \quad \text{W} \quad (49)$$

The first term is the loss due to eddy currents, hysteresis, windage, and friction. The second term is the winding loss (copper loss) in the stator conductors and the third term is the winding loss in the rotor. The factor of 3 is necessary because of the three phases.

The power delivered to the resistance at the right end of Fig. 17 is

$$P_{m,1} = \frac{|I_2|^2 R_2 (1-s)}{s} \quad \text{W/phase} \quad (50)$$

The power $P_{m,1}$ is not actually dissipated as heat inside the motor but is delivered to a load as mechanical power. The total three-phase power delivered to this load is

$$P_m = \frac{3|I_2|^2 R_2 (1-s)}{s} \quad \text{W} \quad (51)$$

To analyze the circuit in Fig. 17, we first need to find the impedance Z_{in} which is seen by the voltage V_1 . We can define the impedance of the right hand branch as

$$Z_2 = R_2 + jX_2 + \frac{R_2(1-s)}{s} = \frac{R_2}{s} + jX_2 \quad \Omega \quad (52)$$

The impedance of the shunt branch is

$$Z_m = \frac{jX_m R_m}{R_m + jX_m} \quad \Omega \quad (53)$$

The input impedance is then

$$Z_{\text{in}} = R_1 + jX_1 + \frac{Z_m Z_2}{Z_m + Z_2} \quad \Omega \quad (54)$$

The input current is

$$I_1 = \frac{V_1}{Z_{\text{in}}} \quad \text{A} \quad (55)$$

The voltage across the shunt branch is

$$V_A = V_1 - I_1(R_1 + jX_1) \quad \text{V} \quad (56)$$

The shunt current I_m is given by

$$I_m = \frac{V_A}{Z_m} \quad \text{A} \quad (57)$$

The current I_2 is given by

$$I_2 = \frac{V_A}{Z_2} \quad \text{A} \quad (58)$$

The motor efficiency η_m is defined as the ratio of output power to input power.

$$\eta_m = \frac{P_m}{P_m + P_{\text{loss}}} \quad (59)$$

The relationship between motor power P_m and motor torque T_m is

$$P_m = \omega_m T_m \quad \text{W} \quad (60)$$

where

$$\omega_m = \frac{2\pi n}{60} = \frac{\pi}{30}(1-s)n_s \quad \text{rad/s} \quad (61)$$

By combining the last three equations we obtain the total motor torque

$$T_m = \frac{90|I_2|^2 R_2}{\pi n_s s} \quad \text{N} \cdot \text{m/rad} \quad (62)$$

A typical plot of motor torque versus angular velocity appears in Fig. 18. Also shown is a possible variation of load torque T_{mL} . At start, while $n = 0$, T_m will be greater than T_{mL} , allowing the motor to accelerate. As n increases, T_m increases to a maximum and then

declines rather rapidly toward zero at $n = n_s$. Meanwhile the torque required by the load is increasing with speed. The two torques are equal and steady state operation is reached at point *a* in Fig. 18. Rated torque is usually reached at a speed about 3 percent less than synchronous speed. A four pole induction motor will therefore deliver rated torque at about 1740 r/min, as compared with the synchronous speed of 1800 r/min. The no load speed will be less than synchronous speed by a few revolutions per minute. The reason for this is that at synchronous speed the rotor conductors turn in unison with the stator field, which means there is no time changing magnetic field passing through these conductors to induce a voltage. Without a voltage there will be no rotor current I_2 , and there is no torque without a current.

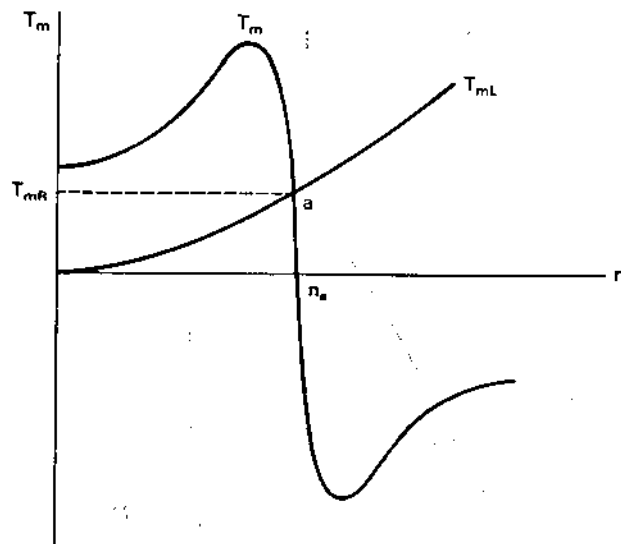

Figure 18: Variation of shaft torque with speed for a three-phase induction machine.

If synchronous speed is exceeded, s , T_m , and P_m all become negative, indicating that the mechanical load has become a prime mover and the motor is now acting as a generator. This means that an induction machine can be connected across a three-phase line, used as a motor to start a wind turbine such as a Darrieus, and become a generator when the wind starts to turn the Darrieus. The Darrieus has no pitch control, the induction machine has no field control, and synchronization is unnecessary, so equipment costs are significantly reduced from those of the system using a synchronous generator.

The circuit of the induction generator is identical to that of the induction motor, except that we sometimes draw it reversed, with reversed conventions for I_1 and I_2 as shown in Fig. 19. The resistance $R_2(1 - s)/s$ is negative for negative slip, and this negative resistance can be thought of as a source of power.

The induction generator requires reactive power for excitation. It cannot operate without this reactive power, so when the connection to the utility is broken in Fig. 19, the induction

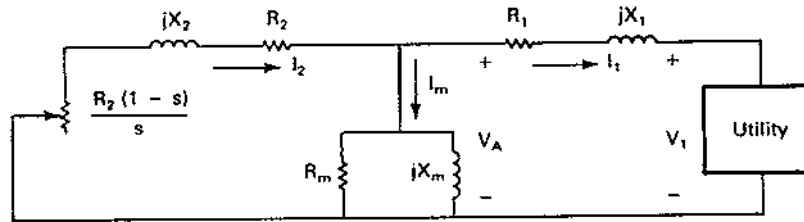

Figure 19: Equivalent circuit of one phase of an induction generator.

generator receives no reactive power and is not able to generate real power. This makes it somewhat less versatile than the synchronous generator which is able to supply both real and reactive power to the grid. The induction generator requirement for reactive power can also be met by capacitors connected across the generator terminals. If the proper values of capacitance are selected, the generator will operate in a self-excited mode and can operate independently of the utility grid. This possibility is examined in Chapter 6.

The rated electrical output power of the induction generator will be very close to the rated electrical input power of the same machine operated as a motor. If we maintain the same rated current I_1 at rated voltage V_1 for both generator and motor operation, the machine will have the same stator copper losses. The rotor current is proportional to I_2 and will be larger for generator operation than for motor operation, as can be seen by comparing Fig. 17 and Fig. 19. This will increase the rotor losses somewhat. The machine is running at 3-5 percent above synchronous speed as a generator, so windage and friction losses are somewhat higher than for motor operation. The saturation of the iron in the machine will be somewhat higher as a generator so hysteresis and eddy current losses will also be somewhat higher. These greater losses are counterbalanced by two effects. One is that the same wind which is driving the turbine is also cooling the generator. A wind turbine application presents a much better cooling environment to an induction machine than most applications, and this needs to be included in the system design. The second effect is that the wind is not constant. Short periods of overload would normally be followed by operation at less than rated power, which would allow the machine to cool. These cooling effects should allow the generator rating to be equal to the motor rating for a given induction machine.

It may well be that generator temperature will be used as a control signal for overload protection rather than generator current or power. The generator is not harmed by delivering twice its rated power for some period of time as long as its rated temperature is not exceeded. Using temperature as a control variable will therefore fully utilize the capability of the machine and allow a somewhat greater energy production than would be possible when using power or current as the control variable.

The analysis of the induction generator proceeds much the same as the analysis of the induction motor. The expressions for impedance in Eqs. 52–54 keep the same form. The negative slip causes the real parts of Z_2 and Z_{in} to be negative, but this is easily carried along

in the computations. The change in assumed direction for I_1 and I_2 forces us to write their equations as

$$I_1 = -\frac{V_1}{Z_{in}} \quad (63)$$

$$I_2 = -\frac{V_A}{Z_2} \quad (64)$$

The voltage V_A is given by

$$V_A = V_1 + I_1(R_1 + jX_1) \quad (65)$$

The real power P_m supplied by the turbine is the same as Eq. 51. The negative sign resulting from negative slip just means that power is flowing in the opposite direction. P_m is now the input power so the generator efficiency η_g would be given by

$$\eta_g = \frac{|P_m| - P_{loss}}{|P_m|} \quad (66)$$

The total real power delivered to the utility by the generator is

$$P_e = 3|V_1||I_1| \cos \theta \quad \text{W} \quad (67)$$

where V_1 is the line to neutral voltage and θ is the angle between voltage and current as defined by Eq. 16.

The total reactive power Q required by the generator is given by

$$Q = 3|I_2|^2 X_2 + \frac{3|V_A|^2}{X_m} + 3|I_1|^2 X_1 \quad \text{var} \quad (68)$$

It is also given by the expression

$$Q = 3|I_1||V_1| \sin \theta \quad \text{var} \quad (69)$$

Example

A three-phase, Y-connected, 220-V (line to line), 10-hp, 60-Hz, six-pole induction machine has the following constants in ohms per phase:

$$R_1 = 0.30 \text{ } \Omega/\text{phase} \quad R_2 = 0.14 \text{ } \Omega/\text{phase} \quad R_m = 120 \text{ } \Omega/\text{phase}$$

$$X_1 = X_2 = 0.35 \text{ } \Omega/\text{phase} \quad X_m = 13.2 \text{ } \Omega/\text{phase}$$

For a slip $s = 0.025$ (operation as a motor), compute I_1 , V_A , I_m , I_2 , speed in r/min, total output torque and power, power factor, total three-phase losses, and efficiency.

The applied voltage to neutral is

$$V_1 = \frac{220}{\sqrt{3}} = 127/0^\circ \text{ V/phase}$$

$$Z_2 = \frac{R_2}{s} + jX_2 = \frac{0.14}{0.025} + j0.35 = 5.60 + j0.35 = 5.61/3.58^\circ \Omega$$

$$Z_m = \frac{jR_m X_m}{R_m + jX_m} = \frac{j(120)(13.2)}{120 + j13.2} = \frac{1584/90^\circ}{120.72/6.28^\circ} = 13.12/83.72^\circ \Omega$$

$$Z_{in} = R_1 + jX_1 + \frac{Z_m Z_2}{Z_m + Z_2} = 0.30 + j0.35 + \frac{(13.12/83.72^\circ)(5.61/3.58^\circ)}{13.12/83.72^\circ + 5.61/3.58^\circ} = 5.29/27.08^\circ \Omega$$

$$I_1 = \frac{V_1}{Z_{in}} = \frac{127/0^\circ}{5.29/27.08^\circ} = 24.01/-27.08^\circ \text{ A}$$

$$\begin{aligned} V_A &= V_1 - I_1(R_1 + jX_1) = 127 - 24.01/-27.08^\circ(0.30 + j0.35) \\ &= 116.76 - j4.20 = 116.84/-2.06^\circ \text{ V} \end{aligned}$$

$$I_m = \frac{V_A}{Z_m} = \frac{116.84/-2.06^\circ}{13.12/83.72^\circ} = 8.91/-85.78^\circ \text{ A}$$

$$I_2 = \frac{V_A}{Z_2} = \frac{116.84/-2.06^\circ}{5.61/3.58^\circ} = 20.83/-5.64^\circ \text{ A}$$

From Eq. 48 we have

$$n_s = \frac{7200}{6} = 1200 \text{ r/min}$$

From Eq. 47 the speed is

$$n = (1 - s)n_s = (1 - 0.025)1200 = 1170 \text{ r/min}$$

The total torque is given by Eq. 62.

$$T_m = \frac{90|I_2|^2 R_2}{\pi n_s s} = \frac{90(20.83)^2(0.14)}{\pi(1200)(0.025)} = 58.01 \text{ N} \cdot \text{m/rad}$$

The total mechanical power is then

$$P_m = \omega_m T_m = \frac{2\pi n T_m}{60} = \frac{2\pi(1170)(58.01)}{60} = 7107 \text{ W}$$

At 746 W/hp, the motor is delivering 9.53 hp to the load. From Eq. 17, the power factor is the cosine of the angle between the input voltage and current, or in this case,

$$\text{pf} = \cos 27.08^\circ = 0.890 \text{ lag}$$

From Eq. 49 the total three-phase losses are

$$P_{\text{loss}} = \frac{3(116.84)^2}{120} + 3(24.01)^2(0.30) + 3(20.83)^2(0.14) = 1042 \text{ W}$$

The efficiency is given by Eq. 59.

$$\eta_m = \frac{P_m}{P_m + P_{\text{loss}}} = \frac{7107}{7107 + 1042} = 0.872$$

The efficiency is 87.2 percent, a typical value for induction motors of this size.

Example

For the machine of the previous example, compute the input current, total starting torque, and total three-phase losses while the machine is being started (while the slip is still essentially unity). Assume the source is able to maintain rated voltage during the start.

With the slip $s = 1$, the impedance Z_2 becomes

$$Z_2 = \frac{0.14}{1} + j0.35 = 0.377/68.20^\circ \Omega$$

The shunt impedance Z_m remains the same as before. The input impedance is then

$$Z_{\text{in}} = 0.30 + j0.35 + \frac{13.12/83.72^\circ(0.377/68.20^\circ)}{13.12/83.72^\circ + 0.377/68.20^\circ} = 0.816/57.92^\circ \Omega$$

$$I_1 = \frac{127/0^\circ}{0.816/57.92^\circ} = 155.58/-57.92^\circ \text{ A}$$

$$V_A = 127 - 155.58/-57.92^\circ(0.30 + j0.35) = 57.07/-10.73^\circ \text{ V}$$

$$I_2 = \frac{57.07 / -10.73^\circ}{0.377 / 68.2^\circ} = 151.38 / -78.93^\circ \text{ A}$$

The total torque is

$$T_m = \frac{90|I_2|^2 R_2}{\pi n_s s} = \frac{90(151.38)^2(0.14)}{\pi(1200)(1)} = 76.59 \text{ N} \cdot \text{m/rad}$$

This torque is 1.25 times the rated running torque for this particular machine. A majority of induction motors will have a starting torque which is about double the rated running torque.

The total three-phase losses will be

$$P_{\text{loss}} = \frac{3(57.07)^2}{120} + 3(155.58)^2(0.30) + 3(151.38)^2(0.14) = 31,500 \text{ W}$$

This number is about 30 times the loss term for the machine operating at full load. Also, when the machine is not rotating, it is not able to circulate any air for cooling, which makes the temperature rise even more severe. The stator windings will have the most rapid temperature rise for starting conditions because of higher resistance, lower specific heat capacity, and poorer heat conductivity than the rotor windings. This temperature rise may be on the order of 10°C/s as long as the rotor is not moving. Obviously, the motor will be damaged if this locked rotor situation continues more than a few seconds.

An unloaded motor will typically start in 0.05 s and one with a typical load will usually start in less than 1 s, so this heating is not normally a problem. If a very high inertia load is to be started, such as a large Darrieus, a clutch may be necessary between the motor and the turbine. Very large motors may need special starting techniques even with a clutch. These will be discussed in the next section.

Example

The induction machine of the previous example is operated as a generator at a slip of -0.025. Terminal voltage is 220 V line to line. Find I_1 , I_2 , input power P_m , output power P_e , reactive power Q , and efficiency η_g . If the rated I_1 is 25 A when operated as a motor, comment on the amount of overload, if any.

From the previous example we have $V_1 = 127/0^\circ$. The impedance Z_2 is given by

$$Z_2 = \frac{0.14}{-0.025} + j0.35 = 5.61 / 176.42^\circ \ \Omega$$

$$Z_{\text{in}} = 0.30 + j0.35 + \frac{13.12/83.72^\circ(5.61/176.42^\circ)}{13.12/83.72^\circ + 5.61/176.42^\circ} = 5.16 / 147.90^\circ \ \Omega$$

$$I_1 = -\frac{127/0^\circ}{5.16/147.90^\circ} = -24.60 / -147.90^\circ = 24.60 / 32.10^\circ \text{ A}$$

$$V_A = 127 + 24.60/\underline{32.10^\circ}(0.30 + j0.35) = 129.16/\underline{4.98^\circ} \text{ V}$$

$$I_2 = \frac{-129.16/\underline{4.98^\circ}}{5.61/\underline{176.42^\circ}} = \frac{129.16/\underline{184.98^\circ}}{5.61/\underline{176.42^\circ}} = 23.02/\underline{8.56^\circ} \text{ A}$$

The total input mechanical power P_m is

$$P_m = \frac{3|I_2|^2 R_2(1-s)}{s} = \frac{3(23.02)^2(0.14)(1+0.025)}{-0.025} = -9125 \text{ W}$$

The machine was delivering 9.53 hp to the mechanical load as a motor, but is now requiring 12.23 hp as mechanical shaft power input as a generator. The total output power is

$$P_e = 3|V_1||I_1| \cos \theta = 3(127)(24.60) \cos(-32.10^\circ) = 7940 \text{ W}$$

The total reactive power Q is

$$Q = 3|V_1||I_1| \sin \theta = 3(127)(24.60) \sin(-32.10^\circ) = -4980 \text{ var}$$

The negative sign means that the induction generator is supplying negative reactive power to the utility, which is the same as saying it is receiving positive reactive power from the utility.

We can compute the efficiency by computing the losses from Eq. 49 and using Eq. 61, or we can merely take the ratio of output to input power.

$$\eta_g = \frac{|P_e|}{|P_m|} = \frac{7940}{9125} = 0.870$$

The output current of 24.60 A is slightly under the rated current of 25 A. If the machine is well ventilated, it should operate at this current level for an indefinite period of time.

6 MOTOR STARTING

Small induction motors with low to medium inertia loads are normally started by direct connection to a source of rated voltage. Above a rated power of a few kW, the high starting currents usually cause a reduction in line voltage. This reduction may prevent the motor from developing adequate torque to start its load. Electronic equipment and lighting circuits connected to the same source may also be affected by these voltage fluctuations. It is customary, therefore, to start the large induction motors on lowered voltages to limit the starting currents and line voltage fluctuations.

This practice is not essential if the supply has sufficient capacity to supply the starting current without objectionable voltage reduction. Motors with ratings up to several thousand

kW are routinely started across line voltage in generating stations, where a starting current of 5 to 10 times the rated current can easily be supplied. The motor itself will not be damaged by these high currents unless they are sustained long enough to overheat the motor.

There are three basic ways to accomplish reduced-voltage starting. These are illustrated in Fig. 20.

1. Line resistance or reactance starting uses series resistances or reactances in each line to provide a voltage drop and reduce the voltage at the motor terminals. After a suitable time delay these components are removed in one or more steps. The notation L_1 , L_2 , and L_3 refers to the three phases of the incoming power line.
2. Autotransformer starting uses tapped autotransformers to reduce the motor voltage. These taps normally provide between 50 and 80 percent of rated voltage.
3. Wye-delta starting is used when the motor is designed for delta operation but has both ends of each phase winding available external to the motor. The phase windings are reconnected by contactors into a wye circuit for starting. Once the motor is running, it is changed back to its normal delta configuration. This technique reduces the voltage seen by each phase by the factor $\sqrt{3}$.

Complete circuits would include push button start and stop, fuses, and undervoltage protection as well as other features to meet electrical codes. In each case a triple-pole switch is moved to the start position until the motor has accelerated the load to almost full speed, and then rapidly thrown to the run position, so that the motor is connected directly across the line.

The autotransformer has the same characteristic as a two winding transformer in that the input and output apparent power in kVA have to be the same, except for any transformer losses. Fig. 21 shows an autotransformer supplying power to an induction motor. V_L and I_L are the voltage and current supplied by the line and V_1 and I_1 are the voltage and current delivered to the motor. For an ideal transformer

$$V_L I_L = V_1 I_1 \quad (70)$$

Transformer operation requires that V_1 be less than V_L , which means I_L will be less than I_1 . Because of the nature of the load, when V_1 is reduced below its rated value, I_1 will also be reduced. The starting current supplied by the line is therefore reduced by both the autotransformer action and by the reduced motor voltage, which makes autotransformer starting rather popular on limited capacity lines.

Example

An autotransformer starting system is used to reduce the voltage to the motor of the examples in the previous section to 0.6 of its rated value. Find the motor starting current I_1 , the line current input I_L to the autotransformer, the total motor losses at start, and the total starting torque.

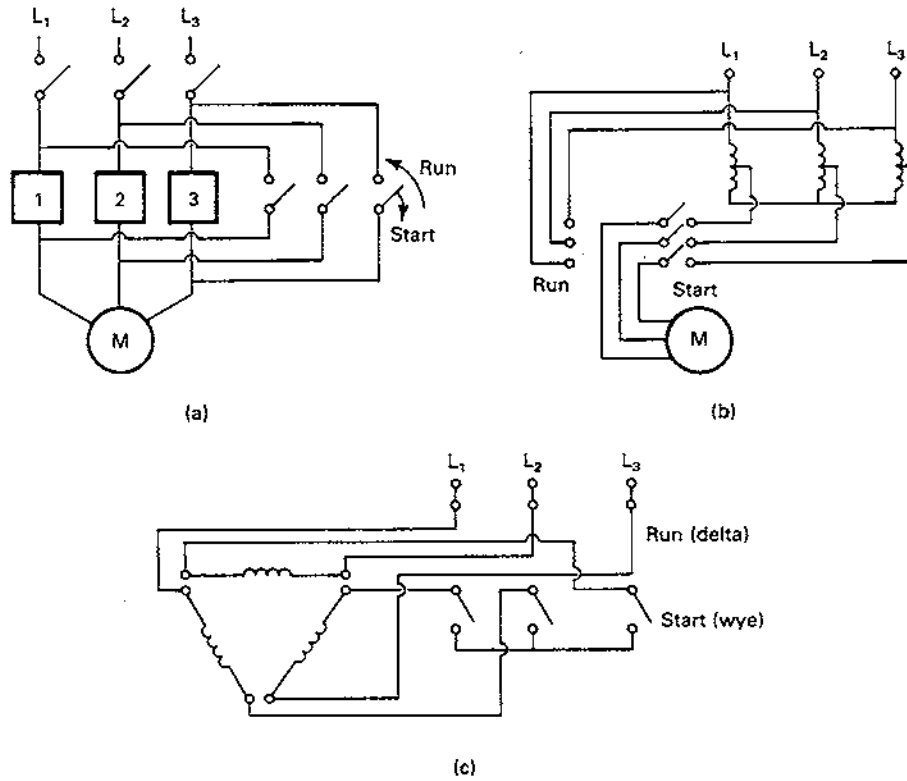

Figure 20: Starting methods for induction motors: (a) line resistance or reactance starting; (b) autotransformer starting; (c) wye-delta starting.

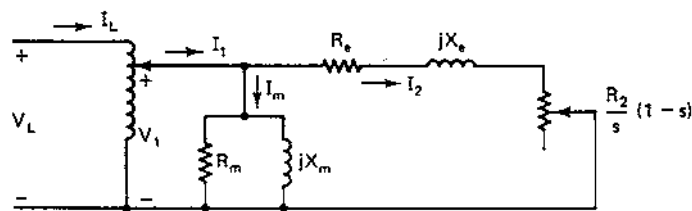

Figure 21: Circuit for autotransformer start of induction motor.

The applied voltage to the motor is

$$V_1 = 0.6(127) = 76.2 \text{ V/phase}$$

The input starting current is also 0.6 of its value from the previous example on motor starting current.

$$I_1 = 0.6(155.58 \angle -57.92^\circ) = 93.35 \angle -57.92^\circ \text{ A}$$

Similarly,

$$I_2 = 0.6(151.38/\underline{-78.93^\circ}) = 90.83/\underline{-78.93^\circ} \text{ A}$$

From Eq. 70 the input current to the autotransformer is

$$I_L = \frac{V_1 I_1}{V_L} = \frac{(76.2)(93.35/\underline{-57.92^\circ})}{127} = 56.01/\underline{-57.92^\circ} \text{ A}$$

This is only a little more than twice the rated running current of the motor, hence should not cause substantial voltage fluctuations.

The total motor losses will be

$$P_{\text{loss}} = \frac{3[(0.6)(57.07)]^2}{120} + 3(93.35)^2(0.30) + 3(90.83)^2(0.14) = 11,340 \text{ W}$$

which is $(0.6)^2 = 0.36$ of the losses during the full voltage start. This is still an order of magnitude greater than the operating losses at full load and would result in damage to the motor if it does not start within 10 to 20 seconds.

The total starting torque is

$$T_m = \frac{90(90.83)^2(0.14)}{\pi(1200)(1)} = 27.57 \text{ N} \cdot \text{m/rad}$$

which is about 46 percent of rated torque. If this torque is not adequate to start the motor load, then the autotransformer taps can be changed to provide a larger starting voltage of perhaps 0.7 or 0.8 times rated voltage, at the expense of larger line currents.

7 CAPACITY CREDIT

Wind generators connected to the utility grid obviously function in the role of fuel savers. Their value as a fuel saver may be quite adequate to justify their deployment, especially in utilities that depend heavily on oil fired generating plants. The value to a utility may be increased, however, if the utility could defer building some conventional generating plants because of the wind turbines presence on the grid. Wind generators would have to have some effective load carrying capability in order to receive such a capacity credit.

Some may feel that since the wind may not blow at the time of the yearly peak load that the utility is forced to build generation equipment to meet the load without considering the wind, in which case the wind cannot receive a capacity credit. This is not a consistent argument because any generating plant may be unavailable at the time of the peak load, due to equipment failure. The lack of wind is no different in its effect than an equipment failure, and can be treated in a standard mathematical fashion to determine the effective capacity of the wind generator.

One way of approaching the question of capacity credit is to consider the wind turbine as an alternative to other types of generation which might be installed by the utility. There is general agreement that the correct criterion for the economic selection of a generating unit is that its cost, when combined with the costs of other generating units making up a total electric utility generating system, should result in a minimum cost of electricity. The established method of checking this criterion is to simulate the total utility system cost over a period of time which represents a major fraction of the life of the unit being considered. The first step in this process is to define alternate expansions of the system capacity which will have equal reliability in serving the forecasted load. Annual production costs (fuel, operation and maintenance) are determined by detailed simulation methods. To these costs are added annual fixed charges on investment, giving total annual revenue requirements. The expansion having lowest present worth of revenue requirements is the economic choice. These economic terms will be discussed further in Chapter 8. The procedures of total utility system cost analysis have been understood and applied for many years, but tend to be complex, costly to use, and time consuming. There is thus a natural tendency to use shortcuts, at least in preliminary analyses.

One shortcut to the detailed simulation method which normally extends over 20 to 30 years is a detailed simulation for a single year. The effect of a changing mix of generation on future production costs can be approximately evaluated by selecting two years for detailed simulation, one at the beginning of the study period and the other at the end. This shortcut will normally give adequate results for preliminary analyses.

This simulation requires that we have a complete year of hourly wind data. This needs to be as typical as possible, which is difficult to determine because of the inherent variability of the wind. If the simulation results of one year suggest that the wind generator may be economically feasible, then perhaps nine other years of wind data need to be passed through the computer. The range of system yearly costs will help establish the actual economic feasibility of the wind generator. Such long time spans of good wind data collected at hub height, or at least 50 m, are not readily available, but are badly needed for these analyses.

Production costs for the simulation year are determined by standard utility techniques. Each generating plant is assigned a scheduled maintenance period. This is a period of typically 4 to 6 weeks each year for coal and nuclear plants, during which the plant is shut down, the turbine is taken apart and cleaned, and other routine and preventive maintenance is performed. These periods are normally scheduled during staggered periods in the spring and fall when the demand for electricity is relatively low.

Operation of the remaining units is scheduled on a chronological, hourly basis. The most economical plants are placed in service first and the least economical last. Nuclear plants have low fuel costs so are operated at maximum power as much as possible. Such plants which are operated a maximum amount are called *base load* plants. Base load coal units are scheduled next, followed by intermediate load and load following coal and oil fired units, which are followed by oil and gas fired peaking turbines. Generation with zero fuel cost, such as hydro and wind, is used as much as possible to reduce operating costs.

The utility bases its plans for expansion on the need to maintain a reliable system. Utilities try to maintain a total installed capacity at least 15 percent greater than the expected yearly peak load. This allows them to continue to meet the required load even if a large generating plant has a forced outage. When the load is not at its peak, several generating plants may have forced outages without affecting the ability of the utility to meet its load with its own generation.

There is a certain probability of a forced outage occurring during a daily operation cycle. This probability varies with the type, age, and general condition of the generating plant. A typical forced outage rate for a hydro plant may be 1.5 percent, while that of a coal fired plant may be 5 percent. A 5 percent forced outage rate means that, on the average, a given plant will be out of service at least a part of the day for one day out of twenty. Forced outages typically take the plant out of service for at least 24 hours before repairs are made and the plant is put back on the line, so the daily peak load would normally occur while the forced outage is present. This means that the daily peak is used in determining reliability of a system rather than hourly loads.

The probability of two generating plants being on forced outage at the same time is just the product of the probabilities that either one will be out. If each has a forced outage rate of 0.05, the probability of both being forced out at the same time is $(0.05)^2 = 0.0025$ or about 0.91 days per year. The probability of additional generation being out at this same time is still smaller, of course.

Suppose for the sake of illustration that we have a utility system with ten 700 MW generators, each with a forced outage rate of 0.05. Suppose that the load for several days is as shown in Fig. 22. The peak load for the first day is between 4900 and 5600 MW, so three generating plants have to be out of service before the utility is unable to meet its load. Two plants being out will cause a loss of load on the third day while four plants would have to be out on the fifth day to cause a loss of load. If the load ever exceeds 7000 MW then the probability of generation being inadequate that day is 1.0

Each day has a certain probability R_d (daily risk) that generation will be inadequate to meet the load. If we add these daily risks for an entire year, we get an annual risk R_a , expressed in days per year that generation will be inadequate[3].

$$R_a = \sum_{i=1}^{365} R_d(i) \quad (71)$$

Example

The daily peak load on the model utility system of Fig. 22 is between 3500 and 4200 MW for 150 days of the year, between 4200 and 4900 MW for 120 days, between 4900 and 5600 MW for 60 days, and between 5600 and 6300 for 35 days. What is the annual risk R_a ?

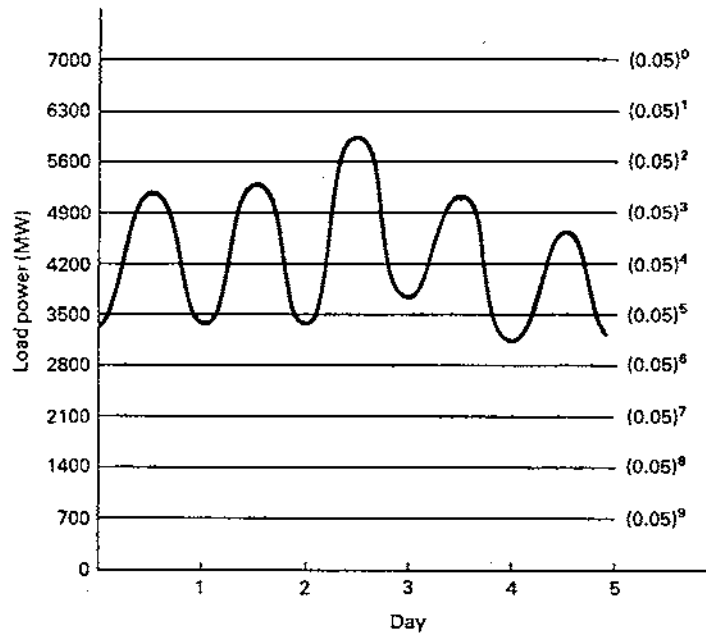

Figure 22: Load variation in model utility system.

$$\begin{aligned}
 R_a &= \sum_{i=1}^{365} R_d(i) = 150(0.05)^5 + 120(0.05)^4 + 60(0.05)^3 + 35(0.05)^2 \\
 &= 4.6875 \times 10^{-5} + 7.5 \times 10^{-4} + 7.5 \times 10^{-3} + 87.5 \times 10^{-3} \\
 &= 95.8 \times 10^{-3} = 0.0958 \text{ day per year}
 \end{aligned}$$

This result shows that generation is inadequate to meet load about 0.1 days per year or about one day in ten years. This level of reliability is a typical goal in the utility industry.

We see that a relatively small number of days with the highest peak load contributes the largest part of the annual risk. If these peaks could somehow be reduced through conservation or load management, system reliability would be improved.

It should be emphasized that even when load exceeds the rating of generators on a system, the utility may still meet its obligations by purchasing power from neighboring utilities or by dropping some less critical loads. Only when the generation of many utilities is inadequate will load actually be lost.

The effective capability or effective capacity of a proposed generating plant is determined in the following manner. The annual risk is determined for the original system for the year under investigation. This requires a loss-of-load probability calculation based on (1) the rating

of each generating plant and its forced outage rate, (2) the daily hourly-integrated peak loads (the greatest energy sales in any one hour of the day), (3) maintenance requirements for each unit, and (4) other special features such as seasonal deratings or energy interchange contracts. The single point resulting from this calculation is spread out into a curve by varying the assumed annual peak load for that year by ± 20 percent and each daily peak by the same fraction. As the assumed peak load increases for the same generation, the annual risk increases. A curve such as the original system curve of Fig. 23 is the result.

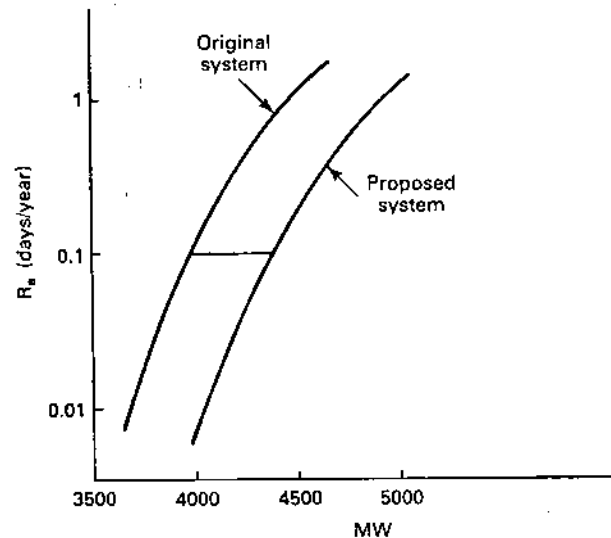

Figure 23: Annual risk before and after adding a new unit.

The proposed new generating plant is then added to the system while keeping all other data fixed. We again vary the annual peak load with the daily peaks considered as a fixed percentage of the annual peak. Adding this unit reduces the risk at a given load, so we consider a somewhat larger range of loads, perhaps a zero to 40 percent increase over the previous midpoint load. The result can be plotted into the second curve of Fig. 23. The distance in megawatts between these curves at the desired risk level is the amount of load growth the system can accept and still retain the same reliability. This distance is the effective capability or *effective capacity* of the new unit. The effective capacity will typically be between 60 and 85 percent of rated capacity for new fossil or nuclear power plants. If it is at 75 percent, this means that a 1000-MW generating plant will be able to support 750 MW of increased load. The remaining 250 MW will be considered reserve capacity.

The effective capacity is not identical to the capacity factor or plant factor, which was defined in Chapter 4 as the ratio of average power production to the rated power. Capacity factor is calculated independently of the timing of the load cycle, while effective capacity includes the effect of the utility hourly demand profile. Effective capacity may be either larger or smaller than the capacity factor. An oil fired gas turbine may have an actual

capacity factor of less than 10 percent because of the limited hours of operation, but have an effective capacity of nearly 90 percent because of its high availability when the peak loads occur. Wind electric plants will almost always be operated when the wind is available because of the zero fuel cost. If the wind blows at the rated wind speed half the time and is calm the other half of the time, then the capacity factor would be 0.5 except for the reduction due to forced and planned outages. If the winds occurred at the times of the utility peaks, then the effective capacity would be close to unity. However, if the wind is calm when the utility peaks are occurring, the effective capacity will be near zero. The timing of the wind plant output relative to the utility hourly demand profile is critical.

General Electric has performed a large study to determine the effective capacity of wind turbines on actual utility systems[5]. They selected a site in Kansas, another in New York, and two in Oregon. Detailed data for Kansas Gas and Electric, Niagara Mohawk, and the Northwest Power Pool were analyzed using state-of-the-art computer programs. Actual load data and actual wind data were used. Results are therefore rather specific and somewhat difficult to extrapolate to other sets of circumstances. However, they represent the best possible estimate of capacity factor and effective capacity that could be obtained at the time of the study, and are therefore quite interesting.

Figure 24 shows the effective capacity and capacity factor for wind turbines on the assumed 1990 Kansas Gas and Electric System. Dodge City wind data for the years 1950, 1952, and 1953 were used in the study. These wind data were recorded at 17.7 m and extrapolated to hub height of a model 1500 kW horizontal axis, constant speed wind turbine by the one-seventh power law equation. A total wind generation capacity of 163 MW or 5 percent of total capacity was assumed. This is often referred to as a *penetration* of 5 percent. A forced outage rate of 5 percent was also assumed. There is no energy storage on the system.

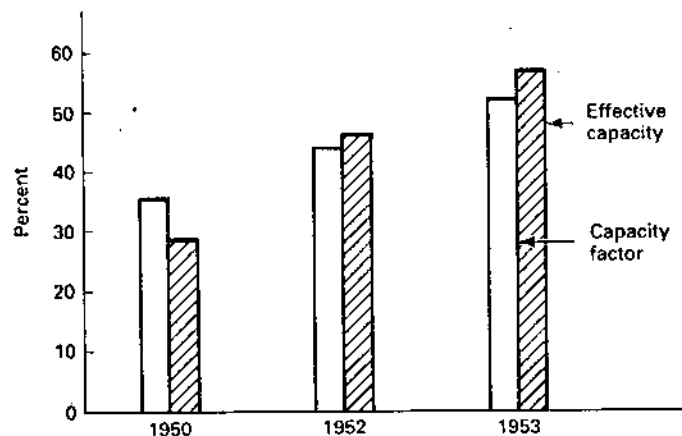

Figure 24: Impact of weather year on capacity factor and effective capacity.

It may be seen that effective capacity varies from less than 30 percent in 1950 to almost

60 percent in 1953. It can also be seen that the effective capacity is slightly larger than the capacity factor for two years and smaller for the third year. The particular year of wind data thus makes a substantial impact on the results. The representiveness of the year or years selected must therefore be considered before any firm conclusions are drawn.

The theoretical output of a MOD-0 located at Dodge City was determined for the years 1948 through 1973 in an attempt to determine the year-to-year variability[6]. The monthly energy production of each m^2 of turbine swept area is shown in Table 5.2 for each of the years in question, as well as the mean and standard deviation for all 26 years. The yearly standard deviation of 39.97 kWh/m^2 was computed from the yearly means rather than the sum of the monthly standard deviations. It may be seen that 1950 was two standard deviations below the mean. The only year worse than 1950 in this 26 year period was 1961 with 349.6 kWh/m^2 . The year 1952 is close to the 26 year mean, but the summer months are somewhat above the mean, which tends to improve the effective capacity in this summer peaking utility. The year 1953 is about one standard deviation above the mean. The only year better than 1953 is 1964 with 518.8 kWh/m^2 . We see that the three years selected cover the range of possible performance rather well. As more and better wind data become available, statistical limits can be defined with greater precision and confidence. In the meantime, for Dodge City winds, Kansas Gas and Electric loads, and a model 1500 kW wind turbine with 5 percent penetration, a reasonable estimate for capacity factor is a value between 35 and 50 percent. The corresponding estimate for effective capacity is between 30 and 55 percent of rated capacity. Other wind regimes and other load patterns may lead to substantially different results, of course.

The effective capacity of the wind plant tends to saturate as more and more of the utility generation system consists of this intermittent random power source. The study assumes that the wind is the same over the entire utility area (no wind diversity) so all the wind generators tend to act as a single generator. The utility needs to have enough generation to cover the loss of any one generator, so penetration levels above 15 or 20 percent of total system capacity would not have much effective capacity. Large amounts of storage would be required to maintain system reliability at higher penetration levels.

Figure 25 shows the variation in effective capacity with penetration for the four cases mentioned earlier. There is a wide variation, as might be expected, with Kansas Gas and Electric being the best and the Columbia River Gorge site of the Northwest Power Pool being the worst. The capacity factors for these two cases were almost identical, or about 45 percent for the wind years chosen. The reason for the low effective capacity at the Gorge site is that the bulk of the annual risk R_a is obtained from just a few days in the Northwest Power Pool, and the wind did not blow on those days in the particular wind year selected.

In a system like the Northwest Power Pool, wind diversity would be expected to improve the effective capacity, perhaps a significant amount. One test case showed that the combined output of wind turbines at both the Gorge and coast sites had a higher effective capacity than either site by itself. More computer studies are needed to determine the actual advantages of diversity.

Table 5.2 Theoretical Energy Production of MOD-0
Located at Dodge City (kWh/m²)

	1950	1952	1953	Mean	Standard Deviation
Jan.	31.6	34.1	40.2	36.3	3.85
Feb.	29.5	35.0	41.8	37.5	3.60
Mar.	38.5	41.0	42.8	41.9	3.79
Apr.	36.0	39.4	43.1	42.3	4.41
May	37.4	33.9	44.3	40.3	4.50
Jun.	38.9	43.5	50.5	39.7	6.72
Jul.	26.8	41.5	38.2	35.3	6.40
Aug.	22.9	36.4	37.3	34.3	6.55
Sep.	24.3	37.1	37.2	37.2	4.58
Oct.	31.3	31.1	41.0	36.7	4.57
Nov.	28.2	36.4	37.9	35.1	5.39
Dec.	22.2	30.5	39.7	37.8	6.27
	367.7	440.1	493.8	454.4	39.97

It would appear from the limited data that effective capacities of wind turbines may vary from 10 to 60 percent for initial penetrations and from 5 to 45 percent at 5 percent penetration. Hopefully, wind diversity will raise the lower limit to at least 15 or 20 percent. We conclude, therefore, that wind turbines do have an effective capacity and that any complete cost analysis should include a capacity credit for the wind machines as well as a fuel savings credit.

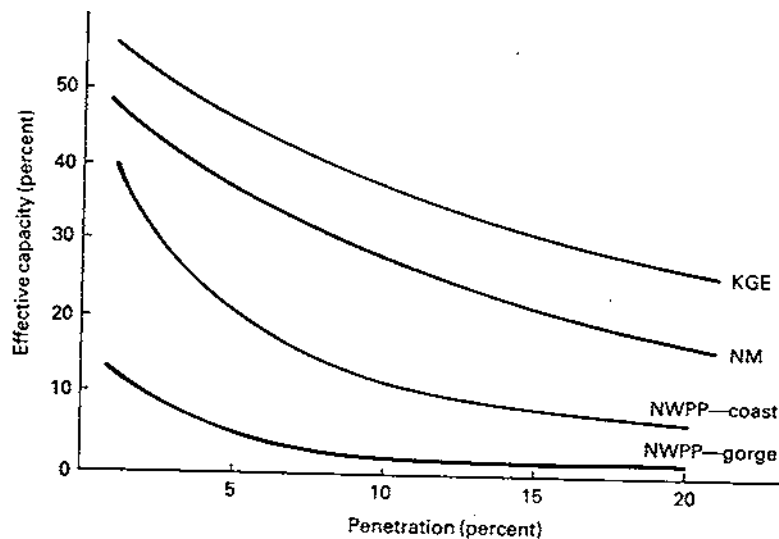

Figure 25: Wind power plant effective capacity versus penetration.

The actual capacity displaced, D_c , depends on the effective capacities of both the wind

plant and the displaced conventional plant.

$$D_c = P_{eR} \frac{E_w}{E_c} \quad (72)$$

In this equation D_c is the displaced conventional capacity in kW or MW, P_{eR} is the rated power of the wind plant, E_w is the effective capacity of the wind plant, and E_c is the effective capacity of the conventional plant.

Example

A utility planning study shows that it needs to add 700 MW of coal fired generation to its system to maintain acceptable reliability. The effective capacity of this generation is 0.75. What nameplate rating of wind turbines with an effective capacity of 0.35 is required to displace the 700 MW of coal generation?

From Eq. 72,

$$P_{eR} = D_c \frac{E_c}{E_w} = 700 \left(\frac{0.75}{0.35} \right) = 1500 \text{ MW}$$

For this particular situation, 1500 MW of wind generation is required to displace 700 MW of coal generation from a reliability standpoint. If, for example, the capacity factor of the coal generation was 0.7 and 0.4 for the wind generation, the wind turbines would produce more energy per year than the displaced coal plant. This means that less fuel would be burned at some existing plant, so the wind turbine may have both capacity credit and fuel saving credit. The utility system must meet both reliability and energy production requirements, so adding wind turbines to maintain reliability may force the capacity factors of other plants on the utility system to change. An example of the economic treatment of this situation is given in Chapter 8.

8 FEATURES OF THE ELECTRICAL NETWORK

The electrical network in which the wind electric generators must operate is a rather sophisticated system. We need to examine its organization so that we can better understand the interaction of the wind generator with the electric utility.

Figure 26 shows a one line diagram of a portion of an electric utility system. Power is actually transferred over three-phase conductors, but one line is used to represent the three conductors to make the drawing easier to follow. We start the explanation of this figure with the generating plant. This could be a large coal or nuclear plant, or perhaps a smaller gas or oil fired generator. The generation voltage is limited to about 25,000 volts because of generator insulation limitations. This is too low for long distance transmission lines, so it is increased through a step-up transformer to one of the transmission voltages for the particular utility. Some utilities use 115 kV, 230 kV, and 500 kV while others use 169 kV, 345 kV, and 765 kV. The higher voltage lines are used for transmitting greater power levels over longer distances.

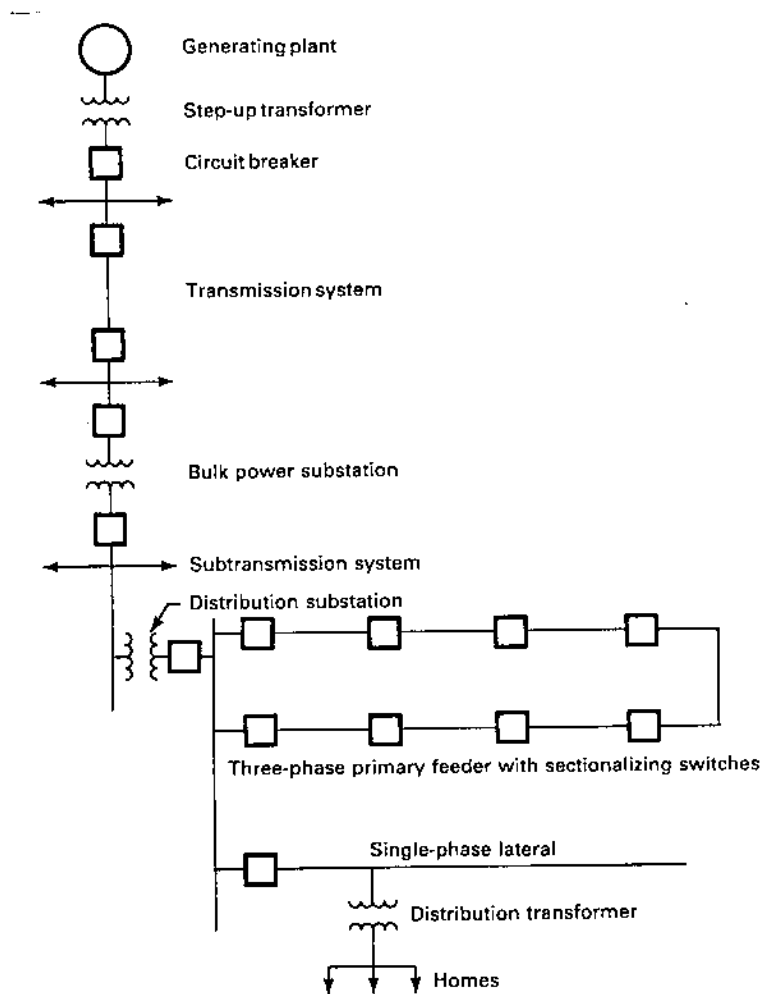

Figure 26: Typical electric utility system.

The next component shown in the one line diagram is a circuit breaker. This device is able to interrupt large current flows and protect the various system components from short circuits. If the short circuit were allowed to continue for a long period of time, even the transmission line would overheat and be destroyed. The circuit breaker is activated by protective relays which sense such parameters as voltage levels, current levels, frequency, and phase sequence on the power line.

The power flows through the transmission line until it reaches a bulk power substation. This is a collection of circuit breakers, switches, and transformers which connects the transmission line to several lines in the subtransmission system if the utility has such a system.

The power then flows to a distribution substation where it is stepped down to distribution

voltages. The substation may feed a loop where every point in the loop can be reached from two directions. This organization allows most of the loads along such a primary feeder to be served even if a section of distribution line is not operable, due to storm damage, for example.

There will also be single-phase lateral or radial lines extending out from the distribution substation. These are connected to distribution transformers to supply 120/240 volts to homes along the line. These lines generally operate at voltages between 2.4 and 34.5 kV. These circuits may be overhead or underground, depending on the load density and the physical conditions of the particular area to be served. Substation transformer ratings may vary from as small as 1000 to 2500 kVA for small rural applications up to 50,000 or 60,000 kVA. Distribution transformer ratings are typically between 5 and 50 kVA.

The first responsibility of the design engineer is to protect all the utility equipment from faults on the system. These faults may be caused by lightning, storm damage, or equipment malfunction. When a fault occurs, line currents will be much larger than normal and a circuit breaker will open the line. A simple distribution substation protection scheme is shown in Fig. 27. The circuit breakers are adjusted so only the one nearest the fault will open. That is, if a fault occurs on the load side of circuit breaker CB4, only CB4 will open. The others will remain closed. Many of the circuit breakers in use are of the automatic reclosing variety, where the circuit breaker will automatically reclose after a fraction of a second. If the fault was caused by lightning, as it normally is, the electric arc between conductors will have time to dissipate while the breaker is open, so service is restored with minimum inconvenience to the customer. If the fault is still present when the breaker closes, it will open again, wait a fraction of a second, and close a second time. If the fault is still present, the breaker will open and remain open until the maintenance crew repairs the problem.

The larger transformers will be protected by differential current relays. This is a relay which compares the input and output current of a transformer and opens a breaker when the current ratio changes, indicating a fault within the transformer. There may be an underfrequency relay which will open a breaker if the utility frequency drops below some specified value. A number of other protective devices are used if required by the particular situation.

Once the system is properly protected, the quality of electricity must be assured. Quality refers to such factors as voltage magnitude, voltage regulation with load, frequency, harmonic content, and balance among the three phases. The electric utility goes to great lengths to deliver high quality electricity and uses a wide variety of methods to do so. We shall mention only the methods of controlling voltage magnitude.

The voltage in the distribution system will vary with the voltage coming in from the transmission lines and also with the customer load. It is adjusted by one or more of three possible methods. These are transformer load tap changing, voltage regulators, and capacitor banks. In the tap changing case, one of the transformer windings will have several taps with voltage differences of perhaps two percent of rated voltage per tap. The feeders can be connected to different taps to raise or lower the feeder voltage. This is done manually, perhaps on a seasonal basis, but can also be done automatically. Automatic systems allow the taps to

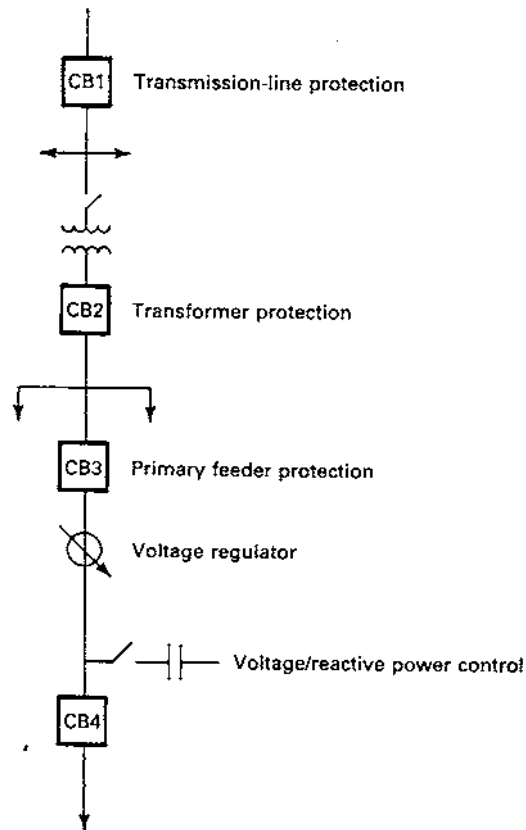

Figure 27: Distribution substation protection.

be changed several times a day to reflect changing load conditions.

The voltage regulator acts as an autotransformer with a motor driven wiper arm. This can adjust voltage over a finer range than the tap changing transformer and responds more rapidly to changes in voltage. It would be continually varying throughout the day as the loads change.

Capacitor banks are used to correct the power factor seen by the substation toward unity. This reduces the current flow in the lines and raises the voltage. They are commonly used on long distribution lines or highly inductive loads. They may be located at the substation but are often scattered along the feeder lines and at the customer locations. They may be manually operated on a seasonal basis or may be automatically switched in or out by a voltage sensitive relay.

All of these voltage control devices operate on the assumption that power flows from the substation to the load and that voltage decreases with increasing distance from the substation. A given primary feeder may have 102 percent of rated voltage at the substation and 98 percent

at the far end, for example. This assumption is not necessarily valid when wind generators are added to the system. Power flow into the feeder is reduced and may even be reversed, in which case the line voltage will probably increase as one gets closer to the wind generator. We may have a voltage regulator that is holding the primary feeder voltage at 102 percent of rated, as before, but now the voltage at the far end may be 106 percent of rated, an unacceptably high value. It should be evident that wind generators can not be added to a distribution system without careful attention being given to the maintenance of the proper voltage magnitude at all points on the system.

We see in this simple example a need for greater or more sophisticated monitoring and control as wind generators are added to a power system. Existing power systems already have very extensive monitoring and control systems and these are becoming increasingly more complex to meet the needs of activities like load management and remote metering. We shall now briefly examine utility requirements for monitoring and control of their systems.

The structure of the power monitoring and control system in the United States is shown in Fig. 28. It can be seen that there are many levels in this system. At the top is the National Electric Reliability Council and the nine Regional Councils. These Regional Councils vary in size from less than one state (Electric Reliability Council of Texas (ERCOT)) to the eleven western states plus British Columbia (Western Systems Coordinating Council (WSCC)). Some of the Regional Councils function as a single power pool while others are split into smaller collections of utilities, covering one or two states. A *power pool* is a collection of neighboring utilities that cooperate very closely, both in daily operation of an interconnected system and in long range planning of new generation.

The reliability councils are primarily concerned with the long range planning and the policy decisions necessary to assure an adequate and reliable supply of electricity. They are usually not involved with the day to day operation of specific power plants.

Each power pool will have an operating center which receives information from its member utilities. This operating center will also coordinate system operation with other power pools.

Each large power plant will have its own control center. There may also be distribution dispatch centers which control the operation of substations, distribution lines, and other functions such as solar thermal plants, wind electric generators, storage systems, and load management, and gather the necessary weather data. Some utilities will not have separate distribution dispatch centers but will control these various activities from the utility dispatch center.

It should be mentioned that each utility is a separate company and that their association with one another in power pools is voluntary. The utilities will coordinate both the long term planning of new power plants and the day to day operation of existing plants with their neighbors in order to improve reliability and to reduce costs. Each utility tries to build enough generation to meet the needs of its customers, but there are periods of time when it is economically wise for one utility to buy electricity from another. If load is increasing by 100 MW per year and a 700-MW coal plant is the most economical size to build, a utility

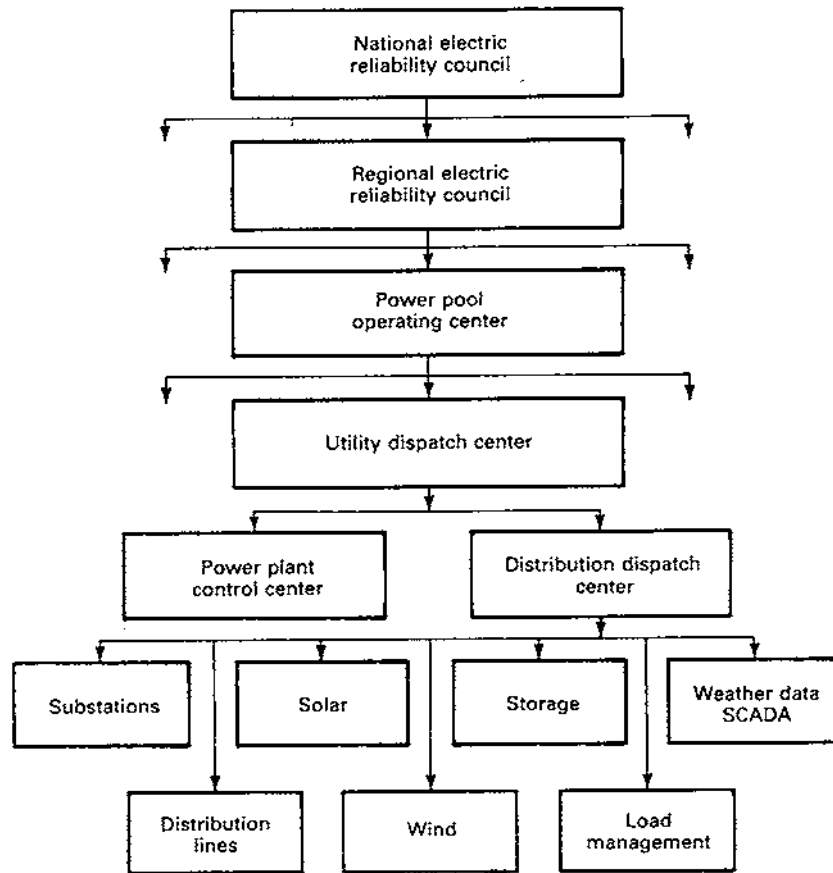

Figure 28: Monitoring and control hierarchy.

may want to buy electricity from another utility for two or three years before this coal plant is finished and then sell the surplus electricity for three or four years until the utility is able to use all of its capacity.

There are also times when short term sales are economically wise. One utility may have an economical coal plant that is not being used to capacity while an adjacent utility may be forced to use more expensive gas turbines to meet its load. The first utility can sell electricity to the second and the two utilities can split the cost differential so that both utilities (and their customers) benefit from the transaction. Such transactions are routinely handled by the large computers at the power pool operating center. Each utility provides information about their desire to buy or sell, and the price, to this central computer, perhaps once an hour. The computer then matches up the buyers and sellers, computes transmission line costs, and sends the information back to the utility dispatch centers so the utility can operate its system properly.

The power pool operating center will also receive status information on the large power plants and major transmission lines from the dispatch centers for emergency use. If a large power plant trips off line due to equipment malfunction, this information is communicated to all the utilities in the pool so that lightly loaded generators can be brought up to larger power levels, and one or more standby plants can be started to provide the desired spinning reserve in case another plant is lost. *Spinning reserve* refers to very lightly loaded generators that are kept operating only to provide emergency power if another generator is lost.

Power flows may also be coordinated between power pools when the necessary transmission lines exist. The southern states have a peak power demand in the summer while the northern states tend to have a winter peak, so power flows south in the summer and north in the winter to take economic advantage of this diversity.

Since the wind resource is not uniformly distributed, there may be significant power flows within and between power pools from large wind turbines. These power flows can be handled in basically the same way as power flows from other types of generation. The challenge of properly monitoring and controlling wind turbines is primarily within a given utility, so we shall proceed to look at this in more detail.

Most utilities have some form of *Supervisory Control And Data Acquisition* (SCADA) system. The SCADA system will provide the appropriate dispatch center with information about power flows, voltages, faults, switch positions, weather conditions, etc. It also allows the dispatch center to make certain types of adjustments or changes in the system, such as opening or closing switches and adjusting voltages.

The exact manner of operation of the SCADA system depends on the operating state of the power system. In general, a power system will be found in one of five states: normal, alert, emergency, in extremis, and restorative. The particular operating state will affect the operation of the wind generators on the system, so we shall briefly examine each state[1].

In the *normal* operating state, generation is adequate to meet existing total load demand. No equipment is overloaded and reserve margins for generation and transmission are sufficient to provide an adequate level of security.

The *alert* state is entered if the probability of disturbance increases or if the system security level decreases below a particular level of adequacy. In this state, all constraints are satisfied, such as adequate generation for total load demand, and no equipment is overloaded. However, existing reserve margins are such that a disturbance could cause overloads. Additional generation may be brought on line during the alert state.

A severe disturbance puts the system in the *emergency* state. The system is still intact but overloads exist. Emergency control measures are required to restore the system to the alert or to the normal state. If the proper action is not taken in time, the system may disintegrate.

When system disintegration is occurring, the power system is in the *in extremis* state. A transmission line may open and remove most of the load from a large generator. The generator speeds up and its over-frequency relay shuts it down. This may make other generation inad-

equate to meet load, with generators and transmission lines turning off in a domino fashion. Emergency control action is necessary in this state to keep as much of the system as possible from collapse.

In the *restorative* state, control action is taken to pick up lost load and reconnect the system. This can easily take several hours to accomplish.

System disintegration may result in wind generators operating in an island. A simple island, consisting of two wind turbines, two loads, and a capacitor bank used for voltage control in the normal state, is shown in Fig. 29. If the wind turbines are using induction generators, there is a good possibility that these generators will draw reactive power from the capacitor bank and will continue to supply real power to the loads. This can be a planned method of operating a turbine independently of the utility system, as we shall see in the next chapter. Without the proper control system, however, the voltage and frequency of the island may be far away from acceptable values. Overvoltage operation may damage much of the load equipment as well as the induction generators themselves. Frequencies well above rated can destroy motors by overspeed operation. Under frequency operation may also damage motors and loads with speed sensitive oiling systems, including many air conditioning systems.

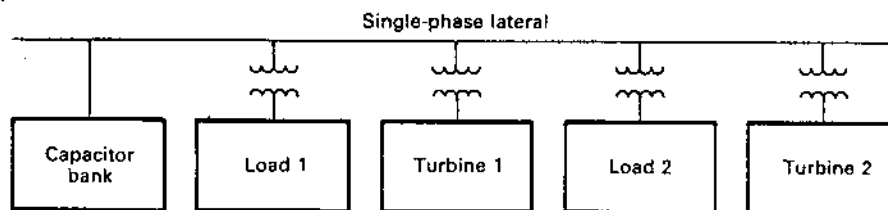

Figure 29: Electrical island.

In addition to the potential equipment problems, there is also a safety hazard to the utility linemen. They may think this particular section of line is dead when in fact it is quite alive. In fact, because of the self-excitation capability of the induction generator, the line may change from dead to live while the linemen are working on it, if the wind turbines are not placed in a stop mode.

All of these problems can be handled by proper system design and proper operating procedures, but certain changes in past operating procedures will be necessary. In the past, the control, monitoring, and protection functions at a distribution substation have generally been performed by separate and independent devices. Information transfer back to the dispatch center was very minimal. Trouble would be discovered by customer complaints or by utility service personnel on a regular maintenance and inspection visit to the substation. An increasing trend is to install SCADA systems at the substations and even to extend these systems to the individual customer. A SCADA system will provide status information to the dispatcher and allow him to make necessary adjustments to the distribution system. At the customer level, the SCADA system can read the meter and control interruptible loads such

as hot water heaters. Once the SCADA system is in place, it is a relatively small incremental step to measure the voltage at several points along a feeder and adjust the voltage regulator accordingly. This should minimize the effect of wind generators on the distribution lines.

At the next level of control, the larger wind electric generators will have their own computer control system. This computer could be intertied with the SCADA system so the utility dispatcher would know the wind generator's power production on a periodic basis. It would be desirable for the dispatcher to be able to shut the wind turbine down if a severe storm was approaching the turbine, for example. It would also be desirable for the dispatcher to be able to shut the turbine down in emergency situations such as islanding. There may also be times when the utility cannot effectively use the wind power produced that the dispatcher would also want to turn the turbine off. This would normally occur late at night when the electrical demand is at its minimum and the large steam turbine generators on the utility system have reached their minimum power operating point. The large generators will be needed again in a few hours but have to operate above some minimum power in the meantime. Otherwise they have to be shut down and restarted, a potentially long and expensive operation. It would be more economical for the utility to shut down a few wind turbines for a couple of hours than to shut down one of their large steam units.

The division of computer functions between the dispatch center and a wind turbine presents a challenge to the design engineer. As much local control as possible should be planned at the wind turbine, to improve reliability and reduce communication requirements. One possible division of local and dispatcher control is shown in Table 5.3. At the wind turbine is the capability to sense wind conditions, start the turbine, shut it down in high winds, synchronize with the utility grid, and perhaps to deliver acceptable quality power to an electrical island or an asynchronous load. There are also sensors and a communication link to supply information to the dispatch center on such things as operating mode (is the turbine on or off?), power flow, voltage magnitude, and the total energy production for revenue metering purposes. The dispatch center will examine these parameters on a regular basis, perhaps once an hour, and also immediately upon receipt of an alarm indication. The dispatch center may also be able to turn the turbine on or off, or even to change the power level of a sophisticated variable-pitch turbine.

The benefits of such two-way communication and control can be significant. It can improve system reliability. It can also improve operating economics. It may even be able to control operation of electrical islands. Certainly, it will help to reduce equipment losses from system faults, and to improve the safety of maintenance operations.

The costs can also be quite significant. A utility considering a new distribution dispatch center can expect the building, interfaces, displays, information processors, and memory to an installed cost of at least \$700,000 in 1978 dollars[2]. A FM communications tower which can service an area of 30 to 40 km in radius would cost another \$50,000. At each wind generator, the cost of communications equipment, sensors, and control circuitry could easily exceed \$10,000. This does not include the circuit breakers and other power wiring.

TABLE 5.3 Communication and Control
between a Large Wind Turbine Generator
and a Dispatch Center

Under Local Control
(a) Start Capability
(b) Synchronization
(c) Stand-Alone Capability
(d) Protection
Information to Dispatch Center
(a) Operating Mode (on/off)
(b) Power Flow
(c) Voltage Magnitude
(d) Revenue Metering
Control from Dispatch Center
(a) Change Operating Mode
(b) Change Power Level

If there were 75 wind turbines being monitored and controlled by the dispatch center, and all the dispatch center costs were to be allocated to them, each wind turbine would be responsible for \$10,000 of equipment at the dispatch center and another \$10,000 of equipment at the turbine. This \$20,000 would present a major obstacle to the purchase of a 5 kW wind generator priced at \$8000, but not nearly as much of an obstacle to a 2.5 MW wind generator priced at \$2,000,000. In one case the monitoring and control equipment cost 2.5 times as much as the wind generator itself, and only 1 percent of the wind generator cost in the second case. This is another economy of scale for wind generators. In addition to turbine cost per unit area decreasing with size, and power output per unit area increasing with size because of greater height and therefore better wind speeds, the cost of monitoring and control per unit area also decreases with turbine size.

The probable result of these economic factors is that small wind generators, less than perhaps 20 kW maximum power rating, will not be monitored and controlled by a dispatch center. Each small wind generator will have its own start, stop, and protective systems. The utility will somehow assure itself that voltage magnitudes are within acceptable limits and that electrical islands cannot operate on wind power alone and continue to operate the system in a manner much like the past. This should be satisfactory as long as the total installed wind generator capacity is significantly less than the minimum load on a feeder line.

On the other hand, large wind turbines will almost certainly be monitored and controlled by the appropriate dispatch center. This control can result in significant benefits to both the utility and the wind turbine, with acceptable costs.

9 PROBLEMS

1. In the circuit of Fig. 30, the applied single-phase voltage is 250 V and the frequency is 60 Hz. The magnitude of the current in the series RL branch is $|I_2| = 10$ A.

- What is the real power supplied to the circuit?
- What is the net reactive power supplied to the circuit? Is it positive or negative?
- What is the power factor of the circuit and is it leading or lagging?

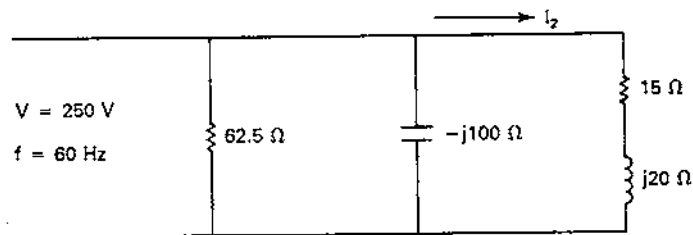

Figure 30: Circuit diagram for Problem 1.

2. In the circuit of Fig. 31, a total real power of 4000 W is being supplied to the single-phase circuit. The input current magnitude is $|I_1| = 8$ A.

- Find $|I_2|$.
- Find $|V_2|$.
- Assume that $V_2 = |V_2|/0^\circ$ and draw V_2 , I_2 , I_c , and I_1 on a phasor diagram.
- Determine X_C .

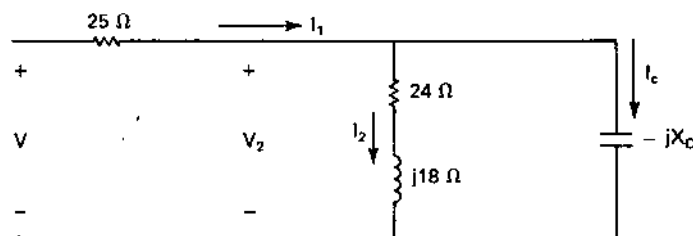

Figure 31: Circuit diagram for Problem 2.

3. A load connected across a single-phase 240-V, 60-Hz source draws 10 kW at a lagging power factor of 0.5. Determine the current and the reactive power.

4. A small industry has a number of induction motors which require a total apparent power of 100 kVA at a lagging power factor of 0.6. It also has 20 kW of resistance heating. What is the total apparent power required by the industry and what is the overall power factor?
5. A single-phase generator supplies a voltage E to the input of a transmission line represented by a series impedance $Z_t = 1 + j3 \Omega$. The load voltage V is $250 \angle 0^\circ$ V. The circuit is shown in Fig. 32.
- With switch S_1 open, calculate the current I_1 , and the real power, reactive power, and power factor of the load.
 - Calculate the generator voltage E .
 - Calculate the power lost in the transmission line.
 - With switch S_1 closed and the voltage V remaining at $250 \angle 0^\circ$, find the capacitor current I_c , the new input current I_1 , and the new overall power factor.
 - Calculate the new generator voltage and the new transmission line power loss.
 - List two advantages of adding a capacitor to an inductive load.

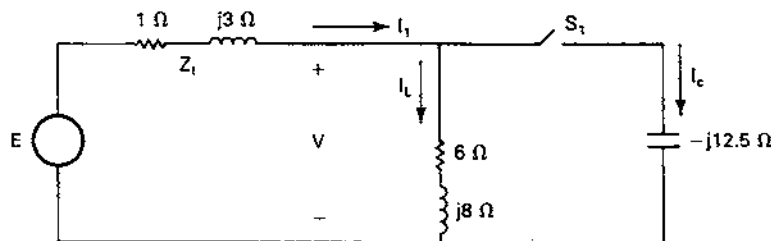

Figure 32: Circuit diagram for Problem 5.

6. A three-phase load draws 250 kW at a power factor of 0.707 lagging from a 440-V line. In parallel with this load is a three-phase capacitor bank which draws 60 kVA. Find the magnitude of the line current and the overall power factor.
7. A wind turbine of the same rating as the MOD-1 has a synchronous generator rated at 2000 kW (2500 kVA at 0.8 power factor) at 4160 V line to line. The machine impedance is $0.11 + j10 \Omega$ /phase. The generator is delivering 1500 kW to a load at 0.9 power factor lagging. Find the phasor current, the phasor generated voltage E , the power angle δ , the total pullout power, and the ohmic losses in the generator stator.
8. The field supply for the machine in the previous problem loses a diode. This causes $|E|$ to decrease by 10 percent. Real power being delivered to the utility grid is determined by the wind power input and does not change. What is the new power angle δ and the new total reactive power being supplied to the utility grid?

9. A 500-kW Darrieus wind turbine is equipped with a synchronous generator rated at 480 V line to line and 625 kVA at 0.8 power factor. Rated current is flowing and the current leads the voltage by 40° . What are the real and reactive powers being supplied to the load?
10. A MOD-OA generator is rated at 250 kVA, 60 Hz, and 480 V line to line. It is connected in wye and each phase is modeled by a generated voltage E in series with a synchronous reactance X_s . The per unit reactance is 1.38. What is the actual reactance per phase? What is the actual inductance per phase?
11. The generator in the previous problem is connected to a circuit with a chosen base of 1000 kVA and 460 V. Find the per unit reactance on the new base.
12. A three-phase induction generator is rated at 230 V line to line and 14.4 A at 60 Hz. Find the base impedance, the base inductance, and the base capacitance.
13. A 11.2-kW (15 hp), 220-V, three-phase, 60-Hz, six-pole, wye-connected induction motor has the following parameters per phase: $R_1 = 0.126 \Omega$, $R_2 = 0.094 \Omega$, $X_1 = X_2 = 0.248 \Omega$, $R_m = 92 \Omega$, and $X_m = 8 \Omega$. The rotational losses are accounted for in R_m . The machine is connected to a source of rated voltage. For a slip of 2.5 percent find:
 - (a) The line current and power factor.
 - (b) The power output in both kW and hp.
 - (c) The starting torque ($s = 1.0$).
14. A three-phase, 440-V, 60-Hz, eight-pole, wye-connected, 75-kW (100-hp) induction motor has the following parameters per phase: $R_1 = 0.070 \Omega$, $R_2 = 0.068 \Omega$, $X_1 = X_2 = 0.36 \Omega$, $R_m = 57 \Omega$, and $X_m = 8.47 \Omega$. For a slip of 0.03 determine the input line current, the power factor, and the efficiency.
15. A three-phase, 300-kW (400-hp), 2000-V, six-pole, 60-Hz, wye connected squirrel-cage induction motor has the following parameters per phase that are applicable at normal slips: $R_1 = 0.200 \Omega$, $X_1 = X_2 = 0.707 \Omega$, $R_2 = 0.203 \Omega$, $X_m = 77 \Omega$, and $R_m = 308 \Omega$. For a slip of 0.015 determine the input line current, the power factor, the torque, and the efficiency.
16. The induction machine of the previous problem is operated as a generator at a slip of -0.017 . Find I_1 , I_2 , input mechanical power, real and reactive power, and the efficiency. Comment on any overload.
17. An autotransformer is connected to the motor of problem 7 for starting. The motor voltage is reduced to 0.7 of its rated value. Find the motor starting current, the line current at start, and the starting torque. Note that $s = 1$ at start.
18. The model utility system of Fig. 22 implements a massive conservation and load management program which reduces the daily peak load an average of 700 MW. Compute the new annual risk R_a , assuming the same 7000 MW of generation as in Fig. 22.

References

- [1] Chestnut, Harold and Robert L. Linden: *Monitoring and Control Requirement Definition Study for Dispersed Storage and Generation (DSG)*, General Electric Company Corporate Research and Development Report DOE/JPL 955456-1, Volume 1, October, 1980.
- [2] Chestnut, Harold and Robert L. Linden: *Monitoring and Control Requirement Definition Study for Dispersed Storage and Generation (DSG)*, General Electric Company Corporate Research and Development Report DOE/JPL 955456-1, Volume 5, October, 1980.
- [3] Garver, L. L.: “Effective Load Carrying Capability of Generating Units”, *IEEE Transactions on Power Apparatus and Systems*, Vol. PAS-85, No. 8, August, 1966.
- [4] Jorgensen, G. E., M. Lotker, R. C. Meier, and D. Brierley: “Design, Economic and System Considerations of Large Wind-Driven Generators”, *IEEE Transactions on Power Apparatus and Systems*, Vol. PAS-95, No. 3, May/June 1976, pp. 870-878.
- [5] Marsh, W.D.: *Requirements Assessment of Wind Power Plants in Electric Utility Systems*, Vol. 2, EPRI Report ER-978, January, 1979.
- [6] Odette, D. R.: *A Survey of the Wind Energy Potential of Kansas*, M.S. thesis, Electrical Engineering Department, Kansas State University, Manhattan, Kans., 1976.
- [7] Ramakumar, R., H. J. Allison, and W. L. Hughes: “Solar Energy Conversion and Storage Systems for the Future”, *IEEE Transactions on Power Apparatus and Systems*, Vol. PAS-94, No. 6, Nov./Dec. 1975, pp. 1926-1934.
- [8] Seidel, R. C., H. Gold, and L. M. Wenzel: *Power Train Analysis for the DOE/NASA 100-kW Wind Turbine Generator*, DOE/NASA/1028-78/19, NASA TM-78997, October 1978.

WIND TURBINES WITH ASYNCHRONOUS ELECTRICAL GENERATORS

He gave the wind its weight. Job 28:25.

In the last chapter we discussed some of the features of wind turbines synchronized with the electrical grid. There are a number of advantages to synchronized operation in that frequency and voltage are controlled by the utility, reactive power for induction generators is available, starting power for Darrieus turbines is available, and storage requirements are minimal. These advantages would indicate that most of the wind generated electricity in the United States will be produced in synchronism with the utility grid.

Historically, however, most wind electric generators have been attached to asynchronous loads. The most common load, especially before about 1950, has been a bank of batteries which in turn supply power to household appliances. Other loads include remote communication equipment, cathodic protection for buried pipelines, and direct space heating or domestic hot water heating applications. These wind electric generators have been small in size, usually less than 5 kW, and have usually been located where utility power has not been available.

We can expect the use of asynchronous electricity to continue, and perhaps even to grow, for a number of reasons. The use of wind power at remote communication sites for charging batteries can be expected to increase as less expensive, more reliable wind turbines are developed. Space heating and domestic hot water heating are natural applications where propane or oil are now being used. Existing fossil fueled equipment can be used as backup for the wind generated energy. Another large potential market would be the many thousands of villages around the world which are not intertied with any large utility grid. Economics may preclude the possibility of such a grid, so each village may be forced to have its own electric system if it is to have any electricity at all. An asynchronous system which could operate a community refrigerator for storing medicine, supply some light in the evening, and provide power for cooking meals (to help prevent deforestation) would be a valuable asset in many parts of the world.

One final reason for having asynchronous capability on wind turbines in the United States would be the possibility of its being needed if the electrical grid should fall apart. If any of the primary sources of oil, coal, and nuclear energy should become unavailable for any reason, there is a high probability of rotating blackouts and disassociation of the grid. Wind turbines may be able to provide power to essential applications during such periods if they are properly equipped. Such wind turbines will have to be capable of being started without utility power, and will also require some ability to maintain voltage and frequency within acceptable limits.

The three most obvious methods of providing asynchronous electricity are the dc generator, the ac generator, and the self-excited induction generator. Each of these will be discussed in this chapter. Various loads will also be discussed. The number of combinations of generators

and loads is almost limitless, so only a few combinations will be considered in any detail.

1 ASYNCHRONOUS SYSTEMS

In the previous two chapters, we examined combinations of wind turbines, transmissions, and generators connected to the electrical grid. The electrical grid was assumed to be able to accept all the power that could be generated from the wind. The grid was also able to maintain voltage and frequency, and was able to supply any reactive power that was needed. When we disconnect ourselves from the grid, these advantages disappear and we must compensate by adding additional equipment. The wind system design will be different from the synchronous system and will contain additional features. A possible system block diagram is shown in Fig. 1.

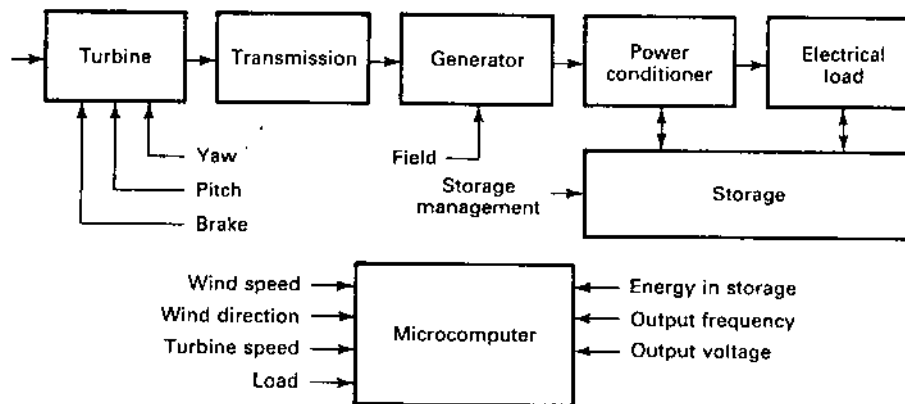

Figure 1: Block diagram of asynchronous electrical system.

In this system, the microcomputer accepts inputs such as wind speed and direction, turbine speed, load requirements, amount of energy in storage, and the voltage and frequency being delivered to the load. The microcomputer sends signals to the turbine to establish proper yaw (direction control) and blade pitch, and to set the brakes in high winds. It sends signals to the generator to change the output voltage, if the generator has a separate field. It may turn off non critical loads in times of light winds and it may turn on optional loads in strong winds. It may adjust the power conditioner to change the load voltage and frequency. It may also adjust the storage system to optimize its performance.

It should be mentioned that many wind electric systems have been built which have worked well without a microcomputer. Yaw was controlled by a tail, the blade pitch was fixed, and the brake was set by hand. The state of charge of the storage batteries would be checked once or twice a day and certain loads would be either used or not used depending on the wind and the state of charge. Such systems have the advantages of simplicity, reliability, and minimum cost,

with the disadvantages of regularly requiring human attention and the elimination of more nearly optimum controls which demand a microcomputer to function. The microcomputer and the necessary sensors tend to have a fixed cost regardless of the size of turbine. This cost may equal the cost of a 3-kW turbine and generator, but may only be ten percent of the cost of a 100 kW system. This makes the microcomputer easier to justify for the larger wind turbines.

The asynchronous system has one rather interesting mode of operation that electric utilities do not have. The turbine speed can be controlled by the load rather than by adjusting the turbine. Electric utilities do have some load management capability, but most of their load is not controllable by the utilities. The utilities therefore adjust the prime mover input (by a valve in a steam line, for example) to follow the variation in load. That is, supply follows demand. In the case of wind turbines, the turbine input power is just the power in the wind and is not subject to control. Turbine speed still needs to be controlled for optimum performance, and this can be accomplished by an electrical load with the proper characteristics, as we shall see. A microcomputer is not essential to this mode of operation, but does allow more flexibility in the choice of load. We can have a system where demand follows supply, an inherently desirable situation.

As mentioned earlier, the variety of equipment in an asynchronous system is almost limitless. Several possibilities are shown in Table 6.1. The generator may be either ac or dc. A power conditioner may be required to convert the generator output into another form, such as an inverter which produces 60 Hz power from dc. The electrical load may be a battery, a resistance heater, a pump, a household appliance, or even exotic devices like electrolysis or fertilizer cells.

Not every system requires a power conditioner. For example, a dc generator with battery storage may not need a power conditioner if all the desired loads can be operated on dc. It was not uncommon for all household appliances to be 32 V dc or 110 V dc in the 1930s when small asynchronous wind electric systems were common. Such appliances disappeared with the advent of the electrical grid but started reappearing in recreational vehicles in the 1970s, with a 12-V rating. There are no serious technical problems with equipping a house entirely with dc appliances, but costs tend to be higher because of the small demand for such appliances compared with that for conventional ac appliances. An inverter can be used to invert the dc battery voltage to ac if desired.

TABLE 6.1 Some equipment used in asynchronous systems

- ELECTRICAL GENERATOR
 - DC shunt generator
 - Permanent-magnet ac generator
 - AC generator
 - Self-excited induction generator (squirrel cage rotor)

- Field modulated generator
- Roesel generator
- POWER CONDITIONER
 - Diode rectifier
 - Inverter
 - Solid-state switching system
- ELECTRICAL LOAD
 - Battery
 - Water heater
 - Space (air) heater
 - Heat pump
 - Water pump
 - Fan
 - Lights
 - Appliances
 - Electrolysis cells
 - Fertilizer cells

If our generator produces ac, then a rectifier may be required to deliver the dc needed by some loads or storage systems. Necessary switching may be accomplished by electromechanical switches or by solid state switches, either silicon controlled rectifiers (SCRs) or triacs. These switches may be used to match the load to the optimum turbine output.

The electrical load and storage components may have items which operate either on ac or dc, such as heating elements, on ac only, such as induction motors, lights, and most appliances, or dc only, such as electrolysis cells and batteries. Some of the devices are very long lived and inexpensive, such as heating elements, and others are shorter lived and more expensive, such as batteries and electrolysis cells. Some items can be operated in almost any size. Others, such as electrolysis cells and fertilizer cells, are only feasible in rather large sizes.

Economics must be carefully considered in any asynchronous system. First, a given task must be performed at an acceptable price. Second, as many combinations as possible should be examined to make sure the least expensive combination has been selected. And third, the alternatives should be examined. That is, a wind turbine delivers either rotational mechanical power or electrical power to a load, both of which are high forms of energy, and inherently expensive. If it is desired to heat domestic hot water to 40°C, a flat plate solar collector would normally be the preferred choice since only low grade heat is required. If the wind turbine

were driving a heat pump or charging batteries as a primary function, then heating domestic hot water with surplus wind power might make economic sense. The basic rule is to not go to any higher form of work than is necessary to do the job. Fixed frequency and fixed voltage systems represent a higher form of work than variable frequency, variable voltage systems, so the actual needs of the load need to be examined to determine just how sophisticated the system really needs to be. If a simpler system will accomplish the task at less cost, it should be used.

2 DC SHUNT GENERATOR WITH BATTERY LOAD

Most people immediately think of a simple dc generator and a battery storage system when small wind turbines are mentioned. Many such systems were placed in service in the 1930s or even earlier. They provided power for a radio and a light bulb or two, and occasionally power for some electrical appliances. Some of the machines, especially the Jacobs, seemed almost indestructible. A number of these machines have provided service for over fifty years. These machines nearly all disappeared between 1940 and 1950, partly because centrally generated electricity was cheaper and more reliable, and partly because some Rural Electrical Cooperatives (REC) would not supply electricity to a farm with an operating wind electric system.

Today, such small dc systems still have very marginal economics when centrally generated electricity is available. Their primary role would then seem to be to supply limited amounts of power to isolated loads such as weather data stations, fire lookout towers, and summer cottages. They may also provide a backup or emergency system which can be used when centrally generated power is not available due to equipment failure or fuel shortages.

A diagram of a simple dc shunt generator connected to a battery is shown in Fig. 2. This circuit has been widely used since copper oxide and selenium rectifiers (diodes) were developed in the 1930s. Silicon diodes with much superior characteristics were developed in the 1950s and are almost exclusively used today. The diode allows current to flow from the generator to the battery, but prevents current flow in the opposite direction. This prevents the battery from being discharged through the generator when the generator voltage is below the battery voltage.

The generator consists of a rotor or *armature* with resistance R_a and a field winding with resistance R_f on the stator. The armature current I_a is brought out of the machine by brushes which press against the *commutator*, a set of electrical contacts at one end of the armature. The generator terminal voltage V_g causes a field current I_f to flow in the field winding. This field current flowing in a coil of wire, indicated by an inductor symbol on the left side of Fig. 2, will produce a magnetic flux. The interaction of this flux and the rotating conductors in the armature produces the generated electromotive force (emf) E , which is given by

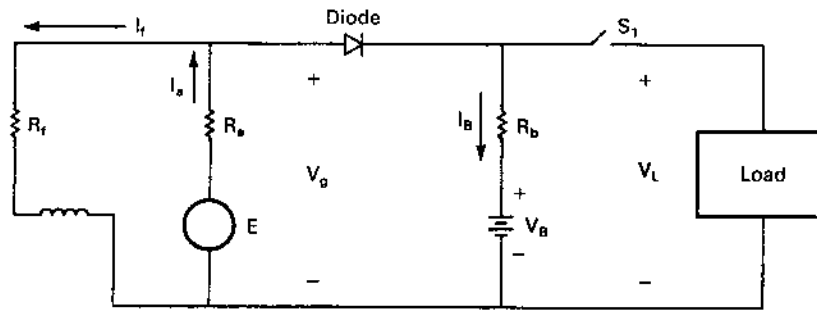

Figure 2: DC shunt generator in a battery-charging circuit.

$$E = k_s \omega_m \Phi_p \quad \text{V} \quad (1)$$

where Φ_p is the magnetic flux per pole, ω_m is the mechanical angular velocity of the rotor, and k_s is a constant involving the number of poles and number of turns of conductors. We see that the voltage increases with speed for a given flux. This means that at low speeds the generated emf will be less than the battery voltage. This has the advantage that the turbine will not be loaded at low rotational speeds, and hence will be easier to start.

The generator rotational speed n can be determined from the angular velocity ω_m by

$$n = \frac{60\omega_m}{2\pi} \quad \text{r/min} \quad (2)$$

The induced voltage E is in series with the resistance R_a of the rotor or armature windings. In this simple model, R_a would also include the resistance of the brushes on the commutator bars.

The current flow I_f (the *excitation current*) in the field winding around the poles is given by

$$I_f = \frac{V_g}{R_f} \quad \text{A} \quad (3)$$

The field winding has inductance, but the reactance ωL is zero because only dc is involved. Therefore only the resistances are needed to compute currents or voltages.

The flux does not vary linearly with field current because of the saturation of the magnetic circuit. The flux will increase rapidly with increasing I_f for small values of I_f , but will increase more slowly as I_f gets large and the iron of the machine gets more saturated. Also, the flux is not exactly zero when I_f is zero, due to the residual magnetism of the poles. The iron tends to act like a permanent magnet after a flux has once been established. This means that the

generated emf E will be greater than zero whenever the armature is spinning, even though the field current is negligible. These effects of the iron circuit yield a plot of E versus I_f such as shown in Fig. 3. E starts at a positive value, increases rapidly for small I_f , and finally levels off for larger I_f . Two angular velocities, ω_{m1} and ω_{m2} , are shown on the figure. Increasing ω_m merely expands the curve for E without changing its basic shape.

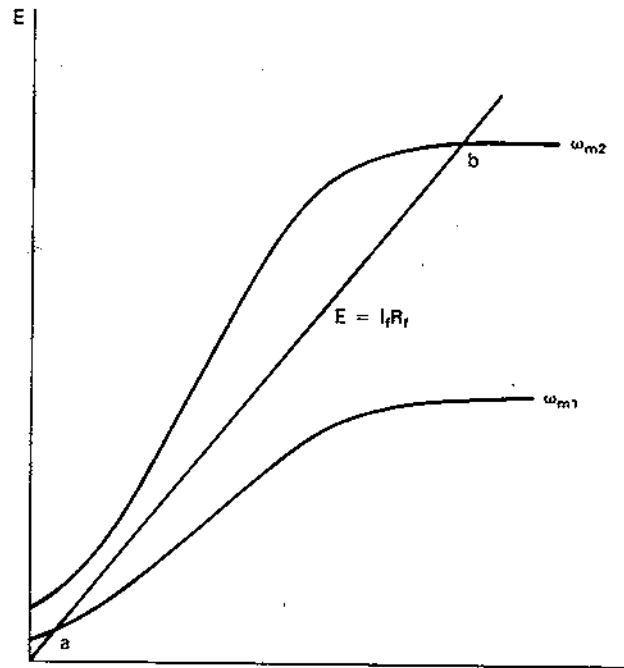

Figure 3: Magnetization curve of dc generator.

The generated emf E is given by Kirchhoff's voltage law as

$$E = I_a R_a + I_f R_f \quad \text{V} \quad (4)$$

R_a is much smaller than R_f , so when the diode current is zero, which causes $I_a = I_f$, the $I_a R_a$ term is very small compared with $R_f I_f$. Therefore, to a first approximation, we can write

$$E \simeq I_f R_f \quad (5)$$

This equation is just a straight line passing through the origin of Fig. 3. We therefore have a voltage E being constrained by both a nonlinear dc generator and a linear resistor. The generator requires the voltage to vary along the nonlinear curve while the field resistor requires it to vary along the straight line. Both requirements are met at the intersection of the nonlinear curve and the straight line, and this intersection defines the equilibrium or *operating*

point. When the generator is turning at the angular velocity ω_{m1} , voltage and current will build up only to point *a*. This is well below the capability of the generator and is not a desirable operating point. If the angular velocity is increased to ω_{m2} the voltage will build up to the value at point *b*. This is just past the *knee* of the magnetization curve and is a good operating point in that small changes in speed or field resistance will not cause large changes in E .

Another way of changing the operating point is to change the field resistance R_f . The slope of the straight line decreases as R_f decreases so the operating point can be set any place along the magnetization curve by the proper choice of R_f . There are some practical limitations to decreasing R_f , of course. R_f usually consists of an external variable resistance plus the internal resistance of a coil of many turns of fine wire. Therefore R_f can not be reduced below the internal coil resistance.

The mode of operation of this generator is referred to as a self-excited mode. The residual magnetism of the generator produces a small flux, which causes a small voltage to appear across the field winding when the generator rotor is rotated. This small voltage produces a small field current which helps to boost E to a larger value. This larger E produces a still larger field current, which produces a still larger E , until equilibrium is reached. The equilibrium point will be at small values of E for low speeds or high field resistance, and will increase rapidly to a point past the knee of the magnetization curve as speed or field resistance reaches some critical value. Once the voltage has built up to a value close to the rated voltage, the generator can supply current to a load.

We now want to examine the operation of the self-excited shunt generator as a battery charger, with the circuit of Fig. 2. We assume that switch S_1 is open, that the diode is an open circuit when E is less than the battery voltage V_B and a short circuit when E is greater than V_B , and that R_B includes the resistance of the diode and connecting wires as well as the internal resistance of the battery. When the diode is conducting, the relationship between E and V_B is

$$E = V_B + I_f R_a + I_B (R_a + R_b) \quad \text{V} \quad (6)$$

The term $I_f R_a$ is a very small voltage and can be neglected without a serious loss of accuracy. If we do so, the battery current is given by

$$I_B \simeq \frac{E - V_B}{R_a + R_b} \quad \text{A} \quad (7)$$

The electrical power produced by the shunt generator when the diode is conducting is given by

$$P_e = EI_a \simeq EI_f + \frac{E(E - V_B)}{R_a + R_b} \quad \text{W} \quad (8)$$

The electrical power delivered to the battery is

$$P_B = V_B I_B \quad \text{W} \quad (9)$$

The electrical power can be computed as a function of angular velocity if all the quantities in Eq. 8 are known. In practice, none of these are known very precisely. E tends to be reduced below the value predicted by Eq. 1 by a phenomenon called armature reaction. The resistance of the copper wire in the circuit increases with temperature. R_a and R_b include the voltage drops across the brushes of the generator and the diode, which are quite nonlinear. And finally, V_B varies with the state of charge of the battery. Each system needs to be carefully measured if a detailed curve of power versus rotational speed is desired. General results or curves applicable to a wide range of systems are very difficult to obtain, if not impossible.

Example

The Wincharger Model 1222 is a 12-V, 15-A self-excited dc shunt generator used for charging 12-V batteries. By various crude measurements and intelligent estimates, you decide that $R_f = 15 \Omega$, $R_a = 0.2 \Omega$, $R_b = 0.25 \Omega$, $V_B = 12 \text{ V}$, and $E = 0.015n + 8 \text{ V}$. This expression for E includes the armature reaction over the normal operating range, hence is much flatter than the ideal expression of Eq. 1. Assume the diode is ideal (no forward voltage drop when conducting) and plot E , I_B , and P_e for n between 0 and 600 r/min.

We first observe that $I_B = 0$ whenever $E \leq V_B$. The rotational speed at which the battery starts to charge is found by setting $E = V_B$ and solving for n .

$$0.015n + 8 = 12$$

$$n = \frac{4}{0.015} = 270 \text{ r/min}$$

The battery current will vary linearly with E and therefore with the rotational speed, according to Eq. 7. We can plot the current I_B by just finding one more point and drawing a straight line. At $n = 600 \text{ r/min}$, the battery current is given by

$$I_B \simeq \frac{0.015(600) + 8 - 12}{0.2 + 0.25} = 11 \text{ A}$$

The electrical power generated is nonlinear and has to be determined at several rotational speeds to be properly plotted. When this is done, the desired quantities can be plotted as shown in Fig. 4. The actual generated E starts at zero and increases as approximately the square of the rotational speed until diode current starts to flow. Both flux and angular velocity are increasing, so Eq. 1 would predict such a curve. When the diode current starts to flow, armature reaction reduces the rate of increase of E . The flux also levels off because of saturation. E can then be approximated for speeds above 270 r/min by the straight line shown, which could then be extrapolated backward to intersect the vertical axis, at 8 V in this case.

The current will also increase linearly, giving a square law variation in the electrical power. The optimum variation of power would be a cubic function of rotational speed, which is shown as a dashed curve in Fig. 4. The discontinuity in E causes the actual power variation to approximate the ideal rather closely, which would indicate that the Wincharger is reasonably well designed to do its job.

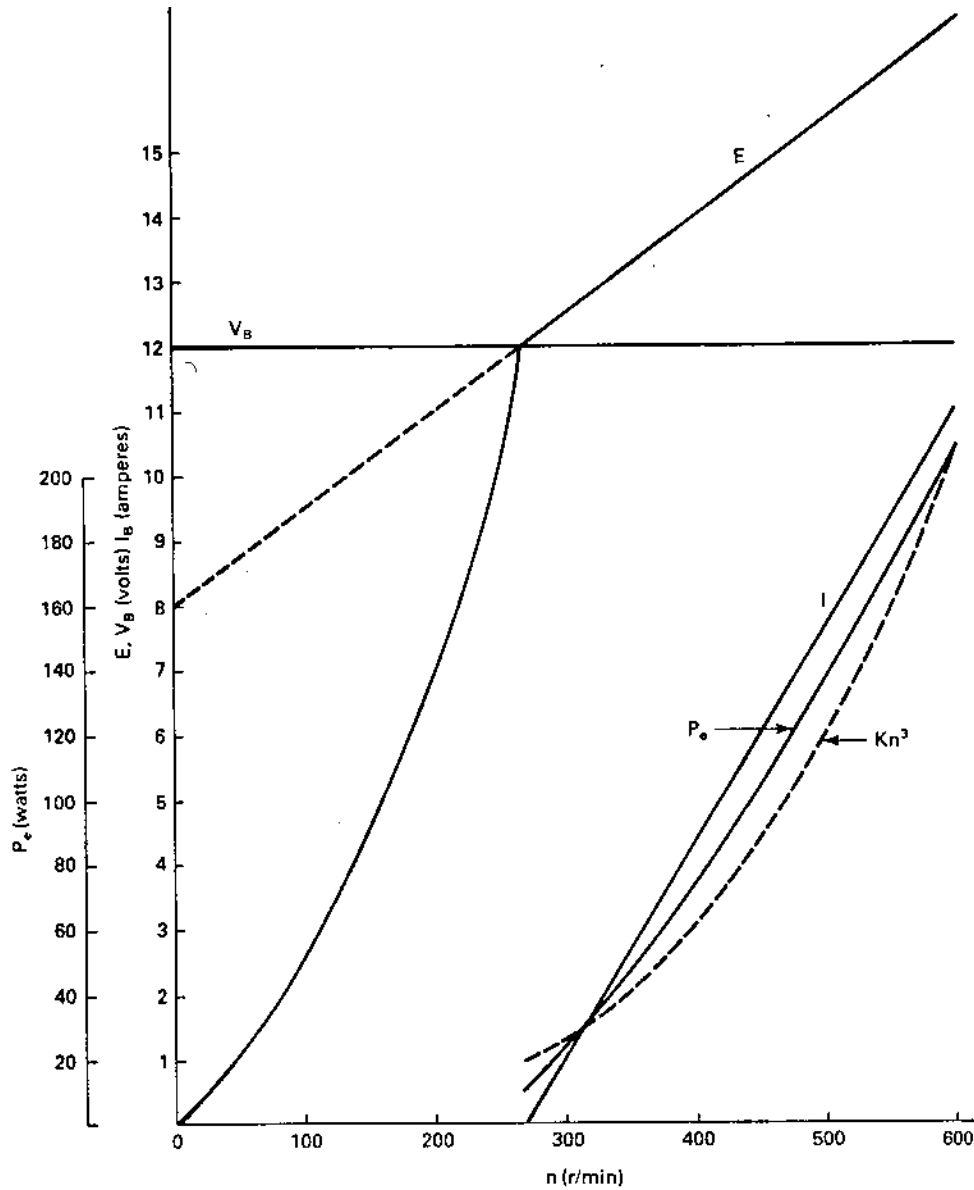

Figure 4: Variation of $E, I_B,$ and P_e for Wincharger 1222 connected to a 12-V battery.

One other aspect of operating shunt generators needs to be mentioned. When a new generator is placed into service, it is possible that there is no net residual magnetism to cause a voltage buildup, or that the residual magnetism is oriented in the wrong direction. A short

application of rated dc voltage to the generator terminals will usually establish the proper residual magnetism. This should be applied while the generator is stopped, so current will be well above rated, and should be applied for only a few seconds at most. Only the field winding needs to experience this voltage, so if the brushes can be lifted from the commutator, both the generator and the dc supply will experience much less shock.

3 PERMANENT MAGNET GENERATORS

A permanent magnet generator is like the synchronous or ac generator discussed in the previous chapter except that the rotor field is produced by permanent magnets rather than current in a coil of wire. This means that no field supply is needed, which reduces costs. It also means that there is no I^2R power loss in the field, which helps to increase the efficiency. One disadvantage is that the reactive power flow can not be controlled if the PM generator is connected to the utility network. This is of little concern in an asynchronous mode, of course.

The magnets can be cast in a cylindrical aluminum rotor, which is substantially less expensive and more rugged than the wound rotor of the conventional generator. No commutator is required, so the PM generator will also be less expensive than the dc generator of the previous section. These advantages make the PM generator of significant interest to designers of small asynchronous wind turbines.

One load which might be used on a PM generator would be a resistance heating system for either space or hot water. Such a system is shown in Fig. 5. The three line-to-neutral generated voltages E_a , E_b , and E_c are all displaced from each other by 120 electrical degrees. The line-to-neutral terminal voltages are also displaced from each other by 120° if the three-phase load is balanced ($R_a = R_b = R_c$). The current I_a is given by

$$I_a = \frac{E_a}{R_s + jX_s + R_a} = \frac{V_a}{R_a} \quad \text{A} \quad (10)$$

where X_s is the synchronous reactance, R_s is the winding resistance, and R_a is the resistance of one leg or one phase of the load resistance.

The neutral current I_n is given by the sum of the other currents.

$$I_n = I_a + I_b + I_c \quad \text{A} \quad (11)$$

If the load is balanced, then the neutral current will be zero. In such circumstances, the wire connecting the neutrals of the generator and load could be removed without affecting any of the circuit voltages or currents. The asynchronous system will need the neutral wire connected, however, because it allows the single-phase voltages V_a , V_b , and V_c to be used for other loads in an unbalanced system. Several single-phase room heaters could be operated independently, for example, if the neutral wire is in place.

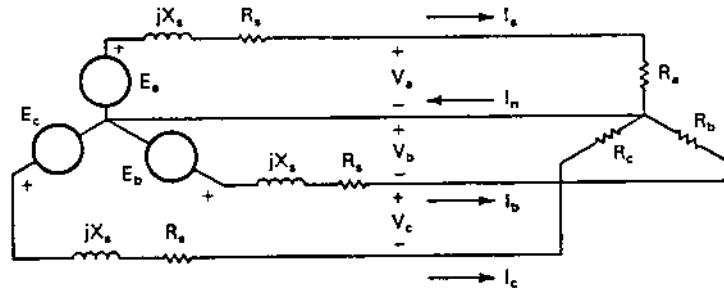

Figure 5: Permanent-magnet generator connected to a resistive load.

It is desirable to maintain the three line currents at about the same value to minimize torque fluctuations. It is shown in electrical machinery texts that a three-phase generator will have a constant shaft torque when operated under balanced conditions. A single-phase generator or an unbalanced three-phase generator has a torque that oscillates at twice the electrical frequency. This makes the generator noisy and tends to shorten the life of the shaft, bearings, and couplers. This is one of the primary reasons single-phase motors and generators are seldom seen in sizes above about 5 kW. The PM generator will have to be built strongly enough to accept the turbine torque fluctuations, so some imbalance on the generator currents should not be too harmful to the system, but the imbalance will need to be minimized to keep the noise level down, if for no other reason.

The electrical output power P_e (the power delivered to the load) of the PM generator per phase is

$$P_e = I_a^2 R_a \quad \text{W/phase} \quad (12)$$

The magnitude of the current is

$$|I_a| = \frac{|E_a|}{\sqrt{(R_s + R_a)^2 + X_s^2}} \quad \text{A} \quad (13)$$

Therefore the output power can be expressed as

$$P_e = \frac{E_a^2 R_a}{(R_s + R_a)^2 + X_s^2} \quad \text{W/phase} \quad (14)$$

The generated voltage E_a can be written as

$$E_a = k_e \omega \quad \text{V} \quad (15)$$

This is basically the same equation as Eq. 1. Here the constant k_e includes the flux per pole since the PM generator is a constant flux machine and also includes any constant factor

between the mechanical angular velocity ω_m and the electrical angular velocity ω . A four pole generator spinning at 1800 r/min will have $\omega_m = 188.5$ rad/s and $\omega = 377$ rad/s, for example. The ratio of electrical to mechanical angular velocity will be 1 for a two pole generator, 2 for a four pole, 3 for a six pole, and so on.

This variation in generated voltage with angular velocity means that a PM generator which has an open-circuit rms voltage of 250 V line to line at 60 Hz when the generator rotor is turning at 1800 r/min will have an open circuit voltage of 125 V at 30 Hz when the generator rotor is turning at 900 r/min. Wide fluctuations of voltage and frequency will be obtained from the PM generator if the wind turbine does not have a rather sophisticated speed control system. The PM generator must therefore be connected to loads which can accept such voltage and frequency variations.

Lighting circuits would normally not be appropriate loads. Incandescent bulbs are not bright enough at voltages 20 percent less than rated, and burn out quickly when the voltages are 10 percent above rated. There will also be an objectionable flicker when the frequency drops significantly below 60 Hz. Fluorescent bulbs may operate over a slightly wider voltage and frequency range depending on the type of bulb and ballast. If lighting circuits must be supplied by the PM generator, consideration should be given to using a rectifier and battery system just for the lights.

It should be noticed that the rating of the PM generator is directly proportional to the rotational speed. The rated current is related to the winding conductor size, which is fixed for a given generator, so the output power $V_a I_a$ will vary as E_a or as the rotational speed. The resistance R_a has to be varied as E_a varies to maintain a constant current, of course. This means that a generator rated at 5 kW at 1800 r/min would be rated at 10 kW at 3600 r/min because the voltage has doubled for the same current, thus doubling the power. The limitations to this increase in rating are the mechanical limitations of rotor and bearings, and the electrical limitations of the insulation.

In Chapter 4 we saw that the shaft power input to the generator needs to vary as n^3 for the turbine to operate at its peak efficiency over a range of wind speeds and turbine speeds. Since n and ω are directly proportional, and the efficiency is high, we can argue that the output power of the PM generator should vary as ω^3 for the generator to be an optimum load for the turbine. The actual variation can be determined by explicitly showing the frequency dependency of the terms in Eq. 14. In addition to E_a , there is the reactance X_s , which is given by

$$X_s = \omega L_s \quad \Omega \quad (16)$$

The term L_s is the inductance of the generator windings. It is not a true constant because of saturation effects in the iron of the generator, but we shall ignore that fact in this elementary treatment.

The frequency variation of the electrical output power is then given by

$$P_e = \frac{k_e^2 \omega^2 R_a}{(R_s + R_a)^2 + \omega^2 L_s^2} \quad \text{W/phase} \quad (17)$$

We see that at very low frequencies or for a very large load resistance that P_e increases as the square of the frequency. At very high frequencies, however, when ωL_s is larger than $R_s + R_a$, the output power will be nearly constant as frequency increases. At rated speed and rated power, X_s will be similar in magnitude to $R_s + R_a$ and the variation of P_e will be nearly proportional to the frequency.

We therefore see that a PM generator with a fixed resistive load is not an optimum load for a wind turbine. If we insist on using such a system, it appears that we must use some sort of blade pitching mechanism on the turbine. The blade pitching mechanism is a technically good solution, but rather expensive. The costs of this system probably far surpass the cost savings of the PM generator over other types of generators.

One alternative to a fixed resistance load is a variable resistance load. One way of varying the load resistance seen by the generator is to insert a variable autotransformer between the generator and the load resistors. The circuit for one phase of such a connection is shown in Fig. 6. The basic equations for an autotransformer were given in the previous chapter. The voltage seen by the load can be varied from zero to some value above the generator voltage in this system. The power can therefore be adjusted from zero to rated in a smooth fashion. A microcomputer is required to sense the wind speed, the turbine speed, and perhaps the rate of change of turbine speed. It would then signal the electrical actuator on the autotransformer to change the setting as necessary to properly load the turbine. A good control system could anticipate changes in turbine power from changes in wind speed and keep the load near the optimum value over a wide range of wind speeds.

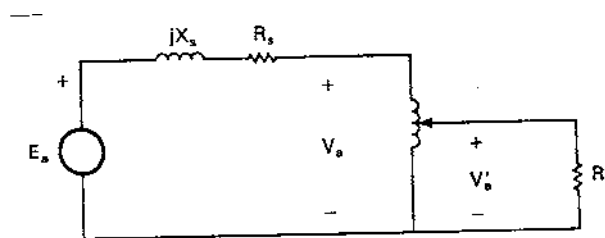

Figure 6: Load adjustment with a variable autotransformer.

One problem with this concept is that the motor driven three-phase variable autotransformer probably costs as much as the PM generator. Another problem would be mechanical reliability of the autotransformer sliding contacts. These would certainly require regular maintenance. We see that the advantages of the PM generator in the areas of cost and reliability have been lost in using a variable autotransformer to control the load.

Another way of controlling the load, which eliminates the variable autotransformer, is to use a microcomputer to switch in additional resistors as the wind speed and turbine speed

increase. The basic circuit is shown in Fig. 7. The switches can be solid state (triacs) which are easily controlled by microcomputer logic levels and which can withstand millions of operating cycles. Costs and reliability of this load control system are within acceptable limits. Unfortunately, this concept leads to a marginally unstable system for the Darrieus turbine and possibly for the horizontal axis propeller turbine as well. The instability can be observed by examining the electrical power output of the Sandia 17 m Darrieus as shown in Fig. 8. The power output to an optimum load is seen to pass through the peak turbine power output for any wind speed, as was discussed in Chapter 4. The load powers for the four different resistor combinations are shown as linear functions of n around the operating points. These curves are reasonable approximations for the actual P_e curves, as was pointed out by the discussion following Eq. 17. We do not need better or more precise curves for P_e because the instability will be present for any load that varies at a rate less than n^3 .

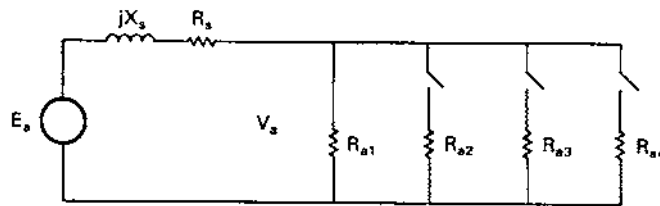

Figure 7: Load adjustment by switching resistors.

We assume that the load power is determined by the curve marked R_{a1} and that the wind speed is 6 m/s. The turbine will be operating at point a . If the wind speed increases to 8 m/s, the turbine torque exceeds the load torque and the turbine accelerates toward point b . If the second resistor is switched in, the load power will increase, causing the turbine to slow down. The new operating point would then be point c . If the wind speed drops back to 6 m/s, the load power will exceed the available power from the turbine so the turbine has to decelerate. If the load is not removed quickly enough, the operating point will pass through point f and the turbine will stall aerodynamically. It could even stop completely and need to be restarted. The additional load must be dropped as soon as the turbine starts to slow down if this condition is to be prevented.

Another way of expressing the difficulty with this control system is to note that the speed variation is excessive. Suppose the resistance is $R_{a1} + R_{a2} + R_{a3}$ and we have had a steady wind just over 10 m/s. If the wind speed would slowly decrease to 10 m/s, the turbine would go to the operating point marked d , and then as it slowed down further, the load would be switched to $R_{a1} + R_{a2}$. The turbine would then accelerate to point e . The speed would change from approximately 50 to 85 r/min for this example. This is a very large speed variation and may pose mechanical difficulties to the turbine. It also places the operating point well down from the peak of the power curve, which violates one of the original reasons for considering an asynchronous system, that of maintaining peak power over a range of wind speeds and turbine rotational speeds. We therefore see that the PM generator with a switched or variable resistive

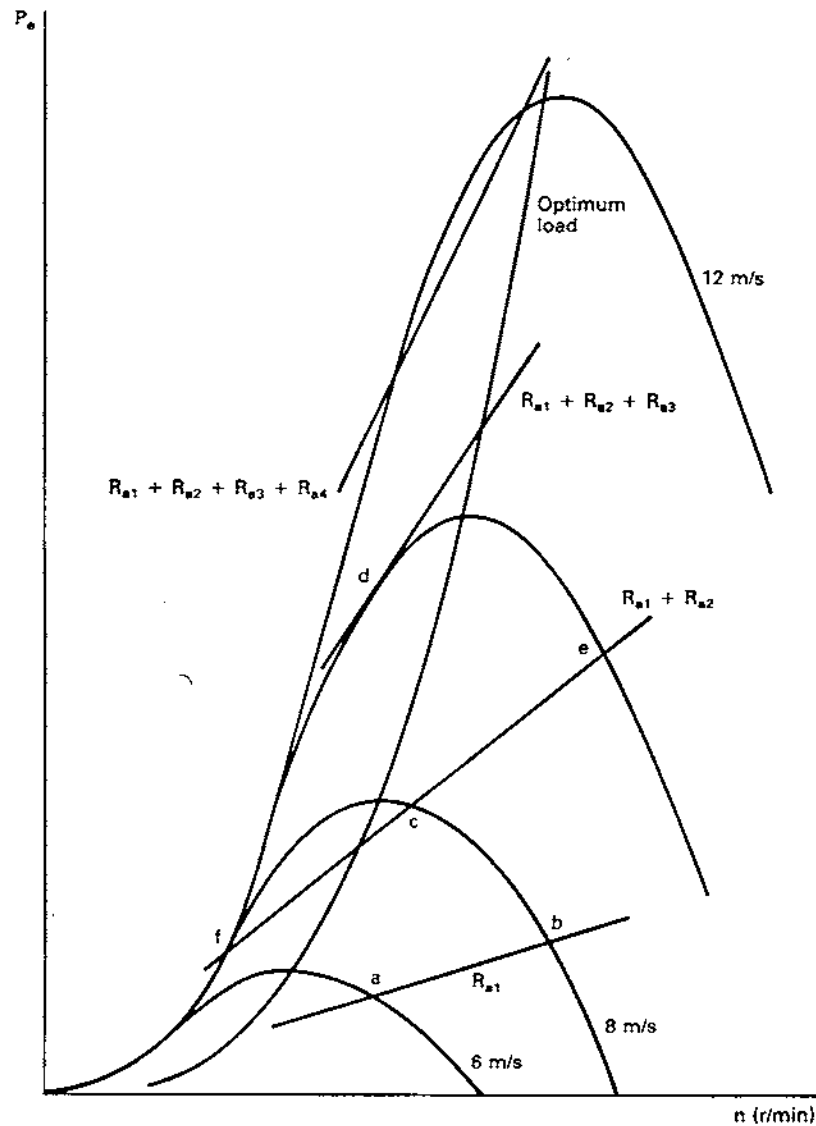

Figure 8: Electrical power output of Sandia 17-m Darrieus in variable-speed operation.

load is really not a very effective wind turbine load. The problems that are introduced by this system can be solved, but the solution will probably be more expensive than another type of system.

Another alternative for matching the load power to the turbine power is a series resonant circuit. This concept has successfully been used by the Zephyr Wind Dynamo Company to build a simple matching circuit for their line of very low speed PM generators. The basic concept is shown in Fig. 9.

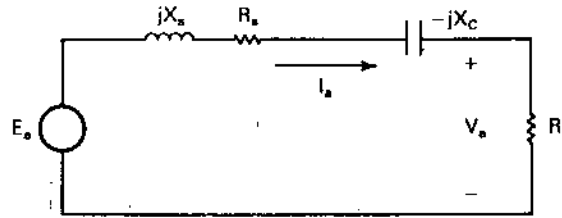

Figure 9: Series resonant circuit for a PM generator.

The capacitive reactance X_C is selected so the circuit becomes resonant ($X_C = X_s$) at rated frequency. The power output will vary with frequency in a way that can be made to match the available power input from a given type of wind turbine rather closely. Overspeed protection will be required but complex pitch changing controls acting between cut-in and rated wind speeds are not essential.

The power output of the series resonant PM generator is

$$P_e = \frac{k_e^2 \omega^2 R_a}{(R_s + R_a)^2 + (\omega L_s - 1/\omega C)^2} \quad \text{W/phase} \quad (18)$$

Below resonance, the capacitive reactance term is larger than the inductive reactance term. At resonance, $\omega L_s = 1/\omega C$. The power output tends to increase with frequency even above resonance, but will eventually approach a constant value at a sufficiently high frequency. L_s can be varied somewhat in the design of the PM generator and C can be changed easily to match the power output curve from a given turbine. No controls are needed, hence reliability and cost should be acceptable.

Example

A three-phase PM generator has an open circuit line-to-neutral voltage E_a of 150 V and a reactance X_s of 5.9 Ω /phase at 60 Hz. The series resistance R_s may be ignored. The generator is connected into a series resonant circuit like Fig. 9. At 60 Hz, the circuit is resonant and a total three-phase power of 10 kW is flowing to a balanced load with resistances R_a Ω /phase.

1. Find C .
2. Find R_a .
3. Find the current I_a .
4. Find the total three-phase power delivered to the same set of resistors at a frequency of 40 Hz.

At resonance, $X_C = X_s = 5.9 \Omega$ and $\omega = 2\pi f = 377$ rad/s. The capacitance is

$$C = \frac{1}{\omega X_C} = \frac{1}{377(5.9)} = 450 \times 10^{-6} \text{ F}$$

The inductance is

$$L_s = \frac{X_s}{\omega} = \frac{5.9}{377} = 15.65 \times 10^{-3} \text{ H}$$

The power per phase is

$$P_e = \frac{10,000}{3} = 3333 \text{ W/phase}$$

At resonance, the inductive reactance and the capacitive reactance cancel, so $V_a = E_a$. The resistance R_a is

$$R_a = \frac{V_a^2}{P_e} = \frac{(150)^2}{3333} = 6.75 \text{ } \Omega$$

The current I_a is given by

$$I_a = \frac{V_a}{R_a} = \frac{150}{6.75} = 22.22 \text{ A}$$

At 40 Hz, the circuit is no longer resonant. We want to use Eq. 18 to find the power but we need k_e first. It can be determined from Eq. 15 and rated conditions as

$$k_e = \frac{E}{\omega} = \frac{150}{377} = 0.398$$

The total power is then

$$\begin{aligned} P_{\text{tot}} &= 3P_e = \frac{3(0.398)^2 [2\pi(40)]^2 (6.75)}{(6.75)^2 + [2\pi(40)(15.65 \times 10^{-3}) - 1/(2\pi(40)(450 \times 10^{-6}))]^2} \\ &= \frac{202,600}{45.56 + 24.10} = 2910 \text{ W} \end{aligned}$$

If the power followed the ideal cubic curve, at 40 Hz the total power should be

$$P_{\text{tot,ideal}} = 10,000 \left(\frac{40}{60} \right)^3 = 2963 \text{ W}$$

We can see that the resonant circuit causes the actual power to follow the ideal variation rather closely over this frequency range.

4 AC GENERATORS

The ac generator that is normally used for supplying synchronous power to the electric utility can also be used in an asynchronous mode[14]. This machine was discussed in the previous

chapter. It can be connected to a resistive load for space and water heating applications with the same circuit diagram as the PM generator shown in Fig. 5. The major difference is that the induced emfs are no longer proportional to speed only, but to the product of speed and flux. In the linear case, the flux is directly proportional to the field current I_f , so the emf E_a can be expressed as

$$E_a = k_f \omega I_f \quad \text{V/phase} \quad (19)$$

where $\omega = 2\pi f$ is the electrical radian frequency and k_f is a constant.

Suppose now that the field current can be varied proportional to the machine speed. Then the induced voltage can be written as

$$E_a = k'_f \omega^2 \quad \text{V/phase} \quad (20)$$

where k'_f is another constant. It can be determined from a knowledge of the rated generated voltage (the open circuit voltage) at rated frequency.

The electrical output power is then given by an expression similar to Eq. 17.

$$P_e = \frac{k_f'^2 \omega^4 R_a}{(R_s + R_a)^2 + \omega^2 L_s^2} \quad \text{W/phase} \quad (21)$$

The variation of output power will be as some function between ω^2 and ω^4 . With the proper choice of machine inductance and load resistance we can have a power variation very close to the optimum of ω^3 .

It may be desirable to vary the field current in some other fashion to accomplish other objectives. For example, we might vary it at a rate proportional to ω^2 so the output power will vary as some function between ω^4 and ω^6 . This will allow the turbine to operate over a narrower speed range. At low speeds the output power will be very small, allowing the turbine to accelerate to nearly rated speed at light load. The load will then increase rapidly with speed so the generator rated power will be reached with a small increase of speed. As the speed increases even more in high wind conditions, some mechanical overspeed protection device will be activated to prevent further speed increases.

If the turbine has pitch control so the generator speed can be maintained within a narrow range, the field current can be varied to maintain a desired load voltage. All home appliances, except clocks and some television sets, could be operated from such a source. The frequency may vary from perhaps 56 to 64 Hz, but this will not affect most home appliances if the proper voltage is present at the same time. The control system needs to have discretionary loads for both the low and high wind conditions. Too much load in low wind speeds will cause the turbine to slow below the desired speed range, while very light loads in high wind speeds will make it difficult for the pitch control system to keep the turbine speed down to an acceptable value. At intermediate wind speeds the control system needs to be able to decide between

changing the pitch and changing the load to maintain frequency in a varying wind. This would require a very sophisticated control system, but would provide power that is nearly utility quality directly from a wind turbine.

It is evident that an ac generator with a field supply and associated control system will be relatively expensive in small sizes. This system will probably be difficult to justify economically in sizes below perhaps 100 kW. It may be a good choice for villages separated from the grid, however, because of the inherent quality of the electricity. Most village loads could be operated directly from this generator. A small battery bank and inverter would be able to handle the critical loads during windless periods.

5 SELF-EXCITATION OF THE INDUCTION GENERATOR

In Chapter 5, we examined the operation of an induction machine as both a motor and generator connected to the utility grid. We saw that the induction generator is generally simpler, cheaper, more reliable, and perhaps more efficient than either the ac generator or the dc generator. The induction generator and the PM generator are similar in construction, except for the rotor, so complexity, reliability, and efficiency should be quite similar for these two types of machines. The induction generator is likely to be cheaper than the PM generator by perhaps a factor of two, however, because of the differences in the numbers produced. Induction motors are used very widely, and it may be expected that many will be used as induction generators because of such factors as good availability, reliability, and reasonable cost[3].

An induction machine can be made to operate as an isolated ac generator by supplying the necessary exciting or magnetizing current from capacitors connected across the terminals of the machine[8, 2, 14]. Fig. 10 shows a typical circuit for a three-phase squirrel-cage induction machine. The capacitors are shown in a delta connection primarily for economic reasons. That is, capacitors built for continuous duty, called motor-run capacitors, are most readily available in 370- and 460-V ratings. Most induction motors in sizes up to 100 kW or more are built with 208-, 230-, or 460-V ratings, so the available capacitors can readily handle the line to line voltages. If the capacitors were reconnected into a wye connection, the voltage across each capacitor is reduced to $1/\sqrt{3}$ of the delta connected value, and the reactive power supplied by each capacitor, ωCV^2 , is then one-third of the reactive power per capacitor obtained from the delta connection. Three times as much capacitance is required in the wye connection, which increases the system cost unnecessarily.

The resistive load is shown connected in wye, but could be connected in delta if desired. There could be combinations of wye and delta connections if different voltage levels were needed.

The steady state balanced load case is usually analyzed in terms of an equivalent line to

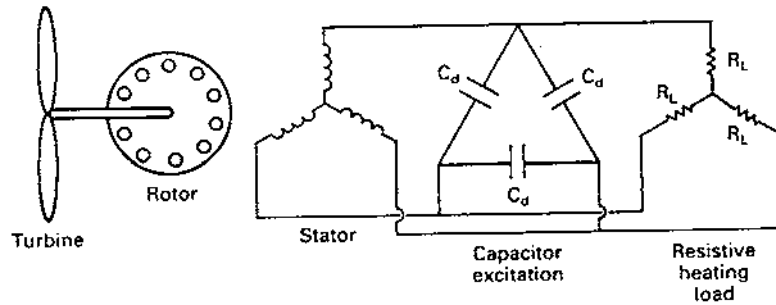

Figure 10: Self-excited induction generator.

neutral single-phase circuit, as shown in Fig. 11. This is the same circuit shown in Chapter 5, except for the capacitor and load resistor which replace the utility connection. For analysis purposes, the capacitor C is the equivalent wye connected capacitance. That is,

$$C = 3C_d \quad \mu\text{F} \quad (22)$$

where C_d is the required capacitance per leg of a delta connection.

This circuit is very similar to that seen in electronics textbooks in a section on oscillators[13]. It is called a negative resistance oscillator. We have a resonant circuit where the capacitive reactance equals the inductive reactance at some frequency, so oscillation will occur at that frequency. Oscillation occurs much more readily when R_L is removed, so normal operation of the induction generator will have R_L switched out of the circuit until the voltage buildup has occurred.

The induction generator produces a small voltage from residual magnetism which initiates oscillation. The terminal voltage will build up from this small voltage to a value near rated voltage over a period of several seconds. Once the voltage has reached an operating value, the load resistance R_L can be switched back into the circuit.

It is possible to stop oscillation in any oscillator circuit by excessive load (too small a value of R_L). As R_L approaches this limit, the oscillator may operate in unexpected modes due to the nonlinearity of the circuit. The waveform may be bad, for example, or the slip of the induction generator may become unusually large. It should be a part of normal design procedures to determine that the maximum design load for a given generator is not too near this critical limit.

While the general operation of the circuit in Fig. 11 is not too difficult to understand, a detailed analysis is quite difficult because of the nonlinear magnetizing reactance. The available solutions have rather limited usefulness because of their complexity[10, 5, 6, 7]. Detailed reviews of these solutions are beyond the scope of this text, so we shall restrict ourselves to a discussion of some experimental results

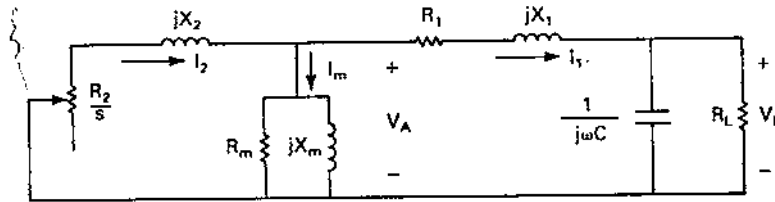

Figure 11: Single-phase equivalent circuit of self-excited induction generator.

First, however, we shall discuss some of the features of the machine parameters shown in Fig. 11. This should aid those who need to read the more detailed literature, and should also help develop some intuition for predicting changes in machine performance as operating conditions change.

The circuit quantities R_1 , R_2 , R_m , X_1 , X_2 , and X_m can be measured experimentally on a given machine. Techniques for doing this are discussed in texts on electric machinery. It should be mentioned that these machine parameters vary somewhat with operating conditions. R_1 and R_2 will increase with temperature between two temperatures T_a and T_b as

$$\frac{R_a}{R_b} = \frac{235 + T_a}{235 + T_b} \quad (23)$$

where T_a and T_b are in Celsius, R_a is the resistance R_1 or R_2 at temperature T_a , and R_b is the resistance at T_b . This expression is reasonably accurate for both aluminum and copper, the common conductors, over the expected range of generator temperatures. The change in resistance from an idle generator at -20°C to one operating on a hot day with winding temperatures of 60°C is $(235 + 60)/(235 - 20) = 1.372$. That is, the resistances R_1 and R_2 can increase by 37 percent over the expected range of operating temperatures. Such variations would need to be included in a complete analysis.

The resistance R_m represents the hysteresis and eddy current losses of the machine. The power lost to hysteresis varies as the operating frequency while the eddy current loss varies as the square of the operating frequency. There may also be some variation with operating voltage. The actual operating frequency will probably be between 40 and 60 Hz in a practical system so this equivalent resistor will vary perhaps 40 or 50 percent as the operating frequency changes. If the machine has low magnetic losses so that R_m is significantly greater than the load resistance R_L , then a single average value of R_m would yield acceptable results. In fact, R_m may even be neglected in the study of oscillation effects if the induction generator has high efficiency.

The reactances X_1 , X_2 , and X_m are given by ωL_1 , ωL_2 , and ωL_m where ω is the electrical radian frequency and L_1 , L_2 , and L_m refer to the circuit inductances. The frequency ω will vary with input power and the load resistance and capacitance for a given set of machine

parameters.

The leakage inductances L_1 and L_2 should not vary with temperature, frequency, or voltage if the machine dimensions do not change. The air gap between rotor and stator may change with temperature, however, which will cause the inductances to change. A decrease in air gap will cause a decrease in leakage inductance.

The magnetizing inductance L_m is a strongly nonlinear function of the operating voltage V_L due to the effects of saturation in the magnetic circuit. In fact, stable operation of this system is only possible with a nonlinear L_m . The variation of L_m depends strongly on the type of steel used in the induction generator.

We obtain L_m from a no-load magnetization curve such as those shown in Fig. 12. These are basically the same curves as the one shown in Fig. 3 for the dc generator except that these are scaled in per unit quantities. The various per unit relationships were defined in Section 5.4. Each curve is obtained under no load conditions ($R_L = \infty$) so the slip is nearly zero and the rotor current I_2 is negligible. The magnetizing current flowing through L_m is then very nearly equal to the output current I_1 . The vertical axis is expressed as $V_{L,\text{pu}}/\omega_{\text{pu}}$, so only one curve describes operation over a range of frequencies. Strictly speaking, the magnetization curve should be the airgap voltage V_A plotted against I_1 (or I_e) rather than the terminal voltage V_L . A point by point correction can be made to the measured curve of V_L versus I_1 by the equation

$$V_A = V_L + I_1(R_1 + jX_1) \quad (24)$$

The magnetization curve will have somewhat different shapes for different steels and manufacturing techniques used in assembling the generator. These particular curves are for a Dayton 5-hp three-phase induction motor rated at 230 V line to line and 14.4 A and a Baldor 40-hp three-phase induction motor rated at 460/230 V line to line and 48/96 A. Measured parameters in per unit for the 5-hp machine were $R_m = 13$, $R_1 = 0.075$, $R_2 = 0.045$, and $L_1 = L_2 = 0.16$. Measured parameters for the 40-hp machine in per unit were $R_m = 21.8$, $R_1 = 0.050$, $R_2 = 0.025$, and $L_1 = L_2 = 0.091$. The 40-hp machine is more efficient than the 5-hp machine because R_m is larger and R_1 and R_2 are smaller, thereby decreasing the loss terms.

We observe that for the 5-hp machine, rated voltage is reached when I_1 is about half the rated current. A terminal voltage of about 1.15 times the rated voltage is obtained for an I_1 of about 0.8 times the rated current. It should be noted that it is possible for the magnetizing current to exceed the machine rated current. The magnetizing current needs to be limited to perhaps 0.75 pu to allow a reasonable current flow to the load without exceeding machine ratings. This means that the rated voltage should not be exceeded by more than 10 or 15 percent for the 5-hp self-excited generator if overheating is to be avoided.

The 40-hp machine reaches rated voltage when I_1 is about 0.3 of its rated value. A terminal voltage of 130 percent of rated voltage is reached for an exciting current of only 0.6 of rated line current. This means the 40-hp machine could be operated at higher voltages than the

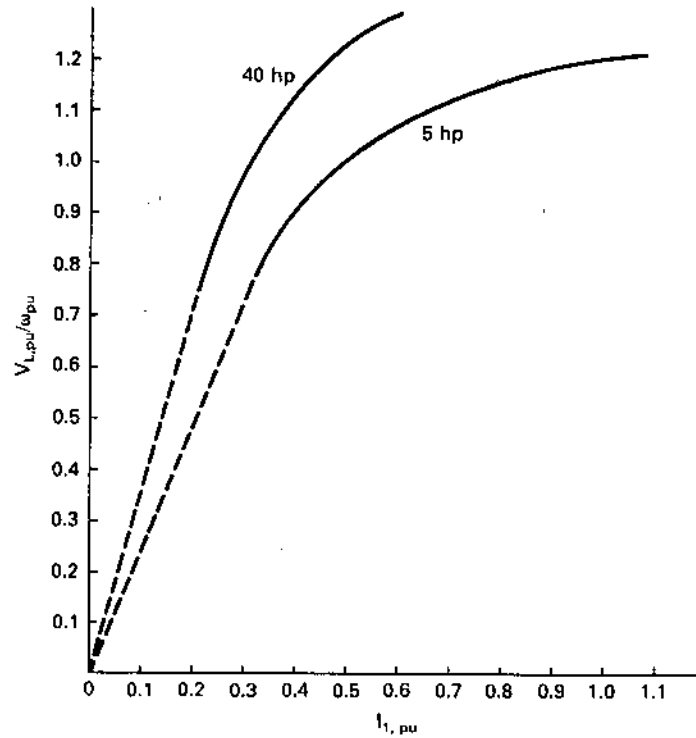

Figure 12: No-load magnetization curves for two induction generators.

5-hp machine without overheating effects. The insulation limitations of the machine must be respected, of course.

The magnetizing current necessary to produce rated voltage should be as small as possible for induction generators in this application. If two machines of different manufacturers are otherwise equal, the one with the smaller magnetizing current should be chosen. This will allow operation with less capacitance and therefore less cost. It may also allow more flexible operation in terms of the operating ranges of load resistance and frequency.

The per unit magnetizing inductance $L_{m,pu}$ is defined as

$$L_{m,pu} = \frac{V_{A,pu}}{\omega_{pu} I_{m,pu}} \quad (25)$$

An approximation for $L_{m,pu}$ which may be satisfactory in many cases is

$$L_{m,pu} \simeq \frac{V_{L,pu}}{\omega_{pu} I_{1,pu}} \quad (26)$$

This is just the slope of a line drawn from the origin of Fig. 12 to each point on the magne-

tization curve. Approximate curves for $L_{m,pu}$ for the two machines are presented in Fig. 13. We see that the inductance is constant for voltages less than about one-half of rated. The inductance then decreases as saturation increases.

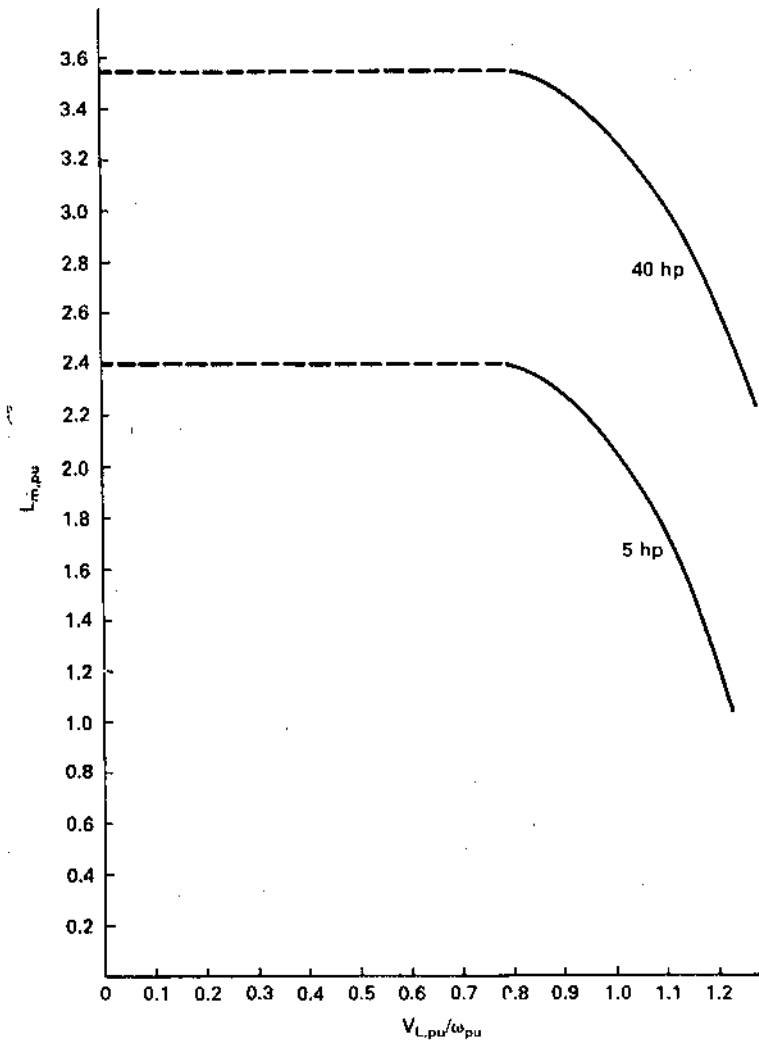

Figure 13: Per unit magnetizing inductance as a function of load voltage.

We see that any detailed analysis is made difficult because of the variability of the machine parameters. Not only must a nonlinear solution technique be used, the solution must be obtained for the allowable range of machine parameters. This requires a great deal of computation, with the results being somewhat uncertain because of possible inadequacy of the machine model and because of inadequate knowledge of the parameter values. We shall leave such detailed analyses to others and turn now to an example of experimental results.

Figure 14 shows the variation of terminal voltage with input mechanical power for the 40-hp machine mentioned earlier. The rated voltage is 230 V line to line or 132.8 V line to neutral. Actual line to neutral voltages vary from 90 to 150 V for the data presented here.

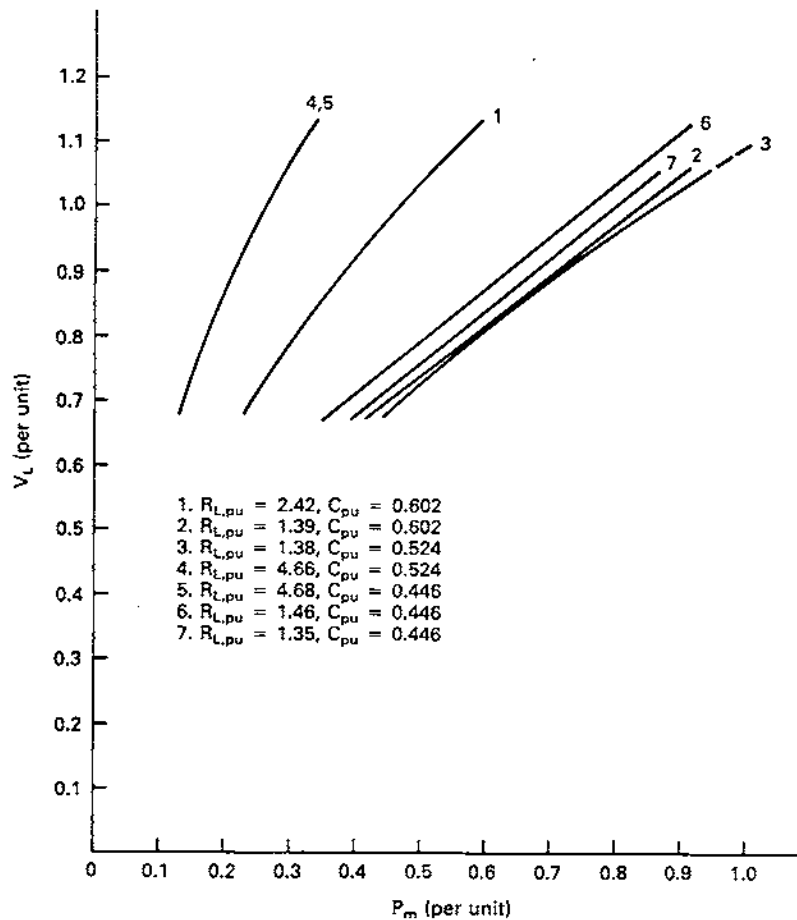

Figure 14: Variation of output voltage with input shaft power for various resistive and capacitive loads for a 40-hp self-excited induction generator.

All resistance was disconnected from the machine in order to establish oscillation. Once a voltage close to rated value was present the load was reconnected and data collected. Voltage buildup would not occur for speed and capacitance combinations which produce a final voltage of less than 0.8 or 0.9 of rated. For example, with 285 μ F of capacitance line to line, the voltage would not build up for speeds below 1600 r/min. At 1600 r/min the voltage would slowly build up over a period of several seconds to a value near rated. The machine could then be operated at speeds down to 1465 r/min, and voltages down to 0.7 of rated before oscillation would cease.

The *base* power for this machine is $\sqrt{3}(230 \text{ V})(96 \text{ A}) = 38,240 \text{ W}$. The *rated* power is $\sqrt{3}(230)(96) \cos \theta$, which will always be smaller than the base power. Because of this feature of the per unit system, the mechanical input power should not exceed 1.0 pu except for very short periods because the machine is already overloaded at $P_m = 1.0$ pu. The base impedance is $132.8/96 = 1.383 \Omega$. The base capacitance is $1/(Z_{\text{base}}\omega_{\text{base}}) = 1/[(1.383)(377)] = 1918 \mu\text{F}$ line to neutral. A line to line capacitance of $385 \mu\text{F}$, for example, would be represented in our analysis by a line to neutral capacitance of $3(385) = 1155 \mu\text{F}$, which has a per unit value of $1155/1918 = 0.602$ pu. A good starting point for the capacitance on experimental induction generators in the 5-50 hp range seems to be about 0.6 pu. Changing capacitance will change performance, but oscillation should occur with this value of capacitance.

Returning to our discussion of Fig. 14, we see that for curve 1, representing a load of 2.42 pu and a capacitance of 0.602 pu, the voltage varies from 0.68 pu to 1.13 pu as P_m varies from 0.22 pu to 0.59 pu. The variation is nearly linear, as would be expected. When the resistance is decreased to 1.39 pu with the same capacitance, we get curve 2. At the same P_m of 0.59 pu, the new voltage will be about 0.81 pu. The electrical power out, V_L^2/R_L , will remain the same if losses do not change. We see that the voltage is determined by the resistance and not by the capacitance. Curves 2 and 3 and curves 4 and 5 show that changing the capacitance while keeping resistance essentially constant does not cause the voltage to change significantly.

Changing the capacitance will cause the frequency of oscillation to change and therefore the machine speed. We see how the speed varies with P_m in Fig. 15. A decrease in capacitance causes the speed to increase, for the same P_m . The change will be greater for heavy loads (small R_L) than for light loads. The speed will also increase with P_m for a given R_L and C . The increase will be rather rapid for light loads, such as curves 4 and 5. The increase becomes less rapid as the load is increased. We even have the situation shown in curve 7 where power is changing from 0.4 to 0.6 pu with almost no change in speed. The frequency will change to maintain resonance even if the speed does not change so we tend to have high slip where the speed curves are nearly horizontal. For this particular machine the efficiency stayed at about 90 percent even with this high slip and no other operational problems were noted. However, small increases in load would cause significant increases in speed, as seen by comparing curves 6 and 7. It would seem therefore, that this constant speed-high slip region should be avoided by adding more capacitance. Curves 7, 3, and 2 show that speed variation becomes more pronounced as capacitance is increased from 0.446 pu to 0.602 pu. We could conclude from this argument that a capacitance of 0.524 pu is the minimum safe value for this machine even though a value of 0.446 pu will allow operation.

We now want to consider the proper strategy for changing the load to maintain operation under changing wind conditions. The mechanical power output P_m from the wind turbine is assumed to vary from 0 to 1.0 pu. A capacitance value of 0.524 is assumed for discussion purposes. At $P_m = 1.0$ pu the voltage is 1.09 pu and the speed is 1.01 pu for $R_L = 1.38$ pu. These are good maximum values, which indicate that good choices have been made for R_L and C . As input power decreases to 0.44 pu the speed decreases to 0.944 pu. If input power is decreased still more, the induction generator gets out of the nonlinear saturation region and

oscillation will cease. We therefore need to decrease the load (increase R_L). Note that there is a gap between curves 3 and 4, so we may have a problem if we change from $R_L = 1.38$ pu to 4.66 pu. The voltage will be excessive on the larger resistance and we may lose oscillation with the smaller resistance, while trying to operate in the gap area. We need an intermediate value of R_L such that the curve for the larger R_L will intersect the curve for the smaller R_L , as is the case for curves 1 and 2.

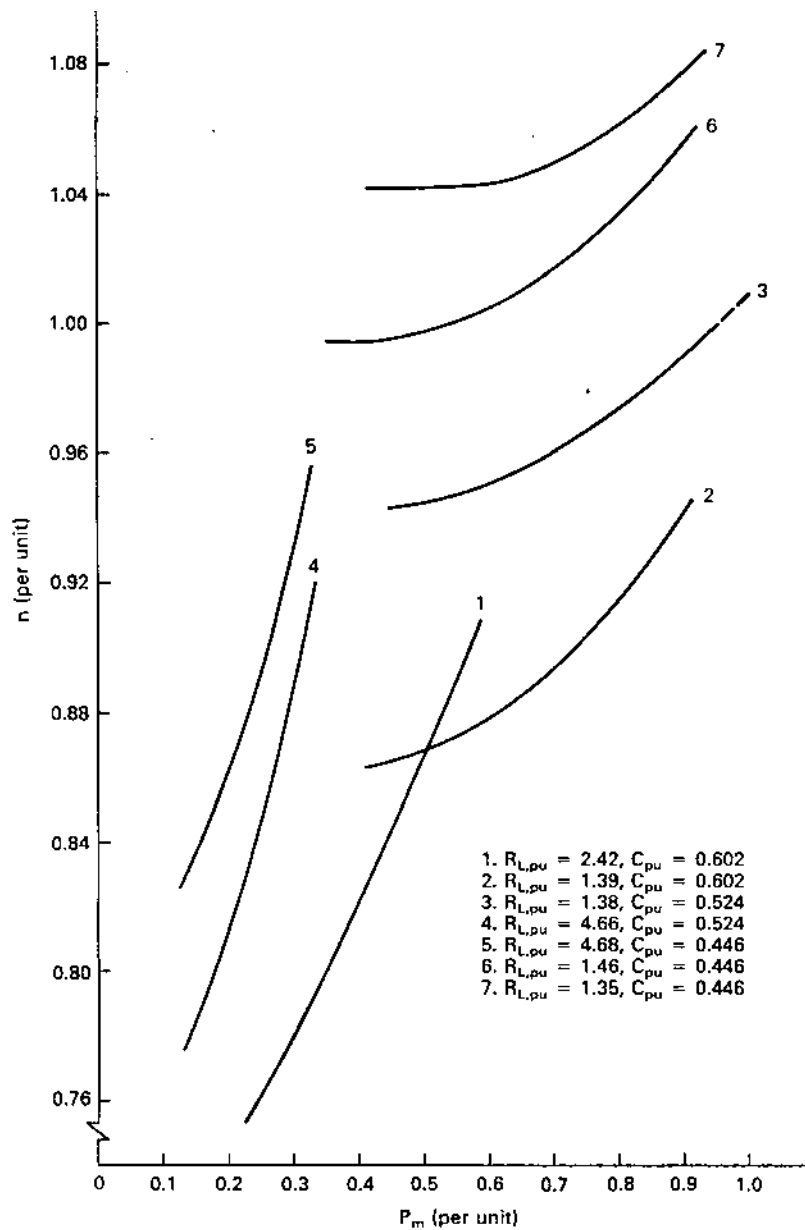

Figure 15: Variation of rotational speed with input shaft power for various resistive and capacitive loads for a 40-hp self-excited induction generator.

Curves 1 and 2 intersect at $P_m = 0.5$ pu so we can visualize a curve for a new value of R_L that intersects curve 3 at the same P_m . This is shown as curve 4' in Fig. 16. If we are operating on curve 4' at $P_m = 0.2$ pu, the speed is about 0.8 of rated. As shaft power increases to $P_m = 0.5$ pu the speed increases to about 0.95 of rated. Additional load can be added at this speed without causing a transient on the turbine since power remains the same. The speed then increases at a slower rate to 1.01 pu at $P_m = 1.0$ pu. If the wind is high enough to produce even greater power, the propeller pitch should be changed, brakes set, or other overload protection measures taken.

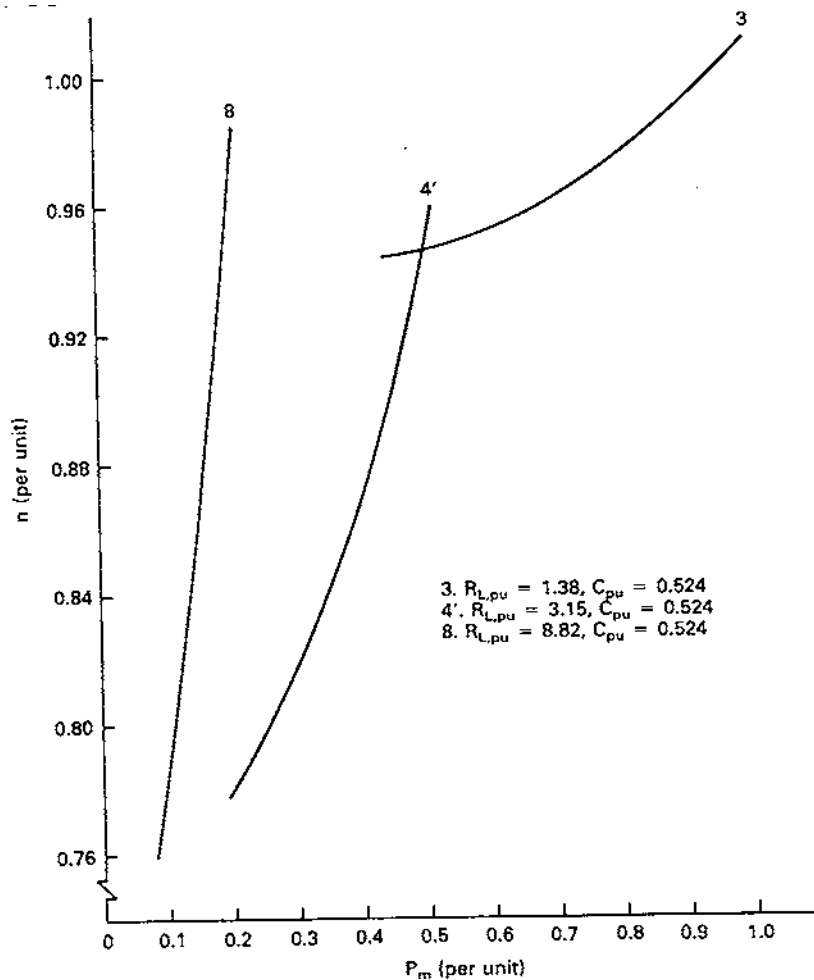

Figure 16: Variation of rotational speed with input shaft power for three well-chosen resistive loads for a 40-hp self-excited induction generator.

The resistance for curve 4' can be computed from Figs. 14 and 15 and the relationship

$$R_L = \frac{V_L^2}{P_e} = \frac{V_L^2}{\eta_g P_m} \quad (27)$$

We are assuming an ideal transmission between the turbine and the generator so the turbine power output is the same as the generator input. If we want actual resistance, we have to use the voltage and power values per phase. On the per unit system, we use the per unit values directly. For example, for $V_L = 1.0$ pu on curve 3 in Fig. 14, we read $P_m = 0.86$ pu. If $R_L = 1.38$ pu, then $P_e = (1.0)^2/1.38 = 0.72$. But $P_e = \eta_g P_m$ so $\eta_g = 0.72/0.86 = 0.84$, a reasonable value for this size machine. If we assume $V_L = 1.15$, $P_m = 0.5$, and $\eta_g = 0.84$ for the curve 4', we find $R_L = (1.15)^2/(0.84)(0.5) = 3.15$ pu.

This value of R_L will work for input power levels down to about $P_m = 0.2$ pu. For smaller P_m we need to increase R_L to a larger value. We can use the same procedure as above to get this new value. If we assume a point on curve 8 of Fig. 16 where $V_L = 1.15$ pu, $P_m = 0.5$ pu, and η_g arbitrarily assumed to be 0.75, we find $R_L = (1.15)^2/(0.75)(0.2) = 8.82$ pu. This resistance should allow operation down to about $P_m = 0.08$, which is just barely enough to turn the generator at rated speed. Speed and voltage variations will be substantial with this small load. There will probably be a mechanical transient, both as the 8.82 pu load is switched in during startup, and as the load is changed to 3.15 pu, because the speed versus power curves would not be expected to intersect nicely as they did in the case of curves 3 and 4'. These transients at low power levels and light winds would not be expected to damage the turbine or generator.

We see from this discussion that the minimum load arrangement is the one shown in Fig. 17. The switches S_1 , S_2 , and S_3 could be electromechanical contactors but would more probably be solid state relays because of their speed and long cycle life. The control system could operate on voltage alone. As the turbine started from a zero speed condition, S_1 would be closed as soon as the voltage reached perhaps 1.0 pu. When the voltage reached 1.15 pu, implying a power output of $P_m = 0.2$ pu in our example, S_2 would be closed. When the voltage reached 1.15 pu again, S_3 would be closed. When the voltage would drop below 0.7 pu, the highest numbered switch that was closed would be opened. This can be done with a simple microprocessor controller.

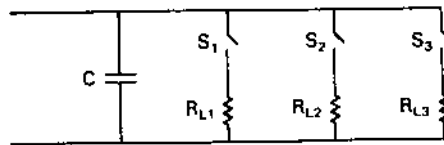

Figure 17: Minimum capacitive and resistive loads for a self-excited induction generator.

6 SINGLE-PHASE OPERATION OF THE INDUCTION GENERATOR

We have seen that a three-phase induction generator will supply power to a balanced three-phase resistive load without significant problems. There will be times, however, when single-phase or unbalanced three-phase loads will need to be supplied. We therefore want to examine this possibility.

Single-phase loads may be supplied either from line-to-line or from line-to-neutral voltages. It is also possible to supply both at the same time. Perhaps the most common case will be the rural individual who buys a wind turbine with a three-phase induction generator and who wants to sell single-phase power to the local utility because there is only a single-phase distribution line to his location. The single-phase transformer is rated at 240 V and is center-tapped so 120 V is also available. The induction generator would be rated at 240 V line to line or $240/\sqrt{3} = 138.6$ V line to neutral. The latter voltage is too high for conventional 120-V equipment but can be used for heating if properly rated heating elements are used.

A circuit diagram of the three-phase generator supplying line-to-line voltage to the utility network and also line-to-line voltage to a resistive load is shown in Fig. 18. Phases a and b are connected to the single-phase transformer. Between phase b and phase c is a capacitor C . Also shown is a resistor R_L which can be used for local applications such as space heating and domestic water heating. This helps to bring the generator into balance at high power levels. It reduces the power available for sale to the utility at lower power levels so would be placed in the circuit only when needed.

The neutral of the generator will not be at ground or earth potential in this circuit, so should not be connected to ground or to the frame of the generator. Some induction generators will not have a neutral available for connection because of their construction, so this is not a major change in wiring practice.

The induction generator will operate best when the voltages V_a , V_b , and V_c and the currents I_a , I_b , and I_c are all balanced, that is, with equal magnitudes and equal phase differences. Both voltages and currents become unbalanced when the generator supplies single-phase power. This has at least two negative effects on performance. One effect is a lowered efficiency. A machine which is 80 percent efficient in a balanced situation may be only 65 or 70 percent efficient in an unbalanced case. The other effect is a loss of rating. Rated current will be reached in one winding well before rated power is reached. The single-phase rated power would be two thirds of the three-phase rating if no balancing components are added and if the efficiency were the same in both cases. Because of the loss in efficiency, a three-phase generator may have only half its three-phase rating when connected directly to a single-phase transformer without the circuit components C and R_L shown in Fig. 18.

It is theoretically possible to choose C and R_L in Fig. 18 so that the induction generator is operating in perfect three-phase balance while supplying power to a single-phase transformer.

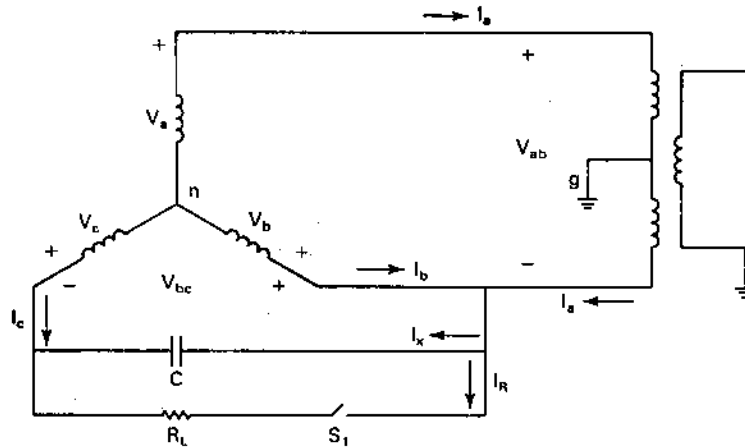

Figure 18: Three-phase induction generator supplying power to a single-phase utility transformer.

The phasor diagram for the fully balanced case is shown in Fig. 19. In this particular diagram, the capacitor is supplying all the reactive power requirements of the generator. This allows I_a to be in phase with V_{ab} so only real power is transferred through the transformer. In the fully balanced case, I_b and I_c must be equal in amplitude to I_a and spaced 120° apart, which puts them in phase with V_{bc} and V_{ca} . The current I_R is in phase with V_{bc} and I_X leads V_{bc} by 90° . By Kirchhoff's current law, $I_R + I_X = -I_c$. When we draw the necessary phasors in Fig. 19, it can be shown that $|I_R| = 0.5|I_a|$ and $|I_X| = 0.866|I_a|$. If we had a constant shaft power, such as might be available from a low head hydro plant, and if we had some use for the heat produced in R_L , then we could adjust C and R_L for perfect balance as seen by the generator and for unity power factor as seen by the utility. The power supplied to the utility is $V_{ab}I_a$ and the power supplied to the local load is $0.5V_{ab}I_a$, so two-thirds of the output power is going to the utility and one-third to the local load.

Unfortunately, a given set of values only produce balanced conditions at one power level. As the wind speed changes, operation will again be unbalanced. It is conceptually possible to have a sophisticated control system which would be continually changing these components as power level changes in order to maintain balance. This system could easily be more expensive than the generator and make the entire wind electric system uneconomical. We, therefore, are interested in a relatively simple system where one or more switches or contactors are controlled by rather simple sensors and logic circuitry. Hopefully, efficiency and unbalance will be acceptable over the full range of input power with this simple system. Capacitance and resistance would be added or subtracted as the power level changes, in order to maintain these acceptable conditions.

Perhaps the simplest way to illustrate the imbalance effects is with an example. Figure 20 shows the variation of the line to line voltages and the line currents for the 40-hp induction

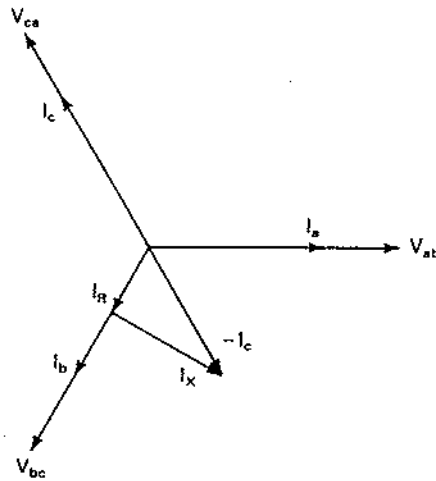

Figure 19: Phasor diagram for circuit in Fig. 18 at balanced operation at unity power factor.

generator described in the previous section. The capacitance $C = 0.860$ pu (actual value is $550 \mu\text{F}$). The resistance R_L was omitted so all the power is being delivered to the utility. The generator voltage of 230 V line to line is used as the base, but the available utility voltage was actually a nominal 208 V. This explains why V_{ab} always has a value less than 1.0 pu, since the utility connection did not allow the generator voltage to reach 230 V.

At values of P_m near zero, the current I_a being supplied to the utility is also near zero. This forces I_b and I_c to have approximately the same magnitudes. As P_m increases, I_a increases in an almost linear fashion. The voltage V_{bc} across the capacitor and the current I_c through it remain essentially constant. The current in phase b decreases at first and then increases with increasing P_m . The voltage V_{ab} to the transformer increases from 0.92 pu to 0.99 pu as P_m increases, due to voltage drops in the transformer and wiring.

The current I_a reaches the machine rating at a value of P_m of about 0.6 pu. As mentioned earlier, a generator should supply up to two-thirds of its three-phase rating to a single-phase load, but because of lower efficiency the generator limit will be reached at a slightly lower value. For this particular machine, the three-phase electrical rating is about 32,500 W. Rated current was reached at 21,000 W as a single-phase machine or 0.646 of the three-phase rating. This is just slightly under the ideal value of 0.667.

The efficiency drops if a larger capacitor is used. This increases I_c , which increases ohmic losses in that winding without any compensating effect on the losses due to imbalance. A value of I_c of about half of rated seemed to give the best performance over this range of input power. This makes its value close to the average values of I_a and I_b for this range of P_m , which is probably close to the optimum value.

If there is enough power in the wind to drive the generator above two-thirds of its rating,

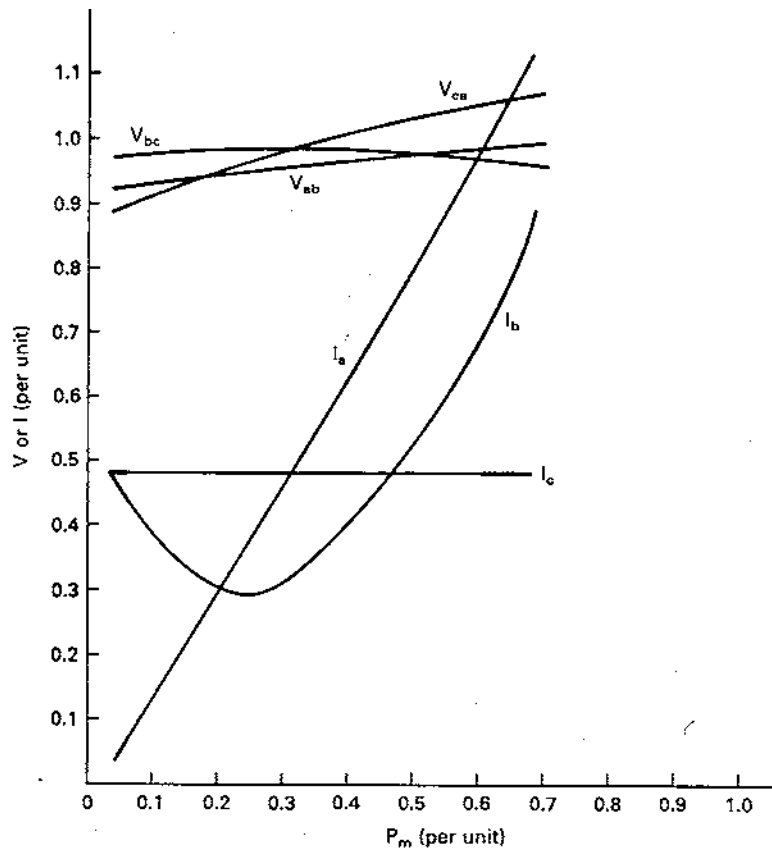

Figure 20: Variation of line-to-line voltages and line currents of 40-hp induction generator connected in circuit of Fig. 18. $R_L = \infty$; $C = 0.860$ pu.

then a resistance R_L can be added to draw off the extra power. As the total generator power increases, so does the reactive power requirements so utility power factor is improved if some additional capacitance is added in parallel with R_L . Figure 21 shows the variation in voltages and currents for $R_L = 3.72$ pu (actual value of R_L is 8.92Ω) and $C = 1.09$ pu (actual value of C is $700 \mu\text{F}$) for the circuit in Fig. 18. The voltage V_{bc} and the current I_c stay nearly constant, as before. The current I_b has a minimum at $P_m = 0.35$ pu and now I_a has a minimum at $P_m = 0.2$ pu rather than increasing monotonically as before. The important item to note is that the three currents and the three voltages are nearly equal at $P_m = 0.6$ pu. This indicates the generator is operating close to balanced conditions at this power level. Adjusting R_L and C will move this balance point either right or left. The balance point shown here is less than that for rated conditions, which means the generator will again be unbalanced when rated current is reached in one of the generator windings. In this particular case rated current is reached in line a for a total electrical power of $27,100$ W or 0.834 of three-phase rating. A smaller resistance and a larger capacitance would be necessary to move the balance point toward that for rated conditions.

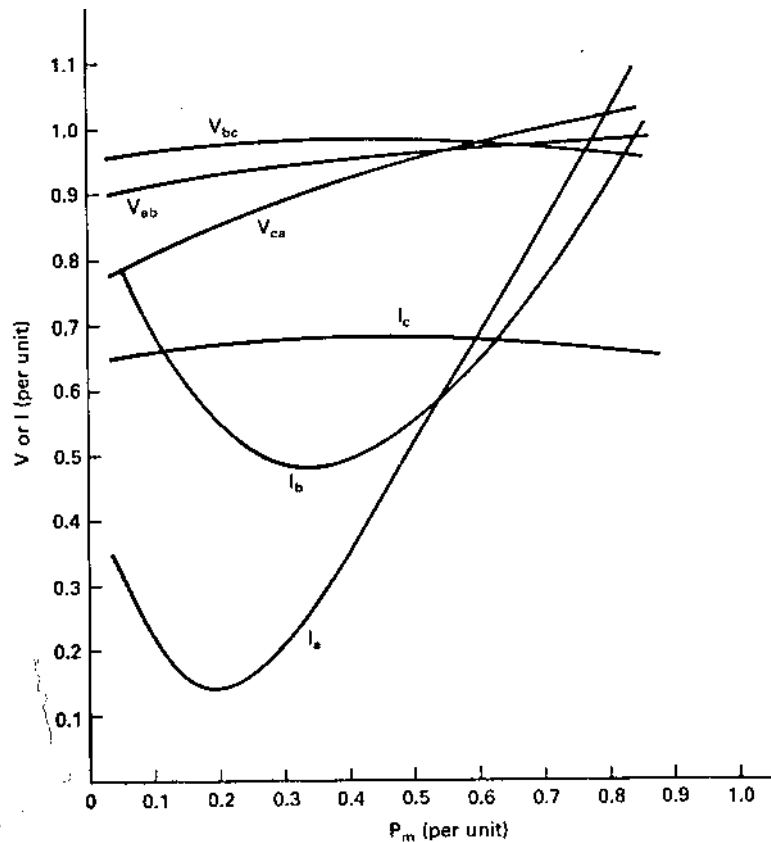

Figure 21: Variation of line-to-line voltages and line currents of 40-hp induction generator connected in circuit of Fig. 18. $R_L = 3.72$ pu, $C = 1.09$ pu.

We see that the three-phase induction generator supplies single-phase power to a utility in an effective manner by just adding a capacitor, or perhaps a capacitor and resistor, between phases b and c . It should be mentioned that the phase sequence connection is important. The phase sequence of the generator should be determined for its direction of rotation with a commercial phase sequence indicator and phases a and b (and *not* a and c) connected to the transformer, with the capacitor then connected between b and c .

Another important point is the matter of connecting the generator to the utility. As the brake is released on the wind turbine, acceleration may be quite rapid while there is no voltage or load on the generator. The single capacitor can produce self-excitation but this will probably not occur before the generator passes through synchronous speed. If the generator speed is substantially different from synchronous speed when the switch is closed, there will be both a mechanical transient on the turbine and an electrical transient on the utility. The generator may supply power levels well above rated to the utility while the generator is slowing down to operating speed. Such transients should be avoided as much as possible.

The proper connection procedure is therefore to sense generator speed and close the switch as close to synchronous speed as possible. For a four pole generator in the 20-50 hp range this should be done between 1800 and 1805 r/min. The mechanical impulse will be minimal with this approach but there will be a few cycles of high magnetizing currents while the magnetic flux is being established.

The same sensor can be used to disconnect the generator from the utility when generator speed falls below synchronous speed. This would mean that the generator has become a motor and is drawing power from the utility to operate the turbine as a large fan to speed air up on its passage through. This should be avoided for obvious economic reasons. The speed sensor therefore needs to be both precise and fast, able to disconnect the generator at, for example, 1798 r/min and reconnect it at 1802 r/min.

7 FIELD MODULATED GENERATOR

Thus far in this chapter we have considered the classical electrical machines that have been available for nearly a century. Other machines which have been developed in the last decade or two are also possibilities for wind turbine applications. One such machine is the field modulated generator developed at Oklahoma State University[11, 1].

This system uses a variable speed, variable frequency, three-phase generator to produce either single-phase or three- phase power at a precisely controlled frequency such as 60 Hz. The generator is operated at a high speed, perhaps 6000 to 10,000 r/min, and at a high frequency, at least 400 Hz. These machines were primarily developed for military applications where they have two significant advantages over conventional generators. One advantage is that they will operate nicely on simple gasoline engines with poor speed regulation in portable applications, and also when directly coupled to jet engines in aircraft. The other advantage is in the favorable kW/kg ratio obtained by higher speed operation. The power rating of a given size machine is directly proportional to speed or frequency so it is important to operate at a high frequency when weight is critical. This is why aircraft use 400 Hz rather than 60 Hz. Weight is not at all critical on wind turbines but the variable speed input, constant frequency output is of considerable interest.

The basic construction of the field modulated generator is that of the three-phase ac generator discussed in the previous chapter. Instead of the typical four poles and 1800 r/min, however, it may have 16 poles and be operated between 6000 and 10,000 r/min. The output frequency at 6000 r/min with dc applied to the rotor field would be $f = np/120 = 6000(16)/120 = 800$ Hz. In operation, the rotor field does not have dc applied to it but rather the desired power frequency, such as 60 Hz. The result in the generator output windings will be the same as in double- sideband suppressed-carrier modulation systems used in radio communications. Instead of 800 Hz there will be the sum and difference frequencies, 740 and 860 Hz. Therefore, the process of recovering the modulating or desired power frequency signal used in the rotor is simply one of demodulating and filtering the output waveform of the generator. The basic

waveforms are shown in Fig. 22.

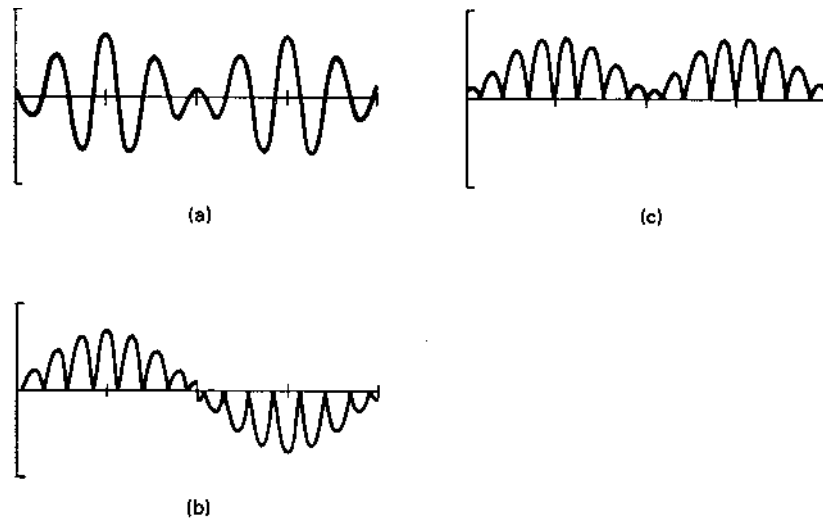

Figure 22: Waveforms of a field-modulated generator: (a) basic waveform; (b) basic waveform rectified; (c) basic waveform rectified and every other half-cycle inverted.

A simplified schematic of a field modulated generator with a single-phase output is shown in Fig. 23. At the far left is a field excitation source which supplies a sinusoidal signal to the field. The diode circuit in the field provides a signal of the same frequency but chopped off in amplitude at two diode drops, or about 1.4 V peak. It will be nearly a square wave and provides triggering information to the silicon controlled rectifiers in the generator output.

Tuning capacitors and a full-wave bridge rectifier are placed across the output of each phase of the generator. The output terminals of each of the three full-wave bridge rectifiers are tied in parallel and then fed into an SCR switching circuit. SCR1 and SCR4 will be turned on during one half cycle of the 60 Hz wave and SCR2 and SCR3 turned on the other half cycle. The desired power will flow into the transformer at the far right of the figure. The components L_1 , C_1 , L_3 , and C_3 help to filter the higher frequency components out of the output waveform. The components L_2 , C_2 , SCR5, and SCR6 serve as a commutating circuit, to help the SCR switching network switch into a reactive load.

We have mentioned earlier that a three-phase generator needs a balanced load in order to maximize its output. This requires that each phase be conducting all the time, which is not obviously the case with the full-wave rectifiers tied together. It would be quite plausible to have one or two phases conducting at a time, with the remainder turned off because of a phase voltage that is too low during a portion of the cycle to overcome the output phase voltages of the other phases. With the proper choice of generator reactance and tuning capacitance, however, each phase will conduct for 360° of an operating cycle. Therefore, at any instant of time all three phases of the generator are supplying current to the load, resulting in nearly

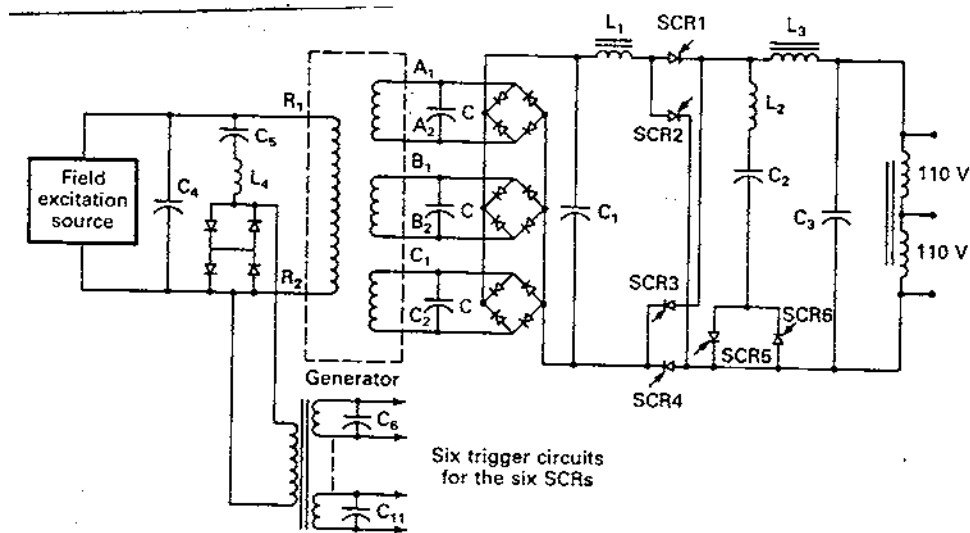

Figure 23: Simplified schematic of field-modulated generator.

balanced conditions as far as the generator is concerned.

The field modulated generator can also be used to generate three-phase power. This requires three separate rotor windings spaced along a single rotor, each with its own set of three stator windings. Each rotor winding is excited separately. Each set of three stator windings has the same electronics circuit as was shown in Fig. 23. The outputs of these three single-phase systems are then tied together to form a three-phase output.

Measured efficiency of a 60 kW field modulated generator tested at Oklahoma State University[1] was approximately 90 percent, quite competitive with other types of generators of similar size. The major disadvantage would be the cost and complexity of the power electronics circuit. It appears that this extra cost will be difficult to justify except in stand alone applications where precisely 60 Hz is required. Whenever frequency deviations of up to 10 percent are acceptable, induction generators or ac generators would appear to be less expensive and probably more reliable.

8 ROESEL GENERATOR

Another type of electrical generator which delivers fixed frequency power over a range of shaft speeds is the Roesel generator, named after its inventor, J. F. Roesel, Jr.[12, 9, 4]. To understand this generator we need to recall that the output frequency of all electrical generators is given by

$$f = \frac{np}{120} \quad (28)$$

where n is the rotational speed in revolutions per minute and p is the number of poles. All the electrical generators we have considered thus far have an even number of poles determined by physical windings on the generator rotor. This forces the output frequency to vary with the rotational speed. The Roesel generator is different in that the number of poles can be changed continuously and inversely proportional to n so that f can be maintained at a constant value.

The basic diagram of the Roesel generator is shown in Fig. 24. The stator, with its windings connected to an external load, is located on the *inside* of the generator. The rotor, which contains the field poles, rotates on the *outside* of the stator. The stator contains an excitation coil wrapped around the exciter head in addition to the usual output windings. The rotor is built in two layers, with the outer layer being high permeability laminated generator steel and the inner layer being a hard magnetizable material such as barium ferrite. Ferrites typically do not have the mechanical strength characteristics of steel, so this design helps to maintain mechanical integrity by having the steel carry the centrifugal forces. The ferrite would have to be much stronger if the rotor were inside the stator.

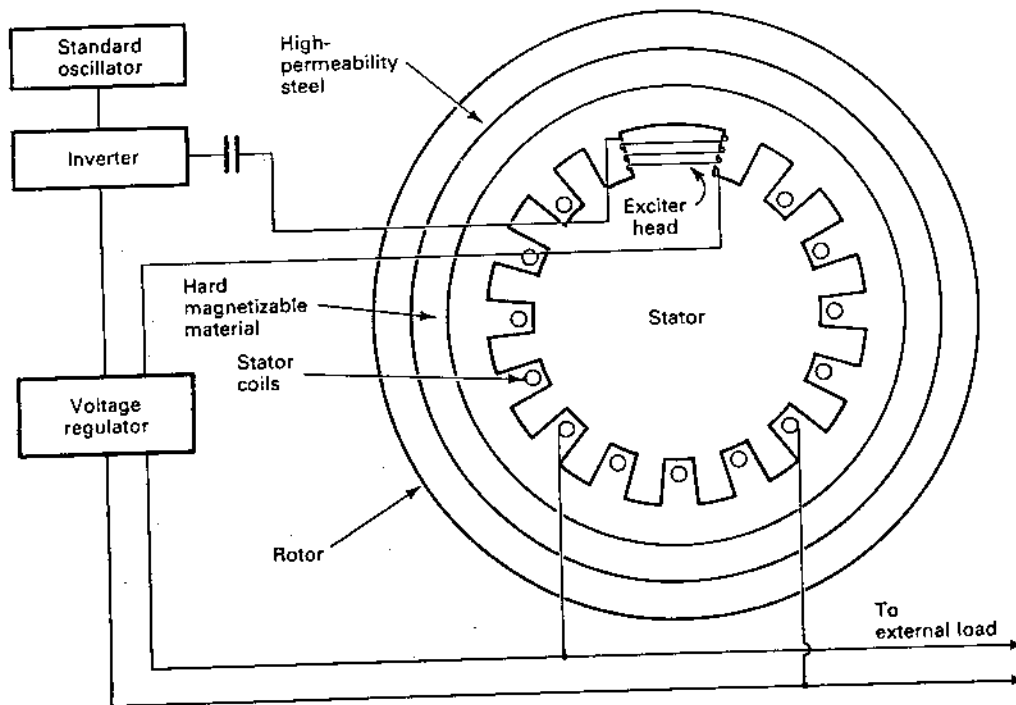

Figure 24: Basic diagram of Roesel generator.

A precise sinusoidal frequency is applied to the excitation coil and magnetizes a pole on

the rotor as it turns around the stator. This is called *writing* a pole. This pole then induces a voltage in the stator windings at the same frequency. The output frequency then has the same precision as the input frequency, independent of shaft speed over a range of perhaps two to one. If the excitation coil is driven by a crystal controlled oscillator with a precision of 0.01 Hz, the output will have the same precision.

As rotor speed increases, the circumferential length of the poles increases, and fewer of them are written around the circumference of the rotor. As rotor speed decreases, the length of the poles shorten, so more of them are written around the periphery of the rotor. There will be an even pole synchronous speed where an even number of equal length poles are uniformly spaced around the rotor. At the other extreme, there will be an odd pole synchronous speed where an odd number of equal length poles are equally spaced around the rotor. Between these extremes there will be fractional poles in the vicinity of the excitor head as poles are being partially rewritten. At the even pole synchronous speed, the poles remain in the same position from one revolution to the next so no rewriting of poles actually takes place. There will be no rotor hysteresis loss in this case, since the rotor iron magnetization does not change with time. At the odd pole synchronous speed, however, every positive pole is being exactly replaced with a negative pole during each revolution, so rotor hysteresis losses will be a maximum at this speed. This loss can be made acceptably small with the proper choice of magnetic materials.

There is an inherent limitation to the range of allowable speeds with any Roesel generator. The stator will have windings that span a given fraction of the circumferential length. Performance will be best when rotor speed is such that one pole has the same circumferential length on the rotor as the stator winding has on the stator. At half of this speed there has to be twice as many poles on the rotor to maintain the same output frequency. We now have two poles spanning one stator coil, which produces a zero net magnetic flux in the coil. The output voltage now becomes zero since there is no time changing flux in the coil. The output voltage will also become zero at twice the original speed. That is, a Roesel generator with a nominal speed of 1800 r/min will have its output go to zero at 900 and 3600 r/min. Practical speed limits would probably be 1200 and 2800 r/min in this case. Voltage regulation would be possible over this range by changing the amplitude of the excitation current to thereby change the flux seen by the stator windings. Such a range of speed is more than adequate for most applications, including variable speed wind turbine generators.

The Roesel generator has several desirable features in its design. One is that there are no brushes or sliprings and no rotating windings. These features help to lower cost and improve reliability. Another feature is that the electronics only have to supply a single-frequency sinusoid of moderate voltage and current. No switching or filtering of the output power is required, with a resultant saving in cost as compared with the field modulated generator. Yet another advantage is that rotor speeds of perhaps 1200 to 1800 r/min represent good design values, as compared with the 6000 to 10,000 r/min of the field modulated generator. The lower speeds will simplify the gear box requirements and probably improve the overall efficiency.

Early versions of the Roesel generator, built in sizes of 1 to 10 kVA by the Precise Power

Corporation, demonstrated the technical feasibility of this concept. Development is continuing on larger sizes. Questions of generator efficiency, reliability, and expected life have not been fully answered but there seem to be no insurmountable problems.

9 PROBLEMS

1. The Jacobs Model 60 is a dc shunt generator used for charging 32-V batteries. It is rated at $I_B = 60$ A and $V_g = 40$ V at 300 r/min. The circuit is that of Fig. 2. Assume $V_B = 34$ V, $R_b = 0.1$ Ω , $R_a = 0.5$ Ω , and $R_f = 40$ Ω . Assume the diode is ideal and the load switch is open. The rotor diameter is 4.4 m and rated windspeed is 12 m/s.
 - (a) Find E at 300 r/min when $I_B = 60$ A.
 - (b) Find the generated power at 300 r/min
 - (c) Find the electrical power delivered to the battery at 300 r/min.
 - (d) Find the ratio of generated power P_e to the power in the wind P_w at rated load and rated windspeed. Assume standard conditions. (Note: The formula for P_w is given in Chapter 4.)
 - (e) Find the rotor speed at which the batteries will just start to charge, ignoring armature reaction. Assume the generator is operating well into saturation so the flux is constant for small changes in I_f , which makes E vary only with rotational speed.
2. A three-phase PM generator connected into a resistive (unity power factor) load is rated at 5 kW, 225 V line to line, 60 Hz, at 1800 r/min. The no load voltage is 250 V line to line at 1800 r/min. The circuit is given in Fig. 5.
 - (a) Find the rated current.
 - (b) Find k_e of Eq. 15.
 - (c) Assume $R_s = 0$ and find X_s .
 - (d) What is the percentage change in P_e (given by Eq. 17) for a 10 percent decrease in speed, if the total three-phase power is 5 kW at 1800 r/min?
3. What is the rated power of the PM generator in the previous problem at 5400 r/min, assuming the rated current does not change with speed?
4. Zephyr Wind Dynamo Company sells a 15-kW, three-phase, 108-pole, 240-V, permanent-magnet ac generator for home heating applications where frequency is not critical. Rated power is reached at 300 r/min.
 - (a) What is the frequency of the generated voltage at rated speed?
 - (b) What rotor speed would yield an output frequency of 60 Hz?

- (c) What is the machine power rating at 60 Hz, assuming rated current is the same at all frequencies?
5. A three-phase PM generator has a no load line-to-line voltage of 250 V at 60 Hz. It is rated at 5 kW, 225 V line to line at 60 Hz. It is connected into the series resonant circuit of Fig. 9. Assume the circuit is resonant at 60 Hz so E_a appears across R_a . Rated current is flowing. Find the necessary series capacitance C and the load resistance R_a . Evaluate P_e at 20 Hz and 40 Hz. Compare these values with the ideal values for a system where P_e varies as n^3 .
6. A 100-kW three-phase ac generator has $X_s = 0.4 \Omega$ when operated at 60 Hz. Rated terminal voltage is 230 V line-to-line. The circuit of Fig. 5 applies and the power output is assumed to be given by Eq. 21. The internal resistance R_s may be assumed to be zero.
- (a) Find the rated current.
- (b) Find the load resistance R_a which absorbs rated power at rated voltage and frequency.
- (c) Find L_s .
- (d) Find the change in P_e for a 10 percent decrease in frequency and also for a 10 percent increase in frequency. How does this compare with the optimum ω^3 variation?
7. A 50-hp three-phase induction motor costs \$1200 in 1982 dollars. The rated current is 58.5 A when connected as 460 V and 117 A when connected as 230 V. It is to be operated as a self-excited induction generator with the circuit shown in Fig. 10. The total reactive power required is 28 kvar reactive at full load and 60 Hz for either voltage. How much line-to-line capacitance is required for self-excitation with each connection, expressed as the total for all three legs? Discuss the economic advantages of using the higher voltage connection, assuming that 460 V (the only rating available) motor run capacitors cost $\$0.50/\mu\text{F}$.

References

- [1] Allison, H. J., R. Ramakumar, and W. L. Hughes: "A Field Modulated Frequency Down Conversion Power System," *IEEE Transactions on Industry Applications*, Vol. IA-9, No. 2, March-April 1973, pp. 220-226.
- [2] Bassett, E. D. and F. M. Potter: "Capacitive Excitation for Induction Generators," *Electrical Engineering*, May 1935, pp. 540-545.
- [3] deMello, F. P. and L. N. Hannett: "Large Scale Induction Generators for Power Systems," *IEEE Transactions on Power Apparatus and Systems*, Vol. PAS-100, No. 5, May 1981, pp. 2610-2618.

- [4] Herman, L. R.: “The Roesel Generator, Constant Frequency with Variable Speed,” Paper A 76 035-6, IEEE Power Engineering Society Winter Meeting, New York, January 25-30, 1976.
- [5] Melkebeek, J. A. A., and D. W. Novotny: “Steady State Modeling of Regeneration and Self-Excitation in Induction Machines,” IEEE Power Engineering Society Winter Meeting, New York, January 30-February 4, 1983.
- [6] Melkebeek, J. A. A.: “Magnetising-Field Saturation and Dynamic Behavior of Induction Machines: Part 1. Improved Calculation Method for Induction Machine Dynamics,” *IEE Proceedings*, Vol. 130, Pt. B, No. 1, January 1983, pp. 1-9.
- [7] Melkebeek, J. A. A.: “Magnetising-Field Saturation and Dynamic Behavior of Induction Machines: Part 2. Stability Limits of a Voltage-Fed Induction Motor and of a Self-Excited Induction Generator,” *IEE Proceedings*, Vol. 130, Pt. B, No. 1, January 1983, pp. 10-17.
- [8] Mohan, N., and M. Riaz: “Wind-Driven, Capacitor-Excited Induction Generators for Residential Electric Heating,” IEEE Power Engineering Society Winter Meeting, New York, January 29- February 3, 1978.
- [9] Ott, R. R., R. J. Barber, and J. F. Roesel, Jr.: “The Roesel Generator: A Unique Variable-Speed, Constant-Frequency Generator,” IEEE 75CH0964-7MAG.
- [10] Ouazene, L., and G. McPherson, Jr.: “Analysis of the Isolated Induction Generator,” IEEE Power Engineering Society Winter Meeting, New York, January 30-February 4, 1983.
- [11] Ramakumar, R., H. J. Allison, and W. L. Hughes: “A Self- Excited Field Modulated Three-Phase Power System,” Paper C 74 318-2, IEEE Power Engineering Society Summer Meeting, Anaheim, Calif., July 1974.
- [12] Roesel, J. F., Jr.: *Electric Power Generator*, U.S. Patent 3,521,149, July 21, 1970.
- [13] Seely, S.: *Electron-Tube Circuits*, McGraw-Hill, New York, 1958.
- [14] Soderholm, L. H., and J. F. Andrew: *Field Control for Wind-Driven Generators*, U.S. Patent Application PB81-129,678, PAT- APPL-6-193 877, filed October 3, 1980.

ASYNCHRONOUS LOADS

Wake up, North Wind. South Wind, blow on my garden. Song of Songs 4.16

We saw in the previous chapter that there are at least six distinctly different electrical generators that will allow a wind turbine to operate in a variable speed mode. The electrical output of these generators varies from rather poor quality, in the sense of widely varying frequency and voltage, to utility quality electricity. We saw that it is possible to have a variable speed turbine and still operate in parallel with the utility network. This design option needs to be considered in the design of each new wind system to determine if more energy can be captured from the wind or if overall equipment costs can be reduced.

If the wind energy system actually operates independently of the utility grid, the character of the load becomes very important to proper system operation. The load needs to be able to accept the highly variable power delivered by the turbine if the system is to work satisfactorily. We saw several instances in the previous chapter where battery or resistive loads could accept such variable power readily. There are many other possible loads which may be proposed for wind turbines and some knowledge of their characteristics will be helpful in any system design. Many of these loads can be operated either with or without electricity as an intermediate step. That is, the mechanical output of a wind turbine can be connected directly to a piston pump for pumping water, or the mechanical output can be converted to electrical form, and then back to mechanical by use of an electrical motor. In either case, we need the characteristics of a piston pump to determine the loading effect on the wind turbine. In this chapter we shall consider a number of loads which might be proposed for use on a wind turbine operating independent of the utility network. These loads therefore can be called asynchronous loads, whether they actually require electrical power or if they only use power in a mechanical form.

The vast majority of wind turbines built in the past have been used for non-electrical applications. Water pumping and grain grinding are classical applications of wind power. Wind turbines have been used for many centuries by a number of cultures for watering livestock, land drainage, irrigation, salt production, and supplying household needs.

We might divide these turbines into two basic types: the indigenous and the American multiblade. The indigenous windmills typically use locally available materials such as wood, sail cloth, and bamboo mats. The American multiblade was developed in the late 1800's and has been used widely in North America and Australia. It has a highly evolved design, uses mass produced steel components, and is available on the international export market. The indigenous turbine will only be regionally available. The indigenous turbine is characterized by locally made components, relatively low capital costs, short life, and high maintenance, which may be a good solution in a country which is short on foreign exchange and long on cheap labor.

These machines compete rather well with all the alternatives except an electric utility

network with inexpensive coal or nuclear generated electricity. The energy they produce will cost perhaps twice the amount per equivalent kWh as centrally generated electricity but perhaps half the amount of a gasoline or diesel engine to accomplish the same task. Therefore, they look very attractive wherever there is no electrical network, whether it is a developing nation or the interior of Australia. Their use is expected to continue and perhaps even accelerate as design improvements are made and oil becomes less available.

Other mechanical applications are beginning to appear which may use these water pumper designs or may require entirely new machines. There is a need in many places for the pumping of substantial amounts of water, but where the flow can basically follow the availability of the wind. City water supplies and large irrigated farms could use large wind machines with mechanical rather than electrical output. Oil wells can be pumped when the wind is available, since in many cases the electrical pumps only operate a few hours a day on the small oil wells. Wind machines can be used to stir water, either to remove ice for stock watering or to add oxygen for pollution control. They can be used to heat water by mechanically stirring it, and thereby compete with oil for space heating, especially in northern latitudes. They can be used to dry grain by operating fans to move either ambient or slightly heated air through a grain bin.

In addition to these basically mechanical loads, home appliances, heat pumps, electrolysis cells, and fertilizer cells may be considered as possible loads for a wind electric generator. We shall now proceed to briefly examine some of these loads.

1 PISTON WATER PUMPS

The water pump may be man's earliest invention for the substitution of natural energy for muscular effort in the fulfillment of man's needs. The earliest pumps, known as Persian wheels or water wheels, were undershot water wheels containing buckets which filled with water when they were submerged in a stream and which automatically emptied into a collecting trough as they were carried to their highest point by the rotating wheel. The motion of the water in the stream provided the energy for the wheel.

Pumps have evolved into many different types over the centuries. They can be broadly divided into two major categories, the *dynamic* and the *displacement*. Energy is continuously added to a dynamic pump and periodically added to a displacement pump.

The dominant dynamic pump is the centrifugal pump, which includes radial flow and axial flow. Displacement pumps may be either reciprocating or rotary, with a number of subdivisions within each type. The vast majority of pumps in operation today are centrifugal, although reciprocating pumps are still normally used with the American multiblade turbine. We shall discuss the two pump types, the reciprocating and the centrifugal, that appear to have the most application to wind turbine systems, starting with the reciprocating type.

A sketch of a basic water pumping wind turbine is shown in Fig. 1. This sketch was

prepared by Aermotor, now a Division of Valley Industries. At one time, the Aermotor turbines accounted for 80-90 percent of all water pumper sales in the United States, hence are likely to appear in old photographs. They are now manufactured in Argentina. Their 1980 sales in the United States were on the order of 3500 units, which was more than the combined production of all electric generating wind turbines in that year.

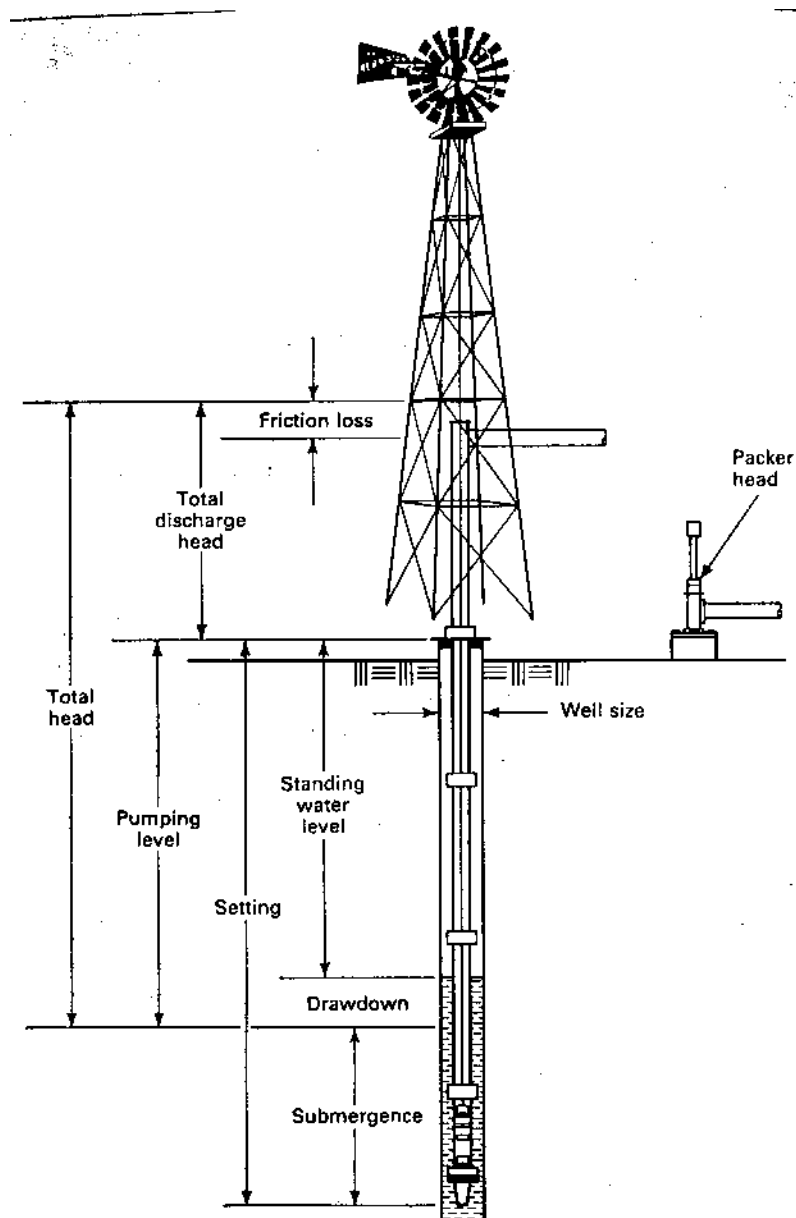

Figure 1: Aermotor illustration of key water pumping terms.

This sketch shows the normal installation with the wind turbine located directly above the well. The turbine is connected to a gear box and crankshaft which converts rotary motion into reciprocating motion on the pump rod. The pump rod enters the well pipe through a packer head which allows the motion of the rod but blocks the water from leaking out. The pump rod then connects to the piston in the pump at the bottom of the well pipe.

The height of the equivalent column of water which is raised by the piston is referred to as the total *head*. It includes the distance from the water level in the well to ground level, from ground level to the height of discharge, and a quantity for friction losses of water flowing in the pipe.

The pumping level is seen to be greater than the standing water level by the amount of *drawdown*. This refers to the decrease in water level during pumping and may vary from an insignificant amount to several meters. Water has to flow back into the well from the subsurface water bearing strata of sand and gravel, called *aquifers*, so the drawdown will be generally proportional to the rate of pumping. The pump is normally located below the maximum draw down level by an amount adequate to ensure proper pump-suction operating conditions. This varies with the piston size, operating speed, flow rate, and pressure, but can be as much as 2 or 3 m.

A picture of a piston pump is shown in Fig. 2. Both the piston and the bottom of the pump have *check valves* which only allow water to flow in the upward direction. When the piston is lifted by the piston rod, the piston valve closes and the piston lifts the entire column of water above it, until water overflows out of the discharge pipe at the top. At the same time, a slight suction is formed under the piston, causing the suction valve to open and water to flow in under the piston. During the next half of the cycle, the piston moves down, causing the suction valve to close and the piston valve to open, so water flows through the piston into position to be lifted during the next half-cycle. The flow of water will be inherently pulsating due to this reciprocal action. This poses little or no problem in filling a tank, but may not be suitable in those applications requiring more uniform pressures and flows.

The piston packing must fit tightly to the cylinder liner to prevent leakage around the piston during the up stroke. The packing will often wear rapidly if the piston moves at a linear speed well above rated, so pump speeds must be limited to reasonable values. Other problems associated with overspeed operation are improper valve action and low suction pressure. If the suction pressure drops too low, the water will vaporize under the piston. This limits the flow and also causes vibration in the pump rod.

The pump size is normally described in terms of the piston diameter, which is the same as the diameter of the inside of the cylinder. The terms piston diameter, cylinder diameter, and pump size are all used interchangeably.

The actual flow to the discharge system is termed the pump *capacity*. The theoretical flow under ideal conditions is called the pump *displacement*. The displacement of the simple pump in Fig. 2 is given by

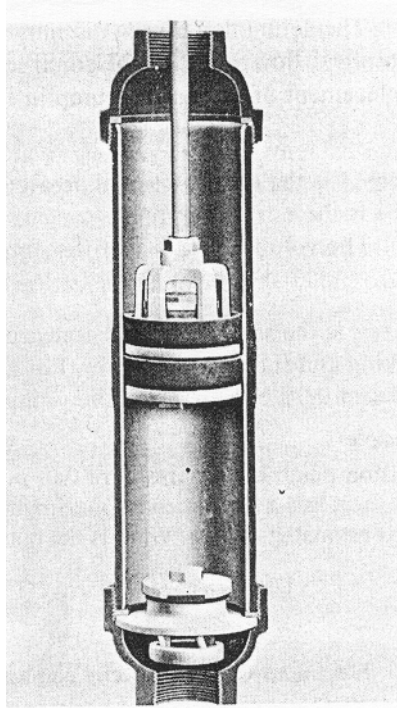

Figure 2: Diagram of piston pump. (Courtesy of Dempster Industries, Beatrice, Nebraska.)

$$D = AL_p f \quad \text{m}^3/\text{s} \quad (1)$$

where A is the cross sectional area of the piston, L_p is the length of the stroke, and f is the number of pump cycles per second.

The volume capacity of the pump is given by

$$Q_v = D(1 - s) \quad \text{m}^3/\text{s} \quad (2)$$

where s is the *slip*. The slip is a measure of the losses due to leakage around the packing and through the valves. For a well built pump, slip is probably between 0.03 and 0.05, increasing as the pump wears.

Example

A piston pump has an area A of 0.01 m^2 and a stroke of 0.2 m . The manufacturers data sheet lists a recommended maximum operating speed of 50 cycles per minute. The slip is estimated as 0.05 . What is the pump volume capacity?

$$Q_v = D(1 - s) = AL_p f(1 - s) = (0.01)(0.2) \frac{50}{60} (1 - 0.05) = 1.58 \times 10^{-3} \text{ m}^3/\text{s}$$

The pump volume capacity can also be expressed as 1.58 L/s, or 5.70 m³/h, or 25.1 gal/min.

We see that the SI expression for volume capacity is well under unity, while the number of liters per second, cubic meters per hour, and gallons per minute are above unity. This makes the non-SI units slightly easier to remember. However, we shall primarily use the SI units, but will lapse into other units occasionally to help the reader understand those units which have been so widely used. The conversion factors for capacity units are that 1 m³/s is equal to 35.315 cubic feet per second, usually abbreviated cfs, and is also equal to 15,850.32 U. S. gallons per minute, abbreviated gal/min or gpm. One cubic meter contains 264.17 U. S. liquid gallons and one cubic foot contains 7.4805 U. S. liquid gallons. River flows in the United States have historically been expressed in cfs while pump capacities are more often given in gal/min.

In power calculations we will need to express capacity in terms of mass flow rather than volume flow. If ambient temperature water is being pumped, it is usually sufficiently accurate to assume that one liter of water has a mass of one kilogram, or 1 m³ has a mass of 1000 kg. We can define a *mass capacity* Q_m kg/s as the mass flow, where $Q_m = 1000Q_v$ if Q_v is expressed in the SI units of m³/s.

The power input to a pump is given by

$$P_m = \frac{gQ_m h}{\eta_p} \quad \text{W} \quad (3)$$

where $g = 9.81$ N/kg is the gravitational constant, Q_m is the mass capacity of the pump expressed in kg/s, h is the head in m, and η_p is the pump mechanical efficiency. The quantity $gQ_m h$ can be thought of as an output power

$$P_o = gQ_m h \quad \text{W} \quad (4)$$

or the energy required to raise a given mass of water a height h , divided by the time required to do it. The mechanical efficiency includes losses in the mechanical friction between the piston packing and the pump cylinder and also the pump rod and the water it moves through. These losses are in addition to those included in the slip. The mechanical efficiency is usually between 0.9 and 0.95 but can be as low as 0.5.

Example

Find the power input to the pump of the previous example if the head is 20 m and the mechanical efficiency is 0.92.

The capacity Q_m is assumed to be 1.58 kg/s. The power input is then

$$P_m = \frac{9.81(1.58)(20)}{0.92} = 337 \text{ W}$$

If the volume capacity is given in the English units gal/min, which we shall call Q_g , and the head is given in feet, Eq. 3 becomes

$$\begin{aligned}
 P_m &= \frac{0.1886Q_g h}{\eta_p} && \text{W} \\
 &= \frac{2.529 \times 10^{-4} Q_g h}{\eta_p} && \text{hp}
 \end{aligned}
 \tag{5}$$

The second expression yields power in horsepower rather than watts. Both expressions are strictly valid only for water with a density of 1 kg/L and may need a correction if warm water or other liquids are to be pumped.

Proper operation of the water pumping system requires that the pump size and turbine size be matched to the total head. The multiblade turbines are typically sold in diameters of 6, 8, 10, 12, 14, and 16 ft. Pump diameters are available in quarter inch increments from 1.75 to 5 inches and in one inch increments above 5 inches. If we put a large diameter pump on a small turbine over a deep well, the turbine will not be able to develop sufficient torque to raise the water column to the discharge level. The pump acts like a brake up to some very high wind speed where torque becomes adequate for pumping to occur. On the other hand, if we put a small diameter pump on a large turbine we may get only a small fraction of the possible capacity.

There is an adjustment on the torque arm of many water pumpers which can help optimize a given system to a particular pumping level. By shortening the torque arm, the length of stroke is shortened and less water is lifted per revolution of the turbine. At the same time the force available to the piston rod increases so that a greater head can be pumped. A system designed for a given head at maximum stroke can be adjusted to satisfactorily pump smaller amounts of water if the water table should become lower. This cannot be done dynamically on these simple machines, but once per season should be adequate to compensate for changes in the water table and in the seasonal wind speeds.

We see in Eq. 3 that the required pump power is directly proportional to the capacity. The capacity is directly proportional to the number of pump cycles per unit time and, therefore, to the turbine rotational speed in r/min. The turbine output then varies as the turbine rotational speed while the turbine input, the power in the wind P_w , varies as the cube of the wind speed. We learned in Chapter 4 that the best match of turbine to load occurs when the load input power varies as the cube of the rotational speed. This allows the turbine to stay at the peak of its coefficient of performance curve over a wide range of wind speeds. The piston pump is not an optimum load for a wind turbine since it presents a relatively heavy load at light wind speeds and a light load at strong wind speeds. The inherent speed regulation is poor in that the pump speed theoretically changes by a factor of eight while the wind speed changes by a factor of two. The speed regulation will not actually be that bad because the slip, mechanical efficiency, and turbine coefficient of performance all deteriorate with increasing turbine speed, but there will still be substantial changes in the turbine speed.

Speed is regulated by turning the turbine sideways to the wind in strong winds. The dual

task of turning the turbine into the wind in light winds and out of the wind in strong winds is accomplished by some rather ingenious mechanisms which we shall not discuss in detail. These have been perfected over many years of experimentation and work very reliably. A picture of the vane mechanism for the Dempster, another well-known water pumper, is shown in Fig. 3.

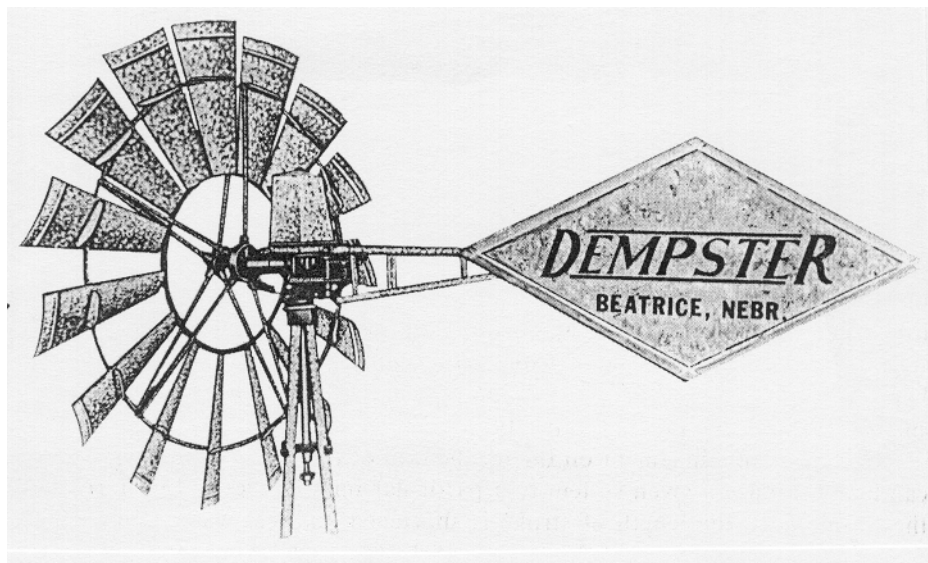

Figure 3: Dempster water pumper. (Courtesy of Dempster Industries, Beatrice, Nebraska.)

We now return to the matter of selecting turbine size and pump size for a given application. Manufacturers data sheets are essential at this point. A typical data sheet for the Dempster water pumper is shown in Table 7.1. This table presents data for five turbine diameters and five cylinder sizes. The original table gave head in feet and capacity in gallons per hour, but these have been converted to meters and liters per second in this table.

We note in the table that the product of head and capacity is almost constant for any given diameter turbine, as would be expected from Eq. 3. The rated wind speed of the Dempster is 15 mi/h (6.7 m/s) so the capacities shown will not be exceeded greatly in stronger winds, due to the speed control mechanism on the turbine.

TABLE 7.1. Dempster Pumping Capacities in a 15 mi/h wind

Cylinder Diameter (in.)	Turbine Diameter									
	6 ft; 5-in. stroke		8 ft; 7.5-in. stroke		10 ft; 7.5-in. stroke		12 ft; 12-in. stroke		14 ft; 12-in. stroke	
	Head (m)	L/s	Head (m)	L/s	Head (m)	L/s	Head (m)	L/s	Head (m)	L/s
2	29	0.137	41	0.205	64	0.167	93	0.217	139	0.185
2.5	19	0.217	27	0.320	42	0.261	61	0.339	91	0.290
3	14	0.309	20	0.463	31	0.375	45	0.487	67	0.416
3.5	10	0.421	15	0.631	23	0.512	33	0.662	49	0.568
4	8	0.549	11	0.820	17	0.668	25	0.864	38	0.742

If we put a larger pump cylinder size on a given turbine, the capacity increases but the maximum head decreases. That is, a 10-ft diameter turbine can pump 0.167 L/s at a head of 64 m or 0.375 L/s at a head of 31 m.

We see also that several different combinations of turbine size and cylinder diameter are possible for a given head. A head of about 20 m, for example, can be pumped by a 6-ft turbine and a 2.5-in. cylinder, a 8-ft turbine with a 3-in. cylinder, a 10-ft turbine with a 3.5-in. cylinder, and a 12-ft turbine with a 4-in. cylinder. The main difference among these combinations is the capacity and, of course, the cost. We have to select the combination which will meet all the load requirements at minimum cost. This will usually require a discussion with the wind turbine distributor and visits with other wind turbine owners in the area who have similar applications.

In these stand alone applications, not only the average wind speed is important, but also the number of consecutive hours or days without wind. The storage tanks must be sized so that storage is adequate for the longest calm period that would be expected. The turbine and pump must then be able to refill the storage perhaps during one day while water is still being withdrawn. The alternative is to go to the well and pump the necessary water by hand, a rather undesirable task. We illustrate some of these ideas in the following example.

Example

You have just inherited 640 acres of grass land in the Kansas Flint Hills. This was part of a large ranch and cattle which grazed this section of land had to go elsewhere to drink. You want to fence it so you have to supply water. The soil is not suitable for building ponds so you have to pump water from a well. The nearest utility line is three km from the well and the cost of installing the line would be \$8000 per km if you wanted to use electricity for pumping. You can buy a new water pumper turbine, tower, pump, and stock tanks for less than \$6000. The initial capital investment of the wind system is less than 25 percent of the utility system, and maintenance on these proven systems is less than the yearly utility bill would be so you decide to buy a water pumper wind turbine. You estimate your pasture will support 100 yearling steers which drink about 45 liters of water each per day. The pumping head is 22 m. You decide on enough stock tank capacity to last through three calm days, with the turbine and pump sized to fill all the storage in one day of rated wind speeds while the cattle

continue to drink. Which size of Dempster turbine and pump listed in Table 7.1 should you choose?

The steers drink a total of $45(100) = 4500$ liters of water per day. A three day storage capacity would, therefore, consist of 13,500 liters of stock tank capacity. The turbine needs to pump this 13,500 liters plus the 4500 liters consumed the fourth day for the tanks to be full the end of the fourth day. To pump 18,000 liters in 24 hours requires an average capacity of 0.208 L/s. Table 7.1 indicates that the 6-ft diameter turbine will not pump at this rate for this total head. The 8-ft turbine with a 2.5-in. cylinder will pump over 0.320 L/s at this head, which meets the basic requirements. A larger size would probably waste money and also waste water when the tanks overflow. In fact, a 2.25-in. cylinder might be preferable to the 2.5-in. cylinder since this limits the flow to a smaller amount and also allows pumping to start in lighter winds.

We should not let this example imply that using a water pumper is always the most economical solution to water pumping needs. If the electric utility lines are already in place close to the well, an electric motor will be cheaper to install and operate. The total energy input to the electric motor pumping 4500 liters per day through a head of 22 m for a six month grazing season will be approximately 100 kWh. The cost increment of the installed 8-ft Dempster turbine over an electric pump is perhaps \$2000 in 1981 dollars. We shall discuss economics in the next chapter, but even without the fine details, we can see that the unit cost of energy is rather expensive. If the \$2000 could draw 15 percent interest, this would be \$300 per year. We would be spending about \$3 per equivalent kWh for the water pumping system. The utility will charge a minimum amount each year for being connected to the power lines, but this charge plus the charge for the actual energy used should be well under \$300 per year. The utility will usually be the best economic choice any time that long stretches of distribution line do not have to be built.

This also points out that energy can have very high prices in small quantities and still be acceptable. It requires perhaps one kWh to pump enough water from a 25 m depth for one cow for one year. If this is at a farm where there are other loads, so the minimum charge for utility connection does not bias the results, the cost of this energy is only a few cents. This amount of energy is small enough and essential enough that a price of several dollars is acceptable if there is no alternative. Studies performed on these small water pumping wind turbines indicate an equivalent energy cost of 20 to 30 cents per equivalent kWh in good wind regimes where all the water can be used¹. This was in 1978 when the average cost of electricity in the United States was under 5 cents per kWh. They still make economic sense, however, if relatively small amounts of water need to be pumped from a well one km or more from existing distribution lines.

2 CENTRIFUGAL PUMPS

The piston pumps which we considered in the previous section are generally used only in relatively small sizes. Larger capacity pumps are usually centrifugal. There are many more centrifugal pumps manufactured today than piston pumps, so we need to examine some of their characteristics.

The centrifugal pump can be thought of as a turbine operating in reverse, so the power input will be proportional to the cube of the speed of the fluid passing through the pump, which is proportional to the pump rotational speed. The centrifugal pump, therefore, makes a good load for a wind turbine, at least near the optimum operating point for the pump.

The important operating characteristics of a centrifugal pump are the capacity Q , the head h , the input power P_m , the efficiency η_p , the rotational speed n , and the diameter d of the rotating wheel or *impeller* which actually moves the liquid being pumped. Relationships among these variables are usually expressed graphically. The number of possible graphs is reduced by defining a dimensionless parameter called the *specific speed* n_s which will be the same for all geometrically similar pumps[12, 17]. It is given by

$$n_s = nQ^{0.5}h^{-0.75} \quad (6)$$

The specific speed can be expressed in any consistent set of units. Historically, the units have usually been r/min for n , gal/min for Q , and feet for h . This choice yields specific speeds between perhaps 500 and 10,000 for most pump designs. Farm irrigation pumps would usually have n_s between 1500 and 5000. If the capacity is expressed in m^3/s and the head in m, we get a different specific speed n'_s , where $n'_s = n_s/51.64$. We shall use the non-SI version to hopefully help the reader understand existing manufacturers data sheets.

Specific speed allows comparison among pumps in much the same way that the Reynolds number allows comparison among pipe flows and airfoils. It is not intended to be a precise value, so is always rounded off to no more than two significant digits. It is calculated at the best or peak efficiency point of pump operation. That is, when it is desired to calculate the specific speed from performance curves, the capacity and head values for the peak efficiency point are used. If a pump has several stages, the specific speed is calculated on the basis of the head per stage. For a given head and capacity, a higher specific speed pump will operate at a higher speed and will be of smaller physical dimensions.

The peak efficiency of a pump varies with many parameters, but generally varies with specific speed and capacity as shown in Fig. 4. We see that the very largest pumps have a peak efficiency of about 90 percent at a specific speed of between 2000 and 3000. The efficiency will decrease as operating conditions change from the optimum conditions for which the pump was designed. Lower capacity pumps of the same quality of design will also have lower peak efficiencies. A pump of one hundredth of the capacity of the largest unit may have a peak efficiency of 65 percent at a specific speed of 2000. The equivalent quality of design for a pump of the same capacity but built for a specific speed of 500 may have a peak efficiency of only 48 percent. We, therefore, want to choose a pump for any wind driven application that has a specific speed large enough to have a good efficiency.

The efficiencies in this figure are representative of what was considered good practice in the days of cheap energy. We can expect pump efficiencies to improve as more efficient pumps become cost effective with increasing energy costs. Candidate pump efficiencies should be carefully investigated for those applications where total energy costs are significant when

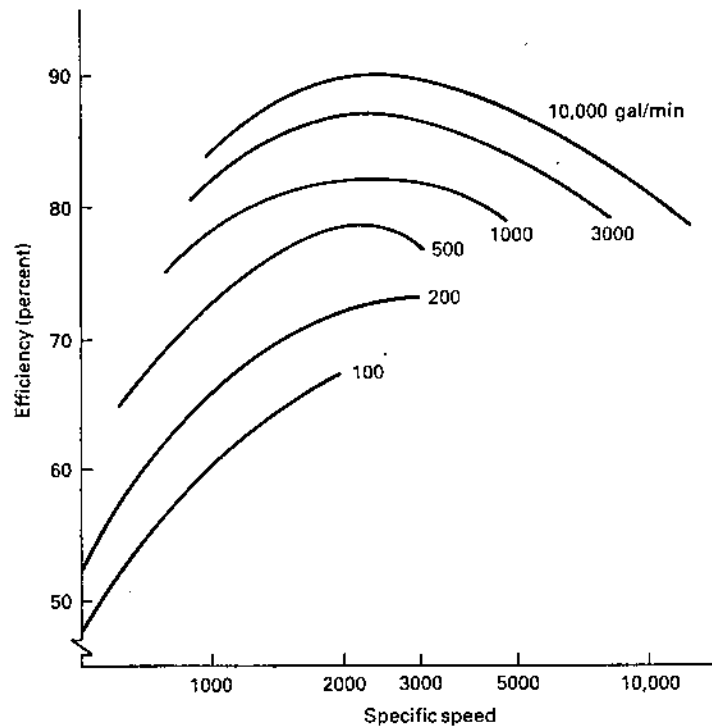

Figure 4: Pump efficiency versus specific speed and size. (From Ref. 2)

compared with initial pump costs.

Pump characteristics at constant speed are usually given as curves of head, efficiency, and input power plotted against capacity, as shown in Fig. 5. We notice in this figure that we have a maximum value of head for zero capacity or flow rate. The head then decreases with increasing capacity until it reaches zero at the maximum capacity. We can think of the head as the height of the column of water which must be lifted by the pump action for water to actually flow. As this height gets greater, the amount of water which the pump action can actually lift against this head will get smaller, finally reaching zero at the maximum head. At this head, the pump impeller is beating against the water in the pump, but no water is actually flowing out of the pump. Instead, the water is flowing around the impeller where it does not fit tightly in the pump housing. The output power, and hence the efficiency, are zero at this point since the capacity is zero. All the power input to the pump is being converted into heat since no useful work is being done. This can be a useful source of heat if we only need to convert mechanical energy directly to heat, but normally would not be a proper way to operate the pump. The heat could boil the water and ruin the pump.

As the head seen by the pump is decreased, more and more water will flow until finally a maximum capacity is reached at zero head. The efficiency, which is proportional to the product of head and capacity, goes through a maximum and decreases to zero at the zero

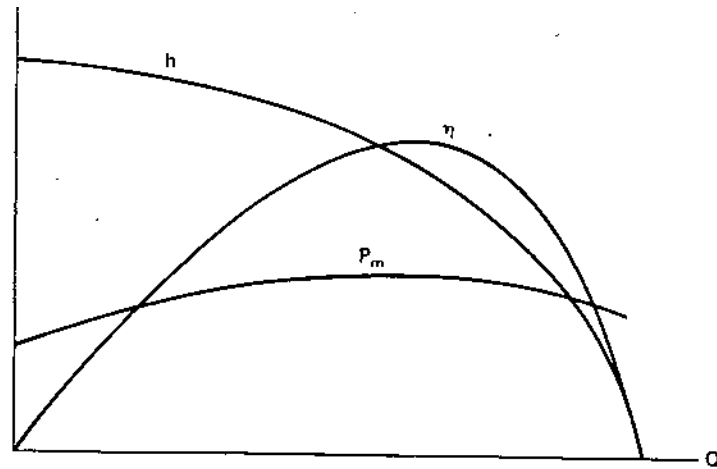

Figure 5: Pump characteristics of head, efficiency, and input power as a function of capacity at constant speed.

head point. The power input is now being used to overcome pumping losses and ultimately appears as a temperature increase in the water flowing out of the pump.

The actual curve of the input power P_m versus the capacity will vary with the specific speed of the pump. At low specific speeds, P_m will increase with capacity. It may peak at around the maximum efficiency point, as shown in Fig. 5, or it may continue to increase until the maximum capacity point is reached. At a specific speed of approximately 4000, the pump power input becomes nearly constant, independent of capacity. At still larger specific speeds, the pump shaft power may actually decrease with increasing capacity.

Suppose now that our pump is operated at some other speed n_2 . A new head versus capacity curve will be obtained as shown in Fig. 6. It can be shown that equivalent points on the two curves are found from the relationships

$$\frac{Q_2}{Q_1} = \frac{n_2}{n_1} \quad (7)$$

$$\frac{h_2}{h_1} = \frac{n_2^2}{n_1^2} \quad (8)$$

If the efficiency remains the same at equivalent points, the input shaft power variation is given by

$$\frac{P_{m2}}{P_{m1}} = \frac{n_2^3}{n_1^3} \quad (9)$$

We immediately note that this is of the proper form to optimally load a wind turbine in variable speed operation.

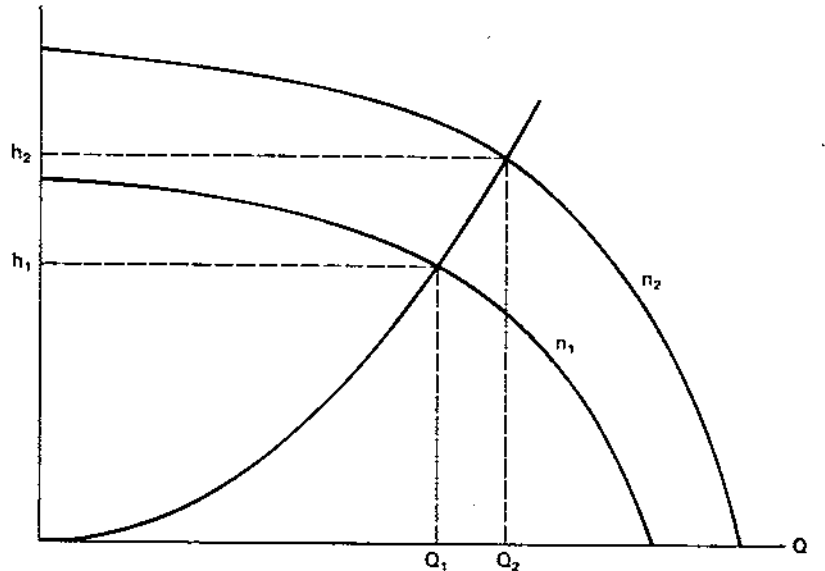

Figure 6: Head versus capacity curves for two different speeds.

Characteristic curves for an actual pump are shown in Fig. 7. The top portion shows the head capacity curves as the impeller size is varied. A given pump housing will accept a maximum size of impeller, but smaller impellers can also be used. A smaller impeller will result in a lower head capacity curve but also requires less input shaft power, as seen by the dashed lines. This can be useful in practical applications where a wind turbine does not have enough power to drive a pump that has been purchased for it[6]. Only the impeller needs to be changed, saving the cost of another entire pump.

Figure 7.7a also shows the pump efficiency for a given impeller. The 8.875-in. diameter impeller will have an efficiency of 65 percent at a head of 74 ft and a capacity or flow rate of 370 gal/min. The efficiency rises to 86 percent at a head of 65 ft and a flow rate of 800 gal/min. It then starts to decrease, reaching 70 percent at a head of 42 ft and a flow rate of 1140 gal/min. Efficiency is above 80 percent for flow rates between 580 and 1080 gal/min. This is a rather efficient pump over a significant range of flow rates.

Also shown on the same figure are a set of dashed lines indicating the input shaft power in *brake horsepower* (bhp). The brake horsepower is the mechanical power $T_m\omega_m$ carried by the rotating shaft and expressed in English units as horsepower. The input shaft power necessary for a given head and capacity can be determined by interpolating between the dashed lines. For example, the 8.875-in. diameter impeller requires 10 bhp at 280 gal/min, 15 bhp at 780 gal/min, and about 17.5 bhp at 1100 gal/min.

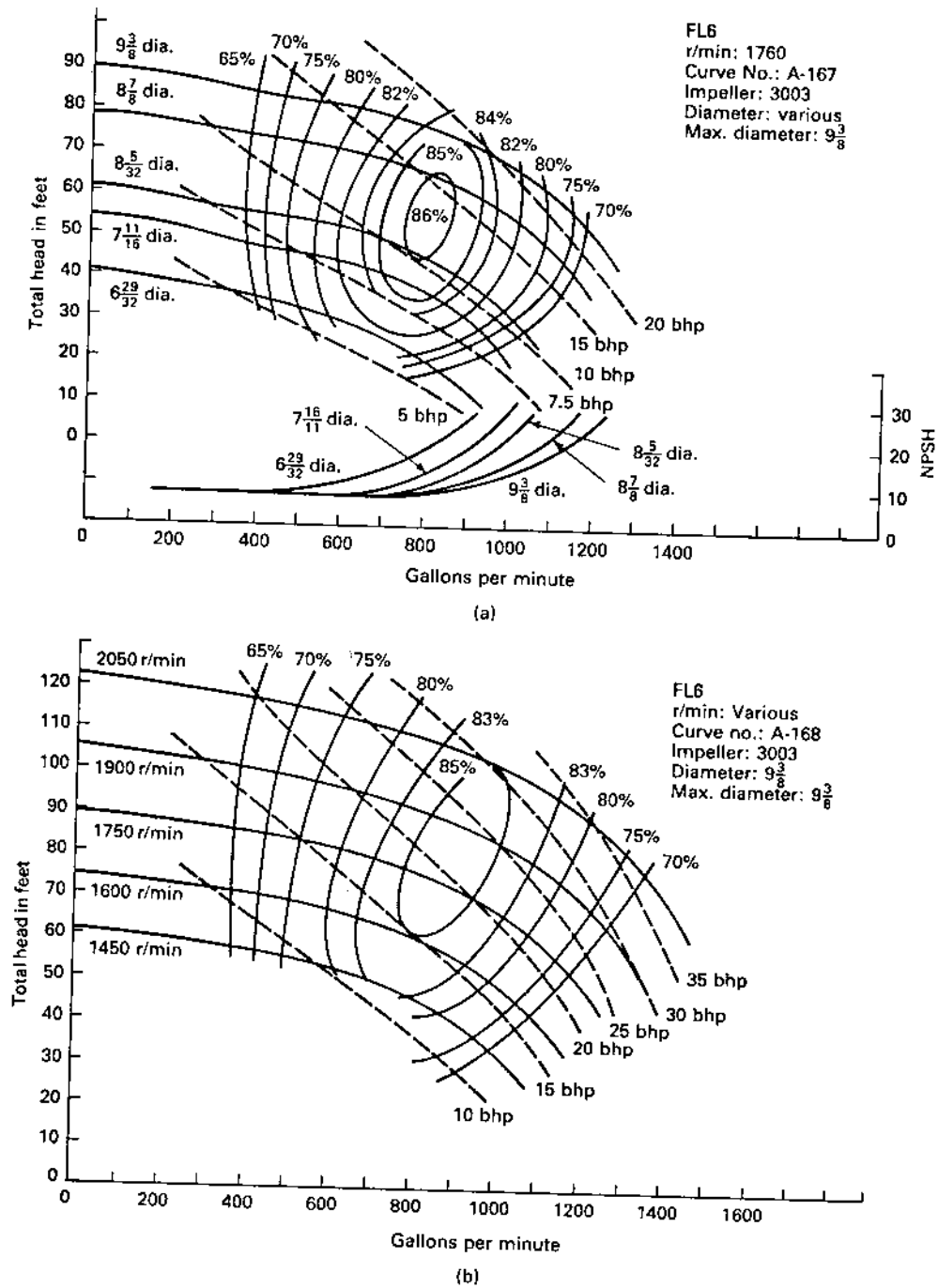

Figure 7: Pump performance curves for Jacuzzi Model FL6 centrifugal pump: (a) head-capacity curves as the impeller size is varied; (b) head-capacity curves for a $9\frac{3}{8}$ -in.-diameter impeller at variable speed. (Courtesy of Jacuzzi Bros. Inc., Little Rock, Arkansas.)

The normal operation of a wind pumping system would be variable speed operation of a given impeller with a fixed head, rather than fixed speed operation of several different impellers at different heads. When we operate the largest possible impeller of Fig. 7a at variable speed, the resulting head capacity curves are shown in Fig. 7b. Suppose we have a fixed head of 80 ft. There will be no flow at all for the pump of Fig. 7b until the pump speed exceeds 1650 r/min. As speed increases further, the operating point moves to the right along the 80-ft head line. The flow rate is 680 gal/min at 1750 r/min, with an efficiency of about 82 percent. At 1900 r/min, the flow rate is 1080 gal/min with an efficiency of 83 percent. The efficiency begins to decrease rapidly at greater speeds, dropping to 70 percent at a flow rate of 1380 gal/min. The input shaft power increases from less than 10 bhp to about 40 bhp along this constant head line.

We can begin to see the importance of careful design of the wind driven pump system. We would not want to use this particular pump if the head were 120 ft or more because of the high rotational speeds required and also because of the losses which would be experienced at wind speeds below cut-in. We would probably not want to use this pump on heads below 60 ft since we are moving into a lower efficiency region with such low heads. The turbine mechanical output power would need to be rated at no more than about 35 bhp, assuming the water source can supply the corresponding flow rates. If we are pumping from a well that can deliver only 500 gal/min, with a head of 80 ft, a turbine rated at more than about 13 bhp will pump the well dry momentarily, probably ruining the pump.

A good design, therefore, requires site specific information about the head and flow rate capability of the source, detailed characteristic curves of a family of pumps, and power versus speed curves of the wind turbine. Satisfactory results will be obtained only when all the system components are carefully matched.

There is another set of curves on Fig. 7a which we have not discussed thus far, but which should be discussed because they indicate another limitation of pump operation. The axis at the right is labeled NPSH, which stands for *Net Positive Suction Head*. To explain this term, we draw on our background in physics and recall that a vacuum in the top of a pipe inserted into a tank of 0°C water exposed to a sea level atmosphere will pull the water up in the pipe to a level of 33.90 ft or 10.33 m above the level in the tank. Pump operation can create a partial vacuum in the input or suction line so it is possible for a pump to be located above the level of water which is to be pumped. A practical limit is about 20 ft because of pump tolerances. The pump and input line will probably need to be filled with water from some source, or *primed*, before pumping can occur, when it is located above the water level.

As pump sizes or rotational speeds increase, however, a dynamic effect becomes apparent which requires the pump to be lowered with respect to the water level. This effect is called *cavitation*, which refers to the formation and subsequent collapse of vapor-filled cavities in the water or other liquid being pumped. When the local pressure at some point on the suction side of an impeller blade drops below the vapor pressure, a bubble of vapor is formed. As the bubble flows through the pump, it will encounter a region where the local pressure is greater than the vapor pressure, at which time it will collapse. This causes noise, vibration, and

mechanical damage to the pump interior if allowed to continue. One way of eliminating this effect is to lower the pump with respect to the water level, thereby increasing the pressure on the suction side of the pump. It may be necessary for a given pump to be mounted below the water level to prevent cavitation. Oftentimes the term Net Positive Suction Head will apply to this situation while the term *Net Positive Suction Lift* will apply to the case where the pump can be located above the water level. We see in Fig. 7a that this particular pump must be located at least 8 ft below the water level under any circumstances. It may need to be as much as 30 ft below the water level at higher flow rates. This does not affect the allowable head between the two reservoirs involved, but does affect the pump location. That is, if water needs to be pumped 80 ft from a lower reservoir to an upper one, the 80-ft head line applies even if the pump is 30 ft below the top of the lower reservoir and 110 ft below the top of the upper reservoir.

The size and orientation of the input and output piping can also affect pump operation and perhaps cause cavitation in what would appear to be a well designed system. The assistance of an experienced pump installer is important to a successful system. The information presented here should allow us to make a tentative design, however, which can then be refined by those more knowledgeable about pumps.

One possible design procedure is the following. We first select a wind speed u_m at which both the wind turbine and the pump can operate at their maximum efficiencies. This wind speed would be somewhere between the cut-in and rated wind speeds of the turbine so the pump can operate around its maximum efficiency point for a good range of wind speeds. A logical wind speed is the speed u_{me} which contributes the maximum energy during the period of interest. If $f(u)$ is the probability density function of the wind speeds, then $u^3 f(u)$ is a maximum for $u = u_{me}$. When $f(u)$ is given by the Weibull function described in Chapter 2,

$$u_{me} = c \left(\frac{2+k}{k} \right)^{1/k} \quad \text{m/s} \quad (10)$$

where k is the shape parameter and c is the scale parameter. During the summer months in the Great Plains u_{me} is typically 8 or 9 m/s.

We then determine the wind turbine power at the wind speed u_{me} . From a knowledge of the pumping head at a given site, we find the necessary mass capacity Q_m which will use this much turbine power. We use Eq. 3 with an assumed pump efficiency appropriate to this power level. This step may need to be repeated if the efficiency of a proposed pump differs significantly from this assumed value.

We can now choose either the actual speed or the specific speed of the pump and solve for the other one from Eq. 6. We want the specific speed high enough to get good pump efficiency, as determined from Fig. 4, but we also want the actual speed to be as low as possible to eliminate the need for extra stages of speed increase in the gearbox. We then go to the manufacturers data sheets to see if there is a standard pump available which meets the requirements for specific speed, head, and capacity at a good efficiency. We would probably

want to examine adjacent units in a family of pumps to see if we are at a good design point.

In general, high pump rotational speeds permit a given capacity with a smaller and less expensive pump than would be required for a pump with the same capacity at lower speeds. Cost tradeoffs between a higher gear ratio, more expensive gear box and a higher speed, less expensive pump should be considered in the design.

The turbine tip speed ratio at the design point would be

$$\lambda = \frac{r_m \omega_m}{u_{me}} \quad (11)$$

where r_m is the turbine radius in meters and ω_m is the angular velocity in rad/s.

The turbine rotational speed in r/min is then

$$n_{\text{tur}} = \frac{30}{\pi} \omega_m \quad (12)$$

The ratio of the pump rotational speed n_p over the turbine rotational speed is the step-up ratio of the gear box, n_p/n_{tur} .

We recall from Chapter 4 that the mechanical power output of the turbine for a standard atmosphere is

$$P_m = 0.647 C_p A u^3 \quad \text{W} \quad (13)$$

where C_p is the coefficient of performance, A is the turbine swept area in m^2 , and u is the wind speed in m/s. We shall assume an ideal gear box and use the same P_m as the mechanical power input to the pump. This is not a bad approximation, but can be easily corrected if necessary. If we need power in horsepower, we simply divide the value obtained from Eq. 13 by 746.

We have selected a design wind speed by using Eq. 10, but we need cut-in and rated wind speeds to find the capacity factor that was discussed in Chapter 4. The cut-in wind speed may be determined by extrapolating the constant pump input power curves, shown as dashed lines in Fig. 7, back to the zero capacity axis, and estimating the pump input power for the specified head. This power is then used in Eq. 13 to find u_c .

The rated wind speed is found in a similar manner. We move to the right in Fig. 7 along a constant head line until we reach the first system limit. This may be a flow rate limitation on the liquid source, a torque or speed limitation on the turbine, or a flow rate that causes the available Net Positive Suction Head to be exceeded. The turbine power at this point is used in Eq. 13 to find u_R .

We recall from Chapter 4 that the capacity factor is given by

$$CF = \frac{\exp[-(u_c/c)^k] - \exp[-(u_R/c)^k]}{(u_R/c)^k - (u_c/c)^k} \quad (14)$$

We have omitted the furling speed term from this expression since it usually is a rather small fraction of the capacity factor. This implies that the turbine has some sort of pitch control or other speed control to limit the power output to its rated value at wind speeds well above the rated wind speed. If this is not the case (if the furling speed and the rated speed are very close together), the correction for furling speed can easily be made.

The average turbine output power or pump input power is then given by

$$P_{m,ave} = (CF)P_{mR} \quad (15)$$

The average pump output power would then be

$$P_{o,ave} = \eta_{p,ave}P_{m,ave} \quad (16)$$

where $\eta_{p,ave}$ is the average pump efficiency for this combination of pump, head, and wind characteristics. It can be estimated by finding the fraction of time spent operating at each wind speed between cut-in and rated, finding the corresponding power, reading a set of curves like Fig. 7b to find the pump efficiency at each power, and taking the average. If this is too much trouble, we can always arbitrarily assume an average pump efficiency of perhaps 80 or 90 percent of the peak efficiency.

Example

A small town in western Kansas has to pump water from their water treatment plant to a storage tank against a total head of 70 ft. They currently use a Jacuzzi Model FL6 pump with an induction motor rated at 1750 r/min to pump water at 960 gal/min for three hours per day to meet the need. The motor and pump are turned off the remainder of the time. The pump impeller is the largest that will fit in the pump housing. The pump is located 25 ft below the water level of the lower reservoir. One of the city commissioners is interested in operating the pump from a wind turbine that is manufactured locally. It is a two-bladed horizontal-axis propeller type turbine that has a peak coefficient of performance of 0.35 at a tip speed ratio of 8. Propeller diameters are available in integer meter lengths. He asks you to tell him what size propeller and what ratio gearbox to use on this system.

As usual, you do not have all the data you would like for a good design, but you do the best you can with what you have. You estimate the Weibull parameters for this site as $k = 2.4$ and $c = 7$ m/s. From Eq. 10 the design wind speed is

$$u_{me} = 7 \left(\frac{2 + 2.4}{2.4} \right)^{1/2.4} = 9.05 \text{ m/s}$$

You tentatively select the induction motor driven pump conditions as the design point for the wind driven pump. That is, you want a turbine that will deliver 20 bhp in this wind speed. You assume the air density to be 90 percent of the sea level value, and solve for the turbine area from Eq. 13.

$$A = \frac{(20 \text{ hp})(746 \text{ W/hp})}{(0.9)(0.647)(0.35)(9.05)^3} = 98.8 \text{ m}^2$$

The rotor diameter for this area is 11.22 m. Since rotors are only available in integer meter lengths, you select the 11 m rotor. This reduces the area by about 4 percent, which in turn increases the wind speed necessary to get 20 hp by slightly over 1 percent or to 9.17 m/s, an amount which seems quite acceptable.

The mechanical angular velocity of the rotor in a wind speed of 9.17 m/s and a tip speed ratio of 8 would be, from Eq. 11,

$$\omega_m = \frac{u_{m\epsilon}\lambda}{r_m} = \frac{9.17(8)}{5.5} = 13.34 \text{ rad/s}$$

The turbine rotational speed in r/min is then

$$n = \frac{30}{\pi}(13.34) = 127.4 \text{ r/min}$$

The pump rotational speed needs to be 1750 r/min at this operating point, so the gear box ratio should be $1750/127.4 = 13.74:1$.

You note from Fig. 7a that the maximum flow rate is 1200 gal/min for a NPSH of 25 ft. This corresponds to a pump speed of 1900 r/min and an input shaft power of 28 hp according to Fig. 7b. The wind speed required for this shaft power is, from Eq. 13 and using a 0.9 air density correction,

$$u_R = \left[\frac{28(746)}{0.647(0.9)(0.35)(\pi/4)(11)^2} \right]^{1/3} = 10.25 \text{ m/s}$$

From Fig. 7a, you estimate by extrapolation that water will start to flow at an input shaft power of about 7.5 hp, which corresponds to a cut-in wind speed of 6.61 m/s. The proposed system will, therefore, pump water at wind speeds between 6.61 and 10.25 m/s. Higher wind speeds can be used if a blade pitching mechanism can restrict the shaft speed to less than 1900 r/min so that shaft power does not increase above 28 hp.

The capacity factor can be determined from Eq. 14 as $CF = 0.207$. The rated power would be 28 hp, so the average power is $(0.207)(28) = 5.79$ hp. The average power required by the electric motor driven pump is 20 hp for three hours averaged over a 24 hour day or $20(3/24) = 2.5$ hp. The wind turbine will have to be shut down over half the time because all the required water has been pumped.

You report to the city commissioner that the system should work satisfactorily if a good speed control system is used.

We should emphasize that pump characteristics vary significantly with pump design. The curves in Fig. 7 are only valid for that particular pump and should not be considered a good representation for all centrifugal pumps. Another pump design may yield a much better load match for a variable speed wind turbine than the one illustrated. It may be necessary to

design the pump and wind turbine together in order to get the best match. There are a number of large scale irrigation projects under study around the world which could use such machines in very large quantities if the cost was acceptable.

3 PADDLE WHEEL WATER HEATERS

A significant amount of energy is used to heat water for the needs of homes, farms, and industry. Wind electric generators can be used to produce electricity for operating resistance heaters, as we have seen. If the only use of the wind generated electricity is to heat water, however, it may be more economical to heat the water directly by mechanical means.

A paddle wheel water heater which can be used for this purpose is shown in Fig. 8. It is basically a cylindrical insulated tank with baffles around the perimeter and paddles on a rotating impeller. This particular design is geometrically simple, has good strength characteristics, and is simple to build[5, 13].

The power input to such a water heater has been found experimentally to be[5]

$$P = 4.69\rho L^{1.09} w^{0.62} b^{0.88} D^{-1.07} H^{0.64} d^{2.84} \omega_m^3 \quad \text{W} \quad (17)$$

where ρ is the density of water in kg/m^3 , L is the length of the agitator blades, w is the width of the agitator blades, b is the width of the baffles, D is the tank diameter, H is the tank height, d is the diameter of the agitator disks, and ω_m is the angular velocity in rad/s . All dimensions are in meters. We notice immediately that the power input is proportional to ω_m^3 or n^3 , the desired variation to properly match or load a wind turbine over a range of speeds. We also notice that when we add up the exponents of the length terms in Eq. 17, the resultant exponent is 5. That is, the power absorbing ability of this heater increases as the fifth power of any one linear dimension if all dimensions are scaled up equally. This compares very favorably with the power rating of an electrical generator, which increases as the volume or the cube of any one linear dimension.

Another advantage of this type of load is the lack of a well defined power limit. Electrical generators are limited by conductor and insulation properties at high temperatures, but the highest temperature of the water heater would be that of boiling water. A simple control valve could dump hot water when wind speeds were high, to maintain non boiling conditions. This means that a wider range of wind speeds between cut-in and rated may be possible with such a load. This could increase the average power output by a significant amount.

Example

A 100 liter paddle wheel water heater has dimensions $L = w = 0.11$ m, $b = 0.089$ m, $D = 0.61$ m, $H = 0.394$ m, and $d = 0.305$ m. What is the power input for a speed of 115 r/min? What is the rate of temperature rise in the tank in $^\circ\text{C}$ per hour, assuming no transfer of water into or out of the tank and no heat loss through the sides of the tank?

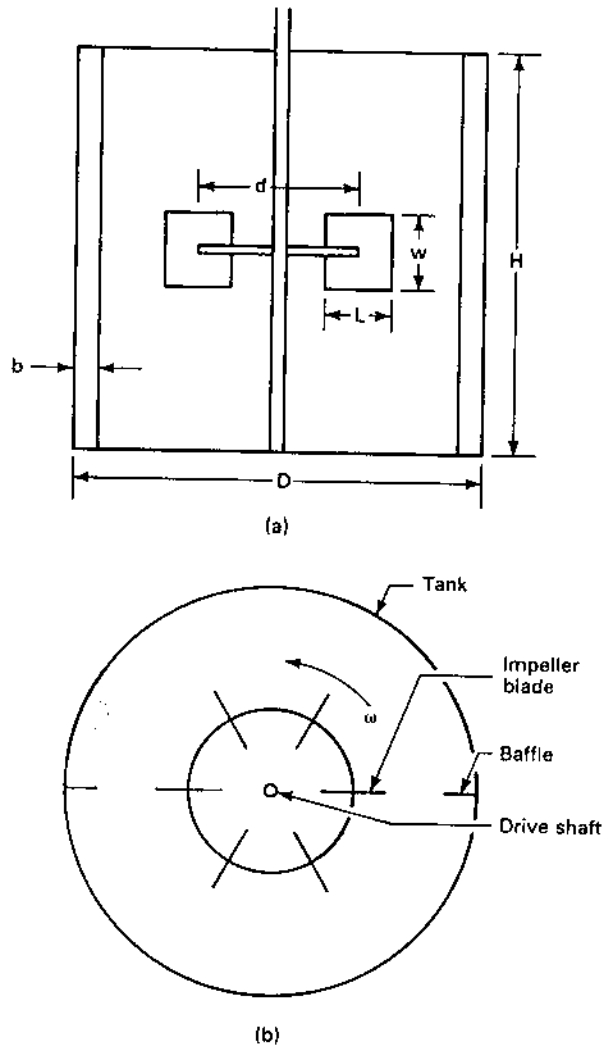

Figure 8: Paddle wheel water heater: (a) side view; (b) top view.

We first compute the angular velocity, $\omega_m = 2\pi n/60 = (2\pi)(115)/60 = 12.04 \text{ rad/s}$. Then from Eq. 17, we find, for water with a density of 1000 kg/m^3 ,

$$\begin{aligned}
 P &= 4.69(1000)(0.11)^{1.09}(0.11)^{0.62}(0.089)^{0.88}(0.61)^{-1.07}(0.394)^{0.64}(0.305)^{2.84}(12.04)^3 \\
 &= 717 \text{ W}
 \end{aligned}$$

For the temperature rise, we know that 1 kcal or 4184 J will raise the temperature of 1 kg of water 1 °C. The application of $717 \text{ W} = 717 \text{ J/s}$ yields a total input of $717(3600) = 2,581,200 \text{ J}$ in one hour,

or $2,581,200/4186 = 616.6$ kcal. The tank contains 100 liters or 100 kg of water, so 616.6 kcal will raise the temperature $616.6/100 = 6.166$ °C in one hour.

This heater may be operated in at least two modes, the high temperature or the preheater modes. In the high temperature mode we have an associated storage tank connected to the heater by a small pump. The pump is turned on when the heater temperature exceeds a preset upper limit and is turned off when incoming cold water drops the heater temperature to a preset lower limit. Only water at the desired final temperature is placed in the storage tank. This would be used in closed loop space heating systems or as a temperature booster for a solar heating system.

In the preheater mode, the heater is placed in the cold water line of a conventional water heater to reduce the energy consumption of that device. Water flow through the heater depends only on the demand of the particular application and not on the available wind power or the temperature of the heater. The application needs to be carefully sized so the average power from the wind does not exceed the original average power consumption of the conventional water heater. If the wind turbine produces too much hot water there could be a substantial waste, both in water and in the incremental cost of an oversized wind turbine.

4 BATTERIES

Most small asynchronous wind electric systems have used lead-acid batteries as a storage mechanism to level out the mismatch between the availability of the wind and the load requirements. They continue to be used in small systems that are isolated from the utility grid, or that need very reliable power. Compared with other components of a wind system, batteries used in these small systems tend to be expensive, short-lived, and not extremely efficient, hence their use has been limited to those applications which can justify the cost.

Batteries are also being used by electric utilities in relatively large scale systems to level out demand variations. In these large scale utility applications, batteries and the associated power conditioning equipment are generally located close to the load centers. They are charged during light demand periods and discharged at peak load times, when the incremental cost of generating electricity may be five times the cost of electricity from the most economical base load units. They have the advantage of increasing the average power flow down existing transmission and distribution lines so construction of new lines can often be deferred. They can be added quickly, because of modular construction. They can be located almost anywhere because of minimal environmental impact and no requirement for cooling water. They also have the advantage of providing reserve generating capacity in the form of “spinning” reserve for the utilities.

A battery bank and power conditioners can also be used effectively by small utilities without their own generation and by industries with high demand charges. The batteries can reduce the peak demand as seen by the generating utility, often with rather substantial

savings.

Battery research is being performed for the electric utilities at the Battery Energy Storage Test (BEST) Facility in New Jersey, on the system of the Public Service Electric and Gas Company[8]. This facility allows the testing of batteries capable of storing several MWh of electrical energy. It provides the final proof to other utilities that a specific battery and power conditioning system is ready for installation on their system.

The first battery type to be tested at the BEST Facility was the conventional lead-acid battery. This battery has seen a number of improvements throughout the years and forms a basis for comparison with other battery types. Other batteries must demonstrate superiority over the lead-acid battery if they are to penetrate the market. The first three advanced batteries scheduled for tests were the zinc chloride, zinc bromide, and beta. Many other batteries are being developed by manufacturers so tests of at least a few other battery types would be anticipated. Results of these tests will be directly applicable to wind electric storage systems, especially in the larger sizes.

We shall now present a brief review of battery characteristics, which should be helpful to those trying to read the literature. We will then mention some of the goals and possible developments of these advanced batteries.

A battery consists of several voltaic cells connected together. The term voltaic comes from the Italian physicist Volta who, about 1800, constructed the first primary cell of record, at least in modern times. (There is some evidence that primary cells were used in electroplating gold in ancient Egypt). A *primary cell* basically uses an irreversible process to make electricity by the consumption of battery material. The familiar lead-acid battery contains *secondary cells* which are reversible. Secondary cells are, therefore, of most interest in wind electric systems, but we shall discuss both types for the sake of completeness.

A voltaic cell consists of two dissimilar materials, usually metals, in an electrolyte. A simple primary cell is shown in Fig. 9. It has one electrode of zinc in a zinc sulfate solution, and another electrode of copper in a copper sulfate solution. The two solutions are separated by a porous membrane which prevents mixing of the solutions but permits diffusion of ions either way. The zinc tends to dissolve in the zinc sulfate solution, forming Zn^{2+} ions. The electrons liberated in this process remain in the zinc strip, giving it a negative charge.

The copper acts just the opposite of the zinc, in that it wants to come out of the copper sulfate and plate onto the copper strip. The copper ions coming out of solution have a charge of +2, so the copper strip gives up two electrons upon the arrival of each copper ion, which makes the copper strip positive. If the circuit is completed through a resistor or other load, electrons will flow from the zinc to the copper in the external circuit, with conventional current flow being from copper to zinc. Current flow in the electrolyte is by sulfate ions, SO_4^{2-} , migrating from the copper strip through the membrane to the zinc strip. The process will continue until the zinc in the zinc strip is entirely dissolved, or until essentially all the copper in the copper sulfate solution has been plated out.

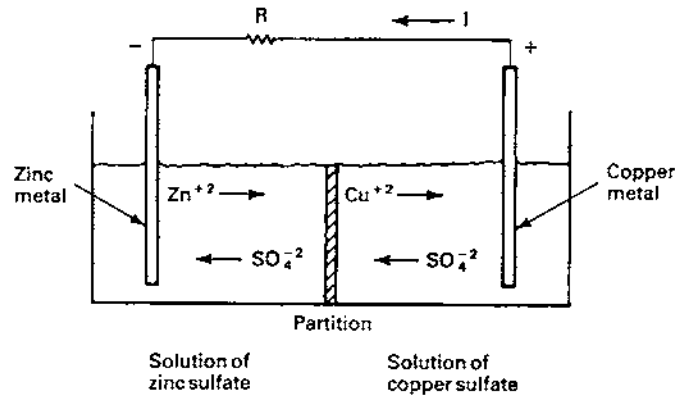

Figure 9: Zinc-copper voltaic cell.

Reversing the current flow will not reverse the chemical process. Once the zinc is dissolved, the only way the cell can be renewed is through a chemical process in which the materials are recycled. This limits the application of this and other primary cells in wind electric storage systems rather substantially. There is a possibility that very large battery storage systems could use wind generated electricity to operate the necessary chemical process, but this will take considerable developmental work. In the meantime, we shall turn our attention to reversible or secondary cells.

The secondary cell which has been used most widely is the lead-acid cell. In its simplest form it consists of a sheet of lead and a sheet of lead dioxide, PbO_2 , placed in moderately dilute sulfuric acid. The lead dioxide may be supported by a sheet or grid of lead. The basic structure is shown in Fig. 10

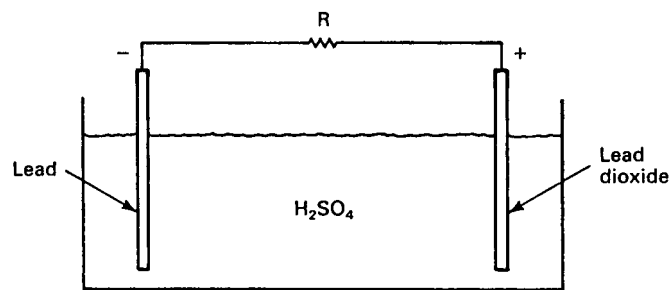

Figure 10: Lead-acid voltaic cell.

During discharge of the cell the lead electrode tends to form lead ions, with the electrons liberated in this process imparting a negative charge to the remaining lead. This forms the negative pole of the cell. In the presence of sulfuric acid the lead ions form insoluble lead

sulfate, which deposits as a white substance on the metallic lead. The reaction for this is described in chemical terms by



The reaction at the lead dioxide electrode can be considered to proceed in two stages. First, the lead dioxide combines with hydrogen ions from the sulfuric acid and electrons from the external circuit to form lead ions and water, according to the equation

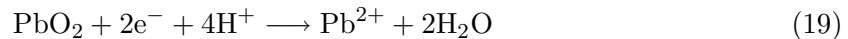

Removing electrons from this electrode gives it a positive charge.

In the second part of the reaction, the lead ions just formed combine with sulfate ions from the sulfuric acid to form lead sulfate.



The overall reaction of the cell during discharge can be written as



We see that both the lead and lead dioxide electrodes become covered with lead sulfate during discharge. We also see that the concentration of sulfuric acid becomes lower during discharge, since the chemical reaction uses up the sulfuric acid and produces water. The reaction will slow down and eventually stop as the plates become covered with lead sulfate and as the sulfuric acid is depleted.

The reverse process occurs when an external source of electricity is connected to the terminals so that current flow is reversed. The lead sulfate is converted to lead and lead dioxide on the appropriate electrodes and the concentration of sulfuric acid is increased. In practice, the process is not completely reversible since some lead sulfate tends to flake off the electrodes and sink to the bottom of the cell where it can not participate in future cycles. Several hundred cycles are possible, however, in a properly built cell that is never allowed to be fully discharged.

The density of sulfuric acid is higher than the density of water, so hydrometer (density) measurements are commonly made to determine the state of charge of a cell. The quantity actually used is the specific gravity, which is the ratio of the density of the electrolyte to the density of water at 4°C. The specific gravity of pure sulfuric acid is about 1.8, but this is substantially higher than what is actually needed in a cell. The proper specific gravity of a cell is a matter of engineering design. There must be enough sulfuric acid to meet the chemical requirements of cell operation and not so much that the acid would destroy the cell materials.

Cells designed for a low specific gravity electrolyte tend to have a longer life and lower standby loss, with less capacity, higher cost, and greater space requirements than cells designed for higher specific gravity electrolytes. Automobile type batteries typically have a fully charged specific gravity of about 1.29 at 25°C. The electrolyte density varies with temperature so specific gravity needs to be measured at a particular temperature. A specific gravity of 1.08 at 25°C would typically indicate a fully discharged battery.

The freezing point of the electrolyte decreases as the specific gravity increases. A specific gravity of 1.225 at 25°C indicates a freezing point of -40°C while a specific gravity of 1.08 at 25°C indicates a freezing point of -7°C . A discharged cell can easily be frozen and its container damaged, while a fully charged cell will not freeze at normal winter temperatures.

The open-circuit voltage varies with the state of charge and also with the manufacturing techniques used in making the cell. Fig. 11 shows the open circuit voltage for the Gates sealed lead-acid cell[7] and for a 12-V marine battery made by Goodyear. The Gates cell varies from 2.18 V at full charge to 1.98 V at full discharge. The Goodyear battery shows a cell voltage of about 2.1 V at full charge and about 1.9 V at full discharge. Other sources[10] indicate a range of voltages between 2.00 and 1.75 V per cell. These variations indicate the importance of using detailed battery information in a design of a wind generation- battery storage system.

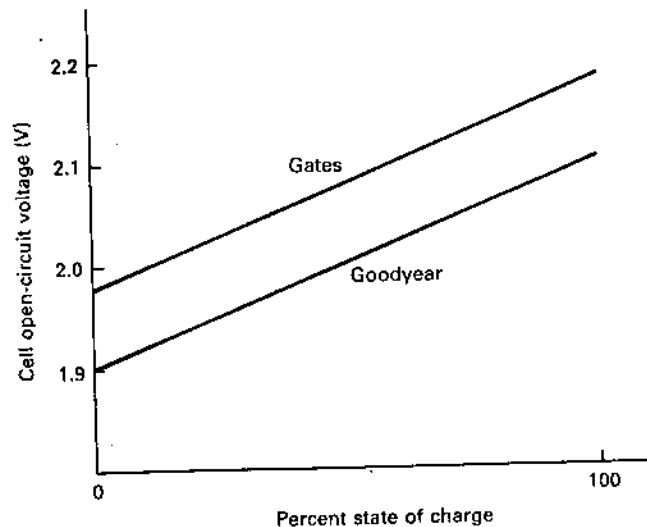

Figure 11: Relationship between the cell open-circuit voltage and the percent state of charge.

One important parameter of any battery is its energy density, expressed in J/kg or Wh/kg. A high energy density means that less mass of battery is necessary to store a given energy. This is not as critical in fixed locations except as it affects cost, but is very important if the battery is to be used in an electric vehicle. The theoretical energy density of a lead-acid battery is 365 kJ/kg (167 Wh/kg), while energy densities that have actually been achieved range from 79 to 190 kJ/kg (22-53 Wh/kg)[4].

The energy density of lead-acid batteries varies with the discharge rate over about a two to one range. This rate dependency is caused primarily by mass transport and ionic diffusion limitations. During discharge, crystals of lead sulfate deposit on the surface and in the pores of the electrodes, reducing the amount of surface area available for reaction, and causing a decrease in pore size that limits access of electrolyte. Simultaneously, the sulfuric acid within the pores becomes depleted and diluted. Higher discharge rates make these effects worse and reduce the total energy that can be recovered.

Another important parameter of any secondary battery is the cycle life. The cycle life of a lead-acid battery is inversely proportional to the depth of discharge, with 200 cycles being an excellent life at a 90 percent depth of discharge. As many as 2000 cycles may be possible if the lead-acid battery is only discharged 20 percent of its capacity. This means that batteries that are deeply discharged each day will last less than a year while batteries that are only lightly discharged may last five to ten years.

One advanced battery which may be a serious competitor with the lead-acid is the *zinc chloride* battery. Zinc and chlorine are low-cost, lightweight, and readily available. The positive plates of this battery are made of graphite while the negative plates are made of zinc. The electrolyte is a solution of zinc chloride, ZnCl_2 , and water. The electrolyte has to be continuously circulated during operation. During the charge cycle, zinc is deposited from the electrolyte onto the zinc plates. At the same time, chlorine gas is liberated at the graphite electrodes. This gas is dissolved in a separate container of chilled water (below 9°C) to form an ice-like solid, chlorine hydrate. The chlorine hydrate, $\text{Cl}_2 \cdot 6\text{H}_2\text{O}$, is stored until the battery is discharged.

During discharge the chlorine hydrate is melted and the evolving chlorine gas is dissolved in the circulating electrolyte. The gas is reduced at the graphite electrodes to become chloride ions. These chloride ions combine with zinc on the zinc electrodes to form more zinc chloride electrolyte. Discharge will stop when the chlorine hydrate is exhausted. The battery can be fully discharged each cycle without major difficulties, a big improvement over the lead-acid battery.

The projected energy density of this battery is 84 Wh/kg, as compared with about 20 Wh/kg for the lead-acid battery[2]. This greater energy density also makes this battery a good candidate for electric vehicles. The operating potential of this battery is about 1.9 V/cell, about the same as the lead-acid battery.

There are several difficulties with the zinc chloride battery which must be solved before it will see wide application. One is that inert gases tend to accumulate in the interior space of the battery because it operates below atmospheric pressure. These need to be detected and removed for proper battery operation. Also the graphite electrode tends to oxidize and deteriorate. This electrode is perhaps the limiting feature of the battery and considerable effort has been given to improving manufacturing techniques for it.

Another battery type of considerable interest is the *zinc bromide* battery. It is somewhat similar to the zinc chloride battery in that the electrolyte, aqueous zinc bromide, is pumped

through the battery. One possible configuration for the battery is shown in Fig. 12. This sketch shows a battery with three cells, so with an open circuit voltage of 1.8 V/cell, the total voltage would be 5.4 V. The two interior plates are called *bipolar* electrodes. They are made of thin sheets of nonporous carbon. The same sheet acts as the positive electrode for one cell and the negative electrode for the adjacent cell. During charge, the surfaces marked with a + will oxidize bromide ions to bromine gas, which is dissolved in the electrolyte. At the same time zinc ions will be deposited as metallic zinc on the surfaces marked with a -. During discharge, the dissolved bromine gas and the metallic zinc go back into solution as zinc bromide.

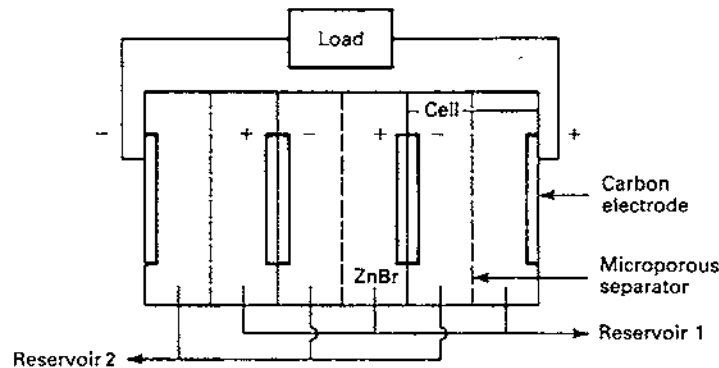

Figure 12: Diagram of a zinc bromide battery.

The bipolar electrodes have no need to be electrically connected to anything, so current flow can be completely uniform over the cross section of the battery. This simplifies the electrical connections of the battery and makes assembly very easy. It also makes the battery more compact for a given stored energy or a given power density.

There has to be a microporous separator in the middle of each cell to reduce the transport rate of dissolved bromine gas across the cell to the zinc on the negative electrode. Any gas that reacts with the zinc directly represents an efficiency loss to the system since the electron transfer necessary to produce the zinc and bromide ions does not produce current in the external circuit. For the same reason, the electrolytes for the two halves of each cell are kept in separate reservoirs. One reservoir will contain electrolyte with dissolved bromine while the other will not. The discharge cycle will continue until all the dissolved bromine is converted to bromide ions, so total discharge is possible without damage to the battery.

Most secondary batteries with zinc anodes have life problems due to the formation of zinc dendrites. This does not occur with this battery because the bromine will react with any dendrites as they form in the separator. Therefore, long cycle life should be possible.

Bromine gas is toxic, but the strong odor gives ample warning of a leak before the injury level is reached. The development difficulties include deterioration of the positive electrode, which limits cycle life. Another difficulty is the high self-discharge rate, where early versions

would lose half their charge in two days while disconnected from the system. This can be improved by a better microporous separator. The energy efficiency is about 60 percent, as compared to about 70 percent for lead-acid batteries, because of this self-discharge problem. This efficiency would probably be acceptable to the utilities if the capital investment, expected life, and reliability were superior to those of the lead-acid battery.

Another battery type with exciting possibilities is the *beta* battery, named after the β -alumina used for the electrolyte. A major difference between the beta battery and the other batteries mentioned earlier is that the beta battery has liquid electrodes and a solid electrolyte. The negative electrode is liquid sodium while the positive electrode is liquid sulfur, with carbon added to improve the conductivity. β -alumina is a ceramic material with a composition range from $\text{Na}_2\text{O} \cdot 5\text{Al}_2\text{O}_3$ to $\text{Na}_2\text{O} \cdot 11\text{Al}_2\text{O}_3$. It is able to conduct sodium ions along cleavage planes in its structure, and therefore acts as both electrolyte and separator between the two liquid electrodes.

One possible construction technique is to use concentric tubes to contain the liquid electrodes, as shown in Fig. 13. In this version we have sodium inside the beta alumina and the sulfur outside, but it will also work with the sodium outside and the sulfur inside. The sulfur container is a mild steel coated with chrome. The two electrodes are electrically and mechanically separated from one another by a ring of alpha alumina at the top of the beta alumina tube. The steel cylinders containing the liquid electrodes are bonded to the alpha alumina ring by a thermal compression process. The alpha alumina ring can also be placed at the top of the cell so only a single steel tube is required as the outer container. Electrical connections are made at the top and bottom of the cell.

The cell open circuit voltage of the beta battery varies from 1.8 to 2.1 V, depending on the state of charge. Operating temperature has to be between 300 and 350°C to maintain the liquid state of the electrodes and good conductivity of the electrolyte. Normal battery losses are adequate to maintain this temperature in a well insulated enclosure if the battery is being cycled every day. An electric heater may be necessary to maintain the minimum temperature over periods of several days without use. The temperature is high enough to be used as a heat source for a turbine generator, which may be a way of improving the overall efficiency in very large installations where significant cooling is required.

During discharge, a sodium atom gives up an electron at the upper steel cylinder. The sodium ion then migrates through the solid electrolyte to form sodium polysulfide, Na_2S_3 , which is also liquid at these temperatures. If the discharge is continued too far, Na_2S_5 is formed. This is a solid which precipitates out and does not contribute to future battery cycles. Therefore, the beta battery cannot be fully discharged.

The energy density goal for the beta battery is 44 Wh/kg, about double that of the lead-acid battery[2]. The fraction of active material that is utilized during a cycle is about three times that of the lead-acid battery. The current density is 7 to 10 times as much as the lead-acid battery. And one of the major advantages is that the raw materials of sodium and sulfur are very abundant and inexpensive. The latter point is very important if these batteries are

to be built in large quantities at acceptably low costs.

Major difficulties seem to be in developing the metal to ceramic seals and in developing the β -alumina electrolyte. Corrosion is a major problem. One problem with the electrolyte is the tendency to accumulate metallic sodium along its grain boundaries, which shorts out the cell. These problems seem to have been largely overcome, so the beta battery may be a major contributor to utility load leveling and to wind energy systems in coming years.

The number of possibilities for battery materials seems almost limitless[4]. The batteries discussed in this section seem to have the highest probability of wide use, but a technological breakthrough could easily move another battery type into the forefront. Whatever the ultimate winner is, these batteries will be used as system components, like transformers, by the utilities. If the utility has enough batteries on its system, it may not be necessary to physically place batteries at wind turbines for storage purposes. Of course, if it is desired to install large wind turbines on relatively low capacity distribution lines, batteries may be very helpful in matching the wind turbine to such a line.

The engineer designing the battery installation will be concerned with a number of parameters, including the voltage, current, storage capacity in kWh or MWh, the energy density per unit area of base (footprint), weight, height, reliability, control, heating and cooling requirements, safety, and maintenance. If the batteries are to be installed at a typical utility substation, the desired total capacity will probably be 100 or 200 MWh. The total battery voltage will probably be in the range of 2000-3000 V dc. These voltages would make maximum use of modern power semiconductors and would reduce current requirements as compared with a lower voltage installation.

A reasonable footprint is about 300 kWh/m² and a height of 6 m would probably be imposed by mechanical constraints. A height of 2 m may be better in terms of maintenance if the greater land area is available. The batteries should be capable of accepting a full charge in 4 to 7 hours and should be able to deliver all their stored energy in as little as 3 hours. They should be capable of more than 2000 charge-discharge cycles and should have an useful life of more than ten years. The energy efficiency, defined as the ratio of the ac energy delivered during discharge to the ac energy supplied during charge, should be at least 70 percent. This definition of efficiency includes both the efficiency of the individual cells and the efficiency of the power conditioning equipment.

Example

Your company is considering installing a 100 MWh beta battery installation at a substation. Individual cells are 0.8 m tall and occupy a rectangular space that is 5 cm on a side. Each cell can store 200 Wh of energy. The energy efficiency is 70 percent, and you assume all the losses occur during the charge cycle. That is, if you put in 200/0.7 Wh during charge, you get back 200 Wh per cell on discharge. The battery installation is to be charged during a five hour period and discharged during a three hour period. Half the losses are used to maintain battery temperature and the other half can be used to provide thermal input to a 25 percent efficient turbine generator. The cells are to be mounted two high, so the total height requirement is less than 2 m. The battery voltage is 2500 V dc.

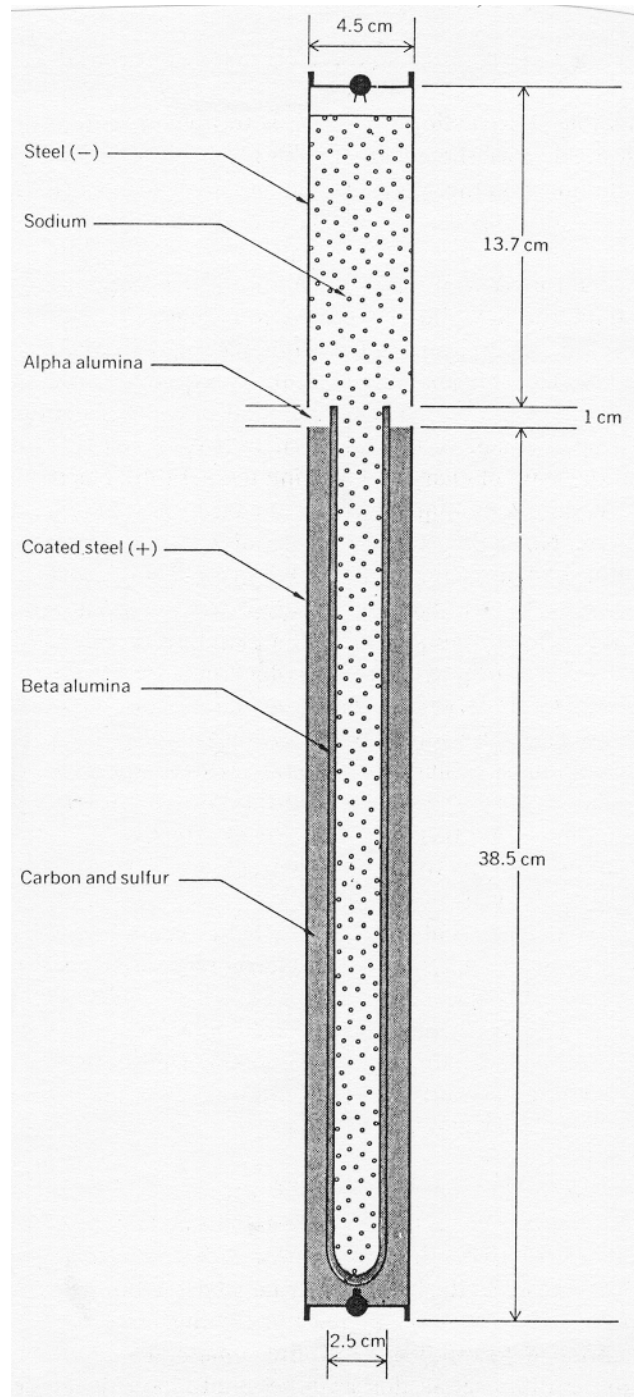

Figure 13: Beta battery cell. (©1979 IEEE)

1. How many cells are required?
2. What is the total land area required?
3. What is the battery current during charge and during discharge?
4. What should be the power rating of the turbine generator if it is to be operated at rated power for four hours during the day?

For part (a), if the total energy storage is $100 \text{ MWh} = 100 \times 10^6 \text{ Wh}$, and each cell contains 200 Wh, the number of cells is $100 \times 10^6 / 200 = 500,000$. This is obviously a significant manufacturing endeavor.

For part (b), if we stack the cells two high, we need only the area for 250,000 cells taking up space 5 cm on a side.

$$\text{Area} = 250,000(0.0025 \text{ m}^2) = 625 \text{ m}^2$$

This is an area 25 m on a side, which may be unacceptably large at some locations. The area can be reduced to one third of this value by stacking the cells six high rather than two high. This would probably have some benefits in terms of lowered losses to the atmosphere and easier recovery of heat for the turbine generator.

For part (c), the total energy required during charge is $100/0.7 = 143 \text{ MWh}$. The average power during charge is then $143/5 = 28.6 \text{ MW}$. Supplying this power at 2500 V dc requires a current of $28.6 \times 10^6 / 2500 = 11,440 \text{ A}$. The average power during discharge is $100/3 = 33.3 \text{ MW}$. The current during discharge would be $33.3 \times 10^6 / 2500 = 13,320 \text{ A}$. These currents are approaching a practical limit for conductors and protective devices, so it may be worthwhile to consider the economics of raising the voltage to 5000 V dc or more and lowering the current a proportional amount.

For part (d), the losses during a 24 hour period are $100/0.7 - 100 = 43 \text{ MWh}$. Half of this amount or 21.5 MWh is available to our turbine generator in the form of 350°C heat. The power output over a four hour period would be $21.5(0.25)/4 = 1.34 \text{ MW}$. If this can be used during the discharge cycle, the effective power rating during discharge would increase from 33.33 MW for the batteries to 34.67 MW for batteries plus waste heat. It would be desirable, therefore, to enter the peak load period of the day with the batteries as hot as possible and leave the peak load period with the batteries as cool as possible. If the batteries would tolerate a 40 or 50°C temperature swing over a three hour period, both the stored heat and the losses could be used to power the waste heat generator.

5 HYDROGEN ECONOMY

The concept of the hydrogen economy has received considerable attention in recent years, especially since 1973[3, 1]. This concept basically describes an energy economy in which hydrogen is manufactured from water by adding electrical energy, is stored until it is needed, is transmitted to its point of use and there is burned as a fuel to produce heat, electricity, or mechanical power. This concept has some disadvantages, primarily economic in nature, but also has some major advantages. One advantage is that the basic raw material, water, is abundant and inexpensive. Another advantage is the minimal pollution obtained from

burning hydrogen. The primary combustion product is water, with minor amounts of nitrogen compounds produced from burning hydrogen in air at high temperatures. Merely lowering the combustion temperature solves most of this pollution problem.

Hydrogen is a widely used gas. In 1973, the world production of hydrogen was about 250 billion cubic meters (9000 billion standard cubic feet). About a third of it was produced and used in the United States, requiring 3 percent of the U. S. energy consumption for hydrogen production. At that time 47 percent of the hydrogen was used for petroleum refining, 36 percent for ammonia synthesis, 10 percent for methanol synthesis, and the remainder for miscellaneous and special uses. These uses include the hydrogenation of edible oils and fats to make margarines and cooking oils, the manufacture of soap, the refining of certain metals, semiconductor manufacture, and as a coolant in large electrical generators. It is a feedstock in organic chemical synthesis leading to production of nylon and polyurethane. And, of course, liquid hydrogen is used as a rocket fuel.

Most of the hydrogen currently produced in the United States is obtained by the reaction of natural gas or light petroleum oils with steam at high temperatures. This reaction produces mostly carbon dioxide and hydrogen. The carbon dioxide can be removed by a scrubbing process in an amine solution or in cold methanol. The hydrogen produced by this reaction is not of high purity, but is satisfactory for large scale uses. In 1973, about 23 percent of the hydrogen produced in the United States was produced from oil, 76 percent from natural gas, and 1 percent by other methods, including electrolysis of water[11].

The use of hydrogen for all of these applications is expected to grow in the future. One possible major growth area would be the liquefaction and gasification of the large U. S. coal deposits. Coal has a high carbon to hydrogen ratio, so carbon has to be removed, or hydrogen added, to make a liquid or gaseous fuel. Most proposed reactions for synthetic fuels call for removing the carbon, but if hydrogen were available at a reasonable price it could stretch out these coal supplies significantly.

Hydrogen can be readily stored in the same types of underground facilities as are now used to store natural gas. This ability to store energy would allow large generating plants of various types, such as nuclear fission, nuclear fusion, wind, photovoltaic, and solar thermal, to operate under optimum conditions for the energy source. The nuclear plant can operate at full capacity day and night. Wind power can be captured when available. Wind energy captured by large wind farms in the High Plains region of the United States during the spring can be stored and transported to the population centers of the eastern United States during later peak demand periods. This can be done much more economically through hydrogen pipelines than in the form of electricity over extra high voltage transmission lines. Many of the existing natural gas pipelines can be readily converted to hydrogen.

The technology for the construction and operation of natural gas pipelines has been well developed. A typical trunk line, 1000 to 1500 km long, consists of a welded steel pipe up to 1.2 m (48 in.) in diameter that is buried underground. Gas is pumped along the line by gas-driven compressors spaced along the line typically at 160-km intervals, using some of the

gas in the line as their fuel. Typical line pressures are 4 to 5 MPa. To convert this to the English unit of pounds(force) per square inch (psi), we note that $1 \text{ psi} = 6894.76 \text{ Pa}$, and find equivalent line pressures of 600 to 750 psi.

A typical 0.91-m (36-in.) pipeline has a capacity of about 11,000 MW on an equivalent energy basis. That is, a pipeline of this size will transport about 10 times as much energy per hour as a three-phase 500-kV overhead transmission line. It requires less land area than the overhead lines and is more accepted by people because it is basically invisible. These factors combine to make the unit costs of energy transportation by pipeline much lower than for overhead transmission lines.

Hydrogen has about one-third of the heating value per unit volume as natural gas. This means that a hydrogen volume of about three times the volume of natural gas must be moved in order to deliver the same energy. The density and viscosity of hydrogen are so much lower, however, that a given pipe can handle a hydrogen flow rate of three times the flow rate of natural gas. Thus where existing pipelines are properly located, they could be converted to hydrogen with the same capacity to move energy. Different compressors are required, however, to pump the lower density hydrogen.

We have examined several asynchronous loads in this chapter, all of which involve some form of energy storage. Water is pumped and stored until needed. Heat is stored in the form of hot water. Wind generated electricity is stored in chemical form in batteries. Wind generated electricity can also be passed through electrolysis cells to produce hydrogen. Hydrogen can be stored for long periods of time and also transmitted over great distances. Technical and economic constraints indicate that only large facilities will be practical for hydrogen production, which is distinctly different from the cases of water pumping, space heating, and even battery charging. We shall examine some of the features of electrolysis cells as asynchronous loads for wind generators in the next section. First, however, we shall consider some of the properties of other fuels, to aid us in making the economic decisions which must be made.

Table 7.2 shows the energy content of several different fuels, some of which are not extensively used for generating electrical power but are included for general interest. Both English and SI units are given since the British Thermal Unit (Btu), pound, and gallon are so deeply entrenched in the energy area. Anyone who would read the literature must be conversant with these English units so we shall present a portion of our discussion using these units.

The energy content or heating values given are all the *higher heating values*. To explain this term, we recall that water vapor is one of the products of combustion for all fuels which contain hydrogen. The actual heat content of a fuel depends on whether this water vapor is allowed to remain in the vapor state or is condensed to liquid. The higher heating value is the heat content of the fuel with the heat of vaporization included. The lower heating value would then be the heat content when all products of combustion remain in the gaseous state. In the United States the practice is to use the higher heating value in utility reports and boiler combustion calculations. In Europe, the lower heating value is used. The lower heating value is smaller than the higher heating value by about 1040 Btu for each pound of water formed

Table 7.2 Heating Values of Various Fuels^a

	Btu/lb	MJ/kg	Btu/gal (liquid)	MJ/L (liquid)
Hydrogen	63,375	147.3	37,442	10.42
Methane	23,875	55.49	83,945	23.37
Propane	21,666	50.35	104,870	29.20
Gasoline	20,460	47.55	120,000	33.4
Kerosene	19,750	45.90	136,000	37.9
Diesel Oil (1-D)	19,240	44.71	140,400	39.1
Diesel Oil (2-D)	19,110	44.41	146,600	40.8
Diesel Oil (4-D)	18,830	43.76	150,800	42.0
Ethyl Alcohol	12,780	29.70	83,730	23.31
Methyl Alcohol	9,612	22.34	63,090	17.56
Anthracite (Pa.)	12,880	29.9		
Low-volatile	14,400	33.5		
Bituminous (W. Va.)				
High-volatile A	14,040	32.6		
Bituminous (W. Va.)				
High-volatile C	10,810	25.1		
Bituminous (Ill.)				
Subbituminous A (Wyo.)	10,650	24.8		
Subbituminous C (Colo.)	8,560	19.9		
Lignite (N. Dak.)	7,000	16.3		

^aSource: Data compiled from *CRC Handbook of Tables for Applied Engineering Science*, first edition, 1970. Reprinted with permission. Copyright CRC Press, Inc., Boca Raton, FL.

per pound of fuel. One pound of hydrogen produces about nine pounds of water, so the lower heating value of hydrogen, for example, would be about $63,375 - 9(1040) = 54,000$ Btu/lb.

We see from the table that hydrogen has a very high heating value on a Btu/lb or a MJ/kg basis, but because of the low density of liquid hydrogen, the heating value per liter is lower than the other liquid fuels. Hydrogen becomes a liquid only at temperatures close to absolute zero and the energy required to liquefy it may be on the order of one third of the energy content of the resulting liquid hydrogen. The capital equipment and energy required for liquefaction will probably prevent liquid hydrogen from being used as a fuel except in special applications. These include space flights and large aircraft where the high energy content per kg may help produce significant cost savings.

We also see that petroleum fuels have lower energy content per kg as their complexity

increases, but that the energy content per liter increases because the density of the fuel is increasing. At the same price per liter or per gallon, diesel oil is a better buy than gasoline because the energy content is greater.

Ethyl alcohol and methyl alcohol have significantly lower energy contents per liter than gasoline or diesel oil, which means they need to be priced at a lower price per liter to be economically competitive. The alcohols are being used more and more for transportation purposes and may have a role in small cogeneration power plants.

Coal is much like crude oil in that its chemical properties vary widely from one field to another, and even within a field. Typical heating values are shown in the table for seven different coals found in the United States. Heating values are seen to vary by over a factor of two, from 14,400 Btu/lb for low-volatile bituminous from West Virginia to 7,000 Btu/lb for lignite from North Dakota. On the average, coals in the Western United States have lower heating values and lower sulfur content than Eastern coals. The lower heating values make the Western coals more expensive to ship, on the basis of delivered energy, while the lower sulfur content makes the Western coals more desirable for environmental purposes.

The gaseous fuels of Table 7.2 are usually sold on a volume basis rather than on a mass basis. We normally see the energy content of hydrogen expressed as 12.1 MJ/m³ (325 Btu per standard cubic foot) rather than a given amount of energy per kg. The heating value of natural gas varies somewhat with the amount of propane, butane, hydrogen, helium, and other gases mixed with the methane, but is usually expressed as 37.3 MJ/m³ (1000 Btu/ft³).

To get an idea of the electrical equivalent of the U.S. consumption of hydrogen, we take the 1973 consumption of 80 billion cubic meters and find a total yearly energy of $(8 \times 10^{10})(12.1) = 97 \times 10^{10}$ MJ = 26.9×10^{10} kWh. The average power is the yearly energy divided by the number of hours in the year, 8760. The result is 30,700 MW. This power level would require 44 electrical generating plants of 1000 MW rating each with a capacity factor of 0.7. It is evident that a rather large investment of electrical generation and electrolysis equipment will be necessary for oil and gas to be eliminated as sources for hydrogen.

It should be evident that selling oil by the gallon, natural gas by the thousand cubic feet, and coal by the ton can lead to confusion by the consumer as to which fuel represents the best buy. An improvement on the system would be to sell fuels by energy content rather than volume or mass. There is a major trend in this direction among the electric utilities, and perhaps it will spread to other sectors of society in the future. Since the Btu is a small unit, this cost is usually expressed in dollars per million Btu, C_{MB} . Since there are 1054 Joules in one Btu, the cost per gigajoule (10^9 J) will be 0.949 times the cost per million Btu.

We may express this cost per million Btu as the cost per unit of fuel (gallons, pounds, etc.) times the number of units of fuel per million Btu.

$$C_{MB} = \frac{\text{cost}}{\text{unit}} \left(\frac{\text{units}}{10^6 \text{ Btu}} \right) \quad (22)$$

Example

In the spring of 1981, delivered costs of fuels to customers in the Kansas Power and Light Co. service area, excluding taxes, were \$2.00 per thousand cubic feet for natural gas with an energy content of 980 Btu per cubic foot, \$1.16 per gallon for No. 1 diesel oil, \$1.14 per gallon for gasoline, \$0.60 per gallon for propane, and \$12.00 per ton (2000 pounds) for Wyoming coal with 8500 Btu/lb energy content. Find the costs of the fuels per million Btu.

For natural gas, the cost C_{MB} is

$$C_{MB} = (\$2.00/\text{unit})(1 \text{ unit}/0.98 \times 10^6 \text{ Btu}) = \$2.04/10^6 \text{ Btu}$$

For diesel oil, the cost is

$$C_{MB} = (\$1.16/\text{gal})(1 \text{ gal}/0.1404 \times 10^6 \text{ Btu}) = \$8.26/10^6 \text{ Btu}$$

For gasoline, the cost is

$$C_{MB} = (\$1.14/\text{gal})(1 \text{ gal}/0.12 \times 10^6 \text{ Btu}) = \$9.50/10^6 \text{ Btu}$$

For propane, the cost is

$$C_{MB} = (\$0.60/\text{gal})(1 \text{ gal}/0.10487 \times 10^6 \text{ Btu}) = \$5.72/10^6 \text{ Btu}$$

For coal, the cost is

$$C_{MB} = (\$12.00/\text{ton})(1 \text{ ton}/2000 \text{ lb})(1 \text{ lb}/0.0085 \times 10^6 \text{ Btu}) = \$0.71/10^6 \text{ Btu}$$

We can see from these numbers that at this point in time coal is the best buy. We also see that natural gas is priced well under the price of other petroleum fuels. This is due to government regulation, and the differential can be expected to disappear in an unregulated market.

The cost per kWh generated by burning one of these fuels depends not only on the cost of the fuel and its energy content, but also on the efficiency with which it is burned. The reciprocal of efficiency, the *heat rate*, is the parameter that is commonly used in power plant calculations.

The heat rate is the number of units of fuel energy that must be used to produce one unit of electrical energy. In the English system this is given as Btu contained in the fuel per kWh of electrical output. In SI, this is given as joules in the fuel per joule of electrical energy output (or MJ/MJ or GJ/GJ depending on one's preference). In this form, it shows clearly the dimensionless nature of the plant efficiency. Average annual heat rates for new 1000 MW coal plants vary from 9700 to 10,200 Btu/kWh (2.84 to 3.00 MJ/MJ) depending on the type of coal used. Since there are 3410 Btu in one kWh, the efficiency of these coal plants varies from $3410/10,200 = 0.334$ to $3410/9700 = 0.352$. The heat rate for oil fired peaking units has tended to be poorer than that for coal fired base units, perhaps 11,000 to 12,000 Btu/kWh

(3.23 to 3.52 MJ/MJ). There are new types of fossil fueled generating plants being developed which use systems like magnetohydrodynamics and combined cycles to get the heat rate down to 8000 Btu/kWh (2.35 MJ/MJ) or less.

The cost of fuel per kWh can be defined as

$$C_{\text{fuel}} = C_{\text{MB}}(\text{heat rate}) \quad (23)$$

where CMB is in dollars per million Btu and the heat rate is in million Btu per kWh generated.

Example

The cost of coal delivered to a plant in Kansas is \$0.71/106 Btu in 1981 dollars. The heat rate is 9800 Btu/kWh. What is the fuel cost per kWh?

$$C_{\text{fuel}} = (\$0.71/10^6 \text{ Btu})(0.0098 \times 10^6 \text{ Btu/kWh}) = \$0.0070/\text{kWh}$$

Example

The cost of residual low sulfur fuel oil delivered to a municipal generating plant in 1981 is \$8.26/106 Btu. The heat rate is 11,000 Btu/kWh. What is the fuel cost?

$$C_{\text{fuel}} = (\$8.26/10^6 \text{ Btu})(0.011 \times 10^6 \text{ Btu/kWh}) = \$0.0909/\text{kWh}$$

Numbers such as shown in these examples are obsolete as soon as they are written, but they do illustrate the fact that oil fired electricity costs considerably more than coal fired electricity. This means that wind machines will probably be used to save oil before they can be justified to replace new coal generation.

We should mention that relatively large amounts of oil and natural gas are used as boiler fuels by the utilities. In 1977, $90.3 \times 10^9 \text{ m}^3$ of natural gas and 574.9 million barrels of oil were burned as boiler fuels[16]. Fossil fuels were used to generate $1,648.7 \times 10^9 \text{ kWh}$, with coal contributing 60 percent of the total, gas 19 percent, and oil 21 percent. The average power from the oil and gas fired units was 75,000 MW.

It is national policy to replace this oil and gas fired electricity with electricity generated from coal and nuclear plants. However, political, environmental, and economic problems are delaying this transition. It appears that significant quantities of oil and gas will be used for boiler fuel for some time.

It seems logical that wind generated electricity would be used first as a fuel saver, so that less oil and gas would be burned when the wind is blowing. This eliminates the extra expenses for storage equipment and results in minimum cost to the electricity customer. The major technical limitation is the capacity of existing transmission lines. That is, a region of the country with 10,000 MW of oil and gas generation may only have 1000 MW of transmission line capacity which could be used to move wind generated electricity into the region. Additional

transmission lines may be almost as politically and economically difficult to build as new coal generating plants within the region. This means that while at least 75,000 MW of wind generation could be utilized nationally in a fuel saver mode if transmission lines were adequate, perhaps only 10,000 to 20,000 MW could actually be utilized in this mode if electrical power had to be transmitted over existing transmission lines. This limitation would not be present if the wind generated electricity were used to make hydrogen, and the hydrogen shipped to the load centers by pipeline.

There will need to be a cooperative effort to use wind and solar electric systems, hydroelectric systems, load management, conservation, and perhaps load leveling batteries to maximize the use of wind and solar systems as fuel savers. Electrolysis of water can logically begin after the use of oil and gas as boiler fuels has been reduced to an absolute minimum. Existing oil and gas generating plants can be maintained as standby units for emergency use.

Of course, there may be special applications, such as off shore wind turbines, where electrolytic production of hydrogen could be justified more quickly than on shore. A great deal depends on the capital costs of wind turbines and electrolysis cells, as well as the cost and availability of fossil fuels. In any event, there will be interest in producing hydrogen from wind generated electricity, so a brief review of the technology is appropriate.

6 ELECTROLYSIS CELLS

It has been known for at least 150 years that water can be decomposed into the elements hydrogen and oxygen by passing an electric current through it. Electrolysis cells are widely used to produce hydrogen in laboratory quantities or where a high purity is required.

A simple electrolysis unit is shown in Fig. 14. There are two end plates and a bipolar plate in the middle, forming two cells. The electrolyte is distilled water with up to 25 percent of some alkaline added, such as sodium hydroxide (NaOH), potassium hydroxide (KOH), or lithium hydroxide (LiOH). An alkaline is used to produce a relatively low resistance in the electrolyte. Distilled water has a very high resistance, which causes unacceptably high losses if used by itself.

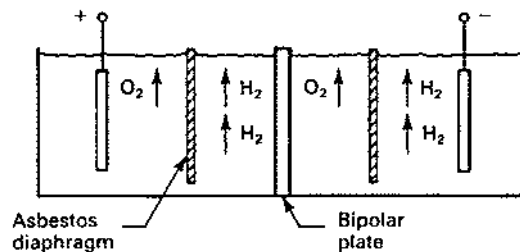

Figure 14: Two electrolysis cells in series.

The plates are mild steel, solid nickel, or nickel-plated steel. There is a diaphragm in the middle of each cell to prevent the mixing of the oxygen and hydrogen produced. The diaphragm is made of asbestos cloth in the older, low pressure systems.

When a direct current is applied, oxygen gas is evolved at the positive terminal of each cell and hydrogen gas at the negative terminal. Only the water is used up in this reaction so additional water must be continually added to maintain the same alkaline concentration.

A simplified version of the chemical process is shown in Fig. 15 for a single cell with a potassium hydroxide electrolyte. Initially, the two plates in the cell are surrounded by a solution of water, positive potassium ions, and negative hydroxal ions. When a voltage difference is applied to the electrodes, the negative ions migrate to the positive plate and the positive ions to the negative plate. If the applied voltage is large enough, four hydroxal ions at the positive electrode will give up one electron each and form one molecule of oxygen and two molecules of water. At the same time, four water molecules at the negative electrode accept one electron each, forming two molecules of hydrogen and four hydroxal ions. Current flow in the electrolyte is carried by the hydroxal ions migrating from the negative to the positive plate.

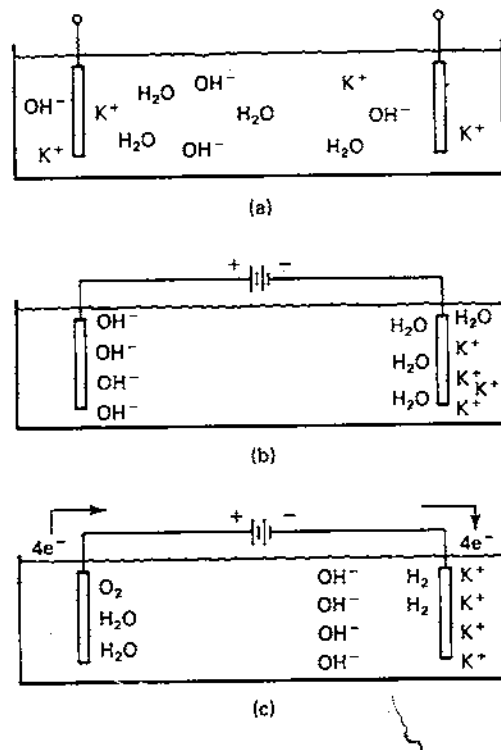

Figure 15: Chemical action in a simple electrolysis cell: (a) no voltage applied; (b) Limited voltage applied; (c) more voltage applied.

The gases which are produced must be captured by *headers* over the plates to prevent them from mixing or being lost to the atmosphere. A simple test tube filled with water and inverted over one of the plates is typically used in freshman chemistry to get a small quantity of hydrogen or oxygen for experimental purposes. Since the chemical formulation of water is H_2O , the volume of hydrogen given off will be twice the volume of the oxygen.

The voltage across each cell necessary to produce hydrogen is 1.23 V (the decomposition voltage of water at room temperature) plus a voltage at each electrode necessary to actually make the reaction occur, called the oxygen or hydrogen overvoltage, plus the voltage necessary to overcome the electrolyte resistance and the resistance of the conductors and plates. The power into each cell is the product of voltage and current. If all the current passes directly through the cells and produces hydrogen, the cell efficiency can be defined as the higher heating value of the hydrogen produced divided by the electrical power input.

$$\eta_t = \frac{(\text{moles of } H_2/\text{sec})(\text{energy/mole})}{VI} \quad (24)$$

The heat of formation or the higher heating value of one mole of hydrogen is 68.32 kcal or 286.0 kJ. As was mentioned in the previous section, the higher heating value includes the heat of condensation of the water vapor in the combustion products. The total value is available only if the combustion gases are cooled below the condensation point, which is not practical in the generation of electricity. The higher heating value is available, of course, when the hydrogen is burned to make steam and the steam is used in space heating applications where condensation occurs.

We recall from freshman chemistry that it requires two faradays of charge to produce one mole of H_2 gas. The current in Eq. 24 is in coulombs per second, so when we combine the current with the terms in the numerator and cancel the seconds, we have

$$\eta_t = \frac{(1 \text{ mole})(286.0 \text{ kJ/mole})}{V(2)(96,493 \text{ C})} = \frac{1.482 \text{ J/C}}{V} \quad (25)$$

This definition of thermal efficiency as heat energy out over electrical energy in is a common definition. It is of interest to note that the maximum theoretical limit of this efficiency is about 1.2 or 120 percent. This does not violate any laws of thermodynamics because we have not included the possibility of heat input to the cell as well as the electrical input. There are operating modes for high performance electrolysis cells where they actually operate in an endothermic mode, extracting heat from the surroundings and adding this energy to the electrical input to produce a given output heat energy. General Electric has reported[14] on a laboratory cell that operated at over 100 percent thermal efficiency up to rather large current densities. However, in most cases cost tradeoffs will result in the most economic operating point being somewhat under 100 percent efficiency.

Historically, electrolytic hydrogen has been made with large low pressure electrolysis cells typically operating at cell voltages between 1.9 and 2.1 V. This corresponds to a thermal

efficiency range of 71 to 78 percent. The energy loss appears as low grade heat which must be removed from the system. The rated current on these large units may be as high as 15,000 A or even more. There will be hundreds of cells in series to yield a reasonable plant operating voltage.

These large electrolysis plants represent proven technology with readily available materials. The cost of the hydrogen produced is rather high, however, because of the inefficient, low pressure electrolysis process which is used. A substantial increase in the use of electrolytic hydrogen depends on an improvement of electrolysis efficiency and a decrease in capital costs.

The bubbles being evolved from the electrodes increase the resistance of the electrolyte. Therefore, one obvious way of improving the efficiency is to increase the operating pressure, since this compresses the bubbles. This has another advantage for some applications in that the gases can be produced at pipeline pressures and do not require compression after generation. The feedwater must be pumped at that same pressure but it requires less energy to pump the liquid than it does to pump the resultant gas.

The effect of pressure on cell voltage is shown in Fig. 16. The cell voltages of conventional alkaline electrolyzers (electrolysis cells) are shown as a band in the upper part of the figure. The horizontal axis is the *current density* of the cell, in A/m² or A/ft². The current density is the total cell current divided by the electrode area. As the current density increases, the cell voltage has to increase because of the resistances of the electrolyte and conductors. As the pressure increases, the electrolyte resistance drops, which lowers the cell voltage and thereby improves the efficiency. At 400 A/ft², the best conventional electrolyzer has an efficiency of about 69 percent, while at 1000 psi (6.895 MPa) the efficiency of a pressurized electrolyzer is 87 percent, and at 3000 psi (20.68 MPa) the efficiency is 91 percent. The high pressure cell is also capable of operating to at least twice the current density of the conventional electrolysis cells. This reduces the cross sectional area of the cell by a factor of two for a given input power, which helps to reduce capital costs. Of course, the high pressure container for the cell will be stronger and more expensive than the container for the low pressure cell. The much smaller volume of the evolved gases makes it possible for the overall capital cost per unit of hydrogen to be lower for the high pressure system.

Efficiency also increases with increasing temperature, as shown in Fig. 17. The cell voltage at 400 A/ft² is about 2.07 V at 80°F and 1.63 V at 400°F. The efficiency increases from 72 percent to 91 percent with this increase in temperature. The reason for this is that water becomes more chemically active at higher temperatures, so that it is easier to split into its constituent elements.

The information on Figs. 7.16 and 7.17 was taken from a high pressure KOH cell developed at Oklahoma State University[9]. The electrodes were made of solid nickel and were able to withstand the corrosive action of hot KOH without damage. These researchers discovered that many materials which would withstand KOH at high pressures or at high temperatures would not withstand the combination of high pressure and high temperature KOH. A great deal of research is being performed on various materials to help develop these high efficiency

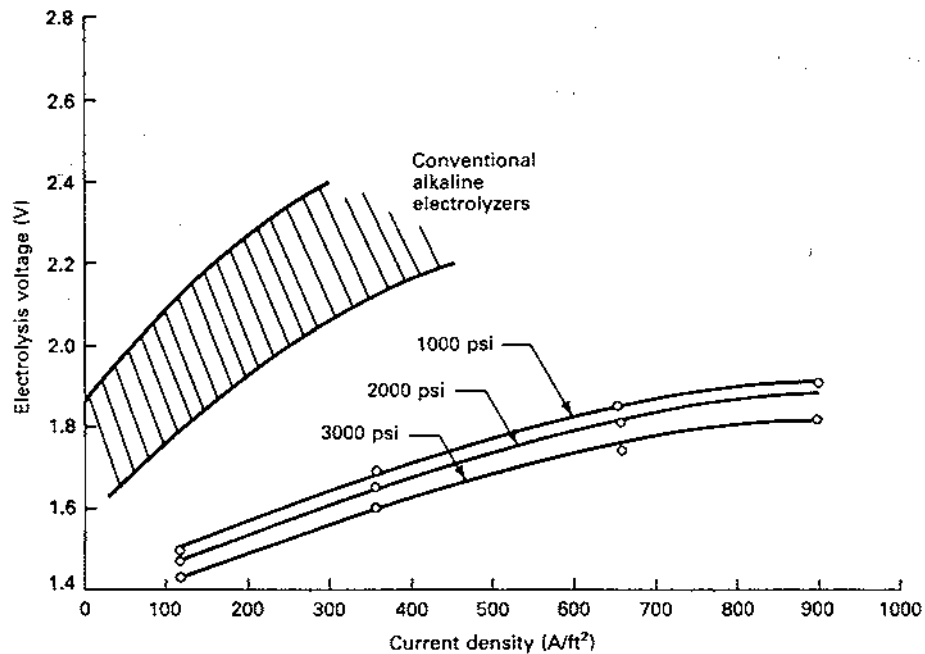

Figure 16: Plot showing the effect of pressure on electrolysis cell characteristics at 400°F.

cells.

The Oklahoma State cell used asbestos sheets to separate the gases between the electrodes. Asbestos is also a standard separator for the low pressure cells. It is chemically an excellent choice since it is not attacked by the hot KOH. It is not such a good separator from a mechanical standpoint, however, since pressure differentials can blow holes in it. The electrolysis unit must then be torn down and rebuilt. The pressure controlling valves on the oxygen and hydrogen lines are difficult to build and operate in such a way as to maintain the very low differential pressures required by the asbestos cloth. These problems indicated the need for a high pressure cell which would not require the use of asbestos.

One recent design solution to this problem is the *solid polymer electrolyte* (SPE) cell. The basic construction of such a cell is shown in Fig. 18.

At the center of the cell is the SPE sheet. This sheet is perhaps 250 μm thick and is made of a perfluorinated linear polymer with sulfuric acid groups integrally linked to the polymeric structure to provide ionic conductivity[14]. This material is essentially a form of teflon which has excellent physical strength and forms a rugged barrier between the generated hydrogen and oxygen gases. When saturated with water the polymer is an excellent ionic conductor and it is the only electrolyte required. Ionic conductivity is provided by the mobility of the hydrated hydrogen ions ($\text{H}^+ \cdot x\text{H}_2\text{O}$). These ions move through the sheet of electrolyte by passing from one sulfonic acid group to another. The sulfonic acid groups are fixed,

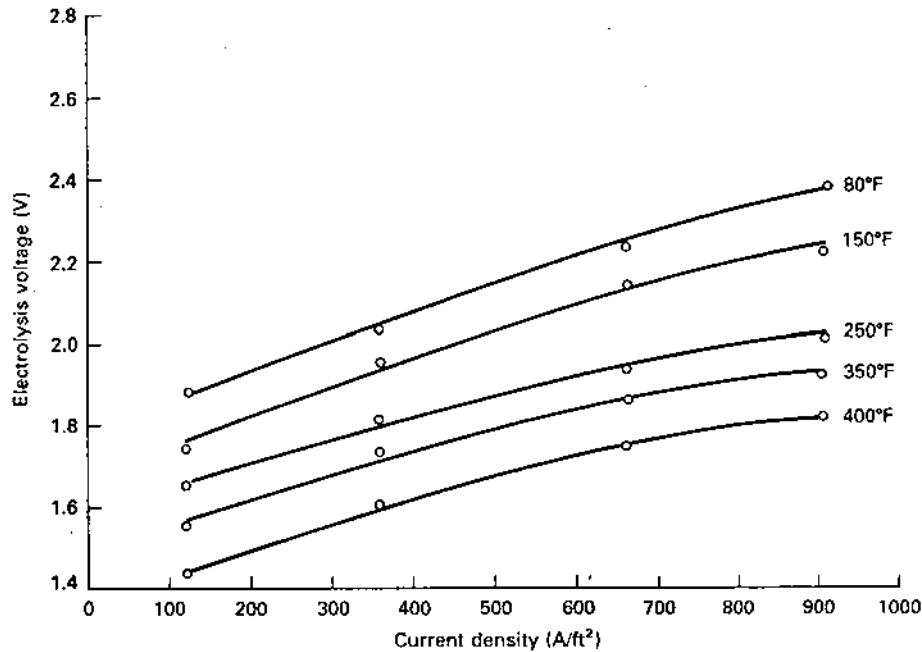

Figure 17: Plot showing the effect of temperature on electrolysis cell characteristics at 3000 psi.

keeping the acid concentration constant within the electrolyte. On the oxygen side, two water molecules are decomposed into one neutral oxygen gas molecule, four electrons which move off to the right within the metal screen, and four positive hydrogen ions which move through the solid electrolyte. These four ions receive four electrons coming from the left and become two molecules of hydrogen gas on the hydrogen side of the solid electrolyte.

The two faces of the SPE sheet are coated with a very thin film of catalyst to help the reaction occur. Platinum black works well but other catalysts are being developed for reasons of cost and availability.

The spaces for the water and gas next to the SPE sheet are formed by a multi-layer expanded metal screen package. The open spaces between the screen strands provide a low resistance flow path for the water and gases. The screen provides physical support for the SPE sheet to help it withstand high differential pressures and acts as an electrical current conductor. The fluid cavities are sealed around the edges by a silicon rubber gasket. This gasket also provides electrical insulation so current flows only where desired. Adjacent cells are separated by a metal sheet which provides mechanical separation of gases but does not contribute directly to gas production.

Early problems with the silicon rubber gasket have led to the testing of other separators. One version replaced the silicon rubber gasket and metal sheet with a sheet of molded carbon

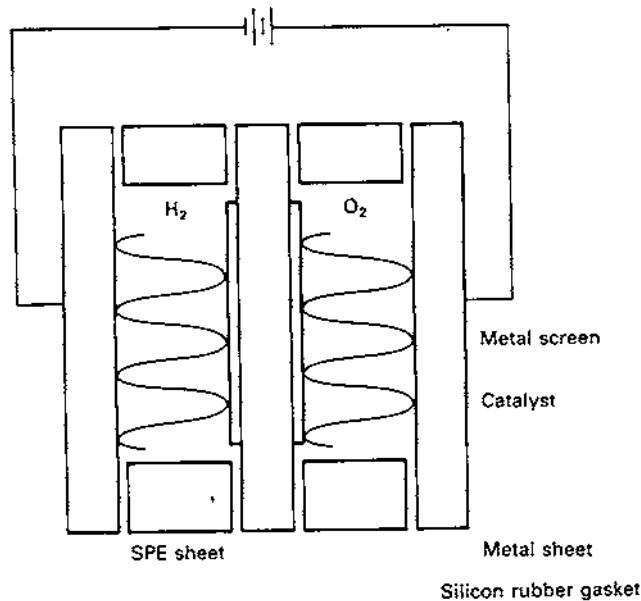

Figure 18: Solid polymer electrolyte electrolysis cell.

and titanium foil shield[15]. This separator is molded from a mixture of carbon and phenolic resin. The SPE sheet itself acts as the gasket. On the cathode (hydrogen) side, porous carbon fiber paper replaced the metal screen. On the anode (oxygen) side, the metal screen is formed of either perforated titanium foil, fabricated by acid etching, or porous titanium plate fabricated by a powder metallurgy process. Other developments in materials can be expected with the SPE cell as it continues toward wide commercialization.

Increasing the temperature increases the efficiency of the SPE cell just as it does with the alkaline cell. An increase in temperature from 180°F to 300°F reduced the cell voltage from 1.83 to 1.70 V at 1000 A/ft² for the GE cell[15]. This corresponds to a thermal efficiency improvement from 81 to 87 percent. Material problems become even more severe at temperatures above 300°F (150°C) so this may be a practical upper limit for temperature.

The efficiency of the SPE cell does not vary strongly with pressure since the current does not have to flow through a liquid electrolyte filled with gas bubbles. In fact, the GE efficiency goal for their SPE cell is 93 percent at 100 psi (0.69 MPa) and 88 percent at 600 psi (4.14 MPa)[15]. If pipeline pressure is not required, it may be more cost effective to operate the SPE cell at relatively low pressures.

It might be mentioned that water only needs to be supplied to the oxygen side of the SPE cell. The water on the hydrogen side is necessary to the reaction but is not used up, except for the water vapor that is carried off by the hydrogen gas. The cell only requires three fluid connections, one for water and two for the gases. This simplifies construction somewhat as

compared with the high pressure alkaline cell.

7 PROBLEMS

1. You visit a farm where a wind turbine is driving a piston pump. You estimate the flow rate to be 0.8 L/s, the stroke to be 0.18 m in length, and the operating speed to be 35 cycles per minute. Estimate the pump diameter. You will need to assume a reasonable slip. Note: Systems installed in the United States prior to the mid 1980s were all sized in English units, so any calculated value should be rounded to the nearest 0.5 inch to express the size.
2. A rancher asks you for advice. His pumping head is 80 m and he needs 7000 liters of water per day, with enough stock tank capacity to last for two calm days. What size Dempster turbine and cylinder do you suggest?
3. Estimate the specific speed of the pump with characteristics shown in Fig. 7, assuming the rated speed is 1750 r/min and the maximum diameter impeller is used.
4. A Jacuzzi Model 25S6M10XP-T submersible turbine pump has a maximum efficiency of 70 percent at a capacity of 130 gal/min, a head of 550 ft, and a rotational speed of 3450 r/min.
 - (a) What is the specific speed?
 - (b) What is the required input power, both in horsepower and kW?
5. The pump in the previous problem is operated at 3000 r/min. Estimate the new head, new capacity, and new input shaft power if the efficiency remains the same. Express in English units.
6. You work for a company that is building a canal to carry water from the Missouri River to Western Kansas for irrigation purposes. The water must be lifted a total of 300 m in a series of stages of 10 to 20 m each. The total amount of water required per year is $4 \times 10^9 \text{ m}^3$. This can be pumped intermittently throughout the year as the canal supplies the necessary storage. You are asked to evaluate the concept of using wind turbines with a 90 m blade diameter to drive the necessary pumps. The wind regime can be characterized by the Weibull parameters $k = 2.2$ and $c = 7.5 \text{ m/s}$. Cut-in, rated, and furling wind speeds are assumed to be $0.6u_m$, $1.1u_m$, and $1.6u_m$, respectively, where u_{me} is given by Eq. 10. The peak pump efficiency is assumed to be 0.9 and the average pump efficiency between cut-in and rated wind speeds is assumed to be 0.85.
 - (a) What is the total average power input to all the pumps on the canal?
 - (b) What is the total rated power input to all the pumps on the canal?
 - (c) How many wind turbines are needed?

- (d) Would you anticipate any problem in clustering the necessary number of turbines at a pumping station and making the mechanical connections between wind turbines and pumps and between pumps and necessary piping? Discuss.
7. A wind turbine manufacturer is offering for sale a 12 m diameter propeller mechanically connected to a Jacuzzi type FL6 centrifugal pump through a 12:1 gearbox. You have an application where large amounts of water need to be pumped against a head of 80 ft and this system could be used to reduce energy consumption by other pumps which are electrically driven. The wind characteristics are described by the Weibull characteristics $k = 2.2$ and $c = 7.5$ m/s. Water starts to flow with a pump power input of 8.5 bhp. Pump power input has to be limited to 35 bhp because of cavitation problems. The turbine efficiency is assumed to be a constant value of 0.32 over the operating range between cut-in and rated wind speeds. The pump efficiency averages about 0.8 under all operating conditions.
- (a) What is the cut-in wind speed?
- (b) What is the rated wind speed?
- (c) How much water will the system pump in a year? Express result in both gallons and m^3 .
8. A paddle wheel water heater has dimensions $L = 0.07$, $w = 0.07$, $b = 0.038$, $D = 0.6$, $H = 0.4$, and $d = 0.2$ m, as defined in Fig. 8. The wheel is turning at a rotational speed of 4500 r/min. What is the power being converted into heat?
9. You install a 40-kW wind turbine on your farm. The rate structures are such that the utility will pay you a much better price for your excess generation if you can guarantee to supply them 10 kW during a 4 hour peak each day. You allow for two calm days in a row and decide on a 80-kWh battery bank with inverter. The 6-V lead-acid batteries have a base that is 0.18 m by 0.26 m. A total of 80 batteries are required, in two banks of 40 batteries each to get the necessary 240 V required by the inverter.
- (a) How big an area is required to store the batteries if they are to be in a single layer? Include space for access to the batteries and space between batteries for cooling. Justify your assumptions.
- (b) Battery efficiency is 0.85 during both charge and discharge. What is the rated current of each 6 V battery during discharge?
- (c) Is battery cooling a problem? Discuss.
10. You are designing a cogeneration power plant for an apartment building. Available fuels include No. 1 diesel at \$1.70 per gallon, ethyl alcohol at \$1.40 per gallon, and methyl alcohol at \$1.30 per gallon. Each fuel is used at the same overall efficiency. Which fuel is the most economical choice, if efficiencies and capital costs are the same in all cases?

11. A large utility is paying \$25/ton (2000 pounds) of coal with a heating value of 11,600 Btu/lb. The coal plant heat rate is 10,200 Btu/kWh. What is the fuel cost per kWh?
12. A municipal utility buys No. 2 diesel oil at \$1.75/gal. The heat rate is 11,300 Btu/kWh. What is the fuel cost per kWh?

References

- [1] Bamberger, C. E. and J. Braunstein: "Hydrogen: A Versatile Element," *American Scientist*, Vol. 63, No. 4, July-August, 1975.
- [2] Birk, J. R., K. Klunder, and J. Charles Smith: "Superbatteries: A Progress Report," *IEEE Spectrum*, March, 1979.
- [3] Gregory, D. P.: "The Hydrogen Economy," *Scientific American*, Vol. 228, No. 1, January, 1973.
- [4] Gross, Sidney: "Review of Candidate Batteries for Electric Vehicles," *Energy Conversion*, Vol. 15, pp 95-112, Pergamon Press, 1976.
- [5] Gunkel, W. W., R. B. Furry, D. R. Lacey, S. Neyeloff, and T. G. Porter: *Development of a Wind-Powered Water Heating System for Dairy Application*, Wind Energy Applications in Agriculture, May 15-17, 1979, NTI-Conf-7905/109.
- [6] Hagan, L. J. and M. Sharif: *Darrieus Wind Turbine and Pump Performance for Low-Lift Irrigation Pumping*, Wind Erosion Laboratory, Kansas State University, Manhattan, Kansas, 1981.
- [7] Hammel, Ron: *Storage Characteristics*, Gates Application Note GAN-001, 1977.
- [8] Hopkinson, J.: "The New Batteries," *EPRI Journal*, October, 1981.
- [9] Hughes, W. L., H. J. Allison, and R. G. Ramakumar: *Development of an Electrical Generator and Electrolysis Cell for a Wind Energy Conversion System*, Report NSF/RANN/SE/GI- 39457/PR/74/1, April 18, 1974.
- [10] Hunt, V. Daniel: *Windpower - A Handbook on Wind Energy Conversion Systems*, Van Nostrand Reinhold, New York, 1981.
- [11] *Hydrogen Tomorrow - Demands and Technology Requirements*, Jet Propulsion Laboratory, California Institute of Technology, Report JPL 5040-1, December, 1975.
- [12] Karassik, I. J., W. C. Krutzsch, W. H. Fraser, and J. P. Messina: *Pump Handbook*, McGraw-Hill, New York, 1976.

- [13] Neyeloff, S. and W. W. Gunkel: “Design of a Direct Wind Energy Converter to Heat Water by Agitation in a Closed Tank,” *Wind Technology Journal*, Vol. 2, Nos. 1,2, Spring and Summer, 1978.
- [14] Nuttall, L. J.: *Prospects for Electrolytic Hydrogen for Chemical/Industrial Plants*, Frontiers of Power Technology Conference, Oklahoma State University, Stillwater, Oklahoma, October 9-10, 1974.
- [15] Russell, J. H.: *The Development of Solid Polymer Electrolyte Water Electrolysis for Large-Scale Hydrogen Generator*, Paper A 79 468-0, IEEE Summer Power Meeting, Vancouver, British Columbia, Canada, July 15-20, 1979.
- [16] *Steam-Electric Plant Construction Cost and Annual Production Expenses 1977*, Report DOE/EIA-0033/3(77), December, 1978.
- [17] Stepanoff, A. J.: *Centrifugal and Axial Flow Pumps, Theory, Design, and Application*, John Wiley, New York, 1948.

ECONOMICS OF WIND SYSTEMS

If one of you is planning to build a tower, he sits down first and figures out what it will cost, to see if he has enough money to finish the job. Luke 14:28.

In earlier chapters we have determined the power and energy production from various types of wind turbines in various wind regimes. The economic goal of maximizing the energy output per dollar of investment has been mentioned several times. We now turn to the matter of determining the total capital investment and operating cost for wind electric generators, so that we can determine the unit cost of electricity. The fuel (wind) may be free, but the equipment necessary to use the fuel tends to be expensive, so economic studies are quite important.

The unit cost of electricity can be determined in a straightforward manner from a knowledge of capital investment and operating costs. The value of the electricity is somewhat more difficult to determine, but must be calculated before intelligent investment decisions can be made. The value must exceed the cost before the purchase of a wind machine can be justified. The ratio of value to cost must be as good as that for alternative sources of electricity before wind can be justified over these alternatives.

The value of wind generated electricity to an electric utility is determined by its fuel savings and by its capacity credit. When the wind is blowing, less oil and coal need to be burned, which represents a savings to the utility. Also, if the utility is able to delete or defer some new conventional generation as a result of adding wind machines, then this represents additional savings to the utility. The effective capacity of wind generators and the associated capacity credit was treated in some detail in Chapter 5.

The cost and value of wind generated electricity will be determined from standard economic models, assuming “business as usual.” This means that we assume ample supplies of natural gas, oil, coal, and nuclear fuel, ready credit to build new generating plants, and no significant political changes. Hidden costs such as air pollution and nuclear waste disposal are ignored, at least until the last part of the chapter. We then observe that many of the plausible changes in “business as usual” operation tend to favor wind generators over conventional generation. Some of these changes will be discussed, but historical methods of evaluating alternative energy sources in general, and wind generators in particular, will be presented first.

1 CAPITAL COSTS

A wind turbine used for electric production contains many components. At the top of the tower of a horizontal axis turbine are the rotor, gearbox, generator, bedplate, enclosure, and various sensors, controls, couplings, a brake, and lightning protection. At the foot of the tower

are the transformers, switchgear, protective relays, necessary instrumentation, and controls. A distribution line connects the wind turbine to the utility grid. Land, an access road, and construction are also required to have a working system. The *capital costs* of all these items must be carefully examined in any engineering study.

Some capital costs, such as distribution lines, land, and access road, can vary widely with the site. These costs would be minimized by placing the wind turbines along an existing road. This would be the normal practice in the Great Plains where there are no major variations in topography. In other parts of the United States and the world, wind turbines will be placed at the best wind site, which may be on top of a mountain several kilometers from roads and power lines. In such cases, these costs may be a substantial part of the total.

The cost per kW of maximum power output varies with the size of wind turbine. Costs of components per unit of size tends to decrease as size increases. For example, Fig. 1 shows the variation of cost of electrical generators with size. Similar curves will be valid for the transformers, distribution line, and other electrical equipment. In this figure, *dc* and *ac* refer to conventional dc and ac machines, both of which require a field current supplied from another source for operation. This increases the cost above that of the machine itself, and also contributes to the losses. The curve marked *PM ac* refers to an ac generator with its field supplied by permanent magnets. This is a simpler machine and potentially more efficient, which makes it desirable for smaller wind turbines. The dc machines cost about twice as much as the ac machines of equal rating, because of greater physical size and complexity. The dc machines tend to be less reliable because of the commutator, and the combination of poorer reliability and greater cost will probably restrict their use on wind turbines.

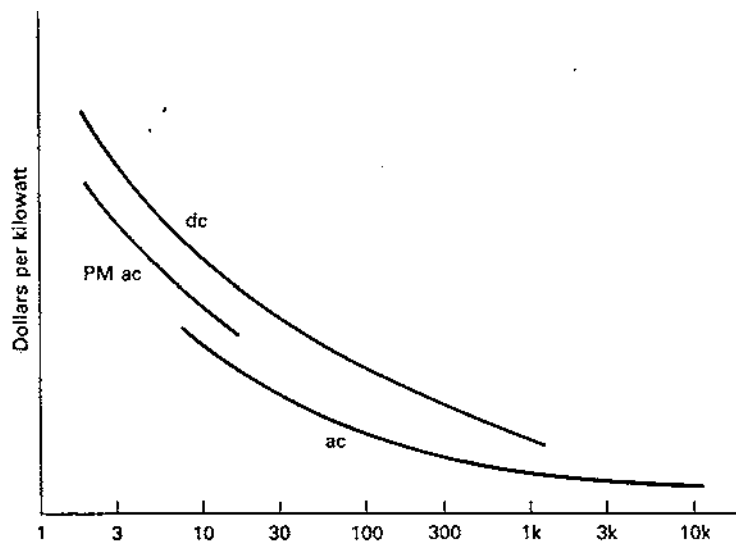

Figure 1: Relative costs of electrical machines.

Construction costs per unit of capacity also tend to go down as the capacity increases.

That is, a tower of double the rating does not usually require double the work to install, at least up to some critical size where locally available equipment and personnel are no longer adequate. On the other hand, the mass of material used increases as the cube of the rotor diameter while the rating only increases with the square of the diameter. Mass is proportional to volume while rating is only proportional to area. Since cost is related to mass, there will be a point where economics of scale are overcome by this basic law, and a turbine larger than some critical size will cost more per kW of maximum power than a turbine nearer this critical size. The critical size will vary with the assumptions made about cost variations, but several detailed studies have indicated that 1500 to 2500 kW may be close to the critical size[11, 13, 8]. Of course, the MOD-5A and MOD-5B are rated at more than 6000 kW, indicating a rather broad range of possible critical sizes.

Once a size has been selected, even more detailed cost studies can be made. The results of independent studies can vary widely, so caution needs to be used[9]. Golding[7] reports the results of three studies performed shortly after World War II which are reproduced in the first three columns of Table 8.1. These studies were all for conventional horizontal axis propeller turbines and were made by people experienced in the construction and operation of large wind machines. The differences between studies are substantial, perhaps illustrating the difficulty of the process.

The fourth column in Table 8.1 is the result of a study on a conceptual 200-kW horizontal axis wind turbine, called the MOD-X in that study[4]. The study was made by the Lewis Research Center after their experiences with the MOD-0 and MOD-0A. The conceptual design for the MOD-X included two pitchable rotor blades mounted on the low speed shaft of a three stage, parallel shaft gearbox. They chose a synchronous generator rated at 200 kW and 1800 r/min. The tower was to be a cantilevered rotating cylinder mounted on a dirt filled factory precast concrete vault foundation. The turbine was to have a teetered hub and a passive yaw drive system. Rated wind speed was 9.4 m/s (21 mi/h) at the hub height of 30 m.

This design resulted in significant cost reductions for foundation, yaw control, and installation, which makes the blades, tower, and gearbox appear relatively expensive as compared with the earlier designs. The predicted cost for the 100th production unit was \$153,360 in 1978 dollars not including administrative and engineering costs and overhead, and \$202,810 including all costs. This resulted in a cost of electricity of 4.34 cents per kWh at a site with an average windspeed of 6.3 m/s at 10 m height for their assumed economic conditions. We shall see later in the chapter how one determines such a figure for cost per kWh.

Table 8.1 Analysis of Construction Costs for Large Wind Turbines

	British Design	Smith- Putnam	P.T. Thomas	MOD-X (200 kW)
Blades(%)	7.4	11.2	3.9	19.6
Hub, blade supports, blade shanks, bearings, main shaft, nacelle(%)	19.5	41.5	5.9	15.2
Tower(%)	8.1	7.7	11.2	20.6
Gearbox(%)	16.7	9.5	2.3	16.5
Electric generator and installation(%)	12.5	3.4	33.6	7.6
Control equipment for speed, yaw, and load(%)	4.4	6.5	8.3	4.4
Foundations and site work(%)	31.4	16.6	20.3	16.1
Engineering(%)	-	3.6	14.5	-
	100.0	100.0	100.0	100.0
Rotor diameter(m)	68.6	53.3	61.0	38.1
Rated power(kW)	3670	1500	7500	200
Rated wind speed(m/s)	15.6	13.4	15.2	9.4
Production quantity	40	20	10	100

Another difference between the three earlier studies and the 1979 study is the improved technology. There have been improvements in the technology of each of the turbine components since 1950, and breakthroughs in at least two areas. These areas are the microcomputer control and the large computer analysis of the turbines. The Smith-Putnam machine required an operator to be present 24 hours per day to check meters, take the machine off the utility grid when the wind speed got too low, and resynchronize the generator with the grid when the wind speed increased. All these functions are now handled automatically by microcomputers. This reduces the operating costs substantially, improves the machine's performance, and reduces the possibility of the machine being damaged by operator error.

Also, the design of the Smith-Putnam machine was accomplished by the use of slide rules and mathematical tables. The design went through about six iterations but really needed several more which could not be allowed because of time constraints. Towers and blades are now designed with large computers, which have the potential of designing adequate structures which are not excessively heavy or expensive. Cost is always related to the mass of materials used, so lighter designs will improve the economic feasibility of wind turbines. The Boeing MOD-2, for example, was designed with a soft tower, which has 27 percent less mass per kW of rating than the stiff MOD-1 tower. This helped the MOD-2 to be more economically competitive than the MOD-1.

The above results have all been for large wind turbines. It is interesting to compare these

results with similar results for small machines, to see if there are any effects of size. Results of a study on small machines[6, 2] are given in Table 8.2. Column one gives the cost percentages for machines currently available in 1980 and column two gives the cost percentages predicted for second and third generation machines in 1990.

TABLE 8.2 Construction Costs for Small Wind Turbines(%)

	1980	1990
Rotor and hub	12.0	20.5
Controls	6.0	6.6
Transmission	11.0	14.5
Generator/power conversion	7.0	11.6
Frame	8.0	2.4
Tower	18.0	7.5
Installation	20.0	25.6
Distribution	16.0	9.5
Shipping	2.0	1.8
	100.0	100.0

We see in this table that the frame and tower are two components which have a good potential for cost reduction, from 26 percent to 10 percent of total cost. The cost of distribution (dealerships, service groups, etc.) would appear to have some potential for cost reduction. As the percentage of these cost components is reduced, then other components become relatively more expensive. We see installation increasing from 20 to 25 percent of the total cost, indicating a need for considerable innovation in this area.

There are no major differences between projected percentage costs for the large and small turbines. Major cost components are blades, transmission, tower, and installation for all turbines, indicating that these components need to be carefully studied for possible cost reductions.

One of the challenges of economic studies is to estimate the cost of the installed wind turbine when it is being produced in large quantities. The cost of the initial few machines is quite high because of many specially made parts and substantial amounts of hand labor while later machines are able to take advantage of higher volume production. A decrease in cost per unit of product with increase in volume has been found to occur in a wide variety of areas, including Model-T Fords, aircraft, steel production, petroleum refining, and electric power generation. The classic example in recent times has been the hand-held calculator, along with other integrated circuit components.

This decrease in cost has been formalized by *learning curves*. These are widely used in many different industries. They are developed from the following mathematical model. If y represents the cost of an object while x represents the cumulative volume, then the *normalized incremental cost* dy/y is assumed to be related to the *normalized incremental volume* dx/x

by the differential equation

$$\frac{dy}{y} = -m \frac{dx}{x} \quad (1)$$

The parameter m is a constant of proportionality and the sign is negative because the cost decreases while the volume increases. We integrate this equation from the cumulative volume x to the volume $x(2^n)$. The cost is decreasing from y_1 to y_2 while the cumulative volume is doubling n times. The result is

$$\ln \frac{y_2}{y_1} = -(mn) \ln 2 \quad (2)$$

Solving for y_2 yields

$$y_2 = y_1 e^{-(mn) \ln 2} \quad (3)$$

The slope s of the cost curve is defined as

$$s = e^{-m \ln 2} \quad (4)$$

The cost y_2 after n doublings of volume is then

$$y_2 = y_1 s^n \quad (5)$$

The plot of y_2 versus n is a straight line on log-log paper. Figure 2 shows plots of normalized y_2 (for $y_1 = 1$) for slopes of 0.95, 0.9, 0.85, and 0.8. Given the cost of the first unit and the slope of the learning curve, one can estimate the cost of the tenth or hundredth unit of production, as well as all intermediate values.

We normally think in terms of the cumulative production volume x rather than the number of volume doublings n , so we need a relationship between n and x . It can be shown that the value of n for an increase in volume from x_1 to x_2 is

$$n = \frac{\ln(x_2/x_1)}{\ln 2} \quad (6)$$

The choice of slope s is critical to economic studies. This requires information about other learning curves from the past as well as careful estimates about how manufacturing costs should go in the future. Historical research has shown[5] slopes of 0.86 for Model-T Fords, 0.8 for aircraft assembly, 0.95 for electric power generation, 0.79 for steel production, and 0.74 for hand-held calculators. Various parts of the wind turbine would be expected to show different learning curves. Components such as blades, hubs, and gearboxes that are essentially unique to wind turbines would have smaller values of s . Electrical generators, on the other

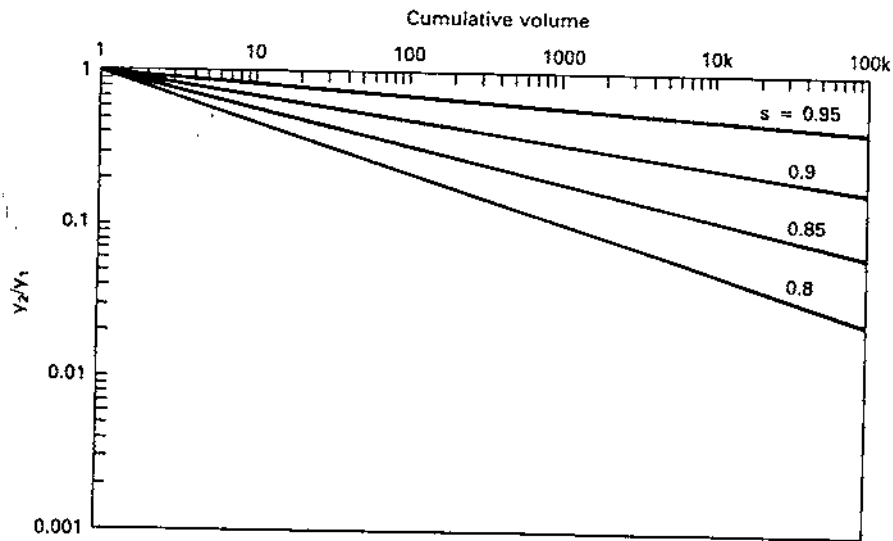

Figure 2: Normalized cost y_2/y_1 versus cumulative volume for several learning curves.

hand, represent a very mature technology with a large cumulative volume so very little cost reduction would be expected for this component. Other components would have intermediate values of s .

Example

The first unit of a new device costs \$1000.00. The device is estimated to follow a $s = 0.83$ learning curve. What is the cost of the hundredth unit?

The value of n would be

$$n = \frac{\ln(100/1)}{\ln 2} = 6.64$$

The cost y_2 is then

$$y_2 = 1000(0.83)^{6.64} = \$290$$

We see that the learning curve is a useful technique in predicting costs in a mass production situation. A manufacturer considering new production equipment will certainly want to use the learning curve in reducing costs so that volume can be increased, which in turn will tend to reduce costs even more. Costs will not decrease as uniformly as Fig. 2 would suggest, but in small steps as new manufacturing equipment is brought into service, with the overall effect approximating a straight line.

Once the costs of a given machine are determined, they must be described to others in

understandable terms. The cost of a wind machine can be described in at least four ways: by *total cost*, *cost per unit area*, *cost per kW of rating*, and the *unit cost of electricity*.

The *total cost* will be given by C_t . C_t for small machines may just refer to hardware shipped from the factory, but C_t for the large machines will almost always include land, access roads, distribution lines, and construction. The latter should be included whenever possible to give a more accurate economic picture. C_t does not include operating or maintenance costs, which are treated separately.

The cost per unit area would be

$$C_a = \frac{C_t}{A} \quad \$/\text{m}^2 \quad (7)$$

where A is the projected area of the turbine in m^2 . C_a can be used to compare turbines of different types, different sizes, and different rated wind speeds. Plant factor or capacity factor as described in Chapter 4 would also need to be specified before any intelligent purchase decisions could be made.

A measure of cost which is widely used is the *cost per kW of rating*,

$$C_{\text{kW}} = \frac{C_t}{P_{eR}} \quad \$/\text{kW} \quad (8)$$

where P_{eR} is the maximum or rated electrical power output of the wind machine. This is the measure commonly used by the utility industry for other types of generation, hence fits naturally into the thinking of many people.

Unfortunately, the measure C_{kW} is not a particularly good measure of cost for wind machines. A machine rated at 100 kW in a 8 m/s wind speed could be rated at 200 kW in a 10 m/s wind speed by just doubling the rating of the generator and the electrical wiring. Electrical equipment is a small part of the total cost, so this change in rating may be accomplished for only a few percent change in C_t . If C_t is \$100,000 for the 100 kW machine and \$102,000 for the 200 kW machine, C_{kW} would drop from \$1000/kW to \$510/kW. But, as we saw in Chapter 4, the capacity factor will drop significantly in making this change, so the total yearly energy production may not increase much and may even decrease from this change in rating. Therefore, C_{kW} may be very misleading. It should be used with care, preferably only when capacity factor can also be specified.

Yet another measure of cost, which is really the most important one, is the *unit cost of electricity*,

$$C_u = \frac{A_n}{W} \quad \$/\text{kWh} \quad (9)$$

where A_n (not to be confused with area A) is the annual cost of W kilowatthours of electricity. W is the net electrical energy produced per year per kW of rating. C_u can represent either

busbar, wholesale, or retail costs. *Busbar* would be the cost at the generating plant, without including costs of transmission and distribution. *Wholesale* would be the price to another electric utility, including costs of transmission. *Retail* is the price to a given class of customer as determined by the regulatory agency, and which may not exactly reflect production costs. In this chapter C_u is normally assumed to be the busbar cost.

2 ECONOMIC CONCEPTS

In order to discuss the costs of wind generating plants and conventional generation further, we must develop some economic concepts. These concepts are developed in more detail in texts on engineering economics[12].

One very important concept is that of *present value* or *present worth*. The present value P_v of a *uniform series* of end of period payments A_n at *interest rate* i lasting for n periods is

$$P_v = A_n \frac{(1+i)^n - 1}{i(1+i)^n} \quad (10)$$

The present value P_v and the series of payments A_n are said to be equivalent in an economic sense. The money is equivalent whether being borrowed or loaned and whether payments are being made or collected. This process is illustrated in Fig. 3. The present value is the value at time 0 or *Year 0*, with equal payments being made at the end of each period. If the period is one year, then the first payment occurs at the end of Year 1, and similarly for the remainder of the n years.

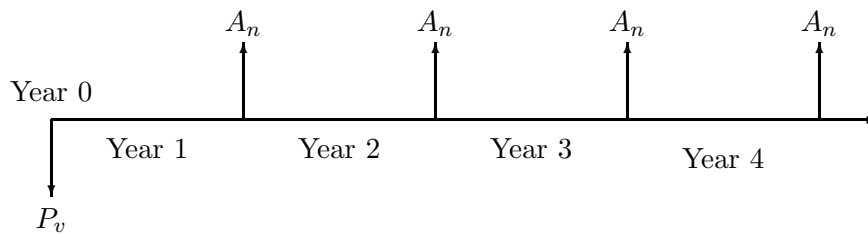

Figure 3: Present value of uniform series of end-of-period payments.

Example

What is the present value of a yearly payment of \$100 for 20 years if the interest rate is 12 percent?

$$P_v = 100 \left[\frac{(1 + 0.12)^{20} - 1}{0.12(1 + 0.12)^{20}} \right] = \$746.94$$

The total paid out is $\$100(20) = \2000 , but this is not the present value because we do not have to spend the entire sum now. We can think of the process as putting a smaller sum of money in the

bank at some interest rate, and then withdrawing part of the original sum plus interest to make the necessary payment. In fact, if \$746.94 is placed in the bank at 12 per cent interest compounded yearly, and \$100 is withdrawn at the end of each year, the account will just reach zero at the end of 20 years. The series of yearly payments of \$100 is considered equivalent to \$746.94 in hand now for economic analysis purposes.

Example

An Enertech 4000 reaches a maximum power of 4.2 kW in an 11-m/s wind speed. The propeller diameter is 6 m. The installed cost at your location is \$10,000 in 1981. You estimate the Weibull parameters at your site to be $c = 8$ m/s and $k = 2.2$. The interest rate is 0.11 and the period of the loan or the desired payback period is 15 years. Find C_a , C_{kW} , and C_u . Do not include factors such as tax credits, inflation, or operation and maintenance costs.

The area is

$$A = \frac{\pi d^2}{4} = \frac{\pi(6)^2}{4} = 28.27 \text{ m}^2$$

The cost per unit area is then

$$C_a = \frac{C_t}{A} = \frac{10,000}{28.27} = \$354/\text{m}^2$$

The cost per kW is

$$C_{kW} = \frac{10,000}{4.2} = \$2380/\text{kW}$$

We need the total yearly energy production W to find the unit cost of electricity. We go back to Chapter 4 and find the capacity factor $CF = 0.380$. The yearly energy production is then

$$W = P_{eR}(CF)(\text{hours/year}) = (4.2)(0.380)(8760) = 13,980 \text{ kWh}$$

The annual payment A_n is found from Eq. 10.

$$A_n = \frac{10,000}{\frac{(1.11)^{15} - 1}{0.11(1.11)^{15}}} = \$1390.65$$

The unit cost of electricity is then

$$C_u = \frac{A_n}{W} = \frac{\$1390.65}{13,980} = \$0.099/\text{kWh}$$

We shall see in later examples that this figure is somewhat higher than the unit cost of coal generated electricity from new coal plants. This means that the installed cost must be significantly reduced before wind machines of this size can displace conventional coal fired generation.

Example

You wish to buy a house and need to borrow \$50,000 to pay for it. The local Savings and Loan Company offers you the money at 15 percent interest per year to be paid back in equal monthly payments over a 20 year period. What is the monthly payment?

The number of periods is $n = (20)(12) = 240$. The yearly interest rate must be adjusted to this monthly period. The monthly interest rate will be $i = 15/12 = 1.25$ percent per month. Equation 10 can then be solved for A_n .

$$A_n = \frac{50,000}{\frac{(1.0125)^{240} - 1}{0.0125(1.0125)^{240}}} = \frac{50,000}{75.94} = \$658.39$$

The total amount that will be paid back to the Savings and Loan will be $(658.39)(240) = \$158,014.75$ so the total interest paid would be \$108,014.75 or a little more than twice the amount originally borrowed.

The preceding present worth analysis does not yield all the desired information during times of inflation. Our utility bills tend to go up each year even when our energy consumption does not go up. We are then faced with the desire to determine the present worth of a series of annual payments which increase each year. The yearly increase depends on both the general inflation being experienced in the nation and the change in cost of the particular item relative to the general inflation. Oil, for example, increased in price more rapidly than the rate of general inflation between 1973 and 1979. The annual rate of increase in a cost in terms of constant dollars is called the *real escalation rate* e_r . Real escalation results from resource depletion, increased demand with limited supply, etc.

When the real escalation is combined with the *general inflation rate* e_i , we get the *apparent escalation rate* e_a . The relationship among these quantities is

$$1 + e_a = (1 + e_r)(1 + e_i) \quad (11)$$

In some situations, such as some product being on the learning curve, or a part of a long term, fixed price contract, the real escalation may be negative. If the real escalation of hand-held calculators is -0.1 in a time when inflation is 0.14, the apparent escalation would be $(1 - 0.1)(1 + 0.14) - 1 = 0.026$. That is, with this negative real escalation, hand-held calculators would be increasing in price at 2.6 percent per year (apparent escalation) while prices of other products are increasing at an average rate of 14 percent per year.

Interest rates are also affected by inflation, tending to be somewhat above the general rate of inflation. Long term data in the power industry suggests that the interest rates have averaged about 4 percent above the inflation rate. For example, if the inflation rate is 6 percent, the interest rate averages about 10 percent. One can then define an *apparent interest rate* i_a as the following function of the actual interest i and the apparent escalation e_a .

$$i_a = \frac{1+i}{1+e_a} - 1 \quad (12)$$

A dollar placed in the bank at interest i will yield $1+i$ dollars a year later. However, these *Year 1* dollars are not worth as much as *Year 0* dollars because of inflation. The $1+i$ Year 1 dollars are actually worth $1+i_a$ Year 0 dollars. Year 0 dollars are sometimes called *constant dollars* while Year 1, Year 2, etc. dollars would be *current dollars*. All economic studies need to be expressed in constant dollars whenever possible so that economic decisions can be based on consistent data.

The *future value* F (in current or Year n dollars) of a present value P_v placed in a bank at interest i is

$$F = P_v(1+i)^n \quad (13)$$

The present worth of a single sum of money F to be paid at Year n with interest i is

$$P_v = \frac{F}{(1+i)^n} \quad (14)$$

Suppose now we want to determine the present worth of an uniform series of payments when the inflation rate is e_i and the real escalation is zero. When expressed in constant dollars, the annual payments look like those shown in Fig. 4. Using Eq. 14 and a summation, the present value of the series would be

$$\begin{aligned} P_v &= \sum_{j=1}^n \frac{A_n}{(1+e_a)^j(1+i)^j} \\ &= A_n \frac{(1+e_a)^n(1+i)^n - 1}{(e_a + i + e_a i)(1+e_a)^n(1+i)^n} \end{aligned} \quad (15)$$

Example:

What is the present value of a yearly payment of \$100 for 20 years if the interest rate is 12 percent and the apparent escalation rate is 9 percent?

$$P_v = 100 \left[\frac{(1+0.09)^{20}(1+0.12)^{20} - 1}{[0.09 + 0.12 + (0.09)(0.12)](1+0.09)^{20}(1+0.12)^{20}} \right] = \$444.52$$

This is a substantially lower value than obtained in the previous example where inflation was not considered. The person who borrows the present value of the previous example, \$746.94, and pays it

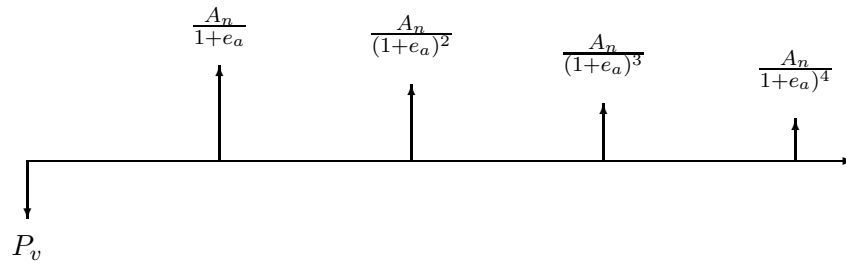

Figure 4: Present value of uniform series of payments when apparent escalation is equal to inflation rate.

back with one hundred deflating dollars each year for 20 years is actually gaining the difference of the present values. He borrows \$746.94 and pays back the equivalent of \$444.52, so he gains \$302.42.

Now we want to determine the present value of an *uniformly escalating* series of payments. These might be for a fixed amount of fuel or energy each year, with the cost increasing at the apparent escalation rate e_a . Each year's payment is higher than the previous year's payment by the factor $1 + e_a$. The series is shown in Fig. 5. The present value of this series is given by:

$$P_v = \sum_{j=1}^n \frac{A_n(1 + e_a)^j}{(1 + i)^j} = A_n(1 + e_a) \frac{\left(\frac{1 + e_a}{1 + i}\right)^n - 1}{e_a - i} \quad (16)$$

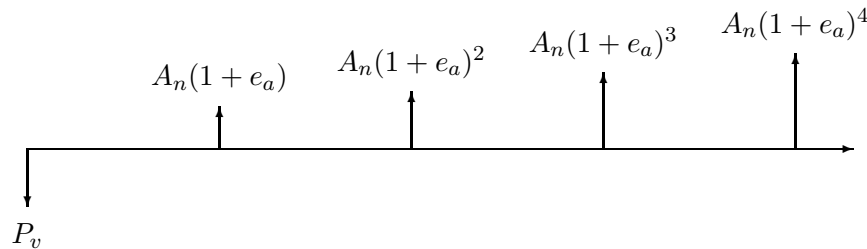

Figure 5: Present value of a series of annual payments increasing at the apparent escalation rate e_a .

Example

You are considering adding some insulation in your home which should save you 1200 kWh of electricity per year. If electricity costs \$0.05 per kWh with an apparent escalation rate of 8 percent, what is the present value of 20 years of payments for this electricity? Assume interest rates are 12 percent.

The Year 0 cost, A_n , of 1200 kWh is $1200(0.05) = \$60$. When we substitute this in Eq. 16 we get:

$$P_v = 60(1 + 0.08) \frac{\left(\frac{1.08}{1.12}\right)^{20} - 1}{0.08 - 0.12} = \$837.24$$

If the insulation costs less than \$837.24 it would be economically acceptable to buy the insulation. If it costs more, then other conservation schemes need to be examined. Of course, uncertainties about escalation and interest rates will cause many small investors to buy the insulation even when the present economic conditions make the purchase economically marginal.

Equations 15 and 16 are easily confused because they contain the same parameters. The difference is that Eq. 15 applies to an *uniform* series and Eq. 16 to an *uniformly escalating* series. In one case the number of current dollars is fixed, while in the other case, the number of current dollars increases each year.

We can always compare economic alternatives by examining the present value of each alternative. However, it is also desirable to compare alternatives by comparing annual costs. We like to know what our monthly or yearly payment will be. The variable annual costs due to escalation makes this comparison difficult, if starting dates and expected plant lifetimes are different. This difficulty is overcome by defining an *equivalent levelized end-of-year cost L* as[11]

$$L = P_v \left[\frac{i(1+i)^n}{(1+i)^n - 1} \right] \quad (17)$$

The expression in the brackets is called the *capital recovery factor*. The levelized cost is determined by first finding the present value P_v for the actual escalating series of payments, such as Eq. 16. Then Eq. 10, which applies to an uniform series of payments, is solved for the annual payment A_n . This annual payment is renamed L to indicate its levelized nature.

Another term which is often used in such economic studies is the *levelizing factor*[3] LF where:

$$\text{LF} = \frac{L}{A_n} = (1 + e_a) \frac{\left(\frac{1+e_a}{1+i}\right)^n - 1}{e_a - i} \frac{i(1+i)^n}{(1+i)^n - 1} \quad (18)$$

A_n is the actual Year 0 annual cost. The levelizing factor will remain constant for a given set of economic assumptions, and therefore provides a convenient means of determining the levelized costs when the first year costs are known.

Example:

Determine the levelized cost and the levelizing factor for the electricity costs of the previous example.

Substituting the present value of \$837.24 into Eq. 17 yields

$$L = (837.24) \frac{0.12(1.12)^{20}}{(1.12)^{20} - 1} = \$112.09$$

$$LF = \frac{112.09}{60} = 1.868$$

The yearly electricity bill after 20 years is $60(1.08)^{20} = \$279.66$. The levelized annual cost of \$112.09 is equivalent to the series of actual annual costs which increase from \$60 to \$279.66. The levelized cost of electricity over this period would be just the levelizing factor times the current cost, or $(0.05)(1.868) = \$0.0934/\text{kWh}$.

3 REVENUE REQUIREMENTS

Wind generators connected to the utility grid may not be owned by the utility but can still be treated by basically the same economic analysis. Different ownership may change the interest rates or the tax status, but the same analysis procedure still applies. We shall, therefore, examine the revenue requirements of the electric utility industry in general, and then specialize our results to wind generators.

The electric utility industry has five unique characteristics that set it apart from other industries[3]:

1. The industry is capital intensive. For a given utility, over half of the revenue from the sale of electricity may be allocated to sustain the capital investment. An even greater fraction is required for generation without fuel costs, such as wind.
2. The industry's investment items generally are long-lived, often in the range 30 to 40 years.
3. The industry has a relatively constant flow of revenue dollars on an annual basis compared to other industries.
4. The industry's product demand and usage is determined by the customer.
5. The industry is mandated to provide reliable, low-cost, environmentally acceptable electricity and for the most part is regulated by government agencies.

These characteristics make the revenue requirement approach to economic studies the most logical of the possible techniques. In this approach, the revenue that would be required to sustain a given alternative is determined and compared to a similarly derived revenue of every other alternative. This method determines the revenue required from the utility customers

and the *rates* for electricity they must pay, and therefore helps the regulators in their role of insuring an adequate electricity supply at the lowest possible cost.

Revenue requirements consist of two components, *fixed costs* and *variable costs*, as illustrated in Fig. 6. Fixed costs include debt repayment, depreciation, income taxes, property taxes, and insurance. Variable costs include fuel, operating, and maintenance costs. Utilities do not usually pay for generating plants from current revenue because it would require present customers to pay for items which would benefit other customers as much as 40 years into the future and because the relatively constant revenue dollars would not normally be adequate to pay for a construction program that may vary widely through time.

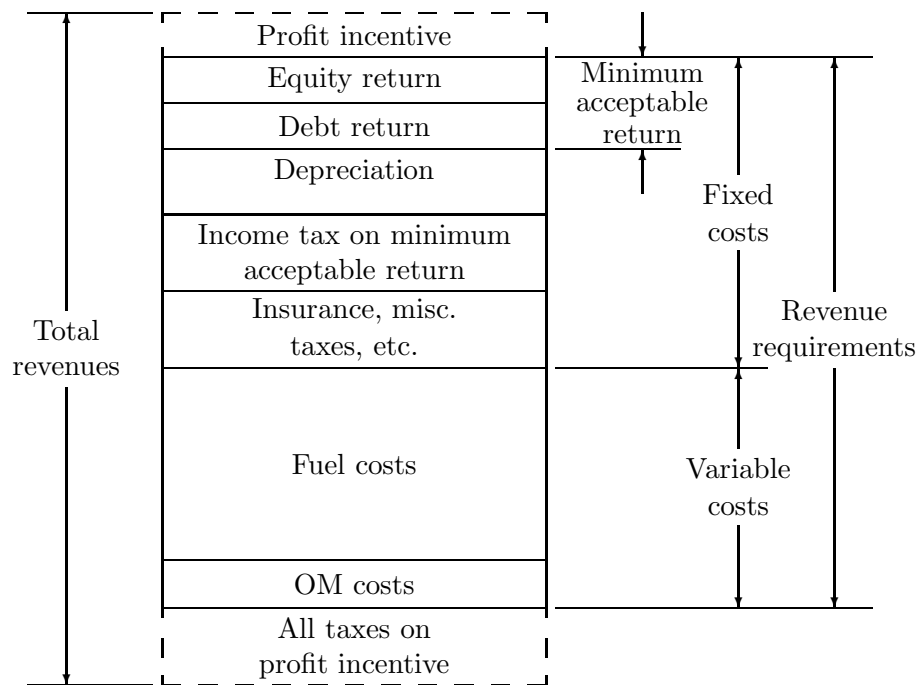

Figure 6: Revenue requirements on investment.

The cost of a new generating plant, therefore, comes from new financing through the sale of bonds and debentures referred to as *debt financing* and from the sale of common and preferred stock, referred to as *equity financing*. The return (the money that the utility must pay for the use of both debt and equity money) is allowed as a revenue requirement for rate-making purposes and is a part of the fixed cost associated with an investment. The other components of the fixed costs include *book depreciation* (an annual charge to repay the original amount obtained from investors), Federal and local income taxes, property taxes, and insurance.

Figure 6 also shows a segment entitled *Minimum Acceptable Return* that is equal to debt and equity return. This is the lowest amount that investors will accept to provide the funds needed by the utility to make the investment. It should also be noted that total revenues must be greater than revenue requirements. The difference is an additional profit incentive.

It and associated taxes are needed to attract investors.

Revenue requirements tend to increase with time because of inflation, but are irregular because of variations in such items as maintenance. These are normally levelized to make the task of comparing alternatives easier. The levelized annual revenue requirements consist of the levelized annual fixed costs and the levelized annual variable costs. In equation form,

$$L = L_f + L_v \quad \$/\text{kW}/\text{year} \quad (19)$$

The levelized annual fixed costs can all be expressed as percentages of the initial capital investment. Typical percentages for a coal generating plant with a 30 year expected life, 6 percent inflation, and 10 percent weighted cost of capital (average interest) are: 10 percent for interest, 1.17 percent for depreciation and retirement dispersion, 4.7 percent for income taxes, and 2 percent for property taxes and insurance[3]. The total is 17.87 percent, which is then normally rounded to 18 percent for discussion purposes. Retirement dispersion is an economic allowance for the fact that actual power plant retirements do not coincide exactly with the initial assumed lifetime, but rather are dispersed around some average lifetime. This requires an adjustment to the depreciation allowance.

This percentage of initial capital investment is called the *levelized annual fixed charge rate*, r_f , or simply the *fixed charge rate*. Depreciation is a small fraction of the fixed charge rate for plants with long lives, so the same fixed charge rate is normally used for plants with expected lives of 25 years or more. The fixed charge rate would be greater for shorter lived plants, typically 23 percent for a 10 year life and 34 percent for a 5 year life[3]. Tax benefits such as the investment tax credit would lower the fixed charge rate.

Unless there is preferential tax treatment for wind generators, the fixed charge rate for utility owned wind turbines will have to be very close to the fixed charge rate for conventional generation. Even if wind machines are privately owned by other groups, the fixed charge rate would probably be quite similar to what it would be if the utilities owned the machines. Any group that owns substantial amounts of generation will be viewed as an utility by investors, and may even be regulated by the local regulatory agency. This allows us to estimate a fixed charge rate for wind machines and thereby quickly determine the fixed cost portion of the cost of electricity produced.

Example:

A wind turbine with a cost of \$800/kW and a capacity factor of 0.3 has a fixed charge rate r_f of 18 percent. What is the fixed charge portion of electric energy costs from this turbine?

The yearly energy produced per kW of rating is

$$W = 8760(0.3) = 2628 \text{ kWh}$$

The annual fixed charge is

$$L_f = 800(0.18) = \$144/\text{kW}$$

The unit cost of electricity due to this fixed charge rate is then

$$C_{uf} = \frac{L_f}{W} = \frac{144}{2628} = \$0.0548/\text{kWh}$$

Variable costs in Fig. 6 consist of *fuel costs* (if any) plus *operation and maintenance* (OM) costs. The OM costs consist of both a fixed and a variable portion. The fixed portion is defined as being invariable with energy generated, transferred, or used. The variable portion depends on the amount of generated power. This would include water, limestone, filter bags, and ash disposal costs for coal generators. Wind generators do not consume anything as they generate electricity, but some maintenance functions will depend on the number of hours of operation, so these functions would represent the variable portion. The variable costs are normally expressed in mills/kWh, where 1 mill = \$0.001 or one tenth of a cent. The fixed OM costs are expressed in dollars per year per kW of rating. The levelized annual variable costs would then be expressed as

$$L_v = L_{\text{fuel}} + L_{\text{fom}} + L_{\text{vom}} \quad \$/\text{kW}/\text{yr} \quad (20)$$

where L_{fuel} is the levelized annual fuel cost, L_{fom} is the fixed OM cost, and L_{vom} is the variable OM cost.

We see that the levelized annual fuel cost L_{fuel} is just the present cost of fuel to generate one kWh, C_{fuel} , times the number of kWh generated per year by each kW of capacity times the levelizing factor.

$$L_{\text{fuel}} = (C_{\text{fuel}})(W)(\text{LF}) \quad \$/\text{kW}/\text{yr} \quad (21)$$

We may also define the levelized annual revenue requirements in dollars per kWh L' rather than the dollars per year per kW of capacity L .

$$L' = \frac{L}{W} \quad (22)$$

Similar expressions hold for the individual components of L , L_f and L_v .

We now want to present a major example of all these computations for a large coal plant. These numbers were developed for the Electric Power Research Institute[3] and thus represent typical utility values for end-of-year 1978.

Example

A large coal plant has the following data assumptions:

Plant cost, C_{kW}	\$900/kW
Levelized fixed charge rate, r_f	0.18
Levelized capacity factor	0.68
Fuel cost	\$0.95/10 ⁶ Btu
Heat rate	10,000 Btu/kWh
Fixed OM costs (year 0)	\$3.00/kW/year
Variable OM costs (year 0)	1.10 mills/kWh
Inflation	0.06/year
Cost of capital	0.10
Startup date	End-of-year 1978
Plant Life	30 years

1. Find the levelized annual fixed costs per kWh.
2. Find the levelized annual variable costs per kWh.
3. Find the present worth of the fuel per kW of plant rating.
4. Find the levelized annual busbar cost of electricity.

The fixed cost per kW of rating is just

$$L_f = C_{kW}r_f = 900(0.18) = \$162.00/\text{kW}$$

The energy produced per year per kW of rating is

$$W = (8760)(0.68) = 5957 \text{ kWh}$$

The levelized fixed cost per kWh is then

$$L'_f = \frac{L_f}{W} = \frac{162}{5957} = \$0.0272/\text{kWh} = 27.2 \text{ mills/kWh}$$

The fuel cost in Year 0 dollars is

$$C_{\text{fuel}} = (\$0.95/10^6 \text{ Btu})(0.01 \times 10^6 \text{ Btu/kWh}) = 9.5 \text{ mills/kWh}$$

The levelizing factor is, from Eq. 18,

$$\text{LF} = (1.06) \frac{\left(\frac{1.06}{1.10}\right)^{30} - 1}{0.06 - 0.1} \frac{0.1(1.1)^{30}}{(1.1)^{30} - 1} = 1.886$$

The levelized annual fuel cost is

$$L_{\text{fuel}} = (0.0095)(5957)(1.886) = \$106.73/\text{kW/yr}$$

Expressed in mills per kWh, this is

$$L'_{\text{fuel}} = (9.5)(1.886) = 17.92 \text{ mills/kWh}$$

The present value of the fuel consumed for each kW of rating is, from Eq. 17,

$$P_v = \frac{106.73}{\frac{0.1(1.1)^{30}}{(1.1)^{30} - 1}} = \$1006.13/\text{kW}$$

The OM costs are

$$L'_{\text{fom}} = \frac{\$3.00}{5957}(1.886) = 0.95 \text{ mill/kWh}$$

$$L'_{\text{vom}} = (1.10)(1.886) = 2.07 \text{ mills/kWh}$$

The total levelized cost per kWh is then

$$L' = 27.2 + 17.92 + 0.95 + 2.07 = 48.14 \text{ mills/kWh}$$

The present worth of the coal is actually greater than the present worth of the plant. However, the revenue requirements necessary for the coal are less than for the plant because expenses such as profit and taxes are not allocated to the fuel.

4 VALUE OF WIND GENERATED ELECTRICITY

We have shown that wind generated electricity has value both from capacity displacement of conventional generation and from saving fuel. A capacity credit can only be given if the construction of the wind turbine actually prevented some conventional generation from being built. The fuel savings mode can always be applied, even when conventional generation is not affected.

Utility companies are faced with many options when planning new generation. Two of the more common options would be to use wind generation to displace new coal generation or to save oil at existing oil fired units. New oil fired units are not being built because of fuel costs, so wind generation cannot displace these. If wind generation is displacing coal generation, then it cannot save oil at the same time. Both options need to be examined by the utility.

We shall now illustrate the use of the various economic tools which have been developed by two lengthy examples. We basically want to know if wind generation is economically competitive with either new coal construction or existing oil generation.

Example

Wind turbines are available to an utility at \$700/kW. The estimated capacity factor is 0.35 and the effective capacity is 0.4. The fixed charge rate is 18 percent, interest is 10 percent, and apparent escalation is 6 percent. Expected operating life time is 30 years. The wind turbines would be used to displace coal generation with the parameters detailed in the example at the end of Section 8.3. This coal generation is assumed to have an effective capacity of 0.76. The OM costs of the wind generators are arbitrarily assumed to be the same as those for coal.

What is the change in revenue requirements involved in replacing 100 MW of coal generation with wind generation?

From Eq. 66 in Chap. 5, the rated power of the wind generators would be

$$P_{eR} = \frac{D_c E_c}{E_w} = \frac{100,000(0.76)}{0.4} = 190,000 \text{ kW}$$

The energy produced by this much wind generation per year would be

$$W_w = (190,000)(0.35)(8760) = 582.5 \times 10^6 \text{ kWh}$$

The energy produced by the 100 MW of coal generation displaced would be

$$W_c = (100,000)(0.68)(8760) = 595.7 \times 10^6 \text{ kWh}$$

The 190 MW of wind generators yield the same power system reliability as 100 MW of coal generation, but the energy production is not as much. We will assume that this energy deficit can be made up by operating other coal plants at a slightly higher plant factor. We will further assume that the appropriate cost per kWh is just the fuel and variable OM costs of the other coal plants since fixed costs have already been justified for these plants. Other assumptions may be better, depending on the particular situation of the utility, but this assumption should be adequate for this relatively small deficit.

The levelized fixed yearly cost for the wind generators is

$$L_f = 700(0.18) = \$126/\text{kW}$$

The energy production per kW of rating is

$$W = (8760)(0.35) = 3066 \text{ kWh}$$

The fixed cost per kWh is then

$$L'_f = \frac{126}{3066} = \$0.0411/\text{kWh} = 41.1 \text{ mills/kWh}$$

The OM costs are

$$L'_{\text{fom}} = \frac{\$3.00}{3066}(1.866) = 1.85 \text{ mills/kWh}$$

$$L'_{\text{vom}} = (1.10)(1.866) = 2.07 \text{ mills/kWh}$$

The extra cost of the energy deficit would be the sum of the fuel cost and variable OM cost of coal generation times the total energy.

$$C = (17.92 + 2.07 \text{ mills/kWh})(595.7 - 582.5) \times 10^6 \text{ kWh} = \$263,900$$

This cost is then spread over all the wind generated kWh to find the levelized cost per kWh.

$$L'_{\text{def}} = \frac{263,900}{582.5 \times 10^6} = 0.45 \text{ mill/kWh}$$

The total levelized busbar wind energy cost per kWh is then

$$L' = 41.1 + 1.85 + 2.07 + 0.45 = 45.47 \text{ mills/kWh}$$

The levelized energy cost of the wind machines is less than that of the equivalent coal generation by 2.67 mills/kWh, therefore the economic choice is wind machines, at least in this particular case.

Example

A municipal utility is entirely supplied by diesel generators. The heat content of the diesel fuel is 146,000 Btu/gallon and the heat rate is 11,500 Btu/kWh. Diesel fuel costs \$1.40/gallon and has an apparent escalation rate of 8 percent while the general inflation rate is 6 percent.

Should the municipal utility buy wind machines as fuel savers? Assume the same parameters as in the previous example.

The cost of the wind generated electricity would be the same as the previous example except for the small charge for extra coal. That is,

$$L' = 45.47 - 0.45 = 45.02 \text{ mills/kWh}$$

From Eq. 23 in Chap. 7, the present fuel cost per kWh is

$$C_{\text{fuel}} = \frac{\$1.40/\text{gal}}{146,000 \text{ Btu/gal}}(11,500\text{Btu/kWh}) = 110.3 \text{ mills/kWh}$$

From Eq. 18, with an apparent escalation of 8 percent and an interest rate of 10 percent, the leveling factor is

$$\text{LF} = (1.08) \frac{\left(\frac{1.08}{1.10}\right)^{30} - 1}{0.08 - 0.10} \frac{0.10(1.10)^{30}}{(1.10)^{30} - 1} = 2.425$$

The levelized cost of oil per kWh is then

$$L'_{\text{oil}} = 110.3(2.425) = 267.48 \text{ mills/kWh}$$

The levelized cost of oil is five times that of wind generated electricity for this set of numbers. This shows that fuel savings may be much better than capacity credit when the fuel being saved is oil and the capacity credit can only be applied to new coal construction. It also shows that oil fired generation should be used as sparingly as possible, ideally only in emergencies.

5 HIDDEN COSTS AND NONECONOMIC FACTORS IN INDUSTRIALIZED NATIONS

We have developed methodology to make simple economic evaluations of wind generators and conventional generation. More detailed models are used by utilities, but this methodology shows at least the main effects of initial investment, fuel costs, operation and maintenance costs, and inflation on both the cost and value of wind generated electricity. There are other factors besides the ones normally found in economic studies which will affect the deployment of wind turbines and it seems appropriate to mention some of these factors here.

It should be noted that wind generated electricity does not have hidden costs to society. Coal plants require the mining and transportation of large quantities of coal, with the problems of strip mine reclamation and polluted water supplies in the producing states. The burning of coal adds rather large quantities of carbon dioxide and sulfur dioxide to the atmosphere, with possible serious consequences to the earth's climate and food producing capability. Nuclear power has enjoyed the benefit of massive government sponsored research and development efforts, the costs of which are not reflected in the normal economic studies. The costs of nuclear waste disposal and cleanup costs of a nuclear accident have historically not been fully included in economic evaluations. These hidden costs are difficult, if not impossible, to quantify, but will surely play a role in the deployment of wind generators because they tend to favor wind generation in the political arena. When the normally assigned costs are about the same, the decision makers will probably decide for wind generation to minimize these hidden costs.

Political action can also affect the results of these economic studies. Artificially low interest rate, long term loans can make economically marginal wind generation economically superior at the stroke of a pen. This makes economic forecasting a hazardous business. For example, the little booklet *Electric Energy from Winds*, written in 1939 but not published until 1946, contains the following statement[10]: "There are many rural areas in our midwest where the farms are so far apart that it probably will never be economically justifiable to supply electric power from transmission lines."

The Rural Electrification Act of 1936 made it possible for almost every farm in the midwest to be tied to a transmission line by 1955. Political action rendered the prophecy incorrect even before it got into print.

Two other factors which affect the economics of wind power are the strong developmental efforts being made in energy storage and load management. Utilities are working to replace peaking oil fired generation with base loaded coal or nuclear generation. Energy storage, such as pumped hydroelectric, batteries, or even flywheels, would supply the peak loads and then be recharged during off peak times. Load management will shift loads, such as domestic hot water heaters, from peak times to non peak times. If storage and load management equipment expand to represent a substantial fraction of the total installed generation capacity, then oil fired peaking equipment would be used only for emergencies. Oil would be burned only when

conventional generation is on forced outage. In such a system, conventional generation will tend to supply the average load rather than the peak load. Peak loads are shifted to a later, non peak time by load management and are partly met by storage which is refilled during offpeak times.

Wind power would augment such a system very nicely. It would act as an energy supplier along with the conventional generation. If the wind did not blow during peak load times, more energy would be drawn from storage and more loads would be delayed to a later time. If conventional generation, storage, and load management were unable to meet the load, then some oil fired generation would be used.

One other factor needs to be mentioned. This is the possibility that fuel supplies for existing conventional generation may not be adequate to meet the demand. Some combination of oil imports being shut off, coal barges frozen in the Ohio River, coal miners on strike, and nuclear fuel unavailable would mean that not enough electricity could be produced to meet the demand, even though the generating plants are otherwise operational. Wind generators would be able to at least reduce the number and severity of the rotating blackouts. Schools and industry may be able to continue operation during the times when the wind is blowing and thus reduce the impact of such fuel shortfalls. The electricity produced during such periods would have substantially greater value to society than the electricity produced in a fuel saver mode. Wind generators may be considered as somewhat of an insurance policy against serious fuel supply problems.

These factors all tend to favor wind generation over conventional generation. If wind systems are about equal to conventional generation on a purely economic basis, then it would seem that the noneconomic factors would tip the scales in favor of wind generation.

6 ECONOMIC AND NONECONOMIC FACTORS IN DEVELOPING COUNTRIES

There are nearly one billion people living in scattered rural areas of developing countries in the continents of Asia, Africa, and South America who have very poor living conditions. These conditions are encouraging a massive exodus to the urban slums, which makes the overall situation even worse in many cases. Most of the developing countries are poor in conventional fossil fuel resources and have to import them with their meager foreign exchange reserves. There appear to be only two technically feasible solutions to their energy problems. One is a commitment to large central nuclear power plants and a power transmission and distribution network. The other is a decentralized system of solar and wind equipment installed at the village level. There are many people[14] who believe that the latter solution is the best and may be the only solution that is politically feasible.

The energy needs of small rural communities fall into three categories: energy to improve living conditions, energy to improve agricultural productivity, and energy for small-scale in-

dustries. It is difficult to set priorities among these needs, but living conditions certainly have to be improved if the people are to have any hope in the future. Comparatively small amounts of energy could meet the basic needs for cooking of food, pumping and purifying drinking water, and lighting of dwellings. Once these needs are met, work can begin on increasing agricultural and industrial productivity.

A rough estimate of the energy needs of a typical village of 200 families is as follows[1]: 88,000 kWh per year for cooking food, 1,000 kWh per year for pumping water, and 26,000 kWh per year for lighting. This averages 315 kWh per day, most of which must be supplied during a three hour period in the evening. The energy required for cooking food is about three-fourths of the total, and any workable system must be able to satisfy the load even if all the villagers choose to cook at the same time. The most obvious solution is a diesel engine and a 100-kW or 150-kW generator, but the cost of fuel makes this unacceptable. This energy use pattern also puts some difficult constraints on any solar or wind systems which might be used. The output of a solar collector will be near zero by the time of the peak load and the wind may be calm at that time also. Storage adequate to meet at last one days load is, therefore, essential. This storage would be in the form of storage batteries for wind and solar electric systems.

Another possibility for the energy system is biogas. Plant, animal, and human wastes can be used to produce methane, which can be stored and used directly for cooking. It is inefficient to use methane directly for lighting so the methane can be used in an internal combustion engine driving an electrical generator to provide electricity for lighting. This holds capital investment to a minimum but requires considerable labor to keep the biogas facility and the internal combustion engine operating.

Studies indicate[14, 1] that the cost of electricity in such remote locations is perhaps a factor of four times as much as the cost enjoyed by people in developed countries with large central coal and nuclear electric generating plants. Solar and wind systems are competitive with conventional systems, but all systems tend to be expensive. The actual amount of energy consumed per person is not large, so costs per kWh can be relatively high and still be acceptable. One problem is that people look at the costs of equipment, the lack of transportation, the lack of trained people, and the centuries-old traditions and customs and conclude that it is not economically feasible to supply electricity to these villages. The villages are left in poverty and hopelessness. City slums are perceived to be a better place to live, with massive migrations of people. The country becomes more unstable and ripe for revolution as this process continues. It can be argued¹³ that the real costs to a developing country and even to the world community of nations is greater if these basic energy needs are not met than if they are met. An improving standard of living in the rural areas would relieve a great deal of human misery and also improve the political stability of the world. As Dr. I.H. Usmani, Senior Energy Advisor, United Nations Environmental Programme, once said, “these villagers must have energy, not at a price, but at any price.”

7 PROBLEMS

1. The first unit of a new line of wind turbines costs \$1500 per kW. If the slope of the learning curve is $s = 0.92$, what is the estimated cost of the hundredth unit?
2. A small wind turbine manufacturer is able to sell unit number 100 for \$5000. If he is on a learning curve with $s = 0.88$, what will unit number 500 cost?
3. If the second wind turbine unit built of a given model costs \$1200/kW, how many units would have to be sold to get the price down to \$800/kW, if the slope of the learning curve is $s = 0.86$?
4. An insulating cover for your electric hot water heater costs \$30 and is claimed to save 120 kWh per year. If interest is at a 12 percent rate and the expected life of the cover is 10 years, what annual payment is equivalent to the present value of the cover? You may ignore inflation.
5. Assume for the situation in Problem 4 that electricity costs \$0.05/kWh at Year 0 and has an apparent escalation rate of 6 percent. What is the present value of 120 kWh/year of electricity used for 10 years? Should you buy the cover or continue to buy the electricity?
6. What is the levelized annual cost and the levelizing factor for the electricity of Problem 5?
7. You are trying to choose between two wind machines. Machine X costs \$10,000 (present value) and has estimated OM costs of \$200/year, increasing each year as the apparent escalation rate, while machine Y costs \$8000 with estimated OM costs of \$400/year. Your bank is willing to finance either machine for 15 years at 13 percent interest. You estimate that the apparent escalation of OM costs will be 9 percent over this period. Both machines produce the same amount of energy each year. Which machine should you buy (i.e. which machine has the lowest present value of capital plus OM costs?)
8. A company offers a line of wind electric generators as shown below. You live in a region where the average wind parameters are $c = 7.5$ and $k = 2.0$. You can borrow money for 15 years at 8 percent interest. You assume an average operating and maintenance cost of 3 percent per year of capital investment. You decide to ignore inflation. Prepare a table showing the cost per unit area C_a , the cost per kW rating C_{kW} , and the unit cost of energy production for each model. You may want to use the material on capacity factor from Chapter 4.

Model	Rated Output (W)	Rated Wind Speed (m/s)	Voltage	Propeller Diameter (m)	Cost
A	1200	10.3	dc	3.0	\$1695
B	1800	10.7	dc	3.5	\$1940
C	2500	11.2	dc	3.8	\$2380
D	4000	10.7	dc	4.4	\$2750
E	6000	13.4	dc	5.0	\$3275
F	1200	10.3	ac, single-phase	3.0	\$2045
G	2000	11.2	ac, single-phase	3.5	\$2475
H	3500	10.3	ac, three-phase	4.2	\$3450
I	5000	10.3	ac, three-phase	5.0	\$3840

9. You can buy a truck with a diesel engine for \$500 more than the identical truck with a gasoline engine. You estimate you will get 25 miles per gallon with the diesel engine and 20 miles per gallon with the gasoline engine. Both gasoline and No. 1 diesel oil sell for \$1.50 per gallon at the present time and you estimate a real escalation rate of 0.08 over the next several years. You hope to drive the truck 100,000 miles during the next seven years with no difference in maintenance costs between the cars. If inflation is 0.10 per year and interest is 0.14 per year, determine the present worth of the diesel oil and gasoline needed over the seven year period. Which truck is the economical choice?
10. A utility is considering installing a number of wind turbines with a total rating of 1000 MW in its service area. The assumed capacity factor is 0.32 and the effective capacity is 0.28. These will displace a coal fired turbine with effective capacity 0.8. The coal plant costs \$900/kW in Year 0 dollars and the price of coal is \$1.35/10⁶ Btu. Operation and maintenance costs of both the coal plant and the wind plant are \$3.00/kW/year fixed costs and 1.10 mills/kWh variable costs (at year 0). The heat rate is 10,000 Btu/kWh. The levelized capacity factor of the coal plant is 0.7. The levelized fixed charge rate is 0.19, inflation is 0.07, and cost of capital is 0.11.

The plant life of both the coal plant and the wind generator is 30 years. System reliability is to be maintained at the same level with either the wind or the coal generation. Any difference in energy production is to be obtained by burning more or less coal at other coal generating plants. How much can the utility afford to pay for the wind turbines?

References

- [1] H.J. Allison: *Final Feasibility Report - An Energy Center in Sri Lanka*, prepared for the Governing Council of the United Nations Environment Program by the Engineering Energy Laboratory, Oklahoma State University, Stillwater, Oklahoma, June 30, 1976.

- [2] Bollmeier, W.S., C.P. Butterfield, R.P. Cingo, D.M. Dodge, A.C. Hansen, D.C. Shephard, and J.L. Tangler: *Small Wind Systems Technology Assessment: State of the Art and Near Term Goals*, Rocky Flats/DOE Report RFP-3136/3533/80/18, February, 1980.
- [3] Colborn, H.W. and J.H. Cronin: *Technical Assessment Guide*, EPRI Special Report PS-1201-SR, July, 1979.
- [4] *200-kW Wind Turbine Generator Conceptual Design Study*, NASA Lewis Research Center Report DOE/NASA/1028-79/1, NASA TM- 79032, January, 1979.
- [5] Cunningham, J.A.: “Using the Learning Curve as a Management Tool,” *IEEE Spectrum*, June, 1980.
- [6] Evans, Michael and Jay Troyer: “Small-Scale Wind: The Promise and the Problem,” *Wind Power Digest*, Spring, 1981.
- [7] Golding, E.: *The Generation of Electricity by Wind Power*, Halsted Press, New York, 1976.
- [8] Jorgensen, G. E., M. Lotker, R. C. Meier, and D. Brierley: “Design, Economic and System Considerations of Large Wind-Driven Generators”, *IEEE Transactions on Power Apparatus and Systems*, Vol. PAS-95, No. 3, May/June 1976, pp. 870-878.
- [9] Kirschbaum, H.S., E.V. Somers, and V.T. Sulzberger: “Evaluation of Offshore Site for Wind Energy Generation,” Paper A 76 398-8 presented at the IEEE Power Engineering Society Summer Meeting, Portland, OR., July, 1976.
- [10] Kloeffler, R. G. and E. L. Sitz: *Electric Energy from Winds*, Kansas State College of Engineering Experiment Station Bulletin 52, Manhattan, Kans., September 1, 1946.
- [11] Marsh, W.D.: *Requirements Assessment of Wind Power Plants in Electric Utility Systems*, Vol. 2, EPRI Report ER-978, January, 1979.
- [12] Newnan, D.G.: *Engineering Economic Analysis*, Engineering Press, San Jose, CA., 1978.
- [13] Putnam, P.C.: *Power from the Wind*, Van Nostrand, New York, 1948.
- [14] Ramakumar, R. and W.L. Hughes: “Renewable Energy Sources and Rural Development in Developing Countries”, *IEEE Transactions on Education*, Vol. E-24, No. 3, August, 1981, pp. 242-251.

WIND POWER PLANTS

The production of large quantities of electricity will require the installation of many wind turbines. There are many economical benefits if these turbines are installed in the clusters that we call wind power plants or windfarms. That is, installation can proceed more efficiently than if the turbines are widely distributed. Operation and maintenance can be done with minimum personnel. Collection of the electricity generated can be accomplished efficiently. The larger amounts of concentrated power can be more easily transformed to higher voltages and distributed on the utility grid.

This chapter presents some of the features of clustering wind turbines. We will examine the placement of turbines in an array, the installation of the turbines, and the required electrical system. There will be some optimum design for which the energy output per dollar of investment is maximum. We shall see how to make such a design in this chapter.

1 TURBINE PLACEMENT

Turbines will typically be placed in rows perpendicular to the prevailing wind direction. Spacing within a row may be as little as two to four rotor diameters if the winds blow perpendicular to the row almost all the time. If the wind strikes a second turbine before the wind speed has been restored from striking an earlier turbine, the energy production from the second turbine will be decreased relative to the unshielded production. The amount of decrease is a function of the wind shear, the turbulence in the wind, the turbulence added by the turbines, and the terrain. This can easily be in the range of five to ten percent for downwind spacings of around ten rotor diameters. Spacing the turbines further apart will produce more power, but at the expense of more land, more roads, and more electrical wire.

We will define two turbine spacings, D_{cw} as the *crosswind* spacing within a row of turbines, and D_{dw} as the *downwind* spacing between rows of turbines. These are calculated as a constant times the number of rotor diameters D_r . The terms are shown in Fig. 1.

For the mid United States from Texas to North Dakota, it appears that a reasonable spacing is four rotor diameters between turbines in a row and ten rotor diameters between rows. The rows would be aligned across the prevailing wind direction, usually in a east-west direction in this part of the world where strong winds are usually from the north or south. We will consider that spacings less than $3D_r$ in a row or $8D_r$ between rows will need special justification.

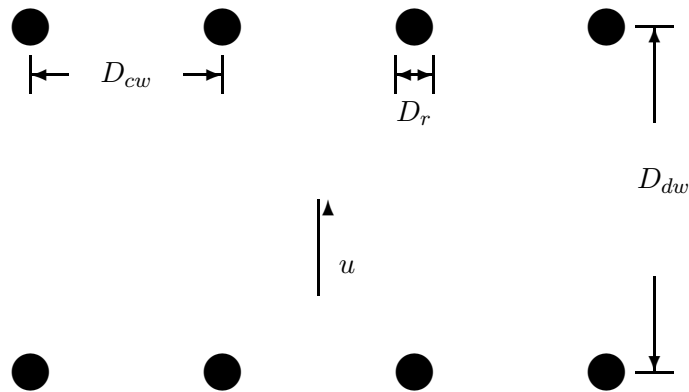

Figure 1: Dimensions of Turbines in a Windfarm

2 SITE PREPARATION

The first step in constructing a windfarm is to acquire the right to use the land. Land may be either purchased or leased, depending on the circumstances. Leasing land for energy production, such as oil or gas production, is common and well understood in this country. It holds the capital costs down to a minimum. It may be the only practical method of acquiring large tracts of ground from many owners if a large windfarm is planned. Depending on the type of turbine and the spacing, most of the land may still be usable for agricultural purposes. For example, a self supported multimegawatt turbine like the MOD-2 requires only a hectare or so (2-4 acres) around its base for maintenance. The probable density of this turbine would be perhaps 4 to 6 per square mile in the Great Plains, which would take less than 5 percent of the land out of production. Leasing should certainly be considered for such an installation.

On the other hand, multimegawatt turbines have not proven themselves cost effective, so windfarms are installed with smaller turbines, mostly in the 50 - 500 kW range. The smaller turbines will have a much greater density on the land and therefore interfere with farming operations to a greater extent. For example, the Carter 300, a guyed turbine rated at 300 kW, with a crosswind spacing of 4 diameters and a downwind spacing of 10 rotor diameters, would have 8 rows of 20 turbines each on a square mile of land. The access roads and guy wires would make it very difficult to grow row crops. It may be best to buy the land, plant it to grass to minimize erosion, and perhaps harvest the grass for cattle feed. The examples to be given later in the chapter will assume that the land is purchased.

In the Great Plains, land is typically sold by the square mile, called a section (640 acres), or by an integer fraction of a section. A half section contains 320 acres, a quarter section contains 160 acres, and so on. A quarter section can be split into two 80 acre tracts, with the dividing line either east-west or north-south. This places some constraints on the amount of land that must be purchased. If 80 acres is not enough, then the next allowable size is probably 160 acres. A half section would probably be the next step after a quarter section,

and should be oriented east-west rather than north-south in order to take advantage of the prevailing winds. Land should always be estimated in increments of 80 acres.

Access roads will be required to each turbine, both for construction and for later maintenance. There may be some sites which do not require access roads because of rocky or sandy soil conditions, but most sites will require graded roads with a crushed rock or gravel surface so work vehicles can reach a turbine site in any kind of weather. The minimum length of access roads would be the total length of all the turbine rows plus the distance across the windfarm perpendicular to the rows plus the distance from the nearest existing road to the windfarm. Some turbine types, such as the Carter 300, may require two access roads per row of turbines. One road would be for access to the base of the turbine and the other road would be to reach the guy point from which the turbine is lowered to the ground for maintenance.

While the length of access roads and the length of electrical wire required to interconnect the turbines is easy to calculate for a given site with a given turbine layout, detailed economic studies involving different windfarm sizes, perhaps with different turbines, are more easily performed with simple formulas which determine these lengths for given assumptions. We will therefore develop the notation which will allow such studies to be performed in an efficient fashion.

We define the power rating of an individual turbine as P_{tur} and the number of turbines in the windfarm as N_{tfarm} . The total power rating of the windfarm, P_{wf} , is then

$$P_{wf} = N_{tfarm}P_{tur} \quad (1)$$

Each row will have some length D_{row} as determined by land and electrical constraints. In the Great Plains, county and township roads usually have a distance between road centerlines of one mile (5280 ft) so a row length of 5000 ft would allow the end turbines to be 140 ft from the road. This would usually be the practical maximum row length in this part of the world. The tentative number of turbines in a row, N'_{trow} , for a tentative row spacing D'_{cw} , would be given by

$$N'_{trow} = \frac{D_{row}}{D'_{cw}} + 1 \quad (2)$$

This calculation should be treated as integer arithmetic. That is, a result of 9.62 would be interpreted as either 9 or 10 turbines per row. Other constraints may require either a smaller or larger value. If four turbines are to be operated from a single transformer, for example, then it may be economically desirable to have the number of turbines in a row be some multiple of four, say 8 or 12 for our tentative calculation of 9.62 turbines per row.

One design choice which must be made is whether to hold the turbine separation at exactly four rotor diameters, for example, and let the row length be less than the maximum possible value, or to fill all available space and let the turbine separation differ from exactly four rotor diameters. One generally wants to use all available land but there may be cases where a small

windfarm is to be installed on a large piece of ground that one would just use the nominal turbine spacing.

Once the actual number of turbines per row, N_{trow} , has been selected, along with the actual row length D_{row} , the actual turbine spacing in a row D_{cw} is given by

$$D_{cw} = \frac{D_{row}}{N_{trow} - 1} \quad (3)$$

The number of rows and the corresponding length of a column of wind turbines, D_{col} , will be determined in a similar fashion. The size of the piece of land and zoning requirements will determine the maximum column length. The maximum number of rows would be used to compute the total number of turbines in the windfarm and the total electrical power rating. There may be financial or technical limitations on the number of turbines or the total power, so fewer rows may be necessary. There may also be a requirement for an even or odd number of rows for economic efficiency of windfarm layout. A rectangular piece of ground would be expected to have the same number of turbines in each row although local terrain features may require some turbines to be omitted from the spot they would otherwise occupy. There may need to be some iteration between the calculation of the number of turbines per row and the number of rows.

Once the column length D_{col} and the number of rows N_{rows} has been selected, the actual down wind spacing D_{dw} can be calculated.

$$D_{dw} = \frac{D_{col}}{N_{rows} - 1} \quad (4)$$

The length of a rectangular fence around the perimeter of the wind farm would be

$$D_{fence} = 2(D_{row} + 2h_t + D_r) + 2(D_{col} + 2h_t + D_r) \quad (5)$$

where h_t is the hub height of a turbine and D_r is the rotor diameter. Increasing the fence length by the hub height plus half the rotor diameter on each side will allow each turbine to be laid down in any direction without the rotor striking the fence. If the turbines do not fill the entire purchased area, then the fence would be longer since it would normally be placed at the boundary. If a section of land was purchased, the length of fence would be approximately four miles.

3 ELECTRICAL NETWORK

We now turn our attention to the electrical network necessary to connect the wind turbines to the electric utility. Most wind turbines generate power at 480 V, three phase, a voltage too

low to transmit long distances. One or more transformers will therefore be required to step up the voltage to the proper level.

The installation must be safe for people to operate and maintain. The wind farm must not adversely affect the utility, and likewise the utility must not damage the wind turbines by normal switching operations. The National Electrical Code (NEC) addresses many situations and may be considered a minimum standard (rather than a design handbook). That is, one can always add more safety equipment beyond the basic requirements of the NEC. The utility will probably require several protective relays and other devices in addition to the NEC requirements to insure compatibility with their system. Utility requirements will probably be higher at first, while wind farms are new, with some relaxation probable with favorable experience.

Cost is also an important factor, so the temptation to add unnecessary safety equipment should be resisted. Safety equipment can fail like any other equipment, so a complex system will require more maintenance than a simple system. A complex system is more difficult for the technician to understand and trouble shoot, increasing the possibility of human error and injury accident. It is good to ask why each utility requirement is listed, to make sure that each item will indeed improve either operator safety or equipment reliability. The same attitude may even be appropriate regarding some of the NEC requirements. For example, if the NEC requires a cable to be buried 24 inches, this would be a consensus figure for acceptable safety for people digging in the earth without knowing the location of the cable. It can be argued that a depth of 5 feet would be safer by a slight margin, but more expensive by a large margin. It may be that in the controlled space of a wind farm that 18 inches or even 12 inches would have acceptable safety. If the wind farm was located in an area with thin soil over thick rock ledges, the difference in cable burial depths could have a substantial cost difference with no significant difference in safety. In such cases, a request to the zoning authorities for a *variance* (formal authorization to construct in a manner different from code specification) might be appropriate.

We will now proceed to discuss the design of a simple windfarm electrical system. An actual design will be somewhat more complex because of local utility requirements or characteristics of the particular wind turbine that is used. We will not discuss details of metering or protective relaying. These are discussed in other courses. The intent is to present an overview of electrical system design, but with enough detail that the general design philosophy can be understood, a rough estimate of costs can be obtained, and the right questions can be asked if one does a complete design.

A one line diagram of a possible electrical system is shown in Fig. 2. There are actually three lines where one is shown because of the three-phase nature of the power system, but one line is easier to draw. The wind turbine generators are shown as small circles. These would have an electrical power output of P_{tur} , probably in the 30-500 kW size range. In this size range, the most likely voltage is 480 V line to line. The MOD-2 class of turbine would use the next higher voltage level of 4160 V line to line. The most common generator type would be the induction generator, but the synchronous generator could also be used, especially in

the larger sizes where the field control equipment is not such a large fraction of cost.

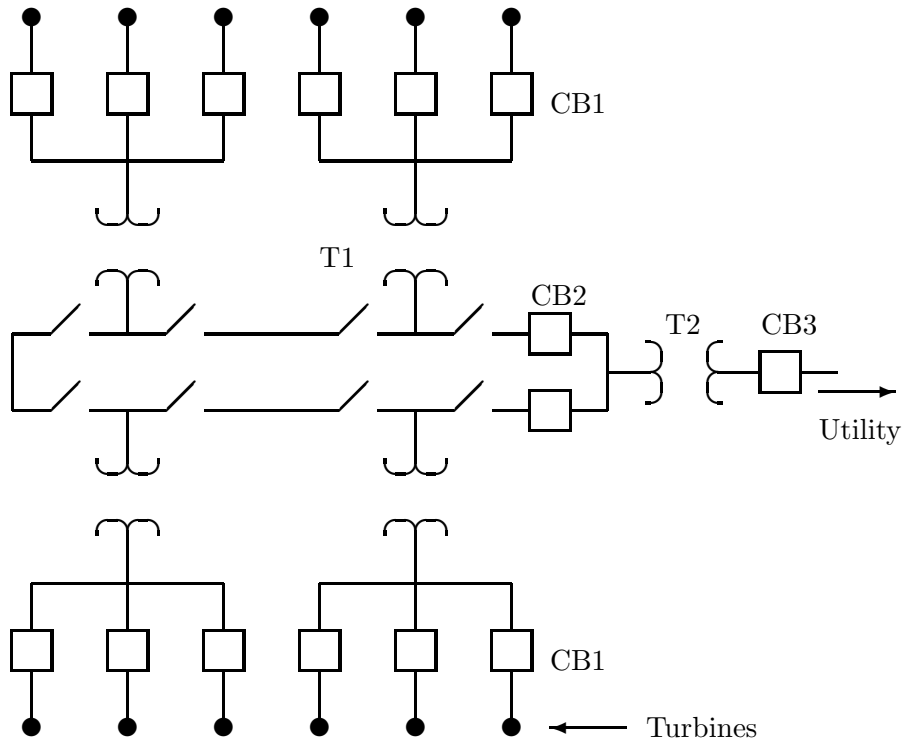

Figure 2: One Line Diagram of Windfarm Electrical Network

Buried conductors connect each generator to a low voltage circuit breaker, which is a part of what is called a unit substation. The circuit breaker must be electrically operated so the generator can be connected to the grid when the wind is adequate and disconnected automatically in low wind conditions. It might be an electromechanical device with a coil and movable contacts or it might be a solid state device with silicon controlled rectifiers doing the switching. The solid state circuit breaker may have greater reliability because of the large number of switching cycles which will be required. It could also be cheaper and easier to maintain.

Next to the bank of circuit breakers will be a stepup transformer to increase the voltage to an efficient level for transmission around the windfarm. The most common value for this will be the 12.47 kV level (line-to-line), with other possible values being 7.2 kV, 12.0 kV, 13.2 kV, and 13.8 kV. The high voltage side of the transformer contains two loadbreak switches for this loop feed circuit. A switch is different from a circuit breaker in that it cannot interrupt a fault current. It will be able to interrupt the rated current of the transformer, however. Both switches would be opened whenever it is necessary to work on the attached wind turbine, the circuit breaker, or the transformer. The advantage of the loop feed is that the remainder of the windfarm can be kept in operation while one unit substation is being repaired. It also

allows for isolation of any section of underground cable that has a fault in it.

The two ends of the loop are connected to circuit breakers labeled *CB2*. These are connected together on the low voltage side of another stepup transformer which increases the voltage from 12.47 kV to that voltage required for transmitting power to the utility. This may be 34.5, 69, 115, 169, 230, or 345 kV, depending on the utility and the existing transmission lines near the windfarm site. There will be another circuit breaker *CB3* on the high voltage side of this transformer, so the entire windfarm can be isolated from the utility if desired.

Figure 2 shows three turbines connected to each unit transformer. This number may be either smaller or larger depending on detailed economic studies. The transformers are a relatively expensive part of the distribution network and are proportionally less expensive in larger sizes, so it will probably be desirable to have T_1 be rated at perhaps 1000 kVA or even larger if available. This means that 20 to 30 turbines rated at 50 kVA could be connected to one transformer. The limitation to this would be the cost, losses, and voltage drops in very long sections of 480 V cable. A good windfarm design would include a check of at least two transformer sizes and the total cost of transformers plus underground cable for each size.

4 SELECTION OF SIZES, LOW VOLTAGE EQUIPMENT

Once the windfarm network is selected, sizes of transformers, circuit breakers, and conductors can be selected. These sizes will vary with the rating of the wind turbine and with the total number of turbines in the windfarm. Any rearrangement of the network of Fig. 2 will also cause sizes to be changed. The following discussion presents some of the key features of selecting component sizes, but should not be considered complete or adequate to actually prepare construction plans for a windfarm.

Circuit Breakers

The circuit breaker *CB1* of Fig. 2 might be designed and sold as a part of the wind turbine package, in which case it would not need to be considered here. Some manufacturers do not include it as a part of the turbine, so we will discuss it briefly. There are two separate functions required here. One is the interruption of high currents during a fault and the other is the more frequent connecting and disconnecting of the generator from the utility grid in daily operation. These functions are typically performed by two separate pieces of equipment, the first being called a circuit breaker, and the second being called a *contactor* or *starter*. They are normally mounted in a steel enclosure and sold as a package.

Table 9.1 shows some selected prices from a Westinghouse catalog for the Class A206 full voltage starter, sold as an enclosed combination with a circuit breaker. The prices are list for the year 1989. Actual costs may vary substantially from those listed, but the relative costs

should be valid.

Table 9.1. Price list for motor starters

NEMA Size	Rated Current	List Price
0	18	906
1	27	936
2	45	1326
3	90	1896
4	135	4314
5	270	9627
6	540	19659
7	810	26403
8	1215	38745
9	1800	51273

The left hand column shows the NEMA (National Electrical Manufacturers Association) size. The larger sizes indicate larger enclosures with greater rated currents, shown in the next column. Each NEMA size can be purchased for nominal motor voltages of 200, 230, 460, and 575 V. The corresponding nominal line voltages are 208, 240, 480, and 600 V. A windfarm in the United States would most likely use 480 V.

There are actually several different types of enclosures. For example, the general purpose enclosure would be used in indoor, dry locations. The watertight enclosure would be used in very wet locations, like a dairy barn where a high pressure hose may be used to clean equipment. The hazardous location starter would be used in grain elevators or refineries where dust or fumes could be a problem. The values given in this table are for a dust tight and rain proof enclosure which would be appropriate for a windfarm.

The turbine generator should have a rated operating current listed on its nameplate. If not, this can be computed from the maximum generator power and the voltage. For a voltage of 480 V and a power of P_{tur} , this is

$$I_{trat} = \frac{P_{tur}}{\sqrt{3}(480) \cos \theta} \quad (6)$$

If the power factor $\cos \theta$ is not specified, it can be assumed as being about 0.85 without serious error.

The circuit breaker $CB1$ would be located at the base of the turbine tower if supplied by the turbine manufacturer or at T_1 if supplied by the windfarm developer.

Wire Sizes

Once the circuit breaker is selected, we must choose underground conductors with adequate ampacity to go between the turbine and the transformer T_1 . *Ampacity* refers to the ability of a conductor to safely carry a given current. That is, the surrounding medium must be able to carry away the heat generated in the conductor without the conductor insulation getting too warm. The 1990 National Electrical Code (NEC) listed 27 different types of conductor insulation, ranging from an operating temperature of 60°C for types TW and UF to 250°C for types PFAH and TFE. Ampacity of a given size conductor increases with the temperature rating of the conductor insulation.

The ampacity also varies with the surrounding medium and its ability to conduct heat away. The ampacity of a conductor buried in wet soil (swamps, coastal regions) is about double the ampacity of the same size conductor buried in very dry soil. The pattern of load flow also makes a significant difference. Starting at ambient temperatures, it requires a day or two of full rated current flow to raise the conductor temperature to its final temperature. This time period is called the *thermal time constant*. Windfarms rarely operate at rated conditions for more than 24 hours continuously, so only extended periods of high winds would be expected to raise the temperature of windfarm wiring to the thermal limit of the insulation, if the conductors were designed for 100 percent load factor.

Given all these factors, it is very difficult to specify a fixed value of ampacity for a given conductor that will apply in every situation. The NEC recognizes this situation and allows engineers with the appropriate training in soils and heat transfer to choose wire sizes based on a detailed analysis for a given installation. Most students in this course do not have such a background, so we will use a NEC table (B-310-10 in the 1990 NEC) that has been prepared for average conditions. Selected values from this table are reproduced in Table 9.2. It applies to the case of three single insulated conductors rated at less than 2000 V which are direct buried in the earth. The ambient earth temperature is assumed to be 20°C , the load factor is assumed to be 100 percent, and the thermal resistance is assumed to be 90. This value of thermal resistance applies to perhaps 90 percent of the soils in the U.S.A. It varies from about 60 for damp soil (coastal areas, high water table) to about 120 for very dry soil.

This table shows ampacities for both copper and aluminum cables. Copper has a higher ampacity for a given wire size but aluminum cables of the same ampacity are perhaps 30 percent cheaper than copper cables. Aluminum cables require special attention at fittings because of the tendency of aluminum to cold flow under pressure. They also require special care because of oxidation problems. At the present time, copper is used for most indoor wiring, except perhaps for the very large sizes, and aluminum is used for most outdoor wiring, both overhead and underground.

Cables are sized according to AWG (American Wire Gauge) or kcmil (thousands of circular mils). A circular mil is a measure of area, like m^2 or acres. It is determined by squaring the diameter of a cylindrical conductor when expressed in thousandths of an inch. That is, a cylindrical conductor of diameter 0.5 inch (or 500 mils) would have an area of $(500)^2 =$

250,000 circular mils = 250 kcmil.

Table 9.2. Ampacities of three single insulated conductors, 600 V class.

AWG kcmil	COPPER		ALUMINUM	
	one circuit	two circuits	one circuit	two circuits
8	98	92	77	72
6	126	118	98	92
4	163	152	127	118
2	209	194	163	151
1	236	219	184	171
1/0	270	249	210	194
2/0	306	283	239	220
3/0	348	321	272	250
4/0	394	362	307	283
250	429	394	335	308
350	516	474	403	370
500	626	572	490	448
750	767	700	605	552
1000	887	808	706	642
1250	979	891	787	716
1500	1063	965	862	783
1750	1133	1027	930	843
2000	1195	1082	990	897

Older literature will show the units of thousands of circular mils as MCM rather than kcmil. The first "M" in MCM stands for the Roman unit of one thousand, and would be a translation of the Greek *kilo* for the same quantity. Changing the name of the unit from MCM to kcmil is a big improvement because it allows a consistent use of multipliers. Using English units is bad enough without also using the Roman notation for multipliers!

The AWG numbers get smaller as the cable diameter gets larger, which is always confusing to the newcomer. There are also four AWG sizes larger than the AWG number 1, which is also confusing. These are 0, 00, 000, and 0000, (or 1/0, 2/0, 3/0, and 4/0) pronounced one ought, two ought, three ought, and four ought. See Appendix C for a more detailed discussion of wire sizes and resistance.

This ampacity table is for insulation rated at 75° C. Higher temperature insulations can also be used, as mentioned earlier, but this is a commonly used value, mostly for economic reasons.

The headings of the columns refer to "one circuit" and "two circuits". The one circuit case for a three-phase system requires three conductors, plus a neutral conductor of the same

size. The neutral carries a very small current in normal operation, so does not enter into the thermal calculations. A trench is dug, perhaps 18 inches wide by 24 to 36 inches deep. A layer of sand is placed on the bottom, to prevent mechanical damage to the conductor insulation from sharp rocks. The three phase conductors are laid in the trench with a nominal separation of 7.5 inches. The neutral conductor is placed anywhere in the trench. Another layer of sand is placed on top of the four conductors before the trench is backfilled with dirt.

If the ampacity of a single circuit is not adequate for a particular installation, a second circuit is added in parallel with the first. The conductors of each circuit must be the same size, so that both the resistance and inductive reactance of each circuit will be the same, so that current will divide evenly between the circuits. The trench for the double circuit case is much wider, approximately 60 inches, to allow a separation of at least 24 inches between circuits. Even with this separation, the heat dissipated by one circuit will raise the temperature of the other circuit. This lowers the allowable ampacity. For example, a 4/0 aluminum circuit will carry 307 A in isolation, but only 283 A when a second circuit is 24 inches away.

The table should have a correction factor applied when the ambient temperature is different from 20°C. At a depth of 36 inches, the ambient soil temperature has a rather small annual variation, being very close to the annual average air temperature above the soil. It makes sense that circuits in Minnesota could carry more current than similar circuits in southern Arizona since the soil temperatures will be different. For example, if the ambient temperature is less than 10°C, the ampacity is increased by 9 to 12%, while if the ambient temperature is greater than 26°C, the ampacity is reduced by 10 to 13%.

Once we find the rated current of the turbine from Eq. 6, we are ready to find the rated current of the conductors connected to the turbine. These currents are not necessarily identical because of code requirements. The National Electrical Code requires “The ampacity of the phase conductors from the generator terminals to the first overcurrent device shall not be less than 115 percent of the nameplate current rating of the generator”, Article 445-5. One reason for this rule is that generators can be operated above their rating by as much as 15% for extended periods of time, and we would not want the conductors to fail before the generator. This rule only applies to this particular section of wire. The remainder of the windfarm circuits are sized according to actual current flow.

For example, a 100 kW, 480 V generator with a power factor of 0.8 will have a rated current of 150 A. We assume that the conditions of Table 9.2 apply. The cable needs a rating of $(1.15)(150) = 173$ A. This is met by a single circuit of AWG 2 copper at 209 A, or by a single circuit of AWG 1 aluminum at 184 A. It is also met by a double circuit of two AWG 8 copper conductors in parallel, which will carry $2(92) = 184$ A, which would meet the generator requirements. Two AWG 6 aluminum conductors in parallel will have the same ampacity.

In smaller wire sizes, the cost of the extra (or wider) trench probably makes a double circuit more expensive than a single circuit. For larger wire sizes, a double circuit may be less expensive and even essential to get the required current. Doubling the wire size does not

double the ampacity. For example, a single circuit of 1000 kcmil copper will carry 887 A, while a double circuit of 350 kcmil copper will carry $2(474) = 948$ A. The double circuit case requires seventy percent of the copper ($(2)(350) = 700$ as compared with 1000 kcmil) and will carry seven percent more current in this case. This saving in copper can easily pay for the cost of a second trench.

Transformers

The next element to be sized is the transformer T_1 . Transformers are always rated in terms of kVA (or MVA) so we have to convert from the generator rating in kW by using the power factor. If the generator is rated at 100 kW with a power factor of 0.8, the kVA rating would be $100/0.8 = 125$ kVA. Since N_{tc} generators are connected to a transformer in this cluster network, the transformer rating would be N_{tc} times this value. Actual available ratings may not match this calculated value, of course. Table 9.3 gives the available sizes and 1991 prices for a popular manufacturer of three-phase distribution transformers.

These particular transformers are padmounted, that is, mounted on a small concrete pad at ground level. They are built as three-phase transformers rather than individual single-phase transformers connected in three-phase.

There are two choices as to the type of connection, either radial feed or loop feed. Radial feed refers to a single path between source and load. If a transformer or distribution line along this path is not operative, then there will not be any electrical service downstream from this point. This connection is cheap and simple, and most residential loads are served from a radial feed for this reason.

Table 9.3. Transformer costs,
480Y/12470 Δ

kVA	NLL	LL	COST
112.5	334	834	\$4500
150	353	1170	5000
225	481	1476	6000
300	554	1872	6500
500	817	2982	8000
750	1112	5184	10000
1000	1364	5910	12500

Adders per transformer for:

Loop Feed	\$600
LBOR Switches	500
Lightning Arresters	400

A loop feed, on the other hand, allows electrical power to reach a transformer in one of two paths, as was shown in Fig. 2. A short in a buried distribution line can be isolated in a loop so that repair work can proceed without power production from any turbine being interrupted. A loop connection is therefore very desirable if it can be justified economically. A windfarm with two transformers T_1 may not be able to justify a loop but one with ten or more transformers would almost certainly need a loop. This adds a total of \$600 to the cost of each T_1 , as seen in Table 9.3.

The switches in a loop are typically of the LBOR (loadbreak oil rotary) type. There are two switches, one for each direction of the loop. Each switch has two positions, on and off. If one switch is on and the other is off, power is coming to the transformer from only one direction and the loop is open at this point. If both switches are off the loop is open and the transformer and the associated wind turbines are not energized. If it is desired to have the loop closed at this point but for the transformer to not be energized, then the circuit between the loop and the transformer must be opened with another device, typically a fuse on the transformer itself. Two of these LBOR switches costs an additional \$500 over the base cost of the transformer.

Also important are lightning arresters, which are devices connected between a phase conductor and ground which start to conduct when the voltage exceeds some rated value, as will happen when lightning strikes the conductor. In a windfarm, lightning will probably hit one of the wind turbines rather than a padmounted transformer or a buried distribution cable, so arresters may not be absolutely essential at this point. However, the windfarm location is likely to be the highest point within several miles, with poorly conducting soils (or rocks). Every thunderstorm is likely to produce several lightning strikes within the confines of the windfarm. Given the unpredictability of lightning, it is probably wise to put arresters on each transformer, at an additional cost of \$400.

The column labeled NLL indicates the No Load Losses for each transformer. The 750 kVA transformer consumes 1112 W continuously while energized, even when no power is flowing through the transformer. This means that 9741 kWh will be dissipated as heat in a one year period, if the transformer is continuously energized. If electricity is worth \$0.05/kWh, this amounts to \$487/year, or almost 5% of the initial cost of the transformer. Less efficient transformers can be manufactured at a lower price, but these can rarely be justified by a careful economic analysis.

The next column, labeled LL, shows the Load Losses in watts for full load conditions. These are the copper losses for the transformer. (We refer to I^2R losses as copper losses even if the transformer is actually wound with aluminum wire.) The economically optimum ratio of LL/NLL depends on the price of electricity and on the duty factor of the transformer. A transformer which is only occasionally operated at full load can have a somewhat higher value of LL as compared with the transformer being operated with a very high duty factor. The values given in Table 9.3 are close to the economic optimum for a typical utility in 1991.

Suppose that the combined rating of a cluster of wind turbines is not exactly equal to a

nominal transformer rating. Should we select the next larger size of transformer, or might we get by with the next smaller size?

Example

Assume that we have five turbines rated at 50 kVA each. Should we select a 300 kVA transformer or a 225 kVA transformer?

The smaller transformer would be operated at 11 percent over its rated value during the times when all turbines were operating at full power. We would save \$6500 - \$6000 = \$500 of initial cost, and 554 - 481 = 73 W of no load losses, amounting to 648 kWh/year. The load losses are higher, of course. Copper losses are proportional to the square of the current, and the current is proportional to the load kVA (since voltage is essentially fixed). Therefore the copper losses at 250 kVA would be, for each transformer,

$$P_{\text{loss},225} = \left(\frac{250}{225}\right)^2 (1476) = 1822 \text{ W}$$

$$P_{\text{loss},300} = \left(\frac{250}{300}\right)^2 (1872) = 1300 \text{ W}$$

The transformers must be operated at this power level for over 1200 hours per year before the extra copper losses exceed the reduced eddy current and hysteresis losses (no load losses) of the smaller transformer. The larger transformer will always have smaller load losses than the smaller transformer for the same load, but the total loss will be less for the smaller transformer whenever the load is less than about 20% of rated. This will be the situation for more than half the time at most wind farms, so a detailed economic study could easily show the smaller transformer to be the economic choice.

But what about damage to the transformer by operating it in an overloaded condition? It turns out that these transformers can be operated at 113 percent of rated power for up to four hours in ambient temperatures of 40° C (104° F) without a reduction in normal life. This would be a no wind condition, but full power operation in a windfarm would always be accompanied by strong winds with resultant cooling. Also it would be rare indeed for full power to be maintained for over four hours at temperatures as high as 40° C. Lower ambient temperatures would also increase the allowable overload. Therefore, it may be appropriate to select a transformer with a rating up to about 10 percent smaller than the generator rating, rather than the next size larger. If this is done, it may be necessary to monitor the transformer temperature during extended periods of high power operation. If the transformer temperature should exceed a safe level, one of the turbines can be shut down until the transformer has cooled down.

5 SELECTION OF SIZES, DISTRIBUTION VOLTAGE EQUIPMENT

The next step is to select the wire size on the high voltage side of T_1 . The rated current is determined from

$$I = \frac{S_{wf}}{\sqrt{3}V} \quad (7)$$

where S_{wf} is the total three-phase VA of the turbines connected to each loop and V is the high side line to line voltage. For the case of 10,000 kVA and a high side voltage of 12,470 V, this is a current of 464 A. The conductor in the loop type circuit needs to be sized to handle all the current of all the generators in case one of the circuit breakers $CB2$ is open.

The appropriate tables in the NEC then need to be consulted. These are Tables 310-81 and 310-82 of the 1990 NEC for copper and aluminum conductors, respectively. The ampacity values for conductors rated at 15 kV are summarized in Table 9.4. The table also includes ampacities for three conductors in a trench or six conductors in two adjacent trenches (or a single wide trench), similar to the low voltage case discussed in the previous section.

Table 9.4. Ampacities of buried conductors, 15 kV class

AWG	COPPER		ALUMINUM	
	one circuit	two circuits	one circuit	two circuits
6	130	120	100	95
4	170	160	130	125
2	210	195	165	155
1	240	225	185	175
1/0	275	255	215	200
2/0	310	290	245	225
3/0	355	330	275	255
4/0	405	375	315	290
250	440	410	345	320
350	535	495	415	385
500	650	600	510	470
750	805	740	635	580
1000	930	855	740	680

The required wire size for a 10,000 kVA collection of turbines (rated current 464 A at 12.47 kV) would be a single circuit of 500 kcmil aluminum, or a double circuit of 3/0 aluminum. The double circuit case would have about half the aluminum of the single circuit case because of better heat transfer characteristics. For typical costs of aluminum conductors and trenching, the single circuit configuration is least expensive up to wire size AWG 4/0, which represents a kVA rating of $\sqrt{3}(12.47)(315) = 6804$ kVA. For a slightly higher rating, say 7200 kVA, it is cheaper to use a double circuit with wire size AWG 1.

Table 9.4 shows that the maximum allowable current is 680 A per circuit for the double circuit case, or a total of 1360 A. This would correspond to a kVA rating of $\sqrt{3}(12.47)(1360)$

= 29,400 kVA. A windfarm with a rating larger than this would need to have two loops, each loop having two circuit breakers *CB2* connected to the low voltage bus on transformer T_2 . It might be cheaper and more efficient to design for two loops for power levels well under this level. Two single circuit loops of approximately the same length as one double circuit loop would certainly be cheaper. The question would be whether the savings in cable would offset the cost of two additional circuit breakers.

Costs for underground conductors in dollars per 1000 ft are given in Table 9.5. The table includes both the 600 V and the 15,000 V rating. The former would be used between the turbine and the transformer T_1 and the latter after T_1 . The thicker insulation of the 15 kV conductor obviously makes it substantially more expensive. There will be three of these conductors in a three-phase circuit (six for the double circuit case), so these prices must be multiplied by three (or six) to get the circuit cost per foot. The price of the 15 kV wire includes a neutral wrapped around the insulation of each conductor, so no additional neutral wire needs to be purchased.

In addition to the cost of conductors, we have the cost of trenching. This will cost about one dollar per foot for the single circuit case in good trenching situations and more where there are rocks or other problems. The cost of trenching will approximately double for the double circuit case.

Table 9.5. Underground aluminum conductor
cost in dollars per 1000 ft of conductor

Size	600 V	15 kV
6	\$107	
4	135	
2	178	\$690
1	253	780
1/0	287	860
2/0	303	1070
3/0	363	1280
4/0	425	1500
250	585	2060
350	799	2800
500	1100	3850
750	1600	5300
1000	2063	7220

The total trench length required for both the low voltage and distribution voltage circuits can be best calculated from a sketch of the site layout. For cases where several turbines are to be connected to one unit transformer it would be wise to check total trench length for more than one possible configuration. For example, if eight turbines are to be connected to one transformer, is it better to put all eight in one row, or should the transformer be connected

to four turbines in one row and four in the adjacent row? We will try to answer this question by example to illustrate the procedure for other configurations.

Figure 4 shows the trenches needed for the 8 turbines connected in one long row or two short rows. The transformer T_1 is physically small compared with D_{cw} , and so is the separation between adjacent trenches. Such small corrections will be ignored in this analysis, but allowance should be made for splices, connections, vertical runs of cable, and crooked trenches when actually ordering the cable. The two turbines nearest to T_1 require a trench length of only $0.5D_{cw}$ in the 1 by 8 configuration, but the two most distant turbines require a trench length of $3.5D_{cw}$. Separate trenches are required because of heating effects. The total trench length for this configuration is then $16D_{cw}$.

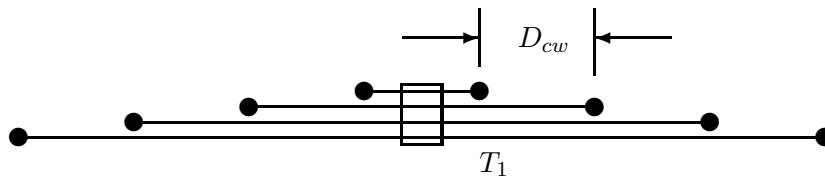

$$(a) D_T = (1 + 3 + 5 + 7)D_{cw} = 16D_{cw}$$

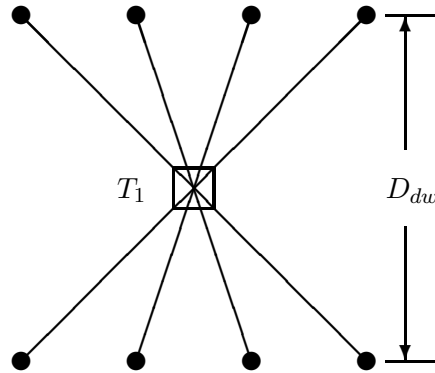

$$(b) D_T = 2\sqrt{D_{cw}^2 + D_{dw}^2} + 2\sqrt{(3D_{cw})^2 + D_{dw}^2}$$

Figure 3: Trench lengths for low voltage wiring for 8 turbines in 1×8 and 2×4 configurations.

When the turbines are connected in a 2×4 configuration, the nearest turbines require a greater trench length while the most distant turbines require shorter trenches than the most distant turbines of the 1×8 configuration. Simple square roots are used to find the trench lengths, with the formula for this particular case shown in Fig. 3. No universal comparison can be made without knowing both D_{cw} and D_{dw} , or at least their ratio. For the case where the downwind spacing is 2.5 times the crosswind spacing, the trench length for this configuration is $13.2D_{cw}$, an 18 percent reduction from the $16D_{cw}$ of the 1 by 8 configuration. This reduces both first cost and operating cost by reducing losses, so the 2×4 would be preferred over the

1×8 for this D_{dw}/D_{cw} ratio.

The 2×4 configuration also has the advantage of lowering the voltage drop from the most distant turbines, and also making the low voltage drop more nearly equal among all the turbines. The ampacity tables presented earlier deal only with heating effects and do not answer the question as to the acceptability of the voltage drop. Voltage drops will be considered in more detail in the next section.

The choice of low voltage configuration will also impact the distribution voltage circuit. This is illustrated in Fig. 4 for the case of 32 turbines in 4 rows of 8 turbines each. Four unit transformers T_1 are required in either case. The solid line shows the minimum trench length for the 1×8 configuration. There will be parallel trenches, with the cable serving as the return for the loop going through the transformer enclosure without physical connection. The dashed line shows the trench layout for the 2×4 configuration, with the arrows indicating a possible location for the transformer T_2 . The bottom portion of the loop would actually be located close to the bottom row of turbines, rather than where it is drawn in the figure. The trench length for the 1×8 configuration is $6D_{dw}$, and $5D_{dw} + 8D_{cw}$ for the 2 by 4 configuration. Using the example of $D_{dw} = 2.5D_{cw}$, the 2×4 requires $20.5D_{cw}$ while the 1×8 requires $15D_{cw}$ of trench. Therefore the 1×8 is better in the distribution voltage trench and poorer in the low voltage trench requirements. It appears necessary to check several possible designs before concluding that one is superior to the others.

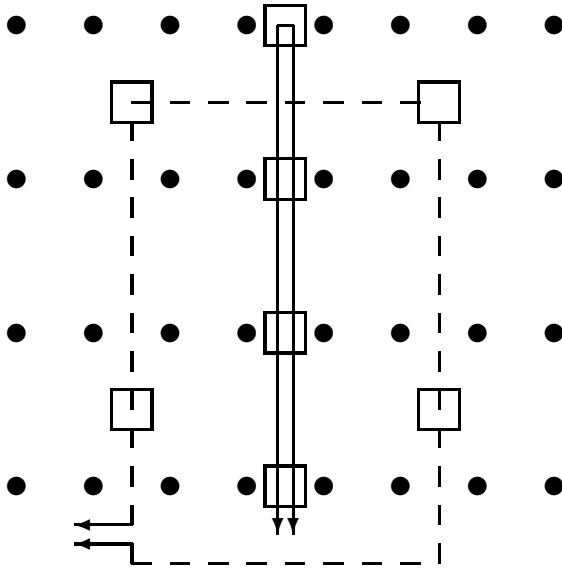

Figure 4: Trench lengths for distribution voltage wiring for 32 turbines in 4 rows, for both 1×8 and 2×4 low voltage configurations.

Distribution voltage trenches are shown which do not cross the low voltage trenches. This is not an absolute technical requirement, but doing it will certainly remove the hazard of low voltage cable crossing over high voltage cable.

After the trench lengths are determined, the circuit breaker *CB2* must be selected. It is quite possible that a good design will result in a rated loop current of 500 A or less. When we go to the catalog to find a breaker with this rated current, however, we are surprised to find that the minimum rating is 1200 A, with only two other choices, 2000 and 3000 A. The reason for this is the strength requirements for withstanding large fault currents. Depending on the impedance of the source, a circuit breaker may be required to interrupt between 10,000 and 50,000 A. It takes a finite amount of time to detect the fault, send a signal to the breaker, mechanically move the contacts, and extinguish the arc, and during this time the contacts must withstand this fault current. Contacts large enough to withstand such fault currents are large enough to handle at least 1200 A on a continuous basis. The breaker can be operated on any value of current less than this, of course. Estimating prices for circuit breakers are shown in Table 9.6.

The transformer T_2 will step up the windfarm distribution voltage to the value necessary to tie into the utility's transmission network. Transformers of this size are not shelf items. Many options must be specified at the time of ordering, and then a specific price can be quoted. We shall present the basic procedure used by Westinghouse to illustrate the concept.

The list price for a Westinghouse three-phase transformer with rating 2500 kVA or larger is given by the formula

$$C = C_1 M_2 M_3 M_4 (1 + PA/100) + C_6 + C_7 \quad (8)$$

where C_1 is the base list price, M_2 is an efficiency multiplier, M_3 is an operating voltage multiplier, M_4 is a frequency multiplier, PA are the percentage adders, C_6 is the cost of load tap changing equipment, and C_7 is the cost of various dollar adders. We shall briefly discuss each of these items.

Table 9.6. Cost of Three-phase circuit breakers.

Voltage, kV	Current	Cost
12.47	1200	\$12,000
34.5	1200	27,450
34.5	2000	29,640
69	1200	29,540
115	1200	62,310
115	2000	67,880
161	1200	85,465
161	2000	99,950
230	2000	119,815
345	2000	237,750

The base list price is determined either by a table lookup or by a formula. The formula used is

$$C_1 = 19800(\text{MVA})^{0.75} + 1.55(\text{BIL}_{\text{kV}})^{1.75} \quad (9)$$

where BIL refers to the Basic Impulse Level expressed in kV. It is a measure of the ability of the transformer to withstand high transient voltages without the insulation breaking down. A 69 kV transformer might have a BIL of 350 kV, for example.

The BIL for a nominal system voltage is shown in Table 9.7.

Table 9.7. Basic impulse levels.

Nominal System Voltage, kV	Basic Impulse Level, kV
15	110
34.5	200
69	350
115	450
138	550
161	650
230	750
345	850

The efficiency multiplier M_2 has to do with the tradeoff between capitol cost and operating cost of a transformer, as discussed earlier in the chapter. The cheapest transformer to build is the most expensive to operate. The total cost of owning a transformer for its lifetime, including

both capital and operating costs, will be minimum for a better transformer. Depending on the particular situation, a typical value for M_2 is 1.3.

The operating voltage multiplier M_3 reflects the extra cost of building a transformer with a non standard BIL. It will be unity for the standard transformer and does not exceed 1.1 for any case. We will assume it to be unity in our case.

The frequency multiplier M_4 is 1.125 for a 50 Hz transformer rather than the standard 60 Hz. This would be used only for windfarms in those countries where the frequency is 50 Hz.

The percent adders PA are the additional percentage costs for such things as reducing the audible sound level, adding taps, changing the cooling system, and adding extra windings. We will assume that none of these extras are necessary for our system.

C_6 is the cost for load tap changing equipment, which can change the transformer ratio under load. It is necessary at some substations to keep the customer voltage within the proper range under all load conditions. Depending on the utility receiving power from the windfarm, it might be necessary in our situation, but we will ignore it for the present.

The dollar adders C_7 would be for built in current transformers, potential transformers, lightning arresters, and such items as relays, special paints, and special tests. This application will require current transformers, potential transformers, and lightning arresters. Other dollar adders could easily total \$20,000. Rather than make the design any more detailed than it already is, we will assume a lump sum of \$20,000 for these miscellaneous dollar adders (in addition to the current and potential transformers and arresters). The estimating costs for these devices are shown in Table 9.8.

Table 9.8. List costs of potential transformers, current transformers, and lightning arresters (before cost multiplier.)

Voltage, kV	Potential	Current	Arrester
12.47	1660	1030	1430
34.5	5630	5690	2280
69	10,420	7750	4090
115	14,550	13,670	7450
161	24,100	21,680	11,590
230	26,970	33,700	17,570
345	43,820	46,840	31,860

Example

What is the list price of a three-phase, 20 MVA, 12.47/69 kV transformer, with an efficiency multiplier of 1.3, including three current and potential transformers and lightning arresters?

The base list price is, from Eq. 9,

$$C_1 = 19800(20)^{0.75} + 1.55(350)^{1.75} = \$231,150$$

The list price is, from Eq. 8,

$$C = 231,150(1.3) + 3(10,420 + 7750 + 4090) + 20000 = \$387,275$$

This price is then multiplied by a discount factor as quoted by the Westinghouse salesman. At the time of this writing, this factor is 0.51, which makes the actual selling price $387,275(0.51) = \$197,510$.

The transformer T_2 must then be connected to the utility grid by an overhead high voltage transmission line. This line may need to be several miles long to reach an existing line. The cost of the transmission line will also vary with the type of terrain, the necessary current capacity, and the local labor costs. In Kansas rough estimates for the total installed costs in 1991 dollars were as shown in Table 9.9.

Table 9.9. Overhead transmission line costs.

34.5 kV	\$27,000/mile
69 kV	46,000/mile
115 kV	76,000/mile
230 kV	153,000/mile
345 kV	250,000/mile

6 VOLTAGE DROP

The voltage drop in a conductor is simply IZ , where I is the phasor current and Z is the complex impedance. The current is known from the load requirements and the resistance is easily calculated or looked up in a table, such as Appendix C. The reactance term, on the other hand, is not as easy to obtain. The inductance of a wire increases as the distance to an adjacent wire (the return path) increases. For overhead transmission lines and for multiconductor cable (two or more conductors inside a plastic sheath) the distances to adjacent conductors are fixed, so tables can be prepared for such cases. Windfarms, however, will have individual conductors spaced at random in the bottom of trenches, so the exact value of reactance could only be obtained by measurement after the trench is backfilled. This is obviously not an acceptable solution to a design problem.

Rather than try to make an exact analysis, we will estimate the voltage drop for the windfarm situation from the voltage drop table for conductors in conduit, as published in the

American National Standard ANSI/IEEE Std 141-1986, affectionately known as the IEEE Red Book. A portion of the table for 600 V conductors is shown in Table 9.10. The table includes data for both copper and aluminum conductors, in conduits (the worst case). There will not be any magnetic materials in the trench, but the distribution of the conductors will cause the voltage drop to be slightly larger than the corresponding values for nonmagnetic conduit.

In using Table 9.10, the procedure is to find the voltage drop for 10,000 A·ft and multiply this value by the ratio of the actual number of ampere-feet to 10,000. The length used is the one way distance from the source to the load.

Example

A 250 kcmil aluminum conductor 480 V circuit is used to supply 300 A to a load 200 ft away. The power factor is 90 percent lagging. What is the voltage drop?

From Table 9.10, the voltage drop for 10,000 A·ft is 1.6 V. The actual number of A·ft is (200 ft)(300 A) = 60,000 A·ft. The total voltage drop from line to line is then

$$(60,000/10,000)(1.6) = 9.6\text{V}$$

This can be converted from a line-to-line value to a line-to-neutral value by dividing by $\sqrt{3}$ or multiplying by 0.577. The percentage drop is $9.6/480 = 0.02$ or 2 percent. This would generally be quite acceptable.

Table 9.10. Voltage drop per 10,000 A·ft
in magnetic conduit, 0.9 pf lag

AWG kcmil	COPPER	ALUMINUM
12	30	48
10	19	30
8	12	19
6	8.0	12
4	5.2	7.9
2	3.4	5.1
1	2.8	4.1
1/0	2.3	3.4
2/0	1.9	2.7
3/0	1.6	2.3
4/0	1.3	1.9
250	1.2	1.6
350	0.95	1.3
500	0.78	0.99
750	0.64	0.79
1000	0.57	0.69

Example

Calculate the voltage drop on a dc system where we have two 250 kcmil aluminum conductors carrying 300 A to a load 200 ft away. The input voltage is 480 V. What is the voltage drop and power loss?

From Table 2 in Appendix C, the resistance of 1000 ft of 250 kcmil aluminum conductor is 0.068 Ω . We have current flow through a total length of 400 ft (200 ft down and 200 ft back) with resistance

$$R = \frac{400}{1000}(0.068) = 0.0272 \ \Omega$$

The voltage drop is

$$V_{drop} = IR = 300(0.0272) = 8.16 \ \text{V}$$

The power loss in the line is

$$P_{loss} = I^2R = (300)^2(0.0272) = 2448 \ \text{W}$$

The voltage drop is less because of the lack of inductive reactance, but not substantially less. The drop due to resistance alone would not be a bad first estimate if Table 9.10 were not available.

7 LOSSES

Voltage drop (IZ) and resistive loss (I^2R) are closely related concepts, but present two different types of constraints. Voltage drop is a technical constraint. We want the voltage at the wall receptacle to be between 114 and 122 V, for example, so the light bulbs have the proper intensity and the electrical appliances work correctly. In the windfarm environment it would not be hard to design for a voltage drop up to 10%, so this is not a significant constraint. On the other hand, resistive loss is an economic constraint, at least for wire sizes adequate to carry the desire current. The economic goal of a windfarm design is to minimize the ratio of capitol cost to net energy production as measured at the windfarm boundary. The gross energy production (the total energy produced by the turbines before losses are considered) is a function of the skill of the turbine designer and of the wind resource at a particular site. Once the turbine and site have been selected, the windfarm designer still has to select wire sizes and other factors to minimize the cost per kWh delivered to the utility.

For example, a given turbine is rated at 220 A. The low voltage wire must have an ampacity of $1.15(220) = 253$ A, which is met by AWG 3/0. A larger wire size would be selected for economic rather than technical reasons. A larger wire size increases the windfarm cost but, by reducing the losses, also increases the energy supplied to the utility. For the wire costs given earlier and for a typical windfarm layout, the cost per kWh hits its minimum at a wire

size of around 350 kcmil. Beyond that point, the wire cost increases more rapidly while the energy saved becomes smaller, so the cost per kWh begins a slow increase.

The low voltage wire loss can be determined from Fig. 5, which shows a single turbine connected to a transformer T_1 by underground conductors in a trench of length D_T . All the low voltage wire in a windfarm carries approximately the same current, so the total loss can be found by using the total low voltage trench length. There are two possibilities, either single circuit or double circuit, shown as Fig. 5b and Fig. 5c. Each of the three conductors in the single circuit case will carry the full turbine current I . The additional ampacity of the double circuit case is obtained by simply paralleling two conductors for each phase. There are now six conductors in the trench, each carrying a current $I/2$.

The power dissipation in the single circuit case is

$$P_s = 3I^2R_s \quad (10)$$

while the power dissipation in the double circuit case is

$$P_d = 6(I/2)^2R_d = 1.5I^2R_d \quad (11)$$

where R_s and R_d are the resistances of a conductor of length D_T . It is tempting to assume that P_d is smaller than P_s because the multiplying factor is half as large (1.5 rather than 3). But it should be remembered that R_d is larger because smaller wire is used in the double circuit case. In fact, the losses will be exactly the same if the conductor size in the double circuit case is half the size of the single circuit conductor. It does not make any difference in losses if the total conductor area of 500 kcmil, for example, is obtained from a single 500 kcmil conductor or from two conductors, each of 250 kcmil area.

Example

A wind turbine rated at 220 A is located 300 ft from its circuit breaker CB1 and transformer T1. Assume that the trench for a single circuit costs \$1/ft and \$2/ft for a double circuit. Wire costs for 600 V conductors are given in Table 9.5. What is the cost/ft for the single and double circuit cases and what is the power loss at rated current for each case?

As mentioned above, the wire must have a rating of $1.15(220) = 253$ A. We see in Table 9.2 that 3/0 aluminum has a rating of 272 A in the single circuit case. Each of the individual conductors in the double circuit case must have a rating of $253/2 = 126.5$ A. This is met by 2 AWG, rated at 151 A. The cost per ft for the single circuit case is

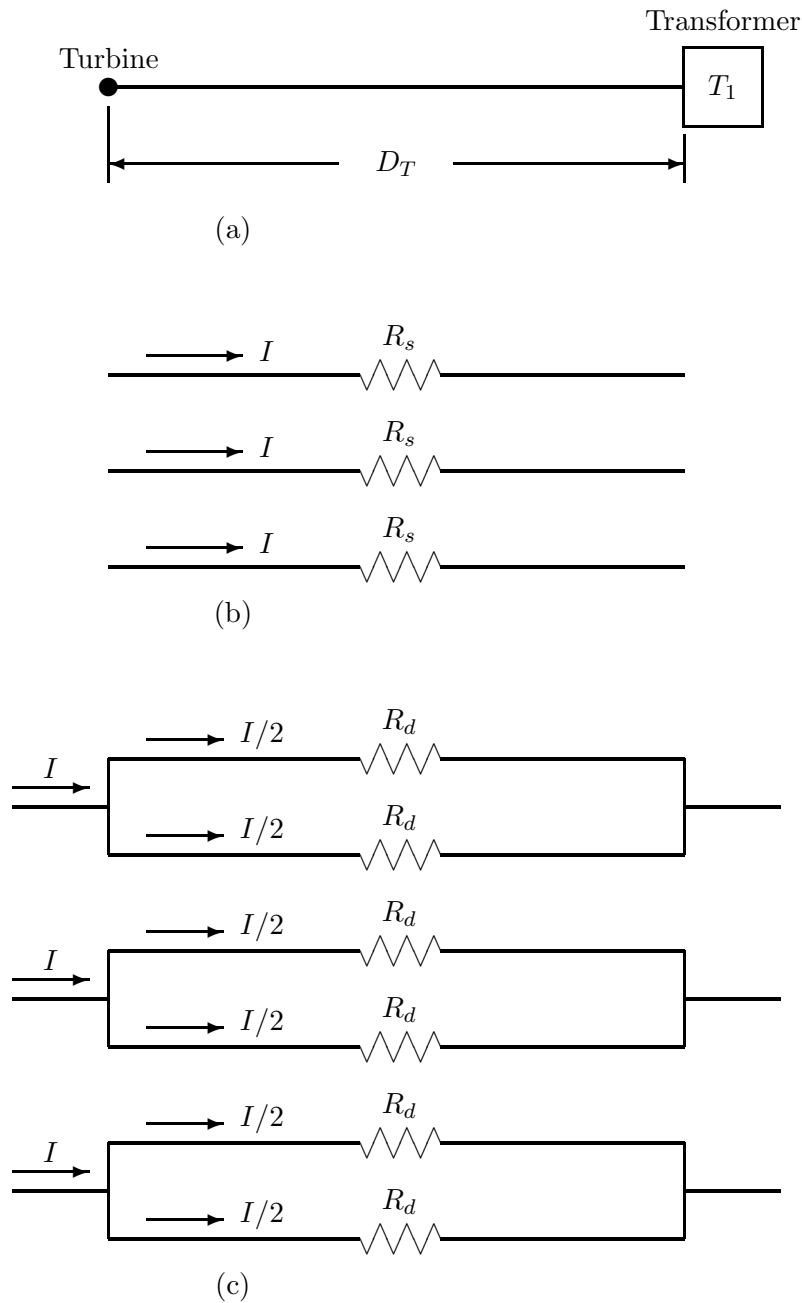

Figure 5: Loss Calculation in Low Voltage Cable

$$C_s = 4(\$0.363) + \$1 = \$2.452/\text{ft}$$

while for the double circuit case it is

$$C_d = 8(\$0.178) + \$2 = \$3.42/\text{ft}$$

Note that both cases includes a neutral of the same ampacity as the three phase conductors.

We now proceed to Table 2 of Appendix C to find the resistance of our conductors. We find that 2 AWG has a resistance of 0.2561 Ω per 1000 ft while 3/0 has a resistance of 0.1013 Ω per 1000 ft. The resistances R_s and R_d of Fig. 5 are therefore

$$R_s = (300/1000)(0.1013) = 0.03039 \ \Omega$$

$$R_d = (300/1000)(0.2561) = 0.07683 \ \Omega$$

The power losses at rated current are

$$P_s = 3(220)^2(0.03039) = 4413 \ \text{W}$$

$$P_d = 1.5(220)^2(0.07683) = 5578 \ \text{W}$$

In this particular case, the double circuit is both more expensive and more lossy than the single circuit. If a sufficiently large ampacity is required, then the double circuit will be less expensive. The losses for a double circuit will always be greater than the losses of a single circuit of the same ampacity.

We now need the yearly energy loss in the low voltage conductors before we can complete our economic analysis. We cannot just multiply the loss at rated current by 8760 hours per year because the turbines are operating at rated current only a small fraction of the year. From the wind speed duration curves and the curve of turbine power versus wind speed we can calculate the fraction of time that the turbine is at each power level. However, this does not give the full picture since the power factor of the generator decreases as power production decreases. This means that if a rated current of 220 A, for example, occurs at rated power, the current at half power will be greater than $220/2 = 110$ A. A detailed analysis will require a histogram of current versus time for one year, which may be more trouble than it is worth.

A crude estimate of low voltage loss can be obtained by starting from the capacity factor CF for turbines at this site. A capacity factor of 0.2, for example, means that the yearly energy production of a turbine can be calculated by assuming the turbine is producing full

power for 20% of the time and is off the remaining time, or is producing 20% power all the time. In the first case, the yearly energy loss would be

$$W_{s1} = (0.2)(8760)(3)(I)^2 R_s \quad (12)$$

and in the second case, if we assume the current drops to $0.3I$ for 20% power,

$$W_{s2} = (1.0)(8760)(3)(0.3I)^2 R_s = 0.45W_{s1} \quad (13)$$

W_{s1} is an upper bound for conductor losses. Depending on the variation of current with power, W_{s2} is a reasonable estimate for the lower bound of losses. An assumption of $0.6W_{s1}$ or $0.7W_{s1}$ should be adequate for most purposes.

A similar argument can be made for the load losses of transformer T_1 . The current will be the same as in the low voltage conductors, and the resistance will just be that of the transformer windings. An estimate of $(0.6)(CF)(8760)P_{LL}$ should be quite acceptable.

The no load losses of T_1 can be found by multiplying the no load power from Table 1 by the number of hours per year that the transformer is energized. Significant amounts of energy can be saved by opening the circuit breakers CB2 during long periods of low winds. These circuit breakers are not intended for frequent cycling, but a few times each week should be acceptable.

The losses of the distribution voltage conductors can be determined in a manner similar to that of the low voltage conductors. Actually, the losses in these conductors will be much lower than the low voltage conductor losses and can be ignored without significant error. The reason for this is that the distribution voltage conductors must be sized for the worst case condition of one circuit breaker open and all the loop current flowing through the other one. In this case, the loop current increases from zero next to the open circuit breaker to rated at the operating circuit breaker. The average current in the loop would be approximately half the rated current, with losses on the order of one fourth the losses we would expect if the entire loop carried the same current. In normal operation, however, both circuit breakers CB2 will be operating, so the maximum current in the loop will be half the rated current. At some point around the midpoint of the loop, the current will actually be zero. The losses in this case will be on the order of one tenth the expected losses for a uniform current throughout the loop. This will usually be less than 0.5% of the energy produced by the windfarm, hence is not very significant.

8 PROTECTIVE RELAYS

The circuit breakers are operated by a variety of protective relays which sense various operating conditions that may be harmful to the utility, the windfarm, or to operating personnel. Some functions, such as overcurrent, would be common to all the circuit breakers. Others, such as

a synchronism check relay, might only be located at one circuit breaker location. The relays need to be carefully coordinated so the windfarm operation will be both safe and economical. Several of the possible relays will be briefly discussed here.

Overcurrent relays are very important in preventing damage to equipment due to equipment failure or faults. They have two types of overcurrent operation. One is for moderate overcurrent conditions of perhaps five or six times rated current for a short period of time (a second or so). This could be experienced during normal operation, such as the starting of an induction motor, and should not cause the circuit breaker to open. If this current is sustained for several seconds, however, the circuit should be opened. A relay circuit involving the product of time and current is used, so that a larger overcurrent will cause relay operation in a shorter time.

The other operating mode is the so-called instantaneous trip mode. Under fault conditions, when conductors have shorted together, the current may be 20 times the rated current or more. This very large current is never a part of normal operation, so the relay is built to operate as quickly as possible under such conditions.

Overfrequency and underfrequency relays will operate when the windfarm is disconnected from the utility grid. The utility grid operates at a very precise 60 Hz in the U.S.A. so that any significant deviation from this frequency means the windfarm is not connected to the frequency controlled grid. It is possible that the utility lines could open at some distance from the windfarm, leaving some utility load attached to the windfarm. Depending on the load, the wind speed, and the presence of power factor correcting capacitors, wind driven induction generators could supply this load for some time, but at frequencies probably quite different from 60 Hz. This could result in damage to utility customer equipment and also in physical harm to linemen repairing the utility transmission system. Therefore the main circuit breaker to the windfarm must be opened when the frequency is outside some range (perhaps 59 to 61 Hz), and not reclosed until the utility lines again have 60 Hz present on them.

It is not obvious that all the circuit breakers need utility quality overfrequency and underfrequency relays connected to them. One set at the main transformer may be adequate, with perhaps some less expensive relays set for a wider frequency range at the individual turbines, as a backup for the main circuit breaker.

Overvoltage and undervoltage relays will probably also be required. If the windfarm is disconnected from the utility, both voltage and frequency will shift away from the proper values. It is conceivable that frequency would stay in the proper range while the voltage went either higher or lower than what is acceptable. It is also possible that a voltage regulator system would fail on the utility side, so that frequency is still controlled by the utility but the voltage is incorrect. Again, a sophisticated set of relays at the main circuit breaker and a crude set at the turbines may be all that is required.

Power directional relays indicate whether power is flowing from the utility to the windfarm or from the windfarm to the utility. The induction generators will automatically operate as motors in light wind conditions, driving the turbines as fans, a condition which obviously must

be prevented for long term operation. However, reverse power may be acceptable or even necessary during some operating conditions, so considerable sophistication may be required. If the turbines need to be started by utility power, as in the case of Darrieus turbines, then reverse power will flow during the starting cycle. Also, depending on the length and energy requirements of the turbine shut-down and start-up cycles, it may be justified to allow reverse power flow during wind lulls if the average power flow over a 10 or 30 minute period is toward the utility.

Another relay which would be required for the main circuit breaker at least would be one that detects reverse phase or the loss of one phase of the three-phase system. Actual reversed phase sequence would be unlikely after the windfarm electrical system is once correctly wired, but the loss of one phase is not uncommon, caused either by a broken line or the failure of a circuit breaker to reclose properly. Induction generators would try to support the voltage on the lost phase, with possible heavy fault currents.

A synchronism check relay prevents a circuit breaker from closing if the windfarm generators are out of phase with the utility. It would not be required during normal startup conditions with induction generators since these would not have a voltage present at the time of connection to the utility. However, if the utility should have a circuit breaker opened elsewhere on the system, perhaps due to lightning, which recloses after a few tenths of a second, the induction generator voltages will not have had time to decay to zero, and will most probably be out of phase. The resulting high currents and torques could easily damage both the generators and the turbines. The safest approach would be to do a complete shutdown of the windfarm when utility power is lost for any reason, and then initiate a standard startup. With more experience, and fast acting solid state controls, it may be possible to add capacitance and local resistive load at the windfarm to maintain voltage, frequency, and phase so that automatic reclosing of the windfarm into the utility would be feasible.

Other relays may be considered for specific protection of devices. A differential relay may be used on the main transformer to detect differences between input and output, which would indicate an internal fault. It could also be used on the generators, but may be difficult to justify economically in the windfarm setting. A ground overcurrent relay may be used to detect large currents flowing in the ground connection of a wye connected transformer, which would indicate certain types of system failure. Other relays could be used as well.

9 WINDFARM COSTS

We have considered the costs of the electrical equipment necessary to connect wind turbines to the utility grid, hopefully in enough detail to illustrate the process. Prices of electrical equipment can change substantially over short periods of time, and labor costs vary with the part of the country, the remoteness of the site, and the site terrain, so the actual figures used for examples will not be accurate in most situations. One should always call suppliers and contractors to get current prices.

There are other costs associated with installing a windfarm. Somewhat arbitrarily, we have grouped these into the following categories:

1. Electrical
2. Turbine
3. Fixed
4. Auxiliary

We have just considered the electrical costs in detail. This includes the low voltage wire, the distribution voltage wire, trenches, transformers T_1 and T_2 , and circuit breakers CB2 and CB3.

Turbine costs include the following:

1. Purchase price of the turbine
2. Shipping
3. Import duty (for imported turbines)
4. Import broker fee
5. Concrete and other foundation costs
6. Labor
7. Circuit Breaker CB1

Fixed costs are those costs which are not strongly sensitive to the size of the windfarm, such as buildings and legal documents. We include the following in this category:

1. *Permits*. These are required and granted by local government agencies.
2. *Zoning*. Agricultural land will probably need to be rezoned to industrial use (or other category) before a permit can be granted.
3. *Wind Study*. Wind speeds need to be measured at the proposed site for an appropriate amount of time (up to a year) before a decision is made to build a windfarm.
4. *Power Purchase Agreement*. This would include the engineering and legal fees incurred in writing an agreement with the utility buying the electricity produced by the windfarm.

5. *Engineering Design.* A Professional Engineer must perform a detailed design for the windfarm and prepare a set of plans which can be used for construction. This would include the electrical design plus the soil tests, earthwork, and footings necessary to long operation of the windfarm.
6. *Control Building.* Each windfarm will have a building or portion of a building to house the computers, meters, controls, and maintenance personnel. The computers (if not the maintenance personnel) will require this space to be clean and climate controlled.
7. *Maintenance Building.* This would be a building or portion of a building where maintenance and repair operations are conducted. It should be large enough to house the largest item which might be repaired. It may need an overhead crane to lift and move parts. This may be a final assembly building during construction, where tower pieces are connected together, the blades are bolted to the hub, etc.
8. *Visitor Center.* This might be a part of the Control Building or it might be a totally separate facility. Careful attention should be given to this requirement for the first few windfarms in a given part of the country so that visitors can be properly cared for.
9. *Meteorological Tower.* This would be a tower located near the Control Building with anemometers at several heights. Wind speed data would be used for monitoring wind turbine performance and such tasks as starting turbines after low wind conditions and stopping them in high wind conditions.

The Auxiliary costs are those costs related to construction, which vary with the size of the windfarm or the character of the turbines. They include:

1. *Land.* It will probably not be feasible to use the land in a windfarm for any purpose other than grazing, and that would probably not be worth the nuisance of keeping gates closed, so it will probably be necessary to purchase the land for the windfarm.
2. *Access Roads.* Gravel roads are needed within the site so the turbines can be repaired in wet weather. A road is also needed from the site to the nearest all weather road. This could be a substantial expense in remote or mountainous regions. It could be significant even in places like Kansas if the township or county road bridges were not adequate so several bridges needed to be built.
3. *Grading.* There may be earthwork necessary besides building roads and parking lots. Sharp peaks or gullies may affect the wind flow enough to justify some earth leveling activity.
4. *Vehicles.* A windfarm will probably require one or two pickup trucks and a larger truck for moving large components around the site.

5. *Crane.* Windfarms with turbines that tilt over on a hinged base will not require a crane, but a crane would be very desirable for turbines that do not tilt over. A crane can always be rented, but the extensive use of such a machine on a windfarm could easily justify its purchase.
6. *Fence.* A windfarm in grazing land would require a barbed wire fence to keep cattle out. Depending on population densities and insurance requirements, it may be necessary to build a fence to keep people out of the windfarm area. Such a fence would need to be at least six feet tall, of the chainlink type.
7. *Overhead Line.* The windfarm will need to be connected to the nearest utility transmission line by an overhead line.

Table 9.11 shows estimates used by Nordtank for a 10 MW windfarm, which can be used if no better figures are available.

Table 9.11. Nordtank cost estimates
for a 10 MW windfarm.

Item	Cost
Permits	\$30,000
Zoning	15,000
Wind Study	17,000
Engineering	42,000
Power Purchase Agreement	30,000
Control Building	80,000

Table 9.12 shows estimates for other costs.

Table 9.12. Estimates of other costs for Kansas.

Land.	About \$400 per acre for grazing land and \$800 per acre for farm land. This includes a premium over present costs which may be necessary to get the good sites.
Foundations.	Concrete costs between \$40 and \$50 per cubic yard delivered to the site. Installed cost, including steel, may be close to \$100 per cubic yard.
Access Roads.	About \$6 per linear foot for places where extensive grading is not required. Western Kansas is less expensive, perhaps \$1 per linear foot.
Visitor Center.	\$100,000 should be adequate.
Maintenance Building.	\$150,000.
Meteorological Tower.	\$6000 or more.
Fence.	\$2/ft for barbed wire, \$6/ft for 6 ft tall 9 gauge chain link plus \$1/ft for 3 barbed wires on top.
Crane.	Winch and cable 50 ton \$500,000 or hydraulic \$600,000. Rental cost \$150/hr or \$4000/week. Rental includes operator but does not include travel.
Bulldozer.	Clearing brush \$1500/acre, or \$110/hr for D-8.
Labor.	Estimate at least \$15/hour for skilled labor.

10 PROBLEMS

- An underground loop is being designed for a windfarm that will carry 8 MVA at a voltage of 13.2 kV line-to-line. Compare the installed costs of the loop for the one- and two-circuit cases.
- A wind turbine is rated at 110 A, 480 V, three-phase, 91.5 kVA, and 80 kW. It is to be connected by single-circuit underground aluminum conductors to a transformer 300 ft away.
 - What is the minimum wire size according to Table 9.2?
 - What is the rated current of this wire?
 - What is the power loss in the three phase conductors between turbine and transformer under full load conditions, in watts and also as a fraction of the rated power?
 - What wire size would you select to reduce the fractional loss of the previous part to less than 2 percent?
- A three-phase transformer rated at 750 kVA, 480/12470 V has no load losses at rated voltage of 1112 W and copper losses at rated current of 5184 W. What are the total transformer power losses when it is operating at 60 percent of rated current and 95 percent of rated voltage?

4. Vulcan Materials uses rectangular copper conductors 6 inches by 12 inches in cross section and a total circuit length of 400 ft to carry 15,000 A of direct current to a set of electrolysis cells. What is the power loss in 400 ft of this conductor, assuming the conductor temperature is 20°C? Use the techniques in Appendix C.
5. A wind turbine rated at 200 kVA, 480 V, three-phase, is located 500 ft from its step-up transformer and circuit breaker. Assume that the turbine operates at full power 10 percent of the time, half power 40 percent of the time, and is off the remaining 50 percent of the time.
 - (a) What is the minimum wire size of aluminum underground cable, according to the National Electrical Code?
 - (b) What is the voltage drop in the conductors, assuming a power factor of 0.9?
 - (c) What is the yearly energy loss in the conductors *between* turbine and transformer.
6. An underground 12.47 kV loop carries 200 A in a three-conductor, single-circuit configuration. Full current flows 20 percent of the time and zero current the other 80 percent. Energy losses cost 5 cents/kWh, escalating at 3 percent per year. The wire is purchased on a 20 year note at 9 percent interest. Should you buy 1/0 AWG aluminum wire at \$860/1000 ft or 4/0 AWG aluminum wire at \$1500/1000 ft?
7. A wind turbine rated at 250 kVA, 480 V, three-phase, is connected by aluminum underground cable to a circuit breaker/starter and transformer located 700 feet away.
 - (a) What size wire should be used, according to the NEC?
 - (b) What is the rated current of this wire?
 - (c) What NEMA size of circuit breaker/starter should be used?
 - (d) Estimate the line-to-line voltage drop in volts for this installation when operating at rated kVA and 0.9 power factor lag.
8. An underground 12.47 kV loop is being designed to carry 10 MVA.
 - (a) Assuming aluminum wire, is it more economical to use one circuit or two? Include trenching costs.
 - (b) Is there any advantage to increasing the voltage from 12.47 kV to 13.8 kV? Explain.

APPENDIX A: CONVERSION FACTORS

To convert from	to	multiply by
acre	ft ²	43,560
atmosphere	pascal	1.01325×10^5
barrel (oil, 42 gal)	m ³	0.15899
Btu (mean)	joule(J)	1056
Btu/h	watt(W)	0.293
calorie (mean)	joule(J)	4.190
cm Hg (0°C)	pascal	1.333×10^3
degree Celsius	kelvin(K)	$T_K = T_{°C} + 273.15$
degree Fahrenheit	degree Celsius	$T_{°C} = (T_{°F} - 32)/1.8$
degree Fahrenheit	kelvin(K)	$T_K = (T_{°F} + 459.67)/1.8$
foot	meter	0.3048
ft ³	gallon (US liquid)	7.4805
gallon (US liquid)	m ³	0.003785
hp	watt(W)	745.7
in. Hg (32°F)	pascal	3.386×10^3
in. of H ₂ O (39°F)	pascal	2.491×10^2
kelvin	degree Celsius	$T_{°C} = T_K - 273.15$
knot	mi/h	1.151
knot	km/h	1.852
knot	m/s	0.5144
kWh	Btu	3410
kWh	joule(J)	3.6×10^6
liter	m ³	0.001
m/s	mi/h	2.237
m/s	knot	1.944
m ³	gallon (US liquid)	264.17
m ³ /s	cfs	35.315
m ³ /s	gal/min	15,850
mile (statute)	meter	1609
mile (statute)	feet	5280
mile (nautical)	meter	1852
mi/h	feet/s	1.467
mi/h	km/h	1.609
mi/h	knot	0.8690
mi/h	m/s	0.447
N·m	pound-feet	0.7376
N·m	pound-inch	8.8507
psi	pascal	6.895×10^3

APPENDIX B

ANSWERS TO SELECTED PROBLEMS

2.1 (a) $\rho = 1.146 \text{ kg/m}^3$; (b) $\rho = 1.423 \text{ kg/m}^3$

2.3 (a) $p = 92.5 \text{ kPa}$; (b) $p = 83.5 \text{ kPa}$; (c) $p = 59.3 \text{ kPa}$

2.5 $T_g = 15^\circ\text{C}$

2.7 $\bar{u} = 8.773 \text{ m/s}$, $\sigma^2 = 1.012$, $\sigma = 1.006$

2.10 (a) $\Gamma(1.8333) = 0.94066$; (b) $\Gamma(1.3571) = 0.89046$

2.13 711 hours/year between 8.5 and 9.5 m/s, 699 hours/year greater than 10 m/s, 0.0019 hours/year greater than 20 m/s.

2.15 (a) $\bar{u} = 11.18 \text{ knots}$, $\sigma = 0.1262$; (b) 8.86 to 13.50 knots, one month outside; (c) from best month 10.89 to 17.71 knots, from worst month 6.88 to 11.18 knots; both intervals include the long-term monthly mean.

2.17 $u_w = 0.369u_{DC} + 8.51 \text{ knots}$, $r = 0.476$

2.18 (a) $u = 41.66 \text{ m/s}$ once every 20 years; (b) $u = 78.67 \text{ m/s}$ once every 500 years.

3.1 0–1.109, 1.109–1.328, 1.328–1.547, 56.672–57.000

3.2 1.28 s

3.4 6.44 m/s

4.1 1943 kW

4.2 15 m/s

4.4 4876 m², 78.79 m

4.6 (a) 9.82; (b) 22.44; (c) 0.273

4.8 (a) 0.264, 19,010 kWh; (b) 0.413, 29,770 kWh; (c) 0.576, 41,500 kWh

4.9 The 25-kW machine produces 48,180 kWh per year while the 60-kW machine produces 32,540 kWh per year.

4.11 3.5 inches

4.13 (a) $\theta = 1.921 \cos 0.262t \text{ rad}$; (b) 5.296 s; (c) Yes! Large currents flow during the out of phase condition.

5.3 $I = 83.33 / -60^\circ$, $Q = +17.32 \text{ kvar}$

5.4 $S = 113.14 / +45^\circ \text{ kVA}$, $\text{pf} = 0.707 \text{ lag}$

5.5 (a) $I_1 = 25 / -53.13^\circ \text{ A}$, $P = 3750 \text{ W}$, $Q = 5000 \text{ var}$, $\text{pf} = 0.60 \text{ lag}$; (b) $E = 325.96 / 4.40^\circ$;

(c) $P = 625$ W; (d) $I_c = 20/90^\circ$ A, $I_1 = 15/0^\circ$ A, $\text{pf} = 1$; (e) $E = 268.79/9.64^\circ$, $P = 225$ W; (e) reduces reactive power requirement and reduces power line loss.

5.7 $I = 231.3/ - 25.84^\circ$ A, $E = 4009.0/31.10^\circ$, $\delta = 31.10^\circ$, $P = 962.9$ kW/phase, ohmic losses = 17.65 kW.

5.11 $X_{s,\text{pu,new}} = 6.01$

5.18 $R_a = 0.00479$ days/year or about 1 day in 209 years.

6.2 (a) $I_a = 12.83$ A; (b) $k_e = 0.383$; (c) $X_s = 4.91$ Ω ; (d) 16 percent decrease.

7.2 The 14-ft-diameter propeller and 2.5-in.-diameter cylinder clearly meet the requirements. The 12-ft-diameter propeller and 2-in.-diameter cylinder will probably be quite satisfactory at a lower cost.

7.4 (a) $n_s = 350$; (b) $P_m = 19,260$ W = 25.83 hp.

7.5 $h_2 = 416$ ft, $Q_2 = 113$ gal/min, $P_{m2} = 12.66$ kW

8.1 \$862

8.3 13 units

8.5 $P_v = \$44.88$. You should buy the cover.

8.7 $P_{v,X} = \$12,275.92$, $P_{v,Y} = \$12,551.84$. You should buy machine X.

APPENDIX C: WIRE SIZES

The resistance of a long, straight conductor of uniform cross section is given by the expression

$$R = \rho \frac{\ell}{A} \quad (C.1)$$

where R is the resistance in ohms, ℓ is the length of the conductor, A is the cross-sectional area of the conductor, and ρ is the resistivity. In the SI system, length is in meters and area is in m^2 , so ρ is obviously given in ohm-meters. This expression is quite straightforward to use, as shown in the following example.

Example. What is the resistance of a square copper conductor with resistivity 1.724×10^{-8} ohm-meters, cross-section 0.5×0.5 cm, and a length of 100 m?

$$R = \rho \frac{\ell}{A} = 1.724 \times 10^{-8} \frac{100}{(0.5 \times 10^{-2})(0.5 \times 10^{-2})} = 0.06896 \ \Omega$$

Most wire used in the United States is based on the English system, and probably will be for years to come, so it is important for engineers to also be familiar with this system. The unit for resistivity is *ohm circular mils per foot*. This measure of area is quite interesting because it is perhaps the only *circular* measure in existence. Other measures are square (or rectangular). That is, we think of 10 square meters as the area of a rectangle, say 2 meters wide by 5 meters long. The area of a circle of diameter d is $(\pi/4)d^2$ expressed in square measure. The presence of the transcendental number π means that the area of circles will always be rounded off to some arbitrary number of digits, and that we can never have both the diameter and the area accurately expressed with two or three significant digits as long as we describe circles with square measure.

The alternative, of course, is to define a circular measure for circular areas, as shown in Fig. C.1. The unit of diameter size used for wires is the *mil*, where 1 mil = 0.001 inch. The area of any circular wire in circular mils is equal to the square of its diameter in mils.

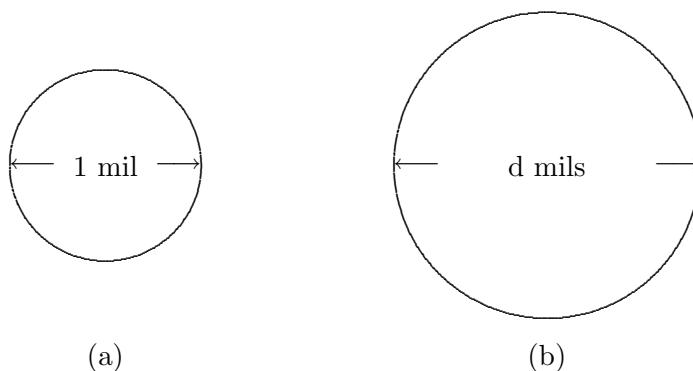

Figure C.1: Circular areas

Area of (a) = $\pi d^2/4 = (\pi/4)$ square mils = 1 circular mil.

Area of (b) in circular mils = $(d \text{ in mils})^2$

Area of (b) in square mils = $(\pi/4)(d \text{ in mils})^2$

Number of square mils = $(\pi/4) \times$ number of circular mils

Example. What is the resistance of a copper wire 500 feet long having a diameter of 0.1 inch, if the resistivity is 10.37 ohm circular mils per foot?

The diameter of the wire is 100 mils (0.1 inch \times 1000 mils/inch) and its area in circular mils is d^2 , or 10^4 circular mils. Substitution of these values in Eqn. 1 gives

$$R = \rho \frac{\ell}{A} = 10.37 \frac{500}{10^4} = 0.5185 \Omega$$

If we have to find the resistance of a rectangular conductor, we simply find the area in square mils and multiply by $4/\pi$ to get the corresponding number of circular mils.

Example. What is the resistance of 1000 feet of a copper conductor 0.1 \times 0.2 inch in cross section, if $\rho = 10.37$ ohm circular mils per foot?

The cross section of the conductor is $100 \times 200 = 2 \times 10^4$ square mils. Converting to circular measure gives $(4/\pi)(2 \times 10^4)$ circular mils.

$$R = \rho \frac{\ell}{A} = 10.37 \frac{1000}{(4/\pi)(2 \times 10^4)} = 0.4075 \Omega$$

Resistivity for some common metals is given in Table C.1.

Table C.1. Resistivity ρ at 20°C.
Selected from CRC Handbook of Tables
for Applied Engineering Science

Material	Ohm		α Temp. coefficient
	Ohm-meters	circular mils per foot	
Aluminum wire	2.82 $\times 10^{-8}$	17.0	0.0039
Brass	7.0 $\times 10^{-8}$	42.1	0.002
Constantan	49 $\times 10^{-8}$	295	0.0001
Copper wire	1.724 $\times 10^{-8}$	10.37	0.00393
Gold	2.35 $\times 10^{-8}$	14.1	0.004
Iron (pure)	9.7 $\times 10^{-8}$	58.4	0.00651
Lead	20.6 $\times 10^{-8}$	124	0.00336
Manganin	44 $\times 10^{-8}$	265	0.00001
Mercury	98.4 $\times 10^{-8}$	592	0.00089
Nichrome	100 $\times 10^{-8}$	602	0.004
Nickel	6.85 $\times 10^{-8}$	41.2	0.0069
Platinum (pure)	10.5 $\times 10^{-8}$	63.2	0.00393
Silver	1.59 $\times 10^{-8}$	9.57	0.0041
Tungsten	5.65 $\times 10^{-8}$	34.0	0.0046

The last column in Table C.1 shows the temperature coefficient of resistance, α , which is the rate at which the resistance changes with temperature. In the case of metals, the change in resistance is positive; that is, the resistance increases with the rise in temperature. This change is very small for special alloys such as Manganin (composed of copper, manganese, and nickel). There are other materials, such as carbon, electrolytes, gaseous arcs, and ceramic materials, that possess a negative temperature coefficient, which means that the resistance decreases with the rise in temperature. The usual explanation for this phenomenon is that the electron current carriers in a metal experience more collisions in a thermally excited lattice, thus increasing the resistance. On the other hand, a rise in temperature in electrolytes and conducting gases results in the presence of more ions serving as carriers, thus tending to increase the current for a given potential difference, which is a decrease in resistance.

The temperature coefficients change somewhat with temperature, but these values in Table C.1 can be considered reasonably accurate over the temperature range of -50°C to 100°C , which includes most cases of interest.

If the resistance of a wire is R_1 at temperature T_1 , the resistance R_2 at temperature T_2 is given by

$$R_2 = R_1[1 + \alpha(T_2 - T_1)] \quad (C.2)$$

Example

If the resistance of a coil of copper wire is $10\ \Omega$ at 20°C , what is the resistance at 50°C ?

$$R_2 = 10[1 + 0.00393(50 - 20)] = 11.18\ \Omega$$

The resistance has increased almost 12% with a 30°C increase in temperature. This shows that if precise values of electrical losses are required, one must use the actual temperature of the wire in calculating the resistance.

Only two metals are widely used as electrical conductors, copper and aluminum, so we will focus our attention on them. Conductors are made in many different sizes to meet needs for a given current carrying ability. If the diameter is 460 mils (0.46 inch) or smaller, the size is specified by a number called the American Wire Gauge (AWG). If the diameter is 500 mils or larger, the size is specified by the wire area expressed in thousands of circular mils, kcmil. A partial list of wire sizes is given in Table C.2, along with the diameter, area, and resistance per 1000 ft at a temperature of 20°C . The odd sizes are omitted for wires of 3 gauge through 29 gauge, since they are rarely used. The very small sizes are also omitted since their fineness makes them difficult to handle.

If intermediate values are needed, one can use the fact that the areas of two adjacent wire gauges are always in a constant ratio with each other, for the AWG portion of the table. For example, the ratio of areas of 4/0 and 3/0 wires is $211.6/167.8 = 1.261$, and likewise for all

the other adjacent sizes. For wires that are two gauge sizes apart, like 6 gauge and 4 gauge, the ratio is $41.74/26.25 = 1.590 = 1.261^2$. A span of 10 gauge numbers yields a change of area of $(1.261)^{10} = 10.166$ or approximately a factor of 10. The resistance is inversely proportional to area, so if the resistance of a 10 gauge copper wire is about 1Ω per 1000 ft, then the resistance of a 20 gauge wire will be about 10Ω per 1000 ft.

The selection of a value of 1.261 for the ratio between areas of adjacent gauge sizes means that the potential benefit of having diameters expressed in integers has been lost, except for the 250 and 1000 kcmil conductors. It could have been done in a manner similar to resistor sizes, where each standard value is about 10 % larger than the previous size, but rounded off to two digits. But it is too late to make such a choice now, so we must learn to live with the values given in the table.

There are two different constraints which must be considered in selecting a wire size. First, the I^2R loss in the wire must not result in a temperature rise in the wire that will damage the insulation. Second, the voltage drop in the wire must not excessively lower the load voltage. We will illustrate the second constraint with a short example.

Example

The new well at your country home is 400 ft from your house. The 120-V single-phase induction motor driving the pump draws 30 A of starting current and 10 A of running current. The starting current flows only for a few seconds at most, so is not a factor in determining the wire temperature. You are told that 12 gauge copper wire is rated for 20 A service in residential wiring. This is twice the running current for this situation, which seems like an ample safety margin for thermal considerations. But you want to check the voltage drop also. The current has to flow to the well and back to the house, so the total length of conductor is $2(400) = 800$ ft. The resistance from Table C.2 is

$$R = \frac{800}{1000} 1.588 = 1.270 \Omega$$

The voltage drop while the starting current is flowing is

$$V_{\text{drop}} = IR = 30(1.27) = 38.1 \text{ V}$$

The voltage available to the pump motor is only $120 - 38.1 = 81.9$ V during the starting interval. Single-phase motors do not have very good starting characteristics, and may not start under load if the terminal voltage is less than about 90% of rated, or 108 V for the 120 V system. The proposed wire size is too small.

We see that selecting wire sizes based on thermal considerations alone may easily lead to situations where performance is poor due to voltage drop. In general, we have two choices in such situations. We can increase the voltage rating or we can increase the wire size (or both). A 240 V pump motor costs about the same as a 120 V motor, but draws only half the current for the same power. Insulation on most 12 gauge wire is rated at 600 V, so that is not

a factor. Assuming the new starting current to be 15 A for the new motor, the voltage drop would be 19 V, which is less than 10% of the 240 V rating. Therefore 12 gauge wire would probably work for the 240 V case where it would not work for the 120 V situation.

It should be mentioned that the above analysis is not completely accurate since it ignores the inductance in the wire. This increases the impedance and the voltage drop, so the analysis using only resistance is somewhat optimistic.

Example. Suppose that we are forced to use the 120 V motor in the above example and that we want to select a wire size such the voltage drop during starting will be 10 V. The maximum resistance for the round trip would be

$$R_{max} = \frac{V}{I} = \frac{10}{30} = 0.333\Omega/800\text{ft} = 0.417\Omega/1000\text{ft}$$

The smallest conductor that has a resistance less than 0.417 Ω / 1000 ft is 6 gauge, according to Table C.2. We need four times the volume of copper to meet the voltage drop requirement as we need to meet the thermal requirement.

It is obvious from the table that copper is the better conductor per unit area. However, the specific gravity of aluminum is 2.70 and copper has a specific gravity of 8.96, so aluminum is the better conductor per unit mass. Copper tends to cost more per kg than aluminum, so if there were no other factors, aluminum would always be the conductor of choice. There are two factors that keep aluminum from this status. One is that aluminum oxide is not a conductor while copper oxide is. Copper conductors need no protection from the atmosphere at joints and splices, therefore. The second factor is that aluminum tends to cold flow under pressure. That is, when a screw is tightened onto an aluminum conductor, the aluminum tends to flow away from the high pressure point over a period of months or years so that the conductor becomes loose. The exposed aluminum forms a nonconducting layer of aluminum oxide so we have a high impedance connection. Current flowing through the poor connection heats up the surroundings and has been known to start fires. This fire hazard has caused virtually all household wiring to be made of copper.

On the other hand, overhead and underground wiring outside of buildings tends to be mostly aluminum for cost reasons. Connections can be made of special compression fittings that both prevent cold flow and protect the joint from the atmosphere. If the connection is properly made, aluminum conductors are just as reliable as copper.

Table C.2 Wire Size and Resistance
 (Adapted from Kloeffler and Sitz, Basic Theory in
 Electrical Engineering, Macmillan, 1955)

Size	Diameter	Area	Ohms per	Ohms per
AWG or kcmil	mils	kcmil	1000 ft at 20°C copper	1000 ft at 20°C aluminum
30	10.03	0.1005	103.2	169.2
28	12.64	0.1598	64.90	106.4
26	15.94	0.2541	40.81	69.90
24	20.10	0.4040	25.67	42.08
22	25.35	0.6424	16.14	26.46
20	31.96	1.022	10.15	16.63
18	40.30	1.624	6.385	10.47
16	50.82	2.583	4.016	6.581
14	64.08	4.107	2.525	4.139
12	80.81	6.530	1.588	2.603
10	101.9	10.38	0.9989	1.638
8	128.5	16.51	0.6282	1.030
6	162.0	26.25	0.3951	0.6476
4	204.3	41.74	0.2485	0.4073
2	257.6	66.37	0.1563	0.2561
1	289.3	83.69	0.1239	0.2031
1/0	324.9	105.5	0.09827	0.1611
2/0	364.8	133.1	0.07793	0.1277
3/0	409.6	167.8	0.06180	0.1013
4/0	460.0	211.6	0.04901	0.08034
250	500.0	250	0.04148	0.06800
350	591.6	350	0.02963	0.04857
500	707.1	500	0.02074	0.03400
750	866.0	750	0.01383	0.02267
1000	1000	1000	0.01037	0.01700

APPENDIX D: STREAMS AND WATERWAYS

Wind turbines need to be installed on high ground rather than low ground. The low ground, where water flows, has many names, which can vary with region of the country and with landowners within a region. The following dictionary definitions should be helpful in discussing land features. The definitions are from the Random House Unabridged, Second Edition.

arroyo: (Chiefly in Southwest U.S.) a small steep-sided watercourse or gulch with a nearly flat floor: usually dry except after heavy rains.

brook: a small natural stream of fresh water.

canyon: a deep valley with steep sides, often with a stream flowing through it.

coulee: (Chiefly Western U.S. and Western Canada) a deep ravine or gulch, usually dry, that has been formed by running water.

creek: (U.S., Canada, and Australia) a stream smaller than a river.

ditch: a long, narrow excavation made in the ground by digging, as for draining or irrigating land; trench.

draw: (definition 65a.) a small natural drainageway with a shallow bed; gully. b. the dry bed of a stream. c. (Chiefly Western U.S.) a coulee, ravine.

gorge: 1. a narrow cleft with steep, rocky walls, esp. one through which a stream runs. 2. a small canyon.

gully: a small valley or ravine originally worn away by running water and serving as a drainageway after prolonged heavy rains.

gulch: a deep, narrow ravine, esp. one marking the course of a stream or torrent.

ravine: a narrow steep-sided valley commonly eroded by running water.

rill: a small rivulet or brook.

river: a natural stream of water of fairly large size flowing in a definite course or channel.

slough, slew, slue: (Northern U.S. and Canada) a marshy or reedy pool, pond, inlet, backwater, or the like.

swale: 1. a low place in a tract of land. 2. a valleylike intersection of two slopes in a piece of land.

valley: 1. an elongated depression between uplands, hills, or mountains, esp. one following the course of a stream. 2. an extensive, more or less flat, and relatively low region drained by a great river system. 3. any depression or hollow resembling a valley.

watercourse: 1. a stream of water, as a river or brook. 2. the bed of a stream that flows only seasonally. 3. a natural channel conveying water. 4. a channel or canal made for the

conveyance of water.

waterway: a river, canal, or other body of water serving as a route or way of travel or transport.

A second definition for *waterway* that is not in the unabridged dictionary is “natural or constructed channel covered with an erosion-resistant grass, that transports surface runoff to a suitable discharge point at a nonerosive rate.” The agricultural concept of a waterway is an area that can be driven across by a four wheel drive vehicle in dry weather. It is conceivable that a wind turbine could be located in a waterway, although a few feet away on ground a few inches higher would be a wise choice. There is no reason for a technician to be standing in water while working on a turbine after a heavy rain.

The general size progression of terms would be rill, gully, ravine, draw, and canyon. A rill in a plowed field is a small eroded channel that can be smoothed out by plowing across it. If it gets wide and deep enough that it cannot be farmed across or driven across, then it is called a gully. A ravine is a large gully, which may be difficult to even walk across. In Eastern Kansas, ravines usually have brush in the bottom. The word draw may be used as a synonym for gully or ravine, but often implies an eroded area that is wider and shallower. An eroded area two feet deep and one hundred feet wide would be a draw, while one four feet deep and six feet wide would be a gully.

Canyon refers to a large channel, with no limit on size. This term is rarely used in Kansas, but is common to the states west of Kansas. The term *rill* is a technical term used by people who have studied agriculture. The other terms are commonly known and used by most rural Kansans.

When the emphasis is on the water rather than the results of the water flowing, the progression of size goes as brook, creek, and river. Stream may be used as a generic term. Water flow is continuous during years of normal rainfall. One needs a bridge to cross a brook, creek, or river. Brook is seldom used in Kansas. It may be that people think of a brook as a flow of clear water in the mountains, with trout swimming. A creek then would be a flow of muddy water with catfish in it. A creek in Eastern Kansas usually has trees growing on both sides of it. If water flow is not continuous, then it is called an *intermittent creek*.

The terms such as creek and river are relative in nature. A river is a large creek, but the water flow in a river in Western Kansas may be smaller than the water flow in a creek in Eastern Kansas.

The word *valley* is often used with a modifier, such as river valley or mountain valley. A river valley may be several miles wide, usually with fertile farm land, extending to hills or bluffs on either side. A mountain valley is probably smaller, but a relatively flat region with perhaps a small brook flowing through the center. There are no mountains in Kansas, but there is upland (as opposed to lowland or river bottom land), so perhaps the corresponding term is “upland valley”.