

*A treatise on watch-work,
past and present*

Henry Leonard Nelthropp

A TREATISE
ON
WATCH-WORK,
PAST AND PRESENT.

BY THE
REV. H. L. NELTHROPP, M.A., F.S.A.

~~~~~  
*Tempus vitæ monitor.*  
~~~~~

WITH ILLUSTRATIONS.



LONDON:
E. & F. N. SPON, 48, CHARING CROSS.
NEW YORK: 446, BROOME STREET.

1873.

186. 4. 76.



PREFACE.

THE great desire for education which has sprung up among all classes of the community during the last few years may seem to some persons surprising, and may possibly be said to be overdone; but when we consider the extraordinary facility which now exists for imparting every kind of information; the cheapness of the press; the rapidity of news by electricity; the quickness of travelling, enabling the visiting of far distant noted sites; the general bringing together of great masses for any purpose whatever, more particularly exhibitions and music meetings: it is not to be wondered at, that the desire daily increases to investigate more and more *all* subjects, and to obtain such information as will make man and man equal to each other, if not in fortune, at least in the possession of useful knowledge.

And as a consequence of this thirst for knowledge, schools of every description have multiplied to such an extent that it is no longer a difficulty, as it used to be thirty years ago, to find a school suited to the age, station, and capacity of the pupil.

And further, whereas at one time it was almost impossible to provide instruction in foreign languages, or

the fine arts, now eminent professors may be had at the turn of nearly every street.

Added again to these advantages, are the great benefits which the population as a whole must derive from the establishment of public libraries, and fine art collections; which are not alone confined to London, but are springing up in all centres of wealth.

The consideration of all these things has induced me to devote a portion of my leisure time to the drawing up this *Treatise on Watch-work*; and the hope has encouraged me that it may be the means of attracting the attention of students to a subject long and much neglected, but yet exceedingly interesting.

Books have appeared of late on nearly every given subject; and, at but a small price, highly-illustrated works on art and science daily attract the attention of the anxious inquirer. Strange, however, to say, with the exception of a 'Rudimentary Treatise on Clocks and Watches,' by *E. B. Denison, Esq.*, published some years back, no one has ventured again to treat on the subject.

During the last century very many books were printed giving excellent information on the making of clocks and watches—more particularly in French—but all these works have become extremely scarce, and as a matter of course expensive, far beyond the means of ordinary persons to buy the same.

The present treatise is designed to supply the deficiency by putting it within the power of all to obtain information at a trifling cost.

Perhaps it may be urged that the subject is not of sufficient interest to induce many to give any time to its study—from this I beg to differ.

In an archæological point of view it deserves to be studied. Is it not absurd for persons to visit the South Kensington or other museums deficient in the knowledge of a subject of which there are so many fine examples exhibited? Of what use the many watches of every date, size, and style, when the looker-on can only exclaim, Here is a watch! or is indebted to the printed label for information? How is it possible for even educated men to feel any interest in the exhibition of articles of vertu, if they have never read, or marked, or learnt for themselves the history, the theory, and practice which have made all these objects so much prized and sought after?

Besides, if there is an indescribable pleasure felt by every individual, no matter of what degree, in becoming the possessor of a good going watch, surely that pleasure ought to be enhanced by being able to give a satisfactory reason for the working of the little machine which is carried daily in the pocket. Will then men who are proud of their knowledge remain satisfied to be considered the mere porters of an article sold to them by a dealer for a purpose? and which is well or ill repaired according to the honesty of any jobber employed at random, for it is calculated as a certainty that the possessor lacks the needful knowledge which would make him able to appreciate the really scientific workman.

It may be safely stated that were we to go to our universities or public schools, scarcely half-a-dozen youths could be found who know a single thing beyond the fact that they had a watch given them; that they were told it was a lever; that it goes badly; and is always requiring something or other. Why should this ignorance prevail in this age of universal knowledge?

It is useless to deny that the study of watch-work presents many difficulties, the principal one being this, that it is not easy to obtain the practical information without which theory is in a great measure rendered valueless.

As a rule, watchmakers are not desirous of imparting any information respecting their business; and the dealers know little or nothing beyond the mere necessary knowledge required to carry on their branch of the trade. The student is then apparently arrested at first starting; but it need not be so, for to meet this difficulty I have in this treatise *defined* all the terms *used in the trade*; and I have further furnished drawings adapted to show the working of the escapements.

The knowledge thus given has taken a long time to acquire; and I have by perseverance obtained my information in Switzerland, France, and England. In each country I have visited establishments whose proprietors were willing to answer inquiries, and who felt an interest in the well-doing of their trade, without exacting that a footing should be paid by the purchase of a costly timekeeper.

To one watchmaker in particular, *Mr. George Blackie*,

of Clerkenwell, and 392, Strand, I now take the opportunity of offering my thanks for the great assistance he has given me, in imparting freely a portion of that sound practical knowledge which he has acquired by years of hard work and application to the art of watch-work. I feel also indebted to him for obtaining, without much profit to himself, movements which he knew I was anxious to possess; and for repairing at a reasonable cost others which deserved to be valued on account of their beauty of workmanship.

Without some occasional assistance from practical business men, it is scarcely possible for any ardent lover of the art, or well-wisher of the trade, to do justice to a subject by a mere acquaintance with the statements which have appeared in books.

In the hope of rendering my work more complete, I have in the *Appendix* given a translation of *M. de Lalande's* very excellent treatise on the pitching of wheels and pinions, in which he has laid down everything which is requisite to constitute a perfect pitching.

This treatise by *M. de Lalande* is extremely interesting, as it was written for the express purpose of simplifying the subject, and bringing it within the intellectual capacity of persons brought up to the clock and watch trade; and who possibly would not have been able to take an interest in any over-learned arguments.

It appeared in Lepaute's treatise on clock-work, 1767, a book which *Moinet, Traité générale d'Horlogerie*, says was "reviewed, revised, and augmented by the celebrated Lalande himself."

The student anxious for more information on this branch of the subject is referred to *Professor Willis's* valuable work on the *Principles of Mechanism*, 1870, in which the teeth of wheels, trains, &c., are fully discussed.

I doubt not there will be found very many shortcomings in the following pages ; and I do not wish to conceal my regret that I have not been able to lay my hand on several books which might have enabled me to give more accurate information on the historical portion of the subject. However, such as it is, may this treatise prove entertaining, and above all excite a desire for more knowledge.

LONDON, *Sept.* 1873.

CONTENTS.

CHAP.	PAGE
—♦—	
PREFACE.	
I. A Watch	1
II. Definitions of Words and Terms used in Watch-work	4
III. Tools required for Watch-work	24
IV. Time	32
V. Historical Summary to the End of the Fifteenth Century	36
VI. From A.D. 1500 to the Present Time	55
VII. On Calculations of the Numbers for Wheels and Pinions, their Proportional Sizes, Trains, &c. ..	113
VIII. Of Dial-wheels or Motion Work, Length of Time of Going without Winding up	131
IX. The Verge	139
X. Horizontal, or, more correctly, Cylinder Watch ..	152
XI. The Duplex	159
XII. The Lever	165
XIII. The Chronometer, or Detached Escapement	170
XIV. Repeating Watches	180
XV. Keyless Watches	184
XVI. The Pendulum, or Spiral Spring	187
XVII. Compensation	224
XVIII. Jewelling of Pivot-holes	237
XIX. Clerkenwell	242
XX. Fallacies of the Trade	247
XXI. Incapacity of Workmen	256
XXII. How to choose and use a Watch	261
XXIII. Conclusion	265
Appendix	272
Index	305



ILLUSTRATIONS.



FIGURE	PAGE
1. Callipering	8
1 to 53. Tools	24 to 31
2. Meridian	33
3. Stack-freed	60
4. Verge	140
5. Ditto	141
6. Harrison's going Fusee	143
7. Banking by W. Hardy	147
8. Motion Work	149
9. The Horizontal Escapement	153
10. Horizontal—Diagram	155
11. Escapement by J. B. Dutertre	161
12. The Duplex	163
13. Escapement invented by the Abbé Hautefeuille	165
14. The Lever	167
15. The Detached Escapement of Arnold	171
16. Ditto	173
17. The Detached Escapement of Earnshaw	175
18. Keyless Watch	185
19. The Pendulum, or Spiral Spring	187
20. Pendule Watch	193
21. Arnold's Balance	228
22. Earnshaw's Balance	232

1 to 12. Diagrams in the Appendix.



WATCH-WORK.

CHAPTER I.

A WATCH.

A WATCH may be defined as a portable clock, or time-keeper, being of such a size as is convenient to be carried or worn.

The word watch is said to be derived from the Saxon *wæccan*, to awaken, which would seem to indicate that the earliest watches were alarums; as Shakespeare says:—

“A watch-case, or a common 'larum-bell?”

Second Part of Henry 4th, act 3, sc. 1.

It is, however, much more probable that the term came originally from the watches of the night, and that the portable timekeepers were invented to mark them, much in the same way as in days of old *watchmen* obtained their name from the duty their office required them punctually to discharge, *viz.* proclaim the hours of the night.

A watch consists chiefly of two parts.

1st. The *movement*, or assemblage of wheels, acted upon by a powerful spring, or motive power, main-spring, so arranged as to indicate on a dial the seconds, minutes, and hours of the day of twenty-four hours.

2ndly. The *case*, usually made of gold, silver, or some metal to which a fancy name is applied.

Again, each movement has some particular charac-

teristic which distinguishes it, and which is known by the term *Escapement*, or Scapement.

This escapement consists mainly of two parts—

1st. A wheel, called scape-wheel ; and

2ndly. Certain pallets which are directly attached to or connected with the axis, or verge, or staff of the balance.

The escapement, therefore, may be said to be the effect produced by a wheel on certain pallets, which are connected with the axis of the balance in such a way that the teeth of the wheel can only escape by means of the vibrations of the said balance.

Thus, for example, in the verge, as a tooth of the escape-wheel draws aside a pallet, and has thereby caused a vibration, it escapes, or gets past, the other pallet presents itself to a tooth of the wheel nearly diametrically opposite, which in its turn is drawn aside in order to bring back the balance. This action makes the balance go and come on itself, in fact vibrate like the pendulum to and fro, forming such vibrations as must necessarily moderate and regulate the velocity of the wheel, and, as a matter of course, the whole movement.

“Hence it is that by this mechanism of the escapement the wheels in the movement are prevented from having their revolutions accelerated, which would take place to such a degree as to make the machine run down in a minute or two ; whereas from the resistance opposed by the pallets, it is kept going for twenty-four or thirty hours, for a week or a month, or even

for twelvemonths.”—*T. Reid, Treatise on Clock and Watch-making*, chap. viii., page 172. 1859.

CAMUS makes the following remarks on the escapement wheel:—

“1st. The teeth of that wheel must be larger or farther distant from each other than those of the other wheels; it ought therefore to have fewer teeth than the rest: in watches it has never fewer than thirteen teeth, and never more than seventeen, unless it be very large.

“2nd. When the teeth of the escapement-wheel strike alternately the two pallets of a common balance, the number of them ought to be odd; for the verge of the balance must pass through opposite to the middle of that wheel, in order that its teeth may make alternately equal impressions on the two pallets. But the verge of the balance being thus disposed, if the number of the teeth of the escapement-wheel were even, two opposite teeth of that wheel would meet at the same time, and in the same manner the two pallets, and the balance being impelled at the same time by two equal and opposite forces, would stop. On the other hand, if the number of the teeth of the escapement-wheel were odd, all its teeth would be diametrically opposite to its spaces. While one pallet, therefore, would be met with and impelled by one tooth, the other pallet would be free in the space opposite to that tooth; so that the teeth of the escapement-wheel would never touch both pallets at the same time, but would fall upon them alternately, to give the balance vibrations alternately contrary.”—*A Treatise on the Teeth of Wheels. E. and F. N. Spon, London.*

CHAPTER II.

DEFINITIONS OF WORDS AND TERMS USED IN WATCH-
WORK.

ARBOR.—Axis, is the shaft for a wheel, or pinion.

AXIS.—A fixed line on which any body revolves.

BALANCE.—A balance is a circular ring of metal having every part perfectly equal, with its circumference concentric to an axis terminating at each end in pivots. It is also necessary that this ring should rest in equilibrium on its axis, no matter what the position in which it may be placed.

BALANCE-WHEEL.—The last wheel in the movement, called also escape-wheel, the teeth of which act on the pallets attached to the axis of the balance. The same wheel is termed in clocks the *swing* wheel.

“The drop from each tooth of the swing or balance wheels on their respective pallets, giving one beat or impulse to the pendulum, or balance, in order to keep up or maintain their motion, and were it not for the pallets which alternately stop the teeth of the swing or balance wheels, the motive force would have no check.”

—*Reid*, page 172.

BALL.—The bob of a pendulum; name used to

indicate the mass or weight applied to the lower end of the rod. Shape generally lenticular.

BANKING means stops so placed as to prevent the escapement receiving any injury from the balance moving too great an arc.

BARREL.—A box in shape like a drum, constructed to hold the main-spring; one end having a cover to lift off, in order that the main-spring may be inserted. The winding arbor passes completely through it: one end of the spring is attached to the inside rim of the barrel, the other is hooked on to the arbor.

BAR.—A flat piece of metal screwed at each end into a plate, for the purpose of sustaining a third wheel pivot.

BEVELLED WHEEL.—Commonly used for changing the direction of any two axes. In a bevelled wheel the surface of the teeth converges to a point where the axes of the two wheels ought to meet. When the teeth are oblique then they work with their axes in a different plane, provided the work is to be done only in one direction.

BOLT AND SHUTTER.—Used in large clocks to keep them going during the act of winding. An improved one, invented by *E. B. Denison, Esq.*, which can be thrown out of gear instantly the winding is finished, and has the advantage of causing it to be impossible to commence winding without first raising the lever to its proper height.

BUSHED.—When a pivot hole in a plate, not jewelled, is pierced, it is customary to insert a piece of hard

metal, brass, for the pivot to work into; this process is called bushing. In course of time the pivot hole may lose its proper shape, through friction and bad oil; the hole is again bushed by passing through another piece of brass.

CALLIPERS.—A gauge. An instrument or tool used for the purpose of testing the correctness of the weight of the balance or any other wheel. It is in shape somewhat like the figure eight, 8, and has a joint at meeting of the arms in manner of a pair of scissors. The pivots of the arbor and its wheel are inserted between the points of the callipers when opened, the workman holding the tool upright, strikes gently with a piece of metal the side of the callipers, so as to cause the wheel to revolve, occasionally blowing gently with the breath from mouth; should the wheel be untrue in the distribution of its weight, or not on the flat, that is, perfectly horizontal to the edge of the callipers, the heavy part will fall necessarily downwards, thereby indicating the faulty part; or the wheel will wobble as it revolves, proving it not to be at right angles to its axis. If the wheel be true, and on the flat, it will revolve perfectly, proving each part to be in equilibrium.

Again, when the teeth of the wheels are cut, and the diameter of the pinions is to be taken from them, spring-pinion callipers or gauges are used. For example: if it be required to make a pinion of twelve leaves, open the callipers by means of the screw-button at the side, so as to take in five teeth of

the wheel freely on the points, that is, from the outer flank of the first tooth to the outer flank of the fifth, inclusive.

CALLIPERING.—*Callipering is thus described by Bees, in his Encyclopædia.* “We come next to laying down the plan or calliper of the clock movement on paste-board, to be transferred to the plates of the frame when properly hammered, filed, and scraped, or planed; the disposition of the calliper depends not on the acting, but on the geometrical proportions of the wheels and pinions, conjointly with the disposition of the circles of indication on the face; when the wheels are small, such as we have chosen for our example of a half-second pendulum, the distance from the minute to the second hand will not be too great for an ordinary face, if the arbors are pivoted in a straight line, as in the figure, where the dotted circles represent the geometrical proportions, or the places of the pitch lines, and the complete circles of acting diameters in inches, are supposed to coincide with the extreme ends of the teeth; hence the little spaces contained between the dotted and complete circles, at each side, represent the additional measure and half of each wheel and pinion, such as were determined by calculation, to convert the actual size, or such as are given by the large Table of geometrical diameters and addenda. It is evident, therefore, to the eye, that the distance between any two arbors or pivot holes is always equal to the sum of the geometrical radii of the wheel and pinion, which act together; this considera-

tion renders the business of callipering very simple; for, the centre wheel of 64 being described from any

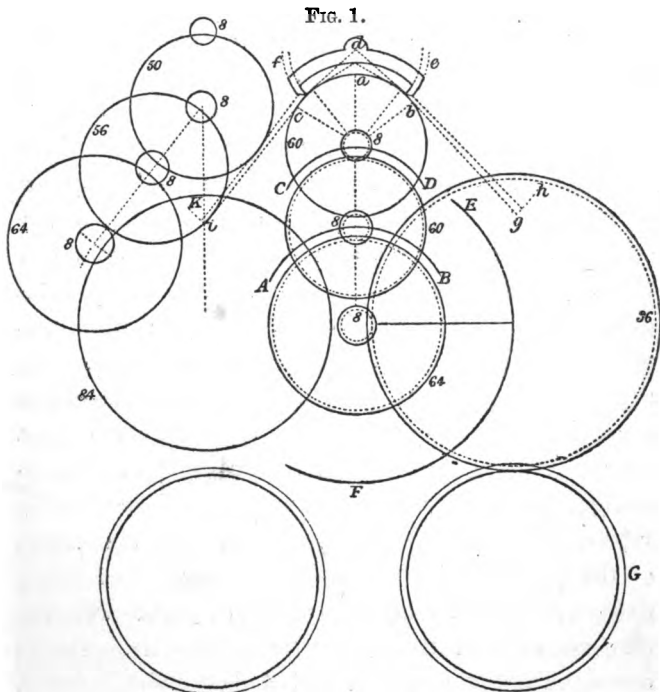

convenient point in the given plane, a portion of a large circle, A B, may be described with an extent equal to $\frac{1.46 \times 0.18}{2} = .82$, or $\frac{82}{100}$ of an inch, which is half the sum of the geometrical radii of the wheel 64, and of its pinion 8, and the pivot hole of the pinion may be in any point of this chord line; we have fixed upon a point in a line parallel to the

side of the plate, from which, as a centre, we describe the second wheel of 60, and also the pinion of 8 on its arbor, to be actuated by the centre wheel of 64; we now take another sweep from this determined point or pivot hole, with the extent $\frac{1 \cdot 19 \times \cdot 16}{2} = \cdot 67$, or $\frac{67}{100}$

of an inch, which is again half the sum of the geometrical radii of the second wheel and its pinion, according to our Table; and the pivot hole of the second arbor, or pallet wheel, may be in any point of the chord CD; but we have said we proposed to have all the pinions in a straight line, another point is consequently fixed upon in a line parallel to the edge of the plate, which could not have been the case if the wheels had been large, like those usually adopted to sustain the great maintaining power of a seconds pendulum.

“Again, with the extent $\frac{2 \cdot 55 \times \cdot 21}{2} = 1 \cdot 37$, or $1\frac{37}{100}$

inches, or sum of the geometrical radii of the great wheel and centre pinion, which it actuates, we describe the portion of a circle EF, in any point of which the pivot hole may be placed for the fusee arbor; we have placed it in our calliper, in a point at right angles to the line of the centres of the train, which is a matter of option, and the spring barrel may be either above, below, or on one side of the fusee, as fancy, or the room left by the other work, may direct. From what has been said, it will be easy to conceive that there is almost an endless variety in calliper-

drawing, the disposition depending on the variable sizes of the wheels and pinions of a movement, compared with the distance from the seconds to the minute hand arbors; but the particulars we have here detailed, being thoroughly understood, will suffice as a guide in all possible cases; for, supposing a face to be previously given, and the centres for the minute and seconds hands already made, the pivot hole for the second wheel may easily be determined by intersection from the two given centres with the respective extents as above determined; provided the diameters of the wheels be calculated large enough for the distance of the given centres; that is, provided the aggregate of the geometrical radii of the two interposed wheels and pinions exceed the said distance."

CANON is a tube intended to pass over an axis, or arbor, and capable of being moved, or rather receiving motion different in duration from that of the axis.

CENTRE OF GRAVITY.—In a pendulum it must be above the centre of oscillation, the latter being a fixed point, the former not so, but in common both are above the centre of the bob or ball.

CENTRE OF OSCILLATION, or percussion of a compound pendulum, is the point where all the weight of the body which oscillates may be brought without changing the time of the vibrations. Called likewise *centre of percussion*, because it is the point where the whole effort combines, where the percussion must be strongest, and where all the parts would remain in equilibrium if the pendulum should be stopped at this

point; supposing that the point of suspension produced no resistance, and became free at the moment of percussion.

CHAIN.—The chain which is used for the purpose of connecting the fusee and barrel is composed of small links, all of the same size, cut out of sheet steel somewhat in the shape of the figure 8, with holes drilled through at equal distance from each end.

These links are of two kinds: one consists of a single piece only, the other of two placed parallel to each other, and they occur alternately. Each end of a single piece is inserted between the ends of the two parallel ones, and connected together by a rivet passing through all three. Great attention must be paid to the drilling of the rivet holes, in order that the chain may bend evenly, and run perfectly straight, otherwise the chain would never coil round the barrel, or on to the fusee. A small hook is placed at each end of the chain, one to attach it to the barrel, the other to the fusee.

Christchurch, in Hampshire, is the place where they are chiefly manufactured.

CHRONOMETER.—This word is compounded of two Greek words, *viz.* χρόνος, time, and μέτρον, a measure, and signifies any instrument specially adapted for the exact measuring of time.

When watchmakers speak of chronometers they usually mean timekeepers intended for the use of navigators, with a detached escapement on Earnshaw's principle.

Pocket watches have of late years received the same name when with Earnshaw's detached escapement and balance compensated for heat or cold.

CLEPSYDRA, from the Greek, κλεπτα, to steal, and υδωρ, water. Near the Acropolis of Athens existed an intermittent spring which obtained the name of Clepsydra.

When instruments for marking time by means of water were introduced they were nicknamed Clepsydræ.

COCK is the part which contains the top jewel work for the balance-staff pivot to work in, and is secured to its place on the plate by a screw and three steady-pins.

COGS.—Teeth which are perpendicular to the plane of a wheel; for instance, the upright teeth in a duplex escape-wheel.

COLLET.—A collar, used to join one or more parts together, and can be removed at pleasure.

CONCENTRIC.—The minute and hour hands of a watch are concentric, for they turn separately around the same centre.

Eccentric is the reverse, not to have the same centre of movement.

CROSSING.—Vibration of the balance.

CYCLOID.—If a circle roll along a straight line, a point in the circumference of this circle will describe a curve which is called a cycloid: for example, a nail in the tire of a carriage-wheel rolling on a level road will trace in the air a cycloidal curve.

DETENT is a click. In an ordinary watch its object is to hold the maintaining spring in action, which

keeps the watch going during the act of winding, and is kept in its place by a thin spring which presses it into the ratchet teeth of the wheel called the-going-in-time-of-winding wheel.

DRAW has reference to the supplementary arc in the construction of lever pallets. The locking face of the pallets is formed at an angle so small as only to produce by the pressure of the scape-wheel a slight tendency inwards, called *the draw*: any excess of angularity on these faces might cause the watch to stop, or, technically, *make it set*.

EPICYCLOID.—When one circle is rolled on another circle, the curve traced by any point in the rolling circle is called an epicycloid to the other.

ESCAPEMENT.—This term usually signifies the effect produced by a wheel on a certain pallet or pallets connected with the axis of the balance; and of the pallets themselves on the wheel to regulate its motion.

The free or detached is that in which the greater part of the vibrations is entirely free, or independent of the wheels, the balance-wheel being locked: when unlocked it gives impulse, which only takes place at every second vibration.

FLY is employed to equalize motion, which it effects by the resistance offered by the air through which it is made to pass. It regulates the striking part of a clock.

FORCE is any cause which moves a body, or changes its motion, or tends to alter its natural condition, be it one of rest or motion, *viz.* its inertia.

In clocks the motive power is the *weight*. In watches the *main-spring*.

FUSEE.—A frustum of a cone round which a spiral thread is cut, and into which the chain passes from the barrel during the act of winding, thereby bending up the main-spring. The arbor on which the barrel turns is so fixed in the plate that it cannot turn when the fusee is winding up.

The spring when wound up is prevented turning back by a ratchet-wheel and click.

GIMBALS.—Ship or box chronometers are always hung on a brass frame which works on pivots, and is designed to correct or prevent as much as possible the effect of external motion reaching the balance.

HALF-TIMEING.—Now out of use; an expression of which present watchmakers are completely ignorant. It means rendering the exertion of the watch-work or wheels equal, or nearly so, to the spiral spring on the balance at the beginning of its vibrations.

The origin of half-timeing dates from the introduction of the pendulum-spring, for it was then perceived that its application made the balance give two vibrations in the same time that previously it gave only one without it.

HEEL.—In a horizontal wheel the two ends of the teeth are designated by the terms point and heel.

HORIZONTAL.—So called because the plane of the scape-wheel is horizontal with the top or fore plate of the movement; the reverse of the vertical or crown wheel in the verge.

INERTIA.—In every body there is a *vis inertiae* which is common to all, *viz.* to remain in whatever condition they may be, either of rest or motion, unless acted on by some external cause.

According to *Sir Isaac Newton*, “*vis inertiae* is a power which is implanted in all matter of resisting any change endeavoured to be made in its actual state.”

The inertia of a body is its quantity of matter considered as resisting the communication of motion.—*Whewell.*

ISOCHRONAL.—Derived from the Greek *ισόχρονος*, equal duration of time.

JEWEL-SLIP.—Contains a small precious stone to cover the back of the jewel hole, and against which the lower balance-staff pivot works; as in like manner the diamond on the top of the cock is the cap or cover of the jewel for the top pivot to work against.

LEVER.—Is a rigid rod movable in one plane about a point which is called the *fulcrum*.

The parts which lie between the fulcrum and the points are called the *arms*.

When these arms are in a straight line, then the lever is called *straight*; when otherwise, a *bent lever*.

MAIN-SPRING.—The motive power; a fine steel spring neither too hard, nor too soft, but of good temper, and capable of being coiled, or turned up close.

A thick or coarse spring will frequently break more easily than a thin one, besides having the disadvantage of taking up too much room in the box or barrel.

When hard it snaps, when soft it relaxes ; a good spring is therefore invaluable.

MOTION WORK.—The parts of a watch which lie between the dial and the fore plate, especially in repeating watches.

PARACHUTE. PUMPING-PIECE.—Very many Breguet watches have this addition to them.

The jewel cover of the balance-staff is not screwed down as in ordinary watches, but is set into a piece of steel which is fixed to a small spring running against the side of the cock, to which it is screwed. Breguet supposed that if the watch received a sharp concussion or fall, the pivot of the balance-staff would most probably escape injury, as the jewel cover being movable, would yield to any undue pressure ; whereas in the usual plan of screwing tight the jewel cover, there is danger that the point of the pivot may break, or as frequently happens become flattened, and so bind the staff and prevent the proper vibration of the balance.

PENDULUM-SPRING.—Called also hair-spring. A fine spring in horizontal coils like a flat disk ; the inner end secured to the arbor of the balance by a collet called the pendulum collet ; and the outer end held by a pin in a stud, which is attached to the top plate.

PINIONS.—Made of steel, and formed into leaves, which pitch or play into the teeth of a wheel.

The wheel drives the pinion.

PITCHINGS.—The communication of the teeth of one wheel with those of another, or with a pinion of any kind.

Pitchings are usually tested by a Geneva pitching

tool, which has an advantage over Mr. Pennington's sector, that the workman can carry them in a correct state to the frame or plate of the watch. The actual working of the pitching is seen in the tool; and the depths or distances at which the pivot holes must be placed can be marked off on the plate (care being taken that the plate is held at right angles to the points), thereby ensuring the correct pitching. It is most essential that these depths or pitchings be correct, as should the wheel be too close on to the pinion a greater power or force is used than requisite; if the pinion be too distant from its wheel the power is partially lost, and an irregularity in the movement becomes at once apparent.

PIVOT.—The ends of an arbor or shaft reduced to a point so as to work into a jewel or brass hole. The part most distant from the point is called *the shoulder*.

PLATES.—Two in number,—

1st. *The top plate.*

2nd. *The pillar-plate.*

The bottom or pillar plate obtains its name from the circumstance of its having four pillars, the ends of which pass through holes in the top plate, and are pinned so as to hold the two together.

A *full plate* watch means one which has the top or fore plate complete; the balance vibrating between the plate and the cock screwed on to the top of it.

A *three-quarter plate* is one which has a portion, or nearly a quarter, taken away, and the cock for the

balance top pivot placed or sunk on a level, or even lower than the plate itself.

Modern watches are mostly of this construction, as it enables the whole of the movement to occupy less space in depth, consequently the cases can be made much more flat than in the old form of watch.

In Geneva watches the fusee is suppressed, and the great wheel is placed on the barrel.

POTENCE.—Is screwed to the inside of the top plate, and contains the jewel work which sustains the lower pivot of the balance-staff in verge watches.

RATCHET-WHEEL is a wheel with saw-like teeth, and which is not capable of pitching-in with either another wheel or a pinion, but has always a detent or click so placed with a spring to press against it and keep it to one way of rotating.

The going-in-time-of-winding wheel is a steel ratchet-wheel.

Inside the fusee is a ratchet-wheel with two clicks, to prevent the fusee going back during the winding.

A ratchet-wheel and click is used to hold the main-spring when bent up.

REMONTOIR.—The motive power passing through the wheels may at times be unequally impressed upon the escapement, either of a clock or watch; hence came the idea of a remontoir, that is, the movement should at intervals be made to wind up either a small weight, or bend up a delicate spring which alone should give its force to the escapement, by which means the pendu-

lum or balance is supposed to be always impelled by an equal and uniform force.

The earliest date of use, 1600.

Huyghens applied some to his clocks.

Harrison had one in his timekeeper which gained him the Parliamentary reward in 1736.

Reid considers them of no great value, more especially in a watch, for the isochronism of the balance-spring is sufficient of itself to correct any inequalities whatever in the motive force.

ROLLER.—Usually fits tight on to the balance-staff, and is the part in a lever or chronometer which receives the impulse that gives motion to the balance.

RUNNINGS OR RUNNERS.—The wheels and pinions which serve for the repeating part of a repeating watch.

SCAPING.—By scaping is meant the arc which the balance must necessarily move in order that the wheel may go forward.

SCREW.—Made of fine steel, having a spiral thread around it, to work into a hole tapped with a similar thread.

SHAKE.—The freedom which it is necessary for all the pivots in watch-work to possess; for if there should happen to be any over-tightness in a pivot, either endways or sideways, the probability is that the watch would immediately stop.

SLOT is a watchmaker's term for a notch or piece cut out of the circumference of a disk, or ruby-roller.

SNAIL.—A particular shaped kind of piece divided into twelve parts, in the form of steps, coming in gradually from the circumference of a circle towards the centre, and is used in the repetition work of repeating watches. It is fixed on to the star-wheel, and so designed as to regulate the striking of the hours.

SNAP.—Watch-cases are said to snap when there is no spring used, to cause them to lift by the pressure of the nail on a push-piece in the handle.

SPRINGER.—This term is generally used with reference to chronometers, and means a workman who is capable of making and fitting a spring to the arbor of the balance, and properly adjusting to time. In the whole of Clerkenwell there are few able to do well this most needful part of a compensated timekeeper, for the simple reason that not only is a correct eye, delicate hand, and good judgment required, but more especially an accurate knowledge of the nature and isochronism of springs. In fact, the springing a chronometer demands of the workman the most complete knowledge of every branch of the watch trade.

SQUARE.—The upper end of the barrel-arbor on to which the key fits for the purpose of winding. A square when needed may be applied to the end of any arbor.

STEADY-PINS are riveted into a supporting piece, and take into holes in the plate made exactly to fit them.

STOP-WORK.—A simple contrivance intended to check

the winding up of the main-spring, and, as its name indicates, to act as a stop.

STRIP is usually said of a wheel when its teeth have received injury from contact with something sharp or cutting; for example, if the ruby-roller of a duplex be broken and a portion remain on the staff, the teeth of the scape-wheel will, by revolving against the jagged edge, be cut off; the wheel is then stript.

STUD.—A small piece of metal designed to hold some portion of the movement, as pendulum-stud, cap-studs, &c.

SWING-WHEEL.—The last wheel in a clock movement, corresponding to the balance-wheel in a watch.

TRAIN.—This term means the beats given by the alternate motion of the escapement, which consists of a determined number in a minute or an hour, and depends on the number of wheels in the movement, their number of teeth, on the number of the pinions, as well as the number of the leaves.

TRUNDLE.—Another name for a lantern pinion; the leaves of which are called staves.

VIBRATION is the movement to and fro of the balance when acted on by some motive power. The distance which it describes in vibrating is measured by arcs, which may be either great or small.

WHEEL.—A circular piece of metal, flat and thin, having its edge cut into a number of teeth, and adapted to communicate motion to another wheel or pinion.

The teeth of a wheel ought to be considered as a

series of levers of the same length having a common centre.

When a wheel turns a pinion it may be said to *drive* it, and when a pinion turns a wheel it may be said to be *leading* the wheel; the one being a quick, the other a slow motion.

“When the curves of the teeth are badly made, the wheel drives the pinion with different degrees of force, from whence it happens—

“1st. (If this wheel communicates its force to a balance), that the balance loses its isochronism, or, which is the same thing, that it vibrates with different degrees of velocity, and that the time of the vibration changes according to the different actions of the wheel on the pinion.

“2nd. That the force of the mover to turn the pinion ought to be greater than it would be requisite if the wheel made the pinion to turn in an uniform manner. This excess of motive force, of itself alone, tends (independently of other variations) to destroy the machine by the friction which it causes, and these at length produce variations to the regulator. If a wheel drives a pinion which is too large, or, which is the same, whose teeth or leaves are more distant from one another than those of the wheel, the force communicated by the wheel will in part be destroyed by the leaves of the pinion which butt against the wheel teeth; this force so destroyed will require that a greater motive force be used to keep up the motion of the machine, from which will result friction, wearing, variations, &c. If a wheel

drives a pinion which is too small, or whose teeth or leaves are less distant than those in the wheel, it will happen that a tooth of the wheel acting on a lever or tooth too short, the pinion will turn with less force and more velocity, as will be seen afterwards. It will again follow from this that a part of the force of the wheel is lost by the drop or fall of the tooth driving, to that of the next which it is to drive; the pinion will then turn with a part only of the force of the wheel. Thus the mover will require to have a greater power than it would have required if the wheel drove the pinion uniformly. This excess of force, and inequalities of the pitchings, will tend to destroy the machine and to make it vary, &c., as above stated.

“And, *lastly*, wheel-work being composed of wheels and pinions whose pitchings are bad in certain movements, each wheel will act on its pinion with the greatest advantage; then, the force transmitted to the regulator will be the greatest possible: and in other instances, each wheel acting on its pinion with the least advantage, the force of the mover will be as it were annihilated. The regulator (pendulum or balance) will receive only small impulsions. Now, the force of the mover ought to be sufficient for the least favourable case in the pitchings; it is, then, too great in the most favourable case, from whence arise the inconveniences which have been already remarked.”—*Treatise on Clock and Watch-making*, by Thos. Reid, page 90.

CHAPTER III.

TOOLS REQUIRED FOR WATCH-WORK.

1. A motion arbor, or arbor for turning wheels on, with a fastening nut.
2. Motion arbor, that screws up to the shoulder, with a small nut to fasten.
3. A plain arbor for collets or tubes, to hold by friction.

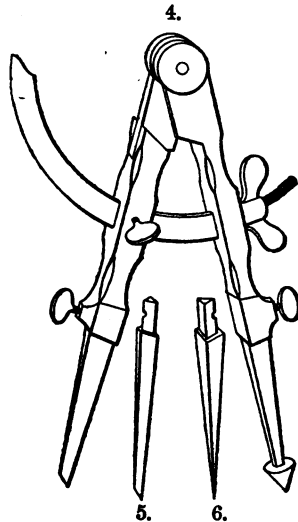
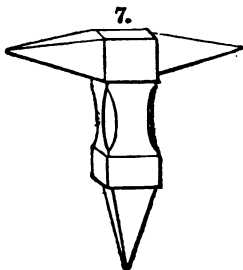
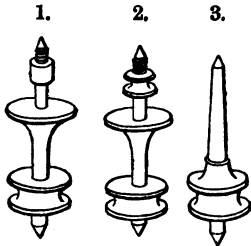

4. A pair of cutting bullet-compasses for fitting any central hole, in describing or cutting circles.
5. A cutting leg for ditto.

6. A marking leg for ditto.
7. A stake or small anvil for hammering on, &c.
8. Common flat short-nosed pliers, for holding fast any piece of metal.
9. A ferrule in two halves, with adjusting screws, so that it may be fitted to any drill or arbor.
10. Common callipers, for measuring diameters.

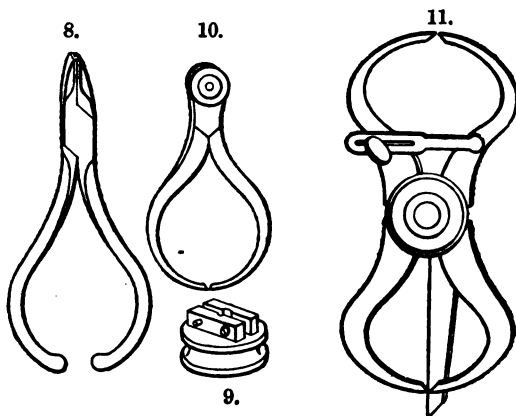

11. A pair of callipers, with a straight-edge, adjustable by a thumb-screw, of use for trying if a wheel is placed at right angles to its arbor, or what is called on the flat; and also if it is perfectly concentric, or in the round.
12. A frame gauge, inside and out.
13. A pinion gauge, with spring and screw adjustment.
14. Beam compasses for cutting out circular pieces of metal from a solid plate, describing large circles, dividing rectilinear and curvilinear lines, &c.
15. A clamp for holding pieces of metal to be filed or riveted.
16. A square, or rectangular piece of brass.

17. A tool for turning pivots in when inserted into the end hole of the turning frame.

18. A drill arbor and drill in a socket for various drills, to be used with a bow and gut.

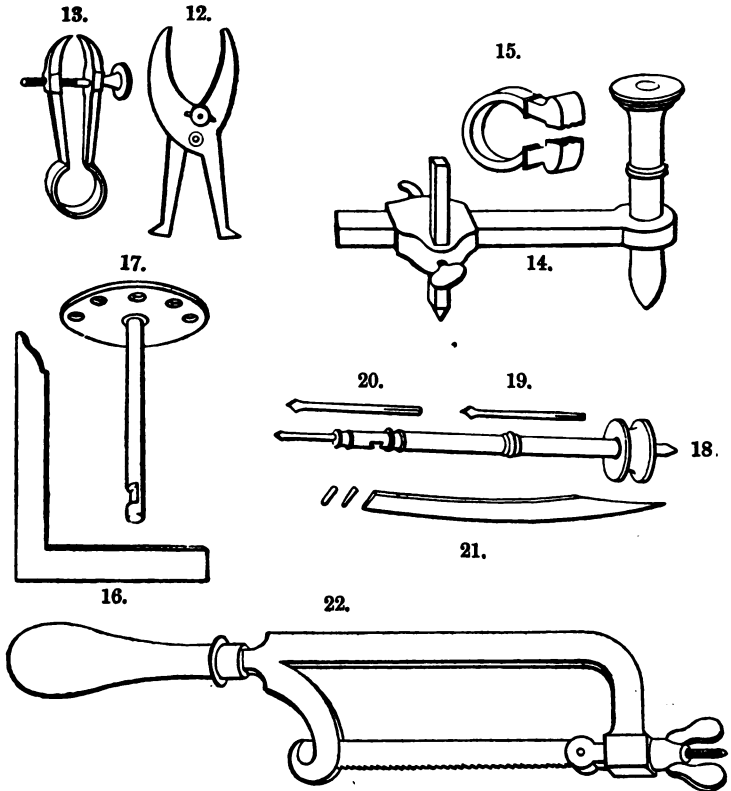

19. A drill detached to fit the said arbor.

20. A drill of larger size.

21. A tool, or graver, for cutting grooves, which may be of various shapes and sizes.

- 22. A saw for metal, with a wooden handle.
- 23. Cutting-pliers for shortening pins, or for cutting wires.
- 24. A detached ferrule for a drill arbor.
- 25. A slit arbor for holding and turning small pieces of metal.
- 26. A screw-plate, with different holes tapped.
- 27. A bench-vice, or vice to be clamped to a bench.

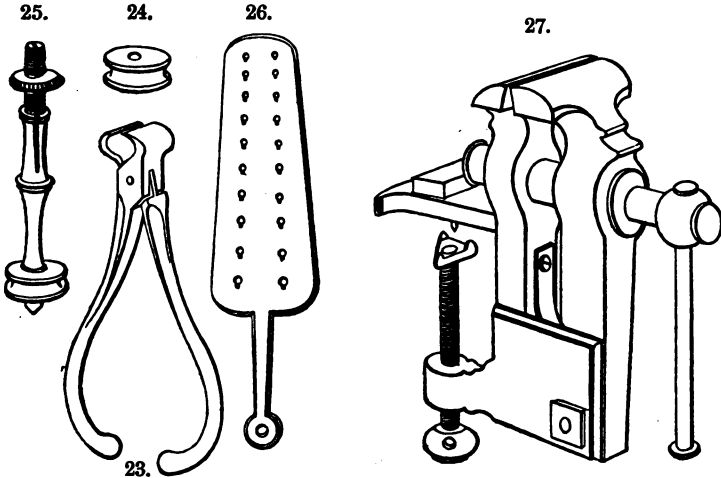

- 28. A hand-vice, for holding a small piece fast.
- 29. Pendulum, or long-nosed pliers.
- 30. Clamping pliers, for holding pins, &c., fast in filing.
- 31. Pivot drill with a friction ferrule.
- 32. A tap, to be held in a hand-vice, for making a female thread in any hole.
- 33. A screwdriver, of which there are various dimensions.
- 34. A drill arbor in a drill frame, to be held in a bench-vice.
- 35. A drill to fit the socket of the arbor when it has a square tapering hole.
- 36. A screwhead tool, including the arbor and frame with a rest, to be put into a bench-vice.

37. A holding piece of ditto, detached from the end of the arbor, and tapped with a female thread to hold the screw to be dressed.

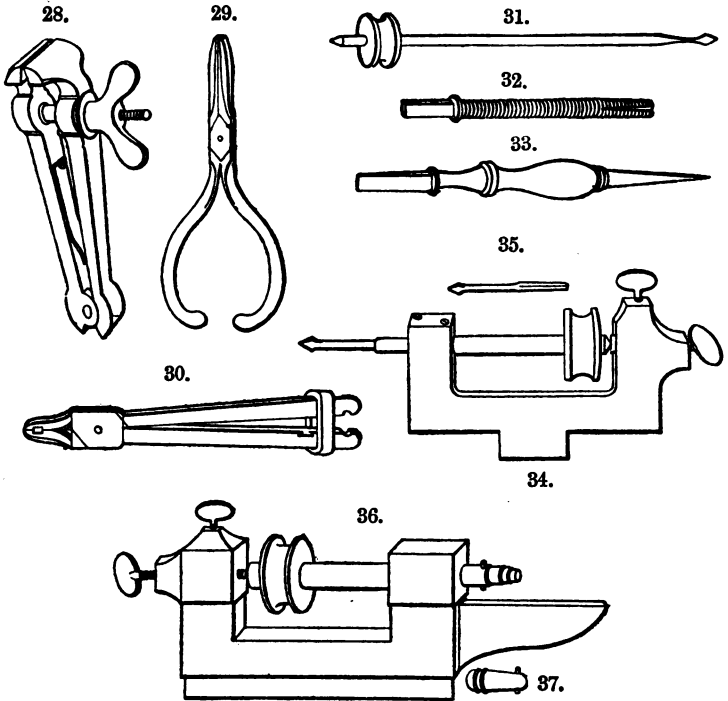

38. A brace for receiving various bits.

39. A chamfering, or counter-sinking, tool, to fit the brace, for which a large drill may be substituted.

40. A pentangular or five-sided broach, to fit ditto.

41. A round broach, to fit ditto.

42. A square broach, to fit ditto.

43. A deepthening tool, for adjusting the engagement of wheels with wheels or pinions.

BERTHOUD gives, chap. xix., vol. i., p. 196, a very accurate

description of the use of this instrument, which he says was known in Lepaute's time:—

“The wheel and pinion being nearly formed, the distance
38.

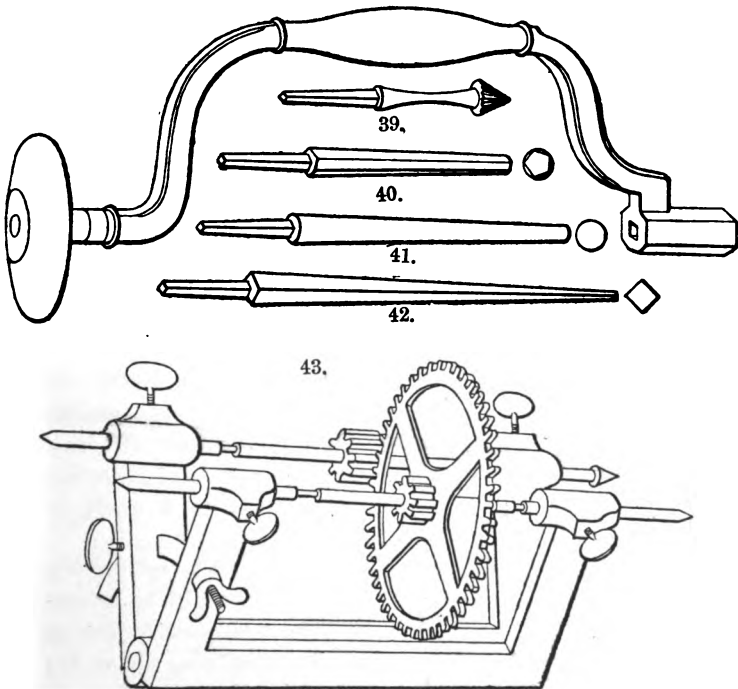

which ought to be between the centre of the wheel and that of the pinion may be determined: we change the curve, if badly made, which is found out by turning the wheel and pinion. When both of them turn with the same velocity and without shocks, it is a proof that the pitching is well done. We learn by the same means if the pinion be too large, for then it butts and leads too much before the line of centres; if too small it moves during a short period with velocity and after the line of centres. This instrument, therefore, serves

to examine into the defects of the pitching, and at the same time enables them to be corrected."

44. Turning frame, or clock-lathe, of which there are various sizes and constructions, some going by a bow like the present one, some by a hand-wheel, and some by the foot with a large wheel and crank actuated by a lever, which is trodden upon.

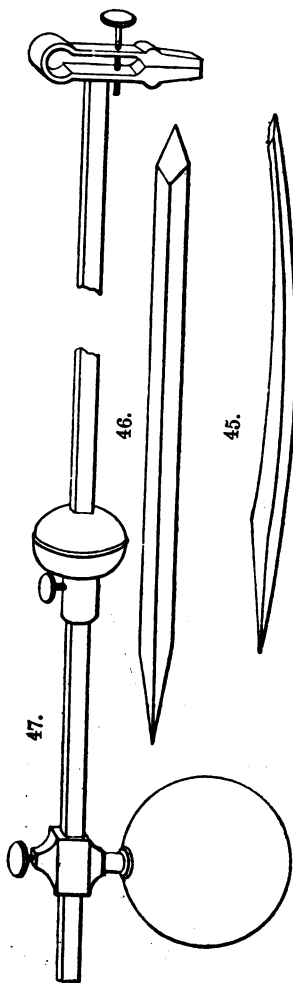

45. A graver for cutting the metal in a turning frame.

46. A large ditto.

47. An adjusting tool for fusees, with sliding weights, to suit any given maintaining power of a clock or watch.

48. A triangular tapering file.

49. A file for slitting or cutting the teeth of pinions.

50. An equalizing file, or file for the spaces between the teeth of a wheel, when cut in an engine.

51. A common hand-file, with a safe edge for ordinary work.

52. A rounding-off file for the ends of the teeth of wheels and leaves of pinions.

53. A file for crossing out, or forming the arms and rim of a wheel.

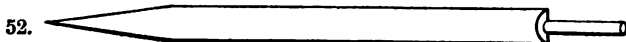
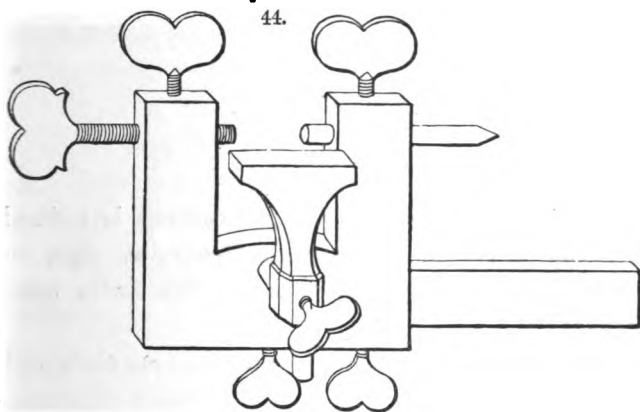

In very small wheels the arms are omitted, and the rim of teeth united to the central boss by a thin continuous plate; such wheels are usually called *plate-wheels*, to distinguish them from those in which arms are *crossed out*.

CHAPTER IV.

TIME.

THE science by which time is measured is termed *Horology* from the Greek word $\Omega\rho\omicron\lambda\omicron\gamma\iota\omicron\nu$, $\Omega\rho\alpha$, an hour, and $\lambda\epsilon\gamma\omega$, to read; hence the Latin word *Horologium*.

The machines adapted to measure time are *clocks* and *watches*.

Before proceeding to a description of the mechanism whereby the hours, minutes, and seconds of the day are indicated, it will be advisable to define the meaning of time.

There are *three* kinds of time :

APPARENT, MEAN, SIDERIAL.

APPARENT, called also *true*, or *solar*, and *astronomical*, is derived from observations of the sun.

MEAN, called also *equal*, or *equated* time, is a mean or average of apparent time, which is not always equal.

SIDERIAL, as its name indicates, is shown by the diurnal revolution of the fixed stars.

APPARENT TIME is taken from the sun at noon, the moment it reaches its highest altitude, and is unequal.

Suppose a true sun-dial, and a clock with seconds, accurately constructed to move equably, be timed to-

gether at noon, it will be found that on only *four* days in the year will they be to the same second of time.

The sun will be either in advance of the clock, or the clock before the sun.

This arises from two causes.

1st.—That the earth rotates around its own axis.

2nd.—That while so doing it moves along its orbit, or ecliptic, or path around the sun.

It is evident that if the earth possessed but one motion, the rotation on its axis, time would be always without variation, and therefore agree with the clock.

In order the better to understand this, the reader has only to examine the diagram in which the sun is represented by the letter S.

The earth by letters A A'.

The meridian of any town by D M.

Ecliptic by O O.

Every place or town has its own meridian which passes at right angles to the equator through the poles, and which if prolonged would pass through

the centre of the sun when at its altitude, *viz.* noon.

Now, when the earth is at A,

Let M D, the meridian of a town, be prolonged to S. Suppose next that the earth has advanced in its

FIG. 2.

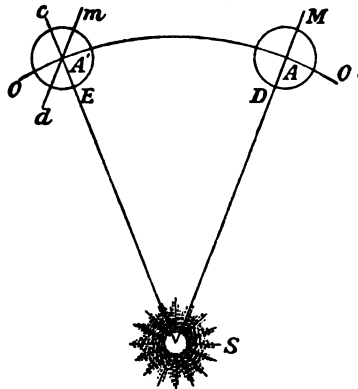

orbit to A' while making one rotation around its axis.

Then the meridian MD will be at md parallel to MD in its first position.

But in this new condition, if prolonged, it will not pass through the centre of the sun as seen by the line CES .

It must still describe an angle EAd before its meridian can pass through the sun. Thus the clock is before the sun by the number of minutes or seconds contained in that angle, or the solar day is longer by so many seconds or minutes.

There is again another consideration—

The earth does not run through its orbit with a uniform motion, for when most distant from the sun it describes a small arc, and when near, a larger arc in the same period of time, called *eccentricity of orbit*, consequently these angles formed by the meridian of any place, and the line drawn through the sun, are always varying every twenty-four hours.

Further, as the meridians are always perpendicular to the equator, and not to the ecliptic, this also would be sufficient to cause an inequality of time in the twenty-four hours, the angle of obliquity being $23^{\circ} 27' 46''$.

It is these inequalities which constitute the equation of time, and which have been calculated and drawn up into *Tables of the Equation of Time*, and may be seen in any nautical almanack.

The **MEAN TIME** is deduced from the *Apparent* by adding or subtracting the equation as directed in these tables.

FLAMSTEAD, Astronomer Royal, drew up the first equation tables in 1672.

A SIDERIAL day is the interval, always uniform, between two successive transits of a fixed star over the same meridians.

The reason why the fixed stars make their revolutions in equal times is due to their immense distance, and to the uniformity of the earth's diurnal rotation around its own axis.

A sidereal day is *shorter* than the mean solar day by as nearly as possible 3 min. 56 sec.

This difference is caused by the apparent annual motion of the sun from west to east, leaving as it were the star behind.

Now keeping this in mind, suppose the sun and any fixed star be observed on any given day to pass the meridian at the same instant of time: when the star returns on the next or following day to the same meridian, the sun will have advanced as nearly as possible a degree easterly; and as the diurnal rotation of the earth on its axis is from west to east, the star will come to the meridian before the sun; and in the course of a year the star will have gained a day on the sun, or the star will have passed the meridian 366 times, sun 365; which reduced to time is nearly 3 min. 56 sec. excess of a mean solar day above a sidereal day.

CHAPTER V.

HISTORICAL SUMMARY TO THE END OF THE FIFTEENTH CENTURY.

THE most ancient method employed for marking time was by *sun-dials*. There is every probability that they were in use from the earliest period of civilization; even the most uneducated races must have perceived that at certain hours of the day the shadows of particular objects lengthened and shortened according as the sun appeared to them in the firmament of the heaven above.

“Le ciel est une horloge constante et perpétuelle: le ciel enveloppe la terre, et dans l’hypothèse de *Ticho*, il tournoit autour d’elle pour mesurer les jours: la lune renouveloit ses phases pour indiquer la semaine: le soleil et la lune parcourent leurs orbes pour faire les mois et les années.”—*History of Modern Astronomy, by Bailly*, vol. i. p. 340.

One decided advantage *sun-dials* possess over every other description of timekeeper is that they indicate the *true time*.

Dials are of different form, construction, and situation, *viz.*: *Erect or direct dials*, which directly face any one of the cardinal points, North, South, East, or West.

Inclining dials, whose planes incline, or bow forward, towards the horizon.

Parallel dials, otherwise called *horizontal dials*, because they lie parallel with the horizon.

Perpendicular dials, such as stand perpendicular to the horizon.

Equinoctial dials, such as are described on the equinoctial plane.

Vertical dials, such as are drawn on the plane of a vertical circle.

Polar dials, those which are described on a plane passing through the poles of the world, and the east and west points of the horizon.

Mural dials, such as are placed against a wall.

Universal dials, those which serve for all latitudes.

THE REV. C. W. KING, Senior Fellow of Trinity College, Cambridge, in his paper on the Clepsydra, published in *Early Christian Numismatics, and other Antiquarian Tracts*, Bell and Daldy, 1873, says:—“Vitruvius assigns to Berossus the Chaldean the invention of the concave sun-dial (the usual form with the ancients), the ‘hemicyclium excavatum et quadrato’; to Aristarchus, of Lamos, the convex kind, the ‘hemisphœrium,’ and also the horizontal dial; to Scopinas, of Syracuse, the vertical, ‘plinthus, lacunar,’ one of which was set up in the Circus Flaminius; to Theodorus that of all latitudes, πρὸς πᾶν κλίμα, an invention implying an extraordinary proficiency in the science.”

Mention is made in the *2nd Book of Kings*, chap. xx. ver. 11, of the sun-dial of Ahaz, B.C. 741 to 726.

L. PAPIRIUS CURSOR set up the first sun-dial at Rome, B.C. 301.

PLINY writes of the sun-dial of Augustus, "Ei qui est in Campo, divus Augustus addidit mirabilem usum ad deprehendus solis umbras, dierumque ac noctium magnitudines, &c."—*Lib.* 36, chaps. 9, 10, 11.

It is reported of the Tartar chief Ulug-beg, grandson of Tamarlin, 1430, that he made use of a gnomon, or metal meridian, as elevated as the cupola of St. Sophia at Constantinople.

In 1653, Cassini, by permission of the Senate of Bologna, placed in the roof of the cathedral of Saint Petronna, a bronze plate having a circular hole pierced in it through which a ray of the sun passed, and cast its reflection on the meridian drawn upon the pavement beneath, exactly at noon. This work was completed in the year 1656.

A few years back any visitor to Paris might have seen an ingenious contrivance placed in the garden of the Palais Royal to indicate noon. A miniature cannon was fixed in such a position as to fire off its charge by means of a ray of the sun passed through a burning glass exactly at midday.

The number of well known sun-dials are too numerous to be mentioned.

THE SAND OR HOUR GLASS is of no great antiquity; and all the arguments based by some French writers on the authority of *Winkelmann*, that it was in use at Rome, fall to the ground when the actual words he made use of are examined.

WINKELMANN mentions an ancient bas-relief now in the Palazzo Mattei, Rome, representing the marriage of Thetis and Peleus, in which Morpheus may be seen holding in his left hand, *not an hour-glass*, but a *Clepsydra*, *similar in form to an hour-glass*.

Throughout the Middle Ages hour-glasses were in daily use in monasteries to indicate the various hours of prayer; and many persons of not advanced age can recollect their use in country villages and churches.

THE CLEPSYDRA evidently, as the name indicates, is of Greek origin, and was known both to Greeks and Romans long before the Christian æra.

There can be little doubt that this instrument in the beginning was extremely simple, probably consisting only of a vessel filled with water which discharged its contents in a given time. Then possibly came an improvement, that the vessel was, by means of a tube leading from a water-tank made to supply continually the vase or vessel with water, which drop by drop fell into a cistern, or basin, on which certain marks or gradations were drawn to indicate the hours of the day.

It was an instrument or machine of some such description which *Ctesibius of Alexandria*, B.C. 145, improved upon by adding a system of wheels moved by the weight of water, and was thereby enabled to indicate the hours, days, months, and signs of the Zodiac.

JULIUS CÆSAR discovered by the clepsydra that the nights were shorter in Britain than in Gaul. So many

mistakes have occurred in all books on Horology respecting the above assertion, that it is advisable to set the matter at rest by giving the actual passage, thereby proving that water-clocks did not exist among the natives, for how could they? but, that the clepsydra used was the special one belonging to Cæsar, which he had brought with him.

Cæsar de Bello Gallico, Book v. § 13. “In hoc medio cursu est insula quæ appellatur Mona; complures præterea minores subjectæ insulæ existimantur; de quibus insulis nonnulli scripserant dies continuos XXX sub bruma esse noctem. Nos nihil de eo pereambationibus reperiebamus nisi certis ex aqua mensuris breviores esse quam in continenti noetes videbamus.”

“In the middle of this passage is an island which is called Mona: several smaller islands besides are supposed to be adjacent, concerning which islands some have written that at the winter solstice the night lasts thirty consecutive days. Upon this point we obtained no information by our inquiries; except that by means of *accurate measurements by water* we perceived that the nights were shorter than on the Continent.”

Plato, Quintilian, Pliny, Cicero, make continual allusion to the clepsydra in their writings, to the use as well as the abuse of them. How various devices were employed to make the water flow fast or slow, till, as Plato declared, “philosophers are much more happy than orators, for these last are the miserable slaves of the clepsydra, whilst the former are at liberty to extend their discourse as long as they please.”

DERHAM, in the sixth chapter of his treatise, *The Antiquity of Clock-work*, says,—

“The first example is the *sphere of Archimedes*; who lived about two hundred years before our Saviour’s days. There is no mention of this sphere in *Archimedes* his extant works; but we have an account of it in others. *Cicero* speaks of it more than once. In his Second Book, *De Natura Deorum*, are these words, “*Archimedes arbitrantur plus valuisse in imitandis Sphæræ conversionibus, quam Naturam in efficiendis,*” &c. And in his *Tusculane Questions*, *Lib. I.* § 25, the Collocutor, proving the soul to be of a Divine Nature, argues from this contrivance of *Archimedes*, and says, “*Nam cum Archimedes Lunæ, solis, quinque errantium motus in Sphæram illigavit, effecit,*” &c. The sense of this is, that *Archimedes* contrived a sphere which showed the motion of the moon, sun, and five planets.

But the most accurate description is that of *Claudian*, in these words,—

Jupiter in parvo cum cerneret æthera vitro,
 Risit, et ad superos talia dicta dedit:
 Huocene mortalis progressa potentia curæ?
 Jam meus in fragili luditur orbe labor.
 Jura poli, rerumque fidem, legesque; Deorum
 Ecce Syracusius translulit arte Senex.
 Inclusus variis famulatur Spiritus Astris,
 Et vivum certis motibus urget opus.
 Percurrit proprium mentitus signifer annum.
 Et simulata novo Cynthia mense redit.
 Jamque; suum volvens audax industria mundum
 Gaudet, et humana Sidera mente regit.
 Quid falso insontem tonitru Salmonea miror?
 Æmula Naturæ parva reperta manus.

In *English* thus,—

When *Jove* espy'd in glass his heavens made,
 He smil'd, and to the other Gods thus said :
 Strange feats when human art so far proceeds,
 To ape in brittle orbs my greatest deeds.
 The heavenly motions, Nature's constant course,
 So here old *Archimede* to art transfers.
 Th' enclosed spirit here each star doth drive ;
 And to the living work sure motions give.
 The Sun in counterfeit his year doth run,
 And *Cynthia* too her monthly circle turn.
 Since now bold man hath worlds of 's own descryd
 He joys, and th' stars by human art can guide.
 Why should we so admire proud *Salmons* cheats
 When one poor hand Nature's chief work repeats ?

From this description it appeareth that, in this sphere, the sun, moon, and other heavenly bodies, had their proper motion ; and that this motion was effected by some enclosed spirit. What this enclosed spirit was I cannot tell, but suppose it to be springs, wheels, or pulleys; or some such means of clock-work ; which being hidden from vulgar eyes, might be taken for some angel, spirit, or divine power ; unless by spirit here you understand some aerious, subtilized liquor, or vapours. But how this, or indeed anything but clock-work, could give such true and regular motions, I am not able to guess.

The next instance I have met with of ancient clock-work, is that famous one in *Cicero*, which, among other irrefragable arguments, is brought in to prove “That there is some intelligent, divine, and wise Being, that inhabiteth, ruleth in, and is as an architect of so great a work, as the world is,” as the Collocutor expresseth

himself. His words (so far as they relate to my present purpose) are these:—"Cum solarium vel descriptum, aut ex Aqua contemplere, intelligere declarari horas arte, non casu," &c. And a little after, "Quod si in Scythiam, aut in Britanniam, Sphæram aliquis tulerit hanc, quam nuper familiaris noster effecit Posidonius, cujus singulæ conversiones idem efficiunt in Sole, et in Luna, et in quinque Stellis errantibus quod efficitur in cælo singulis diebus, et noctibus; quis in illa barbarie dubitet, quin ea Sphæra fit perfecta ratione?" The sum of the Author's meaning is, "That there were *Sun-dials* described, or drawn (with lines, after the manner as our sun-dials are)," and some made with water (which were the *Clepsydræ*, or hour-glasses, before mentioned). "That Posidonius had lately contrived a sphere, whose motions were the same in the sun, moon, and five planets, as were performed in the heavens each day and night."

The age wherein this sphere was invented, was *Cicero's* time, which was about eighty years before our Saviour's birth.

And that it was a piece of clock-work, is not (I think) to be doubted, if it be considered that it kept time with those celestial bodies, imitating both their annual and diurnal motions, as from the description we may gather it did."

Clepsydræ of every form and size seem to have been in use in private dwellings as well as public buildings at Rome. And once a system of wheels became known we can perfectly understand how improvement progressed and spread abroad.

A.D. 490. THEODORIC, King of the Goths, required of *Boëthius*, a distinguished Roman, two clocks which he designed as presents for Gondebault, the King of Burgundy—one a sun-dial, the other hydraulic, to serve by night.

Father *Alexandre* says of them :—

“ Environ l’an 490, le Roi Théodoric envoya à Gondebault, roi de Bourgogne, des horloges avec des personnes qui les scavoient gouverner. Dans l’une de ces horloges on voyoit jusques où peut aller la subtilité de l’esprit humain pour bien représenter toute la disposition et l’arrangement des cieux : sans avoir besoin du soleil on voyoit le cours du soleil ; et les heures étoient marquées bien distinctement par le moyen de l’eau qui s’écouloit goutte à goutte. Ces horloges étoient de l’invention de Cassiodore.”

A.D. 721. HANG or Y. HANG, the Chinese astronomer, made numerous marvellous additions to the clepsydra. It is said that he made a clepsydra to represent the movement of the sun, moon, and planets ; solar and lunar eclipses ; occultations of the stars. Two styles, or needle, marked the *ke*, or 100th part, by day and night, also the hours. When the one needle was on the *ke* a little wooden figure appeared, struck a blow with a hammer on a bell, then disappeared. When the other needle arrived at the hour, a second figure appeared, gave the proper number of blows, then retired.

A.D. 809. HAROUN AL-BASCHID, the celebrated Caliph, sent an embassy to CHARLEMAGNE, bearing presents, among them was a clock set in motion by water. The outer case was of brass, highly ornamented ; the hours were

indicated upon a dial. At the completion of every hour a number of brass balls dropped upon a bell, according to the hour marked, and gave the required sound. Instantly twelve doors opened to allow that number of knights, mounted and armed cap-à-pié, to issue forth, who after prancing their steeds through certain evolutions, retreated into the machine, and the doors closed upon them.

It may be necessary here to state that various opinions have been given as to the *motive power* of this machine. *Mr. King*, in the paper, before mentioned, on the clepsydra, has ventured to conjecture that the clock which Charlemagne received was moved by a spring or weights, because "Eghinhard, a man of considerable education, makes use of the expression 'arte mechanica mirifice compositum,' which he could hardly have applied to so old-fashioned a contrivance as a water-clock." But Father Alexandre Berthoud, and all writers who have investigated the subject, adhere to the opinion that the clock was a clepsydra, though wonderfully improved. Further, there is an unanswerable reason for its being a water-clock; had it been acted on by a new motive power such as a spring or weight, then there must have been a controlling power, in the shape of a balance, which certainly did not exist, otherwise it would have been instantly adopted for all timekeepers, and no incapability of workmen or others could have kept it a secret.

Whatever may have become of the clepsydra sent by Haroun Al-Raschid, there can be no question whatever

that it was only an improvement on the water-clock of Ctesibius.

These are the words of Father *Alexandre* —“ Cette horloge ne parait guères différente de celle de Ctesibius, dont parle Vitruve.”

In order the better to understand the clepsydra it is requisite that the reader should bear in mind, as Berthoud justly says, “ The water fulfils two functions, the one a *regulating power*, the other a *motive power*.”

“ Every drop of water which escapes causes by its fall a beat or interval, which exactly corresponds with the vibrations of our regulators; and it was through the equal duration of each drop that the correctness of these clocks used by the ancients depended: that duration depended not merely on the constant level of the water to a particular height in the reservoir from which the drop escaped; but also, more on the never-varying width of the orifice, or pipe, through which it actually made its escape; and, lastly, on the equal fluidity of the water.

“ The drops of water which accumulate in consequence of their fall, form by their mass, or quantity, the *motive power*, causing the wheels to revolve and mark the hours; whence it is evident that the equal duration of the revolution of the wheels, and as a matter of course the hours, was itself dependent on the regulating or controlling power, that is, on the dropping of the water.”

A.D. 850. PACIFICUS, Archdeacon of Verona, constructed a

clock which marked, besides the hours, the days of the week, the phases of the moon, &c.

It has been a matter of no small dispute among antiquaries whether this Pacificus did or did not employ a weight instead of water, for the motive power.

BAILLY, in his history of Modern Astronomy, argues very forcibly in favour of Pacificus, saying that he was the inventor of an escapement, in which the inertia of a balance was employed to retard and regulate the movement of a train of wheels moved by a weight.

If so able a man as Bailly had given any authority for his assertion, then the words applied to the Arch-deacon might be easily understood:—

“Horologium nocturnum nullus ante viderat.”

Father ALEXANDRE, in his treatise on clocks, before quoted, an exceedingly scarce work, examined into the probability of Pacificus being the inventor of the weight as the motive power, and decides against the claim.

BERTHOUD is also of the same opinion.

There can be little doubt that the eighth and ninth centuries were, with regard to Art and Science, far in advance of the previous ones. History declares that great encouragement was offered to men of talent during the period that CHARLEMAGNE held his magnificent Court at Aix-la-Chapelle; still it is not possible to discover any great progress in Horology, beyond the fact that complicated pieces of work *were* made, yet all moved by water.

The extraordinary clepsydra of Pacificus, the like of which had never before been seen, was remarkable only in having some addition which others had not possessed.

It is more than probable, almost certain, that to the *Moors of Spain* the world is indebted for the great advance in clock-work: and that from Cordova, Grenada, and Barcelona went forth the ideas which gave birth to the weight as a motive power instead of water.

It is well known that during and after the tenth century Science was greatly cultivated in the *monasteries*, whose Abbots being possessed of wealth, influence, and leisure, could assist all who displayed any mental capacity or desire to seek after knowledge.

Astronomy, Algebra, Geometry, Mechanics, Music, Poetry, were all in great repute. And not only the higher Clergy, Archbishops, and Bishops, but even ordinary Monks, vied with each other in their desire to acquire a profound knowledge of such subjects.

Let us render honour to whom honour is due! Let the palm be granted to GERBERT, the Monk, Bishop, Archbishop, and Pope, as the *originator* of the escapement which regulated the train, and the *weight* which imparted to it motion.

A.D. 920. At the village of Belliac, near the town of Aurillac, in Auvergne, was born, of poor parents, GERBERT, who when of sufficient age obtained employment as a shepherd boy.

It is said that when thus engaged he endeavoured to study the stars which shone so brilliantly above him

during his nightly watches; and afterwards amused himself by marking on the sand the various constellations as they had appeared to him.

He seems to have attracted the notice of Father Raymond, of the monastery of St. Gérald, order of St. Bennet, who immediately undertook to place him among the novices and superintend his education.

Once admitted to a place in the monastery, he devoted himself with ardour to study, and in a few years became as learned as his teachers.

About this time *Borel*, Count of Barcelona, came on a pilgrimage to St. Gérald, and hearing of the extraordinary talent of GERBERT, desired to see him. The interview led to no small results, for Borel was so captivated that he at once offered to take him into Spain, then under the dominion of the Moors.

In this year the two travellers crossed the Pyrenees, A.D. 955. journeyed to Catalonia, and took up their residence at Barcelona.

The following year GERBERT went to Cordova, then the Athens of Mahometanism and the residence of Abdel-Rahman III., a Prince who devoted his time and immense wealth to the advancement of Science and the encouragement of men of intellect.

For the space of four years GERBERT sojourned in this Moorish city, attending the lectures of the greatest professors of Andalusia, and forming friendships with men whose talents were of the highest order.

After leaving Cordova he proceeded to Grenada, where he met again Count Borel, and started with him

A.D. 961. for Italy. They arrived at Rome the 29th September, 961, and a few days after received audience of Pope John XII.

Here he was first presented to Otho the Great, and received every kindness from him.

Lothaire, King of France, had about this time sent an ambassador to Otho, who instantly made the acquaintance of GERBERT. Perceiving him to be a man of no common ability, he induced him to leave Rome, in order to return with him to Paris, where they arrived just in time to be present at the King's death.

In Paris, where Louis V., son of Lothaire, now reigned, he received all the attention which his great abilities merited; but a continual thirst for knowledge made him desirous to visit some of the then celebrated monasteries.

He accordingly sought new light at Fleury, Tours, Metz, Verdun, Toul, Liège, Gembloux, Trèves, and at same time acquired the friendship of some of the most distinguished Abbots then living.

At length becoming weary, and feeling his strength over-taxed, he sought quietness and repose at Rheims; but rest was not long permitted him; he was offered and accepted the Professorial Chair which the distinguished Hincmer had occupied. Notwithstanding the multiplicity of his labours, he still found time to pursue his favourite mechanical occupations, and probably made the clock of which it was said, "*Admirabile horologium fabricavit per instrumentum diabolica arte inventum,*"—the usual supposition of the ignorant that that

which could not be explained to their satisfaction must necessarily be the work of Beelzebub.

Certain it is that in 996 he made a clock for Magde- A.D. 996.
burg, which all writers agree in stating had a weight
for the motive power.

After various ups and downs in life, which may be
learnt in any history of the Roman Pontiffs, he became
Pope, under the name of Sylvester II., in the year 999, A.D. 999.
and died the 12th of May, 1003, illustrious for his know-
ledge of Science, independent of his dignity as Pope. A.D. 1003.

From the death of Gerbert the progress in Horology A.D. 1120.
must have been extremely rapid, so much so that in
the *Usages de l'Ordre de Citeaux*, published about the
year 1120, the sacristan is enjoined so to regulate the
clock that it should strike and give forth warning
before the matins.

Birth of PHILIPPE AUGUSTUS, during whose reign A.D. 1165.
striking clocks were common.

THE THIRTEENTH CENTURY was remarkable for its A.D. 1200
to 1300.
revival of art: Byzantine gave place to Gothic archi-
tecture; stained glass took the place of Mosaic work;
sculpture, pottery, enamels, goldsmith's work, all rose
to eminence. Can it be doubted that artists were
trained to the science of Horology?

A CLOCK, according to Stowe, was erected near to A.D. 1288.
Westminster Hall out of a fine of 800 marks imposed
upon Ralph de Hengham, Chief Justice of the King's
Bench, in the sixteenth of Edward I.

CLOCK IN CANTERBURY CATHEDRAL, placed there by A.D. 1292.
Henry the Prior. "Anno 1292, novum orologium

magnum, in ecclesia, pretium xxx li.”—*Cottonian MSS. Galba E. iv.*, 14, folio 103.

- A.D. 1317. CLOCK AT EXETER CATHEDRAL, of which an entry in the Fabric Rolls, 1376, runs—“Circa cameram in boreali, turre pro horologio, quod vocatur *Clock* de novo construendam.”
- A.D. 1326. RICHARD WALLINGFORD (*Vualingofordus*), Abbot of St. Albans, order of St. Benedict, constructed for the abbey a clock which, Leland says, showed the course of the sun, moon, and planets, the rise and fall of the tides; that it continued to go in his time—the latter end of reign of Henry VII. This clock was called *Albion*: “Quod dicitur Albion quasi totum per unum.”
- A.D. 1340. CLOCK AT GLASTONBURY, removed at dissolution to Wells Cathedral.
- A.D. 1344. CLOCK AT PADUA, planned by JACQUES DE DONDIS, made by a workman named Antoine.
- A.D. 1348. CLOCK AT DOVER CASTLE, with the mark \mathcal{JL} ; wheels and frame of wrought iron; escapement, a crown-wheel acting on pallets fixed to a verge, upper end of which was suspended to a cock by a piece of cord, so as to hang perpendicular; lower end, a pivot working into a kind of stud attached to frame; balance, an iron bar, each end terminating in an elbow to which a weight was attached in order to produce equilibrium.
- A.D. 1354. CLOCK AT STRASBOURG CATHEDRAL.—*Conrad Dasy-podius* designed the second clock in the year 1574—*Isaac Hebrecht, fecit*. *M. Schwilgué* in 1838 undertook its complete restoration. The work was finished the 2nd October, 1842.

EDWARD III granted a safe conduct to three Dutch A.D. 1368. orologists, John and William Uneman, and John Lie-tuyt, who were invited from Delft into England. By the Patent they were defended for one year against "injuriā, molestiam, violentiam, dampnum aut gravamen."

CHARLES V., King of France, surnamed the Wise, A.D. 1370. caused to be made at Paris a large turret clock, by *Henry Vick*, a clockmaker, of Wurtemberg, who was invited for the express purpose. He took eight years to complete the work. *John Jouvance* cast the bell on which the hammer of the clock struck the hours. It was on this bell the signal was given for the massacre of Saint Bartholomew, 1572.

The escape-wheel of this clock was a crown-wheel which acted on pallets attached to a vertical rod or axis moving on two pivots; the balance, a heavy bar of iron, was fixed to the upper part of this verge, and had weights placed at corresponding distances on each arm by means of a number of equidistant notches, in order to regulate its vibrations.

The upper end of the verge was suspended by a small cord to a cock fixed to the large cock in which the pivot hole was pierced, for the purpose of keeping it perpendicular and decreasing the friction of the lower pivot.

FROISSART says that Philippe le Hardi, Duke of A.D. 1380. Burgundy, ordered to be taken away from the city of Courtrai a clock which struck the hours, and had it conveyed to the town of Dijon, where it was set up.

A.D. 1391. CLOCK FOR THE CATHEDRAL AT METZ.

A.D. 1401. CLOCK FOR THE CATHEDRAL AT SEVILLE.—About this date *automaton* figures were placed outside clock-towers, above or under the dials, whose duty it was to strike the hours on bells placed near them. They were called *Jacquemart*, possibly after their maker, one Jacques Marck, or Jacquemart, clockmaker, of Lille.

This term *Jacques* seems to have been imported into England, for it became a common expression in Shakespeare's time, "While I stand fooling here, his *Jack o' the clock*."—*Richard II.*, act v., s. 5.

A.D. 1405. LUBECK became possessed of a clock.

A.D. 1495. GIAN RINALDI made a clock for St. Mark's, Venice.

CHAPTER VI.

FROM A.D. 1500 TO THE PRESENT TIME.

IN the previous chapter the brief outline of the History of Horology has been brought to an important date, *viz.* 1495, or the end of the fifteenth century, which may be called its *first period*.

It has seemed advisable to begin this chapter from that date, in order distinctly to mark *the second period*, in which pocket watches, so useful and necessary to the comfort of man, were invented and introduced into England.

A statement has appeared in various books on clock-work, but on very questionable authority, that watches were made late in the fifteenth century, but had such been the case there is every reason to believe that some inventory would have given a description of the watch, as it would have been of such immense value that only a person of note or a crowned head could have been its happy possessor.

Neither *M. de Laborde*, in his *Glossaire* to the *Notice des Emaux du Louvre*, a work displaying indefatigable research, nor *M. Pierre Dubois*, in his 'History of Clock-work, Ancient and Modern,' have been able to give any well-authenticated example of a portable clock

moved otherwise than by weights during the fifteenth century.

M. de Laborde has furnished from inventories of well-known and distinguished personages a very interesting list of clocks, commencing with the date 1365, and ending 1599, well worthy the study of the antiquarian.

M. Pierre Dubois, clockmaker, of Paris, in his short historical account of the clock-work of the *Moyen age et la Renaissance*, has not fixed any date to be relied on for this invention earlier than the sixteenth century.

Octavius Morgan, Esq., M.P., F.S.A., and formerly a Vice-President of the Society of Antiquaries, communicated to the Society in 1849, "Observations on the History and Progress of the Art of Watchmaking, from the earliest period to modern times," in which he says:

"The ancient city of Nuremberg, so famous for the ingenuity as well as the ability of its astronomers, has always laid claim to the merit of the invention of watches, or pocket clocks as they are called by the Germans, and the fact of the early watches having been called proverbially Nuremberg eggs seems to favour their claim. It is certainly the earliest place at which we have any authentic information of their having been made, and we have also the name of the artist who first made them there. John Gabriel Doppelmayr, born at Nuremberg in 1677, and Professor of Mathematics in that city, and in 1733 elected F.R.S., published at Nuremberg in that year his 'Historical Account of the Mathematicians and Artists of Nurem-

berg,' and in his account of the famous mechanics will be found as follows:—

“PETER HELE, a clockmaker, was everywhere held to be a great artist on account of the pocket clocks which, soon after the year 1500, he first made in Nuremberg, with small wheels of steel. The invention, which may with great justice be ascribed to him, being *something quite new*, was praised by almost everyone, even by the mathematicians of the time, with great admiration; he died 1540.” He adds in a note, “On this subject Johannes Cocclæus, in his commentary on the *Cosmographia* of Pomponius Mela, published in 4to at Nuremberg in the year 1511, makes the following announcement:—‘*Inveniuntur in dies subtiliora, etenim Petrus Hele, juvenis adhuc admodum, opera fecit, quæ vel doctissimi admirantur mathematici, nam ex ferro parva fabricat horologia, plurimis digesta rotulis, quæ quocunque vertantur, absque ullo pondere, et monstrant et pulsant XL horas. Etiam si in sinu marsupiore contineantur.*’ This, already so written by Cocclæus in 1511, shows in the clearest way that pocket watches were made in Nuremberg 219 years ago, and he has fairly attributed the invention of them to this artist, since it was the most deserving of admiration and the newest of his time, and which will be considered as a Nuremberg invention; whence also clocks of this kind were for a long time called Nuremberg living eggs, because they at first used to make them in the form of small eggs; which name is even to be found in the German translation of a strange book which F. Rabe-

lais has left behind him, in chapter xxvi. Hence it is evident how erroneous it is to ascribe, as many do, the invention of small striking clocks, as of these pocket clocks, to Isaac Hebrecht, a well-known mathematician, who lived about the beginning of the last century, and dwelt at Strasbourg, whereas our Peter Hele had made them in Nuremberg 100 years before."

Cocclæus, who was born in 1479, accurately describes a striking watch, and seems to speak of it as a remarkable novelty, which excited the admiration of the mathematicians at the time at which he wrote, *viz.* 1511, and laying much stress upon its going without any weight, even in the pocket, attributes the invention of it to Peter Hele, his fellow townsman and contemporary.

In a second paper or continuation of the History and Progress of the Art of Watchmaking, published in the 'Archæologia,' vol. 33, Mr. O. Morgan most satisfactorily comes to the conclusion that the whole credit for the invention of the main-spring is due to Peter Hele: "The cause of the great admiration of the scientific persons of his day was his having made a clock which would go *absque ullo pondere*, and might therefore be carried about the person, and in that, as it seems to me, lay the novelty and merit of his invention; and I am therefore disposed to consider him the inventor until I know of some proof to the contrary."

These two papers from which we have quoted deserve to be printed in a cheap form, together with a catalogue of the invaluable collection of watches which Mr. O. Morgan has the good fortune to possess, and which,

while he was tracing the progress of the art, gave him the power to justify his conclusions from examples actually lying before him.

It would appear that the main-spring, when first applied to a watch, was not enclosed in a barrel, but the outer end of the spring was bent into the form of a hook and fixed to the winding arbor, together with a ratchet-wheel and click. A guard was attached to one of the plates in order to check the outer coil of the spring and prevent its expanding too far. The inner end was made fast to the axis of the great wheel, consequently it was wound up from the centre. The re-expansion set the train in motion.

In the Soltykoff Collection was a watch said to have been made early in sixteenth century, time of Francis I., without fusee. The barrel which contained the main-spring was not movable. The outer coil was fixed to this barrel, the inner being attached to a winding arbor, on which was fitted a small wheel with eight teeth which geared into the great wheel, and so put the train in motion.

A singular contrivance was used to equalize the expanding force of the main-spring, very similar to a watch described by Mr. Morgan. On the great wheel was screwed down an eccentric wheel, having a groove cut into its circumference. The peculiarity of this wheel consisted in its centre being more distant from the circumference at one part than another.

A strong curved spring, having at one extremity a roller, fixed to the plate at its other end, pressed strongly

on the grooved wheel, otherwise termed a snail. The effect produced by this contrivance was, in Mr. Morgan's words, "As this snail makes its revolution, and the power of the main-spring becomes less strong, this retarding spring presses with diminished force, till at length, when the watch is nearly down, and the force of the main-spring considerably weakened, from a peculiar curvature of the snail, the pressure of this spring, having diminished gradually, changes from a retarding to an accelerating action, thus in a degree equalizing the force of the moving power by retarding it whilst it is strong, and accelerating it by a union of its own force when it is weak."

There is every reason to conclude this was the *stack-freed*.

FIG. 3.

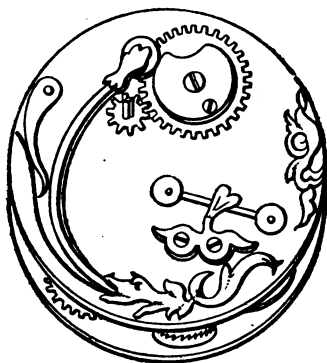

The balance to this watch was merely a bar, with at each end weights to form the equipoise. The circular balance must have been introduced at the latest 1530, as any other form was not adapted for a pocket watch which might be put into any position by the wearer.

In all the early watches the movements were made entirely of *iron* or *steel*.

It may be suggested as a reason for the use only of

iron and steel, that the first clockmakers were in reality locksmiths, and that they worked at all branches of the trade, including clocks. M. de Laborde has given an extract from an 'Inventaire des ducs de Bourgogne,' with the date 1407:—

“A Jehan d'Alcmaige *serrurier*, pour un mouvement, ou petit orloge, acheté de lui pour mettre en la chambre de Madame.”

Brass, though occasionally used for part of the movement, did not become general for the whole construction until after 1560.

AN ASTROLOGICAL CLOCK bearing this date is now A.D. 1525. in the possession of the Society of Antiquaries of London, with the original movement untouched, in which is a *fusee*.

All researches to discover the originator of the *fusee* have proved labour in vain. Berthoud says, “Un artiste savant et ingénieux inventa la fusée, mécanique qui donne au ressort moteur une action aussi uniforme que l'est celle du poids,” and which was doubtless preceded by a mechanism called *stack-freed*, designed for the purpose of regulating the expansion of the main-spring.

M. Pierre Le Roy, in his 'Étrennes Chronometriques,' 1764, says, “It must soon have been perceived that the action of the main-spring was much greater at the height of its expansion than at the end, from which resulted great variations in the time-keeping of the watch; this was remedied by a piece of mechanism called *stack-freed*.” This ingenious method or contriv-

ance preceded the discovery of the fusee, and gave most probably the idea of that fine invention which, selon l'expression de M. Le Roy, est une des plus belles inventions de l'esprit humain.

The following extract is taken from a "Description of an Astrological Clock belonging to the Society of Antiquaries, communicated to the Society by *Captain W. H. Smyth, R.N., K.S.F., D.C.L., Director,*" published in *Archæologia*, vol. 33.

"At a meeting of this Society, holden on the 19th of May, 1808, it was announced from the chair that 'the late Mr. Henry Peckitt, of Compton Street, Soho, having made a bequest to the Society of Antiquaries of an old clock, it was sent by his executrix,' with the following extract from his will:—'The old clock, made by Jacob Zech at Prague, in 1525, must be presented to the Antiquarian Society, along with the key that is in a parcel in a paper upon one of the desk-shelves; and the paper cover, in the inside of which is a descriptive explanation of what I know in relation to it, with the Bohemian verses upon the barrel.'"

The late Mr. Carlisle assured me that this present was received with much gratification; and that our distinguished astronomer, the elder Herschel, after a close examination, gave a high opinion of its value. On referring to the original minutes of that evening, I find it recorded that Dr. Herschel was then introduced as a visitor by Sir Joseph Banks, the President of the Royal Society. The "paper cover" mentioned in the bequest, appears to have been more than once copied, since the

substance of it has oozed out in several publications; but as the exact words have never been given, it may be as well to submit them here:—

“This Horologium was made a present of to James Ferguson (who gave lectures in London, and was the author of astronomical and mechanical pieces) by a gentleman, and when Ferguson died, and his things were sold, I purchased it about the year 1777.

Henricus Peckitt, ex agro boreali Eboracensis natus.

I have not seen nor heard of any older in England. Derham, in his ‘Artificial Clockmaker,’ makes mention of one at Hampton Court Palace; but this was made, as appears by the date, some years before that. When the balance is properly adjusted it will go tolerably well for thirty hours, then it loses time very much. It had formerly, as supposed, a catgut for the barrel instead of a chain, which chain has grazed the swivel or fusee, which Mr. Comyns tells me is the reason of its losing time when almost down. We suppose that the upper circle is a more modern addition to the clock. The inscription upon the barrel of the clock is in old Bohemian verse, as—

IAR·DA·MAHCHT·MICH·IACOB·ZECH
ZV·PRAG·IST·BAR·DAMAN·ZALT·1·5·2·5.

which reads thus,—

YEAR WHEN MADE ME JACOB ZECH
AT PRAGVE IS TRVE WHEN COVNTED 1525.

The same in prose—

The true year that Jacob Zech made me at Prague is when we (or one) count 1525.

Jacobus Zech me fecit in Prague Urbe, Anno Domini 1525.”

Such is Mr. Peckitt's description of the legacy which he bequeathed to the Society; but I hope it will not be deemed looking a gift-horse in the mouth, by at once saying that his account is somewhat unsatisfactory, after the announcement that a "descriptive explanation" would be made. Nor can either of his translations be deemed a faithful translation of the German legend, which he terms *old Bohemian verse*. The characters of this inscription are engraved in a single line, placed round the verge of the flat top of the barrel which shuts up the spring; having a small cross between each word, and a large star after BAR, as a conclusion. There can therefore be no reasonable doubt but that it should read thus—

DAMAN×ZALT×1×5×2×5×IAR×DA×MAHCHT×MICH×
 JACOB×ZECH×ZV×PRAG×IST×BAR*

Now this is rendered most simply by saying, "When we counted 1525 years, then made me Jacob Zech (or rather Jacob the Bohemian) at Prague; it is true." With respect to the advanced poetic claims of this trite memorial, the words might certainly be thrown into a hobbling verse by dividing them into ten-syllable lines, ending with IAR and BAR; but the process is unnecessary. Mr. Peckitt also mentions that Comyns—most probably Alexander Cumming, the celebrated clock-maker—coincided with him in thinking that the "uppermost circle" assuredly comprehends the face or dial, every part of which—plan and execution—bears absolute evidence of contemporaneous construction with the interior machinery. The sole basis for the

above remark appears to be that the hour circle is marked with well-cut Roman numerals, while all the accessories bear the Arabian digits; but such was the usual custom, as is shown by the dials of the Glastonbury, Exeter, and other early clocks; the Roman majuscule characters having been used to express integer numbers, long after the adoption of Arabian figures had become general for other purposes. The chain certainly was a modern addition, and being anomalous, as well as injurious to the soft metal of the fusee, I have removed it.

My own opinion, after due consideration, is that the whole machine—box, dial, hand, zodiac, train, bell, ornaments, and armorial bearings—is just as it issued from Jacob's hands, and consequently, as a most valuable specimen of its era, merits a detailed description.

The body is enclosed in a circular case or box, of gilt brass, measuring $9\frac{3}{4}$ inches in diameter by 5 inches in height. Both the design and workmanship of this case are in excellent taste, and the bold foliated decoration around its sides is finely finished. The arabesque portion is divided by three shields: of these the first, bearing an eagle displayed and crowned, surmounted by a royal crown, shows POLAND; the second, bearing a serpent entwined and wavy pale, crowned, a child issuant from its mouth, and surmounted by a ducal crown, typifies the house of VISCONTI; and the third shield displays the arms of LITHUANIA, a knight armed cap-à-pié, and mounted on a horse proper, holding in his dexter hand a drawn sword, and having pendent

from his neck a shield charged with the Hungarian cross. Such are the bearings on the periphery of the clock-case; and in the centre of the dial-plate is an escutcheon with the arms of Poland on the dexter side, impaled with those of Visconti on the sinister. The whole are clearly and boldly represented; but they are without the discriminating lines of blazonry, having been engraven long before that method of "trick" was invented.

These bearings, together with the date, supply us with an inferential conclusion, so powerful as to be tantamount to conviction, that this clock was actually the property of Sigismund the First, King of Poland, surnamed the Great, and that he presented the handsome gift to Bona Sforza, to whom he was married in 1518, after a custom then prevalent, of which we have instances in Francis to Queen Mary of Scotland, and Henry the Eighth to Anne Boleyn.

* * * * *

An inspection of the interior must command regard. The bottom plate, or lower circle of the case, shows much evidence of design in the Bohemian artist, for it is impressed with four remarkably neat little escutcheons at right angles with each other; on these with higher taste than the mere tradesmen's symbols which then prevailed, the field of each has J. Z., surmounted by a regulating balance and a-portion of an escape-ment,—a powerful governor of the wheels, which may perhaps be assigned to John Megestein, a native of Cologne, who improved clocks in the fourteenth century. On removing this plate the whole of the works

are seen, and, in competent viewers, they excite the utmost surprise respecting their plan, workmanship, and preservation. The wheels for the driving and maintaining powers, as well as for the striking apparatus, are made of iron, and retain certain punched marks, which prove—were proof necessary—that the divisions have been cut with a file by hand; and the levers, being fast to the arbor or verge of the pallets, are capable of vibrating either in a horizontal or vertical position. It is fitted with an expansive powerful spring, coiled in a drum or barrel, as a prime mover; and a hand-made fusee, a kind of truncated cone, for equalizing the variable power of a wound-up spring in all its different states of tension under a motive force.

This fusee is therefore a trusty chronological testimony of old Jacob's ability, and his knowledge of one of the nicest introductions into portable clocks so early as 1525: but here the injurious effects of substituting a modern metallic chain for its original catgut band are very palpable, for, the fusee being made of a metal softer than the steel chain, it is so panned by the action it has undergone that three out of eight spiral threads at the smaller end are nearly destroyed.

Over all these wheels and works there is a long balance, by which the motion is regulated and the beats determined; it consists of an iron bar carrying a screw at each of the ends, with tapped weights of lead for the adjustment of the escapement to time, so that the maintaining power should be accurately transmitted to the regulator.

Though of rough workmanship, it is equal to its duty; and there are two yielding brass arms, acting as the modern bankings do, to keep it in its place during the vibratory motion.

The late Mr. *B. L. Vulliamy* examined minutely this old clock, and in his description of it he says:—

“In this machine the maintaining power is a spring contained in a barrel, pretty much in the same manner as is now practised. The barrel is connected with the fusee by a chain, and this is the only part of the clock that is not in its original state; for it is well known that chains were not employed at so early a period as 1525, when this was made. The fusee is of soft metal, there having been then no engine to cut the spiral line on which the catgut was wound; and the escapement is the verge-and-crown-wheel one, usually called the vertical scape,” &c., &c.

A.D. 1530.

IN THE INVENTORY OF TREASURES belonging to Charles V., existing in the National Library, Paris, will be found the description of two portable clocks or watches.

“*Ung autre orloge rond et plat qui ne sert que de monstre, garny d’or, assavoir; le fond de l’Histoire d’Hercules a personnages levez ayant les deux coulottes et la devise de plus outre, soubstenu sur sept petites testes, ung cercle d’or pour cloture dudit orloge esniellé, et le dessus aussi d’or servant pour la monstre aussi esniellé, les dits trois pièces garnies par dedans de cuivre et chiment: pesant avec la monstre d’or, sans l’orloge et mouvement de fer, iv marcqs v onces xvii esterlins et demy.*”

“Nota.—Donné à l'impératrix comme appert par lettres de sa Majesté du XX^e de Décembre XV^e XXXVIII.

“ *Ung autre moindre orloge rond et plat qui ne sert aussi que de monstre, garny d'or, assavoir ; le cercle avec la monstre tenant ensemble, ayant le dit cercle deux testes et ung anneau pour pendre, avec deux platines d'or, l'une servant pour couvrir la monstre ou est un enfant esniellé, et l'autre qui sert pour le fond esniellé d'aucuns personnaiges et bestes où est escript : omnibus idem ; toute ladite garniture d'or pesant, sans l'orloge et mouvement de fer et sans le cercle de cuivre, i marcq v esterlins.*

“Nota.—Sa Majesté se sert continuellement de ceste orloge en sa chambre.”

GEMMA FRISIUS, a Dutch astronomer, suggested during this year that portable clocks should be used to ascertain the longitude at sea.

PORTABLE CLOCK, presented by Henry the Eighth A.D. 1532. to Anne Boleyn on their marriage, now at Windsor Castle, the property of her Majesty Queen Victoria.

It is thus described by Horace Walpole :—

“A clock of silver-gilt (*brass*), richly chased, engraved, and ornamented with fleur de lys, little heads, &c. On the top sits a lion holding the arms of England, which are also on the sides. This was a present from Henry the Eighth to Anne Boleyn ; and since from Lady Elizabeth Germaine to Mr. Walpole. On the weights are the initial letters of Henry and Anne within true lover's knots ; at the top 'Dieu et mon droit' ; at the bottom, 'The most happy.' One of

the weights, agreeably to the indelicacy of that monarch's gallantry, is in a shape very conformable to the last motto."

Height from base to cornice over face measures five inches and a half, thence to the top of lion's head five more—the body of case four inches square.

The movement quite modern.

A.D. 1538.

INVENTORIES and valuations of religious houses at the time of the dissolution, from Public Record Office. With prefatory remarks and illustrative notes by the Rev. Mackenzie E. C. Walcott, B.D., F.S.A., Precentor and Prebendary of Chichester Cathedral.

Published in 'Archæologia,' vol. 43, Part 1.

The following are the only houses out of the many mentioned in the above publication which at their dissolution possessed a *clock*.

THE LATE PRIORY OF ST. THOMAS NYGHE STAFFORD.—In the church mention is made of 1 clocke.

THE LATE MONASTERY OF DARLEY, IN THE COUNTYE OF DARBY.—The Priory of St. Mary, belonging to Austin Canons, was founded by Robert Ferrers, Earl of Derby, and Hugh, rural dean of Derby before 1121.

This Priory possessed 1 clocke.

DALE PRIORY, CO. DERBY.—The clocke ther vj s.

BARNEWELL PRIORY, CAMBRIDGESHIRE.—The Priory of Austin Canons was founded by Picot, Sheriff of Cambridgeshire, in 1092, but was removed to this site by Pagan Peverell, standard bearer to Robert Duke of Normandy in the holy wars twenty years after. It

took its name from a well frequented by young persons on St. John's Eve for athletic sports.

The minster was dedicated to Sts. Andrew and Giles. The choir was built 1135-70, and the nave consecrated by Bishop Longchamp, May 22nd, 1191. A portion of the cellarage only remains.

J oulde clocke and the stales in the Quere. Vj li. xiiij s. iiij d.

SAWTRE, a Cistercian Abbey, a daughter of Warden Abbey, founded in 1146 by Simon Earl of Northampton.

In the church an old clock, iij s. iiij d.

CLOCK AT HAMPTON COURT PALACE, described by A.D. 1540. Derham; the body in 1711 had been removed; only remaining part the dial and work connected with it; the date 1540 and the initials N. O. on part of work.

It has been conjectured that the N. O., if very carefully examined, would prove to be N. C.; in that case the clock may have been designed by *Nicolaus Cratzer*, who held the position of clockmaker and Astronomer Royal to Henry VIII.

He was born, 1487, at Munich; educated at Cologne and Wyttenberg; after taking the B.A. degree came to England; admitted a Fellow of Corpus Christi College, Oxford, in 1517; shortly after made Astronomer Royal; and probably died in Edward VI.'s reign.

STATUTES of the Corporation of Clockmakers of Paris, A.D. 1544. authorized by Francis I. in the year 1544.

Jewellers forbidden to deal in clocks, &c., unless acknowledged members of the corporation. Persons only to be admitted members on giving a full account

of the art of clockmaking by examination and trial of actual capabilities. Those only were to be eligible for office of Master who were of good life and morals, and had constructed a piece of clock-work to the satisfaction of the master with whom they had served their time as apprentices. All apprentices to be bound by indenture for a term of not less than eight years, &c.

Visitors appointed to inspect the workshops and establishments, authorized to destroy all work either badly constructed, or of inferior materials, &c.

MYRMECIDES.—Father and son were watchmakers at Paris; the latter was noted for his Montre d'Abesse, which was a watch in the form of a pectoral cross, and intended for the use of ecclesiastical ladies.

A.D. 1552. LETTERS PATENT granted by Louis XIV. to the Master Clockmakers of Paris forbidding for the future any exemptions or peculiar favours to workmen contrary to the Charter of the Corporation of Clockmakers of Paris, given in year 1544 by Francis I.

Also, re-enacting that none should open a shop or carry on the trade in Paris, or the neighbourhood, who had not completed the required term of apprenticeship, and complied with all the statutes of the said Corporation.

A.D. 1557. H. CARDAN, inventor of a plan for suspending ship-lamps on gimbals.

A.D. 1557. CLOCK AT BERNE, in Switzerland, constructed by Gaspard Brunner, a Bernese locksmith, but improved and repaired by Angely, a French clockmaker, in 1686.

Beneath the large dial on the eastern side of the

clock tower, is a second, of which the hands revolve once in twenty-four hours, and indicate the position of the sun, phases of the moon, the month, and the day of the month, signs of Zodiac, &c.

To the right of this dial is a figure seated on a kind of throne in a niche, supported on either side by a cock, and a lion holding a sword, each placed on brackets; above the seated figure is a diminutive buffoon, and over his head two bells; beneath the throne is an opening, whence issue a troop of young bears, mostly armed. Previous to the striking of the clock, the cock crows and flaps his wings, then the bears revolve round a circle, whilst the buffoon strikes the four quarters with two hammers on the bells; again the cock crows, and the man, seated on his throne, holding in one hand a sceptre, in the other an hour-glass, which he turns, moves his mouth and sceptre as if counting the strokes which the armed figure of the Duke of Zähringhen, placed in an open bell-cote which terminates the roof of the tower, gives to the large bell; the lion also makes a movement with his head and sword, and the cock crows for the third and last time.

WATCH, formerly the property of Mary Queen of Scots. Shape, a death's head; arms of France and Scotland engraven on separate shields, one on each side of the jaws of skull. Inscription,

EXDONO, FR. R. FR., AD MARIAM, REG. SCOTORUM ET
FR., 1560.

QUEEN ELIZABETH received, as a new year's gift from the Earl of Leicester, a richly-jewelled armlet, "having

in the closing thearof a *Clocke*, and in the fore parte of the same a faire lozengie dyamonde without a foyle, hanging thearat a rounde juell fully garnished with dyamondes, and a perle pendaunt weying xj oz. qrt. dim. and farthing golde weight.

“In a case of purple vellat, all over embroderid with Venise golde, and lyned with greene vellat.”—*Harl. MS.* 4698, page 2.

A.D. 1575. PARKER, Archbishop of Canterbury, bequeathed to Richard, Bishop of Ely, a bamboo walking-cane, having a watch let into the handle.

A.D. 1587. IN CONSEQUENCE of the great persecutions which Protestants had to endure, *Charles Cusin*, of Autun, in Burgundy, watch manufacturer, went and settled in Geneva, where it is said he was the *first* to establish the watch trade.

A.D. 1598. CLOCK AT LYONS, Nicolaus Lyppys, of Bale, fecit; designed after the model of the Strasbourg clock.

A.D. 1610. ROUND WATCHES became the fashion.

A.D. 1611. THE following letter from *Gilbert Earl of Shrewsbury* to *Sir Michael Hikes*, of the year 1611–12, is preserved in the Lansdown MS. in the British Museum, No. 92, art. 80:—

“I perceived by you to-day that you understood My Lord Treasurer’s design was to have a watch, but I conceaved he wysshed a strykyng Clock, made lyke a Watch, to stande oppon a Cubbart, and suche a one (though no new one, and yet under a dozen years ould) I have found oute, and send you by this bearer, which

I pray you deliver to his Lordship from me, and tell him that I am very well perswaded of the truth of it, or else I should be ashamed to send him so gross and rude a piece as this is, and if I hadd thought his Lordship could have well forborne it but for four or five dayes longer, I would have bestowed a new case for it, for this is a very bad one. If his Lordship would not have it stryke, either in the dayes or nights, the striker may be forborne to be wounde up, and so the Watch being wounde up it will go alone. It will goe twenty-six houres, but I wysh it may be wounde up every mornyng or nyght aboute 8 or 9 o'Clock, which will be sufficient untill the next day or nyght at the same tyme.

“I am weary with my longe journey to day to Greenwich, and with waytinge on the Queen, overstandyng myself, and therefore I will hast to bedd, and ever remayne

“Yr. very assured lov: frend,

“GILB. SHREWSBURY.

“This Tuesday nyght.

“To my very good friend

“S^r. Michael Hycks, Knight.”

WATCH GLASSES were introduced to cover the dials A.D. 1615 to 1620.
instead of metal covers.

In the Ashmolean Museum at Oxford is a gold watch in the form of a melon, studded with large turquoises. Maker, *Edward East*.

CHRISTIAN HUYGHENS, born at the Hague the 14th A.D. 1629.

April, 1629. He had obtained as early as 1665 so great a reputation for his profound knowledge of Geometry and Mechanics that Louis XIV. invited him to Paris for the purpose of founding a Royal Academy of Sciences. He resided in Paris from 1666 to 1681, when foreseeing the persecution Protestants were likely to be subjected to, he returned back to Holland, and died there the 5th of June, 1695.

A.D. 1630. JEAN TOUTIN, a goldsmith, of Châteaudun, introduced enamel painting on gold for watch-cases.

A.D. 1631. THE 7TH CHARLES I.—Charter granted, on the petition of the clockmakers residing within the liberties and suburbs of the city of London.

Incorporating all the clockmakers, both free and foreign (*i. e.* persons not free of the city of London), who practise clockmaking in the city of London, and ten miles compass, by the name of the Master, Wardens, and Fellowship of the Art or Mystery of Clockmaking of the city of London, and constituting them one body corporate and politic in deed and in name, to have continuance for ever.

By this charter power is granted to purchase and sell lands, &c.; to plead and defend causes; to elect a Master, 3 Wardens, and 10 Assistants; to make laws for the government of all persons using the art within the city of London; and also to regulate the manner in which all persons using the art throughout England and Wales shall carry on the same.

Power to fine and punish offenders against their laws.

Further, all apprentices to be bound to some free

brother of the Company of Clockmakers for the term of seven years.

Power to elect officers annually on the feast day of Saint Michael the Archangel. The Master to be chosen being a professed clockmaker at the time of his election, &c.

Power to govern and make laws for the regulation of all persons who in anywise use the art, or any part thereof, within England and Wales, whether the several productions of the art are made at home, or brought from foreign parts, or otherwise. To make a general search and view of all productions of the art, &c. To seize and break work if unlawfully made, or made of bad materials, or to cause the same to be amended and made perfect. Faulty and deceitful work to be seized in the king's name.

Further to prevent frauds and abuses on the public, no persons whatever shall import any clocks, watches, 'larums, boxes, sun-dials, or cases for watches, clocks, or 'larums, or any other wares properly belonging to the art or mystery of clockmaking, or offer the same for sale before such work be brought to the Company's Hall to be viewed and marked, upon pain of forfeiture of such work, &c.

Power to the Master, Wardens, and Assistants, or any of them, with the assistance of a constable, to search throughout England and Wales for such foreign clocks, &c., and such as are not lawfully imported and marked, to seize, and prosecute the offenders.

In compliance with the Act of Parliament of 19th A.D. 1632.

Henry VII., the acts and ordinances made by the Master, Wardens, and Assistants of the said Fellowship were accepted, ratified, and approved the 11th day of August, 1632, the 8th Charles I.

The following were named in the Royal Charter to be the first and present officers :—

Master :

DAVID RAMSAY, ESQUIRE.

Wardens :

HENRY ARCHER, JOHN WELLOWE, and SAMPSON
SHELTON.

Assistants :

JAMES VANTROLLYER,	SAMUEL LYNAKER,
JOHN SMITH,	JOHN CHARLTON,
FRANCIS FORMAN,	JOHN MIDNALE,
JOHN HARRIS,	SIMON BARTRAM,
RICHARD MORGAN,	EDWARD EAST.

The first meeting of the Company was held on the 12th October, 1632.

Strange to relate the Company has never possessed a Hall, but its meetings have been regularly held in some city tavern even to the present time.

A.D. 1635. ROBERT HOOKE, born at Freshwater, Isle of Wight, the 18th July, 1635. After the death of his father in 1648, placed with the celebrated painter, Sir Peter Lely, but not able to endure the smell of oil colours. Received into Westminster School under Dr. Busby ;

entered Christ Church, Oxford, 1653; invented the balance or pendulum spring, 1658; applied it to a watch for Bishop Wilkins, 1661. Sir Isaac Newton styled Hooke the "considerer." In 1676 published a description of "Helioscopes and other instruments made by him." In a postscript to this work he complains of Henry Oldenburg for publishing in the 'Philosophical Transactions,' 1674, a description of a watch with a pendulum-spring made by Huyghens, and omitting to state "that this invention was first found out by an Englishman and long since published to the world," and calls it unhandsome proceeding! In 1677, upon the death of Oldenburg, elected Honorary Secretary of Royal Society. In 1691 created M.D. by Archbishop Tillotson. He died at Gresham College the 3rd March, 1703, and was buried at St. Helen's, Bishopsgate Street.

DIAL PLATES enamelled by Paul Viet of Blois. A.D. 1635.

In this year GALILEO, born 1564 at Pisa, published A.D. 1639. his small treatise on the properties of the pendulum which he had discovered at close of the sixteenth or early in the seventeenth century, under the following title:—

L'usage du Cadran ou de l'Horloge Physique universel, par Galilée, Mathématicien du Duc de Florence. Paris, Rocolet, 1639, in 8vo.

No mention is made in this treatise, or any other work, of his having applied the principle to a clock.

Vincent Galileo, his son, it has been asserted, was the first who in the year 1649 adapted a pendulum to a

clock, but with the exception of a statement to that effect in the *Recueil des expériences de l'Académie del Cimento*, there is no authority which can be relied on to prove his having done so.

Mr. THOMAS GRIGNION, a well-known clockmaker of London, who died in 1784, and whose son in 1797 constructed the present clock for the church of St. Paul, Covent Garden, the old church built by Inigo Jones having been destroyed by fire in 1795, authorized his son to make known that *Richard Harris* was the person who first applied a pendulum to a clock, eight years before Vincent Galileo laid claim to having made a clock regulated by a pendulum.

Thomas Grignion, the son, caused a plate to be engraved, bearing date, "Great Russel Street, December 21st 1798," which is in the vestry of the present church, and reads thus:—

"The (new) turret clock and bells of this church were made A.D. 1797, by Thomas Grignion, of Great Russel Street, Covent Garden, the son and successor of Thomas Grignion, who, A. D. 1740, brought to perfection what the celebrated Tompion and Graham never effected, *viz.* the horizontal principle in watches, and the dead beat in clocks, which dead beat is a part of the mechanism of the turret clock. Thomas Grignion, senior, made the timepiece in the pediment at the east end of this parish church, destroyed by fire A.D. 1795. The clock fixed in the turret of the said (late) church, was the first long pendulum clock in Europe, invented and made by Richard Harris of London, A.D. 1641;

although the honour of the invention was assumed by Vincenzo Galilei, A.D. 1649, and also by Huyghens, 1657. This plate is here affixed by Thomas Grignion of this parish, the son of the above Thomas Grignion, as a true memorial of praise to those two skilful mechanicians, his father and Richard Harris, who to the honour of England, embodied their ideas in substantial forms that are most useful to mankind."

Now, the whole authority for this statement attributing the invention to Richard Harris, depends, as Rees says, on the degree of credit which is to be attached to a manuscript marginal note, written at page 12 in an old book, in the possession of Mr. Thomas Grignion, called 'Essayes of Natural Experiments made in the Academie del Cimento, under the protection of the most Serene Prince Leopold, of Tuscany, written in Italian by the Secretary of that Academy, and translated by Richard Waller, F.R.S.,' London, 1684.

(Copy of the Extract):—

"The great clock belonging to Covent Garden has a long pendulum, and was made by Richard Harris, of London, in the year 1641, which was eight years before Vincenzo Galilei put his father's observations into practice, as appears by the date 1649.

"The ingenious Mr. Huyghens applied the pendulum to a clock in the year 1657, and attributed the invention to himself, which created a dispute between him and Vincent Galileo; this last affirming that he had put it in practice in 1649; and the reason of Richard Harris's not appearing (which would have decided the

controversy) in all probability was, that he being only a private workman was entirely unacquainted with any dispute which might happen between Vincent Galileo and Mr. Huyghens, or he might be dead before the dispute arose, it being sixteen years after he made the said church clock."

It will be necessary now to examine into the value, if any, of this marginal note, written no doubt by the elder Grignion against the passage wherein it is asserted that Vincent Galileo adapted the pendulum to a clock at Venice, in 1649.

Mr. Thomas Grignion, senior, was born in the year 1713, just seventy-two years after the clock at St. Paul's, Covent Garden, had been made. Consequently he could only have heard from some person, whose name he has not mentioned, that Richard Harris was the maker.

Again, he does not assert, although it is most probable he had examined the clock, and from the fact of his son being employed to manufacture the new one, it is also likely the firm of Grignion, residents in the parish, had been the care-takers of the old one, that any mark existed on the frame whereby it was natural to conclude the said R. Harris was its maker.

Further, the book in which this marginal note appeared had been translated from the Italian by Mr. Waller, a Fellow of the Royal Society, who was well acquainted with both Dr. Hooke and Mr. Huyghens, each claimants for the honour; and had such a clock been a reality in 1641, would doubtless have recorded his

opinion on the subject at the time of the controversy between Huyghens and others, as to the priority of the adaptation.

It has been plausibly conjectured that Inigo Jones, the architect of St. Paul's, Covent Garden, who was in Italy about 1601 to 1605, and again in the year 1612, had become acquainted with Galileo during one of these visits, and might have had some discussion with the discoverer of the pendulum on its properties, which on his return to England he would most probably repeat, and that he selected Harris as a person capable of understanding the subject. It is possible, but not probable. Had Harris been the John Harris, one of the first Assistants of the Clockmakers' Company, doubtless a well-known and established clockmaker, it would not have been extraordinary for Inigo Jones to have held consultation with a man of his recognized position, but to seek out only "a private workman" seems incredible.

Again, it is not likely that while so many eminent men were living and carrying on the art of clock-making within the city of London, the existence of every one of them should be completely ignored, in order that the architect and authorities of the parish church of St. Paul's, Covent Garden, might reverse established custom, by employing a man without any well-earned reputation as a clockmaker, and without the necessary qualifications for undertaking so very important and costly a work as a turret clock.

Besides, had this Harris applied a pendulum to the

clock of St. Paul's, Covent Garden, is it fair to suppose that the whole of the scientific men of the period would have been totally ignorant of its existence; that not a single one would have gone to see it, or have examined in what way the escapement had been altered so as to adapt it to a pendulum? Can it be imagined that it would not have attracted the attention of that body of learned men who were wont to meet twice a week at Gresham College, previous to their becoming the founders of our present Royal Society?

But there still remains the expression used by Mr. Thomas Grignion in his marginal note, "*has a long pendulum,*" which completely puts an extinguisher on poor Richard Harris. In order duly to weigh and rightly understand its significance, it must be borne in mind that all the early pendulum clocks had crown-wheel and verge escapements, with *short* pendulum rods and light weights, or bobs. Whereas, *long* pendulums, or as they were called, *royal pendulums*, came only into fashion about 1680, after the change of escapement to *anchor pallets*, invented by Dr. Hooke, in 1666, and exhibited by him before the Royal Society just after the Great Fire of London.

So much for Richard Harris.

When the honour of an invention has been for many years attributed to some particular person, it is difficult to make the world believe that an error has been committed; and writer after writer repeats the same story in order to avoid the trouble of minutely investigating the merits of the question. But it may without much

fear of contradiction be here asserted that to the careful searcher after truth, the following conclusions only can be arrived at.

1st. That credit ought to be given to Huyghens, the Dutch astronomer, for being the first to apply the discovery of Galileo to a clock.

2nd. That Dr. Hooke can justly lay claim to having brought the whole matter to perfection by the invention of his anchor escapement, which enabled him to use a long pendulum with a heavy bob, thereby rendering the arcs of vibration shorter, and necessitating much less motive power.

In the year 1656, Huyghens first conceived the idea of applying a pendulum to a clock, and at once set to work to accomplish his task. On the 16th June, 1657, he presented to the States of Holland his first pendulum clock. In the following year Adrien Ulaag, of the Hague, published for him, in Dutch, a short description of this new clock. So the matter rested until 1673, when finding that others claimed the merit of the adaptation, F. Muguët, of Paris, published for him that unrivalled work, *Horologium oscillatorium, sive de motu pendulorum ad Horologia aptato*, wherein he gives not only the construction of his clocks, with drawings, but also establishes the theory (though useless in practice) of the cycloidal cheeks, as a means of rectifying the variations in the lengths of the arcs of vibration of the pendulum.

A FINE WATCH in the possession of O. Morgan, Esq., A.D. 1640. M.P., F.S.A., case gold, enamelled in flowers, by *Chartier of Blois*, movement by *David Bouquet, London*.

Chartier was famous for painting flowers.

In the British Museum a gold egg-shaped watch, by *Robert Grinkin*, said to have belonged to Oliver Cromwell.

A.D. 1655. DEATH OF DAVID RAMSAY, clockmaker to James I., and first Master of Clockmakers' Company.

DR. ROBERT HOOKE invented a wheel cutting engine.

A.D. 1657. WILLIAM DERHAM, author of the '*Artificial Clockmaker*,' was born this year at Stourton, near Worcester. In 1678 took his degree at Oxford; 1689, made Rector of Upminster, Essex; became a Fellow of the Royal Society; 1716, Canon of Westminster; 1730, took degree of D.D.; died 1735, at age of 78.

A.D. 1658. THE THEORY of the pendulum-spring discovered by Dr. Hooke; first applied to a double-balance watch for Charles II., on which was inscribed,

Robt. Hooke Inven: 1658.

T. Tompion, fecit, 1675.

The spring was nearly straight. In 1660 Hooke altered the form by making it *spiral*.

A.D. 1664. THE CHAIN introduced in place of catgut; said to have been invented by one Gruet, of Geneva.

A.D. 1665. DEATH OF DAVID BOUQUET, watchmaker, of London, and Freeman of the Clockmakers' Company.

A.D. 1666. DR. HOOKE invented his escapement for a clock with anchor pallets.

A.D. 1670. DEATH OF BENJAMIN HILL, clockmaker, of London.

Death of *Robert Vauquer*, of Blois, a pupil of Morlière, who, though a native of Orleans, worked at Blois; both

were celebrated for painting watch-cases in enamel of excellent colour.

ON application of the Clockmakers' Company, a coat-A.D. 1671.
of-arms granted by Sir Edward Walker, Garter King-at-
Arms.

EQUATION TABLES, by *Flamsteed*, Astronomer Royal A.D. 1672.
in the year 1675.

GEORGE GRAHAM, born at Gratwick, Cumberland. A.D. 1673.

IN the tenth volume of 'Philosophical Transactions A.D. 1674.
of Royal Society' will be found the following:—

“M. Huyghens sent hither a letter, dated 30th Jan., 1674, acquainting us with an invention of his of very exact pocket watches, the nature and contrivance of which he imparted to us, as he used to do other inventions of his, in an anagram, which he soon after, in a letter of 20th February, explained to us by a full description; for which the Royal Society thought fit to return him thanks, yet so as to intimate to him that Mr. Hooke had *some years ago* invented a watch of the like contrivance.”

REPEATING pocket clocks and watches invented by A.D. 1676.
Mr. Edward Barlow, a priest.

CLOCK at Windsor with brass wheels, *Knibb*, maker. A.D. 1677.

A striking watch, by *Marwick*, of London. A.D. 1680.

W. CLEMENT, a London clockmaker, about this year laid claim to the invention of the royal pendulum. His friend, Mr. John Smith, published in 1694 a small book with title, '*Horological Disquisitions concerning the Nature of Time, &c.*,' in which, at page 3, he says, “among which that eminent and well-known artist, *Mr. William Clement*,

had at last the good fortune to give it the finishing stroke, he being indeed the real contriver of that curious kind of long pendulum which is at this day so universally in use among us." Derham says, "But Dr. Hooke denies Mr. Clement to have invented this," &c.

A.D. 1680. HENRY SULLY, born in 1680, was at an early age placed under Mr. Gretton, a well-known watchmaker in London, to be instructed in the art. On completing his apprenticeship he immediately directed his attention to the construction of a watch which might be the means of discovering the longitude at sea.

He obtained through Sir Christopher Wren an introduction to the Duke of Somerset, and in 1703 to Sir Isaac Newton, who kindly encouraged him to persevere in his attempt.

For a time he gave up the execution of his design, and left England to travel abroad. In 1708 he visited Holland; thence he went to Vienna, and in 1715 he accompanied the Duke of Aremberg into France.

In the year 1716 he presented to the Academy Royal of Sciences a watch with a new escapement; and in 1717 he published at Paris his justly-appreciated work, now extremely scarce, '*Règle artificielle du Temps.*'

In 1737 a second edition appeared, with additions by *Julian Le Roy.*

In 1718 the French Government established at Versailles a clock factory under his direction, consisting of English workmen. Obligated to give up the direction

shortly afterwards, he, under the patronage of the Duke de Noailles, established another at St. Germain. For some reason difficult to explain, both of these establishments were unsuccessful, and after a very short trial completely given up.

Being now at liberty, he applied himself seriously to the construction of a timekeeper to measure the longitude at sea, and in 1723 completed his task.

On the 7th of September, 1726, a satisfactory report was made at Bordeaux, and immediately he published a work, having for title, '*Description abrégée d'une Horloge d'une nouvelle construction, pour la juste mesure du Temps sur Mer.*'

In this work Sully gives the plan of his timekeeper; the principles which guided him in its construction; his experiments; the beautiful application of rollers to the balance-pivots to reduce the effects of friction; his various trials of balance-springs; and full details of the tests to which the instrument or machine was subjected on board ship.

In 1728 this highly-intellectual man lost his life, after a few days' illness, from a cold caught when overheated by exercise. He had received information that a person living in the Faubourg St. Marceau was the inventor of a new escapement, and in over-zeal for his profession, he set out to seek the inventor. The address given him appears to have been a false one; he walked hither and thither through the immense faubourg—a labour in vain; he became overheated, the lungs were attacked, and he died.

It is scarcely possible to form any conjecture as to the loss Horology suffered by his death. He was not only a lover of the art, but a truly talented man, who, had he been spared, would no doubt have gained the highest rewards of merit, and probably have taken from Harrison the palm of being the first to make a timekeeper which should enable the sailor to ascertain with accuracy the longitude when surrounded with a waste of waters.

The incumbent of St. Sulpice granted permission for his interment in that church, and his body was committed, with no small amount of ceremony, to its last resting place, facing the gates of the sanctuary of the high altar, and a little to the west of the meridian, which a few days before his death he himself had traced.

French writers on Horology have complained that the talents of Henry Sully have never been recognized in England as they deserved to be; have insinuated that jealousy barred the door to honour; and that others less meritorious have received palms of merit. How little is the character of the Englishman understood: it is his pride to be able to award the golden medal to his most bitter enemy, provided only he can justly lay claim to it.

Sully could not have been known sufficiently for his talents to receive recognition; and his books could never have had many English readers, from the simple fact, that few were probably capable of reading and understanding French well enough to enter into their scientific merits.

It is not perhaps too late to offer a faint tribute of respect to his memory; to utter a regret that he had not lived to a more advanced life, to mature his early knowledge, and produce such work as would have gained for him, what his genius and love of his art indicated, *a name equal, if not above, all the artists of his age.*

REVOCATION of the Edict of Nantes, which was the A.D. 1685. means of driving out of France many intelligent and industrious workmen, Protestants, who sought refuge in other countries, chiefly England; which accounts for the number of French names engraved on watch-plates made in London at the end of the seventeenth and early in the eighteenth century.

JULIAN LE ROY, born at Tours the 8th of August, A.D. 1686. went to Paris in 1699; received as master clockmaker in 1713; died in 1759.

On the 2nd of March the King in Council ordered, A.D. 1687. on petition of Clockmakers' Company, the patent for repeating clocks and watches *not* to be granted to Mr. Barlow.

DANIEL QUARE gained credit this same year for placing the minute hand concentric with the hour hand.

Mr. O. Morgan has in his possession a small table-clock or watch, with a minute hand concentric with the hour hand, proving the invention to have taken place early in the sixteenth century.

JOHN HARRISON was born at Faulby, near Ponte- A.D. 1693. fract, in Yorkshire, this year. In 1700 the family

removed to Barrow, in Lincolnshire, where he carried on the trade of repairing watches and clocks.

In 1735 he went to London with a timekeeper of his own invention and construction, which, through the interest of Graham and Halley, he was allowed, in 1736, to take on board a king's ship to Lisbon. About 1761 he made another timekeeper, which was thought sufficiently correct to enable him to claim the Government reward offered in 1714.

In 1767 he received the 20,000*l*.

In 1776 he died at his house in Red Lion Square.

A.D. 1695. TOMPION invented his cylinder watch.

A.D. 1700. GEORGE GRAHAM, educated under TOMPION, perfected the *cylinder* escapement.

JOHN ELLICOTT born: 1738, elected a Fellow of the Royal Society; 1751, published his paper, "*Contrivances for Preventing the Irregularity of Pendulums arising from Temperature*;" died suddenly in 1772.

M. FACIO, a native of Geneva, having discovered the art of piercing holes in rubies, &c., repaired to London from Paris with this art as a secret, and with the brothers *De Beaufre*, natives of France, who were residing in London, carried on the business of watch-jewelling.

A.D. 1704. DE BEAUFRE contrived a new escapement, of which the pallets were diamonds, and put the watch into the hands of Sir Isaac Newton for trial.

The *Master, Wardens, and Assistants* of the Clock-makers' Company petitioned Parliament against the bill for the sole applying precious and more common

stones in clocks and watches, brought in on the petition of Nicolas Facio, Peter de Beaufre, and Jacob de Beaufre. The enlarging the terms of the patent was *not* granted. A watch made by Ignatius Huggeford, of London, before the invention of the balance-spring, that had a stone fixed in the cock and balance-work, was bought by the Clockmakers' Company for 2*l.* 10*s.*; the said watch had been produced in the proofs against the bill.

LEPAUTE, born at Montmédy; died at St. Cloud, A.D. 1709. 1789.

THOMAS TOMPION, died November 20th, aged 75; A.D. 1713. was buried in Westminster Abbey.

GEORGE GRAHAM invented his mercurial pendulum A.D. 1715. to counteract the effects of heat and cold; applied to a clock in 1722.

THOMAS MUDGE, born at Exeter; apprentice to Mr. Graham in 1729; 1750, entered into partnership with Mr. Dutton, also an apprentice of Graham's; went to reside at Plymouth in 1771; made clockmaker to the king in 1777. In the year 1793 Parliament voted the sum of 2500*l.*, he having before received 500*l.* as a reward for his marine timekeepers. Died November 14th, 1794.

LE BON, clockmaker, of Paris, presented to the A.D. 1717. Academy Royal of Sciences an equation clock, with movable dial.

CHRISTOPHER PINCHBECK, the discoverer of a metal A.D. 1721. made from copper alloyed with zinc, called *pinchbeck*, and which in appearance nearly resembled gold, re-

moved from St. George's Court, now Albion Place, Clerkenwell, to the Astronomico-musical-Clock, Fleet Street. His son Christopher is described in a scarce print, as of Cockspur Street, clockmaker to his Majesty George III.

A.D. 1722. THE ABBÉ HAUTEFEUILLE invented a new escapement, which has in England received the name of *rack-lever*.

F. BERTHOUD made use of this escapement for some of his marine timekeepers.

HULL, of London, a celebrated cylinder maker.

A.D. 1724. JEAN BAPTISTE DUTERTRE, of Paris, improved on Hooke's two-balance escapement; the nearest approach to the duplex, afterwards perfected by Tyrer.

A.D. 1726. THE gridiron pendulum contrived by JOHN HARRISON.

A.D. 1727. F. BERTHOUD, born the 19th March, at Plancemont, in the canton of Neuchâtel; 1745, became a fixed resident in Paris; died 20th June, 1807.

DEATH OF SIR ISAAC NEWTON.—The clock made by *R. Street*, of London, and which Sir Isaac Newton presented in 1708 to Dr. Bentley, the Master of Trinity College, Cambridge, for the observatory erected over the great gateway, but which was pulled down in the year 1797 in consequence of its ruinous condition, now stands on the staircase at the Master's lodge.

“When I was in Town S^r Isaac Newton gave orders for ye making of a Pendulum Clock which he designs as a present to our new observatory. The sextant will

cost the Colledge 150^l and I believe S^r Isaac's Clock can cost him no less yⁿ 50^l."—*Cotes to John Smith*, October 16th, 1707. *Edleston's Newton's Correspondence with Cotes*, page 198.

Unfortunately, about the year 1857 the late Mr. Hitzmann, clock and watch-maker at Cambridge, received instructions to take away the *original* pendulum, a long rod of wood with heavy iron bob, and put in its place a tubular pendulum, as invented by Mr. Troughton, to compensate for heat and cold.

JULIAN LE ROY, watchmaker, of Paris, commissioned A.D. 1728. Graham to make him a cylinder watch.

GAUDRON, a celebrated Paris clockmaker. Lepaute A.D. 1730. frequently quotes him as a great authority.

NEVIL MASKELYNE, born in London, the 6th A.D. 1732. October; took his B.A. degree at Cambridge in 1754, M.A. 1757, B.D. 1768, and D.D. 1777; ordained in 1755; Fellow of Trinity, 1758; elected F.R.S., 1759; sent to the island of St. Helena to observe transit of Venus over disk of the sun, 1761. In the year 1763 he made a voyage to Barbadoes in order to examine into the goodness of Harrison's timekeeper; 1765, made Astronomer Royal, which appointment he held for forty-six years; 1811, died in the seventy-ninth year of his age.

PETER AUGUSTUS CARON was born the 25th January, A.D. 1732. at the house of his father, a clockmaker, situate in the Rue St. Denis, Paris. At the age of nineteen he invented the escapement known in France as the *double*

virgule, which may be said to be a combination of the cylinder and duplex. He disputed in 1753, with Lepaute, the honour of being the inventor, and was awarded the merit of the discovery by the Academy of Sciences, the 24th February, 1754. He was afterwards the author of the '*Barber of Seville*,' '*The Marriage of Figaro*,' under the name of *Beaumarchais*. He made for Madame de Pompadour a watch, thus described:—

“Une montre dans une bague . . . elle n'a que quatre lignes et demie de diamètre et une ligne moins un tiers de hauteur entre les platines. Pour rendre cette bague plus commode, j'ai imaginé en place de clé un cercle autour du cadran, portant un petit crochet saillant; en tirant ce crochet avec l'ongle, environ les deux tiers du cadran, la bague est remontée; et elle va trente heures.”

At the age of twenty-five he obtained a situation at court, under Louis XV., and received permission, on giving up the watch business, to style himself *Monsieur de Beaumarchais*.

A.D. 1733. REGNAULD of Châlons, one of the first French clock-makers who attempted to compensate a clock against the effects of heat and cold.

A.D. 1734. R. P. DOM. JACQUES ALEXANDRE, author of '*Traité Général des Horloges*.'

A.D. 1736. FLAMENVILLE, an escapement with tumbling pallets. L. Kendall, of London, improved upon it.

Mechanism for going in time of winding first exhibited by Mr. Harrison.

A.D. 1737. '*RÈGLE ARTIFICIELLE du Temps*,' by HENRY SULLY, a second edition by JULIAN LE ROY.

A.D. 1740. Mr. HINDLEY, of York, invented a wheel dividing and cutting engine.

THIOUT THE ELDER was a clockmaker at Paris; he A.D. 1741. published a work in two volumes on practical clock-work, in which he gives a great number of inventions, &c.

ENDERLIN, inventor of an equation clock, also several escapements.

ABRAHAM LOUIS BREGUET, born the 10th January, in A.D. 1747. the canton of Neuchâtel, Switzerland; died the 17th September, 1823. Watches made by this distinguished maker have always been greatly valued, and still command a high price on account of the beauty and finish of the work.

The only foreign artist who ever attempted to excel him was *Buegger*, of Geneva; his watches are however very scarce; must have been extremely costly, to judge by the care and attention which he seems to have devoted to every part of the movement.

THE firm of VALE established at Coventry for watchmaking.

PETER LE ROY, of Paris, invented a dead beat escape- A.D. 1748. ment.

THOMAS EARNSHAW, born at Ashton-under-Lyne, A.D. 1749. Lancashire.

GEORGE GRAHAM, died the 16th November, in the A.D. 1751. seventy-eighth year of his age; was buried in the same grave with his master and friend Tompion, in the nave of Westminster Abbey; a small lozenge-shaped tablet bore the following inscription:—

“Here lies y^e body of Thomas Tompion, who died Nov. 20th, 1713, aged 75. Also, George Graham, Watchmaker and F.R.S., whose curious inventions do honour to y^e British genius, whose accurate performances are y^e standard of mechanical skill. He died y^e 16th Nov., 1751, in y^e 78 year of his age.”

Unfortunately the slab was removed in the year 1838, and the following substituted:—

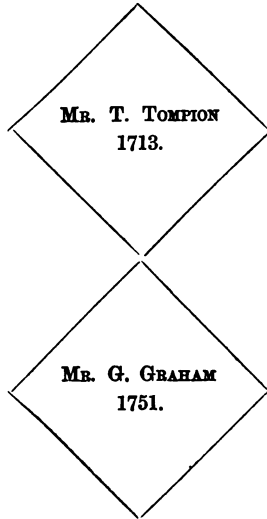

GRAHAM made the scape-wheels of his horizontal watches very different from the present established form. The teeth were from toe to heel cycloidal curves, whereas now they are inclined planes.

Mr. Thomas Grignion, son, in the plate which he caused to be engraven and placed in the vestry of St. Paul's, Covent Garden, says, that his father brought to perfection in 1740 "what the celebrated Tompion and Graham never effected, *viz.* the horizontal principle in watches."

Possibly he may have meant that Mr. Thomas Grignion discovered that the scape-wheel teeth would be more perfect in their action by being made inclined

planes, and consequently, by so making them, brought to perfection the invention of Tompion and Graham.

The author has lately become possessed of a watch by *Graham*, date mark in gold case, 1750, with the above-described scape-wheel.

Also a remarkably fine-made horizontal movement, by *Thomas Grignion*, with the present form of scape-wheel, in good going condition, and an excellent time-keeper. The want of the case unfortunately prevents the date being ascertained.

A. Cumming, in essay on the improvement of watches, says:—

“In the horizontal wheel now universally used, each tooth is formed into an inclined plane or wedge, which acts on the edges of the cylinder, and by that means maintains the vibrations; and these teeth, after performing their office, rest alternately on the internal and external circumference of the cylinder,” &c.

Now, as Graham died in 1751, and continued to the last to make his scape-wheels with these cycloidal curved teeth, it is most probable that the date given by Mr. Thomas Grignion, son, *viz.* 1740, is incorrect, especially as he dated his statement December 21st, 1798.

It is more reasonable to conclude that Mr. Thomas Grignion, the father, who was a man of great reputation, introduced his improvement of inclined planes for the scape-wheel teeth after the death of Graham in 1751, and previous to the publication of A. Cumming's ‘Elements of Clock and Watch-work,’ in 1766.

ANTIDE JANVIER, born at Saint Claude, in the Jura; A.D. 1751.

made a citizen of Besançon the 17th May, 1770; died the 23rd September, 1835.

LE PLAT, clockmaker, of Paris, suggested the application of a remontoir to a clock to be acted on by a current of air.

- A.D. 1753. JOHN ELLICOTT, inventor of a compensated pendulum.
- A.D. 1754. F. BERTHOUD composed an escapement in which the balance makes two vibrations in the time that one tooth only of the wheel escapes, *i. e.* the time in which the balance goes and comes on itself.
- JOHN JODIN published a treatise on escapements.
- A.D. 1755. F. BERTHOUD designed a plan for a chronometer; the same received improvements in 1760; and again in 1768.
- J. A. LE PAUTE, author of a treatise on clock-work. He and his brother constructed the clocks for the Military School, and the Hotel des Invalides, Paris.
- A.D. 1756. THWAITES made a clock for the Horse Guards, which was renewed in 1816 by B. ST. JUST VULLIAMY, a well-known and highly-esteemed clockmaker.
- A.D. 1763. F. BERTHOUD made the *first* pocket watch with *compensation curb*; it was begun in 1763, finished early in 1764, and sold in 1766 to MR. PINCHBECK, of London, for his Britannic Majesty George III.
- A.D. 1764. MR. JOHN ARNOLD made the smallest repeating watch ever attempted, as a birthday gift for George III. —size, less than a silver twopence; weight, 5 dwts. $7\frac{3}{4}$ grains.
- A.D. 1765. LARCUM KENDALL, a noted watchmaker, of London,

constructed a timekeeper on Harrison's principle, which was given to *Captain Cook*, when he commanded the 'Resolution' in 1776, 1777, 1779, 1780.

THOS. MUDGE showed his detached escapement to A.D. 1766.
F. Berthoud.

ALEXANDER CUMMING published the *Elements of Clock and Watch-work*.

LE ROY invented a compensation balance very A.D. 1768. similar to one contrived by Harrison.

LUDLAM, Professor of Astronomy at Cambridge, A.D. 1769. corresponded on the subject of clocks with several eminent men.

THOMAS MUDGE made for Mr. Smeaton a watch with A.D. 1770. compensation curb; also for Queen Charlotte a *lever* watch.

OWEN ROBINSON'S detached escapement.

MR. JOHN ARNOLD obtained a patent for a *helical* A.D. 1775. spring.

LÉPINE introduced his improvements, which consisted A.D. 1776. in the suppression of—

1. The pillar-plate.
2. The fusee and chain.
3. One of the supports to barrel-arbor.

The LÉPINE family were resident at *Ferney*, near Geneva, where *Voltaire* established a watch factory.

BREGUET improved on the Lépine system by causing the main-spring to be wound up at the back of the watch through the dome, instead of by a square through the face of the dial.

JOHN ARNOLD made two marine timekeepers, which

were placed on board the 'Adventure,' tender to the 'Resolution,' under the command of *Captain Cook*.

- A.D. 1778. M. LE CERF, of Geneva, invented a sector pitching-tool.
- A.D. 1780. MR. R. PENNINGTON published the description of a sector, for giving the proportionable sizes of wheels and pinions; and for determining the proper distance of their centres from each other. The instrument of which this is an improvement, was invented by one **Downs**.
- A.D. 1781. THOMAS EARNSHAW's improved spring detent.
- A.D. 1782. JOSIAS EMERY about this time became distinguished for the finish and accuracy of his watches.
 THOMAS TYRER's original patent for the duplex.
 JOHN ARNOLD's patent for epicycloidal scape-wheel teeth.
- A.D. 1784. BREGUET invented an escapement which with the pendulum-stud revolved round the centre of the balance once every minute. Also a new method of coiling the pendulum-spring.
- A.D. 1785. Death of PIERRE LE ROY.
- A.D. 1788. MR. JOSEPH RIDLEY, maker of a sector, and a sector deepening-tool.
 THOMAS WRIGHT, inventor of compensation work.
- A.D. 1791. THOMAS EARNSHAW presented a petition to the Board of Longitude for aid; ditto 1797.
- A.D. 1792. EARNSHAW made a clock for the Archbishop of Armagh.
 WILLIAM HOWELLS invented a detached escapement for clocks and watches, without springs.

PETER LITHERLAND, a patent for the *Rack Lever*. A.D. 1794.

A considerable number of watch-workers from *Loche* A.D. 1795. and *Chaux-de-Fonds* established themselves at BESANÇON, and were the means of introducing the trade into that town.

The *National Convention* of France gave instructions that those men who had left their country on account of their adhesion to the principles of the French Revolution, should be protected and assisted.

ROBERT LESLIE'S patent for a nautical watch ; also, A.D. 1795. patent for a short pendulum to vibrate seconds.

CHARLES HALEY.—Patent for a new escapement A.D. 1796. adapted for marine timekeepers.

DUTIES imposed on clocks and watches. An annual A.D. 1797. duty of five shillings on every clock ; ten shillings on every gold watch, worn or used ; two shillings and sixpence for every silver or metal watch per annum.

This act was repealed. A.D. 1798.

MR. JOHN ARNOLD died the 27th August at Well A.D. 1799. Hall, near Eltham, Kent.

SIMON GOODERICH, of London, took out a patent for the application of a crank as an escapement for clocks.

A DESCRIPTION, with plates, of the timekeeper invented by Thomas Mudge, to which is prefixed a narrative by Thomas Mudge, his son, &c., &c.

THE BOARD OF LONGITUDE voted the sum of 500*l.* to A.D. 1800. T. Earnshaw.

JOHN DE LAFONS invented a new escapement for a A.D. 1801. watch.

THE BOARD OF LONGITUDE came to the following A.D. 1803.

resolution the 3rd March, which was confirmed on the 17th :—

“ Resolved—

“ That the Board are convinced that Mr. Earnshaw’s watches have gone better than any others that have been submitted to trial at the Royal Observatory, and therefore are of opinion that he deserves a reward equal at least to that given by Parliament to Mr. Mudge, provided he will disclose the construction of his timekeepers in such a manner as shall satisfy the Board that other watch-makers will be enabled to construct them with equal accuracy.

“ But as the Board do not think themselves justified in granting, out of the sum usually entrusted to them by Parliament, so large a reward as they think Mr. Earnshaw deserves, they think it expedient that Mr. Earnshaw’s case be stated in their petition to Parliament, and a sum of 2500*l.* more than the usual sum of 500*l.* be asked for, in order to enable the Board to do justice to Mr. Earnshaw’s merits in case the Chancellor of the Exchequer shall agree to the same.

“ That the President of the Royal Society be desired to wait upon the Chancellor of the Exchequer, and request him to consent to the additional grant intended for the reward of Mr. Earnshaw.”

THOMAS EARNSHAW *received the long-contested reward the 27th December, 1805.*

JOHN PRIOR, of Nessfield, near Skipton-in-Craven, Yorkshire, invented a simple striking part for an eight-day clock.

EDWARD MASSEY, of Hanley, Staffordshire, an improved escapement for pendulum clocks.

WILLIAM HARDY, a new method of banking time-keepers. A.D. 1804.

J. M. ELLIOT, patent for a repeating watch, without pinions, pulleys, chain, or rack.

J. WATKINS, a detached escapement for a time-keeper to ascertain the longitude at sea.

JOHN PRIOR contrived an alarum applicable to pocket watches.

WILLIAM HARDY, permanent compensation balance for a watch. A.D. 1805.

HENRY WARD, of Blandford, Dorsetshire, suggested an improved striking part for an eight-day clock, without a train of wheels, and the motion of which is derived from a pendulum.

JOHN ARNOLD, junior, was voted the sum of 1678*l.* by the Board of Longitude.

JOSEPH MOSELEY ELLIOT, patent for new and improved repeaters. A.D. 1806.

WILLIAM HARDY, a method of equalizing the long and short arcs of vibration in timekeepers. A.D. 1807.

GEORGE SAVAGE, a patent for regulating the force for the main-spring. A.D. 1808.

G. SPARK, of Elgin, Elginshire, Scotland, invented a noctuary, or instrument for ascertaining the hour of the night, when connected with a common watch. A.D. 1810.

ADAM REID, of Woolwich, compensation pendulum. A.D. 1811.

GEORGE PRIOR, an improved remontoire escapement for pendulum clocks.

- A.D. 1812. DAVID RITCHIE, of London, a compensation pendulum.
- A.D. 1814. HENRY WARD, of Blandford, an equation work for a clock.
- A.D. 1816. MR. JAMES ALLEN, of London, watchmaker, was awarded by the Honourable the Commissioners of the Board of Longitude the sum of one hundred guineas for his superior method of dividing mathematical and astronomical instruments.
- A.D. 1821. JAMES FERGUSON COLE, an improved detached escapement. In 1830, a resilient lever escapement; also, in 1859, a repellent lever escapement.
Mr. Cole was one of the judges for the Lady Burdett Coutts' prize essay 'Balance Springs.'
- A.D. 1826. THE FIRST ILLUMINATED CLOCK dial in London at St. Bride's Church, Fleet Street.
- A.D. 1827. THE SECOND illuminated dial at the church of St. Giles in the Fields.
- A.D. 1830. G. SAVAGE invented lever chronometer.
- A.D. 1836. MR. JOHN G. ULRICH took out a patent for the application of two springs to the balance; one above, the other below, pinned in opposite directions, whereby the side friction of the balance pivots was greatly reduced.
- A.D. 1838. GEORGE C. PHILCOX, a patent for diamond lever escapement whereby the impulse is given as near as possible to the line of centres.
- A.D. 1840. PROFESSOR WHEATSTONE exhibited before the Royal Society an electro-magnetic clock.
- A.D. 1851. E. B. DENISON, Esq., President of the Horological Institute, designed and superintended the construction

of the *Westminster Clock*. In his *Rudimentary Treatise on Clocks and Watches and Bells*, at page 324, he says: "And now as to the performance of the clock. It reports its own time by electricity to the Royal Observatory, and Greenwich time is telegraphed to the clock-room; so that whenever Mr. Smith (Mr. Dent's old foreman, who still superintends it) sees that it is wrong it can be corrected by the apparatus described at page 246."

Mr. Airey says in one of his annual reports:— "*The rate of the clock is certain to be much less than a second a week.*" Again, the President of the British Horological Institute said at their annual meeting in 1866, "We have it on the authority of Mr. Ellis, of the Royal Observatory, that there is no clock at Greenwich which keeps time so well as Mr. Denison's clock at the Houses of Parliament. Another account from Greenwich gives the rate as being a second in ten days, or ten times more accurate than was stipulated for in 1845. And the last report is that it has only been three seconds wrong on two per cent. of all the days of observation."

MR. BLOXAM, inventor of a superior escapement for A.D. 1853. clocks, but too expensive.

GEORGE BLACKIE made in 1858 an auxiliary com- A.D. 1858. pensation for a balance to a chronometer, which stood first on the rates at the Royal Observatory, Greenwich. The action of this auxiliary being vertical to the plane of the balance, and in the form of a sharp curve, as a matter of course approached the centre more rapidly in heat, and receded from it in a decreasing ratio for cold.

Through the kindness of Mr. G. Blackie, the author has been allowed to examine the rates of several chronometers, taken during the first fifteen days of May, 1873.

The extraordinary exactness of two having the auxiliary compensation is worth recording:—

1st May.—Excessively warm.

2nd May.—Warm.

3rd to 11th May.—Very cold, uncertain weather; direction of the wind, mostly N.W.

12th May.—Very warm; wind, W.

13th and 14th May.—Very cold; wind, N.E.; overcast.

15th May.—Cold.

The chronometers to which the auxiliary had been applied did not vary in their rate except a mere fraction.

Those with ordinary compensation gained as much as two and three seconds on the 12th.

A.D. 1864.

A. PHILLIPPE, of Geneva, inventor of a new watch-barrel with free main-spring, having neither hook nor eye, and without stopwork.

Advantages of this system:—

1. Great economy in the construction of the barrel.
2. Increase in the height of the barrel.
3. Greater preservation of the spring, since its increased width will permit a decreased thickness for the same traction.
4. The setting of the inferior pivot of the arbor much better, on account of the increased height and the dispensing with the squared part.

5. Watches going a longer time without winding up.
6. Freedom from the danger of over-winding.
7. The necessity for repairs less frequent.

G. HORSTMANN, of Bath, a self-winding clock, the A.D. 1866.
principle of which is the expansion and the contraction of fluids consequent upon the natural changes of temperature.

MARCH the 27th, an adjourned meeting of the watch A.D. 1867.
trade took place at the 'Crown Tavern,' Clerkenwell Green, when the following sensible amendment, in opposition to a motion "that the Hall-marking of watch-cases ought to be optional," was passed by a large majority :—

"That in the opinion of this meeting the Hall-marking of watch-cases should be strictly maintained, as a protection to both the public and the honest trader, against fraud on the part of manufacturers or dealers inclined to dishonesty—a discouragement to roguery and a preventive of temptation to the weak."

Mr. William Chaffers, the author of *Hall-marks on Gold and Silver Plate*, says in a very interesting letter to 'The Times' of January 28th, 1873,—

"The standard of the precious metals has been insisted on by the laws of the land for more than 600 years, and the assaying of them was a privilege conferred as early as the year 1300 by Edward I. upon the Goldsmiths' Company of London, who stamped them with the leopard's head as a sign to the public that a piece of gold or silver was actually of the quality thereby signified. It was ordained in 1327 that in all

cities and towns in England where goldsmiths reside, one or two of the craft for the rest of the trade should come to London and have the stamp of a puncheon of a leopard's head marked upon their work, as of ancient time it has been ordained ; and at that early date it was enjoined that three stamps should be put upon the plate.

“First, the goldsmith's mark who made it.

“Secondly, the mark of the assayer (a letter of the alphabet denoting the year).

“Thirdly, the mark of the Goldsmiths' Hall (a leopard's head crowned).

“Another mark of a lion passant, denoting that the piece was standard, was added about 1545.

“In 1423 other towns were privileged to mark plate, but as many had discontinued, another Act was passed in 1700, by which York, Exeter, Bristol, Chester, and Norwich were formally appointed.

“In 1773 Birmingham and Sheffield were also privileged to assay and stamp silver plate, each town placing a stamp of their arms for the purpose of identification.

“These two standards of plate—gold of 22 carats, and silver of 11 oz. 2 dwt.—or sterling, have remained unchanged except for a short period of twenty-five years, when a purer quality of silver was introduced called the new standard, but it was found too soft for general use.

“In 1798 a lower standard of gold, consisting of 18 carats pure gold out of 24, was allowed by the Act,

indicated by the stamp of a crown, and 18 instead of the lion passant.

“In 1854 inferior qualities of gold were legalized, to be stamped in figures setting forth the fineness, *viz.* 15, 12, and 9 carats pure gold out of the 24.

“It may be well to state, for the information of the public, and to put people on their guard in purchasing gold, that whether of the best or worst quality it is still termed so, and sold as warranted gold, although the value ranges from eighty-five shillings to thirty the ounce, &c.

“Hence any purchaser may tell by the stamp the intrinsic value of the article offered for sale, to which must necessarily be added the cost of manufacturing.”

Several discussions have of late taken place with regard to the quality of the materials marked at Goldsmiths' Hall, and certain traders in gold-work have endeavoured to prove that the Hall-mark is not a sufficient guarantee against fraud in the quality of the material used, and have asserted that customers would be quite as safe with the guarantee of a respectable tradesman.

The guarantee of a well-known tradesman is good as long as he may continue to carry on business; but suppose, in case of his death or retiring from the business, the watch be offered for sale, will any dealer in the precious metals be satisfied to buy without testing the quality? Certainly not. Again, suppose the watch to remain in private hands for over 120 years, as in the case of a watch by George Graham, sold lately to a

watchmaker, who by the Hall-mark knew at once that the gold was 22 carats fine, and without hesitation allowed the value of its weight.

Englishmen are much given to wandering about on the Continent; possibly a watch might be offered in exchange for some article of jewellery. Will the foreign dealer accept the guarantee of a firm unknown to him? Hardly probable.

Can the manufacturers of 18-carat goods guarantee that the market shall be supplied only with 18-carat gold watch-cases?

Will there not be watches heavily cased, made purposely to deceive, like the gold chains which when assayed are discovered to be nearly intrinsically worthless.

Whatever may be said by the members of enterprising firms, anxious honourably to advance their own system of doing business, respecting frauds occasionally committed under cover of the Hall-mark, of this fact there is no doubt whatever, that the assays are conducted most fairly and uprightly, and that it will be an unfortunate day for the English watch-trade when watch-cases are not required to be Hall-marked.

A.D. 1870. W. H. CROUCH, of Cambridge, inventor of a new escapement for watches.

A.D. 1872. MORITZ IMMISCH, and MR. HENRY PHILLIPS PALMER, Leominster, were adjudged equal in the competition for the Baroness Burdett Coutts' prize essay, 'Balance Springs.'

CHAPTER VII.

ON CALCULATIONS OF THE NUMBERS FOR WHEELS AND
PINIONS, THEIR PROPORTIONAL SIZES, TRAINS, ETC.

BEFORE attempting to give a description of the five principal scapements, *viz.* the *verge, horizontal, duplex, lever, and chronometer*, it is absolutely necessary to place before the reader the calculations for trains, and the rules for finding the numbers for teeth of wheels, and leaves of pinions.

Mr. *Thomas Reid*, in the second chapter of his *Treatise on Clock and Watch-work*, a most excellent work, has been at great pains to give not only the numbers for the wheel teeth and pinion leaves, but also the calculations for trains; and in doing so he was, no doubt, guided by the great experience he had gained in the actual practice of watch-work.

As a watchmaker of the present day remarked, "Amateurs may know theory, but we understand practice, and can see where the theory will prove useless," a remark which is undoubtedly true, for it is the practice which can alone turn the theory to good account. Mr. Reid not only knew the theories of his art, but a long practice made him able to select such as would prove useful to the workers in watch-work.

The chapter, then, of which the following is a condensation, has been taken nearly word for word from *Reid's Treatise*, with only such alterations as were necessary to adapt it to its present form; the author being of the watchmaker's opinion, that the calculations of a really practical man are more to be desired than those of a mere lover of the art.

To find the number of vibrations in a minute, or in an hour, having the numbers of the wheel teeth and of the pinion leaves; and also to find the numbers for the wheel teeth, having assumed numbers for the pinions, for the balance-wheel, and the number of vibrations required in an hour, &c.

The beats given by the alternate motion of the scapement are a determined number in a minute, or in an hour, called the train, which depend on the number of wheels in the movement, their number of teeth, or the number of the pinions, and the number of their teeth or leaves; the beats in an hour given by a common watch are 17,280.

In a combination of two or more wheels and their pinions, the ratio of the pinions to their wheels being given, the number of revolutions of the last wheel for one of the first can be deduced. The first wheel being supposed to make a revolution in an hour, during which time let it drive a pinion eight times round, concentric with the pinion is a wheel which drives another pinion seven and a half times round; on the arbor of this pinion is a wheel that may at pleasure, or rather *must*, be cut into such a number of teeth as to make up the

required number of vibrations. The wheels and their pinions may be represented thus:—

$$\frac{\text{Wheels } 8 \times 7\frac{1}{2}}{\text{Pinions } 1 \times 1} = 60,$$

which is the number of revolutions that the last pinion must make for one of the first wheel. If the pinions have eight leaves each, then it follows that one of the wheels must have eight times this number of teeth, which will be 64, and the other seven and a half times, equal to 60. The revolutions will be the same to the last wheel, or its pinion, in whatever order the two wheels are taken.

* * * * *

Whatever number of teeth is cut in the balance-wheel it will give double the number of vibrations for every revolution; then if the number of teeth is 15 the vibrations will be 30.

In order to ascertain what the numbers for the wheel teeth of a watch movement should be, three things are requisite to be known or fixed upon:—

1st. The number of beats to be given in a minute, or in an hour.

2nd. The number of the pinions and of their leaves.

3rd. The number of teeth it is intended for the balance-wheel to have.

Rule.—The number of vibrations, or beats, in an hour being multiplied by the number of leaves in each pinion, or, what is the same thing, each pinion being multiplied into one another, and with the product multiply the number of vibrations in an hour; this last

product being divided by double the number intended for the balance-wheel, will give for the quotient such a number, that when divided by prime numbers, first by 2, as often as it will divide by 2 without leaving a remainder; then by 3 as often as it will divide by it; by 5, as often as it will; and by 7, 11, 13, &c., until no remainder is left; and afterwards arranging the divisors, they may be made out so as to have sets of them, which when multiplied into one another, will give the proper numbers for the wheel teeth required.

For the first example, let that of a common watch be taken, where the balance-wheel has 15 teeth; three pinions having six leaves each, and the beats, train, or vibrations in an hour are 17,280. Required the numbers for the teeth of the second, third, and fourth (or contrate) wheels?

$$\begin{aligned} \text{Vibrations per minute } & 288 \times 60 \times 6 \times 6 \times 6 \div 30 \\ & = 124,416. \end{aligned}$$

$$2 \times 3 = 6 \times 3 = 18 \times 3 = 54$$

$$2 \times 2 = 4 \times 2 = 8 \times 2 = 16 \times 3 = 48$$

$$2 \times 2 = 4 \times 2 = 8 \times 2 = 16 \times 3 = 48$$

The divisors here will be found to consist of nine 2^s and five 3^s, which when properly arranged will give for the numbers of the wheel teeth 54, 48, and 48, with a balance-wheel of 15 teeth, and three pinions of 6 each, will give a train of 17,280 beats in an hour.

The train is 18,000 in an hour, the balance-wheel 15 teeth, and three pinions of six leaves each. Required the numbers for the second, third, and fourth wheels?

$$\begin{aligned} \text{Vibrations per minute } & 300 \times 60 \times 6 \times 6 \times 6 \div 30 \\ & = 129,600; \text{ the divisors of which are six } 2^s, \text{ four } 3^s, \text{ and} \\ & \text{two } 5^s. \end{aligned}$$

The numbers for the wheel teeth.

$$3 \times 3 = 9 \times 3 = 27 \times 2 = 54$$

$$2 \times 5 = 10 \times 5 = 50$$

$$2 \times 2 = 4 \times 2 = 8 \times 2 = 16 \times 3 = 48$$

These divisors can be arranged into another set of numbers should it be thought necessary, as thus:—

Numbers given for the teeth of the wheels.

$$2 \times 2 = 4 \times 3 = 12 \times 5 = 60$$

$$2 \times 2 = 4 \times 2 = 8 \times 2 = 16 \times 3 = 48$$

$$3 \times 3 = 9 \times 5 = 45$$

Taking the train 17,280, the balance-wheel 14, two pinions of 8 and one of 7, what must be the numbers for the teeth of the three wheels?

$17,280 \times 8 \times 8 \times 7 \div 28 = 276,480$. The divisors are eleven 2's, 3, and one 5.

Numbers given for the wheel teeth.

$$2 \times 2 = 4 \times 2 = 8 \times 3 = 24 \times 3 = 72$$

$$2 \times 2 = 4 \times 2 = 8 \times 2 = 16 \times 2 = 32 \times 2 = 64$$

$$2 \times 2 = 4 \times 3 = 12 \times 5 = 60$$

If the number 72 is taken for the fourth wheel, then this will be a fourth wheel seconds movement.

The beats in an hour 17,920, two pinions of 8, and one of 7, the balance-wheel 14; required the numbers for the teeth of the second, third, and fourth wheels?

$17,920 \times 8 \times 8 \times 7 \div 28 = 286,720$, whose divisors are thirteen 2's, one 5, and a 7.

Numbers given for the teeth of the wheels.

$$2 \times 5 = 10 \times 7 = 70$$

$$2 \times 2 = 4 \times 2 = 8 \times 2 = 16 \times 2 = 32 \times 2 = 64$$

$$2 \times 2 = 4 \times 2 = 8 \times 2 = 16 \times 2 = 32 \times 2 = 64$$

The beats in an hour being assumed at 18,000, two pinions of 10, and one of 8, the balance-wheel 15 teeth;

required the numbers for the teeth of the second, third, and fourth wheels?

$18,000 \times 10 \times 10 \times 8 \div 30 = 480,000$. The divisors are eight 2^s , one 3, and four 5^s .

Numbers for the wheel teeth.

$$2 \times 2 = 4 \times 2 = 8 \times 2 = 16 \times 5 = 80$$

$$2 \times 2 = 4 \times 2 = 8 \times 2 = 16 \times 5 = 80$$

$$3 \times 5 = 15 \times 5 = 75$$

If the fourth wheel in this is made 80, that is, changing places and numbers with the third wheel, it will become a fourth wheel seconds movement.

Given 18,432 for the beats in an hour, the pinions 8 each, and the balance-wheel 16; required the numbers for the teeth of the three wheels?

$18,432 \times 8 \times 8 \times 8 \div 32 = 294,912$. The divisors are fifteen 2^s , and two 3^s (or one 9, which is the same thing; yet, properly speaking, 9 should never in these cases be expressed, although it may be implied, as it is not itself a prime number).

Numbers for the wheel teeth.

$$2 \times 2 = 4 \times 2 = 8 \times 9 = 72$$

$$2 \times 2 = 4 \times 2 = 8 \times 2 = 16 \times 2 = 32 \times 2 = 64$$

$$2 \times 2 = 4 \times 2 = 8 \times 2 = 16 \times 2 = 32 \times 2 = 64$$

Given 360 beats in a minute, or 21,600 in an hour, the pinions 8 each, and the balance-wheel 15; what numbers will be required for the teeth of the wheels?

$21,600 \times 8 \times 8 \times 8 \div 30 = 368,640$. The divisors are thirteen 2^s , two 3^s , and a 5.

The numbers for the wheel teeth.

$$2 \times 2 = 4 \times 2 = 8 \times 2 = 16 \times 5 = 80$$

$$2 \times 2 = 4 \times 2 = 8 \times 3 = 24 \times 3 = 72$$

$$2 \times 2 = 4 \times 2 = 8 \times 2 = 16 \times 2 = 32 \times 2 = 64$$

Given 18,000 beats in an hour, the pinions 8, and the balance-wheel 15; what numbers will be required for the teeth of the wheels?

$18,000 \times 8 \times 8 \times 8 \div 30 = 307,200$. The divisors are twelve 2's, one 3, and two 5's.

The numbers for the wheel teeth.

$$\begin{aligned} 3 \times 5 &= 15 \times 5 = 75 \\ 2 \times 2 &= 4 \times 2 = 8 \times 2 = 16 \times 2 = 32 \times 2 = 64 \\ 2 \times 2 &= 4 \times 2 = 8 \times 2 = 16 \times 2 = 32 \times 2 = 64 \end{aligned}$$

Given the same as the preceding example, only the balance-wheel 16 in place of 15; to find the numbers for the wheel teeth.

$18,000 \times 8 \times 8 \times 8 \div 32 = 288,000$. The divisors are eight 2's, two 3's, and three 5's.

The numbers for the wheel teeth.

$$\begin{aligned} 5 \times 5 &= 25 \times 3 = 75 \\ 2 \times 2 &= 4 \times 2 = 8 \times 2 = 16 \times 2 = 32 \times 2 = 64 \\ 2 \times 2 &= 4 \times 5 = 20 \times 3 = 60 \end{aligned}$$

Given 20,250 for the train, pinions of 6, and the balance-wheel 15; to find the numbers for the wheel teeth.

$20,250 \times 6 \times 6 \times 6 \div 30 = 145,800$. The divisors are three 2's, six 3's, and two 5's.

The numbers found for the wheel teeth.

$$\begin{aligned} 3 \times 3 &= 9 \times 3 = 27 \times 2 = 54 \\ 3 \times 3 &= 9 \times 3 = 27 \times 2 = 54 \\ 5 \times 5 &= 25 \times 2 = 50 \end{aligned}$$

Given 7200 beats in an hour, the pinions 8, and the balance-wheel 15; to find the numbers for the teeth of the wheels.

$7200 \times 8 \times 8 \times 8 \div 30 = 122,880$. The divisors are thirteen 2^s , one 3, and a 5.

Numbers for the wheel teeth.

$$2 \times 2 = 4 \times 2 = 8 \times 2 = 16 \times 2 = 32 \times 2 = 64$$

$$2 \times 2 = 4 \times 2 = 8 \times 2 = 16 \times 3 = 48$$

$$2 \times 2 = 4 \times 2 = 8 \times 5 = 40$$

Given 14,400 beats in an hour, the pinions 8 each, and the balance-wheel 15; to find the numbers for the teeth of the wheels.

$14,400 \times 8 \times 8 \times 8 \div 30 = 245,760$. The divisors are fourteen 2^s , one 3, and a 5.

Numbers for the teeth.

$$2 \times 2 = 4 \times 2 = 8 \times 2 = 16 \times 2 = 32 \times 2 = 64$$

$$2 \times 2 = 4 \times 2 = 8 \times 2 = 16 \times 2 = 32 \times 2 = 64$$

$$2 \times 2 = 4 \times 3 = 12 \times 5 = 60$$

Making the third wheel 60, and the fourth wheel 64, it becomes a fourth wheel seconds movement.

The beats in an hour being 14,400, the pinions 10 each, and the balance-wheel 15; required the numbers for the wheel teeth?

Vibrations in a minute $240 \times 60 \times 10 \times 10 \times 10 \div 30 = 480,000$. The divisors are eight 2^s , one 3, and four 5^s .

Numbers for the wheel teeth.

$$2 \times 2 = 4 \times 2 = 8 \times 2 = 16 \times 5 = 80$$

$$3 \times 5 = 15 \times 5 = 75$$

$$2 \times 2 = 4 \times 2 = 8 \times 2 = 16 \times 5 = 80$$

The beats in an hour 14,400, two pinions of 12, and one of 10, the balance-wheel 16; what must be the numbers of the wheel teeth?

$14,400 \times 12 \times 12 \times 10 \div 32 = 648,000$. The divisors are six 2^s , four 3^s , and three 5^s .

Numbers for the wheel teeth.

$$2 \times 2 = 4 \times 2 = 8 \times 2 = 16 \times 2 = 32 \times 3 = 96$$

$$2 \times 3 = 6 \times 3 = 18 \times 5 = 90$$

$$3 \times 5 = 15 \times 5 = 75$$

The same as the preceding, only the pinions here are all 12.

$14,400 \times 12 \times 12 \times 12 \div 32 = 777,600$. The divisors are seven 2's, five 3's, and two 5's.

Numbers for the wheel teeth.

$$2 \times 2 = 4 \times 2 = 8 \times 2 = 16 \times 2 = 32 \times 3 = 96$$

$$2 \times 3 = 6 \times 3 = 18 \times 5 = 90$$

$$2 \times 3 = 6 \times 3 = 18 \times 5 = 90$$

Slow trains are suited only for box chronometers; 14,400 has been generally adopted.

* * * * *

When the numbers of the wheel teeth and of the pinion leaves are known, the train or beats in an hour is obtained by multiplying the wheels into one another, and the product by the double of the number of teeth in the balance-wheel, and this last product, divided by the amount of the pinions multiplied into one another, will give for the quotient the number of beats in an hour.

Take, for example, the wheels 72, 64, 64, and 16, three pinions of 8 each, to find the train?

$$72 \times 64 \times 64 \times 32 \div 8 \times 8 \times 8 = \frac{9,437,184}{512}$$

The train or beats in an hour = 18,432.

* * * * *

When the movement is for a fourth wheel seconds, then the train is got by dividing the fourth wheel by

the balance-wheel pinion; the quotient, multiplied by double of the number of teeth in the balance-wheel, and then by 60, will give the beats or train in an hour.

Let the fourth wheel be 80, the balance-wheel 15, and its pinion 8.

Then $80 \div 8 = 10$, and $10 \times 30 \times 60 = 18,000$, the train required.

It may be observed, that the rule for finding the train is nearly the converse of that for finding the teeth of the wheels. And as the number which is decomposed into divisors is the product of the wheel teeth multiplied into one another; so this again being multiplied by double of the number of the balance-wheel teeth, and divided by the train, the quotient will be that number which, when resolved into divisors, and properly arranged, will become numbers for the pinion leaves.

It is evident that if the number 9,437,184 be divided by the train 18,432, then the quotient 512 must be the product of the pinions multiplied into one another. The divisors of 512 are nine 2's, making three sets of $2 \times 2 = 4 \times 2 = 8$, all the pinions being 8.

The product of the wheels 96, 90, 75, and 32, the double of the balance-wheel, being divided by the train 14,400, the quotient will be 1440, whose divisors are five 2's, two 3's, and a 5; arranging them will show the pinions.

Numbers for the pinion leaves.

$$2 \times 2 = 4 \times 3 = 12$$

$$2 \times 2 = 4 \times 3 = 12$$

$$2 \times 5 = 10$$

It deserves to be remarked, that it has been frequently the practice to put an odd number of teeth into the balance-wheel, although the nature of the scape-ment would have allowed one of an even number, all other circumstances being made to accord; this seems to have arisen from the old crown-wheels, whose scape-ment would admit no other number but an odd one.

In movements intended to give seconds by the fourth wheel in a watch or chronometer of any kind, having assumed the train, and the number of the teeth in the balance-wheel, nothing more is wanting than to find the number of turns (and parts of a turn when there are any) that the balance-wheel must make in a minute, from which is derived the number for the balance-wheel pinion, and by it is obtained that for the teeth of the fourth wheel.

The numbers for the teeth of the second and third wheels, and for the third and fourth wheel pinions, whatever they are, ought always to give the revolutions of the fourth wheel, to those of the second wheel in the constant ratio of 60 to 1.

It may be thought unnecessary to mention here, that for this purpose the number of teeth in the second wheel should be eight times that of the third wheel pinion, and those in the third wheel seven and a half times that of the fourth wheel pinion. Indeed, it will be the same thing whether the greater number is put into the second or third wheel, provided the pinions be contained in these numbers 8 times and $7\frac{1}{2}$ times. If the number of teeth in the second wheel, when mul-

tiplied by those in the third wheel, and the product divided by that of the third and fourth wheel pinions multiplied into one another, have 60 for the quotient, they will then be in their proper ratio.

Now, to find the numbers for the balance-wheel pinion, and the fourth wheel in a fourth wheel seconds watch. As a *first example in this way*, we may take the train of a common watch, which in general is 17,280, the number of teeth in the balance-wheel 15, and let the fourth or contrate wheel be supposed to make a revolution in a minute. It is required to find the numbers for the balance-wheel pinion, and for the teeth of the fourth wheel ?

Rule.—Divide the train by 60, the quotient will be the train or beats in a minute, which being subdivided by double the number of teeth in the balance-wheel, will give the number of revolutions (and fractional parts of a revolution when there are any) made by the balance-wheel in a minute. If the revolutions are composed of a whole number, then the pinion may at pleasure be any number which, when multiplied by the whole number in the quotient, will give the number for the fourth wheel teeth. But should the revolutions of the balance-wheel be in whole numbers, and fractional parts of another, the denominator of the fraction determines the number of the pinion; and the number for the fourth wheel teeth is obtained by multiplying the denominator by the whole number, to which the numerator must be added; making what is called an improper fraction, the numerator of which

will represent the number for the fourth wheel teeth, and the denominator that for the pinion, as has been observed. The train 17,280 being divided by 60, will give 288 in the quotient for the train or number of beats in a minute, and this subdivided by 30, the double of the number of teeth in the balance-wheel, will give the number of revolutions and parts of a revolution made by the balance-wheel in a minute, which in this case will give $9\frac{1}{3}$ for the quotient, as thus— $30 \overline{) 288}$ ($9\frac{1}{3}$, which is the same with $9\frac{6}{10}$; the denominator 10 of the fraction represents the number for the pinion, and the whole number 9 being multiplied by it, and the number 6 added, will give the improper fraction $\frac{96}{5}$, of which the numerator 96 represents the number for the fourth wheel teeth. The fraction $\frac{96}{5}$ may be reduced to $\frac{48}{5}$, where 5 represents the pinion, and 48 the fourth wheel. *Ten* for the pinion may be thought too *high*, and if we take 48 for the wheel, and 5 for the pinion, *five* may be thought too *low* a number.

There is, however, nothing impracticable here, whether the pinion 10 or 5 be taken.

Example 2nd.—Let 17,400 be assumed for the train, and 15 for the balance-wheel teeth, what must be the numbers for the balance-wheel pinion, and for the fourth wheel teeth?

$17,400 \div 60 = 290 \div 30 = 9\frac{2}{3}$ or $9\frac{4}{6}$, for the revolutions of the balance-wheel in a minute; the mixed number, $9\frac{4}{6}$, as it is called, when reduced to an improper fraction, will be $\frac{58}{3}$; the numerator 58 being

the number for the fourth wheel teeth, and the denominator 6 for that of the pinion.

Example 3rd.—Take the train of 18,000, and the balance-wheel 15; to find the numbers for the fourth wheel and balance pinion?

$18,000 \div 60 = 300 \div 30 = 10$, the number of revolutions made by the balance-wheel in a minute, which being a whole number, any number may be taken for the pinion; if 7 is taken, then the fourth wheel must be 70; if 8 is taken, then the fourth wheel must be 80.

Example 4th.—Let 18,432 be assumed for the train, and 16 for the balance-wheel; required the numbers for the balance-wheel pinion, and for the fourth wheel?

$18,432 \div 60 = 307\frac{2}{5}$, or $307 \cdot 2 \div 32 = 9 \cdot 6$, the number and decimal parts of the revolutions, which would be made by the balance-wheel in a minute; the pinion here must be 10, and the wheel 96 as represented in the improper fraction obtained from $9 \cdot 6$ or $9\frac{6}{10} = \frac{96}{10}$.

Example 5th.—The train 18,000, the wheel 14?

$18,000 \div 60 = 300 \div 28 = 10\frac{20}{28}$, or $10\frac{5}{7} = \frac{75}{7}$. With the same train and a balance-wheel of 16, the fraction would be $\frac{75}{8}$. The wheel being 18, the fraction would be $\frac{75}{8}$.

Example 6th.—The train 21,600, the wheel 15?

$21,600 \div 60 = 360 \div 30 = 12$, and 12×7 taken here for the pinion will give 84 for the fourth wheel.

Example 7th.—The train 14,400, the wheel 15?

$14,400 \div 60 = 240 \div 30 = 8$; taking 10 for the pinion, and multiplying it by 8, gives 80 for the wheel.

Example 8th.—The train 14,400, the wheel 14?

$14,400 \div 60 = 240 \div 28 = 8\frac{6}{7}$, or $8\frac{6}{7} = \frac{120}{7}$, or $\frac{120}{7}$; for 18,000, $\frac{120}{7}$.

Example 9th.—The same train as the preceding, with a balance-wheel of 13?

$14,400 \div 60 = 240 \div 26 = 9\frac{3}{13}$, or $9\frac{3}{13} = \frac{120}{13}$. This is the only fraction that in this case can be obtained for a balance-wheel of 13 teeth; and although the numbers are rather high, they are not quite impracticable.

Example 10th.—The train 7200, the balance-wheel 12?

$7200 \div 60 = 120 \div 24 = 5$. Taking 12 as the number for the balance-wheel pinion, it will require 60 for the fourth wheel; a pinion of 14 requires 70.

The foregoing examples apply wholly to such movements as are intended for fourth wheel seconds; but even in movements where there are no fourth wheel seconds, numbers for the balance-wheel pinion and fourth wheel teeth may be obtained, provided we have those in the second, third, and balance wheels, and in the third and fourth wheel pinions, along with the assumed train. Let the common train of 17,280 be assumed, the second wheel 72, the third 64, the balance-wheel 15, and the third and fourth wheel pinions 8 each; required the number for the balance-wheel pinion, and that for the fourth wheel?

Rule.—Find how many seconds the fourth wheel

pinion takes to make a revolution; from this number of seconds calculate the train or number of beats given by the balance-wheel during that time, the beats being divided by the double of the number of the balance-wheel teeth; the quotient will give the number of turns (and fractional parts of a turn when there are any) made by the balance-wheel in that time. $72 \times 64 \div 8 \times 8 = 72$; the fourth wheel then makes 72 revolutions in an hour; the seconds in an hour are $3600 \div 72 = 50$, which is the number of seconds for every revolution of the fourth wheel or its pinion; the train in a minute, or 60 seconds, is 288.

Then $60 : 288 :: 50 : 240$, and $240 \div 30 = 8$, the turns made in 50 seconds by the balance-wheel or its pinion; the fourth wheel must be 64, and the balance-wheel pinion 8, which will be turned round 8 times in 50 seconds. If the balance-wheel was 14, then the pinion would be 7, and the fourth wheel 60, as $240 \div 28 = 8\frac{4}{7} = 9\frac{0}{7}$.

Let the train assumed be 18,000, the balance-wheel 15, the second and third wheels 80 each, the third and fourth wheel pinions 10 each; required the numbers for the balance-wheel pinion and fourth wheel teeth?

The fourth wheel pinion takes 56.25 seconds to make a revolution; then, as

$60 : 300 :: 56.25 : 281.25 \div 30 = 9.375$, or $9\frac{3}{8} = 9\frac{5}{8}$, thus 75 is the number for the fourth wheel, and 8 for the balance-wheel pinion.

When a watch movement does not show seconds by

the fourth wheel, it is requisite to know the time that the fourth or contrate wheel takes to make one revolution; for knowing this, the watch can be more speedily regulated or brought to time.

Having the numbers of the teeth in the second and third wheels, and the number of leaves in the third and fourth wheel pinions, it is easy to find the number of turns that the fourth wheel must make for one turn of the second or centre wheel; and the time that the centre wheel takes to make one revolution being an hour, from this can be found the time that the fourth wheel takes to make one revolution.

The numbers of the second and third wheel teeth in a common watch movement, are 54 and 48, the third and fourth pinions are 6 each; then to find the revolutions that the fourth wheel or its pinion must make for one revolution of the second wheel.

Rule.—Multiply the numbers of the second and third wheels into one another, the product divided by that of the third and fourth wheel pinions will give, for quotient, the number of turns that the fourth wheel or its pinion must make for one turn of the second wheel,—

$54 \times 48 = (2592) \div 6 \times 6 (36) = 72$, the number of revolutions which the fourth wheel must make in an hour; if 3600, the number of seconds in an hour, be divided by 72, it will give in the quotient 50, for the number of seconds that the fourth wheel takes to make one revolution.

The wheels 72 and 64, the pinions 8 each; how many

revolutions does the fourth wheel make in an hour, and how many seconds are taken in each revolution?

$72 \times 64 \div 8 \times 8 = 4\frac{60}{4}^s = 72$, the number of turns in an hour; and $3600 \div 72 = 50$, the number of seconds that each revolution takes.

The wheels.		The pinions.		Number of turns in an hour.	Time taken for one revolution.
70 × 64	+	8 × 8	give	70	51·43 seconds.
54 × 50	+	6 × 6	„	75	48 seconds.
75 × 64	+	8 × 8	„	75	48 seconds.
75 × 64	+	10 × 8	„	60	1 minute.
54 × 52	+	6 × 6	„	75·22	47·86 seconds.
80 × 64	+	8 × 8	„	80	45 seconds.

A watch movement may come from the maker with its wheels and pinions properly adapted for the train intended; but this may be rendered of no avail, unless the *finisher* takes the trouble to compute what number of teeth the balance-wheel should have.

CHAPTER VIII.

OF DIAL-WHEELS OR MOTION WORK, LENGTH OF TIME
OF GOING WITHOUT WINDING UP.

Thos. Reid, Chap. III., page 31.

To show how to compute numbers for the teeth of those wheels and pinions which constitute what is commonly called the dial or motion work of a watch, may seem unnecessary, yet to assist those who may not have had practice in this way, a few examples shall be given.

The canon-pinion which goes spring-tight on the arbor of the centre or second wheel, prolonged a little above the surface of the dial, carries the minute-hand round the dial in an hour. If the number of teeth or leaves that it contains be multiplied by the number of teeth or leaves in the minute-wheel pinion, and with the product, divide the product of the hour and minute wheels multiplied into one another; the quotient should then be 12, equal to 12 revolutions of the canon-pinion and minute-hand, or one revolution of the hour-wheel and hour-hand.

Suppose the canon-pinion to have 10 leaves, and the minute-pinion 12, these multiplied into one another will be 120; in this case the hour-wheel must have 36

teeth, and the minute-wheel 40, which multiplied into one another produces 1440, and this divided by 120, gives 12 for the quotient, equal to twelve revolutions of the minute-hand, and one of the hour-hand. Taking four times the number of the canon-pinion will give that of the minute-wheel, and three times the minute-pinion will give that of the hour-wheel. If the numbers of the two pinions are assumed, they will lead to the numbers of the two wheels, unless they are such as to bring in fractional parts into the numbers of the two wheels.

In the case where the canon-pinion is 10, and the minute-pinion 12, their product 120, multiplied by 12 will give 1440; this divided by prime numbers, as was done in the case of finding numbers for the wheel teeth in movements, will give divisors when rightly arranged; to produce numbers for the teeth in the dial-wheels—

The divisors of 1440 are five 2^s, two 3^s, and a 5.

Numbers for the teeth of the dial-wheels.

$$2 \times 2 = 4 \times 2 = 8 \times 5 = 40$$

$$2 \times 2 = 4 \times 3 = 12 \times 3 = 36$$

Twelve being the number of revolutions of the canon-pinion and minute-hand, for one revolution of the hour-wheel and hour-hand, becomes the constant number, by which the product of the canon and minute pinions is multiplied, in order to ascertain numbers for the teeth of the hour and minute wheels.

Let the numbers assumed for the canon and minute pinions be 12 and 14, these multiplied into one another will produce 168, and this again multiplied by 12, the

constant number, will give 2016, whose divisors are five 2's, two 3's, and a 7.

$$\begin{array}{l} \text{The number of teeth for the} \\ 2 \times 2 = 4 \times 2 = 8 \times 2 = 16 \times 3 = 48 \text{ minute-wheel} \\ 2 \times 3 = 6 \times 7 = 42 \text{ hour ditto.} \end{array}$$

If 14 was taken for the canon-pinion, 42 and 12 for the minute wheel and pinion, the hour-wheel 48, the ratio would be the same—that is, 12 to 1.

Let the canon-pinion be 14, and the minute-wheel pinion 16; required the number for the teeth of the minute and hour wheels?

$14 \times 16 \times 12 = 2688$, whose divisors are seven 2's, one 3, and a 7.

$$\begin{array}{l} \text{The number of teeth for the} \\ 2 \times 2 = 4 \times 2 = 8 \times 7 = 56 \text{ minute-wheel} \\ 2 \times 2 = 4 \times 2 = 8 \times 2 = 16 \times 3 = 48 \text{ hour ditto.} \end{array}$$

Although not so direct a method as breaking the number down by divisors, it may be seen that 2688 is divisible by 48 into 56, or *vice versa*. When this is obvious, recourse need not be had to getting the number of the teeth by divisors.

Let another example be taken for dial-wheels where the canon-pinion is 18, and the minute-wheel pinion is 20; what must be the numbers for the teeth of the minute and hour wheels?

$18 \times 20 \times 12 = 4320$. The divisors are five 2's, three 3's, and a 5.

$$\begin{array}{l} \text{The number of teeth for the} \\ 2 \times 2 = 4 \times 2 = 8 \times 3 = 24 \times 3 = 72 \text{ minute-wheel} \\ 2 \times 2 = 4 \times 3 = 12 \times 5 = 60 \text{ hour ditto.} \end{array}$$

To find how long a watch will continue to go before requiring to be wound up, the number of teeth in the first or great wheel, and the number of the pinion which it drives, must be known.

In a common watch, the number of leaves in the second or centre wheel pinion is 12, and makes one revolution in an hour, the number of the great wheel teeth which drives it being 48, for one revolution of which the second wheel pinion must make four, equal to four hours, the great wheel turning with the fusee having seven and a half turns of a spiral groove cut on it; $7\frac{1}{2}$ being multiplied by 4, will give the length of time which the watch will go before it requires to be wound up. 7 multiplied by 4 is equal to 28, the half turn is equal to two more, making in all 30 hours that the watch will go before it can be run down, or require to be wound up; but the winding up of a watch is done regularly, or as nearly as may be, at the end of every twenty-four hours, being a more regular kind of period, and at the same time taking the power of the main-spring more at an equality of force.

In flat watches the movement cannot admit the height of the fusee to have seven turns and a half on it, as in the common sort, because this would require the fusee-chain to be so thin that it would not have strength to resist the force of the main-spring, and therefore liable to be broken, a circumstance which from this cause very frequently takes place; therefore, to prevent such accidents, a less number of turns, such as five or six, should be cut on the fusee, so as to allow

as strong a chain as may be. The second wheel pinion, in place of being one of 12, might be a less number, and that of the great wheel increased, in order that the watch may go 30 hours before being run down; or, if the pinion is required to be one of 12, this will require the number of the great wheel to be still more increased.

Suppose the second or centre wheel pinion to be 12, and the fusee to have six turns and a half cut on it; required the number of teeth for the great wheel, so that the watch will go 30 hours?

Take the proportion of the common watch, where the fusee has seven turns and a half, the great wheel 48 teeth, and the pinion 12, which is the same as in the example taken, and say, as $6\cdot5 : 7\cdot5 :: 48 : \text{number of teeth required}$; it is evident that a greater number than 48 is required, so that 48 must be multiplied by 7·5, and divided by 6·5; the quotient will be found to be nearly 55·4 as a number for the teeth of the great wheel; but this being a fractional number, and impracticable in wheel teeth, the great wheel may be made 56; this, divided by the pinion 12, will give for quotient 4·66 hours for one revolution of the great wheel; when this is multiplied by 6·5 turns made by the great wheel and fusee, it will give 30·29 hours for the time that the watch will go.

The number of the great wheel teeth may be found by another way. Whatever is the number of turns proposed for the fusee to have, by it divide 30, the number of hours which it is intended the watch shall

run; the quotient will be such a number, that when the number of the second wheel pinion is multiplied by it, the product will be the number for the teeth of the great wheel.

For example, let the number of turns on the fusee be 6, and the number of the second wheel pinion 14; to find the number of teeth that the great wheel must have so as the watch shall go 30 hours?

$30 \div 6 = 5 \times 14 = 70$, the number of teeth that the great wheel must have.

If it is proposed for the second wheel pinion to be 10, and the fusee to have 6 turns, what is the number of teeth that the great wheel ought to have so that the watch shall go 30 hours?

$30 \div 6 = 5 \times 10 = 50$, the number of teeth for the great wheel.

The fusee to have 5 turns, the second wheel pinion 10; required the number for the great wheel teeth?

$30 \div 5 = 6 \times 10 = 60$, the number for the teeth of the great wheel.

When flat watches have been required, the movement is sometimes made without a fusee, and in its place is introduced a *large* toothed barrel, in order to admit of a thick and sufficiently strong spring, the barrel having a great number of teeth, and the centre wheel pinion a small number, so as that the spring, the barrel teeth, and the centre or second wheel pinion may contribute as much as possible to give the watch an equable power during the time of running out the 30 hours or a little more.

There is an economy (if the expression may be used) made with the main-spring by means of a fusee, which makes every part of the spring more effective than when a fusee is wanting.

A few more examples may be given, to find the numbers for the great wheel teeth.

It is proposed that the fusee is to have 7 turns, the second wheel pinion 16, and that the watch shall go 30 hours; required the number of teeth for the great wheel?

The hours 30 being divided by 7, the proposed number of turns for the fusee, the quotient is $4\cdot3$ nearly; 16, the number of the second wheel pinion, being multiplied by it, gives $68\cdot8$ as the number for the great wheel teeth, but, being a fractional number, it cannot be used as a number for wheel teeth. The wheel, however, may be cut 68, 69, or 70, as either of them will be near enough.

$30 \div 7 = 4\cdot3 \times 16 = 68\cdot8$, which may be called 69, for the number of the great wheel teeth.

The fusee to have $6\frac{1}{2}$ turns, the second wheel pinion to be 14, and the watch to go thirty hours; required the number for the great wheel teeth?

Thirty hours divided by $6\cdot5$, the turns, the quotient is $4\cdot616$ nearly, which, being multiplied by 14, the pinion, gives $64\cdot624$ for the wheel teeth; 65 or 66 may be taken, as $64\cdot624$ is a fractional number.

$$30 \div 6\cdot5 = 4\cdot616 \times 14 = 64\cdot624.$$

In a box chronometer, where depth of room and great height of fusee can be easily got, let the fusee have 10

turns, a second wheel pinion of 20, and the time required it should go before being run down 40 hours; required the number of teeth for the great wheel?

$40 \div 10 = 4 \times 20 = 80$, the number of teeth.

In a box chronometer the fusee to have 8 turns, the second wheel pinion 18 leaves, and the time it must go 40 hours; required the number of teeth for the great wheel?

$40 \div 8 = 5 \times 18 = 90$, the number required.

When movements come into the hands of the *finisher*, the wheels and pinions are made; therefore a few examples, although very simple, shall be given, in order to know what are the numbers required to be cut on a watch fusee or barrel. In a watch movement, the great wheel having 60 teeth, and the second wheel pinion 10; required the number of turns to be cut on the fusee so as the watch may run 30 hours?

The great wheel, 60, divided by the pinion, 10, the quotient is 6; and 30 divided by 6 gives 5 for the number of turns required.

For $60 \div 10 = 6$, and $30 \div 6 = 5$.

The number of turns which a spring should make in the barrel depends on the number of turns made on the outside of the barrel, measured by the length of the chain which fills the groove on the fusee.

Suppose a chain which fills the fusee measures four turns on the barrel, then the spring ought not to make less than six turns in the barrel. If the chain which fills the fusee measures three and a half turns on the barrel the spring should make about five turns in the barrel.

CHAPTER IX.

THE VERGE.

THE earliest escapement of which there exists any description is the crown-wheel and verge.

It evidently derived its name from the shape of the scape-wheel, which acted on pallets attached to the verge or axis of the balance.

Henry de Vick's clock was a balance-clock on this principle.

All the portable clocks or watches first introduced were as nearly as possible identical to this.

The want of a spiral spring must have rendered them very defective timekeepers.

After application of spiral spring the verge watches were made to keep very good time, but the introduction of other escapements caused their construction to be much neglected, so that workmen became inattentive, and finally incapable of making or properly repairing them.

They may be said now to have gone completely out of use even among workmen.

In describing the verge it will be necessary to take in detail all the various parts of a watch, as the greater portion remain the same in any description

of watch, excepting the actual parts which form the escapement.

1. The movement is contained between two plates, A B and C D, called the fore and pillar plate.

FIG. 4.

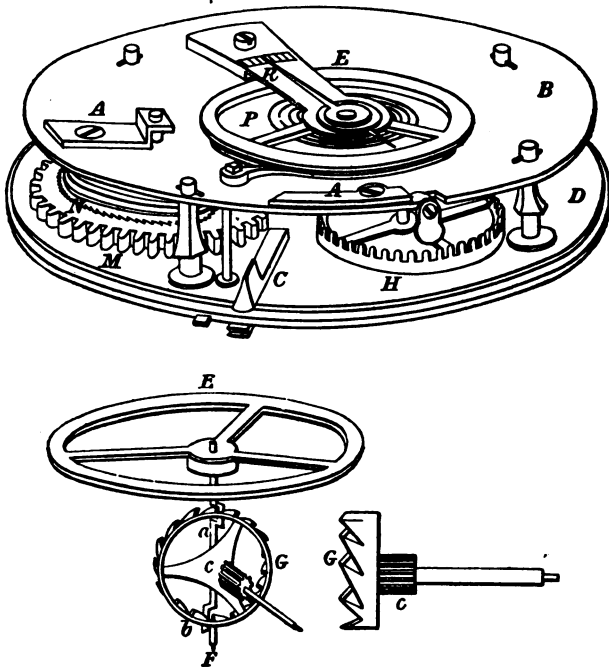

2. E is the balance—a flat circle—made formerly of steel, now of gold or brass, having usually three cross-pieces or arms.

Every part must be of equal weight, so that it may rest in equilibrium with itself, no matter in what posi-

tion placed, and if put in motion, shall revolve evenly, having no one place at which it can repose.

3. F is the arbor or axis on which it is fixed, called verge from the Latin *virga*, rod; having two pallets *a, b*, placed at an angle of not less than 95° , or not exceeding 100° . These pallets escape with the teeth of the crown-wheel G in such a way that the pallets act in opposite directions.

FIG. 5.

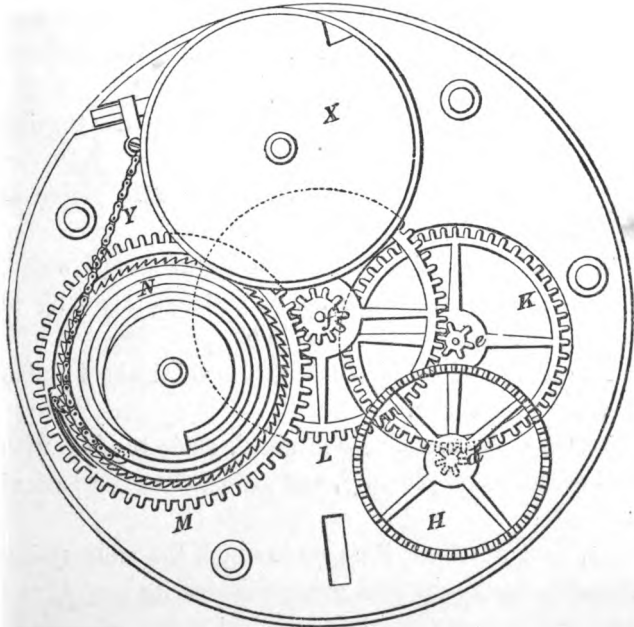

4. The pivots of the balance-staff or verge run into the cock, and a potence screwed on to the fore plate.

5. Those of the crown-wheel G run into the potence

and a counter-potence, which are screwed on to the inner side of the fore plate.

The arbor of the pinion *c* or crown-wheel axis being at right angles to the axis of the balance.

6. G is the crown-wheel cut with an uneven number of teeth, usually 13, 15, 17, and takes its name from its shape being similar to a crown.

7. H is the contrate-wheel, also in shape like a crown, and its pinion *d* turning within the plates. The teeth of the contrate-wheel, placed, as its name seems to indicate, contrary to crown-wheel, pitch into the balance-wheel or crown-wheel pinion so as to turn it.

8. K is the third wheel, with its pinion *e* also turning between the plates.

The teeth of the third wheel pitch into pinion of contrate-wheel in order to drive it.

9. L is the centre wheel, called also second wheel, with its pinion *f*, having an axis sufficiently long to enable it to pass through the dial.

The second wheel pitches with the third wheel pinion *e*, which it can turn.

10. M is the first or great wheel, made to pitch with the second wheel pinion *f*, and attached to the base of the fusee.

11. N is the fusee, the part to which the main-spring through the chain first communicates its power, and may be said to consist of five distinct parts:—

1. The winding arbor, or axis which passes through the whole piece.

2. The great or first wheel, in the hollow part of

which lies a flat spring $a b c$, fig. 1, nearly a complete circle, pinned at about one-fourth of its length b , to the great wheel; the thinnest end reaches over a long-shaped opening g , cut through the metal of the great wheel.

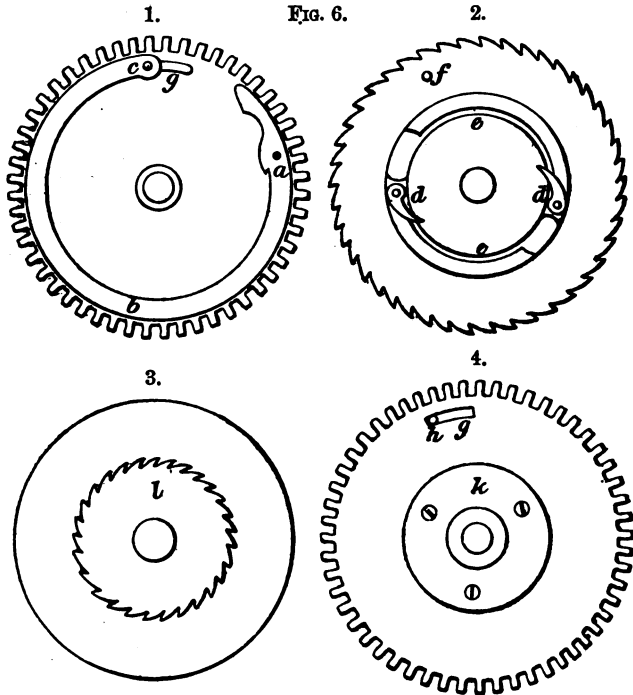

A pin c , passed through the spring so as to be perfectly firm, projects through the opening the exact thickness of the wheel; a portion is allowed to stand above the spring.

3 is a steel wheel, less in size than the great wheel,

fig. 2, whose teeth are ratchet-shaped; it fits over the great wheel with its spring, a hole in its centre fitting on to a pipe in great wheel.

The upper part of the pin *c* passes through a hole *f*, its exact size, and no farther than the thickness of the steel wheel; on its upper side are two detents *d, d*, with their two springs *e, e*.

Note.—That when the steel wheel is in its place it will be incapable of any motion exceeding the length of the opening, *g*, through the great wheel.

4 is the fusee itself (fig. 3). On the inside is fixed a ratchet-wheel *l*, whose teeth are placed in a direction opposite to those of the steel ratchet-wheel, and into which the two before-mentioned detents act in order to prevent the fusee going back, during the winding, by the force of the main-spring.

5 is a collar *k*, fig. 4, which fits on to the axis at the bottom of the great wheel, and is retained in its place generally by a pin passed through the axis, and tends to secure all the parts in their proper places, so that they may move together in one direction.

When the fusee is in its place between the plates, a detent with its spring is so placed as to act in the teeth of the steel ratchet-wheel, sometimes called the going-in-time-of-winding wheel.

Now, the action of this mechanism is extremely simple and beautiful, and proves, if need were required, the great mechanical ability of Harrison.

When the main-spring is wound up, its force draws the flat spring *abc*, as far as it will go, namely, from *g* to *h*, fig. 4, there to remain.

Immediately the action of winding begins, which is the reverse way, the force of the main-spring being taken off, the spring *abc*, as a matter of course, strives to return to its position of rest; and if there were no detent to the steel ratchet-wheel it would do so at once, but it is thereby prevented, and can only run down by the movement of the great wheel, the distance of the opening *gh*, or as nearly as possible a space contained in three teeth of the great wheel; but long before that can be accomplished the winding is concluded, and the main-spring again exerting its full power, drawing up the spring with its pin, *c* to *h*, to be in readiness when required to maintain the action of the watch.

Also on the fusee is a long tooth, projecting, which, when the groove in fusee is filled with the chain, pushes a spring lever fixed to the top plate, having at its end a hook, in such a way that the hook catches the tooth, and so stops the winding.

Foreign watches are usually made without the fusee, the great wheel being fixed to the barrel; when such is the case, a Geneva stop is used, which consists of a small wheel placed on the barrel-arbor, having but one tooth; the said tooth works into the teeth of a wheel set loose on to the watch-plate, and made with just the number of teeth as number of turns that the barrel-arbor ought to make in winding. In its circumference one blank space is left.

The action is thus:—For every turn of the barrel-arbor the one-toothed wheel moves the loose wheel a distance of one tooth, until every tooth is passed, then it becomes jammed in the blank space, so as to prevent the barrel-arbor turning, and stops the winding.

There is great advantage in a fusee, for it makes every part of the main-spring effective.

The chain acts on the upper or smallest end of the fusee at the moment when main-spring is wound up, and at its greatest force, thereby producing a small leverage; gradually as the spring unwinds, the chain acts on thicker part of the fusee; tending to equalize the action of the escapement from beginning to end of unwinding.

12. P. The pendulum or hair spring is a spiral spring coiled flat like a disk; one end is fixed to a collet, which fits spring-tight to balance-staff, the other end is pinned into a brass stud.

13. R. The regulator is a lever which turns on a ring set on the cock where the upper pivot of the balance-staff works: and has two small pins in it, so placed as to embrace the outer coil of the pendulum-spring.

By moving the index to the right, the length of the acting part of spring is shortened, making the vibration faster: if moved to left, lengthened, slower.

14. S. Banking. Pins placed in such a position that the escapement may not overrun itself, or that the balance should receive a check at a certain limit beyond its natural arc of vibration.

In many verge watches the pins were on the potence; in others the banking was by a pin in the balance.

In lever watches the pins are placed near one arm of the lever.

A very excellent mode of banking was invented by Mr. William Hardy, of Chapel Street, near White Conduit House, in year 1804, and received the approbation of many eminent watchmakers. It is suited for the duplex and detached escapement.

A A is the balance to which the pendulum spring is fastened in usual way.

In one of the crosses of the balance is placed a pin P, which stands a little way above its surface; and when the balance is caused to vibrate a complete circle, the pin in its

FIG. 7.

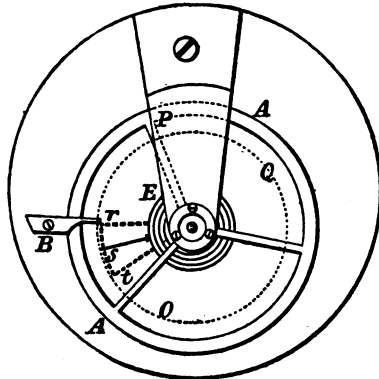

motion will describe the dotted circle P O Q, and just pass clear of the inside of a projection formed on the cock B, which is fastened on the plate by means of a screw; at about one-fourth of a turn of the pendulum-spring, reckoned from its stud E, is placed a very delicate tapering piece of steel s, having a small hole in it, through which the pendulum-spring passes; and it is fastened to it by means of a pin, and stands perpendicular to the curve of the spring.

Let the balance be at rest, as represented by the

figure, the banking pin at P, and the banking piece at *s*.

Suppose the balance is made to vibrate from P towards O, when P arrives at the banking piece *s*, it will pass it without touching, because its extremity *s* lies wholly within the circle traced out by the banking pin. But when the banking pin P has arrived at Q, the banking piece *s* will have advanced to *t*, by the pendulum-spring winding itself up into the figure represented by the dotted curve; and when the banking pin P (now at Q) returns back to P, and passes on from Q towards P to approach B, and so complete the other half of its vibration, before P can arrive at the banking cock B, the pendulum-spring will have unwound itself into the figure described by the dotted curve, and the banking piece *s* will have advanced into the position at *r*, just touching the banking cock.

Its extremity *r*, however, being thrown beyond the dotted circle, must necessarily fall in the way of the banking pin, which arrives there almost at the same moment, and is opposed by it, without the slightest shock to the pendulum-spring.

15. T. The motion work placed between the dial and the fore plate, consisting of—

1. The-canon pinion put spring-tight on the arbor of the second wheel, whose socket or canon goes outside, or beyond the dial, where it is squared for the purpose of having the minute-hand put on it.

2. The minute-wheel and its pinion. The canon-pinion leads the minute-wheel.
3. The hour-wheel having a hollow arbor like a socket, is put on the canon-pinion, and is led by the minute-wheel pinion, which pitches into its teeth. The hour-hand is put on the socket of the hour-wheel just where it projects above the dial.

FIG. 8.

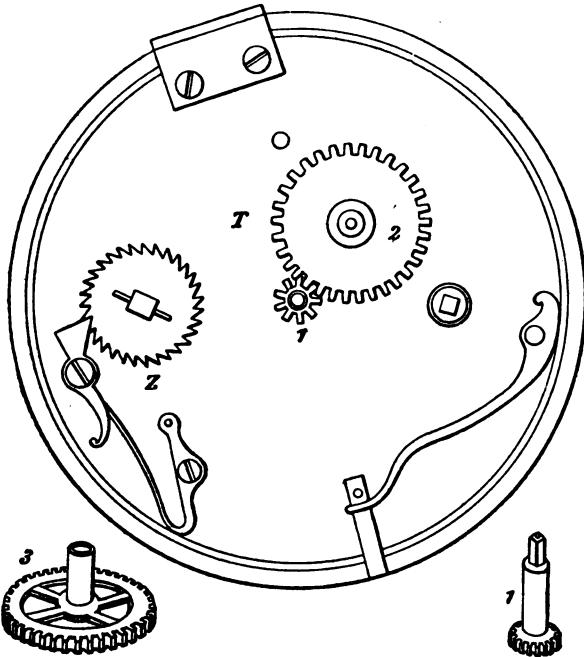

16. W. The dial usually enamelled on copper, with a sunk circle for seconds; the hands steel.

In watches of the present day the hands are moved by a square, on which the winding key fits at back of the watch through the dome or plate, which forms the cover to the movement when the outer case is open.

17. X. The barrel to hold the main-spring.

18. Y. The chain.

19. Z. The ratchet-wheel and click to hold up the main-spring.

In order that the action may be observed, take the key, wind up the main-spring, and set the movement going. This being done, it will be seen that the chain, slowly unwinding from the fusee on to the barrel, causes the great wheel to turn and drive the pinion of the second wheel, and so on till the crown and scape wheel have received motion, to be imparted to the pallets of the verge in such a way that when a tooth of scape-wheel has thrust aside the pallet *a*, and escaped, the other pallet, *b*, presents itself to a tooth of wheel exactly opposite in order to turn it aside: so that the wheel always revolving in one direction the balance is impelled to and fro, or made to go and come on itself, producing through the spiral spring vibrations in uniformity of time.

Verge watches, when properly constructed, have marked good time, but there are many things needful to be attended to, and which become fatal defects when neglected.

1st. The angle of the verge.

2ndly. The teeth of the crown-wheel to be undercut

to an angle of 28 or 30 degrees, and made to escape as near as possible to the body of the verge so as just to clear it.

3rdly. The balance or crown wheel and the contrate-wheel arbors ought not to be too distant from each other, otherwise there will be danger that the contrate-wheel may pitch obliquely into the scape-wheel pinion; for it must be borne in mind that, wherever force is indirectly applied, the work required to be performed will be done to great disadvantage, or loss.

4thly. Oil must never come near the pallets and scape-wheel teeth.

5thly. The great necessity for the main-spring being specially adapted to the fusee; for this escapement is subject to extreme variation from irregular force, and uniform power is one of the requisites for tolerable correctness in its performance.

And lastly. The size and weight of the balance is of the highest importance to the good going of the train.

• CHAPTER X.

HORIZONTAL, OR, MORE CORRECTLY, CYLINDER WATCH.

THE first attempt at a cylinder for watch escapement was made by the celebrated Tompion in the year 1695.

On the verge or axis of the balance was a small steel cylinder, solid, cut across at the middle, and nearly half-way down; in the longitudinal direction, or length of the cylinder, was made a deep notch, angular, so as to form a kind of pallet on the left-hand side; the balance-wheel was flat, but the spaces between the teeth were just wide enough to allow the cylinder to turn freely between them.

In action the effect produced was as follows:—

1st. When a tooth of the wheel had impelled the pallet, on escaping from it, the succeeding or following tooth dropped on the outside of the cylinder near to its right edge; resting actually on the cylinder during the vibration of the balance.

2ndly. After the tooth had passed the right edge and had encountered a slight recoil, it fell again on the pallet, and thereby gave a new impulse which occurred only at every second vibration of the balance.

Great defect of this escapement, which rendered it almost valueless.

The friction of the balance-wheel teeth on the edges of the cylinder, thereby cutting them, and making the cylinder nearly useless.

George Graham, the pupil of Tompion, about the year 1700 succeeded in perfecting the original idea of the man under whom it may be said he had been bred.

In place of a solid cylinder he made a hollow one. On the points of Tompion's wheel he raised small pins with wedge-like teeth.

These two things constitute the main difference in the two systems.

The following is a description of present form of cylinder escapement:—

FIG. 9.

The Horizontal Escapement.

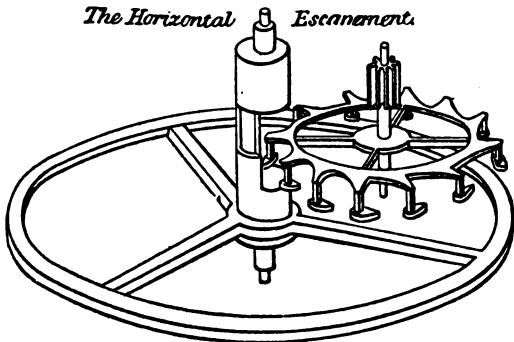

1st. The cylinder must have for internal diameter the clear length of the inclined wedge-like teeth, in such a way that when the tooth be inside the cylinder it shall have sufficient play that the cylinder move

around without the slightest friction, in fact, be perfectly free.

2ndly. The outside of the cylinder must have the same freedom between the point of one tooth and the heel of the other one.

3rdly. A notch or opening must be made across the cylinder, that is to say, its diameter, not quite half-way down, for the purpose of allowing the tooth to enter.

A second notch must be made below the other, to allow bottom of the wheel to pass out.

4thly. The edges of the cylinder formed by these openings must be—

1st. Right-hand one rounded.

2nd. Left one flanced outward.

5thly. The escape-wheel ought to be cut with a double number of teeth, so that every alternate one may be taken away, which will leave equal spaces between the teeth.

6thly. The wedges of the teeth must be inclined planes, and not as Graham's cycloidal curves.

The height of these inclined planes will determine the quantity of the cylinder which must be cut away, and is usually about half the circumference, less the height of the inclined plane of the teeth.

7thly. Two copper or brass plugs must be inserted into ends of the cylinder, so that verge for the pivots may be formed.

Note.—The cylinders made by Graham had a very red copper for these plugs.

The action of the escape-wheel and cylinder as exhibited in diagram.

When a tooth of the wheel is within the cylinder it ought to be as near as possible its diameter.

FIG. 10.

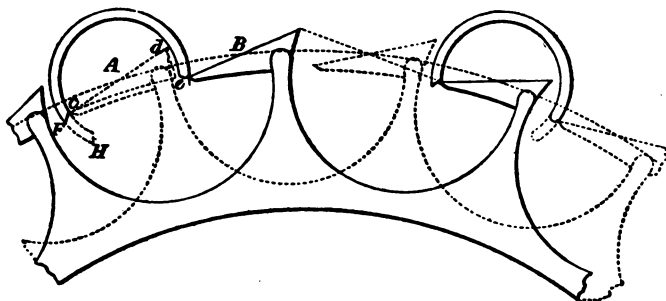

The centre A of cylinder will then divide the inclined plane cd of the tooth into two equal parts; so also B, and for every succeeding tooth.

The circle described through every one of these points is called the line of centres. (*Berthoud.*)

Hence is produced uniformity of action.

Again, the highest part of all the planes being in a circle greater or beyond that on which are the points of the wedges c, e , it stands to reason that if the wheel be driven forward it will make the cylinder turn on its centre.

Therefore the angle of escape will be according to the height of the inclined plane, or $FH = de$.

It is also evident that when a tooth escapes from the right-hand edge, the point of it, c , must fall inside of the

cylinder, where it reposes previously to passing out by impelling left-hand edge *c* F.

Instantly the escape is complete, the point *e* of succeeding tooth drops on outside of the cylinder, where it reposes previous to the return of the balance, when it gets on the rounded edge, thereby giving a new impulse.

Thus the tooth acts on both edges of the cylinder, causing by each impulsion a vibration of the balance in uniformity of time.

It is very clear, from study of the principles of this escapement, that great nicety is required in its execution.

The wheel must be very true.

The planes of the teeth in proportion.

The centres of diameters exact or coinciding.

The stems not too short.

The cylinder must be of good material; the edges well tempered, neither too thick nor too thin, otherwise the deterioration by friction—immense.

Above all these, there is an absolute necessity for the use of the finest quality of oil, the cylinder being moderately charged with the same.

It is desirable that the balance of a cylinder watch be not too large.

Small balances produce a more lively vibration, so that the momentum of the balance exerts more force over the pendulum-spring, and allows the teeth of escape-wheel to pass quickly over edges of the cylinder, thereby causing less tendency to wear.

Some very fine cylinder or horizontal watches have been made by foreign workmen, especially Breguet, who all used ruby cylinders. Unfortunately the expense is very great, and makes the watch a costly article. There does not appear to be any sound reason why cylinders should not be made with ruby edges, instead of being cut out of the solid stone, and afterwards cased in steel.

Defect of the escapement.

The action of heat and cold on the oil.

The wearing of the edges of the cylinder.

No very satisfactory reason has as yet been advanced for this wearing of the cylinder, unless we suppose that the nature and quality of the metal of which the escape-wheel was originally composed may have been the cause.

It is very interesting to examine the cylinder watches made by the great and eminent makers of the last century, and to find that nearly every one of these scientific men made the scape-wheel of brass, large in size, and over heavy.

It is hardly possible to imagine that they could have properly reflected on the effect which would eventually be produced by the constant action of this heavy brass wheel on a fine steel cylinder charged with oil.

The very nature of the brass, porous, even if highly polished, must have enabled it to take up possibly minute particles of steel, which becoming embedded in the tooth would act as a cutting instrument, or file,

and so gradually but surely eat away the edge of the cylinder.

It is strange that foreign workmen should have discovered the necessity of a steel escape-wheel, and so carefully proportioned as to be moderate in size and insignificant in weight.

CHAPTER XI.

THE DUPLEX.

DR. HOOKE, shortly after the invention and application of a pendulum-spring to the balance of a watch, invented a new escapement, called the two-balance one.

This consists of—

1st. On axis of each balance a toothed wheel, so placed as to pitch into one another.

2ndly. On each axis a pallet.

3rdly. A flat balance-wheel composed of a few ratchet or saw-like teeth.

4thly. Arbor of this balance-wheel ran into the frame parallel to those of the two balances at a point equally distant from their centres, so that the three points formed the angles of an equilateral triangle.

5thly. The pendulum or spiral spring was attached to only one balance.

Action of this escapement—

1st. When a tooth of the balance-wheel gave an impulse on one pallet, the other pallet, by the pitching of the two wheels, was brought round or about to meet another tooth instantly the wheel had made its escape from opposite pallet, thus in its turn to receive a new impulse.

2ndly. The intention of these two balances being pitched together was to prevent any bad effect of external motion, and at same time served the purpose of bringing the pallets about alternately, causing a slight recoil to the wheels by reaction of the balances.

About the year 1724 the attention of Jean Baptiste Dutertre, of Paris, was drawn to this two-balance escapement, which Sully seems to think had been thrown aside in consequence of the indifferent execution it had met with.

J. B. Dutertre made several additions.

1st and principal one. On the arbor of the balance-wheel he placed a second and larger wheel having the same number of teeth.

2ndly. The balance-arbors at one point or place were made thicker than usual, in order that notches might be cut across them as deep as the centre; by this means the arbors became in fact semi-cylinders.

3rdly. The larger wheel is placed on its arbor so as to correspond with the semi-cylinders and their notches, care being taken that the points of the teeth just clear the bottom of the notches, alternately passing one to rest on semi-cylindrical part of opposite one.

Action of this escapement as seen in diagram.

Let A and B be the two balances with toothed edges, pitching in with one another. Let D and *d* be the two wheels with ratchet teeth; *d* the larger one.

All three arbors kept in their places outside the potence-plate by separate cocks.

Upon a cross of each balance let there be fixed a pallet, E and F.

On the arbor of each balance at G and H let there be cut across a notch, which will allow the points of the teeth of the larger ratchet-wheel, or wheel of *arrête*, rest, to pass or escape.

Now, when the points of the teeth of the wheel of

arrête *d* get in on the notches G, H, they pass through immediately, and as a consequence the teeth of the impulse-wheel D go forward, and impel either one or other of the pallets E, F. The result produced by this double action is then—

1st. That as one of the teeth of the larger wheel after resting, or reposing on one of the semi-cylinders, is by the returning vibration of the balance allowed to escape through the notch G, a tooth of the impulse-wheel D falls on the pallet E, giving impulse, carrying it forward until it escapes, when,

2ndly. Another tooth of the wheel of *arrête* falls on the opposite semi-cylinder, rests there until return of vibration of second balance B, when it passes the notch H in its turn, allowing the corresponding pallet F to

FIG. 11.

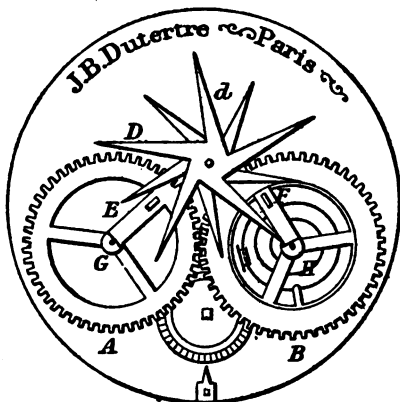

present itself and be impelled by a tooth of impulse-wheel, and so on, &c.

There is little doubt that shortly after this, 1727, Dutertre made an escapement consisting of one pallet only on the axis of balance and a notch below it, but retaining the two wheels—one arrête, the other impulse—on same arbor. The effect of this would be that, when the pallet escapes from the impulse-wheel, the wheel of arrête would rest on the arbor of the pallet, and so leave the vibrations nearly free. On the pallet returning to meet the impulse-wheel teeth, the arbor, being notched into centre, would, as a matter of course, allow the wheel of arrête to pass.

Probably about forty years later, a person of the name of Tyrer perfected what has proved to be one of the finest escapements ever invented, notwithstanding the disuse into which it has fallen, and the antipathy of present scapement-makers.

Tyrer suppressed the two ratchet-wheels on the one arbor, and made a wheel with pointed teeth, like spurs, having upright stems in the intervals, cogs, perpendicular to the plane of the wheel, all formed out of the same piece of brass.

On the balance-staff he placed a steel pallet, like a tongue, and below it a ruby roller, having a small angular notch cut into it.

The action of this escapement differs from Dutertre's, in that the pallet receives the impulse from the upright teeth, and the points of the teeth of repose escape in the notch of the ruby.

There are very many things to be attended to in constructing this escapement which will always render it expensive, as well as necessitate judgment in its adjustment.

FIG. 12.

- A* The Duplex Scape Wheel.
B Steel Pallet with Ruby inserted at *C*.
D The Ruby Roller

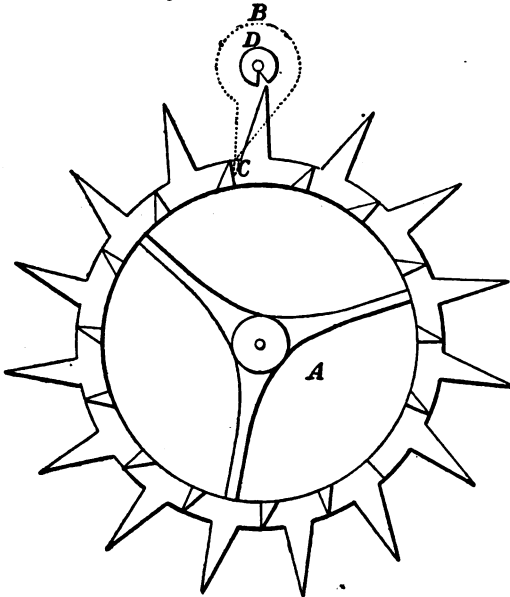

Defects of duplex escapement:—

It must be confessed that it is not adapted for ordinary use by any or every class of persons.

Unfortunately it is a first-class escapement only when kept fixed to any one position, in repose upon a table, or hanging to a watch-stand.

It is not adapted for use by any person who may be obliged to take violent exercise, ride on horseback, &c. As watchmakers say, it will set; that is to say, there is great danger that the wheel of arrête, instead of passing the notch in the ruby, will become fixed, and so cause the watch to stop.

A very sudden jerk will stop the watch.

Again, there is no doubt, from experiments the writer has made, that very violent jerking motion, such as running, or jumping, or riding, will affect the action of escape-wheel, and cause an incorrect beat, thereby accelerating the vibrations of the balance, notwithstanding the resistance of the spiral spring.

CHAPTER XII.

THE LEVER.

IN the year 1722 the Abbé Hautefeuille invented an anchor, or recoiling, escapement, which consisted of two things:—

1st. On the verge or axis of the balance was made a pinion.

2ndly. A rack or toothed segment of a circle was so placed as to work into this pinion, and on its verge were attached anchor-shaped pallets.

Description of the diagram:—

Let C D be the balance-wheel.

A, the escape-wheel.

B, the anchor of escapement, with its inner ends or pallets inclined planes so as to facilitate the escape and cause uniformity of action.

FIG. 13.

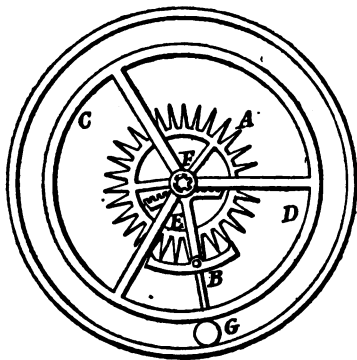

E, the rack.

F, the pinion borne by axis of the balance, which pitches in with the rack, carried on the axis of the anchor-pallets.

G, the counterpoise of the rack.

Now if the movement be set going, instantly the lever has received impulse from the scape-wheel it will be communicated directly, through the rack E, to the pinion on the balance, and so cause a vibration of the balance.

This is the parent of the detached lever.

In order to measure the distance which each arm of the lever must be raised to let a tooth of wheel A escape, it is necessary to measure the number of degrees the rack moves whilst pitching in with the pinion on axis of the balance.

For example, if 36 be the number of degrees of the arc which the rack runs, then 18 degrees, or half, will be the required distance.

This escapement was patented by a Liverpool firm of watchmakers early in the present century.

It afterwards received some slight modifications, one being a complete wheel instead of a rack, or segment of a circle.

The following is the present method of constructing lever watches:—

A is the escape-wheel, having fifteen teeth.

B is the lever with its pallets, which are anchor-shaped and fixed by small screws on to the lever, the whole working together on the same axis.

The space between the pallets is regulated by the width of the scape-wheel teeth: it is usual to have three embraced within the pallets.

FIG. 14.

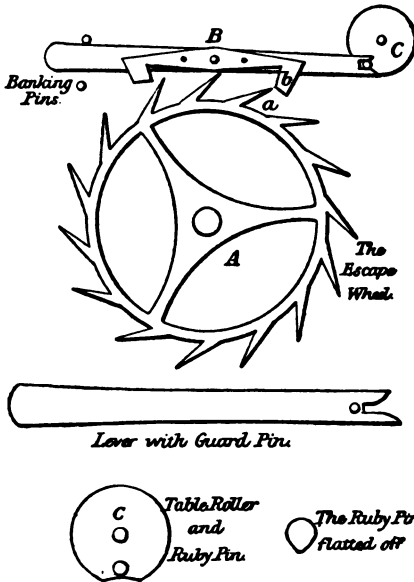

There is no necessity for the arms of the pallets being long; but it is absolutely needed that, whatever may be the angle of the flanches or inclined planes of the pallets, the teeth of the escape-wheel so escape that when a tooth drops on the pallet it shall fall just beyond the corner of the inclined plane, and on the circular part of the dead face of the pallet. A moderate recoil is necessary.

C, a steel disk, called *table-roller*, is placed on the balance-staff, having on under side a cylindrical ruby-pin fixed perpendicularly through its horizontal face, and so situated as to fall into a notch made within the fork of the lever.

Generally about a third of this cylindrical pin is flatted off in order to allow closer bankings.

A small notch, or rather minute segment, is cut out from the circumference of the table-roller, so that a pin, called the *guard-pin*, fixed to the flat side of the lever, just beyond the notch of its fork, may move through it at the same time as the ruby-pin passes through the notch of the lever, in order to prevent the lever making a false escape while the balance is free.

Great attention ought to be paid to this guard-pin, so that there be perfect freedom between it and the roller edge.

Perhaps the old plan of a double roller was the better one. Thus, a second small roller should be fitted on to the balance-staff lower down, just to reach to the back of the ruby-pin, out of which a semicircular piece should be cut to let the guard-pin pass. The upper main disk would, in such a construction, be used exclusively for the ruby-pin.

Now to observe the action ; wind up the main-spring : the escape-wheel starts into motion, and gives immediate impulse to the lever ; for when the balance is at its point of rest it *ought* actually to be pressing on one or other of the pallet planes of impulse.

1st. Let the tooth *a* slide down the inclined plane of pallet *b* and escape, the ruby-pin will slip instantly out of the notch as the balance vibrates, and the balance itself become *detached*, or independent of the train, during the remainder of its vibration.

2ndly. When the balance swings back, having accomplished a turn and a half of vibration, the ruby-pin re-enters the notch, and just moves the lever sufficiently to lift the other pallet outwards and unlock the wheel, causing a momentary recoil; instantly the tooth sliding down the impulse plane allows the next tooth of escape-wheel to advance and drop on to the dead face of the first pallet *b*; meanwhile the ruby-pin passes again out of the notch, and the balance becomes free in the *opposite* direction.

Note.—Every vibration of a lever watch is a beat, while in the chronometer and duplex every *two* vibrations make a beat, or impulse from the motive power.

CHAPTER XIII.

THE CHRONOMETER, OR DETACHED ESCAPEMENT.

IN consequence of the rewards offered by—

1st. Philip of Spain, A.D. 1598.

2ndly. The States of Holland.

3rdly. The British Parliament, in reign of Queen Anne, 1714.

4thly. The Duke of Orleans, Regent of France, 1716, for a timekeeper which would enable the captains of ships to ascertain to a certain extent the longitude at sea, all eminent clock and watchmakers, in whatever country they were residing, immediately applied their inventive powers to the construction of the required timekeepers, in hope of gaining some portion, if not all, of these rewards.

Harrison, Berthoud, Peter Le Roy, Mudge, Arnold, and Earnshaw all succeeded more or less in obtaining money recognition of their inventions. The only one, however, which has been of real use, except the lever, and still maintains its supremacy, is the chronometer, or detached escapement of Earnshaw.

As old John Arnold, who died in 1799, for a time made chronometers thought to be of first-rate construction, it will not be out of place to describe first what he

invented, before giving a description of Earnshaw's work.

The Chronometer, or Detached Escapement of Arnold.

1. The balance-wheel A has twelve teeth, and is calculated to have a train of 14,400.

The seconds hand will mark half a second at every step.

FIG. 15.

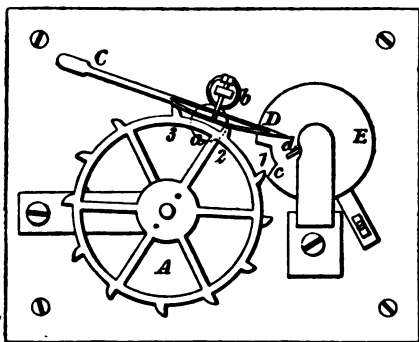

The portion of each tooth which acts is partly in the form of a cycloidal curve, and stands or projects above the plane of the wheel; the other sides are flat, or bounded by right lines, the longest of which forms an angle with the cycloidal curve; on this angle the wheel is locked by a spring detent C D, in which is fixed a small piece of sapphire, or ruby *a*, in order that the locking of the wheel may take place upon it.

2. There is an adjusting screw *b*, by which the detent-piece can be made to have more or less hold of the angle of the tooth.

Care must be taken to make the stone end of the detent-piece of such a length or height as to be free from the inside bottom of wheel.

3. On the balance-staff is the main pallet or roller E, having on right-hand side of it a notch, in which is set a piece of precious stone *c*, called the face of the pallet, for the curved part of tooth to act on.

4. Concentric with the pallet E is a small lifting pallet *d*, designed to unlock the wheel by pressing on the lifting spring D; then carrying it so far inwards as to take the detent and its spring along with it.

By this means the detent-piece of stone getting free of the angle of the tooth at *a*, the wheel moves forward, and the tooth marked 1 gives impulse to the main pallet E.

During the first part of the impulse, the point of the lifting spring parts with the lifting pallet *d*, leaving the detent and its spring at liberty, which causes the detent, by means of its spring, to come quickly to its place at *a* before tooth 1 has escaped, so as to be ready to receive tooth 3 and lock it.

5. Immediately the balance returns from its vibration, caused by this impelling, or impulse, the pallet *d*, meeting with the end of the delicate lifting spring, carries it a certain distance *outwards*, and then parts with it in order to complete the vibration on this side.

It will be seen by the diagram that the point of the adjusting screw opposes the pallet being carried that way, although the lifting spring is not, and yet it is at same time connected with the detent-spring, but ex-

tends so far beyond the end of detent-spring that the lifting pallet *d*, whether going or returning, cannot touch it, and cannot pass either way without meeting with the sides at the end of the lifting spring and working on it.

FIG. 16.

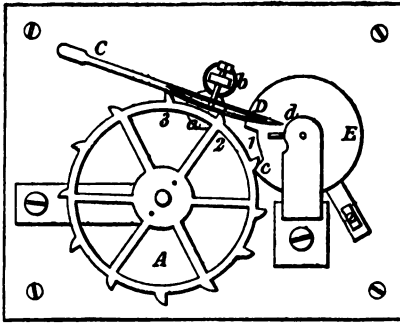

6. The detent-spring is screwed on to one of the frame-plates by the *sole* or *paume*, near to which it is made very thin and weak.

The centre of action, or motion of the detent-piece, may be said to lie at this place.

7. The lifting spring is pinned by one end to the side of the detent-spring, called the outside of it.

8. The unlocking is performed by carrying the detent-spring *inwards*, or towards the centre of the wheel.

The cycloidal part of the tooth then falls nearly on the blunted edge of the face of the pallet, and having given impulse, the wheel escapes to be again locked, and so on.

The wheel is unlocked at every alternate vibration of the balance.

There is one great defect in this escapement which renders it difficult of construction, that is the proportion of the wheel to the main pallet.

It is absolutely required that when the wheel is locked the main pallet stand perfectly free between the teeth.

Also, that the difference of diameter between the wheel and main pallet be as small as possible, so that the impulse from the wheel be direct on to face of the pallet.

Note.—Pocket timekeepers have what is called a quicker train, the seconds' hand making 150 beats upon the dial, or 5 beats in two seconds.

The escapement-wheel has 15 teeth ;

The balance-pinion, 8 leaves ;

And the fourth wheel, 80 teeth ;

The pallet, 50 degrees in diameter measured upon the diameter of the balance-wheel.

Whenever the wheel has 12 teeth, the radius of the pallet will be 30 degrees measured on the circumference of the wheel, and its diameter 60 degrees measured in the same manner, which will make it half the size of the wheel.

If 13 teeth, diameter of pallet $55\frac{1}{2}$ degrees.

„ 14	„	„	$51\frac{1}{2}$	„
„ 15	„	„	50	„

Earnshaw's Detached Escapement.

1st. The balance-wheel, A B, is plain or flat, having 12 or 15 teeth which are much undercut, somewhat like ratchet teeth.

FIG. 17.

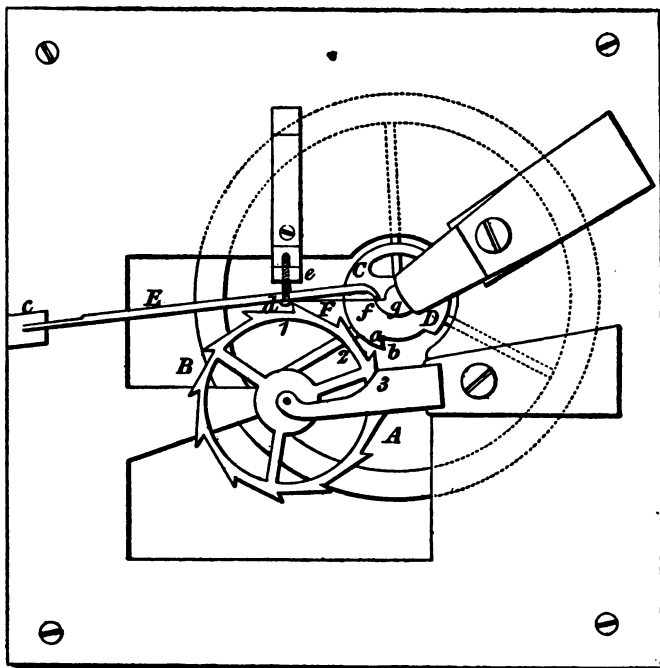

2ndly. The main pallet or roller, C D, has an opening in it, the face being also undercut, into which a piece of ruby or sapphire is set as *a b* for the purpose of preventing wear from the constant action of balance-wheel teeth.

3rdly. The detent-spring *E* is screwed to a stud *c*, which is fixed to the fore plate and made extremely weak near the stud.

It is necessary that the spring should yield at this point in order that the detent on which wheel is locked may receive motion.

This point is the centre of motion.

4thly. The tooth 1 of balance-wheel is supposed to be locked on a flat side of a semi-cylindrical pin, which stands up perpendicularly upon the thick part of the detent-spring, by which means it presses against the inside of the head of the adjusting screw *d*, which works into a fixed stud *e*.

The detent will have more or less hold of the tooth 1, according as it is screwed into the stud *e*.

5thly. *F* is a very delicate spring attached to the inner side of the detent-spring and projecting beyond it, and is called the lifting spring.

The end of the detent-spring is slightly curved, so that this free end of the lifting spring may bear only on the very point of this curve at *f*.

6thly. Concentric with the main pallet, that is, on the arbor of the roller and balance, is a small pallet *g*, placed against the roller, which is flat on its lifting face, and rounded off on the opposite side.

The action of this escapement is as follows.

When the pallet *g* comes against the lifting spring *F*, it carries the detent with it and takes it out from locking a tooth of the balance-wheel 1.

While this is taking place, the main pallet, *C D*, has

advanced sufficiently as to be in the way of receiving impulse from the tooth 3, and before it can escape the lifting pallet *g*, parts with the end of the lifting spring, and so permits the detent and the detent-spring to go back immediately to their place.

The detent will then be ready to receive the tooth 2, by which the wheel is as a matter of course again locked.

The balance having through the impulse given performed its vibration, returns, taking with it the lifting pallet *g*, no longer supported by the detent-spring; whose rounded side will press the lifting spring *F* inwards, but will not be able to carry the detent *E* with it, in consequence of the check produced by the inside head of the adjusting screw *d*.

Once having passed the lifting spring, the pallet *g* goes along with the vibration of the balance, and on its return the face meets again the lifting spring in order to carry away the detent, when unlocking takes place; and so on.

It is to be remarked that this unlocking is performed by carrying the detent outwards from the centre of the wheel; and that when the detent is clear, it lies above the wheel.

It is hardly possible to mention any defects in this escapement if properly constructed.

Care alone is required in the construction that the diameter of the roller be of such a size as to allow the main pallet sufficient hold on the balance-wheel teeth.

And that the lifting spring possess just sufficient force to bring it to its place at the end of the detent-spring.

An escapement so perfect as the above having been invented, it is reasonable to suppose that watchmakers universally would have adopted it as their pattern; yet, strange to say, the Swiss and French still make chronometers on the much-condemned principle of the detent acting on pivots. A small French work on clock and watch making, published in 1863, says, "Each system has its advocates, and opinions are divided as to which ought to have the preference." There is in reality no question as to which ought to have the preference. Earnshaw himself said, "For those pivots must have oil, and when the oil thickens, then the spring of the pivot detent is so affected by it as to prevent the detent from falling into the wheel quick enough; the consequence of this is, irregular time and stoppage of the watch; and if ever such a watch went well for twelve months accident must have favoured it."

English watchmakers have long ceased to make watches with pivot detents.

The author has in his possession a very well-made chronometer watch, foreign make, but with name on the plate of a well-known London house. The gentleman to whom it originally belonged paid 30 guineas for the same—an extremely high price.

Externally, it has all the appearance of a London-made watch.

Internally, it looks Swiss.

The detent is on pivots, with an adjusting spring in form like a balance-spring, attached to the axis which terminates in the pivots; and though it has been carefully treated by a very skilful man, still there is no reliance to be placed upon the watch in some respects, *viz.* its going in all positions and under any circumstances. Stop it will, when least expected; a sudden motion, a slight jerk, in a word for no apparent reason.

The balance has been carefully adjusted for heat and cold. If it were not for this most inexcusable fault of stopping, the watch would be a desirable one; as it is, no condemnation of the principle can be too strong.

The banking is on the plan invented by Mr. Hardy, a small projecting piece being attached to the pendulum-spring. Here again is an instance, a constantly recurring one, of the adoption by foreign makers of an invention purely English.

CHAPTER XIV.

REPEATING WATCHES.

DURING the greater part of the last century, and the first twenty years of the present one, repeater watches were all the rage. Nearly every man of fortune fancied it necessary to be possessed of a watch which he could *see* by day and *hear* by night. The usual price for such a luxury was 70*l.* to 120*l.* Certainly the minute repeaters may be considered the height of self-gratification—just as if it were of consequence to the nervous invalid, “tossing to and fro” in the watches of the night, to learn from his repeater the actual minute of time; perhaps it would have been more satisfactory to receive information only by the hour.

There may have been, among many, one principal reason for the great demand for these watches. Town clocks were scarce articles; village clocks, the chanticleer only.

“She had a cok hight chanticlere,
In all the land of crowing n’as his pere.
His voice was merier than the merie organ,
Wel sikerer was his crowing in his loge
Than is a CLOK, or any abbey orloge.”

Nonnes Preestes Tale. Chaucer, died 1400.

Now, it is scarcely possible to sleep quietly, even in any small town, without being disturbed by the noise

of a neighbouring clock. In London, the Westminster may be heard for miles off. The advantage to be derived from the possession of a repeater now would not be worth the money. At any rate, repeaters have had their day, and are not likely to be again revived, in consequence of the great expense attending the cleaning and repairing, independent of the first cost.

Of all the watches of the last century the self-striking were the most agreeable, only it is very doubtful, judging from the few the writer has seen and examined, if they ever continuously performed correctly.

THE REV. MR. BARLOW was the first inventor, about 1676, of a repeating train, for which two push-pieces were necessary.

DANIEL QUARE, a watchmaker of London, succeeded in making a repeating part perform with only *one* push-piece.

In consequence of an application by Mr. Barlow for a patent for sole making of repeating clocks and watches, the Clockmakers' Company petitioned the King in Council against the grant, and the hearing reasons against it was heard in March 1687.

The Council investigated the merits of the two inventions, and decided in favour of the watch made by Daniel Quare.

Derham says, in chap. ix., page 98:—"About the latter end of King James II.'s reign, Mr. Barlow (the ingenious inventor before mentioned) contrived to put his invention into pocket watches, and endeavoured (with the Lord Chief Justice *Allebone* and some others)

to get a patent for it; and in order to it, he set Mr. *Tompion*, the famous artist, to work upon it, who accordingly made a piece according to his directions.

“Mr. *Quare* (a very ingenious watchmaker in *London*) had some years before been thinking of the like invention, but not bringing it to perfection he laid by the thoughts of it until the talk of Mr. *Barlow's* patent revived his former thoughts, which he then brought to effect. This being known among the watchmakers, they all pressed him to endeavour to hinder Mr. *Barlow's* patent. And accordingly applications were made at Court, and a watch of each invention produced before the King and Council. The King, upon trial of each of them, was pleased to give the preference to Mr. *Quare's*, of which notice was given soon after in the ‘*Gazette*.’

“The difference between these two inventions was, Mr. *Barlow's* was made to repeat by pushing in two pieces on each side the watch-box, one of which repeated the hour, the other the quarter. Mr. *Quare's* was made to repeat by a pin that stuck out near the pendant; which, being thrust in (as now is done by thrusting in the pendant), did repeat both the hour and quarter with the same thrust.”

JULIEN LE ROY in 1728 made a repeating clock for Louis XV. of France, and later improved on the push-piece of *Quare*, which only gave the number of the hour according to the length pushed in, by introducing a mechanism which prevented the watch from striking anything but the true hour, called the *all-or-nothing piece*. He also suppressed the bell, causing the ham-

mers to strike on brass-pieces screwed to the inside of the case.

GRAHAM, in his repeaters, made use of a motion-work invented by one *Stogden*, who died in distress about 1770, a very ingenious contrivance, but requiring great nicety in its execution. *Stogden's* motion strikes the half-quarters, which *Le Roy's* did not.

For a description and drawing of a repeater, the reader had better refer to *Reid*, page 338, who translated it nearly *verbatim* from *F. Berthoud's* 'Essay on Clockwork.'

There are not at present any repeater workers in England; nearly all the old hands must have died off long ago, and no inducement for new men to take their place, fashion having completely destroyed that branch of the watch trade.

Should any gentleman be desirous of buying a repeater watch, it is customary to send the order for the repeating portion to Switzerland, and when received, it is adapted by the London watchmaker to an English movement; in fact, the whole watch is English, with the exception of the repeating work.

CHAPTER XV.

KEYLESS WATCHES.

AT the commencement of the present century watches provided with a mechanism which would cause winding without a key were looked upon with no great favour, and considered merely articles of fancy.

A watch can possess no greater defect than to have too many separate pieces in its interior work; consequently, it could hardly have been conjectured that keyless watches would have become, as at the present day, quite the fashion, and the mechanism be applied even to cheap Swiss goods, price 2*l.* 10*s.*

It is said that the Emperor Napoleon I. possessed a self-winding watch; in fact, a watch which was arranged something like a pedometer, that at every step he took a weight acted on the end of a lever having a weak spring under it, which was attached to a click working into a ratchet-wheel on the barrel-arbor, and so wound up the main-spring.

A short time back an old gold watch of this construction, foreign make, hung in a jeweller's shop window in the Strand, marked at a rather high price—8*l.*, it being worth only a sovereign more than the intrinsic value of the gold.

One method out of many employed in keyless watches to accomplish the winding, is as follows:—

FIG. 18.

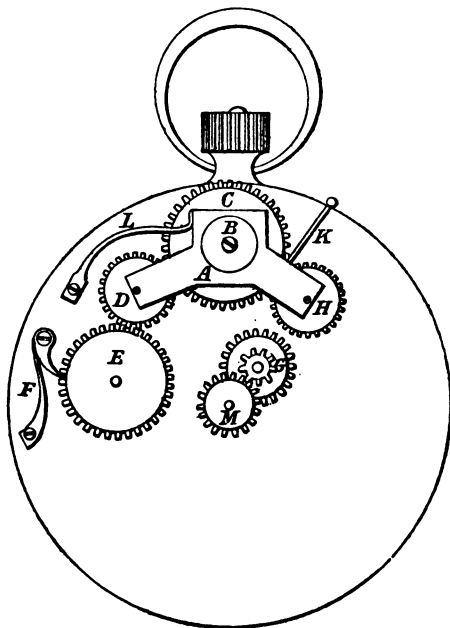

The Construction.

A is a square piece of steel with two short arms.

B, a steel cap, which is screwed down nearly tight into it, a portion being cut out to receive it. The screw forms also the axis of the wheel C. The steel piece moves slightly to the left.

D, a small steel wheel which gears in with C, and also with E, a wheel set on the barrel-arbor.

F is a click with its spring, to prevent the wheel E running back.

G is the minute-wheel pitching into canon-pinion.

M is the hour-wheel pitching into minute-pinion.

H is a steel wheel on second arm of the steel-piece.

K, a push-piece, which by being pressed will cause H to gear into the minute-wheel G, and at the same time discharge the wheel D from the wheel E.

L is a spring so placed as to keep the steel-piece to its exact position for the winding.

In the pendant is an axis, carrying at the end an oblique bevelled-wheel which plays into the wheel C.

The Action.

If the button or handle of the watch be turned to the left, then the wheel C will revolve, causing the wheel D to go round, and so put in motion E, or wind up the main-spring.

If the small knob at the side of the watch-case be pressed in, then the wheel H will instantly gear with G; turn the button to the right or left, and the hands may be set to time.

The whole of this motion work lies under the dial.

CHAPTER XVI.

THE PENDULUM, OR SPIRAL SPRING.

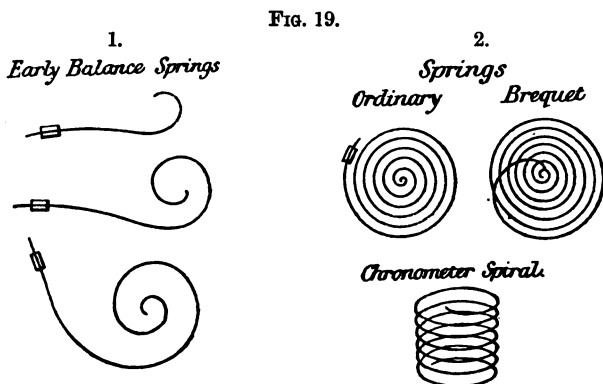

IN the year 1678, the celebrated Dr. Robert Hooke published his lecture entitled "Potentia Restitutiva," or spring.

He begins it thus:—

"The theory of springs, though attempted by divers eminent mathematicians of this age, has hitherto not been published by any. It is now about eighteen years since I first found it out, but, designing to apply it to some particular use, I omitted the publishing thereof.

"About three years since His Majesty was pleased to see the experiment that made out this theory tried at

Whitehall, as also my spring watch. About two years since I printed this theory in an anagram at the end of my book of the description of helioscopes, *viz.* c e i i i n o s s t t u u, *id est, Ut tensio sic vis*; that is, the power of any spring is in the same proportion with the tension thereof; that is, if one power stretch or bend it one space, two will bend it two, and three will bend it three, and so forward. Now as the theory is very short, so the way of trying it is very easy.

“Take, then, a quantity of even-drawn wire, either steel, iron, or brass, and coil it on an even cylinder into a helix of what length or number of turns you please; then turn the ends of the wire into loops, by one of which suspend this coil upon a nail, and by the other sustain the weight that you would have to extend it, and hanging on several weights observe exactly to what length each of the weights do extend it beyond the length that its own weight doth stretch it to, and you shall find that if one ounce, or one pound, or one certain weight doth lengthen it one line or one inch, or one certain length, then two ounces, two pounds, or two weights, will extend it two lines, two inches, or two lengths; and three ounces, pounds or weights, three lines, inches, or lengths; and so forwards. And this is the rule or law of nature, upon which all manner of restituent or springing motion doth proceed, whether it be of rarefaction, or extension, or condensation, or compression.

“Or take a watch-spring, and coil it into a spiral, so as no part thereof may touch another, then provide a

very light wheel of brass, or the like, and fix it on an arbor that hath two small pivots of steel, upon which pivots turn the edge of the said wheel very even and smooth, so that a small silk may be coiled upon it; then put this wheel into a frame, so that the wheel may move very freely on its pivots; fasten the central end of the aforesaid spring close to the pivot hole, or centre of the frame in which the arbor of the wheel doth move, and the other end thereof to the rim of the wheel; then coiling a fine limber thread of silk upon the edge of the wheel hang a small light scale at the end thereof fit to receive the weight that shall be put thereinto; then suffering the wheel to stand in its own position by a little index fastened to the frame, and pointing to the rim of the wheel, make a mark with ink, or the like, on that part of the rim that the index pointeth at; then put a drachm weight into the scale, and suffer the wheel to settle, and make another mark on the rim where the index doth point; then add a drachm more, and let the wheel settle again, and note with ink as before the place of the rim pointed at by the index; then add a third drachm, and do as before; and so a fourth, fifth, sixth, seventh, eighth, &c., suffering the wheel to settle, and marking the several places pointed at by the index, then examine the distances of all those marks, and comparing them together you shall find that they will all be equal, the one to the other, so that if a drachm doth move the wheel ten degrees, two drachms will move it twenty, and three thirty, and four forty, and five fifty, and so forwards."

It would be very clear, from Dr. Hooke's own words, that he must have made his discovery somewhere about 1659 or 1660, were it not for the date 1658 engraved upon the watch with double balance, presented to Charles II. Making allowance for the indefinite term "about eighteen years ago," which may have been strictly correct when the lecture was first commenced, or written previous to its publication in 1678, it is not difficult to account for the short interval of time between the writing and the publishing, so as to be able to conclude that the date upon the watch, 1658, is the correct one.

However, there is little doubt that when the celebrated Dutch astronomer, Huyghens, in 1674, applied a spiral to the balance of a watch, Hooke was extremely indignant, and accused Mr. Oldenburgh, the secretary to the Royal Society, of having made known to learned foreigners discoveries described and deposited in the Registry of the Society.

It is very certain that, as early as 1660, Hooke, with others, intended to procure a patent for this invention of the spiral spring and its application to the balance of a watch, but through disagreement as to terms, Hooke refused to enter into any engagement.

And so the matter rested until, in 1674, Huyghens claimed the discovery.

Derham, in his 'Artificial Clockmaker,' 2nd edition, 1700, says that, "After the publication of Mr. Huyghens' book, 'Horologium Oscillatorium sive de Motu Pendulorum, &c.' Paris, 1673 (for there is not a word of this,

though of several other contrivances); after this, I say, Mr. Huyghens' watch with a spiral spring came abroad, and made a great noise in England, as if the longitude could now be found. One of these the Lord Bruncker sent for out of France (where Mr. Huyghens had a patent for them), which I have seen.

"This watch of Mr. Zulichem's agreed with Dr. Hooke's in the application of the spring to the balance; only Mr. Zulichem's had a longer spiral spring, and the pulses or beats were much slower. That wherein it differs is—

"1st. The verge hath a pinion instead of pallets, and a contrate-wheel runs therein, and drives it round more than one turn.

"2nd. The pallets are on the arbor of this contrate-wheel.

"3rd. Then followeth the crown-wheel, &c.

"4th. The balance, instead of turning scarce quite round, as Dr. Hooke's, doth turn several rounds every vibration.

"As to the great abilities of Mr. Huyghens, no man can doubt that is acquainted with his books, and his share in the 'Philosophical Transactions,' &c.; but I have some reason to doubt whether his fancy was not first set on work by some intelligence he might have of Dr. Hooke's invention from Mr. Oldenburgh or others, his correspondents here in England.

"But whether or not that ingenious person doth owe anything herein to our ingenious Dr. Hooke, it is, however, a very pretty and ingenious contrivance, but

subject to some defects, *viz.* when it standeth still it will not vibrate until it is set on vibrating, which, though it be no defect in a pendulum-clock, may be one in a pocket-watch, which is exposed to continual jogs. Also, it doth somewhat vary in its vibrations, making sometimes longer, sometimes shorter turns, and so some slower, some quicker vibrations."—*Chap. viii., page 96.*

The name pendulum-spring seems to have been taken from the watches known as *pendule* watches, which were no other than common verge and crown-wheel scapements, to which were applied the new invention of a spiral spring.

Mr. Derham says at beginning of chap. viii., page 91: "The reason they are called pendulum-watches is from the regularity of their strokes and motion, which exactness is effected by the government of a small spiral spring running round the upper part of the verge of the balance, which spring is called the regulator. . . . So that the balance was to this spring as the bob of a pendulum, and the little spring as the rod thereof."

But there may be another possible reason; it is not improbable that these new watches had all of them one arm or cross-piece of the balance so made as to represent the bob of a pendulum, and visible to the eye by a portion of the cock being cut open; thus at every vibration of the balance it would have the appearance, as well as regularity, of a pendulum. The author has seen a watch by Steven Hoogendy, Rotterdam, of

this construction :—On the balance-cock, a rural scene, house and garden, to the left ; on right, sun shining brightly on the garden, in which is a large sunflower, turned towards the sun ; motto round the edge of the open part of the cock,

“Je regarde mon soleil.”

Also, a gold-cased watch, by Quare ; and in his own possession a beautifully-made watch, with pierced silver cock, made by Debeaufre, who, without doubt, was the same with whom Facio entered into partnership for

the purpose of watch-jewelling, and against which, in 1704, a pamphlet was published, having for title, ‘Reasons of the English Clock and Watch Makers against the Bill to confirm the pretended new Invention of using precious and common Stones about Watches, Clocks, and other Engines.’

The pendulum-spring to all these watches is in the shape of a figure 6, and they have the balance so arranged that, when hung by the pendant, the bob represents exactly a clock pendulum in motion.

Be it as it may, the term pendulum-spring is hardly a correct one, and applies properly to the spring by which the pendulum-wire, or rod of a clock, is hung in modern clocks in place of the cord, or silk thread, used by the old makers.

FIG. 20.

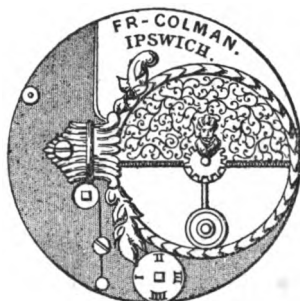

Of a certainty, the discovery of a spiral spring commonly called hair-spring (not because a watch was once found to have a horse-hair attached to the verge of balance instead of an actual spring, but on account of its delicacy, being to all appearance as fine as a hair), fixed to the arbor of the balance, has been the means of producing a wonderful change in the method of marking time by watches, has enabled them to approach as near as possible to the accuracy of the pendulum.

Strictly speaking, it is impossible to make a comparison between the two, because the pendulum moves by the natural law of gravity, whereas the balance swings in a measure independent of gravity through arcs varying to an extraordinary extent, possessing, through the spiral spring, a force which causes it to vibrate, or return on itself from the impulse given in the escapement.

Mudge has justly said, "That the pendulum-spring is the artificial gravity of a watch-balance."

Experiments have proved that the pendulum alters its vibration in different latitudes, whereas the balance measures the same time in all latitudes: the one is the effect of gravity, the other the exertion of the spiral spring; for the vibrations of a balance whose centre of gravity coincides with its centre of motion can have no dependence on gravitation, otherwise it would necessarily vary as the pendulum. Still it must be noted that the effects produced by a spiral spring are not uniform, as it has been found that every length of a given spring is not perfectly isochronous, but only

certain lengths which have to be determined by experiment or trial.

It will then be correct to say that the vibration of a balance depends on two things—

1st. The direct influence of the moment of inertia of the balance itself.

2nd. The force of the balance-spring taken inversely.

For it is evident springs are not always of the same length; the force, therefore, in any given spring must vary inversely as its length.

In conformity with the above rule, it is usual either to reduce the inertia of the balance by decreasing its size and weight, or by shortening the length of spring between the collet and the stud.

The following remarks on this subject by men well known and justly celebrated will, it is to be hoped, prove useful and interesting:—

F. Berthoud. Essai sur l'Horlogerie, Seconde Partie, chap. 26, vol. ii., page 152. Du Ressort Spiral; des Vibrations qu'il produit au Balancier.

La propriété d'un ressort quelconque est, qu'ayant été écarté de son repos par l'effort d'une puissance dès qu'on l'abandonne à lui-même, non seulement il retourne vers le point d'où il étoit parti, mais encore il fait autant de chemin de l'autre côté qu'on lui en a fait faire en le tendant; le ressort ayant alors consumé toute sa force revient sur lui-même, et fait ainsi des vibrations, de même qu'un pendule que l'on écarte de son repos.

1. *Principe.*

La vitesse des vibrations du ressort est d'autant plus grande que ce ressort est plus fort, et au contraire.

2. *Principe.*

Le ressort fait un nombre de vibrations d'autant plus grand que les parties du ressort sont plus dures, et qu'elles éprouvent une moindre destruction par les vibrations ou mouvement du ressort. Ces deux propositions n'ont pas besoin de démonstration.

On démontre par expérience que les vibrations grandes ou petites d'un même ressort sont isochrones, c'est à dire, de même durée.

Il résultera donc de ces propriétés du ressort, qu'étant adapté au balancier, on aura :—

1. *Proposition.*

La vitesse des vibrations d'un balancier mu par un ressort spiral, dépend de la grandeur et du poids du balancier, c'est à dire, de son inertie et de la force du ressort spiral ; si donc le balancier est grand et pesant, le spiral foible, les vibrations seront lentes ; car plus le balancier a d'inertie, et plus sa résistance au mouvement augmente ; et d'ailleurs, plus le spiral est foible, et plus ses vibrations sont lentes.

2. *Proposition.*

Si un balancier grand et pesant, étant mu par un spiral soit foible, fait alternativement des grandes et des petites vibrations, elles ne seront pas isochrones ; car par la nature du balancier, de son inertie, des frot-

tements des pivots, &c., les espaces qu'il parcourra le seront (*sic*) en des temps d'autant plus longs qu'ils seront plus grands; ainsi malgré la tendance du spiral à faire ses oscillations d'égale durée, comme il ne détermine qu'en partie la vitesse du mouvement du balancier, le balancier n'ira ni avec la vitesse qu'il auroit, si étant séparé du spiral, on lui eût communiqué la même impulsion, ni avec la vitesse du spiral, mais avec une vitesse déterminé par l'inertie du balancier et par la force du spiral.

3. *Proposition.*

Si on a un balancier qui soit très-léger, et mu par un ressort spiral qui soit fort :

1. Les vibrations seront très promptes.
2. Soit que le balancier décrive de grands ou de petits arcs, les oscillations seront très approchantes d'être isochrones.

4. *Proposition.*

Plus le ressort spiral sera composé de parties dures, et plus aussi le balancier fera un grand nombre d'oscillations, c'est à dire, qu'un ressort spiral qui est de bon acier bien trempé est infiniment plus propre à conserver le mouvement du balancier, et à lui faire produire des oscillations isochrones.

5. *Proposition.*

Un balancier fait en même temps un nombre de vibrations d'autant plus grand que les frottements des pivots seront moindres.

De l'Isochronisme des Vibrations du Balancier par le Spiral. Traité des Horloges Marines, par F. Berthoud, Paris, 1773.

Précis de la même théorie. Appendice, Histoire de la Mesure du Temps. F. Berthoud, Paris, 1802.

Proposition 1^{re}. Comment on peut obtenir par le spiral l'isochronisme des vibrations du balancier. Si l'on a un balancier simple sans spiral, auquel on veuille alternativement faire décrire de grands et de petits arcs dans le même temps, il faudra que la force ou puissance qui doit lui donner le mouvement change comme les carrés des arcs.

Donc, si au lieu de la puissance, on substitue un ressort spiral, il faudra que la progression de sa force soit telle, que dans tous les arcs correspondans, les produits de sa force augmentent dans la même proportion que celle du balancier (comme le carré des arcs); et dans ce cas les oscillations seront isochrones. Or, si la force ascendante du spiral est en progression arithmétique, en sorte que l'on ait les deux progressions suivantes,

Arcs parcourus, 0, 10, 20, 30, 40, 50, 60, &c.,
Force du ressort, 0, 1, 2, 3, 4, 5, 6, &c.,

je dis que les sommes ou produits de ces forces du ressort spiral dans tous les termes correspondans de ces arcs seront comme les carrés des arcs; ce qui est une suite de la propriété de la progression arithmétique. Ainsi les oscillations d'un balancier quelconque auquel ce spiral sera appliqué, seront isochrones ou de même durée, soit que le balancier décrive de grands arcs ou

de petits arcs : ce qui est évident, puisque les forces ou puissances du spiral donné suivent la même loi par laquelle se fait l'augmentation de force dans le même temps dans le corps en mouvement.

Proposition 2^{me}. Pour donner cette propriété au spiral, on peut l'obtenir en le rendant plus long ou plus court, ainsi qu'il est aisé de le prouver. Si on a un ressort spiral fort long et très foible, en sorte qu'il puisse être bandé par un grand nombre de tours, comme dix par exemple ; supposant de plus qu'étant remonté tout au haut, sa force devienne le double de celle du tour d'en bas : dans ce cas je dis que le premier tour de sa bande augmenteroit environ d'un dixième de la force totale, et que par conséquent la progression ascendante de sa force ne seroit pas assez grande pour suivre la loi du carré des arcs. Ainsi, en appliquant un tel ressort à un balancier, les oscillations libres de ce régulateur ne seroient pas isochrones ; les grand arcs seroient beaucoup plus lents que les petits.

Si, au contraire, on rend le même ressort assez court pour ne pouvoir être bandé que fort peu, alors la progression de sa force augmentera dans une plus grande proportion que celle qui est requise pour l'isochronisme : ainsi les vibrations par les grand arcs seront de plus courte durée que les vibrations par les petits arcs.

Puisqu'un ressort spiral tel que nous venons de le supposer, doit rendre les grand arcs de vibration plus lents lorsqu'il est fort long, et qu'étant plus court les grand arcs de vibration sont au contraire plus vites que les petits, il s'ensuit que ce même spiral aura entre

ces deux termes un point par lequel étant arrêté ou fixé, les oscillations par les grands et par les petits arcs seront isochrones; et ce point est celui où le spiral étant mis en équilibre par des poids, aura la progression de la force parfaitement arithmétique; car, dans ce cas seulement, les sommes de ses forces seront entre elles (dans le mouvement) comme les carrés des arcs.

L'auteur démontre, dans les propositions 3^{me} et 4^{me}, 1^o, que les oscillations du balancier seront encore isochrones après l'application de l'échappement à l'horloge; 2^o, qu'un spiral d'une force quelconque, ayant la progression requise par la loi de l'isochronisme, il conservera cette propriété, soit qu'on l'applique à un balancier qui fasse des vibrations promptes, ou à un balancier qui fasse des vibrations lentes.

Sur les lames d'acier servant à faire des ressorts spiraux.
Traité des Horloges Marines, page 55.

Des moyens de les rendre propres à l'isochronisme, soit par leur épaisseur, soit par la figure spirale, plus ou moins serrée, &c.

Proposition 1^{re}. Les inflexions de deux ressorts d'égale longueur et de force inégale sont en raison inverse de leur force. Si donc on a un ressort qui ait une force double d'un autre ressort, et que tous deux soient de même longueur, le plus foible aura une inflexion double de celle du plus fort, et tous deux seront dans le même état forcé au bout de leur inflexion.

D'où il suit qu'ayant un balancier auquel soit appliqué un spiral d'une longueur donnée, si les grandes

oscillations de ce balancier sont plus promptes que les petites, on parviendra à les rendre isochrones, en employant un ressort spiral plus foible, sa longueur restant la même ; parce que son inflexion devenant plus grande, la progression ascendante de la force diminuera à proportion. On peut donc encore parvenir à l'isochronisme sans changer la longueur du spiral.

Proposition 2^m. Puisque les inflexions des ressorts diminuent à proportion de l'augmentation de leur force, il s'ensuit que plus un ressort sera fort, et plus il devra être long pour parvenir à la progression ascendante de la force convenable à l'isochronisme. Si donc l'on a un balancier grand et pesant qui fasse des vibrations promptes, il faudra que le spiral soit fort long pour que l'augmentation de sa force soit en progression arithmétique ; et, au contraire, dans un petit balancier léger, le spiral, pour être isochrone, doit être foible et court, en sorte que dans les montres de poche même, il est possible d'obtenir l'isochronisme des vibrations par le spiral.

Proposition 3^m. La force d'un ressort spiral étant donnée, on peut parvenir à l'isochronisme sans changer sa longueur, mais en rendant ce ressort plus large.

Proposition 4^m. La progression ascendante de la force d'un même ressort spiral doit changer selon qu'il sera plié plus ou moins grand, c'est à dire, qu'il fera plus ou moins de tours, et que ces tours occuperont plus ou moins d'espace ; car il est évident, si le ressort est d'abord plié en un petit nombre de tours fort grands, les inflexions devant se faire de proche en proche dans toute l'étendue de la lame, en commençant je suppose

au centre, elles agiront comme sur des leviers inégaux ; et la progression ascendante de la force augmentera dans un plus grand rapport que celui convenable à l'isochronisme.

Si, au contraire, le même ressort est plié très-serré par un grand nombre de tours, les inflexions se feront par des leviers plus semblables, et la progression ascendante se fera dans un moindre rapport (celui convenable de la progression arithmétique).

Il suit de cette proposition, qu'ayant deux lames de ressort de même force et de même longueur, si l'on plie l'une des deux de sorte que les tours soient serrés et en grand nombre, et que l'autre soit pliée grande et en peu de tours, ces deux spiraux n'auront pas également la propriété de rendre isochrones les grandes et les petites oscillations du balancier ; celui qui sera plié par un grand nombre de tours serrés sera plus propre à l'isochronisme.

Voilà donc encore un moyen de parvenir à procurer cette propriété au spiral sans changer sa longueur. On peut voir dans le n° 208 du Traité les expériences qui confirment ce principe.

Proposition 5^m. Si la lame qui doit former le spiral n'est pas parfaitement calibrée dans toute sa longueur, la progression ascendante de la force du spiral changera selon que la lame sera plus forte ou plus foible du centre ou du dehors.

Si cette lame est trop forte du dehors, les grandes oscillations du balancier seront plus promptes que les petites ; et pour parvenir à l'isochronisme, il faudra

l'affoiblir par le dehors : si, au contraire, le dehors est plus foible que le centre, les grandes oscillations du balancier seront plus lentes que les petites ; ainsi, en raccourcissant le spiral, on trouvera un point propre à l'isochronisme. Voilà donc encore un moyen pour procurer cette propriété au ressort spiral.

Ce n'a été qu'après avoir établi les principes et la théorie dont on vient de donner l'extrait, que l'Auteur de cette découverte et de sa théorie s'est permis de faire des expériences pour confirmer ses principes. Ces expériences furent faites avec l'instrument qu'il a appelé "*balance élastique*," instrument dont il avoit indiqué les différens usages dans son 'Essai sur l'Horlogerie,' publié en 1763.

Thos. Mudge—Thoughts on the Means of improving Watches, &c., 1765—page 7.

"The conclusion I would draw from what I have said above is, that as the force derived to the balance from the main-spring through a train of wheels is necessarily unequal and irregular, and it is impossible entirely to throw off its agency, all we can do to improve the regularity of watches is to give the balance as great a quantity of motion as possible in proportion to this force ; for whatever motion it has over and above what is produced by this force, is the effect of the pendulum-spring, which is perfectly simple, and is to a balance what gravity is to a pendulum, and I think would not be improperly called the artificial gravitation of the balance."

ARNOLD'S TIMEKEEPER.

Of the Balance-spring,

with the mode of rendering it isochronal, or of adjusting the long and short arcs of vibration of the balance. The terms long arcs and short arcs, large and small arcs, are used indifferently.

The balance-spring may be made of steel wire, hardened and tempered, of steel wire hard rolled, or of gold wire alloyed with copper. Steel wire hardened and tempered is the most elastic, then gold, and lastly, steel wire hard drawn. Springs composed of any of the above substances, if the materials be good, will answer the purpose. The quantity of copper alloy put to the gold has been found to answer in the proportion of from one-eighth to a quarter, and many other proportions may probably do as well.

The form of the spring is helical, or cylindrical, except for a portion of a turn at each end, where it is curved in, and fastened at an equal distance between its centre and circumference, which may be seen by inspecting one end at the stud. . . . It may also be observed that the two end turns are curved in or smaller than the others. Were not these turns to be curved inwards, but left of same diameter with the others, the spring would not have its present easy, concentric motion, but, on the contrary, would jolt, wobble, and be distorted. Whether the balance vibrates an arc of 230 degrees from its point of rest, in its forward direction, or revibrates 230 degrees in its backward direction, making together 460 degrees,

the cylindrical figure of the spring is still preserved. Upon the length of this spring depends the isochronism of the vibrations of the balance; and in every spring of a sufficient length there is a place where all the vibrations—long, short, and intermediate—will be performed in equal times.

When the timekeeper is first set going, and always immediately after cleaning and putting into good order, the main-spring pulling with all its force, the oil applied to the pivots clean and good, and every part performing its functions to the greatest advantage, the balance may vibrate from 180 to 230 degrees from the point of rest, according to the power of the main-spring and the relative weight of the balance. The balance also revibrates on the other side of the point of rest nearly the same arc, but here the vibration is only reckoned on one side.

From continual exertion the main-spring will undergo some diminution of its original power; and very great resistance will be created from the thickening of the oil, and from the accumulation of dirt; so that at the end of a long voyage, suppose three or four years, the arc of vibration of the balance will gradually decrease from 230 to probably 130 degrees, and so on, till in time it will come to rest. From which it must be evident that if the different arcs from 230 to 130 are not all performed in equal times, a great irregularity must from that cause take place. If the large arcs are performed in longer time than the small ones, the timekeeper will accelerate, or go faster and faster; and if the small arcs are performed in longer time than the large ones, it will retard, or go slower and slower. To adjust the long

and short arcs, let the timekeeper, when clean, and the balance vibrating to its greatest extent, go for a few hours; and then, without stopping it, by means of the click and ratchet above the barrel cap, and a key applied to the barrel-arbor square, let the main-spring down a turn or two, till the arc of vibration decreases from 230 to 130 degrees, or thereabout. Then let it go for the same time as before; and if it goes slower with the long arcs than with the short ones, which is generally the case, shorten the spring by drawing it through the lips of the stud. Then try it again in the same manner, and so on, till they are performed in equal times.

If, on the contrary, the short ones should be performed in longer time than the long ones, or the long arcs be performed in less time than the short ones, which amounts to the same thing, the spring must be let out, or lengthened at the stud, and so on repeatedly, until they correspond. If, after letting out the spring several times, there should be no more to spare, a longer spring must be made. The length of the spring in the timekeeper before us is about eighteen inches.

If the spring is made of hard-rolled wire, and the construction should be such as not to leave room for a spring of the usual length, and one much shorter than ordinary should be required, it will be very liable to be overstrained; and if hardened and tempered, or of gold, to break. It will, however, be a good deal relieved and assisted by tapering, the taper end being pinned into the stud nearest the balance.

Note.—The balance stud was on the axis of balance,

just below the balance, into one end of which the spring was pinned fast.

The plate-stud or mouthpiece was screwed upon the upper plate, which opened or shut as a vice, by means of a screw, and by which the balance-spring could be lengthened or shortened at pleasure.

In consequence of the decease of Mr. John Arnold, the following questions were put by the Board of Longitude to his son, who furnished the preceding account:—

Question 1.—Are all these three substances equally good, and applicable in all cases to box and pocket timekeepers? or under what circumstances are they to be separately applied? And what advantage arises from applying one in preference to either of the others? Does not flattening or rolling pendulum wire destroy its elasticity, by crossing the grain of the wire so rolled? If so, do you use any means of making the wire longitudinal? If you do, it is required to explain the method.

Answer.—All these three substances may be equally applicable in all cases to box and pocket timekeepers. Springs made of gold and of tempered steel are attended with more trouble in manufacturing than those of hard-rolled wire, and unless the gold is well compounded, and drawn or rolled perfectly sound, it is liable to break. In springs of tempered steel, the greatest care should be taken that they are, in the first place, hardened from end to end, and then they may be equally tempered throughout. They will be more elastic than gold, and

perhaps better, excepting their liability to rust. Springs of hard-rolled wire are the least elastic of the three, and are subject to loss of their elasticity if made so short as either of the others may be. On this account I leave them about a fourth part longer than the others; and if the material be good they will stand. They are made in less time and with less trouble than either of the others, but liable to rust. I do not know that flattening or rolling the wire destroys or impairs its elasticity; nor do I use any means to make the grain of the wire longitudinal.

Question 2.—How are the above-mentioned balance-springs made; that is, how are they brought to, and known to be of, a proper size for each different watch; how turned into their proper shape, hardened, tempered, &c.? Is it necessary to attend particularly to the evenness of the wire? And if so, how is it known to be of an uniform thickness throughout?

Answer.—I do not (from experience) pretend to know the exact proportionable size of balance-springs. I have made chronometers with springs of the same length and material, some of them making or containing six or seven turns, others nine, ten, and even twelve, consequently differing considerably in size, and yet performing equally well. I should imagine that the best size would be such as that the spring might impel the balance in the centre of percussion, which will be between the centre and circumference of the balance, according as the weight may be disposed.

The springs of hard-rolled wire are turned into their

proper shape by winding them on a cylinder or mould, and screwing each end fast. The cylinder being heated by a blow-pipe until the wire becomes blue, it is taken off, and the ends turned in by a pair of bending pliers, or by drawing them over a round broach. Gold springs are brought to their shape by the same process, only that the mould, which may be of steel, is made blue instead of the wire. Or if the mould is of brass, the screws which fasten the wire may be of steel, and when they become blue, it will be the same thing as if the mould were of steel.

Springs are hardened by being made red hot upon the cylinder, either by a blow-pipe or small charcoal fire, and then immersed in water or oil, and tempered by heating the cylinder with a blow-pipe until the wire becomes blue. There is a very great difference in steel; some sorts will be harder and more elastic at a blue than others at a yellow, and some again will bear letting down below a blue. It also happens sometimes that the very same piece of steel is of a better quality in one part than another. The ends may be turned in by a pair of bending pliers made hot, or the mould may be cut down or spiralled at one end for the first turn of the spring, and it will come off with that end ready turned in. The balance-stud, into which that end is fixed, may be made movable, or to shift, that is, to lengthen or shorten, so as to meet the curve of the spring, and then fastened by two screws. The other end-turn of the spring might also be fashioned in the same way, but as it may require to be shortened to find the isochronal

place, the curve will be continually altering, and must be replaced by the pliers, so that it will probably be useless to do it by the mould.

I think it necessary that the wire should be as even as possible. I do not suppose that any wire was ever of an uniform thickness, but its deviation from uniformity may be known by drawing it through a parallel gauge. The best way I know of to make it as uniform as possible is to grind it between two planes of hard steel with oil-stone dust.

The chronometer, No. 36, which was tried by the Astronomer Royal five-and-twenty years since, had, and still has, the same spring of tempered steel. Everard's chronometer, No. 68, had, and still has, the same spring of gold; and the marine chronometer, No. 82, had, and I believe still has, a spring of hard-rolled steel. Experience is in favour of all three. The length of the spring of No. 36, pocket chronometer, was about eight inches; No. 68, about the same; No. 82, marine chronometer, sixteen inches, and of equal thickness from end to end. I think the gold and tempered steel will retain their identity longer than the other.

Question 3.—What is the necessary length of a spring which shall contain that certain place? And how do you select that place or part from the whole?

Answer.—That certain place is contained many times between the length of five inches and twenty, of and between which lengths vast numbers of springs have been made. Those places are selected from the whole

by continually shortening, as fully described in the method of adjusting the long and short vibrations.

Question 4.—As you do not recommend tapering the spring, but in case of there not being room enough for a spring of a sufficient length, is it necessary to have the balance-spring of equal breadth and thickness, or, in other words, of equal strength in every part? If that is the case, what means do you use to make it so, since scarcely any two following inches of the same wire as it comes from the hands of the wire-drawer are of the same strength, and that a spring made of it, without preparation, would be compounded of various powers?

Answer.—I only recommend tapering for hard-rolled wire, but where there is perfect or great elasticity there is no occasion for it. The best hard-rolled wire will not require it, unless made very short and overstrained, as may be the case in flat and fashionable chronometers, where there is not sufficient room. The tapering is chiefly wanted at the bottom turn, next the balance-stud, which, from its spiral shape, is strained more than the cylindrical turns.

Wire drawn through the plates where the holes are gradually smaller will be of more equal thickness than rolled wire, unless the mill is excellent, as for that purpose it ought to be. The wire should be as equal as possible; but none is perfect, and all springs are and will be compounded of various powers so long as we remain short of perfection. We can only come near it.

Construction of Timekeepers, delivered to the Board of Longitude by Thomas Earnshaw, March 7, 1805.

Balance-spring.—To find out the invisible properties of this apparently simple part of the machine, has given much more trouble than all the rest. The inventor despaired of bringing timekeepers to the state he has done, and unless those hidden properties are known to timekeeper makers, however well they may execute all other parts, they will find their most sanguine expectations frustrated. He has seen watch-makers boast of their timekeepers going well for a month or two; and, from the knowledge he had of the effects produced by the balance-spring, he has told them that a month or two more would destroy their hopes. To explain this: the cylindrical spring being in all its turns of equal distance from the centre, in course every turn will be of equal strength, and called isochronal, and it has been believed that all vibrations, whether long or short, would be performed in the same time; but this is not true, for if a man is to go four miles in the same time that he has gone one mile, he cannot do it with the same power: no, he must have impelling force to quicken his motion, or he will be four times as long in doing it; therefore, instead of the spring being equal in all its parts, it must be made to increase in thickness to the outer end, in such proportion as will cause the balance, when thrown to a greater distance, to return so much the quicker to make them equal; by long perseverance he found how to make

such springs, and then he thought he had got all he wished for. But cruel disappointment nearly broke his heart; for he found he had yet another difficulty to break down, as his watches with such perfect springs were continually losing on their rates. What further to do he was long at a loss to determine; but obstinate in his cause, and resolving not to give it up but with life, perseverance came once more to his aid, and with still more unremitting study, he applied at length the following remedy:—He found in the course of reasoning on bodies, that watch-springs relax and tire like the human frame, when kept constantly in motion, and this may be proved by the following experiment:—Let a watch that has been going a few months go down; let it be down for a week or two, or more, then set it going; and if it be a good timekeeper, so as not to be affected by the weather, it will go some seconds per day faster than it did when it was let down; but it will again lose its quickness in a gradual manner, gaining less and less till it comes to its former rate. Therefore, finding that isochronal springs would not do, and likewise having made springs of such shape as would render long and short vibrations equal in time—constantly lose the longer the watch went,—he then made them of such a shape as to gain in the short vibrations about five or six seconds per day more than the long ones. This quantity could only be found by long experience; and the way he proved this was to try the rate of the watch with the balance vibrating about one-third of a circle, then tried its rate vibrating one

circle and a quarter; and if the short vibrations go slower than the long ones, that watch will lose on its rate; and if they are equal it will likewise lose, but that only from relaxation; and if it gains in the short vibrations more than five or six seconds in twenty-four hours, it will ultimately gain on its rate; but if not more than that quantity, and the timekeeper is perfect in heat and cold, and every other part, the above properties will render it deserving of the name of a perfect timekeeper; and this is the principal cause of his timekeepers excelling others; and also of some of his timekeepers going better than others, though made by himself, the springs of them being made to accord more exactly with the above proportions; and this is the cause which has enabled him to foretell what his timekeepers would do, which Dr. Maskelyne, Crosley, and others could testify. The above effect is produced as follows:—He finds the common relaxation of balance-springs to be about five or six seconds per day on their rates in the course of a year; therefore the short vibrations are made, by the shape of the spring, to go about that quantity faster than the long ones; and as the spring relaxes in going by time, so the watch accumulates in dirt and thickening of the oil, which shortens the vibrations, the short ones then being quicker compensated for the evil of relaxation of the balance-spring. From this it is plain that the causes of error in timekeepers are not undefined and vague in their nature, which has been supposed; for when it is certain that all causes of error may be over-compensated, we

cannot despair of finding out the medium, which may be easily proved by examining the going of the inventor's timekeepers. It will then appear that what errors they are subject to, arise from causes certain and natural, and of course they may be corrected by art.

Earnshaw's Timekeeper for discovering the Longitude.

March 7, 1805.

The Board of Longitude, for the information of the public, and previous to making a final award of recompense, put several questions to the inventor, on such points as appeared capable of further elucidation.

Question 13.—What is the length of the balance-spring in your box timekeeper, and what in your pocket timekeeper?

Answer.—About the usual length of Arnold's, various as his are, from 12 to 20 inches in box timekeepers; and in pocket ones from 5 to 7 inches, just as I can get the wire to answer the purpose.

Question 14.—Are your balance-springs made of soft steel or tempered? And if tempered, in what manner?

Answer.—My balance-springs are made of soft steel, rolled hard, and not hardened with heat and cold, that process not being at all necessary.

Question 15.—How is the balance-spring turned into its proper shape?

Answer.—It is turned round a brass cylinder, and then blued by heat, which sets it into the cylindrical form.

Question 16.—Explain what you mean by this; and how it is performed.

Answer.—All watchmakers know how to draw and taper balance-springs, though they did not know how much they were to be tapered to that certain degree which could only answer the purpose of a complete timekeeper. I perform it in the following manner:—Take a length of balance-spring wire, say about 12 inches for box timekeepers, and draw it between two smooth potence files, beginning from the end about one-sixth of its length; make one draw; the next about two-sixths; and so on, advancing one-sixth every draw, till you come to the top, pressing the files just so hard together as will make them bite, or take hold of the spring; do the same with two oil-stones, only give twelve strokes instead of six, which will take off all burrs which the file left on.

Question 17.—As you say that the balance-spring will continually lose some of its power by use, is there any method of restoring it to its original strength? And what?

Answer.—By giving it rest.

Question 21.—Does altering the length of a balance-spring, of uniform thickness throughout, alter the performance of a watch in any other way except that of making it gain or lose on mean time?

Answer.—I never used the lengthening or shortening the spring for any other purpose but that of making the watch gain or lose. Le Roy published, many years back, that a certain length would produce isochronism; and Arnold says he has used it for that purpose. I use a method truly English, contrived by myself, and produce isochronism by tapering.

On the Properties of a Spiral Spring. Treatise on Clock and Watch-making, by Thomas Reid, page 266.

On nothing does a chronometer depend so much as the good quality of the pendulum-spring; great as the power of the rudder is in controlling and regulating the motions of a ship, it is not more extraordinary than that of this spring in regulating the motions of a chronometer, and we may be allowed to say that it possesses something like invisible properties. It may be set so as to make the machine go fast or slow, in any position required, while neither its length nor the weight of the balance are in any way altered. Le Roy thought he had made a great discovery, and it must be granted to be one, when he found "that there is in every spring of a sufficient extent, a certain length where all the vibrations, long or short, great or small, are isochronous; and this length being found, if you shorten the spring, the great vibrations will be quicker than the small ones; if, on the contrary, it is lengthened, the small arcs will be performed in less time than the great ones."

Notwithstanding this condition of sufficient extent, the isochronous property will remain no longer than while the form of the spring is preserved as it originally was. Should the coils be more compressed or taken in, the long vibrations will now be slower than the short ones; and, on the contrary, if they are more let out or extended, the long vibrations will be faster than the short ones. A more general principle for obtaining the quality of isochronism may be applied, by making

the spring act proportionally, in arithmetical progression according to its tension. Every five degrees of tension should make an equilibrium with a given force or weight of ten grains; suppose, that is, 5, 10, 15, 20, &c., degrees of tension, should be balanced by 10, 20, 30, 40, &c., grains. To try small springs by this process would require a very nice and delicate instrument. The circumstances of the properties of the spring which have just now been mentioned were well known to Hooke. In order to obtain these properties in pendulum-springs for his timekeepers, Berthoud made them thicker gradually, from the outer to the inner end; our old English way is the reverse of this. Whatever may be the form of the springs, whether flat or cylindrical, the best and most direct way is to try them in the timekeeper itself, by taking four hours, going with the greatest force the main-spring can give, and then four hours with the least. It is of consequence to have these springs hard or well tempered.

On the Laws of Isochronism of the Chronometer Balance-spring. Essay by John G. Ulrich, printed in 'Horological Journal,' October, 1872.

On the application of the balance-spring, and its adjustments:—

It is a very general practice, for what is termed an eleven-turn spring, to use only ten and three-quarters, but I find it the safest way to leave it a little longer, so as to have some through the stud to spare in case of

necessity, and to coil the ends at the stud and collet nearly midway between the diameter of the spring and its centre, and if requisite, as is frequently the case, a smaller collet must be made, and the stud made to approach nearer to the centre of the balance.

The spring will then have less dominion over the balance by not being put in tension so quickly; but if it gains in the short vibrations, it shows that the collet is too large, and that it has too much dominion over the balance, which is to be remedied by uncoiling the upper end, and bringing the stud farther from the centre, or by a smaller collet.

If the collet is too small, it will lose in the short vibrations. The quicker way to alter that is to make a larger one.

To try the isochronal properties of the balance-spring:—

Place four pins about a quarter of an inch long, equidistant from each other, and allow the spring to be retained in tension a quarter of a turn by one of the pins resting against a temporary detent placed on the cock (as nearly as possible at right angles to the quiescent point).

Then place a weight upon the first pin that the spring will just sustain, after which turn the balance round another quarter of a turn, and place double the weight upon the next pin; and if the spring sustains that weight, it is isochronal. If it does not sustain that weight, it shows that it will be too slow on the long vibrations, and be gaining in the short ones. Recourse

must then be had to closing the cycloidal cheek at the stud, by which the spring, by being rapidly increased in tension, will have more dominion, and render the long vibrations quicker. A cycloidal cheek is produced by leaving the pin at the stud flat, and a little longer than usual.

The same object may be achieved by altering the formation of the upper curve, or eye of the spring, uncoiling it and increasing the distance of the pinning in from the centre.

On Balance-springs for Pocket Chronometers.

· · · · · ·
· · · · · ·

The few memorable words of the author of chronometer springs (Dr. Robert Hooke), *viz.* "Ut tensio sic vis," in English, "As is the tension so is the force," contain the whole secret.

The particulars of which I will explain in as few words as possible, consistently with rendering the matter intelligible.

If the balance, in moving from the quiescent, or point of rest, to the extent of its vibration, acquires too much tension, it will gain in the long vibrations, and if it does not it will lose, and consequently gain in the short arcs.

To acquire the proper amount of tension is the subject for consideration.

The secret consists in the formation of the curves commonly called the eyes, and of their relative position

to each other, pinning into the stud and collet opposite to each other as nearly as possible.

By opening or closing of the upper curve, making it larger or smaller, the equalizing of the vibrations can generally be obtained after a few trials and experiments.

To obtain a good chronometer at a tolerably cheap rate, recourse must be had to some new method of manufacture, quicker than at present employed, particularly as regards the timing.

There is now much time wasted in equalizing the vibrations by isochronizing the balance-springs, and adjusting them for change of temperature through the want of the means of calculation, which might be most efficiently effected by a few adjusting screws, but which is now done by hand, by bending and torturing the springs by sight and guess with the pliers, whereas, by proper tools, an alteration might be made upon them to an absolute degree of certainty, to less "than the ten-thousandth part of an inch; for instance, by a screw with 100 threads to the inch, moved the 120th part of a turn round, which is very easy to be done."

As a conclusion to this chapter, it may not be out of place to remark on the complete incapacity of ordinary watchmakers to spring a chronometer, or even properly pin the pendulum-spring of an ordinary watch.

Should an anxious inquirer examine the balance-spring of a number of watches, he will be surprised to find in at least two-fifths some glaring mistake.

A constantly recurring one, *viz.* the bending with a pair of pliers the pendulum-spring near the end where pinned into the stud, indicates that the workman and master are both totally ignorant of the nature of springs. They seem to ignore the fact that a spring is composed of a multiplicity of particles closely adhering to each other, forming a continuous wire.

Now, if the wire be bent in any one place, however slightly, the continuity, or evenness of texture of the metal, is broken. And though it is customary to heat and then carefully hammer the affected part, so as to produce an outward appearance of perfectness, still the part where the bend or break in the curve has been, will be different from all the rest, and once pinned into the stud will at that injured point be weaker than the remainder of the spring, and less capable of enduring the necessary strain. The real truth is, that the spring does not possess in that place the same elastic force as the other portion of the spring, and is not adapted for isochronism.

Probably this unscientific process of bending the end of an ordinary pendulum-spring near to the stud into which it is pinned, arose from a desire to alter the curve of the spring so as to change the rate of the watch; whereas the error can never be so corrected properly.

It is then hardly possible to impress too strongly upon watchmakers the positive necessity for the proper springing of a watch.

Prize essays may be written on the subject, but they are of no use to the actual springer, who is a man

possessed of a peculiar talent, gifted to perform in less than an hour what hundreds can never do in a lifetime.

The springer will take a piece of pendulum wire, coil the same to a nicety round the cylinder; harden it by his own process, and according to his own judgment; cut it the exact length; form in an instant the elbows for the eyes; pin it to be perfectly isochronous; and thus finished it will bear the most searching examination by the strictest watchmaker; so that wonder will give place to admiration at the apparent oneness of its action; the perfect regularity of its contraction and expansion: in fact, it will, both internally and externally, be like a broad band, and not a series of coils.

Can the eye and hand accomplish anything more artistic than a cylindrical helix for a box chronometer?

CHAPTER XVII.

COMPENSATION.

BEFORE entering on the question of compensation it will be advisable to give a Table of the expansion of metals.

The first person who seems to have observed that metals changed their length by changes of temperature was Godfroi Wendelinus, canon of Condé, in Flanders, about the year 1648.

The first person who made experiments with a machine called a pyrometer, to try the effect of heat and cold on metals, was Muschenbrock.

Mr. John Ellicott (born 1700, died 1772), a watch-maker of London, soon afterwards invented an improved pyrometer; to be again improved upon by Mr. Edward Troughton, a very celebrated mathematical instrument maker.

Table of the expansion of metals:—

FERGUSON'S.

Iron and steel as	3
Copper	4½
Brass	5
Tin	6
Lead	7

ELLICOTT'S.							
Gold	73
Silver	103
Brass	95
Copper	89
Iron	60
Steel	56
Lead	149

In 1760 Berthoud made experiments with the following results:—

Steel, softened	69
Iron, ditto	75
Steel, tempered	77
Iron, forged	78
Gold, softened	82
Gold wire, drawn hard	94
Copper	107
Silver wire, drawn	119
Brass	121
Tin	160
Lead	193
Glass	62
Mercury	1235

Experiments made by M. de Luc and Dalby gave the following results:—

Glass	·0083
Platinum	·0087
Blistered Steel	·0112
Iron	·0126
Brass wire	·0194
Zinc	·0296
Hammered Zinc	·0308
Mercury	·1835

Mr. Troughton, who had invented a very delicate pyrometer, obtained thereby the expansive ratio of brass to steel to be in

Brass 80 to for steel 49·575.

About the year 1715 Graham endeavoured to make

a pendulum-rod that should counteract the effect of heat and cold, but did not succeed. However, in the year 1722 he made a clock with a mercurial pendulum, that is to say, instead of a metal bob, a vase filled with mercury attached to the rod, which proved successful, and was the first attempt at compensation.

In 1726 Harrison completed his gridiron pendulum; and there is little doubt that he was the first (1749) who applied compensation to the balance of a watch; but as there is no written evidence, the honour is claimed by F. Berthoud, who in 1766 sold a watch to Mr. Pinchbeck, of Cockspur Street, for his Majesty George III.

The compensation piece was made of brass and steel pinned together: one end was fixed to the outside of the fore plate; the other was made to act on a short arm projecting from a movable arbor; a longer arm having the curb pins in it moved nearly in the circle of the outer coil of the spiral spring.

The celebrated Mudge invented a compensation for heat and cold, which he applied to his timekeepers. The system he adopted was more simple than the one above described by Berthoud, but acted in same manner on the spiral spring. He also applied it in 1774 to a watch with cylindrical escapement, a great mistake for so eminent a man to make, as it would be nearly useless, except during the period the oil in the cylinder retained its freshness.

Cylinder watches possess a natural compensation caused by the oil in the cylinder. In warm weather

the oil will be more fluid, consequently there will be a quicker action in the escapement: in cold weather, the oil will thicken, producing thereby a more sluggish motion, and as a matter of course counteracting the shortening or contraction of the pendulum-spring.

Abraham Breguet, born in 1747, died 1823, invented a compensation curb in form like a V, but made to correspond in a great measure with the circumference of the balance, which he applied to his watches.

This curb was made of brass and steel, the brass being inside, and so arranged, by being screwed on to the extremity of the regulating index, that the balance-spring vibrated between one end of it, formed into a heel, and a fixed pin.

The action was simple: in cold weather the space between the heel of the compensation curb and the pin became enlarged through the contraction of the compound laminæ; consequently the balance-spring had more room to vibrate in.

In warm weather the laminæ expanded, thereby reducing the space, and contracting the expansion of the spring.

The defect of this curb was the difficulty of adjustment, which eventually caused it to be set aside.

However, in a lever watch made by Ruegger of Geneva, a great admirer and imitator of Breguet, and renowned for the extreme perfection of his work, the compensation curb acts admirably, as the author has tested it against a chronometer of Arnold's, and found the variation in a week to be very trifling.

Arnold had recourse to various experiments in order to obtain compensation, and finally adopted a system totally different from any of the preceding ones. He placed the compensation in the balance alone, as will be seen by the diagram, judging that it would not be desirable to interfere with the pendulum-spring, but better to allow it perfect freedom, as there would then be greater probability of its performance being good.

FIG. 21.

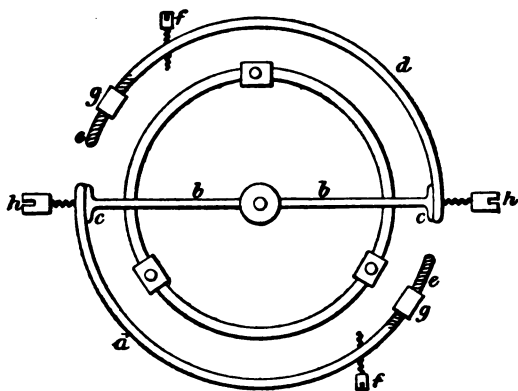

Let *b, b*, represent the arms of the balance, which is screwed upon a collet fixed to the end of the axis.

At extremities of these arms are two shoulders, *c, c*, against which, by means of two screws, are fixed the expansion or compensation pieces *d, d*. These expansion pieces are each composed of two laminæ, the outside being of brass, the inside of steel.

These two pieces are made out of one, the brass being

melted upon the steel all in one piece; it is afterwards cut into two.

d, e, the steel laminæ continued, but made round and tapped.

g, g, brass balls or weights, alike in all respects, made to screw upon each tap.

f, f, are small screws put in through the compound laminæ of brass and steel, designed to adjust for small differences.

h, h, screws to regulate the mean time, and which are tapped into the shoulders *c, c*, passing through the expansion pieces.

In the Specification sent to the Board of Longitude the action is thus described:—

“The long and short vibrations being adjusted, we shall next show how to make the timekeeper perform alike in heat and cold. The balance-spring becomes weaker by heat and stronger by cold, and were the balance to remain of the same diameter, it would go slower in heat and faster in cold, supposing it to go to time when the thermometer stood at temperature. But when the spring becomes weaker by heat, the expansion pieces move toward the centre of the balance, carrying with them the balls *g, g*, by which the diameter of the balance becomes smaller and relatively lighter. When the balance-spring becomes stronger by cold, the expansion pieces move from the centre of the balance, carrying with them the balls *g, g*, by which the diameter of the balance becomes larger and relatively heavier; and when, after repeated trials, the balls are properly

placed at equal distances on each tap, the diameter of the balance will decrease and increase in the same ratio as the spring decreases and increases its strength. The following is the cause of the expansion pieces moving towards the centre by heat, and from the centre by cold:—As the outside lamina of the expansion pieces is of brass, and expands or lengthens more by heat than the inside lamina of steel to which it is attached, it will be easy to conceive how the brass forces the steel inwards; and as the same lamina of brass contracts or shortens more by cold than the steel, it is obvious that it must draw it outwards. (Were the lamina of brass placed inside, and the steel outside, the balance would expand or become larger by heat, and contract or become smaller by cold, and instead of compensating the error of the pendulum-spring it would add to it.)

“The balls g, g , being made of equal weight, may be placed at the ends of the taps at e ; and if the time-keeper, being in a situation where the thermometer will rise to 100 degrees or more, should go faster than when placed in another situation where the thermometer will fall to 32 degrees or lower, it is a proof that the expansion pieces do too much, and that the balls are too heavy. Supposing this to be the case, screw the balls up close to the ends of the expansion pieces at d , and their effect will be less, because, notwithstanding the same degree of heat will occasion the expansion pieces to move inwards the same quantity, or to describe the same angle from c , yet the balls will move through less space at d than at e ; for it is evident

that, if they could slide up to the ends of the expansion pieces next to the arms of the balance, they would not move at all, or at least their motion could not be discovered by any effect that it would produce. If the timekeeper still gains in heat, reduce the balls and screw them up again to *d*. In the next trial, should it lose in heat more than in cold, contrary to what it did before, it is a proof that the expansion pieces do not do enough, and the balls must be unscrewed toward the ends of the taps at *e* until it keeps the same time in heat as in cold. If the balls being at the ends do not do enough, and the timekeeper still loses in heat, increase their size until the adjustment is brought within the compass of the length of the taps, where there is generally room sufficient to correct for a minute of difference in heat or cold per day. By screwing the balls up and down, it may be soon seen how much of error two or three turns will correct in a given time, and by that means discover their proper situation."

The next great improvement was made by Thomas Earnshaw about 1802, who employed only one balance instead of the two combined together by Arnold. He melted the brass on to the steel, whereas Le Roy, in 1768, had only pinned the laminæ together.

According to the diagram, it will be seen that *a, a*, are brass pieces having grooves turned in them, by which means they are enabled to take in the compound rim of the balance, and can be made to slide backward or forward.

b, b , are screws designed to fix them to their place in the rim after the adjustment for heat or cold has been perfected.

d, d , are screws at end of the balance main diameter bar for adjusting to mean time or rating to time.

It is usual for these balances to be made in two pieces.

FIG. 22.

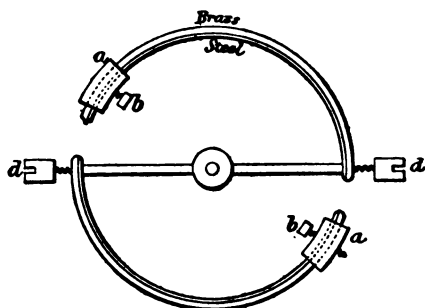

The compound bar when acted on by heat bends necessarily inwards on to the steel side, thereby diminishing the moment of inertia or quickening the vibration of the balance; on contracting again with cold the opposite effect is produced.

Specification given in by Earnshaw to the Board of Longitude in 1805.

“The balance is to be made of the best steel, and turned from its own centre to its proper size; then put into a crucible with as much of the best brass as, when melted, will cover it. The brass melted will adhere to

the steel—if any other metal is used by way of solder, the watch cannot go well ; then turn it to its proper thickness, and hollow it out so as to leave the steel rim about the thickness of a repeating spring to a small-sized repeating watch ; turn the brass to twice or near three times that thickness of steel ; cross it out with only one arm straight across the centre, and at each end of the arm fix two screws opposite to each other through the rim of the balance, to regulate the watch to time ; the diameter of the heads of these screws about equal to the thickness of the balance, a little more or less is not material. The compensation weights should be made of the best brass and well hammered, and a groove turned to let the rim of the balance into it, and this should be cut into fourteen equal parts by a wheel-engine ; then you will have seven pairs of pieces of equal size and weight ; two of these pieces being screwed on the rim of the balance at equal distances will produce an equilibrium, a balance in the full sense of the word, equal in all its parts. In making balances, great care should be taken that they get no bruises or bendings, for if they get a bruise on one side so as to indent the metal, that part will be less affected by heat and cold than the other parts which have not received the same violence to close their pores ; consequently the balances made by rule of thumb, bending, hammering, and filing, without one single truth about them, must, to the poorest mechanic, be inconsistent in the extreme, as no worse method can be taken, and the piece can only go well

by some error compensating for others; for, should there be one stroke of the hammer on the compensation piece on one side of the balance more than on that on the other, heat and cold will produce different effects on them. And if the two metals which compose the compensation for heat and cold be soldered together it is still worse, as then the compensation will be composed of three metals instead of two, three acting bodies, as follows:—The brass has a tendency with every change in the atmosphere to move one way; the steel has a tendency to move the same way, but not so rapidly as the brass; but the force of the brass warps the steel with it; here then they might act pleasantly together; but the middle, or soldering metal, between the brass and steel, having a greater tendency to rapid motion than the other two, and being confined between them, will undo that natural easy accordance which they without it would have possessed, and will act as a third man between two men of equal force, but not so rapid in action as the middle one, warping with him either way his inclination is to move; and the said natural easy accordance in two metals, so necessary to obtain perfection, must not be destroyed by a third.

“Balances are likewise spoiled by bending the compensation pieces; bending cracks and destroys the compact body of the metal. The soldering up these cracks with a metal very different in expansion to the metal cracked is hurtful. Nor is it possible to bend the compensation pieces into a true circle; in that case they form so many parts of different circles, that nothing

regular can be produced, nor a more inconsistent method of making expansion balances be imagined. The mode of making them, as well as the workmanship, are generally wretched in the extreme."

Scarcely any alteration of consequence has taken place of late years in the construction of these compensation balances, which are now generally applied, on Earnshaw's principle, to all first-class lever watches.

This improvement is certainly the nearest approach to perfection in the portable timekeeper of the present day, and no expense ought to be begrudged by men of intellect or money in obtaining from a first-class maker a really well-adjusted compensated lever. The multiplicity of watches possessing apparent compensation now in the market is a great scandal to the trade.

Balances are made of brass and steel with outward appearance of the genuine article; but adjustment has never taken place, that is to say, adjustment for heat and cold. The balance itself will cost little or nothing, and therefore very easy to put it as not; but the time required for adjusting is so great, and the attention daily in attending to it so necessary, that the labour must be paid for; hence a compensation balance for heat or cold is worth not less than five or six guineas; but the money is well bestowed, and the satisfaction the possessor derives from it is over and over again repaid.

It will not be out of place here to state that it is not desirable regulating pins should be inserted in a compensated watch. Few persons have delicacy of hand

or sufficient accuracy of eye to touch so minutely the regulator of a watch as is required when the balance is properly adjusted. Perhaps it would be better that all watches should have what is termed a Breguet balance-spring, which would do away with the necessity of the regulator; though clearly contrary to his intention, English watchmakers put the regulating pins. This spring is decidedly of great advantage to ordinary watches. The isochronism is nearly perfect. It differs from the ordinary balance-spring in having its outer end coiled over the horizontal coils and pinned to a stud in the balance-cock.

CHAPTER XVIII.

JEWELLING OF PIVOT HOLES.

IN all the early watches the pivot holes were pierced in the brass of the plates, but late in the 17th century one Nicolas Facio, a native of Geneva, discovered a method of piercing holes in rubies, which he applied to the purpose of pivot holes, and went to Paris the bearer of this discovery.

For some reason unknown the Paris watchmakers received him coldly, and thought his discovery of no value. Disappointed at the treatment he met with, he started for England, and about the year 1700 entered into partnership with the De Beaufres, Frenchmen then established as watchmakers in London, with the view of applying the discovery to watch-work.

Application seems to have been made only in 1704 for a patent, for in 'London Gazette' of 11th May, 1704, may be read, "Her Majesty having granted to Mr. Nicolas Facio, gentleman, of the Royal Society, Peter De Beaufre, and Jacob De Beaufre, watchmakers, her letters patent, &c., &c., for sole use in England, &c., &c., for fourteen years of a new art, invented by them, of figuring and working precious or common stones, crystal, or glass, and certain other matters, different

from metals, so that they may be employed in watches, clocks, and many other engines, as internal and useful parts of the engine itself, in such manners as were never yet in use," &c.

To judge by the number of watch movements which were shortly afterwards jewelled, this art, notwithstanding successful opposition of Clockmakers' Company to enlarging the term of the patent, must have been instantly appreciated by the well-known makers of the day; and the great advantage which would be derived from it in its application to high-class work thought to be of signal value.

The greatest advantage which can be derived from jewelling the pivot holes consists in the effect on the oil.

In brass holes the metal becomes oxidated by the joint action of the oil and air, and is evident to the eye by the greenish colour of the pivot holes. The oxide thus formed will in time form a metallic soap, which by the working of the pivots will gradually tend to waste both the pivot and the brass; consequently the hole will become larger and the pivot smaller.

Whatever watchmakers may say, it does not seem possible that a properly pierced jewel can be in any way affected by the oil; the only change which can be seen will possibly be on the pivot itself, for in the course of many years it may show signs of wear, but it is most probable that the steel when carefully examined will be found defective.

An eminent scapement maker has certainly declared

that he has himself found jewel holes much worn, or at least changed in shape; but, with all due respect to so great an authority, it would be necessary to consider the various positions in which the watch had been placed, for if pivots were always bearing in one direction, a possible reason might be found for the wear.

There is no reason to doubt that watchmakers of the present day have much to contend against in the varying quality of the oil, and the wretched materials used for jewels. Frequently oil, for reasons difficult to explain, will deteriorate in a very short time.

An eminent watchmaker has observed that the colour of the stone used for the pivot hole as well as its volume will have an effect upon the oil; for example, that oil applied to two box chronometers at the same period has in the one jewelled with rubies of dark colour, their volume being great, deteriorated much more rapidly than in the other, which was jewelled with light or pale-coloured rubies of equal volume, the depth of the pivot holes in each being the same. Also, that the oil, which was prepared by a special and peculiar process, communicated in confidence to the author, and which he is not permitted to divulge, became rapidly bad in a movement jewelled with dark-coloured stones of considerable volume; whereas the same oil lasted a long period perfectly pure when applied to stones nearly white, but of small volume.

Doubtless in the first case the high-coloured stones being softer than the pale ones had much to do with the deterioration of the oil.

In the second case the great volume of the stone was much colder than the less volume, and so acted injuriously on the oil.

The quality of the jewels, and the miserable way in which many are pierced, has made it desirable not to have any jewels except for the balance and scape-wheel pivots.

It seems to be a *sine quâ non* that cheap watches should have jewels nearly as large as the wheels themselves, and possess a lustrous effect, which only the old duffer watches—those made for sale and exportation—formerly rejoiced in.

There is too often one reason why watches do not keep any better time after being cleaned than previously. The watch-jobber has not taken the trouble to remove the jewels and see that every particle of the old oil be cleaned away before he ventures to apply new oil. It is unfortunately too true that in the majority of watches the movement has not been cleaned out entirely; the balance-cock has been unscrewed, and, in case of cylinder watches, a little fresh oil only been put into the cylinder, then the watch returned as properly cleaned and timed. Such conduct in the proprietor of a business establishment is, without mincing words, disgraceful.

Influences on the Oil irregular, &c.

155. The influences of heat and cold on the *oil* applied in clocks *is of a more irregular nature*, for the qualities of the oil are through time changed by the

motion of the clock insomuch that *equal degrees* of *heat* and *cold* will have *different effects at different times*, which makes it impossible to apply a remedy by means of the expansion of metals, and it would even seem that a perfect remedy had been despaired of unless by discontinuing the use of oil. This is also big with difficulties, and at the end we will find that we have (at a considerable expense) *only* substituted a smaller imperfection for a greater.

157. Since a smaller quantity of oil is sooner destroyed by motion than a greater, the effect will be rendered less, and always more proportionable to the cause, by supplying the pivots with a greater quantity of oil, which should be contained in a metal not so liable to corrode as brass, for most oils, unless concentrated by cold, contain more or less of saline acid or aqueous parts, sometimes all the three, which corrode the brass, and the parts thus corroded mix with and destroy the oil. Care must also be taken not to use a soft malleable metal, however fine, for dust, &c., will stick to it and tear the pivots, &c.—*Alexander Cumming*, 'The Elements of Clock and Watch Work.'

CHAPTER XIX.

CLERKENWELL.

It is scarcely possible for any book on watch-work to be considered complete which does not, in some way or other, treat on Clerkenwell, "The land o' watches."

There are many excellent works giving a good account of the environs of London; one of the best is *T. Cromwell's History and Description of the Parish of Clerkenwell*, 1828; but, strange to say, he has not in any way alluded to the great trade which is, and has been for years, carried on within its limits.

Knight in his 'London,' volume iii., has, however, written on the subject, and the student cannot do better than refer to both these works.

CLERKENWELL evidently takes its name from the clerk's well, or well belonging to the clerken, which exists in Ray Street, formerly Hockley-in-the-Hole.— See *Cromwell's History*, pages 261–265.

The *Clerks* here meant were evidently the inferior order of the clergy of the City of London, who enacted dramatic entertainments or mysteries at or near this well. It is possible that they usually assembled here "on their festival days; but it is on record that they met yearly at this place to act some play or history

taken from Holy Scripture.” — *Cromwell's History*, pages 42, 43.

“In the year 1391 these pious dramatists are recorded to have played here three days successively before King Richard II., his queen, and the whole court. These amusements, with more substantial peace-offerings, being presented to the monarch to divert his resentment from the citizens, on account of a late riot, of no great importance, against the Bishop of Salisbury.”

In Clerkenwell existed the far-famed Priory of St. Mary, for nuns of the Benedictine order, dissolved by Henry VIII., 1539.

Also the House and Hospital of St. John, founded A.D. 1110 for the Knights Hospitalers of Jerusalem, dissolved in 1540 by Act of Parliament, thirty-second Henry VIII., “and all the lands belonging to their order here in England and Ireland seized into the king’s hands.”

Stow writes of the Priory church of St. John:—“In the third year of King Edward VI. the church for the most part, to wit, the body and side aisles, with the great bell tower, a most curious piece of workmanship, graven, gilt, and enamelled, to the great beautifying of the city, and passing all others that I have seen, was undermined and blown up with gunpowder. The stone thereof was employed in building of the Lord Protector’s house at the Strand” (Somerset House).

1607. James I. on 9th May granted, by letters patent, “the scite or house of the late Hospital of St. John of Jerusalem, in England, in the county of

Middlesex, and all the scite, circuit, and precinct of the same house, having thereon one great Mansion house and one great Chapel, and containing by estimation five acres, to Ralph Freeman and his heirs, in free and common soccage."

In 1723 the choir of the old Hospital church was converted into a place of public worship for the inhabitants of St. John's, and consecrated by the Bishop of London, under the style, "The Church of St. John, Clerkenwell, in the County of Middlesex."

The boundaries of the parish are thus given:—"Along the whole northern line lies the parish of Islington; to the east, parts of Islington and St. Luke's; south, St. Sepulchre's and part of St. Andrew's; west, parts of St. Andrew's and St. Pancras, together with the river Fleet, now arched over."

The principal streets and squares:—Alesbury Street; Amwell Street; Bagnigge Wells Road; Exmouth Street; Goswell Street; Percival Street; Pentonville, with its streets; Red Lion Street; St. John's Street; Spencer Street; Turnmill Street; Claremont Square; Clerkenwell Green; Mydelleton Square; Northampton Square; St. John's Square.

It is difficult to give any reason why the clock and watch trade should have made its home in Clerkenwell, unless the attractive position so near to the City, so extremely rural, so much frequented from 1619 to 1735 by distinguished residents, rendered it desirable also for those occupied in a business which demands good light and fresh air. It may also be conjectured that

artisans requiring favour and patronage would naturally seek the neighbourhood of such influential persons, more particularly as St. James's had not then risen to any great note for private residences.

Within the limits of Clerkenwell every branch of the watch trade is carried on. Scapement makers; watch jewellers; dial enamellers and painters; case-makers; gilders, &c., &c.: each and all have their workshops adapted to carry on their special branch of the business.

Prescot in Lancashire is the only place which holds up its head above Clerkenwell, and that in making movements only. There the highest class work is made, for the old-established firms cannot yet be surpassed in the perfection and finish of their wheels and pinions.

With this exception the whole trade of the country is within the control of Clerkenwell firms; and no matter whether in London, or Bristol, or York a watch may be sold or given to be repaired, it has at one time or other been in the hands of the Clerkenwell artisan, unless Coventry.

For instance: a watch given at Brighton to some dealer to have the dial bleached, or a jewel replaced, within twenty-four hours it has reached the workshop of some well-known man in Clerkenwell. A case is required for an old watch, which being good is worthy of being retained as a timekeeper; the old case, a pair-cased one, looking heavy and ugly. To Clerkenwell the plates of the movement, in order that size and

depth may be judged, take their way, and in a month the new case is returned to be fitted with the old works by the local man, and given back to the owner as a fine specimen of his handiwork.

Our own-make Watches; our Chronometers, which have beat all others at Greenwich Observatory, where they are sent to undergo trial; *our prize-medal levers; our machine-made* measurers of the flight of time; *all* come from Clerkenwell; and if of old the knights of St. John asserted a sway, how unlimited now is the power of the community existing on the same ground, but inhabiting no grandiose or imposing buildings, and wearing no distinguishing badge; but sending forth portable machines, which guide, influence, and control the minute circumstances of every-day life among all classes of people throughout every quarter of the old and new world.

CHAPTER XX.

FALLACIES OF THE TRADE.

1st. *Converted.*

2nd. *Our own Make.*

3rd. *Geneva Watches.*

4th. *Names on the Dials of Clocks and Watches.*

CONVERTED.—A watch is said to be *converted* when the original escapement is taken out and a new one adapted. Like many conversions, it is not much to be depended on.

The watches usually converted are verges and duplexes, and thus it happens:—

An individual, unknown, inherits from his father, or uncle, or anybody, a large fine verge or duplex watch, probably with heavy gold case and dial; he takes the said watch to an intelligent watchmaker for the purpose of having it cleaned and regulated, intending to carry the same.

Watchmaker.—“ Ah, sir, fine watch, in first-rate condition, well preserved; pity it is a verge.”

Owner.—“ Why?”

Watchmaker.—“ Will never keep time. Accurate time very necessary in these railroad days.”

Owner.—“ True; but why won't it keep time?”

Watchmaker.—"Verges never do, sir! This watch would make a capital lever, or horizontal, if converted."

Owner.—"Indeed!" Then anxious inquiry, "What will be the cost? expensive, eh?"

Watchmaker.—"Oh dear, no. Horizontal about two guineas; lever, three guineas. Then, sir, you will have a watch equal to any twenty-guinea one in my shop. I strongly recommend a lever—the calliper will just suit. As for this dial, rather antiquated; new enamel dial, bold figures, steel hands, &c., &c., total cost, three-and-a-half guineas; allowance for dial, its weight in gold—probable expense, three guineas."

Owner consents to conversion of his really genuine article into, in nine cases out of ten, an indifferent lever. Better by far keep the old watch untouched, or exchange it at once for a modern one. Like the old lamp of Aladdin, too often a really valuable article is exchanged away for a bright new-fashioned one.

The watchmaker did not state to owner that in order to convert the old watch it would be necessary to throw away balance-staff and belongings, crown and contrate wheels; or, in case of duplex, the balance-staff, pallet, ruby-roller, and scape-wheel.

The watchmaker is wise in his generation. The verge he does *not* understand. Duplex, less if it were possible. A job is wanted. He cannot make any part of a watch, but he sends the watch to a Clerkenwell watchmaker, who does the work at trade price, and on its return owner is charged the retail profit.

The innumerable clocks and watches of really scientific men so treated is past counting. Works of art destroyed for the purpose of making—what? difficult to say—probably a profit!

OUR OWN MAKE.

Walk up or down an extensive thoroughfare in London, or any large town, and the attentive observer will perceive in nearly every jeweller's window rows of watches, hung in most cases to labels, which usually run, "First-class lever, jewelled in four holes, maintaining power, &c., *our own make*."

If in search of information, said observer should enter one of these attractive-looking shops; he will probably find facing the entrance or near the window a mysterious corner, partitioned off with glass front, in which is seated a man with glass at eye, intent on examination of some portion of a watch movement. This evidently is the part of the establishment where the watches of "*our own make*" are constructed.

The manufacturer, or rather dealer, is a well-dressed person, ready to attend to every wish of his customer. He recommends his four-guinea levers as strong and serviceable, and declares that he can warrant them, being of his "*own make*."

Evidently this expression "*own make*" is a technical term in the trade, and in use not only in England, but in every country, and simply means—*nothing*.

The watches are most likely Coventry make, if town be a provincial one, prime cost fifty shillings each. In

any case the watches come from the factory of some well-known watchmaker, who supplies the trade, and paints the retail dealer's name on the dial as a matter of course. Honesty is the best policy; better far OWN that the watch is only warranted as good for the money asked.

GENEVA WATCHES.

All foreign watches, that is to say of Swiss make, are termed in the trade *Geneva*; the town usurps the place of the country.

The greater number of Swiss watches come from *Chauxdefonds*, or *Locle*. Both towns are situate on the Jura; the one large, the other very small.

The Neuchâtel watches, as a rule, do not find their way in any number to England.

CHAUXDEFONDS, about five miles from the lake of Neuchâtel, on the Jura, is now a large town, has many well-built houses, and contains a population of 18,000 souls. The only industry which gives occupation to the inhabitants is watch-making.

The visitor to Chauxdefonds will, however, be disappointed on going there to find that there are no watch factories or buildings in which the manufacture is carried on as a whole.

The Chauxdefonds houses are, strictly speaking, watch-finishers, some doing an extensive business, 20,000 watches a year, and having a large capital; others but in a small way, and doing only cheap work.

The various and many parts of a watch, including its

case and movement, are all made separately in different villages, and in what may be called factories, where complex, beautiful, and expensive machinery is employed, but only adapted to each particular part for which designed; the genius of man not yet having been able to invent a machine which will turn out a watch in going condition, as pins or horse-shoe nails, ready to hand.

The watch-finishers have in stock the several parts, which they give out generally in a dozen or two-dozen box at a time, to each class of work-people, to be returned when the portion of work which is their speciality is completed.

The box is divided into small compartments, into which the movement is deposited; the plates, or wheels and pinions, or parts being taken separately.

The workman or woman on returning the box to the *ébaucheur*, or finisher, does so by handing it in at a certain counter where it is received, work examined; and at next counter a similar class of work is given out; each work-person doing always but one and the same class of work.

It is a curious sight to be present at a dinner in the chief hotel of the town, the Fleur-de-lys. The hour is half-past twelve; the guests all men; seldom a female present; commercial travellers, frequently from every part of Europe and America. On certain days the small finishers call at the rooms of each traveller, who hangs a large card with his name and address on the outside of his door. If trade is brisk, watches bring a

good price ; if depressed, offered at a ridiculously small profit for cash. The sellers offer to their customers work according to their requirements ; for watches are prepared to suit every market, European, American, Oriental. The large and wealthy finishers receive the travellers in their counting-houses, and exhibit samples of watches varying in price from 25 francs to 1000 francs, when taken by the gross ; as a rule they do not sell single watches, that belongs to the retail trade.

LOCLE is a village a short distance off by rail, three miles ; about a mile and a half beyond is the French frontier, the Doubs. A vast number of watches are produced in Locle, but it cannot be compared with, or as the saying goes, hold a candle to, its neighbour. Many have a dislike to the Locle work, but good watches have been made there.

For style of work, finish and beauty of cases, temper of metal, it is not possible to find any place in the whole of Switzerland, which can venture to challenge a comparison with the really Geneva-made watch. It is necessary to note that many watches bear Geneva on the plate, or dome, the gold or metal covering of the movement, but have nothing beyond the name in common with Geneva.

The Geneva houses are more properly watchmakers, according to English ideas. They employ skilled hands, and only put their names to work which will bear strict investigation as to its merits.

The cases, like London work, are made by experienced workmen, are of good material, not alloyed to such

an extent as in the mountain work, by which term Chauxdefonds and Locle are known, that it is difficult to discover how much may possibly be "*fine silver or gold.*" The escapement is accurately adjusted; in fact, the best of everything is given for the money. But the work must be paid for; hence the price of a Geneva watch is still high, *viz.* 8 to 20 guineas.

At Geneva is the school for painting on enamel. All those beautiful cases, enamelled to any pattern required, or painted with any lovely view, artistic in every respect, can only be manufactured in that far-famed town, the miniature Paris, as it has been justly called, doubtless from the beauty of its shops and quays.

NAMES ON DIALS OF CLOCKS AND WATCHES.

No more unpardonable deception can be practised than this of placing the name of the seller on the dials of watches and clocks, or even the domes of watches.

The public, ignorant of the meaning, of course imagine when reading these names that the entire machine has been constructed by the person whose name is thus set forth. How can people who are totally ignorant of watch-making suppose that straightforward tradesmen would thus certify to a deception?

The name thus indicated, whatever explanation may be attempted to be given, evidently means, "Here is my name as a watchmaker, and you can always see who made your watch, and tell your friends my address."

The great makers of old placed their names on their

goods, because they stood high in their profession, and there was then much in a name.

“ Good name in man or woman, dear my lord,
Is the immediate jewel of their souls,
Who steals my purse steals trash, 'tis something, nothing ;
'Twas mine, 'tis his, and has been slave to thousands.
But he that filches from me my good name
Robs me of that which not enriches him,
And makes me poor indeed.”

Othello : act iii. scene ii.

Why do the brewers or manufacturers resist any attempt on the use of their names or trade-marks? Because they have a great reputation, and are proud of the same, and do not wish the public to be deceived into buying spurious goods on a false pretence.

Why should not the same honour prevail in the watch trade? Let the trade come forward and answer for themselves, if they can.

Again, can there be anything more absurd than for an English dealer to place his name on the dial of a Swiss watch or a French clock?

“ Good wine needs no bush ” was an old saying ; good watches and clocks made by foreign houses of great name need no English dealer’s name to certify to their quality. Their recognized agents will supply an article, stamped, numbered, named by their employers, and warrant the same as genuine.

Besides, the English public ought to know that clocks or watches, specially made for exportation, seldom bear the same care and attention as those to which a maker fixes his name and stakes his reputation.

Ask a Frenchman of sense and judgment his opinion

of two-thirds of the clocks offered for sale in London, and he would reply that he was not in the habit of buying *camelotte* (rubbish); that he preferred to buy a well-made and finished pendule, and was prepared to give a good price. In a word, if a Frenchman does buy a clock, he seldom hesitates about the price, it being an article of luxury and ornament generally in keeping with the style of decoration and cost of furniture; an article which he purchases but rarely, and on which he can afford to lay out a reasonable sum of money.

An Englishman has no real taste for clocks, does not consider one a necessary article in his drawing-room, and looks to the price much more than the quality.

CHAPTER XXI.

INCAPACITY OF WORKMEN.

MORE watches are ruined by the complete incapacity of the workmen than by fair wear and tear.

As was once remarked by a celebrated oculist, "Most of my patients consult me after their sight has been destroyed by the bungling of would-be oculists," is perfectly true when applied to watches; the greater number when nearly done for are taken to the proper person, who is particularly requested to make them go.

A watch requires cleaning and repairing. The *jobber*, as the ordinary watchmaker's man is called, fits in carelessly to the barrel a new main-spring; the cover does not fit down properly; a file is used to reduce the said cover in order to prevent friction against the barrel-plate. A balance-spring is unpinned from its stud, a very unpardonable error, for why undo that which has been calculated to a nicety? Frequently if the pin has been long unmoved, the steel will give way just at the junction with the pin in the stud hole. Perhaps a new spring may in consequence be required. Again, it often happens that when a new balance-spring is fitted, the proper size and strength is not calculated; too coarse and powerful a spring is not unfrequently

put in. Jewels are constantly cracked or broken by being screwed too tight down; pivots are shortened jewels extracted, and metal substituted, so made as to meet shortened pivots; wheels even damaged that new ones incorrectly callipered may be introduced; the hundred and one mistakes daily made prove that neither master nor man understand their work, or feel sufficient interest in it to take the trouble to improve themselves.

The unfortunate owner of a really good watch is surprised at its constant irregularities, that in despair he places it in the hands of some well-known and honourable man, who electrifies him with the sight of such things as cause it to be a wonder that the watch ever marked time at all.

To give an instance of extraordinary defective work. A gentleman bought at a sale a fine-looking chronometer; desirous of testing his purchase he wound up the main-spring, and set the hands to time; but watch would not go! He then gave it to a first-rate firm of watchmakers, who on examination found that some of the pivots did not work properly in the jewel holes, but were bound; the holes never having been pierced to size to suit the pivots. In a word the chronometer had been made *to sell*, but *not to indicate time*.

An ingenious trick was played off upon a lady. Her watch, a good Geneva one, by Moulinié, was given to a provincial tradesman of high repute to clean. He informed her that the balance-staff bottom pivot was worn, and required a new one; to which she gave her

consent ; and in the end paid his bill, thirteen shillings and sixpence. Strange to relate, watch went worse than ever. By the advice of a friend she placed it in the hands of a real man of business in London, who to her surprise said, "The watch must have new pivots to the cylinder, one has been filed short, the other was worn." The lady declared she had just paid for a new pivot. "You may have paid, very possibly," was the reply ; "the lower pivot has been filed short, and this piece, that is, the balance-cock, has been lowered at end by putting this small piece of soft blotting-paper under the screw end, so as to depress it." Such is the means the countryman employed to gain his money. Cost of second repairs, one guinea. The watch has for the last six years done its duty well !

Again, it is no uncommon thing for watch-cleaners to use such bad oil, or to overcharge the pivots with oil, that in a short time the watch must be taken to pieces and recleaned.

Too frequently the owners of watches, visitors to watering-places, are charged a high price for cleaning and repairing, when no single thing of consequence has been done to their watches. It is only by the total inability of the machine to do its duty, and the positive necessity for giving it to the genuine watchmaker, that the trick has been discovered.

The following extracts from well-known French authors, practical watch and clock makers, might perhaps with advantage be printed and circulated among the watch-workers.

“The art of repairing watches well is quite as important as that of making them well, and oftentimes more is to be gained by sending a watch to the capital, if in need of actual repair, than to entrust it to workmen who probably are incapable of making a bad watch keep time, and very qualified to spoil a good one or at least to make it go badly.”

“We have already said, that although a watch may not keep good time, it is not impossible that it may be a good watch; that is to say, a watch well constructed, of which the materials are properly chosen, the parts well disposed, and the callipering done with judgment and skill. But that which can be called a really good watch is a work as rare as it is curious. How many artists are there who pride themselves on giving to their work the last degree of finish, but who, for want of application, experience, and opportunity, are in truth incapable! I have always seen it with sorrow, and I only avow it but with regret.”—*Traité d'Horlogerie*, by J. A. Lepaute, 1767, page 51.

“I only pretend to speak of the variations in watches produced by natural causes, and concerning which there does not appear to be any remedy. As to those which arise from defect of construction, they are of so many kinds that it is not possible to enumerate them, and the variations which they produce in the best-made watches are often much in excess of those which proceed from natural causes.”

“With regard to those other particulars which include the mechanism and execution of a watch, it is

certain that it is necessary to possess intelligence and to be skilled in the art, so as thoroughly to understand them. This same art demands much time and application in order to possess the ability which is requisite for the making of a good watch."—*Traité de l'Horlogerie*, by Thiout l'aîné, 1741, vol. ii., page 336.

CHAPTER XXII.

HOW TO CHOOSE AND USE A WATCH.

OLD Mrs. Glasse very wisely recommended that before a hare could be cooked it was a necessity to catch it. So of the use of a watch, it is very advisable first to know how to choose it in order to possess one.

In the present enlightened age people seem to select a watch by its external appearance; and judging by the number displayed in every silversmith's window, the trade in consequence ought to be a good one.

An observing pedestrian must have noted the gaping throng survey the trays loaded with timekeepers marked at reduced prices to tempt the passer-by; and if of sharp hearing, have heard ladies observing, "That's the watch I would like to have—how beautiful! the enamel so pretty! the diamonds glittering!" Or the able-bodied workman, "I'd choose that one; it says, 'well adapted for a railway guard or working man.'" Each and all have but one idea—it looks a good one outside, both in size and shape, doubtless the inside is as good; forgetting that a watch is not an article to be purchased according to fancy, or changed away when the novelty is over.

In choosing a watch, the first thing to be observed is

that it is *absolutely* necessary to select a maker who has a reputation, and then visit his establishment in order to make a choice as to convenient size or style.

If the seller be an honest man, the buyer will do well to place confidence in his advice, according to the price intended to be invested.

The buyer can, however, observe several things for himself.

1st. That the case, be it gold or silver, is correctly made and of fair thickness; the hinges close and smooth; the glass well fitted; the dial of clear, bright enamel; the seconds sunk; and the whole of good weight when held in the hand.

2ndly. If when the seller has opened the dome—for it is better a watch-case should be so made, though more expensive—the brasswork look well finished, the edges smoothed off, the steel of a diamond-like polish, the jewels pale in colour, but of a fine clear lustre; and the action of the spiral spring even, when watch be set going; then the chooser may be pretty certain that the watchmaker has offered a fair article for the price asked.

The guarantee of correctness in going will depend in a measure on the maker, for the use will destroy the finest-regulated watch, and the wearer is too frequently to blame, NOT the maker.

The watch being chosen and paid for, how ought it to be used by the possessor?

Now it must be especially noted that a watch is much like a child,—requires uniform treatment; that

is to say plainly, not over-indulged to-day, neglected to-morrow.

1st. A watch should, as much as possible, be kept in one position, suspended by the bow which is attached to the handle or pendant.

2ndly. Kept as nearly as conveniently possible to one temperature. When worn during the day, next the body, the temperature is very high, ranging from 75 to 86 degrees; at night, when hung to a stand, the difference is extraordinarily great, and can be greatly increased by carelessly selecting a part of a bedroom where the influence of cold is extreme, for instance, on a table next the window, or on the chimney-piece.

Thus the watch must necessarily vary between the fourteen hours worn and the ten hours in repose; but if the watch be correctly timed by the maker to position and wear, the variation at end of week will not be great, as the two periods of being worn and in repose will nearly compensate or balance each other.

Even in watches with balances said to be compensated there will be a variation, as in nine out of ten the compensation is not accurate.

3rdly. To wind a watch, it is positively ruinous to do so moving both hands. The old watchmakers, habituated to verges without a maintaining power, always move the watch with a circular motion while in the act of winding; but for watches as at present constructed such motion is unnecessary.

The watch ought to be held vertically, firmly,

steadily in left hand; the winding to be performed by the right hand, making with the key correct half-turns.

4thly. The key ought to fit the square well, but not too tightly.

The handle of the key ought to be at least one and a quarter inch long, which with barrel will make it about an inch and half in length.

There is scarcely a key fit for use; nearly all being made so short that it is almost impossible to get a clear hold between finger and thumb of right hand, and to have sufficient power to wind evenly without giving a succession of jerks, which is most disadvantageous to a fine watch.

The long pencil handle, or Swiss key, is very excellent in the hand of a watchmaker who understands the amount of power needful to apply to the winding, but in no way adapted for general use.

5thly. Let the watch be wound up at nearly same hour daily, 9 a.m. or 10 p.m.

Note.—As a rule ladies seldom pay attention to their watches, and consequently are always finding fault with the maker. Sometimes they forget to wind; often they borrow a key just as occasion offers; and too frequently move the minute-hand with a finger or pin.

Regularity is absolutely necessary if the watch is expected to do its duty regularly!

CHAPTER XXIII.

THE CONCLUSION.

THE reader of the preceding pages, especially the historical summary, must have noticed the extraordinary advance which the science of horology made in England during the 150 years dating from the application of the pendulum-spring by Dr. Robert Hooke, and which might fairly be termed its *third and greatest period*.

Those were *par excellence* the palmy days of watch-work—days in which men were not satisfied to be mere *dealers only*, but aimed at gaining a name and reputation for first-class work and first-rate scapements; men who devoted their time and abilities to the perfecting previous discoveries; so that to possess a watch made by *Tompion, Graham, Quare, Ellicott, Mudge, Arnold, and Earnshaw*, was to have that indeed which was of its kind priceless.

Eheu, quam tempora mutantur, might justly be the motto of to-day. The wise and intelligent Berthoud foresaw, even in 1763 (his day), that the workmen were becoming indifferent to the honour of a good name; so also, in 1859, Mr. Thomas Reid. What would the intellectual men of the last century have said, could they have foreseen the lamentable condition to which the watch trade has been reduced?

Switzerland has adopted the invention of George Graham; made for it a home on the Jura; wisely arranged that all makers should use the same gauge for the plates and wheel-work, and produced thereby a beneficial uniformity.

Here in England the Clerkenwell and the Coventry watchmakers choose a gauge for themselves, regardless of each other; and instead of endeavouring to produce horizontal scapements to compete with the Swiss article, allow the Swiss undisputed possession of a profitable trade.

Even if cylinders and scape-wheels can be made abroad by perfect machinery at a trifling cost, there is no good reason why they should not be imported and fitted to movements and cases manufactured in London.

One great advantage of this system would be excellent watches of well-tempered metal, and cases of a decided quality, *viz.* Hall-marked gold and silver.

Looking at the foreign watch from any point of view, it is only possible to have but one feeling with regard to it, that with some rare exceptions, the desire of profit is so great, that year after year the quality deteriorates, the work becomes more faulty, and the cases possess less of the genuine gold and silver.

The London makers pride themselves wholly on their levers, and disregard, as a rule, all other class of work, forgetting that it is very difficult to make a good lever, and that the expense must always be great.

In order to compete with the Swiss watch trade, cheap and indifferent levers have of late been introduced, of

which it is only necessary to say, "Cui bono?"—"Stop, do not be in a hurry to condemn them," says some jobber, "they have one great advantage, they are continually requiring medical treatment, doctoring at my hands; without them I might not be able to live so well." Good sir, thy reasons are very cogent, so no more, live and let live is a good maxim.

No watch (it is useless to remark on chronometers, which must ever be too expensive for ordinary mortals) can of a surety surpass the lever for every-day wear by a general public. It is, when well constructed, a capital timekeeper; easily and cheaply repaired when out of order, and not subject to set, or stop, on receiving a sudden jerk. Whereas the duplex is very expensive to repair, and apt to stop when the wearer takes any violent exercise. Good silver-cased levers might be sold at 5*l.*, still that is far above a good Swiss horizontal at 2*l.* 10*s.*

At the present moment, with all respect to the trade, no longer worthy of the designation a profession, there is not a rising man, one who can lay claim to the sceptre of Mudge, Arnold, or Earnshaw; further, in a few years it is not probable it will be possible to find in Clerkenwell a workman capable of doing first-class work, for the simple reason that there is no school in which to educate the young generation, or masters who will take the trouble to instil the first principles into the heads of their apprentices; or worse still, youths, who having a certain amount of intelligence will apply themselves to the actual labour of escapement making,

and daily improve their minds by study and application to the innumerable facts absolutely required to be known by the true master-mind !

It is very painful to write thus, and may give offence to some who consider themselves the *élite* of the trade ; but on dispassionately viewing the condition of the wholesale and retail trade, they will be obliged to confess that truth will prevail, and that the great names of past men exist for all to be proud of ; but where in the present day will great or greater ones be found ? Echo answers, Where.

The writer of these pages has avoided throughout, with the exception of one single instance, making any allusion to existing watchmakers ; has not in the faintest manner indicated a preference for one maker more than another, from a wish to be impartial, and with the desire that no person who may have had the courage to read through this treatise may suppose that it is in any way designed as an advertisement.

If a word of advice may be offered in a friendly spirit from the great desire to see the trade improve, to hear again the names mentioned of men as professors of the art of watchmaking, and to see in England an excellence of workmanship far beyond the competition of the foreigner, it would be, *educate, educate*, establish a school, in connection if possible with South Kensington, give rewards ; and revive to a certain extent the powers of the Clockmakers' Company, that to be an *assistant* should be an honour, an indication to the world of a certain knowledge—*not a mere money*.

payment—a positive merit, and a certificate of respectability.

For this purpose it will be necessary to form a committee of practical and scientific men, headed, if possible, by some person of eminence, say the Astronomer Royal, who should draw up a table of rules to be followed by all who succeed in being elected, *after a proper examination*, to membership of the Society or Company. And it should be insisted on as one main feature of membership, that *no foreign work* be sold in any establishment connected with the Society.

Let the *English watchmaker* be wholly and solely the maker and seller of English-made goods. Let the public understand that by going to certain shops they will be able to obtain the best goods at a fair price; and that a name will have a meaning—will be a mark of genuineness, a guarantee of respectability, an indication of merit! For as Berthoud says, in concluding the preliminary discourse to his essay on clockwork:—

“The emulation created by such a society would serve to form artists, who, in starting from the point where their predecessors had left the art, would advance it greatly; for to be a useful member of such a body, it would be needful *to study, to work, to make experiments*, or else remain satisfied to be classed with the mass of bad workmen.

“In a word, there would result an advantage to each member; for the public, at length informed of those to whom it could give its confidence, would cease to buy the wares of dealers who too often deceive, and feel

assured that in going to the recognized artist time-keepers of excellent quality only would be found."

Let the men of Clerkenwell be up and doing (the present glut of work is only temporary). Time and tide stand still for no man. A few years and their occupation will perhaps be gone. Already in America cheap watches are manufactured. Soon the colonies will follow the example; even now good hands find inducement to leave the mother-country. English work is not cared for, and does not command the price of former days.

Watchmakers of Clerkenwell, be advised in time. Machinery will not enable you to do without skilled hands; for notwithstanding all that the advertising houses may assert in the daily papers, a watch cannot be formed by a machine as a whole, though its various parts require different machines to form them.

The mind and the hand of man are required to plan and construct the watch, which is destined to be the masterpiece of Art, the nearest approach to perfection; for, without fear of contradiction, it may be safely asserted that no piece of mechanism can surpass the ship or box chronometer, which during its journey to and fro over hundreds of miles of troubled sea, subjected to extremes of heat and cold, on examination at the end of a year will be found to have undergone but a trifling variation on its daily rating.

What more can be required in the marking of time, the value of which is so inestimable that the merest boy in a counting-house has learnt that it means *money*? What more attractive article can man carry in his

pocket or on his person than a well-adjusted watch? It will be to him a companion, a friend, a regulator—urging him to punctuality in all the occurrences of life; a tell-tale—a tick, tick of warning, too late for the train—too late for business—too late to gain a fortune—but, if the warning be accepted—NEVER TOO LATE TO MEND!

APPENDIX.

A Treatise on Pitchings, in which is determined geometrically the most advantageous Form which can be given to the Teeth of Wheels and the Leaves of Pinions.
By M. LE FRANÇOIS DE LALANDE,* of the Academy Royal of Sciences, Paris, &c.

I. WHEN it is asked what is the most advantageous form which can be given to the tooth of a wheel and the leaf of a pinion, in order that there may be a *perfect pitching* in strict accordance with geometry; by this expression, *perfect pitching*, we understand that which fulfils the following conditions:—

1st. That the force impressed by the wheel to drive the pinion be the least that can possibly be exerted.

2ndly. That the velocity with which the wheel drives the pinion be likewise at each instant the greatest possible, or that the wheel is able to impart.

* JOSEPH JEROME LE FRANÇOIS DE LALANDE, the celebrated astronomer, was born at Bourg, July the 11th, 1732; went to Berlin, 1751; returned to Paris at end of 1752, and then elected a Member of the Academy Royal of Sciences; 1764, he published a large Treatise on Astronomy; in 1772, 'Account of the Transit of Venus;' died at Paris, April the 4th, 1807.

3rdly. That both this force and velocity must be always the same from the moment of contact, to the instant when the wheel ceases to act, or quits the pinion.

4thly. That the friction produced by this tooth during the whole period of the driving be the least possible.

II. Persons employed in the art or business have always neglected this accuracy because they have regarded it as coming under the cognizance of pure geometry; considering either the investigations too difficult to be put in practice, or else not recognizing their great utility. It is desirable to make the ideas of geometricians in this respect better understood, and use every means to efface these prejudices.

III. I hope that the great ease with which the curves necessary to produce a perfect pitching are about to be determined by means of the simple elements of geometry, will inspire artists, jealous of distinguishing themselves by the perfection of their work, with the desire to acquire the little knowledge of geometry which the following principles demand.

IV. If the force with which a wheel drives a pinion be not constant and equal, there will be occasions where the force impressed will be greater than at other times upon the regulator, or the last wheel, which will sometimes produce a quickening, at others a sluggish, motion.

V. If the force be not the least possible, all which is in excess will be pure loss, and only tending to render

the friction more severe, increase the wear and the destruction of the machine. In large clocks this excess of unnecessary force may be exceedingly great; so much so, that some have been seen which required a motive power of not less than 1200 lbs. weight, instead of merely a few pounds, which would have been just sufficient to raise the detents and overcome the friction, had the pitchings not been defective.

VI. If the velocity with which the pinion is driven be not uniform the same inconvenience will occur. There will be shocks in the wheel-work, which will prevent the uniformity of movement, and increase the destruction of certain parts.

VII. From uniformity of the force proceeds the uniformity of friction, which always changes according as the force is variable.

M. DE ROEMER (1675) was the first to perceive, in the last century (as well as M. DE LA HIRE (1695), in the ninth volume of the 'Memoirs of the Academy,' from 1666 to 1699, page 415), the use to which geometry could be applied in this matter. A most excellent treatise on this subject by M. CAMUS* may be found in 'Memoirs of the Academy of Sciences' for the year 1733. M. Le Roy, of the same Academy, has proved certain propositions of this treatise in a manner easy to be understood, as may be seen in the fourth volume of the 'Encyclopædia,' by means of levers, just

* *A Treatise on the Teeth of Wheels, translated from the French of M. Camus, by John Isaac Hawkins. E. & F. N. Spon, 48, Charing Cross London, 1868.*

in the same way as M. de la Hire had done. See page 411 of the 'Ancient Memoirs of the Academy.' I purpose endeavouring, if possible, to make these articles more simple in the order and method of demonstrating them; and by adding such necessary details, as will bring them within reach of the capacity of all men.

VIII. Thus, instead of commencing with a general but complicated proposition, which would be more elegant and would include the whole matter, I will begin with the most simple case, that of a wheel which will drive a pinion, or a lantern whose staves shall be merely lines infinitely drawn out, and so thin as to be represented by mere points,* commencing only on the line of centres, and continuing them beyond. Afterwards I intend to pass on to more complex examples.

In order to understand the train of reasoning of this treatise, it will be necessary to give attention to certain properties of epicycloids, which will be briefly explained.

IX. Suppose a circle A (Fig. 1) to roll upon a right line C D, in the same manner as a wheel upon the road, and that any point whatsoever E of this circle be selected, it will be seen that in the movement of the circle the point E in going from the point C will

FIG. 1.

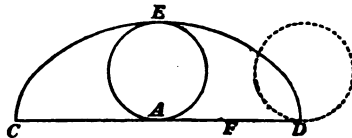

* *Principles of Mechanism*, by ROBERT WILLIS, *Jacksonian Professor of Natural and Experimental Philosophy in the University of Cambridge*. See on the Teeth of Wheels, Art. 130, page 94.

describe a curve $C E D$, called a *cycloid*; the describing point E will have reached to D at the end of the movement, and the line $C D$ will be equal to the circumference of the circle A .

If the same circle A (Fig. 2), in place of rolling on a right line, roll on the circumference of another circle

FIG. 2.

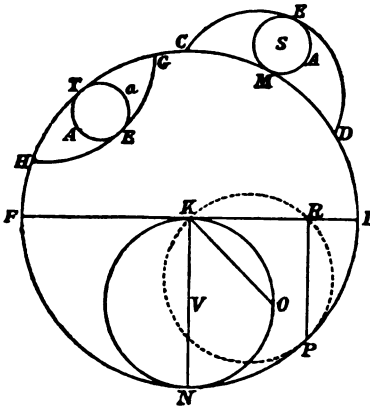

$C M D$, the describing point E , from the time it leaves the point C until it arrives at the point D , will describe another curve $C E D$, more rounded than the former, this is called an *epicycloid*.

X. If the same generating circle $a A$ (Fig. 2), in place of rolling upon the exterior or convex circumference of the circle, move itself within the interior circumference of the circle, from G to H , the describing point E , which was at G , will describe another form of epicycloid $G E H$: it would describe the same curve if its diameter, instead of extending from E to T , were to extend from E to the very opposite part P of the circumference.

XI. If the generating circle (Fig. 2) become equal in diameter to the half of the circle in which it rolls, its circumference will always pass through the centre K of

the circle which serves for the base, and the describing point K will pass over a diameter $I K F$ of the same circle: it is easy by experiment to prove the correctness of this: make two circles of cardboard, one of which must be hollow and of a diameter double the other, which is to roll within it; but it will be easy to prove it geometrically in the following manner:—Since the diameter of the small circle is half the diameter of the large one, its half circumference $K O N$ will be equal to the quarter $I N$ of the other; thus the describing point, which I suppose to be at K , will have arrived at the point I , when the half circle $K O N$ shall have applied all its points successively to those of the arc $N I$, which is its equal; thus the point N will arrive at K , and the point K at I , without quitting the semi-diameter $K I$; if, however, it be still questioned whether the point K of the circle $K O N$ has always been upon the same right line $K I$, let us take the arc $N O$, which is the quarter of the generating circle, and $N P$ which is the eighth part of the circle which stands for base; it is certain that these two arcs are equal, and that the point O will arrive at P , but the line $O K$ is equal to the line $P R$, since $O K$ is the chord of 90° in the small circle, $P R$ the half of the chord of 90° in the large circle, and that the halves of parts in the great circle are equal to whole parts in the small one; thus the point O being at P , the line $O K$ will coincide with the line $P R$; and the point K will be at R , that is to say, still upon the diameter $F I$. The like may be shown with regard to all the other points in which the describing

point K of the small circle passes along a diameter of the large one.

XII. Let us return to the epicycloid of Art. IX. (Fig. 2), described by the generating circle A , rolling on the circle $C D$; it can be well enough seen that all the points of the generating circle will apply themselves successively to as many points of the arc $C D$; by this continuous application the circle A will describe an arc $C D$, equal to the whole of its circumference, and the describing point will trace on this paper an epicycloid $C E D$.

But it is necessary to observe that precisely the same thing will happen if it be supposed that the small circle A be fixed in the air by its centre S ; that it possesses the freedom to turn only on this centre; and that the circle which serves for its base turns also on its centre K together with the paper on which the figure is traced; for the centre of the circle A not changing its position whilst the arc $C D$ is movable, and causing to turn on its centre this generating circle, will be the same thing as when the arc $C D$ being fixed, the circle A was movable; all the points of the generating circle will be successively applied to all the corresponding points of the arc $C D$, and the describing point E of the circle fixed at S will describe on the paper or movable plane of the figure the same epicycloid which it had described on the fixed paper, when the circle was movable; the respective situations of the parts of the figure will be identical in both cases. If the circle $K O N$, in place of rolling within the circumference of the centre $N P I$, revolve around a fixed centre V , whilst the circle

N P I D turning around its own centre K, draws along the circle K O N by its circumference N, the describing point will describe the same line F I on the plane of the circle N P, as in Art. XI.

XIII. It is an essential property of the cycloid, and of all epicycloids, that the line drawn from the point of contact to the describing point be always perpendicular to the cycloid.

CED (Fig. 3) is a portion of a cycloid described by the circle AED; the describing point is E; the point of contact, which changes continually, will be at A, when the describing point E describes the small portion Ee of the cycloid, or we may imagine that at that very instant the circle AED turns very slightly on the point A, in such a way that the line AE describes a small arc Ee of a circle HEG, of which the centre is at A. This circle will be * mixed up with the cycloid at Ee, since both are described by the point E; therefore the line or radius AE, which is perpendicular to its own circle, will also be perpendicular to the cycloid at E: the like may be shown with regard to all the points of the cycloid, and in all the epicycloids similar to Fig. 2.

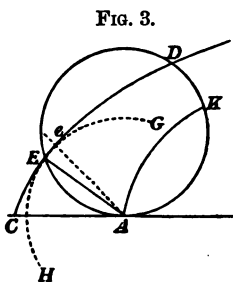

XIV. Next to these preliminary ideas we are about to pass on to the general principles of the demonstrations, which must be well understood before proceeding farther.

Let the circle MK represent a wheel without teeth

* *Confondu*, joined together.

(Fig. 4), and the small circle $M N$ a pinion without leaves; let the wheel drive the pinion by the simple

FIG. 4.

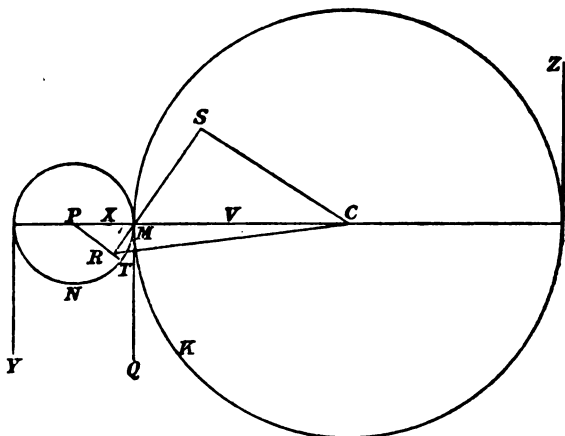

contact of its circumference, from M to N , in such a manner that the pinion be compelled to turn with the wheel, each around its own centre, as was seen in Art. XII., the circle A and the circle $C M D$ of Fig. 2. It is clear that then the circumference of the pinion will have precisely the same velocity as the wheel, since each point of the wheel will cause a point of the pinion to pass on; this will therefore be the greatest velocity that the wheel can impart to the pinion, for it will not be capable of giving a velocity greater than it actually possesses. It is again certain that the wheel will drive the pinion with the greatest velocity of which it is capable, for it will act through a lever $C M$, equal to its radius, in such a way that the motive force impressed at

Z to turn the pinion by means of a wheel, could not act on the point M by a shorter lever, otherwise it would act in the direction M Q, perpendicular to the lever or radius P M of the pinion ; and there is not any other direction more favourable than that which acts perpendicularly.

In the supposition we have just made of the movement of the wheel and its pinion there is no friction, because the wheel and pinion only touch each other in one point, and that the same point of the wheel does not run along different points of the pinion, which would be necessary to produce friction ; or if there be any, it is the smallest possible, because the least amount of friction is that of a rubbing surface of which the direction is parallel to that against which it rubs, or the direction of the movement of the wheel which takes place in the line of the tangent M Q is the same as the direction of the pinion ; the rubbing force is also the smallest possible, since a wheel which ought always to act by its circumference can only act by its radius, and always perpendicularly to the line of centres.

XV. We shall then have satisfied all the conditions of a perfect pitching if we can give teeth to the wheel M K, and leaves to the pinion M N, such that when the teeth of the wheel act on the leaves of the pinion, the force, velocity, and direction of the wheel and pinion at M remain the same as they were in the case which we have just supposed, where the action took place at the point of contact M.

XVI. To accomplish this object, I, in the first place,

consider one of the radii $P T$ as a leaf of the pinion ; through the point of contact M of the two circumferences, I let fall upon it a perpendicular $R M S$; from the centre C of the wheel I draw $C R$, and a line $C S$ perpendicular to the line $R M S$. I am about to prove that the action of the radius $C R$, to drive the point R of the pinion, will be the same as the action of the point M in the case of Article XIV. in order to drive the radius $P M$.

XVII. If the motive power Z , instead of acting through an arm of the lever $C M$ on the point M , acted by means of a lever $C V$, which should be the half of $C M$, it would possess a double advantage ; but if this double gain were applied to the point X of the pinion in such a way that $P X$ should be the half of $P M$, as there would be at the point X a half less amount of force to raise the weight Y , things would remain in the same condition, and the motive force would act with the same force as before on the weight Y .

It would be the same in regard to the velocity. The motive force Z would only give at the point V the half of its velocity, but that amount of velocity applied to the point X would produce a double velocity at the point M ; thus the velocity would be again the same as in the case given at Article XIV.

The same effect would be produced if a quarter or any portion whatsoever of the radius $M C$ of the wheel be cut off, provided that the quarter or any similar portion of the radius $P M$ be taken away ; because, as long as there exists the same relation between the

lever $C V$ or $C M$ through which the motive force acts, and the lever $P X$ or $P M$, by means of which the weight Y or the pinion offers resistance, the force and velocity will be always the same as in Article XIV.

XVIII. In the case where the wheel acts upon the point R of the radius $P R$, the line $R M S$ being drawn perpendicular to $P R$ and $C S$, $C S$ is the lever through which the wheel acts, and $P R$ is the lever through which the pinion resists; for whether the force which pushes the pinion be placed at R , or M , or S , it will always produce the same effect; there is only the distance $C S$ to the centre of the wheel which determines its effort upon the pinion.

Every time that the line of direction $R M S$ passes through the point of contact M of the primitive pinion and primitive wheel, the line $C S$ and the line $P R$ will be in the same relation to each other as $C M$ and $P M$, for the triangles $C M S$, $P M R$ are alike, since the angle $S M C$ is equal to the angle $P M R$, being vertical opposite angles, and the angles at S and R are right angles; thus the two triangles being equal in all respects, their homologous sides will be proportionals, and $C M$ will be to $P M$ as $M S$ is to $M R$; there will then be between the lever of action $C S$ and the lever of resistance $P R$ the same relation as between $C M$ and $P M$; therefore there will be a force and a velocity equal to those we had in Article XIV., when the wheel drew the pinion along by its circumference at M .

XIX. Here, then, is a general proposition which will serve as the groundwork for all we are about to advance.

Every time that the line $M R$, drawn from the point of contact of the two circumferences perpendicular to the leaf of the pinion, shall pass on to the point R , whither the leaf will be led, the pinion being driven through this point there, will receive from the wheel the same force and the same velocity as if it had been drawn along by the point M ; that is to say, its force and velocity will be the greatest possible. Thus, every time that the leaf of a pinion be driven by the tooth of a wheel, it is required that the line drawn from the point of contact of the two circumferences to the driving point, or the touching of the leaf and the tooth, fall perpendicular to the leaf and the tooth.

XX. To apply this principle to a pinion which shall be composed of staves infinitely drawn out into thin lines, represented by mere points, such as A, B, C, D (Fig. 5), it is necessary to recall to mind that the primitive

FIG. 5.

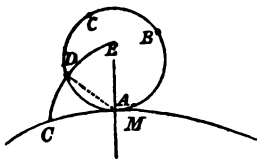

wheel $M C$, drawing along the primitive pinion $M D$ by its circumference, a point D taken in the circumference of this pinion will describe an epicycloid $C D E$, Article XII.; and that it is an essential property

of this epicycloid that the line $M D$, drawn from the point of contact M to the describing point D , be always perpendicular to the curve, Article XIII.; therefore, if we make a tooth having the form of the curve $C E$, it will drive the point D in accordance with the conditions laid down in the preceding Article, that is to say, the line

tive wheel MH draws simultaneously the circumference of the pinion, which turns on the point C , and the circumference of the small circle $CdDM$, which turns on the point O , or that the small circle be drawn by the pinion, which comes to the same thing. When the wheel has described the arc MH , the primitive pinion will have described the arc MV , which is precisely the same length as MH , and the small circle will have described the arc MD , which is likewise equal to the arc MH , since each point of the wheel has been applied to each corresponding point of the pinion and of the small circle, and has passed over as much of the one as the other.

In this movement of the small circle around the centre O , the point D of the small circle will describe on the plane of the wheel an epicycloid HDO , Article XII., and as it rolls also in the pinion, it will describe on the surface of the pinion a right line CD ; or the line MD , drawn from the point of contact M of the two circumferences, is a perpendicular to the epicycloid HDO , Article XIII., the same line MD is perpendicular to CD , for the angle MDC , being formed in a semicircle, $MDdC$, is necessarily a right angle; thus the line drawn from the point of contact M , of the two primitive circumferences to the describing point D , or contact of the leaf and tooth, will be at one and the same time perpendicular both to the leaf and the tooth, which will satisfy the conditions required. We have therefore this general proposition, *if the leaf of a pinion be a rectilineal plane, directed towards the centre, the tooth*

of the wheel which ought to drive this pinion, taking it only in the line of centres, must be an epicycloid generated by the rotation of a circle, of which the diameter is the half of that of the pinion, on the exterior circumference of the wheel.

XXIII. We are now in a position to pass to a more general proposition, and to demonstrate that the pitching will always have the required conditions. If the leaf and the tooth are generated by the revolution of the same generating circle, rolling within the primitive pinion, in order to describe the leaf, and on the outside of the wheel, to describe the tooth. We may remark that that condition has already taken place in Articles XX. and XXII.; for in the first case, Article XX., the pinion itself rolled upon the wheel in order to describe the tooth; and to describe the leaf, which was only a point, it could only roll within itself, but in an infinitely small quantity, that is to say, not at all.

In the second case, Article XXII., the same circle rolled within the interior of the pinion in order to describe a right line, which we supposed the leaf of the pinion to be, and it also rolled upon the circumference of the wheel in order to describe there the tooth.

XXIV. Let us take then any circle $D M C$ (Fig. 7) which shall be smaller than the pinion $A M E$, and of which the centre F shall be always fixed on the line of centres $F M$; the pinion turning from M towards A , and the wheel from M towards B , will draw along the generating circle and

FIG. 7.

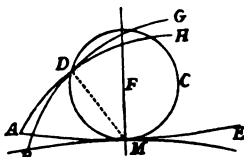

the describing point from M towards D ; then the point D will describe an epicycloid $A D G$ on the surface of the pinion, and another epicycloid $B D H$ on the plane of the wheel, Article XII., those two epicycloids will always touch each other in a point D , since the describing point generates both the one and the other at the same time; the line $M D$ drawn from the point of contact M to the point D , will be always perpendicular to each of them, Article XIII.; since the line $M D$ describes at each instant, exceedingly minute, an arc of a circle, of which the centre is M , and which will form an extremely small portion of each of the curves $A D G$, $B D H$; thus, in giving to the leaf of a pinion the curve $A D G$, and to the tooth of a wheel the form $B D H$, we shall have fulfilled all the conditions of a perfect pitching, which reduce themselves according to Article XIX. to this, that the line drawn from the point of contact to the driving point be always perpendicular to the leaf and to the tooth.

XXV. As it is advantageous that the leaf of the

FIG. 8.

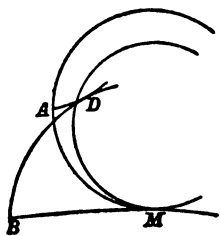

pinion should be convex as well as the tooth, it is necessary that the generating circle should have a diameter greater than the radius of the pinion in order that the leaf may be convex on the side of the wheel, as may be seen in Fig. 8, where $M B$ is the wheel, $M A$ the

pinion, $M D$ the circle which described on the plane of the wheel the tooth $B D$, and on the plane of the pinion

the leaf A D ; finally, it will be always more convenient to make from the leaf A D a right line as we have already said.

It may possibly have been remarked, up to the present, that the wheel having driven the pinion, always beginning at the line of centres, the pitching has been ever taken in projection on the circumference of the primitive wheel, which has increased the wheel by the length of a tooth, and that the primitive pinion has been diminished by the quantity of the pitching; the reason being that the perpendicular drawn from the point of contact M to the leaf and to the tooth, cannot fall without the circumference of the pinion, nor within the wheel, unless both were concave, which is impossible in use.

XXVI. Let us now examine what ought to take place when the wheel drives before the line of centres; this will be the exact opposite of what has been already said, that is to say, the pinion will be increased, and the wheel diminished by the quantity of the pitching. In order to understand the figure which the leaf ought to have, we must consider that if the leaf which is driven by the tooth before the line of centres should turn backwards in order in its turn to drive the tooth, the same curves of the leaf and of the tooth will continue to give a perfect pitching, but then the leaf will in reality drive the tooth after the line of centres; thus the tooth which drives the leaf before the line of centres, or the leaf which drives the tooth after the line of centres, give precisely the same curves.

We ought, then, to transfer to the leaf that which we have up to the present said of the tooth which drove the leaf after the line of centres, that is to say, the same curve ought to roll externally on the pinion in order to describe the leaf, and within the wheel to describe the tooth; there only remains to apply to the pinion which drives, that which we said of the wheel when it drove, in all the preceding Articles.

Thus, in the case where we should desire that the tooth which is driven after the line of centres, or which drives before that line, be a right line tending towards the centre of the wheel, it is necessary that the leaf of the pinion be an epicycloid described by the revolution of a circle of which the diameter is the half of that of the wheel, and which rolls on the circumference of the pinion; this is a consequence of Article XXII.

XXVII. We can actually find what will be the forms of the leaf and tooth when the tooth ought to drive the leaf both before and after the line of centres. To do this, we unite the two preceding cases, and we give to the leaf and tooth the two different curves which are suitable—the one which is only to serve before the line of centres, the other which is designed to drive or to be driven only after the line of centres.

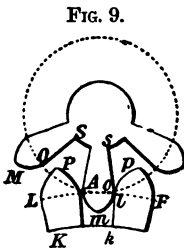

The circumference $L F$ (Fig. 9) is that of the primitive wheel: the circumference $O o$ is that of the primitive pinion; the leaf of the pinion, $s o m$ or $S O M$; the tooth

of the wheel, $p l k$ or $P L K$; each is composed of two parts, the portion $l k$ of the tooth re-entering into the wheel which drives before the line of centres; the portion projecting, $o m$ of the leaf, out of the pinion which is driven before the line of centres; the projecting portion $L P$ of the wheel which drives after the line of centres; the re-entering portion $O S$ of the pinion which is driven after the line of centres. It is therefore before the line of centres that the pinion furnishes the projecting part of the pitching, and it is after the line of centres that the wheel provides it. In the actual line of centres we may say that it is neither the one nor the other, since the leaf and tooth touch each other at A . The portion $l k$ of the tooth, and the portion $o m$ of the leaf will be described by any circle whatever, rolling within the interior $L F$ of the wheel in order to describe $l k$, and upon the exterior $o O$ of the pinion in order to describe $o m$ (XXV.); the portions $L P$ of the tooth and $O S$ of the leaf will be generated by any circle whatever rolling on the exterior of the wheel $L F$ to describe $L P$, and in the interior of the pinion $O o$ to describe $O S$ (XXIII., XXIV.).

If the first circle be found to have for diameter the radius of the wheel, and the second the radius of the pinion, the parts of the teeth $L K$, $l k$, and the portions of the leaves $O S$, $o s$, will be right lines tending towards the centre, Article XI. We have not marked with any letter the parts of the teeth and the leaves which are designed only for symmetry, and take no part in the driving of the pinion; nevertheless it is necessary to

give them the form which will ensure the greatest steadiness and render easy their disengagement; besides, as there are occasions where the wheel-work is under the necessity of going backwards, we are obliged to shape them almost round.

XXVIII. If it be asked what ought to be the shape of the leaf and the tooth, when the pinion which is driven by the tooth should turn backwards to drive it in its turn, it is easy to see that, as the lines of direction and the reciprocal forces are the same, the curves will also be alike. We must only observe this, that the portion of the leaf which was driven *after* the line of centres will thenceforth drive *before* that line, and that the portion of the leaf which was driven *before* will find itself driving *after* the line of centres.

Therefore it will only be necessary to describe the curves in accordance with the preceding articles, and the same pinion which ought to be driven by the wheel will serve to drive it; but if it be desired that the pinion should only drive after the line of centres, we take the pinion such as it was when the wheel drove it before the line of centres.

XXIX. Here then is a general proposition deduced from all we have hitherto said:—1st. The portion which drives after the line of centres ought to exceed the primitive circumference; that which drives before the line of centres ought to fall within, whether it be a leaf or a tooth. 2ndly. The portion which drives after the line of centres, be it a leaf or a tooth, is always described by a circle rolling externally on the primitive

circumference which drives ; and that which is driven is generated by the same circle rolling internally on the circumference which is led.

The portion which drives *before* the line of centres is generated like that which was driven *after*, by a circle rolling within the primitive circumference which drives, and the portion which is driven *before* is generated by the same circle rolling on the outside of the circumference which is driven.

XXX. That which we have up to the present called primitive wheel* and primitive pinion ought to be understood of two circles which bear the exact proportion to each other as the number of teeth in the one is to the number of leaves in the other. I suppose that C and P (Fig. 4) are the centres of a wheel of thirty teeth, and a pinion of ten leaves ; it is clear that the pinion must make three turns for each one of the wheel : it ought therefore to have a circumference and a diameter the third of the circumference and diameter of the wheel. Thus we divide the distance, CP, into four parts ; one of these parts, PM, will be the radius of the pinion, and the remainder, CM, the radius of the wheel : there we shall have the primitive leaf and the primitive wheel.

XXXI. Although the preceding articles have treated of the driving which commences before the line of centres, it is not the less true that we ought to avoid it as much as possible, because there takes place a rubbing in the contrary direction and a kind of butting, when

* See *Principles of Mechanism*, Art. 73, page 56.

the leaf and the tooth enter in with each other; a friction * which is always more severe than that which takes place in the disengaging and escape of a tooth; besides, all the dirt which is pushed back and driven out of the pinion by this last movement is on the contrary brought back and held fast by the movement which takes place before the line of centres.

XXXII. But it is not always possible to begin the driving of each leaf precisely in the line of centres; if the pinion be low-numbered, as is a pinion of eight leaves or less, the wheel will necessarily lay hold before the line of centres, above all if the leaves of the pinion are of the proper size. The Fig. 10 (page 297) represents three leaves of a pinion of eight, of which the right faces driven by the wheel are D A, D B, D C. I suppose that the diameter of the wheel is five times greater than that of the pinion, it ought to have five times more teeth, that is to say, 40; thus each tooth with the space † which corresponds to it will occupy 9° , because the fortieth part of 360 is 9. We take then the arc B E of 9° , and with a circle, of which the diameter is equal to B D, we describe a portion of an epicycloid E G, which will touch at G the leaf D A; give to it alike part G H; but then there will remain only B H for the space of the teeth and the thickness of the leaf, which would be too small, for it is necessary in practice to make the space at the least equal to the complete ‡ tooth, and the

* See *Principles of Mechanism*, Art. 132, page 95.

† *Ibid.*, Art. 74, page 56.

‡ *Au plein*, to the full, evidently means the full width, or complete tooth.

thickness of the leaf equal to that of the tooth, or even a little larger, above all if it is the pinion which drives. It will be necessary then to break off the tooth at F; give to it the like portion F K in such a way that E K be equal to K B, that is to say, the space equal to the full breadth; and make the thickness of the leaf equal to B K. But then the extremity F of the tooth will no longer touch the leaf D A when the succeeding tooth B L finds itself in the line of centres; it is therefore manifest that the tooth B L will have laid hold of the leaf D B before the line of centres.

Thus it is only in pinions above eight or even nine that it is possible to begin the driving on the line of centres by keeping to the rule for curvatures which has just been settled, and that for the solidity necessary; it is then important to make use of pinions which have at least ten leaves, which is always possible, more especially in clocks where the precision which we seek is chiefly necessary. By this construction we shall have in addition the advantage of making the curvature of the teeth less and more uniform, consequently much more easy to be brought into shape.

XXXIII. The principles which we have just established give also the least possible amount of friction, as was exacted by Art. 1, because the effort cannot be less than it actually is; and in following these principles produce the same effect, that the rubbing surfaces cannot possibly come in contact in smaller spaces and experience less resistance.

XXXIV. There remains now only to treat of the

pitching of contrate* or crown wheels, under these conditions that the wheel should drive a pinion C, or be driven by this pinion.

It is necessary to consider the circumference of the wheel in the place where it acts as a right line, perpendicular to the axis of the pinion, and consequently to suppose that the tooth of the wheel which acts upon the leaf is moved in a plane perpendicular to the axis of the pinion, just as if it were a straight rack or toothed ruler.

It is true that this supposition is not exactly correct, above all, if each leaf of the pinion be driven a little too far, that is to say, if the pinion be low-numbered, because the driving point will be a little nearer the centre of the wheel towards the end of the driving than it ought to be if the circumference of the wheel were rectilinear; this difference will be nearly equal to the versed sine of the arc which the wheel described from the line of centres to the end of the driving (which may be extremely small), there will then result a slight friction in the direction of the axis of the pinion, but it is hardly possible to pay any attention to it in theory without a very complicated calculation, from which little advantage can be derived in practice.

XXXV. Let us then suppose a right line CA (Figs. 1 and 3) movable from A to C, and which causes a circle A to move round its centre; we understand by that which has been said in Articles IX. and XII., that this circle will describe by its point E on the plane,

* See *Principles of Mechanism*, Art. 67, page 51.

which we suppose moved itself with that line, a cycloid CED ; and that the line AE , drawn from the point of contact A to the describing point E , will be always perpendicular to that cycloid.

If we desire to give to the line CF teeth, by means of which it can drive the pinion represented by the circle A , by a point A considered as a stave infinitely drawn out into a thin line terminating in this point, it will be necessary to give to those teeth the form of a portion of the cycloid AK (Fig. 3). At the same time

we can imagine that if the line NM (Fig. 10) represents a portion of the primitive circumference of the contrate-wheel, which ought to drive a pinion of which the leaves ORD are radii of the pinion, the teeth of this wheel ought to be portions of the cycloid OP , described by the revolution of a circle, of which the whole diameter is equal to OD , on the line ON .

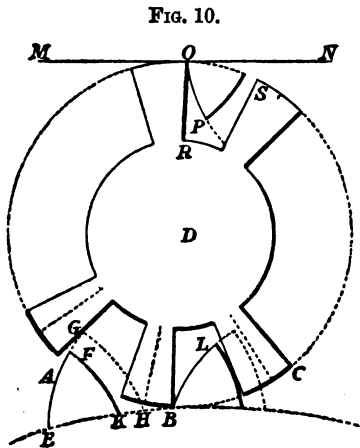

In effect we ought to say in this very case all which has been said in the others, and above all in the general proposition, Article XXIII.; that is to say, the same circle ought to roll within the pinion OS , in order to describe the leaf OR , and on the wheel ON ,

to describe the tooth OP ; the right line being nothing else than a portion of a circle, of which the radius is infinite.

XXXVI. The method which we have followed for the sake of determining the preceding curves does not possess the advantage of being able to determine the form of a tooth fitted to drive any leaf whatsoever of a given figure, as M. de la Hire has done, although in a manner not over-lucid.

M. de la Hire* had perceived the advantage which might often be gained by employing *roulettes* † in the place of staves or leaves of pinions, in machines where there exists a tendency to great friction; he wished therefore to discover the form of teeth adapted to drive these roulettes. Let the pinion DK (Fig. 11) which

FIG. 11.

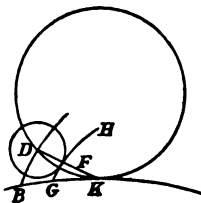

ought to be driven by the wheel $K B$, and which carries the *roulettes* D , be the epicycloid $B D$ which will serve to drive the point B ; in order to find the curve $G H$ fitted to drive the *roulette* of which the radius is $D F$, it is only requisite to describe

from all points of the curve $B D$ small circles of which the radii shall be equal to $D F$, and to draw another curve $G H$ which shall touch them all, this curve will be parallel to the epicycloid

* *Treatise on Mechanics*. Paris, 1695.

† The word *roulette* means a cylinder which revolves on a fixed axis. Professor Willis, at page 91 of his *Principles of Mechanism*, conjectures that the curve of this *roulette* was intended to be roll-traced. The reader is referred to Arts. 123 and 125.

B D, and will produce always on the point F of the *roulette* the same force and the same velocity as the epicycloid B D would produce on the point D ; in reality the point of driving F will always be equidistant from the point D, it will therefore follow the same path as this point D, and with the same velocity ; it will likewise have the same force, since the line D K is alike perpendicular to the epicycloid, the *roulette*, and the curve G F.

XXXVII. By a similar method it is possible to find the curve fitted to drive a leaf A G (Fig. 12) which shall be a radius of the primitive circumference of the pinion B G.

From the point B taken in the line of centres we describe the epicycloid B V N which will serve to drive the point B, as in the Article XX. ; and through the extreme end G of the leaf of the pinion, when arrived at G,

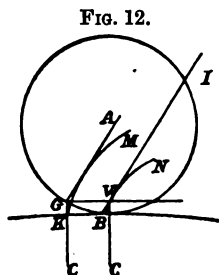

we describe the arc of a circle G V, which has the same centre as the wheel B K ; at the point V where this circle will cut the epicycloid, draw the line V I, which will make with the radius C V of the wheel the angle C V I, equal to the angle C G A ; we must do the same thing for all the points where the leaf G can be met with, and the curve which will touch all the lines V I being applied in the direction K M will produce on the leaf A G the same effect as the epicycloid B V N would have produced on the point G ; for the line V I

will coincide with $G A$, which will become the tangent to the curve at the driving point, in such a way that the movement of the leaf $B G$ will be precisely equal to the movement of the point B if it had been driven by the epicycloid $B V N$.

XXXVIII. In this manner it is possible to suppose for the leaf of the pinion every other curve, ellipse, parabola, hyperbola, &c., placed in any manner whatsoever, and find mechanically the shape of the tooth adapted to drive it uniformly; but these researches would be more curious than useful, and notwithstanding the universality of this method, that which we have given a full account of is infinitely more preferable, in that it serves to exhibit the nature of the curves we employ, and the point of the tooth which at each instant acts upon the pinion.

XXXIX. The same curves may be employed in machinery on various occasions; for instance, the leaves or cams of a mill-shaft placed horizontally, and which raises the hollow or solid pistons* of pumps, powder and paper mills, fulling mills, hammers for forges, floats of wheels used in certain hydraulic machines, wards on the nose of a key-bit, cut in such a way as to be able to overcome the resistance of the springs, and make it impossible through their means for the locks to be opened except with the particular

* There are two kinds of pistons, one with a valve called a bucket, used in common or sucking and lifting pumps; the other without a valve, for forcing-pumps. See *A Course of Experimental Philosophy*, by J. T. Desaguliers, LL.D., F.R.S., 1744, vol. ii., p. 152. Also, *Lectures on Select Subjects*, by James Ferguson, F.R.S.

key; they may also be applied to the bevelled * edge of the bolt, which ought to rub against the staple of the lock in order to facilitate the closing, and in many other circumstances which bear no relation to my subject.

XL. The principles which clockmakers have followed up to the present are very far off those which we have endeavoured to establish; there has been always much difference and uncertainty in their methods, or rather they have never had any defined method. In Germany pinions are made lantern-shaped; in France, like grains of barley; in England, thin-flanked—that is to say, with leaves flatted on the sides. It would appear that fashion has done all, and that experience has not taught a single thing.

A very skilful clockmaker has said that all the rules relating to this subject may be reduced to the gaining of force, and the avoiding of *side pressure* or friction. In order to gain force, he gives to the leaves of the pinions the form of staves of a lantern; that is to say, the most circular possible, provided that they be always driven by the point most distant from the centre. This is all which could well be proposed for the best in default of not going back to those true principles which demand the aid of geometry. In order to avoid side-pressure or friction, the same artist requires that the

* *Chanfrein*, a technical term. *Chanfrein* means to reduce a square piece of metal by the quarters, round off. *Chanfreindre*, to drill a hole in the shape of a cone.—THIOUT L'AINÉ. “On enlèvera l'angle autour du trou, c'est ce que les horlogers appellent *chanfreiner*.”—BERTHOUD, *Essai sur l'Horlogerie*, vol. i., art. 810.

set of teeth of the wheel (or rather the wheel) be more spaced * than filled up; but these two considerations furnish nothing precise, they were on the whole but feeble precautions.

XLI. By that which has been said we can understand why clockmakers exact that pinions which lead should be made larger than when they are driven; for whenever a pinion leads a wheel, if the teeth of the wheel were as large as those of the pinion, they would not be able to disengage themselves.

XLII. It would therefore be of advantage to all clockmakers to trace, according to the method we have laid down, templets,† or callipers for the different

* Clock and watch makers have different methods for taking the diameters of pinions, as well as different sizes. Some take more or less of teeth and space by the pinion-gauge than others do; and the greatest accuracy by this way is not quite attainable, unless having very extensive or nice practice.—REID, p. 113. Although the rule now to be given differs not very materially from the two last, yet it will be found to be a good one, and give such diameters to the pinions as will at all times and cases ensure safe pitching. Multiply the given number of the pinion by 2, to the product add 1, and then divide by 3, the quotient will be the remainder required. Take as an example— $8 \times 2 = 16 + 1 = 17 \div 3 = 5\frac{2}{3}$. Being three teeth, two spaces, and two-thirds of a space, taken by the callipers from the teeth of a wheel not rounded up, and which will be a diameter sufficiently large. In taking the diameter for a leading pinion, it will make but a small difference whether the addenda is 2 or $2\frac{1}{2}$. For a pinion of eight, the diameter in the one case is 6, and in the other $6\cdot08$.—REID, p. 117.

† *Templets*.—The shape of a single tooth adapted for a wheel is traced in the true epicycloidal form by means of *templets*—that is, of a pair of boards whose edges are cut to the curvature or the pitch circle and describing circle respectively, and which may be termed the pitch templet and the describing templet. The latter carries a describing point in its circumference, and by rolling its edge upon that of the pitch templet, the arc required for the face of the tooth is traced upon the drawing-board.—See *Principles of Mechanism*, Art. 173, p. 128.

sizes* of the wheels and pinions they employ; by this means they would soon have the hand in † to that form most advantageous in the shaping of the teeth, and would not lose anything by being able to accomplish their work with ease.

It is usual to advance, as an argument against all new methods, the difficulty of execution, no matter how advantageous they may be. There is, however, a great deal that is arbitrary in this difficulty, for it almost entirely depends on the habits which a great or small number of workmen have contracted in some part of the work; everything which has actually turned out to be easy appeared at its first origin to be impracticable, and all which to-day appears unusual and difficult will become, in the course of time, easy and common-place.

* The method of manufacturing the pinions and smaller wheels used in watch and clock work is very ingenious. A rod of wire, the diameter of which exceeds that of the wheel or pinion to be made, is drawn through an aperture cut in a steel plate, having the exact form and magnitude of the wheel or pinion to be formed. After being forced through this aperture by the ordinary process of wire-drawing, it is converted into a *fluted wire*, the ridges of the fluting corresponding exactly in form and magnitude to the edge of the aperture, and therefore to the teeth or leaves of the pinion or wheel.

This fluted wire, called *pinion wire*, is then cut by a cutter adapted to the purpose into thin slices, at right angles to its length. Each slice is a perfect wheel or pinion; and it is evident that all of them must be absolutely identical in form and magnitude.—*Handbook of Natural Philosophy—Mechanics*, by Dionysius Lardner, D.C.L., Art. 682, p. 352.

† *La main faite*, hand in, or skilled: would soon become skilled in giving to the teeth the shape most advantageous for the pitching.



INDEX.

A.

ADJUSTMENT, 235.
 Advice, 268.
 Ahaz, dial of, 37.
 Alarum, 1.
 Alexandre, Father, 44, 45, 46, 47, 96.
 Allen, J., 106.
 All or nothing, 182.
 Anchor-pallets, 84.
 Anne Boleyn, 69.
 Anne, Queen, 170.
 Apparent time, 32.
 Arbor, 4.
 Arc, 21.
 Archæologia, 58.
 Archimedes, 41.
 Arnold, J., 100, 101, 102, 103,
 170, 228.
 Astrological clock, 62.
 Augustus, 38.
 Automaton, 54.
 Axis, 4, 141.

B.

BAILLY, 36, 47.
 Balance, 4, 140, 195, 232.
 — spring, 195, 204, 212, 215,
 216, 220, 229.
 — wheel, 4, 123, 171, 173.
 Ball, 4.
 Banking, 5, 146.
 Bar, 5.
 Barlow, F., 87, 91, 181.
 Barrel, 5, 59.
 Beaumarchais, 96.
 Bell, 53.
 Berne, 72.
 Berthoud, F., 28, 45, 46, 47, 61,
 94, 100, 225, 226.
 Besançon, 103.
 Blackie, G., 107.
 Bloxham, 107.

Board of Longitude, 103, 207, 215,
 229.
 Boëthius, 44.
 Bolt and shutter, 5.
 Bound, 257.
 Bouquet, D., 85, 86.
 Bow, 263.
 Brass wheel, 157.
 Breguet, 16, 97, 101, 102.
 Bushed, 5.

C.

CÆSAR, JULIUS, 39.
 Callipering, 7.
 Callipers, 6.
 Camus, 3, 274.
 Canon, 10.
 Canon-pinion, 131, 148.
 Canterbury clock, 51.
 Cardan, H., 72.
 Caron, P. A., 95.
 Case, 2.
 Cassini, 38.
 Cassiodorus, 44.
 Centre of gravity, 10.
 — oscillation, 10.
 Chain, 11, 86, 146.
 Charlemagne, 44, 47.
 Charles I., 76.
 Charles V., 53, 68.
 Chartier, 86.
 Chaucer, 180.
 Chaux-de-fonds, 103, 250.
 Christchurch, 11.
 Chronometer, 11, 170.
 Cicero, 39, 41, 43.
 Claudian, 41.
 Clement, W., 87.
 Clepsydra, 12, 39, 43.
 Clerkenwell, 242.
 Clerks, 242.
 Clockmakers' Company, 76, 181.
 — of Paris, 71.

Cocclæus, 57, 58.
 Cock, 12.
 Cogs, 12.
 Cole, J. F., 106.
 Collet, 12.
 Colour of rubies, 239.
 Compensation, 224, 226, 234.
 Concentric, 12.
 Contrate-wheel, 142.
 Converted, 247.
 Coventry, 97, 245.
 Cratzer, N., 71.
 Crossing, 12.
 Crouch, W. H., 112.
 Crown-wheel, 141.
 Ctesibius, 39.
 Cumming, A., 99, 101, 241.
 Curb, 227.
 Cursor, L. Papius, 38.
 Cusin, Charles, 74.
 Cycloid, 12, 276, 279.
 Cycloidal curves, 98.
 Cylinder, 153, 155.

D.

DEALER, 249.
 De Beaufre, 92, 193, 237.
 De Vick, Henry, 53.
 Defects of cylinder, 157.
 — duplex, 163.
 — verge, 150.
 Denison, E. B., Esq., 5, 106.
 Deepthening tool, 28.
 Derham, 41, 86, 190.
 Detached, 169, 170.
 Detent, 12, 171, 174, 177.
 Dials, 36, 37.
 — enamelled, 79.
 Dijon, 53.
 Double-balance watch, 159.
 Dover Castle clock, 52.
 Draw, 12.
 Dubois, 56.
 Duffer watch, 240.
 Duplex, 159.
 Dutertre, J. B., 94, 160.

E.

EARNSHAW, THOS., 97, 102, 104,
 170, 175, 212, 231.
 Earth, the, 33.

East, Edward, 75, 78.
 Eccentric, 12.
 Ecliptic, 33.
 Educate, 268.
 Edward III., 53.
 Elizabeth, Queen, 73.
 Ellicott, John, 92, 100, 224.
 Elliott, J. M., 105.
 Emery, Josias, 102.
 Emulation, &c., 269.
 Enderlin, 97.
 Epicycloid, 13, 276, 279.
 Equation tables, 87.
 Escapement, 2, 13.
 Exeter Cathedral, 52.
 Expansion, &c., 269.

F.

FACTO, N., 92, 237.
 Fallacies, 247.
 Finisher, 138, 251.
 Flamenville, 96.
 Flamstead, 35.
 Fly, 13.
 Force, 13, 195, 200, 273.
 Forming teeth, 290.
 Francis I., 71.
 Free or detached, 12.
 Friction, 281, 294, 295, 301.
 Frisius, Gemma, 69.
 Froissart, 53.
 Fusee, 14, 134, 143.

G.

GALILEO, 79.
 Gaudron, 95.
 Gauge, 6, 266.
 Geneva, 74, 250, 253.
 Gerbert, 48, 49, 50, 51.
 Gimbals, 14.
 Glasses for watches, 75.
 Glastonbury clock, 52.
 Going fusee, 143.
 Gold springs, 209.
 Gooderich, S., 103.
 Graham, George, 87, 92, 93, 97,
 98, 153, 154, 197, 225.
 Gravity, 194.
 Gresham College, 84.

Grignion, Thomas, 80, 98.
Grinkin, Robert, 86.
Gruet, 86.
Guard-pin, 168.

H.

HAIR-SPRING, 194.
Haley, 103.
Half-timeing, 14.
Hall-marks, 109.
Hampton Court clock, 71.
Hand, minute, 91.
Hang, Y., 44.
Hardy, W., 105, 146, 179.
Haroun Al-Raschid, 44.
Harris, Richard, 80, 84.
Harrison, 19, 91, 226.
Hautefeuille, 94, 165.
Heat of body, 263.
Hebrecht, Isaac, 58.
Heel, 14, 98.
Hele, Peter, 57.
Henry VIII., 69.
Hickes, Sir Michael, 74.
Hill, Benjamin, 86.
Hindley, 96.
Hire, de la, 274, 298.
Hockley-in-the-Hole, 242.
Holland, States of, 170.
Honesty, 250.
Hooke, Robert, 78, 85, 86, 87,
159, 187.
Horizontal, 14, 152.
Horologium, 32, 50, 63.
Horstmann, 109.
Howells, W., 102.
How to choose and use, 261.
Huggeford, I., 93.
Hull, 94.
Huyghens, 19, 75, 81, 85, 191.

I.

ILLUMINATED DIALS, 106.
Immisch, M., 112.
Incapable workmen, 256.
Inertia, 15, 196, 232.
Inventories, 56, 68, 70.
Isochronal, 15, 194, 213, 219.
Isochronism, 198, 201, 218.
Isochronous, 217, 223.

J.

JACK O' THE CLOCK, 54.
Janvier, Antide, 99.
Jaquemart, 54.
Jewelling, 237.
Jewel-slip, 15.
Jobber, 240, 256.
Jodin, John, 100.
Jones, Inigo, 80, 83.
Jouvance, 53.

K.

KENDALL, LARCUM, 100.
Key, 150, 264.
Keyless, 184.
King, C. W., Rev., 37, 45.
Knibb, 87.
Knights of Jerusalem, 243.

L.

LABORDE, 56.
Lafons, J. de, 103.
Lalande, F. de, 272.
Le Bon, 93.
Le Cerf, 102.
Leicester, Earl of, 73.
Lepaute, 93, 100.
Lépine, 101.
Le Plat, 100.
Le Roy, Julian, 88, 91, 95, 101,
182, 217.
— Pierre, 61, 97, 102.
Leslie, R., 103.
Letters-patent, 72.
Lever, 15.
Line of centres, 291, 294, 295.
— before the, 290, 292, 293.
— after the, 292, 293.
Litherland, 103.
Locle, 103, 252.
Louis XIV., 72.
Lubeck, 54.
Ludlam, 101.
Lyons clock, 74.
Lyppys, N., 74.

M.

MACHINE MADE, 246, 251, 270.
Main-spring, 15, 59.
Manufacturing, 303.

Marking time, 270.
 Marwick, 87.
 Mary Queen of Scots, 73.
 Maskelyne, N., 95, 214.
 Masterpiece of art, 270.
 Mean time, 32, 34.
 Meridian, 33.
 Metals, expansion of, 225.
 Metz, 54.
 Morgan, O., M.P., F.S.A., 56, 59.
 Morlière, 86.
 Motion work, 16, 131, 148.
 Movement, 1, 140.
 Mudge, 93, 101, 194, 203.
 Myrmecides, 72.
 Mysteries, 242.

N.

NAMES, 253, 254.
 Nantes, edict of, 91.
 Napoleon I., 184.
 Neuchâtel, 250.
 Newton, Sir Isaac, 15, 94.
 Nuremberg, 56.
 — eggs, 56.

O.

OBLIQUITY, 34.
 Oil, 151, 156, 238, 240.
 Oldenburg, 79, 190.
 On the flat, 6, 25.
 Orbit, 33, 34.
 Orleans, Duke of, 170.
 Oscillations, 198.
 Our own make, 246, 247, 249.

P.

PACIFICUS, 46, 48.
 Padua, 52.
 Palais Royal, 38.
 Palmer, H. P., 112.
 Parachute, 16.
 Parker, Archbishop, 74.
 Paume, 173.
 Peckitt, 62, 63, 64.
 Pendant, 186.
 Pendule watches, 192.
 Pendulum, 4, 194.
 — spring, 16, 146, 187, 192,
 193, 203, 209, 221.
 — wire, 207, 208, 222.

Pennington, 17, 102.
 Philcox, G. C., 106.
 Phillippe, A., 108.
 Pinchbeck, 93.
 Pinions, 16.
 Pitchings, 16, 272.
 Pivot detents, 177, 178.
 Pivots, 17.
 Plates, 17, 140.
 Pliny, 38, 40.
 Pompadour, Madame de, 96.
 Posidonius, 43.
 Potence, 18.
 Potentia restitutiva, 187.
 Prescott, 245.
 Prior, John, 104, 105.
 Priory, Barnewell, 70.
 Push-piece, 181.
 Pyrometer, 224.

Q.

QUARE, DANIEL, 91, 181.
 Quintilian, 40.

R.

RACK-LEVER, 166.
 Ramsay, David, 86.
 Ratchet-wheel, 18.
 Rates, 108.
 Rees, 7.
 Règle artificielle, 88.
 Regnauld, 96.
 Regularity, 264.
 Regulating pins, 146, 235.
 Reid, Thomas, 19, 113.
 Remontoir, 18.
 Repairing, 259.
 Repeaters, 180.
 Ridley, Joseph, 102.
 Ritchie, D., 106.
 Robinson, Owen, 101.
 Boemer, 274.
 Roller, 19, 162, 168.
 Roulette, 298.
 Round watches, 74.
 Ruby, 168.
 — cylinder, 157.
 Ruegger, 97, 227.
 Rules for numbers, &c., of wheels
 and pinions, 124, 129.
 Bunnings, 19.

Wheel, bevelled, 5.
— brass, 61, 157.
— primitive, 293.
— steel, 60.
Wind, how to, 263.
Winding, 145.
Winding stop, 145.
Windsor Castle, 69.
Winkelmann, 39.
Wire, 208, 211, 216, 222.

Workmen, 265.
Wright, Thomas, 102.

Y.

Y. HANG, 44.

Z.

ZECH, JACOB, 62, 63.

