

CLOCK

AND
WATCH WORK.

FROM THE
EIGHTH EDITION OF THE ENCYCLOPÆDIA BRITANNICA.

WITH ALL THE LATEST IMPROVEMENTS.

EDINBURGH:
ADAM AND CHARLES BLACK.
MDCCLV.

186. c. 10.

ERRATA.

Page 44, Fig. 10 inverted.

Page 88, line 5 from bottom, insert *not* after *should*.

NOTE.

The reader is requested to bear in mind that this is simply a reprint,—or rather a separate issue of the article with this title in the Eighth Edition of the *Encyclopædia Britannica*.

The article *Dipleidoscope* is in like manner reprinted as an appendix, being intimately connected with the main subject of the book.

ERRATUM.

Page 19, line 20, for 6 $\frac{1}{2}$ read 68.

CONTENTS.

INTRODUCTION,	Page 1
COMMON EIGHT-DAY CLOCK,	3
PENDULUM, Theory of the,	5
Revolving or Conical,	10
Suspension,	12
Shape of Bob,	13
Regulation for Time,	14
Compensation for Temperature,	15
Zinc and Iron (Westminster Clock),	17
Wood and Lead,	18
Mercurial,	19
Other kinds,	19
Compensation for Spring,	20
ESCAPEMENTS,	20
Crown-Wheel,	21
Anchor Recoil,	22
Dead Escapements,	24
Theory of,	25
Effects of Friction,	31
Pin-Wheel,	32
Single-Pin,	34
Denison's Three-legged,	35
Remontoire, or Gravity Escapements,	36
Mudge's,	37
Theory of them,	38
Mechanical conditions,	42
Bloxam's,	44
Denison's,	46

GOING BARRELS,	Page 48
Harrison's,	49
Bolt and Shutter,	50
Denison's,	51
EQUATION CLOCKS,	52
STRIKING WORK, Locking Plate,	53
Repeating,	55
Quarters,	58
ALARUMS,	60
WATCHMAN'S CLOCK,	61
SPRING CLOCKS,	62
American Clocks,	63
TURRET CLOCKS,	63
Royal Exchange,	65
Great Exhibition and King's Cross,	67
Train Remontoires,	68
By Gravity,	70
Denison's Spring Remontoire,	72
Cast-iron Wheels,	75
Cathedral Clock, with Quarters,	76
Do., on 4 Bells,	78
Mode of Fixing,	81
Dials, Concave,	83
Size of,	84
Illumination,	85
Great Westminster Clock,	87
ELECTRICAL DIALS,	90
Shepherd's,	91
Dent's,	92
Denison's Dial work,	94
Clocks, Shepherd's,	95
Time Ball,	97
WATCHES and CHRONOMETERS,	98
Mainspring and Fusee,	99
Solid Key,	100
Geneva Stop,	101
Regulation of Spring,	102
Balance Springs,	104
Timing for position,	104
Compensation Balance,	105
Chronometrical Thermometer,	107

Secondary Compensation,	Page 108
Eiffe's,	110
Dent's,	111
Loseby's,	112
Glass Balance Springs,	113
Dent's Prismatic Balance,	114
Chronometer trials at Greenwich,	115
WATCH ESCAPEMENTS, numerous,	115
Vertical,	116
Lever,	117
Horizontal,	119
Duplex,	120
Detached, or Chronometer,	122
REPEATERS,	125
WATCHES Winding without a Key,	126
Self-Winding and Pedometers,	128
DIAL-MARKER, for observations,	129
Split seconds,	130
TEETH OF WHEELS,	130
Mode of describing, general rule for,	133
Lantern pinions,	134
Driver and Runner,	135
STRIKING CAMS,	137
OIL,	138
DIPLEIDOSCOPE,	140
MERIDIAN MARK,	143

LIST OF ILLUSTRATIONS.

No.	Page
1. Eight-Day Clock, Section of,	3
2. Westminster Clock Pendulum,	17
3. Cam-Wheel Escapement,	21
4. Anchor Recoil Escapement,	22
5. Anchor Dead Escapement,	24
6. Pin-Wheel do.	32
7. Single-Pin do.	34
8. Denison's Three-legged Escapement,	35
9. Gravity Escapement, Mudge's,	37
10. Bloxam's do.	44
11. Denison's do.	46
12. Harrison's going Ratchet,	49
13. Equation Clock Movement,	52
14. Striking Work,	56
15. Dent's Clock, Exhibition pattern,	67
16. Gravity Train Remontoire,	70
17. Denison's Spring Remontoire,	72
18. Cathedral Clock with Quarters,	76
19. Denison's Electrical Dial-Work,	94
20. Watch Movement,	100
21. Regulation of Spring,	102
22. Compensated Balance, Common,	106
23. Dent's, with Secondary Compensation,	111
24. Loseby's, do.	112
25. Dent's Prismatic Balance,	114
26. Vertical Escapement,	116
27. Lever,	117
28. Horizontal,	119
29. Duplex,	121
30. Detached, or Chronometer,	123
31. Keyless Watch,	127
32. Redier's Dial-Marker,	129
33. Epicycloidal Teeth,	133
34. Lantern Pinions,	134
35. Driver and Runner,	135
36. Striking Cams,	138
37. Dipleidoscope,	141

CLOCK AND WATCH WORK.

THE origin of clock work is involved in great obscurity. Notwithstanding the statements by many writers that clocks, *horologia*, were in use so early as the ninth century, and that they were then invented by an archdeacon of Verona, named Pacificus, there appears to be no clear evidence that they were machines at all resembling those which have been in use for the last five or six centuries. But it is certain that for that period at least clocks have been made depending on the action of a weight on a train of wheels, as distinguished from the water clocks, *clepsydræ*, which are well known to have been used many centuries before. However, we intend to confine this article as far as possible to matters of practical interest, as we cannot afford the space to enter into the history of horology; and we will, therefore, at once refer the reader who is curious about it, to the articles on clocks, chronometers, &c., in Rees's Cyclopædia, and the various works there cited. We will only add to the information there given, that it appears from a communication of Captain Smith to the Antiquarian Society in 1851, that there is still a clock in existence at Dover Castle bearing the date 1348, earlier by 30 years than that of the clock made by De Vick for the palace of the French king Charles V., which has generally been described as the earliest clock

of which the actual construction is known. Mr Denison also, in his Rudimentary Treatise on Clocks (of which we have largely availed ourselves throughout this article, and also of various papers by him in the Cambridge Philosophical Transactions, and the Journal of the Society of Arts), mentions a clock in Peterborough cathedral, still in use as to the striking part, of which the construction is more like that of the Dover Castle clock than that of De Vick; and Lord Chief Justice Coke tells us that a clock was set up in Westminster Hall in the thirteenth century out of a fine levied on one of his predecessors in that seat, from which perhaps the appropriate inscription *Discite justitiam moniti* was copied on to the sun-dial on a house now facing the hall.

De Vick's clock having been frequently described before, and the description being of no value except as a matter of curiosity, we shall say no more of it than that it was a large striking clock going one day, and with one hand (the hour hand), and much the same, except in the escapement, as many old church clocks still in existence. Pendulums were not invented for three centuries after; and strange as it may seem, the escapement was much like that which is called the "vertical escapement" in a watch, only the time of vibration depended entirely on the *moment of inertia* of the balance, and not on a spring, that also being of much later invention. We shall, therefore, proceed at once to describe the going part of an eight-day house clock, or of an astronomical clock or "regulator," for in the general arrangement they are the same.

In figure 1, B is the barrel with the rope coiled round it generally 16 times for the 8 days; the barrel is fixed to its arbor K, which is prolonged into the winding square coming up to the face or dial of the clock; the dial is here shown as fixed either by small screws *x*, or by a socket and pin *z* to the prolonged pillars *p p*, which (4 or 5 in number) connect the plates or frame of the clock together, though the dial is commonly, but for no good reason, set on to the front plate

by another set of pillars of its own. The great wheel G rides on the arbor, and is connected with the barrel by the

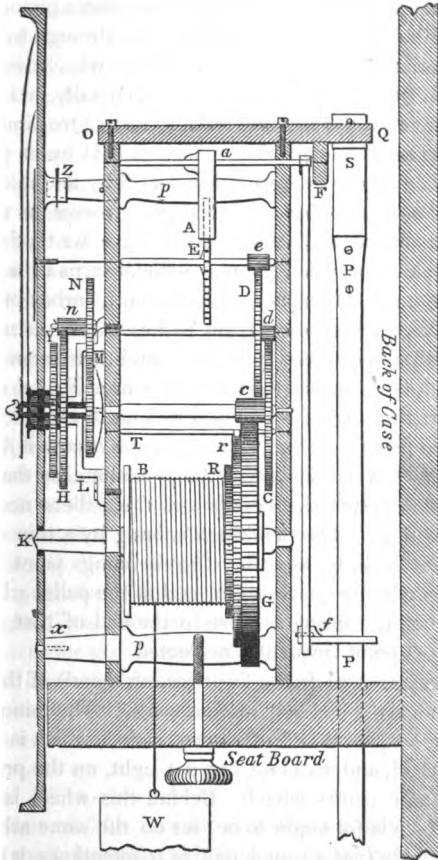

Fig. 1.

ratchet R, the action of which is shown more fully in fig. 12. The intermediate wheel r in this drawing is for a purpose which will be described hereafter, and for the present

it may be considered as omitted, and the click of the ratchet R as fixed to the great wheel. The great wheel drives the pinion *c*, which is called the centre pinion, on the arbor of the *centre wheel* C, which goes through to the dial, and carries the long or minute-hand; this wheel always turning in an hour, and the great wheel generally in 12 hours, by having 12 times as many teeth as the centre pinion. The centre wheel drives the "second wheel" D by its pinion *d*, and that again drives the scape-wheel E by its pinion *e*. If the pinions *d* and *e* have each 8 teeth or *leaves* (as the teeth of pinions are usually called), *c* will have 64 teeth and D 60, in a clock of which the scape-wheel turns in a minute, so that the seconds hand may be set on its arbor prolonged to the dial. A represents the pallets of the escapement, which will be described presently, and their arbor *a* goes through a large hole in the back plate near F, and its back pivot turns in a cock O F Q screwed on to the back plate. From the pallet arbor at F descends the *crutch* F*f*, ending in the *fork* *f*, which embraces the pendulum, so that as the pendulum vibrates, the crutch and the pallets necessarily vibrate with it. The pendulum is hung by a thin spring S from the cock Q, so that the bending point of the spring may be just opposite the end of the pallet arbor, and the edge of the spring as close to the end of that arbor as possible—a point frequently neglected.

We may now go to the front (or left hand) of the clock, and describe the dial or "motion work." The minute hand fits on to a squared end of a brass socket, which is fixed to the wheel M, and fits close, but not tight, on the prolonged arbor of the centre wheel. Behind this wheel is a bent spring which is (or ought to be) set on the same arbor with a square hole (not a round one as it sometimes is) in the middle, so that it must turn with the arbor; the wheel is pressed up against this spring, and kept there by a cap and a small pin through the end of the arbor. The consequence is, that there is friction enough between the spring and the

wheel to carry the hand round, but not enough to resist a moderate push with the finger for the purpose of altering the time indicated. This wheel M, which is sometimes called the minute wheel, but is better called the *hour-wheel* as it turns in an hour, drives another wheel N, of the same number of teeth, and which has a pinion attached to it; and that pinion drives the twelve-hour wheel H, which is also attached to a larger socket or pipe carrying the hour hand and riding on the former socket, or rather (in order to relieve the centre arbor of that extra weight) on an intermediate socket fixed to the *bridge* L, which is screwed to the front plate over the hour-wheel M. The weight W, which drives the train and gives the impulse to the pendulum through the escapement, is generally hung by a catgut line passing through a pulley attached to the weight, as shown in fig. 14, the other end of the cord being tied to some convenient place in the clock frame or *seat-board* to which it is fixed by screws through the lower pillars. It has usually been the practice to make the cases of house clocks and astronomical clocks not less than 6 feet high; but that is a very unnecessary waste of space and materials; for by either diminishing the size of the barrel, or the number of its turns, by increasing the size of the great wheel by one-half, or hanging the weights by a treble instead of a double line, a case just long enough for the pendulum will also be long enough for the fall of the weights in 7 or 8 days. Of course the weights have to be increased in the same ratio, and indeed rather more, to overcome the increased friction.

PENDULUM.

The claim to the invention of the pendulum, like the claim to most inventions, is disputed; and we have no intention of trying to settle it. It was, like many, perhaps most, other discoveries and inventions, probably made by various persons, independently, and almost simultaneously, when the state of science had become ripe for it. That

peculiarly valuable property of the pendulum called *isochronism*, or the disposition to vibrate different arcs in very nearly the same time (provided the arcs are none of them large), was known long before the time of the earliest clocks we have described; for it is said that the ancient astronomers of the East employed pendulums in measuring the times of their observations, counting their vibrations during the phases of an eclipse or transit, and renewing them by a push of the finger when they languished. This knowledge, however, appears itself to have languished before the time of Galileo, if credit is to be given to the well-known story of his being struck with the apparent isochronism of a chandelier hung by a long chain from the roof of the church at Florence. And Galileo's son appears as a rival of Avicenna, Huygens, Dr Hooke, and a London clockmaker named Harris, for the honour of having first applied the pendulum to regulate the motion of a clock train, all in the early part of the seventeenth century. Be this as it may, there seems little doubt that Huygens was the first who mathematically investigated, and therefore really knew the true nature of those properties of the pendulum, which may now be found explained in any mathematical book on mechanics. He discovered, that if a *simple* pendulum (*i. e.*, a weight or *bob* consisting of a single point, and hung by a rod or string of no weight) can be made to describe, not a circle, but a cycloid of which the string would be the radius of curvature at the lowest point, all its vibrations, however large, will be performed in the same time. For a little distance near the bottom, the circle very nearly coincides with the cycloid; and hence it is, that for small arcs, a pendulum vibrating as usual in a circle, is nearly enough isochronous for the purposes of horology; more especially when contrivances are introduced either to compensate for the variations of the arc, or, better still, to destroy them altogether, by making the force on the pendulum so constant that its arc may never sensibly vary. The difference between the

time of any *small* arc of the circle and *any* arc of the cycloid, or an infinitely small arc of the circle, varies nearly as the square of the circular arc; and again, the difference between the times of any two small and nearly equal circular arcs of the same pendulum, varies nearly as the arc itself. If a , the arc, is increased by a small amount da , the pendulum will lose $10800ada$ seconds a-day, which is rather more than 1 second if a is 2° (from zero) and da is $10'$, since the numerical value of 2° is $\cdot035$. If the increase of arc is considerable, it will not do to reckon thus by differentials, but we must take the difference of time for the day as $5400(a_1^2 - a^2)$, which will be just 8 seconds if $a = 2^\circ$ and $a_1 = 3^\circ$. For many years it was thought of great importance to obtain cycloidal vibrations of clock pendulums, and it was done by making the suspension string or spring vibrate between *cycloidal cheeks*, as they were called. But it was in time discovered that all this is a delusion. First, because there is and can be no such thing in reality as a simple pendulum, and cycloidal cheeks will only make a simple pendulum vibrate isochronously; secondly, because a very slight error in the form of the cheeks (as Huygens himself discovered) would do more harm than the *circular error* uncorrected at all, even for an arc of 10° , which is much larger than the common pendulum arc; thirdly, because there was always some friction or adhesion between the cheeks and the string; and fourthly (a reason which applies equally to all the isochronous contrivances since invented), because a common clock escapement itself generally tends to produce an error exactly opposite to the circular error, or to make the pendulum vibrate quicker the farther it swings; and therefore (as was shown by Mr Denison in the Cambridge Philosophical Transactions in 1848) the circular error is actually useful for the purpose of helping to counteract the error due to the escapement, and the clock goes better than it would with a simple pendulum, describing the most perfect cycloid. At the same time, the

thin spring by which pendulums are always suspended, except in some French clocks where a silk string is used (a very inferior plan), causes the pendulum to deviate a little from circular and to approximate to cycloidal motion, because the bend does not take place at one point, but is spread over some length of the spring.

The accurate performance of a clock depends so essentially on the pendulum, that we shall go somewhat into detail respecting it. First, then, the time of vibration depends entirely on the length of the pendulum, the effect of the spring being too small for consideration until we come to differences of a higher order. But the time does not vary as the length, but only as the square root of the length; *i.e.*, a pendulum to vibrate two seconds must be four times as long as a seconds pendulum. The relation between the time and the length of a pendulum is expressed thus:—

$t = \pi\sqrt{\frac{l}{g}}$, where t is the time in seconds, π the well-

known symbol for 3·14159, the ratio of the circumference of a circle to its diameter, l the length of the pendulum, and g the force of gravity at the latitude where it is intended to vibrate; this letter g , in the latitude of London, is the symbol for 32·2 feet, that being the velocity (or number of feet per second) at which a body is found by experiment to be moving at the end of the first second of its fall, being necessarily equal to twice the actual number of feet it has fallen in that second. Consequently, the length of a pendulum to beat seconds in London is 39·14 inches. But the same pendulum carried to the equator, where the force of gravity is less, would lose $2\frac{1}{4}$ minutes a day.

The seconds we are here speaking of are the seconds of a common clock indicating *mean solar time*. But as clocks are also required for sidereal time, it may be as well to mention the proportions between a mean and a sidereal pendulum. A sidereal day is the interval between two successive transits over the meridian of a place by that imaginary point

in the heavens called γ , the first point of Aries, at the intersection of the equator and the ecliptic; and there is one more sidereal day than there are solar days in a year, since the earth has to turn more than once round in space before the sun can come a second time to the meridian, on account of the earth's own motion in its orbit during the day. A sidereal day or hour is shorter than a mean solar one in the ratio of $\cdot 99727$, and consequently a sidereal pendulum must be shorter than a mean-time pendulum in the square of that ratio, or in the latitude of London the sidereal seconds pendulum is $38\cdot 87$ inches. As we have mentioned what is 0 or 24 o'clock by sidereal time, we may as well add, that the mean day is also reckoned in astronomy by 24 hours, and not from midnight as in civil reckoning, but from the following noon; thus, what we call 11 A.M. May 1 in common life, is 23 h. April 30 with astronomers.

It must be remembered that the pendulums whose lengths we have been speaking of are simple pendulums; and, as that is a thing which can only exist in theory, the reader may ask how the length of a real pendulum to vibrate in any required time is ascertained. In every pendulum, that is to say in every body hung so as to be capable of vibrating freely, there is a certain point, always somewhere below the centre of gravity, which possesses these remarkable properties: that if the pendulum were turned upside down, and set vibrating about this point, it would vibrate in the same time as before; and, moreover, the distance of this point from the point of suspension is exactly the length of that imaginary simple pendulum which would vibrate in the same time. This point is therefore called the *centre of oscillation*. The rules for finding it by calculation are too complicated for ordinary use, except in bodies of certain simple and regular forms; but they are fortunately not requisite in practice, because in all clock pendulums the centre of oscillation is only a short distance below the centre of gravity of the whole pendulum, and

generally so near to the centre of gravity of the bob—in fact a little above it—that there is no difficulty in making a pendulum for any given time of vibration near enough to the proper length at once, and then adjusting it by screwing the bob up or down until it is found to vibrate in the proper time.

Thus far we have been speaking of vibrating pendulums ; but the notice of pendulums would be incomplete without some allusion to revolving or *conical* pendulums, as they are called, because they describe a cone in revolving. Such pendulums are used where a continuous instead of an intermittent motion of the clock train is required, as in the clocks for keeping an equatorial telescope directed to a star, by driving it the opposite way to the motion of the earth, to whose axis the axis on which the telescope turns is made parallel. Clocks with such pendulums might also be used in bedrooms by persons who cannot bear the ticking of a common clock. The pendulum, instead of being hung by a flat spring, is hung by a thin piece of piano-forte wire ; and it should be understood that it has no tendency to twist on its own axis, and so to twist off the wire, as may be apprehended : in fact it would require some extra force to make it twist, if it were wanted to do so. The time of revolution of a revolving pendulum may be easily ascertained as follows:—Let l be the length of the pendulum, α the angle which it makes with the vertical axis of the cone which it describes ; ω the angular velocity ; then the centrifugal force $= \omega^2 l \sin \alpha$; and as this is the force which keeps the pendulum away from the vertical, it must balance the force which draws it to the vertical, which is $g \tan \alpha$: and therefore

$\sqrt{\frac{g}{l \cos \alpha}} = \omega$, the angular velocity, or the angle described in 1 second of time ; and the time of a complete revolution through the angle 360° , or 2π , is $\frac{2\pi}{\omega} = 2\pi \sqrt{\frac{l \cos \alpha}{g}}$. That

is to say, the time of revolution of a pendulum of any given length is less than the time of a double oscillation of the same pendulum, in the proportion of the cosine of the angle, which it makes with the axis of revolution, to unity.

A rotary pendulum is kept in motion by the train of the clock ending in a horizontal wheel with a vertical axis, from which projects an arm pressing against a spike at the bottom of the pendulum ; and it has this disadvantage, that any inequality in the force of the train, arising from variations of friction or any other cause, is immediately transmitted to the pendulum ; whereas it will be seen that in several kinds of escapement which can be applied to a vibrating pendulum, the variations of force can be rendered nearly or quite insensible. And it is a mistake to imagine that there is any self-correcting power in a conical pendulum analogous to that of the governor of a steam engine ; for that apparatus, though it is a couple of conical pendulums, has also a communication by a system of levers with the valve which supplies the steam. The governor apparatus has itself been applied to telescope-driving clocks, with a lever ending in a spring which acts by friction on some revolving plate in the clock, increasing the friction, and so diminishing the force as the balls of the governor fly out farther under any increase in the force. And with the addition of some connection with the hand of the observer, by which the action can be farther moderated, the motion can be made sufficiently uniform for that purpose ; though for a clock to be kept going constantly without attendance, some further provisions are necessary, as explained under the head of *train remontoires* in Mr Denison's book. It has indeed been proposed to obtain a uniform motion of the clock train from a vibrating pendulum, by means of a crank attached to a wheel revolving in two beats of the pendulum, and connected with it by a rod so long that it may be considered always nearly horizontal ; since it will be found on investigation that the horizontal velocity of any point in a pendulum swinging freely

varies in the same ratio as that of the end of a crank revolving uniformly. But this will not do in practice, because any increase in the force of the train would immediately make the pendulum desire to increase its arc and its velocity, and the motion of the crank would be no longer uniform, but be checked at the end of every vibration; and if the force were diminished the pendulum would not go far enough to carry the crank past the dead points, and the clock would stop.

PENDULUM SUSPENSION.

The suspension of the pendulum on what are called *knife-edges*, like those of a scale-beam, has often been advocated. But though it may do well enough for short experiments, in which the effects of the elasticity of the spring are wanted to be eliminated, it fails altogether in use, even if the knife-edges and the plates which carry them are made of the hardest stones. A suspension on friction wheels, or the small portion of the entire wheel which is required, has also been used, but only in two instances, by the late Mr Vulliamy, under an erroneous impression respecting the nature of the compensation for temperature required, both for the spring and the rod of a pendulum when of great size. This suspension may, no doubt, be made to answer; but as it involves extreme delicacy of adjustment and great expense, and possesses no corresponding advantage over the common method, it will probably never be used again. The suspension which is now used universally in all but some inferior foreign clocks, which have strings instead, is a thin and short spring, with one end let into the top of the pendulum, and the other screwed between two *chops* of metal with a pin through them, which rests firmly in a nick in the cock which carries the pendulum; and the steadiness of this cock is essential to the accurate performance of the clock. The thinner the spring the better, provided, of course, it is strong enough to carry the pendulum without being bent beyond its elasticity,

or bent short ; not that there is much risk of that in practice. Pendulum springs are much oftener too thick than too thin ; and it is worth notice that, independently of their greater effect on the natural time of vibration of the pendulum, thick and narrow springs are more liable to break than thin and broad ones of the same strength. It is of great importance that the spring should be of uniform thickness throughout its breadth ; and the bottom of the chops which carry it should be exactly horizontal ; otherwise the pendulum will swing with a twist, as they may be often seen to do in ill-made clocks.

The bob of the pendulum used, till lately, to be generally made in the shape of a lens, with a view to its passing through the air with the least resistance. But after the importance of making the bob heavy was discovered, it became almost necessary to adopt a form of more solid content in proportion to its surface. A sphere has been occasionally used, but it is not a good shape, because a slight error in the place of the hole for the rod may make a serious difference in the amount of weight on each side, and give the pendulum a tendency to twist in motion. The mercurial jar pendulum suggested the cylindrical form, which is now generally adopted for astronomical clocks ; and it has also lately been used in the best turret clocks, with a round top to prevent the effect of any bits of mortar or dirt falling and resting upon it, which would alter the time ; it has also been thought to look better than a flat-topped cylinder. There is no rule to be given for the weight of pendulums. It will be shown hereafter, that whatever escapement may be used, the errors due to any variation of force are expressed in fractions which invariably have the weight and the length of the pendulum in the denominator, though some kinds of escapements require a heavy pendulum to correct their errors much less than others. And as a heavy pendulum requires very little more force to keep it in motion than a light one, being less affected by the resistance of the

air, we may almost say that the heavier and longer a pendulum can be made the better; at any rate, the only limit is one of convenience; for instance, it would obviously be inconvenient to put a large pendulum of 100 lb. weight in the case of an astronomical or common house clock. It may perhaps be laid down as a rule, that no astronomical clock or *regulator* (as they are also called) will go as well as is expected of such clocks with a pendulum of less than 12 lb. weight, and no turret clock with less than 1 cwt. Long pendulums are generally made with heavier bobs than short ones; and such a clock as that for the houses of parliament, with a two-seconds pendulum of 6 cwt., ought to go 44 times as well as a small turret clock with a one-second pendulum of 60 lb. Pendulums longer than 14 feet (2 seconds) are inconvenient, liable to be disturbed by wind, and impossible, or at least enormously expensive, to compensate, and they are now quite disused. An old clock with a 56 feet pendulum (4 seconds) was lately removed from Halifax church to be replaced by one with an 8 feet compensated pendulum, and a clock such as we shall have to describe when we come to turret clocks.

PENDULUM REGULATION.

The regulation of pendulums, or their exact adjustment to the proper length, is almost always effected by a nut on the end of the rod, by which the bob can be screwed up or down. In the best clocks the rim of this nut is divided, with an index over it; so the exact quantity of rise or fall may be known, or the exact acceleration or retardation, the amount due to one turn of the nut being previously ascertained. By the calculation used below for compensation of pendulums, it may be seen that if the length of the pendulum rod is l , and the breadth of one thread of the screw is called dl , then one turn of the nut will alter the rate of the clock by $43200 \frac{dl}{l}$ seconds a-day; which would be just

30 seconds, if the pendulum rod is 45 inches long, and the screw has 32 threads in the inch. To accelerate the clock the nut has always to be turned to the right, as it is called, and *vice versa*. But in astronomical and in large turret clocks, it is desirable to avoid stopping, or in any way disturbing the pendulum; and for the finer adjustments, other methods of regulation are adopted. The best is that of fixing a collar, as shown in fig. 2, capable of having very small weights laid upon it, half-way down the pendulum, this being the place where the addition of any small weight produces the greatest effect; and where, it may be added, any moving of that weight up or down on the rod produces the least effect. An addition there of a weight = $\frac{1}{100000}$ th of the weight of the pendulum will accelerate it a little more than 1 second a day, or 10 grains will do that on a pendulum of 15 lb. weight (7000 gr. being = 1 lb.), or an ounce on a pendulum of 6 cwt.; and these small weights can be easily taken off and put on without any risk of disturbing the pendulum. The weights should be made in a series, and marked $\frac{1}{4}$, $\frac{1}{2}$, 1, 2, according to the number of seconds a day by which they will accelerate, and the pendulum adjusted at first to lose a little, perhaps a second a day, when there are no weights on the collar, so that it may always have some weight on, which can be diminished or increased from time to time, with certainty, as the rate may vary.

COMPENSATION OF PENDULUMS.

Soon after pendulums began to be generally used in clocks, it was discovered that they contained within themselves a source of error independent of the action of the clock upon them, and that they lost time in hot weather and gained in cold, in consequence of all the substances of which they could be made expanding as the temperature increases. If l is the length of a pendulum, and dl the small increase of it from increased heat, t the time of the pendulum l , and $t + dt$ that of the pendulum $l + dl$; then

$\frac{t+dt}{t} = \frac{\sqrt{l+dl}}{\sqrt{l}} = 1 + \frac{dl}{2l}$; since $\left(\frac{dl}{l}\right)^2$ may be neglected as very small; or $dt = \frac{t}{2l} dl$; and the daily loss of the clock will be $43200 \frac{dl}{l}$ seconds. The following is a table of the values $\frac{dl}{l}$ for 10° of heat in different substances.

White deal.....	·000024
Flint glass.....	·000048
Steel rod.....	·000064
Iron rod.....	·00007
Brass.....	·00010
Lead.....	·00016
Zinc.....	·00017
Mercury (in bulk, not in length).....	·00100

Thus a common pendulum with an iron wire rod would lose $43200 \times \cdot00007 = 3$ seconds a-day for 10° of heat, and if adjusted for winter temperature would lose about a minute a-week in summer, unless something in the clock happened to produce a counteracting effect, as we shall see may be the case when we come to escapements. We want, therefore, some contrivance which will always keep that point of the pendulum on which its time depends, viz., the *centre of oscillation*, at the same distance from the point of suspension. A vast number of such contrivances have been made, but there are only three which can be said to be at all in common use; and the old *gridiron pendulum*, made of 9 alternate bars of brass and steel is not one of them, having been superseded by one of zinc and iron, exactly on the same principle, but requiring much fewer bars on account of the greater expansion of zinc than brass. Although this is the most modern of the compensated pendulums, in consequence of the working of zinc being a modern art, we will describe it first. And as the centre of oscillation so nearly coincides in all clock pendulums with the centre of

the *bob*, we may practically say that the object of compensation is to keep the bob always at the same height. Fig. 2 is a section of the great Westminster clock pendulum above mentioned. The iron rod which runs from top to bottom ends in a screw with a nut N for adjusting the length of the pendulum after it was made by calculation as near the right length as possible. On this nut rests a collar M, which can slide up the rod a little way, but is prevented from turning by a pin through the rod. On a groove or annular channel in the top of this collar stands a zinc tube 10 feet 6 inches long, and nearly half an inch thick, made of three tubes all drawn together, so as to become like one ; for it should be observed that *cast* zinc cannot be depended on ; it must be drawn. On the top of this tube or hollow column fits another collar with an annular groove much like the bottom one M. The object of these grooves is to keep the zinc column in its place, not touching the rod within it, as contact might produce friction, which would interfere with their relative motion under expansion and contraction. Round the collar C is screwed a large iron tube, also not touching the zinc, and its lower end fits loosely on the collar M ; and round its outside it has another collar of its own, D, fixed to it, on which the bob rests. The iron tube has a number of large holes in it down each side, to let the air get to the zinc tube : before that was done it was found that the compensation lagged a day or two behind the changes of temperature, in consequence

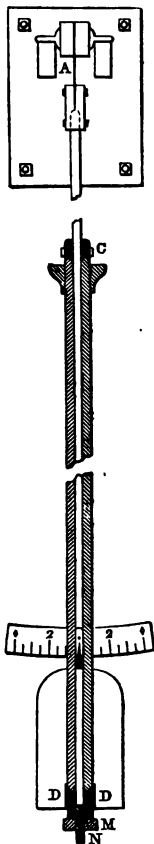

Fig. 2.

of the iron rod and tube being exposed while the zinc tube was inclosed without touching the iron. The bottom of the bob is 14 feet 11 inches from the top of the spring A, and the bob itself is 18 inches high, with a dome-shaped top and 12 inches in diameter. As it is a 2-seconds pendulum, its centre of oscillation is 13 feet from the top A, which is very near the centre of gravity of the pendulum, and higher than usual above the centre of gravity of the bob, on account of the great weight of the compensation tubes. The whole weighs 682 lb., which is half as large again as Mr Vulliamy's Post-office clock pendulum, which was before the heaviest probably in the world, but it is only a wooden one with an iron bob. The same proportions will hold for zinc compensation pendulums of smaller size, the zinc tube and the iron tube being always nearly two-thirds of the length of the main rod. The compensating action is evidently this: the iron rod and tube both let the bob down as they expand, and the zinc column pushes it up; and as the ratio of the expansion of iron to zinc is $\cdot 41$, it will be found that by the above proportions the centre of oscillation will remain at the same height; and experience has ratified the calculation, the pendulum having been now (1854) going for two years in Mr Dent's factory.

The second kind of compensation pendulum in use is still more simple, but not so effective or certain in its action; and that is merely a wooden rod with a long lead bob resting on a nut at the bottom. According to the above table, it would appear that this bob ought to be 14 inches high in a 1-second pendulum; but the expansion of wood is so uncertain, that this proportion is not found capable of being depended on, and a somewhat shorter bob is said to be generally more correct in point of compensation. And we believe that all persons who have tried wood pendulums severely, have come to the same conclusion as Mr Reid did long ago, that they are capricious in their action, and consequently unfit for the highest class of clocks.

The best of all the compensations is undoubtedly the mercurial, which was invented by George Graham, a London clockmaker, above a century ago, who also invented the well-known dead escapement for clocks, and also the horizontal or cylinder escapement for watches, which will be hereafter explained. And the best form of the mercurial pendulum is that which was introduced by the late Mr Dent, in which the mercury is inclosed in a cast iron jar or cylinder, into the top of which the steel rod is screwed, with its end plunged into the mercury itself. For by this means the mercury, the rod, and the jar, all acquire the new temperature at any change, more nearly together, than when the mercury is in a glass jar hung by a *stirrup* (as it is called) at the bottom of the rod; and moreover the pendulum is safe to carry about, and the jar can be made perfectly cylindrical by turning, and also air tight, so as to protect the mercury from oxidation; and, if necessary, it can be heated in the jar so as to drive off any moisture, without any risk of breaking. The height of mercury required in a cast iron jar 2 inches in diameter is about $6\frac{1}{2}$ inches; for it must be remembered in calculating the rise of the mercury, that the jar itself expands laterally, and that expansion has to be deducted from that of the mercury in bulk.

There are several other kinds of compensation which may be found described in Mr Denison's treatise, and other books. But as the mercurial is indisputably the best, though expensive, and the zinc and iron pendulum is both better and cheaper than any of those others, we shall not fill our pages by describing them. We will only add this caution to persons who may be captivated with the apparent simplicity of that class of compensations in which the pendulum spring is drawn up through a slit, so as to shorten it as the length of the pendulum increases, that that method in any of its forms is not to be relied on. All the compensations also on the lever principle, invented by Mr Ellicott, many years ago, are equally fallacious and uncertain; though this, as

well as the spring-shortening methods, do not seem to have been yet abandoned by the French clockmakers—at least they had not at the time of the Great Exhibition in 1851.

We alluded a short time ago to the effect of the spring upon the time of vibration. However thin it may be, it has some tendency to make the pendulum move more quickly than if it were suspended on knife edges; and as all springs are stiffer the colder they are, the spring accelerates the pendulum in cold weather a little more than in hot, though to a far less extent than the variation in the length of the pendulum itself. It is impossible to give any rule for the extra compensation thus required, except such as might be deduced from a large and careful series of experiments on pendulums and springs of various sizes. The late Mr Dent stated in a paper read before the British Association in 1840, that he had found such a spring as is generally used in astronomical clock pendulums to require about $\frac{1}{4}$ th to be added to the ordinary compensation for the rod. It should be remembered that this effect is much greater on a short pendulum than a long one; indeed, on a 2-seconds pendulum of considerable weight it seems not perceptible at all when the spring is of no more than the proper thickness.

ESCAPEMENTS.

The escapement is that part of the clock in which the rotary motion of the wheels is converted into the vibratory motion of the balance or pendulum, which by some contrivance or other is made to let one tooth of the quickest wheel in the train escape at each vibration; and hence that wheel is called the “scape wheel.” Fig. 3 shows the form of the earliest clock escapement, if it is held sideways, so that the arms on which the two balls are set may vibrate on a horizontal plane. In that case the arms and weights form a balance, and the farther out the weights are set, the slower would be the vibrations. If we now turn it as it stands here,

and consider the upper weight left out, it becomes the earliest form of the pendulum clock, with the *crown-wheel* or *vertical* escapement. CA and CB are two flat pieces of steel called *pallets* projecting from the axis about at right angles to each other, one of them over the front of the wheel as it stands, and the other over the back. The tooth D is just escaping from the front pallet CA, and at the same time the tooth at the back of the wheel falls on the other pallet CB a little above its edge. But the pendulum, which is now moving to the right, does not stop immediately, but swings a little further (otherwise the least failure in the force of the train would stop the clock, as the

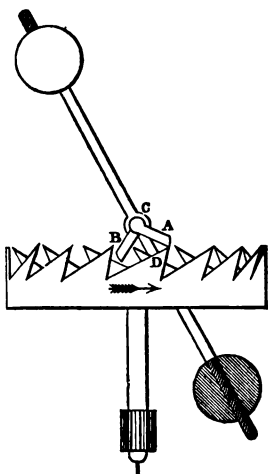

Fig. 3.

escape would not take place), and in so doing it is evident that the pallet B will drive the wheel back a little, and produce what is called the *recoil*; which is visible enough in any common clock with a seconds hand, either with this escapement or the one which will be next described.

It will be seen, on looking at the figure, that the pallet B must turn through a considerable angle before the tooth can escape; in other words, the crown-wheel escapement requires a long vibration of the pendulum. This is objectionable on several accounts; first, because it requires a great force in the clock train, and a great pressure and therefore friction, on the pallets; and besides that, any variation in a large arc, as was explained before, produces a much greater variation of time due to the circular error than an equal variation of a small arc. The crown-wheel escape

ment may indeed be made so as to allow a more moderate arc of the pendulum, though not so small as the 2° usually adopted now in the best clocks, by putting the pallet arbor a good deal higher above the scape-wheel, and giving a small number of teeth to the wheel; and that also diminishes the length of run of the teeth, and consequently the friction, on the pallets, though it makes the recoil very great and sudden; but, oddly enough, it never appears to have been resorted to until long after the escapement had become superseded by the "anchor" escapement, which we shall now describe, and which appears to have been invented by the famous Dr Hooke as early as the year 1656, very soon after the invention of pendulums.

In fig. 4 a tooth of the scape-wheel is just escaping from the left pallet, and another tooth at the same time

falls upon the right hand pallet at some distance from its point. As the pendulum moves on in the same direction, the tooth slides farther up the pallet, thus producing a recoil, as in the crown-wheel escapement. The acting faces of the pallets should be convex, and not flat, as they are generally made, much less concave, as they have sometimes been

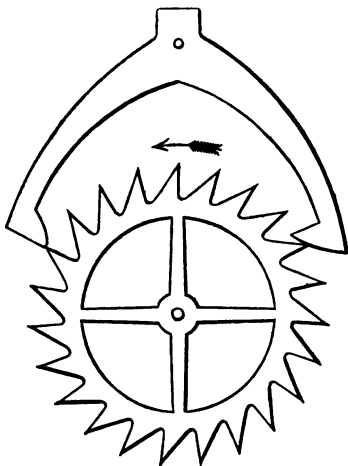

Fig. 4.

made, with the view of checking the motion of the pendulum, which is more likely to injure the rate of the clock than to improve it. But when they are flat, and of course still more when they are concave, the points of the teeth always wear a hole

in the pallets at the extremity of their usual swing, and the motion is obviously easier, and therefore better, when the pallets are made convex; in fact they then approach more nearly to the "dead" escapement, which will be described presently. We have already alluded to the effect of some escapements in not only counteracting the circular error, or the natural increase of the time of a pendulum as the arc increases, but overbalancing it by an error of the contrary kind. The recoil escapement does so; for it is almost invariably found that whatever may be the shape of the pallets, the clock loses as the arc of the pendulum falls off, and *vice versa*. It is, however, unfortunately impossible so to arrange the pallets that the circular error may be thus exactly neutralized, because the escapement errors depend, in a manner reducible to no law, upon variations in friction of the pallets themselves, and of the clock train, which produce different effects; and the result is, that it has long been recognised as impossible to obtain very accurate time-keeping from any clock of this construction.

But before we pass on to the dead escapement, it may be proper to notice an escapement of the recoiling class, which was invented for the purpose of doing without oil, by the famous Harrison, who was at first a carpenter in Lincolnshire, but afterwards obtained the first government reward for the improvement of chronometers. We shall not however stop to describe it, since it never came into general use, and it is said that nobody but Harrison himself could make it go at all. It was also objectionable on account of its being directly affected by all variations in the force of the clock. It had the peculiarity of being very nearly silent, though the recoil was very great. Those who are curious about such things will find it described in the 7th edition of the *Encyclopædia Britannica*, and in others. The recorded performance of one of these clocks which is given in some accounts of it, is evidently fabulous.

DEAD ESCAPEMENTS.

The escapement which has now for a century and a half been considered the best practical clock escapement (though there have been constant attempts to invent one free from the defects which it must be admitted to possess), is the *dead escapement*, or as the French call it with equal expressiveness, *l'echappement à repos*; because, instead of the recoil of the tooth upon the pallet which took place in the previous escapements, it falls dead upon the pallet and reposes there until the pendulum returns and lets it off again. It is represented in fig 5.

It will be observed that the teeth of the scape-wheel have their points set the opposite way to those of the recoil escapement in fig. 4, the wheels themselves both turning the same way, or (as our engraver has represented it) *vice versa*. The tooth B is here also represented in the act of dropping on to the right hand pallet as the tooth A escapes from the left pallet. But instead of the pallet having a continuous face as in

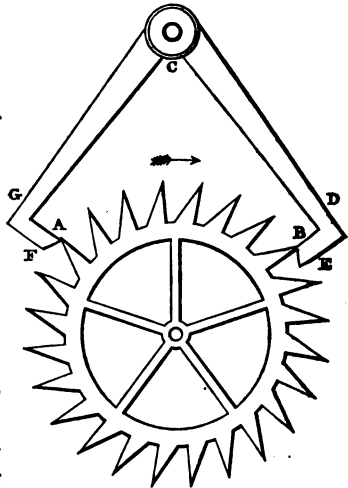

Fig. 5.

the recoil escapement, it is divided into two, of which BE on the right pallet and FA on the left are called the impulse faces, and BD, FG the dead faces. The dead faces are portions of circles (generally of the same circle), having the axis of the pallets C for their centre; and the consequence evidently is, that as the pendulum goes on, carrying the pallet still nearer to the wheel than the position in which a

tooth falls on to the corner A or B of the impulse and the dead faces, the tooth still rests on the dead faces without any recoil, until the pendulum returns and lets the tooth slide down the impulse face, giving the impulse to the pendulum as it goes.

The great merit of this escapement is that a moderate variation in the force of the clock train produces a very slight effect in the time of the pendulum. This may be shown in a general way, without resorting to mathematics, thus :— Since the tooth B drops on to the corner of the pallet (or ought to do so), immediately after the tooth A has escaped, and since the impulse will begin at B when the pendulum returns to the same point at which the impulse ceased on A, it follows that the impulse received by the pendulum before and after its vertical position is very nearly the same. Now that part of the impulse which takes place before zero, or while the pendulum is descending, tends to augment the natural force of gravity on the pendulum, or to make it move faster ; but in the ascending arc the impulse on the pallets acts against the gravity of the pendulum, and therefore tends to make it go slower ; and so the two parts of the impulse tend to neutralize each other's disturbing effects on the time of the pendulum, though they both concur in increasing the arc, or (what is the same thing) maintaining it against the loss from friction and resistance of the air. However, on the whole, the effect of the impulse is to retard the pendulum a little, because the tooth must fall not exactly on the corner of the pallet, but (for safety) a little above it ; and the next impulse does not begin until that same corner of the pallet has come as far as the point of the tooth ; in other words the retarding part of the impulse, or that which takes place after zero, acts rather longer than the accelerating part before zero. Again, the friction on the dead part of the pallets tends to produce the same effect on the time ; the arc of course it tends to diminish. For in the descent of the pendulum the friction acts against

gravity, but in the ascent with gravity, or accelerates the pendulum; and the action on the dead part of the pallets is a little shorter in the ascent than the descent. For these reasons the time of vibration of a pendulum driven by a dead escapement is a little greater than of the same pendulum vibrating the same arc freely; and when you come to the next difference, the variation of time of the same pendulum with the dead escapement under a moderate variation in the force is very small indeed; which is not the case in the recoil escapement, for there the impulse begins at each end of the arc, and there is much more of it during the descent of the pendulum than during the ascent from zero to the arc at which the escape takes place, and the recoil begins, on the opposite tooth; and then the recoil itself is an action on the pendulum in its ascent in the same direction as gravity, and therefore accelerative. And hence it is that an increase of the arc of the pendulum with a recoil escapement is always accompanied with a decrease of the time.

But something more than this general mode of reasoning is requisite in order to compare the real value of the dead escapement with others of equal or higher pretensions, or of the several contrivances that have been suggested for remedying its defects. In the year 1827, Mr Airy, the present astronomer royal, wrote a paper in the *Cambridge Philosophical Transactions*, vol. iii. p. 105, on the disturbances of pendulums and the theory of escapements, which, though erroneous in some of the practical conclusions, is extremely valuable as the mathematical foundation for subsequent investigations; it is too long to insert here, and it may be found in Pratt's *Mechanics*. We shall therefore take it up at the point which is convenient for making the proper deductions from it. He proved, that if ϕ is the disturbing force on the pendulum of length l at the angle θ from zero, a the extreme arc, and g the accelerating force of gravity, the increase of time of one vibration due to the disturbance

$$= \frac{l}{\pi g a^2} \int \frac{\phi \theta d\theta}{\sqrt{a^2 - \theta^2}}$$
 taken between the limits within which the disturbing force acts. He also gives an expression for the increase of the arc; but though of course mathematically correct, it is practically useless, because the increase of the arc for one vibration is no guide at all to what it will reach before the influence of friction and the resistance of the air prevents any further increase.

Proceeding with Mr Airy's formula for the variation of the time, and adopting the farther results obtained by Mr Denison in his paper of 1848, in the eighth volume of the *Cambridge Transactions*, let us call the angle which the impulse faces of the pallets make with the dead faces δ ; then, since the tooth, considered as a prolonged radius of the wheel, ought to be a tangent to the dead face, δ will also be the inclination of the tooth to the impulse face at the beginning of the impulse, and it may be assumed to remain the same throughout: though, in fact, it increases towards the end of the impulse. Let p be the distance of each pallet from their arbor, and Pg the moving force of the clock-weight referred to the points of the scape-wheel, after deducting the force required to move the train, M the mass of the pendulum (supposed to be a simple one) and l its length, and θ the angle which the pendulum makes with the vertical; then the equation of motion of the pendulum is

$$\frac{d^2 \theta}{dt^2} = - \frac{g}{l} \left(\theta + \frac{Pp \tan \delta}{Ml} \right)$$

and therefore ϕ , the disturbing force, is $\frac{g Pp \tan \delta}{Ml^2}$; and the increase of time for one vibration, which we may call

$$\Delta = \frac{Pp \tan \delta}{Ml \pi a^2} \int \frac{\theta d\theta}{\sqrt{a^2 - \theta^2}}$$

If β is the angle before zero at which the impulse begins, and γ the angle after zero at which it ends, and which is

necessarily rather larger than β , then this integral has to be taken between the limits $\theta = -\beta$, and $\theta = \gamma$, and the result is—

$$\Delta = \frac{Pp \tan \delta}{Ml \pi a^2} (\sqrt{a^2 - \beta^2} - \sqrt{a^2 - \gamma^2})$$

And as β and γ are always small compared with a , higher powers than $\frac{\gamma^2}{a^2}$ may be neglected, and the equation may as-

sume the simpler form $\Delta = \frac{Pp \tan \delta}{2 Ml \pi a^3} (\gamma + \beta) (\gamma - \beta)$.

Since in a well-made clock β may be made very nearly = γ , *i.e.* the tooth may be made to drop almost exactly on the corner of the dead face, Mr Airy concludes that "this escapement approaches nearly to absolute perfection." Mr Denison shows, however, that this conclusion is somewhat too rapid; that the accuracy which really is found in the going of a good clock of this kind is due to a cause not apparent in this value of Δ ; that an escapement of another kind, in which Δ is very much larger, admits of still greater perfection, inasmuch as it is not the magnitude but the variation of Δ which measures the goodness of the clock. And besides all this, the assumption that the friction of the pallets does not affect the performance of a dead escapement clock is very far from correct: on the contrary, it has generally more to do with the actual errors of time than all the other causes. In order to arrive at the actual amount of these errors we will proceed with the examination of the quantity Δ .

Let h be the daily fall of the clock-weight Wg , T the number of beats of the pendulum in the day (= 86400 if it is a seconds pendulum); the drop of the tooth at each beat is a little less than the thickness of the pallets, which = $p (\gamma + \beta) \tan \delta$; and therefore we may say (intending to make some deduction afterwards from the actual amount of W for the friction of the train and the loss of force at each drop)—

$$\Delta T = \frac{Wh (\gamma - \beta)}{Ml \ 2 \pi \ a^3}$$

in which you observe that $\gamma + \beta$ has disappeared: $\gamma - \beta$ is seldom made less than $30'$; and therefore we may put

$\frac{1}{720}$ for $\frac{\gamma - \beta}{2 \pi}$, and that reduces the equation to the simple form, $\Delta T = \frac{Wh}{720 \ Ml \ a^3}$.

Now, though the clock weight and its daily fall are constant in any given clock, yet the quantity of this moving force which arrives at the escapement is not constant, because it is diminished by friction, which varies with the state of the oil and other circumstances; and that produces the same effect as if the clock-weight itself varied. Let us call that variation of force on the escapement dW . The clock is also subject to variations of a , the arc of the pendulum, partly depending on these changes in the force of the clock train, but still more upon the variations in the friction on the pallets themselves, so that no definite relation can be established between any increase of arc da , and the variations of force or friction in the train. And in order to learn what effect is produced upon the rate of the clock by any given *small* changes in the arc or the force, we must differentiate the above equation, and we shall have (treating, as we shall throughout, the differences as finite)

$$d\Delta T = \frac{Wh}{720 \ Ml \ a^3} \left(\frac{dW}{W} - \frac{3 \ da}{a} \right)$$

And to this must be added a third term to express the circular error due to the increase of the arc from a to $a + da$. This, as stated before, is theoretically $+10800 \ a \ da$; but practically it is a great deal less, from the effect of the pendulum spring, which has a tendency to isochronize the pendulum, though all attempts to make it do so completely have failed, and no other figures can be given for estimating the actual amount of the circular error. The

quantity we have called $d\Delta T$ is that which is technically called the *daily rate*, only with the sign reversed, as the rate is always called + when the clock is gaining, and assuming the pendulum to be properly adjusted so that the daily rate, but for the escapement errors, would be 0.

Now, as to the numerical value of this quantity in seconds, or fractions of a second: in an ordinary astronomical clock, after allowing for the friction of the train, Wh may be taken as 2 lb. \times 9 in.: l is 39 inches, and M about 15 lb., and α the angle 2° is .035 in numerical value. Therefore

$\frac{Wh}{720 Ml \alpha^3} = 1$ second very nearly. As to the other parts

of the expression for $d\Delta T$, it generally happens that the clock gains if the arc falls off, which shows that the two +

terms, $\frac{dW}{W}$ and the circular error term, then preponde-

rate over the other, involving $\frac{da}{a}$. Sometimes, however, the

contrary is the case, as where the friction on the pallets alone is altered by oiling them, or by the self-polishing which they often perform for themselves in the course of a few months after the clock is made, especially in turret clocks. Mr Denison says in his Cambridge paper of 1853 (vol. ix.), that from experiments made for testing the value of an invention of Mr Loseby's in the Great Exhibition for rendering pendulums isochronous, as well as from observations made before, it is clear that not only can no isochronizing of the pendulum for different arcs counteract the errors of the dead escapement; but that when the variation of time is due to the change of pallet friction, it would be still worse with an isochronous pendulum, because the circular error (as the above equation shows) tends to counteract the other error which is due to the change of arc, da .

Mr Airy showed, in his before-mentioned paper, that the friction on the dead faces of the pallets, if it acted through exactly instead of nearly the same arc before and after zero,

would produce no direct effect upon the time. But it is a great mistake to infer that this friction does not materially affect the clock nevertheless. The fallacy of such an inference is shown at once by the above expressions for the escapement errors; for the effect of all the friction on the pallets is to reduce the arc, or to require a larger force to produce the same arc. And as the cube of the arc appears in the denominator, and a large increase of force is required to produce a small increase of arc, it is obvious that the friction on the pallets indirectly and largely increases all the errors of the escapement, although it may produce very little direct effect upon the time, as compared with that of a free pendulum vibrating the same arc. In order to diminish the friction and the necessity for using oil as far as possible, the best clocks are made with jewels (sapphires are the best for the purpose) let into the pallets. Mr Dent used them in the large clock at the Royal Exchange, probably the first time they had ever been used in a turret clock, though softer and cheaper stones had been occasionally used.

The pallets are generally made to embrace about one-third of the circumference of the wheel, and it is not at all desirable that they should embrace more; for the longer they are, the longer is the run of the teeth upon them, and the greater the friction. In the Great Exhibition Messrs Wagner of Paris had an apparatus for practically illustrating this, which however is obvious enough without any illustration. There is a good deal of difference in the practice of clockmakers as to the length of the impulse, or the amount of the angle $\gamma + \beta$. Sometimes you see clocks in which the seconds hand moves very slowly and rests a very short time, showing that $\gamma + \beta$ is large in proportion to $2a$; and in others the contrary. The transit clock at Greenwich was altered by the late Mr Dent to a short impulse, the escape taking place at only $30'$ after zero; and he was decidedly of opinion that a short impulse was the best, probably because

there is less of the force of the impulse wasted in friction then. It is not to be forgotten, as Mr Bloxam remarks in his paper on escapements in the *Transactions of the Astronomical Society* for 1853, that the scape-wheel tooth does not overtake the face of the pallet immediately, on account of the moment of inertia of the wheel. The wheels of astronomical clocks, indeed of all English house-clocks, are generally made too heavy, especially the scape-wheel, which by increasing the moment of inertia, requires a larger force, and consequently more friction. We shall show presently, from another escapement, how much of the force is really wasted in friction in the dead escapement.

But before proceeding to other escapements, it is proper to notice a very useful form of the dead escapement, which is adopted in many of the best turret clocks, called the *pin-wheel escapement*, the invention of which is commonly ascribed to Lepaute of Paris about the middle of the last century, though it appears to have been used as early by Whitehurst of Derby. Fig. 6 will

sufficiently explain its action and construction. Its advantages are:—that it does not require so much accuracy as the other; if a pin gets broken, it is easily replaced, whereas in the other the wheel is ruined if the point of a tooth is injured; a wheel of given size will work with many more pins than teeth, and therefore a train of less velocity will do, and that in fact sometimes amounts to a saving of one wheel in the train, and a good deal of friction; and

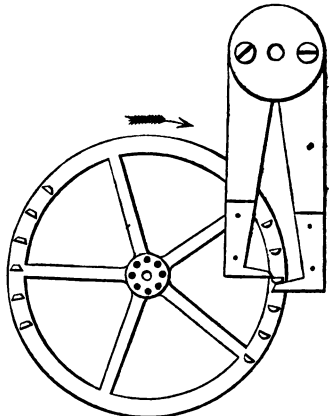

Fig. 6.

the blow on both pallets being downwards, instead of one up and the other down, the action is more steady; all of which things are of more consequence in the heavy and rough work of a turret clock than in an astronomical one. The pins are generally semicylinders, as the upper half of the cylinder would obviously be of no use, and would waste nearly half the force in drop without action. But when the wheel is small, and the pallets short, as they ought to be for the reason before given, it is impossible to get a short angle of escape with semicylindrical pins unless they are very small, and therefore Mr Denison suggested the form on the left side of fig. 6, which Mr Dent used in his Great Exhibition clock, and subsequently in others. The pins are bits of brass wire driven into the wheel, about ten for every inch of diameter, and then the upper half, and a small slice of the bottom, cut off in a cutting engine. The distance of the lowest pallet from their axis should not be more than the diameter of the wheel. The cross section of pallets as now generally made is convex, and not flat, which involves greater accuracy, and therefore greater risk of inaccuracy. It has also been found expedient to make the dead faces not quite dead, but with a very slight recoil, which rather tends to check the variations of the arc, and also the general disposition to lose time if the arc is increased; when so made, the escapement is generally called "half-dead."

Passing by the various other modifications of the dead escapement which have been suggested and tried with little or no success, we proceed to describe one of an entirely different form, which was patented in 1851 by Mr C. Macdowall of Hyde Street, Bloomsbury, though it appeared afterwards that one very similar to it had been tried before, but failed from the proportions being badly arranged. It is represented in fig. 7. The scape-wheel is only a small disc with a single pin in it, made of a ruby, parallel, and very near to the arbor. The disc turns half round at every beat of the

pendulum, and the pin gives the impulse on the vertical faces of the pallets, and the dead friction takes place on the horizontal faces. Its advantages are, that the greatest part of the impulse is given directly across the line of centres, and consequently with very little friction; and therefore, also, the friction on the dead faces is less than usual, and scarcely any oil is required; it is also very easy to make. But there must be two more wheels in the train, consuming a good deal of the force of the clock-weight by their friction, which rather more than makes up for the friction saved in the escapement. It has however been applied successfully to watches, and they appear to be affected by cold less than the common lever watch with its oblique impulse, exactly like that of the common dead escapement. A prize medal was awarded for it in the Exhibition. In order to make the angle of escape not more than 1° , the distance of the pin from the centre of the disc must not be more than $\frac{1}{80}$ th of the distance of centres of the disc and pallets.

With the view of getting rid of one of these extra wheels in the train, and that part of the impulse which is least effective and most oblique, Mr Denison shortly afterwards invented what he called the *three-legged dead escapement*; which, though he afterwards superseded it by his *three-legged gravity escapement*, is still worth notice on account of the exceedingly small force which it requires, thereby giving a practical proof of the large proportion of the force which is wasted in friction in all the other impulse escapements.

In fig. 8, the three long teeth of the scape-wheel are

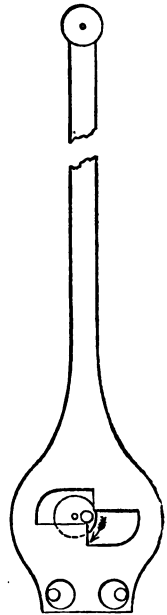

Fig. 7.

only used for locking on the dead pallets DE, which are set on the front of the pallet plate; AB are the impulse pallets, being hard bits of steel or jewels set in the pallet plate; and they are acted on by the three sharp-edged pins which are set in the scape-wheel pointing backwards. As soon as the pendulum moves a little further to the left than is here shown, the long tooth will slip past the dead pallet or stop D, and the pin at B will run after and catch the corner of that impulse pallet and drive it until the wheel has turned through 60° , and then it will escape; and by that time the uppermost tooth will arrive at the stop E, and will slide along it as in the common dead escapement, but with a pressure as much less than that which gives the impulse as the points of the teeth are further from the centre of the wheel than the impulse pins are. But the impulse is here given with so little friction, that even where the points of the teeth were made identical with the pins, the clock-weight required to keep the same pendulum with the same train (a common turret-clock movement), swinging the usual arc of 2° , was only *one-fifth* of what had been required with the common pin-wheel escapement. It appears also that it would be possible so to adjust the recoil of the half-dead pallets that the time would not be affected by any small variation of the force and the arc; since it was found that, when a certain amount of recoil was given, the clock gained instead of losing, under an increase of arc due to an increase of clock-weight. And if the force were kept constant by a train-remontoire, such as will be described here-

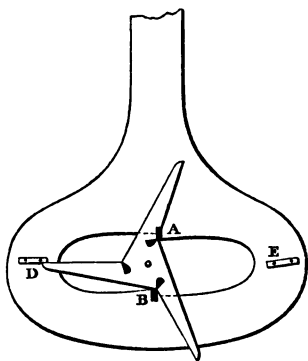

Fig. 8.

only used for locking on the dead pallets DE, which are set on the front of the pallet plate; AB are the impulse pallets, being hard bits of steel or jewels set in the pallet plate; and they are acted on by the three sharp-edged pins which are set in the scape-wheel pointing backwards. As soon as the pendulum moves a little further to the left than is here shown, the long tooth will slip past the dead pallet or stop D, and the pin at B will run after and catch the corner of that impulse pallet and drive it until the wheel has turned through 60° , and then it will escape; and by that time the uppermost tooth will arrive at the stop E, and will slide along it as in the common dead escapement, but with a pressure as much less than that which gives the impulse as the points of the teeth are further from the centre of the wheel than the impulse pins are. But the impulse is here given with so little friction, that even where the points of the teeth were made identical with the pins, the clock-weight required to keep the same pendulum with the same train (a common turret-clock movement), swinging the usual arc of 2° , was only *one-fifth* of what had been required with the common pin-wheel escapement. It appears also that it would be possible so to adjust the recoil of the half-dead pallets that the time would not be affected by any small variation of the force and the arc; since it was found that, when a certain amount of recoil was given, the clock gained instead of losing, under an increase of arc due to an increase of clock-weight. And if the force were kept constant by a train-remontoire, such as will be described here-

after, there would in fact be nothing capable of altering the arc or the time. But on account of the small depth of intersection of the circles of the pins and the pallets, on which its action depends, this escapement requires very careful adjustment of the pallets; and considering the superior qualities of the corresponding gravity escapement, it is not likely to be used, except perhaps in clocks required to go a long time, in which economy of force is a matter of consequence. The pallets should be connected with the pendulum by a spring fork (which indeed is advisable in the other dead escapements with a heavy pendulum, especially the pin-wheel escapement), to prevent the risk of their driving backwards against the scape-wheel when it is not in motion, as it will not clear itself. The distance of the centres should be not less than 25 times the radius of the circle of the edges of the impulse pins.

REMONTAIRE, OR GRAVITY ESCAPEMENTS.

A remontoire escapement is one in which the pendulum does not receive its impulse from the scape-wheel, but from some small weight or spring which is lifted or wound up by the scape-wheel at every beat, and the pendulum has nothing to do with the scape-wheel except unlocking it. When this impulse is received from a weight the escapement is also called a *gravity escapement*; and inasmuch as all the remontoire clock escapements that are worth notice have been gravity escapements, we may use that term for them at once. The importance of getting the impulse given to the pendulum in this way was recognised long before all the properties of the dead escapement, as above investigated, were known. For it was soon discovered that, however superior to the old recoil escapement, it was far from perfect, and that its success depended on reducing the friction of the train and the pallets as far as possible, which involves the necessity of high-numbered pinions and wheels, small pivots, jewelled pallets, and a generally expensive

style of workmanship. Accordingly the invention of an escapement which will give a constant impulse to the pendulum, and nearly free from friction, has been for the last century the great problem of clock-making. We can do no more than shortly notice a very few of the attempts which have been made to solve it. The most simple form of gravity

escapement, and the one which will serve the best for investigating their mathematical properties (though it fails in some essential mechanical conditions) is that invented by Mudge. The tooth A of the scape-wheel in fig. 9 is resting against the stop or detent *a* at the end of the pallet CA, from the axis or arbor of which descends the half fork CP to touch the pendulum. From the other

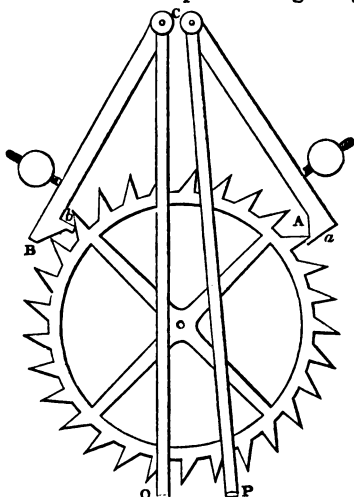

Fig. 9.

pallet CB descends the other half fork CQ. The two arbors are set as near the point of suspension, or top of the pendulum spring, as possible. The pendulum, as here represented, must be moving to the right and just leaving contact with the left pallet and going to take up the right one; as soon as it has raised that pallet a little it will evidently unlock the wheel and let it turn, and then the tooth B will raise the left pallet until it is caught by the stop *b* on that pallet, and then it will stay until the pendulum returns and releases it by raising that pallet still higher. Each pallet therefore descends with the pendulum to a lower point than that where it is taken up, and the difference between them

is supplied by the lifting of each pallet by the clock, which does not act on the pendulum at all ; so that the pendulum is independent of all variations of force and friction in the train.

If the angle of the pendulum after zero, at which it takes up the pallet is called γ , and that at which it leaves the other $\pm \beta$, according as the pendulum is then ascending or descending, the impulse is received through $\gamma \pm \beta$. And if one pallet is taken up just when the other is left, the angle of impulse becomes 2γ , equally divided on each side of zero. Let P be the mass, and therefore Pg the weight of each pallet, p the distance of its centre of gravity from the axis C , and δ the angle which a straight line from C to that centre of gravity would make with the pendulum when they are in contact ; M the mass, and l the length of the pendulum, as before ; then the equation of motion of the pendulum (omitting the small moment of inertia of the pallets as immaterial to this investigation) will be—

$$\frac{d^2 \theta}{dt^2} = -\frac{g}{l} \left\{ \sin \theta + \frac{Pp \sin (\delta + \theta)}{Ml} \right\}$$

This will expand into terms containing $\sin \theta$, for which θ may be substituted because it is very small, and one involving $\cos \theta$, which for the same reason may be treated as $= 1$; those containing θ only produce a permanent alteration of the time, just as if l was altered ; the other is the term to which the escapement errors are due. Mr Denison shows, by following up Mr Airy's calculations, that from this equation may be deduced the result, that the daily increase of time over that of the same pendulum swinging freely, due to this cause, may be thus expressed :—

$$\Delta T = -\frac{Wh(\sqrt{a^2 - \gamma^2} + \sqrt{a^2 - \beta^2})}{Ml \pi a^2 (\gamma + \beta)}$$

Wh being the clock-weight \times its daily fall, after deducting for all the friction involved in moving the train and lifting the pallets. If the descending pallet is left by the pen-

dulum before zero, we must remember that $\gamma + \beta$ becomes $\gamma - \beta$, and consequently ΔT much larger than where the impulse is given through the middle of the arc. If one pallet is taken up by the pendulum just when it leaves the other (which is the best form of the escapement), then $\beta = \gamma$, and the expression assumes the more simple form—

$$\Delta T = - \frac{Wh}{Ml \pi a^2} \sqrt{\frac{a^2}{\gamma^2} - 1}.$$

The - sign indicates that the rate of a pendulum with this escapement is faster than without it, and the difference is a good deal more than the difference the other way in the case of a dead escapement. Hence too it follows that if you reduce the arc in a gravity escapement by lightening the pallets, the clock will not gain, but lose, because lightening the pallets is lowering the centre of gravity of the compound pendulum, which is formed by the pendulum and pallets together. But it does not follow that a gravity escapement must therefore be inferior to a dead one; for the going of the clock depends not on the magnitude, but on the variation, of this quantity ΔT ; and where a gravity escapement is free from the usual mechanical defects, which will be noticed presently, the variation of rate can only arise from some slight change in the arc, owing to a change in the density of the air or in the very small friction of the pallets on their pivots or on the stops. We must therefore differentiate ΔT with regard to a , and then we have—

$$d\Delta T = \frac{Wh}{Ml \pi a^2} \frac{\frac{a^2}{\gamma^2} - 2}{\sqrt{\frac{a^2}{\gamma^2} - 1}} \frac{da}{a}$$

And it is evident that if γ is made $= \frac{a}{\sqrt{2}} = \cdot71a$, this quantity vanishes altogether: that is to say, the variation of the difference of time of a gravity escapement pendulum from a free pendulum of the same length may be made *nothing* by

making the difference itself a *maximum*; for this happens to be a maximum, and not a minimum, though the result would of course be the same in that case, by virtue of the well-known property of maxima and minima. And it is not necessary to adhere strictly to this proportion of a and γ . Mr Denison found that, after allowing for the friction of the train, the quantity $\frac{Wh}{Ml}$ cannot be more than $\frac{1}{1\frac{1}{2}0}$ in the great Westminster clock; and Mr Bloxam found it rather more in an astronomical clock pendulum, as it ought to be, because a light pendulum loses more of its vibration by the resistance of the air than a heavy one; and it will be seen, by applying this value to the above expression for the rate, that the variation will be quite inconsiderable for any such change of arc as is likely to occur in a gravity escapement, even if γ be made as small as $\frac{a}{3}$.

In those escapements where the pendulum leaves one pallet before it takes up the other, the expression for the variation of rate is

$$d\Delta T = \frac{Wh da}{Ml \pi a^3 (\gamma + \beta)} \left\{ \frac{a^2 - 2\gamma^2}{\sqrt{a^2 - \gamma^2}} + \frac{a^2 - 2\beta^2}{\sqrt{a^2 - \beta^2}} \right\}$$

remembering that if the descending pallet is left before zero, $\gamma + \beta$ becomes $\gamma - \beta$; from which it is evident that that kind of escapement is very inferior to the other, although the pendulum being left free in the middle of its swing has a tempting appearance. Indeed this result may be easily arrived at without mathematics, because the angle through which the impulse is given (the difference between the drop and the lift of each pallet), is necessarily smaller when one is dropped before zero; and consequently any given variation of the arc of vibration bears a larger proportion to the arc of impulse, and also to the whole arc through which the pallets act on the pendulum at all. This expression however may be reduced to 0 like the former one, by making α , β , and γ satisfy a certain condition, viz. :—

$$\sqrt{a^2 - \gamma^2} \sqrt{a^2 - \beta^2} = \frac{a^2}{2}$$

Thus if $\gamma = 90'$ instead of $85'$, $\pm \beta$ should = $78'$, a being taken at 2° as usual ; but for the reason just now given, any deviation from these proportions will produce much larger errors where the descending pallet is left before zero than where it is left just when the other is taken up. Mr Bloxam notices the changes of the density of the air as sensibly affecting the arc and the rate of a gravity escapement pendulum ; probably they affect a dead escapement less, because there the friction on the pallets greatly preponderates over every other cause of disturbance. He says (p. 133, note), that though "it has been repeatedly *proved* in works on dynamics that the resistance of the air does not alter the time of vibration, this is only true on the supposition that the resistance is the same in the ascent and the descent;" whereas the current produced by the increasing velocity in the descent prevents the ascent from being retarded as it would be if the air were at rest ; and he has no doubt that any increased density of the air makes the pendulum go slower ; as indeed it must from this cause also, that it practically diminishes the specific gravity of the pendulum ; and therefore a rise of the barometer tends to make the clock gain, some persons have thought, as much as $\frac{1}{4}$ or $\frac{1}{2}$ of a second a-day for one inch. But there does not seem yet to exist any sufficient collection of experiments to allow a definite conclusion to be arrived at as to the magnitude of this disturbance. No doubt the resistance of the air tends to diminish considerably the effect of the circular error, which Mr Bloxam and others have found to be always much less than its theoretical value, even judging from the dead escapement with its large amount of friction.

Besides the above mathematical condition, there are several mechanical ones which are still more essential to the success of a gravity escapement. The first is, that it must be safe from what is called *tripping*. Referring again to

fig. 9, it will be seen at once that if the scape-wheel should happen to move too fast when it is released, the left pallet will not be raised gradually by the tooth B, but be thrown up with a jerk, perhaps so high that the tooth slips past the hook; and then not only will that tooth slip, but several more, and at last when the wheel is stopped it will be running fast, and the points of some of the teeth will probably be bent or broken by catching against the pallet. And even if the pallet is not raised high enough for the tooth to get past or completely trip, it may still be raised so high that the point of the tooth does not rest on the hook exactly where the slope of the pallet ends, but lower, and the friction between them is quite enough to keep the pallet there; and consequently the pendulum does not begin to lift it at the angle γ , but at some larger angle; and as the pallet always descends with the pendulum to the same point the duration of the impulse is increased, and the pendulum made to swing farther. Mr Denison calls this *approximate tripping*, and though not so injurious to the clock as actual tripping, it is obviously fatal to its accurate performance, though it appears not to have been noticed before. Various contrivances have been resorted to for the purpose of getting rid of the liability to trip. Cumming, the first inventor of gravity escapements, used two pairs of pallets, one pair being only for the locking, and not lifted at all by the scape-wheel, but only by the pendulum; and this was effectual; but still the teeth suffered in time from the constant blows on the pallets, and the friction at unlocking was considerable. Hardy's escapement was just the same in principle, but worse, because he set the four pallets on springs instead of pivots, which being stronger in cold weather, and acting on the pendulum at the extremity of its arc, made the clock gain in winter; and accordingly his escapement was taken out of the transit clock at Greenwich by Mr Dent, and replaced by a dead escapement, with a short angle of escape, as before mentioned. The late Captain Kater invented an

escapement in which he attempted to get rid of tripping by making the impulse pallets drop on to an anchor, like that of a dead escapement with the impulse faces cut off, and so unlock the wheel by their own weight. Mr Gowland's escapement was on the same principle as regards the unlocking, but he provided against tripping by putting paddles on to the pallets descending into a pot of oil. M. Gannery of Paris had an escapement in the Great Exhibition also on this principle as to the unlocking, but to prevent the trip he gave the wheel only a few teeth and a long run, with a very gradual rise of the pallets. Mr Bloxam had previously done the same thing with a wheel also of nine teeth, and with much less friction, as will be noticed presently. But on account of the delicacy required in all of these escapements (which we select out of a multitude of others as the best of their respective classes), and other objections, none of them have ever come into use. In fact, none of the inventors of them seem to have felt sufficient confidence in their success to venture upon a coarse and cheap train of wheels; whereas, if a gravity escapement is not so independent of the force of the train that all variations in its friction may be disregarded, it fails in the most essential point, and descends to the condition of a common impulse escapement.

For this reason also it is necessary that it should be independent of oil, or, at any rate, that the friction which affects the pendulum in unlocking should be so small that no difference can be perceived in the arc whether oil is used or not. The oil in the parts which do not affect the pendulum is of no consequence, for the same reason that the friction of the train is of no consequence—if the escapement is what it professes to be. And lastly, it is essential to the success of a gravity escapement that it should be easy to make and tolerably cheap; for, considering the accuracy of performance which can be attained by a highly finished dead escapement clock, there is no chance of superseding it unless you can get at least as much accuracy

with less expense. The only one of the above-mentioned escapements which approaches near enough to satisfying all these conditions to be worth any further description is Mr Bloxam's; and we accordingly give a sketch of it in fig. 10, which is copied (with a little alteration for distinctness) from his own description of it, communicated in 1853 to the Astronomical Society, some years after he had had it in action in a clock of his own; it had also been before described in Mr Denison's book. This drawing will enable any one conversant with these matters to understand its action. He made the pallet arbors cranked, to embrace the pendulum spring, so that their centres of motion might coincide with that of the pendulum as nearly as possible; perhaps an unnecessary refinement; at least the three-legged gravity escapement which we shall presently describe, answers very well

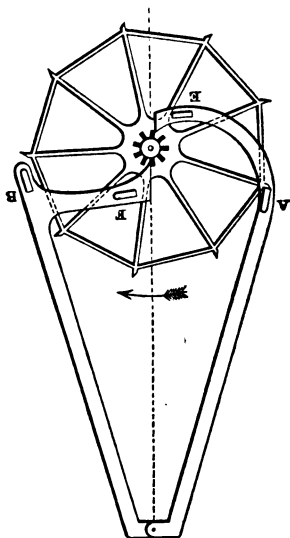

Fig. 10.

with the pallet arbors set on each side of the top of the spring. The size of the wheel determines the length of the pallets, as they must be at such an angle to each other that the radii of the wheel when in contact with each stop may be at right angles to the pallet arm; and therefore, for a wheel of this size the depth of locking can only be very small. The pinion in Mr Bloxam's clock only raises the pallet through $40'$ at each beat, *i. e.* the angle which we called γ is only $20'$; and probably if it were increased to anything like $\frac{\alpha}{\sqrt{2}}$ the escape-

ment would trip immediately. The two broad pins marked E, F, are the fork-pins. The clock which Mr Bloxam had, went very well; but it had an extremely fine train with pinions of 18; and we know that the late Mr Dent was always afraid to adopt the escapement, on account of the great delicacy involved in it; and though the consequent expense would have been of little consequence in the great Westminster clock, yet the risk of the teeth breaking if the wheel got a run, from any accidental lifting of the pallets, and the apparent impossibility of making γ even nearly satisfy the proper mathematical condition without risk of tripping, were considered by the Astronomer Royal and Mr Denison sufficient reasons for not requiring it to be introduced. It should, however, be stated that Mr Bloxam is of opinion that $a = 5 \gamma$ is a better proportion than $a = 3 \gamma$, to counteract the variation of density of the air. It was not till nearly a year after the Westminster clock was begun, that Mr Denison converted his three-legged dead escapement into the gravity escapement, which is used there, and which we shall now describe. It will be observed that in fig. 11 the three teeth or legs are no longer straight, as in fig. 8, but bent, so that the lifting pins and the points of the teeth would lie alternately on the radii of a hexagon. The pins too are no longer sharp, but plain bits of brass wire rivetted into the scape-wheel, which is of steel, in an astronomical clock about $\frac{1}{8}$ th inch thick, and $\frac{1}{2}$ th in a turret clock. The pins raise the pallets by the projecting faces A, B, and the long teeth rest on the stops D, E, which are bits of steel screwed on, and hardened after they are adjusted. The points of the teeth are about six times as far from the centre as the pins are, and consequently their pressure on the stops is not enough to hold the pallets up if they do by accident get thrown too high; and thus the effects of approximate tripping are prevented; for the pallet immediately falls down again, and rests against the pin which lifted it until the pendulum returns and carries

it off: moreover the friction at unlocking is thus rendered insensible. The beat is adjusted by two thumb screws with broad and slightly convex steel heads set in the pendulum rod, which are embraced by brass fork pins from the bottom of the pallets. In turret clocks, where there is plenty of room, there are no beat screws, but the fork pins are made eccentric and so adjustable by the nuts which fix them to the pallets. In the finest clocks the lifting faces of the pallets are jewelled, so that no oil is required. In turret clocks, however, there has been a striking proof that the escapement is sufficiently independent of oil; for the first of these clocks was sent out to the cathedral at Fredericton (indeed Mr Denison was led to invent it from being requested to see if any clock could be made which would go tolerably well through the cold of 40° below zero, which they have there in winter), and the person who takes care of it reports that he could observe no variation of the arc during the last winter, even while the oil was frozen as hard as tallow.

But we have not yet noticed a very material feature in this

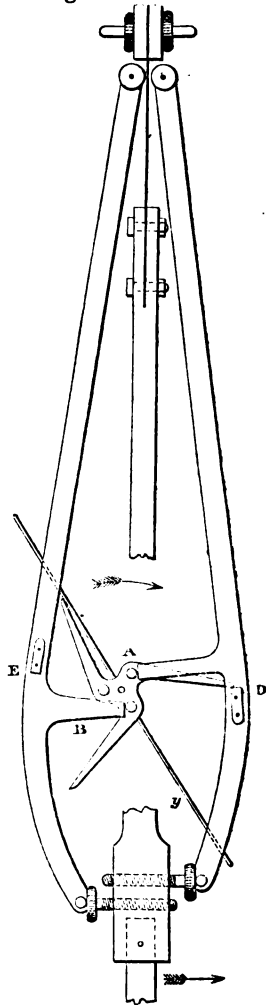

Fig. 11.

escapement, viz., the fly, which is set on the scape-wheel arbor, with a friction spring, just like a common striking fly. It is this which moderates the velocity and renders it safe against tripping, and against any damage to the teeth from an accidental run, the motion of 60° at each beat being quite enough to render the fly effective. In turret clocks the fly is made about 5 inches long in each vane, and $1\frac{1}{4}$ broad; in regulators, or clocks of astronomical size, about $1\frac{1}{2}$ long and $\frac{3}{4}$ broad. The stop E, which is struck upwards, should be set a little higher than the scape-wheel centre; for if not, the blow has a tendency to throw the pallet out and make it trip, if the force is much increased; the other stop D may be about on a level with the centre. The distance of the pins from the centre may be about $\frac{1}{3}$ th of the distance of that centre from the pallet arbors; and the weight of the pallets should be such as to make the pendulum swing not less than 2° , nor more than $2\frac{1}{2}^\circ$: this makes $\alpha = 3\gamma$ or thereabouts. In regulators, the distance of centres has been generally made 6 inches (the scape-wheel being put near the bottom instead of the top of the frame), and in turret clocks 9 inches, except in the great Westminster clock, where it is 12 inches, on account of the great size of the pendulum, which was made before this escapement was invented. For, besides the other advantages, it supersedes the necessity for a long and heavy pendulum, which is generally wanted to resist the variations of force in the escapement; but here no such variations exist, at least none that reach the pendulum. There seems, however, one objection to it for observatory clocks, viz., that the beat makes very little noise; perhaps it might be made loud enough by increasing the weight of the scape-wheel, so as to make the blow on the pallets heavier. Before it was adopted for the Westminster clock, it was tried at the Royal Observatory in a common regulator; and Mr Airy, who was, as we have seen, not likely to be prejudiced in favour of gravity escapements, expressed his complete satisfaction with

its performance, after trying upon it what he described as some "malicious experiments." Several clocks of this kind have been since made by Mr Dent and a few other clock-makers, the turret clocks with cast-iron wheels, and the regulators with pinions of only 8 and even 6 leaves ; and the weight may be doubled without affecting the arc or the rate. It only remains to be added, that it is very easy to make, and requires less delicacy than the common dead escapement ; and as it is not patented, it may be made by anybody. We may now proceed to matters involving merely mechanical, and not mathematical considerations.

GOING BARRELS.

A clock which is capable of going accurately must have some contrivance to keep it going while you are winding it up. In the old-fashioned house-clocks which were wound up by merely pulling one of the strings, and in which one such winding served for both the going and striking parts, this was done by what is called the endless chain of Huygens, which consists of a string or chain with the ends joined together, and passing over two pulleys with deep grooves and spikes in them, so that the chain cannot slip. In one of the two loops or festoons which hang down from the upper pulleys, is a loose pulley, without spikes, carrying the clock-weight, and in the other a small weight only heavy enough to keep the chain close to the upper pulleys. Now, suppose one of those pulleys to be on the arbor of the great wheel of the striking part, with a ratchet and click, and the other pulley fixed to the arbor of the great wheel of the going part. Then (whenever the clock is not striking) you may pull up the weight by pulling down that part of the string which hangs down from the other side of the striking part ; and yet the weight will be acting on the going part all the time. And it would be just the same if you wound up the striking part and its pulley with a key, instead of pulling the string ; and also the same, if there were no striking

part at all, but the second pulley were put on a blank arbor, except that in that case the weight would take twice as long to run down, supposing that the striking part generally requires the same weight \times fall as the going part.

This kind of "going barrel," however, is evidently not suited to the delicacy of an astronomical clock; and Harrison's going ratchet is now universally adopted in such clocks, and also in chronometers and watches, for keeping the action of the train on the escapement during the winding. This fig. 12 (in which the same letters are used as in the corresponding parts of fig. 1) shows its construction. The click of the barrel ratchet R is set upon another larger ratchet-wheel, with its teeth pointing the opposite way, and its click r T is set in the clock-frame. That ratchet is connected with the great wheel by a spring $s s'$ pressing against the two pins s in the ratchet, and s' in the wheel.

When you wind up the weight (which is equivalent to taking it off), the click $T r$ prevents that ratchet from turning back or to the right; and as the spring $s s'$ was kept by the weight in a state of tension equivalent to the weight itself, it will drive the wheel to the left for a short distance, when its end s is held fast,

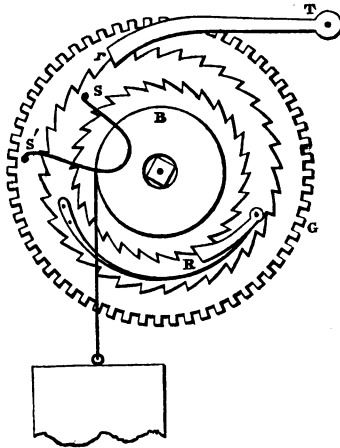

Fig. 12.

with the same force as if that end was pulled forward by the weight; and as the great wheel has to move very little during the short time the clock is winding, the spring will keep the clock going long enough.

In the commoner kind of turret clocks a more simple apparatus is used, which goes by the name of the *bolt and shutter*, because it consists of a weighted lever with a broad end, which shuts up the winding hole until you lift it, and then a spring-bolt attached to the lever, or its arbor, runs into the teeth of one of the wheels, and the weight of the lever keeps the train going until the bolt has run itself out of gear. This spring bolt is sometimes made—and by manufacturers of turret clocks, who ought to know better—in the form of a click, so contrived that in one position of the wheel teeth it will not fall between them, but jams against the top, and stops the clock at once. Moreover, in the common construction of this apparatus there is nothing to ensure its being raised high enough to keep in gear the whole time of winding, if the man loiters over it, or, on the other hand, to enable him to take it out of action when he has done. For this purpose Mr Denison recommends the arbor of the bolt and shutter to be made to *pump* in and out of gear; and, instead of the shutter covering the winding hole, to let it end in a circular arc advanced just far enough to prevent the key or winder from being put on, by obstructing a ring set on the end of the pipe. In order to get the winder on, you must raise the lever high enough for the arc to clear the ring. During the two or three minutes which the clock may take to wind the arc will be descending again behind the ring, so that now you cannot get the winder off again without also pulling the maintaining power out of gear; so that even if it is constructed to keep in action ten minutes, if required, still it will never remain in action longer than the actual time of winding.

In clocks with a train remontoire it is hardly safe to rely on a spring going barrel; and, accordingly, in the Royal Exchange clock, Mr Dent adopted a self-acting gravity one, invented by Mr Airy; but on account of the great expense involved in it, it has never been used again; and where it is of consequence (which it seldom can be

in a large clock) to avoid the duplication of force for the moment before the man begins winding, and after he has done, it may be done by a self-acting apparatus of very simple character which Mr Denison contrived for the great Westminster clock, because such a large clock would require an inconveniently heavy bolt and shutter work, if it was to be done in that way. In that clock a bar hangs obliquely from the arbor of the great wheel, behind it; and in the lower end of this bar is the pivot of the arbor of the winding pinion, and it has a click which takes into a ratchet cast on the back of the great wheel. When you begin to wind up, the bar is prevented from running upwards by the click, and for the time it becomes the same as if the back pivot of the winding arbor, or the fulcrum for turning the winding pinion, was in the great wheel itself; and consequently the act of winding, or turning the barrel to the left by means of the wheel on its end, close to the great wheel, tends also to turn the great wheel itself to the right, which is its proper direction. In fact, the force upon it is rather greater in winding than when not winding, which is of no consequence; if it were, it might be compensated by weighting the lever to the amount of the difference. The winding arbor is very long, the clock frame being no less than $4\frac{1}{2}$ feet wide, and therefore its angular play in the front pivot-hole during the time of winding is very little. It pumps out, so as to pull the pinion out of gear with the winding wheel.

EQUATION CLOCKS.

It is hardly worth while to occupy any space in describing a machine so nearly obsolete as what used to be called *equation* (*i. e.* equation of time) *clocks*. Their object was to show true solar, or sundial time, instead of mean solar time, which, as we all know from the almanacs, is as much as 16 minutes behind the sun in November, and 14 minutes before it in February, and they only agree four times in the year. These clocks were never much used in England:

in Paris, even the public clocks, until the year 1826, were furnished with equation work so as to show solar time. But as the principle of this machinery is remarkable, and may be useful for some other purposes, we will shortly indicate the nature of it.

In fig. 13 let Aa be the hour-wheel of the common dial work, with its arbor prolonged to C , and turning the opposite way to what the hands are intended to turn. The minute-hand is set on a pipe b of the wheel Bb , which rides on the arbor aC . Both of these are bevelled wheels of the same number of teeth, and they are connected by an intermediate bevelled wheel or pinion D , of any number. This pinion rides on the end of the bar ED , which itself rides on the arbor aC , at right angles to it. Now, so long as the end D of the bar ED is held fast, the wheel B , which carries the hand, will turn in one hour exactly as A does, only the opposite way. But if while A is moving uniformly with the clock train, we move ED with its pinion, it will evidently superadd another motion to B besides that which it receives from A . If we move ED through a in the same direction as B is naturally moving, it will give B an additional motion of $2a$; and if we move the bar the other way it will diminish B 's motion by the same angle $2a$. If then the end of the bar is made to travel on the edge of a plate of the shape shown at Qq , turning in a year on a centre O , the hand wheel will be constantly accelerated or retarded from the mean time of the other wheel, according as the point of the plate in contact with D is at a longer or shorter distance

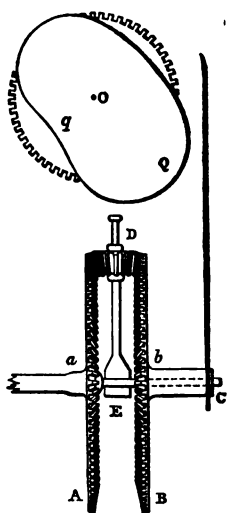

Fig. 13.

from its centre O than the average. The equation plate of course is not really in the position drawn here in order to exhibit its shape, but in a plane parallel to the wheels A and B , and it is driven by a slow train of wheels or an endless screw from the arbor a . Instead of bevelled wheels, it will be the same thing if we put a common pinion between a common spur-wheel on the arbor a , and an internal wheel (*i. e.* a wheel with teeth on the inside of its rim) in the place of B ; only in that case the two wheels will move with different velocities in proportion to the numbers of their teeth. The pinion between them rides on a stud in the side of the bar, which rides on the main arbor at one end, and the other end rests on the equation plate, as before. Or again, it may be done without either bevelled or internal wheels, by an arrangement like that which we shall have to describe (see fig. 16) under the head of train remontoires. Professor Willis, in his *Principles of Mechanism*, gives the name of *encyclical trains* to all these arrangements for adding a secondary motion to a wheel without interfering with the primary motion which it receives from the principal train.

We cannot stop to describe the various contrivances for making clocks show the days of the month, periods of the moon, and other phenomena. The old day of the month clocks required setting at the end of every month which has not 31 days, and have long been obsolete. We have lately seen some cheap clocks made at Wolverhampton (the first attempt at rivalling the American clocks) with day of the month work which does not require setting; but it would take more space to describe than our limits allow, and we must proceed to matters of more common use.

STRIKING CLOCKS.

There are two kinds of striking work used in clocks. The older of them, which is still used in all the foreign clocks, and in most turret clocks in England also, will not allow the

striking of any hour to be either omitted or repeated, without making the next hour strike wrong ; whereas, in that which is used in all the English house clocks, the number of blows to be struck depends merely on the position of a wheel attached to the going part ; and therefore the striking of any hour may be omitted or repeated without deranging the following ones. In turret clocks there is no occasion for the repeating movement ; and for the purpose of describing the other which is called the *locking-plate* movement, we may as well refer to fig. 18, which is the front view of a large clock, striking both hours and quarters on this plan. In the hour part (on the left), you observe a bent lever BAH, called the "lifting piece," of which the end H has just been let off by the snail on the hour wheel 40 of the going part ; and at the other end there are two stops (not shown in the drawing as they were intended to be), one behind, and rather below the other ; and against the upper one the bent end of a short lever 9 B, which is fixed to the arbor of the fly, is now resting. We omit the description of the action of the wheels, because it is evident enough. At D may be seen a piece projecting from the lever AB, and dropping into a notch in the wheel 78. That wheel is the locking wheel or locking plate ; and it has in reality notches such as D all round it, at distances 2, 3, up to 12, from any given point in the circumference, which may be considered as marked off into 78 spaces, that being the number of blows struck in 12 hours. These notches are shown in the locking plate of the quarter part in fig. 18, but not in the hour part, for want of size to show them distinctly. Now, when the arm AB of the lifting piece is raised by the snail a few minutes before the hour, the fly-pin slips past the first of the stops at B, but is stopped by the second and lower one, until the lever is dropped again exactly at the hour. Thus the pin can pass, and would turn once round freely, allowing the train to go on a little ; but before it has got once round, the lifting piece has been lifted again high enough to

let both stops clear the fly-pin, by means of the cylinder, with two slices taken off it, which is set on the arbor of the wheel 90, and on which the end of the lifting piece rests by means of a small roller (to diminish the friction). If the clock has only to strike one, the lifting piece will then drop again, and the fly-pin will be caught by the first stop, having made (according to the numbers of the teeth given in fig. 18), 5 turns. But if it has to strike more, the locking wheel comes into action. That wheel turns with the train, either by pinion 20 as shown here, or by a gathering pallet on the arbor of the second wheel, and it will easily be seen that when once the lifting piece is lifted out of a notch in the locking plate, it cannot fall again until another notch has come under the bit D; and as the distance of the notches is proportioned to the hours, the locking plate thus determines the number of blows struck. It may occur to the reader, that the cylinder and roller are not really wanted, and that the locking plate would do as well without; and sometimes clocks are so made, but it is not safe; for the motion of the locking plate is so slow, that unless everything is very carefully adjusted and no *shake* left, the corner of the notch may not have got fairly under the bit D before the fly has got once round, and then the lifting piece will drop before the clock can strike at all.

Fig. 14 shows the other kind of striking work, being the front view of an English house clock when the dial is taken off. As in fig. 1, M is the hour-wheel, on the pipe of which the minute hand is set; N the reversed hour-wheel, and *n* its pinion, driving the 12-hour wheel H, on whose socket is fixed what is called the snail Y, which belongs to the striking work exclusively. The hammer is raised by the 8 pins in the rim of the second wheel in the striking train, in the manner which is obvious. The hammer does not quite touch the bell, as it would jar in striking if it did, and prevent the full sound; and if you observe the form of the hammer-shank at the arbor where the spring S acts upon

it, you will see that the spring both drives the hammer against

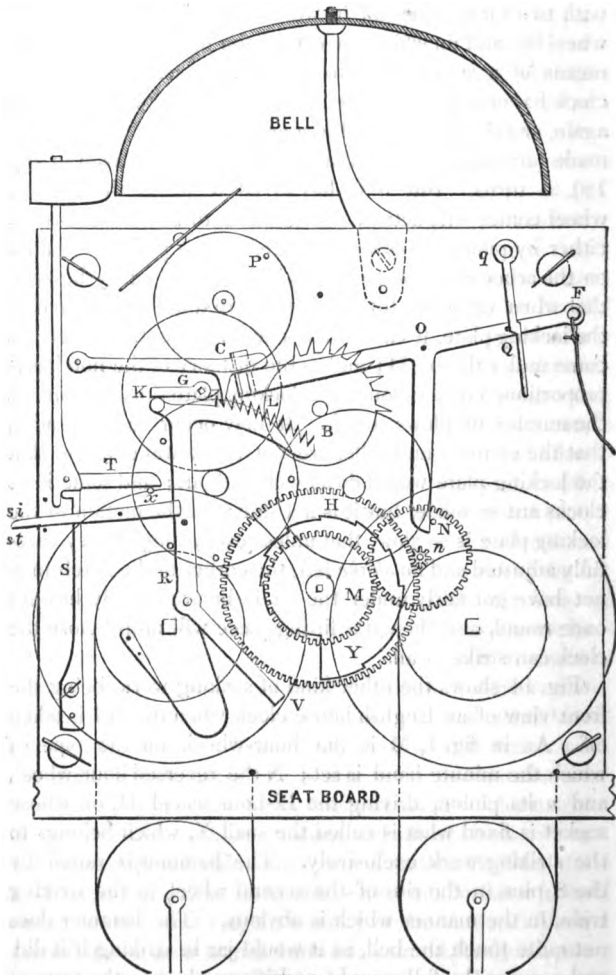

Fig. 14.

the bell when the tail T is raised, and also checks it just

before it reaches the bell, and so the blow on the bell is given by the hammer having acquired momentum enough to go a little farther than its place of rest. Sometimes two springs are used, one for impelling the hammer, and the other for checking it. A piece of vulcanized India rubber tied round the pillar just where the hammer-shank nearly touches it, forms as good a check spring as anything. The pinion of the striking wheel generally has 8 leaves, the same number as the pins; and as a clock strikes 78 blows in 12 hours, the great wheel will turn in that time if it has 78 teeth, instead of 96 which the great wheel of the going part has for a centre pinion of 8. The striking wheel drives the wheel above it once round for each blow, and that wheel drives a 4th (in which you observe a single pin P), 6, or any other integral number of turns, for one turn of its own, and that drives a fan-fly to moderate the velocity of the train by the resistance of the air, an expedient at least as old as De Vick's clock in 1370. The wheel N is so adjusted that within a few minutes of the hour the pin in it raises the *lifting piece* LON so far, that that piece lifts the click C out of the teeth of the *rack* BKRV, which immediately falls back (helped by a spring near the bottom) as far as its tail V can go by reason of the snail Y, against which it falls; and it is so arranged that the number of teeth which pass the click is proportionate to the depth of the snail; and as there is one step in the snail for each hour, and it goes round with the hour hand, the rack always drops just as many teeth as the number of the hour to be struck. This drop makes the noise of "giving warning." But the clock is not yet ready to strike, till the *lifting piece* has fallen again; for as soon as the rack was let off, the tail of the thing called the *gathering pallet* G, on the prolonged arbor of the 3d wheel, was enabled to pass the pin K of the rack on which it was pressing before, and the striking train began to move; but before the 4th wheel had got half round, its pin P was caught by the end of the

lifting piece, which is bent back and goes through a hole in the plate, and when raised stands in the way of the pin P, so that the train cannot go on until the lifting piece drops, which it does exactly at the hour, by the pin N then slipping past it. Then the train is free; the striking wheel begins to lift the hammer, and the gathering pallet gathers up the rack, a tooth for each blow, until it has returned to the place at which the pallet is stopped by the pin K coming under it. In this figure the lifting piece is prolonged to F where there is a string hung to it, as this is the proper place for such a string when it is wanted for the purpose of learning the hour in the dark, and not (as it is generally put) on the click C; for if it is put there, and you hold the string a moment too long, the clock will strike too many; and if the string accidentally sticks in the case, it will go on striking till it is run down; neither of which things can happen when the string is put on the lifting piece.

The snail is sometimes set on a separate stud with the apparatus called a *star wheel* and *jumper* (see Denison's *Rudimentary Treatise*, p. 123); but, as this only increases the cost without any advantage that we can see, we omit any further reference to it. On the left side of the frame we have placed a lever, *x*, with the letters *st* below it, and *si* above. If it is pushed up to *si* the other end will come against a pin in the rack, and prevent it from falling, and will thus make the clock silent; and this is much more simple than the common "strike and silent" apparatus, which we shall therefore not describe.

If the clock is required to strike quarters, a third part, or train of wheels, is added on the right hand of the going part; and its general construction is the same as the hour-striking part; only there are two more bells, and two hammers so placed that one is raised a little after the other. There is a method of making the same part do both the quarter and hour striking; but it is very seldom used, and would take too long to describe here. If there are more

quarter bells than two, the hammers are generally raised by a chime barrel, which is merely a cylinder set on the arbor of the striking wheel (in that case generally the third in the train), with short pins stuck into it in the proper places to raise the hammers in the order required for the tune of the chimes. The quarters are generally made to let off the hour, and this connection may be made in two ways. If the chimes are different in tune for each quarter, and not merely the same tune repeated two, three, or four times, the repetition movement must not be used for them, as it would throw the tunes into confusion—but the old locking-plate movement, as in turret clocks; and therefore, if we conceive the hour lifting piece connected with the quarter locking plate, as it is with the wheel N in fig. 14, it is evident that the pin will discharge the hour-striking part as the fourth quarter finishes.

But where the repetition movement is required for the quarters the matter is not quite so simple; but the principle of it may be shortly described thus:—the quarters themselves have a rack and snail, &c., just like the hours, except that the snail is fixed on one of the hour-wheels M or N instead of on the twelve-hour wheel, and has only four steps in it. Now, suppose the quarter rack to be so placed that when it falls for the fourth quarter (its greatest drop) it falls against the hour lifting piece somewhere between O and N, so as to raise it and the click C. Then the pin Q will be caught by the click Qq, and so the lifting piece will remain up until all the teeth of the quarter rack are gathered up; and as that is done it may be made to disengage the click Qq, and so complete the letting off of the hour striking. (This click Qq, of course, has no existence except where there are quarters.)

These quarter clocks are sometimes made so as only to strike the quarters at the time when a string is pulled—as by a person in bed, just like repeating watches, which are rarely made now, on account of the difficulty of keeping in

order such a complicated machine in such a small space. In this case the act of pulling the string to make the clock strike, winds up the quarter barrel, which is that of a spring-clock (not yet described, but well known to everybody), as far as it is allowed to be wound up by the position of a snail on the hour-wheel, against which a lever is pulled, just as the tail of the common striking rack falls against the snail on the 12-hour wheel; and it is easy to see that the number of blows struck by the two quarter hammers may thus be made to depend upon the extent to which the spring that drives the train is wound up; and it may even be made to indicate half-quarters; for instance, if the snail has 8 steps in it, the 7th of them may be just deep enough to let the two hammers strike three times, and the first of them once more, which would indicate $7\frac{1}{2}$ minutes to the hour. It is generally so arranged that the hour is struck first, and the quarters afterwards. But we cannot afford the space to describe the details of these occasional contrivances.

ALARUMS.

In connexion with these bed-room clocks we ought to mention *alarums*. Perhaps the best illustration of the mode of striking an alarum is to refer to either of the recoil escapements (figs. 3 and 4). If you suppose a short hammer instead of a long pendulum attached to the axis of the pallets, and the wheel to be driven with sufficient force, it will evidently swing the hammer rapidly backwards and forwards; and the position and length of the hammer head may be so adjusted as to strike a bell internally, first on one side and then on the other. Then as to the mode of letting off the alarum at the time required; if it was always to be let off at the same time, you would only have to set a pin in the 12-hour wheel at the proper place, to raise the lifting piece which lets off the alarum at that time. But as you want it to be capable of alteration, this discharging pin must be set in another wheel (without teeth), which rides

with a friction spring on the socket of the 12-hour wheel, with a small moveable dial attached to it, having figures so arranged with reference to the pin, that whatever figure is made to come to a small pointer set as a tail to the hour hand, the alarum shall be let off at that hour. The letting off does not require the same apparatus as a common striking part, because an alarum is not to strike a definite number of blows, but to go on till it is run down; and therefore the lifting piece is nothing but a lever with a stop or hook upon it, which, when it is dropped, takes hold of any one of the alarum wheels, and lets them go while it is raised high enough to disengage it. You must of course not wind up an alarum till within 12 hours of the time upon it is wanted to go off, unless the hour hand is one that turns in 24 hours, instead of 12.

The *watchman's* or tell-tale clock the reader may have seen in one of the lobbies of the House of Commons, and in prisons, and some other places, where they want to make sure of a watchman being on the spot and awake all the night; it is a clock with a set of spikes, generally 48 or 96, sticking out all round the dial, and a handle somewhere in the case, by pulling which you can press in that one of the spikes which is opposite to it, or to some lever connected with it, but no others; and it will be observed, that this wheel of spikes is carried round with the hour hand, which in these clocks is generally a 24-hour one.

It is evident that every spike which is seen still sticking out in the morning indicates that at the particular time to which that spike belongs the watchman was not there to push it in—or at any rate, that he did not do it; and hence its name. At some other part of their circuit, the inner ends of the pins are carried over a roller or an inclined plane which pushes them out again ready for business the next night.

SPRING CLOCKS.

Hitherto we have supposed all clocks to be kept going by a weight. But, as is well known, many of them are driven by a spring coiled up in a barrel. In this respect they differ nothing from watches, and therefore we shall defer all consideration of the construction of the parts belonging to the spring till we treat of watches. It may, however, be mentioned here, that the earliest form in which a spring seems to have been used was not that of a spiral ribbon of steel rolled up, but a straight stiff spring held fast to the clock frame at one end, and a string from the other end going round the barrel, which was wound up; of course such a spring would have a very small range. Spring clocks are generally resorted to for the purpose of saving space, and as clocks are generally made in England, it is impossible to make a weight-clock capable of going a week, without either a case nearly 4 feet high, or else the weights so heavy as to produce a great pressure and friction on the arbor of the great wheel. But this arises from nothing but the heaviness of the wheels, and the badness of the pinions used in most English clocks, as is simply proved by the fact that the American clocks go a week with both less weights and less fall for them than the English ones, and this with no assistance from fine workmanship, for the purpose of diminishing friction, as they are remarkable for their want of what is called "finish" in the machinery, on which so much time and money is wasted in nearly all English clock-work. Moreover, in the American clocks the pinions are all of the kind called *lantern pinions* (see fig. 34), which are pinions having their leaves made only of bits of wire set round the axis in two collars; and, oddly enough, are the oldest form of pinion, as well as the best, acting with the least friction, and requiring the least accuracy in the wheels, but now universally disused in all English and French house clocks. The American clocks prove that they are not too expensive to be used with advantage

when properly made, although so long as there are no *manufactories* of clocks here as there are in America, it may be cheaper to make pinions in the slovenly way of cutting off all the ribs of a piece of pinion wire, so as to reduce it to a pinion a quarter of an inch wide, and an arbor 2 or 3 inches long. The wheels of the American clocks are all stamped, and the holes in the plates also; in fact, there is probably not two shillings worth of mere manual labour in the whole of an American clock movement. There is no doubt that in the making of machines by machinery the Americans are far ahead of us; witness also Colt's revolvers and Hobbs's locks. On the whole, the common English house clocks, so far from having improved with the general progress of machinery, are worse than they were 50 years ago, and at the same time are of such a price that they are being fast driven out of the market by the American plain clocks, and by the French ornamental ones; for their movements are also made by machinery at surprisingly low prices. Indeed, until very lately we were inferior to the French also in a kind of clock in which above all others we ought to be superior to the rest of the world, viz., in the largest kind of clocks, to which we shall now devote a few pages.

TURRET CLOCKS.

Seeing that a clock—at least the going part of it—is a machine in which the only work to be done is the overcoming of its own friction and the resistance of the air, it is evident when the friction and resistance are very much increased, it may become necessary to resort to expedients for neutralizing their effects which are not required with a more moderate friction. In a turret clock the friction is enormously increased by the great weight of all the parts; and the resistance of the wind, and sometimes snow, to the motion of the hands, further aggravates the difficulty of maintaining a constant force on the pendulum; and besides that, there is the exposure of the clock to

the dirt and dust which are always found in towers, and of the oil to a temperature which nearly freezes it all through the usual cold of winter. This last circumstance alone will generally make the arc of the pendulum at least half a degree more in summer than in winter; and inasmuch as the time is materially affected by the force which arrives at the pendulum, as well as the friction on the pallets when it does arrive there, it is evidently impossible for any turret clock of the ordinary construction, especially with large dials, to keep any constant rate through the various changes of temperature, weather, and dirt, to which it is exposed. And yet it is remarkable that, with the two exceptions we shall have to mention, the English clock-makers have universally set their faces against the adoption of any of the contrivances, whether of foreign or of English invention; for the purpose of obtaining a constant force on the pendulum, and have even presumed so far on the ignorance of the public as to assert that the compensation of the pendulum is unnecessary, although turret clocks are of course exposed to greater variations of temperature than any others. The only excuse for such an assertion—and indeed with regard to ordinary turret clocks it is a sufficient one, is, that it is not worth while to provide against the errors from change of temperature while the clock is left exposed to errors quite as large from other causes, against which the makers do not know how to provide.

But in the year 1843 a series of improvements began, which in the course of ten years have completely changed the construction and the character of the best English turret clocks, and they can now be made to go better than the best astronomical clocks; while at the same time the merely superficial refinements which it had become the fashion to introduce as a disguise for the absence of all scientific improvement, have been dispensed with, and the price considerably reduced. In that year, it appears from the papers

which were afterwards published on the subject, the late Mr Dent was engaged to make the large clock for the newly built Royal Exchange, which was desired to be superior to any public clock in England, and with that view was required to satisfy certain conditions proposed for the first time by the Astronomer Royal, and such as could not be satisfied by any clock of the common construction. He had then no factory of his own for making large clocks, and relied on getting it made under his directions by some of the few real manufacturers of such things. But although these persons are generally willing enough to execute the orders of other clockmakers, and even allow them to put their own names on the clocks, Mr Dent found himself unable to get this clock made for him at all, and it was expected as a matter of course that he would be obliged to give up the contract; but with the energy and genius by which that remarkable man raised himself from a tallow-chandler's apprentice to the position of the first horologist in the world, he at once set up a factory for himself at a great expense, and made the clock there; and of this, the first turret clock he had ever made, the Astronomer Royal certified in 1845, that it not only satisfied his conditions, but that Mr Dent had made some judicious improvements upon his suggestions, and that he had no doubt it was the best public clock in the world. The clock tower of the Exchange seems to have been prolific of disputes, for the peal of bells on which the clock was also to play chimes every three hours have had to be recast twice since they were put up, once by the original founders and once by another; and it was not till after the clock had been going eight or nine years that the chimes were allowed to play regularly.

The construction of the Exchange clock, however, was too expensive for general use; and accordingly Mr Dent next devoted himself to simplifying it. At first, he borrowed a good deal from the clocks of Messrs Wagner, the eminent makers of Paris; but by degrees he introduced various mo-

difications of their plans, chiefly from the suggestions of Mr Denison ; and before his death in 1853 the plans which we shall now describe were adopted as the settled forms for the different kinds of the best turret clocks. They have since been followed by his successor, Mr Dent of the Strand and the Royal Exchange, and also by Mr Joyce of Whitchurch (Salop), who had before enjoyed the reputation of one of the best provincial clockmakers ; but as far as we know, by no other makers—certainly by no London ones, though they are free from the incumbrance of patents.

The old, or, as the clockmakers would say, the “long established” form of a turret clock is that of a large iron cage, of which some of the vertical bars take off, and are fitted with brass bushes for the arbors of the wheels to run in ; and the wheels of each train, *i. e.* the striking train, the going, and the quarter train, stand over each other with their pivots all in the vertical bar belonging to that part. Occasionally they have advanced so far as to make the bushes moveable, *i. e.* fixed with screws instead of rivetted in, so that one wheel may be taken out without the others ; but very few of the makers, except the late Mr Vulliamy, admitted even this most obvious improvement. This cage generally stood upon a wooden stool on the floor of the clock room. The French clockmakers long ago saw the objections to this kind of arrangement, and adopted the plan of a horizontal frame or bed, cast all in one piece, and with such smaller frames or cocks set upon it as might be required for such of the wheels as could not be conveniently got on the same level. Mr Dent’s Great Exhibition clock, for which he received the council medal, now at the King’s Cross station in London, was on this plan ; and the adjoining sketch (fig. 15) of the clock at Meanwood church, near Leeds, will sufficiently explain it. All the wheels of the going part, except the great wheel, are set in a separate frame called the movement frame, which is complete in itself and light enough to take off and carry away entire, so that any cleaning or repairs

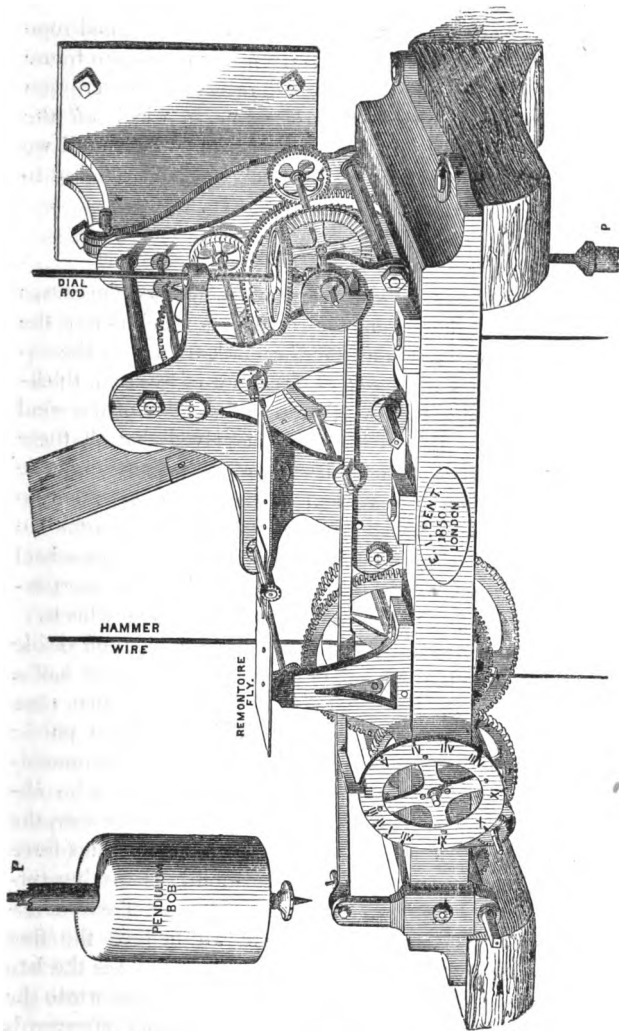

Fig. 15.

required in the most delicate part of the work can be done in the clock factory, and the great wheel, barrel, and rope need never be disturbed at all. Even this movement frame is now dispensed with ; but we will reserve the description of the still more simple kind of frame in which *all* the wheels lie on, or under, the great horizontal bed, until we have described that part of the clock which is referred to by the words "remontoire fly" in fig. 15.

TRAIN REMONTOIRES.

Under the head of escapements we mentioned the causes of error in all the common escapements which derive the impulse to the pendulum from the clock train, viz., the variation of friction arising from dirt, want of fresh oil, thickening of the oil in cold weather, and the action of the wind on the hands. It was long ago perceived that all these sources of error, except the friction of the pallets, might be cut off (assuming the problem of a gravity escapement to be as hopeless as it had come to be considered from the numerous failures) by making the force of the scape-wheel to depend on a small weight or spring wound up at short intervals by the great clock weight and the train of wheels.

This also has the advantage of giving a sudden and visible motion to the minute hand at those intervals, say of half a minute, when the remontoire work is let off, so that time may be taken from the minute hand of a large public clock as exactly as from the seconds hand of an astronomical clock ; and besides that, greater accuracy may be obtained in the letting off of the striking part. However, the attempt to secure the advantage of a more constant force was made many years before the possibility of making turret clocks go with anything like the accuracy of astronomical clocks was contemplated ; and we believe the first maker of a large clock with a train remontoire, was the late Mr Thomas Reid, clockmaker, of Edinburgh, who wrote the article on clocks in the first edition of this work, afterwards

expanded into a well known book, in which this remontoire is described. The scape-wheel was driven by a small weight hung by a Huygens's endless chain, of which one of the pulleys was fixed to the arbor, and the other rode upon the arbor with the pinion attached to it, and the pinion was driven, and the weight wound up by the wheel below (which we will call the 3d wheel), as follows:—Assuming the scape-wheel to turn in a minute, its arbor has a notch cut half through it on opposite sides in two places near to each other. On the arbor of the third wheel, which turns in 10 minutes, suppose, there is another wheel with 20 spikes sticking out of its rim, but alternately in two different planes, so that one set of spikes can pass through one of the notches in the scape-wheel arbor and the other set through the other. Whenever then the scape-wheel completes a half turn, one spike is let go and the third wheel is able to move, and with it the whole clock train and the hands, until the next spike of the other set is stopped by the scape-wheel arbor; at the same time the pinion on that arbor is turned half round, winding up the remontoire weight, but without taking its pressure off the scape-wheel. Reid says that so long as this apparatus kept in good order, the clock went better than it did after it had been removed in consequence of its getting out of order from the constant banging of the spikes against the arbor.

The Exchange clock was made on the same principle, except that instead of the endless chain an internal wheel was used with the spikes set on it externally, which (as we explained under *equation work*) is one of the modes by which an occasional secondary motion may be given to a wheel without disturbing its primary and regular motion. A drawing of the Exchange clock remontoire, and also of the bevelled-wheel plan (like the equation work at fig. 13), which is generally used in the French remontoire clocks, is given in Mr Denison's *Rudimentary Treatise*; and for the reasons which will appear presently, it need not be repeated

here, especially as the following is a still more simple arrangement of a gravity train remontoire, also used by the French. Let *E* in fig. 16 be the scape-wheel turning in a minute, and *e* its pinion which is driven by the wheel *D* having a pinion *d* driven by the second or centre wheel *C*, which we may suppose to turn in an hour. The arbors of the scape-wheel and centre-wheel are of course distinct; their pivots meeting in a bush fixed somewhere between the wheels. The pivots of the wheel *D* are set in the frame *AP*, which rides on the arbors of the centre-wheel and scape-wheel, or on another short arbor between them. The centre wheel also drives another wheel *G*, which again

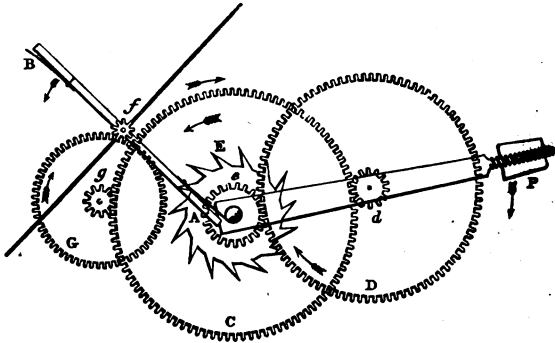

Fig. 16.

drives the pinion *f* on the arbor which carries the two arms *f A*, *f B*; and on the same arbor is set a fly with a ratchet, like a common striking fly, and the numbers of the teeth are so arranged that the fly will turn in the same time as the scape-wheel. The ends of the remontoire arms *f A*, *f B*, are capable of alternately passing the notches cut half through the arbor of the scape-wheel, as those notches successively come into the proper position at the end of every half minute; and as soon as that happens the centre wheel raises the moveable wheel *D* and its frame through a small

angle ; but, nevertheless, that wheel keeps pressing on the scape-wheel as if it were not moving, the point of contact of the wheel C and the pinion *d* being the fulcrum or centre of motion of the lever A *d* P. It will be observed that the remontoire arms *f* A, *f* B have springs set on them to diminish the blow on the scape-wheel arbor, as it is desirable not to have the fly so large as to make the motion of the train, and consequently of the hands, too slow to be distinct. In all the French remontoire clocks in the Great Exhibition the motion was too slow, and consequently less easy to observe accurately than in the Westminster clock, the Royal Exchange, and King's Cross station clocks, in which the half-minute jump of the hands is very distinct. In the French clocks also the fly is generally driven by an endless screw, without the intermediate wheel G ; but there is an enormous loss of force by friction in an endless screw, when driven, and consequently considerable risk of the clock stopping from either cold or wasting of the oil.

In all these gravity remontoires, however, it must have been observed that we only get rid of the friction of the heavy parts of the train and the dial work, and that the scape-wheel is still subject to the friction of the remontoire wheels, which, though much less than the other, is still something considerable. And, accordingly, attempts have frequently been made to drive the scape-wheel by a spiral spring, like the mainspring of a watch. One of these was described in the last edition of this Encyclopædia ; and Mr Airy, a few years ago, invented another, of which two or three specimens were made by Mr Dent. But it was found, and indeed it ought to have been foreseen, that these contrivances were all defective in the mode of attaching the spring, and that they only increased the expense of the clock without any corresponding advantage ; and the consequence has been, that spring remontoires, and remontoires in general, had come to be regarded as a mere delusion. It has, however, now been fully proved, that they

are not so ; for, by a very simple alteration of the previous plans, a spiral spring remontoire may be made to act with absolutely no friction, except that of the scape-wheel pivots, and the letting-off springs A, B, in the last drawing. The Meanwood clock (fig. 15) was the first of this kind ; but it will be necessary to give a separate view of the remontoire work.

In this figure (17), E, e, D, f, A, and B, are the same things as in fig. 16. But e, the scape-wheel pinion, is no longer fixed to the arbor, nor does it ride on the arbor, as had been the case in all the previous spring remontoires, thereby producing probably more friction than was saved in other respects ; but it rides on a stud k, which is set in the clock-frame. On the face of the pinion is a plate, of which the only use is to carry a pin h (and consequently its shape is immaterial), and in front of the plate is set a bush b, with a hole through it, of which half is occupied by the end of the stud k, to which the bush is fixed by a small pin, and the other half is the pivot hole for the scape - wheel arbor. On the arbor is set the remontoire spring s (a moderate - sized musical box spring is generally used), of which the outer end

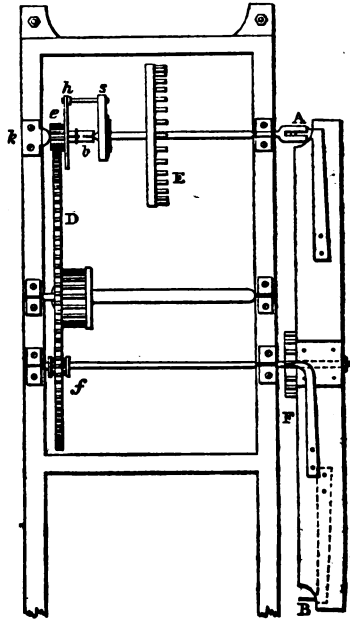

Fig. 17.

musical box spring is generally used), of which the outer end

is bent into a loop to take hold of the pin *h*. In fact, there are two pins at *h*, one a little behind the other, to keep the coils of the spring from touching each other. Now it is evident, that the spring may be wound up half or a quarter of a turn at the proper intervals, without taking the force off the scape-wheel, and also without affecting it by any friction whatever. When the scape-wheel turns in a minute, the letting off would be done, as before described, by a couple of notches in the scape-wheel arbor, through which the spikes A, B, in fig. 16, would pass alternately. But in clocks with only three wheels in the train, it is best to make the scape-wheel turn in two minutes, and consequently you would want four notches and four remontoire arms, and the fly would only make a quarter of a turn. And therefore Mr Denison, who invented this remontoire, made the following provision for diminishing the friction of the letting-off work. The fly pinion *f* has only half the number of teeth of the scape-wheel pinion, being a lantern pinion of 7 or 8, while the other is a leaved pinion of 14 or 16 (and therefore the same wheel D will properly drive both, as will be seen hereafter). The scape-wheel arbor ends in a cylinder about $\frac{1}{4}$ th inch in diameter, with two notches at right angles cut in its face, one of them narrow and deep, and the other broad and shallow, so that a long and thin pin, such as B, can pass only through one, and a broad and short pin A through the other. Consequently, at each quarter of a turn of the scape-wheel, the remontoire fly, on which the pins AB are set on springs, as in fig. 16, can turn half round. It is set on its arbor *f* by a square ratchet and click, which enables you to adjust the spring to the requisite tension to obtain the proper vibration of the pendulum. The fly is not (except in very large clocks) separate from the letting-off arms, because there is found to be no occasion for it; but the blow on the cylinder is diminished by the fly having to pass over a friction spring (which cannot be distinctly shown in this drawing) just before it reaches the

cylinder. It makes, indeed, a considerable noise at each let off, but that is in a great measure from the recoil against the top of this friction spring; and some of these clocks have now been going since the year 1849, without any inconvenience from that cause. And their performance is so much more satisfactory than that of the gravity remontoires, that Mr Dent lately altered the gravity remontoire of the Royal Exchange to a spring one, with the immediate effect of reducing the clock-weight by one third. It should be observed, however, that even a spring remontoire requires a larger weight than the same clock without one; but as none of that additional force reaches the pendulum, that is of no consequence. The variation of force of the remontoire spring from temperature, as it only affects the pendulum through the medium of the dead escapement, is far too small to produce any appreciable effect; and it is found that clocks of this kind, with a compensated pendulum 8 feet long, and of about 2 cwt., will not vary above a second a month, if the pallets are kept clean and well oiled. No turret clock without either a train remontoire or a gravity escapement will approach that degree of accuracy.

The introduction of this remontoire led to another very important alteration in the construction of large clocks. Hitherto it had always been considered necessary, with a view to diminish the friction as far as possible, to make the wheels of brass or gun-metal, with the teeth cut in an engine. The French clockmakers had begun to use cast-iron striking parts, and cast-iron wheels had been occasionally used in the going part of inferior clocks for the sake of cheapness. Mr Vulliamy, we know, proposed, if he did not use them for cheap clocks some years ago; but cast-iron wheels had never been used in any clock making pretensions to accuracy before Mr Dent's clock in 1851, which is stated in the jury report to have only varied 3 seconds in the last 10 weeks of the Exhibition. Since then all the large clocks

made at his factory, either with this remontoire or with the three-legged gravity escapement before described, have been made with cast-iron wheels ; and in 1852 it was determined by the Astronomer Royal and Mr Denison, who were jointly consulted by the Board of Works about the great Westminster clock, to alter the original requisition for gun-metal wheels there to cast-iron. Some persons have expressed their apprehension of cast-iron wheels rusting ; but nothing can be more unfounded, for they are always painted, and the acting surfaces may also be oiled. A remarkable proof of the folly of the clockmakers' denunciations of cast-iron wheels has lately been afforded at the Royal Exchange. In consequence of the bad ventilation of the clock-room, together with the effects of the London atmosphere, some thin parts of the brass-work had become so much corroded that they had to be renewed, and some of it replaced with iron ; and all the polished brass-work and iron-work had become as rough as if it had never been polished at all ; the only parts of the clock which had not suffered from the damp and the bad air were the painted iron-work. The room has now been ventilated, with a draught through it, and all the iron-work, except acting surfaces, is painted. But even in the most favourable positions brass or gun-metal loses its surface long before cast-iron wants repainting.

Fig. 18 is a front view of one of Mr Dent's large quarter clocks, with all the wheels on the great horizontal bed, a gravity escapement, and a compensated pendulum. They are made in two sizes, one with the great striking wheels 18 inches wide, and the other about 15. This pattern has also been followed by Mr Joyce of Whitchurch ; the other London makers, and most of the country ones, still adhere to the old cage-pattern frame, and set their faces against compensated pendulums, improved escapements, cast-iron wheels, and wire ropes, and in fact all the improvements which we are now going to notice. Here the striking is done by cams cast on the great wheels, about $1\frac{1}{2}$ inch

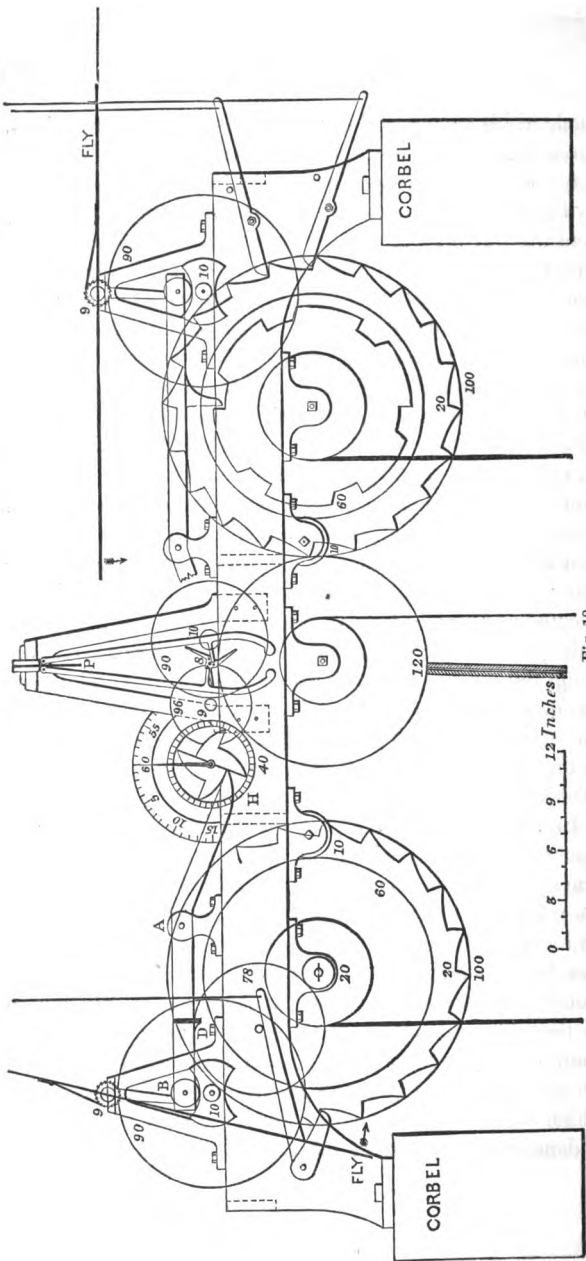

Fig. 18.

broad in the large-sized clocks, which are strong enough for an hour bell of two tons weight and corresponding quarters. Wire ropes are used, not only because they last longer if kept greased, but because a sufficient number of coils will go on a barrel of less than half the length which would be required for hemp ropes of the same strength without overlapping, which it is as well to avoid if possible, though it is not so injurious to wire ropes as it is to hemp ones. By this means also the striking cams can always be put on the great wheel instead of the second wheel, which saves more in friction than could be imagined by any one who had not tried both. In the great Westminster clock it was thought of so much consequence to get the striking from the great wheel, both in the hours and in the quarter chimes on four bells, that eight cam wheels are used for the quarters, as some of the blows are repeated on the same bell too closely to get sufficient drop for the hammer levers without using two alternate hammers to each bell. If that clock had been made on the plan proposed by Mr Vulliamy (who was first consulted, on Sir C. Barry's recommendation), striking from the second wheel, and the friction aggravated by a number of pulleys and hemp ropes, which must have been an inch and a half thick, as he intended, the striking weights would probably have been nearly four tons each, although they have the enormous fall of 170 feet; and the clock would have taken a whole day to wind up. As it is, they will be a ton and a half each, allowing a waste of about a quarter of the force, in friction, and in the interval between the fall of the hammer and its beginning to rise again, which is found enough in clocks of the construction in fig. 18; though in clocks of the common construction two-thirds of the power is often wasted in friction and in the bad arrangement of the hammer work.

We have given the same number of cams to the quarter as to the hour striking wheel, rather for the purpose of suggesting the expediency of omitting the 4th quarter, as has

been done in several clocks lately made from this design. It is of no use to strike the quarters at the hour, and it nearly doubles the work to be done, and if it is omitted it allows the quarter bells to be larger, and therefore louder, than they can be otherwise, because the first quarter bell ought to be an octave above the hour bell; whereas, if they are not heard together, the quarters might be the 4th and 7th of a peal of eight bells; and where cheapness has to be considered, and there are no bells ready for the clock, there need only be two bells, the larger of them being used for the 2d quarter bell, and also for the hours, with a rather heavier hammer. This is the case with the clock by Mr Joyce at the new savings-bank at Chester, made on the plan of fig. 18. Moreover, the omission of the 4th quarter enables you to have the celebrated quarter chimes of St Mary's, Cambridge (with a slight variation only in one of them), with a peal of only eight bells, on the 2d, 3d, 4th, and 7th, and at very little additional cost; whereas the full quarters, on four bells, require a considerable addition to the clock, besides a peal of ten bells, as they must be struck on the 1st, 2d, 3d, and 6th—the 10th being the hour bell. The following are the quarter chimes of the before-mentioned clock of the cathedral at Fredericton, which are followed in the clock for Scarborough church, and those of St Mary's, Cambridge, which are adopted also in the great Westminster clock. The Exchange quarters are different, and very inferior to these; and quarters on the 1st, 2d, 3d, and 4th bells of a peal are still worse, though more common.

Fredericton.	Cambridge.
1st 2347	2d { 3126 }
2d { 4237	{ 3213 } 4th
{ 4324	3d { 1326 }
3d { 3724	{ 6213 }
{ 7324	{ 1236 } 1st
2347	
hour.....8.	hour.....10.

At Cambridge the chimes are set on a barrel which turns twice in the hour, as this table indicates, and which is driven

by the great wheel with a great waste of power ; the clock is wound up every day ; in an eight-day clock it would require a very large weight, and a very much greater strain on the wheels. We have already stated what was done to avoid this in the Westminster clock.

No particular number of cams is required in the striking wheel : any number about 20 will do ; but where four quarters on two bells are used, the quarter striking wheel should have half as many cams again as the hour-wheel ; for if not, the rope will go a second time over half of the barrel, as there are 120 blows on each quarter bell in the 12 hours, to 78 of the hours, while with the three quarters there are only 72. If the two quarter levers (commonly called hammer-tails) are on the same arbor, there must be two set of cams, one on each side of the wheel ; but one set will do if the hammer-tails are placed as in fig. 18. The hour striking lever, it will be seen, is differently shaped, so as to diminish the pressure on its arbor by making it only the difference instead of the sum of the pressures at the two points of action. This *can* be done with the two quarter levers, as shown in Mr Denison's book ; but the arrangement involves a good deal of extra work, and as the quarter hammers are always lighter than the hour, it is hardly worth while to resort to it. The shape of the cams is a matter requiring some attention, but it will be more properly considered when we come to the *teeth of wheels*.

Even in the small matter of the fly ratchets there was room for improvement. They are almost always made with sharp teeth like those of a winding ratchet, and the consequence is, that when made of cast-iron, as they sometimes are, by clockmakers who will not use cast-iron wheels on any account, the teeth get broken off by the click. This may be avoided by making the teeth square, *i.e.* a number of inverted V's set round a circle, and the click only reaching so far that the face of the tooth which it touches is at right angles to the click. The spring need only be very

slight; in many clocks the object seems to have been to make as much noise as possible with all the clicks, both of the flies and barrels. In the Westminster clock, the annoyance of the clattering of the clicks during the several hours it will take to wind is got rid of by stopping their drop on to the teeth by check springs, for which there is plenty of room.

The hammer of a large clock ought to be left "on the lift," when the clock has done striking, especially if it is a clock with a train remontoire, in which the first blow ought to be struck at the moment the hand jumps from $59\frac{1}{2}$ min. to 60, as there are always a good many seconds lost in the train getting into action and raising the hammer. Moreover, when it stops on the lift, the pressure on the stops, and on all the pinions above the great wheel, is only that due to the excess of the power of the clock over the weight of the hammer, and not the full force of the weight, and it is therefore easier for the going part to discharge, and less likely to break the stops.

In fig. 18 the wheel marked 60 in each of the striking parts is a winding wheel on the front end of the barrel, and the winding pinion is numbered 10; a larger pinion will do where the hammer does not exceed 40 lb., and in small clocks no auxiliary winding wheel is needed. But in that case the locking plate must be driven by a gathering pallet, or pinion with two teeth, on the arbor of the second wheel, with a spring click to keep it steady. In all cases the hammer shanks should be not less than two feet long if possible; for the shorter they are, the more is lost by the change of inclination for any given rise from the bell. In some clocks lately put up by Mr Dent with fixed, not swinging bells, the hammer head is set on a double shank embracing the bell, with the pivots, not above it in the French way which makes the hammer strike at a wrong angle, but on each side of the bell at about three-fourths of its height. On this plan less of the rise is lost than in the common mode of fixing. The Westminster clock hammer will be fixed in this way.

The first thing to remark in the going part in fig. 18 is, that the hour-wheel which carries the snails for letting off the quarters and striking, is not part of the train leading up to the scape-wheel, but independent, so that the train from the great wheel to the scape-wheel is one of three wheels only. If it were a dead escapement instead of a gravity escapement clock, the wheel numbered 96 would be the scape-wheel; and as it turns in 90 seconds, it would require 36 teeth or pins for a $1\frac{1}{4}$ sec. pendulum, such as these gravity escapement clocks have. The hour-wheel rides loose on its arbor, or rather the arbor can turn within it, carrying the snails and the bevelled wheel which drives all the dials, and the regulating hand, and it is fixed to the hour-wheel by means of clamping screws on the edge of a round plate on the arbor just behind it, which turn by hand. The regulating hand, it will be seen, turns the wrong way; because, where the dial is opposite to the back of the clock, no bevelled wheels are wanted, and the arbor leads straight off to the back of the dial. It used to be the fashion to put clocks for 4 dials near the middle of the room, so that the leading off rod might go straight up to the horizontal bevelled wheel in the middle, which drove all the others. The clock, however, can generally be set more firmly on corbels, or on cast-iron brackets built into the wall; and it is not at all necessary for the leading off rod to be vertical; provided it is in a vertical plane parallel to all the clock wheels (assuming the clock to stand square with the walls) the rod may stand as obliquely as you please; and when it does, it ought on no account to be made, as it generally is, with universal joints, but the pivots should go into oblique pivot holes at the top and bottom. The joints increase the friction considerably, and are of no use whatever, except where the rod is too long to keep itself straight. Where the rod does happen to be in the middle of the room, and there are three or four dials, the two horizontal bevelled wheels at each end of it must be a little larger than all the others, both the one in the

clock and those of the dial work ; for otherwise the three or four wheels in the middle will meet each other and stick fast.

When the pendulum is very long and heavy, it should be suspended from the wall, unless the clock-frame has some strong support near the middle ; but a six-foot pendulum (which is about the full length for $1\frac{1}{4}$ sec.) of not more than two cwt. may be suspended from the clock-frame, provided it is as strong as it ought to be for the general construction of the clock, and supported on corbels or iron beams. It has generally been the practice to hang the pendulum behind the clock frame ; but inasmuch as the rope of the going part may always be thinner than that of the striking part, and that part requires less depth in other respects, a different and more compact plan is adopted in the clocks we are describing. The back pivots of the going wheels run in bushes on an intermediate bar, three or four inches from the back of the frame, joining the two cross bars, of which the ends are dotted in the drawing. The pendulum cock is set on the back frame, and the pendulum hangs within it. And in the gravity escapement clocks there is yet another thin bar about half way between the back frame and the bar on which the bushes of the wheels are set, the only use of which is to carry the bush of the three-legged scape-wheel ; the gravity arms and the fly go between these two intermediate bars, the fork pins coming down below it, and so reaching the pendulum. The pallets are set in a brass cock screwed to the great pendulum cock. In turret clocks the adjustment for beat in the gravity escapement is not made by screws as in fig. 11, but by eccentric fork-pins with nuts ; of course the same might be done in small clocks, but from the confined space, and the lightness of the gravity arms, it is not so convenient as the beat screws in the pendulum. The fork-pins should be of brass wire, not steel, and no oil put to them.

The same general arrangement will serve for a dead escapement clock with or without a train remontoire, only

the pendulum will not stand so high, and the front end of the pallet arbor must be set in a cock like those of the striking flies, on the front bar of the frame. And for a dead escapement, especially if there is no remontoire, the pendulum should be longer and heavier than that which is quite sufficient for a gravity escapement.

In connection with this subject, we have a word to say about dials. The established form of dial for turret clocks is a sheet of copper made convex, to preserve its shape; and this is just the worst form which human ingenuity could have contrived for it. For, in the first place, the minute hand, being necessarily outside of the hour hand, is thrown still farther off the minutes to which it has to point, by the convexity of the dial; and consequently when it is in any position except nearly vertical, it is impossible to see accurately where it is pointing; and if it is bent enough to avoid this effect of *parallax*, it looks very ill. Secondly, a convex dial at a considerable height from the ground looks even more convex than it really is, because the lines of sight from the middle and the top of the dial make a smaller angle with the eye than the lines from the middle and the bottom, in proportion to the degree of convexity. Obvious as is the remedy for these defects, by simply making the dial concave instead of convex, it has, we believe, never been adopted until Mr Dent introduced this improvement also, at Mr Denison's suggestion, in some clocks for the Great Northern railway, at Doncaster, and on the platform at the King's Cross station. As convex dials look more curved than they are, these look less curved than they are, and in fact might easily be taken for flat ones, though the curvature is exactly the same as usual. There is no reason why the same form should be adopted in stone, cement, slate, or cast-iron, in which materials dials are sometimes, and properly enough, made with the middle part counter-sunk for the hour hand, so that the minute hand may go close to the figures and avoid parallax. When dials are

large, as much as 7 or 8 feet, copper dials, or even cast-iron or slate, are quite an useless expense if the stonework is moderately smooth, as most kinds of stone take and retain paint very well, and the gilding will stand upon it better than it often does on copper or iron. The figures are generally made much too large. People have a pattern dial painted, and if the figures are not as long as one-third of the radius, and therefore occupying, with the minutes, about two-thirds of the whole area of the dial, they fancy they are not large enough to be read at a distance; whereas the fact is, the more of the dial is occupied by the figures the less distinct they are, and the more difficult it is to distinguish the position of the hands; which is what people really want to see, and not to read the figures, which might very well be replaced by 12 large spots. The rule which has been adopted, after various experiments, as the best for the proportions of the dial is this: divide the radius into three, and leave the inner two-thirds clear and flat, and of some colour forming a strong contrast to the colour of the hands, black or dark blue if they are gilt, and white if they are black. The figures should occupy the next two-thirds of the remaining third, and the minutes be set in the remainder, near the edge, and with every fifth minute more strongly marked than the rest; and there should *not* be a rim round the dial, as there generally is, of the same colour or gilding as the figures. The worst kind of dial of all are the things called skeleton dials, which either have no middle except the stonework, forming no visible contrast to the hands (to which state the authorities of Trinity College, Cambridge, have lately altered their well-known double striking clock, put up by the famous Dr Bentley, striking, as it used to be said, once for Trinity and once for his former college, St John's, which had no clock), or else taking special trouble to perplex the spectator by filling up the middle with radiating bars. Where a dial cannot be put without interfering with the architecture, it is much better to have none,

as is the case in many cathedrals and large churches, leaving the information to be given by the striking of the hours and quarters. This also will save something, perhaps a good deal, in the size and cost of the clock, and if it is one without a train remontoire or gravity escapement, will enable it to go better. The size of public dials is often very inadequate to their height and the distance at which they are intended to be seen. They ought to be at least 1 foot in diameter for every 10 feet of height above the ground, and in many cases more, whenever the dial will be seen far off. A list of the sizes of various public dials, including some specimens of too small ones, is given in Mr Denison's book: it is sufficient here to state the above rule as one which ought to be enforced on architects, as they are often not aware of it till too late.

The art of illuminating dials cannot be said to be in a satisfactory state. Where there happens to be, as there seldom is, a projecting roof at some little distance below the dial, it may be illuminated by reflexion, like that at the Horse-guards—about the only merit which that superstitiously venerated and worn out clock has; and perhaps the same thing might be done by moveable lamp reflectors, like those put before shop windows at night, to be turned back against the wall during the day; but such an arrangement would be expensive in working and attendance, even if it could be conveniently arranged. It has also been proposed to sink the dial within the wall and illuminate it by jets of gas pointing inwards from a kind of projecting rim, like what is called in church windows a "hood-moulding," carried all round. But it is a great objection to sunk dials, even of less depth than would be required here, that they do not receive light enough by day, and do not get their faces washed with the rain. The common mode of illumination is by making the dials either entirely, or all except the figures and minutes and a ring to carry them, of glass, either ground or lined in the inside with linen (paint

loses its colour from the gas). The gas is kept always alight, but the clock is made to turn it nearly off or full on at the proper times by a 24-hour wheel, with pins set in it by hand as the length of the day varies, or sometimes perhaps by an entirely self-acting apparatus, which however is somewhat complicated, and an unnecessary expense. But these dials always look very ill by day; and as dials are wanted much more by day than by night, we cannot say that in the present state of the art illumination is to be recommended; and it should not be forgotten that the annual expense of lighting 3 or 4 dials far exceeds the interest of the entire cost of any ordinary clock. Another objection to illuminating large dials from the inside, is that it makes it impossible to counterpoise the hands outside, unless perhaps the counterpoises could be made of glass. And if they are only counterpoised inside, there is no counterpoise at all to the force of the wind, which is then constantly tending to loosen them on the arbor, and that tendency is aggravated by the hand itself pressing on the arbor one way as it ascends, and the other as it descends; and if it once gets in the smallest degree loose, it becomes rapidly worse by the constant shaking. It is mentioned in Reid's book, that the minute-hand of St Paul's cathedral, which is above 8 feet long, used to fall over above a minute as it passed from the left to the right side of XII, before it was counterpoised outside. We observe that, in the conditions to be followed in the Westminster clock, it is expressly required that "the hands be counterpoised externally, for wind as well as weight." The long hand should be straight and plain, to distinguish it as much as possible from the hour-hand, which should end in a "heart" or swell: many clockmakers and architects, on the contrary, seem to aim at making the hands as like each other as they can; and it is not uncommon to see even the counterpoises gilt, probably with the same object of producing apparent symmetry and real confusion.

Before leaving the subject of turret clocks, we will add a few particulars of the great clock for the houses of parliament, which, according to the contract (as appears by the parliamentary papers) was to have been fixed by February 1854, but seems likely to have to wait some years longer before the clock tower is ready for it. The clock itself has been going in Mr Dent's factory for some time. It has been made throughout from Mr Denison's designs, and under his superintendence, that of the Astronomer Royal having been merely nominal, and latterly abandoned altogether. The four dials are to be 22 feet in diameter, the largest, we believe, in the world with a minute-hand; the larger dials on the Continent have only an hour-hand. The minute-hand, on account of its greater length, velocity, weight, friction, and the action of the wind upon it, requires at least 20 times as much force to drive it as the hour-hand. Moreover, this clock goes a week instead of a day, and this again very considerably increases the weight and strength required, especially in the striking parts. The effects of friction and wind with such hands as these would make it impossible for the clock to go even as well as an ordinary church clock if there were no remontoire work; and yet there was a violent opposition made by the other clockmakers to that construction being required or adopted. It has, in fact, both the train remontoire of fig. 17 and the gravity escapement of fig. 11; the former for the purpose of giving a visible motion of the hands at every half minute, when the point of the minute hand will move nearly 7 inches; and the latter because it is the most independent of those causes of variation which are likely to affect a turret clock in such a position.

The great wheel of the going part is 27 inches in diameter; the pendulum is 15 feet long and weighs 680 lb., and the scape-wheel, which is driven by the musical-box spring on the third wheel, weighs about half an ounce. All the wheels except the scape-wheel, are of cast iron, *i. e.* with the teeth cast, not cut, and all have five spokes. The

barrel is 23 inches diameter but only 14 inches long, as this part will not require a rope above $\frac{1}{4}$ inch thick, and 55 turns in the $8\frac{1}{2}$ days, for which that part is to be capable of going, though the striking parts go only $7\frac{1}{2}$ days, so that in case of an accidental omission to wind it up on the proper day, the clock may not stop, but proclaim the neglect by silence. The second wheel is 12 inches in diameter, with a lantern pinion of 12, driven by 180 teeth on the great wheel; it has 120 teeth, and drives the pinion of the spring remontoire and the fly, as described in fig. 17. This part has all the back pivots on the great clock-frame, and the front ones on an intermediate bar laid upon two cross ones, the width of the frame for the striking parts being very nearly 5 feet, whereas only 2 feet is required for that of the going part. The leading-off arbor, however, comes to the front of the great frame, and there are the snails for discharging the striking parts, and also the first pair of bevelled wheels, which are 16 inches in diameter. The winding arbor before described also comes through the front frame.

The size of the hour bell, which was originally given as 14 or 15 tons, and therefore above 9 feet in diameter and nearly 8 feet high, fixes the size of the striking parts; for that determines the weight of the hammer, which must not be less than 4 cwt., according to the usual proportion, with a rise of at least a foot; it will probably be cast from the pattern of the pendulum bob; and that, with the proper allowance for loss by friction, &c., fixes the striking weight at something more than a ton and a half; and that requires a wire rope of a certain thickness ($\frac{1}{2}$ inch); and that must have a barrel of a certain length and diameter for such a number of coils as will give the most convenient arrangement of the striking cams, which are 18 in number, cast on a wheel of 37 inches in diameter; and that size again was necessary in order to keep all the wheels clear of the barrel. The cams are $2\frac{1}{4}$ inches thick, the same thickness as the great wheels; and the hammer lever is of corre-

sponding size. The winding wheel on the end of the barrel, both of the hour and quarters, is of the same size as the respective great wheels; and as a double multiplying power is required for winding up, the second winding wheel and its pinion are also the same as those of the train in each case; these winding wheels push out of gear with the great winding wheels, but not with their own winding pinions, which are made long for the purpose. There is to be a contrivance for stopping the winding when the clock is going to strike, as the winding of each of the striking parts will probably take two hours. The second wheels are a little more than 18 inches in diameter. The second train wheel in each striking part drives a bevelled wheel which drives the fly above the clock on a vertical arbor, as in the Exchange clock, in order to keep it out of the way of people winding or examining the clock. The great wheels all have 180 teeth; the second wheel of the hour-striking part has 105 and a pinion of 15, so that it turns two-thirds round at each blow, and the lifting cylinder upon its arbor has 3 segments cut out of it, and two of them are passed at each blow—probably a novel arrangement, but the most convenient here with reference to the numbers of the teeth. The size of the hour-bell also determines that of the quarters; the largest quarter-bell will be about the same size as the great bell of St Paul's, which weighs $5\frac{1}{2}$ tons. In the quarter part the arrangement is much the same as the hour. The eight cam wheels, which in fact form a chime barrel for the eight hammers of the four bells, have been mentioned already. But the levers are not of the kind shown in the quarters of fig. 18, for they are 19 inches long from the arbor to the end which is pulled down by the cams, and the wire goes up from near the end, the wheel turning the opposite way from the quarter-wheel in fig. 18, so that the weight acts as directly as possible on the levers, with nothing but differential pressures either on their arbor or on that of the great wheel. The great wheels in this part are $38\frac{1}{2}$ inches in

diameter, and the whole mass of the barrel, great wheels, and cam wheels weighs no less than 17 cwt. In fact this clock may be said to be at least eight times as large as a full-sized cathedral clock such as that described in fig. 18, since the wheels of the Westminster clock are rather more than double the size of those in every dimension. The whole of the wheels, except the fly wheels and winding pinions, lie on the top of the great frame, which is a trussed girder frame 19 inches deep (like the girders of the Crystal Palace), resting on two walls 11 feet apart which come right up from the bottom of the tower. The frame will be $15\frac{1}{2}$ feet long; the striking pulleys will be about $2\frac{1}{2}$ feet in diameter, and pivotted in, as clock pulleys always should be. They are generally made too small, and with the pulley running on a thick bolt put through the block or frame, which increases the friction considerably. We may add with reference to the question of the strength of cast-iron teeth, that a segment of one of these great wheels was tried up to breaking point, and it bore a pressure of 6 tons, and then only broke from the pinion not bearing quite flat upon it: the heaviest weight which the teeth can have to bear in action will be about half a ton.

ELECTRICAL CLOCKS, AND DIALS.

The application of electricity to clock-work has engaged the attention of scientific men and of a few clockmakers for some years, and of late they have been brought to a state of sufficient perfection to be used even for astronomical purposes. But it should be understood, that under the term electrical clocks two very different things are comprehended; one being mere dials, of which the hands are driven by electrical connexion with some standard clock, on the principles of the electric telegraph, as was first done by Professor Wheatstone about 15 years ago; and the other kind are clocks kept going by electricity instead of gravity, which, until the improvements made by Mr Shepherd of Leaden-

hall Street, were a complete failure as regards accurate time-keeping, the previous makers having used electricity to impel the pendulum directly, and, of course, failing to get a uniform impulse; whereas Mr Shepherd applied it to raise a small weight, which gives the impulse to the pendulum after the manner of a gravity escapement, but still not without some action on the pendulum, which it is better to avoid, and which may be avoided, as will be explained presently. Without meaning to engage in the unprofitable question of priority of invention, it is proper to mention that there were in the Exhibition of 1851 several foreign electrical clocks on the same principle as Mr Shepherd's, and one of them exactly the same in construction. His large dials erected in the Exhibition certainly failed completely; and it does not appear to us that the tremor of the building, to which he attributed the failure, was sufficient to account for it. But he has since made some further improvements in them, which we shall explain after we have described the construction of electrical dials.

If you take the weight off a common recoil escapement clock, and work the pallets backwards and forwards by hand, you will drive the hands round, only the wrong way: consequently, if the escapement is reversed, and the pallets are driven by magnets alternately made and unmade, by the well known method of sending an electrical current through a wire coiled round a bar of soft iron, the contact being made at every beat of the pendulum of a standard clock, the clock without the weight will evidently keep exact time with the standard clock; and the only question is as to the best mode of making the contact, which is not so easy a matter as it appears to be, on account of the short time in which it has to be done. The first plan was to have a wheel set on the scape-wheel arbor divided into 60 conducting, and 60 non-conducting spaces, with a contact spring pressing upon it. But to this there are several objections; one is the friction, which seriously affects the

going, unless it is a large clock with a heavy pendulum ; and a still more serious evil is, that the contact surfaces will not keep clean enough to ensure the contact, wherever there is rubbing between them, as it promotes oxidation. It seems, that nothing except contact without friction between gold or platinum surfaces will do permanently. The late Mr Dent made an electrical dial, and kept it going in this way long enough to ascertain that it would answer. Then there is the plan (which Mr Shepherd adopts) of letting the pendulum itself make contact with two springs acting near the top, at each vibration ; but the objection to this is, that any variation in the force of the springs from temperature, acting at the extremity of the arc, affects the time of the pendulum, the reason why Hardy's escapement failed, as before stated. Still, by making the springs very weak and the pendulum heavy, this method is probably sufficient for most purposes. Another method which has been lately used at the Royal Observatory, is to make a wheel on the scape-wheel arbor with 60 teeth press a slight spring against a contact plate or another spring at every second, the circuit passing through the two springs. But if any change takes place in the friction between the wheel and the spring, it will affect the going of the clock. With the gravity escapement, indeed, the friction would not signify ; and if a lantern pinion of 6 is used for the three legged scape-wheel, the minute-wheel will have 60 teeth, and will itself do for making the contact.

There is also another method which may be used with the gravity escapement ; and that is, to let the pallets or gravity arms fall against very weak springs which make the contact with pins as in the last case, the current passing through the spring attached to one wire of the battery, and the pin attached to the other. We have seen it tried on the great Westminster clock, with the contact made directly between the pallets and the pins, without any springs, and the current passing to the pallets from the clock-frame through the pivot holes.

This acted very well for a short time, but afterwards failed, whether from a defect of the passage through the pivot holes, or some other cause, was not discovered. The time of contact can be increased, if requisite, by increasing the depth of locking, since the falling pallet will remain in contact with the pin or spring until the unlocking of the other pallet is completed, and the wheel begins to move.

But for electrical *dials* it is better, if possible, to make the hands move only by half-minute jumps, so that the time may be taken exactly, as with a train remontoire; and in that case nothing is required but the three dial wheels, and some kind of scape-wheel or ratchet for driving them. If they are driven by pallets, a scape-wheel of 60 teeth will do; if it is a ratchet-wheel with a driving click, it will want 120 teeth. But here comes in a difficulty of some weight, at least in large dials, and especially in those exposed to wind. In that case it is found that pallets cannot be relied on to drive with certainty, and the ratchet and click must be resorted to. But if the wind happens to be pushing the hand forward at the time of lifting the click, it may run on 3 or 4 teeth at once. To prevent this, two ratchets have been used, set opposite ways, and the clicks so disposed that the wheels can only move one tooth at a time, under the proper action of the driving click; such at any rate is the intention of them; but it does not seem to be always carried into effect; and besides that, it requires great delicacy in construction. Mr Denison has, therefore, lately contrived the following apparatus for this purpose, which has been made by Mr Dent, and, as far as can be yet seen, is successful; at least it has been tried by pressing the wheel both ways more strongly than the wind could, and it remains quite steady. In fig. 19, H is the wheel on the arbor of the minute-hand, with 120 square teeth in it. When the circuit is complete, the magnet M raises the lever L into the position here shown, and with it the driving click A. The pin B at the same time lifts the forward click DG out of the teeth, and

the spring behind it at D sends it forward a little (there being some play left in the pivot hole for the purpose), and makes it trip on to the top of the tooth at G. The top of the lever at F also then reaches the tail of the backward click CF; so that while things are in this state, the wheel cannot go forward without pulling the lever out of contact with the magnet, which no wind would be strong enough to do while it remains a magnet; and as soon as the circuit is broken, the lever ought to go and will go, being pulled down by the weight W, till it rests on the lower banking pin E; and in so doing, the click A will drive the wheel forward one tooth,

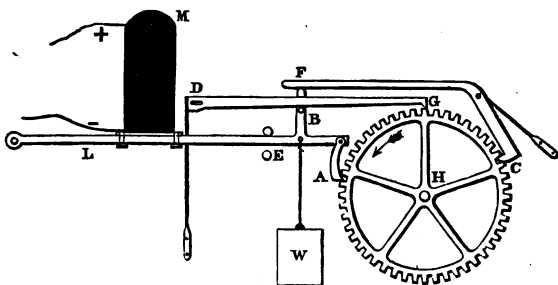

Fig. 19.

and the click DG will drop into the space next after the tooth G, and be pressed back against its spring till it is lifted again by the lever. Another advantage of this plan over those in which the magnet drives the wheel directly is, that the weight is always ready to pull down the lever as soon as the current ceases; so that if there should be any momentary impediment from residual magnetism or otherwise, it will not signify; and, moreover, the wind can never prevent the lever from being lifted; and if there should be any resistance to the hands from wind at the moment when the current ceases, the weight is sure to have the opportunity of overcoming it before the next 29 seconds are over; so that a whole move of the hands can never be lost, which

has always been liable to happen under the other arrangement in large dials.

There is no such difficulty in making the half-minute contact as there is in seconds contact, because plenty of time can always be taken for it ; and it may be done by a slower wheel in the train, and therefore not so liable to affect the force on the pendulum. As the third wheel in the train generally turns in $7\frac{1}{2}$ minutes, there may be 15 pins in it pressing a spring which makes contact, or raising a lever or a spring which drops on to a plate. Where the gravity escapement is used, there may be a snail with two steps on the arbor of the minute-wheel, which will drop the lever on to the contact plate at every thirtieth second, and begin to lift it off again at the thirty-first, the snail being made square at the bottom in order to raise it immediately, and waste as little electricity as possible. It was intended to drive the numerous small clocks in and about the houses of parliament by electrical connection with the great clock ; but as they are finished, and the great clock is not likely to be put up for some years, we suppose this plan will be abandoned, unless the bad going of some of these small clocks, and the cost of winding them, suggests the expediency of replacing them by electrical dials. In that case there ought to be one other strong gravity clock with which they might be connected in case of any accident at the great clock, which would otherwise stop them all. There is apparently to be a small turret clock at the corner facing the Abbey, which would do very well for this purpose, if it is a good one.

Of electrical *clocks*, *i.e.*, clocks where pendulums are kept going by electricity, it is not worth while to notice any before Mr Shepherd's, or the coeval invention of the same kind on the Continent. The latest and best form of his escapement is this: a single pallet like one of the pallets in the pin-wheel escapement (fig. 6) is fixed to the pendulum, and there is a small lever set in the frame, the end of which is lifted on to this pallet at every swing of the pendulum in

one direction by the magnet; and as the pendulum draws the pallet away from the lever end, it slides down the sloped face and gives the impulse. This is a single-beat escapement, of which there are other forms without reference to electricity. They have the advantage that the impulse may be made to end exactly at the same arc of the pendulum after zero as it begins before zero, or even less; but there are countervailing disadvantages in the mode of unlocking (not applying, however, to this electrical method, which has no unlocking), and they have consequently never come into use. Still this escapement is not without friction, and the contact is made by the pendulum pressing against a spring as it approaches the extremity of its swing in one direction, which is objectionable for the reasons before mentioned. So far as we have yet described it, we have got nothing but a self-acting pendulum; the connection with a clock train is made in just the same way as if this were an ordinary pendulum from which the pallets of an electrical dial are to be driven by alternate contact springs on each side of the pendulum.

Another peculiarity of Mr Shepherd's clocks is, that the pallets which drive the train are alternately attracted and repelled, not simply attracted and let loose, and this is stated to economise the force. In order to effect it, there are two batteries which come into action alternately; and there are two permanent straight bar magnets set across the pallet arbor, with their poles opposite ways, so that on one side, say the left, the adjacent ends of the two bars would be north and south, and on the right side south and north. Consequently a temporary horse-shoe magnet, with its poles standing south and north, will attract the left side of the pallet magnets, and a similar magnet will repel the right side; and, therefore, if the current is made to pass one way when the pendulum makes the contact on the right side, and the other way when it makes it on the left, the pallets will be driven both ways by the combined force of the attraction and repul-

sion of both magnets. For this purpose it is only necessary that the right pendulum spring should be connected with the + pole of one battery, and the left spring with the - pole of the other, the other wires of each battery being soldered together, and ultimately connected with the pendulum cock after passing round both the soft-iron magnets.

If anything is to be let off by electricity at a given second in every day, the requisite precision is obtained by Mr Shepherd thus: there are pins for making contact with springs in the minute-wheel, the hour-wheel, and the 12-hour wheel; and it is only when the contact is made with all of them at once that the circuit is complete. In this way the time-ball at the Greenwich Observatory, and also the one in the Strand in connection with it, are let off at one o'clock every day, by the clock pulling a trigger by a temporary magnet. The balls are pulled up by hand a few minutes before one. The Greenwich one is a large covered basket of wicker work, and it descends with a piston plunging into a tube with a bell-mouth to facilitate the entrance, and the piston compressing the air as it goes down, which acts as an elastic cushion to the ball, makes it drop without concussion: there is a small hole at the bottom through which the air afterwards gradually escapes. Mr Shepherd also describes in his pamphlet some apparatus for striking by means of electricity, without the aid of any striking weight. But we have not heard of any such clocks being in use, and we think it not very likely they should be, on account of the greater force which is required for striking than for keeping a pendulum going.

Mr Dent has lately made a self-acting electrical clock on quite a different plan from Mr Shepherd's. It has the three-legged gravity escapement and the usual train, except the great wheel, but has a going ratchet on the centre wheel, with 120 teeth. This is driven by a click on the end of a lever, which is raised the height of one tooth by the magnet at every half minute by any such half-minute contact as

we have before described. It requires, however, a strong battery, as there must always be more force in the ratchet spring than is actually required to drive the escapement. There is no doubt yet room for considerable improvement in all these various contrivances.

WATCHES AND CHRONOMETERS.

We said that we should defer a description of spring-clocks until we came to treat of watches, which, as we all know, have a spiral spring instead of a weight for their maintaining power. They seem to have been made as early as the sixteenth century, though Huygens in the seventeenth was the first discoverer of the important law respecting springs, which he enunciated in the well-known words, *ut tensio sic vis*, the force of a spring varies as the bending of it; which, however, we shall find to be subject to one somewhat inconvenient, and another very convenient exception. The most simple form of mainspring arrangement for a clock or watch is that where the spring has its inner end attached to the arbor, which ends in the winding square, having a ratchet set on it with the click in the clock-frame. The other end of the spring is fixed to the barrel containing it, and on the end of the barrel is the great wheel of the clock or watch. And one advantage of this is, that no going barrel apparatus is wanted, as there is just the same pressure on the train when you are winding up (in fact rather more) as at any other time. But then it will occur to the reader, that by virtue of the rule *ut tensio sic vis*, there must be a much greater force on the train when the watch is wound up than when it is nearly run down. And so there would be, but for that very convenient and singular exception we just now alluded to. For it is found that there is a position of every spring, in which its force does not sensibly alter for four or five turns; and if the spring is such, that this position occurs just at the right degree of tension for using it in a watch barrel, it is evident that we

may use it for a mainspring without any further provision for equalizing its force. We are not sure whether this is the case yet with any of the English mainsprings, but it certainly is with many of the foreign ones; and we can testify to the fact of watches made with those mainsprings going as well as those which are made with English mainsprings and a fusee; and we believe that the late Mr Dent, who had been trying some of these watches for several years before his death, had come to the conclusion that with a mainspring properly made and adjusted, the fusee, chain, and going ratchet, are an unnecessary expense, except perhaps in large chronometers, where not only is a great force required, but a constant force throughout the day, which is not the case in watches.

Fig. 20 shows the general arrangement of a watch or chronometer (it is actually taken from a chronometer). The barrel and fusee will be recognised at once. The fusee is a sort of grooved cone with a concave section; the more rapid swell towards the thick end is required, because one turn of the fusee when the chain is at that end takes much more of it off the barrel than at the thin end; and on the assumption that the force of the spring varies as its tension (except under the circumstances before mentioned), the radius of the cone must increase more rapidly, in order to make the increase of leverage keep pace with the decrease in the force of the spring as it unwinds with an increasing velocity off the thick end of the fusee. The fusee itself is connected with the great wheel by a ratchet and click and going ratchet (of which the spring and click are strongly shown in the figure), just as we described in an astronomical clock. Something is also required to prevent the watch from being overwound, or the chain strained so as to break. This is done by means of a hooked lever set on a hinge in the upper frame-plate (which is taken off in this drawing); and when the watch is nearly wound up, the chain moving upwards reaches this lever, and moves it into such a position

that its hook catches hold of the long tooth projecting from the thin end of the fusee ; and thus the winding is stopped without any strain on the chain by the sudden check. In the Great Exhibition there were some watches by a Mr Jackson, in which the winding was done by a solid key fitting into a square hole in the arbor of a pinion working

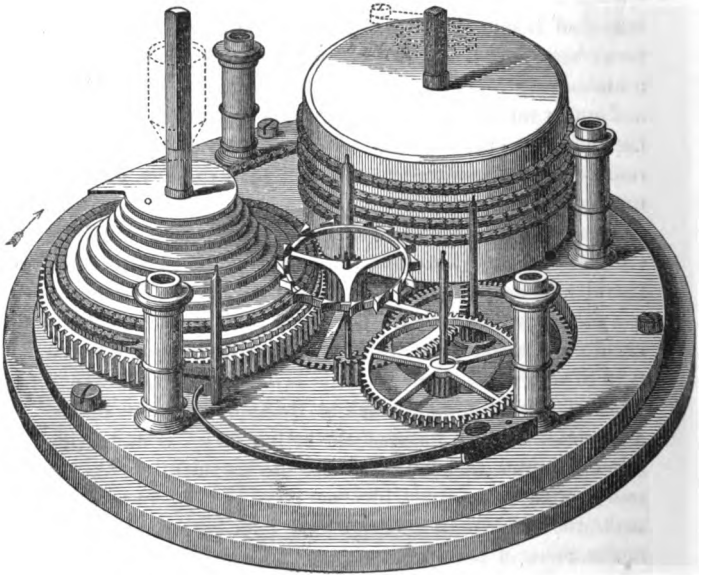

Fig. 20.

into a winding wheel on the fusee, just like the winding pinion in turret clocks. The object was to reduce the size of the fusee arbor, and to avoid the inconvenience of a very short winding square when the watch is wanted to be thin. We doubt whether the advantage is worth the additional cost. But we are surprised that a suggestion of the late Mr Mudge's for the reduction of the friction of the fusee arbor has not been adopted, viz., to make the barrel turn

the opposite way to the fusee, so that the chain may act between the arbor and the centre pinion, thereby making the pressure on the fusee arbor only the difference, instead of the sum, of the force of the spring and the pressure transmitted to the pinion. In watches without a fusee, the solid key plan might be advantageously adopted, as it would not require the addition of a winding pinion; because the winding arbor is then the arbor of the barrel, which does not turn round except in winding, when the friction from the increased size would not signify.

In watches without a fusee the apparatus for preventing them from being overwound is different; it goes by the name of the Geneva stop, and the principle of it is simply this: if two wheels work together, of which one has the spaces between some two or more adjacent teeth filled up, it is evident that that wheel cannot be turned quite round. And it will be the same thing if one of the wheels is only a cylinder with a single tooth in it, and the other has a certain number of notches, not going all round, through which that tooth can pass. If, therefore, a one-toothed wheel of this kind is fixed to the barrel arbor, which is turned by the key, and works into a wheel with only 4 or 5 notches in it and a blank space through which the tooth cannot pass, it will evidently allow the barrel to be wound up the 4 or 5 turns and no more; and as it unwinds it turns the stopping wheel back again with it.

The other parts of a watch do not differ from those of a clock, except in size, and the position in which they are arranged, to bring them within the circle of the dial, until we come to the escapement, and there a different state of things arises, mainly from the fact that the balance of a watch revolves through sometimes as much as 270° , while a clock pendulum only vibrates through 4° or 5° . The balance being common to all the watch escapements, it will be proper first to describe that, and the conditions to which it is subject. The two equal arms, with equal weights at each end, in

fig. 3, are really a balance just as much as the wheel which is commonly used as the more convenient form. But in that figure there is not to be seen that essential element of a modern balance—the thin spiral spring, which you see opening and closing itself at every vibration when you look into a watch. The outer end of this spring is attached to the frame by a cock R (fig. 21), and the inner to the balance at S; and the time of vibration is a compound of the strength of the spring, and the moment of inertia of the balance; for if the spring is perfect, the extent of the vibration does not signify, by virtue of the before-quoted maxim *ut tensio sic vis*, and the further rule (which is one of mathematical certainty, and not empirical and approximate),

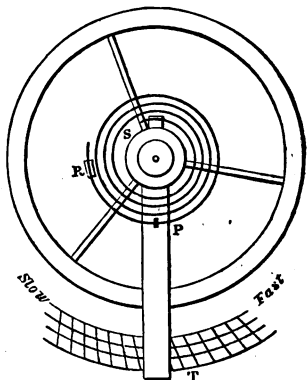

Fig. 21.

that wherever the force varies as the angle of vibration, the time of the body vibrating is the same, whatever the space moved over. And as the force of a spring varies (approximately) inversely as its length, this suggests a ready method of regulating the watch; for it is easy to make a pointer or index, or "regulator" P T, turning on a ring fixed to the watch plate, concentric with the balance, and having two pins in it at P, called *curb pins*, just close enough together to embrace the spring, so that, as the index is moved one way or the other, the length of the spring which is free to vibrate may become shorter or longer. When the regulator has been moved as far as it can go towards *fast*, suppose, and the watch still loses, the spring has to be shortened at the cock R into which its outer end is pinned; and in order that the balance may be capable of alteration, so as

still to stand square with the escapement when the spring is in its neutral state, the other end is not actually pinned to the balance, but the cock S is on a small ring which is set on the axis or *verge* of the balance pretty tight by friction, but capable of being turned by hand.

It has often been complained, and very justly, that it is almost impossible to move the regulator little enough, and with sufficient accuracy, for a very small variation of rate, not merely because the point is often ill adjusted to the scale, but because the divisions themselves are necessarily very small. One way of obtaining greater accuracy, and probably the best, is to make the regulator moveable by a tangent screw acting on its end, and capable of being turned by the watch key; and in an expensive watch, fitted with all the other modern appliances for securing accuracy of performance, the additional expense of this would be well worth incurring. We have seen several watches of this kind. Mr Dent suggests that a cheaper way of doing it, and accurate enough for most watches, would be to make the scale with oblique divisions (as shown in fig. 21), after the fashion of the old form of vernier, and the regulator itself with bevelled edges: by this means a very small motion of the edge of the regulator along the oblique divisions would be very distinctly seen, and it cannot be doubted that this would be a great improvement. In chronometers the adjustment for time is no longer made by altering the effective length of the spring after its length is once fixed, because of the other exception to the rule about the force of a spring varying as its tension, to which we alluded. For it has long been ascertained that a spring has not this isochronous property at all lengths, but only at certain intervals; and therefore it is necessary in an accurate time-keeper to use only one of those lengths of the spring which are isochronous for different arcs of vibration; and that being fixed, the timing of the balance can only be done by altering its moment of inertia, and this is done in chronometers by screws with heavy heads in the

rim of the balance, and set farther in or out as it is wanted to go faster or slower. In marine chronometers, where there is plenty of room for it, the balance spring is generally made in a cylindrical form, with the coils all of the same diameter, instead of the flat spiral used in watches; though it does not seem to be quite clear that the cylindrical form is materially better than the other. It is evident, however, that the goodness of this spring is a matter of primary importance; and in this respect, as well as in mainsprings, there seems some reason for apprehending that our makers are surpassed by the foreign ones. The balance-springs made by M. Lutz of Geneva (by a secret method), stood the tests which the horological jury at the Great Exhibition applied, of pulling out nearly straight, and laying on a hot plate, without altering their form; while those to which special attention was invited by Mr C. Frodsham, a chronometer-maker of reputation in London, were very much distorted under the same operations. The late Mr Dent happened to be present when the springs of M. Lutz were tried, and he expressed great admiration of them.

The timing of a watch for position, as it is called, is a matter which requires some attention. If the balance is not exactly poised on its axis, it will have a tendency to take one position when the watch is carried vertically, as it always is in the pocket; and the time of vibration will be affected by its disposition thus to act as a pendulum. The watch ought therefore to be tried with XII, IX, VI, and III, successively upwards, and if it does not keep the same rate, the balance is not properly poised. Marine chronometers, indeed, being set in *gimbals* (a ring with the two pivots into the box at right angles with the pivots which carry the chronometer) will remain horizontal, though not without some degree of motion under the motion of the ship; and this gives the balance the further advantage of having its weight resting only on the end of the axis or verge, a position in which there is much less friction than

that of a watch carried in the pocket : but there it is not of so much consequence, because the balance is so much lighter than a chronometer balance.

COMPENSATED BALANCES.

The compensation of a balance for temperature is even of more importance than that of a pendulum, especially for chronometers, which are not kept, as watches are, to a tolerably equable temperature by being carried in the pocket. A pendulum requires scarcely any compensation except for its own elongation by heat ; but a balance requires compensation not only for its own expansion, which increases its moment of inertia just like the pendulum, but far more on account of the decrease in the strength of the spring under increased heat. The late Mr Dent, in a pamphlet on Compensation Balances, gave the following results of some experiments with a glass balance, which he used for the purpose on account of its less expansibility than a metal one :—

Temperature.	Vibrations in an hour.
32°	3606
66°	3598·5
100°	3590

If therefore it had been adjusted to go right (or 3600 times in an hour) at 32°, it would have lost $7\frac{1}{2}$ and $8\frac{1}{2}$ seconds an hour, or more than three minutes a-day, for each successive increase of 34°, which is about 15 times as much as a common wire pendulum would lose under the same increase of heat, taking the decrease of elasticity of the spring into account, as well as the elongation of the rod ; and if a metal balance had been used instead of a glass one, the difference would have been still greater.

The necessity for this large amount of compensation having arisen from the variation of the elasticity of the spring, the first attempts at correcting it were by acting on the spring itself in the manner of a common regulator. Harrison's compensation consisted of a compound bar of brass and

steel soldered together, having one end fixed to the watch-frame, and the other carrying two curb pins which embraced the spring as we described at fig. 21. As the brass expands more than the steel, any increase of heat made the bar bend; and so, if it was set the right way, it carried the pins along the spring, so as to shorten it. This contrivance is called a *compensation curb*; and it has often been reinvented, or applied in a modified form. But there are two objections to it: first, that the motion of the curb pins does not correspond accurately enough to the variations in the force of the spring; and, secondly, it disturbs the isochronism of the spring for short and long arcs, because, as we stated a little while ago, that isochronism only subsists at certain definite lengths of the spring. And the compensation which was next invented left the spring untouched, and provided for the variations of temperature by the construction of the balance itself. Fig. 22 shows the plan of the ordinary compensation balance as it has now been used for many years. Each portion of the rim of the balance is composed of an inner bar of steel with an outer one of brass soldered upon it, and carrying the weights, *b, b*, which are screwed to it. As the temperature increases the brass expanding must bend the steel in-

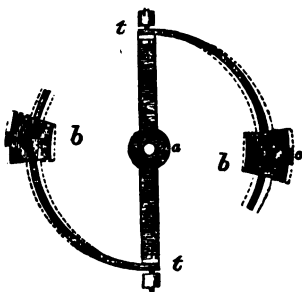

Fig. 22.

wards; and so carries the weights farther in, and diminishes the moment of inertia of the balance. The metals are generally soldered together by pouring melted brass round a solid steel disc, and the whole is afterwards turned and filed away till it leaves only the cross-bar in the middle lying flat and the two portions of the rim standing edgeways. The first person who practised this method of uniting them ap-

pears to have been Thomas Earnshaw—the man who brought the chronometer to the state in which it has remained for the last eighty years, with scarcely any alteration ; although (from a combination against him in his own time, and the indifference of writers on these subjects since) he has not obtained the reputation he deserves, and has been sometimes dismissed in a single sentence, while pages have been bestowed on the works of inferior artists, whose chronometers were always beaten by his whenever they came into competition, and who afterwards copied his inventions, and did their best to prevent his being rewarded for them.

The adjustment of a balance for compensation can only be done by trial, and requires a good deal of time. It must be done independently of that for time ; the former by shifting the weights, because the nearer they are to the cross-bar the less distance they will move over as the rim bends with them. The timing is done by screws with heavy heads (t, t , in fig. 22) just opposite to the ends of the cross-bar, and consequently not affected by the bending of the rim. The compensation may be done approximately by the known results of previous experience with similar balances ; and many watches are sold with compensation balances which have never been tried or adjusted—a matter which a purchaser has no means of ascertaining except by trying the watch himself in two sufficiently different temperatures.

THE CHRONOMETRICAL THERMOMETER.

If a watch or chronometer, going right at a given temperature, is transferred to a higher temperature, it will, of course, lose in proportion to the excess of the new temperature above the old, and the time it is kept there ; and consequently, its difference from the true time will show the quantity of additional heat it has received during that period ; and if its time is observed and registered every day or every week, it will show what has been the mean heat of that day or week. And if, instead of being furnished with a plain balance, it

has one compensated the wrong way, as we may call it, its indications will become still stronger. Such an instrument is called a *chronometrical thermometer*, and is used where the quantity of heat received or lost by some other instrument or apparatus, during a given time, is wanted to be known, without regard to the extremes which the temperature may have reached, or its fluctuations.

SECONDARY COMPENSATION.

When chronometers had been brought to great perfection by the improved workmanship of modern times, and were subjected to more extreme temperatures in the annual trials at Greenwich, it was perceived that there was a residuary error, which was due to changes of temperature, but which no adjustment of the compensation could correct. For if the compensation was adjusted for two extreme temperatures, such as 32° and 100° , then the chronometer gained at mean temperatures; and if adjusted for any two mean temperatures, it would lose for all beyond them. This error was observed, and attempts were made to correct it before anybody had pointed out how it arose: this appears to have been first done in a paper in the *Nautical Magazine* by the late Mr Dent, in the year 1833; and he gave the following illustration of it. The variation of the force of the spring proceeds uniformly in proportion to the temperature, and therefore may be represented by a straight line inclined at some angle to another straight line divided into degrees of temperature. But the inertia of a balance of the common construction cannot be made to vary uniformly according to the temperature, but more rapidly in cold than heat; and consequently its rate of variation can only be represented by a curve, and the curve can only be made to coincide with the straight line representing the rate of variation of the spring, in two points, whether two extremes or two means, or one extreme and one mean point. The same thing may be shown mathematically, as follows: let r be the dis-

tance of the compensation weights b, b , in fig. 22 (which we may assume for convenience to be the whole mass M of the balance) from the centre at some mean temperature, and let dr be their increase of distance due to a decrease of some given number of degree of heat, under the action of the compensation bars. Then the new moment of inertia will be $M (r^2 + 2r dr + dr^2)$, and the ratio of the new to the old will be $1 + \frac{2dr}{r} + \left(\frac{dr}{r}\right)^2$; and the term $\left(\frac{dr}{r}\right)^2$ is now too large to be disregarded, as it might be in pendulums, where, as we saw, the compensation $\frac{dl}{l}$ is only required to be about

$\frac{1}{20}$ th of the $\frac{dr}{r}$ in a balance. It is found that an equal increase of temperature will produce an equal (or perhaps a less) motion ($-dr$) of the weights towards the centre, and therefore the ratio of the decreased moment of inertia to the original one will be $1 - \frac{2dr}{r} + \left(\frac{dr}{r}\right)^2$; so that the increase and the decrease from the mean amount differ by twice $\left(\frac{dr}{r}\right)^2$: in other words, the moment of inertia of the balance varies less in passing from mean to hot temperatures than from mean to cold; and consequently if it is adjusted for mean and cold, it will not have decreased enough at an equal increase from mean to hot, or the chronometer will lose; and if adjusted for the two extremes it will gain at mean temperatures.

The correction of this error is called the *secondary compensation*; and it has lately been the subject of a rather warm controversy, carried on in memorials to the Admiralty, published by parliament, and subsequently in the *Journal of the Society of Arts* for the year 1853, arising from a repeated claim by Mr Loseby, a chronometer-maker of great reputation, to be rewarded by the government for an invention of this kind, which he asserted to be superior to the

many others for the same purpose, some earlier and some later than his own. The Astronomer Royal has four times reported against Mr Loseby's claim, though admitting the general excellence of his chronometers; and it appears, from other examinations of the reports of the annual trials at Greenwich, in the above papers and journal, that when proper means are taken to distinguish the errors of compensation from the general errors which have nothing to do with temperature, Mr Loseby's apparent superiority vanishes altogether. It is obvious that the mere fact of one chronometer going better than another for a certain time proves nothing as to the value of any particular invention it contains, unless some means are taken to distinguish the effects of the error which that invention is designed to correct. We shall give a short description of the principal classes of inventions for this purpose, as several of them are exactly the same in principle.

The first which was disclosed was Mr Eiffe's, who communicated several methods for effecting this object to the Astronomer Royal in 1835. They were afterwards described in a paper edited by Mr Airy for the Admiralty, and they, or some of them, were sufficiently successful to obtain for Mr Eiffe a reward of L.300 as being the first inventor, and having disclosed his invention without a patent. In one of them a compensation curb was used; and though for the reasons we gave before this will not answer for the primary compensation, it possibly may for the secondary, where the motion required is very much smaller. In another the primary compensation bar, or a screw in it, was made to reach a spring set within it with a small weight attached, at some mean temperature, and as it bent further in it carried this secondary compensation weight along with it. The obvious objection to this is (as Mr Loseby remarks), that it is discontinuous; but still the whole motion is so small, not more than the thickness of a piece of paper, that this and other compensations on the same principle appear to

have been on some occasions quite as successful as his own. Mr Eiffe seems to have made some improvements since that time, but the nature of them is not disclosed in any of the papers we have referred to. Shortly after this Mr Molyneux took a patent for a secondary compensation exactly the same as this of Mr Eiffe's, then before the Astronomer Royal.

Another large class of balances, all more or less alike, may be represented by Mr Dent's, which came the next in order of time after the two we have mentioned. He also described several forms of his invention in a pamphlet which he published; and it should be observed, that the one which he there specified as the best of them is not the one which Mr Loseby afterwards selected and described as "Dent's balance," for the purposes of his memorial to the Admiralty. The following is the proper description:—

In fig. 23, the flat cross-bar is itself a compensation bar which bends upwards under increased heat; so that if the weights were merely set upon upright stems rising from the ends of the cross-bar, they would, of course, approach the axis when that bar bends upwards. But instead of the stems rising from the cross-bar, they rise from the two secondary compensation pieces *s t u* in the form of staples, which are set on the cross-bar; and as these secondary pieces themselves also bend upwards, they make the weights approach the axis more rapidly as the heat increases; and by a proper adjustment of the height of the weights on the stems, the moment of inertia of the balance can be made to vary in the proper ratio to

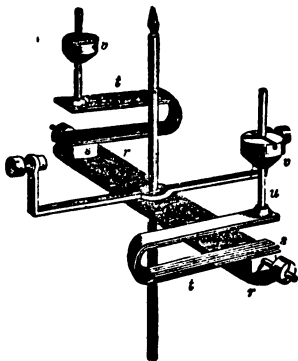

Fig. 23.

the variation of the intensity of the spring. The cylindrical spring stands above the cross-bar and between the staples.

Fig. 24 represents Mr Loseby's mercurial compensation

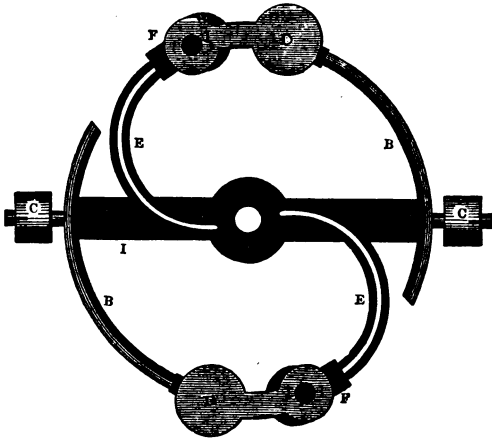

Fig. 24.

balance. Besides the weights *D* set near the end of the primary compensation bars *B*, there are small bent tubes *FE* with mercury in them, like a thermometer, the bulb being at *F*. As the heat increases, not only do the primary weights *D* and the bulbs *F* approach the centre of the balance, but some of the mercury is driven along the tube, thus carrying some more of the weight towards the centre, at a ratio increasing more rapidly than the temperature. The tubes are sealed at the thin end, with a little air included. The action is here equally continuous with Mr Dent's, and the adjustments for primary and secondary compensation are apparently more independent of each other; and this modification of Le Roy's use of mercury for compensated balances (which does not appear to have answered), is certainly very elegant and ingenious. Nevertheless, it is clear,

from the analysis of the Greenwich lists for the last 7 years before referred to, that the advantages of this method over the others is more theoretical than practical; for it appears, that if the six months of trial are divided into three periods, one containing all the coldest weeks, another the hottest, and the third those of moderate temperature only, and whether the division is arbitrarily made into equal periods of eight weeks, or into periods of six weeks of the most extreme temperatures and twelve of the mean, or is made just where the printed register of the temperature shows the greatest breaks to have occurred in each year, still the result is the same, that Dent's compensation has been the most successful in three years out of the seven, and Loseby's in only one. We observe also, that Mr Loseby, in his numerous letters and memorials to the Admiralty and the Society of Arts, does not answer the objection to his claim, that the high place which his chronometers have frequently obtained in the Greenwich lists, not being borne out in that particular respect for which his invention is designed, must be attributed to his personal care and skill in getting up a chronometer for trial in each year; which, however creditable to him, is evidently an argument against the value of his invention rather than in favour of it; and makes it probable that the same care and skill bestowed upon some of the other inventions for secondary compensation would have rendered them still more successful. It is remarkable also, that it has never been adopted by any other chronometer-maker; for although he has recently included it in a patent, it was well known and open to the adoption of everybody for several years before: whereas the principles both of Mr Eiffe's and Mr Dent's methods have been adopted by several other makers.

Chronometers have been made with glass balance-springs, and the published rate of one which was tried some years ago at the Royal Observatory was very good. They have the advantage of requiring very little primary and no

secondary compensation, on account of the very small variation in their elasticity, compared with springs of steel or any other metal. We cannot ascertain any good reason why the use of them has not been extended, except that it is said the workmen resisted their introduction, as they often do resist any improvement involving a material departure from the established modes of construction. It was also stated on a late occasion at the Society of Arts, that glass springs change their rate after a few months; but so do steel springs: it is expressly stated in Mr Eiffe's pamphlet before referred to, that chronometers always gain after a few months' working. But whatever is the cause, very few of these glass spring chronometers appear to have been made even by Mr Dent, who was the author of the one whose rate we have mentioned.

But about a year before his death he invented a very different method of effecting the primary and secondary compensation at once, and without any additional appendage to the balance or addition to the cost. He called it the *prismatic balance*, from the shape of the steel rim, of which the section is shown in fig. 25, BC being the brass, and the dark triangle within it the section of the steel part of the rim. A prism of cast-steel will bend more easily from the edge than the other way, and consequently the motion is greater when it is being curved by heat than when it is pulled straighter by cold; which is exactly what is wanted. It is



Fig. 25.

true that the difference is not quite so great as it ought to be for complete compensation for a very wide range of temperature (above 90°), such as the present Astronomer Royal has for the last few years subjected all the chronometers

which are sent for public trial ; a practice which seems not unlikely to withdraw the attention of the makers from points of greater practical importance, and confine it to this one of secondary compensation for variations of temperature which not one in a hundred of them will have to undergo in real use. It is remarkable that when the chronometer rates were sent to Greenwich after a late arctic expedition, the Astronomer Royal had to report to the Admiralty that the chronometers had all been kept so *warm* that they did not afford the means of arriving at any conclusion as to the relative merits of the different kinds of secondary compensation ; in other words, that it had not come into action, even in an arctic voyage, to any sensible extent. But, although it would be of no use to send a chronometer of this kind to be tried against others in artificial changes of temperature from 21° to 115° , the present Mr Dent (of the Strand) says he has found them quite near enough to the requisite compensation for all ordinary variations of temperature, and also more than usually steady in their rate ; for even in the best chronometers there appear every now and then quite capricious variations, which show that there is yet ample room for improvement in other things besides compensation for an excessive range of temperature.

WATCH ESCAPEMENTS.

There is a greater variety of escapements in use in watches than in clocks. In the Austrian department of the Great Exhibition there was a large watch movement to which thirteen different escapements could be fitted for the purpose of illustration—not that anything like all this number can be said to be in use. The only ones that can be so described are (1.) the old *vertical* escapement, now almost disused ; (2.) the *lever*, very much the most common in English watches ; (3.) the *horizontal* or *cylinder*, which is equally common in foreign watches, though of English invention ; (4.) the *duplex*, which used to be more in fashion for first-

rate watches than it is now ; and (5.) the *detached* or *chronometer* escapement, so called because it is always used in marine chronometers. Of course every watch is in one sense a chronometer ; but the term is conventionally applied only to marine chronometers, and to watches of the same construction, which are thence called pocket chronometers. Besides these five standard movements, we have already mentioned that Macdowall's single-pin escapement (fig. 7) has lately been applied to watches, and that it is in some respects superior to the lever ; but it is more expensive on account of the two additional wheels in the train ; and that, like the *virgule* or *comma* escapement (which is described in most of the French treatises on watches), can hardly be added to the list of escapements in general use, though it is entitled to stand above many others of the thirteen before alluded to.

The vertical escapement is simply the original clock escapement of fig. 3 adapted

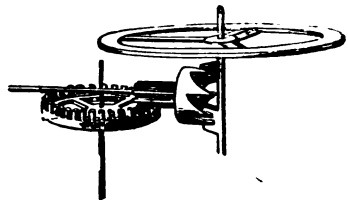

Fig. 26.

to the position of the wheels in a watch and the balance, in the manner here exhibited in fig. 26. It is, as we saw before, a recoil escapement, and the only one of those we have mentioned which is ; and besides that, it requires considerable thickness in the watch to hold the wheel which stands vertically when all the others are horizontal. It is also inferior in going to all the others, and very little cheaper than the lever escapement can now be made ; and for these reasons it is no wonder that it is almost disused.

The lever escapement, as it is now universally made, was invented by Thomas Mudge, a London watchmaker, to whom (or to his son for him), in 1793, a committee of the House of Commons, in opposition to the opinion of the

Board of Longitude, and apparently not understanding the evidence they took, gave a reward of L.3000 for inventing a remontoire escapement for chronometers, not worth a farthing, and indeed, as it turned out, worth a good deal less than nothing to his son, who proceeded to make the chronometers. However, if the reward is considered as given for the invention of the lever escapement, which is now used in all the best watches in the world (except chronometers), it may be said to have been well deserved. It is strange that Graham, the inventor of the dead escapement in clocks, did not hit upon this application of it to watches; an application, too, which avoids the great defect of that escapement in clocks, viz., the dead friction, or the friction on the dead faces of the pallets beyond what is necessary for the locking. Fig. 27 shows its action; of

course the position of the lever with reference to the pallets is immaterial in principle, and is only a question of convenience in the arrangement; but it is generally such as we have given it. If you turn back to fig. 5, the dead escapement in clocks, you will see that this is just the same as if the pallets there vibrated no farther with the pendulum than just enough to let the teeth escape, and left the

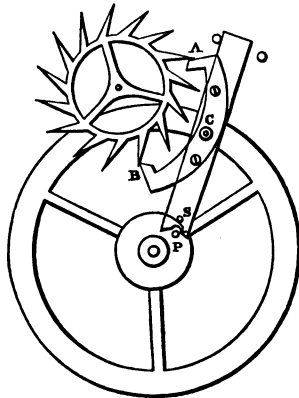

Fig. 27.

pendulum free during all the rest of its swing or "excursion" beyond the angle of escape. The reason why that cannot be done with a pendulum is, that its arc of vibration is so small that the requisite depth of intersection cannot be got between the two circles described by the end S of the lever and any pin in the pendulum which would work into

it ; whereas in a watch the pin P, which is set in a cylinder on the verge of the balance, does not generally slip out of the nick in the end of the lever until the balance has got 15° past its middle position. The pallets are under-cut a little, as it is called, *i.e.*, the dead faces are so sloped as to give a little recoil the wrong way, or slightly to resist the unlocking ; because otherwise there would be a risk that a shake of the watch would let a tooth escape while the pin is disengaged from the lever. There is also a further provision added for safety. In the cylinder, which carries the impulse pin P, there is a notch just in front of P into which the other pin S on the lever fits as they pass ; but when the notch has got past the cylinder, it would prevent the lever from returning, because the safety pin S cannot pass except through the notch, which is only in the position for letting it pass at the same time that the impulse pin is engaged in the lever. The pallets in a lever escapement (except bad and cheap ones) are always jewelled, and the scape-wheel is of brass. The staff of the lever also has jewelled pivot holes in expensive watches, and the scape-wheel has in all good ones. The holes for the balance pivots are now always jewelled, if nothing else is. The scape-wheel in this and most of the watch escapements generally beats five times in a second ; in large chronometers four times ; and the wheel next to the scape-wheel carries the seconds-hand. Macdowall's single-pin escapement is adapted to watches exactly as the dead escapement of clocks is turned into the lever escapement in watches.

Fig. 28 is a plan of the *horizontal* or *cylinder* escapement, cutting through the cylinder which is on the verge of the balance at the level of the tops of the teeth of the scape-wheel ; for the triangular pieces AB are not flat projections in the same plane as the teeth, but are raised on short stems above the plane of the wheel ; and still more of the cylinder than the portion shown at ACD is cut away where the wheel itself has to pass. The author of this escapement was

Graham, and it resembles the dead escapement in clocks in principle more than the lever escapement does, though much less in appearance ; because in this escapement there is the dead friction of the teeth against the cylinder, first on the outside, as here represented, and then on the inside, as shown by the dotted lines, during the whole vibration of

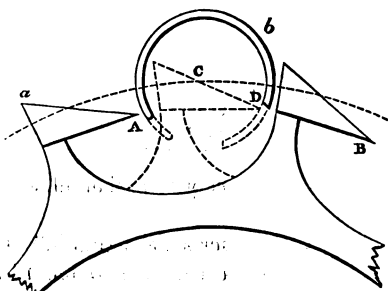

Fig. 28.

the balance, except that portion which belongs to the impulse, whereas in the lever escapement there is not the dead friction, as we explained just now. The impulse is given by the oblique outside edges *A a*, *B b*, of the teeth against the edges *AD* of the cylinder alternately. The portion of the cylinder which is cut away at the point of action is about 30° less than the semicircle. The cylinder itself is made either of steel or ruby, and from the small quantity of it which is left at the level of the wheel, it is evidently a very delicate affair ; and probably this has been the main reason why, although it is an English invention, it has been almost entirely abandoned by the English watchmakers in favour of the lever, which was originally a French invention, though very much improved, as we have seen, by Mudge ; for before his invention the lever had a rack or portion of a toothed wheel on its end working into a pinion on the balance verge, and consequently it was affected by the dead friction, and that of this wheel and pinion besides. This used to be called the rack lever, and Mudge's the detached lever, but the rack lever being now quite obsolete, the word "detached" has become detached from the lever escapement and confined to the chronometer, to which it is more appropriate,

as will be seen presently. The Swiss watches have almost universally the horizontal escapement. It is found that—for some reason which is apparently unknown, as the rule certainly does not hold in cases apparently analogous—a steel scape-wheel acts better in this escapement than a brass one, although in some other cases steel upon steel, or even upon a ruby, very soon throws off a film of rust unless they are kept well oiled, while brass and steel or stone will act with scarcely any oil at all, and in some cases with none.

The *duplex* escapement (fig. 29) is probably so called because there is a double set of teeth in the scape-wheel—the long ones (like those of the lever escapement in shape) for locking only, and short ones (or rather upright pins on the rim of the wheel) for giving the impulse to the pallet P on the verge of the balance. The action of this escapement is very peculiar, and requires some attention to understand it. It is a single-beat escapement, *i. e.* the balance only receives the impulse one way, or at every alternate beat, as in the chronometer escapement, and in a few clock escapements which we have not described, because they have never come into use. When the balance is turning in the direction marked by the arrow, and arrives at the position in which the dotted tooth *b* has its point against the triangular notch V, the

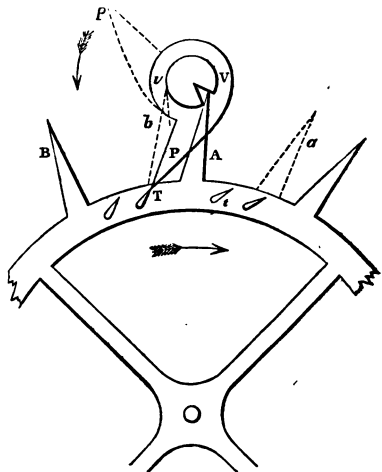

Fig. 29.

balance is turning in the direction marked by the arrow, and arrives at the position in which the dotted tooth *b* has its point against the triangular notch V, the

tooth end slips into the notch, and as the verge turns farther round, the tooth goes on with it till at last it escapes when the tooth has got into the position *A* ; and by that time the long tooth or pallet which projects from the verge has moved from *p* to *P*, and just come in front of the pin *T*, which stands on the rim of the scape-wheel, and which now begins to push against *P*, and so gives the impulse until it also escapes when it has arrived at *t*; and the wheel is then stopped by the next tooth *B* having got into the position *b*, with its point resting against the verge, and there is evidently what we have called dead friction between them ; but as the verge is smaller than the cylinder of the horizontal escapement, and is also made of a jewel, the friction does not seriously affect the motion of the balance. The impulse is also given very directly across the line of centres, and therefore with very little friction, as in the three-legged dead escapement for clocks before described, and in the chronometer escapement which will be next described. A little impulse is also received from the long teeth on the notch ; but the greatest part of that motion is wasted. As the balance turns back, the nick *V* goes past the end of the tooth *b*, and, in consequence of its smallness, it passes without visibly affecting the motion of the scape-wheel, though of course it does produce a very slight shake in passing. It is evident that if it did not pass, the tooth could not get into the nick for the next escape. The objection to this escapement is, that it requires very great delicacy of adjustment, and the watch also requires to be worn carefully ; for if by accident the balance is once stopped from swinging back far enough to carry the nick *V* past the tooth end, it will stop altogether, as it will lose still more of its vibration the next time from receiving no impulsé. The performance of this escapement, when well made, and its independence of oil, are nearly equal to that of the detached escapement, but not quite ; and as lever watches are now made sufficiently good for all but astronomical purposes, for which chronometers are used, and they are cheaper both to

make and to mend than duplex ones, the manufacture of duplex watches has decreased a good deal of late.

The chronometer or detached escapement is shown at fig. 30 in the form to which it was brought by Earnshaw nearly eighty years ago, and in which it has remained ever since, with the very slight difference that the pallet P, on which the impulse is given (corresponding exactly to the pallet P in the duplex escapement), is now generally set in a radial direction from the verge, whereas Earnshaw made it sloped backward or undercut, like the scape-wheel teeth. The early history of escapements on this principle does not seem to be very clear. They appear to have originated in France; but there is no doubt that they were considerably improved by the first Arnold, who died in 1799; (the second, who died in 1842, owed his reputation to his father in the first instance, and afterwards to his partner, the late Mr Dent.) He received several government rewards for improvements in chronometers, though it cannot be said that he deserved them all; for the last and largest of them he got solely through the influence of his friend Sir Joseph Banks, who, after failing to persuade the Board of Longitude to disregard the certificates of the Astronomer Royal, and the further evidence taken by themselves in consequence of Banks's opposition to the grant to Earnshaw, at last, by the help of the First Lord of the Admiralty, Lord Melville, extorted from a majority of the board a further grant of L.1680 to Arnold, for no further invention whatever, but simply to make him equal with Earnshaw, because he had been voted L.3000 for the improvements which enabled his ordinary and cheap chronometers to beat the picked ones of Arnold and the other makers. For among the other proofs of Earnshaw's genius it may be mentioned that he boldly set at defiance the common and stupid prejudice for what is called "high finish," *i.e.* the polishing up of surfaces which have no action, and therefore no friction

on them. In this we are sorry to find that he has not been followed, in chronometers at least, by any body; and Mr Dent, who has adopted the same system in turret clockwork, has on that account met with the same obloquy, on grounds still more absurd; for nothing can be a more ridiculous waste of money than polishing non-acting surfaces, which are never seen after they leave the shop, and besides that, necessarily lose their polish by dirt, oil, and sometimes rust, in the course of a few months. But it is time we should describe the detached escapement, as it has been made ever since the time of Earnshaw, with the slight difference in the shape of the pallet, before alluded to.

In fig. 30 the small tooth or cam V on the verge of the balance is just on the point of unlocking the detent DT from the tooth T of the scape-wheel; and the tooth A will immediately begin to give the impulse on the pallet P, which in good chronometers is always a jewel set in the cylinder; and the tooth V is also a jewel. This part of the action is so evident as to require no further notice. When the balance returns, the tooth V has to get past the end of the detent, without disturbing it; for as soon as it has been unlocked

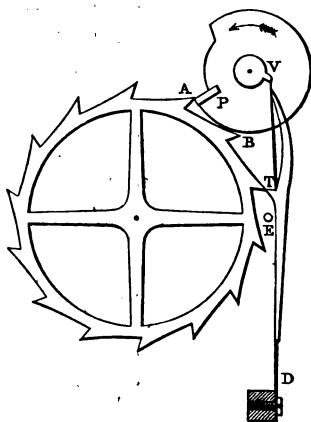

Fig. 30.

it falls against the banking pin E, and is ready to receive the next tooth B, and must stay there until it is again unlocked. It ends, or rather begins, in a stiffish spring which is screwed to the block D on the watch frame, so that it moves without any friction of pivots like a pendulum. The passing is done by means of another spring T V, called

the passing spring, which can be pushed away from the body of the detent towards the left, but cannot be pushed the other way without carrying the detent with it. In the back vibration therefore, as in the duplex escapement, the balance receives no impulse, and it has to overcome the slight resistance of the passing spring besides ; but it has no other friction, and is entirely *detached* from the scape-wheel the whole time, except when receiving the impulse. That is also the case in the lever escapement ; but the impulse in that escapement is given obliquely, and consequently with a good deal of friction ; and besides, the scape-wheel only acts on the balance through the intervention of the lever, which has the friction of its own pivots and of the impulse pin. The locking pallet T is under-cut a little for safety, and is also a jewel in the best chronometers, and the passing spring of gold, as steel will rust. In the duplex and the detached escapements, the timing of the action of the different parts requires great care, *i. e.* the adjusting them so that each may be ready to act exactly at the right time ; and it is curious that the arrangement which would be geometrically correct, or suitable for a very slow motion of the balance, will not do for the real motion. If the pallet P were really set so as just to point to the tooth A in both escapements at the moment of unlocking (as we have drawn it, because otherwise it would look as if it could not act at all), it would run away some distance before the tooth could catch it ; because in the duplex escapement the scape-wheel is then only moving slowly, and in the detached it is not moving at all, and has to start from rest. The pallet P is therefore in fact set a little further back, so that it may arrive at the tooth A just at the time when A is ready for it, without wasting time and force in running after it. The detached escapement has also been made on the duplex plan, of having long teeth for the locking, and short ones or pins nearer the centre for the impulse ; but the advantages do not appear to be worth the additional trouble, and the force

required for unlocking is not sensibly diminished by the arrangement, as the spring D must in any case be pretty stiff, to provide against the watch being held in the position in which the weight of the detent helps to unlock it.

There have been several contrivances for remontoire escapements, some of them certainly far better than Mudge's parliamentary reward escapement ; but there are defects in all of them, and there is, after all, not the same advantage to be obtained by giving the impulse to a watch-balance by means of some other spring instead of the mainspring, as there is in turret-clocks, where the force of the train is liable to very much greater variations than in chronometers or small clocks. We are, however, far from pronouncing, as some persons have done, on the very insufficient ground of these inventions having failed hitherto, that no remontoire escapement for watches can ever succeed. It was predicted with equal confidence, that it could never succeed in turret-clocks ; whereas we now see, that both a train remontoire and a remontoire escapement have succeeded perfectly, and make the clocks keep better time than had ever been known before.

REPEATERS, KEYLESS WATCHES, &C.

Among the pieces of watch-work which have gone very much out of fashion may be mentioned repeating watches, *i. e.* watches which strike the hours and quarters on pushing in the handle. They are now scarcely ever made in England, and with very good reason ; for it is almost impossible to crowd into the space of even a large-sized watch the quantity of wheels and other things required for the repeating work, without unduly interfering with the going part ; and besides that, the striking work itself is very liable to get out of order. We have therefore thought it better in this edition to omit the descriptions of the various inventions of this kind, and to devote the space to matters of more practical importance.

The winding of watches without a key is an object for

which there have been several inventions, and it possesses a considerable advantage besides the mere convenience of being independent of a key ; for as there is then no occasion to open it, the case may be made to fit more closely, and the air is more completely excluded, and consequently the watch will go longer without cleaning ; and it also saves the thickness and the cost of a double back to the case. The first plan of the kind was that of pulling out the knob of the handle, which went into the watch, and had a gathering click attached to it which wound up the fusee, or the barrel, by means of a ratchet. But this was not found to answer ; it was liable to get out of order, and moreover, at every time of winding you pumped fresh air into the watch which soon produced injurious effects. A far better plan is that which is noticed in the horological report of the Great Exhibition as exhibited by Mr Dent, as the proprietor, though not the author of the invention.* It combines the two objects of winding and setting the hands by means of the handle, in the manner we shall now describe. In fig. 31, *d* is a wheel on the barrel with bevelled teeth, and there is another small bevelled wheel on a spindle *b* which ends in a milled head *a* within the handle or *pendant* ; these two wheels cannot conveniently be arranged so as to work into each other without the intervention of a third between them, which is marked *e* in the left hand of the three figures 31. It is easy to see that turning the milled head will wind up the barrel. The same arrangement might of course be applied to the fusee, though it would increase the size ; but in fact these watches are made without one, and we know from those who have worn them for some years that the absence of a fusee could certainly not be discovered from any defect in their performance ; on this point we have expressed our own opinion some pages back. The winding wheel *d* is also made with the well-known contrivance of Breguet, known here by the name of the "tipsy key," when applied to a common winding key ; which enables you to turn the handle the wrong way without doing anything

except moving a ratchet-wheel over its click, and consequently without straining the watch in attempting to wind it the wrong way. The same handle and wheels are also made use of to set the hands thus : There is a small wheel *f* which turns on a stud at the end of the lever *f g h*, and as the lever turns on a pivot at *g*, when its end *h*, which just projects through the rim of the watch, is pushed on one side, the wheel *f* will then be thrown into gear with the winding wheel *d* and the hour pinion in the middle of the watch ;

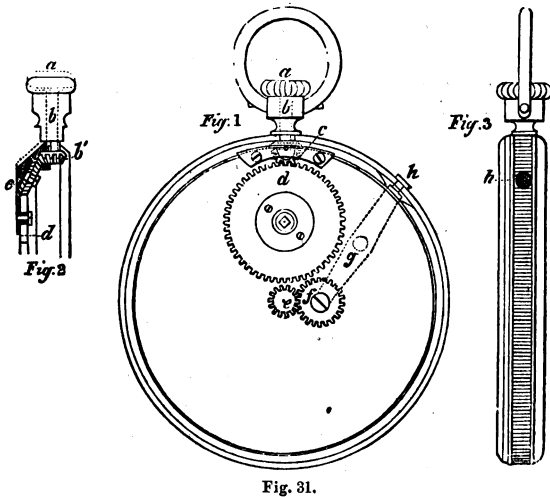

Fig. 31.

and consequently if the handle is then turned it will alter the hands, just as they are usually altered from the back by a key in foreign watches, so that the face need never be opened. Of course, while this is doing, you do at the same time wind up the watch a little if the handle has to be turned the way for winding ; but that is of no consequence, except that you cannot put the hands forward immediately after you have completely wound up the watch. (The arrangement of the lever and the wheel *f* is not quite the same

in Mr Dent's later watches as that given above, and taken from one of his pamphlets; but the principle being the same, we have not thought it worth while to alter the drawing.)

The emperor Napoleon I. had a watch which wound itself up by means of a weighted lever, which at every step he took rose and fell, and, having a gathering click to it, wound up a ratchet attached to the barrel, if it was not then fully wound up. The instrument called the *pedometer* is on the same principle, though its object is different, being merely to count the number of steps you take while the instrument is in your pocket. It is capable of adjustment according to the number of steps which the wearer usually takes in a mile, which he must first count, and set the instrument accordingly, and then it will indicate the distance walked; but without such adjustment it affords no measure of distance at all, and it is on the whole of very little use.

There is a very elegant invention of M. Redier of Paris (to whom a prize medal was awarded in the Great Exhibition), for enabling you to mark the exact time of any observation, without immediately looking off the object, and without the trouble of counting the beats by ear from the watch. In fig. 32, DD is the dial of a large watch (not intended for the pocket, though not so large as a box chronometer), The seconds-hand arbor is in the middle, so as to get the usual space of a minute for the seconds on the dial, and the spaces may be still further divided if necessary. The watch should not have a duplex or a detached escapement, because in them the hand only moves at every other beat, and the quicker the balance beats the more accurate the observations may be. Very perfect going is not necessary for it, any more than for what is called in observatories a *journeyman clock*, i.e. a clock made for very loud beats (which is not generally consistent with very good going), and only set a-going from another clock a short time before it is wanted. The seconds hand is double, the lower one ending in a little cup at B with a small hole in the

bottom ; and the upper one EAB is a spring fixed to the other at E, and the end B a point just going through the hole in the cup. A drop of thick ink is put in the cup, and it is evident that when the upper hand is pulled down its point will make a mark on the dial. The pulling down is done thus :—At A there is a kind of link hung to the marking hand, moving very freely on the arbor of the main seconds hand, and ending in a ring C very near the end of the spring SS, which is fixed to the watch case, and can be pushed in by a knob K from the outside. It would be difficult to exhibit in a drawing the precise form of the pin

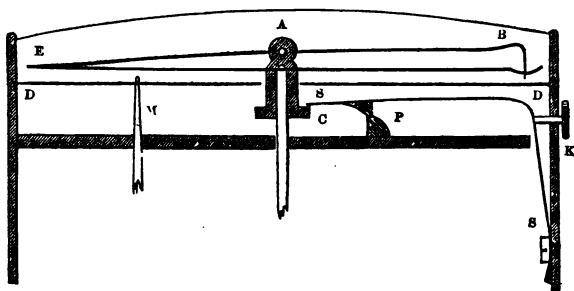

Fig. 32.

P and the inclined plane which passes over it ; but it is such that as soon as the knob is pushed in far enough the inclined plane drops over the end of P, and then the spring strikes down the ring C, and so pulls down the marking hand, and then the inclined plane is brought back sideways past P, so as to be thrown out of the ring immediately, and to leave only a momentary contact with the dial ; it is in fact so momentary that the ink spot is never *run* the least, but is always a distinct and small speck, which gives the time of pushing in the knob within the nearest beat of the balance ; and for the minute, the minute-hand M must be looked at, either a little before or a little after the observation.

Watches have also been made with what are called *split seconds-hands*; the two hands being in their ordinary state together and appearing as one; but when you push in a knob, one of them is stopped, while the other goes on: the time shown by the stopped one is of course the time of the observation. Sometimes this is done by merely connecting the hands by a very slight spiral spring, which will allow itself to be untwisted one or two coils without stopping the watch; and as it cannot be of much use to stop the seconds-hand longer than a minute, this seems to be all that is wanted. There is however another plan, in which these two hands, or at least the socket of one and the arbor of the other are connected by a pair of discs set obliquely on the arbor and the socket respectively, so that whenever the spring which keeps them together is allowed to act, it brings the loose hand up to the hand fixed on the arbor; and it does not signify how long it may be stopped by throwing the discs out of contact.

TEETH OF WHEELS.

The important subject of the *teeth of wheels* is the only one we have now room to notice; and though it belongs to all machines involving wheels, there is none in which it is of so much consequence as in clock-work, because there is none in which friction forms so large an ingredient in all calculations respecting its effects. At the same time we are not going to write a treatise or even an article on all the branches of that important subject, but assuming a knowledge of the general principles of it, to apply them to the points chiefly involved in clock-making. The most comprehensive mathematical view of it is perhaps to be found in a paper by the present Astronomer Royal in the *Cambridge Transactions* many years ago, which is further expanded in Professor Willis's *Principles of Mechanism*. Respecting the latter book, however, we should advise the reader to be content with the *mathematical* rules there

given, which are very simple, without attending much to those of the *odontograph*, which seem to us to give not less but more trouble than the mathematical, and are only approximate after all, and also do not explain themselves, or convey any knowledge of the principle to those who use them.

For all wheels that are to work together, the first thing to do is to fix the *geometrical*, or *primitive*, or *pitch circles* of the two wheels, *i.e.* the two circles which, if they rolled perfectly together, would give the velocity-ratio you want. Draw a straight line joining the two centres; then the action which takes place between any two teeth as they are approaching that line is said to be before the line of centres; and the action while they are separating is said to be after the line of centres. Now, with a view to reduce the friction, it is essential to have as little action before the line of centres as you can; for if you make any rude sketch, on a large scale, of a pair of wheels acting together, and *serrate* the edges of the teeth (which is an exaggeration of the roughness which produces friction), you will see that the further the contact begins before the line of centres, the more the serration will interfere with the motion, and that at a certain distance no force whatever could drive the wheels, but would only jam the teeth faster; and you will see also that this cannot happen after the line of centres. But with pinions of the numbers generally used in clocks, you cannot always get rid of action before the line of centres; for it may be proved (but the proof is too long to give here) that if a pinion has less than 11 leaves, no wheel of any number of teeth can drive it without some action before the line of centres. And generally (using the word in its mathematical sense, of universally) it may be stated that the greater the number of teeth the less friction there will be; as indeed is evident enough from considering that if the teeth were infinite in number, and infinitesimal in size, there would be no friction at all, but simple rolling of one pitch

circle on the other. And since in clock-work the wheels always drive the pinions, except the hour pinion in the dial work, and the winding pinions in large clocks, it has long been recognised as important to have high numbered pinions, except where there is some remontoire escapement or apparatus to obviate that necessity.

And with regard to this matter, the art of clock-making has positively retrograded, and the pinions which are now almost universally used in English and French clocks are of a worse form than those of several centuries ago, to which we have several times alluded under the name of *lantern* pinions, so called from their resembling a lantern with upright ribs. A sketch of one, with a cross section on a large scale, is given at fig. 34 (post). Now, it is a property of these pinions, that when they are driven, the action begins just when the centre of the pin is on the line of centres, however few the pins may be; and thus the action of a lantern pinion of 6 is about equal to that of a leaved pinion of 10; and indeed, for some reason or other, it appears in practice to be even better, possibly from the teeth of the wheel not requiring to be cut so accurately, and from the pinion never getting clogged with dirt. Certainly the running of the American clocks, which all have these pinions, is remarkably smooth, and they require a much smaller going weight than English clocks; and it is evident that this cannot be due to any high finishing of the wheels and pinions, for these clocks are remarkable for the absence of all such finish; which the ignorance of most English mechanics leads them to think the great merit of a piece of clock-work, though requiring less mind than any other part of their work. Mr Dent has for some years used these pinions in the going part of his turret-clocks, and he has lately been applying them to some smaller work for the Astronomer Royal at Greenwich, and to regulators with Mr Denison's escapement. It should be understood, however, that as the action upon these pinions is all after the line of centres when

they are driven, it will be all before the line of centres if they drive, and therefore they are not suitable for that purpose. In some of the French clocks in the Exhibition they were wrongly used, not only for the train, but for winding pinions; and some of them also had the pins not fixed in the lantern, but rolling: a very useless refinement, and considerably diminishing the strength of the pinion. For it is one of the advantages of these pinions that they are very strong, and there is no risk of their being broken in hardening, as there is with common pinions.

The fundamental rule for the tracing of teeth, though one of great simplicity, is, we suspect, not so well known as it ought to be, and therefore we will give it: premising that so much of a tooth as lies within the pitch circle of the wheel is called its *root* or *flank*; and the part beyond the pitch circle is called the *point*, or the *curve*, or the *addendum*; and moreover, that before the line of centres the action is always between the flanks of the driver and the points of the driven wheel or *runner* (as it may be called, more appropriately than the usual term *follower*); and after the line of centres, the action is always between the points of the driver and the flanks of the runner. Consequently, if there is no action before the line of centres, no points are required for the teeth of the runner.

In fig. 33, let AQX be the pitch circle of the runner, and ARY that of the driver; and let GAP be any curve whatever of smaller curvature than AQX (of course, a circle is always the kind of curve used); and QP the curve which is traced out by any point P in the generating circle GAP , as it rolls *in* the pitch circle AQX :

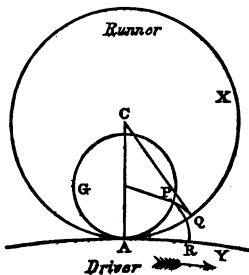

Fig. 33.

and again, let RP be the curve traced by the point P , as the generating circle GAP is rolled *on* the

pitch circle ARY : then RP will be the form of the point of a tooth on the driver ARY , which will drive with uniform and proper motion the flank QP of the runner; though not without some friction, because that can only be done with *involute* teeth, which are traced in a different way, and are subject to other conditions, rendering them practically useless for machinery, as may be seen in Professor Willis's book. If the motion is reversed, so that the runner becomes the driver, then the flank QP is of the proper form to drive the point RP , if any action has to take place before the line of centres.

And again, any generating curve or circle, not even necessarily the same as before, may be used to trace the flanks of the driver ARY , by being rolled within that pitch circle, and on the outside of the runner AQX .

Now then, to apply this rule to particular cases. Suppose the generating circle is the same as the pitch circle of the driven pinion itself; it evidently cannot roll at all, and the tooth of the pinion is represented by the mere point P on the circumference of the pitch circle; and the tooth

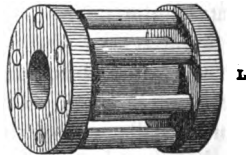
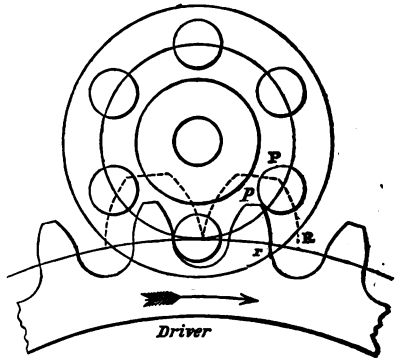

Fig. 34.

to drive it will be simply an *epicycloid* traced by rolling the pitch circle of the pinion on that of the wheel. And we know that in that case there is no action before the line of

centres, and no necessity for any flanks on the teeth of the driver. But inasmuch as the pins of a lantern pinion must have some thickness, and cannot be mere lines, a further process is necessary to get the exact form of the teeth; thus if RP , fig. 34, is the tooth that would drive a pinion with pins of no sensible thickness, the tooth to drive a pin of the thickness $2Pp$ must have the width Pp or Rr gauged off it all round. This in fact brings it very nearly to a smaller tooth traced with the same generating circle; and therefore in practice this mode of construction is not much adhered to, and the teeth are made of the same shape, only thinner, as if the pins of the pinion had no thickness. Of course they should be thin enough to allow a little shake, for freedom of action in case of any impediment; and in clock-work the backs of the teeth never come in contact at all.

Next, suppose the generating circle to be half the size of the pitch circle of the pinion. The curve, or *hypocycloid*, traced by rolling this within the pinion, is no other than the diameter of the pinion, and consequently the flanks of the pinion teeth will be merely radii of it, and such teeth or leaves are called radial teeth; and they are far the most common; indeed no others are ever made (except lanterns) for clock-work. The corresponding epicycloidal points of the teeth of the driver are more curved, or a less pointed arch, than those required for a lantern pinion of the same size and number. The teeth in fig. 35 are made of a different form on the opposite sides of the line of centres CA in order to show the difference between driving and driven or running teeth, where the number of the pinion happens to be as much

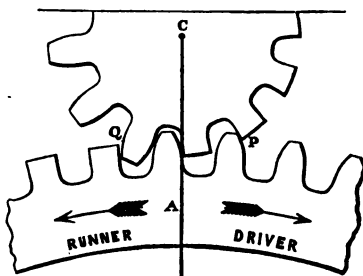

Fig. 35.

as 12, so that no points are required to its teeth when driven, since with that number all the action may be after the line of centres. The great Westminster clock affords a very good illustration of this. In both the striking parts the great wheel of the train and the great winding wheel on the other end of the barrel are the same, and so are their pinions, except that in the train the wheel drives and in winding the pinion drives; and the same is again the case with the second wheel of the train and the second winding wheel. And therefore in the train the pinion teeth have their points cut off, and wheel teeth have their points on, as on the right side of fig. 35; and in the winding wheels the converse, as on the left side; and thus in both cases the action is made to take place in the way in which there is the least friction. Professor Willis gives the following table, "derived organically" (*i. e.* by actual trial with large models), of the least numbers which will work together without any action before the line of centres, provided there are no points to the teeth of the runner, assuming them to be radial teeth as usual:—

Driver	54	30	24	20	17	15	14	13	12	11	10	9	8	7	6
Runner.....	11	12	13	14	15	16	17	18	19	21	23	27	35	32	176

In practice it is hardly safe to leave the driven teeth without points, unless the numbers slightly exceed these; because if there is any irregularity in them, the square edges of those teeth would not work smoothly with the teeth of the driver. Sometimes it happens that the same wheel has to drive two pinions of different numbers. It is evident that, if both are lanterns or both pinions with radial teeth, they cannot properly be driven by the same wheel, because they would require teeth of a different shape. It is true that on account of the greater indifference of lantern pinions to the accuracy of the teeth which are to drive them, the same wheel will drive two pinions of that kind differing in the numbers in the ratio of even 2 to 1, with hardly any sensible shake; but that would not be so

with radial pinions, and of course it is not correct. Accordingly in clocks with Mr Denison's spring remontoire, as in fig. 17, where the scape-wheel or remontoire pinion is double the size of the fly pinion, the larger one is made with radial teeth and the smaller a lantern, which makes the same wheel teeth exactly right for both. In clocks of the construction in fig. 18 there is a case of a different kind, which cannot be so accommodated; for there the great wheel has to drive the second wheel's pinion of 10 and the hour-wheel of 40; the teeth of the great wheel are therefore made to suit the lantern pinion of 10, and those of the hour-wheel (*i.e.* their flanks) then depend on those of the great wheel, and they are accordingly traced by rolling a generating circle of the size of the lantern pinion on the inside of the pitch circle of the hour-wheel; the result is a tooth thicker at the bottom than usual. These are by no means unnecessary refinements; for if the teeth of a set of wheels are not properly shaped so as to work smoothly and regularly into each other, it increases their tendency to wear out in proportion to their inaccuracy, besides increasing the inequalities of force in the train. Sometimes turret clocks are worn out in a few years from the defects in their teeth.

In describing the striking work of a turret clock, fig. 18, we referred to this part of the article for the rule for constructing the cams which raise the hammer. The condition which it is most important for them to satisfy is that the action should begin at the greatest advantage and therefore at the end of the lever; and that when it ceases the face of the lever should be a tangent to the cam at both their points, so that in no part of the motion should the end of the lever scrape on the cam. In the common construction of clocks the first condition is deviated from as far as possible, by the striking pins (which are used by nearly all the clock-makers) beginning to act some distance from the end of the lever; and consequently at the time when the most force is required to lift the hammer there is the least given, and a great deal is

til it becomes like a white soup ; then let it stand till fine oil appears at the top, which may be skimmed off: it will take several months before it has all separated, into water at the bottom, dirt in the middle, and fine oil at the top. And it should not be done in hot weather, because heat makes some oil come out as fine, which in cold would remain among the dirty oil in the middle, and in cold weather that fine oil of hot weather will become muddy. There are various vegetable oils sold at tool shops as oil for watches, including some for which a prize medal was awarded in the Exhibition, but not by any of the mechanical juries ; we have no information as to the test which was applied to it, and none but actual use for a considerable time would be of much value. We have heard of 5 per cent. in power being saved in a manufactory by the use of sperm, instead of sweet oil, to small spindles requiring constant lubrication.

APPENDIX.

The **DIPLEIDOSCOPE** is an instrument invented by Mr Bloxam, whose name has already been mentioned in the article on Clock and Watch Work, for ascertaining the time of solar noon more exactly than can be done by a common sun-dial. It can also be used when the sun is covered with thin clouds, not thick enough to hide it, though sufficient to prevent it casting a distinct shadow. The name is compounded of *διπλός* double, *εἶδος* an image, and *σκοπέω* to see, because in all positions except one it presents a double image of the sun. The instrument is to be fixed by a chronometer so that it may be in the position of showing the single image of the sun exactly at noon; and then at about a minute before noon the two images make their first contact, and at the same time after noon they completely separate, and the times of these contacts and also of the complete coincidence can be observed within two or three seconds. The following is the principle of the construction.

Let ABC be the rectangular section of a prism set so that a ray of the sun SI , and its reflected ray IR_1 , lie in the plane perpendicular to the axis of the prism. It is not solid, but composed of three small glasses of which AB , AC , are mirrors, but BC is only a plain glass not silvered. Consequently, the ray SI will be partly reflected

from BC in the direction IR_1 , but part of it will pass through the glass and be reflected by the mirror AC on to AB, and there reflected again and sent through BC in the direction aR_2 , making some angle α with BC. Suppose the angle of incidence, and therefore of first reflection to R_1 , to be $A - \delta$ (A being the opposite angle of the prism), and the other angles as marked in the figure; and let us see what α the angle of the twice reflected ray will be.

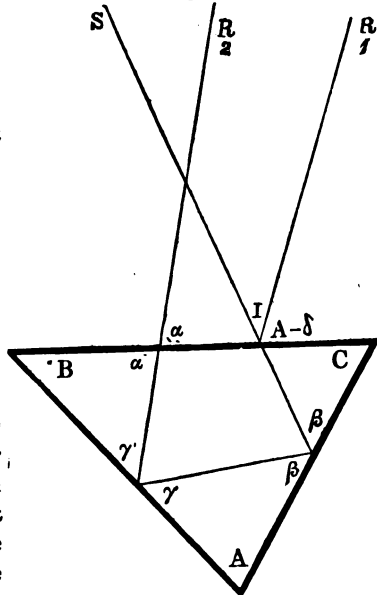

Fig. 37.

Now, $\beta = \pi - (C + A - \delta)$, in the small triangle near C; therefore, in the one near A, $\gamma = \pi - (A + \beta) = C - \delta$; and in the triangle near B, $\alpha = \pi - (B + C - \delta) = A + \delta$. And, therefore, the difference between the directions of the once reflected and the twice reflected rays is 2δ ; and if the prism is so placed that the angle of incidence = the opposite angle of the prism at noon, the rays will then emerge parallel at noon, and the two images of the sun will be seen as one; as noon approaches, the images converge, and after noon diverge, with a velocity double that of the sun itself.

But the plane of incidence and reflexion can only be perpendicular to the axis of the prism twice a-year. Still the same result will take place if it is once set properly. For suppose it to be set perpendicular to that plane at the equi-

nox: then at midsummer the incident and reflected ray IR_1 will lie in planes making the angle ω (the obliquity of the ecliptic) with the equinoctial plane; but SI and IR_1 will be sections of two other planes parallel to the axis of the prism, in which the incident and reflected rays also lie. And, in like manner, the ray reflected from AC will lie in a plane at the angle ω below the equinoctial plane; and that reflected from AB to R_2 also; and the projections of these rays on the equinoctial plane will lie in the same direction as before; and, therefore, the twice reflected and the once reflected rays will emerge parallel, as before, when SI is in the plane of the meridian.

The prism is inclosed in a small solid brass box in the shape of an irregular pyramid about two inches high; and it is made so that it only requires fixing on a horizontal bed. They are only made by Mr Dent, as he is the proprietor of Mr Bloxam's patent. Instead of fixing them and so leaving them exposed to the air, he has lately adopted the plan of fixing a brass plate on the window-cill where the instrument is to stand, with a raised edge against which one side of the diploscope is laid when it is first set by the chronometer, and afterwards whenever it is used. It is generally necessary either to smoke the front glass, or to look at it through a piece of smoked or coloured glass, which is supplied with it, as well as the necessary table of the times of first and last contact for every day in the year. Mr Dent has also lately made them to revolve upon an axis parallel to the earth's axis, and with a graduated hour circle, so that they may be used for any other hour as well as noon. But in this case the instrument can only be used (except at noon) for the latitude for which it is constructed, like a sun-dial, unless it has an adjustment for latitude also, as some of them have.

Some instrument of this kind ought to be kept by everybody who thinks it worth while to have a good clock, and yet has no other means of occasionally obtaining the real

time; more accurately than from railway clocks, or public clocks of ordinary quality. For those who feel any difficulty about using the diploidoscope, or who wish to be quite independent of the setting by a chronometer in the first instance, Mr Denison recommends, in his treatise on clocks, the following simple and independent construction of a sun-dial on a larger scale for noon only, which is quite sufficient for the occasional correction of a tolerably good clock:—Fix a thin plate of metal (protected against rust in any way you please) with a small hole in it, facing the south as nearly as you can, and inclined to the horizon at about 50° (not that the inclination is material), with the hole about nine inches above a stone slab set quite firm and level. Mark the point on the slab exactly under the hole by means of a pointed plum-bob, and call it C. About 11 o'clock see where the bright spot falls on the slab, and call that A, and with radius CA draw as much of a circle as is likely to be wanted for the bright spot again to reach it about 1 o'clock. Mark the place where it does reach it α , and bisect the arc A α in M suppose, and draw a straight line CM, as long as the slab will hold, from C through M. That line is the meridian, and the spot will always fall upon it at solar noon. Before you mark the line strongly, it will be as well to take several observations of this kind at different times, before and after noon, and on different days, and if their bisections agree in falling on the line CM you may be sure it is right. We have seen one of these dials with the gnomon only six inches high, and the time can be taken from it perhaps as accurately as from a diploidoscope, and certainly with far less trouble.

In order that the bright spot may fall on the slab in winter, the distance of its northern edge from C must be rather more than four times the height of the hole above the slab. If this size is inconvenient, there may be a second hole made at half the height, the plate or gnomon not being finally fixed; then on any fine day in the summer half of the year, move

the gnomon until the spot from this second hole also falls on the line CM at noon (it can be done in a moment), and there fix the gnomon. The lower spot will then always fall on the slab if it is made only half the size above mentioned, though in winter the upper one will fall beyond it. It is best to make the slab a light colour, and an equation-table may as well be cut upon it.

THE END.

