

COLLIERY SURVEYING





COLLIERY SURVEYING

A PRIMER

DESIGNED FOR THE USE OF STUDENTS AND
COLLIERY MANAGER ASPIRANTS

BY

T. A. O'DONAHUE, M.E.

EDITOR OF 'MINING ENGINEERING'

FIRST CLASS CERTIFICATED COLLIERY MANAGER

MEDALLIST IN SURVEYING CITY AND GUILDS OF LONDON INSTITUTE

London

MACMILLAN AND CO., LTD.

NEW YORK : THE MACMILLAN CO.

1896

All rights reserved



45401
APR 6 1898

6036736

MLFH

-005

PREFACE

THIS work has been written at the request of a number of students who have read the Articles on Surveying which I contributed to *Mining* some time ago.

The urgent need of an elementary book has been long known to me, and in my endeavours to supply this deficiency I have had the following essential points constantly in view: simplicity of expression, practical application, and variety of illustration. The only thing which has been taken for granted is that the student is possessed of an elementary knowledge of arithmetic; and with this exception, the book contains all the preliminary matter a beginner requires, and forms a complete treatise in itself.

Although no attempt has been made to meet the requirements of any particular examination, the student who masters its contents will find no difficulty in answering successfully almost all the questions on Surveying given in the Colliery Manager's Examination Papers, and should certainly be able to pass the Ordinary Grade Examination of the City and Guilds of London Institute.

If, then, by the use of such simple words as are consistent with clearness, by a minute and forcible exposition of detail, and a sufficiency of explanatory cuts, the learner is assisted in his earlier studies, I shall feel that my object has been attained and my efforts rewarded.

T. A. O'DONAHUE.

WIGAN, 1896.

CONTENTS

CHAPTER I

INTRODUCTION—

	PAGE
Surveying defined	1
The Importance of Colliery Surveying	1
General Survey Practice	3

CHAPTER II

NOTES ON DRAWING—

The Drawing Board	4
„ Paper	4
„ Pencil	4
„ Drawing Pen.	5
„ Ink	5
„ Pricker	5
„ Set Square	5
„ T Square	6
„ Parallel Ruler	6
„ Straight Edge	7
„ Compasses	7
Copying Plans	9

CHAPTER III

GEOMETRY—

Definitions	10
Theorems	15
Problems	19

CHAPTER IV

MENSURATION—		PAGE
Surfaces		22
Solids		26

CHAPTER V

MEASUREMENTS—		
Units of Measurement		28
Methods of Measuring		28
Pacing		28
Wheel		28
Tape		29
Steel Band		29
Rods		29
Chain		29
Staffing out		31
To measure a Line		32
Incline Measuring		33
Offsets		34

CHAPTER VI

THE DETERMINATION OF INACCESSIBLE HEIGHTS AND DISTANCES—

Two points inaccessible from one to the other	37
Two points inaccessible from one to the other, and one inaccessible to the surveyor	39
Two points both inaccessible to the surveyor	39
The height of a tower on level ground	40
The height of a tower on irregular ground	41
The depth of a proposed shaft	41

CHAPTER VII

SURFACE SURVEYING—

General Procedure	43
The Field Book	43

	PAGE
Surveying with one chain line only	44
Triangulation	46
Boundaries	53

CHAPTER VIII

THE MAGNETIC NEEDLE—

The Magnet	55
The Construction of the Magnetic Needle	55
Magnetic Declination	56
Isogonic Lines	57
To find the True Meridian	57
The Influence of Iron or Steel on the Magnetic Needle	58

CHAPTER IX

THE VERNIER—

The Straight Limb Vernier	59
The Arc Vernier	60

CHAPTER X

SURVEYING INSTRUMENTS—

The Hedley Dial	64
To make an Observation with the Dial	69
Improved Dials	71
The Theodolite	73

CHAPTER XI

SURVEYING WITH THE MAGNETIC NEEDLE—

Ordinary Method	76
The Survey Book	79
Surveying with the Magnetic Needle in the Presence of Iron	81

CHAPTER XII

	PAGE
RACKING OR FAST NEEDLE SURVEYING—	
Meridian Base Line Method	86
Method with First Sight as Base Line	90
Method with each Preceding Sight as Base Line	91
Comparison of Various Methods	92

CHAPTER XIII

PLOTTING SURVEYS—	
Plotting Defined	94
Scales	94
Offset Scales	95
Plotting Offsets	95
Protractors	96
Plotting Triangulation Surveys	98
Plotting Underground Surveys	104

CHAPTER XIV

THE CALCULATION OF AREAS—	
The Standard Measure of Area	109
Casting by Triangles	110
Casting by Equalising	111
Casting by Ordinates	114

CHAPTER XV

MISCELLANEOUS—	
Setting out Roadways	117
Descriptive Signs on Colliery Plans	120
Reducing and Enlarging Plans	121
To set out a Right Angle with the Chain	122
Setting out Railway Curves	123

CHAPTER XVI

LEVELLING—	
Levelling Defined	126
The Trigonometrical Method	126

	PAGE
The Clinometer	126
The Geometrical Method	128
The Dumpy Level	128
Simple Flying Levels	129
Simple Section Levelling	130
Compound Flying Levels	132
Bench Marks	133
Compound Section Levelling	133
Correction for Earth's Curvature	137
The Levelling Staff	137
Plotting the Levels	139
Gradient Calculations	141
TABLE OF INCLINE MEASURE	142
EXPLANATION OF TABLE	144

APPENDIX I

PLOTTING MINE SURVEYS	147
---------------------------------	-----

APPENDIX II

EXAMINATION QUESTIONS.

CITY AND GUILDS OF LONDON INSTITUTE—

Mine Surveying	150
--------------------------	-----

COLLIERY MANAGERS—

West Lancashire and North Wales District	156
West Scotland District	157
South-Western District	158
Newcastle District	159
East Scotland District	160
South Staffordshire District	161

SCIENCE AND ART DEPARTMENT—

Mining Examinations	162
-------------------------------	-----

MISCELLANEOUS QUESTIONS AND ANSWERS	162
---	-----

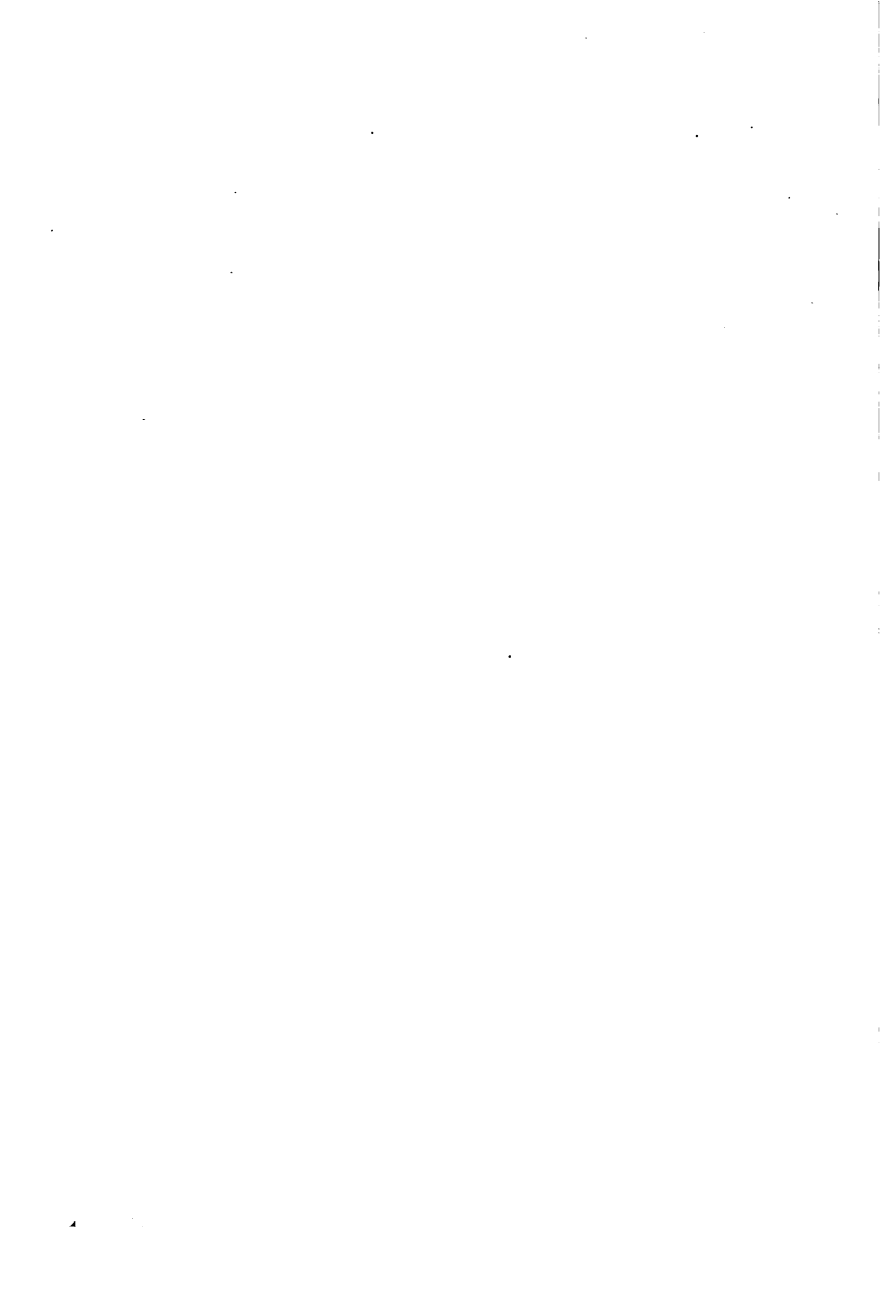

CHAPTER I

INTRODUCTION

SURVEYING is the art of taking such measurements and observations of an object as will enable a true proportionate representation to be drawn on a plane surface. The principles upon which it depends are all embodied in the science of geometry; so that surveying may be said to be a practical application of geometry.

The Importance of Colliery Survey.—The branch of surveying applied to colliery work is divisible into two parts, viz. land or surface surveying, and mine or subterranean surveying. When a coalfield is to be worked, a lease is obtained from the mineral owner, granting powers to get the seams of coal under certain lands. To define the limits or boundaries of the “taking” or area to be worked, a surface survey is required. A survey of the workings of each mine is also necessary to prevent extension under estates other than those for which power to get the coal is granted, and to facilitate the working of the coal generally.

The surveys are drawn or plotted on paper, and thus a map or plan is formed, which gives a comprehensive view of the extent of the “taking,” the state of the mine workings, and their relative positions with respect to the surface.

The importance of correct plans for colliery working will be made manifest by stating more definitely a few of the advantages derived from them.

To lay out the colliery in the first instance, it is necessary

to have an approximate idea of the area of the coal to be worked, so that arrangements can be made accordingly. When the sites of the shafts have been fixed, and they are sunk to the mines to be worked, it is advantageous to know the distance to which the underground workings will have to extend on each side, as this greatly influences the direction of the main roads and haulage planes. As the workings progress, it frequently happens that if a road be driven to connect two points of workings, the haulage can be more cheaply effected or the ventilation improved by substituting a short straight road for a long circuitous route. A pit or shaft is sometimes required to be sunk from the surface to some particular point of vantage underground for ventilation or other purposes. A tunnel or "cross measure drift" is often made to "seat" another mine or the portion of a mine dislocated by a fault at a particular point, and the relative positions of the two points must be known before this can be done. Pillars of coal are usually left unwrought under important buildings to prevent damage, and the correct position for the pillars must be ascertained. These objects can only be accomplished by correct surveys and plans.

To work the mines beyond the limits of the taking, and encroach under neighbouring property, is a very serious matter, and one which has often resulted in heavy financial losses to the proprietors of the colliery concerned. The owner of the minerals thus fraudulently appropriated has it in his power to demand an exceedingly high rate of payment for the mineral abstracted.

Apart from the financial losses which may accrue from incorrect or incomplete surveys or plans, they frequently result in a much more serious matter, namely, loss of life. Several serious accidents have occurred even within recent years, through the workings having been unintentionally allowed to approach so near to abandoned flooded workings as to cause a heavy influx of water, and consequent loss of life.

With a view to minimising the number of accidents from this and other causes, the law now requires an accurate plan of the workings of each mine to be kept, showing the workings up to a date not more than three months previously, and the general direction and rate of dip of the strata, together with a section of the strata sunk through, or a statement of the depths

of the shafts with a section of the seam. Further, where a place is likely to contain a dangerous accumulation of water, the working approaching the place must not at any point within 40 yards of it exceed 8 feet in width, and there must be constantly kept at a distance, not being less than 5 yards in advance, at least one borehole near the centre, and sufficient flank boreholes on each side.

In many districts the surveyor's work includes the royalty estimations, though in some instances the royalty is paid on the actual weight of coal brought to bank. Where the former practice prevails the royalty is estimated from the area of coal gotten, the thickness of the seam being taken to calculate the cubical contents. Thus, in the Lancashire district, from £50 to £200 per foot thick per Cheshire acre—according to the value of the coal—is paid as royalty to the mineral owner. The royalty rents are generally calculated every six months, though in some cases the period is twelve months. The area of coal gotten each half year or year, as may be, is cast from the plan, a survey being made and plotted immediately preceding the estimates to bring them up to date.

General Survey Practice.—Surface surveying as applied to colliery work is usually accomplished by a series of measurements arranged on a principle known as "triangulation." In the case of large surveys, it is customary to check the measurements of the principal lines by taking observations of the angles formed by the lines by means of an angular instrument. This is unnecessary, however, in small surveys of a few acres in extent, unless it is to be plotted on a large scale, as the measurements form a check in themselves. This method is not applicable to underground surveys, so that in addition to the measurements observations must be taken of all angles.

The simplest form of instrument for taking angular observations, in general colliery use, is the Miner's Dial, and the most accurate is the Theodolite.

CHAPTER II

NOTES ON DRAWING

The Drawing Board (Fig. 1).—This is usually made of best seasoned pine of three quarter inch in thickness, and is provided with end pieces to prevent warping. Its surface should be perfectly flat and smooth, and its sides “square off.” The paper upon which the drawing is to be made is tightly stretched on the board, and is held in position by drawing pins pressed through the paper at the corners into the

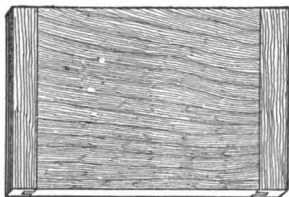

FIG. 1.

wood. Many colliery surveyors dispense entirely with the drawing board, and place the drawing paper on an ordinary table, keeping it in position either by drawing pins or plan weights.

Drawing Paper.—Various kinds and qualities of drawing paper are used, according to the importance of the drawing and the probable length of time it will be required for use. The best paper, mounted on linen or calico, and thoroughly seasoned to prevent shrinkage, should be used for plans of mine workings and others of similar importance.

The Pencil.—To define a line with some degree of accuracy, the lead pencils employed in drafting a plan should be very sharp pointed, and comparatively hard pencils (HH or HHH) are therefore most suitable. A pencil for drawing lines should be sharpened to a flat edge somewhat like the point of a chisel,

as it can thus be made to draw a very fine line without fear of breaking the point.

The Drawing Pen.—The pen (Fig. 2) used by draughtsmen for drawing lines consists of two metal blades joined to an ivory handle, and curved inwards at the bottom so as almost to touch each other. The ink is placed between the two blades with a fine writing pen or the corner of a piece of paper, and the thickness of the line which can be drawn is determined by the width of opening between the points of the blades. A small milled-headed screw, connecting the two blades, allows the distance between them to be varied slightly, and thus alters the thickness of the line as required. In using the pen it should be held in nearly a perpendicular position, having a very slight inclination towards the direction in which the line is being drawn. The ink that remains in the pen after using should be wiped out immediately and the blade points kept perfectly clean.

The Ink.—Indian ink is always used for making drawings; it should be rubbed in water until the liquid becomes quite black. When the ink lines have to be coloured over, a drop of a not very strong solution of bichromate of potash should be put into the ink, as this makes the ink quite "fast." Too much of the solution will turn it brown.

The Pricker.—A pencil mark cannot be made sufficiently small and definite to distinguish a point with the accuracy that is usually necessary in drawing, and a pricker is therefore used for the purpose. A fine-pointed needle held in a clamp which is fitted with a suitable handle (Fig. 3) makes the best pricker, but a needle with its blunt end pressed into a pencil acts practically as well.

The Set Square.—This is a triangular shaped piece of

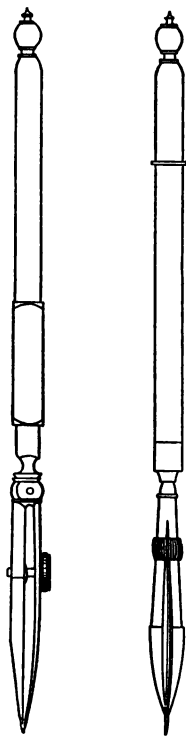

FIG. 2.

FIG. 3.

vulcanite, or some such similar material, one of the angles of which forms a right angle, the two remaining angles may be each 45° (Fig. 4), or 60° and 30° (Fig. 5). Its primary use is



FIG. 4.



FIG. 5.

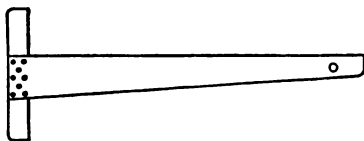

FIG. 6.

to draw one line at right angles to another, to obviate the much less easily accomplished geometrical method. This instrument is used by many persons for drawing short straight lines in preference to the ordinary ruler.

The T Square (Fig. 6).—This consists of two pieces of wood joined at right angles. It is used for the same purpose as the set square, but only in conjunction with a drawing board, the head of the square being placed alongside the end or side of the board as required, and the blade being used as the ruler. Its application is illustrated by Fig. 7.

The Parallel Ruler.—This is the principal appliance

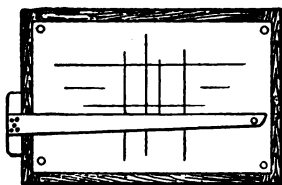

FIG. 7.



FIG. 8.

employed for drawing lines, and greatly facilitates the drawing of parallel lines. In its simplest form (Fig. 8) it consists of two flat rulers connected together by two diagonal pieces of brass, which allow the two rulers to be moved a short distance apart, or brought close together. The position of the rulers with respect to each other is always parallel, and thus any number of parallel lines may be drawn. A much more efficient parallel

ruler (Fig. 9) consists of a bevelled edge piece of timber (more generally of ebony) or brass, to the centre of which is fitted a pair of small wheels joined by a long axle bar. These wheels are capable of revolving, and a slight lateral pressure with the hand will cause the ruler to move. This form of parallel ruler also affords an efficient and handy method of drawing one line at right angles to another. Thus, assume that a line is required at right angles to AB (Fig. 10). Place the ruler with its edge along AB, and with a pencil or a pricker mark any point C in the line AB, and also mark the ruler at this point. Now parallel the ruler up to about D, and make a mark on the paper just at the point where the mark is shown on the ruler. Let this point be D. A line joining DC will then be perpendicular to AB.

The Straight Edge.—The term "straight edge" literally includes all kinds of straight line rulers, but the name is generally applied to very long flat rulers. These rulers are made of pear-tree, mahogany, ebony, or preferably of steel, and range from 3 to 6 feet in length, one edge of the ruler being bevelled. It is of the utmost importance that the ruler for long lines be perfectly straight, or considerable discrepancy will arise in plotting. The ruler, therefore, should be tested often, and should be hung in a vertical position when not in use.

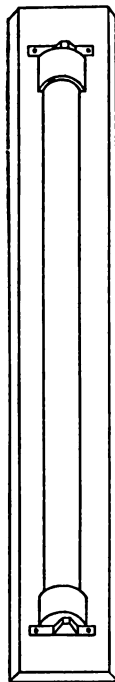

FIG. 9.

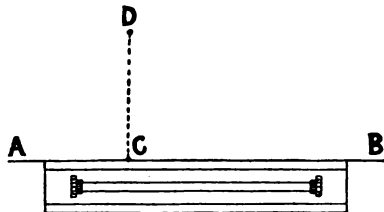

FIG. 10.

The Compasses.

—This instrument consists of two arms of brass or electrum, which are connected in a joint at the top, thus allowing the extremities to be set at varying distances apart. When the arms terminate in

two points (Fig. 11) the compasses are termed dividers, and

are used for transferring distances from a plan to a scale, or *vice versa*. In the other form of compasses, one arm terminates in a fine point and the other in a bow pen (Fig. 12) or pencil holder (Fig. 13). They are used for describing circles or arcs.



FIG. 11.



FIG. 12.

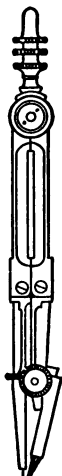

FIG. 13.

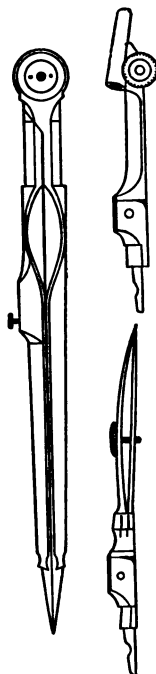

FIG. 14.

As usually supplied by instrument-makers the lower half of one arm of the compasses is detachable (Fig. 14), and the compasses may be used with the pen or pencil, or as dividers, as required. A lengthening bar is also provided so as to give the compasses a greater span when necessary.

Beam compasses (Fig. 15) are sometimes used when the radius of the circle or arc required is too large for the ordinary com-

passes to be employed. The arms of this instrument are provided with boxes or clamps at the upper end, by which they are attached to a lath at any required distance apart.

Copying Plans.—The simplest and most generally adopted method of copying plans is by tracing on transparent cloth or paper. The cloth or paper is stretched tightly over the plan to be copied, and is retained in position by drawing pins or weights, the details of the plan showing through sufficiently to allow of an exact copy being traced in ink or pencil.

When a copy is required on ordinary drawing paper, the plan to be copied may be placed over the new paper and the angular points of the drawing pricked through. Lines are then drawn from point to point as in the original. A much easier method, however, is to make a tracing of the plan and transfer the details from the tracing to the new paper with transfer paper. Transfer paper is made by rubbing one side of some thin

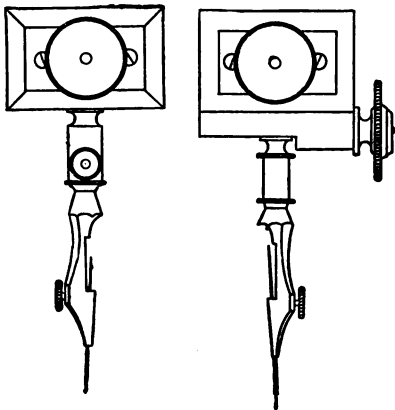

FIG. 15.

paper with black lead. By placing this paper with the black-leaded side down between the proposed plan and the tracing, and going over all the lines of the drawing on the tracing with a blunt-pointed instrument, such as one blade of a drawing pen, a copy will be made in black lead, and can afterwards be inked in.

The dull side of tracing cloth is the better to ink on, but colour should be applied to the back or glazed side as it is much more easily accomplished, and shows up distinctly. The greasy nature of cloth often renders it difficult to make the ink run freely; this is remedied by rubbing the cloth with pounce or powdered chalk before inking in. A little soap put in the colour also answers the same purpose.

CHAPTER III

GEOMETRY

It is essential that an elementary knowledge of geometry be acquired before commencing the actual study of surveying. The extent to which the former subject is treated in this work represents only the parts that are absolutely necessary, and every detail should be thoroughly known before proceeding farther.

Geometry may be divided into three sections, namely, Definitions, Theorems, and Problems. A theorem is an assertion or statement which is to be proved, and a problem is something required to be done.

Euclid has demonstrated a large number of theorems and shown the constructions of numerous problems, but the writer has deemed it sufficient to accept Euclid's proofs for the propositions given in this work. If it is desired to refer to the proofs, almost all will be found in Euclid's *First Book of Geometry*.

Definitions

A point is that which denotes position or beginning of magnitude, but which has no magnitude, *i.e.* has neither length, breadth, nor thickness.

A line is length without breadth. The extremities of a line are points.

A straight line is that which lies evenly between its extreme points, and is the shortest distance between any two points, as AB (Fig. 16).

A plane rectilineal angle is the inclination of two straight lines to one another, which meet in a point, but are not in the

same straight line, as A (Fig. 17). When several angles are at one point, as A (Fig. 18), any one of them is expressed by three letters, of which the letter at the vertex or point where the



FIG. 16.

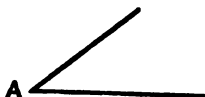

FIG. 17.

lines meet is placed in the centre; thus the angle contained by the two lines BA, AC is expressed as the angle BAC or CAB, and that which is contained by the lines AC, AD is expressed as the angle CAD or DAC.

One angle is said to be less than another when the lines which form that angle are nearer to each other than those which form the other, at the same distance from the vertex. The magnitude of the angle does not depend upon the length of the lines by which it is formed.

There are three kinds of angles, namely, right, obtuse, and acute.

A right angle is made by a straight line standing upon another straight line in such a position as to make the adjacent

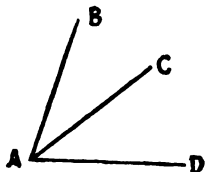

FIG. 18.

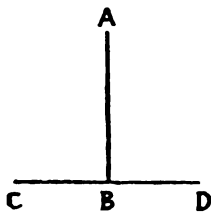

FIG. 19.

angles equal to one another. Thus in Fig. 19 the line AB stands upon the line CD, and makes the angle CBA equal to the angle ABD.

An obtuse angle is greater than a right angle, as Fig. 20.

An acute angle is less than a right angle, as Fig. 21.

A plane triangle is the space enclosed by three straight lines.

A right-angled triangle is that which has one of its angles a right angle, as ABC (Fig. 22). The side AC opposite the



FIG. 20.

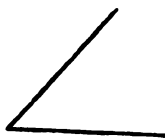

FIG. 21.

right angle is called the hypotenuse, BC is called the base, and AB the perpendicular.

An obtuse-angled triangle has one of its angles obtuse, as Fig. 23.

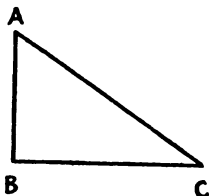

FIG. 22.



FIG. 23.

An acute-angled triangle has all its three angles acute, as Fig. 24.

An equilateral triangle has all its three sides equal, and also its three angles, as Fig. 25.

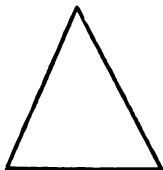

FIG. 24.

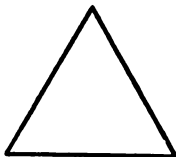

FIG. 25.

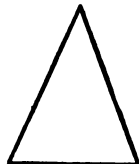

FIG. 26.

An isosceles triangle is that which has two of its sides equal, as Fig. 26.

A scalene triangle has all its three sides unequal, as Fig. 23.

Parallel lines are such that the distance between them is always equal, and if produced ever so far both ways do not meet, as Fig. 27.

A quadrilateral figure is a space included by four straight lines.

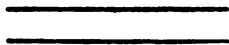

FIG. 27.

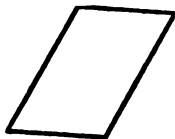

FIG. 28.



FIG. 29.

A parallelogram has its opposite sides parallel and equal, as Fig. 28.

A rectangle is a parallelogram with all its angles right angles, as Fig. 29.

A square is a rectangle with all its sides equal, as Fig. 30.

A diagonal of a quadrilateral is a straight line joining two opposite angles, as in Fig. 31.

Polygons or multilateral figures are those which have more than four sides. If it has five sides it is called a pentagon, if

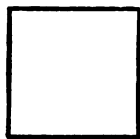

FIG. 30.



FIG. 31.

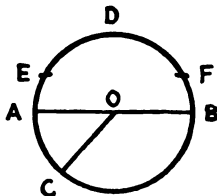

FIG. 32.

six sides a hexagon, if eight sides an octagon, and so on. A regular polygon is one which has all its sides equal, and its angles equal.

A circle is a plane figure contained or bounded by one line, which is called the circumference, and is such that all straight lines from a certain point within the figure to the circumference are equal to one another. This point is called the centre of the circle, as in Fig. 32, O being the centre.

The radius of a circle is a straight line drawn from the centre to the circumference, as OC (Fig. 32).

The diameter of a circle is a straight line drawn through the centre, and terminated both ways by the circumference, as AB (Fig. 32).

An arc of a circle is any part of the circumference, as EDF (Fig. 32).

A chord of a circle is the straight line which joins the ends of an arc.

A segment of the circle is the figure bounded by a chord and the arc it cuts off, as Fig. 33.

A sector of a circle is the figure bounded by two radii and the arc between them, as Fig. 34.

Concentric circles are those having the same centre, and the



FIG. 33.



FIG. 34.

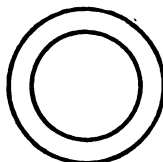

FIG. 35.

space included between their circumferences is called a ring, as Fig. 35.

If the circumference of a circle of any magnitude be divided in 360 equal divisions, then each of these divisions is a degree, that is, the angle contained by two lines drawn from the centre to the circumference, and enclosing exactly one division, is called a degree. In the same manner the $\frac{1}{360}$ th part of the circumference of all circles contains a degree, and all degrees are equal.

For, as was explained previously, it is not the length of the lines which enclose the angle that determine its magnitude, but the distance between the lines at a definite distance from the point of contact. Thus it is easy to understand, that if two lines be drawn at right angles to each other through the centre of a circle, the circle contains four right angles, no matter what the size of the circle may be, and as a right angle contains 90 degrees, four right angles equal 360 degrees. Degrees are

divided into minutes, and minutes are again subdivided into seconds. Thus 60 seconds equal one minute, and 60 minutes equal one degree. For convenience and despatch in writing, a degree is noted by a small cypher ($^{\circ}$) being placed at the top right-hand corner of the figure, a minute by a dash ($'$), and a second by two dashes ($''$), as $42^{\circ} 3' 45''$, which is equivalent to saying 42 degrees 3 minutes 45 seconds. The angle indicated by seconds is so small that it may be discarded entirely.

Theorems

I. The angles which a straight line makes with another upon one side of it are together equal to two right angles. That is, the angles ADC and CDB (Fig. 36) are together equal to two right angles.

Ex. If the angle ADC is 115° , then the angle CDB will be 65° , because there are 180° in two right angles.

II. If two straight lines cut each other the opposite angles will be equal. That is, the angle AEC (Fig. 37) is equal to the angle DEB, and the angle CEB is equal to the angle AED.

III. If a straight line cuts two parallel straight lines the

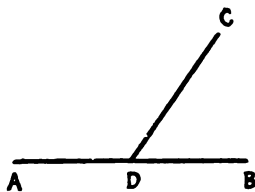

FIG. 36.

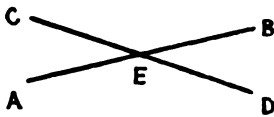

FIG. 37.

alternate angles are equal; the exterior angle is equal to the interior and opposite angle, and the two interior angles are together equal to two right angles. That is, the alternate angles AFG and FGD (Fig. 38) are equal, as also are the alternate angles FGC and GFB; the exterior angle EFB is equal to the interior and opposite angle FGD, and the two interior angles BFG and FGD are together equal to two right angles.

IV. The three angles of every triangle are together equal to two right angles.

V. If one side of a triangle be produced, the exterior angle thus formed will be equal to the two interior and opposite angles. That is, the angle ACD (Fig. 39) is equal to the angles ABC and BAC taken together.

VI. If two sides of a triangle are equal, the angles opposite the equal sides will also be equal; and conversely, if two angles

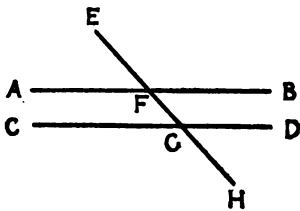

FIG. 38.

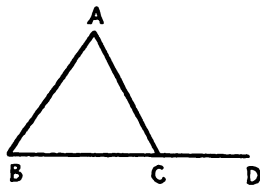

FIG. 39.

of a triangle are equal, the sides opposite to them will also be equal.

VII. If two angles of one triangle are equal to two angles of another triangle, each to each, and the sides adjacent or opposite to the two angles of the other be also equal, the triangles will be equal in every respect.

VIII. If two sides of one triangle are equal to two sides of another triangle, each to each, and the angle contained by the two sides of the one equal to the angle contained by the two sides of the other, the triangles will be equal in every respect.

IX. If each of the angles of one triangle are respectively equal to each of the angles of another triangle, the sides opposite the equal angles will be proportionals, and the two triangles are said to be similar. Thus, if in the triangle ABC (Fig. 40) the angles A , B , and C are respectively equal to the angles D , E , and F in the triangle DEF , the side AB bears the same proportion to DE as BC does to EF and as AC does to DF .

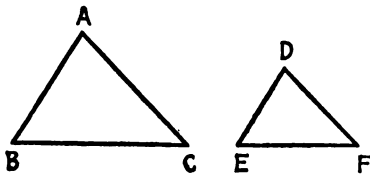

FIG. 40.

Ex. In the triangles ABC and DEF let the sides AB, BC, and CA equal 12, 10, and 8 respectively, and let the side DE of the triangle DE be equal to 8. Then as the three angles of the one triangle are equal to the three angles of the other, each to each, and AB and DE are opposite equal angles, the remaining sides of each triangle will bear the same proportion to each other as AB does to DE, that is, as 12 is to 8. As BC equals 10, EF equals $\frac{8}{12}$ of 10 = $6\frac{2}{3}$, and as CA = 8, FD = $\frac{8}{12}$ of 8 = $5\frac{1}{3}$.

X. Any two sides of a triangle are together greater than the third side.

XI. Parallelograms upon the same base or upon equal bases,

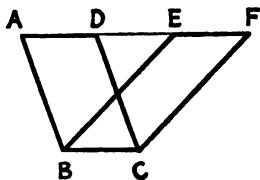

FIG. 41.

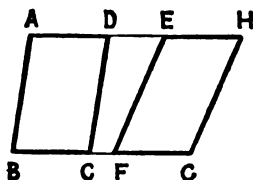

FIG. 42.

and between the same parallel, are equal to one another. Thus the two parallelograms ABCD and EBCF (Fig. 41) are equal (in area) to one another, as also are the parallelograms ABCD and EFGH (Fig. 42).

XII. Triangles upon the same base, or upon equal bases, and between the same parallels, are equal (in area) to one another.

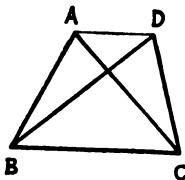

FIG. 43.

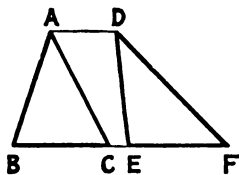

FIG. 44.

Thus the triangles ABC and DBC (Fig. 43) are equal to one another, as also are the triangles ABC and DEF (Fig. 44).

XIII. A triangle is equivalent to half a parallelogram, having

the same base and height. Thus the triangle ABC (Fig. 45) is half the parallelogram DBCE.

XIV. In any right-angled triangle the square described upon the hypotenuse is equal to the sum of the squares described on

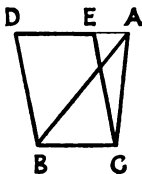

FIG. 45.

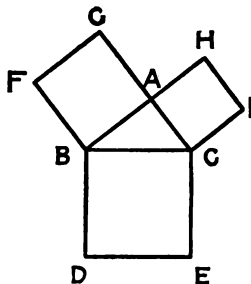

FIG. 46.

the other two sides. Thus the square BDCE (Fig. 46) is equal to the sum of the squares FBAG and ACIH.

Fig. 47 gives a very interesting ocular demonstration of this most important theorem. The squares are divided by straight lines into figures such that those contained by the square on the hypotenuse are equal to those contained by the two squares of the sides adjacent to the right angle.

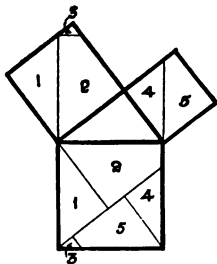

FIG. 47.

Ex. In the triangle ABC the square on BC is equal to the sum of the squares on BA and AC. This may be expressed algebraically as $BC^2 = BA^2 + AC^2$, or let $BC = a$, $BA = b$, and $CA = c$, then the equation may be expressed as $a^2 = b^2 + c^2$. By assigning numbers to any two sides, the magnitude of the third can be found. Let $BA = 16$ and $AC = 12$ to find BC .

$$BC^2 = 16^2 + 12^2 \cdot BC^2 = 256 + 144 = 400 \cdot BC = \sqrt{400} = 20 \text{ Ans.}$$

Problems

I. To bisect a given straight line, that is, to divide it into two equal parts.

Let AB (Fig. 48) be the given line. From the centres A and

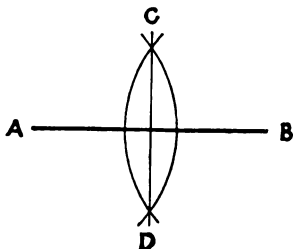

FIG. 48.

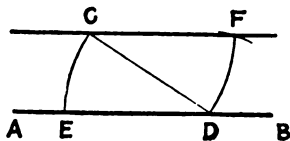

FIG. 49.

B and with any radius—greater than half AB—describe two arcs intersecting each other at C and D. The line joining CD will bisect AB.

II. Through a given point to draw a straight line parallel to a given straight line.

Let AB (Fig. 49) be the given line and C the point. In AB take any point D; join CD. With the centre D and radius DC describe the arc EC, and with the centre E and the same radius

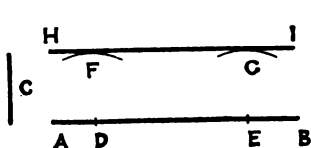

FIG. 50.

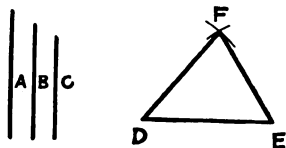

FIG. 51.

describe the arc DF. Make DF equal to EC and join CF. The line CF will be parallel to AB.

III. To draw a line parallel to a given line and at a given distance from it.

Let AB (Fig. 50) be the given line, and C the given distance from it.

In AB take any two points D and E, and with these points as centres and a radius equal to C, describe two arcs F and G. Draw a line HI to touch the arcs; this will be the required line parallel to AB.

IV. To make a triangle whose sides shall be equal to three given straight lines, any two of which shall be greater than the third.

Let A, B, and C (Fig. 51) be the three given lines. Draw any line DE equal to the given line A. From D as centre and with a radius equal to B describe an arc, and from the centre E and with a radius equal to C describe another arc, cutting the former in F; join DF, EF. Then DEF will be the required triangle.

V. To draw a straight line at right angles to a given straight line from a given point in it.

Let AB (Fig. 52) be the given straight line, and C the point in it. From any point D without AB as centre, and with DC

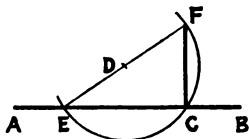

FIG. 52.

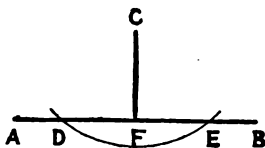

FIG. 53.

as radius, describe a circle cutting AB in E. Join ED and produce it to meet the circumference in F. Join CF. The straight line CF will be at right angles to AB.

VI. To draw a perpendicular to a given straight line from a given point without it.

Let AB (Fig. 53) be the given line, and C the point without it. From the centre C, and with any radius, describe an arc cutting AB in D and E. Bisect DE in F and join CF. Then CF will be the perpendicular required.

VII. To divide a straight line into any number of equal parts.

Let AB (Fig. 54) be the given line. Suppose it is to be divided into four parts.

Draw a line A3, making any angle with AB, and through

B draw B3 parallel to A3. Set off along A3 any three equal divisions (1, 2, 3), and set off similar equal divisions along B3. Join 1 and 3, 2 and 2, and 3 and 1. These will divide AB into four equal parts. Proceed in a similar manner for any number of equal parts.

VIII. To bisect a given angle. Let ABC (Fig. 55) be the given angle. From B as centre, with any radius, describe the

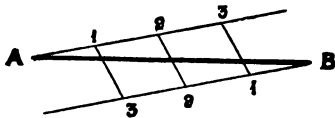

FIG. 54.

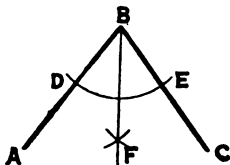

FIG. 55.

arc DE, from D and E as centres, and with the same radius, describe two arcs cutting each other in F; join BF. Then the line BF bisects the angle ABC, and the angle CBF is equal to the angle FBA.

To construct a scale of equal parts.

Take a straight line AZ (Fig. 56), and along it set off any number of equal divisions AB, BC, CD, DE. Divide AB into 10 equal parts. Then if we take AB to represent 10, each of

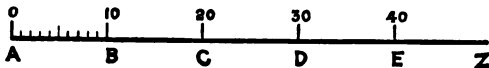

FIG. 56.

the small divisions will represent 1, or assuming AB to represent one, a small division would represent $\cdot 1$. A scale is usually defined by the number of the smaller divisions there are to an inch; thus Fig. 56 would be known as a 20 scale, because AB is half an inch, and consists of 10 small divisions. It may, however, be called a half-inch scale or a 200 scale.

CHAPTER IV

MENSURATION

Surfaces

PROB. I. To find the area of a rectangle when its length and breadth are given.

Multiply the length of the rectangle by its breadth, and the product will be the area.

Ex. 1. If the sides of a rectangle are 12 and 9 feet respectively, what is its area? Answer: $12 \times 9 = 108$ sq. feet.

Ex. 2. How many sq. feet are there in a table which is 10 feet 5 inches long, and 3 feet 8 inches broad? $10\frac{5}{12} \times 3\frac{8}{12} = \frac{125}{12} \times \frac{44}{12} = \frac{1375}{36} = 38$ sq. feet 28 sq. inches.

(This proposition also includes the finding of the area of a square, for a square is a rectangle with its sides equal, therefore its area equals the length of one side multiplied by itself, or the side squared.)

PROB. II. To find the area of a rectangle when the base and diagonal are given.

First find the adjacent side, and then find area by the last problem.

Ex. Let ABCD (Fig. 57) be a rectangle whose diagonal BD equals 125 feet, and whose base BC equals 100 feet. Find the area. From what was shown in the geometrical theorems, the square on BD equals the sum of the squares on BC and DC. Therefore $CD^2 = BD^2 - BC^2$,

$$\therefore CD = \sqrt{(125^2 - 100^2)} = \sqrt{(15,625 - 10,000)} = \sqrt{5625} = 75.$$

The length and breadth being now known, the area of the rectangle can be found by multiplying them together, $100 \times 75 = 7500$ sq. feet = 833 sq. yards 3 sq. feet.

PROB. III. To find the area of a parallelogram. Multiply the base by the height, and the product will be the area.

Let ABCD (Fig. 58) be a parallelogram, and let the length

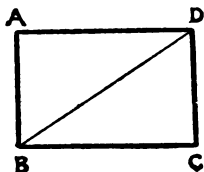

FIG. 57.

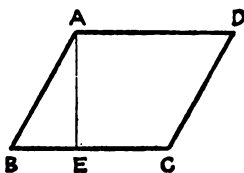

FIG. 58.

of BC be 5. Then if the height of EA is not known it may be measured with the scale. Let EA measure 4. Then the area is $4 \times 5 = 20$ sq. feet.

PROB. IV. To find the area of a triangle. Multiply the base by half the height, and the product equals the area.

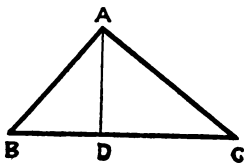

FIG. 59.

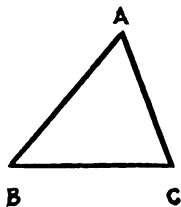

FIG. 60.

Let ABC (Fig. 59) be a triangle whose base BC equals 6 feet, and whose height DA equals 4 feet. Then $6 \times \frac{4}{2} = 12$ sq. feet area.

(Note.—The height AD is a perpendicular dropped from the apex A to the base BC.)

PROB. V. Having the three sides of any triangle given, to find its area.

Find half the sum of the sides, and also the difference between this number and each of the sides; then find the continued product of the half sum, and the three differences and the sq. root of the product will be the area.

Given the side AB (Fig. 60) = 9.2, BC = 7.5, and AC = 5.5, required the area of the triangle.

$$\begin{array}{r}
 9.2 + 7.5 + 5.5 = 22.2 \text{ sum.} \\
 \text{One-half sum} \quad 11.1 - 9.2 = 1.9 \\
 \quad \quad \quad \quad 11.1 - 7.5 = 3.6 \\
 \quad \quad \quad \quad 11.1 - 5.5 = 5.6
 \end{array}$$

then $\sqrt{(11.1 \times 1.9 \times 3.6 \times 5.6)} = \sqrt{425.1744} = 20.619$ the area of the triangle.

PROB. VI. Given any two sides of a right-angled triangle to find the third side, and thence its area.

First find the third side by rule— $\text{Hyp}^2 = \text{sum of the squares of the two other sides}$, and then proceed as in previous problem, or multiply the base by half the perpendicular.

PROB. VII. To find the area of a trapezoid.

Multiply half of the sum of the two parallel sides by the perpendicular distance between them, and the product will be the area.

Let ABCD (Fig. 61) be a trapezoid. The side BC = 40,

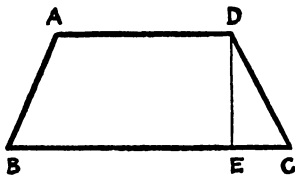

FIG. 61.

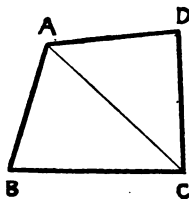

FIG. 62.

AD = 25, and DE = 18; required the area. $40 + 25 = 65 \div 2 = 32.5 \times 18 = 585$ area.

PROB. VIII. To find the area of any quadrilateral.

Divide the quadrilateral into triangles, find the areas of these figures, and the sum of the areas will be the area of the figure.

Let ABCD (Fig. 62) be a quadrilateral; required the area.

Given $AB = 548$ links, $BC = 715$ links, $AD = 751$ links, DC equals 821 links, and the diagonal AC is measured and found to be 967 links. By Prob. V. find the area of each triangle, and add these areas together for the answer.

4 acres 3 roods 27·67 poles.—Ans.

PROB. IX. To find the area of a quadrilateral when one of its diagonals and the perpendiculars on it from the opposite angles are given.

Multiply the diagonal by the sum of the perpendiculars, and half the product is the area.

How many square links in a quadrilateral field $ABCD$ (Fig. 63), a diagonal (AC) of which is 1245 links, and the perpendiculars (BE and FD) are 675 and 450 links respectively.

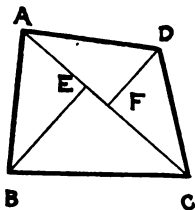

FIG. 63.

$$\frac{1}{2} \times 1245(675 + 450) = \frac{1}{2} \times 1245 \times 1125 =$$

$$700312\cdot5 \text{ sq. links, or 7 acres 0 rood } 0\cdot5 \text{ pole.}$$

PROB. X. Given the diameter of a circle to find the circumference, or the circumference to find the diameter.

- (1) The diameter multiplied by $\frac{22}{7} =$ the circumference; or
 (2) the diameter multiplied by 3·1416 = the circumference.

1. The diameter of a circle is 15, what is its circumference?

$$15 \times \frac{22}{7} = \frac{330}{7} = 47\cdot142; \text{ or, } 15 \times 3\cdot1416 = 47\cdot124.$$

(Note.—The second rule, viz. multiply by 3·1416 is the more correct, but for rough calculations $\frac{22}{7}$ may be used.)

2. The circumference of a circle is 80, what is its diameter?

$$80 \times \frac{7}{22} = \frac{560}{22} = 25\cdot45; \text{ or } \frac{80}{3\cdot1416} = 25\cdot46.$$

PROB. XI. To find the area of a circle.

$$(1) \quad \frac{\text{Diameter}}{2} \times \frac{\text{Circumference}}{2} = \text{area.} \quad \text{: or}$$

$$(2) \quad \text{Diameter squared} \times \cdot7854 = \text{area.}$$

To find the area of a circle whose diameter is 100 and circumference 314·16.

By (1)—314·16

$$\begin{array}{r} 100 \\ 4 \overline{)31416} \\ \underline{7854} \text{ Area.} \\ \hline \end{array}$$

By (2)— $100^2 = 10,000$

$$\begin{array}{r} \cdot 7854 \\ \underline{7854} \text{ Area.} \\ \hline \end{array}$$

PROB. XII. To find the area of a circular ring, or of the space included between two concentric circles.

Multiply the sum of the two diameters by their difference, and this product by ·7854.

Let there be two concentric circles whose diameters are 30 and 20 respectively, what is the area of the ring ?

$$\begin{array}{r} 30 \quad 30 \\ 20 \quad 20 \\ \hline 50 \times 10 = 500 \times \cdot 7854 = 392\cdot 7 \text{ area of ring.} \end{array}$$

PROB. XIII. To find the area of any irregular polygon (*see* Chapter entitled "The Calculation of Areas").

Solids

PROB. XIV. To find the volume or solidity of a rectangular solid.

Multiply the length by the breadth and that product again by the depth.

Ex. What is the solidity of a rectangular solid whose length = 10 feet, breadth = 11 feet, and depth = 5 feet ?

$$10 \times 4 \times 5 = 200 \text{ cubic feet.}$$

PROB. XV. To find the solidity of a cylinder.

Multiply the area of the base by its height.

Ex. What is the solidity of a cylindrical pillar 2 feet diameter and 10 feet high ?

$$\text{Area of base } 2 \times 2 \times \cdot 7854 = 3\cdot 1416.$$

$$\text{Volume} = 3\cdot 1416 \times 10 = 31\cdot 416 \text{ cubic feet.}$$

PROB. XVI. To find the volume of a cylindrical pipe.

Multiply the area of the annular surface, formed by the internal and external diameters of the pipe, by the length.

Ex. What volume of metal is there in a pipe 12 inches diameter (outside), 1 inch thick, and 12 inches long?

$$\begin{array}{r} 12 \quad 12 \\ 10 \quad 10 \\ \hline \end{array}$$

$$22 \times 2 \times .7854 = 34.5576 \text{ sq. inches, area of ring.}$$

$$\text{Volume} = 34.5576 \times 120 = 4146.912 \text{ cubic inches.}$$

PROB. XVII. To find the solidity of a prism.

Multiply the area of the base by the height.

Ex. What is the solidity of a triangular prism whose base is an equilateral triangle, each side being 4 feet, and height 10 feet?

To find area of base $4 + 4 + 4 = 12$, $\frac{12}{2} = 6$, $6 - 4 = 2$,
 $6 - 4 = 2$, $6 - 4 = 2$, $6 \times 2 \times 2 \times 2 = 48$ sq. ft., $48 \times 10 = 480$
 cubic feet.

PROB. XVIII. To find the solidity of a cone or pyramid.

Multiply the area of the base by one-third of the height.

Ex. 1. Find the volume of a cone, the diameter at the base being 10 feet, and height 9 feet.

To find area of base.

$$10 \times 10 \times .7854 = 78.54 \text{ sq. feet.}$$

$$\text{Volume} = 78.54 \times 9 \div 3 = 2356.2 \text{ cubic feet.}$$

Ex. 2. Find the volume of a square pyramid, each side of the base being 4 feet, and height 12 feet.

$$\text{Area of base } 4 \times 4 = 16 \text{ sq. feet.}$$

$$\text{Volume} = 16 \times 12 \div 3 = 64 \text{ cubic feet.}$$

PROB. XIX. To find the solidity of a sphere.

Multiply the cube of the diameter by .5236.

Ex. What is the solid contents of a sphere, the diameter of which is 10 feet?

$$10 \times 10 \times 10 \times .5236 = 523.6 \text{ cubic feet.}$$

CHAPTER V

MEASUREMENTS

Units of Measurement.—To measure a line, it is first necessary to decide upon some length which is to be considered as a unit, and to which other lengths may be compared. The unit of a yard, a foot, or an inch is in the majority of cases adopted for English measurements, but in nearly all surveying measurements a special unit, known as a link, is taken. It was originally used by a Mr. Gunter, who adopted it to facilitate the working out of areas, and the measure consisting of 100 links is called a chain. A link is 7·92 inches in length, and 100 of these, which go to form a chain, will be 22 yards, or 66 feet in length. The reason for adopting such a unit will be apparent, when it is known that there are 10 sq. chains or 100,000 sq. links in an acre, and that there are 80 chains in a mile (linear), and 640 acres in a square mile. As a matter of fact all chains are “link” chains, but when the term has been applied in this book the Gunter’s chain is meant.

Methods of Measuring.—There are various methods of measuring lines, viz.—pacing, the measuring wheel, the tape, the chain, the steel band, and rods.

Pacing.—By walking along the line to be measured, and by counting the number of steps taken, a rough calculation can be made. After a little practice a fairly accurate measurement can be made in this manner, and many persons can measure 100 yards with an error of less than 1 yard.

The Measuring Wheel.—This instrument consists of a wheel some 2 feet in diameter, which is provided with a handle, by means of which the wheel is pushed along the ground. The

number of revolutions which the wheel makes is registered by an index worked by toothed wheels. On even ground it gives fairly good results.

The Tape.—This is used by many persons for ascertaining lengths, but if great care be not taken, it will sometimes cause considerable errors—as much as 1 foot in 100. When kept dry and constantly checked it is a very simple and convenient method of measuring. By surveyors it is principally used for taking offsets, measuring buildings, or for any short lengths.

The Steel Band.—This is much used in the mines of America, and the accuracy of the measurements effected by it is perhaps greater than by a chain. Its greatest disadvantage is its twisting or kinking propensity, which often causes great annoyance.

Rods.—Rods were formerly much in use, when accurate measurements were required, but of recent years surveyors, for the most part, have considered well-constructed chains satisfactory. The rods were usually constructed of deal, but on occasions requiring great accuracy glass rods were used. Thus, in 1874, the base line of the Trigonometrical Survey of the United Kingdom was measured with glass rods. The same line was again measured with a carefully constructed steel chain, and the difference was little more than half an inch in a base line of 27,404 feet.

The Chain.—We thus see that a chain of good construction and constantly checked gives an accurate measurement, and, as it is a very convenient method of measuring, is the one adopted for general work by surveyors in this country. The chain is usually 100 links in length, as previously stated, but for surface work a chain consisting of 100 divisions of a foot each is sometimes used. Each division consists of a bar of iron or steel, and the bars are connected together by small coupling links. Thus the length of the bar in a link chain is about 6 inches, and in a foot chain about 10 inches, the remaining length being made



FIG. 64.

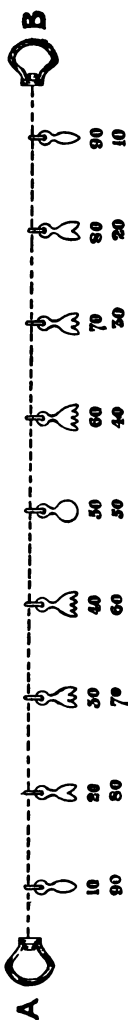

FIG. 65.

up by the coupling links. This allows of the chain being folded up for carrying, as shown in Fig. 64. The reading of both the link and the foot chain is effected in the same manner, and as it is often a source of difficulty to the beginner, an endeavour is made, with the aid of the sketch (Fig. 65), to explain the procedure. At every tenth division on the chain a tag or index of brass about $1\frac{1}{4}$ inches in length is suspended, and as the number of tens from the beginning of the chain is known by the shape of the tag, to read off a certain length, all that is required is to find the preceding tag, and knowing the number of tens which it represents, to add on the odd number of feet or links. But from requiring tags to represent certain numbers on the chain arises a difficulty, viz.—The same end of the chain should be in front each time, but as it is very convenient to have a chain so that any end may be used as a leader, a compromise is effected, and instead of having nine different kinds of tags to represent the tens, from 10 to 90, there are only five. Thus one tag represents both 10 and 90, another 20 and 80, another 30 and 70, and still another 40 and 60, 50 having a special tag for itself.

The index for 10 and 90	has 1 point or finger
” 20 ” 80	” 2 points ” fingers
” 30 ” 70	” 3 ” ” ”
” 40 ” 60	” 4 ” and
” 50	is rounded off at the bottom.

When measuring, it is very easy to tell whether the index is 10 or 90, 20 or 80, or 30 or 70, by noticing the amount of chain run out; but in case of the index for 40 and 60, unless care is taken a mistake may occur, as there is not as much difference between these lengths as the others. As an example of how the chain is

read: if A is the front or leading end of the chain and the measurement is 33, if B be the leading end the same point will be 67.

Staffing Out.—It will be apparent that a straight line of any considerable length could not be measured without some marks to keep the direction. In many cases a conspicuous tree, chimney, or steeple serves to keep the direction, but this does not always come in the line of sight, and some other means must be provided. Staffs of from 7 to 10 feet in length, shod with iron, and painted in feet alternately red, white, and black, so as to be seen distinctly, are fixed in the ground at intervals of about 2 chains or more, exactly in the line which it is required to measure. Assume that the distance between A and E (Fig. 66) is required, and that a staff placed at E can just be seen from the point A, but not distinctly enough for the measurers to see quickly, then a few more staffs must be placed in the same line between them. To accomplish this the surveyor stands at the staff at A, and fixes his head

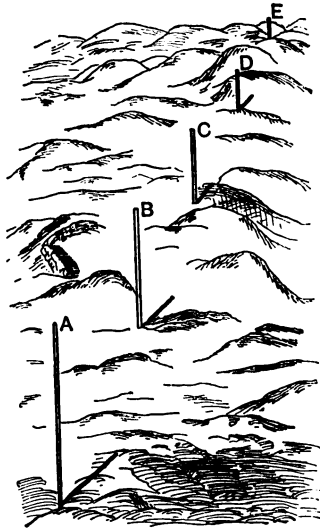

FIG. 66.

so that he can look with an eye on each side of the staff. An assistant then holds a staff at some point between A and E, and is directed by the surveyor to the correct line, as he will be able to see exactly when the staff is in line with A and E; this takes place when the staff E is hidden from sight by the intermediate staff. In the same manner more intermediate staffs may be fixed. Again, assume that a line AB is chosen, and it is required to produce it in the direction of E. The surveyor takes a staff and goes forward to C, looks back in the direction of A, and places the staff in the position at which B hides A from sight. He

then goes on to D and fixes a staff as before. It is, of course, necessary to be able to see at least two staffs before a third can be put in line, but for lines of several chains in length it is best to fix the staffs near enough to each other to enable three, at least, to be seen before another is fixed. The best and most accurate means of staffing out long lines is by means of a telescope with a vertical sighting hair or web, such as are attached to theodolites; in fact, the theodolite is the instrument most generally used for this purpose. For lines less than a mile in length good field-glasses will generally be found to be sufficient for this purpose, unless great accuracy is required.

To Measure a Line.—The line having been staffed out, it now remains to be measured. To do this two persons are employed—one for the front of the chain, the “leader,” and the other for the rear end, the “follower.” Small arrows or iron skewers (see Fig. 64) about one foot long are used to denote the ends of the chain. Many surveyors use ten arrows when chaining, and some even nine, but the writer has found eleven to be the best number, as will be apparent from the following. Assuming that the line AE (Fig. 66) is to be measured, the leader takes ten arrows in one hand, and one arrow and the end of the chain in the other, and pulls the chain in the direction of the staff at B. The follower stands at the point A, holding the other handle of the chain until it is stretched. The leader is then put in the correct line by the follower moving his hand to the right or left. The chain is stretched tight, and the leader pushes the arrow into the ground and advances another chain forward, the follower in this case holding his end of the chain at the arrow stuck in the ground. The chain is again stretched, the follower takes up the arrow at his end of the chain, and thus they proceed until the eleven arrows are put in. Of the arrows, one will be at the last point measured to, and the other ten will be in the hands of the follower, who comes forward with them and gives them to the leader, the one arrow being left in the ground. The leader then proceeds as before, and when it is necessary to know the number of chains measured, it is sufficient to count the arrows in the hands of the follower and add them to the number of tens which have been measured. Now, what happens when only ten arrows are used is this—the ten arrows having been put in, before the leader can proceed

again, to keep the count correct he must have his ten arrows, in which case the follower must keep the mark with his foot at the risk of going wrong. The most practical and correct number to use, therefore, is eleven. Now, suppose the arrows have been exchanged six times, and the follower has five arrows, and there is an arrow down, then the number of chains measured will be 66, or 6600 links.

In some cases the line is ranged out in such a position that it crosses a building or other object which is difficult to measure across. If the line is a short one, it may be deemed advisable to alter its position sufficiently to miss the building; but if the line is of considerable length, this would entail too much trouble, and in fact might be impossible. As, however, the length of the line is required, some means must be devised to ascertain it. The line is measured in the ordinary way until the obstacle is reached, when two stations are formed on the main line, one on each side of the obstacle; and from these, two lines are ranged at right angles to the main lines. The two right angle lines are made of equal length—as short as the circumstances permit—and the distance between them is measured at their outer ends. If the work is properly conducted, this measurement will be equal to the distance between the two stations left on the main line, and may be substituted for it. The measuring of the line then proceeds in the ordinary manner from the second station.

Incline Measuring.—In order to get the correct level measurements on inclines or slopes, it is necessary to ascertain the angle of the inclination and deduct a certain length from the measurement, or to take short measurements up the slope—the chain being held horizontally. For example, if the gradient was not too great 50 links might be taken at each operation, the leader on the top of the slope holding the 50 on the ground, and the follower holding the end of the chain to the required height. When the chain has to be held up, a staff should be placed at the mark exactly vertical, and the chain placed to it in order to ensure its being immediately over the mark. When incline measurements are required to be more accurate than can be ascertained by the foregoing method, an instrument should be employed to find the rate of inclination in degrees, and the actual horizontal measurement can then be calculated.

A full table of deductions, etc., for incline measurements is given on p. 142, but the following approximate rules will be found to be all that are necessary under most circumstances.

To convert degrees into terms of the perpendicular and horizontal.

Approximate rule sufficiently correct for angles less than 20 degrees.

Divide the number of degrees into 57, and the result is the horizontal length per unit rise.

EXAMPLES.—

$$\begin{array}{rcll} 6 \text{ degrees} & = \frac{57}{6} = 6.5 = 1 \text{ in } 6.5 & \text{correct value} & 1 \text{ in } 6.51 \\ 15 \text{ ,,} & = \frac{57}{15} = 3.8 = 1 \text{ in } 3.8 & \text{,,} & 1 \text{ in } 3.74 \\ 20 \text{ ,,} & = \frac{57}{20} = 2.8 = 1 \text{ in } 2.8 & \text{,,} & 1 \text{ in } 2.74 \end{array}$$

To find out how much must be deducted per chain to reduce incline measurements to true level or horizontal measurement.

The following is, so far as the author is aware, an original rule, and is approximately correct up to 45 degrees:—

Square the number of degrees, multiply by $1\frac{1}{2}$ and cut off the two last figures as decimals, which is practically the same as dividing by 100.

EXAMPLES.—

$$\begin{array}{rcll} 2 \text{ deg.} & = 2 \times 2 \times 1.5 = & 6 = & .06 \text{ links per chain to be deducted.} \\ 10 \text{ ,,} & = 10 \times 10 \times 1.5 = & 150 = & 1.5 \text{ ,, ,, ,,} \\ 30 \text{ ,,} & = 30 \times 30 \times 1.5 = & 1350 = & 13.5 \text{ ,, ,, ,,} \end{array}$$

The greatest error in these examples is in the 30 degrees, the correct answer of which is 13.4. It will, therefore, be seen that these rules are sufficiently accurate for ordinary use.

Offsets.—These are short measurements generally taken at right angles to the chain line, from some definite point in it to the object which is required to be put on the plan. As these measurements are plotted on the plan at right angles to the chain line, and as a right angle is usually guessed when taking offsets, it is apparent that such measurements must be comparatively short to avoid errors. The maximum practical length

for offsets depends principally upon the scale to which the survey is to be plotted, and in the author's opinion they should not exceed two-thirds of an inch of that scale. For example, if the scale is to be 30 yards to an inch, the longest offsets should not exceed 20 yards in length; or, if the scale is to be 30 feet to an inch, they should not be more than 20 feet in length. When longer offsets are necessary a cross-staff or some other instrument for setting off a right angle should be employed. Short offsets can be quickly measured with a staff 10 links in length, the link divisions being distinguished by different colours of paint. The tape is preferable, however, for measuring long offsets.

When an object is situated at some distance from the chain line, and its position is required with more than ordinary accuracy, the measurements taken to it from the chain line are arranged in a manner which is known as "scoring." This comprises two or more measurements taken to one point of the

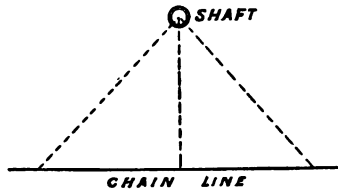

FIG. 67.

object from definite points on the chain line. For example, Fig. 67 illustrates the method by which the position of a shaft is fixed by scoring, three measurements being taken from different points on the chain to the centre of the shaft. The position of

the shaft can then be plotted on the plan with greater accuracy than if a right angle offset was guessed. If buildings are being offsetted it is a good practice to read on the chain line the intersection of a straight line sighted along one of

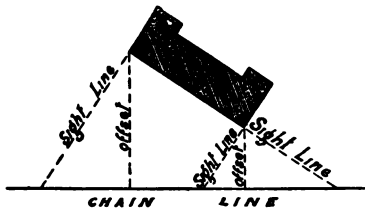

FIG. 68.

the faces of the building (Fig. 68), and if great accuracy is required this line may be measured in order to check the offsets. In case the corners of the erection do not form a

right angle such observations are especially useful in fixing the correct position on the plan. Measurements taken obliquely from the chain line should be distinguished from the right angle offsets by placing a small bracket (—) above them to avoid mistakes in plotting.

CHAPTER VI

INACCESSIBLE HEIGHTS AND DISTANCES

THE most correct method of effecting solutions of problems on triangles, such as are given below, is by trigonometry, but the method more generally adopted for ordinary work is to plot the measurements and angles on paper, and to solve the problems by taking measurements from the plan with a scale. The author has considered it unnecessary to include the subject of trigonometry in this elementary work, but as all the questions that can be solved by trigonometry can also be ascertained by plotting on paper, and as in fact trigonometry is more often employed for checking the plottings, its omission will not render the subject of surveying, as treated in this work, incomplete.

EXAMPLE.—*To find the distance between the two points A and B (Fig. 69), which are inaccessible to each other by reason of the intervening water.*

(1) **With an Angular Instrument.**—Place a dial or theodolite at the point C, whence both stations can be seen. Ascertain the number of degrees in the angle ACB, and measure the two lines AC and CB. The distance can then be found by plotting the angle on paper, marking off the two sides to scale equal to their respective lengths, and measuring the required distance with the scale.

(2) **With the Chain alone.**—Measure AC and BC and produce the lines to E and D, making CE equal to AC, and CD equal to BC. Then the distance DE being measured will give the required distance between A and B. For the angle DCE is equal to the angle ACB, and the sides CD and CE are

each equal to CB and AB respectively; therefore the two triangles ACB and DCE are equal in every respect, and DE equals AB .

Possibly some obstruction might not allow of the lines AC and BC being produced to D and E , when it would be sufficient to produce the lines on to say a and b . Then when the lines Ca , Cb , and ab were measured, together with the original lines AC and CB , by plotting them, the distance between A and B

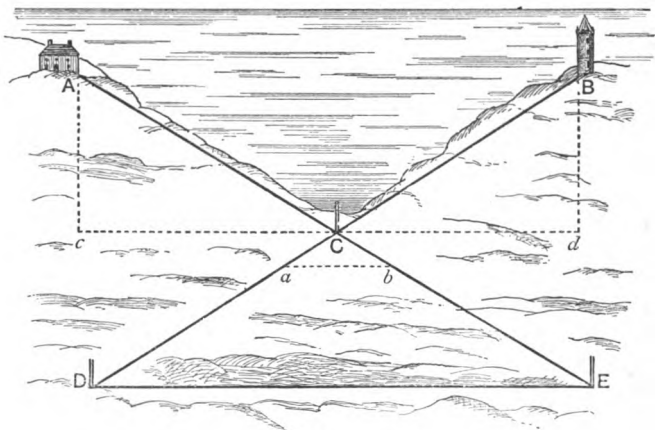

FIG. 60.

could be found. This method is not, however, so accurate as the one previously mentioned, as the farther the lines are produced the more accurate is the work.

(3) **With the Cross Staff and Chain.**—The cross staff is used by surveyors for laying down lines at right angles to each other. A simple form can be made by taking a three-quarter-inch piece of wood, six inches square, and by cutting two grooves along its diagonals, two lines are formed at right angles to each other, which may be used as sights. This is fastened to a staff with a pointed end, so that it can be pushed into the ground with the sights in any required position. To lay down a line at right angles to another, the eye sights along one of the grooves and fixes the staff so that the groove is in

line with the original base line. Then, by looking along the other groove a line can be staffed out at right angles to the first. To return to the example in question.

By means of the cross staff lay down two lines Ac and Bd at right angles to AB , and make AC equal to Bd . Then, if the distance cd be measured, it will be equal to AB , the required distance. As to which of the above methods should be used is a question that would depend upon the circumstances, and to what degree of accuracy the work is required.

EXAMPLE.—*To find the distance between two objects A and B (Fig. 70), one on each side of a river, without crossing it.*

(1) **With an Angular Instrument.**—From B staff out any line BD , and ascertain its length with the chain. Place the angular instrument at B , and find the number of degrees in the angle ABD ; again place the instrument at D , and find the size of the angle BDA . Then by plotting the line BD , the two angles ABD and DBA , and producing the sides of the angles until they meet in a point, the position of A will be fixed on the plan, and its distance from B may be measured with the scale.

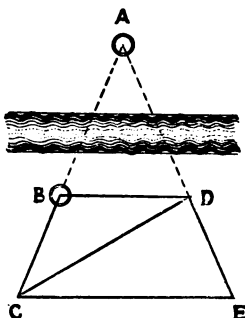

FIG. 70.

(2) **With the Chain only.**

—Fix a staff at the point C in line with A and B , another at any point D , and staff out the line AD to E . Measure BC , CE , ED , DB , and CD . Then, by plotting the two triangles CBD and CED in their correct position to scale, the position of A will be fixed on the paper by producing CB and ED until they meet. The distance between A and B can then be measured from the plan. In the above example it would be well to measure BE (on the ground) to serve as a check on the work.

EXAMPLE.—*To find the distance between two points A and B (Fig. 71), both of which are inaccessible.*

(1) **With an Angular Instrument.**—Staff out any line CD , and measure its length. Place the instrument at C , and ascertain sizes of angles ACD and BCD ; again place the instru-

ment at D, and ascertain sizes of angles BDC and ADC. Then by plotting the line CD, and also the four angles taken, the position of A and B can be fixed on the plan by producing the sides of the angles, so as to meet in two points, and a measurement with a scale between these points will give the distance between A and B.

(2) **With the Chain only.**—Staff out any line CD. Place a staff at any point E in line with A and C, a staff F at the point of intersection between two lines ranged out between AD and BC, and still another G at the point in line with EF, and also with BD. Now measure the following lines EC, CD, DG, and GE, the point F being read off in the last line. Also

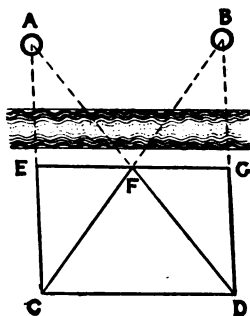

FIG. 71.

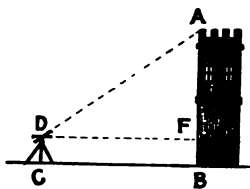

FIG. 72.

measure a diagonal ED, and as a check the other diagonal CG. The quadrilateral figure ECDG can then be plotted, the lines CE and DF produced to meet in a point A, and the lines CF and DG produced to meet in a point B. The distance between A and B can then be measured with a scale.

EXAMPLE.—To find the height of a tower AB (Fig. 72), the surface of the land being level.

Place an instrument at a point C some distance from the tower, ascertain the size of the angle formed by the line DA and a horizontal line DF, and measure the distance CB and the height of the instrument. Now plot a line DF of the length measured (DF being equal to CB); draw a line AB at right angles to DF, and from the point D plot an angle ADF equal

to the angle ascertained by the instrument. Produce the side DA of the angle, and the line BA to meet in A . The height of the tower can then be found by measuring the distance AF on the plan with a scale, and adding on to this length the height of the instrument.

Note.—The horizontal line DF is fixed with the spirit level, which is attached to the instrument.

EXAMPLE.—To find the height of a tower AB (Fig. 73), the surface of the land not being level.

Place an instrument at any point C , and ascertain the size of the angles formed by a horizontal line, and the lines DA to the top of the tower, and DB to the bottom of the tower; measure the distance DB , and reduce the length to horizontal measure DE (see table, p. 142). Now plot the line DE to

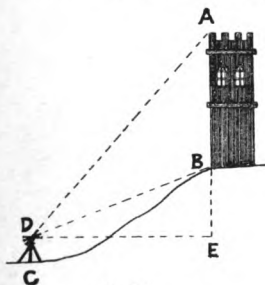

FIG. 73.

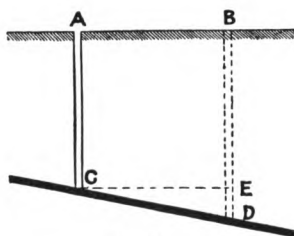

FIG. 74.

the correct measurement, and draw a line AE at right angles to DE . Also plot the angles ADE and BDE , as ascertained by the instrument, and produce the sides of the angles to meet AE . The height of the tower can then be found by measuring with the scale the length of the line AB .

EXAMPLE.—What depth will it be necessary to sink a perpendicular shaft at the point B (Fig. 74) to reach a seam of coal which was found in the shaft AC , the dip of the seam in the direction of AB being given, A and B being in the same level plane? Ascertain the depth of AC , the distance between A and B , and the inclination of the seam in the direction of AB . Plot a horizontal line CE equal to the distance measured between A and B ; through E draw a line at right angles to

CE, and at the point C plot the angle of inclination. Produce the line formed by the angle to meet the line drawn at right angles to CE in D. Measure the distance ED, and add on the depth of the shaft AC. This will give the depth of the required shaft BD.

All problems relating to inaccessible heights and distances can be solved by one or other of the methods described in the above examples.

CHAPTER VII

SURFACE SURVEYING

General Procedure.—Surface surveys are made by ranging out one or more straight lines, the measurements of which are ascertained, and from these lines offsets are taken to all objects which are required to be put on the plan. The lines are set out with a view of making the offsets as short as possible, and consequently their number and position are determined by the locality of the objects which are to be offsetted.

In making a survey it is first necessary to have some idea of the shape and extent of the place to be surveyed. If the survey is a small one, a general view will sufficiently locate it in the mind to determine the positions of the lines. But if it is of such an extent that a comprehensive view cannot be obtained of the whole of it, a walk should be taken over the ground, principally round the limits of the place to be surveyed, and a rough sketch should be made. If a small plan can be obtained, and the Government published plans render that possible in most countries, the matter is much simplified. The main lines of the survey are marked on the sketch or plan in the positions which appear to be the best, and although, when the work is being actually done, it is often found convenient to deviate slightly from the lines first approximately determined, it is seldom that they interfere with the projected arrangement.

The Field Book.—All measurements and notes are written in a book termed the Field Book. This consists of an ordinary note-book, the pages of which are divided into three columns by two lines, usually in red ink, ruled up the centre, and about

half an inch apart. In the centre column all the measurements of the chain lines are booked, and in the right and left columns the lengths of the offsets, and other observations to the right and left respectively are booked opposite the corresponding length on the chain line from which the offsets were taken. It is usual to make a rough sketch of the object to which offsets are taken in the right or left column, as the case may be, and the principal irregularities and bends are defined, thereby greatly facilitating the work of plotting. When there is only one object to be offsetted, such as a fence, it is not essential that a sketch be drawn, as there can be no mistake made as to the object to which the offsets are taken, but even then a sketch showing the proper direction of the bends is desirable, and may often lead to the detection of an error.

The ends of all lines are called stations, and denoted in the book by a small triangle, or by the symbol \odot being placed in the central column above the measurement at which the station was left. Another method of denoting stations, which is perhaps as convenient as any, is to enclose the measurement by a ring drawn round it. A characteristic of survey-booking, which may at first bewilder the beginner, is commencing at the bottom of the page and proceeding upwards. This is done in order that the bookings will be in the same direction as the measurements, and, as will be seen later, this greatly facilitates the booking.

Surveying with one Line only.—The simplest survey is that which can be effected with one chain line, such as a straight road or a narrow field.

The plan of a narrow field, and the method of surveying it by one chain line, is illustrated by Fig. 75. The notes, as given in the Field Book, appear below. No sketch has

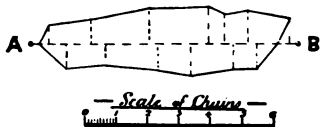

FIG. 75.

been made in the book in this case of the hedge to which the offsets are taken, and consequently a few written observations have been necessary.

Left-hand Offsets	⊙	Right-hand Offsets
	850	
78	824	
	783	Crosses hedge
	718	79
103	690	
	642	80
94	616	
117	565	
	508	102
	400	82
112	375	
	230	67
76	190	
	110	84
56	55	
	20	Crosses hedge
	⊙	
SURVEY OF FIELD (Fig. 75)		MEASUREMENTS IN LINKS

The procedure is as follows: a straight line AB is staffed out in such a position that the offsets to each side of the field will be approximately of equal lengths, and the measurement of this line is commenced from the station at A. The first station is booked at the bottom of the page, and the chain is stretched out in the direction of AB, the follower holding his end of the chain at the station A. The chain is allowed to remain undisturbed on the ground for a short period, during which the surveyor observes that it crosses the hedge at 20, and makes a note in the Field Book to that effect. He then glances at the sides of the field on each side to see if there are any bends in the hedge, to which an offset should be taken from any point on the first chain, and finds that, so far as he can judge, there is a bend on the left-hand side, a right angle offset to which will be at about 55 on the chain. A measurement is therefore taken with the tape from 55 on the chain to the bend in the hedge, and is found to be 56 links. The measurement on the chain, of 55, is booked in the centre column, and the offset, of 56, is booked in the left-hand column opposite to the 55. Being satisfied that there are no more bends which require recording on the first chain, the chain leader is told to proceed, and a

second length is measured, the follower holding his end of the chain at the arrow, which the leader will have left at the forward end of the first chain length. It is then seen that a bend in the hedge on the right-hand side necessitates an offset being taken from 10 on the second chain, and a bend on the left hand from 90 on the chain; these are found to be 84 and 76 respectively, and are booked accordingly. Thus the whole field is surveyed, offsets being taken to all bends which it is thought are irregular enough to show on the scale to which the plan is to be plotted.

The plan of part of a road and the method of surveying it is illustrated by Fig. 76. As in the previous example, a line

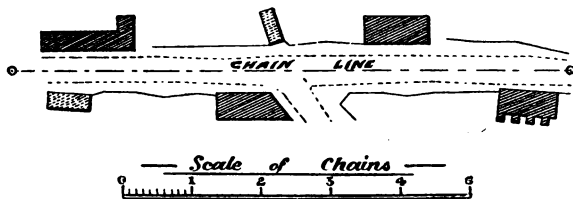

FIG. 76.

is run in the best position for taking offsets, and as there are a number of different objects to be offsetted it has been thought desirable to give a sketch in the Field Book. (See page 47.)

The sides of all buildings fronting the road are offsetted in the first operation, and after all the offsets have been made and the chain line measured, the sketches of the buildings are completed, and each one is measured independently with the tape, and the measurements are written in the book in their proper positions. It will be noticed that in some instances the frontage of the buildings is considerably out of the usual line parallel to the road, and to mark the position on the plan with greater accuracy, the point of intersection in the chain line of a line taken along the side of the buildings is read off, and in one case measured.

Triangulation.—When the survey is of such an extent that one chain line is insufficient, the principal lines are arranged to form one or more triangles, the system being

known as "triangulation." The lines are arranged in this

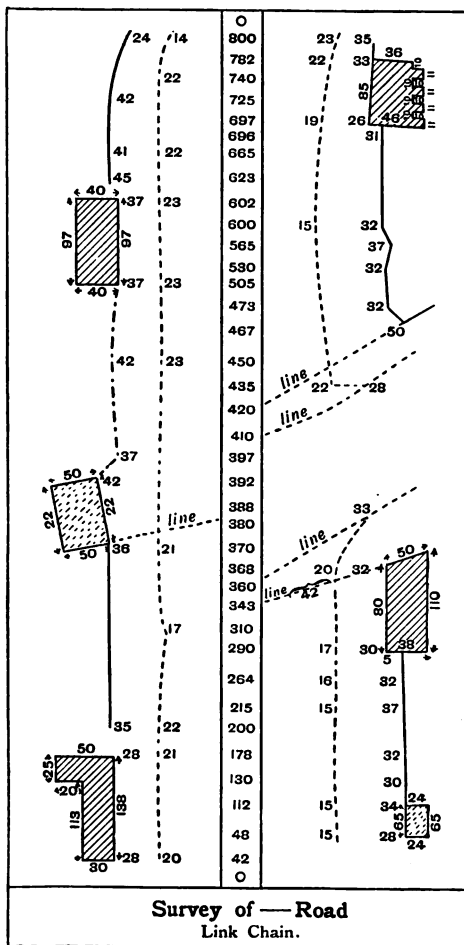

manner, because a triangle is the only figure in which the

sides and angles bear a constant relation to each other. To be more explicit, if three lines of definite length are taken to form a triangle, the angles contained by the three sides are definite angles, and the three sides cannot be made to form a figure containing different angles. This is not the case with any other figures; for example, two unlike quadrilateral figures can be formed with the sides of the one respectively equal to the sides of the others. The reason why the lines of the survey are formed into triangles is then obvious. To check the accuracy of the measurements of the line forming the triangle, a "tie" line is usually run from the apex of the triangle to a station left about midway in the base line. Another method of checking the measurements is to ascertain the angles of the triangles with an angular instrument, in which case the "tie" line may be omitted, though the usual practice in large surveys is to take both checks, and if there is an error it can be more easily located.

In the majority of cases the limits of the survey form a figure of such a shape that it is convenient to arrange the main lines into two triangles, though in some instances one may be sufficient. It may be taken as a rule, notwithstanding what may be said to the contrary, that the main lines should enclose the whole of the survey. In some cases, however, a small elongated position may be left outside, if expedient, and an outer triangle formed to survey it. Strictly speaking, the surveyor has no right to trespass upon the land beyond the limits of the survey, and if an objection

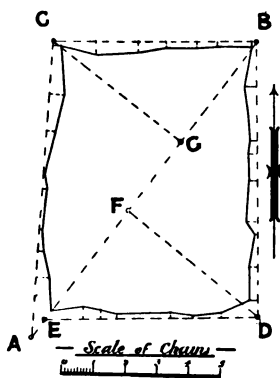

FIG. 77.

is made—a very rare occurrence, however—he must arrange the lines inside the limits of the survey.

As a simple example of triangulation, assume the survey to be of a single field with irregular sides, as shown by the plan (Fig. 77).

The figure is, approximately speaking, oblong, and consequently the lines will be best arranged in two triangles, the main line acting as a base for each triangle. The first and principal line of the survey should be the longest which it is possible to set out, and in the present example AB. This line is first staffed out, and next the lines AC and BC, as near to the hedge as is convenient to afford facility for measuring. In like manner the lines BD and ED are staffed out. The point E is chosen in the line AB, from which to run a line to D, because shorter offsets would be obtained than would be the case if it were run from A. Staffs are also fixed at some such points as F and G in the line AB, for the tie lines. The field bookings are given on pages 50 and 51.

The survey lines are lettered on the plan, and corresponding letters indicate the lines in the Field Book notes. This would not be done in actual practice, however, the letters being inserted mainly to render it more easily understood.

It has been presumed that all the lines have been staffed out before commencing the measurement: this may be done with advantage in a small survey which requires few staffs, but in an extensive survey only the base line AB would be staffed out, and the position of such stations as E, F, and G would be approximated and marked by driving wooden pegs, about two inches square and fifteen inches long, into the ground. It is often found that the peg left to denote a station is not in the best position for the proposed line for which it was left, in which case a portion of the base line must be staffed out again, a measurement taken from the peg to the new station, and a note made in the book showing the correct position of the latter.

It will be noticed that the direction of some of the lines is indicated by the cardinal points of the compass: this is necessary to show on which side of the base line each triangle is formed, as otherwise no one but the person who made the survey would have the requisite knowledge, and the survey would be difficult for any one else to plot. The words "right" and "left" could be substituted for the cardinal points if necessary.

A more extensive survey, and the method of filling in the main triangles, are illustrated by Fig. 78. The positions

of lines 1, 2, 3, 4, 24, 25, and 26, which comprise the two main triangles and their tie lines, are approximately marked on the sketch or small plan which is obtained in the first instance, and the remaining lines are filled in, according to the circumstances.

Now comes the actual survey. Line 1 is staffed out and measured, the line being terminated at both ends by the appearance which the land presents for running the lines 2, 3, 24, and 46.

When measuring the first line of the survey it would be apparent that stations were required for the following lines:— 3 and 46; 8, 39, 11, 13, 40, 20, and 30; 21 and 32; 31, 22, 28, 23, and 27; and 2 and 24; and pegs are therefore left in the most likely position. The probable positions of the lines 25, 4, 26, and 29, could not be determined very accurately when measuring line 1, so no stations would be left for these lines, and the points of line 1, which they run to, are determined by measuring to the nearest stations on the line. For example, when line 25 is staffed out it is found to come between the two first stations of line 1. Staffs are fixed up at these stations, and the point where line 25 cuts line 1 is lined off, and the distance determined by measuring back from the second station and deducting this length from the length of the second station on line 1.

The order in which the lines are run is shown by the numbers enclosed by circles, and their direction by the arrowheads. The small circles on the lines represent stations. It will be noticed by the order of the lines that the two lines necessary to complete the triangle on the north side are first undertaken, and next the tie line, succeeded by the inside filling up lines. The filling in of the inside work is comparatively easy if stations have been left on the main lines in their proper positions. When executing the filling in, it should be commenced in one corner and worked progressively forward, so that no lines may be missed. The triangle being fully completed, the main lines of the other triangles are measured, and the filling in proceeded with as before. The method of running the lines requires no further explanation, if we might except numbers 18 and 19. These lines are set off to form a triangle with the base line 17, and offsets are taken

to the pond. The two lines will form a correct figure when plotted, if the measurements, etc., are correct, but there is nothing to check them. The two lines are generally considered sufficient for getting off ponds, but for an important object a tie line should be run from the junction of the lines 18 and 19 to some fixed point on line 17, to act as a check in the

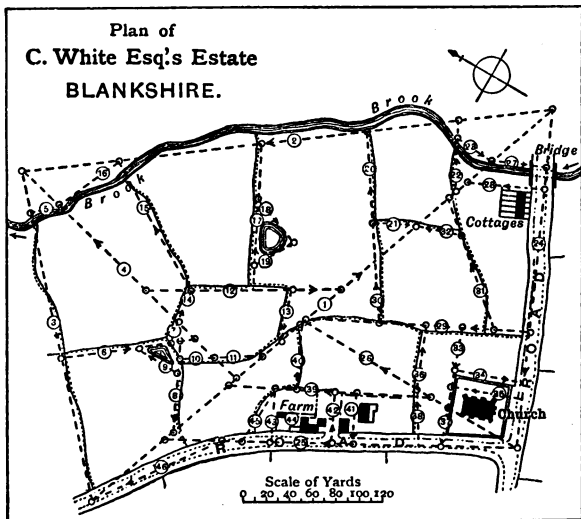

FIG. 78.

same way as the tie line of the main large triangles, or, in the instance shown, line 18 may be produced on to line 1, when the work would be properly checked.

Boundaries.—Offsets are taken to the stump of a hedge, but the ditch is the recognised boundary, and the assumed position for the ditch by surveyors in this country is four feet from the fence.

It is therefore important when offsetting a hedge to note in the Field Book the side on which the ditch lies, and if it crosses at any point a note must be made and the point of

crossing offsetted. The centre of a brook is also an accepted boundary, but no matter whether there be a hedge alongside or not, the centre of the brook is offsetted, and the width taken at intervals. When an estate borders on a road the boundary is taken to the centre of the road, if not otherwise specified.

CHAPTER VIII

THE MAGNETIC NEEDLE

The Magnet.—A magnet is a body which, amongst other remarkable properties, exhibits the phenomenon of settling always in the one position, or, more correctly, in the one direction, comparatively speaking, when allowed free rotation on an axis. The only body which, in a natural state, possesses the properties of a magnet is loadstone, but other bodies may be subjected to a treatment by which they can be formed into most efficient magnets. Iron or steel is the material employed for making artificial magnets. A magnet made from a straight bar and pivoted on a centre is known as a magnetic needle. By its use, directly or indirectly, almost all underground surveys are made, and it is often brought into requisition for surface operations.

The Construction of the Magnetic Needle.—The magnetic needle, employed as a surveying instrument, consists usually of a flat bar of steel which is thickened in the centre and has a hole punched through it. To this is screwed a small conical brass cap with a hard stone, usually of agate, at the apex of the cone. The greater width of the bar is usually in the direction of its height, and the ends are tapered to a point. The needle is pivoted at its centre upon a hard steel point upon which the agate bears, and thus allows the needle to swing in a horizontal plane. When allowed freedom the needle oscillates from side to side for a short period, and finally settles in a line which is approximately north and south, the ends of the needle always maintaining these respective positions with regard to the north and south. The north-seeking end of the needle is

distinguished by a small cross-bar or some other characteristic mark.

Magnetic Declination.—It was at one time thought that the magnetic needle settled in a line which exactly corresponded with the geographical north and south line, but subsequent investigation has shown the fallacy of this supposition. All true magnets at the one place point in one direction, and to distinguish this line from the geographical north and south line it is called “the magnetic meridian.” The difference between the true or geographical meridian and the magnetic meridian is called the magnetic declination. The declination of the needle is not constant, but varies from year to year, and also varies in different localities. In addition to the above the needle is subject to irregular diurnal variations, but these latter are so slight that it is not necessary to consider them. The variation in any particular locality for a short space of time is very slight, but if it be neglected for a space of several years serious errors will result.

The following table shows the declination of the needle from the true meridian at Greenwich for the years indicated:—

DECLINATION OF THE MAGNETIC NEEDLE FROM TRUE NORTH

DATE.	DECLINATION.	DATE.	DECLINATION.
1580	11° 15' east	1888	17° 40' west
1657	0° 00'	1889	17° 35' ”
1818	24° 38' west	1890	17° 29' ”
1880	18° 33' ”	1891	17° 23' ”
1884	18° 8' ”	1892	17° 17' ”
1885	18° 2' ”	1893	17° 11' ”
1886	17° 54' ”	1894	17° 5' ”
1887	17° 49' ”	1895	16° 57' ”
		1896	16° 50' ”

From the above table it will be seen that the magnetic meridian was in 1580 11 degrees 15 minutes east of the geographical meridian, that it gradually receded to the true north until 1657, and proceeded on towards the west till 1818, when it reached its maximum western declination, from which time it has

receded towards the true north. The mean rate of decrease is now about 7 minutes per year. As previously stated, the declination varies in different localities, increasing at the present time west of Greenwich, and diminishing towards the east. The lines through places of equal magnetic declination are known as isogonic lines, and run in a north-easterly direction. These lines are approximately parallel over small tracts of country. The variation at any particular place may be calculated from a map with the following isogonic lines drawn upon it.

Isogonic Lines

From 12 miles west of Isle of Man, by 7 miles west of Wigton, and 3 miles east of Glasgow, has a declination of 20° west in 1896, or $3^{\circ} 10'$ more than at Greenwich.

From 4 miles west of Land's End, by Aberystwith (Cardigan), east point of Walney Island (near Morecambe Bay), 4 miles east of Carlisle, and 20 miles west of Berwick, has a declination of 19° west in 1896, or $2^{\circ} 10'$ more than at Greenwich.

From 12 miles east of Start Point by Bristol, Walsall (Staffs), Wakefield, and 5 miles west of Middlesborough, has a declination of 18° west in 1896, or $1^{\circ} 10'$ more than at Greenwich.

From 8 miles east of Isle of Wight, by St. Albans (Hertford), and Ingoldmells Point (Lincoln), has a declination of 17° west, or $10'$ more than at Greenwich.

From 10 miles east of Dover by 10 miles east of Ramsgate, has a declination of 16° west in 1896, or $50'$ less than at Greenwich.

To find the True Meridian.—To ascertain the amount of declination of the magnetic needle it is first necessary to find the true meridian. There are various methods of doing this, the most common of which is the shadow method. The sun gives shadows of equal lengths from equal distances on each side of the meridian, so that if a staff be placed vertically in the ground, and the length and direction of its shadow be noted some time before the sun has crossed the meridian, and the direction of its shadow be again noted when it is equal in length to the first shadow and the sun has passed the meridian, the true meridian is denoted by a line bisecting the angle formed by the two shadows. The operation is greatly facilitated by

drawing a number of concentric circles or arcs with the staff as centre. The points at which the ends of the shadows touch the circumference of each circle is then marked on each side, and the line joining each pair bisected. They will then check each other, as a straight line should cut the point of bisection in each case and the centre of the staff.

The Influence of Iron or Steel on the Magnetic Needle.—When iron or steel is brought into close proximity with the magnetic needle either end of the needle is attracted towards it. For example, if a knife blade be held within a few inches of the end of the needle, it will cause the needle to deviate from its true course, and move towards the blade. It is therefore apparent that a true observation with the needle cannot be made in the proximity of iron. This is a source of difficulty in the mine, as it becomes necessary to pull up the tram rails and remove them to a distance whilst the bearing of the needle is being ascertained. The surveyor's lamp should be constructed of brass, with copper gauzes, or of some other non-attractive metal. Steel watch chains, heavily ironed shoes, and similar appurtenances, should also be guarded against. The distance to which iron should be moved depends upon its mass and the sensitiveness of the particular needle in use, but for tram rails, 4 yards from the dial is usually sufficient. If the observation is a very important one, or one upon which the remainder of the survey depends, it may be found advisable to increase this distance to 6 or even 8 yards. Even at the present time some surveyors make surveys regularly with the loose needle, without removing the tram rails, under the mistaken impression that if the dial be placed between the rails one counteracts the other. This practice cannot be too strictly condemned, and no survey made under these conditions can be relied upon.

CHAPTER IX

THE VERNIER

A **VERNIER** is an instrument by which readings can be obtained from a scale to a fraction of the divisions into which it is divided. The vernier consists of a small scale which slides along the main scale from which the readings are required, and the divisions of the vernier are such that they are a definite fraction greater or smaller than the divisions on the scale or limb.

When the divisions of the vernier are larger than the limb divisions, it is known as a retrograde vernier, and when they are smaller, as a direct vernier.

Straight Limb Vernier.—Fig. 79 shows a straight limb retrograde vernier fitted to an inch scale (reduced in the sketch). Each inch is divided into ten divisions, therefore each division measures $\frac{1}{10}$ th or $\cdot 1$ of an inch. It will be seen that ten divisions on the vernier equal eleven divisions on the limb, and as the limb divisions are $\frac{1}{10}$ th of an inch, the ten divisions of the vernier equal $\frac{11}{10}$ ths of an inch. Therefore, each division on the vernier equals $\frac{11}{10}$ ths $\div 10 = \frac{11}{100}$ ths of an inch, or, in other words, $\frac{1}{10}$ th + $\frac{1}{100}$ th of an inch, that is, each division of the vernier is $\frac{1}{100}$ th, or $\cdot 01$ of an inch greater than a limb division. Now to read off the measurement, the vernier is slid along until its zero mark exactly coincides with the point to be measured, the end of the limb or scale being the other end of the measurement. It is apparent, from the position shown in the figure, that the reading is between 1.5 and 1.6 inches, or 1.5 + a fraction of $\frac{1}{10}$ th of an inch, and the use of the vernier is to ascertain this fraction correctly. By looking along the vernier divisions it is found that the seventh

exactly coincides with a limb division. Then the reading is $1.5 + .07 = 1.57$. To show how this is arrived at, take the division on the scale which coincides with the 7, namely 8. To obtain the measurement, the seven divisions of the vernier will require to be added, and as each division is $\frac{11}{100}$ ths, seven divisions = $\frac{77}{100}$ ths, or .77. Then, $.8 + .77 = 1.57$ as before. A direct straight limb vernier, giving the same reading as the foregoing, is shown by Fig. 80. The ten divisions of the vernier are equal to nine on the scale, therefore each vernier division is one-hundredth or .01 less than the scale divisions, or each vernier division is .09 of an inch. The numbers of the divisions on the vernier (Fig. 80) are in the opposite direction to those on the retrograde vernier (Fig. 79), but it will be seen that the readings

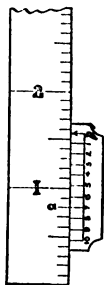

FIG. 79.

are the same, the seventh division on the vernier being the one which coincides with a scale division as before. To reason the admeasurement out, take the division on the scale which coincides with the vernier, namely 2.2. From this there requires to be deducted, so as to obtain the measurement, the number of divisions on the vernier between this point and the zero, namely, seven. Each vernier division = .09 inch, therefore seven divisions = $.09 \times 7 = .63$. Then $2.2 - .63 = 1.57$ as obtained previously.

The Arc Vernier.—The writer has thus far confined himself to the straight limb vernier; but what is of more consequence to the subject of surveying is the arc vernier, which is fitted to angular instruments. The arc vernier is employed to read fractions of a degree, and the limit of this fraction in ordinary mine-surveying instruments is one-sixtieth of a degree or a minute. The ordinary miner's racking dial is graduated to degrees, in which the vernier limit is one-twentieth of a degree, or three minutes. Theodolites and some of the improved miners' dials are graduated to half degrees, and the vernier limit of reading is one minute.

Fig. 81 shows part of the limb graduations and vernier of a dial graduated to degrees. Twenty divisions on the vernier

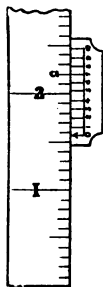

FIG. 80.

equal nineteen on the limb, therefore each vernier division is one-twentieth of a degree, *i.e.* three minutes less than the limb graduations, and this is the limit of the reading of the vernier. The reading is taken from the zero of the vernier in every case, and as readings are taken both to the right and left, a double vernier

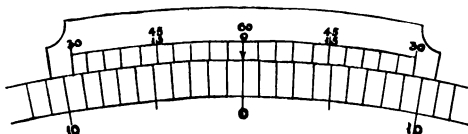

FIG. 81.

is necessary, or, what is equally as good, two half verniers, one on each side of the zero. For example, if a reading is taken to the left, the left half of the vernier is used to read up to thirty minutes, but if this is exceeded the right half of the vernier is brought into requisition, and the top figures are read. In the same manner the right half reads up to thirty minutes, and the left half reads from thirty to sixty when taking readings to the right. On the proceeding half of the vernier the lower figures are read, and on the backward half the top row of figures are read in either case.

A few possible examples showing the vernier reading under or over thirty minutes, both to the right and left of the zero graduation of the limb, will make this clearer. In Fig. 82 the

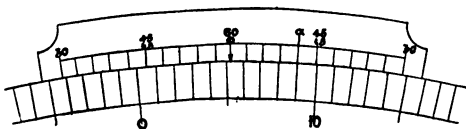

FIG. 82.

vernier is moved to the right of the limb zero. Now what is wanted is the angular distance it has been moved, that is, the number of degrees between the zero of the limb and the zero of the vernier. If, therefore, the graduations on the limb opposite the zero of the vernier are read off, the reading in degrees is obtained. This is found to be between 5 and 6, or 5 degrees + an unknown number of minutes, and it is required to find the

number of minutes by means of the vernier. By looking along the vernier graduations it is found that the one which exactly coincides with a limb graduation is marked *a*. It will be noticed that the coinciding graduation is on the right hand vernier, and as the vernier has been moved from the zero of the limb to the right, it is the proceeding vernier, therefore the lower set of figures of the vernier are read. Counting from the vernier zero it is found that the coinciding graduation is the fourth, and as each division indicates three minutes the reading is twelve minutes. These twelve minutes must now be added to the five degrees previously read, giving as a final reading five degrees twelve minutes.

In Fig. 83 it will be seen that the vernier has again been moved to the right, as this is the direction of the increase in the

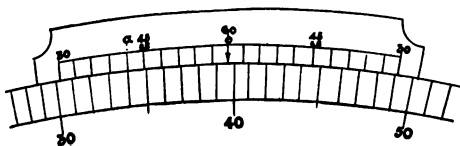

FIG. 83.

numbers of the limb graduations. The reading on the limb opposite the zero of the vernier is between 39 and 40, or $39 +$ a number of minutes which will be determined with the vernier. By looking along the graduations of the vernier until a coinciding line is found, it will be noticed that it is the one marked *a*, and that it is on the left hand vernier, or what in this case is the backward vernier. The reading is therefore taken from the top row of figures which read from the end towards the centre. The coinciding graduation is one nearer the end than that marked 45, and as the numbers decrease in this direction, and each division equals three minutes, the reading is $45 - 3 = 42$ minutes. This added to 39 degrees gives as a final reading 39 degrees 42 minutes.

Taking Fig. 84 next into consideration, it is perceived that the vernier has been moved to the left, and that the limb reading opposite the vernier zero is between 39 and 40, or $39 +$ a number of minutes which will be found with the vernier. Looking along the vernier graduations as before, the coinciding

line is seen to be that marked a , and that it is on the left hand or preceding vernier. We then know that the reading of the vernier must be taken from the lower set of figures, and see that

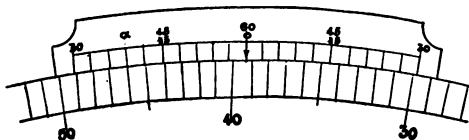

FIG. 84.

it is two graduations or six minutes past the fifteen minutes' division, therefore the reading is 21 minutes. The final reading is therefore 39 degrees 21 minutes.

In Fig. 85 the vernier is again to the left. The limb reading opposite the vernier zero is between 25 and 26, or 25 + a number of minutes yet to be determined. The coinciding vernier

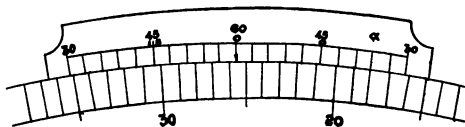

FIG. 85.

graduation is a , and being on the right hand or backward part of the vernier, the vernier reading must be taken from the top row of figures. The " a " graduation is two divisions, or six minutes from the outer edge, which gives as the vernier reading $30 + 6 = 36$ minutes. This added to the limb reading gives a total of 25 degrees 36 minutes.

CHAPTER X

SURVEYING INSTRUMENTS

The Hedley Dial.—A good idea of the construction of the miners' dial can be formed by reference to the accompanying

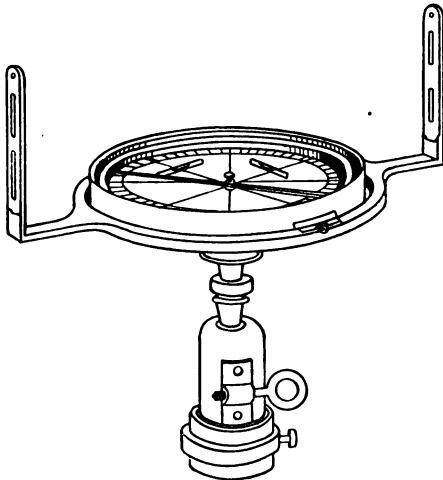

FIG. 86.

illustrations. Fig. 86 shows the ordinary appearance of the miners' dial. Fig. 87 shows the appearance when taking sights in mines of steep inclination with an arc attached, for taking

dip. Fig. 88 is a view of the face or front of the dial, and Fig. 89 the back view.

It consists of a shallow cylindrical brass box on the inside of which is a raised ring, which is graduated into the degrees of a

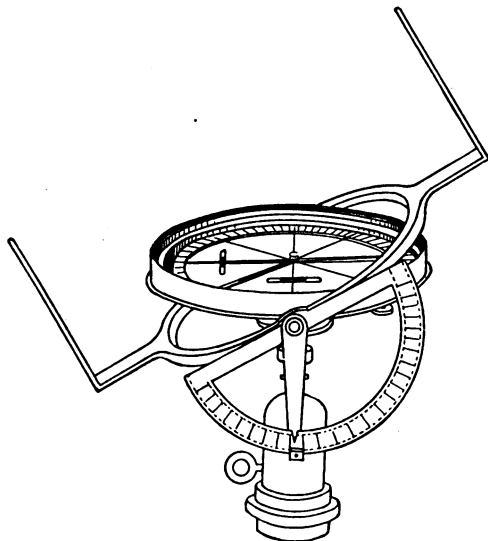

FIG. 87.

circle, viz. 360. On this circle the numbers are marked consecutively from 0 to 360, but on another circle at the base of the box the graduations are in tens, and are numbered from the north and south of the dial towards the west and east on both sides, thus forming four quadrants of 90 degrees each. At the centre of the box is a vertical finely-pointed pin, which supports a magnetic needle. The needle is slightly shorter than the inner diameter of the raised ring, and its height when swinging freely is such that the top of the needle is on a level with the raised ring, thus enabling the position of the needle in relation to the graduations to be read off accurately.

A vernier is connected rigidly to the inside of the box,

immediately above the graduated circle at the north end of the dial, and by removing the peg (*c* Fig. 89), the box with the vernier, etc., can be moved round the circles.

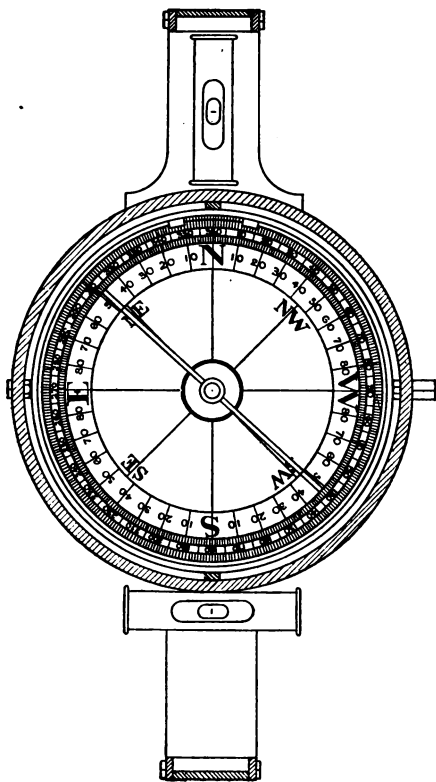

FIG. 88.

The cap (*a*, Fig. 89) fits on a tripod stand which has a ball and socket joint to enable the instrument to be levelled. The inner circles are connected rigidly on the cylindrical piece of metal which forms the cap of the legs, and if the dial be first

clamped on the legs by the screw (*f*) and the peg (*c*) taken out, the sights can be moved in any direction required by turning the large milled head screw (*b*), and as the vernier is in the

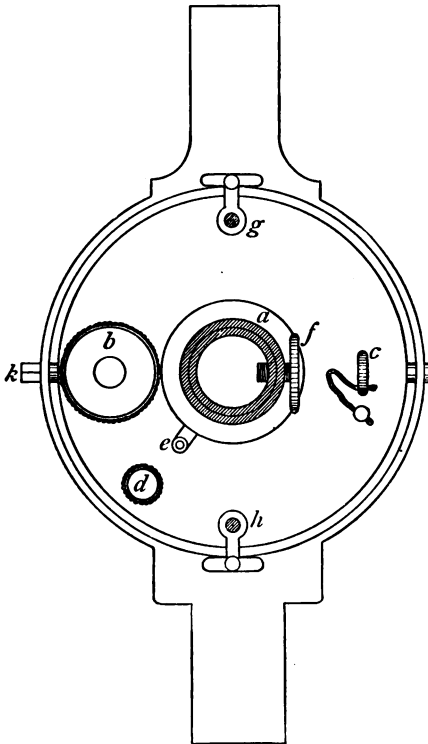

FIG. 89.

exact line between the sights, the angle which the sights have been moved through can be found by noting the number of degrees between the centre of the vernier and the north end of the dial. The sights may be clamped in their new position in relation to the graduated circles by means of the screw (*d*).

The bar or lever (*e*) is employed to throw the needle off its seat when not in use, to preserve it from injury. By pushing the lever inwards the needle is lifted up and pressed against the glass which covers the box. When taking a magnetic bearing the lever is pulled outward, and the needle drops back upon its pivot.

The cams (*g* and *h*) only come into use when taking sights in steep places, or when taking dip. By moving them inwards on their centres the sights can be moved in a vertical direction, as shown by Fig. 87. A graduated arc (Fig. 87) is fitted to the elongated axis (*k*, Fig. 89) of the dial for dip taking.

The sights, an enlarged view of which is shown in Fig. 90,

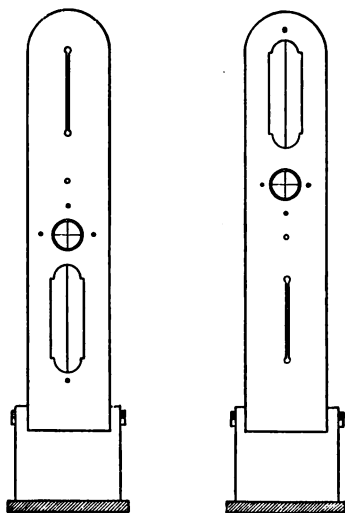

FIG. 90.

are fixed at the north and south ends of the dial. When in use they are in a vertical position as shown, but may be folded down for convenience in carrying. It will be seen that one sight has a comparatively wide opening, bisected vertically by a horsehair or wire stretched across it. To take a sight the eye is applied to the narrow slit, and the dial is turned round until the vertical hair exactly covers or cuts the centre of the sight object, so that to take a sight from either end of the dial it is necessary to have another pair of openings in the sight vanes, but *vice versa*,

and these are shown at the bottom of the vanes. The small circular openings are used for dip taking, and in this case a horizontal hair is required as well as the vertical one. For descriptive purposes it is necessary to be able to distinguish between the two ends of the dial; for this reason one is called the north end and the other the south end.

By the north end of the dial is meant that portion which in its normal position is situated near the N., which represents the north on the graduations of the dial. More correctly it should be called the vernier end, as the vernier is situated at the north end, and, as will be seen subsequently when fast needle surveying is described, the sights may be turned round the graduation plates, and what was formerly the north sight vane may be near the south side graduations on the dial. The vernier, however, moves with the sights, so that there is no difficulty in distinguishing between them, and the vernier end is termed the north end, no matter where situated.

Two levels are fitted to the instrument at right angles to each other, so that it may be levelled with facility. Figs. 76 and 77 represent the dial made by Messrs. Davis & Sons of Derby, and it will be seen that the levels are placed on the face of the dial, while those of Figs. 88 and 89 are shown near the sights. The mode of attachment to the legs is somewhat different also, but the general principle of all miners' dials is the same.

To make an Observation with the Dial.—Being first assured that there is no iron or steel sufficiently near the site chosen to attract the needle, set the tripod of the dial firmly on the floor and place the dial on it. Remove the plate which covers the face of the dial and adjust the instrument to a truly horizontal position. This is done by grasping the dial firmly—preferably with both hands—and exerting a slight pressure up or down as required. The instrument is truly horizontal when the air bubbles of the spirit levels are exactly midway in the glasses. There is usually a file mark on the glass at its centre line, so as the better to know when the bubble is in its correct position. It is essential that the dial be levelled correctly, as the needle may otherwise stick and cause a wrong bearing to be read; and even if the needle swings freely, if the dial leans to one side, it will render the reading slightly inaccurate. More especially it is necessary to have the instrument perfectly horizontal if the angle of inclination or dip has to be taken, or errors will result. If the socket joint of the legs moves too easily or is too stiff, a turn of the thumb-screw, which is attached to the two plates which form a socket for the ball, will rectify it.

Next drop the needle on its pivot by means of the lever. The needle will now oscillate from side to side of its true position, the oscillations gradually becoming less until the needle at length settles in the magnetic north and south line. Whilst the needle is oscillating the dial may be adjusted to the line of sight. Turn the dial round until the north end is towards the sight object—which in the case of an underground observation is a lamp—and with the eye applied to the narrow slit at the south vane adjust the dial so that the vertical hair in the north vane apparently cuts the sight object, and clamp the dial in this position on the legs by means of the screw.

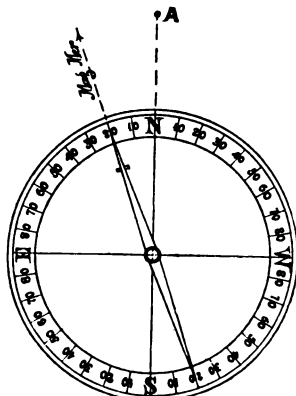

FIG. 91.

The needle having settled, the bearing, as indicated by the north end of the needle, is read off from the circle, which is graduated in quadrants, each reading from 0 to 90. If the north end of the needle points between north and east on the dial, the number of degrees are read off and booked as a north-east bearing; for example, assuming the north end of the needle to point to the division marked 20 between north and east, the bearing would be booked thus, N. 20° E. A reading between north and west is known as north-west, between south and east,

south-east, and between south and west, south-west. The north and south take the precedence in each case, the west and east being read and booked last; that is to say, a bearing would not be called west-south, but south-west, not east-north, but north-east.

It must be clearly understood that there is no relationship between the north end of the needle and the north end of the dial. The north end of the needle may point to the south-west or south-east of the dial as well as to the north-west or north-east.

Fig. 91 is intended to represent a dial face; and here it will

be seen that the east and west are on the contrary sides of north and south to the geographical position. The reason of this will be made clear with the aid of the illustration. The north and south of the dial are placed in the line of sight towards A, and in the instance noted the needle reads N. 20° E. on the dial. Now the direction of the needle is the magnetic meridian, and the line of sight is 20° to the right, that is, to the east, because the east is to the right hand of the north and south line, therefore the magnetic bearing of this line is N. 20° E. It is now apparent that the sight line is north-east, but if the letters E and W were put on the dial face in their ordinary positions, the bearing would read N. 20° W., which is inaccurate. The circumstance which causes this peculiarity is, that it is the position of the needle which is read off with relation to the sight line, and not the sight line to the needle, *i.e.* the meridian; the needle always pointing in the same direction, and the face of the dial being moved about it.

Improved Dials.—Of recent years it has become generally acknowledged that the old form of Hedley Dial is not sufficiently accurate for surveying modern mines, and theodolites have not yet come into favour in this country for general use underground. On account of the difficulty experienced in manipulating the instrument in thin seams, numerous improvements have been made in the miner's dial which render it possible to make surveys in mines accurate enough for almost all practical purposes.

Lean's improved miner's dial is illustrated by Fig. 92. The special features of this instrument are the substitution of a telescope for the sights, and the adoption of a large vertical arc for taking dip. For general survey work the ordinary sight vanes may be used, but for important work the sights are taken off and the arc and telescope substituted. The telescope, which is similar to that of a theodolite, is of the ordinary description, with an eye-piece at one end, and an object-glass at the other. It also has a screw attached on one side of the outer tube for adjusting the length of the tubes according to the distance of the sight. The telescope, as usually fitted to surveying instruments, gives an inverted image of the object sighted. To get an ordinary erect image additional lenses are required, which have the effect, however, of giving a less

distinct image, and they are therefore omitted. Near the eye-piece, and situated between that and the object-glass, is a diaphragm which contains two hairs or webs bisecting each other at right angles, one vertical and the other horizontal. When taking horizontal angles the vertical web is turned until it apparently cuts the centre of the sight object, and for vertical angles the horizontal web is employed. A large spirit level is attached to the under side of the telescope, so

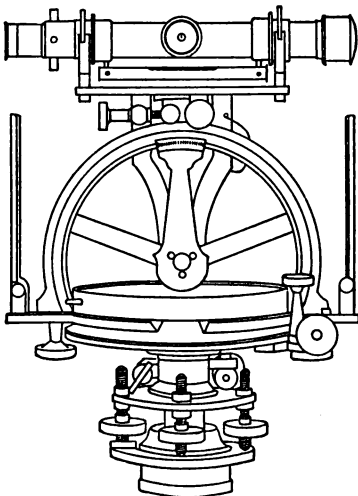

FIG. 92.

that the instrument may be adjusted to a greater degree of accuracy when taking vertical angles than the small spirit levels at the base of the dials admit of. The telescope is supported by two arms, rotating on an axis, which is the geometrical centre of the arc of the circle. To one of these arms is fitted a vernier for reading angles from the vertical arc. Fig. 93 represents an improved form of the Hedley Dial by Messrs. Davis & Son, which will be found to fulfil all ordinary requirements. The special features of this instrument are an outside vernier similar to a theodolite, an improved form of

arc for taking vertical angles, and the sights are interchangeable with a telescope for more accurate work. The advantage of the outside vernier is that the reading is more easily obtained, being in a more accessible position. The arc of the ordinary dial is replaced by a circular box $1\frac{3}{4}$ inch diameter, with a dial plate graduated to degrees and traversed by a hand.

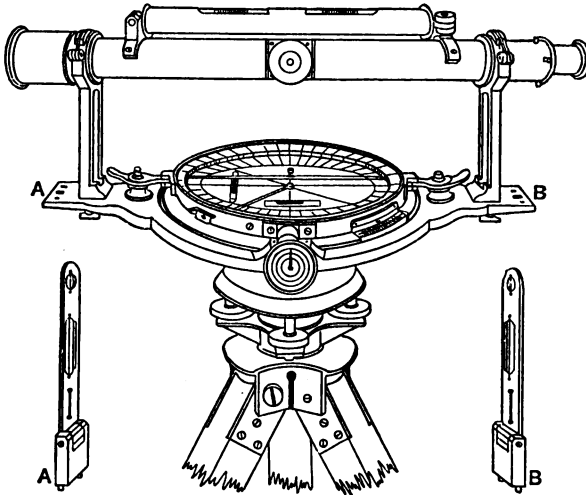

FIG. 93.

The Theodolite.—The theodolite is essentially an improved dial consisting of almost the same arrangements, but with different screws for fine adjustment and reading. For loose needle surveying it is not so convenient as the dial, but for angling in important positions, especially on the surface where it can be manipulated easily, the theodolite is by far the better instrument.

There are various forms of theodolites, but they differ in detail only, the general construction of each being the same. Fig. 94 represents Hoskold's Miner's Theodolite. It consists of two horizontal plates (A), the lower one of which is graduated into degrees consecutively from 0 to 360, and the upper one is

the vernier plate. The vernier plate may be rotated round the graduated plate, and the angle can be read off with the vernier.

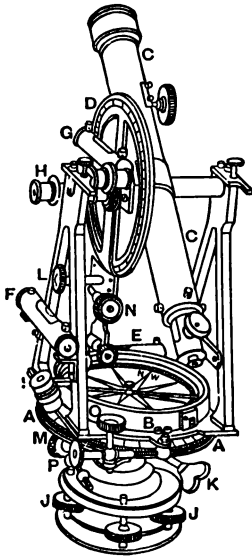

FIG. 94.

On the centre of the vernier plate is the compass box (B), the circle of which is also graduated for magnetic bearings. Above the horizontal plates is fitted a telescope (C), which is capable of moving on a horizontal axis, and at the side of which is fitted a vertical graduated circle (D) for reading vertical angles, the index for it is also provided with a vernier. Two levels (E and F) are fitted on the lower portion of the instrument at right angles to each other for adjusting, and another (G) is placed near the top of the instrument for the more accurate adjustment of the telescope when required for vertical angles. In some instruments this latter level is fitted to the top of the telescope, and is of rather larger size.

The verniers of both the vertical and horizontal graduated circles are provided with microscopes (H and I) for the more accurate reading of

the same. To take a sight with the instrument, it is first levelled with the four screws (J J) joining the parallel plates, between which is the ball and socket joint on the lower part of the figure. The instrument is now turned until the telescope is approximately in the line of sight, and is clamped on the vertical axis above the parallel plate by a thumb screw (K); another screw (L) on the upper portion of the instrument clamping the telescope. The telescope can now be correctly adjusted to the line of sight by a slow motion or tangent screw (M) fitted below the horizontal plates. If the vertical angle is also required, the horizontal cross wire of the telescope must be made to cut the sight object by means of another slow motion screw (N) fitted near the telescope clamping screw. The instrument is now adjusted to the line of sight, and the vertical angle

may be read off. Should the angle which another line makes with this base line be required, then the position of the index of the vernier plate should be at 0° previous to the first adjustment, and the clamping screw (O), which holds it in this position, should be released in order to adjust the instrument to the second line of sight. The graduated horizontal plate is retained stationary, but the vernier plate, together with the telescope, etc., may be turned to the second line of sight. When approximately adjusted the horizontal plates are again clamped by the screw (O), and the more correct adjustment made with another slow motion screw (P). The angle which the vernier plate has passed through may then be read off by the vernier with the dial.

The manipulating screws of a theodolite may be divided into three sets: 1st, the clamping screw (L) and the slow motion (N), which adjusts the telescope; 2nd, similar screws (O and P) for adjusting the vernier plate in a relative position with the horizontal graduated plate when taking a sight; and 3rd, similar screws (K and M) for adjusting the whole of the instrument horizontally on the vertical axis above the ball and socket joint to a line of sight.

In some theodolites two verniers, 180° apart, that is in a straight line with the centre of the circle, are provided for the readings of both the horizontal and vertical angles, to test the construction of the instrument; and if the two verniers give slightly different readings the mean of the two is taken.

CHAPTER XI

SURVEYING WITH THE MAGNETIC NEEDLE

Ordinary Method.—To make a survey underground it is necessary to have some fixed station to commence from or finish at, which is shown on the plan on which the survey is to be plotted. The usual procedure is to have two such stations, one to commence the survey from, and the other to finish at, in order that, when the survey is plotted, it will be apparent whether it is correct or not.

All mines are now provided with two shafts, a downcast and an upcast, and these are included in the surface survey and plotted on the plan. If the shafts are vertical, which is usually the case with coal-mining shafts, we have at once two points on the plan which correspond with two stations underground, and from one of these stations the survey commences. As the mine becomes extensively worked it would be impracticable to survey from the shaft every time, so stations or "dial marks" are left every survey, or alternate survey, for the succeeding ones. The station is left on one of the sights of the survey, and a note is put in the book that a mark has been left at this point. The station is denoted underground by putting a ring of whitewash or paint round the spot, if it is a mine with a good dry roof, or by driving a wooden plug a few inches in diameter into the floor or roof.

As an example of how a mine is surveyed, take the long wall workings shown by Fig. 95. The survey would commence at one of the shafts, say the downcast, and proceed round the workings, and if possible, tie in at the upcast. The measuring

assistant holds a light at the centre of the downcast shaft, and the surveyor proceeds towards A, as far as he can conveniently see the light. Assuming that the road is perfectly straight, and that a light held in the centre of the shaft can be seen at

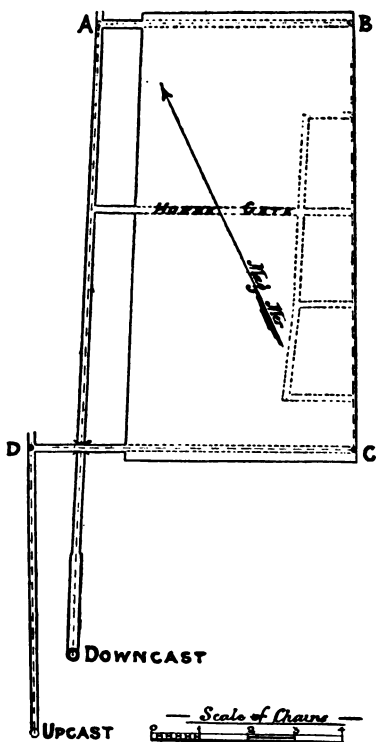

FIG. 95.

A, the surveyor plants the legs of the dial at this point, having previously seen that the iron, if any, has been removed from the locality. The legs of the dial should be so placed that a sight may also be taken along the road to B without having to remove them. The dial is then placed on the legs, the

levelling adjustment made, the needle allowed to swing freely, and the sight taken to the light held at the shaft. The north end of the dial should always be in the direction in which the survey is proceeding, so that in this case the surveyor would look through the north end, and adjust the dial until the vertical hair of the south vane covers the sight object. The dial is then clamped on the legs, and the needle having settled, the bearing is read off. In the meantime an assistant has proceeded towards B, and as the road is straight a sight can be taken to this point. The dial is unclamped but not removed, and with its north vane towards B the bearing is taken. The length from the downcast to the station at A is next measured, the width of the road, the branch gate, and any other point of importance being read off during the measuring. The same is done with the road to B, care being taken to read off the point where the long wall workings begin. The lengths being recorded in the book, the surveyor proceeds with the dial towards C, and the dial is set up at this point; a sight is then taken back to B, a forward sight to D, and the measurements are taken as before. As the return airway from D to the upcast shaft is straight, only one more bearing is required, in which case the dial may be set at D, immediately under the mark at which the sight lamp was held, and a sight taken to the shaft; or the dial may be set up midway between D and the shaft, and a backward and forward sight taken as before. The backward and forward sights should coincide with each other, or nearly so, as the road is straight, and one measurement could be taken from D to the upcast. If the two bearings are different, however, a measurement should be taken from D to the dial, and another measurement from the dial to the shaft. The position of the gates and cross-gate may be fixed with sufficient accuracy, by measuring down each gate to the centre of each cross-gate. It might be found expedient to have permanent station marks left at B and C, from which to commence subsequent surveys, to avoid the necessity of surveying from the shafts.

It is important when a back-sight has been taken to a station left at the end of the fore-sight at the previous setting of the legs, that the light be held in exactly the same vertical line as in the previous observation. To insure this being done,

a small chalk mark should be made on the roof, and the right lamp suspended by a cord held at the mark. When the dial has to be set immediately under a station mark, a plumb-bob should be brought into requisition for ascertaining the correct position.

The Survey Book.—There are two distinct methods adopted of booking underground surveys: one in which a rough sketch of the workings is made as the survey proceeds, the bearing and measurements being placed in their correct position with reference to the sketch; the other in which each bearing is taken as a separate line, and the survey is booked like a surface survey. Perhaps the former method is the simpler and quicker, besides which the approximate position of the workings is known to the surveyor whilst making the survey, and this enables him to proceed with his work with greater facility. The second method, however, recommends itself to certain circumstances. If the roadways are of irregular width, or necessitate numerous side measurements or notes, then this method is the better, as the small space allowed by the sketch does not permit of numerous notes being made. The size of the sketch is of necessity small, as it renders the work difficult if it occupies more than one or two pages of the survey book, whereas in the other case any number of pages may be used.

The bookings¹ of the long wall workings (Fig. 95) by the second method are shown on p. 80. Here it will be seen that each bearing is numbered as a separate line, and reference is made at the bottom of each line to denote from what point the bearing is taken.

The booking of a portion of some "pillar and stall" workings by the first method is shown by Fig. 96. The bearings are written on the side of the road, and the measurements are placed between the two lines representing the road. A star, or some similar mark, is placed at the end of each bearing, and to distinguish

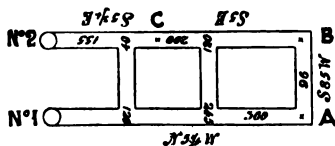
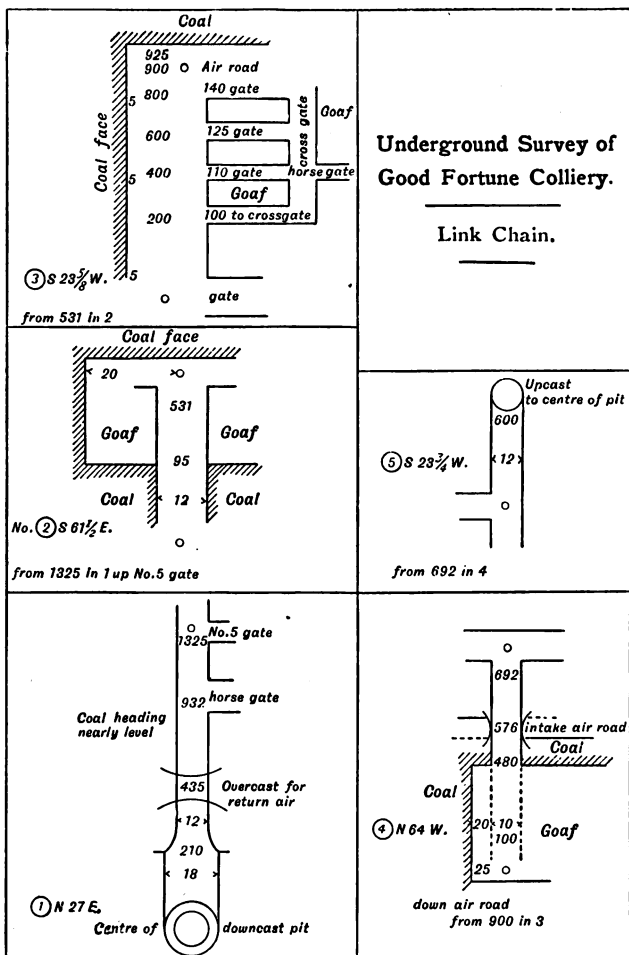

FIG. 96.

¹ From the City and Guilds of London Institute, Mine Surveying Examination Paper, 1893.



the full length measurements of the bearings from the intermediate lengths, they are booked parallel to the road, or a ring is drawn round them, while the intermediate lengths are booked across. The manner in which this would be surveyed is as follows: Commencing say from No. 1 shaft, the surveyor would proceed along the road, occasionally looking back to see if the light held at the centre of the shaft was still in sight; and as the road is straight the dial would be set up at A. As the N. end of the dial should be kept in the direction in which the survey is proceeding, he will look through that end and adjust the dial so that the vertical hair of the south vane will cut the sight lamp held at the shaft. The bearing is now read and the north end of the needle is found to point to N. $5\frac{1}{4}$ W. The assistant then measures from the shaft to A, reading off the measurements at which the cross-roads are passed. The surveyor is in the meantime taking an observation to B, the eye in this instance being applied to the sight vane at the south end of the dial, the north vane pointing forward. The reading is read off as S. 85 W., and the measurement which is taken subsequently gives 96. The dial is now taken up and set again at C, from which point a bearing is taken to B, and another to the centre of the upcast shaft. These bearings, with the measurements, complete the survey, and if the plan upon which the survey is to be plotted has the position of the two shafts laid down upon it, the plotting will check the accuracy of the survey.

Fig. 97 affords a further example of underground surveying in pillar and stall work, and also illustrates the manner in which permanent stations are left. The shaded portion of the roads represents as much as was worked when the previous survey was made, and A and B denote the positions of the stations which were then left for the subsequent surveys. If the plan has now to be "filled up" to date, a survey is commenced from one of the stations, say A, and is completed at the other, B. The necessary bearings and measurements are shown by the bookings on the plan. The two intermediate levels between AC and BD are each measured back to an "old opening," that is, a road which has been previously surveyed and put on the plan. Stations are left at C and D for the next survey.

Surveying with the Magnetic Needle in the

Presence of Iron.—A correct survey may be made with the magnetic needle alone in the presence of iron, providing one correct bearing is obtainable, or a known datum line is laid

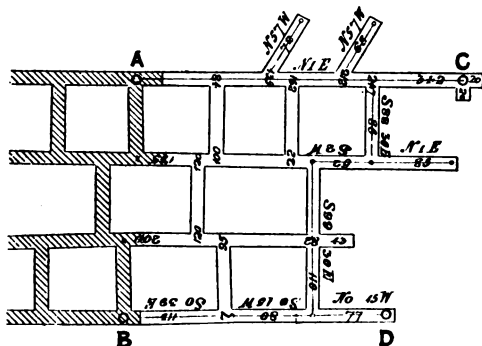

FIG. 97.

down. The method, however, is not much used, as a fast needle survey can be made with only the same amount of trouble and with greater accuracy, but circumstances may arise, such as the loss of the clamping screw, which render a fast needle survey impossible, in which case the method, which may be termed the "correcting deflection" method, may be advantageously adopted.

Take Fig. 98 as an example of a roadway which is to be surveyed, and the point A is the only one at which the absence of iron renders a correct bearing possible. The instrument is

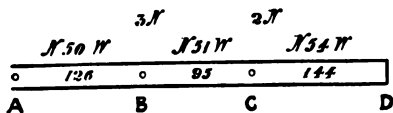

FIG. 98.

fixed at A, and a bearing is taken towards B, which we will presume to be as far as a light can be conveniently seen from A. The bearing being read off, it is found to be N. 50° W., and as there is no attraction on the needle this is a correct bearing, and is booked accordingly. The remaining bearing of the roads

must be calculated from this. The dial is now removed and fixed at B, directly under the mark at which the sight lamp was held, and a back bearing is taken to A. This should read N. 50 W., as it is the same line of sight as was previously taken, but owing to the local attraction of the needle the bearing is found to read N. 47 W. Thus it is plain that the needle has been attracted three degrees north of its true course. A fore-sight is next taken to C, and the bearing reads as N. 48 W. But as the position of the dial has not been altered the needle has been attracted three degrees north, therefore the correct bearing is $48 + 3 = N. 51 W.$ The instrument is now removed to C, and a back-sight is taken to B. This is found to read N. 53 W., and as the correct reading, as calculated from the correct bearing, is N. 51 W., the needle has been deflected two degrees to the west. A fore-sight is next taken to the end of the road D, and the bearing is read off as N. 56 W., but as the deflection is the same as was previously ascertained by the back-sight, namely, two degrees west, the correct bearing is N. 54 W. If the instrument were then placed at D, and the needle was free from disturbance, a back-sight to C should give the bearing N. 54 W., and a check on the work would be thus obtained.

It may so happen that a correct bearing cannot be taken at the commencement of the survey, in which case the readings of both back and fore-sights must be recorded and the correct bearings calculated when a bearing has been taken where the needle has not been attracted. The following shows a method of booking the foregoing survey, presuming D to be the only position at which a correct magnetic bearing can be obtained. The instrument would first be placed at B.

No.	BACK BEARING.	FORE BEARING.	CORRECT BEARING.	DISTANCE.
1. A B	N. 47 W.	...	N. 50 W.	126
2. B C	N. 53 W.	N. 48 W.	N. 51 W.	95
3. C D	N. 56 W.	N. 54 W.	N. 54 W.	144

Correct bearing as obtained with magnetic needle, N. 54 W.

To obtain any degree of accuracy it is necessary when re-

setting the instrument to place it exactly at the mark to which the last fore-sight was taken. The best method of doing this is to have three sets of legs, any one of which will fit the dial. One set is sent ahead for the fore-sight, another remains behind



FIG. 99.

for the back-sight, the third being used for the instrument at the intermediate station. A metal cup (Fig. 99) fitted with two levels fixed at right angles to each other at the bottom of the cup is fixed on the legs at the fore-sight (see Fig. 100). The pivot of the legs on which the dial fits is made to assume a truly vertical position by adjusting with the levels, and the sight lamp is placed in the cup. By these means the centre of the light of the lamp is exactly in the same vertical line as the pivot of the legs. The legs at the back-sight have also a similar cup minus the levels. The levels are not necessary, as

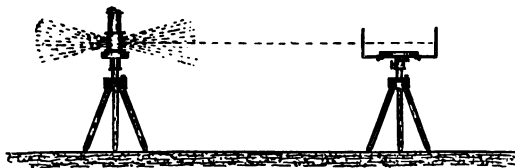

FIG. 100.

the legs have been previously occupied by the dial, except in the case of the first back-sight when the levelling cup is used.

When the back-sight has been taken the legs are sent ahead in preparation for the next sight, while the fore-sight is being taken. The dial is then removed to the set of legs which originally formed the fore-sight, and as these have been levelled with the cup the dial needs little adjusting, and the work is quickly performed. The back-sight cup is placed on the legs just vacated by the dial, and a bearing is taken to it. Mean-

while, the man in charge of the fore-sight cup has taken it, together with the other set of legs, and is adjusting them for the next sight. In this manner the exact position of the stations are retained, and the work can be done accurately and expeditiously.

If three tripods are not obtainable, two may be employed to the same advantage in respect of accuracy, but the work will take considerably longer to do, as no preparation can be made for the fore-sight until the back-sight has been taken.

In the event of only the one tripod being used, as in the ordinary method of loose needle surveying, the sight lamp should be suspended from the roof by a cord, and the station should be marked with chalk. When the dial is brought ahead for the next sight it can be fixed fairly accurately under the mark by the plummet. This method is not, however, as accurate as the former, nor can the work be accomplished so quickly, but if it is a loose needle survey, with the exception of one or two sights it would be impracticable to carry three tripods during the whole period, and the latter method might be adopted.

Where the condition of the seam requires the angle of inclination to be taken at almost every sight the extra tripods will be found especially useful, as the light is held about the same height above the floor of the seam as are the sights of the dial, and thus the true inclination is obtained.

CHAPTER XII

RACKING OR FAST NEEDLE SURVEYING

FAST needle surveying is usually adopted where the presence of iron renders the use of the needle impracticable, and, as it is not always possible to tell whether a station is suitable for a loose needle bearing, many surveyors prefer to take fast needle diallings almost exclusively, merely checking the survey from time to time with the needle, where a correct bearing is deemed possible.

In fast needle diallings, as in the "correcting deflection" method, it is necessary to have one line the correct magnetic bearing of which is known, from which to reduce the fast needle bearings.

Meridian Base Line Method.—There are various methods of racking in use; the one used by the writer, by reason of its numerous advantages, consists in finding the magnetic meridian by means of the loose needle, and using this as a base line for the subsequent angles. The special advantages of this method are, the magnetic bearing is read off immediately, without recourse to calculations, the survey can be checked at any point where a loose needle bearing is possible, and it can be seen at a glance whether the work has been done correctly or not. The description will in all probability be simplified by taking a possible example of the survey made by this method.

Let it be assumed that a survey be required of the road shown by Fig. 101. This is commenced at one extremity where it is possible to obtain a true magnetic bearing with the

needle, which may be in an old disused road near the shaft, or, as in the example referred to at the point A, at the "in-bye" extremity of the road. The dial is set up at A, and the needle is allowed to assume its true position, that is, in the magnetic north and south line. The dial is now gently turned until the zero of the vernier, which is also the zero of the dial graduations, exactly coincides with the north end of the needle, and the dial is clamped in this position on the legs by means of the screw.

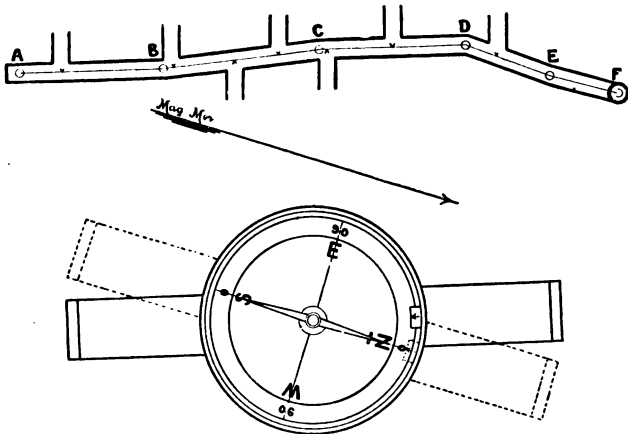

FIGS. 101, 102.









A base line is thus obtained, from which the remainder of the survey may be worked. The peg (c, Fig. 89) is now taken out, and the sights are adjusted (the vernier end being towards the light) to the light held at B by turning the racking screw (b), and are clamped in this position by the small screw (d), which prevents the two main plates of the dial from rotating. The position of the vernier is now read off, and the dial is moved to the legs at B at which the light was held, the vernier being retained in its new position. The dial is now adjusted to the light at A, the south end of the dial being towards the light, and clamped on the legs by the screw (f) as before. The two

plates of the dial are now unclamped by unscrewing *d*, the sights are adjusted towards C, again clamped by *d*, and the reading of the vernier is taken. The dial is next removed to C, the vernier being retained in the position fixed at the last sight. The back-sight is taken to B, the dial clamped on the legs, and the vernier clamp (*d*) removed. A forward sight is taken to D, the vernier clamped in this new position, and the reading is taken and entered in the book. The instrument is taken up and fixed at D, and backward and forward sights are taken as before. In this manner any number of bearings may be taken; and it is advisable at the termination of the survey, or at any other suitable position, to allow the needle to settle in its course, after having previously removed any material which is likely to attract it, and thus obtain a check upon the bearings. If the survey has been correctly made the needle should settle at any station where it is not attracted, exactly in the north and south line of the graduated circle.

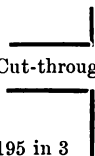
The reading of the dial by this method is different from the manner in which a bearing is read in a loose needle survey in an important detail; for whereas in loose needle surveying the east and west of the dial are on the sides contrary to the geographical position, by this method the bearings must be read as if the east and west were in the ordinary positions. Thus if the vernier reading of the dial is N. 20 W., then it must be booked as N. 20 E., or if S. 6 E. as S. 6 W., and if the outer graduations, which are consecutive from 0° to 360°, are read, then care must be taken that the protractor is graduated in the same direction as the dial. Perhaps the best method is to read off the bearings with the cardinal points N. S. E. W., as it is so simple a matter to transpose the E. and W.

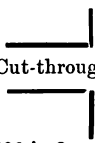
Fig. 102 shows the two positions which the vernier and sights will occupy at the commencement of the survey, viz. at A. The dotted lines show the position of the vernier and sights as adjusted to coincide with the needle, and the firm lines show the position which they occupy when taking the sights to B after the dial has been clamped on the legs.

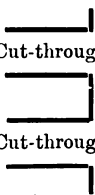
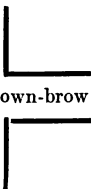
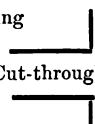
The following shows the bookings of the survey :—

<p>N. 2-9 W.</p>  <p>No. 5 from 116 in 4</p>	<p>⊙ (192)</p> <p>○</p>	<p>⊙ To winding shaft</p> 
<p>N. 3-45 E.</p>  <p>Cut-through</p> <p>No. 4 from 195 in 3</p>	<p>(116) 40</p> <p>○</p>	
<p>N. 17-57 W.</p>  <p>Cut-through</p> <p>No. 3 from 206 in 2</p>	<p>(195)</p> <p>96</p> <p>10</p> <p>○</p>	 <p>Down-brow Place</p>
<p>N. 23-6 W.</p>  <p>Cut-through</p> <p>Cut-through</p> <p>No. 2 from 186 in 1</p>	<p>(206)</p> <p>151</p> <p>64</p> <p>12</p> <p>○</p>	 <p>Down-brow Place</p>
<p>Needle bearing N. 18-6 W.</p>  <p>Cut-through</p> <p>No. 1</p>	<p>(186)</p> <p>⊙</p> <p>54</p> <p>○</p>	<p>⊙ Permanent mark left</p> <p>○ From face of level</p> 
<p>SURVEY FROM A TO SHAFT (FIG. 101)</p>		

Method with First Sight as Base Line.—Another method which is sometimes used is to make the first line of sight the base line for all subsequent angles, the meridian angles being calculated afterwards. By this method it is immaterial whether the loose needle bearing is the first sight or not, though it is advisable to have one at the commencement and another at the finish to check the work.

The procedure is as follows: A back observation is taken with the eye at the vernier end of the dial, from the second station—at which the dial will be first set up—to the first station, and the dial is clamped in this position on the legs, the vernier being at zero. This sight is booked as 00, as it is the base line. The peg which holds the two plates of the dial together is now taken out, and by means of the rack-work the sights are adjusted to the light held at the third station, the vernier end of the instrument being towards the light. The vernier is clamped in this position, and the reading is made by the vernier from the outer graduated circle (*i.e.* 0 to 360). The instrument is now taken up and is set at the third station; a sight is taken to the second station and the dial clamped on the legs in this position, the vernier being retained at the last reading by the clamp until this is accomplished. The vernier clamp is now released and the sights are adjusted by the rack-work to the fourth station. The vernier is clamped in this position and the reading taken as before. The survey thus proceeds, the vernier in every case being retained at the last reading until the back observation is taken and the dial clamped on the legs in this position. As in the methods previously described, the south end of the dial is turned to the light in a back observation, and the north or vernier end in a forward observation.

To reduce the observed angles to meridian angles add the observed angle of each sight to the meridian angle of the base line and the results will be the meridian angles. Should this sum exceed 360 degrees, that amount must be deducted to obtain the meridian angle. It may so happen that a loose needle bearing could not be obtained of the base line, but that one was taken on a subsequent line, in which case the meridian angle of the base line is calculated by deducting the observed angle from the meridian angle of the line of which the loose needle bearing is known. Should the meridian angle be less than the

observed angle, 360 must be added to it to allow of the deduction being made. As an example of how the angles are calculated take the following angles, the first of which is the base line, and of which the magnetic meridian is known :—

No.	MERIDIAN ANGLES.	VERNIER READINGS.
1	80	00
2	85	5
3	33	313
4	83	3
5	210	130

The meridian angle of the base line being known, to calculate the meridian angle of the second observation, the vernier reading 5 must be added to the first meridian angle 80, which gives 85. The third is found in the same manner, but as the sum exceeds 360 that amount has been deducted to give the correct angle thus $80 + 313 = 393$ and $393 - 360 = 33$, which is the meridian angle of the third observation. The fourth and fifth are calculated thus :—

$$80 + 3 = 83 \text{ meridian angle of fourth observation.}$$

$$80 + 130 = 210 \text{ meridian angle of fifth observation.}$$

Assuming that the loose needle bearing was obtained on the third line and not on the first, the meridian angle of the first line would be found by deducting the observed angle 313 from the bearing 33, but as this latter is too small to allow of the deduction being made 360 must be first added thus :— $33 + 360 = 393$ and $393 - 313 = 80$ the meridian angle of the first line.

Method with each preceding Sight as Base Line.

—There is still another method which consists in taking the angle that each bearing makes with the preceding one. The procedure is similar to that previously described, but the vernier is put back to zero and the peg inserted in every case before the back observation is taken. The sights are adjusted to the light for the back observation, the dial is clamped on the legs, and the vernier plate released by withdrawing the peg. The sights are then adjusted to the forward light, the reading

of the vernier booked, the vernier turned back to zero, and the dial is taken up to be placed at the next station.

The observed angles are reduced to magnetic bearings by the same calculations as in the previous method, but it must be remembered that the base line for any particular sight is the one preceding, and not necessarily the first line of sight. If the magnetic bearing of the first line is not known, but a loose needle bearing is obtained on a subsequent line, the calculations must be worked back for each sight.

Although, for the sake of simplicity, minutes have not been recorded in the examples given, yet these should be read off with the vernier in actual practice; especially is this necessary in the last method described, as a quarter of a degree of an error in the reading of one sight also causes an error of this amount in every successive sight, and the error is thus multiplied. This is one of the disadvantages of the system which does not occur in the others. The first method is by far the best for almost all underground work, and a survey may be made to any degree of accuracy required.

When an angular instrument with a sighting telescope is employed, all the observations must necessarily be taken with the dial always pointing in one direction.

This causes the reading in every case to be 180° different from that in the methods previously described, so that to calculate the angles, if the sum of the meridian angle and the vernier reading exceeds 180° this amount must be deducted from it to give the correct bearing, and if the sum of the two angles is less than 180° this amount must be added to it.

Comparison of Various Methods of Surveying.—The facility with which “loose needle” surveys can be made as compared with “racking” will now be apparent. Whereas when surveying with the loose needle the dial only requires setting at every second station, with the “fast needle” the dial must be set at every station, and every sight must be taken twice—once forward, and once backward. Also the same care is not necessary in keeping the stations, and there is less chance of making mistakes. When racking, it is necessary to keep the stations absolutely correct, that is to say, the backward sight must be made with the dial exactly in the position to which the previous forward sight was taken, and the sight must be

taken exactly to the point previously occupied by the dial. The only sure way of doing this is to employ three sets of legs and lamp cups. The reason why it is less essential to keep the stations with the same degree of accuracy in "loose needle" surveys is that each sight depends entirely upon itself, and if the sight-lamp is held a few inches from the station the inaccuracy will be too small to affect the plottings. In "fast needle" surveys, however, the error multiplies with every sight, as one depends upon another.

The writer must not be understood to say that the "loose needle" method is the most accurate, for this is not so, but the most extreme care is required with "racking" to do it correctly, and it is always advisable to check the survey if there is no tie, as there are so many chances of making a mistake.

All important surveys should be made with the fast needle by the "Meridian Base Line" method.

If a loose needle survey is being made, and a few fast needle readings are deemed expedient, either of the other two methods described may be employed, or each bearing may be booked as so many degrees to the right or left of the preceding bearing in each case. To reduce the vernier readings to magnetic bearings by this method, the observed angle in each case is added to or subtracted from the magnetic bearing of the previous sight, deducting 360 if the sum should exceed that amount.

CHAPTER XIII

PLOTTING SURVEYS

PLOTTING is the laying down, from the field-book notes to some definite scale, a representation or plan of the object surveyed.

Scales.—The choice of the scale to which to plot a survey depends principally upon the object for which the plan is intended, and in some degree on the extent of the survey. Though the various plans necessary for the work of a colliery are of many different scales, the “taking,” and consequently the workings, of the mines are usually plotted to one or other of the following scales :—

- 20 yards to an inch.
- 22 yards, or one chain, to an inch.
- 88 feet to an inch.
- 30 yards to an inch.
- 32 yards to an inch.
- 40 yards to an inch.
- 44 yards, or 2 chains, to an inch.

Generally speaking, the best scale for mine plans is 30 yards to an inch, but in many cases the “taking” is of such a considerable extent that the plan would be inconveniently large if plotted to this scale ; in that case it is usual to adopt the scale of 44 yards to an inch.

The Government Ordnance Maps are made to the following scales, and are published in convenient parts, so that single sheets may be had of any particular district :—General Map $\frac{1}{63360} = 1$ inch to a mile ; County Maps $\frac{1}{10560} = 6$ inches to a mile ; Parish Maps $\frac{1}{2500} = 25\cdot344$ inches to a mile, or 208·33

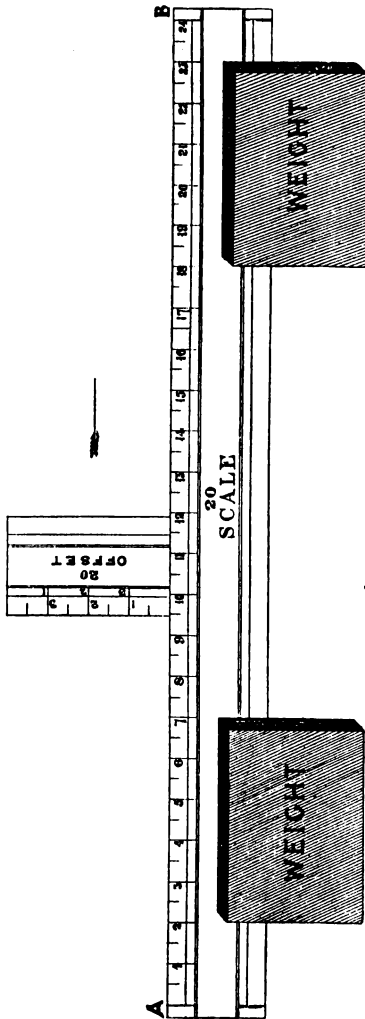

FIG. 103.

feet to an inch: $\frac{1}{1056}$ being 5 feet to a mile, or 88 feet to an inch; $\frac{1}{500}$ being 10.56 feet to a mile, or 41.66 feet to an inch.

The best scales are made of ivory, though those of box-wood are commonly used. They are generally about $12\frac{1}{4}$ inches in length, the divisions occupying 12 inches, and they are feather-edged in order to bring the divisions closer to the paper, thus allowing of more accurate measurements.

Offset Scales.—

These are divided in the same manner as the ordinary measuring scales, but they are considerably shorter, seldom exceeding 2 inches in length. Unlike the measuring scale, however, the first division commences from the extreme end of the scale.

Plotting Offsets.

—To plot offsets the ordinary measuring scale is placed with its edge exactly along the chain line (AB, Fig. 103) from which the offsets were taken, the

zero of the scale being at the commencement (A) of the line. Two plan weights are then laid on this scale, as shown in the figure, to keep it in position. The offset scale is now brought up to the edge of the measuring scale and slid along in the direction shown by the arrow to the point in the chain line, as represented by the scale measurements at which the offset was taken. The position of the offset scale, as shown in sketch, is for an offset at 94. The distance of the object offsetted from the chain line is measured with the offset scale, and a mark is made with the pricker to denote this point. The offset scale is slid along to the point in the chain line from which the next offset was taken, and the process is repeated. Lines are then drawn to connect such of the prick-holes as the field-book notes indicate.

Protractors.—A protractor is an instrument which is employed for plotting angles; it is made in various forms, and of a variety of materials.

The semicircular protractor (Fig. 104) in its best form is

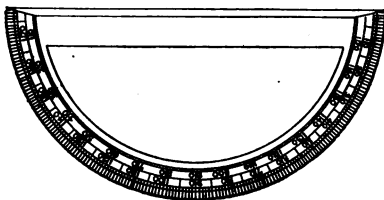

FIG. 104.

constructed of brass or electrum, and is divided into degrees, and in some instances to quarter degrees. The straight bar which connects the ends of the semicircle has its outer edge feathered, and its centre point denoted by a small mark; this point is also the centre of the circle of which the semicircle forms part.

To plot an angle with this protractor the feather-edged side of the straight bar is placed immediately alongside the line which is to form one side of the angle, and its centre is placed at that point of the line from which the angle is to be drawn. A mark is then made on the paper as close as possible to the edge of the protractor, at that graduation which corresponds to the number of degrees required, and after removing the protractor, a line is drawn joining this mark and that point on

the line at which the centre of the protractor was placed. This line, together with the original line, which may be termed the base line, form an angle of the required number of degrees.

The circular protractor (Fig. 105) differs little from the

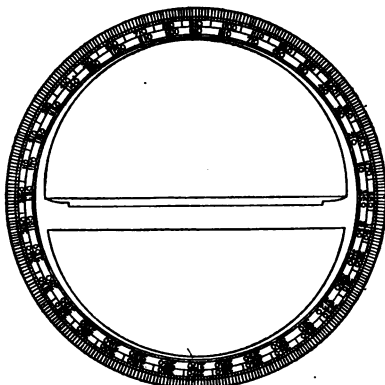

FIG. 105.

semicircular, but it admits of greater accuracy, and is much more convenient for plotting a series of angles.

To plot an angle with this protractor the feather-edged side of the cross bar is placed alongside the base line as before. It will then be seen that the graduations of the protractor which coincide with the line are zero (or what is exactly the same, 360) and 180. If the instrument is also graduated into the quadrants, each from 0 to 90, there will be a zero graduation at each end of the line. The angle is marked off as before described.

When the enclosing lines of an angle have to be produced to a considerable distance, a very slight error in marking at the edge of the protractor will result in a large discrepancy at the extremities of the lines. To ensure the marking being accurately performed, some protractors have an arm (Fig. 106) which rotates on the centre of the protractor, and which is provided with a needle point at the outer end which projects downwards. At the point where the arm crosses the protractor graduations

it is provided with a vernier, the zero of which is set at the angle required to be plotted. A light pressure is then applied to the outer end of the arm, which has the effect of pushing the needle point sufficiently far into the paper to leave a small puncture. A line joining this point and the centre of the protractor makes the required angle with the base line, with which it has been presumed the zero and the 180° graduations of the protractor have been placed in line.

Some protractors are provided with two vernier arms exactly opposite each other, in a straight line, the use of which will be seen later.

The most convenient protractor for plotting the general

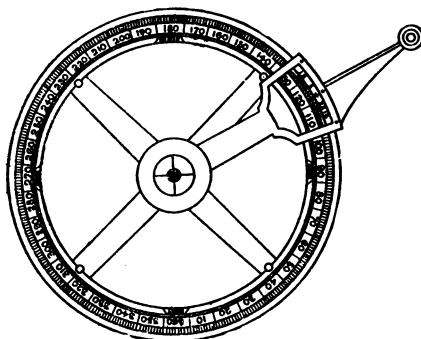

FIG. 106.

mine surveys is that constructed of cardboard (Fig. 107), and if properly made, it is, at least, more accurate than the brass circular protractor without the vernier arms. It consists of a piece of cardboard some 21 inches square, with a circle 16 inches in diameter, graduated to quarter degrees; the central portion of about 12 inches in diameter is cut away, thereby allowing the plotting to be done on the paper inside the circle without removing the protractor.

Plotting Triangulation Surveys.—To plot a triangulation survey the longest line—which is almost always the base line for the triangles—is first drawn on the paper and measured, the remaining sides of the main triangles, together with the tie

lines, are next drawn, and the other lines are plotted in the order in which they were taken. A practical example will best explain the procedure.

As a simple example, take the Field Book notes of the single

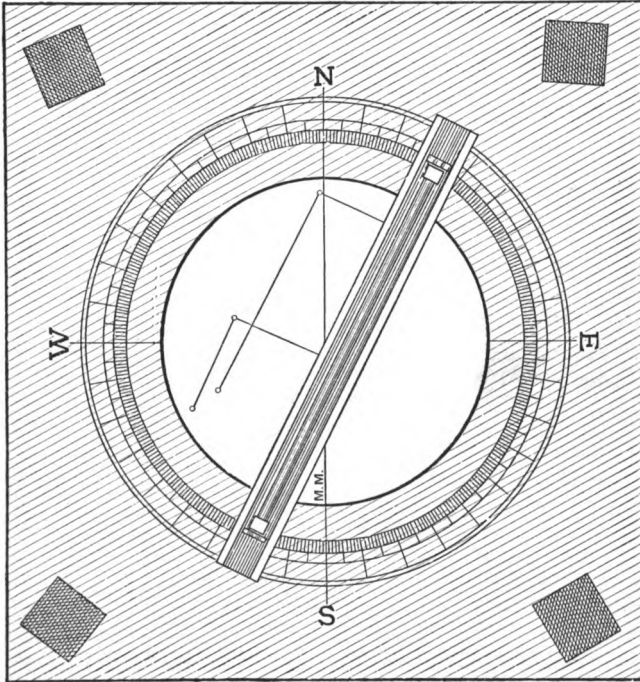

FIG. 107.

field on pp. 50 and 51. These notes and measurements which refer to the chain lines are reproduced below, those having reference to the offsets being omitted.

FIELD BOOK NOTES

CHAIN LINES ONLY

Line 7	526 00	(500 in 1) (686 in 5)
Line 6	866 00	(1170 in 1) (686 in 5)
Bearing E. Line 5	686 00	(00 in 6 and 00 in 7) (70 in 1)
Line 4	508 00	(775 in 1) (638 in 2)
Line 3	935 00	(00 in 1) (638 in 2)
Bearing W. Line 2	638 00	(00 in 3) (1170 in 1)
Bearing N.E.	1170 775 500	(00 in 2 and 866 in 6) (508 in 4) (526 in 7)
Line 1	70 00	(00 in 5) (935 in 3)
MEASUREMENTS IN LINKS		

Draw any straight line (see Fig. 108) on the paper, and having chosen the scale to which the plan is to be made, measure off the length of the main line. In the example given it is clear that line 1 is the main line of the survey, as indicated by its length and the stations upon it. The length of this line is 1170 links, to which length the first line drawn upon the paper is made to correspond. Next mark off the positions of the stations on this line, and write the measurements in pencil alongside their respective stations, so as to more quickly find the stations when other lines have to be drawn to or from them.

Number the line, and draw an arrow-head to indicate in which direction it was run. There is a note in the Field

Book to the effect that the bearing of this line is about N.E., from which basis an approximate N. and S. line, or meridian, should now be drawn.

There is just a possibility of the student marking the south end of the meridian line for the north, to guard against which it must be remembered that although N.E. and S.W. are in the one line their directions are diametrically opposite; and taking the case at issue, that line 1 would have been S.W. had it been run in the opposite direction.

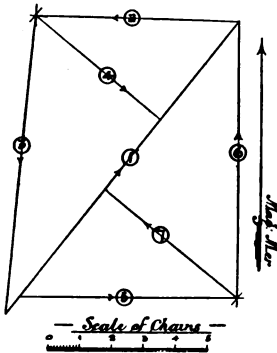

FIG. 108.

Referring to the field notes, it is found that line 2 commences from the end of line 1, and that line 3 commences from the end of line 2 and runs back to line 1. This clearly shows that lines 1, 2, and 3 form a triangle, which may be proceeded with at once.

It is, however, first necessary to know on which side of line 1 the triangle has to be formed; this is indicated by the approximate bearing of line 2, which is booked as W. thus showing that the triangle must be drawn on the left side of the main or base line.

The length of line 2 is 638, to which measurement a pair of pencil compasses are opened, and as this line commences at the end of line 1, this point is taken as a centre, and an arc is drawn to the left of the line. The compasses are next opened to the length of line 3, viz. 935, and as this line ends at the commencement of line 1 this point is taken as a centre, and an arc is drawn cutting the other arc. A line drawn from the point of intersection to the end of line 1 gives the correct position and length for line 2, and another from the point of intersection of the arcs to the commencement of line 1 gives the correct position and length for line 3. Line 4 is run from the end of line 2, which is also the commencement of line 3, to the station at 775 on line 1. By drawing an arc of the correct radius, or a line joining these two points, and applying the scale, it will be seen whether the lines have been measured

correctly or not, as the measurement on the scale should correspond to the length of the line, viz. 508.

Line 5 commences from the station at 70 in line 1, and runs in an easterly direction. Line 6 commences from the end of line 5, and runs back to line 1, which shows that these two lines form, with the base line, another triangle on the right side. This is drawn in a similar manner to the previous triangle, and line 7 is the tie line to check the work.

Each line is numbered and an arrow-head drawn to indicate the direction, and when all the lines have been plotted, they are inked in with blue or red colour. The offsets are then plotted in the manner previously described, care being taken to plot them on the same side of the line as they actually exist, this being shown by the offset measurements being in the right or left-hand column of the book, respectively.

The Field Book notes on page 103 are from the City and Guilds of London Institute Examination Paper for 1894. Only the full lengths and station measurements are given, the intermediate and offset measurements being omitted.

The principal line of the survey, as indicated by its length and the stations on it, is No. 6, though this line would in an actual survey be run first, and has been misplaced to render the plotting more difficult for the student. A straight line is drawn on the paper as before, and the length of the main survey line is measured off, as also are all stations on the line. By referring to the notes it is found that line 1 commences at the beginning of line 6 and ends at the beginning of line 2, also that line 2 ends at the last station but one on line 6. This shows that lines 1 and 2, together with part of line 6, form one triangle. Line 6 is N.E., and line 2, which runs towards the end of line 6, is S.E., so that a little consideration will show that line 2 must be drawn on the left of line 6. Line 1 must necessarily be to the left also, as it joins line 2, though the approximate bearing of line 1 is in itself insufficient to tell us this. Had, however, the approximate bearing of line 1 been given as N.N.E. instead of N.E., it would then have shown that this line had to be to the left of line 6. Lines 1 and 2 are plotted (see Fig. 109) so as to form a triangle with the base line, the apex of the triangle being fixed by drawing arcs with the compasses as previously described.

FIELD BOOK NOTES

CHAIN LINES ONLY

Line 8	282 00	(1388 in 2) (2935 in 6)
Line 7	1410 00	(00 in 5, and 2440 in 4) (1680 in 6)
Bearing N.E. Line 6	3586 3150 2935 1680 00	(660 in 3, and 00 in 4) (1622 in 2) (00 in 8) (00 in 7) (00 in 1, and 2125 in 3)
Bearing W. Line 5	2125 00	(00 in 1, and 00 in 6) (2440 in 4)
Bearing S.W. Line 4	2440 00	(00 in 5, and 1410 in 7) (660 in 3)
Line 3	660 00	(00 in 4) (1200 in 2)
Bearing S.E. Line 2	1622 1388 1200 00	(3150 in 6) (282 in 8) (00 in 3) (3253 in 1)
Bearing N.E. Line 1	3253 00	(00 in 2)
MEASUREMENTS IN LINKS		

Proceeding next with line 3 it is seen that it commences at a station in line 2 and proceeds to the end of line 1; a line is therefore drawn between these two points, and the scale is applied to ascertain if the measurement on the plan corresponds with the measurement given in the Field Book. Line 4 is written in the Field Book as commencing from the end of line 3. This has probably been done to cause the student unnecessary difficulty in plotting; it should have been written as commencing from the end of line 6, for although the ends of lines 6 and 3 are at the same station, line 6 is the more

important line, and the station should have been written as being on that line. This does not, however, affect the accuracy of the bookings, it is simply a question of convenience in plotting. Line 5 commences at the end of line 4 and runs back to line 1, from which it is concluded that lines 4 and 5 form another triangle with line 6, and from the bearing it is apparent that it is on the right hand of this line. Line 7

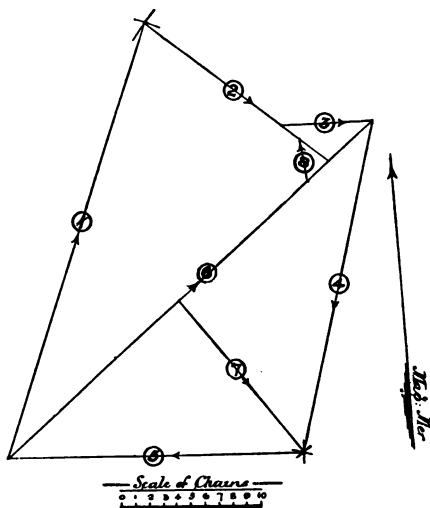

FIG. 109.

commences at an intermediate station on line 6, and runs to the end of line 4 and the commencement of line 5, which is the apex of the second triangle. A line is drawn between these two points, and the scale is applied as before to see if the plan and Field Book measurements correspond. Line 8 runs from a station in line 6 to another in line 2, with the plotting of which there is no difficulty.

Plotting Underground Surveys.—As has been previously stated, the plan upon which the underground survey is usually plotted has the surface, including the shafts, delineated upon it, and also a meridian line. The first survey

is then made from the shaft, and the plottings commence from this point; subsequent surveys, however, may be commenced from a known station. If, however, the survey is to be plotted upon a sheet of paper, which does not show the surface or any workings, then a line may be drawn in any suitable position and be adopted as the meridian line from which to plot the survey. The method of procedure now is, if plotting with a brass circular protractor, to apply the feathered edge side of the cross bar to the meridian line and mark off the centre with a pricker, then, after marking on the plan the N.S.E. and W. points, to commence to mark off on the paper round the edge of the protractor the bearings of the survey. To check the accuracy of the plotting the corresponding bearing on the other side of the protractor should also be marked, then the line joining the two points thus marked off should pass through the point which marks the centre of the protractor. Thus, if a bearing is N. 20 W., in addition to marking off this, the bearing S. 20 E. is also marked. When plotting the first angle of a survey, care must be taken that it is in the correct direction and is not drawn, say S.E. instead of N.W.

Fig. 110 shows how the bearings of the survey given on page 80 are marked off. The bearings and lengths are as follow:—

BEARINGS	LENGTHS
(1) N. 27 E.	1325 from downcast shaft
(2) S. $65\frac{1}{2}$ E.	531
(3) S. $23\frac{5}{8}$ W.	900
(4) N. 64 W.	692
(5) S. $23\frac{3}{4}$ W.	600 to upcast shaft

The first bearing N. 27 E., and the corresponding bearing S. 27 W., are marked off with the pricker, and the figures 27 are pencilled near the marks on each side, so that they may be easily found, the same thing being done with the other bearings; the protractor is then removed, and we have the markings on the paper as shown in the figure, the dotted lines showing the position which the protractor occupied.

Now, if the positions of the shafts are not already denoted on the paper, a point (A, Fig. 111) is chosen in proximity to the

markings to denote the downcast shaft, and the plottings are commenced from this point. A parallel ruler is applied to the two points of the corresponding bearings of the first sight, viz. N. 27 W. and S. 27 E., and if the centre point of the protractor is in the same line, the bearing may be considered as correctly marked, and the parallel ruler is moved along the paper to the mark A, which has been made to denote the shaft, and a line is drawn from this point in a north-easterly direction, that is, towards B. The length of the line is then marked off by means of the scale to which it has been decided to plot the survey, and another line is then drawn from the end of the first,

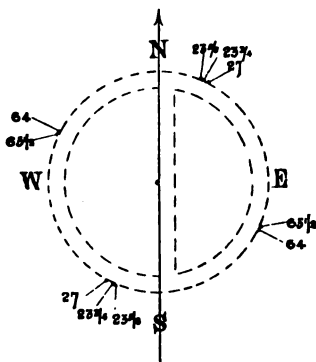

FIG. 110.

parallel to the line joining the markings $65\frac{1}{2}$, in the same manner as the previous line was obtained. The line is marked off to the required length, and so on with the other angles.

If when plotting a survey on a plan the meridian line is a distance away from the part in which the angles have to be plotted, a line is drawn parallel to the meridian line nearer, or even better, upon that part, and the protractor is applied to this line,

for if a number of lines be paralleled for a distance of several feet discrepancies are sure to arise.

To plot a survey with the cardboard protractor, a meridian line is drawn over that portion of the plan at which the survey is to be plotted, and the protractor is placed so that the north and south line coincides with the meridian line, and to prevent it from moving plan weights are placed at each corner (see Fig. 107); the survey is then plotted on the plan on the space inside the graduated circle where the central portion of the card has been cut away. To plot an angle the parallel ruler is placed at the bearing, and on the corresponding bearing opposite, and is then parallel to the station shown on the plan from which the survey was commenced; a line is then drawn and

the length marked off, and all subsequent bearings are plotted in the same manner. It is advisable to mark the centre of the protractor by drawing an east and west line, so as to intersect the meridian, or north and south line, so that a check may be obtained on the plotting. This method is very accurate and expeditious, and the plan is kept clean, as no marks other than the bearing lines have to be made upon it. Having plotted the sight lines, these are inked in red or blue colour, as with surface chain lines, and the lines representing the sides of the road would be drawn in their correct positions afterwards.

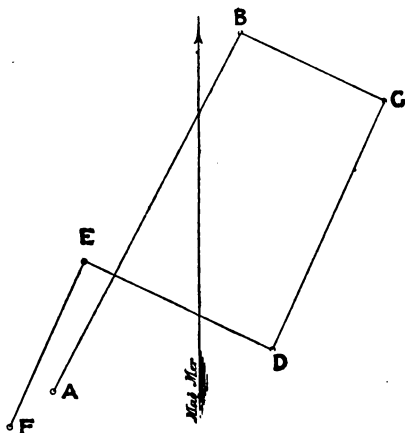

FIG. 111.

In the "pillar and stall" method of working the roadways are usually cut to some approximate definite width throughout the whole of the mine, or all the levels may be cut to one width, and the "brows" to another. In making a survey underground, therefore, a note is made, in the first instance, as to the width of the roads, and they are plotted on the plan accordingly. It would be out of the question to take offsets at every slight irregularity in the road, so that for roads of ordinary width it is assumed that the sides are straight from one station to the next. When, however, a sight has been taken to the extremity of a road, and is not in the centre, it

is advisable to take offsets from the station to each side, and to plot them correctly on the plan. The importance of this would be seen when the roads had extended and the next survey was plotted.

In "long-wall" work the "face" is drawn about one yard from the sight line, and offsets should be taken and plotted of such places as greatly exceed this amount.

CHAPTER XIV

THE CALCULATION OF AREAS

The Standard Measure of Area.—Mine and land areas are usually expressed in acres. A *statute* acre contains 100,000 square links or 10 square chains, which expressed in square yards = 4840. One square mile contains 640 statute acres.

In some mining districts the Cheshire acre, which contains 10,240 square yards, is adopted as the standard of area. The following tables show the difference between the statute and Cheshire measures of area :—

STATUTE MEASURE	CHESHIRE MEASURE
1 acre = 4 roods	1 acre = 4 roods
1 rood = 40 perches	1 rood = 40 perches
1 perch = $30\frac{1}{4}$ sq. yds.	1 perch = 64 sq. yds.

To convert statute acres to Cheshire acres, multiply by 121 and divide by 256, and *vice versa* to convert Cheshire acres to statute acres, multiply by 256 and divide by 121.

To reduce square links to statute acres, all that is required is to move the decimal point five places to the left, and the area is then given in acres and decimals of an acre. The following examples will explain this :—

7,685,463 sq. links	=	76·85463	acres
432,681·5	„	=	4·326815 „
2479	„	=	·02479 „

The decimals of an acre can be reduced to roods by multiplying

by 4 and cutting off the same number of figures as decimals, as there were before, which decimals can be reduced to perches by multiplying by 40 and cutting off the decimals. For example, to express 76·85463 acres, in acres, roods, and perches.

$$\begin{array}{r}
 76\cdot85463 \text{ acres} \\
 \hline
 4 \\
 \hline
 3\cdot41852 \text{ roods} \\
 40 \\
 \hline
 16\cdot74080 \text{ perches}
 \end{array}$$

76 acres 3 roods 16·7408 perches

Casting by Triangles.—The simplest method of finding the area of an irregular figure is to divide it into triangles,

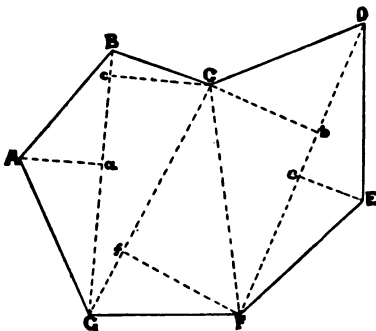

FIG. 112.

calculate the area of each triangle, and add the results together. As an example, take the irregular polygon, ABCDEFG (Fig. 112). This may be divided into five triangles by joining BG, GC, CF and FD. The area of each triangle could then be calculated after first finding the length of each side (see Prob. V. Chap. IV.); but the best method is to drop a perpendicular from the apex of each triangle to its base, and calculate the area by multiplying the base by half the perpendicular, in each case the lengths being found by the scale.

For example, find the area of the polygon, the lengths of the bases and perpendiculars being given as follow :—

$$Aa = 9 \quad GC = 28.4 \quad FD = 35$$

$$GB = 29 \quad Ff = 14.5 \quad Ee = 7.4$$

$$Cc = 11 \quad Cb = 13$$

$$Aa = 9 \quad GB = 29$$

$$\frac{9}{2} \times 29 = \underline{130.5} \text{ area of AGB}$$

$$Cc = 11 \quad GB = 29$$

$$\frac{11}{2} \times 29 = \underline{159.5} \text{ area of BGC}$$

$$Ff = 14.5 \quad GC = 28.4$$

$$\frac{14.5}{2} \times 28.4 = \underline{205.9} \text{ area of GFC}$$

$$Cb = 13 \quad FD = 35$$

$$\frac{13}{2} \times 35 = \underline{227.5} \text{ area of CFD}$$

$$Ee = 7.4 \quad FD = 35$$

$$\frac{7.4}{2} \times 35 = \underline{129.5} \text{ area of DFE}$$

$$130.5$$

$$159.5$$

$$205.9$$

$$227.5$$

$$129.5$$

$$\underline{\underline{852.9}} \text{ area of ABCDEFG}$$

This method of calculating areas is seldom adopted by the surveyor, as it necessitates a large amount of work, especially in the case of a many sided figure, the result also is not satisfactory, as assuming even only a very slight discrepancy in each figure the aggregate of errors would be considerable.

Casting by Equalising.—The best method of casting out areas is that known as “equalising,” which is based on Euclid’s proposition of “triangles on the same base and between the same parallels are equal.” The method consists in constructing a triangle equal to the figure, the area of which is required, and by calculating the area of the triangle the area of the

figure is found. For example, assume that the area of the quadrilateral figure ABCD (Fig. 113) is required.

Produce BC towards E. Join AC, through D draw DF parallel to AC, and join AF. Then the triangle ABF is equal in area to the quadrilateral figure ABCD. The area of the triangle can be found by dropping a perpendicular from the apex A to the base BE, and by multiplying the base by half the perpendicular height.

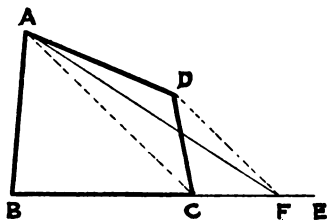

FIG. 113.

Take the polygon ABCDE (Fig. 114) as a further example. Produce BC both ways. Join EC, and through D draw DG parallel to EC. Then join EG, and the quadrilateral figure ABGE is equivalent to the polygon ABCDE. The question is now resolved into constructing a triangle equal to the quadrilateral figure ABGE. Join EB, and through A draw AF parallel to EB. Join EF, and EFG is the required triangle, equivalent to the polygon ABCDE.

In actual practice none of the lines, except those forming the triangle, are drawn, so that the method is not so confusing

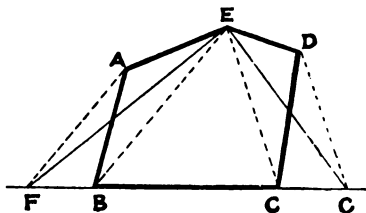

FIG. 114.

as would at first appear, and the writer will endeavour to explain the actual procedure. Take the polygon ABCDEFG (Fig. 115) as an example. This polygon is the same as that given in Fig. 112. Any side of the figure may be taken and produced to form the base of the required triangle. Produce, say DE, indefinitely both ways. Now take a pricker in the right hand, and place the left hand on the parallel ruler at the centre, so as to be able to move it in any required direction. Place the pricker at the point D, and move the ruler until its edge is in line with D and the second bend of the figure, viz. B.

This is done quickly and correctly by first placing the right hand side of the ruler against the pricker, and then moving the left hand side until its edge is at the point B. The ruler being held in position by the pricker at one side, it is necessary to look only at the other, and thus much time is saved. The edge of the ruler being in the line BD, draw it gently down until its edge reaches the point C—the first bend from the point of commencement. Next, remove the pricker from the point D, and insert again at that point in the line HI where the ruler, when drawn to C, crosses. This will be found to be

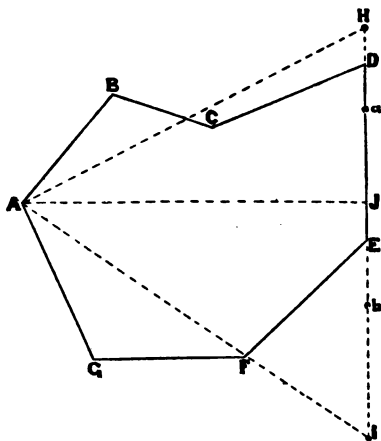

FIG. 115.

at a . In other words, a straight line joining B and D would be parallel to a straight line joining C and a . Now place the ruler in line with A (*i.e.* the third bend) and a , and removing the ruler, push the ruler back until its edge is at the point B. The ruler then crosses the line HI at H, where a mark is made with the pricker, and a line drawn from A to H. The five-sided figure AHEFG is then equal to the seven-sided figure ABCDEFG. It remains to construct a triangle equal to this five-sided figure. Commence by inserting the pricker at the point E, and place the ruler in a line with this point

and the second bend G. Then draw the parallel ruler down to the first bend F, and the point where it will cross the base line will be *b*. Again insert the pricker at *b*, and place the ruler in the line *Ab*, and parallel back to G. The crossing of the ruler on the base line will then be I, and a line is drawn joining AI. AHI is then the triangle required. The course adopted to construct this is simply as follows:—Take the point where the proposed base line touches the figure. Place the ruler to the second bend, and parallel back to the first; next to the third, and back to the second, and so on, no matter how many sides the figure may have. Although the description of the construction of the triangle has taken some time, and may appear intricate, yet after a little practice the student will be able to construct a triangle from which to ascertain the area of a many-sided figure in a few seconds. Let the reader construct a polygon similar to that given in Fig. 115, and try to follow the routine given. He might afterwards test the accuracy of his work by dividing the figure into triangles, as by Rule 1, and ascertain its area in that manner. Now it is still required to find the area of the triangle AHI. Drop a perpendicular (AJ) from the angle A to the base, and with the scale measure HI and AJ. HI is found to measure 45, and AJ 37·9.

$$\frac{45 \times 37.9}{2} = \frac{1705.5}{2} = 852.75$$

The area, as found by the other method, was 852·9.

Casting by Ordinates.—There is still another method of ascertaining areas which is useful when the area is required from the figures in the Field Book notes without recourse to a plan. It is, however, only applicable to small surveys, principally those surveyed with one chain line only, as the calculations necessary in the case of a large triangulation survey would be too numerous to admit of its use. As an example of how the calculations are made, assume that the area of the field given in Fig. 75 p. 44 is required from the Field Book notes. The notes are reprinted on the following page.

Reference to the figure will show that the chain line with the offsets divide the field into a number of trapezoids and triangles, the areas of which may be calculated from the figures given.

To calculate the area of a trapezoid, half the sum of the two parallel sides is multiplied by the perpendicular distance between them. In this example the offsets represent the two parallel sides, and the included length on the chain line the perpendicular distance between them.

To find the area of each of the triangles the included length of the chain line must be multiplied by half the perpendicular.

The figures on the left hand of the chain line have been first dealt with. The chain crosses the hedge at 20 and at 55, there is a left hand offset of 56. A right-angled triangle is thus formed with a base of $55 - 20 = 35$, and with a perpendicular of 56. The area of this triangle is then found by multiplying 35 by 56 and dividing by 2. All the totals have first been added together and divided by 2 afterwards. No. 2 figure is formed by a distance included between 55 and 190 on the chain line, the two offsets 56 and 76, and the line joining the extremities of these offsets. Nos. 3, 4, 5, and 6 are similar and present no difficulty. In No. 7 it will be seen that the last offset, namely 78, is taken from a point on the chain line which is outside the field, as the hedge was crossed at 783. We may, however, calculate the full area of this trapezoid and afterwards deduct the excess portion, which will be a triangle with a base equal to the difference between 783 and 824, and with a perpendicular of 78 (see Fig. 75). This deduction has been calculated in No. 8. Nos. 9 and 15 are triangles, and Nos. 10 to 14 trapezoids, all on the right hand of the chain line. The total products have been divided by 2 to obtain the correct area in links, and divided by 100,000 to reduce them to acres.

CHAPTER XV

MISCELLANEOUS

Setting out Roadways.—It is of the utmost importance for the economic and proper working of mines that the main roads, especially haulage roads, should be kept straight. It also often happens that it is deemed necessary or advisable to

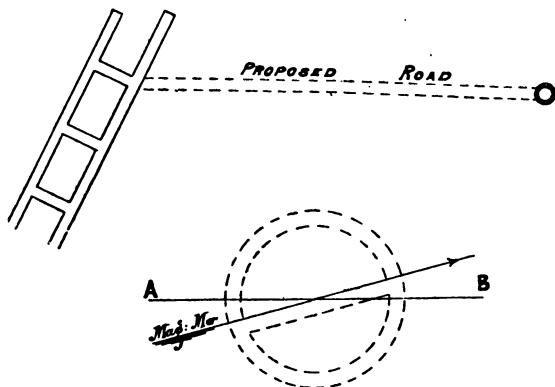

Figs. 116, 117.

drive a road or tunnel from one particular point to another to facilitate the haulage or ventilation, and the manner in which the direction of the road is determined is as follows:—Assume that the required road is one between the underground road and the shaft (Fig. 116). Draw a line (AB, Fig. 117) parallel to the

required road on the meridian line, which we presume to be already on the plan. Now take a brass protractor, and place the N. and S., or 0° and 180° , so as to coincide with the meridian line, and with its centre at the point of intersection of the meridian line and the line AB, as shown by Fig. 117. The bearing of the line (AB) can now be read off from the protractor. The bearing can be found with a cardboard protractor with equal facility, by placing the N. and S. of the protractor as before on the meridian line, next finding the centre of this line by joining the W. and E. points, and then through the centre thus found drawing a line parallel to the proposed road, the bearing can now be ascertained by laying a ruler or straight edge along this line and reading off the bearing which it makes on the protractor. Having now determined the magnetic bearing of the required road, the next consideration is the setting out of the road in the correct direction.

This is done by means of a dial or theodolite. The new road is usually cut for a few yards in the probable direction, so as to give space for operations, and the dial is fixed under the

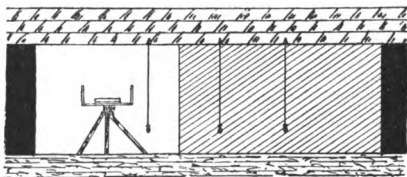

FIG. 118.

point from which the road is to be commenced, as shown by Figs. 118 and 119. The needle of the dial is now allowed to assume its true magnetic position, and when it has settled, the dial is turned round until the bearing read off by the needle on the graduated face is exactly similar to the bearing of the proposed road, and the dial is clamped in this position. "Sight lines" are now set out with the dial in the following manner:—The surveyor looks through the narrow slit at the S. end of the dial farthest away from the new road, and with the dial clamped in its original position, he directs an assistant, who holds a plummet suspended by a string, to some such point that the

string is in the exact line with the vertical hair of the other sight, and a mark is made on the roof at this place. At least two other similar points are determined at a short distance from each other, as shown, and by suspending plummets from these, it can immediately be determined whether a light held at the centre of the face of the workings is exactly in the same line. Thus, by frequently taking observations, the road may be kept absolutely straight in the required direction. If the roadway is comparatively short, and a definite direction need not be maintained to a high degree of accuracy, the points or

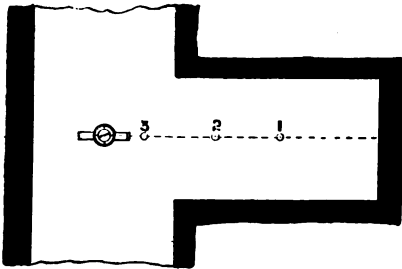

FIG. 119.

positions of the sight lines are marked in chalk, and plummets are placed under these points from time to time; but if greater accuracy is required, wooden plugs are inserted in the roof, and spikes should be driven into them. The lower end of the spike is provided with an eye-hole for the insertion of the string. If the roof of the mine is soft and friable, it may become necessary to drive the spikes into the supporting bar timbers, but as these are apt to move from time to time through the pressure of the roof, it is essential that the lines should be frequently checked.

Theoretically two sight lines are sufficient to sight the road correctly, but there should always be three, so that if one happens to get wrong it can be detected immediately. When fixing the sight lines the first should be placed as far away from the dial as the string can be conveniently seen. The second sight line should be situated midway between the dial and the first, and the third immediately near the dial.

To keep a tunnel at a given inclination, the instrument shown by Fig. 120 is often used. To the centre vertical piece is attached a plummet, and the lower piece is set at the angle of inclination at which it is required the tunnel should be driven. The illustration represents the proper dimensions and angle for an inclination of one in six, the length of the main horizontal beam being 6 feet, and the distance from the bottom of the inclined beam being 1 foot.

Descriptive Signs on Colliery Plans.—There is a certain amount of uniformity adopted in the construction of all

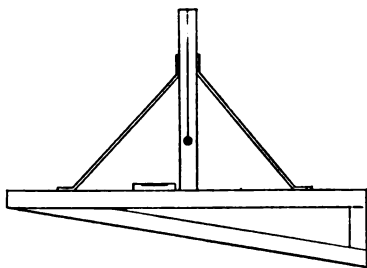

FIG. 120.

plans, so that any one with a slight experience can understand what certain signs indicate. Thus quick fences are indicated by firm lines; ditches, the edges of grass plots, footpaths, and in fact anything not strictly defined, are indicated by dotted lines; post and rail fences by dash and dot lines; curbstones by

thick dash and dot lines; ponds and watercourses by wavy lines, or by blue colour; brick or stone buildings by shading with parallel lines, or by a pink colour; wooden buildings by shading with parallel dotted lines, or by dark gray colour; greenhouses and similar glass edifices, by two series of parallel lines drawn rather wide apart, and at right angles to each other, in addition, sometimes coloured blue; surface roads are often coloured brown (burnt sienna); the boundaries of each estate are indicated by an edge of colour.

It is best to avoid all colour for indicating the surface, except for boundaries of the estates, when the underground workings have to be put on the same plan, because it is usual to colour all the workings, and the surface buildings are then rendered indistinct. When mine royalty is paid on the area of mine gotten, a different colour is used to indicate the area "gotten" each royalty measurement. Main "intake" air courses are coloured blue, and "returns" red, both sufficiently dark to show up

above the other colours. Faults are indicated by red lines with black dotted lines some distance on each side, the distance being determined by the size of the fault; the space between the dotted lines and the red lines is coloured dark gray, and the area thus occupied is allowed for and omitted in the royalty measurements. The size of the fault should be indicated by figures alongside, and its direction by an arrow, the arrow-head being on the down side.

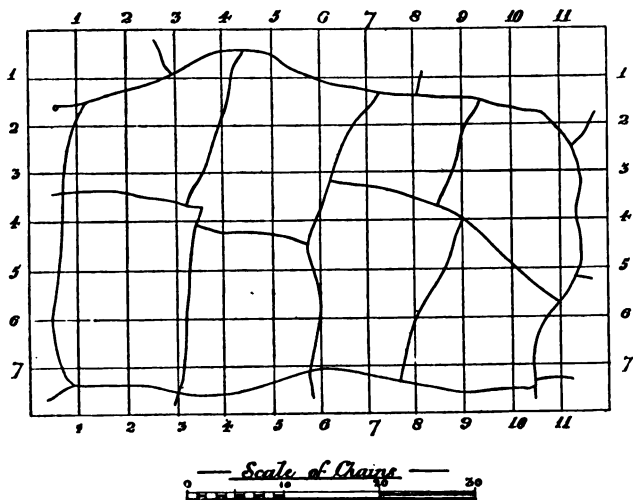

FIG. 121.

Reducing and Enlarging Plans.—It is sometimes required to reduce or enlarge a plan from one scale to another. Enlarging plans is at best very unsatisfactory, but a plan may be reduced with the utmost accuracy. The method most usually adopted for either reducing or enlarging is to divide the original plan into a number of squares of some definite size, and to draw an equal number of squares on the paper upon which the new plan is to be plotted, of the proportionate size to the other squares, as it is required to reduce or enlarge the plan (see Figs. 121 and 122). That is to say, if it were required to reduce a

plan from a scale of 30 yards to an inch to one of 40 yards to an inch, and it were decided to make the squares on the original 1 inch square, the squares for the new plan should be drawn three-quarters of an inch square. Or, to put it in another way, one side of an inch square on the original would represent 30 yards, and to make one on a 40-yard scale to represent a like amount, it would necessarily be three-fourths of an inch. Each square is then filled in so as to correspond with the original, measurements being made from the corners of the squares to the points where the lines of the plan cross the sides of the square, and to all

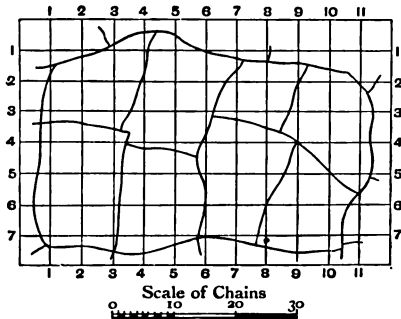

FIG. 122.

bends. Of course one scale is used for taking the measurements from the original plan, and another for plotting on the new one. Proportional compasses save much labour in such work, as they can be set to any two scales, so as to give the correct proportion for every measurement. After having been adjusted for the two scales required, if the compasses are opened to a definite width at one end to get off the length of a line, the opening at the other end represents the correct length of the line to the other scale. It is found convenient to number the intersecting lines forming the squares correspondingly on each plan, thus enabling any particular point to be found more quickly.

To set out a Right Angle with the Chain.—Along the line on which it is required to erect the perpendicular, measure 40 links; for the perpendicular take 30 links on the

chain, hold one end at the main line at the beginning of the 40 measurement, and with the chain stretched taut draw an arc of a circle with the radius of 30 links. The arc can be marked on the ground with a piece of chalk, or an arrow held at the end of the chain. Now take 50 links on the chain, hold one end at the further limit of the 40 measurement, and find the point where the 50 measurement will just cut the arc drawn on the ground. A line drawn from this point to the beginning of the 40 measurement is at right angles to the main line.

Any multiples of 3, 4, and 5 may be used to form a right-angled triangle. Thus the lengths 9, 12, 15, or 12, 16, 20 may be employed. That these lengths will correctly form a right-angled triangle can be proved by the proposition that the hypotenuse squared equals the squares on the base and perpendicular. Thus—

$$5^2 = 3^2 + 4^2; \quad 25 = 9 + 16$$

$$15^2 = 9^2 + 12^2; \quad 225 = 81 + 144$$

Setting out Railway Curves.—Curves are usually set out in radii of chains, though, of course, any radius may be used. If the curve is not a very sharp one, that is, if it is of large radius, the simplest method of ranging it out upon the

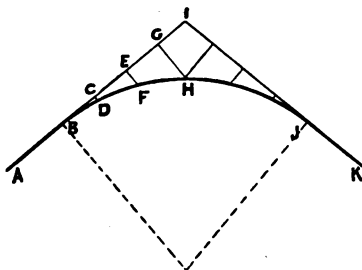

FIG. 123.

ground is to produce the lines representing the straight portions of the railway to meet in a point, and to range out offsets at definite distances along each of these lines. For example, let AB and JK (Fig. 123) be the straight portions of the railway which it is proposed to connect by a curve. Produce AB and

JK to meet in I; along BI measure off a number of equal parts BC, CE, EG, and in a similar manner measure off a number of equal parts along JI. Then range out offsets at right angles to AI from the points C, E, and G, and similar offsets at right angles to JI from the points of division. The length of each offset may be ascertained by plotting the whole on paper, and by applying the scale to each of the lines CD, EF, GH, etc. For sharp curves a better method is to divide the curve into an equal number of arcs, and to range out the offsets from the

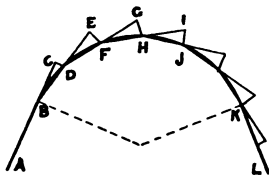

FIG. 124.

chords of the arcs produced. For example, AB and KL (Fig. 124) represent the straight portions of a railway which are to be connected by a curve of a definite radius. Divide the curve into an equal number of arcs BD, DF, etc., and draw a chord to each arc. Produce AB to C, and make BC

equal to the chord BD, and join CD; produce BD to E, make DE = BD or DF, and join EF, and proceed with the remainder in the like manner. The length of the offsets CD, EF, etc., can be found by measuring on the plan, or can be calculated as follows:—

Let R represent the radius of the curve.

$$\begin{aligned} \text{Then CD} &= \frac{BD^2}{2R} \\ \text{and EF} &= \frac{BD^2}{R} \end{aligned}$$

The first and final offsets are exactly half of the intermediate offsets, all of which are equal. To state the formula generally—

$$\text{First offset} = \frac{(\text{Length of Chord}^2)}{2 \text{ Radius}}$$

$$\text{Intermediate offsets} = \frac{(\text{Length of Chord}^2)}{\text{Radius}}$$

Ex. What lengths of offsets are required to set out a curve with 10 chains (220 yards) radius with offsets every ten yards.

$$\text{First offset } \frac{10^2}{2 \times 220} = \frac{100}{440} = \cdot 2272 \text{ yards}$$

$$\text{Intermediate offsets } \frac{10^2}{220} = \frac{100}{220} = \cdot 4545 \text{ yards}$$

It will be noticed that the offsets are not right-angle offsets, but that they form the base of an isosceles triangle.

CHAPTER XVI

LEVELLING

LEVELLING is the finding of a line parallel to the horizon at one or more stations, in order to determine the height or depth of one place in relation to another. There are two methods of performing this, viz. the trigonometrical and the geometrical.

The Trigonometrical Method.—By this method either the length of the line joining the two points of observation, or the horizontal distance between them is measured, and the angle between the two lines is taken with an instrument. The difference in height of the two objects can then be found by trigonometry, or by plotting the angle and measurement. For levelling by this method a clinometer, dial, theodolite, or, in fact, any instrument having a vertical graduated arc may be used. The general principles of the trigonometrical method have been described in Chapter VI on Inaccessible Heights and Distances.

The Clinometer.—Where great accuracy is not required, observations may be made with a clinometer, as this is a very portable instrument, and is easy to manipulate.

In its simplest form (Fig. 125) it consists of a square piece of wood, to which is attached a graduated arc, which has for its centre a corner of the square. From this corner is suspended a light plummet, which being free to swing, will always assume a vertical position. If the lower edge of the square be placed so as to correspond with the inclination of the object, the degrees of dip will be shown by the cord of the plummet crossing the graduations of the arc, thus the reading in the illustration gives an inclination of 28 degrees.

A much more elaborate and accurate form of this instrument is that shown by Fig. 126. It consists of two pieces joined at

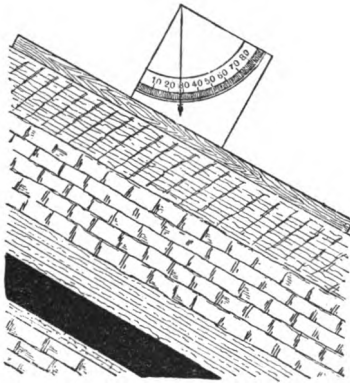

FIG. 125.

the end like a two-foot rule, and provided with a graduated arc for reading off the angle of opening made by the two pieces. If the difference in level of two points in a regularly inclined plane is required, or what is practically the same, the inclination or dip, the clinometer is placed so that its lowest edge corresponds with the inclination of the plane, and the upper piece is gradually raised until it has assumed a horizontal position, which can be

ascertained by means of the spirit level which is attached to the top. The angle which the plane makes with the horizon can then be read off from the graduated arc, and the bearing of the observation can be taken by means of the small magnetic compass which is fitted to the lower arm of the instrument.

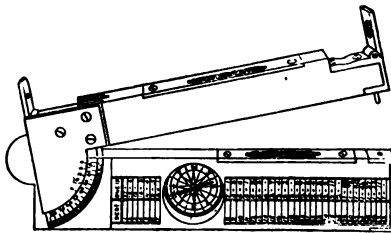

FIG. 126.

If an observation is required to ascertain the height of an object above a given point, and the horizontal distance between them can be measured, the mode of procedure is slightly varied.

The instrument, with the arms closed, is made to assume a truly horizontal position at one of the points of observation, and the upper arm is then raised until a sight taken through the sight vanes, fitted at each end of the arm, coincides with the other point of observation, and then the angle is read off as before. A note must be made of the height of the instrument when taking the observation, as it is so much higher than the point from which the observation is required ; or in lieu of this, the

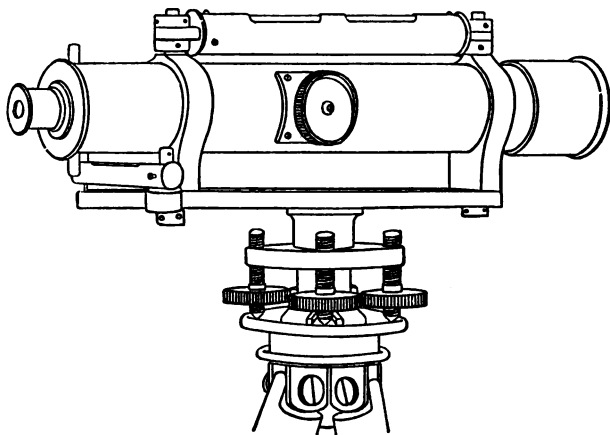

FIG. 127.

sight may be directed to an object placed the same height above the point of observation as the height of the instrument. The same also applies to observations made with the dial or theodolite.

The Geometrical Method.—This is the most accurate method, and consists of constructing a horizontal line with a spirit level fitted to a telescope, and making vertical measurements to the points required from this horizontal line.

The Dumpy Level.—The instrument most generally used for this purpose is the dumpy level (Fig. 127). It consists of a long spirit level accurately fitted to a sight telescope, which is provided with an eye-piece at one end, and with an object-glass at the other. It also contains a diaphragm (Fig. 128), which is

provided with two vertical and one horizontal cross wires or webs. A small cross spirit level is also attached to facilitate the adjustment. The telescope is provided with a focussing arrangement, worked by a large milled head screw on the side, which works a rack and pinion, thus altering the focal length of the instrument by sliding the inner tube in or out as required. The telescope is connected rigidly with a horizontal bar, which is provided at its centre on the under side with a hollow vertical cap. This cap screws on to a vertical spindle which passes through the upper of two parallel circular plates and terminates in a ball and socket joint. The parallel plates are held together by the ball and socket joint, and the lower plate screws on to the head-piece of the tripod stand. Between the parallel plates are four screws which simply rest on the lower parallel plate, but screw into the upper one. To level the instrument, two of these screws, viz. two alternate ones, are manipulated at once, and are turned in opposite directions; this lowers the upper parallel plate at one side, and raises it at the other, the screws being turned until the plate has been brought to the correct position. The correct position is found when the bubble of the spirit level, which is in the same line

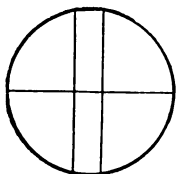

FIG. 128.

as the screws which are being manipulated, is exactly in the centre. This only levels the instrument in one direction, the other two screws being brought into requisition to level it in the other. The long spirit level will, of course, show more accurately than the short one whether the instrument is truly levelled; so that after approximately levelling the instrument transversely with the

small cross level, the telescope should be turned round to a position at right angles to that in which it was first placed, in order that the adjustment in both directions will be finally effected with the longer spirit level.

Simple Flying Levels.—If the difference in level of two points A and B (Fig. 129) is required, not a considerable distance apart, the instrument is set up at any intermediate station that may be convenient for seeing both points of observation. The telescope is made to assume a horizontal position by means of the adjusting screws on the lower part of the instrument, and a sight

is taken in the direction of a graduated staff which is held at A. The staff is held in a perfectly vertical position, and the height where the cross-hair appears to cut the staff is read off, the markings of the staff being such that the height can be read through the telescope. The staff is then held at B, the telescope is turned round, and the point where the cross-hair cuts the staff is again read off. To ascertain the difference in level of the two points, the lesser of the two readings is subtracted from the greater. Assuming the reading at A to be 11·76 and at B 9·26, the difference in level between these two points will be 2·5.

Simple Section Levelling.—If a section of the ground between the points A and B was required, it would be necessary to take intermediate sights as shown at *a*, *b*, *c*, *d*, and *e*, where any change in the inclination occurs. Horizontal measurements must also be taken, so as to fix the position of the sights. The following is a method of recording the observations:—

LEVELS OF GROUND FROM A TO B (Fig. 129)

DISTANCE IN FEET.	SIGHTS.			RISE.	FALL.	REDUCED LEVELS.	REMARKS.
	BACK.	INTER.	FORE.				
0	11·76	10·00	A
7·3	...	10·92	...	·84	...	10·84	<i>a</i>
20·5	...	5·78	...	5·14	...	15·98	<i>b</i>
26·2	...	4·96	...	·82	...	16·80	<i>c</i>
35·5	...	5·20	·24	16·56	<i>d</i>
45·8	...	8·90	3·70	12·86	<i>e</i>
54·8	9·26	...	·36	12·50	B
	11·76			6·80	4·30		
	9·26			4·30			
	2·5	Difference		2·5			
		and 12·5 - 10 = 2·5 the reduced rise					

The first sight to A is a back-sight, and is booked accordingly. The next sights to *a*, *b*, *c*, *d*, and *e* are booked as intermediate sights, and the sight to B is termed the fore-sight. The first four columns denoting the distances and the sight readings, and also the last column of remarks, are booked while the work is

proceeding, and the other three columns are worked out and the totals found after the work is completed. The rise and fall calculations are made by simply taking the difference between each sight and the one preceding. When a reading is less than that of the preceding sight, the difference is booked as a rise. For example, the first sight is 11.76 and the second 10.92, then the second sight has a rise of $11.76 - 10.92 = .84$. Again, the sight to *d* is 5.20, and to *e* is 8.90, therefore there is a fall from *d* to *e* of $8.90 - 5.20 = 3.70$.

Before proceeding to fill in the column of reduced levels, a datum is chosen 10, 20, or 100 feet below the first reading, and the reduced levels are calculated to this datum line. The reason for this is, that the first observation or fore-sight is not necessarily

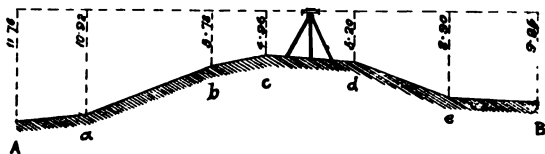

FIG. 129.

the lowest point of the series of levels, as happens to be the case with those recorded above, and if a datum line was adopted at this level, some observations might fall below the datum line, and would require a minus sign in the reduced levels. It is therefore expedient to adopt such a datum line, some distance below the first observation, as the circumstance requires.

In the levels recorded a datum line 10 feet below the first fore-sight is adopted, so that the first sight would be booked in the reduced level column as 10. The second sight to *a* has a rise of .84, as previously calculated; therefore the reduced level for this point is $10 + .84 = 10.84$. For the next point the rise 5.14 is added to the 10.84, and the next is reduced in a similar manner. To ascertain the reduced level for the point *d*, however, the fall .24 is subtracted from the reduced level of the previous sight, and the next two sights are treated in the same manner. The difference of the fore-sight and back-sight, of the falls and rises, and of the assumed datum and the reduced level

of the last observation, will always furnish a check to the calculations. These three remainders should be equal.

Compound Flying Levels.—If the distance is too great, or there are too many irregularities in the surface of the ground to render it possible to do the work by one setting of the instrument, a series of operations connected with each other must be made. For example, if it be required to ascertain the difference in level between the points A and M (Fig. 130), the instrument must be set up a number of times, and the levels taken so that they will form a continuous series. Assuming the starting-point to be A, the staff is held at this point, and the surveyor proceeds towards M (not necessarily in a straight line),

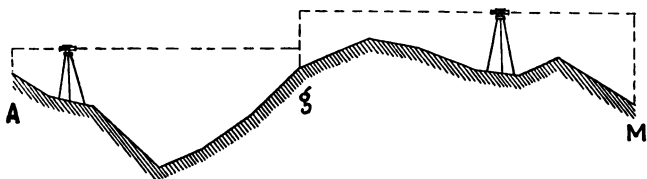

FIG. 130.

and sets up the instrument in some such position as shown, and at such a distance from A as he deems convenient for taking a sight to that point. A sight is now taken to A, and the reading is booked in the back-sight column. The assistant then takes the staff on towards M as far as it can be seen with the level, say to *g*, an observation is made, and the reading is booked as a fore-sight. The instrument is then removed and set again as shown, the staff is not disturbed, however, from the point *g*, until a back-sight is taken from the instrument as set up in its new position, as the accuracy of the work depends upon the staff being retained at the same height, while the position of the instrument is being changed. The back-sight having been taken, the staff-bearer proceeds in the direction of M, and holds the staff at that point, when a fore-sight is taken, and the instrument is again moved. The series of operations thus proceed for any number of times according to the distance and nature of the ground. This is what is termed a "flying survey," and only enables the difference in level between any definite points to be calculated without any relation to the ground between them. When a series of

levels have been taken to form a section, the accuracy of the work is usually checked by flying levels taken from the two extreme points. For example, Fig. 131 represents the operations necessary for making a section of the ground lying between A and M, while Fig. 130 represents how a check would be taken by flying levels back again from M to A. It is unnecessary that the back- and fore-sights, other than the extremes A and M of the repetition survey, should be in the same positions as were taken in the section levels, as we have shown it in the figures; in fact, flying levels might be taken over entirely new ground, the only requirement being that the difference between the levels of the

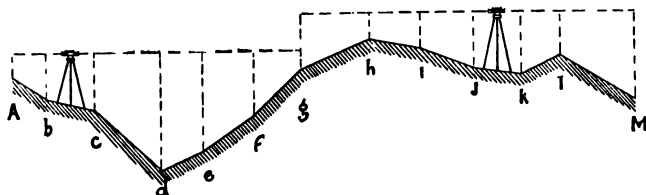

FIG. 131.

two extreme points be found, and if this approximately agrees with the difference as calculated in the section levels, the survey could be accepted as correct. If the position of the back-sights and fore-sights were the same in the flying as in the section levels, it would facilitate matters, in case an error had been made, as it could be ascertained at what setting of the instrument the error was made, and it would not be necessary for the whole of the levelling to be repeated.

Bench Marks.—Another method of checking extensive levels is by means of the bench marks left by the Government Ordnance Surveyors. These bench marks are in the form of a broad arrow, and are left on stone-houses, walls, mile-posts, or any other permanent, convenient, and accessible position. The height of these marks above sea-level may be found by referring to the Ordnance maps, and in order to check a series of levels it is only necessary to commence at one of these marks and tie into another.

Compound Section Levelling.—As has been previously stated, if the difference between the levels of the points A and

M is all that is required, the observations which are rendered necessary between these two points may be taken anywhere without necessitating their position being known. To find the difference in level of two points from compound level readings, the sum of the fore-sights and the sum of the back-sights are taken, and one total is deducted from the other. If, however, a section of the ground is required, the staff must be held at all undulations, and must be in the line of section required. Measurements of all distances must also be made, so that the position of every sight may be fixed. The position of the instrument is not required, and it may be placed on any side of the section line which may be convenient for taking the sights. The following shows the method of booking a compound level survey when a section of the ground is required. The position of the sights are shown by Fig. 131 :—

LEVELS OF GROUND FROM A TO M (Fig. 131)

DISTANCE IN FEET.	SIGHTS.			RISE.	FALL.	REDUCED LEVELS.	RE- MARKS.	
	BACK.	INTER.	FORE.					
0	2·56	10·00	A	
34	...	4·90	2·34	7·66	b	
85	...	6·00	1·10	6·56	c	
153	...	12·26	6·26	·30	d	
196	...	10·48	...	1·78	...	2·08	e	
251	...	6·76	...	3·72	...	5·80	f	
298	5·76	...	1·88	4·88	...	10·68	g	
372	...	2·86	...	2·90	...	13·58	h	
424	...	3·70	·84	12·74	i	
479	...	5·86	2·26	10·48	j	
528	...	6·62	·66	9·82	k	
569	...	4·66	...	1·96	...	11·78	l	
647	9·20	...	4·54	7·24	M	
	8·32		11·08	15·24	18·00			
			8·32		15·24			
		Diff.	2·76	Diff.	2·76			
			and 10·00 - 7·24 = 2·76 Difference					

It will be seen from the bookings that the first sight to A is

termed a back-sight, and that the sight taken to g is termed the fore-sight, as this is the point which forms a basis for the next series of levels. All the sights taken between A and g to ascertain the irregularities of the ground, so as to make a section, are termed the intermediate sights. The sight back to g from the instrument, when fixed in its second position, is a back-sight for the next series of levels, and is booked in the same line as the previous fore-sight taken, but of course in another column. The rise and fall columns are calculated as previously shown in the simple levels. If the reading at any point is less than the one preceding, there is a rise at that point equal to the difference between the two readings, and if it is less, *vice versa*. Thus there is a fall at b of $4.90 - 2.56 = 2.34$, a further fall at c of $6.00 - 4.90 = 1.10$, and a still further fall at d of $12.26 - 6.00 = 6.26$. At e , however, it is found that the reading is 10.48 , and at the preceding point d it is 12.26 , therefore there is a rise at d of $12.26 - 10.48 = 1.78$. Similarly, there is a rise at f of 3.72 . Now, at g there are two readings, and no mistake must be made as to which must be considered, in finding the fall or rise at this point. It is the fore-sight. The difference between the fore-sight and the preceding sight must be taken, and the result booked as a rise or fall of the point g , as the case may be. The reading of f is 6.76 , and the fore-sight to g is 1.88 , therefore there is a rise at this point of $6.76 - 1.88 = 4.88$.

The rise or fall of the point h (Fig. 131) is next required, and the manner of calculating it is as follows:—The difference between the reading at that point and of the back-sight is taken, and the result recorded as a rise or fall, according as the back-sight is greater or less. Thus, in the example, the reading of h is 2.86 , and that of the back-sight immediately preceding is 5.76 ; therefore there is a rise at h of $5.76 - 2.86 = 2.90$. The calculation for each of the following sights is taken in relation to the one preceding, as before, and presents no difficulty. The advantage of adopting a datum line of several feet below the first sight, when calculating the reduced levels, will be apparent in the above example. If the reduced level of A was taken at 0.00 , that of b would be minus 2.34 . For, to ascertain the reduced level of a point with a fall, the amount of fall must be subtracted from the preceding reduced level. If there is a rise, it must be added to the preceding reduced level. The reduced

level of c would be $-2.34 - 1.10 = -3.44$ and that of d would be $-3.44 - 6.26 = -9.70$. These minus signs would create errors, besides being inconvenient to plot, and are obviated by taking a datum line which will be below the lowest point of the survey.

Another and perhaps a simpler method of reducing the levels is shown below. For the rise and fall columns in the previous record shown, one column termed "line of collimation" is substituted.

LEVELS OF GROUND FROM A TO M (Fig. 131)

DISTANCE IN FEET.	SIGHTS.			LINE OF COLLIMATION.	REDUCED LEVELS.	RE- MARKS.
	BACK.	INTER.	FORE.			
0	2.56	12.56	10.00	A
34	...	4.90	7.66	b
85	...	6.00	6.56	c
153	...	12.2630	d
196	...	10.48	2.08	e
251	...	6.76	5.80	f
298	5.76	...	1.88	16.44	10.68	g
372	...	2.86	13.58	h
424	...	3.70	12.74	i
479	...	5.86	10.48	j
528	...	6.62	9.82	k
569	...	4.66	11.78	l
647	9.20	...	7.24	M
	8.32		11.08			
			8.32			
		Diff.	2.76			
			and $10.00 - 7.24 = 2.76$ Difference			

The reduced levels are calculated in the following manner:—
The first reduced level is added to the first back-sight; this total gives the collimation height, and the reduced levels of the intermediate sights and the fore-sight are calculated by subtracting each from this total. When the next fore-sight is calculated to, its back-sight must be added to the reduced level of that point and the next series of sights subtracted as before.

Thus 10.00 having been adopted as the reduced level of the first sight, this amount is added to the back-sight, reading at that point, viz. 2.56, and the total 12.56 is obtained as the collimation height. The reduced level for the next sight is obtained by subtracting the reading, viz. 4.90 from the collimation height of 12.56, thus giving us the reduced level 7.66. The succeeding intermediate sights and the next fore-sight are calculated in the same manner. The reduced level for the fore-sight is $12.56 - 1.88 = 10.68$, and to this is added the reading (5.76) of the back-sight at that point, which gives a total of 16.44 as the next collimation height, from which the next series of sights are calculated by subtracting the readings as before.

Correction for the Earth's Curvature.—The curvature of the earth's crust renders it necessary to make a correction when long sights are taken. The correction for this curvature for 1 mile is 8 inches, but the refracting action of the air reduces the correction to be made to 6.9, or about 7 inches. It will be apparent that for observations less than 150 yards in length the correction is too small to require attention.

The Levelling Staff.—The staff by which the heights are read off by the instrument is so constructed and graduated that the observation can be made to a very small fraction of a foot. The staff (Fig. 132) most commonly used is about 14 feet long, and consists of three parts which slide one within the other, so that it may be reduced to about 5 feet 3 inches in length for convenience in carrying, and the lower portion is about 3 inches broad by $1\frac{1}{2}$ inches deep.

The levelling staffs used underground are of necessity very much shorter than those used on the surface, a convenient size being a 6-foot staff to close down to 2 feet 6 inches. Gee's staff (Figs. 133 and 134), as manufactured by Messrs. Davis and Son, is in a convenient form for levelling underground, and greatly facilitate the work. As the heights of the roads vary considerably underground, it is sometimes possible to take a reading almost to the full height of the staff, while at other times the height does not allow of either of the sliding portions being opened out. If the ordinary staff is employed, a reading cannot be taken to one of the upper parts unless this portion is opened out to its full extent, as the reading would not be continuous; but, as is often the case, recourse is had to "rule of

thumb" calculations, which very often cause errors. To remove this difficulty, Gee's staff is so designed that by means of a band passing over a roller on the top of the sliding piece, a continu-



FIG. 132.

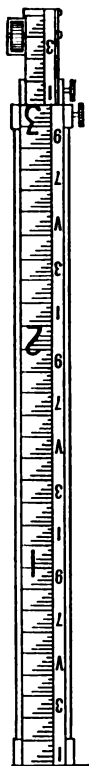

FIG. 133.

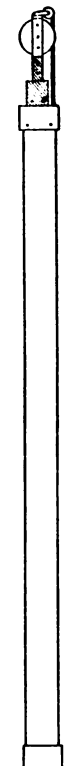

FIG. 134.

ous reading may be taken even when the sliding portion is only partly raised.

The manner in which levelling staffs are graduated is shown by the enlarged sketch (Fig. 135) of a portion of the staff. The

face is divided into three longitudinal columns, the central of which is graduated to hundredths of a foot, each graduation being represented by alternate black and white bands, in order that they may be read at a considerable distance. The feet are denoted by large red figures in the left-hand column, and the tenths of a foot by odd black figures on the right-hand column; the even numbers being omitted so that the other numbers may be made as large as possible. The numbers denoting the tenths of a foot are exactly opposite to the division to which they relate, so that if the cross-hair of the level cuts some portion of the three-tenths division the reading is $\cdot 2 +$ and not $\cdot 3 +$. To facilitate the reading still further, every alternate five-hundredth of a foot is denoted by a black diamond, as shown in the right-hand column.

The student will find no difficulty in reading off any point of the staff in the ordinary way, but the lens of the level gives an inverted image of the staff and all other objects, and the reading is apt to be made incorrectly, if considerable care is not taken; but a little experience is all that is necessary for the observer to become accustomed to the inverted appearance of the staff. On Gee's staff the numbers are inverted to facilitate the reading as shown in the illustration.

It is highly essential that the staff-holder should (a) keep the staff in a truly vertical position while an observation is being taken, and (b) retain the staff on the exact spot during the changing of the instrument from one position to another, as neglect of these are the greatest sources of errors in levelling.

Plotting the Levels.—To plot a series of levels a line is drawn on the paper to represent the datum line, and along this line the horizontal measurements are marked off to denote the points at which the levels were taken. The measurements may be taken in separate lengths for each level, but if the levels

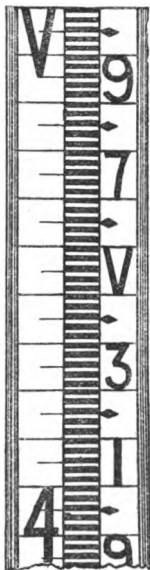

FIG. 135.

are in a continuous length, the measurements may be read off so as to form one total distance, as in the examples given. From the points marked off, lines are drawn at right angles to the datum line to represent vertical heights, and the heights given by the reduced levels are measured off. Lines are then drawn joining the points thus denoted, and a section is obtained.

The vertical heights are usually plotted to a larger scale than the horizontal distances, so that the various inclinations may be more clearly defined. As an example of how the levels are plotted, take the reduced levels and distances given below. It must be understood that the heights given are not those read off by the instrument, but those calculated to a datum line, or as they are usually termed, "reduced levels."

Reduced levels in feet.	Distances in feet.
59·1	0 at A
50·5	68
54·0	118
66·4	198
56·5	261
50·3	302
38·0	356
31·0	401
27·3	472
34·5	540 at B.

The above level survey is shown plotted by Fig. 136. The

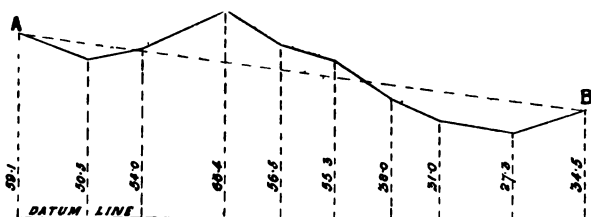

FIG. 136.

datum line is first drawn and the measurements are marked off to a scale of 180 feet to an inch, lines are drawn at right angles

from these points, and the heights are marked off to a scale of 60 feet to an inch. The extremities of these lines are then joined, and the section is shown by the firm line.

Gradient Calculations.—If the inclination of an imaginary line AB (shown dotted) was required, the height of B is deducted from A, and the difference is divided into the distance between the two points. Thus $59.1 - 34.5 = 24.6$, and assuming that the measurement 540 feet is in a straight line $\frac{540}{24.6} = 22$ nearly.

That is, a roadway driven from A to B would incline at the rate of 1 in 22 nearly. The inclination of the line on the figure is greater than this, because the section has not been drawn to a natural scale; but this does not interfere with the accuracy of the figures obtained.

TABLE OF INCLINE MEASURE

The following table shows the comparative lengths of the three sides of a right-angled triangle, and the inclination per yard in inches for every degree of the quadrant :—

NO. OF DEGREES.	INCLINATION PER YARD IN INCHES.	ONE IN.	HORIZONTAL MEASURE, HYPOTHENUSE BEING 1.	VERTICAL MEASURE, HYPOTHENUSE BEING 1.	DEDUCT LINKS PER CHAIN.
I.	II.	III.	IV.	V.	VI.
1	0·63	57·29	·99985	·01745	0·01
2	1·26	28·63	·99939	·03490	0·06
3	1·88	19·09	·99863	·05234	0·14
4	2·51	14·29	·99756	·06976	0·24
5	3·15	11·42	·99619	·08716	0·38
6	3·78	9·51	·99452	·10453	0·55
7	4·42	8·14	·99255	·12187	0·74
8	5·06	7·11	·99027	·13917	0·97
9	5·70	6·31	·98769	·15643	1·23
10	6·34	5·67	·98481	·17365	1·52·
11	6·99	5·14	·98163	·19081	1·84
12	7·65	4·70	·97815	·20791	2·19
13	8·31	4·33	·97437	·22495	2·56
14	8·97	4·01	·97030	·24192	2·97
15	9·64	3·73	·96593	·25882	3·40
16	10·32	3·48	·96126	·27564	3·87
17	11·00	3·27	·95630	·29237	4·37
18	11·69	3·07	·95106	·30902	4·89
19	12·39	2·90	·94552	·32557	5·45
20	13·10	2·74	·93969	·34202	6·03
21	13·82	2·60	·93358	·35837	6·64
22	14·54	2·47	·92718	·37461	7·28
23	15·27	2·35	·92050	·39073	7·95
24	16·02	2·24	·91355	·40674	8·65

NO. OF DEGREES.	INCLINATION PER YARD IN INCHES.	ONE IN.	HORIZONTAL MEASURE, HYPOTHENUSE BEING 1.	VERTICAL MEASURE, HYPOTHENUSE BEING 1.	DEDUCT LINKS PER CHAIN.
I.	II.	III.	IV.	V.	VI.
25	16·78	2·14	·90631	·42262	9·37
26	17·56	2·05	·89879	·43837	10·12
27	18·34	1·96	·89101	·45399	10·90
28	19·14	1·88	·88295	·46947	11·71
29	19·95	1·80	·87462	·48481	12·54
30	20·78	1·73	·86602	·5	13·40
31	21·62	1·66	·85712	·51504	14·23
32	22·49	1·60	·84805	·52992	15·19
33	23·37	1·54	·83867	·54464	16·13
34	24·28	1·48	·82904	·55919	17·10
35	25·20	1·42	·81915	·57358	18·08
36	26·15	1·37	·80902	·58778	19·10
37	27·12	1·32	·79864	·60181	20·14
38	28·12	1·28	·78801	·61566	21·20
39	29·14	1·23	·77715	·62932	22·28
40	30·21	1·19	·76604	·64279	23·40
41	31·29	1·15	·75471	·65606	24·53
42	32·41	1·11	·74314	·66913	25·69
43	33·56	1·07	·73135	·68200	26·86
44	34·76	1·03	·71934	·69466	28·07
45	36·00	1·00	·70711	·70711	29·29
46	37·27	·96	·69466	·71934	30·53
47	38·60	·93	·68200	·73135	31·80
48	39·98	·90	·66913	·74314	33·09
49	41·41	·87	·65606	·75471	34·39
50	42·90	·84	·64279	·76604	35·72
51	44·46	·81	·62932	·77715	37·07
52	46·07	·78	·61566	·78801	38·43
53	47·77	·75	·60181	·79864	39·82
54	49·54	·73	·58778	·80902	41·22
55	51·41	·70	·57358	·81915	42·64
56	53·36	·67	·55919	·82904	44·08
57	55·44	·65	·54464	·83867	45·54
58	57·61	·62	·52992	·84805	47·01
59	59·92	·60	·51504	·85717	48·50
60	62·35	·58	·5	·86603	50·00
61	64·94	·55	·48481	·87462	51·52
62	67·69	·53	·46947	·88295	53·05
63	70·65	·51	·45399	·89101	54·60
64	73·80	·49	·43837	·89879	56·16
65	77·20	·47	·42262	·90631	57·74

NO. OF DEGREES.	INCLINATION PER YARD IN INCHES.	ONE IN.	HORIZONTAL MEASURE, HYPOTHENUSE BEING 1.	VERTICAL MEASURE, HYPOTHENUSE BEING 1.	DEDUCT LINKS PER CHAIN.
I.	II.	III.	IV.	V.	VI.
66	80·86	·45	·40674	·91355	59·33
67	84·81	·42	·39073	·92050	60·93
68	89·10	·40	·37461	·92718	62·54
69	93·77	·38	·35837	·93358	64·16
70	98·91	·36	·34202	·93969	65·80
71	104·53	·34	·32557	·94552	67·44
72	110·80	·32	·30902	·95106	69·10
73	117·73	·31	·29237	·95630	70·76
74	125·56	·29	·27564	·96126	72·44
75	134·37	·27	·25882	·96593	74·12
76	144·40	·25	·24192	·97030	75·81
77	155·90	·23	·22495	·97437	77·50
78	169·36	·21	·20791	·97815	79·21
79	185·20	·19	·19081	·98163	80·92
80	204·10	·18	·17365	·98481	82·63
81	227·34	·16	·15643	·98769	84·36
82	256·11	·14	·13917	·99027	86·08
83	293·13	·12	·12187	·99253	87·81
84	342·60	·10	·10453	·99452	89·55
85	411·27	·09	·08716	·99619	91·28
86	514·52	·07	·06976	·99756	93·02
87	...	·05	·05234	·99863	94·77
88	...	·03	·03490	·99939	96·51
89	...	·02	·01745	·99985	98·25

EXPLANATION OF TABLE

Column I. expresses the inclination in terms of the generally adopted angular measure, viz. degrees. The inclination is given in degrees from the horizontal.

Column II. gives the rise in inches for every yard of horizontal measure; the numbers corresponding with the number of degrees in the preceding column.

EXAMPLE.—A road is 50 yards long (this length represents the horizontal measurement, and not the measurement on the slope), and has an inclination of 6 degrees, how much will one end of the road be higher than the other?

By referring to Column II. of the table, it is found that the figures which correspond with the 6 degrees in the preceding column is 3·78. This is the amount in inches which the road will rise in 1 yard, therefore in 50 yards it will rise fifty times this amount, and $3\cdot78 \times 50 = 189$ inches = 15 feet 9 inches.

Column III. gives the horizontal length per unit rise for each degree. Expressing the inclination in terms of the horizontal per unit rise is a very common method in mining. A more correct heading for this column would be: "Horizontal measure, vertical being 1."

EXAMPLE 1.—A road has an inclination of 14 degrees: express this in terms of the vertical and horizontal.

In a line with 14 in the first column we find 4·01 in the third. Therefore the inclination of the road is 1 in 4·01.

EXAMPLE 2.—A road having an inclination of 12 degrees is 50 yards long (horizontal measurement), what is the perpendicular height?

The table gives 1 in 4·7 for 12 degrees. Then the perpendicular height is $50 \div 4\cdot7 = 10\cdot638$ yards.

Column IV. gives relative lengths of the base and hypotenuse of a right-angle triangle for each degree, the length of the base being given per unit of the hypotenuse. On an inclined road the length of the hypotenuse would be represented by the actual measurement of the road.

EXAMPLE.—A brow dipping 16 degrees measures along the dip 106 yards, what is the horizontal length of the road?

The table gives the horizontal length per unit of the hypotenuse for 16 degrees as ·96126. Therefore the horizontal measurement of the road is $106 \times \cdot96126 = 101\cdot89356$ yards.

Column V. gives the relative lengths of the perpendicular and the hypotenuse of a right-angle triangle for each degree, the length of the perpendicular being given per unit of the hypotenuse.

EXAMPLE.—A brow dipping 16 degrees measures along the dip 106 yards, how much is one end of the brow below the other (*i.e.* the perpendicular height)?

The table gives the vertical rise per unit of the hypotenuse for 16 degrees as ·27564, therefore the perpendicular height of the road is $106 \times \cdot27564 = 29\cdot21784$ yards.

Column VI. gives the amount in links per chain which is to be deducted to convert inclined measurements to horizontal lengths. That is, the amount to be deducted from the hypotenuse to make it equal to the base. This column of figures fulfils the same purpose as Column IV., but not to the same degree of accuracy. As there are 100 links in a chain, the figures given in the column represent what may be termed the percentage of deduction, so that the figures may be employed to find the deduction for yards or feet, as well as link measurements.

EXAMPLE 1.—A road rising 16 degrees measures on the incline 106 yards, what is the horizontal length?

The table gives 3·87 as the amount to be deducted per 100 for 16 degrees, therefore the deduction for 106 will be

$$\frac{106 \times 3\cdot87}{100} = 4\cdot1022 \text{ and}$$

$106 - 4\cdot1022 = 101\cdot8978$ yards the horizontal length of the road. The same example, calculated by the figures in Column IV., gave 101·89356 yards.

EXAMPLE 2.—An inclined road dipping 20 degrees measures 5 chains, how many links must be deducted to give the horizontal measurement?

The table gives 6·03 as the deduction per chain for 20 degrees, therefore the deduction for 5 chains = $6\cdot03 \times 5 =$ 30·15 links.

APPENDIX I

(THE following is a reprint from *Mining* of an article written by the author):—

Plotting Mine Surveys

The writer has no intention of dilating upon any particular method of plotting, nor to propound a new one, but to offer an explanation of a system which facilitates the ordinary method of plotting from meridians. Surveyors are now well aware that the magnetic meridian is constantly deviating, and the usual practice is to check, and if necessary alter about once a year the meridian from which the surveys are plotted. The yearly deviation is only about seven minutes, so that this is quite accurate enough for ordinary purposes. It is customary to adopt two definite points on the surface of the ground from which to ascertain the magnetic meridian. These points are accurately delineated on the plan, and a meridian is plotted from each periodic observation.

It often happens that at extensive collieries where a number of mines are being worked simultaneously, there are as many as twenty plans of workings to be filled up, all in the one estate or "taking," and as the meridian has to be altered on each of these, say every year, they necessitate a considerable amount of labour, especially when—as is almost always the case—the workings extend on all sides of each plan, and meridian lines have to be plotted on several parts of the same plan to bring it sufficiently close to each batch of workings.

Plotting the meridian on several parts of the same plan is no very difficult matter with new plans, but after a plan has been in use for a considerable number of years, and cracks up, it is impossible with any degree of accuracy to parallel a line from one side of the plan to the other. These are the circumstances with which the writer had to deal; a large number of plans—in all conditions—of superposed and adjacent mines; and the plotting of the surveys was greatly

facilitated by adopting a course which, though perhaps not new, is not, so far as the writer's knowledge extends, generally known, and which may be described as follows:—

On the principal surface plan, which usually shows the whole of the "taking," a sufficient number of lines are drawn parallel to a line joining the two points from which the meridian is generally ascertained, and at a definite distance apart, say about 18 ins., to include all parts of the estate. By adopting for this distance some length corresponding to the scale of the plan, such as 500 yards, the lines will be very useful for approximating distances and areas. These lines form what may be termed *meridian base lines*, and similar lines should be drawn on each plan of workings. This is easily accomplished by making a tracing from the original plan, showing the lines and sufficient surface to enable the tracing to be accurately fitted on each working plan. The lines for any particular plan may be then pricked through, the lines being thus kept in the same positions in every case. All that is then necessary is to place a protractor on the base line which is situated nearest to the workings to be plotted, and draw a meridian line.

Assuming that a large cardboard protractor is employed for plotting—and for colliery work this is undoubtedly the best—the full advantage of the base lines may be derived. Instead of plotting a meridian on the plan for each detached portion of workings, the bearing of the base line according to the last observation is plotted on the *protractor* and distinctly marked and dated. When plotting a survey it is not necessary to draw a meridian on the plan, but simply to place the protractor with the line showing the bearing of the base line immediately over any one of the base lines, and the protractor is in its correct position for plotting.

For example, assume that the bearing of the base line as ascertained by the dial, taking an observation between the two points to which the base line is parallel, is N. 10 W. for any particular date. A ruler is placed on the protractor with its edge at N. 10 W. and at S. 10 E., and a line is drawn from the graduations to the inner edge of the protractor. This line is then placed immediately over the base lines on the plan for plotting.

The advantage derived by this course will be patent; whereas in the one case the meridian every time it is changed may have to be drawn in a hundred different places (this is no exaggeration when as many as 20 plans are in use), in the other case only one line has to be drawn, that being on the protractor. Not only have such a large number of meridians to be periodically plotted by the ordinary method, but the old meridian lines must be obliterated, otherwise the lines drawn one over the other will be confusing and tend to create mistakes. The lines cannot be successfully obliterated unless they are left in pencil, and when they are so drawn there is frequently

a difficulty in finding them when they are required. It is not a considerable amount of work in the first instance to draw the meridian base lines on the plans, and when this is done the periodical change in the meridian gives little trouble, and the greater accuracy attained, especially when the plans are old and broken, is alone sufficient to recommend its adoption.

In a mining engineer's office where surveys of numerous different collieries have to be plotted, it would scarcely be practicable to plot the base line of each on the same protractor, and it is not probable that a large number of protractors would be employed, but one protractor might be used in this manner for say two of the most extensive collieries. When only one mine is worked in any particular district there is not much need of adopting this method. In any case there is a considerable advantage in drawing the base lines on the plan, even if the bearing is not plotted on the protractor.

It might be said, and not without some reason, that instead of adopting a base line as above mentioned, it would be more systematic to adopt true north and south as a permanent base line; this, however, has its advantages and disadvantages. In the first place, the true north has first to be found by some reliable and perfectly accurate method. A perfectly correct north and south line could not be calculated from the declination readings given at the observatories, even if the necessary allowances be made for the particular district, as ordinary mining instruments vary some little in the readings. Again, at every observation for a magnetic meridian two calculations would be necessary to fix the true north line on the protractor, with probably a slight error in the second calculation, as it would be necessary to plot the magnetic meridian, and then ascertain by means of the protractor the difference between magnetic and true meridian before the bearing could be marked on the protractor.

When adopting the method described it would be advisable to plot one meridian on each plan in the first instance, so as to avoid confusion and enable any one who was not acquainted with the bearing of the base line to locate the workings.

APPENDIX II

EXAMINATION QUESTIONS

THE following questions from various examinations will give the student some idea of the nature of those generally asked. The first eight questions comprise the full paper given at the City and Guilds of London Institute Mine Surveying Examination (Ordinary Grade) 1894, with the exception of the survey bookings. The underground survey bookings given for the previous year (1893) will, however, be found on page 80, and the survey lines of the surface survey for 1894 will be found on page 103.

Some of the questions given below are beyond the scope of this work, but some others that are deemed to be insufficiently explained in the text have explanatory notes appended to them.

City and Guilds of London Institute

MINE SURVEYING

1. Plot in pencil the surface survey shown in the accompanying sheet A (the candidate may ink it in if he has time to spare). Scale 2 chains to the inch. The measurements are all in links. (1894.)
2. Upon the plan of surface, plotted according to No. 1, lay down in its correct position the underground survey shown in accompanying sheet B. (1894.)
3. An incline is measured, 1200 links in length, the slope is $22^{\circ} 11' 30''$. What is the length of the horizontal base, and what is the difference in level between the bottom and top of the incline? (1894.)
4. At Midsummer in the year 1878, in England, a mining plan was made, and one of the main lines of survey on the surface was found to bear north-west of the Magnetic North Pole 36° ; what was the bearing in regard to the Geographical North Pole? Having

regard to the changes in the declination of the compass needle, what would be the bearing of the same line at Midsummer 1893 as regards the Magnetic North Pole, and also as regards the Geographical North Pole? (1894.)

5. What is the value of 19° . . . ? What is the value of $7\sqrt{736948252}$. . . ? (1894.)

6. The sides of a triangle are 1200, 1100, and 1000 links in length, respectively, what is its area in acres, roods, and perches? Suppose this area to be in a horizontal plane (that is, flat), and to be covered by a seam of coal lying at an inclination of 34° from the horizontal, the thickness of the coal being uniform and measuring, at right angles to the dip, 3 feet in thickness, what is the tonnage of coal in the seam over the above area? (1894.)

7. An estate is divided by a wide and deep river; on each bank is a post; show how to measure the distance from post to post without crossing the river, or shooting a line across. (1894.)

8. Describe an instrument used in mines for taking bearings and measuring angles, also the instruments used for measuring distances. (1894.)

9. Give a short description of the miners' dial with its usual appliances, especially when it is used as a theodolite, the needle being thrown off. (1880.)

10. Describe a Gunter's or land measuring chain. (1881.)

11. Describe the true meridian as compared with the magnetic meridian. How does the adoption of the latter affect plans made from compass observations and added to, as in mine plans, from year to year? (1882.)

12. You are required to traverse over a level in which rails are laid down. How would you proceed to use an ordinary miners' dial under the circumstances, the dial being without a rack, but supplied with two sets of legs? The only true bearing was one taken in a cross-cut north at a distance of, say 5 fathoms off the main level where the traverse is being made, the cross-cut occurring about half way in the traverse. Rule a supposed page of your underground work suited to this purpose, and give say six drafts or bearings all supposed to be affected by the attraction of the rails, the polarity of the whole being governed by the true bearing in the cross-cut north. If time will permit, insert distances and prove your work by plotting. (1883.)

13. The area in acres, roods, and poles is required of an irregular field which was surveyed by running one line through it from end to end (A to B), with offsets taken as shown. No plan to be drawn. Length of line 1550 links.

	B.	
150	1550	0
182	1300	
	1248	175
	1159	55
	980	183
280	865	
202	393	92
	150	75
145	45	
0	0	0
	A.	

(1883.)

14. Plot on a scale of 8 fathoms to an inch the following underground traverse, taken with the ordinary miners' "left hand" dial:—

No.	BEARING.	DISTANCE.			REMARKS.
		Fath.	Ft.	Ins.	
A	355° 30'	10	4	9	From centre of shaft.
B	84° 26'	7	3	2	A at crossing of east level.
C	92° 04'	8	1	9	C at X cut N.
[D ²	342° 09'	7	3	0	D ² End do.
D	96° 05'	3	5	9	End.

(1883.)

15. Illustrate in colours the following parts of a finished plan scale, 8 fathoms to the inch:—A road, 25 feet wide, bounded on each side by a hedge or bank, 6 feet wide, showing a gateway with a cross hedge or two, also a house, 30 feet by 20 feet, abutting on the road, with a pond adjoining open to the road, but with the hedge continued round its other sides. The pond not to be less than 58 feet long and 28 feet wide, and of an oval but irregular shape. A shaft, 10 feet by 6 feet, to be shown in one of the fields surrounded by a burrow or rubbish heap, which is to be sketched in with pen and Indian ink. The whole drawing to be about 1 foot in length. (1883.)

16. In chaining over sloping ground, how do you correct for the inclination? Give a simple rule when the inclination is expressed either in angular measure or as a gradient, *e.g.* 1 in 6, 1 in 15. (1885.)

17. What is meant by the term true meridian? Describe a simple method of approximately determining it. (1885.)

18. State the present deviations. In what manner is the deviation found to vary from year to year? also in travelling from one locality to another at a considerable distance. (1885.)

19. The three sides of a triangle measure 144, 192, and 240 links respectively. Find the area of the triangle in square yards, and the angle opposite to the shortest side. (1885.)

20. Describe the ordinary process of levelling, stating any precautions required to ensure accuracy. (1885.)

21. Work out the following series of levels and plot in the form of a section. Horizontal scale, 1 chain to an inch; vertical scale, 20 feet to an inch. Datum line, 50 feet:—

DISTANCE CHAINS.	BACK-SIGHT.	FORE-SIGHT.
0·70	1·30	8·85
1·50	8·85	2·30
2·45	13·96	5·40
3·60	5·40	0·52
4·05	12·62	8·80
5·40	8·80	1·12
7·00	2·32	7·05
7·40	1·33	9·96
10·20	3·34	5·87
11·35	5·87	9·10

(1885.)

22. Plot on a scale of 2 chains to an inch the following survey:—

	CHAINS.	BEARING.	INCLINATION RISE.
A	2·50	119° 45'	
B	7·47	137° 16'	3° 50'
C	13·03	141° 32'	
D	3·40	196° 50'	
E	6·50	189° 24'	9° 36'
F	11·66	266° 36'	7° 30'
G	5·25	272° 22'	

(1885.)

23. Give a general description of a theodolite, and explain the method in which you would use it in making an underground survey. (1887.)

24. What are the special advantages and disadvantages in the use of the ordinary miners' compass with the theodolite? (1887.)

25. Work out the following series of levels showing the height above the station A of each point taken:—

DISTANCE.	BACK-SIGHT.	INTERMEDIATE.	FORE-SIGHT.
A	12·63		
0·40		9·15	
1·00		7·43	
1·50		5·31	
2·00		4·06	
3·50		2·16	
4·50	9·06		0·42
5·50		7·50	
6·50		6·15	
8·00		3·60	
9·00		2·12	
10·50	10·15		0·75
11·20		8·70	
13·00		4·45	
14·60			3·23

(1887.)

26. Describe the ordinary method of using the theodolite in making an underground survey. Also any special method which may be adopted when great accuracy is required. (1887.)

27. Lay down the following underground survey on the scale of 2 chains to an inch :—

	DISTANCE.	VERTICAL INCLINATION.	HORIZONTAL ANGLES.
Shaft to A	1·90	6° 0'	A = 145° 15'
A B	6·75	4° 35'	B = 177° 30'
B C	4·30	3° 13'	C = 213° 54'
C D	9·77	0° 0'	D = 97° 20'
D E	3·90	6° 46'	E = 130° 13'
E F	6·13	0° 0'	F = 167° 30'
F G	3·01	2° 20'	

The horizontal angles are those on the left hand of a person travelling in the direction of the survey, and the magnetic bearing of the line F G is 30° east of north. (1887.)

28. The difference of level of two points, several miles apart, is required with great exactness, and a levelling instrument of high power is used for the purpose. Under what circumstances would it be necessary to allow for the spherical form of the earth, and in what manner would you make the proper corrections? (1887.)

29. A colliery waggon-way is laid down in a straight line from A

near the shaft to a point B in a direction 40° east of north, and is to be extended to join a main line of railway towards the east, running due north and south. The distance from B to the main line is 30 chains measured due east, and the junction is to be made by a curve 60 chains radius. Show how the waggon-way must be set out, and find what length of line will be required beyond the point B. In setting out the curve from the straight line portion of the railway, what offset must be made at the end of the first chain? (1887.)

30. In the triangle A B C, the angle $A = 37^\circ 45'$, $B = 72^\circ 13'$, and the side $A B = 437$. Find the sides A B, B C, and the perpendicular distance from C to A B. (1887.)

31. In the triangle A B C the side $A B = 365$, $A C = 180$, and the angle $B = 25^\circ 30'$. Determine the angles A and C and the side B C. (1887.)

32. State approximately the declination of the magnetic needle for the year 1885, and the average annual variation. How is the declination found to vary in amount as you travel northwards or eastwards? (1888.)

33. Describe the Hedley Dial. (1888.)

34. It is required to determine the position of a distant point C in the workings of a colliery with reference to the surface. For this purpose a survey is made with the theodolite, above and underground from the shaft A to C, and also to a second shaft B, by which means the underground and surface surveys are connected. Show how you would carry out the survey so as to obtain the most accurate result. Give your idea as to the degree of accuracy attainable by this method, and how far will it depend upon the relative positions of the points A, B, and C, and the nature of the survey between these points? (1889.)

35. What is the declination of the needle at the present time at Greenwich or any other place with which you are acquainted? Will there be any difference? and, if so, about how much, between the declination of the needle at Liverpool and at Hull? What was the declination at Greenwich (or other place) ten years ago (approximately)? (1896.)

36. A vertical pit is 100 yards deep; from the top of the pit an incline is driven which meets a level driven from the pit bottom, at a distance from the pit, measured along the level, of 333 yards. What is the inclination of the incline? What is the length of the incline? (1896.)

37. Explain with sketches the construction of a dial such as is generally used in surveying mines. (1896.)

38. How many right angles are contained in the following figures, a triangle, square, pentagon, hexagon, octagon? (1896.)

Colliery Managers

WEST LANCASHIRE AND NORTH WALES DISTRICT

39. What precautions would you take with a loose needle in surveying underground workings? (1887.)
40. Describe surveying with the fast needle. (1887.)
41. Suppose you were required to take levels along an underground roadway in order to plot a section, showing both roof and floor, state what instruments you would use and how you would proceed. (1887.)
42. In working to the full rise of a seam of which the inclination is 1 in 12 you meet with a rise fault of 10 yards, what will be the length of a rise tunnel to be driven at the inclination of 1 in 6 between the seam at the low side of the fault and the seam on its rise side, supposing the fault to be vertical? (1887.)
43. Describe how you would make a survey of workings where in many places the needle is liable to be affected by attraction. (1889.)
44. What does the Coal Mines Regulation Act 1887 specify as to plans and surveys of underground workings? (1889.)
45. Give a sketch of a page out of a book recording an underground survey. (1889.)
46. How often have underground surveys to be made to comply with the Coal Mines Regulation Act, and what does the Act require as to plans? (1890.)
47. What are the points to be most carefully watched in order to ensure perfect accuracy in an underground survey, and the plotting of the results of the same when using a dial and chain? (1890.)
48. Is it desirable to record on the colliery plan the vertical as well as the horizontal position of the workings? If so, how would you do this? (1890.)
49. Describe the best method of levelling underground in an incline of about 1 in 3. (1893.)
- [See note to 61 and 62.]
50. What are "bench marks," "contour lines," and intermediate sights? (1893.)
- [Contour lines are lines joining points of equal height above sea-level, or horizontal outlines of ground.]
51. How do you check the accuracy of "sight lines" in driving a main road where the roof is liable to give way? (1893.)
52. Define the conditions under which you would make "Theodolite and Magnetic Surveys" respectively, and describe the modes of plotting. (1893.)
53. What has to be guarded against in basing opinions on old plans? (1894.)

54. Describe how you would make an underground survey with fast needle, and how you would connect it with the surface plan.

(1894.)

55. How often do you consider meridians should be taken to ensure the accuracy of colliery plans, and what has to be remembered in this connection?

(1895.)

[See note to 60.]

56. Show by a sketch how you would book an underground survey.

(1895.)

57. What are the requirements of the Coal Mines Regulation Act as to colliery working plans? What further information should they afford in addition to what is legally required?

(1896.)

WEST SCOTLAND DISTRICT

58. Draw to the scale of 2 chains to an inch the plan of a four-sided field, having two adjacent sides at right angles to each other and each $5\frac{3}{4}$ chains in length, and the other sides $7\frac{1}{2}$ chains and $6\frac{1}{10}$ chains in length, respectively.

(1887.)

59. Calculate the area of the above in acres, roods, poles, and yards.

(1887.)

60. What is your experience of changes in the direction of the magnetic meridian, and how would you find what it ought to be at any time? How often would you consider it necessary to check the change in the magnetic meridian?

(1887.)

[About once every twelvemonth, every time a new instrument is used, and at all important surveys.]

61. How would you level a road underground?—(a) Where the strata dip 1 in $2\frac{1}{2}$; (b) where the strata dip 1 in 12, or less.

(1893.)

62. State your reasons for adopting such method.

(1893.)

[Where the strata dips 1 in $2\frac{1}{2}$, and there is a considerable length to be levelled, a theodolite should be used, if the distance is comparatively short, a straight staff and a spirit level could be used satisfactorily; if a dumpy level was used the sights would be so short that an infinite number would be necessary. A dumpy level would be the best instrument for a road dipping 1 in 12, or less.]

63. Plan forty years old with a meridian on it. State how you would put on a new magnetic meridian, and how you would find the variation, if any.

(1893.)

64. Give a short description of how you would make a survey underground—(a) With loose needle; (b) with locked needles or vernier; (c) show how you would book a survey with bearings, distances, and faults all marked on it, and how you would find the varying inclination.

(1893.)

65. In using a compass in a mine show by a diagram the position of the sights in relation to the needle when setting off a bearing N. 45 E.

(1893.)

66. Plot to a scale of 1 inch to a chain the following bearings :
 N. 30° E.—300 links ; S. 60 E.—360 links ; S. 30° W.—300 links ;
 N. 60° W.—360 links. (1893.)

67. Find the area of a field 300 links square, in acres and decimals. What weight of coal is there under it in a seam 4 feet thick ; 30 cubic feet of coal=a ton ? (1894.)

68. Describe fully how you would make an underground survey—
 (a) With magnetic loose needle ; (b) with magnetic needle locked or by vernier ; (c) the various modes of plotting the above you are acquainted with ; (d) show how you mark your bearings in your book. (1895.)

69. Plot the following bearings :—N. 80 E.—205 links, N. 6 E.—157 links, N. 45 W.—96 links, N. 5 W.—103 links, N. 89 W.—87 links, S. 5 E.—103 links, S. 80 W.—205 links, S. 45 E.—96 links, S. 89 E.—87 links, S. 6 W.—139 links. Then calculate the area in acres, roods, poles, and yards. (1895.)

70. Show how to reduce the following measurements taken on inclined planes to horizontal lengths, namely, 347 links at 1 in 4, 570 at 1 in 5, 434 at 1 in 6, and 540 at 1 in 7. (1895.)

71. What is your experience of changes in the direction of the magnetic meridian, and how would you find what it ought to be at any time ? And also how would you correct one on a plan made twenty years prior to date ? (1895.)

72. Describe what benefits, present and future, would arise from having levels of the main roads put on the plans of collieries. What datum would you use for such levels, and give your reasons therefor ? (1895.)

73. Describe how you would set about levelling a dook road having a gradient of 1 in 2. Also show how you would level on a gradient 1 in 25. State your reasons for altering the mode of doing the work. (1895.)

SOUTH-WESTERN DISTRICT

74. Give a description of the ordinary miners' dial, and of a theodolite. (1892.)

75. Give a description of a dumpy level, and show how you would record staff readings and variations of levels in a book. (1892.)

76. Make an ink sketch of a vernier and explain its use and value when fitted to instruments. (1892.)

77. The sides (AB, BC, CD, and DA) of a field measure 28, 45, 60, and 57 yards in length respectively. The angle ABC is a right angle. Find the area of the field in square yards. (1892.)

78. Explain fully how you would keep up a colliery plan and use it as a check upon the quantity raised. (1892.)

79. Make a sketch of a vernier, and explain its use when fitted to instruments. (1894.)

80. Plot the following survey to a scale of 2 chains to an inch :—
S. 11 W.—420 links, S. 40 E.—350 links, N. 10 E.—600 links.

(1894.)

81. Describe any form of miners' dial you are acquainted with, pointing out the advantages you have experienced by the use of it underground.

(1894.)

82. Work out the quantity of coal in 1 acre of a seam of the following section :—Top coal 2 ft. 3 ins., clod 11 ins., bottom coal 2 ft. 9 ins. Specific gravity of coal 1.25.

(1894.)

83. Work out the horizontal base and vertical height of an inclined plane, 26.65 chains long, which rises 1 in 4.

(1894.)

NEWCASTLE DISTRICT

84. Describe the ordinary method of surveying and the instruments employed.

(1893.)

85. In using the magnetic needle, what precautions have you to take in surveying and plotting?

(1893.)

86. Plot the following bearings, and state what should be the course and length of the seventh set to tie with the beginning of the first set :—

No.	BEARING.	LINKS.
1	S. 47 E.	340
2	S. 79½ W.	160
3	S. 30¾ E.	420
4	N. 62½ W.	710
5	N. 41 E.	230
6	N. 62½ W.	340

(1893.)

87. Describe the systems of levelling you are acquainted with, and show how to keep a level book and reduce the levels.

(1893.)

88. Plot the following bearings :—

No.	BEARING.	LINKS.
1	S. 12 E.	332
2	S. 69 E.	357
3	N. 44 E.	475
4	N. 21 W.	260
5	N. 41 W.	400
6	N. 85 W.	802

(1894.)

89. Describe the method of surveying with an ordinary compass and with a theodolite, and state the conditions under which you would make theodolite and magnetic surveys respectively. (1894.)

90. Describe the process of levelling with a spirit level and in the following account fill up the columns for rise, fall, and reduced levels, and also work out the average inclination in inches per yard:—

No.	BACK-SIGHT FEET.	FORE-SIGHT FEET.	RISE.	FALL.	REDUCED LEVELS.	HORIZONTAL DISTANCE LINKS.
1	1·85	10·85				100
2	8·45	1·17				100
3	3·65	11·02				100
4	8·52	0·67				100
5	3·34	9·94				100
6	0·89	8·03				100
7	10·72	3·50				100
8	2·55	8·55				100
9	1·35	8·43				100

(1894.)

91. Describe the instruments used in making surveys underground, and explain the advantages and disadvantages of each. (1895.)

92. Explain fully the process of levelling with a spirit level. Give an example of 6 sets, showing how a levelling book is kept and how the levelling is plotted. (1895.)

EAST SCOTLAND DISTRICT

93. (A), (B), and (C) denote the lengths of the sides of a triangle; how may its area be determined in terms of its sides? (1894.)

94. A coal field in shape is a rectangular parallelogram, the sides one mile and a half mile, respectively, contain three workable seams of coal—

1st Seam 3'·0" thick. Specific gravity 1·28.
 2nd Seam 2'·9" thick. Specific gravity 1·29.
 3rd Seam 2'·6" thick. Specific gravity 1·30.

Required the average available amount of coal in the field, after making a fair deduction for loss in working, there being no special pillars to be left in. (1894.)

[Allow 15 per cent for faults, bad coal, and loss in working.]

95. The working of a colliery extends over the property of several landlords; explain what precautions you would take to give each landlord his due in the matter of lordship or royalty payments. (1894.)

96. Explain how you would do the surveying and plan keeping for the workings of an edge field : angle of dip and rise, say 60° from the horizontal, it being necessary to reckon out the areas of the minerals worked out, as well as keep the workings within the boundary line of the surface. (1894.)

SOUTH STAFFORDSHIRE DISTRICT

97. What is meant by surveying and levelling ? (1889.)

98. Describe the mode of making a survey, with tools and books necessary. (1889.)

99. Describe the manner of making sections, with all tools and books necessary. (1889.)

100. Show the method of an underground survey. (1889.)

101. Describe the instruments necessary for surface and underground surveys and sections, and explain the mode of using them. (1890.)

102. Show the method of making an underground survey. (1890.)

103. How would you proceed to make a survey of a mine where magnetic attraction exists ? (1890.)

104. What is the difference between magnetic and true north ? How would you proceed to fix magnetic north upon your plans ? (1890.)

105. Describe the usual mode of making a surface survey. If you had to make a survey of an estate, as below, how would you proceed to work ? (1890.)

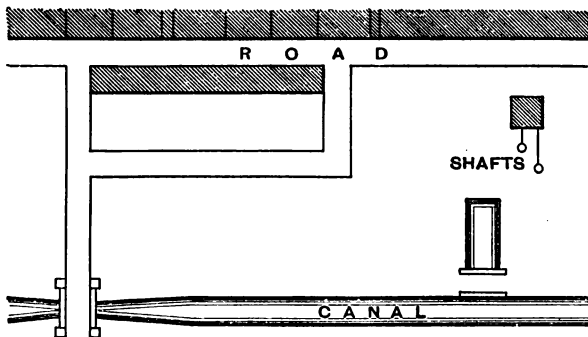

Science and Art Department

MINING EXAMINATIONS

106. How are the workings of mines represented on plans ? (1882.)
107. How much might be expected to be available in an area of 150 acres of a 4-foot seam, allowing one-fifth for faults and waste ? (1884.)
108. What weight of coal may be obtained in a seam 5 feet thick from a drift 6 feet wide per yard driven ? (1885.)
109. How are the surveys of mines made and plotted ? (1886.)
110. How would you keep the true alignment and gradient in driving a gallery ? (1894.)
111. What errors in direction are likely to arise in surveys made with the magnetic needle, and how can such errors be controlled and corrected ? (1895.)
112. On a seam dipping south 1 in 6, what will be the gradient of a road driven north-east ? (1896.)
113. A pit is 16 feet in diameter and 200 yards deep.
How much land will the rock cover when tipped as a square pyramid 32 feet high ? (1896.)

Miscellaneous

114. How may the underground and surface surveys of a mine be connected ?

[If there is a perpendicular shaft, we have at once a station common to both top and bottom, and from which the underground survey commences. The connection can then be made by means of the magnetic meridian, and a second shaft usually affords a tie on the work. If, however, the nature of the mine does not allow of a magnetic needle survey, or, at least, one loose needle observation, being made, one station common to both is not sufficient, as there is no base line to work from. The simplest arrangement in such cases is to suspend two weighted wires down the shaft, as far apart as possible—the weights being placed in liquid to minimise vibration—and to range out base lines both at the surface and along the underground road in line with the two wires. The bearing of this line can then be ascertained on the surface, and the underground survey made from the corresponding line below.]

115. A coal seam is proved by the boreholes A, B and C at the following depths. A is 200 yards deep, B 250 yards, and C 280

yards. The distance between A and B is 430 yards, between A and C 740 yards, and between B and C 960 yards. Find the direction and inclination of the full dip of the seam, assuming the surface of the ground at the boreholes is level.

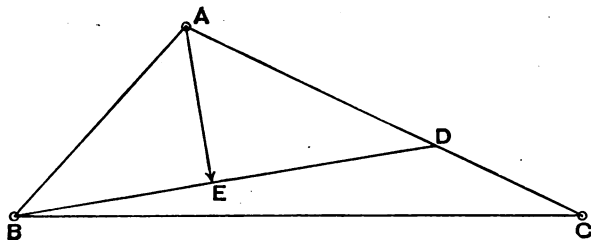

[First find a point between A and C at which the seam is at an equal depth, as at B. A is 200 yards deep and C 280 yards, therefore the seam dips 80 yards in 740 in the direction of AC. If it dips 80 yards in 740, in how far will it dip 50 yards $\frac{740 \times 50}{80} = 462\frac{1}{2}$ yards?

On AC measure off a part AD equal to $462\frac{1}{2}$ yards, and join BD. Then as the seam is at the same depth at B as at D, the line BD is the level course of the seam, and a line drawn at right angles to this will give the direction of the full dip. From A drop a perpendicular AE to the line BD. The depth of the mine at E is 50 yards below E, and by measuring with a scale AE is found to be 264 yards long, therefore the full dip is $\frac{50}{264} = 1$ in $5\cdot3$ nearly.]

THE END

