

FIRST YEAR
COTTON SPINNING COURSE

DUNCAN

FIRST YEAR
COTTON SPINNING
COURSE



FIRST YEAR COTTON SPINNING COURSE

BY

H. A. J. DUNCAN

ASSOCIATE OF THE TEXTILE INSTITUTE
COTTON-SPINNING MILL MANAGER
CHIEF COTTON SPINNING LECTURER, WIGAN AND DISTRICT
MINING AND TECHNICAL COLLEGE



LONDON
SIR ISAAC PITMAN & SONS, LTD.
PARKER STREET, KINGSWAY, W.C.2
BATH, MELBOURNE, TORONTO, NEW YORK
1928

TS1577
.D8

389787
29

29-20418

66.13. Sept. 30, 29

PREFACE

THIS work is based on the Union of Lancashire and Cheshire Institutes Syllabus entirely, with a view to (1) giving the students a definite work of reference, and (2) relieving the teachers of some of the dictation which is at present found necessary in class work.

The writer's cordial thanks are due to the machine makers who have so unselfishly given their help in the making of such clear illustrations, and to his colleagues at Wigan, Messrs. H. Thistlethwaite and D. Grogan, whose assistance has been invaluable.

H. A. J. D.



CONTENTS

PART I

COTTON SPINNING

CHAP.		PAGE
I.	COTTON, GENERAL	1
II.	SPECIAL FEATURES OF KINDS OF COTTON	11
III.	GINNING AND BALING	23
IVa.	COTTON SPINNING MACHINERY	27
IVb.	BALE BREAKERS	38
V.	THE MIXING OF COTTON	45
VI.	MIXING AND BLOWING ROOM MACHINERY	56
VII.	CARDING	83
VIII.	DRAWFRAMES	92
IX.	BOBBIN AND FLYFLAMES	100
X.	RING SPINNING FRAMES	112
XI.	MULE SPINNING	129

PART II

TEXTILE MATHEMATICS

I.	ARITHMETIC	147
II.	MENSURATION	165
III.	ALGEBRA	170
IV.	GRAPHS	179
V.	LOGARITHMS	183

PART III

TEXTILE DRAWING	191
TEST PAPERS	207
SYLLABUS OF FIRST YEAR COURSE IN COTTON SPINNING	224
INDEX	229

ILLUSTRATIONS

FIG.	PAGE
1. Sea Island Cotton Bolls	2
1A. Cotton Seeds with Fibres Attached	3
2. Cotton Fields—Gathering the Raw Material	17
2A. Section Through Saw Gin	24
2B. Single-action Macarthy Gin	24
3. Hopper Bale Breaker	28
4. Hopper Feeding Machine	29
5. Exhaust Opener and Lap Machine	30
6. Single Scutcher and Lap Machine	31
7. Single Scutcher and Lap Machine	32
8. Revolving Flat Carding Engine	33
9. Drawing Frame	34
10. Intermediate or Roving Frame	35
11. Ring Spinning Frame	36
12. Self-acting Mule	37
13. Sectional View of Hopper Bale Breaker	40
14. Spiked Lifting Lattice	41
15. Spiked Lifting Lattice	41
16. Plan and Elevation of Mixing Lattices	48
17. Pneumatic Delivery for Cotton Mixings	49
18. Pneumatic Delivery for Cotton Mixings (Plan and Elevation) tion)	51
19. Patent Rivet Catcher	52
20. Section Through Intermediate Delivery Box	53
21. Section Through Last Delivery Box	54
22. Hopper Feeder with Filling Motion	58
23. Platts' Feeder, Opener, and Bale Breaker	60
24. Lattice Feeding Machine	63
25. Dust Trunk	65
26. Lattice Feeder and Crighton Opener	67
27. Double Exhaust Opener and Lap Machine	71
28. Single Scutcher and Lap Machine	72
29. Arrangement of Beater Bars, Cages, and Fan	74
30. Buckley Opener Cylinder	74
31. Porcupine Cylinder with Cast-iron Toothed Discs	76
32. Porcupine Cylinder with Steel Blades	76
33. Improved Toothed Beater	77
34. Two-blade Beater	77
35. Three-blade Beater	77
36. Exhaust Opener Beater	78
36A. Conical Beater for Crighton Opener	79
36B. Crighton Opener Bars	79
37. Gearing of Single Horizontal Opener	80
38. Plan of Single Beater Scutcher	81

ILLUSTRATIONS

ix

FIG.		PAGE
39.	Revolving Flat Carding Engine	85
40.	Improved Five Setting Point Flexible Bend	87
41.	Bullough's Bend	88
42.	Diagram of Coiler Gearing	90
43.	Gearing Plan of Card	91
44.	Section of Drawing Frame	93
45.	Ermen's Clearer	95
46.	Coiling Motion	96
47.	Gearing for Drawing Frames	98
48.	Section of Flyframes	102
49.	Creel for Flyframes	103
50.	Creel for Flyframes (End Elevation)	104
51.	Methods of Cleaning Drawing Rollers	106
52.	Section of Roller Stand	108
53.	Gearing Plan of Flyframe	109
54.	Spindle Footstep Lubricator	110
55.	Passage of Cotton Through a Ringframe	113
56.	Dead Weighting	115
57.	Lever Weighting	115
58.	Lappet of Thread Board	116
59.	Elevations of Various Creels	117
60.	" Simplex " Flexible Spinning Spindles	118
61.	Simplex Flexible Spinning Spindles for Spinning on Paper Tubes	120
62.	Tape Drive to Spindles of Ring Spinning Frames	121
63.	Tin Rollers of Ringframe	122
64.	Traveller for Regulating Yarn Wound on Bobbin	123
65.	Blinker Separators	124
66.	Section of Ring Spinning Frame	126
67.	Separators	127
68.	Gearing from Tin Roller Shaft to Rollers (Ringframe)	128
69.	Section Through Creel and Carriage (Mule)	130
70.	Platts' Drawing-out Motion	134
71.	Side-elevation of Spindle Drive	135
72.	Side-elevation of Spindle Drive	136
73.	Platts' Taking-in Motion	138
74.	Taking-in Motion, Strap Controlled	139
75.	Gearing of Self-acting Mule	141
76.	Mule Spindles	143
77.	Mule Roller Traverse	146
78.	Wrap Block for Slivers and Rovings	149
79.	Yarn Wrap Reel	149
80.	Sensitive Balance	150
81.	Knowles' Balance	150
82.	Conditioning Oven	154
83.	Example of Use of Graphs	180
84.	Example of Use of Graphs	181
85.	Example of Isometric Drawing	192
86.	Example of Isometric Drawing	193
87.	Plan and Elevation	193
88.	Plan and Elevation	194

FIG.		PAGE
89.	Plan and Elevation	195
90.	Scales Used in Drawing	196
91.	Standard Whitworth Nut	197
92.	Bolt, Nut, and Lock Nut	198
93.	Pitch of Thread	199
94.	Pitch of Thread	199
95.	Fastening Pulleys to Shafts	200
96.	Types of Rivets Before being Driven in	202
97.	Types of Rivets After being Driven in	202
98.	Single Riveted Lap Joint	203
99.	Double Riveted Lap Joint	203
100.	Rivets and Rivet Joints	204
101.	Box Coupling	204
102.	Flanged Coupling	204
103.	Sectional Shading for Various Materials	205

FIRST YEAR COTTON SPINNING COURSE

PART I COTTON SPINNING

CHAPTER I

THE COTTON PLANT (*Botanical Classification*)

THE cotton plant, like all other trees, shrubs, plants, etc., has a botanical importance quite independent of its wonderful commercial value to the staple industry of Lancashire and other places.

Also, as we find in the case of roses, etc., there are many types of cotton plant, each of which has its own peculiar characteristics. The botanical name given to the cotton plant is—

GOSSYPIUM

and the following are the chief types of the plant.

1. *Gossypium Barbadosense*. Originally grown in the Barbados, and the best type of cotton grown.

2. *Gossypium Herbaceum*. A very hardy plant as the name implies, found growing commonly in India and Egypt.

3. *Gossypium Hirsutum*. A hairy plant. This is the usual type of American cotton.

4. *Gossypium Arboreum*. Tree cotton. Grows to a much greater height than the ordinary types of cotton, and generally gives fruit for a few years instead of being planted annually.

5. *Gossypium Neglectum*. Grown chiefly in India.

6. *Gossypium Peruvianum*. A native of Peru.

There are, of course, other types, but the above are the principal classes which we cotton users are likely to come into contact with.

The Growth of the Plant, etc.

The cotton plant is essentially a tropical one, and for this reason we only find it grown in the world's areas approximately 40° N. and S. of the Equator.

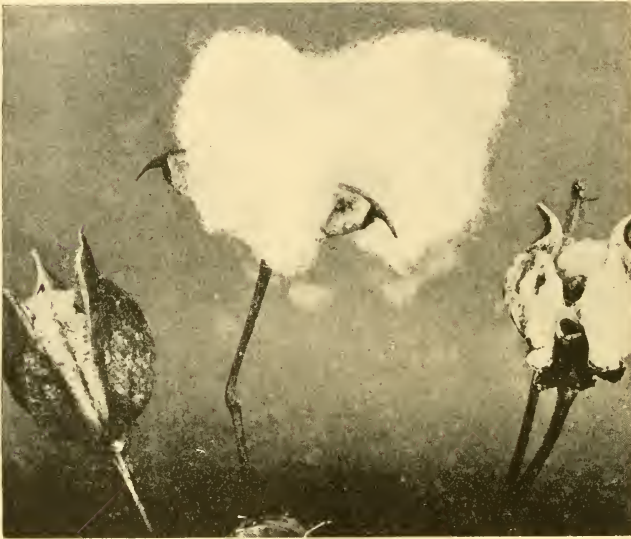

From "Cotton" (Peake)

FIG. 1. SEA ISLAND COTTON BOLLS

Owing to the tremendous variation in the seasons in different countries the time of growth of the cotton plant varies very considerably, but its general method of cultivation is the same, although in some districts natural conditions are ample for successful results, whereas other districts have to employ artificial methods.

The plant grows somewhat as follows: The ground is broken up and furrowed and the seed sown in the furrows. About

10 to 14 days after sowing the young shoots appear, and a little later defective plants, etc., are weeded out. The bud appears about 2 months after sowing, a month later the flower, and the pod will burst not more than 2 months after the flower has appeared.

It will be seen, therefore, that the cultivation of the cotton plant to its ripe state takes round about $3\frac{1}{2}$ to 5 months, although this time will depend to a very large degree on local conditions.

During the earlier periods of the plant's life frequent rains

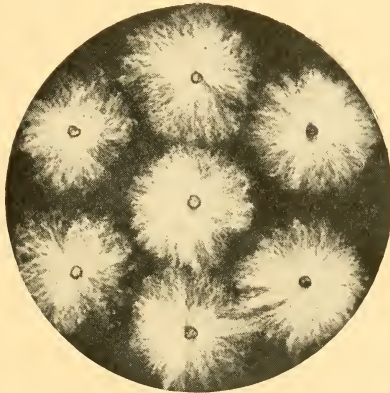

From "*Bleaching, Dyeing, Printing, and Finishing*" (Mc.Myn)

FIG. 1A. COTTON SEEDS WITH
FIBRES ATTACHED

of a light nature are desirable, but when the pod is ripening, dry, hot weather is essential.

The cotton pod is about the size of a small apple and is the container for the seeds, usually about thirty in number. It is these seeds which give us our raw cotton, which is nothing more nor less than a fibrous, downy covering for the seeds, intended by nature as an aid to the carrying of these seeds to new ground for future growth ; industry, however, stepped in and found a better use for these fibres.

In weight there is about twice as much seed as cotton fibre, so that only about one-third of that which is picked is useful from a cotton spinning point of view, although the seeds, which

are separated from the fibres by the process known as ginning, are carefully selected for the following year's crop.

The cotton is picked by hand, and as the fibres adhere very firmly to the seeds at one end, it is quite impossible to pick one without the other, and, of course, a certain amount of stalk, leaf, etc., is also picked with them. Particularly is this the case in America where such a large crop has to be dealt with in the shortest possible time. When the cotton plant ripens the pods burst and expose the cotton and seeds, and it is due in a great measure to this exposure that sand and other foreign matter are picked with the cotton.

The average cotton seed is the same size as a pea. As is the case in the growth of all plants, there are several agents which have an injurious effect on the cotton plant; the chief of which are: (1) too dry or too wet weather; (2) too hot or too cold weather; (3) insects. Probably the most serious is (3), as the insect pest can quite easily ruin a large proportion of the crop. So serious is this trouble that the plants are sprayed periodically, and in America during the past two years aeroplanes have been used for the spraying of gases to kill these pests.

The best known insects are the *Boll Weevil* and the *Cotton Caterpillar*.

One of the solutions used for their extermination is a mixture having as some of its ingredients arsenic and red lead.

The best conditions for the growing of cotton may be summarized as follows—

1. A light, loamy soil containing limy substances.
2. A temperature ranging from about 70° to 80° F. during growth.
3. A good rainfall or else good irrigation.
4. A humid atmosphere.

THE PROPERTIES OF COTTON FIBRES

Ripe cotton fibres are twisted cylindrical tubes, being about the same width throughout their length except for about the last one-twentieth farthest away from the seed which tapers off to a point (these pointed ends are broken off in the initial processes). They are about 1,200 times as long as they are broad, and are coated with wax to the extent of about one-hundredth of their total weight, and this wax softens and helps

to make the fibres pliable in the warm, humid atmosphere of the mill.

Ripe cotton is made up of the following : cellulose, carbon, and water ($C_6H_{10}O_5$), and the cotton pod when developed is called *boll*, while cotton immediately after picking is called *seed cotton*.

When comparing one lot of cotton with another for quality and value, the following are the properties from which we should make our comparison.

- | | |
|-----------------------|--|
| 1. Natural twist. | 6. Colour. |
| 2. Length of fibre. | 7. Elasticity. |
| 3. Strength of fibre. | 8. Cleanliness. |
| 4. Fineness. | 9. Freedom from short-cut fibres, neppy, or dead fibres. |
| 5. Uniformity. | |

Cotton fibres vary very considerably in length, being from about $2\frac{1}{4}$ in. in the best Sea Islands to about $\frac{5}{8}$ in. in the poorest Indian, and invariably the longest fibres are the thinnest, so that we find Sea Islands $\frac{1}{1600}$ in. in diameter, while Indian is something like $\frac{1}{1100}$ in.

The longest and thinnest fibres make the finest and best yarns because they contain the most natural twists, and we are able to get the largest number of fibres in the cross-section of the yarn.

In colour cotton is, generally speaking, from white to creamy, but there are many exceptions, the most notable being Brown Egyptian (this is really golden in colour) and Red Peruvian (which is the deepest coloured cotton grown).

Natural Twist

This is the most important and distinctive feature of the cotton fibre, and is probably the principal reason that it is the most used textile fibre in the world. The cause of this natural twist is that when the fibres are ripening the sap, which runs up the hollow in the centre of the fibre, is withdrawn into the seed, thus causing the fibre to twist round.

Natural twist helps in a very large degree to make strong, round, solid yarns, by making the fibres cling to one another in a manner which is quite impossible in other textile fibres.

Long thin fibres such as Sea Islands contain the most

natural twists, round about 300 per in., Egyptian have about 180, while Indian have only just over 100 per in.

THE DEFECTS IN COTTON

As is only to be expected, cotton contains quite considerable amounts of impurities and several very troublesome defects, the chief of which are—

- | | |
|-----------------------------|---------------------|
| 1. Seeds. | 7. Broken fibres. |
| 2. Seed husks. | 8. Unripe fibres. |
| 3. Broken leaf and stalk. | 9. Dead fibres. |
| 4. Sand and Mineral matter. | 10. Motes. |
| 5. Excessive moisture. | 11. Stained fibres. |
| 6. Nep. | |

In addition to the above all cotton contains a certain percentage of short fibre, which is taken out in the scutching, carding, and combing processes.

Seeds

These are all supposed to be removed by the ginning process, but owing to the imperfections of the machines and other causes some get to the mill and are removed by the opening and scutching processes.

The best of the seeds are selected for the following year's crop, while the remainder are used up for the manufacture of cattle food, cotton seed oil, and manure.

Seed Husks, Broken Leaf, and Stalk

These are found in the cotton for two reasons: (1) Faulty picking, and (2) Faulty ginning.

No matter how much care is taken in picking, which is done by hand, mechanical means, up to the present at any rate, having failed, some of these impurities are bound to get into the cotton, on account of the fact that the cotton bolls are so close to the leaves.

Especially is this the case in American cotton, where speed of picking is the first essential.

Sand and Mineral Matter

These impurities also are in a large measure due to faulty picking, but in many instances they are unavoidable, as when

the bolls burst, the fibres being exposed are susceptible to gathering any sand, dust, etc., which may be blown about by the winds. It must not be forgotten, however, that in many cases sand and metal are put into the bales as a means of adulteration.

Excessive Moisture

Owing to its absorbing nature cotton will, in its natural state, contain about 7 to 8 per cent of moisture, but tests often reveal the fact that there is even more than this, and we must come to the conclusion that at times water is deliberately added in a dishonest manner. The moisture testing oven soon shows up this matter, and, of course, a claim can be made against any excess.

Nep

This may be either natural or artificial, and consists of little white balls of knotted cotton fibres about the size of a pin head. It is one of the most troublesome things we have to deal with in the mill, as these white specks are very difficult to remove from the cotton. Naturally, they are formed by the dead and unripe fibres curling round the good fibres, but probably an equal amount is caused by the early machinery through which the cotton passes. Careless ginning and bad setting of the opener, scutcher, and card are causes of nepped cotton, and the American saw gin, by its rough action upon the fibres, causes a great deal of "nep."

Over-beating or too close bar-and-beater setting on scutchers, or careless setting on the card, will also cause much nepped cotton.

Broken Fibres

These can be attributed pretty well *in toto* to the ginning process, and again the saw gin is the worst culprit. That is one reason why it is never used for the better class cottons.

Unripe and Dead Fibres

Certain proportions of these are bound to appear in any cotton, and they are of no practical value for the following reasons: (1) They have no natural twist; (2) They are thin and ribbon-like instead of being hollow and round; (3) They will not take dye well and are very bad for bleaching purposes.

Stained Fibres

These also are a great nuisance in the mill and are caused by : (1) Crushed seeds ; (2) Rusty bale bands ; (3) Damp ; (4) Mud, etc., due to careless transportation and imperfect coverings (especially American bales).

Motes

Hard matted clusters of cotton fibres, probably due to damp, or oil from crushed seeds. Usually taken out in the scutching and carding processes.

GENERAL NOTES ON COTTON, ETC.

1. Generally speaking, the names of cottons are obtained from the place of growth or shipment, although there are exceptions, such as *Sakellaridis*, which obtains its name from the name of the discoverer of the seed.

2. It is usual to replant fresh seeds each year and so get annual crops, but certain types of tree cotton are exceptions to this rule and will give fruit up to five or six years.

3. The usual height of cotton plants is from 3 to 6 ft. ; tree cotton, however, will grow up to 15 to 20 ft. high.

4. The seeds are usually planted in drills about 5 ft. apart, leaving an ample passage for attention.

5. *Lint* is the name given to cotton after it has been ginned, i.e. *lint* is cotton without seed. Egypt gives most lint per acre, about 300 lb., against America 200 lb., and about 160 lb. for India.

6. Cotton is the most popular and most used textile fibre for the following reasons : (a) Its natural colour and physical features are suitable for yarns and cloths ; (b) Its length is very convenient for mechanical treatment ; (c) It requires less treatment after picking before being ready for the mill than any other fibre ; (d) It is cheaply and easily converted into yarn and cloth, especially in the ordinary qualities.

It is, of course, the shortest textile fibre.

7. The other leading textile fibres are wool, silk, jute, and flax, the finest goods being made from silk, the warmest from wool, the coarsest, such as bagging, from jute, and the strongest, such as domestic thread, from flax and linen. Others of smaller importance are rami or China grass, hemp, asbestos, and lastly, one which is gaining rapidly in importance, artificial silk.

China grass, flax, hemp, and jute are very strong, silk and

wool are strong, cotton is only moderately so, and asbestos is weak.

Silk and wool are very elastic, cotton is only moderately so, and the others are inelastic. Silk is exceedingly smooth, wool and cotton moderately so; flax, China grass, jute, and hemp in the raw state may be classed as rough in comparison, but when cleaned of all impurities the resultant thread becomes smooth.

Asbestos has a greasy smoothness, but its use for yarns and fabrics is limited by its coarseness and weakness. The strength of the combined fibres of silk, wool, and cotton make them easy to weave both in warp and weft, but the other fibres, owing to their stiffness and inelastic nature are much more difficult to manipulate, especially as a warp yarn.

8. The following are the five methods usually adopted for distinguishing the presence of different textile fibres.

- (a) General observation.
- (b) Microscopic examination.
- (c) Chemical tests.
- (d) Dyeing tests.
- (e) Burning tests.

Example. To distinguish wool and silk from cotton and flax: picric acid will dye wool and silk almost a fast yellow, and will have no effect on cotton or flax.

THE WORLD'S COTTON GROWING AREAS

Owing to the great strides which have been made during the past few years in the encouragement of cotton growing in many parts of the British Empire, it is really very difficult to enumerate all the world's present and possible cotton growing areas, and the following list must not by any means be considered as exhaustive or final, but must be taken more as a general guide.

The vast bulk of the cotton grown, however, is produced in three countries only, namely, U.S.A., India, and Egypt, in proportions somewhat as follows—

U.S.A.	60 per cent
India	15 „
Egypt	5 „
Other countries	20 „

100 per cent

A few years ago the percentages were as follows—

U.S.A.	70 per cent
India	17 „
Egypt	7 „
Other countries	6 „
					100 per cent

and as most of the places included in "other countries" are British colonies, it will at once be seen that great headway has been made, thanks in no small degree to the Empire Cotton Growing Corporation, although the question of finance has been, up to now at any rate, a harassing feature.

The following is a list of the more important cotton growing countries: United States of America, India, Egypt (including Sudan), Africa (East and West), South America (Brazil and Peru), the Bahama Islands, China, and Russia.

Places of less importance but which are undoubtedly increasing their production are: Uganda, Syria, Japan, Rhodesia, West Indies, Smyrna, Cyprus, Turkestan, Mexico, Queensland, etc.

The following was the 1914 cotton crop—

U.S.A.	14,610,000 bales
India	5,987,000 „
Egypt	966,000 „
Other countries	7,737,000 „
					Total	29,300,000 bales

The 1926 American cotton crop was 17,900,000 bales, which is a record.

Below is a list of the world's principal raw cotton ports.

England	.	.	.	Liverpool and Manchester
France	.	.	.	Le Havre
Belgium	.	.	.	Antwerp
Germany	.	.	.	Bremen
Holland	.	.	.	Amsterdam
Egypt	.	.	.	Alexandria
India	.	.	.	Bombay
China	.	.	.	Shanghai
U.S.A.	.	.	.	New York, Orleans, Houston, Galveston, Charlestown

CHAPTER II

THE SPECIAL FEATURES OF VARIOUS KINDS OF COTTON

1. Sea Islands

THIS cotton derives its name from the fact that it originates from the Bahama Islands, and it is of the *Gossypium Barbadosense* type (native of Barbados). Nowadays, however, we find many classes of Sea Islands cotton as the seeds have been planted in other districts, but none of these classes, although good, are as good as the real Sea Islands cotton, which is easily the best cotton grown in the world. When compared with other cottons for amount grown it probably goes to the bottom, as there are only about 30,000 to 40,000 bales produced annually, which is, of course, a very minute portion of the world's total supplies.

The reasons for the superiority of Sea Islands cotton over all other growths are as follows—

1. The climatic and atmospheric conditions of the places of growth are such as to ensure the best possible results (i. e. warm and moist).

2. These conditions are helped to a very considerable extent by fertilizers, and if found necessary, the most skilful irrigation is added.

3. The soil is light and loamy and contains the best natural ingredients for good growth.

4. The seeds are picked with the greatest possible care and skill.

5. During growth the utmost care is taken in weeding out defective plants, pruning, and picking.

6. It is only ginned by the Macarthy gin (which is most gentle in its treatment of the cotton) and, generally speaking, it is only made up into lightly-pressed bales of from 250 to 300 lb. weight, although the writer has dealt with Sea Islands bales weighing 620 lb. each

All these conditions make Sea Islands cotton absolutely unrivalled, no matter how it is considered, whether with regard to length, fineness of staple, regularity of natural twist, or colour.

It must be understood, however, that this type of cotton is very expensive and troublesome to grow, is hard to gin, and extremely difficult to manipulate in the mill, as it contains a large proportion of short, unripe, and dead fibres, is very neppy, and, generally speaking, although there are some few exceptions, it will not mix with any other kind of cotton.

For these reasons it is only used for the production of the very finest counts and highest qualities of yarns, which yarns are used for the making of goods which rival and imitate silk, such as fine muslins and the very finest lace. It is always combed and very often double and even treble combed, taking out anything up to 30 per cent of waste at the comber.

The counts spun from Sea Islands cotton range, usually, from about 100s to 350s, and the writer knows of one firm spinning a limited quantity of 440s, and we are given to understand that even finer counts than these have been spun.

In colour it is a very light cream, practically white. The principal growing centres for this type of cotton are: the Bahama Islands, the coastlines of Florida, South Carolina and Georgia, Peru, West Indies, Fiji Islands, and a few other places, but, as mentioned previously, all the latter are inferior to the first named.

The leading cotton market for Sea Islands cotton is Charleston, and it has been found that Edisto Island gives the very best cotton.

The staple has been found occasionally to reach 2.25 in., but the average length is about 1.8 in., and the average diameter about $\frac{1}{1560}$ in.

Name of Cotton	Where Grown	Length	Diam.
Sea Islands (Proper)	Edisto, John, James, Port Royal, St. Simon, etc.	1.6 in. to 2.25 in. Av. 1.8 in.	$\frac{1}{1580}$
Florida S.I. . . .	Coast of Florida, S. Carolina, Georgia	1.25 in. to 1.75 in.	$\frac{1}{1560}$
Peruvian S.I. . . .	Peru from S.I. seed .	1.5 in.	$\frac{1}{1500}$
Fiji S.I.	Fiji Islands	1.6 in. to 2 in.	$\frac{1}{1570}$

2. Egyptian Cotton

Following Sea Islands in quality and much exceeding it in quantity is Egyptian cotton, which has an annual crop of round about 1,000,000 bales, of an average weight of some 725 lb. each.

The success of the quality of Egyptian cotton is due practically entirely to the fact that the cotton-fields are situated on or near the banks of the river Nile, which rises each year to such an extent that it overflows its banks, for many miles in places, and when it recedes it leaves a muddy, loamy soil, which has proved by experience to be the finest possible material for the growth of the cotton plant.

This deposit is, of course, carried down by the river from its source, and, seeing that the rainfall in Egypt is very small, artificial irrigation has to be resorted to, with the result that dams, canals, large concrete tanks, etc., have been erected to hold the overflow waters when the river recedes, in order to ensure an ample water supply for the plants during growth.

In colour, Egyptian cotton varies from a light cream to a distinctly golden tint (known as Brown Egyptian), and in one case, that of Abassi, it is practically white. The length of staple varies from about $1\frac{5}{8}$ in. in the best Sakellaridis, to about $1\frac{1}{8}$ in. in the poorest Uppers, whilst the average diameter is something like $\frac{1}{1475}$ in.

Until recently it was not the general practice to mix Egyptian cottons, with the exception of a small quantity of the best being blended with the poorer Sea Islands, but since the Sudan cotton-fields were opened up quite a fair amount of Sudan is mixed with good quality Sakellaridis, in fact many of these Sudan growths are from Sakellaridis seeds.

Egyptian cottons are suitable for the spinning of both twists and wefts, and the counts vary according to mill conditions, but the best Sakellaridis combed cotton (16 per cent waste) will spin a very good 150s weft. So good are the spun results that the best sewing threads, shirtings, etc., are manufactured from these cottons.

Abassi (i.e. White Egyptian) is another variety which will blend successfully with the best types of American cotton (such as Benders and Peelers).

Practically the whole of the Egyptian crop is ginned by the Macarthy gin, and the chief port of exportation is Alexandria. Egyptian bale particulars are as follows—

Total weight (average)	750 lb.
Density	36 to 38 lb. per cub. ft.
Tare	22 lb.
Measurement	50 × 30 × 20 in.
Bands	11

The present-day varieties in order of quality are as follows—

Name	Date	Where Grown	Length	Diam.	Colour	Remarks
Sakellaridis	. 1906	Lower Egypt, i.e. Delta	inches 1 $\frac{3}{8}$ to 1 $\frac{3}{4}$	$\frac{1}{1550}$	Very light cream	Large amount grown
Abassi	. 1893	Lower Egypt	1 $\frac{1}{4}$	$\frac{1}{1350}$	White	
Nubari	. 1905	Very little grown				60 per cent of Egyptian crop
Assili	. 1906					
Zagora	. 1921	Upper Middle and	1 $\frac{3}{8}$ to 1 $\frac{1}{4}$	$\frac{1}{1450}$	Deep golden	
Ashmouni	. 1860	Lower Egypt				
Mit Afifi	. 1882					

* Known as the Brown varieties.

3. Sudan Cotton (British Empire)

Another cotton growing area which must be linked with Egypt, and which is becoming one of the important fields is the Sudan, where the Empire Cotton Growing Corporation are doing such great work.

A good quality of cotton is being produced, particularly with the imported Sakel seed, and we can look forward to still further improvement in the near future. Sudan bales arriving in this country at the present time are averaging about 430 lb. weight each.

It is estimated that in the course of the next 10 to 15 years the production of cotton in the Sudan will have increased to 1,000,000 bales per annum of cotton as good as that produced in Egypt.

The chief place of cultivation is in the area between the White and Blue Niles (i.e. Gezira Plain), although there are also other areas under cultivation.

The three chief types grown in the Sudan are Sakel, Ashmouni, and Uplands American in approximately the

following percentages : 45, 45 and 10, and the present crop is about 100,000 bales per annum.

4. South American Cottons

These include chiefly Brazilian and Peruvian growths, but other minor cotton-fields in South America are Argentine, Chile, Colombia, Dutch W. Indies, Surinam, Ecuador, Guatemala, Hayti, San Domingo, Mexico, Nicaragua, Paraguay, Porto Rico, San Salvador, Uruguay, and Venezuela ; and serious endeavours are now being made to improve the productions of these countries, both in quantity and quality.

Up to the present the qualities produced in these minor cotton-fields does not exceed, generally speaking, that of U.S.A. cottons.

Brazil, however, produces a vast quantity, something like 1,000,000 bales of 500 lb. each per annum, and succeeds in keeping a quite good quality. The country being entirely tropical or sub-tropical, is eminently suited for the growing of cotton, and with care and skill there is no reason why the quality should not improve.

Methods of cultivation, etc., are, however, very primitive, and the saw gin is practically universal throughout the country.

Baling also is not attended to as it ought to be, and very little encouragement is given to careful picking with the result that there is a tremendous amount of dirty and stained cotton.

Brazilian cotton is harsh and wirey, a dull white in colour, and fairly strong, and is used for both twist and weft yarns up to 70s or so, being often mixed with U.S.A. cottons.

The following are some of the chief types of Brazilian

Name	Length	Diameter
Pernam	1.3 in.	$\frac{1}{1250}$
Maranham	$1\frac{1}{4}$ in.	..
Paraiba	$1\frac{1}{8}$ in.	..
Ceara	$1\frac{1}{8}$ in.	..
Maceio	$1\frac{1}{8}$ in.	..
Nahia	$1\frac{1}{8}$ in.	..
Aracati	$1\frac{1}{8}$ in.	..
Santos*	$1\frac{1}{8}$ in.	..

* From American seed, softer than the above

cotton, and it will be noticed that most of them receive their name from the district in which they are grown.

Peruvian cotton is of three chief types, and is grown principally on the coasts.

They are as follows: (1) Rough Peruvian; (2) Smooth Peruvian; (3) Tanguis Peruvian, and, of course, some cotton is grown from Sea Islands seed as has been previously mentioned. They have an average staple of $1\frac{1}{4}$ in., with a diameter of $\frac{1}{18000}$ in., and like Brazilian will spin up to about 70s, but whereas rough Peruvian is harsh and crinkly and used in large quantities for mixing with wool, smooth Peruvian is much softer and smoother, and suitable for cotton yarn spinning.

Tanguis is supposed to be a mixture between smooth and rough, and it is now said to constitute the major portion of the crop.

A little cotton from Egyptian seed is also grown in Peru. There is also a Red Peruvian cotton, but it is not grown in large quantities on account of its colour not being adaptable for bleaching, dyeing, etc.

5. U.S.A. Cottons

As has been previously mentioned, the great preponderance of the world's cotton crop is grown in U.S.A., and as the cotton grown is suitable for making up into goods for domestic purposes, such as towels, etc., there is a very large demand for it.

The 1926 crop, which was a record, was about 18,000,000 bales of 500 lb.

The following are the thirteen principal states in which cotton is grown in large quantities: North Carolina, South Carolina, Mississippi, Louisiana, Georgia, Texas, Florida, Arkansas, Alabama, Tennessee, Virginia, Oklahoma, and Missouri. These cottons are mostly of the Hirsutum type and are of two principal classes, viz., short- and long-staple Upland, these types being split up in their turn into many other varieties.

It must be remembered, of course, that Sea Islands cotton is also grown on the coast lines of North and South Carolina, Florida, and Georgia.

Short-staple Uplands cotton (in which are included Orleans or Gulf cotton, Texas, etc.) comprises about 90 per cent of the

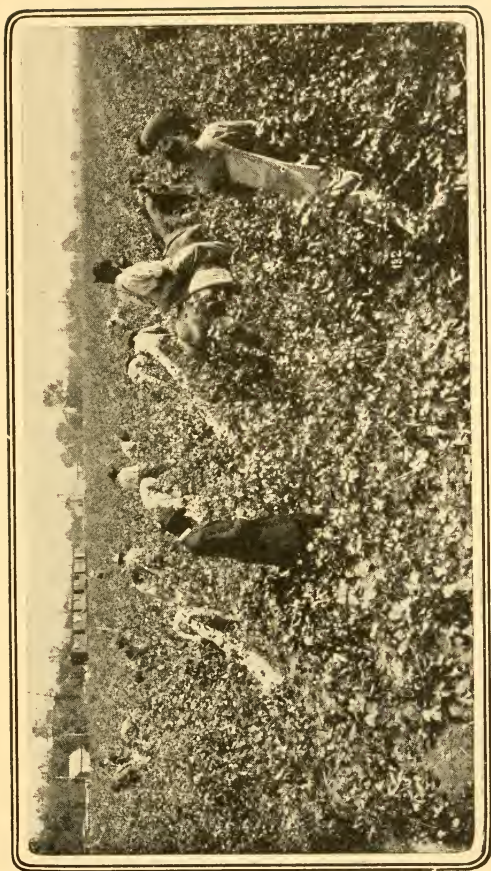

FIG. 2. COTTON FIELDS—GATHERING THE RAW MATERIAL
(“*Illustrated London News*”)

American cotton crop, and is suitable for the spinning of any counts up to about 50s, having an average staple of about 1 in.

Long-staple Uplands (in which are included such special cottons as Benders, Peelers, and Allan-Seed) will spin up to about 100s, average staple $1\frac{3}{8}$ in.

American cotton will pass through the mill easily and cheaply, and is, compared with Egyptian cotton, not often combed, although a large trade of semi-combed American Yarns has sprung up these last few years.

American bale particulars are as follows—

Density, 15 to 30 lb. per cub. ft.

Weight, 500 lb.

Badly covered and banded.

Cylindrical bales are 35 in. long by 22 in. diameter, weigh about 250 lb., and have a density of about 35 lb. per cub. ft.

American cottons are mostly white in colour.

Name	Length	Diameter	Remarks
Long-staple Uplands	$1\frac{3}{8}$ in. to $1\frac{1}{4}$ in.	$13\frac{1}{2}$ in.	Includes Benders, Peelers, Nashville, Allansseed, etc. Best grown, fibres strong, soft, light creamy colour
Texas— Mobile			90 per cent of American crop
Ordinary Uplands	1 in.	$13\frac{1}{10}$ in.	Dull white colour

6. Indian Cottons

In point of quantity these cottons rank second only to U.S.A., as the production is about 5,500,000 bales of 400 lb. each per year, and it is hoped that this will be increased to 6,000,000 bales in the next few years. In quality Indian cotton is the worst which is grown to any extent, over 75 per cent of the crop having a staple which does not exceed $\frac{7}{8}$ in., some being below $\frac{1}{2}$ in., and a few of the very best Indian cottons reaching as high as $1\frac{1}{8}$ in.

It is hoped that by the introduction of more up-to-date irrigation methods, more careful attention of plants, and more skilful picking, to improve the quality to such an extent that

there will be about 2,000,000 bales of cotton having a staple of $1\frac{1}{16}$ in. to $1\frac{1}{8}$ in. Ginning is done mostly by roller gins.

Below will be found the particulars of the chief types of Indian cotton grown at the present time.

Name	Length	Diameter	Remarks
Hingunghat . . .	$1\frac{1}{16}$ in.	$\frac{1}{1200}$	Best, light golden
Broach . . .	1 in.	„	Deep colour, clean
Oomras . . .	1 in.	„	Dirty, but strong
Dhollera . . .	1 in.	„	Dirty but strong, dull white
Tinnevelly . . .	1 in.	„	Dull cream, mod. clean
Dharwar . . .	1 in.	„	Cream, irregular
Madras . . .	1 in.	$\frac{1}{1175}$	Dirty, mod. strong
Comptah . . .	1 in.	„	Dirty and weak
Bengal . . .	1 in.	„	Strong, harsh, dirty
Scinde . . .	1 in.	$\frac{1}{1155}$	Dull white, weak

Counts from 30s downwards.

Fifty per cent of the Indian cotton crop is used by the Indian mills themselves, and Japan is her best raw cotton customer, taking close on 2,000,000 bales per annum.

7. China Cottons

Although authentic statistics are difficult to obtain, it is believed that the output of raw cotton per annum in China is about 2,000,000 bales of 500 lb. each.

The staple is very short, somewhere about $\frac{5}{8}$ in. ; its natural colour is khaki, and in many instances it is not suitable for the spinning of yarns, but is used for mixing with wool, etc.

Methods of cultivation, etc., are very primitive, so much so, that even to-day, a considerable amount of the crop is ginned by hand, although recently a number of Japanese roller gins have been introduced.

8. Minor Cotton Fields in Europe

(a) *Russia*. The two principal cotton growing areas are Turkestan and Transcaucasia, and a cotton very like Indian with a staple of about $\frac{7}{8}$ in. is produced, although in some parts, where American cotton seed has been kept pure, a staple of $1\frac{1}{8}$ in. is obtained.

Although the production has been 1,000,000 bales, at present it is about 200,000 bales of 500 lb. each.

(b) *Bulgaria*. This country grows a few thousand bales per annum at her southern end, of the following three types—

Kaskova, $\frac{9}{16}$ in. to $\frac{13}{16}$ in. staple.

Turkestan, $\frac{5}{8}$ in. to 1 in. staple.

Upland-American, $\frac{3}{4}$ in. to $1\frac{3}{16}$ in staple.

(c) *Greece*. Its production is about 9,000 to 10,000 bales per annum, all of which is needed for home consumption. Attempts to grow Egyptian cotton here have failed.

(d) *Italy*. Southern Italy and Sicily produce about 5,000 bales per annum of Upland-American, Biancavilla, and Terranova cottons, which have a staple of about 1 in.

(e) *Spain*. It is said that there are about 2,000,000 acres of land in Southern Spain (the Seville district), suitable for the growing of cotton equal in quality to American.

9. Minor Cotton Fields in Asia

The following are the cotton-fields—

Afghanistan, Dutch East Indies (staple $\frac{7}{8}$ in.), Indo-China, Japan (4,500 bales), Korea, Philippines, Siam, Turkey, Smyrna.

10. Africa

Fields are Belgian Congo (20,000 bales— $1\frac{1}{8}$ in. staple); French colonies, including Algeria, French West Africa (Senegal, Ivory Coast, Guinea, Togo, and Dahomey), French Sudan, Madagascar; Italian colonies (Eritrea, Somaliland); Portuguese colonies (Angola, Mozambique, Inhambane). Togo produces $\frac{7}{8}$ in. staple Hirsutum cotton and some Togo Sea Island with a staple of $1\frac{1}{16}$ in. to $1\frac{1}{2}$ in.

11. British Empire Growths

(a) *Uganda*. Has the second highest production in the Empire, about 250,000 bales per annum of cotton which has a staple of 1 in. to $1\frac{3}{16}$ in.; the lint being fine, silky, strong, and regular. Both roller and saw gins are used.

Crop will probably increase to 500,000 bales in next few years.

2. Lengths of lint are roughly as follows—

Indian and Chinese	$\frac{1}{2}$ in. to 1 in.
Asia Minor	$\frac{3}{8}$ in. to $1\frac{1}{8}$ in.
Brazilian	$\frac{3}{4}$ in. to $1\frac{1}{4}$ in.
Russian	1 in. to $1\frac{1}{8}$ in.
West African and American Upland		1 in. to $1\frac{1}{8}$ in.
East African	1 in. to $1\frac{1}{4}$ in.
Peruvian	1 in. to $1\frac{1}{2}$ in.
Long-staple American Upland		$1\frac{1}{2}$ in.
Egyptian	$1\frac{1}{4}$ in. to $1\frac{3}{4}$ in.
Florida and Georgia Sea Island		$1\frac{1}{2}$ in. to $1\frac{3}{4}$ in.
Carolina and West Indian Sea Islands		2 in. and over

3. Diameters are—

Sea Islands -00064
Upland -00077
Rough Peruvian -00078
Brazilian -0008
Indian -00084

Some details of this chapter are from *Cotton and its Production* (Johnson).

CHAPTER III

COTTON GINNING AND BALING

THE first mechanical process to which the cotton is subjected is that of ginning.

As has previously been stated cotton is picked by hand, it being quite impossible to pick the cotton without the seed, and it is left to the fairly brutal process of ginning to effect this separation of fibres from seeds.

Before the introduction of automatic machinery cotton was very largely ginned by hand, although long ago in India some attempt at machinery was made by using the Churka gin, which was simply a pair of wooden rollers worked on the mangle principle. Other primitive gins were the foot roller gin and the bow gin.

Speaking generally, the proportion of seed to cotton fibre in Egyptian and American cottons is 2 to 1, while in Indian cotton it is as high as 3 to 1.

The tremendous strides made in the cotton industry, and hence the necessity of increased production of raw cotton, has made it that the old-fashioned methods of ginning were quite incapable of coping with the weight required, and so the introduction of power machinery was an essential feature in this development.

Nowadays there are two chief types of gin.

1. The saw gin.

2. The Macarthy roller gin.

Another gin, but one nothing like as popular as the two mentioned above, is the knife roller gin, which, although different somewhat in actual detail, is in many respects similar in principle to the Macarthy gin.

A still more recent improvement in ginning is the introduction of a *cylinder seed cotton opener* for treatment of the seed cotton before it is actually acted upon by the gin.

It has been found that all seed cotton is more or less matted together on account of the interlacing of the fibres, and especially is this so in the case of American and Indian cottons.

The seed cotton opener is so made that it disentangles and

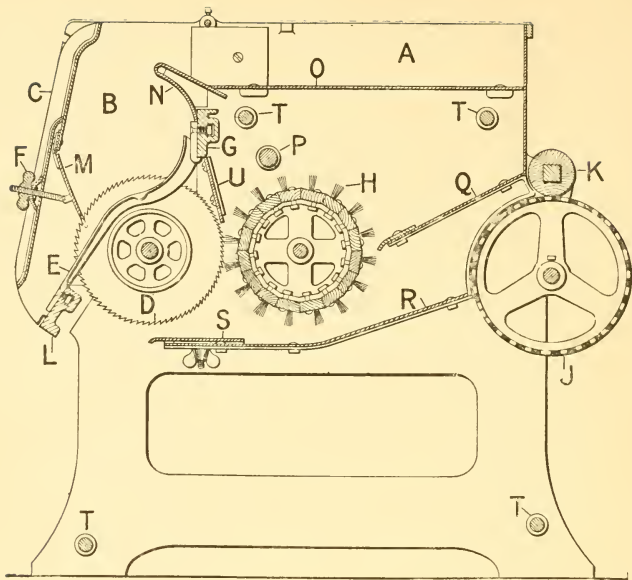

Dobson & Barlow, Ltd.)

FIG. 2A. SECTION THROUGH SAW GIN

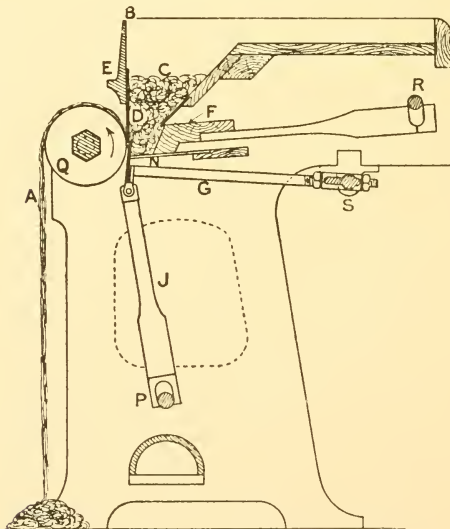

FIG. 2B. SINGLE-ACTION MACARTHY GIN

straightens the fibres, and also helps, by the action of a fan, to take away some of the foreign impurities, and so considerably increases the production of the gin itself.

In America, where the cotton is only roughly ginned, most seeds, after ginning, still have a very considerable number of short fibres adhering to them, and these seeds are again ginned by a closer set machine.

The cotton thus produced at this second ginning process is known as *linters*, and is used chiefly for packing purposes, such as glassware, etc.

BALING

Any attempt to transfer the cotton lint from the country of growth to the country of manufacture in its natural loose state would be ridiculous, although it would be a very pleasing thing for the mills if they could receive it exactly as it is ginned.

For the sake of making transport as cheap and as economical as possible, therefore, all cotton is very tightly compressed into bale form before being shipped.

Weights and sizes of bales have already been mentioned, and all that remains to be said is that the cotton is usually baled by hydraulic presses and the bands are put on while the bales are under pressure, so that we have a solid, compact, mass of cotton, held very firmly and prevented from expanding by the metal bands.

All that remains now is to ship the cotton, and it is in this bale form that we receive it in our mills in Lancashire. It is from this point that the real process of manufacture commences.

Cotton Bales

Cotton bales from U.S.A. present a ragged and untidy appearance on reaching the mills for the following reasons : (1) they are badly covered in the beginning at the press ; (2) cotton samplers treat the cotton far too roughly ; (3) the coverings are damaged through forcing the bales too tightly in and out of the ship ; (4) bands are often broken by crane hooks.

Other faults common in U.S.A. bales are : (1) sometimes lumps of sand are put in the bales wilfully at the press ; (2) water is added.

Very damp cotton is subject to forming into hard cakes or "bump" cotton.

Occasionally bales are damaged in transit to the mill, becoming dirty and wet on the outside, due to bad covering or dirty transport wagons or being left standing on dirty ground. The term "country damage" is applied to such cases. Partly due to this bad baling various forms of round bales have been introduced, but have not made great progress.

American cotton bales are much more subject to damage by fire than the harder pressed bales from the East, such as India and Egypt.

Egyptian bales are the best packed which come into this country.

CHAPTER IV A

COTTON SPINNING MACHINERY

THE process order of the machinery in a modern cotton spinning mill is as follows—

1. The bale breaker and mixings.
2. The hopper feeder.
3. Opening and scutching machinery.
4. The carding engine.
5. The sliver lap machine.
6. The ribbon lap machine.
7. The comber.
8. The drawframe (three heads).
9. Bobbin and flyframes (slubber, intermediate, and roving frame).
10. The mule or ring spinning frame.

N.B. (a) In the case of carded yarns 5, 6, and 7 are omitted, the carded sliver passing directly to the drawframe.

(b) When producing the coarser yarns sometimes only two bobbin and flyframes are used instead of the usual three.

(c) For the specially fine counts we sometimes find an extra flyframe introduced (i.e. a fourth) known as the fine jackframe.

THE SERIES OF OPERATIONS IN COTTON SPINNING
(Functions Performed by each Machine Marked *x*)

Machines	OPERATIONS						
	Opening	Cleaning	Regularizing	Drafting	Producing Paralleliza- tion of Fibres	Twisting	Winding
Bale breaker	<i>x</i>	<i>x</i>	<i>x</i>	<i>x</i>	—	—	—
Opener	<i>x</i>	<i>x</i>	<i>x</i>	<i>x</i>	—	—	—
Scutcher	<i>x</i>	<i>x</i>	<i>x</i>	<i>x</i>	—	—	—
Card	<i>x</i>	<i>x</i>	<i>x</i>	<i>x</i>	—	—	—
Comber	—	<i>x</i>	<i>x</i>	<i>x</i>	<i>x</i>	—	—
Draw frame	—	—	<i>x</i>	<i>x</i>	<i>x</i>	—	—
Flyer frames	—	—	<i>x</i>	<i>x</i>	<i>x</i>	<i>x</i>	<i>x</i>
Ring frame	—	—	<i>x</i>	<i>x</i>	<i>x</i>	<i>x</i>	<i>x</i>
Mule	—	—	<i>x</i>	<i>x</i>	<i>x</i>	<i>x</i>	<i>x</i>

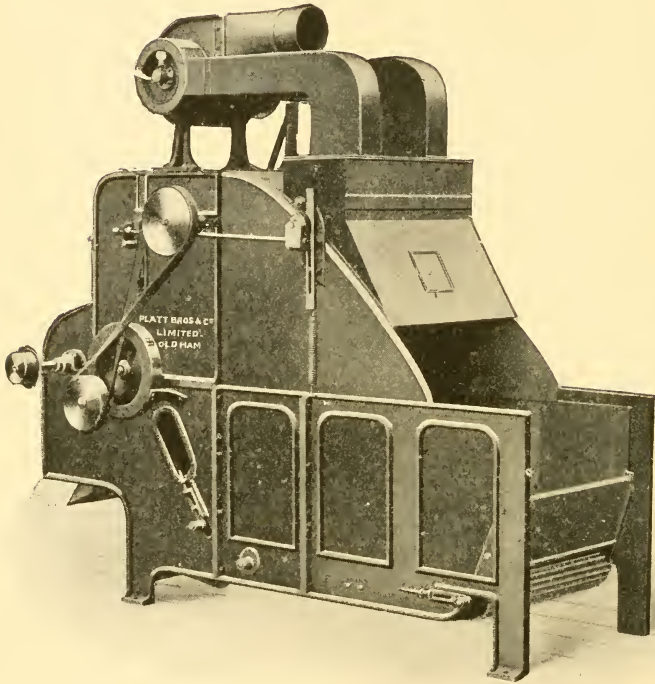

(Platt Bros.)

FIG. 3. HOPPER BALE BREAKER OR IMPROVED COTTON
PULLING MACHINE

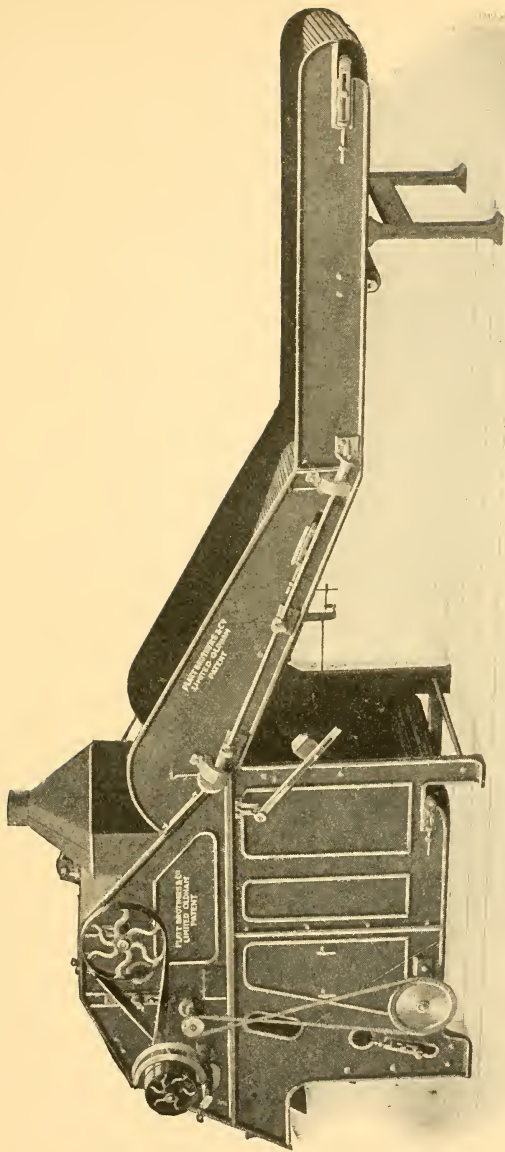

(Platt Bros.)

FIG. 4. AUTOMATIC HOPPER FEEDING MACHINE

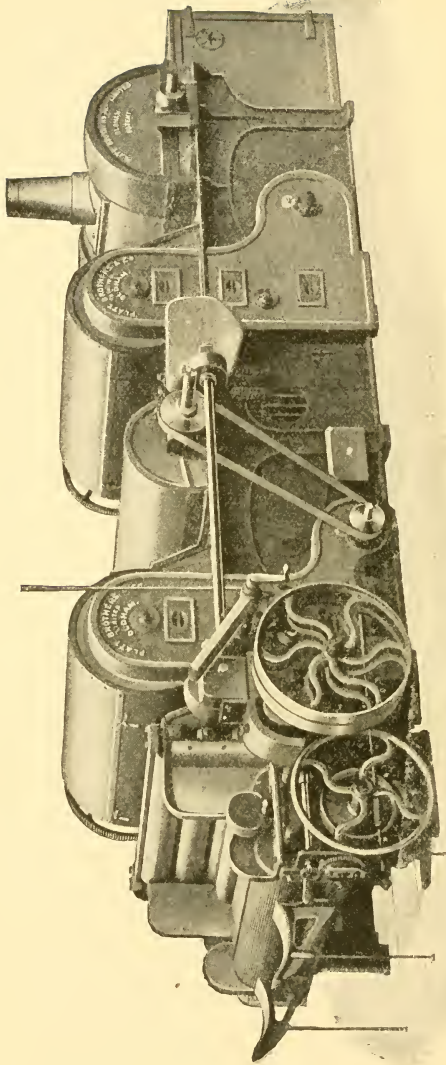

(Platt Bros.)

FIG. 5. EXHAUST OPENER AND LAP MACHINE

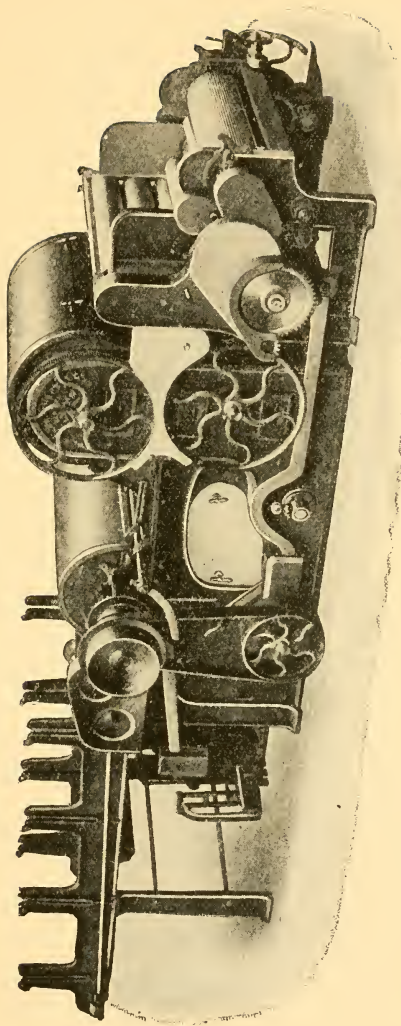

(Platt Bros.)

FIG. 6. SINGLE SCUTCHER AND LAP MACHINE

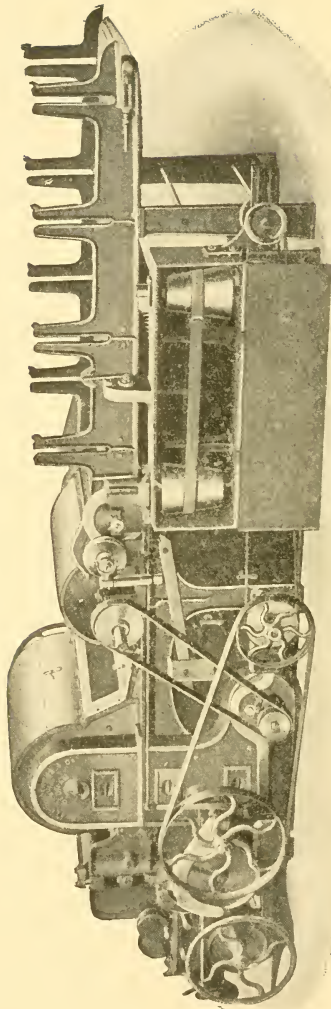

(Platt Bros.)

FIG. 7. SINGLE SCUTCHER AND LAP MACHINE

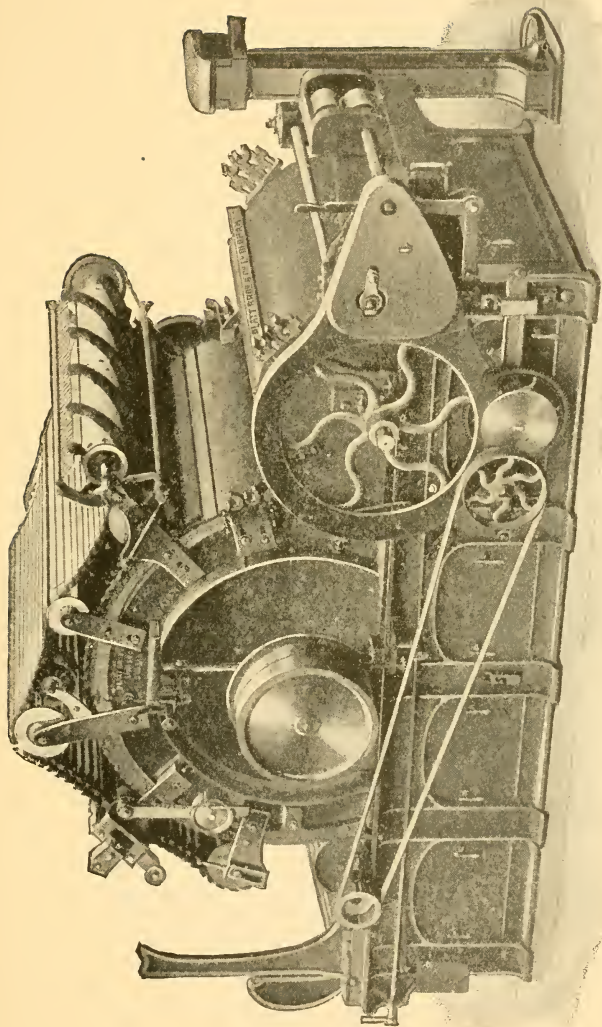

(Platt Bros.)

FIG. 8. REVOLVING FLAT CARDING ENGINE

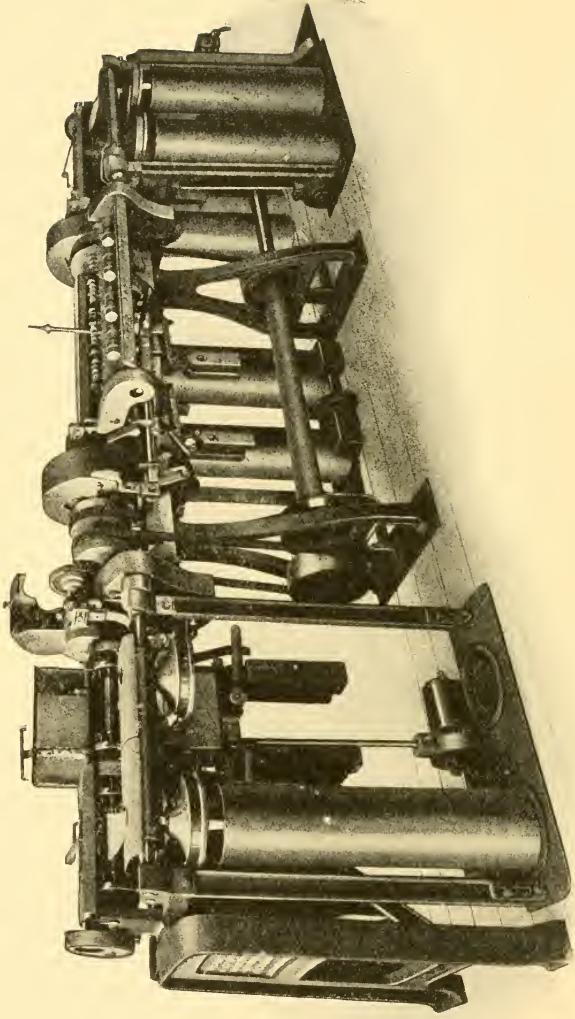

(Platt Bros.)

FIG. 9. DRAWING FRAME

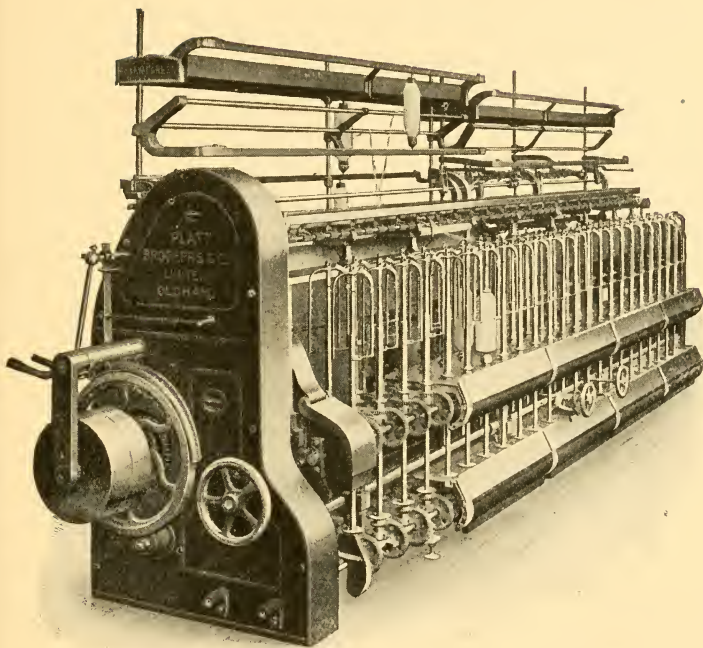

(Platt Bros.)

FIG. 10. INTERMEDIATE OR ROVING FRAME

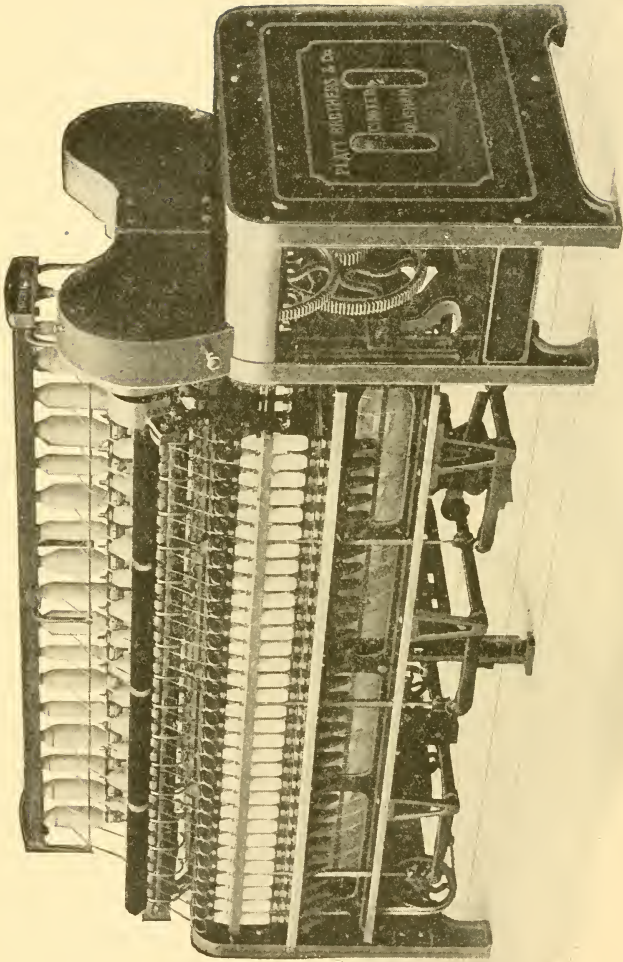

FIG 11. RING SPINNING FRAME

(Platt Bros.)

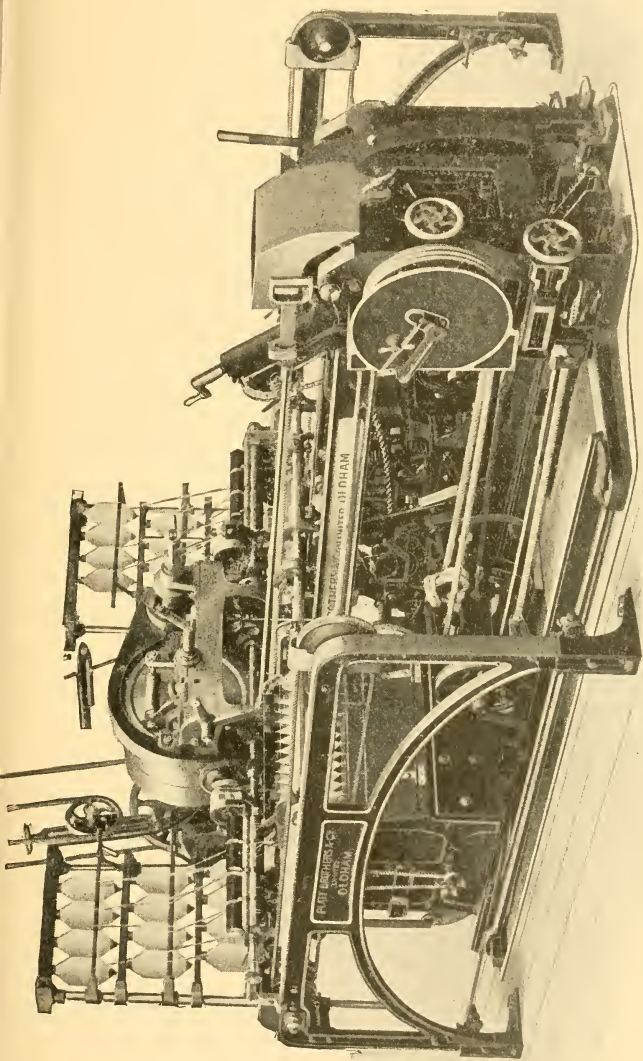

FIG. 12. SELF-ACTING MULE WITH RIM AT BACK

(Platt Bros.)

CHAPTER IV_B

BALE BREAKERS OR COTTON PULLERS

ON arrival at the mill the bales of cotton are weighed, etc., and then put in the bale stores until such time as they are needed for use.

It will be seen at once that cotton in the hard, matted, compressed state in which it appears in bale form, is quite useless for the spinning of yarns, and the first thing that the spinner must do is to make some serious attempt to get the cotton back into that soft state which it was in after ginning ; because it must essentially be open and loose to make it possible to relieve it of the many impurities it contains.

The first mechanical treatment to which the cotton is submitted in the mill, then, is that of passing it through the bale breaker, or as it is sometimes called, the cotton puller.

For many years this operation was done by hand, but later the *roller bale breaker* was introduced, being a machine consisting chiefly of four pairs of spiked and fluted rollers, heavily weighted, usually by strong springs, and each succeeding pair of rollers is made to revolve at a considerably greater speed than the preceding pair.

The result was that when the hard pieces of cotton from the bales were fed to this machine they were pulled asunder by the "draft" in the rollers.

The great danger of this machine was the tremendous risk of fire, as these spiked rollers coming up against any metal substance such as pieces of bale iron, studs, etc., were practically certain to cause sparks.

About 1901 the roller bale breaker was superseded by the hopper bale breaker, and the advantages of this machine are so obvious that it is now used practically universally.

The Hopper Bale Breaker

The use of the automatic hopper feeder having proved so successful, the hopper bale breaker was soon afterwards introduced, and it is a modification of the feeder.

The great popular features of the machine are—

1. The gentleness, no less effective, with which it treats the cotton.
2. The combing effect on the cotton rather than a plucking effect.
3. Its general freedom from fire risks, there being no heavy rollers in the machine.
4. Its cleanliness owing to the introduction of the fan.
5. Its considerably greater opening and cleaning power.
6. Its increased production, one machine will comfortably fulfil the requirements of a mill spinning 40,000–50,000 lb. of yarn per week.
7. Its simplicity ; beyond the ordinary oiling and cleaning it requires practically no attention at all, being very seldom out of order.
8. Its great assistance in simplifying the work of the opener and scutcher.

Action of the Machine

Before explaining the action of the machine the question of mixing must be mentioned, the commercial and other reasons of which will be explained later.

It is usually at the bale breaker that the first attempt to blend the cotton is made, and to do it most effectively the following system must be adopted : first lay out the bales to be mixed as near to the feed lattice as possible, take off the bands, which may be done either by an axe or by cutters, preferably the latter to avoid sparks and fire risks, and then take off the tare, and tear off large pieces of cotton from each bale in turn roughly according to the proportion to be used, placing them on the feed lattice. By the time the cotton has passed through the machine and been deposited in the mixing bin, it will be fairly well blended if the above system is adopted.

Fig. 13 shows a sectional view of the hopper bale breaker, and the hopper *A* receives the cotton from either the feed lattice or by having it thrown straight in by hand. The bottom lattice *B* carries the large pieces of cotton to the spiked lifting lattice *C*, which is of very strong construction, and this lattice now lifts it up until it comes into contact with the spiked evener roller *D* travelling at a high speed in the opposite direction. Owing to the very close setting between the spikes of the lifting apron and the evener roller, it is quite impossible

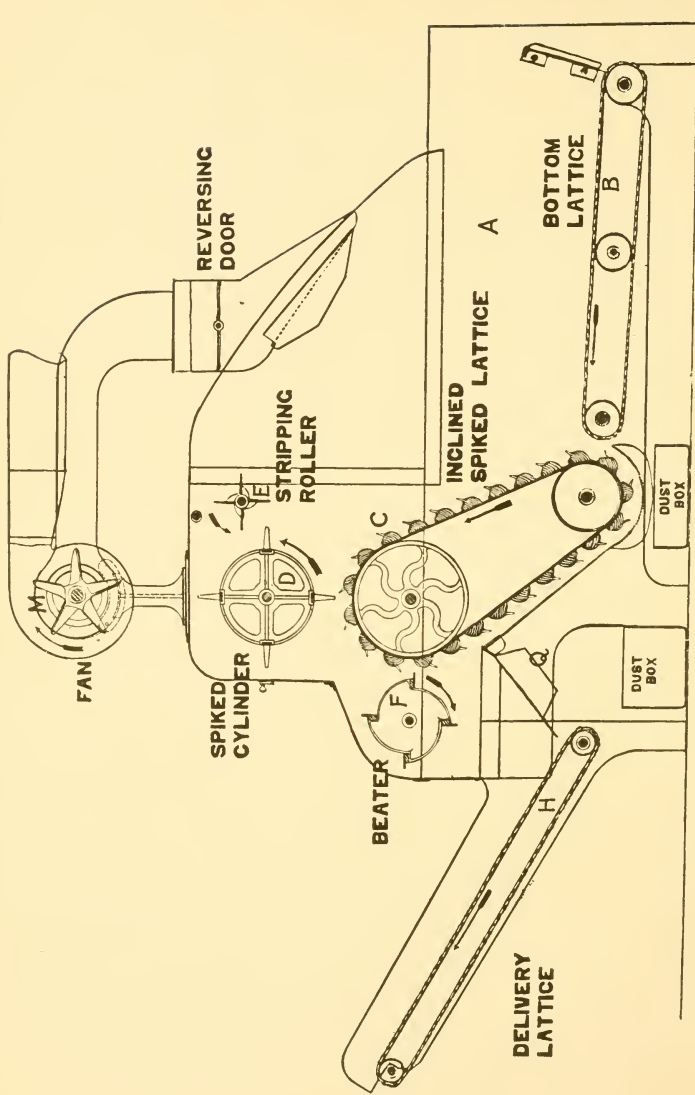

(Platt Bros.)

FIG. 13. SECTIONAL VIEW OF HOPPER BALE BREAKER

for any large pieces to pass forward, and so they are thrown back into the hopper. It will be seen that it is here that the combing and tumbling action takes place. The evener roller gets its spikes cleaned by the evener stripping roller *E*, in order to prevent the cotton stringing.

When the cotton is in sufficiently small pieces and soft enough the spiked lattice carries it forward and the stripping roller *F* knocks it off the spikes on to the grid bars *Q*, after which it falls on to the delivery lattice *H* which takes it to the

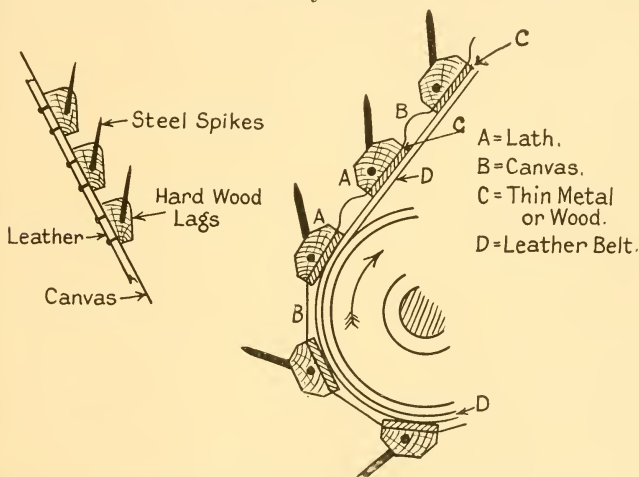

FIG. 14. SPIKED LIFTING LATTICE

FIG. 15. SPIKED LIFTING LATTICE

next machine, or, as is also done, it falls off the grid *Q* on to the lattices which take it to the mixing bins.

The fan *M* collects all the dust which would otherwise pass into the room, and by means of tin trunks sends it to the dust chamber. Sometimes this fan is coupled up to both the feed and the delivery of the machine. A suitable grid is also placed under the lifting lattice as shown, and dust boxes catch foreign matter and droppings.

Constructional Notes

1. The machine is made from 36 in. to 48 in. wide, the former being very popular.

2. From $1\frac{1}{2}$ to $2\frac{1}{2}$ h.p. is required.

3. Lifting aprons may be made from very strong, endless canvas sheets mounted on leather belts which come into contact with the driving bowls, the spikes being attached to strong strips which are in turn secured firmly to the sheet and the belts. Types of lifting lattices are shown in Figs. 14 and 15.

4. Sometimes the evener roller is self-stripping, although this is more generally found in the hopper feeder.

5. A responsible person should inspect and, if necessary, overhaul the machine at least twice a year, and all bearings, shafts, etc., should be well picked, cleaned, and oiled each time the machine is going to run.

6. All bands and straps should be kept in good condition as the drive is naturally a fairly heavy one.

Speeds, etc.

1. The stripping roller is the chief driving part, and the fast and loose pulleys or motor are attached to this shaft.

2. Good running speeds are as follows : spiked lifting lattice 200 ft. per min. ; evener roller 120 r.p.m. ; evener stripping roller 300 r.p.m. ; stripping roller 350 r.p.m. ; fan 1,000 r.p.m. These speeds, however, will vary with circumstances such as type of cotton being opened, amount of treatment necessary, distance fan has to send dust, etc.

3. The length of time required to open one bale will vary according to the setting of evener roller to lifting lattice, and the speeds of the various parts, but working under equal mechanical conditions it will take longer to open an American bale of 500 lb. than an Egyptian bale of 750 lb. on account of the fact that the American cotton is much softer in itself, and hence has a greater tendency to cling to the spikes, etc. Under ordinary circumstances we might expect about 8 min. for an Egyptian bale and 3 or 4 min. longer for an American.

Adjustments

1. The bearings of the evener roller are adjustable so that the spikes can be set to the required distance from the spikes of the lifting apron, usually from $\frac{1}{2}$ in. to 1 in.

2. All lattices have the bearings of the lattice bowls movable so that the required tension can be put on the lattices, in order to allow for the stretching of the leather, etc.

3. For the best results never overfill the hopper, three-quarters full is ample.

4. Bale breakers are either coupled direct to the hopper feeder or else to the mixing lattices which deliver the cotton into the mixing bins, the former being the usual method adopted in the American section of the trade and the latter in the Egyptian section.

5. The perforated door for the air trunk is now made reversible in order to give the fan more uniform conditions, and to relieve the machine of its dirt and dust more easily.

6. When coupled direct to the hopper feeder a knocking-off motion is arranged in order to prevent the bale breaker from overfilling the feeder.

7. Many people use up their soft waste (i.e. good cotton, which is waste owing to broken ends, etc.), and their bobbin waste, by mixing it with the raw cotton at the bale breaker, but the writer finds from experience that soft waste is better used at the hopper feeder, as, if used at the breaker, being very open it wraps round the spikes of both lifting lattice and evener roller, especially the latter, and is very troublesome indeed.

No matter where it is used, however, it should be used sparingly and worked in with the cotton as evenly as possible.

For bobbin waste it is much the best plan to have the bobbin waste machine coupled direct to the opener by means of a trunk, and to have the speed of delivery of the opened bobbin waste not more than 1 or 2 per cent of the total cotton passing to the opener, as too much bobbin waste tends to cause stringy laps, which is an evil for the carding process to overcome.

SPEED CALCULATIONS

When a pulley on a shaft drives, through the medium of a strap, another pulley on a driven shaft, the surface speed of the strap remains constant so long as the driving pulley is not altered, and independent of how much the driven pulley is altered.

This being so, it will be seen that the revolutions of the driven pulley will alter in direct proportion to the circumference of the pulley, in order to maintain the same surface speed.

If a pulley 10 in. diameter making 100 r.p.m. drives a

pulley of 5 in. diameter, the revolutions of the 5 in. diameter pulley will be in direct proportion to their circumferences.

$$= 100 \times \frac{10 \times 3\frac{1}{7}}{5 \times 3\frac{1}{7}}$$

$$= 200 \text{ r.p.m.}$$

Now as π (or approx. $3\frac{1}{7}$) is common to both we can ignore it, and so work in direct proportion to their diameters.

The rule, then, for speed calculations is as follows—

To find the revolutions of any driven pulley or wheel *multiply the revolutions of the driver by all the drivers and divide by all the drivens.*

N.B. All pulleys taken by diameter. All wheels taken by the number of teeth they contain.

Expressed as an equation it will read as follows—

$$\text{Revs. of driven} = \frac{\text{Revs. of driver} \times \text{Drivers}}{\text{Drivens}}$$

Example. Speed of flywheel is 75 r.p.m., diameter of flywheel is 25 ft., driving 8 ft. line shaft pulley. A 4 ft. drum on line shaft drives a 24 in. pulley on countershaft. Find the speed of the countershaft.

$$\begin{aligned} \text{Speeds of countershaft} &= 75 \times \frac{25}{8} \times \frac{4}{2} \\ &= \underline{\underline{468.75 \text{ r.p.m.}}} \end{aligned}$$

CHAPTER V

THE MIXING OF COTTON

PROBABLY the most important factor in the spinning of cotton yarns is the blending of the cotton to give the best results, and it is no exaggeration to say that cotton well mixed is half spun.

It is a well-known fact that although "lots" of cotton are bought which come from the same areas the individual bales vary very considerably, and when many different "lots" are bought the variation is considerably greater.

It is absolutely necessary that in the production of a certain yarn the following properties must remain as near as possible constant the whole time—(1) strength and (2) colour, as any change in these two properties would mean that our customer would very soon cancel the order.

A judicious blending of the cotton is the only way in which this constancy can be obtained.

Also when firms are spinning a definite quality week after week it is quite impossible to expect that it will be possible always to get the same mark of cotton, even assuming that the mark is very even in all respects, so that here again careful mixing will have to be resorted to.

Again, now that our many colonies are growing cotton, but not in large enough quantities to guarantee a full year's supply, means have to be found whereby these "Empire cottons" can be suitably mixed with other growths.

Any attempt to lay down a definite rule as far as mixing is concerned would be ridiculous, as circumstances will determine to a very large extent what must be done in the matter, but certain points must be observed such as the following—

1. The colours of the cottons must be similar (e.g. we should never dream of mixing Brown Egyptian with Texas cotton).
2. Their staple lengths must not be unlike (e.g. it would be silly to mix Sudan Sakel with Brazilian).
3. A very harsh cotton will not mix successfully with a soft one.

At what process this mixing shall take place is also a point which varies to a very large extent, and according to requirements might be at : (1) the bale breaker and mixing stacks ; (2) the finisher scutcher ; (3) the sliver lap machine ; (4) the drawframe ; (5) in the creels of roving frames ; (6) in the creels of the mule or ringframe.

For instance, if two cottons are to be mixed together and one is considerably dirtier than the other and contains more short fibre, it would probably be more economical to pass them through the blowing room processes separately as the dirty one will require more beating, and as they would probably need different treatment at the comber also, it would be better to blend them at the drawframe or else in the creels of the frames or spinning machines.

The popular way of mixing, however, is to put the cotton through the bale breaker in the proportion required and to pass it, either by mixing lattices or the pneumatic mixing arrangement, to the mixing stacks or bins, and to spread it there in a horizontal manner.

When the cotton is to be used at the hopper feeder it should be taken from the stacks in a vertical manner so that even blending is assured. The advantages of mixing in this manner are—

1. By letting the mixing stand for a few days it attains a natural working condition of dryness and assumes the temperature of the mill, that is, the fibres become pliable.

2. The fibres tend naturally to loosen themselves in this condition, and are then in a better state to undergo the opening process.

3. Variations are eliminated as far as it is possible to do so, and different classes of cotton can be mixed together quite successfully.

4. Stacks are convenient for feeding from for the next process, i.e. the hopper feeder.

Within reason, the larger these mixing stacks are the better. They should be placed so that they are as near as is reasonably possible to the feed lattice of the hopper feeder, and made so that there is no danger of the cotton from one stack getting mixed with that from another.

The price of the various cottons will also have an important bearing on the methods of blending.

MONEY'S MIXING TABLE

$\frac{3}{4}$	White Egyptian and	$\frac{1}{4}$	Peruvian for	60s. to 70s.
$\frac{2}{3}$	" "	$\frac{1}{3}$	" "	50s. to 60s.
$\frac{1}{3}$	" "	$\frac{2}{3}$	" "	40s. to 50s.
$\frac{2}{3}$	" "	$\frac{1}{3}$	American	30s. to 50s.
$\frac{2}{3}$	Peruvian	"	"	up to 40s.
$\frac{1}{2}$	"	"	"	" 36s.
$\frac{2}{3}$	American	"	Surat	" 30s.
$\frac{1}{2}$	"	"	"	" 25s.
$\frac{1}{3}$	"	"	"	" 20s.
$\frac{1}{2}$	Surat	"	Waste	" 15s.

COTTON MIXING CALCULATION

Three types of cotton A, B, and C are to be mixed together in the proportion of 2 parts of A, 7 parts of B, and 3 of C. If A costs 14.75d. per lb., B 14d., and C 13.75d., what will be the price per lb. of the mixing and the cost of 20,000 lb. ?

(*N.B.* These prices were the ruling "spot" prices for Sakel, 3rd May, 1927.)

2 lb. of A at 14.75d.	=	29.50
7 lb. of B at 14.00d.	=	98.00
3 lb. of C at 13.75d.	=	41.25
<hr/>		
12 lb. of mixing	=	168.75
<hr/>		

Price per lb.	=	$\frac{168.75}{12}$
	=	14.06 pence
<hr/>		

Cost of 20,000 lb.	=	14.06 × 20,000
	=	<u>£1171 13s. 4d.</u>

COTTON CARRIERS

As has been previously mentioned, the cotton is carried from the bale breaker to either the hopper feeder or else to the mixing stacks, and it is the latter arrangement that I now wish to refer to.

This carrying of the cotton is done in two ways by (1) mixing lattices, and (2) pneumatic mixing arrangements. The former is still more popular, but it is the writer's belief that the latter possess so many tremendous advantages that the day cannot be far distant when they will be universally adopted.

Mixing Lattices

This means of transferring the cotton from the bale breaker to the mixing stacks, has been popular for many years, is cheap to install, requires very little attention, is not cumbersome, and is certainly efficient.

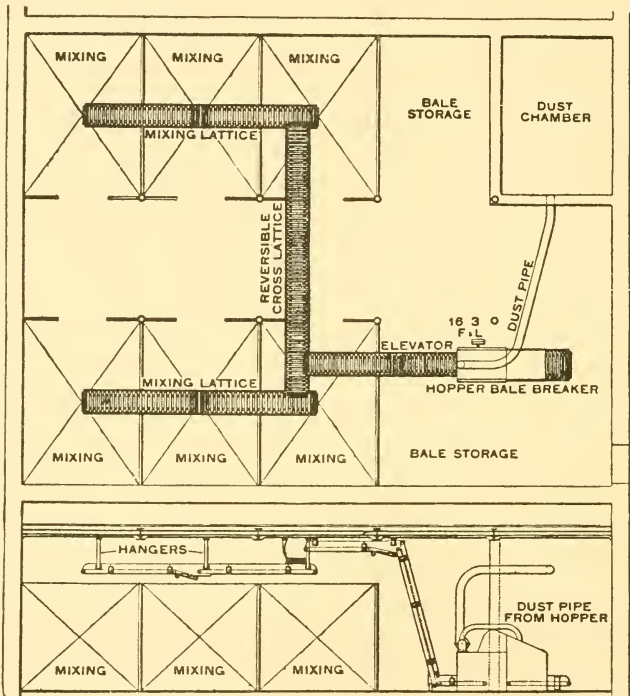

(Dobson & Barlow, Ltd.)

FIG. 16. PLAN AND ELEVATION OF MIXING LATTICES

How these mixing lattices must run from the bale breaker depends entirely on the positions of the bale breaker and the stacks, e.g. if the bale breaker is in the room above the mixing room the cotton will fall through the floor on to the lattice, and then be carried to the stack required by having the lattices running in the correct direction, or if the bale breaker and

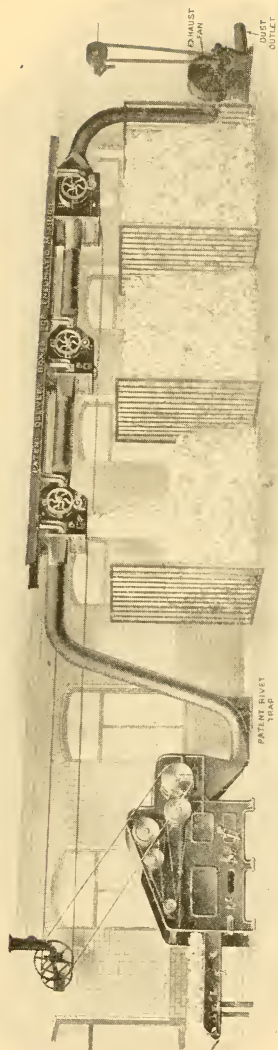

549

FIG. 17. PATENT PNEUMATIC DELIVERY ARRANGEMENT FOR COTTON MIXINGS
(Dobson & Barlow, Ltd.)

mixings are in the same room it will be necessary to drop the cotton from the bale breaker on to a lattice which will give it to elevating lattices, and these in their turn will give it to overhead lattices as before, or if the mixing room is above the bale breaker, then the elevating lattices would pass through the floor. Fig. 16 shows an arrangement of lattices for six mixing stacks on the same floor as the bale breaker. The lattices are made reversible by means of a simple clutch gear arrangement.

Pneumatic Conveyors

This method of transferring the cotton to the stacks by means of air suction has many advantages over the ordinary mixing lattices, the only disadvantages being that the system is more costly to install, and is probably a little heavier.

The advantages are as follows—

1. Owing to the fact that the cotton is enclosed in trunks the whole distance from breaker to stack the rooms concerned are freed from that terrible evil dust, so that not only are the machines and cotton much cleaner, but the workers are employed under much more congenial and hygienic conditions.

2. Owing to the action of the fan the opening process is going on throughout the passage of the cotton through the trunk.

3. The cotton being freed of a considerable amount of dust, the work of the subsequent machines is made easier.

4. A rivet or hard metal trap is fixed in the trunking as shown in Fig. 19, so that risk of fire is also considerably reduced.

5. Within reason, the distance that the cotton has to travel is immaterial, as also is the position of bale breaker and mixing stack.

Dobson & Barlow, Ltd., deserve every credit for being the pioneers of the pneumatic mixings.

Fig. 17 shows a general view of the arrangement, the fan being shown, the dust outlet, of course, passing to the dust chamber, which will be explained later. The illustration of the delivery box is self explanatory, although it will be seen that there is a slight difference in construction between the intermediate and last delivery.

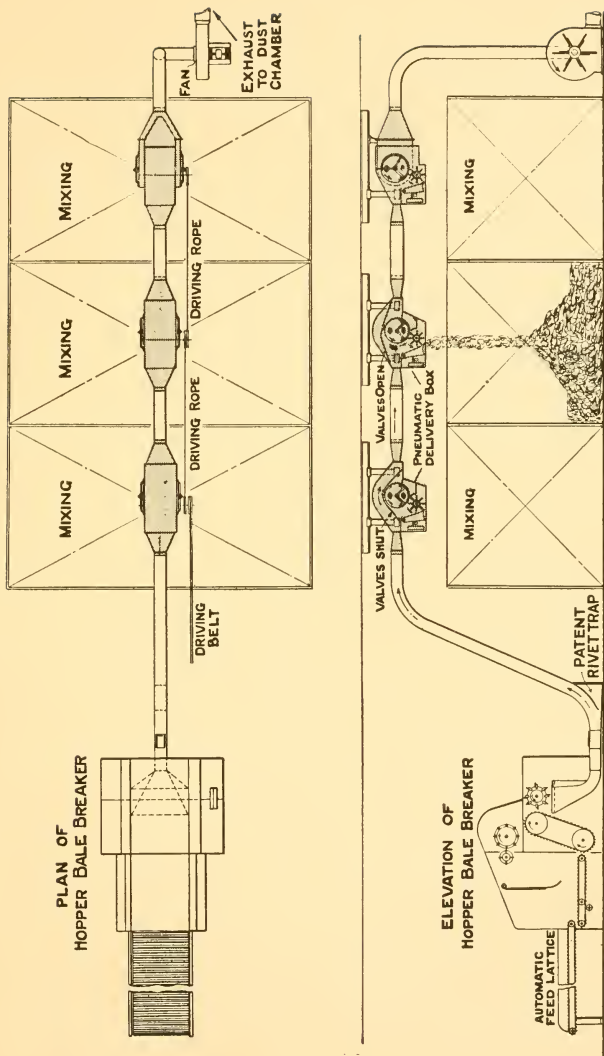

(Dobson & Barlow, Ltd.)

FIG. 18

TO PNEUMATIC MIXINGS
AND FAN.

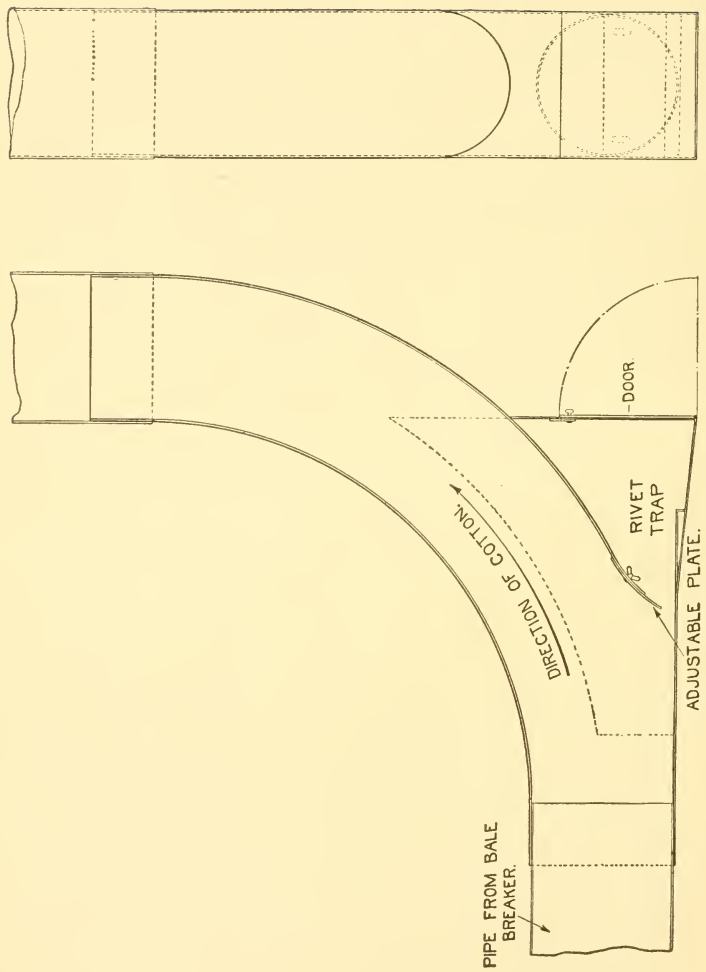
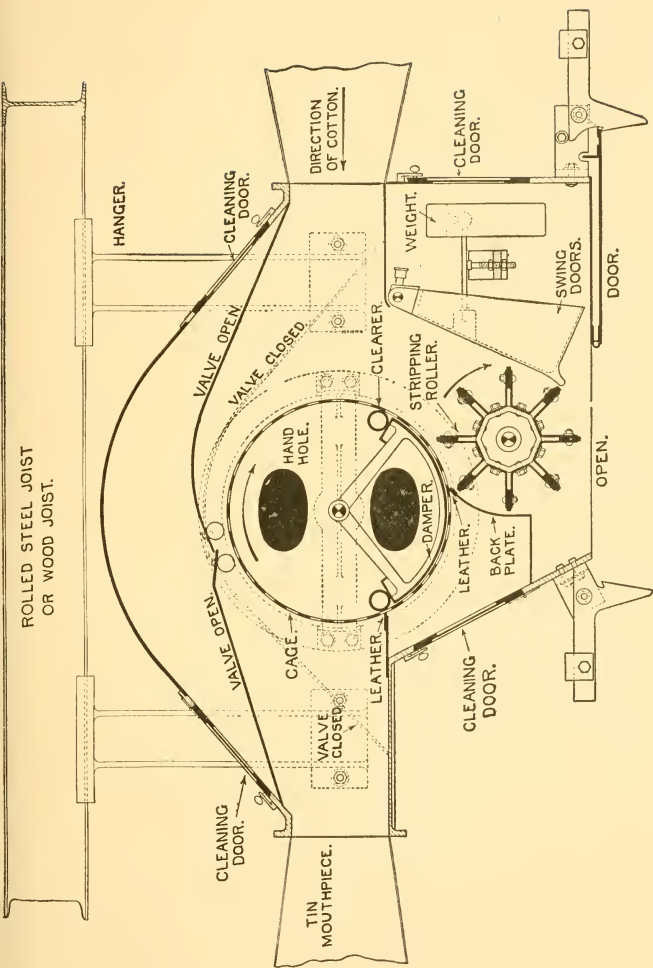
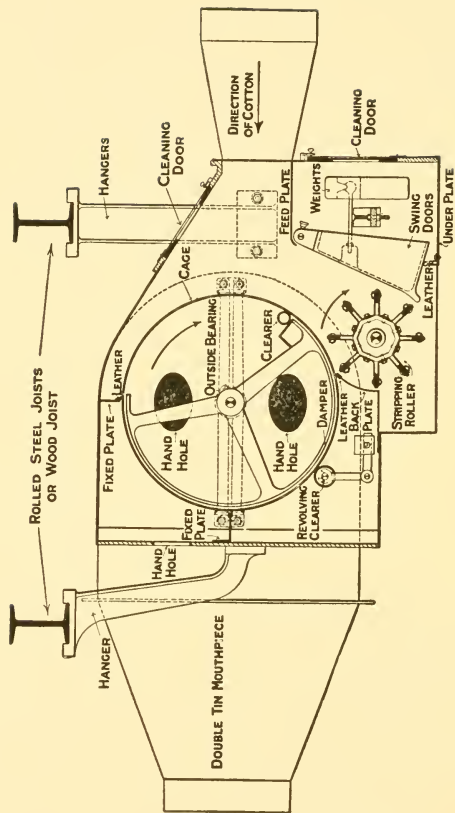

FIG. 19. PATENT RIVET CATCHER, IN PIPE FROM HOPPER BALE BREAKER TO BOXES
(Dobson & Barlow, Ltd.)



(Dobson & Barlow, Ltd.)

FIG. 20. SECTION THROUGH INTERMEDIATE DELIVERY BOX



(Dobson & Barlow, Ltd.)

FIG. 21. SECTION THROUGH LAST DELIVERY BOX

The principle is precisely the same as the cages of openers and scutchers, that is, the action of the fan draws the cotton on to the cage, but only the dust can pass through the perforations and then the stripping roller knocks the cotton off the cage and into the mixing stack. Kept clean and well oiled, these delivery boxes will give little or no trouble.

Distance between spikes of evener roller and spikes of lifting lattice when feeding to pneumatic should be about $\frac{1}{4}$ in. only.

Pneumatic cage speed = 100 r.p.m.

Fan from 1,700 to 2,000 r.p.m., according to distance.
 $\frac{1}{4}$ h.p. per box.

CHAPTER VI

MIXING AND BLOWING ROOM MACHINERY

Combined Machines

BEFORE proceeding further, it must be explained that although we shall treat the mixing and blowing room machinery as separate units, which, of course, they are, it is usual to have them set up for working purposes in combination.

In all up-to-date spinning plants some of these machines will be combined, and the number will depend on such questions as the following : (1) whether there are mixing stacks or not ; (2) what class of cotton is to be treated (i.e. its quality, staple length, state of cleanliness, etc.). It will be seen quite clearly that the cleanliness or otherwise of the cotton will determine to a very large extent the number and type of beating instruments to be used.

The following are typical examples of machinery used in mills to-day, but cannot by any means be considered as standard, as peoples' opinions of correct beating vary very considerably.

1. Mill using Indian cotton and spinning average 20s counts. No mixing stacks. Hopper bale breaker, hopper feeder, porcupine cylinder (24 in. diameter, known as lattice feeder) fed by trunks to two Crighton vertical openers, then by further trunks to a double exhaust opener (i.e. having two beating instruments, two sets of cages and lap forming parts). Feed controlled automatically, and cotton not touched by hand from the time it is broken from the bale until it is formed into an opener lap.

2. Mill using American cotton and spinning average 45s counts, with mixing stacks. The combination would start this time at the hopper feeder and would then be as above, except that there would probably be only one vertical opener.

3. Until more or less recently the Egyptian section did not use vertical openers, and their combination simply comprised hopper feeder, lattice feeder, and opener, but it is becoming

more popular now to have one Crighton opener in the series.

4. For Sea Islands cotton a combination machine would be used, but having considerably less beating powers than for other cottons, on account of the tenderness of the fibres.

In these combined machines feed regulating motions, which will be explained in detail later, are usually applied immediately before the lattice feeder if used, and if not, then immediately before the first beater of the opener.

THE HOPPER FEEDER

Nowhere is the development of cotton spinning machinery more pronounced than in the case of the hopper feeder. Prior to the invention of this machine the cotton was spread on to a lattice behind the opener by hand, and in this way the first attempt at making an even density of cotton was made.

The degree of evenness was entirely dependent on the human element, a frail creature indeed ; as the spreading of the cotton evenly on the opener feed lattice was liable to such variations as are easily caused by : (1) the skill or otherwise of the worker ; (2) the time of the day (a monotonous job of that sort would certainly not be done as well in the late afternoon as in the morning) ; (3) the state of "openness" of the cotton being fed.

With the invention of the automatic hopper feeder, however, all this was changed, and it was very soon seen that it was a tremendous improvement on the hand method, with the result that it is now the universal way of feeding to an opener. The many advantages of the automatic feed are : (1) owing to the much more even laps produced by the blowing room machinery, vastly superior yarns are spun in every respect ; (2) owing to its combing action it aids the work of the opener, scutcher, and card by softening, opening, and cleaning the cotton ; (3) by permitting of the combination of machinery it saves labour.

Action of Machine

The hopper feeder's action is precisely the same as that of the bale breaker, the only difference being that the construction

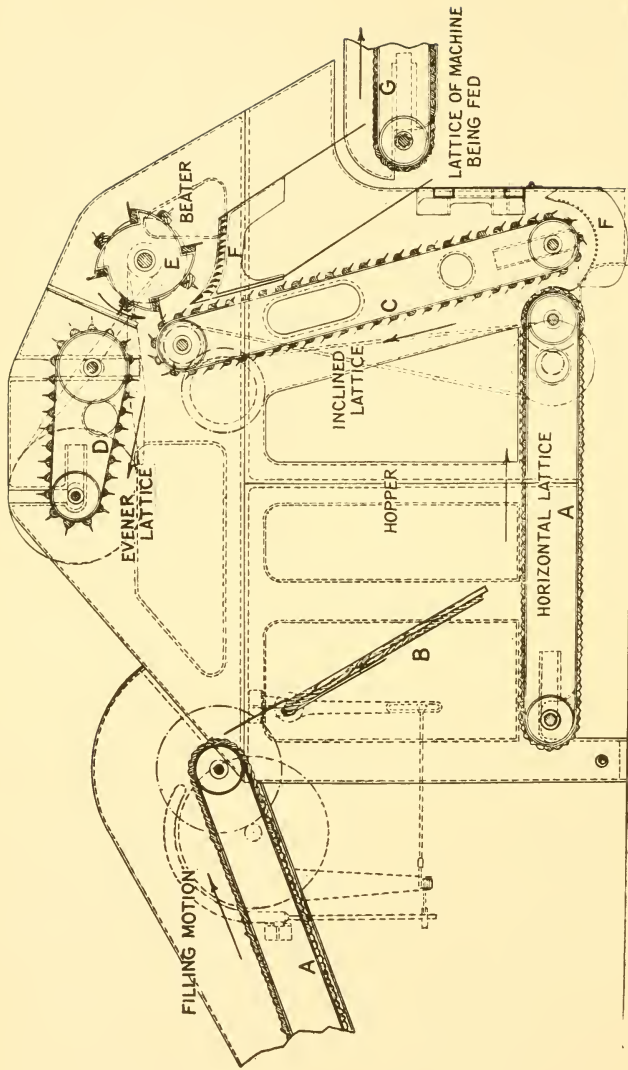

FIG. 22. HOPPER FEEDER WITH FILLING MOTION

(Platt Bros.)

of the various parts is not as strong, and the settings, owing to the more open state of the cotton, are closer.

A = Feed lattice.

B = Full box knocking-off door.

C = Spiked lifting lattice.

D = Spiked evener lattice (this is a roller in most makes).

E = Stripping roller.

F = Cleaning grid (both for stripping roller and lifting lattice).

G = Delivery lattice (i.e. feed lattice to next machine either regulating motion and lattice feeder or opener).

Settings

1. The evener lattice or evener roller spikes should be set at the required distance from the spikes of the lifting lattice to give the correct weight of lap per yard, and this setting will vary according to the cotton being used; the heavier the cotton the closer the setting. A good setting is about $\frac{3}{8}$ in.

2. The knocking off door for regulating the amount of cotton in the hopper should be set so that it stops the feed of cotton when the hopper is about threequarters full, as it has been found that this amount of cotton in the hopper helps to keep an even feed passing to the opener.

3. The regulating motion should be set either immediately before the lattice feeder or the opener.

Speeds

The speeds of the various parts vary, but the following would give good results.

1. Spiked lifting lattice about 140 ft. per min.

2. Spiked evener roller about 120 r.p.m., or if a spiked evener lattice about 140 ft. per min.

3. Stripping roller about 350 r.p.m.

4. Fan about 1,200 to 1,400 r.p.m.

Constructional Notes

1. In all lattice work it is important to remember that for good work it is essential that the leather to which the wood lattice is attached, and which runs over the lattice bowls, should have the piecing facing in the right direction (i.e. it should not run so that the piecing will strike the bowl first, but should come away from the bowl last).

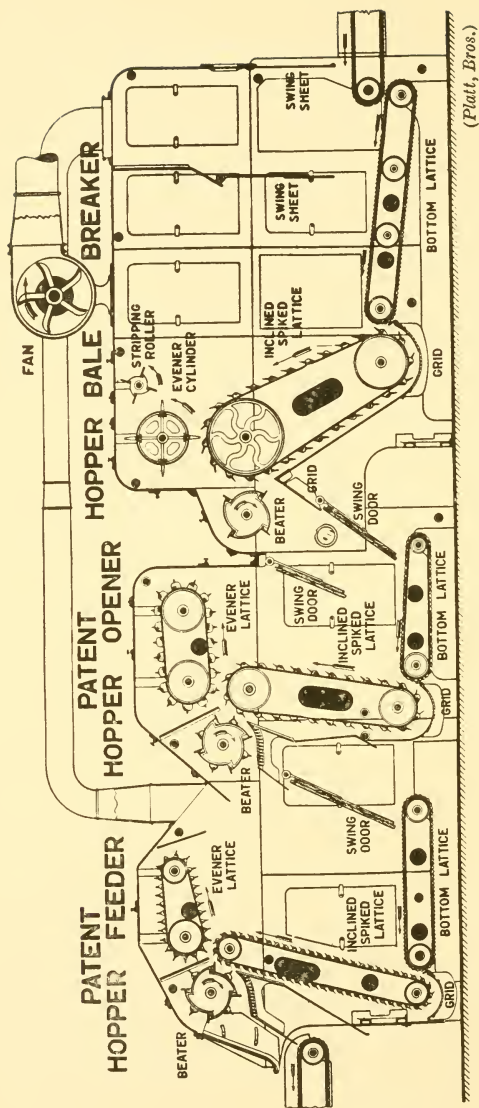

FIG. 23. PLATT'S FEEDER, OPENER, AND BALE BREAKER

(Platt, Bros.)

2. The hopper feeder is made usually 36 in. wide and takes about $1\frac{1}{2}$ h.p. to drive.

3. A typical spiked lifting lattice has fifty-four wooden ribs, each rib containing thirty spikes in its 36 in. width, spikes exposed about $1\frac{1}{4}$ in. to $1\frac{1}{2}$ in.

4. A fan is usually coupled to the hopper feeder in the same way as the bale breaker.

5. The self-stripping evener roller is a development which does away with the need for a cleaner roller for the evener. It consists of a spiked roller, the spikes of which are loosely hinged to a central shaft, and surrounding the spikes is a perforated cylinder which works on bosses which are eccentric from the main shaft. Each spike passes through a perforation, and the outer cylinder is so set that when the spikes are in contact with the cotton they are fully out through the perforations, but as they pass out of action they recede and clean themselves automatically due to the perforated cylinder; they then proceed to advance again and are ready for the next beat on the cotton.

6. The erection of both bale breakers and hopper feeders is similar, and should present no difficulty as all is straightforward going.

THE OPENING AND SCUTCHING PROCESSES.

The object of the machines used up to now in the manufacture of cotton yarns (i.e. bale breaker and hopper feeder) has been to make the cotton sufficiently open to be treated successfully by the opening and scutching processes, and as the next machine to deal with the cotton will be the lattice feeder (24 in. cylinder opener), which is really the first of the opening machines, it will be as well if, before proceeding any further, the objects of scutching machines are clearly defined.

Objects of Opening and Scutching

1. To extract as much as possible of the many impurities which are to be found in all cottons, such as sand, seed, leaf, stalk, dust, motes, etc.

2. To beat or "scutch" the cotton into a very fleecy condition.

3. To form the loose cotton into a compact and uniform sheet and to roll it up into a lap ready for the next process.

In spite of the state of efficiency now obtaining in blowing room machinery, it must be remembered that many of these impurities succeed in getting through openers and scutchers and reach the card, comber, and in some odd cases even the bobbins.

There is no attempt in this process to treat the fibres individually, that is left for the card and comber, but a very serious effort is made to give the cotton its first start on the way to even, solid yarn, by making the lap sheet as even, both in density and weight per yard, as it is possible. This is done by the aid of regulating motions and the doubling of laps together, in a manner which will be explained in full later.

The cotton is opened in the main by the action of high speed beaters of many types, and in all cases it is driven by these beaters across a series of dirt bars which permit of the impurities falling out by their own weight.

It is cleaned by being drawn on to slow-travelling perforated cages by means of powerful fans, the dust passing through the cages and into the dust flue.

Finally, it is made into a lap by passing through heavily weighted calendar rollers and lap forming parts.

While it is admitted that a certain amount of damage is done to the fibres by the scutching process, the damage is not very great as the fibres are treated in small masses, not individually, and so act as a cushion for one another.

A cotton fibre is an elongated hollow cylinder approximately the same diameter throughout its length, except for about the last twentieth farthest away from the seed, when it tapers off to a point. These small pointed pieces at the end break off more in the opening and scutching processes than anywhere else, and it can be well understood that the invisible loss due to this and other causes is very high in the blowing room, about 1 to 2 per cent.

THE LATTICE FEEDER

This machine is fed automatically from the hopper feeder, and provides not only a very efficient means of preliminary cleaning and opening, but also is the first place where a deliberate attempt is made to make an even length of cotton by mechanical means, and thirdly, helps to pass the cotton through the trunks by the draught and sweeping action of the

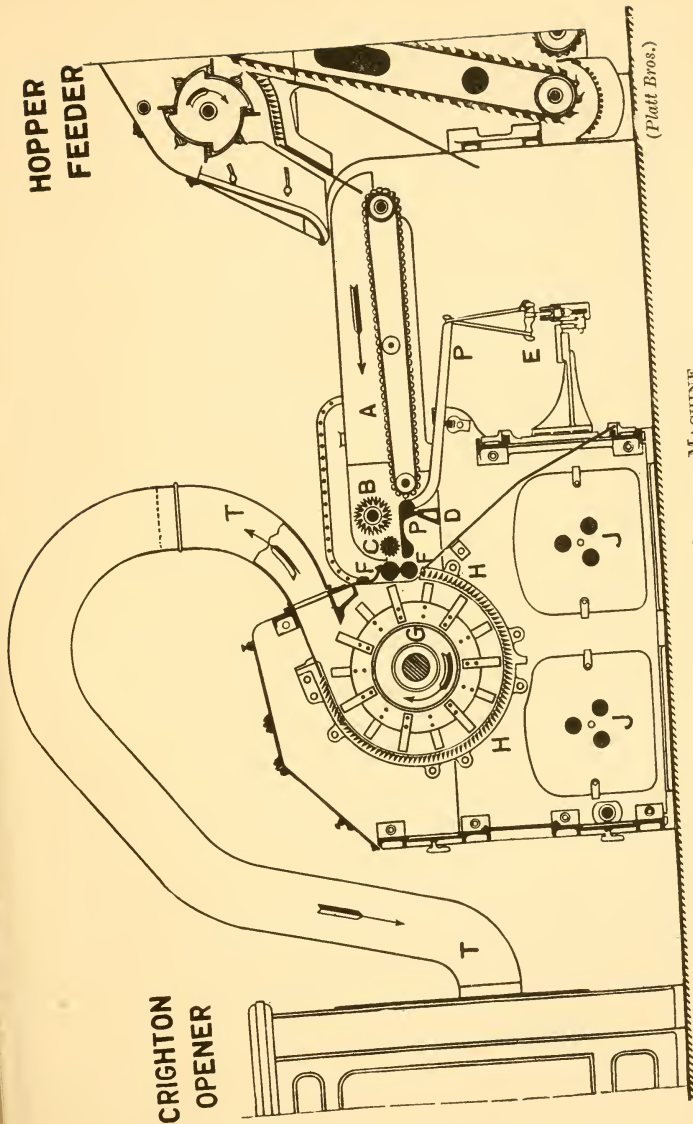

FIG. 24. LATTICE FEEDING MACHINE

beater in conjunction with the fan of the exhaust opener. The cotton is carried in this manner between lattice feeder and opener for, in some cases, quite long distances, and must essentially be getting cleaner and more open as it passes through the trunks.

Action of Machine

The cotton is fed to the machine on the feed lattice *A* (Fig. 24), which is the delivery lattice of the hopper feeder), which, with the aid of the spiked collecting roller *B*, carries it to the feed pedal roller *C*, under which are the pedals *PP*, which in their turn are coupled up to the cone drums, and control the speed of the roller *C* according to requirements. The pair of rollers, *FF*, are driven at a faster rate than *C*, and the result is that the cotton is continually fed to the beater without any fear of "bagging."

The beater *G* is of the cylinder type, and has surrounding it a series of dirt bars *H* through which the impurities pass. An improved feature is that the cylinder now acts upon the cotton for nearly threequarters of its stroke, as against only a quarter in the old type machines.

The rapidly-revolving beater knocks out a good deal of sand, seeds, etc., which fall through the dirt bars on to the floor under the machine, and the cotton then passes forward through the trunk *TT* to the next machine, whether it be vertical opener or exhaust opener.

Constructional Details

1. Collecting cages can be applied to the machine if required.
2. The only roller which has a variable speed is the pedal roller *C*.
3. The knives on the cylinders are bent alternately so that the whole of the surface of the cotton receives the "beat." A typical beater contains 12 plates with the necessary making-up pieces, and 14 knives on each plate, making 168 knives in all, and is 24 in. diameter.

Speeds

The speed of the beater to ensure good results might be about 750 r.p.m., while the pedal roller making about 12 r.p.m.

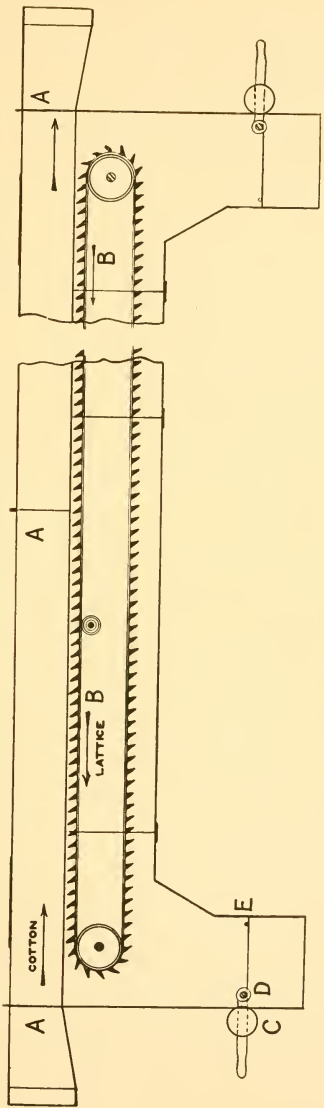

(Platt Bros.)

FIG. 25. DUST TRUNK AND SELF-CLEANING LATTICE

would ensure a weekly production of about 20,000 to 25,000 lb. Pedal roller $2\frac{3}{4}$ in. diameter.

Settings

The distance between knives of beater and dirt bars for obtaining good results on Egyptian cotton is about $\frac{7}{16}$ in.

Exhaust Feed Trunks

The use of this method of transferring the cotton from the lattice feeder to the opener is very popular indeed, and due to the sucking power of the fan the cotton can be carried long distances in this manner, and, of course, it is clean and convenient to use these feed trunks on all possible occasions. They are usually circular tin pipes of from 9 in. to 12 in. diameter, and their advantages are as follows.

They dry the cotton, open it, loosen it, and allow any heavy impurities to fall out and thus considerably reduce the risk of fire.

The Self-cleaning Lattice

Still further to increase the cleaning power of the exhaust feed trunk, many times we find fitted into the feed trunk at some convenient position the self-cleaning lattice, which, as Fig. 25 shows, travels very slowly in the opposite direction to the travel of the cotton.

The air current draws the cotton through the trunk *A* and over the lattice *B*, so that dirt, etc., falls into the bars of the lattice, and is finally deposited in the boxes at the end. When the dirt attains a certain weight the weighted door *CDE* overbalances, and the dirt then drops either on to the floor or into a bag, and the door closes again.

Very slow motion is given to the lattice *B* by a pulley, worm, and worm-wheel drive of simple form.

THE CRIGHTON OR VERTICAL CONICAL OPENER

If the above machine is used the feed trunk feeds the cotton to the vertical opener at the bottom as shown in Fig. 26 at *A*, and it is delivered from the beater at the top at *B*, passing into the exhaust feed trunk again, or, if necessary, on to a pair of cages, although the latter is seldom the case.

This type of opener is generally to be found used for the treatment of Indian and American cottons, the reason being

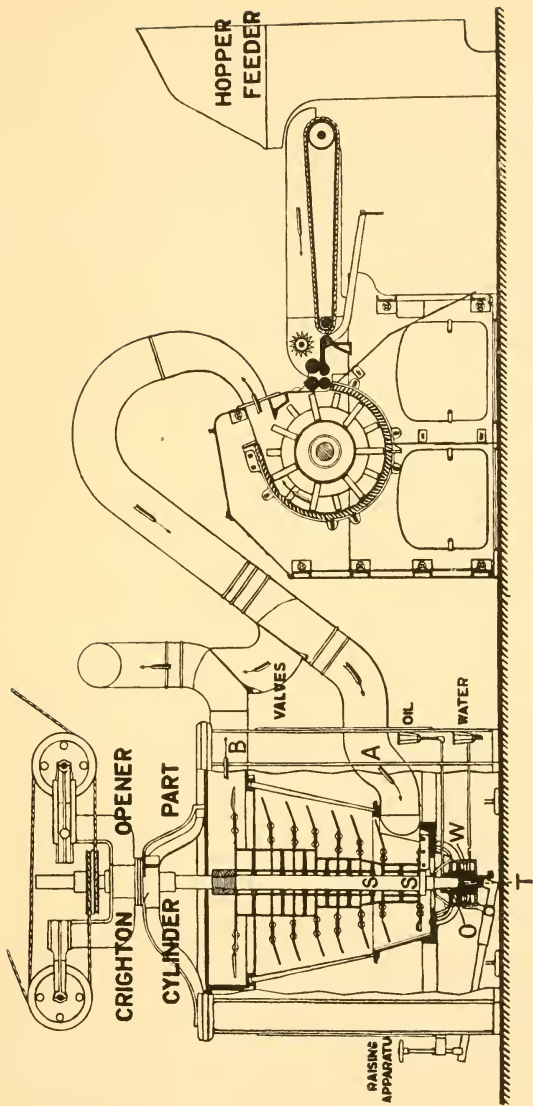

FIG. 26. LATTICE FEEDER AND CRIGHTON OPENER

that they are dirtier and not as good in quality as the other cottons ; although it is now used with a fair amount of frequency for Egyptian cotton also, but never for Sea Islands, as it is considered that owing to its construction it is rather brutal in its action on the fibres.

The advantages claimed for the vertical conical beater are—

1. It possesses more cleaning and opening power than any other beater, owing to the fact that there is a cleaning grid all round the beater from top to bottom, and the cotton stays in the beater longer than in other cases.

2. Any dirtier, more matted, or heavier portions of cotton will not rise as quickly as light, clean portions, which makes it that the very cotton which requires the most beating gets it. An obvious disadvantage, however, is that the dirt has to be driven through the bars sideways, and is therefore not particularly helped by gravity.

Action

The cotton is fed to the bottom of the beater, the exhaust fan constantly pulling the cotton in the direction of the delivery.

As the beater knives act on the cotton it gradually becomes lighter, and so rises until it passes out of the beater chamber at the top.

Construction

The beater consists of 6 or 7 circular plates of varying diameters from about 15 in. to 30 in, with the necessary making-up pieces, and on these plates are riveted knives, alternately bent upwards and straight. The plates and making-up pieces are threaded on to and keyed to the beater shaft. The shaft has two bearings, one at the top of ordinary construction and one at the bottom known as the footstep. This footstep has the following special features.

The beater shaft *S* (Fig. 26) revolves on a loose steel washer *T*, which can be renewed when worn, the shaft itself being case-hardened at the bottom.

Surrounding the shaft is an oil bath *O*, so that the beater shaft fork is running completely in oil, and very often round this again is a bath of water *W*, which in its turn keeps the oil cool. Each of these baths can be renewed or tested for height by the respective feed pipes.

Speeds

The speed of the beater, if in connection with the feed trunk, would be about 700 r.p.m., or if connected to cages, etc., about 900 to 1,000 r.p.m.

Settings

An ingenious arrangement is used whereby the vertical shaft rests on a lever which can be raised or lowered at will at the side of the machine, according to the distance required between the outer edges of the knives and the dirt bars (which might be about 168 in number).

Good settings for Egyptian cotton are 1 in. space.

Periodically the dirt bars of all blowing room machinery should be well cleaned and blackleaded in order to prevent sticking.

Before the introduction of the special footstep this type of machine was very liable to fire, due to the foot of the shaft getting very hot, but this trouble has now been practically eliminated.

EXHAUST OPENERS

The cotton now passes by means of a trunk into the first beater of the exhaust opener.

There are many types of exhaust openers in use, both single and double (that is with either one beater or with two beaters), but the one chosen for explanation is, to say the least, very popular.

Before proceeding with the explanation of the action of this opener (which is Platt Bros. double exhaust opener), it will be as well to mention something about one or two other types.

One of the most successful earlier introductions to blowing rooms was the Buckley opener (made by Taylor, Lang & Co.), which at the time was a vast improvement on anything that had been previously introduced.

It consists, like all openers and scutchers, of a beater or beaters, cages, and laps forming parts, but its special feature is its beater, which is the very large cylinder type, 41 in. diameter and having also opening spikes on its top cover. The advantages claimed for this opener are as follows—

(1) It has an upstroke against all other types, striking the

cotton downwards, and this makes it that the cotton is acted upon by the cylinder and dirt bars for about threequarters of the circumference, against about a quarter in the downstroke beaters (this advantage has been allowed for in many of the latest types of beater, as although they still strike downwards, the passage of the cotton is so made that it is acted upon for threequarters of the circumference).

2. It is this upstroke which permits the introduction of these strong spikes into the top cover, which considerable helps in the opening and cleaning processes.

Dobson & Barlow, Ltd., and some other makers still make the 41 in. cylinder, but with a downstroke instead of an upstroke.

The Double Exhaust Opener

The machine about to be explained is probably the most popular type of opener used at the present time, and is made by practically all machine makers ; the one to be explained being Platt's.

The cotton is drawn from the lattice feeder or cylinder part of the Crighton opener, as the case may be, down the trunk, and is presented to the cylinder *A* (Fig. 27) by the drawing power of the fans *B*, which are keyed to the cylinder shaft and are placed one on each side of the cylinder. This cylinder beats it and passes it over the dirt bars *C*, the fans *B* then drawing it out at the sides and passing it down the passage *D* to the first pair of cages *E*. These cages are either of perforated tin or else, as is probably best, of wire gauze, and as their interiors are exhausted by the fans *F* they act as fine sieves, and small particles of dust, etc., are taken out of the cotton and discharged by the fans through the aperture *G* into the dust chamber underneath. The cotton then passes through the cage delivery rollers *H* and second beater feed rollers *I*, and is given to the second beater *J*. This beater, which might be either two-blade, three-blade, or cylinder (18 in. diameter), passes the cotton over the dirt bars *K* and the dust box *L*, and deposits it in a level sheet on the second pair of dust cages *M*, which again are acted upon by the fan *F*. It now passes through the calendar rollers *N*, and is made into a lap at *O*. The above explanation is equally true for intermediate and finishing scutchers, their action on the cotton being precisely

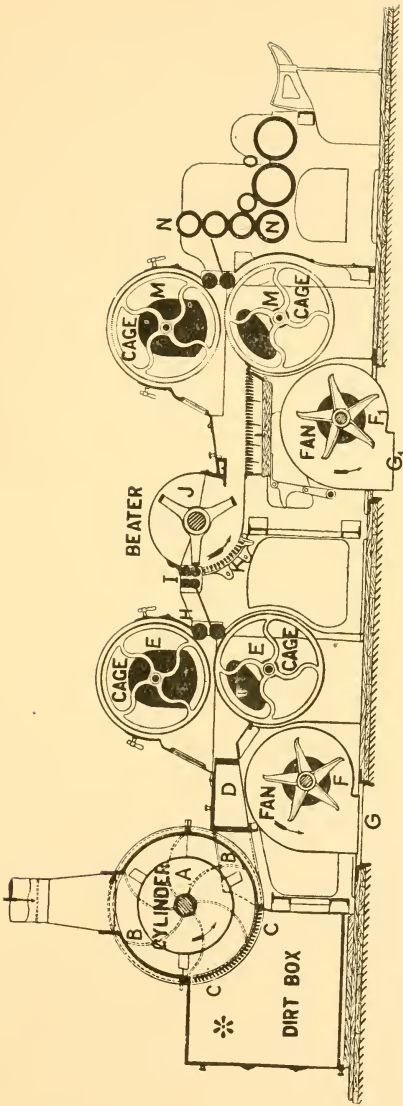

(Platt Bros.)

FIG. 27. DOUBLE EXHAUST OPENER AND LAP MACHINE

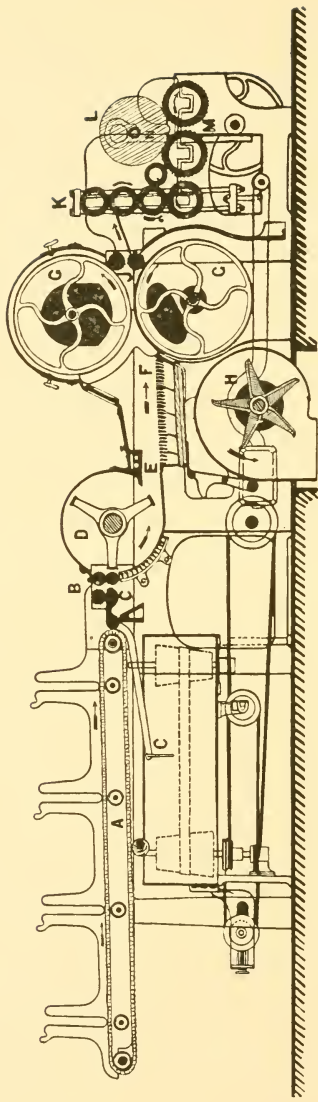

(Platt Bros.)

FIG. 28. SINGLE SCUTCHER AND LAP MACHINE

the same, the chief difference being that scutchers have their own regulating motion, and are fed from laps.

THE DOUBLING OF LAPS

The greatest ideal to attain in cotton spinning is an absolutely regular thread ; that is, regular per unit weight and of equal diameter (or thickness) throughout its length, and to do this it will be found that the cotton is doubled together at every possible process.

It will be seen quite easily that if the opener lap, which obviously must have many little irregularities, were to be passed direct to the card an even sliver would not be produced, and for this reason we double four laps together at the finisher scutcher. If intermediate scutchers are used four are also doubled here, so that in that case the total number of doublings would be sixteen.

The minimum, however, is 4, and the result is that any irregularity in any one lap is reduced to one-fourth by this doubling, and in practice we find that the thin places in one lap tend to counterbalance the thick places in some of the other laps, and the result is that the lap sheet fed to the carding engine is very even indeed.

It follows, then, that this duty of intermediate and finisher scutchers is in itself a very important one, quite independent of the fact that they also continue and help to perfect the cleaning of the cotton.

Cages and Fans

The cages are used in conjunction with the fan for two principal reasons : (1) to form the cotton after beating into a sheet, which, when calendered, will not tend to stick, and (2) to draw from the cotton as much as possible loose dirt and light dust.

Some makers advocate the two cages to be the same size, while others have the top cage the larger.

It is claimed for the latter idea that the larger amount of cotton drawn on to the top cage tends to absorb the smaller amount on the bottom cage, and so reduces the tendency of lap licking.

The fan exhausts the air, dust, fly, etc., from the inside of the cages and passes them to the dust flue.

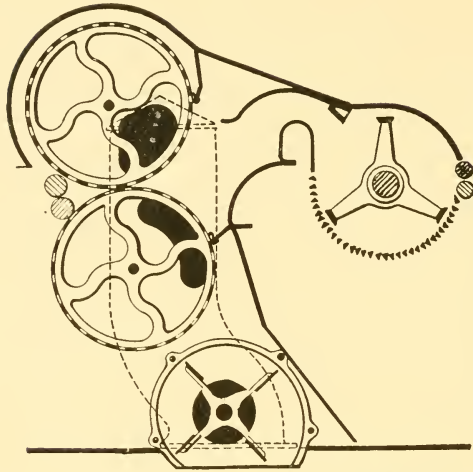

(Dobson & Barlow, Ltd.)

FIG. 29. ARRANGEMENT OF BEATER BARS, CAGES,
AND FAN

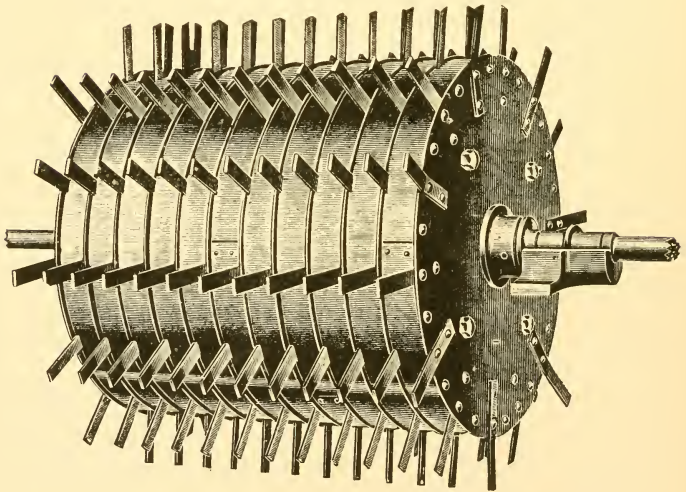

(Howard & Bullough, Ltd.)

FIG. 30. BUCKLEY OPENER CYLINDER
(41 in. diameter.) (Pedestal Cap Removed)

Dust Flues

The usual method adopted nowadays is that of having cellars beneath the blowing room, and each machine has its own flue attached to the fan, in order to permit easy escape for the dust and air.

Lap Licking

This is caused by two layers of cotton sticking to one another when unrolling at the next process, and makes unnecessary waste and uneven work. It should be remedied as soon as it is noticed, as if allowed to go on it will be very troublesome indeed.

TYPES OF BEATING INSTRUMENTS

Figs. 30 to 36B show some of the many types of beating arrangements at present in use.

Beater speeds may be somewhat as follows—

2-BLADE BEATERS

Indian cotton	1,450 r.p.m.
American cotton	1,300 r.p.m.
Egyptian cotton	1,050 r.p.m.
Sea Islands cotton	900 r.p.m.

Three-blade beaters will have speeds from 150 to 200 r.p.m. less.

Opener beaters make from 550 to 900 r.p.m., according to the class of cotton being treated, the higher speeds being for the dirtier cotton.

Fans in blowing room machinery make from 1,000 to 1,500 r.p.m.

Cylinder beaters of 18 in. diameter make something like the same speeds as three-blade beaters.

WEIGHTS OF SCUTCHER LAPS

Scutcher laps vary in weight per yard according to the counts being spun, and the following is simply a guide to the producing of good results—

For Coarse counts (up to 40s)	12 oz. per yd.
„ Medium counts (up to 90s)	11 oz. „
„ Fine counts (above 90s)	9½ oz. „

The total weight of a scutcher lap varies from about 30 lb. to about 50 lb.

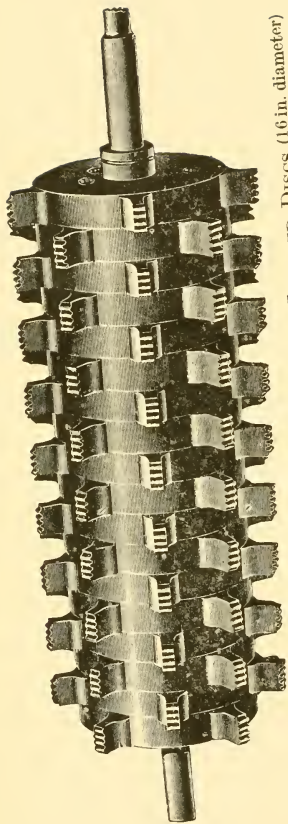

FIG. 31. PORCUPINE CYLINDER WITH CAST IRON TOOTHED DISCS (16 in. diameter)

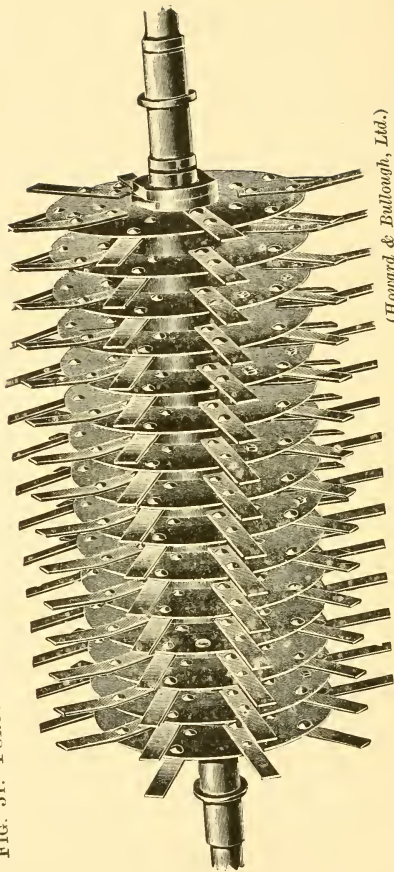
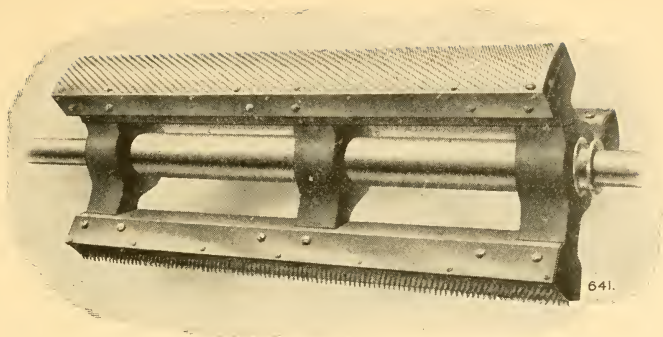
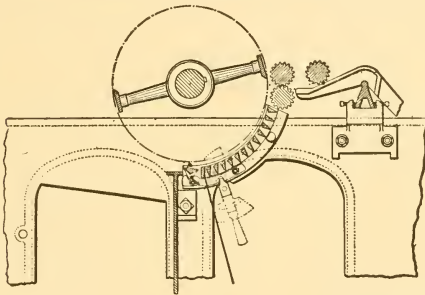

FIG. 32. PORCUPINE CYLINDER WITH STEEL BLADES (24 in. diameter)
(Howard & Bullough, Ltd.)



(Dobson & Barlow, Ltd.)

FIG. 33. IMPROVED TOOTHED BEATER (KIRSCHNER)



(Howard & Bullough, Ltd.)

FIG. 34. 2-BLADE BEATER

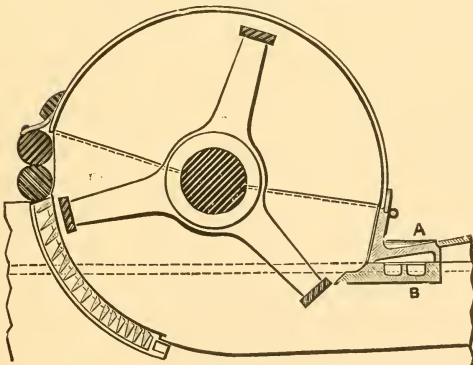

(Platt Bros.)

FIG. 35. 3-BLADE BEATER

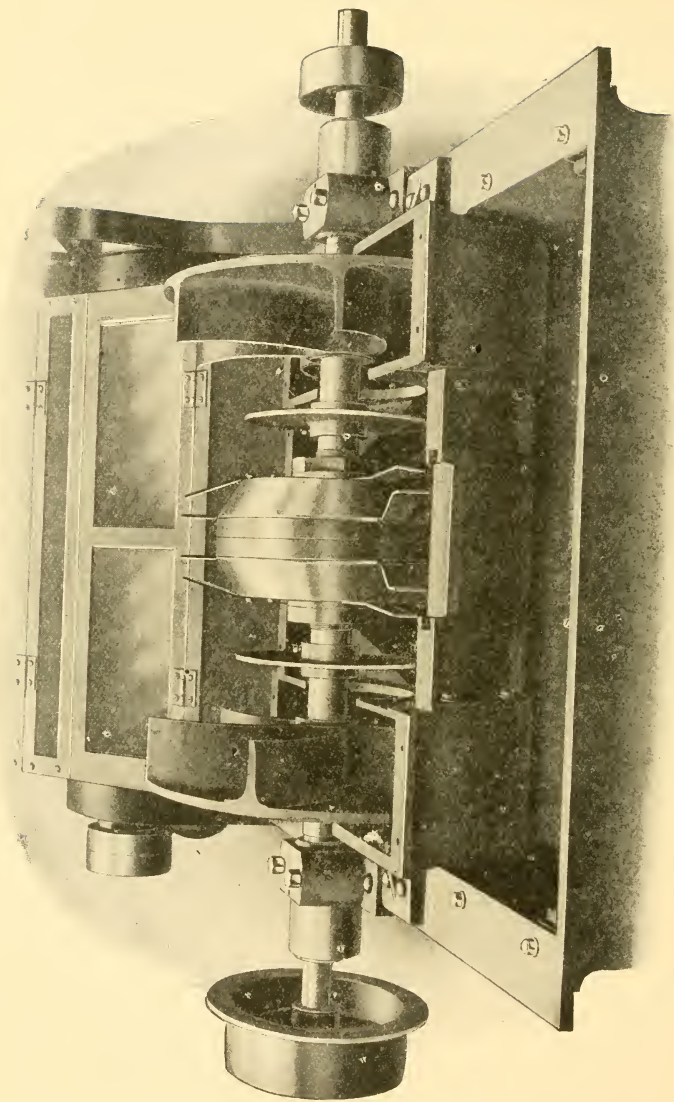
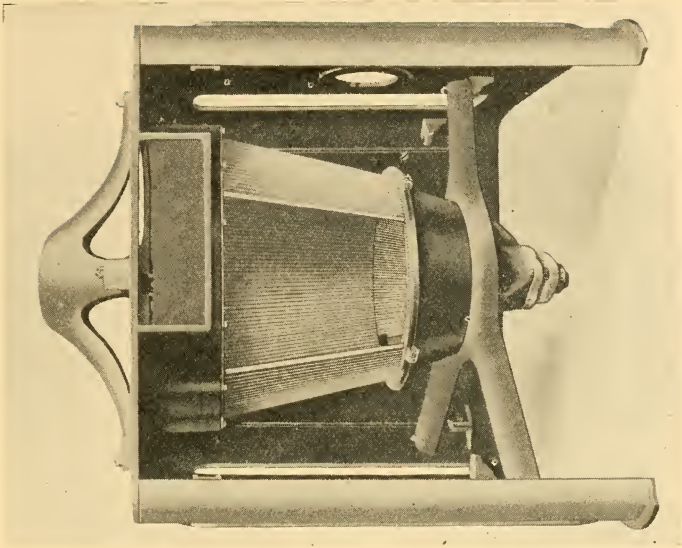

FIG. 36. EXHAUST OPENER BEATER

(Tweedales & Smalley, Ltd.)



(Brooks & Doxey)

FIG. 36B. CRICHTON OPENER BARS

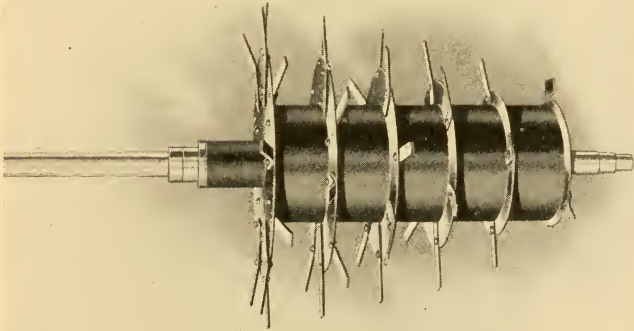

(Brooks & Doxey)

FIG. 36A. CONICAL BEATER FOR CRICHTON OPENER

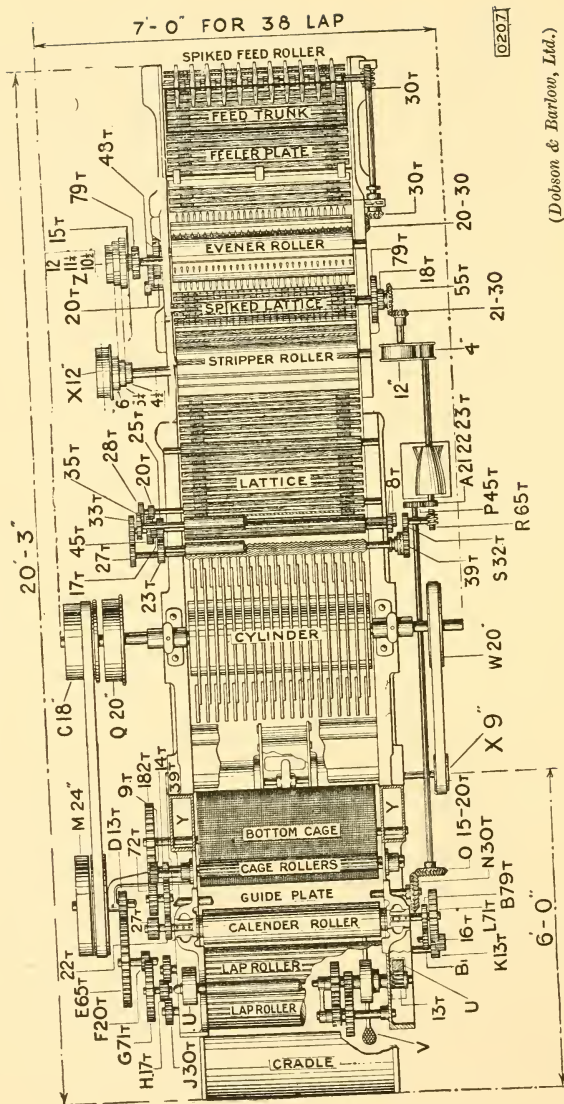

(Dobson & Barlow, Ltd.)

FIG. 37. PLAN OF GEARING OF SINGLE HORIZONTAL OPENER

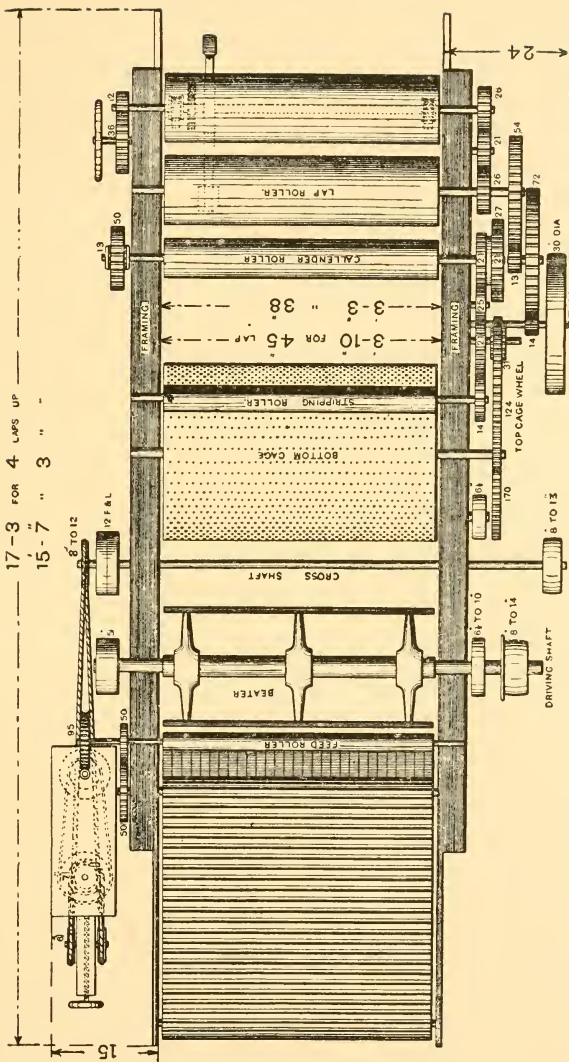

(Hetherington's)

FIG. 38. PLAN OF SINGLE BEATER SCOUTER

DRAFT CALCULATIONS

In conjunction with "doublings" probably the most important operation in cotton spinning is "drafting."

"Drafting" means drawing out or attenuating the cotton fibres, usually by means of revolving rollers. For instance, if 1 yd. of drawframe sliver passed through a slubber is drawn out to 6 yd. of roving, the "draft" in this case is six.

This drawing out process is done by the surface speed of the front rollers exceeding that of the back rollers by, in this particular case, six times. It will be seen that the draft will be determined by the *surface speed* of the respective parts, so that we must not simply look at it from the point of view of the revolutions, but must also take into account the circumferences, or more correctly (seeing that π will be common), the diameters of the respective parts.

To find the draft in any machine, therefore, we must *divide the surface speed of the delivery by the surface speed of the feed*.

The above rule will determine the theoretical draft in the machine (i.e. the draft being actually put in according to the gearing), and other ways of finding the actual draft would be to compare the weight of the cotton per unit length at the feed and delivery, or actually to time the respective parts.

Looked at from this point of view, it will be seen that a draft calculation simply involves two-speed calculations, and there is no necessity to have a special rule for drafts at all.

In all machines having drafts there is always one wheel, known as the draft wheel, which is used for altering, whenever it is desired to increase or decrease the draft.

CHAPTER VII

CARDING

AFTER scutching the cotton has been reduced to a very soft, fleecy condition, but it must be remembered that the scutching process only deals with the cotton fibres in mass, and in no way attempts to deal with individual fibres, so that the fibres in the lap which we now feed to the card are crossed and entangled with each other in all directions. Also, in spite of the present-day efficiency of machinery, quite a fair amount of sand, seed, husks, shell, motes, leaf, etc., still remain in the cotton after scutching, and, of course, no attempt has been made to rid the cotton of gin cut, short, dead or unripe fibres, nep, etc.

From the above remarks it will be seen that the duties of the carding engine are very extensive, and may be summarized as follows—

1. To extract the shell, sand, leaf, etc., left in the cotton by the blowing room machinery.

2. To remove from the cotton nep, and a proportion of short, dead, unripe, or gin cut fibre, i.e. to increase the spinning value of the cotton, the longer fibres being the valuable ones as far as the spinning of good, even yarns is concerned.

3. To loosen the fibres, separate them, etc., in order that the work of the drawframe, which is to make them parallel, may be done with perfection.

4. To make a round strand of loose, soft cotton, known as a sliver, from the lap sheet presented to it by the scutcher.

The carding engine is the first machine which treats the cotton fibres individually.

The Revolving Flat Carding Engine

Although there are other types of carding engines besides the one about to be explained, the most popular one is undoubtedly the flat carding engine.

The principal organ of the carding engine is the cylinder, which is usually 50 in. diameter (without wire), and it is driven from the line shaft at from 160 to 180 r.p.m. according

to the cotton being carded, about 165 being a good speed for Egyptian cotton and 175 for American. All other parts of the machine are driven either directly or indirectly from the cylinder, as a reference to the gearing plan (Fig. 43) will show.

The scutcher lap *O* (Fig. 39) is placed on the fluted lap roller *P*, and unwound by frictional contact with it. It passes along the smooth feed plate or "dish feed," as it is sometimes called, and under the fluted feed roller *Q*, of usually $2\frac{1}{4}$ in. diameter, which presents it to the takerin *K*. The takerin, which is covered with metallic saw-tooth wire, is $9\frac{3}{4}$ in. diameter over the wire, and makes round about 400 r.p.m. As the movement of the lap along the feed plate is only at the rate of about 5 to 12 in. per minute, it will be seen that there is a tremendous draft between feed roller and takerin, which, of course, opens the cotton to a very fine degree. The takerin strikes the cotton downwards and over the mote knives and undercasing *L*, and it is here that the heavier impurities are driven from the cotton, as the mote knives are set very close to the teeth of the takerin ($\frac{10}{1000}$ in. being quite common) as also is the undercasing (about $\frac{34}{1000}$ in.).

The takerin teeth are set to within about $\frac{7}{1000}$ in. or $\frac{10}{1000}$ in. of the wire teeth of the cylinder *A*, and the cylinder sweeps the cotton off the takerin in an upward direction. The wire with which the cylinder, doffer, and flats are covered, is very fine and contains from 450 to 700 points per sq. in., according to the cotton being treated. Egyptian cotton may be carded with 120s wire ($5 \times 120 = 600$ points per sq. in.), while American may have 100s wire ($5 \times 100 = 500$ points per sq. in.).

It is these many millions of wire points which open, loosen, and comb out the nep and a proportion of the short, unripe, and dead fibres, as the wires are bent at the middle or knee to give them strength and flexibility.

The cylinder *A* takes the fibres up to the flats *B* which are strips of metal on which are fastened the wire, and which are screwed to an endless chain. The flats cover practically the whole of the upper portion of the cylinder and move very slowly (about $2\frac{1}{2}$ in. to 6 in. per min.) in the same direction as the cylinder, but the wire teeth are set in the opposite direction, which gives the necessary opening and combing effect. These flats are moved slowly out of action for the sole purpose of

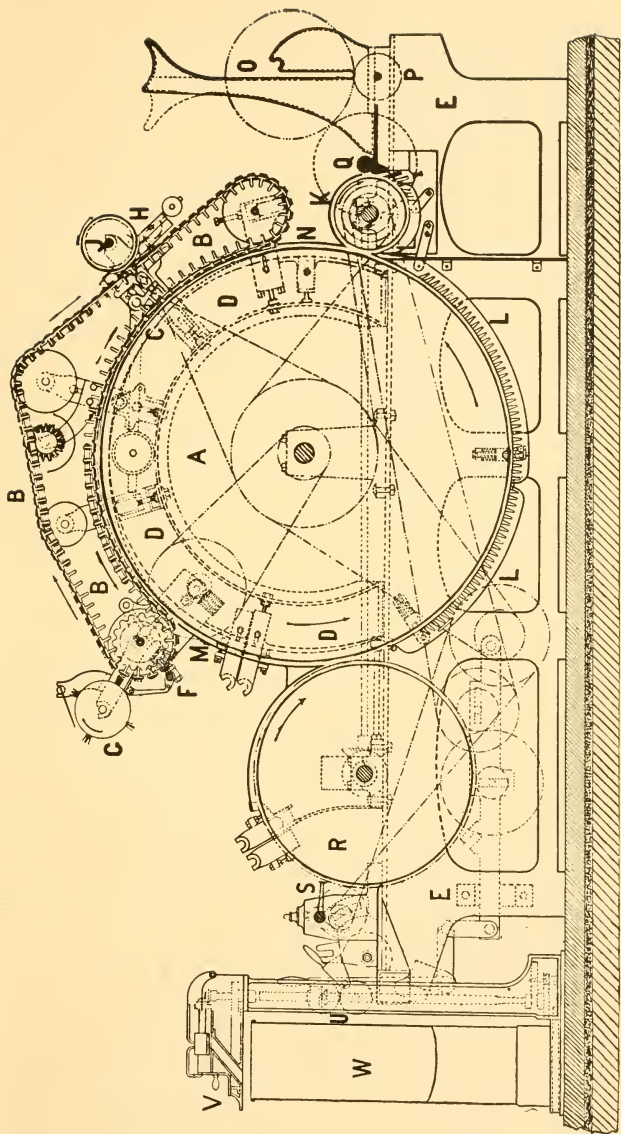

(Platt Bros.)

FIG. 39. REVOLVING FLAT CARDING ENGINE

making it possible to strip them by the stripping comb *F* and clean them with the cleaning brush *G*. The flat strips contain the nep and much of the short fibre, etc.

The cylinder then gives the fibres to the doffer *R*, whose surface moves in the same direction as the cylinder, but its teeth are set opposite to that of the cylinder. The doffer may be from 24 in. to 28 in. diameter without wire, and, like the flats, is set at about $\frac{7}{1000}$ in. from the cylinder wire. It makes about 11 r.p.m. for Egyptian, and 14 or more for American cotton. The doffer now carries the fibres underneath itself and the web is stripped off by the doffer comb *S*, making from 1,400 to 1,600 double strokes per min. This comb is set at about $\frac{10}{1000}$ in. away from the doffer teeth.

The web is then condensed in a trumpet (i.e. made into a sliver), passes through the calendar rollers *U*, through the coiler top *V*, and into the can *W*.

Other points of importance are—

1. The cylinder also has an undercasing *L*.
2. There may be from 90 to 110 flats on a card, with from 32 to 48 in action over the cylinder at one time.
3. *M* is the front plate, and an alteration of the distance of this from the cylinder determines the amount of flat strips. *N* is the back cover plate.
4. *H* is the flat grinding motion, while *J* shows the grinding roller in action.
5. The cylinder and doffer wires become filled with fly during running, and are periodically stripped with a stripping brush (twice or three times a day). The card has to be stopped for this purpose.
6. The flat strips fall on to the doffer cover after being stripped by the comb *F*.
7. The production of a card varies from 250 to 800 lb. per week, according to the speed of doffer and feed part and the kind of cotton being carded.
8. Carding engines are from 38 in. to 48 in. wide on the wire.
9. The draft in a card is round about 100.

Card Waste

The waste taken out by the card is split up into two parts, one known as "strips" and the other as "fly." "Strips" are taken from the wire of the cylinder, doffer, and flats, while

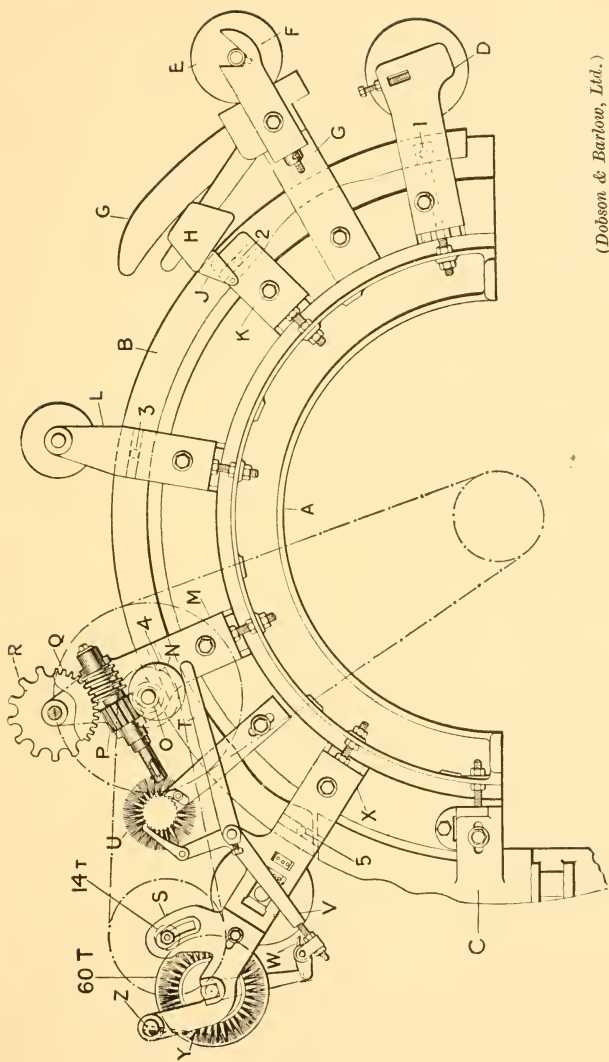

(Dobson & Barlow, Ltd.)

FIG. 40. IMPROVED FIVE SETTING POINT FLEXIBLE BEND

“fly” is the waste that flies off the takerin, cylinder, and doffer, and is deposited on the floor underneath the machine and drawn periodically by hand.

The total waste taken out varies from 5 to 10 per cent according to requirements.

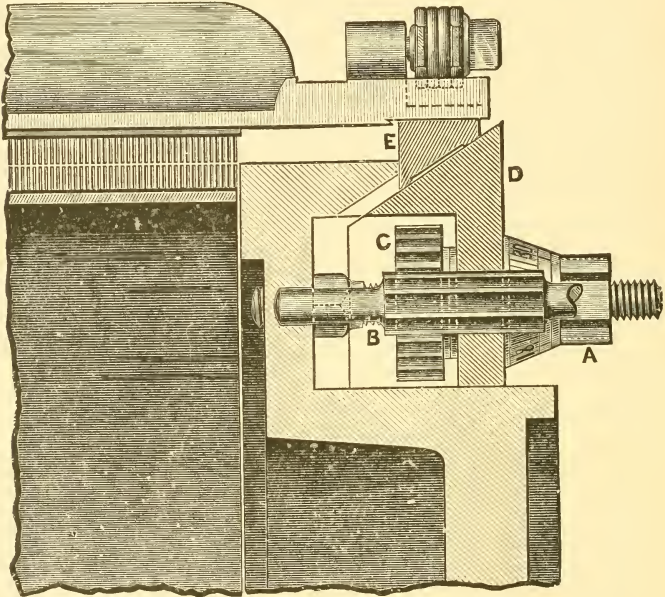

(Howard & Bullough, Ltd.)

FIG. 41. BULLOUGH'S BEND

Flexible Bends

The flexible bend gets its name because, within certain limits, it is capable of being pulled into a part circle of reduced diameter, in order to maintain concentricity of flats and cylinder.

It performs a very important function on the card, as in time, due to working and grinding, the teeth of flats and cylinder get worn shorter, and it is necessary to keep them set at the required distance apart ($\frac{7}{1000}$ in.) to get the best results. The flats move slowly over the surface of these flexible bends.

Fig. 40 shows Dobson & Barlow's flexible bend at *B*, with the five setting points 1, 2, 3, 4, 5. It will be noticed that the setting screws pass through the card side *A*. Plugs in the setting brackets pass through holes drilled in the bend, so that the setting operation is very simple.

Fig. 41 shows Howard & Bullough's bend.

The Coiler

The coiler (Fig. 42) receives its motion from the bottom calender roller *B*, the bevels *GH* giving motion to the upright shaft *J*, which in turn drives the coiler top roller *X*, the tube wheel *T*, and the can bottom wheel *O*. The revolution of the can is slowly in the opposite direction to the tube wheel, and as the tube is not central with the can the sliver is placed in the can so that easy withdrawal at the next process is assured.

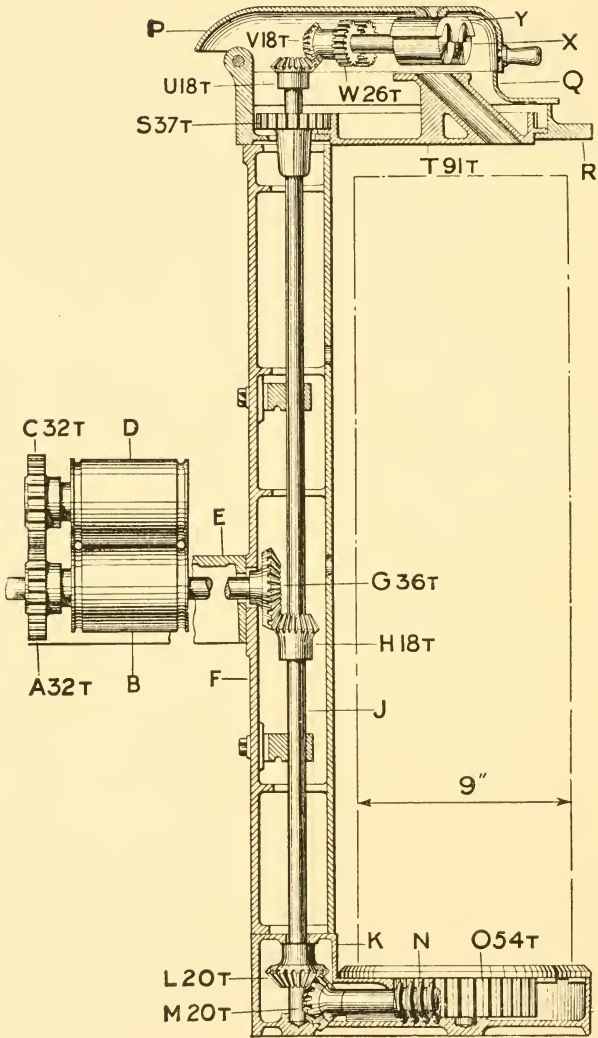
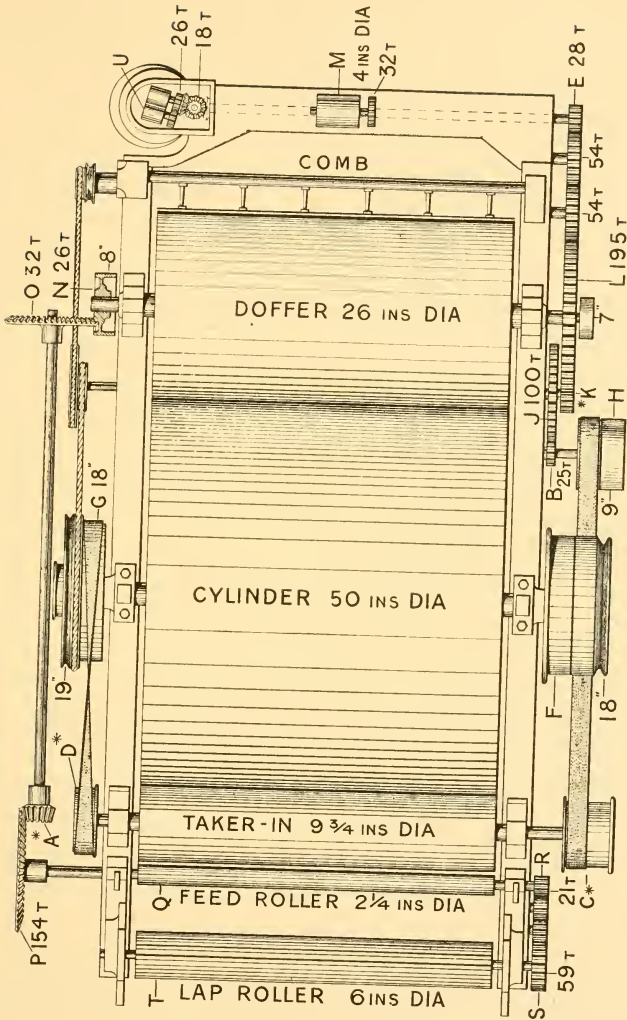

FIG. 42. DIAGRAM OF COILER GEARING



(Dobson & Barlow, Ltd.)

FIG. 43. GEARING PLAN OF CARD

CHAPTER VIII

DRAWFRAMES

THE drawframe is the machine always used before the slubbing frame which is the first flyframe, and in the case of mills spinning carded yarns it is the only machine between the carding engine and the slubbing frame.

It is a very simple machine, exceedingly productive, and performs two very important operations, which improve the quality of the finished yarn to an inestimable degree.

Its first duty is that of making the sliver uniform in weight per yard and even throughout its length, and this is done, as in the case of the finisher scutcher, by doubling.

Mills usually use three heads of drawframe, i.e. the cotton passes through three distinct drawframes, and at each frame doubling takes place. The popular number of slivers doubled together is six, and the draft in the rollers is usually about the same as the number of slivers, so that as this happens three times it will be seen that the total doublings are $6 \times 6 \times 6 = 216$, which tells us at once that any error in the card sliver, and card slivers are certainly fairly uneven, is reduced to a very fine degree by the time it has passed through all the drawframes.

The second duty of the drawframe is to make all the fibres parallel, and this is done by passing the cotton through four lines of drawing rollers, each line moving at a greater surface speed than the previous line, and suitably set.

This parallelization of the fibres is absolutely essential, as without it it would be impossible to draw them out to the required degree of fineness in spun yarns, and a round, even thread could not be produced.

Passage of Cotton through Drawframe

Fig. 44 shows a section of the drawframe as made by J. Hetherington & Sons. The card or comber sliver is drawn from the cans through the sliver guide, which consists of a plate having holes drilled into it which are only large enough

in diameter to allow the sliver to pass through, and will prevent any knots from passing forward.

There is a slight draft (say 1.05) between the "single"

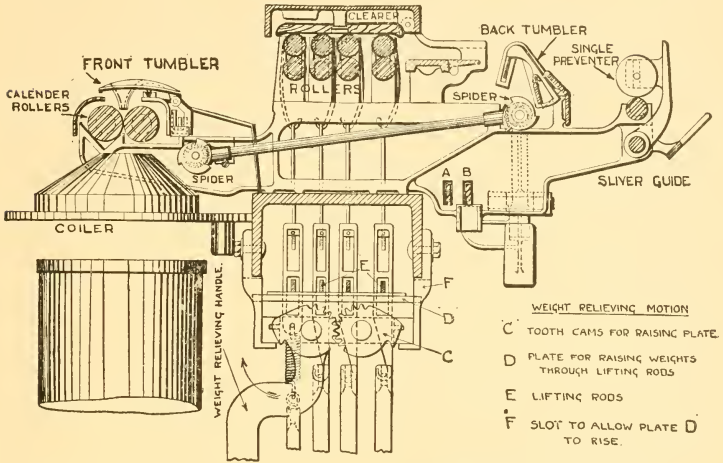

(J. Hetherington & Sons, Ltd.)

FIG. 44. SECTION OF DRAWING FRAME

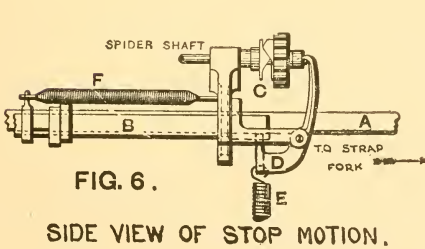

FIG. 6.
SIDE VIEW OF STOP MOTION.



(J. Hetherington & Sons, Ltd.)

FIG. 44B. SPIDER

preventor rollers and the back pair of drawing rollers, so that as the slivers are drawn into the machine they are always tight between these two points, between which are placed the tumblers or spoons, one for each sliver. These tumblers are

very sensitively balanced, so that if an end breaks, or a can runs empty, or a particularly light sliver comes forward, they immediately fall so that their lower ends come into contact with the spider shaft, and stopping this, the strap is placed on the loose pulley by the action of a spring and the machine is immediately stopped. This quick stopping of the machine prevents the broken end from passing into the drawing rollers, and so prevents uneven work, and assures a good piecing.

The slivers now pass through the four pairs of drawing rollers, and here are doubled together and drawn out to the required amount, and the resultant sliver passes through the front trumpet, which is also coupled to the automatic stop motion, and so stops the machine when an end breaks at the front, through the calender rollers, and into the can.

A reference to the illustration will bring to the student's notice the following important details.

1. The "single" preventor rollers are so named because due to the fact that they keep the sliver tight over the tumbler they prevent any excessively thin slivers from passing forward, as the least reduction of pressure on the tumbler causes it to overbalance and stop the machine.

Also it will be seen that, due to the introduction of these "single" preventor rollers, as soon as the broken or thin end of the sliver leaves the preventor rollers the tumbler will fall, and so the machine will be at a standstill long before the end can possibly have reached the back drawing roller.

The cross shaft connecting the front and back spider shafts is clearly shown in the illustration, while the stop motion itself is also shown.

2. The drawing rollers have both top and bottom clearers, the top usually being of the slow-moving, endless, and self-cleaning type (Ermen clearer), while the bottom may be either flat or circular clearers.

3. The weight-relieving motion is applied to take the weight off the top rollers when taking off a roller lap or when the machine is left standing for any length of time, in order to prevent the leather rollers from becoming flattened or marked by the flutes of the bottom rollers.

4. A good speed of front drawing roller is 300 to 350 r.p.m.

5. Spring weight hooks are used for the "dead" weights on the front line of rollers to enable faster running of the front

roller, and to help to increase the life of the leather covering of the top roller.

The Drawing Rollers

Fig. 45 shows the drawing rollers in position on the roller stand, and the Ermen clearer. The roller stands are adjustable by means of the set screws underneath, so that any required setting can be obtained.

It is usual to make the top rollers slightly less (say $\frac{1}{32}$ in. or $\frac{1}{16}$ in.) than the bottom rollers in order to prevent the leather

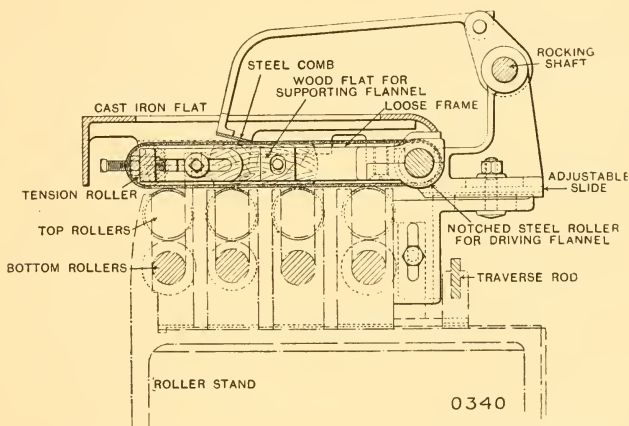

(Dobson & Barlow, Ltd.)

FIG 45. ERMEN'S CLEARER

rollers from becoming fluted through continual contact with the bottom fluted rollers, and the flutes of the bottom steel rollers are also cut of slightly varying pitch for the same reason. In all machines having draft rollers it is usual to have the bottom roller next to the front roller (i.e. second from front) less (say, $\frac{1}{8}$ in. or $\frac{1}{16}$ in.) than the others, as this enables us to get closer settings.

The number of leather-covered top rollers varies, but the popular method is to have the front two leather covered and the back two fluted.

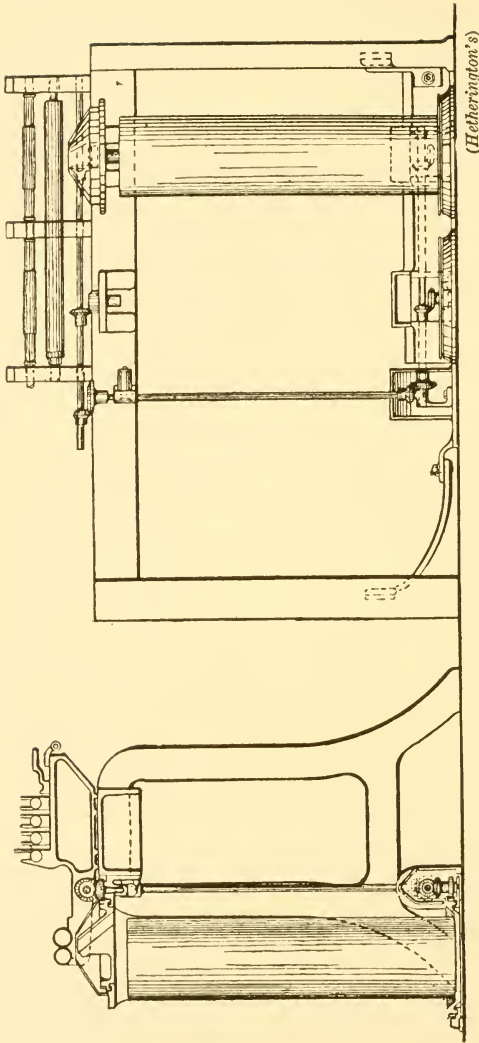

FIG. 46. COILING MOTION

The following are roller diameters and settings which would give good results for the cotton named—

	Front	2nd	3rd	Back
EGYPTIAN AND SEA ISLANDS—	inches	inches	inches	inches
Top	$1\frac{7}{16}$	$1\frac{7}{16}$	$1\frac{7}{16}$	$1\frac{7}{16}$
Bottom	$1\frac{1}{2}$	$1\frac{3}{8}$	$1\frac{1}{2}$	$1\frac{1}{2}$
Setting	$1\frac{1}{2}$	$1\frac{5}{8}$	$1\frac{3}{4}$	$1\frac{3}{4}$
AMERICAN—				
Top	$1\frac{3}{16}$	$1\frac{3}{16}$	$1\frac{3}{16}$	$1\frac{3}{16}$
Bottom	$1\frac{1}{4}$	$1\frac{1}{8}$	$1\frac{1}{4}$	$1\frac{1}{4}$
Setting	$1\frac{1}{4}$	$1\frac{3}{8}$	$1\frac{5}{8}$	$1\frac{5}{8}$
INDIAN—				
Top	$1\frac{3}{32}$	$1\frac{3}{32}$	$1\frac{3}{32}$	$1\frac{3}{32}$
Bottom	$1\frac{1}{8}$	1	$1\frac{1}{8}$	$1\frac{1}{8}$
Setting	$1\frac{1}{8}$	$1\frac{3}{8}$	$1\frac{1}{2}$	$1\frac{1}{2}$

The weights on the draft rollers might be somewhat as follows—

Front, 40 to 44 lb. per roller.

Other lines, 32 to 40 lb. per roller.

The Coiler Motion

From Fig. 46 it will be seen that, although simple, the drawframe coiler motion is slightly different from that of the carding engine.

The following terms are important in connection with drawframes—

Boxes. This is the name often given to drawframes.

Heads. This denotes the number of series of drawframe rollers the sliver passes through, and is usually three, i.e. when the cotton is said to pass through “three heads of boxes” we mean that the cotton passes through three distinct drawframes, and if there are six ends up at each drawframe the total doublings would be $6 \times 6 \times 6 = 216$.

Deliveries. By this we mean the number of times the same

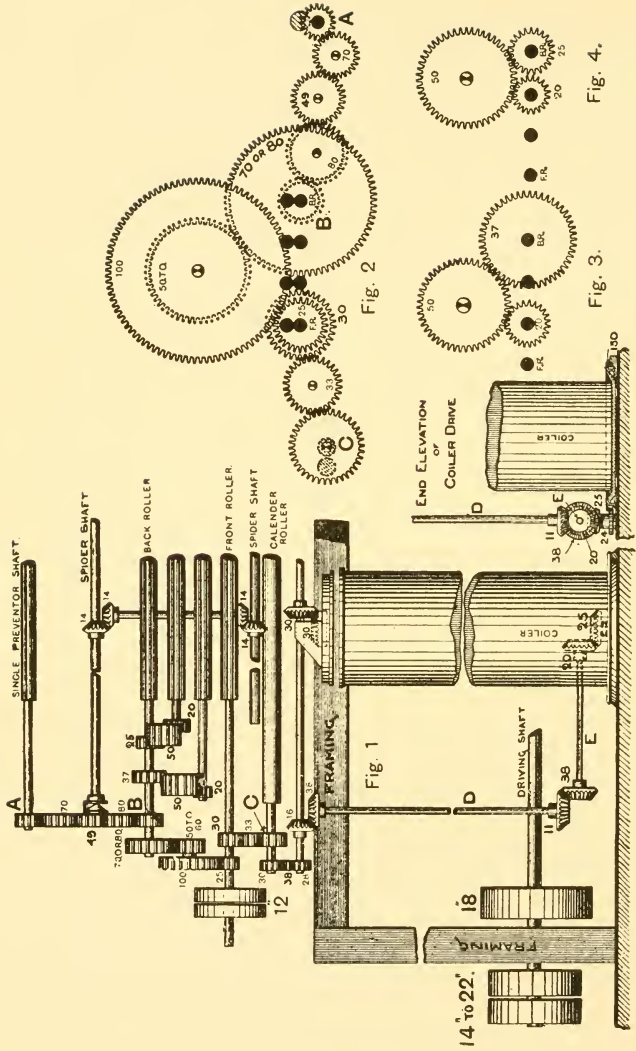

FIG. 47. GEARING FOR DRAWING FRAMES

(Hetherington's)

process takes place in any one drawframe. Seven or eight deliveries are quite common in one machine.

A set of drawframes three head seven delivery, then, will mean that there are three processes of drawing, and seven deliveries in each process, or a total of twenty-one deliveries. Tenters are usually paid according to the number of deliveries they operate.

CHAPTER IX

BOBBIN AND FLYFRAMES

THESE machines vary in number according to the counts to be spun, and consist of slubber, intermediate, roving-frame, fine jackframe.

For coarse counts it is usual to use two only, viz., slubber and large bobbin roving-frame. For medium and medium-fine counts three are employed, viz., slubber, intermediate, and roving-frame.

For very fine counts it is usual to use all four machines in the order mentioned. It is usual to double two ends at each of these machines except the slubber, in order to still further reduce the amount of error in the finished article. This doubling does not take place at the slubber because this frame is fed from drawframe cans, and two of these to each end would take up far too much floor space, whereas in the case of the other flyframes the creels can easily be adapted without affecting the floor space in the least.

The work done by all these flyframes is similar, as is the construction of the machines themselves, the only difference being that all the parts of the machines are lighter and less in size in the later flyframes, as, of course, the bobbins are made less at each succeeding process.

It will be as well to point out here, that in spite of the fact that in theory all dirt and foreign matter has been taken out of the cotton before it passes into the drawframe, a certain amount always remains, and by passing the slivers and rovings through the drawing rollers of all the later machines, we assist a good deal of the dirt out of the cotton, and it is deposited on the various roller beams, as when all is said and done "drafting" by the use of rollers is "opening."

Another point of great importance is that the drawframe sliver produced at the finisher drawframe is only just barely strong enough in bulk to pull out of the can at the slubbing frame, and as the thinning out process is continued at the flyframes, it is essential to insert sufficient twist to give the roving the necessary strength to draw off in the creel of the next machine.

The objects of bobbin and flyframes, then, may be summarized as follows—

1. To continue the drawing out process so that finally a suitable mule or ring yarn shall be produced.

2. To put into the roving sufficient twist to enable it to be unwound at the creel of the next machine.

3. To wind the roving on to suitable bobbins, the finer the roving the less the bobbins will be.

With reference to No. 1, it used to be generally recognized that the following were reasonable drafts: drawframe (if six ends up) six; slubber, intermediate, and roving-frame six; mule and ringframe twelve to fourteen; and bobbins were made pretty well according to these drafts.

Nowadays, however, drafts of twenty or even more are used at both mule and ringframe, and a serious attempt has been made recently to reduce the number of flyframes necessary in the cardroom, by increasing the draft. J. Hetherington & Sons have produced an "Inter-rover" frame which is capable of drafts unthought of in any flyframe a few years ago, and, of course, there are now many systems of high drafts applied to mules and ringframes.

A list of twists necessary to be put into rovings will be found on page 160, the better cottons requiring the lesser twist, and if worked to the figures mentioned would give good results.

In actual practice, however, the correct amount of twist to be put into rovings is that amount which will just allow these rovings to be drawn off in the creel of the next process, and no more, as any excess is simply unnecessarily lost production; it will be seen shortly that an increase of twist on any flyframe, etc., means a proportionate decrease of production.

The winding mechanism, which is probably the most important part of any flyframe, will be taught in full in the second year course, but the student must know that conical-ended bobbins are made to prevent the cotton from dropping under or over, and that frames are generally made with the bobbins moving faster than the spindles, i.e. bobbin-leading frames.

PASSAGE OF COTTON THROUGH A FLYFRAME

The cotton is drawn from the can or creel by the revolution of the back drawing rollers, and passes through the three

lines of drawing rollers, where it is drafted to the necessary degree.

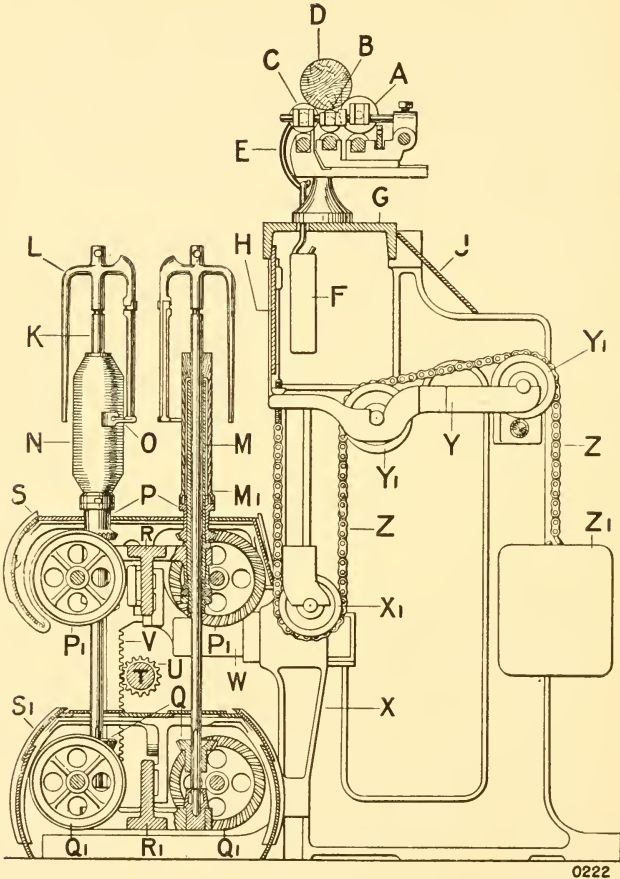

(Dobson & Barlow, Ltd.)

FIG. 48. SECTION OF FLYFRAMES

From here the end of cotton passes through a hole in the top of the flyer, which is attached to the spindle, out of a hole

at the side of the flyer top, down the flyer leg, round the presser (usually three times round) and on to the bobbin.

By a careful examination of Fig. 48 it will be seen that the bobbins are driven quite independently of the spindles, which are driven at a speed necessary to give to the roving the

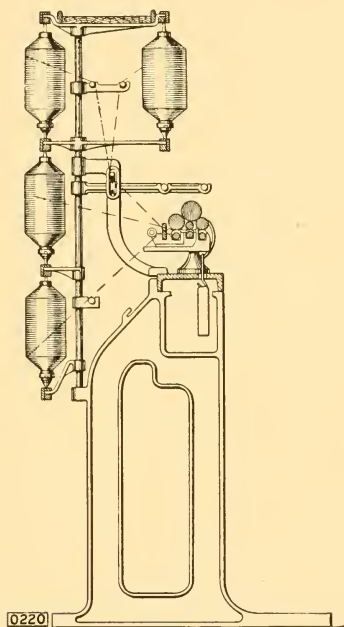

(Dobson & Barlow, Ltd.)

FIG. 49. CREEL FOR FLYFRAMES

requisite amount of twist. This twist is imparted to the roving between the nip of the front drawing rollers and the flyer top, as the cotton is virtually gripped at these two points while the spindles are revolving.

The bobbins, which are carried on the top rail, make sufficient extra revolutions to the spindles to permit the cotton roving to be wound on to themselves, and these revolutions are continually reducing in number as the diameter

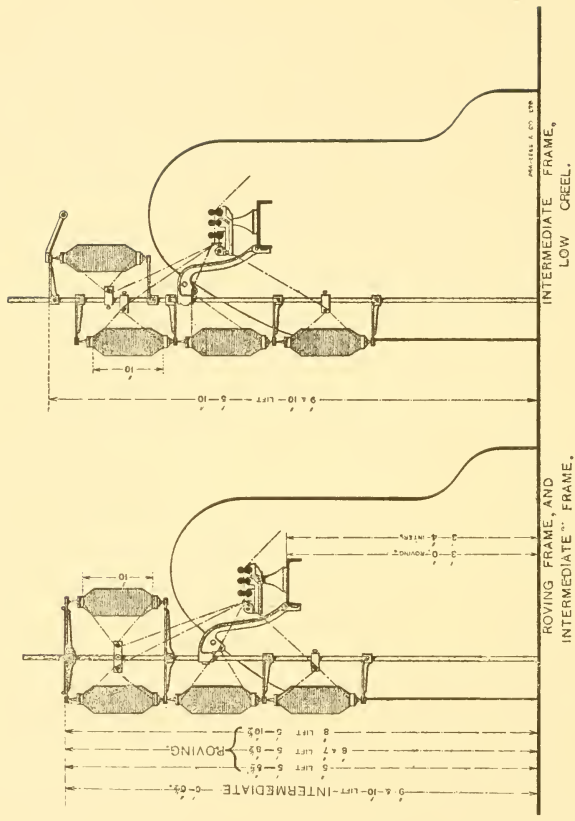

(Asa Lees & Co., Ltd.)

FIG. 50

of the bobbins increase, but are *always* greater than those of the spindles, otherwise no winding would take place.

The top rail moves slowly up and down, gradually reducing its amount of movement at both ends and so forming the conical ends on the bobbins.

Before passing into the drawing rollers the roving from the creel passes through a hole or eye in the traverse bar which moves slowly, backwards and forwards across the width of the leather rollers, and is used to prevent "channeling" of the leather by the roving continually running in the same place.

These traverse motions are applied to all machines having drawing rollers in one form or another, and one type is explained in Chapter XI.

Bobbin and flyframes have in nearly all cases two rows of spindles, and the total number of spindles varies from about 60 in a slubber to 240 or more in a roving or fine jackframe.

Bobbins vary in size from about 12 in. in the case of a slubber to as low as 6 in., and sometimes even 5 in. in the case of a fine jackframe. The length taken up by the cotton on a bobbin is known as the "lift," while the gauge of a flyframe is generally denoted as "so many spindles in so many inches," viz., a roving-frame might be 6 in. lift, eight spindles in 18 in. (or $4\frac{1}{2}$ in. gauge), i.e. four spindles in each row.

The Drawing Rollers

There are three lines of drawing rollers, the bottom lines being all fluted metal rollers, while the top lines vary very considerably according to circumstances.

In some cases the top rollers are all leather covered and weighted with "dead" or lever weights, while in others this only applies to the front and middle rollers, the back one being a large self-weighted plain metal one.

Probably the most popular method adopted, however, is to have, in the case of roving-frames and fine jackframes at any rate, only the front top roller leather covered and weighted, the middle top roller being plain metal polished, self-weighted, and of small diameter, while the back top roller is large self-weighted as previously mentioned. Various methods of cleaning these top rollers are shown in Fig. 51, and the bottom rollers are usually cleaned with flannel-covered, circular, friction clearers.

Roller diameters vary, not only being less in the later flyframes, but also according to the type of cotton being

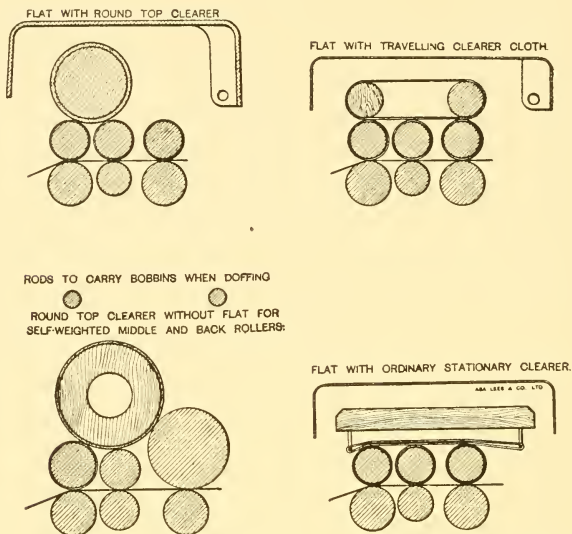

(Asa Lees & Co., Ltd.)

FIG. 51

produced, but the following would give good results for Egyptian cotton, and less, of course, for American cotton.

	Front	Middle	Back
SLUBBERS—			
Top	$1\frac{5}{16}(w)$	$1\frac{1}{8}(w)$	$2\frac{1}{4}$
Bottom	$1\frac{3}{8}$	$1\frac{1}{4}$	$1\frac{3}{8}$
INTERMEDIATES—			
Top	$1\frac{5}{16}(w)$	$\frac{7}{8}$	$2\frac{1}{8}$
Bottom	$1\frac{3}{8}$	$1\frac{1}{4}$	$1\frac{3}{8}$
ROVING FRAMES—			
Top	$1\frac{3}{16}(w)$	$\frac{3}{4}$	2
Bottom	$1\frac{1}{4}$	$1\frac{1}{8}$	$1\frac{1}{4}$

(w) = "dead" weighted.

Settings are always greater than the length of staple being used.

The cap bar nebs, in which the top rollers run, are made adjustable, so that any required position of top roller can be obtained.

USUAL WEIGHTS FOR FLYFRAME ROLLERS

Kind of Machine	Kind of Cotton	Front	Middle	Back
Slubber . . .	Indian, American, and Russian	lb. 18	lb. 24	Saddle and Bridle
" . . .	Egyptian and Sea Islands . . .	16	20	" " " Self-weighted
Intermediate . . .	Indian, American, and Russian	14	12	" " " Self-weighted
" . . .	Egyptian and Sea Islands . . .	16	20	Saddle and Bridle
" . . .	" " " " . . .	14	18	" " " Self-weighted
" . . .	" " " " . . .	12	10	" " " Self-weighted
Roving . . .	Indian, American, and Russian	18	24	Saddle and Bridle
Roving and Jack	Egyptian and Sea Islands . . .	16	20	" " " Self-weighted
Roving . . .	" " " " . . .	10	10	" " " Self-weighted
Jack . . .	" " " " . . .	8	"	" " " "

When one considers that frames contain up to 240 spindles or more in some cases, it will be seen at once that the bottom drawing rollers are a tremendous length, and being of such small diameter would be damaged if any attempt were made to send them to the mill in one piece.

This being so, they are made in short lengths of about 18 in. or 20 in. of mild steel, and in some cases are case-hardened all over to prevent injury, whereas in others only the bearings are case-hardened.

Each piece of bottom roller has the following special features: immediately next to the bearing is a square or "spigot" end which is slightly tapered, and the other end of the roller has a square socket into which the "spigot" ends fits very accurately, thus forming what is known as a "spigot joint," and producing any required length of roller in one working piece, but which for transit, repair, cleaning, etc., can be easily pulled to pieces.

Driving of Rollers and Spindles

Fig. 53 shows the complete flyframe drive, but as the student is only required to understand the driving of rollers and spindles, that part only will be explained.

To the Spindles. The frame driving shaft receives its revolutions through the strap from the line shaft, and passes straight through the gearing portion of the machine as shown.

On the inside of the driving pulleys and flywheel is the wheel *H*, which through the large carrier wheel drives the spindle shaft wheel *K*. On these spindle shafts are screwed the skew gear wheels *L*, each of which drives its own spindle pinion *M*. It will be seen that the revolutions of the spindles on a flyframe is constant.

To the Rollers. On the inner end of the frame driving shaft is the *twist wheel B*, which drives, through a carrier, the inside

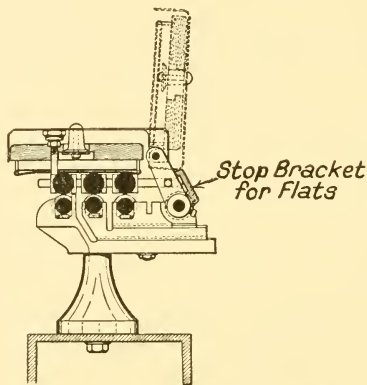

(Asa Lees & Co.)

FIG. 52. SECTION OF ROLLER STAND

top cone drum wheel *V*. At the out end of the top cone drum shaft is the wheel *W* which drives the large front roller wheel *X*. From here the draft roller gearing is the same in principle as that of the drawframe.

Seeing that the speed of the spindles is constant, it will be seen that any alteration of twist in the roving must be made by reducing or increasing the speed of delivery of the front drawing roller according to requirements, and this is done by making an alteration of the driving twist wheel *B*, a larger wheel increases the speed of front roller and so reduces the twist and vice-versa.

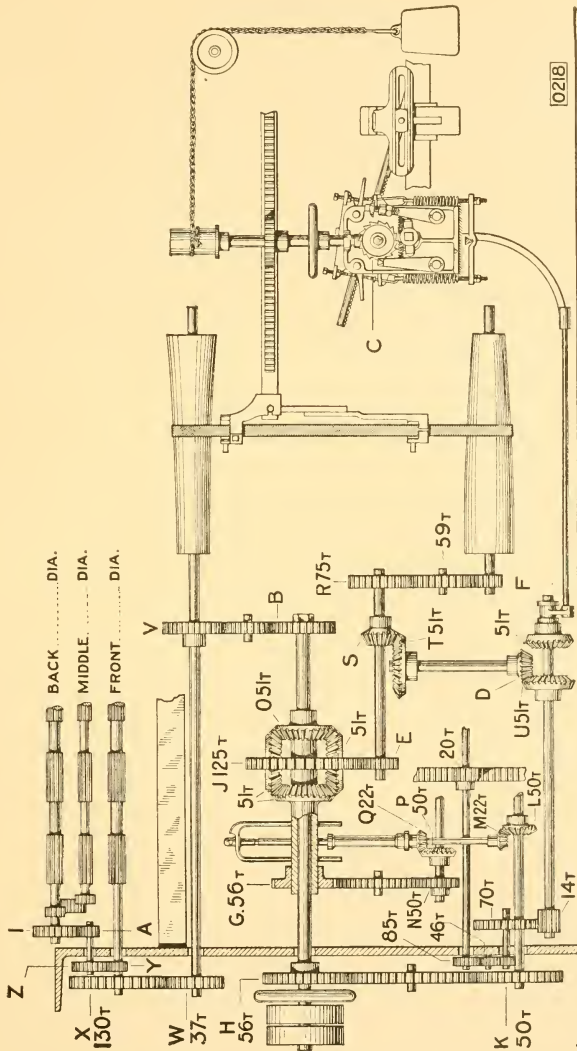

0218

(Dobson & Barlow, Ltd.)

FIG. 53. GEARING PLAN OF FLYFRAME

Spindles

Spindle speeds on flyframes may be somewhat as follows—

Slubbers	400 to 600 r.p.m.
Intermediates	600 to 800 „
Roving-frames	900 to 1,100 „
Jackframes	Up to 1,300 „

Front roller speeds may be as follows—

Slubbers	90 to 200 r.p.m.
Intermediates	70 to 180 „
Roving frames	50 to 130 „

Flyframe spindles are steel rods of from $\frac{5}{8}$ in. to $\frac{7}{8}$ in. diameter according to the machine they are for, and are

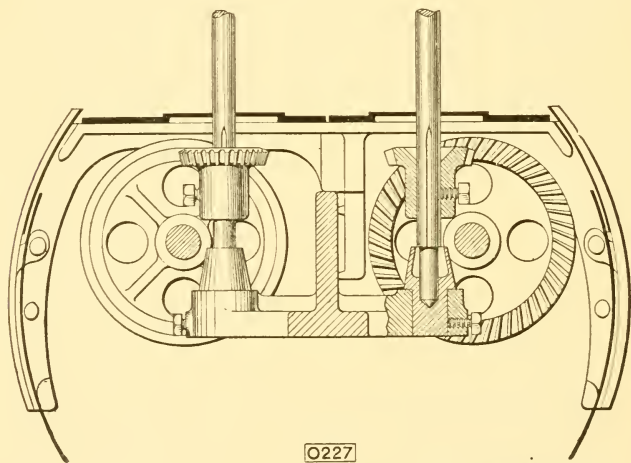

(Dobson & Barlow, Ltd.)

FIG. 54. SPINDLE FOOTSTEP LUBRICATOR

slotted at the top and shaped slightly to hold the top cross pin of the flyer, and so make them revolve as one unit. At the bottom, known as the spindle foot, the spindle is tapered to a point to allow it to fit well into the spindle footstep. The footstep is set-screwed to the spindle rail as shown in Fig. 54.

In order to effect perfect lubrication of the spindle footsteps, the makers groove the spindle from that part where it is reduced in thickness to form the footstep, as shown in Fig. 54,

and extend the groove up the spindle to just above the top of the spindle wheel. They further make a recess or groove in the top of the spindle wheel so as to form an oil cup, and the oil placed therein flows down the groove to the footstep. This entirely does away with the necessity of having to lift the spindle out to oil the footstep. The footstep itself is entirely encased, so that it is impossible for dirt or fly to get into the oil chamber.

Collars and Bearings

Each flyframe spindle has two bearings, one in the spindle footstep as just mentioned, and the other is carried up and down in the lifter rail, so that all spindles pass through a collar in the lifter rail.

There are two types of collars, long and short, and both are very extensively used, each being able to claim several advantages. The long collar passes almost through the bobbin, and as a result holds the spindle much higher up, towards the top, and so gives much steadier running to the spindle than is possible with the short collar, and this is a very important factor in these days of high speeds.

The short collar does not enter the bobbins at all, is much lighter and cheaper, and is much less likely to bind the spindle due to dirt, fly, etc., than the long collar.

Probably the chief advantage of the short collar over the long collar is the fact that in using it a much less diameter bobbin can be used than is the case with a long collar, and so more roving can be put on the bobbin, and in the long run this means greater production.

CHAPTER X

RING SPINNING FRAMES

THERE are two chief methods of spinning yarns : (1) mule spinning, and (2) ring spinning.

The first will be explained in the next chapter, while in the present chapter we will deal with the ringframe.

Like flyframes, the spinning of yarns on ringframes is continuous, i.e. the roving is drawn out, twisted and wound on the bobbin simultaneously, and this is made possible by the use of a hardened steel ring and traveller which encircles the spindle.

The use of the ringframe is very popular indeed, and, while the mule holds sway in this country, abroad there are many more "rings" than mules.

Another continuous spinning machine which at one time was very popular for the spinning of yarns is the flyer throstle spinning frame, which is the machine originally invented by Arkwright. Nowadays this machine is more used for the doubling of yarns than for the spinning of them. It makes a very uniform, solid, round yarn, but is now chiefly confined to the spinning of special low counts.

Yarn spun on the flyer throstle was called "water twist" because the machine was originally driven by water-power, and this is still a market term for certain types of strong, well-twisted yarn spun either on the ringframe or the "throstle."

THE RINGFRAME

Perhaps the chief reason for the success of the ringframe is that compared with the mule, spindle for spindle, it is capable of much higher productions, the mule being an intermittent spinning machine, as will be seen later.

Up to now, however, it has not been found possible to spin as fine counts on "rings" as mules, and the mule has advantages in the producing of a more even yarn, which, it would appear, can never be attained by the ringframe. I refer to "carriage drafting," "ratch," etc.

Ringframes are two-sided machines.

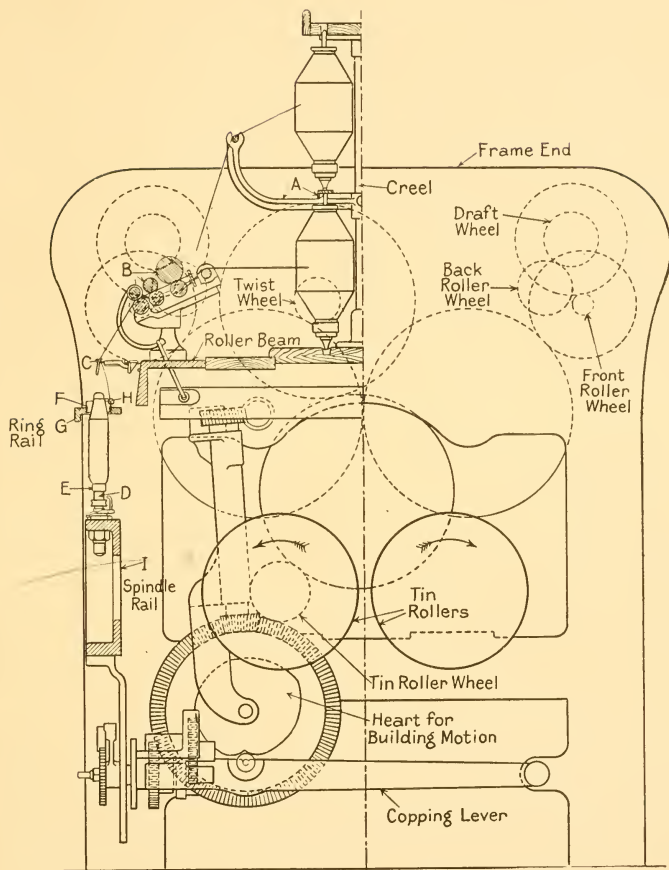

(Howard & Bullough, Ltd.)

FIG. 55. PASSAGE OF COTTON THROUGH A RINGFRAME

Passage of Cotton through a Ringframe

The roving is drawn by the draft rollers from the bobbins *A* in the creel as shown in Fig. 55, passes through the traverse guide and into the three lines of draft rollers *B*, where the necessary counts are obtained by the use of the usual draft gearing. From here the yarn passes through the thread wire *C*, which is set directly over the centre of the spindle *D*, through the steel traveller *H*, which revolves on the ring *F* in the ring rail *G*, and so on to the bobbin *E*. *I* is the rigid spindle rail which supports the spindles as shown.

The yarn is shaped on the bobbins by the movement of the ring rail *G*, which receives an upward and downward movement through the medium of a "heart" cam. This movement is slow upwards and fast when going down, the fast downward movement being given to put binding coils of yarn on to the bobbin, and so help to make the yarn easy to unwind at the next process.

RINGFRAME DETAILS

The Draft Rollers

One of the chief features of the ringframe is its system of draft rollers, as it is the only frame which has inclined roller stands, and the whole of the rollers are in this way tilted from the horizontal.

This is done to allow the twist to run up the yarn as near as possible to the "nip" of the front drawing rollers, and so to make the yarn as strong as possible, and reduce the number of broken ends.

The amount of this inclination varies, as the softer and finer the yarns are, the weaker they are, and so more inclination of rollers is required. For twist yarns it is from 15° to 30° , while for weft yarns it is from 30° to 45° , although the usual amount is round about 25° to 27° , as it has been found that if this is exceeded, piecing-up is made very difficult, and the top rollers, clearers, etc., are inclined to lean forward excessively.

There are two chief methods of weighting the rollers: (1) dead weighting, and (2) lever weighting, and both are shown in Figs. 56 and 57, being self-explanatory. Students are advised to notice particularly the cap bars *A* and the traverse rod *B*.

Bottom rollers are made of diameters to suit the staple of the cotton. Front and back rollers might have the following diameters: for Egyptian cotton $1\frac{1}{8}$ in., American 1 in., Indian $\frac{7}{8}$ in.; with middle roller $\frac{1}{8}$ in. less in each case.

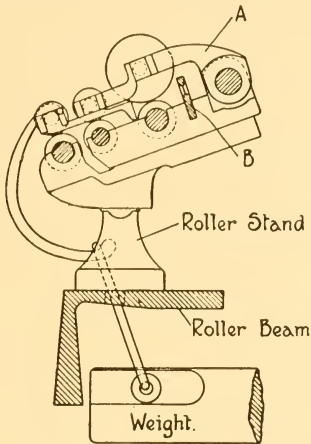

FIG. 56. DEAD WEIGHTING

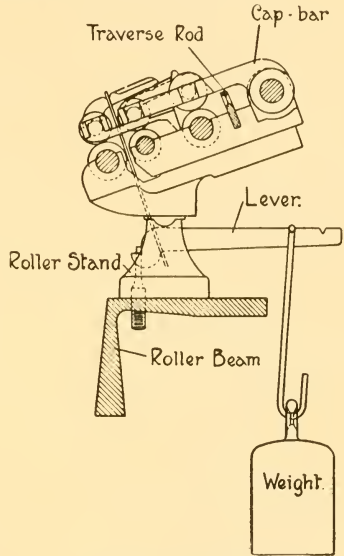

FIG. 57. LEVER WEIGHTING

(Howard & Bullough, Ltd.)

The Thread Boards.

The thread guide, which is fitted into the lappet (Fig. 58) and is set directly over the centre of the spindle, would normally be in the way when it is required to take a bobbin off for piecing-up or any other purpose, and so each lappet is hinged to a metal rail *A*, which makes it possible for each lappet to be raised independently at will.

Also when doffing is taking place it is necessary to have some means of lifting *all* the thread wires simultaneously, and dropping them again after doffing, and this is done by having the metal rail *A* in its turn hinged to the roller beam and operated as shown by the handle.

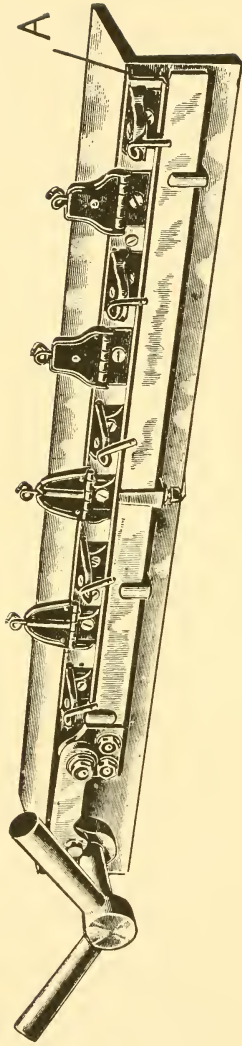

LAPPET RAIL IN LOWEST POSITION

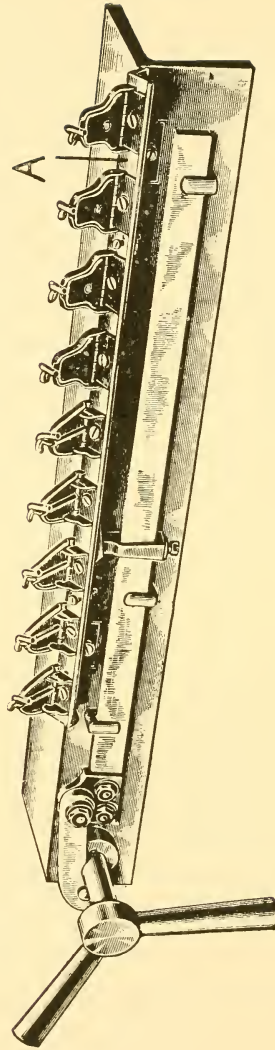

ALL LAPPETS RAISED SIMULTANEOUSLY.

(Howard & Bullough, Ltd.)

FIG. 58

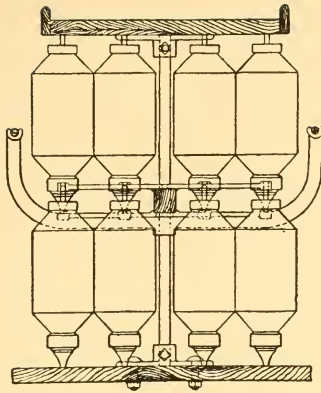

1

" Birkenhead " type for Double Roving

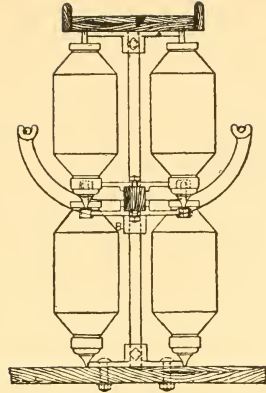

2

" Birkenhead " type for Single Roving

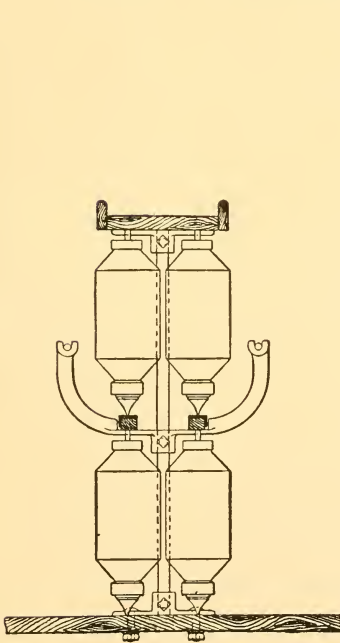

3

Ordinary Vertical type for Single Roving

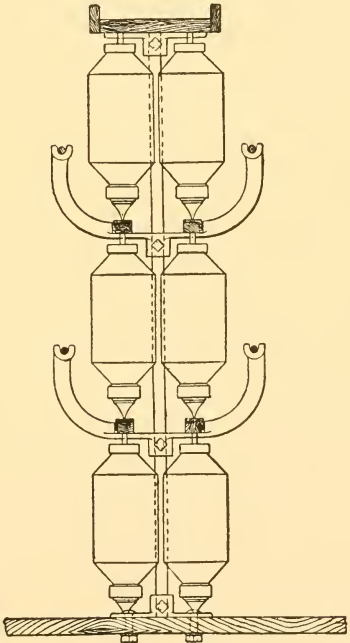

4

Ordinary Vertical type for Double Roving
(*J. Hetherington & Sons, Ltd.*)

FIG. 59. ELEVATIONS OF VARIOUS CREELS

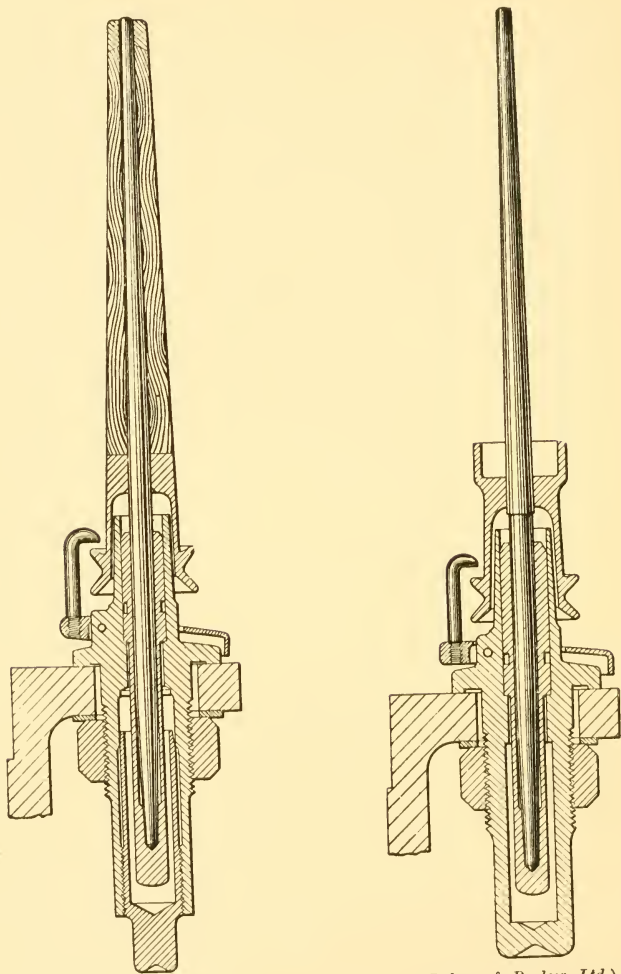

(Dobson & Barlow, Ltd.)

FIG. 60. PATENT "SIMPLEX" FLEXIBLE SPINNING SPINDLES
With and without bobbin cup.

The thread wires are about 5 in. below the roller nip and about 2 in. above the spindle top.

Creels

Fig. 59 shows various types of ringframe creels as made by J. Hetherington & Sons.

Spindles and Spindle Rails.

The spindle rail (*I* in Fig. 55) runs the length of the frame on both sides, and is drilled to receive all the spindles and poker bars (which give the movement to the ring rail). The spindles, which must be set absolutely concentric with the rings in the ring rail, are self-contained, the footstep and bolster bearings being in one piece. It is this footstep and bolster bearing which is securely fastened to the spindle rail, and a reference to the illustrations (Figs. 60 and 61) will show that an inner tube fits into this bolster, and is secured by means of a small spring, and the spindle itself then fits into the inner tube. The bolster is so made that there is always oil at the foot of the spindle. The spindle-holder is to prevent the tendency of the spindle to work upwards during running.

The spindle has a slight flexibility at the spindle point due to the use of the inner tube.

Ringframe spindle band is usually tubular and $\frac{1}{8}$ in. diameter, but in recent times tape driving has been introduced as shown in Fig. 62, one endless tape driving four spindles, two on each side of the frame. The tape drive gives, it is claimed, a more uniform spindle speed, and hence more uniform turns per inch in the yarn.

Spindle speeds vary from about 7,000 to 10,500, and the highest speed can be used for about 30s to 40s counts, much lower or higher counts requiring a reduction of spindle speed.

Tin Rollers.

Ringframes may have one or two lines of tin rollers.

In the case of the two-line system, the contact surfaces always revolve in the same direction, but this may be either outwardly or inwardly. Fig. 63 shows the "inward" rotation of tin rollers. It will be seen that tin rollers *F* and *C* drive the opposite line of spindles *B D*.

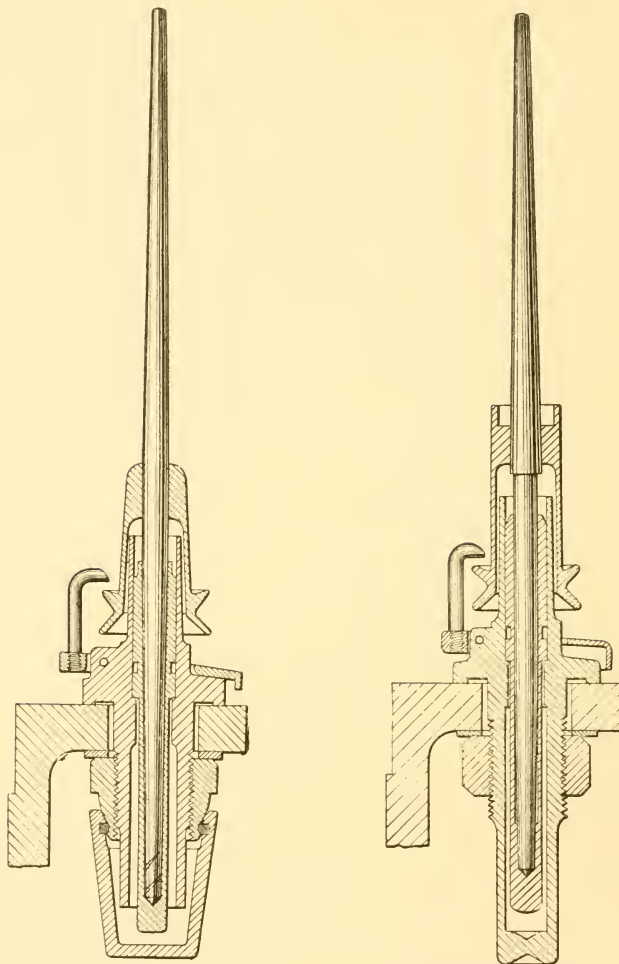

(Dobson & Barlow, Ltd.)

FIG. 61. PATENT "SIMPLEX" SPINNING SPINDLES, FOR SPINNING ON PAPER TUBES

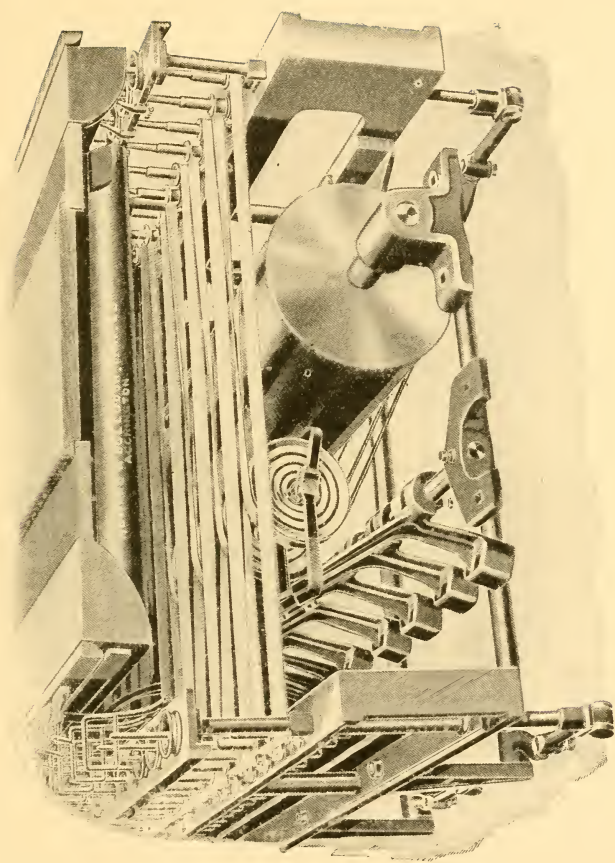

(Howard & Bullough, Ltd.)

FIG. 62 PATENT TAPE DRIVE TO SPINDLES OF RING SPINNING AND DOUBLING FRAMES

Ring Rail, Rings and Travellers.

The ring rail is mounted on the poker bars which are coupled to the building motion, and by the action of the "heart" cam the ring rail is made to move up and down, and so shape the yarn on the bobbin. The ring rail is made in pieces, each piece being drilled to receive a certain number of rings.

These rings are of forged steel, hardened and polished, and

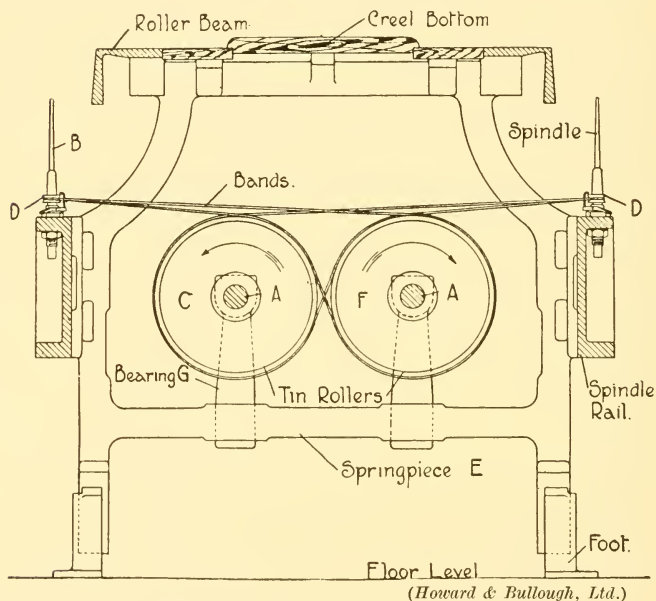



FIG. 63. TIN ROLLERS OF RINGFRAME

may be held in position in the ring rail by means of a small set-screw, or they may be clamped in. It is essential that the spindle should be set absolutely central with the ring.

The gauge of ring spindles may be $2\frac{3}{4}$ in. for 20s counts and below with a ring $1\frac{3}{4}$ in. diameter, while for finer counts these two figures might be $2\frac{5}{8}$ in. and $1\frac{5}{8}$ in.

The traveller, which performs what is probably the most important duty on a ringframe, is a small piece of steel

shaped  which clips on to the ring, and through which the yarn passes on its way to the bobbin.

It is the traveller (Fig. 64) which regulates the amount of yarn wound on to the bobbin by lagging behind the spindle in speed due to the pull of the yarn on the traveller.

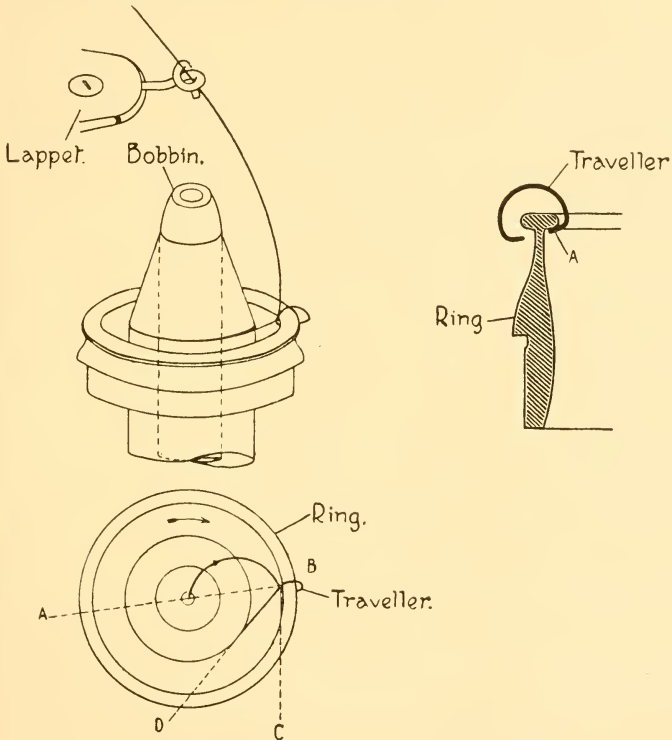

(Howard & Bullough, Ltd.)

FIG. 64

Also seeing that the yarn passes through the traveller from the thread guide, it will be seen that the traveller actually puts the twist in the yarn, i.e. if the revolutions of the spindle are 9000 r.p.m. and those of the traveller 8900, and the yarn delivered is 500 in., then the twist per inch in the yarn will be

$\frac{8900}{500}$, and the revolutions of the spindle used for winding the yarn on to the bobbin will be $9000 - 8900 = 100$.

In some cases a traveller clearer is fitted to the ring rail, being a small piece of upright steel set just to miss the traveller

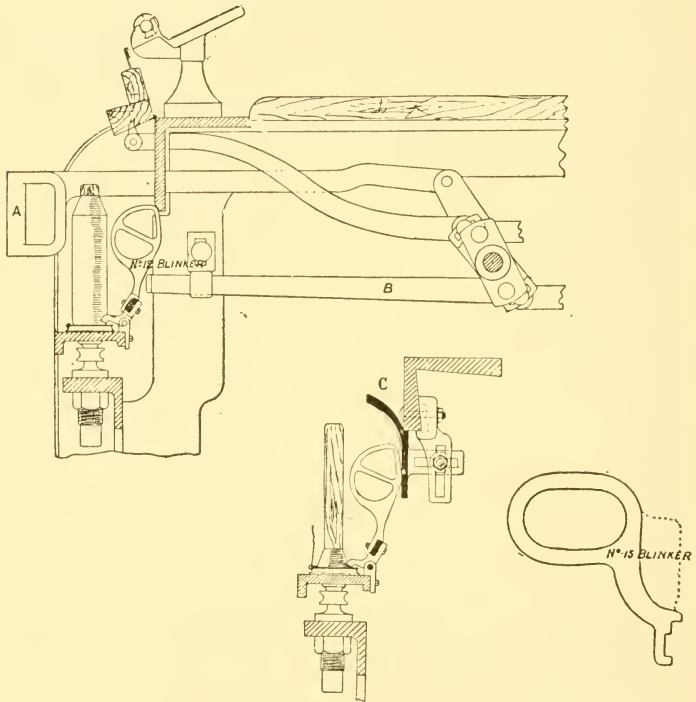

(Platt Bros.)

FIG. 65. BLINKER SEPARATORS

in its revolution, and for the purpose of driving off any dirt or fly which gathers on the traveller during working.

Travellers are graded as follows—

18, 17, 16 . . . 1, 1/0, 2/0 . . . 16/0, 17/0, 18/0

the first being the heaviest and working down lighter, and, of course, the finer the counts the lighter the traveller will have to

be. The strength of the yarn, twist being put in, etc., will also affect the size of traveller to be used.

ANTI-BALLOONING APPLIANCES

Owing to the high speeds adopted in ring spinning there is always a tendency for the yarn to fly out between the thread guide and the traveller, and unless prevented from doing so, the tendency would be for the threads to touch and break each other.

This flying out of the threads is known as "ballooning," and the greater the distance between the thread guide and the traveller, the greater will be the "balloon," i.e. it is always worst at the early part of the building of the bobbin. A certain amount of ballooning is necessary and is a good thing, as a good "balloon" shows that there is no tendency to strain the threads by having them too tight.

Excessive ballooning can, of course, be regulated by having heavier travellers, but in order to make a certain amount possible we use *separators* (Figs. 65, 66, 67, 68), and in many cases these separators are tilted out of action by the ring rail when the bobbins are half full.

By placing these separators between the spindles it is possible in some cases to get $\frac{1}{4}$ in. closer spindle gauge.

They must, of course, be absolutely smooth, free from any sharp corners, and project sufficiently to prevent threads from ballooning round the front.

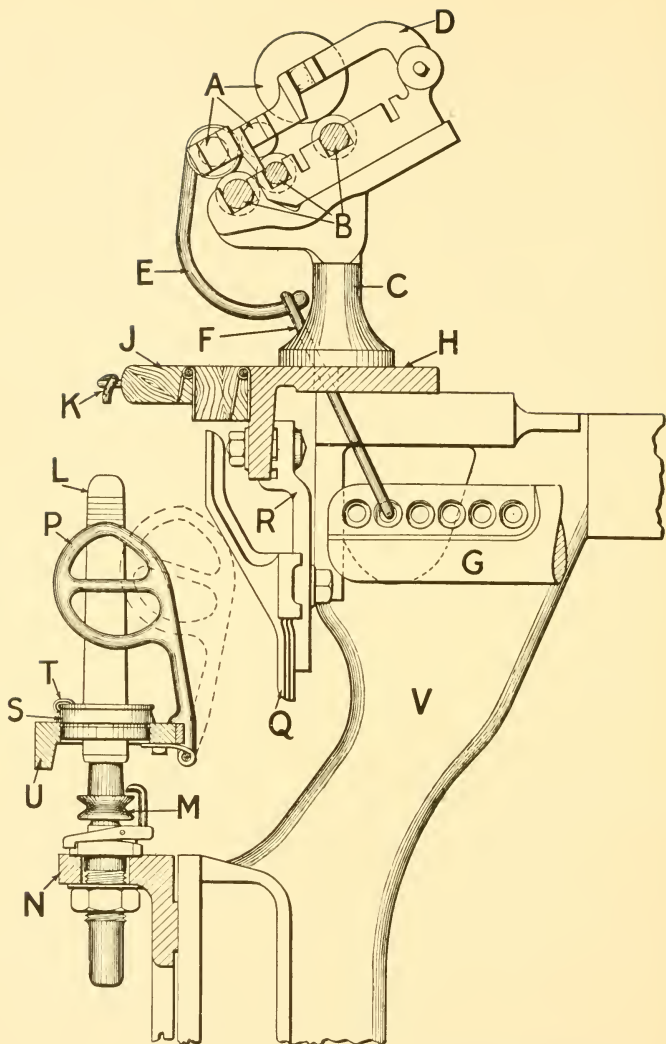

(Dobson & Barlow, Ltd.)

FIG. 66. PART SECTION OF RING SPINNING FRAME
(Showing separator)

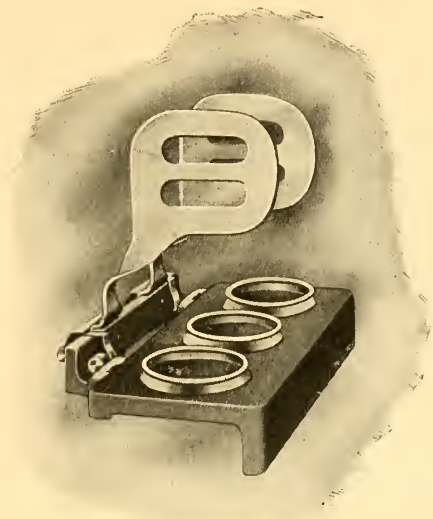

(J. Hetherington & Sons, Ltd.)

FIG. 67. SEPARATORS DOWN (IN ACTION)

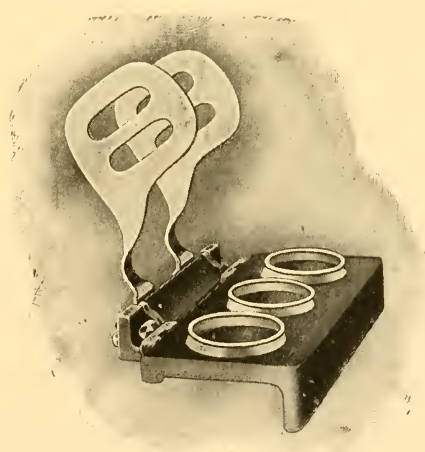

(J. Hetherington & Sons, Ltd.)

FIG. 67A. SEPARATORS UP (OUT OF ACTION)

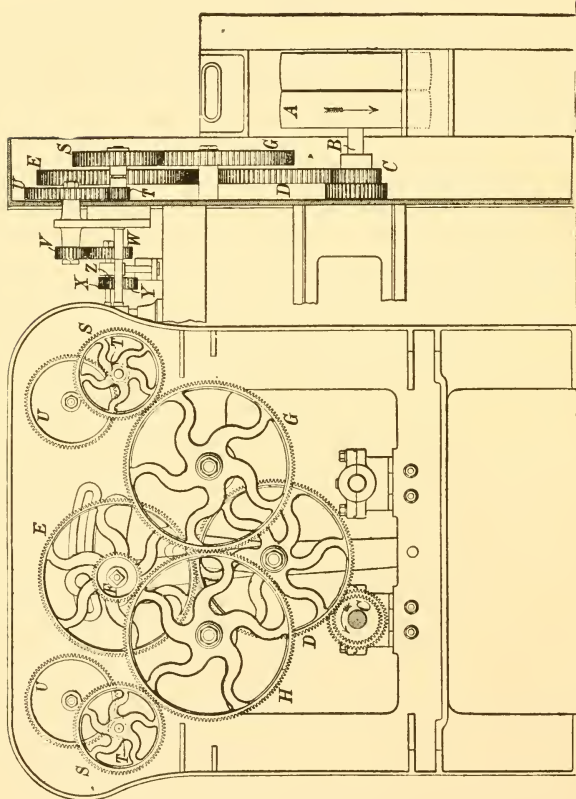

(Howard & Bullough, Ltd.)

FIG. 68. GEARING FROM TIN ROLLER SHAFT TO ROLLERS
Particulars of a 3 ft. wide frame with 10 in. tin rollers

- A Driving pulley from 9 to 18 in. diameter, and 3 to 5 in. wide.
- B Driving shaft, 800 revs. per minute, gives 8,500 actual revs. Spindle, with $\frac{7}{8}$ in. wharves and 10 in. tin rollers.
- C Tin roller wheel, 31 to 66 teeth, advancing by 5.
- D Large arm carrier, 140 teeth.
- E Twist wheel carrier, 140 teeth.
- F Twist wheel from 30 to 66 teeth.
- G Front roller carrier, 150 teeth.
- H Front roller carrier, 150 teeth.
- S Front roller end wheel, 80 teeth.
- T Front roller wheel, 16 teeth.
- U Crown wheel, 80 teeth.
- V Draft wheel, 30 to 60 teeth.
- W Back roller wheel, 50 to 60 teeth.
- X Middle roller driving wheel, 21 teeth for 1 in. back roller.
- Y Middle roller carrier wheel, 28 teeth.
- Z Middle roller wheel, 17 teeth for $\frac{3}{4}$ in. middle roller.

CHAPTER XI

MULE SPINNING : THE SELF-ACTOR MULE

The Chief Objects of Mule Spinning.

THE chief object of the mule is to convert the roving or twisted strands of cotton delivered from the jackframe into a thread of a predetermined fineness, strength, and regularity, and also to place the thread so produced into a compact formation which is termed a cop, and proves to be (if produced on the right lines) an ideal commercial article admitting a maximum of handling with a minimum of deterioration of the spun yarn, and consequently the lowest possible percentage of waste when passing through subsequent processes. The mule, unlike most other textile machines, is intermittent in its action, and this fact permits of a more judicious treatment of the material in process than would be the case of a machine which is continuous in action.

To ensure the production of the best possible quality of yarn at the mule, it is essential that the roving fed to the mule shall be perfectly clean and composed of fibres uniform in length and diameter, parallel to each other, and containing a minimum of twist consistent with the carrying requirements from mule creel to rollers.

The Passage of Cotton from Creel to Spindle.

Fig. 69 shows a cross-section through mule creel, rollers, and carriage. The roving bobbins *A'* are sustained by wooden pegs or skewers, which are pointed at the lower end and inserted into porcelain bearings to allow of easy rotation, being held vertically by the creel rod and supports *A*. From the bobbin the roving passes over guide wires, through the traversing guide *B*, and then through three pairs of revolving rollers, each pair having a greater surface speed than the preceding pair, thus having the effect of attenuating or drafting the roving. The relative speeds of the front pair to the back pair of rollers is governed by the degree of fineness required in the thread, and is controlled by gearing at the

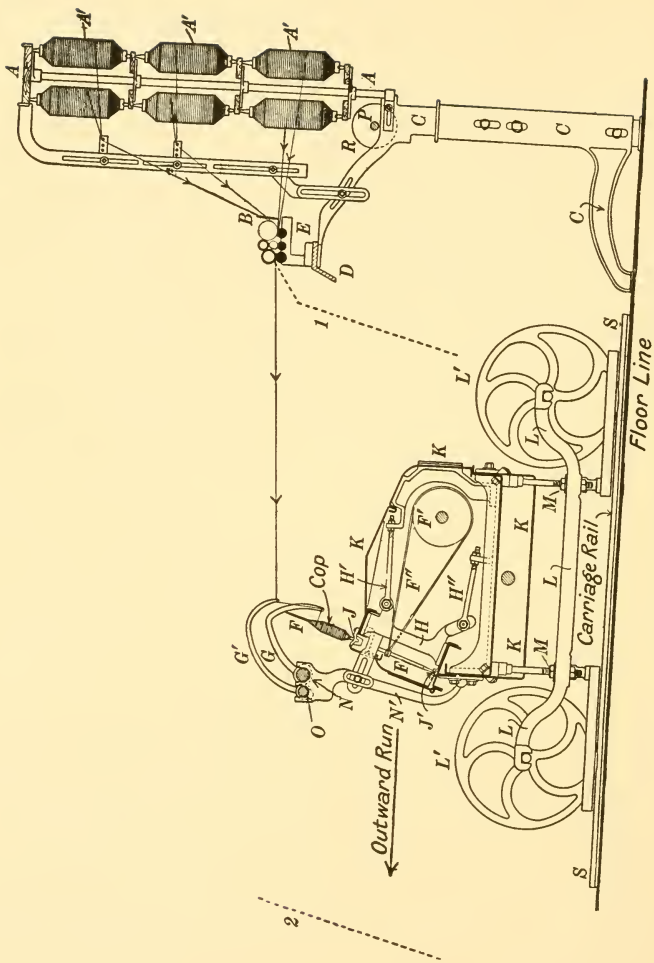

FIG. 69. SECTION THROUGH CREEL AND CARRIAGE
 (Dobson & Barlow, Ltd.)

headstock. Assuming the counts of roving fed and the speed of front roller to be unchanged, the degree of fineness of yarn delivered is increased by slowing down the feed, or vice versa, by speeding up the feed. From the nip of the front pair of rollers the yarn is twisted by the revolving spindle F , around which the yarn is coiled, and secured at a point just above the bearing J .

The creels, drawing rollers, and carriage extend to the right and left of the central mechanism or headstock. The number of spindles carried in one mule carriage may vary from 600 in the older type of mule up to 1200 for twist and 1400 for weft yarns in modern mules. The distance from centre to centre of spindles may be from 1 in. to $1\frac{3}{16}$ in. for pin cop and weft yarns, and $1\frac{3}{16}$ in. to $1\frac{3}{8}$ in. for twist yarns, and for very coarse waste yarns the distance from centre to centre of spindle may reach $2\frac{1}{2}$ in.

The length of a mule over-all very rarely exceeds 145 ft., and the layout of component parts is as follows: The main central shaft, termed the rim shaft, is parallel to the line shaft and counter shaft. The front line of rollers is at right angles to rim shaft and extends the whole length of the mule, with middle and back rollers set parallel to front line and being adjustable for distance from centre to centre, are adaptable to various classes of cotton. The spindles, which are set in line and at an inclination from the vertical towards the rollers, are parallel to the rollers and have their upper extremities in one common plane, which is slightly lower than that occupied by the rollers.

The spindles F and tin rollers F' , which drive the spindles through the medium of thin endless bands F'' , are all supported by the carriage K , which is capable of being moved horizontally outwards from and inwards towards the rollers on the rails S . This outward and inward movement covers a uniform distance, and is called the carriage "stretch" or "draw."

The dotted line 1 in Fig. 69 represents the spindle in its maximum inward position, and the dotted line 2 in its maximum outward position.

Each spindle runs in two brass bearings, one at the spindle foot shown at J' , and the other a certain distance above the wharve or small band pulley shown at J . Connecting the top and bottom bearings is a series of brackets H , which are

regularly spaced along the mule at intervals of about 4 ft. Attached to each bracket *H* are two adjusting rods, the top one *H'* and the bottom one *H''*, each making a connection from *H* to a cast-iron bracket secured to the back of the carriage.

By means of the rods *H'* and *H''* the angle of inclination of the spindles is adjusted, and when set correctly the duty of *H'* and *H''* is to keep the whole mule of spindles steady and perfectly in line. Each tin roller is about 7 ft. in length made up of sections of sheet tin rolled to form a cylinder of 5 in. or 6 in. diameter and supplied at each end with a stamped steel block bored out to receive a short shaft about 9 in. by 1 in. by means of which each roller is connected to its neighbour, so that when coupled together the whole line of rollers revolves as one and is supported in bearings (placed between each roller) which encircle a portion of the short connecting shafts.

Extending the whole length of the mule are two faller shafts *N* and *O*, which are parallel to the rollers and situated in front of the spindles. Regularly spaced along these bars are a series of sickles, *G* and *G'*, secured to the shafts by set-screws, and each sickle having a perforation near the tip through which passes a wire known as the faller wire. The duty of the wire passing through *G* is to control the spacing of coils of yarn as it is wound on the cop, and therefore the shape of the cop, whilst the wire carried by *G'* keeps the yarn at a suitable tension whilst the winding operation is being performed. The whole weight of the traversing parts of the mule, which are carriage, spindles, tin rollers, and faller mechanism is supported at intervals of about 8 ft. by the screws *M*, bearer brackets *L*, and bowls *L'*. The screws *M* are the means by which the carriage is levelled, raised or lowered to suit requirements. The rails *S* must be set at right angles to the roller beam and perfectly level.

The roller beam *D* is angular in section as shown, and its top surface planed and carries roller stands *E* at regular intervals of about 17 in., which form the bearings for the drawing rollers. The spring-piece brackets *C* are placed at intervals of about 4 ft. and support the creels *A*, back shaft and scrolls *PR*, roller beam and rollers *DE*. Adjustments for height of rollers and creel are obtained through the slots shown in *C*.

Method of Driving the Rollers, Spindles, and Carriage During the Outward Run.

The mechanism in operation during the outward run is termed the drawing out motion, and whilst in action the actual spinning of yarn is being performed. The front roller is delivering the drawn fibres at the required density and linear velocity, the spindles are revolving at a high rate inserting twist into the fibres, whilst the carriage carrying the spindles is moving outwards, keeping the twisted yarn at the correct tension.

The front roller and carriage are driven through the medium of clutch boxes, the main advantage being that either clutch may be disengaged independently of the other, and as the motion is derived from one source, this is an essential feature of medium and fine count mules, because on these mules jacking or ratching is employed.

Jacking is the term applied to the movement of the carriage after the front roller clutch box has opened and the front roller stopped. The effect of jacking is to subject the yarn between the nip of front rollers and spindle points to a tightening or stretching process, and to a certain degree, corrects defective drafting by pulling thick soft places out and possibly breaking thin places down.

Explanation of Fig. 70.

During the outward run of mule carriage the down belt is on the pulley *A*, which is keyed to the rim shaft *B*. Fast to *B* is a rim pinion *C*, which drives through a single or double carrier wheel, the back change or speed wheel *D*, which is secured to the end of the side shaft *D'*. At the other end of *D'* is secured a small level *E*, which is in gear with a sleeve bevel *F*.

The sliding half of roller clutch box *F''* is loose on the front roller *F'*, and has a peg cast on to its inside which is engaged with a recess in a disc which is keyed to *F'*, so that the rotation of *F'* with the clutch box closed gives motion to the front roller *F'*.

Cast on to *F'* is a long sleeve, and at the end a wheel *G* is secured. The whole including *F'*, sleeve, and *G* being loosely mounted on the front roller.

G drives *G'*, which has a bevel cast on to it and is mounted

loosely on the extended boss of the wheel *J*. *J* runs loosely on a central spindle *J'*, which is secured to the framing and shown projecting. Fast on the front roller is the wheel *H* driving *H'*, which has a bevel cast on to it and runs loosely on the spindle *J'*. *J* depends for its motion on the axial revolutions of the arm carrying the bevels *R* and *R'*, the arm being secured by set-screws to the extended boss of *J*.

J drives the gain wheel *K*, which revolves on a short shaft secured to the framing, and compounded with *K* is the gain

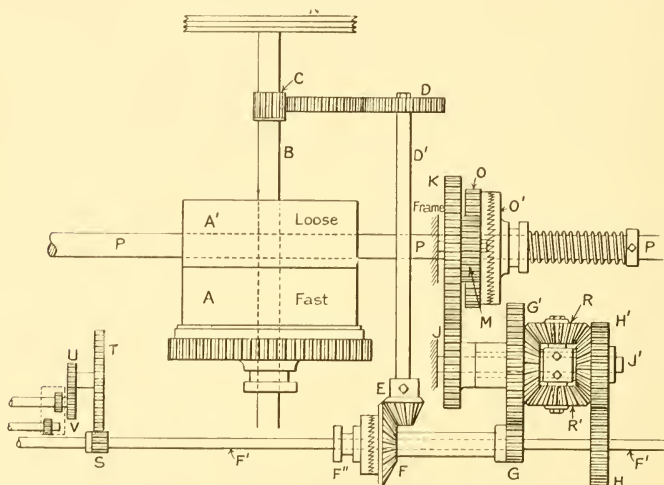

FIG. 70. PLATT'S DRAWING-OUT MOTION

pinion *M* driving the spur wheel *O*, which is the rotating half of the carriage box. The carriage box is constructed like the front roller box. The sliding half *O'* has cast to its inner face two pegs, which engage with a disc keyed to the back shaft *P*. Therefore the revolutions of *O* with box closed equal the revolutions of back shaft *P*. (The relative position of the back shaft to the carriage is shown in cross-section Fig. 69). *P* extends the whole length of the mule parallel to rollers and carriage, and is usually $1\frac{1}{2}$ in. in diameter. Keyed to the back shaft *P*, at convenient distances, are six drums about $5\frac{1}{2}$ in. in diameter, shown at *R*, Fig. 72. Secured to each drum are two

ropes which are wrapped around in opposite directions, one leaving the drum *R* passes round a guide pulley *B*, to a second pulley *C*, and then to a tightening rack *E*, which is carried by a bracket fixed to the front of carriage *K*. The other rope passes from *R*, round guide pulley *A*, thence to a second rack at *E*.

A glance at Fig. 72 will show how the revolution of *P* in the direction indicated will draw the mule outwards. Referring again to Fig. 70, the alteration of the wheel *D* would change

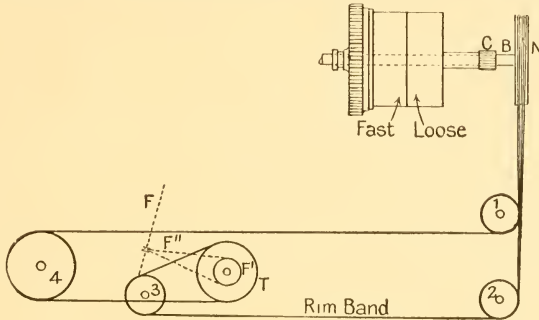

FIG. 71

the speed of *F'* and *P* in the same ratio. To change the ratio between *F'* and *P* the wheels *K* or *M* must be changed.

Drive of Back and Middle Drawing Rollers.

Fast to front roller at each side of headstock is the pinion *S* driving the large crown wheel *T* secured to a short shaft, at the opposite end of which is secured the draft change wheel *U*, which drives a change wheel *V* fast to the end of the back roller. Secured to the back and middle roller are two small pinions, and in gear with both is a broad carrier shown dotted, thus transmitting motion from the back to the middle roller.

Carriage Draft or Gain.

This is a term which means the excess outward speed of carriage over the surface speed of front bottom roller during the same period, and gain can be advantageously introduced when spinning medium and fine yarns. Its effect on the yarn

is akin to that of jacking previously stated, but its performance occurs during that period of the outward run in which the front roller is revolving, so that its application is very gradual.

In some of the lower classes of American and Indian yarns and coarse warp yarns it is necessary to reverse the conditions so far as gain is concerned, and have a roller gain over carriage to counteract the milling up or shrinking of yarn due to the application of twist to a yarn of large diameter and coarse

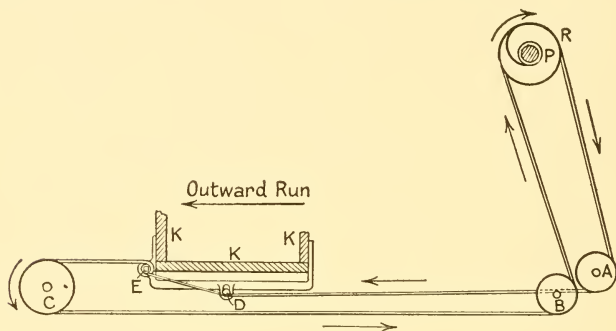

FIG. 72

individual fibres, thereby preventing excessive breakage of yarn.

The Drive of Spindles.

During the outward run the spindles receive their motion through individual bands from the tin rollers, which are driven by an endless band from grooved pulley *N* (in Fig. 70) which is secured to the rim shaft *B*. A side elevation of the drive is given in Fig. 71. The pulleys 1, 2, 3, and 4 are simple carrier pulleys, *T* is the driven pulley fast on the tin roller shaft. The tin roller *F'* drives the spindle *F* through the band *F''*. The pulleys *N*, *T*, 1, 2, 3, and 4 are treble-grooved on modern mules.

Objects of Drawing-up or Taking-in.

It must be understood that the outward and inward run of the mule are performed by two totally distinct motions known

as the drawing-out and the taking-in motions. Both motions cannot operate simultaneously, and though they are not interdependent one on the other, they must be arranged on a block system, so that the operation of one of the motions ensures the disengagement of the other.

When we consider that the length of a mule of 1,000 spindles $1\frac{3}{8}$ in. gauge is about 120 ft., and the weight of the travelling parts, namely, tin rollers, spindles, middle piece and gearing, faller mechanism and carriage, bowls and bearer brackets is approximately 3 tons, and drawing up of same occupies about $3\frac{1}{2}$ sec., and is performed, say, four times per minute, this function calls for the most efficient mechanism so as to eliminate variation in speed of inward run.

There are two methods of performing taking-in, Fig. 73, through the medium of strap or endless rope from counter shaft, transmitting the motion through a friction and cone to the scroll shaft, or, Fig. 74, a strap from counter shaft to fast and loose pulleys on the side shaft which is geared direct to the vertical drawing-up shaft.

Taking-in by Friction, Fig. 73.

At the completion of the outward run the cam *O* has made half a revolution, and being connected with the top portion of *N*, rocks the lever on the fulcrum *N'*. The link *M* is hung on the end of *N*, and therefore lifted a little. The lower portion of *M*, being slotted, there is no movement of *L*. The carriage box lever *R* fulcrumed at the lower end is also rocked a little, due to the upward movement of the projecting bowl on the under side of *N*. This rocking of *R* opens the carriage clutch (not shown), and also puts the spring *P* in tension. The spring cannot pull the lever *L*, because the bowl *J* is under the opposite end *K*. As soon as backing-off is completed, *J* moves away from *K* and allows the spring *P* to pull upwards the lever *L*, fulcrumed at *L'*, thus giving a downward movement to the cone *D* until it engages with the friction *E*.

The pulley *O''* is driven by rope from the counter-shaft. The bevel *A* is keyed to the same shaft as *O''* and drives *A'*, which is keyed to the vertical shaft *B* which revolves in the footstep bracket *C*. *D* is loosely mounted on *B*, and has two pegs cast on the inside which engage with recesses in the disc shown dotted and keyed to shaft *B*. *E* is loosely mounted on

the shaft *B*, and cast on the under side is the small bevel driving the scroll bevel *A''*, which is keyed to the shaft *S*.

The scrolls *F*, *G*, and *H* are also keyed to *S*. A band is attached to *F* and passes to the carriage round a half moon bracket and back to the other *F*. The check band passes round *G*, from there under the carriage to a carrier pulley on the floor, and thence to the front of carriage; whilst the band

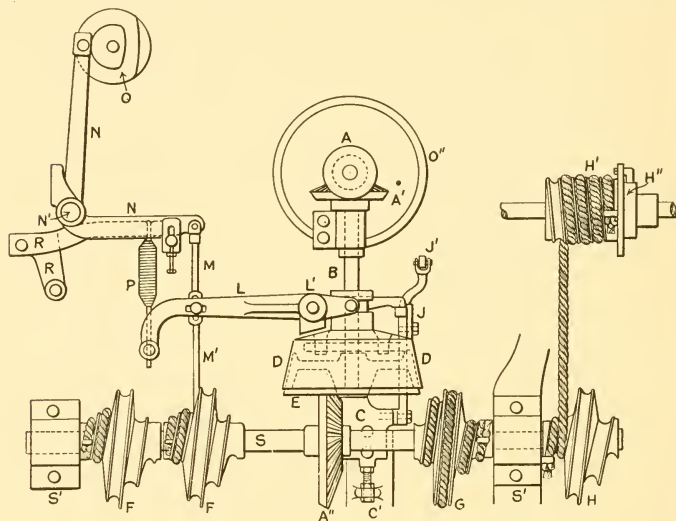

FIG. 73. PLATT'S TAKING-IN MOTION

attached to *H* passes straight to the coarse scroll on the back shaft.

Therefore, immediately *D* makes contact with *E* the shaft *S* starts to revolve, winding the bands on to *F* and *H* and unwinding the band from *G*, thus drawing the carriage in. The scrolls are so designed to start the inward run at a minimum speed, increase to a maximum, and then back to a minimum so as to hit the back stops lightly.

When the carriage is on the head, a catch secured to the framing is engaged with a stud on the carriage to keep the carriage steady whilst backing-off. This catch must be

released before the carriage can be drawn up, the lower link M' performs this function, receiving its movement from the lever L when the dish is engaging. When the carriage is alighting at the back stops the cam O changes again, making another half a revolution, bringing the top of N nearer to the centre of O , this depresses the link M and the lever L , thus disengaging the dish D from E . At the same time R is rocked

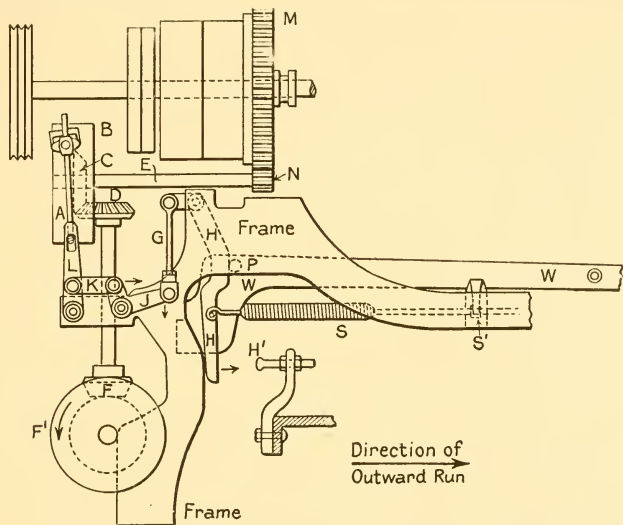

(Dobson & Barlow, Ltd.)

FIG. 74. TAKING-IN MOTION, STRAP CONTROLLED

back again, engaging the carriage clutch ready for the drawing-out operation.

Description of Fig. 74, Taking-in by Strap.

When the motion is in the position shown, the strap will be on the backing-off pulley A , which is keyed to the shaft E . When the mule, which is on the outward run, reaches the head, the lever W makes its first change. The bowl P carried by W drops about 2 in., thus keeping in contact with the straight face of H . The 2 in. movement of W opens the carriage clutch, and the mule stands at the head. The strap fork is released,

and backing-off takes place. When the fallers lock the long lever *W* makes a second change in the same direction, thus placing the bowl *P* opposite the recess of *H*, and allowing the spring to pull *H* in the direction of arrow. *H* is fulcrumed about 3 in. from the top end, and therefore gives a downward movement to the link *G*, which, in turn, rocks the lever *J* as shown, and through the connecting link *K* moves the strap fork *L*, fulcrumed at the lower end, and places the belt on to the drawing-up pulley *B*. This pulley runs loosely on the shaft *E*, and cast on to its spokes is the bevel *C*, gearing with bevel *D*, which is keyed on top of vertical shaft. On the lower end is another bevel *F* also keyed to the shaft and gearing with the scroll shaft bevel *F'*, rotating it in the direction shown and drawing the mule up.

At the completion of the inward run the adjustable stud *H'*, which is carried by the carriage, comes into contact with the lower end of *H*, pushing it far enough to allow the lever *W* and bowl *P* to return to spinning position, and at the same time transferring the belt to the backing-off pulley *A*.

References for Fig. 75

- | | | | |
|----------|--|----------------------|--|
| <i>A</i> | Draft wheel. | <i>c</i> | Backing-off pinion on side shaft. |
| <i>B</i> | Twist wheel. | <i>d</i> | Backing-off cone wheel. |
| <i>C</i> | Back change wheel. | <i>e</i> | } Top bevels for upright drawing-up shaft. |
| <i>D</i> | Rim pulley. 2, 3 grooves. | <i>f</i> | |
| <i>E</i> | Gain wheel. | <i>g</i> | Bottom bevel for upright drawing-up shaft. |
| <i>F</i> | Shaper wheel. | <i>h</i> | Scroll shaft bevel. |
| <i>G</i> | Fast rim shaft pulley. | <i>i</i> | Spur on back shaft. { Roller turning |
| <i>H</i> | Loose rim shaft pulley. | <i>j</i> | } Click and spur { Motion wheel. } whilst winding. |
| <i>J</i> | Rim shaft spur wheel. | <i>k</i> | |
| <i>K</i> | } Compound carrier. | <i>l</i> | Top carrier wheel. |
| <i>L</i> | | } For jacking motion | <i>m</i> |
| <i>M</i> | Side shaft bevel. | | <i>n</i> |
| <i>N</i> | Bevel and catch wheel. | <i>p</i> | Middle roller wheel. |
| <i>O</i> | Carrier spur wheel. | <i>q</i> | Front roller. |
| <i>P</i> | Gain pinion. | <i>r</i> | Middle roller. |
| <i>Q</i> | Back shaft spur wheel and catch box. | <i>s</i> | Back roller. |
| <i>R</i> | Side shaft bevel. | <i>t</i> | Tin roller pulley. |
| <i>S</i> | Long boss bevel and catch wheel. | <i>u</i> | Tin roller. |
| <i>T</i> | Roller gear catch box. | <i>v</i> | Spindles. |
| <i>U</i> | Side shaft spur wheel | <i>x</i> | Tin roller wheel. |
| <i>V</i> | Change wheel. | <i>y</i> | Twist worm. |
| <i>W</i> | Worm on end of shaft | <i>z</i> | Winding drum wheel. |
| <i>X</i> | Worm wheel. | 2 & 5 | } Leading to back shaft. } Drawing-up carriage } scroll. |
| <i>Y</i> | Spur wheel and catch plate. | 3 | |
| <i>Z</i> | Coupling-piece wheel. | 4 | |
| <i>a</i> | Band pulley for drawing-up and backing-off side shaft. | | |

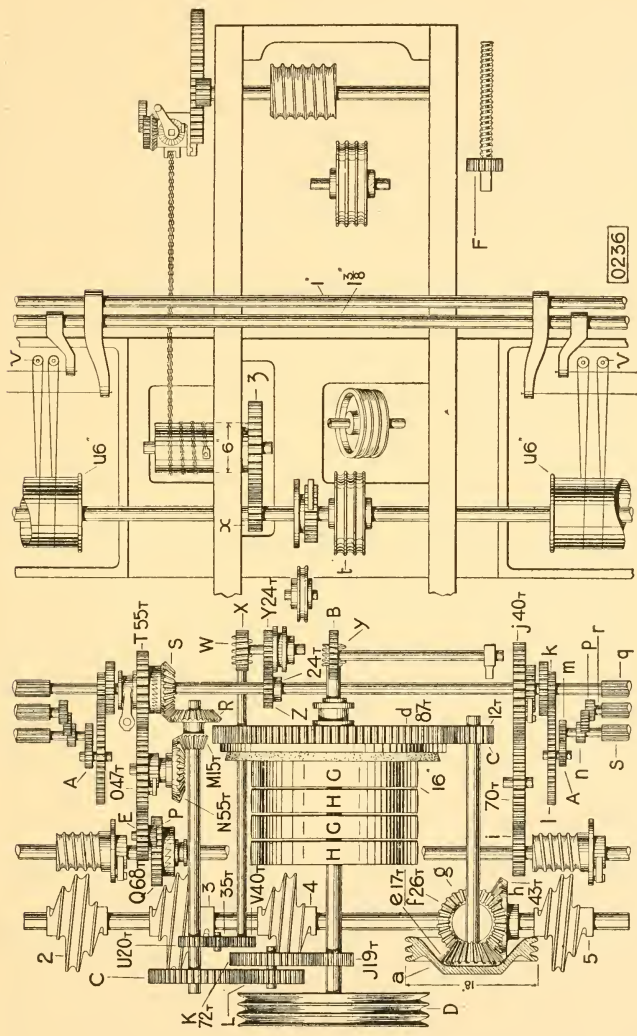

(Dobson & Barlow, Ltd.)

FIG. 75. GEARING PLAN OF SELF-ACTING MULE
(See p. 140 for References)

Delivery of Rollers whilst Winding.

The motion for driving the rollers during the inward run of carriage usually consists of a direct train of three wheels, shown in the gearing plan of Dobson & Barlow's mule (Fig. 75).

A spur wheel *i* fast to the back shaft drives through a large carrier wheel on to the wheel *j*, loosely mounted on the front roller and carrying a click catch. There is a ratchet wheel at this point (keyed to the front roller) having an extended boss, which is recessed to accommodate a spectacle spring which is engaged with the click catch. Whilst the roller box is closed during the outward run the speed of the front roller keeps the click catch disengaged from the ratchet wheel, but as soon as the mule starts on the inward run, the direction of rotation of *i* on the back shaft is reversed, causing the catch to engage with the ratchet wheel at *j*, and conveying motion to the front roller. The length of yarn delivered whilst winding is usually about 4 in.

Details of Spindles.

The construction of the spindle, complete with wharve or small driving pulley, calls for the highest skilled workmanship. Fig. 76 gives an idea of the fine limits to which the spindle is made, and are the dimensions given by Dobson & Barlow, Ltd. The centre line at each gauge point is the nominal size, whilst the lines above and below, which are $\frac{1}{8}$ in. apart, represent the tolerance permissible. The spindle, complete with wharve, passes through many operations, i.e. forging, rough centring, rough stretching, grinding, glazing, intermediate centring, wharving, polishing, final stretching, setting, testing, and examining.

Bevel of Spindle.

The spindles revolve in brass bolster bearings *J* and foot-steps *J'*, Fig. 69, specially designed for easy lubrication and retention of the lubricant. *J* is supported by the bracket *H*, and sustains the spindles at an inclination from the vertical. This inclination is termed bevel, and is necessary to facilitate the insertion of twist without breakage of ends, but if the inclination is too great a portion of the yarn wound on the previous draw may be drawn off the spindle, especially when the cop is nearing completion.

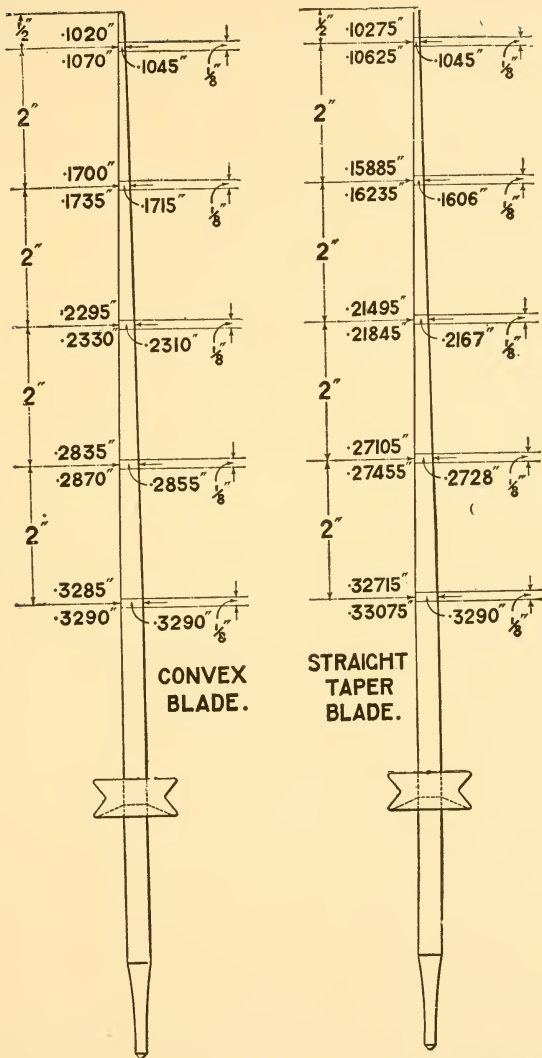

(Dobson & Barlow, Ltd.)

FIG. 76. MULE SPINDLES

A table for required length of spindle and bevels for twist yarns recommended by Mr. Hardman, of Dobson & Barlow's, is given below—

Spindle Length	Counts	Bevel
inches		inches
17	30s/ 40s	$4\frac{3}{4}$
17	50s/ 60s	$5\frac{1}{4}$
$16\frac{1}{2}$	80s/100s	$5\frac{1}{2}$
$15\frac{3}{4}$	120s/150s	$5\frac{3}{4}$
$15\frac{1}{2}$	200s upwards	$6\frac{1}{2}$

For soft weft yarns $\frac{1}{4}$ in. more in each case.

Spindle Gauge.

This term is given to the distance from centre to centre of each spindle, which may vary according to the class of work to be performed.

For pincops spun for the shuttle of a loom the gauge used is 1 in. to $1\frac{1}{8}$ in., and for twist and doubling weft yarns $1\frac{1}{4}$, $1\frac{5}{16}$, or $1\frac{3}{8}$ in. Occasionally the pincops are spun on twist gauge mules, but the production cost is increased thereby, as the number of cops from the pincop mule against the number from a twist gauge mule of the same length will be approximately 1400 to 1180.

Spindle Taper.

The spindle is essentially tapered from a point just above the top bolster of about $\frac{5}{16}$ in. diameter right to the tip, which is about $\frac{1}{8}$ in. diameter. This taper allows the full cops to be removed from the spindle with ease, the $\frac{1}{8}$ in. diameter tip puts only a minimum of strain on the yarn during twisting, and the $\frac{5}{16}$ in. at the bolster gives a suitable bearing surface combined with a maximum of strength and minimum of weight.

Stretch Lengths.

Stretch is the term applied to the travel outwards of the carriage, and the distance varies according to the class and counts of yarn being spun.

The full range of stretches for all classes of cotton is from 72 in. for very coarse yarn to 56 in. for very fine. It is impossible to obtain this range on one mule, but the stretch is sometimes altered 1 in. or 2 in. more or less than that specified by the machine makers. It is bad practice to change the stretch without making compensative changes to copping, winding, and taking-in mechanism.

The Construction of Carriage.

The carriage is built in sections of 12 ft. to 15 ft. in length, which, when being erected at the mill, are coupled together to form one length, the joints being such as to ensure the complete length being perfectly straight when built up. The design of carriage combines strength and rigidity with a minimum of weight, and ensures that the component parts retain their respective positions. In these respects the modern steel carriage is superior to the wood carriage.

Roller Traverse.

The simple traverse is in general use on mules, and comprises mechanism which actuates the roving guide rod behind the

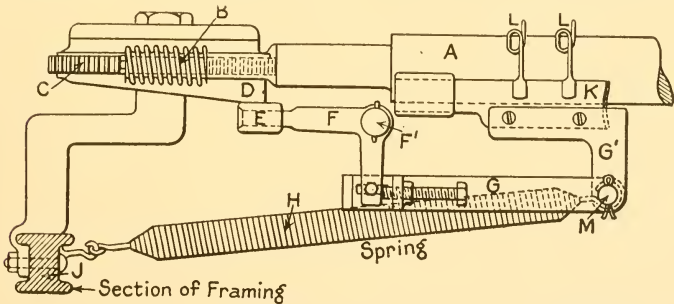

FIG. 77. MULE ROLLER TRAVERSE

drawing rollers in a horizontal direction, the object of this motion being to utilize the maximum width of the leather-covered top front roller, thereby preventing channelled leathers and ensuring a maximum life of the leather, regular

drafting, and, obviously, the lowest possible cost of upkeep of leather covering.

Fig. 77 shows a simple traverse motion as made by Platt Bros. & Co., Ltd. Fast to the bottom back roller *A* at the out end of the mule is a worm *B*, single, double, or treble thread, driving the cam wheel *C*, on the under side of which is cast a cam *D*. Kept in contact with the cam profile is a bowl *E*, carried by a cranked lever *F*, fulcrumed at *F'*. The motion given to *F* is communicated through *G* and *G'* to the traverse rod *K*, which is either perforated to receive the roving or carries wire guides *L*.

The spring *H* is strong enough to exert sufficient power on *G* to keep the bowl *E* always in contact with cam face, ensuring the reciprocation of *K*. The correct position of guide wires *L* is obtained by the adjusting screw on the connecting rod *G*.

The speed of traverse can be increased by substituting the single worm *B* for double or treble worm, or by using a double throw cam *D*.

PART II

TEXTILE MATHEMATICS

CHAPTER I

ARITHMETIC

Tables of Weights and Measures Used in Cotton Spinning

Table of Weight.

24 grains	=	1 pennyweight	(dwt.)
437.5	„	= 1 ounce	(oz.)
7,000	„	= 1 pound	(lb.)

Table of Length.

54 in.	=	1 thread = circumference of wrap reel.
80 threads	=	1 lea = 1 skein = 120 yd
560 threads	=	840 yd. = 7 leas = 1 hank.

Rule for Finding Counts.

To find the hank or *counts* of any given roving or cotton yarn ascertain the number of *hanks* of 840 yd. each there are in 1 lb.

EXAMPLES

1. What will be the counts of yarn which weighs 50 gr. per 4 leas ?

$$\begin{aligned} \text{Weight per hank} &= \frac{50 \times 7}{4} \\ \text{Counts} &= \frac{7000 \times 4}{50 \times 7} \\ &= \underline{\underline{80\text{s counts}}} \end{aligned}$$

2. If 15 hank roving were wrapped what would be the weight of 60 yd. ?

$$\begin{aligned} \text{Weight of 1 hank} &= \frac{7000}{15} \text{ gr.} \\ \text{Weight of 60 yd.} &= \frac{7000}{15 \times 7 \times 2} \\ &= \underline{\underline{1 \text{ dwt., } 9\frac{1}{3} \text{ gr.}}} \end{aligned}$$

3. Drawframe sliver weighs 13 dwt. 12 gr. per 6 yd. What is its hank ?

$$\begin{aligned} 6 \text{ yd. weigh} & \quad \cdot \quad \cdot \quad 324 \text{ gr.} \\ 1 \text{ hank weighs} & \quad \cdot \quad \cdot \quad \frac{324}{6} \times 840 \end{aligned}$$

$$\begin{aligned} \text{Hank} &= \frac{7000 \times 6}{324 \times 840} \\ &= \underline{\underline{\cdot 154 \text{ hank}}} \end{aligned}$$

4. A scutcher lap is $\cdot 00165$ hank ; what is its weight per yard to the nearest $\frac{1}{4}$ oz. ?

$$\begin{aligned} \cdot 00165 \times 840 \text{ yd.} &= 7000 \text{ gr.} \\ \therefore 1 \text{ yd.} &= \frac{7000}{\cdot 00165 \times 840} \text{ gr.} \\ &= \frac{7000}{\cdot 00165 \times 840 \times 437\cdot 5} \text{ oz.} \\ &= 11\cdot 55 \text{ oz.} \end{aligned}$$

\therefore to nearest $\frac{1}{4}$ oz. lap weighs $11\frac{1}{2}$ oz. per yard.

FURTHER EXAMPLES

1. What length of 74s counts will there be in $\frac{1}{2}$ oz. ? (1942·5 yd.)
2. 30 yd. of slubber roving weigh 12 dwt., 2 gr. What is its hank ?
(·862 hank.)
3. A cop of 60s twist weighs 10 dwt., 7 gr. Ignoring the weight of the tube, what length is on this cop ? (1778·4 yd.)
4. The lap from a ribbon lap machine weighs 25 dwt. per yard ; what is its hank ? (·01386 hank.)
5. If 60 yd. of jackframe roving weigh 1 dwt. 7·25 gr., what is its hank ? (16 hank.)
6. What will be the weight of 4 leas of 72s yarn ? (2 dwt. 7·5 gr.)

After learning the use of constants, which appears next, students are advised to check all the above answers by this method. Also, students are strongly advised that until they become thoroughly conversant with counts calculations they should make all their calculations in the ordinary manner, and use the constants for no other purpose except the checking of answers.

Note.

When slivers, rovings, and yarns are being tested the machine used for measuring off the correct lengths is called the wrap reel, and is made in two forms, one for use in the cardroom, which has a cylindrical surface with a circumference of 36 in.,

and the other for the wrapping of yarns, which has a reel or "swift" of hexagon shape with a perimeter of 54 in. ($1\frac{1}{2}$ yd., which is known as 1 thread).

These wrap reels are made with indicators to denote the

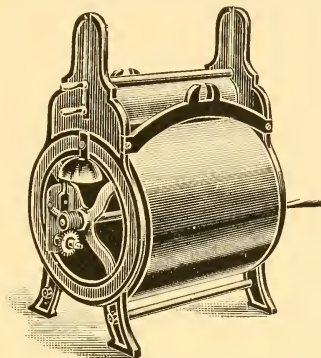

(John Nesbit, Ltd.)

FIG. 78. WRAP BLOCK FOR
SLIVERS AND ROVINGS

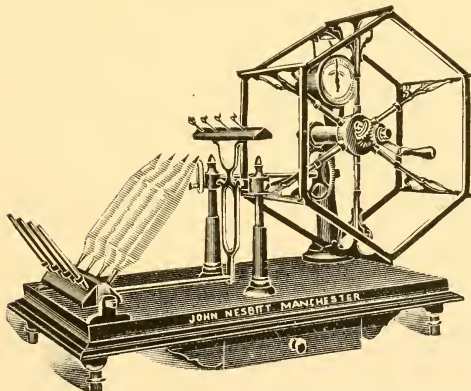

(John Nesbit, Ltd.)

FIG. 79. YARN WRAP REEL

length being wrapped on, and in the case of the yarn reel a traverse motion is also fitted to prevent overlapping of the threads.

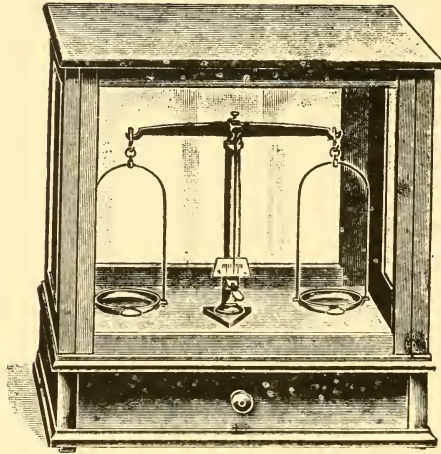

(John Nesbit, Ltd.)

FIG. 80. SENSITIVE BALANCE

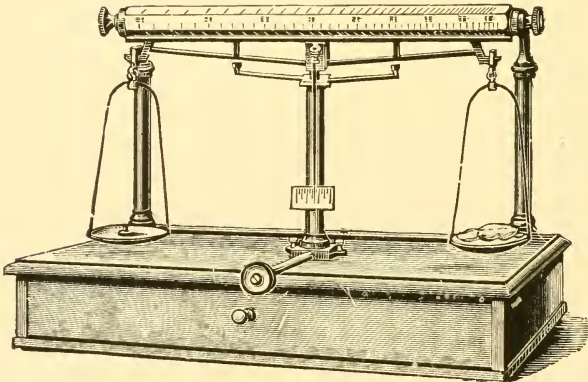

(John Nesbit, Ltd.)

FIG. 81. KNOWLES BALANCE

When the lengths required have been measured on these reels, the sliver, roving, or yarn is then carefully weighed on a very sensitive balance.

Constants.

An explanation of the use of constants will be made simpler by the following—

What are the counts of yarn which weighs x gr. per lea ?

$$\text{Weight of 1 hank} = 7 \times x$$

$$\begin{aligned} \text{Counts} &= \frac{7000}{7 \times x} \\ &= \frac{1000}{x} \\ &= \underline{\underline{\quad}} \end{aligned}$$

It will be seen from the above that to find the counts one has to divide the length in grains of 1 lea into the constant number 1000.

Constants for other lengths are arrived at in the same manner.

In using constants, therefore, to find the counts, divide the weight in grains into the constant number for the length weighed.

The constants are as follows—

Length	Constant
1 hank	7000
4 leas	4000
1 lea	1000
60 yd.	500
30 yd.	250
6 yd.	50
2 yd.	16.66
1 yd.	8.33

EXAMPLES

1. Find the counts of 1 lea of yarn weighing 1 dwt. 1 gr.

$$\begin{aligned} \text{Counts} &= \frac{1000}{25} \\ &= \underline{\underline{40s.}} \end{aligned}$$

2. What is the weight in grains of 1 yd. of comber sliver which is .185 hank ?

$$\begin{aligned} \text{Weight} &= \frac{8.33}{.185} \\ &= \underline{\underline{45 \text{ gr. per yd.}}} \end{aligned}$$

Percentages.

Although students have already learnt this, it will perhaps be as well if some slight revision of the subject were done at this stage, as the question of percentages enters into so many textile problems.

EXAMPLES

1. The total running cost of a certain mill is £1982 10s. per week and the wage bill is £274 5s. What percentage of the running costs is the wage bill ?

$$\begin{aligned} \text{£1982 10s. represents } & 100\% \\ \therefore \text{ £274 5s. } & \text{,, } \frac{\text{£274 5s.}}{\text{£1982 10s.}} \times 100\% \\ &= \frac{5485}{39650} \times 100 \\ \text{Wage bill} &= \underline{\underline{13.84\%}} \end{aligned}$$

2. A waste test is taken on a comber with the following results : weight of good sliver = 15 dwt., weight of waste = 2 dwt. 2 gr. What is the waste per cent being taken out by this machine ?

$$\begin{aligned} \text{Good sliver} &= 360 \text{ gr.} \\ \text{Waste} &= 50 \text{ gr.} \\ \text{Total cotton} &= 410 \text{ gr.} = 100\% \\ \therefore \text{ Waste } \% &= \frac{50 \times 100}{410} \\ &= \underline{\underline{12.20\% \text{ of waste}}} \end{aligned}$$

3. A driven pulley should make theoretically 275 r.p.m., but there is a slippage by the driving belt of 2 per cent. What is its actual speed ?

$$\begin{aligned} \text{Theoretical speed} &= 275 \text{ r.p.m.} = 100\% \\ \text{Actual speed} = 100 - 2 &= 98\% \\ &= 275 \times \frac{98}{100} \\ &= \underline{\underline{269.5 \text{ r.p.m.}}} \end{aligned}$$

4. The sliver from a certain card weighs 10 lb. 4 oz. and the card is taking 7·25 per cent of waste out of the cotton. What weight of cotton has passed through this card to produce this amount of sliver ?

$$\text{Waste \%} = 7\cdot25 \therefore \text{Good sliver} = 100 - 7\cdot25 = 92\cdot75\%$$

$$164 \text{ oz.} = 92\cdot75\%$$

$$\begin{aligned} \therefore \text{Amount of cotton passed through} &= 164 \times \frac{100}{92\cdot75} \\ &= 176\cdot92 \text{ oz.} \\ &= \underline{\underline{11 \text{ lb. } 0\cdot82 \text{ oz.}}} \end{aligned}$$

5. Spinners in Bolton are paid 95 per cent above the Bolton Standard List which is 23·14 pence per 1000 hanks for 80s twist. What is the present-day price per 100 lb. for this yarn ?

$$\begin{aligned} \text{Standard price per 100 lb. of 80s} &= 23\cdot14 \times \frac{80}{1000} \times 100 \\ &= 185\cdot12 \end{aligned}$$

$$\begin{aligned} \therefore \text{Present-day price per 100 lb. of 80s} &= 185\cdot12 \times \frac{195}{100} \\ &= 360\cdot98 \end{aligned}$$

Or 361 pence per 100 lb.

It will be seen that the only difficulty is to decide which part of the question represents the 100 per cent, and it can be safely assumed that whether it be money, cotton, or anything else 100 per cent represents the *original amount*.

FURTHER EXAMPLES

1. The weekly coal consumption at a certain mill is 46 tons, and it is used with 92 per cent efficiency. What weight of coal is wasted per week ? Express your answer in tons, cwt., qr., and lb.

(3 tons 13 cwt. 2 qr. 19 lb.)

2. When ascertaining a spinner's price list he is allowed $3\frac{1}{2}$ per cent for stopped time. What length of stoppage does this represent in a 48-hour working week ? (1 hour 40 minutes 48 seconds.)

3. 15,000 lb. of cotton is put through the mill under the following conditions : waste at blowing room 4 per cent ; at cards 5·5 per cent ; in frames 2·5 per cent ; at mule 1·25 per cent. What is the production of yarn and the total waste per cent ? (13,102 lb., 12·65 per cent.)

4. A set of cops weighs 116·5 lb., but 2·25 lb. of this are tubes. What percentage of the total is paper ? (1·93 per cent.)

5. Two bales of cotton weighing 742 lb. and 673 lb. each respectively are mixed together. What percentage of the mixing is each of them ?

(52·44 per cent and 47·56 per cent.)

Loss and Regain.

All textile materials are capable of absorbing from the atmosphere a certain amount of moisture, and in the case of cotton the figure is 7·834 per cent.

The term used for materials of this kind is "hygroscopic."

By this is meant that if cotton were dried until it contained absolutely no moisture at all, on being again exposed to the atmosphere it would again absorb moisture up to this amount.

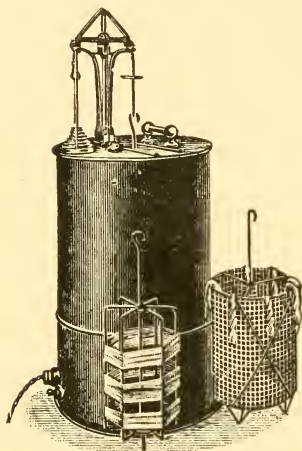

(John Ne-bit, Ltd.)

FIG. 82. ELECTRICALLY HEATED
CONDITIONING OVEN

cotton is in a "standard" condition when 108½ lb. contains 8½ lb. of moisture, which by the following calculation will be found to be 7·834 per cent.

$$8\cdot5 \times \frac{108\cdot5}{100} = 7\cdot834 \text{ per cent.}$$

To find the amount of moisture in cotton a moisture-testing oven is used as shown in Fig. 82.

Heat is applied to get rid of the moisture, but should never exceed in the case of cotton 212° F., and the cotton is weighed both before, during, and after the test, and the necessary

Owing to the fact that cotton can contain very nearly twice this amount of moisture without altering its appearance, and in some cases water is added fraudulently, it will be seen that a "standard" was necessary for the trade, so that claims could be made against any cotton which contained more moisture than the "standard" allowed. In the case of *cotton* this "standard" is that known as a "regain" of 8½ per cent, which means that if 100 lb. of absolutely dry cotton, i.e. cotton from which every particle of moisture has been extracted, were exposed to the atmosphere, it would absorb 8½ lb. of moisture; so that

calculation is then made to ascertain the percentage of moisture.

EXAMPLES

1. A skip of yarn weighing 327 lb. net is tested for moisture as follows: 2 lb. of cops are taken from the skip, and when absolutely dry are found to weigh 1 lb. 12½ oz. Allowing a "regain" of 8½ per cent, can any claim be made for excess moisture? If so, what will be the amount if the yarn is 32d. per lb.?

Dry weight	=	28.5 oz.
Allowing 8½% regain, weight	=	$\frac{108.5}{100} \times 28.5 = 30.9225$ oz.
Original weight	=	32.0
Correct conditioned weight	=	30.9225
Excess moisture	=	1.0775
∴ Total excess moisture	=	$\frac{1.0775}{2} \times \frac{327}{16}$ lb.
	=	11 lb.
∴ <i>Amount of Claim</i>	=	$11 \times 32d. = \underline{\underline{£1\ 9s.\ 4d.}}$

2. If a bale of cotton is in its natural state and weighs 745 lb., what weight of moisture is in the bale? (8½ per cent regain.)

By standard, percentage of moisture	=	7.834
∴ Weight of moisture	=	$\frac{7.834}{100} \times 745$
	=	<u>58.36 lb.</u>

FURTHER EXAMPLES

1. What should be the weight of 364 lb. of perfectly dry cotton when in its natural condition? (8½ per cent regain.) (394.94 lb.)

2. What is the weight of moisture in 1 lb. of cotton which contains 7½ per cent of moisture? (1.2 oz.)

3. If 1 lb. of cops is taken from a skip of yarn weighing 320 lb. for testing and when dry weighs 14.4 oz., what is the correct conditioned weight of the yarn when a regain of 8½ per cent is allowed? (312.48 lb.)

Square Roots.

Although it is perhaps not strictly correct to teach the following method of finding the square root of a number (i.e. that number which, when multiplied by itself will equal the original number) and the correct method will be taught when we are dealing with the question of logarithms later, still it is

probably as well that each student should know that this can be done by arithmetic.

EXAMPLES

1. Find the square root of 379.47.

$$\begin{array}{r}
 1 \quad | \quad 3,79.47, \quad | \quad 19.48 \\
 \underline{1} \\
 29 \quad | \quad 279 \\
 \underline{261} \\
 384 \quad | \quad 1847 \\
 \underline{1536} \\
 3888 \quad | \quad 31100 \\
 \underline{31104} \\
 \quad | \quad \dots \\
 \underline{ } \\
 \text{Ans.} = \underline{\underline{19.48}}
 \end{array}$$

2. Find the square root of 42.

$$\begin{array}{r}
 6 \quad | \quad ,42.00,00, \quad | \quad 6.480 \\
 \underline{36} \\
 124 \quad | \quad 600 \\
 \underline{496} \\
 1288 \quad | \quad 10400 \\
 \underline{10304} \\
 1296 \quad | \quad 9600 \\
 \underline{9600} \\
 \text{Ans.} = \underline{\underline{6.48}}
 \end{array}$$

From these two examples it will be seen that the method adopted is as follows—

1. Mark off the figures of the number, the square root of which is to be found, in pairs from the decimal point, both to the right and to the left.

2. Find the square root of the figure or two figures on the immediate left, and put it in the place of both the divisor and the quotient.

3. Proceed as in ordinary division.

4. Bring down the next pair of figures.
5. Now double the quotient and put it into the position of the next divisor, and proceed as in ordinary division, putting the number both in the quotient and the divisor.
6. Continue this until you have got the required number of figures in your answer.

EXAMPLES

- | | | | | | |
|----|-------------------------|--------|--|--|-----------|
| 1. | Find the square root of | 99. | | | (9·949.) |
| 2. | | 110. | | | (10·488.) |
| 3. | | 26·72. | | | (5·169.) |
| 4. | | ·365. | | | (·6043.) |
| 5. | | 1·961. | | | (1·400.) |

SQUARE ROOTS

No.	Square Root	No.	Square Root	No.	Square Root	No.	Square Root
·5	0·707	27	5·196	55	7·416	83	9·110
·75	0·866	28	5·291	56	7·483	84	9·165
1	1·0	29	5·385	57	7·549	85	9·219
2	1·414	30	5·477	58	7·615	86	9·273
3	1·732	31	5·567	59	7·681	87	9·327
4	2·0	32	5·656	60	7·745	88	9·380
5	2·236	33	5·744	61	7·810	89	9·433
6	2·449	34	5·830	62	7·874	90	9·486
7	2·645	35	5·916	63	7·937	91	9·539
8	2·828	36	6·0	64	8·0	92	9·591
9	3·0	37	6·082	65	8·062	93	9·643
10	3·162	38	6·164	66	8·124	94	9·695
11	3·316	39	6·245	67	8·185	95	9·746
12	3·464	40	6·324	68	8·246	96	9·797
13	3·605	41	6·403	69	8·306	97	9·848
14	3·741	42	6·480	70	8·366	98	9·899
15	3·872	43	6·557	71	8·426	99	9·949
16	4·0	44	6·633	72	8·485	100	10·0
17	4·123	45	6·708	73	8·544	101	10·049
18	4·242	46	6·782	74	8·602	102	10·099
19	4·358	47	6·855	75	8·660	103	10·148
20	4·472	48	6·928	76	8·717	104	10·198
21	4·582	49	7·0	77	8·774	105	10·246
22	4·690	50	7·071	78	8·831	106	10·295
23	4·795	51	7·141	79	8·888	107	10·344
24	4·898	52	7·211	80	8·944	108	10·392
25	5·0	53	7·280	81	9·0	109	10·440
26	5·099	54	7·348	82	9·055	110	10·488

Square Roots Applied to Spinning Calculations.

Theoretically, rovings and yarns are perfectly round, and as the weight of anything with a constant length varies directly as its area, and as the areas of circles vary directly as the squares of their diameters, it will be seen that the weight of equal lengths of given yarns will vary directly as the squares of the diameters of these yarns.

In other words, the counts of yarns vary inversely as the squares of the diameter.

(We already know that the finer the count, i.e. the higher the number, the less is the diameter.)

From the above it will be seen that the basis of measurement of yarns depends upon the diameters, so that *the diameters will vary as the square root of the counts.* (We already know that the coarser the count the greater is the diameter.)

EXAMPLES

1. If 60s yarn is .0058 in. diameter, what will be the diameter of 32s. yarn ?

$$\begin{aligned} \text{Diameter of 32s} &= .0058 \times \frac{\sqrt{60}}{\sqrt{32}} \\ &= \underline{\underline{.0079 \text{ in.}}} \end{aligned}$$

Now many of the change wheels on cotton spinning machinery have relation to the diameter of the roving or yarn in this respect, that they control the building of this roving or yarn on to cops and bobbins, and the space taken up by the roving or yarn will be determined by their diameter, or their counts, so that the number of teeth in these wheels will vary as the square root of the counts.

For example.

The builder wheel on a mule for 50s counts is 48s, and for finer counts a larger wheel would be required, and vice versa.

What builder wheel would be required for 84s counts.

$$\begin{aligned} \text{wheel required} &= 48 \times \frac{\sqrt{84}}{\sqrt{50}} \\ &= 48 \times \frac{9.165}{7.071} \\ &= \underline{\underline{62s \text{ builder wheel.}}} \end{aligned}$$

The lifter wheel on a bobbin and flyframe controls the speed of movement of the lifter rail, and the coarser the roving the larger this wheel will have to be, in order to space out the roving correctly.

If a 19s lifter is required for 10 hank roving, what lifter will be required for 16 hank roving ?

$$\begin{aligned} \text{wheel required} &= 19 \times \frac{\sqrt{10}}{\sqrt{16}} \\ &= 19 \times \frac{3.162}{4} \\ &= 12.52 \text{ lifter wheel} \\ &\quad \text{Say a 13s. wheel.} \end{aligned}$$

The following rules can be applied, therefore—

To find the builder wheel required on flyframes, mules, or ringframes (sometimes called ratchet or star wheel), multiply the builder wheel on by the square root of the counts required and divide by the square root of the counts on

$$\text{builder wheel required} = \text{wheel on} \times \frac{\sqrt{\text{counts required}}}{\sqrt{\text{counts on}}}$$

For a flyframe lifter wheel it is—

$$\text{Lifter wheel required} = \text{wheel on} \times \frac{\sqrt{\text{counts on}}}{\sqrt{\text{counts required}}}$$

and were it not for the fact that special twists are put into rovings and yarns, the lifter wheel rule would also be applicable to twist wheels.

Twists in Rovings and Yarns.

It is necessary to put twist into rovings and yarns for the following reasons: In the case of rovings unless twist were inserted the strand of cotton would not be strong enough to pull off at the next process.

In yarns twist is inserted to give the yarn its required strength, and the amount of twist varies according to the articles being manufactured from the yarn. Again *these twists will vary as the square roots of the counts.*

The following formula is used when ascertaining the amount of twist required in rovings and yarns

$$T = K\sqrt{C}$$

where T = twist per inch required

K = constant number

C = counts or hank.

The constant numbers are as follows—

BOBBIN AND FLYFRAMES

Cotton	Slubbers	Inter-mediate	Rovers	Jacks
Indian and Low American	1.3	1.2	1.5	
American and Low Egyptian	1.0	1.16	1.25	.9
Good Egyptian and Sea Islands	.7	.78	1.1	.9

For yarns they are—

INDIAN AND AMERICAN COTTON

Mule twist	3.75
Mule weft	3.25
Ringframe twist	4.00
Ringframe weft	3.25

EGYPTIAN COTTON

Mule twist	3.606
Mule weft	3.183
Ringframe twist	3.606
Ringframe weft	3.25

EXAMPLES

1. What number of turns per inch must be put into 60s Egyptian mule twist yarn ?

$$\begin{aligned} T &= K\sqrt{C} \\ T &= 3.606 \times \sqrt{60} \\ &= 3.606 \times 7.745 \\ &= \underline{\underline{27.93 \text{ turns per inch}}} \end{aligned}$$

2. What would be the correct twist to put into 16 hank roving (Egyptian) ?

$$\begin{aligned} T &= K\sqrt{C} \\ T &= 1.1 \times \sqrt{16} \\ &= 1.1 \times 4 \\ &= \underline{\underline{4.4 \text{ turns per inch}}} \end{aligned}$$

The constants given for bobbin and flyframes would give good results, but in actual practise it is usual to find the correct amount of twist required, i.e. that amount which will assure us that the roving will unwind without breaking at the next process ; as any excess means unnecessarily lost production.

From the above examples, etc., students will see that square roots form a very important part of many textile machinery and yarn calculations.

The Numbering of French Counts.

Seeing that we do a vast amount of trade abroad it is necessary that we should understand the foreign system of numbering yarns, which is, of course, different to our own.

Abroad the metric system is used, and the standards adopted are the metre (39·37 in.) for length, and the kilogram (2·204 lb.) for weight.

The basis is as follows—

1000 metre weighing 500 grm. ($\frac{1}{2}$ kilo) = No. 1s counts.

2000 " " " " = " 2s "

3000 " " " " = " 3s "

and so on.

This length of 1000 metre is termed a hank, and each hank is divided into 10 skeins of 100 metres each.

The skeins are wrapped on a wrap reel having a perimeter of 1·425 metres (56·1 in.) making 70 revolutions to a skein.

From the above it will be seen that *the number of hanks (of 1000 metres each) there are in 500 grm. is the French count.*

It is essential that we should have a convenient and simple way of determining English counts from French, and vice versa, and the following will show how this constant number is arrived at.

Let us take 1s French counts and find the English equivalent.

$$\begin{aligned}
 & 1000 \text{ metres} = 500 \text{ grm.} \\
 & = (1000 \times 39\cdot37) \text{ in.} \qquad = \frac{2\cdot204}{2} \text{ lb.} \\
 & = 39370 \text{ in.} \qquad = 1\cdot102 \times 7000 \text{ gr.} \\
 & = \frac{39370}{36} \text{ yd.} \qquad = 1\cdot102 \times 7000 \text{ gr.}
 \end{aligned}$$

$$\begin{aligned} \therefore 1 \text{ yd} &= \frac{1.102 \times 7000 \times 36 \text{ gr.}}{39370} \\ \therefore 1 \text{ hank English (840 yd.)} &= \frac{1.102 \times 7000 \times 36 \times 840}{39370} \\ \therefore \text{English counts} &= \frac{7000 \times 39370}{1.102 \times 7000 \times 36 \times 840} \\ &= \underline{\underline{1.18 \text{ English counts.}}} \end{aligned}$$

From the above we get the following rules—

To change French counts to English multiply the French by 1.18.
To change English counts to French divide the English by 1.18,
or multiply the English by .847.

EXAMPLES

1. Find the French counts of the following English 25s, 64s.

$$\text{French counts} = 25 \times .847 = \underline{\underline{21.175 \text{ counts}}}$$

$$\text{,, ,,} = 64 \times .847 = \underline{\underline{54.208 \text{ counts}}}$$

2. Find the English counts from the following French 38s, 98s.

$$\text{English counts} = 38 \times 1.18 = \underline{\underline{44.84 \text{ counts}}}$$

$$\text{,, ,,} = 98 \times 1.18 = \underline{\underline{115.64 \text{ counts}}}$$

The following useful English and French equivalents should be remembered by all students.

$$1 \text{ inch} = 2.54 \text{ centimetres}$$

$$1 \text{ centimetre} = \frac{1}{100} \text{ metre.}$$

$$1 \text{ metre} = 39.37 \text{ inches} = 3 \text{ feet } 3\frac{5}{8} \text{ inches} = 3.281 \text{ ft.}$$

$$1000 \text{ metres} = 1 \text{ kilometre} = \text{approx. } \frac{5}{8} \text{ of a mile.}$$

$$1000 \text{ grammes} = 1 \text{ kilogramme} = 2.204 \text{ lb.}$$

The Doubling of Yarns.

This is a very important process in the cotton trade, vast weights of yarn being doubled or twisted together for the sewing thread and other branches of the manufacturing side of the industry.

It is therefore very important that we should be able to

calculate at once the resultant counts when two or more single yarns are doubled together.

Assume that 60s and 40s single yarns are doubled together, what would be the resultant yarn ?

$$1 \text{ hank (840 yd.) of 60s} = \frac{1}{60} \text{ of a lb.}$$

$$1 \text{ hank of 40s} = \frac{1}{40} \text{ of a lb.}$$

$$\therefore 1 \text{ hank of the doubled yarn} = \frac{1}{60} + \frac{1}{40}$$

$$= \frac{40 + 60}{2,400}$$

$$= \frac{100}{2400}$$

$$\therefore \text{resultant counts} = \frac{2400}{100}$$

$$= 24\text{s.}$$

equivalent to 48/2 fold yarn.

To find the resultant counts when two yarns are doubled together, multiply them together for a dividend and add them together for a divisor.

A and B are two yarns doubled together. What will be the resultant counts ?

$$1 \text{ hank of } A = \frac{1}{A} \text{ of a lb.}$$

$$1 \text{ ,, ,, } B = \frac{1}{B} \text{ ,, ,,}$$

$$1 \text{ ,, ,, resultant} = \frac{1}{A} + \frac{1}{B}$$

$$= \frac{B + A}{AB}$$

$$\therefore \text{resultant counts} = \frac{A + B}{AB}$$

which is the rule expressed algebraically.

We can also make a rule for three counts being doubled together, A , B , and C as follows—

$$1 \text{ hank of } A = \frac{1}{A}$$

$$1 \text{ ,, ,, } B = \frac{1}{B}$$

$$1 \text{ ,, ,, } C = \frac{1}{C}$$

$$\begin{aligned} 1 \text{ hank of resultant} &= \frac{1}{A} + \frac{1}{B} + \frac{1}{C} \\ &= \frac{BC + AC + AB}{ABC} \end{aligned}$$

$$\therefore \text{resultant counts} = \frac{ABC}{BC + AC + AB}$$

EXAMPLES

1. Two yarns are doubled together and give a resultant count of 22.5 (equivalent to 45/2 fold yarn). One of them is 50s, what is the other ?

$$\begin{aligned} \frac{AB}{A + B} &= 22.5 \\ \frac{50 \times B}{50 + B} &= 22.5 \\ 50 \times B &= 22.5(50 + B) \\ 50B &= 1125 + 22.5B \\ 50B - 22.5B &= 1125 \\ 27.5B &= 1125 \\ B &= 40.9 = \underline{\underline{\text{the other count}}} \end{aligned}$$

2. Three single yarns 60s, 30s, and 20s are doubled together. What is the resultant count ?

$$\begin{aligned} &\frac{ABC}{AB + AC + BC} \\ &= \frac{60 \times 30 \times 20}{1800 + 1200 + 600} \\ &= \frac{36000}{3600} \\ &= 10s \end{aligned}$$

Equivalent to 30/3 fold yarn.

CHAPTER II

MENSURATION

A FEW revisional notes and formulae.

1. *A square* has all its sides equal in length and all its angles are right-angles (90°). It is also a rectangle.

2. *A rectangle* has its two opposite sides equal in length and all its angles right-angles.

3. *A parallelogram* has its two opposite sides equal in length and parallel to one another, and its two opposite angles equal to one another.

4. *A rhombus* is a parallelogram having all its sides equal, but its angles are not right-angles.

5. *A trapezium* is a four-sided figure which has two of its sides parallel.

6. *A quadrilateral* is any four-sided figure.

Areas are expressed in square measure, i.e. square inches, square feet, etc.

Area of a rectangle = length \times breadth.

Area of a parallelogram = base \times altitude.

The altitude is the perpendicular distance between one of the sides taken as base, and the apex.

Area of a rhombus = half the product of the diagonals.

7. *A triangle* is any three-sided figure.

8. *An equilateral triangle* is a triangle which has all its three sides equal in length and its three angles equal (60° each).

9. *An isosceles triangle* is a triangle having two of its sides and two of its angles equal.

10. *A right-angled triangle* is a triangle which has one of its angles 90° .

11. *An obtuse angle* is an angle over 90° .

12. *An acute angle* is an angle under 90° .

Area of a triangle = $\frac{1}{2}$ (base \times perpendicular height)

$$\text{or } \frac{\text{base} \times \text{altitude}}{2}$$

in other words, it is half of a parallelogram of the same dimensions.

The three angles of any triangle total 180° , or half the number of degrees there are in a circle.

The Circle.

The number of times that the diameter of a circle is obtained in the circumference is 3.1415926, etc., and the following are used according to the degree of accuracy required: 3.1416 or $\frac{22}{7}$ or $3\frac{1}{7}$. Students can generally be satisfied by using $\frac{22}{7}$.

This number is denoted by the Greek letter π (pronounced "pi").

$$\text{Radius} = \frac{1}{2} \text{ diameter}$$

$$\text{Circumference} = \pi \times \text{diameter, written } \pi D \text{ or } 2\pi r$$

$$\text{Area of a circle} = \pi r^2$$

$$\text{but } r = \frac{D}{2}$$

$$\begin{aligned} \therefore \text{area} &= \pi \times \left(\frac{D}{2}\right)^2 \\ &= 3.1416 \times \frac{D}{2} \times \frac{D}{2} \\ &= \underline{\underline{.7854D^2}} \end{aligned}$$

Volumes.

Volumes are expressed in cubic measure, i.e. cubic inches, cubic feet, etc.

Volume of a rectangular body

$$= \text{length} \times \text{breadth} \times \text{height}$$

Volume of a cylinder

$$= \text{area of base } (\pi r^2) \times \text{length}$$

EXAMPLES

1. Find the area of a cardroom which is 130 ft. long and 120 ft. broad. (15,600 sq. ft.)
2. A triangle has a base of 7.36 in. and a perpendicular height of 5.13 in. What is its area? (18.88 sq. in.)
3. A cast-iron flyframe weight has the following dimensions: 10 in. long, 5 in. broad, and 6 in. thick. What is its weight if 1 cub. in. of cast-iron weighs .26 lb. ? (78 lb.)

4. A steel shaft is $3\frac{1}{2}$ in. diameter and 9 ft. 6 in. long. What is its weight if steel = .283 lb. per cub. in. ? (310.5 lb.)

$$\text{Volume of a ball or sphere} = \frac{4}{3}\pi r^3.$$

5. Find the weight of a 6 in. steel governor ball ; steel = .283 lb. per cub. in. (32 lb.)

6. The tank in the sprinkler tower of a mill has the following inside measurements : 15 ft. long, 10 ft. wide, and 6 ft. 6 in. deep.

If the water is filled to within 6 in. of the top and 1 cub. ft. of water weighs $62\frac{1}{2}$ lb., what is the weight of water in the tank in tons ?

$$\text{Volume of water in tank} = 15 \times 10 \times 6 \text{ cub. ft.}$$

$$\text{Weight of water in tank} = 15 \times 10 \times 6 \times 62.5 \text{ lb.}$$

$$\text{Weight of water in tons} = \frac{15 \times 10 \times 6 \times 62.5}{2240}$$

$$= 25.11 \text{ tons}$$

7. Assume a coiler can measuring 36 in. long by 9 in. diameter to be closely packed with cotton sliver, with a core or hole right through the centre 2 in. diameter. How many cubic feet of cotton does the can contain ? (1.26 cub. ft.)

8. The air in a cotton conveyor pipe 14 in. diameter is found to have a velocity of 50 ft. per second. Find the volume of air passing through per minute. (3208.3 cub. ft. per minute.)

9. If the floor space required for one carding engine is 10 ft. 2 in. \times 5 ft. 3 in., what is the total area in square feet of 80 carding engines ? (4270 sq. ft.)

10. From the following particulars calculate the cost of covering a card cylinder with wire. The cylinder is 50 in. diameter and 42 in. wide, and the fillet is 2 in. wide and costs 10d. per foot. Allow 6 ft. extra for finishing off (ending).

$$\text{Circumference of cylinder} = \frac{22}{7} \times 50$$

$$\text{No. of wraps of fillet to cover cylinder} = \frac{42}{2} = 21$$

$$\text{Length of fillet} = \frac{22}{7} \times \frac{50}{12} \times 21 = 275 \text{ ft.}$$

$$\text{Total length of fillet} = 275 + 6 = 281$$

$$\text{Cost} = 281 \times 10\text{d.}$$

$$= \underline{\underline{\pounds 11 \text{ 14s. 2d.}}}}$$

11. A steam pipe is 4 in. diameter and the metal is $\frac{3}{8}$ in. thick ; if the pipe is of cast-iron which weighs .26 lb. per cub. in. and is 15 ft. long, find its weight.

$$\text{Area of pipe (outside)} = \frac{22}{7} \times 2 \times 2$$

$$= \frac{88}{7} \text{ sq. in.}$$

$$\begin{aligned}
 \text{Area of inside hole} &= \frac{22}{7} \times \frac{13}{8} \times \frac{13}{8} \\
 &= \frac{1859}{224} \\
 \therefore \text{Area of metal} &= \frac{88}{7} - \frac{1859}{224} \\
 &= \frac{957}{224} \text{ sq. in.} \\
 \therefore \text{Weight of pipe} &= \frac{957}{224} \times 15 \times 12 \times \cdot 26 \\
 &= \underline{\underline{200 \text{ lb.}}}
 \end{aligned}$$

12. Find the amount of leather required to cover a double boss mule top roller if each boss is 2 in. long and $1\frac{1}{2}$ in. diameter.

(18·85 sq. in.)

13. If the front roller of a flyframe is $1\frac{1}{8}$ in. diameter and its speed is 100 r.p.m., what length of roving would be delivered from the roller in feet per hour?

(1767 ft. per hour.)

14. Find the linear velocity in feet per minute of a ringframe driving belt. The tin roller shaft makes 840 r.p.m. and is fitted with a 14 in. pulley. Neglect slippage.

(3080 ft. per minute.)

15. A card cylinder is 44 in. wide and 50 in. diameter. Find the weight of this cylinder if the metal (cast-iron = ·26 lb. per cub. in.) is $\frac{1}{2}$ in. thick. Shaft and spokes weigh 179 lb.

$$\begin{aligned}
 \text{Area of outside of cylinder} &= \frac{22}{7} \times 25 \times 25 \\
 &= \frac{13750}{7} \text{ sq. in.} \\
 \text{Area of inside of cylinder} &= \frac{22}{7} \times \frac{49}{2} \times \frac{49}{2} \\
 &= \frac{52822}{28} \text{ sq. in.} \\
 \therefore \text{Area of metal} &= \frac{13750}{7} - \frac{52822}{28} \\
 &= \frac{2178}{28} \text{ sq. in.} \\
 \therefore \text{Weight of cylinder shell} &= \frac{2178}{28} \times 44 \times \cdot 26 \text{ lb.} \\
 &= 890 \text{ lb.} \\
 \therefore \text{Total weight} &= 890 + 179 \\
 &= \underline{\underline{1069 \text{ lb.}}}
 \end{aligned}$$

16. Three pipes are the following inside diameters: 3 in., $4\frac{1}{2}$ in., and 5 in. What will be the diameter of a single pipe which will have

80 per cent of the total cross-sectional area of the three pipes mentioned ?

$$\text{Area of 3 in. pipe} = \frac{22}{7} \times \frac{3}{2} \times \frac{3}{2} = \frac{99}{14} \text{ sq. in.}$$

$$\text{Area of } 4\frac{1}{2} \text{ in. pipe} = \frac{22}{7} \times \frac{9}{4} \times \frac{9}{4} = \frac{891}{56} \text{ sq. in.}$$

$$\text{Area of 5 in. pipe} = \frac{22}{7} \times \frac{5}{2} \times \frac{5}{2} = \frac{275}{14} \text{ sq. in.}$$

$$\text{Total area of 3 pipes} = \frac{99}{14} + \frac{891}{56} + \frac{275}{14}$$

$$= \frac{2387}{56} \text{ sq. in.}$$

$$80\% \text{ of this area} = \frac{2387}{56} \times \frac{80}{100} = \frac{2387}{70} = \frac{341}{10} = 34.1$$

$$\therefore \text{Radius} = \sqrt{34.1 \times \frac{7}{22}}$$

$$= 3.294 \text{ in.}$$

\therefore Diameter of required pipe

$$= \underline{\underline{6.588 \text{ in.}}}$$

17. A 4 in. steam pipe passes straight round a cardroom 2 ft. from the wall. If the room is 130 ft. by 120 ft., what is the total radiating surface of the pipe in square feet ? (507 sq. ft.)

18. A bale of Egyptian cotton weighs 742 lb. and is 50 in. \times 30 in. \times 20 in. What is the weight per cubic foot of the cotton ? (42.74 lb. per cub. ft.)

19. The floor space in the cotton warehouse is 155 ft. by 88 ft. How many bales of Egyptian cotton 3 ft. high by 2 ft. 7 in. wide by 1 ft. 10 in. broad can be stacked in this warehouse, stood on end ?

$$\text{Floor space} = 155 \text{ ft.} \times 88 \text{ ft.}$$

$$155 \text{ ft.} = 1860 \text{ in.}$$

$$2 \text{ ft. } 7 \text{ in.} = 31 \text{ in.}$$

$$\therefore \text{No. in line down length of room} = \frac{1860}{31} = 60$$

$$88 \text{ ft.} = 1056 \text{ in.}$$

$$1 \text{ ft. } 10 \text{ in.} = 22 \text{ in.}$$

$$\therefore \text{No. of lines} = \frac{1056}{22} = 48$$

$$\therefore \text{Total number of bales} = 60 \times 48$$

$$= \underline{\underline{2880}}$$

20. A warehouse is 180 ft. long, 90 ft. wide, and 13 ft. high. Find (1) the area of the floor in square feet ; (2) the cubic feet of air in the warehouse. (16,200 sq. ft. and 210,600 cub. ft.)

CHAPTER III

ALGEBRA

Simple Equations.

THE student having had lessons in elementary algebra up to and including "simple equations," we will commence by doing some revision of this subject.

Firstly, then, an *equation* consists of two algebraical expressions separated by an equality sign, which shows that the two expressions, one on the right side and the other on the left side, are equal to one another. An equation which has only one unknown quantity (usually denoted by the letter x) is called a *simple equation*.

Seeing that both sides of the equation are equal to one another, it follows that so long as we add to, or subtract from, or multiply by, or divide by, the same amount on both sides of the equation, the equation will still hold good. Now the above fact is of vast importance, as it will be found that in all cases by doing one of these four things the equation can be simplified and solved.

EXAMPLES

1. $6x + 3 = 15.$
Subtract 3 from each side of the equation.

$$6x + 3 - 3 = 15 - 3$$

$$6x = 12$$

Divide both sides by 6

$$\therefore x = \underline{\underline{2}}$$

2. $\frac{1}{3}x + \frac{1}{3}x = x - 3.$
Multiply both sides by 6 (to clear the fractions)

$$3x + 2x = 6x - 18$$

Subtract $6x$ from both sides

$$3x + 2x - 6x = -18$$

Multiply both sides by -1

$$\therefore x = \underline{\underline{18}}$$

It will be seen from the above that any term in an equation may be taken from one side to the other by changing its sign,

and we usually get the known quantities on the right side and the unknown quantities on the left side.

$$3. \quad 5(x-3) = 4(x-2).$$

Clear the brackets first

$$5x - 15 = 4x - 8$$

Transposing

$$5x - 4x = -8 + 15$$

$$\therefore x = \underline{\underline{7}}$$

$$4. \quad 3 - 7(x-1) = 5 - 4x$$

$$3 - 7x + 7 = 5 - 4x$$

$$-7x + 4x = 5 - 7 - 3$$

$$-3x = -5$$

$$\therefore x = \underline{\underline{\frac{5}{3}}}$$

Find the value of x in the following equations—

$$1. \quad \frac{10x+1}{5} - 1 = 5x - 2$$

$$2. \quad 5 - 4(x-3) = x - 2(x-1)$$

$$3. \quad 7x - 3 \cdot 35 = 6 \cdot 4 - 3 \cdot 2x$$

$$4. \quad 5x - 17 + 3x - 5 = 6x - 7 - 8x + 115$$

Check your answer in all cases by substituting the value of x you have obtained, and seeing if the equation holds good under that condition. If not, your answer is wrong.

All equations can be checked in this manner.

The Application of Simple Equations to Formulae.

When the student has mastered simple equations he will be able to see that formulae of all types are actually equations, and are both formed and solved on algebraic principles.

For instance, taking a formula with which the student is already acquainted—

In doubled yarns

Let x = one single yarn and y = the other

$$1 \text{ hank of } x = \frac{1}{x} \text{ lb.}$$

$$,, \quad ,, \quad y = \frac{1}{y} \text{ lb.}$$

$$\therefore \text{1 hand of resultant} = \frac{1}{x} + \frac{1}{y} = \frac{y \star x}{xy}$$

$$\therefore \text{resultant count} = \frac{x + y}{xy} \cdot \frac{84}{177}$$

This is now, of course, a formula.

Transformation of Formulae.

Take a well-known formula (the area of a circle).

$$A = \pi r^2$$

$$\text{or } \pi r^2 = A.$$

To find the value of r , using algebraic principles

$$r^2 = \frac{A}{\pi}$$

$$\therefore r = \sqrt{\frac{A}{\pi}}$$

This transformation is very important, as we are liable to have to find the value of any one of the quantities in this or any other formula.

The circumference of a circle

$$C = \pi D$$

$$\therefore D = \frac{C}{\pi}$$

In speed calculations we have learned that

$$\text{The speed of a driven pulley} = \frac{\text{Speed of Driver} \times \text{Drivers}}{\text{Driven}}$$

$$\text{or } Dn = \frac{Dr \times Drs}{Dns}$$

Any of these terms can now be expressed in relation to the others

$$Dr = \frac{Dn \times Dns}{Drs}$$

$$Drs = \frac{Dn \times Dns}{Dr}$$

and so on.

Later the students will be taught the following—

$$H = \frac{PALS}{33000}$$

where H = indicated horse-power of a steam engine

P = pressure per square inch

A = area of cylinder in square inches

L = length of stroke in feet

S = number of strokes per minute.

This formula can be transformed according to the term of which it is required to find the value.

$$P = \frac{H \times 33000}{ALS}$$

$$A = \frac{H \times 33000}{PLS}$$

$$L = \frac{H \times 33000}{PAS}$$

$$S = \frac{H \times 33000}{PAL}$$

It now becomes clear that no matter what the unknown quantity is in any formula, it can be found without difficulty by the correct use of algebraic principles.

EXAMPLES

1. The line shaft makes 480 r.p.m. and a 28 in. pulley on it drives the beater pulley which makes 1100 r.p.m.; ignoring slippage, what will be the size of the beater pulley to the nearest $\frac{1}{2}$ in. ?

Call the pulley x .

$$\text{Now by the formula } 480 \times \frac{28}{x} = 1100$$

$$\therefore x = \frac{480 \times 28}{1100}$$

$$x = 12.22 \text{ in.}$$

To the nearest $\frac{1}{2}$ in. = 12 in. pulley

2. The following formula is used for finding the breaking weight of a beam when loaded in the middle

$$W = \frac{CBD^2}{L}$$

If $W = 2750$ lb., $C = 350$, $D = 4$, and $L = 14$, find the value of B .

$$B = \frac{W \times L}{C \times D^2}$$

$$B = \frac{2750 \times 14}{350 \times 4 \times 4}$$

$$\therefore B = \underline{\underline{6.875}}$$

From these explanations and examples it will be seen that all textile problems can be simplified to a very marked degree by the use of algebra.

Factors.

To resolve algebraic expressions into factors, divide the expressions by the common factor, enclose the quotient in brackets, and place the common factor outside the bracket as a coefficient.

$$x^2 + ax$$

x is common to both expressions

$$\therefore x^2 + ax = x(x + a)$$

again

$$a^3 - a^2b$$

a^2 is common to both expressions

$$\therefore a^3 - a^2b = a^2(a - b)$$

EXAMPLES

Resolve into factors—

1. $a^3 - a^2$.

Ans. $a^2(a - 1)$

2. $10c^3 - 25c^4d$.

Ans. $5c^3(2 - 5cd)$

3. $4b^5 + 6a^2b^3 - 2b^2$.

Ans. $2b^2(2b^3 + 3a^2b - 1)$

4. $7p^2 - 7p^3 + 14p^4$.

Ans. $7p^2(1 - p + 2p^2)$

Harder Factors.

$$(x + 2)(x + 1) = \begin{array}{r} x + 2 \\ x + 1 \\ \hline x^2 + 2x \\ + x + 2 \\ \hline x^2 + 3x + 2 \\ \hline \hline \end{array}$$

Which is : the product of the first term of each expression, plus the product of the two inner terms and the two outer terms added together, plus the product of the second term of each expression. Now working conversely, we must work to this rule. Example—

Factorize $x^2 + 5x + 6$

Build the factors up as follows—

$$(x \quad)(x \quad) = x^2$$

$$(x + 2)(x + 3) = x^2 + 5x + 6$$

again

$$x^2 - 15x + 54$$

$$(x \quad)(x \quad) = x^2$$

$$(x - 9)(x - 6) = x^2 - 15x + 54$$

Factorize the following—

- | | |
|-----------------------|---------------------------------|
| 1. $x^2 - 13x + 36$ | <i>Ans.</i> $(x - 9)(x - 4)$. |
| 2. $y^2 - 24y + 95$. | <i>Ans.</i> $(7 - 19)(y - 5)$. |
| 3. $x^2 - 12x + 27$ | <i>Ans.</i> $(x - 9)(x - 3)$ |
| 4. $x^2 + 8x + 7$. | <i>Ans.</i> $(x + 7)(x + 1)$. |

The Difference of Two Squares.

The difference of the squares of any two numbers is equal to the product of the sum and of the difference of the two numbers.

$$(a + b)(a - b) = \frac{a + b}{a - b}$$

$$\frac{a^2 + ab}{-ab - b^2}$$

$$\frac{a^2}{-b^2}$$

So in finding the difference of two squares we can use the formula

$$a^2 - b^2 = (a + b)(a - b)$$

EXAMPLES

1. $(27)^2 - (14)^2$
 $= (27 + 14)(27 - 14)$
 $= 41 \times 13$
 $= 533$
2. $(297)^2 - (284)^2$
 $= (297 + 284)(297 - 284)$
 $= 581 \times 13$
 $= 7553$

Find by factors the value of

1. $(51)^2 - (49)^2$. *Ans.* (200).
2. $(1001)^2 - 1$. *Ans.* (1,002,000)
3. $(9)^2 - (8)^2$ *Ans.* (17).
4. $(12)^2 - (9)^2$. *Ans.* (63).

Fractions.

Fractions in algebra follow the same rules as in arithmetic

e.g.
$$\frac{1}{5} + \frac{2}{7}$$

$$= \frac{7 + 10}{35} = \frac{17}{35}$$

and
$$\frac{1}{a} + \frac{1}{b}$$

$$= \frac{b + a}{ab} = \frac{a + b}{ab}$$

i.e. find the lowest common multiple of the denominator and work exactly as in arithmetic.

EXAMPLE

1. Find the value of $\frac{a}{b} - \frac{2}{a} + \frac{3}{b}$
- $$= \frac{a^2 - 2b + 3a}{ab}$$
- $$= \frac{a^2 + 3a - 2b}{ab}$$

Simultaneous Equations.

When two equations are satisfied by the same values of the unknown quantities they are simultaneous equations.

In order to solve these equations we must obtain an equation with only one unknown quantity, and to do this we must adopt some means of getting rid of the other unknown quantity.

The following will explain the method adopted—

$$\begin{array}{l} (1) \quad 3x + 5y = 50 \\ \text{and } (2) \quad 4x + 3y = 41 \end{array} \left. \vphantom{\begin{array}{l} (1) \\ (2) \end{array}} \right\} \text{Equation to be solved}$$

multiply (1) by 4 $= 12x + 20y = 200$

„ (2) „ 3 $= 12x + 9y = 123$

$$\begin{array}{r} \text{subtract (2) from (1)} \\ \hline 11y = 77 \end{array}$$

$$\therefore y = 7$$

To find the value of x now substitute the value of y found, in either (1) or (2).

$$(1) \quad 3x + 35 = 50$$

$$\therefore 3x = 15$$

$$\therefore x = 5$$

$$\text{and } y = 7 \left. \vphantom{\begin{array}{l} \therefore x = 5 \\ \text{and } y = 7 \end{array}} \right\} \text{Ans.}$$

$$\begin{array}{l} \text{again } (1) \quad 4x + 5y = 4 \\ \text{and } (2) \quad 5x - 3y = 79 \end{array} \left. \vphantom{\begin{array}{l} (1) \\ (2) \end{array}} \right\} \text{Equation to be solved}$$

multiply (1) by 3 $12x + 15y = 12$

„ (2) „ 5 $25x - 15y = 395$

$$\begin{array}{r} \text{add (1) to (2)} \\ \hline 37x = 407 \end{array}$$

$$x = 11$$

substitute $x = 11$ in (1) $44 + 5y = 4$

$$5y = -40$$

$$y = -8$$

$$\text{and } x = 11 \left. \vphantom{\begin{array}{l} y = -8 \\ \text{and } x = 11 \end{array}} \right\} \text{Ans.}$$

Note. When eliminating if the signs are alike subtract, if the signs are unlike add

A further example—

$$x + 2y = 13$$

$$\text{and } \frac{2x}{3} - \frac{y}{5} = 1$$

Eliminate fractions by multiplying (2) by 15

$$10x - 3y = 15$$

$$\text{Multiply (1) by 10} \quad 10x + 20y = 130$$

$$\text{Subtract (1) from (2)} \quad \underline{-23y = -115}$$

$$\therefore y = 5$$

$$\text{Substitute in (1)} \quad x + 10 = 13$$

$$\therefore \left. \begin{array}{l} x = 3 \\ \text{and } y = 5 \end{array} \right\} \text{Ans.}$$

EXAMPLES

Solve the following equations—

$$1. \quad \begin{array}{l} 5x = 7y - 21 \\ 21x - 9y = 75 \end{array} \quad \left\{ \begin{array}{l} x = 7 \\ y = 8 \end{array} \right.$$

$$2. \quad \begin{array}{l} 5x - 7y = 11 \\ 18x = 12y \end{array} \quad \left\{ \begin{array}{l} x = -2 \\ y = -3 \end{array} \right.$$

$$3. \quad \begin{array}{l} 4x - y = 1 \\ \frac{x}{2} + \frac{3y}{7} = 4 \end{array} \quad \left\{ \begin{array}{l} x = 2 \\ y = 7 \end{array} \right.$$

$$4. \quad \begin{array}{l} \frac{3}{5}x - y = 7 \\ 4x + 5y = 0 \end{array} \quad \left\{ \begin{array}{l} x = 5 \\ y = -4 \end{array} \right.$$

Always check your answers by substitution.

CHAPTER IV

GRAPHS

THE use of graphs and squared paper should be thoroughly appreciated by the student. In making periodical records of any description, the fluctuations or steadiness of the records is shown more plainly by graphs than by tabulated data.

Two quantities, results of a number of experiments or observations, can best be represented by the use of *squared paper graphs*.

By commencing at the lowest left-hand corner of the squared paper, the lowest horizontal line may be taken as one *axis*, OX , or the *axis of abscissae*, the vertical line on the extreme left may be taken as the other *axis*, OY or the *axis of ordinates*.

After obtaining the results of observations or experiments, a scale is decided upon and the points plotted out on the square paper.

EXAMPLE I

In the following table the price of raw cotton, on 1st July, 1914, is taken as basis (100), and the price at the various dates given is calculated as a percentage of the basis figure.

	<i>Price</i>
July, 1914	100
July, 1915	79
July, 1916	133
July, 1917	292
July, 1918	349
July, 1919	315
July, 1920	405
July, 1921	118
July, 1922	207

Let OX = Price.
and OY = Date.

Example No. 1 shows a graph that may be kept for cotton price fluctuations, or production fluctuations, and are generally adopted in mills and workshops where an efficient system of records is kept (Fig. 83).

There is another type of graph, however, where the reading on OX has a direct ratio on OY . The results of experiments or observations being taken and the points plotted on the squared paper, it is found on joining the points that a straight line is formed. This shows that the value of X has a direct bearing on the value of Y , and from this we can obtain an "equation of a straight line," which is—

$$y = ax + b$$

Having obtained various results of x and y , by substituting the numbers for x and y , and forming two equations, we are able, by simultaneous equations, to find the constant values of " a " and " b ." This is done by the results in the following examples.

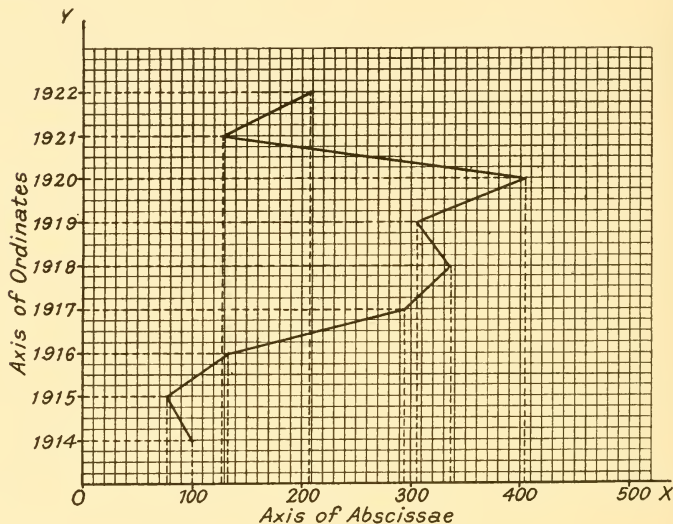

FIG. 83

EXAMPLE II

The distance across the flats, and the diameters of a number of Whitworth nuts are given—

Diameter of screw	$\frac{1}{2}$ in.	1 in.	$1\frac{1}{4}$ in.	$1\frac{1}{2}$ in.
Distance across flats	$\frac{7}{8}$ in.	$1\frac{5}{8}$ in.	2 in.	$2\frac{3}{8}$ in.

Plot the graph and find the equation (Fig. 84).

Let OX = diameter of screw.

OY = distance across screw.

Scale $OX \sim 8$ squares = $\frac{1}{2}$ in.

$OY \sim 8$ squares = 1 in.

As the result of the plotting is a straight line, then the equation is $y = ax + b$.

$$\therefore \frac{7}{8} = a \times \frac{1}{2} + b$$

$$1\frac{5}{8} = a \times 1 + b$$

$$\frac{3}{4} = \frac{1}{2}a \quad \therefore a = 1\frac{1}{2}$$

$$\text{And } 1\frac{5}{8} = 1\frac{1}{2} + b \quad \therefore b = 1\frac{5}{8} - 1\frac{1}{2} = \frac{1}{8}$$

From this we get the rule

$$y = 1\frac{1}{2}x + b, \text{ or}$$

The distance across flats of a hexagon nut is one and a half times the diameters of the screw + $\frac{1}{8}$ in.

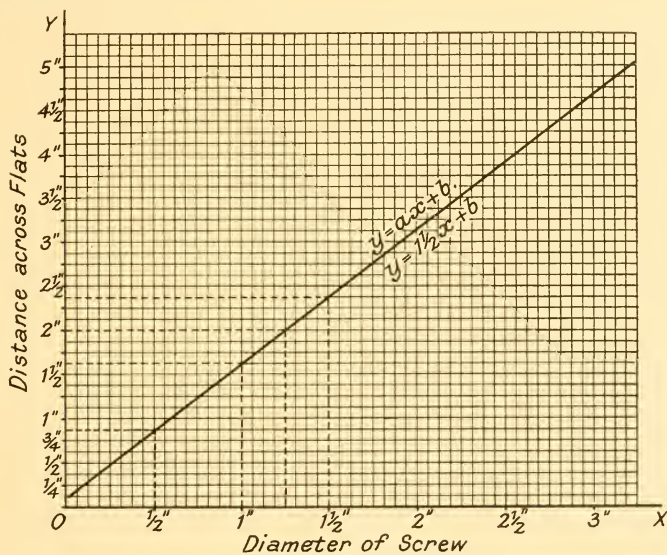

FIG. 84

FURTHER EXAMPLES

3. The following table shows how the width of a sunk key varies with the diameter of a shaft.

Diameter of shaft	1 in.	2 in.	3 in.	4 in.
Width of key	$\frac{3}{8}$ in.	$\frac{5}{8}$ in.	$\frac{7}{8}$ in.	$1\frac{1}{8}$ in.

Prove the law is \sim width of key = $\frac{\text{Diameter of shaft}}{4} + \frac{1}{8}$ in.

4. The table below gives comparative numbers of English and French counts. You are required to plot the curve and find the law for transforming French to English.

English	5	10	20	30	40	60
French	4.23	8.47	16.94	25.41	33.88	50.82

Ans. English = French \times 1.18.

5. The following are the weights in grains of 1 lea of yarn and the counts.

Weight in grains of 1 lea	$6\frac{1}{4}$	8	10	25	50
Counts of yarn	160	125	100	40	20

Plot the graph and find the weight of 80s counts.

6. The following are relative weights of equal volume of water and cotton seed oil.

Water	1	5	9	12
Cotton seed oil	.925	4.625	8.325	11.1

Plot the graph and find the law.

CHAPTER V

LOGARITHMS

Indices.

THE index or power of any expression (say, x) is indicated as follows—

x^2 which means $1 \times x \times x$ (i.e. twice).

x^5 „ „ $1 \times x \times x \times x \times x$ (i.e. 5 times)

x^n „ „ $1 \times x$, n times.

x^0 „ „ $1 \times x$, 0 times = 1.

\sqrt{x} = square root of x or the number which raised to the power 2 would equal x .

This can also be expressed as a fractional index as follows—

$$\sqrt{x} = x^{\frac{1}{2}}$$

$$\sqrt[3]{x} = x^{\frac{1}{3}}$$

$$\sqrt[n]{x} = x^{\frac{1}{n}}, \text{ and so on.}$$

The reciprocal of a number is unity (1) divided by that number.

The reciprocal of 10 = $\frac{1}{10}$ or 0.1 or 10^{-1}

„ „ „ $x = \frac{1}{x}$ or x^{-1}

Now $10^3 = 1 \times 10 \times 10 \times 10 = 1000$

$10^2 = 1 \times 10 \times 10 = 100$

$10^1 = 1 \times 10 = 10$

$10^0 = 1 \times (10 \text{ no times}) = 1$

$10^{-1} = \frac{1}{10} = .1$

$10^{-2} = \frac{1}{100} = .01 = \frac{1}{10^2}$

$10^{-3} = \frac{1}{1000} = .001 = \frac{1}{10^3}$

The base 10 is the one used in common logarithms, which are those generally used, so that the logarithms of numbers will be as follows—

Number		Logarithm	
Between 10,000	and 1,000	Between 4 and 3	such as 3.7642
„ 1,000	„ 100	„ 3	„ 2 „ 2.2895
„ 100	„ 10	„ 2	„ 1 „ 1.3276
„ 10	„ 1	„ 1	„ 0 „ .4784
„ 1	„ .1	„ 0	„ -1 „ -1.9628
„ .1	„ .01	„ -1	„ -2 „ -2.7346
„ .01	„ .001	„ -2	„ -3 „ -3.2291
„ .001	„ .0001	„ -3	„ -4 „ -4.5725

A common logarithm, therefore, is in *two parts*, a whole number and a decimal.

The whole number is called the *characteristic*. The decimal part is called the *mantissa*.

The *characteristic* is always *one less than the number of digits* in the number, *when the number is greater than unity*, and is also *positive*.

The *characteristic* is always *one more than the number of ciphers or noughts* after the decimal point *when the number is less than unity*, and is also *negative*.

The *mantissa* is found from the table of logarithms and is always *positive*.

To indicate the negative sign of the characteristic, it is written over, not in front, of the figure.

Seeing that logarithms are actually algebraical indices they follow the same rules, so that in working calculations adopt the following methods—

To Multiply. Add the logarithms of the numbers together and extract the antilogarithm.

To Divide. Subtract the logarithm of the divisor from the log of the dividend and extract the antilogarithm.

To Find the Power of a Number. Multiply the logarithm of the number by the *index* and extract the antilogarithm.

To Find the Root of a Number. Divide the logarithm of the number by the *root* and extract the antilogarithm.

In order to avoid the danger of using the wrong table

LOGARITHMS

	0	1	2	3	4	5	6	7	8	9	1	2	3	4	5	6	7	8	9		
10	0000	0043	0086	0128	0170	0212	0253	0294	0334	0374	4 9 13 17	21	26	30	34	38					
											4 8 12 16	20	24	28	32	37					
11	0414	0453	0492	0531	0569	0607	0645	0682	0719	0755	4 8 12 15	19	23	27	31	35					
											4 7 11 15	19	22	26	30	33					
12	0792	0828	0864	0899	0934	0969	1004	1038	1072	1106	3 7 11 14	18	21	25	28	32					
											3 7 10 14	17	20	24	27	31					
13	1139	1173	1206	1239	1271	1303	1335	1367	1399	1430	3 7 10 13	16	20	23	26	30					
											3 7 10 12	16	19	22	25	29					
14	1461	1492	1523	1553	1584	1614	1644	1673	1703	1732	3 6 9 12	15	18	21	24	28					
											3 6 9 12	15	17	20	23	26					
15	1761	1790	1818	1847	1875	1903	1931	1959	1987	2014	3 6 9 11	14	17	20	23	26					
											3 5 8 11	14	16	19	22	25					
16	2041	2068	2095	2122	2148	2175	2201	2227	2253	2279	3 5 8 11	14	16	19	22	24					
											3 5 8 10	13	15	18	21	23					
17	2304	2330	2355	2380	2405	2430	2455	2480	2504	2529	3 5 8 10	13	15	18	20	23					
											2 5 7 10	12	15	17	19	22					
18	2553	2577	2601	2625	2648	2672	2695	2718	2742	2765	2 5 7 9	12	14	16	19	21					
											2 5 7 9	11	14	16	18	21					
19	2788	2810	2833	2856	2878	2900	2923	2945	2967	2989	2 4 7 9	11	13	16	18	20					
											2 4 6 8	11	13	15	17	19					
20	3010	3032	3054	3075	3096	3118	3139	3160	3181	3201	2 4 6 8	11	13	15	17	19					
21	3222	3243	3263	3284	3304	3324	3345	3365	3385	3404	2 4 6 8	10	12	14	16	18					
22	3424	3444	3464	3483	3502	3522	3541	3560	3579	3598	2 4 6 8	10	12	14	15	17					
23	3617	3636	3655	3674	3692	3711	3729	3747	3766	3784	2 4 6 7	9	11	13	15	17					
24	3802	3820	3838	3856	3874	3892	3909	3927	3945	3962	2 4 5 7	9	11	12	14	16					
25	3979	3997	4014	4031	4048	4065	4082	4099	4116	4133	2 3 5 7	9	10	12	14	15					
26	4150	4166	4183	4200	4216	4232	4249	4265	4281	4298	2 3 5 7	8	10	11	13	15					
27	4314	4330	4346	4362	4378	4393	4409	4425	4440	4456	2 3 5 6	8	9	11	13	14					
28	4472	4487	4502	4518	4533	4548	4564	4579	4594	4609	2 3 5 6	8	9	11	12	14					
29	4624	4639	4654	4669	4683	4698	4713	4728	4742	4757	1 3 4 6	7	9	10	12	13					
30	4771	4786	4800	4814	4829	4843	4857	4871	4886	4900	1 3 4 6	7	9	10	11	13					
31	4914	4928	4942	4955	4969	4983	4997	5011	5024	5038	1 3 4 6	7	8	10	11	12					
32	5051	5065	5079	5092	5105	5119	5132	5145	5159	5172	1 3 4 5	7	8	9	11	12					
33	5185	5198	5211	5224	5237	5250	5263	5276	5289	5302	1 3 4 5	6	8	9	10	12					
34	5315	5328	5340	5353	5366	5378	5391	5403	5416	5428	1 3 4 5	6	8	9	10	11					
35	5441	5453	5465	5478	5490	5502	5514	5527	5539	5551	1 2 4 5	6	7	9	10	11					
36	5563	5575	5587	5599	5611	5623	5635	5647	5658	5670	1 2 4 5	6	7	8	10	11					
37	5682	5694	5705	5717	5729	5740	5752	5763	5775	5786	1 2 3 5	6	7	8	9	10					
38	5798	5809	5821	5832	5843	5855	5866	5877	5888	5899	1 2 3 5	6	7	8	9	10					
39	5911	5922	5933	5944	5955	5966	5977	5988	5999	6010	1 2 3 4	5	7	8	9	10					

The copyright of that portion of the above table which gives the logarithms of numbers from 1000 to 2000 is the property of Messrs. Macmillan and Company, Limited, who, however, have authorized the use of the form in any reprint published for educational purposes.

LOGARITHMS

	0	1	2	3	4	5	6	7	8	9	1	2	3	4	5	6	7	8	9
40	6021	6031	6042	6053	6064	6075	6085	6096	6107	6117	1	2	3	4	5	6	8	9	10
41	6128	6138	6149	6160	6170	6180	6191	6201	6212	6222	1	2	3	4	5	6	7	8	9
42	6232	6243	6253	6263	6274	6284	6294	6304	6314	6324	1	2	3	4	5	6	7	8	9
43	6335	6345	6355	6365	6375	6385	6395	6405	6415	6425	1	2	3	4	5	6	7	8	9
44	6435	6444	6454	6464	6474	6484	6493	6503	6513	6522	1	2	3	4	5	6	7	8	9
45	6532	6542	6551	6561	6571	6580	6590	6599	6609	6618	1	2	3	4	5	6	7	8	9
46	6628	6637	6646	6656	6665	6675	6684	6693	6702	6712	1	2	3	4	5	6	7	7	8
47	6721	6730	6739	6749	6758	6767	6776	6785	6794	6803	1	2	3	4	5	5	6	7	8
48	6812	6821	6830	6839	6848	6857	6866	6875	6884	6893	1	2	3	4	4	5	6	7	8
49	6902	6911	6920	6928	6937	6946	6955	6964	6972	6981	1	2	3	4	4	5	6	7	8
50	6990	6998	7007	7016	7024	7033	7042	7050	7059	7067	1	2	3	3	4	5	6	7	8
51	7076	7084	7093	7101	7110	7118	7126	7135	7143	7152	1	2	3	3	4	5	6	7	8
52	7160	7168	7177	7185	7193	7202	7210	7218	7226	7235	1	2	2	3	4	5	6	7	7
53	7243	7251	7259	7267	7275	7284	7292	7300	7308	7316	1	2	2	3	4	5	6	6	7
54	7324	7332	7340	7348	7356	7364	7372	7380	7388	7396	1	2	2	3	4	5	6	6	7
55	7404	7412	7419	7427	7435	7443	7451	7459	7466	7474	1	2	2	3	4	5	5	6	7
56	7482	7490	7497	7505	7513	7520	7528	7536	7543	7551	1	2	2	3	4	5	5	6	7
57	7559	7566	7574	7582	7589	7597	7604	7612	7619	7627	1	2	2	3	4	5	5	6	7
58	7634	7642	7649	7657	7664	7672	7679	7686	7694	7701	1	1	2	3	4	4	5	6	7
59	7709	7716	7723	7731	7738	7745	7752	7760	7767	7774	1	1	2	3	4	4	5	6	7
60	7782	7789	7796	7803	7810	7818	7825	7832	7839	7846	1	1	2	3	4	4	5	6	6
61	7853	7860	7868	7875	7882	7889	7896	7903	7910	7917	1	1	2	3	4	4	5	6	6
62	7924	7931	7938	7945	7952	7959	7966	7973	7980	7987	1	1	2	3	3	4	5	6	6
63	7993	8000	8007	8014	8021	8028	8035	8041	8048	8055	1	1	2	3	3	4	5	6	6
64	8062	8069	8075	8082	8089	8096	8102	8109	8116	8122	1	1	2	3	3	4	5	5	6
65	8129	8136	8142	8149	8156	8162	8169	8176	8182	8189	1	1	2	3	3	4	5	5	6
66	8195	8202	8209	8215	8222	8228	8235	8241	8248	8254	1	1	2	3	3	4	5	5	6
67	8261	8267	8274	8280	8287	8293	8299	8306	8312	8319	1	1	2	3	3	4	5	5	6
68	8325	8331	8338	8344	8351	8357	8363	8370	8376	8382	1	1	2	3	3	4	4	5	6
69	8388	8395	8401	8407	8414	8420	8426	8432	8439	8445	1	1	2	2	3	4	4	5	6
70	8451	8457	8463	8470	8476	8482	8488	8494	8500	8506	1	1	2	2	3	4	4	5	6
71	8513	8519	8525	8531	8537	8543	8549	8555	8561	8567	1	1	2	2	3	4	4	5	5
72	8573	8579	8585	8591	8597	8603	8609	8615	8621	8627	1	1	2	2	3	4	4	5	5
73	8633	8639	8645	8651	8657	8663	8669	8675	8681	8686	1	1	2	2	3	4	4	5	5
74	8692	8698	8704	8710	8716	8722	8727	8733	8739	8745	1	1	2	2	3	4	4	5	5
75	8751	8756	8762	8768	8774	8779	8785	8791	8797	8802	1	1	2	2	3	3	4	4	5
76	8808	8814	8820	8825	8831	8837	8842	8848	8854	8859	1	1	2	2	3	3	4	4	5
77	8865	8871	8876	8882	8887	8893	8899	8904	8910	8915	1	1	2	2	3	3	4	4	5
78	8921	8927	8932	8938	8943	8949	8954	8960	8965	8971	1	1	2	2	3	3	4	4	5
79	8976	8982	8987	8993	8998	9004	9009	9015	9020	9025	1	1	2	2	3	3	4	4	5
80	9031	9036	9042	9047	9053	9058	9063	9069	9074	9079	1	1	2	2	3	3	4	4	5
81	9085	9090	9096	9101	9106	9112	9117	9122	9128	9133	1	1	2	2	3	3	4	4	5
82	9138	9143	9149	9154	9159	9165	9170	9175	9180	9186	1	1	2	2	3	3	4	4	5
83	9191	9196	9201	9206	9212	9217	9222	9227	9232	9238	1	1	2	2	3	3	4	4	5
84	9243	9248	9253	9258	9263	9269	9274	9279	9284	9289	1	1	2	2	3	3	4	4	5

LOGARITHMS

	0	1	2	3	4	5	6	7	8	9	1	2	3	4	5	6	7	8	9
85	9294	9299	9304	9309	9315	9320	9325	9330	9335	9340	1	1	2	2	3	3	4	4	5
86	9345	9350	9355	9360	9365	9370	9375	7380	9385	9390	1	1	2	2	3	3	4	4	5
87	9395	9400	9405	9410	9415	9420	9425	9430	9435	9440	0	1	1	2	2	3	3	4	4
88	9445	9450	9455	9460	9465	9469	9474	9479	9484	9489	0	1	1	2	2	3	3	4	4
89	9494	9499	9504	9509	9513	9518	9523	9528	9533	9538	0	1	1	2	2	3	3	4	4
90	9542	9547	9552	9557	9562	9566	9571	9576	9581	9586	0	1	1	2	2	3	3	4	4
91	9590	9595	9600	9605	9609	9614	9619	9624	9628	9633	0	1	1	2	2	3	3	4	4
92	9638	8643	9647	9652	9657	9661	9666	9671	9675	9680	0	1	1	2	2	3	3	4	4
93	9685	8689	9694	9699	9703	9708	9713	9717	9722	9727	0	1	1	2	2	3	3	4	4
94	9731	9736	9741	9745	9750	9754	9759	9763	9768	9773	0	1	1	2	2	3	3	4	4
95	9777	9782	9786	9791	9795	9800	9805	9809	9814	9818	0	1	1	2	2	3	3	4	4
96	9823	9827	9832	9836	9841	9845	9850	9854	9859	9863	0	1	1	2	2	3	3	4	4
97	9868	9872	9877	9881	9886	9890	9894	9899	9903	9908	0	1	1	2	2	3	3	4	4
98	9912	9917	9921	9926	9930	9934	9939	9943	9948	9952	0	1	1	2	2	3	3	4	4
99	9956	9961	9965	9969	9974	9978	9983	9987	9991	9996	0	1	1	2	2	3	3	3	4

students are advised to use only the logarithm table, and for that reason only the logarithm table is put in this work.

To find the antilogarithm, work in the logarithm table the reverse way, i.e. find the mantissa in the table and extract the arithmetical value.

EXAMPLES

1 Multiply 17.23 by 16.02.

$$\text{Log. of } 17.23 = 1.2363 \quad (17 \text{ is between } 10 \text{ and } 100)$$

$$\text{Log. of } 16.02 = 1.2046$$

$$\text{Add} \quad \quad \quad 2.4409$$

$$\text{Antilog. } 2.4409 = 276 \quad (\text{Characteristic } 2 \text{ is between } 100 \text{ and } 1000)$$

$$\text{Ans} = 276$$

To find the log. of 17.23.

Look in log. table opposite 17 and under 2 then add the log. under 3 in the final columns, i.e.

$$2355 + 8 = 2363$$

2. Divide .2743 by .0658.

$$\text{Log. of } .2743 = \bar{1}.4383$$

$$\text{Log. of } .0658 = \bar{2}.8182$$

$$\text{Subtract} \quad \quad \quad .6201$$

$$\text{Antilog. of } .6201 = 417 \quad (\text{between } 1 \text{ and } 10)$$

$$\text{Ans.} = 4.17$$

3. Find $(14.59)^3$.

$$\text{Log. of } 14.59 = 1.1640$$

$$\text{Multiply by index } 3$$

$$3.4920$$

$$\text{Antilog. } 3.4920 = 3104 \quad (\text{between } 1000 \text{ and } 10,000)$$

$$\text{Ans.} = \underline{\underline{3104}}$$

4. Find $\sqrt{29.46}$.

$$\text{Log. of } 29.46 = 1.4692$$

$$\text{Divide by root } 2 \quad \underline{2 \mid 1.4692}$$

$$.7346$$

$$\text{Antilog. } .7346 = 5427 \quad (\text{between } 1 \text{ and } 10)$$

$$\text{Ans.} = \underline{\underline{5.427}}$$

USEFUL INFORMATION

Electricity.

A *watt* is the practical unit of electrical power.

Watts = ampères \times volts.

1000 watts = 1 kilowatt.

Electrical horse-power = $\frac{\text{volts} \times \text{ampères}}{746}$

Unit of electricity = 1 kilowatt hour.

Cotton Spinning Machinery Horse-powers.

1 Double opener	10 h.p.
1 Single scutcher	5 "
1 Card75 "
12 Deliveries drawframe	1 "
40 Slubber spindles	1 "
80 Intermediate spindles	1 "
100 Roving and jack spindles.	1 "
120 Twist mule spindles, 9500 r.p.m.	1 "
150 Weft mule spindles, 9500 r.p.m.	1 "

Temperatures at atmospheric pressure—

	Freezing Point	Boiling Point
Fahrenheit	32°	212°
Centigrade	0°	100°
Reamur	0°	80°

To change Centigrade to Fahrenheit multiply by 1.8 and add 32.

To change Fahrenheit to Centigrade subtract 32 and then divide by 1.8.

Weights of Materials.

	<i>lb.</i>		<i>lb.</i>
1 cub. ft. Lead . . .	710	1 cub in. . .	.41
„ Copper . . .	550	„32
„ Brass . . .	520	„3
„ Steel . . .	490	„283
„ Wrought iron . . .	480	„28
„ Cast iron . . .	450	„26
„ Aluminium . . .	160	„09
„ Concrete . . .	126		
„ Brick work . . .	112		
„ Coal . . .	80		
„ Water . . .	62.5		
„ American Cotton . . .	28	500 lb. bale.	
„ Egyptian cotton . . .	38	750 lb. bale.	

General Information.

- 1 fathom . . . = 6 ft.
- 1 mile . . . = 1760 yd. = 5280 ft.
- 1 knot . . . = 6080 ft. per hr. = 1.15 miles per hr.
- 60 miles per hr. . . = 88 ft. per sec.
- 1 ton . . . = 2240 lb.
- 1 gal. of fresh water = 10 lb.
- 1 in. deep of rain = 5.2 lb. per sq. ft. = 100 tons per acre.
- 1 cub. ft. salt water = 64 lb.
- The unit of work = 1 lb. weight raised 1 ft. high.

The British unit of heat is the heat necessary to raise the temperature of 1 lb. of water through a difference of 1° Fahrenheit.

Atmospheric pressure is 14.7 lb. per sq. in.

PART III

TEXTILE DRAWING

Introduction to Machine Drawing.

MANY students are of the opinion that the subject "Machine Drawing" is unnecessary in the "Textile Technology" courses, but as the subject is taught to enable textile students intelligently to interpret drawings and diagrams of textile machinery, and not solely that he may become proficient in the art of draughtsmanship, it will be seen that the subject can be really useful to him.

The student should provide himself with a drawing board, tee square, a 45° and a 60° set square (celluloid preferred). A set of instruments, comprising pencil compasses, ink compasses, drawing pen, and dividers. For mechanical drawing a pencil marked HH, and for freehand drawing a pencil marked HB. The HH pencil should be sharpened with a chisel point, and the HB pencil with a round point. A good rule and a set of scales are also required, but the scales may be made by the student by following the instructions in this book.

In making a working drawing, it is not only necessary to draw it to scale, but it should also be fully dimensioned. A *poor* drawing *well dimensioned* is better to work to than a *good* drawing *badly dimensioned*. Keep your dimensions away from the drawing as much as possible to enable you to show them as clearly as possible.

Principles of Projection.

As a drawing is used to convey the ideas to the workman engaged in making the machine or detail, it is necessary to show all the necessary detail.

There are two types of drawings.

1. Isometric drawings.
2. Drawings with plan and elevations.

An isometric drawing is one which shows all that can be seen from a given point. One view only is required.

Drawings with plan and elevations shows the detail of machine from every side, and each plan or elevation is viewed at right-angles to the face which you are drawing. In making a drawing of this description it is necessary to make at least two views of the object which you are drawing.

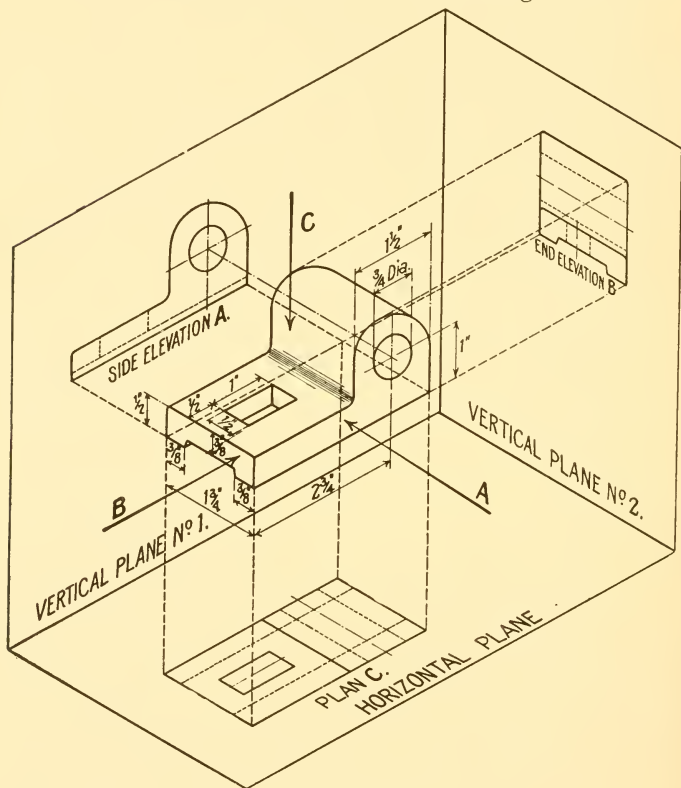

FIG. 85

Fig. 85 shows an object in *isometric view* or *perspective* being projected to its different elevations. It will be seen that the object is always between the eye and the drawing. Side elevation A, is viewed in direction of arrow A, end elevation B is

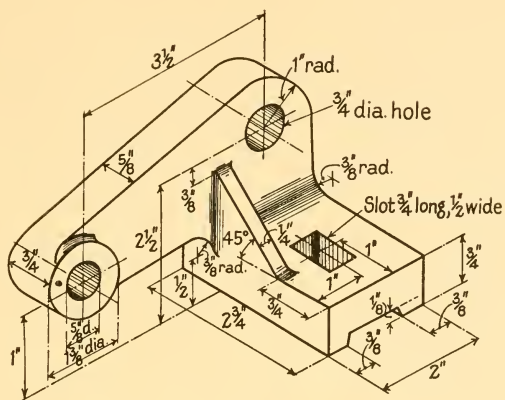

FIG. 86

Draw three views of this bracket.

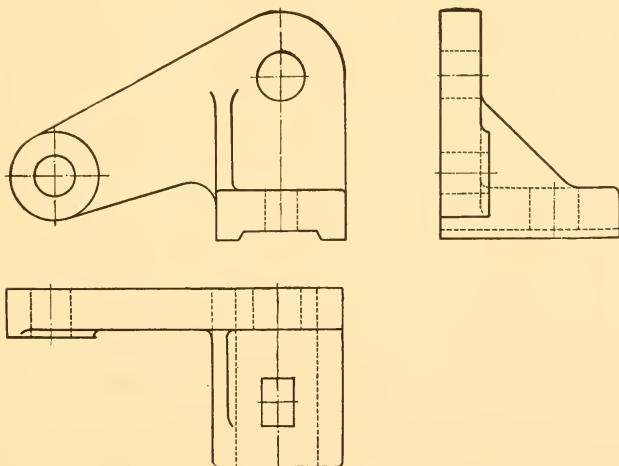

FIG. 87

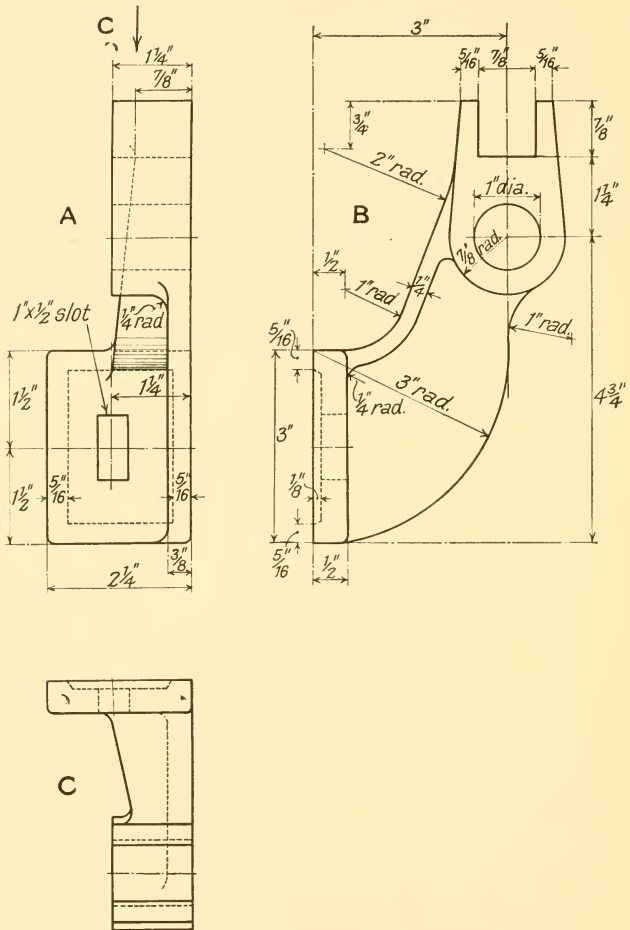

FIG. 88

Given views *A* and *B*, draw view *C*, looking in direction of arrow *C*.

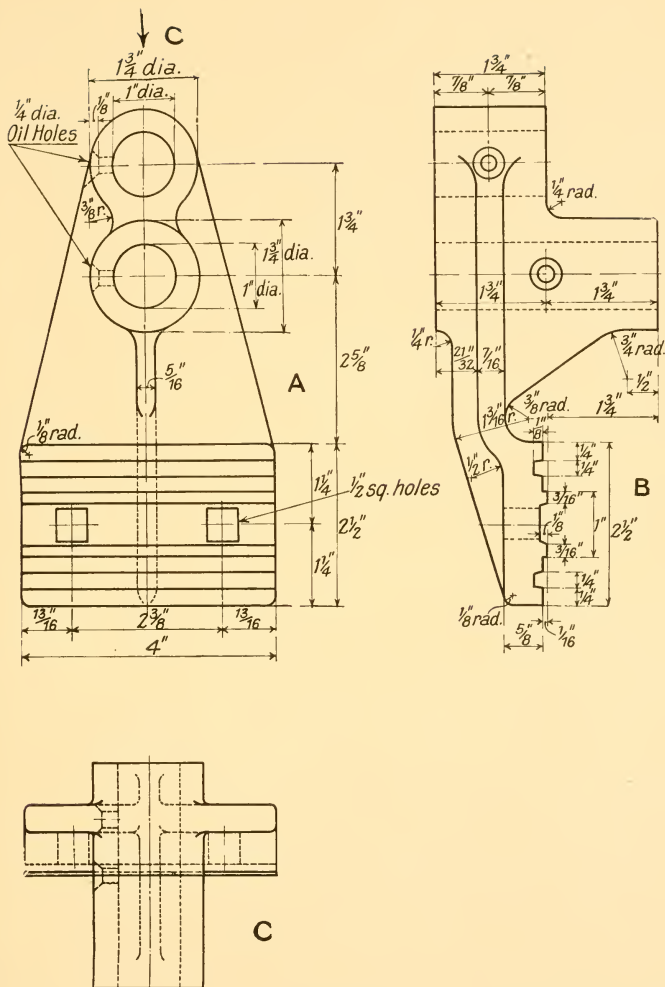

FIG. 89

Given views A and B, draw view C, looking in direction of arrow C.

viewed in direction of arrow *B*, and plan *C* in direction of arrow *C*. All lines that can be seen from the outside are shown in full and lines that cannot be seen, such as the bore in end elevation *B*, are shown in dotted.

The student should make the *dots* as even as possible, say, about $\frac{1}{8}$ in. long, with about $\frac{1}{3\frac{1}{2}}$ in. between each dot. All centre lines and dimension lines should be *thin chain lines*, i.e. a line about 2 in. long, a space about $\frac{1}{16}$ in., a dot, a space $\frac{1}{16}$ in., and another line 2 in. long, to be repeated to full length of line. Dimension lines to be terminated at each end by a clear arrow head. All dimensions should be shown very clearly.

When a detail is complicated, too many dotted lines are apt to confuse the workman. In cases like this an extra view is

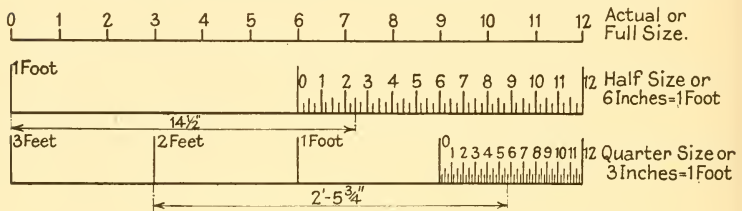

FIG. 90. SCALES

added, called a *sectional elevation*, which is a view showing the object cut through at a definite point, and drawn viewed at right-angles to the face that has been cut.

In the examples Figs. 87, 88, 89, no instructions are given, but the student will be able to follow how the drawing has been built up. Some of these examples are the Examination Papers set by the Union of Lancashire and Cheshire Institutes.

Scales.

The use of scales is necessary when a drawing has to be made of some object that is too big to be drawn full size on the drawing paper.

To prepare a scale the following method is adopted. Scale required *half size*.

Six inches actual size will represent 1 ft. on the scale. Divide this 6 in. into twelve equal parts, each of these representing 1 in. If each one of these latter parts are again divided

into eight equal parts, each would represent $\frac{1}{8}$ in., from which we may get $\frac{1}{8}$ in., $\frac{1}{4}$ in., or $\frac{1}{2}$ in.

One portion only representing 1 ft. need be divided up as stated above, as will be seen in the following illustration.

By a little care and thought on the part of the student any scale can be made by following the principles outlined above.

First choose the scale required, then divide the first foot into twelve equal parts to represent inches, then the inches into

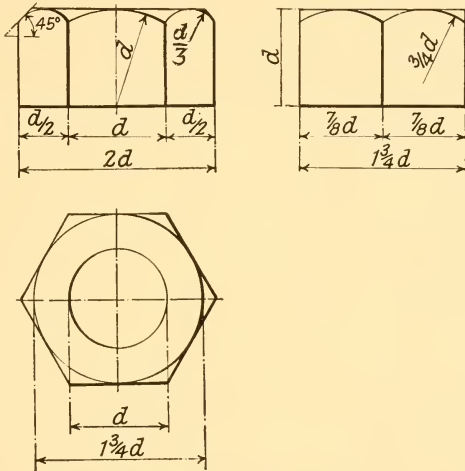

FIG. 91. STANDARD WHITWORTH NUT

eight parts to represent $\frac{1}{8}$ in. The reading of a scale is illustrated on the half-size scale, $14\frac{1}{2}$ in. being measured off. A better illustration, however, is shown on the quarter-size scale. To measure off 2 to $5\frac{3}{4}$ in., take 2 ft. from the zero line to the left side and $5\frac{3}{4}$ in. from zero line to the right side.

Nuts and Bolts.

The approximately correct formula for proportions of Whitworth nuts is

$$\text{Distance across flats} = 1\frac{1}{2} \times \text{dia. of screw} + \frac{1}{8} \text{ in.}$$

For drawing purposes, however,

where d = diameter of screw

Df = distance across flats

Dc = distance across corners

then $Df = 1\frac{3}{4}d$.

$Dc = 2d$.

The full proportions are given in Fig. 92. It would be advantageous to the student to draw three views of nuts of

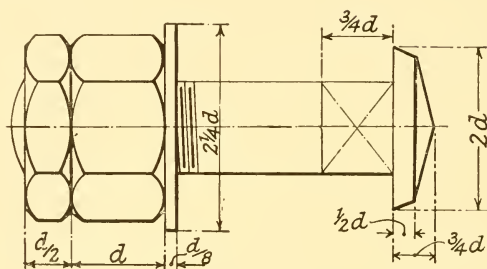

FIG. 92. BOLT, NUT, AND LOCK NUT

various sizes. The approximate proportions of a standard lock nut are also given.

Screws and Screw Threads.

A screw thread is set out in the form of a *helix*, that is to say, if the screw was set vertical and a small spigot placed in the recess of the screw thread, it would, upon revolving the screw at a constant speed, rise or fall at a constant velocity. The pitch of a screw is the distance from the centre line of one screw thread to the centre line of the adjacent screw thread. When speaking of pitches of screw thread, these are generally expressed in terms of number of threads per inch. The commonest form of screw thread is the "Whitworth" thread, introduced by Sir Joseph Whitworth. The angle of this thread is 55° , rounded top and bottom to one-sixth of the depth. (Fig. 93).

The only other thread used on textile machinery, and this very rarely, is the square thread. (Fig. 94).

Diameter of Screw	No. of Threads per Inch	Diameter of Screw	No. of Threads per Inch
inches		inches	
$\frac{3}{16}$	24	$\frac{7}{8}$	9
$\frac{1}{4}$	20	1	8
$\frac{5}{16}$	18	$1\frac{1}{8}$	7
$\frac{3}{8}$	16	$1\frac{1}{4}$	7
$\frac{7}{16}$	14	$1\frac{3}{8}$	6
$\frac{1}{2}$	12	$1\frac{1}{2}$	6
$\frac{5}{8}$	11	$1\frac{5}{8}$	5
$\frac{3}{4}$	10	$1\frac{3}{4}$	5

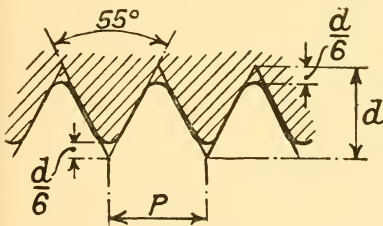

FIG. 93

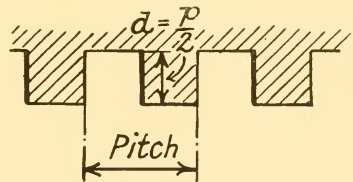

FIG. 94

Fastening Pulleys, etc., to Shafts.

There are different methods of fastening pulleys to shafts, but the two most common methods are: (1) by means of keys, (2) by means of set screws.

Keys. There are different types of keys, and those commonly used on textile machinery are described below.

(a) *Saddle Key.* For light work only. Keyway cut in boss of pulley, and one face of key hollowed out to fit shaft. The opposite face of key has a taper of about $\frac{1}{8}$ in. per foot or 1 in 96. This key is fitted with a *gib head* at the thick end of key to make it easily removable.

(b) *Flat Key.* The commonest type of key used on textile machinery. A flat is filed on the shaft the same width as the key. The top side of the key is tapered as in the case of the

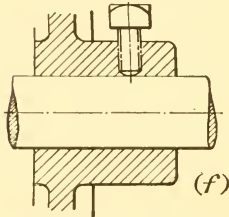
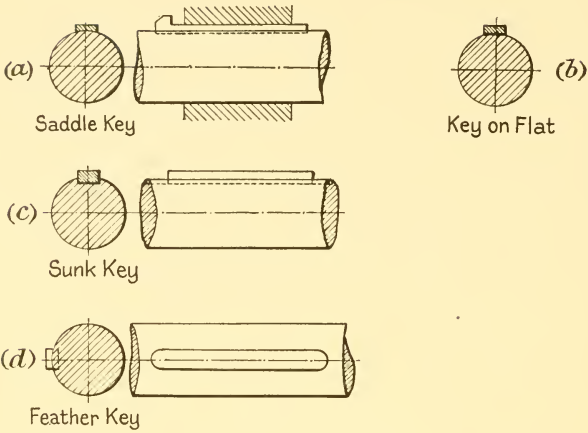

Boss of Pulley Secured by Set Screw.

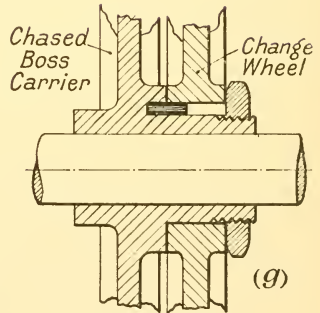

Method of Carrying Change Wheels.

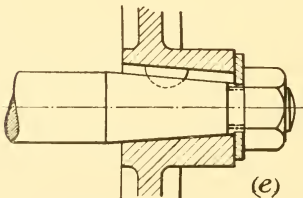

Application of "Woodruff" Key.

FIG 95. FASTENING PULLEYS TO SHAFTS

saddle key, and the sides are a "push" fit in the keyway. The key is either driven in the boss of the pulley or the pulley driven on the key, according to its position on the machine.

(c) *Sunk Key*. Used for heavy work. A keyway is cut in both shaft and boss of pulley, but the keyway in the boss is deeper at the sides than it is in the shaft.

This may be rather misleading to the student, but by referring to Fig. 95c, it will be seen that half the key is in the shaft and half in the boss on the vertical centre line only, and as the periphery of the shaft recedes from the horizontal centre line, the depth of the keyway at the sides is much less in the shaft than in the boss.

A formula easily remembered by the student for the proportions of sunk keys is given below, but although often used, these proportions are not universally adopted by engineers.

Let D = diameter of shaft.

$$\text{then width of key} = W = \frac{D}{4} + \frac{1}{8} \text{ in.}$$

$$\text{thickness of key at thick end} = T = \frac{5}{8} W.$$

(d) *Feather Key*. Used for sliding dogs of clutches etc. The shaft is key-seated by a vertical cutter. Key is fitted in shaft, and keyway in boss made an easy fit on key, to allow boss to slide freely on shaft. The feather key has no taper, and is sometimes secured in keyway of shaft by countersunk-headed set screws.

(e) *Woodruff Key*. This key, used when a taper end is turned on shaft to ensure concentricity, is an easy fit in the keyway of the boss, and the wheel or pulley is held endways by means of a nut screwed on to the end of the shaft forcing the wheel on to the taper.

A taper spigot and bore is an ideal way of ensuring concentricity of a wheel or pulley on a shaft. Due to the clearance necessary between the outside diameter of a shaft and the bore in a boss, there is always the risk of "tilting" when keying with a taper key, thereby tending to make the boss run eccentric with the shaft, and due to this, it is always policy for correct alignment of two shafts coupled together by flanged

couplings, to machine the spigot and recess of the couplings after they have been fitted to the shafts.

Illustrations are also shown (*f*) of the method of fastening a pulley to a shaft by means of a set screw, and (*g*) method of carrying change wheels on a chased boss carrier.

Rivets and Riveted Joints.

The introduction of the steel carriage for the mule, and recent Factory Act orders making guards for all gears compulsory, will make the subject of riveted and welded joints more interesting to textile students than has hitherto been the case. Although in these cases the strength of rivets is of no



FIG. 96. TYPES OF RIVETS BEFORE BEING DRIVEN IN



FIG. 97. TYPES OF RIVETS AFTER BEING DRIVEN IN

great importance, figures giving these strengths are tabulated below.

The diameter of rivet heads is approximately $1\frac{3}{4}$ times the diameter of the rivet.

It would be interesting to the student at this point to study the riveting of the blades to the cylinder plates on the opener in the spinning laboratory.

As will be seen from Fig. 96, the rivets are first made with a head, these are heated to a white heat in the case of iron rivets, and a bright cherry red in the case of steel rivets. After being placed in position on the joint to be made, the other head is formed either by hand or machine.

We now come to the size and pitch of rivets for varying thicknesses of plate.

PROPORTIONS OF RIVETED LAP JOINTS

Thickness of Plate in Inches	Diameter of Rivet in Inches	Diameter of Hole in Plate in Inches	Single Riveted in Inches	Double Riveted in Inches
$\frac{1}{4}$	$\frac{5}{8}$	$\frac{11}{16}$	2	3
$\frac{5}{16}$	$\frac{11}{16}$	$\frac{3}{4}$	$2\frac{1}{16}$	$3\frac{1}{8}$
$\frac{3}{8}$	$\frac{3}{4}$	$\frac{13}{16}$	$2\frac{1}{8}$	$3\frac{1}{4}$
$\frac{7}{16}$	$\frac{13}{16}$	$\frac{7}{8}$	$2\frac{3}{16}$	$3\frac{3}{8}$
$\frac{1}{2}$	$\frac{7}{8}$	$\frac{15}{16}$	$2\frac{1}{4}$	$3\frac{1}{2}$

Professor Unwin gives the formula for diameter of rivets in relation to thickness of plate.

$$d = 1.2\sqrt{t}.$$

Where d = diameter of rivet and t = thickness of plate.

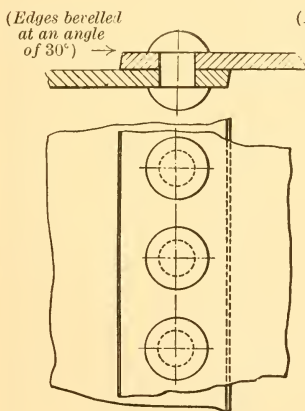

FIG. 98
SINGLE RIVETED LAP JOINT

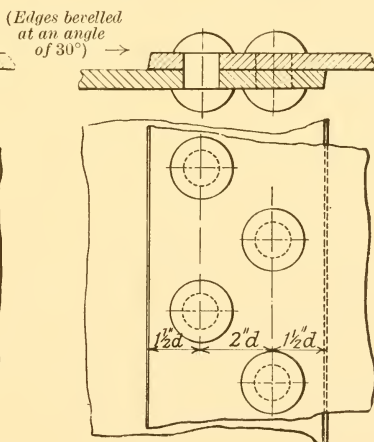
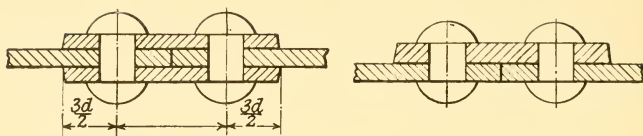

FIG. 99
DOUBLE RIVETED LAP JOINT

Couplings.

(1) "Muff" or Box Coupling. Used for small shafts, which should butt together. The coupling is plain cylindrical in shape and is keyed to shafts.



DOUBLE STRAP

SINGLE STRAP

FIG. 100. RIVETS AND RIVET JOINTS

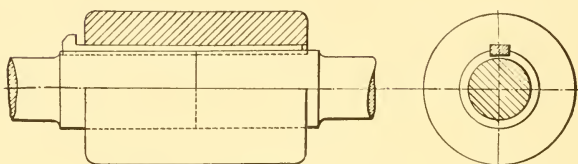

FIG. 101 BOX COUPLING

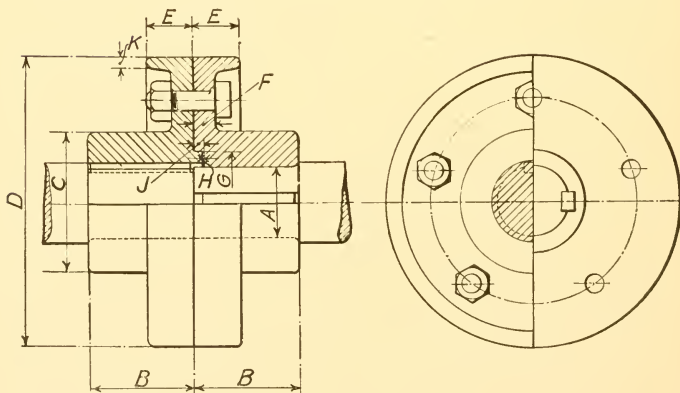

FIG. 102. FLANGED COUPLING

2. *Flanged Couplings.* The spigot on the one side and the recess on the other should be machined when the coupling halves are each fitted to its own shaft, as this ensures correct alignment.

PROPORTIONS OF FLANGED COUPLINGS

A	B	C	D	E	F	G	H	J	K	Bolts	
										No.	Dia.
in.	in.	in.	in.	in.	in.	in.	in.	in.	in.		in.
1	1 $\frac{3}{4}$	2 $\frac{1}{4}$	4	1 $\frac{1}{16}$	5 $\frac{5}{16}$	1 $\frac{1}{2}$	1 $\frac{1}{4}$	9 $\frac{9}{32}$	1 $\frac{1}{4}$	5	3 $\frac{3}{8}$
1 $\frac{1}{4}$	2 $\frac{3}{16}$	2 $\frac{3}{4}$	5	1 $\frac{3}{16}$	3 $\frac{3}{8}$	1 $\frac{7}{8}$	1 $\frac{1}{4}$	9 $\frac{9}{32}$	1 $\frac{1}{4}$	5	3 $\frac{7}{16}$
1 $\frac{1}{2}$	2 $\frac{5}{8}$	3 $\frac{3}{8}$	6	1 $\frac{5}{16}$	7 $\frac{7}{16}$	2 $\frac{1}{4}$	1 $\frac{1}{4}$	9 $\frac{9}{32}$	1 $\frac{1}{4}$	5	1 $\frac{1}{2}$
1 $\frac{3}{4}$	3 $\frac{1}{16}$	4	7	1 $\frac{1}{16}$	1 $\frac{1}{2}$	2 $\frac{5}{8}$	1 $\frac{1}{4}$	9 $\frac{9}{32}$	1 $\frac{1}{4}$	5	1 $\frac{5}{16}$
2	3 $\frac{1}{2}$	4 $\frac{1}{2}$	8	1 $\frac{3}{16}$	9 $\frac{9}{16}$	3	1 $\frac{1}{4}$	9 $\frac{9}{32}$	1 $\frac{5}{16}$	5	5 $\frac{5}{8}$
2 $\frac{1}{4}$	3 $\frac{1}{16}$	5 $\frac{1}{16}$	9	1 $\frac{5}{16}$	5 $\frac{5}{8}$	3 $\frac{3}{8}$	1 $\frac{1}{4}$	9 $\frac{9}{32}$	1 $\frac{5}{16}$	5	1 $\frac{1}{16}$
2 $\frac{1}{2}$	4 $\frac{3}{8}$	5 $\frac{5}{8}$	10	1 $\frac{7}{16}$	11 $\frac{11}{16}$	3 $\frac{3}{4}$	1 $\frac{1}{4}$	9 $\frac{9}{32}$	1 $\frac{5}{16}$	5	3 $\frac{3}{4}$
3	5 $\frac{1}{4}$	6 $\frac{3}{4}$	12	1 $\frac{11}{16}$	13 $\frac{13}{16}$	4 $\frac{1}{2}$	1 $\frac{1}{4}$	9 $\frac{9}{32}$	1 $\frac{3}{8}$	5	4 $\frac{7}{8}$

Materials Used in Textile Machinery Construction.

Cast Iron. Used for machine framings, roller beams, roller stands, bearing pedestals, levers, etc.

Wrought Iron. Used for nuts, bolts, washers.

Mild Steel. Used in place of wrought iron wherever possible.



Cast Iron



Wrought Iron



Steel



Brass



Wood



Lead

FIG. 103. SECTIONAL SHADING FOR VARIOUS MATERIALS

Mild Steel. Used for shafts, top and bottom rollers, spindles, flyers, and pressers, and generally where the material has to withstand a torsional stress.

Malleable Iron. (Castings which are placed in powdered red hæmatite, and kept at a bright red heat for varying periods of time according to size of casting.) Used for mule sickles, tin roller blocks, knee brakes for ringframe spindles.

Tin (Alloy). Used for mule and ringframe tin rollers,

perforated roving rods for mules, flyframes and ringframes, pneumatic conveyer pipes for blowing rooms, sliver plates, etc.

Brass. Used for roller footsteps, spindle footsteps and bolsters, bushes for bearings, etc.

Sheet Steel. Used for flyframe casing plates, carriages for mules, lap guards for ribbon and sliver lap machines, and machine guards, etc.

Leather. Used for mule frictions, brake blocks for lap building motions on openers, sliver and ribbon lap machines, belting, etc.

Wood is used for various parts of textile machinery, such as carriages for mules, creels for mules, flyer and ringframes, bobbins and skewers, lap rollers, etc.

Alloys. An alloy is produced by melting two or more metals together. Copper, tin, zinc, and lead are the principal metals used in the manufacture of alloys. The best known alloy is *brass*.

In making a sectional elevation through a detail, the various materials have a special sectioning of their own as detailed in Fig. 103.

TEST PAPERS

By courtesy of the Union of Lancashire and Cheshire Institutes, we are enabled to give the following papers in COTTON SPINNING, TEXTILE MATHEMATICS, and TEXTILE DRAWING, set for the FIRST YEAR COTTON SPINNING COURSE, during the years 1925, 1926, and 1927.

COTTON SPINNING

1925 (3 Hours)

GENERAL INSTRUCTIONS

Not more than *ten* questions may be answered.

Make sketches to illustrate your answers wherever possible.

A slide rule may be used.

All steps leading to the required result must be shown in immediate connection with the question.

The maximum number of marks obtainable is 70.

1. Draw up a table similar to that shown below, but with all particulars filled in—

Name of Cotton	Length of Staple	Colour	Feel	Maximum Counts	Other Properties
Egyptian (Sakellaridis)					
Egyptian (Uppers)					
American (Texas)					
Peruvian (Rough)					

2. Sketch and describe a hopper bale breaker and show how it may be connected to either a mixing lattice or pneumatic delivery system.

3. Sketch and describe a hopper feeder showing clearly how the feeding of the cotton is automatically regulated.

4. Make a gearing plan of a single scutcher and indicate the principal change places.

5. What are the functions of a taker-in on a carding engine? Make a sectional elevation showing the feed roller, feed plate, taker-in, mote knives, and underceasing, in their correct relative positions.

6. What are the objects of the flexible bend on a carding engine? Briefly describe, and with the aid of sketches, illustrate any such bend with which you are acquainted.

7. From the following particulars calculate the surface speed in feet per minute of—

(a) Taker-in 9 in. diameter.

(b) Cylinder, 50 in. diameter.

(c) Doffer, 24 in. diameter.

Lineshaft 150 revolutions per minute with pulley 21 in. diameter, driving pulley on cylinder shaft 18 in. diameter, cylinder end pulley 18 in. diameter driving 7 in. pulley on taker-in, 5 in. pulley on opposite end of taker-in driving a 12 in. pulley with which is compounded a 30's wheel gearing with 100's carrier; the latter carrier is compounded with a 40's wheel which drives the 192's doffer wheel.

8. What are the functions of a drawing frame? Describe any such frame with which you are familiar.

9. What are the objects sought in flyframes? Name the principal essential parts of one kind of flyframe.

10. Illustrate by clearly defined sketches how all three lines of rollers on a flyframe are driven, and indicate the position of the change wheel for regulating the draft.

11. If four leas of yarn weighs 4 pennyweights 2 grains, what are the counts?

12. Make a neat sketch showing how the spindle of a ring frame is carried by the spindle rail, and on the same sketch show the ring rail in relation to the spindle at the two extremities of the lift.

13. Why are the drawing rollers of a ring frame usually inclined at an angle? What is the most common angle?

14. Describe what takes place in a mule during one complete cycle of operation.

15. What are the functions of a roller traverse motion as applied to the mule? Sketch and describe any motion with which you are acquainted.

16. Why are the spindles in a mule carriage placed at an angle? What is this angle usually called, and what is the approximate amount for medium counts?

1926 (3 Hours)

Not more than *eight* questions may be answered.

1. Draw up a table similar to that shown below, but with the particulars filled in—

Name of Cotton	Length of Staple	Colour	Feel	Maximum Counts	Other Properties
Egyptian (Sakellaridis)					
American (Memphis) .					
Peruvian (Rough) .					
Sea Islands . . .					

2. What are the functions of the evener roller in a hopper bale breaker? Sketch and describe any type with which you are acquainted.

3. Sketch and describe a pneumatic mixing installation and state its advantages as compared with ordinary mixing lattices.

4. Name at least three different kinds of beating devices employed in openers and scutchers, and explain how each acts upon the cotton.

5. Sketch a sectional elevation of a carding engine, showing the lap, feed plate, feed roller, licker-in, cylinder, flats, doffer, and calender rollers, in their correct relative positions.

Also state the speed of all the above parts for any cotton with which you are acquainted.

6. How is the cotton taken from the doffer of a carding engine? Sketch and describe the mechanism, and give the approximate speeds of the moving parts.

7. Sketch the drawing rollers of a drawing frame showing the path of the sliver, and how it is guided to and from the rollers.

8. Make a neat sketch and describe the gearing of all three lines of drawing rollers of any flyframe with which you are familiar. You are to indicate clearly the change places.

9. On an intermediate frame the front roller is $1\frac{1}{4}$ in. diameter, and the back roller $1\frac{1}{3}$ in. diameter ; the front roller pinion has 20 teeth, the crown wheel 90 teeth, the change pinion 35, the back roller wheel 45 teeth. Find the draft.

10. By means of a sketch illustrate the driving of the spindles on both sides of a ring frame having two lines of tin rollers.

11. Sketch and describe the driving of mule drawing rollers and explain exactly what happens during a complete cycle of operations.

12. What are the functions of a roller traverse motion ? Describe any such motion with which you are acquainted.

1927 (3 Hours)

Not more than *eight* questions may be answered.

1. Describe what is meant by the following terms, stating how they affect the ultimate use of the cotton to which they refer—harsh or smooth ; coarse or fine ; regular or irregular staple ; long or short staple. [10]

2. Why is long and fine staple cotton like that grown in the Sea Islands, more suitable for high-class goods than the shorter staple cotton found in the Southern States of North America ? [8]

3. What are the objects sought by installing a cotton mixing plant ? Sketch the plan and elevation of a mixing room, showing the bale breaker in the centre of the room but at the extreme right-hand end with the feed near the said end-wall. There are to be six mixings, i.e. three on each side of the room. You may show either mixing lattices or the pneumatic delivery boxes. [8]

4. Sketch and describe how the dust and dirt are conveyed from either an opener or scutcher, and explain what you consider are the essential features of an efficient installation in this respect. [8]

5. Sketch and describe a combined exhaust opener installation where the hopper feeder and poreupine opener are in an upper room, and the cotton is conveyed in pipes, thence through a dust extractor and a vertical opener to a horizontal

exhaust opener. The pipes must be so arranged that the cotton may, if desired, be passed from the dust extractor to the exhaust opener without passing through the vertical opener. For what kind of cotton would you consider this installation suitable? [10]

6. What are the functions of the taker-in on a cotton card? Make a sectional view showing the above in conjunction with the mote knives and undercasing. What would be the speed of the taker-in for working cotton suitable for spinning either (a) 60's good Egyptian, or (b) 30's good American? [8]

7. Sketch and describe the coiler of a card. Why does the can revolve as well as the coiler "press" or delivery wheel? Why is the can not set exactly over the centre of the press wheel? [8]

8. What are the objects sought by the use of the draw frame? Why are stop-motions so very important on this machine? Sketch and describe any stop motion with which you are acquainted. [8]

9. From the following particulars make a sketch of the drawing roller gearing of a drawframe. Front roller wheel 20 teeth driving a "crown" or top carrier wheel of 110 teeth, with which is compounded a draft wheel of 65 teeth, driving a wheel of 100 teeth on the back roller. The back roller is fitted with a 48's wheel which drives through a carrier to a 16's wheel on second roller (or the third roller counting from the back); also the back roller has a 25's wheel which drives an 18's wheel on the third roller (or second from back). The diameters of the rollers are: front, $1\frac{3}{8}$ in.; second, $1\frac{1}{4}$ in.; third and fourth, $1\frac{3}{8}$ in. Find the draft between front and back. [8]

10. Sketch the spindle of a roving frame, showing how it is supported by the footstep and the collar respectively. Explain the objects of the collar, and show how the support given to the spindle differs where long and short collars are used respectively. [8]

11. What is the reason for placing the rollers of a ring spinning frame at an angle to the horizontal? Make a neat sketch of the rollers and stand in relation to the roller beam, and show the thread guides and spindle in the correct relative positions. [10]

12. Define carriage draft in a mule. How does the carriage derive its motion, both during the outward and inward run? [8]

TEXTILE MATHEMATICS

1925 (2½ Hours)

Not more than *eight* questions may be answered.

1. The resultant counts of two single yarns A and B doubled together may be obtained by dividing the product of the singles by their sum. Write this down in algebraical form, and find the counts of a two-fold yarn made up of one end of 30's and one of 60's.

2. From the following particulars calculate the cost of covering a card cylinder with wire—

Cylinder 50 in. diameter \times 42 in. wide ; wire fillet 2 in. wide, price of fillet tenpence per foot.

3. If a drawing frame consisting of six deliveries and six ends to each delivery is stopped 4 seconds when each back can is empty, and assuming that each back can contains sufficient sliver to run 120 minutes, what is the percentage time lost during a working day of 8½ hours ?

4. For practical purposes it is approximately correct to say that the diameter of a cotton yarn is reduced in inverse proportion to the square root of the counts. Find, therefore, by what percentage the diameter of a 36's yarn is less than that of 16's counts.

5. The following table gives the comparative numbers of French and English counts for cotton yarns. Plot a chart showing the relation between the two systems, and from this chart find the French counts equivalent to 120's English, and the English equivalent of 44's French—

English counts	10	26	46	84	96	110
French counts	8.47	22.02	38.96	71.15	81.31	101.64

6. Assuming a coiler can, measuring 36 in. long \times 9 in. diameter, to be closely packed with cotton sliver, and allowing for a core or hole of 2 in. diameter throughout the centre of the can, how many cubic feet of cotton does the can contain ?

7. If 80,000 lb. weight of cotton during its progress through

the mill, loses in waste 2,400 lb. in the blowing room, 1,800 lb. in the card room, and 1,400 lb. in the spinning room, calculate the percentage of waste made at each process.

8. The air in a cotton conveyor pipe 14 in. diameter is found to have a velocity of 50 ft. per second ; find the volume of air passing through per minute.

9. If the total draft between the back and front rollers of a roving frame is 6, and the draft between the middle and front rollers 4.5 times that of the draft between the back and middle rollers, what is the draft between each pair of rollers ?

10. By the use of logarithms, calculate the value of r from the following equation: $1716 = 4.2r^3$.

11. The centrifugal force of a ring frame traveller = $0.00034 WRN^2$ grains. When W = weight of traveller, say 1.5 grains, R = effective radius in feet to centre of traveller, which measures say 0.905 in., N = revolutions per minute of traveller, say 8,000.

From the above particulars find the centrifugal force of the traveller.

12. Plot the following quantities on squared paper and ascertain from the graph the probable twist constant required to produce the maximum strength of yarn.

Breaking strength of 20's yarn from Egyptian cotton .	8	12	17	20.6	22.2	21.5	19	17
Twist constant	1.5	2	3	4	5	6	7	8

1926 (2½ Hours)

Not more than *eight* questions may be answered.

1. The total draft between back and front rollers of a drawing frame is 5.94. If the draft between third and front rollers is 3.3 and the draft between second and third is $1\frac{1}{2}$ times greater than the draft between first and second, find the draft between each pair of rollers.

NOTE. The total draft is the *product* of the intermediate drafts.

2. The following results were obtained during an experiment to determine the relation between the resistance of

friction and the pressure which produces friction when the surfaces are in actual uniform motion—

Pressure in lb. between surfaces producing friction . . .	11.4	18.4	22.4	29.4	39.4	50.4	60.4	74.4	88.4	118.4
Resistance in lb. of friction = force parallel to surfaces . . .	1.8	2.7	3.5	4.3	5.7	7.3	8.7	10.8	12.8	17.2

Plot the above on squared paper and find the value of μ when resistance of friction = μ times pressure between surfaces.

3. Suppose you had a large rolled steel joist 30 ft. long and sectional dimensions as Fig. 1. You have no means of weighing it, but you know that one cubic inch of mild steel weighs 0.28 lb. What is its weight ?

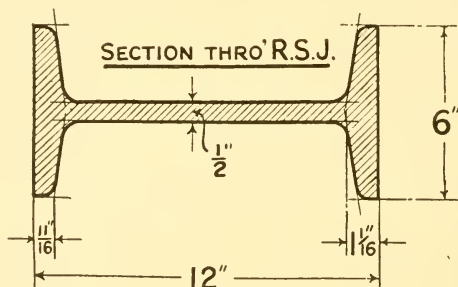

FIG. 1

For the purposes of this question the radii of the corners and edges may be ignored.

4. Centrifugal force F may be calculated from the following formula—

$$F = \frac{WV^2}{gr}$$

Where W = weight in lb., V = velocity of object in feet per second, $g = 32$, r = radius of the circular path of the object in feet, find the centrifugal force of a ring frame traveller weighing 2 grains, and revolving on a ring having an effective radius of 1 in. and making 10,080 revolutions per minute. (1 lb. = 7,000 grains.)

5. A certain room in the mill is required by Factory Act to have the whole atmosphere changed four times every hour by means of an exhaust fan. If the room measures 150 ft. long by 100 ft. wide and 12 ft. average height, and the machines and operatives occupy 15 per cent of the total space, how many cubic feet per minute must the fan exhaust ?

6. The French hank is equal to 1,000 metres, and the number or counts of yarn is indicated by the number of hanks required to weigh 500 grammes. Find the French counts of a sample of yarn 6,600 metres long weighing 100 grammes.

Also what would be the English counts of the yarn if one metre equals 39.37 in. and 1,000 grammes equals 2.2047 lb. ?

7. The following table shows the comparison between cotton yarn counts and artificial silk yarn counts or "denier." You are required to plot these quantities on squared paper, and from the graph determine the point at which the denier and cotton counts are represented by the same number—

Cotton counts . . .	10	16	24	35	44	60
Equivalent denier in artificial silk . . .	528	330	220	150	120	88

8. The horse-power which may be safely transmitted by mild steel shafting running under good normal conditions, may be determined from the following formula—

$$H.P. = \frac{d^3 \times R}{80}$$

Where d = diameter of shaft in inches and R = number of revolutions per minute.

From this formula and by the use of *logarithms*, find the diameter of a shaft that will safely transmit 74 h.p. when making 520 revolutions per minute.

9. If, in producing yarn, 35,000 lb. of cotton are used per week, of which 4 per cent is taken out in the blowing room, 10 per cent in the card room, and 2 per cent in subsequent processes, what would be (a) the weight of finished yarn ? (b) the overall percentage of waste ?

10. Find the diameter of a main steam pipe capable of feeding 4 branch pipes of the following diameters: 1 in., $1\frac{1}{2}$ in., 2 in., $2\frac{1}{4}$ in.

NOTE. The capacity of main pipe must be made equal to 75 per cent of the total capacity of the branch pipes.

11. If the tension in the tight side of a driving belt is 2.6 times the tension in the slack side, and their difference is 153.6 lb., find the mean tension in the belt.

12. The following rule may be used for calculating the counts of yarn from any given length. Multiply the length L in yards by 100 and divide by 12 times the weight W in grains. Write this down mathematically in the form of an equation, and find the weight in grains of 720 yards of 60's twist.

1927 ($2\frac{1}{2}$ Hours)

Not more than *eight* questions may be answered.

1. A flyframe front roller $1\frac{1}{4}$ in. diameter runs at 150 revolutions per minute. Calculate the roller delivery in inches per minute, and turns per inch when the spindle speed is 550 revolutions per minute. [8]

2. An elongation test on a piece of card cylinder filleting 2 in. wide, 12 in. long, gave the following results—

Load in lb.	50	100	150	200	250	300	350	400
Extension in inches.	.075	.145	.215	.290	.360	.435	.500	.568

Plot the above figures on squared paper and draw a straight line connecting the points.

From your graph find the extension when the load is 325 lb. (Note card filleting is put on at this tension.) If the total extension was .96 in. when the specimen broke, calculate the percentage elongation. [10]

3. A scutcher fan, when running at 1,340 revolutions per minute delivers air through a $12\frac{1}{2}$ in. diameter pipe at a velocity of 75 ft. per second. Calculate the volume of air discharged in cubic feet per minute. [8]

4. A scutcher lap measures 38 in. long by 14 in. diameter; find its diameter when one-half the weight of the cotton has been unwound. For the purpose of this example you must

assume that the density of the cotton is constant throughout, and you must also ignore the weight and size of the lap rod. Express the smaller diameter as a percentage of the original diameter. [8]

5. A card is fed with 1,650 lb. of cotton from which 1,584 lb. of sliver are produced; the flat strips weigh 35 lb. and the fly 27 lb. What is the percentage loss at each of the above points? Also find the percentage "invisible" loss. [8]

6. The maximum deflection in inches of a beam supported at both ends, and uniformly loaded, is given by the formula—

$$D = \frac{5}{384} \times \frac{wl^3}{EI}$$

Where w = the total load on the beam,

l = the length in inches,

E = the modulus of elasticity of the material,

I = the moment of inertia of the beam,

by the aid of *logarithms*, find D when $w = 10$ tons, $l = 20$ ft., $E = 15,000$ tons per sq. in., $I = 220$. [10]

7. What is the daily cost in winter of lighting a spinning room containing 12 pairs of mules, if each pair is provided with eight 100 watt lamps, and the current is supplied at 0.75 pence per unit? For the purpose of this question, assume an average of 4 hours per day with all lights on. [8]

8. Find the diameter of a single pipe, the sectional area of which shall be equal to 75 per cent of total sectional area of the following pipes—

2 pipes 1 in. diameter.

3 „ 1½ in. „

4 „ 2 in. „

[8]

9. Using A for one count and B for the other, write the following rule in algebraic form—

To obtain the counts of unequal singles twisted together, multiply the single counts together for a numerator, add the single counts together for the denominator, and the answer is the count required.

Find the resultant counts of one end of 46's twisted with one end of 120's. [8]

10. Coal is stored in a space measuring 40 yd. long by

30 yd. wide, and is stacked to an average height of 8 ft. If coal thus stored weighs 50 lb. per cubic foot find—

(a) The total quantity in tons.

(b) The value at 25 shillings per ton. [8]

11. Artificial silk yarn counts are based on the weight in deniers of 476 metres. There are 8533.5 deniers in a lb.

Find the equivalent counts of artificial silk yarns to that of 35's cotton counts.

(1 metre = 39.73 in.) [10]

12. Calculate the length of a butt jointed belt suitable for driving a mule rim shaft, the distance between the centres of countershaft and rim shaft being 9 ft. 6 in., the countershaft pulley 22 in. diameter, and the pulley on rim shaft 18 in. diameter. [8]

TEXTILE DRAWING

1925 (3 Hours)

GENERAL INSTRUCTIONS

Not more than *two* questions may be answered, one of which must be Question 1.

You are expected to prove your knowledge of machinery, as well as your capability of drawing neatly to scale. You are therefore to supply details omitted in the sketches, to fill in parts left incomplete, and to indicate, by diagonal lines, parts cut by section planes.

No credit will be given if the candidate shows that he is ignorant of projection. The centre lines should be clearly drawn.

You may draw and sketch on both sides of the numbered sheet of drawing paper supplied.

A slide rule may be used.

The number of marks assigned to each question is given in brackets. The maximum number of marks obtainable is 70.

1. Fig. 1 shows two elevations of a simple bearing commonly used on textile machinery. You are required to draw, full size, (1) a front elevation exactly as shown; (2) an end elevation, but drawn in section as cut along line *XY*; (3) a plan. [60]

2. Sketch three kinds of keys suitable for securing a pulley to a shaft. [10]

3. Show by means of a freehand sketch, approximately full size, how a draft wheel is compounded with the "crown" or carrier wheel. [10]

END ELEVATION.

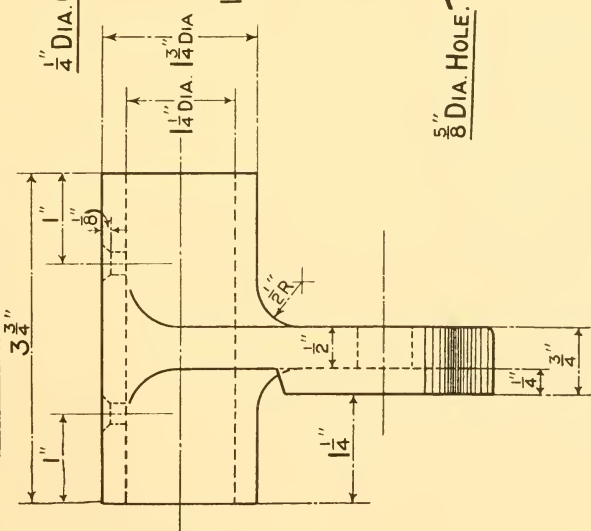

FRONT ELEVATION.

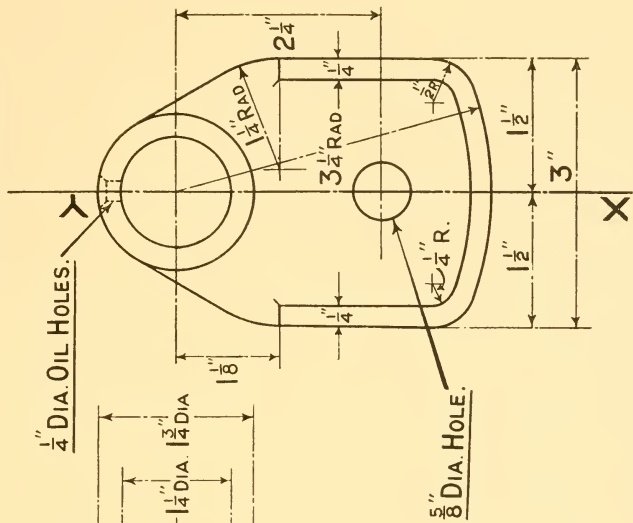

FIG. 1

1926 (3 Hours)

Not more than *two* questions may be answered, one of which must be Question 1.

1. Draw, full size, the two views of the bracket shown in Fig. 1, and add a third view directly underneath the front elevation as seen when looking in the direction of the arrow \times .

NOTE. Dimensions and dimension lines are not required.

[55]

2. Make a well proportioned sketch, half of which should be in section and the other in outside elevation, of a coupling suitable for joining together *either* (a) any two lengths of fly frame bobbin or spindle driving shafts *or* (b) any two lengths of mule back scroll shaft.

[15]

3. What is a knuckle joint and in what instances is it a necessity? Sketch any such joint with which you are acquainted.

[15]

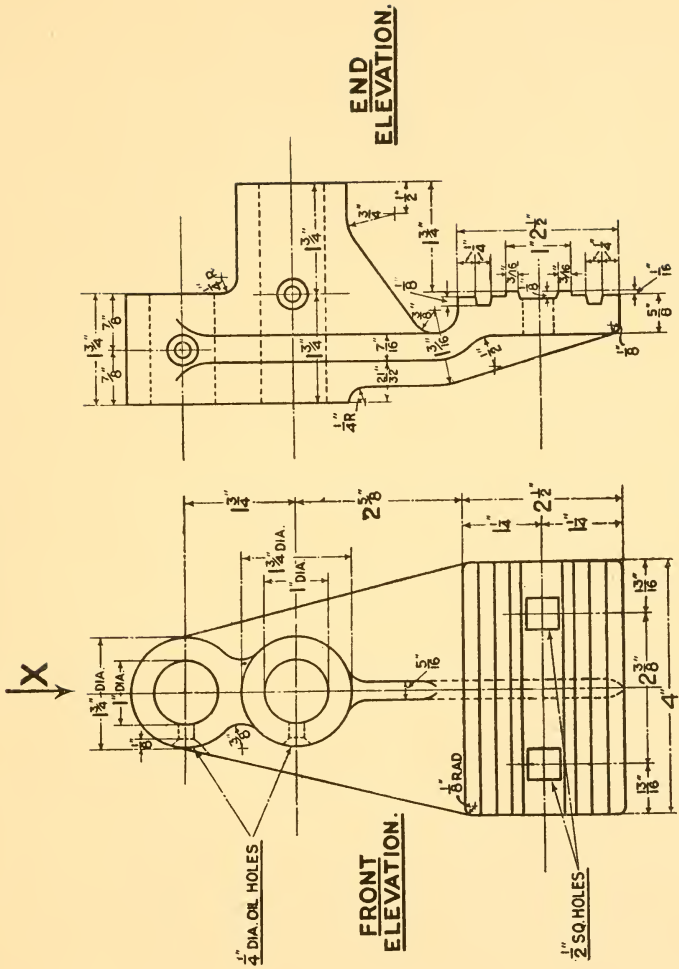

FIG. 1

1927 (3 Hours)

Not more than *two* questions may be answered, one of which must be Question 1.

1. Fig. 1 shows two views of a common form of bracket used in textile machinery. You are required to draw (full size) the two views shown, and to add a third or plan view directly under the front elevation, as seen when looking in the direction of arrow *W*.

NOTE. Dimension lines and dimensions must *not* be shown. [50]

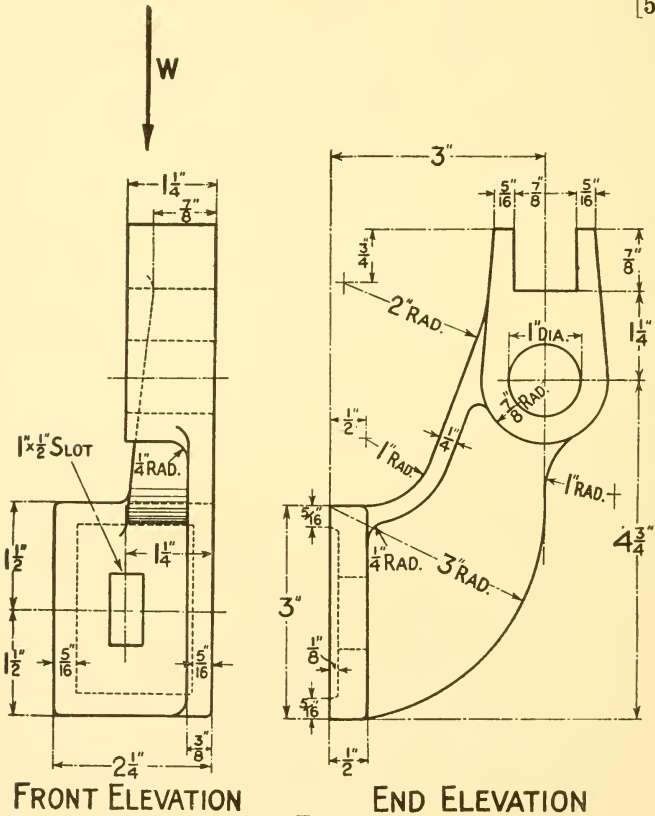

FIG. 1

2. By means of neatly made sketches, draw, freehand (except the circles, which should be drawn with compasses), approximately full size, the boss of a pulley or wheel secured to a shaft by the following means—

- (1) An ordinary flat key.
- (2) A woodruff key.
- (3) A half-inch set screw.

NOTE. The shaft is $1\frac{1}{2}$ in. diameter, and the boss 3 in. diameter. [20]

3. Make a scale of 3 in. to 1 ft. to measure 3 ft., the first foot to be subdivided so as to measure to a quarter of an inch. [10]

SYLLABUS OF THE FIRST YEAR COURSE IN COTTON
SPINNING, OF THE UNION OF LANCASHIRE AND
CHESHIRE INSTITUTES

COTTON SPINNING (THEORY) 2 hours per week.

TEXTILE MATHEMATICS 2 hours per week.

TEXTILE DRAWING AND COTTON SPINNING (PRACTICAL)
Alternately 2 hours per week.

COTTON SPINNING

1. A short statement of all the processes of cotton spinning, with actual examination by students of cotton in all stages, from raw cotton to spun yarn.

2. A brief survey of the cultivation, ginning, baling, and distribution of cotton, with actual finger ginning of a piece of cotton by each student.

NOTE. *The above two clauses are intended for class work only, and not for examination purposes.*

3. The ordinary properties of cotton ; structure, length, diameter, colour.

4. The special features of Sea Islands, Egyptian, South American, North American, and Indian cottons. Amount grown.

5. The principles of opening and cleaning cotton by opening and scutching machinery. The ordinary construction, objects, and working of hopper bale-breakers, hopper feeders, openers, and scutchers ; cotton conveyors. Passage and disposal of cotton, dust, and undesirable matter. Various kinds of beating instruments, diameters, speeds, and direction of principal organs. Speed calculations—methods of driving various parts ; gearing plans.

6. The principles and objects of cotton carding. The characteristics, ordinary construction, and working of the revolving flat carding engine ; passage of cotton through this card, with

speeds, diameters, directions, and actions of parts, from lap to sliver; flexible bends. The coiler, speed calculations, methods of driving the various parts, gearing plan.

7. Drawing Frames. Principles and objects of the drawing frame; passage of cotton through machine, with diameters, speeds, directions, and method of driving the various parts; gearing plan; coiler arrangements.

8. Bobbin and Fly Frames. Principles and objects of these machines. Method of producing rovings; construction and driving of roller and spindles (not building and winding arrangements). Creel arrangements, passage of cotton through machine; long and short collars. Methods of supporting the rollers. Speed calculations.

9. Tables of weights and measures used in the cotton mill.

10. Ring and Flyer Spinning Frames. Principles and objects of these machines; driving, weighting, and working of draft rollers; tin rollers; spindles, rings, travellers; inclined roller stands; creels speed calculations, gearing plan; clearers, spindle bands; thread-board mechanism; anti-ballooning appliances; ring rails and spindle rails.

11. Mule Spinning. Passage of cotton from creel to spindle; principles and objects of mule spinning; methods of driving rollers, spindles, and carriage during out-going of carriage; also of rollers and carriage during in-going of carriage; carriage drafting; details of spindles, such as bevel gauge, length, wharve, footstep, bolster, and taper; stretch lengths; carriage construction; simple roller traverse motions.

NOTE. *It is not intended that the mechanisms dealt with in paragraphs 5 to 11 should be treated in great detail.*

MATHEMATICS

1. Arithmetic. Revision of vulgar and decimal fractions; rough checks; averages and percentages; cotton yarn weights and measures, basis of British system of numbering yarns; loss and regain and their effect upon values; square roots; the application of square root to spinning calculations and yarn diameters; British and metric systems; counts, hanks, diameters of yarns, and areas of yarns, how expressed; methods of finding the results when two or more yarns are twisted together.

2. Mensuration. Perimeters and areas of a quadrilateral,

triangle, and circle, with practical applications; areas of irregular plane figures; areas of cylindrical surfaces and calculations thereon, such as quantity of leather required for rollers, filleting for card cylinder, etc.; radiating surfaces of pipes: surfaces, volumes, and weights of rectangular and cylindrical bodies, application to bales of cotton, boxes, skips; and questions on storage capacity.

3. Algebra. Solution of simple equations; formation and use of formulae; transformation of formulae so as to express each quantity in terms of the others; evaluation of any quantity in a formula when the values of the other quantities are given; simple algebraic relations between counts, twists, and diameters of yarns per inch; formulae involving plus and minus signs in addition to multiplication and division signs; proportion and variation; simple factors; taking out a common factor; difference of two squares; simple algebraic fractions; addition and subtraction of simple algebraic fractions; evaluation of more difficult formulae; solution of simultaneous equations of the first degree.

4. Graphs. Rectangular co-ordinates; general exercises in plotting; importance of choice of scales; plotting of data, e.g. practical applications of graphs to production and waste, production and price questions; rise and fall of prices, etc.; correction of errors of observation; interpolation; simple algebraic graphs.

5. Laws of indices, logarithms and antilogarithms, practical applications.

6. Principles of the slide rule explained, and its application.

DRAWING

The instruction in this subject is intended to enable textile students to interpret intelligently drawings and diagrams of textile machinery, and also to enable them to make useful dimensioned sketches and working drawings of simple parts of the machinery which they may be called upon to operate, adjust, or supervise. The machine parts or models used by the students should be, as far as possible, those to be found in a mill, on account of the interest which they will create, but there is neither the time nor the necessity for students to attempt anything complicated or difficult. Drawings should be dimensioned and nearly finished.

1. Students should be instructed in the use of instruments, use and construction of scales, the common methods of fastening together the parts of machines, and conventional methods of representing screw threads, etc., proportions of bolts and nuts, rivets.

2. The instruction should also include the application of the principles of projection to the making, to any required scale, of plans, elevations and sections of simple brackets, levers, cranks, flange and box couplings for shafts, cotter joints, pulleys, hangers, wall boxes, simple bearings, knuckle joints. Neat freehand sketches of the sections and details of textile machines to illustrate descriptive matter.



INDEX

PART I

COTTON SPINNING

CALCULATIONS—

- Cotton mixing, 47
- Draft, 82
- Speed, 43

CARDING—

- Card waste, 86
- Coiler, 89
- Flat carding engine, 83
- Flexible bends, 88

COTTON—

- African, 20
- Baling of, 24
- Botanical, 1
- British Empire fields, 20
- China, 19
- Defects in, 6
- Egyptian, 13
- General notes on, 8
- Ginning of, 23
- Growth of, 2
- Indian, 18
- Minor fields in Asia, 20
- — in Europe, 19
- Mixing of, 45
- Properties of fibres, 4
- Sea Islands, 11
- South American, 14, 15
- Sudan (Empire), 14, 15
- U.S.A., 16
- World's growing areas, 9

DRAWFRAMES—

- Coiler, 97
- Drawing rollers, 95
- Passage of cotton, 92

FLYFRAMES—

- Collars, 111
- Drawing rollers, 105
- Drive of rollers and spindles, 107

FLYFRAMES—(contd.)

- Objects of, 100
- Passage of cotton, 101
- Spindles, 110

MULE SPINNING—

- Objects, 129
- Self-actor mule :
 - Details, 142
 - Inward run of carriage, 137
 - Outward run of carriage, 133
 - Passage of cotton, 129
 - Roller traverse, 145

OPENING AND SCUTCHING—

- Beating instruments, 75
- Combined machines, 56
- Crighton vertical opener, 66
- Double exhaust opener, 70
- Doubling of laps, 73
- Hopper bale breaker, 38
- feeder, 57
- Lattice feeder, 62
- Objects of, 61
- Pneumatic conveyors, 48
- Self-cleaning lattice, 66

RING SPINNING—

- Details, 114
- Objects of, 112
- Passage of cotton, 112

PART II

TEXTILE MATHEMATICS

- COTTON count constants, 151
- counts, 147

- DIFFERENCE of two squares, 175
- Doubling of yarn, 162

- FACTORS, 174
- Fractions (algebraic), 176
- French counts, 161

GRAPHS, 179

LOGARITHMS, 183

Logarithm table, 185

Loss and regain, 154

MENSURATION, 165

PERCENTAGES, 152

SIMPLE equations, 170

Simultaneous equations, 177

Square roots, 155

— root table, 157

TRANSFORMATION of formulae, 172

USEFUL information, 188

WEIGHTS and measures used in
spinning, 147

PART III

TEXTILE DRAWING

COUPLINGS, 203

ISOMETRIC drawing, 192

MATERIALS used in textile ma-
chine manufacture, 205Methods of fastening pulleys to
shafts, etc., 199

NUTS and bolts, 197

PLANS and elevations, 193, 194,
195

Principles of projection, 191

RIVETS and riveted joints, 202

SCALES, 196

Screws and screw threads, 198

AN ABRIDGED LIST OF
TECHNICAL BOOKS

PUBLISHED BY

Sir Isaac Pitman & Sons, Ltd.

PARKER STREET, KINGSWAY

LONDON, W.C.2

The prices given apply only to Great Britain

A complete Catalogue giving full details of the following
 books will be sent post free on application

ALL PRICES ARE NET

	<i>s. d.</i>
ABRASIVE MATERIALS, THE MANUFACTURE AND USE OF. A. B. Searle	2 6
A.C. PROTECTIVE SYSTEMS AND GEAR. J. Henderson and C. W. Marshall	2 6
ACCUMULATOR CHARGING. W. S. Ibbetson	3 6
ACCUMULATORS, MANAGEMENT OF. Sir D. Salomons	7 6
AERONAUTICS, ELEMENTARY. A. P. Thurston	8 6
AEROPLANE DESIGN AND CONSTRUCTION, ELEMENTARY PRINCIPLES OF. A. W. Judge	7 6
AEROPLANE STRUCTURAL DESIGN. T. H. Jones and J. D. Frier	21 0
AIRCRAFT AND AUTOMOBILE MATERIALS—FERROUS. A. W. Judge	25 0
AIRCRAFT AND AUTOMOBILE MATERIALS—NON-FERROUS AND ORGANIC. A. W. Judge	25 0
AIRSHIP, THE RIGID. E. H. Lewitt	30 0
ALCOHOL, INDUSTRIAL AND POWER. R. C. Farmer	2 6
ALTERNATING CURRENT BRIDGE METHODS OF ELECTRICAL MEASUREMENT. B. Hague	15 0
ALTERNATING CURRENT CIRCUIT, THE. P. Kemp.	2 6
ALTERNATING CURRENT MACHINERY, DESIGN OF. J. R. Barr and R. D. Archibald	30 0
ALTERNATING CURRENT MACHINERY, PAPERS ON THE DESIGN OF. C. C. Hawkins, S. P. Smith, and S. Neville	21 0

	<i>s. d.</i>
ALTERNATING CURRENTS, THEORY AND PRACTICE OF. A. T. Dover	18 0
ALTERNATING CURRENT WORK. W. Perren Maycock	10 6
ARCHITECTURAL HYGIENE. B. F. and H. P. Fletcher.	10 6
ARITHMETIC OF ALTERNATING CURRENTS. E. H. Crapper	4 6
ARITHMETIC OF ELECTRICAL ENGINEERING. Whit- taker's	3 6
ARITHMETIC OF TELEGRAPHY AND TELEPHONY. T. E. Herbert and R. G. de Wardt	5 0
ARMATURE WINDING, PRACTICAL DIRECT CURRENT. L. Wollison	7 6
ARTIFICIAL SILK AND ITS MANUFACTURE. J. Foltzer. Translated by T. Woodhouse	21 0
ARTIFICIAL SILK: ITS MANUFACTURE AND USES. T. Woodhouse	5 0
AUTOMOBILE AND AIRCRAFT ENGINES. A. W. Judge	30 0
BALL AND ROLLER BEARINGS, HANDBOOK OF. A. W. Macaulay	12 6
BAUDÔT PRINTING TELEGRAPH SYSTEM. H. W. Pendry	6 0
BELTS FOR POWER AND TRANSMISSION. W. G. Dunkley	2 6
BIOLOGY, AN INTRODUCTION TO PRACTICAL. N. Walker	5 0
BLASTING WITH HIGH EXPLOSIVES. W. G. Boulton	5 0
BLUE PRINTING AND MODERN PLAN COPYING. B. J. Hall	6 0
BLUE PRINT READING. J. Brahdry	10 6
BOILER INSPECTION AND MAINTENANCE. R. Clayton.	2 6
BOOKBINDING AND THE CARE OF BOOKS. D. Cockerell	10 6
BOOKBINDING CRAFT AND INDUSTRY. T. Harrison	3 0
BREWING AND MALTING. J. Ross Mackenzie	8 6
CABINET MAKING, ART AND CRAFT OF. D. Denning	7 6
CABLE AND WIRELESS COMMUNICATIONS OF THE WORLD, THE. F. J. Brown	7 6
CABLE JOINTING, THE ART AND CRAFT OF. C. G. Watson	6 0
CALCULUS FOR ENGINEERING STUDENTS. J. Stoney	3 6
CAMERA LENSES. A. W. Lockett	2 6
CAPSTAN AND AUTOMATIC LATHES. P. Gates	2 6
CARBURETTOR HANDBOOK. E. W. Knott	10 6
CARPENTRY AND JOINERY. B. F. and H. P. Fletcher	10 6

	<i>s.</i>	<i>d.</i>
CENTRAL STATIONS, MODERN. C. W. Marshall . . .	2	6
CERAMIC INDUSTRIES POCKET BOOK. A. B. Searle . . .	8	6
CHEMICAL ENGINEERING, INTRODUCTION TO. A. F. Allen . . .	10	6
CHEMISTRY, A FIRST BOOK OF. A. Coulthard . . .	3	0
CLUTCHES, FRICTION. R. Waring-Brown . . .	5	0
COAL CARBONIZATION. J. Roberts . . .	25	0
COAL CUTTING MACHINERY. G. F. F. Eagar . . .	2	6
COLLIERY ELECTRICAL ENGINEERING. G. M. Harvey . . .	15	0
COLOUR IN WOVEN DESIGN. R. Beaumont . . .	21	0
COMPRESSED AIR POWER. A. and W. Z. W. Daw . . .	21	0
CONCRETE AND REINFORCED CONCRETE. W. Noble Twelvetrees . . .	3	0
CONDENSING PLANT. I. V. Robinson and R. J. Kaula . . .	30	0
CONTINUOUS CURRENT ARMATURE WINDING. F. M. Denton . . .	2	6
CONTINUOUS CURRENT DYNAMO DESIGN, ELEMENTARY PRINCIPLES OF. H. M. Hobart . . .	10	6
CONTINUOUS CURRENT MACHINES, TESTING OF. C. F. Smith . . .	2	6
CONTINUOUS CURRENT MOTORS AND CONTROL APPARATUS. W. Perren Maycock . . .	7	6
COSTING ORGANIZATION FOR ENGINEERS. E. W. Workman . . .	3	6
COTTON-SPINNERS' POCKET BOOK. J. F. Innes . . .	3	6
COTTON-SPINNING MACHINERY. Wm. Scott Taggart . . .	2	6
CRYSTAL AND ONE VALVE CIRCUITS, SUCCESSFUL. J. H. Watkins . . .	3	6
DETAIL DESIGN OF MARINE SCREW PROPELLERS. D. H. Jackson . . .	6	0
DIESEL ENGINES, MARINE—LOCOMOTIVE—STATIONARY. D. L. Jones . . .	21	0
DIESEL ENGINE, THE. A. Orton . . .	2	6
DIRECT CURRENT DYNAMO AND MOTOR FAULTS. R. M. Archer . . .	7	6
DIRECT CURRENT ELECTRICAL ENGINEERING. J. R. Barr . . .	15	0
DIRECT CURRENT ELECTRICAL ENGINEERING, THE ELEMENTS OF. H. F. Trewman and G. E. Condliffe . . .	5	0
DIRECT CURRENT MACHINES, PERFORMANCE AND DESIGN OF. A. E. Clayton . . .	16	0
DRAWING AND DESIGNING. C. G. Leland . . .	3	6

	<i>s. d.</i>
DRAWING, MANUAL INSTRUCTION. S. Barter	4 0
DRAWING OFFICE PRACTICE. H. P. Ward	7 6
DRESS, BLOUSE, AND COSTUME CLOTHS, DESIGN AND FABRIC MANUFACTURE OF. R. Beaumont	42 0
DROP FORGING AND DROP STAMPING. H. Hayes	2 6
DYES AND THEIR APPLICATION TO TEXTILE FABRICS. A. J. Hall	3 0
DYNAMO, HOW TO MANAGE THE. A. E. Bottone	2 0
DYNAMO: ITS THEORY, DESIGN, AND MANUFACTURE, THE. C. C. Hawkins. Vol. I	21 0
Vol. II	15 0
Vol. III	30 0
ELECTRIC BELLS. S. R. Bottone	3 6
ELECTRIC CABLES. F. W. Main	2 6
ELECTRIC CIRCUIT THEORY AND CALCULATIONS. W. Perren Maycock	10 6
ELECTRIC CRANES AND HAULING MACHINES. F. E. Chilton	2 6
ELECTRIC FURNACE, THE. F. J. Moffett	2 6
ELECTRIC GUIDES, HAWKINS'. 10 volumes, each	5 0
ELECTRIC HEATING, INDUSTRIAL. J. W. Beau- champ	2 6
ELECTRIC LAMP INDUSTRY. G. A. Percival	3 0
ELECTRIC LIGHTING AND POWER DISTRIBUTION. Vol. I. W. Perren Maycock	10 6
Vol. II	10 6
ELECTRIC LIGHTING IN FACTORIES. L. Gaster	6
ELECTRIC LIGHT FITTING, PRACTICAL. F. C. Allsop	7 6
ELECTRIC MINING MACHINERY. S. F. Walker	15 0
ELECTRIC MOTORS AND CONTROL SYSTEMS. A. T. Dover	15 0
ELECTRIC MOTORS — DIRECT CURRENT. H. M. Hobart	15 0
ELECTRIC MOTORS—POLYPHASE. H. M. Hobart.	15 0
ELECTRIC MOTORS, A SMALL BOOK ON. C.C. AND A.C. W. Perren Maycock	6 0
ELECTRIC MOTORS, SMALL. E. T. Painton	2 6
ELECTRIC POWER SYSTEMS. W. T. Taylor	2 6
ELECTRIC TRACTION. A. T. Dover	21 0
ELECTRIC WIRING, FITTINGS, SWITCHES, AND LAMPS. W. Perren Maycock	10 6
ELECTRIC WIRING DIAGRAMS. W. Perren Maycock	5 0
ELECTRIC WIRING TABLES. W. Perren Maycock	3 6
ELECTRICAL CONDENSERS. P. R. Coursey	37 6
ELECTRICAL EDUCATOR, PITMAN'S. J. A. Fleming. 2 Vols.	63 0

	<i>s. d.</i>
ELECTRICAL ENGINEERING, ELEMENTARY. O. R. Randall	5 0
ELECTRICAL ENGINEERING FOR MINING STUDENTS. G. M. Harvey	5 0
ELECTRICAL ENGINEERS' POCKET BOOK. Whittaker's	10 6
ELECTRICAL INSTRUMENT MAKING FOR AMATEURS. S. R. Bottone	6 0
ELECTRICAL INSTRUMENTS IN THEORY AND PRACTICE. Murdoch and Oswald	12 6
ELECTRICAL INSULATING MATERIALS. A. Monkhouse, Jr.	21 0
ELECTRICAL INSULATION. W. S. Flight	2 6
ELECTRICAL MACHINES, PRACTICAL TESTING OF. L. Oulton and N. J. Wilson	6 0
ELECTRICAL POWER ENGINEERS' LIBRARY. Three volumes, each 7s. 6d. ; Complete set	20 0
ELECTRICAL TECHNOLOGY. H. Cotton	12 6
ELECTRICAL TERMS, DICTIONARY OF. S. R. Roget	7 6
ELECTRICAL TRANSMISSION OF ENERGY. W. M. Thornton	2 6
ELECTRICITY. R. E. Neal	3 0
ELECTRICITY AND MAGNETISM, FIRST BOOK OF. W. Perren Maycock	6 0
ELECTRICITY IN AGRICULTURE. A. H. Allen	2 6
ELECTRICITY IN STEEL WORKS. W. McFarlane	2 6
ELECTRIFICATION OF RAILWAYS. H. F. Trewman	2 6
ELECTRO-DEPOSITION OF COPPER. C. W. Denny	2 6
ELECTRO MOTORS: HOW MADE AND HOW USED. S. R. Bottone	4 6
ELECTROLYTIC RECTIFIERS. N. A. de Bruyne	3 6
ELECTRO-TECHNICS, ELEMENTS OF. A. P. Young	5 0
ENGINEER DRAUGHTSMEN'S WORK	2 6
ENGINEERING FACTORY SUPPLIES. W. J. Hiscox	5 0
ENGINEERING HAND-SKETCHING AND SCALE-DRAWING. T. Jackson and P. Bentley	3 0
ENGINEERING INQUIRIES, DATA FOR. J. C. Connan	12 6
ENGINEERING PRINCIPLES, ELEMENTARY. G. E. Hall	2 6
ENGINEERING SCIENCE, PRIMER OF. E. S. Andrews. Part 1, 2s. 6d. ; Part 2, 2s. ; Complete	3 6
ENGINEERING WORKSHOP EXERCISES. E. Pull	3 6
ENGINEERS' AND ERECTORS' POCKET DICTIONARY: ENGLISH, GERMAN, DUTCH. W. H. Steenbeek	2 6
ENGLISH FOR TECHNICAL STUDENTS. F. F. Potter	2 0
EXPLOSIVES, MANUFACTURE AND USES OF. R. C. Farmer	2 6

	<i>s. d.</i>
FIELD MANUAL OF SURVEY METHODS AND OPERATIONS. A. Lovat Higgins	21 0
FIELD WORK FOR SCHOOLS. E. H. Harrison and C. A. Hunter	2 0
FILES AND FILING. Fremont and Taylor	21 0
FILTRATION. G. L. Wollaston	2 6
FITTING, PRINCIPLES OF. J. G. Horner	7 6
FIVE FIGURE LOGARITHMS. W. E. Dommett	1 0
FLAX CULTURE AND PREPARATION. F. Bradbury.	10 6
FOUNDRYWORK. B. Shaw and J. Edgar	2 6
FUEL ECONOMY IN STEAM PLANTS. A. Grounds	5 0
FUEL OILS AND THEIR APPLICATION. H. V. Mitchell	5 0
FURS AND FURRIERY. C. J. Rosenberg	30 0
GAS AND GAS MAKING. W. H. Y. Webber	3 0
GAS, GASOLINE, AND OIL ENGINES. J. B. Rathbun	2 6
GAS ENGINE TROUBLES AND INSTALLATIONS. J. B. Rathbun	2 6
GAS AND OIL ENGINE OPERATION. J. Okill	5 0
GAS, OIL, AND PETROL ENGINES. A. Garrard	6 0
GEOMETRY, THE ELEMENTS OF PRACTICAL PLANE. P. W. Scott. Also in Two Parts, each Is.	2 6
GRAPHIC STATICS, ELEMENTARY. J. T. Wight	5 0
GRINDING MACHINES AND THEIR USES. T. R. Shaw	2 6
HANDRAILING FOR GEOMETRICAL STAIRCASES. W. A. Scott	2 6
HIGH HEAVENS, IN THE. Sir R. Ball	5 0
HOSIERY MANUFACTURE. W. Davis	7 6
HOUSE DECORATIONS AND REPAIRS. W. Prebble	2 6
HYDRAULICS. E. H. Lewitt	10 6
HYDRO-ELECTRIC DEVELOPMENT. J. W. Meares	2 6
ILLUMINANTS AND ILLUMINATING ENGINEERING, MODERN. Dow and Gaster	25 0
ILLUMINATING ENGINEERING, THE ELEMENTS OF. A. P. Trotter	2 6
INDUCTION COILS. G. E. Bonney	6 0
INDUCTION COIL, THEORY OF THE. E. Taylor-Jones	12 6
INDUCTION MOTOR, THE. H. Vickers	21 0
INTERNAL COMBUSTION ENGINES. J. Okill	3 0
IRONFOUNDING. B. Whiteley	3 0
IRONFOUNDING PRACTICAL. J. G. Horner	10 0
IRON, STEEL AND METAL TRADES, TABLES FOR THE. J. Steel	3 6
KINEMATOGRAPH STUDIO TECHNIQUE. L. C. MacBean	2 6

	<i>s. d.</i>
KINEMATOGRAPHY (PROJECTION), GUIDE TO. C. N. Bennett.	10 6
LACQUER WORK. G. Koizumi	15 0
LEATHER CRAFT, ARTISTIC. H. Turner	5 0
LEATHER WORK. C. G. Leland.	5 0
LENS WORK FOR AMATEURS. H. Orford	3 6
LETTERING, PLAIN AND ORNAMENTAL. E. G. Fooks	3 6
LIGHTNING CONDUCTORS. Sir O. Lodge.	15 0
LOGARITHMS FOR BEGINNERS. C. N. Pickworth	1 6
LOUD SPEAKERS. C. M. R. Balbi	3 6
LOW TEMPERATURE DISTILLATION. S. North and J. B. Garbe	15 0
LUBRICATION AND LUBRICANTS. J. H. Hyde	2 6
MACHINE DESIGN. G. W. Bird.	6 0
MACHINE DRAWING, PREPARATORY COURSE TO. P. W. Scott.	2 0
MACHINES, THEORY OF. L. Toft and A. T. J. Kersey	12 6
MAGNETO AND ELECTRIC IGNITION. W. Hibbert	3 6
MANURING LAND, TABLES FOR MEASURING AND. J. Cullyer	3 0
MARINE SCREW PROPELLERS, DETAIL DESIGN OF. D. H. Jackson	6 0
MATHEMATICAL TABLES. W. E. Dommett	4 6
MATHEMATICS, ENGINEERING APPLICATIONS OF. W. C. Bickley.	5 0
MATHEMATICS FOR ENGINEERING STUDENTS. G. E. Hall	5 0
MATHEMATICS, MINING. G. W. Stringfellow	2 0
MECHANICAL ENGINEERING DETAIL TABLES. J. P. Ross	7 6
MECHANICAL ENGINEERS' POCKET BOOK. Whit-taker's	12 6
MECHANICAL HANDLING OF GOODS. C. H. Woodfield	2 6
MECHANICAL REFRIGERATION. H. Williams	20 0
MECHANICAL STOKING. D. Brownlie	5 0
MECHANICAL TABLES	2 0
MECHANICS' AND DRAUGHTSMEN'S POCKET BOOK. W. E. Dommett	2 6
MECHANICS FOR ENGINEERING STUDENTS. G. W. Bird	5 0
MERCURY-ARC RECTIFIERS AND MERCURY-VAPOUR LAMPS. J. A. Fleming	6 0
METAL TURNING. J. G. Horner	6 0
METAL WORK, PRACTICAL SHEET AND PLATE. E. A. Atkins	7 6

	<i>s.</i>	<i>d.</i>
METAL WORK—REPOUSSÉ. C. G. Leland . . .	5	0
METALLURGY OF CAST IRON. J. E. Hurst . . .	15	0
METALLURGY OF IRON AND STEEL, THE. Based on Notes by Sir Robert Hadfield . . .	2	6
METALWORKERS' PRACTICAL CALCULATOR. J. Matheson	2	0
METRIC AND BRITISH SYSTEMS OF WEIGHTS AND MEASURES. F. M. Perkin	3	6
METRIC CONVERSION TABLES. W. E. Dommett . . .	1	0
MINERALOGY. F. H. Hatch	6	0
MINING CERTIFICATE SERIES, PITMAN'S—		
MINING LAW AND MINE MANAGEMENT. A. Watson	8	6
MINE VENTILATION AND LIGHTING. C. D. Mottram	8	6
COLLIERY EXPLOSIONS AND RECOVERY WORK. J. W. Whitaker	8	6
MINING MACHINERY. T. Bryson. (<i>In Preparation</i>)		
ARITHMETIC AND SURVEYING. R. M. Evans.	8	6
METHODS OF WORKING. Prof. Ira C. F. Statham. (<i>In Preparation</i>)		
MINING EDUCATOR, THE. J. Roberts	63	0
MINING, MODERN PRACTICE OF COAL. Kerr and Burns. Part 1, 5s. ; Parts 2, 3 and 4, each . . .	6	0
MINING SCIENCE, JUNIOR COURSE IN. H. G. Bishop	2	6
MOLLIER STEAM TABLES AND DIAGRAMS, THE . . .	7	6
MOTIVE POWER ENGINEERING FOR STUDENTS OF MINING AND MECHANICAL ENGINEERING. H. C. Harris	10	6
MOTOR BOATS. F. Strickland	3	0
MOTOR CONTROL, INDUSTRIAL. A. T. Dover.	2	6
MOTOR-CYCLIST'S LIBRARY, THE. Each	2	0
A. J. S., THE BOOK OF THE. W. C. Haycraft		
B. S. A., THE BOOK OF THE. "Waysider"		
DOUGLAS, THE BOOK OF THE. E. W. Knott		
MOTOR CYCLING FOR WOMEN. B. and N. Debenham		
P. and M. THE BOOK OF THE. W. C. Haycraft		
RALEIGH HANDBOOK, THE. "Mentor"		
ROYAL ENFIELD, THE BOOK OF THE. "R. E. Ryder"		
RUDGE, THE BOOK OF THE. L. H. Cade		
TRIUMPH, THE BOOK OF THE. E. T. Brown		
MOTORIST'S LIBRARY, THE—		
AUSTIN TWELVE, THE BOOK OF THE. R. Garbutt and R. Twelvetrees.	5	0
CLYNO CAR, THE BOOK OF THE. E. T. Brown. (<i>In the Press</i>)		
STANDARD CAR, THE BOOK OF THE. "Pioneer"	6	0

	<i>s.</i>	<i>d.</i>
MOTOR INDUSTRY. H. Wyatt	3	0
MOTOR TRUCK AND AUTOMOBILE MOTORS AND MECHANISM. T. H. Russell	2	6
MUNICIPAL ENGINEERING. H. Percy Boulnois	2	6
MUSIC ENGRAVING AND PRINTING. W. Gamble	21	0
NAVAL DICTIONARY, ITALIAN-ENGLISH AND ENGLISH-ITALIAN. W. T. Davis	10	6
NITROGEN, INDUSTRIAL. P. H. S. Kempton	2	6
OIL POWER. S. H. North	3	0
OILS, PIGMENTS, PAINTS, VARNISHES, ETC. R. H. Truelove	2	6
OSCILLOGRAPHS. J. T. Irwin	7	6
PATENTS FOR INVENTIONS. J. E. Walker and R. B. Foster	21	0
PATTERN CONSTRUCTION FOR GARMENT MAKERS, THE SCIENCE OF. B. W. Poole	45	0
PATTERN-MAKING. B. Shaw and J. Edgar	2	6
PATTERN-MAKING, PRINCIPLES OF. J. G. Horner	4	0
PETROL CARS AND LORRIES. F. Heap	2	6
PHOTOGRAPHER, THE COMPLETE PRESS. Bell R. Bell	6	0
PHOTOGRAPHIC CHEMICALS. T. L. J. Bentley and J. Southworth	3	6
PHOTOGRAPHIC TECHNIQUE. L. J. Hibbert	2	6
PHOTOGRAPHY, COMMERCIAL. D. Charles	5	0
PLAN COPYING IN BLACK LINES FOR HOT CLIMATES. B. J. Hall	2	6
PLYWOOD AND GLUE, THE MANUFACTURE AND USE OF. B. C. Boulton	7	6
PNEUMATIC CONVEYING. E. G. Phillips	2	6
POWER FACTOR CORRECTION. A. E. Clayton	2	6
POWER STATION EFFICIENCY CONTROL. J. Bruce.	12	6
POWER WIRING DIAGRAMS. A. T. Dover	6	0
PRINTING. H. A. Maddox	5	0
PYROMETERS. E. Griffiths	7	6
QUANTITIES AND QUANTITY TAKING. W. E. Davis	6	0
RADIOACTIVITY. J. Chadwick	2	6
RADIO COMMUNICATION, MODERN. J. H. Reyner	5	0
RADIO YEAR BOOK	1	6
RAILWAY ELECTRIFICATION. H. F. Trewman	21	0
RAILWAY SIGNALLING: AUTOMATIC. F. R. Wilson	2	6
RAILWAY SIGNALLING: MECHANICAL. F. R. Wilson	2	6
RAILWAY TECHNICAL VOCABULARY. L. Serraillier	7	6
REFRACTORIES FOR FURNACES, ETC. A. B. Searle	5	0
REINFORCED CONCRETE. W. N. Twelvetrees	21	0

	<i>s.</i>	<i>d.</i>
REINFORCED CONCRETE MEMBERS, SIMPLIFIED METHODS OF CALCULATING. W. N. Twelvetrees	5	0
REINFORCED CONCRETE, DETAIL DESIGN IN. E. S. Andrews	6	0
RETOUCHING AND FINISHING FOR PHOTOGRAPHERS. J. S. Adamson	4	0
RUSSIAN WEIGHTS AND MEASURES, TABLES OF. Redvers Elder	2	6
SEED TESTING. J. S. Remington	10	6
SEWERS AND SEWERAGE. H. G. Whyatt	2	6
SHIPBUILDING AND THE SHIPBUILDING INDUSTRY. J. Mitchell	3	0
SHOT-GUNS. H. B. C. Pollard	6	0
SILVERWORK AND JEWELLERY. H. Wilson	8	6
SLIDE RULE. A. L. Higgins	6	6
SLIDE RULE. C. N. Pickworth	3	6
SOIL, SCIENCE OF THE. C. Warrell	3	6
SPARKING PLUGS. A. P. Young and H. Warren	2	6
SPECIFICATIONS FOR BUILDING WORKS. W. L. Evershed	5	0
STAINED GLASS WORK. C. W. Whall	10	6
STEAM ENGINE VALVES AND VALVE GEARS. E. L. Ahrons	2	6
STEAM LOCOMOTIVE CONSTRUCTION AND MAINTENANCE. E. L. Ahrons	2	6
STEAM LOCOMOTIVE, THE. E. L. Ahrons	2	6
STEAM PLANT, THE CARE AND MAINTENANCE OF. T. E. Braham	5	0
STEAM TURBINE THEORY AND PRACTICE. W. J. Kearton	15	0
STEAM TURBO-ALTERNATOR, THE. L. C. Grant	15	0
STEELS, SPECIAL. Based on Notes by Sir R. Hadfield. T. H. Burnham	5	0
STEEL WORKS ANALYSIS. J. O. Arnold and F. Ibbotson	12	6
STENCIL CRAFT. H. Cadness	10	6
STORAGE BATTERY PRACTICE. R. Rankin	7	6
STRENGTH OF MATERIALS. F. V. Warnock	12	6
STRUCTURAL STEELWORK. W. H. Black	2	6
STRUCTURES, THEORY OF. H. W. Coultas	15	0
SURVEYING AND SURVEYING INSTRUMENTS. G. A. T. Middleton	6	0
SURVEYING, TUTORIAL LAND AND MINE. T. Bryson	10	6
SWITCHBOARDS, HIGH TENSION. H. E. Poole	2	6
SWITCHGEAR, HIGH TENSION. H. E. Poole	2	6
SWITCHING AND SWITCHGEAR. H. E. Poole	2	6

	<i>s.</i>	<i>d.</i>
TELEGRAPHY. T. E. Herbert	18	0
TELEGRAPHY, ELEMENTARY. H. W. Pendry	7	6
TELEGRAPHY, TELEPHONY, AND WIRELESS. J. Poole	3	0
TELEPHONE HANDBOOK, PRACTICAL. J. Poole	18	0
TELEPHONES, AUTOMATIC. F. A. Ellson	5	0
TELEPHONY. T. E. Herbert	18	0
TELEPHONY, THE CALL INDICATOR SYSTEM OF AUTOMATIC. A. G. Freestone	6	0
TELEPHONY, THE DIRECTOR SYSTEM OF AUTOMATIC. W. E. Hudson	5	0
TEXTILE CALCULATIONS. G. H. Whitwam	25	0
THERMODYNAMICS, APPLIED. W. Robinson	18	0
TIDAL POWER. A. M. A. Struben	2	6
TIN AND THE TIN INDUSTRY. A. H. Munday	3	0
TOOL AND MACHINE SETTING. P. Gates	2	6
TOWN GAS MANUFACTURE. R. Staley	2	6
TRACTION MOTOR CONTROL. A. T. Dover	2	6
TRANSFORMERS AND ALTERNATING CURRENT MACHINES, THE TESTING OF. C. F. Smith	2	6
TRANSFORMERS FOR SINGLE AND MULTIPHASE CURRENTS. Dr. G. Kapp	15	0
TRANSFORMERS, HIGH VOLTAGE POWER. W. T. Taylor	2	6
TRANSFORMERS, SMALL SINGLE-PHASE. E. T. Painton	2	6
TRANSPORT LIBRARY—		
AIR TRANSPORT, COMMERCIAL. Lieut.-Col. Ivo Edwards and F. Tymms	7	6
PORT ECONOMICS. B. Cunningham	6	0
RAILWAY OPERATION, MODERN. D. R. Lamb	7	6
RAILWAY RATES, PRINCIPLES, AND PROBLEMS. P. Burt	6	0
RAILWAY STATISTICS. A. E. Kirkus	5	0
ROAD TRANSPORT, HISTORY AND DEVELOPMENT OF. J. Paterson	6	0
TRANSPORT UNDERTAKINGS, THE RIGHTS AND DUTIES OF. H. B. Davies	5	0
TRIGONOMETRY FOR ENGINEERS, PRIMER OF. W. G. Dunkley	5	0
TRIGONOMETRY FOR NAVIGATING ENGINEERS. W. P. Winter	10	6
TURBO-BLOWERS AND COMPRESSORS. W. J. Kearton	21	0
TURRET LATHE TOOLS, HOW TO LAY OUT	6	0
UNION TEXTILE FABRICATION. R. Beaumont	21	0

	<i>s. d.</i>
VENTILATION, PUMPING, AND HAULAGE, THE MATHEMATICS OF. F. Birks	5 0
VOLUMETRIC ANALYSIS. J. B. Coppock	3 6
VOLUMETRIC WORK, A COURSE OF. E. Clark	4 6
WATER MAINS, THE LAY-OUT OF SMALL. H. H. Hellins	7 6
WATER POWER ENGINEERING. F. F. Fergusson	2 6
WATERWORKS FOR URBAN AND RURAL DISTRICTS. H. C. Adams	15 0
WEAVING. W. P. Crankshaw	3 0
WEAVING AND MANUFACTURING, HANDBOOK OF. H. Greenwood	5 0
WEAVING, EMBROIDERY AND TAPESTRY. A. H. Christie	10 6
WEAVING FOR BEGINNERS. L. Hooper	5 0
WEAVING, HANDLOOM. L. Hooper	10 6
WEAVING WITH SMALL APPLIANCES. L. Hooper—	
(1) THE WEAVING BOARD	} Each 7 6
(2) TABLET WEAVING	
(3) TABLE LOOM WEAVING	
WELDING, ELECTRIC. L. B. Wilson	5 0
WELDING. ELECTRIC ARC AND OXY-ACETYLENE. E. A. Atkins	7 6
WIRELESS TELEGRAPHY AND TELEPHONY, AN INTRODUCTION TO. J. A. Fleming	3 6
WIRELESS TELEGRAPHY, CONTINUOUS WAVE. B. E. G. Mittell	2 6
WIRELESS TELEGRAPHY, DIRECTIVE. Direction and Position Finding, etc. L. H. Walter	2 6
WOOD-BLOCK PRINTING. F. Morley Fletcher	8 6
WOODCARVING. C. G. Leland	7 6
WOODCARVING DESIGN AND WORKMANSHIP. G. Jack	8 6
WOODWORK, MANUAL INSTRUCTION. S. Barter	7 6
WOOLLEN YARN PRODUCTION. T. Lawson	3 6
WOOL SUBSTITUTES. R. Beaumont	10 6
WORKSHOP GAUGES. L. Burn	5 0
WRITING AND ILLUMINATING AND LETTERING. E. Johnston	8 6
X-RAYS, INDUSTRIAL APPLICATION OF. P. H. S. Kempton	2 6
YARNS AND FABRICS, TESTING OF. H. P. Curtis	5 0
ZINC AND ITS ALLOYS. T. E. Lones	3 0





LIBRARY OF CONGRESS



0 018 533 778 9

