





5971

LESSONS IN

# PRACTICAL ELECTRICITY

PRINCIPLES, EXPERIMENTS, AND  
ARITHMETICAL PROBLEMS

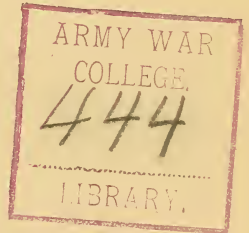
AN ELEMENTARY TEXT-BOOK

BY

*notes*  
C. WALTON SWOOPE

ASSOCIATE MEMBER AMERICAN INSTITUTE OF ELECTRICAL ENGINEERS  
INSTRUCTOR OF APPLIED ELECTRICITY AT THE  
SPRING GARDEN INSTITUTE,  
PHILADELPHIA

**FOURTH EDITION**



NEW YORK

D. VAN NOSTRAND COMPANY

23 MURRAY AND 27 WARREN STREETS

1903

QC 523  
.S95  
1903

---

Copyright, 1901, by C. WALTON SWOOPÉ.

---

By Transfer  
SEP 8 1916



## PREFACE

Five years ago the author prepared a private edition of "Lessons in Practical Electricity," which was published by the Spring Garden Institute for the use of its evening classes in practical electricity.

The demand for the book arose from two facts: First—these classes, being composed of young men engaged in various occupations who desired to obtain a beginner's knowledge of the principles and arithmetic of applied electricity, were very large; Second—an unsuccessful attempt was made to obtain a book suitable for thoroughly supplementing a combined course of lectures and individual laboratory work.

The educational success attained at the Institute, and also at several other schools which secured the privilege of obtaining copies of the edition (now exhausted), and the fact that the former situation had again to be met, seemed to warrant the preparation of the present volume, which has been entirely re-written and several hundred new illustrations introduced.

In day and evening schools of applied sciences the lecture room demonstrations and experiments are supplemented by individual laboratory work on the part of the student, this being recognized as essential to his best interests. Since the work of instruction is thus divided between the lecture hall and the laboratory, an attempt has been made to combine in this book: (1) the principles of electricity upon which the practical applications of to-day depend; (2) the experimental demonstration of these principles; (3) the elements of the arithmetic of electricity used in making practical electrical measurements and calculations.

Illustrations have been generously introduced to make the principles clear, in preference to pictures of electrical machinery in common use, these being supplemented by numbered experiments, which may be conducted with simple and inexpensive, yet efficient, apparatus such as that described, which was designed for, and is now used by the Institute.

A knowledge of fractions, decimals and simple proportion will enable the student to make nearly all the calculations, but if deficient in these subjects, he is advised to study the same in connection with this part of the book.

The numbered formulæ used throughout the text are simple expressions for the accompanying rules; the derivation of each being explained and illustrated by a practical problem completely solved, with each step indicated by the proper formula.

Questions at the end of each lesson are introduced as a special home work feature, and numerical unsolved problems, with answers, are also given at the end of many of the lessons for the same purpose.

A number of reference tables of useful information and experimental data have been inserted, and two large instruction plates inclosed in the cover pocket.

In the Appendix will be found a summary and index of the formulæ explained and used in the book, also some mensuration formulæ.

Permission for the reproduction of some cuts from Professor Jamieson's "Elementary Electricity" has been kindly granted by the publishers.

Prepared from necessity, rather than from any desire to increase the copious number of books on the subject, it is hoped that this volume will achieve the desired object and assist other collaborators in the same field.

PHILADELPHIA, September, 1901.

# CONTENTS.

## LESSON I.

### MAGNETISM.

	PAGE
Natural Magnets—Artificial Magnets—Definition of a Magnet— The Poles—Magnetic Attraction and Repulsion—Two Kinds of Magnetic Force—The Two Poles Inseparable—Magnetic Substances—Magnetisable Metals—Classification of Mag- nets—Questions, . . . . .	1

## LESSON II.

### MAGNETISATION.

To Make an Artificial Magnet—Magnetising Each Half Sepa- rately—Magnetisation by Divided Stroke—Magnetisation by an Electric Current—Magnetisation by an Electromagnet— Making Permanent Steel Magnets—Compound or Laminated Magnets—Horseshoe Magnets—Horizontal Magnetic Needle —Questions, . . . . .	6
--	---

## LESSON III.

### MAGNETIC FIELDS.

Magnetic Force—Magnetic Lines of Force—The Magnetic Field— Making Magnetic Fields—Axis and Equator of Bar Magnet— Questions, . . . . .	14
--	----

## LESSON IV.

### THEORY OF MAGNETISM.

The Nature of Magnetism—Experimental Proof of the Molecu- lar Theory of Magnetism—Breaking a Magnet—Magnetic Sat- uration—The Magnetic Difference Between Iron and Steel— Retentivity and Residual Magnetism—Destruction of Mag- netism by Heat—Strength of a Magnet—Lifting Power of a Magnet—Questions, . . . . .	22
--	----

## LESSON V.

## MAGNETIC INDUCTION.

	PAGE
Magnetic Induction Experiments—Magnetic Induction—Action and Reaction Equal and Opposite—Magnetic Inductive Effect of Like and Unlike Poles—Reversed Polarity—Consequent Poles—Magnetic Screens—Questions, . . . . .	28

## LESSON VI.

## MAGNETIC CIRCUITS.

Magnetic Circuits—Magnetic Bodies Free to Move—Test for the Distribution of Magnetism—Testing Distribution by a Needle's Oscillation—Pole Pieces, Armatures, and Keepers—Questions, . . . . .	36
---	----

## LESSON VII.

## EARTH'S MAGNETISM.

The Earth's Magnetism—Polarity of the Earth—The Earth's Magnetic Field and Equator—Graphical Field of the Earth's Magnetism—The Magnetic Meridian—Declination—Inclination or Magnetic Dip—Magnetic Maps or Charts—The Mariner's Compass—Magnetisation by the Inductive Effect of the Earth's Field—The Earth's Field Directive, Not Translative—Neutralizing the Earth's Attractive Force for a Needle—Astatic Needles—Questions, . . . . .	41
---	----

## LESSON VIII.

## VOLTAIC ELECTRICITY.

Electricity—Electrical Effects—Generation of Electric Currents by Chemical Means—A Current of Electricity—Simple Voltaic Cell—Volta's Pile—The Circuit—Conductors and Insulators—Direction of the Current—Poles or Electrodes and Plates—Detector Galvanometer—Potential and Electromotive Force—Chemical Action in a Voltaic Cell—Why the Hydrogen Appears at the Copper Plate—Polarization—Table II. Polarization Test—On What the Electromotive Force of a Cell Depends—Table III. The Electro-Chemical Series—Local Action—Amalgamation—Questions, . . . . .	49
--	----

## LESSON IX.

## BATTERIES

Primary Batteries—Open Circuit Cells—Closed Circuit Cells—Remedies for Polarization—The E. M. F. of Cells—Smee Cell—Bichromate Cell—Fuller Bichromate Cell—Partz Acid	
---	--

Gravity Cell—Bunsen and Grove Cells—Daniell Cell—  
 Leclanche Cell—Gonda Leclanche Cell—Carbon Cylinder  
 Cell—Edison-Lalande Cell—Chloride of Silver Cell—Dry  
 Cells—Classification of Cells—Chemicals for Cells and Some  
 Chemical Symbols—Questions, . . . . . 63

LESSON X.

ELECTROLYSIS.

Effects of the Current—Heating Effect—Magnetic Effect—Chemical  
 Effect—Electrolysis—Electrolysis of Copper Sulphate—  
 Electrolysis of Zinc Sulphate—Electrolysis of Lead Acetate—  
 Electroplating—Electrotyping—Polarity Indicator—Secondary  
 Batteries, Storage Batteries or Accumulators—Direction  
 of Current in an Accumulator on Charge and Discharge—  
 Commercial Storage Batteries—Questions, . . . . . 77

LESSON XI.

MEASUREMENT OF CURRENT STRENGTH.

Strength of Current—Variation of Current and Current's Effects  
 —How the Effects Vary with the Current Strength—Variation  
 of Effects with the Same Current Strength Through Dis-  
 similar Apparatus—Measurement of Current Strength—Defini-  
 tion of the Unit of Current Strength—Definition of a Unit  
 Quantity of Current Strength—The Ampere-Hour—Weight  
 Voltameters—Voltmeter Calculations—Construction of the  
 Gas Voltmeter—Current Strength Used in Electroplating  
 and in Commercial Apparatus—Questions and Problems, . . 87

LESSON XII.

RESISTANCE.

Resistance—Table V. Conductors and Insulators—The Unit of  
 Resistance—Laws of Resistance—Table VI. Resistance of a  
 Mil-Foot of the Metals—Calculation of Resistance—Wire  
 Measure—The Circular Mil—The Square Mil—The Wire  
 Gauge—Table of Conductivity and Resistivity of Metals—In-  
 ternal Resistance of a Battery—Questions and Problems, . . 103

LESSON XIII.

OHM'S LAW AND BATTERY CONNECTIONS.

Electromotive Force (Pressure)—Table IX. Electromotive  
 Forces of Batteries and Dynamos—Ohm's Law—Ohm's Law  
 Applied to a Battery Circuit—Methods of Varying Current  
 Strength—The Size of a Cell—Cells Connected in Series to  
 Increase the E. M. F.—Cells Connected in Parallel or Multi-

	PAGE
ple for Quantity—The Internal Resistance of Cells in Series— Current from Cells in Series—The Internal Resistance of Cells in Parallel or Multiple—Current from Cells in Parallel or Multiple—Advantage of Parallel Connection—Advantage of Series Connection—Cells grouped in Multiple Series—In- ternal Resistance of Any Combination of Cells—Current Strength from Any Combination of Cells—Cells Connected in Opposition—Questions and Problems, . . . . .	118

## LESSON XIV.

### CIRCUITS AND THEIR RESISTANCE.

Conductance of a Circuit—Resistances in Series—Equal Resist- ances in Parallel (Joint Resistance)—Unequal Resistances in Parallel—Conductivity Method for Conductors in Parallel— Resistances Joined in Multiple-Series—Division of Current in a Divided Circuit—Potential Difference in Multiple Cir- cuits—Current in Branches of Multiple Circuits—Shunts— Rheostats—Resistance of Connections—Laboratory Rheo- stats—Table X. Resistance of Commercial Apparatus— Questions and Problems, . . . . .	140
---	-----

## LESSON XV.

### ELECTROMAGNETISM.

Electromagnetism—Direction of the Lines of Force of a Straight Current-Carrying Wire—Deflection of a Horizontal Magnetic Needle—Right-Hand Rule for Direction of Whirls—Right- Hand Rule for Direction of Current or Deflection of Needle —Magnetic Field of a Circular Wire Carrying a Current— Magnetic Field of a Circular Current—The Helix and Sole- noid—Testing the Polarity of a Solenoid—Rules for Deter- mining the Polarity of a Solenoid—Graphical Field of a Sole- noid—Questions, . . . . .	153
---	-----

## LESSON XVI.

### GALVANOMETERS.

Principle of the Galvanometer—Detector Galvanometer—The Use of Long and Short Coil Galvanometers—Classification of Galvanometers—Relative Calibration of a Tangent Galva- nometer—The Tangent of an Angle—Student's Combination Tangent Galvanometer—Directions for Setting up Student's Combination Galvanometer—Variation of Needle's Deflection With the Turns and Diameter of Coil—Use of the Tangent Galvanometer as an Ammeter—Thomson Mirror Reflecting Galvanometer—Astatic, Differential and Ballistic Galvanome- ters—Table XI. Natural Sines and Tangents—Table XII. Tangent Galvanometer Constants—Questions, . . . . .	167
---	-----

LESSON XVII.

ELECTROMAGNETS.

	PAGE
Magnetisation of Iron and Steel by an Electric Current—Magnetic Field of an Electromagnet—Attractive Force of a Solenoid for an Iron Core—Magnetic Circuits—Typical Forms of Electromagnets, Their Construction and Use—Magnetising Force, Ampere-Turns—Reluctance—Coarse and Fine Wire Electromagnets—Testing the Attractive Force of an Electromagnet—Table XIII. Tractive Force and Magnetic Induction—Questions, . . . . .	184

LESSON XVIII.

AMMETERS

Measurement of Current Strength, Ampere-Meters—Gravity Ammeter—Connecting Ammeters in Circuit—Balance Beam Ammeter—Thomson Inclined Coil Ammeter—Weston Ammeter—Weston Ammeter Shunt—Questions, . . . . .	200
---	-----

LESSON XIX.

ELECTRICAL WORK AND POWER.

Force—Different Kinds of Force—Mass and Weight—Work—Power—Horse Power of a Steam Engine—Difference Between Energy, Force, Work, and Power—Electrical Work—Electrical Power—Heat and Work—Equivalents of Mechanical and Electrical Work—Electrical Horse Power—The Kilowatt—The Watt-Hour and Kilowatt-Hour—Electrical Power Calculations—Electrical Power Formulæ—Power from Cells—Efficiency of a Battery—Questions and Problems, . . . . .	209
--	-----

LESSON XX.

MEASUREMENT OF PRESSURE.

Electromotive Force and Potential Difference—Hydraulic Analogy to Illustrate "Volts Lost"—Volts Lost in an Electric Circuit—Variation of P. D. in a Circuit—Variation of Potential Difference with Variation of External Resistance—Table XIV. Variation of Current, Pressure, and Resistance—Measurement of E. M. F. and P. D.—Construction of Voltmeters—Weston Voltmeter—Connecting Voltmeters—Measuring High Voltages with Low Range Instrument—Volts Lost in Wiring Leads—Comparison of E. M. F. of Cells by the Potentiometer.—Questions and Problems, . . . . .	228
--	-----

CONTENTS.

LESSON XXI

MEASUREMENT OF RESISTANCE.

	PAGE
Measurement of Resistance (Fall of Potential Method)—Measuring the Resistance of Arc and Incandescent Lamps while Burning—Measurement of Resistance (Substitution Method)—Drop Method of Comparison—Voltmeter Method—By Weston Instruments—Measurement of Resistance—Wheatstone Bridge (Principle of Slide Wire Pattern)—Lamp Chart Analogy of Wheatstone Bridge—Construction and Use of Slide Wire Bridge—Student's Wheatstone Bridge (Lozenge Pattern)—Operating the Bridge—To Measure a Higher Resistance Than That in the Rheostat—To Measure a Low Resistance—The Best Selection of Resistances for the Bridge Arms—Commercial Wheatstone Bridge—Direct Reading Ohmmeter—Questions and Problems, . . . . .	247

LESSON XXII.

ELECTRICAL DEVELOPMENT OF HEAT.

Heating of Conductors and Their Safe Carrying Capacity—Table XV. Current-Carrying Capacity of Copper Wires—Electrical Development of Heat—Electrical Equivalent of Heat—Joule's Law—Relation Between Heat, Mechanical and Electrical Energy—Relation of Fahrenheit and Centigrade Thermometer Scales—Relation of Resistance to Temperature—Table XVI. Temperature Coefficients—Fuses and Cut-Outs—Table XVII. Gauges of Different Wires Fused by 100 Amperes—Electric Cautery, Blasting, Welding, and Cooking—Questions and Problems, . . . . .	265
---	-----

LESSON XXIII.

ELECTRODYNAMICS.

Reaction of a Current-Carrying Wire on a Magnet—Automatic Twisting of a Current-Carrying Wire Around a Magnetic Pole—Rotation of a Current-Carrying Wire Around a Magnetic Pole—Electrodynamics—The Magnetic Fields of Parallel Currents—Laws of Parallel and Angular Currents—Currents in Angular Conductors—The Electro-dynamometer Portable Dynamometer Ammeter—Dynamometer Wattmeter Thomson Recording Wattmeter—Questions, . . . . .	276
---	-----

LESSON XXIV.

ELECTROMAGNETIC INDUCTION.

Electromagnetic Induction—Currents Induced by a Magnet in a Wire—To Find the Direction of the Induced Current (Fleming's Right-Hand Rule)—Upon what Factors the Induced	
---	--



PAGE

E. M. F. Depends—Currents Induced in a Coil by Motion of a Magnet—Primary and Secondary Coils—Lenz's Law of Induced Currents—Classification of Induced Currents—Currents Induced by Electromagnetism—Five Methods of Producing Induced Currents—Table XVIII. Induction Currents—Variation of Induced E. M. F., with the Rate of Change of Magnetic Lines of Force (Faraday's Law)—Eddy Currents—(Arago's Rotation)—Mutual Induction—Self-Induction—Gas Lighting Spark Coil—Inductance—Reactance and Impedance—Choke Coils—Neutralizing the Effects of Self-Induction—Questions, . . . . . 293

LESSON XXV.

THE INDUCTION COIL.

Principle of the Induction Coil or Transformer—The Induction Coil—The Action of the Coil—Action of the Condenser—Construction of Induction Coils—Wehnelt Electrolytic Interrupter—Spark Coil Data—Vacuum Tubes—Roentgen Rays (X-Rays)—The Fluorescing Screen and Fluoroscope—The Telephone—The Microphone Principle—The Blake Microphone Transmitter—The Telegraph—The Signal System and Circuits—Electric Waves—Wireless Telegraphy—Questions, . . . . . 315

LESSON XXVI.

DYNAMO-ELECTRIC MACHINES.

The Dynamo—Classification of Dynamos—A Simple Dynamo—Alternating Current Dynamo—Graphic Representation of an Alternating Current—Magneto Alternator—Simple Direct Current Dynamo—Graphic Representation of a Direct Current—Multi-Coil Armatures—Gramme Ring Armatures—Induced E. M. F. in a Ring Armature—Siemens Drum Armature—Advantages of Drum and Ring Armatures—Drum-Wound Ring Armatures—Open Coil Armatures—Questions, 334

LESSON XXVII.

ARMATURES.

Armature Core Construction—Eddy Current Loss—The Commutator and Brushes—Armature Core Insulation—Armature Winding—Armature Core Loss—Hysteresis—Armature Reactions—The Act of Commutation of an Armature Coil—Sparking at the Brushes—Position of the Brushes—Causes of Sparking—Capacity of a Dynamo—Commercial Rating of Dynamos—Losses in a Dynamo—Efficiency of a Dynamo—Questions, . . . . . 355

LESSON XXVIII.

DIRECT CURRENT DYNAMOS.

PAGE

Bipolar Field Magnets—Multipolar Field Magnets—Multipolar Field Armature Circuits—Constant Current and Constant Potential Dynamos—Classification of Dynamos According to Their Field Excitation—The Self-Exciting Principle of Direct Current Dynamos—The Shunt Dynamo (Constant Potential, D. C.)—Action of the Shunt Dynamo—Action of the Series Dynamo (Constant Current)—Compound Machines (Constant Potential)—Compound Dynamos in Parallel—The Equalizer—Questions and Problems, . . . . . 372

LESSON XXIX.

DIRECT CURRENT MOTORS.

Comparison Between a Dynamo and Motor—Principles of the Motor—Direction of Rotation of Series and Shunt Motors—Position of the Brushes on a Motor—Counter Electromotive Force of a Motor—Normal Speed of a Motor—Mechanical Work Performed by a Motor—Torque—Output and Rating of Motors—Motor Speed and Torque—Methods of Motor Speed Regulation—Speed Regulation of Series Motors—Series Motors for Railway Work—Operating Motors—Efficiency of a Motor—Electric Traction—Questions and Problems, . . . 393

LESSON XXX.

ELECTRIC LIGHTING.

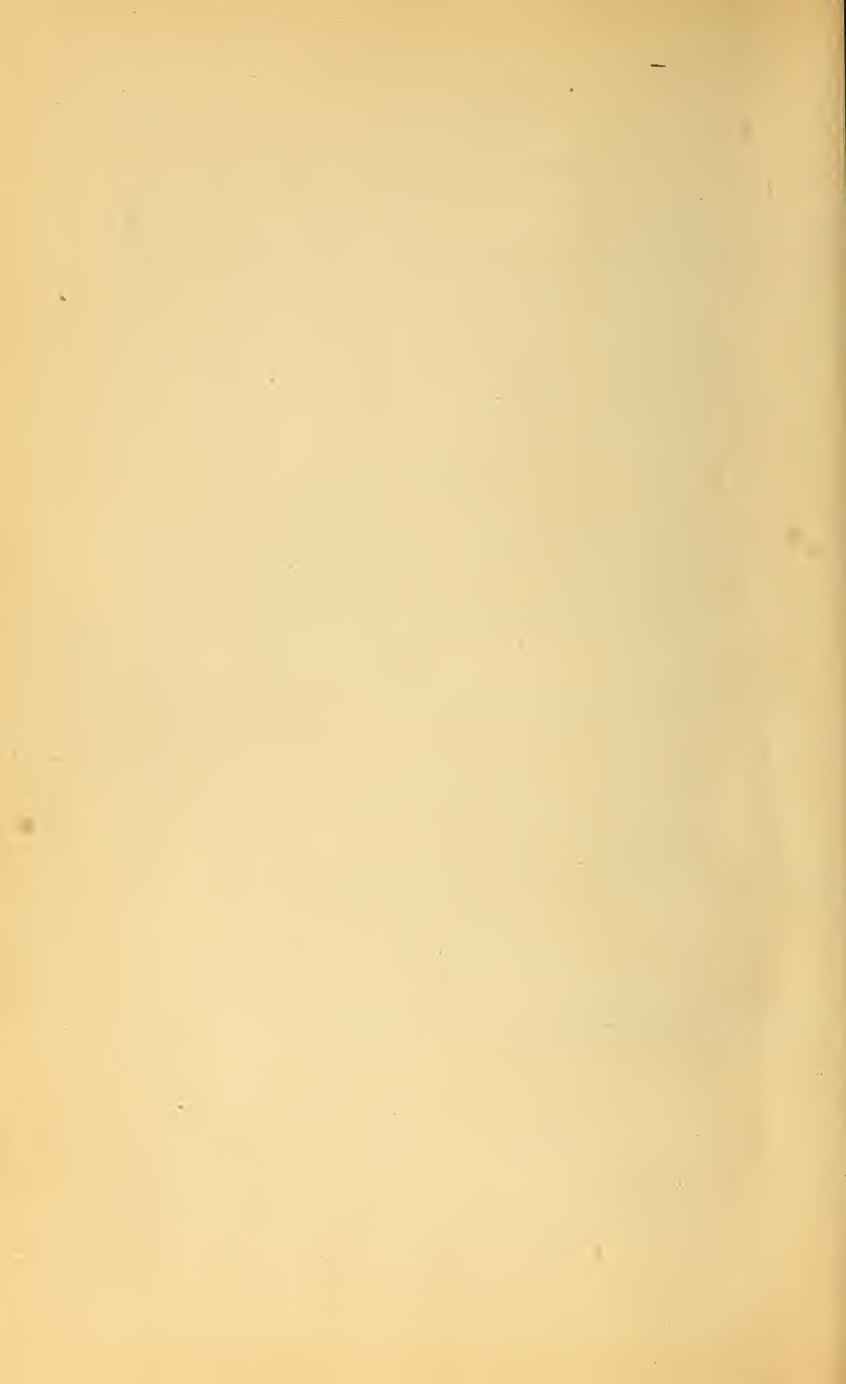
The Electric Arc—Crater of the Arc—Types of Arcs—Rating of Arc Lamps—Arc Lamp Carbons—Arc Lamp Regulation—Inclosed Arcs—Alternating Current Arcs—Arc Lamp Circuits—Incandescent Lamps—The Lamp Filament—Commercial Rating of Incandescent Lamps—Life and Efficiency of a Lamp—Incandescent Lamp Circuits—Potential Distribution in Multiple Lamp Circuits—Loss on Transmission Lines—Incandescent Wiring Calculations—The Three-Wire System—Motor Wiring Calculations—Questions and Problems, . . . 415

LIST OF TABLES.

TABLE		PAGE
I.	Oscillation Test, . . . . .	38
II.	Polarization Test, . . . . .	59
III.	Electro-Chemical Series, . . . . .	60
IV.	Value of Current Strengths Used in Practice, . . . . .	101
V.	Conductors and Insulators, . . . . .	105
VI.	Resistance of a Mil-Foot of the Metals, . . . . .	110
VII.	B. & S. Wire Gauge, . . . . .	113
VIII.	Comparative Conductivity and Resistance of Metals, . . . . .	115
IX.	E. M. F. of Batteries, . . . . .	118
X.	Resistances of Commercial Apparatus, . . . . .	150
XI.	Natural Sines and Tangents, . . . . .	173
XII.	Tangent Galvanometer Constants, . . . . .	176
XIII.	Tractive Force and Magnetic Induction, . . . . .	198
XIV.	Variation of Current Pressure and Resistance, . . . . .	235
XV.	Current Carrying Capacity of Copper Wires, . . . . .	266
XVI.	Temperature Coefficients, . . . . .	272
XVII.	Gauges of Different Wires Fused by 100 Amperes, . . . . .	273
XVIII.	Induction Currents, . . . . .	303
XIX.	Sparking Distances in Air, . . . . .	321
XX.	Spark Coil Dimensions, . . . . .	323
XXI.	Insulation Test, . . . . .	359
XXII.	Motor Test, . . . . .	401
XXIII.	Definition of Practical Electrical Units, . . . . .	445
XXIV.	Equivalents of Units of Length, . . . . .	446
XXV.	Equivalents of Units of Area, . . . . .	447
XXVI.	Equivalents of Units of Volume, . . . . .	447
XXVII.	Equivalents of Units of Weight, . . . . .	448
XXVIII.	Equivalents of Units of Energy and Work, . . . . .	449
XXIX.	Comparative Table of Gauges, . . . . .	450
XXX.	Decimal Equivalents, . . . . .	451
XXXI.	Volts Loss on Copper Wire, . . . . .	451
XXXII.	Useful Equivalents of Electrical Heating, . . . . .	452

APPENDIX.

	PAGE
Summary of Formulæ, . . . . .	436
Mensuration Formulæ, . . . . .	443
Tables XXIII to XXXII, . . . . .	445
Instruction Plates (2), . . . . .	Cover pocket.



# LESSONS IN PRACTICAL ELECTRICITY.

## LESSON I.

### MAGNETISM.

Natural Magnets—Artificial Magnets—Definition of a Magnet—The Poles—Magnetic Attraction and Repulsion—Two Kinds of Magnetic Force—The two Poles Inseparable—Magnetic Substances—Magnetisable Metals—Classification of Magnets—Questions.

**1. Natural Magnets.**—The name magnet was first applied by the ancients to brown-colored stones, known as magnetic oxide of iron ( $\text{Fe}_3\text{O}_4$ ) because these, as taken from the earth, possessed the peculiar property of attracting small pieces of iron or steel. Later the Chinese discovered that if a piece of the ore were freely suspended by a string it possessed the important property of pointing always in a particular direction, nearly north and south; hence they gave it the name of *lodestone* (meaning leading stone), and used it in this manner to navigate their ships. Excellent iron is made from magnetic oxide of iron which is found in the United States (Arkansas) and various other parts of the world. In studying the magnetic attractive force of a piece of lodestone by means of iron filings, it will be found that the attraction for the filings seems to be centered at two or more points on the stone, while at other points no filings are attracted.

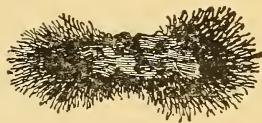


Fig. 1.—Natural Magnet Attracting Iron Filings.



Fig. 2.—Magnetised Steel Bar Attracting Iron Filings.

**2. Artificial Magnets.**—The natural magnet possesses yet a third important property, namely, that of imparting all of its properties to

a piece of hard iron or steel when they are rubbed together without apparently losing any of its original force. This steel (a piece of clock spring or a knitting needle will answer) will now attract filings, when freely suspended come to rest in a northerly and southerly direction, and can be used to magnetise another piece of steel.

Strong artificial magnets are not made from the lodestone, as its magnetic force is not strong, but by better methods to be mentioned later. Figs. 1 and 2 illustrate a natural and artificial steel magnet attracting filings.

**3. Definition of a Magnet.**—Given two pieces of similar steel, one of which is a magnet and the other not magnetised, how would you determine the magnet? Plunge each piece of steel into iron filings; only the magnetised bar will attract them. Suspend each specimen separately in a stirrup fastened to the end of an untwisted thread, the magnet will come to rest pointing nearly north and south. When turned from this position it again assumes it, while the piece of unmagnetised steel, when so suspended, will rest indifferently in any position. As a third test, the magnetised piece of steel

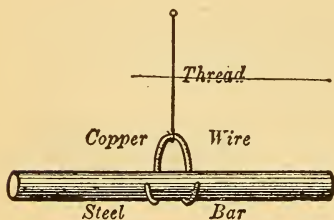


Fig. 3.—Testing a Magnet.

can impart its power to another piece of steel. From these tests then we can define a *magnet as a piece of steel, or other magnetised substance, which possesses the properties of attracting other pieces of steel or iron, or magnetisable bodies to it, and of pointing, when freely suspended in a horizontal position, toward the north pole of the earth.*

**4. The Poles.**—The ends of a magnet are termed its poles. The end which points toward the north geographical pole is generally called the North pole, and is usually marked on that end of the magnet by an **N**, or a line cut in the steel, while the other unmarked end is the South (**S**) pole.

By the term *polarity* we mean the nature of the magnetism at a particular point; that is, whether it is **N** or **S**-seeking magnetism.

**5. Magnetic Attraction and Repulsion.**—Suspend a bar magnet in a stirrup, as in Fig. 3, ascertain and mark its

**N**-pole and then bring near it the **N**-seeking pole of another bar magnet held in your hand. The **N**-end of the suspended magnet is repelled by the **N**-end of the magnet in your hand,



Fig. 4.—**N**-Pole Repels **N**-pole.

while the **S**-end of the suspended magnet is attracted by this same **N**-end. In a similar manner it will be found that the two **S**-poles, repel each other, while either **S**-pole attracts the unlike, or **N**-pole. Repeat the above experiments with two pieces of magnetite, first ascertaining their **N** and **S**-seeking points. The **N**-seeking pole of one piece repels a like, or **N**-pole, of the other piece, but attracts a **S**-pole; thus, *Like poles repel each other but unlike poles attract each other.*



The same experiment can be made with a piece of magnetite and a bar magnet. If the poles of two bar magnets, one held in each hand, be plunged into iron filings and then the **N**-poles approached to each other, the magnetic force of repulsion will be clearly noted by the repellent action of the



Fig. 5.—**S**-Pole Attracts **N**-Pole.

filings on the two magnets. If unlike poles are thus approached, the attractive force is shown by the filings bridging the air gap between the poles.



### 6. Two Kinds of Magnetic Force.—

The above experiments would indicate two kinds of magnetism, or two kinds of magnetic poles, which attract or repel each other, one pole tending to move toward the geograph-

ical **N**-pole, and the other pole, toward the geographical **S**-pole. Since we have called the **N**-pointing, or marked pole, the **N**-pole, and have shown that like poles repel each other, then the magnetism of the earth near the **N**-geographical pole must be of the opposite kind, or **S**-magnetism, since unlike poles attract each other. The true **N**-magnetic pole of the earth's magnetism is considered in ¶ 48.

**7. The Two Poles Inseparable.**—If a piece of steel be rubbed with only one pole of a magnet it will have a **N** and **S**-pole. Upon breaking it into two equal pieces each piece will have a **N** and **S**-pole. It is impossible to produce a magnet with only one pole. A steel bar may have more than two poles, ¶ 40, but always, at least, two opposite poles.

**8. Magnetic Substances.**—There is a distinction between magnets and magnetic substances. A magnet attracts only at its poles, each of which possesses opposite properties. A piece of iron will attract a magnet, no matter what part of it is approached to the magnet; it does not possess fixed poles or a neutral point, while a magnet has at least two poles, one of which always repels one pole of another magnet.

**9. Magnetisable Metals.**—The *magnetic metals* used in practice are *steel* and *iron*. Beside these, the metals nickel, cobalt, chromium, and cerium are attracted by a magnet, but only very feebly. Nickel and cobalt are the best of this class, but are very inferior to iron or steel. For practical purposes all other substances such as copper, lead, gold, platinum, wood, rubber, glass, etc., may be regarded as unmagnetisable, or *non-magnetic* substances. Magnetic attraction or repulsion will, however, take place through these substances.

#### 10. Classification of Magnets.—

Magnets.	{	Natural—The lodestone.	
		Artificial—Steel rubbed with lodestone.	
Artificial Magnets.	{	Permanent—Steel bar magnet.	
		Temporary {	Iron under the influence of a permanent steel magnet.
			Electromagnet—Iron magnetised by an electric current.

#### QUESTIONS.

- ✓ 1. What is a natural magnet?
- ✓ 2. What three important properties does it possess?
- ✓ 3. How would you locate the poles on a natural magnet?



4. Distinguish between a natural and an artificial magnet.

5. You are given two similar bars of steel, only one of which is magnetised. What tests would you apply to determine which one is magnetised?

6. Define a magnet.

7. State the law regarding magnetic attractions and repulsions.

8. How would you prove that a magnet must always have at least two poles?

9. What is the difference between a magnet and a magnetic substance?

10. Describe how you would magnetise a sewing needle with a piece of lodestone.

11. What do you mean by polarity?

12. A bar magnet is floated on a cork, the **N**-end is toward the observer. What occurs when a **S**-pole is approached to the **S**-end of the floating magnet? What effect when the **N**-end is approached to this same end?

13. What is the difference between a permanent and a temporary magnet? Give an example of each class.

14. You are given a hard steel bar with a notch filed at one end. How would you magnetise it by using the **N**-pole of a magnet so that the notched end would have a **N**-pole?

15. A number of steel needles are inserted vertically into an equal number of corks which are then floated in a jar of water with the eyes of the needles upwards. How will the needles behave when the **N**-pole of a bar magnet is approached to them?

16. Suppose that the eyes of the needles in question 15 are of **S**-polarity, how will they act when the **S**-pole of a magnet is approached to them?

17. What two tests would you apply to prove that although a piece of iron attracts the **N**-pole of a suspended bar magnet yet it is not itself a magnet?

18. Give a general classification of magnets, citing an example to illustrate each class.

## LESSON II.

### MAGNETISATION.

To Make an Artificial Magnet—Magnetising Each Half Separately—Magnetisation by Divided Stroke—Magnetisation by an Electric Current—Magnetisation by an Electromagnet—Making Permanent Steel Magnets—Compound or Laminated Magnets—Horseshoe Magnets—Horizontal Magnetic Needle—Magnetic Dip Needle—Questions.

**11. To Make an Artificial Magnet.**—Secure a piece of hard-tempered steel (about 6'' x  $\frac{1}{2}$ '' x  $\frac{1}{4}$ '') and mark one end with a file, which will be the N-pole. Place the steel on a table and, beginning at the unmarked end of the steel bar, stroke its entire length with the south end of a strong artificial magnet. Lift the magnet clear at the end and return again for a second stroke in the direction of the dotted line

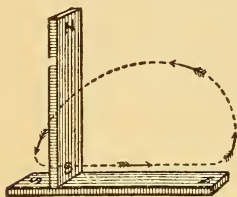


Fig. 6.—Single Stroke.

and arrows in Fig. 6. Stroke it about ten times in this manner and then repeat a similar stroking process on the other three sides of the bar. Plunge the newly made steel magnet into filings or small tacks, and note the distribution of magnetism. Suspend it horizontally in the stirrup and observe whether the marked end points toward the north when it comes to rest. Note that the N-pole in the magnet you have made was always touched last by the S-pole of the magnetising magnet. One pole always induces the opposite pole in any magnetisable body at the point which was touched last by the S-pole of the magnet. One pole always induces the opposite pole in any magnetisable body at the point where the pole last leaves that body. ¶ 36.

**12. Magnetising Each Half Separately.**—A better magnet will be obtained by magnetising each half separately, as illustrated in Fig. 7. Stroke one-half of the steel bar with the S-pole, beginning at the centre and following the direction of the dotted line. Repeat this a number of times on each side; then using the N-pole, stroke the other half in the same way. A horseshoe-shaped magnet can be used to magnetise another piece of steel by stroking in the direction

of the arrows, as in Fig. 8. In stroking the opposite side, the same limb of the horseshoe must be brought into contact

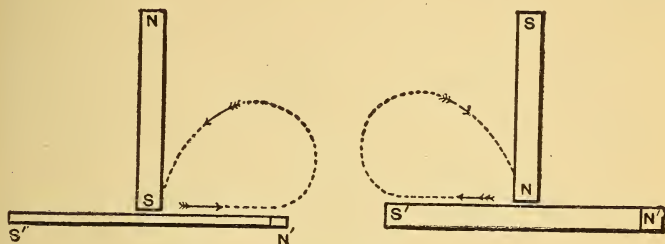


Fig. 7.—Magnetising Each Half Separately.

with the same pole, as before. A piece of soft iron laid across the ends of the horseshoe while being magnetised will give better results.

**13. Magnetisation by Divided Stroke.**—Place the steel bar to be magnetised on two other bar magnets, as shown in Fig. 9. Take two additional magnets, one in each hand, with the polarities indicated, and proceeding from the centre, with unlike poles, stroke towards the ends in the direction of the dotted lines. Turn the bar over and repeat the operation about ten times on each side.

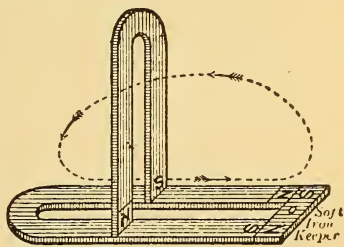


Fig. 8.—Magnetising a Horseshoe Magnet.

**14. Magnetisation by an Electric Current.**—If a number of turns of insulated wire be wrapped around the steel bar

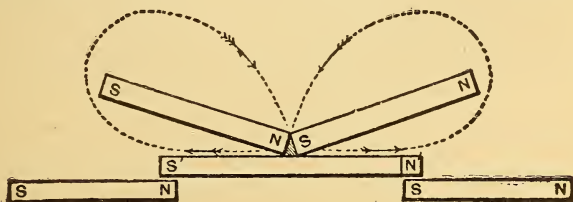


Fig. 9.—Magnetisation by Divided Stroke.

to be magnetised, and a strong current of electricity passed through the coil from a battery or dynamo, as in Fig. 10, the steel will be permanently magnetised with a **N** and **S**-pole, after the current is turned off. Tapping the end of the steel with a hammer, while it is under the influence of the current, will produce better results. Instead of winding the wire around the bar, the bar can be inserted in a spool containing many turns of insulated wire (such as EM, Fig. 11, which can be slipped off of its iron core) when a stronger magnet will

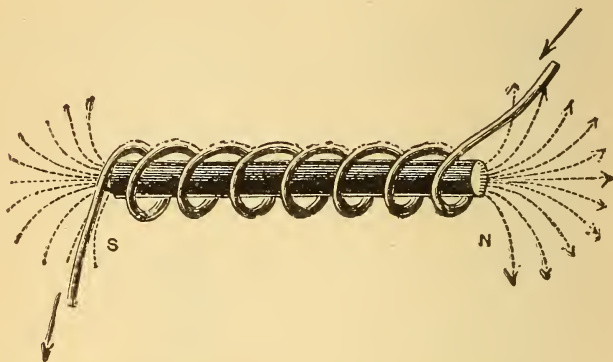


Fig. 10.—Magnetisation by an Electric Current.

be obtained. In making a horseshoe magnet by this method insert one limb all the way in the spool; turn on the current; tap it; turn off the current; remove this limb, and insert the other limb in the opposite end of the coil and repeat the operations. You will now have a magnet, the strength of which, until the saturation point of the steel is reached, will depend on the current strength, and the number of turns of wire on the spool.

**15. Magnetisation by an Electromagnet.**—A bar electromagnet (i. e., the above spool and its iron core) may be substituted for the permanent steel magnets used in the previous methods for making a magnet, or two bar electromagnets connected by a piece of soft iron forming a horseshoe electromagnet may be used (see Fig. 11.) In this case the current is passed through one spool in one direction, and then through the other spool in the opposite direction, when the

free ends of the core will have a **N** and **S**-pole. One-half of the bar to be magnetised can now be stroked over one pole,

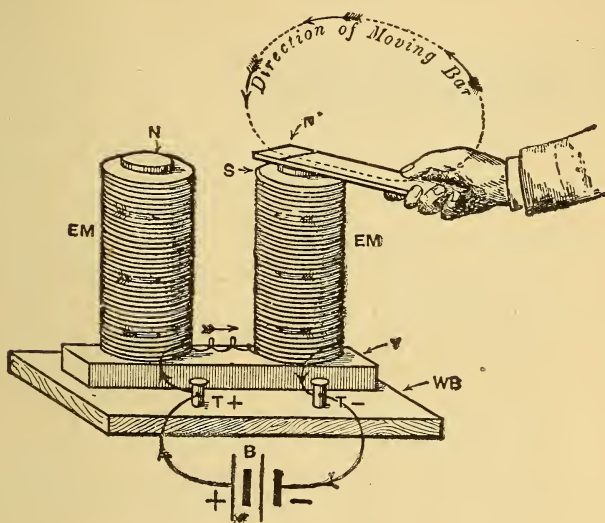


Fig. 11.—Magnetisation by an Electromagnet.

beginning at its middle point and following the direction of the dotted lines in Fig. 11, stroke on all sides, and then stroke the other half of the bar on the other pole.

**16. Making Permanent Steel Magnets.**—The artificial magnets in paragraphs 2 and 11 are called permanent magnets because they retain their magnetism permanently, to a certain extent, after magnetisation. Some qualities of steel which possess good machine tool properties are not adapted



Fig. 12.—Round Bar Magnet.

to making good permanent magnets. Steel containing a certain percentage of manganese cannot be magnetised, while some brands of cast steel, spring steel, and mild plate steel are readily magnetised, but do not retain their magnetism

permanently. Jessop's steel is well adapted to making good permanent magnets. Select a piece of good, close-grained, rolled steel that has not been heated since it was made and

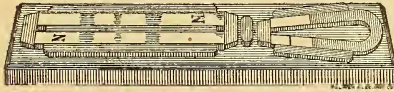


Fig. 13.—Student's Bar Magnet Set.

cut it (about  $6'' \times \frac{1}{4}'' \times \frac{1}{4}''$  or  $12'' \times 1'' \times \frac{3}{16}''$ ). Temper the steel glass-hard by heating it to a moderately bright red temperature and then plunging edgewise into water or oil. It will become very brittle and can be magnetised by any of the methods hereafter given. A permanent magnet will have its strength materially weakened if subjected to shocks or blows, a high temperature, or brought carelessly into contact with the poles of other strong magnets.

**17. Compound or Laminated Magnets.**—If a thick piece of steel be magnetised and then placed in an acid bath (such as nitric acid) for some time, whereby the outer surface is eaten off, and then tested for magnetic qualities, it will be found to be almost entirely demagnetised. From this experiment it is inferred that the magnetism has



Fig. 14.—Compound Bar Magnet.

only penetrated the surface of the steel. If a permanent magnet then be made up of a number of thin pieces of steel, magnetised separately, and fastened together with like poles at the same end, it will be stronger than one of solid steel of the same dimensions, because it is more thoroughly magnetised. Such magnets can be made in any form and are known as *compound* or *laminated* magnets.

**18. Horseshoe Magnets.**—When a straight bar of steel is bent into the form of a horseshoe, and then properly magnet-

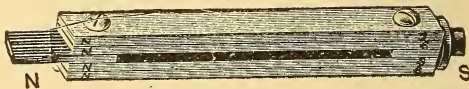


Fig. 15.—Compound Magnet with Soft Iron Pole Pieces.

ised, the end of one limb will be a **N**-pole and the other a **S**-pole. By bringing the poles close together in this manner, the magnet will lift, or attract much more than the sum of

the attractive forces when used separately ; because, in a bar magnet only one pole could be used at a time, while now both poles act together. A piece of soft iron, called the "keeper," is placed across the ends of the poles when they are not in use, to assist in preventing the loss of magnetism.

Fig. 16 illustrates a horseshoe magnet of rectangular cross section with its keeper attached. Fig. 13 illustrates the proper method of putting away two bar magnets with their keepers, to prevent loss of magnetism ; the unlike poles are placed at the same end, with the keeper connecting them. A laminated, or compound



Fig. 16.—Horseshoe Magnet and Keeper.

horseshoe magnet, built up of a number of separate horseshoes and fastened together with their like poles at the same end, is depicted in Fig. 17. Laminated horseshoe magnets are used in electrical measuring instruments, magneto-electric generators, and in telephones.

**19. Horizontal Magnetic Needle.**—The magnetic needle with its stand is shown in Fig. 18. It consists of a thin

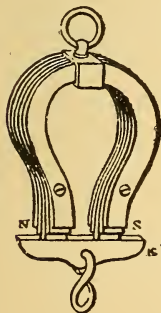


Fig. 17.—Compound Horseshoe Magnet With Keeper.

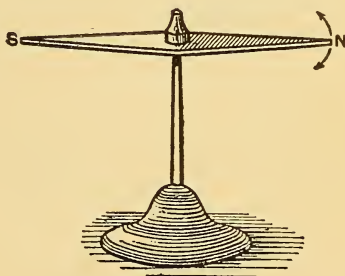


Fig. 18.—Horizontal Magnetic Needle.

piece of magnetised steel in the form of an elongated lozenge, in the centre of which a hole has been drilled, and a glass, agate, or brass V-shaped jewel affixed, so that the needle

will swing freely when poised on a hardened steel point. The needle takes up a position **N** and **S** when at rest similar to the suspended bar magnet. Sometimes the needle is suspended from a vertical support by a cocoon silk fibre, in which case it is much more sensitive, due to the elimination of the friction in the poised form. Both types are much used commercially in electrical detecting and measuring instruments, as in the mariner's compass, galvanometers, etc.

**20. Magnetic Dip Needle.**—This needle is made in the form of a lozenge, similar to the horizontal needle, but it is poised or suspended by means of a shaft running through the

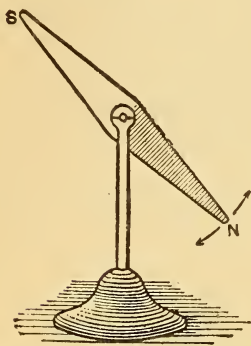


Fig. 19.—Magnetic Dip Needle.

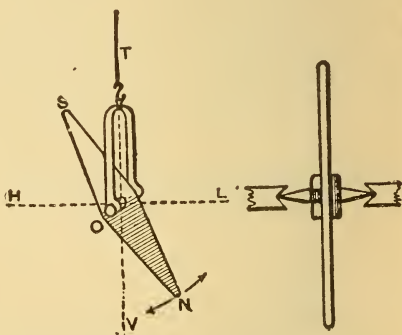


Fig. 20.—Magnetic Dip Needle.

centre of the lozenge at right angles to it, and is held in position by brass V centres, or agate bearings, as shown in Figs. 19 and 20. It is thus free to turn vertically. In some types the cradle holding the horizontal shaft is poised on a steel needle, or swung by fibre suspension. The needle is thus free to take up a position **N** and **S**, and to incline on its axis. The principle and use of the dipping needle is explained in ¶ 52.

### QUESTIONS.

1. How would you magnetise a steel sewing needle by the method of magnetising each half separately, so that the eye would be a **N**-pole? Give sketch.
2. How would you magnetise a steel horseshoe magnet by the



“Divided Stroke Method” so that the marked end would be a **N**-pole? Give a sketch to illustrate your answer.

— 3. What is an electromagnet?

— 4. Given a coil of wire, a battery, and a piece of iron, how would you magnetise the iron? What kind of a magnet would it be after the circuit was disconnected?

— 5. How would you magnetise a steel horseshoe by an electromagnet? Suppose you only had a coil of wire connected to a battery, how then would you proceed?

— 6. What kind of steel would you select to make a good, permanent magnet?

— 7. What care is necessary in handling permanent magnets?

— 8. What is a compound magnet? How would you put four horseshoe magnets together to make a compound magnet?

— 9. What is the advantage of laminated magnets over those made from solid steel?

— 10. Describe a horizontal magnetic needle. For what purpose is it used?

— 11. What is a dip needle? How does it differ from a horizontal needle?

— 12. Show by a sketch how three bar magnets should be put away without keepers, so that they would retain their magnetism.

— 13. A laminated permanent magnet is constructed of four strong bar magnets but appears to be very weak. What do you suppose the trouble is, and how would you prove the supposition?

— 14. A piece of hard steel, bent in the form of a U, is to be magnetised so that both ends will have **N**-polarity. Illustrate by a sketch how you would proceed to magnetise it by the “divided stroke” method, using four permanent magnets, and indicate all the polarities.

— 15. How would you magnetise a steel pen, using a horseshoe magnet, so that the point would be a **N**-pole? Give two tests you would make to prove that you had magnetised it correctly. Make sketch.

## LESSON III.

### MAGNETIC FIELDS.

Magnetic Force—Magnetic Lines of Force—The Magnetic Field—  
Making Magnetic Fields—Axis and Equator of Bar Magnet—  
Questions.

**21. Magnetic Force.**—The force exerted by one magnet on another, to attract or repel it, or to attract iron filings, or pieces of iron, is termed magnetic force. It is not perceptible to any of the senses. When the magnet has been plunged into filings, the space thus occupied is shown to be permeated with the force, and the filings serve as a useful indicator to show the nature of the force and its direction and distribution in the space surrounding the magnet. The magnetic force is not the same at all distances, but decreases as the distance from the magnet increases. The attractive force between a magnet and a piece of soft iron is mutual, that is, the iron attracts the magnet just as much as the magnet attracts the iron. This may be illustrated by suspending a piece of iron in a stirrup, as in Fig. 3, and noting the distance at which it is attracted by a magnet, and then suspending the magnet and permitting the iron to occupy the previous position of the magnet; or the magnet may be floated on a cork in a jar of water, and it will be equally attracted by the piece of iron.

**22. Magnetic Lines of Force.**—The magnetic force emanates in all directions from a magnet. To ascertain the direction of the force in the space surrounding a magnet, a

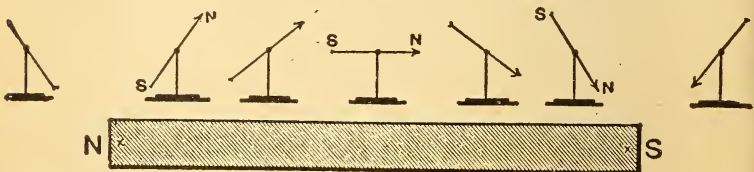


Fig. 21.—Exploring the Magnetic Field with a Dip Needle.

small dipping needle, as in Fig. 21, or a magnetised sewing needle suspended by a thread from its centre, as in Fig. 22, may be used. With the bar magnet flat on the table, place the exploring needle a short distance above the magnet, midway between its two poles. The needle takes up a position parallel to the magnet, with its **N** and **S**-poles attracted by the unlike poles of the magnet, the attractions of the poles being equal. Now move the dipping needle a little to the right of the middle position, and it inclines to the magnet, the angle of inclination increasing as you approach the pole, till it becomes vertical at the pole; if carried past the end of the bar it still inclines to the pole, indicating by its resultant position the direction of the magnetic force at this point. In a similar manner the dipping position underneath the magnet may be noted. Place the magnet on a sheet of paper and make a similar exploration of it with your suspended needle. Mark with a pencil on the paper a dot and **X** to represent the **N** and **S**-pole of the needle when it comes to rest for each particular position. A line may then be drawn connecting each dot with its **X**, and the direction of the magnetic force around the magnet will be illustrated graphically in the form of a curve similar to Fig. 23. From these experiments it is deduced that magnetic force is exerted in all directions from a magnet. In similar manner, another series of positions could be taken about

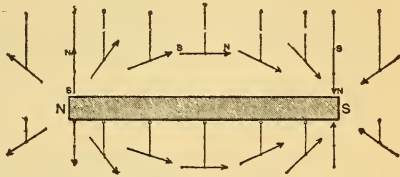


Fig. 22.—Exploring the Magnetic Field.

one-eighth inch farther distant from the magnet, and another curve indicating the direction of the magnetic force obtained. The entire space surrounding the magnet for a considerable

needle when it comes to rest for each particular position. A line may then be drawn connecting each dot with its **X**, and the direction of the magnetic force around the magnet will be illustrated graphically in the form of a curve similar to Fig. 23. From these experiments it is deduced that magnetic force is exerted in all directions from a magnet. In similar manner, another series of positions could be taken about

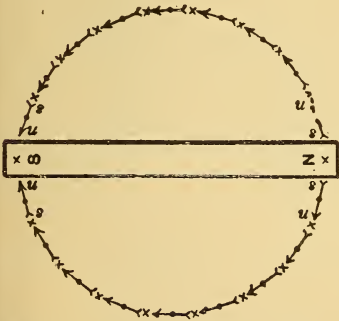


Fig. 23.—Plotting Needle's Position.

one-eighth inch farther distant from the magnet, and another curve indicating the direction of the magnetic force obtained. The entire space surrounding the magnet for a considerable

distance from it will thus be found to be permeated with magnetic lines of force. Similar explorations made on the other side of the magnet will give the same results.

**23. The Magnetic Field.**—The space which is permeated by the magnetic lines of force surrounding a magnet is conventionally called the *magnetic field of force*, or simply a magnetic field. It is also assumed that the magnetic lines

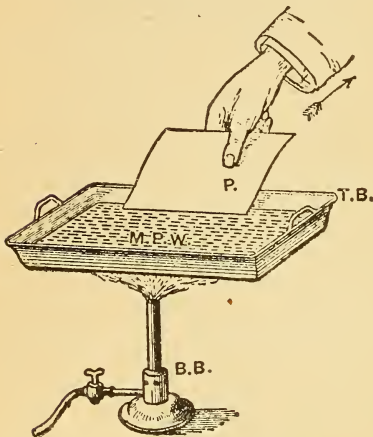


Fig. 24.—Coating Paper with Paraffin Wax.

of force emanate from the **N**-pole of a magnet, pass through the surrounding medium, re-enter the **S**-pole and complete the path, or circuit from the **S**-pole to the **N**-pole, through the magnet itself. Every line or curve of magnetic force must have a complete circuit; hence, as already proven, it is impossible to have a magnet with only one pole. *The magnetic lines complete their circuits independently, and never cut, cross, or merge into each other.* The internal field

is much smaller in cross section than the external field, due to the fact that the steel is a much better conductor of magnetic lines of force than the surrounding medium. Because of this concentration of lines of force inside the magnet they are crowded together where they leave the magnet at the **N**-pole, and where they enter at the **S**-pole. The strong attraction at the poles, and none at the middle of the magnet is thus accounted for.

**24. Making Magnetic Fields.**—Lay a bar magnet flat on a table and cover it with a sheet of cardboard. Obtain some sifted iron filings from which the dust has been removed and enclose them in a pepper-box or piece of gauze netting. Sift the filings over the cardboard, while gently tapping its edge with a lead-pencil. The filings being magnetic bodies, arrange themselves in the direction of the magnetic curves of lines of force and thus produce a graphical

representation of the magnetic field surrounding the magnet, as in Figs. 25 and 26. When it is desired to make a perma-

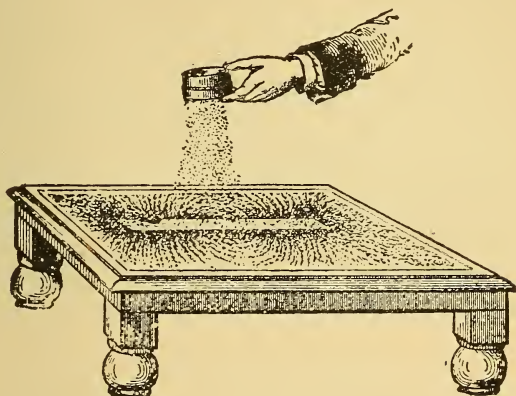


Fig. 25.—Making Magnetic Field of a Bar Magnet.

nent record of the magnetic field, a piece of paraffin-coated paper is used in place of the cardboard. After the field is

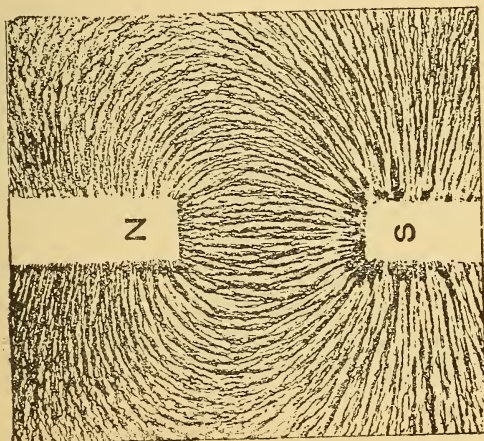


Fig. 26.—Magnetic Field Between Unlike Poles.

produced, the flame of a Bunsen burner is gently applied, heating the paraffin, which upon cooling fixes the iron fil-

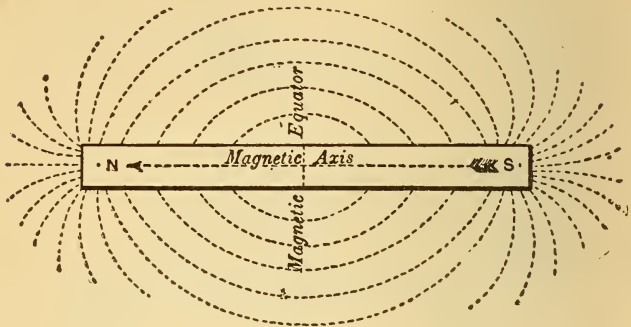


Fig. 27.—Bar Magnet.

ings to the paper. Paraffin paper can be prepared by dipping unglazed paper into a tray of melted paraffin. See Fig. 24. If the field is produced on sensitized photographic paper and then properly exposed to the light, and afterwards developed, permanent graphical records will be obtained. The student should produce all the cases of fields (Figs. 26 to 33), tem-

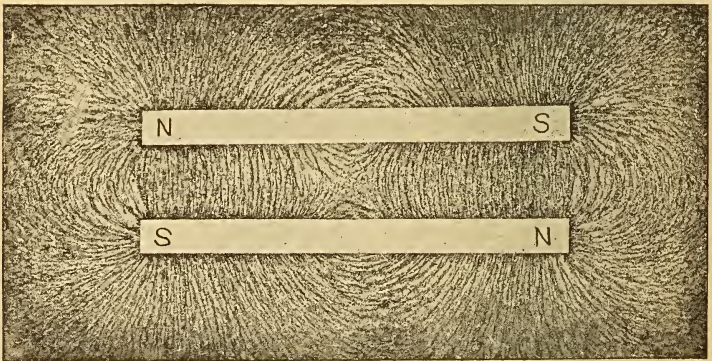


Fig. 28.—Two Parallel Bar Magnets, Unlike Poles Adjacent.

porarily at least, study each one in detail as it is made, and reproduce the same by a sketch at the time it is being made.

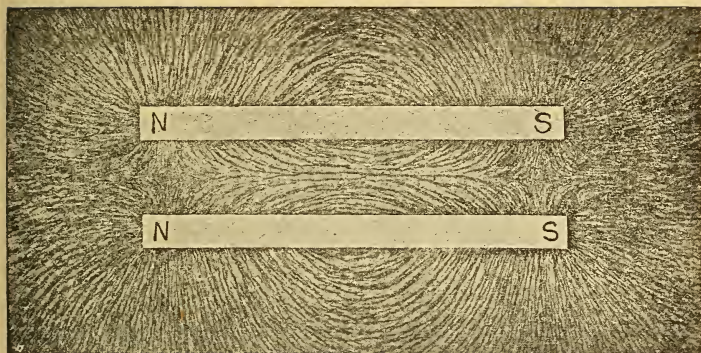


Fig. 29.—Two Parallel Bar Magnets, Like Poles Adjacent.

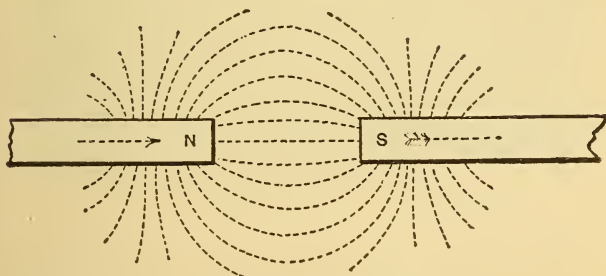


Fig. 30.—Note-book Sketch of Fig. 26.

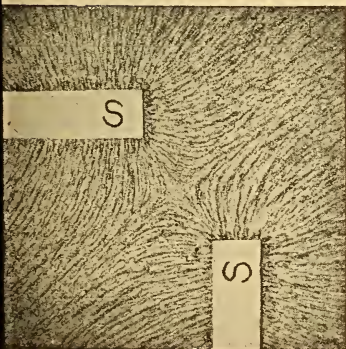


Fig. 31.—Repulsion Between Like Poles.

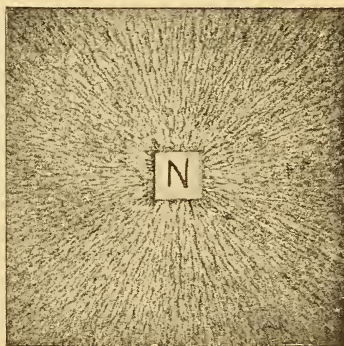


Fig. 32.—Magnetic Field of the End of a Bar Magnet.

Many other possible combinations of magnets to produce these magnetic figures will occur to the student. A thorough knowledge of the direction of lines of force, as depicted by

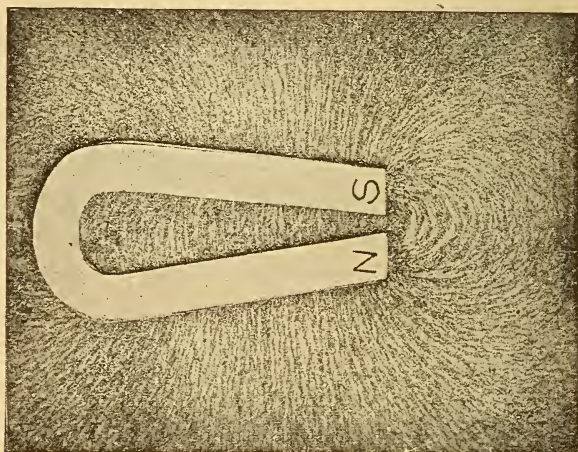


Fig. 33.—Magnetic Field of a Horseshoe Magnet.

the graphical representations of magnetic fields, will greatly assist in the understanding of the phenomena of electro-magnetism and electromagnetic induction, to be considered later.

**25. Axis and Equator of Bar Magnet.**—The straight line joining the N and S-poles of a bar magnet is called the magnetic axis (Fig. 27). A line drawn through the neutral point at right angles to the axis is called the magnetic equator. The *neutral point* may be defined as the position midway between the poles where by the aid of iron filings no external magnetism is shown.

#### QUESTIONS.

1. What is magnetic force? How would you prove its existence and direction around a magnetised steel bar?
2. How would you prove that a piece of iron attracts a magnet just as much as the magnet attracts the iron?
3. Give your idea of magnetic lines of force and state how you



would explore these lines around a bar magnet. Illustrate your answer by a sketch.

- 4. What is a magnetic field?
- 5. Describe a process for permanently making magnetic fields.
6. What is meant by internal and external field? Show by a sketch the direction of the lines of force in both.
- 7. A piece of steel attracts the **N**-pole of a magnet. Would this phenomenon positively prove that the steel is magnetised? Give a reason for your answer.
8. A bar magnet and a horseshoe magnet are laid flat on a table so that their neutral lines form one straight line, **N**-pole opposing **N**-pole. Sketch the graphical field you would expect to see if iron filings were used.
- 9. Sketch a bar magnet and indicate its axis and magnetic equator.
10. Six horseshoe magnets are arranged symmetrically around the circumference of a circle with their poles pointing toward its centre. The adjacent poles are in the order **NS, SN, NS**, etc. Make a sketch showing the direction of the lines of force as you would expect to see them when iron filings are used.
11. What is meant by the neutral point of a bar magnet?
12. Illustrate by a sketch the neutral point, and, also, the axis and equator of a horseshoe magnet.
- 13. Two bar magnets with like poles adjacent are laid on a piece of cardboard parallel to each other. A horseshoe magnet is placed so that its poles are directly opposite but a little distance from the bar magnet's poles. Sketch the resultant magnetic field you would expect to see from this combination if iron filings were used.

## LESSON IV.

### THEORY OF MAGNETISM.

The Nature of Magnetism—Experimental Proof of the Molecular Theory of Magnetism—Breaking a Magnet—Magnetic Saturation—The Magnetic Difference Between Iron and Steel—Retentivity and Residual Magnetism—Destruction of Magnetism by Vibration—Destruction of Magnetism by Heat—Strength of a Magnet—Lifting Power of a Magnet—Questions.

**26. The Nature of Magnetism.**—What is known as the *molecular theory of magnetism* is offered as an explanation of the phenomenon arising from the magnetism of a piece of steel or iron. The theory, which is beautifully illustrated by

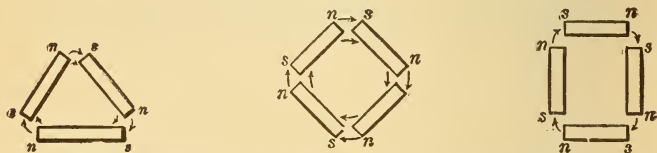


Fig. 34.—Possible Arrangements of Molecules (Magnified).

the experiments following, assumes that in a bar of steel, each of all the individual particles, or molecules which compose it, is a magnet. If the steel or iron is unmagnetised, then the particles arrange themselves promiscuously in the steel, but according to the law of attraction between unlike poles; the magnetic circuits are satisfied internally, and there is no resulting external magnetism. Fig. 34 illustrates (highly magnified) several possible positions, in which the particles in a solid steel bar may arrange themselves, when there is no external magnetism. When the steel bar is stroked with a magnet, or placed in a current-carrying coil of wire, the particles rearrange themselves according to the law of attraction, symmetrically with the axis of the coil, thus breaking up the closed magnetic circuits, and so making

evident external magnetism. An enlarged view of this arrangement of the particles is shown in Fig. 37.

**27. Experimental Proof of the Molecular Theory of Magnetism.**—Fill a small glass test-tube with coarse steel filings, and insert a cork in the mouth of the tube. Test each end separately for magnetism by bringing it near a suspended needle. Either end attracts the same pole of the needle, proving thereby that it is not magnetised. Treat the tube now as a steel bar, and being careful not to shake it, proceed



Fig. 35.—Glass Tube of Steel Filings Before Magnetisation.

to magnetise it by any of the methods previously given. Test again with the needle; one end repels one of the needle's poles and attracts the other pole. *Always make a repulsion test to prove that a body is a magnet.* Now shake the tube thoroughly so as to intermingle the filings, repeat the tests above, and you find that the tube is no longer a magnet, but has been demagnetised. The filings are now indiscriminately arranged in the tube with the magnetic circuits of the numerous small magnets completed through each other, Fig.

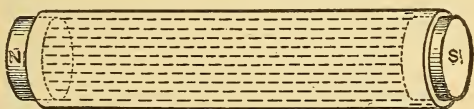


Fig. 36.—Glass Tube of Steel Filings After Magnetisation.

35; hence no external magnetism. When rearranged in the tube under the influence of magnetic force, they assumed symmetrical positions, each one lying in line with, or parallel to its neighbor, N-pole next to S-pole and so on, Fig. 36. The result of this rearrangement of a number of small magnets would be an accumulation of the lines of force, which, when they reached the end of the tube would have no other path to complete their circuit; so that the tube presents the characteristics of a bar magnet. Fine particles of magnetic

oxide of iron (lodestone) mixed with water may be poured into a tube. When the tube is shaken it is impervious to light,

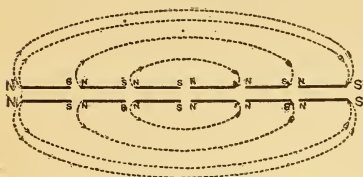


Fig. 37.—Magnified Position of Steel Filings.

because of the satisfied internal arrangement of the magnetic circuits; when placed in a coil of wire carrying a current the particles rearrange themselves longitudinally so that when viewed from the end of the tube they offer less obstruction to the light.

**28. Breaking a Magnet.**—The breaking of a magnet further supports the molecular theory of magnetism. Magnetise a long, thin piece of hard-tempered steel, and mark the **N**-pole. Break it in half and test each piece separately. In one-half the **N**-pole remains **N**, as previously marked, but a

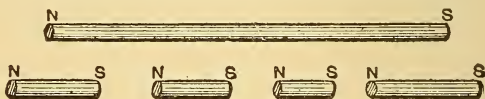


Fig. 38.—Breaking a Steel Magnet.

new **S**-pole is developed, while in the other piece the **S**-pole remains as before and a new **N**-pole is developed. Break these pieces again, Fig. 38, and each part is a perfect magnet, with the poles distributed as in the previous case. Break the

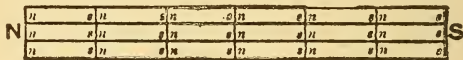


Fig. 39.—Magnified Arrangement of Particles in a Bar Magnet.

remaining pieces until they become too small to be broken, testing each one, and every one is still a magnet. The conclusion is, then, that a steel or iron magnet is an aggregation of small magnets, arranged in the magnified position shown in Fig. 39.

**29. Magnetic Saturation.**—We cannot see the molecules of iron or steel changing their relative positions under the influence of magnetism, but these experiments are in-

tended to show what probably takes place when steel or iron is magnetised. According to the theory, the magnetised iron or steel has its molecules irregularly disposed, as the steel filings were in the tube when shaken. Magnetisation turns them around on their axes until they are arranged symmetrically. When they have all been turned around the bar is said to be saturated, or completely magnetised; it cannot be further influenced by magnetism, however strong the force.

**30. The Magnetic Difference Between Iron and Steel—Retentivity and Residual Magnetism.**—Magnetise a bar of steel by insertion in a coil carrying a current of electricity, and then a bar of soft wrought iron of the same dimensions. Test the attractive power of each by nails or filings, while the current is on, and it is found that the soft iron possesses the greater attractive force. When the current is off, the steel possesses far superior attractive properties to the iron, which it retains, for the most part, permanently. The soft iron is magnetised very slightly. The magnetism remaining in the iron is known as *residual magnetism*, and is a most important factor in operating dynamos, since upon it their self-exciting properties depend. The molecules of iron and steel offer some resistance to the force tending to turn them on their axes. The resistance of the steel molecules being much greater, it is difficult to turn them around, but on being once turned around it is equally as difficult for them to turn again to their original position due to the intermolecular friction; hence the resulting permanent magnetism. On the other hand, the molecules of soft iron turn very readily when under the influence of a magnetic force, but assume their original position when the influencing force is removed, as the internal molecular friction is much less, thus accounting for the temporary magnetism in iron. That the particles do not regain their exact original position is shown by the slight trace of magnetism, called residual magnetism, always found in any piece of iron after having been magnetised. The power to retain magnetism is called *retentivity*. The greater the retentivity of a magnetisable body, the more resistance it offers to being magnetised; hence, we see why it is more difficult to magnetise a piece of hard steel than one of soft iron.

**31. Destruction of Magnetism by Vibration.**—Magnetise a piece of soft iron bar and carefully test its polarity by

the needle. Holding it in the hand, pointing east and west, strike the end several blows with a brass or wooden mallet. Upon again testing, you find its qualities as a magnet have been entirely destroyed. You have assisted the few remaining molecules to assume their original position; or you have demagnetised the bar. Slight shocks are sufficient to demagnetise soft iron; steel retains with tenacity the properties of a magnet, but its magnetic strength is impaired by shocks or vibrations; hence, electrical instruments containing permanent steel magnets should be handled with care. *Good bar magnets should not be dropped* on the floor or table. Many practical uses are made of the qualities of soft iron with respect to the ease with which it can be magnetised and demagnetised. Telegraph sounders and the soft iron armature cores in dynamos, are magnetised and demagnetised many hundred times in a minute.

**32. Destruction of Magnetism by Heat.**—Magnetise a thin strip of steel. Test its polarity. Heat the strip in a Bunsen flame to a bright red color; permit it to cool, and repeat the polarity tests. It is found to be entirely demagnetised. Suspend a small piece of soft iron by a brass chain, heat the iron with a flame, and approach to it a bar magnet. The iron is not attracted until it becomes cool. Heat is a mode of molecular motion; that is, it sets in vibration the particles of the magnetised steel strip, and assists them to satisfy

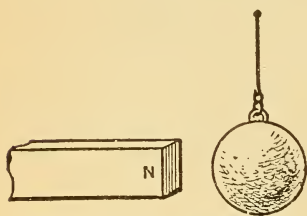


Fig. 40.—Red Hot Iron Ball is Non-Magnetic.

their original internal magnetic condition. On the other hand, it has been found that magnets have their strength increased when subjected to very low temperatures.

**33. Strength of a Magnet.**—The strength of a magnet is the amount of free magnetism at the poles, and is not the same as the *lifting power*, which is dependent upon the shape of the poles as well as upon the shape and quality of the body to be lifted. The strength of a magnetic pole is, therefore, measured by its action on another pole at a distance. If one bar magnet repels a magnetic needle, with twice the force of repulsion as that due to another magnet placed at

the same distance from the needle, we would say the strength of the first magnetic pole was twice that of the second magnetic pole. In magnetic measurements a unit strength of pole is adopted by which the strength of any other pole can readily be compared.

**34. Lifting Power of a Magnet.**—The lifting or portative power of a magnet depends on the strength and form of the magnet. Small magnets lift more in proportion to their weight than large ones. A horseshoe magnet will lift three or four times as much as a bar magnet of equal weight. A long bar magnet will lift more than a short one of equal weight. A magnet with rounded or chamfered ends will lift more than one of the same weight with ends dressed square, even though they are magnetised equally. If a horseshoe magnet has a little weight added to it daily it will be found to attract considerably more than would have been possible if the weight had been originally added. When this weight becomes excessive, so that the armature is detached, the magnet's strength falls to its original value. This growth of the lifting power is a curious and unexplained phenomenon. Electromagnets may be so powerfully magnetised as to require a force of 200 pounds per square inch to separate the keeper from the magnet's poles.

#### QUESTIONS.

1. Explain what you understand by the molecular theory of magnetism. Give sketches.
2. Sketch several possible positions of the molecules in an unmagnetised piece of steel.
3. What is meant by a magnetically satisfied condition? Give sketch.
4. Sketch the position of iron filings in a test tube before and after it has been magnetised.
5. How would you experimentally prove your idea of the molecular theory of magnetism? Give sketch.
6. A magnet is broken into five pieces. Sketch the pieces and their resultant polarity in the order in which they were broken.
7. Explain how, by successively breaking up a bar magnet, you support the molecular theory of magnetism. Give sketch.
8. According to the molecular theory of magnetism, explain what you mean by magnetic saturation.
9. Why is it that hard steel makes a better permanent magnet than soft iron?
10. What do you understand by retentivity? Give an example to illustrate your answer.

## LESSON V.

### MAGNETIC INDUCTION.

Magnetic Induction Experiments—Magnetic Induction—Action and Reaction Equal and Opposite—Magnetic Inductive Effect of Like and Unlike Poles—Reversed Polarity—Consequent Poles—Magnetic Screens—Questions.

**35. Magnetic Induction Experiments.**—(1) Separate a piece of soft iron bar from a magnet by a piece of paper or wood, as in Fig. 41. Plunge the iron into filings; it attracts many more filings while under the influence of the bar magnet than it would do otherwise. It is a temporary magnet made inductively by the influence of a permanent magnet.

(2) Hold the bar magnet vertically with one end in contact with an end of the iron. Plunge the other end of the iron again into filings. It now attracts more filings than before. Magnetic induction thus takes place between bodies in contact or separated from each other.

Interpose between the adjacent ends of the magnet and iron bar pieces of brass, lead, glass, rubber, copper, etc. The filings are attracted to the same degree, when the same distance is maintained, as when these bodies are not interposed.

(3) Support a piece of iron rod about eight inches long, horizontally,

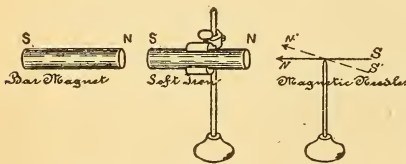


Fig. 42.—Magnetic Induction.

in line with, and on the same height, as a poised magnetic needle, when it is pointing toward the N and S, as in Fig. 42. Leave a small distance between the end of the iron rod and the N-pole of the needle. The N-pole of the needle induces a S-pole in the iron nearest to it, and a N-pole at the far end, and is attracted to the bar by the phenomenon of magnetic induction. With the N-pole of a bar magnet approach the far end of the iron rod, and the needle is repelled away

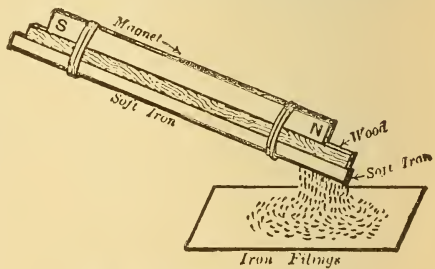


Fig. 41.—Magnetic Induction.



from the iron rod. The bar magnet (the inducing body) being stronger than the needle, induces a S-pole in the end of the iron nearer to it, and a N-pole in the other end ; thus not only neutralizing the needle's inductive effect, but demagnetising the iron, and magnetising it again in the opposite direction. When the magnetising body is removed the needle assumes its former inductive position, provided that the iron is very soft. This experiment proves that the iron has poles when inductively magnetised. To prove that the bar magnet is not repelling the needle, repeat the test without the iron bar interposed and with the magnet at the same distance, when the needle will be only slightly deflected.

(4) The amount of deflection will not be altered in the above experiment when pieces of non-magnetic bodies are interposed. Interpose a text-book while the needle is repelled, and the repulsion is exactly the same as before.

**36. Magnetic Induction.**—A piece of soft iron, when placed in the magnetic field of another magnet, becomes itself a temporary magnet, having at least two unlike poles, and a neutral point. The iron is the *body under induction*, the magnet the *inducing body*, and the phenomenon known as *magnetic induction*. It may be defined as the action and reaction which occur when the magnetic lines of force, emanating from a magnetic body, make evident the latent magnetism in another magnetic body, either with or without contact between them. Magnetic induction, therefore, takes place when the body is in contact with, or separate from the inducing body. The phenomenon of magnetic induction always precedes the attraction of a magnet for a magnetic body, and takes place through all non-magnetic mediums, whether they are solids, liquids, or gases. One pole induces the opposite pole at that part of the body under induction nearest to the inducing pole, and a like pole at the most remote point. Magnetic induction in iron may be explained by the molecular theory, when it is remembered how readily the molecules of soft iron turn on their axes when subjected to the lines of force of a magnetic field. Each individual iron filing becomes a magnet by induction before it is attracted, and when attracted, acts inductively on its neighbor in the same manner. The methods given in paragraphs 12, 13, 14, etc., for making magnets are based on the principle of magnetic induction, which the student should now apply to each case.

**37. Action and Reaction Equal and Opposite.**—Bring the end of a piece of unmagnetised steel near to one of the

poles of a poised needle, approaching from an eastern or western direction, as in Fig. 43, the needle is deflected from its original position toward the steel. It induces an unlike pole in the end of the steel nearer to it, and a like pole at the other end. The two unlike poles attract each other. The steel bar tends to move toward the needle, but is not free to move; the needle can and does move. The unmagnetised steel bar thus becomes a magnet before the needle can be attracted to it. A piece of soft iron of the same size and at the same distance, will produce a greater deflection of the needle than the steel, because it is more readily magnetised. Comparative tests can thus be made of the susceptibility of different specimens of iron and steel

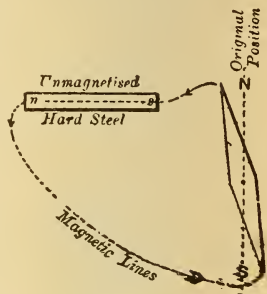


Fig. 43.—Needle Attracted.

to the same magnetising influence. There is in all such cases, first, the inductive action of the needle's magnetism on the bar, and then the reaction from this induced magnetism upon the needle, causing it to be deflected. The action being greater upon soft iron than upon steel, the reaction is also greater. In all cases of magnetic induction the action and reaction are equal and opposite. As there is a stronger magnetic field (a greater number of lines of force) near the needle than at a

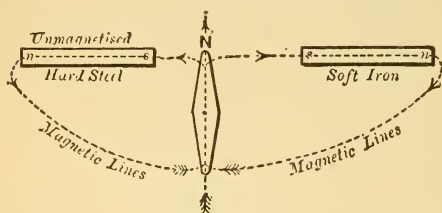
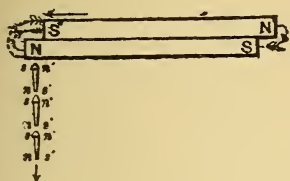


Fig. 44.—Needle Balanced.

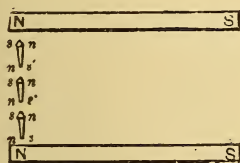
short distance from it, the less the distance between the inducing body and that under induction, the greater will be the inductive action. By placing the bars, one on each side of the same pole of the magnetic needle and at right angles to it and moving the iron bar away until the needle is balanced in a N and S direction, as in Fig. 44, you can prove by the greater distance of the iron than the steel bar from the needle that the former is more susceptible than the latter to magnetic induction.

38. Magnetic Inductive Effect of Like and Unlike Poles.—Suspend from a horizontally supported bar magnet

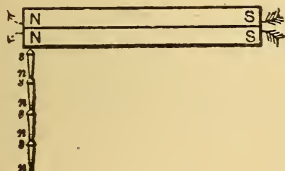
three soft iron nails, one below the other, as depicted in the first diagram of Fig. 45. The resulting inductive effects of the bar magnet on the nails is indicated by the polarities marked to the left of the nails. Each nail head has induced in it a **S**-pole, while all the points are **N**-poles. Now slide over the top of the bar magnet the *unlike* or **S**-pole of a similar magnet. The resultant inductive polarities due to this magnet are marked to the right of the nails. This second magnet induces a **N**-pole at the head of every nail, and a **S**-pole at every point. The result is a *demagnetising inductive effect* upon the nails, so that their magnetism being neutralized, they drop off by reason of their own weight. The same chain of demagnetising inductive effects will occur if a *like*, or **N**-pole, is brought up from underneath the suspended nails. (See second diagram.) In the third diagram of Fig. 45 a *like*, or **N**-pole, is moved over the top of the magnet, and its inductive effect upon the nails is to reinforce the magnetism already at each nail head and point, so that more nails may now be added. The increased magnetising inductive effect will also be noted if an *unlike* pole is brought up from underneath, as in the last dia-



Demagnetising Inductive Effect of an Unlike Pole.



Demagnetising Inductive Effect of a Like Pole.



Increased Magnetising Inductive Effect of a Like Pole.

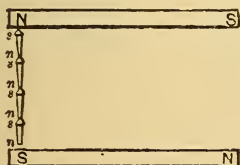


Fig. 45.—Increased Magnetising Inductive Effect of an Unlike Pole.

gram. Two magnets thus placed, with their like poles together, will not support twice as many nails as one magnet, for although they act unitedly upon the nails, they are, in a measure, opposing each other. For this reason also compound magnets are not so strong as the sum of the strengths of the individual magnets of which they are composed.

**39. Reversed Polarity.**—If two *like* poles of a strong and weak magnet be approached to each other, as a compass needle not free to move and a bar magnet, repulsion will take place up to within a certain distance between the like poles, after which attraction occurs. Then the inductive effect of the stronger magnet has demagnetised the less powerful magnet, and remagnetised it again oppositely, or as we say, reversed its polarity. Magnetic needles often have their polarity thus reversed, so that the marked end points **S** instead of **N**. *In making any tests with a needle always allow it to come to rest first in the earth's field, as the polarity may have been reversed since it was last used.*

**40. Consequent Poles.**—With a reversal of polarity sometimes more than two poles are manifest in the body having its polarity reversed. In such cases the body will have a number of intermediate poles and neutral points, which may be readily shown by plunging its entire length into iron filings. Such intermediate poles are called *consequent poles* and arrange themselves as shown in Fig. 46. A bar thus magnetised practically consists of several magnets put together end to end, but in the reverse order **NS**, **SN**, **NS**, etc. The nature of each pole can be tested, while it is attracting iron filings, by bringing near it a bar magnet with some filings attracted to it. The attraction or repulsion between the filings can be noticed at a considerable distance.

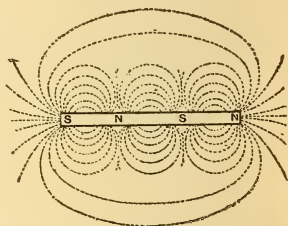


Fig. 46.—Consequent Poles.

**41. Magnetic Screens.**—Permit a magnet to deflect a magnetic needle from its **N** and **S**-position; the deflection is not altered, if any non-magnetic substance be interposed between the needle and the magnet, such as a piece of wood, glass, or rubber, Fig. 47. The needle's lines of force complete their circuit through the non-magnetic body to the mag-

net, as shown in Fig. 47. A piece of iron, however, when interposed between the magnet and the needle, acts as a *magnetic screen* and reduces the deflection of the needle toward the magnet. A needle, free to move, takes up a position in the earth's magnetic field with its magnetic lines parallel with, and in the same direction as the earth's lines of force. When a magnet is approached to it, it assumes a position which is the resultant of the two forces now acting upon it. No effect is produced by interposing a non-magnetic body, such as a board, but when a piece of iron is interposed part of the lines of force of the magnet (Fig. 48) are now employed in

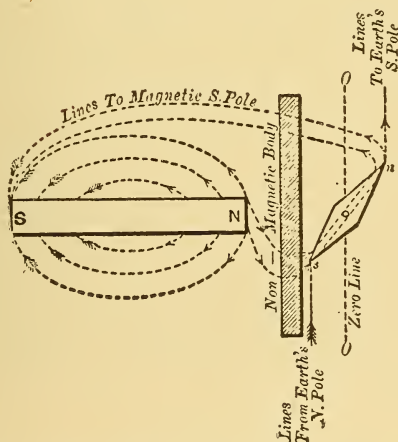


Fig. 47.—Needle Deflected Through Non-Magnetic Body.

magnetising the iron plate by induction. The needle produces a similar effect on the other side of the plate, and being free to move, deflects slightly, until its lines of force are proportionately accommodated between the earth's magnetism and the magnetism of the iron plate. When a thick iron plate is used it forms a perfect shield to the needle against the action of the bar magnet. If a compass needle were placed in the centre of a thick iron sphere it would be entirely screened from any external magnetism. This principle is utilized in the manufacture of heavy cast-iron boxes

for measuring instruments which are to be placed on switch-boards near magnetic fields. Watches are often inclosed in a hunting case made of soft iron to protect their steel main springs from becoming magnetised from any cause. Should

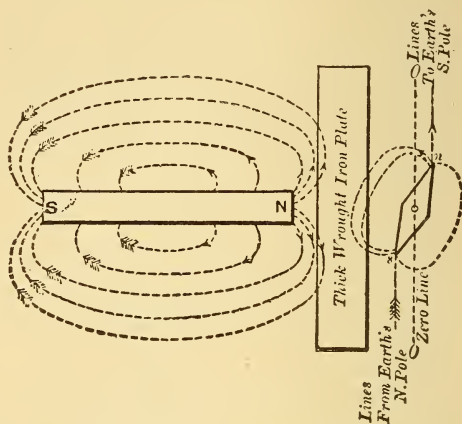


Fig. 48.—Needle Screened from Magnet by a Magnetic Body.

the spring become magnetised the watch generally runs slow, due to the force of attraction between the poles of the spring. Non-magnetic bodies are employed in the springs of non-magnetic watches.

### QUESTIONS.

1. Cite and illustrate by sketches an experiment to illustrate the phenomenon of magnetic induction.
2. A bunch of sewing needles is suspended by a thread passing through the eyes, above the N-pole of a bar magnet. State three magnetic phenomena which take place. Give sketches.
3. How do you explain the phenomenon of magnetic induction by the molecular theory?
4. Apply the principle of magnetic induction to a piece of steel you are required to magnetise by rubbing it from one end to the other with one pole of a bar magnet. Give sketches illustrating the stages of magnetisation.
5. A piece of iron and then steel are each held three inches from a poised needle. Which piece will deflect the needle most, and why?
6. Give sketches illustrating four cases of the increased and decreased magnetic inductive effect, of like and unlike poles, of two bar magnets.

7. A magnetic chain of steel pins is formed from one of the poles of a bar magnet. When the chain is removed from the pole it still remains intact. How do you account for this? Give sketch.

8. A chain of soft iron nails is made from the pole of a magnet. Upon attempting to remove the chain all the particles of iron separate from each other. Give sketch and explanation.

9. A compass is supposed to have its polarity reversed. What do you understand by this?

10. How would you correct the reversal of polarity in a compass with two bar magnets so that the arrow head would point N? You cannot get at the needle to stroke it, but there is a stop on the side of the case so that the needle can be held at rest. Give sketch.

11. Upon testing a bar magnet with iron filings it is found to attract filings at the centre and also at each end. How do you account for this? Give sketch to illustrate your answer.

12. A watch is placed in a small pocket-case, which looks like hard rubber, to prevent it from becoming magnetised. What is the case made of, and what is the principle involved?

13. What are consequent poles? Illustrate your answer by a sketch.

14. A bar magnet repels a poised needle 45 degrees, at a distance of 4 inches. An incandescent lamp bulb, containing a vacuum is interposed between needle and magnet. Will the deflection be greater or less? Why?

15. Give several examples of substances that could be interposed in question 14 without disturbing the needle. What are these substances called?

16. A piece of hard steel is interposed in question 15. How is the deflection affected? Give sketch showing the direction of the lines of force between the needle, the steel, and the bar magnet.

17. What is a magnetic screen, and for what purpose is it used?

18. How would you diminish the earth's attractive force on a magnetic needle?

19. A horseshoe magnet is laid flat in a suspended fibre stirrup. What position will it take up when allowed to come to rest in the earth's field?

20. Why is it necessary to harden a piece of steel before it is magnetised?

21. What is residual magnetism, and what is its particular value?

22. State several ways in which you could destroy, or materially weaken the strength of a good permanent magnet. Give reasons for your answer.

23. What care should be exercised in handling instruments containing permanent magnets?

24. A piece of iron is suspended in a stirrup and attracted by the poles of a horseshoe magnet located some little distance underneath it. The N-pole of the bar magnet is approached to one end of the piece of iron, and it is repelled. State the condition of the bar at first and what occurred to cause the repulsion. Give sketches to illustrate the answer.

25. What is your idea of the lifting power of magnets?

## LESSON VI.

### MAGNETIC CIRCUITS.

Magnetic Circuits—Magnetic Bodies Free to Move—Test for the Distribution of Magnetism—Testing Distribution by a Needle's Oscillation—Pole Pieces, Armatures, and Keepers—Questions.

**42. Magnetic Circuits.**—A simple magnetic circuit is one composed wholly of a magnetic substance throughout its entire length, and having a uniform cross-sectional area, as, for example, an iron ring, Fig. 178. In a *compound magnetic circuit* the lines of force pass consecutively through several magnetic or non-magnetic substances, as, for example, an iron ring with a section removed, Fig. 178. The lines would then pass from the iron through an air-gap back to the iron again. If the ring were cut into quarters, four air-gaps would be introduced into the magnetic circuit. A *closed magnetic circuit* is one affording a complete magnetic path for the lines of force through magnetic substances, for example, an electromagnet core, the keeper of which is wrought iron, the limbs of steel, and the yoke of cast iron. See ¶ 195.

**43. Magnetic Bodies Free to Move.**—If a graphical magnetic field be made of a bar magnet and a piece of iron lying in the field, it will be noted that the magnet's field is distorted, and many of the lines pass through the piece of iron. Magnetic lines of force always choose the path of least resistance. If the piece of iron is arranged free to move in the field, it will turn and take up such a position as to accommodate through itself the greatest number of lines of force. If instead of being a magnetic body it is a magnet, it will move, under the influence of the magnetic field in which it is placed, not only so as to accommodate through itself the lines of force of the field, but also in a particular direction, so that its lines will be in the same direction as those of the field. Thus, **N**-lines merge from one point and enter as **S**-lines at another point (Figs. 47 and 48 will serve to illustrate this principle). The fundamental principle in many forms of electrical meas-



uring instruments and electro-mechanical devices is that a magnetic body, free to move under the influence of a magnetic field, tends to move, so as to accommodate through itself, the greatest number of lines of force of the field. If the movable body is a magnet it moves in a particular direction so that its own internal magnetic lines will be in the same direction as those of the field in which it is placed.

**44. Test for the Distribution of Magnetism.**—According to the molecular theory of magnetism, the relative strength of free magnetism along a bar magnet, increases from zero at the centre until it reaches its maximum near the ends, or poles.

To prove this, support a long bar magnet horizontally and apply a number of soft iron nails in chains to successive points on the supported magnet. No nails will attach themselves to the magnet at the neutral line, but a gradually increasing number may be suspended until the poles are reached, but beyond the poles not quite so many. See lower half of Fig. 49.

In this figure the dotted vertical lines above the magnet have been drawn of such length as to graphically represent the relative quantities of free magnetism at different points on the bar magnet, and the ends of these lines have been joined by a curve which represents to the eye the relative amount of free magnetism at all points on the bar.

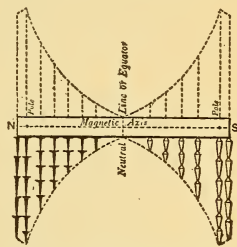


Fig. 49.—Testing Magnetic Distribution by Tacks.

and the ends of these lines have been joined by a curve which represents to the eye the relative amount of free magnetism at all points on the bar.

**45. Testing Distribution by a Needle's Oscillation.**—A bar magnet may be tested for free magnetism by causing a needle to oscillate at successive points near the magnet, from pole to pole. Support the bar magnet vertically, and hold the needle close to the magnet (always at the same distance from the magnet for each position selected); deflect the needle from the position it takes up with reference to the magnet, and then count how many vibrations forward and backward it makes in a given time (one-half minute), which will be the rate of oscillation of the needle. Find how many oscillations are made at other positions equidistant from the magnet in the same time. Move the needle away from the magnet, and ascertain how many oscillations it makes in the same time, when under the influence of the earth's magnetism alone. After making a number of tests, as at the positions shown in Fig. 50, square the number of oscillations for each position, and subtract from each value thus obtained, the square of the oscillations that the needle made in the earth's field. The resulting numbers will be a

series of values representing the quantities of free magnetism along the bar. These numbers may be plotted to scale on lines drawn at right angles to the magnet at points corresponding to the positions

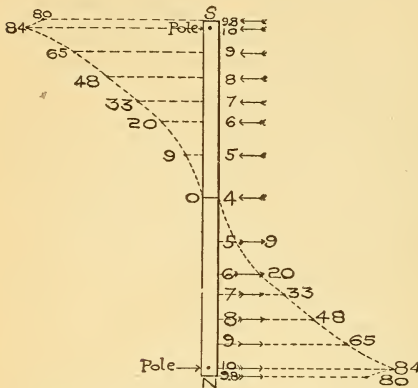


Fig. 50.—Testing Magnetic Distribution by the Needle.

selected, as in Fig. 50, and by connecting all the points by a line, a graphical representation of the free magnetism along a bar magnet is obtained. For example, suppose that a magnetic needle makes four to-and-fro swings in one-half minute, under the influence of the earth's magnetism, and seven oscillations in one-half minute, when near the pole of a magnet, then  $(7^2 - 4^2)$  equals  $(49 - 16)$  equals 33, so that 33 represents the length of the line to be drawn to any convenient scale at this position of the needle. The following

table records the data of a needle oscillating test, and Fig. 50 illustrates the plotting of the curve, and also shows the number of oscillations obtained at each position. At the neutral line it will be noted that the oscillations are four, the same number as obtained in the earth's field above :

Table I.—Oscillation Test.

Oscillations.	Oscillations squared.	Oscillations squared minus Earth's Oscillations squared.	Relative Quantities of Free Magnetism.
At centre 4	16	16 — 16	0
“ 5	25	25 — 16	9
“ 6	36	36 — 16	20
“ 7	49	49 — 16	33
“ 8	64	64 — 16	48
“ 9	81	81 — 16	65
At pole 10	100	100 — 16	84
“ 9.8	96	96 — 16	80

**46. Pole Pieces, Armatures, and Keepers.**—To concentrate and direct the magnetic lines of force, which extend in all directions from the poles of a magnet, pole pieces made of iron in a variety of shapes are fastened to the magnet's poles.

*Pole pieces* of soft iron, Fig. 51, are attached to the ends of the limbs of the magnet, and serve to direct or concentrate most of the lines of force between them. In a dynamo these magnetic lines are cut by the rotation of a bundle of wires wrapped upon an iron core, constituting what is known as



Fig. 51.—Permanent Magnet with Iron Pole Pieces (P) and Armature (A).

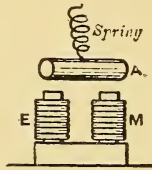


Fig. 52.—Electromagnet with Armature (A).

the armature, represented in Fig. 51 by A. An *armature* is a magnetic body placed between or near, but not touching, the poles of a magnet, and is free to be rotated or moved to and from the poles. A different type of armature from that used in a dynamo is illustrated in Figs. 52 and 53, where a piece of iron is attracted to the poles against the action of a spring. A *keeper* is a piece of soft iron placed across the poles to connect them. Fig. 54. Its function is to provide a complete short circuit, or closed path, for the magnetic lines between two unlike poles.

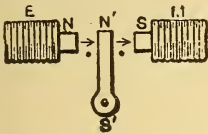


Fig. 53.—Polarized Armature.

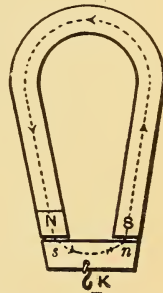


Fig. 54.—Horseshoe Magnet with Keeper.

The magnetism induced in the keeper reacts on the magnet, and not only helps to maintain the strength of the magnet, but also serves to augment it. A magnet deprived of its keeper gradually loses its magnetism. Steel is much more readily demagnetised than magnetised, so that magnets require careful handling when in use and should be provided with keepers when put away.

## QUESTIONS.

1. A horseshoe magnet attracts a compass needle. A piece of soft iron is placed across the poles of the magnet and the needle returns to nearly its natural position. Explain this.

2. Explain and illustrate by sketches the difference between a simple, a compound magnetic circuit, and a closed magnetic circuit.

3. How would you magnetise a steel key-ring so that it would have two poles?

4. A steel sphere is attracted by a bar magnet but does not roll toward it. When a soft iron sphere is substituted and placed at the same distance from the same magnet, the attractive force causes it to roll to the magnet. How do you account for this, since the same magnet was used in both cases?

5. How would you put away three bar magnets without keepers so as to preserve their magnetism?

6. Magnetisation always precedes attraction of an unmagnetised body for one that is magnetised. How would you prove this statement in the case of a piece of soft iron attracted by a magnet.

7. A short rod of unmagnetised soft iron is suspended in a stirrup, and placed along the equator of a bar magnet a little distance from it. What position will it take up with reference to the magnet? Give sketch.

8. A short piece of magnetised steel is substituted for the piece of iron in question 7. What position will it take up? Give sketch.

9. Give a concise statement as to the movement of a magnetic body (when free to move), if placed in a magnetic field.

10. A piece of iron is fastened at right angles to a poised magnetic needle at the neutral point so that it extends over each side equally. What effect will it have on the position the needle will take up in the earth's field? Give sketch.

11. A steel magnet is substituted for the piece of iron in question 10. What position will the combination now take up? Give sketch.

12. The following number of oscillations were recorded in a test for distribution of free magnetism of a bar magnet. At the ends 10, then 12, 10, 8, 6, and at the centre 4. The needle oscillated four times in the same length of time when under the influence of the earth's field alone. Find the relative quantities of free magnetism for each position. Plot the points to scale and draw a curve to illustrate the magnetic distribution.

13. Sketch the positions a test needle would occupy when used to explore the field of a horseshoe magnet.

14. How would you magnetise a horseshoe magnet with two bar magnets, so that both ends would have a N-pole and the S-pole located where the neutral point generally is located? Give sketch.

15. The pole of a bar magnet projects over the edge of the table and a piece of iron is attracted to it. Another magnet is brought near the projecting pole and the iron drops off. How do you account for this? Give sketch.

16. You are given a compass needle, and two exactly similar bars, one of iron, the other of steel. How would you distinguish the iron from the steel bar? Give sketch.

## LESSON VII.

### EARTH'S MAGNETISM.

The Earth's Magnetism—Polarity of the Earth—The Earth's Magnetic Field and Equator—Graphical Field of the Earth's Magnetism—The Magnetic Meridian—Declination—Inclination or Magnetic Dip—Magnetic Maps or Charts—The Mariner's Compass—Magnetisation by the Inductive Effect of the Earth's Field—The Earth's Field Directive, Not Translative—Neutralizing the Earth's Attractive Force for a Needle—Astatic Needles—Questions.

**47. The Earth's Magnetism.**—Lay a bar magnet flat on the table and hold over it a freely suspended magnetic needle at different positions from pole to pole, as in Fig. 49. At the **N**-pole the needle will be vertical, with its **S**-pole pointing down; when opposite the neutral point, or equator, it will be horizontal; when over the **S**-pole it will be vertical, with its **N**-pole pointing downward. A freely suspended needle carried around the earth from its **N** to its **S**-geographical pole will take up similar positions. At a point near the **N**-geographical pole the needle becomes vertical, with its **N**-pole pointing down; at the earth's equator it is horizontal, and near the **S**-geographical pole it again becomes vertical with its **S**-pole pointing down. The earth may thus be regarded as a huge magnet, with two magnetic poles. Suppose a hole to be drilled through the earth's centre from pole to pole, making an angle of about 20 degrees with its axis, and a bar magnet of somewhat less length than the diameter of the earth to be inserted with its **N**-pole pointing toward the **S**-geographical pole, the resulting distribution of magnetism would be similar to the earth's magnetism.

**48. Polarity of the Earth.**—We have called the **N**-seeking, or marked pole of a magnet, its **N**-pole, and, as unlike poles attract each other, it will naturally be inferred that the nature of the magnetism near the earth's **N**-geographical pole is **S**-magnetism. The true **S**-magnetic pole is located in the northern hemisphere, while the true **N**-magnetic pole is in the southern hemisphere, Fig. 56. The earth's true mag-

netic **S**-pole is not coincident with its **N**-geographical pole, but about 1400 miles west of it. The **N**-magnetic polar region has not been definitely located.

**49. The Earth's Magnetic Field and Equator.**—The geographical equator is an imaginary belt passing around the earth midway between its poles. So also, the magnetic equator is an imaginary line encircling the earth midway

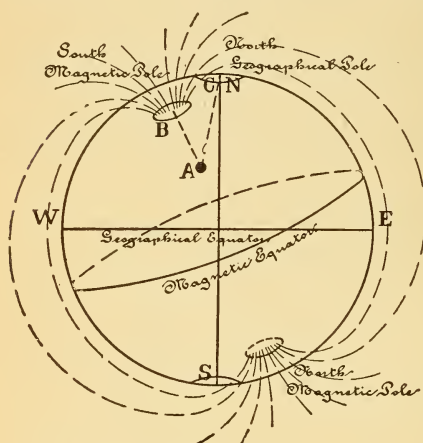


Fig. 56.—The Earth's Magnetic Poles and Equator.

between its magnetic poles (Fig. 56) and connecting all those points which show no magnetic dip, or where the needle was found to be horizontal (see ¶ 52). This magnetic equator is somewhat irregular in form, owing to the irregular distribution of the earth's magnetism. The lines of force of the earth's magnetic field may be considered to emanate from the true **N**-magnetic pole in the southern hemisphere, and curve around over the surface of the earth, entering again at the true **S**-pole. The lines of force act on a freely suspended magnet in such a manner, that it turns on its axis, until it lies as nearly as possible in the direction of the lines of force, according to the principle enunciated in ¶ 43.

**50. Graphical Representation of the Earth's Magnetic Field.**—Magnetise a large steel sphere, such as is used in roller bearings, by placing it between the unlike poles of two bar electromagnets so that its diameter and the axis of the magnets form a straight line. When plunged into filings the poles are readily observed. Cut a hole, equal to the diameter of the ball, in a sheet of cardboard and place it over the sphere horizontally so that its plane passes through the axis of the sphere containing the poles. Make a graphical field by the aid of iron filings, as shown in Fig. 58, and you

have a typical representation of the magnetic lines of force surrounding the earth, and called the earth's field.

**51. The Magnetic Meridian—Declination.**—Just as the geographical meridian is an imaginary line, drawn on the earth's surface in a plane which passes through the geographical poles of the earth and a given place, so, also, the *magnetic meridian* may be regarded as an imaginary line drawn on the earth in a plane which passes through the magnetic poles of the earth and a given place, or a line in the vertical plane containing the axis of a magnetic compass needle at any given place. At most places the geographical and magnetic meridians differ, and the angle between them is known as the *angle of declination* of any given place.

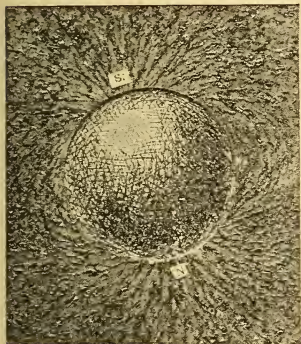


Fig. 58.—Field of a Magnetised Steel Sphere Representing Earth's Field.

It indicates just how far away from the true geographical north the compass needle points. This angle of declination is very slowly, but constantly changing. In New York city in 1900, the declination was  $9^{\circ} 12'$  W., which means that when the compass needle comes to rest at this place the true geographical north will be  $9^{\circ} 12'$  to the east of the direction the needle points.

Suppose a person to be located at point A, Fig. 56, the direction of true north is along the line AC, while the compass needle at position A points along line AB. The angle between these lines is the angle of declination. In Columbus, Ohio, and Charleston, S. C., in 1900, the declination was zero; that is, the true N-pole was just in line with the magnetic pole at these points, or the two meridians coincided. Moving west from point A, Fig. 56, the declination decreases until a locality is found in central Asia where the meridians again coincide.

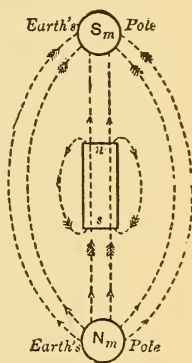


Fig. 59.—The Polarity of the Earth and a Magnet.

Places in the Atlantic Ocean, Europe, and Africa, between these lines of no declination, would have a declination west of the true N, while at places on the other side of the globe between these lines the needle would point east of the true north. In steering ships at sea by the compass, references are made to a chart, giving the localities corresponding to the different values of the declination of the needle.

**52. Inclination or Magnetic Dip.**—If a long knitting needle be carefully balanced and suspended by a silk thread, it will assume a horizontal position. When magnetised its N-end will point downward, or dip toward the earth's magnetic S-pole. This needle being free to move in all directions, takes up a position along the lines of force of the earth's field. The angle which the needle makes with the horizontal is termed the *angle of dip*. The dip needle (see ¶ 20) is horizontal at the magnetic equator, and the angle of dip increases as you go toward either pole, the needle being

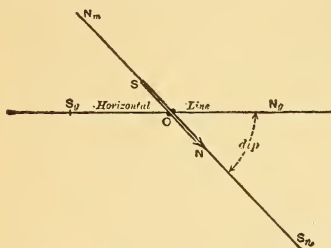


Fig. 61.—Angle of Dip.

vertical at the poles. At New York city in 1900, the dip was  $70^{\circ} 6'$  N., which means that the knitting needle, or dip needle, as shown in Fig. 19, will take up a position with its axis at  $70^{\circ} 6'$  with the horizontal plane with its N-end pointing downward, Fig 61.

**53. Magnetic Maps or Charts.**—Magnetic maps are prepared, on which the places of equal magnetic dip are connected by lines which run similar to the parallels of latitude, but quite irregular, and are called *isoclinic* lines. Similarly, lines connecting places of equal magnetic declination are called *isogonic* lines. They correspond with the meridians of longitude, but are also irregular. Such maps are prepared from time to time by the United States Geodetic Survey, and are used in determining localities, especially in connection with the mariner's compass on board ships.

**54. The Mariner's Compass.**—In small pocket compasses the magnetic needle is poised on a jewel bearing, and above a graduated scale, fastened to, or engraved on the containing box. In using this compass, it is first necessary to



permit the needle to come to rest pointing **N** and **S**, and then gently twist the box around until the point marked **N** on the scale, is directly under the **N**-pole of the needle. The true geographical north will then be so many degrees east, or west of the position the needle assumes when pointing to the **N**, or marked position, on the scale. See ¶ 51. In the mariner's compass the needle is fastened to the underside of the cardboard scale, and needle and scale swing around together, the **N**-point on the scale always pointing to the north.

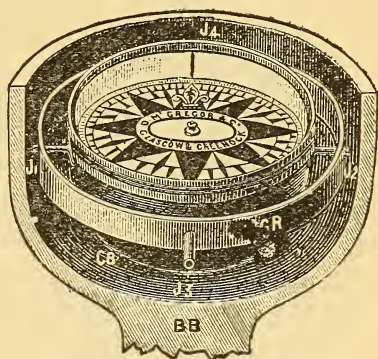


Fig. 62.—Mariner's Compass.

When it is desired to steer in any particular course, as northwest, the ship's helm is turned till the northwest on the movable dial is opposite a fixed vertical black line (termed the "lubber line") which is drawn on the inside of the bowl, J4, Fig. 62, in line with the direction of the ship's motion. The compass box is supported on gimbal bearings, so that no matter how much the ship may roll or lurch the card will always be level. The construction and method of support are shown in the sectional view, Fig. 62, and the plan in Fig. 63. Many precautions have to be taken in adjusting a ship's compass, to compensate for several errors likely to arise, caused by the influence on the needle of the hull, or the cargo, or electric light wires in the vicinity, etc.

**55. Magnetisation by the Inductive Effect of the Earth's Field.**—Procure a soft iron bar about 14 inches long, test it for polarity, and then hold it in one hand in the magnetic meridian, with one end pointing or dipping downward at an angle of about 70 degrees to the horizontal, Fig. 64. Strike the bar several hard blows with a hammer, and then test for polarity. The lower end will be found to possess a **N**-seeking pole, and the upper end a **S**-seeking pole. Reverse the bar, after first demagnetising it by blows while held in an east and west direction, and the lower end is again

magnetised and becomes N-seeking. The earth's field has induced poles in the bar by induction, the hammer blow simply assisting the molecules to turn around according to the molecular theory. In a like manner tests made with a compass needle on iron and steel girders in buildings under construction, will show that the bodies have been magnetised by the inductive action of the earth's field. It seems probable that the natural magnet, or lodestone, is due to the earth's magnetic inductive action.

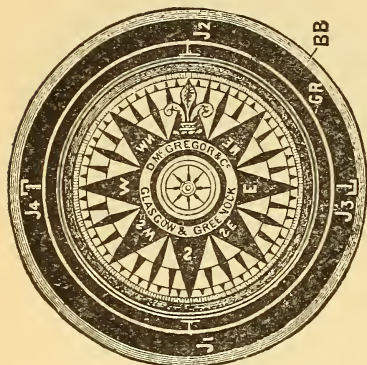


Fig. 63.—Plan of Compass Card and Bowls.

#### INDEX TO FIGS. 62 AND 63.

CB represents Compass Bowl and Card.

J<sub>1</sub>J<sub>2</sub> represents Compass Bowl Journals.

GR represents Gimbal Ring.

J<sub>3</sub>J<sub>4</sub> represents Gimbal Ring Journals.

BB represents Binnacle Bowl.

l represents Lubber Line (Fig. 62.)

S-position, due to the earth's field, but is not attracted toward the side of the basin nearest to the earth's magnetic S-pole, as might be expected, we being so much nearer the south than the north magnetic pole. The poles

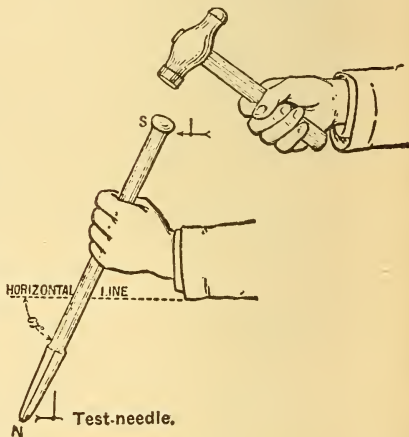


Fig. 64.—Magnetisation by the Earth's Field.

of the earth are so far away that the short distance between the two poles of the bar ceases to be of any account, when compared with the distance of these poles from the earth's poles. The forces of attraction

and repulsion on one pole may, therefore, be considered equal and opposite, so that the bar is simply directed, and there is no motion of translation. The distance through which the earth's magnetic pole attracts the N-pole of a magnetic needle is less than the distance through which the S-pole of the needle is repelled by the earth's S-pole. This difference in the distances between the two poles of the earth is so small (equal to the length of the magnet) that the force of attraction is

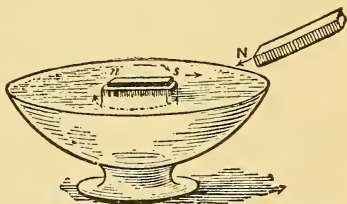


Fig. 65.—The Earth's Force not Translative.

practically no greater than that of repulsion. The needle, therefore, turns in the direction of the two forces, but there is no motion of translation. If the pole of another magnet be approached to the floating magnet, Fig. 65, at such a distance that the length of this magnet is considerable, as compared with the distance between the two magnets, then the floating needle will be both directed and attracted.

**57. Neutralizing the Earth's Attractive Force for a Needle.**—Hold above, and parallel to a compass needle, a bar magnet with its N-pole pointing in the same direction as

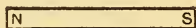
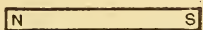
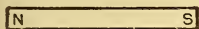


Fig. 66.—Neutralizing the Earth's Attractive Force for a Needle.

the needle's N-pole, Fig. 66. If the height of the bar is considerable, the needle is not appreciably affected. Slowly lower the magnet, and a point will be found where the needle will be observed to waver. If the magnet be fixed at this

position the needle will stand in any position given to it, showing that the earth's directive attracting force has been *neutralized*. If the bar magnet is further lowered, the needle

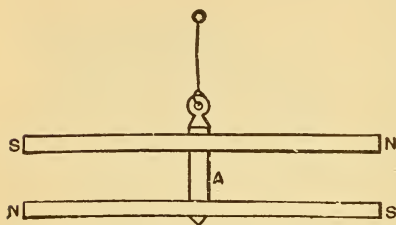


Fig. 67.—Astatic Needle.

swings around and takes up the position shown in the right hand diagram of Fig. 66. A bar magnet used to neutralize the earth's field in this manner is used in some galvanometers. (See Fig. 163.)

### 58. Astatic Needles.

—If two similar bar magnets, equally magnetised, be fixed to a rigid support, one above the other, with unlike poles at the same end, Fig. 67, the system will be independent of the earth's magnetism, and will come to rest in any desired position. When two needles are so arranged they form what is called an *astatic needle*. Astatic means without polarity, and such needles are used in very sensitive galvanometers, Fig. 167.

## QUESTIONS.

1. Explain your idea of the earth's magnetism. Make sketch.
2. What is meant by the polarity of the earth's magnetism?
3. How do you account for the fact that the N-pole of a magnet always points N, since like poles repel each other?
4. Sketch the position a test needle will take up if used to explore the earth's field.
5. What is the earth's magnetic equator? Give sketch.
6. What do you understand by the magnetic meridian? Give sketch.
7. Describe and illustrate what is meant by magnetic declination.
8. A long knitting needle is carefully balanced so that when suspended in an east and west position it remains horizontal, but when pointing N and S it acts as if one end had been weighted. How do you account for this? Give sketch.
9. Of what value are magnetic charts and how are they constructed? Give sketch.
10. What do you understand by an inclination of  $70^{\circ} 6' N$ ?
11. How does the construction of a mariner's compass used on board ship differ from a little magnetic test needle?
12. A soft iron bolt is held in the earth's magnetic meridian at the proper angle of inclination, with the head pointing downward and struck several blows with a hammer. The head is then presented to the N-pole of a compass needle. How does it affect the needle?

## LESSON VIII.

### VOLTAIC ELECTRICITY.

Electricity—Electrical Effects—Generation of Electric Currents by Chemical Means—A Current of Electricity—Simple Voltaic Cell—Volta's Pile—The Circuit—Conductors and Insulators—Direction of the Current—Poles or Electrodes and Plates—Detector Galvanometer—Potential and Electromotive Force—Chemical Action in a Voltaic Cell—Why the Hydrogen Appears at the Copper Plate—Polarization—Table II—Polarization Test—On What the Electromotive Force of a Cell Depends—Table III—The Electro-chemical Series—Local Action—Amalgamation—Questions.

**59. Electricity.**—The word electricity has been applied to an invisible agent which makes itself known to us by various properties, commonly termed *electrical effects*, or *manifestations*. While the exact nature or constitution of electricity is not known, the laws governing electrical phenomena are clearly understood and defined, just as the laws of gravitation are known, although we cannot define the constitution of gravity. Electricity is neither *matter* nor *energy*, yet it can be associated with matter, and energy can be spent in moving it. Its commercial advantage is due to the fact that energy can be spent in generating electrical force at one point, which can be transmitted and utilized at some distant point. Electricity can neither be created nor destroyed, but it can be transformed in its relations to matter and energy, and be moved from place to place. While it is neither a gas nor a liquid, its behavior sometimes is analogous to that of a fluid, so that it is said to *flow* through, or around a wire. This expression of "flowing," however, should be regarded as a convenient expression for the phenomena involved rather than an accurate account of what really transpires when a wire possesses electrical properties.

**60. Electrical Effects.**—The manifestations produced by electricity may be divided into four distinct classifications for studying the subject. First, *electricity when at rest* is known as *statical electricity* and the bodies electrified are said to be *statically charged*; the term *electrostatics* applies to this subject.

Second, *electricity in motion* differs from statical electricity and is treated as a *current of electricity*. Third, *electricity in motion produces magnetism* which has been termed electro-magnetism. Fourth, when *electricity is vibrated* very rapidly it produces a fourth state, known as *electrical waves*. All these phenomena are very intimately associated with each other, and are due to the one invisible agent, *electricity*. In this book we will limit the study to *currents of electricity* and *electromagnetism*, which form the basis of a great many practical electrical applications.

### 61. Generation of Electric Currents by Chemical Means.—

**Experiment 1:** Fill a tumbler two-thirds full of dilute sulphuric acid (one part acid to 20 parts water) and partially immerse in the same a strip of sheet zinc, say one inch wide by five inches long. Bubbles of gas immediately collect on the zinc, and then detaching themselves, rise to the surface of the liquid, being rapidly replaced by other bubbles as the action continues. These bubbles of gas are hydrogen (one of the gases of which water is composed) and when collected, by displacing water in an inverted test tube held over them, this gas may be ignited, and will burn with a pale bluish flame.

If the zinc remains in the acid for some time it wastes away or is dissolved in the liquid.



Fig. 69.—Copper and Zinc in Acidulated Water.

**Exp. 2:** Place a strip of copper, of about the same dimensions, partially in the acid as before. No bubbles of gas are seen rising from the copper. If this metal is allowed to remain for some time it will not apparently be acted upon by the acid.

**Exp. 3:** Place the strips of copper and zinc in the tumbler of acid, not permitting them to touch each other, inside or out. Hydrogen gas continues to rise from the zinc as before, but there is no action on the copper plate. Bring the outer extremities of the copper and zinc strips into contact, Fig. 69, and torrents of bubbles are *now seen to rise from the copper strip*, in addition to the bubbles rising from the zinc strip. If collected, the gas evolved from the copper proves to be hydrogen, the same as that rising from the zinc. If the action is permitted to continue for some time, upon examination the zinc is found to have wasted away, while the copper remains unchanged. Break the external contact between the plates and the action at the copper instantly ceases, but the zinc wastes away as before.

**Exp. 4:** Remove the zinc strip from the liquid, and while it is still wet with the acid rub over its surface a little mercury. Upon being replaced in the solution the acid does not attack it. Repeat Exp. 3 with this "amalgamated zinc" (see ¶ 76), and note that now bubbles rise only from the copper plate, when the ends of the two strips are brought together, and that none rise from the zinc plate, but that it is still the zinc plate which wastes away.

**Exp. 5 :** Connect wires of any metal to the copper and zinc plates, being sure that you have bright metallic contacts. Bring the extremities of these two wires together after they have been brightened and hydrogen gas is seen to rise from the copper plate as before, while there is no action at the zinc.

When the wires are separated the action ceases, but commences again as soon as connection is made. Interpose *between* the two connecting wires pieces of glass, mica, rubber, paper, wood, porcelain, etc., or connect the two plates by a bridge made of any of these materials, *no action appears at either plate.*

It thus requires a connection between the two plates to cause chemical action, and this connection must be of a particular kind. It would seem that the plates exert an influence upon each other through the connecting wire. We will now ascertain whether the connecting wire possesses any extraordinary qualities when thus connected with these dissimilar plates.

**Exp. 6 :** Set up a poised magnetic needle pointing **N** and **S**. Bring above and parallel to it a portion of the connecting wire used in the last experiments (as in Fig. 70).

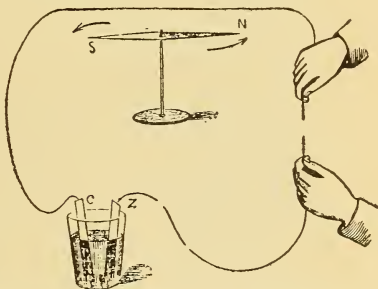


Fig. 70.—Deflection of the Magnetic Needle.

When the ends of the wires are brought together the needle immediately turns upon its axis at right angles, or nearly so, to the wire, after a few vibrations, and remains in this position until the connection is broken, when it assumes its normal position. The deviation of the needle from its original position is termed the *deflection of the needle*. Note that chemical action continued in the tumbler as long as the needle was deflected, and at the expense of the zinc rod.

**Exp. 7** With the wire arranged as in Exp. 6, interpose pieces of tin, steel, copper, iron, lead, gold, brass, aluminum, etc., between the connecting wires, and the needle is deflected as before. When pieces of paper, glass, wood, mica, etc., are interposed, however, there is no deflection of the needle, which again proves the necessity of a suitable connector between the copper and zinc plates.

**Exp. 8 :** Test an iron rod by iron filings for magnetism. It does

not attract them. Wind a few turns of cotton-covered wire around the iron rod and plunge it into the filings, after first connecting the ends of the wires to the two plates in the tumbler. Filings are now attracted to the iron core, but drop off when the connection to the plates is broken. This then, is a temporary magnet, produced by the magnetic properties possessed by the wire.

**62. A Current of Electricity.**—From the foregoing experiments it appears, that when zinc and copper are immersed in an acid solution and connected by a wire, the wire possesses *unusual magnetic properties*. The cause of this magnetic effect, and other effects associated with it to be noted later on, is attributed to electricity, and the property possessed by the wire said to be due to a transference of electricity from one plate to the other, the wire acting as a conducting medium. When we speak of a current “flowing through the wire from plate to plate,” it is simply a convenient expression used to describe the phenomena involved, although we do not know what actually transpires.

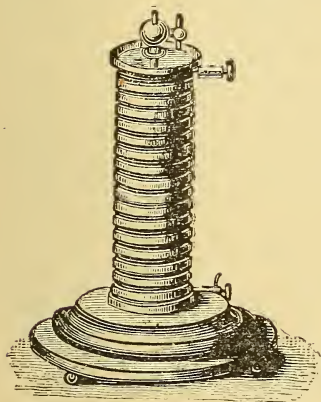
An ebonite or glass rod is *electrified* when rubbed with flannel, silk, etc., and possesses the power of attracting light bodies to it, and also of attracting or repelling another similarly electrified rod, according to the nature of its *electrification*. When the portion of a rod so electrified is touched by the hand, or other conductor, the electrification disappears and the body is said to be discharged. The two plates in the tumbler may be said to be electrified to different degrees of electrification, and when they are connected by a wire, the electrification discharges from the higher to the lower electrified plate. The action of the acid upon one plate more than the other, however, tends to keep the plates at different states of electrification and the successive discharges through the connecting wire become so intensely rapid that they form practically a *continuous current* of electricity.

**63. Simple Voltaic Cell.**—When two *dissimilar* metals are partially immersed in acid solution, which is capable of acting chemically upon one of them more than upon the other, when they are connected by a wire, the combination constitutes a voltaic cell. The name voltaic is derived from an Italian physicist, Volta, who first discovered the cell in 1800. It is sometimes called a galvanic cell, after Volta's contemporary, Galvani. Correctly speaking, the word battery applies to a number of such cells connected together, though

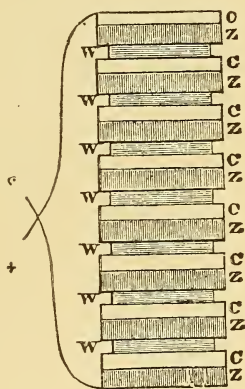


the name is commonly applied to a single cell. The solution in which the metals are immersed is called the electrolyte, or exciting fluid, or excitant.

**64. Volta's Pile.**—Volta's pile, which is the parent of all batteries, consists of a number of discs of copper (C) and zinc (Z), Fig. 71, with a cloth or blotting paper (W) moistened with salt water and placed between them. When the end discs are connected by wires brought into contact, the same phenomena occur as already described with the Volta cell.



Volta Pile.



Connections of Volta Pile.

Fig. 71.

Volta soon found that better results were obtained by using the two metals immersed in an acid solution, hence our simple voltaic cell.

Fig. 71 also illustrates a Volta pile made for experimental purposes. It is equivalent to a number of Volta cells with the zinc of one cell connected to the copper of the next one, and so on.

**65. The Circuit.**—Considering again our simple voltaic cell, Fig. 70, the term *circuit* is applied to the *entire path* through which the transference of energy takes place, or the current of electricity is supposed to flow, and the wire joining the plates is called the *conductor*. The circuit then consists of not only the conductor between the plates outside of the cell, but the liquid conductor between the plates inside of the cell; hence we speak of the *internal circuit* and the

external circuit. The *complete circuit* includes the conducting wire, the two plates which act as conductors, and the liquid between them. Bringing the two extremities of the wires into contact is called *making*, or *closing* the circuit, and their separation again, *opening*, or *breaking* the circuit.

**66. Conductors and Insulators.**—The substances which when interposed between the terminal wires of a voltaic cell do not interfere with the deflection of the magnetic needle (as the metals), are known as *conductors* of electricity, because they allow the current to flow through them, while other substances so interposed, as glass, wood, mica, etc., interfere with the action in the cell and upon the needle, and are therefore called *insulators*. A classified list of conductors and insulators is given in ¶ 125.

**67. Direction of the Current.**—

**Exp. 9:** Place the conducting wire of a voltaic cell over and parallel with a magnetic needle when it is pointing **N** and **S**, Fig. 72.



Fig. 72.—Direction of the Current.

Close the circuit and note whether the **N**-pole of the needle points east or west when the current is flowing. Say it is deflected to the east. Now reverse the wire connections at the battery plates (that is, connect the end of wire

which was attached to the zinc to the copper, and vice versa), the **N**-pole of the needle now points west if the wire is held as before.

This experiment indicates that electricity exists in part, as a magnetic force around a wire, and on account of the behavior of the needle, that this force has direction. For this reason electricians have agreed to assume that the electricity flows from the *copper* terminal to the *zinc* terminal through the conducting wire, and from the *zinc* plate to the *copper* plate through the solution.

**68. Poles or Electrodes and Plates.**—The copper plate is called the *negative plate* or element, and the zinc plate the *positive plate* or element, while the external end of the copper plate or any wire connected thereto is called the *positive pole* or electrode (no connection whatever with magnetic pole), and

the external end of the zinc plate, or wire connected thereto, the *negative pole* or electrode, Fig. 73. If we bring the + (plus sign for the positive) and - (minus sign for negative) wire from a cell together, making the circuit, the current

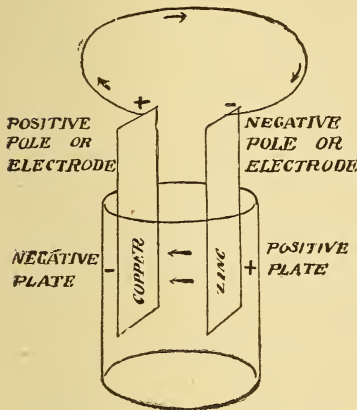


Fig. 73.—Nomenclature of a Voltaic Cell.

passes from the + (copper) to the - (zinc) terminal across the junction, and also from the + plate (zinc) to the - plate (copper) through the cell. In any electro-generative device that pole is considered *positive from which the current flows*, and that pole *negative to which the current flows*. As Zn, stands for zinc, and negative begins with the letter N, this may aid in remembering the terminals or poles. In any cell the *positive plate* (generally zinc) is the one most acted upon, the current being supposed to start at the surface of this

plate, travel through the solution to the copper plate, and from the copper terminal to the zinc terminal through the external circuit.

**69. Detector Galvanometer.—**

**Exp. 10:** From Exp. 9 it was shown that if a current passes over a needle it is deflected to the east or west, according to the direction of the current. The student should now prove that the needle is deflected oppositely if the wire be held underneath, but parallel to it, according to the direction of current in the wire. Note also that for the *same direction* of current underneath the needle

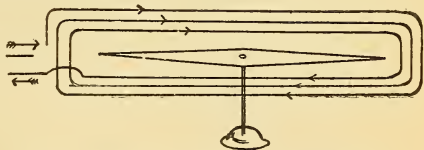


Fig. 74.—Simple Detector Galvanometer.

as above it, the deflection is opposite to what it previously was. Now bend the wire around the needle, at rest, parallel to it, so that the current flows over the needle and under the needle in opposite directions. The deflection is now in the same direction, and *greater* than before. Make several convolutions and the deflection is still increased, Fig. 74. A few turns of wire wrapped around a pocket compass, parallel

to the needle when it is pointing **N.** and **S.**, constitutes a simple form of *detector galvanometer*, and when inserted in a battery circuit will indicate by the deflection of the needle that a current is flowing. Various types of galvanometers are described in Lesson XVI.

**70. Potential and Electromotive Force.**—Suppose two vessels partially filled with water are connected by a pipe and placed on a table at the same level. The connecting pipe is full of water, yet there is *no current* of water flowing through the pipe because the pressure at each end is *the same*. When one vessel, A, Fig. 75, is raised above the other, B,

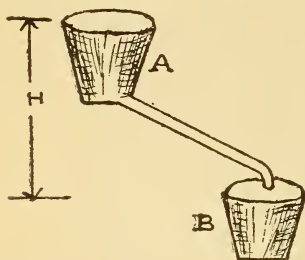


Fig. 75.—Water Analogy for Potential Difference.

then there is a *difference in pressure* between the two ends of the pipe, and a current of water *flows* from the *higher* to the *lower* level, due to this difference of pressure (or head) between the two points. It is not necessary to know the height of vessel A or B above the sea level, but the height or head (H) between the two vessels. Similarly, if two points on a copper bar are elevated to the same temperature there is no

transference of heat from one point to the other. If, however, one point is at a higher temperature than the other there is then a difference in temperature between the points and a transference of heat from the point of higher to the point of lower temperature.

The word *potential* as used in an electric sense is analogous to pressure in gases, head in liquids, and temperature in heat. In the Volta cell then we have two bodies raised to different electrical potentials (see ¶ 62), and to the difference of potential between them is due the current flowing through the wire connecting the plates. The greater this difference of potential the greater the current, or effect of the current produced.

Potential is the force which moves electricity through the circuit. The total force required to cause the current to flow through the entire circuit is called the *Electromotive Force*, whereas a *difference of potential* would exist between two points in a circuit, which would cause the current to flow just between these two points. Electromotive force (abbrev-

viated E. M. F.) is the total difference of potential (abbreviated P. D.) that is maintained in any circuit.

**Exp. 11 :** Insert two similar pieces of copper or zinc in the acidulated tumbler of water and test for a current by a detector galvanometer. The needle is not deflected. The similar plates being both electrified to the same degree there is no difference of potential between them, hence no current. This is analogous to the two vessels of water placed on a level.

**71. Chemical Action in a Voltaic Cell.**—A continuous potential difference is maintained between the zinc and copper plates when they are connected chiefly by the action of the exciting liquid upon the zinc. The chemist symbolizes sulphuric acid,  $H_2SO_4$ , meaning that it is composed of two parts hydrogen ( $H_2$ ), one part sulphur (S), and four parts oxygen ( $O_4$ ). The  $SO_4$  part of the acid has a strong affinity for the zinc, and when the cell circuit is completed, attacks the zinc and forms zinc sulphate ( $ZnSO_4$ ) which is dissolved in the water, and may be reclaimed by filtering after considerable zinc has wasted away. For every portion of the  $SO_4$  part of the sulphuric acid which unites with the zinc, two parts of hydrogen gas are liberated, which escape from the solution as already noted in the experiments. The zinc thus replaces the hydrogen in the acid, setting it free. The chemical action may be expressed as follows :

$$Zn + H_2SO_4 = ZnSO_4 + H_2.$$

Zinc and sulphuric acid produce zinc sulphate and hydrogen.

Every time the circuit of a cell is completed, and as long as it is completed, this chemical action takes place, the zinc gradually wasting away, also the power of the acid to attack the zinc gradually becoming exhausted. Thus the electrical energy is maintained in the external circuit to perform useful work by the expenditure of so many pounds of zinc and acid inside the cell. The chemical energy contained in a lump of coal is converted into kinetic energy when burned under a steam boiler. Zinc might be similarly burned to produce steam, but its cost would be prohibitive, and for this reason batteries are not cheap generators of electricity for electric lighting and power purposes. In coal and zinc there is stored up chemical energy which may be expended by bringing together suitable substances and converted into heat and electrical energy, as is done when zinc is practically burned in a battery.

### 72. Why the Hydrogen Appears at the Copper Plate.

—As already stated, when zinc is immersed in sulphuric acid, hydrogen is liberated and rises in bubbles to the surface of the solution. In the voltaic cell it was noticed that the hydrogen bubbles rose from the copper, yet no bubbles were seen to pass through the solution. Many chemists believe that the instant an element is liberated from a compound (as the  $H_2$  from the  $H_2SO_4$ ) it possesses unusual readiness to enter into combination with other molecules. At the instant the circuit is closed, Fig. 76, the  $SO_4$  of molecule 1 unites with a molecule of zinc, setting free a molecule of hydrogen; this instantly unites with the  $SO_4$  of molecule 2, forming a new molecule of  $H_2SO_4$  and setting free the  $H_2$  of molecule 2. This action continues until the last free molecule of  $H_2$  appears at the copper plate and rises to the surface.

### 73. Polarization.

**Exp. 12:** Connect a Volta cell to a detector galvanometer wound with a few turns of wire and note the angle of deflection of the needle. Allow the current to flow for a while, and note that the deflection

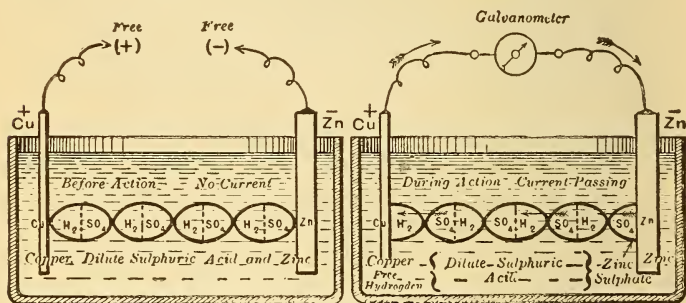


Fig. 76.—The Chemical Action in a Voltaic Cell when the Circuit is Closed. The molecules of dilute sulphuric acid are represented by the ovals.

gradually falls and becomes much less than at first. Brush off the bubbles adhering to the hydrogen plate with a swab and the deflection is increased, thus indicating a stronger current; but it soon falls again when the copper plate becomes coated with the hydrogen gas.

The copper plate coated with hydrogen becomes practically a hydrogen plate. Now the effect of using a plate of hydrogen and zinc in a cell would be to set up a current from the hydrogen to the zinc inside the cell and from the zinc to the hydrogen outside of the cell. As this tendency acts against

the direction of the ordinary copper to zinc current it weakens the current from the cell. When the cell becomes weakened in this manner by a coating of hydrogen bubbles on the negative plate it is said to be polarized and the phenomenon called *polarization*. Polarization, then, is an evil, which, if properly overcome by arresting the bubbles in some manner, would permit the cell to give a strong current as long as any zinc remained to be acted upon. The attempt to prevent the polarization has given us the many varied types of cells now on the market.

The following test made on a Leclanche cell, ¶ 88, will illustrate the phenomenon of polarization. The cell was connected to a circuit of low resistance, and readings of a voltmeter, ¶ 235, were taken at one-minute intervals for five minutes, in which the E. M. F. dropped from 1.41 to .63 volts. The cell was then allowed to stand on open circuit for five minutes, and one-minute readings taken, to note its *recuperation*. At the end of the fifth minute the former E. M. F. was not regained, but only 1.18 volts. One-half hour after the test, a measurement then made showed the original E. M. F. of 1.41 volts.

Table II.—Polarization Test.

Discharge.		Recuperation.	
0 minutes,	1.41 volts.	0 minutes,	.63 volts
1 "	1.03 "	1 "	.87 "
2 "	.80 "	2 "	.97 "
3 "	.70 "	3 "	1.06 "
4 "	.65 "	4 "	1.14 "
5 "	.63 "	5 "	1.18 "

**74. On What the Electromotive Force of a Cell Depends.**—If two similar plates of zinc are immersed in an acid solution, Exp. 11, and connected, there is a tendency to opposite currents, which neutralize each other; since there is no difference of potential between them, no current flows. *The essential parts of any cell, then, are two dissimilar metals immersed in an acid solution, one of which is more readily acted upon by the acid than the other.* The greater the difference in intensity of chemical action the greater the difference of potential, and the greater the current strength which depends upon the difference of potential.

Other metals than copper and zinc may be used in cells, and as acids attack the different metals with varying intensities of chemical action, some combinations will produce better results than others. For example, a cell composed of zinc and lead plates, immersed in dilute sulphuric acid, will

not deflect a magnetic needle to so great an angle as a zinc-copper cell of the same size, because a higher difference of potential is set up between zinc and copper than between zinc and lead.

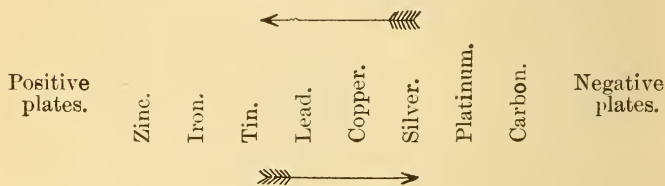
The electromotive force of a cell is dependent also on the solution used to attack the zinc, so that the same battery plates immersed in different acids would indicate different potential differences, for the combination in each solution used. Using the same solution, however, this force is independent of the size of the plates, *a small battery having the same potential difference, or E. M. F., as a large one of the same kind.*

In the following list of substances, known as the *electro-chemical series*, those most acted upon (electro-positive plates) by dilute sulphuric acid are placed at the left-hand of the list, while those least acted upon (negative plates) are at the right-hand end of the list.

The arrangement would be different for other acids used.

**Table III.—The Electro-chemical Series.**

Direction of current through external circuit.



Direction of current through solution.

The difference of potential in a lead-silver cell would be less than a lead-carbon cell, while an iron-carbon cell would be greater, and a zinc-carbon cell still greater. For this reason zinc and carbon, being cheap commercial products, are extensively used in batteries. The arrows indicate the direction of current through the internal and external circuits. In a lead-carbon cell the carbon would be the positive and the lead the negative terminal: while in a lead-zinc cell the lead is the positive terminal and the zinc the negative terminal. Considering the plates in the list, any substance is *positive* to any substance which *follows* it, and *negative* to any *preceding* it.



**Exp. 13:** Using some similar strips of lead, copper, carbon, and zinc, make up different types of cells in dilute sulphuric acid. Connect each combination to the detector galvanometer and note the direction that the needle swings, the value of the deflection, and to which terminal each plate was connected. Note that when *lead* is connected to the *same terminal* of the galvanometer, and *carbon* used with it, the deflection is in the *opposite direction* to that when *zinc* is used with *lead*, which illustrates that in one instance the current leaves the lead terminal (+), and in the other instance flows to it (—).

**Student's Experimental Cell.**—A simple form of experimental cell with which numerous experiments can be made is illustrated in Fig. 76-A. A glass U tube is clamped to a vertical block on a base support by means of a rubber band. Suitable connections on the top of the block afford means for rapidly inserting rods, of the different metals in the electrochemical series, in the electrolyte held in the U tube, and the chemical action is clearly visible. The device may be used as an electrolytic cell, also as a calorimeter when an iron wire spiral is inserted in the tube, and, again, as a convenient fuse block for determining the heating and fusing effects of the current on the different metals.

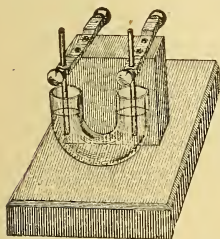


Fig. 76-A.—Student's Experimental Cell.

**Exp. 14:** Connect a galvanometer wound with *many turns* of *fine wire* to a Volta cell and note the value of the needle's deflection. Slowly withdraw the plates from the liquid and you note that the deflection of the needle remains the same until the circuit is broken at the surface of the liquid. This proves that the E. M. F. is independent of the area of the plates immersed. (See ¶ 74.) Move the plates further apart or closer together and the deflection is not changed, if the galvanometer is wound as above. The E. M. F. of a cell is independent of the distance between the plates.

**75. Local Action.**—When a pure piece of zinc (which it is difficult to obtain) is used in a cell there is no action at the zinc except when the cell is in use. The ordinary commercial zinc contains many impurities, such as small particles of carbon, iron, tin, lead, etc., and when a rod of such zinc is placed in a cell these foreign particles form numerous local voltaic cells on the surface of the zinc inside the cell, with the result that the zinc is being continuously eaten away, whether the cell is in action or at rest. These small currents divert just so much strength from the regular battery current, thereby weakening it. Fig. 77 illustrates a magnified particle of iron on a zinc rod, and a local current



Fig. 77.  
Local Action.

would flow from the iron to the zinc through the solution and from the zinc to the iron across the junction. This is known as *local action*. In some cells local action is also caused by a difference in the density of the liquid at various parts of the cell. In this case the zinc near the top of the liquid is ordinarily wasted away, and may be entirely eaten off.

**76. Amalgamation.**—Local action may be prevented by thoroughly cleaning the zinc with sand paper, then immersing it in dilute sulphuric acid and while still wet applying mercury (quicksilver) by means of a rag swab. A bright amalgam is formed over the surface of the zinc and it is said to be *amalgamated*. The mercury dissolves the outer layer of zinc, forming a zinc-mercury amalgam. The foreign particles are either covered up from the action of the acid, or drop down to the bottom of the cell, or carried off by any remaining local action. The mercury does not prevent the zinc from being dissolved during the action of the cell, but continues to re-form an amalgam as the zinc wastes away. Zinc for battery plates is sometimes cast with a small percentage of mercury in its composition.

### QUESTIONS.

1. Explain what you understand by the word electricity.
2. How does electricity manifest itself?
3. What is the action of dilute sulphuric acid on zinc?
4. What is a simple cell?
5. Explain the action in a simple voltaic cell. Give sketch.
6. Give your idea of a "current" of electricity.
7. What is an electrolyte?
8. Describe and illustrate Volta's pile.
9. What is meant by an open and closed circuit?
10. Distinguish between the internal and external circuit of a cell.
11. What are insulators?
12. What is meant by a good conductor?
13. State an experiment you would make to determine whether a body was an insulator or a conductor.
14. Give a reason for attributing direction to a current.
15. Which way does a current flow inside a Volta cell?
16. Sketch a simple Volta cell, name all the parts, and show the direction of the current in the internal and external circuit.
17. Distinguish between poles and plates.
18. Which is the negative electrode in a lead-copper cell in  $H_2SO_4$ ?
19. Which is the positive plate in a lead-iron cell?
20. What is a detector galvanometer, and for what is it used? Give sketch.

## LESSON IX.

### BATTERIES.

Primary Batteries—Open Circuit Cells—Closed Circuit Cells—Remedies for Polarization—The E. M. F. of Cells—Smee Cell—Bichromate Cell—Fuller Bichromate Cell—Partz Acid Gravity Cell—Bunsen's and Grove's Cells—Daniell's Cell—Leclanche Cell—Gonda Leclanche Cell—Carbon Cylinder Cell—Edison-Lalande Cell—Chloride of Silver Cell—Dry Cells—Classification of Cells—Chemicals for Cells and Some Chemical Symbols—Questions.

**77. Primary Batteries.**—*Primary* batteries are so called to distinguish them from *secondary* batteries (storage batteries or accumulators, ¶ 107). Primary batteries are divided into two general classes, according to the manner in which they are to be used, known as *open circuit* cells and *closed circuit* cells.

**78. Open Circuit Cells.**—Open circuit cells are used for *intermittent work*, where the cell is in service for short periods of time, such as in electric bells, signaling work, and electric gas lighting. In cells of this class polarization does not have much opportunity to occur, since the circuit is closed for such a short period of time; hence, these cells are always ready to deliver a strong current when used intermittently. If kept in continuous service for any length of time the cell soon polarizes or “runs down,” but will recuperate after remaining on open circuit for some little time.

**79. Closed Circuit Cells.**—In the *closed circuit* type of cell, *polarization is prevented* by chemical action, so that the current will be constant and steady till the energy of the chemicals is entirely expended. This type of cell is adapted for furnishing current continuously, as in the service of small lamps, motors, electroplating, etc.

**80. Remedies for Polarization.**—In the simplest form of cell, as zinc, copper, and dilute sulphuric acid, no attempt has been made to prevent the evil of polarization, ¶ 73; hence, it will quickly polarize when the circuit is closed for any length of time, and may be classified as an *open circuit*

cell. When polarization is remedied by chemical means, the chemical added is one that has a strong affinity for hydrogen and will combine with it, thus preventing the covering of the negative plate with the hydrogen gas. The chemical used for this purpose is called the *depolarizer* and may be used either in a *solid* or *liquid* form, which gives rise to several forms of cells, such as cells with a single fluid, containing both the acid and the depolarizer; cells with a single exciting fluid and a solid depolarizer, and cells with two separate fluids. (See ¶ 94.)

In the *double fluid* form of cell the zinc is immersed in the liquid (frequently dilute sulphuric acid) to be decomposed by the action upon it, and the negative plate is surrounded by the liquid depolarizer, which will be decomposed by the hydrogen gas it arrests, thereby preventing polarization. The two liquids are sometimes separated by a porous partition of unglazed earthenware, keeping the liquids from mixing, except very slowly, but not preventing the passage of hydrogen or electricity.

Place sufficient mercury in a small battery jar to cover the bottom and fill the jar with a sal-ammoniac solution. Suspend a piece of zinc from the top of the jar and you have a zinc-mercury cell. Make connections with the mercury by a piece of rubber-covered wire. Connect the cell to a short coil galvanometer and note the falling deflection of the needle, due to polarization. When the cell becomes sufficiently polarized drop into the solution a piece of mercuric chloride ( $\text{HgCl}_2$ ) the size of a pin head. The galvanometer needle instantly shows a much larger deflection. The hydrogen has been removed by the chlorine in the mercuric chloride. When the chlorine becomes exhausted polarization sets in again. The mercuric chloride is thus a chemical depolarizer.

**81. The E. M. F. of Cells.**—Considering the electromotive force of one particular type of cell as a standard of E. M. F., another type of cell will possess either a greater or less force in comparison with it. The unit of electromotive force is called the volt, and is about the pressure set up by a Volta cell, so that if a cell has an E. M. F. of 1.4 volts we mean that it possesses 1.4 times the force of a Volta cell. Cells are, therefore, rated by their E. M. F. In ¶ 136 will be found a table of E. M. F.'s of the different types of cells.

**82. Smee Cell.**—This cell is an example of the mechanical means used to overcome polarization. A plate of lead or silver is suspended between two zinc plates in dilute sul-

phuric acid. The silver or lead plate is covered with a fine, powdery deposit of platinum, which gives the surface a rough character, so that the bubbles of hydrogen will not readily adhere to it as they are formed, but rise to the surface of the solution. Another mechanical method to overcome polarization is to rotate the electro-negative plate, thus preventing bubbles of gas from adhering to it; but as this necessitates a constant force to keep the plate in motion, the cell would not be very economical. No *mechanical* method can wholly prevent the collection of hydrogen on the negative plate. This can only be accomplished by furnishing some chemical with which the hydrogen, as soon as it is liberated, will combine. The E. M. F. of a Smee cell is about 0.65 volt.

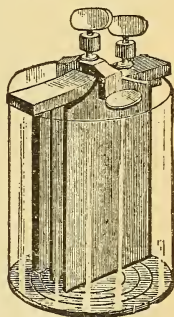


Fig. 78.—Smee Cell.

**83. Bichromate Cell.**—In this type of cell polarization is prevented by chemically arresting the hydrogen gas, so that it never reaches the negative plate. The same will be true of most of the cells now to be described. Bichromate of soda or bichromate of potassium is the depolarizer, to which is added water and sulphuric acid for attacking the zinc. The bichromates are rich in oxygen, for which hydrogen has a strong affinity. Carbon and zinc plates are used, and this type made up in several forms and termed chromic acid cells. In the Grenet (Gren-ā') form a zinc plate is suspended by a rod between two carbon plates, Fig. 79, so that it does not touch them, and when the cell is not in use the zinc is withdrawn from the solution by raising and fastening the rod by means of a set-screw, as the acid attacks the zinc when the cell is on open circuit. This cell has an E. M. F. of over 2 volts at first, and gives a strong current for a short time, but the liquid soon becomes exhausted, as will be noted by the change in the color of the solution from an orange to a dark red, and must be replenished. The zinc should be kept well amalgamated and out of the solution except when in use. It is a good type of cell for experimental work, and about two cells would perform nearly all of the experiments in this book. A simple substitute for this type of cell would be a number of electric light carbons fastened together to form the negative plate and several zinc rods for the positive

plate, which could be removed at will and then rinsed in water.

To make a solution for a bichromate cell take 3 ounces of finely powdered bichromate of potash and 1 pint of boiling water; stir with a glass rod, and after it is cool add slowly, stirring all the time, 3 ounces of sulphuric acid. The solution should not be used until cool. In mixing a battery solution always *pour the acid gently into the water*, while stirring, to dissipate the heat. *Never pour water into acid*. If bichromate of soda is used as above take 4 ounces bichromate of soda,  $1\frac{1}{4}$  pints boiling water, and 3 ounces of sulphuric acid. These battery solutions are sometimes termed *electropoin fluids*.

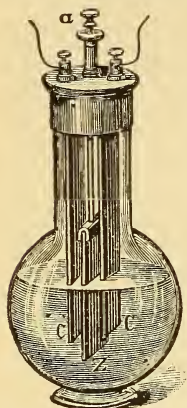


Fig. 79.—Grenet Cell.

Zinc and carbon in bichromate solution.

**84. Fuller Bichromate Cell.**—This double fluid cell has the advantage over the Grenet type, in that the zinc is always kept well amalgamated and does not require removal from the solution. A pyramidal block of zinc, to which a metallic rod covered with gutta-percha is attached, is placed in the bottom of a porous cup, Fig. 80, and an ounce of mercury is poured in. The cup is filled with a very dilute solution of sulphuric acid or water, and then placed in a glass or earthen jar containing the bichromate solution and the carbon plate. The acid diffuses through the porous cup rapidly enough to attack the zinc, which, being well amalgamated, prevents local action. The hydrogen travels from the zinc through the porous cup and combines with the oxygen in the potassium bichromate. The E. M. F. is about 2.14 volts, and the cell is used for open circuit or semi-closed circuit work. Another form of the Fuller type is shown in Fig. 81.

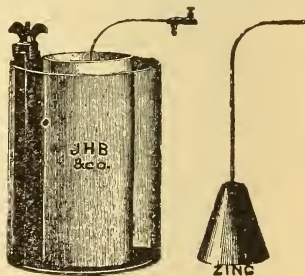


Fig. 80.—Fuller Cell.

Zinc in dilute  $H_2SO_4$  in porous cup, carbon in a bichromate solution.

**85. Partz Acid Gravity Cell.**—In the Partz acid gravity form of cell, Fig. 81-A, the electrolyte which surrounds the zinc is either magnesium sulphate or common salt.

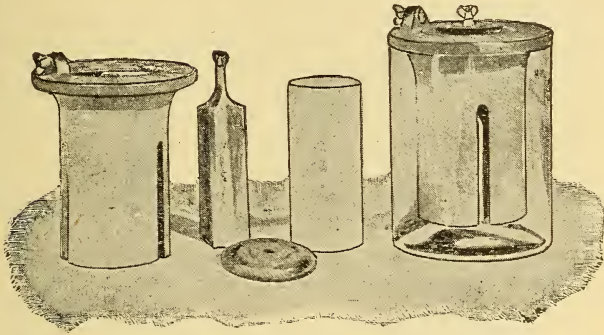


Fig. 81.—Fuller Cell.

Zinc in porous cup with mercury and dilute  $H_2SO_4$ , carbon in a bichromate solution.

The depolarizer is a bichromate solution which surrounds the perforated carbon plate located in the bottom of the jar. A vertical carbon rod fits snugly into the tapered hole in the carbon plate, and extends through the cover forming the positive pole. The depolarizer, being heavier than the electrolyte, remains at the bottom of the jar, and the two liquids are thus kept separate. This depolarizer is placed on the market in the form of crystals, known as sulpho-chromic salt, made by the action of sulphuric acid upon chromic acid. When dissolved, its action is similar to that of the chromic acid solution. After the cell has been set up with everything else in place the crystals are introduced into the solution, near the bottom of the jar, through the vertical glass tube shown, and slowly dissolve and diffuse over the surface of the carbon plate. When the cell cur-

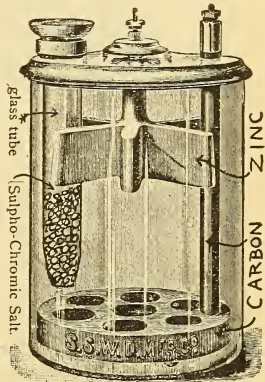


Fig. 81-A.—Partz Cell.

rent weakens a few tablespoonfuls of the salt introduced through the tube will restore the current to its normal value. The cell should remain undisturbed to prevent the solution from mixing. Its E. M. F. is from 1.9 to 2 volts, and the 6 in. x 8 in. size has an internal resistance of about .5 ohm. Since the depolarization is quite effective, the cell may be used on open or closed circuit work.

**86. Bunsen and Grove Cells.**—These cells are examples of the two fluid type, in which the solutions are separated by a porous partition. Bunsen's battery has a bar of carbon immersed in strong nitric acid contained in a porous cup. This cup is then placed in another vessel containing

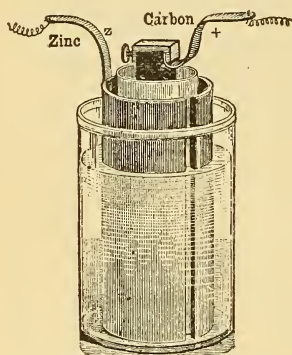


Fig. 82.—Bunsen Cell.

Carbon in  $\text{HNO}_3$  porous cup, zinc in dilute  $\text{H}_2\text{SO}_4$ .

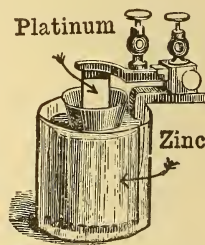


Fig. 83.—Grove Cell.

Platinum in  $\text{HNO}_3$  in porous cup, zinc in dilute  $\text{H}_2\text{SO}_4$ .

dilute sulphuric acid, and immersed in the same liquid is a hollow, cylindrical plate of zinc, which nearly surrounds the porous cup. The hydrogen, starting at the zinc, traverses, by composition and recombination, the sulphuric acid, passes through the porous partition, and immediately enters into chemical action with the nitric acid, so that none of it reaches the carbon. There are produced by this action water, which in time dilutes the acid; and orange-colored poisonous fumes of nitric oxide, which rise from the battery. If the nitric acid first be saturated with nitrate of ammonia, the acid will last longer and the fumes be prevented. Strong sulphuric acid cannot be used in any battery; generally 12 parts by



weight, or 20 by volume, of water are added to one part of sulphuric acid.

Grove used a strip of *platinum instead of carbon* in his cell. A solution of bichromate of potassium (as in ¶ 83) is frequently substituted for the nitric acid in the porous cup, thereby avoiding disagreeable fumes. Bunsen's and Grove's batteries produce powerful and constant currents, and are well adapted for experiments, but they require frequent attention, and are expensive, so that they are little used for work of long duration. E. M. F., of these cells, 1.75 to 1.95 volts.

**87. Daniell Cell.**—This battery is made in many forms and called by various names, such as Gravity battery, Blue-stone Cell, Crowfoot battery, etc. An explanation of the theory

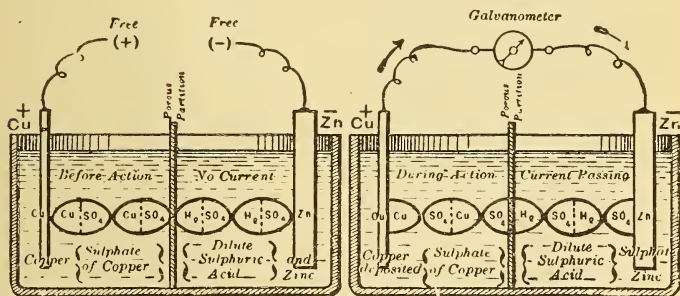
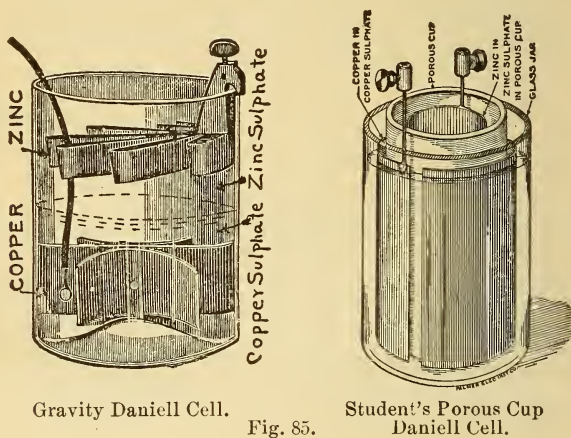


Fig. 84.—Chemical Action in the Daniell Cell when the Circuit is Closed.

of a simple form will answer for all forms of this class, and it is of importance, since the cell is much used in practice for giving constant currents of long duration. It is, therefore, a closed circuit battery. Zinc and copper elements are used. In Fig. 84 they are separated by a thin partition of unglazed pottery. On the zinc side of the partition is put dilute sulphuric acid ( $\text{H}_2\text{SO}_4$ ), or simply water, if the cell is not required for immediate use; on the copper side is placed sulphate of copper ( $\text{CuSO}_4$ ), dissolved in water, together with some sulphate of copper crystals (bluestone) to maintain the supply of copper sulphate solution. When the circuit is closed, as shown by Fig. 84, the zinc combines with the ( $\text{SO}_4$ ) of the sulphuric acid forming sulphate of zinc ( $\text{ZnSO}_4$ ), and thus sets free the two molecules of hydrogen ( $\text{H}_2$ ).

This hydrogen gas passes through the porous partition, but instead of collecting on the sides of the copper plate, it meets with the sulphate of copper ( $\text{CuSO}_4$ ), and having a greater natural affinity for the ( $\text{SO}_4$ ) than the copper ( $\text{Cu}$ ) possesses, it displaces the copper, and forms sulphuric acid, ( $\text{H}_2\text{SO}_4$ ) setting free pure metallic copper, which is deposited upon the copper plate. This continuous extraction of metallic copper from the solution would soon weaken it, were it not for the fact that the copper crystals dissolve and thus automatically keep the solution saturated. To maintain a



Gravity Daniell Cell.

Fig. 85.

Student's Porous Cup Daniell Cell.

constant current for an indefinite time, therefore, it is only necessary to keep the supply of copper crystals and zinc maintained. The cell has an E. M. F. of about one volt and gives a small, but steady current. The "gravity type" of this cell, which is used in this country for telegraphy (closed circuit work), is illustrated in Fig. 85.

A student's small Daniell cell is also shown in Fig. 85. It is of the double fluid type. A rod of freshly amalgamated zinc is placed in the porous cup in a solution of zinc sulphate, with a specific gravity of 1.1. The porous cup is placed in a glass jar containing a solution of copper sulphate of the same specific gravity, and surrounded by a sheet of copper. It is advisable to short-circuit the cell for about ten minutes before using. Under the above conditions the E. M. F. is 1.05 volts. The cell should be set up with a new solution each time it is required and taken apart and cleaned after use. The cur-

rent on short circuit is small, about  $\frac{1}{2}$  ampere, but since polarization is eliminated it is a good cell to use for electrical measurements where a constant source of E. M. F. is required, as in Lesson XXI.

**88. Leclanche Cell.**—This very common form of cell is an example of the single solution type, with a solid depolarizer surrounding the negative element, which is generally carbon, the positive element

being zinc, Fig. 86. The liquid used is a strong solution of ammonium chloride, commonly known as sal-ammoniac, and much resembles table salt. In the porous cup type of cell, a carbon slab is placed in the porous cup and surrounded by a mixture of small pieces of carbon and manganese dioxide, the top being covered by means of pitch, leaving one or two small holes for air and gas to pass through. The depolarizer will take care of a limited amount of the hydrogen produced when the cell is on closed circuit, but if the circuit be closed for any length of time polarization occurs. The cell is thus of the open circuit class, and will furnish a

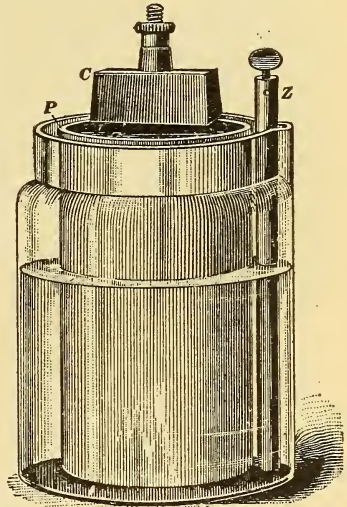


Fig. 86.—Leclanche Cell.

Carbon in porous cup with  $MnO_2$ , zinc in sal-ammoniac solution.

good current where it is required only intermittently. Zinc is dissolved only when the cell is being used. This type of cell, or its modification, is used for gas lighting and bell work. The cell requires very little attention. Water must be added as the solution evaporates, and the zinc rod replenished when necessary. The E. M. F. is about 1.48 volts and the internal resistance is about 4 ohms.

**Directions for setting up the Leclanche Cell.**—1. Place in the glass jar six ounces of ammonium chloride (sal-ammoniac), pour in water until the jar is one-third full and stir thoroughly.

2. Put in the porous cup, and add water if necessary until the level of the water is within  $1\frac{1}{2}$  inches of the top of the porous cup.

3. Put the zinc in place and set the cell away, without connecting up, for ten or twelve hours, to allow the liquid to thoroughly soak

into the porous cup, which will lower its level to about two-thirds the height of the jar, at which level it should be kept, by adding water as it evaporates. The cell is then ready for use.

**89. Gonda Leclanche Cell.**—This cell is a modification of the porous cup type, in which the manganese has been mixed with some gelatinous binder, and compressed into slabs, under hydraulic pressure. Two such slabs or prisms, one on each side of the carbon plate, are held in position by rubber bands, Fig. 87. A zinc rod and a sal-ammoniac solution are used. This cell was designed to dispense with the porous cup.



Fig. 87.—Gonda Leclanche Elements.

**90. Carbon Cylinder Cell.**—Carbon possesses a natural power to prevent a limited amount of polarization by absorbing the hydrogen gas coming from the zinc rod, so that we find it used in a variety of shapes for open circuit cells, which gives rise to as many different names, such as *Samson*, *Hercules*, *Law*, *National*, *Standard*, etc.

In all these types of cells, Fig. 88, sal-ammoniac and zinc are used, and by corrugating the carbon, fluting it, or making concentric cylinders, special merits are obtained in each case. Fig. 89 illustrates a carbon cylinder

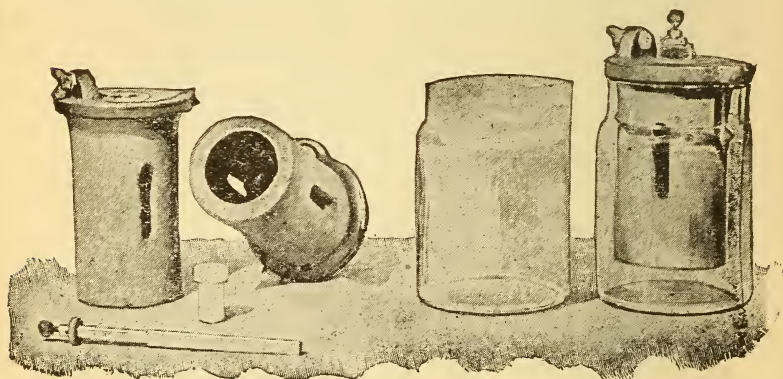


Fig. 88.—Elements of a Carbon Cylinder Cell.  
Zinc, carbon and sal-ammoniac solution.

cell of the Standard Carbon Co., in which the carbon is made in the form of a porous cup and then filled with oxide of manganese to prevent polarization. Still another form of the same make is shown in Fig. 90, in which the space between the two concentric carbon cylinders has been filled with oxide of



Fig. 89.—Elements of Carbon Cylinder Cell with Depolarizer.

Zinc, manganese dioxide in a porous cup and sal-ammoniac solution.

manganese and then sealed in. The zinc rod is prevented from touching the carbon by being first inserted through a porcelain insulator. About 4 to 6 ounces of sal-ammoniac are generally used for cells of ordinary size. The salt is placed in the jar, water poured in until it is about two-thirds full, and then stirred till all the salt is dissolved. When the carbon cylinder is inserted the solution should be within  $1\frac{1}{2}$  inches of the top of the jar. These cells should not be put in warm places, as over the heater in a cellar, on account of the rapid evaporation of the electrolyte. The E. M. F. is from 1.4 to 1.6 volts for the different forms of this type.

**91. Edison-Lalande Cell.**—As in the Leclanche type, this cell is a single fluid battery with solid depolarizer, but is admirably adapted for use on *closed circuit work*, as for small motors, electrotyping, telegraphy, etc. Zinc is the positive, and black oxide of copper ( $\text{CuO}$ ), the negative element. The exciting liquid is a solution of caustic potash. The oxide of copper is obtained by the process of roasting copper turnings; it is then

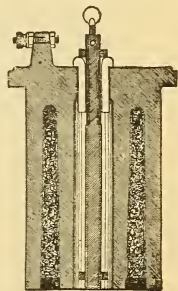


Fig. 90.

Section through carbon cylinder showing  $\text{MnO}_2$  depolarizer.

ground into a fine powder and compressed into solid blocks, from which plates of a suitable size are cut.

These plates are suspended from the cover of the battery jar, Fig. 91, by a light framework of copper, one end of the framework terminating as the positive pole of the battery.

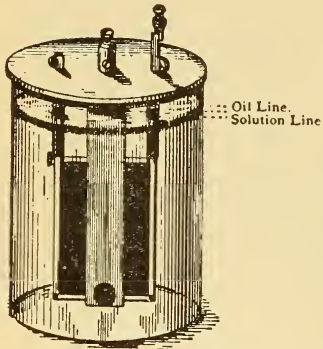


Fig. 91.—Edison-Lalande Cell.  
Zinc and copper oxide in caustic  
potash solution.

On each side of the copper oxide element is suspended a zinc plate, which is prevented from coming into contact with the copper oxide plate by means of vulcanite buttons. When the circuit is closed and the cell in action, the water is decomposed, the oxygen, forming with the zinc, oxide of zinc, which in turn combines with the potash to form a double salt of zinc and potash, which dissolves as rapidly as it is formed. The hydrogen liberated by the decomposition of the water reduces the

copper oxide to metallic copper. The reduced copper is of great purity and can again be converted into copper oxide. It is important to see that the oxide plates are entirely submerged in the caustic potash solution. Heavy paraffin oil is poured on top of the solution, so as to form a layer about one-quarter inch deep on the surface, to keep out the air. When oil is not used creeping salts are formed and the life of the battery is reduced fully two-thirds. The E. M. F. is low, only 0.7 of a volt, but the internal resistance is also very low, so that quite a large current can be drawn from the cell. It is made in a number of different sizes, ¶ 140.

**92. Chloride of Silver Cell.**—This cell is another example of the single fluid type with a solid depolarizer, and is used extensively in portable testing sets where a large number of small cells are mounted in a case. The elements are small wires, or rods of zinc and silver, and on the silver is cast the solid depolarizer, silver chloride, which is reduced to metallic silver by the hydrogen gas. The chloride of silver may be melted in a porcelain crucible and cast around the wire in a carbon mold. A small cylinder of vegetable

parchment surrounds the silver wire and the chloride, to prevent internal short circuits. The zinc rod and silver wire are held in a paraffin stopper, the silver wire of one cell being wedged into the zinc rod of the next, and so on, when a number are connected in series. The elements are sealed in a small glass tube containing the electrolyte, which may be zinc sulphate, zinc chloride, or caustic potash.

With zinc sulphate the E. M. F. is 1.1 volts.

**93. Dry Cells.**—These cells differ from those already described, in that the exciting fluid is combined with some special absorbent, such as sawdust, etc., or is made into a jelly. In the Gassner type of cell the zinc element is in the form of a cylinder, which holds the other element (carbon) and the exciting mixture. The carbon rod or plate occupies about one-half the space in the cell, and the space between the carbon and zinc cylinder is filled with the following mixture, the proportions being by weight: Oxide of zinc, 1 part; sal-ammoniac, 1 part; plaster, 3 parts; chloride of zinc, 1 part; water, 2 parts. Dry cells being portable, are very convenient for use where only an intermittent current is required. The E. M. F. is about 1.4 volts.



Fig. 92.—Dry Cell.

**94. Classification of Cells.—**

Batteries { Primary.  
                  { Secondary.

Primary batteries :

Classified by polarization { Open circuit cells—(Grenet, Leclanche.)  
  { Closed circuit cells—(Daniell, Lalande,  
  { Fuller.)

Classified by construction { Single fluid cells—(Grenet, Leclanche,  
  { Lalande.)  
  { Double fluid cells—(Bunsen, Grove,  
  { Daniell, Fuller.)

Single fluid cells with { Liquid depolarizer—(Grenet type.)  
  { Solid depolarizer—(Leclanche, La-  
  { lande.)

Double fluid cells with liquid depolarizer—(Bunsen, Grove, Daniell.)

**95. Chemicals for Cells and Some Chemical Symbols.—**Copper Sulphate (blue vitriol),  $\text{CuSO}_4$ Zinc Sulphate (white vitriol),  $\text{ZnSO}_4$ Ammonium Chloride (sal-ammoniac),  $\text{NH}_4\text{Cl}$ Bichromate of Soda,  $\text{Na}_2\text{Cr}_2\text{O}_7$ Bichromate of Potassium,  $\text{K}_2\text{Cr}_2\text{O}_7$ Chromic Acid,  $\text{CrO}_3$                       Lead Peroxide,  $\text{PbO}_2$ Caustic Potash,  $\text{KOH}$                       Sulphuric Acid,  $\text{H}_2\text{SO}_4$ Caustic Soda,  $\text{NaOH}$                       Nitric Acid,  $\text{HNO}_3$ Copper Oxide,  $\text{CuO}$                       Hydrochloric Acid,  $\text{HCl}$ Manganese Dioxide,  $\text{MnO}$                       Silver Chloride,  $\text{AgCl}$ Lead Oxide,  $\text{PbO}$                       Zinc Chloride,  $\text{ZnCl}_2$ **QUESTIONS.**

1. Since the hydrogen gas is evolved from the zinc when it is placed in dilute acid, how do you account for the fact that in a Volta cell when connected to a circuit, the hydrogen gas is evolved at the copper plate, yet the copper is not attacked by the acid?

2. Upon what does the E. M. F. of a cell depend?

3. Would you expect a very large cell to have the same E. M. F. as a small one of the same kind made up in test tube? Why?

4. Give a list of some materials used in cells, in the order of their potential difference in dilute sulphuric acid.

5. A cell is composed of copper and iron in dilute sulphuric acid. Draw a sketch indicating the + and — plates and electrodes, and the direction of current, when the plates are connected.

6. Of what use is local action in a cell? How is it prevented?

7. What is the distinction between open and closed circuit cells?

8. Why are there so many different makes of cells on the market, and what is the general distinction between them?

9. Describe a two-fluid cell. Give an example.

10. What is a depolarizer? Give an example of a cell with a solid and liquid depolarizer, and state how the depolarizer acts in each.

11. Describe the Daniell cell and illustrate the chemical action.

12. Describe a bichromate cell of the Grenet type. Make a sketch.

13. How does the Fuller cell differ from the Grenet cell, since the chemicals and plates used are identical?

14. Describe the Leclanche porous cup type of cell. How is polarization prevented in this cell?

15. How does the Edison-Lalande cell differ from the Leclanche cell, since they both use solid depolarizers?

16. Which of the two cells mentioned in question 15 would you use for a spark-ignitor on a gas engine?

17. In what respect does a dry cell differ from a fluid cell?

18. Form a table of all the cells you know of, giving the + and — plates, electrolyte used, depolarizers, name and type (open or closed circuit) in the different columns of the table.

19. Describe fully the action of the Edison-Lalande cell.



## LESSON X.

### ELECTROLYSIS.

Effects of the Current—Heating Effect—Magnetic Effect—Chemical Effect—Electrolysis—Electrolysis of Copper Sulphate—Electrolysis of Zinc Sulphate—Electrolysis of Lead Acetate—Electroplating—Electrotyping—Polarity Indicator—Secondary Batteries, Storage Batteries or Accumulators—Direction of Current in an Accumulator on Charge and Discharge—Commercial Storage Batteries—Questions.

**96. Effects of the Current.**—A current of electricity is not a material substance, and, therefore, has no dimensions (length, breadth, or weight) by which it can be studied or measured. *An electric current is studied by the effects it produces, all of which are commercially utilized.* The effects manifested by a current of electricity are: *Heating Effect, Magnetic Effect, Chemical Effect, and Physiological Effect.* The first three of these effects are treated in this book. A current passed through the body produces muscular contractions, which are said to be due to the physiological effect. Electro-therapeutics deals with the study of this effect.

By a *direct* or *continuous current* is meant one which flows always in the same direction and has the same strength, as, for example, the current from a battery. In a *pulsating current* the direction is uniform, but the current strength varies. Most direct current dynamos furnish a pulsating current, but the pulsations are so rapid that the current becomes practically continuous. In an *alternating current* the direction is reversed at short intervals, and the current strength also varies periodically. Dynamos, called alternators, furnish such a current. The variations occur so rapidly that the current appears to be constant in the circuit.\*

#### 97. Heating Effect.—

**Exp. 15:** Connect the terminals of a bichromate cell to a piece of No. 32 iron wire about one inch long. The wire becomes so hot that

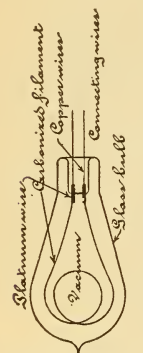
\* In most of the following pages the references to current strength are true for direct currents, and exceptions must be made if other currents are considered.

it is luminous, illustrating both the *heating* and *lighting* effects of a current of electricity. The chemical energy inside of the cell is thus converted into electrical energy outside of the cell in the form of heat and light. If the current is strong enough the wire will be entirely melted.

**Exp. 16:** Substitute a piece of copper wire of the same size and length as the iron wire in Exp. 15. A smaller change of temperature will be noted.

**Exp. 17:** Close the circuit of the cell without any fine wire in the circuit. More heat is now generated inside of the cell than in the external conducting wires.

Every wire which conducts a current of electricity becomes heated to some extent as a result of the current, because the best conductors offer some opposition (resistance) to the flow of the current, and it is in overcoming this resistance that the heat is developed. If the wire is large in cross-sectional area and the current small, the heat developed will be so small in amount as not to be recognized by the touch, yet, nevertheless, some heat is evolved from the wire; upon the other hand, with a small wire and a large current it becomes quite hot. As the heat increases with the resistance of the conductor used, by employing a poor conductor we obtain both light and heat. This principle is used in the incandescent electric lamp, which consists of a fine filament of carbonized material inclosed in a glass bulb, from which the air has been exhausted, Fig. 93. The current is passed through the filament and heats it to a state of incandescence. The globe is exhausted, thereby preventing combustion of the filament, which would occur if it were heated in the air. Of the



Point where  
Glass is sealed

Fig. 93.—Electric Incandescent Lamp.

electric energy expended in the lamp, only about 5 per cent is represented by the light emitted, while the balance appears as heat, so that such a lamp, while convenient, is not an efficient source of illumination. The heating effect of the current is also utilized in the various electric cooking utensils on the market, in electric welding, electric smelting, and in reducing metals from their ores.

**98. Magnetic Effect.**—A wire carrying a current of electricity deflects a magnetic needle. When insulated and coiled around an iron core the current magnetises the core. If the current flowing through a wire be sufficiently strong, the wire

will attract iron filings, proving the existence of the magnetic field around the wire. This subject is treated under Electromagnetism, Lesson XV.

**99. Chemical Effect.**—We have noted in a simple Volta cell, ¶ 71, how electrolytic decomposition takes place inside the cell when a current is flowing. The current is also capable of decomposing certain chemical compounds (liquids) outside of the cell, when it is passed through them, breaking up the compounds into their constituent parts. Liquids may be divided into three classes: (1) *Those which do not conduct electricity at all*, such as many of the oils, particularly petroleum; (2) *liquids which conduct without decomposition*, as mercury and molten metals, which conduct just as solids; (3) *liquids which are decomposed when they conduct a current*, as the dilute acids, solutions of metallic salts, and some fused compounds.

**Exp. 18: Electrolysis of Water.**—Fill the U tube, Fig. 94, with water, and add a few drops of sulphuric acid to make the liquid a better conductor. Connect the terminals of two bichromate cells joined in series, ¶ 141, to the two platinum terminals shown in the U tube, so that the circuit will be completed through the acidulated water. Have the corks quite loose in the U tube for the gases to escape. When the circuit is completed bubbles of gas immediately rise from both platinum plates, more, however, from the platinum plate connected with the negative pole of the battery. The gases may be collected separately by the forms of apparatus shown in Figs. 99 and 100, or collected together in one tube in the form of voltameter shown in Fig. 97.

During this electro-chemical action the current decomposes the water, liberating hydrogen gas at the negative battery pole, and oxygen gas at the positive battery pole. Twice as much hydrogen as oxygen gas is liberated. Water is composed of these two gases, hydrogen and oxygen, in the proportion of two parts of hydrogen to one of oxygen (or  $H_2O$ ) and the current breaks up the water into its constituent parts, Fig. 97. If brass or copper plates are used, the positive plate will be attacked by the action, and no oxygen will be evolved.

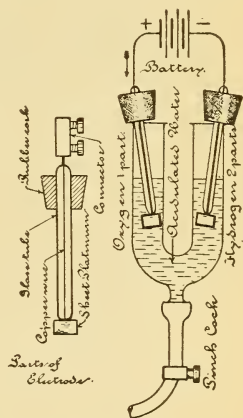


Fig. 94.—Glass U Tube with Electrodes Forming an Electrolytic Cell.

**Exp. 19:** Reverse the direction of the current through the solution, by changing the battery terminals, and note that the hydrogen and oxygen gases are now liberated on the opposite electrodes from Exp. 18, which is another reason for supposing that the current has direction; the opposite deflections of the magnetic needle being a former proof.

**100. Electrolysis.**—A large number of chemical compounds in a state of fusion, or dissolved in certain solvents can, like the acidulated water, be separated into their constituent parts by the passage of an electric current through them. Any substance that is capable of being decomposed by an electric current is called an *electrolyte* (as in a Volta cell) and the process is termed *electrolysis* (meaning loosening by electricity). Plates of carbon, lead, platinum or other metals are used to conduct the current to and from the solution, according to the substance to be electrolyzed.

These plates are called electrodes, and the plate by which the current *enters* the electrolyte is called the positive electrode or *anode* and the plate by which it *leaves* the solution is called the negative electrode or *cathode*. The constituent parts of the electrolyte which are liberated at the surface of the electrodes are called *ions*; the ion liberated at the positive electrode being called the *anion*, and that which appears at the negative electrode the *cation*. Any vessel or apparatus used for performing or measuring electrolysis is called a *voltameter*. In the electrolysis of water hydrogen is the cation and oxygen the anion.

### 101. Electrolysis of Copper Sulphate.—

**Exp. 20:** Fill the U tube, Fig. 94, with a solution of copper sulphate, made by dissolving some copper sulphate crystals (bluestone) in water, and subject the solution to electrolysis, as in the case of the water, using platinum electrodes. Metallic copper is deposited upon the negative electrode, that is the plate becomes copper-plated. Oxygen gas is liberated at the positive platinum electrode and sulphuric acid is formed.

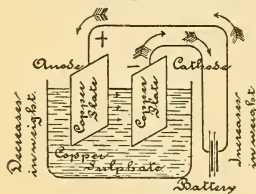
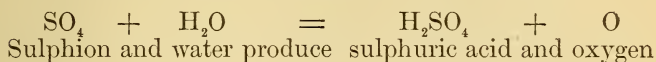


Fig. 95.—Copper Voltameter.

The chemical symbol for copper sulphate is  $\text{CuSO}_4$  and by electrolysis it is separated into  $\text{Cu}$  (metallic copper) and  $\text{SO}_4$  (sulphion). The hydrogen gas liberated at the negative plate displaces the  $\text{Cu}$  of the  $\text{CuSO}_4$  forming  $\text{H}_2\text{SO}_4$  (sulphuric acid), and deposits the  $\text{Cu}$  on the negative plate, while oxygen gas is liberated at the + platinum plate,

as before. If the action is allowed to continue for some time, all the metallic copper is taken from the solution and deposited. This will be noted by the solution changing from a deep to a pale blue, as the change gradually takes place from copper sulphate to sulphuric acid. The action is represented as follows :



**Exp. 21 :** Reverse the direction of current in Exp. 20 and note that now the copper-coated platinum plate becomes the positive electrode, with a platinum plate for the negative electrode. The latter has metallic copper deposited upon it, while the former metallic copper on the positive plate is returned again to the solution.

**Exp. 22 :** Substitute two copper electrodes for the platinum electrodes and repeat Exp. 20. Metallic copper is again deposited upon the negative electrode (increasing its weight) but from the positive electrode no gas is evolved, yet this plate wastes away, or is dissolved in the solution, thereby losing in weight.

When a copper positive plate is used, the  $\text{CuSO}_4$  is separated into Cu on the negative plate, and  $\text{SO}_4$  which attacks the positive plate, and forms a new molecule of  $\text{CuSO}_4$  (copper sulphate). Thus as a molecule of copper sulphate is decomposed, a new molecule is formed, keeping the solution constant. Just as much metallic copper is thrown down into solution from the positive plate, as is taken from the solution and deposited on the negative plate. The art of electroplating is based on the above experiments.

## 102. Electrolysis of Zinc Sulphate.—

**Exp. 23 :** Dissolve some crystals of zinc sulphate,  $\text{ZnSO}_4$  (white vitriol) in water. Refill the U tube, Fig. 94, with this solution and subject it to electrolysis. Use platinum electrodes and metallic zinc is deposited upon the negative electrode and oxygen gas is evolved from the positive electrode. Reverse the direction of current. The previously deposited zinc is deposited again into solution while the other electrode now receives a deposit of zinc. Oxygen gas is not evolved from the positive electrode till all of the zinc has been thrown down into solution.

**Exp. 24 :** Repeat Exp. 23, using two zinc strips as electrodes, and note that the positive strip wastes away, and the negative zinc strip gains in weight. The action of the *Edison electrolytic meter* for measuring current is dependent upon this principle, being then a zinc voltameter.

### 103. Electrolysis of Lead Acetate.—

**Exp. 25:** Prepare a solution of lead acetate, and pass it through filter paper to clear the solution. Fill the U tube, Fig. 94, and subject it to electrolysis, using platinum electrodes. Metallic lead is deposited at the negative plate, and oxygen gas appears at the positive plate. In addition to coating the platinum plate the lead will be deposited in a beautiful tree-like form extending out into the solution from the negative plate. The solution becomes weaker as the extraction of metallic lead continues. When the current is reversed, the former positive plate receives the deposit in the "tree form," but oxygen gas is not now liberated from the positive plate, until the lead previously deposited is dissolved in the solution. This experiment is very suitable for illustration in a lantern projection cell, as well as for laboratory work.

**104. Electroplating.**—The art of depositing a coating of metal upon any object is termed electroplating, and is based upon the principles of electrolysis already explained. The metal held in solution is always deposited on the object to be plated, which must be connected to the negative pole of the source of electricity, while a plate of the metal from which the coating is derived, as nickel, copper, gold, or silver is used as the positive plate. In plating with gold or silver the bath (electrolyte) is always alkaline, and generally a cyanide of the metal to be deposited is used for the solution. In plating an iron spoon with silver, for example, the iron is cleaned, to remove all dirt and grease, and then first receives a deposit of copper in a copper bath, as silver will not deposit upon iron. Articles of iron, steel, zinc, tin, and lead cannot be silvered or gilded unless first coated with a thin covering of copper. After a thin coating of copper, the spoon is transferred to a silver bath, properly connected up and a coating of the desired thickness deposited, after which it is cleaned and brightened on a buffing wheel.

Other substances beside metals can be electroplated by first preparing the surface with a coating of powdered graphite, or plumbago, upon which metal can be deposited. A very low voltage is used in electroplating, since the character of the deposit depends upon the density or strength of current used, ¶ 123. If electrolytic action takes place too rapidly, the deposit is soft, coarse-grained, and liable to prove unsatisfactory, while a small current gives a good, hard, close-grained deposit. The potential varies with the electrolytes used, generally from 1 to 3 volts being applied to the bath.

**105. Electrotyping.**—Suppose an electrotype is desired

from a column of standing type. An impression in wax, or plaster of Paris, is carefully made of the type, and the wax mould dusted over with powdered graphite to make the surface a conductor. The mould is connected as the negative plate in a copper plating bath and receives a thin coating of metallic copper. After removal from the bath the copper deposit is removed from the mould and backed, or filled in with type metal to about the depth of one-eighth inch. When cool, the back is planed smooth, fastened to a block of wood, and can then be used in the press. The copper mould is generally so thin that it is necessary to back it up with the type metal, owing to the pressure to which the electrotype is to be subjected. In this manner the electrotypes for the pages of many books are made from the standing type, and may be used for taking thousands of impressions.

**106. Polarity Indicator.**—The positive and negative poles of a direct current electric light, or power circuit, can be determined by dipping the terminals, at some little distance apart, into a tumbler of water. As twice as much hydrogen gas is evolved at the negative wire as oxygen at the positive wire, the polarity of the circuit is readily determined. Care must be taken not to bring the wires into contact, or some damage would occur, due to too much current flowing through such a low resistance circuit. A solution of iodide of potassium, with a little starch added, is sometimes sealed in a glass tube and terminals provided, by which a current can be passed through, and the polarity of the circuit determined. This is called a polarity indicator. Iodine is liberated at the positive terminal and turns the starch blue around this terminal.

**107. Secondary Batteries, Storage Batteries or Accumulators.**—

**Exp. 26.**—Place two copper strips in a solution of zinc sulphate contained in a small battery jar. Connect the terminals of the copper strips to a galvanometer, and note that the needle is *not* deflected, because the combination does not conform to the definition of a voltaic cell, ¶ 63. Disconnect, and substitute for the galvanometer, two bichromate cells connected in series (connect carbon to zinc). By electrolysis, hydrogen gas would be evolved at the negative plate, but having a greater affinity for the  $\text{SO}_4$  part of the zinc sulphate ( $\text{ZnSO}_4$ ), than the zinc, it displaces it, forming sulphuric acid ( $\text{H}_2\text{SO}_4$ ) and metallic zinc is deposited on the negative copper plate. After the action continues a little while, disconnect the battery and again connect the electrolytic cell to the galvanometer and note that the needle is now deflected.

A secondary battery, storage battery or accumulator, is a voltaic cell, the positive and negative plates of which are formed or deposited by electrolysis, produced by a separate source of electricity. *No electricity was stored* in Exp. 26, but a chemical action took place, which changed the plates into two dissimilar metals and the salt (zinc sulphate) into an acid, capable of attacking one of them, thus conforming to the definition of a primary cell. The current performing the electrolysis is termed the *charging current*, and the secondary cell is said to be *charged*, meaning that it will again generate current when connected to a circuit. This is called *discharging* the cell. The chemical action on discharge of our simple type of accumulator will be obviously the same as in the Volta cell, since the plates (copper-zinc) and the acid formed (sulphuric) are identical with the Volta cell. On discharge, the zinc is decomposed by the acid, and when it is all dissolved in the solution the cell is entirely discharged and must be re-charged again by electrolysis.

**108. Direction of Current in an Accumulator on Charge and Discharge.**—Upon charging the accumulator, Exp. 26, the direction of current inside the cell was from copper to zinc; upon discharge, the current inside the cell travels in the opposite direction (zinc to copper, as in a Volta cell), so that the positive terminal of an accumulator is connected to the *positive* terminal of the charging lines, and this same terminal will again be positive on discharge.

**Exp. 27:** Fill the U tube with acidulated water and connect the voltameter, Fig. 99, to two bichromate cells. After passing the current for a short time, causing an evolution of gas, disconnect the batteries and connect the voltameter to a galvanometer. A deflection of the needle indicates that a current is now passing through the voltameter in an opposite direction to the former battery current.

### 109. Commercial Storage Batteries.—

**Exp. 28:** Place two lead strips in the U tube, Fig. 94, fill with acidulated water and connect the plates to a detector galvanometer. No deflection is noted. Now connect the plates to two bichromate cells (in series), and after passing a current for a short time examine the plates, and you will find that the positive plate has become brownish in color, while the negative plate is the same as before. Connect the plates to the galvanometer, and note that the needle indicates the discharging current.

Lead plates in dilute sulphuric acid were first used by Planté, from whom this type of cell takes its name. The



action in charging such a cell is as follows: Electrolysis of water liberates oxygen on one plate (the positive) which combines with the lead to form lead peroxide ( $\text{PbO}_2$ ), while hydrogen accumulates on the other plate (the negative). On discharging the cell the oxygen of the peroxide plate combines with the hydrogen of the liquid, liberating oxygen, which, in turn, combines with the hydrogen of an adjacent molecule, until finally the hydrogen on the other plate is reached. Commercial storage batteries are modifications of the above type. The E. M. F. of such a secondary cell is about 2.1 volts. Fig. 96 illustrates the construction of an accumulator.

The discharging current depends upon the area of the plates used, while the length of discharge depends upon the weight of the plates. To increase the rate of discharge, a number of plates are fastened to one terminal forming the negative element, or grid, and one less than the number used form the positive element (the active plate). The plates are then dovetailed together, and prevented from touching each other by the insertion of rubber bands or ebonite strips. The solution used is dilute sulphuric acid (about a 20 per cent. solution). The lead plates are sometimes perforated, and into the perforations of the positive plates is pressed red lead, while the negative perforations are filled with finely divided particles of metallic lead.

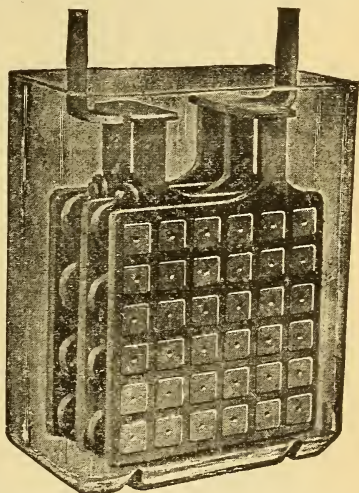


Fig. 96.—Chloride Accumulator.  
Positive element, two plates; negative element, three plates.

### QUESTIONS.

1. Name all the effects of an electric current and give a commercial application of each.
- ✓ — 2. Explain the principle of an electric incandescent lamp.
- ✓ — 3. Why is it that the lead wires to a lamp do not get as hot as the circuit inside the glass bulb?

4. How would you classify liquids according to their conducting power, and the chemical effect of the current upon them?
5. What do you mean by electrolytic decomposition?
6. What is an electrolyte?
7. What is electrolysis?
8. How would you find the polarity of an electric light circuit with a tumbler of water? Give sketch.
9. Define the terms anion, cathode, anode, cathion.
10. What is a voltameter? Give sketch.
11. Give the action in the copper voltameter, also a sketch.
12. Give two reasons for inferring that current has direction.
13. What is the action in a copper voltameter when a platinum plate is substituted for a copper plate? Give sketch.
14. State briefly your idea of the art of electroplating.
15. What effect upon an electrolytic deposit will be noted when too strong a current is used?
16. How does electrotyping differ from electroplating?
17. What is a polarity indicator, and how is it used?
18. What is an accumulator?
19. How does a storage battery differ from a primary battery?
20. What does a storage battery store?
21. Explain the action in a simple type of storage battery. Give sketch.
22. What is meant by the terms charging and discharging?
23. How would you connect a storage battery to a circuit to be charged? Show by a sketch the polarity of the cell and the polarity of the charging line.
24. Describe fully a commercial type of storage battery. State the actions on charge and discharge. Give sketch.
25. When is a storage battery discharged?

## LESSON XI.

### MEASUREMENT OF CURRENT STRENGTH.

Strength of Current—Variation of Current and Current's Effects—How the Effects Vary with the Current Strength—Variation of Effects with the Same Current Strength Through Dissimilar Apparatus—Measurement of Current Strength—Definition of the Unit of Current Strength—Definition of a Unit Quantity of Current—The Ampere-Hour—Weight Voltameters—Voltmeter Calculations—Construction of the Gas Voltameter—Directions for Using the Gas Voltameter—Measuring Current Strength by a Gas Voltameter—Current Strength Used in Electroplating and in Commercial Apparatus—Questions and Problems.

**110. Strength of Current.**—Either the magnetic, heating, or chemical effect of an electric current may be employed to determine whether a current is flowing through a wire. If the magnetic effect of a current flowing through a wire is greater than that of another current, the *intensity* of the current, or the *strength* of the current, must be greater, since the magnitude of any of the current's effects varies with the current assumed to be flowing. We express the rate of flow of water through a pipe as so many *gallons per second*, which expression includes a definite quantity of water and a unit of time; that is, at a rate of flow of one gallon per second, we mean that one gallon passes any point in the pipe once every second. By the *strength of an electric current* we mean the rate of transfer of electricity past any point in the circuit in a unit of time (the second). It is obvious that the magnitude of the effects of the current may be used to measure the strength of the current.

#### **111. Variation of Current and Current's Effects.**—

**Exp. 29:** Pass a current under a force of one volt through a coarse wire galvanometer and note the deflection. Repeat the experiment with twice the applied pressure, two volts, and the deflection of the magnetic needle is *less than twice* as much as before, although the force is doubled and the *current strength*, varying as the force, must also have been doubled.

**Exp. 30:** With an applied pressure of 4 volts note the amount of gas generated from dilute sulphuric acid in 2 minutes by the appara-

tus in Fig. 99. Repeat the experiment with 8 volts and note that in the same time twice the volume of gas is generated.

**Exp. 31:** Using copper sulphate and two copper plates, carefully weighed before the test, apply a force of 2 volts for 10 minutes and then re-weigh the plates. The negative plate has gained in weight exactly what the positive plate lost. Repeat the experiment with 4 volts for the same length of time and the weight is increased to double what it was before.

**Exp. 32:** Coil a number of turns of No. 30 iron wire around the bulb of a thermometer, and place it in a small test tube containing a measured quantity of water. Place the test tube in a larger vessel containing sawdust to prevent heat radiation. Apply a force of 4 volts for 10 minutes and by aid of the thermometer note the rise in the temperature of the water. Repeat the experiment with 8 volts for the same period of time, with the same quantity of water, and at the previous starting temperature. Neglecting the heat lost by radiation, the increase of temperature is nearly four times as great as in the first test, although the current was only doubled. If the current had been tripled, the temperature rise would have been 9 degrees, and with *the current* quadrupled the rise would have been 16 degrees, and so on.

### 112. How the Effects Vary with the Current Strength.

The above experiments may be made simultaneously when the circuit is arranged, as in Fig. 97, in which nearly all the effects of the current are represented. The circuit is made up as follows: starting from the positive battery terminal the current would flow (1) through a few turns of coarse wire in the galvanometer coil; (2) a large number of turns of coarse wire on the spools of the electromagnet; (3) a dilute solution of sulphuric acid in the mixed gas voltmeter, the current to pass between platinum electrodes; (4) a solution of copper sulphate, the current to pass between copper electrodes; (5) a number of turns of No. 30 iron wire wound around the bulb of a thermometer and immersed in a vessel of water placed in sawdust; (6) through the carbon filament of an incandescent lamp; (7) through a switch to the negative pole of the battery, and (8) from the negative pole of the battery through it to the positive pole.

When the switch is closed, the current produces the following effects simultaneously: The magnetic needle is deflected; it requires a certain number of pounds pull to detach the keeper from the electromagnet; hydrogen and oxygen gas rise in the graduated test tube, displacing the acidulated water therein; metallic copper is deposited from the copper positive plate and deposited upon the copper negative plate, so that it thereby gains in weight; heat is evolved in the

vessel containing the iron coil of wire; very dim light is given by the incandescent lamp; zinc is being decomposed in the batteries furnishing the electrical energy to produce all these effects outside of the battery.

All the effects are produced the instant the switch is closed, but only four can be noted instantly—the needle's deflection, the attractive force of the magnet, the evolution of gas, and the brilliancy of the lamp. The weight of copper deposited, gas liberated, and the number of degrees rise in temperature, due to a current flowing for only an instant is so small as to be practically unmeasurable. By allowing the current to flow for a certain period of time a measurable quantity is obtained, which divided by the time in seconds gives the magnitude of the effect per second, or the current strength. Keep the switch closed for about five minutes ( $5 \times 60 = 300$  seconds), then by dividing the volume of gas generated in 300 seconds by 300 we obtain the gas generated per second, and similarly with the gain in temperature and the gain in weight of the negative copper plate.

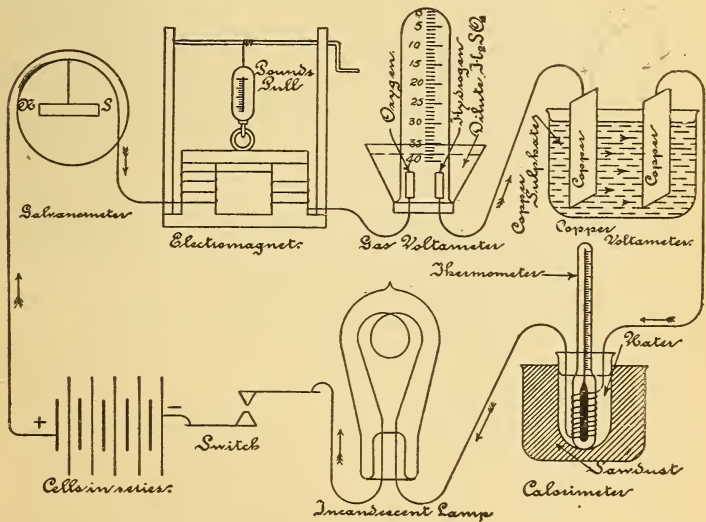


Fig. 97.—The Effects of the Current and their Variation with a Variation in Current Strength.

This is a simple series circuit and the current is the same in all parts of it,

We thus get a series of results of the different effects, all corresponding to the same strength of an electric current, flowing for a unit of time. The intensity of current that deflected the needle in one part of the circuit, or magnetised the iron core of the electromagnet, is exactly the same as that which decomposed the acidulated water or the copper sulphate, or heated the iron wire. This is a simple *series* circuit, although made up of a number of different conductors, and the *current is the same in all parts of a series circuit*; that is, the rate of flow past any point selected is the same. The order of the arrangement of the apparatus is also immaterial. By increasing the E. M. F. of our battery so that twice the pressure is applied to this same circuit, we double the current strength or rate of flow. The switch is closed for the same time as before, and the results noted for comparison. A third test may also be made, using three times the force. The record of three such tests, with apparatus as arranged in Fig. 97, is as follows :

#### Tests of Current's Effects.

	Test 1.	Test 2.	Test 3.
Galvanometer, deflections . . . . .	25	37	42
Electromagnet, pounds pull . . . . .	54	65	70
Gas voltameter, volume of gas generated per second . . . . .	.17	.34	.51
Copper voltameter, gain in weight per second .0003	.0003	.0006	.0009
Calorimeter, degrees rise per second . . . . .	.1	.4	.9
Incandescent lamp, candle-power . . . . .	5	8	12

From the above tests the following facts will be noted : The deflection of the galvanometer needle is not directly proportional to the current, doubling the current, not doubling the deflection. The number of pounds pull, or attractive force, is not directly proportional to the current strength. The volume of gas generated is exactly proportional to the current, and if the current had been quadrupled the gas generated per second would have been four times as great, and so on. The deposit of copper is directly proportional to the current, doubling the current, also doubling the gain in weight. The rise in temperature was not doubled, but increased four-fold ; with three times the current strength the rise is nine-fold, the temperature rise thus increases directly as the square of the current strength ; for example, 1 unit of current produces 1 degree rise ; 2 units, 4 degrees

rise; 3 units, 9 degrees rise, etc.; the lamp's luminosity is not directly proportional to the current.

**113. Variation of Effects with the Same Current Strength Through Dissimilar Apparatus.**—If the series circuit, Fig. 97, had contained two pieces of each apparatus of widely varying dimensions of plates, convolutions in the coils, size of wire, etc., what would have been the result? The current strength would have been the *same* in *each* part of the circuit as before. The fine wire galvanometer would produce a larger deflection than one of a few turns of the same diameter. The electromagnet, with the greater number of turns, would have the greater attracting power. A gas voltameter with small plates, widely separated, would evolve the *same volume* of gas as a voltameter with much larger plates placed close together, since the gas evolved is proportional to the rate of flow of electricity, which is the same through both instruments, and hence independent of the size of the electrodes or their distance apart. Similarly, in two copper voltameters in the *same* series circuit, the weight of copper deposited is independent of the size of the plates or their distance apart, and would be the same for each voltameter, however constructed. More heat would be generated by the coil of many turns of fine wire. The current flowing through a circuit is the same in all parts of that circuit; thus, if at two different points in a circuit a gas voltameter be inserted, the gas evolved at the one point will be exactly equal to that evolved at the other point.

**114. Measurement of Current Strength.**—To compare different strengths of current some arbitrary standard must be adopted. If we defined our unit of current strength as such a rate that flowing every second would deflect our magnetic needle, ¶ 112, 25 degrees, we would also have to specify the length of needle, diameter of coil, number of turns, place where the needle was set up, etc., which would make it an impractical standard. Also in the case of the electromagnet, all the dimensions and quality of the iron, the keeper and the wire, etc., would have to be stipulated. If we would express the unit of current strength as such a rate of flow that would attract a keeper with 54 pounds, then, again 2 units of current do not attract the keeper 108 pounds, as might be expected, but only 65 pounds. (See test, ¶ 112.) The current strength is directly proportional, however, to the

amount of gas generated per second or the amount of metal deposited per second, so that of all the effects the chemical one is the best adapted for furnishing a standard unit of current strength, since such a standard will be independent of the apparatus used to produce the effect. The heating and magnetic effects are employed in various practical instruments for measurements, but they are standardized by the chemical effect.

### 115. Definition of the Unit of Current Strength.—

*The strength of current is directly proportional to the amount of chemical decomposition it can produce in a given time, and as a steady current passed through a solution of nitrate of silver in water, in a silver voltameter, deposits silver at the rate of 0.001118 grams per second, this value is taken as a unit of current strength and called one ampere.\**

One ampere will deposit in one second :

.0003286 grams of copper in a copper voltameter ;

.0003386 grams of zinc in a zinc voltameter.

One ampere will also decompose .00009326 grams of dilute sulphuric acid per second. One ampere will also evolve .1733 cubic centimeters of mixed gas per second in a gas voltameter (when the temperature is 0° Centigrade and the atmospheric pressure 76 centimeters of mercury).

### 116. Definition of a Unit Quantity of Current.—

Distinction must be made between the total quantity of electricity that passes through a circuit in a given time, and the rate of flow of electricity during that time. For example, at the rate of flow of one gallon per second, 3600 gallons of water would be delivered to a tank in an hour, the total quantity being readily distinguished from the rate of flow. We might consider the *gallon per second* as a unit of quantity and name it, but this has not been done in hydraulics, although it is done in the case of electricity. The total quantity of water equals the rate multiplied by the time in seconds ; thus, at a rate of flow of 8 gallons per second, in 60 seconds, the total quantity delivered would be 480 gallons, which same quantity could be delivered to a tank in one second if the rate were 480 gallons per second, or in one-half second if the rate were 960 gallons per second, or in 480 seconds if the rate were only one gallon per second. Similarly the *unit quantity of*

\*Values given by Ayrton.

One ounce = 28.34 grams.



electricity is the amount of electricity that flows per second past any point in a circuit when the current strength is one ampere, and this unit quantity has been called the coulomb. If a current strength of one ampere flows for 60 seconds, then the total quantity is 60 ampere-seconds, or 60 coulombs of electricity.

FIRST: TO FIND THE TOTAL QUANTITY OF ELECTRICITY PASSING THROUGH A CIRCUIT IN A GIVEN TIME :

*Multiply the current strength (expressed in amperes) by the time (expressed in seconds).*

- Let C = current strength in amperes ;
- Q = the total quantity of electricity in coulombs ;
- t = time the current flows (in seconds) ;

Then :

Quantity = current strength  $\times$  time,  
 or coulombs = amperes  $\times$  seconds,  
 or substituting the above symbols,  

$$Q = C \times t \dots \dots \dots (1).$$

**Prob. 1:** An incandescent lamp requires a current of one-half an ampere to maintain its proper brilliancy. If the lamp is lighted two hours what quantity of electricity will be consumed ?

2 hours =  $60 \times 60 \times 2 = 7200$  seconds.  
 By Formula (1)  $Q = C \times t = \frac{1}{2} \times 7200 = 3600$  coulombs.  
 $C = \frac{1}{2}$  ampere,  $t = 7200$  seconds.

SECOND: TO FIND THE AVERAGE CURRENT STRENGTH (IN AMPERES) WHEN THE TIME THE CURRENT FLOWS, AND THE QUANTITY OF ELECTRICITY ARE KNOWN :

*Divide the quantity (in coulombs) by the time (in seconds).*

Current strength = Quantity  $\div$  time,  
 or Amperes = Coulombs  $\div$  Seconds,  
 or Amperes =  $\frac{\text{Coulombs}}{\text{Seconds}},$

or by substitution  $C = \frac{Q}{t} \dots \dots \dots (2).$

**Prob. 2:** What is the average rate of current strength in a lamp circuit if the electrical consumption was 54000 coulombs and the current used for 5 hours ?

5 hours =  $60 \times 60 \times 5 = 18000$  seconds.  
 By Formula (2)  $C = \frac{Q}{t} = \frac{54000}{18000} = 3$  amperes.  
 $Q = 54000$  coulombs,  $t = 18000$  seconds.

THIRD: TO FIND THE TIME (IN SECONDS) REQUIRED FOR A GIVEN QUANTITY OF ELECTRICITY (IN COULOMBS) TO PASS A POINT IN A CIRCUIT :

Divide the quantity of electricity (in coulombs) by the rate of flow (in amperes).

$$\text{Time} = \frac{\text{Quantity}}{\text{Current Strength}},$$

$$\text{or Seconds} = \frac{\text{Coulombs}}{\text{Amperes}},$$

$$\text{or by substitution } t = \frac{Q}{C} \dots \dots \dots (3).$$

**Prob. 3:** How long a time will be required to pass 18000 coulombs through an electroplating bath if the average rate of current strength is 6 amperes?

$$\text{By Formula (3) } t = \frac{Q}{C} = \frac{18000}{6} = 3000 \text{ seconds, or } \frac{3000}{60} = 50 \text{ minutes.}$$

$$Q = 18000 \text{ coulombs, } C = 6 \text{ amperes.}$$

**117. The Ampere-Hour.**—The *coulomb* is a very small unit of quantity. A larger unit, the *ampere-hour*, is often used. One *ampere-hour* would be the quantity of electricity that would pass any point in a circuit in one hour, when the strength of current is one ampere. One ampere-hour obviously equals 2 amperes for one-half hour; 4 amperes for one-quarter hour, or one-quarter ampere for 4 hours and so on. One ampere-hour also equals 3600 coulombs.

The capacity of batteries is rated in ampere-hours. For example a 100 ampere-hour cell would mean one in which sufficient chemicals were present to maintain one ampere for 100 hours; 2 amperes, for 50 hours, etc. An ampere-hour recording meter is placed in a lamp circuit so that it will record the total quantity of electricity that has been utilized, or the total ampere-hours.

TO FIND THE AMPERE-HOURS CONSUMED BY ANY ELECTRICAL APPARATUS:

Multiply the average strength of current (in amperes) by the time (expressed in hours) that the current has been maintained.

$$\text{Ampere-hours (quantity)} = \text{Amperes} \times \text{hours};$$

$$\text{Amperes} = \frac{\text{Ampere-hours}}{\text{hours}};$$

$$\text{Hours} = \frac{\text{Ampere-hours}}{\text{Amperes}}.$$

**Prob. 3-A:** A current of 6.5 amperes was maintained by a cell for 4 hours. What quantity of electricity has been used?

Quantity = amperes  $\times$  hours =  $6.5 \times 4 = 26$  ampere-hours.

Suppose the cell has a capacity of 78 ampere-hours, how long could the above current be maintained?

$$\text{Hours} = \frac{\text{Quantity}}{\text{Amperes}} = \frac{78}{6.5} = 12 \text{ hours.}$$

**118. Weight Voltmeters.**—Current strength may be determined by a weight voltmeter, one in which the weight of metal deposited or weight of water decomposed, serves to determine the rate of flow; or a gas voltmeter in which the volume of mixed gas to be evolved is used to determine the current strength. A weight voltmeter is illustrated in Fig. 98. The two outside plates form the anode, and are joined together and to one binding post, while the cathode is placed between them and connected to the other binding post. The cathode thus receives a deposit on both sides. An adjustable arm serves to lower the plates into the electrolyte. A gas voltmeter is described in ¶ 120.

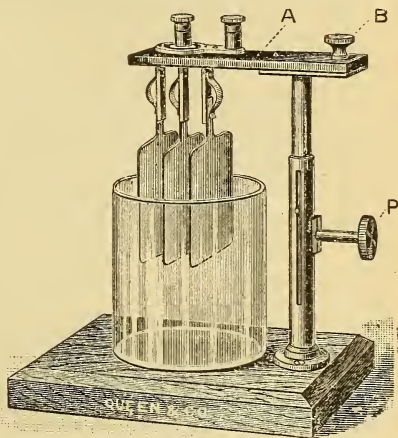


Fig. 98.—Construction of a Weight Voltmeter.  
One cathode between two anodes.

**119. Voltmeter Calculations.**—FIRST: TO CALCULATE THE STRENGTH OF AN UNKNOWN CURRENT (IN AMPERES) WHICH HAS PASSED THROUGH A WEIGHT VOLTAMETER:

*Find the weight of metal deposited per second by dividing the total gain in weight by the time (in seconds) the current flows through the instrument; divide this quotient by the weight deposited by one ampere in one second, and the result is the strength of current expressed in amperes.*

Let  $C$  = current strength in amperes;

$W$  = total gain in weight;

$t$  = time in seconds current flows;

$K$  = weight deposited by one ampere in one second.

Substituting for the above statement then :

$$\begin{aligned} \text{Amperes} &= \frac{\text{weight gained}}{\text{gain per ampere-sec.} \times \text{time.}}, \\ \text{or } C &= \frac{W}{K \times t} \dots \dots \dots (4). \end{aligned}$$

If W is expressed in grams:

- K for a copper voltameter is .0003286 gram ;
- K for a zinc voltameter is .0003386 gram ;
- K for a silver voltameter is .001118 gram ;
- K for a sulphuric acid *weight* voltameter is .00009326 gram ;
- K for a sulphuric acid *gas* voltameter is .1733 cubic centimeter.

**Prob. 4:** The negative plate of a copper voltameter has increased in weight by 1.818 grams in thirty minutes. What was the average rate of current strength?

By Formula (4)  $C = \frac{W}{K \times t} = \frac{1.818}{.0003286 \times 1800} = 3.073$  amperes.  
 K for copper is .0003286, t = 30 minutes = 30 × 60 = 1800 sec.

SECOND: TO FIND THE WEIGHT OF ANY METAL THAT WILL BE DEPOSITED IN A VOLTAMETER BY A GIVEN CURRENT IN A GIVEN TIME :

*Multiply the current strength by the time (in seconds) and this product by the weight deposited by one ampere in one second (K), the result is the weight expressed in grams (one pound = 453.59 grams).*

$$\begin{aligned} \text{Weight (gained)} &= \text{Current} \times \text{time} \times K, \\ \text{or } W &= C \times t \times K \dots \dots \dots (5). \end{aligned}$$

**Prob. 5:** In an electroplating bath how many grams of zinc will be deposited by a current of 5 amperes in 45 minutes?

By Formula (5)  $W = C \times t \times K = 5 \times 2700 \times .0003386 = 4.5711$  grams.  
 K for zinc = .0003386.  
 t = 45 minutes = 45 × 60 = 2700 seconds.

THIRD: TO FIND THE TIME REQUIRED TO ELECTROLYTICALLY DEPOSIT ANY GIVEN WEIGHT OF METAL WITH A GIVEN CURRENT STRENGTH :

*Divide the weight by the current strength, and by the weight deposited by one ampere in one second (K), the result is the time expressed in seconds.*

$$\text{Time} = \frac{\text{Weight (gained)}}{\text{Current} \times K},$$

$$\text{or } t \text{ (seconds)} = \frac{W}{C \times K} \dots \dots \dots (6).$$

**Prob. 6:** How long a time will be required to deposit 5.9328 grams of silver on a copper-plated teaspoon with a current of 2 amperes ?

By Formula (6)  $t = \frac{W}{C \times K} = \frac{5.9328}{2 \times .001118} = 2653$  seconds, or  $\frac{2653}{60} = 44$  minutes 13 seconds.

K for silver = .001118 gram.

**120. Construction of the Gas Voltameter.**—The gas voltameter is convenient for individual laboratory use with a large body of students, as it obviates the necessity of a pair of scales for each student. A demonstration type of instrument is shown in Fig. 100. A student's voltameter is illustrated in Fig. 99, and is composed as follows :

- 1 brass stand (16 inches high)
- 1 glass U tube
- 2 platinum electrodes sealed in a glass tube and connected by a copper wire, to which connectors are attached
- 2 rubber corks for electrodes
- 1 glass burette, graduated from 0 to 30 cubic centimeters and reading in tenths of a cubic centimeter
- 2 adjustable clamps
- 8 inches rubber tubing
- 2 brass connectors
- 1 pinch cock, for use when it is used as an electrolytic cell for copper, etc.

**121. Directions for Using the Gas Voltameter.**—

- (1) Attach both clamps to the stand.
- (2) Attach one end of the rubber tube to the glass U tube and *carefully* clamp it by the lower clamp on to the stand.
- (3) Attach the other end of the rubber tube to the burette and *carefully* clamp it by the upper clamp.
- (4) Adjust the position of both clamps so that the zero position of the burette is about one-half inch below the level of the top of the U tube.
- (5) Pour the acidulated water into the mouth of the burette till the water in the U tube is about one-half inch from the top, the height of liquid in the burette should be on a level with or *above* the zero mark.
- (6) With the electrodes

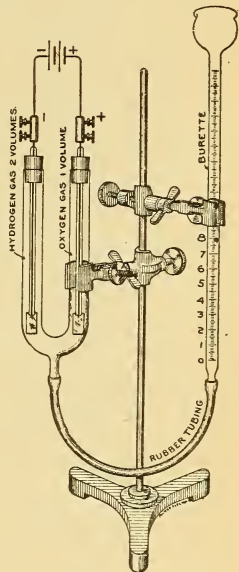


Fig. 99.—Student's Sulphuric Acid Gas Voltameter.

inserted through the corks, place each one in position, *carefully*, by giving a slight twist to the right as the cork enters. (7) The water level in the U tube and burette should now be the same, or further adjustment must be made to attain this result. The level in the burette does not necessarily have to correspond with the zero graduation, but must not be below it. (8) Unclamp the burette and hold it nearly horizontal. The liquid will not run out if the corks are tight, so that this is the *air leakage test*. (9) Attach the connectors and wires from the source of E. M. F. (which should be 2 or more volts) having a final switch in the circuit.

In electrolyzing any substance a back or contrary E. M. F. is set up in opposition to the decomposing current, due to the chemical affinity of the substances dis-united, which tend to re-unite. Sufficient force must therefore be applied to overcome this force of chemical affinity. For example, in the case of water this opposing force is about 1.5 volts, so that it requires a greater force than 1.5 volts to electrolyze water, hence our two cells are joined in series.

**Exp. 33:** Close the switch connecting the above voltameter in circuit. Bubbles of gas rise in the U tube from both electrodes, displace the water and force it up the burette. Twice the volume of gas (hydrogen) is collected over the negative electrode that is collected over the positive electrode (oxygen). Run the test till the volume of hydrogen gas occupies nearly the whole limb of the U tube when the switch should be opened.

**Exp. 34:** With the gases collected in Exp. 33, lower the burette as far as possible (to decrease the hydrostatic head). Remove the cork for an instant from the hydrogen limb and *quickly* apply a lighted match. The hydrogen burns with a pale bluish flame. *Replace the cork quickly* so that the solution is not forced out of the U tube. Now remove the cork from the oxygen, extinguish the flame of the match and *quickly* apply the glowing spark to the oxygen; the match immediately bursts into a flame again. *Replace the cork quickly*. Oxygen gas does not burn, but supports combustion. If both gases are collected in a single tube, as in the form of the voltameter used in Fig. 97, when a lighted match is presented to the mouth of this tube the hydrogen, instead of burning, explodes with a violent report, due to the presence of the oxygen.

**122. Measuring Current Strength by a Gas Voltameter.**—FIRST: TO FIND THE CURRENT STRENGTH WHEN A VOLUME OF GAS IS EVOLVED IN A GIVEN TIME:

*Divide the volume of gas evolved by the time (in seconds) and this quotient by the volume of gas evolved by one ampere in one second (K).* The result is the current in amperes (subject to corrections when greater accuracy is required).\*

---

\*Neglecting temperature, barometric pressure and hydrostatic head.

$$\text{Current} = \frac{\text{volume of gas generated}}{\text{time (seconds)} \times K},$$

$$\text{or } C = \frac{V}{t \times K} \dots \dots \dots (7).$$

K for the mixed gases or the two gases evolved separately = .1733 c. c. (§ 115).

Second: The volume of gas (in cubic centimeters) which will be evolved by a given current in a given time is

$$\text{volume evolved (c. c.)} = \text{current} \times \text{time (seconds)} \times K,$$

$$\text{or } V = C \times t \times K \dots \dots \dots (8).$$

Third: Also the time required to evolve a certain quantity of gas with a given current is

$$\text{time (seconds)} = \frac{\text{volume}}{\text{Current} \times K},$$

$$\text{or } t = \frac{V}{C \times K} \dots \dots \dots (9).$$

**Exp. 35:** Set up the gas voltameter again according to the directions in § 121. To correct error caused by the decrease in volume of the gases, due to the weight of the liquid in the burette at the end of the test, lower the burette before the test so that the height of liquid in it is about on a level with the bottom of the U tube. Secure a watch (preferably with a second hand). Note the level of the liquid on the burette scale before starting the test. Close the switch, noting the exact time. Allow the gas to be evolved till either the hydrogen limb of U tube is nearly full, or the liquid in the burette approaches the end of the scale. *Do not run above scale limit.* Note the time of opening the switch, also the height of the liquid in the burette.

**Prob. 7:** The following data is recorded in Exp. 35. Find the strength of current.

- Level in burette before test 2.6 c. c.
- Level in burette after test 28.8 c. c.
- Volume of gas evolved = 28.8 - 2.6 = 26.2 c. c.
- Time of closing switch 8.40 - 15.
- Time of opening switch 8.45 - 15.
- Length of run = 5 minutes = 5 × 60 = 300 seconds.

$$\text{Total gas generated per second} = \frac{26.2}{300} = .0873 \text{ c. c.}$$

One ampere in one second (one coulomb) generates .1733 cubic centimeters of gas per second, therefore  $\frac{0.0873}{.1733} = .5$  ampere,

$$\text{or by Formula (7) } C = \frac{V}{K \times t} = \frac{26.2}{.1733 \times 300} = .5 \text{ ampere.}$$

When more accurate calculations are desired the following formula is used to find the current strength :

$$C = \frac{V \times h \times 273}{.1733 \times 76 (273 + C^\circ) \times t} \dots \dots \dots (10).$$

V = volume of gas in c. c.  
 h = height of barometer in centimeters.  
 C° = temperature of room, Centigrade, where test is made.  
 t = time (in seconds) gas is evolved.

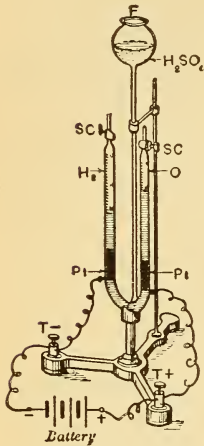


Fig. 100.—Gas Voltmeter. Hoffman's Lecture Room Form.

**Prob. 8 :** In an experiment the volume of gas generated in a gas voltameter was found to be 20 cubic centimeters in 50 seconds, its temperature (taken as the temperature of the room) was 20 degrees, Centigrade scale, the pressure of the atmosphere was equal to 75 centimeters of mercury. What was the current strength ?

By Formula (10)

$$C = \frac{20 \times 75 \times 273}{.1733 \times 76 (273 + 20) \times 50} = 2.12 \text{ amperes.}$$

To find the volume of gas generated by a known current :

$$V = \frac{.1733 \times C \times 76 (273 + C^\circ) \times t}{h \times 273} \dots \dots (11).$$

**Prob. 9 :** What volume of gas would be produced in a gas voltameter in 30 seconds by a steady current of 18 amperes, supposing the temperature of the gas so produced is 20 degrees C. and the barometer stands at 77.5 centimeters ?

By Formula (11)  $V = \frac{.1733 \times 18 \times 76 (273 + 20) \times 30}{77.5 \times 273} = 98.49 \text{ c. c.}$

**123. Current Strength Used in Electroplating.**—If the metallic deposition is performed too rapidly the deposit becomes open and of a powdery appearance. A low current density produces a hard, close grained surface. The usual densities used in practice are :

- Copper acid bath, 5 to 10 amperes per square foot of area to be plated.
- Copper cyanide bath, 3 to 5 amperes per square foot of area to be plated.
- Nickel, double sulphate, 6 to 8 amperes per square foot of area to be plated.
- Gold, chloride in cyanide, 1 to 2 amperes per square foot of area to be plated.
- Silver, double cyanide, 2 to 5 amperes per square foot of area to be plated.



**Prob. 10:** A piece of sheet-iron, six inches square, is to be plated on both sides in a copper acid bath. What current strength is required?

From ¶ 123: Current density for copper cyanide bath is 5 to 10 amperes per square foot—

Say 8 amperes, 144 square inches = 1 square foot.

Area of plate (both sides) =  $6 \times 6 = 36$  square inches  $\times 2 = 72$  square inches.

$$\frac{72}{144} = .5 \text{ square foot at 8 amperes per square foot} = 4 \text{ amperes.}$$

**Table IV.—Value of Current Strengths Used in Practice.**

The strength of current required to operate a 110 volt, 16 candle-power, incandescent lamp is about . . . . .	0.5 ampere
For an enclosed 110 volt arc lamp . . . . .	5 amperes
For an open-air arc lamp . . . . .	8 to 10 amperes
For a trolley car equipped with two 25 horse power motors when fully loaded . . . . .	75 amperes
For a 110 volt fan motor . . . . .	$\frac{1}{2}$ to 2 amperes
For the average electric bell . . . . .	$\frac{1}{10}$ ampere
For the average telegraphic circuit . . . . .	.025 ampere
For 110 volt Weston voltmeter, full scale deflection . . . . .	.0006 ampere
For electrical welding . . . . .	20 to 50,000 amperes

**QUESTIONS.**

1. What do you understand by current strength?
2. State some experiments you would make to ascertain how the effect of a current varies with its strength.
3. Which effects of the current are directly proportional to it?
4. Which effects do not vary directly with the current strength?
5. An electromagnet attracts its keeper with a force of 18 pounds. If twice the E. M. F. be applied to the magnet coils, what will be the comparative result?
6. A coil of iron wire carrying a current is thrown into a tumbler of water for 10 minutes and the temperature is changed 6 degrees. The current is now exactly doubled for the same length of time. What is the change in temperature?
7. Which is the most suitable effect of the current by which it can be measured? Give reason for your answer.
8. What would be the objection to considering the standard unit of current strength, as of such a strength that would deflect a galvanometer needle 30 degrees?
- ✓ 9. A current strength is said to be 5 amperes. What do you understand by this expression?
- ✓ 10. What is the unit of current strength? Give example.
- ✓ 11. Explain the difference between the terms "current strength" and "quantity of electricity."
- ✓ 12. What is the unit of electrical quantity?
- ✓ 13. Five coulombs are used every second by a lamp. What is the current strength?

14. Why is it that you cannot electrolyze water with one Daniell cell?

15. Platinum and copper plates are dipped into a solution of zinc sulphate and a current passed from the platinum to the copper plate. How are the plates affected?

16. Give an example of chemical composition and deposition in the same circuit.

17. Copper and platinum plates are dipped into copper sulphate. What is the action when the current is passed from the copper to the platinum plate?

### PROBLEMS.

1. How many ampere-hours will be recorded by a meter through which 160 amperes has passed for three-quarters of an hour? *Ans.* 120 ampere-hours.

2. A 100 ampere-hour Edison-Lalande cell is discharged through an electromagnet at a  $2\frac{1}{2}$  ampere rate. How long will the cell maintain this current through the magnet? *Ans.* 40 hours.

3. A meter records 500 ampere-hours. It was in circuit 5 days for 10 hours each day. What was the average rate of current used? *Ans.* 10 amperes.

4. How many coulombs have passed through an arc lamp in three-quarters of an hour if the current was 10 amperes? *Ans.* 27,000 coulombs.

5. What current strength is required to deposit 5 grams of copper upon an iron spoon in 35 minutes? *Ans.* 7.8 amperes.

6. A meter records 54,000 coulombs in 3 hours. What was the average strength of current? *Ans.* 5 amperes.

7. How many grams of copper will be deposited on an iron plate used for a ship's hull in 10 hours if the average strength of current is 25 amperes? *Ans.* 295.74 grams.

8. The two terminals of an electric light circuit are dipped into a tumbler containing 5 grams of acidulated water. How long would a current of 3 amperes flow before the water was entirely decomposed? *Ans.* 4 hours 57 min. 51 sec.

9. Using a current density of 5 amperes per square foot, how long a time is required to copper plate both sides of a square iron plate measuring 4 feet on a side, supposing sufficient thickness is attained when the coating weighs 4 grams per square foot? *Ans.* 40 min. 33 sec.

10. An inverted test tube, capacity 40 c. c., is filled with acidulated water, and the terminals, of several cells in series, are introduced underneath the tube. In 5 minutes half of the tube was filled by gas. What was the strength of current in the circuit? *Ans.* 0.384 ampere.

11. The negative zinc plate of an Edison electrolytic meter increased in weight during a certain time, 3.455 grams. This amount represents one one-thousandth part of the current used by the consumer. With how many ampere-hours should he be charged? *Ans.* 2834 ampere-hours.

12. What bill would you render for the current consumed in Prob. 11 if the station's rate was 1.5 cents per ampere-hour. *Ans.* \$42.51.

## LESSON XII.

### RESISTANCE.

Resistance—Table V. Conductors and Insulators—The Unit of Resistance—Laws of Resistance—Table VI. Resistance of a Mil-Foot of the Metals - Calculation of Resistance—Wire Measure—The Circular Mil—The Square Mil—The Wire Gauge—Table VII. B. & S. Wire Gauge—Table of Conductivity and Resistivity of Metals—Internal Resistance of a Battery—Questions and Problems.

**124. Resistance.**—All bodies offer some opposition to the passage of an electric current through them. Pipes offer opposition to the flow of water through them, due to the friction between the running water and the sides of the pipes.

Electrical *resistance* is the opposition offered by any substance to the flow of an electric current through it. No conducting body possesses perfect conductivity, but every conductor offers some resistance to the passage of a current. All bodies conduct differently, some offering more opposition to the flow of current than others. If the opposition is small, the conductivity is good, and the body is classed as a *conductor*. When the opposition (resistance) is high, the *conductivity* is poor, and the substance is classed as a poor conductor, which ranks it as a good *insulator*. The property of an insulator is to obstruct the flow of current. With a good conductor for conducting current, and a good insulator for confining it to the conductor, we have the practical conditions for handling electricity. The metals and alloys are good conductors. *Resistance* is the reciprocal of *conductivity*. The greater the conductivity of a body the less its resistance; the one decreases in the same ratio as the other increases. *Conductivity* (the property of conducting) is sometimes called *conductance*. *Resistance* is sometimes called *resistivity*.

**Exp. 36:** Connect spool 1 of the resistance spool set, Fig. 101, to a student's Daniell cell with the detector galvanometer, Fig. 153, in circuit, and note the deflection of the needle.

**No. 1.**

This spool is wound with  
**25 ft. of No. 24 B. & S.  
 Copper Wire.**

Diameter, .0201 inch  
 Circular mil area ( $d^2$ )=  
 .0201 x 0201=404 C. M.  
 Ohms per 1000 feet=25.695  
 Feet per ohm =38.918  
 Ohms per pound =21.050  
 Pure Copper Wire, Specific  
 Gravity 8.9,  
 Resistance at  
 75° F.

**No. 2.**

This spool is wound with  
**50 ft. of No. 24 B. & S.  
 Copper Wire.**

Diameter, .0201 inch  
 Circular mil area ( $d^2$ )=  
 .0201 x 0201=404 C. M.  
 Ohms per 1000 feet=25.695  
 Feet per ohm =38.918  
 Ohms per pound =21.050  
 Pure Copper Wire, Specific  
 Gravity 8.9,  
 Resistance at  
 75° F.

**No. 3.**

This spool is wound with  
**25 ft. of No. 18 B. & S.  
 Copper Wire.**

Diameter, .0403 inch  
 Circular mil area ( $d^2$ )=  
 .0403 x .0403=1624 C. M.  
 Ohms per 1000 feet=6.3911  
 Feet per ohm =156.47  
 Ohms per pound =1.3023  
 Pure Copper Wire, Specific  
 Gravity 8.9,  
 Resistance at  
 75° F.

**No. 4.**

This spool is wound with  
**25 ft. of No. 24 B. & S.  
 German Silver Wire.**

Diameter, .0201 inch  
 Circular mil area ( $d^2$ )=  
 .0201 x .0201=404 C. M.  
 Ohms per 1000 feet=480.834  
 Feet per ohm =2.008  
 Ohms per pound =393.93

(18% German Silver.)



Fig. 101.—Resistance Spool Set.

**Exp. 37:** Connect spool 2 in place of 1, and note the deflection, which is smaller than before. Why?

**Exp. 38:** Connect spool 3 in place of 2, and note the deflection. It is greater than either 1 or 2. Why is this so, since it is of the same *length* and *material* as 1?

**Exp. 39:** Substitute spool 4 for 3, and note the deflection. This is smaller than in any of the other cases. Spool 4 is of exactly the same *length* and *cross-sectional area* as spool 1. Why is the deflection so much smaller?

**Exp. 40:** Connect several bichromate cells in series with spool 4, and pass a current through it for a short time. The spool becomes warm. Now connect it again in the same circuit as in Exp. 39, and note that the deflection is smaller than before. Why is this so, since it is exactly the same *length*, *area*, and *material* as in Exp. 39?

**125. Conductors and Insulators.**—In the following table the substances are arranged in the order of their *conductance*, the best conductors being at the top, and the best insulators at the bottom of the list. Any substance in the table is approximately a *better conductor* than any substance which *follows* it; thus, lead is a better conductor than mercury, but not so good as zinc. A slight variation in the quality of a substance would change its position in the list with reference to some other substance; for example, some marble is useless for switchboards on account of metallic veins running through it. The same is true of slate, so that the position of these substances on the list is approximate.

Table V.—Conductors and Insulators.

Good Conductors (metals and alloys).	{	Silver	}	
		Copper		
		Aluminum		
		Zinc		
		Brass (according to composition)		
		Platinum		
		Iron		
		Nickel		
		Tin		
		Lead		
		German silver (copper 2 parts, zinc 1, nickel 1)		
		Platinoid (German silver 49 parts, tungsten 1 part)		
		Antimony		
Mercury				
Bismuth.				
Fair Conductors.	{	Charcoal and coke	}	
		Carbon		
		Plumbago		
		Acid solutions		
		Sea water		
		Saline solutions		
		Metallic ores		
Living vegetable substances				
Moist earth.				
Partial Conduc- tors.	{	Water	}	
		The body		
		Flame		
		Linen		
		Cotton		
		Mahogany		} Dry Woods.
		Pine		
		Rosewood		
		Lignum vitæ		
		Teak		
Marble.				
Non-Conductors or Insulators.	{	Slate	}	
		Oils		
		Porcelain		
		Dry leather		
		Dry paper		
		Wool		
		Silk		
		Sealing wax		
		Sulphur		
		Resin		
		Gutta percha		
Shellac				
Ebonite				

(Continued on page 106.)

Non-Conductors or Insulators.	}	Mica Jet Amber Paraffin wax Glass (varies with quality) Dry air.
-------------------------------	---	---

**126. The Unit of Resistance.**—The unit of resistance is called the *Ohm*, and is the resistance that would be offered to the flow of an electric current by a column of mercury 106 centimeters (or 41.7322 inches) high, having a cross-sectional area of 1 square millimeter (or .00155 square inch) at 0° Centigrade (or 32° Fahrenheit). This is the *Legal Ohm*. In practice the value of the ohm, corresponding to the above standard, is as follows, *approximately* :

1 ohm = 1000 feet of copper wire  $\frac{1}{10}$  inch diameter (No. 10 B. & S.).

1 ohm = 250 feet of copper wire  $\frac{1}{20}$  inch diameter (No. 16 B. & S.).

1 ohm = 2 pounds of copper wire  $\frac{1}{20}$  inch diameter (No. 16 B. & S.) or (125 feet per pound).

1000 feet of copper wire nearly  $\frac{15}{32}$  inch diameter (0000 B. & S.) = .04967 ohm.

1000 feet of copper wire  $\frac{3}{1000}$  inch diameter (40 B. & S.) = 1063 ohms.

In calculating or measuring very low resistances one-millionth of the value of an ohm is sometimes used and called the *microhm*.

To express a resistance in microhms multiply by 1,000,000 or

$$\text{Microhms} = \text{ohms} \times 1,000,000 \quad \dots \dots \dots (12).$$

$$\text{Ohms} = \frac{\text{microhms}}{1,000,000} \quad \dots \dots \dots (13).$$

In measuring very high resistances one million ohms are used as the unit and called a *megohm* (often abbreviated meg.).

$$\text{Megohms} = \frac{\text{ohms}}{1,000,000} \quad \dots \dots \dots (14).$$

$$\text{Ohms} = \text{megohms} \times 1,000,000 \quad \dots \dots \dots (15).$$

**Prob. 11:** What is the equivalent resistance in megohms of 47,500,000 ohms?

By Formula (14)  $\frac{47,500,000}{1,000,000} = 47.5$  megohms.

**Prob. 12:** Give the equivalent resistance in microhms of .00385 ohm.

By Formula (12)  $.00385 \times 1,000,000 = 3850$  microhms.

**Prob. 13:** What is the equivalent resistance in ohms of 225 microhms?

By Formula (13)  $\frac{225}{1,000,000} = .000225$  ohm.

**127. Laws of Resistance.**—From the experiments made with the resistance spool set, ¶ 124, the following laws are deduced:

**I.** *It is the mass or weight (cross-sectional area) of a material which conducts and not its surface.* This can be proved by using a wire tube in comparison with a solid wire of the same diameter in the experiments in ¶ 124. Law I, Fig. 102.

**II.** *The resistance of a conductor is directly proportional to its length.* 2,000 feet of copper wire .1 inch diameter will have 2 ohms resistance; 10,000 feet, 10 ohms, etc. Law II, Fig. 102.

**III.** *The resistance of a conductor is inversely proportional to its cross-sectional area, and in the case of round wire inversely proportional to the square of the diameter.* Area varies inversely as the diameter squared, or area varies as  $\frac{1}{d^2}$  (see note below).

A wire one-half inch in diameter has four times as great a resistance as a wire one inch in diameter, because as the area increases the resistance decreases. For example: No. 24 (B. & S.) wire has a diameter of .02 inch, and No. 30 has a diameter of .01 inch, or one-half the diameter of No. 24; 39 feet of No. 24 has a resistance of one ohm, and 9.75 feet of No. 30 equals one ohm (which is nearly  $\frac{39}{2^2} = \frac{39}{4} = 9.75$ ).

Law III, Fig. 102.

The area of a circle varies directly as the square of its diameter and is equal to  $\frac{3.1416}{4} \times \text{diameter squared}$  or  $.7854 \times d^2$ . For example,

a wire 1 inch in diameter has an area of  $1 \times 1 \times .7854 = .7854$  inches, while the area of a wire 2 inches in diameter equals  $2 \times 2 \times .7854 = 3.1416$  inches. Thus the second wire has twice the diameter of the first wire, and *not only twice but four times* the area of the first wire. The areas of round wires vary directly as the squares of their diameters.

IV. The resistance of a conductor of given length and cross-section depends upon the material of which it is made. For example, the resistance of 1,000 feet of copper wire  $\frac{1}{16}$  inch diameter (No. 10 B. & S.) is about 1 ohm, while the resistance of a piece of iron wire of the same length and cross-section is about 6.3 ohms, and a similar piece of German silver 12.8 ohms. Law IV, Fig. 102.

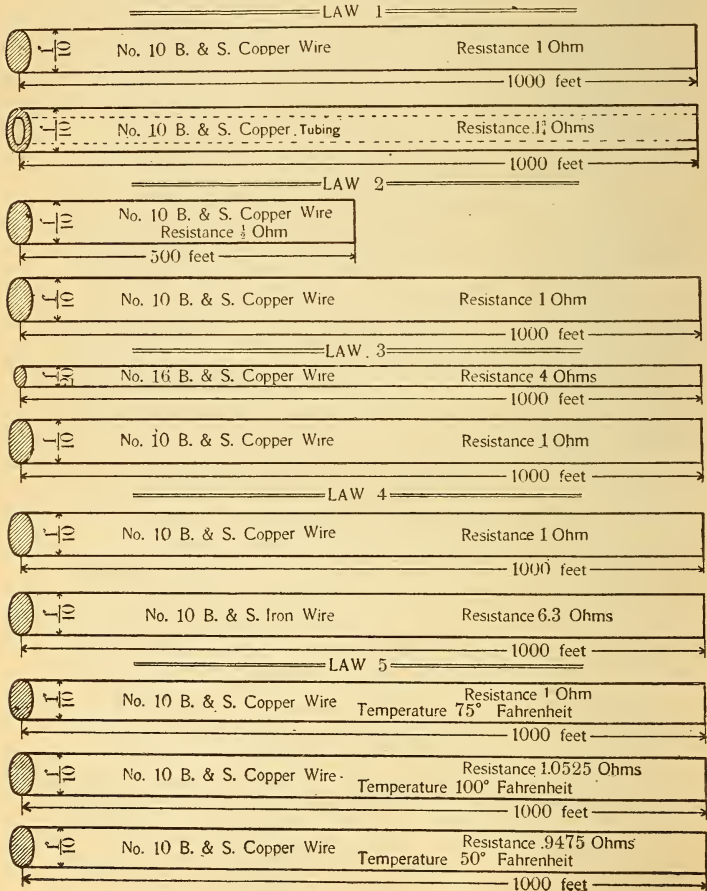


Fig. 102.—Laws of Resistance for Electrical Conductors.



**V.** *The resistance of a conductor depends upon the temperature and is affected by any other cause which modifies its molecular condition.* The comparative resistances of the copper, German silver, etc., in Law IV, are only true for a definite temperature. If these substances are heated the resistance of the copper is increased nearly 10 times as much as that of the German silver, and 20 times as much as an alloy called platinoid. Law V, Fig. 102.

*All metals have their resistance increased by an increase of temperature. Carbon and all electrolytic conductors (battery solutions) decrease in resistance as the temperature increases.* The resistance of copper increases about one-quarter of one per cent (.0021) for each degree temperature rise, *Fahrenheit* scale. See ¶ 262. The *hot* resistance of the carbonized filament of an incandescent lamp is about one-half the *cold* resistance.

**VI.** *The resistance of a conductor is always constant at the same temperature, irrespective of the strength of current flowing through it, or the electromotive force of the current.* If a conductor offers 5 ohms to a current of one ampere, it offers the same amount to a current of 10 amperes (provided the temperature is constant).

**128. Calculation of Resistance.**—One foot of copper wire  $\frac{1}{1000}$  inch diameter has a resistance of 10.79 ohms at 75° Fahrenheit. Ten feet will have 107.9 ohms. One foot of copper wire  $\frac{2}{1000}$  inch diameter will have one-fourth the resistance, ( $\frac{1}{d^2}$  or  $\frac{1}{2^2}$ ) or 10.79 divided by 4 = 2.69 ohms. If

this last wire were iron it would have 6.3 times the resistance, or 16.947 ohms. *Resistance varies directly as the length, inversely as the cross-sectional area, and with the material of the conductor.*

Let R represent resistance in ohms;

L “ length in feet;

D “ diameter (expressed in thousandths of an inch);

K “ resistance of 1 foot .001 inch diameter.

Then by above statement:

$$\text{Resistance} = K \times \frac{\text{Length}}{d \text{ (squared)}}$$

$$\text{or } R = \frac{K \times L}{d^2} \dots \dots \dots (16).$$

**Prob. 14:** Find the resistance of 1000 feet of copper wire .1 inch in diameter.

$$\text{By Formula (16) } R = \frac{K \times L}{d^2}.$$

K for copper = 10.79.

.1 inch = 100 thousandths = 100 mils.

Substituting,

$$R = 10.79 \times \frac{1000}{100 \times 100} = 1.079 \text{ ohms.}$$

The value of K is constant for the same wire, but different for each metal, and for copper at 75° Fahr. it is 10.79 ohms (K). The value of K for other metals can be taken from the table below, and the resistance of any wire can be calculated when its dimensions are known. The resistance obtained corresponds with the temperature for which K is given. The following table gives the resistance of a foot of wire, .001 inch diameter, or the values of K for different metals when the temperature is 68° Fahr. See ¶ 262. K therefore is the resistance of 1 mil-foot.

**Table VI.—Resistances of a Mil-Foot of the Metals (Values of K).**

Silver, 9.84	Zinc, 36.69	German Silver, 128.29
*Copper, 10.79	Platinum, 59.02	‡Platinoid, 188.93
†Aluminum, 17.21	Iron, 63.35	Mercury, 586.24

**Prob. 15:** Substitute an iron wire for the copper wire in Prob. 14, and find its resistance.

$$\text{By Formula (16) } R = \frac{K \times L}{d^2}.$$

Substituting,

$$R = 63.35 \times \frac{1000}{100 \times 100} = 6.335 \text{ ohms.}$$

K for iron = 63.35.

Iron has thus about six times the resistance of copper.

**129. Wire Measure.—The Circular Mil.**—In wire measure a mil is one one-thousandth of an inch ( $\frac{1}{1000}$ , or .001-inch, or 1 mil). The area of a round wire 1 mil in diameter is 1 circular mil. If the wire is 2 mils in diameter ( $\frac{2}{1000}$ , or .002-inch, or 2 mils), then it has a circular mil area of 4 circular mils, the result being obtained by expressing the diameter of the wire in mils and squaring it (multiplying it by itself). The circular mil is used as the unit of area in the calculation of round wires for electrical purposes (the square mil for rectangular wires). It is the area of a circle having

\*Copper is given at 75° Fahr., this being the average temperature under which it is used.

† Value for annealed aluminum (conductivity 54).

‡ German silver 49 parts, tungsten 1 part.

a diameter of  $\frac{1}{1000}$  inch; hence the square of any diameter, expressed in thousandths of an inch, will give as a product the number of circular units that can be placed side by side in a square, the sides of which are equal to the diameter that has been squared, the united area of the small circles contained within such a square being equal to the area of the large circle. This is illustrated in Fig. 103, where the large circle represents a wire three mils in diameter, and the small circles are the circular mils (9) whose united areas equal the area of the large circle. One circular mil equals .000000785 square inch.

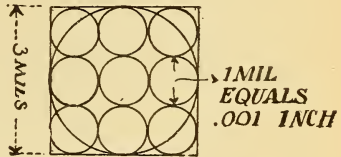


Fig. 103.—Area of the Large Circle Equals 9 Circular Mils.

1.—TO FIND THE CIRCULAR MIL AREA OF ANY ROUND WIRE WHEN ITS DIAMETER IN INCHES IS KNOWN :

*Express the diameter as a whole number in mils and square it.*

- Let  $d$  = diameter;
- $d^2$  = diameter squared;
- C. M. = circular mil area.

Then,

$$C. M. = d^2 \dots \dots \dots (17).$$

**Prob. 16:** What is the circular mil area of a wire  $\frac{1}{4}$  inch diameter?

$$1 \text{ inch} = \frac{1000}{1000}; \text{ therefore, } \frac{1}{4} \text{ inch} = \frac{250}{1000} \text{ or } 250 \text{ mils.}$$

$$\text{By Formula (17) } C. M. = d^2 = d \times d = 250 \times 250 = 62500 \text{ C. M.}$$

2.—TO FIND THE DIAMETER OF ANY WIRE WHEN THE CIRCULAR MIL AREA IS KNOWN :

*Extract the square root of the circular mil area. The result is the diameter expressed in mils,*

$$\text{or } d = \sqrt{C. M.} \dots \dots \dots (18).$$

**Prob. 17:** What is the diameter of a wire if the area is 6530 C. M. (No. 12 B. & S.)?

$$\text{By Formula (18) } d = \sqrt{C. M.} = \sqrt{6530} = 81 \text{ mils nearly, or } .081 \text{ inch diam.}$$

**130. The Square Mil.**—Circular mil area applies to round wires, and is nearly one-quarter (.2146) larger than the true square inch area of round wires. Many conductors

now used are rectangular in cross-sectional area, so that it is sometimes necessary to find their equivalent area in round wire measure. One square mil equals .000001 square inch.

**3.—TO FIND THE AREA OF A RECTANGULAR WIRE IN SQUARE MILS :**

*Express the dimensions in mils and find the product of the dimensions.* The result is square mils.

Let  $c$  = thickness (in mils);  
 $d$  = width (in mils).

$$\text{Sq. mils} = c \times d \dots \dots \dots (19).$$

**Prob. 18:** A copper ribbon for a field coil measures  $\frac{5}{8}$  inch  $\times$   $\frac{1}{4}$  inch. Find its square mil area.

$\frac{5}{8} = .625$ , or 625 mils  $\frac{1}{4} = .125$ , or 125 mils.

By Formula (19) Sq. mils =  $c \times d = 125 \times 625 = 78125$  sq. mils.

**4.—TO CONVERT CIRCULAR MIL AREA INTO SQUARE MIL AREA :**

*Multiply the circular mil area by .7854.* The result is square mils.

One circular mil = .7854 square mil.

Therefore,

$$\text{sq. mils} = \text{C. M.} \times .7854 \dots \dots (20).$$

**Prob. 19:** What is the square mil area of a wire  $\frac{1}{4}$  inch diameter?

By Prob. 16 its C. M. area was calculated to be 62500 C. M.

By Formula (20) Sq. mil area =  $\text{C. M.} \times .7854 = 62500 \times .7854 = 49087.5$  sq. mils.

**5.—TO CONVERT SQUARE MIL INTO CIRCULAR MIL AREA :**

*Multiply the square mil area by 1.2732.* The result is circular mils.

One square mil = 1.2732 mils.

Therefore,

$$\text{C. M.} = \text{sq. mils} \times 1.2732 \dots (21).$$

**Prob. 20:** Find the circular mil area of the copper wire in Prob. 18.

By Prob. 18 Sq. mil area = 78125.

By Formula (21) C. M. =  $\text{sq. mils} \times 1.2732 = 78125 \times 1.2732 = 99468.75$  C. M.

**131. The Wire Gauge.**—A number of wire gauges have been originated by different manufacturers of wire, such as the B. & S. gauge (Brown & Sharpe Manufacturing Co.), commonly called the *American gauge*, which is the one generally used in this country; B. W. G. gauge (Birmingham Wire Gauge), known as the *English Standard Gauge*; W. & M. gauge (Washburn & Moen Manufacturing Co.), etc. Tables

Table VII.—Copper Wire Table.

American Wire Gauge (Brown &amp; Sharpe).

Giving weights, length and resistances of soft copper wires of Mathiessen's standard conductivity at a temperature of 24°C. (75.2 F).

Gauge.	Diameter	Area.	WEIGHT		LENGTH.		RESISTANCE	
			Inches.	Circular Mils.	Lbs. per 1000 ft.	Lbs. per ohm.	Feet per lb.	Feet per ohm.
0000	0.4600	211600	640.5	12890	1.561	20130.	0.04967	0.00007755
000	0.4096	167800.	508.0	8107	1.969	15960.	0.06264	0.0001234
00	0.3648	133100.	402.8	5101	2.482	12660	0.07898	0.0001960
0	0.3249	105500.	319.5	3207	3.130	10040	0.09960	0.0003118
1	0.2893	83690.	253.3	2017	3.947	7963	0.1256	0.0004957
2	0.2578	66370.	200.9	1269	4.977	6314	0.1584	0.0007883
3	0.2294	52630.	159.3	798.3	6.278	5008	0.1997	0.001254
4	0.2043	41740.	126.4	501.8	7.914	3971	0.2518	0.001993
5	0.1819	33100.	100.2	315.5	9.980	3149	0.3176	0.003170
6	0.1620	26250.	79.46	198.5	12.58	2497	0.4004	0.005039
7	0.1443	20820.	63.02	124.8	15.87	1981	0.5048	0.008012
8	0.1285	16510.	49.93	78.49	20.01	1571	0.6367	0.01274
9	0.1144	13090.	39.63	49.37	25.23	1246	0.8028	0.02025
10	0.1019	10380.	31.43	31.04	31.82	987.5	1.012	0.03221
11	0.09074	8234.	24.93	19.52	40.12	783.6	1.276	0.05122
12	0.08081	6530.	19.77	12.28	50.59	621.2	1.610	0.08144
13	0.07196	5178.	15.68	7.722	63.79	492.7	2.029	0.1295
14	0.06408	4107.	12.43	4.857	80.44	390.7	2.559	0.2059
15	0.05707	3257.	9.858	3.054	101.4	309.8	3.227	0.3274
16	0.05082	2583.	7.818	1.922	127.9	245.7	4.070	0.5208
17	0.04526	2048.	6.200	1.206	161.3	194.9	5.132	0.8277
18	0.04030	1624.	4.917	0.7599	203.4.	154.5	6.471	1.316
19	0.03589	1288.	3.869	0.4779	256.5	122.5	8.160	2.092
20	0.03196	1022.	3.092	0.3005	323.4	97.14	10.29	3.328
21	0.02846	810.1	2.452	0.1890	407.8	77.07	12.97	5.291
22	0.02535	642.4	1.945	0.1189	514.2	61.10	16.37	8.413
23	0.02257	509.5	1.542	0.07475	648.4	48.47	20.63	13.38
24	0.02010	404.0	1.223	0.04702	817.6	38.43	26.02	21.27
25	0.01790	320.4	0.9699	0.02956	1031	30.49	32.80	33.83
26	0.01594	254.1	0.7692	0.01859	1300.	24.17	41.37	53.78
27	0.01420	201.5	0.6100	0.01169	1639.	19.17	52.16	85.51
28	0.01264	159.8	0.4837	0.007359	2067	15.20	65.78	135.9
29	0.01126	126.7	0.3836	0.004626	2607.	12.06	82.94	216.2
30	0.01003	100.5	0.3042	0.002909	3287.	9.583	104.6	343.8
31	0.008928	79.70	0.2413	0.001829	4145.	7.583	131.9	546.6
32	0.007950	63.21	0.1913	0.001150	5227.	6.013	166.3	869.2
33	0.007080	50.13	0.1517	0.0007237	6591.	4.768	209.7	1382.
34	0.006305	39.75	0.1203	0.0004550	8311.	3.781	264.5	2198.
35	0.005615	31.52	0.09543	0.0002963	10480.	2.999	333.4	3493.
36	0.005000	25.00	0.07568	0.0001800	13210.	2.378	420.5	5556.
37	0.004453	19.83	0.06001	0.0001132	16660.	1.886	530.2	8834.
38	0.003965	15.72	0.04759	0.00007101	21010.	1.496	668.5	14080.
39	0.003531	12.47	0.03774	0.00004478	26500.	1.186	843.0	22330.
40	0.003145	9.888	0.02993	0.00002816	33410.	0.9408	1063.	35510.

This table is based on the following values: - Resistance in terms of the international ohm. Specific gravity of copper = 8.89. Mathiessen's standard resistivity, one metre-gramme of soft copper = 0.14365 B. A. U. at 0°C, 0.141729 international ohms at 0°C. Mathiessen's temperature coefficient = 1.09612 at 24°C.

of these gauges will be found in the Appendix. The above (Table VII) gives the B. & S. gauge. The first column gives the manufacturer's number; for example, the scale in B. & S. gauge is from No. 0000 (four naughts) wire (460 mils diam., nearly  $\frac{1}{2}$  inch) to No. 40 (3 mils diam., or  $\frac{3}{1000}$

inch), the sizes decreasing as the gauge numbers increase. The diameter, C. M. area, weight, length and resistance are also given for each size of wire.

**132. Wire Calculations.—Case 1.—Given Length and Area of Any Wire to Find Its Resistance :**

*The resistance of any wire is equal to its length multiplied by the resistance of a mil-foot (K) and this product divided by its area.*

- Let L = length of the wire (in feet) ;
- R = resistance (in ohms) ;
- C. M. = circular mil area (diam<sup>2</sup>) ;
- K = resistance of one mil-foot.

Then,

$$R = \frac{K \times L}{C. M.} \dots \dots \dots (22).$$

**Prob. 21 :** A copper wire has a cross-sectional area of 8234 C. M. and is 1050 feet long. What is its resistance ?

By Formula (22)  $R = \frac{K \times L}{C. M.}$  K for copper = 10.79.

$$R = \frac{10.79 \times 1050}{8234} = 1.37 \text{ ohms.}$$

L = 1050 feet. C. M. = 8234.

**Case 2.—Given Resistance and Area to Find the Length :**

*The length of any wire is equal to its resistance, multiplied by its circular mil area, and this product, divided by the resistance of a mil-foot (K).*

$$L = \frac{R \times C. M.}{K} \dots \dots \dots (23).$$

**Prob. 22 :** What is the length of German silver wire wound on a resistance spool, if its resistance is 500 ohms and the size of wire No. 20 B. & S. ?

By Formula (23)  $L = \frac{R \times C. M.}{K} = \frac{500 \times 1022}{128.29} = 3983.16 \text{ feet.}$

R = 500 ohms, C. M. = 1022, K = 128.29.

No. 20 B. & S. = 1022 mils (from Table VII). K for German silver = 128.29 (from Table V).

**Case 3.—Given Length and Resistance to Find the Area :**

*The area in circular mils of any wire is equal to its length multiplied by the resistance of a mil-foot (K) and this product divided by its resistance.*

$$C. M. = \frac{L \times K}{R} \dots \dots \dots (24).$$

**Prob. 23:** What is the circular mil area of 1,000 feet of a certain iron wire, if its resistance is 30 ohms?

By Formula (24)  $C. M. = \frac{L \times K}{R} = \frac{1000 \times 63.35}{30} = 2111.6 \text{ C. M.}$

K for iron = 63.35 from Table V.  
L = 1000 feet, R = 30 ohms, K = 63.35.

**Case 4.—Given the Area to Find the Weight.**

The weight per mile (5280 feet) of any bare copper wire is equal to the area in circular mils divided by the constant 62.5. Copper wire weighs about 555 pounds per cubic foot; iron wire weighs about 480 pounds per cubic foot.

Pounds per mile (bare copper wire) =  $\frac{C. M.}{62.5} \dots \dots (25).$

Pounds per foot (bare copper wire) =  $\frac{C. M.}{62.5 \times 5280} (26).$

Pounds per mile (bare iron wire) =  $\frac{C. M.}{72.13} \dots \dots (27).$

**Prob. 24:** The circular mil area of a No. 10 B. & S. wire is 10,380. How many pounds of bare copper wire will be required for two lines running a distance of 5 miles?

By Formula (25) lbs. per mile =  $\frac{C. M.}{62.5} = \frac{10380}{62.5} = 166.08 \text{ lbs. per mile.}$

$166.08 \times 5 \times 2 = 1660.8 \text{ lbs.}$

**133. Table of Conductivity and Resistivity of Metals.**

Silver being the best conductor has consequently the highest conductivity. In the following table the first column gives the conductivities, and the second the resistivities. The conducting power of silver being noted as 100, the values for all other metals are proportionally less. On the other hand, if the resistivity of silver be taken as 1, all the other metals will have proportionally higher values.

**Table VIII.—Comparative Conductivity and Resistance of Metals.**

	Conductivity. (Comparative Conductance.)	Resistivity (Comparative Resistance.)
Silver (annealed) . . . . .	100.	1.
Copper (annealed) . . . . .	99.	1.01
Silver-copper alloy (equal parts) . . . . .	86.6	1.15
Gold (annealed) . . . . .	78.	1.28
Aluminum . . . . .	54.	1.84
Zinc . . . . .	30.	3.3

(Continued on following page.)

(Table VIII concluded.)

	Conductivity (Comparative Conductance.)	Resistivity. (Comparative Resistance.)
Brass (according to composition) . . . . .	—	—
Iron . . . . .	16.1	6.21
Tin . . . . .	15.5	6.25
Platinum . . . . .	10.6	9.43
Lead . . . . .	8.9	11.2
Nickel . . . . .	7.9	12.6
German silver . . . . .	7.5	13.3
Platinoid (Ger. silver 49 parts, tungsten 1) . . . . .	5.2	19.2
Antimony . . . . .	3.9	25.6
Mercury . . . . .	1.6	62.5
Bismuth . . . . .	1.2	83.3

RELATIVE RESISTANCES.

Nitric acid—commercial value—@ 15 to 28°C. . . . .	1,100,000
Sulphuric acid—1 to 12 parts water—@ 15 to 28°C. . . . .	2,000,000
Common salt—saturated solution—@ 15 to 28°C. . . . .	3,200,000
Sulphate of copper . . . . .	18,000,000
Distilled water—not less than . . . . .	10,000,000,000
Glass—@ 200°C. . . . .	15,000,000,000,000
Gutta percha—@0°C. . . . .	5,000,000,000,000,000,000

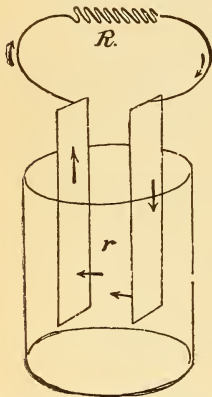


Fig. 104.—The Internal and External Resistance of a Cell.

**134. Internal Resistance of a Battery.**—Resistance in a voltaic circuit may be divided into two parts: *internal resistance* (*r*), which the current encounters in passing through the liquid from one plate to the other, and *external resistance* (*R*), or that of the outer circuit. See Fig. 104. The current that a cell will give, therefore, depends upon its internal resistance, and will be greater the less this resistance, and *vice versa*. The internal resistance is governed by the same laws as the external resistance. Thus :

$$r \text{ (internal resistance)} = K \times \frac{\text{distance of plates apart (L)}}{\text{areas of plates submerged (d}^2\text{)}}$$

or the internal resistance varies with

- (1) The electrolyte used,
- (2) Distance of plates apart,
- (3) Size, or area of plates.

A good battery, therefore, should have a low internal resistance.



## QUESTIONS.

1. The conductivity of a porcelain rod is very low. How will this affect its insulating qualities?
2. What is the function of an insulator?
3. The resistance of 5 pounds of No. 36 platinoid wire is very high. How does this affect the conductivity?
4. A battery sends 5 amperes through a piece of copper wire. Would the same cell send more or less current through another piece of copper wire twice as long but of double the area of the first piece?
5. If the second wire in question 4 was twice the length and twice the diameter of the first wire, what would be your answer?
6. Current from a cell flowing through a piece of iron wire deflects a galvanometer needle 40 degrees. When a piece of aluminum of similar dimensions to that of the iron is substituted, the deflection is 55 degrees. How do you account for this, since both wires are exactly the same size?
7. The resistance of an incandescent lamp is 500 ohms cold. Will it be more or less when the lamp is lighted? Why?
8. One mile of a certain iron wire has a resistance of 6 ohms. What will be the resistance of one-quarter of a mile of the same wire?

## PROBLEMS.

1. The insulation of a wire measures 16.75 megs. What is its equivalent resistance in ohms? *Ans.* 16,750,000 ohms.
2. What is the circular mil area of a wire  $\frac{3}{16}$  inch in diameter? *Ans.* 35156 C. M.
3. The circular mil. area of a wire is 5625. What is its diameter? *Ans.* 75 mils.
4. An armature is wound with copper bars  $\frac{3}{16}$  by  $\frac{3}{8}$  of an inch. What is their equivalent area in circular mils? *Ans.* 89522 C. M.
5. The resistance of the series coil of a dynamo is .0065 ohm. Express its resistance in microhms. *Ans.* 6500 microhms.
6. What is the square mil area of a No. 12 B. & S. copper wire? *Ans.* 5128.662 sq. mils.
7. What is the resistance of 5 pounds of No. 18 B. & S. wire, allowing 5 per cent for insulation? *Ans.* 6.251 ohms.
8. The coils of a rheostat, constructed of No. 8 iron wire, have a resistance of 10 ohms. What length of wire was required? *Ans.* 2606.14 feet.
9. A rectangular wire has a square mil area of 20616.75. What is the equivalent circular mil area? *Ans.* 26249 C. M.
10. What size of B. & S. wire has an equivalent area to the wire in Prob. 9? *Ans.* No. 6.
11. Calculate the resistance of 2000 feet of No. 6 B. & S. copper wire. *Ans.* 0.822 ohms.
12. Construct from your *own calculations* by the use of formulæ a wire gauge table for No. 12 B. & S. copper wire. Give circular mil area, square mil area, pounds per mile, pounds per foot, pounds per ohm, feet per pound, feet per ohm, ohms per pound and ohms per foot.

## LESSON XIII.

### OHM'S LAW AND BATTERY CONNECTIONS.

**Electromotive Force (Pressure)**—Table IX. Electromotive Forces of Batteries and Dynamos—Ohm's Law—Ohm's Law Applied to a Battery Circuit—Methods of Varying Current Strength—The Size of a Cell—Cells Connected in Series to Increase the E. M. F.—Cells connected in Parallel or Multiple for Quantity—The Internal Resistance of Cells in Series—Current from Cells in Series—The Internal Resistance of Cells in Parallel or Multiple—Current from Cells in Parallel or Multiple—Advantage of Parallel Connection—Advantage of Series Connection—Cells Grouped in Multiple Series—Internal Resistance of Any Combination of Cells—Current Strength from Any Combination of Cells—Cells Connected in Opposition—Questions and Problems.

#### 135. Electromotive Force (Pressure):

**Exp. 41:** Connect a Daniell cell in series with spool 4 of resistance spool set, ¶ 124, and a detector galvanometer, and note the value of the deflection. Now substitute a bichromate cell for the Daniell cell, using the same spool, and the deflection is greater than before. The E. M. F. of the bichromate cell is higher than that of the Daniell cell, and therefore causes a larger current to flow through the same resistance. Any other type of cell used would cause more or less current to flow through the spool, depending upon its E. M. F. (pressure in volts).

In a battery, the E. M. F., which is the primary cause of the current, is dependent on the nature of the plates and the solution used, *but independent of their size or distance apart.*

In a dynamo the E. M. F. is set up by revolving a bundle of wires in a magnetic field, and depends upon the strength of the field, the number of wires revolved, and the speed.

#### 136. Electromotive Force of Batteries and Dynamos.—

The following table gives the electromotive forces of the different cells described in Lesson IX :

**Table IX.—E. M. F. of Batteries.**

Bunsen . . . . .	1.75 to 1.95 volts.	Grove . . . . .	1.75 to 1.95 volts
Chloride of Silver	1.1 "	Harrison . . . . .	2.5 "
Daniell . . . . .	.98 to 1.08 "	Leclanche type	1.4 to 1.6 "
Dry cell . . . . .	1.4 "	Partz . . . . .	1.95 to 2. "
Edison-Lalande	.7 "	Smee . . . . .	.65 "
Grenet type . . . . .	1.8 to 2.3 "	Storage battery	2.1 "

Dynamos generate from a few volts to thousands of volts, according to the purpose for which they are designed.

Incandescent lighting dynamos, direct current . . . . .	125 volts
Alternating current dynamos, at brushes . . . . .	1000 to 2000 volts
Electric railway generators (direct current) . . . . .	550 volts
Electroplating dynamos . . . . .	2 to 6 volts
Magneto generators . . . . .	700 to 2000 volts
Commercial power circuit generators . . . . .	250 to 500 volts
Series arc light dynamos . . . . .	2800 to 8000 volts

**137. Ohm's Law.**—IN ANY CIRCUIT THROUGH WHICH A CURRENT IS FLOWING WE HAVE THE THREE FOLLOWING FACTORS PRESENT: (1) THE **pressure** OR POTENTIAL DIFFERENCE, EXPRESSED IN **volts**, CAUSING THE CURRENT TO FLOW. (2) THE OPPOSITION OR **resistance** OF THE CIRCUIT, EXPRESSED IN **ohms**, WHICH MUST BE OVERCOME BEFORE THE CURRENT CAN FLOW. (3) THE **current strength**, EXPRESSED IN **amperes**, WHICH IS MAINTAINED IN THE CIRCUIT, AS A RESULT OF THE PRESSURE OVERCOMING THE RESISTANCE. A DEFINITE AND EXACT RELATION EXISTS BETWEEN THESE THREE FACTORS, PRESSURE, CURRENT STRENGTH, AND RESISTANCE IN ANY CIRCUIT, WHEREBY THE VALUE OF ANY ONE FACTOR MAY ALWAYS BE CALCULATED WHEN THE VALUES OF THE OTHER TWO FACTORS ARE KNOWN. THIS RELATION, KNOWN AS **Ohm's Law**, is **very important\***, SINCE IT FORMS THE BASIS FOR ALL CALCULATIONS IN ELECTRICAL ENGINEERING. IT MAY BE SUMMARIZED AS FOLLOWS :

**First.**—The current strength in any circuit is equal to the electromotive force applied to the circuit, divided by the resistance of the circuit.†

Let **E** = E. M. F., potential difference or available pressure, expressed in volts, applied to any circuit;

**R** = Resistance of the circuit, expressed in ohms;

**C** = Current strength, expressed in amperes, to be maintained through the circuit ‡. Then by the above statement

$$\begin{aligned} \text{Current} &= \frac{\text{Pressure}}{\text{Resistance}}, \\ \text{or Amperes} &= \frac{\text{Volts}}{\text{Ohms}}, \\ \text{or } C &= \frac{E}{R} \dots \dots \dots (28). \end{aligned}$$

\*Lesson XX is devoted to a further discussion of the practical application of Ohm's Law.

† Ohm's Law, as stated above, applies to direct currents flowing in any circuit. †† is modified to some extent in alternating current calculations. See ¶ 297.

‡ I is used in some books as the symbol for current strength.

The following five statements and formulæ are directly derived from the above general statement of Ohm's Law, and are all therefore included in the expression  $C = E \div R$ .

Problems are solved under each case to illustrate the interpretation of each statement made.\*

**Prob. 25:** An incandescent lamp has a resistance (hot) of 220 ohms, and is connected to an electric light main, across which 110 volts potential difference is maintained. What current will flow through the lamp?

$$\text{By Formula (28)} \quad C = \frac{E}{R} = \frac{110}{220} = \frac{1}{2} \text{ ampere.}$$

$$E = 110 \text{ volts, } R = 220 \text{ ohms.}$$

**Second.**—*The current strength in any circuit increases or decreases directly as the E. M. F., or potential difference, increases or decreases, when the resistance is constant. With a constant pressure the current increases as the resistance is decreased, and decreases as the resistance is increased, or briefly, the current varies directly as the E. M. F. and inversely as the resistance.*

$C = \frac{E}{R}$ , with  $R$  constant,  $C$  varies directly as  $E$ . With  $E$  constant the greater  $R$ , the less  $C$ , and *vice versa*.

**Prob. 26:** In Prob. 25, if the pressure is increased to 440 volts, what current will the lamp receive?

$$\text{By Formula (28)} \quad C = \frac{E}{R} = \frac{440}{220} = 2 \text{ amperes.}$$

$$E = 440 \text{ volts, } R = 220 \text{ ohms.}$$

This problem illustrates the increase of  $C$  with increase of  $E$  with a constant  $R$ .

**Prob. 27:** In Prob. 25, if the pressure is reduced to 55 volts, what current will the lamp receive?

$$\text{By Formula (28)} \quad C = \frac{E}{R} = \frac{55}{220} = \frac{1}{4} \text{ ampere.}$$

$$E = 55 \text{ volts, } R = 220 \text{ ohms.}$$

This problem illustrates the decrease of  $C$  with the decrease of  $E$  when  $R$  is constant.

**Prob. 28:** In Prob. 25 the voltage is again 110, but a lamp of 110 ohms resistance is used. What current will it receive?

$$\text{By Formula (28)} \quad C = \frac{E}{R} = \frac{110}{110} = 1 \text{ ampere.}$$

$$E = 110 \text{ volts, } R = 110 \text{ ohms.}$$

With  $E$  constant,  $C$  increases as  $R$  decreases.

---

\* Some problems refer to cells and circuits connected thereto, but the principles and connections are the same as those involved in direct current, electric lighting, and power calculations. Problems on these subjects are given in later lessons.

**Prob. 29:** In Prob. 25 the pressure is 110 volts and another lamp of 440 ohms is used. What current will it receive?

By Formula (28)  $C = \frac{E}{R} = \frac{110}{440} = \frac{1}{4}$  ampere.

$E = 110$  volts,  $R = 440$  ohms.

Therefore, as  $R$  increases, when  $E$  is constant,  $C$  decreases.

**Third.**—*The electromotive force required to maintain a certain current strength in a circuit of known resistance, is numerically equal to the product of the current strength and the resistance.*  
 $E = C \times R$ .

By the above statement,

**Pressure = Current Strength  $\times$  Resistance,**

or **Volts = Amperes  $\times$  Ohms,**

or  **$E = C \times R$  . . . . . (29).**

**Prob. 30:** What pressure is required to cause 10 amperes to flow through an arc lamp if the resistance (hot) is 4.5 ohms?

By Formula (29)  $E = C \times R = 10 \times 4.5 = 45$  volts.

$C = 10$  amperes,  $R = 4.5$  ohms.

**Fourth.**—*The pressure varies directly as the current and resistance. For example, if a greater current is to be sent through the same resistance, a greater pressure must be applied; also, if the same current is to be passed through a higher resistance a greater pressure must be applied.*  $E = C \times R$ .

**Prob. 31:** What pressure is required to cause 15 amperes to flow through the lamp in Prob. 30?

By Formula (29)  $E = C \times R = 15 \times 4.5 = 67.5$  volts.

$C = 15$  amperes,  $R = 4.5$  ohms.

**Prob. 32:** If the lamp in Prob. 30 had a resistance of 9 ohms, what pressure must have been applied to have 10 amperes flow through it?

By Formula (29)  $E = C \times R = 10 \times 9 = 90$  volts.

$C = 10$  amperes,  $R = 9$  ohms.

Problems 31 and 32 illustrate how  $E$  increases directly with  $R$  and  $C$ . If either  $R$  or  $C$  had been decreased  $E$  would have been decreased also.

**Fifth.**—*The resistance required to be inserted in any circuit, so that a given current will flow by reason of a known pressure, is equal to the pressure to be applied, divided by the current strength that is to be maintained.*  $R = \frac{E}{C}$

By the above statement,

$$\text{Resistance} = \frac{\text{Pressure}}{\text{Current strength}},$$

$$\text{or Ohms} = \frac{\text{Volts}}{\text{Amperes}},$$

$$\text{or } R = \frac{E}{C} \dots \dots \dots (30).$$

**Prob. 33:** An electric heater is constructed of No. 18 iron wire and sufficient heat is radiated when the wire carries 10 amperes. The heater is placed across 110 volts. What will be the value of its hot resistance?

$$\text{By Formula (30) } R = \frac{E}{C} = \frac{110}{10} = 11 \text{ ohms (hot).}$$

$$E = 110 \text{ volts, } C = 10 \text{ amperes.}$$

**Sixth.**—*The resistance required for any circuit varies directly with the pressure applied, and inversely as the value of the current to be maintained.* For example, with a constant pressure the resistance must be halved if the current is to be doubled; on the other hand, with a constant current to be maintained in a circuit at double the pressure, the resistance must be doubled.

**Prob. 34:** In Prob. 33 the current required is 20 amperes and the pressure the same as there given. What will be the hot resistance required?

$$\text{By Formula (30) } R = \frac{E}{C} = \frac{110}{20} = 5.5 \text{ ohms.}$$

$$E = 110 \text{ volts, } C = 20 \text{ amperes.}$$

**Prob. 35:** If the pressure is 220 volts in Prob. 33, what resistance will be required?

$$\text{By Formula (30) } R = \frac{E}{C} = \frac{220}{10} = 22 \text{ ohms.}$$

$$E = 220 \text{ volts, } C = 10 \text{ amperes.}$$

Problems 34 and 35 illustrate the sixth statement made above.

**138. Ohm's Law Applied to a Battery Circuit.**—*When the total E. M. F. is used in Ohm's Law, the total resistance of the circuit must also be used in calculating the current strength.* For example, when an electromagnet of .4 ohm is connected to a cell of 2 volts E. M. F. the current through the spool will not be  $E \div R$  or  $2 \div .4 = 5$  amperes, as might first be supposed. It requires a certain portion of the 2 volts to cause the current to flow through the cell's internal resistance. *The internal resistance must be added to the external resistance to obtain the total resistance of the circuit, which is to be divided into the total pressure to obtain the current strength.* If the internal

resistance of the above cell is .6 ohm, then the total resistance is  $.4 + .6 = 1$  ohm, and the current equals  $E \div R = 2 \div 1 = 2$  amperes, or less than one-half of our first result.

Let  $R =$  the total external resistance of the circuit (in ohms);  
 $r =$  the internal resistance of the circuit (in ohms).

Then  $R + r =$  total resistance of the circuit (external + internal).

Then Ohm's Law becomes,

$$C = \frac{E}{R + r} \dots \dots \dots (31).$$

Small  $r$  represents the internal resistance, in ohms, of a cell, or the resistance of the windings of a dynamo, which would be the dynamo's internal resistance.

**Prob. 36:** If a bichromate cell, E. M. F. 2 volts, internal resistance .5 ohm, is connected to an electromagnet having a resistance of 1.5 ohms, what current will the magnet receive?

By Formula (31)  $C = \frac{E}{R + r} = \frac{2}{1.5 + .5} = 1$  ampere.  
 $E = 2$  volts,  $R = 1.5$  ohms,  $r = .5$  ohm.

Ohm's Law applies *equally as well to any part of a circuit as to the whole circuit.* When applied to part of a circuit, *care must be exercised to use the value of the pressure applied to the resistance of that portion of the circuit considered, when E will still represent the volts applied and R the resistance of the part of the circuit to which E is applied.* When E is used as the total pressure, R, to correspond, must be the total resistance. When E is used as the pressure applied to part of a circuit, R must be the resistance of that part to which this pressure is applied. This double application of the law is illustrated in Probs. 36, 37, 38, and 39, which should be carefully studied.

**Prob. 37:** The E. M. F. of a cell is 2 volts, its internal resistance, .5 ohm. A number of different resistance spools are joined together *in series* and connected to the cell. By electrical measurement it is found that the pressure causing the current to flow through a .4 ohm spool is .6 volt. What is the value of the current flowing through this spool? Make a sketch of the circuit.

By Formula (28)  $C = \frac{E}{R} = \frac{.6}{.4} = 1.5$  amperes.  
 $E = .6$  volt,  $R = .4$  ohm.

Since the current is the same in all parts of a *series circuit*, 1.5 amperes must flow through each of the other spools men-

tioned; also through the internal resistance of the cell. This problem also illustrates the difference between E. M. F. and potential difference. See ¶ 70. The difference of potential, or pressure between the spool terminals, is .6 volt, while the E. M. F. is 2 volts. In Ohm's Law E represents either value. See ¶ 138, also Lesson XX.

**Prob. 38:** What portion of the total E. M. F. in Prob. 37 is used in overcoming the internal resistance of the cell?

By Formula (29)  $E = C \times R$ ,

from which is derived  $E = C \times r$  . . . . . (32).

This gives the pressure lost or volts drop inside the cell, ¶ 230.

By Formula (32)  $E = C \times r = 1.5 \times .5 = .75$  volt.

$C = 1.5$  amperes,  $r = .5$  ohm.

**Prob. 39:** What portion of the E. M. F. is available for the other spools in the series circuit of Probs. 37 and 38?

By Formula (30)  $R = \frac{E}{C} = \frac{2}{1.5} = 1.333$  ohms ( $R + r$ )

$E = 2$  volts,  $C = 1.5$  amperes.

Resistance of cell (.5) plus resistance of one spool (.4) = .9 ohm.

$1.333 - .9 = .433$  ohm for balance of spools.

By Formula (29)  $E = C \times R = 1.5 \times .433 = .6495$  volt.

$C = 1.5$  amperes,  $R = .433$  ohm.

From Formula (31)  $C = \frac{E}{R + r}$  we may also change Formulæ (29) and (30) to include the internal resistance, as follows:

By Formula (29)  $E = C \times R$ .

Substituting  $E = C \times (R + r)$  . . . . . (33).

By Formula (30)  $R = \frac{E}{C}$ ;

substituting  $(R + r) = \frac{E}{C}$ ;

by transposition  $R = \frac{E}{C} - r$  . . . . . (34).

Also  $r = \frac{E}{C} - R$  . . . . . (35).

**Prob. 40:** A cell with an internal resistance of 2 ohms sends a current of .035 ampere through the electromagnets of a bell having a resistance of 48 ohms. What is the E. M. F. of this cell?

By Formula (33)  $E = C \times (R + r) = .035 \times (48 + 2) = .035 \times 50 = 1.75$  volts.

$C = .035$  ampere,  $R = 48$  ohms,  $r = 2$  ohms.

**Prob. 41:** A current of .25 ampere is maintained through a circuit by an E. M. F. of 2 volts; the internal resistance of the cell is 1.5 ohms. What is the value of the external resistance?

By Formula (34)  $R = \frac{E}{C} - r = \frac{2}{.25} - 1.5 = 6.5$  ohms.

$E = 2$  volts,  $C = .25$  ampere,  $r = 1.5$  ohms.



**139. Methods of Varying Current Strength.**—By Ohm's Law the current through any circuit may be regulated in two ways since  $C = E \div R$ ; by increasing the pressure,  $E$  (the dividend), or by decreasing the resistance,  $R$  (the divisor), the current strength,  $C$  (the quotient) will be increased; or by decreasing the pressure, or increasing the resistance the current will be decreased. For example, 25 volts will cause 5 amperes to flow through 5 ohms.  $C = E \div R$ . If the pressure is raised to 35 volts the current strength will be 7 amperes. Current from any cell may thus be *decreased* by inserting resistance in the cell circuit. If sufficient current, however, cannot be obtained from a cell, and as the E. M. F. is a fixed quantity for each type of cell, the E. M. F. may be increased by joining two or more cells together, so that the total E. M. F. is the sum of the E. M. F.'s of the separate cells. This will be better understood from the hydraulic analogies in ¶ 141.

**140. The Size of a Cell.**—It has been stated that the E. M. F. of a cell is the same for the same type of cell, without regard to size, but that the current depends on the size. In Fig. 105 the cylindrical tank, A, has a capacity of 100 gallons of water under a pressure of 10 pounds per square inch, due to the weight of the piston. Neglecting the weight of the water, the pressure gauge will record a pressure of 10 pounds. When the valve is opened the water will be discharged at the rate of about one gallon per minute, under a pressure of 10 pounds per square inch, so that at this rate it will require 100 minutes to empty the tank.

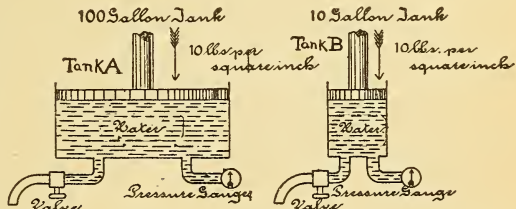


Fig. 105.—Two Cylindrical Tanks of Different Capacities, Containing Water Under Pressure.

A similar tank, B, has a capacity of 10 gallons of water under a pressure of 10 pounds per square inch, due to the piston. Neglecting the weight of the water, the pressure gauge will record 10 pounds also. The diameter of the pipe is the same size as in tank A, and when this valve is opened the water will flow out at the rate of one gallon per minute under a pressure

of 10 pounds per square inch as before, thus requiring only ten minutes to empty tank B. In both tanks the pressure and the rate of flow are the same, but tank A will maintain the

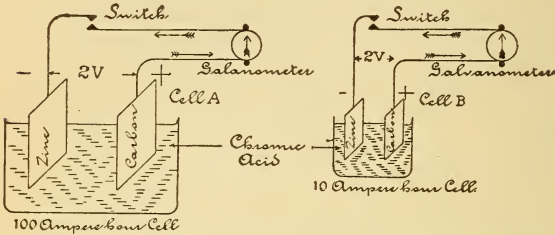


Fig. 106.—Two Cells of Different Size but Having the Same E. M. F.

current of water ten times as long as tank B. Now consider Fig. 106, in which the large cell A has a capacity of 100 am-

pere-hours (see ¶ 117) and an E. M. F. of 2 volts. When the switch is closed the galvanometer indicates, say 45 deflections, corresponding to a current strength of one ampere, and sufficient chemicals and zinc are present to maintain this current for 100 hours when the pressure is 2 volts and the rate of flow one ampere. Consider now a similar small cell B, which has a capacity of 10 ampere-hours and an E. M. F. of 2 volts. When the switch is closed through the same galvanometer the deflections are 45, as before, corresponding to a current strength of one ampere, sufficient chemicals and zinc being present to maintain this current for only 10 hours when the pressure is 2 volts and the rate of flow one ampere (neglecting the internal resistance). Thus the quantity of electricity depends on the size of the cell. If a large drain pipe had been used in tanks A and B, they would have been emptied more rapidly since the rate of flow would have been greater. If a galvanometer wound with a larger wire had been used, the cells A and B would not have maintained the current for so long a time, the rate of flow being greater.

**141. Cells Connected in Series to Increase the E. M. F.**—Consider the hydraulic analogy in Fig. 107, where the two similar cylindrical tanks A and B have a capacity of 100 gallons each. The pressure on the water in tank A and connecting pipe C is 10 pounds per square inch, due to the weight of the piston, so that the pressure gauge No. 1 indicates 10 pounds per square inch. In tank B the pressure on the water is 10 pounds per square inch, due to the pressure of

the piston on tank A above it, plus 10 pounds per square inch, due to the weight of its own piston, so that gauge 2 will register 20 pounds per square inch. The weight of the water is neglected. When the valve in the drain pipe of tank B is opened this tank will deliver the same quantity of water (100 gallons) as would be delivered by tank A, but at double the pressure. The rate of flow is, therefore, twice as rapid. If a number of similar tanks were connected in like manner above A, the pressure on gauge 2 would be increased 10 pounds per square inch for each tank added, although the quantity of water delivered through the valve would be the same as that of one tank. Consider now Fig. 108, where two cells, each having a capacity of 100 ampere-hours, and an E. M. F. of 2 volts are joined together so that the E. M. F.'s are in the same direction.

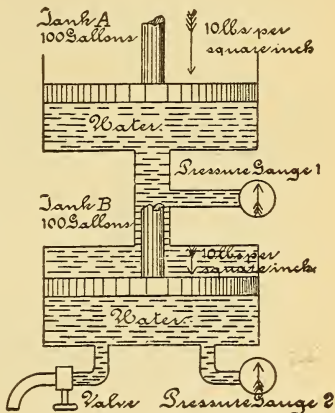


Fig. 107.—Two Cylindrical Tanks, Full of Water, Connected in Series for Pressure.

Gauge 2 records twice the pressure indicated upon gauge 1.

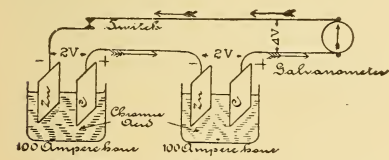


Fig. 108.—Two Cells Connected in Series for Pressure.

The galvanometer indicates twice the pressure of one cell.

Cells connected in this manner are joined in series. The total pressure applied to the galvanometer when the switch is closed is twice the pressure of one cell (neglecting internal resistance) or 4 volts. The total quantity of electricity that will pass through the galvanometer is the same as would be delivered by each cell separately, 100 ampere-hours, although, since it is delivered at twice the pressure of a single cell, the rate of flow is twice as great as with one cell. When a number

of similar cells are thus connected in series the pressure applied to the galvanometer will be increased by 2 volts for each cell so added, but the total quantity of electricity that can be delivered will be equal to the capacity of only one cell.

#### 142. Cells Connected in Parallel or Multiple for Quantity.

—In Fig. 109. two similar cylindrical tanks have a capacity of 100 gallons each, and are connected by a pipe, C, in which a pressure gauge is attached. The piston in each tank exerts a pressure of 10

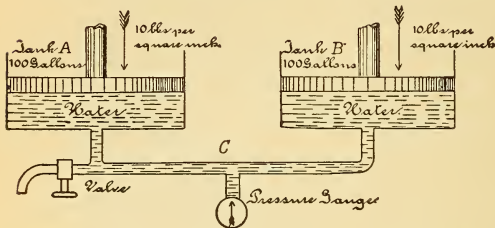


Fig. 109.—Two Cylindrical Tanks, Full of Water, Connected in Parallel for Quantity.

The pressure gauge records the pressure due to only one tank, but the quantity of water delivered is equal to the sum of the two capacities.

square inch, but the pressure gauge records only 10 pounds pressure, the same as though only one tank were used. The addition of any number of similar tanks will not increase the pressure, which will always remain 10 pounds per square inch.

The weight of water is neglected. Although the pressure is not increased, the quantity of water which can be drawn from the valve in the drain pipe increases in proportion to the number of tanks so added; thus, the total capacity of 2 tanks is 200 gallons; 6 tanks, 600 gallons. In Fig. 107 the tanks were arranged in series to add their pressures together, while in this case the tanks are arranged in parallel to add their volumes together.

In a cell, the total quantity of electricity depends upon the amount of zinc to be acted upon. Suppose the cell gives 1

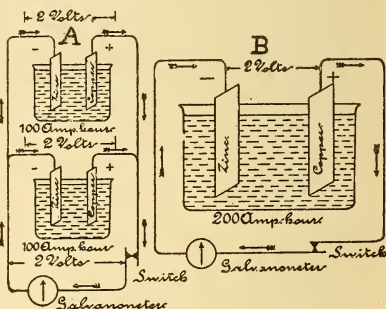


Fig. 110.—Two Cells Connected in Parallel for Quantity.

The total capacity and E. M. F. of the two small cells are exactly equal to that of the larger cell.

ampere-hour for each square inch of zinc exposed to the acid, then by increasing the area of the zinc plates a greater quantity of electricity can be obtained from the cell. This can be done in two ways: by making one very large cell, as B, Fig. 110, or by connecting the like plates of two or more smaller cells as in A, Fig. 110. Here the zinc plates of two cells are connected by a wire, forming one large zinc plate with double the area, the copper plates being similarly connected. *Cells so connected are arranged in parallel or multiple.* When the switch is closed in arrangement A the galvanometer is subjected to 2 volts pressure, neglecting internal resistance, which pressure would not be increased, no matter how many cells were thus connected. The total quantity of electricity that will flow through the galvanometer will increase in proportion to the number of cells so added. The two cells in A, therefore, could maintain 1 ampere through the galvanometer for 200 hours at a pressure of 2 volts, as could also the larger cell B. The advantage, then, of having small cells is that they can be arranged either for pressure or quantity, as may be desired, by connecting them in series or in multiple.

**Exp. 42:** Using a galvanometer of high resistance, compare the E. M. F.'s of different types of cells and record the deflections, the value of which will vary exactly as the E. M. F. varies.

**Exp. 43:** Connect unlike poles of two similar cells (which is termed joining cells in series) and attach the two remaining terminals to a high resistance galvanometer. The deflection is greater than with one cell, because the E. M. F.'s of the cells have been added together and greater pressure is applied to the galvanometer circuit. If the deflections are directly proportional to the current, their value will be nearly doubled. Add three similar cells in series and the pressure is three-fold, and so on.

**Exp. 44:** Connect two dissimilar cells in series (for example a Daniell cell, 1.1 volts, and Leclanche cell, 1.5 volts) with a high resistance galvanometer, and the deflection is greater than with either cell alone. The pressure applied to the galvanometer is equal to the sum of the two pressures in series ( $1.1 + 1.5 = 2.6$  volts).

**Exp. 45:** Record the deflections produced by one cell (say a Daniell) connected to a high resistance galvanometer. Using two similar cells, connect the positive poles by one wire, and the negative poles by another wire, and attach lead wires from these junctions to the galvanometer (when like poles are thus connected the cells are joined in *parallel* or *multiple*). The deflection is not perceptibly greater than with one cell, because the E. M. F. of two or more similar cells, joined in parallel, is the same as the E. M. F. of 1 cell; hence, two Daniell cells in parallel, 1 volt each, total E. M. F. 1 volt; 10 such cells in multiple, total E. M. F. 1 volt; 10 such cells in series, total E. M. F. 10 volts. In the above experiments a galva-

nometer of many turns of fine wire is used, so that little current will flow from the cells, and the deflections represent nearly the true pressure, ¶ 233.

### 143. The Internal Resistance of Cells in Series.—

When a number of cells are connected in series, and to an external circuit, the current flowing through the external circuit must pass through each cell so connected, Fig. 111, requiring, therefore, a certain fraction of the total E. M. F. to overcome the resistance of each cell.

TO FIND THE TOTAL INTERNAL RESISTANCE OF A NUMBER OF SIMILAR CELLS CONNECTED IN SERIES :

*Multiply the resistance of one cell by the number so connected.*

Let  $r$  = internal resistance of 1 cell;

$ns$  = number ( $n$ ) of cells in series ( $s$ ).

Then  $r \times ns$  = total internal resistance of cells in series (36).

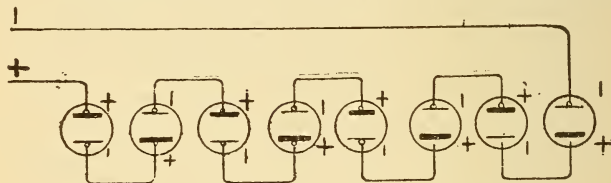


Fig. 111.—Eight Cells Connected in Series for Pressure.

The pressure is eight times that of one cell, as is also the total internal resistance.

**Prob. 42 :** Ten Daniell cells, with an internal resistance of 2 ohms each, are connected in series. What is the total internal resistance?

By Formula (36) total  $r = r \times ns = 2 \times 10 = 20$  ohms.

$r = 2$  ohms,  $ns = 10$  cells.

### 144. Current from Cells in Series.—

TO FIND THE CURRENT THAT WILL BE MAINTAINED IN AN EXTERNAL CIRCUIT FROM A NUMBER OF CELLS IN SERIES :

*Find the total E. M. F. applied by multiplying the E. M. F. of 1 cell by the number connected in series. Find the total internal resistance by Formula (36). Then by Ohm's Law the Current equals the E. M. F.  $\div$  the total resistance.*

Let  $E$  = E. M. F. of one cell ;

$r$  = internal resistance of one cell ;

$ns$  = number of cells in series ;

$R$  = external resistance.

Then  $C = \frac{E \times ns}{(r \times ns) + R} \dots \dots \dots (37).$

**Prob. 43:** Ten Daniell cells are joined in series to two spools of wire in series, one 4 ohms, the other 6 ohms. E. M. F. of one cell = 1 volt; internal resistance of one cell = 2 ohms. What current will flow through the circuit?

By Formula (37) 
$$C = \frac{E \times ns}{(r \times ns) + R} = \frac{1 \times 10}{(2 \times 10) + 10} = \frac{10}{30} = \frac{1}{3}$$
 ampere.

E = 1 volt, ns = 10 cells, r = 2 ohms, R = 6 + 4 = 10 ohms.

**145. The Internal Resistance of Cells in Parallel or Multiple.**—When a number of similar cells are connected in multiple, Fig. 112, and to an external circuit, the total current flowing through the external circuit does not pass through the resistance of each cell as in the series case, but is divided among the cells in proportion to the number in parallel. The internal path for the total current is of much lower resistance

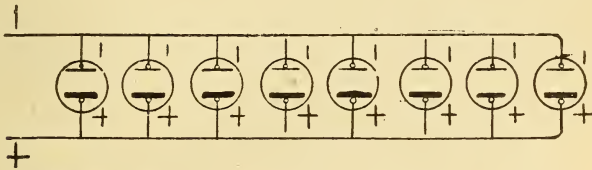


Fig. 112.—Eight Cells Connected in Parallel for Quantity.

The pressure is the same as that of one cell; the total internal resistance one eighth of that of one cell; the current nearly eight times that of one cell.

than the resistance of one cell. Cells connected in parallel have their like plates connected, Fig. 112, forming practically one large cell, the positive and negative plates of which are equal in area to the sum of the areas of the separate cells. The area of the conducting liquid is proportionately increased, and consequently, the internal resistance decreased. (See ¶ 134.)

TO FIND THE INTERNAL RESISTANCE OF A NUMBER OF CELLS IN PARALLEL :

*Divide the resistance of one cell by the number connected in parallel.*

Let r = the internal resistance of one cell;

    nq = the number of cells in multiple or parallel.

Then  $\frac{r}{nq} = \text{total internal resistance of cells in parallel (38).}$

**Prob. 44:** In Prob. 43 the cells are joined in parallel. What is now the internal resistance?

By Formula (38) total internal resistance =  $\frac{r}{nq} = \frac{2}{10} = \frac{1}{5}$  ohm.

$r = 2$  ohms,  $nq = 10$  cells.

**Exp. 46:** Connect a very large Daniell cell to a *low resistance* galvanometer and record the deflections (say 60). Now join a much *smaller similar* cell to the same galvanometer and the deflections are much less (say 20). The pressure is the same in both cases, but the internal resistance of the small cell is higher, and since  $C = E \div R + r$  (Formula 31), the current and the deflections must be less. Connect 3 of the smaller cells in parallel, Fig. 112, and to the galvanometer, and the deflections are now equivalent to the one large cell. The pressure is no higher since the cells are in parallel, therefore the total internal resistance of the three cells must be equal to the one large cell, since the current and pressure are the same.

**146. Current from Cells in Parallel or Multiple.**—To FIND THE CURRENT THAT WILL BE MAINTAINED IN A CIRCUIT FROM A NUMBER OF SIMILAR CELLS JOINED IN PARALLEL :

Find the total internal resistance of the cells in parallel by Formula (38). Divide the E. M. F. of one cell by the sum of the external and internal resistances (according to Ohm's Law).

Let  $E =$  E. M. F. of one cell;

$r =$  internal resistance of one cell;

$\frac{r}{nq} =$  total internal resistance of the cells in parallel;

$R =$  the total external resistance.

Then,

$$C = \frac{E}{\frac{r}{nq} + R} \dots \dots \dots (39).$$

**Prob. 45:** Ten Daniell cells are joined in parallel and to an external resistance of 10 ohms. E. M. F. of 1 cell = 1 volt. Internal resistance of 1 cell = 2 ohms. Find the current through the external circuit.

By Formula (39)  $C = \frac{E}{\frac{r}{nq} + R} = \frac{1}{\frac{2}{10} + 10} = .09$  ampere.

$E = 1$  volt,  $r = 2$  ohms,  $nq = 10$  cells,  $R = 10$  ohms.

By comparison with Prob. 43, it will be noted that with this particular external resistance the series arrangement of the cells is much better, as nearly four times the current flows through the circuit when the cells are in series as when connected in multiple.

**147. Advantage of Parallel Connection.**—Cells are connected in parallel when it is desired to obtain the maximum



current through a low external resistance circuit, or when a small current is required for a long period of time. When so grouped the cells are equivalent to one very large cell, and are arranged to give a large quantity of electricity. When connected to a low external resistance, as compared with the internal resistance, the strength of current will also be large, while with a high external resistance the current will be small. The total quantity of electricity available from the supply of the chemicals can thus be used rapidly or slowly, as economy may demand. The following problems will illustrate this case :

**Prob. 46 :** What current will flow through a resistance of .1 ohm from a Leclanche cell of 1.4 volts E. M. F. and an internal resistance of .4 ohm ?

$$\text{By Formula (31) } C = \frac{E}{R + r} = \frac{1.4}{.1 + .4} = 2.8 \text{ amperes.}$$

$$E = 1.4 \text{ volts, } R = .1 \text{ ohm, } r = .4 \text{ ohm.}$$

**Prob. 47 :** What will be the current in Prob. 46 with ten such cells in parallel ?

$$\text{By Formula (39) } C = \frac{E}{\frac{r}{nq} + R} = \frac{1.4}{\frac{.4}{10} + .1} = \frac{1.4}{.04 + .1} = 10 \text{ amperes.}$$

$$E = 1.4 \text{ volts, } r = .4 \text{ ohm, } nq = 10 \text{ cells, } R = .1 \text{ ohm.}$$

**Prob. 48 :** Suppose the ten cells in Prob. 47 are connected in series. What current will flow through the circuit ?

$$\text{By Formula (37) } C = \frac{E \times ns}{(r \times ns) + R} = \frac{1.4 \times 10}{.4 \times 10 + .1} = \frac{14}{4.1} = 3.41$$

amperes.

$$E = 1.4 \text{ volts, } ns = 10 \text{ cells, } r = .4 \text{ ohm, } R = .1 \text{ ohm.}$$

The parallel grouping is therefore preferable in the above problems if the greatest possible current strength is desired in the external circuit.

**148. Advantage of Series Connection.**—A series grouping is employed when the external resistance is the principal one to be overcome and the maximum current strength is desired in the circuit. The advantage of this method will be shown by the following problems :

**Prob. 49 :** A Leclanche cell, 1.4 volts and internal resistance of .4 ohm, is connected to an external resistance of 100 ohms. What current will flow through the circuit ?

$$\text{By Formula (31) } C = \frac{E}{R + r} = \frac{1.4}{100 + .4} = \frac{1.4}{100.4} = .01394 \text{ ampere.}$$

$$E = 1.4 \text{ volts, } R = 100 \text{ ohms, } r = .4 \text{ ohm.}$$

**Prob. 50:** Connect ten similar cells in parallel in Prob. 49 and find the current.

By Formula (39) 
$$C = \frac{E}{\frac{r}{nq} + R} = \frac{1.4}{\frac{.4}{10} + 100} = \frac{1.4}{100.04} = .013994 \text{ ampere.}$$

$$E = 1.4 \text{ volts, } R = 100 \text{ ohms, } r = .4 \text{ ohm.}$$

Ten cells so connected to this external resistance are, therefore, not much better than one cell. Compare with Prob. 44, where the external resistance was very low.

**Prob. 51:** Connect the cells in Prob. 50 in series and find the current strength.

By Formula (37) 
$$C = \frac{E \times ns}{(r \times ns) + R} = \frac{1.4 \times 10}{(.4 \times 10) + 100} = \frac{14}{104} = .13 \text{ ampere.}$$

$$E = 1.4 \text{ volts, } ns = 10 \text{ cells, } r = .4 \text{ ohm, } R = 100 \text{ ohms.}$$

With the cells in series ten times the current is passed through this resistance as when the cells are connected in parallel. In ¶ 146 the multiple combination proved to be best adapted for a particular circuit, while in this case the series grouping is desirable. The student should make a thorough comparison of the problems in ¶¶ 146 and 147.

**149. Cells Grouped in Multiple-Series.**—A combination of the series and multiple grouping of cells is sometimes desirable when a number of cells are available, to give either

the maximum current through an external resistance, or to increase the capacity of the cells for maintaining a current in a circuit for a long period of time. For example 8 volts E. M. F. is required to light a small lamp, and 8 cells are available with an E. M. F. of 2 volts each. Arrange one

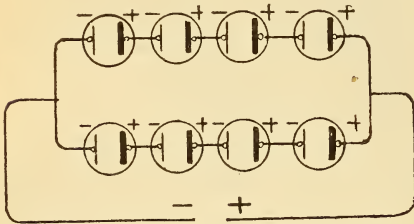


Fig. 113.—Multiple-Series Grouping of Cells.

Four cells in series, two groups in parallel. Total E. M. F. equal to that of one group. Total internal resistance equal to one-half that of one group.

group of 4 cells in series which will give the desired E. M. F., 8 volts\*. Suppose this group would cause the lamp to burn 4 hours. Arrange a second group of 4 cells in series and join this group in multiple with the first group, Fig. 113. The total E. M. F. is still 8 volts, but with two groups in parallel

\*Neglecting the internal resistance. See ¶ 226.

the quantity of electricity available has been doubled, so that the lamp will now burn 8 hours. Such a grouping of cells is called a *multiple-series* combination (practically a multiple of series). Two cells, each having an E. M. F. of 8 volts and an internal resistance of four times one of the above cells, could be placed in multiple and substituted for the 8 cells.

TO FIND THE CURRENT FROM A MULTIPLE-SERIES ARRANGEMENT OF CELLS JOINED TO AN EXTERNAL RESISTANCE :

Compute the E. M. F. and internal resistance of one group by Ohm's Law (Formula 37).

Consider the results as the data for one cell and then make calculations for the number of such cells (groups) arranged in parallel (by Formula 39).

**Prob. 52:** A multiple-series combination of 8 cells is joined to an external resistance of 3 ohms. The cells are arranged 4 in parallel, 2 groups in series, Fig. 114. Each cell has an E. M. F. of 2 volts and an internal resistance of .5 ohm. What current will flow through the external circuit?

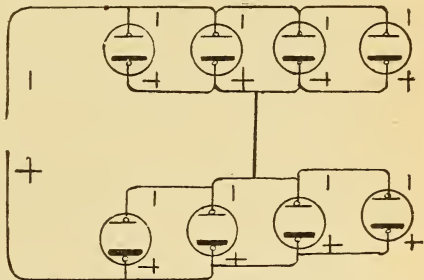


Fig. 114.—Series-Multiple Grouping of Cells. Four cells in parallel, two groups in series, equivalent to two cells in series and four groups in parallel.

E. M. F. of 1 group = 2 volts.

E. M. F. of 2 groups in series =  $2 \times 2 = 4$  volts.

By Formula (38) Internal resistance of 1 group =  $\frac{r}{nq} = \frac{.5}{4} = .125$  ohm.

E = 2 volts,  $nq = 4$  cells in 1 group,  $r = .5$  ohm.

By Formula (36) Internal resistance of 2 groups in series =  $r \times ns = .125 \times 2 = .25$  ohm.

$r$  of 1 group = .125 ohm,  $ns = 2$  groups.

By Formula (31)  $C = \frac{E}{R + r} = \frac{4}{3 + .25} = 1.23$  amperes.

$R = 3$  ohms,  $r$  of 2 groups in series = .25 ohm ;  $E = 4$  volts, 2 groups in series.

### 150. Internal Resistance of any Combination of Cells.—

TO FIND THE INTERNAL RESISTANCE OF ANY MULTIPLE-SERIES COMBINATION OF CELLS :

Multiply the resistance of one cell by the number of cells in one

group and divide the product by the number of groups in multiple. The number of cells in each group must be the same.

Let  $r$  = resistance of one cell;  
 $ns$  = number of cells in series in one group;  
 $nq$  = number of groups in parallel.  
 Total internal resistance of any combination of cells =  

$$\frac{r \times ns}{nq} \dots \dots \dots (40).$$

**Prob. 53:** Find the internal resistance of a combination of 24 cells arranged 6 in series, 4 groups in multiple. Each cell has a resistance of 4 ohms.

By Formula (40) Total resistance =  $\frac{r \times ns}{nq} = \frac{4 \times 6}{4} = 6$  ohms.  
 $r = 4$  ohms,  $ns = 6$  cells in one group,  $nq = 4$  groups in multiple.

**151. Current Strength from Any Combination of Cells.**

—TO FIND THE CURRENT THAT WILL BE MAINTAINED IN AN EXTERNAL CIRCUIT FROM ANY MULTIPLE-SERIES COMBINATION:

*Divide the total E. M. F. of one series group by the sum of the combined internal and external resistances.*

Let  $C$  = Current in external circuit;  
 $E$  = E. M. F. of one cell;  
 $ns$  = number of cells in series in one group;  
 $nq$  = number of groups in parallel;  
 $r$  = internal resistance of one cell;  
 $R$  = external resistance.

Then by Ohm's Law, Formulæ (37) and (39),

$$C = \frac{E \times ns}{\frac{ns \times r}{nq} + R} \dots \dots \dots (41).$$

**Prob. 54:** Find the current that would flow through an incandescent lamp, hot resistance 2 ohms, when connected to 24 cells arranged 4 in series and 6 in parallel. Each cell has an E. M. F. of 2 volts and an internal resistance of 3 ohms.

By Formula (41)  $C = \frac{E \times ns}{\frac{ns \times r}{nq} + R} = \frac{2 \times 4}{\frac{4 \times 3}{6} + 2} = \frac{8}{4} = 2$  amperes.

$E = 2$  volts,  $ns = 4$  cells in one group,  $r = 3$  ohms,  $nq = 6$  groups in parallel,  $R = 2$  ohms.

**152. Cells in Opposition.**—When two cells are joined in parallel their E. M. F.'s are in opposition, since each one tends

to send a current through the other. If the E. M. F.'s are equal no current will flow through the connecting wires. Two equal forces, acting in direct opposition, produce equilibrium; if, however, the forces are unequal, then motion is produced in the direction of the greater force. For example, if the pressure acting downward on each piston in tank A and B, Fig. 109, is the same, no water will flow through the connecting pipe. Suppose the total downward pressure on A is 10 pounds and on B 30 pounds, then a current of water will flow from B to A, due to the difference in pressure between the opposing forces, 20 pounds (30 lbs. — 10 lbs). The piston at A will move upward. When two cells of unequal E. M. F.'s are connected in opposition a current will flow through the connecting wires and internal resistance in the direction of the higher E. M. F.

TO FIND THE CURRENT IN ANY CIRCUIT WHEN THE E. M. F.'S ARE IN OPPOSITION :

*Divide the difference between the E. M. F.'s by the sum of the external and internal resistances.*

The opposing E. M. F. is called the *Counter E. M. F.* and is usually represented by  $\mathcal{E}$ .

Formula (31)  $C = \frac{E}{R + r}$  may include the above statement when expressed thus  $C = \frac{E - \mathcal{E}}{R + r}$ .

**Prob. 54-A:** Four Daniell cells, each having an E. M. F. of 1 volt and internal resistance of 2 ohms, are connected in series and in opposition to an accumulator having an E. M. F. of 2 volts and an internal resistance of .05 ohm. The resistance of the connecting wire is 0.2 ohm. What is the charging current?

By above Formula  $C = \frac{E - \mathcal{E}}{R + r} = \frac{4 - 2}{.2 + (4 \times 2) + .05} = .24$  ampere.

E. M. F. =  $E \times ns = 1 \times 4 = 4$  volts,  $\mathcal{E} = 2$  volts,  $r = r \times ns = 2 \times 4 = 8$  ohms + .05 = 8.05 ohms,  $R = .2$  ohm.

### QUESTIONS.

1. An electromagnet connected to a Leclanche cell attracts many more filings than when it is connected to a Daniell cell. Why?

2. Upon what factors do the E. M. F.'s of a battery and dynamo depend?

3. An incandescent lamp receives insufficient current to properly illuminate it. Why is this, and what is necessary in order that it may burn at candle power?

4. A lamp requiring 4 volts is connected to two bichromate cells of 2 volts E. M. F. each, joined in series. It fails to light properly, though the E. M. F. of the two cells is 4 volts. Why is this?

5. A small size Daniell cell deflects a galvanometer 40 degrees, while a larger one of the same type produces 55 deflections. Why is this, since the E. M. F. of the cells is the same?

6. The cells in question 5, when connected to another galvanometer, both indicate the same deflection. How do you account for this?

7. Two Partz cells are connected in series and to a large electromagnet; there are apparently no more filings attracted to the magnet than when one cell was used. If the iron is not nearly saturated, why is this, since the E. M. F. has been doubled?

8. Two Edison-Lalande cells are connected in parallel and to a galvanometer. The deflection is much greater than when only one cell was connected. Give reasons, since the E. M. F. is the same in both cases.

9. A Bunsen cell has an E. M. F. of 2 volts and an internal resistance of .4 ohm. Why will not this cell give 7 amperes through a very low external resistance?

10. If you are given the choice of two small Daniell cells or one large Daniell cell of twice the capacity of the small ones, which would you prefer? Why?

11. Would you connect two cells having an E. M. F. of 0.7 and 2.4 volts respectively in series? Give a reason for your answer.

12. Would you connect the cells mentioned in question 11 in parallel? Give reason for your answer.

13. The zinc rods of two Fuller cells are connected by a wire, and wires are led from the two carbon terminals to a galvanometer. The cells are in good condition and the connections tight, but the needle is not deflected. Give reason and illustrate your answer by a sketch.

14. If you are asked to select a good open circuit cell, what requirements should it fulfill?

15. The voltage applied to the terminals of a lamp is to be doubled, but the lamp must not receive any more current than before. Explain how this could be accomplished.

#### PROBLEMS.

1. What pressure must be applied to an incandescent lamp if it has a resistance of 55 ohms and requires 2.2 amperes? *Ans.* 121 volts.

2. A Daniell cell has an E. M. F. of 1 volt and an internal resistance of 2.2 ohms. What current will flow through an electromagnet connected to it, wound with 150 feet of No 18 B. & S. copper wire? *Ans.* 0.312 ampere.

3. The current through the field magnets of a dynamo is 2 amperes and the applied pressure 120 volts. What is the resistance of the circuit? *Ans.* 60 ohms.

4. The E. M. F. of a cell is 2.44 volts, its internal resistance .6 ohm, and it is connected to a circuit of 1.4 ohms. What pressure is required to send the current used through the battery? *Ans.* 0.732 volt.

5. A bell circuit is operated by 3 Leclanche cells in series. Each cell has an E. M. F. of 1.4 volts, and an internal resistance of .4 ohm. What current will the bell receive if its resistance, including the line, is 20 ohms? *Ans.* 0.198 ampere.

6. To operate a small motor 6 Grenet cells are connected in parallel. Each cell has an E. M. F. of 2 volts and an internal resistance of .6 ohm. The total external resistance is .9 ohm. What current will the motor receive? *Ans.* 2 amperes.

7. Some miniature incandescent lamps are lighted by 24 Edison-Lalande cells, arranged 4 in series and 6 groups in parallel. Each cell has an E. M. F. of .7 volt and an internal resistance of .15 ohm, and the external circuit has a resistance of .21 ohm. What current do the lamps receive? *Ans.* 9 amperes.

8. Four Leclanche cells, E. M. F. 1.4 volts each, and internal resistance of .4 ohm each, are to operate an electric gas igniting circuit of 15 ohms resistance. Would you connect the cells in series or in parallel? Prove your answer by calculation. *Ans.* 0.337 ampere.

9. Calculate the current from all symmetrical combinations of 6 cells connected to an external resistance of 2 ohms. Each cell has an E. M. F. of 1.4 volts and an internal resistance of .5 ohm. *Ans.* Series = 1.68 amperes; parallel = .67 ampere; 2 in series, 3 groups in parallel = 1.2 amperes; 3 in series, 2 groups in parallel = 1.52 amperes.

10. A Harrison cell E. M. F. 2.5 volts, internal resistance .4 ohm and a dry cell 1.5 volts and .6 ohm internal resistance are connected in parallel. What current will flow through the connecting wire? *Ans.* 1 ampere.

11. A Daniell cell, Grenet cell, and Leclanche cell having E. M. F.'s of 1.1, 2, and 1.4 volts and internal resistances of 2.0, 0.3, and 0.5 ohms respectively, are connected in series to a resistance of 3 ohms. What current flows through the external resistance? *Ans.* .77 ampere.

12. Eight cells are joined in series-multiple; 4 cells in multiple, 2 groups in series, Fig. 114. Each cell has an E. M. F. of 2 volts and an internal resistance of .5 ohm. The cells are connected to a small incandescent lamp having a hot resistance of .75 ohm. What current will the lamp receive? *Ans.* 4 amperes.

## LESSON XIV.

### CIRCUITS AND THEIR RESISTANCE.

Conductance of a Circuit—Resistances in Series—Equal Resistances in Parallel (Joint Resistance)—Unequal Resistances in Parallel—Conductivity Method for Conductors in Parallel—Resistances Joined in Multiple-Series—Division of Current in a Divided Circuit—Potential Difference in Multiple Circuits—Current in Branches of Multiple Circuits—Shunts—Rheostats—Resistance of Connections—Laboratory Rheostats—Table X. Resistance of Commercial Apparatus—Questions and Problems.

**153. Conductance of a Circuit.**—THE CONDUCTANCE OF A CIRCUIT IS THE RECIPROCAL OF ITS RESISTANCE. (The reciprocal of a number is the quotient obtained by dividing one by that number, as the reciprocal of  $4 = \frac{1}{4}$ ; of  $\frac{2}{3} = \frac{3}{2} = 1\frac{1}{2}$ .) The unit of conductance is the *mho* (ohm spelled backward). A wire of 1 ohm resistance has a conductance of 1 mho; if of 2 ohms resistance,  $\frac{1}{2}$  mho; 8 ohms resistance,  $\frac{1}{8}$  mho;  $\frac{2}{3}$  ohm resistance,  $\frac{3}{2}$  or  $1\frac{1}{2}$  mhos. The resistance of a circuit is the reciprocal of its conductance. A wire of 7 mhos conductance has  $\frac{1}{7}$  ohm resistance. If in Ohm's Law, conductance is used instead of resistance, and K represents the conductance of a circuit in mhos.

Then,

$$C = E \times K;$$

$$E = \frac{C}{K};$$

$$K = \frac{C}{E} \dots \dots \dots (42).$$

**154. Resistances in Series.**—TO FIND THE TOTAL RESISTANCE OF A NUMBER OF RESISTANCES CONNECTED IN SERIES:

*Find the sum of the resistances connected.* In Fig. 115, A equals 40 ohms; B equals 160 ohms; total resistance equals  $40 + 160 = 200$  ohms. The same current will flow through A as through B.



**155. Equal Resistances in Parallel—Joint Resistance.**

In Fig. 116 the two resistances, A and B, are connected in parallel, and then in series with the battery wires. If the resistance of A is equal to that of B, the conductance will also be equal and the current will divide, one-half flowing through

A and the other half through B. Since the total area of the conducting circuit has been increased, the combined or *joint resistance* of A and B will be less than either resistance separately. If the resistance of A equals that of B then the area will have

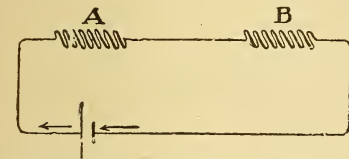


Fig. 115.—Two Unequal Resistances in Series.

been doubled, and the joint resistance equal to one-half that of A or B. Thus A and B = 10 ohms each; joint resistance =  $\frac{1}{2}$  of 10 or 5 ohms. With three equal resistances in parallel the joint resistance will be  $\frac{1}{3}$  the value of one of the resistances.

TO FIND THE JOINT RESISTANCE OF ANY NUMBER OF EQUAL RESISTANCES CONNECTED IN PARALLEL :

*Divide the value of a single resistance by the number connected in parallel.*

Let R = a single resistance;  
 nq = number of equal resistances in parallel;  
 J. R. = joint resistance.

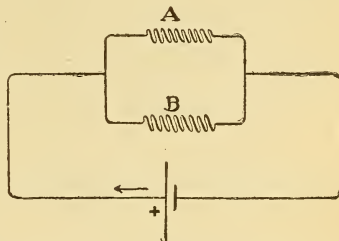


Fig. 116.—Two Unequal Resistances in Parallel.

$$\text{Then, J. R.} = \frac{R}{nq} \dots \dots (43).$$

TO FIND THE NUMBER OF EQUAL RESISTANCES CONNECTED IN PARALLEL (nq) WHEN THE JOINT RESISTANCE (J. R.) AND VALUE OF A SINGLE RESISTANCE (R) ARE KNOWN :

*Divide the value of a single resistance by the joint resistance.*

$$\text{Thus, } nq = \frac{R}{\text{J. R.}} \dots \dots (44)$$

TO FIND THE VALUE OF A SINGLE RESISTANCE (R) WHEN THE JOINT RESISTANCE AND THE NUMBER OF EQUAL RESISTANCES IN PARALLEL ARE KNOWN:

*Multiply the joint resistance by the number of equal resistances connected in parallel.*

$$R = J. R. \times nq \dots \dots \dots (45).$$

**Prob. 55:** Ten incandescent lamps are connected in parallel, Fig. 117. Each lamp has a resistance (hot) of 220 ohms. What is the total or joint resistance of the lamp circuit?

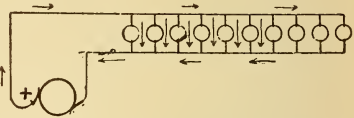


Fig. 117.—Ten Incandescent Lamps Connected in Parallel and to a Dynamo.

By Formula (43)

$$J. R. = \frac{R}{nq} = \frac{220}{10} = 22 \text{ ohms.}$$

R = 220 ohms, nq = 10 lamps in parallel.

**Prob. 56:** The joint resistance of 55 lamps connected in parallel is 4 ohms. What is the resistance of 1 lamp?

By Formula (45)  $R = J. R. \times nq = 4 \times 55 = 220 \text{ ohms.}$   
 $J. R. = 4 \text{ ohms, } nq = 55 \text{ lamps.}$

**Prob. 57:** The joint resistance of a number of electromagnets connected in parallel is 8 ohms and the resistance of 1 magnet, 40 ohms. How many magnets are connected?

By Formula (44)  $nq = \frac{R}{J. R.} = \frac{40}{8} = 5 \text{ electromagnets.}$

R = 40 ohms, J. R. = 8 ohms.

**156. Unequal Resistances in Parallel.**—In Fig. 118, two unequal resistances, 3 and 7 ohms respectively, are connected in parallel. The joint resistance will be less than either resistance considered separately.

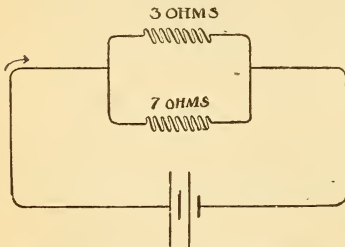


Fig. 118.—The Joint Resistance of Two Unequal Resistances in Parallel.

TO FIND THE JOINT RESISTANCE OF TWO UNEQUAL RESISTANCES CONNECTED IN PARALLEL:

*Divide the product of the resistances by their sum.*

- Let R = first resistance;
- $R_1$  = second resistance;
- J. R. = joint resistance.

Then the joint conductivity =  $\frac{1}{R} + \frac{1}{R_1} = \frac{R_1 + R}{R \times R_1}$  mhos,

and the joint resistance =  $1 \div \frac{R_1 + R}{R \times R_1} = \frac{R \times R_1}{R + R_1}$  ohms,

or J. R. =  $\frac{R \times R_1}{R + R_1}$  . . . . . (46).

**Prob. 58:** Find the joint resistance of two coils in parallel, having a resistance of 3 and 7 ohms respectively. Fig. 118.

By Formula (46) J. R. =  $\frac{R \times R_1}{R + R_1} = \frac{3 \times 7}{3 + 7} = 2.1$  ohms.

R = 3 ohms, R<sub>1</sub> = 7 ohms.

IF MORE THAN TWO UNEQUAL RESISTANCES ARE CONNECTED IN PARALLEL :

*First find the joint resistance of two wires, and considering this as a single resistance, combine it with a third resistance, and so on.*

**157. Conductivity Method for Conductors in Parallel.**

TO FIND THE JOINT RESISTANCE OF ANY NUMBER OF RESISTANCES CONNECTED IN PARALLEL :

*Find the sum of the conductivities of the different paths through which the current flows and the joint resistance will be the reciprocal of the sum thus obtained.*

**Prob. 59:** Find the joint resistance of 2 coils having 3 and 7 ohms resistance respectively, Fig. 118, by the conductivity method.

By ¶ 157 joint conductivity =  $\frac{1}{3} + \frac{1}{7} = \frac{7 + 3}{21} = \frac{10}{21}$  mho.

Joint resistance =  $\frac{21}{10} = 2.1$  ohms.

Compare with Problem 58.

**Prob. 60:** Find the joint resistance of 3 coils of wire having resistances of 2, 4 and 8 ohms respectively, Fig. 119.

By ¶ 157 joint conductivity =  $\frac{1}{2} + \frac{1}{4} + \frac{1}{8} = \frac{4 + 2 + 1}{8} = \frac{7}{8}$  mho.

Joint resistance =  $\frac{8}{7} = 1.142$  ohms.

**158. Resistances Joined in Multiple-Series.**—The same method of calculation is used as that already given for the internal resistance of cells, ¶ 145.

WHEN THE RESISTANCE OF ALL THE SERIES GROUPS ARE THE SAME :

*Find the resistance of one group, and divide this sum by the number of groups in parallel.*

WHEN THE GROUPS ARE OF UNEQUAL RESISTANCE :

Find the sum of the series resistances in one group, and treat this as a single resistance proceed as in ¶ 157.

**159. Division of Current in a Divided Circuit.**—The division of current in the branches of a multiple circuit is directly proportional to the conductance of the branches, or inversely proportional to their resistance.

If A and B, Fig. 116, are equal in resistance and a current of 12 amperes flows from the battery, 6 amperes will flow through A, and 6 amperes through B. If A has a higher resistance than B (and consequently a lower conductance), then the greater portion of the current will flow through the lower resistance of B (which has a higher conductance.)

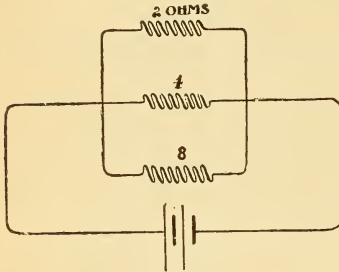


Fig. 119.—Three Unequal Resistances in Parallel.

If A has 2 ohms resistance and B 1 ohm, then *twice* as much current will flow through B as through A ; or

the current is divided into three parts, one-third of which flows through A and two-thirds through B. If the total current is 12 amperes, A then receives 4 amperes and B 8 amperes.

**Prob. 61 :** A current of 39 amperes is passed through 3 coils of wire joined in multiple, Fig. 120, having the following resistances : A = 8, B = 12, and C = 16 ohms respectively. How many amperes will each coil receive ?

$$\text{By ¶ 157 joint conductance} = \frac{1}{8} + \frac{1}{12} + \frac{1}{16} = \frac{6 + 4 + 3}{48} = \frac{13}{48} \text{ mho.}$$

$$\text{The conductance of A} = \frac{6}{48} \text{ mho, of B} = \frac{4}{48} \text{ mho, and of C} = \frac{3}{48} \text{ mho.}$$

Consider the current to divide into 13 parts (6 + 4 + 3), 6 parts of which pass through A, 4 through B, and 3 through C, or directly as their conductances.

$$\text{Current through A} = \frac{6}{13} \text{ of } 39 = 18 \text{ amperes ;}$$

$$\text{B} = \frac{4}{13} \text{ of } 39 = 12 \text{ amperes ;}$$

$$\text{C} = \frac{3}{13} \text{ of } 39 = 9 \text{ amperes.}$$

$$\text{Total current, . . . . } 39 \text{ amperes.}$$

**160. Potential Difference in Multiple Circuits.**—THE POTENTIAL DIFFERENCE REQUIRED TO BE MAINTAINED BETWEEN THE POINTS WHERE SEVERAL CIRCUITS BRANCH AND WHERE THEY AGAIN UNITE, is equal to the sum of the currents in all the branches, multiplied by the joint resistance of the branches.

$E$  = potential difference across branches;  $C, C_1, C_2,$  etc. = current in the branches;  $J. R.$  = joint resistance of the branches, Fig. 119.

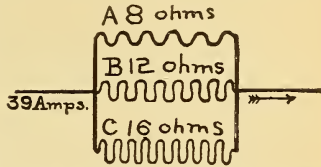


Fig. 120.—Finding the Current Strength through the Branches of a Divided Circuit.

$$E = (C + C_1 + C_2, \text{etc.}) \times J. R. \dots \dots (47).$$

**Prob. 62:** Three coils, A, B, and C, have a resistance of 8, 12, and 16 ohms respectively. Find the potential difference required to send 18 amperes through A, 12 amperes through B, and 9 amperes through C.

From Prob. (61) Joint conductance =  $\frac{13}{48}$  mho, therefore

$$\text{Joint resistance} = \frac{48}{13} = 3.69 \text{ ohms.}$$

By Formula (47)  $E = (C + C_1 + C_2) \times J. R. = (18 + 12 + 9) \times 3.69 = 143.9$  volts.

$C = 18$  amperes,  $C_1 = 12$  amperes,  $C_2 = 9$  amperes,  $J. R. = 3.69$  ohms.

**161. Current in Branches of Multiple Circuits.**—THE CURRENT, IN ANY BRANCH OF A MULTIPLE CIRCUIT, IS FOUND, by dividing the potential difference between where the branches divide and unite, by the separate resistance of each branch.

The separate resistances of the branches of a multiple circuit may be found by dividing the potential difference across any branch by the current flowing through any branch, according to Ohm's Law.

**Prob. 62-A:** Find the current through each branch of the divided circuit in Fig. 119, if the potential difference is 24 volts.

By ¶ 161  $C = \frac{E}{R} = \frac{24}{2} = 12$  amperes.

Also  $\frac{24}{4} = 6$  amperes and  $\frac{24}{8} = 3$  amperes.

**162. Shunts.**—If the current passing through the galvanometer G, Fig. 121, is too large, or the wire with which it is wound too small to carry a large current, only a small frac-

tion of the total current may be passed through the galvanometer, the remainder passing through the wire, S, connected across the galvanometer terminals. The wire, S, forms a

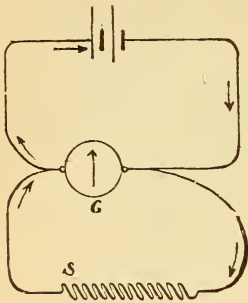


Fig. 121.—A Shunted Galvanometer.

“by-path” for the current, and is called a *shunt*, and the galvanometer is said to be *shunted*. If the resistance of the galvanometer is 1 ohm and the shunt 1 ohm, then as much current will flow through the shunt as through the galvanometer. If the resistance of the galvanometer is 2 ohms and the shunt 1 ohm, then twice as much current will flow through the shunt as through the galvanometer; that is, the galvanometer reading must be multiplied

by 3 to obtain the total current flowing from the battery. The value 3 is called the *multiplying power of the shunt*, that is, it is the amount by which the shunt multiplies the range of the galvanometer. Any galvanometer (ammeter or voltmeter) may, therefore, have its range of indication increased by shunting it.

- Let  $G$  = galvanometer resistance;
- $S$  = shunt resistance;
- $C$  = total current in the joint circuit;
- $C_g$  = current in the galvanometer circuit.

The multiplying power of a shunt is the ratio of the total current flowing in the circuit,  $C$ , to that part of it,  $C_g$ , which flows through the galvanometer. The total current,  $C$ , bears the same ratio to the galvanometer current,  $C_g$ , that the sum of the resistances,  $G + S$ , bears to the shunt resistance.

$$\text{Thus : } \frac{C}{C_g} = \frac{G + S}{S},$$

$$\text{or } \frac{G + S}{S} = \frac{G}{S} + \frac{S}{S} = \frac{G}{S} + 1.$$

**1. TO FIND THE MULTIPLYING POWER OF A SHUNTED GALVANOMETER :**

*Divide the galvanometer resistance by the resistance of the shunt and add one to the quotient.*

Multiplying power of a shunt ( $n$ ) =  $\frac{G}{S} + 1 \dots (48).$

**Prob. 63:** Find the number by which the readings on a Weston voltmeter must be multiplied (or the multiplying power of the shunted galvanometer) in Fig. 122, when resistance of voltmeter (galvanometer) is 5000 ohms, and resistance of shunt placed across its terminals is 500 ohms.

By Formula (48)  $n = \frac{G}{S} + 1 = \frac{5000}{500} + 1 = 10 + 1 = 11.$

The readings are to be multiplied by 11 to obtain the true value of the total current flowing.

**2. TO FIND THE CURRENT FLOWING THROUGH A SHUNTED GALVANOMETER,  $C_g$ , WHEN THE TOTAL CURRENT,  $C$ , FLOWING THROUGH THE CIRCUIT IS KNOWN :**

*Divide the total current by the ratio of the galvanometer resistance to the shunt resistance, plus one.*

$$C_g = \frac{C}{\frac{G}{S} + 1} \dots \dots \dots (49).$$

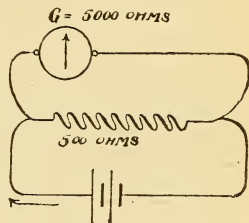


Fig. 122.—Current Through a Shunted Galvanometer.

**Prob. 64:** If 30 amperes flow from the battery in Fig. 122, when the galvanometer resistance is 5000 ohms and the shunt 500 ohms, what current will flow through the galvanometer?

By Formula (49)  $C_g = \frac{C}{\frac{G}{S} + 1} = \frac{30}{\frac{5000}{500} + 1} = \frac{30}{11} = 2.7$  amperes.

**3. TO FIND THE VALUE OF A SHUNT'S RESISTANCE TO GIVE A CERTAIN MULTIPLYING POWER ( $N$ ) :**

*Divide the galvanometer resistance by the multiplying power desired, minus one.*

- Let  $n$  = the desired multiplying power ;
- $S$  = shunt's resistance ;
- $G$  = galvanometer resistance.

Then,  $S = \frac{G}{n - 1} \dots \dots \dots (50).$

**Prob. 65:** What must be the resistance of a shunt to give a multiplying power of 100, when used with a galvanometer of 5000 ohms resistance? Fig. 122.

By Formula (50)  $S = \frac{G}{n - 1} = \frac{5000}{100 - 1} = \frac{5000}{99} = 50.5$  ohms.

In practice  $n$ , is generally 10, 100, or 1000.

These three shunt coils, calculated for any particular galvanometer, are arranged in a plug box, called a shunt box, similar to Fig. 125, and by withdrawing the plugs any particular shunt can be quickly connected to the galvanometer. The multiplying power is stamped on the box to correspond with each plug. This shunt box can only be used with the galvanometer (ammeter or voltmeter), for which it was calculated. Shunt boxes are sometimes called *multipliers*. By connecting a shunt across a galvanometer the resistance of the circuit is decreased. If it is desired to keep the resistance the same as when the galvanometer was not shunted, another resistance, known as a *compensating resistance*, is added in series with the shunted galvanometer. The value of the resistance to be added equals

$$G \times \frac{n-1}{n}.$$

**163. Rheostats.**—The usual method of regulating and controlling the current required for various electrical purposes is by inserting, or taking out of a circuit, resistance. It will be seen, from

Ohm's Law,  $C = \frac{E}{R}$ , that if

the pressure ( $E$ ) is constant the current ( $C$ ) can readily be regulated by increasing or decreasing the value of  $R$ ; that is, changing the resistance in circuit.

An adjustable resistance or any apparatus for changing the resistance without opening the circuit is called a *rheostat*. The function of a rheostat is to absorb electrical energy, and this energy, which appears as heat, is wasted instead of performing any useful work. A rheostat may be constructed of coils of iron wire, iron plates or strips; carbon, either pulverized in tubes or in the form of solid rods or discs; German silver, platinoid, etc., wound on spools; columns of liquids, as water and mercury, etc. The cross-sectional area of the material must be sufficient to carry the current without excessive heating. In rheostats used for

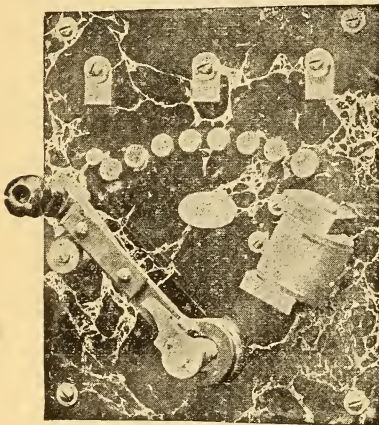


Fig. 123.—Commercial Type of Rheostat.



regulating the current in commercial electric circuits no great degree of accuracy of the resistance coils is required, as is the case in laboratory rheostats, ¶ 165. Fig. 123 illustrates a

*commercial type of rheostat*, in which the various coils are connected to brass buttons or contact segments. By moving a metallic connecting arm over the segments the coils are thrown in or out of circuit, and the resistance thus readily adjusted, as shown in the diagram of connections, Fig. 124. In some types of rheostats the wire is wound around an iron framework which has been previously dipped into a fireproof insulating enamel. The advantage of this construction is that the heat from the wire is dissipated much more rapidly, so that a much

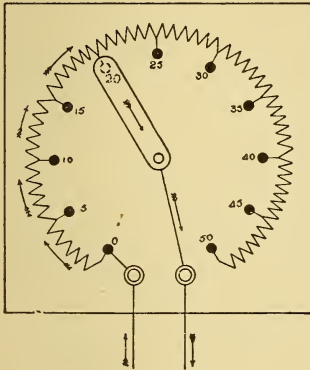


Fig. 124.—Commercial Rheostat.

Diagram of connections of the resistance coils.

smaller wire can be used to carry a given current. The size of such an enameled rheostat, required for absorbing a given amount of energy, is much smaller than one made of coils of wire stretched between an iron supporting frame-work.

#### 164. Resistance of Connections.—

When two surfaces are pressed *lightly* together the resistance of the contact is much greater than if the surfaces of contact are *firmly* pressed together. For this reason all

joints in electrical conductors should be soldered to decrease the resistance of contact; all binding screw contacts and connections should be thoroughly cleaned and of a bright

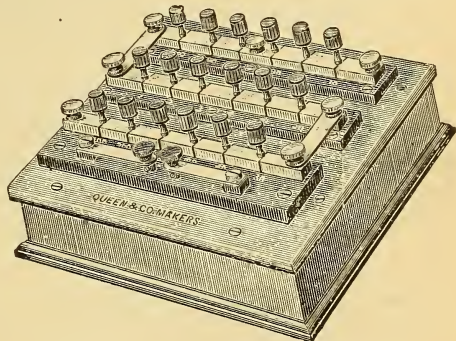


Fig. 125.—Laboratory Type of Rheostat.

metallic color when used, and screwed down so as to clasp the wires firmly.

**165. Laboratory Rheostats.**—For making electrical measurements accurately standardized resistance boxes are required. The current passed through these rheostats is generally a fraction of an ampere, so that the resistance wire, mostly German silver or platinoid, is small in size and is wound on spools which are contained in a case, as shown in Fig. 125. Brass strips are mounted on the top of the case, and the terminals of each coil connected to two adjacent strips as shown in detail in Fig. 126. The insertion of a tapered metal plug into a tapered hole formed by the adjacent strips, short circuits or cuts out the resistance coil. By removing the plugs, resistance is inserted in the circuit in which the box is connected. The accurate resistance of each coil is stamped on the box, as shown in

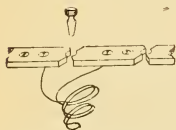


Fig. 126.—Connection of a Resistance Coil.

Fig. 234, so that the resistance in circuit is found by the addition of the values of the coils unplugged. The coils are wound *non-inductively*, ¶ 299, and the size of the wire used must be such that no appreciable error will be introduced by the heating of the coils.

**Table X.—Resistances of Commercial Apparatus.**

GALVANOMETERS.

Thomson mirror galvanometer, . . . . .	1 ohm to 350,000 ohms.
“ “ “ common resistance, . . . . .	5,000 “
D’Arsonval galvanometer, . . . . .	1 ohm to 750 “
“ “ common resistance, . . . . .	250 “

AMMETERS.

Resistance is less the larger the size of instrument required.  
 Weston, 15 amperes capacity, . . . . . .0022 ohm.

VOLTMETERS.

Cardew voltmeters for 100 volts, about, . . . . .	500 ohms.
Weston “ “ 150 “ “ . . . . .	150000 “

BATTERIES.

Gravity cell, . . . . .	2 to 4 ohms.
Leclanche, . . . . .	1 “
Bichromate, . . . . .	.4 “
Edison-Lalande, 300 ampere-hours, . . . . .	.02 “
Accumulator, 100 ampere-hours, . . . . .	.005 “

TELEGRAPHY.

Sounders, . . . . .		20 ohms.
Neutral relays, . . . . .	80 to 300	" "

TELEPHONY.

Bell telephone, about, . . . . .		75 ohms.
Call bell, from, . . . . .	75 to 1000	" "
Magneto armature, . . . . .		500 "
Induction coil, primary, . . . . .		0.28 "
" " secondary, . . . . .	12 to 160	" "

DYNAMOS AND MOTORS.

Armature resistance (warm) .5 K. W. dynamo or motor, about, . . . . .	4.	ohm.
And between brushes, 3 K. W. dynamo or motor, about, . . . . .	0.4	" "
And between brushes, 20 K. W. dynamo or motor, about, . . . . .	0.025	" "
And between brushes, 100 K. W. dynamo or motor, about, . . . . .	.0055	" "
And between brushes, 200 K. W. dynamo or motor, about, . . . . .	.0024	" "

ALTERNATING CURRENT TRANSFORMERS.

0.5 K. W. capacity, primary, 21.8 ohms, secondary, . . . . .	.04	ohm.
2. " " " 5.5 " " . . . . .	.015	" "
20. " " " 0.48 " " . . . . .	.0015	" "

INCANDESCENT LAMPS.

At 52 volts, a 16 candle-power lamp (hot), . . . . .	48 ohms.
" " " " 24 " " " " " " " " . . . . .	32 "
" 110 " " 10 " " " " " " " " . . . . .	343 "
" " " " 16 " " " " " " " " . . . . .	215 "
" " " " 24 " " " " " " " " . . . . .	144 "
" " " " 32 " " " " " " " " . . . . .	107 "
" " " " 50 " " " " " " " " . . . . .	69 "

HUMAN BODY.

The resistance of the human body varies widely with the position of electrodes, their area, the dryness of the skin, the duration of application, and the current strength. A very low resistance recorded, was 214 ohms from surface of head to surface of right calf, and 500 ohms from hand to hand, each immersed to the wrist in salt water. Average resistance under latter conditions, 1000 ohms.

QUESTIONS.

1. The arc lamps connected to a series dynamo are joined in series with it. How is the resistance of the circuit affected as additional lamps are inserted in the circuit?
2. What is a shunt? What advantages does it possess when used with a galvanometer?
3. A number of incandescent lamps are connected in multiple and to a dynamo. How will the resistance of the circuit be affected if one lamp is turned off?

4. What advantage does an enamel type of rheostat possess over one constructed in the ordinary manner?

5. State for what uses laboratory and commercial types of rheostats are designed, and also the essential differences between them.

6. An electric heater consists of coils of iron wire through which a current of 2.5 amperes flows, when joined in parallel with an incandescent lamp which receives one ampere? Which object possesses the higher resistance? Give proof for answer.

7. If a joint in an electrical current is mechanically stronger than the wire of which it is made, why should it be necessary to solder it?

8. Two resistances, A and B, having 3 mhos and 1.5 ohms respectively, are connected in parallel and to a source of current. Which one will receive the greater current?

### PROBLEMS.

1. Four hundred incandescent lamps are connected in parallel to a dynamo circuit. Resistance of the line .5 ohm and hot resistance of 1 lamp 220 ohms. Potential difference at dynamo terminals 112 volts. What current flows through the circuit? Give sketch. *Ans.* 106.66 amperes.

2. What length of No. 24 B. & S. copper wire would have an equivalent resistance to the joint resistance of 2 lamps connected in parallel? One lamp has a resistance of 110 ohms, the other 33 ohms. Give sketch. *Ans.* 950.27 feet.

3. Three copper electroplating baths are connected in parallel and to a dynamo which furnishes 117 amperes to them. The resistance of the baths is, No. 1, 24 ohms; No. 2, 36 ohms; No. 3, 48 ohms. What current does each bath receive? Give sketch. *Ans.* 54; 36; 27 amperes.

4. What potential difference must be maintained across the multiple circuit in Prob. 3? *Ans.* 1296 volts.

5. Sketch and name six combinations of 4 incandescent lamps connected to a pair of supply lines. Each lamp has a resistance of 220 ohms (hot) and the potential across the mains is 110 volts. What current will each combination receive? *Ans.* .125; 2; .5; .2; .376; .3 amperes.

6. In a trolley car, 5 lamps, each requiring  $\frac{1}{2}$  ampere and 100 volts, are connected in series and between the line and track across which 500 volts potential is maintained. If 10 cars wired as above were running, what would be the joint resistance of the lamp circuit and how much current would flow from the power station? *Ans.* 100 ohms J. R.; 5 amperes.

7. The resistance of an ammeter shunt is 0.2 ohm and the instrument with its leads 24 ohms. What pressure is required to send 10 amperes through the joint resistance of the ammeter and its shunt in parallel? *Ans.* 1.9 volts.

8. How much of the current flows through the ammeter in question 7? *Ans.* .082 ampere.

9. What is the multiplying power of the above shunt? *Ans.* 121.

10. Two electromagnets of 8 and 20 ohms respectively are joined in parallel. If 10 amperes flow through the 8-ohm magnet, what current does the 20-ohm magnet receive? *Ans.* 4 amperes.

## LESSON XV.

### ELECTROMAGNETISM.

Electromagnetism—Direction of the Lines of Force of a Straight Current-Carrying Wire—Deflection of a Horizontal Magnetic Needle—Right-Hand Rule for Direction of Whirls—Right-Hand Rule for Direction of Current or Deflection of Needle—Magnetic Field of a Circular Wire Carrying a Current—Magnetic Field at the Centre of a Circular Current—Magnetic Polarity of a Circular Current—The Helix and Solenoid—Testing the Polarity of a Solenoid—Rules for Determining the Polarity of a Solenoid—Graphical Field of a Solenoid—Questions.

#### 166. Electromagnetism.—

**Exp. 47:** Connect three or four chromic acid cells in parallel, close the circuit through a heavy bare copper wire, and then plunge the wire into iron filings. The filings are attracted to all sides of the wire, as though it were a magnet. Any part of the wire will attract

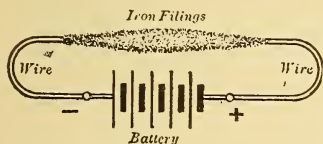


Fig. 127.—A Current-Carrying Wire Attracting Iron Filings.

the filings when the current is flowing, and the attraction will be equal on all sides of the wire, Fig. 127. When the circuit is broken the filings drop off of the wire.

*Electromagnetism*, as distinguished from magnetism in a permanent steel magnet, is the magnetism produced around a conductor when a current flows through it. A current of electricity is defined, in part, as the

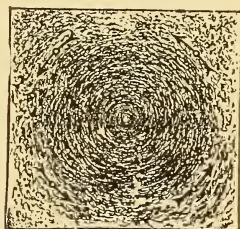
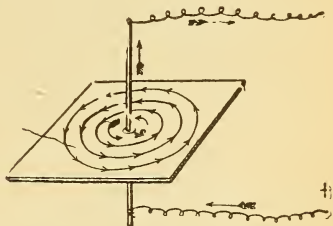


Fig. 128.—Graphical Magnetic Field of a Current-Carrying Wire. Made by iron filings.

magnetic field set up around a current-carrying conductor. Every wire carrying a current possesses this magnetic field,

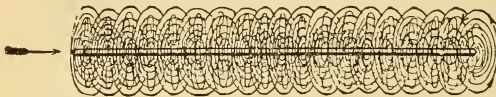


Fig. 129.—Magnetic Whirls of a Current-Carrying Wire.

which fact can be proved by bringing a compass needle

near the wire. The magnetic field of the wire acts on the magnetic field of the compass needle, and it is deflected.

**Exp. 48:** Pass a heavy copper wire vertically through the centre of a piece of cardboard held horizontally, upper view of Fig. 128, and send a strong current through the wire. Tap the card while sifting filings upon it, and they arrange themselves in concentric circles around the wire and at right angles to it. The plan view of Fig. 128 illustrates a graphical field made in this manner. By using paraffin paper the field may be fixed by applying heat.

The filings are magnetic bodies free to move, and arrange themselves in the circular direction of the magnetic lines of force surrounding the wire. A compass needle held near the wire will take up a position tangent to the circular field at any point, whether the current be passed up or down the wire. The magnetic field, around a straight wire carrying a current, consists of a cylindrical whirl of circular lines, their density decreasing as the distance from the wire increases, as illustrated in Fig. 129. The circular lines of force, or *magnetic whirls*, do not merge into, cross, or cut each other, but complete their circuits independently around the wire.

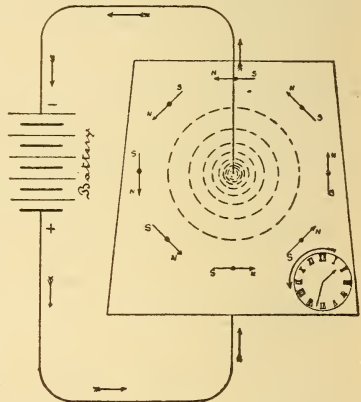


Fig. 130.—Current Flowing Up—Whirls Anti-Clockwise.

### 167. Direction of the Lines of Force of a Straight Current-Carrying Wire.—

The compass needles on the horizontal cardboard arrange themselves in the direction of the current's field.

**Exp. 49:** Pass a wire vertically through a sheet of cardboard held horizontally. Arrange a number of poised needles or compasses

around the wire in the form of a circle, Fig. 130, of such diameter that all the needles point nearly N and S. Pass a strong current through the wire from a battery so that the current flows up, or toward you as you look down upon the cardboard.

When the current flows up through the wire, Fig. 130, the needles, being magnetic bodies, arrange themselves around it in the direction of the circular lines of force, also so that the needles' magnetic lines of force are in the same direction as the magnetic lines of the circular field, ¶ 43. The N-poles of the needles point in the same direction as the magnetic lines of the current, and these lines pass through each of the needles, entering at the S-pole and emanating at the N-pole. The direction of the field with the current flowing up is left-handed, or opposite to the direction in which the hands of a watch

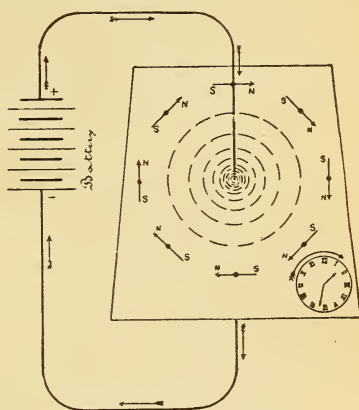


Fig. 131.—Current Flowing Down—Whirls Clockwise.

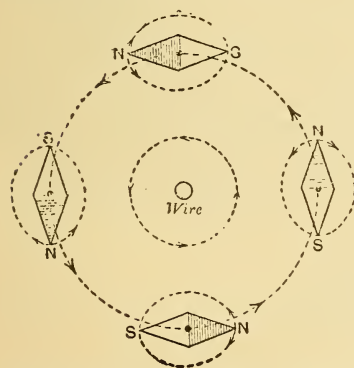


Fig. 132.—Direction of Whirls when the Current Flows Toward You—Anti-Clockwise.

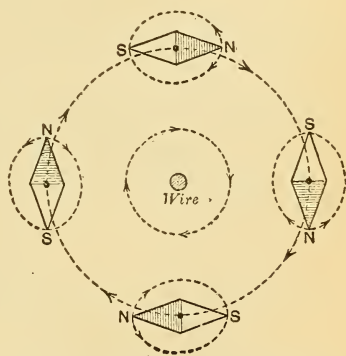


Fig. 133.—Direction of Whirls when the Current Flows Away from You—Clockwise.

would move, as shown in Fig. 130 and also 136, where the wire is supposed to be passed through the watch with the

current flowing toward you as you look at its face. Reverse the direction of the current so that it now flows down through the cardboard, or along the wire in the same direction that you are looking. The needles now reverse their direction, and the **N**-poles point around the wire in the opposite direction to what they did in the previous case, Figs. 131 and 133. The direction of the lines of the circular field is therefore reversed, or is in the same direction as the hands of a watch move, Figs. 131 and 136.

The direction of a current's circular magnetic field is the same as the natural direction of the magnetic lines through a poised or suspended needle when brought under the influence of the current's field. The direction the needles take up around the wire, right-handed or left-handed, is another reason for assuming that a current has direction. The direction of current in any vertical wire can thus be determined by a single magnetic needle, by noting the general direction its **N**-pole points when presented near to the wire.

If the **N**-pole points clockwise as you look down upon it the current is flowing from you, or in the same direction as that in which you are looking; if anti-clockwise, the current is flowing toward you. Compare Figs. 132 and 133 with Fig. 136.

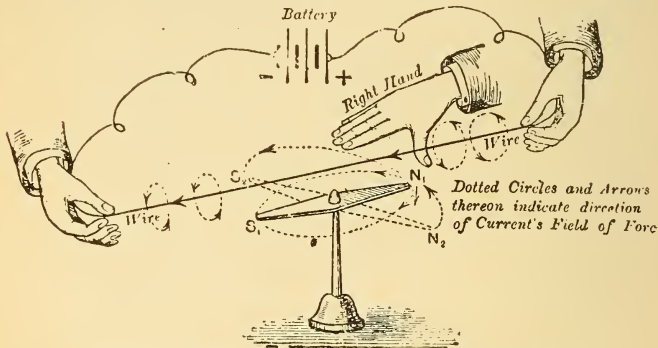


Fig. 134.—A Magnetic Body Free to Move, etc., ¶ 43.

**Exp. 50:** Figs. 132 and 133 show a plan view of the position of the needles on a horizontal piece of cardboard, with a vertical wire passed through it, when the current flows in opposite directions. Using a single compass needle, the student should verify the diagrams and make notebook sketches.



**168. Deflection of a Horizontal Magnetic Needle.**—When a wire is held horizontally over a poised magnetic needle, pointing **N** and **S** (or in the magnetic meridian), Fig. 134, and a current passed through it, the needle is deflected and tends to take up a position at right angles to the wire. When the current is sufficiently strong, the needle moves, so that it will accommodate through itself the greatest number of magnetic lines of the circular field, and also to such a position that its own natural magnetic lines will be in the same direction as the current's lines of force.

Considering Fig. 134, the current flows over the needle from right to left (also **N** to **S**). As you look along the wire in the direction of the current the direction of the whirls is right-handed or clockwise, as indicated by the dotted circles in Fig. 134, and also on the lower diagram of Fig. 136, the **N**-pole

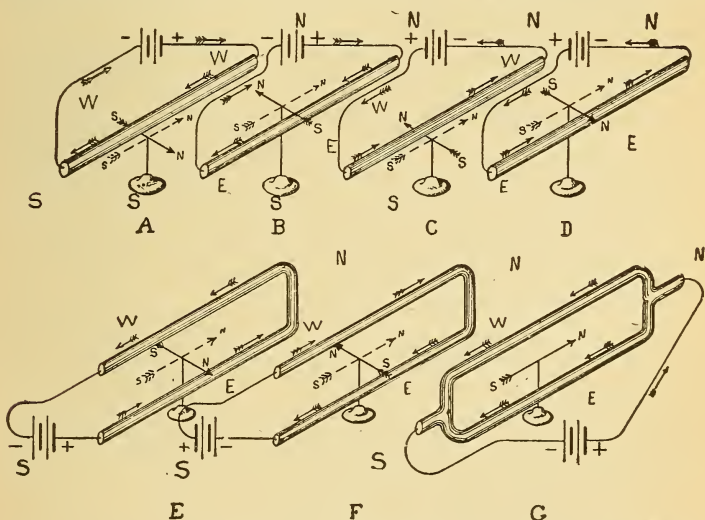


Fig. 135.—Resultant Deflections of the Magnetic Needle When Placed Near to a Current-Carrying Wire.

of the needle,  $N_1$ , moves to the position,  $N_2$ , at right angles to the wire, and in the direction of the field underneath the wire (which is from  $S_2$  to  $N_2$ ), so that the direction of the whirls and the needle's natural lines are coincident.

Consider the right hand, Fig. 134, as **N**, and the left hand

as **S**. The direction of the current's field underneath the wire is then from west to east, and the **N**-pole of the needle is deflected east. When a current flows from **North Over a needle to South** the **N**-end is deflected **East**. See A of Fig. 135. This may be remembered by the combination of the above letters,

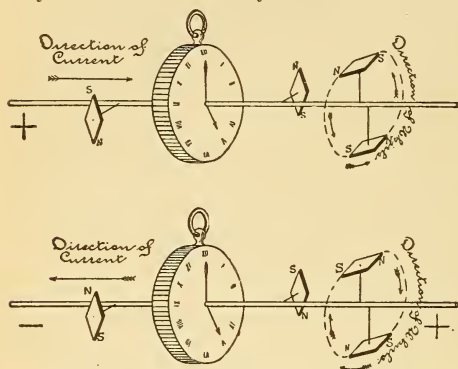


Fig. 136.—Clock Rule for the Direction of Whirls Around a Straight Wire.

which forms the word **NOSE**. The converse of this statement is also true. If a needle held under a wire pointing **N** and **S** is deflected east when the current is flowing, the direction of the current is from **N** to **S**. Obviously, when the needle is held above the wire in Fig. 134, the **N**-pole will point west, since the direction of the circular field above the wire is opposite to its direction underneath the wire (B, Fig. 135). Now consider the battery terminals reversed in Fig. 134, so that the current flows from **S** to **N** (left to right); the direction of the circular field is reversed and the **N**-pole of the needle points west.

When a current flows from **South to North Over a needle**, the **N**-end is deflected **West**. (C of Fig. 135.) This combination forms the word **SNOW**. The converse is also true: if the **N**-pole of a needle held under a wire pointing **N** and **S** is deflected west, the direction of the current is from **S** to **N**. With the current from **S** to **N**, when the needle is held above the wire, the **N**-pole is deflected east (D of Fig. 135). When a current flows from **N** to **S** over a wire in the magnetic meridian and from **S** to **N** under it, the **N**-end of the needle is deflected east to an increased extent. (Compare A and D with E of Fig. 135.) This forms a single turn, or convolution, and increasing the number of convolutions increases the extent of the needle's deflection till it assumes a position at right angles to the wire when the current is sufficiently strong. With the

current reversed in the above condition, the N-end of the needle is deflected west. (Compare B and C with F, Fig. 135.) The current flowing in *opposite directions*, above and below the needle, *increases* the amount of deflection. Equal currents flowing above and below the needle, in the *same direction*, produce *no deflection*. (G, Fig. 135.) If two unequal currents flow, one above and the other below the needle, the needle obeys the directive force of the stronger current.

**Exp. 51:** A simple form of apparatus for studying the relation between a needle's deflection and the direction of current, called an Oersted stand, is shown in Fig. 137. It consists of two parallel brass rods provided with binding posts and supported from a wooden base. With it the student should verify all the cases given in Fig. 135 and make notebook sketches.

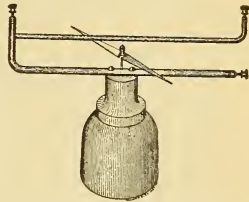


Fig. 137.—Oersted Stand for Studying the Needle's Deflections by a Current.

**169. Right-Hand Rule for Direction of Whirls.**—IF THE DIRECTION OF CURRENT IN ANY CIRCUIT IS KNOWN, THE DIRECTION OF THE CIRCULAR MAGNETIC FIELD AROUND THE WIRE MAY BE FOUND AS FOLLOWS:

Place the palm of the outstretched RIGHT hand above the wire, with the fingers pointing in the direction of the current, and the outstretched thumb extended at right angles and UNDERNEATH the WIRE. (See right hand, Fig. 134.) The direction in which the thumb points will indicate the direction of the circular field around the wire.

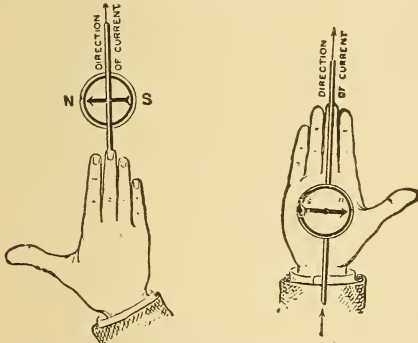


Fig. 138.—Right-Hand Rule for Finding Direction of Current or Needle's Deflection.

TO FIND THE DIRECTION THE N-POLE OF A NEEDLE WILL BE DEFLECTED BY A CURRENT:

Arrange the wire above and parallel to the needle when it is at

**170. Right-Hand Rule for Direction of Current or Deflection of Needle.**

vest, and place the palm of the outstretched RIGHT hand on the wire, with the fingers pointing in the direction of the current, Fig. 138, the outstretched thumb at right angles to the hand will point in the direction that the N-pole of the needle will turn.

TO FIND THE DIRECTION OF THE CURRENT WHEN THE DIRECTION OF DEFLECTION OF THE N-POLE OF THE NEEDLE IS KNOWN :

Arrange the wire N and S over the needle, and place the palm of the RIGHT hand over the wire, with the outstretched thumb at right angles to the wire and pointing in the direction that the N-pole turns. The fingers point in the direction that the current flows. This rule also holds good if the compass is above the wire and the right hand below it, Fig. 138.

### 171. Magnetic Field of a Circular Wire Carrying a Current.—

**Exp. 52:** Arrange a circular turn of wire vertically and in the magnetic meridian so that one-half of the circle will be above a horizontal piece of cardboard, as in Fig. 139. Pass a current through the wire, and while tapping the cardboard sift iron filings over it.

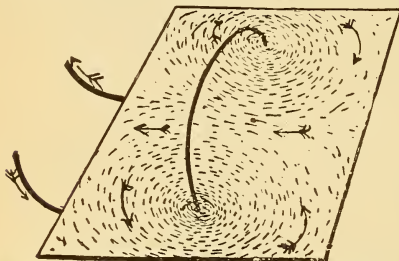


Fig. 139.—Graphical Field of a Circular Current.

Made with the aid of iron filings.

the iron filings arrange themselves circularly around the wire. Near the centre of the loop the filings are nearly parallel with its axis. Explore the field inside and out with a compass needle ; the needle at any point lies in the direction of the filings at this point, and its N-pole points in the direction of the current's field. The arrows in Fig. 139 indicate the direction of the whirls, and the several positions of the needle.

Apply the right-hand test, ¶ 170, and it will confirm the position the needles take up at any point. On one side of the loop all the whirls enter it in the same direction, and emerge from the opposite side as is further shown in Fig. 140.

**172. Magnetic Field at the Centre of a Circular Current.**—If a magnetic body, A, Fig. 140, be held above the circular loop, through which a current is flowing, it will tend to move downward through the loop, with its axis coinciding with the axis of the loop, until its position accommodates

through itself the greatest number of lines of force of the current's field, ¶ 43. There will be the same tendency in B, Fig. 141, where the current is flowing in a rectangular circuit; but it will be seen from inspection of the two figures that many more of the current's lines act upon the magnetic body, A, when the circuit is in the form of a circular loop than when in a rectangular or any other form, Fig. 141. If the distance between

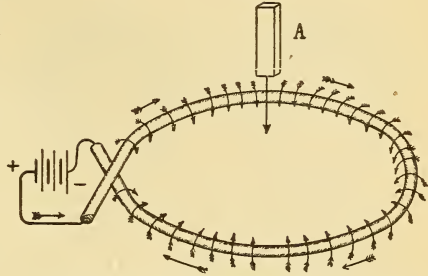


Fig. 140.—Attraction of Magnetic Body (A) by the Magnetic Field of the Circular Current.

the two parallel wires in the rectangular circuit is equal to the diameter of the circular loop, Fig. 140, it can be mathematically and experimentally proved that the strength of the magnetic field, at the centre of the circular current, is 1.57 greater than the strength of field midway between the two straight currents. For this reason nearly all magnet windings, bobbins of galvanometers, etc., are made circular to obtain the maximum magnetic effect of the current.

**173. Magnetic Polarity of a Circular Current.**—Under the subject of magnetism, we assumed the magnetic lines of force to pass out from the N-pole of a bar magnet and enter the magnet again at its S-pole; a similar reasoning is applied to the magnetic lines of force of an electric circuit. In the

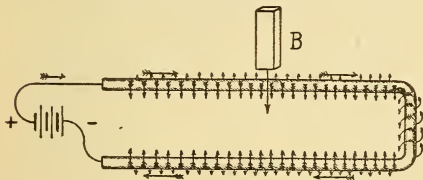


Fig. 141.—Attraction of Magnetic Body (B) by the Current's Field.

single turn of the copper ribbon, A, Fig. 142, the current flows around the loop in the direction of the hands of a watch as viewed from the nearer end. The circular whirls are also clockwise, if you look along the ribbon

in the direction of the current. The magnetic whirls, therefore, all enter the loop through its nearer side, or face; consequently, this face possesses S-polarity, and as the same

lines emanate again from the more distant face, that face is of N-polarity. The single turn of wire, therefore, possesses polarity similar to a bar magnet, and when free to move will

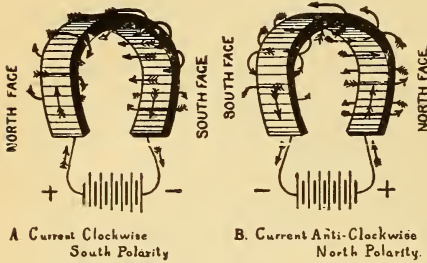


Fig. 142.—Polarity of a Single Turn of Wire.

take up a position in the earth's field with its N-face pointing toward the N; also, its N-face will be repelled by the N-pole of a bar magnet, or similar loop, and attracted by the magnet's S-pole, according to the law of attraction and repulsion between magnets. When the current is sent the opposite way around the single turn, B, Fig. 142, the direction of the whirls is reversed and the lines now emanate from the nearer or N-face of the loop, and enter by the more distant S-face. The polarity of the loop is, therefore, reversed as compared with the previous case. The above principles may be demonstrated by Exp. 53.

**Exp. 53:** Fasten a piece of copper and zinc to a large cork. Connect the plates by a circular turn of heavy wire, Fig. 143, and immerse them in a jar containing dilute sulphuric acid. Present a bar magnet's S-pole to the N-face of the turn in the direction of its axis; the coil will be attracted, and carrying the cell with it, move along the magnet till it reaches the middle point, or equator. The figure also illustrates the direction of the current's and magnet's magnetic lines. The laws of attraction and repulsion should be verified and sketches made.

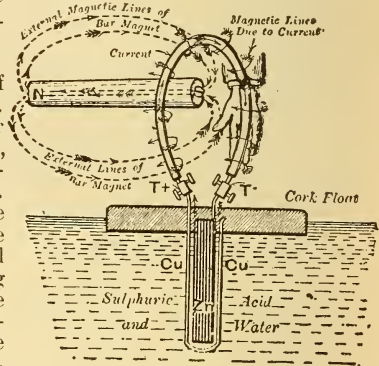


Fig. 143.—Testing the Polarity of a Single Turn of Wire.

The turn is connected to a floating battery and is free to move.

**174. The Helix and Solenoid.**—A coil of wire wound so as to follow the outlines of a screw without overlaying itself is termed a *helix*, Fig. 144, and may be wound right or left-

handed. The polarity can be reversed by re-winding in the opposite direction and passing the current, as indicated in Fig. 144, or by simply sending the current through the helix in the opposite direction.

A *solenoid* is a coil of wire, generally wound on a wooden or brass spool, the length of which is much greater than the diameter, Fig. 145. The winding is always in the same direction, layer upon layer, similar to the winding of a spool of thread.

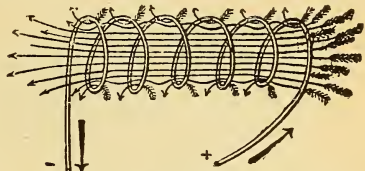


Fig. 144.—Direction of the Field of a Helix.

The spirals of a helix or solenoid are equivalent in their magnetic action to as many circular currents as there are convolutions of wire, since their axes lie in the same straight line. The magnetic whirls of each turn inside the helix are in the same direction as every other turn, and the direction of the magnetic field along, and parallel to the axis of the solenoid, is straight and fairly uniform to within a short distance of the ends. The total field is the sum of the magnetic lines of each individual turn as illustrated in the helix, Fig. 146, where the whirls of one convolution are depicted as joining on to the next, the sum of all

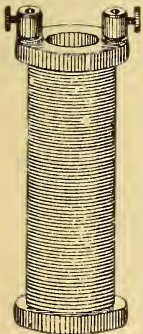


Fig. 145.  
Solenoid.

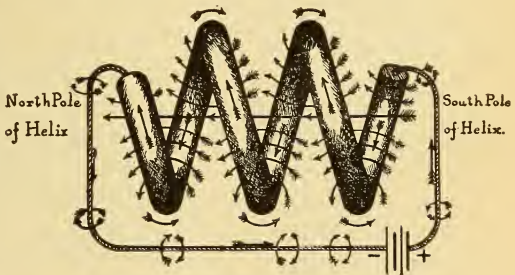


Fig. 146.—Polarity of the Helix.

The whirls of one turn unite with those of the next.

the turns constituting the field, or total number of lines of force passing through the helix. This diagram shows the direction of current through the helix, the direction of the

whirls around each convolution, and the resulting polarity. The action is similar for another set of convolutions wound over this set in the same direction, or for a solenoid composed

of any number of layers of winding, the field increasing with the number of turns and layers so wound.

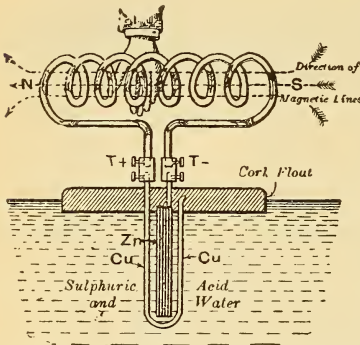


Fig. 147.—Testing the Polarity of a Helix.

The helix is connected to a floating cell.

contact is made. One groove is connected to each binding post by a wire, the groove stamped A, corresponding with post A, so that the direction of the current may be traced. When a current is sent through the coil it takes up a position N and S just as in the case of the poised needle, and is also repelled or attracted by another magnet or solenoid, the polarity being as explained for a single convolution, ¶ 172.

**176. Rules for Determining Polarity of a Solenoid.**—Clasp the solenoid, or helix, in the *right hand* so that the fingers point around it in the direction that the current flows. The outstretched thumb, at right angles with the fingers, will point in the direction of the N-pole of the solenoid, Fig. 149.

To find the direction of current around the coil when the polarity is known: clasp the coil with the right hand, so that

**175. Testing the Polarity of a Solenoid.**—When a current is passed through a solenoid it is termed an electromagnetic solenoid, and in its action it behaves similar to a magnet. It may be tested by the floating cell arrangement, Fig. 147, which is similar to that described in Exp. 53, or by the poised solenoid, Fig. 148, in which the two terminals dip into two concentric circular grooves containing mercury in which contact

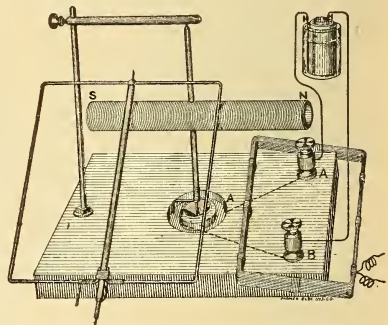


Fig. 148.—Ampere Frame Stand with Coils.

The movable coils are poised on needle points and the terminals dip in concentric mercury cups.



the thumb outstretched at right angles will point toward the N-pole, then the fingers will point in the direction of the current.

If on viewing the end of a solenoid the current flows around that end, in the same direction that the hands of a watch move, Fig 150, that end is S-polarity. If the current flows around the coil against the direction in which the hands of a watch move, that end possesses N-polarity.

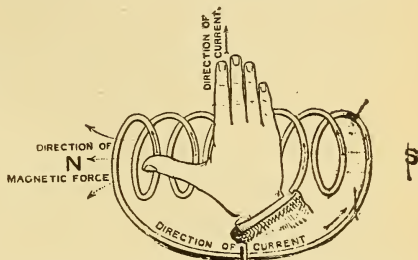


Fig. 149.—Right-Hand Rule for the Polarity of a Solenoid.

**177. Graphical Field of a Solenoid.**—The distribution of magnetism around a solenoid is very similar to that of a bar magnet, and can be studied by the iron filing diagram, Fig. 151.

**Exp. 54:** Cut a piece of cardboard to fit around a solenoid, as in Fig. 151. Place the cardboard horizontally so that its plane is in the axis of the coil. Pass a current through the coil, and while gently tapping the cardboard sift iron filings on it to produce a graphical field.

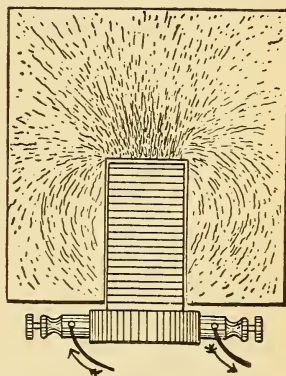


Fig. 151.—Magnetic Field of a Solenoid.

Made by iron filings upon a horizontal piece of cardboard.

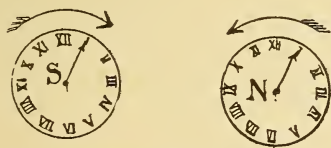


Fig. 150.—Clock Rules for Polarity.

**Exp. 55:** Wind a helix about 1 inch in diameter and 4 inches long. Cut a tongue in a sheet of cardboard equal to the inside diameter of the helix, and pass it horizontally through the helix with its plane in the axis of the helix. Make a graphical internal field of the helix. The direction of the lines of force may also be explored by a compass needle.

## QUESTIONS.

1. A feed wire for the overhead trolley line is conducted up a vertical wooden pole from an underground duct. When you approach the pole from the **S** the **N**-end of a compass needle held in your hand is deflected east. Is the current flowing up or down the pole?

2. One end of an arc lamp solenoid attracts the **N**-pole of a compass needle. What is the direction of the current around the coil when viewed from this end?

3. There is a leak to ground on a telegraph line between two stations 50 miles apart, so that the current transmitted does not reach the receiving apparatus. State how, by the use of a compass needle, you would proceed to accurately locate the point at which the leak exists? Make sketch.

4. Two parallel lines, one above the other, are stretched in a **N** and **S**-direction, and an equal current flows through each in the same direction. A compass is held midway between the wires. How will its needle be affected? Make sketch.

5. Six successive turns are made in a right-hand direction around a lead pencil, and the following six successive turns are wound in the opposite direction. A current is passed through the wire. Sketch the direction of the magnetic field you would expect to see if iron filings were used, and indicate the polarity and direction of the current.

6. A current is sent through a coil of wire wrapped around a tumbler in the same direction that the fingers of the right hand point when claspng it to drink. What is the polarity of that end of the coil you observe while drinking?

7. A current is passed through a wire held east and west over a compass needle. How will the needle be affected? Make sketch.

8. You are given the terminals of a cable containing the positive and negative poles of 5 batteries. The terminals are to be connected so that the cells will all be in series. How would you proceed by the use of a galvanometer to determine the polarity and make the connections? Give sketch.

9. The **N**-pole of a bar magnet, lying on a table with its axis pointing east and west deflects the **N**-pole of a compass needle 20 degrees. A wire carrying a current is held over the compass in a **N** and **S**-direction and the deflection is now only 12 degrees. How do you account for this?

10. What is the direction of current through the wire in question 9? Make sketch.

11. An electric light wire is run up the **S**-wall of a building from the first to the second story. Walking toward the wire the **N**-pole of a compass held in your hand is deflected east. What is the direction of the current in the wire? Make sketch.

12. There is a break in a 5-pound spool of magnet wire. How would you proceed to locate it by the use of a battery and galvanometer?

## LESSON XVI.

### GALVANOMETERS.

Principle of the Galvanometer—Detector Galvanometer—The Use of Long and Short Coil Galvanometers—Classification of Galvanometers—Relative Calibration of a Galvanometer—Tangent Galvanometer—Table XI. Natural Sines and Tangents—The Tangent of an Angle—Student's Combination Tangent Galvanometer—Directions for Setting up Student's Combination Galvanometer—Variation of Needle's Deflection with the Turns and Diameter of the Galvanometer Coil—Use of the Tangent Galvanometer as an Ammeter—Table XII. Tangent Galvanometer Constants—Thomson Mirror Reflecting Galvanometer—Astatic Differential and Ballistic Galvanometers—D'Arsonval Galvanometer—Questions.

**178. Principle of the Galvanometer.**—An instrument which measures a current by its electromagnetic effect is called a galvanometer. Galvanometers are used for detecting the presence of an electric current in any circuit, and for determining its direction, strength and pressure. Their construction is based on the principle that a magnetic needle, or its equivalent, is deflected when brought under the influence of a magnetic field, such as that of a wire through which a current is flowing. A simple galvanometer consists essentially of a magnetic needle poised or suspended in the centre of a coil of wire, and provided with a circular scale, graduated in degrees, on which the deviation, or deflection, of the needle may be noted. When such an instrument is connected in a circuit the presence of the current is shown by the deflection of the needle. The direction of the current is shown by the

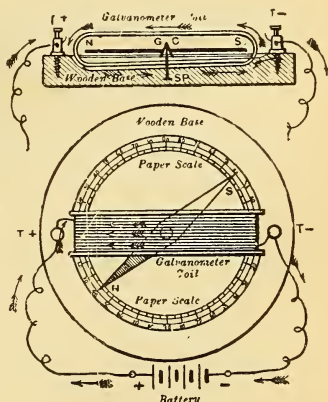


Fig. 152.—Simple Galvanometer.

side towards which the N-pole of the needle moves, ¶ 168. The strength of current is indicated by the amount of the needle's deflection; since the position the needle takes up depends upon the relative magnitude of the magnetic forces, due to the current and the earth. The earth's magnetism may be considered to be approximately constant at any particular place.

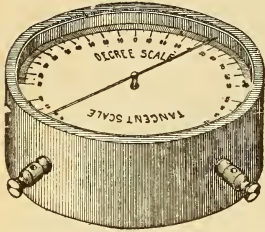


Fig. 153.—Student's Detector Galvanometer.

To obtain the maximum effect of the current's field, the galvanometer wire or coil, when no current is flowing, is arranged parallel to the magnetic needle when it is at rest, so that the plane of the coil passes through the axis of the needle and the magnetic meridian. *Galvanometers*

*are usually set up to conform to the above conditions before sending a current through them; the current's field will then act at right angles to the earth's field, and the position the needle will take up when the current flows is the resultant of these two forces. A certain amount of the current's field is therefore used to overcome the earth's attraction for the needle before it moves at all. When the needle is deflected to 90 degrees, or at right angles to the wire, it is in the maximum position of the current's field. The value of the deflection is dependent upon the current flowing through the coil, but is not proportional to the current; that is, if one current produces twice the number of deflections of another current the former is not of twice the strength, ¶ 182. With the needle parallel to the coil, or at the zero scale position, a small current deflects*

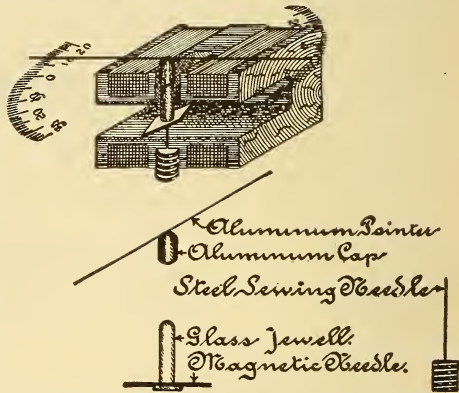


Fig. 154.—Construction of Student's Detector Galvanometer.

the needle parallel to the coil, or at the zero scale position, a small current deflects

it considerably, but as the angle the needle makes with the coil increases, a much greater magnetic force is required. For example, it requires a greater force to deflect the needle one degree from the 45-degree position than to deflect it one degree from the 15-degree position. The galvanometer coil may be wound with a great many turns of fine wire, in which case the instrument is said to be sensitive; that is, the needle is appreciably deflected by a very small current; or it may be composed of a few turns of very heavy wire, in which case it is intended for use with large currents.

By the *sensibility of a galvanometer* is meant the amount of current required to produce a given deflection. The sensibility is sometimes rated in ohms. For example, a galvanometer with a sensibility of 2 megohms, ¶ 126, means that if it is connected in series with 2 megohms and a potential of 1 volt applied to the circuit, the movable system will be deflected one division of the scale. The sensibility of a galvanometer, therefore, depends upon the number of times the current circulates around the coil, the distance of the needle from the coil, the weight of the needle, and the amount of friction produced by its movement. The needle is usually quite small, and often a compound one. See ¶ 187. In very sensitive galvanometers the coils are wound with thousands of turns of very fine wire, and shunts are generally used in connection with them.

### 179. Detector Galvanometer.—

A student's detector galvanometer is illustrated in Fig. 153, and the sectional parts in Fig. 154. A circular glass-covered box contains the magnetic system inclosed in a rectangular coil of finely wound wire. An aluminum pointer is fixed to an aluminum cap, Fig. 154, and the magnetic needle fastened to a glass jewel. The cap telescopes the jewel and the pointer is arranged at right angles to the needle. One-half of the dial is graduated in degrees and the other half in divisions corresponding to the tangents of the various angles, ¶ 184. In adjusting this instrument for use, turn the box around till the pointer is directly over the zero mark on the scale; the pointer will then point east and west, and the magnetic needle at right angles to it will be in the magnetic meridian, as will also the coil of wire. The coil is wound with No. 30 B. & S. magnet wire, and has a resistance of about 30 ohms. The instrument is very sensitive; a current of about .00001 ampere will deflect the needle 1 degree.

### 180. The Use of Long and Short Coil Galvanometers.

In making electrical measurements it is necessary to use current. Suppose it is desired to measure the resistance of

the cotton insulation around a piece of wire, Fig. 155 ; a current must be passed from the sheet of tin foil wrapped around the insulated wire, through the cotton insulation to the wire itself. The value of this current is to be noted on the galvanometer. The current will be very small that flows through, say one-eighth inch of cotton, so that the galvanometer must be extremely sensitive to record such a minute current, therefore the coil should be small in diameter and wound with many turns of very fine wire, and the needle arranged to eliminate as much friction as possible. On the other hand, suppose it is desired to indicate the current flowing through a number of incandescent lamps if a fine wire or long coil galvanometer is connected in series with the lamps; either the resistance would be so high that the lamps would not light, or the coil would be heated and destroyed, due to an excessive current passing through it, ¶ 257.

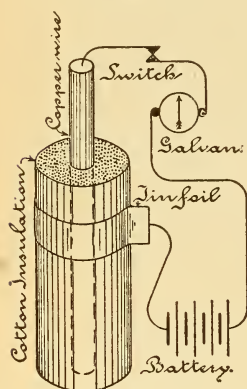


Fig. 155.—Measuring Insulation Resistance.

A short thick coil galvanometer of a large diameter, containing one or more turns, and consequently very low resistance, is suitable for this case. The total magnetising force deflecting the needle may be the same as before, but produced by a large current circulating around a few turns instead, of a small current, around thousands of turns, ¶ 197.

Long coil galvanometers of very high resistance are used to measure electrical pressure, and when properly standardized their scales are graduated directly in volts and the instrument then becomes a *voltmeter*, ¶ 233. The standardization consists in experimentally determining the position of the needle, when the coil is subjected to different known pressures, and marking these values on the scale ; the process is called *calibration* and the galvanometer is calibrated absolutely as a direct reading instrument. It is still the current that deflects the needle, and its strength is dependent upon the pressure. Short coil galvanometers of very low resistance have their scales calibrated to read directly in amperes, and thus become *amperemeters* or *ammeters*, ¶ 203.

**181. Classification of Galvanometers.**—According to the

principle of action, galvanometers may be divided into two classes ; first, those in which the magnet or magnetised body is arranged to move and the coil held stationary, and second, those in which the magnet is stationary and the coil arranged to move. Each class is largely used in practice for laboratory and commercial purposes, and constructed in a variety of forms. In construction, the winding used may be “*long coil*” or “*short coil*,” and the method of supporting the magnetic system either by suspension, by poising it, or by delicate springs. The deflections may be noted either by a pointer attached to the magnetic system and moving over a graduated scale, or by a small mirror attached to the system. A ray of light focused upon the mirror is reflected upon a scale at some distance and greatly enlarges a small movement of the magnetic system. In another method the image of the scale deflection is observed on the mirror by a telescope located at about the same distance as the scale, ¶ 189. Long coil galvanometers may be used as short coil galvanometers when a shunt is employed, ¶ 162.

### 182. Relative Calibration of a Galvanometer.—

**Exp. 56 :** Shunt the detector galvanometer, ¶ 162, with about 4 feet of No. 18 magnet wire and connect the shunted instrument in series with the gas voltameter, ¶ 120, and a source of E. M. F. Allow the current to pass for about five minutes and note the average deflection of the needle. (Find the average deflection by dividing the sum of all the readings, taken at one-half minute intervals, by the number of readings so taken.) Calculate the current by Formula (7), corresponding to the average deflection it produced, and place results in table for comparison. Repeat a number of such tests and calculations, using each time a different E. M. F. In such a test the following results were obtained from the calculations for a particular shunted galvanometer :

Degrees.	Amperes.
25	0.5
35	0.75
40	1.0
45	1.05

The above shunted galvanometer is said to be *calibrated relatively*. Suppose that when it is used in another circuit with the same shunt, the deflection produced by an unknown current is 30 degrees, then by reference to the table the approximate current will be .62 ampere, since .5 ampere produces 25 deflections and .75 ampere, 35 deflections. That the deflections are not proportional to the current is also shown

by this test. If a new scale were made for the instrument and .5 ampere substituted for the 25 degree mark and so on, then we would have an *absolute calibration* of the instrument, or practically, a shunted ammeter, ¶ 209.

**Exp. 57:** Connect a rheostat of several hundred ohms in series with the detector galvanometer, ¶ 179, to one Daniell cell, assumed to give 1 volt E. M. F., and record the deflection corresponding to this pressure. Make a number of tests, using each time a different number of cells connected in series, and tabulate results as below :

Deflections.	Volts.
17	1
30	2
40	3
45	4

The galvanometer is now *relatively calibrated as a voltmeter*. Suppose a dry cell, when connected to the galvanometer and extra resistance in series, gives 21 deflections ; then its E. M. F. is between 1 and 2 volts, approximately 1.4 volts by proportionate calculation from the test. The calibration could be made absolute, as in Exp. 56.

**183. Tangent Galvanometer.**—The tangent galvanometer is so called because a particular function of each angle of the needle's deflection, called a tangent, is directly proportional to the current flowing through the instrument. There is, therefore, a direct law between the current and deflections when the instrument is properly constructed. The magnetic needle, which should be very small as compared with the diameter of the coil (for example, needle .75 inch, diameter of coil 8 inches), is poised or suspended in the centre of a coil of large diameter, of one or more turns, Fig. 158. In the centre of such a coil the magnetic field is practically uniform, Fig. 139. The axis of the needle is parallel to the coil when no current is flowing, both being, therefore, in the magnetic meridian.



Fig. 157.—The Tangent of an Angle.

**184. The Tangent of an Angle.**—

Instead of measuring an angle in degrees of an arc, it may be reckoned by some function of the angle. In Fig. 157 the position of the galvanometer needle when pointing to zero on the circular scale is represented by the line AB. Draw an indefinite line, AF, perpendicular to AB, and tangent to the circle at point A. Suppose the needle is now deflected by the current to a point along the line BC, making the angle ABC of a certain number of degrees. The line, AC, is called the tangent of the angle ABC. The



value of the tangent of an angle (length of line AC) increases as the angle opens out or increases; thus, if another current deflects the needle along the line BD, making the angle ABD of so many more degrees, the tangent of this angle is represented in value by the length of the line AD. When the needle is deflected at right angles, or 90 degrees, the radius prolonged will not intersect the tangent line, or, the tangent of 90 degrees is infinity. The values of the tangents vary from 0 to infinity. If the value of the radius be unity, or one, the tangent of 45 degrees will be equal to one (that is, the length of line AB = AC), so that the value of the tangent of any angle less than 45 degrees will be less than one, and of a larger angle than 45 degrees more than one. The value of the tangents for each angle is given in the following table. For example, the tangent of 70 degrees is 2.7475, which means that if the length of radius AB is 1, the length of the line AC is 2.7475 times as great as the radius.

Table XI.—Natural Sines and Tangents.

∠	Sin.	Tan.	∠	Sin.	Tan.	∠	Sin.	Tan.	∠	Sin.	Tan.	∠	Sin.	Tan.
0°	.0000	.0000	18°	.3090	.3249	36°	.5878	.7265	54°	.8090	1.3764	72°	.9511	3.0777
1	.0175	.0175	19	.3256	.3443	37	.6018	.7536	55	.8192	1.4281	73	.9563	3.2709
2	.0349	.0349	20	.3420	.3640	38	.6157	.7813	56	.8290	1.4826	74	.9613	3.4874
3	.0523	.0524	21	.3584	.3839	39	.6293	.8098	57	.8387	1.5399	75	.9659	3.7321
4	.0698	.0699	22	.3746	.4040	40	.6428	.8391	58	.8480	1.6003	76	.9703	4.0108
5	.0871	.0875	23	.3907	.4245	41	.6561	.8693	59	.8572	1.6643	77	.9744	4.3315
6	.1045	.1051	24	.4067	.4452	42	.6691	.9004	60	.8660	1.7321	78	.9781	4.7046
7	.1219	.1228	25	.4226	.4663	43	.6820	.9325	61	.8746	1.8040	79	.9816	5.1446
8	.1392	.1403	26	.4384	.4877	44	.6947	.9657	62	.8829	1.8807	80	.9848	5.6713
9	.1564	.1564	27	.4540	.5095	45	.7071	1.0000	63	.8910	1.9626	81	.9877	6.3138
10	.1736	.1763	28	.4695	.5317	46	.7193	1.0355	64	.8988	2.0503	82	.9903	7.1154
11	.1908	.1944	29	.4848	.5543	47	.7314	1.0724	65	.9063	2.1445	83	.9925	8.1443
12	.2079	.2126	30	.5000	.5774	48	.7431	1.1106	66	.9135	2.2460	84	.9945	9.5144
13	.2250	.2309	31	.5150	.6009	49	.7547	1.1504	67	.9205	2.3559	85	.9962	11.43
14	.2419	.2493	32	.5299	.6249	50	.7660	1.1918	68	.9272	2.4751	86	.9976	14.30
15	.2588	.2679	33	.5446	.6494	51	.7771	1.2349	69	.9339	2.6051	87	.9986	19.08
16	.2756	.2867	34	.5592	.6745	52	.7880	1.2799	70	.9397	2.7475	88	.9994	28.64
17	.2924	.3057	35	.5736	.7002	53	.7988	1.3270	71	.9455	2.9042	89	.9998	57.29

When it is desired to compare the relative strength of two currents, each is passed through the tangent galvanometer, properly set up, and the corresponding deflections noted. The first current will bear the same relation to the second current that the tangent of the first angle bears to the second angle. The value of the tangents is taken from the table. Calling C and C<sub>1</sub> the two currents to be compared and d and d<sub>1</sub> the deflections produced by these currents respectively, then :

$$C \text{ is to } C_1 \text{ as } \tan d \text{ is to } \tan d_1,$$

$$\text{or } \frac{C}{C_1} = \frac{\tan d}{\tan d_1} \dots \dots \dots (51).$$

$$\text{Or } C = \frac{C_1 \times \tan d}{\tan d_1}$$

**Prob. 66:** A tangent galvanometer is deflected  $17^\circ$  when inserted in series with a solenoid and a Daniell cell. When a Grenet cell is substituted the deflection is  $31^\circ$ . What is the relative strength of current through the solenoid when the Grenet cell is used?

By Formula (51)  $C = \frac{C_1 \times \tan d}{\tan d_1} = \frac{C_1 \times .3}{.6}$ , or  $C = \frac{1}{2} C_1$ , or

the Grenet cell current was twice as strong as the current from the Daniell cell.

$$\hat{\alpha} = 17^\circ, \tan d = .3, d_1 = 31^\circ, \tan d_1 = .6.$$

**Prob. 67:** If one ampere deflects the needle of a tangent galvanometer  $5^\circ$  how many amperes will deflect it  $50^\circ$ ?

From Formula (51)  $C_1 = \frac{C \times \tan d_1}{\tan d} = \frac{1 \times 1.1918}{.0875} = 13.6$  amperes.

$C = 1$  ampere,  $d = 5^\circ$ ,  $\tan d = .0875$ ,  $d_1 = 50^\circ$ ,  $\tan d_1 = 1.1918$ .

If a tangent galvanometer is constructed or adjusted so that one ampere deflects the needle  $45^\circ$ , since the tangent of  $45^\circ$  equals one, the value of any other angle of deflection will represent the value of the current in amperes passing through the instrument.

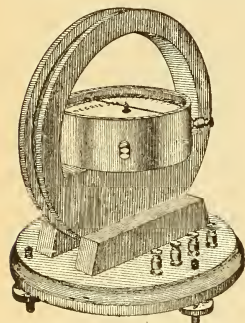


Fig. 158.—Student's Tangent Galvanometer.

### 185. Student's Combination Tangent Galvanometer.—

For many laboratory measurements the combination tangent galvanometer, illustrated in Fig. 158, may be used. It consists of the detector galvanometer (described in ¶ 179) placed in position in the tangent coil frame, 8 inches in diameter, constructed of hard wood and mounted on a suitable base. The detector galvanometer is readily removed from the frame so that it may be used separately when desired. When placed

in position its needle is in the centre of the coils on the frame and the current is passed through the outer coils only. There are four coils of No. 18 wire wound on the frame with two turns per coil. The terminals of each coil are connected to binding posts; the figure shows the binding posts of two coils, the other four posts being on the opposite side. Three brass leveling screws underneath the base are used to level the instrument so that the glass jewel rides freely on its pivot.

Fig. 159 shows a diagram of the method of winding. The coils are all wound in the same direction, B representing the beginning of a coil and E its ending. The advantage of the separate coils is that they

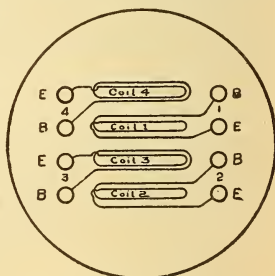


Fig. 159.—Method of Winding Coils in Student's Tangent Galvanometer.

may be connected up in a number of different ways to illustrate the law of series and parallel circuits, and the magnetic effect upon the needle by varying the number of turns around it. Figs. 160 A, B and C, illustrate several connections of the galvanometer coils, and the turns, or number of times the total current would flow around the needle are also given in each case.

**186. Directions for Setting up Student's Combination Galvanometer.—**

Seat the detector galvanometer on the horizontal support of the coil frame, Fig. 158, by means of the projecting wooden pin. Turn the frame so that it points N and S, with its plane in the magnetic meridian. You cannot see the magnetic needle directly underneath and parallel to the frame when it is at rest, and for this reason the pointer is fixed at right angles to it. Now revolve the detector gal-

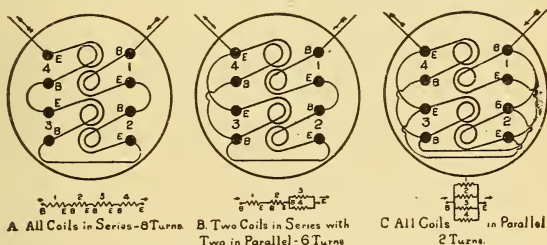


Fig. 160.—Connections of Coils in Student's Tangent Galvanometer.

vanometer on its wooden pivot so that the zero position on the scale lies directly underneath the pointer. Send a current through the four coils in series, and the deflection is, say  $44^\circ$  to the right; reverse the current, and if the deflection is  $44^\circ$  to the left, the needle and coil are in the magnetic meridian. If the latter deflection had been  $48^\circ$  then the coil frame must be moved a little in the opposite direction to that of the greater deflection, and zero position again adjusted to the pointer with no current flowing. This adjustment should be made until the needle deflects equally on both sides of the zero mark for the same strength of current. Deflections may be read from the degree scale of the instrument and the tangents obtained from the table, or the deflections on the tangent scale are directly proportional to the current. The resistance of the four coils connected in series is .165 ohm, and a current of 0.25 ampere sent through them will deflect the needle  $45^\circ$ .

**187. Variation of Needle's Deflections with the Turns and Diameter of the Galvanometer Coil.—**

**Exp. 58:** Send a current of known strength, say .5 ampere, around one coil of the galvanometer, ¶ 185, and note the deflection on the tangent scale. The current flows twice around the needle, since there are two turns per coil. Pass the same strength of current through two coils in series. The current flows four times around the

needle and it is deflected to a value on the tangent scale double that of the first case. If three coils are used in series the tangent scale value is tripled. Note also the degree scale deflections, and compare the value of the tangents taken from the table for each deflection.

The sensibility, ¶ 178, of the galvanometer is therefore directly proportional to the number of convolutions of wire on the coil. If the coil had been increased to twice the diameter and the same strength of current passed twice around it, the tangent of the angle of deflection would have been just one-half that produced by the same current flowing twice around the smaller coil; therefore, the sensibility is also inversely proportional to the diameter of the coil, decreasing the diameter, increasing the sensibility, and vice versa.

### 188. Use of the Tangent Galvanometer as an Ammeter.

The value of any current sent through the tangent galvanometer may be calculated directly in amperes from the following formula, when the dimensions of the instrument are known. The needle is supposed to move in a horizontal plane and not controlled by any force but the earth's magnetism.

Let  $C$  = current in amperes ;

$r$  = radius of coil in inches ;

$N$  = number of turns in coil ;

$d$  = angle of deflection of needle ;

$H$  = a constant from the table below.

$$\text{Then, } C = \frac{H \times r}{N} \times \tan d \dots \dots \dots (52).$$

The constant,  $H$ , given in the following table represents the horizontal force of the earth's magnetism for the place where the galvanometer is used. It may be approximated for other localities not indicated. The values given were furnished by the U. S. Geodetic Bureau for the epoch 1900 and are for square inch measure. Each value has been multiplied by  $\frac{2\pi}{10}$  so that Formula (52) is correct as given.

**Table XII.—Tangent Galvanometer Constants.—Values of  $H$ .**

Boston	.699	New Haven	.731
Chicago	.759	Philadelphia	.783
Denver	.919	Portland, Me.	.674
Jacksonville	1.094	San Francisco	1.021
London	.745	St. Louis	.871
Minneapolis	.681	Washington	.810
New York	.744		

Since the tangent of the angle of deflection in Formula (52) is always to be multiplied by a constant number,  $\frac{H \times r}{N}$ , for a particular instrument and place, this value is called the *constant of the galvanometer*.

TO FIND THE CURRENT IN AMPERES FLOWING THROUGH THE INSTRUMENT :  
*Multiply the tangent of the angle of deflection by the galvanometer constant.*

Let  $K =$  constant of the galvanometer  $= \frac{H \times r}{N}$  ;

$C =$  current in amperes ;

$d =$  deflection of needle.

Then.  $C = K \times \tan d \dots \dots \dots (53).$

**Prob. 68 :** A Daniell cell is connected to 4 coils of the student's tangent galvanometer connected in series, ¶ 154, and the needle is deflected 30 degrees. The diameter of the coil is 8 inches, and with 4 coils in series with 2 turns per coil, the total turns are 8. What current is flowing through the instrument if it is located in New York ?

By Formula (52)

$$C = \frac{H \times r}{N} \times \tan d = \frac{.744 \times 4}{8} \times .5774 = .214 \text{ ampere.}$$

$H$  for New York  $= .744$ ,  $r = 4$  inches radius,  $N = 8$  turns,  $\tan d = .5774$ .

**Prob. 69 :** What is the constant of the galvanometer in Prob. 68 ?

$$K = \frac{H \times r}{N} = \frac{.744 \times 4}{8} = .372.$$

**Prob. 70 :** A bichromate cell is connected to the galvanometer referred to in Probs. 68 and 69. What current flows through the instrument if the needle is deflected 50 degrees ?

By Formula (53)  $C = K \times \tan d = .372 \times 1.1918 = .443$  ampere.

$K$  for the galvanometer  $= .372$  from Prob. 69,  $\tan d = 1.1918$ .

### 189. Thomson Mirror-Reflecting Galvanometer. —

In this type of instrument, Figs. 161 and 162, great sensibility has been attained by bringing the coil as close as possible to the needle and winding it with many turns of very fine wire. On the back

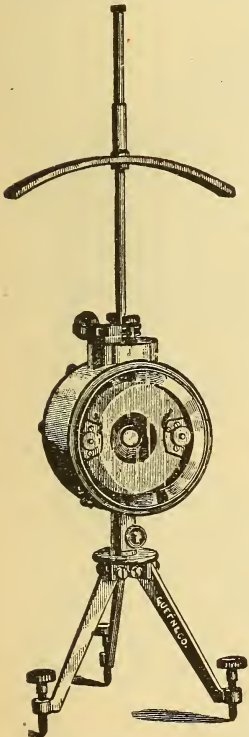


Fig. 161.—Thomson Mirror-Reflecting Galvanometer (single coil).

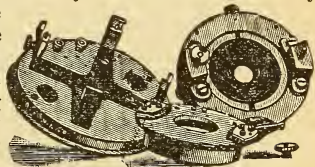


Fig. 162.—Details of the Coil.

of a small mirror, about  $\frac{1}{2}$  inch in diameter, are fastened by shellac, a number of magnetic needles with their  $N$ -poles in one direction. The mirror is suspended in the centre of the coil, so that the needles hang

horizontally, by a fine cocoon silk fibre which extends the entire length of the vertical brass tube shown in Fig. 161. To facilitate the insertion of the magnetic system in the centre of the coil, it is wound in two sections, which are bolted together in the cylindrical brass box, leaving a small space between them through which the fibre suspension passes. The coil is completely enclosed from the atmosphere, which assists in rendering the instrument *dead-beat* in its action, *i. e.*, so that the magnetic system may come to rest almost instantly without first making a number of vibrations when the circuit is made and broken through the instrument. The pent up air produces a cushion effect upon the vibrating mirror, causing it to come to rest more quickly. The cylindrical box is mounted on a tripod, provided

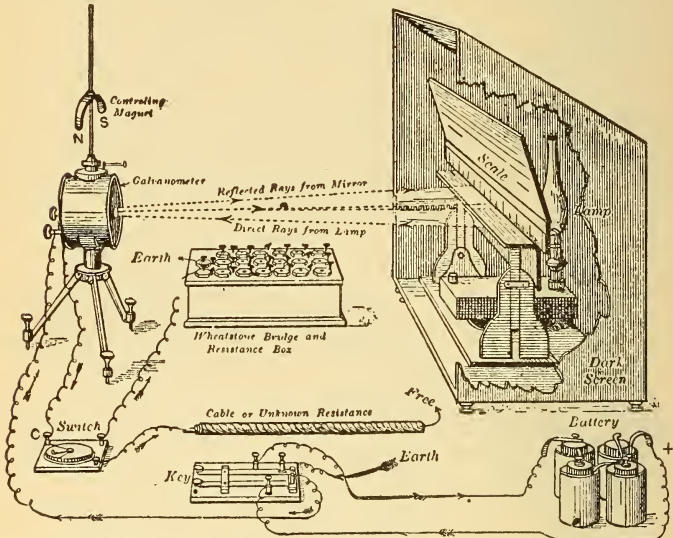


Fig. 163—Thomson Mirror-Reflecting Galvanometer with Lamp, Stand, Scale and Connections of Apparatus for Measuring the Insulation Resistance of an Electric Cable.

with leveling screws, and can be rotated on its vertical axis. The curved controlling magnet, arranged on the vertical tube, can either be revolved, or raised and lowered, with regard to the magnetic needle. By turning it around the axis of the tube the mirror with its needle may be deflected to any position on the scale and the sensibility increased or decreased by raising or lowering the magnet, thereby increasing or decreasing its attraction for the needle. The instrument is most sensitive when placed with its coil in the magnetic meridian, with the controlling magnet elevated to such a position that its force upon the mirror's magnet just balances the action of the earth's attractive force upon the same.

A mirror reflecting galvanometer with its lamp, stand and scale, is shown in Fig. 163, and requires a darkened room for its operation.

A small vertical slit is cut in the lamp screen below the scale, and the ray from the lamp passing through this slit strikes the galvanometer mirror, which is about one yard distant. The galvanometer is adjusted so that the reflected beam of light strikes the scale. The zero position on the latter is located at the centre so that the beam swings to the right or left of zero, and is brought to zero position by the controlling magnet, or by twisting the fibre suspension by means of the knurled knob at the top of the tube. The angle between the original beam of light and the reflected beam will be twice the angle of the deflection of the mirror; the deflections of the spot of light on the scale, however, are practically proportional to the strength of currents through the instrument. When a telescope is substituted for the lamp, as in Fig. 164, a dark room is not required.

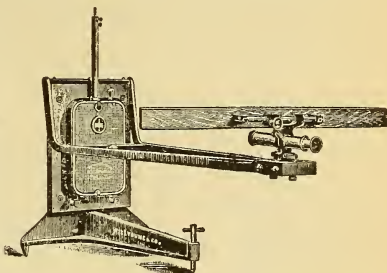


Fig. 164.—D'Arsonval Mirror-Reflecting Galvanometer with Scale and Reading Telescope.

The scale readings are reflected in the mirror and their value observed by means of the telescope.

The scale readings are reflected in the mirror and their value observed by means of the telescope.

### 190. Astatic, Differential and Ballistic Galvanometers.

If two needles of equal strength are fastened to a vertical rod with like poles in opposite directions



Fig. 165.—Connections of Single Coil Astatic Galvanometer.

forming an astatic needle, ¶ 58, and suspended, the earth's field has almost no directive force on the magnetic system. Since the earth's attraction for this needle has been thus neutralized, a much smaller current will deflect it than when the earth's directive force has to be overcome. This principle is

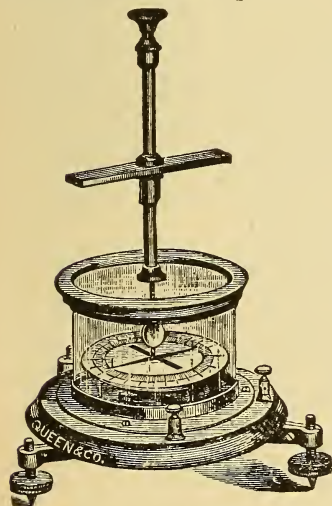


Fig. 166.—Single Coil Mirror-Reflecting or Direct Scale Astatic Galvanometer.

used in increasing the sensibility of galvanometers. In Fig. 165, the galvanometer coil surrounds the lower needle and the direction of current between the two needles tends to turn them the same way. This method is used in the astatic galvanometer, Fig. 166, which is

arranged so that the deflections may be read from the circular scale, or the instrument may be used as a mirror-reflecting galvanometer, by means of the small mirror attached to the vertical fibre suspension. A controlling magnet is also provided to bring the needle system to zero and alter its sensibility. A coil sometimes surrounds each needle as shown in Fig. 167, in which case they are connected so that the direction of current in both coils will tend to turn the system in the same direction.

The Thomson mirror-reflecting astatic galvanometer, Fig. 168, is so constructed. The instrument is illustrated with the front swung open so that each half of each coil, as well as the astatic system, may be noted. The needles are compound and fastened to a small mica disc and rigidly joined together by a fine glass rod; midway between the needles is fastened the mirror, mounted on a mica vane and secured to the

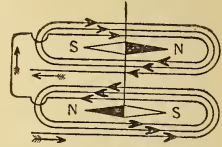


Fig. 167.—Connections of Double Coil Astatic Galvanometer.

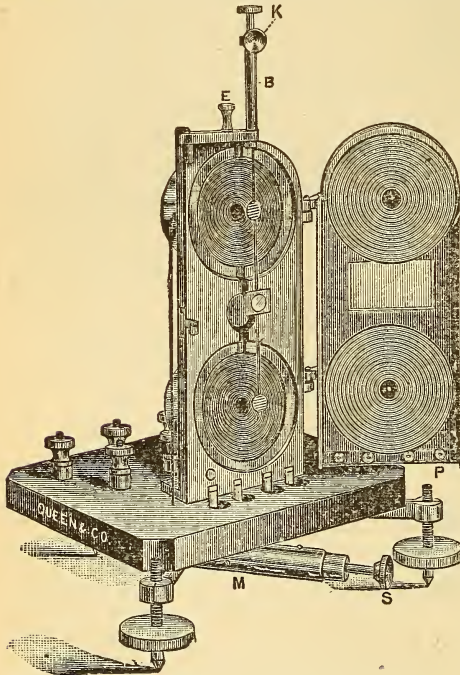


Fig. 168.—Thomson Mirror-Reflecting Double Coil Astatic Galvanometer with Case Open.

glass rod. The mica vane assists in damping by fanning the air when the needles are deflected. The whole system is suspended by a cocoon fibre attached to the upper end of the glass rod and extending through and protected by the vertical brass tube. When the door is closed the mirror may be seen through a glass window. Binding posts are provided for the terminals of each coil and the coils may be connected in series, parallel, etc., care being exercised to have the direction of current as given in Fig. 167. The coils of each needle may be used separately for comparing two different current strengths at the same time, when the direction of the current in each is such as to tend to turn the mirror oppositely.

When so used the instrument is called a *differential galvanometer*. In a special form of mirror reflecting galvanometer called a *ballistic*



*galvanometer*, used for measuring momentary currents (as induction currents or the discharge of a condenser, ¶ 303), the magnetic system is constructed so as to have considerable weight, and arranged to give the least possible damping effect. If a momentary current be passed through its coils, the impulse given to the needle does not cause appreciable movement of the magnetic system until the current ceases, owing to the inertia of the heavy moving parts, the result

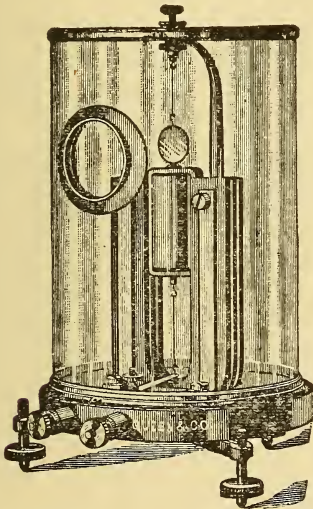


Fig. 169.—D'Arsonval Mirror-Reflecting Galvanometer.  
Vertical magnet form.

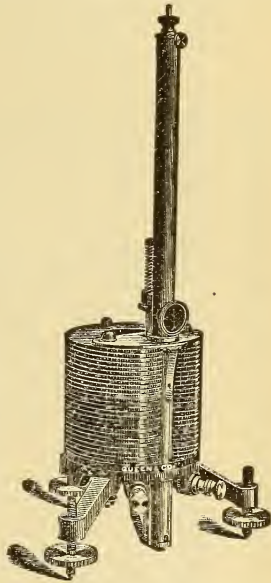


Fig. 170.—D'Arsonval Mirror-Reflecting Galvanometer.  
Horizontal magnet form.

being a slow swing of the needle. The maximum deflection is noted on the scale just at the point where the system ceases to move and begins to swing back to zero.

**191. D'Arsonval Galvanometer.**—This galvanometer, illustrated in Figs. 169 and 170, is an example of that class in which the magnet is large and stationary, and the galvanometer coil small and free to move, when a current is sent through it. A coil of wire wound upon a rectangular bobbin is suspended by fine silver wires between the poles of a laminated horseshoe magnet, so that the horizontal axis of the coil is at right angles to the magnetic lines of force between the

poles of the magnet. When a current is led to and from the coil by means of the suspension wires above and below it, the coil becomes a magnetic body, and tends to turn so that its lines of force will be in the same direction as those of the permanent magnet field. This tendency to rotate is opposed by the torsion of the suspension wire. The coil will move to the right or left, depending upon the direction of current through it. A stationary piece of soft iron is arranged in the

centre of the coil and supported from the back, its purpose being to increase the strength of the magnetic field in which the coil moves. By properly shaping the pole pieces the magnetic field may be so varied that the deflections will be directly proportional to the current.

If the coil is wound upon a non-magnetic metallic frame, the instrument is very dead-beat, as the instant the coil moves induced currents are set up in the coil frame, and are in such a direction as to tend to stop its movement, ¶ 292. A mirror is attached to the coil so that the instrument may be used with a telescope and scale, Fig. 164; or a pointer may be added, fixed at right angles to the mirror and made to sweep over a circular scale attached to the magnets. Another form of D'Arsonval galvanometer is shown in Fig. 170, in which the magnets are horizontal. The coil is suspended in a brass tube containing a window, opposite the mirror. The tube is clamped in position between the specially shaped pole pieces and can be readily removed and replaced by another of higher or lower resistance, as desired. Details of the tube and its casing are shown in Fig. 171. The system is suspended by



Fig. 171.—Details of Removable Suspension Coil and Tube.

a phosphor bronze strip, and the coil can be adjusted by turning the knurled knob at the top of the tube. A fine spring at the bottom serves to lead the current from the coil and oppose its motion. The advantage of this type of instrument over that of the Thomson form is, that it is not affected by the earth's or other external magnetic fields, so that it may be used in close proximity to dynamos. This principle is used in the construction of the Weston instruments, ¶¶ 208 and 235.

## QUESTIONS.

- ✓ 1. State how you would proceed to measure the current flowing through a number of incandescent lamps with a long coil, high resistance galvanometer.
2. The sensibility of a certain galvanometer is four megohms. What is meant by this statement?
3. Give two general classifications of galvanometers: first according to the principles employed in their construction; second, according to their construction.
- ✓ 4. Upon what factors does the sensibility of a galvanometer depend?
- ✓ 5. Why is it necessary to construct such very sensitive instruments?
- ✓ 6. What is meant by the absolute calibration of a galvanometer?
7. What advantage does a dead-beat galvanometer possess over one that is not so constructed?
- ✓ 8. Explain the difference between a differential and a ballistic galvanometer.
- ✓ 9. Give three methods of damping the needle of a galvanometer.
10. How would you arrange a low resistance sensitive galvanometer so that it could be used for measuring electrical pressure?
11. Explain how a galvanometer can measure electrical pressure, since the deflection of its magnetic system is dependent upon the strength of the current actuating it.
12. What are the advantages of a D'Arsonval galvanometer?
13. Make a sketch of a double coil astatic galvanometer with the coils joined in parallel. Show the direction of current around the needle, and indicate the direction in which the system will be deflected by the current.
14. Why is an astatic galvanometer more sensitive than one with a single needle?
15. An unknown current deflects the needle of a tangent galvanometer 27 degrees; the galvanometer constant is .65. What is the strength of current in amperes flowing through the instrument? *Ans.* .33 ampere.
16. In question 15 how many amperes will deflect the needle of the galvanometer 38 degrees? *Ans.* .507 ampere.
17. A current of 5 amperes is sent through the galvanometer in question 15. What will be the corresponding deflection of the needle? *Ans.* 82°.
18. Make a diagrammatic sketch of the coils of the student's galvanometer, similar to those depicted in Fig. 160, when it is connected: (1) two coils in series, two groups in parallel; (2) one coil in series, with two in parallel and the remaining coil in series with them.

## LESSON XVII.

### ELECTROMAGNETS.

Magnetisation of Iron and Steel by an Electric Current—Magnetic Field of an Electromagnet—Attractive Force of a Solenoid for an Iron Core—Magnetic Circuits—Typical Forms of Electromagnets, their Construction and Use—Magnetising Force, Ampere-Turns—Reluctance—Coarse and Fine Wire Electromagnets—Testing the Attractive Force of an Electromagnet—Magnetisation Curve—Tractive Force of an Electromagnet—Table XIII. Tractive Force and Magnetic Induction—Questions.

#### 192. Magnetisation of Iron and Steel by an Electric Current.—

**Exp. 59:** Wind a number of turns of insulated wire around an iron bar, Fig. 172, and send a current through the wire. Plunge the bar into iron filings, and it attracts them mostly at the ends; and when the current is interrupted the filings drop off. Test the polarity of each end of the bar with a compass. Note that upon looking at the end of the bar which repels the N-pole of the compass the current flows around the winding in the opposite direction to that in which the hands of a watch move, Fig. 172.

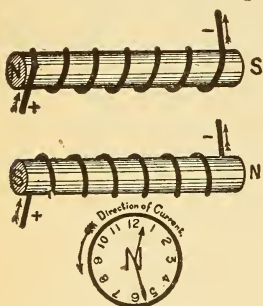


Fig. 172.—Current Anti-Clockwise—N-Polarity.

When viewing that end which attracts the N-pole of the compass, the current flows around the wire in the direction that the hands of a watch move. Figs. 172 and 173 illustrate the polarities of a steel bar, according to the clock rule, for all possible changes in either the direction of current or the direction of winding with a given direction of current.

**Exp. 60:** Remove the bar from the coil and note that the polarity of each end of the helix is the same as with the bar inside of it; the magnetism was, however, much stronger when the bar was inserted in the coil. If suspended or poised, see Fig. 148, the helix and its

iron core will take up a position in the earth's field similar to the helix or compass needle. It will also attract or repel the poles of a like helix and core according to the law of attraction and repulsion.

are bent out of their natural direction and converge into the steel. There are now more lines of force passing through the space occupied by the steel than when this space was occupied by air alone. *The capability of any substance for conducting magnetic lines of force is termed its permeability*, therefore the permeability of the steel is much greater than that of air. When a piece of soft iron is substituted for the steel, even more lines of force will pass through the same space, showing that the permeability or conducting power of iron is greater than that of steel. The permeability of iron may be as high as 2000 times that of air, or 2000 times as many lines of force will pass through space when occupied by iron as when it is occupied by air. An iron bar inserted in a helix or solenoid

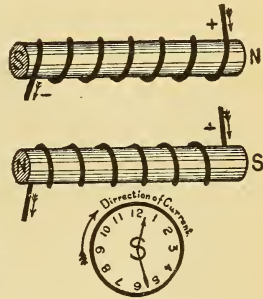


Fig. 173.—Current Clockwise—S-Polarity.

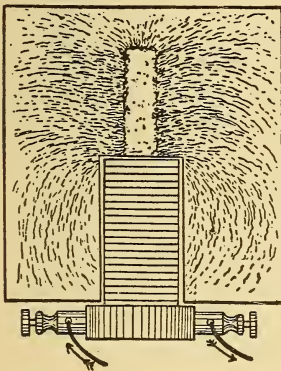


Fig. 174.—Magnetic Field of a Solenoid and Core.

Made with iron filings on a horizontal piece of cardboard.

is a much better conductor of the magnetic whirls inside the solenoid than the air, so that the strength or attractive force of the solenoid is materially increased, though the magnetising current is the same as before. *An iron core introduced into a solenoid carrying a current becomes strongly magnetised, and is called an electromagnet.* The direction of the lines of force through the iron core of the solenoid is the same as their natural direction through the solenoid alone, so that all the laws for polarity of the solenoid given under electromagnetism, Lesson XV, apply also to an electromagnet. By applying the principle of the molecular theory of magnetism, ¶ 26, the phenomenon of magnetism in the iron bar produced by the magnetic effect of the current will be understood. The current's natural magnetic field acts inductively upon the molecules of

phenomenon of magnetism in the iron bar produced by the magnetic effect of the current will be understood. The current's natural magnetic field acts inductively upon the molecules of

the iron bar, causing them to change the relation of their internal magnetic circuits with respect to each other, thus producing an external field near the ends of the core, very much in the same way that a permanent magnet acts on them. The current's magnetic field simply makes evident the latent magnetism of the iron. This molecular action also accounts for the permanent magnetism produced in a piece of steel inserted in a solenoid after the current ceases, since the internal molecular friction prevents many of the molecules from resuming their original positions.

**193. Magnetic Field of an Electromagnet.**—The graphical field of a solenoid and core, or straight bar electromagnet, would be similar to that of a solenoid alone, as in Fig. 151, except that the filings would be attracted more closely together, illustrating the greater density or number of lines of force due to the iron core. A compass needle, used to explore the field, will take up the same position as with the solenoid alone, but it is now affected at a much greater distance. The magnetic lines of force emanate from the **N**-pole of the bar electromagnet, and completing their path through the external medium enter the magnet again at its **S**-pole. If the iron core of the solenoid be pulled out somewhat from the coil and a field made, the magnetic lines are conducted further away from the coil before returning to it, as in Fig. 174. The polarity is still the same as before, but the poles are not so strong as when the whole internal field of the solenoid was composed of iron.

**194. Attractive Force of a Solenoid for an Iron Core.**—When under the attractive influence of a solenoid, an iron bar is subjected to a pull, the magnitude of which depends upon the relative position of the two bodies and the magnetising current. If either body is free to move, and the force sufficiently strong, it will move to accommodate through itself the greatest possible number of lines of force. This attractive force may be weighed by arranging the core upon one end of a balance arm, with the solenoid directly below it, and placing weights in the scale pan to balance the force of the current's field upon the iron. While balanced, as in Fig. 175, test the polarity of the bar by a compass, and it is magnetised by induction, ¶ 36, with the polarities as shown. Note that part of the magnetic lines from the solenoid complete their circuit through the core, entering at its upper end,

which is consequently **S**-polarity (**S** where lines enter), they emanate from the lower or **N**-end and pass through the coil. Place the solenoid nearer to the core, or lower the core to it, and the pull is considerably increased, as noted by the additional weights required to be added to balance the current's attractive force. The strongest pull will take place

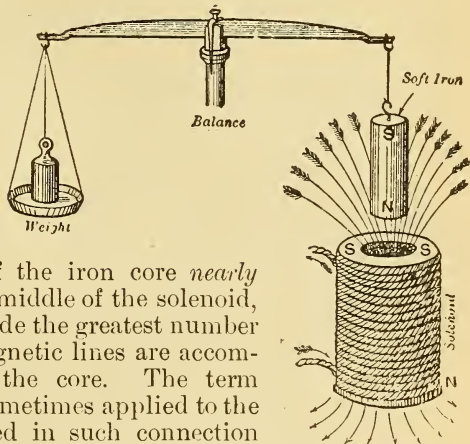


Fig. 175.—Weighing the Magnetic Attraction of a Solenoid for its Iron Core.

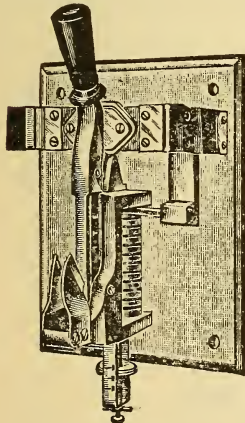


Fig. 176.—Automatic Circuit Breaker.

When the current becomes excessive the magnetic field of the few series turns of wire attracts a solenoid which releases a spring and the switch opens.

when the middle of the iron core *nearly* coincides with the middle of the solenoid, as when they coincide the greatest number of the current's magnetic lines are accommodated through the core. The term "sucking coil" is sometimes applied to the solenoid when used in such connection with its core. This principle is extensively used to operate the feeding mechanism in arc lamps, Fig. 177; to automatically open switches in electric circuits when the current becomes excessive, as in the circuit breaker, Fig. 176, and in commercial instruments for measuring current and pressure, as in Fig. 191.

**195. Magnetic Circuits.**—A simple magnetic circuit, ¶ 42, of uniform cross-section is represented by the solid iron ring in A, Fig. 178, around which a number of turns of insulated wire have been wound. The direction of the current and resulting polarity of the coil is shown, while the arrows indicate the direction of the lines of force around the ring, which is the same as that in which the

hands of a watch move. If a ring, so magnetised, be plunged into iron filings it will not show any external poles, since the magnetic lines have a complete circuit through the iron. When a small air-gap is made by sawing out a small section of the ring, B, Fig. 178, a *compound circuit* is formed, and the lines of force are compelled to pass through the air gap to complete their circuit, so that a strong **N** and **S**-pole is produced where the cut has been made, and the space is permeated with lines of force. The lines of force through the iron circuit are not nearly so dense as before, since the resistance of the circuit has been increased, and with the same magnetising force the magnetic lines diminish as the resistance of the circuit increases, just as in an electric circuit the current decreases when with a constant pressure the resistance is increased. If the removed section of the ring is now replaced and the ring again plunged into iron filings while the core is magnetised, a great many filings will be attracted at the two joints, thus illustrating *magnetic leakage*. The density in the ring is not now so great as when it was solid, since the joints offer opposition to the magnetic lines, as is shown by some lines being forced through the air across the joint. A ring with two poles is shown in C, Fig. 178, the winding

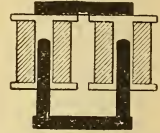


Fig. 177.—Pair of Solenoids with Iron Yoke and U-Shaped Movable Core.

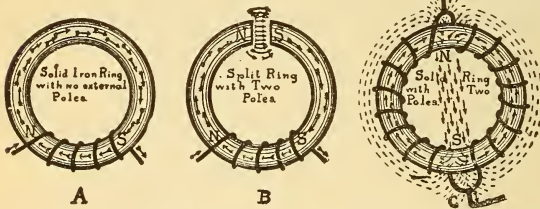


Fig. 178.—The Magnetic Polarity of an Iron Ring.

being in the same direction through-out the ring, and the ends of the wire being joined together. Current is passed in from any point and flows around each half of the ring in an opposite direction to a diametrically opposite point and then back to the battery. The arrows indicate the direction of current and magnetic lines of force, from which it will be seen that a *consequent* **N**-pole is produced at the top of the ring and a **S**-pole at the bottom. The lines of force complete their path through the air from pole to pole, as will be noted by plunging the ring into iron filings.



**Exp. 61:** Connect a horseshoe electromagnet, Fig. 179, with a source of current so that the limbs are like poles. Attract the keeper and then plunge the magnet into iron filings. One pole is produced in the centre of the keeper and the opposite pole in the bend of the horseshoe. The magnetic distribution is similar to the solid ring with two poles in C, Fig. 178.

**196. Typical Forms of Electromagnets, Their Construction and Use.**—If the bar electromagnet, Fig. 172, is bent around into a U shape, as in the right-hand view of Fig. 179, it forms a horseshoe electromagnet, thereby increasing the attractive power,

¶ 18. Instead of winding the insulated wire directly upon the core it is generally wound

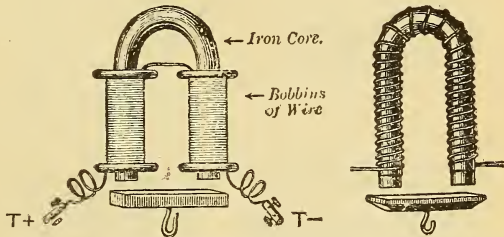


Fig. 179.—Horseshoe Electromagnets with Keepers.

upon a wooden or brass bobbin several layers deep, which is then slipped over the soft iron horseshoe core, as in the left-hand view of Fig. 179. The spools are then connected by wires so that the current will flow around each spool in the opposite direction, as viewed from the end of the core, when the limbs will have opposite polarity, Fig. 180. The attractive force of the magnet may be tested by means of a keeper of the same cross-sectional area, provided with a handle or hook and is found to be quite strong between the poles of the electromagnet. Instead of a forged horseshoe it may be composed of three parts, as in Fig. 180, where the two iron cores or limbs are connected by an iron yoke of

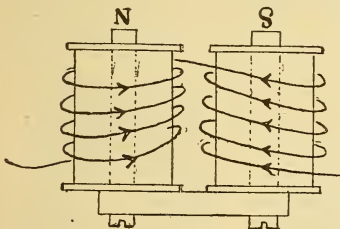
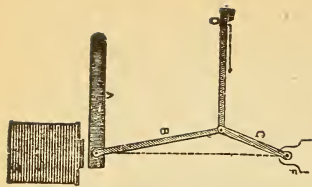


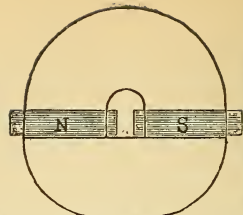
Fig. 180.—Direction of Current Around Horseshoe Magnet.

equal cross section and secured by machine screws. The direction of current and resulting polarity are also illustrated.

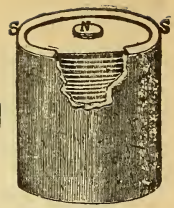
Horseshoe electromagnets are used in many practical applications of electricity, as in electric bells, automatic gas lighting burners, electric locks, etc., and are designed and con-



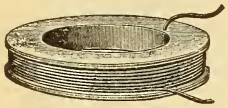
1. Froment's Equalizer, with Stanhope Lever.



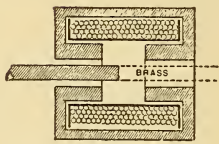
2. Stump Magnet.



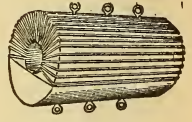
4. Iron Clad Magnet.



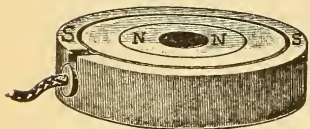
5. Forbes' Magnets.



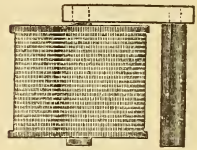
6. Ayrton & Perry's Tubular Iron-Clad Magnet.



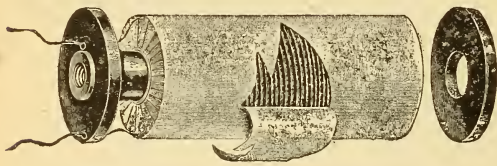
3. Dr. Joule's Magnet.



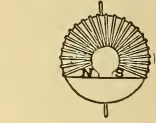
5A. Forbes' Magnets



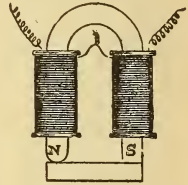
7. Club-Footed Magnet.



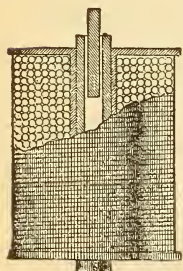
12. Varley Duplex Magnet.



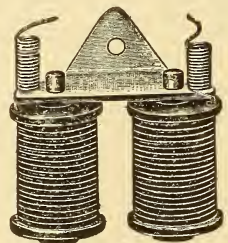
8. Called a "PARADOX. The rounded end has greatest tractive power.



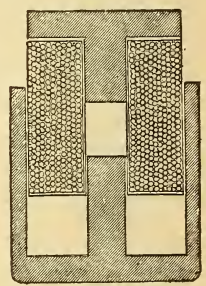
8. Called a "PARADOX. The rounded end has greatest tractive power.



9. Magnetic Pop Gun.



10. Typical Two-Pole Magnet.



11. Steven's and Hardy's Plunger Magnet.

Fig. 181.—Typical Forms of Electromagnets.

constructed to meet special requirements, according to the particular work to be performed by them. When it is desired to construct an electromagnet that will respond quickly to a current of short duration, as in bells and telegraph sounders, the bobbin windings and cores are made as short as possible. To give a very powerful attraction at a short distance, a short cylindrical bar magnet surrounded by an outer iron tube and united at the bottom by an iron yoke, No. 4 and 5 A of Fig. 181, is a good form; the iron jacket forms a return path for the lines of force and the poles are concentric. This type is known as an ironclad electromagnet, and is adapted for lifting purposes in factories, etc., since the windings are well protected and not liable to be injured by rough usage. To attract iron across a wide air gap requires a horseshoe electromagnet with

comparatively long limbs to accommodate the windings, because it requires a great many turns of wire to provide sufficient exciting power to drive the lines of force through the air. To obtain a gentle pull over a long range, a solenoid or long tubular coil and a long movable core is used, as in Figs. 175, 177, and No. 6 and 11 of Fig. 181. For nearly all purposes the iron parts, including the yoke and keeper, should be arranged to form as nearly as possible a closed magnetic circuit, as in No. 2, Fig. 181.

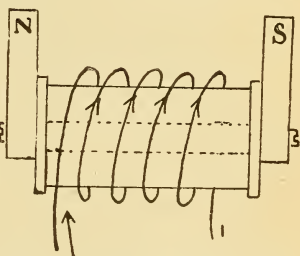


Fig. 183.—Electromagnet with the Coil on the Yoke.

In No. 7 of Fig. 181, the winding is contained on a bobbin mounted on one spool. As much wire is required as if two spools were used, but one bobbin is saved. To be efficient the wire should be close to the iron core so that it may be brought under the inductive influence of as many of the current's magnetic whirls as possible. In Fig. 183, the solenoid is slipped on to the yoke, which is provided with short, stumpy pole pieces, for some specific purpose. A magnet with a slightly rounded or chamfered pole has an increased attractive power, since the lines of force become

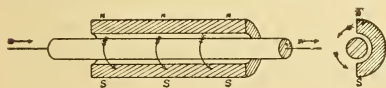


Fig. 184.—Straight Wire Electromagnet.

increased attractive power, since the lines of force become

very dense at the pole when they are thus slightly reduced, No. 8 of Fig. 181. In the electromagnet, No. 12 of Fig. 181, bare wire is used for winding, instead of insulated wire, but between each convolution is wound a silk or cotton thread to insulate the turns. The wire and thread are wound simultaneously by a specially constructed machine and known as Varley duplex winding. The layers are insulated from each other by paper, the advantage being that since the thickness of the insulation between the adjacent turns is greatly reduced by this method, many more turns per layer may be obtained than with ordinary winding, thus producing a greater magnetising force. To produce magnets of equal strength one-third of the weight of copper is saved by using the duplex winding in comparison with the ordinary winding.

A simple straight wire electromagnet is shown in Fig. 184, the indicated polarity of which should assist in fixing clearly in the student's mind the direction of the magnetic whirls of a straight wire. A piece of one-eighth inch diameter iron gas pipe is sawed into two equal sections lengthwise and a straight wire carrying a current is placed in one section, as shown in Fig. 184. Looking in the direction the current is flowing the whirls are clockwise, so that the lines of force enter the lower edge of the pipe (consequently it is **S**-polarity) and emanate from the upper or **N**-edge. When dipped into iron filings they form an arch between the poles, as in the case of a horseshoe magnet, and many more filings are attracted than at the part of the wire not so surrounded with iron. The polarity will be reversed by reversing the current. If the other half of the pipe is used as a keeper it will be readily attracted when the current is sufficiently strong, forming a closed magnetic circuit around the wire. The wire now passes practically through a straight tube, and when again dipped into filings considerable leakage will be shown at the two joints.

### 197. Magnetising Force, Ampere-Turns.—

**Exp. 62 :** Connect the coils of an electromagnet wound with many turns of wire in series with another magnet wound with a few turns of wire and join them to a battery. Plunge each magnet into iron filings. The magnet wound with many turns attracts more filings, yet since they are in series the current strength is the same through each magnet. The magnetism depends upon the turns, as well as upon the current strength.

**Exp. 63 :** Note the number of pounds required to detach a keeper from the poles of its magnet when the spool is wound with 400 turns of fine wire and 1 ampere is passed through it, say 18 pounds is required. Now substitute another spool wound with 40 turns of much larger wire through which 10 amperes are sent. The keeper is detached by a force of 18 pounds as before.

A very weak current circulating a great many times around an iron core will produce the same magnetising force, or pounds pull, as a much larger current flowing only a few times around the core. The magnetising force of a solenoid, or any coil of wire, is directly proportional to the strength of current and the number of times it flows around the coil, but is independent of the number of lines of force set up by it, which latter will depend upon the nature of the magnetic circuit. Magnetising force may be expressed in ampere-turns; 1 ampere-turn being 1 ampere flowing once around a coil of wire, or  $\frac{1}{2}$  ampere flowing around 2 turns, etc.

TO FIND THE TOTAL MAGNETIZING FORCE OF A COIL :

*Multiply the number of turns upon it by the strength of current passing through it.*

For example: four amperes circulating 25 times around a coil produce a magnetising force of 100 ampere-turns. The same force could be produced by 2 amperes and 50 turns, or 100 amperes and 1 turn, or 100 turns and 1 ampere, or 1000 turns and one-tenth ampere, etc., the product of the turns and current in each case being 100.

Let C = current in amperes ;

T = number of turns.

Then,

$$\text{Magnetising Force} = C \times T \dots \dots \dots (54).$$

$$\text{Also } C = \frac{\text{Magnetising Force}}{T} \dots \dots \dots (55).$$

$$T = \frac{\text{Magnetising Force}}{C} \dots \dots \dots (56).$$

**198. Reluctance.**—The magnetising force or *magnetomotive force*, as it is called, is the force set up by the ampere-turns, which drives the magnetic lines, or *magnetic flux*, through the magnetic circuit, just as an electromotive force causes a current of electricity to flow through an electric circuit. A magnetic circuit offers a resistance, called *reluctance*, to the magnetic lines, and this reluctance must be overcome by the magnetis-

ing force before induction is invoked. The number or density of lines of force per square inch of the circuit is called the induction per square inch and corresponds with the current in an electric circuit. It depends upon the magnetising

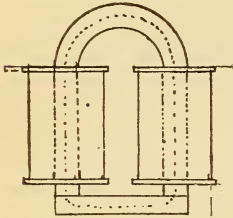


Fig. 185.—The Dotted Centre Line Represents the Mean Length of the Magnetic Circuit.

force and reluctance. The length of the magnetic circuit in Fig. 185 is shown by the dotted line. The reluctance of all non-magnetic bodies is practically the same, and when any such are interposed in a magnetic circuit the number of lines of force is greatly diminished. In magnetic calculations the magnetising force of the circuit is divided by the magnetic

reluctance of the circuit to obtain the magnetic density, and by adopting units for the terms force, reluctance, and density, calculations are made similar to those used in an electric circuit, but are more complex.

$$\text{Induction} = \frac{\text{Magnetising Force}}{\text{Reluctance}}$$

To force one unit line of magnetic force through an air path 1 inch long and 1 square inch in cross-section we must apply a magnetomotive force (M. M. F.) of .25 ampere-turn.

To force one unit line of force through one inch of soft iron of equal cross-sectional area requires a M. M. F. of only .00208 ampere-turn, or, the air has about 1200 times the magnetic reluctance of soft iron. Iron may be magnetised so that there are 120000 lines of force per square inch. To produce this value in the above air gap would require, therefore, .25 multiplied by 120000 or 30000 ampere-turns. The reluctance of a good magnetic joint is equal to about 8 inches of iron having the same cross-section.

**Prob. 71:** One thousand feet of wire are wound on a magnet coil. The average length of one turn is 3 inches. A current of 5 amperes is passed through the coil. What is the magnetising force?

By Formula (54) Magnetising Force =  $C \times T = 5 \times 4000 = 20000$  ampere-turns.

$$1000 \text{ feet} \times 12 = 12000 \text{ inches, } \frac{12000}{3} = 4000 \text{ turns,}$$

$$\text{current} = 5 \text{ amperes, } 3 \text{ inches} = \text{length of 1 turn.}$$

**199. Coarse and Fine Wire Electromagnets.**—Although the same results may be accomplished by using coarse wire magnets as those wound with much smaller and more expensive wire, each type has its advantage according to the way in which it is to be used. For example, the magnets of an electric bell, telephone, or telegraph instrument are wound with fine wire and located at a considerable distance from the battery, so that there may be only a fraction of an ampere through the line. The line can thus be small in area when the magnetising force, ampere-turns, will be produced by a small current and thousands of turns. If it is desired to operate a small electromagnet from an electric light circuit, it is wound with very fine wire, so that its resistance will be high enough to permit it to be inserted in the circuit without heating. The current taken from the line will also be small in this case and the operation of the magnet inexpensive. On the other hand, if a coarse wire magnet had been used in this latter case, the same magnetic pull would have been obtained by using more current, and at an increase in the cost of operation. When the electromagnet is to be used in series with a line carrying current, as in a series arc lamp, a circuit breaker, or a street-car controller, the wire is made large and of low resistance, so as not to obstruct the flow of current, since the whole current passes through the coil, and the magnetising force is then produced by a large current and a few turns.

**200. Testing the Attractive Force of an Electromagnet.**—The magnetism of an electromagnet increases as the current through it is increased, up to the saturation point (see ¶ 29), but is not directly proportional to the current; that

is, if one ampere, through a certain magnet requires a force of 56 pounds to detach its keeper (see test below) when 2 amperes are passed through it, twice the force, or 112 pounds, is not required, but usually much less. To make a test of the effect of different current strengths upon the attractive power, the magnet and keeper may be arranged in connection with a spring balance and windlass, as shown in Fig. 186. When the crank is turned the pounds pull may be

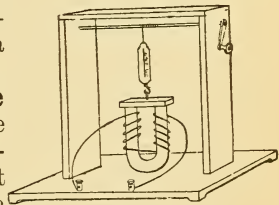


Fig. 186.—Testing the Attractive Force of an Electromagnet.

noted till the detachment of the keeper takes place. A test made in this manner upon a small soft iron core electro-magnet, wound with 500 turns, and a soft iron keeper gave the following results when different current strengths were passed through it.

**Test of the Attractive Force of an Electromagnet.**

Amperes.	Pounds pull.	Magnetising force Amperes $\times$ turns.
1	56	500
2	72	1000
3	80	1500
4	86	2000
5	90	2500
6	93	3000
7	95	3500
8	96	4000
9	96	4500

With a current of 1 ampere (500 ampere-turns), 56 pounds pull were required to detach the keeper; upon doubling the current, instead of doubling the attractive force of the magnet to 112 pounds, it was only increased to 72 pounds, and with triple the current and magnetising force the attractive force was represented by 80 pounds. It will be noted also that the gain for each additional ampere is not the same, in the first instance being 16 pounds for the second ampere increase, 8 pounds increase for the third, and 6 pounds for the fourth ampere, and so on. Finally 8 amperes produce the same amount of attraction as 9 amperes, so that all the molecules have been brought under the inductive influence of the current, or the saturation point of the iron has been reached. If 86 pounds attractive force is produced above with a current of only 4 amperes, it will not be practical to use twice as much current to obtain a gain of only 10 pounds.

If the current be now gradually decreased from 9 amperes to 8, to 7, etc., the pounds pull is a little greater for each corresponding current than in the above test, since all the molecules of iron do not turn back to their original position after being magnetised. Thus, with 0 ampere we would have the pull due to the *residual magnetism*, ¶ 30. If a cast-iron



or hard-steel keeper had been used in the above test, each would have given a different set of results lower in value than those given, although the current and turns remained unchanged. This is due to the different reluctances of these bodies, permitting less magnetic lines to travel through them than through the soft iron.

**201. Magnetisation Curve.**—Unlike the constant resistance offered by a piece of copper to different strengths of an electric current, the reluctance of a piece of iron varies with each density of the lines of force accommodated through it, and this variation bears no constant ratio to the number of lines of force passing through it. For this reason *curves of magnetisation* are constructed for different specimens of iron, showing the relation of the induction to the magnetising force at different stages of magnetisation. In the curves shown in Fig. 187, the values representing the ampere-turns are laid off proportionally on the horizontal line and the resulting magnetisation plotted to scale on the vertical line. Horizontal and vertical lines are drawn from each of the corresponding points and an X placed at their intersection. Lines drawn to connect the X's form a continuous line or curve, which represents the magnetisation. The curve gradually slopes upward with each increased exciting current until the saturation point is reached, after which any further magnetising force does not produce an increase in the induction as will be noted by the curve sloping off to the horizontal.

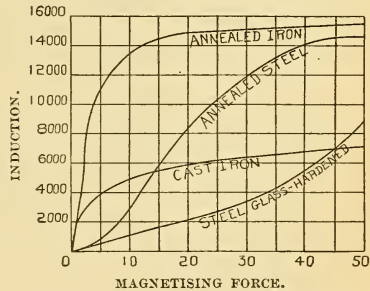


Fig. 187.—Magnetisation Curves of Steel and Iron.

With a given magnetising force in ampere-turns the relative induction may be found from the curves.

**202. Tractive Force of an Electromagnet.**—The following table gives the relation between pounds pull of an electromagnet for each square inch area of the poles in contact with the keeper and the number of lines of force per square inch. It is given so that the student may form some idea of the attractive force of a piece of iron. When it is stated, for example, that iron is magnetised to 45000 lines

per square inch, it means that the iron is magnetised to 45000 lines per square inch.

per square inch, this means that if it were in the form of a horseshoe, the poles of which had a total area of one square inch, it would require a force of 28 pounds to detach the keeper. It will generally be a little less than the values given, since allowance must be made for magnetic leakage between the limbs and the resistance between joints. The lifting, or adhesive power of an electromagnet is called its *tractive power*, or simply *traction*.

**Table XIII.—Tractive Force and Magnetic Induction.**

Magnetic lines of force per square inch.	Tractive or lifting force. Pounds per square inch.
6450	.577
12900	2.308
19350	5.190
25800	9.228
32250	14.39
38700	20.75
45150	28.26
51600	36.95
58050	46.72
64500	57.68
70950	69.77
77400	83.07
83850	97.47
90300	113.1
96750	129.7
103200	147.7
109650	166.6
116100	186.8
122550	208.1
129000	230.8

Suppose 40 pounds are required to detach a keeper from its magnet and that the total area of the poles is 2 square inches, what is the density in lines of force per square inch? First find the pounds tractive force per square inch, which equals 40 divided by 2 or 20 pounds per square inch. From the table we note that the magnetic density in lines of force per square inch corresponding to a tractive force of 20 pounds is 38700. From the above table we see that an electromagnet is capable of lifting 200 pounds for each square inch of cross-section when sufficient magnetisation is used, and before the saturation limit is reached, and that the lifting power may be directly increased by increasing the area of contact and working the iron at the same density per square inch.

## QUESTIONS.

1. The pole of an electromagnet having a soft steel core deflects a compass needle 44 degrees when held at a distance of one foot. A soft iron core is substituted for the steel and the deflection is now 58 degrees. How do you account for this, since neither the distance nor the current strength is altered?

✓ — 2. Define magnetic permeability.

3. Which magnet core mentioned in question 1 possesses the greater permeability?

✓ — 4. What is the difference between an electromagnet and a solenoid?

5. Give an original application of the solenoid and core.

6. Wind a steel key ring with insulated wire so that when a current is sent through the windings the ring will possess two diametrically opposite poles. Illustrate by sketches the direction of winding, direction of current, and direction of the magnetic lines of force.

✓ — 7. What kind of poles are produced in the key ring in question 6?

✓ — 8. Explain and illustrate by sketches the economy obtained by using a duplex-wound magnet instead of one ordinarily wound.

9. An electric bell wound with few turns of low resistance wire is located ten miles from the push button and batteries, but fails to ring when its circuit is complete, the batteries being in good condition and properly connected. What change would you make in the bell to correct the defect? Why?

✓ — 10. What is reluctance?

✓ — 11. How does the magnetic reluctance of air compare with that of iron?

12. An electromagnet connected in series with some incandescent lamps connected in parallel, increases the resistance of the circuit abnormally though it possesses the proper number of pounds pull. What change in connections and construction would you suggest so that the magnet would still possess the same lifting power and the lamps burn at their proper candle power?

13. A certain electromagnet possesses an attractive power of 37 pounds per square inch, due to a current of 5 amperes. Would you expect the magnet to have double this attractive force per square inch when 10 amperes are passed through it? Why?

14. The magnetomotive force of a solenoid is doubled. How would this affect the number of lines of force threading through it?

15. What is your answer to question 14 when the solenoid possesses a brass core? A soft iron core?

16. It requires 60 pounds to detach a keeper from a certain electromagnet and 74 pounds for an exactly similar magnet and current strength except that the poles are slightly rounded or chamfered. Why is this?

## LESSON XVIII.

### AMMETERS.

Measurement of Current Strength, Ampere-Meters—Gravity Ammeter—Connecting Ammeters in Circuit—Balance Beam Ammeter—Thomson Inclined Coil Ammeter—Weston Ammeter—Weston Ammeter Shunt—Questions.

**203. Measurement of Current Strength, Ampere Meters.**—An *ammeter* which is the commercial name for ampere meter, is a galvanometer designed to show by direct reading the number of amperes of current flowing through any circuit in which it may be inserted. The voltameters and tangent galvanometer previously described for measuring current strength are used in the laboratory for standardizing commercial direct-reading instruments, required for portable use or upon station switchboards. A great variety of ammeters have been invented, based upon the principles given in ¶ 180. A good ammeter should have a *very low resistance*, so that very little of the energy of the circuit in which it is inserted will be absorbed by it: the needle should be *dead beat*, ¶ 189, and so sensitive as to respond to minute variations of current; the scale divisions not cramped at either end of the scale, but even throughout; and the accuracy of the instrument should not be impaired when in close proximity to powerful magnetic fields, as switchboard conductors or dynamos. Ammeters are divided according to their use, into two classes: (1) a *portable type*, generally of a high class of construction and accuracy, used for measurements of precision, and (2) the *switchboard type*, in the construction of which such refinement of precision is not required. In some makes of both types the *whole current* passes through the ammeter, while in others the ammeter is *shunted*, ¶ 209. The shunt may either be contained within the instrument case, or it may be external to the instrument. In the latter case special leads used in the calibration are furnished to connect the shunt with its instrument. *Milliammeters* are ammeters in which the scale is graduated to read directly in thousandths of an ampere.

**204. Gravity Ammeter.**—In this simple type of ammeter, the magnetising current overcomes the attraction of gravity for a piece of suspended iron. The current passes around a helix of *heavy wire*, which is bent in the arc of a circle, Fig. 188. A soft iron core bent to the same arc is suspended, so that one end is free to be sucked up into the helix by the field of the magnetising current. A pointer attached to the movable iron core swings over the scale, and will assume a different position for each value of the magnetising current.

The instrument is calibrated by inserting it in series with a laboratory standard and marking the value of each current passed through it on the scale corresponding to each position of the pointer. Suppose that when 10 amperes were sent through the helix the core was in such a position as to accommodate through itself the greatest number of the magnetic lines of the helix, then the limit of the scale was attained and the capacity of the instrument was 0 to 10 amperes. By attaching a small weight to the core, if the wire were of sufficient size to carry the current, the capacity could readily be made 0 to 20 amperes. The division per ampere would, however, be about one-half as large. The objection to this type of instrument is that the movement of the core is much greater at some positions than at others for the

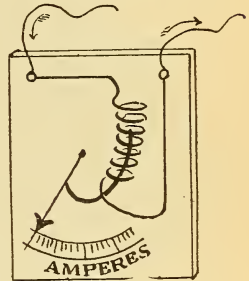


Fig. 188.—Solenoid Gravity Ammeter.

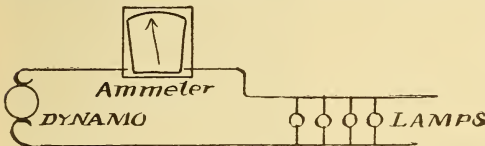


Fig. 189.—Ammeter Correctly Connected in Series with the Circuit.

same increment of current, giving a scale of unequal divisions, and generally cramped at each end. The instrument is not dead beat, is readily affected by magnetic fields, and can only be used in a vertical position.

**205. Connecting Ammeters in Circuit.**—Since the total current to be measured in any circuit must flow through an ammeter, an *ammeter must always be connected in series with the circuit* and between the generator and apparatus receiving the current, as in Fig. 189. Suppose the coil in a gravity

ammeter has a resistance of .1 ohm and that it is *incorrectly* placed in parallel with some incandescent lamps connected to a dynamo, Fig. 190. How much current will flow through the ammeter if the pressure is 110 volts between the

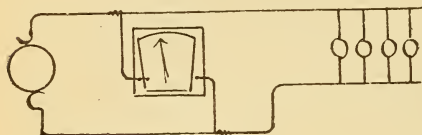


Fig. 190.—Ammeter *Incorrectly* Connected in Parallel with the Circuit.

mains? The current that would flow through the ammeter would be by Formula

$$(28) C = \frac{E}{R} = \frac{110}{.1} =$$

1100 amperes or enough to *totally destroy* the instrument by

excessive heating, since the current-carrying capacity of the wire would be far below this value. ¶ 257.

**206. Balance Beam Ammeter.**—In the form of ammeter, illustrated in Fig. 191, a horizontal beam is supported on a knife bearing. An iron core made up of a bundle of soft iron wires is suspended by a hook from one end of the beam and is balanced by a counterweight on the other end. The current to be measured is passed through a coil of a few turns of heavy wire located directly below the core, and attracts it, to a certain distance, for each value of the current sent through the coil. A pointer attached to the beam swings over the scale, which is calibrated to read in amperes. A plumb-bob indicates when the instrument is properly leveled. The instrument depicted illustrates a 0 to 300 scale, and can be calibrated for a larger capacity, say 0 to 400 amperes, by sliding the counterweight along the beam toward the right, when a greater magnetic pull than before would be required for each position of the core. A 150 ampere instrument, of this type, contains 6 turns of No. 0 B. & S. copper wire, the resist-

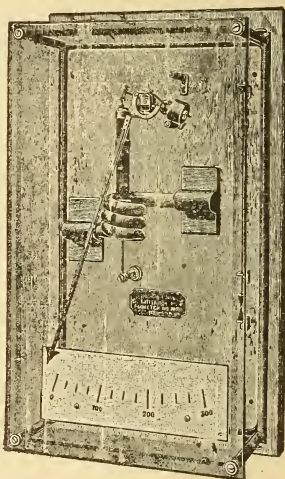


Fig. 191.—Balance Beam Gravity Ammeter—Westinghouse Type.

ance of the instrument being about .0001 ohm. The instrument may be calibrated for an alternating or direct current circuit.

**207. Thomson Inclined Coil Ammeter.**—In many types of ammeters, beside the above, the magnetic body is a piece of iron, rather than a magnet, and placed so that it will gradually move to accommodate through itself the lines of force of the magnetising coil. The Thomson inclined coil ammeter utilizes this principle and is constructed in the portable and switchboard patterns. A view of the portable type, with cover removed, is shown in Fig. 192, and a sectional view in Fig. 193. A circular coil of wire, C, is mounted with its axis inclined to the horizontal. Through the centre of the coil is passed a vertical shaft mounted between jewel centres and carrying a pointer at its upper end. A small iron vane, A, is attached to the shaft at an angle, and the movable system is controlled by the two flat springs, S.

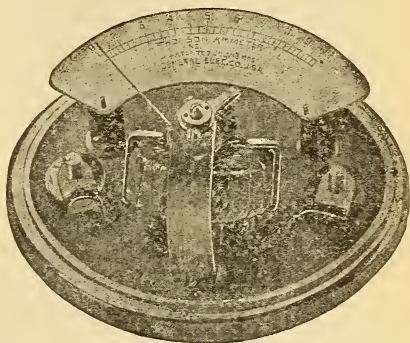


Fig. 192.—Thomson Inclined Coil Ammeter.

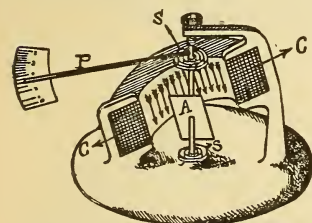


Fig. 193.—Construction of Inclined Coil Ammeter.

When current is passed through the coil the vane tends to turn against the action of the springs, so as to become parallel to the lines of force indicated by the direction of the arrows. The turning of the shaft causes the pointer, P, to sweep over the scale. The coils for large sizes of instruments are generally wound with a few turns of flat insulated copper ribbon having a very low resistance. These meters are adapted for use with alternating or direct currents.

**208. Weston Ammeter.**—The construction of this instrument is based upon the principle of the D'Arsonval galvanometer, ¶ 191. A general view of a portable instrument is

shown in Fig. 194, and interior views in Figs. 195 and 196.

A permanent horseshoe magnet, M, is fitted with soft iron pole pieces, P P, Fig. 197, between which a stationary cylinder of soft iron, C, is supported by a brass piece extending across the pole pieces. The iron cylinder is smaller in diameter than the bore of the pole pieces, so that the magnetic lines of force pass across this air gap, making a very strong and uniform magnetic field. The movable system

is shown in Fig. 198. It consists of a rectangular coil of wire, wound upon a bobbin of thin sheet copper or aluminum and delicately suspended between jewel bearings. The terminals of the coil are connected to the horizontal spiral springs, against which the coil acts when it tends to rotate, the springs serving to also conduct the current to and from the coil. A thin aluminum knife-edge pointer attached to the bobbin and swinging over the scale, Fig. 195, indicates the angle of deflection of the coil. This coil is mounted concentrically with the iron cylinder and pole pieces in the air gap, as shown in Fig. 196, where part of the pole piece,

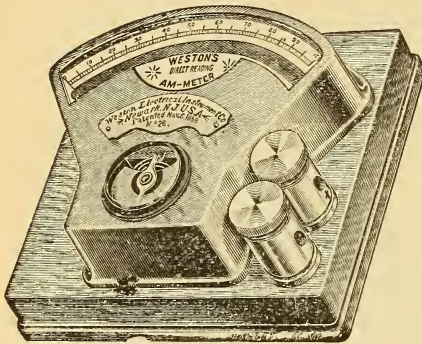


Fig. 194.—Weston Ammeter with Self-Contained Shunt.

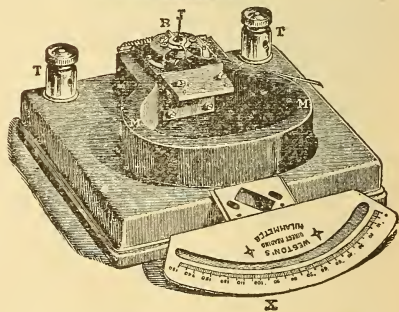
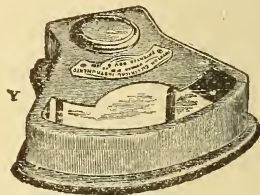


Fig. 195.—Weston Ammeter with Cover Removed Showing D'Arsonval Galvanometer.



etc., have been cut away. When a current is sent through it, by the springs, the coil tends to move through the magnetic field, to take up a position so that its lines of force will be in the same direction as those of the field. It will so move until the torsion of the springs is balanced by the force tending to move the coil, when the pointer will indicate the angle of deflection. The angle of deflection is nearly proportional to the current throughout the movement, which gives a very uniform scale, as can be seen from Fig. 195. The metallic bobbin on which the coil is

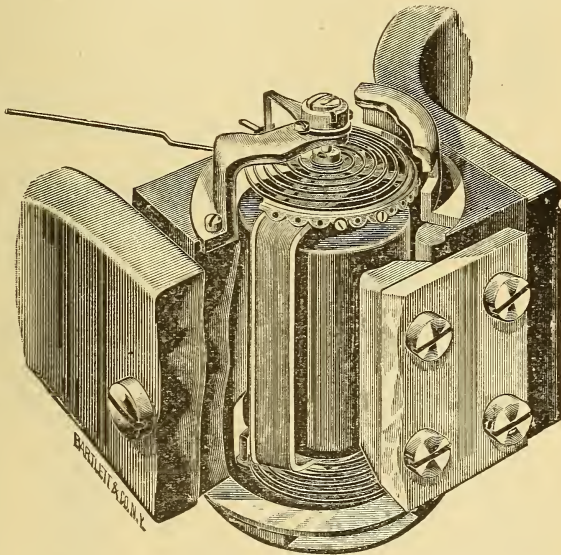


Fig. 196.—Method of Mounting the Movable Coil in Weston Instruments.

wound has an electromotive force induced in it, only while the coil is moving, which causes eddy currents, ¶ 292, to flow around the bobbin in the opposite direction to the current in the coil. These momentary currents tend to stop the motion of the coil, and have the effect of preventing the needle from oscillating, thus bringing it to rest quickly at the proper position and making the instrument very dead-beat, ¶ 189. The movable coil is extremely light, the friction small, and the instrument very sensitive to minute variations

of current. A current of about .015 ampere will give a full scale deflection of the pointer. The instrument is carefully balanced, so that it may be used in a horizontal or vertical position. An ammeter, however, should always be calibrated in the position in which it is to be used. A mirror is located just below the scale of the portable instruments. By looking down on the pointer so that it is directly over its reflection in the mirror, errors in reading the scale divisions due to *parallax*\* are thus avoided. In Weston instruments the post marked + is the one by which the current should enter the instrument so that the coil will be deflected in the right direction.

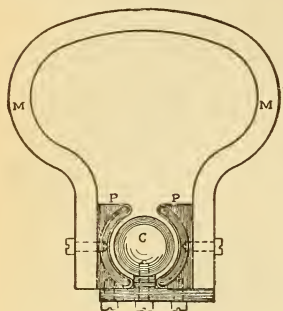


Fig. 197.—The Magnetic Circuit of the Weston Instruments.

#### 209. Weston Ammeter Shunt.—

Only a small portion of the total current to be measured is sent through the movable coil, the remainder passing through a shunt, ¶ 162. The shunt is made of a special resistance

alloy, and contained either in the instrument, in a separate portable case, or on an external block, Fig. 199, as in the switchboard type of instruments. The lead wires to the shunt, the instrument and the shunt, are all numbered to correspond, so that when used together the indications agree with the calibration. The shunt leads should never be shortened, because the decreased resistance in the shunt circuit would permit more current to flow through it, so that the indicated readings would be higher than the actual current flowing. The resistance of the

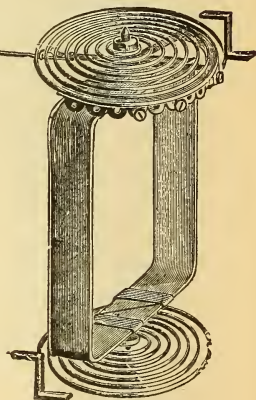


Fig. 198.—The Movable Coil, Springs and Pointer of Weston Instruments.

\*The apparent angular displacement of an object when seen from two different points of view.

instrument and its shunt is very low, little energy, therefore, being lost when it remains continually in circuit. A 15 ampere shunted instrument has a joint resistance of .0022 ohm. A number of shunts are sometimes furnished in a separate case for a single portable instrument, which is called a *multiplier*, and is used for increasing the range or capacity of the instrument. For example, with a shunt of .004 ohm in Fig. 199, suppose the coil receives sufficient current to deflect the pointer entirely across the scale, and this deflection corresponds to 50 amperes in the main circuit. The difference in pressure between the shunt terminals by Ohm's Law is equal to  $C \times R = 50 \times .004 = 0.2$  volt. Now the shunt is reduced in resistance to one-half .004 or .002 ohm, and the pressure applied to the movable coil for the same current is equal to  $C \times R = 50 \times .002 = .1$  volt, or the coil will receive only one-half the former current, and thus be deflected to the middle of the scale.

The range of the ammeter is now 0 to 100 amperes, or each scale reading must be multiplied by 2 to obtain the true value of the current when used with this shunt. In the same manner with a reduction of the

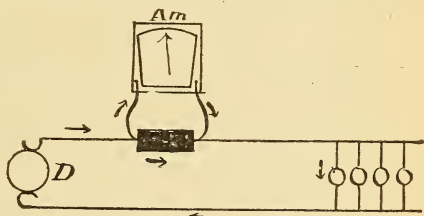


Fig. 199.—Connections of an Ammeter with a Portable Shunt.

shunt's resistance to one-third of its original value, the range is increased three-fold and the readings are multiplied by 3. One advantage of an external shunt in switchboard instruments for power stations is, that instead of running heavy copper cables to a distant ammeter, a shunt may be inserted in the cable circuit and the two small size shunt leads wired to the instrument, thus effecting an economy in copper and construction. A *Weston ammeter* may be used without its shunt as a *millivoltmeter*, in which case it is quite sensitive and adapted to many electrical measurements. When resistance is added in-series with it, it becomes a long coil galvanometer, and may be calibrated as a direct reading voltmeter, ¶ 180. The same mechanical construction is employed in Weston voltmeters, ¶¶ 234 and 235, the only difference being in the value of the extra resistance added and the method of connecting it to the instrument.

To measure currents larger than the capacity of an ammeter.

Let  $R$  = resistance of shunt required ;

$r$  = resistance of ammeter ;

$A$  = range of ammeter ;

$A_1$  = desired range of ammeter.

$$\text{Then, } R = \frac{A}{A_1 - A} \times r \dots \dots \dots (57).$$

The indicated readings obtained must be multiplied by  $\frac{A_1}{A}$  to be correct.

**Prob. 71-A:** (1) What will be the resistance of a shunt required to increase the capacity of an ammeter from 150 to 600 amperes? Resistance of the instrument .009. (2) What will be the multiplying power of the shunt?

By Formula (57)  $R = \frac{A}{A_1 - A} \times r = \frac{150}{600 - 150} \times .009 = .003$  ohm.

Multiplying power of the shunt  $= \frac{A_1}{A} = \frac{600}{150} = 4$ , or by Formula (48)

$$n = \frac{G}{S} + 1 = \frac{.009}{.003} + 1 = 4.$$

#### QUESTIONS.

1. What is the advantage of a Weston type of ammeter over one constructed to actuate upon the solenoid and core principle?

2. In what respect does the Thomson inclined coil ammeter differ from the Westinghouse balance beam type?

3. An ammeter of 200 amperes capacity is required to be located 50 feet from the main generator cables. What economy would be attained by using a shunt type of instrument in this case?

4. In a station shunt type ammeter a pair of shunt leads are used which are the same length as those furnished with the instrument, but of a smaller size. How will this affect the meter's indications?

5. An ammeter with its leads has a resistance of 50 ohms, and the shunt, a resistance of 0.1 ohm. If 20 amperes are flowing through the shunt what current does the ammeter receive? *Ans.* 0.04 ampere.

6. In question 5, if 20 amperes are flowing through the circuit to which the shunted ammeter is connected, what current flows through the ammeter? *Ans.* 0.0399 ampere.

7. A solenoid ammeter having a resistance of 0.5 ohm is incorrectly connected in parallel with 10 incandescent lamps in parallel. Each lamp has a resistance of 220 ohms and requires 0.5 ampere. What current will flow through the ammeter when the circuit is closed? *Ans.* 220 amperes.

8. It is desired to use a solenoid ammeter of only 50 amperes capacity in a circuit through which 150 amperes are flowing. How would you do this?

9. How much resistance would you add if the instrument in question 8 had a resistance of .06 ohm? Make a sketch. *Ans.* 0.03 ohm.

10. By what should the indications of the ammeter in question 9 be multiplied in order to obtain the true reading? *Ans.* 3.

## LESSON XIX.

### ELECTRICAL WORK AND POWER.

Force—Different Kinds of Force—Mass and Weight—Work—Power—Horse Power of a Steam Engine—Difference Between Energy, Force, Work, and Power—Electrical Work—Electrical Power—Heat and Work—Equivalents of Mechanical and Electrical Work—Electrical Horse Power—The Kilowatt—The Watt-Hour and Kilowatt-Hour—Electrical Power Calculations—Electrical Power Formulæ—Power from Cells—Efficiency of a Battery—Questions and Problems.

**210. Force.**—Force is defined as that which produces motion, or a change of motion or matter; thus force must always be applied to any body to cause it to move. To increase, decrease, or stop this motion, that is to change it, force must again be applied. For example, to start a loaded wheelbarrow force must be applied, either by pushing or pulling it, but when it is set in motion less force will be required to keep it in motion; to cause a change in motion, that is to increase or decrease the speed, extra force must be applied. Force does not always produce motion, but only tends to produce it, as when a man tries to push a laden freight car he applies all his muscular force, but no motion results.

**211. Different Kinds of Force.**—There is the *force of gravitation*, in virtue of which all bodies free to move will fall from a higher to a lower level. The force exerted by a man riding a bicycle or a horse drawing a carriage are examples of *muscular force*. An engine draws a train of cars by reason of the *mechanical force* applied, which is due to the expansion of the steam in the steam cylinder. A mixture of air and illuminating gas in a room is ignited and the explosion wrecks the room; the action is due to the *chemical force* exerted. The force which produces or tends to produce a flow of electricity is *electromotive force*. The force which sets up magnetic lines of force is *magnetomotive force*. The rate at which a train moves depends upon the force exerted by the engine, so also, the rate of flow of electricity depends upon the amount of electromotive force applied.

**212. Mass and Weight.**—The *mass* of a body is the quantity of matter in it; the *weight* of a body is due to the force of gravity acting upon this matter. Since the force of gravity diminishes as we ascend from the earth's surface, the attraction for a mass of matter will diminish, or it will weigh less on the top of a high mountain than at the sea level; the mass of matter, however, would be the same in each case. Weight is not, therefore, the same thing as mass, but we can conveniently measure a body by its weight.

**213. Work.**—Work is done when force overcomes a resistance, or, *work is force acting through space* ( $W = F \times S$ ).

$$\begin{aligned} \text{Work} &= \text{Force} \times \text{Distance,} \\ \text{or Work} &= \text{Pounds} \times \text{Feet} = \text{Foot-pounds.} \end{aligned}$$

Work is not always done when a force acts; for instance, a man pushes with all his force against a brick wall; he is exerting force, but doing no work because no motion results, nor is any resistance overcome. If a weight be lifted, work is done directly in proportion to the weight and to the distance through which it was moved. Thus, the work done in lifting 4 pounds to a height of 3 feet is equivalent to 12 foot-pounds of work. Exactly the same work is performed when 2 pounds are raised 6 feet; or 6 pounds raised 2 feet; or 12 pounds raised one foot. Work does not always consist in raising weights; the steam engine does work by hauling a train, due to the expansive force of steam acting upon the piston; an explosion of powder in a cannon causes an iron ball to traverse a certain distance. The chemical action in a cell sets up a force which causes a current to flow through an electric motor and the motor drives an automobile weighing so many pounds a certain number of feet every minute, hence the total foot-pounds of work are performed electrically. The work in each case is measured in foot-pounds. Whether work be done mechanically, chemically, thermally, or electrically, it can be expressed in foot-pounds. The total amount of work done is independent of time, that is, the same work may be performed in one hour or one year. When different amounts of work performed in different times are to be compared, then reference is made to the time, or rate of working, or the power.

**214. Power.**—Power is the rate at which work is done, and is independent of the amount of work to be done.

$$\text{Power (rate of working)} = \frac{\text{WORK}}{\text{TIME}} = \frac{\text{FOOT-POUNDS}}{\text{TIME}} = \text{Foot-pounds per unit of time.}$$

For example, it requires four hours for a particular engine to draw a train from one station to another, while another engine may draw the same train the same distance in two hours. One engine is thus twice as powerful as the other, because it can do the same work in one-half the time. When the train had reached its destination it would have represented the same amount of work done, no matter whether it had traveled at one mile per minute or one mile per hour, leaving, of course, friction and air resistance out of account.

Power is estimated according to the amount of work done in a given period of time. As mechanical work is measured in foot-pounds, mechanical power would thus be so many foot-pounds per minute, or per second. The mechanical unit of power is the horse power.

ONE MECHANICAL HORSE POWER = 33000 FT. LBS. PER MINUTE, or

$$\frac{33000}{60} = 550 \text{ ft. lbs. per second.}$$

If a body weighing 33000 pounds be raised one foot every minute then we have a rate of working equal to one horse power; or if 16500 pounds be raised two feet per minute, the rate of working is the same, one horse power. If the work were continued at the same rate for one hour, we would have a larger unit of work, or the *horse-power-hour*. When we say that an engine is developing 40 horse power we mean that it is performing  $550 \times 40 = 22000$  foot-pounds of work every second.

**215. Horse Power of a Steam Engine.**—The horse power of a steam engine may be readily calculated from data obtained from it while it is working. The mean pressure of the steam upon the piston is found by attaching a graphical recording indicator to the steam cylinder which shows the various steam pressures during a stroke of the piston. From this "card," as it is termed, the average or mean effective pressure throughout the stroke is obtained. The speed of the engine must be noted while the card is taken but the length of stroke in feet, and area of the piston-head in square inches should be previously obtained.

The following formula may then be used to ascertain the rate of working, or horse power developed corresponding to the above conditions :

$$\text{Horse power of a steam engine} = \frac{P \times L \times A \times N}{33000} \dots (58).$$

When  $P$  = mean effective steam pressure in pounds (from indicator card) ;

$L$  = length of stroke in feet ;

$A$  = area of piston-head (in square inches) ;

$N$  = number of strokes per minute (twice the number of revolutions).

**Prob. 72:** From an indicator card the mean steam pressure is 45 lbs., the speed of the engine 275 revolutions, length of stroke 12 inches, area of piston-head one-half a square foot. What horse power is developed by the engine?

$$\text{By Formula (58) H. P.} = \frac{P \times L \times A \times N}{33000} = \frac{45 \times 1 \times 72 \times 550}{33000} = 54 \text{ H. P.}$$

$P$  = 45 lbs.,  $L$  = 12 inches = 1 foot,  $A$  =  $\frac{1}{2}$  sq. ft. = 72 sq. in.

$N$  = 275 revolutions  $\times$  2 strokes per rev. = 550.

**216. Difference Between Energy, Force, Work, and Power.**—It is important that the student should thoroughly understand the meaning of the above terms. *Energy* is the capacity to do work. *Force* is one of the factors of work and has to be exerted through a distance to do work, the work being reckoned as the product of the force and the distance through which it has been applied. *Work* is done when energy is expended or when force overcomes a resistance. *Power* is the rate of working.

**217. Electrical Work.**—Work is force acting through space, or energy expended, therefore, resistance is overcome when work is performed. Force may exist without work being performed, as when you push against a table and do not move it, no work is done, yet the force exists. An electrical force exists between the two terminals of a battery, tending to send a current of electricity from one to the other through the air. The force is not sufficient to overcome the resistance, of the air, therefore no current flows and the battery is not doing any work ; the same is true with a dynamo when running on open circuit. When a wire is connected across the battery terminals, the force overcomes the resistance of the wire and electricity is moved along, around or through the wire, which becomes heated. The electrical work, or



energy expended, is represented by the amount of heat generated in this instance, ¶ 257. With a small lamp connected to the battery, the work is represented by the heat and light given by the lamp as well as the heat given to the remainder of the circuit. The total work performed is the product of the force, the current, and the time that the current is maintained, or

$$\text{Electrical Work} = \text{Volts} \times \text{Amperes} \times \text{Time.}$$

*The unit of electrical work is the amount of work performed by a current of one ampere flowing for one second under a pressure of one volt and is called a joule.*

Since an ampere flowing for one second is equal to one coulomb, ¶ 116, a joule is, therefore, one volt-coulomb and is analogous to the mechanical unit of work, the foot-pound, which has no special name. The volt-coulomb is not so great as the foot-pound, however,

$$1 \text{ joule} = .7375 \text{ foot-pound};$$

$$1 \text{ foot-pound} = 1.356 \text{ joules.}$$

Larger units of electrical work are given in ¶ 221.

TO FIND THE TOTAL ELECTRICAL WORK, IN JOULES, PERFORMED IN ANY CIRCUIT :

*Multiply the volts causing the current to flow by the current and the time it flows, expressed in seconds.*

$$\begin{aligned} \text{Joules} &= \text{volts} \times \text{amperes} \times \text{seconds,} \\ \text{or } J &= E \times C \times t \dots\dots\dots (59). \end{aligned}$$

When  $t$  = the time in seconds;

$J$  = work in joules.

**Prob. 73:** A current of 20 amperes is maintained through a number of incandescent lamps for one hour by a pressure of 110 volts. How much electrical work has been performed?

By Formula (59)  $J = E \times C \times t = 110 \times 20 \times 3600 = 7920000$  joules.

$E = 110$  volts,  $C = 20$  amperes,  $t = 60 \times 60 = 3600$  seconds.

TO FIND THE TOTAL ELECTRICAL WORK, IN JOULES, PERFORMED IN ANY PART OF THE CIRCUIT WHEN THE CURRENT STRENGTH AND RESISTANCE ARE KNOWN :

*Multiply the square of the current by the resistance, and this product by the time the current flows.*

$$\begin{aligned} J &= C \times C \times R \times t, \\ \text{or } J &= C^2 \times R \times t \dots\dots\dots (60). \end{aligned}$$

By substituting for E in Formula (59) its value  $C \times R$ , we get Formula (60). Also by substituting the value of C, which equals  $E \div R$  in Formula (59), we obtain an expression to find work in joules when the volts and resistance are known.

By Formula (59)  $J = E \times C \times t$ .

Substituting,  $C = \frac{E}{R}$  then  $J = \frac{E \times E}{R} \times t$ ,

or  $J = \frac{E^2}{R} \times t \dots \dots \dots (61)$ .

**Prob. 74:** A current of 5 amperes is passed for one-half hour through an arc lamp, the resistance of which is 4 ohms, hot. How much energy has been expended?

By Formula (60)  $J = C^2 \times R \times t = 5 \times 5 \times 4 \times 1800 = 180000$  joules.  
 $C = 5$  amperes,  $R = 4$  ohms,  $t = \frac{1}{2}$  hour = 1800 seconds.

**Prob. 75:** The resistance of the copper cables connecting a dynamo with its switchboard is .1 ohm, and 2 volts are required to send the full load current through them. How much energy is expended in 10 hours?

By Formula (61)  $J = \frac{E^2}{R} \times t = \frac{2 \times 2}{.1} \times 36000 = 1440000$  joules.

$E = 2$  volts,  $R = .1$  ohm,  $t = 60 \times 60 \times 10 = 36000$  seconds.

**218. Electrical Power.**—Power is the rate at which energy is expended, and is independent of the total work to be accomplished. The rate of working, or the power is found by dividing the total work by the time required to perform it.

$$\text{Electrical Power} = \frac{\text{Electrical Work}}{\text{Time}}$$

The unit of electrical power is a unit of work performed in a unit of time, or a joule per second, and is called a *watt*. Therefore :

$$\text{Watts} = \frac{\text{work}}{\text{time}} = \frac{\text{joules}}{\text{seconds}} = \frac{\text{volts} \times \text{amperes} \times \text{seconds}}{\text{seconds}} = \text{volts} \times \text{amperes}.$$

*One watt therefore equals one volt multiplied by one ampere, or 2 volts by .5 ampere, etc.*

1. To FIND THE RATE IN WATTS AT WHICH ENERGY IS EXPENDED IN A CIRCUIT :

*Multiply the current in amperes by the pressure causing it to flow.*

Let  $W$  = watts expended ;  
 $C$  = current in amperes ;  
 $E$  = pressure in volts.

Then, watts = volts  $\times$  amperes,

$$W = E \times C \dots \dots \dots (62).$$

2. TO FIND THE CURRENT WHEN THE WATTS AND PRESSURE ARE KNOWN :

*Divide the watts expended by the voltage causing the current to flow.*

From Formula (62)  $W = E \times C$ .

Therefore,

$$\text{Amperes} = \frac{\text{Watts}}{\text{Volts}} \text{ or } C = \frac{W}{E} \dots \dots \dots (63).$$

3. TO FIND THE PRESSURE WHEN THE WATTS AND CURRENT ARE KNOWN :

*Divide the watts expended by the current flowing.*

From Formula (62)  $W = E \times C$ .

Therefore,

$$\text{Volts} = \frac{\text{Watts}}{\text{Amperes}} \text{ or } E = \frac{W}{C} \dots \dots \dots (64).$$

**Prob. 76 :** How many watts are consumed by one hundred incandescent lamps connected in multiple to a 110-volt circuit, supposing each lamp to have resistance (hot) of 220 ohms ?

$$C = \frac{E}{R} = \frac{110}{220} = \frac{1}{2} \text{ ampere per lamp.}$$

$$W = E \times C = 110 \times \frac{1}{2} = 55 \text{ watts per lamp. } 55 \times 100 = 5500 \text{ watts.}$$

**Prob. 77 :** What current is required to operate a 50-watt lamp on a 100-volt circuit ?

$$\text{By Formula (63) } C = \frac{W}{E} = \frac{50}{100} = \frac{1}{2} \text{ ampere.}$$

$$W = 50 \text{ watts, } E = 100 \text{ volts.}$$

**Prob. 78 :** A 500-watt motor requires a current of 10 amperes. What E. M. F. is necessary to operate it ?

$$\text{By Formula (64) } E = \frac{W}{C} = \frac{500}{10} = 50 \text{ volts.}$$

$$W = 500 \text{ watts, } C = 10 \text{ amperes.}$$

**219. Heat and Work.**—One of the most important discoveries in science is that of the *equivalents of heat and work* : that is, that a definite quantity of mechanical work can always produce a definite quantity of heat, and, conversely, this heat,

if the conversion be complete, can perform the original quantity of work.

All kinds of energy (chemical, mechanical, electrical, etc.) are so related to each other that energy of any kind can be changed into energy of any other kind. This statement is known as the doctrine of *correlation of energy*. When one form of energy disappears an exact equivalent of another form takes its place, so that the sum total of the energy is not changed. This is known as the doctrine of *conservation of energy*. These two principles constitute the corner-stone of physical science.

### 220. Equivalents of Mechanical and Electrical Work.

Dr. Joule, of England, was the first to ascertain the relation existing between mechanical work, heat, and electricity.

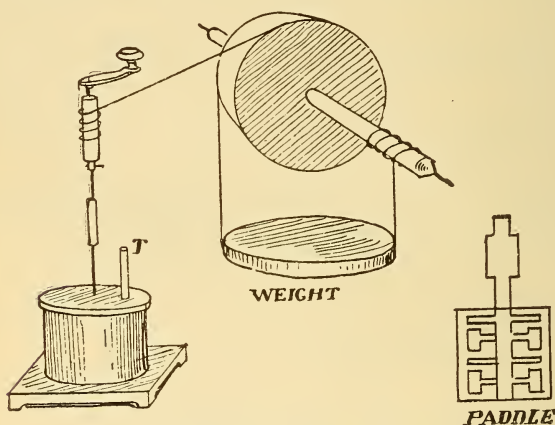


Fig. 200.—Dr. Joule's Paddle Wheel Experiment.

In an experiment he caused a paddle-wheel to revolve in a vessel filled with water, by means of a falling weight attached to a cord and wound around the axle of the wheel, Fig. 200. The resistance offered by the water to the motion of the paddles was the means by which the mechanical motion of the weight was converted into heat, which resistance raised the temperature of the water. From this experiment it was found that 778 foot-pounds of work would raise the temperature of 1 pound of water  $1^{\circ}$  Fahrenheit;

also by the doctrine, ¶ 219, the heat which would raise 1 pound of water  $1^{\circ}$  Fahrenheit would also raise 778 pounds 1 foot. The quantity, 778 foot-pounds, is called the *mechanical equivalent of heat*, or Joule's equivalent. If now we heat the pound of water by a current of electricity until its temperature is raised  $1^{\circ}$  we will have done the same work electrically as was previously done mechanically. An apparatus similar to our calorimeter, ¶ 112, would be suitable for this experiment. The current in amperes and the pressure in volts must be accurately read from instruments.

From this experiment it was found that a current of 1 ampere flowing through the coil for 1 second, under a pressure of 1 volt (or 1 watt expended) would do the same work as .7375 foot-pound expended in 1 second. The rates of working are thus equal since the same work in each case has been accomplished in the same time. Therefore :

**One watt = .7375 foot-pounds per second,  
or 1 foot-pound = 1.356 watts.**

Now since 550 foot-pounds per second are equivalent to 1 mechanical horse power, ¶ 214, an equivalent rate of electrical working would, therefore, be :

$$\frac{550}{.7375} = 746 \text{ watts} = 1 \text{ electrical horse power.}$$

A current of 1 ampere and 746 volts, or 1 volt and 746 amperes, etc., maintained through the calorimeter coil for 1 second would heat the water to exactly the same temperature that it would be heated by the paddle wheels when, in 1 second, 550 pounds fall through a distance of 1 foot, or 1 pound falls through 550 feet, etc. If these rates of working are continued for equal periods of time, as an hour, or a day, the water is raised to the same temperature by either method, so that the total work performed is also the same.

**221. Electrical Horse Power.**—From ¶ 220, the method of obtaining the equivalent of a mechanical horse power in electrical units was given. The watt being a very small unit of power, the larger unit, an *electrical horse power*, is often used.

TO FIND THE ELECTRICAL HORSE POWER (H. P.) MAINTAINED IN ANY CIRCUIT, OR PART OF A CIRCUIT ;

Multiply the volts causing the current to flow by the current expressed in amperes and divide this product by 746.

$$H. P. = \frac{\text{Watts}}{746} = \frac{\text{volts} \times \text{amperes}}{746} = \frac{E \times C}{746},$$

$$\text{or } H. P. = \frac{E \times C}{746} \dots \dots \dots (65).$$

**Prob. 79:** A dynamo maintains a pressure of 110 volts across an electric light circuit when the ammeter indicates 100 amperes; what horse power is being developed by the machine?

By Formula (65)  $H. P. = \frac{E \times C}{746} = \frac{110 \times 100}{746} = 14.7 \text{ H. P.}$

**222. The Kilowatt.**—The *kilowatt* (abbreviated K. W.) is a larger unit of electrical power. *One kilowatt equals 1000 watts*, or is about  $1\frac{1}{3}$  times as large as the horse power unit.

$$\text{Kilowatts (K. W.)} = \frac{\text{Watts}}{1000} = \frac{E \times C}{1000} \dots \dots (66).$$

$$\text{Watts} = \text{K. W.} \times 1000 \dots \dots \dots (67).$$

$$1 \text{ H. P.} = 0.746 \text{ K. W.}$$

$$1 \text{ K.W.} = 1.34 \text{ H. P.}$$

**Prob. 80:** What is the capacity in kilowatts of a generator carrying a load of 120 volts and 500 amperes?

By Formula (66)  $K. W. = \frac{E \times C}{1000} = \frac{120 \times 500}{1000} = 60 \text{ K. W.}$

**Prob. 81:** How many amperes will be maintained by a 40 K. W. dynamo at a pressure of 100 volts?

By Formula (67)  $\text{Watts} = \text{K.W.} \times 1000 = 40 \times 1000 = 40000 \text{ watts.}$

By Formula (63)  $C = \frac{W}{E} = \frac{40000}{100} = 400 \text{ amperes.}$

**223. The Watt-Hour and Kilowatt-Hour.**—The joule is a very small unit of electrical energy or work, so that larger units are generally used in practice. A *watt-hour* is one watt exerted or expended for one hour. It is equivalent to 3600 watt-seconds or 60 watt-minutes.

$$\text{Watt-hours} = \text{watts} \times \text{hours.}$$

The dials of consumer's meters, used to measure the electrical energy supplied for lighting and power, generally record watt-hours, ¶ 275. A *kilowatt-hour* is a larger unit of electrical work and is equal to 1000 watts or 1 K. W. expended in one hour, or 500 watts expended in two hours, etc.

$$\text{KILOWATT-HOURS} = \text{K. W.} \times \text{HOURS.}$$

An electrical *horse-power-hour* is one electrical horse power maintained for one hour, or 746 watts maintained for one hour.

$$\text{Horse-power-hours} = \text{H. P.} \times \text{hours.}$$

Electrical energy is generally supplied from stations at a fixed rate per horse-power-hour or kilowatt-hour. The total cost of producing a kilowatt-hour varies with many station conditions; from about 2 to 7 cents per kilowatt-hour is the range in a number of plants.

**224. Electrical Power Calculations.**—The following rules and formulæ have been derived either by transposing the formulæ in ¶¶ 220 to 224, or by combining them with the formulæ given in Lesson XIII, Ohm's Law. This lesson is practically a continuation of Ohm's Law and is very important, as by it many practical electrical problems are solved. The formulæ apply equally well to the whole or any part of a circuit; as, for example, to the lead wires to a lamp, as well as to the lamp itself, or the internal resistance of a battery or dynamo. *Caution must be exercised to use the volts lost or drop, ¶ 230, in the particular part of any circuit considered, also the resistance of, and the current through this part only.* The symbols used to represent the quantities are as given heretofore, and are again enumerated as follows:

E = pressure, E. M. F. or difference of potential, causing the current to flow, expressed in volts;

R = resistance of the circuit or part of the circuit expressed in ohms;

C = current in amperes;

W = watts expended or lost in the resistance;

H. P. = electrical horse power (746 watts);

K. W. = kilowatt (1000-watts).

**Case 1.**—GIVEN CURRENT AND PRESSURE TO FIND WATTS LOST OR EXPENDED:

*The watts expended in any circuit equals the product of the current and the pressure causing it to flow, Formula (62).*

$$W = E \times C.$$

**Prob. 82.**—Find the energy expended in a lamp requiring 110 volts and  $\frac{1}{2}$  ampere.

$$\text{By Formula (62)} \quad W = E \times C = 110 \times \frac{1}{2} = 55 \text{ watts.}$$

**Case 2.**—GIVEN CURRENT AND RESISTANCE, TO FIND THE ENERGY EXPENDED IN WATTS:

*The watts lost or expended in any circuit are equal to the current squared multiplied by the resistance. This is often called the C-square R loss.*

$$W = C^2 \times R \dots \dots \dots (68).$$

This formula is obtained by substituting the value of  $E = C \times R$  in Formula (62)  $W = E \times C$ , which gives  $W = C \times R \times C = C^2 R$ .

**Prob. 83:** The resistance of the field magnets of a dynamo is 220 ohms and the magnetising current, 2 amperes. What energy is expended?

By Formula (68)  $W = C^2 R = 2 \times 2 \times 220 = 880$  watts.  
 $R = 220$  ohms,  $C = 2$  amperes.

**Case 3.**—GIVEN RESISTANCE AND PRESSURE, TO FIND THE WATTS EXPENDED :

*The watts lost or expended in any circuit are equal to the square of the pressure divided by the resistance.*

$$W = \frac{E^2}{R} \dots \dots \dots (69).$$

This formula is obtained by substituting the value of  $C = \frac{E}{R}$  in Formula (62)  $W = E \times C$ , then  $W = E \times \frac{E}{R} = \frac{E^2}{R}$

**Prob. 84:** The hot resistance of a 110-volt incandescent lamp is 220 ohms. What energy is expended in the lamp every second it burns?

By Formula (69)  $W = \frac{E^2}{R} = \frac{110 \times 110}{220} = 55$  watts.  
 $E = 110$  volts,  $R = 220$  ohms.

Compare this result with Prob. 82.

**Case 4.**—GIVEN WATTS EXPENDED AND CURRENT, TO FIND THE RESISTANCE :

*The resistance is equal to watts expended divided by the square of the current.*

$$R = \frac{W}{C^2} \dots \dots \dots (70).$$

This formula is found by transposing Formula (68).

**Prob. 85:** A 55-watt incandescent lamp requires  $\frac{1}{2}$  ampere. What is its resistance?



By Formula (70)  $R = \frac{W}{C^2} = \frac{55}{.5 \times .5} = \frac{55}{.25} = 220$  ohms.  
 $W = 55$  watts,  $C = \frac{1}{2}$  ampere.

Compare this answer with Probs. 82 and 83.

**Case 5.**—GIVEN WATTS EXPENDED AND RESISTANCE, TO FIND THE CURRENT :

*The current equals the square root of the watts divided by the resistance.*

$$C = \sqrt{\frac{W}{R}} \dots \dots \dots (71).$$

This formula is obtained by transposing Formula (68).

**Prob. 86 :** If the hot resistance of a 55-watt lamp is 220 ohms, what current will it require ?

By Formula (71)  $C = \sqrt{\frac{W}{R}} = \sqrt{\frac{55}{220}} = \sqrt{\frac{1}{4}} = \frac{1}{2}$  ampere.

$W = 55$  watts,  $R = 220$  ohms. Compare with Probs. 82, 84, and 85.

**Case 6.**—GIVEN WATTS EXPENDED AND PRESSURE, TO FIND RESISTANCE :

*The resistance equals the square of the pressure divided by the watts expended.*

$$R = \frac{E^2}{W} \dots \dots \dots (72).$$

This formula is obtained by transposing Formula (69).

**Prob. 87 :** What is the resistance of a 55 watt, 110 volt incandescent lamp ?

By Formula (72)  $R = \frac{E^2}{W} = \frac{110 \times 110}{55} = 220$  ohms.  
 $E = 110$  volts,  $W = 55$  watts.

**Case 7.**—GIVEN WATTS EXPENDED AND RESISTANCE, TO FIND THE PRESSURE :

*The pressure is equal to the square root of the product of watts and resistance.*

$$E = \sqrt{W \times R} \dots \dots \dots (73).$$

**Prob. 88 :** What pressure must be applied to an incandescent lamp of 220 ohms hot resistance so that it will receive 55 watts ?

By Formula (73)  $E = \sqrt{W \times R} = \sqrt{55 \times 220} = 110$  volts.  
 $W = 55$  watts,  $R = 220$  ohms.

**225. Electrical Power Formulæ.—**

The above cases are summarized as follows :

$W = E \times C$ . . . . .	Formula (62).
$W = C^2 \times R$ . . . . .	“ (68).
$W = \frac{E^2}{R}$ . . . . .	“ (69).
$E = \frac{W}{C}$ . . . . .	“ (64).
$E = \sqrt{W \times R}$ . . . . .	“ (73).
$E = C \times R$ . . . . .	“ (29).
$C = \frac{E}{R}$ . . . . .	“ (28).
$C = \frac{W}{E}$ . . . . .	“ (63).
$C = \sqrt{\frac{W}{R}}$ . . . . .	“ (71).
$R = \frac{E}{C}$ . . . . .	“ (30).
$R = \frac{E^2}{W}$ . . . . .	“ (72).
$R = \frac{W}{C^2}$ . . . . .	“ (70).

If it is desired to use the larger unit of power, the horse power, the above formulæ may be changed by remembering that 1 horse power = 746 watts, and they will then be as follows :

From Formula (65)	$H. P. = \frac{E \times C}{746}$ . . . . .	(65).
From Formula (68)	$H. P. = \frac{C^2 \times R}{746}$ . . . . .	(74).
From Formula (69)	$H. P. = \frac{E^2}{746 \times R}$ . . . . .	(75).
From Formula (65)	$E = \frac{H. P. \times 746}{C}$ . . . . .	(76).
From Formula (65)	$C = \frac{H. P. \times 746}{E}$ . . . . .	(77).
From Formula (75)	$R = \frac{E^2}{H. P. \times 746}$ . . . . .	(78).
From Formula (66)	$K. W. = \frac{E \times C}{1000}$ . . . . .	(66).
From Formula (68)	$K. W. = \frac{C^2 \times R}{1000}$ . . . . .	(79).
From Formula (69)	$K. W. = \frac{E^2}{1000 \times R}$ . . . . .	(80).

**226. Power from Cells.**—The amount of power that can be furnished by a cell is directly proportional to the square of its E. M. F. divided by its internal resistance and is equal to the number of watts expended by the cell on short circuit. Let  $W$  represent the power in watts from a single cell, then from Formula (72) we get

$$W = \frac{E^2}{r} \dots \dots \dots (81).$$

The power obtained from any number of similar cells is equal to the power of one cell multiplied by that number, and is independent of the grouping, provided that it is symmetrical. For example, the amount of power a Leclanche cell can furnish if the E. M. F. is 1.5 volts and internal resistance .25 ohm =

$$\frac{E^2}{r} = \frac{1.5 \times 1.5}{.25} = 9 \text{ watts.}$$

The power furnished by ten cells would be  $10 \times 9 = 90$  watts. If arranged all in series then the total E. M. F. = 15 volts and total internal resistance = 2.5 ohms, Formulæ

$$(36) \text{ and } (37), \text{ and } W = \frac{E^2}{r} = \frac{15 \times 15}{2.5} = 90 \text{ watts.}$$

If arranged all in parallel then the total E. M. F. = 1.5 volts and the internal resistance = .025, Formulæ (37) and (38),

$$\text{and } W = \frac{E^2}{r} = \frac{1.5 \times 1.5}{.025} = 90 \text{ watts as before, also 2 cells}$$

in series and 5 groups in parallel equal 90 watts as before, etc. In the above cases all the energy is expended inside the cell. For a steady current of maximum value through the external circuit, its resistance should be equal to the internal resistance of the battery. This is also the condition for a maximum rate of working or activity. The maximum economy for installing a number of cells required for any given rate of working is attained when the work is performed satisfactorily by the minimum number of cells. This condition is obtained when the total power the cells can maintain on short circuit is equal to four times the power required from them for the external circuit.

To find the number of cells required for maximum economy of installation for any power to be developed: *Multiply the power in watts required by the internal resistance of one cell and divide the product by the square of the E. M. F. of one cell.*

Let  $N$  = number of cells required ;  
 $W$  = watts required in external circuit ;  
 $r$  = internal resistance of one cell ;  
 $E$  = E. M. F. of one cell.

$$N = \frac{4 \times W \times r}{E^2} \dots \dots \dots (82).$$

**Prob. 89:** How many chromic acid cells will be required for maximum economy of first installation to light a 12-watt incandescent lamp? Each cell has an E. M. F. of 2 volts and an internal resistance of .5 ohm.

By Formula (82)  $N = \frac{4 \times W \times r}{E^2} = \frac{4 \times 12 \times .5}{2 \times 2} = 6$  cells.

$W = 12$  watts,  $E = 2$  volts,  $r = .5$  ohm.

The cells in Prob. 89 could be arranged in any symmetrical combination to produce the 12 watts in the external circuit. Suppose the 12-watt-lamp required 6 volts, then all the cells would be placed in series, Fig. 201. The E. M. F. of the battery would be 12 volts and the internal resistance  $6 \times .5 = 3$  ohms, or the energy expended on short circuit by Formula (81)  $W = \frac{E^2}{r} = \frac{12 \times 12}{3} = 48$  watts, or four times the energy

required by the lamp. The resistance of the lamp is 3 ohms, Formula (72), and when connected to the 6 cells in series will receive 2 amperes, Formula (37). The pressure sending the current through the cells is  $C \times r = 2 \times 3 = 6$  volts, or one-half the E. M. F., and 6 volts are also maintained across the lamp terminals. The external power is thus  $2 \times 6 = 12$  watts and the watts lost in the cell 12 watts, or the total watts = 24, or one-half the power the cells could deliver on short circuit.

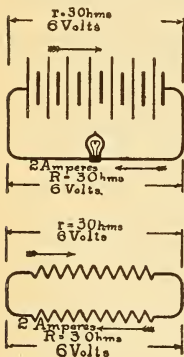


Fig. 201.—“Volts Lost” on the Internal Resistance.

**227. Efficiency of a Battery.**—By efficiency is meant the relation of the useful work done to the total energy expended. A perfect battery, or dynamo (that is, one with no internal resistance), would deliver all of the energy to the external circuit, but as some portion of it is lost in the internal resistance the useful energy is always less than the total energy expended. If the total energy expended is represented

by 100, and one-half of this amount is unavailable for useful work, the efficiency would be 50 per centum or 50 per cent. In no machine, then, can the efficiency be 100 per cent.

TO FIND THE EFFICIENCY OF A BATTERY :

*Divide the resistance of the external circuit by the resistance of the external circuit plus the resistance of the battery.*

$$\text{Eff.} = \frac{R}{R + r} \dots \dots \dots (83).$$

**Prob. 90;** What is the efficiency of the battery in Prob. 89? The total resistance of the battery is 3 ohms and the resistance of the lamp is 3 ohms.

By Formula (85)  $\text{Eff.} = \frac{R}{R + r} = \frac{3}{3 + 3} = .50$  or 50%.

The total watts expended in ¶ 226 are 24, and the useful watts in the lamp 12, so that the efficiency is the ratio of

$$\frac{\text{Useful watts}}{\text{Total watts expended}} = \frac{12}{24} = .50 = 50\%, \text{ as before.}$$

Let  $W$  = useful energy expended (in watts);

$w$  = useless energy expended (in watts).

Then,  $\text{Eff.} = \frac{W}{W + w} \dots \dots \dots (84).$

### QUESTIONS.

- ✓ 1. What is the difference between force and work?
2. Define mass; energy; power; weight.
- ✓ 3. What is the unit of (a) mechanical power? (b) Of mechanical work? (c) Of electrical work? (d) Of electrical power?
4. Cite examples illustrating the conservation and correlation of energy.
- ✓ 5. How would you ascertain, by experiments, the mechanical equivalent of work performed by an electric current?
- ✓ 6. What is the difference between a kilowatt and a kilowatt-hour?
7. A battery used in electroplating has an efficiency of 70 per cent. What do you understand by this statement?

### PROBLEMS.

1. How much electrical energy is expended in maintaining a 16 candle power incandescent lamp, supposing that it has a resistance of 220 ohms (hot) and is taking 0.5 ampere? How many watts per candle power? How many such lamps can be maintained at full candle power by one mechanical horse power? *Ans.* 55 watts; 3.43 watts; 13 lamps.

2. A number of 100-volt incandescent lamps are being lighted by a dynamo generating 112 volts at the brushes. The resistance of the leads carrying current to the lamps is .05 ohm. Each lamp requires 50 watts. How many lamps are burning? *Ans.* 480 lamps.

3. (a) What size of generator (kilowatt capacity) should be purchased for a 500 light installation, supposing that standard 55 watt, 16 candle power incandescent lamps are to be adopted? (b) What would be the K. W. capacity of a motor required to be substituted for a 25 horse power gas engine. *Ans.* (a) 27.5 K. W. ; (b) 18.65 K. W.

4. In constructing a solenoid and core to actuate a lever, 500 feet of number 18 B. & S., D. C. C. magnet wire were wound upon a brass spool. A table of heating limits gives 2 amperes as a safe carrying capacity for this size of wire under these conditions. Using this current, how much extra resistance must be added to place the coil across a line of 110 volts potential difference? *Ans.* 51.68 ohms.

5. The above solenoid is to operate in series with the field magnets of a dynamo having 30 ohms resistance. (a) How much extra resistance must now be added to place the fields and coil in series across the above mains so as to receive the same current? (b) How many feet of No. 18 B. & S. iron wire are required to construct a rheostat for the extra resistance in this problem? (c) If the average length of each turn on the solenoid is 4 inches, what is the magnetising force? (d) How much energy is consumed in the solenoid? *Ans.* (a) 21.68 ohms ; (b) 555 feet ; (c) 3000 A. T. ; (d) 13.28 watts.

6. A street car is driven by two four-pole series motors. Each field magnet has a resistance of .125 ohm, the armature .125 ohm and an extra rheostat (diverter) has a resistance of 4 ohms. E. M. F. between trolley wire and rails is 500 volts. Neglecting the counter E. M. F. of the motors, find the current the motors will receive in the following positions of the controller switch: (a) First point: Both motors in series, all field coils in series, extra resistance in series. (b) Fourth point: Both series motors in parallel and the extra resistance in series with them. (c) What power is the car receiving on the fourth point? (d) Make a sketch of both controller combinations. *Ans.* (a) 95.238 amperes ; (b) 115.942 amperes ; (c) 77.7 H. P.

7. An electric automobile is equipped with 40 storage batteries which are connected, through the controller switch, for the first speed, 20 cells in series and two groups in parallel. Each cell has an E. M. F. of 2 volts and an internal resistance of 0.1 ohm. The resistance of the motors, extra resistance and leads at this combination is 0.5 ohm. (a) What is the value of the current required to start the vehicle? (b) How much energy is expended at the start? *Ans.* (a) 26.6 amperes ; (b) 1064 watts.

8. While visiting an electric light station you note the following indications of instruments on the switchboard: voltmeter 115, ammeter 330. The plant operates the two-wire direct current system and uses 55-watt, 110-volt incandescent lamps. (a) How many lamps, at the instant of reading, are burning? (b) What is the load on the generator expressed in kilowatts and electrical horse power? *Ans.* (a) 660 lamps ; (b) 37.95 K. W. ; 50.87 H. P.

9 A compound wound dynamo is connected to a circuit to which the following apparatus is wired: 150 incandescent lamps, each re-

quiring .6 ampere ; 3 arc lamps, 10 amperes each ; various electrical cooking and heating appliances requiring when all are at work 20.5 amperes ; two electroplating and electrotyping baths arranged in series across the mains and taking a maximum current of 5 amperes ; 10 storage batteries in series with a lamp bank resistance across the mains and requiring a charging current of 10 amperes. The two-wire direct current system is used and a constant potential difference of 110 volts is maintained between mains. What is the output of the generator in electrical horse power, supposing that the maximum current ever required is 75 per cent. of that taken when the whole installation is at work? *Ans.* 17.19 H. P.

10. Two arc lamps of 2000 and 1200 C. P., having a hot resistance of 6 and 3 ohms respectively, and an incandescent lamp with 18 ohms resistance, are all placed in parallel across a pair of mains. An ammeter in the main circuit indicates 20 amperes. (a) What current is each lamp receiving? (b) What is the difference of potential between the mains? (c) What is the power absorbed by each lamp? (d) How many candles per watt in the 2000 C. P. lamp? *Ans.* (a) 6, 12, 2 amperes ; (b) 36 volts, P. D. ; (c) 216, 432, 72 watts ; (d) 4.6 C. P.

11. The mean effective steam pressure from an indicator card is 50 pounds ; the speed of the engine, 290 revolutions ; length of stroke 10 inches ; area of piston head 0.75 square foot. What horse power is developed by the engine? *Ans.* 75.927 H. P.

12. How many watts are expended in an arc lamp having a hot resistance of 4.5 ohms and requiring 50 volts? *Ans.* 555 watts.

13. What is the current flowing through an electromagnet having a resistance of 50 ohms and requiring 200 watts? *Ans.* 2 amperes.

14. What is the maximum power obtainable from a Grenet cell of 2 volts, E. M. F. and an internal resistance of .02 ohm? *Ans.* 200 watts.

15. How many cells are required for maximum economy of installation to operate an electromagnet requiring 20 watts? Each cell has an E. M. F. of 2 volts and an internal resistance of .5 ohm. *Ans.* 10 cells.

16. If the magnet in question 14 has a resistance of 5 ohms and requires 10 volts, what is the best arrangement of the cells and what is the efficiency? *Ans.* 80 %.

## LESSON XX.

### MEASUREMENT OF PRESSURE.

Electromotive Force and Potential Difference—Hydraulic Analogy to Illustrate “Volts Lost”—Volts Lost in an Electric Circuit—Distribution of Potential in a Circuit—Variation of Potential Difference with Variation of External Resistance—Table XIV. Variation of Current, Pressure and Resistance—Measurement of E. M. F. and P. D.—Construction of Voltmeters—Weston Voltmeter—Connecting Voltmeters—Measuring High Voltages with a Low Range Instrument—Measurements with a Voltmeter—Volts Lost in Wiring Leads—Comparison of E. M. F. of Cells by the Potentiometer—Questions and Problems.

**228. Electromotive Force and Potential Difference.**—*Volts lost or “Drop” in a Circuit.*—Electromotive force is the total force generated, potential difference is any part of the total E. M. F., ¶ 70. The E. M. F. of any generator is not available for use in the external circuit, since part of it is required to cause the current to flow through the internal resistance of the generator (battery or dynamo). By the expressions *fall of potential*, “*drop*” or “*volts lost*” in any part of a circuit is meant that portion of the E. M. F. which is used in causing the current to flow between the two points considered. For example, the “volts drop” across a lamp means the potential difference across the lamp terminals, it is the force which is causing the current to flow through the lamp. Two “volts lost on the line” means that this much pressure is lost or used in sending the current through the line. The E. M. F. is the sum of all the potential differences, as, the drop on the line plus the drop on the lamp plus the drop on the internal resistance of the generator. The term “*volts lost*” or “*volts drop*” implies that energy is lost, since energy is the product of volts and current, Formula (62); pressure could not be lost in any circuit unless a current had been transmitted by it.

**229. Hydraulic Analogy to Illustrate “Volts Lost.”**  
A hydraulic analogy may assist somewhat in understanding the fall of potential or volts drop in an electric circuit. In Fig. 202, T is a



cylindrical tank filled with water under pressure due to the weight of the piston P, and AB is a pipe for transmitting the water to point B. With the valve at B closed the pipe is full of water, but there is no current through it. The gauges at A and B, each indicate 60 pounds per square inch, which represents the water-motive-force or power to move the water. When the valve is opened quarter-way

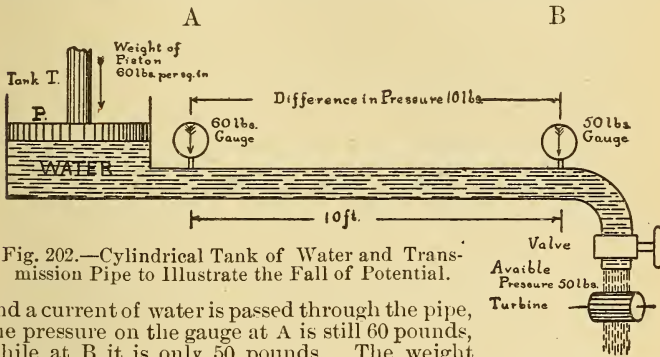


Fig. 202.—Cylindrical Tank of Water and Transmission Pipe to Illustrate the Fall of Potential.

and a current of water is passed through the pipe, the pressure on the gauge at A is still 60 pounds, while at B it is only 50 pounds. The weight of water is neglected. There is thus a difference in pressure of 10 pounds, between the two points A and B, and this force has been used or lost in overcoming the friction or resistance offered by the sides of the pipe to the running water. The available pressure at the B end of the pipe, which might be used for driving a turbine, is only 50 pounds, while the total pressure is 60 pounds. There is thus not a loss of quantity of water, but a loss of energy, as work has been performed in moving the water. Suppose the pipe to be of uniform bore and 10 feet long, then a gauge inserted at a point one foot from A would indicate 59 pounds; at two feet, 58 pounds, etc.; or there is a gradual fall or drop of pressure along the pipe which is directly proportional to the length when the resistance is uniform, or a drop of one pound per foot in length.

The difference in pressure between any two points is the pressure required to send the current between these points, and is found by subtracting the pressure of that gauge which is more distant from the generating source from the pressure of the gauge nearer to it. The valve is now opened half way and the gauge at A still indicates 60 pounds, while that at B now indicates 40 pounds. A difference in pressure of 20 pounds is required to cause the increased current to flow through the pipe, leaving only 40 pounds available pressure to be applied to the turbine at B. A force of two pounds is required to send the increased current through each foot of the pipe, and the sum of the pressures lost in the 10 feet equals 20 pounds, or the difference in pressure between the points A and B. If the valve at B is opened still further the difference in pressure between A and B will be greater, since more water will flow, and the available pressure at B will be correspondingly less. If the transmitting pipe considered above is replaced by one much larger in diameter, the resistance will

be less, and less pressure therefore will be lost in transmitting the water, so that a greater available pressure will result.

Suppose that the pipe AB is composed of several pieces of different sizes joined together, Fig. 203; with no current flowing the pressure at gauge B is equal to that at A. With the valve opened quarter way gauge A indicates 60 pounds and gauge B 50 pounds, as before, or a loss in pressure between the two points A and B of 10 pounds, which causes the current to flow between them. While the current of water may be the same as before and the total pressure lost also the same, the distribution of the lost pressure is not the same since the resistance of the pipe is not uniform, it being practically a number of pipes of different sizes, and therefore different resistances, connected in series. The greatest difference in pressure will be between points having the greatest resistance, such as the length of pipe of small diameter, where four pounds are required to send the current of water through this section of the pipe, while only two pounds are required to send the same current through the larger adjacent section. The opposition to be overcome in the pipe of smaller diameter is twice as great as in the larger pipe, since twice the pressure is required to send the *same* current through it. In hydraulics, calculations are made to deliver water at a certain rate of flow and under a certain pressure, in which case the pressure and energy lost in transmitting the water must be considered. The same is true in calculating the sizes of pipes for gas lighting, and of wires for carrying electric currents, ¶ 239.

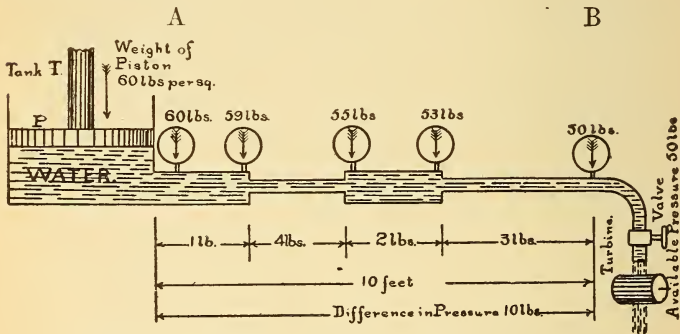


Fig. 203.—Hydraulic Analogy of the Fall of Potential.

**230. Volts Lost in an Electric Circuit.**—Consider now an electric circuit in which a generator (battery or dyamo) is supposed to maintain a constant pressure of 60 volts between two parallel lines at the point A, Fig. 204, as indicated by a high resistance galvanometer or voltmeter. With no current flowing from the generator the voltmeter will indicate 60 volts at point B (neglecting the pressure used to

transmit the small current used by the voltmeter). By closing the switch at B one lamp is lighted, and an ammeter indicates 1 ampere flowing through the circuit. The voltmeter at A still indicates 60 volts, but the voltmeter at B only 50 volts. There is, therefore, a difference in pressure between points A and B of 10 volts, which is used in overcoming the resistance of the line and causing the one ampere to flow through it. The available pressure at point B to perform useful work in the lamp is, therefore, only 50 volts and causes one ampere to flow through it. There is no loss of current but a loss of energy on the line ( $10 \times 1 = 10$  watts) that is, work has been performed in transmitting the current from A to B just as in the case of the water. If 10 volts are required to send one ampere through the line, by Formula (30), its resistance will be 10 ohms.

If the wire is of uniform area and 10 feet in length, from A to B, the voltmeter will indicate 59 volts when placed across the line at points 1-1, one foot distant from A; 58 volts at 2 feet, or

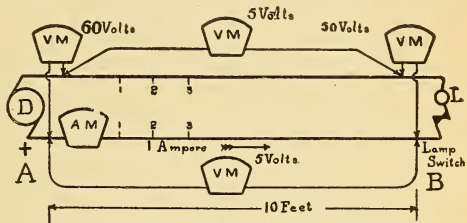


Fig. 204.—“Volts Drop” in an Electric Circuit.

or the fall of potential along the line is directly proportional to its length and resistance. Since the total resistance of the line is 10 ohms the resistance of one wire is 5 ohms and the difference in potential required to send one ampere through 5 ohms is  $E = C \times R = 1 \times 5 = 5$  volts. (Formula 29.) A voltmeter placed across one side of the line to include 10 feet of its length will indicate a potential difference of 5 volts drop or loss on this side, and the same drop on the other side of the line. Since there are 5 volts drop on 10 feet of wire of uniform resistance the drop per foot will be  $\frac{1}{2}$  volt, or 1 volt for every 2 feet, etc. The voltmeter when placed in parallel with any length of the wire will indicate the difference of potential between the points included.

Now turn on the switch with a second lamp of such resistance that the ammeter indicates 2 amperes, Fig. 205. The voltmeter at A still indicates 60 volts as before, but that at B

now indicates only 40 volts. The difference in pressure between points A and B is 20 volts, since twice the current through the same resistance requires double the pressure to be applied. The available pressure applied to the lamps is 40 volts. If the wires considered above were just double the area, only one-half of the pressure would be lost on the leads, and therefore one-half of the energy lost, and a higher available P. D. at point B would be maintained.

Suppose the transmitting line to be composed of several wires of different sizes connected in series as represented

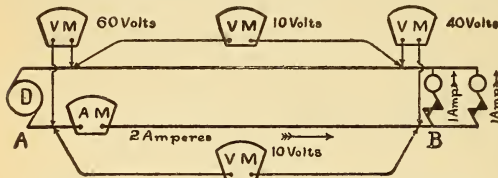


Fig. 205.—“Volts Drop” in an Electric Circuit.

by the heavy and thin lines in Fig. 206. With one lamp connected at B, the voltmeter may read 50 volts, as before, but the fall

of potential or drop on the line, 10 volts, will not now be uniform, since the resistance is not uniform. The greatest potential difference or drop will be between the points of highest resistance. Consider the equal lengths of wire E F and F G of *unequal areas*. The *current* is the *same* through each, but the voltmeter indicates 3 volts when connected across points E F, and only 1 volt when placed across points F G. The thin wire E F has three times the resistance of the wire F G, since three times

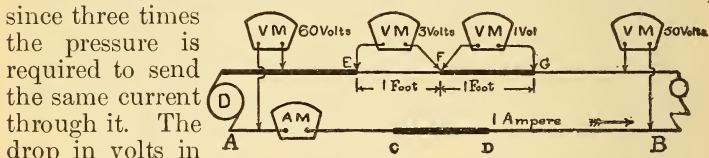


Fig. 206.—“Volts Drop” in an Electric Circuit.

the pressure is required to send the same current through it. The drop in volts in other portions of the circuit may be measured in the same manner, the sum of all the readings being equal to the total loss on the line, or 10 volts. The watts lost in E F are also three times as great as in F G, or three watts and one watt respectively, Formula (62). The total watts generated at point A with one lamp in circuit =  $60 \times 1 = 60$  watts. *The watts lost on the line* =  $10 \times 1 = 10$  watts, thus 50 watts are expended in the lamp. By Formula (84) the efficiency of this part of the circuit will be  $50 \div 60 = .83\frac{1}{3} = 83\frac{1}{3} \%$ .

**231. Distribution of Potential in a Circuit.**—In the above illustrations the pressure was assumed to be maintained constant at point A. Consider now a battery or dynamo D, Fig. 207, with an internal resistance ( $r$ ) of 4 ohms connected to one lamp at B, 10 feet distant from A. The voltmeter at A indicates 60 volts as before, and with one ampere flowing through the lamp, 50 volts at B. Ten volts are required to send one ampere through the lead wires, and since the internal resistance of the generator is 4 ohms, 4 volts will be required to send one ampere through it,

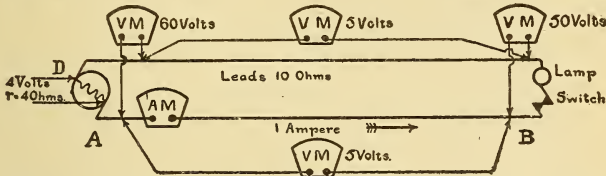


Fig. 207.—E. M. F. and Potential Difference in an Electric Circuit.

Formula (29). The total pressure or E. M. F. is, therefore,  $4 + 10 + 50$  or 64 volts. The voltmeter across the generator terminals, however, indicates the potential difference or that portion of the E. M. F. available in the external circuit, 60 volts. If the lamp at B is turned out the voltmeters at both points A and B will indicate 64 volts, or the E. M. F. of the source of electricity. Now connect two lamps in circuit, Fig. 208; the resistance of one lamp is 50 ohms, and of two in parallel it is 25 ohms, Formula (43). The total resistance of the

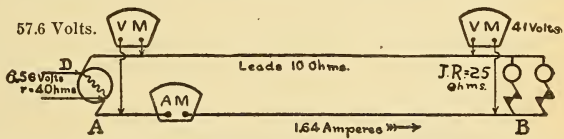


Fig. 208.—E. M. F. and Potential Difference in Electric Circuit.

circuit,  $R + r = 10 + 25 + 4 = 39$  ohms, and the current, therefore, equals  $64 \div 39$  or 1.64 amperes, Formula (28). The voltmeter at B indicates  $1.64 \times 25 = 41$  volts, Formula (29), while voltmeter at A indicates  $1.64 \times (10 + 25) = 57.4$  volts potential difference at the generator terminals. The drop on the internal resistance is  $4 \times 1.64 = 6.56$  volts or total E. M. F.  $6.56 + 57.4 = 64$  volts (nearly). If the lamps require 50 volts to send sufficient current through them to give the proper amount of light, with 40 volts across

their terminals they will now burn dimly, since each lamp does not receive one ampere, as before. The total E. M. F. must be increased, say by adding more cells in series, or increasing the field strength of the dynamo, if 50 volts are to be maintained across the two lamps in parallel. If one lamp is then turned out the other lamp receives a greater pressure than 50 volts, since the drop on the leads and internal resistance is less when the current through them is diminished. The E. M. F. must therefore be decreased as the current is decreased and increased when the current increases. In a battery installation for lighting lamps a special switch is designed to connect, or disconnect several end-cells as the voltage regulation may require. This switch is called an

*end-cell switch*. In a dynamo the E. M. F. is varied by increasing or decreasing the field strength of the electromagnets.

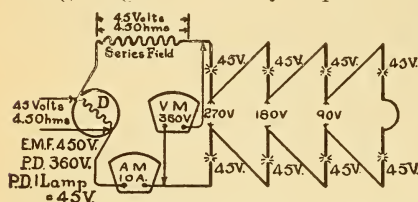


Fig. 209.—E. M. F. and Potential Difference in a Series Arc Light Circuit.

resistance of the series field is 4.5 ohms and the armature has a resistance of 4.5 ohms. (a) What pressure will be indicated by a voltmeter placed across the brushes? (b) What is the E. M. F. of the generator? (c) How much energy is lost in the internal and external circuits? (d) What is the electrical efficiency? See Fig. 209.

$$\text{By Formula (30)} \quad R = \frac{E}{C} = \frac{45}{10} = 4.5 \text{ ohms per lamp.}$$

$$\text{Resistance of 8 lamps in series} = 8 \times 4.5 = 36 \text{ ohms.}$$

By Formula (29)  $E = C \times R = 10 \times 36 = 360$  volts potential difference (a).

$$\text{Total resistance, } r + R = 4.5 + 4.5 + 36 = 45 \text{ ohms.}$$

$$\text{By Formula (33)} \quad E. M. F. = C \times (R + r) = 10 \times 45 = 450 \text{ volts (b).}$$

By Formula (62)  $W = E \times C = 360 \times 10 = 3600$  watts external circuit.

By Formula (62)  $W = E \times C = 450 - 360 = 90$  volts  $\times 10 = 900$  watts internal circuit (c).

By Formula (84).  $\text{Eff.} = \frac{W}{W + w} = \frac{3600}{3600 + 900} = .80 = 80$  per cent. (d).

**Prob. 91:** Eight arc lamps are connected in series to a series dynamo, Fig. 209, each lamp requires 45 volts and 10 amperes. The re-

**232. Variation of Potential Difference with Variation of External Resistance.—**

**Exp. 64:** Connect a voltmeter to a Grenet cell and also a variable resistance, R, in series with an ammeter, Fig. 210. With switch, S, open, the voltmeter indicates 2 volts or the E. M. F. of the cell. Adjust arm A of the rheostat so that a very high resistance will be connected to the cell, say 100 ohms, when switch, S, is closed. The voltmeter now indicates 1.999 volts or the potential difference is nearly equal to the E. M. F. when the external resistance is high, since very little current flows. Now reduce R to about 9.6 ohms ; if the cell's resistance = .4

ohm,  $r + R = 10$  ohms and the current  $= \frac{2}{10} = .2$  ampere. The voltmeter indicates  $C \times R = .2 \times 9.6 = 1.92$  volts potential difference which is causing .2 ampere to flow through 9.6 ohms, the remaining .08 volt is required to send the same current through the internal resistance.

Reduce the external R to .4 ohm and the voltmeter indicates 1 volt P. D. Since the external resistance is now equal to the internal resistance there is 1 volt drop inside the cell. Short circuit the cell by a very low resistance and the voltmeter indicates practically zero, the current from the cell is a maximum and all of the E. M. F., 2 volts, is used in sending the current through the cell's internal resistance. The preceding experiments may be summed up in the following table, which can be verified by the apparatus in Fig. 210 :

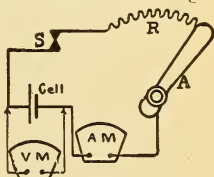


Fig. 210.—Variation of P. D. and Current with a Variation of Resistance.

**Table XIV.—Variation of Current, Pressure, and Resistance.**

Ohms External Circuit, R.	Volts Across Battery, P. D.	Amperes, C.
Infinity	Equal to E. M. F.	0
Great compared with r	Very little less than E. M. F.	Small
R, say any value	$\frac{R}{R+r} \times \text{E. M. F.}$	$\frac{\text{E. M. F.}}{R+r}$
Small compared with r	Small	Large
0	0	Maximum and equal to $\frac{\text{E. M. F.}}{r}$

The following formulæ derived from Ohm's Law will be found useful in calculating the internal resistance and potential difference :

Let E = E. M. F. in volts ;

P. D. = Potential difference (P. D.) in volts.

$$C = \frac{P. D.}{R},$$

$$C = \frac{E - P. D.}{r} \dots \dots \dots (85).$$

$$C = \frac{E}{R + r}.$$

By combining the first and third equations we get,

$$\frac{P. D.}{R} = \frac{E}{R + r},$$

$$\text{or } P. D. = \frac{R \times E}{R + r} \dots \dots \dots (86).$$

$$\text{From Formula (85) } r = \frac{E - P. D.}{C} \dots \dots \dots (87).$$

By Formula (87) a cell's internal resistance may be measured by noting the voltmeter and ammeter readings when it is connected, as in Fig. 210.

**Prob. 92:** The E. M. F. of a Leclanche cell is 1.4 volts; P. D., measured at the battery terminals when .8 ampere is flowing, is 1 volt. What is the cell's internal resistance?

$$\text{By Formula (87) } r = \frac{E - P. D.}{C} = \frac{1.4 - 1.}{.8} = \frac{1}{2} \text{ ohm.}$$

$$E = 1.4 \text{ volts, } P. D. = 1 \text{ volt, } C = .8 \text{ ampere.}$$

**Prob. 93:** The E. M. F. of a dynamo is 112 volts; resistance of lamp circuit 5 ohms; resistance of armature .05 ohm. What P. D. will a voltmeter indicate when placed across the brushes?

$$\text{By Formula (86) } P. D. = \frac{R \times E}{R + r} = \frac{5 \times 112}{5 + .05} = 110.8 \text{ volts.}$$

$$E = 112 \text{ volts, } R = 5 \text{ ohms, } r = .05 \text{ ohm.}$$

**233. Measurement of E. M. F. and P. D.**—Consider first the following hydraulic analogy in which it is desired to measure the true water pressure at the point C in a pipe, Fig. 211, through which a current of water is flowing from point A to point B. Instead of using a spring gauge which consumes no water in making the measurement, we will use a turbine wheel at point C. A jet of water is therefore forced against the wheel, which revolves at a particular speed for a given pressure at point C, say, 1600 revolutions per minute, corresponding to a pressure of 50 pounds per square inch at C. *Is this the accurate pressure at point C, or is it the pressure that would be recorded by a spring gauge if inserted at point C?* No. The turbine in measuring the pressure will increase the flow of water at point C, as some water must necessarily discharge



through it. The accurate pressure will not be recorded, but a lower pressure than that which exists when the turbine is not connected. The increased current of water through the pipe from A to C, due to the turbine outlet, causes a greater loss in pressure. If the turbine were made exceptionally small and sensitive so that a very minute stream of water from the outlet would actuate it, it would more nearly record the true pressure at point C, since very little more current would then flow than when it was disconnected. This turbine pressure meter must therefore be constructed so that only a very small amount of water will be used by it in measuring the water pressure.

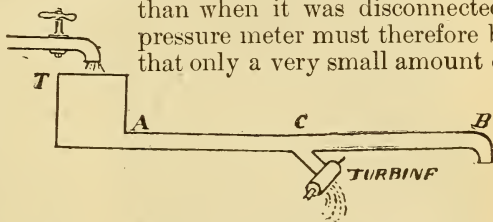


Fig. 211.—Measurement of Hydraulic Pressure.

To measure the electrical difference of potential between two points requires a galvanometer constructed with a very high resistance, so that only a very minute current will flow through it, at the same time the current must be of sufficient strength to actuate the movable system, which is generally quite sensitive, ¶ 180. *To measure electrical pressure some current must therefore be used, and the true pressure will be greater than the indicated pressure by an amount equal to the volts lost on the line and generator which are required to transmit the voltmeter current to the instrument. The less this current the more accurate the indication, consequently the best voltmeters have a very high resistance and their current is practically negligible.* When a voltmeter is placed in parallel with any part of a circuit the resistance of the circuit is practically the same as before, since the voltmeter resistance is so very high the current in the circuit is not materially changed, and the calibrated indication records, not the current in the circuit, or the current through the voltmeter, but the difference in pressure between the voltmeter terminals. The movement of its magnetic system, of course, depends upon the current flowing through the voltmeter, but the scale is calibrated by applying known E. M. F.'s to its terminals and marking the position of the needle with reference to the scale for each particular pressure applied, ¶ 180. In an ammeter the whole current passes through the instrument, or its

shunt, and the instrument measures the current. A voltmeter measures the current flowing through it, but the *calibration is in terms of the pressure causing this current to flow*. See Exp. 57, ¶ 182.

**234. Construction of Voltmeters.**—The same principles employed in the construction of ammeters, ¶ 204, etc., are employed in constructing voltmeters, the only difference being that the windings are of very fine wire, suitable to the small current that is to be carried, and that extra resistance coils are generally added in series with the voltmeter coils to produce an instrument of very high resistance, for the reasons already given. The

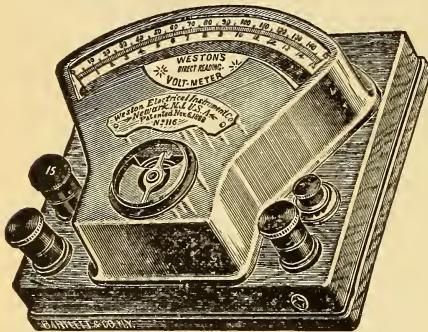


Fig. 212.—Weston Double Scale Voltmeter.

method of calibration is given in ¶ 182.

**235. Weston Voltmeter.**—The same construction is employed in this make of voltmeter as in the Weston ammeter, ¶ 208, extra resistance being connected in series with the movable coil and the terminals brought out to binding posts, Fig. 213. A double-scale Weston voltmeter is shown in Fig. 212, suitable for use with pressures as high as 150 volts. The 150 volt coil terminates in the lower right and left-hand binding posts, and the current enters by the right-hand post marked +. A push-button above this post serves to close the circuit. The resistance of the 150 volt coil is about 150,000 ohms, and there are 150 divisions on the upper, or black ink scale, or one division per volt. The 15 volt coil terminates in the lower right-hand and upper left-hand posts, and has a resistance of about 1500 ohms. There are ten divisions on this red ink scale per volt, so that one-tenth, five-hundredths

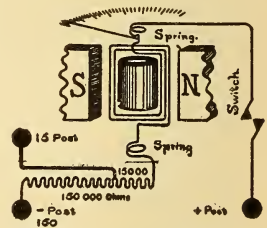


Fig. 213.—Connections of Weston Double Scale Voltmeter.

or even twenty-five thousandths of a volt may easily be read from this scale. In using a double scale voltmeter, *if in doubt about the value of the voltage to be measured, always use the higher reading scale first*, then if the value is below the limit of the low reading scale, the left-hand terminal may be readily changed to the upper post marked 15. If 150 volts are directly applied to the low reading scale the instrument will be seriously damaged and probably the insulation destroyed by a larger current flowing through it than the windings will carry. This wire may be as small as .001 inch in diameter. For the same reason any voltmeter should not be subjected to a higher voltage than is indicated upon its scale. Voltmeters are calibrated by means of standard cells and are made up according to the range of the instrument desired, by means of the extra resistance to be added. In a *milli-voltmeter* the scale is graduated to read in divisions, representing one-thousandth part of a volt, or one millivolt.

With a good voltmeter many practical electrical measurements may be made, some of which are given in the Appendix.

**Prob. 94:** A 150 volt coil of a Weston voltmeter has a resistance of 150000 ohms. What current will it receive when placed across a circuit of 100 volts P. D. ?

$$\text{By Formula (28) } C = \frac{E}{R} = \frac{100}{150000} = .00066 \text{ ampere.}$$

$$E = 100 \text{ volts, } R = 150000 \text{ ohms.}$$

**236. Connecting Voltmeters.**—Voltmeters are connected directly across the line, the P. D. of which is required, or in parallel with the conductor between the ends of which the voltage is required. Figs.

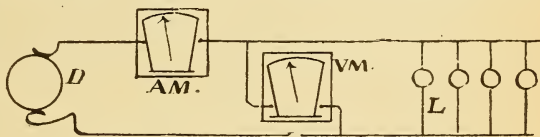


Fig. 214.—Connections of a Volt and Ammeter to a Circuit.

204, 205, etc., illustrate the proper connection for measuring the potential in the different parts of a circuit. *A voltmeter is never connected in series with the line and an ammeter never across or in parallel with the line, but always in series with it*, see Fig. 214. The following problems will illustrate the reason for each particular connection.

**Prob. 95:** In Fig. 214 the dynamo, D, maintains 110 volts across the mains at the lamps when 22 lamps are connected. Each lamp has a resistance of 220 ohms. What current will be indicated by the ammeter?

$$\text{By Formula (43)} \quad J. R. = \frac{R}{nq} = \frac{220}{22} = 10 \text{ ohms.}$$

$$\text{By Formula (28)} \quad C = \frac{E}{R} = \frac{110}{10} = 11 \text{ amperes.}$$

**Prob. 96:** Suppose the voltmeter, in Prob. 95, has a resistance of 110000 ohms and is incorrectly placed in series with the lamps. What current will the lamps receive, assuming the potential to be 110 volts?

$$\text{By Formula (28)} \quad C = \frac{E}{R} = \frac{110}{110000 + 10} = .0009 \text{ ampere.}$$

The lamps will not illuminate with this current since 10 amperes were required before.

**Prob. 97:** Suppose the above ammeter has a resistance of .1 ohm and is incorrectly connected across the circuit, like the voltmeter in Fig. 214, what current will it receive if the P. D. is 110 volts?

$$\text{By Formula (28)} \quad C = \frac{E}{R} = \frac{110}{.1} = 1100 \text{ amperes.}$$

Unless the ammeter had a current carrying capacity of 1100 amperes it would be destroyed by the excessive heat caused by such a large current.

**237. Measuring High Voltages with a Low Range Instrument.**—Suppose it is desired to measure the potential difference between a trolley line and the track which is about 550 volts, and only a 150 volt instrument is available. Connect

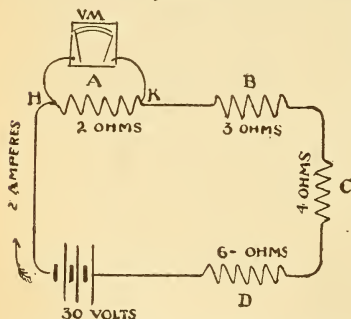


Fig. 215.—Measuring the "Volts Drop" with a Voltmeter.

resistances of 2, 3, 4, and 6 ohms respectively, are connected in series and to a battery. The spools may represent lamps, magnets, or

five 110-volt lamps in series and to the track and line, and parallel the voltmeter with each lamp respectively. The sum of the voltages across each lamp equals the P. D. between the line and the track. In a similar manner other high voltages may be ascertained.

### 238. Measurements with a Voltmeter.—

**Exp. 65:** Four spools of wire

A, B, C, and D, Fig. 215, with

any other electrical devices. When the battery circuit is closed through the above circuit, and the voltmeter connected directly across its terminals, 30 volts potential difference is indicated. The total external resistance is  $2 + 3 + 4 + 6 = 15$  ohms, and the 30 volts potential difference indicated by the voltmeter is the pressure causing the current to flow through this external resistance. The current is, by Formula (28)  $30 \div 15 = 2$  amperes.

To measure the proportion of the total P. D., 30 volts, causing the current to pass through the 2-ohm spool, A, Fig. 215, the voltmeter is placed in parallel with it, or connected to the points H and K, and indicates 4 volts. When the voltmeter is connected across the 3 ohm spool B, 6 volts are indicated. The current is the same as through spool A, the resistance, however, being  $1\frac{1}{2}$  times as great as A requires, also  $1\frac{1}{2}$  times the voltage that A requires. Spool C has 4 ohms, or twice the resistance of A and the voltmeter indicates 8 volts.

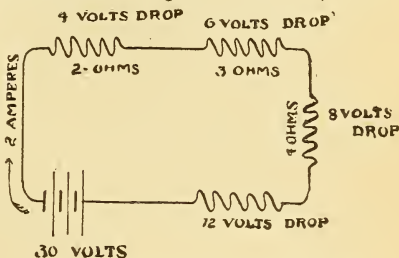


Fig. 216.—E. M. F. and Potential Difference in a Circuit.

By Formula (29) the voltage required to send 2 amperes through 4 ohms is calculated to be 8 volts, also in spool A the calculated voltage is

$E = C \times R = 2 \times 2 = 4$  volts. The results of the measurements across the four spools by a voltmeter are indicated in Fig. 216, the sum of the volts drop on all the spools is  $4 + 6 + 8 + 12 = 30$  volts or the potential difference measured at the battery. The total external resistance is 15 ohms, the current 2 amperes, and by Formula (29) the potential difference equals  $C \times R = 15 \times 2 = 30$  volts. Suppose the internal resistance of the cells,  $r$ , is 5 ohms, then  $E = C \times r$  or  $2 \times 5 = 10$  volts drop in the cells. If the voltmeter is connected across the battery it indicates the P. D. 30 volts, when 2 amperes are flowing. If the external circuit is now opened the voltmeter indicates the E. M. F. of the cells, which is the sum of all the former potential differences in the circuit or  $30 + 10 = 40$  volts E. M. F. or the indication of the voltmeter now.

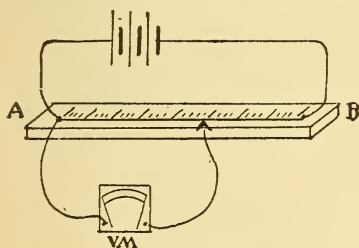


Fig. 217.—Fall of Potential Along a Wire.

**Exp. 66.**—In Fig. 217, a fine German silver wire, uniform in size, is stretched on a board between binding posts, AB, and a scale of inches arranged directly above it. The wire is connected in circuit with one or more cells, preferably of the Daniell type, so that the current flowing through the wire will be constant. If the terminals of a

galvanometer or voltmeter are held on the wire, so as to include a portion of its length between them, as in Figure 217, the potential difference between the points embraced will be represented by the value of the deflection. One terminal may be fixed stationary at point A and the other terminal gradually moved along the wire toward B. The deflection increases as you proceed toward B. For example, with six inches between voltmeter terminals the drop is .4 volt ; 12 inches, .8 volt, etc.

Since the current is the same in all parts of the circuit the same deflection will be produced for equal distances on the wire, provided its resistance is uniform. If a copper wire of the same size is connected in series with the German silver, the volts drop on 12 inches of copper will about equal the drop on 1 inch of German silver, since the latter has about twelve times the resistance of copper, and to send the same current through it, therefore, requires twelve times the pressure. The student should make a comparative table of lengths and deflections for several different wires of the same size joined in series, as the following :

Inches.	Copper	German Silver	Iron
	Deflections.	Deflections.	Deflections.
5 . . . . .			
10 . . . . .			
15 . . . . .			
Etc. . . . .			

**239. Volts Lost in Wiring Leads.**—The size of wire required to conduct a given current a certain distance may be

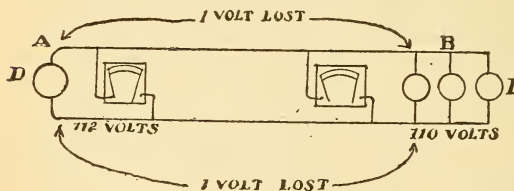


Fig. 218.—“Volts Lost” in Wiring Leads.

L, located at a distance of 100 feet. The potential at meter is 112 volts and at lamps 110 volts. There are thus 2 volts dropped on the line, or two volts are required to send 20

readily obtained by finding its resistance by Ohm's Law. In Fig. 218 a dynamo, D, is supplying current, 20 amperes, to a number of lamps,

amperes through the 200 feet of copper wire. By Formula (30) the resistance of the line equals  $E \div C = 2 \div 20 = .1$  ohm per 200 feet, or .5 ohm per 1000 feet. From the wire table, on p. 113, is found the nearest size of wire corresponding to .5 ohm per 1000 feet, which is a No. 7.

As a check upon this calculation the table of carrying capacities, ¶ 257, should be consulted to further ascertain whether the wire is large enough.

**240. Comparison of E. M. F. of Cells by the Potentiometer.**—The potentiometer is a simple instrument for measuring potential differences, or the E. M. F. of a cell. It consists of a fine German silver wire, AB, stretched between binding posts on a wooden base provided with a scale, Fig. 219. Current is passed through this wire in one direction, A to B, from several constant current cells, so that there is a constant P. D. between the ends of the wire, AB.

If this potential difference is known, the cell, the E. M. F. of which is to be determined, is connected in series with a galvanometer, and then in shunt with the potentiometer wire, so that its current will be in opposition to the potentiometer current. When the drop on the length of the potentiometer wire is equal and opposite to the cell's E. M. F. no current will flow through the galvanometer, and its needle will stand at the zero position. This point is determined by sliding the movable contact, C, along AB, till balance of the needle is obtained at zero. Then the E. M. F. of the cell bears the same relation to the P. D. between the ends of the potentiometer wire, AB, as the distance included between the cell terminals, AC, bears to the whole length of the potentiometer wire, AB.

The potentiometer wire scale may be graduated to read in volts instead of inches. Thus 36 inches with 3 volts P. D. maintained would be 12 inches per volt. If the E. M. F. of one cell is known and used as a standard of E. M. F. the E. M. F. of any other cell may be determined from this standard.

The standard cell is first connected to the potentiometer wire, Fig. 219, and the distance, AC, on the scale divisions noted when balance is attained. The cell of unknown

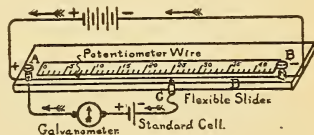


Fig. 219.—Connections of Potentiometer.

E. M. F. is then substituted for the standard, being connected in opposition as before, and the distance AD noted when balance is obtained.

The following relation then exists when AC equals length on potentiometer wire balanced by the standard cell, and AD equals length balanced by the unknown cell :

$$\frac{\text{E. M. F. Standard}}{\text{E. M. F. Unknown}} = \frac{\text{Length AC}}{\text{Length AD}}$$

$$\text{Or unknown E. M. F.} = \frac{\text{E. M. F. Standard} \times \text{AD}}{\text{AC}} \quad (88).$$

When the potentiometer wire is graduated in volts, a voltmeter may be readily calibrated or re-calibrated, by substituting it for the cell and galvanometer, and noting the deflections on the voltmeter scale due to different potential differences applied by moving the flexible slider along the potentiometer wire.

**Prob. 98:** In a potentiometer test the standard cell, 1.05 volts E. M. F., produced a balance when 12 inches of the potentiometer wire were included between its terminals. What is the E. M. F. of two other cells measured if the potentiometer readings to produce balance were respectively 8 and 20 inches?

By Formula (88) Unknown E. M. F. =  $\frac{\text{E. M. F. Standard} \times \text{Length AD}}{\text{Length AC}} = \frac{1.05 \times 8}{12} = .7$  volt, E. M. F. of the first cell.

E. M. F. of Standard cell = 1.05 volts, AD = 8 inches, AC = 12 inches.

Also  $\frac{1.05 \times 20}{12} = 1.75$  volts, E. M. F. of the second cell.

### QUESTIONS.

1. The E. M. F. of a cell measured by a voltmeter is 1.8 volts. When connected to a spool of wire the voltmeter across the battery terminals indicates only .7 volt. Account for the volts lost, and state what pressure is applied to the spool.

2. Four coils of wire having resistances of 1000, 100, 10 and 1 ohms respectively are successively connected to a battery of 10 volts E. M. F. What will be the comparative value of the readings of a voltmeter placed across the terminals as compared with the E. M. F.? State also the comparative current strength in each case.

3. It is desired to measure the P. D. across a 250-volt power circuit, and only a voltmeter with a 100-volt scale is at hand. How would you make the measurement using this instrument?



4. The greater the current flowing through a voltmeter or ammeter the greater the deflection of its magnetic system. How then does a voltmeter measure electrical pressure?

5. In a potentiometer test balance of the galvanometer needle is attained with a standard cell of 1.05 volts for 210 divisions. For another cell the balance is attained at 430 divisions. What is the E. M. F. of the unknown cell? Give complete sketch.

6. What is the essential requirement in order to measure E. M. F. accurately, and how is it fulfilled in voltmeter construction?

7. Since the mechanical construction and resistance of the movable coil of a Weston voltmeter and ammeter are both the same, what then is the essential difference in the instruments?

8. Make a sketch of the internal connections of a Weston voltmeter.

9. What is a potentiometer, and for what is it used?

### PROBLEMS.

1. Find the size of wire required to conduct current to 100 55-watt lamps in parallel, located at a distance of 125 feet from the dynamo, which maintains a constant pressure of 112 volts at its terminals. The lamps receive 110 volts. *Ans.* No. 2 B. & S.

2. What power is lost in the leads in question 1? *Ans.* 100 watts.

3. What P. D. must be maintained at the terminals of a dynamo so that 150 lamps, in parallel, each requiring 55 watts at 110 volts, will receive their proper current? Resistance of leads .02 ohm. *Ans.* 111.5 volts.

4. If the internal resistance of the armature in problem 3 is .05 ohm, what E. M. F. is developed by the machine? *Ans.* 115.25 volts.

5. How much resistance must be inserted in series with two 50-volt 50-watt lamps, to allow them to be placed in series across a 220 volt circuit? *Ans.* 120 ohms.

3. We desire to run a motor, requiring 1 ampere, at 6 volts from an Edison circuit of 110 volts potential difference. If two 50-volt 50-ohm (hot) incandescent lamps are connected in series with the motor, how much additional resistance must be added to meet the requirements? *Ans.* 4 ohms.

7. One hundred incandescent lamps, 110 volts 55 watts each, are to be installed in a private house. The distance from the meter to the general centre of distribution on the second floor is 150 feet. Potential at the meter is 113 volts and at the point of distribution 111 volts. Calculate the size and weight of wire required, using the two-wire direct current system. *Ans.* No. 1 B. & S., 73.5 or 76 lbs.

8. It is believed that the amount of power lost on a certain feeder in a central station is excessive. You are consulted and asked to determine the power so lost and the yearly cost of the same. The data furnished by the company is as follows: station runs 10 hours per day; the cost of producing an electrical horse-power-hour is 3.5 cents; the average daily load on this feeder is 100 amperes; the size of wire is No. 2. B. & S. gauge, and the distance to the point of distribution is 1000 feet; the system used is two-wire direct current. *Ans.* \$555.74.

9. You are required to construct an electric heater for a trolley car, and find by experiment that 10 amperes flowing through a No. 16 B. & S. iron wire will radiate sufficient heat for the purpose. Assuming that the potential difference between trolley wire and track is 500 volts, find the length of wire required to properly place the stove in parallel with the circuit. (Neglect the rise in resistance due to the heat.) *Ans.* 2038 feet.

10. The two field magnets of a bipolar dynamo have a resistance of 55 ohms each, and are connected in series and placed in shunt with the brushes where 110 volts are maintained. (a) What is the field exciting current? (b) What is the total magnetising force, if the length of wire on each spool is 12,000 feet and the mean length of one turn 2 feet? (c) What will be the exciting current when the fields are placed in parallel with the brushes? *Ans.* (a) 1 ampere; (b) 12,000 A. T.; (c) 4 amperes.

11. (a) How much resistance would you insert in circuit with a 50 volt 50-watt incandescent lamp, to allow it to be properly placed across a 110-volt circuit? (b) How many feet of No. 18 B. & S. German silver wire are required to make a rheostat for this purpose? *Ans.* (a) 60 ohms; (b) 759 feet.

12. Four electromagnets having resistances of 4, 6, 8 and 10 ohms respectively, are connected in series and to a battery having an internal resistance of 2 ohms. When the switch is closed a voltmeter, across the battery terminals, indicates 56 volts. (a) What will be the indications of a voltmeter when paralleled with each spool? (b) What will the voltmeter indicate when placed across the cells when the magnets are disconnected? (c) What will be the efficiency of the battery when connected to the circuit? *Ans.* (a) 8, 12, 16 and 20 volts; (b) 60 volts; (c) 93 per cent.

13. What will be the drop on 500 feet of No. 0 wire used as an overhead trolley line at the instant when it is supplying current to four cars, each requiring 70 amperes? *Ans.* 14.2 volts.\*

---

\*The student is advised to calculate resistances rather than take them from the wire table. Answers given for problems are based upon calculations from the formulæ given in this book.

## LESSON XXI.

### MEASUREMENT OF RESISTANCE.

Measurement of Resistance (Fall of Potential Method)—Measuring the Resistance of Arc and Incandescent Lamps While Burning—Measurement of Resistance (Substitution Method)—Drop Method of Comparison—Voltmeter Method—By Weston Instruments—Wheatstone Bridge (Principle of Slide Wire Pattern)—Lamp Chart Analogy of Wheatstone Bridge—Construction and Use of Slide Wire Bridge—Student's Wheatstone Bridge (Lozenge Pattern)—Operating the Bridge—To Measure a Higher Resistance Than That in the Rheostat—To Measure a Low Resistance—The Best Selection of Resistances for the Bridge Arms—Commercial Wheatstone Bridge—Direct Reading Ohmmeter—Questions and Problems.

**241. Measurement of Resistance.**—I. FALL OF POTENTIAL METHOD (*Ammeter and voltmeter required*).—This is a very simple method for measuring an unknown resistance directly by Ohm's Law when an ammeter, a voltmeter and a source of current are available. Suppose the unknown resistance, *A*, Fig. 220, is the armature or field magnet of a dynamo. Connect the resistance to be measured in series with the ammeter and the source of electricity. Connect the voltmeter in parallel with, or across the resistance. Make simultaneous readings of both instruments. The unknown resistance is calculated from Formula (30)  $R = E \div C$ .

In using this method precaution must be taken not to pass a greater current through the object to be measured than it will carry without heating, ¶ 257, otherwise a higher resistance than the true one will be measured. Generally the larger the current used, without heating, the greater the accuracy, because the voltmeter gives a higher reading. This

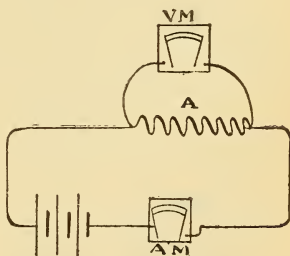


Fig. 220.—Fall of Potential Method for Measurement of Resistance.

is especially true for measuring low resistances and for which this method is quite suitable. A milli-voltmeter will give greater accuracy when the resistance is quite low, as, for example, the series field of a large dynamo which may be .0001 ohm. On the other hand, when the method is applied to high resistances the current will be small and a milli-ammeter can be used to advantage.

**Prob. 99:** What is the resistance of the object A, Fig. 220, if the respective readings of ammeter and voltmeter are 4 and 36?

$$\text{By Formula (30) } R = \frac{E}{C} = \frac{36}{4} = 9 \text{ ohms.}$$

$$C = 4 \text{ amperes, } E = 36 \text{ volts.}$$

**Prob. 100:** The resistance of a bonded rail is to be measured by the above method. The current through the rail and its copper joint is 500 amperes, the drop across the joint is 25 millivolts. What is the resistance in microhms?

$$\text{By Formula (30) } R = \frac{E}{C} = \frac{.025}{500} = .00005 \text{ ohm.}$$

$$E = 25 \text{ millivolts} = .025 \text{ volt, } C = 500 \text{ amperes.}$$

$$\text{By Formula (12) } .00005 \times 1000000 = 50 \text{ microhms.}$$

**242. Measuring the Resistance of Arc and Incandescent Lamps While Burning.**—The fall of potential method,

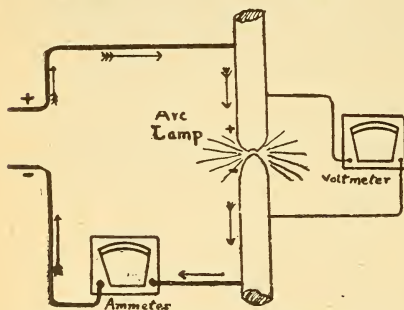


Fig. 221.—Measuring the Resistance of an Arc Lamp While it is Burning.

¶ 241, is adapted to this measurement. Connections are shown for measuring an arc lamp while it is burning, in Fig. 221, and for measuring the hot resistance of one or more incandescent lamps while burning, in Fig. 214. Suppose the pressure across the arc is 42 volts and the current 10 amperes, then the hot resistance is  $42 \div 10 = 4.2$  ohms, Formula (30). This resistance is much less than when the carbon tips are in contact when the lamp is not burning. The resistance of carbon decreases with the temperature rise.

**Prob. 101 :** A series arc-light dynamo is supplying a constant current of 10 amperes to a lamp circuit with a potential difference at the dynamo brushes of 2745 volts. Each lamp requires 45 volts and the resistance of the line is equal to the resistance of 1 lamp. (a) What is the resistance of the external circuit? (b) How many lamps are burning? (c) What is the resistance of 1 lamp? (d) How many lamps can be maintained by 1 electrical horse power? (e) How many electrical horse power are delivered by the dynamo? (f) What is the length of this series circuit if it is constructed of No. 6 B. & S. copper wire?

Solution :  $2745 - 45 = 2700 =$  volts drop on all the arc lamps.  
 $45 =$  volts drop on the leads.  
 $\frac{2700}{45} = 60$  lamps burning (b).

By Formula (30)  $\frac{45}{10} = 4.5$  ohms resistance 1 lamp (c).

By Formula (30)  $\frac{45}{10} = 4.5$  ohms resistance of line.

Total resistance  $= (4.5 \times 60) + 4.5 = 274.5$  ohms (a).

By Formula (62) watts per lamp  $= 45 \times 10 = 450$ .

$\frac{746}{450} = 1.65$  lamps per H. P. (d).

By Formula (65) H. P.  $= \frac{E \times C}{746} = \frac{2745 \times 10}{746} = 36.79$  H. P. (e).

By Formula (23)  $L = \frac{R \times C. M.}{K} = \frac{4.5 \times 26250}{10.79} = 10947.63$  feet (f).  
 No. 6 B. & S. = 26250 C. M.

**243. Measurement of Resistance.—II. SUBSTITUTION METHOD** (*Galvanometer and graduated rheostat required.*)—Connect the unknown resistance, X, and the galvanometer in series, and to one or more cells, preferably of the closed circuit type, as shown in Fig. 222. Note the deflection of the galvanometer needle. Now substitute the graduated rheostat for the unknown resistance and adjust it till the needle attains its former deflection.

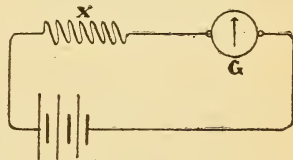


Fig. 222.—Substitution Method.

The resistance in the rheostat is now equal to the unknown resistance, since the current through the galvanometer is the same as before, and the pressure also the same.

If the unknown resistance is so small that the galvanometer needle is deflected off the scale, the rheostat may be inserted in series with the unknown resistance, and the resist-

ance unplugged till a suitable deflection is obtained. Then the unknown resistance is removed and resistance added by the rheostat till the deflection is the same as before; the resistance so added is equal to the unknown resistance.

**Prob. 102:** With the connections, as shown in Fig. 222, the deflection of the galvanometer with the unknown resistance in circuit was 25°. With the rheostat substituted it was found necessary to unplug 47 ohms to obtain a deflection of 25°. Therefore, 47 ohms is the resistance of the unknown object.

**Prob. 103:** When a small incandescent lamp was connected for cold resistance measurement, as in Fig. 222, the needle was deflected off the scale. The rheostat was inserted in series and 55 ohms unplugged when 40 deflections were indicated. The lamp is now removed and the deflections are 47. It required 12 ohms to be added to the circuit to reduce the deflections to 40, therefore 12 ohms is the cold resistance of the incandescent lamp.

**244. Measurement of Resistance.—III. DROP METHOD OF COMPARISON** (*A standard known resistance, or a graduated rheostat and a voltmeter required*).—This method is very convenient for many practical measurements.

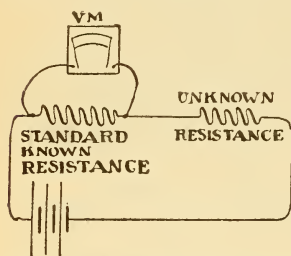


Fig. 223.—Measurement of Resistance by the Drop Method of Comparison.

No ammeter is required. The known and unknown resistances are connected in series and to a source of constant current, Fig. 223. The drop across each resistance, as measured by the voltmeter, is directly proportional to that resistance, since the current is the same through both resistances. The drop on the known resistance also bears the same relation to the

drop on the unknown resistance as the value of the known resistance bears to the value of the unknown resistance, or, calling the known resistance the standard and the unknown resistance  $X$ , then :

$$\frac{\text{Drop on Standard}}{\text{Drop on } X} = \frac{\text{Resistance of Standard}}{\text{Resistance of } X}$$

$$\text{Or unknown resistance } X = \frac{\text{Res. of Standard} \times \text{Drop on } X}{\text{Drop on Standard}} \quad (89).$$

A high resistance galvanometer, the deflections of which are proportional to the current, may be used instead of the voltmeter and the value of the deflections substituted in the

formula. In this method the current used should not be strong enough to heat the resistance appreciably. The most accurate results are obtained when the standard resistance is selected as near as possible to the supposed value of the unknown resistance. If the current is not very steady several readings should be taken of each measurement and the average value used in the formula. With suitable selected standards this method is adapted for measuring either high or low resistances with accuracy.

**Prob. 104 :** With the connections as shown in Fig. 223, the drop on the standard resistance of 5 ohms was 2 volts, while the drop on the unknown resistance was 10 volts; the unknown resistance then is 5 times as great, or 25 ohms, or

$$\text{By Formula (89) Resistance of } X = \frac{5 \times 10}{2} = 25 \text{ ohms.}$$

**245. Measurement of Resistance.—IV. VOLTMETER METHOD** (*Voltmeter of known resistance required*).—This method

is especially adapted for measuring high resistances, as insulation of wires, etc. The voltmeter is connected directly across the source of E. M. F., which should be as high as possible, within the limits of the scale, and the deflection noted (which we will call  $d$ ) by closing the switch  $K$ , Fig. 224. Switch  $K$ , is now open and the unknown resistance inserted in series with the voltmeter (call this deflection  $d_1$ ), and the resistance of the voltmeter,  $r$ . The formula for finding the value of the unknown resistance  $R$  is

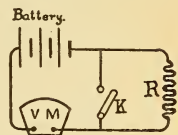


Fig. 224.—Measurement of Resistance by the Use of a Voltmeter.

$$R = r \left( \frac{d}{d_1} - 1 \right) \dots \dots \dots (90).$$

Derivation of Formula (90).—Since the E. M. F. is constant, the drop through the voltmeter alone equals  $C \times r$  which is also equal to the drop through the voltmeter and extra resistance or  $C_1 R + C_1 r$ . The deflection  $d$  or  $d_1$ , of the voltmeter needle is proportional to the current, therefore :

$$\begin{aligned} dr &= d_1 R + d_1 r, \\ \text{transposing } dr - d_1 r &= d_1 R, \\ \text{dividing by } d_1 \frac{dr}{d_1} - \frac{d_1 r}{d_1} &= R, \\ \text{or } \frac{dr}{d_1} - r &= R, \\ \text{or } r \left( \frac{d}{d_1} - 1 \right) &= R. \end{aligned}$$

**Prob. 105:** When the voltmeter in Fig. 224, is directly connected across the source of E. M. F. 110 volts are indicated; when placed in series with the unknown resistance, 4 volts are indicated, see Fig. 155. What is the value of the unknown resistance if the voltmeter has a resistance of 150000 ohms?

By Formula (90)  $R = r \left( \frac{d}{d_1} - 1 \right) =$

$$150000 \left( \frac{110}{4} - 1 \right) = 150000 \times \left( \frac{110}{4} - \frac{4}{4} \right) =$$

$$150000 \times \frac{106}{4} = 3,975,000 \text{ ohms, or } 3.975 \text{ megs.}$$

$d = 110$  volts,  $d_1 = 4$  volts,  $r = 150000$  ohms.

**246. Measurement of Resistance.**—V. By WESTON INSTRUMENTS.—A number of practical applications of the foregoing methods are illustrated in a catalog issued by the Weston Electrical Instrument Company.

**247. Measurement of Resistance.**—VI. WHEATSTONE BRIDGE (*Principle of the slide wire pattern*).—In Fig. 225 two unequal resistances,  $ab$  and  $cd$ , are connected in parallel and to a source of constant E. M. F. The drop across the wire,

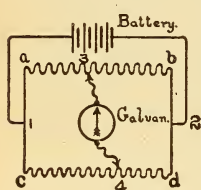


Fig. 225.—Principle of the Wheatstone Bridge.

$ab$ , is equal to the drop across the wire,  $cd$ , say 3 volts between points 1 and 2, the drop for any given length on  $ab$  is, however, not equal to the drop on the same length of  $cd$ , since the resistances are unequal. If some point as 3 is selected along  $ab$ , and the difference of potential between this point and  $a$  is 2 volts, then a corresponding point on  $cd$  can be found, as point 4, between which and  $c$  there will also be a difference of potential of 2 volts. This may readily be found by connecting one terminal of a galvanometer to point 3 and sliding the other terminal along  $cd$  until the galvanometer is not deflected when point 4 is found. Since there is no difference in potential then between points 3 and 4, no current flows through the galvanometer, consequently its needle remains at zero. If a piece of heavy wire were connected to points 3 and 4 under these conditions, no current would flow through it, nor would the current in the circuit be disturbed.

If after a balance is so obtained the slider at 4 is moved nearer to  $c$ , the current divides at 3 and part flows to points 3 and 4 through the galvanometer, deflecting it to the right of zero, say, since the difference in pressure between  $c$  and 4



is less than 2 volts, while that between a and 3 is 2 volts. If, in the same manner, the slider at 4 is moved toward d, there is a greater drop across c-4 than a-3, and the current at 4 divides, part flowing to point 2 by 4-3 through the galvanometer, and deflecting its needle now in the opposite direction, or to the left. When the balance of the galvanometer needle is obtained the volts drop across a-3 is equal to the drop across c-4, and the drop across 3-b equal to the drop across 4-d. The value of the resistance a-3 bears the same ratio to that of c-4 as resistance 3-b compared with 4-d.

For example, if a-3 is 6 ohms and c-4 is 12 ohms, when a balance is obtained whatever is the resistance of 3-b, it will be just one-half as great as the resistance of 4-d. This relation enables any unknown resistance, such as 3-b, to be measured when the others are known, by balancing the potential differences in the divided circuit by moving the sliding contact 4 to the point of balance.

$$\frac{\text{Res. a-3}}{\text{Res. c-4}} = \frac{\text{Res. 3-b}}{\text{Res. 4-d}}$$

we get

$$\text{Res. 3-b} = \frac{\text{Res. a-3} \times \text{Res. 4-d}}{\text{Res. c-4}}$$

When balance is obtained the values of the three resistances, a-3, c-4 and 4-d are substituted in the above formula and the unknown resistance, 3-b, is readily calculated.

### 248. Lamp Chart Analogy of Wheatstone Bridge.—

The balancing of potentials may be practically illustrated by a number of 16-C. P. 50-volt lamps (50 ohms hot), arranged as shown in Fig. 226 and connected to a dynamo circuit. Two lamps are connected in series at A, making the total resistance 100 ohms, which is connected in series with two lamps connected in parallel at C, the joint resistance of which is 25 ohms, Formula (43). The total resistance of A and C in series is, therefore, 125 ohms. If 125 volts are maintained across points 1 and 2, the circuit, AC, will receive one ampere, the drop

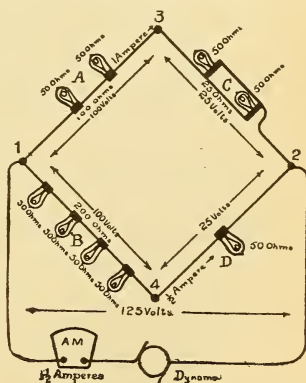


Fig. 226.—Lamp Chart Analogy of the Wheatstone Bridge.

across the lamps at A will be 100 volts and across the lamps at C, 25 volts. The A lamps burn at normal candle power, but the C lamps, dimly since they get only  $\frac{1}{2}$  ampere each.

Consider now the lower half of the circuit. At B, 4 lamps are connected in series so that resistance of B = 200 ohms, Formula (36) plus 1 lamp in series with them at D = 250 ohms for this lower circuit. The current therefore through B and D is one-half ampere, Formula (28), and all the lamps burn dimly since the drop across each lamp is only  $125 \div 5 = 25$  volts. The drop across B is therefore 100 volts, the same as it was across A, and 25 volts across D, or the same as across C. Now since the drop across 1-3 is exactly the same as that across 1-4, 100 volts, if points 3 and 4 are connected by a wire no current will flow through it and the lamps will burn with the same brilliancy as when 3 and 4 are not connected. If the resistance of the lamps is fairly uniform and a voltmeter is connected across 3 and 4 it will not show any appreciable deflection. If the wire across 3 and 4 is removed from 4 and placed, say to the right of the lamp at D,

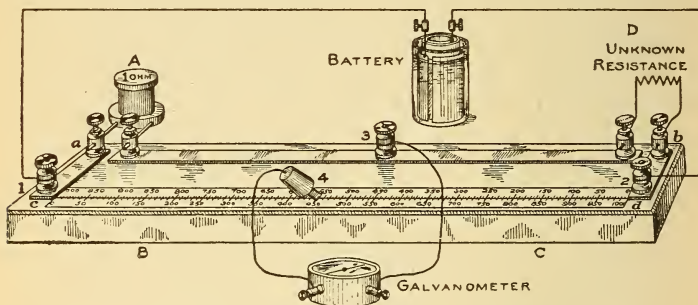


Fig. 227.—Student's Slide Wire Bridge.

Complete connections for measuring the unknown resistance at D are depicted. The student's Daniell cell and detector galvanometer are used.

then the condition of balance is destroyed, the lamps at A are subjected to 125 volts and burn above c. p. while lamps at C are cut out of circuit and the wire 3-4 carries the current flowing through the lamps at A.

This lamp chart should assist the student in understanding how the potentials are balanced in the slide wire bridge and the Wheatstone bridge, ¶ 250.

**249. Construction and Use of Slide Wire Bridge.**—A simple form of slide wire bridge for measuring resistance is depicted in Fig. 227. A piece of German silver or platinoid wire, about No. 24, is stretched between binding posts, cd, mounted on a wooden base. Directly under the wire is a paper double scale about 22 inches long, graduated in 1000 equal divisions with zero at either end, to facilitate taking readings from either point, c or d.

Strips of copper mounted on the base, support additional posts for reception of the spool resistance terminals and serve to make electrical connections. The small letters and figures indicate the same points on this bridge as shown in the diagram, Fig. 225, by which its principle was explained, ¶ 248.

A resistance spool, with copper terminals, shown in detail in Fig. 228, and wound non-inductively, ¶ 299, is inserted in the binding posts at A, Fig. 227, and corresponds to the former resistance a-3.

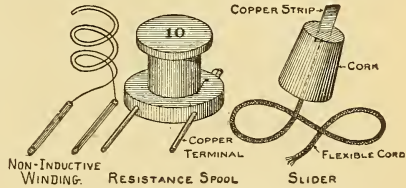


Fig. 228.—Details of Resistance Spool and Slider.

The unknown resistance, 3-b, is connected to the posts at D. The battery is connected across points 1 and 2, as before, and one galvanometer terminal to post 3, the other galvanometer post is connected to the flexible wire slider shown in detail in Fig. 228. The slider is moved along the wire, cd, till some point, as 4, is found where the needle is not deflected.

When balance is obtained the unknown resistance is calculated by the Formula in ¶ 248, as follows :

$$\text{Unknown Res.} = \frac{\text{Res. a-3} \times \text{length 4-d}}{\text{length c-4}}$$

Referring to Figs. 227 and 229 :

- Let A = known resistance ;
- B = length of wire between c and point 4 when balance is obtained ;
- C = length of wire between point 4 and d when balance is obtained ;
- D = value of unknown resistance.

Then by the above formula,

$$\text{Resistance of D} = \frac{\text{Res. of A} \times \text{length C}}{\text{length B}} \dots \dots \dots (91).$$

$$\text{More briefly } D = \frac{A \times C}{B}.$$

Several different spools are furnished with the bridge, such as 1, 10 and 100 ohms, and the proper spool to be inserted at point A, should be as near in value to the resistance to be measured as can be approximated before measurement. The error in measurement is less when this is the case.

The contacts should be clean and all wires fastened tightly, the slider should also be cleaned. Care must be exercised in moving the slider over the bridge wire so that it is not scraped, since the accuracy of measurement depends upon the uniform cross-section of the bridge wire. It is best to make several trial contacts at different points and note the direction of the needle's deflection, instead of running the slider along the wire. The same approximate pressure of the hand should be applied in making contact with the slider in different measurements. One or two cells in series will be sufficient for ordinary measurements and a switch can be introduced into this circuit to prevent the current from heating the wire, and also to prevent polarization, when open circuit cells are used. The slide wire bridge is adapted for measuring low resistances and is a laboratory instrument; the Wheatstone bridge, ¶ 250, is a commercial instrument for measuring high or low resistances.

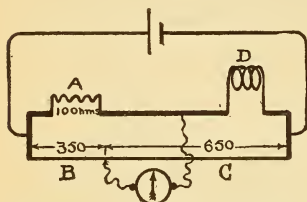


Fig. 229.—Slide Wire Bridge Connections.

When inserted in the bridge the following data is recorded when balance is obtained: the 10 ohm spool was selected,  $B = 350$  scale divisions read from the left-hand zero mark,  $C = 650$  divisions read from right-hand zero mark. What is the value of the unknown resistance at  $D$ , Fig. 229?

$$\text{By Formula (91) } D = \frac{A \times C}{B} = \frac{10 \times 650}{350} = 18.57 \text{ ohms.}$$

$A = 10$  ohms,  $C = 650$  divisions,  $B = 350$  divisions.

**Prob. 107:** In another measurement with the slide wire bridge,  $A = 100$  ohms,  $B = 100$  divisions,  $C = 900$  divisions. What is the value of the unknown resistance?

$$\text{By Formula (91) } D = \frac{A \times C}{B} = \frac{100 \times 900}{100} = 900 \text{ ohms.}$$

**Prob. 108:** What is the value of an unknown resistance measured by the slide wire bridge when  $A = 1$  ohm,  $B = 900$  divisions,  $C = 100$  divisions.

$$\text{By Formula (91) } D = \frac{A \times C}{B} = \frac{1 \times 100}{900} = .11 \text{ ohm.}$$

Problems 107 and 108 illustrate about the range of the bridge with the spools furnished, but the per cent of error in measurement increases as the resistance to be measured increases, and measurements are more accurate for low resistances with this type of bridge.

**250. Student's Wheatstone Bridge** (*Lozenge Pattern*).—

The Wheatstone bridge is based upon the same principle of balancing potentials in a divided circuit as explained in ¶ 248.

In Fig. 230 a simple diagram of the circuit is given. A, B, C, and D are called the arms of the bridge. The unknown resistance is connected at D, a variable rheostat at C, and resistance spools are inserted in the arms, A and B. The connections and apparatus required for making measurements by the student's lozenge bridge are illustrated in Fig. 232. One of the spools of the resistance set, which was previously calculated by Formula (22) is inserted in the D arm for verification of the calculation by electrical measurement. The apparatus illustrated comprises the following parts: lozenge bridge with spools, student's Daniell cell, adjustable graduated rheostat, double contact key, and detector galvanometer. The arms are lettered to correspond with the diagram, Fig. 231.

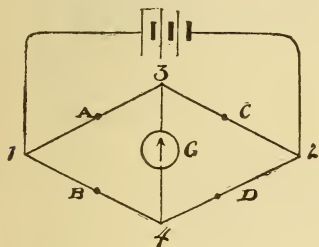


Fig. 230.—Principle of the Wheatstone Bridge.

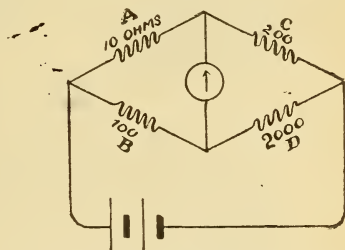


Fig. 231.—Principle of the Wheatstone Bridge.

The resistance in the arm, A, bears the same relation to that in B as the resistance in the rheostat at C does to the unknown resistance at D. Spools are selected for A and B and the resistance of C varied till the galvanometer needle stands at zero.

A balance of the resistances in the bridge arms is illustrated in Fig. 231. The proportion is shown by the values of the resistances in the arms which is as 10 is to 100, so is 200 to 2000, or

$$\frac{\text{Res. of A}}{\text{Res. of B}} = \frac{\text{Res. C}}{\text{Res. D}}$$

$$\text{Res. of D} = \frac{\text{Res. of B} \times \text{Res. of C}}{\text{Res. of A}}$$

$$\text{Res. of } D = \frac{B \times C}{A} \dots \dots \dots (92).$$

Six spools are provided with this particular bridge ; 2 one-ohm, 2 ten-ohm, and 2 one-hundred-ohm spools. For the proper selection of spools see the following paragraphs.

The double contact key, Fig. 232, is practically two button switches mounted on the same base, the upper switch connected to the two adjacent posts marked B, closes the battery circuit when a slight pressure is applied. The lower switch is connected to the other two posts

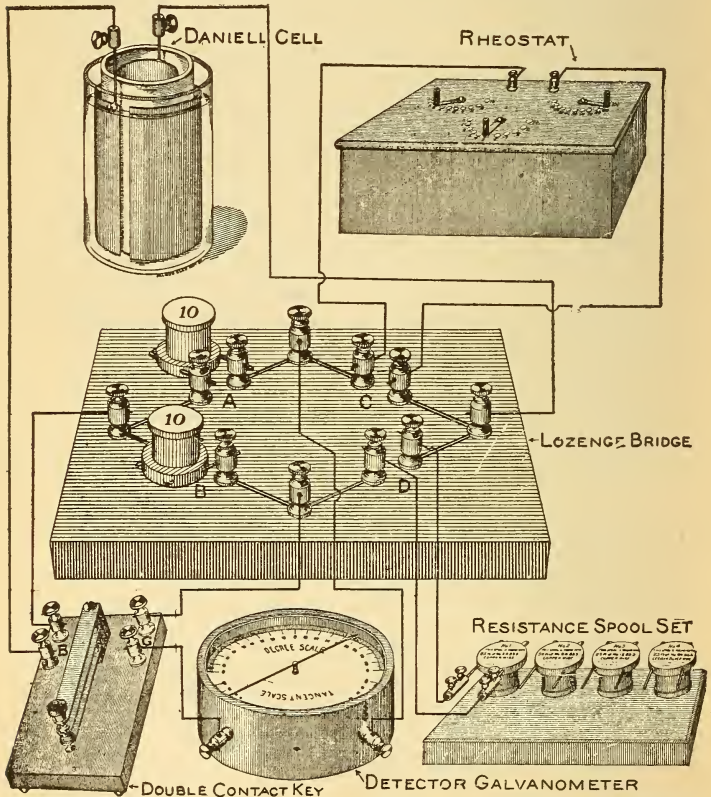


Fig. 232.—Student's Wheatstone Bridge (Lozenge Pattern) with the Necessary Apparatus Required for Measuring Resistance. Connections should be made as depicted.

marked G, and is inserted in series with the galvanometer, Fig. 232. When the button is depressed two independent circuits are closed in this order. On breaking the circuits the galvanometer circuit breaks first. The battery circuit must always be closed before the galvanometer circuit in order to allow the current to become steady before closing the galvanometer key, hence the use of the double contact key.

**251. Operating the Bridge.**—Make the bridge connections as given in ¶ 250, and Fig. 232. Suppose the unknown resistance, a coil of wire connected at D, is about 20 ohms. Connect a 10 ohm spool in arms A and B. Connect the battery through the double contact key to posts marked B, likewise the galvanometer through the posts marked G. See that all connections are bright and tight. Insert resistance in the graduated rheostat to the value of what you suppose D will measure. Depress the double contact key and note *direction* of needle's deflection, say *to the left*. Release the key and add more resistance to the circuit by changing the position of the rheostat arm. If on depressing the key the deflection now is still *to the left but less than before*, release the key and *add more resistance*. If on the next trial the needle swings *to the right, too much resistance has been added* and some must be taken out of the rheostat circuit. Proceed in this manner till a balance is obtained. If on the first trial adding resistance had further increased the needle's deflection, too much had been taken out at the start. In the above case the needle swinging to the *right of zero* means that the rheostat's resistance *must be decreased* while the needle swinging to the *left of zero* indicates *too low a resistance* in the rheostat.

With the same pole of the battery always connected to the same bridge post, this relation of the needle's deflection will always hold good, and in such a case could be marked on the instrument, as is done in the portable bridge sets. Suppose a balance is obtained when 18 ohms are in the rheostat circuit.

$$\text{Then by Formula (92)} \quad D = \frac{B \times C}{A} = \frac{10 \times 18}{10} = 18 \text{ ohms.}$$

When the A and B arms have equal resistances they will always cancel in Formula (92), so that the unknown resistance is then equal to the amount inserted in the rheostat circuit, and can be read directly from it without reference to the formula. With equal resistances in the A and B arms, which should always be as near as possible to the unknown resistance, the maximum resistance that the bridge will

measure is limited to the resistance contained in the rheostat, which, in the student's rheostat, illustrated in Fig. 232, is 160 ohms.

**252. To Measure a Higher Resistance Than That in the Rheostat.**—By inspection of Formula (92) Res. of  $D = \frac{B \times C}{A}$  it will be observed that the value of resistance in the

A arm is the divisor, so that if a low resistance spool is selected for it and a high resistance spool for the arm, B, the quotient will be high. For example, let  $B = 100$  ohms,  $A = 1$  ohm, and suppose that balance against some unknown resistance was obtained when 150 ohms had been inserted in the rheostat, then

$$D = \frac{100 \times 150}{1} = 15000 \text{ ohms,}$$

or the bridge is capable of measuring a much higher resistance than that contained in the rheostat.

**253. To Measure a Low Resistance.**—

In this case the divisor A, in Formula (92) should be very large and B small, hence select spools for arms A and B accordingly. For example, let arm B = 10 ohms, and A = 100 ohms and balance obtained against some unknown resistance when 2 ohms were inserted in the rheostat, then

$$D = \frac{B \times C}{A} = \frac{10 \times 2}{100} = \frac{20}{100} = .2 \text{ ohm,}$$

or the bridge will measure a much lower resistance than any contained in the rheostat. Suppose a balance is obtained in another measurement when  $B = 1$ ,  $A = 100$  and  $C = 2$ ,

then,  $D = \frac{B \times C}{A} = \frac{1 \times 2}{100} = \frac{2}{100} = .02 \text{ ohm.}$

**254. The Best Selection of Resistances for the Bridge Arms.**—The best selection of spools for the greatest accuracy in measurement depends upon the resistance of the galvanometer and the internal resistance and E. M. F. of the cells used with the bridge, so that no specific rule can be given beyond the varying of the ratios, as in ¶¶ 252 and 253.

**255. Commercial Wheatstone Bridge.**—The student's bridge, illustrated in Fig. 232, is a laboratory form for teaching the principles involved. A portable commercial bridge is shown in Fig. 233. The case contains the rheostat, bridge, switch, and galvanometer. The unknown resistance to be measured is connected to the left-hand binding posts and the



battery to the right-hand pair of posts. In many portable bridges the battery is also contained within the case. Resistance is inserted in the arms by removing the plugs, as shown in detail in Fig. 235. A general plan of the portable bridge and its connections is depicted in Fig. 234. The letters and figures correspond to the previous diagrams, so that the lozenge may be traced out, though the parts are not arranged in the form of a lozenge. The A and B arms are provided with three different resistances, as in the student's type, which can here be used separately or all in series. The current divides at point 1 and unites again at point 2, and the galvanometer is placed across points 3 and 4, as in Fig. 230. The lozenge principle of Fig. 234 is further shown in detail in Fig. 235.

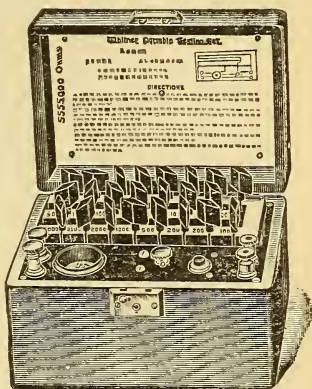


Fig. 233.—Portable Wheatstone Bridge Set (Commercial Type). The galvanometer and rheostat are contained in this case.

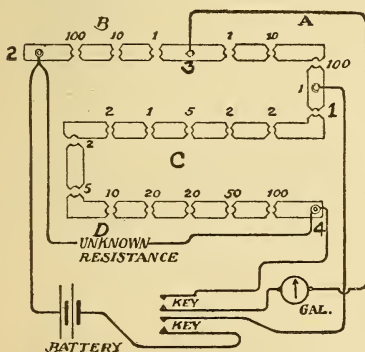


Fig. 234.—Arrangement and Connections of the Portable Wheatstone Bridge Set.

In using this type of bridge particular care must be observed to have the plugs tight, by giving them a slight twist to the right while inserting them. The galvanometer is delicate and the key should be tapped, rather than held down, so as to note the direction of deflection. This prevents the needle from being violently deflected when the system is not balanced. When a balance is nearly obtained the key may be held down for a longer time. For accurate measurements the current should not pass through the spools for any length of time, since their heating and consequent change in resistance is thus avoided. The choice of resist-

ance arms and method of operating are as given heretofore. For measuring low and medium resistances one or two cells in series may suffice to operate the bridge. The higher the E. M. F. used the more accurate the results. For very high

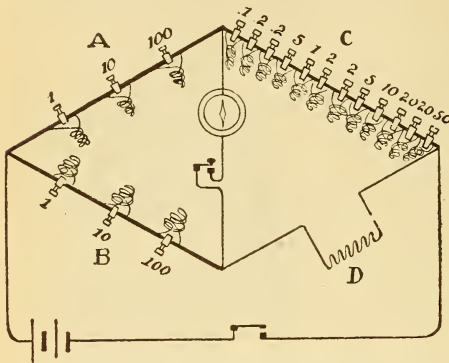


Fig. 235.—The Lozenge Diagram Applied to the Portable Wheatstone Bridge.

resistances, insulation resistance, etc., a number of cells, generally mounted in a separate case, ¶ 92, are employed.

**256. Direct Reading Ohmmeter.**—This instrument measures automatically the resistance of any device that may be connected to its terminals. The resistance can be directly read from the dial of the instrument when the battery circuit is closed. An ohmmeter indicates the relation existing between the potential difference at the ends of a conductor and the current flowing through it, since the resistance in ohms is the ratio of volts ÷ amperes, Formula (30). The principle of action is as follows: Two coils, A, A, Fig. 236, are connected in series and to the source of current used in making the measurement, generally several cells for low resistance and a magneto, ¶ 322, for high resistance. Between these coils is suspended between jewel bearings a movable coil, B, at an angle to the coils A, A. The movable coil and resistance to be measured are connected in series and in shunt with the stationary coils A, A. This connection is made by joining the unknown resistance to the binding posts 1-2. Current is led to the movable coil by the springs, S, as in the case of the Weston movable coil, Fig. 198.

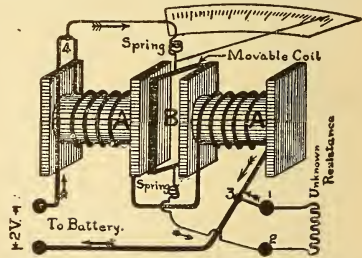


Fig. 236.—Construction and Connections of a Direct Reading Ohmmeter.

When the instrument is connected to the unknown resistance the current divides at point 4 in proportion to the resistances of the two circuits, and since the axes of the coils are at an angle, the movable coil tends to turn against the action of the springs so that its lines of force are in the same direction as the lines of force of the stationary coils. A pointer fixed to the movable coil swings over a scale graduated in ohms. With a low resistance connected to the instrument, the field of the movable coil is strong and that of the stationary coil weak, since the current divides between the two paths in proportion to the resistance. As the external resistance to be measured becomes higher, thus decreasing the current through the movable coil, the field of the stationary coil becomes stronger, so that the movable coil continues to be deflected and a very uniform scale is obtained. By using two sets of independent windings on the stationary coils, the instrument may be constructed with a double scale. The external appearance of the Weston portable ohmmeter is similar to that of the Weston voltmeter, Fig. 212, except that the push button is omitted and there are four or more binding posts. In one size of double scale instrument the capacity is 0 to 50 and 50 to 100 ohms, in one ohm divisions, and the instrument is to be used with an E. M. F. of 2 volts. For measuring high resistances, as the insulation of wires, a magneto-generator is used, capable of generating several hundred volts, and the scale of the ohmmeter graduated in megohms.

In some types of ohmmeters the magneto is mounted in the case with the instrument. When the value of the unknown resistance is not desired a magneto machine ¶ 322, is often used to test for insulation. The E. M. F. is several hundred volts but the current it will give is very small on account of its high internal resistance. A magneto is rated according to the value of the resistance its E. M. F. can maintain sufficient current through to ring a bell in series with it. For example, a 20000-ohm magneto means that if the *insulation* being tested is *less* than 20000 ohms, the bell will ring, thus indicating the fact. The higher the rating of a magneto the greater will be its E. M. F.

## QUESTIONS.

1. What is the fundamental principle in the working of the Wheatstone bridge?
2. The highest and lowest resistances in the rheostat of a Wheatstone bridge are 10000 and .1 ohms respectively. The A and B arms have each 1, 10, and 100 ohm coils. What are the highest and lowest resistances the bridge is capable of measuring?
3. Make complete sketch of a slide wire bridge connected up to measure the resistance of 10 pounds of No. 10 B. & S. copper wire.
4. How does an ohmmeter differ from a Wheatstone bridge? Upon what principle does it operate? Make sketch.
5. One terminal of a magneto is connected to an electric light wire and the other to the ground. When the armature is revolved the bell fails to ring. What does this indicate?

## PROBLEMS.

1. The drop across the series field coil of a dynamo carrying 250 amperes is .7 volt. What is its resistance? *Ans.* .0028 ohm.
2. A rheostat, battery, galvanometer and unknown resistance are joined in series. With 40 ohms unplugged the deflections are 33. The unknown resistance is cut out of circuit and 45 additional ohms are inserted to reduce the deflection to its former value. What is the value of the unknown resistance? Give sketch. *Ans.* 45 ohms.
3. You are required to measure the insulation resistance of an electromagnet using a proportionate deflection detector galvanometer, sensibility .00001 ampere for one degree and a 250 volt power circuit. The needle is deflected 3 degrees. What is the insulation resistance? Give sketch. *Ans.* 8,333,333 ohms or 8.3 megs.
4. The field magnets of a dynamo having a resistance of 84 ohms are connected in series with the field magnets of another machine and a current sent through the circuit. The drop on the latter field coils is 111 volts, and on the 84-ohm coils, 37 volts. What is the resistance of the second set of field magnets? Give sketch. *Ans.* 252 ohms.
5. An insulation test of a 110-volt multiple circuit is made with a Weston voltmeter (resistance 150000 ohms). The voltmeter indications are: positive to earth, 2 volts; negative to earth, 5 volts. What is the insulation resistance of each lead? Give sketch. *Ans.* Positive, 8.1 megs; negative, 3.15 megs.
6. Balance is obtained in a Wheatstone bridge when  $A = 10$  ohms;  $B = 100$  ohms; rheostat 14 ohms. What is the value of the unknown resistance? Give sketch. *Ans.* 140 ohms.

## LESSON XXII.

### ELECTRICAL DEVELOPMENT OF HEAT.

Heating of Conductors and their Safe Carrying Capacity—Table XV. Current Carrying Capacity of Copper Wires—Electrical Development of Heat—Electrical Equivalent of Heat: Joule's Law—Relation Between Heat, Mechanical and Electrical Energy—Relation of Fahrenheit and Centigrade Thermometer Scales—Relation of Resistance to Temperature—Table XVI. Temperature Coefficients—Fuses and Cut-Outs—Table XVII. Gauges of Different Wires Fused by 100 Amperes—Electric Cautery, Blasting, Welding, and Cooking—Questions and Problems.

**257. Heating of Conductors and Their Safe Carrying Capacity.**—Heat is caused by the molecules of a body being set in motion. To produce this motion the expenditure of a definite amount of mechanical energy is required. When a current of electricity passes through a wire, a certain amount of work is performed in overcoming the resistance of the wire, and this work appears as heat generated, according to the principle of conservation of energy, ¶ 219. This fact becomes very noticeable when the wire is small and the current large; the wire may then become so hot that it is melted by the current, ¶ 97. The increase in the temperature of a wire due to the current, depends upon its weight or sectional area. For example, consider two copper wires, one weighing one pound, and the other twice as long but weighing four pounds, offering, therefore *equal resistance* to a current passed through them. The wires will not be raised to the same temperature, although the amount of heat evolved in each case is exactly the same. This is true because there is more metal to heat in one case than in the other. Thin wires, therefore, heat much more rapidly than thick ones of a like resistance when traversed by the same current. Since the resistance of metals increases as their temperature rises, a thin wire will have its resistance increased as it becomes heated, and will continue to grow warmer and warmer until its rate of loss of heat by conductance and convection to the surrounding air equals the rate at which the heat is evolved by the current.

**Exp. 67:** When a chain made of alternate links of platinum and silver wire of the same size, is connected to several cells joined in series, the platinum links become red-hot but the silver links remain comparatively cool. The resistance of platinum is about 6 times as great as silver, but its capacity to absorb heat only about one-half as great, hence its rise in temperature is about twelve times as great as that of the silver for the same current.

The rise in the temperature of a bare wire in air is usually greater than that of the same wire covered with insulating materials. The effect of the latter is to increase the surface from which the heat is radiated and carried away by convection. Wood being a very poor conductor radiates little heat, so that less current should be allowed for wires in wooden mouldings. The heating of a wire by a current is not objectionable except that it increases the loss of energy by the rise in resistance. The real limit of the current carrying capacity of a wire is at such a rise of temperature that the insulation is liable to be damaged. The National Electrical Code of the Fire Underwriters allows an elevation of temperature above the surrounding air of 27° to 30° F. for rubber covered wires used in carrying electric current. Figures are given in the following table for this elevation. The current can be increased nearly 60 per cent above these conservative figures without any injurious effect. Wires with "weatherproof" insulation will carry still more current, since they are not so readily affected by heat.

**Table XV.—Current Carrying Capacity of Copper Wires.**

B. & S.	Amperes.	B. & S.	Amperes.
18	3	4	65
16	6	3	76
14	12	2	90
12	17	1	107
10	24	0	127
8	33	00	150
6	46	000	177
5	54	0000	210

The carrying capacity of copper wires used in dynamos varies from 600 to 1000 circular mils per ampere, according to the amount of ventilation the wire may receive. A much larger allowance must be made for contact surfaces in a

circuit, as between the brushes of a dynamo and the commutator, the clips of a switch, etc.; about 100 amperes per square inch of contact surface is an average value. Switches are constructed and rated according to their carrying capacities.

**258. Electrical Development of Heat.**—I. HEAT DEVELOPED IS DIRECTLY PROPORTIONAL TO THE RESISTANCE OF THE CIRCUIT.—In Fig. 237 two independent glass bulbs are connected with a graduated glass U tube and fastened to a suitable base by the vertical brass arm, B-2. Platinum wires are inserted in each bulb through a cork and connected to the binding posts, 1, 2, 3, as shown, post 2 being a common terminal for the wires in both bulbs. Suppose the wire, BC, in the right-hand bulb is exactly *double the length* of the wire in the left-hand bulb, but of the *same size*. Partially fill the graduated U tubes with water, close the stop-cocks and connect several cells in series to posts 1 and 3, when both platinum wires will be in series and the current the same through each of them. Permit the current to flow for a short time. The column of water in the open side of the right-hand U tube rises to about double the height above the normal position that the column in the left-hand tube does. A

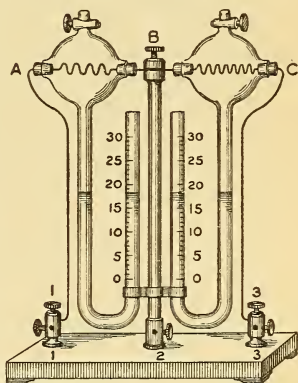


Fig. 237.—Apparatus for Studying the Laws Governing the Heating Effect of an Electric Current.

gas under constant pressure expands by a definite fraction of its volume for a given increase of temperature, consequently the air in the bulb, BC, must have been raised to double the temperature of that in the bulb, AB, or double the quantity of heat must have been evolved from the wire of twice the length, by the current. *The heat generated in any wire is directly proportional to its resistance.* In a cell furnishing current to an external circuit, twice the heat is evolved from the inside of the cell, if the plates are separated to twice their original distance and the current the same in both cases.

2. HEAT DEVELOPED IS PROPORTIONAL TO THE SQUARE OF THE CURRENT.—To prove this statement, connect an ammeter in series with either of the bulbs in Fig. 237 by using two adjacent posts, 1-2 or 2-3. Note the value of the current in amperes, and the corresponding number of cubic centimeters rise of the level of the liquid in the U tube in a given time. Now double the current strength, and the liquid in the U tube rises, not to twice the former height, but to *four* times the former height in the *same* time. If the current is tripled the liquid rises to nine times the height recorded in the first test, and when quadrupled to sixteen times the first height, etc. For example, one ampere produces 3 divisions rise; 2 amperes produce 12 divisions rise ( $(2 \times 2) \times 3$ ); 3 amperes produce 27 divisions rise ( $(3 \times 3) \times 3$ ), all tests being run for the same length of time. The heat developed is directly proportional to the square of the current.

3. HEAT DEVELOPED IS DIRECTLY PROPORTIONAL TO THE TIME.—This statement is so apparent that it need not be further considered.

**259. Electrical Equivalent of Heat.**—**JOULE'S LAW.**—Dr. Joule first discovered that the development of heat was proportional to :

1. *The resistance of the conductor ;*
2. *The square of the current ;*
3. *The time during which the current flows.*

The heat ( $H$ ) developed in a unit of time is directly proportional to the amount of power expended in overcoming the resistance of the conductor, or to the product of current  $C$ , through the conductor, and the difference of potential  $E$  between its extremities, or  $H = E \times C$ . If the resistance of the wire remains constant, the value of  $C$  varies directly as  $E$ , so that by doubling  $E$ ,  $C$  will also be doubled or the heat developed will be proportional to the square of the current as experimentally demonstrated in ¶ 258. *The British Thermal Heat Unit (written B. T. U.) is defined as the amount of heat required to raise one pound of water  $1^\circ$  Fahrenheit (written  $1^\circ F.$ ) at its maximum density.*

A P. D. of 1 volt maintained across a resistance of 1 ohm for one second develops .0009477 of such a unit. The number of heat units developed in any number of seconds therefore is,



Heat Units (H) = .0009477 × E × C × t . . . (93).

t = the time in seconds. Substituting for E its value C × R,

then H = .0009477 C<sup>2</sup>R t . . . . . (94).

Also since W = C<sup>2</sup>R,

H = .0009477 × watts × seconds . . . . . (95).

TO FIND THE TOTAL HEAT UNITS DEVELOPED IN A GIVEN TIME IN ANY CIRCUIT:

Multiply the watts expended by the time the current flows and this product by .0009477, as in Formula (95). Formula (94) will give the same result.\*

**Prob. 109.**—How many heat units are evolved in one-half hour by a 110-volt incandescent lamp consuming a current of ½ ampere?

By Formula (93) H = .0009477 × E × C × t =  
 .0009477 × 110 × .5 × 1800 = 93.8223 heat units.  
 E = 110 volts, C = ½ ampere, t = ½-hour = 1800 seconds.

TO FIND THE CURRENT REQUIRED TO PRODUCE ANY GIVEN NUMBER OF HEAT UNITS BY A KNOWN E. M. F. IN A GIVEN TIME:

Use the following formulæ derived directly by transposition from Formula (93):

$$C = \frac{H}{.0009477 \times E \times t} \dots \dots \dots (96).$$

$$t = \frac{H}{.0009477 \times E \times C} \dots \dots \dots (97).$$

**Prob. 110:** A 110-volt ½-ampere incandescent lamp is immersed in a vessel containing 1 pound of water. How long a time will be required to raise the water to the boiling point? The temperature of the water before the test is 60° F. Neglect losses, due to radiation, etc., and assume that all the energy is converted into heat.

Solution: The water must be raised 212° – 60° = 152°. 1 lb. × 152 = 152 heat units to be given to the water.

By Formula (97) t =  $\frac{H}{.0009477 \times E \times C} = \frac{152}{.0009477 \times 110 \times .5} = 2916$  sec.  
 $\frac{2916}{60} = 48$  min. 36 sec. till water boils.

**Prob. 111:** What current will be required by a lamp immersed in the above pound of water to boil it in one-half hour? The E. M. F. is 110 volts; heat losses to be neglected.

Solution: Solve by Formula (96). Ans. 0.8 ampere.

---

\* If the Centigrade scale is used and the gramme unit employed, then Formula (93) becomes H = .24 EC t, since .24 heat unit is evolved by one watt in one second. In this case the heat unit is called the *calorie*, and is the amount of heat required to raise one gramme of water one degree.

**260. Relation Between Heat, Mechanical and Electrical Energy.**—Referring to ¶ 217, Formula (60) etc., we find that the electrical work performed in a circuit is proportional to the same factors as the heat development, Formula (94). This is true, since the electrical work appears as heat. The following problem will illustrate the relation between electrical work, in joules, ¶ 217, and electrical heat, in heat units or B. T. U.

**Prob. 112:** A current of 4 amperes flows through 2 ohms for 3 seconds. (a) Find the work performed in joules. (b) Find the number of heat units developed in the circuit.

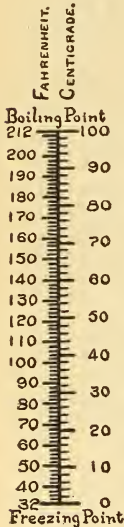
By Formula (60)  $J = C^2R t = 4 \times 4 \times 2 \times 3 = 96$  joules (a).

By Formula (94)  $H = .0009477 C^2R t = .0009477 \times 4 \times 4 \times 2 \times 3 = .0909792$  heat unit.

Therefore 96 joules = .0909792 heat unit ;  
1 joule = .0009477 heat unit.

The relation between mechanical energy, electrical energy and heat energy, ¶ 220, is then as follows :

MECHANICAL ENERGY—ELECTRICAL ENERGY—  
778 foot-pounds = 1005.2 joules =  
HEAT ENERGY.  
1 B. T. U.



**261. Relation of Fahrenheit and Centigrade Thermometer Scales.**—Since both of these scales are much used in referring to the resistance of a wire at a particular temperature, the relation between them is given by the formulæ below, and also shown diagrammatically by Fig. 238. On the Fahrenheit scale the melting point of ice is placed at 32° and the boiling point at 212°, while on the Centigrade scale the melting point of ice is placed at zero and the boiling point at 100°. Therefore 100° C. = 212 — 32 = 180° F. or the ratio of C.° to F.° is as 5 to 9. In converting a Centigrade reading into a Fahrenheit reading 32 must be added, since the zero is 32° below Centigrade, and conversely 32 must be subtracted from a Fahrenheit reading.

1. TO CONVERT FAHRENHEIT TO CENTIGRADE : *Subtract 32, multiply by 5 and divide by 9.*

$$C^{\circ} = \frac{(F^{\circ} - 32) 5}{9} \dots \dots \dots (98).$$

2. TO CONVERT CENTIGRADE TO FAHRENHEIT: *Multiply by 9, divide by 5 and add 32.*

$$F^{\circ} = \frac{C^{\circ} \times 9}{5} + 32 \dots \dots \dots (99).$$

**Prob. 113:** A field magnet spool is stated to have a resistance of 25 ohms at 15.5° C. Express this temperature in degrees Fahrenheit.

By Formula (99)  $F^{\circ} = \frac{C^{\circ} \times 9}{5} + 32 = \frac{15.5 \times 9}{5} + 32 = 59.9$  or nearly 60° F.

**Prob. 114:** The resistance of a unit foot of copper wire was stated to be 10.79 ohms at 75° F. What is the corresponding temperature in the Centigrade scale?

By Formula (98)  $C^{\circ} = \frac{(F^{\circ} - 32) 5}{9} = \frac{(75 - 32) \times 5}{9} = 24^{\circ} C$  nearly.

**262. Relation of Resistance to Temperature.**—Refer to Law V of the Laws of Resistance, ¶ 127, for the relation of temperature to resistance of wires. The percentage change of resistance of a wire with a unit change of temperature is known as the *temperature coefficient*. For example, the resistance of 1000 feet of wire one-tenth inch in diameter is about 1 ohm at 76° F., Fig. 102, and at 100° F. the resistance is increased to 1.0525, while at 50° F. the resistance is only .9475 of an ohm. This change in the resistance of a wire due to the temperature rise or fall is a very important matter in electrical calculations and measurements, and must always be taken into consideration. The following formulæ and temperature coefficients will enable the student to calculate the resistance of different metals at different temperatures :

- Let R = the original resistance ;
- R<sub>1</sub> = the resistance after a rise or fall in temperature ;
- F° = number of degrees rise or fall ;
- T = the temperature coefficient for Fahrenheit scale or the change per degree per ohm.

*The formula for finding the increase in resistance due to a rise in temperature is :*

$$R_1 = (R \times T \times F^{\circ} \text{ Rise}) + R \dots \dots (100).$$

*And the formula for a fall in temperature is :*

$$R_1 = R - (R \times T \times F^{\circ} \text{ fall}) \dots \dots (101).$$

When the Centigrade scale is used select the temperature coefficient (T) for this scale and substitute C° for F° in the above formulæ. The following temperature coefficients (values of

T) are given for some metals. The figures represent the amount 1 ohm would increase or decrease in resistance when subjected to a rise or fall of so many degrees F. or C. For example, 1 ohm of copper wire for a rise of 1° F. has a resistance of 1.0021; 10 ohms for 1° = 10.021; or 10 ohms for 10° = 10.21 by Formula (100).

Table XVI.—Temperature Coefficients.

Metal.	(Values of T.)	
	Fahrenheit Scale.	Centigrade Scale.
Silver . . . . .	.002094	.00377
Copper . . . . .	.002156	.00388
Aluminum . . . . .	.002167	.00390
Platinum . . . . .	.001372	.00247
Iron . . . . .	.002517	.00453
Tin . . . . .	.002028	.00365
Lead . . . . .	.002150	.00387
Bismuth . . . . .	.001967	.00354
Mercury . . . . .	.000489	.00088
German silver. . . . .	.000244	.00044

The resistance of copper wire thus increases nearly one-quarter of 1 per cent (.0021) for each degree F. for each ohm, and iron wire more than one-quarter of 1 per cent (.002517).

**Prob. 115:** The resistance of the field magnets of dynamo is 55 ohms at 70° F.; after a ten-hour run the temperature of a thermometer placed against them, for a short time, is 94°. (a) What is their resistance at this temperature? (b) What would be the resistance at 40° F.?

By Formula (100)  $R_1 = (R \times T \times F.^\circ \text{ rise}) + R = (55 \times .002156 \times 24) + 55 = 57.845$  ohms (a).

$R = 55$  ohms,  $T$  for copper wire = .002156,  $F.^\circ = 94 - 70 = 24^\circ$  rise.

By Formula (101)  $R_1 = R - (R \times T \times F.^\circ \text{ fall}) = 55 - (55 \times .002156 \times 30) = 51.442$  ohms (b).

$R = 55$  ohms,  $T = .002156$ ,  $F.^\circ = 70^\circ - 40^\circ = 30^\circ$  fall.

**263. Fuses and Cut-Outs.**—When a piece of copper and lead wire of the same size are connected in series and a current passed through them so that their temperature is increased, the lead will melt when a temperature of 612° F. is attained, while

it will require a temperature of 1996° F. to melt the copper. Lead containing a small percentage of tin is used for electric fuses on account of the low temperature at which it melts. A fuse consists of such a leaden wire or strip which is inserted in series with the circuit it is desired to protect, and designed so as to melt, and thus automatically open the circuit when the current through it becomes excessive.

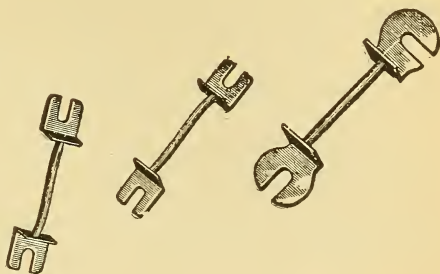


Fig. 239.—Copper Tipped Link Fuses for Cut-Outs.

The fuse is mounted on a porcelain block and the appliance termed a cut-out. The carrying capacity of a fuse depends upon its cross-section, and fuse wire is generally rated to be of so many amperes capacity, meaning that it will carry this current without melting or "blowing," as it is termed, and melt on a slight increase in current above its capacity. The function of a fuse, therefore, is to open the circuit before the temperature rise due to an excessive current from any cause, has opportunity to heat the conductors. A circuit breaker, Fig. 176, performs the same function. The gauges of different wires fused by a current of 100 amperes, is given in the following table :

Table XVII.—Gauges of Different Wires Fused by 100 Amperes (Preece).

Copper	No. 17 B. & S.	Iron	No. 10 B. & S.
Aluminum	15 "	Tin	6 "
Platinum	13 "	Lead	6 "
German Silver	13 "	Tin Alloy	5 "
Platinoid	12 "		

#### 264. Electric Cautery, Blasting, Welding and Cooking.

In surgery a thin platinum wire heated to a white heat by the current is used for many operations instead of a knife.

Platinum is chosen because it is the most refractory metal but is readily fused when the current is too strong.

*In blasting*, the fuse is surrounded by some combustible material in proximity to the explosive. A current sent from a distant battery, through copper wires, melts the fuse or heats the platinum wire, as the case may be, and the combustible is ignited and the powder exploded.

*In electric welding* the terminals of the parts to be joined, form the electrodes of the source of supply, which is generally of a low voltage but capable of giving a large volume of current. When the circuit is completed at the electrodes most of the energy is expended at this junction, since it is of higher resistance than the other parts of the circuit, and appears as heat. The current in such operations is often obtained from transformers and may be several hundred amperes at a few volts pressure.

In the *water-pail system of welding* a direct current of about 200 volts is used and the metallic tank containing, for example, a solution of ordinary washing soda, is connected to the positive pole of the supply source. The tongs are connected to the negative pole and the piece to be heated clamped in them and immersed in the solution when it becomes heated to a welding heat. The heating is due to the film of hydrogen which collects around the negative pole (by electrolysis, ¶ 100) and greatly increases the resistance at that point. In welding, two pair of tongs connected to the negative pole may be used simultaneously.

*In electric cooking* utensils, iron or other high resistance wire is wound around some insulator of electricity, as a porcelain or asbestos tube, and these coils inserted in the utensil desired. The heat is radiated to some good heat conductor in the vicinity of the coils, as for example, the copper bottom or sides of an electric tea-kettle. The wire is proportioned so that it will contain sufficient resistance to be placed in multiple with an incandescent lamp circuit and permit enough current to flow through it to maintain a temperature somewhat below its fusing point. A good heat conductor, as copper, may be coated with some insulating enamel and the wire wound directly upon it. This method is used in some makes of rheostats, ¶ 163. The advantage is that the heat is radiated so rapidly that the wire will carry a much larger current than under other conditions.

## QUESTIONS.

1. A cell is short-circuited by a thick piece of copper having a low resistance as compared with that of the cell; the current from the cell is a maximum. Where will the most heat be developed?
2. Cite an experiment to prove that heat developed in a circuit is proportional to the square of the current.
3. Equal lengths of No. 10 and No. 20 B. & S. copper wire are connected in series and to a cell. Is there any difference in the strength of current through, or heat evolved from, either wire?
4. A thermometer is immersed in a vessel containing dilute sulphuric acid and a plate of zinc and copper. When the extremities of the plates are connected by a wire the temperature rises. Explain this.
5. The size of wire for carrying 62 amperes with rubber covered insulation is calculated to be, in a certain instance, No. 6 B. & S. Would you use this size of wire? Why?

## PROBLEMS.

1. How many heat units are evolved in 10 hours from an arc lamp requiring 10 amperes and 45 volts? *Ans.* 15352.74.
2. How many pounds of water can be raised from 80° Fahr. to boiling point by the heat evolved in Problem 1, neglecting all losses? *Ans.* 116.3 lbs.
3. With an E. M. F. of 110 volts what current must be passed through a coil of iron wire, immersed in 2 pounds of water so that it will boil in 45 minutes? The temperature of the water at the start is 60° Fahr. *Ans.* 1.08 amperes.
4. The hot resistance of an electrical laundry iron is 22 ohms and it is connected across a 110-volt main. Suppose the iron to be thrown into a vessel containing 4 quarts of water, the temperature of which is 60° Fahr., and the current turned on for 15 minutes. What will be the temperature of the water at the end of the time, not deducting losses for radiation, etc? *Ans.* 118.62° Fahr.
5. Give the equivalent amount of energy in joules and foot-pounds expended in the arc lamp in question 1. *Ans.* 16,200,000 joules; 11,947,500 foot-lbs., or 11,946,902 foot-lbs.
6. The length of the Institute concentric power cable, laid in ducts under Broad street, is 300 feet; the size of conductor, No. 4 B. & S.; suppose that the temperature in the ducts on a warm summer day is 104° Fahr., and during a blizzard in winter, 40° Fahr. (a) What will be the resistance of the cable in each case? (b) If the cable is delivering 30 Kilowatt at 1100 volts, what will be the lost power on the line, at the summer temperature as above? (c) What will be the cost of this loss, running 5 hours a day for 6 months (180 days) at 7½ cents per horse-power-hour? *Ans.* (a) .1647 ohm at 104° Fahr.; .1434 ohm at 40° Fahr.; (b) 122.479 watts; (c) \$11.082.

## LESSON XXIII.

### ELECTRODYNAMICS.

Reaction of a Current-Carrying Wire on a Magnet—Automatic Twisting of a Current-Carrying Wire Around a Magnetic Pole—Rotation of a Current-Carrying Wire Around a Magnetic Pole—Electrodynamics—The Magnetic Fields of Parallel Currents—Laws of Parallel and Angular Currents—Currents in Angular Conductors—The Electro-Dynamometer—Portable Dynamometer Ammeter—Dynamometer Wattmeter—Thomson Recording Wattmeter—Questions.

**265. Reaction of a Current-Carrying Wire on a Magnet.**—Every action is accompanied by an equal and opposite reaction, or, “action and reaction are equal and opposite,” ¶ 57. For example, you elongate a spring in one direction by applying a force of one pound; the spring also exerts an equal force in the opposite direction, or else it would break. A ship displaces an amount of water which is equal to its own weight, the force of buoyancy is therefore equal and opposite to the force exerted by the weight of the ship, or else it would sink. In Lesson XV it was shown how a magnet was deflected by the magnetic field of a wire carrying a current. When the current flows over the needle, say from **N** to **S**, and the needle is *free to move*, the **N**-end is urged by the current's field to the east and the **S**-end, to the west. Since the field of the wire repels the magnet's field the magnet's field also repels the field of the wire, and if it were free to move it would move in the opposite direction to that of the magnet. In ¶ 170 the right-hand rule was given for the direction in which the needle would turn, the following rule employing the left hand will indicate the direction that the wire will move when the magnet is stationary. *Arrange the wire over the needle and place the palm of the LEFT HAND over the wire as before, ¶ 170; the outstretched thumb at right angles to the hand will indicate the direction the wire will move.*

**Exp. 68** :—Insert the rectangular coil of a single turn of wire, Fig. 148, in the ampere frame as shown in Fig. 240. Arrange the horizontal portion of the coil in the magnetic meridian, and by the use of



a pocket compass find the direction of current around the wire. Open the circuit and lay a bar magnet on the ampere frame base, arranged so that the current flows over it from **N** to **S**, as in Fig. 240. The magnet is now stationary and the wire free to move. When the current flows through the wire it is deflected west. Apply the left-hand rule, ¶ 265, to this case.

**Exp. 69:** Explore the magnetic field both inside and outside of the rectangular coil by noting how the wire moves when the magnet is brought into its vicinity. The wire tends to move in all cases to such a position that its own lines of force are in the same direction as those of the field of the magnet.

**266. Automatic Twisting of a Current-Carrying Wire Around a Magnetic Pole.**—That a wire tends to move so that its

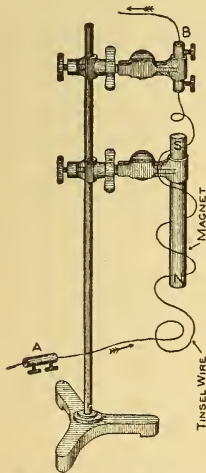


Fig. 241.—The Flexible Tinsel Wire Winds Around the Magnet when a Current is Sent Through it.

itself around the magnet in a right-hand spiral, or so that the polarity at **N** is increased by the current's field as before.

magnetic field will be in the same direction

as the lines of force of the magnet's field is further demonstrated as follows: a bar magnet is clamped vertically in a stand and raised several inches from the table, Fig. 241, a connector is clamped above it, and a piece of tinsel wire, which is a very flexible conductor, is supported from the connector and connected to a battery as shown. When the current is sent up the wire from **A** to **B**, the wire twists or winds itself around the magnet in a left-hand spiral, that is, so that the current circulates around the magnet anti-clockwise as viewed from the **N**-pole end.

The current, therefore, tends to increase the magnetism of the magnet and the lines of force of both are in the same direction. When the current is reversed, the tinsel unwinds and again twists

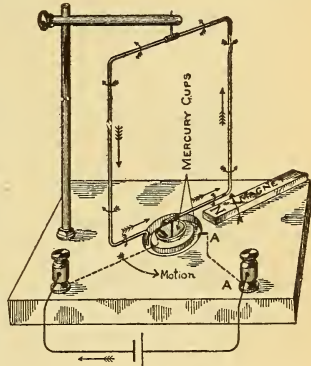


Fig. 240.—The Movable Current-Carrying Coil is Repelled by the Stationary Bar Magnet.

**267. Rotation of a Current-Carrying Wire Around a Magnetic Pole.**—Since the tendency of a magnet is to urge a wire carrying a current to a position at right angles to it, continuous rotation of the wire can be produced if the wire be arranged free to move and in such a manner that it will never attain such a position.

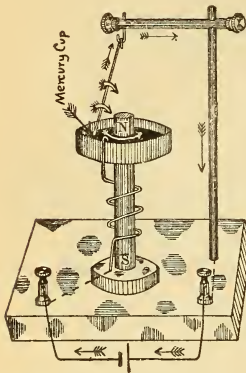


Fig. 242.—Rotation of a Current-Carrying Wire Around a Magnetic Pole.

The magnetic field of the electromagnet is nearly at right angles to the field of the wire, and the wire rotates about the pole, when the current is passed through it, according to the principle that *a magnetic body free to move, tends to move so that its lines of force will be in the same direction as the lines of the field in which it is placed.*

The direction of rotation can be determined before the current is turned on by the following left-hand rule:

Place the thumb, first and second fingers of the left hand all at right angles to each other, as in Fig. 243, and the hand so that the first finger indicates the direction of the lines of force of the magnet, and the second finger the direction of the current in the wire; the thumb will then indicate the direction of motion of the wire. Applying the left-hand rule to Fig. 242, we find that the wire will rotate in the direction opposite to the hands of the clock. It tends to wind around the pole in such

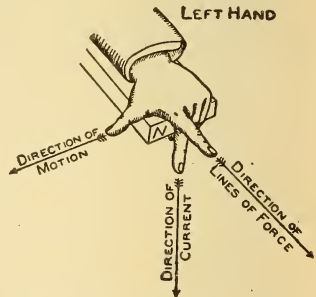


Fig. 243.—Left-Hand Rule for Determining the Direction of Rotation of a Moving Wire in a Magnetic Field.

This rule applies to motors.

a direction as to increase the magnetism of the pole, just as in the automatic twisting experiment, ¶ 266.

This rule is very convenient for determining the direction of rotation of motors, ¶ 358. The moving wire in Fig. 242 is analogous to the armature of the motor, and the electro-magnet, its field.

If the direction of current through the armature and field of Fig. 242 be reversed, as by changing the binding post terminals, the direction of rotation will be the same as before, because the current through the moving wire and the polarity of the field are both reversed, therefore, the same relation exists as before, which can be proved by the left-hand rule. If, now, only the current in the wire be reversed, or only the polarity of the field, then the direction of rotation is reversed, as proved by the left-hand rule.

To reverse the direction of rotation of a motor, therefore, *reverse the direction of current either through the armature or the field magnets, but not through both.*

A permanent magnet can be substituted for the electro-magnet in Fig. 242, as the same principles are involved. The wooden ring could be lowered to the middle position of the magnet and the wire prolonged when a greater part of its field would be in the magnet's field.

If the ring were located on the base, Fig. 242, and the wire, AB, extended the whole length of the magnet, one pole would tend to urge it in one direction and the other pole in the opposite direction, so that if the poles were of equal strength the wire would not rotate.

Another device to produce continuous rotation is illustrated in Fig. 244, and called Barlow's wheel. The edge of a pivoted copper disc dips into a trough of mercury located between the poles of a horseshoe magnet. The magnet's field acts at right angles to the current's field since the current flows from the periphery of the disc to its axis, and the disc rotates in the direction of the hands of a clock, Fig. 244, as can be determined by the left-hand rule.

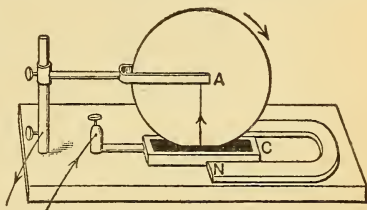


Fig. 244.—Barlow's Wheel.  
Faraday's disc dynamo driven as a motor.

**268. Electrodynamics.**—The term *electrodynamics* is applied to the study of that part of electricity which treats of the force exerted by one current upon another. We have just noted the reciprocal action between a current and a magnet, and now in electrodynamics, the mutual action of the currents upon each other is to be considered. Every wire through which a current is flowing is surrounded by a magnetic field, and the magnetic fields of two wires react upon each other. This reaction may take place between two neighboring wires in the same circuit through which a current is

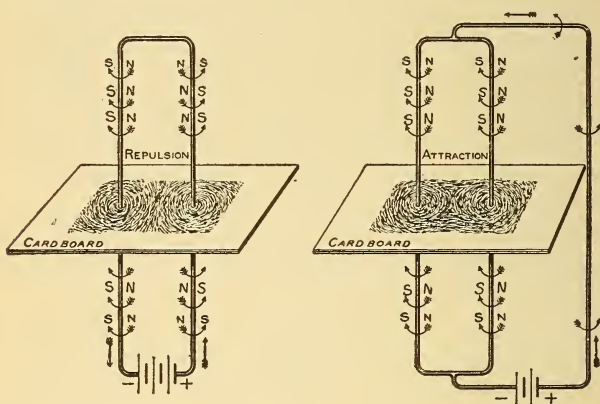


Fig. 245.—Parallel Currents Flowing in the Same Direction Attract Each Other; if in Opposite Directions they Repel Each Other.

flowing, or it may occur between wires in two independent circuits, the action depending on the relation between the two magnetic fields.

**269. The Magnetic Fields of Parallel Currents.**—The magnetic field of a straight wire carrying a current was illustrated in Fig. 128. If you regard magnetic lines as being of **N**-polarity when their direction is toward you, and of **S**-polarity when their direction is away from you, then when the direction of the whirls is kept in mind, the **N** and **S**-polarity of a straight wire may be readily remembered. In the left-hand diagram of Fig. 245 the direction of the current, the direction of whirls and polarity of the wire are indicated. The wires pass through a piece of cardboard upon which, by the aid of iron filings, the graphical field is made. The cur-

rent in the parallel wires flows in the *opposite* direction, so that the two adjacent sides are of the same polarity, thus causing a force of repulsion to exist between them. The wires tend to move away from each other. The field is very condensed between the wires and elongated outside of them. Midway between the wires the lines of force are in the same direction and fairly uniform for a small area; it is here that the needle of the tangent galvanometer is placed. (Compare with Fig. 139.) The repulsion between the wires may be demonstrated by the following experiment.

**Exp. 70:** Support from a suitable stand a wire connector and suspend from the same two long, parallel, vertical pieces of tinsel wire arranged close to each other and connected to a source of current, A, Fig. 246. When the circuit is closed, the currents being in opposite directions repel each other, and the wires move apart as depicted, according to the principles of ¶ 269.

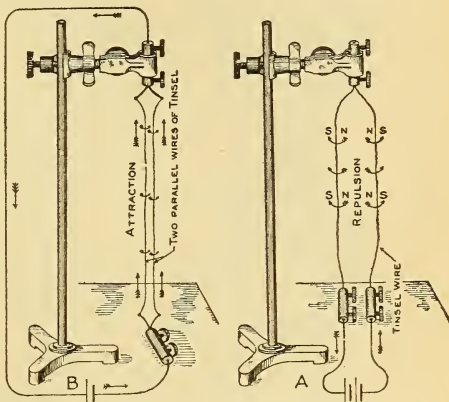


Fig. 246.—Attraction and Repulsion Between Suspended Tinsel Wires Carrying Currents.

A—Currents in the opposite direction—repulsion.  
B—Currents in the same direction—attraction.

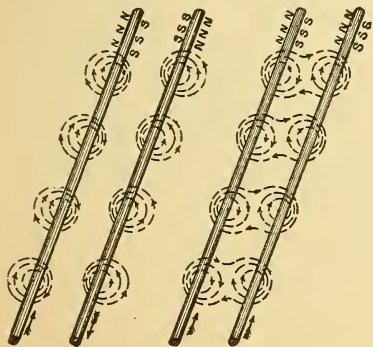


Fig. 247.—Attraction and Repulsion Between Parallel Currents.

In the right-hand diagram, Fig. 245, the currents in the parallel wires are in the same direction and the polarities of the adjacent wires unlike, so that attraction results according to the law for unlike polarities. This is noted in the filing diagram, where the field on the outside of the wires is very much condensed and elongated between these

wires. There are also continuous curves embracing both wires, due to the union of some of the magnetic lines of both wires. The wires tend to be drawn together by the tension along these lines of force. This attraction is demonstrated in Exp. 71.

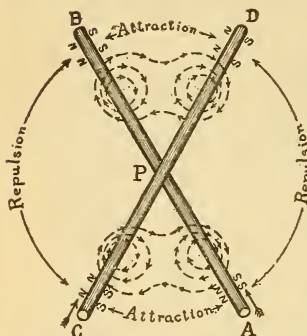


Fig. 248.—Attraction and Repulsion Between Angular Currents.

BUT IF THE CURRENTS ARE IN THE OPPOSITE DIRECTION THEY REPEL EACH OTHER. See Fig. 247. This law is true for independent circuits or for two parts of the same circuit.

2. TWO WIRES CROSSING EACH OTHER AT AN ANGLE ATTRACT EACH OTHER IF THE CURRENTS IN EACH OF THEM FLOW EITHER TOWARD THE POINT OF CROSSING OR AWAY FROM IT; BUT THEY REPEL EACH OTHER WHEN THE CURRENT FLOWS TOWARD IT IN ONE WIRE AND AWAY FROM IT IN THE OTHER. See Fig. 248 and Exp. 74. The motion tends to make the wires not only parallel, but also coincident. This law is very important, and upon its principle are constructed electro-dynamometers and watt meters, ¶¶ 272, 273, etc.

3. THE FORCE BETWEEN TWO PARALLEL CURRENTS IS PROPORTIONAL TO THE PRODUCT OF THE CURRENT STRENGTHS AND TO THE LENGTH OF THE WIRES CONSIDERED, AND VARIES INVERSELY

**Exp. 71:** Pass the current through the two parallel tinsel wires in B, Fig. 246, in the same direction, and although the wires are separated for some distance they move toward each other, according to the principle in ¶ 269.

**270. Laws of Parallel and Angular Currents.**—1. PARALLEL WIRES CARRYING CURRENTS AND FLOWING IN THE SAME DIRECTION ATTRACT EACH OTHER;

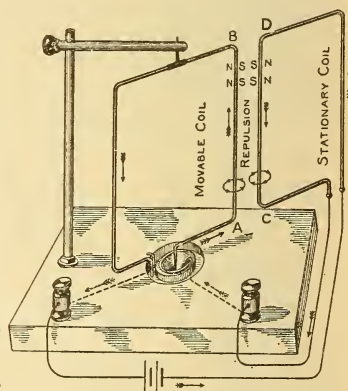


Fig. 249.—The Movable Coil (AB) May be Attracted or Repelled by the Stationary Coil (CD).

AS THE DISTANCE BETWEEN THEM. The first and second laws may be further demonstrated by the ampere-frame coil described in ¶ 175.

**Exp. 72:** Connect the ampere-frame coil and rectangular coil in series, and to a source of current, Fig. 249. Trace the direction of current in each coil. Hold one side of the rectangular coil, CD, parallel and close to one side of the movable coil, AB. The wire AB is repelled and moves away from CD when the currents are in opposite directions, Fig. 249. Invert the coil CD so that the current flows in the same direction through both, and the movable coil is attracted and will follow CD if it is carried around the axis of the coil AB.

**Exp. 73: Roget's Jumping Spiral.**—A further proof of the first law is demonstrated by the following apparatus: a phosphor bronze spring is supported vertically by a stand, Fig. 250. The lower end dips into a cup of mercury, MC. Current is passed through the spring and flows around each convolution in the same direction, hence the magnetic fields of all the convolutions attract each other, and the length of the spiral is shortened to such an extent that the lower end is pulled out of the mercury cup, thus breaking the circuit. Gravity now pulls the spring down again and the circuit is re-established, only to be broken by the same action. The spring thus vibrates continuously like the vibrator of an electric bell. An iron rod lowered down through the centre of the spiral, so that it does not touch the convolutions, greatly increases the action by increasing the magnetic effects of the whirls around each wire. In any solenoid or electromagnet, the magnetic field, therefore, tends to bind the wires closer together, as in Roget's spiral, since the current is in the same direction through all the turns, and all the convolutions are parallel.

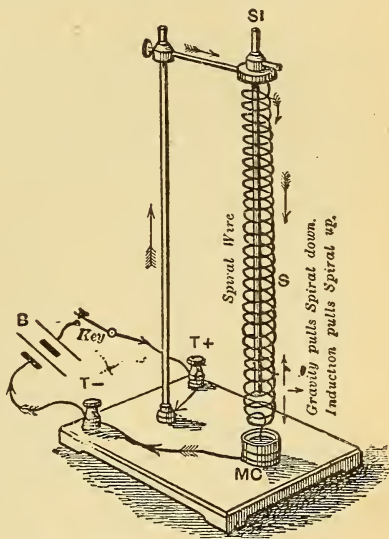


Fig. 250.—Roget's Jumping Spiral.  
It illustrates the law of parallel currents flowing in the same direction.

continuously like the vibrator of an electric bell. An iron rod lowered down through the centre of the spiral, so that it does not touch the convolutions, greatly increases the action by increasing the magnetic effects of the whirls around each wire. In any solenoid or electromagnet, the magnetic field, therefore, tends to bind the wires closer together, as in Roget's spiral, since the current is in the same direction through all the turns, and all the convolutions are parallel.

**271. Currents in Angular Conductors.**—In Fig. 248 two insulated wires AB and CD make an angle with each other, and the currents flow from A and C toward P, and the por-

tions AP and CP attract each other, according to Law 2. This is indicated by the polarity of the wires and the direction of the whirls around them.

Currents also flow away from P, toward B and D, and similar attraction takes place according to Law 2. Now consider the current and polarity in the part of the wire AP and PD. In AP the current flows toward P, and in PD away from P, and repulsion exists as indicated. This law can be experimentally demonstrated by the apparatus described in Exp. 74.

**Exp. 74:** Inside of the movable rectangular coil AB, Fig. 251, is clamped a fixed coil CD. The two coils may be connected in series or to two independent circuits. The movable coil, AB, is turned so that its plane makes an angle with the plane of the coil, CD. If the current be sent through the coils so that it flows along AB and CD either toward or away from their angle of intersection, the coil, AB, will move in the direction of the arrows till its plane coincides with that of CD, or till they are parallel, according to Law 2. If, now, the current through *either* but not both of them be reversed, the coil, AB, will move against the direction of the arrows and complete one-half revolution, till its plane coincides with CD, when B will be directly above C. This motion is in accordance with the latter half of Law 2, when the currents flow in one wire toward the point of crossing, and in the other wire away from it.

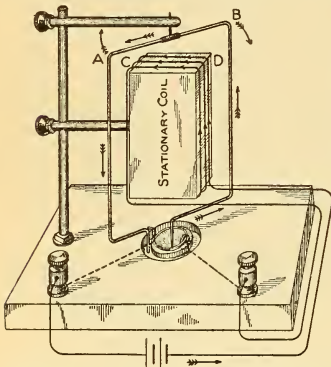


Fig. 251.—Angular Currents Tend to Become Parallel and Flow in the Same Direction.

**272. The Electro-Dynamometer.**—The electro-dynamometer is an instrument for measuring current strength by the reaction between two coils, one of which is fixed and the

other movable, and through which the current to be measured is passed. The general appearance of the laboratory type, known as a *Siemens dynamometer*, is illustrated in Fig. 252, and the diagram of the circuits is shown in Fig. 253. The fixed coil, CD, containing a number of turns of wire is fastened to a vertical support. The movable coil, AB, of a very few turns of wire, is large enough to embrace the fixed coil when their planes are at right angles to each other, and is suspended by a strong piece of thread below the cardboard dial. The ends



of this coil, being free to move, dip into two cups of mercury, located one above the other along the axis of the coil. Connections are made as indicated, so that the two coils are in series when connected to an external circuit. The planes of the coils should be at right angles to each other. When the current flows through both coils, the movable coil tends to turn, according to Law 2 for angular currents.

The force measured is the force which must be applied to keep the movable coil at right angles against the turning effort

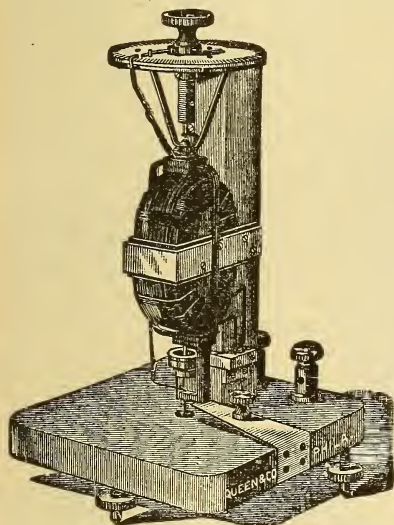


Fig. 252.—Siemens Dynamometer.  
Laboratory pattern.

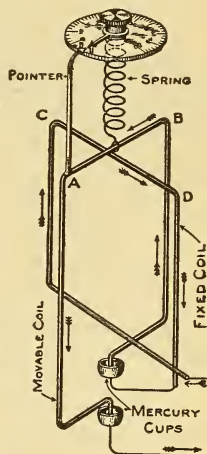


Fig. 253.—Connections  
of Siemens Dyna-  
mometer.

due to the current. One end of a spring, *S*, is rigidly fastened to the movable coil, and the other end terminates in a mill-headed screw on the face of the dial, which can be turned so as to apply torsion to the spring. The movable coil carries an index pointer bent at right angles, which swings between two stop pins on the dial and rests directly over a fixed zero line when the coils are at right angles. To the torsion screw is attached a pointer which sweeps over a degree scale. When the movable coil is deflected against a stop pin the torsion screw is rotated in a direction to oppose the current's action,

and when the coil is brought back to its original position the number of degrees through which the torsion pointer was turned, is noted.

The current is directly proportional to the square root of the angle of torsion. For example, if with one current the number of degrees noted was 36 and with another current, 144, then the currents are to each other as the square roots of 36 and 144, or as 6 is to 12, or one current is twice as strong as the other. To determine the current in amperes, the square root of the angle of torsion is multiplied by a constant found by calculation and furnished by the makers. The Siemens dynamometer is an accurate instrument connected in circuit like an ammeter and

has the advantage of being adapted for use with either direct or alternating currents.

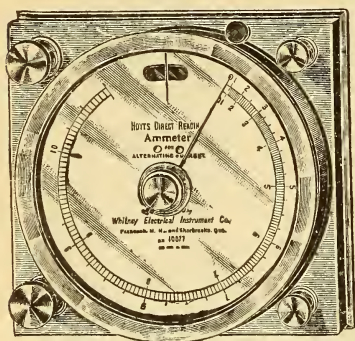


Fig. 254.—Dynamometer Ammeter for Alternating or Direct Currents. Portable Form.

### 273. Portable Dynamometer Ammeter.

—A portable commercial form of electro-dynamometer for use as an alternating or direct current ammeter is illustrated in Fig. 254. The operation and principles involved are substantially the same as those given for the Siemens dynamometer, ¶ 272, but the scale is

graduated to read directly in amperes. When used on a direct current circuit more accurate results are obtained by taking the average value of two readings made with the current reversed. The fixed coil is divided into two coils wound with a different number of turns, each of which is inserted in series with the movable coil and brought out to separate posts. Thus, if it is desired to measure a current known to be between one-tenth and 1 ampere, the right-hand binding posts are used, and if between 1 and 100 amperes, the left-hand posts are used. This arrangement produces a double scale instrument whereby a small current can be measured with much greater accuracy.

**274. Dynamometer Wattmeter.**—The energy in watts

expended in a circuit is equal to the product of the volts,  $E$ , and the current  $C$ , or  $W = E \times C$ , Formula (62). These factors may be determined by a volt and an ammeter and multiplied together, or the multiplication may be automatically performed by using a form of Siemens dynamometer which measures the watts directly, and is, therefore called an indicating wattmeter. Siemens dynamometer wattmeter operates upon the same principles as the dynamometer ammeter, ¶ 272, but the two coils are not connected in series. The *stationary coil*, or the ampere coil, is connected in series with the line like an ammeter, Fig. 255, and is wound with a few turns of *heavy wire* having a *low resistance*. These terminals are brought out to two binding posts, as shown at the left of the Weston direct reading portable wattmeter, Fig. 256. The *movable coil*, or volt coil, is wound with a few turns of very *fine wire* and connected in series with a *high resistance*, the terminals being brought out to independent binding posts, as shown at the top of the Weston instrument. A push button switch is inserted in the volt coil circuit. The movable coil thus corresponds to the voltmeter and is connected to any circuit in the same manner as a voltmeter.

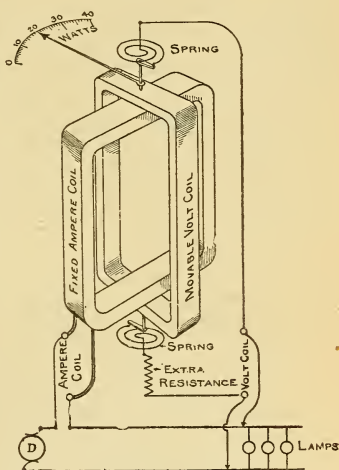


Fig. 255.—Connections of a Dynamometer Indicating Wattmeter.

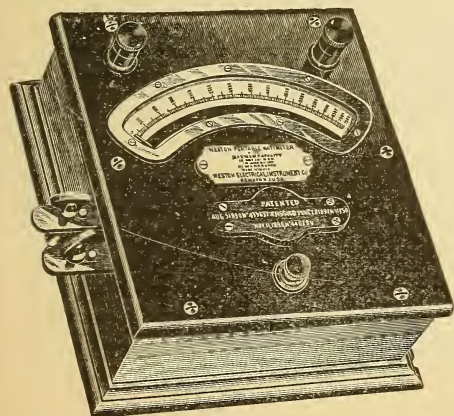


Fig. 256.—Weston Direct Reading Wattmeter.

are brought out to two binding posts, as shown at the left of the Weston direct reading portable wattmeter, Fig. 256. The *movable coil*, or volt coil, is wound with a few turns of very *fine wire* and connected in series with a *high resistance*, the terminals being brought out to independent binding posts, as shown at the top of the Weston instrument. A push button switch is inserted in the volt coil circuit. The movable coil thus corresponds to the voltmeter and is connected to any circuit in the same manner as a voltmeter.

The current in the volt coil will vary as the potential difference between its terminals and the current through the ampere coil will vary as the current in the circuit in which it is inserted. The force acting upon the movable coil, or the force required to bring it to zero, depends on the current through both coils, or directly upon the watts expended in them. In the Weston portable instrument the movable coil is constructed and mounted similar to the coil shown in Fig. 198. The movable coil turns against the torsion of the spring and its pointer swings over a scale graduated in watts. The instrument is, therefore, direct reading, as in the case of a voltmeter. In Fig. 255 the proper connections of the instrument for measuring the watts consumed by the incandescent lamps are shown. The pointer indicates the watt consumption by the lamps. (Compare with Fig. 214.)

The Weston instrument requires no adjustment to secure a balance of the forces acting, and so momentary fluctuations are readily noted on the scale. This instrument can be used on any circuit and is rated according to the carrying capacity of the ampere coil and the potential to be applied across the volt coil. For example, in a 1500-watt instrument the maximum current is 10 amperes and the maximum voltage 150 volts. The capacity of the volt coil can be increased to any desired range by the use of a portable box of extra resistances, called a *multiplier*, connected in series with it.

**275. Thomson Recording Wattmeter.**—The Weston indicating wattmeter, ¶ 274, gives the instantaneous values of the watts expended in a circuit, just as a voltmeter indicates the fluctuations in volts. To find the watt-hours consumption of electrical energy by such a meter, it will be necessary to multiply the average of a number of readings taken during a given time, by that time, expressed in hours, ¶ 223. As the name implies, the readings of a Thomson recording wattmeter, give the total watt-hours consumption of energy, or it automatically multiplies the average of the instantaneous indications by the time. It is, more correctly speaking, therefore, a joulemeter, ¶ 217. Its principle of operation is that of the Siemens dynamometer, ¶ 272, but, the movable coil rotates. The method of producing this rotation may be demonstrated as follows :

In Fig. 251 continuous rotation of the coil, AB, around the coil, CD, could be produced, if at each instant the coil, AB, became par-

allel to CD, the current were automatically reversed through it. With the single turn and a strong current, sufficient repulsive impulse would be produced to move it through  $180^\circ$ : if the current be now reversed it will receive a similar repulsive impulse and will be repelled through another  $180^\circ$ , and so on. There will thus be two reversals and two impulses given to the movable coil each revolution, and continuous rotation produced. The force producing the rotation will still be dependent upon the current in both coils as in the dynamometer. A uniform force for producing rotation would require several coils similar to AB and arranged about a vertical axis, with their planes at angles to each other, so that as one coil moved away from the stationary coil another would take its place. Such an arrangement would be practically a motor, the moving coils forming the *armature* and the stationary coil the *field*. A worm on the armature shaft engaging with the train of wheels of a cyclometer dial would record the speed, and since the number of revolutions in an hour depends on the current through the coils during that time the cyclometer dial could be calibrated in watt-hours, provided the speed were proportional to the energy supplied.

The Thomson recording wattmeter is a simple type of motor, driven by the same electrical energy which it is to

measure; its rotation during any period is proportional to the power in watts delivered to the circuit during that time. The movable coil or armature revolves between two stationary coils with its axis at right angles to the axes of these coils, as shown in Fig. 257, where the meter cover is removed. The movable coil, Fig. 258, is a drum-wound armature, ¶ 328, without an iron core, and the current through its coils is reversed automatically by the commutator, ¶ 323, thus causing it to revolve. Current is led to the commutator by the wiping

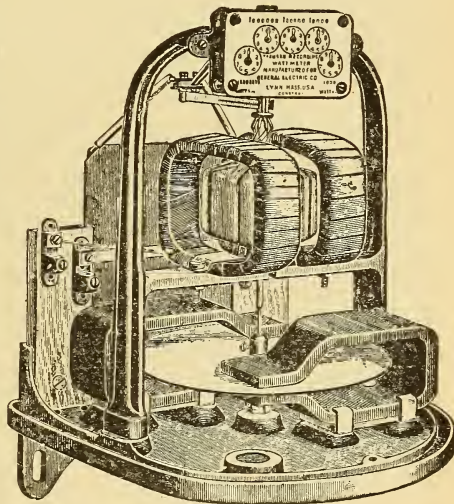


Fig. 257.—Thomson Recording Wattmeter with Case Removed.

contacts or *brushes*, B. A worm, S, on the upper end of the armature shaft engages a set of wheels which records the watt-hours on a dial. The armature is very light and delicately poised between jewel centres, so that the friction is reduced to a minimum here as well as in the train of wheels.

To the lower end of its shaft is rigidly fixed, at right angles, a copper disc which rotates with it in the magnetic field of three

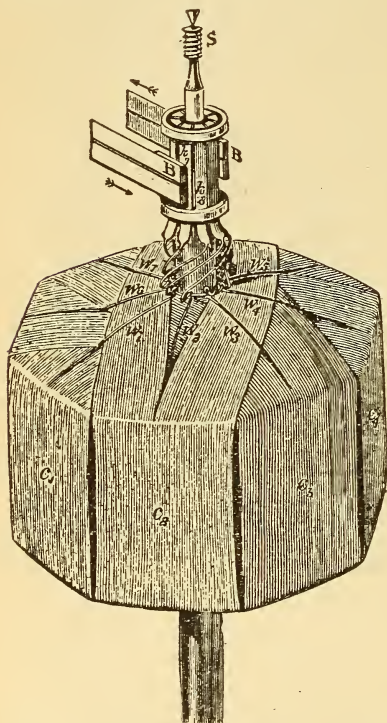


Fig. 258.—Drum-Wound Armature of Thomson Recording Wattmeter.

permanent stationary steel horseshoe magnets. The N-poles of these magnets are above and the S-poles below the copper disc, and it cuts the magnetic lines of force as it revolves. Eddy currents, ¶ 292, are induced in the copper disc, and the reaction of their magnetic field tends to retard the rotation. The amount of this retarding effect is directly proportional to the speed of rotation. Since the angular force causing the armature to rotate is directly proportional to the magnetic field of the currents in the two coils, and the retarding angular force also proportional to the magnetic field set up, the armature must rotate at such a speed that the electromagnetic driving torque is exactly equal to the electromagnetic

retarding torque. Then with a constant pressure maintained in the wattmeter coils for any length of time, the number of revolutions of the armature, and therefore the travel of the dial hands will also be constant during the time, and proportional to the energy supplied.

A high resistance is inserted in series with the armature and it is connected to a circuit just like the volt coil of the indicating wattmeter in Fig. 255. The stationary current coils are wound in the same direction to produce the field, and are connected in series with the circuit, as in Fig. 259. The meter dials are graduated in watt-hours and read like a gas meter. The speed of the motor is materially reduced by the drag produced by the copper disc so that the dial reading is multiplied by a constant, the value of which is given on the dial; a constant of 6, therefore, means that the meter dial has recorded only 1-6 of the energy and its indication must be multiplied by 6 to obtain the true watt-hour consumption. The constant is used to avoid a high speed of rotation. Thomson wattmeters can be used on alternating or direct current circuits, and are made in different sizes according to the current carrying capacity of the ampere coil. The amount of extra resistance in the armature circuit depends on the voltage to which it is to be subjected. These meters are extensively used on commercial motor circuits and in individual house electric light service, similar to a gas meter, and are sensitive enough to record the energy through even one lamp when connected to the supply circuit.

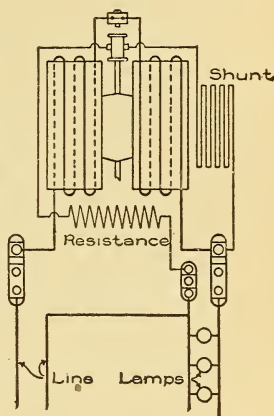


Fig. 259.—Connections of a Thomson Recording Wattmeter.

### QUESTIONS.

- Two parallel wires are stretched from vertical supports, the measured distance between them being 2 inches. A current is sent through the wires, and the distance is now only  $1\frac{3}{4}$  inches. How do you explain this?
- What is the direction of the current in the wires in question 1?
- The current is reversed in both wires in question 1. How will they now be affected?
- Make a complete sketch of a Thomson recording wattmeter connected between the two street mains, entering a consumer's building, and the parallel lamp circuit.
- A Siemens dynamometer is connected in series with some incandescent lamps, and the torsion head must be turned through  $121^\circ$

to bring the movable coil to zero position. Some lamps are now turned off and the angle corresponding with the zero position is  $81^\circ$ . The constant of the instrument is 2. What is the strength of current in each case? *Ans.* 22; 18 amperes.

6. Make sketch in detail of a Weston indicating wattmeter connected to a motor circuit so as to indicate the power being absorbed.

7. Two wires cross each other at an angle of  $60^\circ$  and the current flows through them in an opposite direction. Will they tend to move so as to increase or decrease the angle of crossing?

8. What is the advantage of a dynamometer ammeter over one constructed upon the D'Arsonval principle?

9. Explain the difference between an indicating and recording wattmeter, stating the principles involved in each.

10. A vertical wire carrying a current rotates around the S-pole of a magnet in a direction against the hands of a clock as viewed from the S-pole end. Is the current flowing up or down the wire?

11. A copper disc is mounted between the poles of a horseshoe magnet and current passed from its centre to the circumference. Make a sketch indicating the direction in which the disc will rotate.

12. How can you change the direction of rotation of the disc in question 11?

13. Make complete sketch of connections of a double scale dynamometer ammeter.

14. Current is passed downward through a vertical wire, and a bar magnet with its N-pole held uppermost is placed near to and parallel with the wire. Suppose the magnet to be flexible, like a piece of tinsel, what will occur? Make sketch.



## LESSON XXIV.

### ELECTROMAGNETIC INDUCTION.

Electromagnetic Induction—Currents Induced by a Magnet in a Wire—To Find the Direction of the Induced Current (Fleming's Right-hand Rule)—Upon What Factors the Value of the Induced E. M. F. Depends—Currents Induced in a Coil by Motion of a Magnet—Primary and Secondary Coils—Lenz's Law of Induced Currents—Classification of Induction Currents—Currents Induced by Electromagnetism—Five Methods of Producing Induced Currents—Table of Induction Currents—Variation of Induced E. M. F., with the Rate of Change of Magnetic Lines of Force (Faraday's Law)—Eddy Currents (Arago's Rotations)—Mutual Induction—Self-Induction—Gas Lighting Spark Coil—Inductance—Reactance and Impedance—Choke Coils—Neutralizing the Effects of Self-Induction—Questions and Problems.

**276. Electromagnetic Induction.**—In Lesson XV a current of electricity flowing through a wire was found to set up around the wire a magnetic field, Fig. 129. The magnetic field was maintained around the wire at the expense of chemicals inside the cell. If a wire be arranged so as to form a closed circuit and then moved across a magnetic field, a current of electricity is produced in the wire; in other words, if we artificially produce around the wire the magnetic whirls, a current of electricity flows through it when the circuit is complete. The English physicist, Michael Faraday, discovered (in 1831) that electric currents could be induced in a closed circuit by moving magnets near it, or by moving the circuit across a magnetic field. Currents that are so generated are known as *induction currents* and the phenomenon termed *electromagnetic induction*. (Compare with magnetic induction, ¶ 36.) This is a most interesting and valuable branch of the study of electricity, as upon its principles is based the operation of many forms of commercial electrical apparatus, such as dynamos, transformers or induction coils, telephones, etc.

**277. Currents Induced in a Wire by a Magnet.**—A sensitive galvanometer, G, Fig. 260, is removed from the in-

fluence of the bar magnet, NS, and connected by a piece of copper wire. If a portion of the wire, AB, is *quickly moved down* past the pole of the magnet a *momentary current* is induced in the wire, causing the galvanometer needle to be deflected, say to the right of zero, when it will again return to the zero position. If the wire is again *moved up* past the same pole another *momentary current* is induced in the wire in the *opposite direction* to the former current, as indicated by the *momentary deflection* of the galvanometer needle, which now swings to the left of zero. If the induced current, then, flows from A to B on the downward motion it will flow from B to A on the upward motion. If the wire be moved rapidly up and down past the magnet, the current will alternate in direction with each direction of motion, or an *alternating current*,

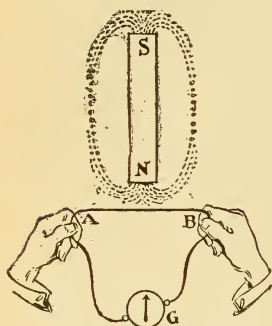


Fig. 260.—Current Induced in a Wire by Moving it Past a Magnet.

¶ 320, will be induced in the wire. When this motion is rapid, and consequently the alternations, the needle does not have sufficient time to take up the respective positions due to the opposite currents flowing around it, and, therefore, remains at zero, appreciably vibrating, however. The induced current is constant, but alternating in direction.

(1.) *If the wire is held stationary and the magnet moved, the same results are noted.*

(2.) *If the opposite pole is used, the direction of the current in each instance is opposite to what it was before.*

(3.) *An electromagnet used instead of the permanent bar magnet will produce the same results.*

(4.) *The induced current does not weaken the magnet, but is produced by the expenditure of muscular energy, just as in a cell the current is produced by the expenditure of chemical energy.*

(5.) *The momentary induced current is greatest when the wire is moved so as to cut the magnetic lines of force at right angles.*

(6.) *The direction of current in the wire is at right angles to the direction of the lines of force of the magnet.*

(7.) *Current in any wire depends upon the E. M. F. causing it to flow, so that properly speaking, an E. M. F. is induced in the*

wire when it is made to cut magnetic lines of force, and a current flows when the circuit is complete, due to this induced *E. M. F.*

(8.) If the wire is cut at any point, in Fig. 260, an *E. M. F.* is maintained at the terminals of the wire, when motion occurs, just as an *E. M. F.* exists at the terminals of a cell on open circuit tending to cause a current to flow, ¶ 70.

**278. To Find the Direction of the Induced Current.**—**FLEMING'S RIGHT-HAND RULE.**—Place the thumb, the first and second fingers of the right hand all at right angles to each other, Fig. 261, and in such relation to the wire that the first finger points in the direction of the lines of FORCE of the magnet, and the thumb, in the direction of motion; the SECOND FINGER will then indicate the DIRECTION OF THE INDUCED CURRENT.

Applying this rule to the wire, AB, Fig. 262, which is being moved down past the N-pole of the magnet we find that the direction of current is from B toward A.

If either the polarity or direction of motion be reversed, the current in the wire AB will be reversed, as can be proved by this rule. If both the polarity and motion are reversed the current is in the same direction as in the figure. The student should prove these statements by the above rule.

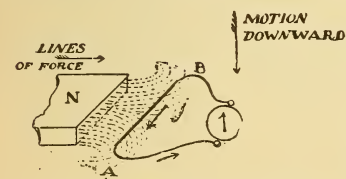


Fig. 262.—Application of Fleming's Rule.

toward B, Fig. 262, while it is being moved downward across the lines of force, the direction of these lines underneath the wire is from left to right, and the direction of motion such that if the magnetic lines were flexible they would be wrapped around the conductor in a direction *opposed to the motion of the hands of a clock*. Since the tendency of the induction is, in this case, to produce magnetic whirls, the direction of which is *anti-clockwise* as you look along the wire, the current set up flows toward you, or from B toward A. (Compare with Fig. 130.)

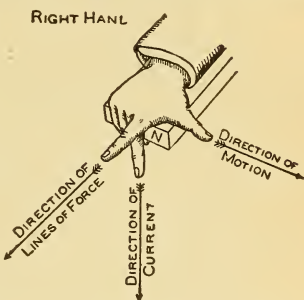


Fig. 261.—Right-Hand Rule for Determining the Direction of Induced Current—Fleming's Rule.

### 279. Upon What Factors the Value of the Induced E. M. F. Depends.—

(1.) If the wire AB, Fig. 260, be moved *very rapidly* past the pole of the magnet, the momentary induced E. M. F., and therefore the current is greater than when it was moved more slowly, as indicated by the magnitude of the needle's deflection.

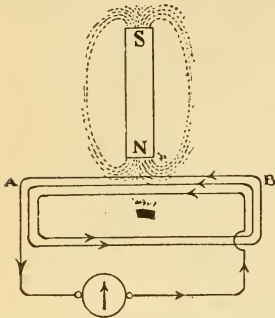


Fig. 263.—Increasing the Induced E. M. F. by Increasing the Number of Cutting Wires.

(2.) If a stronger bar magnet, as two similar magnets with like poles together be used, the induced E. M. F. will be greater than when only one magnet is used, as will be indicated by the galvanometer needle. The rate of motion should be the same in each case.

(3.) If more than one wire be made to cut the magnetic field, Fig. 263, a greater E. M. F. will be induced than when only one wire or turn is moved past the pole at the same speed. This will be indicated by the greater momentary deflection of the galvanometer needle. From the above statements, then, the induced electromotive force is dependent upon, and it can also be proved to be proportional to,

(a) *The number of magnetic lines of force cut, or the strength of the field;*

(b) *The speed or rate at which the lines of force are cut;*

(c) *The number of wires cutting the lines of force.*

### 280. Currents Induced in a Coil by Motion of a Magnet.—

Instead of moving the wire down past the magnet in Fig. 260, the wire may be coiled up, as in the solenoid, Figs. 264 and 266, and connected to the galvanometer. If now either a permanent or an electromagnet be thrust into the solenoid, a momentary induced current will flow

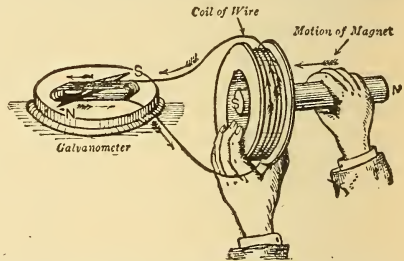


Fig. 264.—The Polarity of the Induced Current Tends to Stop the Motion Producing It—Lenz's Law.

around the galvanometer according to the conditions given in ¶ 277.

**Exp. 75:** Connect the student's galvanometer, Fig. 153, to the secondary coil, Fig. 266, and using the bar magnet set, Fig. 13, make experiments to verify all the statements given in ¶ 277.

**Exp. 76:** With the same apparatus as in Exp. 75, prove statements (a) and (b) in ¶ 279. Using one magnet, the momentary deflections of the needle will be about 25 for an average thrust.

**Exp. 77:** To prove statement (c), ¶ 279, substitute for the secondary coil used in Exp. 75 the solenoid depicted in Fig. 145, which contains a different number of turns of wire.

**Exp. 78:** Connect a cell to the detector galvanometer, Fig. 153, and note whether the needle is deflected to the right or left of zero when the current enters by the right-hand binding post. Having determined the direction of deflection for a particular direction of current through the instrument, substitute for the coil the secondary coil, and repeat the experiments enumerated in ¶ 277. Find the direction of the induced current in the coil by tracing the direction of the winding, noting the direction of deflection of the galvanometer needle and using Fleming's right-hand rule, ¶ 278. Make note-book sketches.

**281. Primary and Secondary Coils.**—The word *primary* is often used as an abbreviation for *primary coil*. The *primary coil* is the coil producing the induction, or it is the inducing body, while the *secondary coil*, or *secondary*, is the body under induction. In Fig. 264 the bar magnet is the primary body and the coil, the secondary body. In Fig. 266 an electro-magnet is substituted for the bar magnet, and is called the *primary coil*.

**282. Lenz's Law of Induced Currents.**—If Exp. 78 be carefully performed it will be found that, as the N-pole of a magnet is thrust toward the coil, the direction of the induced current will be such as to make the face of the coil near to the magnet's pole of the *same polarity* as that pole, Fig. 264; hence, *there is a magnetic repulsion between the magnet and the coil when one is being approached to the other*. When the magnet's pole is withdrawn the *direction of the induced current is reversed*; the face near the magnet has now, therefore, *opposite polarity* to the pole of the magnet, and consequently *attraction exists between them*. *In each instance the magnetic attractions or repulsions tend to oppose the motion of the magnet*. The above statements are expressed concisely in LENZ'S LAW, as follows:

IN ALL CASES OF ELECTROMAGNETIC INDUCTION THE DIRECTION OF THE INDUCED CURRENT IS SUCH AS TO TEND TO STOP THE MOTION PRODUCING IT. To produce the induced current

energy must be expended in bringing the magnet to the coil and in taking it away. If the magnet is made to approach by hand, muscular energy is expended; if attached to the end of the piston rod of a steam engine and moved in and out of the coil, mechanical energy is expended and a constant but alternating current produced. It will also be seen that if the coil terminals are open or disconnected very little energy will be required to move the magnet, since there will now be no attractions and repulsions to overcome.

The extra energy required when the coil is closed is expended in producing the induced current, and it is in this way that *mechanical energy is converted into electrical energy in the dynamo*. It will be further noted that with a given rate of motion the alternating E. M. F. will be constant, and,

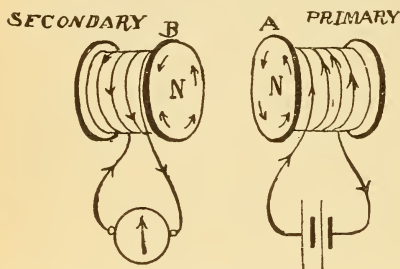


Fig 265.—The Polarity of the Induced Current Tends to Stop the Motion Producing It.—Lenz's Law.

since the resistance of the coil is constant, the current will also be constant. Suppose a galvanometer of much lower resistance is connected to the coil, Fig. 264. The current will now be greater, since the resistance is decreased, and, consequently, the watts will be greater,  $W = E \times C$ , so that more energy must be expended in producing the E. M. F. than before, because the magnetic field of the coil to be overcome has been increased by the increase of current strength. *When lamps are added in parallel to the circuit of a dynamo the resistance of the circuit is lowered, Formula (43), therefore the E. M. F. causes more current to flow through the lower resistance and more mechanical energy must be expended in proportion to the additional electrical energy furnished.*

Lenz's Law is further illustrated in Fig. 265, where the primary body, A, is an electromagnet with its polarity as indicated. On moving this electromagnet *toward* the secondary coil, B, the induced current flows so as to make the near face of B of N-polarity, and *repulsion* results as before. During the *recession* of the primary from the secondary coil the polarity of the secondary is *reversed* and *attraction* exists, *opposing*

their separation. The attractions and repulsions take place only while the coil is moving. If the coil stops the induced current in the secondary also stops, even though the current still flows in the primary coil. See also ¶ 292.

**283. Classification of Induction Currents.**—Induction is produced whenever a conductor is cut by magnetic lines of force, no matter how this cutting may be accomplished. The induction resulting from different combinations of moving magnetic fields and conductors may be classified as follows:

- (a) *Magneto-electric induction,*
- (b) *Electromagnetic induction,*
- (c) *Mutual induction,*
- (d) *Self-induction.*

In *magneto-electric induction* a permanent magnet is used to produce the magnetic field, and either the wire or the field may be moved to produce induction.

In *electromagnetic induction* the magnetic field of a current or an electromagnet is utilized to produce the induction. Mutual induction and self-induction are defined in ¶¶ 293 and 294 respectively.

**284. Currents Induced by Electromagnetism.**—Momentary induction may be produced in the secondary circuit of the student's induction coil, Fig. 266, by any of the following methods:

1. *By moving either the primary or secondary circuit.*

When both coils are stationary and one surrounds the other:

2. *By making or breaking the primary circuit.*
3. *By altering the strength of the current in the primary circuit.*
4. *By rapidly reversing the direction of the current in the primary circuit.*
5. *By moving the iron core when a current is flowing through the primary circuit.*

A momentary induced current which flows in the opposite direction to that of the current producing it, is defined as an *inverse current*, and one which flows in the same direction, a *direct current*. The above methods for producing induction are treated in the following paragraphs.

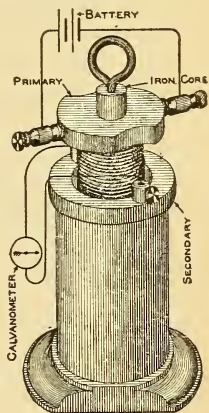


Fig. 266.—Student's Experimental Induction Coil.

A simple form of student's induction coil is illustrated in Fig. 266. The primary is a wooden spool wound with 2 layers of No. 15 B. & S. insulated copper wire, with the terminals securely fastened to binding posts, which are mounted at right angles to the coil. The latter is drilled to permit free movement of a three-eighth inch soft iron core to which is attached a brass eye bolt. Resistance of primary is about .07 ohm. Six layers of No. 30 B. & S. wire are wound on the secondary coil, which has a resistance of about 20 ohms.

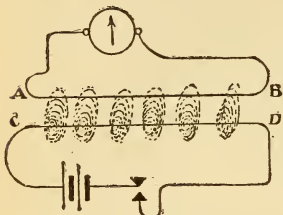


Fig. 267.—The Magnetic Field of the Primary (CD) Cuts the Secondary (AB).

285. **First Method.**—*Moving Either the Primary or Secondary Circuit.*—When either the primary or secondary circuit is moved relatively to the other the results are the same as those given for a permanent magnet in ¶ 277, and should be verified by the apparatus shown in Fig. 266. The principle involved may be further explained as follows: consider the switch closed in the primary circuit, CD, of Fig. 267; magnetic whirls surround the wire as in Fig. 129. Now move the secondary wire, AB, *toward* CD, and it is cut by the lines of force of the primary circuit, producing a momentary current during the motion. The direction of this induced current is opposed to that of the primary current as indicated, Fig. 268, and it is an *inverse* current. If the secondary be moved *away* from the primary, Fig. 269, the secondary circuit is again cut by the primary, and a *direct* momentary current is induced.

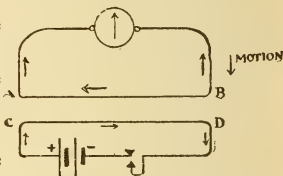


Fig. 268.—Inverse Induced Secondary Current.

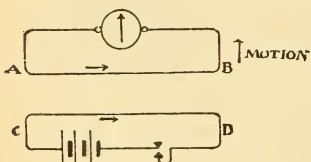


Fig. 269.—Direct Induced Secondary Current.

286. **Second Method.**—*Making or Breaking the Primary Circuit.*—Consider both circuits stationary in Fig. 267. At the instant the switch is closed the magnetic lines of force spring from the primary, CD, cut the secondary circuit, AB, and an inverse momentary current flows through the secondary, left-hand diagram, Fig. 270, for the period of time required



to establish the electromagnetic field around the primary, ¶ 315. When the switch is opened the magnetic lines of the primary will collapse upon it and again cut the secondary, but in the opposite direction, producing a direct

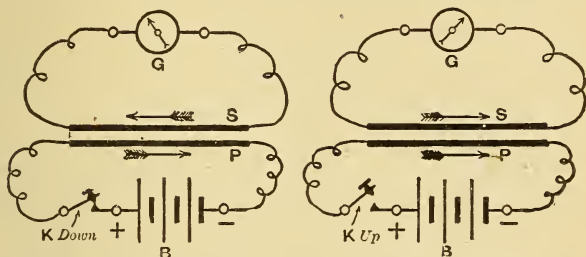


Fig. 270.—Inverse Induced Current on “Make” of Circuit, Direct Current on “Break.”

current, right-hand diagram, Fig. 270. If the primary switch be automatically closed and opened a great many times per second, the momentary induced currents will become constant in duration, but will change their direction with

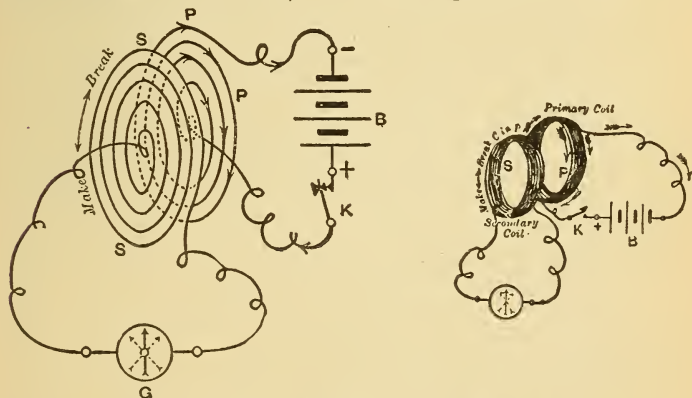


Fig. 271.—Direction of Momentary Induced Currents in the Secondary Circuit.

each make and break of the primary. Whether the circuits are wound in flat spirals or in cylindrical coils, Fig. 271, the same principles apply. The induction coil, ¶ 300, is constructed on this principle.

**287. Third Method.**—*Altering the Strength of the Pri-*

*mary Current.*—If a rheostat be introduced into the primary circuit the current can be altered without breaking the circuit, Fig. 272. When the resistance is *decreased* a momentary *inverse* current is induced in the secondary circuit, since the *magnetic lines* of the primary at the instant of change in resistance *are greater* than before, or spring outward. With an increase in resistance the primary lines cut the secondary in the *opposite direction* as they collapse toward the primary wire, and a direct momentary current is induced.

**288. Fourth Method.**—*Reversing the Direction of the Primary Current.*—A switch arranged to automatically reverse the primary current many times per second would produce an *alternating current*, the magnetic whirls of which would be continually rising, falling, and changing their direction with each reversal. A secondary wire brought into the vicinity of a wire carrying such a current would be continually cut by its magnetic lines of force, and a constant induced alternating current obtained, the variations of which would be like those in the primary circuit. When an electromagnet is supplied with an alternating current, the polarity reverses with each reversal of current so that the magnet's field is continually in motion, and will cut any conductor in its vicinity. The

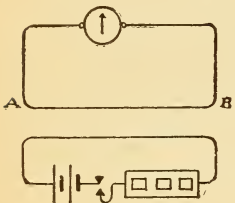


Fig. 272.—Momentary Induced Currents by Varying Strength of Primary Current.

alternating current transformer is dependent on this principle and an alternating current dynamo, ¶ 320, generates a current of this character.

**289. Fifth Method.**—*Moving the Iron Core.*—If a piece of iron be so moved, relatively to the primary and secondary circuits, that it increases the magnetic lines of force of the primary wire, an inverse current is induced in the secondary, lasting only while the increase takes place. When moved so as to produce a decrease of primary lines a direct induced current results. This principle is used in an *inductor type of an alternating current generator*. The induction is produced by rotating iron poles between the stationary primary and secondary circuits.

**290.—Table of Induction Currents.**—The character and methods of producing induced currents are summarized as follows :

Table XVIII.—Induction Currents.

By means of	Momentary INVERSE currents are induced in secondary circuit.	Momentary DIRECT currents are induced in secondary circuit.
Magnet. . . . .	While <i>approaching</i> .	While <i>receding</i> .
Current. . . . .	While approaching or beginning or increasing in strength.	While receding or ending or decreasing in strength.

**Exp. 79:** With the student's induction coil, Fig. 266, all of the above cases should be verified and the results noted. To ascertain whether the induced current is a direct or inverse one the relation between the galvanometer deflection and the current should be determined, as in Exp. 78.

**291. Variation of Induced E. M. F. with the Rate of Change of Magnetic Lines of Force.**—*Faraday's Law.*—To produce induction in a closed coil located in a magnetic field it must be so moved that the number of lines of force threading through it are constantly changing.

*The induced E. M. F. is proportional to the rate of change of the magnetic lines threading through the coil.* For example, take the closed coil of wire, A, Fig. 273, located in a *uniform* magnetic



Fig. 273.—No Induced Current in a Loop When Moved so That There is No Rate of Change of the Magnetic Lines Through It.

field, NS, with its plane at right angles to the lines of force. When the coil is moved vertically downward across the field to position B, magnetic lines of force are cut, but no induction results since the number of lines of force threading through the coil have not been altered.

From another standpoint the upper half of the coil cuts the lines in the *same direction* as the lower half, consequently the direction of the induced E. M. F. in each half is the same, or the E. M. F.'s are opposed to each other, and, being of the same value, no current can flow. If the coil A be held either

in a vertical position or at an angle, and then moved across the field in the direction of the arrows to either position, D or C, no induction will take place for the same reasons. If the coil be now turned through any angle to its vertical position, say  $45^\circ$ , as shown in position B, Fig. 274, the number of lines of force threading through it are altered (decreased), and during the angular motion an induced current flows around the ring in the direction of the arrow. In this case each half of the coil cuts the lines of force in an opposite direction, consequently the induced E. M. F.'s are also opposite in direction and in series with each other. The current, therefore, flows around the ring.

When moved through the next  $45^\circ$ , or from B to C, the rate of change of magnetic lines through the coil continues, and is greater than when it is moved from A to B. This will be seen by noting the comparative number of lines above coil B, which pass over it instead of threading through it at

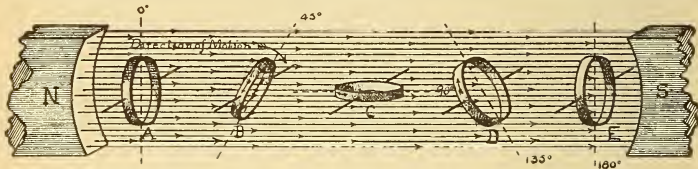


Fig. 274.—Phases of Induction in a Closed Loop When Rotated in a Magnetic Field—Principle of the Dynamo.

this angle of inclination,  $45^\circ$ , and have, therefore, been emptied out. At the position of coil C, all the lines of force above it have been emptied out of the coil. The rate of change at this position is a maximum, and the induced E. M. F. then varies from 0 in position A, to its maximum value at position C,  $90^\circ$  from A. If the motion be continued from C to D, many lines of force will now be emptied into it and induction will occur. The direction of the induced current is indicated, and is found by Fleming's rule. The induced E. M. F. gradually decreases during the motion from C to D, because the rate of change in the number of the lines of force increases in the same ratio as it decreased during motion from B to C. Motion from D to E corresponds to that from A to B, and in E all the lines are again flowing through the loop, causing no induction at this position, since there is no rate of change. During the revolution of the coil through

180°, from position A to E, the E. M. F. gradually increases from 0 to a maximum of 90°, and gradually decreases again to 0 at 180°. The same will be true of the second half of the revolution, 180° to 360°, except that the direction of current is the *reverse*, since moving a conductor up past lines of force produces an opposite direction of current from that obtained when it is moved down past the same lines. In one revolution of the coil there are thus two alternations of current, and two points of maximum E. M. F., at 90° and 270°, and two points of zero E. M. F.—that is, when the current changes its direction at 0° and 180°. When this loop is mounted on a shaft and so rotated, we have the principle of a simple *alternating current* dynamo, or alternator, ¶ 320.

*Faraday's Law* is as follows: LET ANY CONDUCTING CIRCUIT BE PLACED IN A MAGNETIC FIELD; THEN IF BY A CHANGE IN POSITION OR A CHANGE IN THE STRENGTH OF

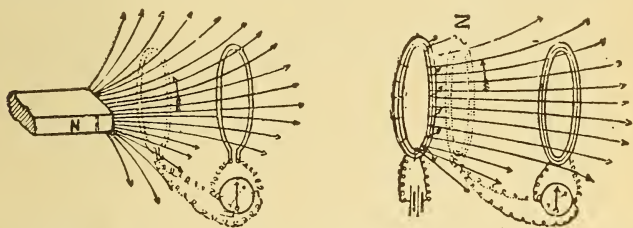


Fig. 275.—The Induced E. M. F. Depends Upon the Rate of Change of the Magnetic Lines Through the Loop—Faraday's Law.

FIELD, THE NUMBER OF LINES OF MAGNETIC FORCE PASSING THROUGH OR INTERLINKED WITH THE CIRCUIT IS ALTERED, AN E. M. F. WILL BE INDUCED IN THE CIRCUIT PROPORTIONAL TO THE RATE AT WHICH THE NUMBER OF LINES IS ALTERED. By referring to Fig. 275, it will be understood how Faraday's Law applies to all our previous induction experiments. In the positions of the secondary circuits shown by the solid lines, the number of lines through them is a minimum. When moved up close to the primary, as in the dotted positions, a great many more lines fill the coils, which are also emptied out again during recession.

Lenz's Law, ¶ 282, may also be applied to the motion of the coil in Fig. 274. The direction of current indicated by the arrows on the rings is found by Fleming's rule, and is

such that if the ring be viewed from the **N**-pole side as it is being moved away from this pole the induced current flows around it clockwise, producing a **S**-pole on this face with resulting attraction for the **N**-pole, from which it is receding. Muscular or mechanical energy must, therefore, be expended in moving the ring through the angular position in proportion to the electrical energy developed in it.

**292. Eddy Currents—Arago's Rotations.**—When a magnet is suspended over a copper disc and the disc rotated, induced currents are generated in the disc, which tend to oppose the motion producing them. If the magnet be free to move it will be dragged around in the same direction that the disc rotates. According to Lenz's Law, the direction of the current in the part of the disc moving toward the magnet

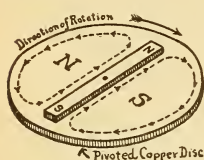


Fig. 276.—Eddy Currents Induced in a Copper Disc Rotated Under a Stationary Permanent Magnet.

pole will be of the same polarity as the pole being approached, therefore tending to repel the magnet, while that in the receding part of the disc will be of the opposite polarity, thus attracting the magnet. Both actions, then, tend to urge the magnet in the same direction and to cause its rotation. If the magnet be held stationary and the disc revolved, considerably more force must be applied to turn it than when the magnet is not near it. Each part of the disc, as it comes under the influence of the magnet, is subjected to rapidly succeeding increases and decreases in the number of lines of force threading it.

Such currents induced in masses of metals either by being rapidly cut by the moving field or by moving in the field are called *eddy currents*. The direction of the eddy currents in the copper disc for a particular case is shown in Fig. 276. The magnet is stationary and the disc rotated clockwise. The currents circulate around the disc in the form of two semi-circles. In the left-hand one the direction is anti-clockwise, producing a **N**-face on the disc which repels the **N**-pole of the magnet, and tends to stop the motion producing it. On the right-hand side a **S**-face is produced, attracting the **N**-pole, and again tending to stop the motion of the disc, according to Lenz's Law. When the magnet is free to move, it will tend to move so that its poles will always be over the unlike poles induced in the disc, but as soon as

the magnet moves the paths of the eddy currents also change. They will always be set up with the magnet as their diameter, and each half of the disc will be of opposite polarity. The position which the magnet seeks is never attained and continuous rotation results as long as the disc is rotated. If pieces of wire gauze are pressed against the disc directly under each pole of the stationary magnet, Fig. 276, forming wiping contacts, or *brushes*, and the brushes connected to a galvanometer, the needle will be deflected by the eddy currents when the disc is rotated.

*Faraday's disc dynamo* consisted of a copper disc rotated between the two poles of a magnet, Fig. 277, the current being led off from the centre and edge of the disc by brushes. Barlow's wheel, Fig. 244, when rotated by hand will give current to an external circuit, illustrating the convertibility of a motor and dynamo. When electromagnets are used they must be excited by a separate source of current.

A compass needle in a metal case will come to rest very quickly, because by its oscillating motion it induces eddy currents in the case which tend to stop the motion of the needle.

The eddy currents circulating in solid conductors are converted directly into heat and are the source of much loss of energy and other derangements in dynamos, motors and transformers. To avoid them as far as possible, the solid conductor, as the iron core of an armature or induction coil, is made up of laminations, the plane of which is parallel to the lines of force of the field, See ¶ 332. Eddy currents circulate in the metallic bobbin of the D'Arsonval galvanometer coil when it moves in its magnetic field and tend to stop the motion according to Lenz's Law. It is for this reason that the Weston instruments are so dead-beat. The same action also takes place in the copper disc rotated between permanent magnets in the Thomson wattmeter.

**Exp. 80:** Strongly magnetise a bar electromagnet and strike one pole with a piece of flat sheet copper and you find a cushioning effect is produced. You are unable to strike the pole with as great force as when the current is off. Eddy currents are induced in the copper,

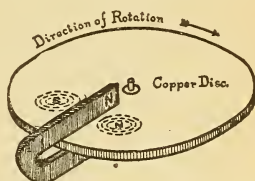


Fig. 277.—The Eddy Currents Tend to Oppose the Motion Producing Them.

the reaction of the magnetic field of which tends to oppose the motion. The same is true if you try to quickly lift the sheet of copper from the pole.

**Exp. 81:** Suspend a copper penny by a thread between the poles of a horseshoe electromagnet. Twist the thread up and permit it to unwind. Send a current through the magnet and the motion of the penny ceases, due to the reaction of the eddy currents which stop it, but when the circuit is broken the thread carrying the penny continues to untwist.

**Exp. 82:** Excite an electromagnet from a source of alternating current. Hold a piece of sheet copper over one pole, and it is strongly repelled, and if held there against the repelling force it will get very warm. The moving alternating current field cuts the copper sheet and eddy currents are induced as before. If the electromagnet has a solid iron core it will also get quite hot for the same reason. The cores of alternating current electromagnets are made of bundles of wire to increase their resistance to the flow of eddy currents. The rapid magnetisation and demagnetisation of the iron core of an electromagnet by an alternating current also produces heat as a result of the molecular friction between the particles of the iron, ¶ 30. A certain amount of the electrical energy is converted into heat in this manner and is termed the *hysteresis* (hister-ee'-sis) loss.

*Hysteresis* may be defined as the molecular friction between particles of iron or steel when they are subjected to rapid changes in magnetisation. See ¶ 336.

**293. Mutual Induction.**—The induction due to two independent electric circuits reacting upon each other is called *mutual induction*. The previous examples of induction in a secondary circuit due to current flowing in the primary circuit illustrate mutual induction. Parallel conductors carrying independent alternating currents react upon each other by reason of the mutual inductive influence between them. Mutual induction in telephone circuits often gives rise to cross-talk unless the line is so constructed that the induction effects are neutralized, ¶ 299.

**294. Self-Induction.**—*Self-induction* is defined as the cutting of a wire by the lines of force of the current flowing through it. When a current begins to flow along a wire the magnetic whirls spring outward from the wire and cut it. This cutting of the wire by its own lines of force induces in it a momentary *inverse E. M. F.*, or an *E. M. F.* which opposes the *E. M. F.* causing the current to flow, and is called a *counter E. M. F.* With a steady current the induction is only momentary, therefore a brief interval of time must elapse before the current passed through the circuit reaches its normal value. When the current flowing through the wire



is stopped, the magnetic field collapses, and in so doing again cuts the wire, but in the *opposite direction*. A momentary induced E. M. F. is set up which is now *direct*, or in the same direction as the E. M. F. which previously caused the current to flow. The effects of self-induction are therefore to oppose the starting of a current by reason of the inverse E. M. F. which must be overcome before the current can flow, and to momentarily *retard the cessation of the current* by reason of the direct induced E. M. F. when the circuit is broken. Momentary currents of self-induction are also produced in any circuit by any change in current strength through it, whereby the number of lines of force surrounding or interlinked with it is increased or decreased.

The effects of self-induction are scarcely noticeable in a straight wire carrying a current, but when it is coiled up, as in a helix the magnetic field of every turn cuts many adjacent turns and the E. M. F. is increased, being proportional to *the current, the number of turns and the magnetic lines through the coil*. When the coil contains an *iron core* the effects of self-induction are *very much greater*. One very noticeable effect is the *bright spark* appearing at the point of *breaking a circuit* containing wire wound around an iron core. No effect is noticed on closing such a circuit on account of the counter E. M. F., but at break a spark appears, due to the momentary induced direct current which tends to prolong the current in the circuit. The induced E. M. F. at break is very much higher than was the applied E. M. F. This induced current of self-induction is sometimes called the *extra current*. If the terminals at the point of break are held, one in each hand, and then separated, the body will receive a shock, the intensity of which will depend upon the size of the coil and the current used. No shock will be felt upon placing the hands across the battery, thereby indicating that the E. M. F. of self-induction is much higher than the battery E. M. F.

**295. Gas Lighting Spark Coil.**—The function of the spark coil used in electric gas lighting is to increase the self-induction of the circuit at break, as when the chain of a ratchet burner is pulled. A coil is inserted in series with the battery circuit and the burner, and the heat of the spark on breaking the circuit is sufficient to ignite the gas.

Such a coil, Fig. 278, consists of about 2 pounds of No. 16 insulated copper wire wound around an iron core 1 inch in diameter and 8

inches long. The core is not solid, but consists of a bundle of soft iron wires, which greatly increases the inductive action by diminishing the eddy currents, ¶ 292.

**Exp. 83:** Connect a galvanometer in parallel with a helix of fine wire, Fig. 279. Close the circuit and the needle is deflected, say to the right of zero, and the current divides between the galvanometer and the helix. Move the needle, by hand, to the zero position, and

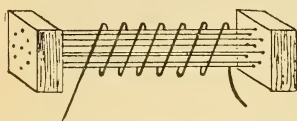


Fig. 278.—Gas Igniting Spark Coil with Laminated Core.

place some obstacle in the way so as to prevent it turning again to the right of zero. Now release the battery key and a momentary current, due to the self-induction of the helix, flows around the galvanometer needle, momentarily deflecting it in the opposite direction. The induced current through the helix, at break of circuit, is in the same direction as the battery current was, but flows in the opposite direction through the galvanometer connected to it. This is shown by the dotted arrow in the figure.

**Exp. 84:** In Fig. 279 an incandescent lamp is connected in shunt with an electromagnet and through the switch, K, to a battery of an E. M. F. equal to that required by the lamp. The resistance of the magnet should be such that with current flowing the lamp filament is just perceptibly red. At the instant of closing the switch the momentary self-induction of the electromagnet acts like resistance against the current, causing most of it to flow through the lamp, which glows brighter for a moment and then becomes dim as the current attains its steady value. On breaking the circuit the lamp again glows very brilliantly since it is in circuit with the electromagnet. The energy stored in the magnetic field is thus converted into a momentary direct current of a high E. M. F. and lights the lamp. The fields of a dynamo should not be broken when fully excited since the E. M. F. may become so high as to cause a puncture of the insulation at two or more points, and thus complete the circuit through the iron core, and cause a ground, ¶ 312. The self-induction at break of such a circuit is termed the *field discharge*.

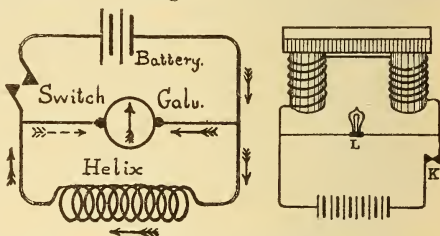


Fig. 279.—Experiments Illustrating the Extra Current of Self-Induction.

**296. Inductance.**—The cause of the self-induction is due to the property possessed by the wire or coil called *inductance*, just as the resistance of a wire is that property of it which opposes the flow of a current through it. A coil or wire, therefore, possesses inductance whether current is passing

through it or not. The amount of inductance offered by a coil depends on the number of turns of wire in the coil and on the magnetic conductivity of the medium surrounding it. A coil of 50 turns wound around an iron core has a very much higher inductance than a coil of 50 turns without an iron core. A coil of 15 turns wound on an iron core has less inductance than one of 60 turns wound on a similar core. The inductance of a coil or circuit is measured by the E. M. F. induced in it when the inducing current varies at any given rate. The unit of inductance is called the *henry* (the symbol for which is "L"), and is the induction produced in any circuit when the induced E. M. F. is one volt, and the current through the circuit varies at the rate of one ampere per second. The secondary coil of a 2-inch spark coil, ¶ 306, has an inductance of about 51 henrys; a 2.5 ohm electric bell, .012 henry or 12 millihenrys; the fields of a 3.5 K. W. 100-volt, shunt dynamo, 13 henrys.

**297. Reactance and Impedance.**—When an alternating current flows through a circuit containing inductance, the effects of self-induction will become continuous instead of momentary, and will considerably retard the flow of current through the circuit as long as it is maintained. The *apparent resistance* of a circuit to an alternating current is greater than the ohmic resistance. The cause of this apparent additional resistance is due to the effect of self-induction, and is termed *inductive resistance*, or reactance. Reactance is the effect of self-induction expressed in ohms. It, therefore, differs from inductance in that it exists only while the current flows. A coil has no reactance unless the current flows through it and the rate of flow is varied. This spurious resistance (reactance) in any circuit is measured in ohms, and is equal to the product of its inductance, the number of times the current flow is reversed per second and a constant (6.28). Ohm's Law, in its simplest form, is thus not applicable to calculations of circuits for alternating currents. The R in Ohm's Law for alternating currents includes the calculation of the resistance of the circuit plus the calculation of its reactance. The total opposition offered to the flow of an alternating current by the resistance and the reactance is called the *impedance*. On account of the reactance, a larger size of conductor must be used in alternating current circuits than when direct currents are used.

### 298. Choke Coils.—

**Exp. 85 :** In Fig. 280 a solenoid of several ohms resistance wound in the ordinary manner, is connected in series with an incandescent lamp and to a source of direct current (D. C.) by throwing the switch, S, down. The brilliancy of the lamp is practically the same with the solenoid in circuit as when it is cut out by the key, K. Neither is there any change in the lamp when an iron core is inserted in the coil.

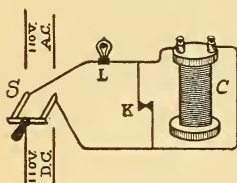


Fig. 280.—Effects of Self-Induction.

Now the circuit is connected to a source of alternating current (A. C.) by throwing S up. With the solenoid out of circuit the lamp burns as brilliantly as before, but when it is inserted, as by opening key, K, the lamp burns dimly. The current through it has been decreased by the self-induction of the solenoid. If an iron core is now gradually inserted in the coil, the current is gradually decreased, since the inductance is being increased, and the lamp may not give any illumination. The self-induction chokes back the current, so that less current is taken from the line. A device for regulating the candle power of lamps in an alternating current circuit is based on this principle, and is called a *choke coil*. The flow of alternating currents can thus be regulated much *more economically* than direct currents, since in the latter case regulation is effected by absorbing the energy in the extra resistance.

**Exp. 86 :** The following measurements made on a coil of wire wound inductively when carrying a direct and alternating current will further illustrate the property of self-induction. In Fig. 281 the coil AB, without an iron core, is connected in series with an electro-dynamometer and to a source of direct current. The pressure required to cause a known current to flow through the coil is 30 volts. The coil is then subjected to an alternating current pressure of such a value that the amperes through it, as indicated by the dynamometer are the same as before, and the potential difference across it is found to be 100 volts. A pressure of 100 volts alternating current is therefore required to send the same current through the coil as was maintained by 30 volts direct current. The difference in the two pressures is required to overcome the opposition due to the self-induction.

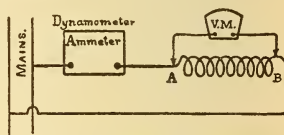


Fig. 281.—Effects of Self-Induction.

**299. Neutralizing the Effects of Self-Induction—Inductive and Non-Inductive Circuits.**—Self-induction in a coil may be neutralized by winding one-half of the coil in a right-hand direction and the remainder in the opposite direction. This is accomplished in practice by folding the length of wire to be used at its middle point and starting at this point, winding both halves as a single wire, when the termi-

nals will be conveniently arranged for connection. The magnetic effects of the current flowing in one direction neutralize those of the same current flowing in the opposite direction and the coil now offers practically the same resistance to either an alternating or direct current. Such a circuit is said to be *non-inductive* and contains practically no inductance, while an ordinarily wound coil constitutes an *inductive circuit*. No polarity would result from inserting an iron core in a non-inductively wound coil since the current through one-half of the turns would tend to magnetise one end with a **N**-pole, while in the other half the tendency would be to produce a **S**-pole at the same end.

The coils of laboratory rheostats and Wheatstone bridges are wound non-inductively, Fig. 126, so that they will have no magnetic influence on a galvanometer, and also so that the currents in the bridge arms may reach their maximum value simultaneously. Self-induction is neutralized in alternating current lighting and power circuits by placing the lead and return wires as close together as possible. For this reason *concentric cables* are used for such circuits. An incandescent lamp is practically a non-inductive resistance, while an electromagnet is an inductive resistance.

### QUESTIONS.

1. The **N**-pole of a bar magnet is thrust through a key ring and quickly withdrawn without touching it; the action is continued for a time and the ring becomes warm. How do you explain this?

2. Is the direction of the induced current in question 1 clockwise or anti-clockwise, as viewed from the side next to you, when the bar magnet is withdrawn from the ring? Make a sketch.

3. State three factors upon which the induced E. M. F. is dependent when conductors are moved through a magnetic field.

4. A cell connected to a galvanometer indicates 50 deflections. A portion of the connecting wire is coiled up and an electromagnet excited from another cell is plunged into the coil. The galvanometer needle momentarily indicates only 30°. Explain this and make sketch to illustrate your answer.

5. The two ends of a 5-pound reel of bell wire are connected to each other, and it requires more muscular force to quickly insert and remove an electromagnet from the centre of the reel than when the two ends are free. Explain fully. Make sketch.

6. The E. M. F. of a dynamo is too low and the field cores are fully saturated so that the voltage cannot be raised in this manner. How would you increase it and still use the same machine?

7. Two sets of parallel independent circuits supply current to some incandescent lamps. At the instant of turning out all the lamps on

one set of mains the others burn more brightly. Explain fully and give detail sketch of the direction of currents in the circuits, etc.

8. An electromagnet is inserted in a coil of wire and the terminals of the latter then joined to a galvanometer but there is no momentary deflection of the needle. Explain why.

9. At the instant of breaking the electromagnet circuit in question 8 the needle is deflected  $40^\circ$ , while on making it again the deflections are only .35. Explain this and make sketch.

10. Two pieces of thick copper wire are joined to a battery, and when the ends are brought in contact and separated there is no perceptible spark. An electromagnet of high resistance is connected to the same battery and a bright spark appears when the circuit is broken. Since the E. M. F. of the battery is the same as before and the resistance so much higher than before, how do you account for the phenomenon?

11. A solid iron core electromagnet is excited by an alternating current. The core becomes very hot though the wire is sufficiently large to carry the current without becoming warm. State two reasons for the heating.

12. Using a copper mallet, why is it impossible to strike the pole of a strong electromagnet with as hard a blow as when the magnet is not excited?

13. State two phenomena occurring in the copper mallet when the pole of the electromagnet, in question 12, is struck.

14. Make a sketch of a copper disc rotating between two horseshoe permanent magnets, as in the Thomson recording wattmeter. Indicate polarities and directions of rotation and eddy currents.

15. Ten volts alternating current cause 5 amperes to flow through a straight insulated copper wire 20 feet long. The same wire is now coiled up and the current is only 3 amperes, yet the pressure and resistance of the wire are exactly the same as before. How do you explain this?

16. Why is a choke coil more economical than a rheostat?

17. The resistance of an electromagnet is 10 ohms but its apparent resistance to an alternating current is 15 ohms. What is meant by this expression?

## LESSON XXV.

### THE INDUCTION COIL.

Principle of the Induction Coil or Transformer—The Induction Coil—Action of the Coil—Action of the Condenser—Construction of Induction Coils—Wehnelt Electrolytic Interrupter—Table XIX. Sparking Distances in Air—Spark Coil Data—Table XX. Spark Coil Dimensions—Vacuum Tubes—Roentgen Rays (X-Rays)—The Fluorescing Screen and Fluoroscope—The Telephone—The Microphone Principle—The Blake Microphone Transmitter—The Telegraph—The Signal System and Circuits—Electric Waves—Wireless Telegraphy—Questions.

#### 300. Principle of the Induction Coil or Transformer.—

An induction coil, or transformer, consists of two independent coils in which, by induction, an alternating or interrupted electromotive force, maintained across one of the coils, is made to produce a higher or lower electromotive force in the other coil. Such a coil consists of three principal parts: the primary, the secondary, and the iron core. In Fig. 282 two independent coils are wound upon an iron ring. When

the secondary is connected to a galvanometer and a current passed through the primary from a battery, the galvanometer needle will be momentarily deflected at "make" and "break" of primary, as in our previous experiments. The currents in the primary magnetise the iron core, and the lines of force in the core thread through

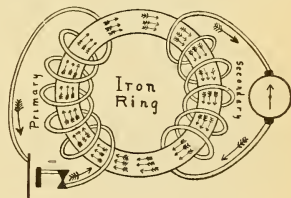


Fig. 282.—Closed Circuit Transformer.

the secondary coil producing induction effects. If the battery current is sent through the secondary, induction is produced in the primary as before. This simple ring form of closed iron circuit transformer represents the principle of construction in all induction coils or transformers. In Fig. 283 the iron circuit is of the open type and the primary wound upon an iron core, while the secondary is insulated from and wound on top of it. The induction is produced either

by an interrupter in a direct current circuit or by an alternating current.

In all transformers the relation of the induced E. M. F. generated in the secondary circuit to that employed in the primary, is nearly proportional to the ratio of the number of turns in each circuit. For example, if the primary contains 100 turns and the secondary 2000 turns, then the induced E. M. F. will be about twenty times as great as that used in the primary. If this secondary contained only fifty turns then the E. M. F. would be only half as great as that in the primary.

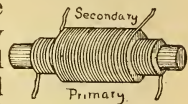


Fig. 283.—Open Circuit Transformer.

By a proper proportioning of the turns, then, any desired E. M. F. may be obtained from the secondary terminals.

The function of an induction coil is to *transform the energy* delivered to its primary from any given voltage to a higher or lower voltage. While a current of low pressure may thus be transformed into one of a very high pressure, the latter loses in current what it gains in pressure, so that the watts

in the secondary are no greater than those developed in the primary, but always a little less, owing to various losses in transformation and the C square R loss in the secondary circuit.

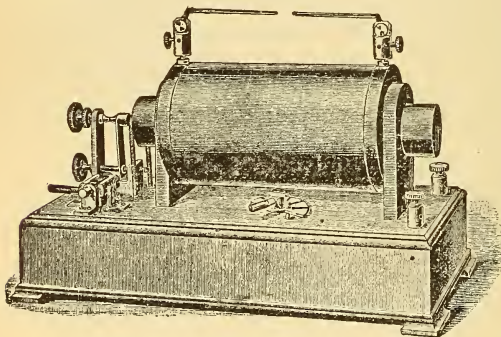


Fig. 284.—Induction or Spark Coil.  
For use with direct currents.

### 301. The Induction Coil.—

The principle of the transformer is utilized in induction coils constructed to generate very high electromotive forces, capable of overcoming the resistance of the air and causing sparks to pass across air gaps. The induction coil, or *Rhunkorff's inductorium*, Fig. 284, is a *step-up-transformer* since, by induction, it raises the voltage of several cells connected to its primary to thousands of volts at the secondary terminals. It consists of a straight laminated core, made up of a bundle of soft charcoal iron wires



around which is wound the cylindrical primary coil, composed of several layers of heavy wire, while a secondary coil composed of thousands of turns of fine wire, is wound over the primary, similar to Fig. 283. The inner or primary coil is connected to a battery through an automatic interrupter, Fig. 285. At the "make" and the "break" of the primary circuit currents are induced in the secondary according to the laws of induction, ¶ 284, and appear as a series of sparks passing through the air from one secondary terminal to the other. The general appearance of such a coil is shown in Fig. 284, and its connections, in Fig. 285,

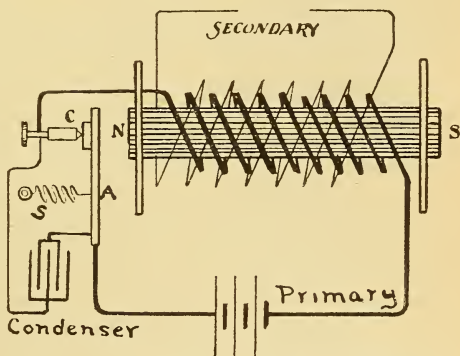


Fig. 285.—Diagram of Connections of a Spark Coil.

**Exp. 87:** The student's induction coil illustrated in Fig. 266, may be mounted on a base provided with a contact screw and vibrator arm, when induced currents can be produced automatically from the secondary coil. This arrangement is shown in Fig. 286, where the connections can be readily traced. Using the primary alone, the automatic action of the electric bell is illustrated. When short lengths

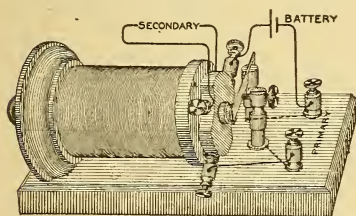


Fig. 286.—Student's Induction Coil as a Spark Coil.

of brass tubing are attached to the secondary terminals and then clasped, one in each hand, a peculiar muscular contraction is produced, due to the high voltage of the induced E. M. F. This is the physiological effect of an electric current, ¶ 96.

### 302. Action of the Coil.

The action of the automatic interrupter used on induction coils is shown in Fig.

285. The current from the battery flows through the soft iron pivoted armature, A, free to move, to the stationary contact post, C, the armature being held in contact with the point, C, by the spring, S. From C the current circulates around the primary core and returns to the battery. The contact screw ter-

minates in a piece of platinum wire and there is also a piece of sheet platinum fastened to the vibrator arm at the point of contact with the screw C. Platinum is used to prevent the oxidation due to the spark at the contact points. The instant the current flows through the primary coil it strongly magnetises the iron core, NS, which core attracts the armature by overcoming the tension of the spring. This breaks the primary circuit, the magnetism of the core ceases, and the spring pulls

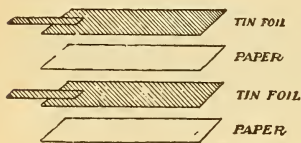


Fig. 287.—Detail of Condenser Construction.

back the armature again "making" the circuit so that the same events are repeated. The armature vibrates continually as in an electric bell, and the circuit is "made" and "broken" thousands of times per minute. An *inverse* induced current in the secondary corresponds with each "make" of primary, while a "direct" current is induced on "break" of primary. Interrupted currents in the primary, therefore, produce alternating currents in the secondary.

The *self-induction* in the *primary circuit* has a very important bearing upon the action of the coil. At "make" of primary the counter E. M. F. opposes the battery current, and reduces the time rate of change of the current upon which the induced E. M. F. depends, while at "break," the self-induced current in the primary tends to prolong or increase the primary current, preventing its rapid fall to zero by sparking across the break. A *rapid rate of magnetisation and demagnetisation of the iron core means a great rate of change of the lines of force threading through the secondary coil, and hence a high E. M. F.* A condenser, ¶ 303, is added for the purpose of suppressing this spark across the primary break and of aiding the primary current to fall abruptly to zero.

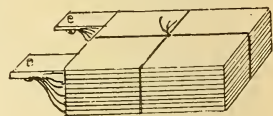


Fig. 288.—Plates of a Condenser Assembled and Connected.

**303. Action of the Condenser.**—A condenser for a spark coil consists of two sets of interlaid layers of tin-foil separated by sheets of paper coated with paraffin or shellac, Fig. 287.

The alternate layers of tin-foil are connected to each other, and two common terminals are thus formed, as depicted in

Fig. 288. There is no electrical connection between the condenser terminals, but if they are connected to a source of very high E. M. F. the plates become electrified or charged, and may be discharged when a proper path is afforded. The condenser is located in the base of the coil shown in Fig. 284, and its terminals connected across the primary break, points A and C of Fig. 285.

The condenser action is as follows: when current flows through the primary at "make," Fig. 285, no energy can be stored up in the condenser, but it appears as the magnetic field in the core and surrounding primary. At "break" the extra current of self-induction in the primary, instead of overcoming the resistance of the spark-gap, charges the condenser, and the core is more *quickly demagnetised*. At "break" also there is a complete discharge circuit for the condenser back through the battery and the primary coil, in the *opposite direction* to the *previous* primary current; the condenser thus aids in quickly demagnetising the iron core by tending to set up lines of force in the opposite direction. If the primary current is re-made before the *reverse condenser current* disappears, as is practically the case, the battery current has to first overcome this obstructing current before it can produce any effect. Thus the inductive effect of the "make" circuit is *retarded* by the condenser. With the use of a condenser then the E. M. F. of the "direct" secondary current at break is *exalted*, while that of the "inverse" secondary current on "make" is *diminished*. The consequence is that when the secondary discharge has to overcome much resistance only the former current is able to pass, and the secondary discharge *becomes practically an intermittent current of high voltage in one direction only*. In medical induction coils where no condenser is used the secondary charges are practically equal.

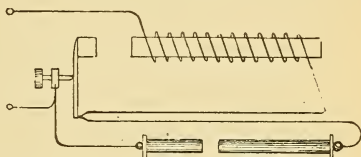


Fig. 289.—Primary Shock Coil.

The voltage generally applied to the primary of the ordinary induction coil varies from about 4 to 15 volts according to the size. A higher voltage causes excessive sparking and destruction of the platinum contacts. Specially constructed inde-

pendent vibrators are used with modern high class coils which can be connected directly to an electric light circuit of 110 volts or more. The vibrator is practically a relay, ¶ 313, which makes and breaks the current in the independent primary circuit by means of another pair of platinum contact points. This circuit can also be supplied from a 110-volt circuit and the current regulated by a rheostat.

**304. Construction of Induction Coils.**—Induction coils may be divided, according to their use, into two general classes, medical or therapeutic coils and spark coils. In the former, the winding is designed so as not to produce such a high E. M. F. as in a spark coil, and consequently no condenser is required. Some means for varying the intensity of the shock is provided, such as altering the number of turns in circuit in the secondary coil by a selector switch, or by so constructing the secondary that it may be gradually withdrawn from the primary. Regulation may also be effected by varying the position of a brass tube enclosing the iron core.

The tube screens the iron core from the action of the primary current, thereby weakening the magnetic field cutting the secondary circuit. Instead of magnetising the core, a portion of the energy of the primary circuit is thus expended in producing eddy currents in the tube. The iron core is composed of a bundle of soft charcoal iron wires, about No. 22 gauge. For medical coils the number of layers in the primary is generally from 4 to 6 and the size of wire used No. 24, 22, or 20, according to the dimensions of the coil, while

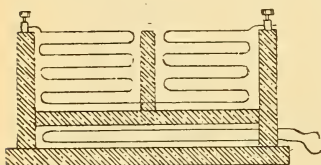


Fig. 290.—Sectional Winding of the Secondary of a Spark Coil.

the secondary is wound with No. 34 or 36. The primary will thus have considerable self-induction which is not a great disadvantage in these coils.

Spark coils are usually rated according to the number of inches that the spark will jump between the secondary terminals through the air. Thus a two inch coil means that the E. M. F. is high enough to cause sparks to pass when the terminals are separated at a distance of two inches. The self-induction of the primary must be very low and so it is wound with about 2 layers of a much larger size wire than that used

in medical coils. The primary must be thoroughly insulated from the secondary, and also the coils of the secondary from each other when it is wound in sections. With insufficient insulation the induced E. M. F. is liable to cause a spark to pass from the secondary to the primary, or between sections of the secondary, instead of across the terminals. When the insulation is so punctured by the spark at two or more points the spark will always thereafter take the path of least resistance, in preference to that between the secondary terminals. When the coil is designed to produce a spark over 1.5 inches the secondary should be wound in a number of sections separated from each other by proper insulation. In Fig. 290, the secondary is wound in two sections as the potential difference between layers is less than when wound in a single coil. The sections must be so connected that the current will circulate through all of them in the same direction.

In Fig. 284 a commutating switch for reversing the current in the primary circuit, is mounted near the left-hand end of the base, thereby changing the polarity at the secondary terminals. Another selector switch near the centre of the base serves to connect more or less of the condenser's capacity across the points of "break." The following table gives the sparking distance and approximate corresponding E. M. F. between opposed sharp needle points :

Table XIX.—Sparking Distances in Air.

Volts.	Distance. (Inches.)	Volts.	Distance. (Inches.)
5000	.225	60000	4.65
10000	.47	70000	5.85
20000	1.00	80000	7.1
30000	1.625	100000	9.6
35000	2.00	130000	12.95
45000	2.95	150000	15.00

NOTE.—These values are correct for effective sinusoidal voltages.

**305. Wehnelt Electrolytic Interrupter.**—Instead of the electromagnetic vibrator previously described, the electrolytic effect of the current may be utilized to break the primary current of an induction coil. The Wehnelt interrupter consists of a vessel containing dilute sulphuric acid in which is immersed a lead plate and a glass tube having a small piece of platinum wire (about  $\frac{1}{4}$  inch of No. 24)

sealed in its lower end. External connection is made with the platinum wire by filling the tube with mercury, or as in the electrode in Fig. 94. If this electrolytic cell be connected to a source of sufficient power so that 12 volts or more are maintained across it, with the *platinum as the anode\** and the *lead plate as the cathode*, gases will be liberated by electrolysis. The oxygen gas enveloping the platinum tip practically insulates it from the solution, and the circuit is interrupted when the evolution of gas ceases and the circuit is again "made." The action is very rapid, and the "makes" and "breaks" quick and sharp. The cell emits a buzzing noise and a yellowish light surrounds the platinum wire. A Wehnelt interrupter connected in series with the primary of a small spark coil will cause it to give a much larger spark than when the mechanical interrupter is used. The frequency of the interrupter depends upon the area of platinum exposed, the self-induction of the coil and the voltage. This interrupter in series with the primary coil may be operated from 110 volts.

**Prob. 116:** The primary of an induction coil is wound with 100 turns of No. 14 copper wire and the secondary, with 35,000 turns. Ten volts cause a current to flow through the primary. What is the approximate E. M. F. at the secondary terminals?

By ¶ 300,  $\frac{35000}{100} = 350$ , or there are 350 times as many turns on the secondary as on the primary.

$$10 \times 350 = 3500 \text{ volts, secondary.}$$

$$E = 10 \text{ volts in primary, ratio of transformation} = 350.$$

**Prob. 117:** The resistance of the primary in Prob. 116 is 0.5 ohm, and if the loss in conversion of the energy to the higher potential is 50 per cent what will be the approximate current strength in the secondary circuit?

$$\text{By Formula (28) } C = \frac{E}{R} = \frac{10}{.5} = 20 \text{ amperes in primary.}$$

$$\begin{aligned} \text{By Formula (62) } W &= E \times C = 10 \times 20 = 200 \text{ watts in primary.} \\ 50\% \text{ of } 200 \text{ watts} &= 100 \text{ watts in secondary.} \end{aligned}$$

$$\text{By Formula (63) } C = \frac{W}{E} = \frac{100}{3500} = .028 \text{ ampere.}$$

NOTE.—The above problem is only approximate, since other factors enter into the calculation. It should assist, however, in understanding the relation between the expended primary energy and that appearing as a high potential spark in the secondary.

**306. Spark Coil Data.**—The following dimensions are given for several sizes of spark coils, similar to that depicted in Fig. 284, so that the student may be guided if he attempts construction. †

\* If the platinum wire be connected by mistake as the cathode, it will be melted. See ¶ 264.

† In a book entitled *Induction Coils and Coil Making*, by Allsop, will be found complete data for constructing and operating spark coils. The data for a 12 inch coil, as given, requires 12 pounds of No. 36 silk covered wire, or about five miles in length.

Table XX.—Spark Coil Dimensions.

	$\frac{3}{8}$ inch	$\frac{1}{2}$ inch	1 inch	2 inches
Length of spark.				
Size of bobbin ends . . . . .	$2\frac{1}{8} \times 1\frac{1}{4}$	$2\frac{1}{2} \times \frac{5}{16}$	$3 \times \frac{3}{8}$	$4 \times 2\frac{3}{4} \times \frac{3}{8}$
Length of bobbin . . . . .	4	$5\frac{1}{2}$	$6\frac{1}{2}$	$6\frac{1}{2}$
Length and diameter of core.	$4\frac{1}{2} \times \frac{7}{16}$	$6 \times \frac{5}{8}$	$6\frac{1}{2} \times \frac{3}{4}$	—
Size of base	$7\frac{1}{4} \times 3\frac{1}{4} \times 1\frac{1}{2}$	$9 \times 5 \times 2$	$14\frac{1}{2} \times 6 \times 1\frac{3}{4}$	$12 \times 7\frac{1}{2} \times 3\frac{1}{4}$
Size of tinfoil sheets . . . . .	$4 \times 2$	$5\frac{1}{2} \times 3\frac{1}{4}$	$6 \times 4$	$6 \times 6$
Number of tinfoil sheets . . . . .	36	40	40	60
Size of paper sheets . . . . .	$5 \times 3$	$6\frac{1}{2} \times 4\frac{1}{4}$	$9 \times 5$	—
Primary coil . . . . .	No. 18	No. 18	2 layers No. 16, silk covered.	2 layers 14 B. W. G. silk covered.
Secondary coil	$\frac{3}{4}$ lb. No. 40	1 lb. No. 40	$1\frac{1}{4}$ lbs. No. 38	$2\frac{1}{2}$ lbs. No. 36

Two large induction coils, capable of giving a 45-inch spark between their secondary terminals, and weighing 1500 pounds each, were recently constructed by an American firm for the Japanese government. The primary interrupter was actuated by a small motor and the rate of interruptions was capable of being varied between wide limits. With 40 volts maintained across the primary circuit, a current of 30 amperes produced a very heavy 42-inch spark.

**Exp. 88:** The *mechanical effect* of the spark from an induction coil may be observed by holding a piece of cardboard between the terminals when the spark is passing. The card will be perforated, leaving a bur on each side. Thin plates of any non-conductor can be punctured in like manner.

**Exp. 89:** To observe the *heating effect*, place a small quantity of gunpowder on a glass plate and arrange the terminals of the coil so that the spark will pass through it. On closing the battery circuit, the heat developed by the spark causes the powder to explode.

**Exp. 90:** The *chemical effect* is illustrated by moistening a piece of blotting paper with the solution used in the polarity indicator, ¶ 106. Attach one of the secondary terminals to the edge of the paper, hold the other in the hand by an insulator, and trace designs on the paper when the coil is in action. The discharge decomposes the chemical salt, as shown by the blue mark. The action is the same as given in ¶ 106.

**307. Vacuum Tubes.**—Vacuum tubes, first devised by Geissler, are thin glass tubes, variously shaped and provided

with a platinum connection at each end of the tube, which extends a short distance into it. The tubes are then partially exhausted and filled with either a gas, liquid, or solid, and sealed up. On connecting the terminals to the secondary of a spark coil, and starting the coil in action, a beautiful discharge takes place, filling the tube with a luminous glow. The fluorescent effect depends upon the material introduced into the tube. The electric spark will not pass through a vacuum. The high potential maintained across the tube causes the molecules of gas to become positively and negatively electrified, and the resulting attractions and repulsions which occur produce a

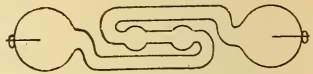


Fig. 291.—Geissler Tube.

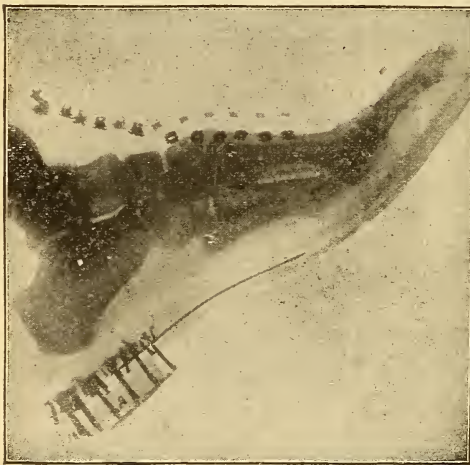


Fig. 292.—Radiograph of the Human Foot in a Shoe.

Made by Roentgen rays.

violet molecular bombardment, causing the fluorescent effect.

**308. Roentgen Rays (X-Rays).**—While experimenting with a vacuum tube, excited from an induction coil, William Roentgen, of Germany, discovered that a sensitized photographic plate, concealed from daylight, but lying near the vacuum tube, indicated exposure to light when developed. Upon further investigation he found that a light was emitted from the vacuum tube, not perceptible to the human eye, but capable of penetrating many substances, as wood, metal, paper, etc. When different substances are interposed between a protected sensitized plate and an excited vacuum tube,

indicated exposure to light when developed. Upon further investigation he found that a light was emitted from the vacuum tube, not perceptible to the human eye, but capable of penetrating many substances, as wood, metal, paper, etc. When different substances are interposed between a protected sensitized plate and an excited vacuum tube,



capable of producing rays of this light, it penetrates them with different intensities, according to their density, so that the sensitized plate, upon development, shows the shadows of the objects interposed. A photographic print negative is termed a *radiograph*. When the human hand is placed between the protected plate and the tube the plate is scarcely affected directly underneath the bones, because they are nearly

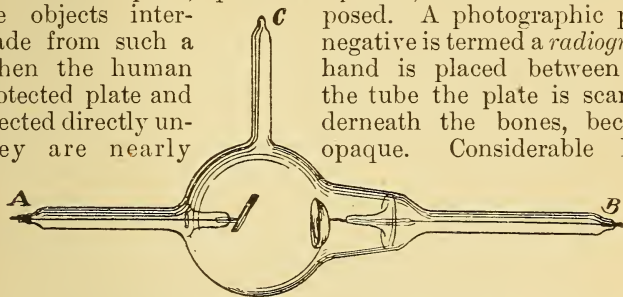


Fig. 293.—Focus Tube for X-Ray Work.

penetrates the flesh and affects portions of the plate directly underneath it. A print made from such a negative gives shadows of the bones and a faint outline of the flesh. The shadows of the bones in all animal bodies can thus be made, and broken bones and foreign objects, such as bullets, needles, etc., accurately located.

A radiograph of the human foot in a shoe is illustrated in Fig. 292. The nails of the shoe, etc., as well as the bones of the foot, are clearly discernible. Professor Roentgen first called the rays of this peculiar light X-Rays, but they are usually named in his honor, Roentgen rays.

A common form of tube used in X-ray work, called a focus tube, is illustrated in Fig. 293. A concave aluminum reflector extends a short distance inside the glass tube and a wire attached thereto terminates at point B. This reflector is connected to the

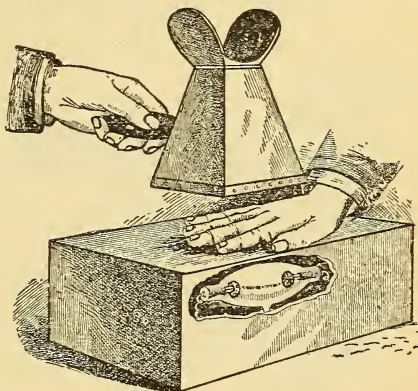


Fig. 294.—Examining the Bones of the Hand by the Fluoroscope.

negative pole of the induction coil and forms the cathode of the tube. The anode is a piece of sheet platinum inclined at about  $40^\circ$  to the axis of the tube, similarly connected to the positive pole of the induction coil at point A. The tube is exhausted to a fairly high vacuum and the X-rays emanate from the tube below the platinum anode.

**309. The Fluorescing Screen and Fluoroscope.**—A piece of paper or board coated with certain crystals, as platinobarium cyanide, or tungstate of calcium, and placed near a fluorescing vacuum tube in a darkened room, becomes a *fluorescent screen*, whether it be looked at from the crystal coated or the opposite side. The light is of a pale greenish yellow cast. If the hand be interposed between such a screen and the tube, the shadow of the bones can be plainly seen on the screen, the bones intercepting some of the Roentgen rays, and thus causing the shadow. Wood readily allows the rays to pass through it, so that if an inch board be held between the hand and the screen, the shadow is still visible. In the fluoroscope such a fluorescing screen forms the bottom of a box, the opaque sides of which slant inward toward the top where an opening is left for observation, Fig. 294. The day-

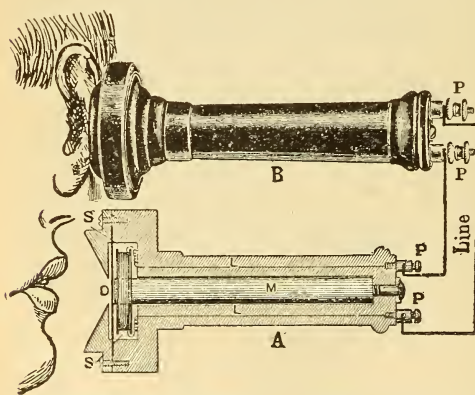


Fig. 295.—Transmission of Speech by the Bell Telephone.

The transmitter and receiver are exactly alike.

light is thus excluded and the shadows of objects interposed between the fluoroscope and the tube are plainly visible upon the enclosed fluorescing screen. Fig. 294 illustrates the manner of viewing the bones of the hand. The tube is not generally enclosed, however, as shown in the cut.

### 310. The Telephone.

—An instrument designed for the transmission of articulate speech by an electric current is called a telephone. A section and perspective view of a *Bell telephone* is shown in Fig. 295. A

small spool of fine wire encircles one end of a bar magnet mounted in a rubber tube, the ends of this coil being carried to the far end of the tube and connected to the binding posts, PP. A thin circular iron diaphragm is located very close to the pole of the magnet, at the coil end, and is supported by a conical-shaped piece of rubber, attached to the tube, which serves either as a mouthpiece or ear trumpet. When two such instruments are connected by wires, as in Fig. 295, either one may be used as a transmitter and the other as a receiver. No battery is required.

When a person talks to the disc of the transmitter, A, the sound waves striking it cause it to vibrate. The disc is magnetised by induction from the magnet's pole, and as it vibrates the number of lines of force threading through the coil are constantly being increased and decreased as the disc approaches and recedes from the coil. Alternating induced currents are thus set up in the coil, which currents flow through the line to the coil of the receiver at B. When the direction of the arriving current is such as to reinforce the magnetism of the receiver's magnet its disc is strongly attracted, and when the current produces a demagnetising effect the disc flies back. The disc of the receiving telephone is thus compelled to repeat every movement of the disc in the transmitter, and the vibrations of the receiver produce sound in the same manner as the vibrations of a drum. This telephone transmitter is practically an alternating current dynamo, driven by the energy of the human voice, while the receiver is a motor driven by the current from the generator.

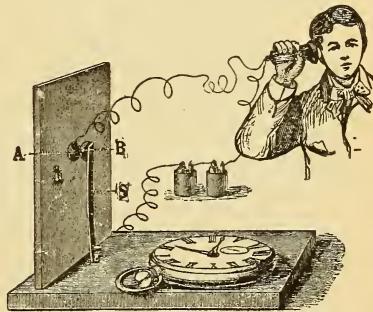


Fig. 296.—Apparatus to Illustrate the Principle of the Microphone.

**311. The Microphone Principle.**—A microphone is a device for rendering faint or distant sounds distinctly audible, and is used in many telephone transmitters,

¶ 312. The principle involved is the production of an unsteady electric current by a variable resistance introduced into the circuit. A simple form is illustrated in Fig. 296. A and B

are two carbon buttons one of which is fastened to a thin pine wood sounding board and the other to a brass spring, S, which causes B to touch A. The buttons are connected in circuit with a telephone and battery. While the current is flowing the least motion, caused by sound waves or other means, will vary the contact resistance between the buttons, and thus vary the current strength in the telephone circuit. The induced currents in the telephone cause the disc to reproduce the original sounds. The telephone may be located at a considerable distance from the microphone, when the reproduced sound, as the ticking of a watch, will be as audible as though produced close to the ear.

**312. The Blake Microphone Transmitter.** — The induced electric currents set up by the human voice in the Bell

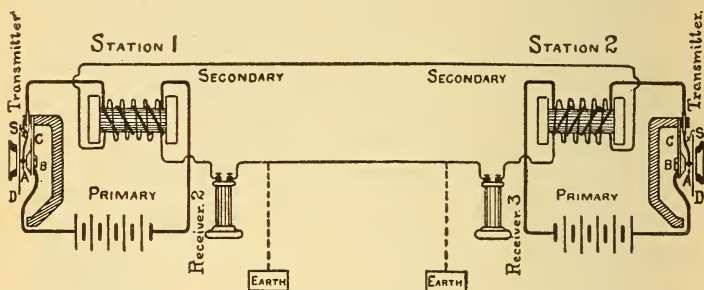


Fig. 297.—Connections of a Telephone System for Two Stations.  
Blake microphones are used as transmitters and Bell telephones as receivers.

telephone, become materially weakened when they have to flow over lines of considerable length and resistance, so that the sounds in many cases become inaudible. In commercial telephone systems the Bell telephone is used as a receiver only, the microphone principle being used in the construction of the transmitter, so that the sound of the voice is only required to regulate or vary an electric current already generated by a battery, instead of being used to generate the current. The general arrangement of two telephone stations will be understood from Fig. 297. Each transmitter is a microphone, in which the spring, S, supports a small carbon button, A, against which rests the hammer shaped end, B, of another spring, C. The springs are insulated from each

ether, and are connected in series with a battery circuit and the primary of a small induction coil.

Sound waves cause a vibration of the diaphragm, D, and the varying pressure it exerts between the carbon button and the hammer, causes variations in the battery circuit, as in the microphone. The induced secondary current flows through the receiver of station No. 1, and through the line to the Bell receiver and the secondary coil at station No. 2, causing the diaphragm of the receiver to vibrate in unison with that of the transmitter and so produce articulate speech. One wire from each receiver, as at points 2 and 3, may be connected directly to the earth through a gas or water pipe and a saving in

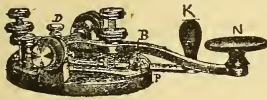


Fig. 298.—Telegraph Transmitting Key.

copper effected by using only one transmission line. The system would then be working on a *ground return*, the earth acting as the other conductor. A *ground* is the contact of a conductor in any circuit with the earth, permitting an escape of current if another ground exists.

**313. The Telegraph.**—The telegraph instrument is an apparatus for transmitting signals by the aid of an electric current. It consists of the *line, the transmitter or key, the receiver or sounder, the relay and the battery.* The line between two stations is generally a single iron wire with a ground return. The *transmitter key* is depicted in Fig. 298. It consists of a

brass lever with its axis pivoted at AA, carrying a platinum contact point, B, which is brought into contact by depressing the knob against the action of the spring, S. On depressing the lever by the knob, N, the two platinum points, B, P, connected to the line by posts C and D, are brought into contact and complete the circuit. When not in use the circuit is closed by the switch, K. The *sounder*, Fig. 299, consists of a brass lever with its axis pivoted at C, and carries an iron armature, A, of the

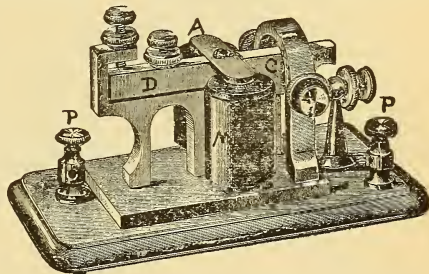


Fig. 299.—Telegraph Sounder.

axis pivoted at C, and carries an iron armature, A, of the

electromagnet, M, which is connected in circuit by two binding posts, P, P. A clicking sound is produced at each "make" of the circuit and a spring pulls the armature back on "break" of circuit. In long lines the current, due to the high resistance, may be so small as to render the clicks of the sounder inaudible, when a relay is used. A *relay*, Fig. 300, is a small switch operated by an electromagnet wound with many turns of fine wire. The magnet, M, is inserted in the main circuit by the posts, 3 and 4, and the platinum contact points, S, S, are brought in contact when the armature, L, of the magnet is attracted against the action of the spring, B. This switch, S, S, is inserted in a local circuit with a battery and sounder by the posts, 1 and 2. Thus a very weak current through the relay brings into action a strong local current which operates the sounder.

**314. The Signal System and Circuits.**—A series of armature clicks separated by intervals of long or short duration constitute the signals transmitted. A short interval between clicks is called a "dot," and a longer interval a "dash." By different combinations of the "dashes" and "dots" an alphabet is constructed and words spelled from

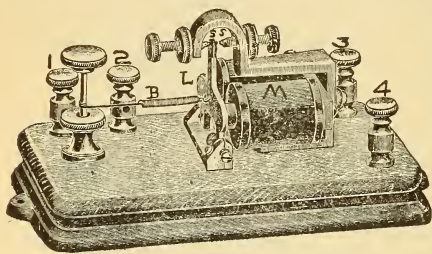


Fig. 300.—Telegraph Relay.

the signals received. The alphabet devised by Morse is generally used. Low voltage dynamos or closed circuit batteries are used for operating telegraph systems. Connections for three stations provided with relays and local circuits are given in Fig. 301. When one of the stations signals to another the third also receives the signal, since all the relays are in series. The function of the small cut-out switch on the transmitter key is to preserve the continuity of the line since it is in series with it, as shown in Fig. 301.

**315. Electric Waves.**—The magnetic field surrounding a conductor through which a current is flowing changes for each change in current strength. When the current strength increases, the magnetic field around the conductor enlarges

or expands outward in all directions, but with a decrease in current strength, the field returns again toward the conductor. If instead of a slowly increasing and decreasing current in any circuit we consider electric oscillations of very high rapidity, as the discharge of an induction coil, then part of the energy of the magnetic field is radiated off into space in all directions as electromagnetic waves corresponding to the ripples on the surface of a pond when a stone is thrown into it. Only a portion of the energy of the magnetic field returns again to the circuit. Electricity travels at the rate of 186,400 miles per second, and these waves are also propagated

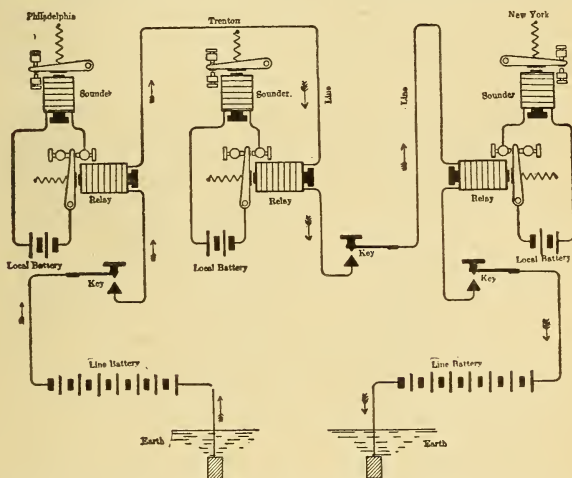


Fig. 301.—Connections for Three Telegraph Stations Using Relays.  
One transmitting wire is used and a ground return.

at this speed. There are also about 230 million waves radiated per second. To propagate these waves with the best results from an induction coil, the secondary terminals are connected to brass spheres, between which the discharge occurs.

**316. Wireless Telegraphy.**—In wireless telegraphy signals are transmitted through space by electric waves. These waves are not obstructed by trees, houses, hills, fog, etc., and may be transmitted on land or across water. The system requires a *transmitter* and a *receiver*. The transmitter is gen-

erally an induction coil capable of giving from a 3 to a 6-inch spark between brass spherical terminals, the spark gap being regulated to obtain the best results for any given conditions. One terminal of the secondary is also connected to a vertical wire or "mast," which assists in the propagation of the waves while the other terminal is grounded, Fig. 302. A telegraph key, Fig. 298, is introduced into the primary circuit of the induction coil, whereby the "dot" and "dash" system of signals may be used. Details of the *receiving apparatus* are shown in Fig. 302. A small glass tube (say  $\frac{1}{4}$  inch inside diameter) contains two plugs of silver, separated from each other by a small gap (about .04 inch), which space is *partially* filled with a mixture of silver and nickel filings, and forms what is called the *coherer*. The plugs are connected in

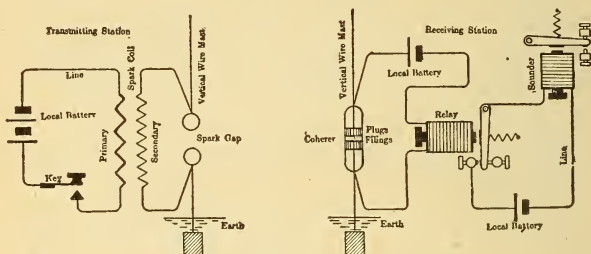


Fig. 302.—Connections of Transmitting and Receiving Stations for the Wireless System of Telegraphy.

The stations may be located miles apart with no metallic connections between them.

circuit with a battery and a relay of several hundred ohms resistance. One plug is also connected to a *vertical receiving mast*, and the other to the ground. The relay is made to close a local circuit containing a battery and telegraph sounder, Fig. 299. Owing to poor contact between the silver plugs and the filings the resistance of the coherer may be 1000 ohms or more, so that the battery cannot send sufficient current through it to operate the relay. When the coherer is struck by an electromagnetic wave, propagated from the distant spark coil, just as a chip floating on a pond would be struck by a ripple, the filings *cohere* and lower the resistance of the coherer to about 5 ohms. The battery now sends a current through it which operates the relay, and the signal transmitted is reproduced by the sounder. If the coherer be



gently tapped the filings will *decohere*, and their resistance become as high as before. This can be automatically accomplished by locating the coherer tube near the sounder armature, so that in reproducing the signal it taps the tube, and thus "decoheres" it after each signal. Signor Marconi, who first perfected the system, uses an exhausted coherer tube with sealed-in electrodes, this being more sensitive, as the particles do not become oxidized. Telegraphic communication by wireless telegraphy has been established between ships at sea and the mainland for a distance of more than one hundred miles. The ship and the shore station were equipped with duplicate transmitting and receiving instruments.

### QUESTIONS.

- ✓ — 1. How does an induction coil differ from a primary battery?
- ✓ — 2. What is the difference between the current flowing from a battery and that from the secondary of an induction coil?
3. The primary of an induction coil is wound with 480 turns of wire and the secondary, with 80 turns. If 1200 volts are maintained across the primary terminals, what will be the relative voltage across the secondary terminals?
4. An interrupted current in the primary of an induction coil produces an alternating current in the secondary circuit. Explain fully how one secondary terminal can then be called a cathode and the other an anode.
- ✓ — 5. Make a complete sketch of an induction coil with condenser, and indicate the directions of current in primary and secondary circuits at "make" and at "break."
- ✓ — 6. What is the advantage of using a condenser with an induction coil?
- ✓ — 7. What is the objection to using a solid iron core in the construction of an induction coil?
8. Make sketch of Wehnelt interrupter connected to an induction coil. Indicate direction of currents.
9. What is a fluorescing screen and how is it used for practical purposes?
- ✓ — 10. Explain the principle of action in a simple telephone transmitter.
11. What is a microphone?
12. What advantage does a microphone transmitter possess over that of a simple type of transmitter?
13. Make complete sketch of a transmitting and receiving telephone station using Blake microphone transmitters.

## LESSON XXVI.

### DYNAMO ELECTRIC MACHINES.

The Dynamo—Classification of Dynamos—A Simple Dynamo—Alternating Current Dynamo—Graphic Representation of an Alternating Current—Magneto Alternator—Simple Direct Current Dynamo—Graphic Representation of a Direct Current—Multi-Coil Armatures—Gramme Ring Armature—Induced E. M. F. in a Ring Armature—Siemens Drum Armature—Advantages of Drum and Ring Armatures—Drum-Wound Ring Armatures—Open Coil Armatures—Questions.

**317. The Dynamo.**—The dynamo is a machine for converting mechanical energy into electrical energy by means of electromagnetic induction. A dynamo does not create electricity, but generates or produces an induced electromotive force, which causes a current to flow through a properly insulated system of electrical conductors external to it. The amount of electricity obtainable from such a generator is dependent upon the mechanical energy supplied. In the circuit *external* to a dynamo the E. M. F. causes the electricity to flow from a higher or positive potential to a lower or negative potential, just as water flows from a higher to a lower level. In the *internal circuit* of a dynamo the E. M. F. causes the current to flow from a lower potential to a higher potential, just as water is pumped or forced from a lower to a higher level. The action of a dynamo is based upon

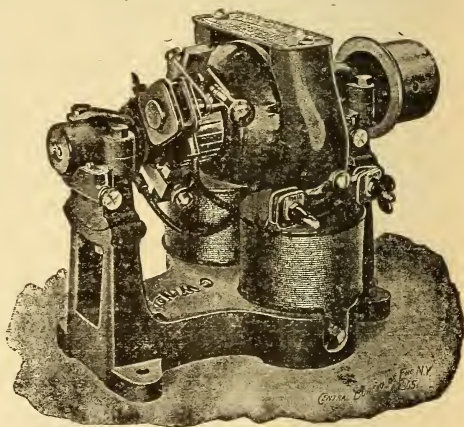


Fig. 303.—Bipolar Dynamo or Motor.



the principles of electromagnetic induction, discovered by Faraday, and fully considered in Lesson XXIV.

The dynamo consists essentially of two parts: a *magnetic field*, produced by electromagnets, and a number of loops or coils of wire wound upon an iron core, forming the *armature*, and so arranged that the number of the magnetic lines of force of the field threading through these coils will be constantly varied, thereby producing a continuous E. M. F.

**318. Classification of Dynamos.**—According to their mechanical arrangement, dynamos may be divided into three classes:

1. *A stationary field magnet and a revolving armature,*
2. *A stationary armature and a revolving field magnet,*
3. *A stationary armature and a stationary field magnet, between which is revolved an iron core.*

In the first class provision is made for conducting the current from the armature either by collector rings, ¶ 320, or by a commutator, ¶ 323. In the second class provision is made for conducting the current to the revolving field by collector rings, while in the third class there are no moving wires nor contacts. Dynamos may be further classified according to their design and mechanical construction into,

1. *Direct current machines,*
2. *Alternating current machines, or alternators.*

In direct current dynamos the field magnets are usually stationary while the armature revolves; in alternators, the armature is usually stationary while the field magnets revolve, while in some types both are stationary while an iron core is revolved. All dynamos are practically alternators—that is, machines in which alternating currents are generated. When provided with a suitable commutator, ¶ 323, the current is made direct in the external circuit, but still alternates in the machine.

**319. A Simple Dynamo.**—Consider the single closed loop of wire, ABCD, Figs. 305 and 306, which is mounted on a shaft and may be rotated around its horizontal axis in the uniform magnetic field, NS, in the direction of the arrow. The direction and variation in magnitude of the induced E. M. F. is the same as that given under Faraday's Law for the different positions of a loop during a complete revolution in Fig.

274 and ¶ 291.\* At the position ABCD, Fig 306, there is no induced E. M. F. in the loop, since all the lines of force of the field thread through it. During the first quarter of a revolution, the lines of force threading through the loop are gradually diminished at an increasing rate, and the E. M. F., depending on the rate of change of the lines of force through it, increases in magnitude with its direction from b to a in the right-hand side of the loop, and from c to d in the left-hand side. At the position of one-quarter revolution, indicated by abcd, the plane of the loop is parallel to the lines of force so that none thread through it, and the arrows indicate the direction of the current. The rate of change is now a maximum as is also the E. M. F.

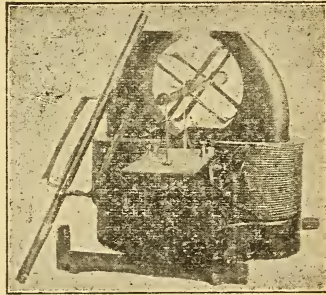


Fig. 305.—Generation of an E. M. F. by the Rotation of Rectangular Coils of Wire in a Magnetic Field.

The field magnets are excited from a source of current and the terminals of the coil are connected by brushes and lead wires to a voltmeter.

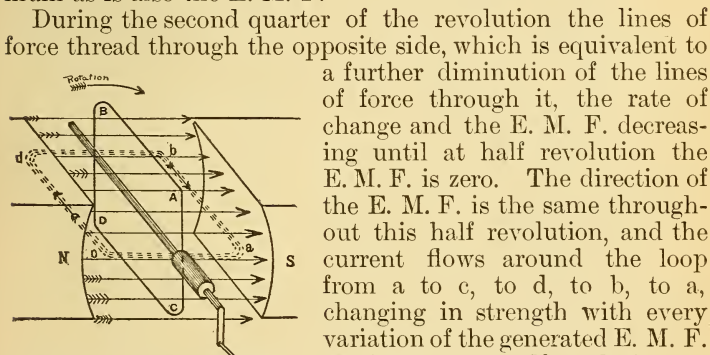


Fig. 306.—Direction and Magnitude of the Induced E. M. F. in a Dynamo.

During the second quarter of the revolution the lines of force thread through the opposite side, which is equivalent to a further diminution of the lines of force through it, the rate of change and the E. M. F. decreasing until at half revolution the E. M. F. is zero. The direction of the E. M. F. is the same throughout this half revolution, and the current flows around the loop from a to c, to d, to b, to a, changing in strength with every variation of the generated E. M. F. During the next half revolution the same variations in E. M. F. occur but the induced E. M. F. is in the opposite direction. The current is therefore reversed twice in every revolution, or an alternating current flows around the loop.

\* The student is advised to read again ¶ 291 which fully explains the fundamental principle of the dynamo.

**320. Alternating Current Dynamo.**—To utilize the current flowing in the above closed loop when it is rotated in the magnetic field, some mechanical device must be used to lead or collect the current from the rotating loop so that it will flow through a circuit external to it. Two collector rings are used for this purpose and consist of rings of copper mounted on a wooden or hard rubber hub, Fig. 307, this being mounted on the shaft with the loop. The rings are insulated from each other and from the shaft. The terminals of the loop are connected, one to each ring, and stationary strips of copper, P and M, termed *brushes*, rest upon the rings and are connected to the external circuit.

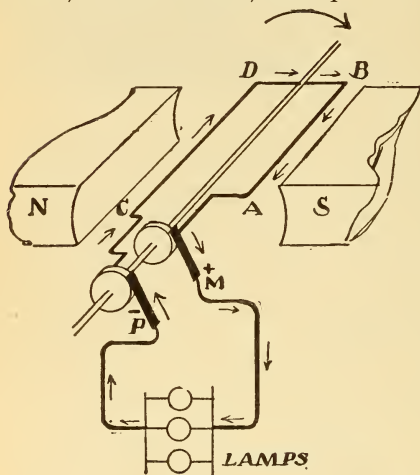


Fig. 307.—Simple Alternating Current Dynamo.

At the instant depicted in the revolution brush M is positive.

brush, and around the loop from C to D, to B, etc. Now consider the second half revolution, Fig. 308. The direction of current in the wires AB, and CD, is reversed, Fleming's rule, and current flows from D to C, through brush P, now positive, then through the lamps in the opposite direction to that in Fig. 307, and through brush M, now negative, to AB, to D, etc. In every revolution the polarity of the brushes changes twice, or there are *two alternations of current per revolution in the external circuit*. The number of alternations per minute in any alternator equals the *speed in revolutions per minute mul-*

to the external circuit. When the loop is revolved a sliding or wiping contact is thus established and the current is conducted to the external circuit.

During the first half revolution of the loop, ABCD, Fig. 307, the direction of current in AB is from B toward A, and from brush, M, which is therefore positive to the external circuit, composed of incandescent lamps in parallel. From the lamp terminals the current flows back to brush P, the negative

plied by the number of poles. The number of times which the alternations occur is usually expressed simply as the *frequency*, thus, a frequency of 7200 alternations per minute means 7200 reversals of current. The frequency is usually expressed for the period of one minute.

**Student's Experimental Dynamo and Motor.**—A simple apparatus for studying the principles of induction and commutation in a dynamo, is illustrated in Fig. 309, and consists of a horseshoe electromagnet fitted with cast-iron pole pieces and mounted on a wooden base. A rectangular coil of No. 26 copper wire is mounted on a hard-wood shaft, provided with pointed steel ends and suspended between two brass V centres, suitably supported by a brass framework extending from the pole pieces. The framework also carries two insulated brush holders. At one end of the shaft the coil terminals are connected to a pair of collector rings mounted upon it, while the same terminals are also connected to a two-part commutator at the other end of the shaft. By reversing the position of the coil between the pole pieces the brushes will rest either upon the rings or upon the commutator. The electromagnets have a resistance of 1.3 ohms each and are to be excited from a source of current. The brushes may be connected to a detector galvanometer, and when the shaft is rotated by hand either the alternating or direct current may be studied. The resistance of the rectangular coil is 5 ohms.

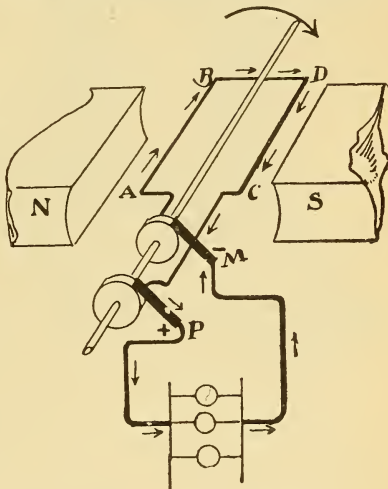


Fig. 308.—Simple Alternating Current Dynamo.

Direction of current in the coil at one-half revolution from the position in Fig. 307. Brush M is now negative.

When connected as a shunt motor the rectangular coil will make several hundred revolutions with an applied E. M. F. of 4 volts.

**Exp. 91:** Separately excite the magnets (connected in series) of the student's experimental dynamo, Fig. 309, so that one pole piece will be N and the other S, and adjust the brushes so that they will bear lightly upon the *collector rings*. Connect the brushes to the detector galvanometer, Fig. 153.

(a) Revolve the shaft slowly and note the alternating deflection of the galvanometer needle.

(b) Increase the speed and note that the needle remains at zero with a perceptible vibration.

(c) Turn the coil to the vertical position, break the field circuit, and note the galvanometer deflection; make the field and again note the deflection. Why are the deflections opposite?

(d) Reverse the polarity of the fields and repeat (c), noting results.

(e) Turn the coil so that it is horizontal; make and break the circuit as in (c). The galvanometer needle is not appreciably deflected. Why is this so, since it was stated that this was the maximum position of induction of a loop rotated in a bipolar field? Why is it different in each case?

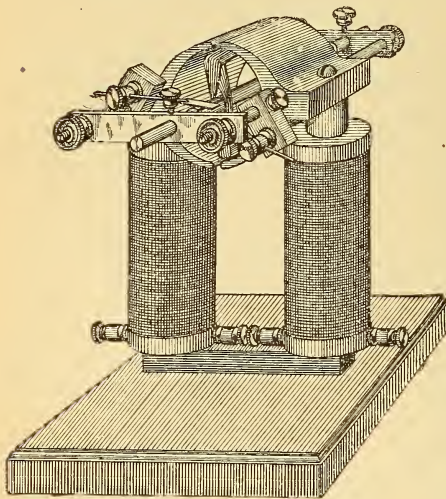


Fig. 309.—Student's Experimental Dynamo and Motor.

### 321. Graphic Representation of an Alternating Current.—

The changes in direction and magnitude of an alternating current are usually represented diagrammatically. For example, suppose an alternating current of 5 amperes to flow for one second

in a positive direction, and then be automatically reversed and flow for one second in the opposite or negative direction, and reversed again, this *cycle* of events continuing at regular intervals while the current flows.

The action is represented in Fig. 310, where the horizontal line, P K, is divided into equal distances, PC, CF, FK, etc., representing intervals of time. The vertical line, AM, at right

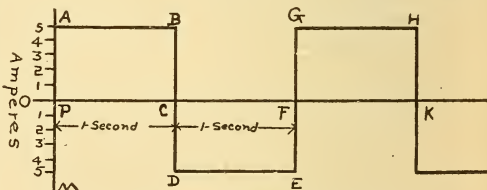


Fig. 310.—Graphical Representation of an Alternating Current.

angles to it is divided into distances representing units of current, the current being in a positive direction when indicated above PK, and negative, when below PK. When the



switch is closed the current immediately rises to its full strength of 5 amperes, or from P to A, and 5 amperes are maintained constant in a positive direction for one second, A to B. When point B is reached at the end of the first second the current falls abruptly to zero, B to C, and rises to 5 amperes in a negative direction, and is maintained for an equal interval of time, D to E, when it again falls to zero, at F, and repeats the same cycle of events in equal intervals of time. The line PABCDEFHGK is called the *current wave*.

In Fig. 310 the current is depicted as being of constant strength during each second, while it was shown in ¶¶ 291 and 320 that during rotation of the loop the current and E. M. F. varied. This variation in magnitude is represented in Fig. 311, which is constructed similar to Fig. 310, but the current gradually rises to its maximum value of 5 amperes, P to A, and as gradually diminishes again to zero, A to B, during the first second, which may also represent one-half revolution of the loop. Corresponding with the second half revolution, the current gradually rises from B, reaching its maximum negative value at C (three-quarter revolution), and falling again to zero at D, and so on. In an alternating current dynamo the

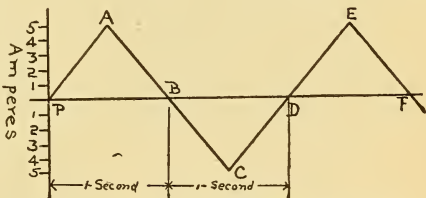


Fig. 311.—Graphical Representation of an Alternating Current.

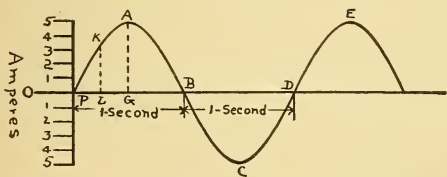


Fig. 312.—Graphical Representation of an Alternating Current.

alternating current wave is not so abrupt as that depicted in Fig. 311, but more truly represented by the undulatory curve, Fig. 312, which represents the same variations as before. Thus at the end of one-half second the current reaches its maximum value, 5 amperes, represented to scale by the line AG, while the value of the current at one-quarter second is equal to the line LK, or about 3 amperes.

current gradually rises from B, reaching its maximum negative value at C (three-quarter revolution), and falling again to zero at D, and so on. In an alternating current dynamo the

**322. Magneto Alternator.**—The E. M. F. of a dynamo depends upon,

- (a) *The number of lines of force cut by the armature wires,*
- (b) *The number of cutting wires,*
- (c) *The speed at which the lines of force are cut.*

The E. M. F. of the single loop armature, Fig. 308, will therefore be increased by winding it upon an iron core called the *armature core*, as in Fig. 313, which greatly increases the number of lines of force between the poles **N** and **S**, and also by winding a great many turns in the same direction around this core. Fig. 313 illustrates a Siemens *shuttle armature*, which is revolved between the poles of

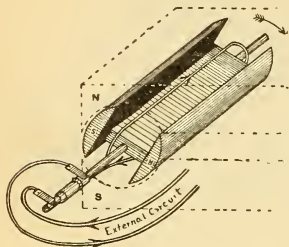
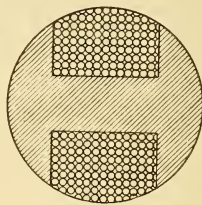


Fig. 313.—Siemens Shuttle Armature.



Cross-section of Shuttle Armature.

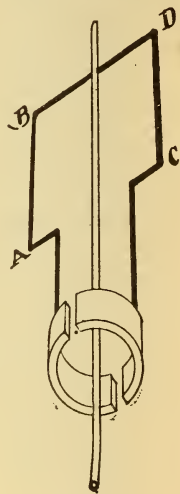


Fig. 314.—Single Armature Coil with Two-part Commutator.

the permanent magnets, **NS**, and called a *magneto generator*, because the field is produced by permanent magnets. Only one turn is illustrated, but the shuttle is filled with wire, as in the cross-sectional view. This construction is only employed in small machines, Fig. 318, such as those used for magneto telephone call systems, and magnetos used in testing insulation of lines, ¶ 256. In dynamos for generating large currents, a stronger field must be employed and the armature core laminated to prevent excessive loss of energy by eddy currents, etc.

**323. Simple Direct Current Dynamo.**—When it is desired to have the current from a generator flow always in one direction in the external circuit, like a battery current, for such purposes as charging accumulators, electroplating, etc.,

a commutator must be substituted for the collector rings in the simple alternator of Fig. 308. The function of a commutator is to reverse or commute the alternating current of a dynamo at the proper instant in each revolution before it flows through the external circuit. A two-part commutator, connected to the single loop, is shown in Fig. 314. It is practically a split ring, mounted upon a hub insulated from the shaft, with the parts of the ring also insulated from each other, as shown in the section, Fig. 315.



Fig. 315.—Section of Two-Part Commutator.

Brushes rest upon the split ring at diametrically opposite points. The connections of a simple direct current dynamo are illustrated in Figs. 316 and 317, from which the act of commutation can be studied. In Fig. 316 the wire AB is rotated down past the S-pole. The direction of current is from B to A, by Fleming's rule, and to the external circuit by brush M, which is positive; then from the lamps to the negative brush and around the loop, CDBA. When the loop is rotated one-half revolution, Fig. 317, AB is now moving up past the N-pole and the direction of current in it is reversed. Its terminal, however, is not now in contact with brush M, as before, but connected to brush P. Current flows to the external circuit from the brush M, which is still positive, though the current in the armature has been reversed, as in an alternator. Brush M is consequently always positive and brush P always negative, or the current in the external circuit is a direct current flowing in one direction only.

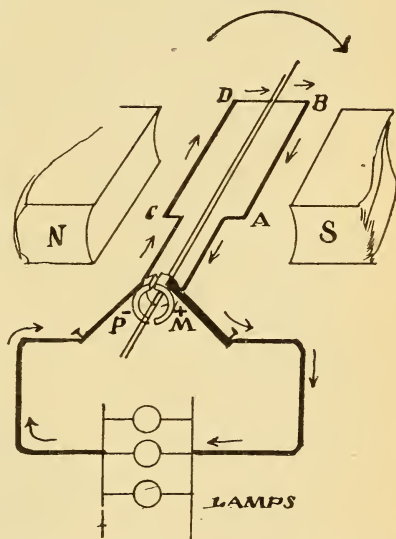


Fig. 316.—Simple Direct Current Dynamo.

At the instant depicted in the revolution brush M is positive.

The act of commutation occurs at the instant when the wire, moving down past the **S**-pole, commences to move up past the **N**-pole, either terminal of the coil being connected

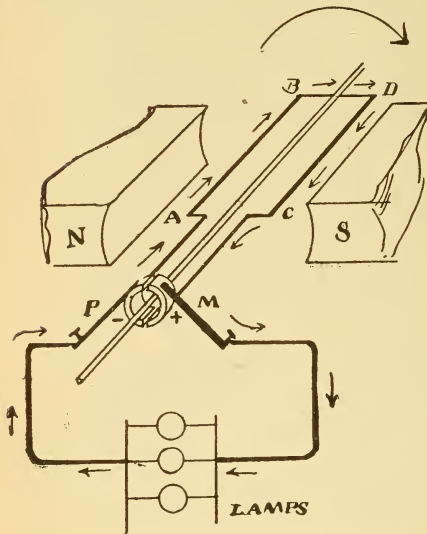


Fig. 317.—Simple Direct Current Dynamo.

Direction of current in the coil at one-half revolution from the position in Fig. 316.  
Brush M is positive as before.

91, page 339. Adjust the brushes so that they bear lightly upon diametrically opposite points of the *two-part commutator*.

(a) Upon revolving the shaft slowly the needle is now deflected to one side of the zero mark.

(b) Reverse the direction of rotation, and the direction of deflection (or polarity of the brushes) is now reversed.

(c) Increase the speed and the deflection increases. Why?

(d) Increase the field strength by grouping the magnet coils in parallel, so that the poles will be **N** and **S**, and the deflection is greater when the speed is the same as before. Why?

with one brush for one-half revolution and with the other brush for the other half of the revolution. With a two-part commutator, the current in the external circuit is interrupted twice in each revolution. A single coil armature of this type is shown in Fig. 319, where the armature core is omitted. The direction of the current is indicated by the arrows in Fig. 320, when the coil is rotated clockwise, as viewed from the commutator end.

**Exp. 92:** Make the same connections for the student's experimental dynamo as given in Exp.

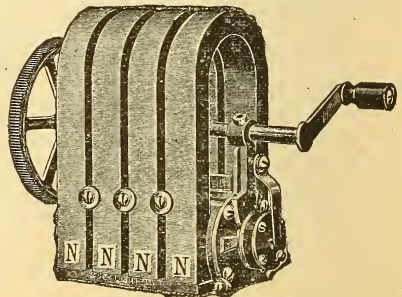


Fig. 318.—Magneto Dynamo.

**Exp. 93:** (a) Repeat Exp. 78, page 297, to determine the direction the galvanometer needle deflects for a given direction of current.

(b) Test with a compass and mark the polarity of the pole pieces.

(c) Determine, with the aid of the galvanometer, the positive brush for a particular direction of rotation.

(d) Apply Fleming's rule, ¶ 278, and note whether the polarity determined by this method agrees with that already determined.

(e) Reverse the polarity of the fields and again prove Fleming's rule.

### 324. Graphic Representation of a Direct Current.—

The same method is applicable for illustrating the direction and magnitude of a direct current as given in ¶ 321 for an alternating current. Since

there is no reversal of current in the external circuit, the curve will lie above the time line, Fig. 321, and represent the magnitude of E. M. F. or current at each instant during the rotation of the loop in the two-pole field. The curve

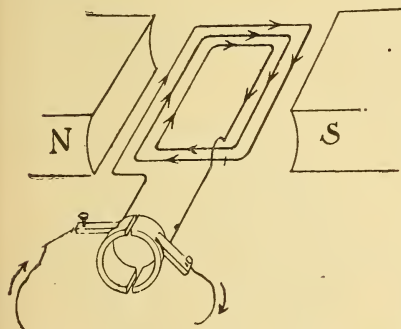


Fig. 320.—The Induced E. M. F. of Each Turn is in Series With Every Other Turn.

other, when, at the instant shown, the current in the vertical coil will be zero, while that in the horizontal coil will be a maximum. As rotation is continued the current in the one coil, ABCD, increases as that in the other, abcd, decreases until, at quarter revolution, current in coil A is maximum and in coil a, zero, and so on. There will thus always

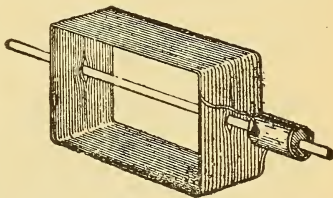


Fig. 319.—Single Coil Armature With Many Turns.

indicates a pulsating current flowing always in one direction.

### 325. Multi-Coil Armatures.—

With an armature wound with a single coil of wire the current in the external circuit is very pulsating as the coil passes through the various phases of induction represented by the curve in Fig. 321.

In Fig. 306, consider two coils to be placed at right angles to each

be current flowing in one of the two coils, so that if they are properly joined to an external circuit the current will be less pulsating than when a single coil is used. This is depicted in the current curve of Fig. 322, where the solid undulatory line represents the pulsating character of the current produced by the two coils acting together in the same circuit. The current is thus never zero in the line as in the curve in Fig. 321.

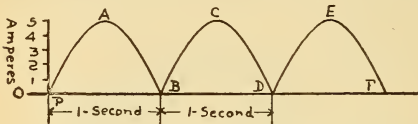


Fig. 321.—Graphical Representation of a Direct Current.

The armatures of dynamos are wound with many coils of wire, so that the current may be continuous in the external circuit.

**326. Gramme Ring Armature.**—A four-coil direct current Gramme ring armature is illustrated in Fig. 323. The ring is made of a number of laminated sheets of soft iron and the coils wound upon it. The ending of each coil is joined to the beginning of the adjacent coil, so that the winding forms a complete closed circuit, or the coils are all in series. At the junction of each coil with its neighbor a lead wire is run to a commutator section, so that instead of the former two-part commutator one with four sections is now used. As the number

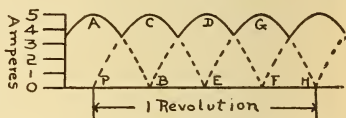


Fig. 322.—Graphical Representation of a Direct Current.

of coils is increased the commutator sections are increased, as will be noted in the armatures depicted in Figs. 324, 325, and 329. An eight-coil ring armature is depicted in Fig. 324, rotating against the hands of a clock in a bipolar field. The connections are the same as those given above. The direction of current in the two halves of the ring is indicated by arrows and is found by Fleming's rule.

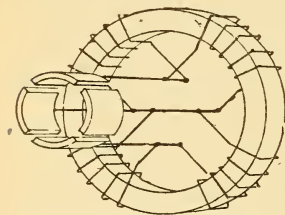


Fig. 323.—Four-Coil Gramme Ring Direct Current Armature.

When the external circuit is closed the induced current flows in both halves of the winding toward the upper or positive brush, and returns from the external circuit to the

lower or negative brush, circulating up again through each half of the armature. The windings in the halves of the armature are in parallel with the brushes. As each coil passes from under the influence of the **N**-pole and comes into action under the **S**-pole, commutation takes place and the direction of current through it is reversed, as will be seen from tracing the direction of the currents in the two upper coils, which are opposed to each other. The brush is located at this point of opposition and serves to conduct the current from both halves of the ring to the external circuit. The brushes resting upon two adjacent bars will thus short-circuit each coil for an instant as it passes from pole to pole, and this short-circuiting should occur when there is zero E. M. F. in the coil, or at that instant when the magnetic lines threading through it are a maximum, which will be when its plane is at right angles to the lines of force threading through the iron ring. The act of commutation is further described in ¶ 338 and Fig. 351.

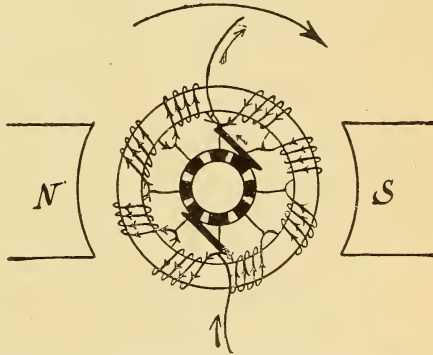


Fig. 324.—Eight-Coil Gramme Ring Direct Current Armature.

327. **Induced E. M. F. in a Ring Armature.**—The upper and lower coils in the right-hand half of the ring armature, Fig. 324, will have about the same E. M. F. induced in them, say 2 volts each, while the two coils between them will have a higher E. M. F. at the same instant, say 4 volts each, since they occupy nearly the position of the maximum rate of change of the lines threading through them. The total E. M. F.

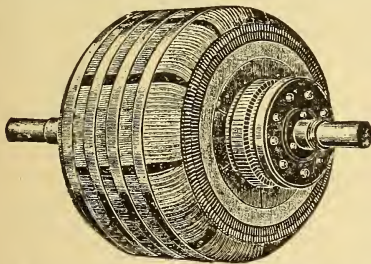


Fig. 325.—Multi-Coil Gramme Ring Direct Current Armature. Smooth core pattern.

each, while the two coils between them will have a higher E. M. F. at the same instant, say 4 volts each, since they occupy nearly the position of the maximum rate of change of the lines threading through them. The total E. M. F.

of this half of the ring, since these *four coils* are in *series*, will therefore be  $2 + 4 + 4 + 2$  or 12 volts, and since similar induction takes place in the other half of the ring at the same instant, there will be a total of 12 volts induced in it. The windings of the *two halves* being in *parallel*, the E. M. F. at the brushes will also be 12 volts, just as though each half represented a cell of 12 volts E. M. F. and the two

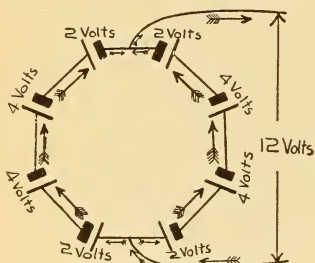


Fig. 326.—Battery Analogy of Induced E. M. F. in a Ring Armature.

cells were placed in parallel. The current in the external circuit will be the sum of the currents in each half of the windings. If it is 10 amperes, 5 amperes will flow through each half of the ring. The adding together of the E. M. F.'s in the coils, and the current flowing from them, may be understood from the following battery analogy. In Fig. 326, eight cells represent the above armature coils and are connected 4 in series and 2 groups in parallel. The E. M. F. across the lead wires is 12 volts, and with 10 amperes in the external circuit 5 amperes flow through each group of cells. The E. M. F. of one group of cells is the sum of the E. M. F.'s of the cells connected in series in that group, or  $2 + 4 + 4 + 2 = 12$  volts, and the E. M. F. of 2 groups in parallel is 12 volts. If 10 amperes flow through the external circuit, 5 amperes will flow through each group of cells.

By employing 8 coils on this ring armature the current is less pulsating than in the four-coil armature, Fig. 323, and is represented by the wave in Fig. 327. As the armature

coils are further increased, the wave becomes more nearly a straight line, but there will always be a slight pulsation of the current.

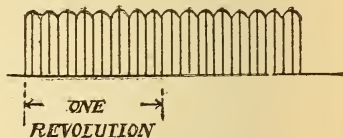


Fig. 327.—Direct Current Wave of a Multi-Coil Armature.

**Prob. 118:** The joint resistance of the two halves of an 8-pole ring armature is .5 ohm. This is called the *armature resistance* and would be measured between the brushes. What is the resistance of the wire upon the armature?



By Formula (45)  $R = J. R. \times nq = .5 \times 2 = 1 \text{ ohm.}$

$J. R. = 0.5 \text{ ohm, } nq = 2 \text{ halves in parallel.}$

$R =$  resistance of one-half the armature, therefore the total resistance of the wire upon it  $= 1 \times 2 = 2 \text{ ohms.}$

The resistance of the armature winding is thus four times the joint resistance from brush to brush in this type of armature.

**Prob. 119:** The resistance of the eight coils, in series, upon the ring armature, Fig. 324, is 4 ohms, what is the *armature resistance* from brush to brush?

The resistance of one-half of the armature is  $4 \div 2 = 2 \text{ ohms.}$  The joint resistance of the two halves in parallel is,

$$\text{By Formula (43) } \frac{2}{2} = 1 \text{ ohm.}$$

The resistance of the wire upon this ring armature is therefore *four* times its joint resistance.

**Prob. 120:** The E. M. F. generated by the ring armature in Fig. 324 is 12 volts, the armature resistance 1 ohm, an incandescent lamp connected to the brushes 2 ohms, leads to lamp 1 ohm. What current will the lamp receive? See Fig. 328.

$$\text{By Formula (31) } C = \frac{E}{R+r} = \frac{12}{2+1+1} = 3 \text{ amperes.}$$

$$R = 2 + 1 = 3 \text{ ohms, } E = 12 \text{ volts, } r = 1 \text{ ohm.}$$

**Prob. 121:** What potential will a voltmeter indicate when placed across the brushes in Prob. 120? See Fig. 328.

$$\text{By Formula (29) } E = C \times R = 3 \times (2 + 1) = 9 \text{ volts.}$$

$$C = 3 \text{ amperes, } R = 2 + 1 = 3 \text{ ohms.}$$

The pressure required to send 3 amperes through the armature will be  $E = C \times r = 3 \times 1 = 3 \text{ volts,}$  or  $12 - 9 = 3 \text{ volts.}$

By substituting a pair of collector rings for the commutator, the ring armature of Fig. 324 will give an *alternating current* to the external circuit. The winding is the same but only two lead wires are taken from the coils, at points diametrically opposite and connected one to each collector ring. With the increased

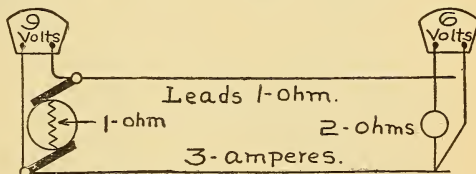


Fig. 328.—E. M. F. and P. D. of an Armature.

number of coils the alternating E. M. F. is increased, since the E. M. F.'s in the coils at any instant are in unison. The commutator and collector rings may both be mounted on the same armature shaft, when the machine will give either a direct or alternating current, or both, at the same time to two

independent circuits. The dynamo would then be called a *double current generator*. The collector rings would be connected one to each diametrically opposite section of the commutator; for example, 1 and 5 in Fig. 324.

**328. Siemens Drum Armature.**—Instead of winding the armature coils upon a laminated ring, they are sometimes

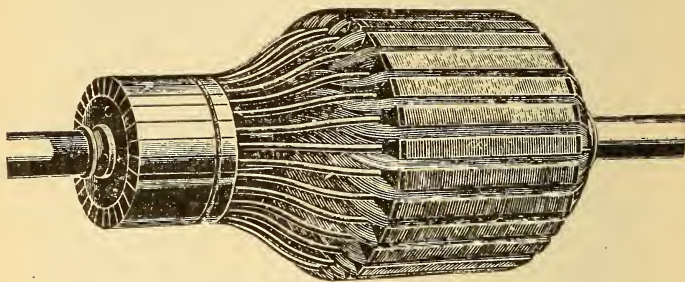


Fig. 329.—Multi-Coil Siemens Drum Armature.  
Tooth-core pattern.

wound upon a cylindrical laminated iron core made by assembling, upon the armature shaft, thin sheets of soft iron; after being properly insulated the coils are wound upon the core, and connected in series and to the commutator in the

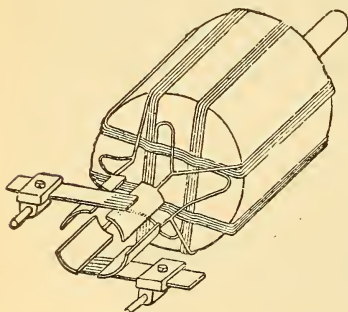


Fig. 330.—Four-Coil Siemens Drum Armature.

same manner as that given for the ring armature. Fig. 330 depicts a four-coil Siemens drum armature with its commutator, suitable for a bipolar field. In practice a great many coils are wound upon the core covering its entire area, the commutator sections increasing with the subdivision of the armature coils. The induced E. M. F. in that part of a coil under one pole is in the opposite direction to that in the other half of the

coil so that the two E. M. F.'s are in series, as in two consecutive coils in the ring armature. Both halves of the drum armature coils are in parallel with the external circuit so that

the induced E. M. F. is that generated by one-half of the total conductors upon the core, and each half of the windings deliver one-half of the total current flowing to the external circuit.

**329. Advantages of Drum and Ring Armatures.**—The difference between the ring and drum armature is that in the former, the *active wire* of each coil cutting the magnetic lines

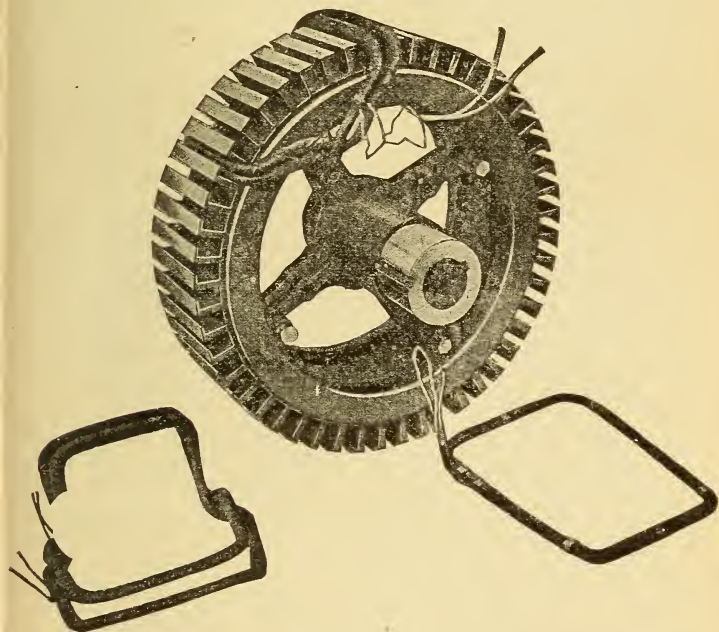


Fig. 331.—Tooth-Core Armature Body With Two Formed Coils in Position.

The wound and formed coils are also illustrated. The armature is intended for a six-pole field.

of force is that part located only on the periphery of the ring while that on the ends and inside of the ring cuts no lines of force, and is termed *dead wire*.

This serves only to conduct currents from one active conductor to the next. In the drum type there is less dead wire, since each half of the coil cuts magnetic lines of force, and that on the ends of the core is only inactive and serves

to connect the active conductors. The  $C^2R$  loss in a ring winding will thus be greater than in a drum armature of the same capacity. On the other hand, in ring armatures the coils can be much better insulated from each other, and are more readily accessible for repairs than in the drum armature. For these reasons high voltage direct current arc lighting dynamos are generally constructed with ring armatures. A combination of the drum and ring winding in what are known as *drum-wound ring armatures* is extensively used in practice and further described in ¶ 330.

**330. Drum-Wound Ring Armatures.**—Some of the advantages of both the drum and ring windings are obtained by using a *slotted laminated ring* armature core and winding the wire, drum fashion, upon this ring, Fig. 331.

There are thus two active conductors for each coil, as in the drum type, and the width of the coils is such that when one of these conductors is passing under a **N**-pole the other passes under a **S**-pole. The direction of a current will thus be opposite in each half of the coil underneath the poles, and so flow around the coil in the same direction. Fig. 331 depicts an armature having a slotted *tooth core* built up from punchings of thin sheet iron and held in position by two flanged iron rings securely fastened to the spider arms, as shown. The coils are first wound, then properly shaped upon formers, removed, wrapped with insulation, varnished and baked, and then placed in the slots of the armature core. The winding is held down by clamps at each end and the coil terminals properly connected to the commutator. The coils shown are intended for a six-pole field, which is practically three bipolar fields, and constitute a *multipolar field*, ¶ 346. In some types of large size dynamos, solid copper bars, properly insulated, varnished, baked, etc., are placed in the armature slots, which are lined with mica formed tubes. The bars are then connected by flexible formed terminals, according to the method of winding.

**331. Open-Coil Armatures.**—The armatures previously described are called *closed coil armatures*, because the coils are all connected, forming a closed winding around the armature. When very high potentials are to be generated, as, for example, 8000 volts for a series constant current arc-lighting circuit, ¶ 348, the closed coil winding is not as suitable, since the potential difference between adjacent commutator bars

becomes very high, and may jump or "flash" from bar to bar, or even from brush to brush. Open coil armatures are designed to obviate this difficulty, and are used principally for arc lighting.\* A simple form of open coil armature is depicted in Fig. 332. Two coils, A, B, wound at opposite positions on the ring core are connected in series, and the two remaining terminals to two diametrically opposite commutator bars, 1, 2. Another set of two coils, C, D, are wound in a position at right angles to the former coils, connected two in series, and to two independent diametrically opposite bars, 3 and 4. At a particular instant of revolution, shown in Fig. 332, the coils C and D have the maximum E. M. F. induced in them, and are connected to the

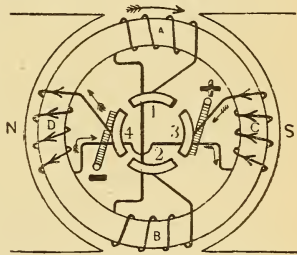


Fig. 332.—Open-Coil Armature.

external circuit by the brushes, while coils A and B are in the position of zero induction and out of circuit at this instant. An instant later coils A and B will be in the active position and connected to the circuit with coils C and D cut out. Two independent two-part commutators are used instead of that shown in Fig. 332 and placed side by side, Fig. 333, one set overlapping the other. The brush is made equal to the width

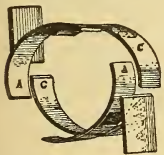


Fig. 333.—Commutator for an Open-Coil Armature.

of both sets of bars, and by this arrangement the external circuit is not broken each time a pair of coils is switched out of circuit. With the four-coil armature the current would be very pulsating in the external circuit, so that more coils are used in practice and more commutator segments, or several commutators similar to Fig. 333, placed side by side on a shaft, and their respective

brushes connected in series or parallel with the external circuit, so as to obtain the maximum inductive effect of all the active coils. For example, the open-coil armature of a 160-light Brush arc generator is wound with 32 bobbins, and at one instant of revolution there

\*In Brush and Thomson-Houston direct current arc-light generators and in Westinghouse alternating current arc generators. The Wood, Excelsior, and Western Electric dynamos are closed coil ring armatures, subdivided into a great many sections to reduce the potential between adjacent commutator bars.

are 2 sets of 4 coils each in series; 2 sets of 4 coils each in series, with 2 groups in parallel, and 2 sets of 4 bobbins each out of circuit. The E. M. F. generated by this armature is 8000 volts.

### QUESTIONS.

- ✓ — 1. How does a dynamo differ from a primary battery?
- ✓ — 2. Give three classifications of dynamos according to their mechanical construction.
- ✓ — 3. How does an alternator differ from a direct current dynamo?
4. Sketch four positions of a single rectangular coil of wire at each quarter of a revolution when rotated in a bipolar field, the terminals of the coil being provided with two collector rings. Indicate polarities and direction of current in the internal and external circuits in each sketch.
5. Make sketches when the terminals of the coil in question 4 are connected to a two-part commutator.
6. The armature of a dynamo revolving at 1000 revolutions generates 110 volts. State three ways in which you can increase the voltage.
7. What is the difference between a drum, a ring, and a drum-wound ring armature? State the advantages of each.
8. What is the advantage of open-coil armatures over the closed-coil type?
9. Make sketch of a 12-coil direct current bipolar ring armature with two turns per coil; indicate direction of current in the armature and external circuit.
10. The resistance of the wire wound upon a bipolar ring armature is 20 ohms. What is the armature resistance? *Ans.* 5 ohms.
11. The armature in question 10 generates an E. M. F. of 50 volts. What current will flow through some lamps joined in parallel with it having a joint resistance of 4 ohms; resistance of lead wires 1 ohm? *Ans.* 5 amperes.
12. What will be the P. D. indicated by a voltmeter, in question 11, when placed (1) Across the lamps? (2) Across the brushes? *Ans.* (1) 20 volts; (2) 25 volts.

## LESSON XXVII.

### ARMATURES.

Armature Core Construction—The Commutator and Brushes—Armature Core Insulation—Table XXI. Insulation Test—Armature Winding—Armature Core Loss—Hysteresis—Armature Reactions—The Act of Commutation of an Armature Coil—Sparking at the Brushes—Position of the Brushes—Causes of Sparking—Capacity of a Dynamo—Commercial Rating of Dynamos—Losses in a Dynamo—Efficiency of a Dynamo—Questions.

#### 332. Armature Core Construction—Eddy Current Loss.—

The armature core which is introduced into the magnetic circuit to lower its reluctance, is an electrical conductor also, and when rotated in the magnetic field will have currents induced in it, according to the principles of electromagnetic induction. A certain

portion of the energy driving the armature is thus expended in producing useless electric currents, *eddy currents*, ¶ 292, in the core, and which do not appear in the external circuit; this is termed *eddy current loss*, and constitutes one of the

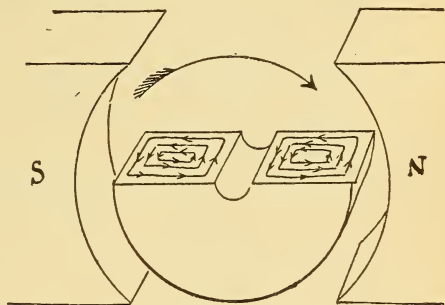


Fig. 334.—Eddy Currents in the Armature Core.

internal losses of a dynamo. A section of a solid armature core is illustrated in Fig. 334, and the direction of the induced eddy currents (found by Fleming's Rule, ¶ 278), indicated at this particular position of the armature core in the course of its revolution. The heat produced by these currents is chiefly at the outer surface of the core, where the eddies are strongest. The armature wires being wound on the surface will also be heated and their resistance in-

creased, and as a result the  $C^2R$  loss will be increased. There are thus two evil effects of the eddy currents.

Eddy current losses may be considerably diminished by building the armature up of a series of thin discs of soft sheet iron or steel, the surfaces of which have been allowed to oxidize (rust), thus introducing an insulator



Fig. 335.—Sheet Iron Armature Core Disc.  
.015-inch thick.

between the sheets, which decreases the electrical conducting power of the core. Sometimes pieces of tissue paper are interposed between the sheets, or brass discs introduced at intervals to break the continuity of the circuit, and also to afford armature ventilation. A single sheet iron punching of a tooth-core ring armature is represented in Fig. 335, while the effect of lamination is shown in Fig. 336, in which the eddies are confined to each lamination.

Only four laminations are purposely shown in the core, in Fig. 336, to magnify the effect. The thickness of the metal from which they are punched may be .015 inch, so that a great many separate pieces are required for a single armature core.

**333. The Commutator and Brushes.**—A commutator consists of a number of bars or segments of drop-forged, hard drawn copper, assembled around an iron hub and thoroughly insulated from the hub and from each other, Fig. 337; mica is used for the insulation. The bars must be securely held in place, since a high or low bar would cause a break in the circuit each time it passed under the brush and destructive arcing would result. A simple method of construction is illustrated in Figs. 338, 339, etc. A brass or iron hub of the shape shown in the sectional view, Fig. 338, drilled to receive the armature shaft, is insulated with a sleeve

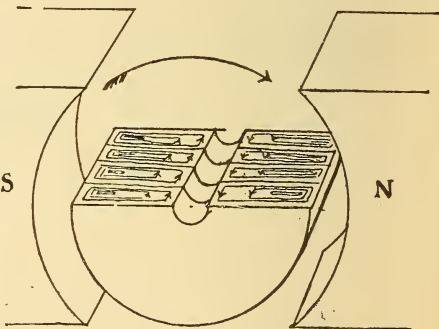


Fig. 336.—Laminated Armature Core.  
The thickness of the discs is magnified to show the eddy currents.

and destructive arcing would result. A simple method of construction is illustrated in Figs. 338, 339, etc. A brass or iron hub of the shape shown in the sectional view, Fig. 338, drilled to receive the armature shaft, is insulated with a sleeve



and formed collar made of sheet mica, when it is ready for the reception of the bars which are forged with grooves in the ends, as in Fig. 339. The projecting insulated tongue on the hub fits into a corresponding groove in a bar, and when all the bars are assembled around the hub, with strips of mica between each, they are locked in place by the projecting insulated V-tongue of a washer screwed upon the hub and backed up by a lock-nut. A partial section through the commutator is shown in Fig. 340, in which the heavy line represents the insulation, and from which the manner of locking the bars will be understood. A lug extends at right angles from one end of each bar to which the armature wire is soldered.

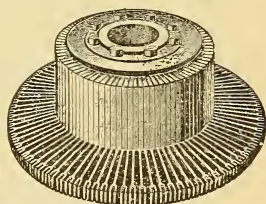


Fig. 337.—Commutator for a Direct Current Dynamo or Motor.

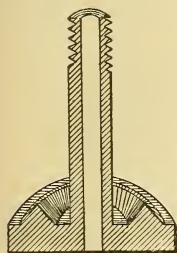


Fig. 338.—Commutator Hub.  
Made of brass or iron.

Carbon brushes, copper plated to decrease their resistance, are secured in a brush holder and made to press against the commutator by spring pressure. Details of the brush holder are shown in Figs. 304 and 361. The brush holder stud or shaft is securely bolted to, but insulated from, the rocker arm, and connected by flexible cables to the external circuit. The function of the rocker arm is to move the position of the brushes upon the commutator so that the current is led away from the armature at the proper point of commutation. Fixed copper brushes are used upon alternators because there is no tendency to spark at the brushes, as in direct current machines, and copper is a much better conductor. In very low voltage dynamos copper brushes are used to advantage.

**334. Armature Core Insulation.**—The armature cores of all large generators are slotted for the reception of the conductors and are called tooth-core armatures, Fig. 341. Mica tubes, formed by the aid of heat, from sheets built up of many thicknesses of mica united by shellac, etc., are fitted into the

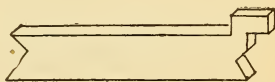


Fig. 339.—Forged Copper Commutator Bar.

slots and formed rings or segments of the same material are used upon the ends of the cores. The quality of the insulation and the care required in insulating increases directly with the

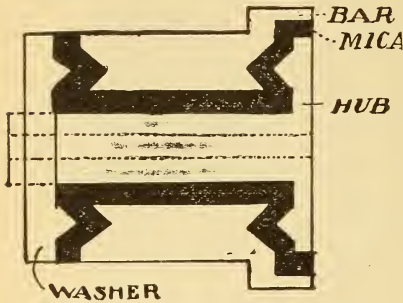


Fig. 340.—Sectional View of a Commutator.

potential to be developed by the armature; an armature wound to develop 1000 volts requiring a better degree of insulation than one wound for only 125 volts. Smooth core armature bodies are used in some small machines and are generally wound with several layers of linen or silk, then shellaced and baked in an oven to drive out all moisture. The armature discs are bolted between end flanges, the circumference of which are slotted for the reception of small fibre wedges, which serve as guides for the coils to be wound upon the core, Fig. 342. The insulation is pierced and the wedges driven into the slots.

The quality of an insulating material is tested by subjecting it to a high potential and ascertaining at what voltage the insulation "breaks down," or conducts, instead of insulates. The specimen to be tested, as a piece of paper or fibre, may be interposed between two plates connected to a source of high

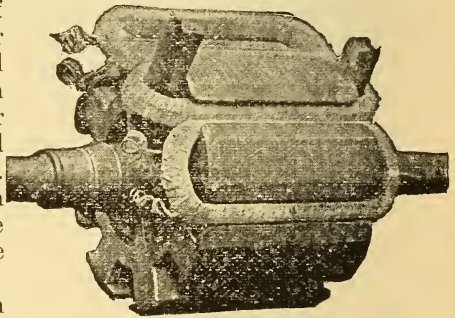


Fig. 341.—Tooth-Core Armature Body With Formed Coils in Position.

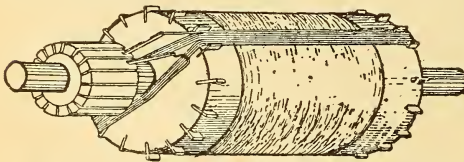


Fig. 342.—Drum Armature Showing the Method of Winding a Coil.

potential, which is capable of being regulated. The voltage is then increased till a spark passes from plate to plate through the specimen, thereby puncturing it, as in Exp. 88, page 323. The following insulating materials and the voltages at which they "broke down" under test will give the student some idea of what is meant by insulating qualities.

Table XXI.—Insulation Test.

"Break Down" Voltage	Thickness in Inches	Material
2000	.013	ordinary shipping tag
500	.010	soft grey wrapping paper
800	.015	varnished linen
800	.016	white gummed tape
1500	.031	varnished canvas
2000	.037	red sheet fibre
5000	.022	yellow press-board
6500	.018	mica and cheese cloth
8500	.035	grey press-board

The insulation of electrical machinery is usually tested by applying several times the voltage that the apparatus is designed to stand; for example, a 1000 volt armature may be subjected to 10,000 volts, one terminal of the high potential source being connected to the core, and the other to the copper windings. If there is any defect in the insulation, upon application of the high voltage it will readily be noted on indicating instruments in the testing circuit.

**335. Armature Winding.**—After complete insulation of the armature core it is ready to receive the armature wires. In large tooth-core bodies the conductors are generally in the form of straight bars of rectangular cross-section which have been previously insulated. One or more bars are inserted in each slot, and the coils formed by connecting their ends to other bars by flexible formed end terminals soldered to them, provision being made for commutator taps at the ends of the proper coils, when the armature is for a direct current machine. There are many kinds of armature connections, each designed for a specific purpose, such as series winding, double or triple multiple-winding, multiple-wound two-circuit winding, etc.\* A small smooth-core drum armature body for a two-pole field is depicted in Figs. 342 and 343. Suppose it

\* Armature winding is treated in books relating to dynamo design.

is to be wound as a closed coil series wound armature with 8 coils and 3 turns per coil. The armature core is divided into 16 divisions by the fibre wedges alluded to in ¶ 334, and the first coil wound in division 1 and 9; the second, in 2 and 10, and so on. Commence to wind the beginning of coil No. 1

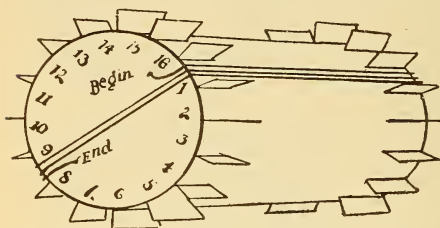


Fig. 343.—Position of the Coils on a Drum Armature.

in division 1, and it will end in division 9, Fig. 343; commence coil No. 2 in division 2, wind in the same direction as coil No. 1, and it will end in division 10, and so on. The coils should then be bound to the armature core by mounting it in the lathe and winding several bands around them, each consisting of a number of turns of phosphor bronze wire. Mica is interposed between the band wires and the armature wires, and the former soldered together, thus producing a solid band. A commutator with 8 bars will be required since there are 8 coils and the coils are to be joined in series. Connect the beginning of coil No. 1 to bar 1 and the ending of coil No. 1 to bar 2, Fig. 344; the beginning of coil No. 2 to the ending of coil No. 1 at bar 2; the ending of coil No. 2 to bar 3 and to the beginning of coil No. 3, and so on until finally the ending of coil 8 will connect to the beginning of coil 1 at bar 1. The coils are thus all in series around the armature;

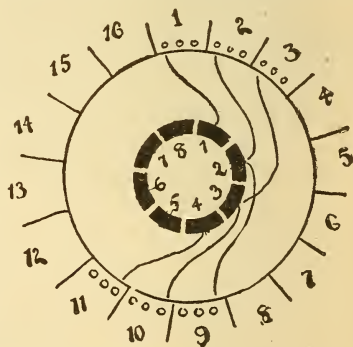


Fig. 344.—Connecting the Armature Coils to the Commutator.

forming the connecting links between the coils. Many more turns could be wound per layer, and more layers per division, to increase the induced E. M. F. After the first set of coils is wound a second set may be wound on top of them, with

proper insulation between them; 16 bars would have been required had this method been adopted in Fig. 343. The method of varying the winding according to the potential desired is illustrated in Fig. 345, which represents the number of wires per coil on an 8 H. P. dynamo when it is wound for 125 volts, as in A; 250 volts, in B; 500 volts, in C. The size of the wires decreases as the voltage increases, since for the same power the current will be less, and the turns increase in direct proportion to the voltage, there being 3, 6, and 12 turns

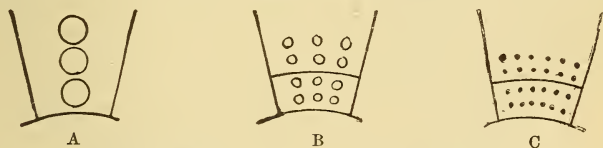


Fig. 345.—Windings of an 8 H. P. Armature.

A—125 volts. B—250 volts. C—500 volts.

per coil corresponding to 125, 150, and 500 volts. The speed and field strength are the same for each armature. In B and C two coils are shown per division, but they are connected in series as in case A. In a series closed circuit *ring winding* the same method will apply as given above. The end of the first coil is connected to the beginning of the second, and the junction, to commutator bar No. 2, and so on, until the ending of the last coil is connected to the beginning of the first coil and to bar No. 1. This method is outlined in the multi-polar ring armature in Fig. 359.

### 336. Armature Core Loss—

**Hysteresis.**—The iron core of an armature rotating in a two-pole field will be subjected to two opposite magnetic inductions in each revolution. For example, consider the polarity of the core at one instant during its revolution, Fig. 346; the left-hand side of the ring has a **S**-pole induced in it by the **N**-pole of the field magnet, while the right-hand side of the ring possesses an induced **N**-pole from the **S**-pole of the field magnet at the same instant. At one-half revolution of the ring from this point that part which previously possessed induced **N**-polarity is now inductively magnetised with a **S**-pole, and the other half, with a **N**-pole. The ring is thus

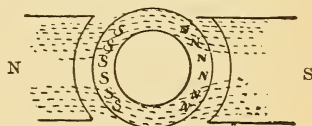


Fig. 346.—Armature Core Loss—Hysteresis.

subjected to two opposite magnetisations in each revolution. Suppose the speed to be 2000 revolutions per minute, then

there will be 4000 reversals of magnetisation per minute in the core. Heat is developed as a result of the hysteresis (page 308, Exp. 82). A portion of the energy required to drive the armature is thus expended in heating the core and does not appear as useful electrical work. The heat so generated also heats the copper wires wound upon the armature core, increasing their resistance and the  $C^2R$  loss, so that still more energy is wasted which does not appear as useful energy. This is called hysteresis loss in a dynamo.

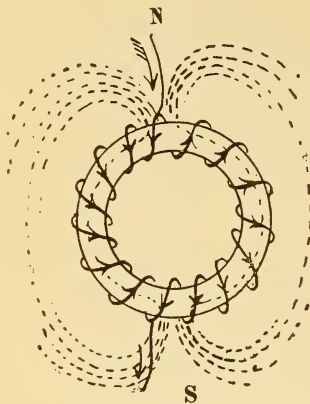


Fig. 347.—Magnetic Field Produced by Current Circulating Through the Armature.

### 337. Armature Reactions.

The current flowing from an armature circulates through its internal windings, and produces magnetic poles in the armature core which react upon the magnetic field and distort it.

Suppose current to be flowing in the direction indicated, from the armature windings depicted in Fig. 347, a **N** and a **S**-pole are produced at diametrically opposite points, where the current enters and leaves the armature by the brushes, just as in the case of the plain iron ring C, of Fig. 178.

Now when this armature is placed in its field and current flows from it, Fig. 348, its poles induce two poles in each of the field cores by magnetic induction, with the polarities as indicated.

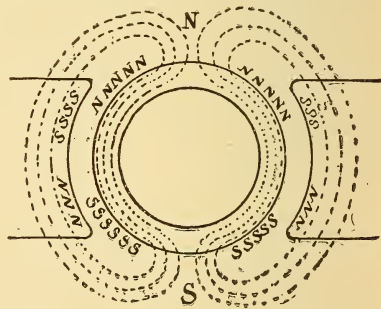


Fig. 348.—Reaction of the Armature Field Upon That of the Field Magnets.

One induced pole in each field core tends to strengthen the number of lines of force threading from the field to the armature core, while the other induced pole tends to neutralize the field magnetism or to produce neutral points in the field at the opposite ends of a diameter. This will be more clearly understood from Fig. 349, which represents the resultant distorted magnetic field produced by the cross-magnetising effect of the armature upon the field. The neutral points near two of the pole tips and the points where the lines are crowded under the other two pole tips are shown by the aid of iron filings. In the armature core, N and S represent the poles induced by the field magnets, while the poles in the core due to the armature current are represented by s and n.

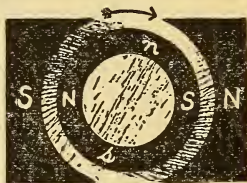


Fig. 349.—Distortion of the Magnetic Field Due to the Cross-Magnetising Effect of the Armature Current.

The position of maximum induction then is not along the horizontal line, as considered in the ideal dynamo ¶ 319, but along a line inclined at an angle to it, the angle increasing as the current from the armature increases. As a result of this field distortion the position of minimum inductive

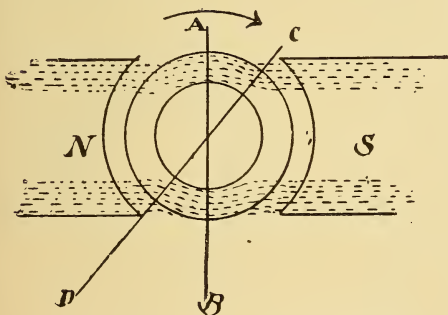


Fig. 350.—Neutral Points Produced by the Armature Reaction.

action in the armature coils will not be along the vertical line A B, Fig. 350, but along a line somewhat in advance of it, in the direction of the armature rotation, as the line CD which passes through both neutral points in the field and is known as the *neutral line*, or plane.

Commutation of an armature coil must therefore take place as the coil passes the neutral line. The brushes should be set at diametrically opposite points (in a bipolar dynamo) and then shifted to a position corresponding with the neutral

line. The angle of advance of the neutral line from the vertical position will depend upon the current flowing from the armature (the field distortion increasing with the current) being shifted forward for an increase, and backward for a decrease in the armature current. The brushes must therefore be shifted forward in the direction of rotation for an increase of current from the machine and backward, for a decrease. When the brushes are not set to correspond with the neutral point, sparking at the brushes will result.

**338. The Act of Commutation of an Armature Coil—Sparking at the Brushes.**—The act of commutation of an armature coil, that is, the moment it is passing from under the influence of one pole to come under that of the other, is illustrated in Fig. 351. For an instant, each coil is completely short-circuited by the toe of the brush, and any induced E. M. F. in the coil will cause a current to flow through it. As the coil moves away from the brush

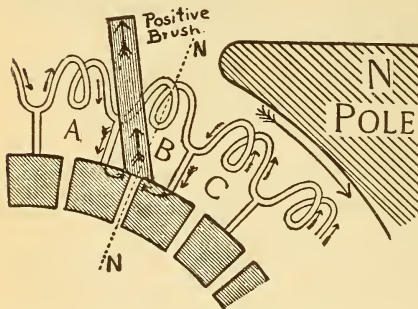


Fig. 351.—The Act of Commutation of an Armature Coil.

At the instant shown coil B is short-circuited by the brush.

this circuit is broken and a bright spark appears at the point where the commutator bar leaves the brush, due to the self-induction of the coil produced by this current. Each coil is thus short-circuited as it passes underneath each brush, so that the sparking may become continuous when the dynamo is running. If the E. M. F. induced in an armature coil of .01 ohm resistance is only .1 volt at the neutral point, by Ohm's Law the current for the instant will be  $\frac{E}{R} = \frac{.1}{.01} = 10$  amperes.\*

If the brushes are not exactly at the neutral point, the coils are then short-circuited before they reach the neutral

\* Suppose that the brush in Fig. 351 had been made of copper instead of carbon, as is generally used, its resistance would have been less and a greater current would have circulated around the short-circuited coil, increasing the self-induction and probably melting a piece of the brush by the heat of the arc.



point, and the E. M. F. in them is higher, causing a greater current to rise for the instant, which is noticed by an increase in sparking at the brushes. *To find the neutral, or non-sparking point of a dynamo, when it is running, the brushes are rocked backward or forward until the sparking practically disappears, or until a point is found where it becomes a minimum.* The tendency of a dynamo to spark can be entirely eliminated if, in construction, the armature is divided up into many coils. Each coil will then have only a few number of turns, which will keep the self-induction down, when the induced E. M. F. will be very small, as a small coil can more nearly occupy the neutral point. The modern dynamo has been so perfected that the sparking has been entirely eliminated. Many dynamos, however, do spark at the brushes, but the fault lies in the manner of adjusting the brushes, etc., rather than in the machine itself. Some of the causes of sparking are given in ¶ 340.

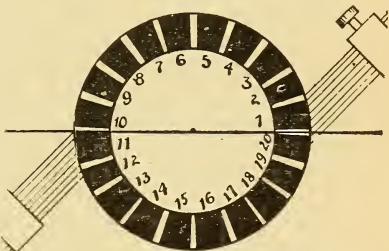


Fig. 352.—Brushes Set Diametrically Opposite on the Commutator of a Bipolar Dynamo.

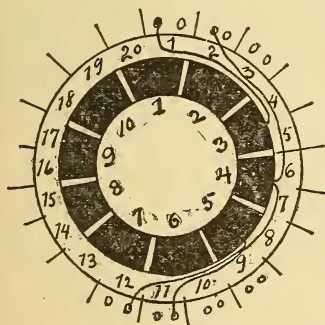


Fig. 353.—Armature Winding.

**339. Position of the Brushes.**—The brushes must be first set on the commutator at the opposite ends of the diameter, in bipolar dynamos, or diametrically opposite. This is usually done by counting the number of bars in the commutator and then properly dividing them. Suppose that a commutator has 20 bars, the toe of the brush should then be set to the insulation line between bars 1 and 20, and between bars 10 and 11, as in Fig. 352. In multipolar dynamos there are usually as many sets of brushes as pole pieces, so that the whole number of commutator bars is

be set to the insulation line between bars 1 and 20, and between bars 10 and 11, as in Fig. 352. In multipolar dynamos there are usually as many sets of brushes as pole pieces, so that the whole number of commutator bars is

divided into four equal parts for a 4-pole machine, and so on. Suppose a commutator of a 4-pole dynamo to consist of 144 segments, then the toes of the brushes would be set to the insulation line between 144 and 1; 36 and 37; 72 and 73, and 108 and 109. To facilitate the construction and manipulation of the brushes in bipolar dynamos, the armature coils are so connected that the brushes can be set at the ends of a horizontal diameter, and still be in connection with the armature coil as it is passing through the neutral point. This is accomplished by *connecting the armature on the quarter*, as it is termed. In Fig. 353 the terminals of coil 1 are not connected to the commutator bar immediately below it, but carried around to a distance of one quarter the whole number of bars and connected to bar 3. It

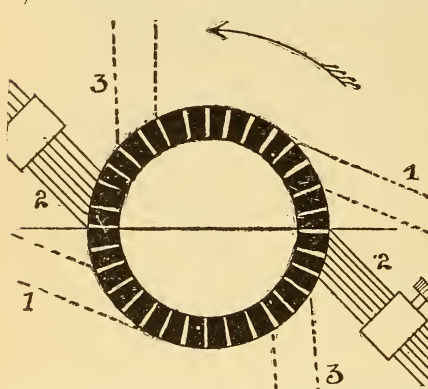


Fig. 354.—Shifting the Position of the Brushes.  
3—No load. 2—Half load. 1—Full load.

will thus be seen that while coil 1 is in the vertical position, its terminals are at the end of a horizontal diameter, at which point the brushes should be located. In Fig. 354 is shown the relative position of the brushes of a 2-pole dynamo; 1st, running full load; 2d, half load; 3d, no load.

The brushes are therefore gradually advanced from position 3 to position 1 as the dynamo is loaded, and likewise rocked backward from 1 to 3 as the load is diminished. The shaft which holds the brushes is attached to a cradle or arm, which can be moved to properly shift the brushes; hence the name "rocker arm." In some makes of dynamos the brushes, after being rocked to the neutral point, need not be again adjusted for any change in load. The neutral point in these machines is made practically constant by designing the armature so that the armature poles will be saturated on light load. The neutral line will then be practically constant, instead of advancing with the increase in load. On account of the very

high potential used in arc light dynamos a small amount of sparking at the brushes is permissible.

#### 340. Causes of Sparking.--

1. Brushes are not set at the neutral point. They should be rocked till this position is found.

2. Brushes are not properly spaced with reference to the commutator bars. They should be accurately and equally spaced by counting the bars between them.

3. Brushes are not set with sufficient pressure against the commutator.

4. Brushes are not set to obtain the full area of contact with the commutator.

5. A high, low, or loose commutator bar causing poor contact with the brush.

6. Loose connection between armature coil and commutator bar. This will be noted by a peculiar blue snapping spark just as this particular bar passes under the brush.

7. Commutator is worn in ridges, causing an uneven surface for brush contact.

8. Armature section is short-circuited by a breakdown in the insulation, either in the coil or between commutator bars, causing a heating of the armature. If the machine can be stopped for a short time this coil should be disconnected, its ends taped, and a wire of the same size as that used in the armature used as a bridge to connect the commutator bars formerly connected to the detached coil. The continuity of the armature circuit will thus be maintained and the machine can be run till the coil can be rewound.

9. Overload on the dynamo. This will be noted by the ammeter in the circuit, also by the sparking of the brushes and the increased temperature rise of the machine.

10. Collection of dirt and grease on the commutator, which assists in preventing a good brush contact.

11. Commutator bars are short-circuited by a collection of carbon or copper dust around them. The commutator should be kept clean, and generally requires no lubricant when carbon brushes are used.

**341. Capacity of a Dynamo.**—With sufficient power applied to a dynamo it is possible to greatly increase the current which can be taken from it, but a limit is soon reached in one or more of three ways.\*

---

\* The student should read again ¶ 282 upon Lenz's Law for induced currents.

*First.* By an excessive drop in the machine, due to an overload, which decreases the P. D at the brushes, when the lamps connected thereto will then receive insufficient current and burn dimly. The E. M. F. can be increased by increasing the speed, but from a mechanical standpoint there is a limit to the speed of rotation which cannot be exceeded, so that some of the load must be removed from the external circuit when this condition is attained.

*Second.* By an excessive heating of the dynamo. As previously stated the heat from the armature increases four-fold when the current from it is doubled, ¶ 259. A machine might be operated with its copper conductors slightly below red-heat, but since this would destroy the insulation of the wires, internal closed circuits would then be formed, and the energy would not be conducted to the external circuit. It is not desirable to work a machine above the boiling point of water (212° F.) and generally the permissible rise is about 70° above the surrounding air. In a hot engine room at a temperature of 100° F. then, the machine would be run at 170° F. The temperature of a generator is determined by running it from 6 to 10 hours at full load, stopping it, and then placing thermometers against the hottest parts for a short time, as a half-hour, a piece of cotton-waste or other non-conductor of heat being laid over the thermometer.

*Third.* By excessive sparking at the brushes of the generator. This subject is treated in ¶ 338.

**342. Commercial Rating of Dynamos.**—Dynamos are rated in size, according to the number of kilowatts which they are capable of maintaining in the circuit external to their terminals within the limit of permissible heating. For example, a 60-K. W. 100-volt generator means that the machine will deliver 60 K. W. to the circuit external to its terminals,\* and that 100 volts P. D. will be maintained at this output across the terminals. The current, therefore, at full load will be, by Formula (63)  $60000 \div 100 = 600$  amperes.

Owing to the electrical losses in the armature and fields the total K. W. generated is higher than the machine's rat-

---

\*The potential difference at the brushes and the terminals of shunt dynamos is practically the same, but in a series or compound wound dynamo the potential at the brushes is higher than that at the terminals, on account of the  $C \times R$  drop in the series field, ¶¶ 351 and 353. The student should keep this point in mind when solving problems.

ing. For example, the 60-kilowatt machine alluded to may develop 62.5 K.W., of which only 60 K.W. can be utilized in the external circuit. Compare with the power from cells, ¶ 226.

**343. Losses in a Dynamo.**—There are two classes of losses in a dynamo,

- (1.) *Mechanical losses,*
- (2.) *Electrical losses.*

(1) The mechanical losses include the friction between the rotating armature shaft and its journal bearings and the friction of the brushes upon the commutator. These friction losses are practically the same at all loads, and consume a certain percentage of the power supplied to the machine, which does not therefore appear as useful energy in the external circuit.

(2) The electrical losses include the  $C^2R$  losses in the armature and fields, the losses due to eddy currents, ¶ 332 and hysteresis, ¶ 336. All the losses may be summed up then as due to,

- (a) *Mechanical friction,*
- (b) *Electrical friction (resistance),*
- (c) *Magnetic friction (hysteresis).*

**344. Efficiency of a Dynamo.**—The meaning of the term efficiency is given in ¶ 227. There are two efficiencies of a dynamo,

- (a) *Electrical efficiency,*
- (b) *Commercial efficiency.*

(a) **ELECTRICAL EFFICIENCY.**—Electrical efficiency is the ratio of the electrical energy delivered to the external circuit to the total energy generated. The total electrical energy generated is equal to the energy delivered to the external circuit plus the  $C^2R$  loss in the armature and the  $C^2R$  loss in the fields or,

$$\text{By Formula (84) } \text{Eff.} = \frac{W}{W + w},$$

when  $W$  = useful electrical energy,  
and  $w$  = energy lost in the machine.

TO OBTAIN THE ELECTRICAL EFFICIENCY OF A DYNAMO :

*Find the sum of the energy delivered, the loss in the armature*

coils, and the loss in the field coils, and divide the energy delivered by this sum.\*

Let  $W$  = useful or available energy ;  
 $w$  = loss in armature ( $C^2r$ ) ;  
 $w_1$  = loss in field coils ( $C^2r$ ).

Then, Elec. Eff. =  $\frac{W}{W + w + w_1} \dots (102)$ .

**Prob. 122:** A dynamo delivers 40 K.W. to an external circuit and there is .6 K.W. lost in the field coils and 1 K.W. lost in the armature. What is the electrical efficiency ?

By Formula (102) Elec. Eff. =  $\frac{W}{W + w + w_1} =$   
 $\frac{40}{40 + 1 + .6} = .96 = 96 \text{ per cent.}$

$W = 40 \text{ K. W.}, w = 1 \text{ K. W.}, w_1 = .6 \text{ K. W.}$

The electrical efficiency varies with the size of the dynamo ; a 1-K. W. dynamo may have as low an efficiency as 50 per cent ; a well designed 40-K. W. dynamo, 96 per cent, and generators of several thousand K.W. 98 per cent or more.

(b) **COMMERCIAL EFFICIENCY.**—Commercial efficiency is the practical rating of the machine and is the ratio of the energy delivered by it to the energy supplied to it, or,

$$\text{Commercial Efficiency} = \frac{\text{Output}}{\text{Intake}}$$

Commercial efficiency therefore includes the mechanical, electrical, and magnetic losses given in ¶ 343. The commercial efficiency is always less than the electrical efficiency and varies with the size of the machine and the load it is supplying. For example, a 40-K.W. generator has an electrical efficiency of 96 per cent, while the commercial efficiency is,

at $\frac{1}{4}$ overload	89	per cent
at full load	91	“
at $\frac{3}{4}$ load	89	“
at $\frac{1}{2}$ “	87	“
at $\frac{1}{4}$ “	84	“

**TO OBTAIN THE COMMERCIAL EFFICIENCY :**

*Divide the energy delivered by the dynamo by the sum of the mechanical, electrical, and magnetic losses.*

\*The eddy currents and hysteresis losses are usually included in the mechanical losses since there is no direct method of measuring them.

Formula (84) applies to the commercial efficiency.

**Prob. 123:** It requires 44 K. W. (58 H. P.) to drive the 40-K. W. dynamo mentioned in Prob. 122. What is its commercial efficiency?

By Formula (84) Com. Eff. =  $\frac{W}{W+w} = \frac{40}{44} = .90 = 90$  per cent.  
 $W = 40$  K. W.,  $W + w = 44$  K. W.

QUESTIONS.

1. What is meant by laminating an armature core? Why is this necessary?
2. State three ways in which energy is unavoidably and uselessly expended in the internal actions of a dynamo.
3. What are the neutral points of a dynamo?
4. Locate the neutral points in a bipolar dynamo when the armature rotates against the hands of a clock.
5. What is the hysteresis loss in a dynamo?
6. Sketch the position of a pair of brushes properly set upon a 48-part commutator in a two-pole field.
7. Why should a coil be commutated as it passes through the neutral point?
8. Sketch the position of brushes properly set upon an 8-pole armature having 192 segments.
9. Since a two-part commutator is so simple in construction, why are armature windings sub-divided into many coils, thus necessitating many commutator bars?
10. In some dynamos it is necessary to change the position of brushes for changes in the current flowing from the machine. Why is this?
11. State some causes for sparking at the brushes of a dynamo.
12. A piece of mica subjected to an insulation test is said to have broken down at 4500 volts. What is meant by this?
13. A ring armature contains a defective coil. How would you temporarily remedy the trouble so that the machine could be operated?
14. What is the difference between the electrical and commercial efficiency of a dynamo?
15. Explain what determines the capacity of a dynamo.
16. The electrical efficiency of a 180-K. W. dynamo is 90 per cent. How much electrical energy is developed? *Ans.* 200 K. W.
17. If it requires 325 H. P. to drive the dynamo in question 16, what is its commercial efficiency? *Ans.* 74 per cent.

## LESSON XXVIII.

### DIRECT CURRENT DYNAMOS.

Bipolar Field Magnets—Multipolar Field Magnets—Multipolar Field Armature Circuit—Constant Current and Constant Potential Dynamos—Classification of Dynamos According to their Field Excitation—The Self-Exciting Principle of Direct Current Dynamos—Residual Volts—The Shunt Dynamo (Constant Potential)—Action of the Shunt Dynamo—Action of the Series Dynamo (Constant Current)—Compound Machines (Constant Potential)—Compound Wound Dynamos in Parallel—The Equalizer—Questions and Problems.

**345. Bipolar Field Magnets.**—In the smaller size of dynamos employing a two-pole or bipolar field, the magnetic circuit has been designed in a variety of forms; the horseshoe type of field, as used in the Edison bipolar dynamo; the inverted horseshoe type, Fig. 303, used in the Crocker-Wheeler and other makes, and the Manchester type of fields are very common forms. In the inverted horseshoe type the winding may be either upon the yoke as A, Fig. 355, or upon each limb, as C, in the same figure. The yoke thus serves as a bed-plate for the machine as well as to conduct the magnetic lines of force. In the Manchester pattern there is a closed magnetic circuit, B of Fig. 355, also Fig. 356. The

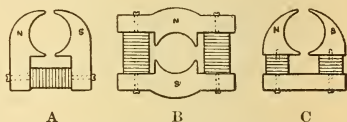


Fig. 355.—Bipolar Field Magnets.

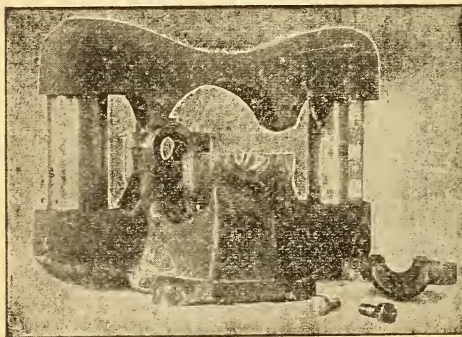


Fig. 356.—Manchester Type of Field Frame.



yokes are cast iron, the lower one forming the bed-plate, and the magnet cores are of soft wrought iron. The magnet coils are connected so that the upper end of each limb tends to produce the same pole, a *consequent pole* is thus formed in each yoke, and the lines of force pass from yoke to yoke across the gap in which the armature is inserted. The direction of the magnetic lines of force is depicted in Fig. 357.

**346. Multipolar Field Magnets.**—The objection to a bipolar field is, that with a dynamo of large output the speed at which its armature would have to rotate to generate commercial voltages, would be prohibitive from a mechanical standpoint. By arranging a number of electromagnets with their poles extending inward from

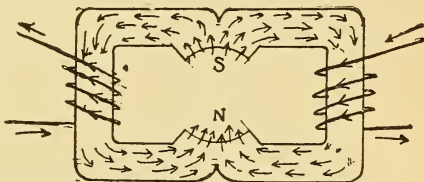


Fig. 357.—Magnetic Circuit of Manchester Field Frame.

an iron ring, forming a multipolar field ring, the conductors upon the armature, revolving between them, cut the magnetic lines of force many more times in one revolution, so that, as the size of the machine increases the speed decreases. Slow speed is an advantage in any apparatus with moving parts, because there is less liability of derangement, less wear, and hence less need of frequent renewal of such parts. If a two-pole 45-K. W. dynamo is required to run at 1000 revolutions per minute to generate an E. M. F. of 125 volts, a four-pole dynamo of equal output will run at only 500 revolutions;

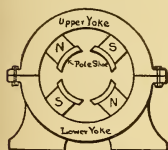


Fig. 358.—Multipolar Field Ring.

one of eight poles, at only 250 revolutions per minute. Many four-pole field yokes are octagonal, but when more poles are required the ring form is used. The field magnet cores are generally cylindrical in form and constructed of cast "mild" steel (soft steel) containing a very small percentage of carbon, the magnetic quality of which is nearly equal to that of wrought iron. This is a much cheaper construction than where they are forged from wrought iron. The wrought iron or cast steel cores are cast-welded into the plain cast iron field ring, which, in the larger sizes, is generally divided into two parts,

for convenience in handling. The coils are wound in the lathe, upon cast brass bobbins, which can be slipped directly over the cores and fastened in place by bolts. Joints should be omitted in the magnetic field circuit for the reason given in ¶ 198, and all sharp corners, bolts, etc., should be rounded to prevent magnetic leakage.

**347. Multipolar Field Armature Circuits.**—The circulation of current through the windings of a ring armature rotating in a four-pole field is shown in Fig. 359. The direction of rotation is clockwise, and the direction of current through the windings under any particular pole can be found by Fleming's Rule, ¶ 278. The currents in the windings under

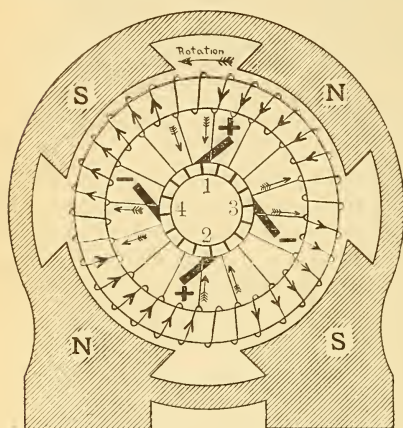


Fig. 359.—Direction of Current Through the Windings of a Ring Armature Rotating in a Four-Pole Field.

the upper **N** and **S**-poles are opposed to each other and flow to the external circuit by the + brush 1 and back to this half of the armature by — brushes 3 and 4. At the same instant the opposed currents in the lower windings flow to the external circuit by + brush 2 and return to the armature through — brushes 3 and 4. The armature is thus divided into four circuits and four brushes are required and must be placed between the poles so as to short-circuit the coils as they pass through the neutral space. In this form of winding there is no difference of potential between the + brushes, so that they are connected in parallel, as are also the negative brushes, and then to the external circuit. In multipolar machines there are as many brushes as pole pieces,\* and all the + brushes are generally connected to one main generator cable, forming the + terminal of the machine, and likewise to the negative brushes.

\*Since opposite commutator bars are of the same potential on this four-pole dynamo they may be joined by a cross-connecting wire and two brushes, as 2, and 4, dispensed with. This can only be done when there is an even number of coils. The armature is said to be "cross-connected."

**348. Constant Current and Constant Potential Dynamos.**—Alternators and direct current dynamos may be classified according to their design as follows :

- (1.) *Constant potential dynamos,*
- (2.) *Constant current dynamos.*

With *constant potential dynamos* the voltage is maintained constant across two or more parallel mains in which the current varies according to the resistance of the multiple circuit. Incandescent lighting, indoor arc lighting, motors and street railway systems are operated from *multiple circuits* connected to constant potential generators. In a *constant current dynamo* the current is maintained constant through an external series circuit connected to it, while the E. M. F. varies with each change in the resistance of the circuit. Street arc lamps are operated in series from constant current machines. The strength of the current is usually 9.6 amperes and the voltage may vary from 45 to 8000 volts according to the number of lamps in circuit. The reason for operating these lamps in series is that they are generally distributed over a very large area, and a great economy in copper is effected by employing a small wire, generally about No. 6, for the series circuit and using a high voltage. The distribution of voltage throughout the circuit is much more uniform than would be possible with a multiple system, so that all the lamps regulate properly.

**349. Classification of Dynamos According to Their Field Excitation.**—The current for magnetising the field magnets of a dynamo may be supplied from a separate generator or by the machine itself, when it would be styled either a *separate* or *self-exciting* dynamo. The methods of *excitation* are, of course, independent of the field construction and depend only upon the connections. A *compound wound* machine is one in which the method of exciting the field magnets is a combination of two simple methods. Dynamos may be classified according to the methods used to excite the field magnets as follows :

#### 1. Simple Machines.—

(a) **MAGNETO MACHINES, FIG. 318.**—The field magnets are permanent magnets and the machine used only for signalling or testing. It may give D. C. or A. C. currents.

(b) SERIES MACHINES, A, FIG. 360 (*Constant Current*).—The field magnets are connected in series with the armature and wound with a few turns of heavy wire having a low resistance, so as not to oppose the main current flowing through them.

(c) SHUNT MACHINES, B, FIG. 360 (*Constant Potential*).—The field magnets are connected in parallel or shunt with the armature and are wound with many turns of small wire having a high resistance, compared with the armature, since only a small portion of the main current flows through them.

(d) SEPARATELY EXCITED MACHINES, D, FIG. 360 (*Constant Potential*).—Current for the field magnets is supplied from a separate dynamo.

### 2. Compound Machines.—

(e) SERIES AND SHORT SHUNT MACHINES, F, FIG. 360 (*Constant Potential*).—The field cores contain two independent spools. One is wound with a few turns of heavy wire, forming the *series coil* and connected in series with the main circuit, the other, with a great many turns of smaller wire, forming the *shunt coil* and connected in shunt with the armature.

(f) SERIES AND LONG SHUNT MACHINES, G, FIG. 360 (*Constant Potential*).—The same as (e) except that the shunt field shunts not only the armature but also the series field; hence it is called a *long shunt*.

### 3. Alternating Current Machines.—

(g) SEPARATELY-EXCITED MACHINES, D, FIG. 360 (*Constant Potential*).—The field magnets are excited from an auxiliary dynamo called an *exciter*. Alternators require an exciter, since the alternating current cannot be employed to excite the fields. The exciter may be either a separate dynamo or an independent direct current winding upon the alternator shaft, Fig. 360, H.

(h) SEPARATE COIL, SELF-CONTAINED MACHINES, C, FIG. 360.—Separate coils wound on the armature core are connected to an independent commutator, which furnishes current for the field magnets.

(j) SERIES AND SEPARATELY-EXCITED MACHINES, E, FIG. 360.—Two independent field windings correspond to the series

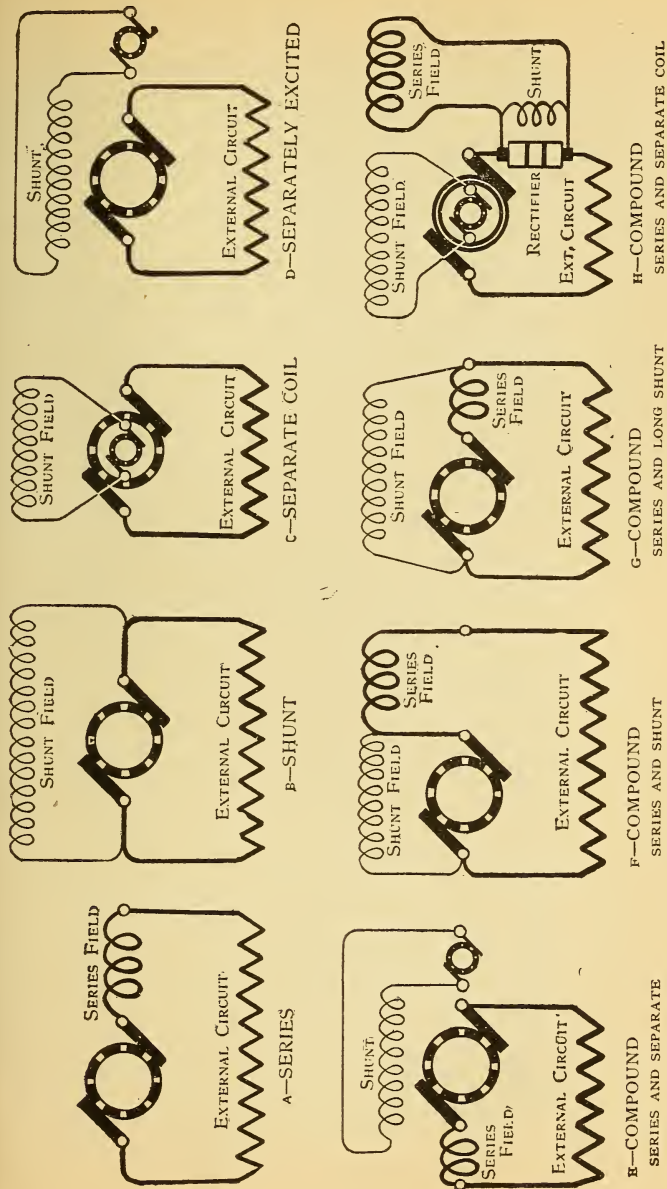


Fig. 360.—Classification of Dynamos According to the Method of Exciting the Field Magnets.

and shunt coils of F. The shunt coil is supplied from an exciter, while the main current, commuted, flows through the series field coils. This method is employed in *composite* wound alternators, a portion of the main alternating current is commuted by a special device called a *rectifier*, located on the armature shaft. Its function is to change that portion of the alternating current intended for the series coils, into a direct current for producing the magnetisation. A self-contained separate coil alternator, composite wound, is depicted in H, Fig. 360. Details of the principal types are given in the paragraphs which follow.

**350. The Self-Exciting Principle of Direct Current Dynamos—Residual Volts.**—In very early dynamos the field magnets were always separately excited by either a battery or magneto machine. With the discovery of residual magnetism, ¶ 30, their self-exciting principle was recognized. If the soft iron or steel cores of a dynamo have once been magnetised they retain permanently a small amount of their magnetism. An armature revolving in even so weak a field as that due to residual magnetism will cut some lines of force, and as a result there is an E. M. F. maintained at the brushes without any excitation. This is often spoken of as the *residual volts*, and will be indicated upon a voltmeter connected to the brushes, when the field circuit is open, and the armature revolves at its proper speed. This E. M. F. may be from 2 to 10 volts or more, depending upon the quality of the iron, the number of armature conductors, etc. If now the field circuit be connected to the brushes, a current will flow through the field magnets due to the residual volts; the number of lines of force of the field increases with this increase in field strength; the induced volts also increase and cause additional current to flow around the fields, resulting in a further increase of voltage at the brushes. This action continues until the maximum voltage of the machine is attained. The process has been termed "the building up of the fields," and may be noted either on a voltmeter, or by the gradual increase in the brilliancy of a lamp connected to the brushes, called a *pilot lamp*, when any direct current dynamo starts to generate. Ten to twenty seconds may be required from the time the field switch is closed until the armature generates its full voltage. A machine may refuse to build up, owing to the loss of its residual magnetism, when the cores should be remagnetised.

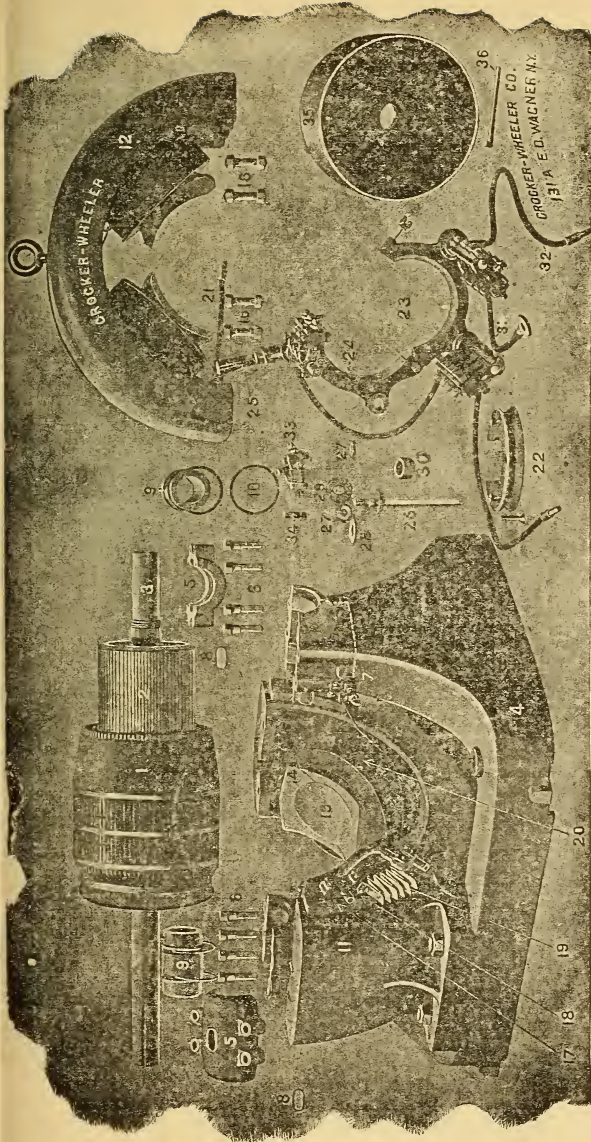


Fig. 361.—Dissected Multipolar Dynamo.

- |                                 |  |  |  |                                   |
|---------------------------------|--|--|--|-----------------------------------|
| 1. Armature (includes 2 and 3). | 9. Journal box.                              | 21. Field cable.                       | 26. Brush stud.                                | 30. Brush stud insulating sleeve. |
| 2. Commutator.                  | 10. Oil ring.                                | 22. Rocker seat with screws.           | 27. Brush stud nut.                            | 31. Brush stud cable.             |
| 3. Shaft.                       | 11. Lower magnet frame (includes 13 and 14). | 23. Brush rigging (includes 24 to 34). | 28. Brush stud insulating washer (round hole). | 32. Armature cable.               |
| 4. Base.                        | 12. Upper magnet frame (includes 13 and 14). | 24. Rocker (includes 25).              | 29. Brush stud insulating washer (oval hole).  | 33. Brush holder.                 |
| 5. Bearing cap.                 | 13. Pole.                                    | 25. Rocker handle.                     | 34. Brush.                                     | 34. Brush.                        |
| 6. Bearing cap screws.          |  |  | 35. Pulley.                                    | 35. Pulley.                       |
| 7. Oil cock.                    |  |  | 36. Pulley key.                                | 36. Pulley key.                   |
| 8. Oil hole cover.              |  |  |  |                                   |

**Prob. 124:** The resistance of the armature of a dynamo is .15 ohm and that of the field magnets, 100 ohms. With open fields the armature generates 6 volts, due to the residual magnetism. What current will flow around the field to start the building-up process when the field circuit is closed?

By Formula (31)  $C = \frac{E}{R + r} = \frac{6}{100 + .15} = .059$  ampere.

**351. The Shunt Dynamo—Constant Potential.**—In a shunt dynamo, Fig. 362, the field coils are of comparatively high resistance as compared with the armature; for example, the multipolar field of a 125-volt, 11-K. W. dynamo has a resistance of about 40 ohms, and the armature resistance is only .095 ohm. The field

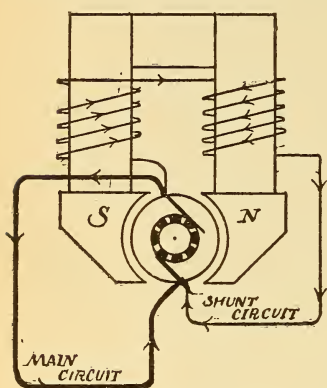


Fig. 362.—Shunt Dynamo.

The field magnets are connected across the brushes. B—Fig. 360.

force cut by the armature, and the induced volts at the brush terminals. Inserting resistance in the field rheostat lowers the voltage at the brushes.

*The current flowing through the shunt field is equal to the potential difference at the brushes, divided by the resistance of the field plus the resistance in the field rheostat, Formula (28).*

*The current flowing through the armature of a shunt dynamo is the sum of the currents in the field circuit and in the external circuit. The volts drop in the armature is equal to its resistance multiplied by the current flowing through it, Formula (29).*

The resistance of the armature is usually measured by the drop method, ¶ 241, and will be higher after the machine

amperes, and the induced volts at the brush terminals. Inserting resistance in the field rheostat lowers the voltage at the brushes.

*The current flowing through the shunt field is equal to the potential difference at the brushes, divided by the resistance of the field plus the resistance in the field rheostat, Formula (28).*

*The current flowing through the armature of a shunt dynamo is the sum of the currents in the field circuit and in the external circuit. The volts drop in the armature is equal to its resistance multiplied by the current flowing through it, Formula (29).*

The resistance of the armature is usually measured by the drop method, ¶ 241, and will be higher after the machine



has been carrying a load for some time, on account of the heating effect.

**352. Action of the Shunt Dynamo.**—In starting a shunt dynamo, after proper speed is attained, the machine is brought up to the required voltage by the field rheostat, and then the main switch connecting it with the external circuit is closed. Suppose that the voltmeter indicates 112 volts potential difference when the external circuit is open. The E. M. F. will be a little higher than this value and equal to  $112 \times C \times r$ , where  $C$  equals the current through the fields and  $r$  equals the armature resistance. A voltmeter, therefore, placed across the brushes of any self-exciting dynamo indicates the potential difference rather

than the E. M. F. If the field rheostat is adjusted for any particular voltage with the main circuit open, say 112 volts, and the switch is now closed so that more current flows from the armature, the voltmeter at once indicates a lower voltage, say 108 volts. If the speed is the same as before, this loss is due to two

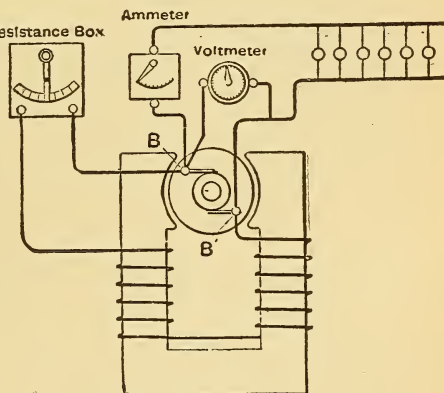


Fig. 363.—Regulating the E. M. F. at the Brushes of a Shunt dynamo by the Shunt Field Rheostat.

causes: *first*, there is an increased drop in the armature due to the additional current flowing through it, which lowers the potential difference at the brushes; *second*, the potential difference at the brushes being lowered, less current flows around the field, so that there are not quite so many lines of force cut as before. When the load is switched on to a shunt dynamo, the resistance in the field *rheostat* must therefore be *diminished* so that the voltage will be raised to its former value.

Again, in the above case, if after the voltage is raised from 108 to 112 volts the load be disconnected, the voltmeter will indicate a higher voltage than 112 volts, say 116, and resistance must now be *inserted* in the field *rheostat* to lower the

voltage. The potential difference at the brushes thus varies, in a shunt dynamo, with each change in load, *increasing as the load decreases and decreasing as the load increases*. If the current fluctuations are wide and quite frequent, as on trolley lines where the cars are started and stopped so often, an attendant would be constantly required to manipulate the rheostat, or some automatic device employed for this purpose, so that this machine is not suitable for such work. Shunt dynamos are adapted to cases where the load is constant when they will require very little attention after the proper regulation has been made; they are classified as constant potential dynamos and may be connected in parallel when

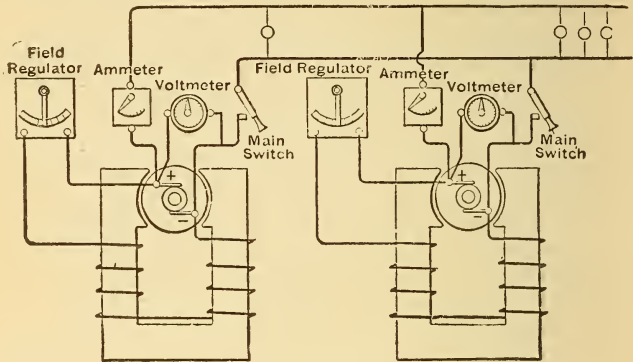


Fig. 364.—Two Shunt Dynamos Connected in Parallel.

The voltage across the mains is equal to that of one machine, the maximum current on the mains, equal to the sum of that of the two machines.

their voltages are equal. Shunt dynamos may be connected in parallel by connecting the positive and negative brushes as in Fig. 364. The voltage is the same as with one machine, but the current output will be the sum of the currents each machine can furnish separately. The voltage of the machine, to be paralleled with other dynamos, should be adjusted equal to, or a little higher than their potential, when it can be connected to the common circuit. Such machines are practically self-adjusting to load conditions. If one machine runs a little faster than the rest it will do more work, and vice versa. Shunt dynamos will also operate in series, but if the machines are of different sizes, the current in the external cir-

cuit is limited to the capacity of the smaller machine. The polarity of the brushes of a shunt dynamo may be changed by either reversing the field connections to the brushes, or by reversing the direction in which the armature rotates. In the latter case the brushes will also have to be changed to agree with the direction of rotation.

**Exp. 94:** The following test, No. 1, was made upon a 1.25-K. W. shunt wound dynamo and illustrates the falling of potential at the brushes as the load increases. The voltmeter was placed across the brushes, the ammeter, in series with some lamps joined in parallel, and the shunt field rheostat adjusted so that the E. M. F. was 110 volts with no load. The rheostat was *not adjusted* thereafter during the test.

Test No. 1.

Test No. 2.

Speed	Volts at brushes	Amperes	Speed	Volts at brushes
1540	110	1	2110	100
"	106	2	2200	104
"	103	3	2290	108
"	100	4	2380	112
"	98	5	2470	116

**Exp. 95:** The above test, No. 2, illustrates how the induced volts vary proportionally with the speed. The field magnets were separately excited so that the lines of force cut were the same at all speeds.

**Prob. 125:** A shunt dynamo, Fig. 365, maintains 110 volts across 100 incandescent lamps joined in parallel, requiring 55 watts and 110 volts each. The lamps are located 100 feet from the dynamo and the resistance of the leads is .02 ohm ; 6.5 K. W.

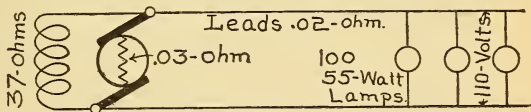


Fig. 365.—E. M. F. and P. D. of a Shunt Dynamo.

are required to drive the dynamo. Resistance of armature .03, and fields 37 ohms. Find the following:

- (a) P. D. at brushes ; (b) total E. M. F. generated ; (c) watts lost in the armature ; (d) in the field ; (e) in the leads ; (f) in the lamps. (g) What is the electrical efficiency ? (h) What is the commercial efficiency ?

By Formula (63)  $C = \frac{W}{E} = \frac{55}{110} = \frac{1}{2} \times 100 = 50$  amperes for lamps.

(29)  $E = C \times R = 50 \times .02 = 1$  volt drop in leads.  
 $110 + 1 = 111$  volts P. D. at brushes (a).

$$(28) C = \frac{E}{R} = \frac{111}{37} = 3 \text{ amperes through the fields.}$$

50 + 3 = 53 amperes through the armature.

$$(29) E = C \times R = 53 \times .03 = 1.59 \text{ volts lost in arma-}$$

ture.

1.59 + 111 = 112.59 volts total E. M. F. (b).

$$(62) W = E \times C = 1.59 \times 53 = 84.27 \text{ watts lost arma-}$$

ture (c).

111 × 3 = 333 watts lost in fields (d).

1 × 50 = 50 watts lost in leads (e).

110 × 50 = 5500 watts lost in lamps (f).

$$(102) \text{ Elec. Eff.} = \frac{W}{W + w + w_1} = \frac{5500 + 50}{5550 + 84.27 + 333}$$

= .93 = 93 per cent (g).

$$(84) \text{ Com. Eff.} = \frac{W}{W + w} = \frac{5550}{6500} = .85 = 85 \text{ per cent (h).}$$

### 353. Action of the Series Dynamo (*Constant Current*).

—In a series dynamo, Fig. 366, the field coils are in series with the armature, and have a low resistance, since the current from the armature flows through them to the external circuit.\*

The field ampere-turns of a series dynamo, as distinguished from the shunt machine, are the product of a much larger current and a less number of turns. With the armature running at a constant speed, the E. M. F. and current from a series dynamo will vary with every change in the resistance of the external circuit, since each change of current alters the field magnetising current, and consequently, the E. M. F. induced in the armature. In practice the current from a series dynamo is required to be constant, irrespective of the resistance of the external circuit, while the voltage is altered to suit the conditions of the circuit. It is thus a *constant current dynamo*. The regulation is accomplished by either of two general methods. In the first

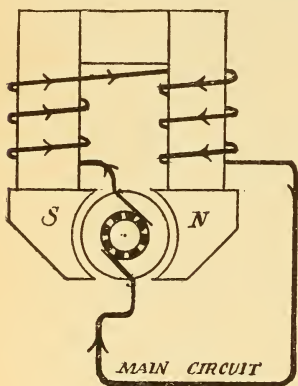


Fig. 366.—Series Dynamo.

The fields are in series with the armature. A—Fig. 360.

For example, the field magnets of a 160-light Brush series arc dynamo have a resistance of 17.2 ohms and the armature for the combination given in ¶ 331, has a resistance of 18 ohms. The loss in the armature is thus nearly the same as in the field.

method the armature used is of the open coil type, ¶ 331, and the position of the brushes is automatically moved so as to be in connection with the armature coils while they are passing through any stage of induction, from the points of maximum induced E. M. F. to the minimum, or neutral points. Any change in the current strength tending to change the field magnetism is thus neutralized by a corresponding opposite change in the E. M. F. The automatic regulator is usually a solenoid and core attached to the brushes and actuated by the main current. This method is utilized in the Thomson-Houston arc light dynamo. In the second method an adjustable rheostat is placed in shunt with the series field magnets, Figs. 366, 367, and the main current divides in proportion to the resistances of the two circuits. The arm of the rheostat is automatically moved by a solenoid and core arrangement actuated by the main current. If the resistance of the external circuit is suddenly lowered, the increased current immediately actuates the solenoid and rheostat arm in a direction to decrease its resistance, thereby shunting more current from the field circuit, and preventing the rise of E. M. F. When the external resistance is increased the resistance in the rheostat is automatically increased and more current flows around the field magnets, thus increasing the E. M. F. This second method is used in the Brush arc light generator. Obviously a series dynamo will not self-excite when the external circuit is open, and will not "build up" when the external resistance is very high. This may be overcome by momentarily short-circuiting the machine while the external circuit is closed, when the E. M. F. will rise to a sufficient value to start the action. With a sensitive automatic regulator a series machine may be short-circuited without injury, since the larger current which

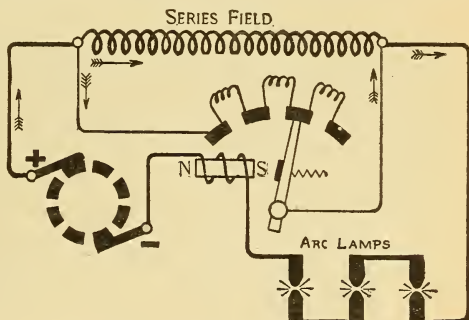


Fig. 367.—Regulating the Voltage of a Series Dynamo by Shunting the Series Field.

When the external resistance is increased the resistance in the rheostat is automatically increased and more current flows around the field magnets, thus increasing the E. M. F. This second method is used in the Brush arc light generator. Obviously a series dynamo will not self-excite when the external circuit is open, and will not "build up" when the external resistance is very high. This may be overcome by momentarily short-circuiting the machine while the external circuit is closed, when the E. M. F. will rise to a sufficient value to start the action. With a sensitive automatic regulator a series machine may be short-circuited without injury, since the larger current which

would tend to flow, immediately actuates the automatic mechanism in such a manner as to decrease the E. M. F.

**354. Compound Machines** (*Constant Potential*).—The compound wound dynamo is designed to automatically give a better regulation of voltage on constant potential circuits than is possible with a shunt machine, and possesses the characteristics of both the series and shunt dynamos. The shunt field is the same as in the shunt dynamo, and independent series field spools are added, through which the main current flows. These are connected so as to increase the magnetism of each pole produced by the shunt winding, Fig. 368. With no current in the external circuit the machine separately excites by its shunt field. When current flows to the external circuit the voltage at the brushes is not lowered, as in the shunt dynamo, since the series winding

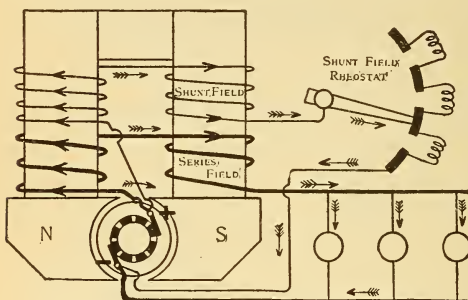


Fig. 368.—Compound Wound Dynamo.

The series and shunt field act in unison. F—Fig. 360.

strengthens the field by the current flowing through it, and thus raises the voltage in proportion to the increased current. By a proper selection of the number of turns in the series coils, the voltage is thus kept automatically constant for wide fluctuations in load without changing the shunt field rheostat. If a greater number of turns is used in the series coil than required for constant voltage at all loads, the voltage will rise as the load is increased, and thus make up for the loss on the transmission lines, so that a constant voltage will then be maintained at some distant point from the generator. The machine is then said to be *over-compounded*. This over-compounding is usually designed for a rise of voltage from 5 to 10 per cent of that of the machine, from no load to full load. In design, the field coils are wound with a greater number of turns than actually required, and the machine is accurately compounded by a running load test after completion. These adjustments are made by placing a German

silver shunt in parallel with the series field so that the main current divides between the two circuits, Z, Fig. 371; also 19, of Fig. 361. The length of the shunt can then be regulated to send sufficient current around the series coils to produce the desired compounding. In a short shunt compound wound generator the shunt field is subjected to a higher voltage than in the long shunt connections. The E. M. F. applied to the shunt field in the latter case for any particular load, being equal to the E. M. F. at the brushes plus the drop on the series field, F and G of Fig. 360. Compound wound direct current dynamos are used in incandescent electric light-

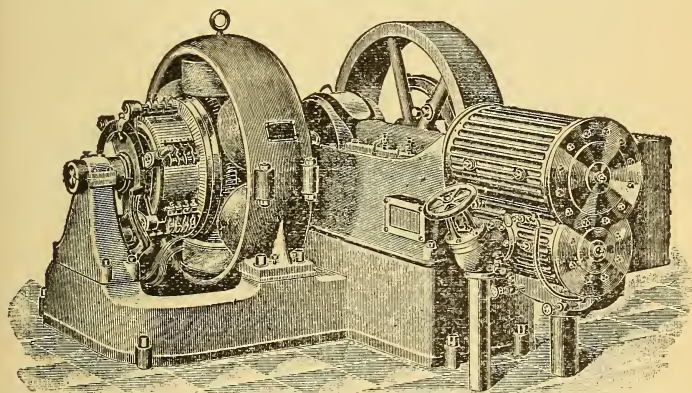


Fig. 369.—100-K. W. 125-Volt Multipolar Compound Wound D. C. Dynamo  
Direct-connected to a Steam Engine.

Output at brushes, 800 amperes at 125 volts. Speed, 270 revolutions. Poles, 6. Approximate horse power required to drive generator, 150 H. P. Approximate weight: armature and commutator, 2,950 pounds; generator complete, 11,200 pounds.

ing stations and in electric railway power stations where the load is very fluctuating. A short circuit on a compound wound dynamo overloads the machine, since the excessive current flowing through the series field tends to keep the voltage at its normal value. Unless the line is automatically opened under such a condition either by a fuse or circuit breaker, the machine and its driving engine will be damaged. To avoid heavy short circuits, which would damage such generators as well as their engines, they are protected by automatic circuit breakers, Fig. 176.

**Exp. 96:** The following test was made on the 1.25-K. W. dynamo, referred to in Exp. 94. The series field was short-circuited in the previous tests. Both fields are acting in the present case. The machine was adjusted to 110 volts by the shunt field rheostat as before, and *not changed* during the test. It will be noted that the potential is constant whether 1 lamp or 5 lamps are in circuit. Compare with the shunt dynamo test in ¶ 352.

### Compound-Wound Dynamo Test.

Speed.	Volts at Brushes	Amperes.
1540	110	1
1540	110	2
1540	110	3
1540	110	4
1540	110	5

**Prob. 126:** A compound wound dynamo supplies 100 amperes at 112 volts to a group of lamps located 75 feet from the generator. Resistance of leads .02 ohm; armature .01 ohm; series coil .02 ohm; shunt coil 40 ohms; 14 K. W. are required to drive the machine, Fig. 370. Find the following:

(a) P. D. at brushes; (b) total E. M. F. generated; (c) watts lost in the leads; (d) in the series; (e) in the shunt; (f) in the armature; (g) in the lamps. (h) What is the electrical efficiency? (k) What is the commercial efficiency?

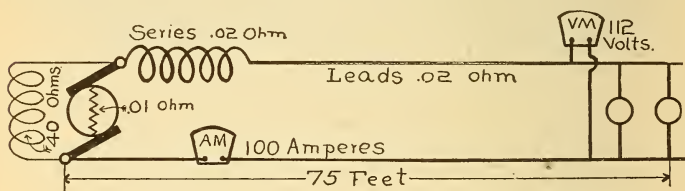


Fig. 370.—E. M. F. and P. D. of a Compound Wound Dynamo.

By Formula (29)  $E = C \times R = 100 \times .02 = 2$  volts drop in leads.  
 $112 + 2 = 114$  volts P. D. at terminals.

(29)  $E = C \times R = 100 \times .02 = 2$  volts drop on series field.

$114 + 2 = 116$  volts P. D. at brushes (a).  
 116 volts across shunt field.

(28)  $C = \frac{E}{R} = \frac{116}{40} = 2.9$  amperes through shunt field.

$100 + 2.9 = 102.9$  amperes, total current through armature.



$$(29) E = C \times R = 102.9 \times .01 = 1.029 \text{ volts drop in armature.}$$

$$E. M. F. = 112 \text{ volts (lamps) } + 2 \text{ volts (leads) } + 2 \text{ volts (series) } + 1.029 \text{ volts (armature) } = 117.029 \text{ volts (b).}$$

$$(68) W = C^2 R = 100 \times 100 \times .02 = 200 \text{ watts (c);}$$

$$= 100 \times 100 \times .02 = 200 \text{ watts (d);}$$

$$= 2.9 \times 2.9 \times 40 = 336.4 \text{ watts (e);}$$

$$= 102.9 \times 102.9 \times .01 = 105.884 \text{ watts (f).}$$

$$(62) W = E \times C = 114 \times 100 = 11400 \text{ watts external circuit (g).}$$

$$117.029 \times 102.9 = 12042.28 \text{ watts generated.}$$

$$(102) \text{ Elec. Eff. } = \frac{W}{W + w + w_1} = \frac{11400}{12042.28} = .94$$

$$= 94\% \text{ (h).}$$

$$(84) \text{ Com. Eff. } = \frac{W}{W + w} = \frac{11400}{14000} = .81 = 81\% \text{ (k).}$$

**355. Compound Wound Dynamos in Parallel—The Equalizer.**—Compound wound dynamos are generally run in parallel, but more care must be exercised in connecting them in circuit than with the shunt machine. In order to connect several compound wound dynamos in parallel a special regulating device, called an *equalizing bar* must be used. The function of this equalizer is to enable each machine to take its share of the load and to make the load on the machines so paralleled, independent of slight changes in speed. The equalizing bar, Fig. 371, connects the brush of one dynamo, to which the series field is attached, to the corresponding brush of another dynamo. Both brushes, so connected, are of the same polarity and also of the same potential when the machines run at the same voltage. The action is as follows: suppose the compound wound dynamo No. 1, Fig. 371, is carrying a load and it is desired to parallel machine No. 2 with it; the latter is brought up to speed and its voltage regulated by the shunt field rheostat till a voltmeter indicates that it is equal to that of No. 1. Though the terminals of the loaded and free machines are now equal in voltage the voltage at the brushes of the loaded machine will be higher than that of the other, by an amount equal to the drop on the series field of No. 1. There is thus a difference of potential between the two ends of the equalizing bar, and when this switch (E) is closed, some current flows

through the equalizer and around the series field of machine No. 2 to the external circuit. The line switch  $S^2$  is now closed and the free machine takes some portion of the load and is further regulated by its shunt field rheostat. When complete equalization of load occurs there will be no current in the equalizer. If the speed of either machine falls, thereby lowering its voltage, current from the other machine will flow through the equalizer and strengthen its series field, thus increasing the voltage. There is thus sometimes no current in an equalizer while at other times it may be flowing in either one direction or the other. To reduce the  $C^2R$  loss, the equalizer should be as short as possible and as large

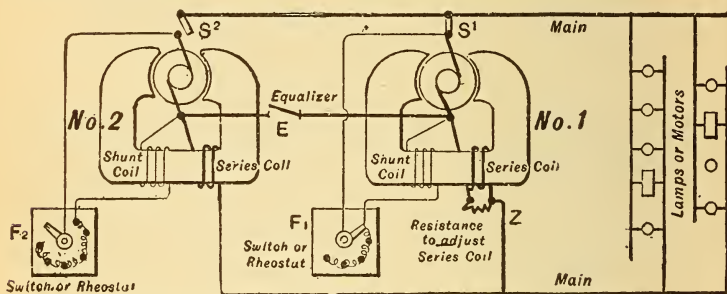


Fig. 371.—Two Compound Wound Dynamos Connected in Parallel.

as the main dynamo cables. A triple pole switch is generally used for coupling a compound dynamo with others, the middle blade of which is slightly longer than the other two, and is connected to the equalizer. When the switch is closed the equalizer is thus connected first, and the main terminals a little later. In shutting down a dynamo in parallel with others the main line terminals are first disconnected and then the equalizer, which is performed in one operation with the triple pole switch alluded to above. The voltage should then be lowered by inserting all the resistance of the shunt field rheostat in circuit, when this field circuit switch may be opened, and then the speed reduced. Any number of compound dynamos may be operated in parallel. If the machines are of different capacities they may also be run in parallel, provided that the voltages are the same, and resistances of the series fields made inversely proportional to the

current capacities of the several machines to be connected. Each machine will then take load in proportion to its capacity. The series fields can be adjusted by adding several turns of extra wire to this circuit, as required. See Plate II.

### QUESTIONS.

1. Why are large dynamos constructed with multipolar rather than bipolar fields?

2. Sketch a ring armature located in a six-pole multipolar field, indicating the polarity of brushes and fields, and direction of current from the armature.

3. What is the distinction between constant current and constant potential dynamos?

4. What is a compound-wound dynamo?

5. Since the field magnets of a self-exciting dynamo are not supplied with current from any external source, how is it possible for the machine to generate?

6. A 110-volt incandescent lamp is connected to the terminals of a series machine running at its proper speed and capable of generating 4000 volts, yet the lamp fails to light. Why is this?

7. The main switch of a shunt dynamo is closed and then the machine started up, but it refuses to "build up." Why is this?

8. A large number of lights are suddenly switched off from a circuit connected to a shunt dynamo. What two actions will immediately occur at the generator and how will you counteract them?

9. What are "residual volts"?

10. Give two reasons for the fall of potential at the brushes of a shunt dynamo when the current from it is increased.

11. What is the advantage of a compound-wound generator over a shunt type of machine?

12. What is the difference in the method of regulating the field magnetising force of a series and shunt machine?

13. A generator is compounded for 10 per cent of its rated voltage. What is meant by this and how is it accomplished?

14. What is meant by an over-compounded generator?

15. Since an alternating current is not suitable for magnetising its field magnets, how can an alternator be self-exciting?

16. What is an exciter, and for what is it used?

17. What will be the effect of joining two shunt dynamos in series if one machine is rated at 45 K. W. and the other at 100 K. W? Both machines have the same E. M. F.

18. What is an equalizing bar, and for what purpose is it used?

19. How would you proceed to parallel a compound wound D. C. machine, which is "shut down," with two others carrying loads?

20. How would you disconnect and shut down one of the machines in question 19?

21. Make diagrammatic sketches of all the different methods of field excitation with which you are familiar.

## PROBLEMS.

1. A series dynamo has a resistance of .03 ohm ; the field coils, .01 ohm ; the machine is connected to an arc lamp requiring 14 amperes and having a resistance of 4 ohms ; the resistance of the lead wires is .4 ohm. The machine requires  $1\frac{1}{2}$  H. P. to drive it. Find the following : (a) Total E. M. F. generated. (b) P. D. at the brushes. (c) Electrical efficiency. (d) Commercial efficiency. *Ans.* (a) 62.16 volts ; (b) 61.74 volts ; (c) 99 % ; (d) 77 %.

2. A shunt dynamo is connected to 150 lamps, connected in parallel, each having a resistance of 60 ohms (hot), and requiring .85 ampere. The resistance of the armature is .02 ohm ; field magnets, 22 ohms ; leads neglected. (a) Find the E. M. F. (b) What is the P. D. ? *Ans.* (a) 53.596 volts ; (b) 51 volts.

3. A compound wound short shunt dynamo is connected to 700 incandescent lamps in parallel, each having a resistance of 220 ohms (hot) and requiring 110 volts. Resistance of leads, .02 ohm ; shunt field, 40 ohms ; series field, .015 ohm ; armature, .025 ohm. It requires 70 H. P. to drive the machine. Find the following : (a) E. M. F. generated. (b) P. D. at brushes. (c) Drop on series field. (d) Watts lost in shunt field. (e) Watts lost on the line. (f) Electrical efficiency. (g) Commercial efficiency. (h) Make complete sketch. *Ans.* (a) 131.076 volts ; (b) 122.25 volts ; (c) 5.25 volts ; (d) 373.565 watts ; (e) 2450 watts ; (f) 88 % ; (g) 78 %.

4. The series coil of a short shunt compound dynamo, connected to 450 .6-ampere 100-volt lamps in parallel, is .009 ohm. The resistance of the leads is .2 ohm. (a) What is the P. D. at the brushes ? (b) At the machine terminals ? *Ans.* (a) 156.43 volts ; (b) 154 volts.

## LESSON XXIX.

### DIRECT CURRENT MOTORS.

Comparison Between a Dynamo and a Motor—Principles of the Motor—Direction of Rotation of Series and Shunt Motors—Position of the Brushes on a Motor—Counter Electromotive Force of a Motor—Normal Speed of a Motor—Mechanical Work Performed by a Motor—Torque—Output and Rating of Motors—Motor Speed and Torque—Methods of Motor Speed Regulation—Speed Regulation of Series Motors (Second Method)—Series Motors for Railway Work—Operating Motors—Efficiency of a Motor—Electric Traction—Questions and Problems.

#### **356. Comparison Between a Dynamo and a Motor. —**

A dynamo is a machine for generating electrical energy by moving conductors in a magnetic field, the force necessary to maintain the motion being supplied by a steam engine or other source of power. An electric motor is just the reverse of a dynamo, and is a machine for converting electrical power supplied to it into mechanical power at the motor pulley. When the field magnets of a dynamo, as Fig. 303, are excited and a current is passed through its armature by means of the brushes, the armature will revolve in the magnetic field. The rotation is due to the electrodynamic action between the magnetic field of the current-carrying wires upon the armature, and that produced by the field magnets. An electric motor, for direct currents, is constructed in the same manner as a dynamo. Any machine that can be used as a dynamo will, when supplied with electrical power, run as an electric motor, and conversely, an electric motor, when driven by mechanical power, will supply electrical energy to the circuit connected to it. Thus, a dynamo and motor are convertible machines, and the previous lessons upon the construction of dynamos will apply equally as well to the electric motor. Motors are classified in the same manner as dynamos and may be,

- (a) *Series wound,*
- (b) *Shunt wound,*
- (c) *Compound wound.*

The fields may be either bipolar or multipolar, and since the number of poles determines the number of neutral points, there must be as many brushes as poles, except when the commutator is cross-connected, page 333.

**357. Principles of the Motor.**—The principles involved in the rotation of the armature conductors, when placed in a magnetic field, are fully discussed under the subject of electrodynamics, Lesson XXIII. It was there experimentally shown how a single loop, placed in a magnetic field, could be made to rotate, by commutating the current through it at the proper instant in a revolution, ¶ 275, and how the turning

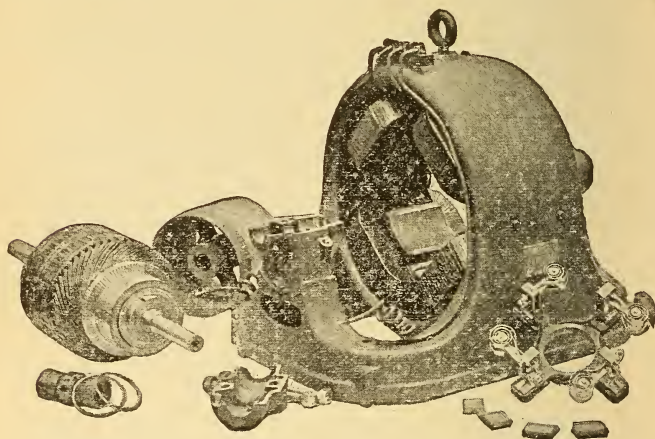


Fig. 372.—Parts of a 20-H. P. Direct Current Slow Speed Motor.

K. W., 15. Volts, 250. Amperes, 60. Speed, 600 revolutions per minute. Average net weight, 2460 pounds. Diameter of pulley, 14 inches; face, 8 inches.

effort was increased by increasing the number of loops or coils and arranging them at different angles with reference to the field.\* When the loops are angularly disposed around an iron core, as in a Gramme or drum ring armature, and then placed in a powerful magnetic field and a current passed through them, each loop tends to move to the position in which it encloses the greatest number of the lines of the field. The direction in which each loop will move will be such that its lines of force will be in the same direction as the

\* The student is advised to again read ¶ 275.

lines of force of the field ; the force with which it will move, or the turning effort or torque, ¶ 362, will depend upon the strength of current flowing through it (that is, the strength of current driving the motor), the size of the loop, and the density of the lines of force through it. When the loop arrives at the position where it accommodates the greatest number of the lines of force through it in the same direction as its own lines, the force, or turning effort, stops. If moved past this position the electrodynamic force is reversed and now tends to turn the coil back to the position of maximum lines of force through it. To obtain continuous rotation, the current through each loop must be reversed at the instant that the turning effort ceases. These reversals are automatically performed by the commutator. The drum or Gramme ring armatures fulfill these conditions, their commutators reversing the current through the coils at the proper instant, when the brushes are correctly set and adjusted.

In a dynamo the direction of current in the armature is such as to oppose the motion producing it, Lenz's Law ; the reaction increased as the current from it increased, thereby requiring additional power to drive it as the load increased. The reaction of the current in the armature of a dynamo is thus opposed to the direction of rotation of the armature.

In a motor, the reaction of the magnetic field of the armature conductors upon the magnetic field surrounding them is such as to move the armature wires across the field in the same direction as the armature rotates, and it is this force which is used to perform mechanical work at the motor pulley. The greater the load applied to the pulley of a motor the greater will be this force or turning effort (torque), and consequently the greater the current taken by the motor armature from the supply mains.

**358. Direction of Rotation of Series and Shunt Motors.**—The direction of rotation of a motor, or that in which any dynamo will rotate when used as a motor, can be found by the left-hand rule, page 278, when the polarity of the field magnets and the direction of current through the armature have been ascertained. Place the left hand, as shown in Fig. 243, so that the fingers correspond with the polarity and direction of current in the single armature coil motor, Fig. 373, and it is found that the loop will rotate in the direction of the hands of a clock. The direction of rota-

tion of a motor can be changed by reversing the current either through the armature or through the fields, but not through both. If both are changed, the motor will run in the same direction as before. See page 279.

A series dynamo when supplied with current becomes a *series motor*, Fig. 366, and will run in the opposite direction to its motion as a generator. Reversing the direction of cur-

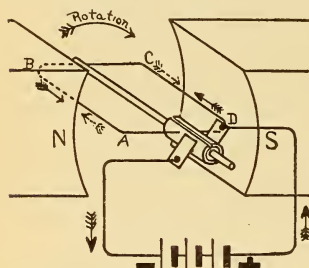


Fig. 373.—Single Loop Armature Driven as a Motor.

The dotted arrows indicate the direction of counter E. M. F.

rent at its terminals will not change the direction of rotation, since the current still flows through the armature in the same direction as through the field, Fig. 366. Reverse either the armature or field connections to change the direction of motion.

A shunt dynamo runs in the same direction when used as a *shunt motor*, Fig. 362, as when used as a generator. This will be seen from Fig. 362; if the current, from an external source, enters by the lower brush it will flow up through the armature in the same direction as when it is used as a dyamo, but the current through the fields will be reversed from the direction indicated in the figure, since the fields are in parallel with the brushes.

**Exp. 97:** Connect the student's experimental dynamo, Fig. 309, as a shunt motor, Fig. 362; adjust the brushes so as to make contact with the *collector rings*; place the armature coil with its plane horizontal and pass a current through the motor. The coil is urged around until its plane becomes vertical, when rotation ceases, according to the principle outlined in ¶ 357. Incline the coil at any angle to the vertical position, and upon closing the circuit it rotates to the vertical position and stops.

**Exp. 98:** Now adjust the brushes upon the *two-part commutator* and repeat Exp. 97. The coil rotates continuously in one direction at several hundred revolutions per minute. The direction of current is reversed by the commutator at each half revolution.

**Exp. 99:** Find the polarity of the field magnets with a compass, also the polarity of the supply line, and note whether the direction of rotation is according to the left-hand rule, page 278.

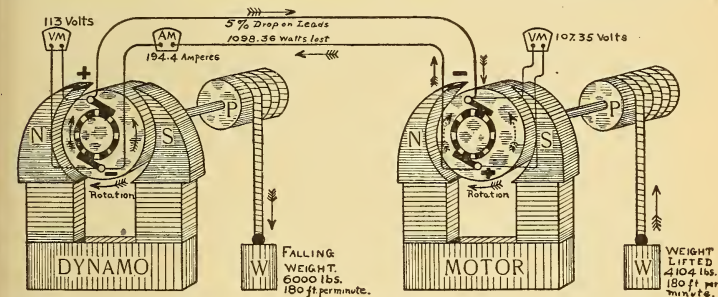
**Exp. 100:** Reverse the current at the motor terminals and the direction of rotation is the same as before. Why? Now reverse the direction of rotation, ¶ 267.

**Exp. 101:** Connect the motor armature in series with the two field



coils in parallel, so that the poles have the proper polarity, N and S. It is now a series motor. (a) Apply the left-hand rule, page 278, for the direction of rotation of the armature. (b) Reverse the direction of rotation, as in ¶ 267.

**359. Position of the Brushes on a Motor.**—The reaction of the armature current upon the field of a motor distorts it just as in a generator, ¶ 337. The lines of force are, however, now crowded together under the opposite pole tips to those illustrated in Fig. 349. The neutral line, or plane will, therefore, advance backward against the direction of rotation of the motor, and it is at this position commutation in a motor should take place. The brushes are set in the same manner as given for a dynamo in ¶ 339, but are *rocked backward against the direction of rotation* till the neutral point or non-sparking position is found. The angle of advance against the direction of rotation will increase as the current taken by the



H. P. driving dynamo = 32.7.  
 Efficiency of dynamo, 90%.  
 Useful watts generated = 21967.2 (29.4 H. P.)

Watts intake by motors, 20868.84 watts.  
 Efficiency of motor, 80%.  
 Useful power developed by motor, 22.3 H. P.

General efficiency of the entire transmission system, 68%.

Fig. 374.—Electrical Power Transmission.

motor increases, or as the work it is required to perform increases, and decrease as the load is removed. The conditions and remedies for the sparking at the brushes of a motor are the same as those given in ¶ 340.

**360. Counter Electromotive Force of a Motor.**—The armature wires of a motor, rotating in its own magnetic field, cut the lines of force just as if it were being driven as a dynamo, and consequently there is an induced E. M. F. in them. By applying the right and left-hand rules to the single coil in Fig. 373, it will be seen that if it is rotated clockwise, the di-

rection of the induced E. M. F. will tend to send a current around the coil from A to B, to C, to D, while when supplied with current as a motor, to rotate in the same direction, the applied pressure will oppose the induced pressure and cause a current to flow from D to C, to B, to A. This induced motor pressure is called the Counter Electromotive Force (abbreviated C. E. M. F.) and is always in such a direction as to oppose the direction of the pressure applied to the motor terminals, or to that of the supply mains. The dotted arrows, in Fig. 373, indicate the direction of the counter E. M. F. and the solid arrows, that of the applied E. M. F. as found by the right and left-hand rules. This counter E. M. F. is a very important property possessed by the motor, as will be shown later on. A motor, without load, will run at such a speed that its counter E. M. F. will very nearly equal the applied pressure.

The counter E. M. F. of a motor running at any speed will be the same as when it is run as a generator at this speed, provided the field strength is the same in both cases, hence to find the counter E. M. F. of a motor at any speed: run it as a generator at this speed and measure the induced E. M. F. by a voltmeter. The counter E. M. F. may also be observed by connecting a lamp across the terminals of a shunt motor, running without much load, and opening the main supply circuit when the lamp will still be illuminated and gradually become dim as the speed of the motor decreases. A voltmeter connected across the motor terminals will also indicate, by the direction of the needle's deflection, that the counter E. M. F. is opposed to that of the line E. M. F. when the supply switch is opened.

TO FIND THE CURRENT FLOWING THROUGH THE ARMATURE OF A MOTOR :

*Subtract the counter E. M. F. from the applied E. M. F. and divide this result by the armature resistance.* Ohm's Law for a motor, then, is as follows :

- Let **E** = E. M. F. applied at motor brushes ;  
**ℰ** = counter E. M. F. developed by motor ;  
**C** = current through motor armature ;  
**r** = internal resistance of motor armature.

$$\text{Then, } C = \frac{E - \mathcal{E}}{r} \dots \dots \dots (103).$$

$$\text{Also by transposition, } \mathcal{E} = E - (C \times r) \dots \dots \dots (104).$$

The counter E. M. F. can never equal the E. M. F., but is always less by an amount equal to the drop in the motor armature ( $C \times r$ ). The difference between a dynamo and motor is as follows :

**Dynamo.**

THE MECHANICAL DRIVING FORCE IS EQUAL AND OPPOSITE TO THE COUNTER ELECTRODYNAMIC FORCE.

THE E. M. F. IS GREATER THAN THE PRESSURE AT THE TERMINALS.

**Motor.**

THE ELECTRODYNAMIC DRIVING FORCE IS EQUAL AND OPPOSITE TO THE MECHANICAL FORCE OF THE DRIVEN MACHINERY.

THE COUNTER E. M. F. IS LESS THAN THE PRESSURE AT THE TERMINALS.

TO FIND THE COUNTER E. M. F. OF A MOTOR :

*Multiply the resistance of the armature by the current flowing through it and subtract this product from the E. M. F. applied to the motor brushes, Formula (104).*

The counter E. M. F. of a motor depends upon the same factors as those governing the induced E. M. F. in a dynamo, and is directly proportional to,

- (a) *The number of lines of force cut,*
- (b) *The number of conductors upon the armature,*
- (c) *The speed at which the lines of force are cut.*

TO FIND THE MECHANICAL POWER DEVELOPED BY A MOTOR :

*Multiply the counter E. M. F. by the current through the armature.*

$$W = \mathcal{E} \times C \dots \dots \dots (105).$$

The mechanical power developed includes that required for mechanical friction losses and the power which is expended in eddy currents and hysteresis.

**Prob. 127 :** A small motor is connected to a 110-volt circuit ; the counter E. M. F. at a particular speed is 100 volts ; the resistance of the armature is 2 ohms. What current is being supplied to the motor ?

By Formula (103)  $C = \frac{E - \mathcal{E}}{r} = \frac{110 - 100}{2} = 5$  amperes.

$E = 110$  volts,  $\mathcal{E} = 100$  volts,  $r = 2$  ohms.

**Prob. 128 :** The armature resistance of a shunt wound motor is .5 ohm, and at a certain load 10 amperes flow through it ; the drop across the motor brushes is 110 volts. What is the counter E. M. F. ?

By Formula (104)  $\mathcal{E} = E - (C \times r) = 110 - (10 \times .5) = 105$  volts.

$E = 110$  volts,  $C = 10$  amperes,  $r = .5$  ohm.

**Prob. 129:** What current would the motor referred to in Prob. 127 receive if it had no counter E. M. F.?

$$\text{By Formula (28)} \quad C = \frac{E}{R} = \frac{110}{2} = 55 \text{ amperes.}$$

$$E = 110 \text{ volts, } R = 2 \text{ ohms.}$$

**Prob. 130:** (a) What power is developed by the motor in Prob. 127? (b) What power is supplied to the motor? (c) What is the commercial efficiency of the motor (friction losses being neglected)?

$$\text{By Formula (105)} \quad W = \mathcal{E} \times C = 100 \times 5 = 500 \text{ watts (a).}$$

$$\text{By Formula (62)} \quad W = E \times C = 110 \times 5 = 550 \text{ watts (b).}$$

$$\text{By Formula (84)} \quad \text{Com. Eff.} = \frac{W}{W + w} = \frac{500}{550} = .90 = 90\% \text{ (c).}$$

There is no counter E. M. F. induced in a motor armature until it begins to revolve, so that the current flowing through it, when stationary, is equal to  $E \div R$ , as in Prob. 129. When

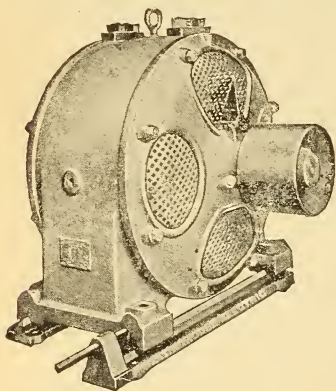


Fig. 375.—Motor Windings Protected by Cast Iron Housing.

the armature begins to rotate, the current through it gradually diminishes, since the counter E. M. F. rises with the speed. It requires more energy to start a motor than to maintain it at any particular speed, ¶ 210, so that the counter E. M. F. automatically acts like resistance in a circuit, and decreases the current as the speed increases.

The great advantage, then, of counter E. M. F. in a motor is that it regulates the current without absorbing the electrical energy, as in a rheostat, where the extra energy is dissipated as heat; motors can thus be run very economically. The automatic regulation of the current, as the motor attains its normal speed, is shown in the following experiment :

**Exp. 102:** An ammeter is connected in series with the armature of a small motor and the current noted for several speeds read from an automatic speed indicator (tachometer) as follows :

Table XXII.—Motor Test.

Speed—Revolutions per minute.	Amperes.	Speed—Revolutions per minute.	Amperes.
0	20.0	1600	7.8
500	16.2	1800	6.1
1000	12.2	1950	5.1

At the maximum speed the motor in the above test receives 5.1 amperes, or about one-fourth of the current which would flow through it at rest. If some machinery be now connected to the motor pulley by a belt, the motor will slow down somewhat, thus decreasing the counter E. M. F. and permitting more current to flow through the armature to perform the extra work. When the load is removed the motor increases in speed, thus increasing the counter E. M. F. and decreasing the current taken from the line. There is thus a continual automatic adjustment between the current supplied to a motor and the work it has to perform, or *the electrical power taken from the supply mains by a motor is directly proportional to the mechanical power it is required to develop at its pulley.* This drop in speed of a shunt motor, running fully loaded, may be 5 per cent less than the speed the motor attains when running free.

**361. Normal Speed of a Motor.**—Suppose a shunt dynamo maintains a P. D. of 110 volts at its brushes when driven at a speed of 1800 revolutions, and that it is now run as a motor, and 110 volts maintained across the brushes. The field strength will be the same as when it was run as a generator, but the speed at which the motor will run will be less than 1800 revolutions, because at this speed the counter E. M. F. would be equal to the applied E. M. F., and this would be impossible, since the motor would then receive no current from the line. The counter E. M. F. equals the applied E. M. F. minus the drop in the armature, Formula (104).

Suppose the above motor attains a speed of 1600 revolutions. When run as a generator, the induced E. M. F. per revolution will be  $\frac{110}{1800} = .061$  volt per revolution. At 1600 revolutions the counter E. M. F. equals  $1600 \times .061 = 97.6$  volts. The drop in the armature is thus the difference between the applied pressure and the counter E. M. F., or  $110 - 97.6 = 12.4$  volts. If the resistance of the motor armature is .2 ohm, then the current the armature receives when running at 1600 revolutions, is  $12.4 \div .2 = 62$  amperes, Formula (28). The watts lost in the motor armature

will be, Formula (62),  $12.4 \times 62 = 768.8$  watts; the watts applied to the armature, Formula (62),  $110 \times 62 = 6820$  watts (9.1 H. P.), and the useful power\* developed by the motor will be equal to the product of the counter E. M. F. and the armature current, Formula (105), or  $97.6 \times 62 = 6051.2$  watts (8.1 H. P.). Suppose the motor fields receive 3 amperes, then the energy from the line expended in the fields  $= 3 \times 110 = 330$  watts; or total energy supplied to the motor  $= 6820 + 330 = 7150$  watts (9.5 H. P.) *intake* and motor *output*  $= 6051.2$  watts (8.1 H. P.). The commercial efficiency of the motor is from Formula (84) and ¶ 369.

$$\frac{\text{Output}}{\text{Intake}} = \frac{8.1}{9.5} = .85 = 85\%.$$

*The speed which any motor attains is such that the sum of the counter E. M. F. developed and the drop in the armature is exactly equal to the applied E. M. F.* This is expressed by the following formula derived by transposition from Formula (104):

$$\begin{aligned} \text{Counter E. M. F.} + (C \times r) &= \text{applied E. M. F.}, \\ \text{or } \mathfrak{E} + (C \times r) &= E \dots \dots (106). \end{aligned}$$

The drop in the armature of a motor is a small percentage of the applied pressure, about 2 per cent of the terminal pressure in a 500-K. W. motor and about 5 per cent in a 1-K. W. motor, so that the counter E. M. F. nearly equals the applied E. M. F. Since the power driving a motor equals the applied pressure times the current, most of which is usefully expended in mechanical output, the counter E. M. F. is an essential and valuable feature of the motor, rather than a detriment to its operation.

**362. Mechanical Work Performed by a Motor-Torque.**—The mechanical work performed by a motor depends upon two factors, the speed and the torque, and is equal to the product of these factors, ¶ 213. The term "torque" is applied to the twisting force which is produced in the armature when a current is sent through it, and represents the effort made to cause rotation. This effort is made up of two components; first, the pull, measured in pounds, and second, the length of arm at which this pull acts; that is, the distance measured in feet from the centre of the

\*Neglecting friction losses, etc.

shaft to the point at which the pull is applied. For example, suppose that the turning effort of the motor pulley, P, one foot in radius, Fig. 376, is just balanced when a weight of 1000 pounds is supported from the pulley; the torque, which is measured in foot-pounds, is in this case, 1 foot  $\times$  1000 lbs. = 1000 ft. lbs. No work is performed by the motor, since the pulley does not revolve ( $W = F \times S$ , ¶ 213). Suppose now that the armature pulley has a radius of 2 feet, and that the electrodynamic force is sufficient to lift a weight of 1000 pounds, Fig. 376; the motor torque is then 2 feet  $\times$  1000 lbs. = 2000 ft. lbs.\* At each revolution of the pulley the weight will be lifted a distance equal to its circumference,† or  $2\pi \times r = 2 \times 3.1416 \times 2 = 12.5664$  feet; the amount of work performed per revolution = 12.566 ft.  $\times$  1000 lbs. = 12,566 ft. lbs. If the motor makes 500 revolutions per minute the total work performed =  $12566 \times 500 = 6,283,000$  ft. lbs., and since one mechanical horse power = 33,000 ft. lbs. of work performed per minute, page 211, the rate of working in the above motor is  $6,283,000 \div 33,000 = 190.3$  horse power.

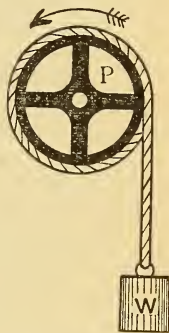


Fig. 376.—Motor Pulley.

**363. Output and Rating of Motors.**—The capacity of a motor to perform useful work is limited by the same conditions as those governing the capacity of a generator, ¶ 341. Motors are commercially rated according to the amount of power they will maintain at full load, at their pulleys, within the limit of permissible heating. For example, a 10-K. W. 110-volt motor will, when supplied with 110 volts at its terminals, develop 10 K. W. or 13.4 horse power at the pulley. A dynamo will have less capacity when driven as a motor than when driven as a generator, since in the latter case the driving engine furnishes the additional power to overcome the friction and internal losses, while a motor must develop this extra power. For example, suppose it requires 17 K. W. from an engine to drive a dynamo with 15 K. W.

\* With a pulley 1 foot in radius, the corresponding torque would lift 2000 pounds.

† The Greek letter  $\pi$  (pi) represents the relation between the diameter of a circle and its circumference, and is equal to 3.1416. Circumference of a circle =  $\pi \times d$ , where  $d$  = the diameter.

output, wound to deliver 100 amperes to the external circuit at full load, and this machine is to be used as a motor. The permissible intake, within the heating limit, will be 15 K. W. at 100 amperes, and since 2 K. W. were previously required for friction losses, eddy currents, etc., only about 13 K. W. output will be available at the motor pulley. A motor will thus be somewhat larger than a generator of the same capacity.

**364. Motor Speed and Torque.**—There are three different classes of work to be performed by motors, requiring as many different conditions of motor speed and torque, as well as a particular type of motor for the work to be performed.

First. When a motor is required to drive a crane, a hoist, or an elevator, it must run with constant torque at a variable speed, since the load is constant and is to be moved at varying rates of speed.

Second. A motor used to drive a line shaft in a machine shop must run at constant speed, regardless of the number of machines in operation, or the work being performed by them, which illustrates the case of variable torque and a constant speed.

Third. Both of the above conditions are encountered in street railway work where the motor is required to develop a variable torque and variable speed; for example, in starting a car the torque required is a maximum and the speed a minimum; when the car gains some headway the torque diminishes and the speed increases.

Thus, according to the character of the work to be performed, motors must develop either,

- (a) *Constant torque at variable speed,*
- (b) *Variable torque at constant speed,*
- (c) *Variable torque at variable speed.*

A series wound motor operated from constant potential mains is generally used for cases (a) and (c), while a shunt motor operated from a constant potential circuit fulfils the conditions required in case (b). Ordinarily, direct current motors are built for 110, 220 or 500-volt constant potential circuits; the advantage of the higher potential motor being, that for a given amount of power to be developed, a smaller size lead wire is required; for example, the size of wire required to



transmit 10 K. W. at 500 volts must be sufficient to carry 20 amperes, Formula (63); at 200 volts, 50 amperes; and at 100 volts, 100 amperes. The greater the number of field poles the lower will be the motor speed to develop any given power.

**365. Methods of Motor Speed Regulation.**—The following two methods are usually employed for regulating the speed of motors connected to constant potential circuits:

(1) *By inserting resistance in the armature circuit of a shunt wound motor.*

(2) *By varying the field strength of series motors by switching sections of the field coils in or out of circuit.*

*First method.*—This method is depicted in the upper half of Fig. 378. When the switch, A, is closed the motor fields are first excited and by moving the arm, S, of the rheostat to point 1, the armature circuit is completed with the extra resistance in series with it. Suppose a shunt motor to be operated from a 100-volt circuit, requiring 50 amperes to produce the required torque for a particular load, and that the resistance of the armature and extra resistance in series with it, 1 to 5, Fig. 378, is 2 ohms. By Formula (29) the drop on this resistance with a current of 50 amperes through it is 100 volts, so that the motor armature is not required to develop any counter E. M. F., or it remains at rest, supporting the weight from its pulley but not moving it. Reduce the resistance in the armature circuit to, say 1.5 ohms, by moving S to point 3; the motor armature now turns and runs at such a speed that the counter E. M. F. will be equal to the value of drop on the resistance so cut out (or  $50 \times .5 = 25$  volts) and the weight is lifted at a proportionate speed. With the armature at rest 5 K. W. ( $100 \times 50$ ) were uselessly expended in heating the resistance; in the second instance a portion of this energy appeared as useful work. Continue to decrease the resistance in the armature circuit by moving arm S to the right, and the speed increases and a greater portion of the energy is available for useful work. This is not an economical method of regulating the speed of a motor, since the energy taken from the line (5 K. W.) is the same whether the motor be running at a very slow speed or at a high one. The rheostat used for series regulation of this character must be of such a capacity as to carry nearly the entire intake of the motor without injurious heating.

**366. Speed Regulation of Series Motors — Second Method.**—The method of regulating the speed of a series wound motor, by increasing or decreasing its field strength by varying the turns around the field, is illustrated in Fig.

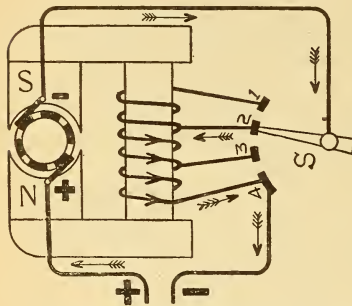


Fig. 377.—Speed Regulation of a Series Motor.

377. The current through the motor armature will flow through all the field windings when the position of the switch arm, S, is on point 1, so that the field will then have its maximum strength and will be decreased as the arm is moved to point 2, 3, etc. *Increasing the field strength of a motor decreases its speed, while decreasing the field strength increases the speed.\** This is shown by the following ex-

ample. Suppose a street car to be running on a level road at such a speed that the motor develops a counter E. M. F. of 400 volts, while the applied E. M. F. is 500 volts; assume the resistance of the armature to be 1 ohm. The motor current will be :

$$\text{By Formula (103) } C = \frac{E - \mathcal{E}}{r} = \frac{500 - 400}{1} = 100 \text{ amperes.}$$

The power developed by the motor will be,

$$\text{By Formula (105) } W = \mathcal{E} \times C = 400 \times 100 = 40000 \text{ watts (53.6 H. P.).}$$

Suppose it is desired to run the car more slowly. *Increase the field strength*, say 10 per cent, by moving switch, S, so as to insert more turns in the field circuit. The counter E. M. F. at the same speed as before would be 10 per cent higher, or 440 volts, and the current received by the motor,

$$\text{By Formula (103) } C = \frac{E - \mathcal{E}}{r} = \frac{500 - 440}{1} = 60 \text{ amperes,}$$

or the power now developed,

$$\text{By Formula (105) } \mathcal{E} \times C = 440 \times 60 = 26400 \text{ watts (35.3 H. P.).}$$

\* In a dynamo increasing the field strength increases the E. M. F., while decreasing it decreases the E. M. F.

Since it required 53.5 horse power to maintain the first speed the car must now run more slowly when the motor develops only 35.3 H. P.

Under the conditions of maximum field strength of a motor, as with switch S on point 1, the torque will be greatest for any given current strength, and the counter E. M. F. also greatest at any given speed. The current through the armature of the motor, to perform any given work, will thus be a minimum, as well as the speed at which the motor has to run, in order to develop sufficient counter E. M. F. to permit this current to flow. If the field strength could be increased indefinitely it would then be possible to make the motor develop a very high counter E. M. F. at a very low speed. With very light loads, then, to be moved at a slow rate of speed, the motor would take current from the line in proportion to the load. Suppose the load is to be moved more rapidly; decreasing the field magnetising force permits the motor to attain a higher speed to generate its necessary counter E. M. F. at the reduced field strength, with correspondingly more current taken from the line, since the rate of working at the higher speed is increased. Regulation of speed by varying the field strength is limited in range of action, since the field saturation point is soon reached; on the other hand, with too low a field strength the armature reaction upon the field produces excessive field distortion, sparking, etc.

The speed of a series motor may be nearly doubled by this method of regulation, that is, if the lowest permissible speed is 250 revolutions it may be increased to 500 revolutions. In practice this regulation is effected by commutating the field coils, from series to parallel; for example, suppose 50 amperes to flow through two sections of a field coil containing 100 turns each, the total turns are therefore 200 and the magnetising force, Formula (54),  $50 \times 200 = 10000$  A. T. With the two coils in parallel and 50 amperes through the circuit the total magnetising force is now only 5000 A. T., so that the field strength is diminished. By this method the resistance of the motor circuit is also lessened, so that, to some extent, the method includes the rheostat control described in ¶ 365, but is far more economical for the reasons given above. A rheostat inserted in the field circuit of a shunt motor will regulate the speed, within limits, in the same manner.

**367. Series Motors for Railway Work.**—Series motors

are used for railway work, because they best fulfill all the requirements, such as powerful torque at starting, variable speed and economical speed regulation for varying loads. When two motors are used their armatures and field coils are connected in series with each other and an extra resistance, which prevents too great a rush of current from the mains before the car starts. As the car gains headway a barrel cylinder switch termed a *series-parallel controller*\* gradually cuts the extra resistance out of circuit and commutates the field windings from series connection to parallel, and, finally, connects each motor directly across the mains, or between the overhead trolley line and the track, which is used as the ground return; one terminal of the station generator being connected to the trolley line and the other to the track. The fields of series railway motors are designed so as to become saturated with less than the total current required by the motor at full load. When the resistance of the field circuit is diminished a higher P. D. is applied at the motor brushes, causing a higher speed to be maintained by reason of the additional armature current. This current also flows around the field, but being saturated there is no tendency to decrease the speed, as would be the case if the field were below saturation point. In this manner different E. M. F.'s may be applied to the armature without affecting the field strength. Complete connections for two standard series motors, as used on the ordinary trolley car, are given in Plate II.

**368. Operating Motors.**—The resistance of the armature of motors is very low; for example, the armature of a 220-volt 10-K. W. shunt motor has a resistance of about .2 ohm. If this motor were directly connected to the supply mains, as by closing the switch A, Fig. 378, a much greater current than that required for full load would flow through it before any counter E. M. F. could be developed, resulting in damage to the windings; the low resistance would practically short-circuit the mains, causing an excessive drop of voltage. See Prob. 129. For this reason a rheostat, called a *starting box*, Fig. 378, is always inserted in the armature circuit of a shunt motor to prevent this extra rush of current before the motor attains its speed. The value of this extra resistance should be such that, when added to the armature resistance,

---

\* Plate II illustrates a general electric type K series-parallel controller, and gives a diagram of the several combinations.

it would permit only the full load current taken by the motor to flow from the mains. As the motor attains some speed, and counter E. M. F., this resistance is gradually cut out by moving arm, S, from post 1, to 2, to 3, etc., until at point 5 the line is directly connected across the motor. For example, to start the shunt motor close switch, A, when the motor fields will be excited; move the arm, S, of the starting box to point 1, when the armature circuit will be completed in series with the extra resistance; cut out the extra resistance as the motor attains speed by gradually moving S to point 5. To stop the motor, open the main switch, A, and then place the arm of the starting box on the off position, so that the motor will be ready for re-starting.

In an *automatic motor starting box*, such as that depicted in Fig. 123, the arm, S, carries a small piece of iron, P, Fig. 378, and turns against the action of a spring; an electromagnet, M, in series with the shunt field is mounted on the

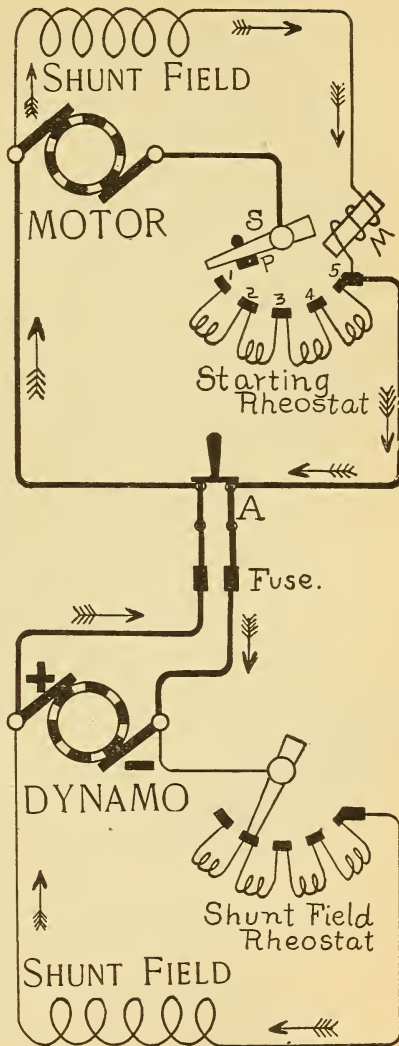


Fig. 378.—Connections of a Shunt Motor to a Dynamo Circuit.

box, and when arm, S, rests on point 5 it is held there by the electromagnet against the action of the spring. The advantage of this arrangement is, that if for any reason the main power supply circuit should be interrupted, the starting box arm will automatically open the circuit and shut the motor down, instead of permitting the motor armature to cause a short-circuit across the mains when the power is again turned on.

Shunt motors should be started with the driven load disconnected, it being switched on to the motor when the maximum speed is attained. *In starting a shunt motor always be sure that the fields are first excited* (test their attractive power with a penknife), since without the field excitation the armature could not generate a counter E. M. F., but would take an excessive current from the line.

The resistance and the self-induction of the armature and fields of a series motor tend to check the sudden rush of current through it, so that in some cases this motor might be directly connected to the mains without injurious effects. Usually, however, some extra resistance is connected in the motor circuit, and gradually cut out as before.

**369. Efficiency of a Motor.**—The commercial efficiency of a motor, as in the case of the dynamo, ¶ 344, is the ratio of the output to the intake. The energy furnished to the motor is readily measured, and from this must be subtracted the losses in the motor to obtain the available energy. These losses are divided into two classes: the  $C^2R$  losses in the armature and fields, and the mechanical losses, which include friction, eddy currents and hysteresis.

**Prob. 131:** The pressure applied to a motor having a resistance of 2 ohms is 110 volts. What power is developed by the motor when the counter E. M. F. is (a) 80 volts? (b) 55 volts? (c) 40 volts?

$$\text{By Formula (103) } C = \frac{E - \mathcal{E}}{r} = \frac{110 - 80}{2} = 15 \text{ amperes.}$$

$$\text{By Formula (105) } W = \mathcal{E} \times C = 80 \times 15 = 1200 \text{ watts (a);}$$

$$\text{also } \frac{110 - 55}{2} = 27.5 \text{ amperes,}$$

$$\text{and } 27.5 \times 55 = 1512.5 \text{ watts (b);}$$

$$\text{also } \frac{110 - 40}{2} = 35 \text{ amperes,}$$

$$\text{and } 35 \times 40 = 1400 \text{ watts (c).}$$

From this problem it will be noted that the power developed by a motor increases as the counter E. M. F. decreases, until the counter E. M. F. equals one-half the applied E. M. F., after which point the motor develops less power as the counter E. M. F. decreases. The maximum work is done when the counter E. M. F. is just equal to one-half the applied E. M. F.

**370. Electric Traction.**—The chief factor in stationary motors is the work the motor can perform without becoming too warm or decreasing too much in speed, while in street car motors the most prominent factor is the torque, or the tractive force, the motor is capable of developing at different speeds with different loads.

*The tractive force is the force exerted by the motor on the car in the direction of its motion.*

On a level road the tractive force of a motor varies with a number of conditions, such as road bed, track, lubrication of journals, weight, etc.

*The tractive force varies directly as the weight of the car and the passengers carried.* For average conditions about 25 pounds tractive force (torque) are required for each ton propelled by the motor on a level road, with a speed of from 6 to 10 miles per hour. For example, to propel a car weighing 6 tons, with passengers aboard weighing 3 tons, will require a tractive effort on a level of  $9 \times 25$  or 225 pounds.

TO FIND THE WATTS REQUIRED TO PROPEL A STREET CAR ON A LEVEL ROAD AT A CERTAIN SPEED :

*Multiply the tractive force by the speed in feet per minute to obtain the foot-pounds of work performed per minute, and divide by 33,000 to obtain the horse power ; multiply the H. P. by 746 to obtain the watts output of the motor, and divide this product by the efficiency of the motor to obtain the watts required by the motor from the line, Formula (107).*

Let W = watts required by the motor on level road ;

F = tractive force = 25 lbs. per ton ;

% M = efficiency of the motor ;

T = weight of the car and passengers, in tons ;

S = speed of car, in feet, per minute.

$$\text{Then, } W = \frac{T \times F \times S}{33000} \times 746 \div \% M \dots \dots \dots (107.)$$





TO FIND THE TOTAL WATTS REQUIRED FOR A CAR TO ASCEND A GRADE :

Add the watts required for a level road to the additional watts required for the grade, Formula (109).

$$\text{Total watts required} = W + W_1 \dots \dots \dots (109).$$

**Prob. 133:** How many watts must be supplied to the motors in Prob. 132, in order that the car will ascend a 10 % grade ?

$$\text{Vertical rise in feet per minute} = 880 \times .10 = 88.$$

$$\text{Total weight of car, in pounds} = 10 \times 2000 = 20000.$$

$$\text{Foot-pounds of work per minute} = 20000 \times 88 = 1,760,000.$$

$$\text{Horse-power} = \frac{1760000}{33000} = 53.3$$

$$\text{Watts output of motors} = 53.3 \times 746 = 39761.$$

$$\text{Watts required by motors} = \frac{39761}{.75} = 53015, \text{ or by Formula (108)}$$

$$W_1 = \frac{\% G \times S \times T_1}{33000} \times 746. \quad \frac{.10 \times 880 \times 20000}{33000} \times 746. \\ \frac{\% M}{.75} = \frac{\dots}{.75} = 53015.$$

By Formula (109) total watts required =  $W + W_1 = 6564.8 + 53015 = 59579$  watts or 59.5 K. W.

QUESTIONS.

1. How does a motor differ from a dynamo ?
2. What is the difference between a shunt and series motor ?
3. A series dynamo rotates clockwise. What will be the direction of rotation when it is used as a motor ?
4. A shunt dynamo runs in a counter clockwise direction. How will it run when driven as a motor ?
5. What is necessary in order to properly run the shunt dynamo in question 4 as a shunt motor and in a clockwise direction ?
6. Since the counter E. M. F. of a motor permits less current to flow through it than if it did not exist, and the turning effort of a motor depends on the current through the armature, of what advantage then is the counter E. M. F. ?
7. State two methods by which you can prove a motor to possess counter E. M. F.
8. How would you measure the counter E. M. F. of a motor ?
9. Upon what factors does the counter E. M. F. depend ?
10. A shunt motor is called a *constant speed* motor ; how is it possible then for the motor to take current from the line in proportion to the power it develops, since if it always runs at constant speed the counter E. M. F. would be constant, and therefore the current constant ?
11. Why is it impossible for the counter E. M. F. of a motor to attain a value equal to the applied E. M. F. ?
12. A 15-K. W. shunt motor is to be used as a dynamo. Will its output be more or less than 15 K. W. ? Why ?

13. What factors determine the mechanical work which can be performed by a motor?
14. What is meant by motor torque?
15. What is the difference between motor speed and motor torque?
16. State the conditions of torque and speed that motors are required to develop in commercial work, and the kind of motor adapted to each case.
17. Explain two methods of motor speed regulation, stating the advantage or disadvantage of each method. Illustrate your answer by sketches.

### PROBLEMS.

1. A shunt motor having an armature resistance of 2 ohms and a field resistance of 125 ohms is connected to a 250-volt main and develops a counter E. M. F. of 220 volts. What current is taken from the line? *Ans.* 17 amperes.
2. What mechanical power is developed by the motor in problem 1? *Ans.* 4.4 H. P.
3. If there are 500 watts lost in mechanical friction, hysteresis and eddy currents in the motor in problem 1, what useful power can the motor develop? *Ans.* 3.7 H. P.
4. What is the commercial efficiency of the motor mentioned in the above problem? *Ans.* 65 %.
5. Fifty amperes flow through a motor armature having a resistance of 3 ohms when it is connected to a 250 volt supply circuit. What counter E. M. F. is developed? *Ans.* 100 volts.
6. What mechanical power is developed by the motor armature in problem 5? *Ans.* 6.7 H. P.
7. A shunt motor runs at 1400 revolutions; when connected to a 220-volt circuit and driven as a dynamo it generates 220 volts P. D. at a speed of 1600 revolutions. What is the counter E. M. F. when the machine is used as a motor? *Ans.* 182 volts.
8. The resistance of the armature in problem 7 is 2 ohms. What current flows through it when it is run as a motor? *Ans.* 19 amperes.
9. The fields of the motor in problems 7 and 8 receive 5 amperes; if 458 watts are required for mechanical losses what is the commercial efficiency? *Ans.* 56 %.
10. A motor pulley has a diameter of 18 inches and runs at 400 revolutions per minute when exerting a pull of 2000 pounds. (a) What is the motor torque? (b) What horse power is being developed by the motor? *Ans.* (a) 1500 ft. lbs.; (b) 114.2 H. P.
11. The counter E. M. F. of a motor is 230 volts; the current through the armature 25 amperes, its resistance 4 ohms. What is the applied E. M. F.? *Ans.* 330 volts.
12. A street car is propelled by two motors, driven from a battery of accumulators weighing  $2\frac{1}{2}$  tons, which is placed beneath the car seats; the motors weigh 1 ton, the car 4 tons, the passengers aboard  $2\frac{1}{2}$  tons, the efficiency of the motor is 80%. What power is supplied to the motors from the battery when the car is running on a level road at 8 miles per hour? *Ans.* 4942 watts.
13. The street car, in problem 12, is required to ascend an 8 % grade at the reduced speed of 4 miles per hour. What is now the total power taken from the cells? *Ans.* 20794 watts.

## LESSON XXX.

### ELECTRIC LIGHTING.

The Electric Arc—Crater of the Arc—Types of Arcs—Rating of Arc Lamps—Arc Lamp Carbons—Arc Lamp Regulation—Inclosed Arcs—Alternating Current Arcs—Arc Lamp Circuits—Incandescent Lamps—The Lamp Filament—Commercial Rating of Incandescent Lamps—Life and Efficiency of a Lamp—Incandescent Lamp Circuits—Potential Distribution in Multiple Lamp Circuits—Loss on Transmission Lines—Incandescent Wiring Calculations—The Three-Wire System—Motor Wiring Calculations—Questions and Problems.

**371. The Electric Arc.**—When a current of from 6 to 10 amperes, under a pressure of about 45 volts, is passed through two carbon rods, with their ends first in contact and afterward gradually separated a short distance, as one-eighth inch, a brilliant arc of flame called the *electric arc*, is established between them. This arc is composed of carbon vapor; that is, the high temperature caused by the passage of the current through the resistance of the contact surfaces causes the carbon to practically boil and the vapor thus arising, being a much better conductor than the air, conducts the current across the gap from one carbon tip to the other. This volatilization occurs chiefly at the end of the positive carbon terminal where the current enters the arc, and this point is also the seat of the highest temperature and maximum light-emitting power. As the arc is maintained across the gap, disintegration of the carbon takes place, the carbons waste away, and a cup-shaped depression, termed the *crater*, is formed in the *positive carbon*, while the tip of the negative carbon has a conical form, Fig. 379. The negative carbon being at a lower temperature than the positive, the vapor of the boiling carbon condenses upon its surface as pure graphite. Both carbons waste away, but the consumption of the positive carbon is about twice as rapid as that of the negative, since it is this carbon from which most of the vapor comes and part of which is re-deposited as graphite on the negative cone-tipped carbon.

**372. The Crater of the Arc.**—The light emitted by any

heated body increases with its temperature. The temperature of the carbon in the crater, when in a state of ebullition, is about  $3500^{\circ}\text{C}$ ., this being the hottest portion of the arc, and consequently the point from which the most light is

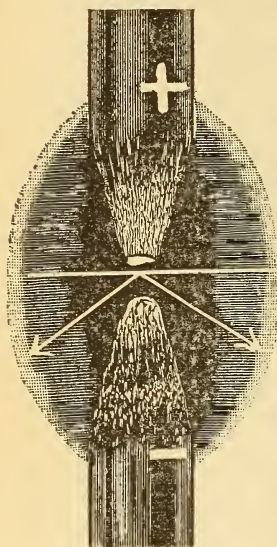


Fig. 379.—The Electric Arc.

The white area in the positive carbon represents the crater; the arrows indicate the direction of the maximum zone of illumination.

emitted. The intense heat in the crater will be realized when it is considered that platinum (one of the most refractory metals, melting at  $1775^{\circ}\text{C}$ .), melts like wax when placed in the arc, and diamonds and many other substances are readily fused. About 12 per cent of the energy supplied to an electric arc appears as light, the balance being represented by the heat evolved. About 85 per cent of the light emitted from an arc lamp is reflected from the crater, so that arc lamps are usually arranged with the carbons vertical and with the positive carbon above the negative, so that the light is reflected downward, the maximum illumination being in a zone surrounding the lamp at an angle of about  $40^{\circ}$  to the horizontal, and indicated by the arrows in Fig. 379. The amount of light emitted by an arc lamp is thus dependent upon the luminous area of the crater and this is dependent upon the number

of amperes flowing through the arc; the greater the area of the crater the greater the strength of current required to keep the increased area at the boiling point, since the temperature at which carbon boils, like that of other substances under constant pressure, is practically constant. A crater one inch in area emits, approximately, as much light as 100,000 candles, but since its area depends on the quality of the carbon used, as well as the current, the crater area is not used as a standard of light.

**373. Types of Arcs.**—When the electric arc is “struck” or “sprung” by bringing the carbon electrodes together and again separating them for a short distance, the arc possesses

peculiar characteristics depending upon the length of the gap between the ends of the carbons. When this distance is too small the arc will emit a peculiar hissing noise, and is then called a *hissing arc*. The noise is probably due to the too rapid volatilization of the carbon. An arc hisses when the current strength is increased beyond the practical limit for the size of carbon and particular length of the arc employed. When very powerful currents are used and the carbons are quite close together, a *roaring* of the arc occurs. *Spluttering sounds* produced by the arc are probably due to impurities in the carbon.

When the distance between the carbons is increased slightly, a point is found where the arc burns quietly and steadily, and it is then termed a *normal* or *silent arc*; if this distance be exceeded the arc *flames*. In a *flaming arc*, the light emitted is greatly decreased and the carbon consumption rapidly increased. The normal arc is a medium between the hissing and the flaming arc and in commercial lamps, automatic regulation, ¶ 376, is employed to feed the carbons as they are consumed, and thereby maintain the proper length of arc required for normal or silent burning. When the current is maintained constant the resistance of the arc varies directly as its length; it will decrease as the area of conducting vapor is increased, and also as the temperature increases.

**374. Rating of Arc Lamps.**—The ordinary commercial arc lamps are rated as equivalent to the light given by from 1200 to 2000 candles. A lamp requiring 45 volts and 10 amperes consumes 450 watts, and lamps are often rated in watts rather than candle power on account of the difficulties arising in candle power measurements. Such a 450-watt lamp corresponds approximately to one rated at 2000 C. P., and a 300-watt lamp, to one of 1200 C. P. The so-called 2000-candle power lamp emits from about 600 to 700 candle power in one direction in the zone of maximum illumination, Fig. 379. The voltage used in practice varies from 45 to 47 volts drop across the arc, and the current, from 6 to 10 amperes, according to the amount of light required, a common value being 9.6 amperes and 47 volts at the arc.

In search-light projectors much larger currents are used, as from 50 to 250 amperes, with voltages of from 47 to 53 across the arc. The voltage at the terminals of an arc lamp will be greater than that across the arc, since there is some

drop on the solenoids or magnets used in the lamp's regulation, ¶ 376.

**375. Arc Lamp Carbons.**—Carbon rods are generally used in arc lamps, and are composed of coke, tar, or the graphite deposited in the inside of retorts used for manufacturing illuminating gas. The material selected is ground to a fine powder and mixed with some binder, as molasses, to make the particles adhere firmly; the mass is then molded to the proper form, baked, and finished.

In *cored carbons* an inner core of soft carbon, having a higher conductivity than the solid carbon, tends to confine the current to the centre of the rod, and, consequently, the crater of the arc. In solid carbons the crater travels around the end of the carbon, the current always tending to take the shortest path of least resistance; with cored carbons the travel is reduced and the distribution of light is more steady. From 3 to 6 volts less are required across the arc with cored carbons, since the softer carbon volatilizes at a somewhat lower temperature. Carbons, copper-plated to within a short distance of the pointed end, last longer than when not so plated, and also offer less resistance to the flow of current through the circuit. The diameter of carbons is proportional to the current to be conducted, and is about 5-16 inch for a 6-ampere lamp and 9-16 inch for a 10-ampere lamp. A 2000-C. P. lamp, having a positive carbon 12 inches in length and a negative carbon 7 inches in length, will burn about 9 hours.

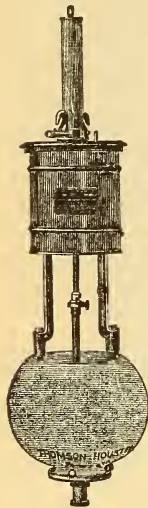


Fig. 380.—Single Carbon Automatic Feed Arc Lamp.

The arc is exposed to the air and the lamp trimmed nightly.

In an alternating current arc the crater alternates from one carbon to the other with each reversal of current, so that both carbons are consumed equally when the rods are horizontal. When vertical, the upper carbon will be consumed about eight per cent faster, owing to the action of the ascending currents of heated air.

**376. Arc Lamp Regulation.**—After an arc is struck, and the electrodes separated for a fixed distance, the consumption of carbon gradually widens the gap until the resistance becomes so high that the current will not pass when the lamp

goes out; to light it again the carbons must be brought into contact and then separated. In an automatic feeding lamp the carbons are moved together automatically as they are consumed, so that the length of the gap is maintained constant and consequently the distribution of light is continuous.

A simple means for producing automatic feeding is depicted in Fig. 381 and embodies the principle involved in the construction of the Brush differential series automatic feed arc lamp. The two carbon rods are represented by E and F, and are connected in series with the series solenoid A, and to the main

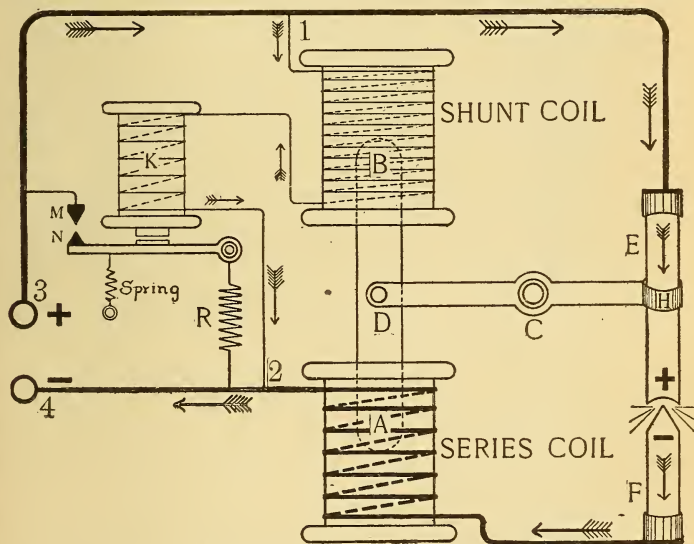


Fig. 381.—Diagram of Connections of an Automatic Feed Differential Arc Lamp.—Clutch Type Pattern.

supply line by the lamp terminal binding posts 3 and 4. The upper or positive rod, E, passes through a clutch, H, supported by the horizontal brass lever, DH, pivoted at C, and also fastened to an iron core, AB, at point D. The series solenoid is wound with a few turns of heavy wire of sufficient size to carry the total current flowing through the lamp. Directly above this coil is located the shunt solenoid B, of a much higher resistance than A, which is connected in shunt with the arc, across the points 1, 2. The action is as follows: the carbons

are in contact until the current is turned on ; when current flows through the lamp from post 3, it divides at point 1 and flows mostly through the series coil circuit which is of lower resistance. The series solenoid is thus magnetised and draws the iron core, AB, downward, which motion raises the positive carbon a certain fixed distance and strikes the arc. As the lamp burns, the length of gap and its resistance increases, which shunts more current around the shunt solenoid, when at a certain instant, its attractive force for the iron core AB overcomes that of the series coil and the core is thus lifted upward by the shunt solenoid ; this action lowers the positive carbon to its former fixed distance, corresponding to the normal length of the arc. The two coils thus work in opposition to each other, illustrating the differential principle, and the length of the arc is maintained practically constant. If for any reason the clutch at H should fail to release the upper rod, the resistance of the gap would continue to increase and an abnormal current, flowing through the shunt coil and the magnet, K, would attract its keeper. This action closes the switch, MN, which automatically cuts the lamp out of circuit and at the same time introduces a resistance, R, in parallel with the shunt coil to carry the current to other lamps operated in the same series circuit. When arc lamps are provided with such an automatic cut out, and connected in series, there is no danger of interrupting the service by the failure of one lamp to properly burn. In double carbon lamps, when one set of carbons is consumed the other set is automatically switched into circuit and the period for which the lamp will give illumination is thus doubled.

**377. Inclosed Arcs.**—When an arc is maintained in the open air the consumption of carbon is quite rapid ; for example,  $1\frac{1}{2}$  inches of carbon per hour ; if, however, the arc is inclosed from the air, thereby diminishing the supply of oxygen for supporting perfect combustion, the consumption of carbon is much slower ; for example, 3-20 of an inch per hour, or the lamp may burn 150 hours without trimming. A small glass globe, about 6 inches long and 3 inches in diameter, is tightly fitted to the lower carbon, so that it passes up through the globe which is covered, at its upper end, with a corrugated iron washer having a central hole slightly larger than the diameter of the carbon rod used, thus permitting it to move freely. When the arc is struck



the available oxygen is soon exhausted and the bulb is then filled with a hot atmosphere of nitrogen, carbon monoxide, and carbon dioxide. The little oxygen which enters through the crevice between the upper carbon rod and the washer is very desirable, since it unites with the carbon to form a gas. If all the oxygen were entirely excluded the carbon would quickly be deposited on the inside of the bulb and interfere with the light. In time the bulb becomes coated on the inside with a light-colored deposit, due chiefly to impurities in the carbon; it should then be replaced by a new one. In an inclosed arc the gap may be much longer, without a rapid combustion of carbon, since the oxygen is eliminated; the potential at the arc is thus increased with its increased length to about 80 volts and the current of the average lamp decreased to about 5 amperes. The chief advantages of inclosed arcs are the saving of carbon and the diminished cost of labor for trimming. An open-air arc is trimmed nightly and an inclosed lamp, probably once every ten days.

### 378. Alternating Current Arcs.

—In arcs fed from an alternating current there is not a continuous flame, but the arc is lighted and extinguished with each reversal of current. When the reversals are greater than 100 per second the flicker is not ordinarily noticeable. There is no crater, since each carbon acts as a positive at every other alternation, and the carbon consumption is nearly the same, ¶ 375. Cored carbons are always used in alternating current lamps to secure a sufficient supply of the carbon vapor to maintain the current's path at the instant the arc is extinguished, when the current reverses. For this reason the current required for alternating current arcs must be larger than for direct current arcs, usually about 15 amperes, with 30 to 35 volts drop across the arc,

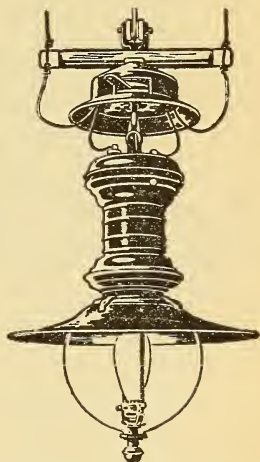


Fig. 382.—Single Carbon Automatic Feed Inclosed Arc Lamp.

The arc is inclosed in the inner globe and the lamp will burn for 150 hours with one set of carbons.

**379. Arc Lamp Circuits.**—Arc lamps are operated from constant potential or constant current circuits, and supplied by either direct or alternating currents. Special features of mechanical construction are embodied in the lamps according to the circuit from which they are to be supplied. When it is required to operate 45-volt series arc lamps from 110-volt constant potential circuits, two lamps are connected in series with sufficient extra resistance to give the proper drop across the lamps. Resistance is also added in series with inclosed lamps so that one lamp may be operated from a 110-volt constant potential main, or two in series, with extra resistance placed across 220 volts. Choke coils, ¶ 298, are used to regulate the current when the lamp is designed for A. C. circuits. Arc lamps for street lighting service are usually operated in series on constant current circuits because the lights are distributed over a large area and the energy can be much more economically supplied at a high pressure and a small current. For example, 100 arc lamps requiring 50 volts and 10 amperes each, when connected in series, may be operated from a No. 6 B. & S. copper wire having a resistance of about 2 ohms per mile. The resistance of a circuit 5 miles long is 10 ohms and when carrying 10 amperes, the drop on the line is 100 volts, Formula (29), and the loss on the line 1000 watts, Formula (62), or 1-K. W. The potential difference at the generator terminals will be 5100 volts. The total energy supplied to the lamps and line is 51 K. W. and the efficiency of transmission 98 per cent ( $50 \div 51$ ). To operate the same number of lamps from a low voltage constant potential multiple circuit, the dynamo must deliver 1000 amperes, and for the same loss on the line the weight of copper would be more than 1000 times as great as that on the series circuit. See problem 91, page 234, also ¶¶ 348 and 353.

**380. Incandescent Lamps.**—In an incandescent electric lamp the light is produced by heating to a state of incandescence, a high resistance solid conductor which is not readily fused by the passage of a current through it. A slender carbon thread, termed a *filament*, is used as the conductor and is hermetically sealed in a vacuum in a glass globe, to prevent it from burning, ¶ 97. Two platinum wires are sealed in the lower part of the glass bulb and are connected to the terminals of the filament, and their other ends, to two copper wires which make connection with the lamp base, Fig. 93,

page 78. Platinum is used to pass through the glass because it expands and contracts at the same rate as the glass and the vacuum is thereby preserved at all times. The lamp base consists of two pieces of brass insulated from each other, secured to the lamp bulb by cement and arranged so as to hold the lamp securely when it is placed in a retaining *socket* connected to the main supply leads. By a switch in this socket, the current from the mains is turned off or on to the lamp as desired.

**381. The Lamp Filament.**—The so-called “squirted filaments” are generally used in incandescent lamps. One type is made by dissolving cotton in a solution of zinc chloride which produces a viscous, semi-transparent liquid in which the fibrous appearance of the cotton almost disappears. This gelatinous material is forced or squirted through a small hole into a vessel of alcohol, which causes it to set and sufficiently harden for handling. After washing, the material resembles cooked vermicelli and is wound upon a drum and dried, when it possesses considerable strength and has the appearance of cat-gut string, such as used on a violin. It is then cut into suitable lengths and carbonized by being placed in a crucible surrounded by charcoal, so as to exclude the air, and then heated for several hours in a furnace. The effect of the carbonization is to drive off everything from the material but the carbon, which is left as a conducting thread. The filaments are then carefully measured as to their length and diameter, and assorted for the different sizes of lamps in which they are to be used; the length of filament is nearly proportional to the voltage, and the surface, to the candle power.

The filaments are next treated by the “flashing” process, the object of which is to insure strength and uniformity in resistance. This is accomplished by inserting the filament in a closed vessel containing hydrocarbon gas and then raising it to incandescence by passing an electric current through it. The action deposits carbon on the filament and if some points are of a higher resistance than others, their temperature will be correspondingly higher and more carbon will be deposited at such places. Measuring instruments are inserted in circuit with the filament under treatment and the deposit continued until the desired resistance is attained. The filament is then ready for mounting upon the platinum leading-

in wires and is secured to them by a paste of carbon and molasses. The platinum wires, P, are sealed in the end of a glass tube, A, Fig. 383, which is sealed into the blown glass bulb of the ordinary shape. The upper end of the bulb

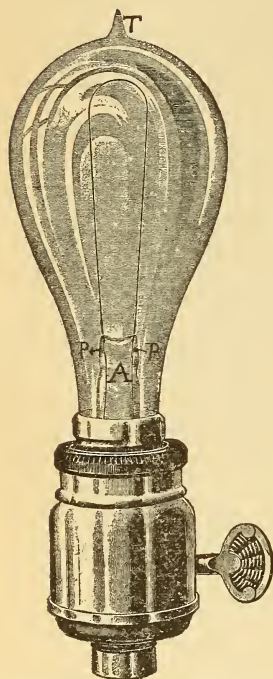


Fig. 383.—Incandescent Lamp and Retaining Socket.

terminates in a glass tube which is connected to the air pump. After the proper degree of exhaustion this tube is heated and sealed leaving the pointed tip, T, on the end of the lamp.

**382. Commercial Rating of Incandescent Lamps.**—After exhaustion and sealing of the bulb the lamp is compared with a standard of illumination, while measurements of the pressure at its terminals and current flowing through it are made. The pressure is marked on each lamp, also the corresponding candle power and the watts consumption. The standard lamp in general use is rated as equivalent to the light given by 16 candles, and may consume from 50 to 60 watts. A 110-volt 55-watt 16-candle-power lamp requires .5 ampere, Formula (63); the hot resistance is therefore 220 ohms, Formula (30); the watts per candle are  $55 \div 16 = 3.4$  watts, or the candles per watt =  $16 \div 55 =$

.29. Lamps are usually made for 50 to 60-volt, 110 to 115-volt and 220-volt constant potential circuits; a 16-C. P. lamp requiring 55 watts will therefore take 1 ampere on a 50-volt circuit; .5 ampere on 110-volt; and .25 ampere on 220-volt circuit, the resistance of the filament increasing with the voltage when the candle power is constant. For any particular voltage the higher the candle power of the lamp the larger the area of its filament, the less its resistance, and consequently the more current it will take. See page 151. A lamp should not be subjected to a voltage higher than its rating; with a slight increase in pressure the brilliancy increases rapidly

since the temperature rises with the increased current, and the life of the lamp is shortened. For example, if the filament of a 110-volt lamp has such a resistance that it will carry one-half ampere, without a dangerous rise in temperature; when subjected to 220 volts the current through it is doubled and the heat is so intense as to destroy the filament. A lamp supplied with 110 volts alternating current will give the same candle power as when supplied with 110 volts direct current.

**383. Life and Efficiency of a Lamp.**—After a lamp is in service for a period of time the carbon filament disintegrates, or wears away, and there appears a blackened deposit upon the inside of the globe. The disintegration reduces the diameter of the filament, increases its resistance and consequently diminishes the current and the light from the lamp; finally the filament breaks, and the lamp is said to have “burned out.” The average life of the standard 16-C. P. lamp used in practice is from 600 to 800 hours, and even though the filament does not then break, the candle power falls off so rapidly with the disintegration that it is often cheaper to use a new lamp instead of the old one, which consumes current but gives little light. *The efficiency of a lamp is the ratio of the number of candles it will produce to the watts absorbed by it.* A high efficiency in average use is about 3 watts per candle when the life is about 800 hours. If the lamp is constructed with a large filament so as to give the same light at a reduced temperature, with 4 watts per candle, the life will be several thousand hours. The average efficiency used in practice is about 3.5 watts per candle. High efficiency lamps are suitable for mains where the pressure is very closely regulated, since the variation of two or three volts above the usual lamp voltage will materially shorten the life of the lamp. On the other hand, low efficiency lamps will not have such a rapid rise in temperature for a small variation in voltage and are therefore mostly used in cases where the supply voltage is not so closely regulated.

**384. Incandescent Lamp Circuits.**—Incandescent lamps are usually operated from low voltage constant potential circuits and supplied by direct or alternating currents. With a potential of 500 volts, as in street car service, the lamps are grouped in multiple series; for example, 5 100-volt lamps in series, or 10 50-volt lamps in series being placed across the

mains. A constant current series incandescent lamp system, for suburban street lighting, is sometimes employed, in which case automatic cut-outs connected to each lamp, preserve the continuity of the line in case any lamp burns out. Series incandescent lamps are introduced in arc circuits and are constructed with very large filaments to carry from 5 to 10 amperes; the drop across the lamp is only a few volts; for example, 6 volts for a 10-ampere 16-C. P. lamp.

### 385. Potential Distribution in Multiple Lamp Circuits.

---In a series circuit the drop on the lead wires does not interfere with the regulation of the voltage at the terminals of each lamp and the current being constant, the lamps burn at the normal candle power. In multiple circuits, however, the drop on the lead wires is an important factor and requires that the lamps be so distributed, and the size of the wire so proportioned, that each lamp will receive, approximately, the same voltage. For example, consider 200 110-volt incandescent lamps to be connected in parallel at various distances along a pair of mains extending 500 feet from the dynamo, and that the P. D. at the generator terminals is 112 volts; the lamps near the generator end of the mains will receive a higher potential than 110 volts and burn above candle power, with the result of frequent lamp renewals, while those near the distant end of the line will receive less than 110 volts and burn below candle power. In order to overcome this difficulty, *centres of distribution* are planned in wiring construction, and the lamps are grouped so as to be supplied from these centres. Feed wires are run from the generator to the points of distribution, and a constant potential maintained at these points by regulation at the generator. No lamps are connected to the feeders. Several sets of mains are run from these centres and supply sub-centres of distribution, to which the lead wires to the lamps are connected. The total drop or fall in voltage from the generator to the lamps in such a feeder and main system radiating from a central supply station, may be from 10 to 20 per cent of the generator voltage, so that the dynamo is run at a correspondingly higher voltage than that required by the lamps. For example, the size of conductors may be so proportioned that when carrying full load their resistance produces a drop of 10 volts on the feeders, 3 volts on each set of mains radiating therefrom, and 2 volts on each set of sub-mains. Such a system of sub-division of the trans-

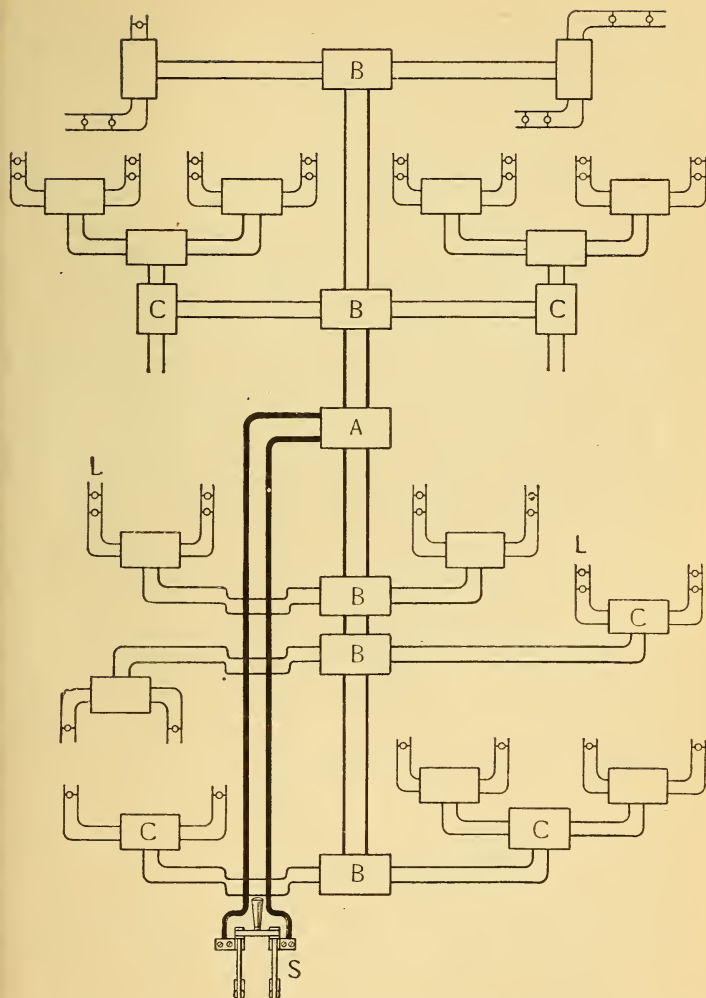


Fig. 334.—Plan for the Distribution of Potential in Electric Light Wiring of Either a House or Ceiling of a Factory by the Two-wire Multiple System.

A, B, C are fusible cut-outs introduced wherever the size of wire changes. The thickness of the lines represents the relative size of the wire.

mitting conductors is worked out upon an elaborate scale for lighting large and compact areas, as in the house and store service of cities supplied from a central generating plant. In the wiring of a house for about 50 standard 110-volt 16-C. P. lamps, the drop in voltage, at full load, will be about 2 per cent of the pressure supplied at the service mains. Knowing the current to be required by any feeder as, for example, that to the third floor for 20 lamps, about 10 amperes, the size of wire is readily calculated as in ¶¶ 239 and 387. With an isolated plant in a large office building the drop may be 5 per cent of the generator voltage. In a building of 20 floors, a pair of main feeders may be run from the generator room to, say every 4 floors; there will thus be 5 sets of feeders, each being calculated to supply the given current with a 5 per cent loss on the line. The feeders terminate in cut-outs arranged in junction boxes, and sub-feeders are carried to each of the four floors to be fed from one junction. Mains are run from these points to smaller local centers with a loss of from  $\frac{1}{2}$  to 1 per cent allowed in calculations for these lines.

**386. Loss on Transmission Lines.**—*The weight of copper wire required for conducting current to lamps or motors, with the same loss on the transmitting line, is inversely proportional to the square of the voltage supplied to the lamps or motors.* For example, suppose 50000 watts (50 K. W.) are transmitted to some distant centre of distribution; 1000 watts the permissible loss on the line; the weight of copper required, when the energy is delivered at 50 volts, to be 1000 pounds; then the comparative weight of copper for other voltages according to the above law is given as follows:

Energy Transmitted.			Loss on the Line.			Copper Required.
K. W.	Volts.	Amperes.	Volts Drop.	Amperes.	Watts.	Pounds.
50	100	500	2	500	1000	1000
50	200	250	4	250	1000	250
50	500	100	10	100	1000	40
50	1000	50	20	50	1000	10

As the voltage, at which the above energy is transmitted increases, the current to be conducted on the line decreases, thereby decreasing the size of the wire, increasing its resist-



ance and the line drop. As the drop on the line increases the current is proportionally reduced and the line loss the same.

In the electrical transmission of power to long distances, economy of copper is attained by transmitting the energy at a very high voltage and reducing it to a working value, within the danger limit, at the receiving station. For example, several thousand horse power are transmitted from Niagara Falls to Buffalo, about 26 miles, at 20000 volts. The current is an alternating one, and at Buffalo the voltage is reduced by transformers to the proper values for lighting and power purposes. In a western transmission plant the power is transmitted at 80000 volts with a greater reduction in weight of copper but requiring special insulating materials for such a high potential.

**387. Incandescent Wiring Calculations.**—The simplest method for calculating the size of wire required to conduct current to any given number of lamps, with any permissible drop in voltage on the line, is to find the resistance of the line by Ohm's Law and then consult the wire gauge table and the table of safe carrying capacities, pages 113 and 266. See also ¶ 239.

A general formula to find the size of wire directly in circular mil area required to carry any direct current any distance, with any given loss on the line, is derived by combining Formulæ (22) and (30) as follows :

$$\text{By Formula (22) } R = \frac{K \times L}{C. M.}$$

$$(30) R = \frac{E}{C}$$

$$\text{Therefore } \frac{K \times L}{C. M.} = \frac{E}{C}$$

$$\text{and } E \times C. M. = K \times L \times C,$$

$$\text{or } C. M. = \frac{K \times L \times C}{E}$$

Copper being generally used as the conductor,  $K = 10.79$ , and this formula becomes

$$C. M. = \frac{10.79 \times L \times C}{E} \dots \dots \dots (110).$$

Where C. M. = circular mil area ;

$K = 10.79$  = resistance 1 mil-foot of copper wire ;

$L$  = length of circuit in feet ;

$C$  = current in amperes ;

$E$  = volts drop on the line.

TO FIND THE SIZE OF COPPER WIRE IN CIRCULAR MILS, TO CONDUCT ANY GIVEN DIRECT CURRENT, ANY DISTANCE WITH A GIVEN DROP ON THE LINE :

*Multiply the total length of the line, in feet, by the resistance of a mil-foot, 10.79, and this product by the current, in amperes, to be conducted; divide this product by the volts lost on the line. Formula (110).*

The circular mil area so found must be compared with the table of carrying capacities, page 266. By using a very excessive drop on the line the circular mil area calculated by Formula (110) in some cases would be much too small for the current to be conducted, and hence the necessity of a check upon the calculations, by the table of carrying capacities. *Usually the distance from the generator to the centre of distribution is given for the two-wire multiple system, and this distance must be multiplied by 2 to obtain the total length of the circuit, L in Formula (110).*

**Prob. 134:** One hundred 55-watt 110-volt lamps are connected in parallel and to a centre of distribution located 125 feet from the dynamo which generates 113 volts P. D.; the potential at the distributing centre is 111 volts. What size wire is required for the feeder?

$$\text{By Formula (63) } C = \frac{W}{E} = \frac{55}{110} = .5 \text{ ampere per lamp.}$$

$$100 \times .5 = 50 \text{ amperes to be conducted.}$$

$$113 - 111 = 2 \text{ volts drop on the line.}$$

$$\text{By Formula (110) } C. M. = \frac{10.79 \times 125 \times 2 \times 50}{2} = 67437 \text{ C. M.}$$

$$L = 125 \times 2 = 250 \text{ feet, } C = 50 \text{ amperes, } E = 2 \text{ volts.}$$

Consulting the table, page 113, the size of wire nearest to 67437 C. M. is No. 2 B. & S. = 66370, which is smaller than that required. Always use the next larger size of wire to that calculated, or in this problem a No. 1 B. & S., which will give a little less drop than 2 volts. Consult the safe carrying capacity table, page 266, and it is found that No. 1 will carry 107 amperes, and will thus readily carry 50 amperes. A much smaller wire could have been used in this problem, as a No. 5, which carries 54 amperes, but the line drop and loss would then have been correspondingly larger, since the resistance of the circuit is increased. The line loss is a constant factor—that is, the watts,  $50 \times 2 = 100$ , lost on the line in the above problem are constant, so long as this load is constant, and will cost each year a cer-

tain sum for this loss, while the cost of the line installation is only the first cost. The most economical conductor is installed when it is possible to make the yearly cost of the power lost on the lines equal to the interest on the value of the copper invested. The *volts lost* or drop on any circuit may be measured by a voltmeter, ¶ 231, or calculated by Formula (29), when the current and resistance of the circuit are known, or from the following Formula, obtained by transposing Formula (110) :

$$E = \frac{10.79 \times L \times C}{C. M.} \dots \dots \dots (111)$$

TO FIND THE VOLTS LOST OR DROP IN ANY CIRCUIT (of copper wire) :

*Multiply 10.79 by the length of the circuit in feet, and this product by the current, in amperes; divide this result by the circular mil area of the wire.*

**Prob. 135:** An ammeter, connected in series with a circuit of copper wire 200 feet long, indicates 25 amperes; the size of wire measured by a wire gauge is No. 10 B. & S. What is the drop on the line?

By Formula (111)  $E = \frac{10.79 \times L \times C}{C. M.} = \frac{10.79 \times 200 \times 25}{10381} = 5.2$  volts.

TO FIND THE POWER LOST ON ANY LINE :

*Multiply the volts drop on the line by the current flowing through it,  $W = E \times C$ , Formula (62).*

**Prob. 136:** (a) What power is lost on the line in Prob. 134? (b) What is the cost of this loss for 10 hours per day for 365 days at 10 cents per kilowatt hour?

By Formula (62)  $W = E \times C = 2 \times 50 = 100$  watts (a).

By ¶ 223.  $365 \times 10 = 3650$  hours  $\times 100$  watts = 365000 watt-hours.

$$\frac{365000}{1000} = 365 \text{ K. W.-hours.}$$

$$365 \times .10 = \$36.50 \text{ (b).}$$

**388. The Three-Wire System.**—In the three-wire multiple system two dynamos are joined in series, and the lamps connected between a centre or neutral wire joined to the junction of the machines, and the positive and negative wires of the system, Fig. 385. When all the lamps are in circuit, Fig. 385, no current flows through the middle wire, and it can be disconnected at the generators without affecting the system. If only three lamps are connected on the No. 1 side of the system, then current for the two extra lamps not paired flows through the middle wire from the + brush of

No. 2 generator. The middle wire is now positive. If three lamps are out on the No. 2 side of the system, then current for the three lamps on the No. 1 side flows from the + terminal of generator No. 1 and returns to it by the middle wire, which is now negative. The middle wire, therefore, may have no current flowing through it, or current flowing in either one direction or the other, depending upon whether the lamps on both sides of the system are accurately balanced, which is the aim in practice. For this reason it is called the neutral wire. When all the lamps are turned off on one side of the system

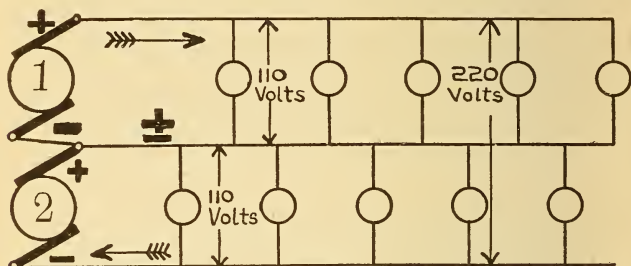


Fig. 385.—Incandescent Lamps Operated in Parallel from the Three-Wire System.

the neutral wire carries the current for all the lamps on the other side. Motors wound for 220 volts are connected to the two outside wires and do not, therefore, interfere with the balancing of the system.

The electromotive force is double that of the ordinary two-wire multiple system and the current required for any given number of lamps is reduced to one-half that required on the two-wire system. The chief advantage of the system is the saving effected in copper by its use, about  $\frac{2}{3}$  of the weight of copper being required, as compared with the two-wire system. For example, suppose 1000 pounds of copper are required for a given number of lamps operated from the 110-volt two-wire system. If the voltage be doubled, the weight of copper required is  $\frac{1}{4}$  as much as before for the same loss, or 250 pounds for the two wires. Now since in the three-wire system one extra wire is required, if it is made the same size as the others, as is often the case, it will weigh  $\frac{1}{2}$  of 250 pounds, or 125 pounds, and the three wires will weigh 375 pounds, or only  $\frac{2}{3}$  of the weight of copper is required by this

system. The joint resistance of 10 110-volt, 220-ohm lamps on the two-wire system is 22 ohms, Formula (43), while on the three-wire system the joint resistance of the same number of lamps, two in series, 5 groups in parallel, is 88 ohms. The joint resistance of the lamps being four times greater on the three-wire system than on the two-wire system, the resistance of the lead wires will also be four times greater for the same percentage of loss, and therefore only one-fourth as large as those required for the two-wire system.

TO FIND THE SIZE OF WIRE REQUIRED FOR THE THREE-WIRE SYSTEM :

Find the size of wire required for the same number and kind of lamps on the two-wire system, by Formula (110), and divide the number of circular mils, so obtained, by 4, Formula (112).

$$C. M. = \frac{10.79 \times L \times C}{4 \times E} \dots \dots \dots (112).$$

**Prob. 137:** The lamps referred to in Prob. 134, page 430, are to be operated from the three-wire system. What size of wire will be required?

By Formula (112)  $C. M. = \frac{10.79 \times L \times C}{4 \times E} = \frac{10.79 \times 125 \times 2 \times 50}{4 \times 2} = 16859 \text{ C. M.}$

From Table VII, page 113, No. 8 B. & S. = 16510 C. M. and from Table XV, page 266, No. 8 will carry 33 amperes. Since the current on the three-wire system is one-half that for an equivalent number of lamps on the two-wire system, the No. 8 wire in this problem will only carry 1-2 of 50, or 25 amperes, and is therefore sufficiently large. The neutral wire may be made the same size as the outside wires; sometimes it is made one-half as large since it is hardly probable that all the lamps on one side of a well balanced three-wire system will be out and the others all burning. A further increased saving of copper is then attained.

**389. Motor Wiring Calculations.**—TO FIND THE SIZE OF WIRE, IN C. M., TO TRANSMIT ANY GIVEN HORSE POWER ANY DISTANCE, WHEN THE VOLTAGE AND EFFICIENCY OF THE MOTOR ARE KNOWN :

Multiply the rated horse power of the motor by 746 then by the length of the circuit in feet and then by 10.79; divide this result by the product of the voltage required by the motor and the drop on the line multiplied by the efficiency of the motor, Formula (113).

Average motor efficiency.

1 H. P. . . . .	75 per cent.
3 H. P. . . . .	80 "
5 H. P. . . . .	80 "
10 H. P. . . . .	90 "

Let  $E$  = voltage required by motor ;

$e$  = drop on the lines ;

H. P. = horse power of motors ;

% M = efficiency of motor, expressed as a decimal ;  
then from Formula (110) is derived,

$$C. M. = \frac{H. P. \times 746 \times L \times 10.79}{E \times e \times \% M} \dots (113).$$

**Prob. 138 :** What size of wire is required to conduct current to a 220-volt 5 H. P. motor located 150 feet from the meter ; the drop on the line is to be 5 volts and the efficiency of the motor is 80% ?

$$\text{By Formula (113) } C. M. = \frac{H. P. \times 746 \times L \times 10.79}{E \times e \times \% M} = \frac{5 \times 746 \times 150 \times 2 \times 10.79}{220 \times 5 \times .80} = 13720 \text{ C. M.}$$

H. P. = 5, 80% = .80,  $L = 150 \times 2 = 300$  feet,  $E = 220$  volts,  $e = 5$  volts.

From Table VII, page 113, No. 8, B. & S. = 16510 C. M. The motor requires 21 amperes, calculated by Formula (114) in Prob. 139 ; and from Table XV, page 266, the carrying capacity is 33 amperes, so that No. 8 is the proper size of wire.

TO FIND THE CURRENT REQUIRED BY A MOTOR WHEN THE HORSE POWER, EFFICIENCY, AND VOLTAGE ARE KNOWN :

Multiply the H. P. by 746 and divide this product by the voltage of the motor multiplied by its efficiency, Formula (114).

$$C = \frac{H. P. \times 746}{E \times \% M} \dots (114).$$

**Prob. 139 :** What current will the motor in Prob. 138 receive ?

$$\text{By Formula (114) } C = \frac{H. P. \times 746}{E \times \% M} = \frac{5 \times 746}{220 \times .80} = 21 \text{ amperes.}$$

H. P. = 5,  $E = 220$  volts, % M = 80 = .80.

TO FIND THE HORSE POWER DEVELOPED BY A MOTOR :

Multiply the pressure applied to the motor terminals by the current supplied to it and multiply this product by the efficiency of the motor ; divide this result by 746, Formula (115).

$$H. P. = \frac{C \times E \times \% M}{746} \dots (115).$$

This formula is obtained by transposing Formula (114.)

**Prob. 140 :** A current of 45 amperes is supplied to a motor, having an efficiency of 85 per cent, under a pressure of 220 volts. What horse power is developed by the motor ?

$$\text{By Formula (115) } H. P. = \frac{C \times E \times \% M}{746} = \frac{45 \times 220 \times .85}{746} = 11 \text{ H. P.}$$

$C = 45$  amperes,  $E = 220$  volts, % M = 85 = .85.

## QUESTIONS.

1. What is the chief distinction between an arc and an incandescent lamp?
2. What is the crater of an arc, and where is it located? Give sketch.
3. What is the relative consumption of carbon in a lamp used, (a) on direct current circuits; (b) on alternating current circuits?
4. From what part of the arc is the most light emitted and what is the general direction of its reflection?
5. What is your answer to question 4 when the arc is fed by an alternating current?
6. What is the cause and disadvantage of a flaming arc?
7. What adjustment is required for an arc lamp which hisses badly?
8. What is the advantage of cored carbons over solid carbons for arc lamps fed from alternating current circuits?
9. Why are arc carbons copper plated?
10. Why is the drop, in volts, across a normal arc between cored carbons less than when solid carbons are used?
11. Describe the principle of action in a differential arc lamp? Give sketch.
12. What is the difference between an inclosed and an open air arc?
13. State two advantages of the inclosed arc lamp.
14. Why are arc lamps for street lighting generally operated in series?
15. How are incandescent lamp filaments made?

## PROBLEMS.

1. A 110-volt 16 C. P. lamp requires 55 watts. Give the following: (a) watts per candle; (b) candles per watt; (c) lamps per horse power; (d) lamps per K. W. *Ans.* (a) 3.4 watts per C. P.; (b) .29 candle per watt; (c) 13 lamps per H. P.; (d) 18 lamps per K. W.
2. To transmit 100 K. W. a certain distance at 1000 volts, 900 pounds of copper are required. How many pounds of copper will be required to transmit the same energy at 3000 volts, with the same loss on the line as before? *Ans.* 100 lbs.
3. Two hundred 55-watt 110-volt lamps are connected in parallel and are fed from a centre of distribution located 100 feet distant from the generator;  $2\frac{1}{2}$  volts are to be lost on the main feeders. What size of wire will be required? *Ans.* No. 0 B. & S.
4. What power is lost on the feeder in problem 3? *Ans.* 250 watts.
5. A series arc circuit, 5 miles in length, is constructed of No. 6 B. & S. wire and carries 10 amperes. (a) How many volts drop on the line? (b) What power is lost on the line? (c) What is the yearly cost of the power lost on the line, running 10 hours a day for 365 days at 10 cents per K. W. hour? *Ans.* (a) 108.5 volts; (b) 1085 watts; (c) \$396.025.
6. The lamps in problem 3 are to be supplied from a three-wire multiple system. What size wire will be required? *Ans.* No. 5 B. & S. (when checked by Table XV).
7. With 6 volts drop on the line what size wire is required to carry current for a 10-H. P. 220-volt motor, located 150 feet from the source of supply; efficiency 90%? *Ans.* No. 7 B. & S.
8. What current will the motor in problem 7 receive? *Ans.* 37 amp.

## APPENDIX.

### SUMMARY OF FORMULÆ.

The following formulæ have been derived in this book, and a problem solved to illustrate the manner of using each one.

In the text the formulæ are referred to by numbers, so that the formula corresponding to any number desired is readily obtained from this summary, as is also the page where the formula is fully explained.

Page		Formula Number
93.	$Q = C \times t$ . . . . .	(1).
93.	$C = \frac{Q}{t}$ . . . . .	(2).
94.	$t = \frac{Q}{C}$ . . . . .	(3).
96.	$C = \frac{W}{K \times t}$ . . . . .	(4).
96.	$W = C \times t \times K$ . . . . .	(5).
97.	$t = \frac{W}{C \times K}$ . . . . .	(6).
99.	$C = \frac{V}{t \times K}$ . . . . .	(7).
99.	$V = C \times t \times K$ . . . . .	(8).
99.	$t = \frac{V}{C \times K}$ . . . . .	(9).
100.	$C = \frac{V \times h \times 273}{.1733 \times 76 (273 + C^\circ) \times t}$ . . . . .	(10).
100.	$V = \frac{.1733 \times C \times 76 (273 + C^\circ) \times t}{h \times 273}$ . . . . .	(11).
106.	Microhms = ohms $\times$ 1000000 . . . . .	(12).
106.	Ohms = $\frac{\text{microhms}}{1000000}$ . . . . .	(13).



Page	Formula Number
106.	$\text{Megohms} = \frac{\text{ohms}}{1000000} \dots\dots\dots (14).$
106.	$\text{Ohms} = \text{megohms} \times 1000000 \dots\dots\dots (15).$
109.	$R = \frac{K \times L}{d^2} \dots\dots\dots (16).$
111.	$C. M. = d^2 \dots\dots\dots (17).$
111.	$d = \sqrt{C. M.} \dots\dots\dots (18).$
112.	$\text{Sq. mils} = c \times d \dots\dots\dots (19).$
112.	$\text{Sq. mils} = C. M. \times .7854 \dots\dots\dots (20).$
112.	$C. M. = \text{sq. mils} \times 1.2732 \dots\dots\dots (21).$
114.	$R = \frac{K \times L}{C. M.} \dots\dots\dots (22).$
114.	$L = \frac{R \times C. M.}{K} \dots\dots\dots (23).$
115.	$C. M. = \frac{L \times K}{R} \dots\dots\dots (24).$
115.	$\text{Pounds per mile (bare copper wire)} = \frac{C. M.}{62.5} \dots\dots (25).$
115.	$\text{Pounds per foot (bare copper wire)} = \frac{C. M.}{62.5 \times 5280} \dots\dots (26).$
115.	$\text{Pounds per mile (bare iron wire)} = \frac{C. M.}{72.13} \dots\dots (27).$
119.	$C = \frac{E}{R} \dots\dots\dots (28).$
121.	$E = C \times R \dots\dots\dots (29).$
122.	$R = \frac{E}{C} \dots\dots\dots (30).$
123.	$C = \frac{E}{R + r} \dots\dots\dots (31).$
124.	$E = C \times r \dots\dots\dots (32).$
124.	$E = C \times (R + r) \dots\dots\dots (33).$
124.	$R = \frac{E}{C} - r \dots\dots\dots (34).$

Page		Formula Number
124.	$r = \frac{E}{C} - R$ . . . . .	(35).
130.	Total internal resistance of cells in series = $r \times ns$ .	(36).
130.	$C = \frac{E \times ns}{(r \times ns) + R}$ . . . . .	(37).
131.	Total internal resistance of cells in parallel = $\frac{r}{nq}$ .	(38).
132.	$C = \frac{E}{\frac{r}{nq} + R}$ . . . . .	(39).
136.	Total internal resistance of any combination of cells = $\frac{r \times ns}{nq}$ . . . . .	(40).
136.	$C = \frac{E \times ns}{\frac{r \times ns}{nq} + R}$ . . . . .	(41).
140.	$\left. \begin{array}{l} C = E \times K \\ E = \frac{C}{K} \\ K = \frac{C}{E} \end{array} \right\}$ . . . . .	(42).
141.	$J. R. = \frac{R}{nq}$ . . . . .	(43).
141.	$nq = \frac{R}{J. R.}$ . . . . .	(44).
142.	$R = J. R. \times nq$ . . . . .	(45).
143.	$J. R. = \frac{R \times R_1}{R + R_1}$ . . . . .	(46).
145.	$E = C + C_1 + C_2$ etc. $\times J. R.$ . . . . .	(47).
146.	Multiplying power of a shunt (n) = $\frac{G}{S} + 1$ . . . . .	(48)
147.	$Cg = \frac{C}{\frac{G}{S} + 1}$ . . . . .	(49).
147.	$S = \frac{G}{n - 1}$ . . . . .	(50).

Page	Formula Number
173.	$\frac{C}{C_1} = \frac{\tan d}{\tan d_1}$ . . . . . (51).
176.	$C = \frac{H \times r}{N} \times \tan d$ . . . . . (52).
177.	$C = K \times \tan d$ . . . . . (53).
193.	Magnetising Force = $C \times T$ . . . . . (54).
193.	$C = \frac{\text{Magnetising Force}}{T}$ . . . . . (55).
193.	$T = \frac{\text{Magnetising Force}}{C}$ . . . . . (56).
208.	$R = \frac{A}{A_1 - A} \times r$ . . . . . (57).
212.	Horse Power of a steam engine = $\frac{P \times L \times A \times N}{33000}$ . (58).
213.	$J = E \times C \times t$ . . . . . (59).
213.	$J = C^2 \times R \times t$ . . . . . (60).
214.	$J = \frac{E^2}{R} \times t$ . . . . . (61).
215.	$W = E \times C$ . . . . . (62).
215.	$C = \frac{W}{E}$ . . . . . (63).
215.	$E = \frac{W}{C}$ . . . . . (64).
218.	H. P. = $\frac{E \times C}{746}$ . . . . . (65).
218.	K. W. = $\frac{E \times C}{1000}$ . . . . . (66).
218.	Watts = K. W. $\times 1000$ . . . . . (67).
220.	$W = C^2 \times R$ . . . . . (68).
220.	$W = \frac{E^2}{R}$ . . . . . (69).
220.	$R = \frac{W}{C^2}$ . . . . . (70).

Page		Formula Number
221.	$C = \sqrt{\frac{W}{R}}$ . . . . .	(71).
221.	$R = \frac{E^2}{W}$ . . . . .	(72).
221.	$E = \sqrt{W \times R}$ . . . . .	(73).
222.	$H. P. = \frac{C^2 \times R}{746}$ . . . . .	(74).
222.	$H. P. = \frac{E^2}{746 \times R}$ . . . . .	(75).
222.	$E = \frac{H. P. \times 746}{C}$ . . . . .	(76).
222.	$C = \frac{H. P. \times 746}{E}$ . . . . .	(77).
222.	$R = \frac{E^2}{H. P. \times 746}$ . . . . .	(78).
222.	$K. W. = \frac{C^2 \times R}{1000}$ . . . . .	(79).
222.	$K. W. = \frac{E^2}{1000 \times R}$ . . . . .	(80).
223.	$W = \frac{E^2}{r}$ . . . . .	(81).
224.	$N = \frac{4 \times W \times r}{E^2}$ . . . . .	(82).
225.	$Eff. = \frac{R}{R + r}$ . . . . .	(83).
225.	$Eff. = \frac{W}{W + w}$ . . . . .	(84).
236.	$C = \frac{E - P. D.}{r}$ . . . . .	(85).
236.	$P. D. = \frac{R \times E}{R + r}$ . . . . .	(86).
236.	$r = \frac{E - P. D.}{C}$ . . . . .	(87).
244.	Unknown E. M. F. = $\frac{E. M. F. Standard \times AD}{AC}$ . . . . .	(88).

- | Page | Formula Number  |
|------|---|
| 250. | Unknown Resistance $X = \frac{\text{Res. of Standard} \times \text{Drop on } X}{\text{Drop on Standard}}$ . (89). |
| 251. | $R = r \left( \frac{d}{d_1} - 1 \right)$ . . . . . (90).  |
| 255. | Resistance of $D = \frac{\text{Res. of } A \times \text{length } C}{\text{length } B}$ . . . . . (91).            |
| 258. | Resistance of $D = \frac{B \times C}{A}$ . . . . . (92).  |
| 269. | Heat Units (H) = .0009477 $\times E \times C \times t$ . . . . . (93).  |
| 269. | $H = .0009477 C^{\circ} R t$ . . . . . (94).  |
| 269. | $H = .0009477 \times \text{watts} \times \text{seconds}$ . . . . . (95).  |
| 269. | $C = \frac{H}{.0009477 \times E \times t}$ . . . . . (96).  |
| 269. | $t = \frac{H}{.0009477 \times E \times C}$ . . . . . (97).  |
| 270. | $C^{\circ} = \frac{(F^{\circ} - 32) \times 5}{9}$ . . . . . (98).   |
| 271. | $F^{\circ} = \frac{C^{\circ} \times 9}{5} + 32$ . . . . . (99).   |
| 271. | $R_1 = (R \times T \times F^{\circ} \text{ Rise}) + R$ . . . . . (100).   |
| 271. | $R_1 = R - (R \times T \times F^{\circ} \text{ Fall})$ . . . . . (101).   |
| 370. | Elec. Eff. = $\frac{W}{W + w + w_1}$ . . . . . (102).   |
| 398. | $C = \frac{E - \mathcal{E}}{r}$ . . . . . (103).  |
| 398. | $\mathcal{E} = E - (C \times r)$ . . . . . (104).   |
| 399. | $W = \mathcal{E} \times C$ . . . . . (105).   |
| 402. | Counter E. M. F. + $(C \times r) = \text{applied E. M. F.}$ . . (106).  |
| 411. | $W = \frac{T \times F \times S}{33000} \times 746$ . . . . . (107).   |
|      | $\% M$  |
| 412. | $W_1 = \frac{\% G \times S \times T_1}{33000} \times 746$ . . . . . (108).  |
|      | $\% M$  |

Page		Formula Number
413.	Total watts required = $W + W_1$ . . . . .	(109).
429.	$C. M. = \frac{10.79 \times L \times C}{E}$ . . . . .	(110).
431.	$E = \frac{10.79 \times L \times C}{C. M.}$ . . . . .	(111).
433.	$C. M. = \frac{10.79 \times L \times C}{4 \times E}$ . . . . .	(112).
434.	$C. M. = \frac{H. P. \times 746 \times L \times 10.79}{E \times e \times \%M}$ . . . . .	(113).
434.	$C = \frac{H. P. \times 746}{E \times \%M}$ . . . . .	(114).
434.	$H. P. = \frac{C \times E \times \%M}{746}$ . . . . .	(115).

## MENSURATION.

Some of the following formulæ are often used in electrical calculations.

### Properties of The Sphere.

Let  $d$  = diameter ;

$r$  -- radius ;

$c$  = circumference ;

$\pi$  = 3.1416.

Then :

$$\text{Volume} = \frac{4}{3} \pi r^3 = 4.1888 \times r^3.$$

$$\text{Volume} = \frac{1}{6} \pi d^3 = 0.5236 \times d^3.$$

$$\text{Volume} = \frac{1}{6} \frac{c^3}{\pi^2} = 0.01689 \times c^3.$$

$$\text{Volume} = \frac{1}{6} d \times \text{area of the surface.}$$

$$\text{Volume} = \frac{2}{3} d \times \text{area of the great circle.}$$

$$\text{Volume} = \frac{2}{3} \text{ volume of the circumscribing cylinder.}$$

$$\text{Volume} = 0.5236 \text{ volume of the circumscribing cube.}$$

### AREA OF THE SURFACE OF A SPHERE.

$$\text{Area} = 4 \pi r^2 = 12.5664 \times r^2.$$

$$\text{Area} = \pi d^2 = 3.1416 \times d^2.$$

$$\text{Area} = \frac{c^2}{\pi} = .3183 \times c^2.$$

$$\text{Area} = d \times c.$$

$$\text{Area} = 4 \times \text{area of the great circle.}$$

Area = area of a circle whose d is twice d of sphere.

Area = curved surface of the circumscribing cylinder.

$$\text{Area} = \frac{6 \times \text{volume}}{d}.$$

#### RADIUS OF A SPHERE.

$$\text{Radius} = \sqrt[3]{\frac{3 \text{ volume}}{4 \pi}} = 0.62035 \sqrt[3]{\text{volume}}.$$

$$\text{Radius} = \sqrt{\frac{\text{area surface}}{4 \pi}} = \sqrt{.07958 \times \text{area surface}}.$$

$$\text{Circumference} = \sqrt[3]{6 \pi^2 \text{ volume}} = \sqrt[3]{59.2176 \times \text{volume}}.$$

$$\text{Circumference} = \sqrt{\pi \times \text{area of surface}}.$$

$$\text{Circumference} = \frac{\text{area surface}}{d}.$$

#### The Circle.

$$\text{Circumference} = \pi d.$$

$$\text{Diameter} = \frac{c}{\pi} = c \times 0.31831.$$

$$\text{Area} = d^2 \times \frac{\pi}{4} = .7854 \times d^2.$$

$$\text{Area} = c^2 \times .07958.$$

$$\text{Area} = r^2 \times \pi.$$

$$\text{Area} = \frac{d}{4} \times \text{circumference}.$$

#### The Ellipse.

$$\text{Area} = \text{Product both d's} \times .7854.$$

#### The Cylinder.

Area = circumference  $\times$  altitude plus area of both ends

Volume = area of base  $\times$  altitude.



Table XXIII.

## RECAPITULATION.

## DEFINITIONS OF PRACTICAL ELECTRICAL UNITS.

Quantities to be Measured.	Synonyms.	Symbol.	Name of Practical Unit.	Comparative Values.	REMARKS.
					Fundamental or absolute or C. G. S. Units are: Centimeter (C) for Length. Gramme (G) for Mass. Second (S) for Time.
Current.	Strength. Intensity. Rate of Flow. Coulomb per Sec. Volume (obsolete).	C	Ampere.	Coulombs ÷ Seconds. Volts ÷ Ohms.	One Ampere deposits .0003-286 gramme, or .004991 grain of copper per second on the plate of a copper voltmeter.
Quantity.	Ampere - Second.	Q	Coulomb.	Amperes × Seconds.	One hour = 3,600 seconds; hence one ampere-hour = 3,600 ampere-seconds, or = 3,600 coulombs.
Electromotive Force. Difference of Potential.	Pressure. Tension.	EMF or E	Volt.	Amperes × Ohms. Joules ÷ Coulombs.	One volt = .333 standard Daniell cell (zinc sulphate of a density of 1.4 and copper sulphate of a density of 1.1).
Resistance.		R	Ohm.	Volts ÷ Amperes.	One legal ohm is the resistance of a column of pure mercury, 1 square millimeter in section and 106 centimeters long, at °Centigrade. 1 true ohm = 1.00283 legal ohms.
Capacity.		K	Farad.	Coulombs ÷ Volts.	The microfarad, one-millionth of a farad, has been generally adopted as a practical unit; the farad is too large a unit for practical use.
Power Activity.	Electrical H.P. Rate of doing Work. Effect. Work ÷ Time.	P or Pw. or HP	Watt. (Volt-ampere).	Volts × Amperes. (Amperes) <sup>2</sup> × Ohms. (Volts) <sup>2</sup> ÷ Ohms. Joules ÷ Seconds.	One watt = $\frac{1}{746}$ electrical horse power. One electrical horse power = $\frac{\text{volts} \times \text{amperes}}{746}$ One electrical horse power = $\frac{(\text{amperes})^2 \times \text{ohms}}{746}$ One electrical horse power = $\frac{(\text{volts})^2}{746 \text{ ohms}}$
Work, Heat, Energy.	Power × Time.	W or Wj.	Joule. (Volt-coulomb.)	Watts × Seconds. Volts × Coulombs. (Amperes) <sup>2</sup> × Ohms × Seconds. (Volts) <sup>2</sup> × Seconds ÷ Ohms	One joule is the work done or heat generated by a watt in a second. One joule is the heat necessary to raise .238 gramme of water 1° C.; or one joule = .238 calorie or therm. One joule = .7375 foot-pound in a second.

Table XXIV.—EQUIVALENTS OF UNITS OF LENGTH.

	Millimeter	Centimeter	Meter	Kilometer	Mil	Inch	Foot	Yard	Mile (Statute)	Mile (Geog'hl)
Millimeter	1	.01	.001	.000001	39,370.79	.039371	.063281	.001094	.0000006	.0000007
Centimeter	.10	1	1	.00001	393,707.9	.3937079	.032809	.010936	.0000062	.000007
Meter	1000	100	1	.001	39,370.79	39,370.79	3,280.90	1,093.63	.000621	.000716
Kilometer	1,000,000	100,000	1000	1		39,370.79	3280,899	1093,633	.621382	.716330
Mil	.025399	.0025399	.0000254		1	.001	.000083	.000028		
Inch	25,3994	2,53994	.025399	.0000254	1000	1	.083333	.027777	.0000158	.000015
Foot	304,7945	30,47945	.304795	.0003084	12000	12	1	.333333	.000189	.000104
Yard	914,3835	91,43835	.914384	.0009144	36000	36	3	1	.000568	.000493
Mile (Statute)		160,931.4	1,609,314	1,609314		63,360	5280	1760	1	.868382
Mile (Geog'ph.)		185,329	1853,29	1,85329		72,963.2	6080.27	2026.76	1.1516	1

Table XXV.

EQUIVALENTS OF UNITS OF AREA.

	Square Millimet'r	Square Centime'r	Circular Mil	Square Mil	Square Inch	Square Foot
Square Millimeter	1	0.10	1978.6	1550.1	.00155	.0000108
Square Centimeter	100	1	197,861	155,007	155007	.001076
Circular Mil	.000507	.0000051	1	78540	$8 \times 10^{-7}$	
Square Mil	.000645	.0000065	1.2733	1	.000001	
Square Inch	645.132	6.451	1,273,238	1,000,000	1	.006944
Square Foot	92,898.9	928.989			144	1

Table XXVI.

EQUIVALENTS OF UNITS OF VOLUME.

	Cubic Inch	Fluid Ounce	Gallon	Cubic Foot	Cubic Yard	Cu. Cen- timeter	Liter	Cubic Meter
Cubic Inch	1	.554112	.004329	.000578		16.3862	.016386	
Fluid Ounce	1.80469	1	.007812	.001044		29.5720	.029572	
Gallon	231	128	1	.133681	.00495	3785.21	3.78521	.003785
Cubic Foot	1728	957.506	7.48052	1	.037037	28315.3	28.3153	.028315
Cubic Yard	46,656	25,852.6	201.974	27	1	764,505	764.505	.764505
Cubic Centimeter	.061027	.033816	.000264	.000035		1	.001	.000001
Liter	61.027	33.8160	.264189	.035317		1000	1	.001
Cubic Meter	61027	33816	264.189	35.3169	1.3080		1000	

Table XXVII.

## EQUIVALENTS OF UNITS OF WEIGHT.

	Grain	Troy Ounce	Pound Avs.	Ton	Milli-gram	Gram	Kilo-gram	Metric Ton
Grain	1	.020833	.000143		64.799	.064799	.000065	
Troy Ounce	480	1	.068041		31,103.5	31.1035	.031104	
Pound Avoird'pois	7,000	14.5833	1	.000447		453.593	.453593	.000454
Ton		32,666.6	2240	1			.001016	1.01605
Milligram	.015432	.000032	.000002		1	.001	.000001	
Gram	15.4323	.032151	.002205		1000	1	.001	
Kilogram	15,432.3	32.1507	2.20462	.000984	1,000,000	1000	1	.001
Metric Ton		32,150.7	2204.62	.98421		1,000,000	1000	1

Tables XXIV to XXVIII taken from Professor Sloane's Arithmetic by permission of the publisher.

APPENDIX.

Table XXXVIII.—EQUIVALENTS OF UNITS OF ENERGY AND WORK.

	Erg	Meg-Erg	Gram Degree C	Kilogram Degree C	Pound Degree C	Pound Degree F	Watt Second	Kilogram Meter	Foot Pound	Horse-Power Second English	Horse-Power Second Metric
Erg	1	.000001									
Meg-Erg	1,000,000	1	.024068	.000024	.000053	.000095	10-7	.001019			
Gram Degree C		41,548.7	1	.001	.002205	.008968	4.15487	42,355.5	.423535	3.06355	.00557
Kilogram Degree C		41,548.7	1000	1	2.2046	3.9683	4154.87		423.535	3063.55	5.57
Pound Degree C		18,846.5	453.59	.45359	1	1.8	1884.65		192.114	1389.6	2.52652
Pound Degree F		10,470.1	251.995	.251995	.555556		1047.03		106.730	772	1.40364
Watt Second	10 <sup>7</sup>	10	.24068	.000241	.000531	.000955	1	10,138.7	101937	.737337	.0013406
Gram Centimeter	981	.000981	.0000235				.000098	1	.00001	.000072	
Kilogram Meter	98.1 × 10 <sup>6</sup>	98.1	2.36108	.002361	.005205	.009870	9.81	100,000	1	7.23328	.013152
Foot Pound		13.55626	.326425	.000326	.000720	.001295	1.35626	13,825.3	.138253	1	.0018182
Horse-Power Sec. English		7459.43	179.486	.179486	.3957	.71243	745.943		76.0392	550	1
Horse-Power Sec. Metric		7357.5	177.075	177.075	.390375	.70275	735.75		75	542.436	1

Table XXIX.

COMPARATIVE TABLE OF GAUGES.

Giving the respective diameter and area of each number.

Gauge No.	American Wire Gauge (Brown & Sharpe)		Birmingham Wire Gauge (Stubs)		Standard Wire Gauge	
	Diameter	Area	Diameter	Area	Diameter	Area
	Inches	Cir'lar Mills	Inches	Cir'lar Mills	Inches	Cir'lar Mills
7-0					0.500	250000.
6-0					0.404	215300.
5-0					0.432	186600.
4-0	0.4600	211600.	0.454	206100.	0.400	160000.
3-0	0.4096	167800.	0.425	180600.	0.372	138400.
2-0	0.3648	133100.	0.380	144400.	0.348	121100.
1-0	0.3249	105500.	0.340	115600.	0.324	105000.
1	0.2893	83690.	0.300	90000.	0.300	90000.
2	0.2576	66370.	0.284	80660.	0.276	76180.
3	0.2294	52630.	0.259	67080.	0.252	63500.
4	0.2043	41740.	0.238	56640.	0.232	53820.
5	0.1819	33100.	0.220	48400.	0.212	44940.
6	0.1620	26250.	0.203	41210.	0.192	36860.
7	0.1443	20820.	0.180	32400.	0.176	30980.
8	0.1285	16510.	0.165	27230.	0.160	25600.
9	0.1144	13090.	0.148	21900.	0.144	20740.
10	0.1019	10380.	0.134	17960.	0.128	16380.
11	0.09074	8234.	0.120	14400.	0.116	13460.
12	0.08081	6530.	0.109	11880.	0.104	10820.
13	0.07196	5178.	0.0950	9025.	0.092	8464.
14	0.06408	4107.	0.0830	6889.	0.080	6400.
15	0.05707	3257.	0.0720	5184.	0.072	5184.
16	0.05082	2583.	0.0650	4225.	0.064	4096.
17	0.04526	2048.	0.0580	3364.	0.056	3136.
18	0.04030	1624.	0.0490	2401.	0.048	2304.
19	0.03589	1288.	0.0420	1764.	0.040	1600.
20	0.03196	1022.	0.0350	1225.	0.036	1296.
21	0.02846	810.1	0.0320	1024.	0.032	1024.
22	0.02535	642.4	0.0280	784.	0.028	784.0
23	0.02257	509.5	0.0250	625.	0.024	576.0
24	0.02010	404.0	0.0220	484.	0.022	484.0
25	0.01790	320.4	0.0200	400.	0.020	400.0
26	.01594	254.1	0.0180	324.	0.018	324.0
27	.01420	201.5	0.0160	256.	0.0164	269.0
28	0.01264	159.8	0.0140	196.	0.0148	219.0
29	0.01126	126.7	0.0130	169.	0.0136	185.0
30	0.01003	100.5	0.0120	144.	0.0124	153.8
31	0.008928	79.70	0.0100	100.	0.0116	134.6
32	0.007950	63.21	0.0090	81.	0.0108	116.6
33	0.007080	50.13	0.0080	64.	0.0100	100.0
34	0.006305	39.75	0.0070	49.	0.0092	84.64
35	0.005615	31.52	0.0050	25.	0.0084	70.56
36	0.005000	25.00	0.0040	16.	0.0076	67.76
37	0.004453	19.83			0.0068	46.24
38	0.003965	15.72			0.0060	36.00
39	0.003531	12.47			0.0052	27.04
40	0.003145	9.888			0.0048	23.04
41					0.0044	19.36

**TABLE XXX.—DECIMAL EQUIVALENTS**  
OF EIGHTHS, SIXTEENTHS, THIRTY-SECONDS AND SIXTY-FOURTHS OF AN INCH.

Eighths.	Thirty-Seconds.	Sixty-Fourths.	Sixty-Fourths
$\frac{1}{8}$ = .125	$\frac{1}{32}$ = .03125	$\frac{1}{64}$ = .015625	$\frac{1}{128}$ = .0078125
$\frac{2}{8}$ = .250	$\frac{2}{32}$ = .0625	$\frac{2}{64}$ = .03125	$\frac{2}{128}$ = .015625
$\frac{3}{8}$ = .375	$\frac{3}{32}$ = .09375	$\frac{3}{64}$ = .046875	$\frac{3}{128}$ = .0234375
$\frac{4}{8}$ = .500	$\frac{4}{32}$ = .125	$\frac{4}{64}$ = .0625	$\frac{4}{128}$ = .03125
$\frac{5}{8}$ = .625	$\frac{5}{32}$ = .15625	$\frac{5}{64}$ = .078125	$\frac{5}{128}$ = .0390625
$\frac{6}{8}$ = .750	$\frac{6}{32}$ = .1875	$\frac{6}{64}$ = .09375	$\frac{6}{128}$ = .046875
$\frac{7}{8}$ = .875	$\frac{7}{32}$ = .21875	$\frac{7}{64}$ = .109375	$\frac{7}{128}$ = .0546875
<b>Sixteenths.</b>	$\frac{8}{32}$ = .25	$\frac{8}{64}$ = .125	$\frac{8}{128}$ = .0625
$\frac{1}{16}$ = .0625	$\frac{9}{32}$ = .28125	$\frac{9}{64}$ = .140625	$\frac{9}{128}$ = .0703125
$\frac{2}{16}$ = .125	$\frac{10}{32}$ = .3125	$\frac{10}{64}$ = .15625	$\frac{10}{128}$ = .078125
$\frac{3}{16}$ = .1875	$\frac{11}{32}$ = .34375	$\frac{11}{64}$ = .171875	$\frac{11}{128}$ = .0859375
$\frac{4}{16}$ = .250	$\frac{12}{32}$ = .375	$\frac{12}{64}$ = .1875	$\frac{12}{128}$ = .09375
$\frac{5}{16}$ = .3125	$\frac{13}{32}$ = .40625	$\frac{13}{64}$ = .203125	$\frac{13}{128}$ = .01015625
$\frac{6}{16}$ = .375	$\frac{14}{32}$ = .4375	$\frac{14}{64}$ = .21875	$\frac{14}{128}$ = .0109375
$\frac{7}{16}$ = .4375	$\frac{15}{32}$ = .46875	$\frac{15}{64}$ = .234375	$\frac{15}{128}$ = .01171875
$\frac{8}{16}$ = .500	$\frac{16}{32}$ = .5	$\frac{16}{64}$ = .25	$\frac{16}{128}$ = .0125
$\frac{9}{16}$ = .5625	$\frac{17}{32}$ = .53125	$\frac{17}{64}$ = .265625	$\frac{17}{128}$ = .01328125
$\frac{10}{16}$ = .625	$\frac{18}{32}$ = .5625	$\frac{18}{64}$ = .28125	$\frac{18}{128}$ = .0140625
$\frac{11}{16}$ = .6875	$\frac{19}{32}$ = .59375	$\frac{19}{64}$ = .296875	$\frac{19}{128}$ = .01484375
$\frac{12}{16}$ = .750	$\frac{20}{32}$ = .625	$\frac{20}{64}$ = .3125	$\frac{20}{128}$ = .015625
$\frac{13}{16}$ = .8125	$\frac{21}{32}$ = .65625	$\frac{21}{64}$ = .328125	$\frac{21}{128}$ = .01640625
$\frac{14}{16}$ = .875	$\frac{22}{32}$ = .6875	$\frac{22}{64}$ = .34375	$\frac{22}{128}$ = .0171875
$\frac{15}{16}$ = .9375	$\frac{23}{32}$ = .71875	$\frac{23}{64}$ = .359375	$\frac{23}{128}$ = .01796875
	$\frac{24}{32}$ = .75	$\frac{24}{64}$ = .375	$\frac{24}{128}$ = .01875
	$\frac{25}{32}$ = .78125	$\frac{25}{64}$ = .390625	$\frac{25}{128}$ = .01953125
	$\frac{26}{32}$ = .8125	$\frac{26}{64}$ = .40625	$\frac{26}{128}$ = .0203125
	$\frac{27}{32}$ = .84375	$\frac{27}{64}$ = .421875	$\frac{27}{128}$ = .02109375
	$\frac{28}{32}$ = .875	$\frac{28}{64}$ = .4375	$\frac{28}{128}$ = .021875
	$\frac{29}{32}$ = .90625	$\frac{29}{64}$ = .453125	$\frac{29}{128}$ = .02265625
	$\frac{30}{32}$ = .9375	$\frac{30}{64}$ = .46875	$\frac{30}{128}$ = .0234375
		$\frac{31}{64}$ = .484375	$\frac{31}{128}$ = .02421875
			$\frac{32}{128}$ = .025

**TABLE XXXI.**

VOLTS LOST ON COPPER WIRE.

Table of volts lost or drop per ampere per 1,000 feet of conductor. (Calculated by  $E = C \times R$ . Formula (29).) Copper wire, B. & S. gauge (70° F.).

Size, B. & S.	Volts Drop per Ampere per 1,000 Feet.	Size, B. & S.	Volts Drop per Ampere per 1,000 Feet.
0000	.0493	17	5.088
000	.0621	18	6.415
00	.0783	19	8.089
0	.0987	20	10.20
1	.1242	21	12.86
2	.1570	22	16.22
3	.1980	23	20.45
4	.2496	24	25.79
5	.3148	25	32.52
6	.3970	26	41.01
7	.5006	27	51.72
8	.6312	28	65.21
9	.7958	29	82.23
10	1.040	30	103.7
11	1.266	31	130.7
12	1.596	32	164.9
13	2.012	33	207.9
14	2.537	34	262.2
15	3.200	35	330.6
16	4.035	36	416.8

**PROBLEM.**—How many volts would be lost in carrying 10 amperes a distance of 2,000 feet on a No. 6 B. & S. Wire?

Solution, from Table XXXI: .3970 volt is lost per ampere per 1,000 feet, or .7940 volt per 2,000 feet for one ampere, or 7.940 volts per 10 amperes,  $E = C \times R$ .

Table XXXII.

## Useful Equivalents for Electric Heating Problems.

BY H. WARD LEONARD, ELEC. ENG.

Unit.	Equivalent Value in other Units.	Unit.	Equivalent Value in other Units.
1 K. W. Hour =	1,000 Watt hours. 1.34 horse power hours. 2,656,400 ft. lbs. 3,600,000 joules. 3,440 heat units. 366,848 kilogram metres	1 Ft. Lb. =	1.36 joules. 1383 k. g. m. 0.00000377 K. W. hours. 0.00291 heat units. 0.000005 H. P. hour.
	229 lbs. coal oxidized with perfect efficiency. 3 lbs. water evaporated at 212° F 22.9 lbs. of water raised from 62° to 212° F 8 cents at usual rates for electric heating	1 Watt =	1 joule per second. 00134 H. P. 0.01 K. W 3.44 heat units per hour 73 ft. lbs. per second. 003 lbs. of water evaporated per hour 44.24 ft. lbs. per minute.
1 H. P. Hour =	.746 K. W hours. 1,980,000 ft. lbs. 2,580 heat units. 273,740 k. g. m. 172 lbs. coal oxidized with perfect efficiency. 2.25 lbs. water evaporated at 212° F 17.2 lbs. water raised from 62° F. to 212° F 6 cents at usual rates for electric heating.	1 Watt per Sq. in. =	8.26 thermal units per sq. ft. per minute. 120° F above surrounding air (Japanned cast iron surface.) 66° C above surrounding air (Japanned cast iron surface.)
		1 Heat Unit =	1,048 Watt seconds. 772 ft. lbs. .252 calorie (Kg.-d.) 108 kilogram metres. 000291 K. W hour 000388 H. P hour 0000667 lbs. coal oxidized. 00087 lbs. water evaporated at 212° F
1 K. W. =	1,000 Watts. 1.34 H. P. 2,656,400 ft. lbs. per hour 4,424 ft. lbs. per minute 73.73 ft. lbs. per second 3,440 heat units per hour 673 heat units per minute 9.55 heat units per second. 229 lbs. coal oxidized per hour. 3 lbs. water evaporated per hour at 212° F	1 Heat Unit per Sq. Ft. per min. =	121 Watts per square inch. 0174 K. W 0232 H. P
		1 Kilogram Metre	7.23 ft. lbs. 0.0000366 H P. hour 00000272 K. W hour 0092 heat units
1 H. P. =	746 Watts. 746 K. W. 33,000 ft. lbs. per minute 550 ft. lbs. per second. 2,580 heat units per hour. 43 heat units per minute 71 heat units per second. .172 lbs. coal oxidized per hour. 2.25 lbs. water evaporated per hour at 212° F	1 Lb. Bitu- minous Coal Oxidized with perfect efficiency =	15,000 heat units. .98 lbs. Anth'cite coal oxidized. 2.1 lbs. dry wood oxidized. 15 cu. ft. illuminating gas. 4.37 K. W hours (theoretical value.) 5.81 H P hours (theoretical value) 11,500,000 ft. lbs. (theoretical value.) 13.1 lbs. of water evaporated at 212° F
		1 Lb. Water Evaporated 212° F =	.33 K. W. hour. .44 H P. hour 1,148 heat units. 124,200 k. g m. 1,210,000 joules. 887,800 ft. lbs. 076 lbs. of coal oxidized.
1 Joule =	1 Watt second 00000278 K. W. hour 102 k. g m. 00094 heat units. 73 ft. lbs.		



# INDEX.

(Figures refer to the numbered pages.)

## A.

Accumulator,  
Commercial, 84.  
Direction of current in, on  
charge and discharge, 84.  
Principle of, 83.  
Alternating current, 294, 337.  
dynamos, 376.  
from a direct current arma-  
ture, 349.  
Graphic representation of, 340.  
Alternator, Magneto, 342.  
Alternations, To find the number  
of, in a dynamo, 338.  
Amalgamation, 62.  
Ammeter, Balance beam, 202.  
Connecting, in circuit, 201.  
Connections for a shunted, 207.  
Dead beat, 178, 200.  
Dynamometer, 286.  
Gravity, 201.  
inclined coil, Thomson, 203.  
Increasing the range of read-  
ing of, 208.  
shunt, Weston, 206.  
Use of tangent galvanometer as  
an, 176.  
Weston, 203.  
Ammeters, Resistance of, 150.  
Ampere, Definition of, 92.  
Ampere-hour unit, 94.  
Ampere-hours,  
To find number of, consumed  
by apparatus, 94.  
Ampere meters, 200.  
Ampere-turns, 192.  
Anion, 80.  
Anode, 80.  
Arc,  
Alternating current, 418, 421.  
Crater of, 415.  
Flaming, 417.  
Hissing, 417.  
Inclosed, 420.  
Light from, 416.  
projectors, Current required  
for, 417.

Arc,  
Silent, 417.  
Temperature of, 416.  
The electric, 415.  
Arcs,  
Types of, 416.  
Arc lamp,  
Automatic cut-out for, 420.  
Brush, 419.  
Candle power of, 417.  
carbons, 418.  
circuit, Fall of potential in, 234.  
circuits, 422.  
differential, Principle of, 419.  
Inclosed, 420.  
regulation, 418.  
Arc lamps,  
Measuring resistance of, while  
burning, 248.  
Rating of, 417.  
Arc lighting,  
Dynamos for, 353.  
Armature,  
Active wire on, 351.  
Battery analogy of induced  
E. M. F. in a ring, 348.  
circuits, Multipolar field, 374.  
Brush arc light, 353.  
Closed coil, 352.  
coil, The act of commutation  
of, 364.  
connected on the quarter, 366.  
core construction, 355.  
core insulation, 357.  
core loss, hysteresis, 361.  
cross-connected, 374.  
Dead wire on, 351.  
Drum-wound ring, 352.  
Gramme ring, 346.  
Induced E. M. F. in a ring, 347.  
Multi-coil, 345.  
reactions, 362.  
resistance, 348.  
Shuttle, 342.  
Siemens drum, 350.  
Single coil, 345.  
Tooth core, 352, 356.

- Armature,  
winding, 359.  
Armatures,  
Advantages of drum and ring,  
351  
Eddy current loss in, 355.  
Open-coil, 352.  
Pole pieces and, 38.  
Resistance of, 151.  
Astatic needles, 48.

## B.

- Blasting, Electric, 273.  
Barlow's wheel, 279.  
Battery,  
Amalgamation of zinc for, 62.  
Bichromate, 65.  
Bluestone, 69.  
Bunsen, 68.  
Carbon Cylinder, 72.  
Chemical action in a simple, 57.  
Chloride of silver, 74.  
circuit, Ohm's Law applied to,  
122.  
Closed circuit, 62.  
Crow-foot, 69.  
Daniell, 69.  
Definition of, 59.  
depolarizer, 64.  
Double fluid, 64.  
Dry, 75.  
Edison-Lalande, 73.  
Efficiency of a, 224.  
E. M. F., On what it depends,  
59.  
Fuller bichromate, 66.  
Gonda Leclanche, 72.  
Gravity, 69.  
Grenet, 65.  
Grove, 68.  
Internal resistance of, 116.  
Leclanche, 71.  
Leclanche, Directions for setting up, 71.  
Local action in, 61.  
Open circuit, 63.  
Parts of, 55.  
Partz acid gravity, 67.  
polarization, 58.  
polarization, Remedies for, 63.  
Primary, 63.  
Recuperation of, 59.  
Simple voltaic, 52.  
Size of, 125.  
Smee, 64.  
solution, Bichromate, 66.  
Student's experimental, 61.  
Student's Daniell, 70.

## Battery.

Why the hydrogen appears at the copper plate in, 58.

## Batteries,

- Chemicals and chemical symbols for, 76.  
Classification of, 75.  
Current strength from any combination of, 136.  
in parallel, Advantage of, 132.  
in parallel, Current from, 132.  
in parallel, Internal resistance of, 131.  
in parallel or multiple for quantity, 128.  
in multiple-series, 134.  
in opposition, 136.  
in series, Advantage of, 133.  
in series, Current from, 130.  
in series, E. M. F. of, 64.  
in series, to increase the E. M. F., 126.  
in series, Internal resistance of, 130.  
Internal resistance of any combination of, 135.  
Power from, 223.  
Resistance of, 150.  
Table of E. M. F.'s of, 118.  
Brushes, 338, 356.  
Causes of sparking at, 367.  
Carbon and copper, 364.  
of a motor, Position of, 397.  
Position of, in a dynamo, 365.  
Shifting position of, 366.

## C.

- Carbons,  
copper plated, 418.  
Cored, 418.  
for arc lamps, 418.  
Carrying capacity of conductors,  
Safe, 265.  
Cathion, 80.  
Cathode, 80, 326.  
Cautery Electric, 273.  
Cell (See also battery).  
Cells, Comparison of the E. M. F. of, by the potentiometer, 243.  
Number of, required for maximum economy, 223.  
Power from, 223.  
Choke coils, 312.  
Collector rings, 338.  
Coherer, 332.  
Commutation  
of an armature coil, The act of, 364.  
The act of, 344.

- Commutator  
 construction, 355.  
 for an open-coil armature, 353.  
 Simple two-part, 343.
- Compass, Mariner's, 44.
- Condenser, Action of, with an induction coil, 318.
- Conductance defined, 103.  
 of a circuit, 140.
- Conductors and insulators, 54, 104.  
 Table of insulators and, 105.
- Conductivity method for calculating resistance, 143.  
 Table of, for metals, 115.
- Controller, Series-parallel, 408.
- Conservation of energy, 216.
- Consequent poles, 32, 188, 373.
- Cooking, Electric, 273.
- Correlation of energy, 216.
- Coulomb, Definition of, 92.
- Counter E. M. F. of a motor (See Motor).
- Circular mil,  
 area, Calculation of, 111.  
 defined, 110.
- Circuit  
 Application of Ohm's Law to, 123.  
 breaker, 187.  
 Definition of, 53.  
 Division of current in a divided, 144.
- Circuits, Current in branches of multiple, 145.  
 Inductive and non-inductive, 312.  
 Magnetic, 36, 187.  
 Potential difference in multiple, 145.
- Current,  
 Alternating, 77. (See also Alternating Current).  
 Chemical effect of, 79.  
 Chemical generation of, 50.  
 Continuous, 52, 77.  
 deflects magnetic needle, 51.  
 Direction of, 54.  
 Division of, in a divided circuit, 144.  
 Direct, 318.  
 direct, Graphic representation of, 345.  
 Effects of, 77.  
 effects, Variation of, through dissimilar apparatus, 91.  
 Extra, of self-induction, 309.  
 Heating effect of, 77, 265.  
 How the effects vary with, 88.  
 Inverse, 318.  
 Magnetic effects of, 78.
- Current,  
 Measurement of, the strength of, 91.  
 Measurement of, by a gas voltmeter, 98.  
 of electricity, 50.  
 pressure and resistance, Variation of, 235.  
 Pulsating, 77.  
 Strength of, 87, 92.  
 To find quantity of, flowing through a circuit, 93.  
 Unit quantity of, 92.  
 Variation of, and current's effects, 87.  
 wave, 341.
- Currents, Eddy, 306.  
 in angular conductors, 283.  
 induced in a wire by a magnet, 293.  
 induced, To find the direction of, 295.  
 induced in a coil by motion of a magnet, 296.  
 induced, Lenz's law of, 297.  
 induced by making or breaking the primary circuit, 300.  
 induced by moving either the primary or secondary circuit, 300.  
 induced by altering the strength of the primary current, 301.  
 induced by reversing the direction of the primary current, 302.  
 induced by moving the iron core, 302.  
 induction, Table of, 302.  
 Laws of parallel and angular, 282.  
 Magnetic fields of parallel, 280.  
 Test on effects of, 90.
- Current-carrying capacity of copper wires, 266.
- Current-carrying wire,  
 Automatic twisting of, around a pole, 277.  
 Direction of magnetic field around, 154.  
 Reaction of, on a magnet, 276.  
 Rotation of, around a magnetic pole, 278.  
 Rule for direction of magnetic field around, 159.
- Current strength,  
 from any combination of batteries, 136.  
 Calculation of, 119.  
 Measurement of, 200.

Current strength,  
 Methods of varying, 125.  
 To find average, 93.  
 To calculate an unknown, 95.  
 used in practice, Value of, 101.  
 Cut-outs, Fuses and, 272.  
 Cycle, 340.

## D.

Dip, Magnetic, 44.  
 needle, 12.  
 Dynamometer ammeter, Portable,  
 286.  
 Siemens, 285.  
 wattmeter, 286.  
 Dynamo,  
 Alternating current, 338.  
 and motor. Comparison be-  
 tween, 393, 399.  
 brushes. (See Brushes.)  
 Capacity of, 367.  
 Compound wound, 375.  
 Constant current, 384.  
 Constant potential, 380.  
 Definition of, 334.  
 Double current, 350.  
 Efficiency of, 369.  
 equalizer, 389.  
 Experimental motor and, 339.  
 Faraday's disc, 307.  
 Losses in a, 369.  
 Magneto, 375.  
 Parts of, 335.  
 On what the induced E. M. F.  
 of, depends, 303, 342.  
 Over-compounded, 386.  
 regulation, Series, 385.  
 regulation, Shunt, 381.  
 Self-exciting, 375.  
 Separately excited, 375, 376.  
 Separate coil, self-contained,  
 376.  
 Series, 376.  
 Series and long shunt, 376, 387.  
 Series and short shunt, 376.  
 Series and separately excited,  
 376.  
 series, Action of, 384.  
 series, Potential difference at  
 terminals of, 368.  
 Shunt, 376.  
 shunt, Action of, 381.  
 shunt, Principle of, 380.  
 shunt, Potential at terminals  
 of, 368.  
 Simple direct current, 342.  
 Simple type of, 336.  
 Test on 1.25-K. W., 383, 388.  
 To find the neutral point of, 365.

## Dynamos,

Classification of, 336.  
 Classification of, according to  
 their field excitation, 375.  
 Commercial rating of, 368.  
 compound, Connections for two,  
 in parallel, Plate II.  
 Compound, 386.  
 Constant current, 375.  
 Constant potential, 375.  
 in parallel, Compound wound,  
 389.  
 Self-exciting principle of di-  
 rect current, 378.  
 shunt, in parallel, Connecting,  
 382.  
 Table of E. M. F.'s of, 119.

## E.

Earth, Polarity of, 41.  
 Earth's Magnetism. (See Magnet-  
 ism.)  
 Eddy currents, 306.  
 Eddy current loss in armatures, 355.  
 Efficiency, Commercial, of a dyna-  
 mo, 370.  
 Electrical, of a dynamo, 369.  
 of a battery, 224.  
 of a motor, 410.  
 of power transmission, 397.  
 Electrical effects, 49.  
 Electric Waves, 50, 330.  
 Electricity, Nature of, 49.  
 Electrification, 52.  
 Electrodes, Poles, plates and, 54.  
 Electro-chemical series, 60.  
 Electrodynamics, 280, 284.  
 Electrolysis,  
 Definition of, 80.  
 of water, 79.  
 of copper sulphate, 80.  
 of lead acetate, 82.  
 of zinc sulphate, 81.  
 Electrolyte defined, 80.  
 Electrolytic interrupter for spark  
 coils, Wehnelt, 321.  
 meter, Edison, 81.  
 Electromotive force and potential  
 difference, 228.  
 Calculation of, 121.  
 Generation of, 118.  
 induced in a ring armature,  
 347.  
 induced, Upon what factors the  
 value of, depends, 296.  
 induced, Variation of, with the  
 rate of change of the mag-  
 netic lines of force, 303.  
 Measurement of, 236.

- Electromotive force,  
 of a battery, 59.  
 of batteries, 64.  
 of batteries and dynamos, 118.  
 of batteries, Comparison of, by  
 the potentiometer, 243.  
 of a motor, Counter, 397.
- Electromagnet, Testing the attract-  
 ive force of an, 195.  
 Definition of, 185.  
 Magnetic field of an, 186.  
 Polarity of, 184.  
 Coarse and fine wire, 195.  
 Typical forms of, and their  
 uses, 189.
- Electromagnetism, 50, 153.  
 Electromagnetic induction, 293.  
 Electroplating, Process of, 82.  
 Electrostatics, 49.  
 Electrotyping, Process of, 82.  
 Energy, Relation between mechani-  
 cal and electrical, and heat,  
 270, 449.  
 Equalizing bar, 390.  
 Equivalents of mechanical and  
 electrical work, 216, 449.

**F.**

- Faraday's law of electromagnetic  
 induction, 303.  
 Field excitation, Classification of  
 dynamos according to their,  
 375.  
 Field discharge, 310.  
 magnets, Bipolar, 372.  
 magnets, Multipolar, 373.  
 rheostat, 381.  
 Fluoroscope, Fluorescing screen  
 and, 326.  
 Foot-pound, Definition of, 210.  
 Force, Definition of, 209.  
 Different kinds of, 209.  
 Formulæ, Electrical power, 222.  
 Mensuration, 443.  
 Summary of, 436.  
 Fuses and cut-outs, 272.  
 Fusing point of various sizes of  
 wire by 100 amperes, 273.

**G.**

- Galvanometer, Astatic, 179.  
 Ballistic, 179.  
 Construction of student's de-  
 tector, 169.  
 D'Arsonval, 181.  
 Deat-beat, 178, 200.  
 Detector, 55, 169.  
 Differential, 179.

- Galvanometer,  
 long and short coil, The use  
 of, 169.  
 Principle of the, 167.  
 Relative calibration of, 171.  
 shunted, To find the current  
 through, 147.  
 Tangent, 172.  
 tangent, Directions for setting  
 up student's, 175.  
 tangent, Student's combina-  
 tion, 174.  
 tangent, Table of constants for,  
 176.  
 tangent, Use of, as an ammeter,  
 176.  
 Thomson mirror-reflecting, 177.  
 Galvanometers, Classification of,  
 170.  
 Resistance of, 150.  
 Gas Voltmeter (See Voltmeter).  
 Geissler tubes, 324.  
 Generator (See Dynamo).

**H.**

- Heat and work, 215.  
 Electrical development of, 265.  
 Electrical equivalent of, 268.  
 Laws of the electrical develop-  
 ment of, 267.  
 Mechanical equivalent of, 217.  
 Relation between mechanical  
 and electrical energy and,  
 270.  
 unit, British thermal, 268.  
 units, Calculation of electrical,  
 269.  
 Heating of conductors and their  
 safe carrying capacity, 265,  
 266.  
 effects of the current, 77.  
 Useful equivalents of electrical,  
 452.  
 Helix and solenoid, The, 162.  
 Henry, Definition of the, 311.  
 Horse power, Electrical, 217.  
 Mechanical, 211.  
 of a steam engine, 211.  
 Hydraulic analogy to illustrate  
 "volts lost," 228.  
 Hysteresis, 308, 361.

**I.**

- Impedance and reactance, 311.  
 Incandescent lamp,  
 Candle power of, 424.  
 circuits, 425.

- Incandescent lamp,  
 circuits, Potential distribution  
 in multiple, 426.  
 Commercial rating of, 424.  
 Construction of, 78, 422.  
 Life and efficiency of, 425.  
 filament, Manufacture of, 423.
- Incandescent lamps,  
 Measuring the resistance of,  
 while burning, 248.  
 Resistance of, 151.  
 wiring, 426, 428.  
 wiring calculations, 429.
- Inductance, 310.
- Induced currents (See Currents).  
 E. M. F. (See E. M. F.).
- Induction coil, Action of, 317.  
 Action of condenser with, 318.  
 or transformer, Principle of,  
 315.
- Induction coils, Construction of,  
 320.  
 Wehnelt electrolytic interrup-  
 ter for, 321.  
 Primary and secondary of, 297.
- Induction currents (See also Cur-  
 rents).  
 currents, Classification of, 299.  
 currents, Table of, 302.  
 Electromagnetic, 293.  
 Extra current of self-, 309.  
 Faraday's law of electromag-  
 netic, 303.  
 Magnetic, 194.  
 Mutual, 308.  
 Self, 308.  
 self-, Neutralizing the effects  
 of, 312.
- Inductive and non-inductive cir-  
 cuits, 312.
- Insulation, Breaking down of, 359.  
 of armature cores, 357.  
 test, 359.
- Insulator defined, 103.
- Insulators,  
 Table of conductors and, 105.  
 and conductors, 54, 104.
- Ions, 80.

**J.**

- Joint resistance, 141.
- Joule, Definition of, 213.
- Joule's law for the heating of con-  
 ductors, 268.  
 equivalent, 217.

**K.**

- Keepers, 38.
- Kilowatt, Definition of, 218.
- Kilowatt-hour, Definition of, 218.

**L.**

- Lamps (See Arc and Incandescent).
- Lenz's Law of induced currents,  
 297.
- Local action in a battery, 61.

**M.**

- Magnet, Artificial, 1.  
 Axis of, 20.  
 Breaking a, 24  
 Compound and laminated, 10.  
 Definition of, 2.  
 Equator of, 20.  
 Horseshoe, 10.  
 Lifting power of, 27, 198.  
 Making a permanent steel, 9.  
 Natural, 1.  
 Poles of, 2.  
 Strength of, 26.  
 To make an artificial, 6.  
 Two poles of, inseparable, 4.
- Magnets,  
 Classification of, 4.
- Magnetic  
 action and reaction equal and  
 opposite, 29.  
 attraction and repulsion, 2.  
 bodies free to move, 36, 203.  
 circuit, Compound, 188.  
 circuit of Manchester field  
 frame, 373.  
 circuits, 36, 187.  
 declination, 43.  
 dip needle, 12.  
 effect of a current, 78.  
 field, 16.  
 field at the centre of a circular  
 wire, 160.  
 field of a circular wire, 160.  
 field of an electromagnet, 186.  
 field of a solenoid, 165.  
 field of a straight current-car-  
 rying wire, 153.  
 field of the earth and its  
 equator, 42.  
 fields of parallel currents, 280.  
 fields, Making, 16.  
 force, 14.  
 force, Two kinds of, 3.  
 inclination or dip, 44.  
 induction, 29.  
 induction experiments, 28.  
 induction, Tractive force and,  
 198.  
 inductive effect of like and un-  
 like poles, 31.  
 leakage, 188.  
 lines of force, 14.  
 maps or charts, 44.

**Magnetic**  
 meridian, 43.  
 needle, Deflection of, by a current, 157.  
 needle, Horizontal, 11.  
 polarity, Reversed, 32.  
 saturation, 24.  
 screens, 32.  
 substances, 4.

**Magnetisable metals**, 4.

**Magnetisation by divided stroke**, 7.  
 by an electric current, 7.  
 by an electromagnet, 8.  
 curve, 197.  
 of iron and steel by an electric current, 184.

**Magnetising force—Ampere-turns**, 192.  
 force of a coil, To find, 193.

**Magnetism, Destruction of, by heat**, 26.  
 Earth's, 41.  
 earth's, Graphical representation of, 42.  
 Molecular theory of, 22.  
 molecular theory, Experimental proof of, 23.  
 Nature of, 22.  
 Neutralizing the earth's, 47.  
 Oscillation test for, 38.  
 Residual, 196.  
 Test for distribution of, 37.

**Magneto alternator**, 342.  
 dynamo, 375.

**Mass and weight**, 210.

**Megohm**, 106.

**Microhm**, 106.

**Microphone principle, The**, 327.  
 transmitter, Blake, 328.

**Milliammeter**, 200.

**Millivoltmeter**, 207.

**Motor**,  
 Advantage of counter E. M. F. of, 400.  
 and dynamo, Comparison between, 393.  
 and dynamo, Difference between, 399.  
 Automatic regulation of speed of, 401.  
 brushes, Position of, 397.  
 Counter E. M. F. of, 397.  
 Direction of rotation of series and shunt, 395.  
 Efficiency of, 410.  
 Mechanical work performed by a, 402.  
 Neutral point of, 397.  
 Normal speed of a, 401.  
 Operating a, 408.

**Motor**,  
 Output and rating of, 403.  
 Principle of the, 394.  
 regulation, Methods of, 405.  
 Shunt, 396.  
 Speed of, 402.  
 speed and torque, 404.  
 speed regulation, Methods of 405.  
 speed regulation, Series, 406.  
 Starting a shunt, 410.  
 starting box, 408.  
 starting box, Automatic, 409.  
 street car, Calculations for performance of, 411.  
 Student's experimental, 396.  
 test, 401.  
 To find counter E. M. F. of, 399.  
 To find mechanical power developed by, 399.  
 To find the current through armature of, 398.  
 torque, 402, 404.  
 Tractive force of, 411.  
 wiring calculations, 433.

**Motors**,  
 Classification of, 404.  
 for railway work, Series, 407.

**Multiple circuits (See Circuits)**.

**Multipliers**, 148.

**N.**

**Neutral point**, 362.  
 of a dynamo, To find, 365.

**Non-inductive winding**, 150.

**O.**

**Ohm, Definition of**, 106.

**Ohm's Law**, 119.  
 applied to a battery circuit, 122.

**Ohmmeter, Direct reading**, 262.

**P.**

**Parallax, Errors due to**, 206.

**Parallel connections, Advantage of**, 132.  
 connection of batteries, 128.

**Permeability**, 185.

**Pilot lamp**, 378.

**Polarity indicator**, 83.  
 of a circular current, 161.  
 of an iron ring, 188.  
 of a solenoid, Testing the, 164.  
 of a solenoid, Rules for determining, 164.  
 Reversed, 32.

- Polarization of a battery, 58.  
 Remedies for, 63.  
 test, 59.
- Pole, Negative, 54.  
 pieces, armatures and keepers, 38.  
 Positive, 54.
- Poles, Consequent, 32, 188, 373.  
 or electrodes and plates, 54.
- Potential difference and electromotive force, Measurement of, 236.  
 difference, Electromotive force and, 228, 241.  
 difference, Variation of, with variation of external resistance, 235.  
 in a circuit, Distribution of, 233, 241.
- Potentiometer, Comparison of the E. M. F. of cells by, 243.
- Power, 210.  
 calculations, Electrical, 215, 219.  
 Difference between energy, force, work and, 212.  
 Electrical, 214.  
 formulæ, Electrical, 222.  
 from cells, 223.  
 transmission, 428.  
 transmission, Efficiency of, 397.  
 Units of electrical, 217.  
 Unit of mechanical, 211.
- Pressure, current and resistance, Variation of, 235.  
 Measurement of electrical, 228.

## R.

- Radiograph, 324.
- Railway calculations, Street, 411.  
 motors, Connections for two, Plate I.  
 work, Series motors for, 407.
- Reactance, Impedance and, 311.
- Reluctance, 193.
- Rheostat, Automatic motor starting, 409.  
 Commercial, 148.  
 Dynamo field, 381.  
 Motor starting, 408.
- Rheostats, Laboratory, 150.
- Roentgen rays, 324.
- Roget's jumping spiral, 283.
- Resistance, Apparent, 311.  
 Calculation of, 109, 121.  
 Compensating, 148.  
 external, Variation of, with potential difference, 235.  
 Inductive, 311.

- Resistance,  
 Joint, 141.  
 Laws of, 107.  
 of a battery, Internal, 116.  
 of commercial apparatus, 150.  
 of solutions, Table of, 116.  
 of metals, Table of, 115.  
 of electrolytic conductors, 109.  
 of human body, 151.  
 of connections, 149.  
 of wire, To calculate, 114.  
 of metals, 109.  
 of an armature, 348.  
 of battery solutions, 109.  
 of arc and incandescent lamps while burning, Measuring, 248.  
 of carbon, 109.  
 of mil-foot of the metals, 110.  
 Property of, 103.  
 Temperature and, 109.  
 to temperature, Relation of, 271.  
 Unit of, 106.
- Resistance, Measurement of,  
 by student's Wheatstone bridge, lozenge pattern, 257.  
 by fall of potential, 247.  
 by the substitution method, 249.  
 by the drop method of comparison, 250.  
 by voltmeter method, 251.  
 by Weston instruments, 252.  
 by Wheatstone slide wire bridge, 252.

- Resistances,  
 in parallel, Equal, 141.  
 in parallel, Unequal, 142.  
 in parallel, Conductivity method for calculating, 143.  
 in multiple-series, 143.  
 in series, Calculation of, 140.  
 of commercial apparatus, 150.
- Residual Magnetism, 196.  
 volts, 378.
- Resistivity defined, 103.

## S

- Self-Induction, 308.  
 Neutralizing the effects of, 312.
- Series connection of batteries, 126.  
 connection of batteries, Advantage of, 133.
- Shunt, Weston ammeter, 206.  
 To find the multiplying power of, 146.  
 To find the value of, for a certain multiplying power, 147.



Shunted galvanometer, To find the current through, 147.

Shunts, 145.

Sines and tangents, Table of natural, 173.

Slide wire bridge, 254.

Solenoid, Attractive force of, for an iron core, 186.

Graphic field of a, 165.

Helix and, 162.

Spark coil, Gas lighting, 309. dimensions, 322.

(See also Induction Coil).

Sparking,

Causes of, 367.

distances in air, 321.

Square mil defined, 111.

area. Calculation of, 112.

Storage Battery (See Accumulator).

## T.

Tangent galvanometer (See Galvanometer).

of an angle, The, 172.

Tangents, Table of natural sines and, 173.

Telegraph apparatus, Resistance of 151.

key, 329.

relay, 330.

signal system and circuits, 330.

sounder, 329.

Telegraphy, Wireless, 331.

Telephone, apparatus, Resistance of, 151.

Bell, 326.

Temperature coefficients, 272.

Relation of resistance to, 271.

Thermometer scales, Relation between Fahrenheit and Centigrade, 270.

Three-Wire System, 431.

Torque of a motor, 402.

Traction, Electric, 411.

Transformer, Step-up, 316.

Principle of the induction coil or, 315.

Transformers, Resistance of, 151.

## U.

Units of area, Equivalent of, 447.

of energy and work, Equivalent of, 449.

of heat, Equivalent of, 452.

practical electrical, Definitions of, 445.

of volume, Equivalent of, 447.

of weight, Equivalent of, 448.

## V.

Vacuum tubes, 323.

Voltages, Measuring high, with a low range instrument, 240.

Voltaic cell (See Battery).

Voltmeter calculations, 95.

Copper, 95.

Definition of, 80.

gas, Construction of, 97.

gas, Directions for using, 97.

Measurements with a, 240.

Weight, 95.

Volta's Pile, 53.

Voltmeter, Measuring high voltages with a low range, 240.

method for measuring resistance, 251.

Weston, 238.

Voltmeters, Construction of, 238.

Connecting, 239.

Resistance of, 150.

Volts lost, Hydraulic analogy to illustrate, 228.

in an electric circuit, 230.

in wiring leads, 242.

on copper wire, Table of, 452.

## W.

Watt, Definition of, 214.

Watt-hour, Definition of, 218.

Wattmeter, Dynamometer, 286.

Thomson recording, 288.

Weston direct reading, 287.

Welding, Electric, 273.

Wheatstone bridge, Best selection of arms for, 260.

Commercial, 260.

Lamp chart analogy of, 253.

lozenge pattern, 257.

Operating, 259.

slide wire pattern, 252.

To measure high and low resistance with, 260.

Wire calculations, 114.

gauge, B. & S., for copper wire, 113.

gauges, 112.

gauges, Comparative table of, 450.

measure, The circular mil, 110.

weight of, To calculate, 115.

Wires, Calculation of circular mil area of, 111.

fused by 100 amperes, Gauges, of, 273.

Wiring, Arc lamp, 422.

calculations, Incandescent, 429.

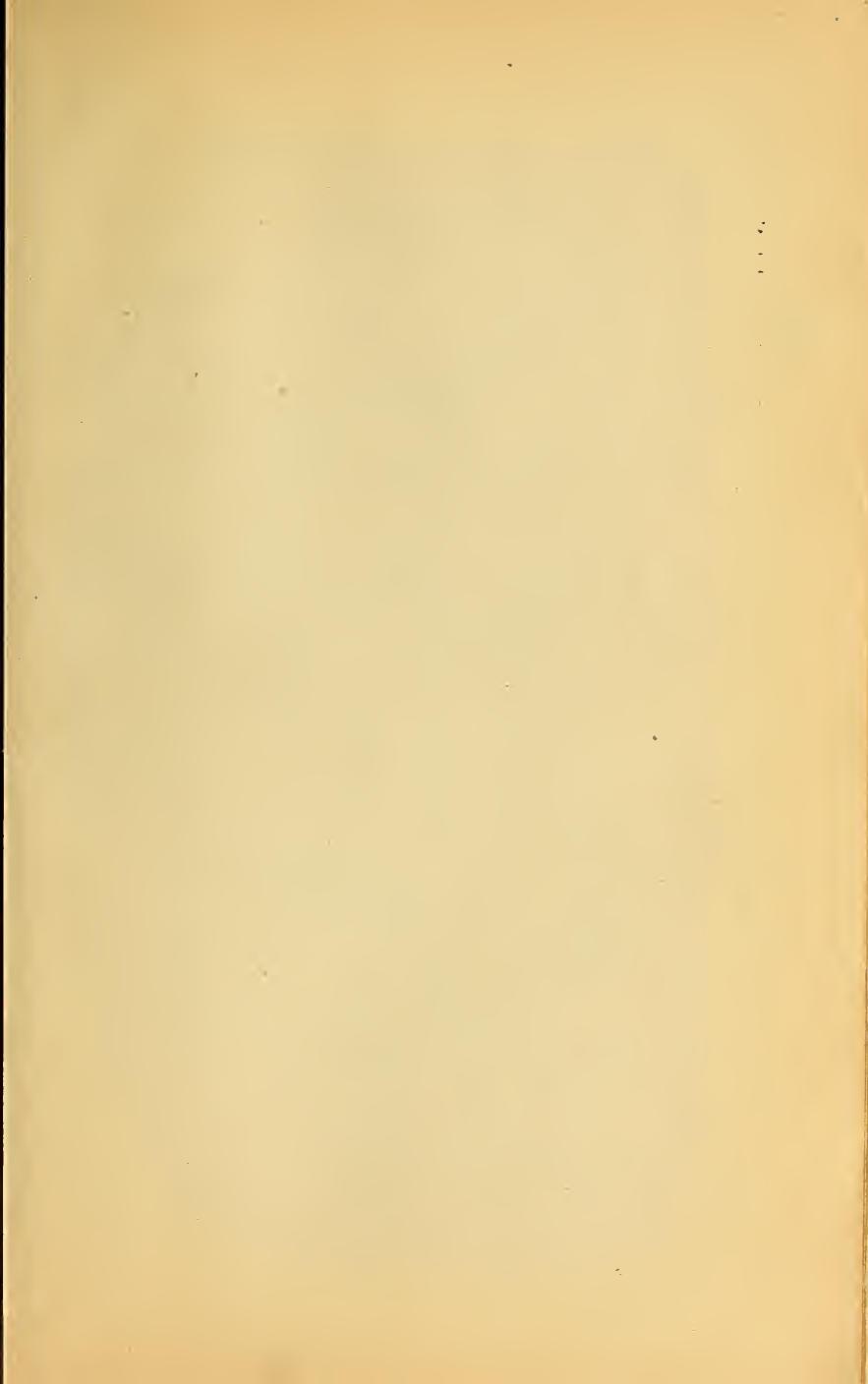
*See p. 270 for formula, conversion of Fahrenheit to Centigrade & converse.*

Wiring,  
  calculations, Motor, 433.  
  Incandescent lamp, 426.  
  leads, Volts lost in, 242.  
  Loss on transmission lines in,  
    428.  
  Three-wire system of, 431.  
  Two-wire multiple system of,  
    426.  
Wireless telegraphy, 331.  
Work, 210.

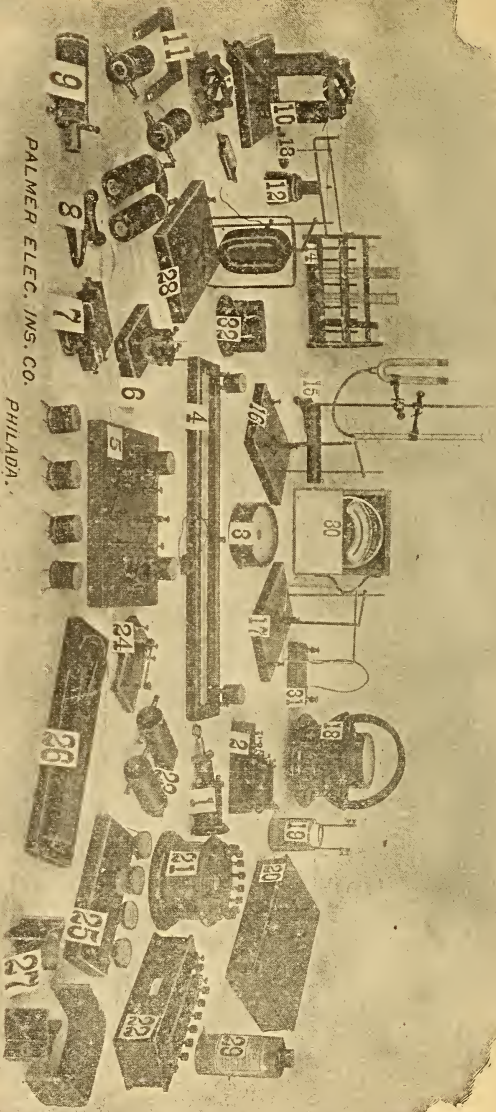
Work,  
  Calculation of electrical, 213.  
  Electrical, 212.  
  Equivalents of mechanical and  
    electrical, 216, 449.  
  Heat and, 215.  
  performed by a motor, 402.  
  Unit of, 210.

**X.**

X-Rays, 324.



PALMER ELEC. INS. CO.  
PHILADA.



STUDENT'S INDIVIDUAL SET OF LABORATORY INSTRUMENTS.

# Key to Plate of Student's Laboratory Instruments,

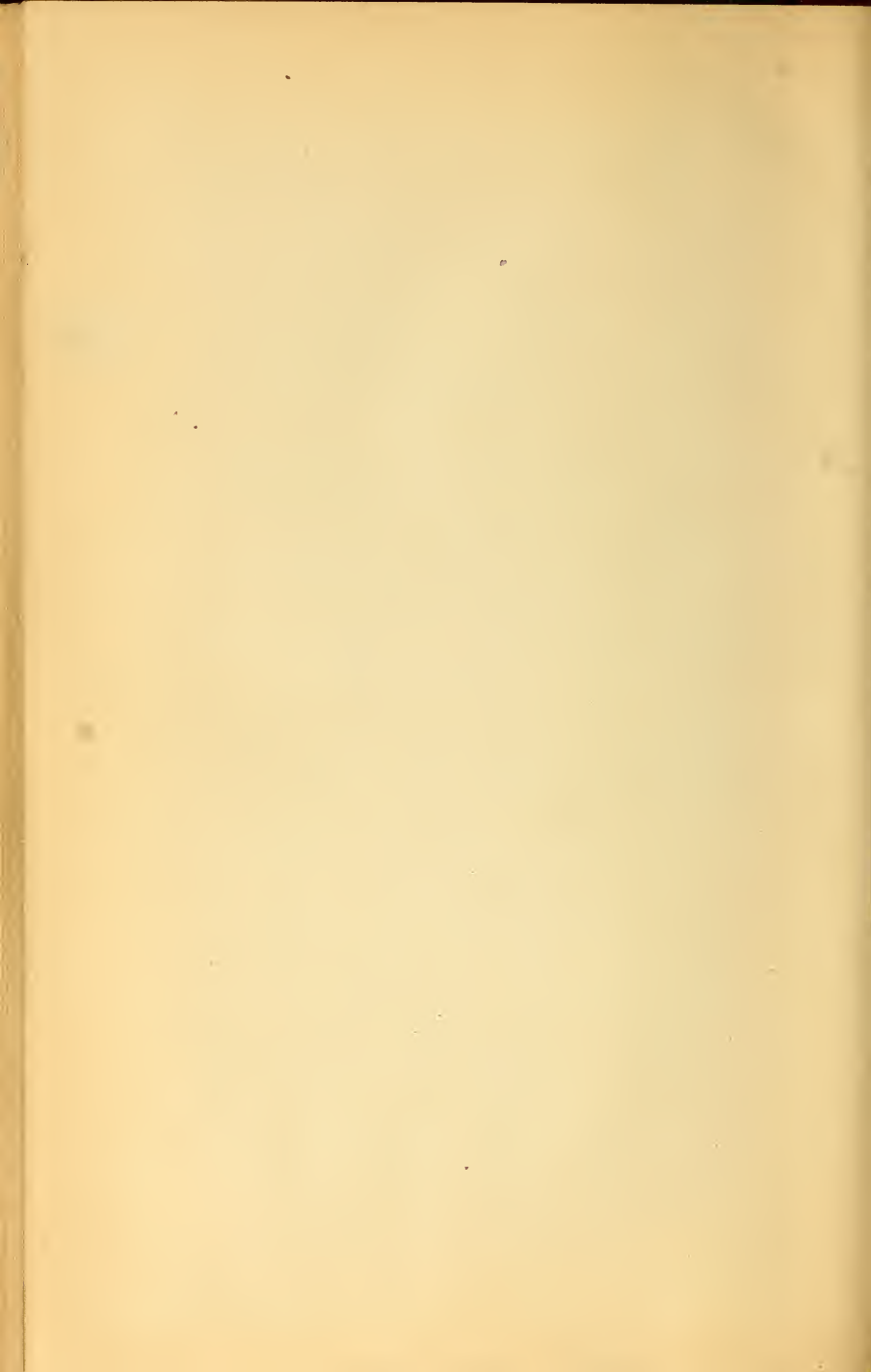
1. Induction coil  
(primary--secondary--iron core).
2. Induction coil (No. 1) mounted on base with automatic vibrator.
3. Detector galvanometer.
4. Slide wire bridge with resistance spools and slider.
5. Wheatstone lozenge bridge with spools.
6. Experimental cell (volta cell, voltmeter, accumulator, calorimeter, fuse block).
7. Reversing switch (Mercury commutator).
8. Horseshoe electromagnet with keeper and handle. (Solid iron core.)
9. Solenoid and core.
10. Experimental dynamo and motor.
11. Details of experimental dynamo and motor.
12. Oersted stand.
13. Poised magnetic needle.
14. Test tube rack and glass test tubes.
15. Gas voltmeter and electrolytic cell.
16. Poised solenoid (Ampere frame apparatus).
17. Poised rectangular coil (Ampere frame apparatus).
18. Combination tangent galvanometer (Includes No. 3).
19. Daniell cell (Porous cup type).
20. Graduated swinging arm rheostat.
21. Graduated rheostat (Plug type, round pattern).
22. Graduated rheostat (Plug type, rectangular pattern).
23. Horseshoe electromagnet (with detachable yoke of rectangular cross-section).
24. Double contact key.
25. Resistance spool set.
26. Bar magnet set (two  $6 \times \frac{1}{2} \times \frac{1}{4}$  bar magnets; one  $3 \frac{1}{2}$  horseshoe magnet).
27. Permanent horseshoe magnet with detachable pole pieces.
28. Poised and stationary rectangular coils—Dynamometer principle.
29. Dry cell.
30. Combination volt and ammeter—0-15, 0-150 volts; 0-15 amperes.
31. Shunt for No. 30 ammeter.
32. Small motor.

## PALMER ELECTRICAL INSTRUMENT COMPANY,

Arch and 13th Streets, Philadelphia, Pa.

MANUFACTURERS OF ELECTRICAL INSTRUMENTS FOR SCHOOLS AND COLLEGES.

Complete catalog furnished upon request.



LIST OF WORKS  
ON  
ELECTRICAL SCIENCE

PUBLISHED AND FOR SALE BY

D. VAN NOSTRAND COMPANY

23 Murray & 27 Warren Streets

NEW YORK

---

- ABBOTT, A. V.** The Electrical Transmission of Energy. A Manual for the Design of Electrical Circuits. Third edition, revised. Fully illustrated. 8vo, cloth, . . . . . \$4.50
- ANDERSON, GEO. L., A. M.** (Captain U. S. Artillery). Handbook for the use of Electricians in the Operation and Care of Electrical Machinery and Apparatus of the United States Seacoast Defenses. Prepared under the direction of the Lieutenant-General commanding the Army. With many figures and engravings. 8vo, cloth. Illustrated, . . . . . \$3.00
- ARNOLD, E.** Armature Windings of Direct-current Dynamos. Extension and Application of a General Winding Rule. Translated from the original German by Francis B. DeGress, M. E. With numerous illustrations. 8vo, cloth, . . \$2.00
- ATKINSON, PROF. A. A.** Electrical and Magnetic Calculations. Second edition, revised, . . . . . \$1.50
- ATKINSON, PHILIP.** The Elements of Dynamic Electricity and Magnetism. 12mo, cloth, . . . . . \$2.00
- Elements of Electric Lighting, including Electric Generation, Measurement, Storage, and Distribution. Tenth edition, fully revised and new matter added. Illustrated. 8vo, cloth, . . . . . \$1.50
- Power Transmitted by Electricity and applied by the Electric Motor, including Electric Railway Construction. Third edition, fully revised and new matter added. Illustrated. 12mo, cloth, . . . . . \$2.00
- BIGGS, C. H. W.** First Principles of Electricity and Magnetism. A book for beginners in practical work. With about 350 diagrams and figures. Illustrated. 12mo, cloth, . . . . . \$2.00
- BLAKESLEY, T. H.** Alternating Currents of Electricity. For the Use of Students and Engineers. Third edition, enlarged. 12mo, cloth, . . . . . \$1.50
- BONNEY, G. E.** The Electro-plater's Handbook. A Manual for Amateurs and Young Students on Electro-metallurgy. 60 illustrations. 12mo, cloth, \$1.20

- BOTTONE, S. R.** Electrical Instrument-making for Amateurs. A Practical Hand-book. Sixth edition. Enlarged by a chapter on "The Telephone." With 48 Illustrations. 12mo, cloth, . . . . . \$0.50
- Electric Bells, and all about them. A Practical Book for Practical Men. With over 100 Illustrations. 12mo, cloth, . . . . . \$0.50
- The Dynamo: How Made and How Used. A Book for Amateurs. Sixth edition. 100 Illustrations. 12mo, cloth, . . . . . \$0.90
- Electro-motors: How Made and How Used. A Hand-book for Amateurs and Practical Men. Illustrated. 12mo, cloth, . . . . . \$0.75
- BUBIER, E. T.** Questions and Answers about Electricity. A First Book for Beginners. 12mo, cloth, . . . . . \$0.50
- CARTER, E. T.** Motive Power and Gearing for Electrical Machinery; a treatise on the theory and practice of the mechanical equipment of power stations for electric supply and for electric traction. Illustrated. 8vo, cloth, . . . . \$5.00
- CROCKER, F. B., and S. S. WHEELER.** The Practical Management of Dynamos and Motors. Twelfth thousand. Illustrated. 12mo, cloth, . . . \$1.00
- CROCKER, F. B.** Electric Lighting. Vol. I, The Generating Plant. Fifth edition, revised. 8vo, cloth. Illustrated, . . . . . \$3.00
- Volume II. Distributing Systems and Lamps. Third edition. 8vo, cloth. Illustrated, . . . . . \$3.00
- DYNAMIC ELECTRICITY.** Its Modern Use and Measurement, chiefly in its application to Electric Lighting and Telegraphy, including: 1. Some Points in Electric Lighting, by Dr. John Hopkinson. 2. On the Treatment of Electricity for Commercial Purposes, by J. N. Schoolbred. 3. Electric Light Arithmetic, by R. E. Day, M. E. Fourth edition. 18mo, boards. (No. 71 Van Nostrand's Science Series), . . . . . \$0.50
- EWING, J. A.** Magnetic Induction in Iron and Other Metals. Third issue. Illustrated. 8vo, cloth, . . . . . \$1.00
- FLEMING, Prof. J. A.** The Alternate-current Transformer in Theory and Practice. Vol. I: The Induction of Electric Currents. 500 pp. Fifth edition. Illustrated. 8vo, cloth, . . . . . \$3.50
- Vol. II: The Utilization of Induced Currents. Third edition. 594 pp. Illustrated. 8vo, cloth, . . . . . \$5.00
- FOSTER, HORATIO A.** (with the collaboration of eminent specialists). Electrical Engineers' Pocket-book. 1000 pp. Illustrated with many cuts and diagrams. Third edition, revised. Pocket size, limp leather, with flap, . . \$5.00
- GORE, Dr. GEORGE.** The Art of Electrolytic Separation of Metals (Theoretical and Practical). Illustrated. 8vo, cloth, . . . . . \$3.50
- GUY, ARTHUR F.** Electric Light and Power, giving the Result of Practical Experience in Central-station Work. 8vo, cloth. Illustrated, . . . . . \$2.50
- HASKINS, C. H.** The Galvanometer and its Uses. A Manual for Electricians and Students. Fourth edition, revised. 12mo, morocco, . . . . . \$1.50
- Transformers; Their Theory, Construction, and Application Simplified. Illustrated. 12mo, cloth, . . . . . \$1.25
- HAWKINS, C. C. M. A., A. I. E. E., and WALLIS, F., A. I. E. E.** The Dynamo; its Theory, Design, and Manufacture. 190 Illustrations. 8vo, cloth, . . . . . \$3.00



- HAY, ALFRED.** Principles of Alternate-Current Working. 12mo, cloth. Illustrated, . . . . . \$2.00
- HOBBS, W. R. P.** The Arithmetic of Electrical Measurements. With numerous examples, fully worked. Ninth edition. 12mo, cloth. . . . . \$0.50
- HOSPITALIER, E.** Polyphased Alternating Currents. Illustrated. 8vo, cloth, . . . . . \$1.40
- INDUCTION COILS:** How Made and How Used. Tenth edition. 16mo, cloth. (No. 53 Van Nostrand's Science Series.), . . . . . \$0.50
- INCANDESCENT ELECTRIC LIGHTING:** A Practical Description of the Edison System, by H. Latimer. To which is added The Design and Operation of Incandescent Stations, by C. J. Field; a Description of the Edison Electrolyte Meter, by A. E. Kennelly; and a Paper on the Maximum Efficiency of Incandescent Lamps, by T. W. Howells. Fifth edition. Illustrated. 16mo, cloth. (No. 57 Van Nostrand's Science Series.), . . . . . \$0.50
- JEHL, FRANCIS.** Member A. I. E. E. The manufacture of Carbons for Electric Lighting and other purposes. A Practical Hand-book, giving a complete description of the art of making carbons, electros, etc. The various gas generators and furnaces used in carbonising, with a plan for a model factory. Illustrated with numerous diagrams, tables, and folding plates. 8vo, cloth. Illustrated, . . . . . \$1.00
- KAPP, GIBBERT. C. E.** Electric Transmission of Energy and its Transformation, Subdivision, and Distribution. A Practical Hand-book. Fourth edition, revised. 12mo, cloth. . . . . \$3.50
- Alternate-Current Machinery. 190 pages. Illustrated. (No. 96 Van Nostrand's Science Series.), . . . . . \$0.50
- Dynamos, Alternators, and Transformers. Illustrated. 8vo, cloth, . . . \$4.00
- KEMPE, H. R.** The Electrical Engineer's Pocket-book; Modern Rules, Formulæ, Tables, and Data. 32mo, leather, . . . . . \$1.75
- KENNELLY, A. E.** Theoretical Elements of Electro-dynamic Machinery. Vol. I. Illustrated. 8vo, cloth, . . . . . \$1.50
- KILGOUR, M. H.,** and **SWAN, H.,** and **BIGGS, C. H. W.** Electrical Distribution: Its Theory and Practice. Illustrated. 8vo, cloth, . . . . . \$4.00
- LEVY, C. L.** Electric Light Primer. A simple and comprehensive digest of all the most important facts connected with the running of the dynamo and electric lights, with precautions for safety. For the use of persons whose duty it is to look after the plant. 8vo, paper, . . . . . \$0.50
- LIVERMORE, VIRGIL B.** and **JAMES WILLIAMS.** How to Become a Competent Motorman; being a practical treatise on the proper method of operating a street railway motor-car; also giving details how to overcome certain defects. Endorsed by the leading railroad managers of the United States. 16mo, cloth. Illustrated, . . . . . \$1.00
- LOCKWOOD, T. D.** Electricity, Magnetism, and Electro-telegraphy. A Practical Guide and Hand-book of General Information for Electrical Students, Operators, and Inspectors. Revised edition. 8vo, cloth. Profusely Illustrated, . . . . . \$2.50

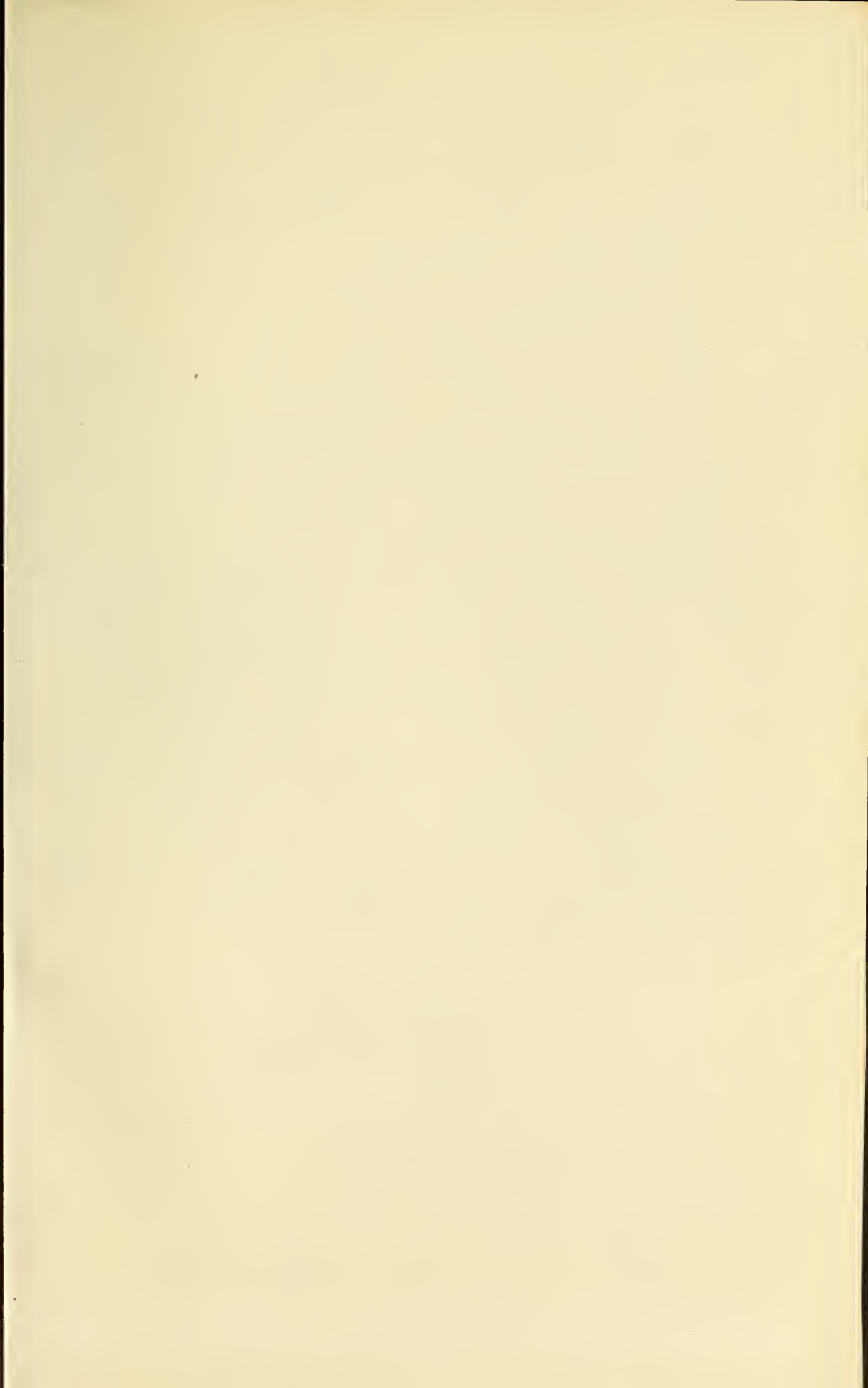
- LODGE, PROF. OLIVER J.** Signalling Across Space Without Wires: being a description of Hertz and his successors. Third edition. Illustrated. 8vo, cloth, . . . . . \$2.00
- LORING, A. E.** A Hand-book of the Electro-magnetic Telegraph. Fourth edition, revised. 16mo, cloth. (No. 39 Van Nostrand's Science Series,) . . . \$0.50
- MANSFIELD, A. N.** Electromagnets; Their Design and Construction. 16mo, cloth. (No. 64 Van Nostrand's Science Series,) . . . . . \$0.50
- MORROW, J. T., and REID, T.** Arithmetic of Magnetism and Electricity. 12mo, cloth, . . . . . \$1 00
- MUNRO, JOHN, C. E., and JAMIESON, ANDREW, C. E.** A Pocket-book of Electrical Rules and Tables, for the use of Electricians and Engineers. Fifteenth edition, revised. With numerous diagrams. Pocket size, leather, . \$2.50
- NIPHER, FRANCIS E., A. M.** Theory of Magnetic Measurements, with an Appendix on the Method of Least Squares. 12mo, cloth, . . . . . \$1.00
- OHM, Dr. G. S.** The Galvanic Circuit Investigated Mathematically. Berlin, 1827. Translated by William Francis. With Preface and Notes by the Editor, Thos. D. Lockwood. 16mo, cloth. (No. 102 Van Nostrand's Science Series,) . \$0.50
- ODIN, MAURICE A.** Standard Polyphase Apparatus and Systems, containing numerous photo-reproductions, diagrams, and tables. Third edition, revised. 8vo, cloth, illustrated, . . . . . \$3.00
- PALAZ, A., Sc. D.** A Treatise on Industrial Photometry, with special application to Electric Lighting. Authorized translation from the French by George W. Patterson, Jr. Second edition, revised. 8vo, cloth. Illustrated, . . . \$4.00
- PARSHALL, H. F., and HOBART, H. M.** Armature Windings of Electric Machines. With 140 full-page plates, 65 tables, and 165 pages of descriptive letter-press. 4to, cloth, . . . . . \$7.50
- PERRINE, F. A. C., A. M., D. Sc.** Conductors for Electrical Distribution; their Materials and Manufacture, the Calculation of Circuits, Pole Line Construction, Underground Working, and other uses. 8vo, cloth. Illustrated. Net, . . . . . \$3.50
- PLANTÉ, GASTON.** The Storage of Electrical Energy, and Researches in the Effects created by Currents combining Quantity with High Tension. Translated from the French by Paul B. Elwell. 89 Illustrations. 8vo, cloth, . . . . \$4.00
- POPE, F. L.** Modern Practice of the Electric Telegraph. A Hand-book for Electricians and Operators. An entirely new work, revised and enlarged, and brought up to date throughout. Illustrated. 8vo, cloth, . . . . . \$1.50
- POOLE, J.** The Practical Telephone Hand-book. Illustrated. 8vo, cloth, . \$1.50
- PRITCHARD, O. G.** The Manufacture of Electric Light Carbons. Illustrated. 8vo, paper, . . . . . \$0.60
- PREECE, W. H., and STUBBS, A. J.** Manual of Telephony. Illustrated. 12mo, cloth, . . . . . \$4.50
- RAM, GILBERT S.** The Incandescent Lamp and its Manufacture. 8vo, cloth, . . . . . \$3.00
- RANDALL, J. E.** A Practical Treatise on the Incandescent Lamp. Illustrated. 16mo, cloth, . . . . . \$0.50

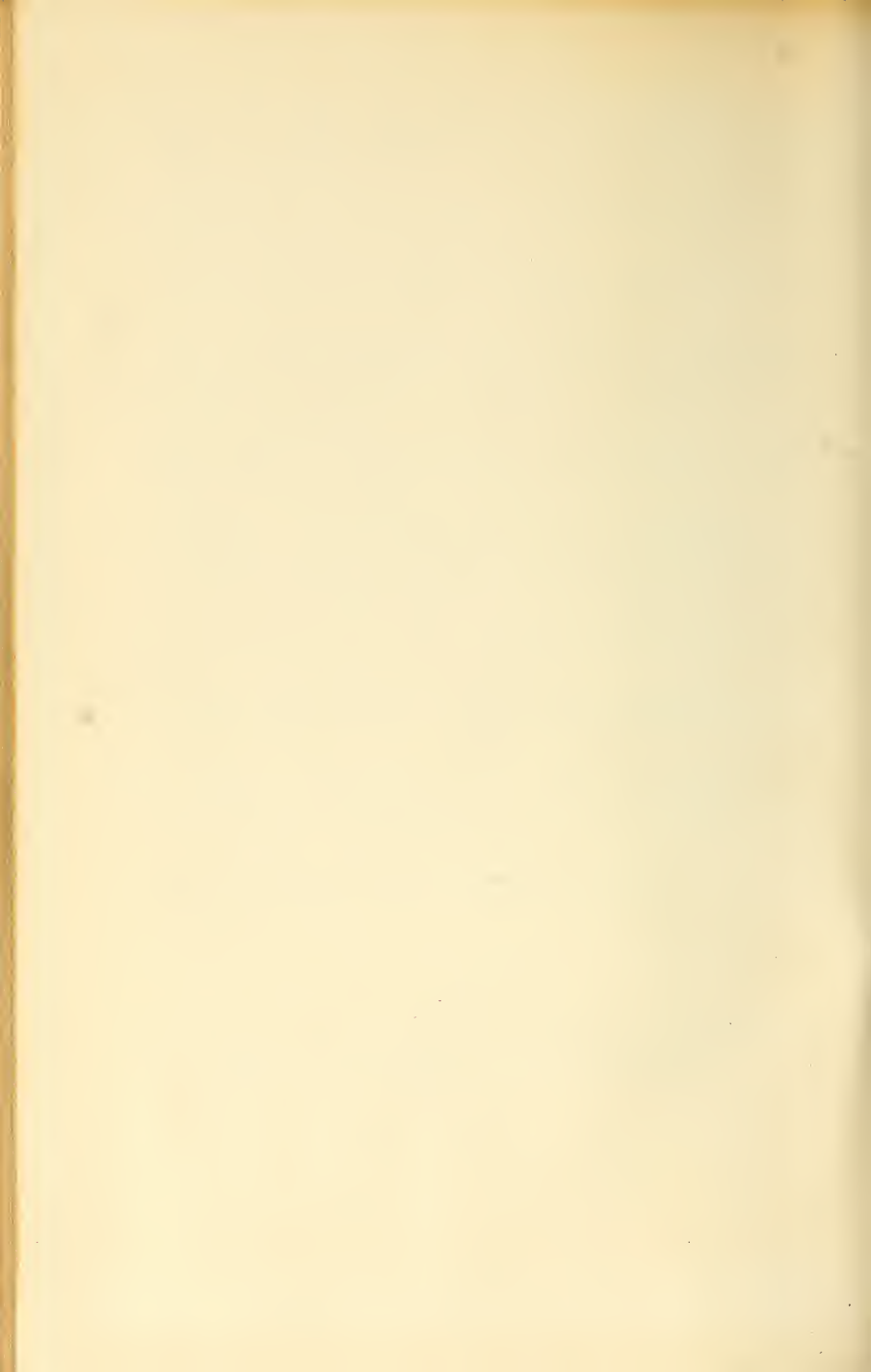
- RUSSELL, STUART A.** Electric-light Cables and the Distribution of Electricity. Second edition, revised. Illustrated. 8vo, cloth, . . . . . \$3.00
- SALOMONS, Sir DAVID, M. A.** Electric-light Installations. Vol. I. Management of Accumulators. A Practical Hand-book. Eighth edition, revised and enlarged. 12mo, cloth. Illustrated, . . . . . \$1.50
- SALOMONS, SIR DAVID, M. A.** Vol. II: Apparatus, . . . . . \$2.25  
 ——— Vol. III: Application, . . . . . \$1.50
- SCHELLEN, DR. H.** Magneto-electric and Dynamo-electric Machines: Their Construction and Practical Application to Electric Lighting and the Transmission of Power. Translated from the third German edition by N. S. Keith and Percy Neymann, Ph. D. With very large Additions and Notes relating to American Machines, by N. S. Keith. Vol. I, with 353 illustrations. Third edition, . . . . . \$5.00
- SHELDON, PROF. S., Ph. D., and HOBART, MASON, B. S.** Dynamo-electric Machinery; Its Construction, Design, and Operation. Direct Current Machines. Third edition. 8vo, cloth. Illustrated, . . . . . net, \$2.50  
 ——— Alternating Current Machines; being the second volume of the authors' "Dynamo-electric Machinery; Its Construction, Design, and Operation. With many diagrams and figures. (Binding uniform with Vol. I.) Second edition. Illustrated. 8vo, cloth, . . . . . net, \$2.50
- SLOANE, PROF. T. O'CONNOR.** Standard Electrical Dictionary. 300 illustrations. 8vo, cloth, . . . . . \$3.00
- SNELL, ALBION T.** Electric Motive Power: The Transmission and Distribution of Electric Power by Continuous and Alternate Currents. With a Section on the Applications of Electricity to Mining Work. Second edition. 8vo, cloth. Illustrated, . . . . . \$4.00
- SWOOPE, C. W.** Lessons in Practical Electricity: Principles, Experiments, and Arithmetical Problems. Fourth edition. 8vo, cloth. Illustrated, . . net, \$2.00
- THOM, C., and JONES, W. H.** Telegraphic Connections, embracing recent methods in Quadruplex Telegraphy. 8vo, cloth. Twenty colored plates, \$1.50
- THOMPSON, EDWARD P.** How to Make Inventions; or, Inventing as a Science and an Art. An Inventor's Guide. Illustrated. 8vo, paper, . . . \$1.00
- THOMPSON, PROF. S. P.** Dynamo-electric Machinery. With an Introduction and Notes by Frank L. Pope and H. R. Butler. Fourth edition. Fully illustrated. (No. 66 Van Nostrand's Science Series), . . . . . \$0.50  
 ——— Recent Progress in Dynamo-electric Machines. Being a Supplement to "Dynamo-electric Machinery." Illustrated. 16mo, cloth. (No. 75 Van Nostrand's Science Series), . . . . . \$0.50
- TREVERT, E.** Practical Directions for Armature and Field-magnet Winding. 12mo, cloth. Illustrated, . . . . . \$1.50
- URQUHART, J. W.** Dynamo Construction. A Practical Handbook for the Use of Engineer Constructors and Electricians in Charge. Illustrated. 12mo, cloth, . . . . . \$3.00

- WATT, ALEXANDER.** The Electro-plating and Electro-refining of Metals; being a new edition of Alexander Watt's "Electro-deposition," revised and largely re-written by Arnold Philip, B. Sc. With many figures and diagrams. 8vo, cloth. Illustrated, . . . . . net, \$4.50
- Electro-Metallurgy Practically Treated. Eleventh edition, considerably enlarged. 12mo, cloth, . . . . . \$1.00
- WALKER, FREDERICK.** Practical Dynamo-building for Amateurs. How to Wind for any Output. Illustrated. 16mo, cloth. (No. 98 Van Nostrand's Science Series.), . . . . . \$0.50
- WALKER, SYDNEY F.** Electricity in our Homes and Workshops. A Practical Treatise on Auxiliary Electrical Apparatus. Illustrated. 12mc, cloth, . \$2.00
- WEBB, H. L.** A Practical Guide to the Testing of Insulated Wires and Cables. Illustrated. 12mo, cloth, . . . . . \$1.00
- WEEKES, R. W.** The Design of Alternate Current Transformers. Illustrated. 12mo, cloth, . . . . . \$1.00
- WEYMOUTH, F. MARTEN.** Drum Armatures and Commutators. (Theory and Practice.) A complete treatise on the theory and construction of drum-winding, and of commutators for closed-coil armatures, together with a full résumé of some of the principal points involved in their design; and an exposition of armature reactions and sparking. 8vo, cloth. Illustrated, . . . . \$3.00
- WILKINSON, H. D.** Submarine Cable-Laying, Repairing, and Testing. 8vo, cloth, . . . . . \$5.00
- WORDINGHAM, HENRY C.** Central Electrical Stations; their Design, Organization, and Management. With 136 diagrams and folding plates. 8vo, cloth. Illustrated, . . . . . net \$7.50
- WORMELL, R.** Electricity 'n the Service of Man. A Popular and Practical Treatise on the Application of Electricity in Modern Life. From the German, and edited. with copious additions, by R. Wormell, and an Introduction by Prof. J. Perry. With nearly 850 Illustrations. 8vo, cloth, . . . . . \$3.00
- YOUNG, J. ELTON.** Electrical Testing for Telegraph Engineers. With Appendices consisting of Tables. 8vo, cloth. Illustrated, . . . . . \$4.00

---

**\*\* A General Catalogue—96 pages—of Works in all branches of Electrical Science furnished gratis on application,**





LOWER A.C. BUS  
UPPER D.C. BUS

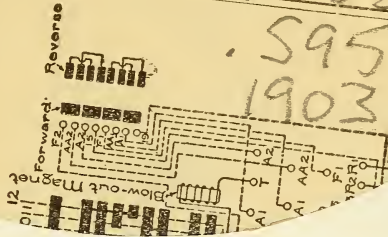
CIRCUIT BREAKER

GEN. EL. SECONDARY

ENG. BOILER

QC523

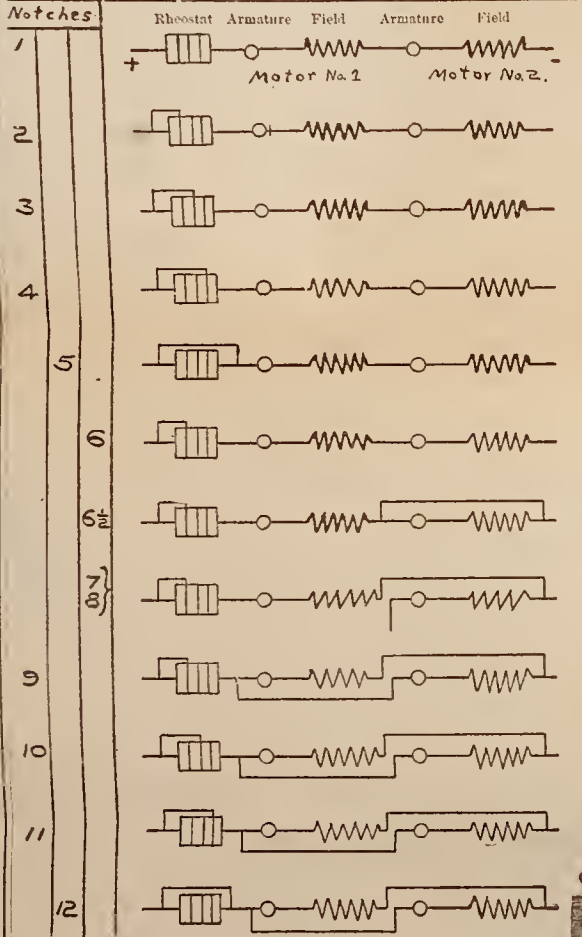
.595  
1903



Resistance  
Running  
Transition

**G. E. - K10 - STREET CAR CONTROLLER**  
DIAGRAM OF CONNECTIONS.

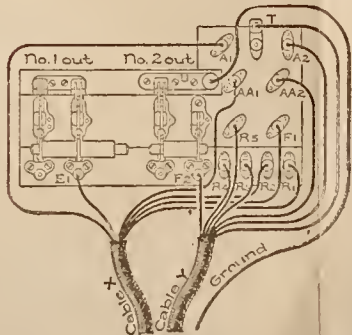
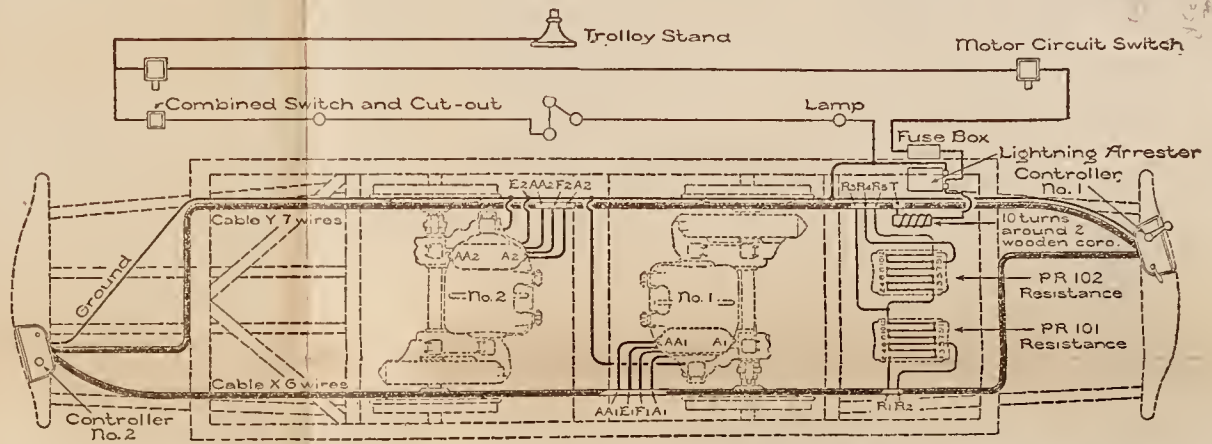
Controller Notches—1, 2, 3, and 4 used for starting.  
" " 5, " " slow speed.  
" " 12, " " high speed.



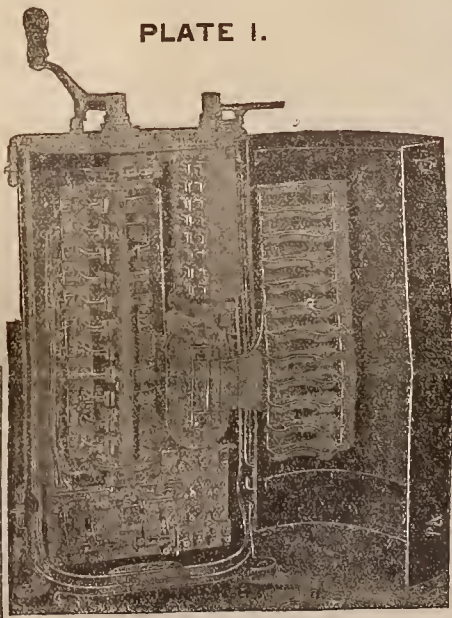
**KEY TO CONTROLLER COMBINATIONS.**

- Notch 1.—Two Motors in series with all resistance in circuit.
- " 2.—Two Motors in series, 1/4 resistance cut out.
- " 3.—Two Motors in series, 1/2 resistance cut out.
- " 4.—Two Motors in series, 3/4 resistance cut out.
- " 5.—Two Motors in series, all resistance cut out.
- " 6.—Two Motors in series, 1/4 resistance cut out.
- " 6½.—Two Motors in series, 1/4 resistance cut out; one motor shunted.
- " 7.—One Motor in circuit, 1/4 resistance cut out; other motor cut out.
- " 8.—One Motor in circuit, 1/2 resistance cut out; other motor cut out.
- " 9.—Two Motors in parallel and in series with 1/4 resistance cut out.
- " 10.—Two Motors in parallel and in series with 1/2 resistance cut out.
- " 11.—Two Motors in parallel and in series with 3/4 resistance cut out.
- " 12.—Two Motors in parallel with all resistance cut out.

**CAR WIRING FOR K10 CONTROLLERS WITH TWO MOTORS**

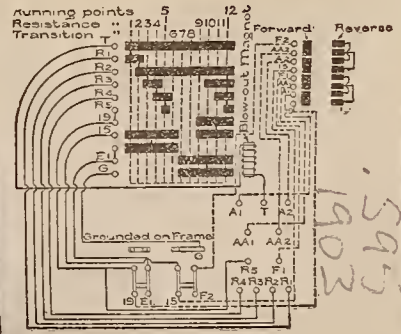


**PLATE I.**



**CONTROLLER WITH FRONT OPEN.**

Left-hand barrel switch makes the 12 combinations. Upper right-hand switch reverses the current through both motor armatures, changing their direction of rotation. Below this an electro-magnet, with hinged pole-piece (shown open) carrying asbestos wiper; when mag-closed they prevent arcing between the switch fingers, and the mag-closed field blows out the arc as the switch is revolved. In bottom of controller, cable connections, as given in left-hand diagram.

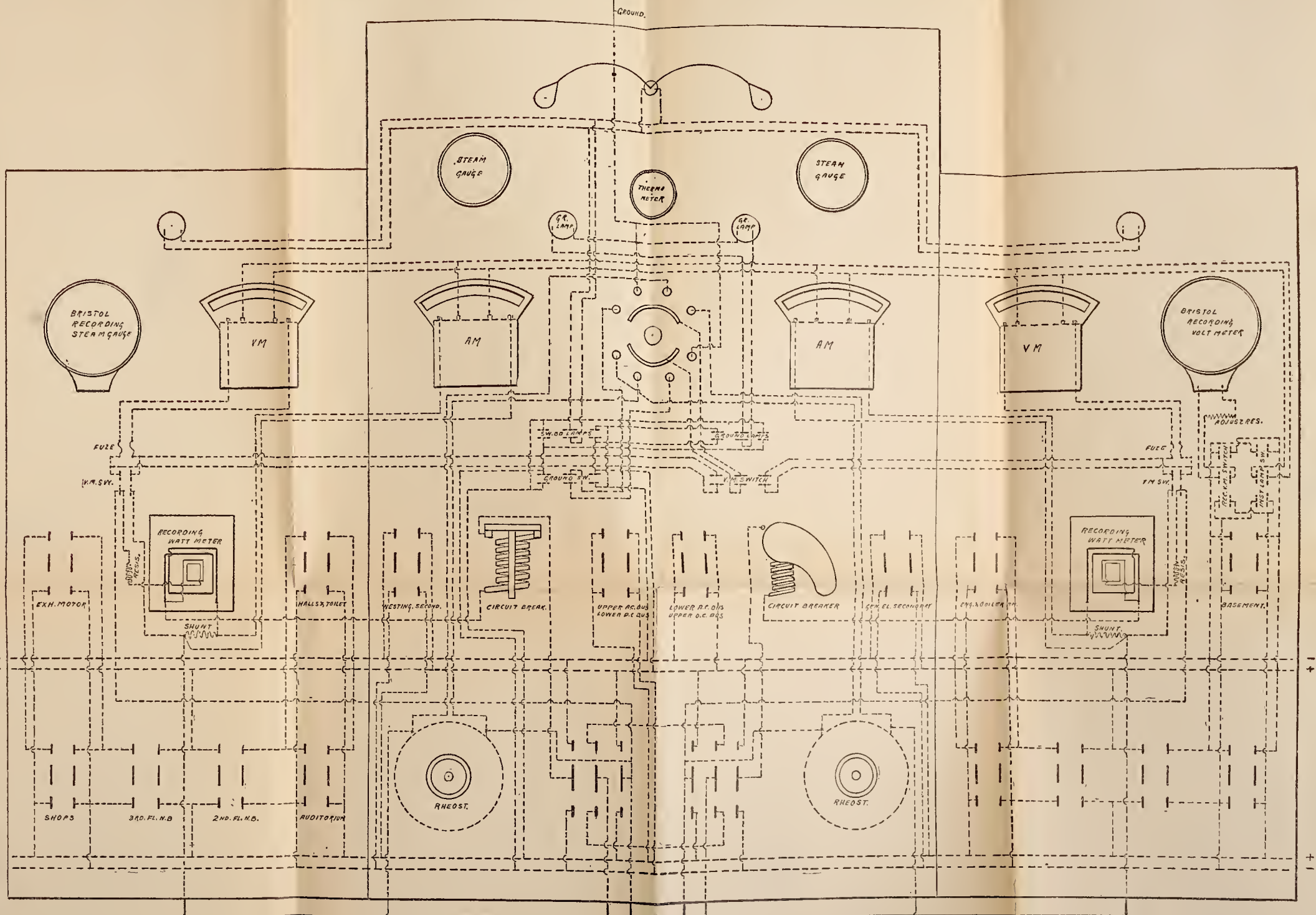


**KEY TO WIRING DIAGRAM.**

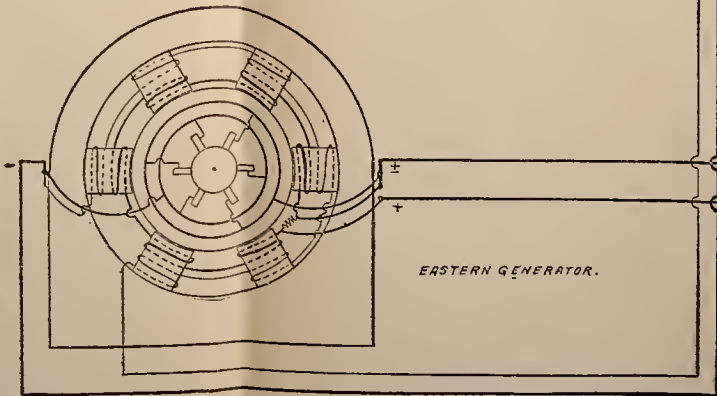
- A<sub>1</sub>—Positive armature terminal of Motor No. 1.
- AA<sub>1</sub>—Negative armature terminal of Motor No. 1.
- E<sub>1</sub>—Positive field terminal of Motor No. 1.
- F<sub>1</sub>—Negative field terminal of Motor No. 1.
- A<sub>2</sub>—Positive armature terminal of Motor No. 2.
- AA<sub>2</sub>—Negative armature terminal of Motor No. 2.
- E<sub>2</sub>—Positive field terminal of Motor No. 2.
- F<sub>2</sub>—Negative field terminal of Motor No. 2.
- T—Connection from TROLLEY LINE.
- G—Connection to Ground on Motor Frame.
- R<sub>1</sub>—Positive terminal from extra resistance (PR 101).
- R<sub>2</sub>—Tap from extra resistance (PR 101).
- R<sub>3</sub>—Negative terminal from extra resistance (PR 101), or positive terminal extra resistance (PR 102).
- R<sub>4</sub>—Tap from extra resistance (PR 102).
- R<sub>5</sub>—Negative terminal from extra resistance (PR 102).

Handwritten notes and signatures on the right margin, including '1903' and '593'.





40-K. W. Engine Type, Compound Wound, Direct Current Westinghouse Generator.



QC523  
505  
1903

FROM WESTERN GENERATOR.

**PLATE II.**  
**DIAGRAM OF CONNECTIONS**  
of the  
**DIRECT-CURRENT SWITCHBOARD**

Spring Garden Institute  
LIGHTING AND POWER PLANT.

Two Generators { Capacity, 40 K. W. each (Total Capacity, 1450-16 C. P. Lamps).  
{ Volts, 115—Amperes, 350—Speed, 275—Poles, 6.

—DATA—  
GENERATORS ARE  
Direct Driven.  
Direct Current.  
Compound Wound.  
Multipolar.  
Slow Speed.  
Westinghouse Manufacture.

- NOTE 1. The western generator has been omitted from sketch; the connections are the same as for the eastern generator.  
2. The switch marked "Upper A. C. Bus Lower D. C. Bus" will connect the upper bus-bars of the Alternating Current Switchboard with the lower bus-bars of the Direct Current Switchboard. The switch to the right of it performs the same function for the other pair of bus-bars on both boards.  
3. Switches marked "Gen. El. Secondary" and "Westing. Second." are the secondary terminals of the General Electric and Westinghouse 15 K. W. transformers. With the direct-current generator switches out and the dynamos shut down, the circuits from the A. C. and D. C. Boards can be supplied from one or both transformers.  
4. The cable marked ± is the equalizing bar, # 355, and connects through the middle pole of the generator switches, the positive terminals of both generators (back of the series). It is in circuit only when the dynamos are parallel on one pair of bus-bars, and serves to equalize the load between them.  
5. By the intercommunicating switching system, any part of the plant can be operated on the alternating current transformers, and any other part on the direct-current generators, or the whole plant from either the A. C. or D. C. system.

LIBRARY OF CONGRESS



0 003 715 358 8

