MP512



AIR RIFLE INSTRUCTION MANUAL

European American Armory Corp.
3855 North U.S. Highway One
Cocoa, Florida 32927
(321) 639-4842
www.eaacorp.com
E-mail: eaacorp@bv.net

© Copyright EAA Corp. 3/00

EAA MODEL: MP512 AIR RIFLE INSTRUCTION MANUAL

WARNING AND INSTRUCTION MANUAL PLEASE READ THESE INSTRUCTIONS

Record the serial number of your Air Rifle:

CAUTION: Air Rifles are not toys. This Air Rifle is recommended for only adult use. Misuse or careless use may cause serious injury or death. Dangerous within 500 yards.

Do NOT Cock or handle your Air Rifle BEFORE you read and understand the instructions and warnings contained in this manual.

10 LIFE SAVING WARNINGS:

1. Thinking the air rifle is unloaded does not mean it is unloaded. If a pellet is in the chamber and the rifle has been cocked, this rifle can be fired. Always treat your air rifle as if it is loaded.
2. Always point the muzzle of any air rifle in a safe direction whether the rifle is loaded or unloaded.
3. No hands over the muzzle / No Way / No Time / No How.
4. Only use lead pellets manufactured to industry standards. If the pellet doesn't feed into the chamber, don't force it - there is a reason - determine the reason before continuing.
5. Never alter your air rifle or allow anyone not connected with or authorized to represent the manufacturer to modify, change, or adjust any of the working parts of your air rifle.
6. Learn to regularly clean and inspect your air rifle.
7. Wear eye protection whenever you shoot your rifle or when around others using air rifles. You only get one set of eyes .
8. This air rifle is extremely powerful and is not designed for the beginner. This class of air rifle is intended for use by experienced adult shooters.
9. Your air rifle can not think. You must be alert and thoughtful at all times to insure your safety and the safety of the people and property near you... No Drugs...No Drinking... No Horse Play... Never shoot a pellet at water or a hard surface...

SAFETY WARNING:

Your rifle is equipped with an automatic safety that automatically engages when the air rifle is fully cocked. When fully cocked, the upward spring pressure stops and the safety moves to the forward position covering red dot on the trigger. If the safety is disengaged (moved rearward so as to expose red dot on the trigger), you can re-engage this safety by again cocking (folding down) the barrel. To assure the safety is engaged, when the barrel is fully down, give the safety a slight push and watch the automatic safety button pop into the safety position. Do not disengage this safety until you are ready to fire the air rifle. Once this safety has been disengaged the trigger will function. Do not snap the air rifle shut. The barrel of this air rifle is also a cocking lever and should never be excessively slammed close.

HEALTH WARNING

This air rifle fires lead pellets. Lead and lead compounds are known to the State of California to cause cancer, birth defects and reproductive toxicity. Discharging, handling or cleaning an air rifle may result in lead exposure. Have adequate ventilation at all times. Do not put lead pellets in your mouth. Wash hands thoroughly after exposure.

GENERAL INFORMATION

This is a spring-piston air rifle. It is powered by a powerful spring in the receiver which acts as a piston compressing air in a chamber located behind the breech. The air is not compressed until the air rifle is fired. Cocking the air rifle compresses the spring piston and should only be done prior to firing. Avoid leaving the spring-piston under full compression for extended periods.

SPECIFICATIONS: MP512

CALIBER177 INCHES
BARREL LENGTH 17.70 INCHES
OVERALL LENGTH ... 41.34 INCHES
WEIGHT 6.17 POUNDS

SPECIFICATIONS: MP512M

CALIBER22 INCHES
BARREL LENGTH 17.70 INCHES
OVERALL LENGTH .. 41.34 INCHES
WEIGHT 6.17 POUNDS

OPENING AND COCKING YOUR AIR RIFLE

Grasp the rifle by the pistol grip or middle forearm with your dominate hand. Keep your fingers off the trigger and away from the breech. With the barrel pointing upwards, push the front of the barrel down so as to break open the action(Fig. 1). Now push the barrel completely down so as to complete the cocking action (you should hear a click sound at the end of the cocking action)(Fig.2). Keep your fingers away from the trigger and breach at all times when cocking the air rifle. Do not

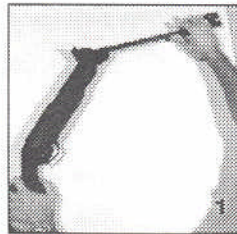

pull past the click sound and never use excessive force when cocking the air rifle. If you have not completely cocked the rifle, the barrel can swing back

sharply if you let go of the barrel while cocking. The barrel could hurt you if let go while cocking, by hitting you or if your fingers were in the breech, pinching your fingers. Make certain that the rifle is cocked before letting go of the barrel. Your rifle is equipped with an automatic safety. The safety will only engage when you cock the rifle (Fig3). Warning: opening the breech does not mean the safety will re-engage when the breech is closed. If the safety has been disengaged, you must re-cock the air rifle until you see the safety moved to the forward position and covering the red dot on the trigger. If you see any portion of the red dot on the trigger, the safety has been disengaged.

LOADING YOUR AIR RIFLE

With the barrel down in the cocked position and the safety engaged, you may now load the rifle. Keep one hand on the barrel to restrain the barrel and place a pellet into the chamber (Fig4). Make sure the pellet skirt is flush with the breech face. If the pellet is not fully seated, it will be deformed when the rifle is closed and will not be accurate when shot. (Use pellet seater to seat pellet into pellet chamber for best accuracy)

CLOSING YOUR AIR RIFLE

To close the rifle, swing the barrel up until it snaps closed (Fig5). Do not force the barrel into the closed position or swing it violently. Never slam the barrel shut. Once the barrel is closed, the rifle is ready to fire.

DO NOT UNCOCKING YOUR AIR RIFLE

If the air rifle is cocked you must fire the rifle to uncock the rifle. Make sure the rifle is pointed in a safe direction when firing.

Never try and fire the rifle with the breach open.

FIRING YOUR AIR RIFLE

With the gun loaded as instructed above and the safety engaged. Point your Air gun at the target you wish to hit. Please read and understand all safety warning before you fire this or any air gun.

Disengage safety (Fig. 6) and fire the loaded air gun at the target you wish to hit. Please read and understand all warnings and this instruction before you load and fire your air gun.

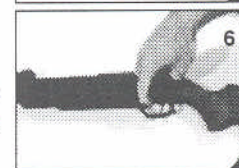
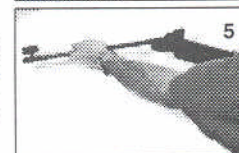
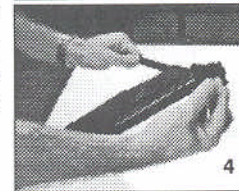
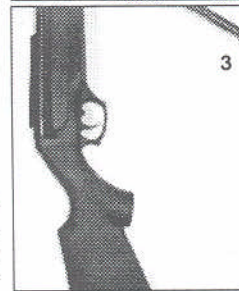

EXTERNAL CONTROL PARTS

1. Safety button is in front of the trigger and is engaged when you cock the air rifle. To remove the safety simply push it to the rear until it has fully covered the red dot on the trigger. To re-engage the safety you must go through the cocking procedure again even if you did not fire the rifle. To re-engage the safety if you have disengaged the safety and not fired the rifle, you must re-cock the air rifle. Make sure the safety covers the red dot on the trigger after you have completed cocking the rifle. (Never touch the safety button while cocking the rifle, the safety is designed to function automatically when the rifle is being cocked. The safety does not replace safe rifle handling)

2. Trigger located in center of the trigger guard.

3. The stock of your air rifle is one piece and is made from plastic. A loose stock may cause poor accuracy. Do not over tighten the stock screw. Make sure that the stock is tight to the receiver of the air rifle.

4. The barrel of your air rifle is made of ordnance steel and has grooved rifling. Never put the barrel in a position where it could be bent or damaged. When cocking the rifle, make sure that you do not force the barrel down or over cock the rifle in such a way that you may bend the barrel. A bent barrel will lead to accuracy problems or could even lead to a pellet being stuck in the barrel. After shooting, always clean the barrel with a light oil.

5. The sights on your air rifle are designed for accuracy. The front sight is an all metal tunnel foresight. The rear sight is all metal with click micrometer adjustment for windage and elevation and aperture. To change the front sight inserts, loosen the retaining sleeve by turning the knurled ring at the rear of the sight hood counter-clockwise.

Caution: Never shoot a spring-piston air rifle without a lead pellet! Firing the air rifle without a pellet allows the piston/cylinder to slam against the front of the air compression chamber. The resistance of the pellet creates a cushion of air for the piston. Never fire damaged or used pellets.

Caution: Use only factory new lead air rifle pellets. Use only the correct size pellets. Do not use steel shot or darts which may damage the rifled bore and which cause greater re-bound and ricochet.

WARNINGS -- READING THESE SAFETY RULES WILL SAVE YOUR LIFE OR THE LIFE OF SOMEONE ELSE

**NOTE: IT IS A VIOLATION OF FEDERAL LAW
TO SHIP A LOADED WEAPON.**

- Learn how to handle, load, unload, operate, fire and care for your air rifle.
- NEVER PLAY with your air rifle. It is a potentially dangerous weapon that can cause serious personal injury or death.

- Always keep the air rifle pointed in a safe direction. NEVER point any weapon (loaded or unloaded) at any person or anything you do not intend to shoot. Always keep your air rifle unloaded until ready to fire and make sure that it is unloaded before cleaning.
- Keep your finger OFF the trigger until you are actually aiming at the target and ready to shoot.
- Never rely on a air rifle's "safety" to protect you from unsafe handling. A safety is only a mechanical device, not a substitute for common sense and good safety procedures.
- Never leave a air rifle unattended or where it could fall and fire.
- If an air rifle is hit sharply or dropped, damage to the internal precision mechanism may result and consequently an accidental firing.
- Store air rifles and pellets separately beyond the reach of children. Make sure the air rifle and lead pellets are properly locked and secured so children and un- trained individuals will be denied access.
- Test your air rifle's operation and safeties ONLY at a shooting location while the rifle barrel is pointed in a safe direction.
- Know your target and what is beyond. Ask yourself what your pellet will hit if it misses the target or passes through the intended target. Remember, a fired pellet can travel over 400 yards (including a ricochet).
- Never pull an air rifle toward you by the muzzle. Don't climb a tree, cross a ditch or fence with a loaded air rifle.
- Do NOT leave your air rifle cocked for long periods of time or store it cocked.
- Always empty air rifles before entering a house, car, truck, boat, RV, camp or any building.
- When receiving a air rifle, always open the action and make sure it is unloaded. NEVER accept anyone's word that an air rifle is "unloaded" or "empty". You should also inspect it by passing a cleaning rod through the bore to make sure it is clear.
- Avoid exposure to lead by firing where there is adequate ventilation. After cleaning your air rifle and/or handling lead pellets, wash your hands.
- Keep air rifles unloaded when not actually in use. Load the air rifle only when preparing to fire.
- Never fire a pellet to clear a barrel.
- ALWAYS WEAR protective shooting glasses when firing air rifles.
- Never drop your air rifle. If you do drop it, unload it and check it for proper function before using it again.
- Don't alter or modify your air rifle.
- Do not remove any internal safety or safety device on the air rifle. Safety

mechanisms are designed to protect you from injury or death.

- Do maintain and keep your air rifle clean. Keep in a dry place away from other metals and water. If your air rifle shows sign of corrosion or improper operation, have it serviced by a competent gunsmith.
- Keep the muzzle pointed in a safe direction when loading and unloading your air rifle. Never point the muzzle at any person or any animal.
- Never shoot at hard flat surfaces or water....bullets ricochet.
- Never let water, snow, mud or other material enter the barrel. Keep the barrel free of any obstruction.
- Use only the correct size lead pellets for your air rifle. Do NOT use steel shot or darts.
- Teach children NOT to touch an air rifle or pellets.
- Remember an air rifle has the capability of taking your life or the life of someone else. Be careful with your air rifle -- an accident is almost always the result of not following basic safety rules.
- WRITE US concerning any items or circumstances which you don't understand and which might relate to your safety and the operation of your air rifle.

CARE AND CLEANING

Caution: Make sure the air rifle is unloaded before cleaning (Follow uncocking instructions to insure air rifle is not cocked and loaded)

Caution: In lubricating the air compression chamber, use only a special lubricant with a high flash point designed specifically for use inside of an air compression chamber

(A) To lubricate the air compression chamber and air compression seal, follow cocking instructions and cock the air rifle. Put a few drops of special light oil into the vent hole that leads into the compression chamber. Now cock and uncock the rifle in several different angles so the oil spreads around the piston chamber. Do not over oil (no more than 3 or 4 drops on each lubrication). The air rifle chamber should be oiled every 500 pellets.

(B) In order to lubricate the mainspring, you must first remove the stock. Turn the action over and apply 6 to 10 drops of a light oil directly onto the spring. Reattach the stock and cock and uncock in different positions so as to spread the oil around the spring. The main spring should be oiled every 3,000 to 5,000 pellets or every six months.

(C) The cocking lever linkage and barrel pivot points should be very lightly oiled every six months.

Caution: It is better to under lubricate than to over lubricate. Over lubrication will void your warranty. Do not use firearm cleaners or low flash point oils in the air compression chamber and near the vent and breech seal as this will cause dieseling and damage the seal.

Caution: Only a competent gun smith should disassemble the rifle for further cleaning or maintenance.

LIMITED REPAIR WARRANTY

European American Armory Corp. air rifles are warranted to the original retail customer for 90 days from the date of purchase against factory defects in metal parts. All metal parts and labor to repair them or replacement at our option are covered. Mainsprings, seals and stock are warranted to the original retail customer for a period of 30 days from the verified purchase date against defects. Parts and labor to repair mainsprings, seals and stock will be provided for 30 days from the verified purchase date. Evidence of proof of purchase is necessary for all warranty repair service. Transportation to and from our repair facilities, damage caused by failure to perform normal maintenance, sales outside the United States, damage due to non factory lead pellets, steel shot or darts, or any unauthorized repair, modification, misuse, abuse, or alteration of the product is not covered by this Limited Repair Warranty.

Any implied warranties, including the implied warranties of merchantability and fitness for a particular purpose, are limited to 90 days from date of original retail purchase. Consequential or incidental damages and/or expenses, or any other expenses are not covered by this warranty.

To obtain warranty performance send your air gun freight pre paid with proof of retail purchase and \$10.00 for return freight to:

European American Armory Corp.
3855 North U.S. Highway One
Cocoa, Florida 32927

WARNING

Altering or modifying parts and/or safeties is dangerous and will void the warranty. This air rifle was manufactured to perform properly with the original parts as designed. It is your duty to make sure any parts you buy are made for this air rifle and are installed correctly and that neither the replacements nor originals are altered or changed. Your air rifle is a complex precision tool with many parts that must relate correctly to other parts in order for proper and safe operation. Putting an air rifle together wrong or with incorrect or modified parts can result in a damaged air rifle, serious injury or death to you and others through malfunction. Always have a qualified gunsmith work on your air rifle or at least check any work not performed by a gunsmith.

ALL PARTS ORDERS ARE SUBJECT TO A \$10.00 CHARGE FOR SHIPPING AND HANDLING. For parts and service contact: European American Armory Corp., 3855 North U.S. Highway One, Cocoa, Florida 32927 Phone: (321) 639-4842 ext 0, e-mail: www.eaacorp.com , web site: www.eaacorp.com

STATEMENT OF NON-LIABILITY

Air Rifles are not classified as firearms by the U.S. Gun Control Act of 1968. Air Rifles are not generally considered to be weapons; however, they can cause serious injury, death and property damage. Thus, they should be handled with great care. Safety is your responsibility. Neither the manufacturer, nor European American Armory Corporation, assume any responsibility for personal injury, death or property damage resulting from either intentional or accidental discharge or for the function of any air rifle subjected to influences beyond our control.

KEEP THIS BOOKLET AND PROOF OF PURCHASE IN A SECURE LOCATION , RECORD THE SERIAL NUMBER OF YOUR AIR RIFLE IN THIS BOOKLET.

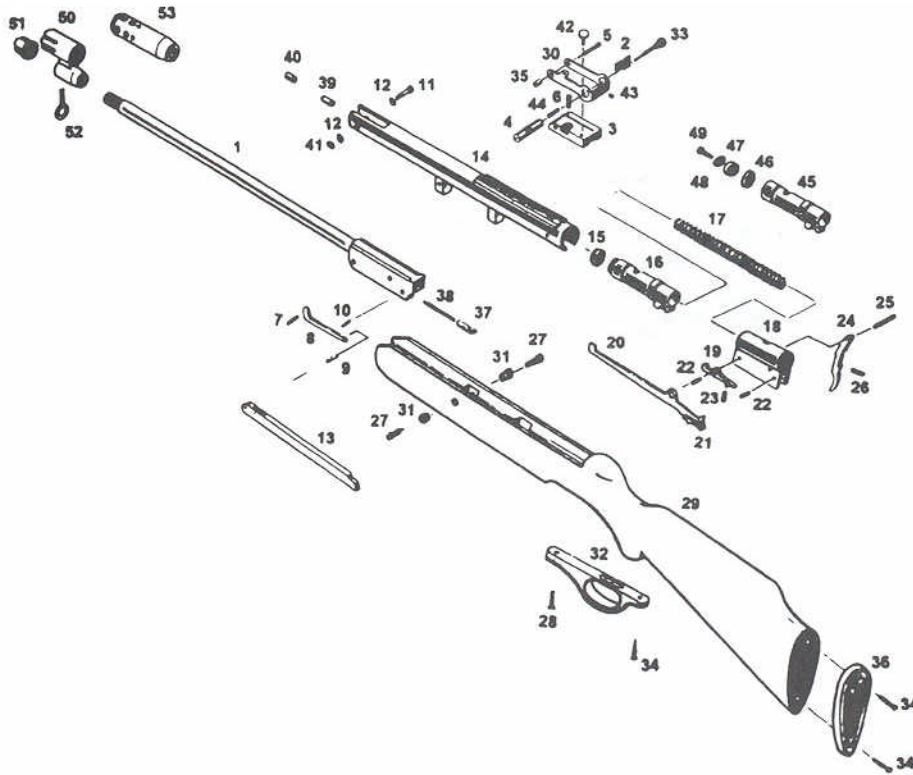

MP512 Part List

- | | | |
|------------------------------|-----------------------------------|---------------------------------|
| 1. Barrel | 19. Sear | 37. Self-releasing latch |
| 2. Sight Leaf | 20. Locking lever | 38. Self-releasing latch spring |
| 3. Rear-sight base | 21. Safety slide | 39. Wedge |
| 4. Rear notch plate | 22. Sear and locking lever pin | 40. Barrel rubber gasket |
| 5. Pin | 23. Sear and locking lever spring | 41. Nut |
| 6. Rear-sight spring | 24. Trigger | 42. Adjusting screw |
| 7. Hinge pin | 25. Trigger housing pin | 43. Screw |
| 8. Hinge | 26. Trigger spring | 44. Rear notch spring |
| 9. Cocking lever pin | 27. Stock screw, rear | 45. Stock |
| 10. Self-releasing latch pin | 28. Stock screw, rear | 46. Piston |
| 11. Barrel pin | 29. Stock | 47. Collar |
| 12. Washer | 30. Frame | 48. Piston gasket |
| 13. Cocking lever assy. | 31. Eyelet | 49. Piston screw |
| 14. Receiver | 32. Trigger guard | 50. Front-sight base |
| 15. Collar | 33. Screw | 51. Front-sight base nut |
| 16. Piston | 34. Wood screw | 52. Front-sight |
| 17. Mainspring | 35. Nut | 53. Muzzle attachment |
| 18. Trigger housing | 36. Butt pad | |

 **WARNING**

Children are attracted to and can operate firearms that can cause severe injuries or death.

Prevent child access by always keeping guns locked away and unloaded when not in use. If you keep a loaded firearm where a child obtains and improperly uses it, you may be fined or sent to prison.

 **ADVERTENCIA**

A los niños les atraen las armas de fuego y los pueden hacer funcionar. Ellos pueden causarse lesiones graves y la muerte.

Evite que los niños tengan acceso a las armas de fuego guardándolas siempre con llave y descargadas cuando no las esté utilizando. Si usted tiene un arma de fuego cargada en un lugar en que un niño tiene acceso a ella y la usa indebidamente, le pueden dar una multa o enviarlo a la cárcel.