

**Editor:**

Rosette K. Kabuleta  
(GTZ – PREEEP)

**Text, Technical Diagrams and Photography by:**

Leonard Mugerwa  
Job Mutyaba  
Ritah Mubbala

**Cover page design by:**

Haruna Lubwama

**Advisory:**

Philippe Simonis (GTZ - PREEEP)  
John Kuteesakwe (GTZ - PREEEP)  
Godfrey Ndawula (MEMD)

**Published by:**

Ministry of Energy and Mineral Development (MEMD)  
Promotion of Renewable Energy and Energy Efficiency Programme (PREEEP)

Supported by the German Technical Cooperation (GTZ)

**Date:**

First Edition: November 2004

Second Edition: November 2008

© 2008 MEMD – PREEEP

## Table of Contents

ACKNOWLEDGEMENT .....	IV
INTRODUCTION .....	V
THE TECHNICAL MODIFICATIONS IN THE ROCKET STOVE DESIGN .....	VI
BASIC FACTS ABOUT THE INSTITUTIONAL ROCKET STOVES .....	VIII
1.0 ECONOMIC ASPECTS (PAYBACK) .....	X
THE FIXED INSTITUTIONAL ROCKET STOVE.....	1
2.0 THINGS TO CONSIDER BEFORE BUILDING THE INSTITUTIONAL ROCKET STOVE .....	2
2.1 STOVE CONSTRUCTION MATERIALS .....	3
2.2 BRICKWORK .....	4
2.3 METALWORK.....	4
2.2 MATERIAL PURCHASE .....	4
3.0 STOVE PLANNING .....	5
3.1 MAPPING OUT THE STOVE POSITION.....	5
3.2 DETERMINING THE STOVE BASE DIMENSIONS .....	5
3.3 OBTAINING THE LENGTH OF THE COMBUSTION CHAMBER (L) .....	8
4.1 PREPARING THE MORTAR; .....	9
5.0 BUILDING THE STOVE .....	10
6.0 FINISHING THE STOVE .....	15
THE MOBILE INSTITUTIONAL ROCKET STOVE.....	16
1.0 THINGS TO CONSIDER BEFORE BUILDING THE MOBILE INSTITUTIONAL ROCKET STOVE .	16
1.1 SHELTER.....	16
1.2 TOOLS.....	16
1.3 SAFETY GEAR.....	17
2.0 STOVE PLANNING .....	17
2.1 BONDING AND INSULATING .....	17
2.2 MOBILE ROCKET INSTITUTIONAL STOVE FABRICATION.....	17
2.3 PURCHASE AND DELIVERY .....	18
2.4 STOVE ASSEMBLY .....	18
2.5 STOVE SIZING.....	19
3.0 MAIN PARTS OF THE MOBILE STOVES .....	20
3.1 THE SAUCEPAN SKIRT .....	20

3.2 COMBUSTION CHAMBER BLOCK (WITH AN AIR BYPASS).....	20
3.3 BASE PLATE.....	21
3.4 THE STOVE/SAUCEPAN STAND ASSEMBLY.....	21
3.5 TOP RING .....	22
3.6 STOVE TECHNICAL DRAWING .....	23
4.0 FABRICATING THE STOVE .....	25
4.1 THE OUTER SKIRTING .....	25
4.2 THE INNER CYLINDER .....	27
4.3 THE COMBUSTION CHAMBER BLOCK .....	27
4.4 BASE PLATE .....	27
4.5 STOVE ASSEMBLY .....	28
4.6 STOVE INSULATION .....	30
APPENDIX: RELATIONSHIP BETWEEN SAUCEPAN / POT DIAMETER AND COMBUSTION CHAMBER .....	34

## **Acknowledgement**

This publication is attributed to the work done by several players.

- The initial work on the firewood saving rocket stoves in Uganda was done through the then Energy Advisory Project (EAP) in the Ministry of Energy and Mineral Development (MEMD), supported by the German Technical Cooperation (GTZ).
- The rocket – elbow combustion chamber was invented by Dr. Larry Winiarsky at Aprovecho Research Centre, Oregon, USA. Peter Scott of Aprovecho cooperated with GTZ – EAP to introduce it in Uganda in 2003.
- The prototype rocket stoves were developed and tested at the premises of the Uganda Industrial Research Institute in 2003 – 2005 and at the Faculty of Technology Makerere University Kampala in 2007. The support from Dr. Izael Pereira da Silva of the Centre for Research in Energy and Energy Conservation (CREEC) is acknowledged.
- This revised edition of the household stove manual has been published with the support of the GTZ - Promotion of Renewable Energy and Energy Efficiency Programme (PREEEP), for use as a training tool for stove artisans.

## Introduction

Uganda faces a biomass energy crisis marked by an increasing imbalance between the supply and the demand for the firewood by households, institutions and industries. One of the most effective strategies to sustainably contribute towards the reduction of this problem is through an extensive dissemination of biomass energy efficient technologies.

The biomass energy efficient technologies have been developed to improve energy efficiency for household, institutional and industrial practices. They include the domestic and institutional firewood stoves and the firewood baking oven. The institutional rocket stoves have overall efficiencies of over 40% (average) compared to the traditional (open) 3-stone fire stove at 15.6 %, in a laboratory high power water-boiling test<sup>1</sup>.

These improved stoves help the users to have firewood savings of 50 – 60 % when compared to the traditional (open) 3-stone stove<sup>2</sup>. This implies that the amount of firewood used by a family in one day with a traditional 3-stone fire can be used for 2 – 3 days with the rocket stove. Yet another advantage of using the institutional rocket stove is the fact that investment on stove construction can be recovered in a relatively short time through money save as a result of firewood savings.

The main objective of developing the improved firewood stoves is to achieve relatively efficient firewood combustion and maximising heat transfer to the food being cooked.

The purpose of this manual is to provide to stove artisans a practical tool to use in construction of institutional rocket stoves.

---

<sup>1</sup> MEMD – EAP stove rest report: Ref:

<http://www.crest.org/discussiongroups/resources/stoves/Scott/Uganda%20report.htm>

<sup>2</sup> MEMD – EAP: Institutional rocket stove end-users impact survey, April 2007

## The Technical Modifications in the Rocket Stove Design

Following the impressive performance of the prototype rocket stoves in comparison with the traditional 3-stone fire stove, the Ministry of Energy and Mineral Development (MEMD) through the then Energy Advisory Project (EAP), supported the private producers to disseminate several hundreds of the institutional rocket stoves. A monitoring and evaluation exercise that was conducted revealed that the institutions that adopted these stoves were able to:

- Increase efficiency in firewood use and to reduce environmental degradation through the adoption and optimum utilisation of the institutional rocket stoves.
- Improve the working conditions of the kitchen staff that are exposed to the hazardous smoke and intense heat emission from the traditional 3-stone stoves.
- Prepare and serve meals in time.

However it was also noted that several institutional rocket stoves did not have firewood shelves because they had been worn out by fire. The other challenge was that the most of the institutional stove owners buy and use wet firewood because the dry firewood is rare on the market.

In a GTZ regional workshop on household energy<sup>3</sup> held at Mulanje Malawi in March 2007, some of these technical aspects were highlighted. It was agreed that there was need to have a design review in order to enhance stove performance, durability and user satisfaction.

EAP introduced several modifications in the institutional rocket stove design in order to improve the stove's efficiency and durability and to enhance user satisfaction. The major modifications include:

- Introducing a bypass air inlet in the design as a replacement for the firewood shelf which is easily destroyed by the fire,
- Incorporating a charcoal grate in the combustion chamber to trap the large hot coals to enhance their combustion prior to becoming ash,
- Fitting the saucepan design with a flange at the top to seal off the exhaust gases emission in the kitchen and to minimise the indoor air pollution by directing the smoke through the chimney. The flange also enhances the saucepan support at the stove ring thereby reducing the wear of the saucepan supports below.
- Coating the stove top with a waterproof surface e.g. terrazzo to protect it from the effects of food spillage
- Removal of the butterfly valve from the chimney because it is no longer necessary.

It was concluded that for optimum performance, the institutional rocket stoves should henceforth be disseminated with the features described above. It is recommended that such stoves are constructed by qualified technicians who have considerable experience in the technical specialities of masonry / building construction, metal fabrication and industrial ceramics.

This revised institutional rocket stove manual (November 2008 edition) describes the step-by-step construction procedure of the modified institutional rocket stoves with the bypass air inlet.

---

<sup>3</sup> GTZ Report : GTZ Workshop on Household Energy, Mulanje, Malawi, 8 – 13<sup>th</sup> March 2007

## **Disclaimer**

Whereas relative to the traditional 3-stone (open) fire place the firewood institutional rocket stoves are believed to offer significant benefits to the user(s) including firewood savings, reduced time for cooking and reduced indoor air pollution and whereas this stove construction manual is believed to be a useful tool for instruction in the procedure for the construction of firewood institutional rocket stoves, neither the Uganda Ministry of Energy and Mineral Development nor the German Technical Cooperation assumes responsibility for the completeness or usefulness of the information herein. Additionally neither the Uganda Ministry of Energy and Mineral Development nor the German Technical Cooperation assumes liability in respect of any claim(s) that may arise in the event of any injuries and / or damages that may occur during the design, construction, use, maintenance or misuse of any stoves that may be constructed on the basis of the design or procedure described herein.

## **BASIC FACTS ABOUT THE INSTITUTIONAL ROCKET STOVES**

The institutional rocket stoves are able to achieve maximum transfer of heat to the food because they heat at least 90% of the saucepan surface area and have insulation around the combustion chamber and fire passages.

The institutional rocket stoves are made in two versions:

1. the fixed rocket stoves
2. the mobile rocket stoves

Fixed rocket stoves are built in permanent shelters using bricks and mortar for the body work. They are more expensive but also more durable. When they are handled well, these stoves can last more than 10 years with only minor repairs required. They are made for a wider range of saucepan capacities than the mobile versions.

The mobile version of the rocket stoves are easy to fabricate. They are made primarily of steel. These stoves are lighter and are meant to be used where there is no permanent shelter. They are recommended for use with saucepans up to 150 litres. They are also cheaper to fabricate.

The choice of stove to be built is therefore determined by a combination of factors including:

1. capacity of saucepan desired/ number of people to be served
2. shelter needs
3. financial limitations
4. lifetime expectancy

### **Advantages of using the Institutional Rocket Stoves**

**1. Saves money:** These stoves have been tested and proven to be economical in firewood consumption. For example, an institution that spends UGX 600,000 on firewood per term using a traditional stove will only use firewood of less than 200,000 Shillings per term if they properly use a rocket stove. By using less firewood these stoves reduce firewood expenses.



**2. Cooks Faster:** When compared to a 3-stone open fire, the institutional rocket stoves cook a given quantity of food in half the time. Where kitchen staff has been spending 4 hours to cook beans, it will only take 2 hours while using the institutional rocket stoves.

**3. Less smoke:** The rocket stoves hardly produce smoke. A bit of smoke is produced only when lighting the fire. (*Note: The stove will also produce some smoke if wet firewood is used*). *Kitchen staffs enjoy a smoke-free kitchen. No more tears!*

**4. Easy to Use:** A user does not have to blow air into the stove to fan the flame. Once lit, the stove fire will burn continuously unless one stops putting firewood into the stove.

**5. Safe to Use:** These stoves are safe to use because the fire is shielded. The kitchen staffs are therefore protected from fires and burns.

**6. Environmentally Friendly:** These stoves use less firewood leading to reduction of the deforestation rate.

## 1.0 ECONOMIC ASPECTS (PAYBACK)

The table below is a comparison of the costs involved between the traditional and institutional rocket stoves<sup>4</sup>.

Parameter	Institutional rocket stove	Traditional stove
Investment (2 pot stove)	4,600,000 /=	1,200,000 /=
Firewood consumption per year	9 trucks a year	27 trucks a year
Average cost per unit truck	400,000 /=	400,000 /=
Annual running costs	3,600,000 /=	10,800,000 /=
Minimum expected life time	5 years	----

- **Extra investment costs for improved type**

$$4,600,000 - 1,200,000 = 3,400,000$$

- **Annual savings for improved type**

$$10,800,000 - 3,600,000 = 7,200,000$$

- **Simple payback period**

= Investments / annual savings

$$\frac{3,400,000}{7,200,000} = 0.5 \text{ years}$$

= 6 months

This means that in less than a year the money invested is recovered.

**In 5 years, over UGX 50,000,000 (fifty million) can be saved from this 2-pot stoves.**

---

<sup>4</sup> Data from a school that switched from traditional stoves to institutional rocket stoves

## PART 1

### The Fixed Institutional Rocket Stove



**Photo 1: A fixed Institutional Rocket Stove in use**

## 2.0 Things to Consider Before Building the Institutional Rocket Stove

### 1. Shelter

Ensure that a shelter is in place to house and protect the stove from intrusion and unfavourable weather conditions e.g. rain.

### 2. Tools

The institutional rocket stove has two components: -

- i. The brickwork
- ii. The metal work

The common building construction tools are required for the brickwork while metal fabrication tools are required for the metal work.

	<b>Brickwork tools</b>	<b>Purpose</b>
1	Hoe	Digging foundation base and mixing ingredients
2	Pick axe	Digging foundation base
3	Shovel or Spade	Extract soil from foundation base and mixing ingredients
4	Jerry can	Fetching water
5	Sieve	Sifting ingredients
6	Trough ( <i>karaayi</i> )	Measuring materials by volume and carrying mixtures
7	Trowel	Placing mortar and smoothing plaster
8	Measuring Tape	Taking measurements
9	Spirit level	Inspecting horizontal level for laid bricks
10	Plumb line	Inspecting vertical level for laid bricks
11	Try Square	Inspecting right angled corners
12	Building line	Inspecting brick layer levels
13	Wooden float	Smoothing plaster
14	Claw Hammer	Driving and removal of nails
15	Sledge Hammer	Driving foundation pegs into the ground
16	Wall Chisel	Split, cut into, notch bricks and walls
17	Bow Saw	Slicing pumice into regular shaped slabs

	<b>Metal fabrication Tools</b>	<b>Purpose</b>
1	Hacksaw	Cutting sections to length
2	Vice	Holding sections when being cut to length
3	Hammer	Driving chisel
4	Chisel	Cutting metal sheet
5	File	Smoothing metal edges
6	Measuring Tape	Taking linear measurements
7	Try Square	Inspecting right angled corners
8	Anvil (or equivalent)	Base for hammering
9	Arc welding set	Joining metal pieces
10	Pick hammer	Removes slag from welded metal parts
11	Angle grinder	Smoothing the welded joints
12	Wire brush	Cleaning metal surfaces prior to welding

### 3. Safety Gear<sup>5</sup>

	<b>Device</b>	<b>Purpose</b>
1	Eye Shield	Protection of eyes against radiation during welding
2	Leather gloves	Protection of hands from fire during welding
3	Leather apron	Protection of body and clothes during welding
4	Nose Mask	Protection against inhaling of toxic gases during welding
5	Industrial boots	Protection of feet during welding
6	Helmet	Protection of the head during welding
7	Overalls	Protection of clothes during welding
8	First Aid Kit <sup>6</sup>	Treatment for injuries
9	Eye goggles	Protection for the eyes e.g. when grinding

### 2.1 Stove Construction Materials

The quantities below are estimated for a stove of dimensions 140 x 140 x 116cm accommodating a saucepan of capacity 250 L. For other sizes saucepans, the quantities can be adjusted accordingly.

<sup>5</sup> Recommended for use where available

<sup>6</sup> Professional workshop practice recommends that a First Aid kit should be in place.

## 2.2 Brickwork

N	ITEM	SPECIFICATIONS	QUANTITY
<b>1</b>	<b>Brick Structure</b>		
1.1	Bricks	12 X 12 X 22 cm, Fired clay	600
1.2	Curved Bricks	Hollow, Semi circular, Fired clay	140
1.3	Sand	Lake Sand	0.5 Ton(s)
1.4	Sand	River Sand	0.5 Ton(s)
1.5	Cement	OPS / PPS	6 Bag(s) =@ 50kg
1.7	Water		25 Jerrycan(s) @ 20 Litres
<b>2</b>	<b>Heat Insulation</b>		
2.1	Pumice	Porous	1.5 Sack(s) @ 100L
2.2	Fire cement		1 bag
2.3	Grog	High Temperature Mixture (HTM)	4 bags
2.5	Fire bricks <sup>7</sup>	High Temp (4"x3"x9" Kajjansi)	30
2.6	Vermiculite	Exfoliated	3.5 Sack(s) @ 100L
2.8	Quarry	8 x 12 X 2", Fired clay	10 Pc(s)

## 2.3 Metalwork

	ITEM	SPECIFICATION	QUANTITY
1	Stove Frame	Angle section (40X40X3mm)	1 Pc(s)
2	Grate	Cast iron (1.5"X10X10mm)	2 Pc(s)
3	Ash scoop	Mild steel	2 Pc(s)
4	Saucepan ring/stabilizer	Ø 12mm X 6m	1 Pc(s)
5	Saucepan	250L 3mm bottom, 2mm side (stainless steel- human food grade)	1 Pc(s)
6	Saucepan lid	Aluminium/ stainless steel(human grade) type	1 Pc(s)
7	Welded mesh	4X8" G10	1 Pc(s)
8	Chimney	Galvanised 5.5" G24	1 Pc(s)

## 2.2 Material purchase

Purchase the stove brickwork construction materials and deliver them at the stove construction site.

### Caution:

1. Materials like vermiculite, pumice, cement, sodium silicate and wall tiles are expensive and should be stored in a secure room.
2. Cement, vermiculite, pumice and sodium silicate should be kept in a dry place

<sup>7</sup> These can be replaced by the fired clay liners of appropriate dimensions

## 3.0 Stove Planning

### 3.1 Mapping out the stove position

Choose a corner in the kitchen to be occupied by the stove. This will minimise the possibility of accidental damage and it will also be useful in preventing the stove from direct intake of cold air.

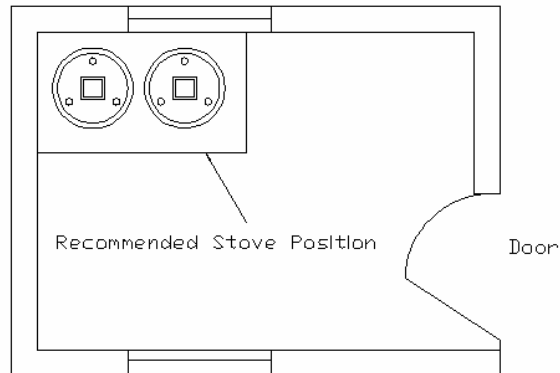
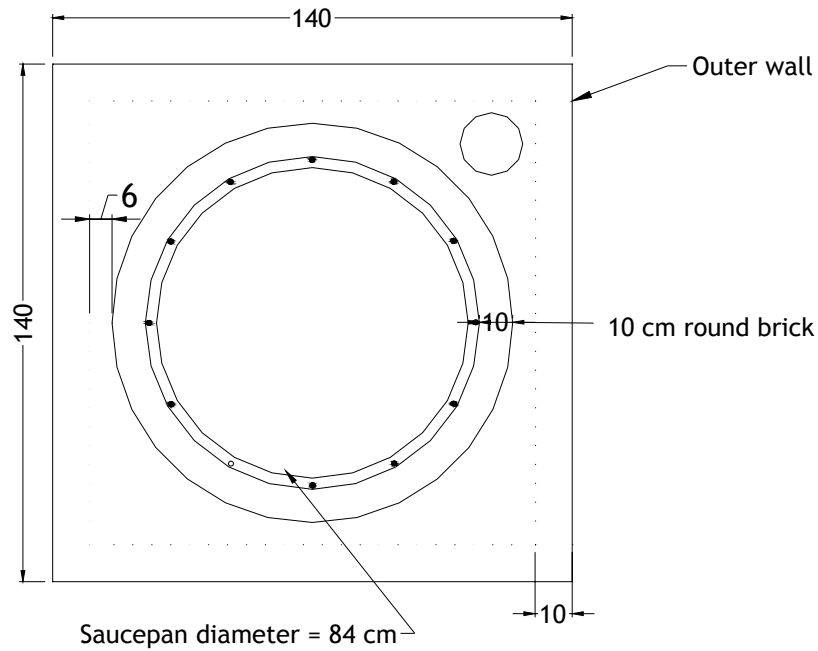

**Figure 1: stove positioning**

### 3.2 Determining the stove base dimensions

- Using the largest pot diameter used for cooking in the institution, the width of the combustion chamber is determined from the table in the appendix. E.g. for a 250 L saucepan with diameter 84 cm the chamber width is 24 cm.
- The combustion chamber cross-section area, height and size are read from the same table (i.e.  $A=576 \text{ cm}^2$ ,  $H=60 \text{ cm}$ ,  $K=36 \text{ cm}$ ).
- Add 2X2 cm to the saucepan diameter to obtain the inner diameter for the curved bricks structure/ assembly.
- Add 2X10 cm for the width of the curved bricks' width. (assumed when 10 cm curved brick)
- Add 2X6 cm for the insulation width.
- Add 2X10 cm for the outer wall bricks. (assumed when 12m wide selected bricks finish)

This gives the minimum width of the stove. In our example therefore, the stove width,  $W=84+4+20+12+20=140$ .

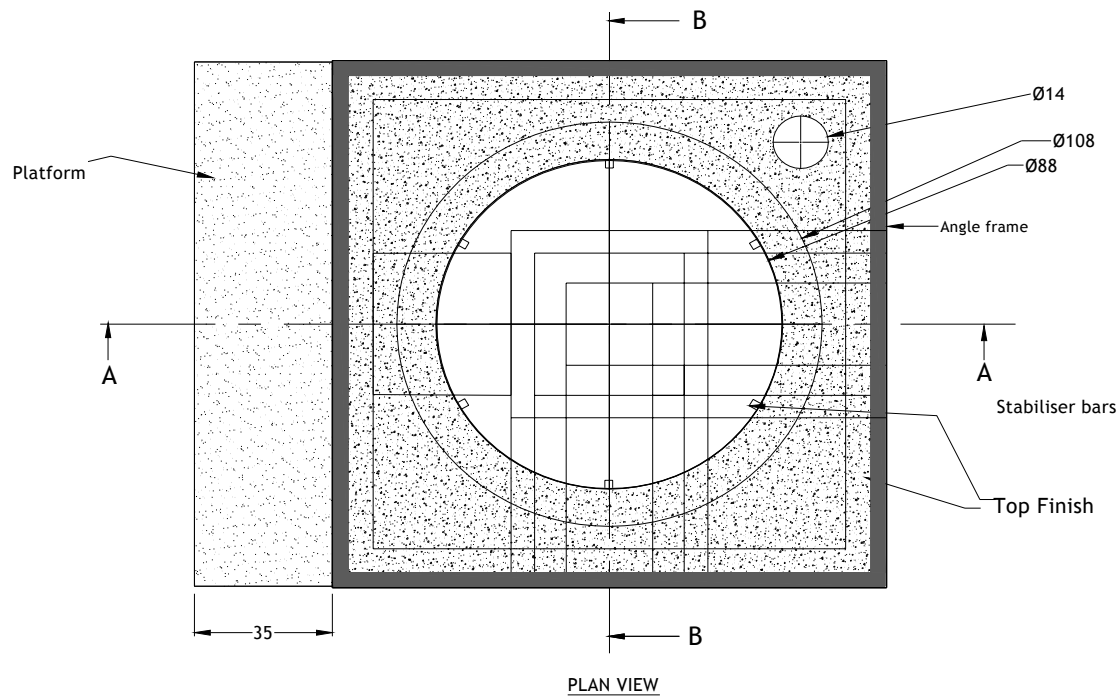

**Figure 2: Stove plan dimensions**

The base area of the stove, for instance, will be about 140X 140cm, when built to accommodate saucepans of diameter 84 cm.

In case of ordinary (local) bricks of varying dimensions, the stove width and length should be varied to taking into consideration the brick sizes.





### The Fixed Institutional Rocket stove

Capacity: 250 Litres  
 Fuel: Firewood  
 Dimensions: cm  
 Designed by: GTZ - PREEEP  
 Drawn by: Job Mutyaba  
 Date: June 2008

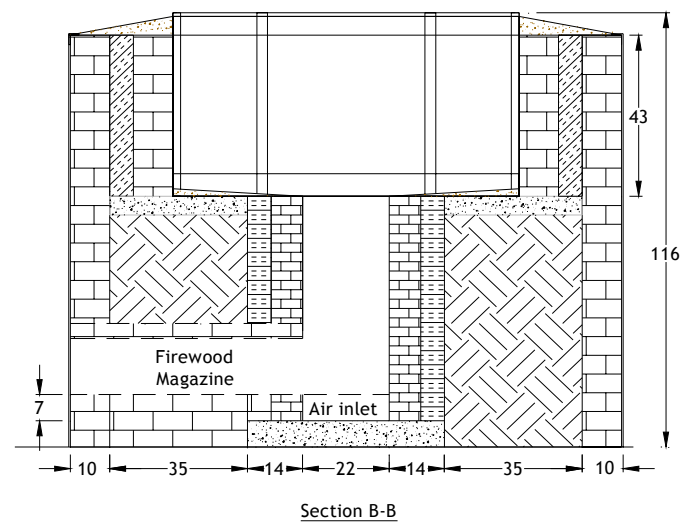
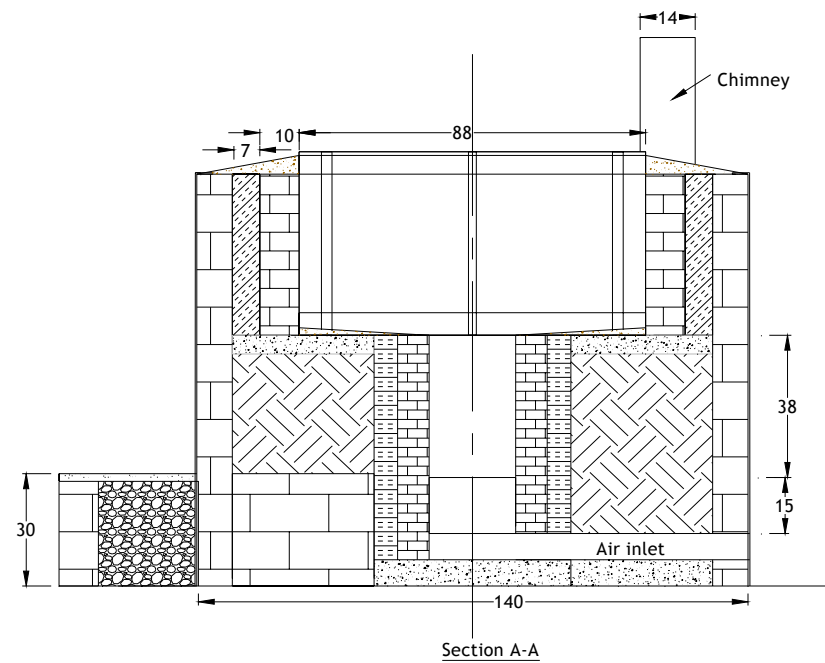
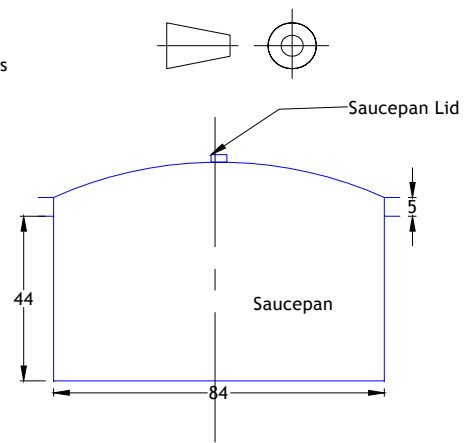

Figure 3: Technical diagrams of the stove

### 3.3 Obtaining the length of the combustion chamber (L)

- Draw the outline of the stove base on paper with dimensions clearly marked
- Following these drawings, make a floor plan where the stove is to be built.
- Mark off the centre of the fuel magazine opening.
- Draw the diagonal lines across the outline and mark where they cross each other as shown in figure 4.
- Measure the distance between this point and the centre point of the stove fuel magazine opening.
- This gives the distance from the opening to the centre of the combustion chamber (b).
- To b add a half of the stove width  $\frac{1}{2}J$ .
- This gives the total length of the combustion chamber fuel magazine.

i.e.  $L = b + \frac{1}{2}J$

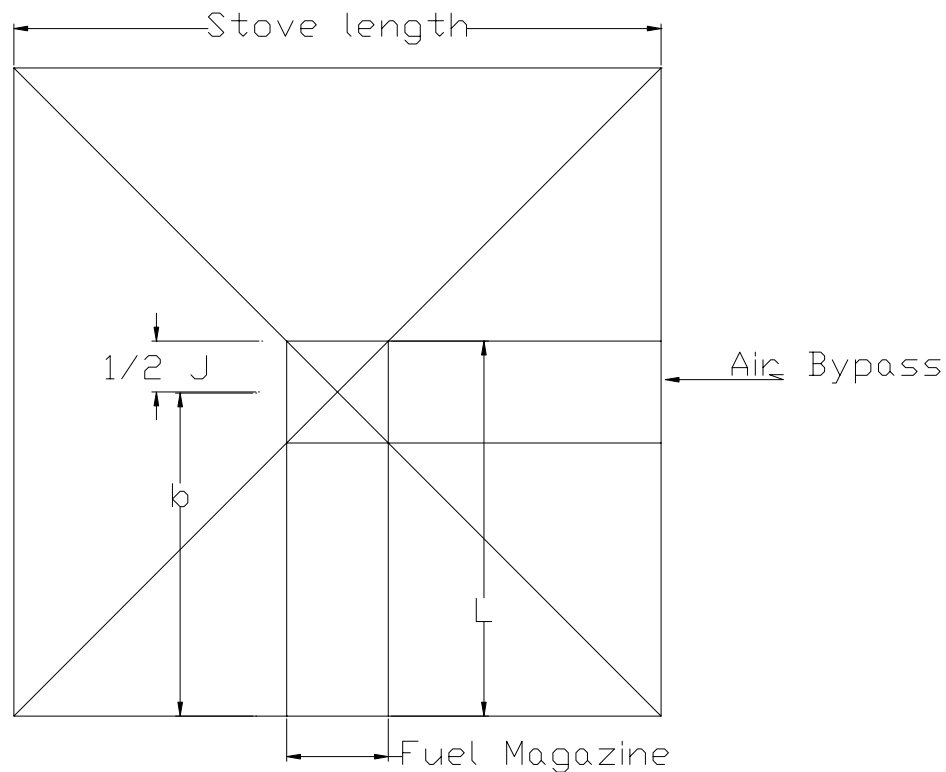

Figure 4: Locating the combustion Chamber

## 4.0 Preparation of materials

Prepare the construction materials for the stove as described below.

### 4.1 Preparing the mortar;



Photo 2: preparing mortar

**4.1.1** Using the sieve, sift the sand to obtain fine granules.

**4.1.2** Mix the sand and cement, in the volumetric ratio 3 : 1

**4.1.3** Blend the mixture to homogeneity.

**4.1.4** Slowly add water to the mixture just to make it mouldable

### 4.2 Preparing the insulation mortar

1. The grog and cement are mixed in the ratio 2 : 1
2. Adding water, the mixture is blended to homogeneity using a shovel.

## 5.0 Building the stove



Photo 3: setting out



Photo 4: Digging the foundation



Photo 5: Construction of the foundation

**Note:** In case the stove is to be built in a kitchen with a concrete floor, skip steps 5.1 – 5.3

5.1 Mark out the foundation on the ground using a string, sticks or chalk, measuring tape and try square

5.2 Excavate a foundation of 30 cm wide by 30 cm or more depth.

5.3 Lay the foundation by first wetting the ground with water, and then place some mortar and then bricks in the excavated space.



**Photo 6: construction out on a concrete slab**

5.4 Build the first course of the outer wall using either selected or ordinary bricks. Ensure that the air inlet and firewood magazine are planned for.



**Photo 7: Stove Building**

5.5 The air inlet and firewood magazine are built using the fire resistant mortar and special firebricks/ clay liners. A grate is inserted in combustion chamber as shown in photo 7.



**Photo 8: Combustion chamber construction**

5.6 The combustion chamber wall is built using fire bricks. 6-7cm pumice insulation is placed surrounding the firebrick wall. A support wall is built behind the firewood magazine to provide extra strength against impact of insertion of firewood.



Photo 9: combustion chamber building

5.7 Continue to build the walls of the combustion chamber using the fire bricks, maintaining the inside cross section as uniformly as required.



5.8 Raise the combustion chamber walls and the support walls to the required height (H) as given in the table (appendix 1)

Insulation

Support wall

Combustion chamber wall



**Photo 11: filling the stove body with debris**



**Photo 12: Centering the saucepan stabiliser**



**Photo 13: The saucepan stabiliser**

5.9 Add a layer of mortar at the base of the space between the outer wall and the support wall. Fill this space with debris up to about 5 cm below the combustion chamber level. Cover the debris with grog and cement mortar. Make sure to slant the mortar finish slightly downwards to the combustion chamber top.

5.10 Cut a mesh of length equal to the inner dimensions of the stove body.

5.11 Cut out a provision for the combustion chamber.

5.12 Using diagonally fixed strings, the centre of the combustion chamber is located. Place the saucepan stabiliser onto the stove and centre it.



Photo 14: Construction of the saucepan skirt



Photo 15: The provision of the chimney

5.12 Using the insulation mortar, build the circular brick wall up to the top. Replace the saucepan several times to ensure the 2 cm gap is maintained. Remember to leave a brick space in the last course of round bricks for the chimney opening.

5.13 **Note:** The saucepan stabiliser should be levelled before further construction.

5.14 Fill the gap between the inner round brick wall and the outer wall with insulation (vermiculite and/or pumice)

5.15 Fix the chimney before setting the top slab



## 6.0 Finishing the stove



Photo 16: Fixing the chimney pipe



Photo 17: A slab on top of the stove



Photo 18: Grinding a stove with a terrazzo finish

- 6.1 Place a wire mesh around the saucepan ring. Fix the chimney (see photo 16) and make the top slab. Allow the slab to set before making the stove finish.
- 6.2 Cover this with grog and cement mortar. It should extend all over the brickwork. Give it a smooth finishing, slightly slanting outwards.

Weld the angle section into a frame to fit the outer edges of the stove. Fit this frame on the stove inserting it into the ground.

This will protect the stove edges from damage

- 6.3 If terrazzo was used as a slab on the top surface, after 1 day it should be grinded with an angle grinder.

## PART 2

### The Mobile Institutional Rocket Stove

#### 1.0 Things to consider before building the Mobile Institutional Rocket Stove

##### 1.1 Shelter

Ensure that shelter is in place to house and protect the mobile Institutional rocket stove from intrusion and unfavourable weather conditions e.g. rain.

##### 1.2 Tools

For the most part, the stove is metallic therefore metal fabrication tools are required for the metallic components. For bonding purposes cement mixing tools are required.

	<b>Mortar mix tools</b>	<b>Purpose</b>
1	Hoe	Mixing ingredients
3	Shovel or Spade	Mixing ingredients
4	Jerry can	Fetching water
5	Sieve	Sifting ingredients
6	Trough ( <i>karaayi</i> )	Measuring materials by volume and carrying mixtures
7	Trowel	Placing mortar and smoothing plaster
8	Bow Saw	Cutting pumice into regular shaped blocks

	<b>Metal fabrication Tools</b>	<b>Purpose</b>
1	Hacksaw	Cutting sections to length
2	Vice	Holding sections when being cut to length
3	Hammer	Driving chisel, removing of slag
4	Chisel	Cutting metal sheet
5	File	Smoothing metal edges
6	Measuring Tape	Taking linear measurements
7	Try Square	Measuring right angles
8	Anvil (or equivalent)	Base for hammering
9	Arc welding set	Joining metal pieces
11	Sheet metal rolling equipment	Rolling the sheet metal
12	Pick hammer	Removing slag from welded joints

### 1.3 Safety Gear

	Device	Purpose
1	Eye Shield	Protection of eyes against radiation during welding
2	Leather gloves	Protection of hands from fire during welding
3	Leather apron	Protection of body and clothes during welding
4	Nose Mask	Protection against inhaling of toxic during welding
5	Industrial boots	Protection of feet during welding
6	Helmet	Protection of head during welding
7	Overalls	Protection of clothes during welding
8	First Aid Kit	Treatment for injuries
9	Eye goggles	Protection of eyes

### 2.0 Stove Planning

(The quantities below are estimated for a stove whose saucepan capacity is 100L. For bigger saucepans, the quantities can be adjusted accordingly.)

#### 2.1 Bonding and insulating

	ITEM	SPECIFICATION	QUANTITY
1	Cement	Portland	1 Bag
2	Water		2 Jerry cans (@ 20 L = 40L)
3	Pumice	Porous	1 bag (@ 100 L)
4	Sodium Silicate	Liquid	10 L Jerry can
5	Vermiculite	Exfoliated	½ Bag
6	Quarry tiles		

#### 2.2 Mobile rocket institutional stove fabrication

	ITEM	SPECIFICATION	QUANTITY
1	M.S. Plate	4' x 8' x 2 mm	2 Pcs
3	Angle bars	40X40X3mmX6m	1 Pc
4	Firewood shelf	Steel Fabricated	1 Pc
5	Welding rods (1 pack)	G.10	1 Packet
6	Rebar	½ ". x 40mm x 12.7 mm	1 bar
7	Flat section	4 mm x 50 mm	2 bars
8	Flat section	4 mm x 25 mm	1 bar

### **2.3 Purchase and delivery**

Purchase the mortar constituents and deliver them at the site. Note: cement, vermiculite and pumice should be kept indoors in a dry room.

Materials for metal fabrication should be delivered to a metal fabrication workshop. The metal work fabrication will be dealt with at a later stage.

### **2.4 Stove Assembly**

The Mobile institutional stove is made up of largely two main parts (see diagram below) namely:

1. the saucepan skirt and
2. the combustion chamber.

In the construction of the stove these two main parts are the main areas of focus. Other parts include:

1. firewood shelf
2. handles

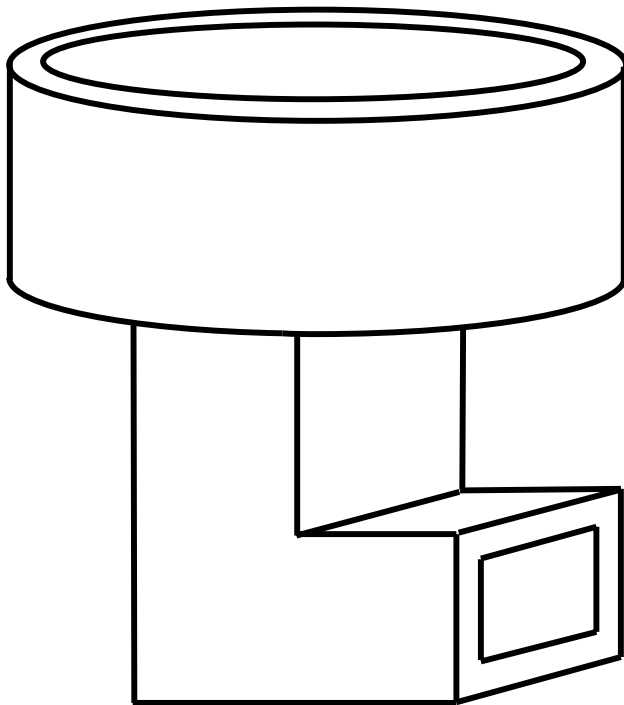

**Fig 5: A representation of the institutional mobile stove**

## 2.5 Stove Sizing

The size of the stove is determined using the size of the saucepan that will be used for cooking in it. The saucepan capacity is therefore the first thing that should be determined. Below are the steps taken in planning the stove parameters

1. Determine the saucepan capacity in litres
2. Measure the saucepan diameter at different points on the top and bottom of the saucepan. Use the largest saucepan diameter as the value, **d**.
3. From the table at the end of this manual, read combustion chamber values **J, K, H** for the given saucepan capacity
4. Determine the saucepan skirt diameter **D**, Outer cylinder diameter **D<sub>1</sub>** and **P** following the simple calculations from the table below.

Measurement Key	Denotation
Saucepan diameter	d
Saucepan Skirt	$D=d+4$
Overall Diameter	$D_1=D+5$
Saucepan skirt height	P

*(See appendix for more)*

For example, if  $D = 63$  cm

Saucepan skirt diameter =  $D + 4 = 67$  cm

Overall diameter =  $D + 4 + 5 = 72$ cm

*Note: To minimise wastage of metal, ensure that proper planning is done.*

### 3.0 Main Parts of the Mobile stoves

#### 3.1 The saucepan skirt

The Saucepan skirt (figure 6) houses the saucepan during cooking. It is made of an outer and inner metal sheet. Vermiculite or any other appropriate insulation is put between the two circular sheets and the assembly is sealed off with a top ring (figure 9).

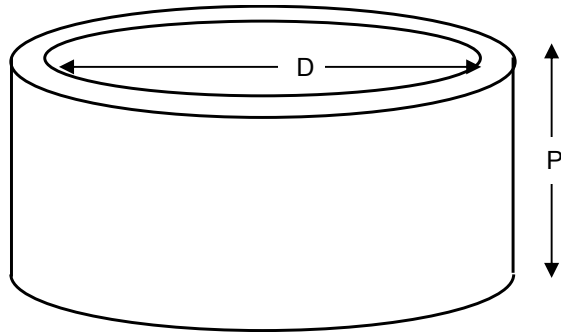

Figure 6: The saucepan skirt

#### 3.2 Combustion chamber block (with an air bypass)

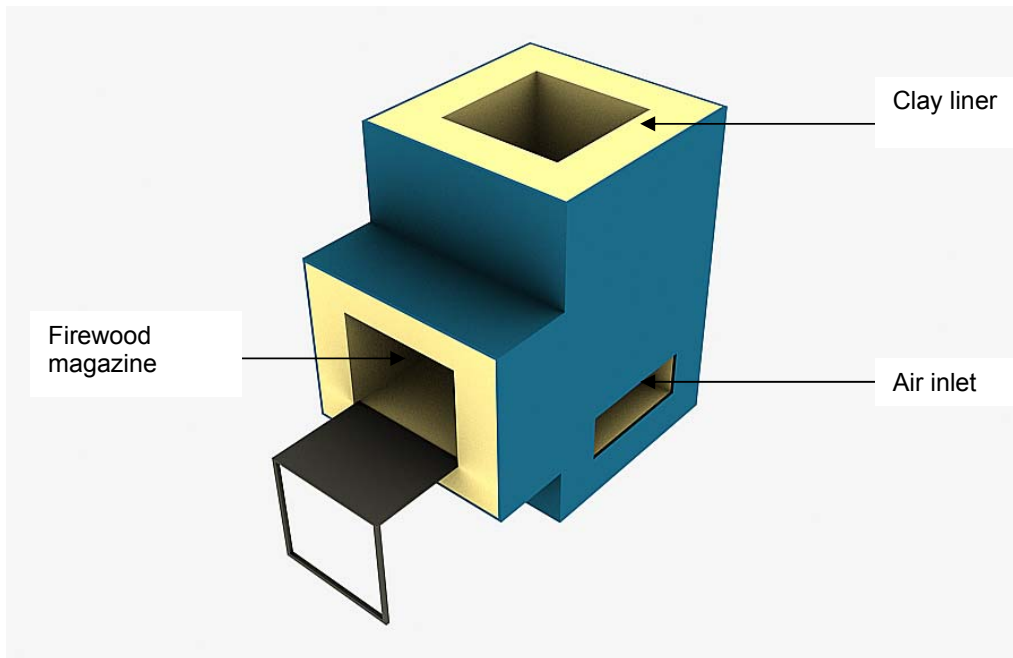

Figure 7: A combustion chamber block with a separate air inlet

### 3.3 Base plate

This circular plate (figure 8) forms the base of the saucepan skirt. Onto it, the skirting, the stove stands and the saucepan stands are welded. It is also welded to the combustion chamber box so that the flames and hot gases pass through the square opening found in the centre of the base plate.

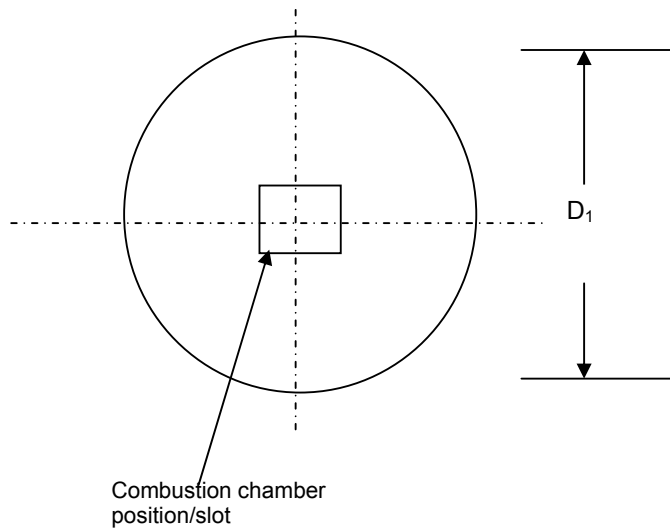
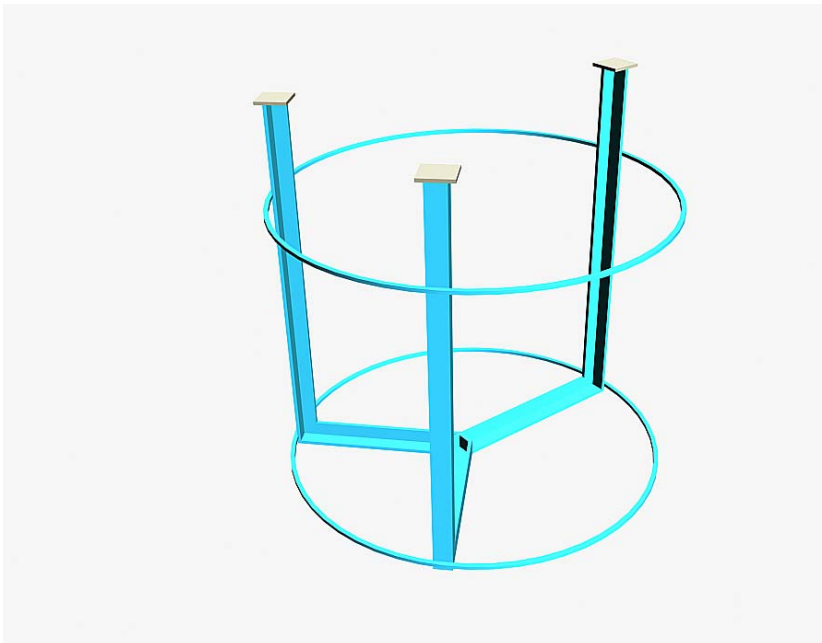
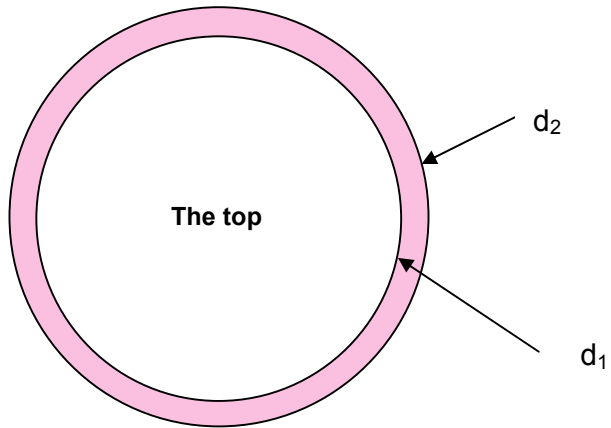

Figure 8: A base plate with a square hole for the combustion chamber

### 3.4 The stove/saucepan stand assembly



### 3.5 Top Ring



**Figure 9: The diameters  $d_1$  and  $d_2$  of the top ring**

The top ring covers the insulation material in the saucepan skirt.  $d_1$  and  $d_2$  are inner and outer diameters respectively



### 3.6 Stove Technical Drawing

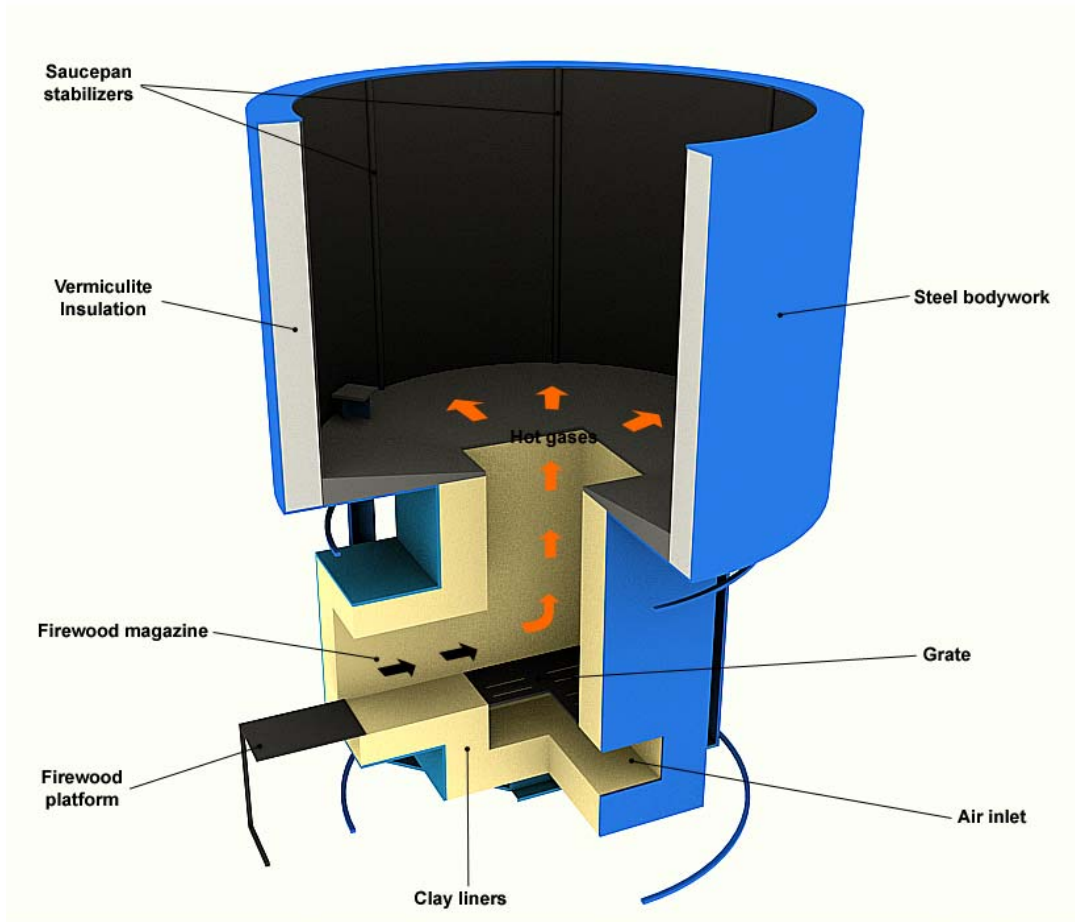
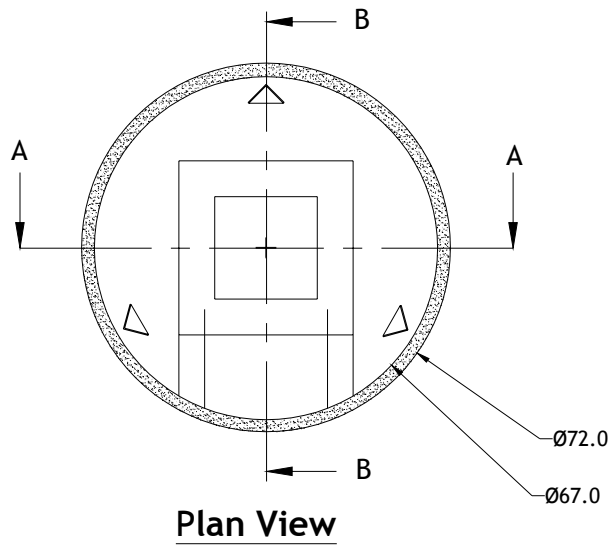

Figure 10: A sliced section showing the different parts of the mobile rocket stove

The third angle orthographic projection views of the stoves, on the next page, were developed by GTZ - PREEEP to aid in visualisation of the stove.



### The mobile institutional stove

Capacity: 100L  
 Dimensions: cm

Design: GTZ - PREEEP  
 Drawn by: Job Mutyaba  
 Date: June 2008

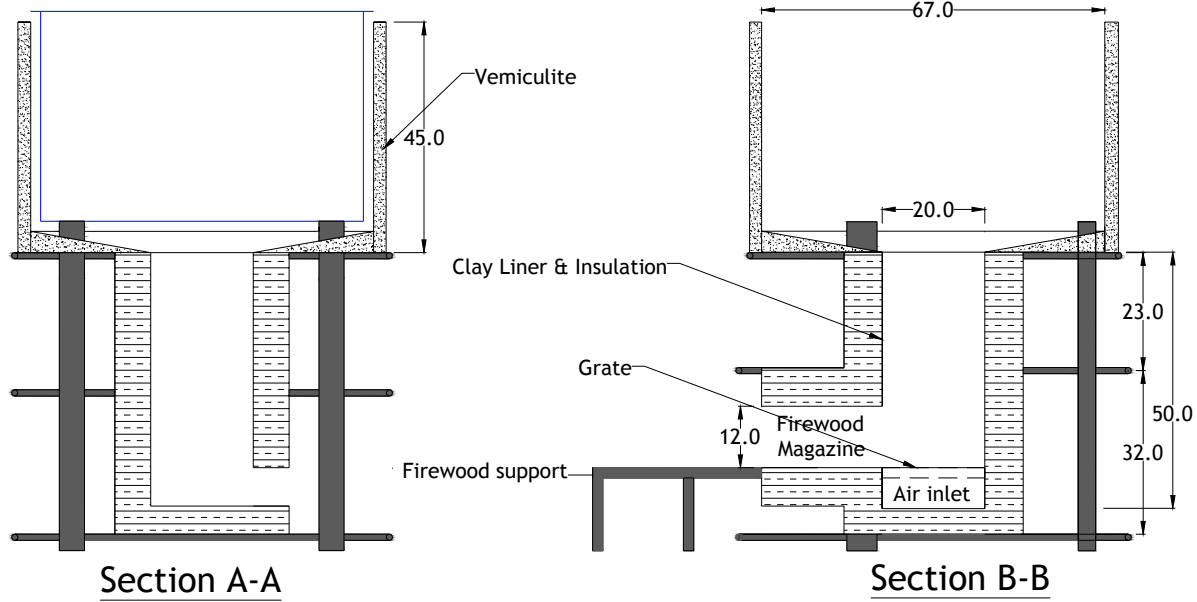
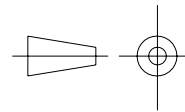

Figure 11: Technical diagrams of the mobile institutional rocket stove

## 4.0 Fabricating the stove

### 4.1 The outer skirting



Photo 19: Marking off measurements



Photo 20: Metal cutting with an Angle grinder



Photo 21: Metal rolling

- Lay down a mild steel (MS) plate of 4'x 8'x2mm (122x244x0.2cm).
- Measure and mark off a rectangle of Length ( $\pi \times D_1$ ) and width, P on the sheet metal.
- If it is not long enough, measure off the required additional piece from another similar metal sheet (sheet 1). Mark off rectangle of length  $\pi * D$  by P. (Sheet 2) e.g. for a 100L saucepan, Length = 230 cm and Width = 40 cm
- Use an angle grinder with a metal cutting disc to cut off the marked sheets 1 and 2
- Alternatively the metal sheets could be cut with a hammer driven chisel
- Using a metal roller (3- roll), curve the metal sheets as shown



**Photo 22: Metal rolling with simple hand tools**

**Note:** Alternatively, the metal sheets can be rolled manually using an I-beam



**Photo 23: Welding the rolled metal sheet**

- Weld the edges of the curved metal together to form a cylinder.



**Photo 24: A finished saucepan skirt in cylindrical shape**

#### 4.2 The inner cylinder

This one is fabricated in a similar manner as that of the outer cylinder. From the drawings, for 100 L saucepan,  $D = 67 \text{ cm}$ ,  $L = 40 \text{ cm}$

E.g. for 100 L stove,

The length of plate will be  $\pi \times D = 3.14 \times 67 \text{ cm} = 210 \text{ cm}$

Width of plate will remain 40 cm

#### 4.3 The combustion chamber block



Photo 25: Marking off dimensions for the combustion chamber

- Take measurements from the metal sheet and cut out all sides of the metal box.
- Weld the cut pieces of the combustion chamber block together.

#### 4.4 Base Plate



Photo 26: Bending a base plate

- Using chisels or any other appropriate cutting tool, cut out a circular piece of diameter  $D_1+2$ . Bend the ends using a hammer to make a 2cm vertical fold.
- Insert the outer cylinder into the base plate so that the outer cylinder sits in the curved part of the base plate

#### 4.5 Stove assembly



**Photo 27: Welding the outer cylinder onto the base plate**



**Photo 28: Using an angle grinder with a metal cutting disc to cut out a hole in the base plate**

- Weld the base plate onto the outer cylinder as shown.

- Cut out the slot for the combustion chamber in the centre of the base plate
- The combustion chamber box is then welded onto the stove skirts
- Cut out slots into the base plate through which the stands are inserted.
- Angle lines (40X40X3mm) or square hollow sections (40X40mm) can be used.
- The framework of the stove stands should be reinforced with cross members, appropriately fitted to aid the stability of the stove.

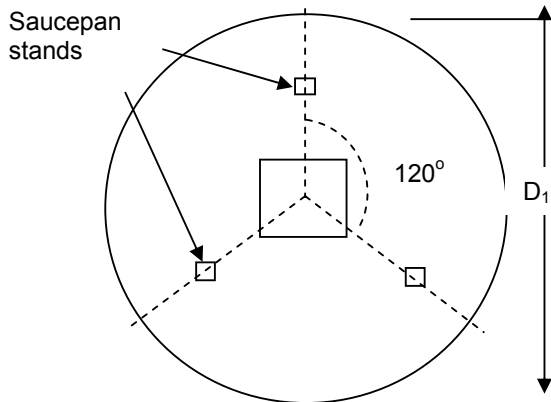

**Figure 12: Positioning of the saucepan stands**

- **Note:** the saucepan stands also double as the stove stands. The size and shape of the slots will depend on the cross-sectional area and shape of the stands respectively.

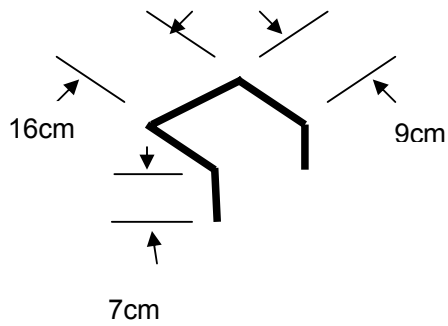

**Photo 29: Making a top ring**

- From a flat metal sheet, cut out the top ring that is illustrated in figure 9 on page 30
- Cut a flat section of width 5cm and length equal to the circumference of the outer diameter ( $\pi \times D_1$ )
- Curve it to form a cylindrical shape and weld it along the outer diameter of the top ring

### Handles

Use a 12 cm diameter round bar to make the handles. The total length of the bar for two handles is 96 cm.



**Figure 13: How to make the stove handles**

#### **4.6 Stove insulation**

- Prepare the insulation mortar in the volumetric ratio cement : grog as 1 : 2
- Add water and use a spade to mix to thoroughly.

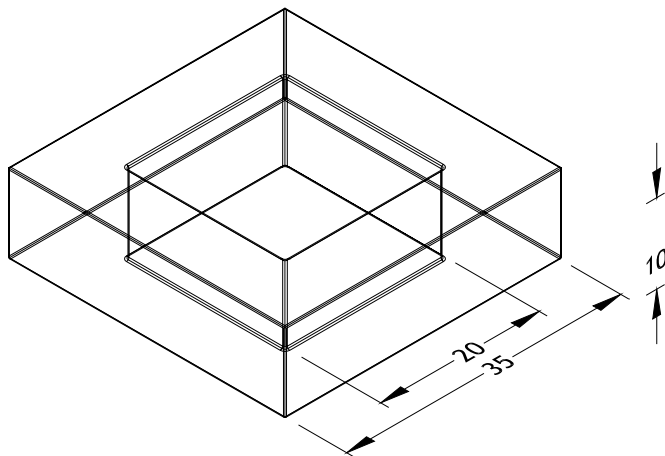

**Figure 14: A Clay Liner<sup>8</sup> for a 100 L institutional stove**

<sup>8</sup> Liners should be made by a qualified industrial ceramist. They should have insulation properties and must be abrasion resistant.





**Photo 30: Using grog to bind the combustion chamber box with the liner**

- Clay liners are fitted into the combustion chamber box. The liners are bonded to the combustion chamber box with grog mortar.

- **Note:** When quarry tiles are used, they should be lined along the entire combustion chamber to protect the chamber from abrasion while in operation. Pumice blocks are used to insulate the stoves while tiles protect the pumice from wear due to abrasion.
- In this case, cut the pumice into slabs of 5 cm thickness. Size them to fit in the combustion chamber box. Use the mortar to bond the pumice to the metallic wall and to the quarry tiles.



**Photo 31: The inside of a chamber with an insulation slant set onto the base plate**

- Cover the base plate with a thin layer of pumice making a slant such that the height above the slant from at the end of skirt is not less than 1cm when measured from the saucepan base

- Bond the pumice with the insulation mortar (cement, grog and water).
- Use the insulation mortar to cover and smooth the slants.
- Smoothen using a trowel.
- Grind all sharp edges of the metallic stove body to make it smooth.
- Clean the metallic stove body with a wire brush to remove dirt and rust.  
Paint the stove to protect the steel body from rust etc.



**Fig 15: A finished institutional mobile rocket stove**

**Appendix: Relationship between Saucepan / Pot Diameter and Combustion Chamber**

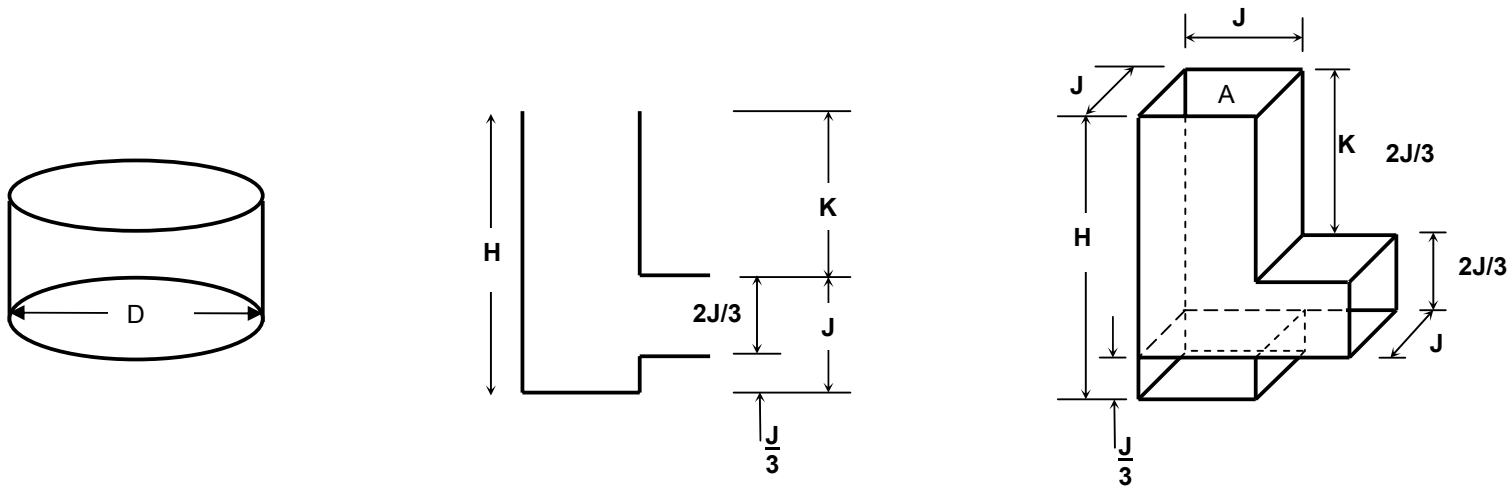

The rocket elbow combustion chamber

Notation	Pot Capacity (L)	J (cm)	$K = 1.5 \times J$ (cm)	$H = K + J$ (cm)	Chamber Area (cm <sup>2</sup> )	Chamber Sizing (cm)
	20-40	15	23	38	225	15 x 15
	41-60	16	24	40	256	16 x 16
	61-80	18	27	45	324	18 x 18
1	81-100	20	30	50	400	20 x 20
2	101-150	21	32	53	441	21 x 21
3	151-200	22	33	55	484	22 x 22
4	201-230	23	35	58	529	23 x 23
5	231-300	24	36	60	576	24 x 24