

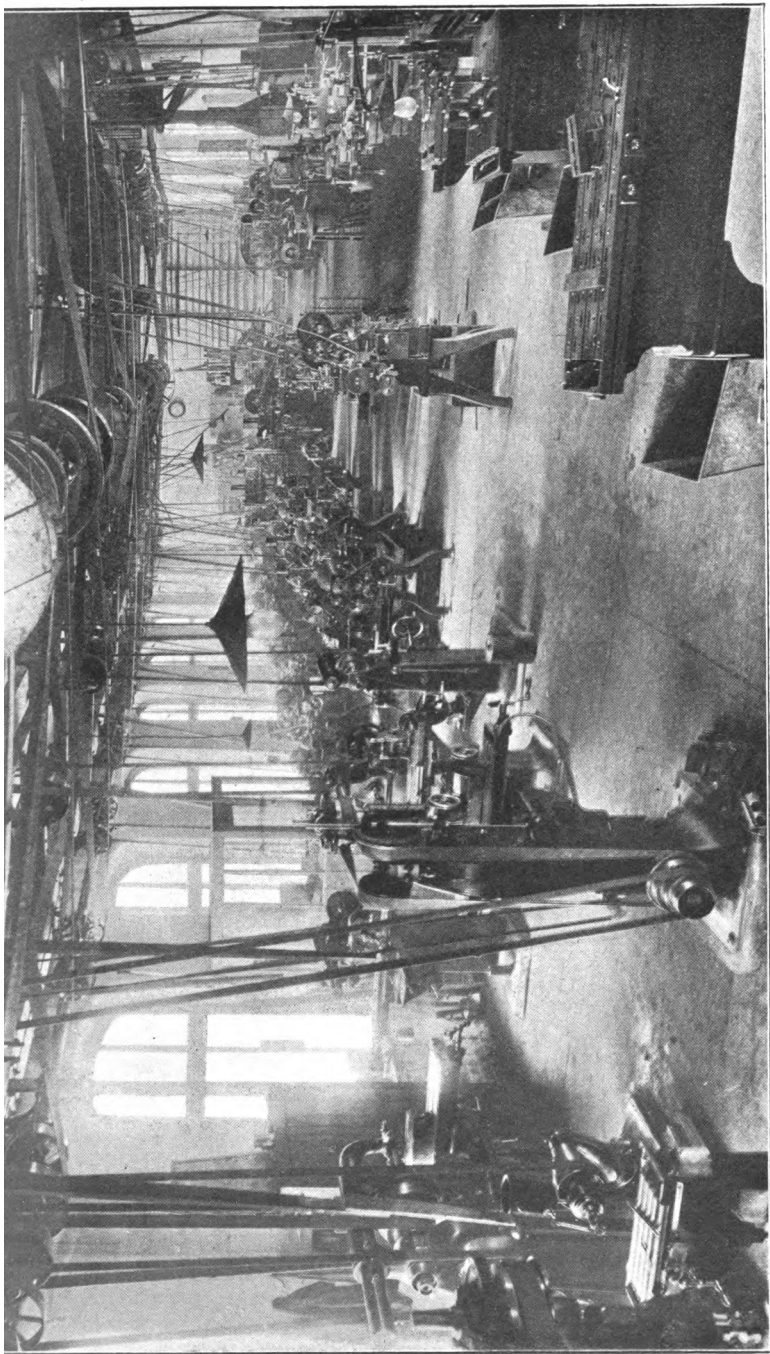

MACHINE TOOLS
AND
WORKSHOP PRACTICE



MODERN GRINDING ROOM.

MACHINE TOOLS
AND
WORKSHOP PRACTICE
FOR
ENGINEERING STUDENTS
AND APPRENTICES

BY
ALFRED PARR
INSTRUCTOR IN FITTING AND MACHINE SHOP, AND FORGE
UNIVERSITY COLLEGE, NOTTINGHAM

WITH AN INTRODUCTION BY
WILLIAM ROBINSON, M.E., M.Inst. C.E.
PROFESSOR OF ENGINEERING UNIVERSITY COLLEGE, NOTTINGHAM



WITH 510 ILLUSTRATIONS!

LONGMANS, GREEN, AND CO.
39 PATERNOSTER ROW, LONDON
NEW YORK AND BOMBAY

1905

All rights reserved

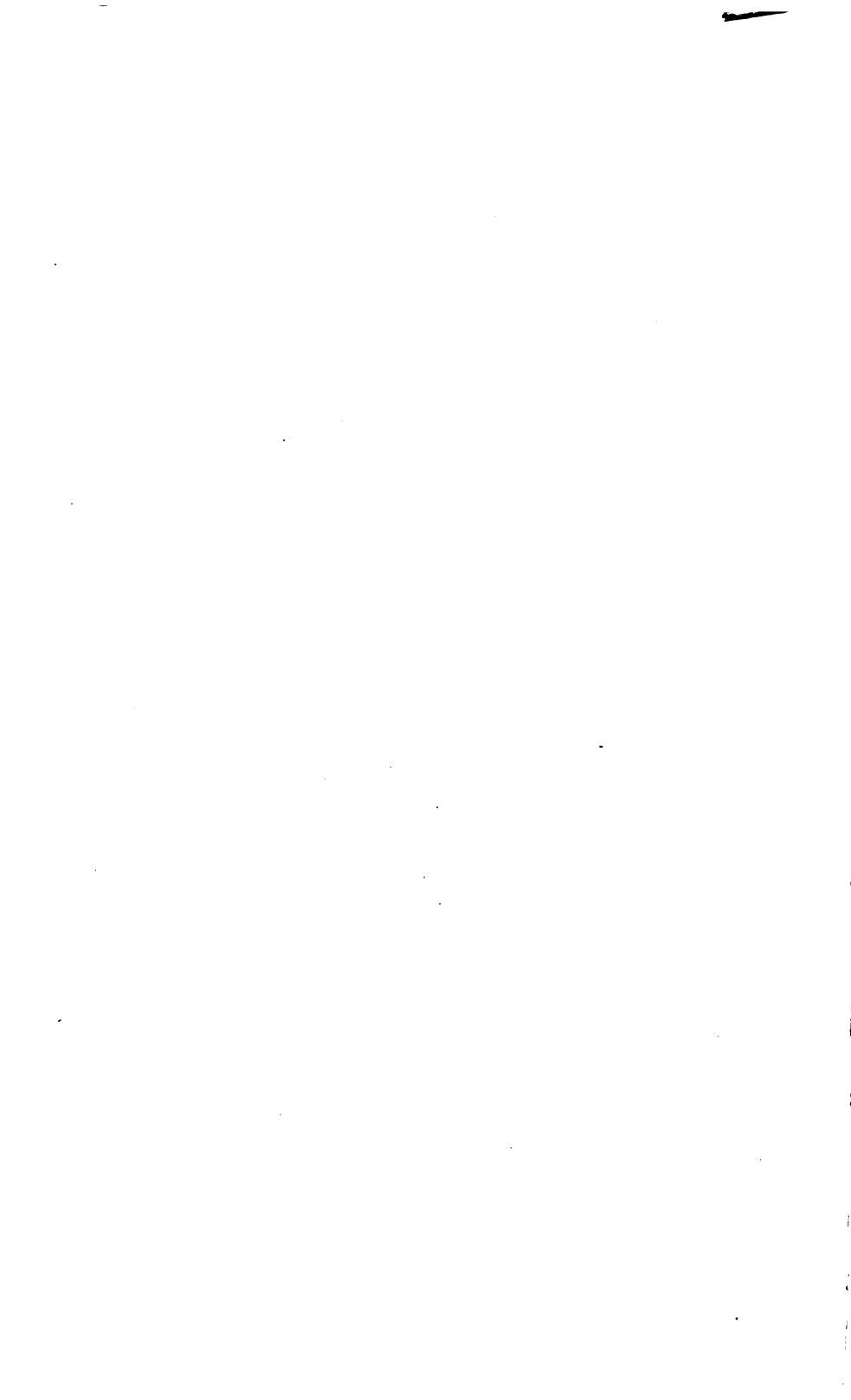

87234
SEP 5 1905

6933637

TJH
.P24

INTRODUCTION

THIS text-book has grown out of the course of instruction on machine tools and workshop practice at University College, Nottingham.

Exact *measurement*, always of first importance, is becoming more necessary in modern mechanical workshop practice, owing to the use of interchangeable parts in machine construction.

Skilled turners and fitters seldom produce work, measured by the time-honoured calipers or ordinary standard plug and ring gauges, to within 0·001 inch. The best limit gauges are accurate to within 0·0001 inch, and can be more readily and rapidly used than the micrometer. Measuring instruments which depend on the feeling of touch and pressure are liable to introduce personal errors of variable amount. At the best, only a *closer approximation* can be attained, since absolute accuracy in physical measurements is impossible. Thus, the ordinary Whitworth machine measures $\frac{1}{100,000}$ inch, or about $\frac{1}{4000}$ millimetre. The electric micrometer may enable us to measure small dimensions and magnitudes of the order $\frac{1}{5,000,000}$ millimetre, and reveal elevations on a plane surface, or errors in a screw thread, which no machine yet made can remove. Perhaps grinding gives the closest approximation to the true plane and cylinder, still the removal of a height by this means is likely to produce a hollow. Obviously, the ordinary workman nowadays has urgent need of a knowledge of his limitations and of the methods of making delicate measurement, in order to produce work cheaply within a definite limit of accuracy. He is aided by labour-saving automatic machine tools and limit gauges.

The next essential is a thorough grip of the principles underlying the action of modern machine tools, and of the methods employed to standardise and specialise work. For instance, the tendency is to use the lathe largely as a roughing-out machine, whilst the grinding machine, along with limit-gauges for standard size of interchangeable parts, takes the place of the fitter, except in general work. Working to limit-gauges is found to be less expensive than using single accurate gauges, and further reduces the cost of erection of the parts of a machine.

The technical press constantly calls attention to improvements and developments in grinding, milling, and turret-lathe work. And are there not many handbooks and tables giving a summary of facts and figures intended for the trained practical engineer?

The aim of this text-book is to explain the construction and use of machine tools in a connected form, which long experience in practical shopwork and teaching has proved to be suitable for students attending technical colleges, and for apprentices or beginners in machine shops.

The book covers a large range of subjects, and cannot fail to be of great service to the practical worker, helping him to study the action of the machine tools he uses, pointing out how to do various kinds of work, and enabling him to understand and appreciate the most approved methods of organizing and doing work in modern practice.

WILLIAM ROBINSON, M.E., M.INST. C.E.,

*Professor of Engineering, University College,
Nottingham.*

PREFACE

THE increasing demand for technical instruction by engineering students and apprentices has led me to prepare this book in the hope that it may prove useful as an aid to the working of machine tools, and to workshop practice generally.

The number of machine tools is constantly being increased, and the method of doing work is very different to that which was in operation several years ago.

In every branch of work the introduction of new ways of doing things has caused a division in the class of operatives. Many machines are working automatically on repetition work with a result quite as surprising as it is satisfactory. This has, therefore, caused a specially skilled class of tool-makers to be employed in the preparation of cutting tools, on the one hand, while the machines themselves can be operated by men of only slight experience.

The chapters on *Measurement*, *Turret Lathes*, *Grinding*, and *Milling* have been prepared and illustrated in detail, these being considered most important.

The subjects have been taken up in the order found by experience in teaching to be most suitable for the beginner to grasp. Several old students have kindly assisted me in the revision of this work.

My thanks are due to many engineers and firms referred to, and to Mr. Claude W. Hill, A.M.I.C.E., M.I.E.E., M.I.M.E., for a contribution on the "Method of Working."

I have also had willing assistance in the preparation of this book from Messrs. The Brown and Sharpe Manufacturing Co., Providence, R.I., U.S.A.; Messrs. The Jones and Lamson Machine Co., Springfield, Vermont, U.S.A.; and Messrs. The Unbreakable Pulley Co., Manchester, for some particulars on the transmission of power.

ALFRED PARR.

UNIVERSITY COLLEGE, NOTTINGHAM,

December 12, 1904.



CONTENTS

CHAPTER I.

MEASUREMENT.

Standards of length—Subdivision of standards—Degrees of accuracy—Measuring and gauging instruments—Accuracy of form and finish—"Whitworth's" measuring machine—Micrometers—Protractors—Calipers—Verniers—Caliper gauges—Limit gauges—Thickness gauges—Depth gauges—Reference discs—End measuring rods—Spirit-levels—Interchangeable and systematic gauging 1-26

CHAPTER II.

MARKING OR LINING-OUT TOOLS AND PROCESSES.

Marking-out table and tools—Setting-out brackets—Connecting rods—Shaping machine bed—Eccentric shafts—Shrouded pinion—Nut on angle plate—Uses of surface plates—Uses of scribing blocks—Straight edges—Squares—Compasses—Method of securing work with clips and bolts—Ancient bolts and nuts 27-41

CHAPTER III.

MATERIALS.

Manufacture of cast iron—Blast furnace—Pig iron—Analysis of cast iron—Production of wrought iron—Manufacture of mild steel—Reverberatory furnace—Bessemer and Siemens-Martin processes—Cementation process—Crucible cast steel—Air hardening steel—Hæmatite steel making at Barrow—Nature and properties of the various materials—Tenacity—Elasticity—Ductility—Malleable cast iron—Aluminium—Manufacture of copper—Copper depositing—Phosphor bronze—"Delta" metal—Gun metal—Babbitt's metal—Production of metallic bars—Solders—Leaden pipe manufacture 42-56

CHAPTER IV.

DRILLS AND DRILLING MACHINERY.

	PAGE
Twist drill manufacture—High speed attachment to drill—Drill lubricator— Undercutting tool—Automatic tapping appliance—Grip socket for taper shanks—Breast drills—Ratchet drills—Portable power appliance—Sensi- tive bench and pillar drills—Double-gearred drill, with sliding table swing, and universal drilling machine	57-77

CHAPTER V.

TURRET LATHES.

The Hartness flat turret lathe—Details of working parts—Special chasing tool —Accuracy of screw threads—Hexagon turret, Nos. 2 and 6—Brass turn- ing lathe—Capstan lathe—Screw machine and tools—Gisholt lathes for a variety of work—Overhead magazine to turret	78-103
--	--------

CHAPTER VI.

TREADLE AND POWER LATHES.

Complete treadle, description of parts—Bed—Saddle—Headstocks—Guide screw—Tool-room lathe—Milling attachment—Conical and parallel bear- ings—Whitworth lathe (2 plates)—Details—Seller's straight bed lathe— Loose headstock—Fly wheel and pulley lathe—Treble-gearred lathe— Double railway wheel lathe—12-in. centre heavy lathe—Cutting from same —8-ft. facing lathe	104-125
--	---------

CHAPTER VII.

LATHE APPLIANCES.

Lathe centres—Conical—Square—Countersink—Half-reduced cup—Oil groove —Combination—Centre truing arrangement—Hand centering (portable)— Pat revolving centre—Universal jaw chucks—Combination jaw chucks— Two-jaw chucks—How to make steel mandrels—Barlow's expanding mandrels—Screw mandrels—Bench straightening press—Mandrel press— Stays: centre, travelling and finger—Shaft-turning rest	126-140
---	---------

CHAPTER VIII.

BORING MACHINES.

Duplex boring machines, "Lee and Hunt"—Single horizontal type by "Muir" —Sellers—Boring and tapping machine—Boring and tapping machine, by Selig Sonnenthal—Boring and milling machine, by Anglo-American Machine Tool Co., Ltd.—Portable cylinder boring machine for boring cylinders in their places, by Selig Sonnenthal & Co., Ltd.—Geared vertical boring and turning mill, by Lee and Hunt—Large 12-ft. geared vertical boring and turning mill, by William Sellers & Co., Philadelphia	141-152
---	---------

CHAPTER IX.

LATHE WORK.

	PAGE
Chasing studs—Split threads—Drunken threads—Inside and outside chasing tools—Method of striking threads—Hand turning, iron and steel—Tools for same: graver, square nose, round nose, side tool, etc.—Parkinson's lathe—For turning and chasing by pull over rest or capstan spiral jaw chuck (Taylor's)—Difference in form of brass turning tools—Set of brass tools for hand milling machine for brass work—Taper turning; setting lathe for same—Examples of saddle boring—Cast-iron cranks—Bent and forged cranks—Piston rings—Driving shaft—Change wheels calculating same for screw cutting—Single and compound trains	153-177

CHAPTER X.

GRINDING WHEELS AND MACHINES.

Examples of tools ground—Tool-grinding machine—Universal grinding machine, by Brown and Sharpe—Mounting emery grinding wheels—Duplex grinder—Diamond tools for truing wheels—Appliances used to support pieces during grinding—Lang's pat grinder—Commutator grinder—Grinding coupling rods—Saw-sharpening machine—Saw teeth—Emery band machine—Polishing and buffing machinery	178-216
---	---------

CHAPTER XI.

COLD IRON AND STEEL SAWING MACHINES—PLANING, SHAPING, AND SLOTTING MACHINES.

Advantages of sawing—Method of mounting and driving saws—Hack saws—Band sawing machines—Shaping machines—Link motion for quick return—Central drive to ram—"Hendy" pillar shapers—Details of drive—Slotting machines—Spiral geared planing machine—Crank-driven plane—Open-side planing machine; examples of uses of same.	217-235
--	---------

CHAPTER XII.

MILLING MACHINES, MILLING CUTTERS, AND APPLIANCES.

Universal milling machine, with details of construction—Spiral headstock, foot stock, etc., by Brown and Sharpe—Two-spindle milling machine, by "Muir"—Backing-off milling cutters—Form cutters—Formed cutters—Worm and gear cutters—Slab milling cutter—Various examples of milling cutters at work—Straddle mills—Gang mills—"Addy's" expansion cutter—Hand-feed milling machines—Vertical milling—Slab milling machines—Cutters with inserted teeth	236-267
--	---------

CHAPTER XIII.

GEARING AND GEAR CUTTERS.

Spur gear-cutting machine (G. Birch & Co., Manchester)—Double helical gears—Mild steel castings—Turning large gear—Built-up wheels—Setting out wheel teeth—Straight and bevel—Construction of wheel teeth—Hobbing cutters—Cutting teeth of a worm wheel—Hindley worm—Data for gear teeth	268-289
--	---------

CHAPTER XIV.

CUTTING TOOLS, AND HOW TO USE THEM.

	PAGE
Cutting defined—Process of true cutting action—Cutting edges, various forms— Pointed and broad-nosed tools—Angle of tool—Angle of clearance—Side and top rake—Roughing tools—Finishing tools—Controlling features affect form of tool—Complete set of tools for turning and screw cutting— Tool holders, advantages of—Hardening and tempering tools, cutters, etc.	290-309

CHAPTER XV.

FITTING, ERECTING, VICE WORK AND TOOLS.

Fitting hammers—Shafting hammers—Set of Whitworth taps—Uses of taps and master taps—Surface plates—File manufacture—Grade and names of files —Art of filing—Chipping chisels—Forging a chisel—Templets—Parallel and machine vice—Taylor's form vice—Example of fitting knuckle joint— Vice clamps—Keys and key fitting—Slot drilling machine	310-338
--	---------

CHAPTER XVI.

FORGE SHOP TOOLS, AND FORGING PROCESSES.

Angle iron work—Angle iron smiths—"Bulldozer" bending machine— Examples of bent work—Fan blowers—Forging hearths, engine and blower combined—Ryder's forging machine—Tongs—Flat and hollow bits—Pliers —Example of forged axle—Anvil—Swage block—Swages and fullers—Set hammers—Striking hammers—Forms of welds—Steam hammers—Method of mounting hammers—Valve gear—Tups—Tools used at steam hammer— Stamping dies—Pneumatic hammers	339-362
--	---------

CHAPTER XVII.

HYDRAULIC MACHINE TOOLS AND RIVETING.

Hydraulic riveting, single, double—Caulking and caulking tools—Principles of hydraulics—Hydraulic press—Pascal's law; vessel illustrating same— Accumulators—Accumulator valves explained—Hydraulic punching machine—Hydraulic jack—Hydraulic flanging press—Boiler shell bender, stationary—Hydraulic riveters—Portable riveters at work—Hydraulic machine tools—Hydraulic notes	362-382
--	---------

CHAPTER XVIII.

TRANSMISSION OF POWER.

Driving pulleys—Cast-iron (split)—Wrought-iron pulleys—Wrought-iron pulleys with screw cone bushes—Wooden pulleys—Balancing—Iron pulleys— Friction clutches, with hollow sleeve—Friction clutches to speed cone—
--

	PAGE
Friction clutches to reversing pulleys—Friction clutches to bevel wheels— Friction clutches applied to shaft couplings—Flange couplings—Compression couplings—Examples of shafts coupled out of line—Swivel bearings— Ball thrust bearings, diagram—Speeding, by cone pulleys—Swivel bearings supported by beam—Swivel bearings on pillars—Counter shaft and hangers—Speeding by pulleys and belts—Roller bearings—Tackle for lifting and shifting material—Overhead runways	383-411

CHAPTER XIX.

METHODS OF WORKING.

Lathe work—Cutting speeds—Milling.—Planing—Slotting and shaping . .	412-418
---	---------

APPENDIX.

Measuring machine, by Dr. Shaw—Section of screw threads—Section of union joint—Chain wheel and chain driving, "Renolds"—Tables and data .	419-432
--	---------

INDEX	433
-----------------	-----



LIST OF ILLUSTRATIONS.

FIG.		PAGE
	<i>Frontispiece</i>	
1.—	British standard yard	1
2.—	Standard metre	4
3.—	Kilogram weight	4
4.—	Setting calipers	6
5-12.—	Calipers and dividers	8
13-15.—	Limit gauges	10
15A.—	Cylindrical gauge	11
16—	Standard reference discs	11
17.—	End measuring rod	12
18.—	Whitworth measuring machine	15
19.—	Richard's measuring machine	16
20.—	Lathe test indicator	16
21.—	Small micrometer caliper	16
22.—	Vernier caliper for gear teeth	17
23, 24.—	Micrometer calipers	17, 18
25.—	Interchangeable micrometer	19
26—	Screw-thread micrometer	20
27.—	Sliding micrometer caliper	21
28, 29.—	Vernier caliper	21
30, 31.—	Universal bevel protractor	22
31A.—	Bevel square	23
32.—	Thickness gauge	24
33.—	Spirit level for testing shafting	24
34.—	Electrician's non-magnetic spirit level	24
35.—	Pocket level	25
36-38.—	Depth gauges	25
39.—	Example of work and tools—marking-out table	28
40.—	Bracket to be bored	28
41.—	Templet for "marking out" holes in shaping machine bed	29
42-44.—	Eccentric shafts: 1, 2, and 3 throws	32
45.—	Bracket to be bored	33
46.—	Shrouded pinion and sleeve	34
46A.—	Core box	34
47.—	Work set on angle plates	36
48.—	Ancient bolts	39
49.—	Chucking clip	40
50.—	Method of securing work with clips	40
51-54.—	Clips, various forms	40, 41
55.—	Reverberatory furnace	44
56.—	Examples of cold iron twisted and bent	45
57.—	Crucible cast steel fractured	47

FIG.	PAGE
58.—Phosphor bronze specimen. "Tensile test"	54
59.—Section of a mild steel casting	55
60.—Leaden pipe manufacture	56
61.—Making twist drills	61
62.—High-speed sensitive drilling attachment	62
63.—Oil-tube twist drill	63
64.—" " socket	64
65.—Facing tool worked by hand	64
66–68.—Payton's patent universal machine tappers	65
69, 70.—Machine tappers	66
71, 72.—Grip sockets	66
73, 74.—Breast drills	67
75.—Ratchet brace	68
76.—Rotary engine for drilling	69
77.—Sensitive pillar drill	71
78.—" " bench drill	71
79.—Geared drilling machine	72
80.—Belt-driven radial drill	74
81–84.—Universal radial drilling machines	75, 76, 77
86.—Hartness turret lathe	79
87.—Enlarged view of turret	80
88.—Tool slide	81
89, 90.—"Turner" and stay combined	83
91.—Spring-collet chuck	85
92.—Roller feed	86
93.—Hartness automatic die	87
94.—Form of chaser	88
95.—Testing pitch of tap	89
96.—Micrometer gauging a screw	90
97.—Gauging pitch of a long screw	91
98, 99.—Hexagon turret lathes	92
100.—Brass-finisher's lathe	93
101.—Assembling room	(<i>facing</i>) 92
102.—Capstan lathe.	94
103.—Herbert's valve chuck	94
104.—Small capstan lathe	95
105.—Automatic screw machine	97
106.—Tools for automatic screw machine	98
107.—"Gisholt" lathe—motor-driven	99
108.—Plan of turret lathe	100
109.—Turret lathe operating on five-step speed cone	101
110.—" " " " " " small fly-wheels.	101
111.—" " " " " " boring and turning valves	102
112.—Overhead magazine	102
113.—Small treadle lathe	105
114.—Conical bearings	106
114A.—Journal bearings	107
115, 116.—Front slide lathes	108, 109
116A.—Gear-cutting attachment	110
117.—Six-inch tool-room lathe	111
117A.—Slot-drilling attachment	112
118, 119.—Whitworth & Co.'s 9-in lathe.	(<i>facing</i>) 112
120.—Sellers' straight-bed lathe	115
121.—Loose headstock	116
122.—Pulley and fly-wheel lathe	117

LIST OF ILLUSTRATIONS.

xix

FIG.	PAGE
123.—Duplex axle lathe	119
124.—Double railway-wheel lathe	119
125.—12-in. high-speed lathe	120
126.—Steel shaving cut at 120 ft. per minute :	121
127.—12-in. lathe	122
128, 129.—8-ft. lathe for turning fly-wheels	123, 124
130.—Ordinary centre	127
131.—Square centre	127
132.—Countersinker	127
133.—Half centre	127
134.—Reduced centre	127
135.—Cup centre	127
136.—Oil groove centre	127
137.—Combined drill and countersink	127
138.—Centre-truing machine	128
139.—Portable centering appliance	129
140.—Revolving centre	130
141-143.—Combination jaw chucks	131
144.—Universal four-jaw chuck	132
145-147.—Two-jaw chucks	132, 133
148, 149.—Drill chucks	134
150-152.—Expanding mandrels	136
153.—Screw mandrel	137
154.—Straightening centre press	137
155.—Mandrel press	137
156.—Movable or centre stay	138
157.—Travelling finger stay	139
158.—Special rest	140
159, 160.—Duplex cylinder boring machines	142, 143
161, 162.—Horizontal boring and facing machines	144
163.—Floor boring machine	145
164.—Heavy boring machine	146
165.—Horizontal boring and tapping machine	147
166.—" " " milling machine	148
167.—Portable cylinder boring machine	149
168.—Vertical turning and boring mill	150
169.—12-ft. vertical turning and boring mill	151
170.—Stud to be chased	153
171-172.—Outside and inside chasers	154
173.—Hand turning tools	155
174-175.—Universal three-jaw chuck for brass	157
176.—Hand tools for brass turning	158
177.—Taylor's brass-finishing machine	160
178, 178A.—Gauge for taper turning and boring	164
179.—Boring crank-shaft bearings, for small engine	165
180.—Lathe "packed up" boring engine cylinder	165
181.—Lathe jig for plummer blocks	166
182.—Cast-iron crank	167
183.—Disc crank	168
184.—Section of piston and rings	168
185A.—Junk rings	169
185BCDE.—Various forms of pistons	169, 170
186.—Turning the oval on locomotive engine crank shafts (Mid-land Railway Works, Derby)	171
187.—Turning the oval	172

FIG	PAGE
248.—Power hack-saw	219
249.—Metal band saw	220
250.—Rotary planing machine	221
251.—24-in. stroke shaping machine	222
251A.—Quick return by link and die	223
252, 253.—“Hendey Pillar” shaping machine	(facing) 224
254.—Slotting machine	225
255.—Spiral-gear plane	228
256.—Crank-driven planing machine	230
257.—Plate-edge planing machine	231
258.—Open side plane, with two saddles and three tables	232
259.— ” ” planing machine, with two tool boxes	233
260-260A.—Examples of open side planing	234, 235
261.—Universal milling machine	238
262.—Section through saddle of universal milling machine	239
263.—Longitudinal section of universal milling machine	240
264-265.—Spiral headstocks and tailstocks	241
266.—Duplex milling machine by Muir	242
267.—“Backing off” milling cutter, by Selig Sonnenthal	243
268-270B.—“Formed” cutters	243, 244
271.—“Form” cutter	244
272.—Gear cutter	245
273.— ” ” worn out	245
274.—Plain slab milling cutter	245
274A.—Side milling cutter, with inserted teeth	245
274B.—Plain slab milling cutter, with inserted teeth	245
275.—End mill	245
276.—Fluting a tap	246
276A.—Cutter for grooving tap	246
277.—Fluting a reamer	246
278-280.—Metal slitting saws	246
281.—Correct diameter of milling cutter	247
282.—Straddle mills	248
283, 284.—Milling nuts and bolts	248
285.— ” cutters interlocked	248
286.— ” slots	249
287.— ” fixture	249
287A.—Tee-slot cutter	250
288.—Milling a surface, and squaring one side	250
289.— ” rack teeth	250
290.—Rounding ends of work	250
291.—Milling two sides of a slot	251
292.— ” the keyways in two shafts	251
293.—Cutter with notched teeth	252
294.—Large mill with notched teeth operating	252
295.—Milling face and sides at one cut	253
296-298.—Straddle and gang mills in section	253, 254
299.—Correct position of cutter and work	254
300.—Fluting a reamer	255
301.—Milling cutters interlocked	255
302.— ” motor pinions	255
303.—Straddle mills at work	256
304.—Plain milling machine surfacing machine bed	257
305.—Gang cutters milling a slide	258
306.—Milling between the arms of a wheel	258

FIG.	PAGE
307.—Boring and facing cylinder	259
308.—Milling angular keyway	259
309.—Cradle jig for milling	260
310.—Angular cutter	261
310A.—Addy's patent expansible cutter	262
311.—Hand-feed milling machines	264
312.—Vertical milling machine	265
313.—Slab milling machine	266
314.—Example of milling cutter work	267
316.—Automatic gear-cutting machine	271
317, 318.—Double helical steel gears	272, 273
319, 320.—Built-up gear wheels	274, 276
321.—Turning the rim of a cast-steel gear	277
322.—Bevel gears	278
322A.— „ gear-cutting machine	278
323.—Setting out bevel wheels	278
324.—Section of 3 bevel wheels	279
325.—Bevel gear. Diagram for dimensions	281
326.—Setting bevel-gear cutter out of centre	282
327.—Milling faces of worm wheel	284
328.—Cutting worm wheel teeth	284
329.—Worm hob with relieved teeth	285
329A.—“Hindley worm”	286
330.—Construction of straight-toothed wheels	(facing) 286
331.—Correct position of tool	290
332.—Various positions of sliding tools	291
333.—Height gauge	292
334.—(When broad-nosed), tool for finishing	292
335.—Tooling sides of collar	293
336.—Knife tools	293
337.—Stiff knife tool	294
338.—Spring tool	294
339.—Parting tools	295
340, 341.—Groove-cutting tool	295
342.—Undercutting tools	296
343A.—Dovetail cutting tools	297
343B.—Whitworth standard screw-pitch gauge	298
344.—Various forms of screw threads	298
344A.—Screw-cutting tools	299
345.— „ gauge	299
346.—Examples illustrating the various uses of gauges	300
346A.—Screw-cutting gauge testing drill (Wyke's patent)	301
347.—Tool holder	302
348.— „ „ at work	302
349.— „ „	302
350, 351.—Swivel tool holders	302
352.—Planing tools	303
353.—“Profile” steel tools	304
353A.—Hand reamer	304
353B.—Reamer	304
353C.—Profile steel turning tool	304
353D.—Forged drill	304
353E.—Expanding reamer	304
354.—Hardening cutter	308
355.—Hand chipping hammers	310

	PAGE
356.—Set of hand taps	312
357.—Surface plate	314
358.—Sections of files	317
359.—Grade of files	319
360.—Chipping chisels	322, 323
361.—Parallel vice	325
362.—Novel vice	326
363.—Machine vice	327
363A.—Parallel vice	327
363B.—Taylor's machine vice	328
364.—Knuckle joint	329
365.—Vice clamps	333
366.—Hand vice	333
367.—Various methods of fitting keys	334
368.—Slot-drilling machine	336
368A.—Smith's fan or blower	338
369.—Sections of angle iron	339
370.—Single-gear "Bulldozer"	340
371.—Double-gear "Bulldozer"	341
372.—Bent work by above	341
373.—Water tuyere	342
374.—Iron hearth	342
374A.—Modern hearth	342
375.—Portable hearth	342
376.—Root's blower	343
377.—Tongs: flat and hollow bits, pliers	345
378.—"Ryder" forging machine	346
379.—Anvil and swage block	346
380.—Forged axle	347
380A.—Tools used at anvil	348
381 A B C.—Forms of welds	350
381D.—Pump joint prepared for welding	351
382.—Steam hammer (30 cwt.)	352
383.—Method of fixing steam hammer	354
384.—Combined valve gear	354
385.—Hand-worked valve gear	355
386.—Steam hammer tups	355
387.—Tools used at steam hammer	356
388.—Steam hammer (1 cwt.)	358
389.—" " (10 cwt.)	359
390.—Stamping dies	360
391, 392.—Pneumatic belt-driven hammers	360, 361
393.—Rivets and riveting	363
394.—Pascal's law (1)	365
395.—Vessel in illustration of Pascal's law (2)	365
396.—Hydraulic press	366
397.—" accumulator (diagram)	368
397A.—Accumulator	369
398, 399.—Supply and relief valve	370
400.—Tangye's hydraulic jack	371
401.—Hydraulic punching machine	372
402.—" flanging press	373
403.—Boiler shell-plate bender	374
404.—Hydraulic riveter (details of arrangement)	375
405.—Stationary hydraulic riveter	376

FIG.	PAGE
405A.—Solid type, portable	377
406.—Portable hydraulic riveter for furnace mouths	378
406A.—Special form of portable riveter at work	379
407.—Hydraulic machine tools	(facing) 380
408.—Portable riveter at work	380
409.—Fielding type pat portable riveter	381
410.—Split pulley	383
411.—Wrought-iron pulley	384
412.—Cast iron pulley	385
413.—Wood pulley	386
414.—Balancing a pulley	386
415.—Friction clutch with hollow sleeve	387
416.— " " to speed cone	388
417.— " " reversing pulleys	389
418.— " " bevel wheels	389
419.— " " double-armed pulley	390
420.— " coupling	390
421.—Flange coupling	391
422.—Sellers' compression couplings	391
423.— " " coupling	392
424, 425.—Shafts coupled out of line	393
426.—Swivel bearing in section	397
427, 428.—Ball thrust bearings	398
429.—Speeding cone pulleys	399
430.—Wall box and bearing	400
431.—Swivel bearing supported by beam	401
432.— " " on pillars	402
433.—Counter shaft and hanger	403
434-436.—Examples of speeding	404
437, 438.—Roller bearings	405
439.—Crossed belt	407
440.—Driving at an angle	407
441.—Quarter twist return	407
442, 443.—Tapering cones	407
444.—Stepped cones	407
445-448.—Tackle for lifting and shifting material	408, 409
448A.—" Blackwall " hitch	410
449.—Sections of union joint	(facing) 417
449A.—Modern store room—finished work	(facing) 419
450.—Shaw's electrical measuring machine	419
451.—Whitworth standard screw threads	421
452.—American standard screw threads	421
453.—Acme standard screw threads	421
454.—British association standard screw thread	423
455.—Sharp " V " standard screw thread	423
456.—International (French) standard screw thread	423
457, 458.—" Renold " patent silent chains	430
459.—Silent chain-tooth form	430
460.—New wheel and chain	430
461.—Worn and lengthened chain	431
462.—Driving a counter shaft	431

MACHINE TOOLS

AND

WORKSHOP PRACTICE

CHAPTER I.

MEASUREMENT.

THE "unit" from which our measurements of length have been taken is the "imperial" or "standard yard." In the strong room of the Standards Department of the Board of Trade, London, a bronze bar is kept. It is composed of copper 16, tin $2\frac{1}{2}$, and zinc 1 ounce avoirdupois. It is 38 in. long, and of section $1" \times 1"$.

Let Fig. 1 represent the bar. At AA are inserted two golden studs. On the head of each stud a very fine line is engraved, and the distance between these fine lines when the bar is at the temperature of 62° Fahr.

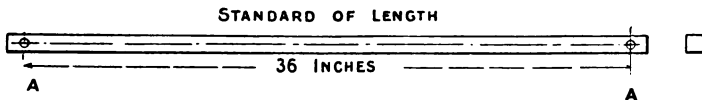

FIG. 1.

is one "Standard" or "British" yard, and was adopted as such by Act of Parliament, passed in 1855. Forty copies were made, and one of these, of bronze, No. 11, was presented to the United States by the British Government in 1856.

The yard is the "unit" or standard measure of length from which other Imperial measures, whether Linear, Superficial, or Solid, are ascertained. There are several copies of the standard yard in this country which have been divided into three equal divisions called feet; the foot is subdivided into twelve equal parts called inches.

Further subdivisions of one inch into 8, 16, 32, or 64 parts, are termed respectively "eighths," "sixteenths," "thirty-seconds," or "sixty-fourths," each subdivision being half of the preceding.

Cylindrical standard gauges are also kept in the Standards Department of the Board of Trade, and consist of external and internal gauges from 6 inches diameter to 0.1 of an inch.

Measurements are taken in various ways according to the size, shape, and importance of the object measured.

Standard rules are much used in making measurements. These are prepared by machines which "engrave" the fine lines to a high degree of accuracy in both "British" and "Decimal" systems. "Scales" have divisions representing one-half, one-quarter, one-eighth, etc., actual size. Pattern-makers' rules are a fractional part larger than standard size ($\frac{1}{8}$ in. to each foot, the amount by which some patterns are in excess of the casting required). All rules are not engraved, some have their divisional lines standing above the surface of the steel; these, however, are not used on machined, *i.e.* tooled work, but are used in the forge and foundry, where rigorous accuracy in absolute measurement is of less importance.

The "scales" are used in the drawing office, and may be made of "boxwood," "paper," or "ivory." Steel rules, "plated" to prevent oxidization, find a place there.

Boxwood rules are generally 2 ft. long and hinged at the centre. The best kinds are bevelled on one edge, which, of course, brings the lines close to any surface when laid upon it.

Paper scales are very convenient, as fine "needle-points" may be used upon their surface without being in any way damaged. It is, therefore, almost essential for students commencing "machine drawing" to use these scales.

Ivory rules are finely lined and finished; they are made two and four fold, and are exclusively used on drawings.

Steel rules are made 2, 3, 4, 6, 12, 24, or 36 inches in length, and in special cases much longer.

Uses of Steel and other Rules.—We may transfer a measurement from a steel rule to another object, but our setting of the tool, whether dividers, compasses, calipers, or trammels, will depend upon our sense of sight; this is called "line measure." Strictly speaking, measurements thus obtained are only approximate, and, as a matter of fact, can be worked to only as such.

EXAMPLE (1).—Suppose eight workmen were asked to measure a rod of iron, whose actual length at first was 5 in., and each told to reduce the length by filing away one-eighth of an inch, using only a steel rule to measure with. If each workman actually filed one-eighth of an inch away, neither more nor less, the rod when finished would be 4 in. long. Such, however, would not be found to be the case when comparing the rod with a known standard 4 in. long.

End and Line Measurement. **EXAMPLE (2).**—A pulley may be required to fit tightly on a $2\frac{1}{2}$ -in. shaft, and to be 20 in. in diameter, and 6 in. wide on the "face."

The diameter and width may be satisfactorily ascertained by a steel rule, because these dimensions are not particular to $\frac{1}{1000}$ th of an inch, so that a steel rule will answer for all practical purposes in such

work. The bore of the pulley cannot be measured with a steel rule, because the difference between a sliding fit and a driving fit is too small an amount for a steel rule to indicate to the naked eye. It will be necessary to transfer the measurement of a "fixed standard" and compare the bore of the pulley with it. That is, a cylindrical gauge of $2\frac{1}{2}$ in. or a rod $2\frac{1}{2}$ in. long must be used, and the diameter of the hole compared with this length.

From such examples it will be seen that there is a distinct difference between the use of a rule and that of a gauge. The former tells us dimensions by the sense of *sight*, the latter by the sense of *touch*.

Measurement.—Steel rules are, therefore, for "line" measures, and are made fairly reliable. Of course, the price regulates the quality, and three shillings is not a large outlay for a good rule.

A 12-in. rule, to be of general service, should contain the following measurements:—

It should be marked on four edges.

The first edge, inches subdivided into 8ths, 16ths, 32nds, and 64ths.

The second, inches into 12ths, 24ths, and 48ths.

The third, inches into 10ths, 20ths, 50ths, and 100ths.

The fourth into millimetres.

It is far better to have *one* steel rule which contains all the divisions we are likely to want in the several departments than to have two or three rules with different measurements; as, for instance, a "London" measure, *i.e.* inches into eighths and subdivisions of eight; another, "decimal" into tenths and subdivisions of ten.

In ordinary practice, where subdivisions of eight are worked to absolutely, rules are frequently used having these divisions and no other, but, as previously stated, their use is very limited.

In the Royal Arsenal and many other large establishments the Decimal System is used, whereby one inch is taken as the standard, and from which subdivisions of tenths are taken as a basis of calculation. Both steel rules and gauges are made in this system.

Another useful instrument is the micrometer gauge, by means of which measurement may be easily made to $\frac{1}{10000}$ part of an inch.

The above system is superior to that of divisions of eight, since it is much more convenient to calculate divisions of ten. The rules are marked as follows: inches into tenths, twentieths, fiftieths, and hundredths respectively, and the fixed gauges on the same principle.

The Metric System. New Standard Metre.—Figs. 2 and 3 show the forms of the new metric standards of length and mass respectively (*Prototypes Nationaux*) delivered to the Board of Trade by the International Committee of Weights and Measures at Paris, on the 28th of September, 1889; a third and final standard being received from the Committee in December, 1894.

The two standards received in 1889 include a "line" standard metre measure (*mètre-à-trait*) and a kilogram weight. The standard received in 1894 is an "end" standard metre (*mètre-à-bouts*).

These three standards, together with other similar standards supplied to twenty-one different states, are (*inter alia*) the outcome of the results

of the labours of the International Committee for nearly twenty years.

The standards were verified at the Bureau International des poids et mesures (Pavilion de Breteuil, Sèvres, *près* Paris), which Bureau was established under a metric convention, dated the 20th of May, 1875, signed by twenty high contracting states, exclusive of Great Britain, who finally joined the convention in September, 1884.

The Committee is founded and maintained by common contribution from all countries who are parties to the convention.

The Committee was charged in 1875 with the construction, restoration, and verification of new metric standards (*Prototypes Internationaux*)

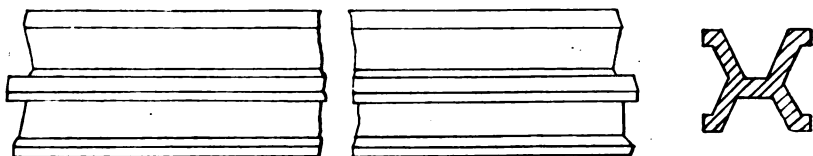

FIG. 2.—Standard metre.

to replace the original metric standards of France (*mètre et kilogramme des archives*), and with the verification of copies of the new standards for all the contracting states. By such means the international accuracy of metric standards is now assured throughout the world. The two metric standards above referred to are made of iridio-platinum, or an alloy of 90 per cent. of platinum and 10 per cent. of iridium.

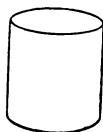

FIG. 3.—
Kilogram
weight.

The metres are in transverse section nearly of the form of the letter X, known as the tresca form (Fig. 2), an economic form (iridio-platinum being a costly metal), scarcely affected by heat, practically non-oxidizable, and well adapted for receiving finely engraved lines. In fact, the alloy appears to be of all substances the least likely to be affected by time or circumstances, and has been preferred for standard purposes to rock crystal, gold, etc.

The lines in the *mètre-à-trait*s are very fine, and are barely visible to the naked eye.

The iridio-platinum standards were constructed in London under the care of George Mathey, Esq., F.R.S., and were finished by Messrs. Brunner, M. Collot, and M. Laurent, of Paris. The lines on the metre were traced by M. G. Tresca at the Conservatoire des arts et matiers, Paris.

The actual relation of our prototype metre, No. 16, is as follows :—

$$\text{At } 0^{\circ} \text{ C., No. 16} = 1 \text{ metre} - 0.6\mu + \frac{\mu}{0.2} \text{ at } 0^{\circ} \text{ C.}$$

Here μ means one micron, or $\frac{1}{1000}$ of a millimetre (or nearly 0.00004 inch), so that metre 16 may be said to have been verified with an accuracy of one part in five millions (Chaney).

The Commercial Value of a Standard.—The nation having at its disposal a standard of length, the question arises, “What use can be made of it commercially, and how do we know when we have a copy of the standard?”

In 1893 the Brown & Sharpe Manufacturing Co. decided to make a new standard to replace the one they had at that date. Mr. O. J. Beale was detailed to do this work. He prepared steel bars about 40 in. long by $1\frac{1}{4}$ in. square, and after planing them they were allowed to rest for several months. At the end of these bars he inserted two gold plugs, the centres of which were about 36 in. apart, and a little beyond these two others about one metre apart. A bar was placed in position upon a heavy bed. This was so arranged that a tool-carrier could be passed over the bar. The tool-carrier consisted of a light framework holding the marking tool. One feature of the marking was that the point of the marking tool was curved and had an angle, so that if dropped it made an impression in the form of an ellipse. In graduations ordinarily, the line, when highly magnified, is apt to present at its ends an impression less definite than in the centre, by reason of the form of the objective. The line made with the tool, as stated, is short, and that portion of the line is read which passes, apparently, through the straight line in the eye-glass of a microscope. In order to make these lines as definite as possible, the point was lapped to a bright surface. After being placed in position, the microscope, which could be placed on the front of the tool-carrier, was set to compare with the graduations on the standard bar from which the new bar was to be prepared. After such a setting the readings were made by three persons, and by turning the lever the marking tool was dropped, making a very fine line, so fine indeed, that when the authorities in Washington began the examination of the bar, later on, they declared that no line had been made upon these studs.

After making the first line, the carriage was moved along to compare with the other line on the standard, and after the correction had been made by the use of the micrometer in the microscope, the marking tool was again dropped, giving the second line, which was intended to mark the limit of one yard over all. The same operation was repeated in the marking of the metre. The whole of this work was done, of course, with the greatest care, and, while the theoretical portion of it appears very simple in detail, it required a great deal of time and patience before the last line could be made. The bar thus marked was taken to Washington and, in Mr. Beale's presence, was compared by the attendants with bronze No. 11, and later with Low Moor bar, No. 57.

In comparing this standard, a process was gone through which was similar to that used in marking it. The bar, properly supported, was placed upon a box that rested upon rolls, and on this same box was placed the Government standard with which the Brown & Sharpe standard was to be compared. The standard was placed in position under the microscope, and after being properly set to the standard, the bar to be measured was placed under the microscope, and by the micrometer screw of the microscope the variation was measured.

Three comparisons were made by each of the attendants on each end before determining the reading of the microscope, and after such comparisons, and many repetitions of them, the value of the standard No. 2 was found to be $36\cdot00061$ in. for the yard and $1\cdot0000147$ m. for the metre.

After this work had been done, Mr. Beale prepared a second standard, which he called No. 3, and after examining, as shown above, the error was found to be $0\cdot00002$ in. to the yard and $0\cdot000005$ m. for the metre. Observing these variations as compared with the standards originally made, we find they are very close, and it is doubtful if many repeated trials would furnish more accurate work when we remember

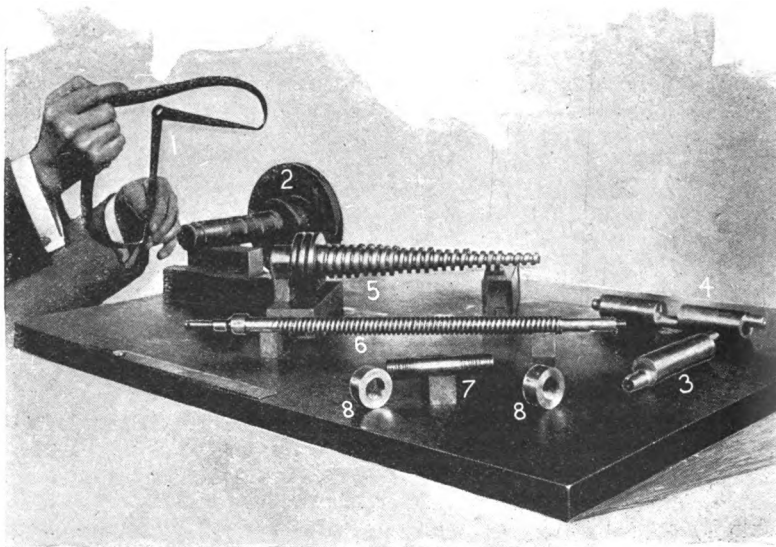

FIG. 4.—Setting calipers.

that out of the forty original standards made but two are correct at 62 degrees Fahrenheit.

After establishing a yard, the problem of obtaining an inch comes next, and this was made by subdividing the yard into two equal parts, these into three, and the three again subdivided into six parts. It should be particularly noted that no mention has been made of a standard inch, as there is none, the standard yard only existing, the subdivision of which falls upon those undertaking standard work. There is a remarkable agreement between at least three leading firms of gauge-makers in this country and abroad, and each came to the result by its own method of subdividing the standard yard.

Use of Measurement. Calipers.—Calipers are of two kinds; those which are used to obtain the diameters of cylindrical shafts or discs are

called "outside" calipers, and those used to span the "bore" of a cylinder or other internal surfaces are "inside calipers." The half-tone, Fig. 4, shows a cylinder cover (2) the diameter of whose flange has been spanned by the outside calipers, and from which the "insides" are being gauged or set.

This gauging by the calipers does not tell us the exact number of inches, or fraction of inches, any piece of work may be; this is not their function.

Calipers are not measuring tools, but rather instruments by the aid of which measurements may be transferred from one object to another.

The operation is always delicate, and can only be properly done in one way. Referring to Fig. 4, it will be seen that the inside calipers are held in the left hand, with the extremity of one leg resting on the end of the long finger; then with the outside calipers held as shown, and with the lower leg cushioned on the same finger, a slight movement with the left hand brings the two upper extremities in contact.

This contact pressure is obtained by the "sense of touch," and is frequently set to within one twenty-five thousandth of an inch of error. These calipers being jointed enables them to be used as shown, with the jaws set 8 in. apart, or, if it were desired, any intermediate sizes down to 4 in. could be equally well spanned.

For work of less dimensions, pocket calipers are used. These should always be made in two distinct pairs, *i.e.* outside and inside. There are, however, some calipers which are made to perform double duty, being so constructed that when the outsides span a 2-in. shaft, the opposite end shows a pair of insides opened 2 in. apart. These are not to be relied upon, because, to keep them accurate, equal wear would be essential. Another objection is their clumsiness for handling.

A very useful form of calipers is shown in Figs. 5 and 6. The joint is so made as to be drawn together by means of a screw, and may be tightened to any degree. There is a further improvement by having a short additional leg and a screw-locking arrangement. This permits the calipers to be inserted in the cavity of a chambered hole; then the small leg is set and secured. By releasing the calipers at the main joint they can be withdrawn; then by simply closing them on to the small leg, the gap between the jaws is exactly the thickness of the piece originally measured. A further advantage is that no amount of jar, or even dropping on the floor, can disturb the fixity of the joint.

Calipers are made in several other forms. Those shown in Figs. 7-12 are the "Fay" patent, by "Starrett." Fig. 7 shows thread calipers. These are used in sizing screw threads, which necessitates the broad points. Figs. 8 and 9 are for use on general work, as are also

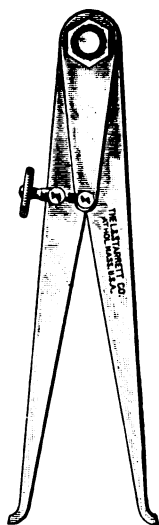
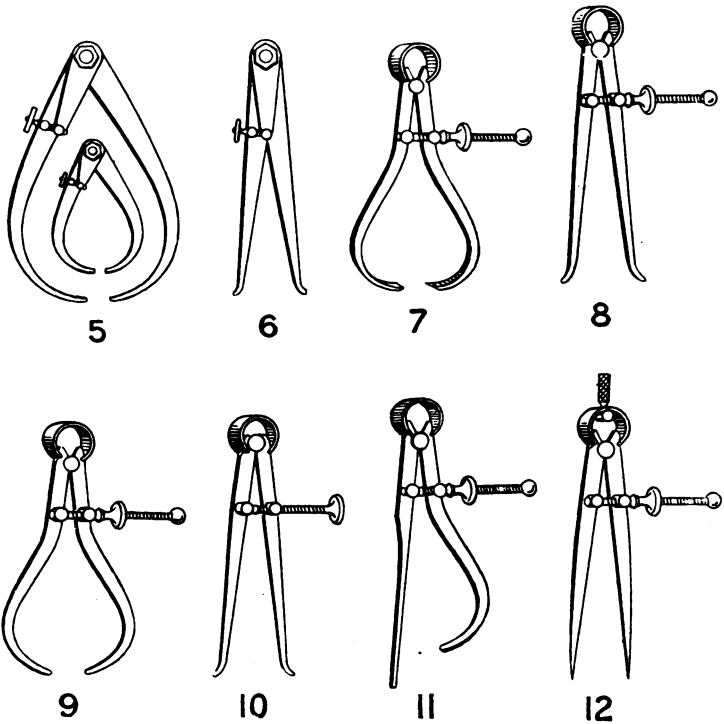

FIG. 6.

Figs. 10 and 11. The latter are specially made for use in measuring the distance of a slot or keyway from a surface. The inside face of the long leg is flat and true. This is set against the wall of the keyway, whilst the curved leg is adjusted to the required distance.

A pair of spring dividers of similar construction is shown in Fig. 12. It should be stated that in some cases the solid nut is replaced by a spring nut; the latter, being split, can be instantly withdrawn or closed, thereby saving the time usually occupied in screwing.



Calipers and Dividers.

Students and apprentices, before attempting to make calipers for their own use, should note: The best calipers are of steel throughout, the joint large, the holes reamed, the rivet turned and well fitted, the points rounded in respect to length, and transversely also hardened and tempered. The "outside pair," when closed, should admit an ellipse between the bows.

Final Test of Calipers.—Open the bows, and close them gradually in one hand. If they close with an equal pressure, they will be a useful pair. If, however, they close with jerks, this proves that the joint is faulty, and, therefore, unreliable for particular work.

In making inside calipers, the above process is adopted, except in the shaping and final bending of the legs. The legs must be finely tapered and thinned towards the points; the bending should be done while the legs are held by a temporary rivet. The angle formed by the bend is less than a right angle, thus enabling the points to reach the root of a recess or counterbore. The points should not be bent to a large curvature, or they will not be useful in gauging a hole at its *root*. For this see Figs. 4, 6, and 10.

"Spring bow" calipers ought not to be sprung over the surface of a piece of work when gauging it, but "passed over," with just a perceptible touch. The bow, or springy portion of the calipers, is extremely sensitive, and will at once indicate when the *faintest* contact is made between the caliper points.

Limit Gauges.—In the manufacture of machinery, where interchangeability is an essential feature, it is necessary to adopt definite amounts of tightness and looseness, or *limits* when fitting one part to another; within which limits work will be regarded as satisfactory, and after standards have been adopted, it is essential that gauges should be at hand to maintain them accurately.

The advantages of the system of using limit gauges is being appreciated more and more in the manufacture of machines and tools, as by the use of this system the time consumed in testing and gauging is reduced to a minimum, and the duplication of parts is insured, together with a corresponding reduction in the cost of production. For example, if it is desired to have a large number of $\frac{5}{8}$ -in. (0.625) shafts made, all of which should fit the same sized bearing, it would be comparatively expensive to grind all these shafts to 0.625 in. standard, as the case required, and the time spent in gauging and testing would amount to a large percentage of the time of production. But if a variation of 0.001 is allowed in the diameter, the time required to grind these shafts can be reduced considerably; all shafts which are ground less than 0.624 in. and more than 0.625 in. being rejected. To work conveniently and economically between these limits the workmen should be provided with limit gauges, or *snap* gauges, as they are commonly called. These gauges are not only used as references for finishing operations, but are of great advantage in roughing work for finishing. By this method the same amount of stock is left on each piece, thus enabling the operator who finishes the pieces to work to much better advantage than if the pieces were of various sizes.

A very convenient form, shown in Fig. 13, is that having both sizes embodied in one gauge. Openings are provided, one at each end, giving the maximum and minimum limits. Gauges of this type are stamped with the words "Go on" and "Not go on." The larger end, or the end that should "go on," receives the most wear, has longer wearing surfaces, and rounded corners, while those of the other end are cut off at an angle, thus enabling the operator to easily and quickly distinguish the larger from the smaller end without looking at the sizes stamped upon the gauge. When these gauges are made of good steel and properly hardened they wear very slowly.

To reduce the wear of the gauge to a minimum, the work should be passed between the jaws only once in testing, and the work should be small enough to pass between the jaws of the large end. In no case should the piece be "jammed" through the gauge.

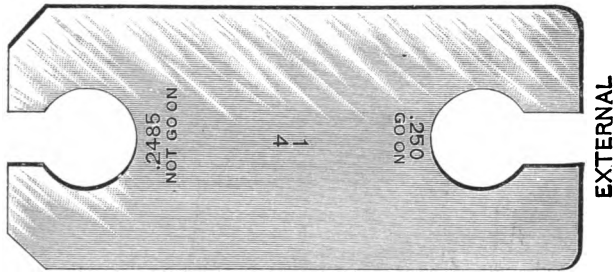

FIG. 13.

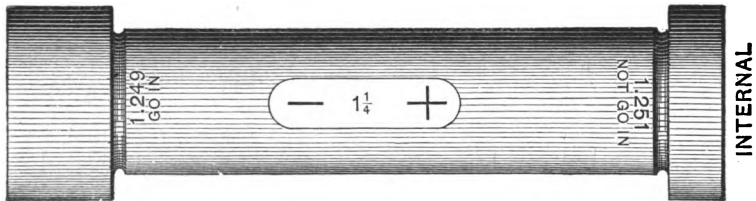

FIG. 14.

Gauges for internal work are used in a similar manner (see Fig. 14).

Standard Caliper Gauges.—Perhaps the most desirable for general shop use are the standard caliper gauges (Fig. 15). They are light and convenient, one end being used for inside, and the other for outside measurements. Their use renders impossible the mistakes that often occur in setting calipers, and eliminates to a large degree the personal errors which appear when work is measured in the ordinary way, thus securing greater uniformity in the duplication of machine parts.

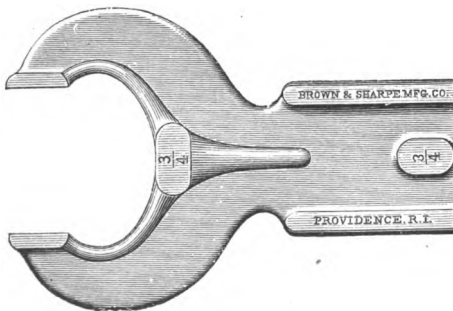

FIG. 15.—Limit gauge.

Fig. 13 is a $\frac{1}{4}$ -in. gauge, made of one piece of steel, hardened and ground to a high degree of accuracy. The sizes commence at $\frac{1}{4}$ in., and rise by $\frac{1}{16}$ in. to $2\frac{1}{2}$ in. ;

above this up to 7 in. they advance by $\frac{1}{8}$ in. These gauges answer equally well on some classes of work with the cylindrical external and internal gauges, but the latter have a greater range of usefulness (Fig. 15A). For instance, an internal gauge will tell us if a bored hole is parallel and cylindrical because it resembles the shaft or axle to a perfect degree. With it work may be bored and tested or gauged

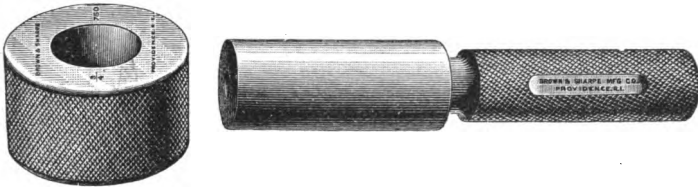

FIG. 15A.—Cylindrical gauge.

to a degree of accuracy which will warrant a perfect fit of the shaft or axle without a trial being necessary.

Standard Reference Discs (Fig. 16) are a somewhat recent addition to the tool-room, and one which will still further reduce the possibility of error. These serve well in shop practice in testing measuring tools, setting calipers, etc. The discs are used generally in place of standard cylindrical gauges, but are not to be recommended for constant use as substitutes for these. They are designed to serve principally as reference, not as working, gauges. The smallest is $\frac{1}{4}$ in., and they rise by $\frac{1}{16}$ in. to 3 in. diameter.

End Measuring Rods are of hardened steel (Fig. 17) accurately ground, so that the ends form sections of true spheres, whose diameters are equal to the length of the rods; they are used when making rings, cylinders, etc., and as reference tools in setting calipers, etc., or in comparing gauges and work of a simple character.

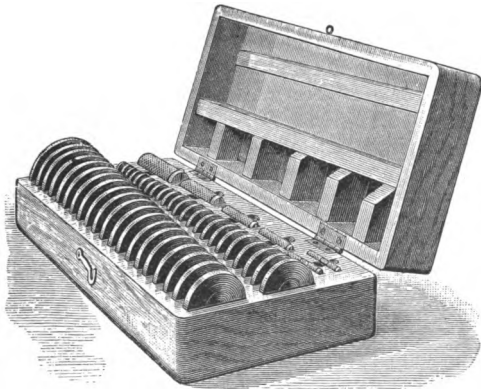

FIG. 16.—Standard reference discs.

They are also useful for measuring parallel surfaces, since the spherical ends will pass such surfaces without cramping, like spheres of the same diameter.

Originally a "mété" or movable gauge was used, consisting of a metal tube plugged and pointed at one end, whilst at the other a rod of iron could be inserted and secured at any position by a set-screw; these extended rods were very liable to alteration during use.

The Wire Gauge.—The legal standard wire gauge was established by the Board of Trade in an Order in Council issued on August 23, 1883. This order came into force on March 1, 1884. There is consequently now only one wire gauge that can be legally used for buying and selling wire in Great Britain. The Board of Trade standard wire gauge is not an instrument, but is simply a table of numbers, and each number represents "equivalents in parts of an inch," or "equivalents in metric millimetres" given opposite each number in the table. We give a copy of that table, and with it a table of wire gauges used in the United States of America for comparison.

It will be observed that the Stubs' wire gauge and the Birmingham wire gauge are the same. Unfortunately, the Board of Trade standard wire gauge was described in the order of the council as B.W.G., thus confusing it with the Birmingham wire gauge, with the result that makers of gauges took advantage of this, and stamped "B.W.G." on the wire gauges they made and sold. In cases of dispute, however, no wire

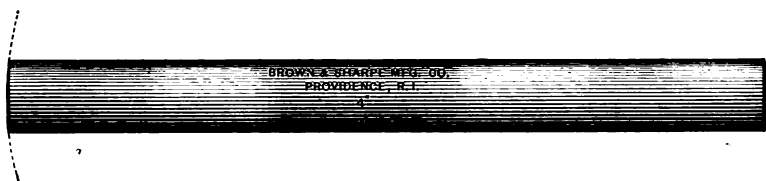

FIG. 17.—End measuring rod.

gauge can now be produced in a court of law unless it has been verified and stamped by an inspector of weights and measures.

There are now in England passing as B.W.G.—

- (1) The standard wire gauge ;
- (2) Stubs' wire gauge ;
- (3) Imperial wire gauge ;
- (4) Iron wire gauge ;

a multiplicity which causes inconvenience and irritation in trade.

Had the Board of Trade described the gauge as the British Standard Wire Gauge (B.S.W.G.), all other gauges would have been disestablished, and much inconvenience and confusion prevented.

Method of obtaining a Working Fit.—There is a little difference allowed in measurement when fitting together two cylindrical objects, so as to give freedom when working. Hence we have what is known as a "working fit."

This difference in diameter may be scarcely appreciable in some work, and still be sufficient, or it may be free enough to shake, and yet be no serious detriment.

All this depends upon two things: what the work is, and what is expected from it.

Let us take two common examples. First: Suppose a steam-engine piston is turned and fitted to the cylinder, just a "free fit," so that it will travel from end to end without obstruction; and for the second:

The "poppet" of a lathe headstock, which must be turned and carefully fitted into its place by "grinding" with flour, emery, and oil, a process which burnishes both the "bore" of the hole and the steel poppet alike, with this result also (if the work is skilfully done) there is a perfect coincidence between the two surfaces, without the slightest amount of slack fitting from end to end. Now, both the piston and the poppet are "sliding fits" when finished; but there is this difference, the piston has not to be so good a fit as the poppet, because the piston-rings do the work of exactly fitting the cylinder. On the other hand, if the lathe poppet were turned like the piston, it would be useless, because it has important work to do, and any appreciable looseness would at once condemn it as unfit for the purpose intended, *i.e.*, keeping in perfect alignment in any position.

Very much depends upon the formation of the cutting tools used when finishing cylindrical pieces to be fitted into bored holes; for instance, wrought iron and mild steel "shafting" is turned with one cut only, but axles, spindles, and many other steel forgings require two or more roughing cuts before the final cut can be taken.

Especially is this the case when the work is short, but has to be considerably reduced in dimensions in the lathe instead of taking the trouble to first forge it into shape. The cutting edges of a lathe tool for finishing should be made so as to present a curved lead to the work followed by a little parallel facet which merges into a short curved decline.

Some discretion is required when using these tools, because of their tendency to "dig," which will be sure to happen when finishing slender rods, unless the cut is a very small one. The reason for having the flat facet on the tool-nose is that it reduces the traversing marks, and leaves the work smooth enough to need little or nothing to be finished by filing and polishing. Very small work which refuses a broad-nosed tool can be better treated by a tool having a small curvature instead of a flat facet at the point of contact; let the traverse be made exceedingly fine—say forty revolutions to 1 in. of feed, then, with a liberal supply of lubricant the speed may be considerably increased, and more satisfactory results obtained. The chief features of the modern turret lathe are a plenteous flow of lubricant, a high speed, and a fine feed.

Bicycle-hub forming machines, screwing and stud-making machines, are examples of this plan.

When putting on the finishing cut, to test the final size, a standard cylindrical gauge (or reliable duplicate) ought to be measured, very carefully noting the pressure, which should be the same over both gauge and work. In well-ordered shops engaged on repetitionary work a limit gauge would be first used (see Limit Gauges), so that by its use the amount of finishing is known.

Cast iron will finish to a better surface with a spring tool having a broad nose, which really acts as a scraping tool. Some castings, however, are so porous as to make it extremely difficult to remove the "pitted marks," and in such cases a second spring-tool cut should be taken at as high a rate of speed as is possible without softening the tool. Afterwards

the surface is scraped with hand tools while the work revolves at a high velocity.

Filing is to be avoided as far as possible, as the original roundness is to some extent sure to be sacrificed by the file. The hand-scraping tools are held on an elbow-rest fixed under the tool-clamps.

The rest is brought close up to the revolving casting, and to prevent the tool from chattering a thin strip of leather is placed beneath it; this considerably reduces the tendency to vibrate.

When scraping up surfaces which form right angles, but have a fillet, especially in large castings, chattering can scarcely be avoided, but these marks can be eliminated by using a piece of coarse sandstone, worked uniformly against the surface, which must revolve at a high speed.

Brass will admit of much similar treatment to cast iron, but wrought iron, mild steel, malleable cast iron, and tool steel, will not scrape up with hand-scrapers. In fact, when machining these metals, cutting tools with more acute angles have to be used. There may be occasionally a casting made in malleable iron, which will scrape up well, but there is a lack of homogeneity, and therefore no reliance can be placed on it in this respect.

Immeasurable Differences.—When it is intended to make the fit between an axle and wheel extremely tight, the shaft is left a little in excess in diameter, and the wheel boss is heated to expand the hole until the axle will pass in freely. Afterwards water is poured on, and the wheel contracts, and grips the shaft.

In railway shops the driving-wheels are forced on to the axles by hydraulic pressure, but for work of less dimensions—such, for instance, as the phosphor bronze bushes which are to act as bearings for spindles, or shafts in machine tools—the fits are tightly made by “drawing” the bushes home by means of a stout bolt and nut and two or more smoothly-faced washers.

The difference in diameter between the two fitting parts is immeasurable by ordinary tools (about $\frac{1}{400}$ of an inch), but it is always perceptible to the “touch” or “feel” of the calipers. Another case is that of reproducing a facsimile of any standard. Here the pieces are to agree exactly. The difference allowable is scarcely perceptible to the “feel,” because it is really only so much as a little polishing with emery and oil will remove. This is only to be properly done by care and experience, but to those untaught it may be of interest to know that there are many pieces of work made so near to the gauge that trial is only made because it is satisfactory. Indeed, in the Ordnance Department of the Royal Arsenal the taper portion of the guns are never tried in position until they are suspended and shrunk in place finally. That is to say, the internally tapered shell is made to a gauge in one of the workshops, and the huge gun is turned to a similar taper in another workshop, but the fitting is done away from either, and so accurate is the coincidence between the two pieces that it can be pre-determined how far the taper-gun will telescope its shell without any external force other than gravity being made use of.

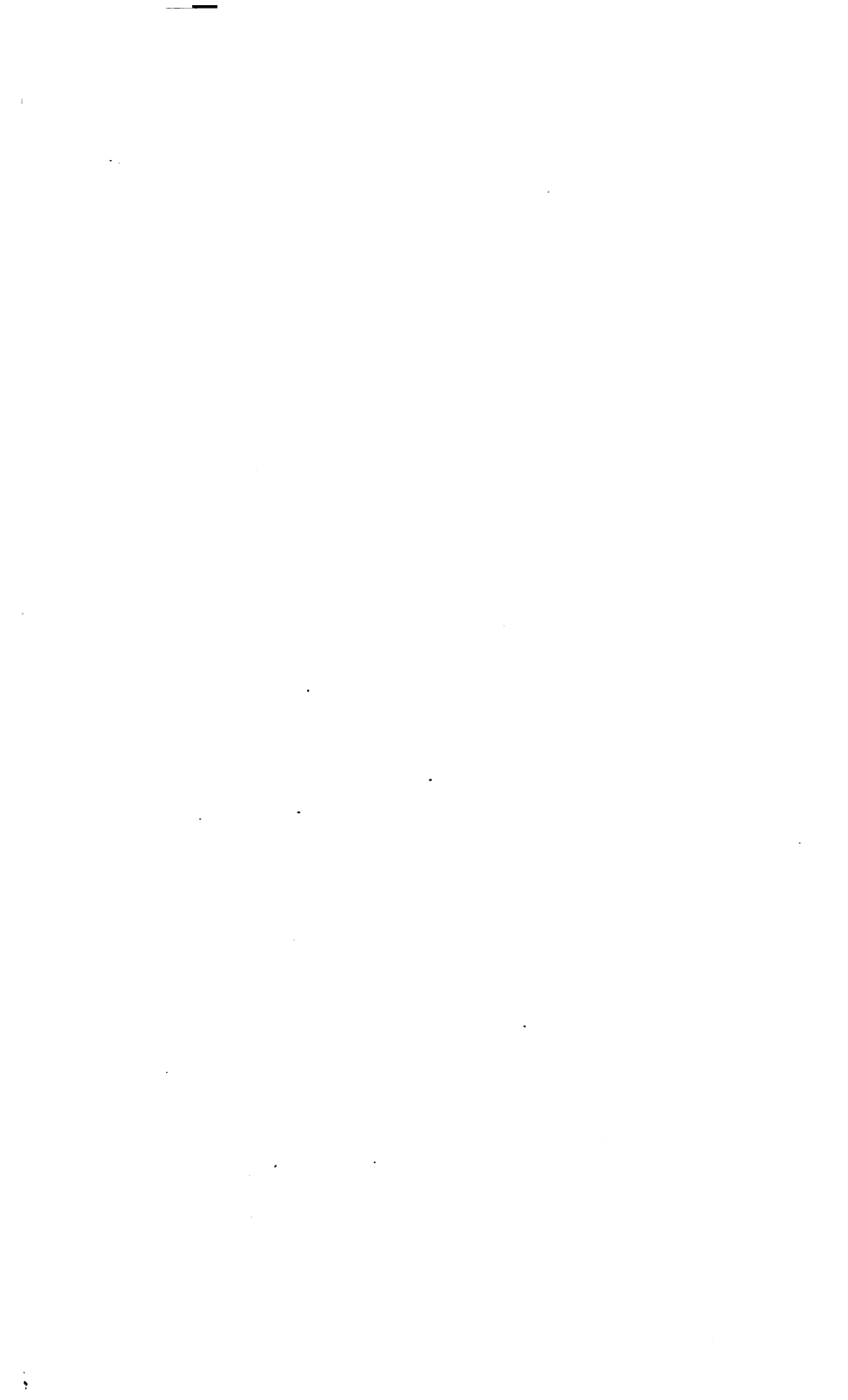

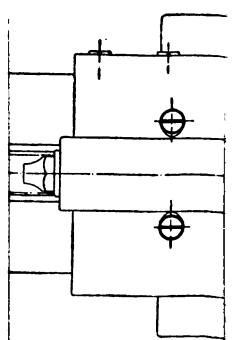
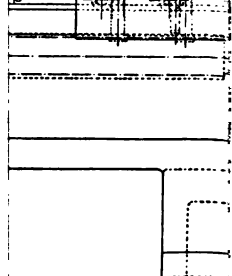
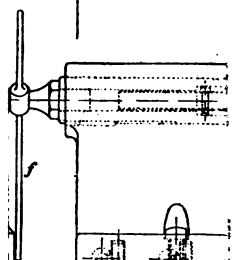
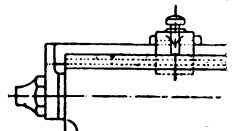
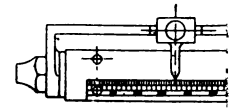

CHINE.
& Co., LTD., MANCH

The "Whitworth" Measuring Machine.—In the construction of instruments of precision, as well as in the manufacture of all kinds of "standards" of reference, such as the gauges previously shown, it is imperative to have a machine which will measure accurately.

The machine illustrated in drawing No. 18 is from a drawing supplied by Sir W. G. Armstrong, Whitworth & Co. of Manchester, to whom I am indebted for this and other drawings. This machine is capable of detecting a difference of $\frac{1}{100000}$ part of an inch in the length of two bars. Four views of the machine are shown, viz. a sectional elevation, a plan, and two end views, from which the construction may be clearly seen. In the front elevation, two bars, A and B, are supported by three movable stays, CDE. The lengths of A and B are 4 in. and 8 in. respectively, and their position being registered, they may be removed for duplicates to be tested. At *f* is a feeler, *i.e.*, a movable piece of steel which is accurately made of a uniform thickness throughout. This feeler is used as a gauge, by being suspended between the bar and the two headstock centres whenever comparisons are being made. From the foregoing it must be understood that the feeler is always delicately balanced before any indications are noted—a proof that the sense of touch is keener than the sense of sight. Running in each headstock is a micrometer screw of 20 threads per inch, and the movable headstock is also fitted with an index wheel, having 250 divisions by any movement of which the "poppet" is caused to advance $\frac{1}{20} \times \frac{1}{250} = \frac{1}{5000}$ of an inch. At the opposite end of the machine is a similar screw of 20 threads per inch, but with a graduated wheel having 500 divisions, and above the poppet a vernier is located, thus causing a reading of one division on the vernier to represent $\frac{1}{20} \times \frac{1}{5000} \times \frac{1}{10} = \frac{1}{100000}$.

The precision of this machine doing its duty according to the foregoing is due to the high-class workmanship in all the movable parts. Especially the accuracy of pitch in the 20-thread screws, and the perfect coincidence between these and the nuts fitting them; that is, there must be no backlash. Then in the finely divided wheels these must be spaced exactly with 250 and 500 lines respectively, and, lastly, the true fitting of the sliding poppets.

A smaller type of machine by Geo. Richards, Manchester, reading to $\frac{1}{100000}$ inch is seen in Fig. 19.

Lathe Test Indicator. "Setting" Work true on Face Plate.—The amount of error is not always to be detected by a fixed point held against a revolving piece of work. Supposing the work has been bored previously, and has to be re-set. Such pieces for boring or drilling are first mounted in the lathe; it is the practice to "set" the part to be bored to a circle previously described, and "dotted" with a fine-pointed punch. In setting such work a *test indicator* may be used to advantage (Fig. 20). This little instrument multiplies the error of the revolving work. The finger is carried in a universal joint which oscillates, causing the opposite end of the finger to move in an eccentric path until the work is "set" to revolve absolutely true.

Micrometer Calipers.—Micrometer calipers form convenient and accurate tools for external measurement. They are graduated to read

English measure to thousandths and ten-thousandths of an inch. They are also made to read to hundredths of a millimetre. The measuring

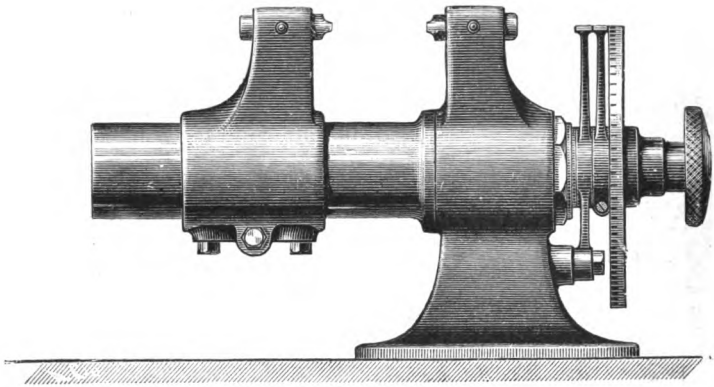

FIG. 19.—Richard's measuring machine.

screw, being encased, is protected from dirt and injury. The wearing parts are hardened, and provided with means of compensation for wear.

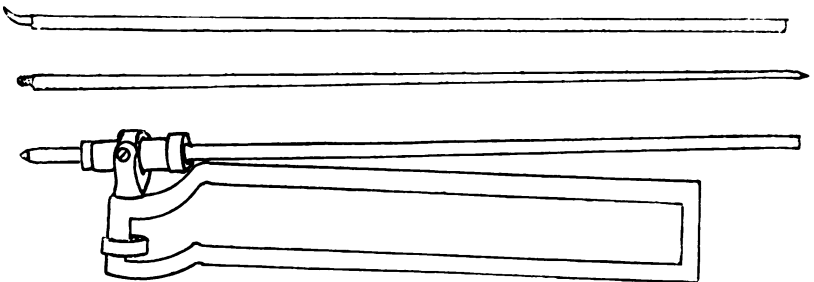

FIG. 20.—Lathe test indicator.

It will be noticed there are decimal equivalents stamped on the frame for the immediate expression of readings in eighths, sixteenths, thirty-seconds, and sixty-fourths of an inch.

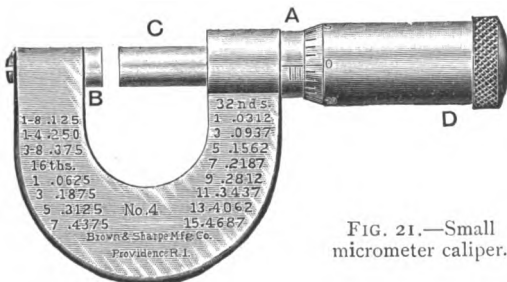

FIG. 21.—Small micrometer caliper.

The chief mechanical principle embodied in the construction is that of a screw free to move in a fixed nut. An opening to receive the work to be measured is afforded by the

backward movement of the screw, and the size of the opening is

indicated by the graduations. The pitch of the screw C is forty to the inch. The graduations on the barrel A, in a line parallel to the axis of the screw, are forty to the inch, and figured 0, 1, 2, etc.,

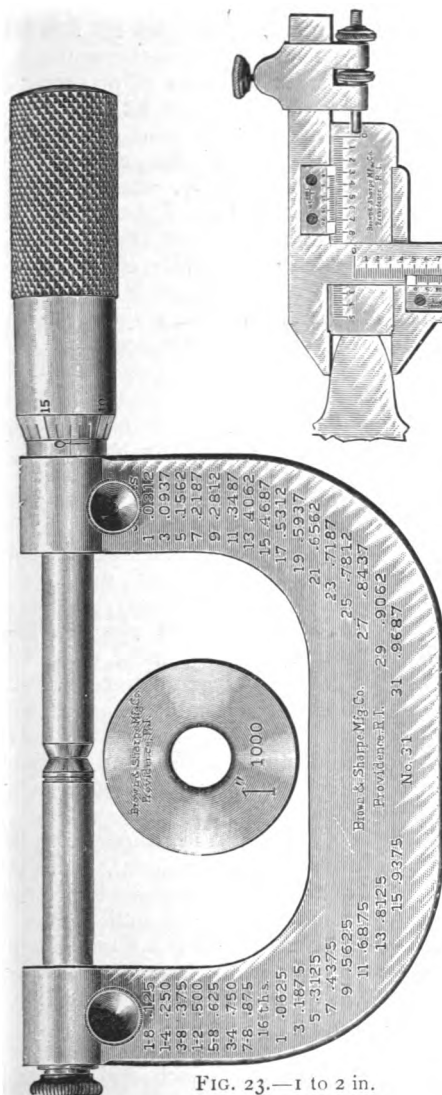

FIG. 23.—1 to 2 in.

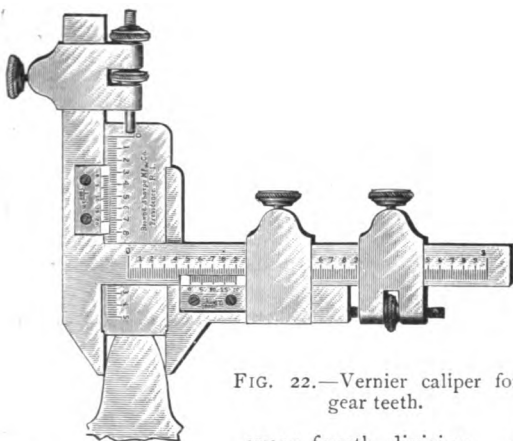

FIG. 22.—Vernier caliper for gear teeth.

every fourth division. As these graduations conform to the pitch of the screw, each division equals the longitudinal distance traversed by the screw in one complete revolution, and shows that the caliper has been opened $\frac{1}{40}$ or $\frac{25}{1000}$ of an inch.

The bevelled edge of the thimble D is graduated into twenty-five parts, and figured every fifth division, 0, 5, 10, 15, 20. Each division, when coincident with the line of graduations on the barrel A, indicates that the gauge-screw has made $\frac{1}{25}$ of a revolution, and the opening of the caliper increased $\frac{1}{25}$ of $\frac{25}{1000} = \frac{1}{1000}$ of an inch.

Hence, to read the caliper, multiply the number of divisions visible on the scale of the barrel by 25, and add the number of divisions on the scale of the thimble, from zero to the line coincident with the line of graduation on the hub. For example: As the caliper is set in Fig. 24, there are three whole

divisions visible on the barrel. Multiplying this number by 25, and adding 5, the number of divisions registered on the scale of the thimble, the result is eighty-thousandths of an inch ($3 \times 25 = 75 + 5 = 80$). These calculations are readily made mentally.

Explanation of Graduation of Micrometer Calipers for Reading to Ten-thousandths of an Inch.—The readings in ten-thousandths of an inch are obtained by means of a vernier or series of divisions on the barrel of the caliper.

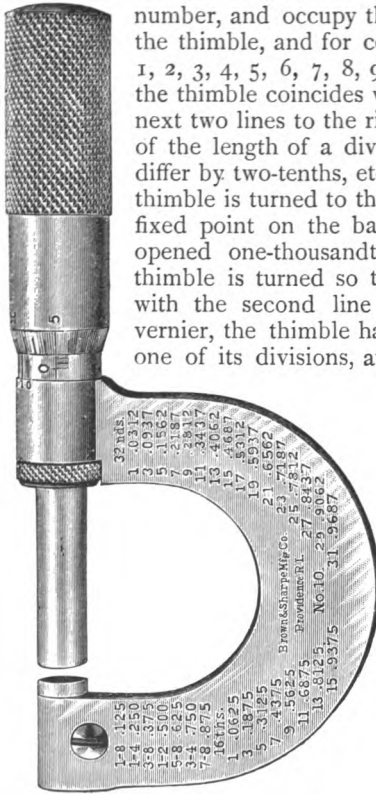

FIG. 24.—Micrometer caliper.

the thimble is coincident. If the second line of the thimble coincides (figured 1), add one ten-thousandth; if the third line (figured 2), two ten-thousandths, etc.

Micrometer Calipers. *Micrometer below 1 in.*—The micrometer (Fig. 21) is used for measuring all sizes less than an inch, and is graduated to read to thousandths of an inch by the divisions shown on thimble, and *ten-thousandths* of an inch by a *vernier* on the front of the barrel. The milled nut clamps the spindle after setting, and keeps it intact (see Fig. 24).

These divisions are ten in number, and occupy the same space as nine divisions on the thimble, and for convenience in reading are figured 0, 1, 2, 3, 4, 5, 6, 7, 8, 9, 0. Accordingly, when a line on the thimble coincides with the first line of the vernier, the next two lines to the right differ from each other one-tenth of the length of a division on the thimble; the next lines differ by two-tenths, etc. When the caliper is opened, the thimble is turned to the left; and when a division passes a fixed point on the barrel, it shows the caliper has been opened one-thousandth of an inch. Hence, when the thimble is turned so that a line on the thimble coincides with the second line (end of the first division) of the vernier, the thimble has moved one-tenth of the length of one of its divisions, and the caliper opened one-tenth of one-thousandth, or one ten-thousandth of an inch. When a line on the thimble coincides with the third line (end of the second division) of the vernier, the caliper has been opened two ten-thousandths of an inch, etc. See lower cut of graduations, where a line on the thimble coincides with the fourth line (end of third division of the vernier), and the reading is three ten-thousandths of an inch.

To read the caliper, note the thousandths, as usual, then the number of divisions on the vernier commencing at 0 until a line is reached with which a line on the

Micrometer 1 to 2 in.—Fig. 23 is used in measuring all sizes above one inch and less than two inches by thousandths of an inch. Instead of the milled nut, a set-screw is provided to clamp the spindle in position.

Interchangeable and Adjustable.—A micrometer caliper for much larger work is given in Fig. 25. Three measuring points are furnished: the long point measures from 3 to 4 in., the intermediate point from 4 to 5 in., and the short point from 5 to 6 in. These rods are inserted into the frame, and secured in the bearing by means of a knurled nut at the outer end of the frame. There is also provision for adjustment as wear occurs by means of the two lock nuts shown on the rods in figure.

Screw-thread Micrometer Caliper.—This instrument is designed for the accurate measurement of V-threads on screws, standard screws, taps, and thread gauges by measuring the actual threads. The distinctive feature in the construction of this caliper is that the end of the movable spindle is pointed, and the fixed end, or "anvil," is V-shaped (see Fig. 26).

Method of Working.—Enough is taken from the end of the point, and the bottom of the V is carried down low enough so that they will not rest on the bottom or top of the thread to be measured, but on

the cut surface. As the thread itself is measured it will be seen that the actual outside diameter of the piece does not enter into consideration. Thus, by measuring one-half of the depth of the thread from the top on each side, the diameter of the thread, as indicated by the caliper, or the pitch diameter, is the full size of

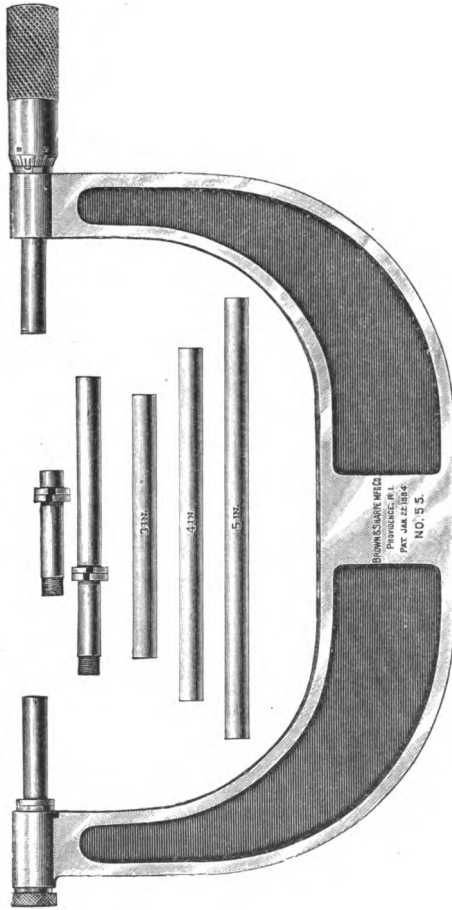

FIG. 25.—Interchangeable micrometer.

the thread less the depth of one thread. This depth may be found as follows:—

Depth of Whitworth standard threads	= 0.64 ÷ number of threads to 1 inch.
Depth of sharp V-threads (60°)	= 0.866 ÷ " " "
Depth of U.S. standard thread	= 0.6495 ÷ " " "

When the point and anvil are in contact, the O represents a line drawn through the plane AB, and if the caliper is opened to 0.500 in., it represents the distance of the two planes 0.500 in. apart.

Limit of Range.—While the movable point measures all pitches, the fixed "anvil" is limited in its capacity, for if it is made large enough to measure a $\frac{1}{4}$ -in. pitch thread, it would be too wide at the top to measure a 24-pitch thread, or *vice versâ*; then the thread would not obtain a proper bearing on the anvil. Thus each caliper is limited in the range of threads that the anvil can measure.

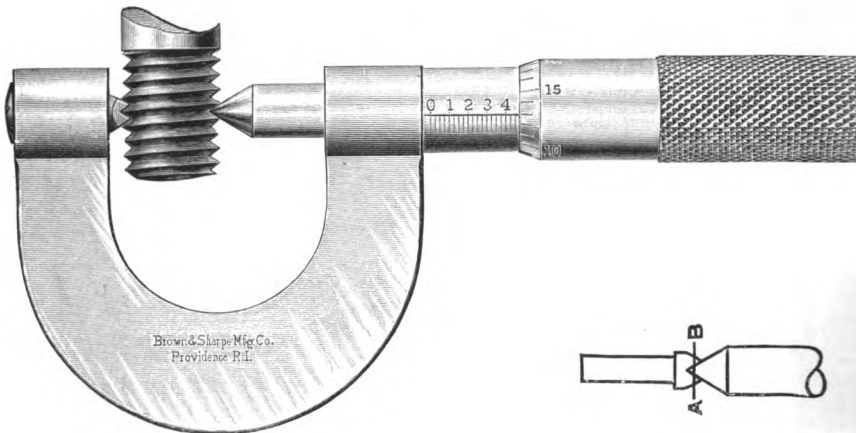

FIG. 26.—Screw-thread micrometer.

Sliding Micrometer Caliper.—Fig. 27 is a sliding micrometer caliper, and measures all sizes up to 6 in. long and 4 in. diameter by thousandths of an inch. The slide can be set accurately by means of the graduated lines on the bar, while fractions of an inch are obtained by means of the micrometer screw.

Vernier Calipers.—Two views of a vernier caliper are given in Figs. 28 and 29. The front side is graduated to read by means of a vernier to thousandths of an inch for accurate work.

The back side is convenient for a large class of work where extreme accuracy is not required; the graduations are to $\frac{1}{64}$ in. These instruments are useful to those engaged on high-class mechanisms; and in tool-making, where extreme accuracy in working is essential, they are in daily use.

The Vernier and its Use.—On the bar of the instrument is a line of inches numbered 0, 1, 2, etc., each inch being divided into ten

parts, and each tenth into four parts, making forty divisions to the inch. On the sliding jaw is a line of divisions (called a vernier, from

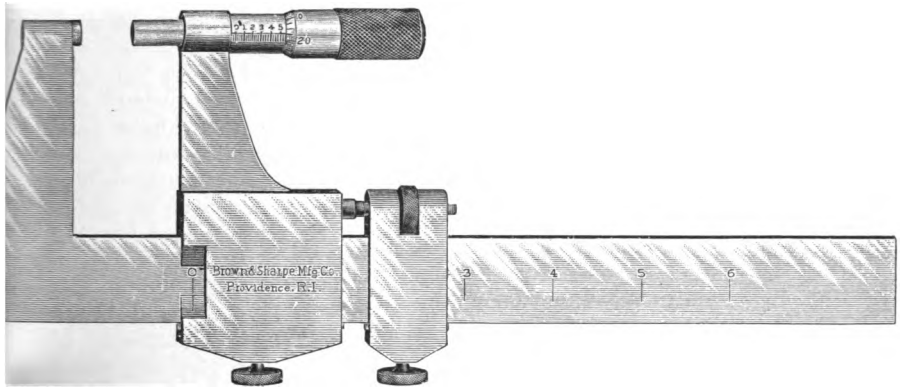
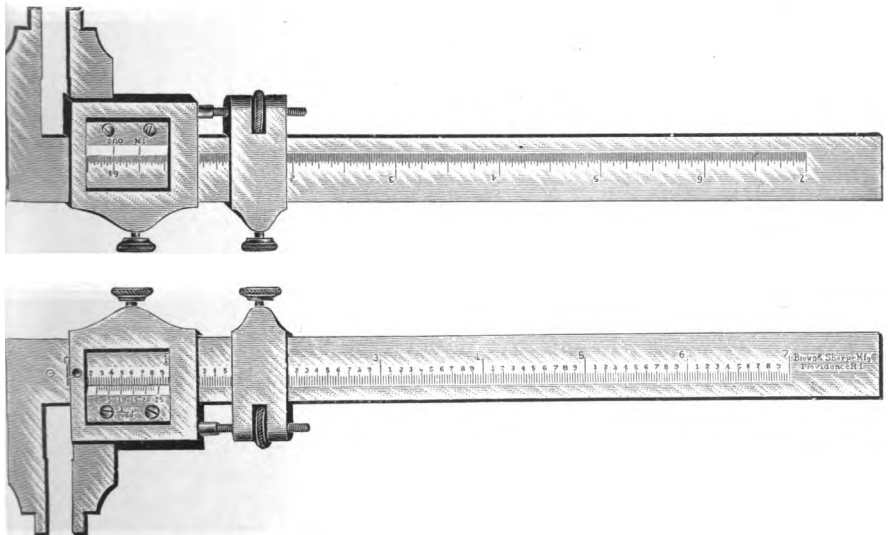

FIG. 27.—Sliding micrometer caliper.

the inventor's name) of twenty-five parts, numbered 0, 5, 10, 15, 20, 25. The twenty-five parts on the vernier correspond, in extreme length, with twenty-four parts, or twenty-four fortieths of the bar; consequently each division on the vernier is smaller than each division



FIGS. 28, 29.—Vernier calipers.

on the bar by 0.001 part of an inch. If the sliding jaw of the caliper is pushed up to the other, so that the line marked 0 on the vernier

corresponds with that marked 0 on the bar, then the two next lines to the right will differ from each other by 0.001 of an inch, and so the difference will continue to increase by 0.001 of an inch for each division, till they again correspond at the line marked 25 on the vernier. To read the distance the caliper may be open; commence by noticing how many inches, tenths, and parts of tenths the zero point on the vernier has been moved from the zero point on the bar. Now count upon the vernier the number of

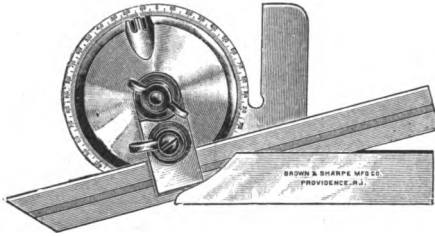

FIG. 30.—Universal bevel protractor.

divisions, until one is found which coincides with one on the bar, which will be the number of thousandths to be added to the distance read

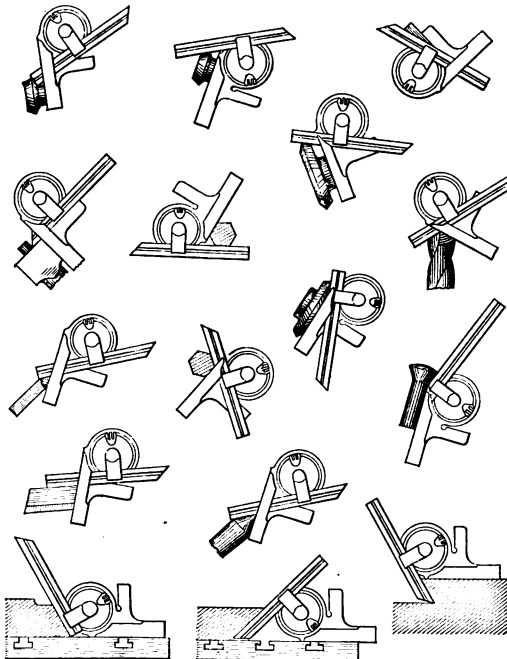
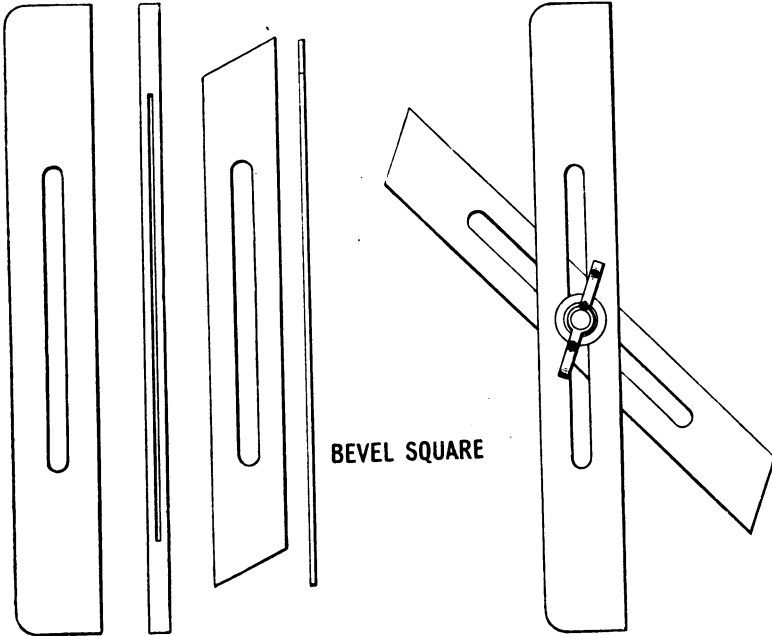

FIG. 31.

off on the bar. The best way of expressing the value of the divisions on the bar is to call the tenths one-hundred thousandths (0.100), and the fourths of tenths, or fortieths, twenty-five thousandths (0.025).

Referring to Fig. 29, it will be seen that the jaw is open two-tenths and three-quarters, which is equal to two hundred and seventy-five thousandths (0.275). Now suppose the vernier was moved to the right so that the tenth division should coincide with the next one on the scale, which will make ten-thousandths (0.010) more to be added to



BEVEL SQUARE

DETAILS

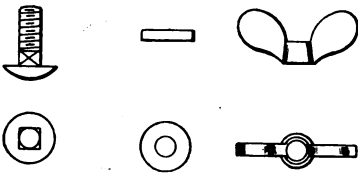

FIG. 31A.

two hundred and seventy-five thousandths (0.275), making the jaws to be open two hundred and eighty-five thousandths (0.285).

In making inside measurements with the 6-in. vernier and the pocket vernier calipers, two and one-half tenths or two hundred and fifty thousandths

(0.250) of an inch, and with the 12-in. and 24-in. verniers, three-tenths or three-hundred thousandths (0.300) of an inch should be added to the apparent reading on the vernier side for the space occupied by the caliper points. When the other side of the instrument is used, no deduction is necessary, as there are two lines, one indicating inside and the other outside measurements.

Universal Bevel Protractor.—Protractors are instruments by which angles are set out in degrees. Fig. 30 is the Brown and Sharpe Universal

Bevel Protractor, and is adapted for those classes of work in which angles are to be laid out or established.

The circular dial is graduated in degrees round the entire circle,

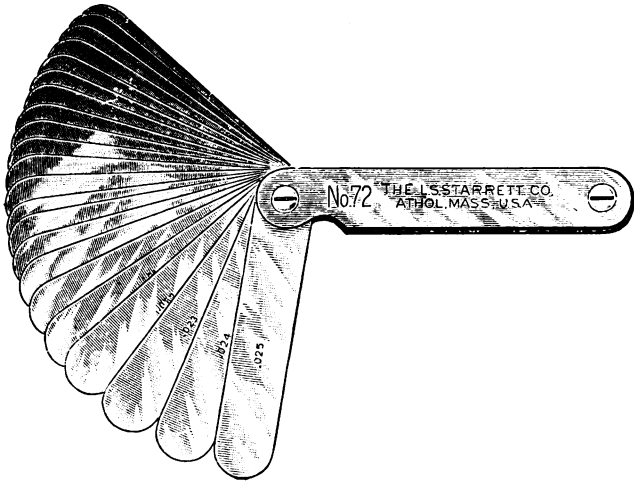

FIG. 32.—Thickness gauge.

and is recessed below the face to protect it as the bevel is used. This combination of "bevel" and protractor render it indispensable for setting



FIG. 33.—Spirit level for testing shafting.

out and gauging work in the tool-room. The blade can be moved either way its full length, and clamped independently of the dial. The



FIG. 34.—Electrician's non-magnetic spirit level.

many uses to which the instrument can be put cannot all be cited here, but further comment is unnecessary after looking at some of its applications in Fig. 31. A fitter's bevel square is shown in Fig. 31A.

Thickness Gauge, or "Feeler."—Thickness gauges (Fig. 32) are

used either singly or in combination, to ascertain the width of gap between two surfaces, also to test the thickness of sheet material.



FIG. 35.—Pocket level.

The leaves vary in thickness by $\frac{1}{1000}$ in., running from 0'004 to 0'025.

Spirit-levels.—Spirit-levels are used to test the alignment of shafts, tables, beds, and other fitting parts of machinery. The under surface of a level is scraped to a true plane, so that it will lie even. Fig. 33 shows

one of these instruments made with a concave groove running the length of its base, which renders it useful when testing the evenness of shafts. In addition to the longitudinal glass, the base is fitted with a cross-level which removes the necessity of changing the position

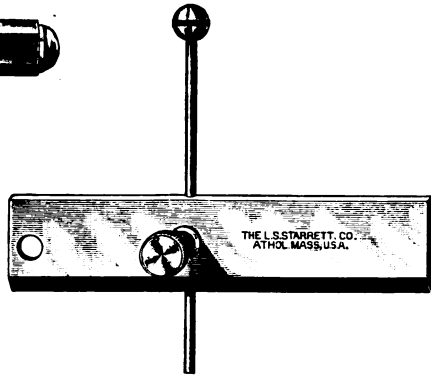

FIG. 36.—Depth gauge.

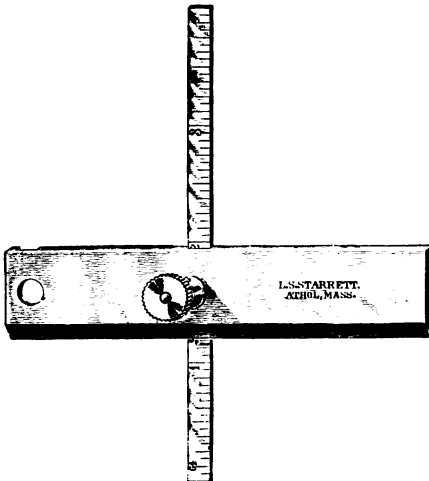

FIG. 37.—Depth gauge.

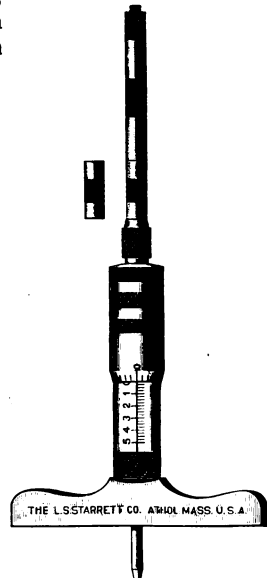

FIG. 38.—Depth gauge.

of the instrument so frequently. Fig. 34 is a non-magnetic level, being designed for use in electrical work. Fig. 35 shows a pocket level made of steel and plated; the length is $2\frac{1}{2}$ in.

Depth Gauges.—Depth gauges are used to measure the depths of grooves in milled and planed work, also in lathe face plate work, when one surface has to be turned to a definite distance from another surface. The gauge can be set to the depth required, and secured by the set-screw. Fig. 36 shows a gauge in which the wire is held by a friction spring inside the nut. Fig. 37 is a similar gauge, except that a marked scale is substituted for the wire rod.

The gauge shown in Fig. 38 admits of a more accurate setting; it has a micrometer screw reading to $\frac{1}{10000}$ in. Standard collars are passed on the spindle when the depth of the recess to be measured is considerable. A lock nut at the top of the spindle prevents any changing after the gauge has been set.

CHAPTER II.

“MARKING” OR “LINING-OUT” TABLE AND TOOLS.

WHEN castings and forgings are delivered into the machine shop, they are first placed on a marking-off table, and “set out” for machining. It is the practice for templates to be made to dimensions on drawing for each type of engine or machine, a practice which greatly facilitates the marking, and whereby the templates serve as guides, and sometimes as gauges, for the machine operatives. The above system can be generally applied to duplicate work. When, however, it is not practised, drawings fully dimensioned are supplied.

Whichever system is adopted, a careful and reliable workman is sought for the post of marking off. He is obviously required to thoroughly understand all kinds of drawing details, and be able to trace them out, frequently from complicated elevations, end views, or plans, and is responsible for each part being correctly tooled and fitted to the lines scribed.

“Marking tables” vary in dimensions from 4 ft. to 12 ft. long. The upper surface is truly planed, as are also the edges which are truly at right angles to the face and to each other. The under side of the table is strengthened with ribs, similar to a surface plate, to keep it true under varying conditions. The table should be set by the aid of a spirit-level to lie even in all directions, and supported in such a manner as to remain firm under any load. Such a table is shown in Fig. 39, provided with a complete set of tools, as follows: Nos. 1 and 2, large and small squares; Nos. 3, 4, and 5, scribing blocks; No. 6, parallel blocks; Nos. 7, and 8, vee blocks; No. 9, compasses; No. 12, large straight-edge.

Tools not numbered.—Accurate steel rule, marked in terms of British and decimal measures. A plumb-bob and spirit-level, pair of inside and outside calipers, also odd-leg calipers, trammels and scriber, centre and prick punch.

EXAMPLE.—The engine connecting-rod, No. 10, is mounted on parallel and vee blocks *after* machining, while the centre and other dotted lines are tested with the scribing block (a temporary pin being inserted in the fork end). The example, No. 11, represents a rough, forged fork end, marked off for machining; the centre line shown would be marked similarly on the opposite side of fork. The inner circle

shows the diameter of the hole. The outer circle shows the amount to be removed by shaping, slotting, or profiling machine, as the case may require.

Small and important mechanisms are frequently assembled on a surface plate, which has been scraped up perfectly true. This is found

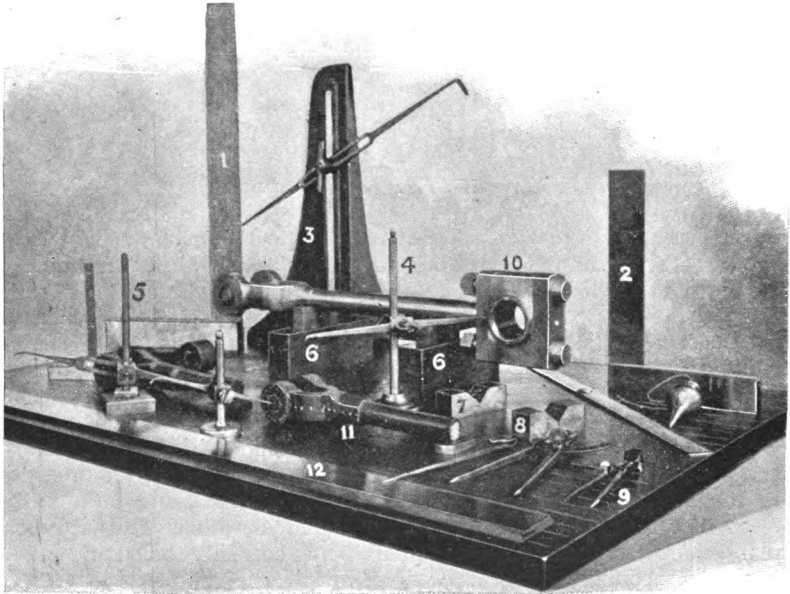

FIG. 39.—Example of work and tools—marking-out table.

advantageous, especially where the marking has to be done at different stages—that is to say, after a piece of work has been lined out and “tooled,” it is sometimes necessary to fit it to some other part or parts before the final marking and tooling can be done. When important lines have to be made at a definite distance apart on some forging or

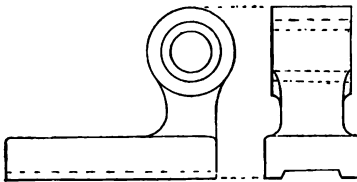

FIG. 40.—Bracket to be bored.

casting of irregular form, an angle plate is used, to which the work is secured. Castings which are provided with cores are bridged over with thin metal, or plugged up at their extremities with wood; even in the latter case it is frequently necessary to insert a tin strip, so that the centre when struck out will be contained by the strip.

Wood is good enough for one or two tooling operations, but where the centres have to be retained, often for a considerable period, wood is unsuitable.

EXAMPLE 1.—Suppose the bracket in Fig. 40 has been faced on the foot, and the hole shown cored has to be bored accurately to the dotted circle. There would be no reason why a wooden plug should not be inserted, just to remain until the dotted circle has been described.

EXAMPLE 2.—Let us take an engine cylinder where the valve spindle bearings are required to be at a given distance apart, and at a given distance from the centre of cylinder bore.

Here we have quite a different case. Some of these centres will be in use for a considerable time, therefore wooden plugs will be unsuitable. Again, when erecting engines, etc., with holes bridged with thin steel or brass strips, very fine lines and dots may be made, which will serve until the “ setting ” is finished.

Marking templates are growing in numbers daily, as the interchangeable system, now extensively adopted, becomes universal. When

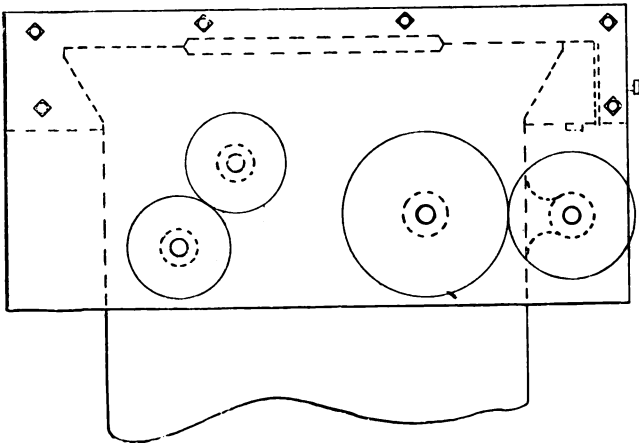

FIG. 41.—Templet for “ marking out ” holes in shaper machine bed.

a “ shaper ” body is being marked, a further example is seen in locating all the bearings at once from one templet (see Fig. 41). After the upper surface and vees of the machine body have been planed, a counterpart of that surface and vees is fitted thereon at one end. This counterpart or templet has an apron with a series of holes made in it, each hole being bushed to receive a fitting cylindrical gauge-marker.

The marker consists of a finely pointed scriber, inserted in the end of the cylindrical rod in such a position that by rotating the marker a finely traced circle is made on the boss of the machine to be bored.

By this arrangement the exact centres for each longitudinal bearing is obtained precisely, and the gear-wheels will subsequently be correctly meshed when placed upon their respective shafts.

Besides this, the marking is done without any measurements whatsoever being necessary, and also in considerably less time than is the case where drawings are used.

It may here be pointed out that holes to be bored in huge castings are generally previously "cored out." There are some points of advantage in this, viz.—

1. A "boring-bar" can be passed through the cored holes.
2. There being less metal to remove, the time in boring is reduced.
3. The metal is generally more dense, or close grained.

On the other hand, it is most desirable that the "core" is in its right place when the casting is finished. If it occurs that a core is out of position, the consequence may be serious. Any error in this direction is doubled when it comes to measurement from the boring bar.

Setting out Machine Bed.—EXAMPLE.—Let us suppose a casting for a machine bed or body is made having a long bearing, the outer diameter of which is 4 in., but whose hole or core is $2\frac{1}{4}$ in. diameter, and has dropped out of position $\frac{1}{4}$ in.

Now, if the core were central with the outer diameter, and the casting had to be bored $2\frac{1}{2}$ in., when finished there would then be $\frac{3}{4}$ in. thickness of metal each side of the bored hole. But the core in this case is eccentric with the boss, or, to put it another way, it is $\frac{1}{4}$ in. out of alignment with some other hole or surface. If it needs "tooling," the boss will be $\frac{1}{2}$ in. thick only on one side, while on the opposite side it will be 1 in. thick. But the cutting has been all one-sided, and although the finished size of $2\frac{1}{2}$ in. is reached, all the black or scale has not been removed.

It therefore follows that, since it is absolutely necessary to have a truly bored and smoothly finished hole, more metal will have to be removed, leaving the hole $\frac{1}{8}$ in. too large, and reducing the thin side of bearing to $\frac{7}{16}$ in.

This clearly shows us that a bent or eccentrically made core in any casting which has to be machined may be sufficient to condemn the work altogether. It would be well for the student to note the following important points respecting cores in iron or other castings:—

1. The amount to be removed by tooling any cored casting should always be sufficient to "clean up" without using a reamer, *i.e.*, it should be smooth and true.

2. Before "lining out," long holes should be thoroughly examined and tested for alignment.

3. Castings in halves should be well jointed, and, where practicable, small articles may be sweated together, or otherwise made secure with screws or cotters, which pass into lugs, or ears.

This refers to bearings, pulleys, and similar split work, which may be disturbed at the joints if left insecure at any point.

4. After correctly "setting," cored work is best faced before boring, as *measurements across uneven surfaces are unreliable*, and especially so to a beginner.

Cored Work.—There is no economy in "coring" some kinds of work below, say, $\frac{7}{8}$ in. diameter; the time spent in machining is worth more than the weight of metal removed from a solid casting. Especially is this the case in long holes of small diameter—say, for instance, a $\frac{3}{4}$ -in. core to be bored to 1 in. diameter 2 ft. through an iron

casting. Here we have an instance showing the difficulty and loss of time in attempting to restore truth to a casting with a bent or eccentrically made core. The first drill passed through must go at an exceedingly slow pace, as must also the second; then a boring-tool must be inserted, taking a number of very fine cuts, otherwise the bend will overcome the cutting action of the tools, and cause them to dip and yield at every revolution of the work. Whereas in sound, solid castings a $\frac{7}{8}$ -in. drill could be first passed through the work; then a second drill would be inserted, leaving just a scraping cut for the reamer; each tool being propelled as fast as practicable, without softening the cutting edges.

Shafts and axles are generally centred by using a pair of "odd-leg" calipers, as shown in Fig. 11, Chapter I. The position is changed four times, and the mean of the crossed lines is taken. Large shafts, 3 in. diameter, can be centred equally well by using an ordinary pair of "outside" or inside calipers. When the end of a shaft is cut off obliquely the position of the centre is more difficult to find, but judgment and care will overcome this.

Short shafts, axles and rods are more correctly centred on a table whilst they are rotated in vee blocks. The blocks should be placed as near the ends of the work as is practicable (since it may be bent or irregular throughout its length) and a scribing block used at each end of the work, the finger of which is first adjusted approximately to the shaft centre. The pieces are afterwards square-centred, and drilled ready for turning.

Cranks or crank shafts are set out on the throws after the parallel part has been straightened and roughly turned, or, in the case of small cranks, after the parallel portions have been finished.

"Setting out" Eccentric Shafts.—Eccentric shafts may be forged, or turned, out of solid (Example 42).

Let us take a forging for a punching machine driving shaft. The parallel portions will be turned and finished, and the shaft let into place.

It is next placed on vee blocks, and a horizontal line scribed through the centre, passing through the forged throw; then, without disturbing the work, the scribing block is carried to the opposite end of shaft, and a line is scribed here also. Let the distance be $\frac{3}{4}$ in. between the centres of the main part of shaft and that of the eccentric. With this as radius, set a pair of compasses, and describe a circle around the original centre of shaft.

Where the circle and line meet, a fine centre dot should be made, before the shaft is removed from its horizontal position. To obtain this new centre a facing cut or two would first be taken from the ends of the shaft previously to marking. This is done to more correctly gauge the exact distance the new centre will be from the old one. In enlarging the small dot, a couple of centre punches would be required of different strengths.

As the hole is made larger, the compasses are used frequently to test the result, and when it is large enough, a small hole is drilled down each new centre, and the work is ready for the lathe. Square centering must

not be thought of in this class of work, because we have no control of the shaft: when set revolving it would gravitate, the heavy side sagging or pulling the shaft downwards; thus the centre would at once be lost, and the work spoilt. Very large shafts are drilled with a hand or breast drill after centre-punching; but great care is exercised, or the drill may take a different course from the one desired.

Another example, much the same as the last one, may be given—a punching and shearing machine shaft. This time there are two eccentric portions to be arranged for. Here we will suppose the shaft to be 8 in. diameter on the main part, and 6 in. diameter on the eccentrics. The shaft would be turned and finished as before, and the ends faced. It would then be fixed on parallel or vee blocks, a line scribed, passing through the centre at each end of the shaft, and a circle described at a

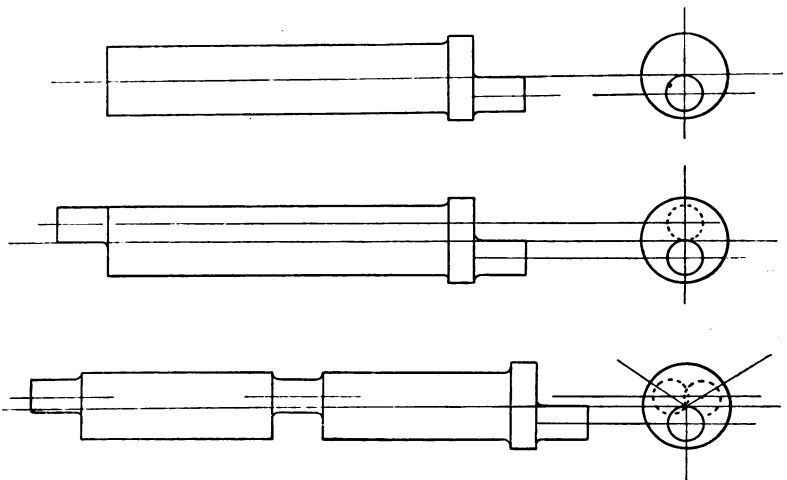

FIGS. 42, 43, 44.—Eccentric shafts: 1, 2, and 3 throws.

distance shown. Since in a punching and shearing machine one tool is operating while the other is free, it is customary to place the eccentrics exactly opposite each other, as shown in Fig. 43. Thus a centre dot would be made at two opposite sides of the circle at the points of intersection.

These large diameter shafts with a comparatively small "throw" are good examples to illustrate "marking out" and "machining" huge pieces of steel on their own centres, *i.e.*, without "crank blocks."

A further example of this class is shown in Fig. 44, which represents a main-driving steel shaft for a punching, shearing, and scrap-shearing machine. In this case there are three distinct tools, none of which are operating at the same instant, but all of which are actuated by the same shaft. Assuming the shaft body has been let into its bearings, it is then rested on a horizontal plane and a line drawn across each centre with

the scribing-block as before, a circle having been struck, the radius of which is equal to the “throws.” Then with a centre dot on one end of the line bounded by the circle previously struck, an arc is described equal to 120 degrees, and from this point another arc similar is made, and again, back to the original point. In other words, from a given point the circle is divided into three equal parts.

Having dotted each point of intersection, the same treatment is given to the other end of the shaft (care being taken that the points of starting are the same, and that the shaft is not disturbed in its position until both ends are marked out alike). The compasses are kept in frequent use until the three centres at each end of the shaft have been properly made. After this the holes are drilled with a breast drill, and the shaft is ready for the eccentric portions to be turned. The central throw, *i.e.*, the one to operate the scrap shears, is cut out and finished first, otherwise the centres for that throw would be cut away, were we to commence one of the end throws first.

Brackets are marked differently according to their importance (Fig. 45).

1. The holes may be bored true to their bosses and parallel with their feet. After this a number are placed on a shaft together, and their feet marked and machined, or where a small facing strip only is provided, the feet are simply chipped and filed.

2. The bracket is placed on its foot and the correct height to centre of boss is marked with scribing block. A line is drawn across the foot, say a bare $\frac{1}{8}$ in., which is next removed by milling, shaping or slotting machine. A correct bracket is mounted in a lathe by passing a shaft through its bore, and afterwards securing the foot to an angle plate, previously fastened temporarily to the lathe face-plate. Then, by placing a stop on the angle plate abutting against the foot, this template or standard bracket may be removed, and the new brackets to be bored are quickly mounted, set, and bored; following each other in this way the holes will all be alike and at the same distance from the base.

3. Another method, but one attended with less accurate results, is to “machine up” the foot first, and afterwards, with a sheet-iron template placed over the boss and foot, the position of the hole is located and traced through with a scribe.

4. The best and quickest results are obtained by the use of a jig, no marking or setting whatever being necessary.

Setting and Machining Irregular Work.—Irregularly shaped iron castings, which should be symmetrical, are mostly moulded and cast

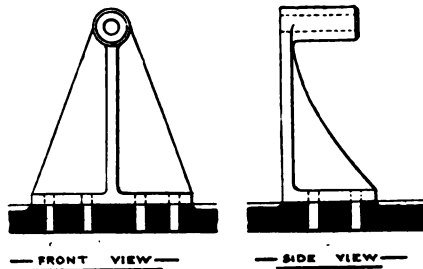
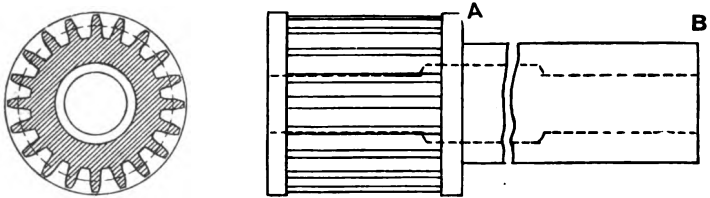

FIG. 45.

from defective patterns. Although a pattern may appear to be satisfactory, yet the castings produced from it may be far from being so. Iron patterns give better results than do those made of wood, and in consequence of this, where a considerable number of small castings are required to be exactly alike, it is the practice to have half the pattern secured to an iron plate. Thus, in castings for sewing-machines and similar small mechanisms, what is known as "Plate Moulding" is adopted in the foundry.

The castings produced are so near a facsimile of the pattern as to be highly satisfactory, although the original cost of the pattern is considerable. This is obvious from the fact that the coincidence between the two halves of the mould must be accurate, thereby causing much care and judgment in the fitting and finishing stages. Where, however, it is not the practice to make moulds other than from wood patterns, or partly iron and partly wood, it frequently becomes a case for the turner to exercise his skill in setting and machining such work.

An example of this is given in Fig. 46, which represents a casting of a shrouded pinion with a long sleeve requiring to be turned and bored.



SHROUDED PINION & SLEEVE.

FIG. 46.

This is a typical example to illustrate the importance of true patterns, and care in moulding. The casting, we will assume, is for gearing as in a Lathe, Drill or Milling Machine headstock. The tooth-wheel is

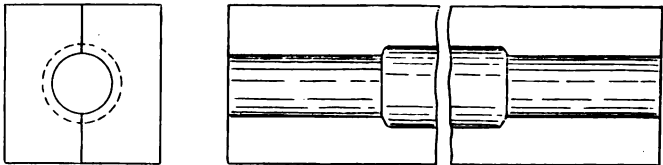

CORE BOX.

FIG. 46A.

of iron (machine cut), therefore turned and bored truly, and the stem and flanges are of wood. A core box is also required similar to Fig. 46A, and made to the dimensions shown.

Now, the cardinal point is the correct fitting of the stem, or stalk, in the iron pinion. Here it may, I think, be easily understood that any

appreciable slackness or eccentricity will be reproduced in the casting at A, and proportionately increased at the end B.

The error takes two forms, axial and diametrical, sometimes one, or the other, or both. In the former case the error is hardly appreciable near to the pinion, but increases more and more right on to the end of the stalk. In the latter case the pinion may revolve truly whilst the barrel takes a decidedly eccentric path. An error of $\frac{1}{8}$ in. out of line is not detected until the pinion is truly chucked, and then it may be sufficiently large to condemn the work, each detailed part being made to a gauge. For the reason already referred to, eccentrically cored holes are troublesome and costly where standards and templates are worked to as a system.

To make a casting of this description come into use would only be attended with troubles of the following kind :—

1. Increased diameter of shaft as a forging.
2. Increased diameter of steel mandrel.
3. Excess in labour, *i.e.* owing to light cuts.
4. Decrease of outer diameter of barrel.
5. (Most important of all) *Deviation from “ system of standards for all work.”*

Apart from the above reasons, it will be seen that the chamber has not to be tooled, but it is nevertheless eccentric, and must ever remain so, if the other parts are to be “ brought in.”

A pinion with a long barrel or sleeve is chucked the same as a pinion without a sleeve; this being so, there is no compensating or allowance, however long a sleeve may be. If the pinion is set diametrically true at every point, the flanges will also be set even, without attention. Where there has been any “ cobbling ” in the mould, the teeth may appear lumpy in places on their periphery and sides. In such cases it is advisable to note the internal faces of each flange, and to gauge the depth of the teeth by their roots. To do this a finely pointed scriber must be placed in the tool-box, and by using the transverse slide the depth can be accurately ascertained for one tooth; then, by rotating the saddle screw and withdrawing the scriber, the lathe may be now revolved for a portion, and the scriber again inserted; this process, repeated five or six times in the revolution, will easily indicate when the roots of the pinions are true—all this “ setting ” being done without looking at the barrel until finally set.

Angle-plate Work.—Angle plates are much used in lathe work and in drilling, planing, milling, and other machine tools.

The plates vary in size from two or three inches to several feet long, and also in shape, but all are of right-angle section. They are subject to more or less rough usage, since they are general appliances. For this reason they should be stoutly made, with ribs placed between the angles at suitable intervals. The holes through which the bolts are inserted should not be over-crowded, it being preferable to drill a hole through the plate according to special requirement than to have a plate rendered weak by numerous holes, many of which may possibly be useless.

For repetitious work the practice is to keep angle plates made for the purpose. After considerable use angle plates yield to the pressure of the bolts, and consequently need to be systematically overhauled and "trued up." A reliable workman invariably tests the angle plate for accuracy by means of an L-square before securing his work upon it, and sets it "off" accordingly. The importance of having a true square is obvious, also the necessity of setting the work truly on the plate surface, although the work is previously marked out, and centre dotted for guidance.

An example of this is given in Fig. 47, which is to represent a gun-metal casting for a square thread nut to fit a screw, lined and dotted for boring and screw-cutting. The setting in this case admits of nothing

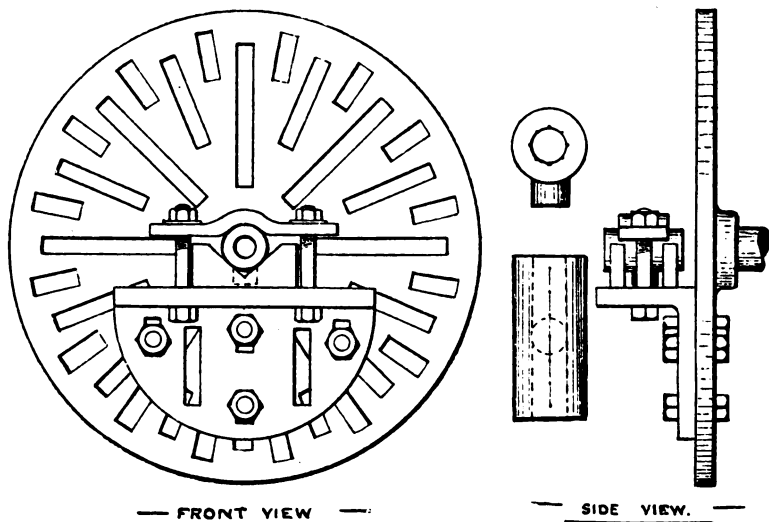

FIG. 47.—Work set on angle plates.

but perfect working to the lines shown on the top and the dotted circle at the end. Since the small stem has been turned and fitted in a hole to receive it, any error in setting will prevent the stem fitting, and thus spoil the work. The casting has been turned and made to fit the slide in which it will finally be located (a frequent practice in machine-tool construction where the space for the nut is very limited, and where cast-iron lugs are sometimes substituted, though never so durable).

To "mark out," the nut is driven or screwed into its place in the slide, and a circle is traced on one of its faces. The slide is next made to stand at a right angle, and a line is scribed running the whole length of the nut horizontally, as shown. In fixing the nut on the angle plate, alignment is obtained by the use of the square and a pair of vee blocks

(which act as a pair of parallel strips for work having a flat under surface).

After the nut has been truly set to the dotted line by the use of a "centre indicator" secured in the tool-rest, it is next clamped firmly to the angle plate by a clip bridging across the vee blocks, care being taken not to disturb the work while securing it. Another and a good method by which the central position can be located approximately, is to wind out the loose head poppet until the centre almost touches the nut to be bored. Then by slowly rotating the lathe face plate, it will at once be seen how far the "nut is out of truth."

However much or little this may be, the nut is not disturbed, but the angle plate is gently "tapped" with a lead mallet, the bolts being eased a little for the purpose. Above the nut, at a suitable distance, a weight is placed on the face plate to act as a balance to the angle plate, the correct position for which is obtained by first removing the back gearing of the lathe, and then pulling the plate quickly round by hand, the heaviest part finally coming to rest at the bottom, until a perfect balance is obtained, which is done by altering either the size or the position of the balance weight.

Angle plates are also used to support plummer blocks, etc., whilst they are bored. In such work, when the blocks are cast from good patterns, a stop may be secured to the angle plate to just touch the end or corner of the block when truly set, and the stop acts as a guide for correctly indicating the position in which other blocks are to be placed.

The angle plate is thereby converted into a jig, and the setting is reduced to a minimum (supposing the base of the blocks to have been tooled previously). It is, perhaps, at the drilling machine where an angle plate is most in request, to hold "planed" or "milled" work whilst it is drilled or bored; the practice being to secure the angle plate to the machine table with the vertical face overhanging when it is required to secure castings or forgings having projections, the perpendicular alignment of the plate being ascertained by placing a true square on the vertical face of the plate, and then putting a spirit-level on the top of the square.

Another way is to use an ordinary plumb-bob let into a thin steel plate. The latter can be used where it is not so convenient to get a square and spirit-level. Drilling machines of the radial type are now being fitted with an auxiliary table, one surface of which is hinged, in order that the work placed upon the table may be swung round into any angle from the vertical spindle.

By the use of this appliance, holes, running at inclinations from the vertical, may be easily drilled or bored on the same table without the trouble of re-setting, which is a great advantage in some classes of work where the "setting" occupies a considerable portion of the actual time spent on the work.

When articles to be shaped are to be machined at an angle—such, for instance, as strips for slides—it is usual to drill three or four holes and tap them; then, by the strip being screwed to an angle plate, the

cutting tool can be set and the bevel machined to a gauge much more satisfactorily than when the work is done in a machine vice, or otherwise clamped to the machine table.

A further use is to secure the angle plate to the table of a planer, shaper, or milling-machine table, and then to make a temporary table by fastening a second angle plate to it. In this way a number of small pieces of work may be arranged on the table and clamped from beneath it, thus leaving their upper surface and sides free for tooling. This method applies instead of a machine vice; and since three surfaces of a considerable number of small pieces can be treated simultaneously, it is a very satisfactory and economical process.

Sometimes, when heavy castings are being fixed to be planed, angle plates are secured to the table of the machine, and after the work has been "set," stops are inserted between the end of the work and the face of the angle plate. This is done to prevent end movement while deep cuts are taken.

In the "setting" of large castings to a boring-machine bar, angle plates are found useful. An example of this occurs when a hole has to be bored at a measured distance from a certain face or foot on the casting. If an angle plate is secured to the foot, the mete or rule may be placed directly touching it. When an angle plate is not used, a straight-edge has to be held whilst the measurement is obtained or tested.

Machine Bolts and Nuts.—The bolts and nuts used at the various machine tools are frequently required to hold work fast for a considerable time during the process of machining. They are thus put to the test, both as to the fitting of the nuts on the bolts and as to the material (wrought iron or mild steel) of which they are made. Mild steel is the best material, because of its superior tensile strength, but many good bolts in use are forged from the best brands of wrought iron.

When bolts have been used to carry heavy loads, and thus subjected to severe stresses, they will give no warning, but break off suddenly. This is because they have become "fatigued." Such bolts, becoming bent and straightened cold, invariably fracture, breaking off like "cold short" iron, exhibiting a sparkling, crystalline appearance, with little or no fibre. It is, therefore, obvious that with such uncertainty there is a danger of work moving, which is always more or less serious.

The elasticity may be considerably restored by annealing. The strength of a bolt and nut is calculated to carry a certain load, assuming the nut to be a good working fit. If the nut shakes loosely on the bolt, the strength is diminished, and if used the danger is increased. Such bolts should be shortened and "re-threaded," and new full-threaded nuts put on as required.

The bolts in general use are provided with either square, hexagon, or tee heads (mushroom heads are too weak). Square and tee headed bolts are made having square necks, which prevent their turning; while hexagon-headed bolts may be used with advantage on tables or face plates with round holes.

A simple and quick method is to place the nut in the table slot of

a plane, shaper or milling machine, and then invert the bolt. Special nuts made from rectangular bars are kept at each machine. By the above arrangement a clear table can be kept to receive the work. This is an advantage sometimes when fixing heavy castings, as by the method of placing the bolts first there is great danger of the casting getting foul when it is lowered on the table.

Washers.—Washers are used to give the nuts a true setting on the clips, and to protect the corners of the nuts from getting jammed. They are also used to fill up the space between the nuts and clips when excessive bolts are used. Washers are purposely made larger than their

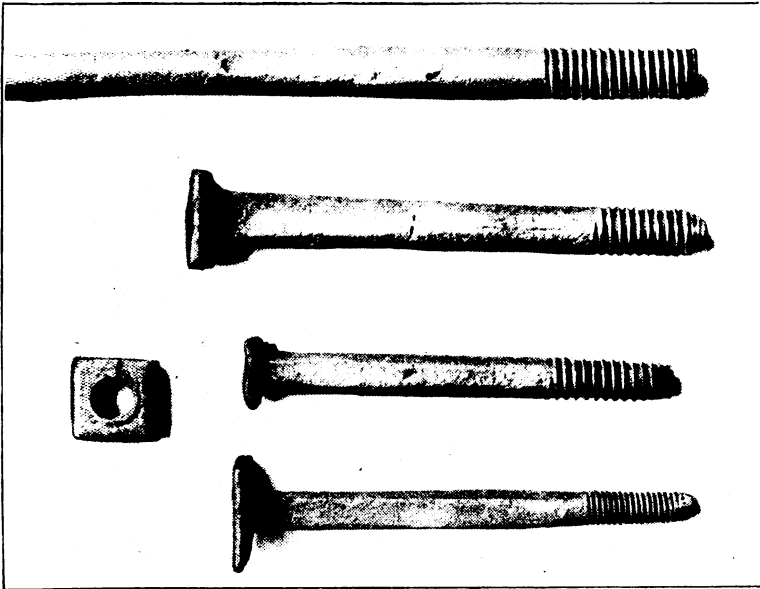

FIG. 48.—Ancient bolts.

respective bolts. Thus a $\frac{5}{8}$ -in. bolt is fitted with a washer $\frac{11}{16}$ in. in the hole; there is, however, an idea that *any* washer will do if it will pass over the bolt. This is wrong, because of the scant bearing surface left for the nut, which, when screwed tightly down, forces its way partially through the washer, expanding and bursting it possibly, also upsetting the position of the clip and work.

Standard Nuts and Bolts.—Before the present system of uniformity in screw-threads, much difficulty arose in consequence of fine threads being cut on large bolts, and coarse ones on bolts of a small diameter. (See Fig. 48, taken from photograph of ancient bolts and nuts. Note size of threads and form of bolt-heads.)

Clips and their Uses.—Clips are used to hold fast work to the tables or face plates of machines and lathes, which are usually provided with square, rectangular or tee slots.

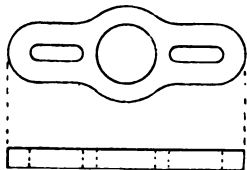

FIG. 49.—Chucking clip.

Square and rectangular slots pass clean through the tables and plates at suitable intervals. Tee slots are usually made where it is not practicable to insert a bolt from the back of the plate or table as seen in large machine tools, such as planes, shapers, millers, etc., or in the base plates of boring or drilling machines.

Tee slots have many points in their favour:—

1. Bolts may generally be placed close up to the work.
2. Bolts are held firmly by their heads, and therefore cannot turn.
3. Bolts may be inserted into nuts previously placed to receive them, in which case “headless bolts” or studs can be used to advantage.

In Fig. 49 a “chucking clip” is shown. This is used with equal advantage at the lathe or drill to hold small wheels, collars or circular plates while being bored or drilled.

For instance, a number of circular

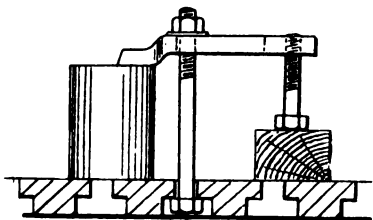

FIG. 50.

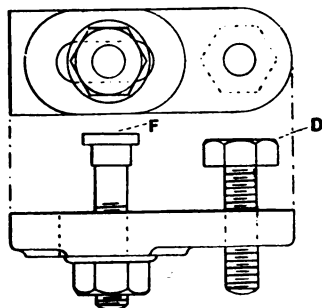

FIG. 51.

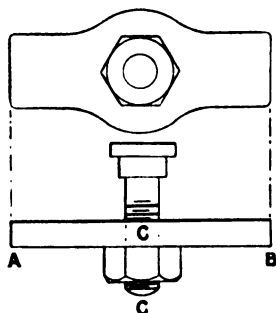
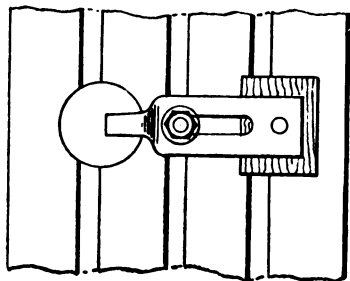

FIG. 52.

lock nuts may be bored and screw-cut together with the aid of the chucking-clip, or conical bushes (difficult to hold in a jaw chuck) may be quickly secured and bored. There are no packings required, so

that all the pressure is received directly from the two bolts to the clip and the work beneath it.

It is important to notice that a clip is never allowed to secure a piece of work unless the holding-down bolt is placed *nearer* to the work than to the packings. If we look at Fig. 50 we shall find the bolt to be very close to the work. This is also the case in Fig. 51; but in Fig. 52, since the bolt is placed in the centre of the clip, the pressure on the two extremities must be equal. Fig. 53 is also wrong, as

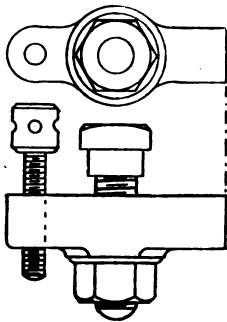
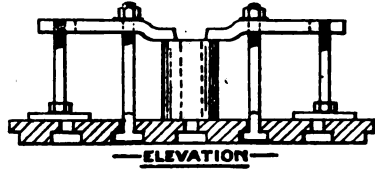

FIG. 53.

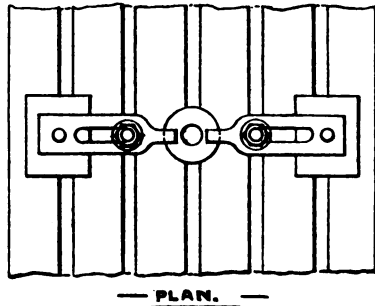

FIG. 54.

will be seen by the short arm carrying the supporting screw. Fig. 54 is to show two finger clips in use. If we consider the clip as a lever and the bolt the movable weight, we shall remember that the gripping power is least when the bolt is placed near that end of the clip which is farthest from the work it secures.

CHAPTER III.

MATERIALS.

Cast Iron.—Cast iron is obtained by smelting iron ore in a blast furnace. It is fusible, but will not temper nor weld. It is stronger than wrought iron in compression, but much weaker in tension.

According to the proportions of the charge put into the furnace, the pig iron or cast iron obtained differs in appearance, in strength and in other properties. The differences of quality are due to differences of composition of the cast iron, and especially to differences in the amount and condition of the carbon it contains. The classes of pig iron produced by a furnace run in the following order, viz.: No. 1, No. 2, No. 3, No. 4, grey forge, strong forge, mottled and white, which gradually increase in hardness from No. 1 down to white, which is the hardest of pig iron. Each class is known by the appearance of its fracture, which varies considerably. The grey forge and harder qualities are used for conversion into wrought iron. The greyer or foundry irons, known as Nos. 1, 2, 3 and 4, are used for foundry purposes.

The Blast Furnace is constructed chiefly of bricks, the internal part being lined with large lumps of fire-brick, the height varying from 50 to 100 ft., and the internal diameter at different points of the furnace varying in proportion. The widest part of a furnace is at the top of the bosh, which may be from 18 to 20 ft. in diameter, and is about 26 ft. above the hearth, or bottom, of the furnace. The lower part for a distance of about 8 ft. above the hearth is known as the well, in which are fixed, at equal distances apart round the circumference of the furnace, the tuyeres, through which the blast is blown. The tuyeres, which are usually made of wrought iron, vary in number from four to ten. The blast is blown into the furnace, which is charged with ore, fuel, and limestone, at a pressure of from 5 to 12 lbs. on the square inch, and at a temperature of from 1000° to 1500° F. It is produced by means of powerful blowing engines, which consist of a steam cylinder and a blowing or air cylinder; from here the blast is conveyed through wrought-iron tubing, 3 or 4 ft. in diameter, to the hot-blast stoves, which are of two kinds, viz., "pipe stoves" and "patent brick stoves." The former consist of cast-iron pipes U-shape, each leg being about 12 in. in diameter, and 10 to 15 ft. in length; these are so fixed in cast-iron boxes that a continuous passage is made through which the

blast passes on its way to the furnace. The pipes are enclosed in a brick chamber, each containing fifteen to twenty pipes. Waste gases from the furnace are conveyed to these chambers, in which they are burned, thereby raising the temperature of the pipes to an almost melting heat, which obviously raises the temperature of the air or blast as it passes through them.

The furnace is fed from the top; the iron ore, fuel (coal and coke) and limestone—the latter being used as a flux—are raised in iron barrows by a cage, worked either by winding engines or hydraulic power. The proportions of the charge vary according to the quality of iron required, and also according to the quality of fuel used and the composition of the iron ore.

The iron is cast or run from the furnace every eight or twelve hours, according to the working of the furnace, and also the capacity of the well. It is drawn from the furnace through what is known as the "tapping hole," and then runs along a main channel, and from this into a series of smaller channels, from which run short parallel lines or moulds about 3 ft. long called "pigs," each pig when cast weighing about 1 cwt.

As the iron is reduced from the ore it sinks to the bottom of the furnace in a molten state, and immediately above this floats the slag, which is run from the furnace at a point about 2 ft. 6 in. above the "tapping hole." The weight of slag produced by a furnace is more than equal to the weight of iron made. Various methods are adopted in dealing with the slag. In some cases it is run on to open beds, and varies from 1 or 2 in. to 12 in. in thickness. When cool enough to be handled—it may have to be watered—it is broken up by means of picks and hammers, and loaded into either waggons or trams. It is then usually passed through a stone-breaker, which delivers it into a revolving screen, having variously sized holes through which the slag passes into waggons ready for sale, it being used for either repairing or making macadamized roads.

Another method of dealing with slag from the furnace is to run it into cast-iron boxes, which hold from one to two tons. Before the slag is run in, either one or two iron stakes are placed in the box which serve to lift by when the slag is set, the lifting being usually done by means of a crane.

ANALYSIS OF CAST IRON.

	White.	Mottled.	Grey.
	Per cent.	Per cent.	Per cent.
Iron	94'56	94'08	94'56
Carbon	3'1 { ^{0'01} 3'1} combined	3'1 { ^{1'5} 1'5} combined	3'0, 3'01
Silicon, sulphur, phos.	1'8	1'45	1'8
Manganese	0'50	1'37	0'5

Shrinkage of Castings.—The usual allowance for each foot in length is as follows:—

	Inch.		Inch.
In large cylinders	3/32	In zinc	5/16
In small cylinders	1/16	In lead	1/8
In beams and girders	1/16	In tin	1/4
In thick brass	5/32	In copper	3/16
In thin brass	1/8	In bismuth	5/32
In cast-iron pipes	1/8		

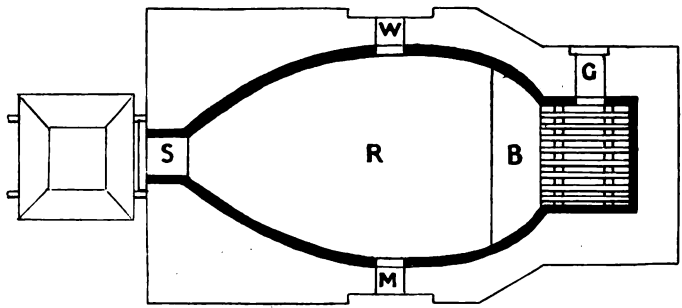
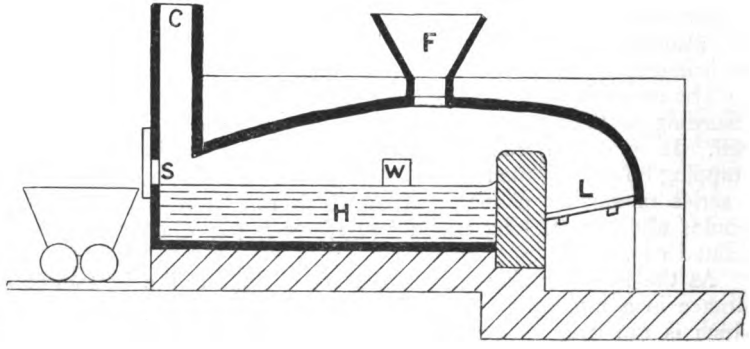

FIG. 55.—Reverberatory furnace.

C, flue ; F, feeding hopper ; H, bed of the furnace ; W, working hole ; G, fire hole ; S, slag hole ; M, metal hole ; R, hearth of the furnace.

Production of Wrought Iron.—White iron is found to be most suitable for this purpose. In the blast furnace it has taken up the impurities, carbon, silicon, phosphorus, sulphur, and manganese, and all these must now be removed. The process of removing the impurities is termed “puddling.” The cast iron is melted in a reverberatory furnace (Fig. 55), the working bottom of which, as well as the

lining (or fettling), consists mainly of oxides of iron (red hæmatite and smithy scales).

The oxygen from the oxide burns off the impurities. The escape of these products of combustion from the interior of the mass causes it to appear to boil. Hence the process sometimes called "pig-boiling." As the impurities are removed, the mass becomes pasty, because pure iron has a higher melting point than impure iron. This pasty mass is then worked up into "blooms." These blooms are then squeezed and beaten out under steam hammers and elongated, and finally passed under powerful rolls, where they are formed into square, rectangular and round bars or rods.

The process is called "shingling."

The wrought iron thus produced varies in quality, and, however



good, may be improved by being cut up and re-puddled.

Wrought Iron.—The presence of phosphorus causes wrought iron to be more easily broken than bent; such iron is termed "cold short."

The presence of copper or sulphur causes the iron to be brittle at a working heat. Iron which behaves thus is termed "red short."

The best qualities of iron contain as much as 99 per cent. of pure iron, and 1 per cent. of other impurities.

In some brands, however, the carbon will reach as much as 3 per cent. to 4 per cent., the steely character of the iron being quite apparent on fracture.

Common iron is not considered as being of a sufficiently reliable quality to admit of its being forged into parts for the construction of engines or machines, and therefore finds no place in the workshop.

On the other hand, good wrought iron is a tough and fibrous metal, capable of being bent whilst cold (see examples of rods and bars twisted and tied, Fig. 56), or forged whilst hot into almost any shape without showing fracture. It has a great tensile strength, and is much used in all constructional work.

Besides being called round or square, iron is also branded according to quality.

The purest and best kinds are exceedingly tough, among which are "Swedish Iron," also "Low Moor," and "Charcoal Iron," "Butterley," and "Staffordshire Irons."

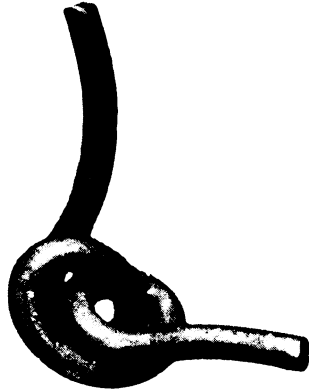



FIG. 56.—Examples of cold iron twisted and bent.

The latter are marked as follows:—

“ Bridge ” and “ girder ” quality . . .	Butterley	
“ Boiler ”	” . . .	B.
“ Best,” “ Best ”	” . . .	B.B.
“ Treble Best ”	” . . .	B.B.B.

The above suffices to show that iron is made in different qualities to suit the various purposes in general engineering.

The iron is caused to assume its form by being passed through powerful rolls.

Referring to the illustration (Fig. 369), it will be seen that the iron is rolled from a large mass to one or other of the angular sections: also round, or square, according to the rolls used.

Malleable Iron Castings.—Malleable iron castings are made from white pig and scrap iron, and are afterwards cast in the ordinary manner. But at this stage the castings are brittle and hard. After dressing they are placed in an oven along with powdered hæmatite (peroxide of iron), the oxygen from which combines with the carbon, which is thus partially removed from the iron, leaving the product malleable.

The charged oven is first sealed, and then heated to a bright red heat, which is kept uniform for about a week, the time varying according to the size of the castings to be annealed.

The oven is then allowed to cool down slowly. Castings which have been thus treated may be bent when cold, but will not stand forging like wrought iron, because a core of iron containing carbon still remains in the centre of each casting. The castings are stronger and tougher, but, for the reason above stated, undue hammering will produce fracture.

It should be pointed out that in metallurgy “malleable iron” is that product which will stand hammering and rolling out into thin sheets. This refers to wrought iron, and must not in any way be taken as referring to castings, even though they have been annealed.

Steel Manufacture, Cementation Process.—Steel is a compound of iron with a small percentage of carbon. The kinds and qualities of steel vary partly by the method of production, and partly by the amount of carbon they contain. In the cementation process wrought-iron bars are placed in a box along with charcoal, and are heated in a furnace. The bars thus heated are kept at a uniform temperature, during which time they have absorbed carbon from the charcoal. On removal they are found covered with blisters, hence the name “blister steel.” The quality is known to be good by the numerous small and even-sized blisters that appear, while large blisters at irregular intervals indicate a poor quality and want of homogeneity in the original bar.

Shear steel is the name given to blister steel after it has been cut up, reforged and welded. This product again cut up and similarly treated gives us double shear steel.

Crucible cast steel, commonly called tool steel, is made by melting blister steel in crucibles. Small pieces of scrap iron, or spiegeleisen, are added according to the quality and temper of the steel required; or

scraps of Bessemer steel mixed with spiegeleisen, instead of the blister steel, may be used.

After the molten steel has been poured into an ingot mould and solidified it is then forged under steam hammers into round or rectangular bars, the round sections being finally passed between rolls which give a smooth and planished surface, as well as leaving the product uniform in dimensions.

The best brands of cast steel for tools are those, containing a comparatively large percentage of carbon, with a small percentage of phosphorus and nickel. Their appearance on fracture is very uniform and lead-like, the granular particles, being dense and compact, resembling

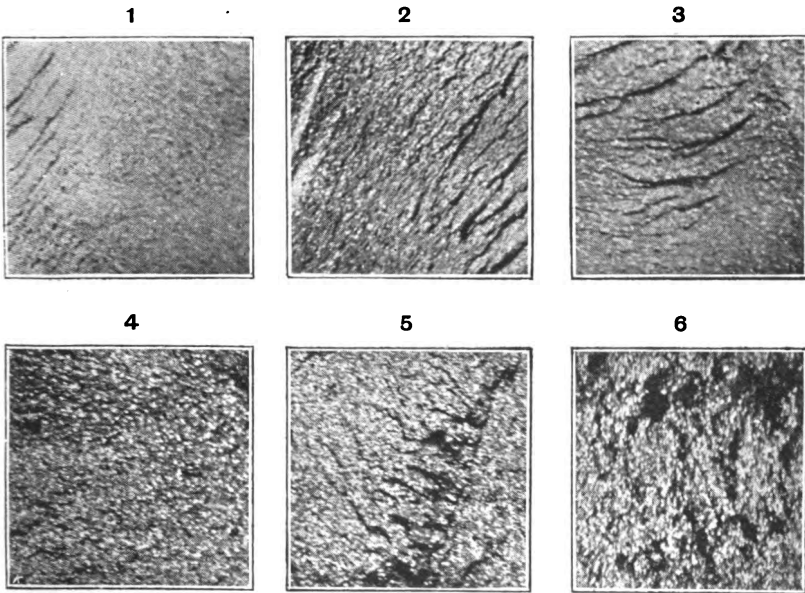

FIG. 57.—Crucible cast steel fractured.

bling the specimen shown in Fig. 57. Such brands of steel are called "high grade," and require careful treatment in the hands of the tool-smith.

High-grade tool steel will not admit of being heated above a blood-red heat without deteriorating, and if allowed to remain in the fire to a bright red it will quickly lose its power of cohesion, and will crumble under the blows of a hammer. It should therefore be forged into tools at the proper heat, which can only be correctly judged after much practice. The best qualities for ordinary cutting tools (Fig. 58, Nos. 1, 2 and 3), show the most compact grain on fracture. The other qualities, with more open grain, are best suited for tools submitted to shock or percussion, such as hammers and chisels.

Self-hardening Tool Steel.—The Bethlehems Steel Co., of Pennsylvania, patented a self-hardening tool steel, which will work at a higher temperature and run at a higher cutting speed than the ordinary carbon tool steel. This air-hardening steel is compounded with chromium in the proportion of at least 1 per cent., with at least 1 per cent. of tungsten. The best results, however, were obtained with chromium 1 per cent., and tungsten 4 per cent. The efficiency or cutting speed of tools treated with this process increases with the temperature to which they are subjected above the “breaking-down point,” from temperatures of 1725° F. to 1850° F.; but when heated above 1850° F., and from this temperature to the point where the steel softens or crumbles when touched, the increase in the cutting speed of the tool is very striking, reaching its maximum at these high temperatures.

Another discovery the above inventors found is that the cutting speed of the tools treated at the “high heat” is materially increased by holding the tool for several minutes at a temperature between 450° F. and 1350° F.; for the best results, between 700° F. and 1240° F. This can be effected by checking the cooling of the tool after its temperature has fallen below 1350° F., and maintaining it at the desired point or points for the required time, or preferably by reheating the tool and holding it at the point or points determined upon. This supplemental treatment is called the “low heat” treatment, and it must be noted that in this “low heat” treatment the tools, if raised above 1240° F., and from that up to 1350° F., must be maintained at such temperatures for only a very short time; while below 1240° F. no deterioration takes place by exposure to the chosen heat for a long time: an exposure of at least five minutes is suggested. Air-hardening steel is manufactured at Sheffield by several firms. At a recent test of the cutting capacity of the steel, some record speeds and feeds were obtained.

Bessemer Steel.—In the Bessemer process, the impurities in the cast iron are burnt out by blowing a blast of air through the molten iron directly it leaves the blast furnace. This operation is performed in a large pear-shaped vessel, known as the converter, which is mounted on trunions, and through the perforated bottom of which a powerful air blast can be forced.

The converter is tilted into a horizontal position, and a quantity of molten cast iron is run in. The air blast is then started, and the converter immediately swung back into a vertical position. In a short time the whole of the impurities are burnt out. The stage at which this operation is complete is sharply marked by the sudden disappearance of the flame from the open mouth of the converter. Once more the converter is swung into a horizontal position, and the blast stopped; the exact quantity of carbon required to convert the pure iron in the converter into steel is now added, and dissolved in the molten iron. Spiegelessen, or ferro-manganese, an iron ore rich in carbon, is generally used for this purpose. The blast is turned on for a few moments in order to thoroughly mix the materials, after which the contents are poured out into the casting ladle.

The operation of converting pig iron into steel lasts about twenty

minutes, and the iron is kept molten during this period by the heat given out by the burning impurities within its mass.

The following analysis gives an idea of what occurs in the converter:—

Impurities in pig iron.	Impurities in iron after blast has been passed 20 min.	Impurities in the steel (ferro-manganese added).
Graphite 2'5	—	0'37
Carbon 1'0	0'19	
Silicon 2'26	—	—
Phosphorus 0'07	0'17	0'09
Manganese 0'41	—	0'63
Sulphur 0'11	0'093	0'09

Steel Manufacture, Siemens Martin Process.—In this process (invented by Dr. Siemens) molten cast iron is introduced into a reverberatory furnace; to this is added a mixture of scrap wrought iron and steel which, by being previously heated, is quickly acted upon.

When this has become thoroughly mixed with the molten cast iron, a small quantity of spiegelessen is added, this being rich in carbon and manganese. The amount of carbon left in the metal is ascertained by testing a small quantity.

A small portion of the molten metal is removed by a ladle. After this has solidified it is broken up and tested by the chemist on the works.

If found satisfactory, the change is tapped, run into ladles, and finally into moulds.

The furnace is made to rotate, and is supplied with a blast of hot air.

Hematite Steel-making at Barrow.¹—The steel converter has a capacity for twenty tons of metal. The converter is elevated sufficiently to allow the ladle standing on a crane below to receive the contents of steel, and also to allow a bogie on a road beneath the converter to receive the slag.

Each converter is actuated by means of a powerful pair of hydraulic rams, having a rack and pinion acting in opposite directions. In front of the converter is a platform supported by iron columns, to which access is obtained by an inclined roadway, along which the molten iron is brought from the mixer in ladles.

A locomotive places the ladle of iron in front of the mouth of the converter, a hook engages itself on to a pin fastened on the ladle, and lifts it up gradually until the whole of its contents are poured into the converter. Spiegelessen is charged into the converter in a similar manner, the cupola being at one end of the platform and on the same level as the converter.

The ladle is transferred by crane to a centre, or casting crane, from which the heat is cast into moulds. The moulds are placed on bogies,

¹ See *Engineering*, Nov. 22, 1901.

each bogie carrying two moulds. They move forward under the nozzle of the ladle as required, the centre crane remaining stationary.

Each mould is made to hold two tons of steel, and in order that the arrangement of casting should work well, about a hundred bogies are always in use, the consequence being that there is a constant stream of bogies and moulds in circulation, and by keeping them running in proper order the moulds become cool by the time they are required without recourse to water-cooling.

When the ingots have remained in the moulds ten minutes, the bogies are drawn forward to the ingot strippers. This is a very useful machine which, with a minimum of labour, strips the mould from the ingot and places them on an empty bogie that they may return to the yard to cool before being used again.

The ingots, still on the bogie but stripped of their moulds, are taken to gas-heated pits. These gas-fired pits take the form of a long passage or channel, 5 ft. 6 in. wide and 6 ft. 6 in. deep, at either end of which is a set of generators.

There are five lids to each pit, and they hold twenty ingots; that is, four ingots under each lid or door.

When the ingots are sufficiently heated they are taken out of these pits by hydraulic cranes, and are placed upon a train of live rollers which convey them to the cogging mill, which is worked by high-pressure steam engine. The rolls have five grooves, and when the bloom has passed through the last groove it is conveyed on roller gearing to the shears, where the rough ends are cut off. This prevents collars and other troubles arising during subsequent rolling.

Manufacture of Mild Steel. Roughing Mill.—After shearing it passes in a straight line to the roughing mill; this mill consists of a 28-in. train, and is driven by a pair of reversing engines.

In usual work a bloom makes five passes in this mill, and then proceeds to the finishing mill, which passes it another five times, and thence on live rollers to the saw, where it is cut into the requisite lengths. After sawing each rail is placed on the hot bank. When the rails are cold they pass on roller gearing to the finishing bank, where they are straightened, drilled, and finished.

Plates are rolled in the rolling mill, the rolls being each 7 ft. 6 in. long; the plates vary from $\frac{1}{4}$ in. to 2 in. thick.

Treatment of Thin Plates of Steel.—It is the practice to give a smooth surface to thin sheets, but it is always done at the expense of their ductility. Such plates or sheets are rolled at a low temperature, and therefore made hard, hence for many purposes they are annealed; the treatment generally consisting in packing them in large piles into boxes, which are intended to exclude the air from them whilst they are heated. The boxes are heated up slowly, which may take from a few hours to a day, according to size, and then maintained from eight to twenty-four hours or more at full red heat, and allowed to cool down very slowly, heating and cooling taking altogether from one to three days.

This gradual heating and cooling, if carried at all to excess as

to temperature or length of time, will undo the good of reheating by promoting the growth of grain, and, if too much air gets in, by burning out the carbon, so that in either case the plates may be more brittle than before.

The more rapidly it is possible to heat the sheets up, and the less time they are kept hot once they have reached cherry red, the smaller the grain and the tougher they will be.

Wire Rods and Wire.—Though the area of these is relatively small, wire rods are rolled so fast, especially in continuous mills, that they finish at a good red heat; and being wound in compact coils, which are often stacked in large heaps, they cool slowly, and are not so hard as could be expected.

Correct Treatment of Steel.—Wire rods for drawing are usually first pickled, swilled, lime-washed, and annealed, and then after every two or more drawings (according to the reduction, the carbon contained, etc.) re-annealed lightly.

There is, no doubt, a tendency to draw through as large a number of holes as possible, thus minimizing annealing.

Cold drawing has a very marked hardening effect, and if carried a little too far may easily make the steel brittle.

Rods predisposed to brittleness, either by finishing above critical temperature, and thus leaving the grain too coarse, or by finishing at or near blue heat, are, when subjected to the further hardening and straining effects of pickling and cold drawing, almost certain to become very brittle.¹

Copper.—Copper is found in large quantities in many parts of the world; either in the metallic state, or as an ore.

One mass of metallic copper found in Minnesota was calculated to weigh 500 tons.

The ores are very numerous, the most important being: copper pyrites, or yellow copper ore (sulphide of copper and iron), and vitreous copper ore (sulphide of copper).

Copper pyrites is the most abundant ore. It contains 34·8 per cent. of copper. It occurs in the north of Europe, in England, especially in Cornwall, Devonshire, and Anglesey, and in many parts of Asia, Africa, America, and Australia. The copper of this country is chiefly produced from copper pyrites, yielded by the mines of Devonshire and Cornwall. This ore contains about 8 per cent. of copper. It is conveyed to the coal districts of South Wales to be smelted.

The first process of smelting is to calcine the ore. This is done by heating it in a calcining oven, which expels the arsenic and sulphur contained in the ore, and oxidizes the copper and iron to a black powdery mass.

This powder is then melted in a highly heated oven, and when liquid, is well stirred, to allow the metallic sulphide to separate from the earthy matter. This metallic sulphide, containing about 33 per cent. of copper, is drawn off into a vessel of water, where it granulates as *coarse metal*.

¹ See *Engineering*, Nov. 15, 1901.

The *coarse metal* is again calcined, melted, and poured into water. It is now termed "fine metal," and contains about 60 per cent. of copper.

Another repetition of the above process brings it to the state of *coarse copper*, which contains 80 to 90 per cent. of pure copper.

This coarse copper is exposed to a high temperature in a roasting furnace, by which volatile matters are expelled, and the metals become oxidized. It is drawn from this furnace as *blistered copper*, almost wholly free from sulphur, iron, and other impurities.

The *blistered copper* is transferred to a refining furnace, covered with charcoal, and brought to a liquid state. The copper obtained from this last furnace is tough and malleable, and fit for manufacturing purposes.

Copper is also largely obtained from weak Spanish ores, containing 2 per cent. to 4 per cent. of copper by the wet process. These ores generally contain 45 per cent. to 48 per cent. of sulphur, and are used at alkali works in the production of vitriol.

The residual ore is returned to the metal-extracting works, and roasted with salt. The copper becomes soluble, and is washed out and precipitated in the metallic state by scrap iron.

Copper depositing by the Electrolysis Process (Elmore's).—The bars of copper are melted in an ordinary furnace, and granulated by being run into a tank of water. These are next placed on a copper tray at the bottom of the tank, which serves as the anode, or positive terminal.

Above this tray is a copper cylinder revolving on a horizontal axis, and constituting the cathode, or negative terminal; a solution of copper sulphate or blue vitriol is the electrolyte. The revolving cylinder is completely immersed in this, and contact is made with it by a copper brush. Pressing upon its surface is an agate burnisher, which is applied to the cylinder, much as the tool is to a piece of work in the lathe, only that it is placed nearly vertically instead of horizontally.

The traversing motion is obtained by means of a horizontal shaft located at the back of the tank, and extends the whole length of a set of tanks. This shaft, for a length at one of its ends equal to that of a single tank, is provided with a screw thread, which, by working in a stationary nut, causes the burnisher in each tank to travel from end to end of the revolving cylinder to which it is applied.

At the end of the traverse its motion is automatically reversed, and it returns in precisely the same manner. It is this burnishing process that is claimed to be the cause of the remarkable tensile properties that the deposited metal appears to possess.

Phosphor Bronze.—Phosphor bronze is an alloy consisting chiefly of copper and tin, to which phosphorus is added.

There is some experience required at the time of mixing to obtain the best results, owing to the behaviour of the different materials, the phosphorus is not added until a few minutes before the molten metal is poured, which takes place only when at the proper temperature.

The qualities used as anti-friction metal are the best, and are used

for bearings, bushes, slide valves, eccentric straps, and other wearing parts of engines and machines.

Phosphor bronze, however, cannot be greatly varied in its constituent quantities without in some way lowering its quality.

It is usual, therefore, to supply it in ingots for foundry use, or bars, sheets, and wire for engineering or electrical purposes, direct from the manufacturers.

Phosphor bronze is the strongest copper alloy, and therefore is much used for pumps and other parts of hydraulic machinery; being highly tensile and tough, it is good for castings subjected to great stress. The following test was made from specimen (Fig. 58) supplied by the Phosphor Bronze Co., London:—

Marks on specimen.	Dimensions.		Length between gauge points.	Load at yield point.		Ultimate load.		Elongation.			Section at fracture.	Contraction ($\frac{\text{section at fracture}}{\text{original section}}$) $\times 100$.
	Linear dimensions, in inches.	Sectional area, sq. inches.		Total tons.	Per sq. inch, tons.	Total tons.	Per sq. inch of original area.	Total on 10 in., per cent.	Local on 2 in., at fracture, per cent.	General on 8 in. at ultimate load, per cent.		
Phosphor B	Round 0.87	0.595	—	23.5	39.6	23.6	39.8	—	—	—	0.714d	—

Brass and Bronze.—Alloys of copper and zinc are called brass. Two parts copper and one zinc make yellow brass. Three parts copper and one zinc make hard brass.

Bronze, or Gun Metal.—Alloys of copper and tin are called bronze or gun metal. A good mixture is 90 per cent. copper, 10 per cent. of tin. Harder quality, 85 per cent. copper, 15 per cent. of tin.

Manganese or White Bronze.—Copper, 70 per cent.; manganese, 30 per cent. Some mixtures contain a small percentage of tin. This alloy does not oxidize, and will stand forging or rolling.

Aluminium Bronze.—From 90 to 95 per cent. bronze, 5 to 10 per cent. of aluminium.

Babbitt's Metal.—Tin, 96 parts; zinc, 8 parts; copper, 4 parts. This metal is an anti-friction metal, and may be pasted into bearings, and afterwards rebored.

Aluminium.—The ordinary aluminium is about 99 or 99.25 per cent. pure, the impurities being iron and silicon in about the following proportions: aluminium, 99.25 per cent.; silicon, 0.50 per cent.; iron, 0.25 per cent. Pure aluminium practically does not corrode under atmospheric influences, but forms a thin film of oxide which protects the metal from water, and there is no further corrosion.

The action of salt water on pure aluminium is extremely slight, and it withstands the action of sea water much better than iron or steel.

Aluminium melts at a temperature of 1157° F., compared with zinc, 779° F.; silver, 1733° F.; and copper, 1929° F. Aluminium does not volatilize at any temperature ordinarily produced by the combustion of carbon, even though this temperature be kept for a considerable number of hours. It oxidizes, however, and therefore it is not advisable in making castings of aluminium to raise the metal much above the melting point or allow it to remain melted for any great

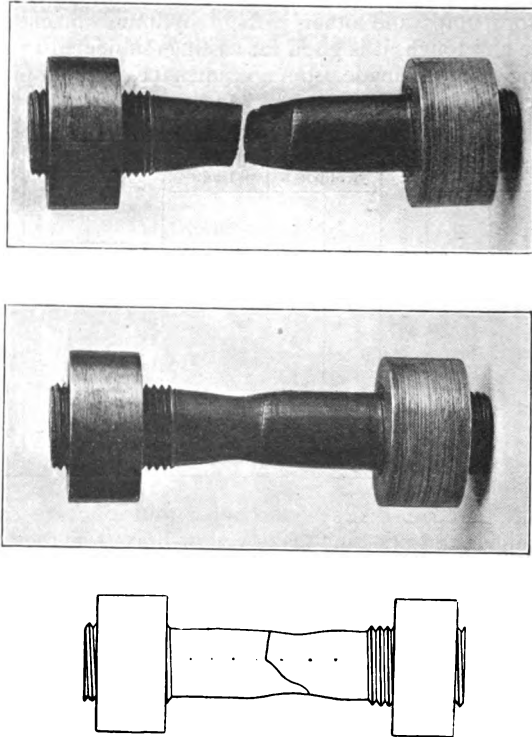

FIG. 58.—Phosphor bronze specimen. “Tensile test.”

length of time. Under ordinary temperatures the hardness of aluminium varies according to its purity, the purest metal being the softest. The coefficient of linear expansion of aluminium, 98.5 per cent. pure, is 0.0000206° C., that of iron being 0.00001718° C.

The shrinkage of pure aluminium in casting is about $\frac{17}{84}$ in. to the foot, but for general purposes it may be as $\frac{1}{4}$ in., the same as for brass.¹

Production of Metallic Bars.—A comparatively novel way of producing metallic bars of all sections is by forcing hot metal, in a plastic

¹ *Mech. World, Diary.*

state, through a die from which it issues in the form of bars of the section required.

This process, which is the invention of Mr. Alexander Dick, is used by the Delta Metal Company, of which he is the managing director, to produce their "delta" metals. The metal, which is heated to a temperature of plasticity, about 1000° F. or more, is placed in a cylinder, at one end of which is a die of the same section as the work to be produced. This cylinder, which has not only to stand the pressure to which the metal is subjected, but also the high temperature of the metal, is composed of a series of concentric steel tubes between which is packed a dense non-conducting material, over all being a strong steel casing.

The die plate, which is formed with either one or several openings, is fixed in a holder from which it may be readily removed, as different dies are required to be used. As the die and holder are heated previous to each operation, the die is fitted into a shouldered recess in the holder, which is coned to seat in a hollow metal block. This block is

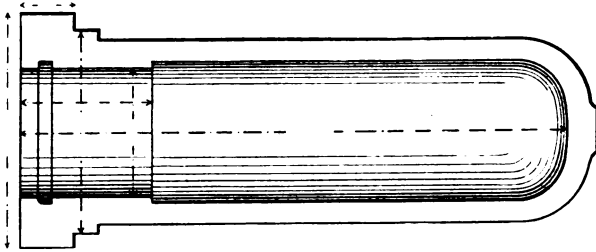

FIG. 59.—Section of a mild steel casting.

held in position by a pair of gripping jaws actuated by hydraulic pressure. The die holder and gripping jaws are carried in a strong crosshead.

Pressure is applied by an hydraulic ram 18 in. diameter, working under a pressure up to about 2 tons per square inch. The ram has an extension of reduced diameter, which forms the plunger of the cylinder, out of which the metal is forced. When pressure is applied, the hot metal is forced out of the cylinder through the die, issuing in the form of rods of the required section. The overall dimensions of the apparatus are about 16 ft. long, 6 ft. wide, and 5 ft. high. The quality of metal produced by this method is superior to that produced by rolling, owing to the great pressure applied.

Some tests made at Woolwich Arsenal with delta metal bars produced by this process show a tensile strength of 48 tons per square inch with 32½ per cent. elongation on 2 in.; against 38 tons per square inch and 20 per cent. elongation of rolled bars of the same section.

The metals which are produced by this process are alloys of various kinds.

Some of them are based upon the introduction and chemical combination of definite quantities of iron in copper-zinc alloys, others are

special bronzes. Some of them give very good results when tested for compression and tension. They are also malleable, and highly non-corrosive, which makes them very useful for propellers, propeller-blades, also for hydraulic and other work, where machinery is exposed to water, and where they are used instead of iron or steel.

There are also metals which are alloys specially suited for use in bearings instead of white or Babbitt's metals. Others are used for drawing into wire for electrical and other purposes.

Manufacture of Leaden Pipes.—Leaden pipe is made by forcing the partially congealed lead through dies, in which a core is inserted,

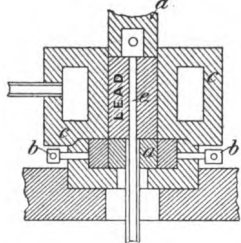

FIG. 60.—Leaden pipe manufacture.

by hydraulic pressure. The essential part of the apparatus is shown in Fig. 60. The die (*a*) is simply a metallic disc in which is an aperture which fixes the outside diameter of the pipe to be made. This opening flares downwards. The die is inserted in a collar, which in turn rests in the bed-piece, and is adjustable so as to bring the die accurately in line by means of set-screws. (*b*) Resting above the die and bed-piece is the lead receptacle. (*c*) This is a heavy cylinder having an annular chamber formed in it to receive the steam by which it is kept hot.

(*d*) is the presser-plunger working downward, and in it is inserted the core (*e*) which enters the die aperture.

The metal is drawn off directly from the kettle, and the plunger is at once brought down upon it so that it may be kept under moderate pressure until sufficiently congealed. The press is then set in operation, and the lead is forced through the annular space between the core and the die, and emerges in the form of pipe.

The process is quite rapid, and there is nothing to do but reel up the pipe as it is drawn. As soon as one charge is withdrawn, or rather partially so, as a portion is left in the chamber to which the new charge unites, more lead is admitted from the furnace, and the operation is repeated. The amount of pipe made at a single pressure depends upon the weight of same when finished. Thus an extra light 1-in. pipe weighs 2 lbs. to the foot, and the chamber may, for example, hold 135 lbs. Therefore, 67½ ft. of pipe are produced at each descent of the plunger. Different sizes of pipe are produced by substituting suitable dies and cores. The die is easily reached by lifting the chamber (*e*), which is done by attaching the same to the presser plunger and elevating the latter.¹

¹ *Spon's Workshop Recipes*, vol. 3, pp. 360, 361.

CHAPTER IV.

DRILLS AND DRILLING MACHINES.

DRILLS are tools used to cut holes through solid metal, and may be caused to rotate either by machine or by hand power.

Some holes have to be made of definite sizes and accurately located in position; the exact size of the holes and the proper place they take are more or less particular according to the following rules taken from the best practice:—

1. Holes which are to be made perfectly accurate in size and position are drilled and reamed through a controlling guide called a "jig."

2. Holes which are to be used as bearings for axles or shafts are drilled and reamed.

3. Holes which are to be "tapped" are drilled only.

4. Holes which are for "clearance" are drilled to a larger size than the diameter of the rod, axle, shaft, or screw which may have to pass through them.

5. "Cored" holes are usually made too large for drilling (see "Cores," Fig. 46), but if to be enlarged, the process is called "boring," this being generally done with a bar and cutters exactly the same as in ordinary boring-machine work. Whatever the work may be, it is customary to "mark out" all that has to be drilled by the aid of a pair of compasses and a centre punch; the practice being to "set" the work as truly as is practicable to the circle scribed, and then start the drill cutting. As the drill penetrates the metal, the exact position of the work relative to the centre of the drill should be closely watched and corrected by means of a drawing chisel if the point of the drill is not entering the circle correctly. This is easy to do in small work, and is effected by chipping a groove with a round-nosed chisel, at a point in the circle directly opposite to that where the drill has wandered most from the original centre. It is advisable that the *groove should reach the root of the hole, and that the chipping is done before the drill enters on its periphery.* The chipping is done simply to give a correct centre for the drill to enter, and obviously cannot be effective after the drill has made the hole equal to its own diameter.

Work treated as above should be relieved of its fastenings to some extent until the drill has found a true path concentric with the dotted circle originally scribed, otherwise there will be a side tension on the

drilling-machine spindle, caused by the drill rubbing hard on the hole on one side, with the result that a hole, more or less out of proper alignment, will be made.

In large work under a radial drilling machine the work may be secured once for all, because the drill is moved by means of the swing-arm and saddle-screw. Also, in a machine provided with tables having a longitudinal and transverse slide the same applies.

Cored Holes bad for Drilling.—Cores inserted in a mould prevent the flow of molten metal wherever they may be placed.

There are two main reasons for inserting cores, viz. to keep the castings as light as possible (which is very important in some castings), and to make holes instead of cutting them out of solid metal.

In the latter case great care must be exercised; cored holes may or may not need subsequent tooling.

If we look at a cast-iron face plate for a lathe we have an example showing a number of cored holes which need no subsequent tooling. The holes are not made to lighten the plate, but for use when securing objects to be turned or bored.

There are, however, many instances where cored holes are objectionable, especially in small castings, viz. cored holes cannot be made uniformly true, straight, and in their proper place. They refuse to be coerced by a drill point, and, worst of all, frequently resist the progress of the drill when only a small amount of metal has to be removed, owing to the cutting being unequally distributed. The scaly walls of the holes are more or less hard, and the sand from the core is a great enemy to the cutting edges of the drill. For these reasons the speed at which the drill revolves is less than is the case when the metal to be cut is solid; besides this, the holes to be cut from solid metal are always truer than those which were previously cored.

Twist Drills.—Twist drills are almost universally used in preference to those forged from round or flat bars of steel.

Standard Taper Shanks.—Twist drills are made with taper shanks to fit a standard taper gauge. These are carried in specially prepared sockets adapted to fit a given-sized machine spindle. Drills of this class range from $\frac{1}{4}$ in. to 4 in. diameter.

Standard Taper Shanks.—Drills are also made with taper shanks square in section to fit ordinary ratchet braces for hand use.

Parallel Shanks.—Another kind of twist drill is one with a parallel shank used principally in screw or chucking machines, and in ordinary drilling machines when carried in self-centering chucks.

Drills of this make are stocked in all sizes from $\frac{1}{16}$ in. to $1\frac{1}{4}$ in., rising by $\frac{1}{32}$ in.

For the following hints on some of the special points in the manufacture of twist drills, together with those on grinding, point-thinning, and driving, I am indebted to the makers, Messrs. Smith and Coventry, Manchester.

Testing New Drills.—Testing is an important point in the manufacture. Each drill is used to make a hole in wrought iron, and fed at

a coarse rate; the holes are afterwards gauged. To obtain the best results from a twist drill it is necessary that the drilling-machine spindle should rotate truly in its bearings. It is obvious that if a twist drill is driven eccentrically it is in great danger of being broken, especially in drilling deep holes.

Grinding Twist Drills.—Three points must always be watched when grinding twist drills—

1. Both lips must be exactly of the same length.
2. Both lips must have the same clearance angle.
3. Both lips must be equally inclined to the axis of the drill, or, in other words, both lips must be of the same angle.

Effect of Bad Grinding.—If we examine the holes drilled by twist drills which have *not* been ground to fulfil the above conditions, we find—

1. That the hole produced is of greater diameter than the drill, because one lip is longer than the other, and therefore the point is not in the centre of the drill.
2. The lip having the greater clearance will dig into the metal, whilst that with the lesser clearance will not cut so freely, and thus a horizontal strain will be introduced, which will generally break the drill.
3. If the inclination of the two lips is not the same, we get one lip longer than the other, and the hole produced, as above stated, is larger than the drill itself.

It has been found that by thinning the points of twist drills their efficiency is enormously increased, and the power required to drive them is very much diminished.

Method of driving Twist Drills.—The most mechanical method of driving a drill, and the one which ensures the drill running perfectly true, is by means of the taper-shank.

The drilling-machine spindle is bored to the standard taper of the shank of the largest drill used in it; where, however, a parallel hole already exists, a socket may be used with a shank turned to fit it.

The sockets and drills are removed from the machine by a steel drift made with a slight taper.

Cutting Speeds and Feeds.—The periphery speed of the drill and the rate of feed given are those suitable for drilling wrought iron. The same amount of work can be performed in cast iron, but it is best to reduce the speed one-fifth, and increase the traverse of the spindle in the same ratio.

We have arranged the cutting speeds and feeds at those which we have found from experience do not distress the drills or cause undue wear and breakage. Where all the conditions are favourable—that is to say, when you have a homogeneous clean metal to drill, a rigid machine, and a drill running true, and ground so that both lips are doing equal work—much higher results can be obtained than are indicated in the above table; e.g. we have repeatedly drilled a $\frac{1}{2}$ -in. hole through a wrought-iron block $2\frac{1}{2}$ in. deep in 1 minute.

CUTTING SPEEDS AND FEEDS FOR TWIST DRILLS.

Diameter of drill.	Max. cutting speed (revs. per minute).	No. of revs. per inch of feed.	Diameter of drill.	Max. cutting speed (revs. per minute).	No. of revs. per inch of feed.
Inch.			Inch.		
$\frac{1}{8}$	650	300	$1\frac{3}{8}$	60	100
$\frac{3}{16}$	480	300	$1\frac{1}{2}$	55	100
$\frac{1}{4}$	320	200	$1\frac{3}{4}$	45	100
$5\frac{1}{8}$	270	150	2	34	100
$\frac{3}{8}$	230	150	$2\frac{1}{4}$	32	100
$\frac{7}{8}$	180	150	$2\frac{1}{2}$	30	100
$1\frac{1}{2}$	150	100	$2\frac{3}{4}$	28	100
$\frac{5}{8}$	130	100	3	26	100
$\frac{3}{4}$	110	100	$3\frac{1}{4}$	24	100
$\frac{7}{8}$	90	100	$3\frac{1}{2}$	22	100
1	70	100	$3\frac{3}{4}$	20	100
$1\frac{1}{8}$	67	100	4	17	100
$1\frac{1}{4}$	64	100			

The above table of speeds must be increased for high speed steels—*i.e.* air-hardening.

Making Twist Drills.—The depth of groove in a twist drill diminishes as it approaches the shank, in order to obtain increased strength at the place where the drill is otherwise generally broken.

The variation of depth is conditional, depending mainly on the strength it is desirable to obtain, or the usage the drill is subject to, as in different classes of work.

To secure variation in the depth of the groove the spiral head-spindle is elevated slightly, depending in this case on the length of flute, for which, when 2 in. or less in length, the angle may be $\frac{1}{2}$ degree; 2 to 5 in., $\frac{3}{4}$ degree; 5 in. and over, 1 degree. This is generally satisfactory in this respect in our own work, as the drills are seldom very long.

When large drills are held by the centres, the head should be depressed in order to diminish the depth of groove. The outer end of the drill is supported by the centre-rest, and when quite small should be pressed down firmly as illustrated, Fig. 61, until the cutter has passed over the end. The elevating screw of this rest is hollow, and contains a small centre-piece with a vee groove cut therein to aid in holding the work central. This piece may be made otherwise to adapt it to special work.

Another, and very important, operation on the twist drill is that of "backing off" the rear of the lip so as to give it the necessary clearance, to prevent excessive frictional resistance.

In the illustration, Fig. 61, the bed is turned about half a degree,

as for cutting a right-hand spiral ; but, as the angle depends upon several conditions, it will be necessary to determine what the effect will be under different circumstances.

A slight study of the figure will be sufficient for this, by assuming the effect of different angles, mills, and the pitches of spirals. The object of placing the bed at an angle is to cause the mill E to cut into the lip at C', and have it just touch the surface at e.

The line *r* being parallel with the face of the mill, the angular

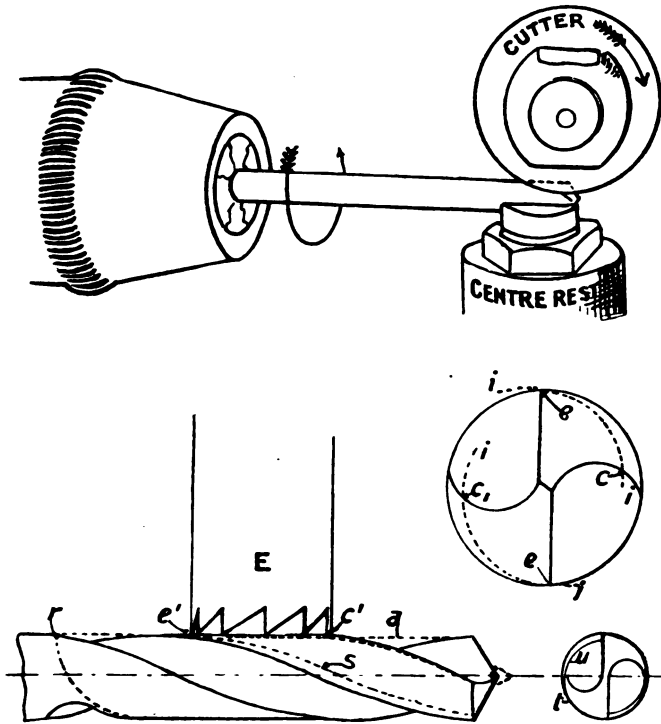

FIG. 61.—Making twist drills.

deviation of the bed is clearly shown at *a* in comparison with the side of the drill.

From a little consideration it will be seen that while the drill has a positive traversing and rotative movement, the edge of the mill at *e'* must always touch the lip a given distance from the front edge ; this being the vanishing point, if such we may call it. The other surface forming the real diameter of the drill is beyond the reach of the cutter, and is so left to guide and steady it while in use.

The point *e* shown in the enlarged section, Fig. 61, shows where the cutting commences and its increase until it reaches a maximum

depth at c , where it may be increased or diminished according to the angles employed in the operation, the line of cutter action being represented by ii .

Before backing off, the surface of the small drills, in particular, should be oxidized by heating until it assumes some distinct colour. The object of this is to clearly show the action of the mill on the lip of the drill, for when satisfactory a uniform streak of oxidized surface from the front edge of the lip back is left untouched by the mill, as

represented by the cut at e' . It is found a great advantage to grind drills after they are hardened, as they can be made to run true with the shank. If tapered back about 0.003 in. in 6 in., it will be found that this clearance will cause them to run better. To grind the drill it is necessary to make it with a 60° point, as shown in Fig. 61, so that it will run in a countersunk centre. After grinding, this point can be ground off when the drill is sharpened. It is sometimes preferred to use left-hand cutters, so that cut will begin at the shank end.

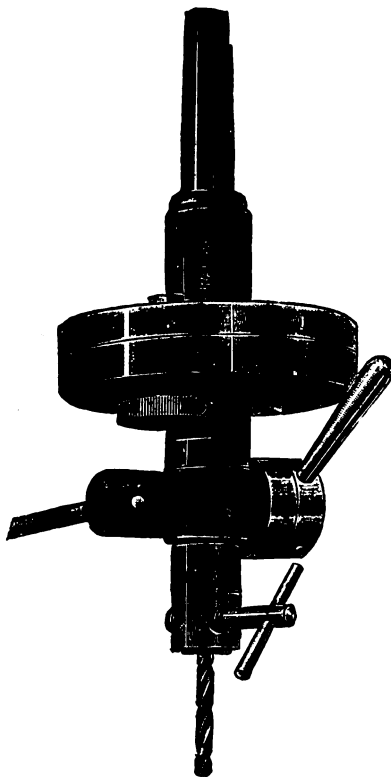

FIG. 62.—High-speed sensitive drilling attachment.

Grinding Twist Drills.—In addition, the following is appended as having been taken from the best practice:—

If the clearance of a drill is insufficient or imperfect, it will not cut. When force is applied, it resists the power of the drilling machine, and is crushed or split.

It is well to start a drill, after grinding, by hand, observing the character of the chips, which should characterize a clean-cutting tool. In wrought metal the chip will sometimes attain a length of several feet.

Drills, properly made, have their cutting edges straight when ground to a proper angle, which is 59° .

Grinding to less angle leaves the lip hooking, and is likely to produce a crooked and irregular hole.

The grinding lines to a drill are placed slightly above the centre to allow for the proper angle of point, which is an important factor. This angle is an index to the clearance.

If the angle is too much, the drill cuts rank. If not enough, the drill may not cut.

High-speed Sensitive Drilling Attachment.—Work of large dimensions requiring to be drilled with very small drills cannot be taken to a small machine. To do the work in a large machine is not satisfactory, owing to the comparatively low speed the machine spindle revolves at. Fig. 62 is an appliance which may be attached to the drilling-machine spindle in the same manner as an ordinary drill.

By an arrangement of gearing inside, the speed of the little chuck is multiplied four times. There is also a device which can be adjusted so that the drill and chuck will stop instantly should the drill meet with any undue strain, thus preventing it from breaking.

The feeding is accomplished by the usual arrangement on the machine, or by the lever shown at the right of the attachment.

The rod extending to the side of the column is to prevent the whole attachment from revolving.

Twist Drill with Oil Tube (Fig. 63).—Twist drills with oil tubes are used in high-speed drilling in ordinary and turret lathes.

The end of the shank is bored out, and the ends of the oil tubes enter the bottom of the "chamber" so formed; a collet, or sleeve, fitting



FIG. 63.—Oil-tube twist drill.

the holes in the turret head, is slipped over the shank, each size of drill requiring its own collet, or special drills with shanks to fit a given turret. An oil pipe is passed through the top and middle of the turret down into a chamber reaching the shank of the drill, and by means of a small pump the oil is forced into this chamber, and out through the tubes, which run along the drill to the cutting lips, enabling the drill to do a great deal more work than by the old practice.

The drill remains stationary, and the work should revolve at a high rate of speed.

Oil-feeding Socket for Drilling Machine (Fig. 64).—A constant stream of oil is carried to the cutting lips of the drill, and prevents its heating or sticking in the hole. The drill can be run at a higher rate of speed, and requires sharpening less frequently. It is necessary to hang a bucket, with a stop-cock near the bottom, over the drilling machine, and connect it with a tube on the side of the socket; the collar should be held stationary by screwing on to it a piece of $\frac{1}{4}$ in. gas-pipe, and letting the pipe rest against the column of the machine.

The oil is conveyed through channels in the collar and in the body of the socket, into the orifices in the shank of the drill, and so through the tubes of the drill to the point. The sockets are bored to the standard taper.

Facing Tool worked by Hand.—Fig. 65 is a small appliance for

facing the underside of bosses or other seatings for bolt heads and nuts. It will be seen that the screw is adapted for various thicknesses of metal, the adjustment being effected by means of the washer and nut.

The cutter rides on a key, and as the work proceeds the nut is tightened until the facing is "tooled up." A double-ended tap-wrench is used to rotate the screw. Such work but on smaller pieces which can be easily moved, are drilled and faced at the ordinary drilling machine, with a left-hand cutter. Where it is, however, not convenient

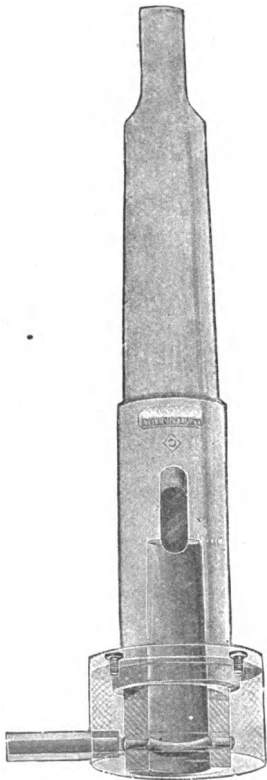

FIG. 64.—Oil-tube socket.

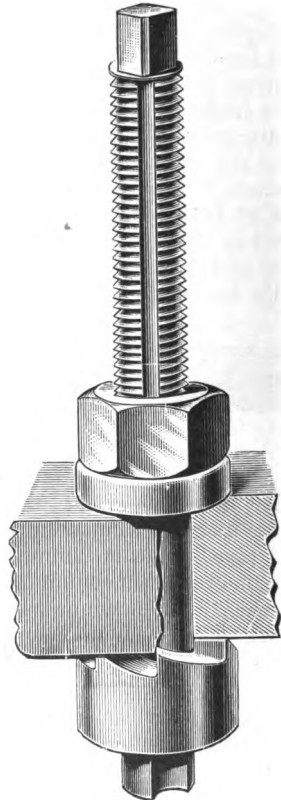
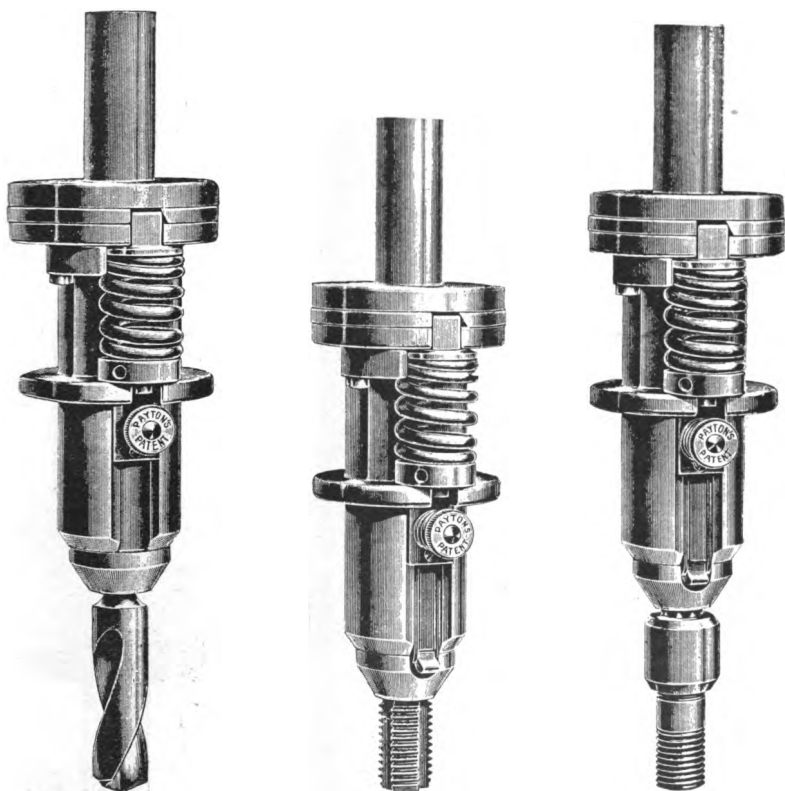

FIG. 65.—Facing tool worked by hand.

to move heavy castings to the machine, this appliance (Anderson's Patent) serves a good purpose.

Payton's Patent Universal Machine Tapper.—The instrument shown in Figs. 66, 67, 68, is for drilling and tapping holes, and for fixing studs in the same. This "machine tapper" is designed to take taps up to 2 in. diameter. The shank is fitted to the machine spindle, and the drill, tap, or stud holder, is carried by the chuck at the opposite end, as shown.

The drill stock is secured in the chuck by a spring. When the appliance is working, the safety-spring is employed, which would yield to any obstacle, and so prevent the drill or tap breaking. After the hole is drilled and tapped, say, in a cylinder flange, a stud may be inserted in the stock, and screwed into its place. The advantage is considerable, the tapping is reliably straight with the hole, and of course the stud follows exactly the tapping; many studs can be put in place in



FIGS. 66, 67, 68.—Payton's patent universal machine tappers.

this manner in less time than was formerly occupied by two men in fixing *one stud*.

Messrs. Smith & Coventry, Manchester, make another kind (Figs. 69, 70), called Pearn's "Lightning" Tapper. This is made with a taper shank to fit any drill or screwing machine either working vertically or horizontally.

Advantages.—It is claimed that all holes are tapped to one depth, straight, and alike, without any risk of taps breaking. Fig. 68 shows

the yielding coupling driving and starting to tap. Fig. 70 shows the yielding coupling slipping when the hole is tapped.

Construction.—When different-sized taps are to be used, adjustment is made by screwing or unscrewing the nut at the top of the spring.

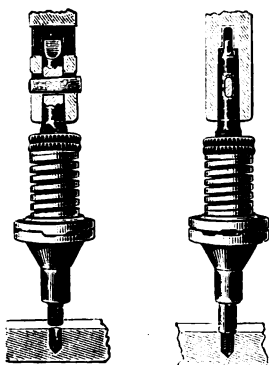

FIGS. 69, 70.—Machine tappers.

This gives the necessary pressure power to the spring to drive the taps, but also leaves it free to yield before breaking the tap.

One tap only is required for each size up to $1\frac{1}{2}$ in.; above $1\frac{1}{2}$ in. two taps are supplied.

Grip Socket for Taper Shank Drills.—Figs. 71, 72 illustrate a grip socket for taper-shank twist drills. To prevent the strain being put entirely on the tang, a groove is milled in the shank of the tool, deepest at the large end, so that the bottom of the groove has a taper, the reverse of that of the outside of the shank.

A key in the socket fits the groove, and when the tool is put in place a turn of the eccentrically counter-bored collar, shown in the cut, *locks* the key in place. The tool cannot turn in the socket or be removed until the collar is turned back again, and the key released.

Portable Drilling Appli-

ances.—Portable drilling appliances have been much improved by the drill-holders being constructed to take in drills similar to those used in a modern drilling machine. In Figs. 73, 74 two views are shown of breast drills, each having a self-centering two-jaw chuck with jaws removable, so that small pin drills may be carried when required.

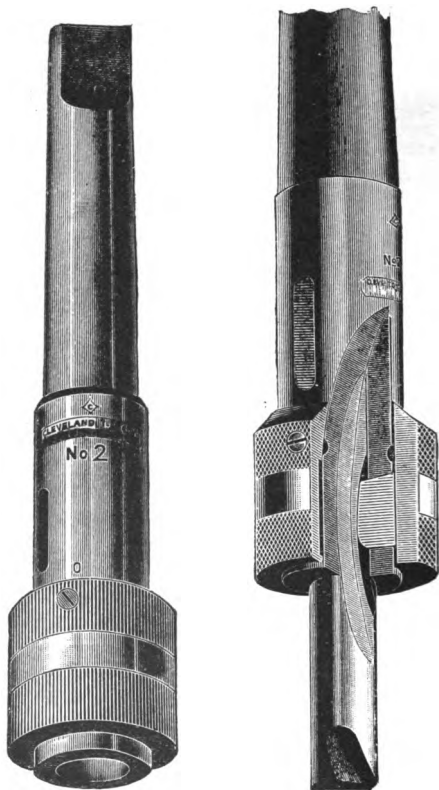

FIGS. 71, 72.—Grip sockets.

A and B show two types of jaws, A being used for small drills, B having coarser teeth for the larger sizes.

A spanner is not wanted to fasten the drill in place. The octagonal nut D, being a counterpart of the jaws A and B, gives sufficient grip to the drill when screwed by hand. Another feature is that there is no wobbling in this type, and for many purposes true running is essential. Since all the pressure required to do the work of feeding and rotating the drill has to be put in the appliance by the operative, only holes of small diameter are drilled in this way. Instead of this, a bow drill is sometimes used, and it has one good

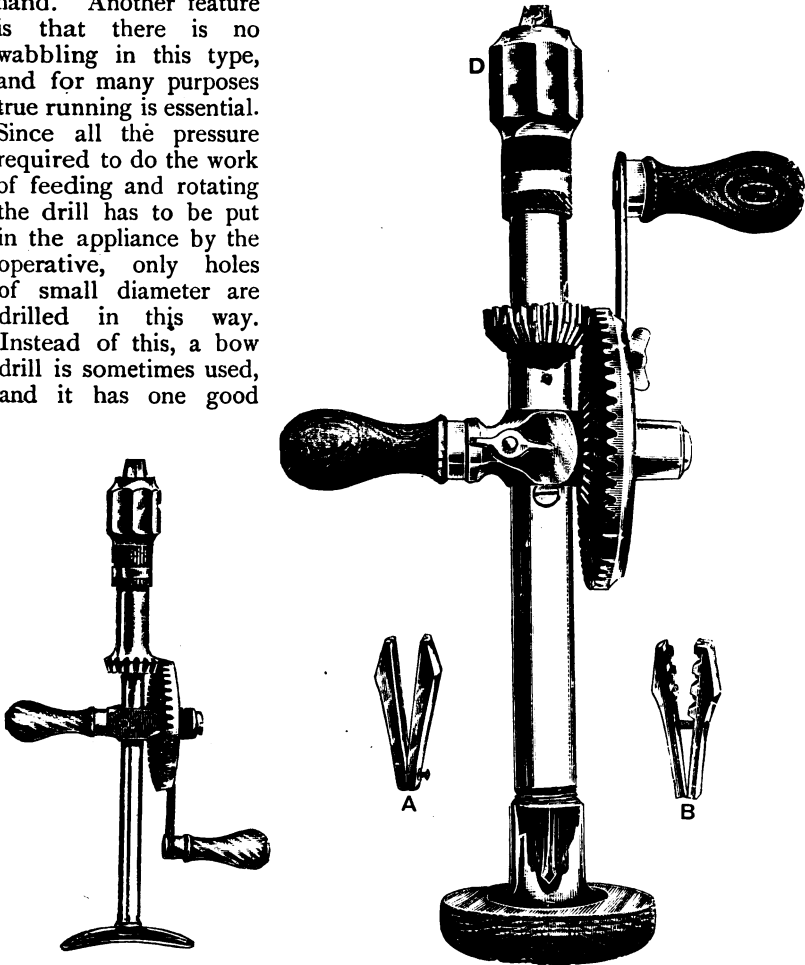

FIG. 73.

Breast drills.

FIG. 74.

feature, a man can get close over his work to drill it. This, however, only refers to very small holes.

The ratchet brace shown in Fig. 75 is a very useful tool for drilling holes in awkward places, where a power drill could not be used, and in

heavy work which would be costly to shift and fix under a drilling machine. It is light, and quickly rigged, wherever a plate or other support can be found to receive a centre hole into which the steel point of the socket screw may be located. The construction of the

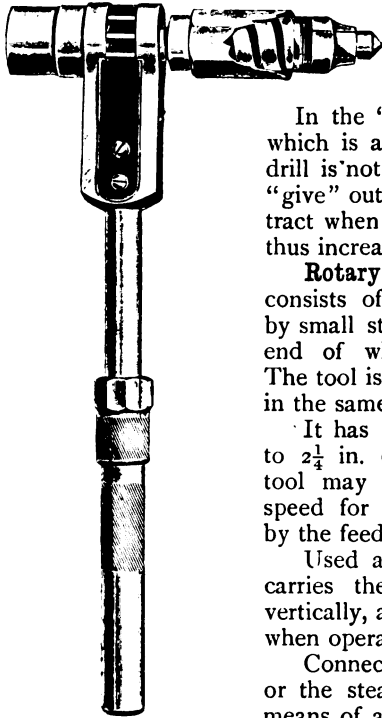

FIG. 75.—Ratchet brace.

brace is partly to view in the figure. The arm may be dis-jointed near its centre, thus making the appliance more compact when drilling in cramped places.

In the "socket" a spiral spring is inserted, which is a good introduction; by its use the drill is not only more steadily fed, but it would "give" out when the drill is finishing, and contract when passing through any harder metal, thus increasing the life of the drills.

Rotary Engine.—The above appliance consists of a small rotary engine, connected by small steel gears with a drill spindle, the end of which is a taper socket (Fig. 76). The tool is fastened to the work to be drilled in the same manner as a ratchet drill.

It has a capacity to drill holes from $\frac{5}{8}$ in. to $2\frac{1}{4}$ in. diameter. The power to run this tool may be steam or compressed air; the speed for the different-size drills is regulated by the feed-valve and feed-screw.

Used as a reamer, the weight of the tool carries the reamer through when operated vertically, and only a slight pressure is needed when operated horizontally.

Connection between the end of the air or the steam pipe and the drill is made by means of a $\frac{1}{2}$ -in. steam hose. The length of this hose determines the area within which the drill can be operated. Thus, a hose fifty

feet long will allow drilling at any point in a circle of 100 ft. in diameter.

These portable drilling appliances are convenient in bridge and ship building, also in boiler shops.

On Drilling Machines. *General Remarks.*—Drilling machines are of two kinds, viz. those in which the work has first to be correctly located to suit the drill, and those in which the drill is moved to suit the work.

Sensitive Drill.—In the former class are included sensitive drills, these being engaged exclusively on making small holes.

Pillar and Bench Type.—In this class of machines may be found pillar and bench drilling machines respectively. A small self-centering chuck is generally carried at the end of the drill spindle to suit twist drills having parallel shanks.

Ungearred Machines.—"Ungearred," or, as they are frequently called, "single-gearred machines," means that the machines are belt-driven.

Gearred Machines.—"Gearred" or "compound-gearred," means that there is a set of gears which may be used to reduce the speed of the drill spindle when large holes are to be made.

In the latter class the work is generally of large dimensions, rendering it inconvenient to locate it exactly beneath the point of the drill.

Vertical Drilling Machine.—Vertical machines fitted with movable

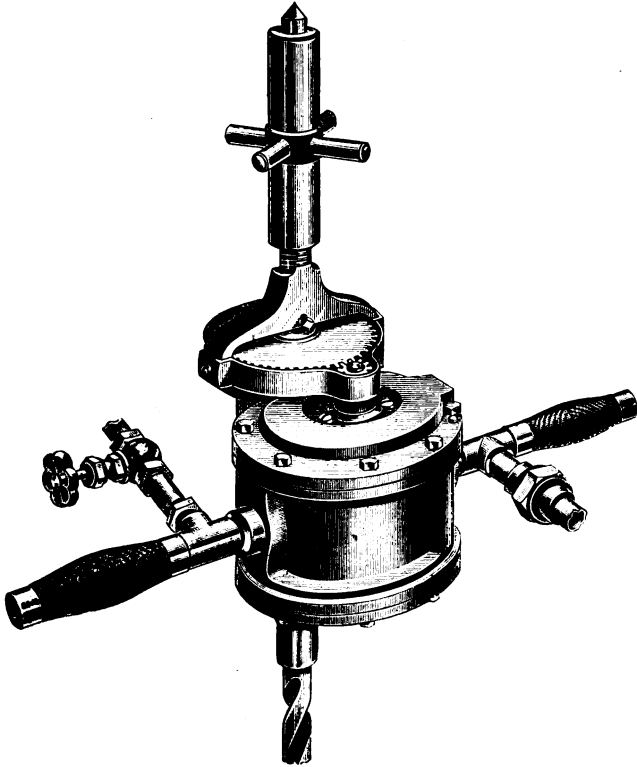

FIG. 76.—Rotary engine for drilling.

tables, *i.e.* tables moved by means of screws and slides. All the above machines require that the line of the work to be drilled shall be placed precisely under the axial line of the drilling spindle.

Universal Drilling Machine.—A universal drilling machine carries a spindle which can be swung into any part of a circle; that is to say, a hole can be drilled by one of these machines in any conceivable position.

Radial Drilling Machine.—A radial drilling machine carries the

drill spindle on a slide which is movable along an arm, and the arm movable on an axis fixed vertically.

The arm can generally be swung through the greater part of a circle.

Gang Drills.—“Gang drills” is a term given to a series of similar machines placed in alignment, and each receiving power from the same driving shaft.

Each machine is actuated by independent stopping and starting gear.

This arrangement proves to be very satisfactory in several respects ; considerably less room is required by thus grouping the machines ; and a further advantage is that, parts of machines requiring to be drilled in several places, the drills need not be changed so frequently, since the work can be passed along.

In this way a great number of parts, required in the small-arms, sewing-machine, and cycle trades can be treated with ease and dispatch.

Many of the holes are extremely particular ; these are drilled through a “jig,” which practice will be shortly explained. Less important holes are drilled direct without a guide.

Multiple drilling machines are also constructed to operate simultaneously on the same piece of work. By this arrangement a series of holes can be made at a set distance apart, and on a given straight line. The distance between the holes can be varied, but the alignment is unalterable.

Another type of “multiple drill” is used in the boiler shop. These are used in drilling the transverse and longitudinal seams in cylindrical boilers. The spindles are arranged in two or three groups of five, each carried by brackets on heavy columns, the columns being adjustable along the machine bed, each column being provided with an electric motor for moving it along the bed, and each bracket has a motor for operating the drills.

There are many other instances of multiple drilling ; in fact, these machines are being constructed in a variety of forms to suit modern requirements.

Sensitive Drilling Machines.—A sensitive drilling machine is one in which the progress of the drill is felt or known as the feed is imparted. These machines are usually void of wheel gearing, and are fed by hand.

A lever directly actuates the drill spindle, which is well seen in Fig. 77.

By moving the lever the spindle is at once made to descend, and any obstacle—such, for instance, as a hard or soft place, *i.e.* a blow-hole—is at once detected.

There is a decided advantage when drilling small accurate work to feel the progress of the drill, especially when the point of the drill has passed through the work ; then it is that the feed is required to be given most carefully. This progress has to be ascertained in the larger and geared machines, either by measuring the distance through which the drill has

passed, or, where practicable, looking or feeling for the point of the drill as it cuts its way through the under side of the work.

The spindles of the "pillar" type are balanced, as is also the table of the machine. The machine carries its own countershaft, and is thereby self-contained. It will also be noticed that there are few parts likely to get out of order, and by driving in the manner shown, smooth running, so desirable for fine work, is ensured.

A bench sensitive drilling machine is given in Fig. 78; this has a fixed table and an independent overhead motion, but in other respects is much similar to Fig. 77.

Geared Drilling Machine.—Another type of drilling machine is one in which the table has capacity to rise and fall, or to move transversely

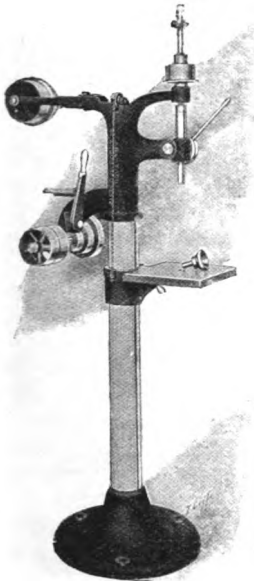

FIG. 77.—Sensitive pillar drill.

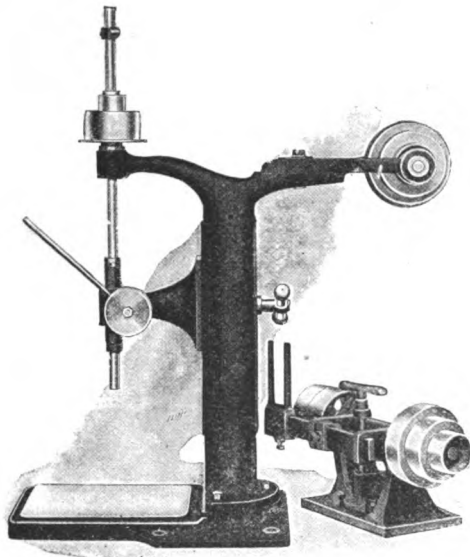

FIG. 78.—Sensitive bench drill.

or longitudinally on compound slides. In this form the slides are convenient, as by their use the most accurate work can easily be set centrally with the drill spindle, instead of the troublesome method necessary to fixed-table drilling machines.

The large hand-wheel shown in Fig. 79 operates the worm and worm-wheel; on the axis of the latter a pinion is keyed, which meshes with a rack shown in the centre of the vertical slide. Thus, by rotating the hand-wheel, the knee carrying the table is made to rise or fall as required. When it is more convenient, the base plate supports the work; the table being swung on its hinge out of the way, leaves a clear space. Then, of course, the work has to be set precisely in alignment with the spindle and drill.

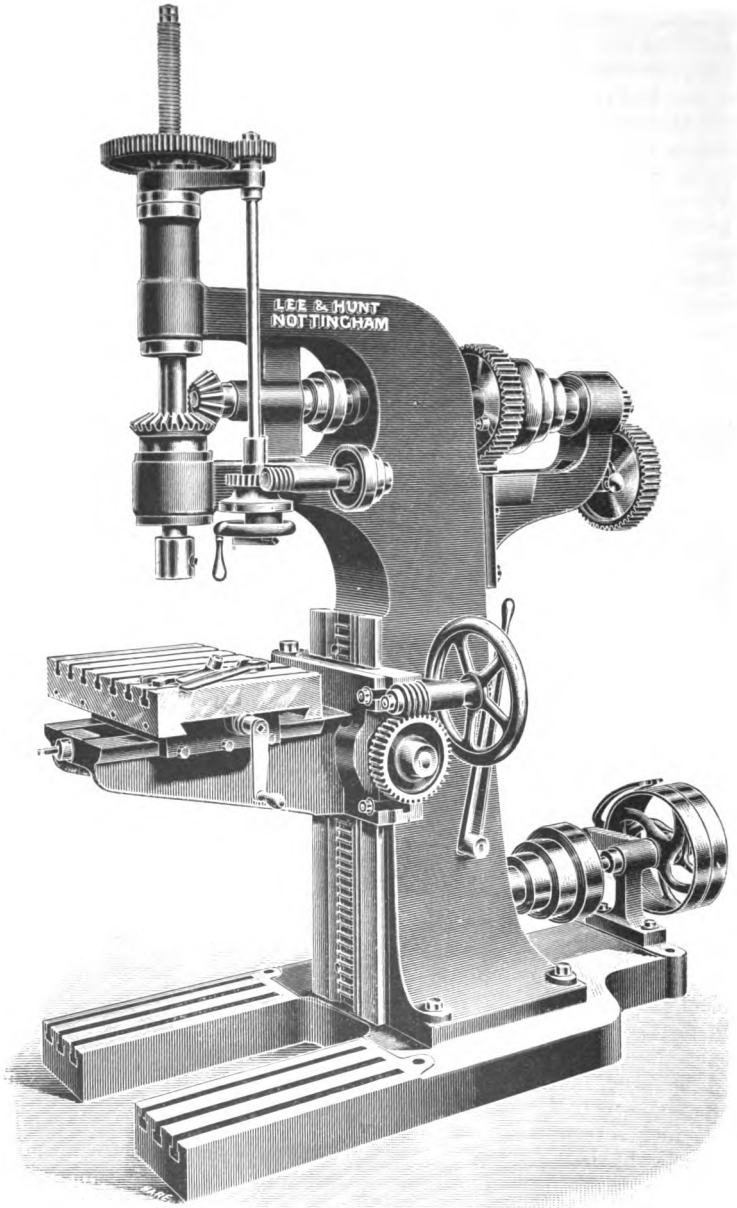

FIG. 79.—Geared drilling machine.

Belt-driven Radial Drilling Machine. *Gearing on Spindle.*—The drilling machine illustrated in Fig. 80 is belt-driven, with back gear direct on the drill-spindle.

This method of driving is now being adopted, it being generally acknowledged as a good system.

Advantages. 1. *Ease in drilling Small Holes.*—The advantages claimed are, that it admits of the machine being used for small holes under the best conditions, viz. high speed without gear, also that less power is absorbed for drilling or boring large holes, as the power is multiplied at the spindle instead of at the first driver.

2. *Driving Power less when geared direct.*—The arm carrying the cross slide is hinged to swing over, to suit work secured to the base plate, or when it is secured to the side of the table.

Rise and Fall of Table.—The table has a rising and falling motion. This feature renders the machine very useful where a general class of work has to be drilled on the table, as well as heavy pieces requiring the use of a pit in which to lower them.

Saddle Traverse.—The saddle is moved along the arm by means of a worm and hand-wheel, or it may be moved rapidly without the hand-wheel, except for short adjustment.

Ball Bearings.—The thrust on the spindle end is taken by ball bearings to reduce the friction.

Tapping Arrangement.—When tapping is to be done, the position of the gears is changed, so as to reverse the direction of the drill spindle.

Tension on Belt.—The driving belt for the spindle is kept in tension by a spring acting on the idler pulley at the outer end of the arm. The machine is by the Anglo-American Machine Tool Co.

Radial Drilling Machine.—Fig. 81 represents a radial drilling machine of the universal type. The column carrying the drill arm will rotate through a complete circle.

These machines are convenient for drilling and boring large pieces of work which it is difficult to move about. Such work is placed either in a pit at one side of the machine or upon a floor plate.

The drilling head is carried on the end of the radial arm in such a manner that the spindle may be set in a horizontal plane, a vertical plane, or a plane inclined at any angle to the surface of the table, or it may be swung to any angle in either plane. The radial arm is adjustable in height above the table up to 4 ft.

These features enable the machine to drill holes in almost any conceivable position within the space covered by the limits of travel.

The machine is driven by a vertical shaft passing through the centre of the column, carrying on its upper end pulley or bevil gears as may be required by the location. The column, 15 in. diameter, is mounted on a table 6 ft. in diameter and 30 in. high, which is considered a convenient height for holding work.

The cone pulleys driving the machine are not in view, being carried on the opposite side of the radial arm. The arm is adjustable horizontally by hand, but is raised or lowered by power or by hand.

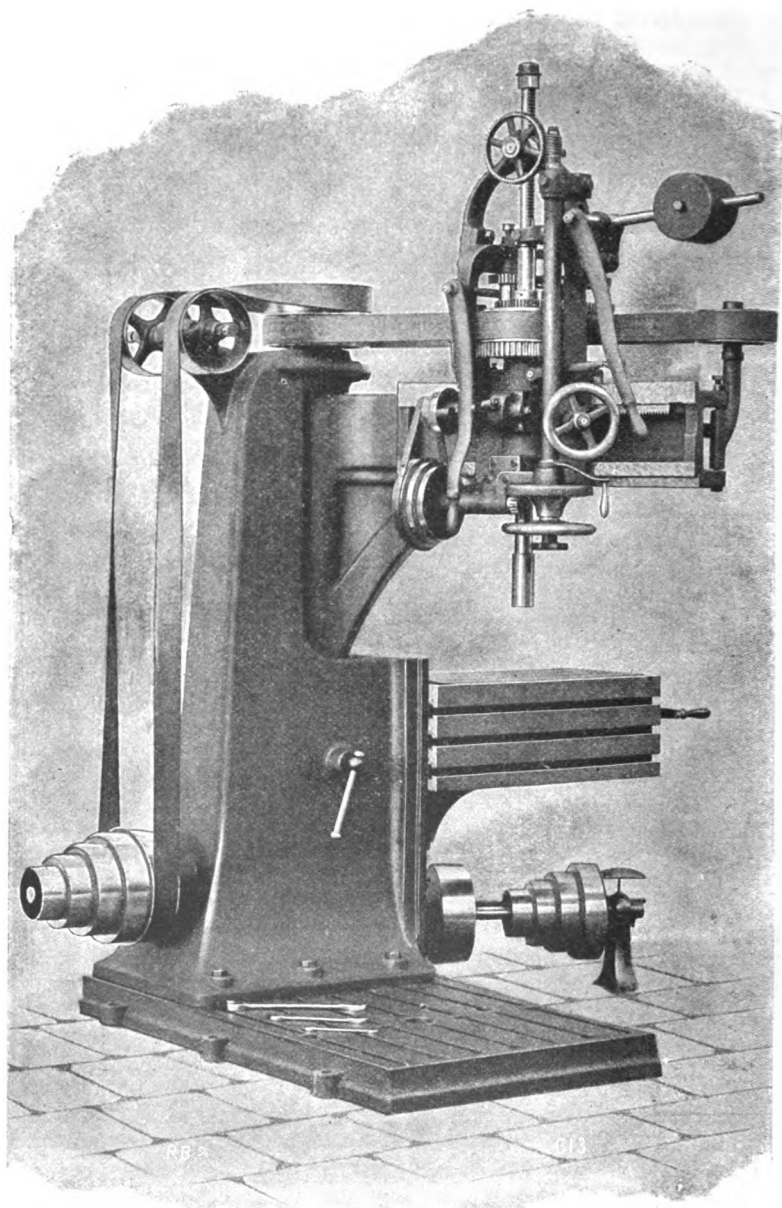

FIG. 80.—Belt-driven radial drill.

The extreme radius of the drill, measured from centre of column, is 8 ft.

Figs. 82, 83, 84, show the drill spindle in various positions. The machine is by Wm. Sellers & Co., Philadelphia.

Drilling Jigs. *Construction and Use.*—A drilling jig consists essentially of a pattern plate, provided with one or more holes.

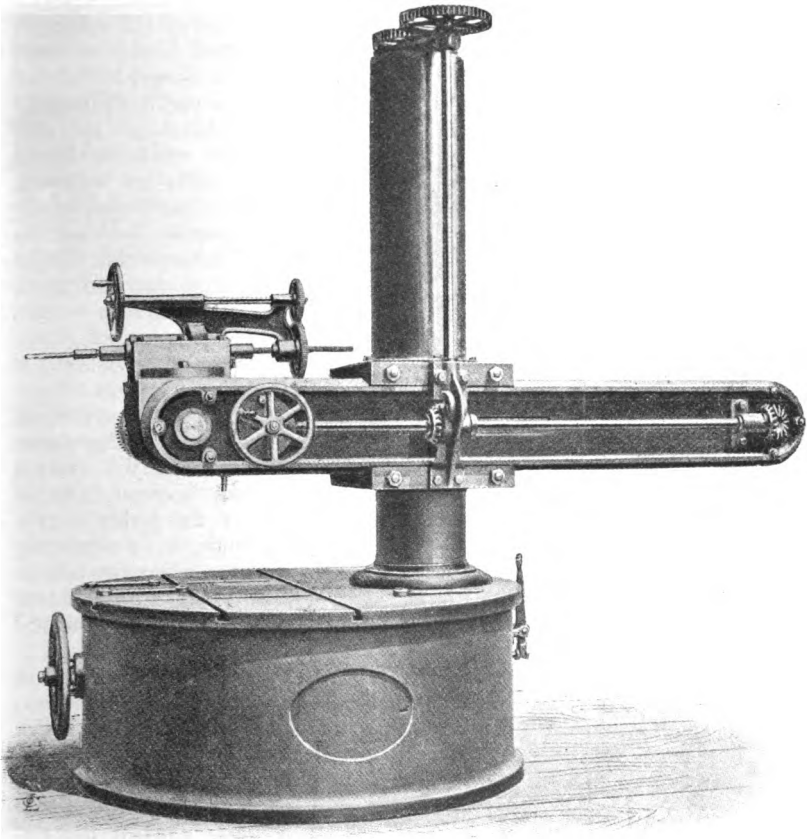

FIG. 81.—Universal radial drilling machine.

Ground Bushings of Hardened Steel.—It is the practice to correctly locate the pattern holes in the jig plate, and to fit each hole with a bushing of hardened steel.

The bushes are carefully finished by grinding the external and the internal surfaces to correct size by the aid of small emery or corundum wheels.

Correct Pattern kept for Reference.—When a jig plate has been prepared and satisfactorily finished, it may then be used with care, as a guide through which the holes in other pieces can be drilled, tapped, or reamed, as the case may be.

When one piece of work has been made, and the location of the holes is satisfactory in every respect, such a piece is best kept for purposes of reference.

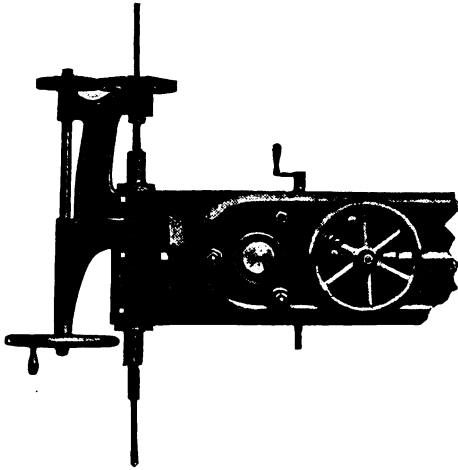

FIG. 82.

Drill Shanks all made alike to Gauge.—The best way to use a drilling jig is to have all the drill shanks, reamer shanks, and cutter-bar shanks, made exactly alike in dimensions.

Bushes fit One Gauge.—In this case the bushings are accurately ground to fit one standard gauge, whatever sizes the holes to be drilled may be.

Tool Edges preserved.—By adopting the above arrangement the cutting edges of all the tools are considerably preserved, because they do not come in contact with the hardened walls of the holes of the bushings, as is obviously the case when the bushes are bored to the same diameter as the finished holes in the work.

Steady Bearing.—A further important advantage is, that when at work the drills and reamers are kept perfectly steady, owing to the good fitting contact between the enlarged portion on the drill shank and the bushes.

Lubrication and Cleanliness.—This perfect sliding contact is preserved by the careful use of a lubricant, and by keeping the parts quite clean.

Uniformity in Product.—We have seen a number of machines working on this system with most excellent results. The holes drilled and reamed were alike to $\frac{1}{1000}$ of an inch; each article was pierced with

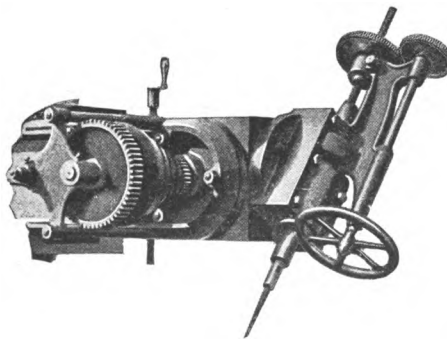

FIG. 83.

a number of different-sized holes, each hole serving as a bearing for an axle or a shaft, the latter being finally fixed in place without adjustment ever being necessary.

Where the above system is not practised, there are various-sized bushes used on the same jig plate, *i.e.* each bush is ground to one standard diameter; but bars, reamers, and drills, of different diameters have their own respective bushes. It will therefore be clear that a considerable number of different-sized bushes are necessary, and since they have to be frequently removed and others substituted, there is a risk of fracture and an increase of wear.

The length of these bushes is about one and a half diameter of the hole; and the space between the under side of the bush and the top side of the work is made as little as is practicable. In this way the steadiness of the tools when cutting is ensured.

When holes have to be made at set angles to other holes or surfaces, there are two methods of doing the work. Either the jig plate swings, or the drill spindle. In the former case there is generally a stop, against which the swing jig is turned to; while in the latter case the swing head of the drilling machine is turned over to the correct angle, as indicated by the marking which is shown in degrees on the rim of the turning joint.

Right-hand and left-hand brackets, when used to support the opposite ends of spindles or shafts, may be drilled and reamed, while clamped between two jig plates. Each plate carries a separate set of bushes, and after the work has been machined on one side, the jig is simply reversed with the underside turned uppermost. Thus two plates may be held in one jig without removal while they are drilled, reamed, milled, and profiled respectively.

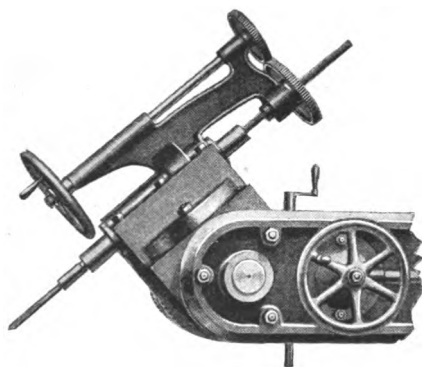

FIG. 84.

CHAPTER V.

TURRET LATHES.

TURRET lathes are now made in all sizes, from the smallest, operating on minute watch screws and studs, to the largest, now suitable for the work in a general engineering workshop.

A representative type of machine for doing lathe work, particularly that class coming between $\frac{1}{2}$ in. and 2 in. diameter, and less than 24 in. long, is here given in detail: The Hartness Flat Turret Lathe, made by The Jones and Lamson Machine Co. (Fig. 86).

This lathe differs from other turret lathes principally in the form of its tool carriage and its tools; the turret is a flat circular plate, mounted on a low carriage, containing controlling mechanism.

An important feature lies in the manner the turret is connected to the carriage, and the carriage to the bed; for unless these are perfectly rigid, they will not afford perfect control of the cutting tools.

By referring to Fig. 87 it will be seen, in this enlarged view of the turret, that the base on which the various holders are secured is of large diameter. This is one of the distinct features of the machine. This base is scraped and padded to its seating on the carriage, and is secured by an annular gib.

In a similar manner the carriage is fitted to the vee's of the bed, but in this case the gibs pass under the outside edge of the bed, the breadth of this bridge from V to V being sufficient to form an unyielding support to the tools.

A further advantage is obtained by having the *turret flat*, since the indexing mechanism can be located with the index pin directly under the working tool so close as to permit no loss of motion between the tool and the locking pin.

Hartness Flat Turret Lathe.—The turret is turned automatically to each position the instant the tool clears the work on its backward travel, and it is so arranged that, by raising and lowering the trip screws near the centre of the turret, it may be turned to three, four, or five of the six places without making any other stop.

The power feed for the carriage is actuated by a worm shaft, the worm being held into the wheel by a latch which is disengaged by the feed stops.

There are six feed stops, each being independent and adjustable. These stops are notched, flat bars placed side by side on the top of the bed. The lever in Fig. 88 actuates the tool slide.

The headstock is necessarily squat to mate the turret, and is mounted on the bed, beneath which a box-shaped leg is placed, so as to give as

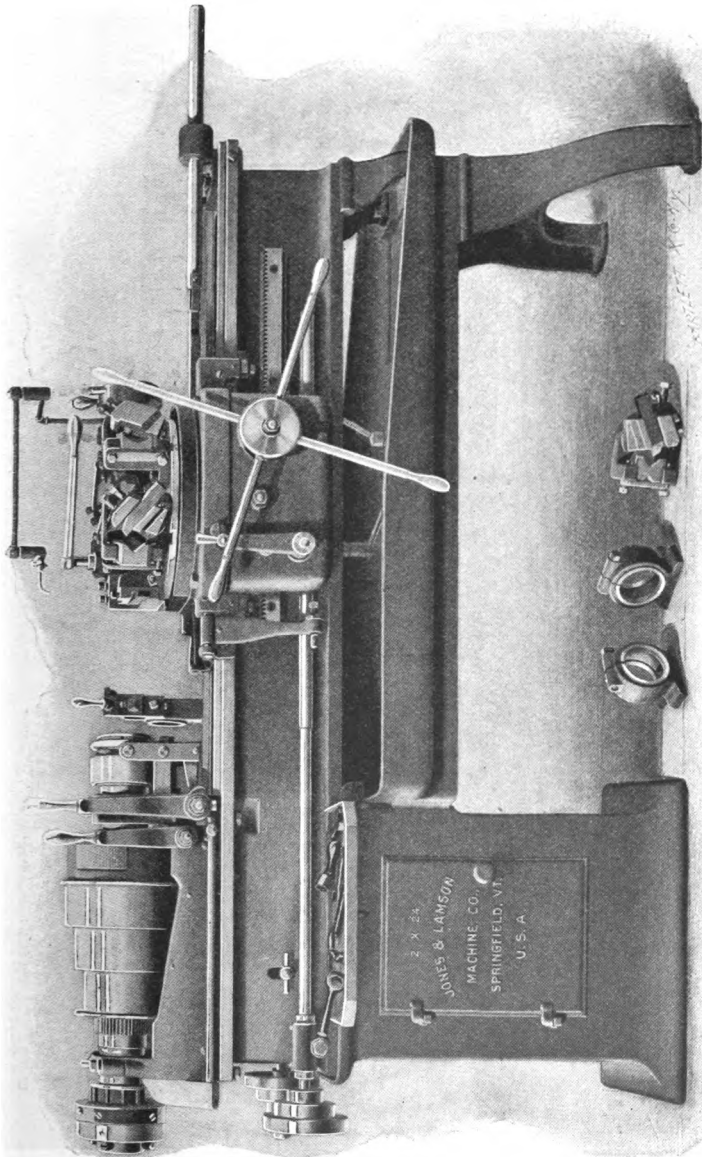

FIG. 86.—Hartness turret lathe.

rigid a support as possible. Too much attention was formerly given

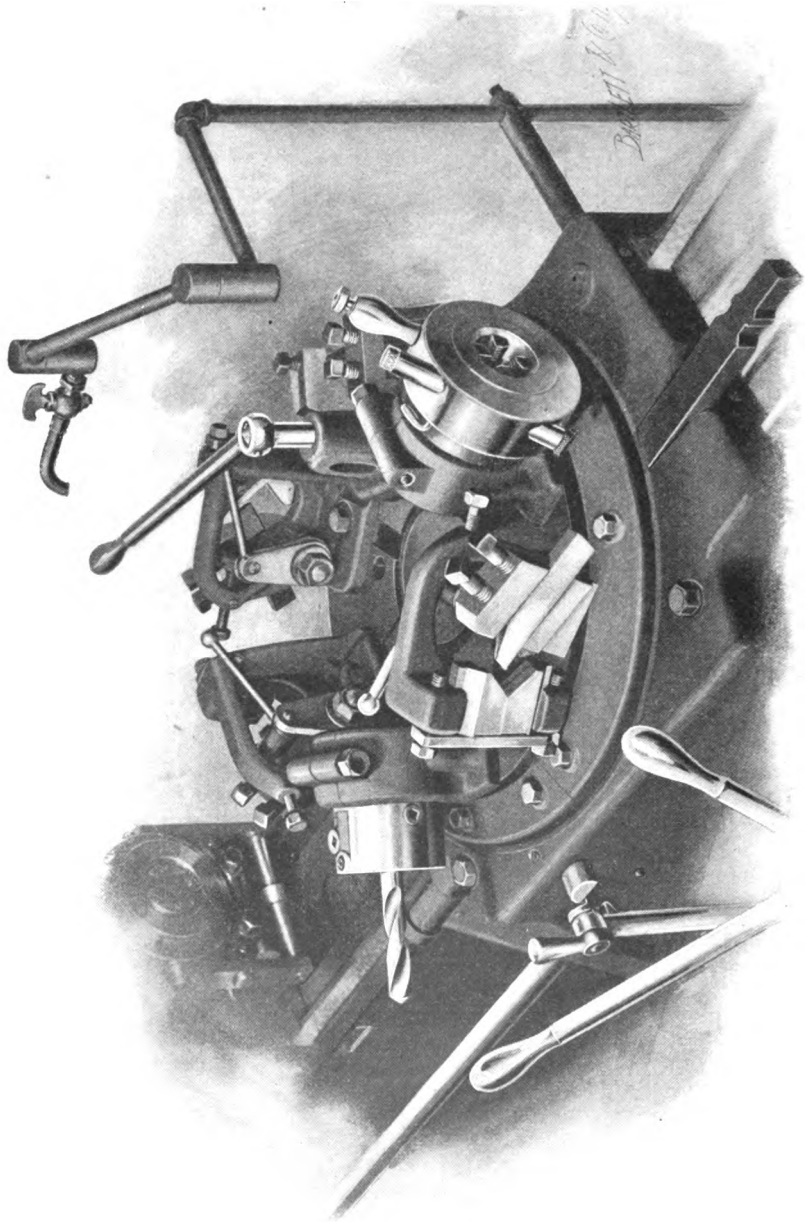

FIG. 87.—Enlarged view of turret.

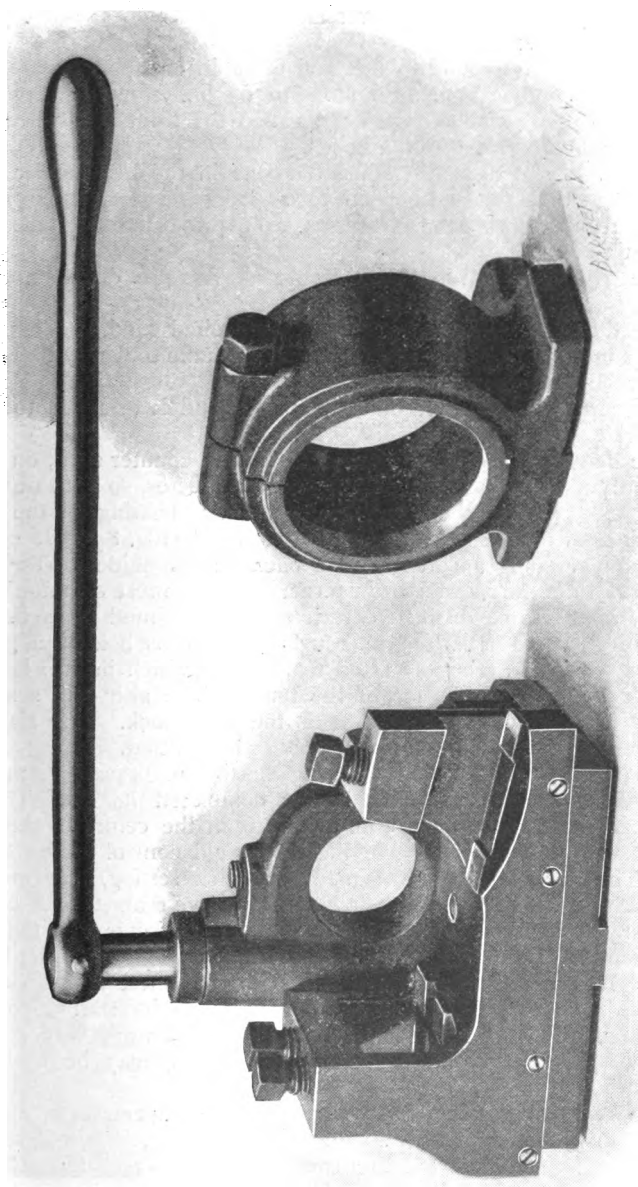

FIG. 88.—Tool slide.

to elegance. This, however, is not the case to-day, hence the solid and rigid appearance of the turret lathe above, which shows a proper balancing of parts.

The spindle is ground to size, and fitted in phosphor-bronze bearings. The spindle is made hollow to $2\frac{1}{8}$ in. diameter. It carries externally a cone and a large gear, called the front gear wheel (not seen in the figure, owing to the hood).

The back gear is placed below the cone in the head, and a triple gear is (sometimes) placed beneath this.

The regular back gear gives a 4 to 1 proportion, but the triple makes it 16 to 1.

The triple gear is used for all screws above $1\frac{3}{8}$ in. diameter, and in chucking work of large diameter.

The die carriage carries a die of any desired kind, and a pointer for shaping the end of a shaft or bolt, or the same tool may be used as a turner when reducing the stock.

The carriage is mounted on a sliding bar, and is arranged to swing into working position.

The head is driven through a triple friction counter shaft, on which shaft the pulleys are provided with extended bosses, so as to distribute equally the "pull of the belt" over the entire bearing on the shaft. The principal tool used is called the "turner" (Fig. 89). It consists of a frame holding a cutter, and a back rest or guide for the work. There are three forms of these "turners" in the most commonly used outfits, but the same distinctive feature may be found in each. The cutter in Fig. 90 is 1 in. by $\frac{1}{2}$ in. rough steel. It is held in a pivoted tool-box which is accurately fitted to a frame, which in turn is firmly secured to the upper surface of the turret. The adjusting screw for effecting the size of the work acts on the tool block. Any size may be turned from 0 to 2 in. after the tool has been fitted.

A cam is provided for withdrawing the tool to prevent its marking the work in running off after having completed its cut. The top surface of the turret is only 3 in. distant from the centre of the work, thus making it possible to give the most rigid control of the cutting tool. The back rests are designed for quick setting, and may, by use of the latch, be withdrawn to pass over large diameters to begin a cut at any part of the work. The left-hand turner cuts with the backward motion of the lathe, and feeds from, instead of towards, the chuck. In the use of this "turner" both the cutter and back rests are withdrawn to pass over the work to reach its starting-point at the chuck. Since the left-hand turner starts its work very close to the chuck, slender work, being thus supported, may be accurately turned.

The cross slide (Fig. 88) is made in a compact form, and the sliding block, closely fitted and gibbed to its base, is bolted securely to the turret. A long lever and a small pinion and rack furnish means for feeding the cross slide tools. The tool holder will admit drills, reamers, taps (or holders to receive them). The taper turner is adapted for long tapers and other forms of varying diameters. These variations

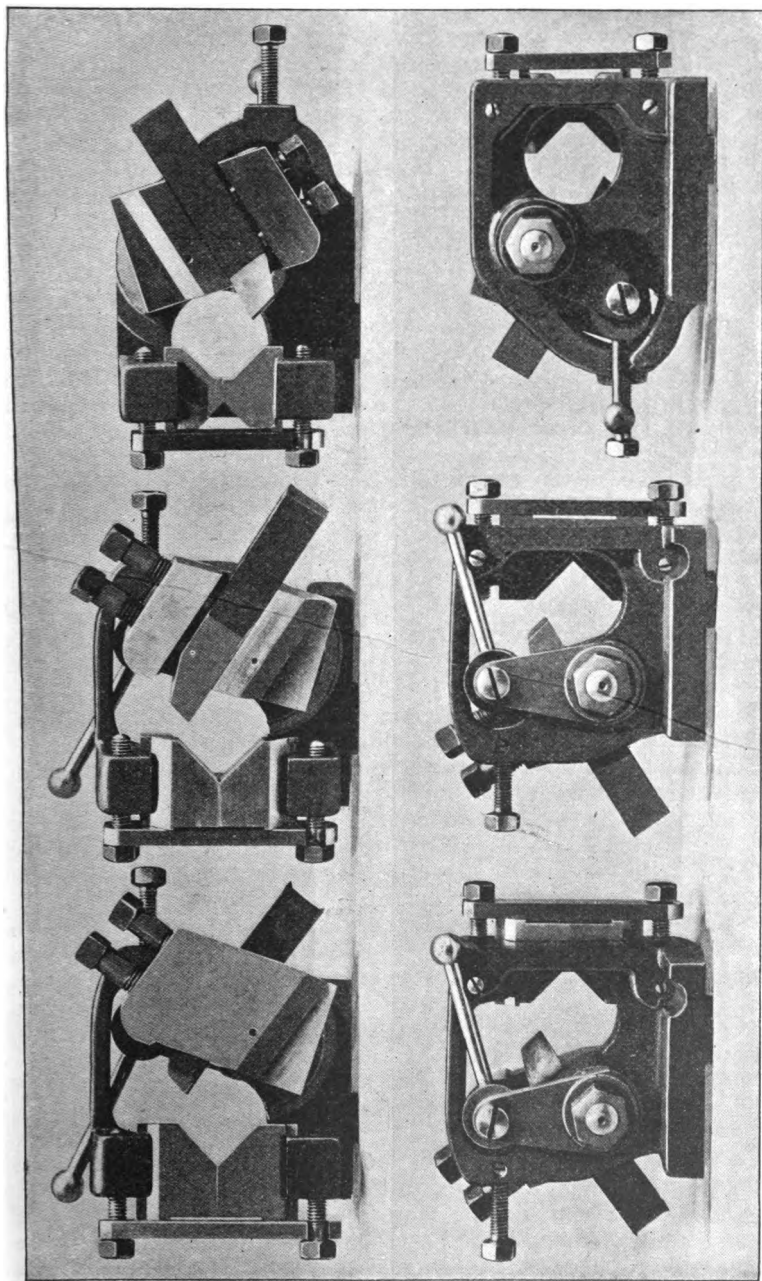

Figs. 89, 90.—“Turner” and stay combined.

of diameter are produced by a templet or former, which acts upon the tool-block, causing it to swing in or out of the work.

The back rests may be arranged to precede or follow the cutter. When the work is being made from the bar, the back rest must precede the cutter; but when taper bolts are to be turned from bolt forgings, then the back rest may follow the cutter.

The work is held in the wobble chuck, which is especially designed for this purpose. This chuck allows a free lateral movement of the outer end of the work, and rigidly supports only the head end, which it grips, and then acts as a driver and universal joint or centre.

The automatic chuck and roller feed handle the rough bars of round, square, octagon, hexagon, and flat stock, presenting a new length, and gripping it while the machine is running.

The automatic chuck is one of the essential features of the machine in its equipment for turning work from full lengths of bars. Its firm grip gives a rigid presentation of the work, which is of paramount importance. This chuck is only used in connection with the roller feed, which will shortly be described. Next in importance to the turret is the construction of this chuck, and, like the turret, this has grown out of other less perfect devices.

Since the first automatic chuck was made, there has been a gradual development and improvement.

Three distinct types have so far been made:—

The first could be called a spring-collet chuck, the second a direct-wedge chuck, and the one as now made might be called a parallel-gripping collet chuck (Fig. 91), shown open and closed and in section.

The spring-collet chuck was first made for gripping drawn stock, the diameter of which varied but little. This chuck was a success when used on such stock, but when applied to handling rough bars of rolled stock, it failed to give satisfaction. The varying diameters of this rough stock would cause the spring collet to pinch either at one end or the other. On large bars it would pinch at the back of the collet, and on small ones at the front, causing frequent breakage of the collet, and always an uncertain grip.

Special collets were required for holding hexagon and square bars. The second type, called the direct-wedge chuck, gripped the rough stock of varying diameters, but it was not so constructed that both the square and hexagon stock could be held by the same chuck, because it pinched at either three or four points. A greater fault than this, however, soon developed when the chuck was put into use. The jaws of the chuck had their seat in a loose ring, instead of in the main body of the chuck. Their sides were closely fitted to the main body, but the pinching of the stock was done by the loose ring, and hence, when the chuck was closed on the work, it was simply pinched within a ring that was loosely connected to the spindle.

The third type is the one shown in the various views (Fig. 91), called a parallel-gripping collet chuck, and was designed to overcome the foregoing troubles. The grip on the work is parallel, and it is



OUTER SLEEVE

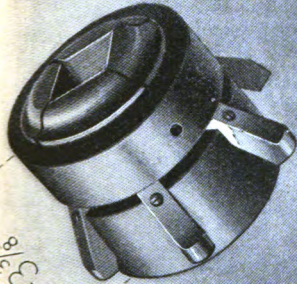

CHUCK BODY

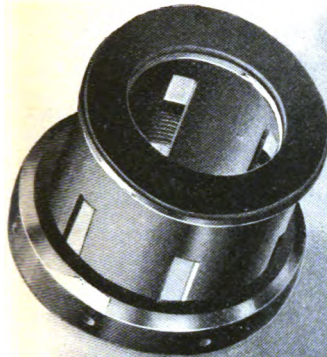

INNER SLEEVE
AND ADJUSTING COLLAR

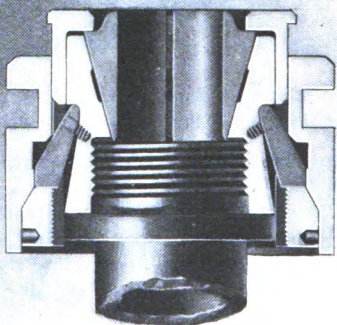

CLOSED

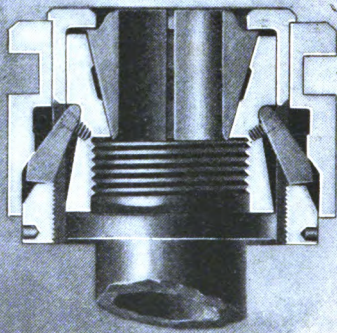

OPEN

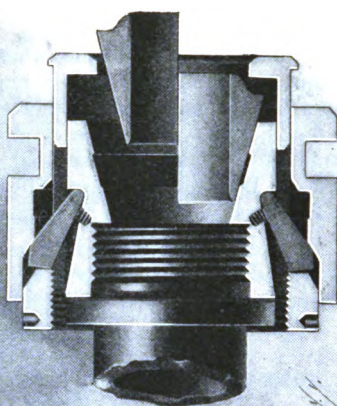

REMOVING JAWS

Fig. 91.—Spring-collet chuck.

rigidly fixed to the spindle when the chuck is closed. Bars of any section can be secured in this chuck. The various views of the chuck render further comment unnecessary.

Roller Feed.—The roller feed (Fig. 92) pushes the bar through the spindle and chuck till the end strikes the stock-stop on the turret carriage; then the rolls slip until the chuck is closed.

This feed is started into action by the same lever and motion that

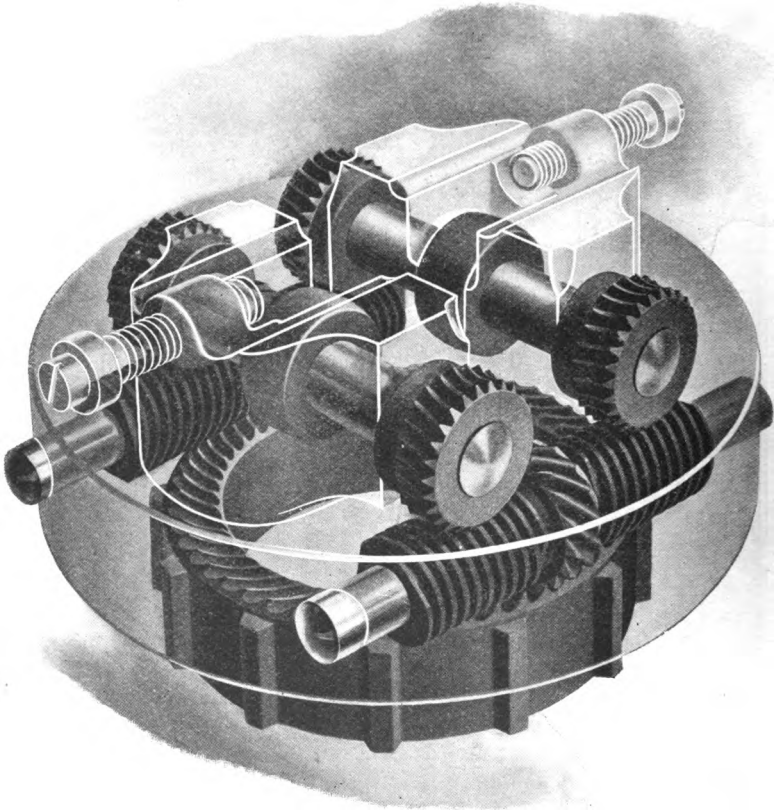

FIG. 92.—Roller feed.

opens the chuck. Its friction rolls are held by stiff springs in contact with the bar of stock.

The first stock feed was actuated by a weight, and was so connected to the bar as to keep a longitudinal pull on it, so that, as soon as the chuck was open, the descending weight forced the bar through the chuck and spindle until it struck the stop on the turret.

This weight feed gave very satisfactory results on short work of

small diameter, but when applied to work of more than $\frac{5}{8}$ in. diameter it was found unsteady.

A further development was the ratchet feed, which was operated by the stroke of the chuck lever. This was, and is to-day, a satisfactory feed for certain kinds of work. Its principal fault was that it required a tube through the spindle, which reduced the capacity of the spindle for receiving large bars; and since the work was moved only by its motion, it was limited to use on short work and light bars.

The roller feed was the next device to be applied to feed the bar through the spindle. This has been proved the most satisfactory; it works quickly without acceleration of speeds, and since the power is received from the machine, it works equally well on light and heavy bars.

The Automatic Die.—This is made in two sizes to receive dies

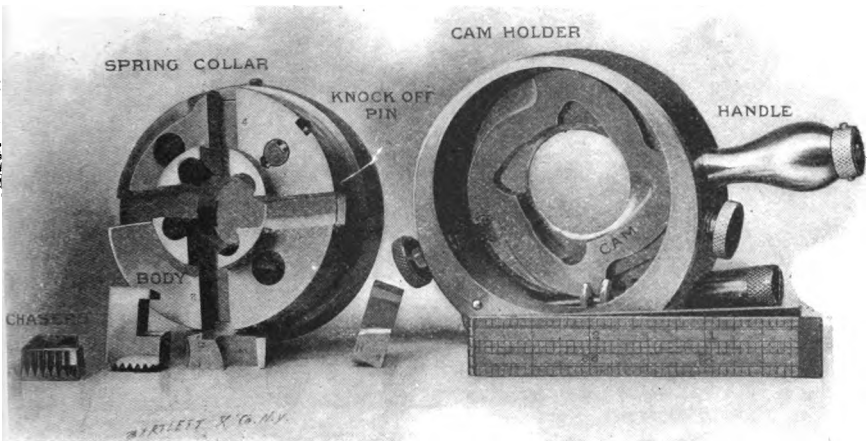

FIG. 93.—Hartness automatic die.

from $\frac{1}{4}$ in. to $1\frac{1}{4}$ in., and from $1\frac{3}{8}$ in. to 2 in. respectively (Fig. 93). They are fitted with right or left hand chasers for cutting Whitworth, Sellers, or metric standards, also half vee threads.

The die opens automatically when the travel of its holder or shank is retarded.

The cam for controlling the chasers takes its bearing close to the cutting strains, hence there is no tendency for the chaser to get away from its work by canting or tipping.

The connection between the shank and the body of the die is a double universal joint, allowing the die to assume any position required by the work. This connection remains flexible under the torsional strain of cutting, and provides a compensation for the slight, but important, change of alignment that takes place in all turret machines as soon as a die begins to cut.

Latch-pin.—The latch-pin, which holds the cam into close adjustment, is provided with two latch surfaces, one for a roughing cut, and the other for a finishing cut. Turning the latch halfway round changes it from one to the other without disturbing the principal adjustment for size. With this feature it is claimed that smooth screw threads can be cut when the lead is very coarse. It is seldom used on standard threads below 1 in. diameter.

Form of Chaser.—The process of forming the chaser teeth is such that the front or working teeth have a correct working clearance, while the back teeth have no clearance, but, instead, take a bearing on the

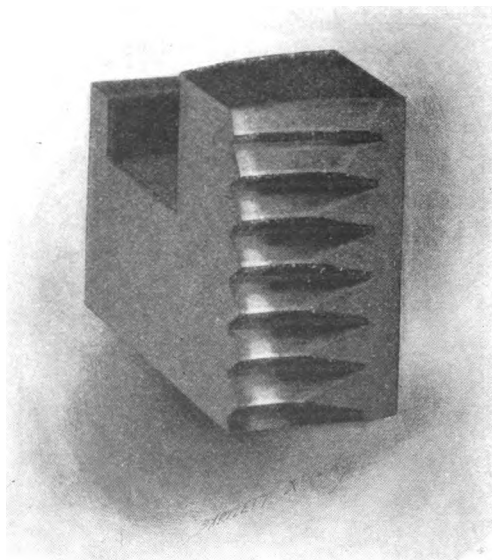

FIG. 94.—Form of Chaser.

work a little beneath the face of the chaser, thus forming substantially a lead nut, which rides on the thread produced by the front teeth, thus governing the lead of the screw.

The chaser teeth are formed by special milling machines, provided with means for recording correctly the angles and positions of approach of the work to the cutters, so that a knowledge of the clearance and contact of each tooth is obtained. The chasers are milled so as to be interchangeable.

Grinding.—When in use the faces of the chaser teeth are ground frequently to maintain the correct degree of rake and a keen cutting

edge. This form of chaser is obviously superior to those made by the use of hobs or taps. The chasers made by the latter plan have always a more or less rubbing and burnishing action.

Hardening of Chasers.—In the process of hardening hobbled chasers the compressed or burnished metal, which has been squeezed into shape by the hobbing action of the tap, is quick to assume a more natural position, and this results in a distorted thread.

By the Jones and Lamson's method it is only the extreme edges of the chaser teeth that are hardened (Fig. 94), leaving the rest part soft, hence no appreciable change takes place. The error is corrected in the milling machine before hardening is done by the process above referred to, and is not dependent upon the accuracy of the leading screw to control the movement. Screws cut with chasers thus treated are made with an error in lead of less than $\frac{1}{84}$ in. in 18 in. This error is extremely small when compared with *some* "standard" taps, and it is to be regretted that even some leading screws show an error many times as great.

Correct Lead in Taps.—The inventors, after considerable experience and close investigation, say, respecting the correct lead in taps, etc., "If the lead of the work produced does not correspond to the nut into which it is fitted, do not condemn the

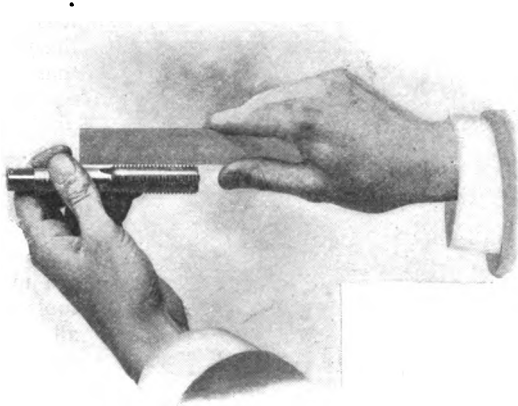

FIG. 95.—Testing pitch of tap.

die, but measure the lead of both the work and taps with a scale, providing you can get both in a length of 4 or 6 in. It is practically impossible to make taps that will lead accurately on account of varying results in hardening." (This element of uncertainty is eliminated in their dies, as above referred to.)

How to make Good Fitting Screws. *Error in Taps.*—The error of lead in taps is usually so great that it is plainly visible in 1 in. or $1\frac{1}{2}$ in. of length. A scale (rule) placed on the top of the teeth will show at the even inches and at the $\frac{1}{2}$ in. gradations if the pitch is an even number to the inch (Fig. 95). Measure the diameter of the taps, and see that there are no burrs or fins at the bottom of the threads to spoil the shape of the *threads in the work*.

Shape, Lead, and Diameter.—The three distinct dimensions of a screw thread should be measured separately.

The shape and lead should be measured when the die is made ; in other words, the die should cut a correct shape and lead. Then the third dimension, the diameter, should be measured when the die commences on a lot of screws, and occasionally thereafter.

The thread may be measured by the ordinary micrometer snap or gauge, taking the diameter at the top of the thread (Fig. 96).

As the die becomes worn, the lead should be measured occasionally. This can be done by cutting a thread 6 in. or 12 in. long, and measuring it with a good scale (Fig. 97). The various forms of screw-leads measuring devices may be used with economy of time and material, but such gauges should be handled with special care, and obviously tested by the foregoing method.

Alfred Herbert's Hexagon Turret Lathe (Fig. 98).— This machine represents one size of a type which is coming into very extensive use for the production of articles which can be made from



FIG. 96.—Micrometer gauging a screw.

bars of mild steel. In the great majority of such work it is much cheaper to produce the pieces required from bars than from forgings, and the use of forgings is therefore diminishing in work of this class. The above machine can turn out pieces up to 2 in. diameter \times 29 in. long. The main feature of the machine is that all reductions in diameter are made with one cut, the tools being so designed that all strains are self-contained within them.

The downward pressure upon the tool itself is resisted by the upward pressure of the work upon the steady plates, thus converting the action into a merely torsional one. The action of the tool upon the bar can be likened to the action of the drill, with the difference that it takes place on the outside of the bar instead of in its interior, and the steadies also give a burnishing action upon the work, producing a very high finish.

The tools which are bolted to the hexagon turret form practically part of the machine, and are adaptable for a great variety of work, rendering the provision of special tool outfits entirely unnecessary.

The headstock has friction gearing, and the chuck can be operated without stopping the lathe. The feed is changed by a lever under the headstock, and is provided with six automatic stops, namely, one for each tool. A pump is supplied, giving a very copious supply of oil to the turret. The die head is of the self-opening variety, and will screw up to $1\frac{1}{4}$ in. diameter ; it has attachments by means of which a light finishing cut may be taken over the thread.

Hexagon Turret Lathe with Patent Chasing Saddle.—A machine intended for chuck work mainly, either in cast iron, steel, or bronze, is illustrated in Fig. 99. The spindle is made hollow to receive bars up to $2\frac{1}{2}$ in. diameter, when it is desired to turn pieces direct from the bar.

The headstock is fitted with duplex gearing, which can be thrown in or out while the lathe is running, and which is so arranged, in conjunction with two speeds on the countershaft, as to give six properly graduated speeds for each step of the cone pulley. By changing the position of the belt eighteen speeds are available. It will be noticed that this machine is of a compact design, the bed being extended to the floor line beneath the fast headstock to give rigid support.

There are two saddles, each carrying a turret. The main turret is hexagonal, each face has a tool hole for holding shank tools, boring bars, etc., large tools for repetition work being bolted directly to the faces of the turret. The turret is set at an angle to allow long tools to clear the pilot wheel, but all the tools are true to the centre line when brought in straight alignment for action. There is an independent stop fitted for each face of the turret; these trip the feed automatically, and also act as dead stops.

The square turret mounted on the front saddle has room for four tools, and is fitted with a patented mechanism for chasing, by the action of which it is claimed that both external and internal screw threads can be accurately and rapidly cut without the possibility of cross threading. This chasing motion is entirely independent of the feed motions.

These machines are in use in a large number of the leading workshops, and by motor-car engineers for producing gear blanks, and parts of the transmission mechanism of motor cars.

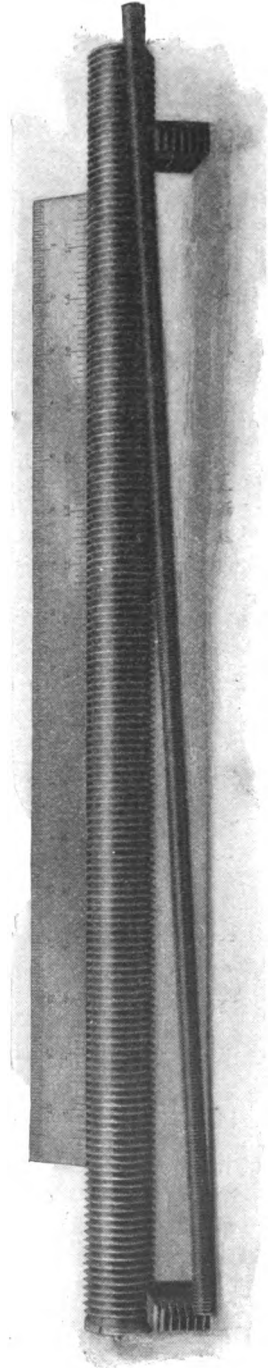

FIG. 97.—Gauging pitch of a long screw.

These parts are usually made from large pieces cut off from round bars, or from large drop forgings. On suitable work it is estimated that one turret lathe will displace five to six ordinary engine lathes.

A "Brass Finisher's" Turret Lathe.—This lathe is shown in

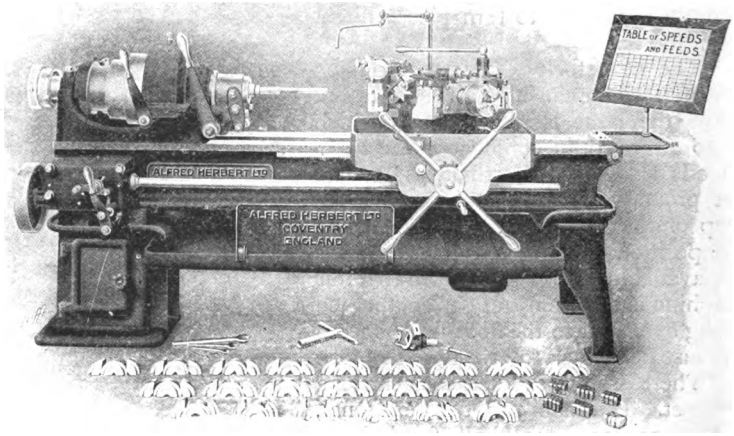

FIG. 98.—Hexagon turret lathe.

Fig. 100. It is fitted with a two-jaw self-centering chuck on the spindle, and at the opposite end carries a gear communicating motion to a guide

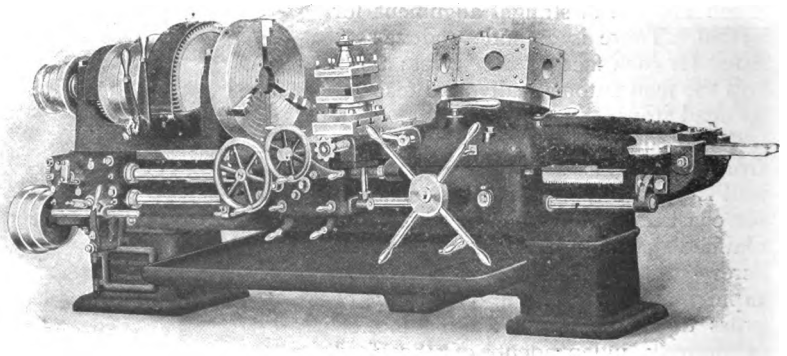

FIG. 99.—Hexagon turret lathe.

screw through pinions. Working on the screw is a die which operates through a shaft a turn-over slide rest.

The slide rest carries the chasing tool, which is only used for chasing, and when not in use is turned over on its axis, *i.e.* the back shaft.

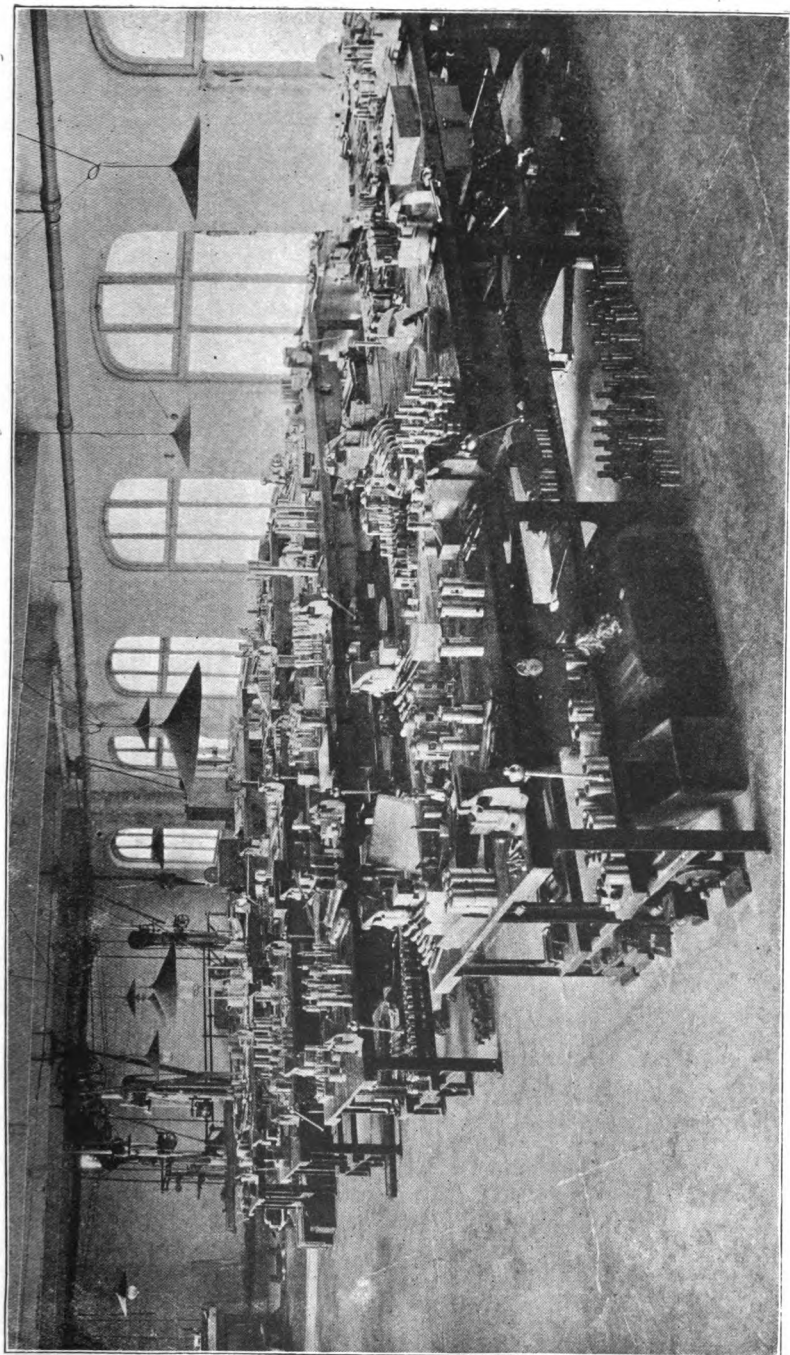

FIG. 101.—ASSEMBLING ROOM.

[To face p. 92.]

The guide screw and die are both movable, and are substituted when a screw of different pitch requires to be chased; thus the different screw threads are cut without the aid of change wheels. The changes of cutting, turning, and boring are in this arrangement effected with ease and facility.

The turret can carry a full complement of tools for any specific work, and thereby effects a considerable saving of time after once fixing. Internal and external screws, with right or left hand threads of 8, 11, 14, 19 and 28 per inch (which are the standard pitches) can readily be cut by simply changing the guide screw and die. The concentric chuck is not always used, but chucks having three or four jaws;

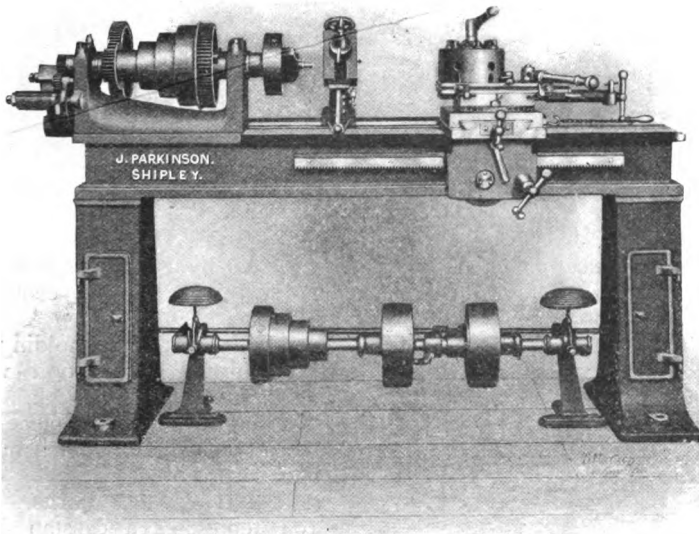

FIG. 100.—Brass-finisher's lathe.

universal, or independent, or "bell" chuck may be fixed on the spindle as required.

Capstan Lathes.—The lathe illustrated in Fig. 102 is also fitted with a special saddle for chasing square or vee threads by means of a "leader" (screw).

Four different pitches, either right or left hand, can be cut by each leader, the change being made by levers. By means of a frictional arrangement on the headstock, the back gearing may be removed and single speed introduced without having to stop the spindle. The capstan slide has an automatic feed, and is fitted with a dead stop for each tool. The spindle is hollow, and will take bars up to 2 in. diameter; when,

however, required, this lathe is equally adapted for chuck work in cast iron, steel, or brass.

Revolving Valve Chuck.—The valve chuck shown in Fig. 103 is fitted with ball bearings to the revolving jaws, whereby the friction is

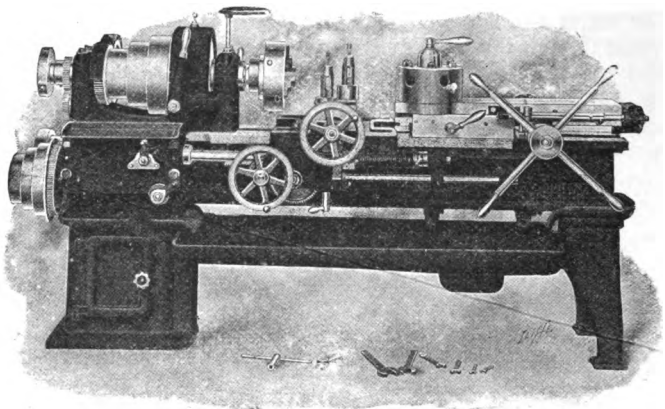

FIG. 102.—Capstan lathe.

so much reduced that the jaws can be rotated by using the spanner on the square shaft B without slackening the chuck, and consequently without shifting the work.

The dividing mechanism is provided with a screw for holding the catch firmly in position when dealing with heavy work. The dividing plate is in one piece with the jaw spindle, by which means back-lash is obviated.

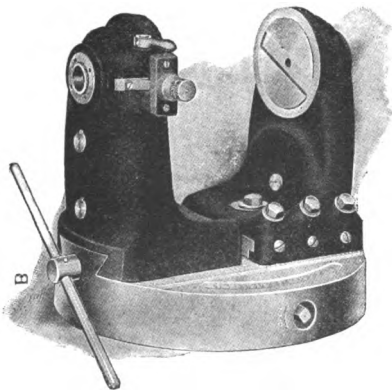

FIG. 103.—Herbert's valve chuck.

Small Capstan Lathe.—Fig. 104 represents a capstan lathe made for high-speed brass and steel work from the bar. It will admit $\frac{1}{2}$ in. through the automatic chuck. This chuck is operated by a hand lever, which also moves the bar forward in the chuck. The chuck is adjusted for varying diameters by two knurled nuts at the rear end.

The capstan slide revolves automatically upon the backward stroke; this slide has two independent adjustable stops, thus providing greater ease in setting than when only one stop is provided. The cut-off rest carries two tools, one at the front and one at the back, and has adjustable stops in both directions. The operating lever passes through

a split bearing, and can be clamped upon the shaft in any position found most suitable. A special feature of this machine is that it is made dust-proof.

On these high-speed machines dust is the great enemy of accuracy and durability. It is therefore imperative to protect the vital parts from the action of dust. In order to withstand the shocks inherent to high-speed work, the locking mechanism is made of tempered tool steel. Another feature, to obtain a uniformity in running, is that the speed cones are carefully turned inside and fitted to their spindles by a cone bearing, no keys being used. On these light spindles keys have been found in many cases to spring the work out of truth.

The following are some of the leading dimensions :—

Height of centres, $4\frac{5}{8}$ in. ; width of belt, $1\frac{3}{4}$ in.

Largest diameter of cone pulley, 7 in.

Working stroke of capstan, $4\frac{5}{8}$ in.

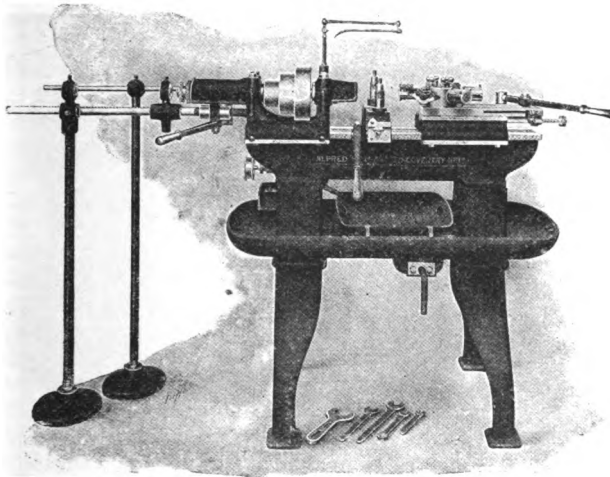

FIG. 104.—Small capstan lathe.

Automatic Screw Machine.—The machine shown in Fig. 105 is suitable for producing bolts, screws, pins, collars, bushes, etc., direct from the bar, up to about 8 in. long \times 2 in. diameter.

The machine is equipped with a set of standard cams and tools ; that is to say, such cams and tools as will produce any of the above kinds of work without requiring any alteration to suit the different pieces. When the machines are employed upon one kind of work all the time, special cams and tools are used, but in general practice the standard arrangement is preferred, on account of its more useful application to a wider range of work, or in cases where on simple work having few operations it is advisable to produce two pieces at each cycle of the machine.

The spindle of the machine is fitted with an automatic chuck for gripping and releasing the bar, and automatic arrangements for feeding

the bar forward to the required length. The chuck is operated by levers at the rear of the headstock, which in turn receive their motion from cams carried by the left-hand drum. The bar is fed forward by means of a spring collet which slides forward, carrying the bar with it when the chuck is open, and which slides back upon the bar when the chuck is closed.

The tube carrying this collet is actuated by an adjustable cam on the left-hand cam drum. The cut-off slide, which usually carries a forming tool on the front and a cutting-off tool at the back, is held in its central position by a spring. The tools are operated by levers actuated by cams attached to the disc shown beneath it, the depth of cut being regulated by screws at the upper ends of the levers. The turret slide rotates automatically on the back stroke, and is operated by hard steel cam strips attached to the right-hand cam drum.

The feed motion for actuating the cam shaft is driven from the

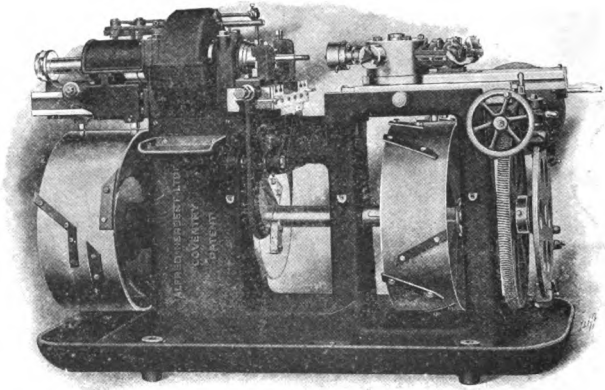

FIG. 105.—Automatic screw machine.

counter shaft, and has two speeds, one very much quicker than the other.

The fast speed is used for the idle movements of the machine, such as opening the chuck, feeding the bar forward, withdrawing the tools, rotating the turret, and bringing the tools up to their work, and the slow speed is used for the actual cutting movements of the machine.

The proportions of time during which the cam shaft is rotating fast and slow are governed by adjustable dogs upon the cam disc shown at the extreme right hand of the machine. These dogs can be set to suit the work being done, so that the quick speed comes into operation the instant the cutting tools have completed their operations, thus reducing the time to the minimum.

The spindle is driven by means of gears and high-speed pulleys at the back, and can be driven at two speeds, either forward or reverse, thus enabling the turning operations to be done at high cutting speeds,

and at the same time providing for the slow speeds which are necessary for screwing. Many special adaptations of the machines are made for special work, such as the production of engine studs, condenser ferrules, locomotive-firebox stays, and detached pieces made from castings or forgings, second operations on pieces cut off from the bar, etc.

The number of separate operations which can be performed by machines having standard tools and cams are seven, viz. five turret operations and two cross-slide operations; some of these can be made to do alternative kinds of work, such as turning or boring without altering the cams.

The following is an example of the work which can be done on a machine with standard cam and tools:—

The chuck opens, and the bar feeds forward to the required length. The bar may be (a) Coned on its end, with the tool in the first turret hole, or it may be *centered or faced, on the end*. (b) Rough turned with a box tool, fixed in the second turret hole, or drilled, or rough turned and drilled, at the same time with a box tool carrying a drill. (c) Finish turning or reaming, or finish turning and reaming at the same time in third turret hole, using a box tool carrying a reamer. (d) Form with a tool on the front of the cross slide, the bar being supported either by a steady bush, carried in the fourth turret hole, or by a steady peg, as required. (e) Screw with self-opening die; the head is carried in the fifth turret hole. (f) Finally cut off with a tool carried on back of the cross slide.

It will be seen from the above that these operations provide for a great variety of work.

When short pieces of work are required, the turret-slide cam drum and the turret slide can be adjusted into different positions so as to enable them to be brought close up to the chuck, thus enabling short tools to be used, and at the same time providing for the adjustment away from the chuck for doing long pieces.

Tools for Automatic Screw Machine.—A few standard tools are illustrated in Fig. 106 (A, B, C, D, E, F, & G), for straightforward work, such as pins, bolts, screws, and studs.

A represents a starting tool for trueing up and pointing the end of a bar in order to prepare it for the box tool on work of any considerable length.

B is a centering and facing tool used on the end of a bar preparatory to drilling.

C shows an adjustable box tool so arranged that as many as three different diameters may be turned simultaneously; it is also provided with a cutter for finishing the end of the work.

D is a self-opening die head, having four dies which are provided with a roughing and finishing attachment, operated by the lever shown.

By means of an adjustable stop contained within the body of the die head, the dies open automatically when the desired length of thread has been cut.

The dies are mounted in sliding jaws, and can quickly be removed for sharpening when necessary.

E represents a steady bush and holder for supporting the work while the forming tool is cutting.

The forming tool is shown at F fitted to its holder by means of a dovetailed projection, which gives a very firm grip and also enables the tool to be taken out for grinding and returned with certainty to its correct position.

After finishing, the work is parted from the bar by a cutting-off tool, shown at G.

"Gisholt" Turret Lathe.—Fig. 107 represents a specially powerful turret lathe, designed to cope with a general class of work. As will be

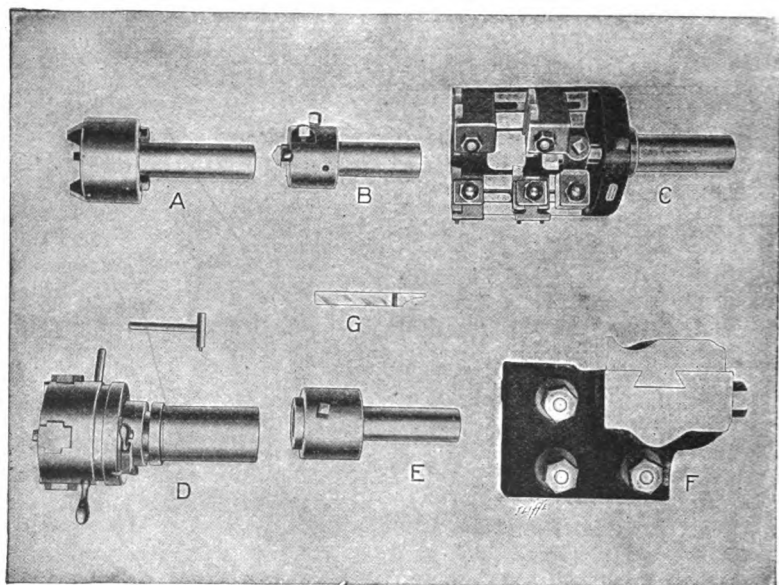

FIG. 106.—Tools for automatic screw machine.

seen, the speed cone is dispensed with, the lathe being fitted with an electric motor. Among other features of this tool are the two saddles to carry the cutting tools; these are constructed with a view to minimize chatter, *there being no overhanging parts*, and all surfaces being large. The leading saddle carries the tools for operating on external surfaces, and may be traversed further along the bed than is customary in ordinary lathes, to allow the turret saddle to get near the work.

The hexagonal turret will carry six tools, and an intermediate stay is fixed to support boring bars; an additional bearing is obtained in the hollow spindle, thus making a rigid bar of what might otherwise appear to be a slender one. The spindle, which is of large dimensions, carries a universal chuck, which may be driven direct through the spur wheel

shown attached to it. The lathe has a 24-in. swing, and is used for boring, facing, turning, and screw cutting.

Regarding the range of speed of the motor on the machine, the normal speed is about 960 revolutions with a controller that gives a

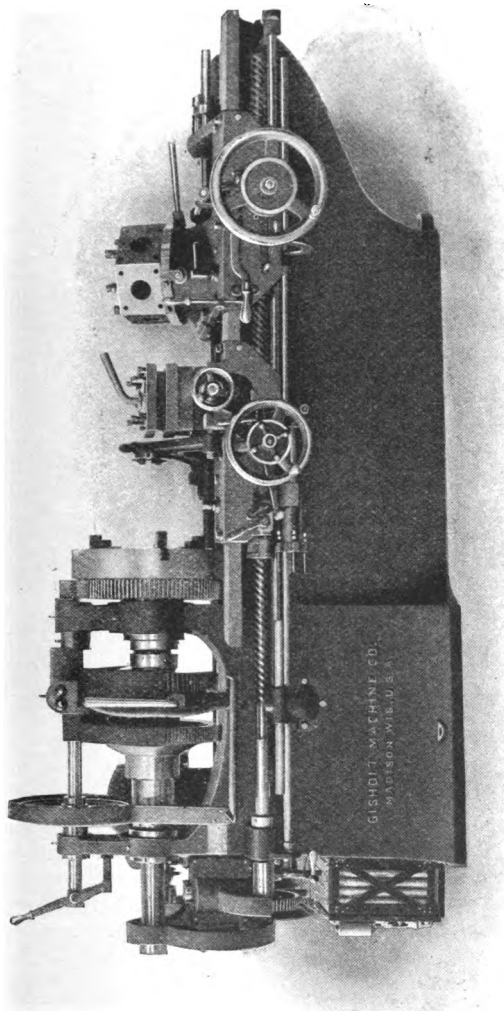

FIG. 107.—“Gisholt” lathe—motor-driven.

variation of speed below normal of 50 per cent., and above of 20 per cent., the controller giving nine variations.

The motor used is a 3-H.P., and may be either 110 or 220 volts for

the speed given. The turret lathe is made by the Gisholt Machine Co., Madison, Wis., U.S.A., to whom I am indebted for the cut and particulars.

In lathes of this type every conceivable point of advantage appears to have been considered in the design. The bed, which is of box section, extends to the floor, and in this respect is of a most rigid type; there is only one headstock, and it is cast to the bed. The broad-nosed tools are operated as easy as the single-pointed tools in a lathe of the ordinary class. A plan of one of these lathes is given in Fig. 108, which explains better than words many of the special features of the lathe.

There is no sparing of surface contact; the carriage is broad, long, and massive, as indeed are all the moving parts. Nothing appears to

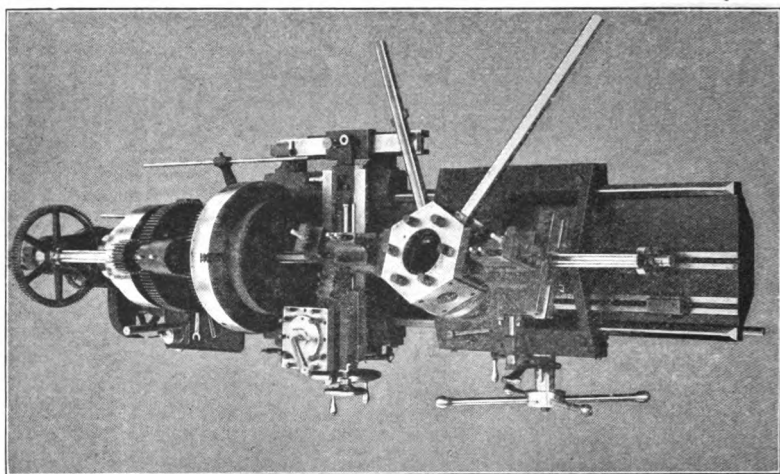

FIG. 108.—Plan of turret lathe.

come amiss to the tools when several are operating simultaneously; a fact which will be more manifest in the modern lathes directly driven by electric motors, as in Fig. 107. Both the saddle carrying the roughing tools and turret carriage are fitted with independent nuts to engage with the guide screw for screw cutting. Figs. 108, 109, 110, 111 show some of the uses to which the lathe may be put. Speed cones (Fig. 109) are commenced by a tool bar with double cutters, which bore and face the three largest steps. The bar is fixed to the face of the turret, and is also supported at the outer end by a bar which fits a bush carried by the chuck. The second and third tools are boring bars for roughing and finishing.

The fourth and fifth tools are standard facing heads, with cutters for boring and facing the largest step. The speed cone is then removed

and mounted on a mandril, supported from a bushing in the chuck and running in a holder at the outer end.

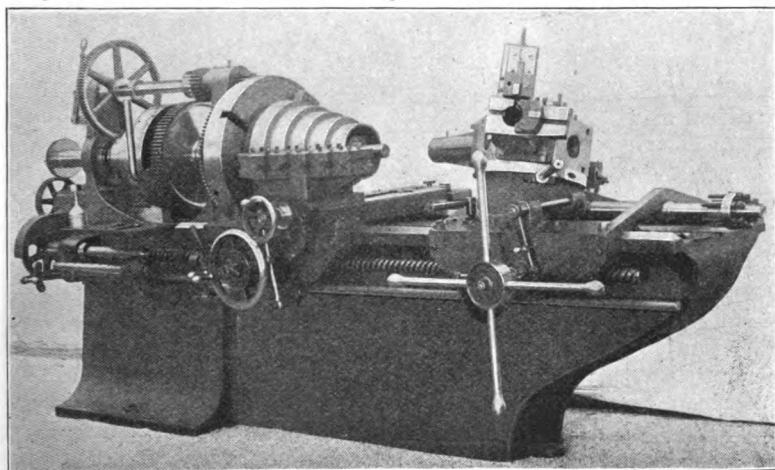

FIG. 109.—Turret lathe operating on five-step speed cone.

A cone plate fitting the bore of the largest step, and a bush fitting the bored hole are placed on the mandril, and the cone pulley is pressed

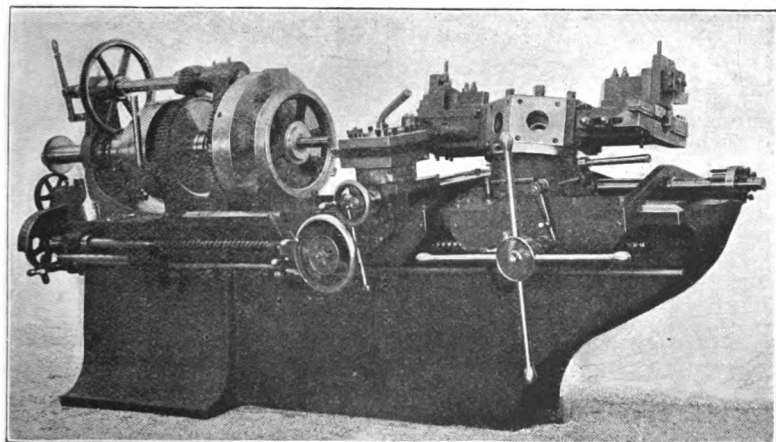

FIG. 110.—Turret lathe operating on small fly-wheels.

on them. The pulley is driven through studs passing from a driver on the chuck into holes in the speed-cone plate.

The tool holder being removed, the special double-pulley turning

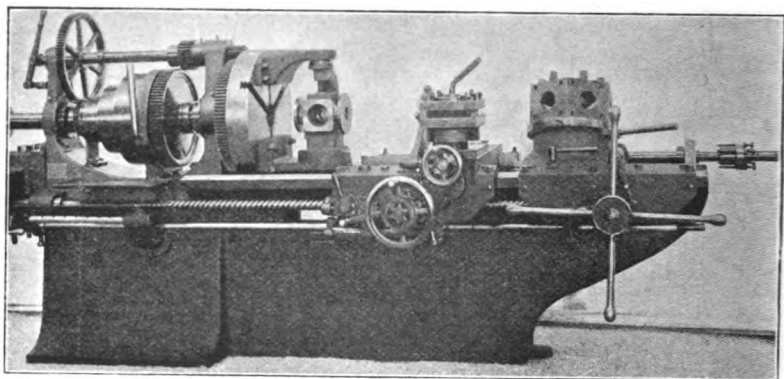

FIG. 111.—Turret lathe boring and turning valves.

tool is mounted in its place, one set of cutters for roughing, after which the second set is brought into action for finishing.

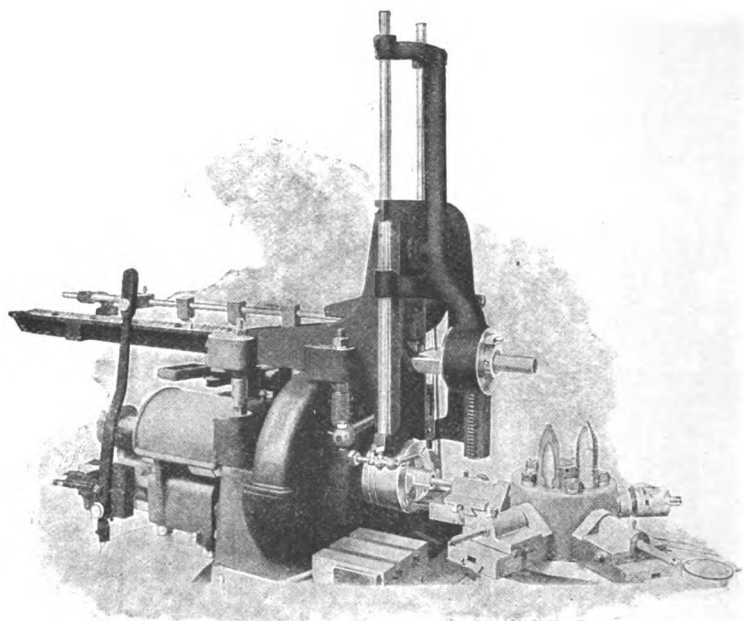

FIG. 112.—Overhead magazine.

Overhead Magazine applied to Automatic Screw Machine (Fig. 112.)—This illustration represents a magazine attachment for

chucking castings or other detached pieces on an automatic screw machine.

The pieces are placed by the operator in a trough over the spindle of the machine, and are automatically fed forward one by one by means of ratchets, upon a longitudinal bar over the trough. This bar is operated by a lever at the rear end of the machine, which receives its motion from a cam on the cam drum, which operates the chuck. The pieces are pushed out of the trough into a carrier, which is seen in the illustration in its uppermost position.

The carrier then descends, and a pusher on the turret pushes the piece into the chuck, which grips it. The turret pusher at the same time releases a spring catch in the carrier, which enables it to be turned through a semicircle by the action of a flat helical spring, thus enabling the carrier to be raised without colliding with the work which is gripped in the chuck. In rising to its first position, the carrier is rotated again through half a circle by a rack attached to the machine frame, and as soon as it reaches its former position the catch springs into place and holds it. These magazines are operated by levers, actuated by cams upon the cam shaft of the machine. The attachment in question is only one of a variety which is made to suit special repetition work. It illustrates, however, the idea and the tendency of modern automatic machinery to develop along this line.

CHAPTER VI.

TREADLE AND POWER LATHES.

AN Amateur's Lathe is a general machine tool, and should be handy, compact, and accurately fitted in every detail. The sliding and revolving parts should be specially free, but without any appreciable shake when submitted to the severest tests.

To obtain this result, the gears should be machine-cut, the driving spindle truly fitted to its bearings, and also be in perfect alignment with the bed and the loose head poppet of the lathe.

All slides must be scraped to a surface, and be adjustable to a minute degree.

A separate rest should be used whenever much hand turning is to be done, so that the top rest and the transverse slide may be kept as free as possible from fine chips and dust.

It is also much handier, when very small articles are to be turned, since the loose headstock can be brought closer up to the hand rest and work, than it can be by using the automatic saddle.

The treadle motion must be balanced to stop anywhere in a revolution. Its shaft should be carried on hardened centre points, and supported with rollers at two points, so that the friction is as small as is practicable when the crank shaft is rotated.

The sliding portions must be scraped, and accurately "padded" to a true surface, so that there is perfect coincidence of the whole surface in contact as well as perfect freedom of movement in any position.

Small Screw-Cutting Lathe.—Small lathe spindles are best when fitted in conical bearings, so that any appreciable looseness may at once be detected and remedied by the adjusting lock nuts. It cannot be too strongly emphasised that this part of a lathe is most important, and although may only occasionally need attention, it should *not* be attempted by an amateur. A truly turned and fitted steel spindle, once properly adjusted to both front and back bearings (which bearings are preferably of hard phosphor bronze), will run for years with proper care and lubrication. There is a tail or thrust pin at the extremity of the spindle, which keeps the spindle in position, and acts somewhat as a check to the pushing tendency of drills when boring is being done, or when the loose poppet centre is tightened too hard on the work. The adjustment of the tail pin is also important, especially in heavier lathes, where the thrust is greater. It is a good practice to insert a disc of hard leather between the faces of spindle end and thrust pin.

Heat is not communicated through it, and it does not need lubricating so frequently as when the faces of the hardened steel are in direct contact.

An amateur's or small general lathe, with screw-cutting and self-acting arrangement, is shown in Fig. 113. A reversing motion is fitted

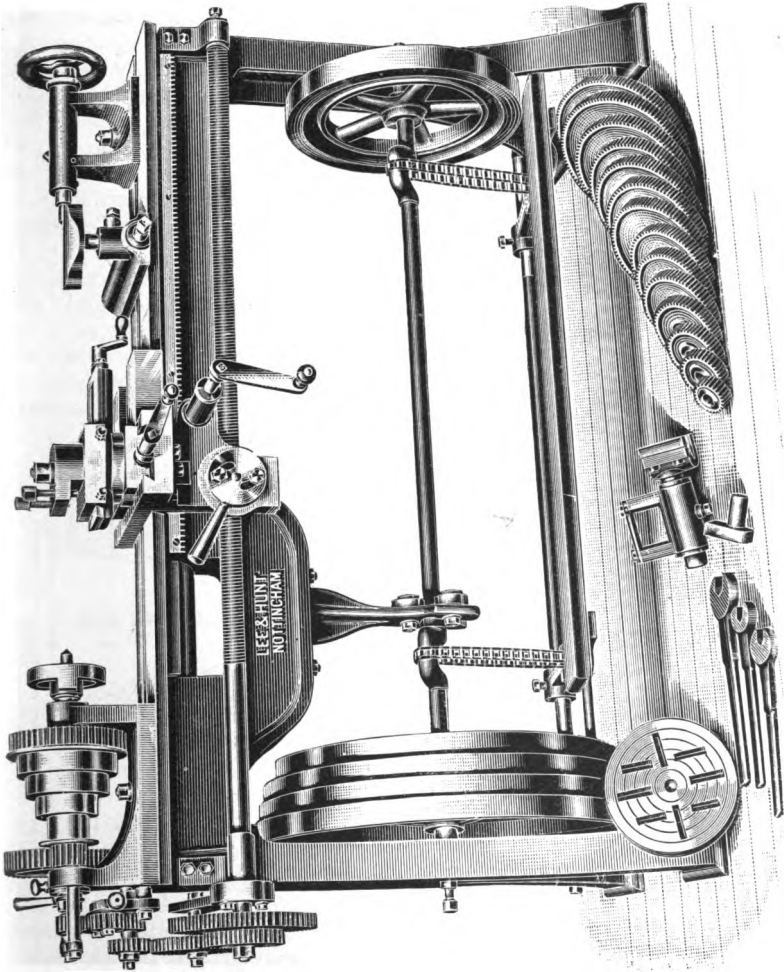

FIG. 113.—Small treadle lathe.

to the fast headstock, which changes the direction in which the guide screw revolves. By this device left-hand screws may be cut, or the saddle traversed, towards the loose headstocks for other purposes.

Conical and Parallel Bearings for Lathes. *Conical.*—Conical bearings are as a rule fixed in small lathe headstocks, and parallel

bearings in large ones (see Fig. 114). This is done because for light lathes adjustable cones are most suitable, these being highly sensitive and easy running, while for heavy lathes journal or parallel bearings give the best results.

Parallel Bearings.—The front bearing receives the *greatest load*, has *more friction*, and therefore *more wear* than the back bearing. The front neck of the spindle is made much larger and longer on account of this.

Axial Pressure.—The axial pressure is taken up partly by the good fitting contact between the flanges of the spindle and the sides of the bearing, and partly by the thrust pin, the hardened face of which is directly touching the hard face of the tail end of the spindle when properly adjusted.

Ball Bearings.—Intermediate between the thrust pin and the spindle end ball bearings may be placed. When these are adopted, very good results are obtained, as the amount of friction is considerably reduced.

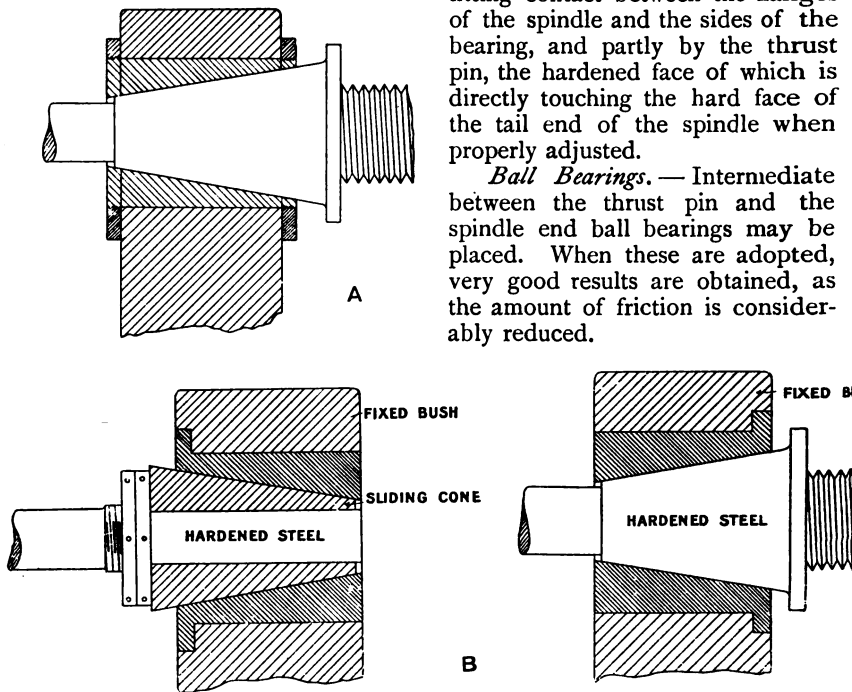

FIG. 114.—Conical bearings.

Various Forms of Conical Bearings.—Referring to the “Whitworth” type (Fig. A), the cones are both tapered in one direction; in this case the back bush has a lateral adjustment obtained by the lock nuts, one of which is screwed on each side of the bearing.

Fig. B is a more general practice: here both bush bearings are fitted tightly into the headstock, and the taper mouths are both outside.

A conical bush slides and rides on a feather key fitted in the spindle, and is adjusted by a pair of lock nuts screwed on the spindle end. From these two forms others have been designed, some are made with a ball race on one side while others have the conical portion outside

of the bush, and the inside bored straight to receive a spindle turned parallel.

Parallel Bearings.—This brings us to consider parallel bearings. It has been already said that these are best adapted to lathes of the heavier type, especially those in which the work is fixed on to a face plate, or to an angle plate, or is carried in a jaw chuck.

It is obvious that, with an overhanging weight of several hundred pounds on the front bearing, there is great danger of the wear on the bearing being irregular, and the risk is more with a conical neck than is the case with one made parallel-faced at each end with fitting collars. A further advantage is that the adjustment is easy, quick, and effective,

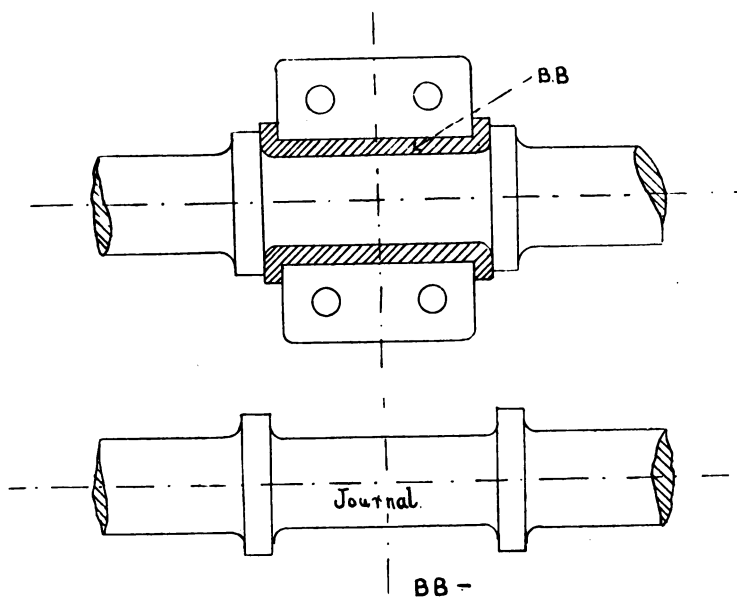

FIG. 114A.—Journal bearings.

i.e. by tightening the cap the upper half of the bearing is pressed directly on to the spindle *when heavy cutting* has to be done, and as quickly relieved when a high speed is desirable.

A journal bearing is given in Fig. 114A.

Front-slide Lathes.—Front-slide lathes are generally of small dimensions, and are specially adapted for light work. One of the simplest of this type is a 5-in. centre single-gear lathe shown in Fig. 115.

Overhanging Headstocks.—The headstocks are constructed to lean over towards the front of the bed, in order to bring the work conveniently near to the rest.

Two Rests.—In this arrangement there are two rests—hand and

compound—which are made to travel in unison by a rack and pinion driven from the compound rest. They are connected by an adjustable link, which is a saving of time in the setting of either one for work.

When the slide rest is in use, the hand rest is slid past in front of the fast head; when the hand rest is required, the compound one is slid past the loose headstock. There is no need, therefore, to take either rest off to substitute one kind for the other on the same carriage. This renders the lathe useful for jobbing shop work and for amateurs.

A 4-in. centre lathe, very much the same as the one just described, is shown in Fig. 116. It will, however, be noticed that in this arrangement, instead of the compound rest being fitted directly on the top of the bracket which forms the carriage, it is fitted to a separate bracket which has a vertical sliding movement on the carriage. This can be utilized in many ways. It forms a vertical slide for carrying milling cutters or drill spindles driven from an overhead motion; or it may be used for the adjustment of work which has to be operated on at different heights with drills or cutters driven by the headstock.

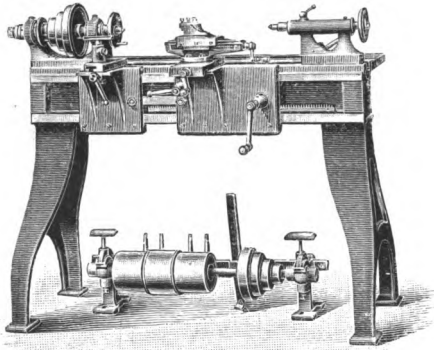

FIG. 115.—Front slide lathe.

This lathe can also be used for the attachment of a boring table. The boring table is fitted with a nut into which the cross-slide screw works, and affords a ready means for exact adjustment of the tool points. The vertical slide has an adjustment to zero by micrometer, and has a 4-in. rise and fall.

The cross slide also has a micrometer adjustment

to zero, reading on one side to $\frac{1}{1000}$ in., and on the other to the common divisions of an inch.

This lathe is fitted with a self-acting surfacing motion which is driven from the front of the carriage at the right hand, and arranged with a telescope feed bar and universal joints to drive at whatever height the vertical bracket slide may happen to be in.

The headstock pulley is fitted with a division plate, with a series of holes to be read at sight. A tangent wheel and screw is fitted to the cone pulley with a swing frame; and a set of change wheels of fine pitch for dividing, wheel cutting, etc., is shown. A wheel-cutting attachment can also be fitted on the cross slide in place of the slide rest, to be driven by overhead motion. The fast heads in these lathes are fitted with spindles having parallel necks running in bearings of hard metal.

The thrust arrangement is of a special character, being taken between the front and back of the collar, so that the adjustment is not altered if the spindle becomes warm with running. The whole fitting is enclosed,

and runs in oil, and the end of the mandrel, which is hollow, stands clear at the back, so that split chucks can be fitted to the spindle. The swing frame to the guide screw is fitted with a special locking arrangement for locking the frame in any position.

The loose heads are clamped by means of an eccentric, which grips the bed.

6-in. Centre Tool-room Lathe.—Fig. 117 is a 6-in. screw-cutting lathe, constructed to do the necessary work in an engineer's tool room (in such rooms as are not equipped with a full complement of machine tools). It may be used for the cutting of spur, bevel, or worm gears, or dividing, milling, slot drilling, and shaping, also for fluting or grooving with various cutters, either serrated or of the "fly" type. The details of the other working parts are much the same as in Fig. 116 previously described.

The countershaft has swivel bearings, is extended at the right hand, and carries a cone pulley for gut band for driving the attachments for wheel cutting, slot drilling, etc., on the slide rest. The large speed pulley is to obtain the necessary high speed when fly-cutters are used. The wheel-cutting appliances are made to fit on the top of the cross slide in place of the ordinary slide rest (Fig. 116A). The cutter spindle is hollow, to receive mandrels for carrying the

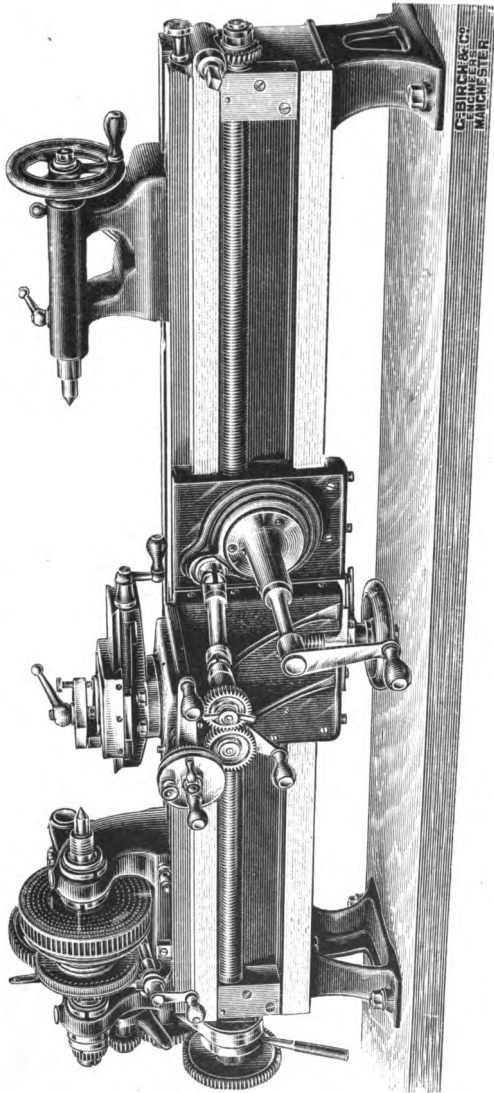

FIG. 116.—Front slide lathe.

cutters, and is driven by spur gearing, and a grooved pulley driven from the overhead.

When fly cutters are used, the driving pulley can be put on the cutter spindle to obtain the requisite speed. The cutter spindle is carried by compound slides, which swivel on the upright standard, both this and the swivel on the cross slide being fully graduated.

When the mandrel is fixed in a horizontal position, the machine can be used for slot drilling, nut shaping, or milling small work held between the lathe centres.

A slot-drilling frame is also made for use with the lathe (Fig. 117A), and can be held in the slide rest. It consists of a square stem, fitted with a steel mandrel, with hardened bearings running in bronze bushes.

The spindle is geared for use in heavy work, but when a greater speed is required, the top pulley can be thrown out of gear, and the spindle driven direct by a pulley on the large wheel. The front end of the spindle is coned to receive cutters, rose cutters for iron and steel, and slot drills for iron and brass work.

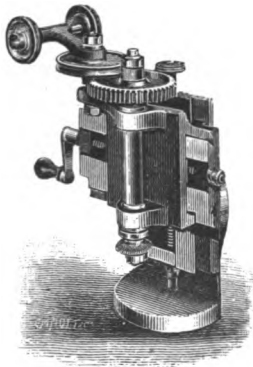

FIG. 116A.—Gear-cutting attachment.

In large shops outside the tool room these lathes would scarcely be considered an acquisition, because the several operations they are capable of performing are done on several distinct machines, but in small shops such types are much in request, since they will perform the work of several machines.

Self-acting, Sliding, Surfacing, and Screw-cutting Lathe. *Details.*—On Plate 119 are details of a complete lathe by Messrs. Sir W. G. Armstrong, Whitworth & Co., Limited, Manchester.

Independent Four-jaw Chuck.—A, B, and C, shows three views of an independent four-jaw chuck. In the front elevation, A, the

screws by means of a collar and taper pins is shown in section.

Dog Chuck.—The next is a “dog” chuck, D, with four movable jaws; the work in this chuck is gripped by vee-thread set-screws.

Bell Chuck, Construction and Use.—A chuck made to hold barrel work or similar pieces where the length exceeds the diameter is illustrated in Fig. 119 E. This “bell” chuck, E, is provided with two rows of screws equally spaced, which are easily adapted to suit work of various diameters. By means of a bell chuck short lengths of round iron or steel can be firmly held whilst they are bored, faced, and screw cut, as the case may be. It would be possible to hold these pieces in an ordinary jaw chuck, but owing to the shortness of the “bite” of the jaws, the end of the work would require to be carried by a “collar” or “centre stay,” to give a sure support.

Combined Collar Stay and Drill Rest.—This collar (plate) stay, F,

is made with a drill rest attached. The arrangement is very convenient,

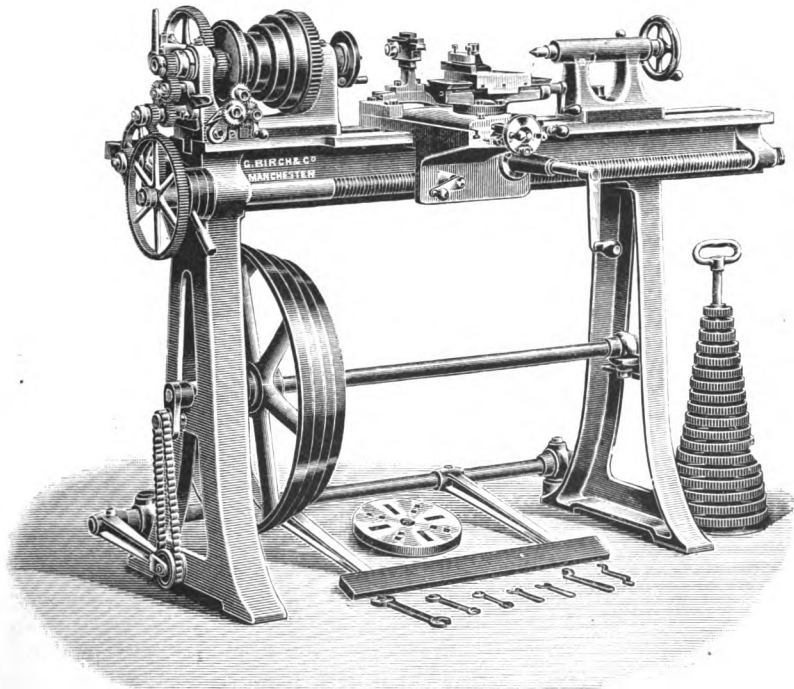
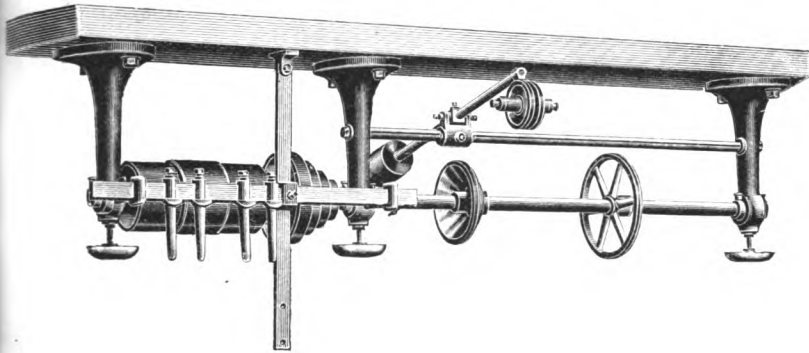

FIG. 117.—Six-inch tool-room lathe.

as the rest is used *close* up to the plate, and when not required may be swung out of the way.

Centre Stay for Shafts.—The centre stay, G, is used to support shafts at any interval along the bed; there are wooden dies to fit the shafts, usually made of oak, or if softer wood is used, the stay is fitted with this, and drilled and bored to receive a steel liner, the liner being secured by means of wooden screws. Steel-lined dies are very durable, the surface of which, if properly cared for, quickly becomes burnished, and when in that condition there is no danger of the work getting scratched, as the parts in contact are always carefully lubricated. See “Uses of Stays to Lathes,” Chapter VII. pp. 138.

Double Carriers—Clements Driver.—The carriers, H, shown in Fig. 119, are used along with the “Clements” driver, I. By this arrangement each arm of the carrier receives an equal thrust parallel

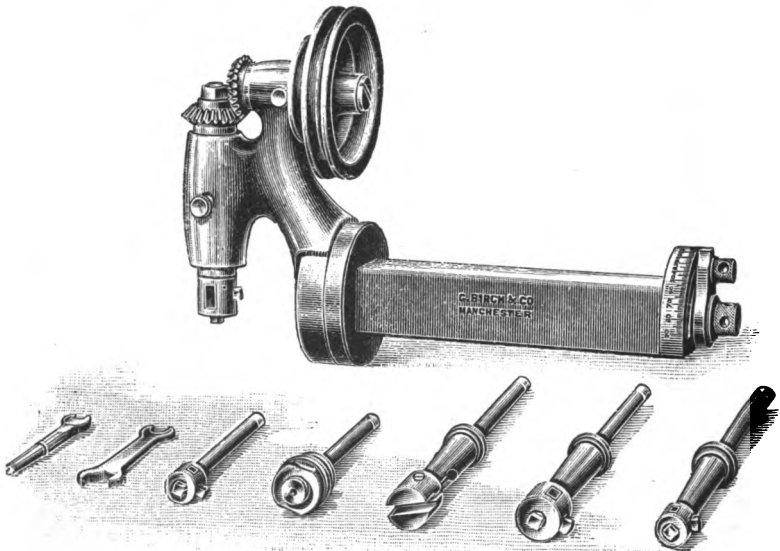
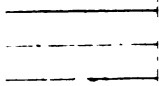
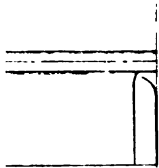

FIG. 117A.—Slot-drilling attachment.

to itself, the driving pins being secured to an oscillating plate, which can move along a little distance, and so equalize the pressure on the two ends of the carrier.

Description of Lathe (Figs. 118, 119).—Nine-inch self-acting, sliding-surfacing, and screw-cutting lathe with double geared fast headstock, with cone pulley and steel spindle, running in parallel gun-metal bearings. The sliding and surfacing motions of the saddle are obtained from a backshaft behind the bed, and the necessary feed motion is obtained from the spindle of the fast headstock, through reversing gear for right or left hand sliding, and a train of wheels behind the bed for giving cuts of 8, 16, 24, and 32 per inch. A clutch motion on the front of the rest enables the sliding or surfacing feeds to be connected up at leisure. The guide screw is reserved for screw cutting only. The



TS DRIVER

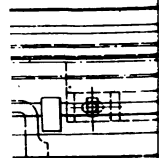

G. ARMSTRON

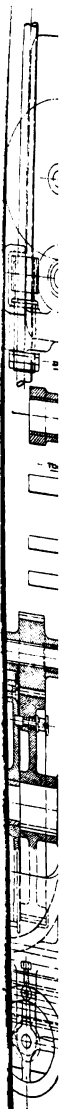

VATIO
DETAI

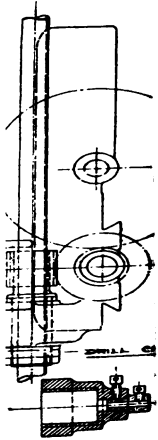
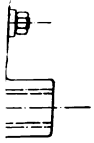

TOOL HOLD

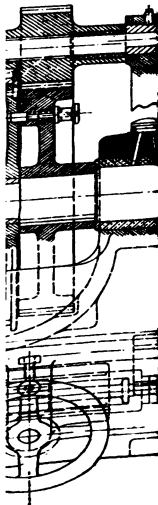

VATION
DETAILS OF

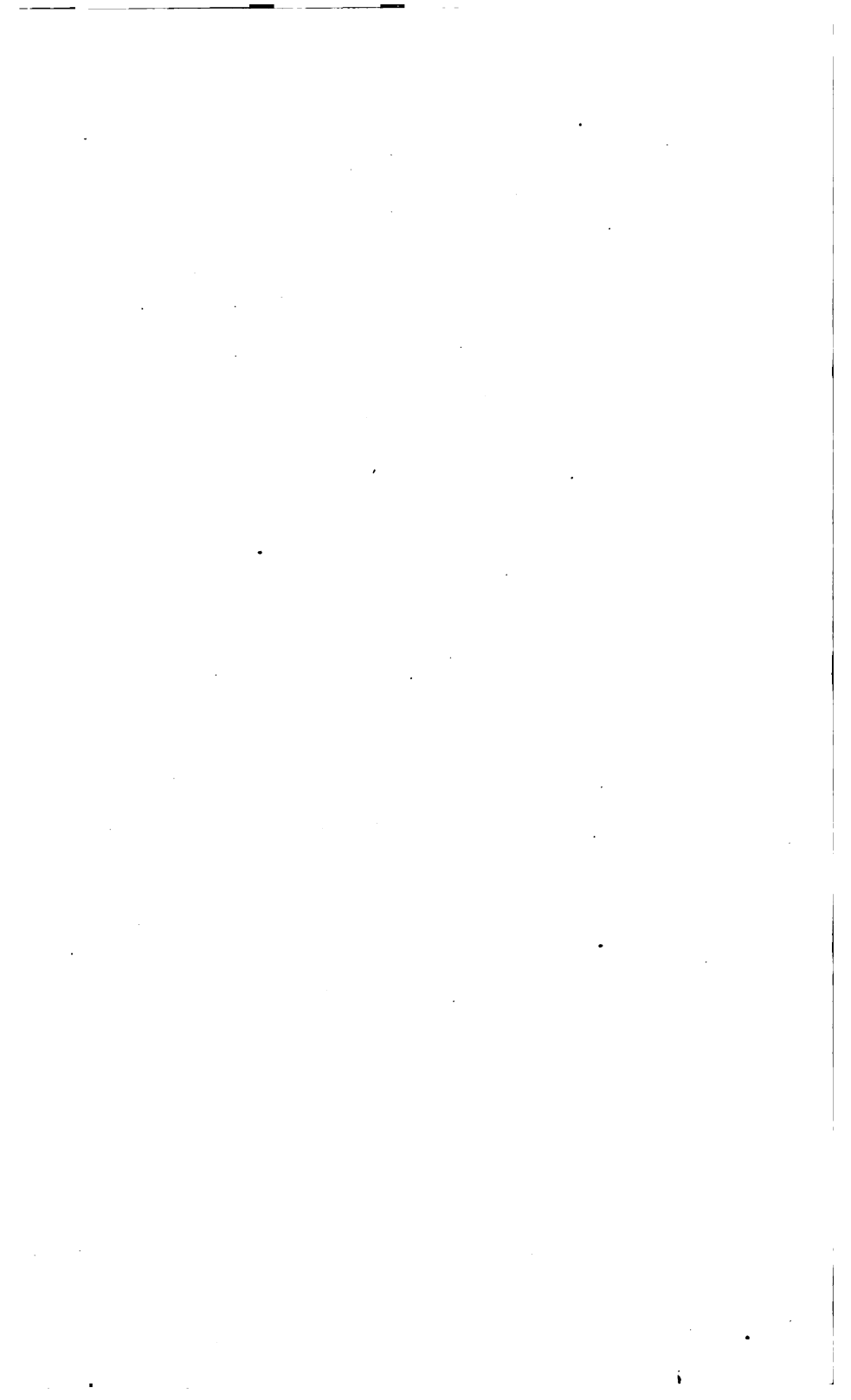

change wheels are connected up at the end of the bed to suit the various pitches of threads to be cut. Reversing motion on the back of the fast headstock enables right or left hand threads to be cut. The loose headstock is arranged with a special bolt by which it can be tightened up into position on the bed with a small movement of the lever. The top driving and strap shifting apparatus is shown with wall brackets, but these are frequently substituted by ceiling hangers.

All the gear of these machines are machine cut from the solid, including both driving wheels, change or feed wheels, and are protected where necessary. We have not shown these wheels guarded, as it would hide the mechanism.

The details on the other tracings are as follows:—

With regard to the fast headstock shown on this sheet, it will be seen that the backshaft and the double gear is thrown out by an eccentric arrangement, and the lock-bolt in the wheel in the front of the cone pulley can be pulled out.

The bearings of the headstocks are made of hard brass, and the back bearing is fitted, as shown, with thrust collars (T), the lock-nuts at the rear of the bearing keeping the spindle up.

The reversing motion is shown fairly in detail in this view, and there are three positions, one for right-hand, one for left-hand cutting, and the central position, which disengages the feed altogether. The spring and the taper peg are used to define the relative positions of these reversing motions. Self-acting and sliding and surfacing motions, and the four changes of feeds, 8, 16, 24, and 32 cuts per inch, are obtained as shown on headstock in plan. There is a sliding key, which when moved along can engage in any one of the four sets of wheels shown. It can also lay in a position between any of these wheels, and when in that position no motion takes place; and as soon as this key is slid over and engages with any one of the wheels, then motion takes place on the backshaft. This sliding key is manipulated, as shown in the front view of the headstock at the bottom of the sheet.

There is a hand wheel in the front of the bed, and this hand wheel has pressing against it a little pointer, which is forced outwards by a spiral spring. There are four recesses on the back of the hand wheel, and when the pointer is in any one of these recesses, then the key engages with the other wheels, and the number stamped on the periphery of the hand wheel indicates it is geared up for either 8, 16, 24, or 32 cuts per inch.

Referring to the details of the saddle and rest on this sheet, of which there are plan, end view, and side elevation shown, it will be seen that the backshaft is carried in brackets from the back of the saddle, and this backshaft in turn drives a worm wheel, which is keyed on to a pinion, driving a spur wheel on a shaft, which runs across the saddle, just in front of the recess where the loose headstock fits. When motion is required for surfacing, the cross handle on the front of the rest is tightened, and the effect of this is to draw the worm and the small pinion on to the cone referred to. If it is required to connect up the sliding arrangement, then the cross handle in front of the shaft, on

which is keyed a large spur wheel, is then screwed up, and there are two cones, both of them which tighten the pinion shown in plan; and through this pinion and spur wheel in front of the saddle, and rack pinion gearing into the rack in the bed, the self-acting sliding motion of the lathe is obtained. When motion is not required to either the sliding or surfacing, the cross handle is backed off and the cones left free, consequently the worms at the back of the saddle and spur wheel simply revolve, and no motion takes place. For the quick hand traverse along the bed a pinion is fitted on a little stud on the right-hand side of the front of the saddle, and a lever attached. This pinion gears into a spur wheel, and from that drives the rack pinion working into the rack in front of the bed. There is a quick withdrawing motion on this rest by means of a screwed bush, which is screwed into the front of the saddle, and a half-turn of this bush is sufficient to withdraw the tool quickly.

The clam nuts gearing into the guide screw are thrown in and out of gear by means of the rod shown on the left-hand side of the saddle, and this rod through the lever works the cam with eccentric wheels in, and opens or closes the clam nuts on to the guide screw. The guide screw is supported at intervals by brackets on the inside of the bed.

Two Sets of Driving Pulleys.—In most lathes of this type two sets of overhead pulleys are used, which increase still further the range of speeds obtainable. Where a variety of operations are necessary, as is generally the case with the working of a fully equipped lathe, a large range of speeds is convenient to the different cutting tools.

In some lathes made with back gearing an eccentric shaft is used to engage and disengage the wheel teeth.

Loose Headstock.—The "loose" or "movable" headstock is capable of sliding along the lathe bed, and may be secured at any required distance from the fast headstock. A steel centre is fitted to the "poppet," the point of which is in the same axial line with the point of the centre carried in the fast headstock spindle. Between these centres the work to be turned is placed. Fig. 119 illustrates a loose headstock in section. At the opposite end of the poppet to which the centre rides, an internal square thread is cut to receive the long screw, the screw being prevented from end play by a collar, plate, and hand wheel. The hand wheel is fitted to the poppet screw by a key, and further kept in place by a nut.

By rotating the hand wheel the poppet is extended. This extension should *always* be as little as is convenient, as the more the poppet is extended, the greater is the vibration at the end of it, and the less true is the cutting action of the tool. To compensate in some measure for this vibration a lock bolt is fitted, having a hollow side which grips the poppet when drawn up by means of the screw and nut (handle) attached.

Another method is to slit open the headstock at the mouth of the hole, and by having a projection on the side of the head a stud is fixed vertically into it. A forging, acting as a nut, is made in handle form fitting the stud, then by tightening the nut the slit is partially closed, and the poppet is accordingly gripped.

Sellers' Lathe.—Fig. 120 represents an 8-in. centre lathe by Messrs. William Sellers and Co., of America. The motion of the saddle along

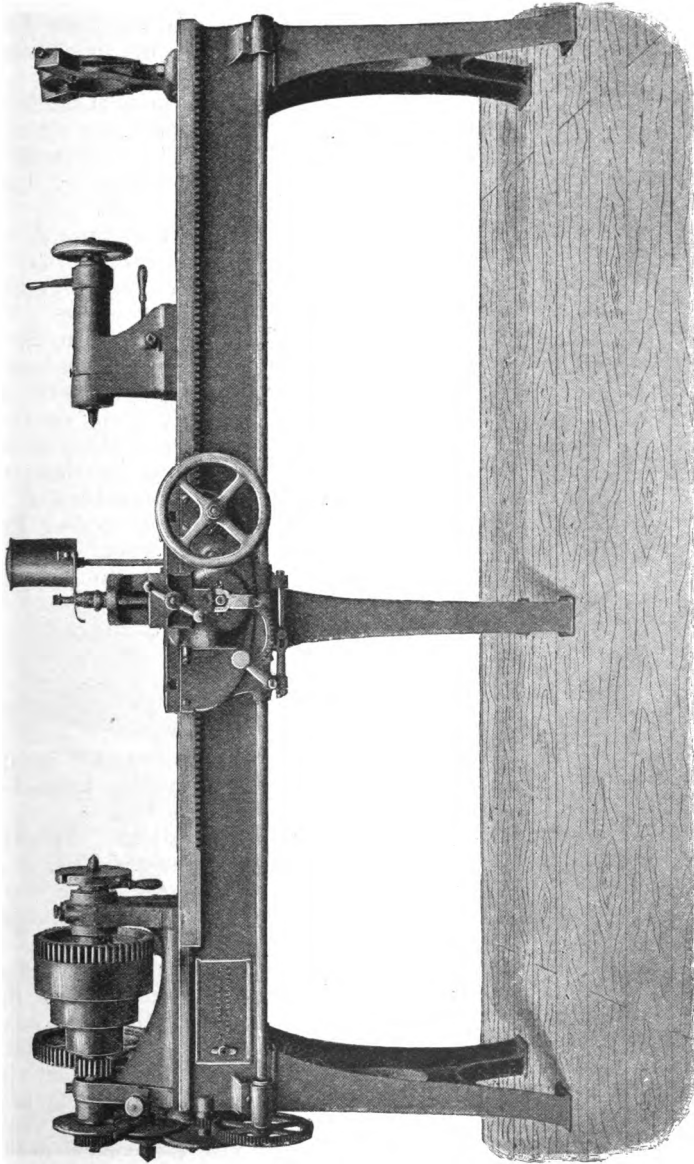

FIG. 120.—Sellers' straight-bed lathe.

the bed is by rack and pinion actuated from the feed shaft in front of lathe.

The leading screw being used only when screws are to be cut, is thus preserved from irregular wear, and, by its position, from damage. At the outer end of the lathe spindle a friction disc is placed, which is put in contact with others on the swing plate, and connected with these discs is a lever which controls the feed of the traversing shaft by a simple movement.

The fast headstock spindle revolves in a parallel bearing at the front and a conical one at the back. To prevent end motion of the spindle, a hardened steel ring is secured to it, which is confined between a hardened steel thrust collar and the end of the back bearing. All the parts are confined in an oil box to insure constant lubrication.

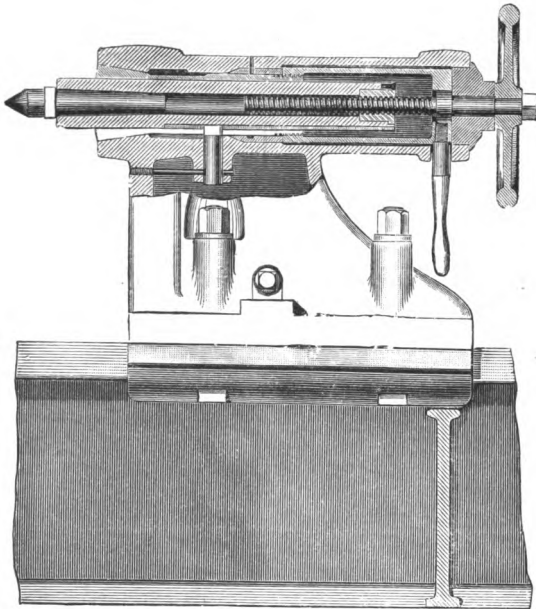

FIG. 121.—Loose headstock.

The Loose Headstock.—Fig. 121 is a sectional elevation which shows the construction to be of a special character. The lever near the hand wheel controls the movement of the poppet by clamping it concentrically in two places (see Fig. 120, where lever is moved into a vertical position). The upper part is adjustable for taper turning. The under V-clamp serves as a sure grip to the headstock, and is actuated by means of a lever instead of a wrench.

Steel Spindle.

Hardened Necks to be ground.—The lathe

spindle is made from a steel forging by turning it *nearly* down to proper dimensions; then, after hardening, it is finished by grinding.

Effect of Warping.—The bearings are similarly treated so that absolute truth is obtained, a feature almost unattainable before the practice of grinding with small emery wheels was established. We have seen bearings with forty years' wear on them, with portions of their surface still black from the effects of hardening. This proved that the material was good, also that it was thoroughly hardened, but the warping produced by the above process could not be corrected even by years of wear.

Compensation for Wear.—Referring to Fig. 118, the conical necks of the spindle are compensated as wear takes place, by drawing them further in contact with their respective bearings.

Function of Lock Nuts.—This is effected by tightening up the lock nuts at the outer end of the back bearing. When properly adjusted,

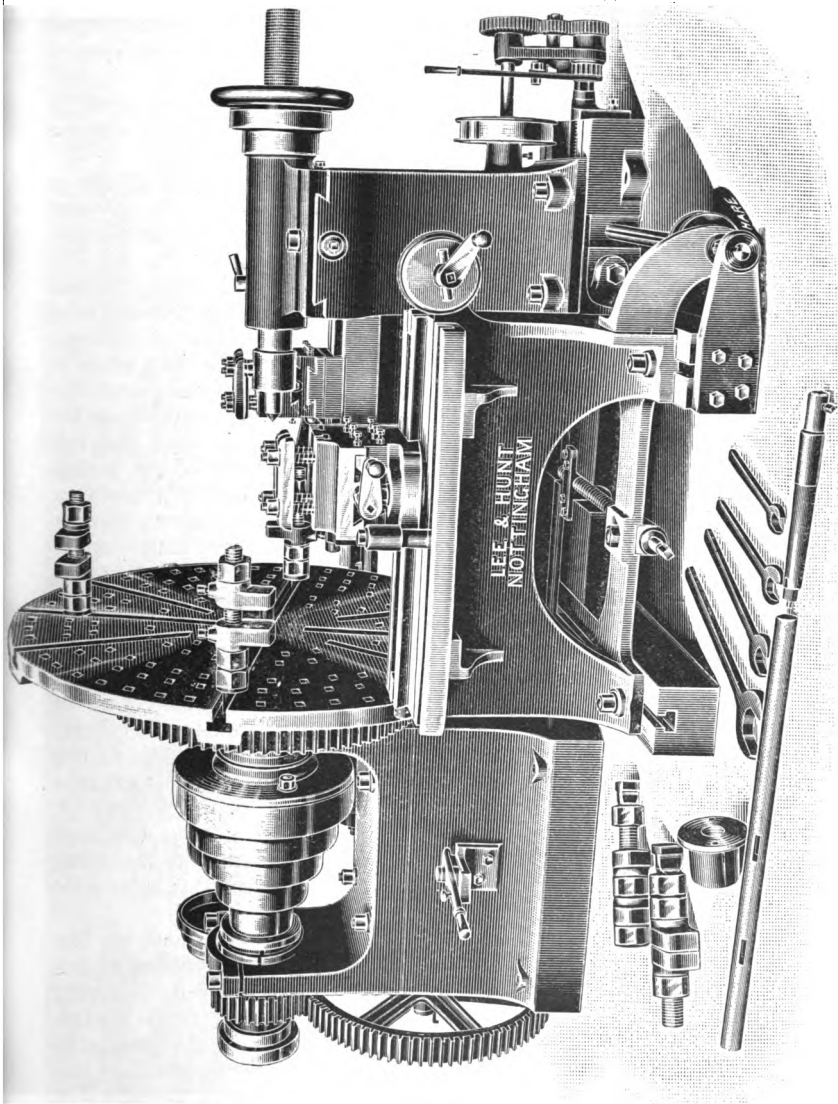

FIG. 122.—Pulley and fly-wheel lathe.

there is no appreciable axial movement of the spindle if care is taken to have the lock nuts screwed tightly against each other as well as the cone.

Function of Thrust Pin.—The extreme face of the spindle end is also pressed against by a thrust pin, the idea being that, as the conical necks of the spindle wear, such wear will be met by the hardened face of the thrust pin.

This arrangement is extremely sensitive, but when properly adjusted and carefully attended to, it is probably the best method of driving a small lathe spindle.

Oval Bearings.—The best of conical bearings will work oval if allowed to get loose, and then no amount of adjustment will restore them to truth.

Pulley and Fly-wheel Lathe.—The lathe illustrated in Fig. 122 is specially built to turn, bore, and face pulleys or fly-wheels. A tool rest is located on each side of the lathe, which may be actuated automatically or by hand.

These slide rests are secured to separate standards, which are capable of transverse adjustment by the screw shown at the centre of bed; thus admitting pulleys or fly wheels up to 5 ft. 4 in. diameter. A forming arrangement is carried on the upper part of the standards, into which a stud, attached to the slide rest, may travel. When this is engaged, the face of the pulley is rounded. While the pulley is being operated on by two cutting tools acting on the face, a boring bar is used and fed automatically to bore the hole to standard size. One end of the boring bar is passed through a bushing in the fast headstock, which gives to it increased rigidity, and therefore coarser feeds can be given than is the case with a bar supported only at one end. The face plate carries special drivers, which are provided with clamps to grip the arms of pulleys whilst they are machined.

Duplex Axle Lathe.—Axles for railway carriages, waggons, etc., are turned in a special lathe, which is fitted with two movable headstocks and two traversing saddles. The saddles are actuated by independent leading screws, each being driven by a headstock fitted in the centre of the bed. The driving shaft passes from the speed cone to the central headstock, thereby communicating a positive drive to the middle of the axle, and at the same time to a powerful eccentric, which is situated at the opposite side of the headstock to the Clements driver.

By referring to Fig. 123, it will be seen that an axle may be placed between the headstock centres and turned in each journal at the same time. This type of lathe is known as a “treble-geared duplex-axle lathe.”

Double Railway Wheel Lathes.—The lathe represented in Fig. 124 is constructed specially to turn or bore two railway-engine wheels at the same time, and will take in driving wheels up to 8 ft. diameter. It is obvious, when these lathes are operating on the faces of two steel driving wheels, all the working parts are put to the test as to strength and rigidity. The bed, which is of box section, is cast in one piece, and touching the floor line throughout its length, is the basis of support for the huge headstocks and saddles. It will be noticed, by referring to Fig. 124, that the driving-cone shaft at its outer end has a shrouded pinion, which meshes with a large spur wheel, whose axis

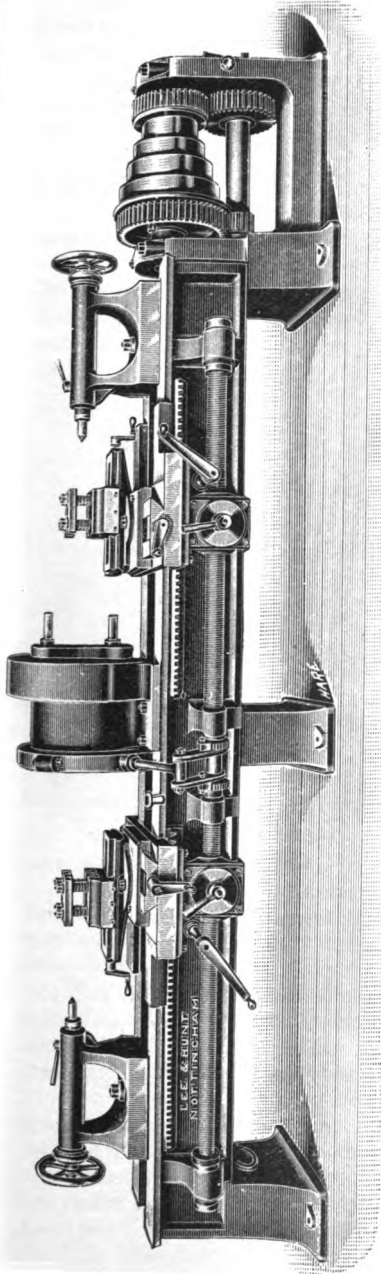

FIG. 123.—Duplex axle lathe.

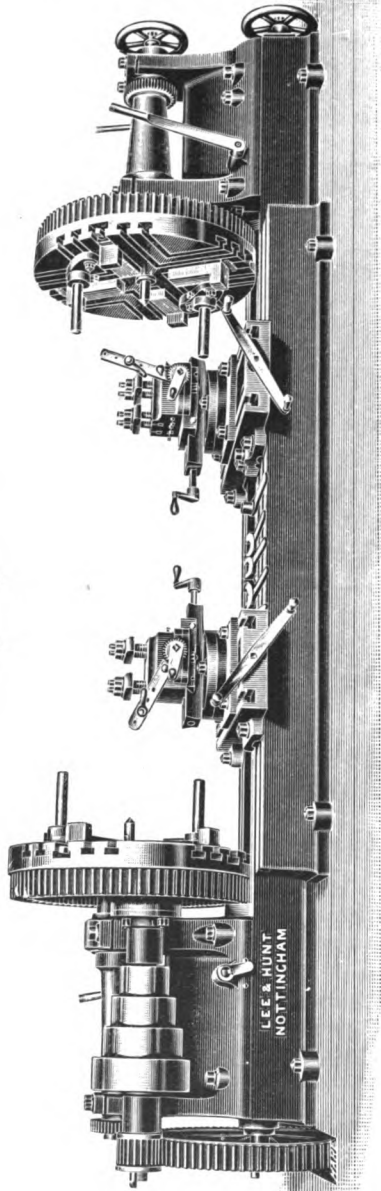

FIG. 124.—Double railway-wheel lathe.

is the main driving shaft, and which shaft runs the whole length of the lathe bed.

On the driving shaft are two sleeve pinions, which operate the large spur gears attached to the right-hand and left-hand face plates respectively. The sleeved pinions, which carry feather keys, are operated by a clutch and lever, to be put in or out of gear as required. Beneath the right-hand headstock (which is a fixture) another pinion is housed, which may be engaged with an internal gear at the back of face plate.

By using the internal gear the lathe is run at a much quicker speed, which is suitable for boring or bossing a wheel.

Thus these duplex lathes may be engaged as above, or, if required, one headstock may be used to bore or turn a tyre on its face plate, whilst the other may be run at a high speed for boring or bossing wheels.

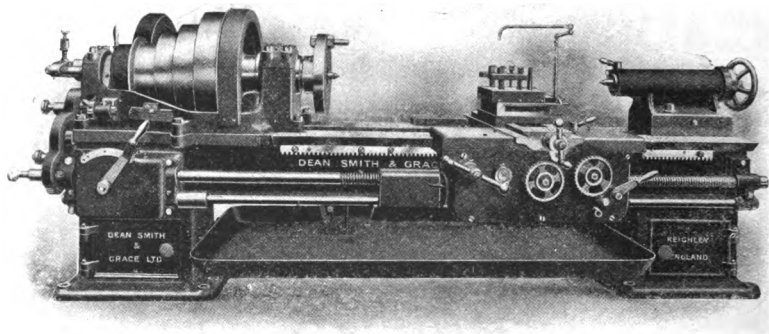

FIG. 125.—12-in. High-speed lathe.

The compound slide rests can be swivelled into any position, and fed automatically by ratchets and pails from an overhead shaft.

Each face plate carries four gripping jaws for chucking tyres and wheels, and, in addition, two drivers for work carried between the centres.

The headstock at the right is movable along the bed, and is fitted with a sliding poppet, as in ordinary lathes. In some cases an extra pair of slide rests are used; then the cutting tools are placed in an inverted position to meet the work as it revolves in an upward direction.

12-in. Centre Lathe.—The lathe shown in Fig. 125 has been designed to turn at the high rate of speed and feed which is now obtainable by the use of a special kind of air-hardening tool steel.

It will be observed that the proportions of the sliding and revolving parts are made larger so as to give strength and rigidity to the tool when heavy cuts are taken.

The feeding is done through gears which are located in a box in front of bed, and range from 4 to 32 cuts per inch—that is to say, an alteration of the lever shown in front of the fast headstock causes a pinion to slide on a shaft until it gears with one or other of a small train of wheels, directly operated by gears which receive their motion from the lathe spindle; thus, a positive drive is always obtained without the removal of the wheels from their respective positions on their shafts.

The dimensions of the headstock are exceptional for a 12-in. lathe, which accounts to a great extent for the power obtained. This is obvious if we consider the sizes of the spindle and its bearings, and the dimensions of the speed cone. The front bearing is $8\frac{1}{2}$ in. long to receive the spindle whose journal is 6 in. diameter, while the cone is made for a 4-in. wide belt, the smallest diameter being 13 in. and the largest 28 in. diameter.

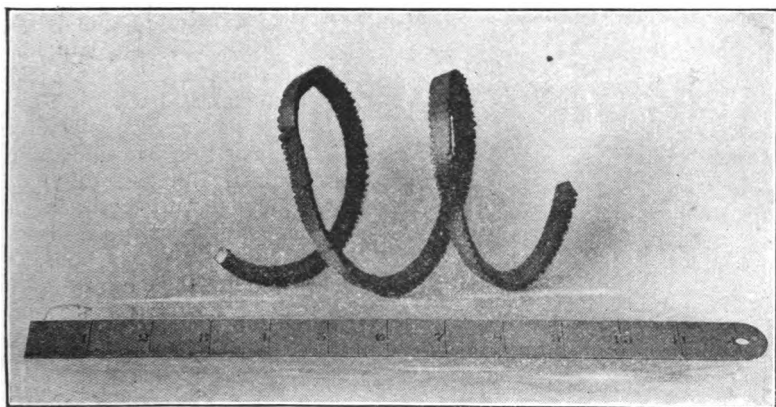

FIG. 126.—Steel shaving cut at 120 ft. per minute.

These proportions are much in excess of those found in ordinary 12-in. centre lathes, and are of the latest Anglo-American practice. It is interesting to note that 20 to 25 ft. per minute was considered a good rate for a lathe to operate on a shaft of iron or mild steel.

The cutting shown in Fig. 126 was removed from a shaft at the rate of 120 ft. per minute in the above lathe, which is manufactured by Messrs. Dean, Swift, and Grace, of Keighley.

Lang's 12-in. Centre Lathe.—Fig. 127 shows a powerful lathe of 12-in. centre, made with an extended base to give a rigid support to the bed when heavy cuts are taken. The fast headstock spindle is made of hard crucible steel, and is ground to fit parallel gun-metal bearings. The feed motion is obtained by moving the lever shown below the fast head. This enables the workman to change the rate of sliding, or surfacing feed, without stopping the lathe or withdrawing the tool from the work. The loose head is fitted with a transverse

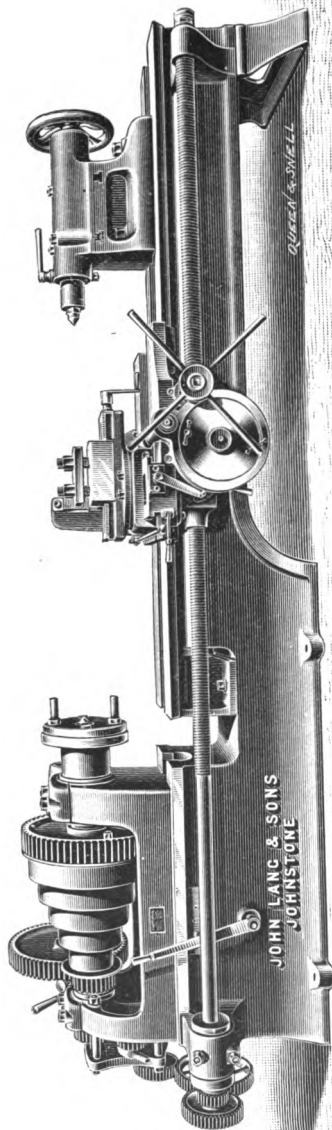

FIG. 127.—12-in. Lathe.

slide for setting the centre in perfect alignment, or for taper turning. The gears and racks are machine-cut, as are the teeth of the change wheels.

8-ft. Face-plate Lathe.—The two illustrations (Figs. 128 and 129) represent a powerfully built tool designed for turning fly-wheels. The face plate is 8 ft. in diameter, bolted to a flange forged on the end of the spindle. The latter, which is of steel, runs in parallel gun-metal bearings 9 in. in diameter in front, and 8 in. in diameter at back. At the back of the face plate an annular ring is bolted, the internal rim of which is provided with teeth, forming a gear of 5 ft. 8 in. diameter. A long spindle, parallel to the main spindle, carries the step cone and back gearing. The face plate makes one revolution for eighty-five of the cone pulley.

There are three slide rests on pillars arranged as shown in Fig. 128; the central one is used when boring is being done, while the other two are working on the wheel face and sides. The cutting tool on the furthest rest has to meet the object as it rotates upwards, therefore it is fixed in an inverted position.

Each outer rest is fitted with a curvilinear motion for turning convex rims, while the central rest is operating on the bore or

hub of the wheel—that is to say, the three rests may be engaged simultaneously or, if desired, independently.

The rests are fitted with a variable feed gear of $\frac{1}{16}$ in., $\frac{3}{32}$ in., $\frac{1}{2}$ in., and $\frac{3}{4}$ in. respectively, the prime mover of which is located in a box near the base, consisting of four pairs of gear wheels; this receives its motion from a vertical shaft which is driven by bevil gearing, driven directly from the reversing-motion shaft shown at back of headstock in Fig. 129.

Thus, from the base of the lathe, a system of bevel gears transmit motion along the various shafts directly to each of the three rests.

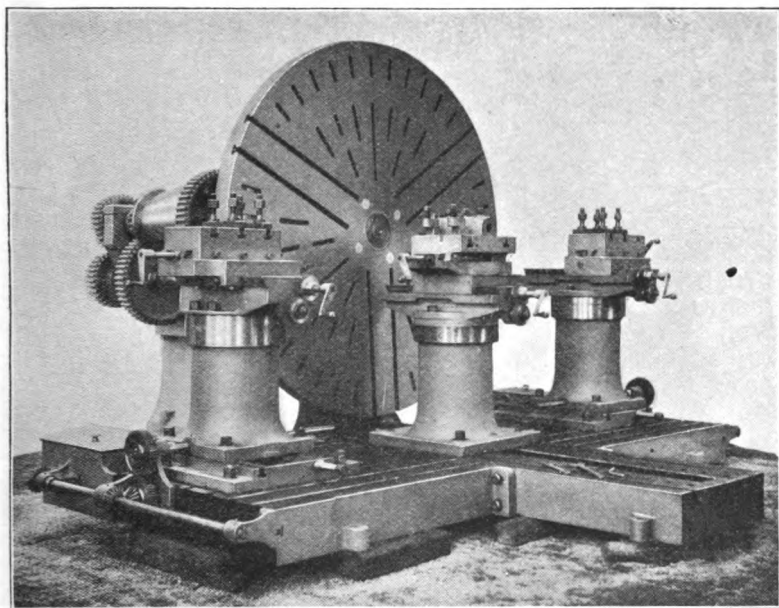

FIG. 128.—8-ft. Lathe for turning fly-wheels.

This application of the change-feed gear is very good, working as it does on a sliding feather; it is easy of adjustment, and self-contained.

The chains originally used were made to actuate a lever and catch, at the end of each rest screw; these received their motion from an overhead shaft, and on this account were more or less troublesome. It should be mentioned that when this type of lathe is at work, the pillars do not move along the bed, but the slide rests which carry the cutting tools alone move.

When, however, it is necessary to turn fly-wheels of smaller diameter, the holding-down bolts are released, and the frames on which the pillars rest are moved to the required position; while wheels of narrower or

wider dimension can be set for by simply moving the position of the pillars carrying the rests, these being moved by the screws shown at the end of each frame.

In a face lathe the entire weight has to be supported, and the strains set up by the cutting tool have to be taken by one headstock alone. It has therefore to be of sufficient strength.

Break Lathe.—Break lathes are made with their beds adjustable. This type of lathe is convenient for boring, and for turning pieces which will not “swing” in an ordinary gap lathe.

The fast headstock is carried on a standard with a projecting base

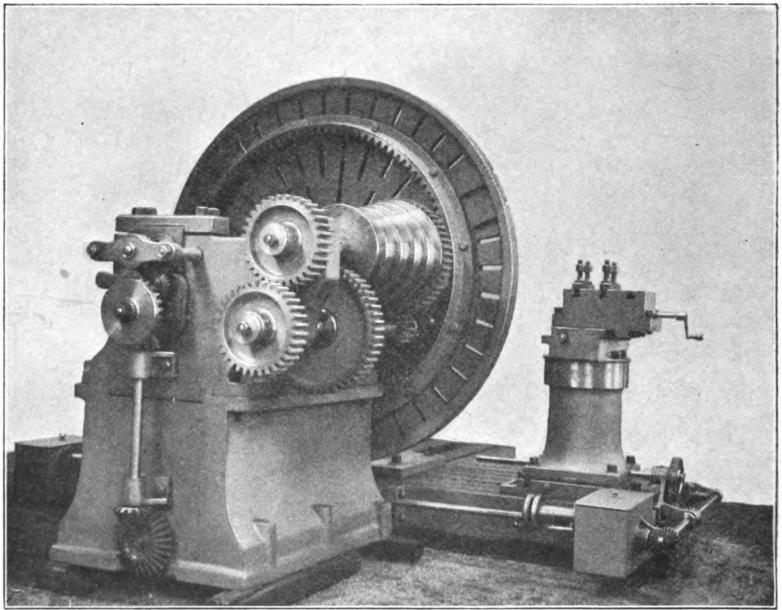

FIG. 129.—8-ft. Lathe for turning fly-wheels.

plate, which passes beneath the bed supporting it for a considerable distance. A long screw is fitted beneath the bed and headstock to give the necessary sliding motion, the nut being carried by the bed.

The movable bed is adjusted so as to clear the work as required, and is then secured. Some of the largest break lathes are fitted with a portable pillar rest. On the face plate in these lathes large fly-wheels can be turned and bored simultaneously.

Break lathes are measured similarly to ordinary lathes; thus a 20-in. break lathe is one which will swing work 40 in. diameter over the top of the bed. When the bed is set back, however, the lathe will accommodate pieces 7 or 8 ft. diameter.

Hendey Norton Lathes.—The arrangement of “change wheels” is different to that adopted by British machine-tool makers. In this lathe there are 12 change wheels keyed to the leading screw, the wheels being encased in a box. On a sleeve another pinion is carried which may be slid along its shaft, the shaft being located beneath the leading screw. An intermediate wheel carried by this mechanism is pivoted so as to engage with the change wheels on the leading screw.

In this way the ratio of the revolutions of the guide screw to that of the lathe spindle is obtained without the trouble of removing the wheels from their axis. The driving wheels at the end of the head-stock are altered only when the screw to be cut is one outside the limit of the twelve wheels on the screw end.

Turning by means of a Nest of Gears.—The turning done in these lathes is by means of these gears, but in this case a finer train at the outside is used. When turning, as in screw cutting, there is the same range of twelve speeds, which is very convenient where a limited variety of work is to be done.

CHAPTER VII.

LATHE APPLIANCES.

Lathe Centres.—Lathe centres are made of crucible-cast steel of a high grade. After annealing, the steel may be turned to fit a standard taper hole, the plug of which is used to test the centre holes in all lathe spindles and poppets under construction. Centres thus made are perfectly interchangeable for all lathes of a given size.

A complete set of centres for an ordinary lathe consists of a pair of conical points (Fig. 130), a square centre (Fig. 131), or a countersink (Fig. 132), and a half centre (Fig. 133).

A general screw-cutting lathe requires, in addition, centres of a much reduced diameter (Fig. 134), also centres of more than the usual length.

Work which has been turned to a conical point is supported on a centre similar to Fig. 135, and in some heavy lathes the poppets are fitted with oil-grooved centres similar to Fig. 136.

At present a uniform angle of centre point has not been adopted in British workshops. For heavy work we generally find centres made to an angle of 90° . Small work is often centred to 75° , while in Anglo-American lathes the centres are usually turned to 60° (see "Slocomb's" drill and counter-sink combined (Fig. 137)). There is also a growing desire for centre shanks to be standardized, similar to twist drills, *i.e.* to the Morse taper (see Morse table).

When this is adopted, twist drills, reamers, and all fluted tools can be carried equally in the poppet and fast-headstock spindle of the lathe, as well as in the milling and drilling machines. This will also be of service in boring fixed work on a lathe saddle, and for many pieces carried in ordinary jaw-chucks.

Hand reamers will then be used only in such work as cannot be conveniently toolled in one or other of the above machines.

It is important to have all centres turned and kept strictly true to one definite angle, where work has to be passed from one lathe to another. Thus a set of mandrels, originally made with their centre holes all alike, will soon be spoilt in a shop where all the lathe centres are turned up to different angles.

Lathe centres quickly lose their points if not carefully used; they are then useless for small work.

A beginner must work at a lathe some time before he can understand

how much, and how often adjustment must be given to the poppet centre to prevent it from binding the revolving work too hard. Although the pressure may be correct at first, it quickly increases as the work becomes heated and expands.

The proper adjustment depends upon: (1) the depth of the cut; (2) the rate of feed and speed; (3) the diameter of the work; (4) the shape of the tool; (5) the amount of lubricant.

Lathe centres, when worn, are now retued by emery wheels. This method has many advantages; it is unnecessary to soften the centre points, and the danger of the true but soft centre warping during the hardening process is obviated.

Centre Trueing Machine.—Fig. 138 represents a centre grinding appliance by Messrs. Luke and Spencer, Broadheath, Manchester. The emery wheel is driven by a belt as follows:—

A grooved pulley, P, screwed to the spindle nose carries a gut band, which passes over the guide pulley GG to a small pulley P₁ at the opposite end of whose spindle is located the emery wheel E. The stem of T fits into the

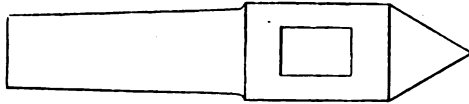

FIG. 130.—Ordinary centre.

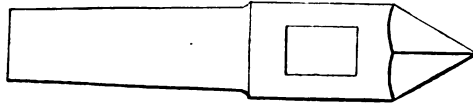

FIG. 131.—Square centre.

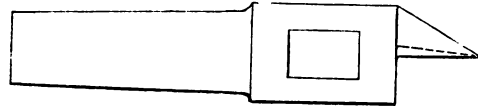

FIG. 132.—Countersinker.



FIG. 133.—Half centre.

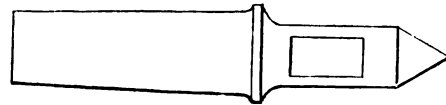

FIG. 134.—Reduced centre.

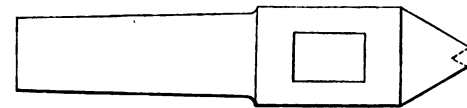

FIG. 135.—Cup centre.

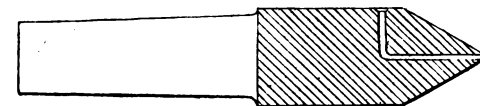

FIG. 136.—Oil groove centre.

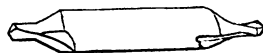

FIG. 137.—Combined drill and countersink.

upper part of the arm A, and is capable of a vertical adjustment to suit the gut band D.

When the correct position of T has been obtained, collar C is secured by a set screw in such a position as to compress the coil

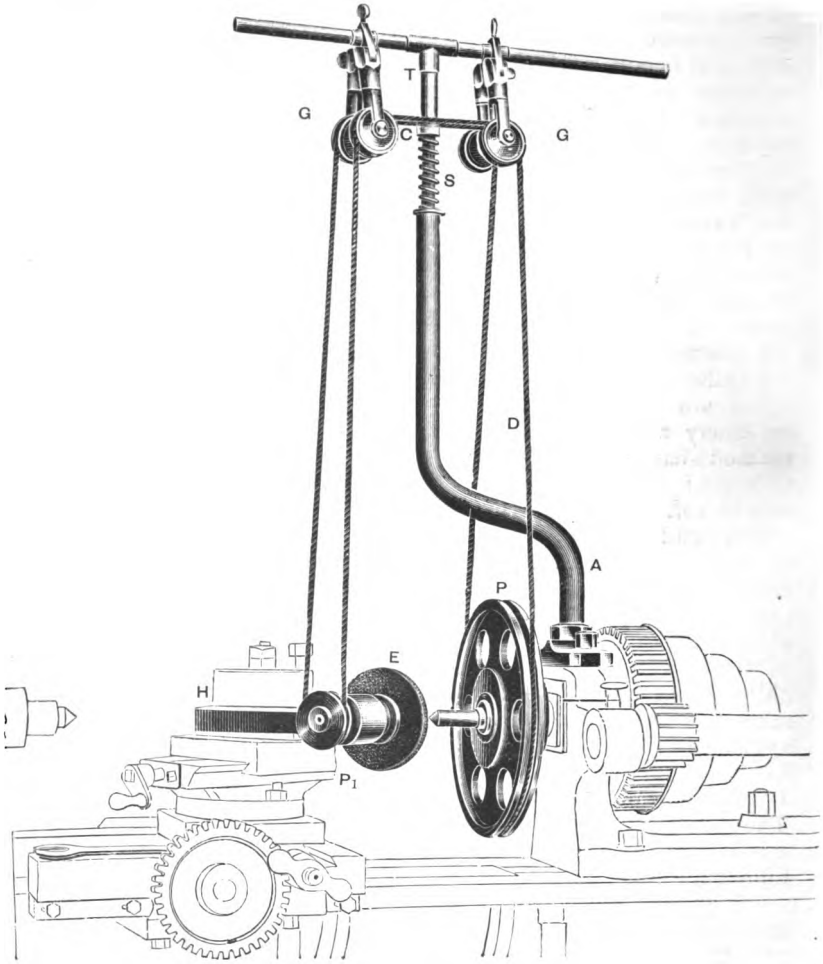

FIG. 138.—Centre-truing machine.

spring S. The holder, H, is fitted in the tool rest, and the emery wheel is fed by means of the slide rest across the conical point of the centre. The wheel revolves at a high rate of speed, and will resharpen a lathe centre in a few minutes.

Lathe Centres and their Uses. *Square Centering.*—When the approximate position of the centre has been obtained on a piece of work which is to be turned, a small hole is made in its surface by means of a centre punch. The work is then mounted in the lathe, and “square centred.” A centre having four flats filed to meet at sharp corners is fixed in the loose-head poppet, the poppet being out as *little* as practicable to prevent leverage or vibration. An elbow rest is fixed in the tool rest, and the work made to revolve.

The rest is *gently* pressed against the work as it revolves at a high speed, and the square centre made to advance until a hole has been made suitably deep. The rest and the centre are lubricated either with soapy water or oil.

When a satisfactory centre for the work has been obtained, it is well to withdraw the rest, and allow the square centre time to correct any small error in the roundness of the hole, which is caused by irregularities on the work's surface.

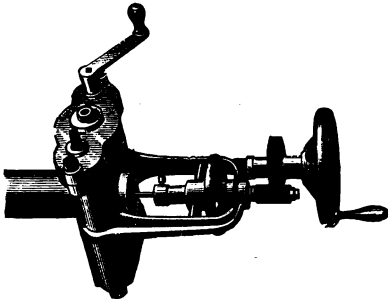

FIG. 139.—Portable centering appliance.

A small tool is now largely used, which drills and centres at one operation, but these are limited to small, light work (Slocomb's patent, Fig. 136).

Instead of lifting heavy shafts into a lathe to be centred, a small, portable centering machine is used (Fig. 139).

The machine grips the shaft by a vee chuck moved by set-screws on each side of the jaws. The small drill is then fed into the shaft by means of gears actuated by the hand wheel shown. This machine is made by Messrs. George Richards & Co., Broadheath, Manchester.

To obtain a perfectly smooth and accurately shaped hole, a centre, having half the cone removed, is found very effectual (see Fig. 132). The hole is quite burnished by the fitting portion of the cone. In all work done between the centres of a lathe the ends should be faced before turning any other part, otherwise the centre hole will wear unequally.

A centre with a little less than half the cone filed away is used when facing is being done, so that the tool may cut freely down the face to the edge of the centre hole; the cut-away portion is sometimes extended so far as that shown in Fig. 133, and is called a “half centre.” This

centre is also useful when cutting small screws, especially those having square threads, left-hand pitch, in which case the cutting tool has to clear. Instead of the half centre, centres of very small diameter are frequently used for screw-cutting slender shafts (see Fig. 134).

These centres are so small that the screw-cutting tool, when set to the smallest diameter of the screw, clears the largest diameter of the centre. In some cases an old centre is drilled through, and a piece of steel is used of a small diameter to act as a centre for the above class of work.

Columns and pipes are faced in lathes having huge centres of cast iron, which are bored to fit steel shanks, on which they rotate. These

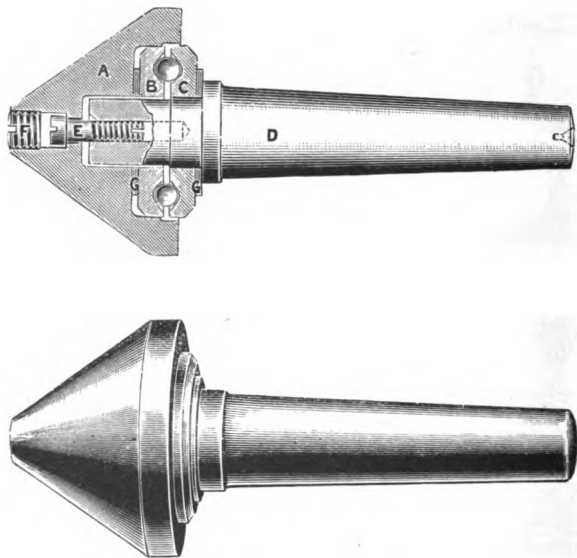

FIG. 140.—Revolving centre.

conical castings are made in a variety of sizes to suit different cored holes in the columns or pipes.

Where the pipes are of a fixed diameter solid centres are sometimes used, but these are not so good as those which revolve with the work; For it is obvious that as large cored holes are invariably rough and irregular at the mouth, a fixed centre is certain to get worn and scored with the sand and scale.

Revolving Centre.—To further reduce friction, a revolving centre fitted with ball bearings has been devised by Mr. Charles Taylor, Birmingham (Fig. 140). It will be seen that the front part A revolves with the work, thereby reducing the cutting or wearing away of the centre when a hollow body is being turned.

The pressure is taken by a row of balls, which revolve in a race in BC, which is of tool steel, hardened and ground to the correct angle. The ring B is secured to the front part A with which it revolves; the ring C is firmly attached to the shank D, which is fitted to the loose poppet in the lathe head-stock. The parts A and D are held together by the screw E, F being an additional screw to prevent dirt accumulating round screw E. GG are hard fibre packing.

Jaw Chucks.—Jaw chucks are of two main kinds: Independent chucks, where each jaw moves separately; Universal chucks, where the jaws move simultaneously to or away from the centre. The former are used on the heavier classes of work and such as is of an irregular outline; the latter, for holding circularly shaped pieces of work, such as wheels which have to be bored.

The combination jaw chuck illustrated in Figs. 141-144 can be used both as an independent and as a universal chuck. In the sectional view of Fig. 142 an annular ring, having teeth cut on one face, is seen to engage with bevel wheels on the screws, which actuate the four jaws, so that any movement given to one screw is transmitted to the other three. Thus a universal chuck is obtained when the annular ring engages the bevel wheels.

When the jaws are to be used independently, the pinions and annular gear are unmeshed. This is done by moving the steel shoes attached to the thumb-nuts, passing through the slots in shell (Fig. 141) by means of a guide into the

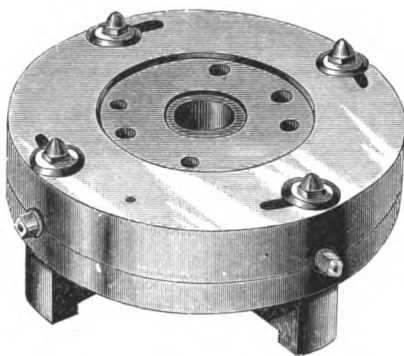

FIG. 141.



FIG. 142.

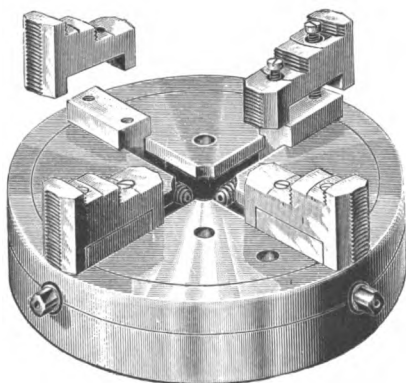

FIG. 143.—Combination jaw chuck.

pockets into the loose ring, upon which the annular gear rests. This movement allows the gear to drop away the pinions.

To return the connections, the outer end of each jaw is set exactly on to the circular line around the face of the chuck (see Fig. 144), and the steel shoes are moved up the incline, out of the pockets in the loose ring by means of the thumb-nuts before alluded to.

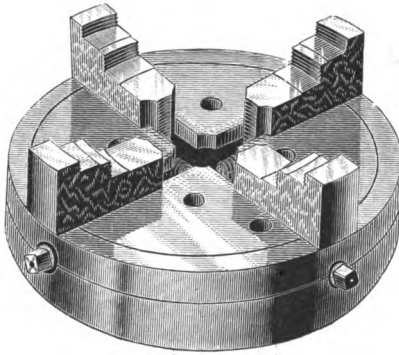

FIG. 144.—Universal four-jaw chuck.

Fig. 143 shows the method of reversing the jaws of this chuck. By the removal of two screws in each jaw the upper portion is at once liberated, and may be reversed.

This is obviously better than unseating the whole jaw from its screw, as is usually done. This chuck is the patent of Messrs. E. Horton and Son, Con., U.S.A.

Two-jaw Chucks.—These are used for holding work such as valves and brass cocks, which cannot be held in three-jaw chucks. Three

chucks of this type are shown in Figs. 145, 146, 147. Fig. 145 represents a two-jaw chuck made with a box body and universal jaws. The boss is cast on the body. The chucks illustrated in Figs. 146, 147 are made without a boss. They are secured to the catch-plate of the lathe. A slip jaw of hard steel secured by a dovetail joint is seen in Fig. 145. The chuck illustrated in Fig. 146 is provided with a central vee groove for holding round or square stock, drills, reamers, or taps. The screw is located at one side of the jaws, thus enabling it to be used on hollow spindle machines.

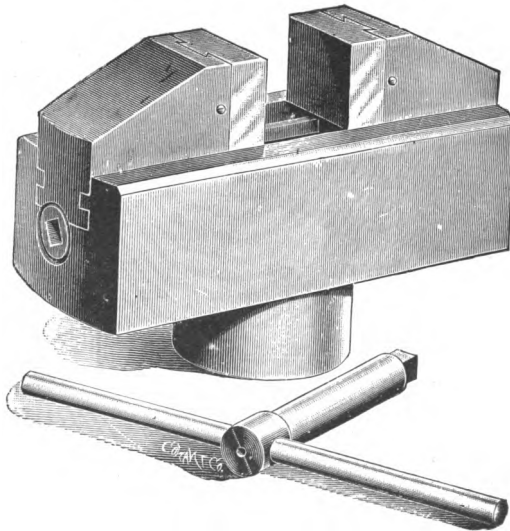

FIG. 145.—Two-jaw chuck.

The screw is located at one side of the jaws, thus enabling it to be used on hollow spindle machines.

Drill Chucks.—Drill chucks are used in holding small drills, both in

the drilling machine and the lathe. The "Horton" chuck suitable for drills from $\frac{1}{32}$ in. to $\frac{1}{2}$ in. diameter is self-centering, the two jaws being actuated by a right and left hand screw (Figs 148-149.) The body of the chuck is composed of one piece of metal, in which holes are bored to receive the screws and jaws. The teeth on the bite of the jaws are constructed to overlap, so that a drill of small dimensions can be held with the same truth as one of a larger size.

(1) All parts are made of hardened steel, and the bearing surface of the jaw is large, so that the drill is firmly gripped.

(2) This chuck is a great improvement on the old "set-screw" chuck, which would only take drills whose shanks were of one diameter. The "Little Hercules" chuck has three jaws

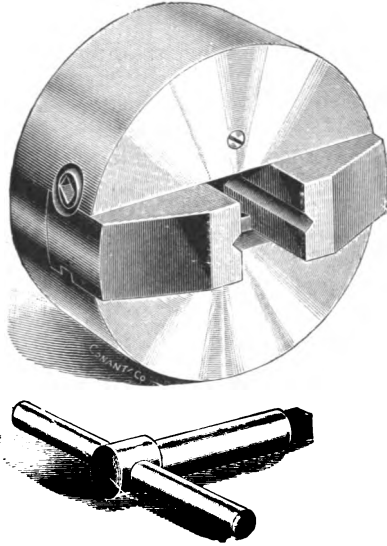

FIG. 146.—Two-jaw chuck.

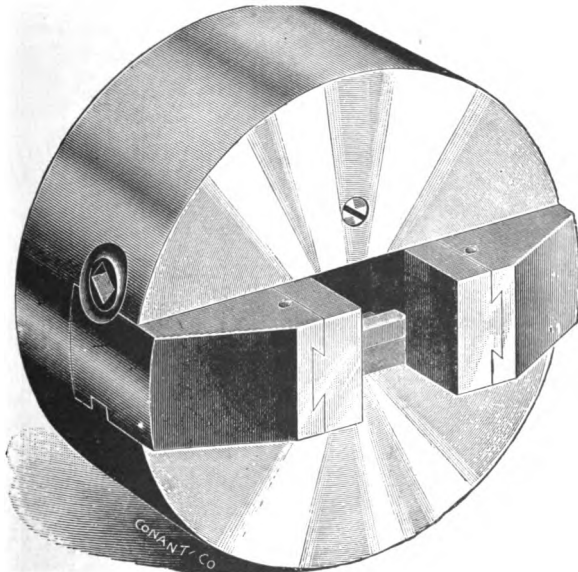

FIG. 147.—Two-jaw chuck.

which rotate eccentrically in such a manner as to make the chuck

self-gripping. The largest drill admitted is $1\frac{1}{16}$ in. diameter, while the diameter of the chuck is $4\frac{3}{8}$ in. Other notable chucks are "Westcott's" Little Giant, a powerful tool adapted to both round and square shanks, up to $\frac{3}{4}$ in. diameter. For small work "Cushman's," "Acme," and "Boss" drill chucks are serviceable tools.

Railway-wheel Chucks.—Railway wheels are turned in a jaw chuck which is made up of four iron castings, each of the castings being fitted with a screw and movable steel jaw, and secured by strong bolts to the driving plate of the lathe. This chuck has two advantages: any part needing repair is easily removed, and only one driving plate is needed, since the jaws and frames can be removed when turning instead of boring has to be done.

Strength of Lathe Plates.—In the past, driving plates have usually

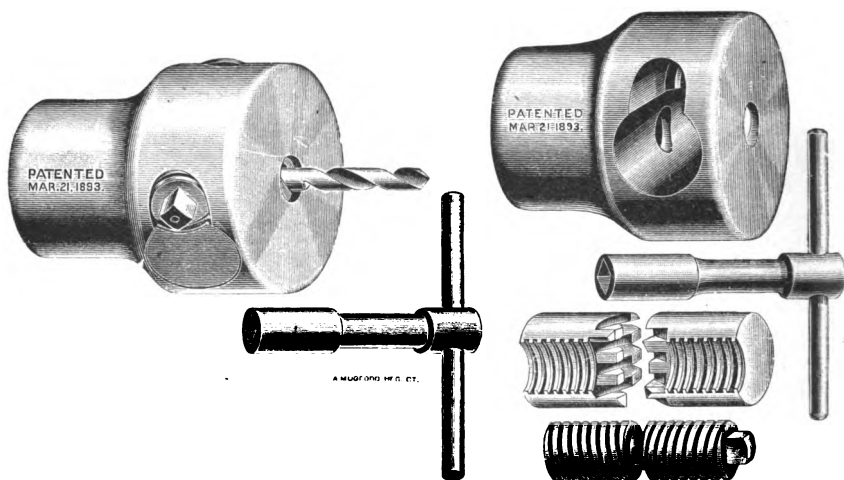

FIGS. 148-149.—Drill chucks.

been too light and weak. This error is now being corrected by many modern tool makers.

When a face plate has been distorted by holding untrue work, so as to have a permanent set, the only remedy is to take a cut off. This leaves the plate weaker than before. Large plates are specially liable to be distorted. As every "trueing up" further weakens the plate, it is essential that it should in the first instance be made stout enough to stand the stresses it may be subjected to without springing or warping.

Mandrels.—A mandrel is a truly turned rod or shaft upon which articles that have been bored are mounted to be turned or milled. It is obviously essential that a mandrel should accurately fit the work it supports, without any springing or bending. The best material of which to make mandrels up to 2-in. diameter is crucible cast steel. Above 2-in. diameter mild steel is suitable. Some large mandrels are made of cast iron, in which case the ends are faced with steel.

Standard mandrels may be purchased in sets ranging from $\frac{1}{4}$ -in. to 6-in. diameter.

How to make a Mandrel.—The following are the principal points to be observed in making a mandrel:—

The steel, having been cut into suitable lengths, is annealed. The pieces are next faced in the lathe so as to be slightly hollow at each end. The centre holes are then square-centred, and a small drill passed down the root of each, say to a depth of $\frac{3}{16}$ in. or $\frac{1}{4}$ in. This small hole preserves the point of the lathe centre from being worn away.

The mandrel is next turned down to about $\frac{1}{20}$ in. above the finished size, and further reduced at the ends to receive a lathe carrier.

A flat is milled or shaped on each reduced portion for the carrier screw point to bear on.

The next process is to harden the faces of the mandrels, this being done to protect the centre holes from damage, and to reduce friction when the mandrel is revolving in the lathe. After being hardened, the mandrel is mounted in the lathe and finished by being turned or ground parallel for a suitable distance (according to the length of the work) to the standard size, the remaining portion being left a little in excess by a gradual taper. This slight increase in diameter serves to secure the work when the mandrel is forced into it.

It is very important to test the truth of the mandrel both *before* and *after* the work is mounted. Too much care cannot be given to this particular by apprentices and students. Mandrels, as a rule, are caused to revolve eccentrically for one or more of the following reasons:—

(a) By neglecting to protect the centre hole when the mandrel is driven into the work.

(b) By forcing the mandrel into a bent or otherwise irregularly shaped hole.

(c) By omitting to properly lubricate the poppet centre.

In order to protect the mandrel centre from being distorted, lead or copper hammers are used. Deep holes which have a slight bend are straightened before the mandrel is inserted, by the use of a lead lap and the usual emery and oil. Wherever it is practicable, the lap is placed between the lathe centres, and the object to be lapped is moved backwards and forwards longitudinally over the lap, whilst the latter is made to revolve at a high speed.

Improper lubrication of the loose headstock centre is perhaps the most frequent cause of trouble. Experience alone will teach the student how to manipulate the loose head poppet centre so as to reduce friction without sacrificing the true fitting of the mandrel between the lathe centres.

This observation, of course, equally applies to all turning, where sufficient heat is generated by the cutting tool to cause the work to expand. The amount of expansion depends upon the depth of cut, upon the speed of rotation and the rate of feed, and upon the amount of lubrication of the cutting tool.

When rods or shafts are being turned, constant attention has to be given to the loose head poppet, lest the work should expand, wear

away, and fire the centre point of the loose head poppet. We will now consider a few of the more important types of mandrel.

Expanding Mandrels.—Such a mandrel is shown in Fig. 150. It will be seen that the rotation of the screw collar causes the split pieces to travel along the taper piece, thus expanding the mandrel.

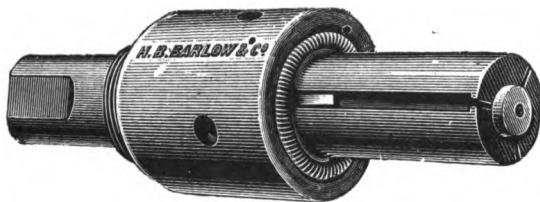

FIG. 150.—Expanding mandrel.

- (1) No hammering required, and work easily fixed and removed.
- (2) Work more firmly held and more uniformly supported.
- (3) A less number of mandrels required to fit all holes in a given range.

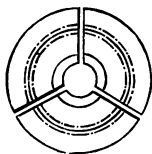

FIG. 151.—Expanding mandrel.

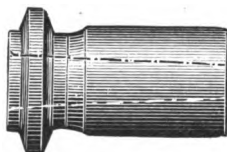

Fig. 152 shows a flange mandrel that can be bolted to the face plate of a lathe; it has stepped dies, so as to take two diameters of work. The dies are prevented from turning on the taper spindle by three keys, as shown in the figure. Fig. 151 shows a split die which is made of steel, and has a range of expansion suitable for taking work whose diameter is not more than $\frac{1}{32}$ in. off standard size.

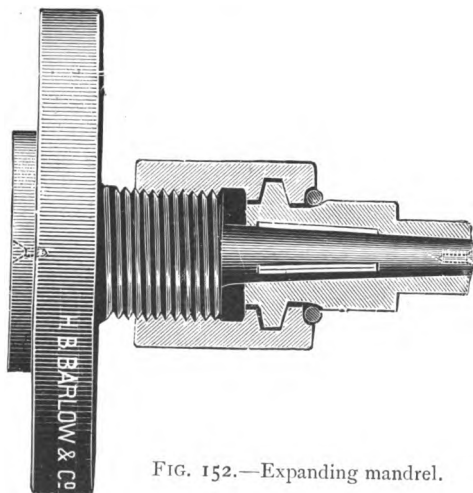

FIG. 152.—Expanding mandrel.

Screw Mandrels.—

These are used to support work which has been previously threaded. They are provided with a fixed shoulder, against the true face of which the end of the work is placed, or a loose collar may be slid on, against the face of which the work rests. They are made to suit all standard screw threads, and for special work as required (Fig. 153).

If good results are to be obtained, the "fit" between the work and the mandrel must be accurate, and the face of the shoulder truly turned.

These mandrels are employed to hold screwed pipe flanges and similar work, also in repetitious practice of machine-tool building high-class parts.

EXAMPLE.—Small chucks and face plates may thus be machined and stocked in quantities, instead of having to wait until their respective lathes have been run and tested.

Deep holes of more than 5 in. diameter are usually chambered, so that parallel mandrels are not needed.

It is the practice in such work to fix two collars on a stout shaft at the proper distance apart and turn them to the required dimensions. This type of mandrel is frequently employed to support small engine cylinders when the flanges are being turned.

Straightening and Centering Press.—A very useful appliance is represented in Fig. 154, combining a pair of adjustable centres and a straightening press.

The shaft to be straightened is placed between the centres, revolved by hand, and the bends chalked in the ordinary way.

It is then placed on the vee blocks underneath the press screw, and straightened according to the markings. The vee blocks are adjustable so as to suit long or short bends. Instead of the centres being actuated by a screw, they are fitted with spring plungers, so that the shafts may be instantly inserted or removed.

Mandrel Press.—Mandrel presses of the type shown in Fig. 155 are now much used on light work with very satisfactory results. There are several advantages to be gained in forcing a mandrel into the work by means of a press. The pressure is always along the axis of the mandrel, a very important thing, especially with long slender mandrels. Again, the pressure in this case being gradual, there is much less tendency to burst the boss of a wheel or pulley than is the case when the mandrel is struck with a hammer or mallet.

Hydraulic presses are often used for inserting and removing large mandrels.

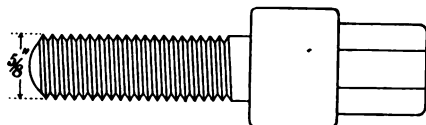

FIG. 153.—Screw mandrel.

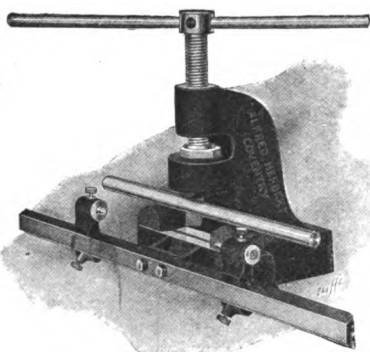

FIG. 154.—Straightening centre press.

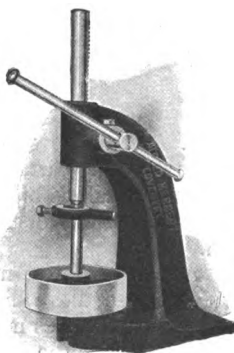

FIG. 155.—Mandrel press.

Uses of Stays to Lathes.—Lathe stays are used to support work while it is being turned or screw-cut, or when boring long shafts, etc. There are four distinct types.

1. A collar "stay" is shown in Fig. 119 (see Whitworth Lathe). This is useful to support the end of a spindle or shaft while being bored. The essential part of the stay is that the centre of each hole in the collar is in perfect alignment with the lathe centres.

The end of the shafts to be bored are bevelled to the same taper as the hole in the collar, and when the stay is used the collar is passed over the centre of the lathe, and the stay at once is self-set. A collar stay therefore is very useful in supporting light work.

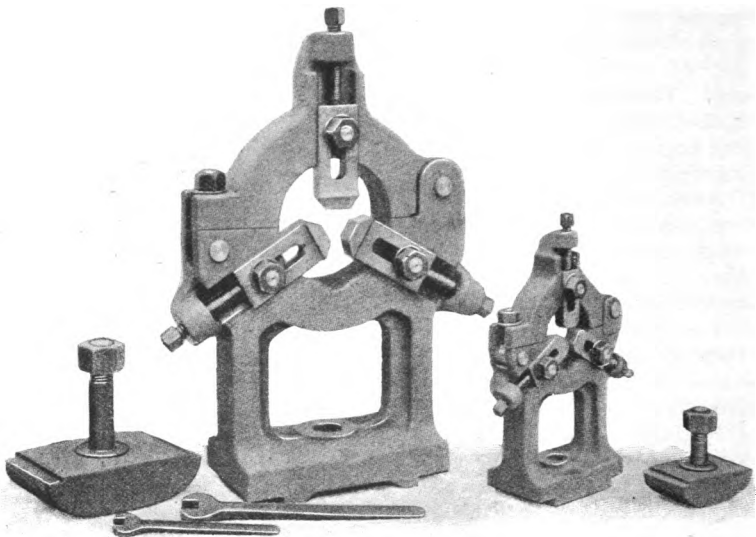

FIG. 156.—Movable or centre stay.

2. A movable stay is shown in Fig. 156, which has three adjustable dies, two being carried in the lower part of the stay, and one at the top. The upper half is hinged, so that work which has to be removed can be replaced without disturbing the setting, by simply releasing the locking pin.

Another form of movable stay is one of cast-iron uprights and base, with wooden dies which are adjustable to suit different kinds of lathes. By placing the dies next the work, much larger diameters can be accommodated, since the width between the uprights is limited.

EXAMPLE.—A piece of work is to be bored after turning; the stay will take 11 in. between uprights, but the part to be supported is 12 in. diameter.

Let the stay casting be as follows: uprights $3\frac{1}{4}$ in. wide, 11 in. apart,

with $\frac{3}{4}$ in. slots running vertically, the distance between the centres of slots being $1\frac{1}{4}$ in. Dies must be cut to fit the work, and four bolt holes marked through the stay slots for each half of the die.

Very heavy work will require wedging up, both dies being kept in contact. The lower die is held by passing wedges between its base and the lathe bed.

The upper die should be kept in position by wedging wood on the top, between the die and an overhanging ledge of metal cast at right angles to the uprights.

The dies are best cut from hard wood, but good well-seasoned pine answers satisfactorily if not hammered or allowed to warp.

3. Travelling stays or back stays are used to support the cutting tool along its journey, being carried by the saddle to which they are

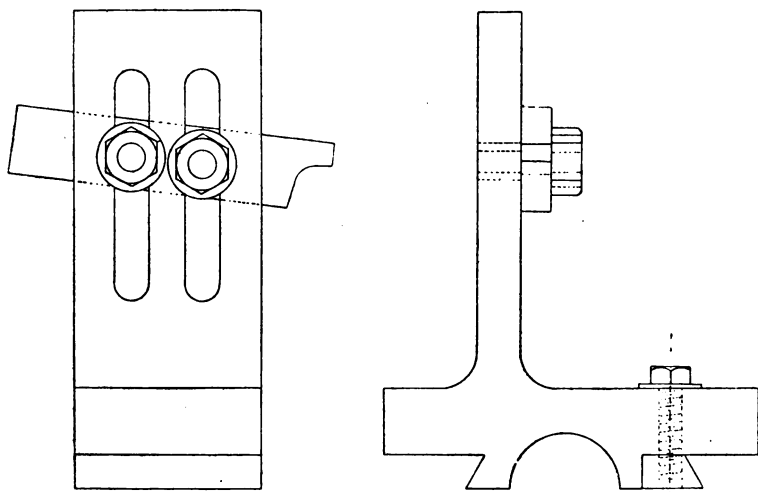

FIG. 157.—Travelling finger stay.

fitted by scraping, and secured by vee strips and set-screws. Small spindles and screws are conveniently turned or cut by the use of a "finger" stay shown in Fig. 157. The die or finger, as it is called, may be a right angular notch to suit various diameters of rods, but a better plan is to drill a hole and cut away the lower portion sufficient to leave a substantial radii of the work to be supported. There is, however, a limited use to this type of stay, as it is too weak to support substantial cutting.

Fig. 119 (4) illustrates a back stay used with hard wood dies lined with steel; the dies are interchangeable to suit various spindles and shafts, and the stay is adjustable vertically and transversely.

Some makers prefer a cylindrical column on to which the upper half of the stay is passed and retained by a set-screw; heavy cutting with coarse traverse is found too much for this design of stay, though for

thin shafts, where the amount to be removed is slight, this is a convenient and easily adjusted stay.

Large shafts are frequently turned by three cutting tools acting at equal distances around the shaft's periphery. The tools are carried in holders which are actuated independently; one tool roughs out the shaft, another reduces it nearly to size, while a final cut is taken by a scraping tool. The steel used is of the self-hardening class, which permits of a coarse traverse and much increased speed.

Since the head carrying the tools is secured to the saddle, it forms a compact mass and is capable of attacking the metal with much more ease than is the case when the cutting tools are simply carried in the slide rests. At a convenient distance from the cutter head a travelling stay fits the shaft, thus keeping it in a uniform position, as near the cutting tools as is possible.

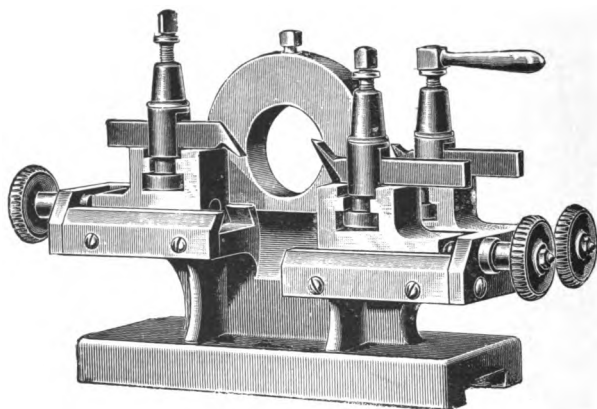

FIG. 158.—Special rest.

Shaft-turning Rest.—A special rest for shaft turning is given in Fig. 158. This portable rest can be secured to any lathe of a given height of centre, and is fitted with three tools, each of which may be operated independently by a screw and slide.

Two Tools roughing down.—The two leading tools rough down the shaft, one of these being inverted to meet the cut.

This is obviously good, because where a single tool is employed the cutting force is all on one side of the lathe centres, but by the above method the cutting forces are balanced.

Finishing Tool.—The “following” tool is made with a broad nose, to take just a scraping cut, which leaves the shaft beautifully smooth and true.

Travelling Stay.—Forming a part of the rest is the travelling stay, which slides over the turned shaft close to the finishing tool. The stay is important; by it the alignment of the shaft is maintained between the lathe centres, the shaft is held up to the tools, and the vibration is reduced to a minimum. See also “Back Stay,” Fig. 119.

CHAPTER VIII.

BORING MACHINES.

Duplex Boring Machines.—Boring machines, like many other modern tools, have increased in variety, so that special forms of work may be easily set and tooled.

Two different types of machines are illustrated in Figs. 159–160, by Lee and Hunt, Nottingham. Taking Fig. 159, it will be seen that the boring bars have only a revolving movement, the cutter heads being stationary on the bars.

Here the work is mounted on the saddles, or carried in the two large cradles which are secured to each saddle. The cradles may be brought close together, or extended according to the length of the object to be bored, and the saddles traversed along the bed.

Each bar may be worked independently; for instance, one bar may be used to bore cylinder liners while held in the cradles, while the other bar may be engaged in boring the cylinders.

The cylinder liners held as above are thus self-set. Referring to Fig. 160, it will be noticed that there is a special feature, in that the two boring bars are placed at right angles to each other, the machine being designed to bore at the same time the large round bearing for the cylinder and the two bearings for the crank shaft in the bed of a gas or oil engine.

The large cast-iron boring bar revolves in an adjustable bearing in the headstock, and carries an automatic boring head, shown near extending end of the bar. The boring head is traversed by means of a screw actuated by the differential gear located at the opposite end of the bar.

The bar is driven by a worm and wheel, and is fitted with a face plate carrying a facing slide, which is used when machining the seating of cylinders. The steel boring bar, which is carried in the two upright bearings, is directly at right angles to the large bar, and has a similar feed motion to it.

The driving-cone shaft gives motion to both bars; but either bar may be set to work independently as required, and in this capacity resolves itself into a machine for an increased variety of boring work of both large and small dimensions.

Horizontal Boring Machine.—Figs 161–162 represents a cylinder-boring machine by Messrs. William Muir & Co., Manchester. In this machine the headstock containing the driving gear is mounted and

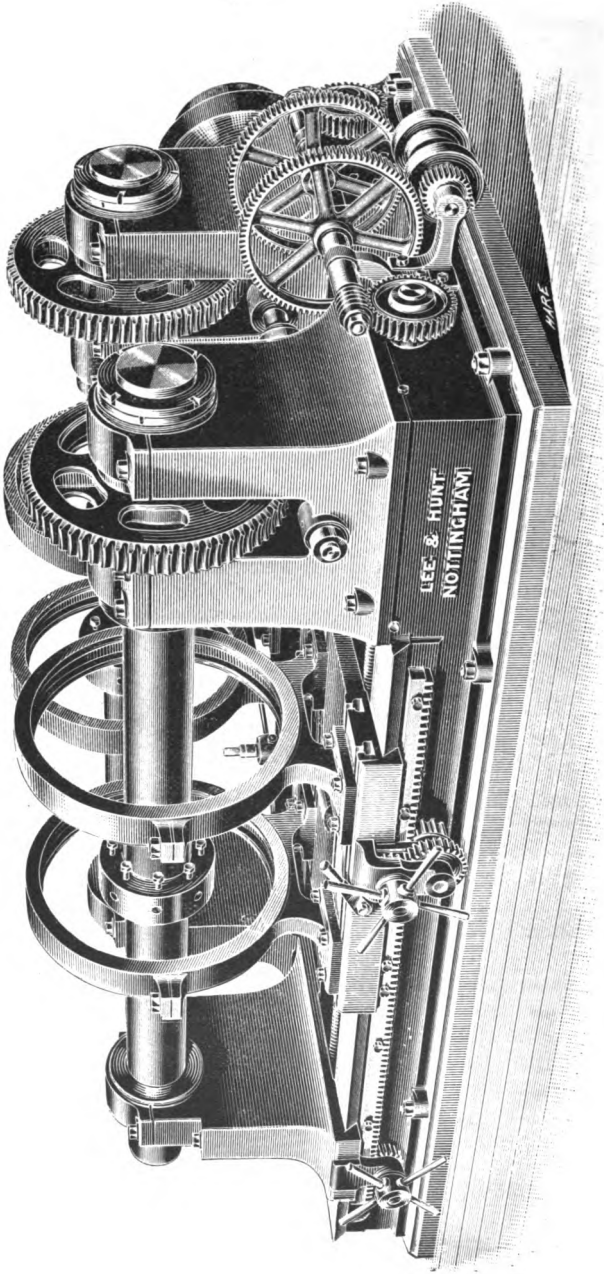

FIG. 159.—Duplex cylinder boring machine.

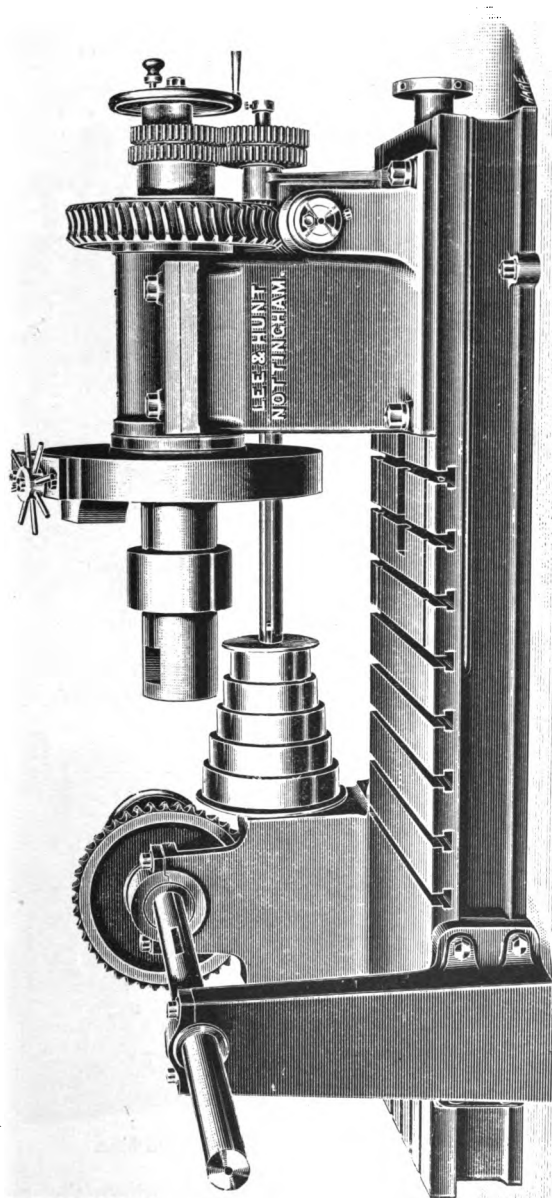

FIG. 160.—Duplex cylinder boring machine.

bolted to the bed. The boring bar is fixed to a flange on the driving spindle, and revolves with it.

When a cylinder is to be bored and faced, it is securely clamped to

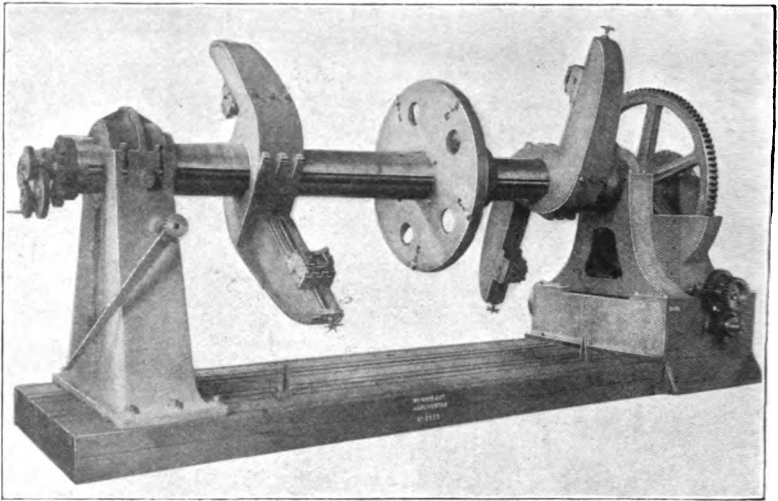

FIG. 161.—Horizontal boring and facing machine.

the machine bed, and the bar is passed through and secured in position. Then the "boring head," carrying the cutters, is traversed by means

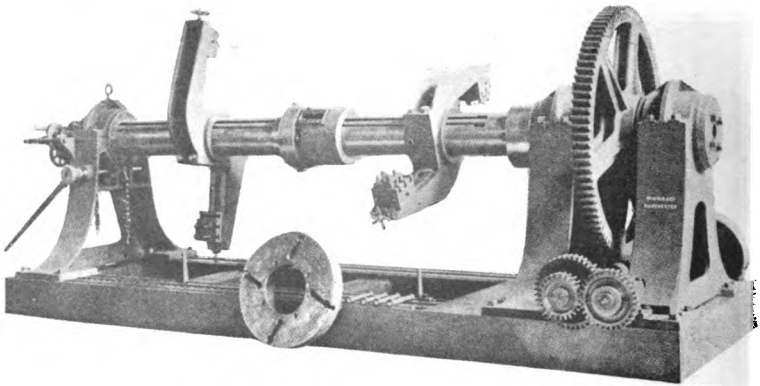

FIG. 162.—Horizontal boring and facing machine.

of the long feed screw through the cored hole where the piston is to work.

The facing arms are of the double-ended type, each being made

in two parts, and fitted with compound slides carrying the cutting tools.

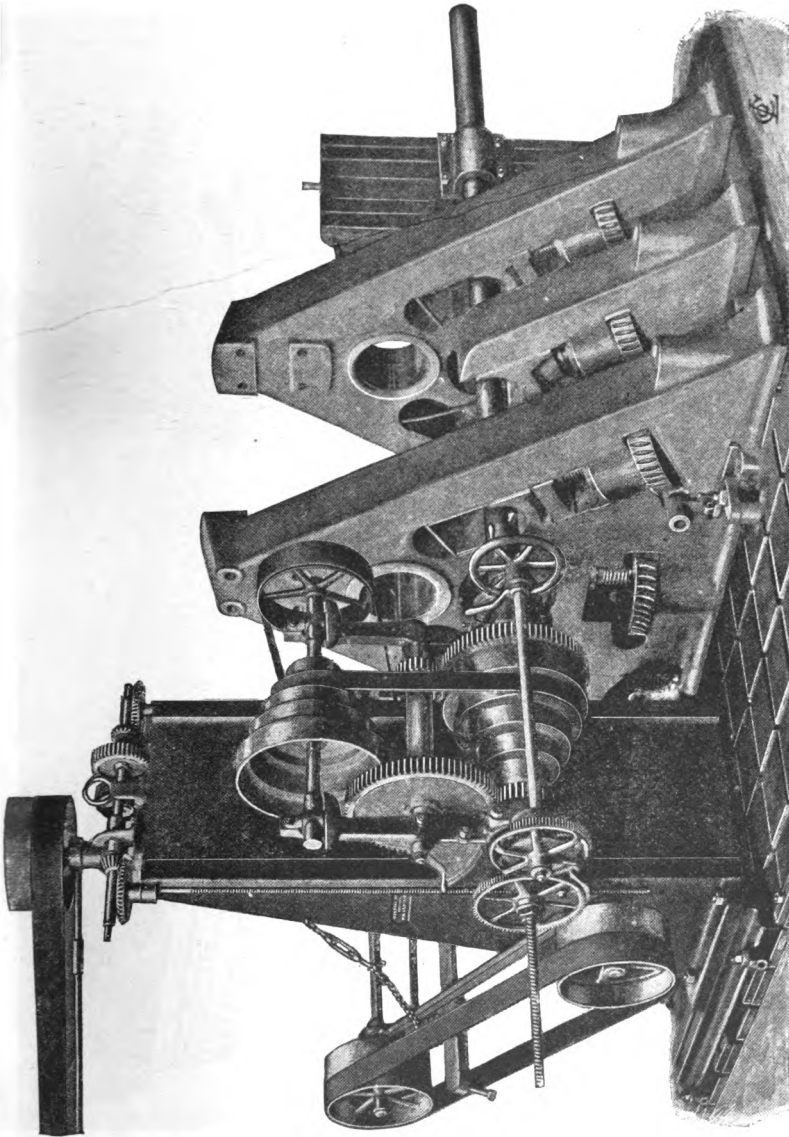

FIG. 163.—Floor boring machine.

By this arrangement, as the arms rotate, the slides are operated by means of the feed screws, which are provided with star wheels at their

outer extremity. It will be noticed that adjustable stops are placed on the machine bed, by colliding with which the star wheels actuate the

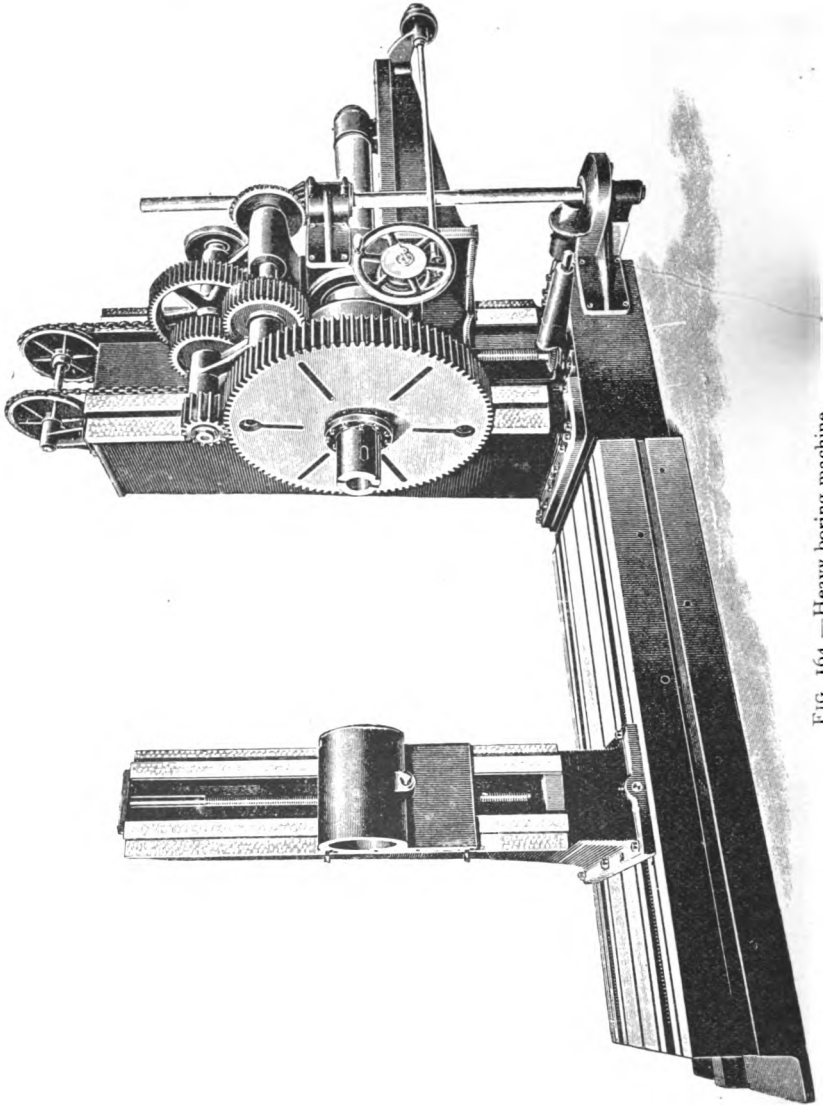

FIG. 164.—Heavy boring machine.

feed screws as they revolve, thus putting on the cut at each revolution of the arms.

Floor Boring Machine.—This illustration, from actual practice, gives

an excellent idea of the usefulness of these machines. Such work, as is shown in Fig. 163, may be set upon the floor plate, and the machine moved from one hole to another, so as to ensure their parallelism

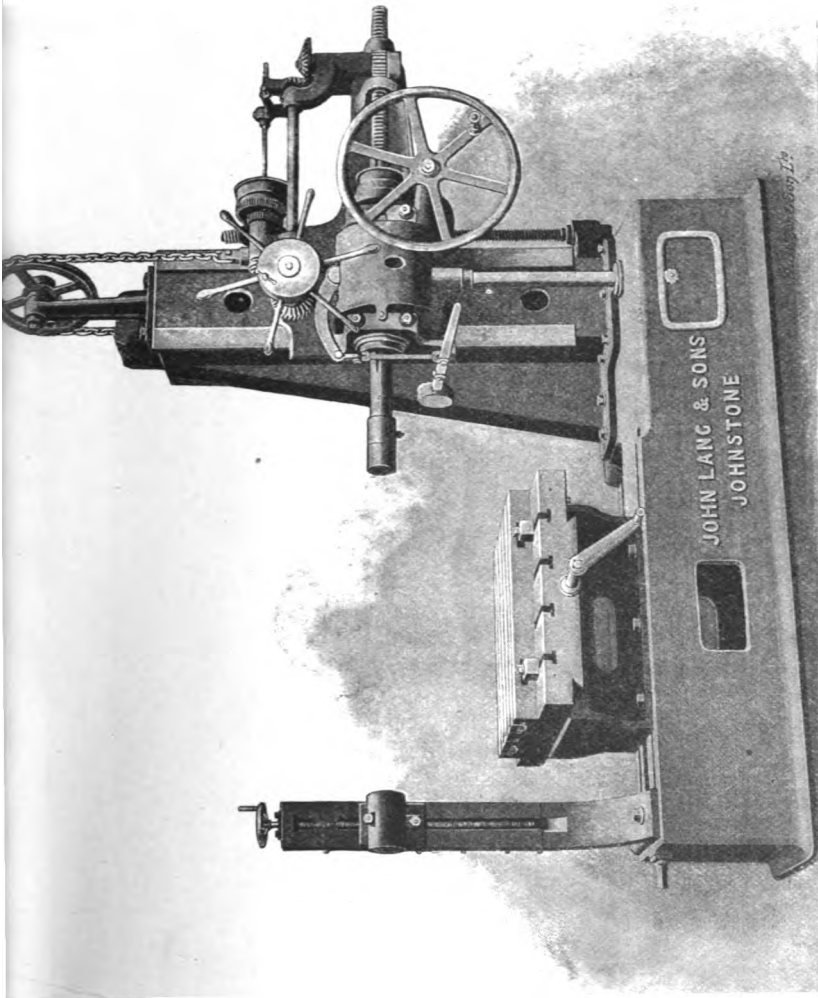

FIG. 165.—Horizontal boring and tapping machine.

without the necessity of re-setting the work. Instead of the belt drive, many of these machines are fitted with an electric motor. The machine is built by Messrs. Wm. Sellers & Co., Philadelphia.

Heavy Boring Machine.—Fig. 164 is a boring machine constructed

for heavy work by Messrs. Selig, Sonnenthal & Co. The spindle carrying the boring bar is 8 in. diameter, and has a feed of 30 in.

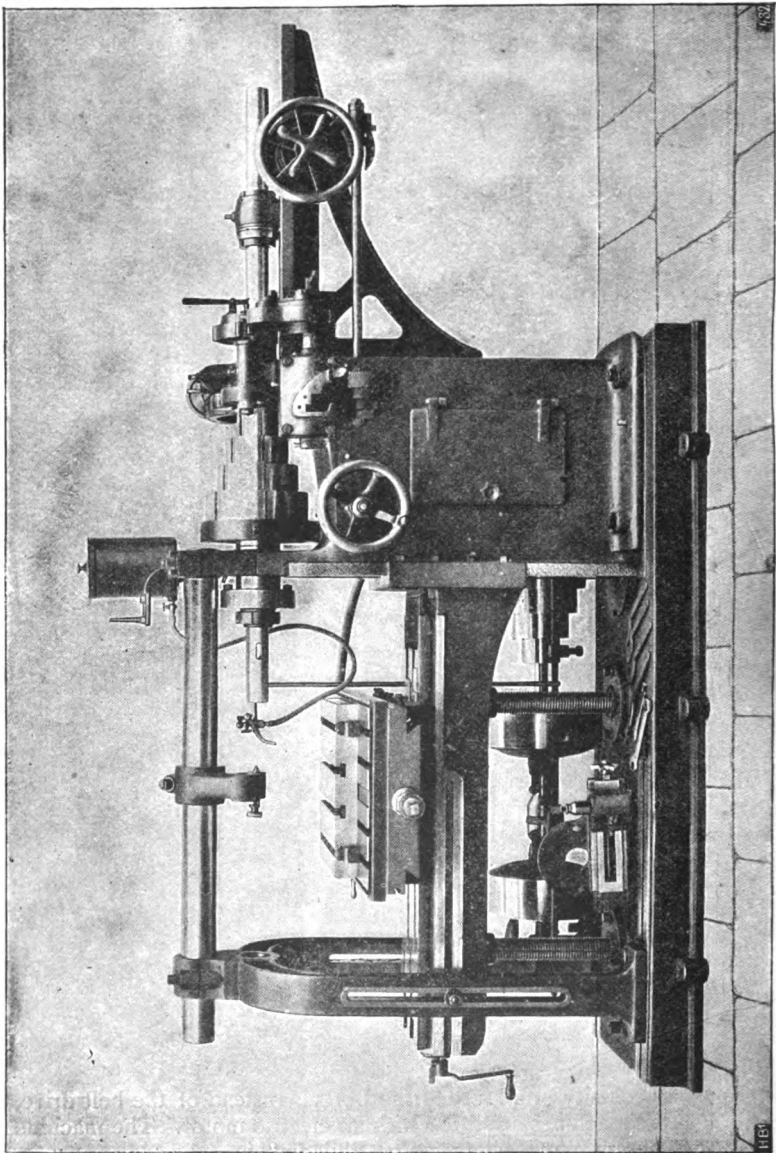

FIG. 166.—Horizontal boring and milling machine.

Work having centres 30 in. to 72 in., measured from the base,

and up to 14 ft. 6 in. long, can be fixed on to the machine table for boring.

Horizontal Boring and Tapping Machine.—A combined boring and tapping machine is illustrated in Fig. 165 by Messrs. J. Lang & Sons, Johnstone.

The feeding mechanism can be raised or lowered by power, and in this respect is similar to Fig. 164.

In this case the table has longitudinal and transverse adjustment. The machine carries convenience for drilling, tapping, stud inserting, and stud trimming, as well as for general boring-bar work.

The tapping is done on this machine with ordinary hand-working taps. By means of this arrangement, such work as engine cylinders can be bored for piston, and the flanges drilled and studs inserted without removal from the machine table.

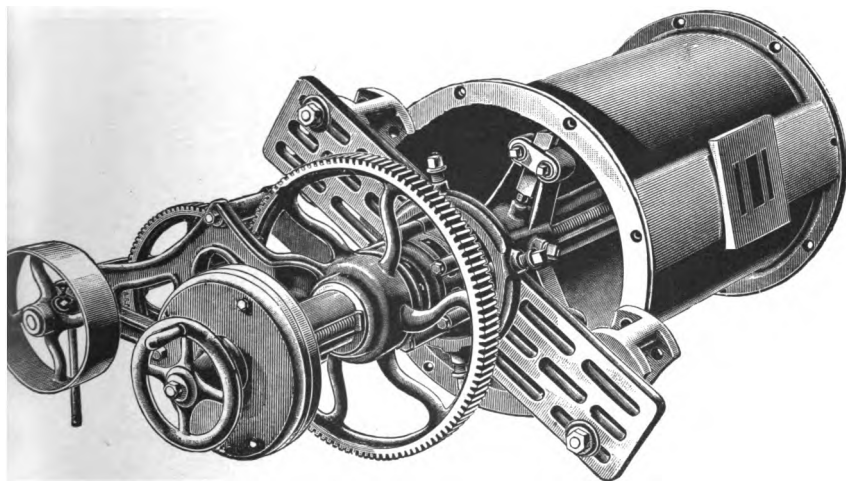

FIG. 167.—Portable cylinder boring machine.

Horizontal Boring and Milling Machine.—A machine designed for horizontal boring and milling is given in Fig. 166 by the Anglo-American Machine Tool Co., London.

The main table, which is gibbed to the body of the machine, has an automatic vertical feeding movement; also the transverse table has feeds in both directions. This renders the machine useful for milling the faces on pieces of work which are set for boring.

The engraving shows the machine prepared for circular milling, with the support for the end of the cutter mandrel carried by a swing bracket on a shaft above the boring bar.

The outer bearing to the boring bar is movable along the base plate, so as to give a rigid support when heavy cutting has to be done on short work.

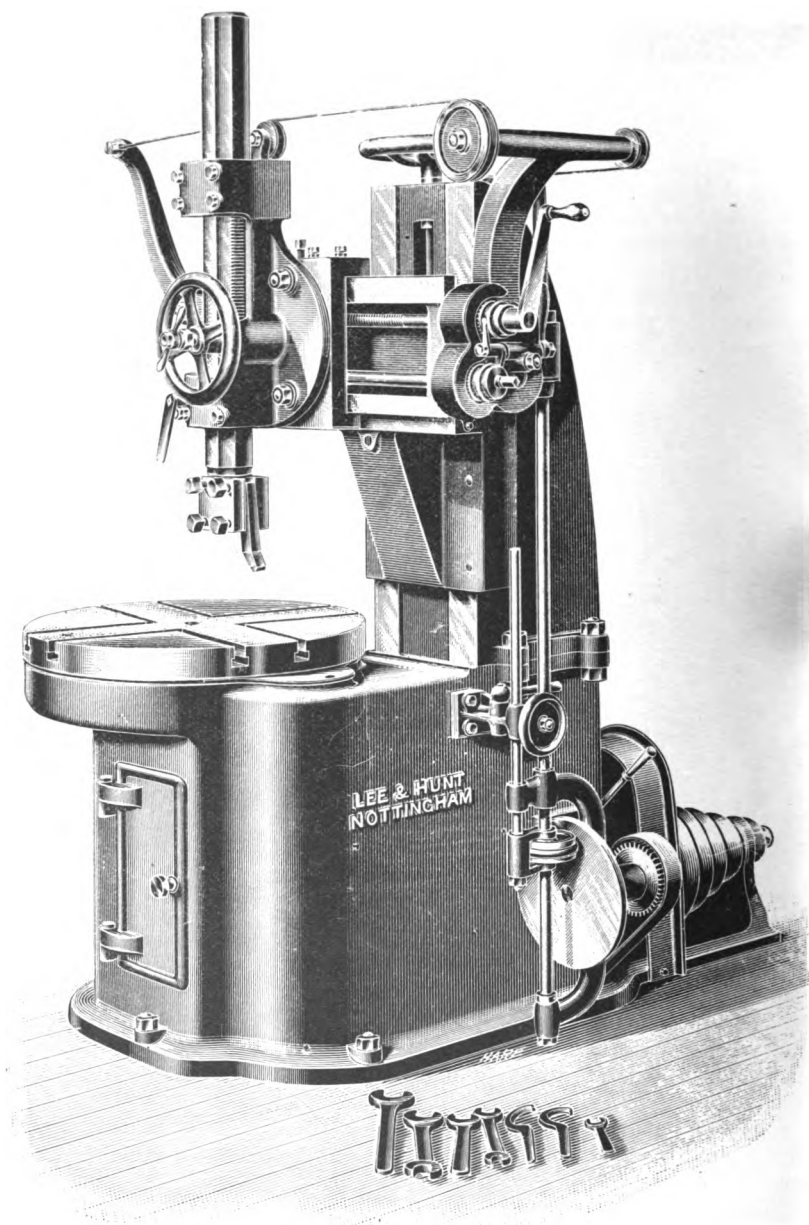

FIG. 168.—Vertical turning and boring mill.

Portable Cylinder Boring Machine.— Fig. 167 is a machine designed for re-boring steam-engine cylinders and similar work in place.

It is so constructed that the piece being bored serves as the bed or

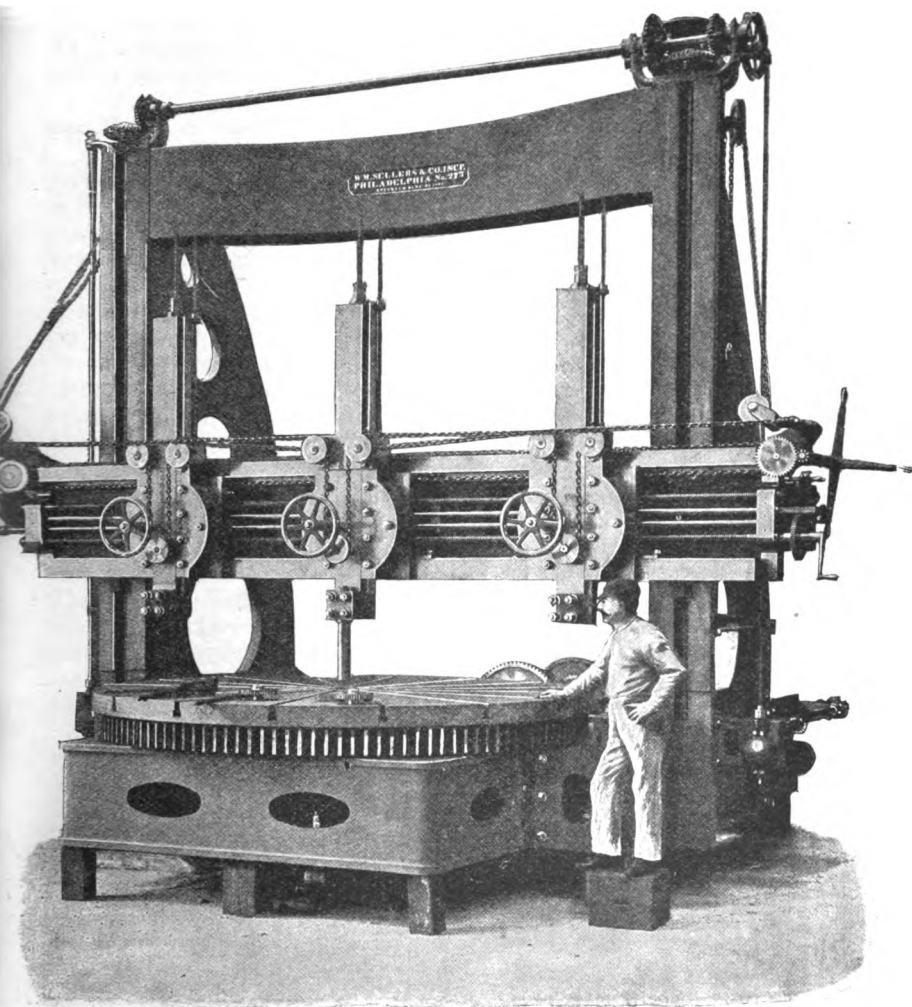

FIG. 169.—12-ft. Vertical turning and boring mill.

support of the bar. It is only necessary to remove the cylinder cover and piston, and the cylinder is bridged across the face by the large plate, which also serves as a bearing for the boring bar.

The cutter heads are fed by a screw in one side of the bar, and are

operated by the feed-casing on the end that contains the gearing, by altering the position of which two changes can be made.

The boring bar is driven by a train of gears, and can be worked by belt or hand power. At the opposite end of the bar, a self-centering chuck guides the path truly concentric with the stuffing box, while the plate is rigidly held at the other end by the clips and bolts shown. In those cases where there is no support for the chuck a second cross head is used.

Vertical Turning and Boring Mill.—Fig. 168 illustrates a vertical turning and boring mill.

These upright lathes are specially powerful and compact. The design is to give solidity to the table and tool, and to insure a steady but positive drive. The table of the machine is supported by an annular bearing, which extends to the circumference. In this respect an ordinary lathe, with a face plate of similar dimensions, is not so well supported.

The tool bar is massive, and is housed in two bearings which are adjustable. The bar has an automatic vertical traverse by means of a rack and pinion, while the transverse slide is fed by a screw.

By reference to the figure, it will be seen that a large disc is located on a pinion shaft near the base of machine. In contact with the disc is a leather-faced wheel; this is known as a frictional feed motion, and may be instantly released or reversed as required.

These mills are used in boring and turning cylinders, valves, pulleys, wheels, etc. Deep cuts and coarse feeds can be taken at high speeds without causing chatter.

12-ft. Boring and Turning Mill.—Heavy work of large diameter is turned and bored in a special boring and turning mill (in place of the facing lathes) in the American and in some British workshops.

A machine of the type illustrated in Fig. 169, made by Wm. Sellers & Co., Philadelphia, has capacity to turn a wheel or plate 16 ft. diameter. There are three saddles, each being provided with an independent feed movement. By this arrangement a wheel can be bored with a tool supported in the table bushing at one end, and carried by the central slide, while the two outer slides carry tools operating on the wheel's periphery. All the feeds are actuated by a mechanism from either end of the cross slide. The vertical slides, which are made of steel, have a stroke of 4 ft. When very large pieces are to be turned, the upright standards can be worked back automatically. Castings 9 ft. 6 in. deep can be admitted beneath the cross head.

CHAPTER IX.

LATHE WORK.

Screw Cutting Iron and Steel with Hand-Tools.—The art of chasing screws in iron or steel by means of hand tools can be acquired only after considerable practice. Fig. 170 represents defective screw threads which are sure to be imitated by a beginner.

Drunken Threads.—At A are shown threads almost like parallel rings, having a sharp crook on each thread as if in some way to compensate for the lack of inclination in the remaining part of the threads. Threads of this description are produced either by sliding the chasing tool at an irregular rate on the tool rest of the lathe, or by a seam in the iron (this latter is always disastrous to a screw, even when the threads have first been partially cut in a lathe with the aid of change wheels and a guide screw).

A double-threaded screw is sometimes produced. This is done by sliding the chasing tool too rapidly along the lathe rest, so that the threads appear as shown in Fig. B.

A correctly finished stud is shown in Fig. D. Hand-chased screws and studs are being replaced by screws and studs made in capstan, or chasing lathes, or in special screwing machines. Fig. C shows a stud turned and finished, ready to be chased, to fit a $\frac{5}{8}$ -in. Whitworth nut.

Tools required.—An elbow rest having a smooth and even surface; a diamond-pointed tool, *i.e.* a graver ground keen; a chasing tool having eleven threads per inch, are the necessary tools for work.

The graver and the chasing tool should be securely placed into their respective handles; and in order that the tools may be firmly controlled, the distance from point of tool to end of handle should not be less than 12 in. The chasing rest should be fixed a little below the centre line, and parallel to the work.

Chasing Screw Threads.—The first thing is to chamfer the end of the stud. Then look at the pitch of the chaser, and with the graver held hard on to the rest, try, by giving a slight but even twist to the

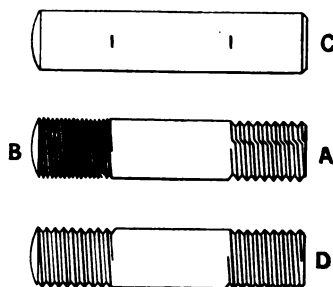
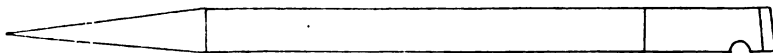
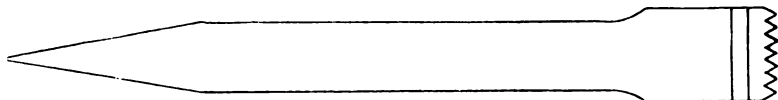

FIG. 170.—Stud to be chased.

wrist, to produce a spiral cut on the revolving work, which resembles the pitch of the teeth of the chasing tool. To do this effectively the first time is scarcely to be expected; but, when properly experienced, a workman can produce a spiral so near and so true that the chaser will follow the groove, and so make a threaded screw from its guidance.

The workman's right hand should grasp the loose poppet, while the left hand holds the tool by the handle. The pressure is given from the workman's shoulder, which should well cover the extremity of the tool handle. By this means the depth of the cut is regulated; and to a



Outside chasers.

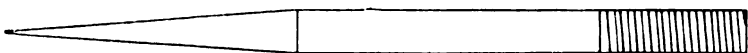
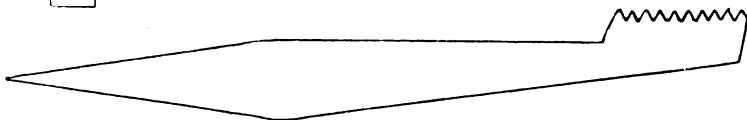

Inside chasers.

FIGS. 171-2.

certain extent, by a uniform movement of the body, the chaser is kept up to its cut as it traverses along. To assist the chaser, when making a start, a gentle pressure from the thumb of the right hand is often helpful. Good chasing depends entirely upon judging the sliding movement of the tool in combination with the rate at which the work revolves, and the inclination at which the cutting edges of the chaser is presented to the revolving work.

Each size of screw has a different number of threads per inch; therefore it is obvious that experience is necessary to enable one to chase screws creditably. Care must also be given to keep the tool

sliding parallel, so as to make the angles of the threads uniform, and not to reduce the diameter by taking repeated cuts without repeated measurement. A pair of broad-nosed calipers must be used to gauge the work, as it approaches a finish. It is absolutely necessary to gauge long screws, and to carefully reduce those parts which are of largest diameter as the work proceeds.

Chasing Screws.—The speed of the lathe varies with the diameter and the pitch of the screw. 120 to 160 revolutions for studs and small screws give good results. An additional support to the tool rest is

necessary for large screws, and may easily be given by fixing a bolt and nut vertically, either between the saddle slide or the top of the rest and the underside of the tool rest. Chasing is generally done in a simple lathe on work from $\frac{1}{4}$ in. to 1 in. diameter, but where best work, and where truth in the running is imperative, the screws must be cut in a lathe having a set of change wheels

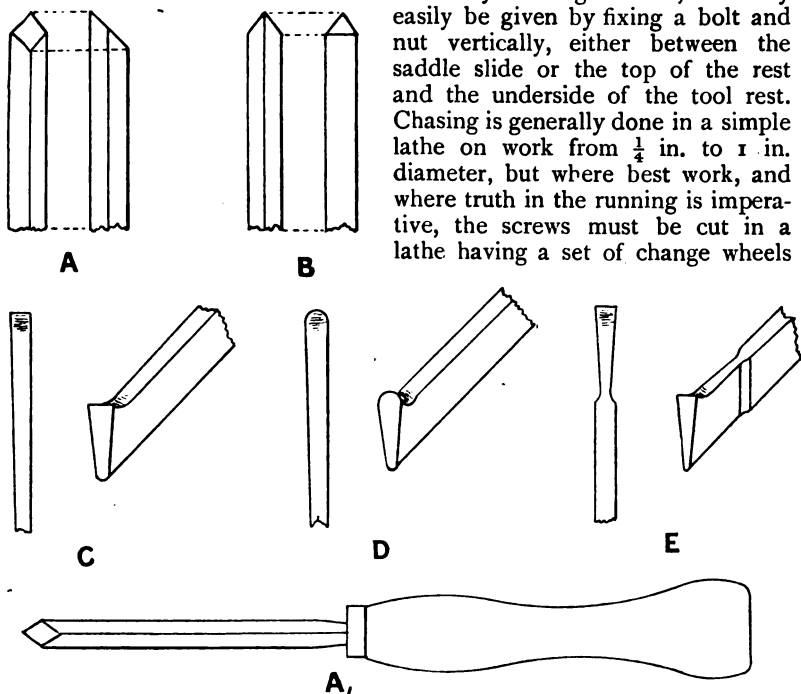

FIG. 173.—Hand turning tools.

and a reliable guide screw. Inside and outside chasing tools are shown in Figs. 171-2.

Hand Turning, Iron and Steel.—The chief forms of hand-turning tools are shown in Fig. 173. The graver or diamond point A, is the most useful: it has two cutting edges and two heels, and can be used equally well as a roughing out or as a finishing tool. A₁ represents the tool fitted to a wooden handle, which should be made with a flat end, as shown, to receive pressure from the operative's shoulder (see Fig. 170, Chasing Stud).

B is a side-facing tool, made from a triangular file. C, D, and E,

are square-nose, round-nose, and parting tools respectively. In using any one of the above tools, the heels must be held firmly down on the rest, so that a full control of the cutting edge is obtained. To a beginner this is not easy work, the tendency being to let the tool follow the work as it rotates, although its path is more or less eccentric.

Flat and convex surfaces are cut with tools similar to A and C; hollow surfaces are cut with D. The parting tool shown at E is used for cutting off the finished work; these vary from $\frac{1}{16}$ in. to $\frac{1}{4}$ in. wide, according to the size of the work to be cut off. Chasers are *not* provided with sharp heels, their function being to travel evenly along the rest (see Chasers, Fig. 171).

Cutting Angles.—The cutting edge of A is placed on the rest with its point downwards, and is moved upwards to the right or left according to the direction of the cut; while B, C, D, and E, have their cutting edges uppermost. A = 45° , B = 60° , C and D = 70° to 85° .

Brass Turning—Tools and Appliances.—Brass turning is done in three different kinds of lathes: (a) *turret lathes*, which are fitted with the necessary tools, each being fed automatically in turn; (b) *hand lathes*, in which the whole of the work is turned or chased by tools held in the hands of the operator; (c) *traversing lathes*, by means of guide screws, which are essentially screw-cutting lathes, and are either provided with “master screws” and a set of gears actuated by a lever, or by the ordinary change wheels.

There are two kinds of brass, “rolled” and “cast.” “Rolled” brass is usually made in rods of definite shape and dimensions, the sections being round, square, or hexagonal; the latter being used for hexagonal-headed screws. These rolled bars are usually homogeneous in structure, and soft to cut, and are true to shape to within $\frac{1}{20000}$ in. of accuracy.

For the above reasons, rods of rolled brass are used in “capstan” lathes, which are provided with hollow spindles, through which the rods may be passed and secured by one of the various chucks. By this device of hollow-spindle lathes, articles may be rapidly turned from solid stock, which otherwise would be cast from a pattern and then mounted in the lathe, each casting requiring a separate setting, which considerably increases the time in doing the work.

The cutting tools carried in “capstan” or “turret” lathes are now frequently made to fit the contour of the work, which method not only does away with measurement, but considerably increases the output, since the whole surface of the work is frequently being cut at the same instant. This will be seen more fully by referring to Capstan Lathes by Messrs. Jones and Lamson, and Messrs. Alfred Herbert (Chapter V.).

Plate Moulding.—Brass castings are made with as little metal to be removed as is consistent with the size and shape of the article required; it is also the practice to have the patterns so constructed that they leave the cores easily, and, to facilitate the moulding, plates are made upon which half a pattern is secured. True castings are thus obtained which require a minimum of tooling and hand dressing. These castings are held in a two, three, or four-jaw chuck, which may, or

may not, be self-centering, and tooled with capstan tools in a similar manner to the rolled brass (see Taylor's Spiral Chuck, Figs. 174, 175).

It is a custom to use fixed tools wherever it is practicable, and also to machine the various parts in great quantities; this method is not only much quicker in setting work, but the tools are only set when a change has to be made. It is, however, still the custom for some work to be turned and finished with hand tools.

Now brass, owing to its peculiar behaviour when cutting, is treated differently to either wrought iron or steel. The hand tools are different in shape and length, and are not held in the same manner as when turning iron or steel (see Hand Tools for Brass, Fig. 176). The rest is provided with two or three small holes drilled on its surface, into any of which a short taper-fitting pin may be inserted. This pin, standing above the surface of the rest, say $\frac{3}{4}$ in. or $\frac{7}{8}$ in., is used as a fulcrum for the side of the tool, while the hands are guiding the tool through a curved path, regulating the length and depth of the cut.

The tools are not provided with heels, and do not stand on the rest as in other metal turning. The rest is never placed so close to the work as to prevent the extremity of the tool from overhanging it. This is an essential point always to be observed in brass turning by the use of hand tools.

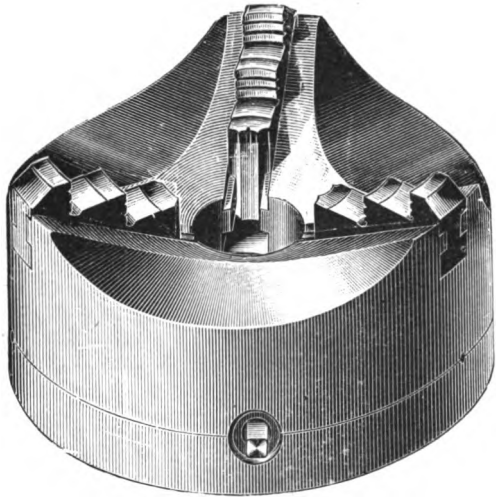

FIG. 174.—Universal three-jaw chuck.

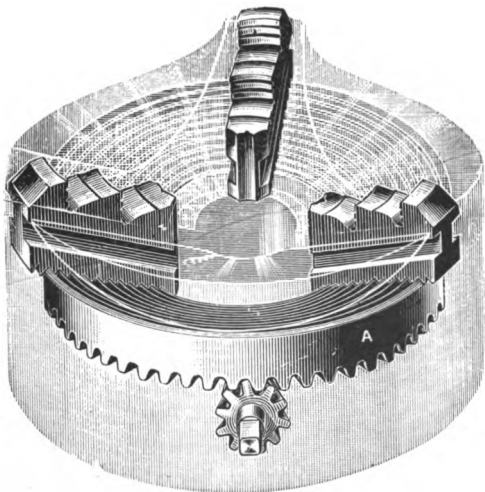

FIG. 175.

These tools may be divided into two kinds—those used in roughing out the metal and those used in finishing.

A roughing or ripping tool is shown at A, Fig. 176; the upper surface is quite flat, and the end or nose of the tool rounded. All surface work is first cut with the above tool; following upon this is the planisher D, D' or E, according to the shape of the piece operated on.

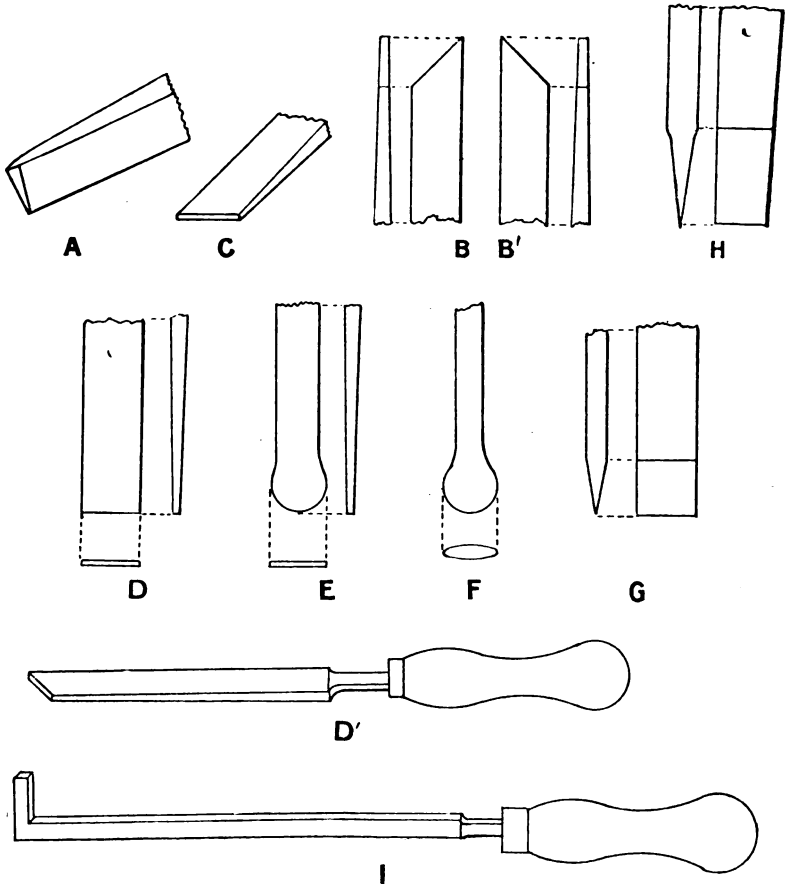

FIG. 176.—Hand tools for brass turning.

The cutting edges of the tools are dressed on an oil stone when the finishing cuts are to be taken. The action is more scraping than cutting, owing to the obtuse angle (85° to 90°) of these tools.

Side tools are shown at B and B' for facing left and right hand respectively.

Those parts of the work which are "fitted" are polished with (FF),

(O) or (OO) emery cloth—this is to remove every trace of marking left by the tools; while such parts as are to view, but which do not fit or work together, are finally burnished. A burnishing tool, F, gives a brilliant lustre wherever it is applied. After the turning is all done the tool F is pressed against the surface of the work as it rotates at a fast speed, with the effect that what was previously (comparatively) a dull surface is transformed into a highly lustrous one.

These burnished surfaces are preserved from being tarnished by giving to them a coat of "lacquer" (shellac varnish), which is applied with a camel-hair brush. It is essential that all surfaces should be rinsed in a strong solution of soap and water, so that all traces of grease are removed. After this, the parts are dried and then warmed, so that the lacquer may the more easily be fixed. A second coat is not always given; where however it is done, the first coat must be thoroughly dry before a second is attempted, as the lacquer easily turns lumpy.

Internal surfaces are turned with tools which are held on a supplementary tool rest (I). Chasing is also sometimes done in this way. It is obvious that deep holes cause more dip to the tool nose than shallow ones, and for this reason the rest I is useful. Accurate work to be done in this way requires much practice, but with the growing practice of turret and other self-acting lathes this skill is less called into request than where the former machines are in use. See Fig. 167.

Making Small Brass Screws.—Small screws in brass are turned directly from the rod in high-speed lathes, provided with hollow spindles. A suitable length of stock protrudes from the chuck. This is faced, roughed, and turned to correct size by different tools carried in a capstan. A fourth operation is that of screwing, this is effected by means of dies, which cut the thread at one traverse and then either open or reverse, according to the type of over-head arrangement.

A hinged slide is then lowered from the back shaft which, carries two cutting off tools, one operating at the front and the other at the back of the screw, the work of parting is quickly effected. By this means many small screws can be produced correct to gauge without any alteration of the tools.

Making Large Screws in Brass Work.—Steam, hydraulic, and other important fittings are screw cut in lathes having guide screws and change wheels. In such work the method of procedure is precisely similar to that when screw-cutting iron and steel, except that the brass work may be rotated much faster than the iron or steel.

Brass-finishing Machine.—The machine illustrated in Fig. 177 is for milling two facets on a piece of work at the same time, on a vertically supported slide.

When the tools are to operate together on a brass fitting, it is screwed down in position; and the cutters carried respectively in the two horizontal spindles are set revolving.

Each head stock on the bed of the machine has an independent longitudinal adjustment for adjusting the side cutters, while the vertical adjustment is obtained by manipulating the hand wheel beneath the body of the machine. In addition to this vertical movement there is a

transverse slide, carrying a capstan and a division plate which may be moved by a lever or screw according to the class of work required.

Small Lathe Work (Drilling). *Drilling and Boring.*—Small holes in circular iron castings are drilled and bored in the lathe in preference

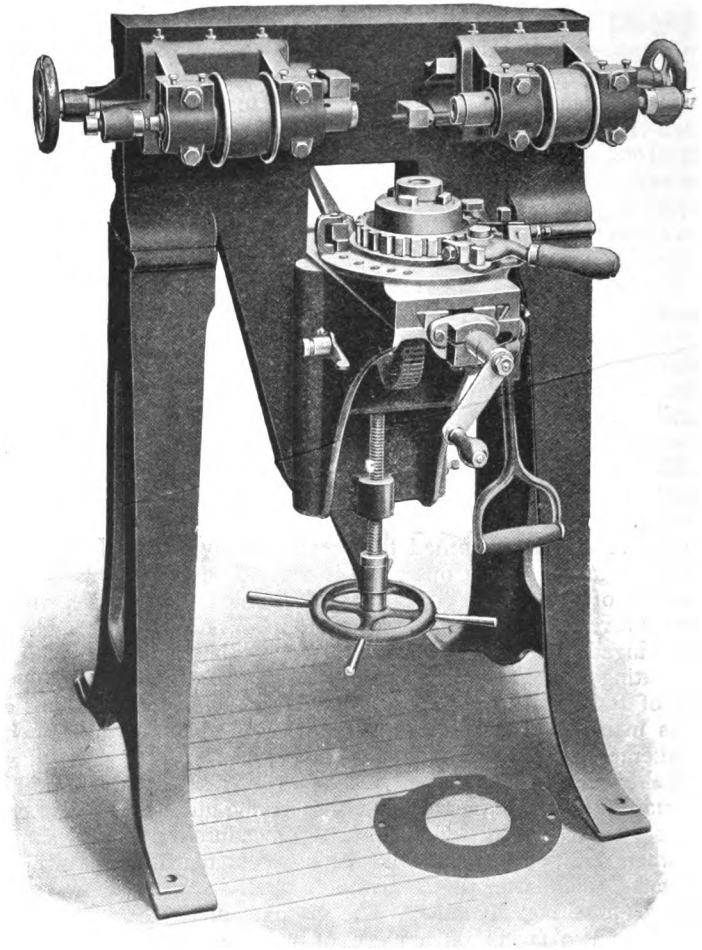

FIG. 177.—Taylor's brass-finishing machine.

to the drilling machine, owing to the fact that in the former case the work can be tested and controlled in a better way than is possible in the latter machine (unless a jig is used).

Self-centering jaw chuck.—The most general practice is to secure the

casting in a self-centering chuck, and with the following equipment the work is quickly done.

Pointed Drill and Following Drill—Reamer.—Assuming the casting to be solid, a finely pointed drill is passed through it by means of the loose head poppet, a second drill follows, and finally a fluted reamer. This only applies when the second drill leaves the hole true.

Boring Tool.—Any uneven portion is removed by a boring tool, which is fixed in the tool rest; this is also followed by the reamer.

Drill Rest and Drill Holder.—A drill rest is made from a rectangular bar of wrought iron, from $\frac{3}{4}$ " to $1\frac{1}{2}$ " square, according to the size of the lathe. A slot is made at one end to allow the drill to pass. A much better kind is one provided with a loose cap and two adjusting screws, which can be adapted easily to large or small drills.

How to use Drill Rest and Drill Holder.—A drill holder is made of square iron, and bent over at one end to grip the drill. After a piece of work has been set to revolve truly, the drill rest is secured in the tool box as near the work as is convenient, the drill point should be on the centre line, and passed *freely* through the rest. The drill holder controls the path of the drill to some extent, and is therefore held with a uniform pressure with the left hand, while with the right hand on the poppet wheel the drill is fed to its cut.

Making Spiral Springs.—Springs are made by winding suitable wire on to a steel rod or mandrel rotating between the centres of a lathe.

Closed Coil Springs.—The wire may be secured by being passed through a hole drilled near one end of the mandrel; or by the screw of a carrier placed for the purpose at the end of the mandrel, next the loose headstock.

Use of Guide.—When the wire is not very springy it may be satisfactorily fed without a guide by one operator, while another stops and starts the lathe. A much better arrangement is to pass the wire through a round hole, slightly larger than itself, drilled through a square bar which is held in the lathe tool box and traversed at a suitable speed. By this method the wire is guided accurately, and the tension has to be put on by hand.

Use of Vee Clamps.—Springs of larger diameter cannot be made in the above manner. The necessary tension has to be obtained by clamping the wire between two plates provided with a small vee notch, which are fixed in the lathe tool box.

Use of Clams.—Hard wire, such as piano wire, is only successfully wound into coil springs, when, in addition to the above apparatus, a pair of clams are used. The jaws of the clams are faced with vulcanite, so that they shall not damage the spring. The vulcanite is easily replaced when worn out.

Compact Spring.—The advantage of using the clams is that the wire is more thoroughly bent, and a spring of the same diameter as the mandrel is obtained. If clams are not used, mandrels of less than the proper size are necessary to compensate for the expansion of the spring, which occurs immediately it is released.

Coarse Springs.—Coarse springs are made in a screw-cutting lathe, the wire being fed through vee clamps held in the tool box, which is traversed at the proper speed by change wheels. Where it is imperative that the pitch of the coil shall be uniform, it is the practice to first cut a shallow groove of the correct pitch on the mandrel, *i.e.* to make a bed in the mandrel for the coil to lie in.

Sure Pitch.—The channel is of larger dimensions than the wire, so that the wire will not rub against the sides as it is being wound on under tension.

A further advantage in thus relieving the sides of the groove is that, by so doing, the friction is considerably lessened when the spring is being removed by screwing the mandrel out of it.

Ball Turning.—Balls may be turned from castings which have projecting stems on two opposite sides, by which they may be held, while roughing cuts are taken; the finishing being done in a chuck by a hand-cupping tool, after the stems have been removed. A better plan is to use a slide rest which can be rotated about a vertical axis by a worm and wheel fixed beneath it.

The diameter of the ball to be turned is decided by the distance that the point of the cutting tool is placed from the axis of the worm wheel. The cutting edge must be exactly on the centre line of the work, otherwise projections will be left on the finished ball, and, further, the tool will not cut nicely. In any case the ball must be changed about in the chuck, so that every part receives its full share of treatment.

Taper Turning.—Taper work may be turned in four different ways. No. 1. *Poppet Head.*—The most general is to have a transverse slide to the loose headstock, actuated by a screw fitted to the lower part, and passing into a nut near the base, but high enough to clear the lathe saddle.

No. 2. *Fast Head.*—In other lathes the fast headstock is fitted with movable screws, the guiding lugs being threaded to receive them. By having the screws exactly fitting the space between the “ways” of the bed any appreciable movement given to them is at once sufficient to throw the headstock out of alignment with the bed.

Neither of the above methods is commendable, as the work is not carried evenly between the points of the centres.

No. 3. *Swivel to Slide Rest.*—For short work the compound slide is made to swivel in its seating, while the headstocks are in no ways interfered with. The slide-rest screw, being fed by hand, is less able to take heavy cuts than when the saddle is fed automatically, and it also wears away the nut.

No. 4. *Former Plate.*—In turning some long tapers a former plate is secured to the back of the bed, against which a roller is fed or pressed by means of a lever and weight. The lever is secured to the transverse slide, and, since the screw is removed, the rest is directly under the control of the lever, and it is made to advance or recede according to the shape of the former plate. By this arrangement, parallel, taper, or any other irregular form can be turned to the pattern required without any special skill or attention of the operative.

Where this is not the case, the setting must be done in another way. The loose headstock is not required. Place a piece of parallel shafting truly in a jaw chuck, and *set the tool on the centre line*, and proceed as in the last example. The tool should be pointed, so that the actual length of travel can be clearly defined.

There are many lathes with no other provisions for taper turning than that obtained by swivelling the slide rest (which, of course, is adapted for short lengths only). There is an example of this in the Whitworth lathe (Fig. 118). Here both headstocks have projecting tongues, which accurately fit between the ways of the bed, in addition to which the fast head is provided with bolt holes (see end elevation, Fig. 118), through these the permanent fixity, and the correct alignment of the headstock is secured.

Gap Lathes.—Gap lathes are made with a loose part bridging the bed near the fast headstock. In such lathes large face plates may hold pieces of work which can be set and tooled. These, to be done in a lathe without a gap, would necessitate that the height of the centres should be considerable. These lathes should, like other lathes, be used mainly for the work for which they were designed.

It may be mentioned that few lathes behave exactly the same under heavy cutting when used with, and without, the bridge.

Taper Turning and Boring Gauges.—*Use of Gauge to set the Proper Amount of Taper.*—This is generally done with the use of a taper gauge (Fig. 178). The gauge is mounted between the centres of the lathe, and a tool fixed so as to almost touch it; then, by holding a piece of writing paper between the gauge and the tool, the rest is swivelled until the paper is gripped with equal tension at each end of the gauge A B.

How to originate a Taper without Gauge.—This can be done from a parallel shaft. In this case the amount of difference between the tool nose at A and the line B is equal to half the actual taper only (Fig. 178A).

By referring to the figure, it will be obvious that just as the tool leaves the parallel shaft by virtue of the rest being swivelled the diameter is increased by twice the amount shown: *e.g.* let the distance between AB = 4 in., and the taper be $\frac{1}{2}$ in. larger at B than at A, then the amount of difference measured at B will be $\frac{1}{4}$ in. It is here important to note that the height of the trial tool is the same as the height of the tool used in turning. Any deviation from this, either above or below it, will give quite a different result.

Position of Cutting Tool.—It is therefore best to fix *all* tools on the *centre line*. The above use of a parallel shaft applies when setting the lathe for taper boring; of course the shaft should be stout enough to keep rigid between the centres. To verify the setting two fine lines are traced round the shaft, where the taper is defined by absolute measurement, and a metal strip, equal in thickness to one half the taper, is used as a gauge.

True Alignment.—It is assumed that there is true alignment between the fast and the loose headstocks.

Exceptional Work (Figs. 179, 180).—In the absence of special boring machines or a lathe having a large swing it is then necessary to convert a small machine tool into a comparatively large one. An example of this is seen in Fig. 179, which represents a 6-in. centre lathe, converted into one of 13 in. centres by fitting two parallel blocks seen between the headstocks and lathe bed in the cut.

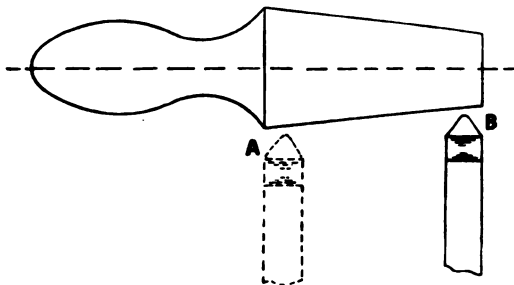

FIG. 178.—Gauge for taper turning and boring

It is only fair to state that this was not a temporary "rig up," but was used for turning up a steel crank shaft, and boring the engine bed bearings to receive the crank, in addition to boring the cylinder to receive a liner. This was exceptionally good practice for the engineering students, because all the clips and cutters had to be forged and adapted by them, as well as fixing the work in correct position. The fixing was

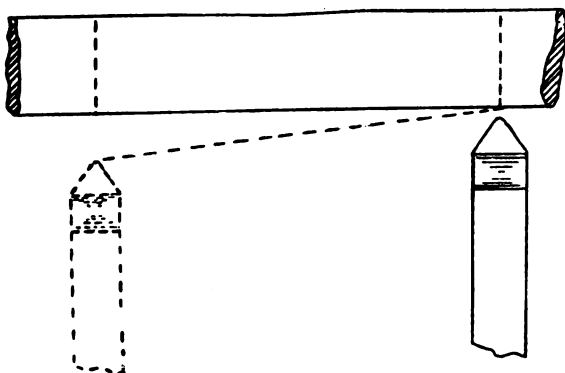

FIG. 178A

rendered the more difficult because the lathe saddle had no holes into which bolts could be placed, and, owing to the sliding or traversing of the saddle, the work could in no way be braced to the lathe bed. By referring to Fig. 180 it will be seen that the engine bed is of a larger area than the surface of the saddle on which it rests.

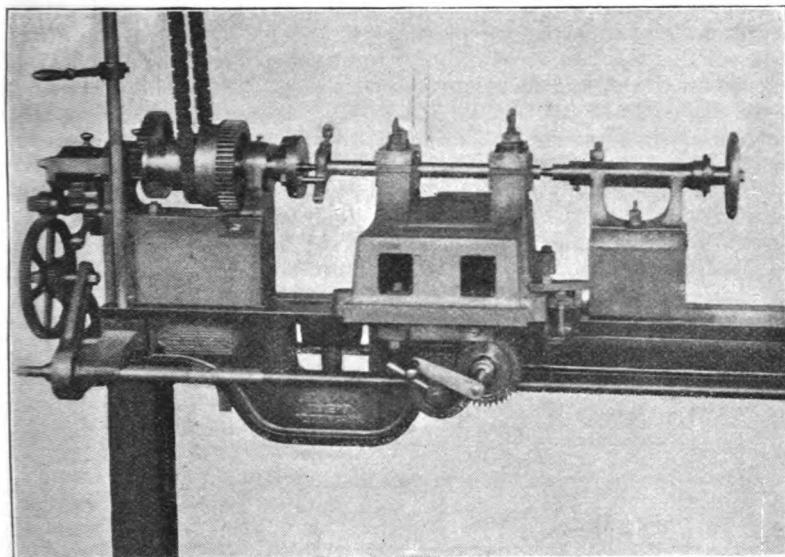

FIG. 179.—Boring crank-shaft bearings, for small engine.

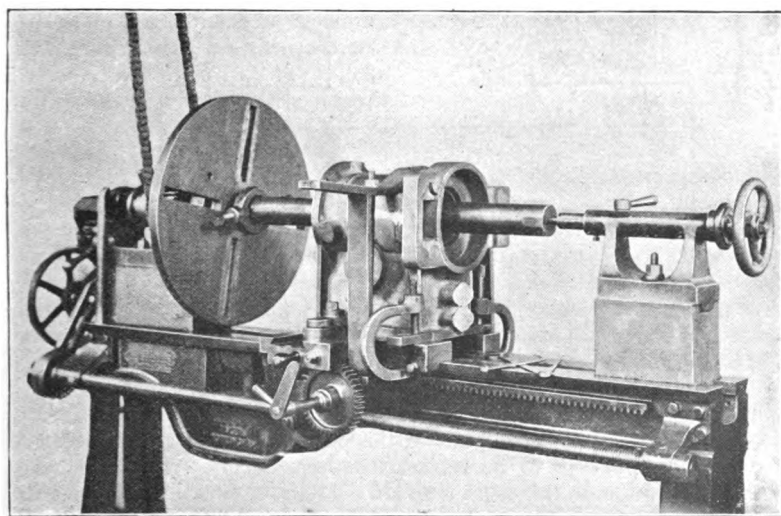

FIG. 180.—Lathe "packed up" boring engine cylinder.

The work, however, was successfully finished by taking light cuts and using a fine traverse. The bearings were of hard gun-metal.

Lathe Saddle Work.—Boring.—Many articles can be more easily set for boring and facing when resting on the lathe saddle, or held to it by a suitable jig than by an ordinary boring machine. The lathe may not be fitted with a turret or any special device, only with the jig which holds the work. If the spindle is hollow the end of the boring bar may be housed in it, which is a decided advantage, inasmuch as there is neither the necessity of a fixed centre, nor a face plate on the live spindle. This readily permits a casting to be faced with a left-hand cutter at the back of the boss as easily as the facing at the front of the boss with a right-hand cutter. A very short boring bar can be used, and with close supports the vibration is reduced to a minimum.

Cast-iron jig. Example.—Let a large number of cast iron brackets be required with $1\frac{3}{4}$ in. holes, and their bosses to be faced. Here we

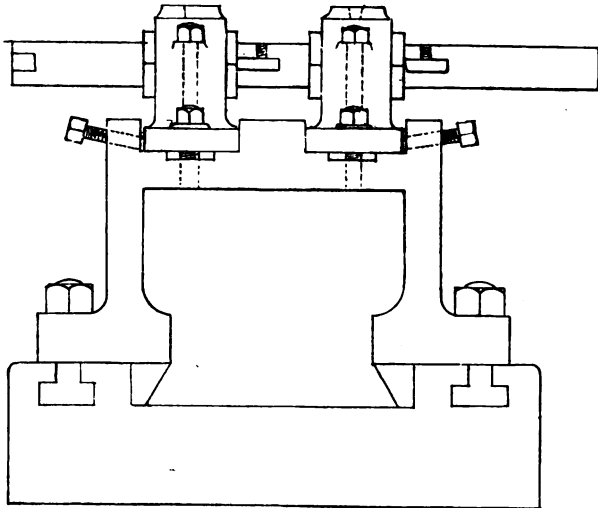

FIG. 181.—Lathe jig for plummer blocks.

have assumed the castings to be previously planed or milled on their bases and sides. The jig shown in Fig. 181 is suitable for the work, and is so simple that further explanation is unnecessary.

Duplicate Boring.—By having two sets of cutters the holes are bored simultaneously to within $\frac{1}{32}$ in. of finished size.

Two Bars.—The second bar carries one cutter only, and is therefore not disturbed, except to be replaced as wear occurs. The bosses are faced with cutters in the usual manner.

Shell Reamer.—A standard $1\frac{3}{4}$ in. shell reamer would be passed through the holes after the facing had been completed. Brackets bored and faced in this manner are alike to gauge, while the time occupied is but small.

Crank Shafts.—Crank shafts are forged and welded, or bent into

shape in a die (see Fig. 372). The method of making the shaft depends much upon the length of the shaft, and the number of throws or cranked portions required.

Single throw shafts are forged from one slab of steel, and the length extended, if necessary, by welding an additional piece. The same process is adopted for two or three throw crank shafts, but the slabs are welded at 40° to 120° respectively, *i.e.* for engine work. Shafts which are formed in dies are usually of small dimensions, these also being welded to increase their length, or when two, three, or more throws are required.

There is a division of opinion as to the best material from which cranks should be forged, whether good iron or mild steel, also, whether block, cranks, or bent cranks are the best. It is contended that bent cranks have advantage, inasmuch as the fibre of the material runs lengthwise down the arms and around the throws. The larger sizes are bent by a powerful hydraulic press, and the ends are forced inwards while the throws are being formed. By this system fewer heats are required, and the deterioration of quality in the material is much reduced.

When a crank shaft has to work in a limited space the webs are flattened to an elliptic form so as to be as stiff as possible. After bending, the bearings are turned, while in block cranks more than 30 per cent. in weight has to be cut away.

The Grantham Crank and Iron Company, Grantham, who make a speciality of bent cranks, take a 7-in. shaft of iron 14 ft. long, and bend it into a three-throw crank by the aid of hydraulic machinery in considerably less time than if the crank were forged from slabs of steel and welded. In large crank shafts the webs are generally formed from a solid block; in this case it is better not to attempt bending, neither could massive shafts be bent so that the arms or webs shall be a limited distance apart. This is obvious, owing to the curves necessarily formed by bending a round shaft to form a right angle.

Cast-iron cranks are (Figs. 182, 183) also used for driving, but when made of this material, the arm has a web in the centre which considerably strengthens it. For heavy driving a double web runs each side between the knave and crank pin boss. Mild steel castings, however, are stronger than cast iron, and are frequently used, in which case the webs are unnecessary.

High-speed engines of the horizontal type usually are constructed with a disc crank shown in Fig. 183. The disc is made of cast iron, and the crank pin of mild steel, opposite which a balance weight is

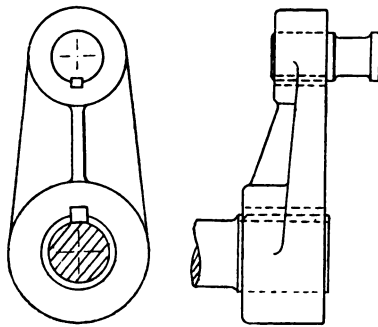

FIG. 182.—Cast-iron crank.

placed to compensate for it and the connecting-rod end. By this arrangement the centrifugal force is uniformly distributed, thus at all points an equal drive is obtained. Crank pins may be secured in several different ways, either by hydraulic or other pressure, in which case the hole is bored slightly less in diameter than the pin. The crank

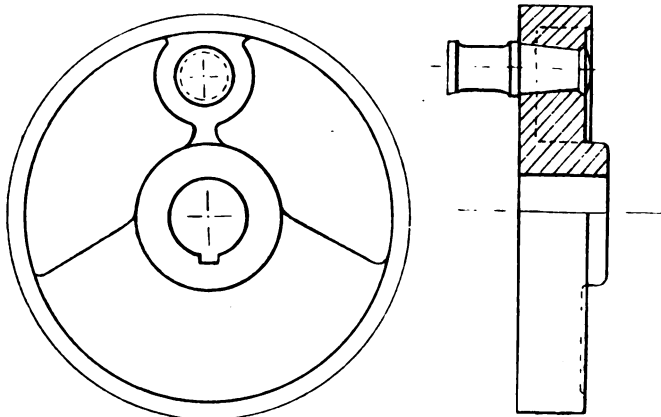

FIG. 183.—Disc crank.

is then heated to admit the pin a little way; the pressure is then applied. Treated thus, there is no need for riveting. Another plan is to turn the crank-pin taper, and then rivet the end over, further securing it with a taper-pin.

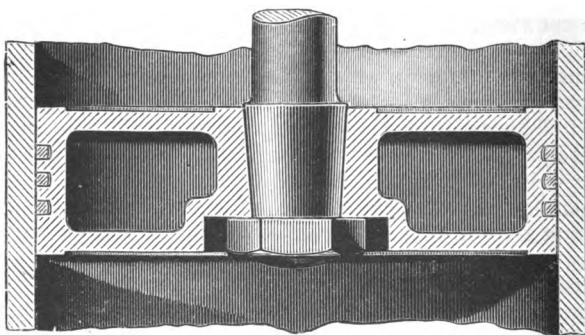

FIG. 184.—Section of piston and rings.

Pistons and Piston Rings.—Piston rings are made of cast iron or mild steel. Those of the former material are turned in the lathe; a tool holder containing two tools is frequently used for the purpose. By the use of tools of this class the rings are bored and turned at the same setting simultaneously. A cylinder is held to the face plate of the lathe

and the rings are machined and cut off by the aid of a parting tool. In the most recent practice several turning tools are cutting at the same time.

“Ramsbottom” rings for locomotive engine cylinders are usually $\frac{3}{8}$ in. in excess of the bore diameter, and are made of steel by rolling it

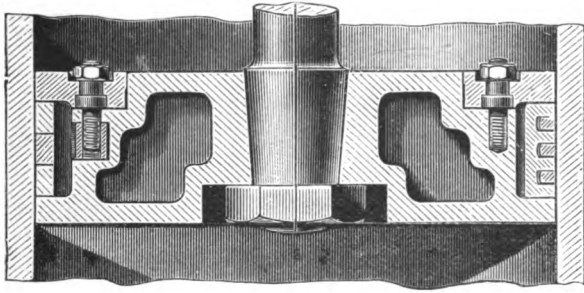

FIG. 185A.—Junk rings.

into the required section, and afterwards by winding it on a mandrel of suitable section.

Pistons.—A piston is a turned metal disc, broad enough to receive two or three rings. The diameter of the piston is slightly less than the bore of its cylinder; the pressure-tight joint being made by the piston rings, which are sprung into place, as shown in Fig. 184. The piston may be fitted to its rod in several different ways according to its purpose.

The locomotive-engine type of piston has a taper equal to 1 in 16 bored partway through it, according to which the piston rod is turned to fit, the end being provided with a nut and cotter-pin to keep it in place, or it may be like a crank-pin riveted over.

Junk Rings.—Junk rings are annular in shape and are fitted to the piston by bolts and screws. The piston rings are thus fitted into place without force (see Fig. 185A). The illustrations show different forms of pistons, but each are fitted with Ramsbottom rings, which are all made to standard sizes. There are three other kinds of piston shown here, but the expanding ring is fitted to all (see Fig. 185B C D E).

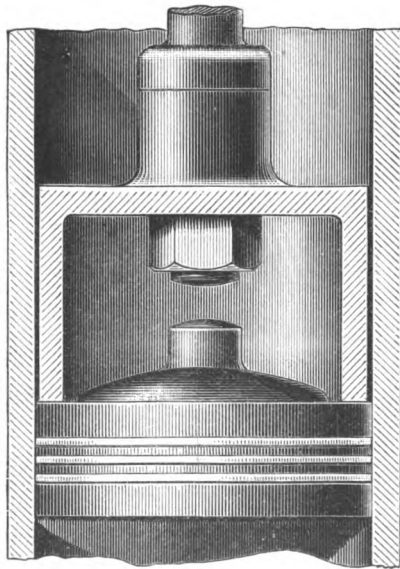

FIG. 185B.

Turning the Ovals on Locomotive Engine Cranks.—Figs. 186 and 187 are to show the arrangement by which the ovals on a two-throw

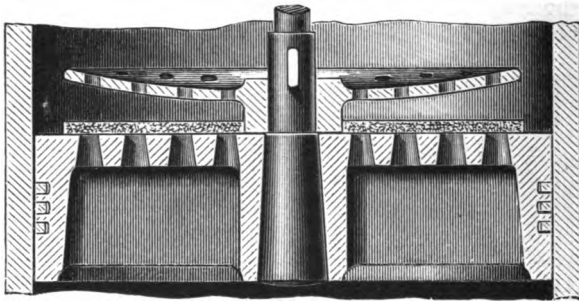

FIG. 185c.

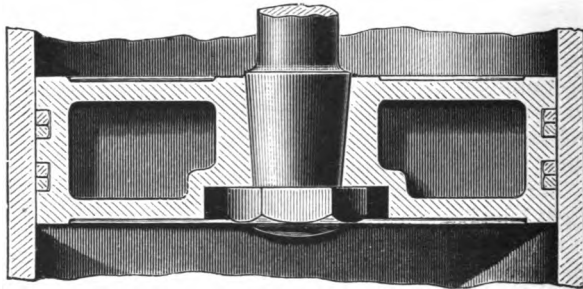

FIG. 185d.

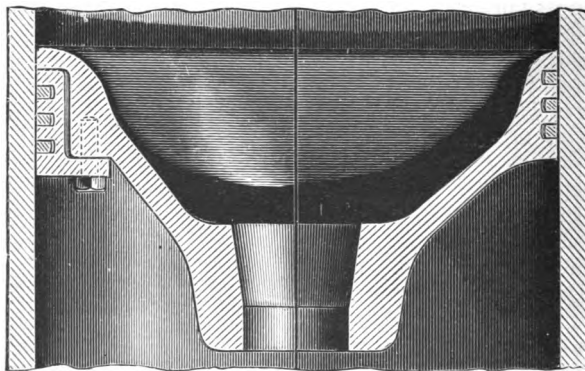

FIG. 185e.—Various forms of pistons.

crank shaft are turned to receive the strengthening straps. To obtain a uniform grip at all points the straps are shrunk on hot. Two crank shafts with the straps in place are clearly seen, one on the floor of the

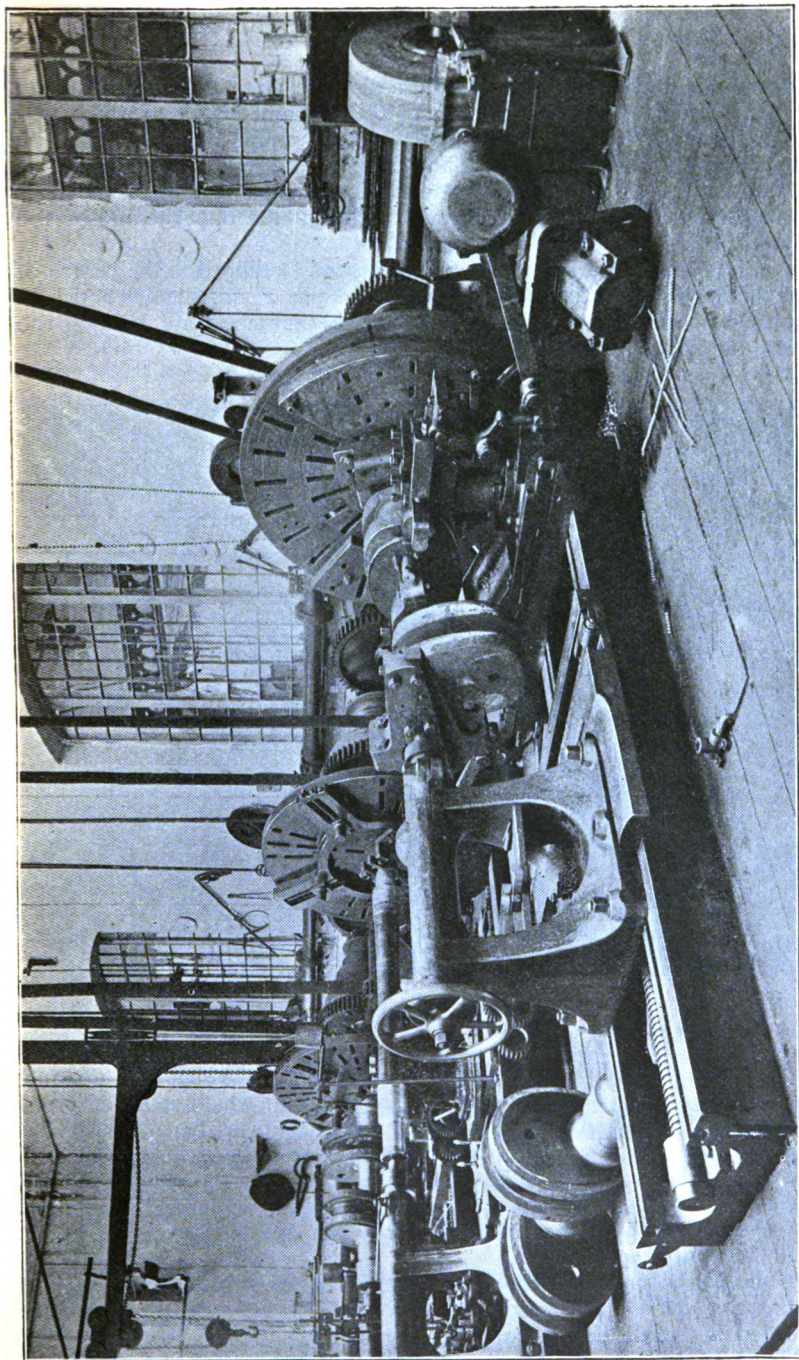

FIG. 186.—Turning the oval on locomotive engine crank shafts (Midland Railway Works, Derby.)

shop, and another in a lathe at a little distance off. The crank-turning lathe is provided with a face plate of 6 feet diameter, on to which two heavy weights are secured to balance the crank axle. A massive bracket is also bolted to the face plate of the lathe; the bracket is provided with a cap and screws to hold the crank in place while it is being turned. A similar bracket is carried at the opposite end of the shaft in which the centre is located.

The shaper plate is made in two parts, and is clipped to the centre of the axle; but in addition to this a steel pin $2\frac{1}{2}$ in. diameter passes through shaper plate, crank axle, and bracket on face plate, holding the axle in correct position.

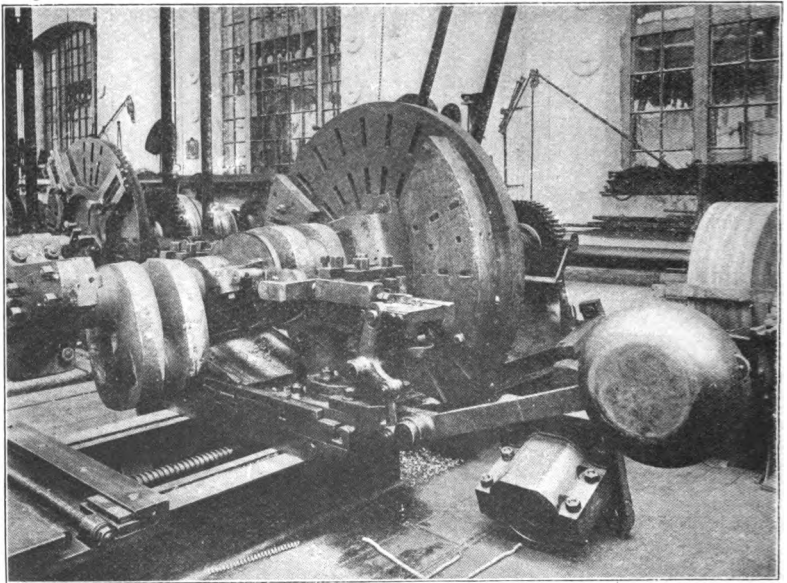

FIG. 187.—Turning the oval.

There is a slide rest at work on each side of the shaper plate, and each rest carries a cutting tool and a holder in which a roller 6 in. diameter is pivoted. Each roller is made to press hard against the shaper plate by a weight of 450 lbs. shown at the end of a system of levers. Thus when the lathe is set in action, since the rest screws are removed, the cutting tools are caused to make a reciprocating motion and thereby produce an exact contour of the shaper plate on the crank as the work proceeds.

Screw-cutting Lathes.—Screw-cutting lathes are made in a variety of forms, but all are provided with a master screw, which is generally called a "guide screw," or "leading screw." This screw is a very

important part of a lathe and should therefore be reliable, as it controls the rate of movement the tool works at whenever screws are being cut.

Guide Screw.—Besides the lathe having an accurately pitched guide screw, it is also essential that the workmanship is of the best possible kind and finish for every detail in the whole construction.

Now, a lathe is necessarily a copying machine, and it is therefore obvious that any work done on a lathe is accurate only to the same extent as the lathe itself is accurate in construction.

A modern lathe to be built such as above possesses the following features—

Bed.—The bed should be provided with broad surfaces and well stayed with webs at frequent intervals so as to be perfectly rigid under any load.

Fast Head.—The fast headstock carrying the driving spindle must be made with large bearings, and have a broad as well as a long base accurately padded, by scraping on its under surface, to the surface of the bed.

Steel Spindle.—The spindle should be of steel and provided with “necks” (bearings) of large diameter to ensure a steady and reliable drive for all kinds of work. It must revolve perfectly truly from end to end, and should therefore be hardened and finally ground true with emery wheels (see Fig. 192).

The Saddle.—The saddle or carriage must have a broad surface in contact with the bed and carry deep vee strips to ensure a full and even fit when traversing over heavy cuts of steel. The most recent practice is to gib the slides with an additional stay, usually made to a right angle.

Rules for calculating Change Wheels for Screw Cutting.—Screw-cutting lathes usually are fitted with guide screws $\frac{1}{2}$ in. or $\frac{1}{4}$ in. pitch. Whitworth lathes are supplied with change wheels commencing at 15 teeth and advancing by 5 teeth up to 150. Other lathes have 22 wheels advancing by 5 teeth from 20 to 120. There are two with 40 teeth for convenience of cutting screws similar to the guide screw.

Pitch.—The pitch of a screw is the distance that the screw advances in one revolution, that is the distance between the centres of two threads.

Rule 1. For calculating number of teeth in change wheels: Form a fraction whose numerator is the number of threads per inch in the guide and whose denominator is the number of threads per inch in the screw to be cut. Multiply this fraction above and below by a suitable number to get the teeth for the change wheels. The numerator so obtained represents the drivers, the denominator the followers. The wheel on the spindle end is a driver, that on the guide screw a follower.

EXAMPLE 1.—In a lathe having a guide screw of $\frac{1}{4}$ in. pitch, it is required to cut a screw with 6 threads per inch—right hand (Fig. 188).

Guide screw $\frac{1}{4}$ in. pitch or 4 threads per inch. Screw to be cut 6 threads per inch. Fraction required is $\frac{4}{6}$; multiplying this by $\frac{10}{10}$ we get $\frac{4 \times 10}{6 \times 10}$ or $\frac{40}{60}$ 40 and 60 for the number of teeth on the driver and follower respectively.

Method of Gearing the Wheels.—Having selected the wheels the

driver (40) is first put on the spindle end, then the follower (*i.e.* 60) is fixed on the guide screw. The socket stud and the quadrant are loosened, and a suitable wheel is put on the socket to gear with the 60; the stud is then secured, and the quadrant revolved until the teeth of socket or intermediate wheel engage with those of the driver (20). The quadrant is then fastened, and the gear is complete.

NOTE.—Care must always be taken to revolve the train by hand *before starting the lathe*. This will show at once whether the teeth are properly meshed and if everything is clear.

Rule 2.—When the screw to be cut has not a definite number of threads per inch, find a complete number of inches containing a complete number of threads, both of the screw to be cut and the guide screw.

EXAMPLE 2.—A screw of $\frac{3}{8}$ -in. pitch is to be cut in a lathe having a guide screw of $\frac{1}{2}$ -in. pitch.

Here the guide screw = 6 threads in 3 in.
and the screw to be cut = 8 threads in 3 in.

$$\text{Ratio} = \frac{6}{8} = \frac{3}{4} \times \frac{10}{10} = \frac{30}{40} = \frac{\text{driver}}{\text{follower}}$$

the driver being the wheel on the spindle end.

EXAMPLE 3.—It is required to cut a screw 16 threads per inch in a lathe having a guide screw of 4 threads per inch.

$$\frac{4}{16} \times \frac{5}{5} = \frac{20}{80} \text{ or } \frac{30}{120} = \frac{\text{driver}}{\text{follower}}$$

EXAMPLE 4.—To cut 28 threads per inch in a lathe with guide screw 4 threads per inch.

$$\frac{4}{28} \times \frac{5}{5} = \frac{20}{140}$$

Compound Train.—Here we require a wheel with 140 teeth, which is not supplied in all lathes, therefore a compound train must be employed.

$$= \frac{4}{28} \times \frac{5}{5} = \frac{20}{70} \times \frac{50}{100} = \frac{20}{70} \frac{50}{100} \frac{\text{drivers}}{\text{followers}}$$

EXAMPLE 5.—To cut a screw of $1\frac{7}{16}$ -in. pitch, guide screw $\frac{1}{2}$ -in. pitch.

$$\begin{aligned} \text{Here the guide screw} &= \frac{1}{2}\text{-in. pitch} = \frac{8}{16} \\ \text{Screw to be cut} &= 1\frac{7}{16}\text{-in. pitch} = \frac{23}{16} \\ \text{Ratio} &= \frac{8}{23} \end{aligned}$$

Bringing these to lowest terms—

$$\begin{aligned} &= \text{guide screw threads in } 23 \text{ in.} = 46 \\ &= \text{screw to be cut in } 23 \text{ in.} = 16 \\ &= \frac{46}{16} \times \frac{5}{5} = \frac{230}{80} \div 2 = \frac{115}{40} \frac{\text{driver}}{\text{follower}} \end{aligned}$$

Compound train for example 5—

$$= \frac{115}{80} \times \frac{100}{50} = \frac{115}{80} \frac{100}{50} \frac{\text{drivers}}{\text{followers}}$$

The preceding remarks can be summarised by the following formula:—

$$\frac{\text{Pitch of screw to be cut}}{\text{Pitch of guide screw}} = \frac{\text{Product of teeth of drivers}}{\text{Product of teeth on followers}}$$

Screw Cutting. Double Threads.—Screws having two or more starting places are usually made by first cutting one thread, and then lowering the quadrant plate, while the lathe spindle is made to rotate for a portion of a circle. The exact amount of rotation is decided by the kind of screw to be made—that is, whether two, three, four, or whatever number of starting places or “leads” are required. It is customary to fix a change wheel on the spindle end, which will be devisable by the number of leads which the screw must have.

EXAMPLE 6.—To cut a screw with two starting places: $\frac{1}{2}$ -in. pitch in a lathe having a guide screw of $\frac{1}{4}$ -in. pitch, $\frac{40}{20}$ or $\frac{60}{30}$, 60 being placed on the spindle and 30 on the guide screw.

After cutting the first thread, lower the swing plate out of gear, and rotate the lathe spindle half a revolution; *i.e.* after thirty teeth have passed, the quadrant is again raised, and the wheels engaged while the second thread is cut.

Another plan is to withdraw the socket on which the intermediate wheel rides, and return it when the mark on the spindle wheel agrees with the one on the socket wheel.

There is, however, a certain risk of the “backlash” being made more or less by either of the above methods, and consequently a possibility of error in the “spacing” of the threads, *i.e.* the tool may cut more to one side than another, thus leaving the width of the threads unequal. To obviate this, it is better to divide the front-gear wheel in the headstock into as many divisions as there are starting places in the required screw (where pitch will agree to this). By this arrangement there is not the same probability of error, and indeed the screws may be cut without even stopping the lathe.

Screw Cutting. Multiple Threads.—When the work has two or more starts, it is sometimes the practice to have holes drilled in the work for the tool to either start or finish in. The position of the holes has to be accurately set out.

Drilled Holes for Tool.—There is an advantage in having holes for the tool, as the full depth of the cut can then be made to a definite distance, otherwise the cut has to be “put on” or released gradually while the saddle is traversing.

Use of Multiple Threads.—Multiple threads are frequently cut on comparatively small screws to obtain a quick movement, but the depth of the thread is diminished, and the strength of the screw reduced.

Stop on Lathe Bed. Engaging Nut for Odd Pitches.—It is necessary to fix a stop to the lathe bed when screws are to be cut which are not a multiple of the guide screw—as 1, 3, 5, assuming G. S. = $\frac{1}{2}$ -in. pitch, and the nut can only be engaged every alternate revolution of the guide screw.

Engaging Nut for Even Pitches.—When, however, even numbers are being cut, as 2, 4, 8, 12, the nut will engage correctly at every revolution of the screw, and at any position along the lathe bed.

Marking for Position of G. S. to Spindle.—When cutting an odd pitch screw, the saddle is first brought up to the stop, and the lathe rotated by hand until the nut will slide *easily* into its place in the guide screw. A chalk mark is then made on the face plate and on the guide screw. After a cut has been taken, the saddle is wound back to its stop, and the lathe rotated until the chalk marks relatively agree, and the nut again engaged, and a second cut is taken, and so on. An experienced workman will count the number of revolutions necessary to make the marks agree without stopping the lathe.

Referring to Example 1, the screw to be cut will have its threads lean in the same direction as the guide screw, viz. right hand. When left-hand screws are to be cut, there are two intermediate wheels in the train, causing the guide screw to rotate in an opposite direction.

Reversing Motion.—To relieve this, many lathes are fitted with a reversing motion (see Whitworth Lathe, end elevation, Fig. 118). This consists of a plate and three-pinions, one of which, engaging with a similar wheel on the spindle end, gives motion to an axle on which the driver is fixed.

By changing the position of the above plate about its axis the pinion is ungeared, and a movement upward or downward causes the change wheels to rotate the guide screw in different directions. This arrangement is very useful for screw cutting, while for "traversing" lathes it is most economical. Since there is the same rate of speed to the driver as when it is on the spindle end, reversing motion is ignored in making calculations.

Screw Cutting in the Lathe. Tool Making.—In making the tools for screw cutting, it is very important to notice that the angle of the tool is sufficient to give a clearance to the cutting edges, and no more.

There is no definite angle at which a tool is to be made when the screws to be cut are not of the same diameter. In cutting vee threads there is, however, a possibility of making one or two tools with sufficient clearance, so that they will answer for screws ranging from $\frac{1}{4}$ in. to $1\frac{1}{2}$ in. diameter.

It is to be remembered that a Whitworth vee thread is rounded at top and bottom to a depth of $\frac{1}{6}$ of its pitch, and therefore a tool made for a small screw would be too sharp for a larger one, or *visa versa* a tool made suitable for a $1\frac{1}{2}$ in. diameter screw would be too stunted for one of $\frac{1}{4}$ in. diameter. Besides this, as will be presently shown, there is no economy in repeatedly altering tools.

It is a generally adopted system now, where a tool-room is kept going, to have a staff of men making tools and keeping them in repair. This does away entirely with workmen altering the tools, or making and tempering them, and is a decided saving where it is properly carried out for the following reasons. Instead of each operative leaving his machine, and attending to tool making or repairing (which in itself is a serious loss of the time the machines are capable of running), and where great numbers of men are employed, the aggregate time the machines are standing has been found to be considerable, a boy fetches all tools and returns with new ones. Another good feature is

the discipline of the shop. Again, where a tool-room is kept, all tools being attended to by skilful mechanics ensures their accuracy in shape, rake, and temper. Lastly, because where tool fitters are employed, dupli-

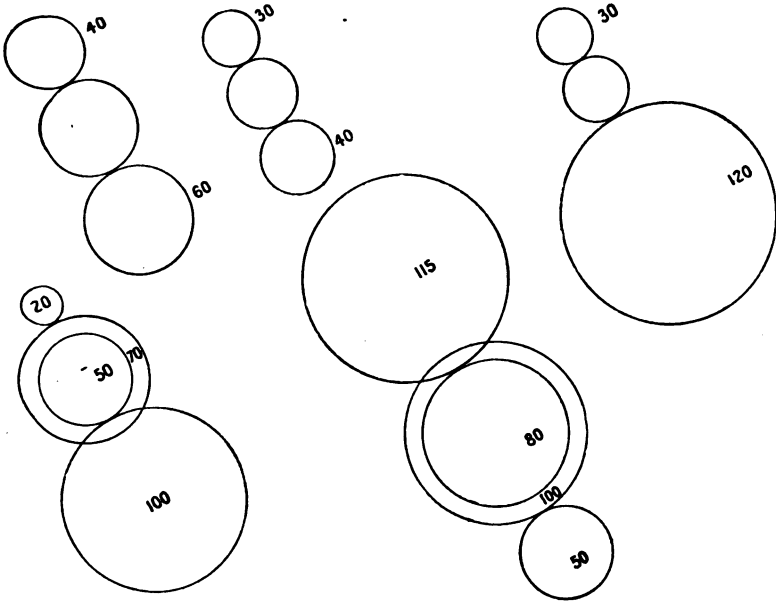

FIG. 188.—Examples of gearing change wheels.

cates of all tools are kept, so that there is only a minimum of time lost by the machines standing, *i.e.* simply while the tools are changed.

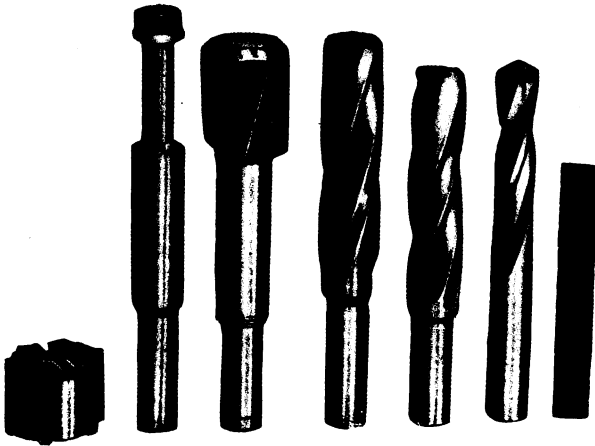

FIG. 189.—Group of tools ground.

CHAPTER X.

GRINDING WHEELS AND MACHINERY.

THE old method of grinding by using wheels of grit or sandstone is gradually, but surely, giving place to the use of emery, or corundum wheels. It would be impossible even to refer to all the uses to which grinding wheels may be put, seeing they are alike indispensable in the tool room, the machine shop, and foundry fettling shops.

Special machines are made to carry these comparatively small discs, and most of them are made to work automatically and by hand. Fig. 190 is a grinding machine by Messrs. Smith and Coventry, Manchester. Fig. 190A shows a machine by Luke and Spencer, of Manchester. This machine carries a very hard grinding wheel, and is used exclusively for sharpening tools. A universal grinding machine is represented on Fig. 191, made by Messrs. Brown and Sharpe, of America, details of this machine and some of its uses will be considered later.

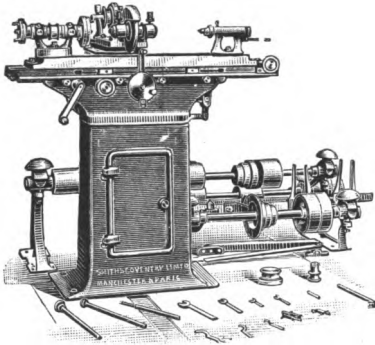

FIG. 190.

Emery Wheels.—Rock emery stone, which is imported, is crushed by machinery. The finely divided grains are afterwards compressed with glutinous matter into a variety of shapes of wheels or bars to suit different purposes. The wheels are graded as coarse, medium, or fine; they are also classed according to their size, and the nature of the metal they have to work upon. Some are intended to work dry upon cast iron, brass, etc., while with others, made to work upon cutting tools and hardened portions of machinery, it is customary to use water. If these were used dry, the steel tools would be immediately softened, and their temper destroyed. These wheels are much superior to grindstones, especially in small tool grinding. They cut more quickly and smoothly and their side faces may be used as well as their periphery. Screw-cutting tools, which would have to be softened and filed, can readily be ground with emery wheels and their temper and form maintained.

Another important use is the grinding of engine connecting rods after hardening; this will be treated later.

It is well known to all engaged in the manufacture of high-class

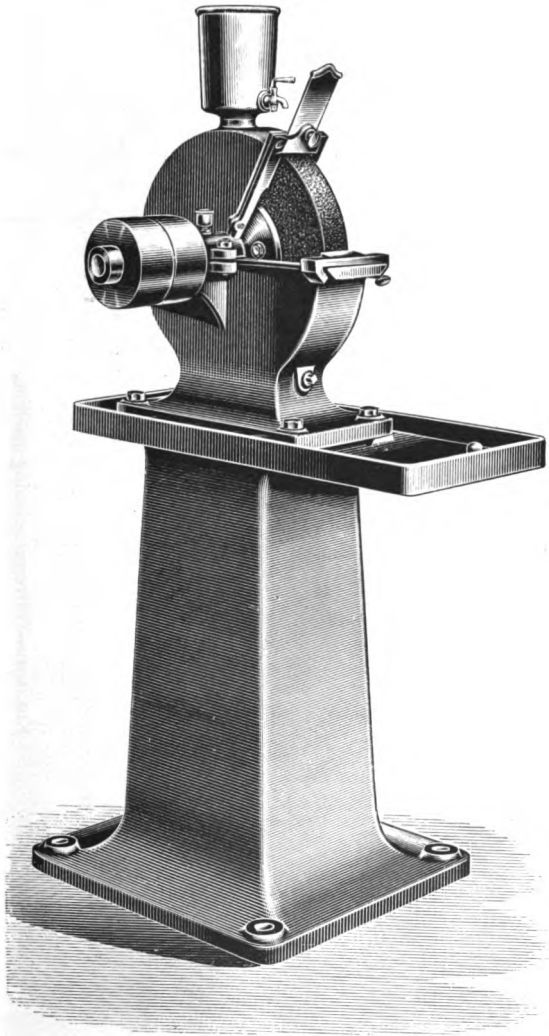

FIG. 190A.—Tool grinder.

machines and instruments of precision that the lathe is incapable of producing accurate work even in the softer metals, and in operating upon hardened surfaces it fails altogether.

It is very important to have journals and other wearing surfaces smooth and true when they are finished. If they are imperfectly made their tendency is to become worse by wear. In fact, success in the manufacture of machine tools demanding accuracy depends largely

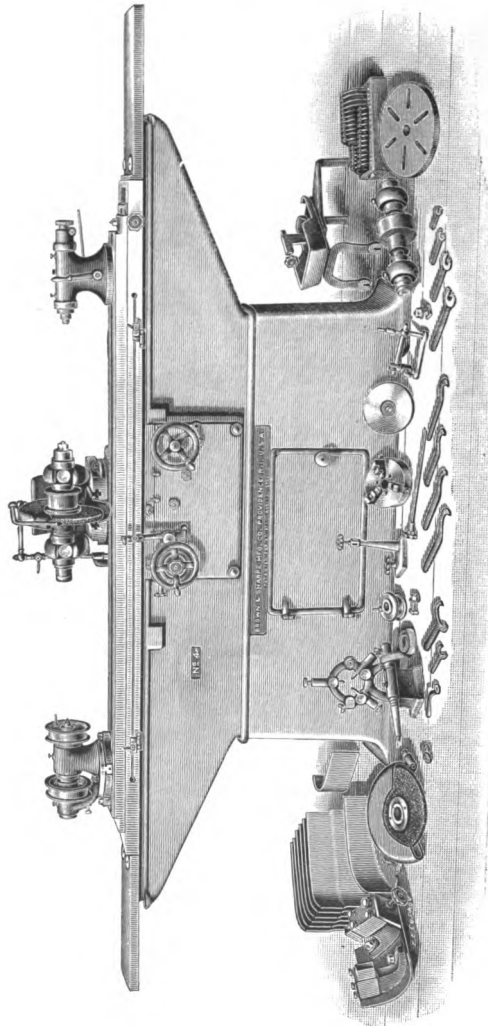

FIG. 191.—Universal grinding machine.

upon methods which will produce better work than the lathe. The only successful method employed at the present time to meet this want is to use the lathe as a roughing tool, to bring the work approximately

to the desired size, and then to finish by grinding with emery wheels in a suitably designed machine.

The introduction of hardened spindles (Fig. 192), bearings, etc., into

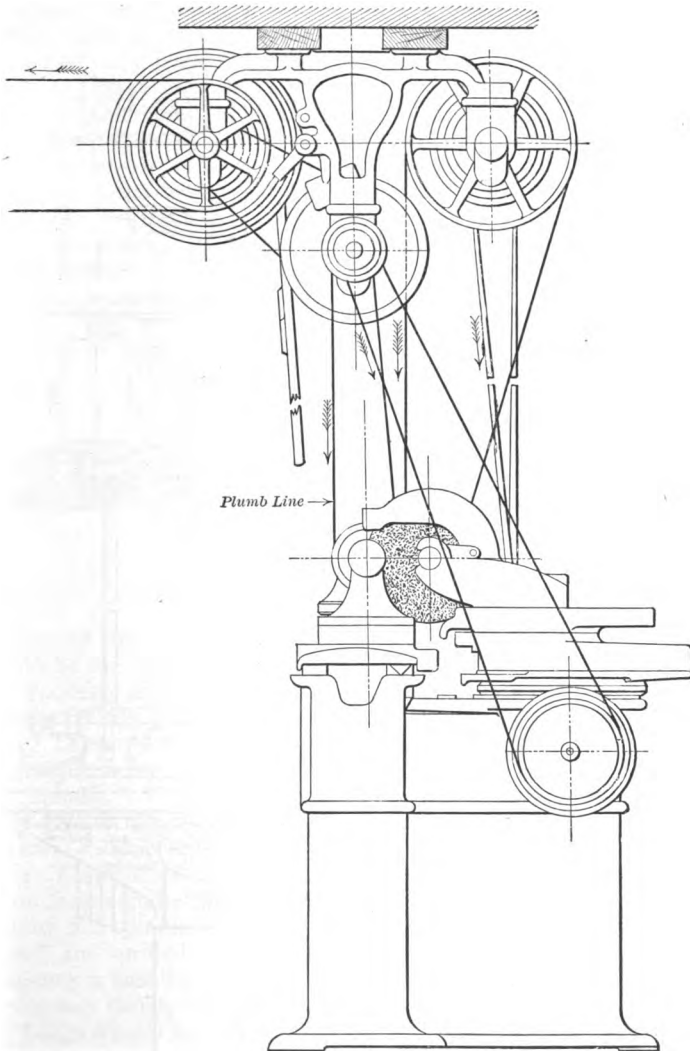

FIG. 191B.—Universal grinding machine, end view.

lathes, milling machines, drilling machines, etc., which are most valuable, would be impossible without the use of suitable grinding

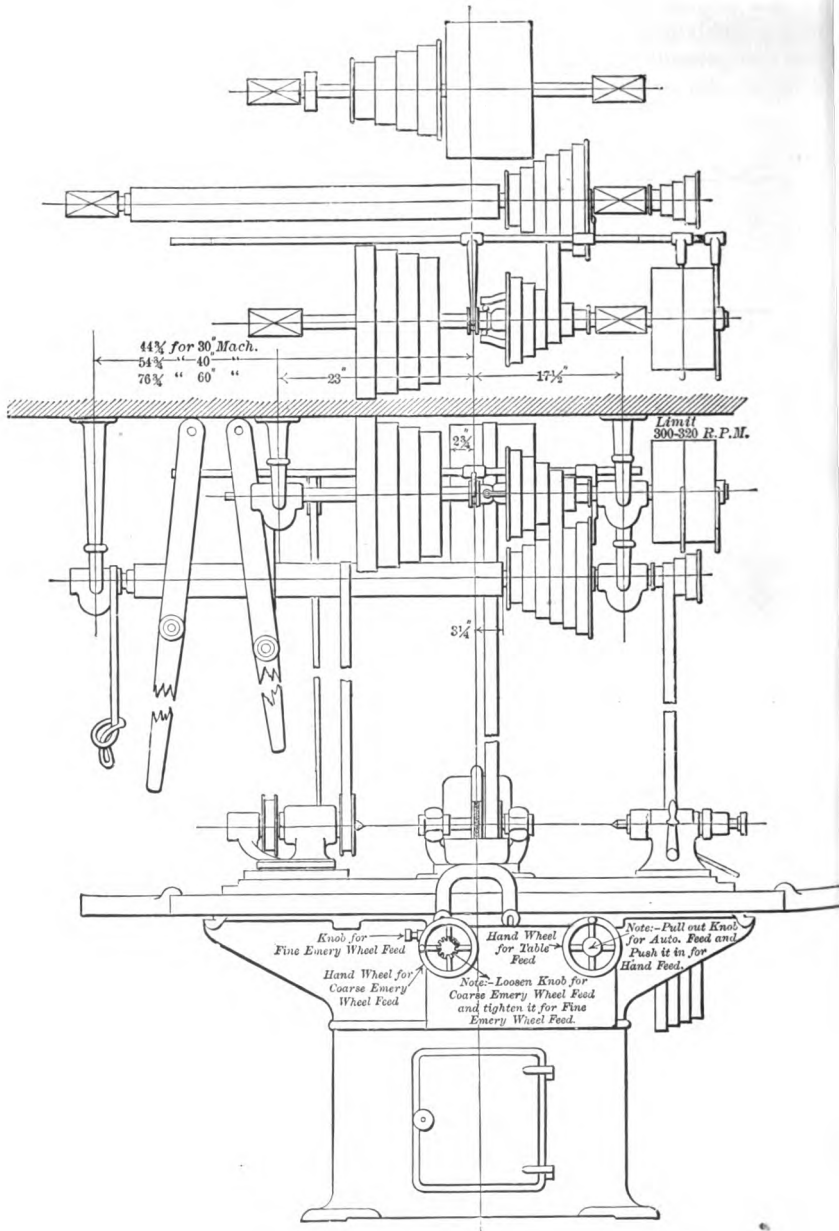

FIG. 191C.—Universal grinding machine, showing overhead arrangement.

machinery. By thus finishing such work as crank pins, valve rods and piston rods of locomotive and other engines, a vast amount of saving is effected in the cost of production as well as a great improvement in the quality and durability of the work.

That it costs much less to finish off work by grinding with emery wheels than by the old method on the lathe, has been repeatedly proved by experience. As grinding wheels for a given amount of work cost less than files, emery cloth, etc., it is readily seen that the saving, together with the time required to do the work, is a material one whether the grinding is done for making accurate fits or rough sizing.

In many instances actual practice shows that soft steel can be worked to much better advantage by grinding than in the lathe, as the stock can be removed more rapidly, and the sizing cut usually is saved; accuracy is incidental to the process, and costs nothing.

An important point in emery wheels is that they should be securely held in position. It is also equally important that the holding device shall be symmetrical, because of the great centrifugal force, especially in wheels of considerable dimensions. It is not, however, safe to grip

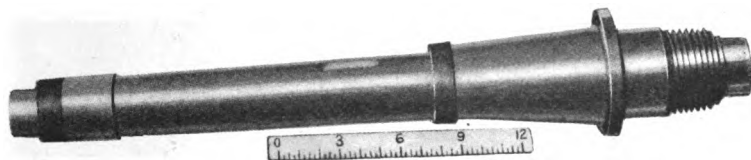

FIG. 192.—Lathe spindle hardened and ground.

a wheel of emery as though it were iron, because it may crack, as indeed would be the case with a wheel of a thin section.

To guard against breakage when mounting a wheel it is the practice to observe the following points:—

1. There should be washers of rubber, felt or blotting paper inserted between the faces of the wheel and the flanges which grip it to the spindle. These preserve the emery from getting unduly crushed and give a better grip to the wheel than if secured with an equal pressure without them.

2. Flat wheels, which are made with small bores, should be a loose fit on their spindles, the reason for this, which is most important, is that should the spindle get heated and expand it would burst the emery wheel and probably do serious damage. To prevent this bursting tendency a bushing of lead is given to the wheels which would melt before any damage could be done to the emery.

Large wheels are mounted in various ways, one of which is shown in Fig. 193, where the cast iron bush and flange are made in one piece, and the boss is extended through the wheel to receive a loose washer. It will be seen that this arrangement is superior to one having two washers dependent on the bolts for location. Immediately above the core of the wheel the faces are undercut in the manner shown

(Fig. 193) and the flange washers made to fit. A dovetail joint is useful, as the wheel is securely held true both on the face and circumference.

An ingenious arrangement is shown in Figs. 194, 194A and B, by which face wheels may be securely held and the mechanism adjusted as the wear of the wheel requires. The back plate is bored to fit the spindle of the machine, between which and an internal iron ring the back flange of the grinding wheel is gripped. India-rubber washers are first inserted between the iron and the wheel; the whole is then enclosed in a brass hoop, or shield, and this is secured to the back plate with countersunk screws. The brass hoop is screw cut on its outer circumference and a lock nut threaded to fit is shown in section (Fig. 194). The diameter is tapered a little and at intervals saw slits are made which enable the hoop to yield to the pressure of the lock nut and thus grip the wheel. As the wheel

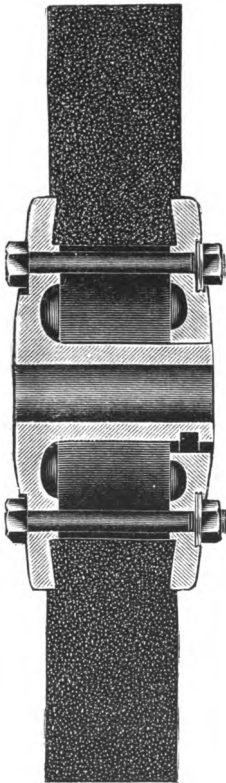

FIG. 193.—Mounted emery wheel.

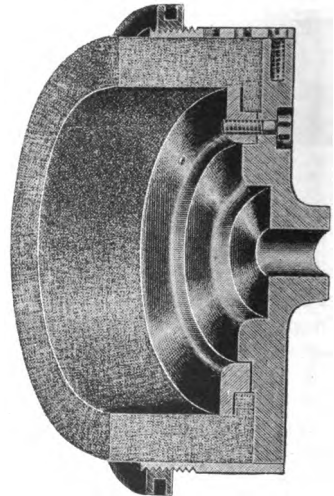

FIG. 194.—Emery wheel and mounting in section.

wears the screws are removed, the lock nut slackened, and the hoop is set back, until the second series of screw holes are visible. This setting back may be repeated several times; each setting makes the projecting portion of the wheel in all respects equal to new.

When truing emery wheels the best results are obtained by securing the diamond tool in a tool rest (see Fig. 196); when it is held by hand there is more or less vibration. The discs of emery are made into almost every conceivable shape to suit the various tools. The practice is to first note the nature of the material to be ground, and the

amount of metal to be removed, then the shape of the work decides the shape of the wheel. The wider the wheel the better the result, that is a general rule, but it sometimes occurs that a narrow wheel must be used, in which case the grade should be in harmony with the work the wheel has to do.

Fig. 195 is a duplex grinder. Figs. 196 and 197 illustrate the truing of a grinding wheel on the side and face respectively by means of a black diamond.

A satisfactory emery wheel is an important factor in the production of good work. Too much, however, must not be expected of one wheel. A variety of shapes, sizes, and grades of wheels is necessary to bring out all the possibilities of grinding machinery; the same as a

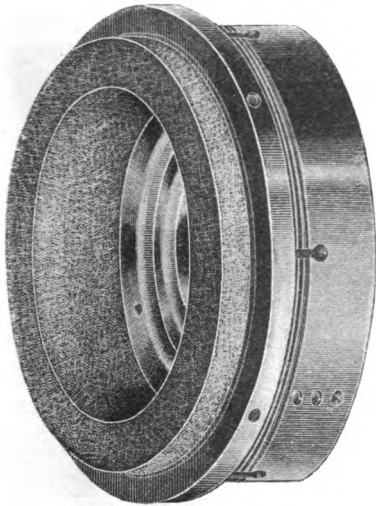

FIG. 194A.—Emery wheel mounted.

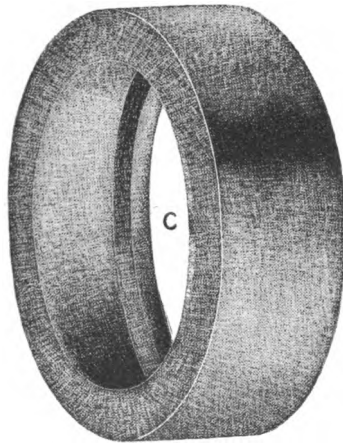

FIG. 194B.—Emery wheel.

variety of shapes and sizes of tools are necessary to obtain the best results from the lathe or milling machine.

These suggestions are not offered as positive rules, but as the embodiment of experience and as representing the methods which eminent firms have found in their own practice as desirable.

In machine grinding it is most desirable, in order that the cut may be constant and give the least possible pressure and heat, to break away by the act of grinding the particles of the wheels as they become dull. It is this faculty of yielding to or resisting the breaking out of these particles that is called the grade. As a rule, the harder the material to be cut, the coarser the wheel required to produce a given finish. For example, coarser wheels are required to produce a given surface upon hardened steel than upon soft steel. While finer wheels are required to produce the same surface upon brass or copper than upon either hardened or soft steel. Wheels for soft steel are harder than for

hardened steel or cast iron. For brass, copper, and rubber they are much softer.

The temper of a wheel is dependent upon the quality of the

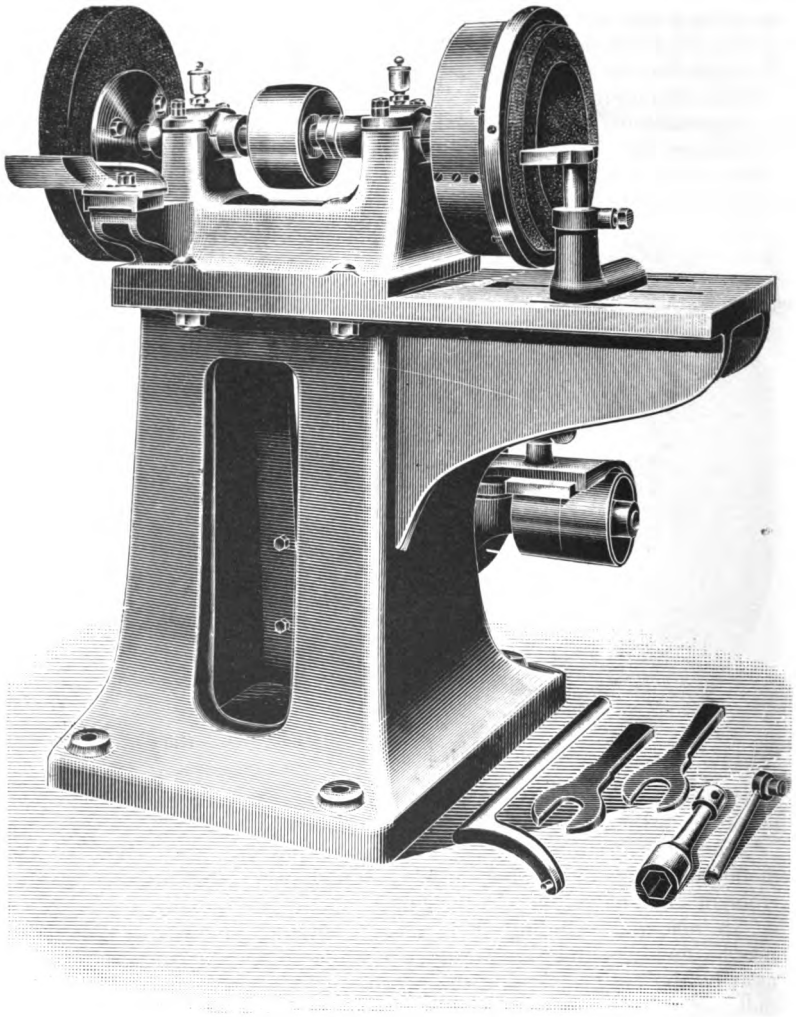

FIG. 195.—Duplex grinder by Luke and Spencer.

corundum particles to withstand dulling ; so that the better the material the better the temper. A wheel is soft or hard according to the amount and character of other materials combined in the process of manufacture. If a wheel is hard and heats or chatters it can often be made more

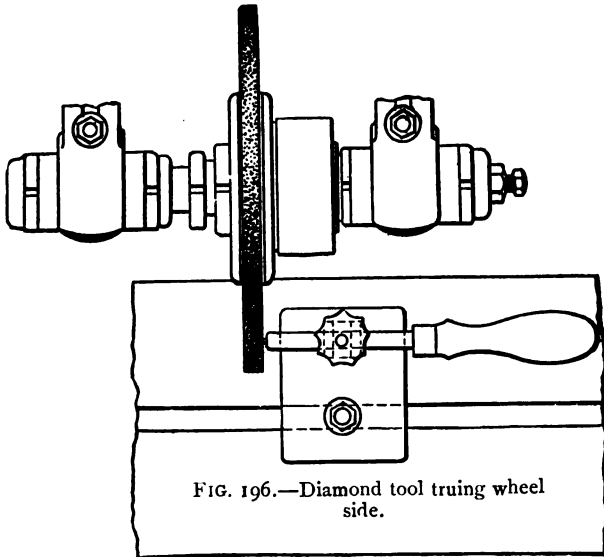

FIG. 196.—Diamond tool truing wheel side.

effective by turning off a part of its cutting surface; but it must be clearly understood that while this will sometimes prevent a hard wheel from heating or chattering the work, such a wheel will not prove as economical as one of the full width and proper grade.

Grade of Wheels.—The width should be in proportion to the amount of metal to be removed with each revolution; and as the wheel cuts in proportion to the number of particles in contact with the work, less metal will be removed by a narrow wheel than by one that is of full width. The feed will also have to be finer if a narrow-faced wheel is used.

If the wheel is of the right grade it will, as a rule, improve the quality of the work if used with full width of face. Judgment should be used in deciding upon the width of wheel to be used, as sometimes

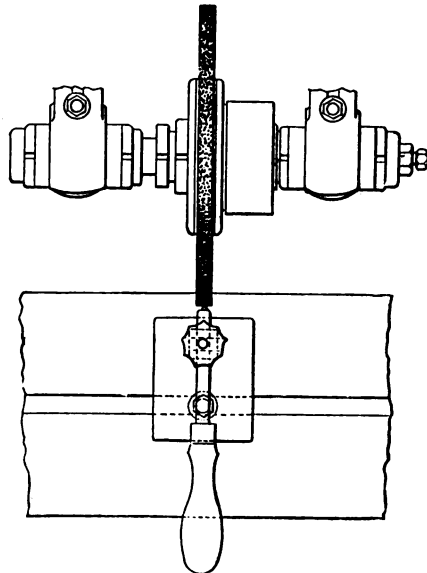

FIG. 197.—Diamond tool truing wheel rim.

the work is of such size and shape as to make it necessary to use a wheel with a narrow face. Where this is the case, and strength will admit, the wheel should be of the same width throughout. Wide wheels and fast table feeds can be used on all work where the wheel can pass one quarter to one half of its thickness beyond the end of the work or over a recess; but a narrower wheel is the best when grinding against shoulders not recessed, or when the recess is narrow. It has been generally considered that a wheel $\frac{1}{2}$ in. wide is the widest that can be used for the latter purpose: thus it is that makers often furnish a wheel of this size with their machines; but the Universal Grinding Machine (Fig. 191) will take wheels as follows: 16-in. machine, to $\frac{1}{4}$ -in. face; 30-in. and 40-in. machines, from $\frac{1}{2}$ -in. to $\frac{3}{4}$ -in. face; and the 60-in., 72-in., and 96-in. machines, from $\frac{1}{2}$ -in. to 1-in. face.

Many operators of grinding machines think it is better in all cases to turn off a portion of the face of the wheel, leaving in some instances little more than a knife edge. While this method is often necessary in dry grinding, as the heat produced by a wide cut will cause the wheel to chatter, it is not recommended as economical in general practice. The reduction of the face of the wheel necessarily increases the time to do the work; that is, a wheel $\frac{1}{8}$ in. wide cannot be fed more than $\frac{1}{32}$ in., while one $\frac{1}{2}$ in. wide can be fed $\frac{1}{8}$ in. or more, and a $\frac{3}{4}$ -in. wheel $\frac{1}{4}$ in. or more per revolution of the wheel.

Emery Wheels.—With a wheel that is too hard for the work these feeds must be much less, as such a wheel will leave feed marks if not fed slowly. The more emery in contact, the deeper the cut, and the faster the feed that can be taken. The following illustration will serve to show the advantages of a wide-faced wheel:—

A piece of steel easily affected by heat was ground with a $\frac{1}{2}$ -in. full-faced wheel, plenty of water being used. Eight thousandths was taken from the diameter in five minutes, and no chattering or eccentric grinding occurred. The piece was then put into another machine, and ground dry with a narrow-faced wheel about $\frac{1}{8}$ in. In the latter case much difficulty was experienced from the wheel grinding on one side, and at the end of five minutes only one and a half thousandths had been ground off.

A wheel is most efficient at the point just before it ceases to crumble. The faster it is run at this point, the more metal will be removed, and the more economically the work will be produced. Occasionally, however, it is necessary to run a wheel more slowly, as the slower it runs the coarser it cuts, and it is less likely to change the temperature. As a general rule, on any given material, the softer the wheel the faster it should run. Should a wheel heat or glaze, more effective work can often be obtained by running it slower. If, on the other hand, it is too soft, it can often be made to hold its size and grind straight by using a higher speed.

The speed of work and cut of wheel bear such close relation to each other that it is best to consider them together. The surface speed of the work should be proportional to the grade and speed of the wheel. For example, if a piece 1 in. in circumference is being ground

successfully with a given wheel, and the wheel is sizing accurately in response to the gradations on the cross-feed wheel, a piece 2 in. or 3 in. in circumference would, with the same wheel and number of revolutions, show a coarser surface; and the wheel would cut larger than shown by the gradations on the cross-feed wheel.

On the other hand, if the same surface speed were used in both cases, the results would be the same. The revolution of a piece of work in a grinding machine can be compared to the table feed of the milling machine. With a cutter running at a suitable speed to cut steel, there is a feed at which the cutter will do its work easily; and there is also one so fast as to break the teeth, providing the machine has sufficient power. There would also be more heat generated with the fast feed; and if the cutter is run after it has lost its keen edge, it will generate more heat until it becomes so dull that heat enough to draw the temper will stop further work.

Furthermore, a cutter whose temper is hard enough for one piece of work may entirely fail on another. So it is with a wheel. One that is suitable for cutting soft steel will become glazed when used on hardened steel or cast iron; and if the wheel is used after the particles are dull, it will generate more and more heat, and on account of the pressure required will not produce round or straight work.

A wheel for machine grinding must cut without pressure, to effect which it must always be *sharp*; this is maintained by the breaking out of the particles. Therefore a wheel of the proper grade to cut at a given work speed possesses "sizing power." It will thus be seen that the work speeds should always bear the proper relation to the cut of the wheel, regardless of the diameter of the work; just as in milling, the amount of feed bears relation to the cutter and material, regardless of the length of piece being milled. Any change of axis of work will cause error either from poor centres, carelessness in cleaning the centres, or from change of temperature produced by the action of the wheel.

Inaccurate and sometimes spoiled work is the result of poor fitting centres. Care should be taken to have all centres of the standard angle 60° , and large enough to give good bearing surfaces. The centres of both lathes and grinding machines should accurately fit the centres of the work, and should be kept clean and well oiled.

Change of axis of the work makes the wheel, after cutting uniformly around the entire circumference, cut more upon one side of the work than the other; this is something beyond the control of the machine. If the cut on one side is uniform from end to end, it would be caused by the wear of the centres to the same side, or by some foreign substance on the same side in each centre; both of these cases will, however, seldom, if ever, occur.

The cutting on one side may occur at one end, and still be concentric at the other; this would be caused either by the wear of one centre, or by the introduction of some foreign substance. When the change of axis is caused by a change in temperature, the cut is always deepest at a point midway between the centres; but trouble from this

cause will not arise until all of the turning marks are ground out, and the wheel has cut entirely around the piece.

By change in temperature one should not understand that the change is necessarily sufficient to be detected by hand.

It is probable that very few pieces of steel are so uniform in texture that they will not change their outline with a very slight change of temperature, even though the temperature be the same throughout the piece. It is also well known that the slightest increase in temperature, unevenly distributed, of a piece of steel will cause a change of outline.

For example: If the finger is placed on one side of a bar, it will cause an elongation of the metal directly under it, and the heat of the finger will be absorbed by the bar, as shown in Fig. 198, leaving as the warmest

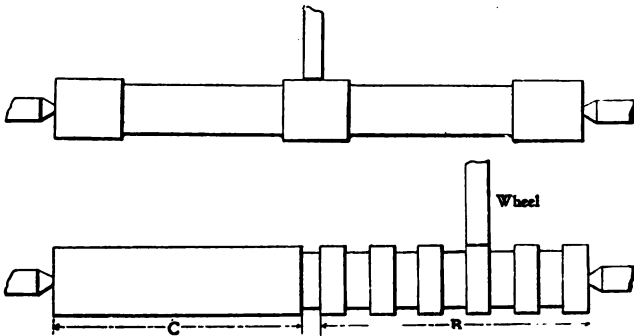
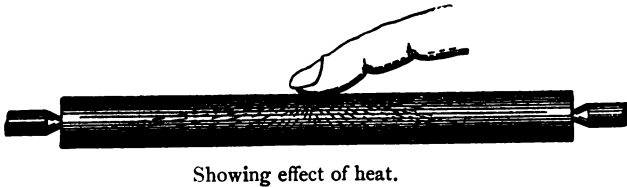

FIG. 198.

part that portion where the heat enters. The amount of expansion is necessarily very small, but when one considers that a "clean-cutting" wheel in many instances will show sparks with a cut less than one-hundredth part of one-thousandth of an inch, it is readily understood how a very slight change of outline will be detected by the grinding machine.

Grinding.—The application of the wheel to the work is best understood by reference to Fig. 198. When the red-hot sparks of steel pour from the bar it is easily seen that there is considerable heat at the point of contact, and since the heat is necessarily greater at the point than elsewhere, the bar will constantly bend towards the wheel. In such cases the workmen speak of the wheel as "drawing in," when in

reality it is the work that approaches the wheel by revolving with a greater expansion under the wheel than at any other point.

As a rule, the bar will not bend with perfect uniformity, owing to the tension within itself. A given amount of heat being more effective on one side than the other, the wheel cuts deeper on the side so affected. The expansion is thus constantly increased until the bar is bent enough for it to revolve without touching the whole circumference. After which, as the heating is so much greater on one side, the bending increases.

The heat being almost instantly distributed upon the removal of the wheel, the bar will return to its normal position, and leave the other side of greater radius, so that on its return the wheel will cut on the opposite side, and cause the bar to bend this side towards the wheel, thus leaving it elliptical in form. If, as sometimes happens, these two bends have been exactly opposite, the next cut of the wheel will be on two points, and if the bar is of perfectly even tension on these two sides it will continue to cut both sides, but usually the bar will not bend exactly opposite at first. The successive cuts will therefore be somewhat as follows: First, completely around the circumference; second, on one side; third, the opposite side; fourth, at right angles; fifth, opposite again, and so on. In grinding tubing the change due to expansion is more aggravated, as the hollowness of the piece operated upon does not permit of such a rapid conduction of the heat to the opposite side of the axis.

It is easy to be deceived as to the amount of error in roundness when judging by the sparks from the wheel. For example: a piece 36 in. long and $3\frac{1}{2}$ in. diameter was being ground, showing sparks from one side only. Without correcting the error, the piece was measured with a micrometer; its error was so slight that it could not be detected, and an indicator held against it showed no motion.

Another experiment was made with a hardened plug 1 in. in diameter. It was first ground round and straight, then carefully measured, replaced in the machine, and the wheel advanced until sparks were just visible. When ground this amount, it was again measured, and found to have been reduced about one-hundredth part of one-thousandth of an inch.

The accuracy of the work, therefore, must be very great, when, with a suitable wheel and plenty of water, a long piece can be ground showing sparks over its entire circumference, and with such a light cut that they are barely visible. This result is obtained without difficulty.

As the area of the work increases, the feed should be coarser, in order that the wheel may travel the entire length or area of the piece while its diameter is practically unchanged.

Water should be used on such classes of work as are injuriously affected by a change of temperature caused by grinding. It should also be used upon work revolving upon centres, as in this class of work a slight change in temperature will cause the wheel to cut on one side of the piece after it has been ground apparently round.

In very accurate grinding water is especially useful, for the exactness

of the work will be affected by a change in temperature which is **not** perceptible to the touch. It is well to use the water over and over again, as there is thus less difference between the temperature of the water and the work than if fresh water were used. Work that will grind smooth with water will often develop minute vibrations when grinding dry. There is apparently a rapid fluctuation of temperature which causes the work to approach and recede from the wheel very rapidly, thus leaving a mottled or rough surface. If fine work is required, the water should run upon the work smoothly. A fluctuating supply of water will sometimes cause a fluctuation of the cut sufficient to mar the work, and nearly always enough to show change of sparks.

Work to be ground can be mounted in different ways, as follows : On the live spindle of the headstock ; on the two centres, being driven by the headstock pulley ; or upon two dead centres, the work in this case being revolved by the dead-centre pulley. Pieces ground internally are generally driven by the headstock pulleys. The advantage of grinding on two dead centres is that any possible error that may be in the spindle bearings does not affect the work. In grinding straight work both ends should be calipered. If one end measures more than the other, the error may be corrected by swinging the table a little, using the adjusting screw at the end of the same. When slight tapers are desired, for either external or internal grinding, the adjustment is obtained by setting the swivel table to the proper angle. When more abrupt tapers are wanted for work ground on centres, or for internal surfaces, the wheel slide is set to the proper angle. By placing the wheel slide and the swivel table at proper angles, two tapers, for either external or internal work, may be obtained without changing the settings of the machine, as in Fig. 209 : the one automatically by the longitudinal movement of the table ; the other by operating the cross-feed by hand.

When an abrupt taper is required on work held on the headstock spindle, independent of the footstock, the taper is more conveniently obtained by swivelling the headstock than by setting the wheel slide. In this case the work is driven by the headstock pulley. Vibration or chatter of the work is the cause of much trouble if means of prevention are not understood. In a well designed and constructed machine the vibration of its parts is reduced to a minimum, and provision is made for changes of speed to avoid this difficulty. The wheel spindle must have long journals and be a very tight fit in the bearings, as shown at C D in Fig. 199, which is a sectional view. The belting should be spliced and glued, the use of rivets is not recommended.

The Universal Machine, shown in Fig. 191, has capacity to do a general class of work on cones, of hard or soft steel, cast iron, either soft or chilled brass, copper and rubber, or may be adapted to sharpen cutters. Improvements are frequently added and patented. Therefore it is impossible to treat on all the uses to which a universal grinding machine may be put.

In addition to the changes of speed above referred to, it is frequently necessary to use a rest or support for the work. There are two kinds of these rests ; one is commonly known as the back rest, and remains at

the same point of the work, regardless of the position of the wheel ; the other, the " follow " rest, remains opposite the cutting point of the wheel, and is used to absorb vibration caused by the emery wheel, especially during the grinding of long slender pieces. The rest should be so placed that only the high points of the work will touch as it is revolved. When used, it is of the greatest assistance in producing accurate work.

The cut of the wheel and the pressure on the rest may be increased as the work approaches a perfectly cylindrical form. In other words, when work is commenced upon a piece, the rest should be considered more as an absorbent of the vibration than as a support. After the work has become quite round, the rest can be used to regulate the size at

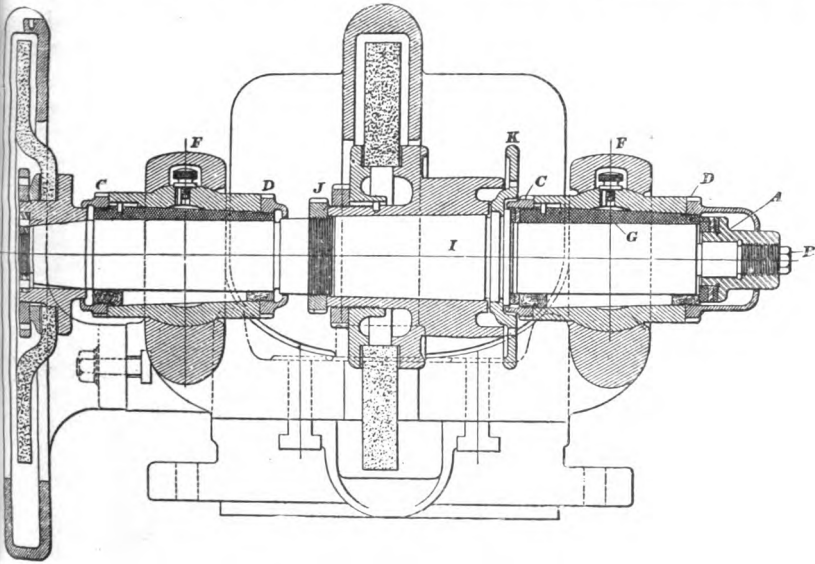

FIG. 199.—Section showing spindle, bearings, and emery wheels in position.

different points. This method of using the rest is particularly advantageous in grinding work that is apt to be large midway between the ends.

Slender work, as a rule, until it becomes approximately cylindrical, requires a very coarse feed when the follow rest is used. For long slender work the follow rest is the best ; remaining as it does at a fixed distance from the wheel, it serves to size the work, and enables work to be ground straight that would otherwise be forced from the wheel and made to " chatter." The sag of a bar sometimes causes it to be ground large in the centre. This is something over which the machine can have no control, and the operator must help it by manipulating the follow rest, giving it sufficient pressure to hold the work against the wheel at that point. A small difference in size between the centre and the ends of work is often caused by the work being forced away from

the wheel by its own cut when near the centre, thus necessitating the use of a rest, even though no vibration is possible. The back rest is used both with and without a spring. When used with a spring, as

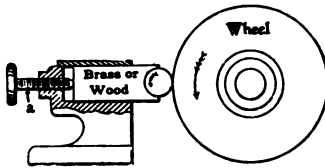

FIG. 200.—Follow rest.

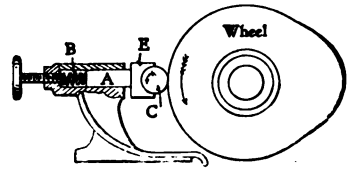

FIG. 201.—Spring rest.

shown in Fig. 201, it is commonly known as a spring rest, and is used in grinding taper work. The rest remains in a fixed position relative to

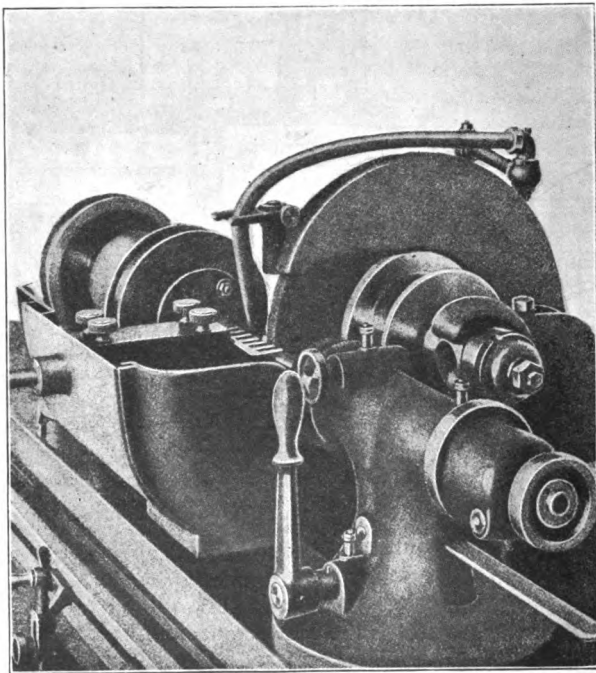

FIG. 202.—Grinding taper pieces with spring-rest in position.

the work, and by the action of the spring the shoe will always press against the surface of the work.

If the rest were rigid, similar to the "follow rest" (Fig. 200), and moved against the work by the screw *a*, it would fail to reach the

work as soon as the wheel had cut away the surface; besides this it would "chatter" until it could be forced against the new diameter, this being a difficult operation, without changing the size of the cut. There are also certain imperfections which might be left by the lathe that would prevent round grinding, if the rest were forced against the work as the follow rest is.

Fig. 201 shows a section through a spring rest; the shoe A is of brass or other soft metal, the end E being made to approximately fit the work to be ground. The spring B keeps the shoe in close contact with the work. The work when revolving tends to climb on the shoe, thus keeping the pressure upon the surface C, which gives support to the work on the under side.

The shoes of both spring and follow rests should be of brass, soft metal, or wood, thus allowing the revolving work to wear the surface away sufficiently for it to fit the constantly varying size of the work. As a rule, brass or soft metal is best, but wood is used when metal would scratch the surface of the work. The shoe should have sufficient surface to last well, but not enough to retard the wear mentioned. The shoe of a spring rest should move freely in the slide and be of sufficient mass to absorb slight vibrations.

As shown in Fig. 202, the spring holds the shoe in contact with the work, and the pressure is regulated by the thumb-screw. In fitting a shoe of this description, it should first bear well on the under side of the work; the wear will quickly fit it to the work, and the shoe will always have a firm bearing underneath. They should never be made of hard material or of vee shape.

It is not always necessary for the shoe of a spring rest to bear entirely around one half of the circumference of the work. A shoe of sufficient mass will prevent vibration; and, as it is soft material, will soon wear to fit the varying circumference. Fig. 203 shows a form of shoe which is particularly well adapted for work requiring unusual steadiness; a shoe similar to this is shown in position on a machine which is fitted for grinding large numbers of pieces similar to that shown in Fig. 204. In this case the follow rest could not be used, as the pieces were to be ground to a slight taper. If only a small number were to be ground, no rest would be necessary; but when both economy and accuracy are required, and deep and rapid cuts must be taken, a proper rest must be used in order that the work may be kept steady under the cut, as under these conditions the wheel will more readily maintain duplicate sizes. Fig. 205 shows a form of shoe for grinding tubing.

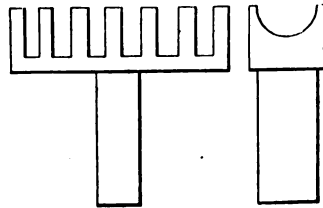

FIG. 203.—Shoe.

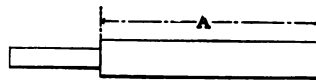

FIG. 204.—Example to be ground.

"An example of plain grinding" is shown in Fig. 206 as done on a universal grinding machine. In employing this method the automatic longitudinal feed is used; the wheel is brought against the work by means of a cross feed, the work being held by the centres and driven by the large dead-centre pulley. The wheel, however, is on the end of the spindle instead of the centre, the object being to grind up to a shoulder, collar, or piston, as shown; the length of the stroke is regulated by adjusting the reversing mechanism.

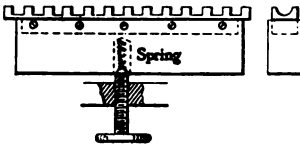

FIG. 205.

Grinding External Tapers.—The arrangement of the machine for grinding external tapers is shown in Fig. 207. It is the same in all respects as for plain grinding, except that the swivel table is set at the

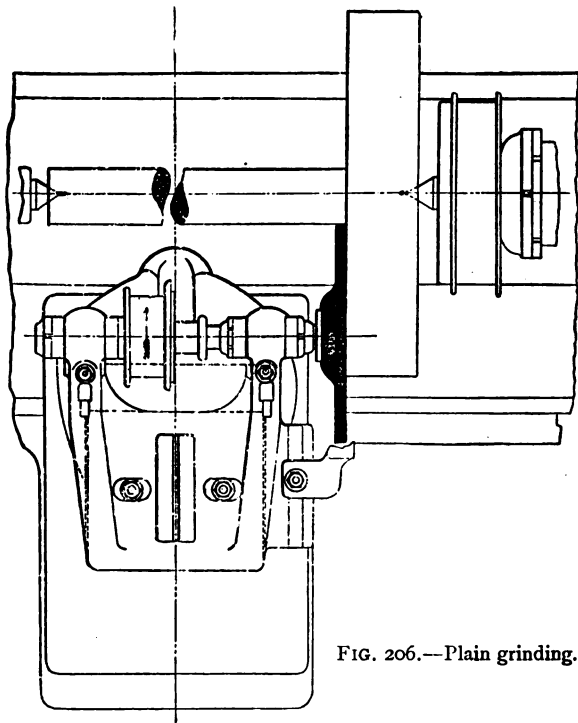

FIG. 206.—Plain grinding.

proper angle. The reading on the scale marked degrees, it should be remembered, is one half the whole taper. Where the work is to be ground to a fit, it is usually placed in the machine in the manner shown, the smallest end of the taper being towards the headstock. The wheel

and the table are operated, the work driven, and the length of the stroke regulated the same as in plain grinding.

When an abrupt taper, similar to that shown in Fig. 207A, is to be ground, the swivel table remains parallel to the ways of the bed as in plain grinding, but the wheel bed is set to the required angle, thus bringing the line of motion of the wheel slide, when operated by the cross feed, parallel with the taper to be obtained. The wheel platen is set at right angles with the line of movement of the wheel slide indicated by the arrow, and the face of the wheel is thus brought parallel with the line of the desired taper. The work is revolved by the dead-centre pulley, as shown in cut, and the wheel is moved over the surface of the work by the cross feed.

The method of grinding two tapers with one setting of the machine, when one of the tapers is not more than 10° , is shown in Fig. 209.

For grinding the slight taper the swivel table is set as in Fig. 207A, and for grinding the more abrupt taper the wheel head is set as in Fig. 207. But the wheel platen is here set to bring the face of the wheel parallel with the longest surface to be ground. Were the abrupt taper longer than the slight taper, it would be well to set the wheel platen as in Fig. 207A, so that the face of the wheel would be parallel with the line of taper. In obtaining the angle at which the wheel bed is to be set when the swivel table has been set over, it should be remembered that the angle must equal the sum of the two tapers. The abrupt taper is ground by feeding the wheel across the work by hand. The slight taper is ground while the table is fed automatically.

When, as suggested by Fig. 209, a spindle and bearing are both to be ground (somewhat similar apparatus is also shown in Fig. 208 and 210 by Smith & Coventry, Manchester), the bearing is ground first and the spindle is fitted to it. For convenience in fitting the work, the bearing may be placed as shown by the dotted lines, and supported so that it will not touch the spindle as the latter revolves. The spindle thus need

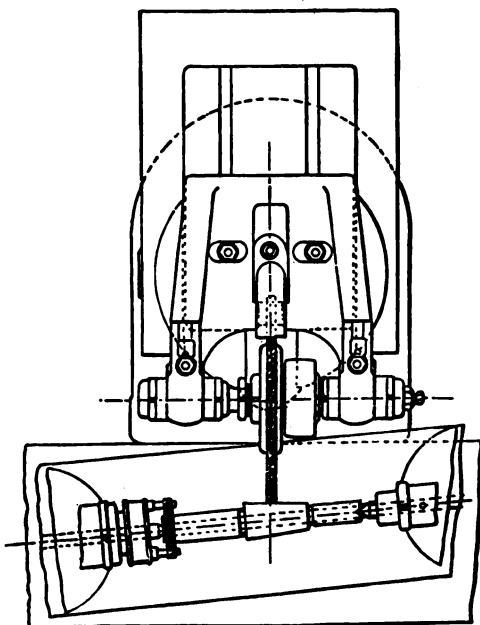

FIG. 207.—External grinding—a slight taper.

not be removed from the centres when it is necessary to try it in its bearing.

Grinding Internal Tapers.—In grinding the bearing the machine is set as shown in Fig. 211. Provision is made for grinding the slight taper by swivelling the wheel bed. As in external grinding the bed is set so that the line of motion of the wheel slide will be parallel with the line of the taper to be ground. The angle with the ways of the machine in this case, the swivel table having been set over, is equal to the difference in

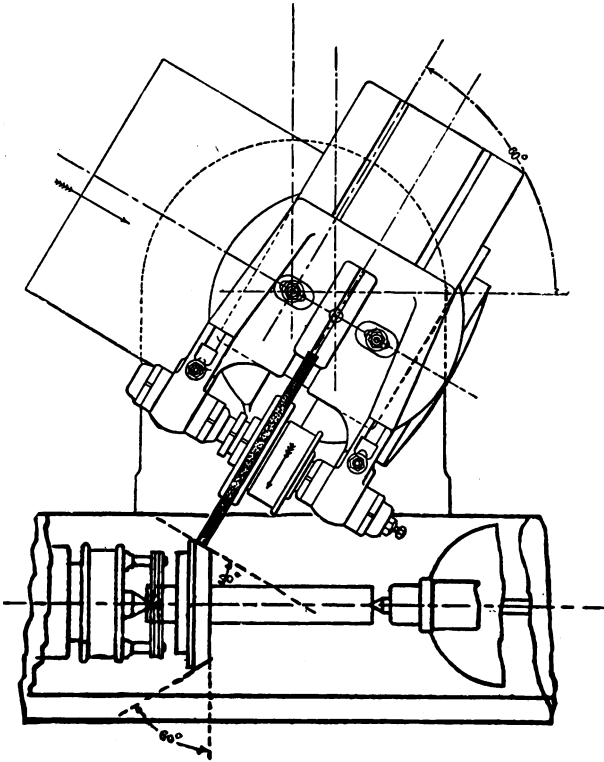

FIG. 207A.—Grinding an abrupt taper.

the angles of the tapers. As in external grinding, the abrupt taper is ground by feeding the wheel across the work by hand, and the slight taper is ground while the table is fed automatically.

Fig. 212 shows a method of squaring the ends of bushings. Fig. 213 illustrates plain internal grinding.

The wheel is turned away on the side, leaving a narrow cutting edge, and should be very soft. If the axis of the mandril and the axis of the wheel spindle are exactly parallel, the surface will be perfectly

flat and at right angles with the axis. A convex or concave surface can be obtained by varying the relation of the axes.

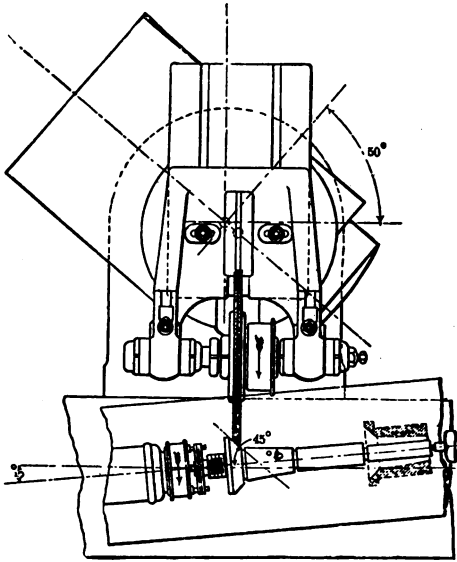

FIG. 208.—Grinding external tapers.

Truing Centres.—The accuracy of all work ground on centres is so dependent upon the centres being true, that the operation shown in

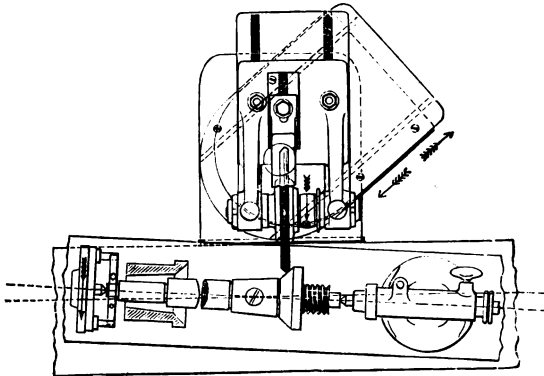

FIG. 209.—Grinding external tapers.

Fig. 214 is frequently seen. To grind or true a centre it is only necessary to set the headstock to the proper angle.

A great deal of odd work in manufacturing machinery can be done on these machines; for example, the spiral head box may be swung by

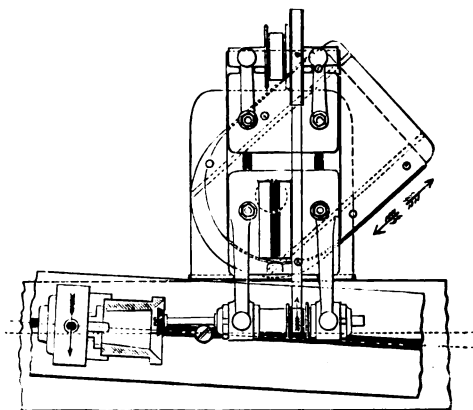

FIG. 210.—Grinding internal tapers.

hand on the centres and the curved surface satisfactorily ground. Fig. 215 is another illustration of the class of work that can be ground

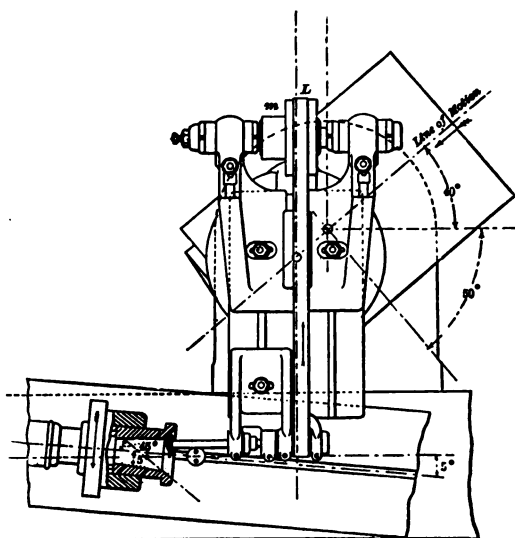

FIG. 211.—Grinding internal tapers.

by swivelling the headstock, in which may be included grinding the sides of collars, washers, milling cutters, etc. The plate on disc shown

is held in the chuck, and the headstock is turned at right angles to the sliding table. The wheel is brought against the work by the cross feed, and the automatic-table feed can be used for passing the work in front

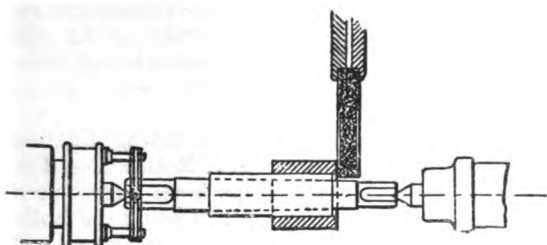

FIG. 212.—Squaring the ends of the bushings.

of the wheel. It is evident that the surfaces ground in this manner may be plain, concave, or convex, according to the setting of the headstock.

Two surfaces may be ground on pieces held in the headstock with only one setting of the machine. For example: If the portion of the work ground, as in Fig. 209, was detached from the shaft or mandril, and it was desired to grind the flat and bevel surfaces, the headstock would be turned at right angles to the table, as in Fig. 213, and the wheel bed would be set at such an angle that the line of motion would be parallel with the taper.

Use of centre rest (Fig. 217) is shown in connection with work held in the chuck on the headstock spindle, the work being driven as shown in Fig. 211, and the swivel table set to produce the required taper. The cut also illustrates the use of an indicator to determine if the work runs true.

The chuck shown in section, Fig. 216, is made use of in grinding discs, such as thin milling cutters, saws, etc. This chuck holds the work by means of a bushing expanded in the hole in the centre of the

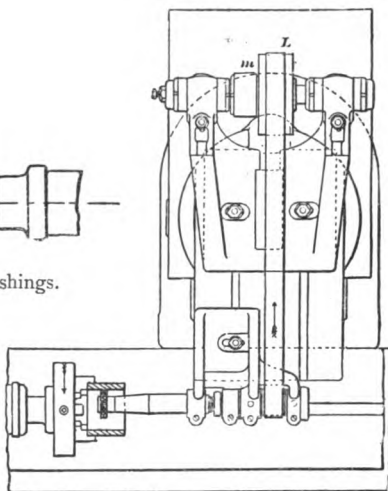

FIG. 213.—Grinding.

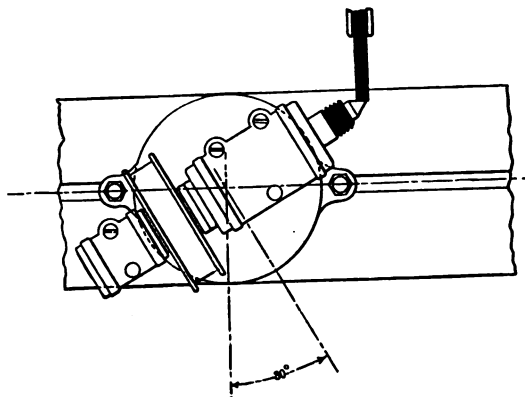

FIG. 214.—Truing centres.

piece to be ground. The work is held by the expansion bushing C, which is expanded by the screw B, and drawn tightly against the face plate by turning the knob A.

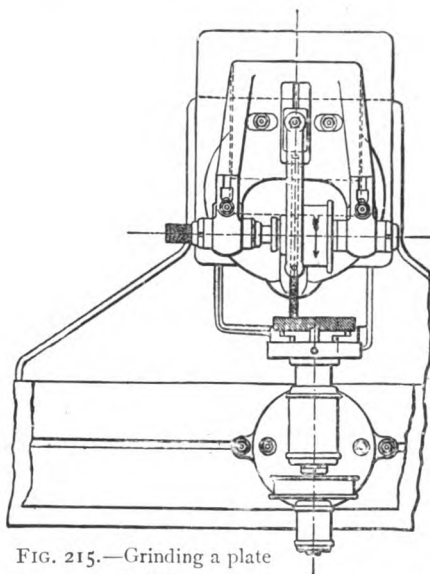

FIG. 215.—Grinding a plate or disc.

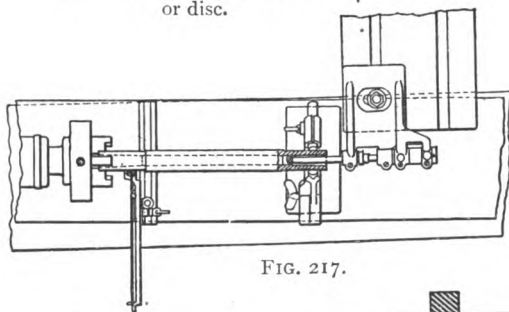

FIG. 217.

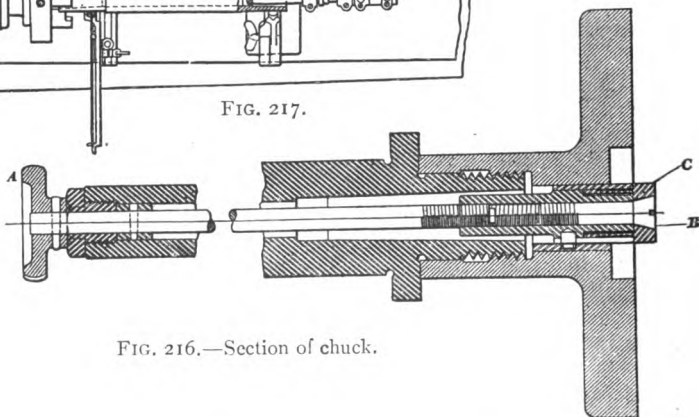

FIG. 216.—Section of chuck.

plate by turning the knob A. Different sizes of bushings are inserted to fit the various sizes of holes in the work as required.

Grinding Cutters and Reamers.—The machines are used for grinding the holes in milling, form, and gear cutters, as well as for grinding their sides. They are also suitable for grinding the teeth or cutting edges of a variety of cutters and reamers, and when used for this class of work, a tooth rest is bolted to the wheel plate at one of the T slots, when the rest is stationary with the

wheel; or it may be bolted to the table, thus travelling with the work. The ordinary place for the tooth rest when in use is directly in

front of the wheel, as in Fig. 218, which shows the grinding of the face of a side milling cutter, the cutter being held on a mandril. To obtain the necessary amount of clearance or backing-off to the tooth, the end of the rest which supports the tooth must be set a little lower than the centre of the wheel, so that the ground surface will have the proper clearance angle. For this kind of work the wheel must be small enough to clear the tooth next above the one being ground. Fig. 219 is a top view showing a reamer on centres.

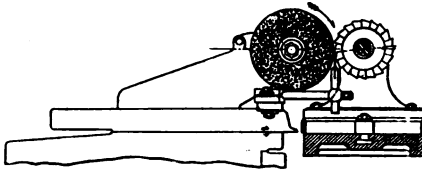

FIG. 218.—Use of tooth rest.

The machine is operated by grasping with one hand the shank of the reamer, or the mandril as the case may be, and holding the tooth firmly upon the tooth rest, while the other hand is engaged in feeding the reamer or cutter across the face of the wheel. When a tooth has been run by the wheel and off the tooth rest, the reamer or cutter may be turned to bring the next tooth upon the rest, and the table moved in the opposite direction while it is being ground. Thus a tooth can be ground at every stroke of the table, when the grinding is done

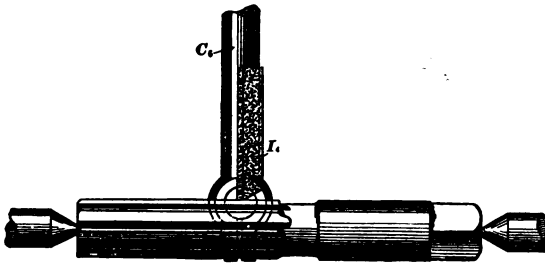

FIG. 219.—Sharpening reamer.

simply for the purpose of sharpening, but when it is necessary to grind a cutter to a certain diameter it must, of course, be ground repeatedly until the required size is obtained.¹

Speeding of Emery-wheel Machines.—Speeding of wheels is a matter too little thought of. It should be a rule to run a wheel at as high a speed as is practicable without injury to it, and since the grade varies according to the work, so does the speed need to vary proportionately.

¹ Brown and Sharpe on "Grinding."

APPROXIMATE SPEEDS OF EMERY WHEELS FOR GENERAL PURPOSES.

Diameter.	Revolutions per minute.	Diameter.	Revolutions per minute.	Diameter.	Revolutions per minute.
Inches.		Inches.		Inches.	
1	20000	6½	3150	16	1250
1½	15000	7	2850	18	1100
2	10000	7½	2650	20	1000
2½	8150	8	2550	22	930
3	6800	9	2200	24	850
3½	5850	10	2000	26	785
4	5000	11	1850	28	730
4½	4500	12	1700	30	660
5	4100	13	1550	36	550
5½	3700	14	1450	1 metre	520
6	3400	15	1360		

Luke and Spencer's Tool Grinder.—A wheel 36 in. diameter is shown in Fig. 220 mounted and running in a trough similar to a grindstone. On one side a slide rest, A, is fitted, and is constructed to hold tools at any desired angle while being ground.

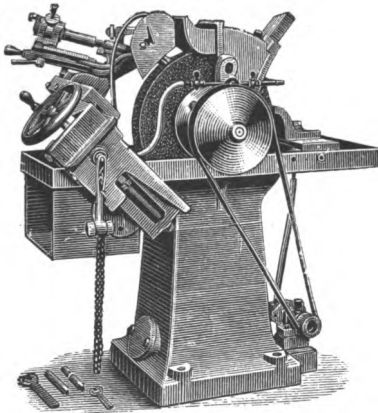

FIG. 220.—Duplex grinder.

The machine serves well to illustrate the advantages of emery wheels for sharpening, turning, shaping, planing, and other cutting tools. In the swivel holder a pattern tool is first adjusted to the angle required; afterwards a quantity of similar tools may be ground at the same setting. Thus by first obtaining the best cutting angle, all the tools may be kept correctly ground. This is not found to be the case where each workman grinds his own tools; some grind the tools with insuffi-

cient clearance on both side and top rake, while, on the other hand, others give too much angle. Where tool rooms exist this is obviated.

On the opposite side of the wheel, Fig. 218, another appliance, B, is seen. This is an arrangement for holding twist drills; this, however, will be dealt with when considering drills. It will be seen that beneath the trough of the machine an automatic pump is provided; this supplies a stream of water to the periphery of the wheel.

Another very useful type of grinding machine is one somewhat like a planing machine in appearance and movements. The work to be ground, such as engine cross heads, guide bars, and other flat parts, which have been hardened, is clamped to the table of the machine, which then travels under a horizontal spindle carried in bearings on the

cross slide. A small amount of error is thus quickly ground away, leaving the surface beautifully smooth, straight, and true.

A further use for machines of this class is where very hard gun-metal

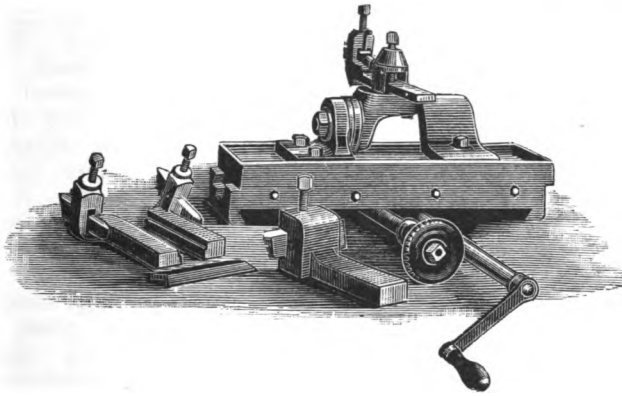

FIG. 220A.—Tool rest enlarged.

castings are made with only a little in excess of the required thickness. Such castings are ground in these surfacing machines, instead of undergoing the ordinary "tooling" in a milling or planing machine. The accuracy of the work is increased by giving a horizontal travel to the cross slide carrying the grinding wheel. This motion is actuated by a connecting rod, the length of whose stroke can be varied. Case-hardened work is ground best with the aid of water. Brass and gun metal are ground dry.

Lang's Patent Sharpening Machine.—When sharpening a twist drill it should first be seen that the metal behind each lip is well backed off, as shown at A, Fig. 221. In practice, this is better and more quickly done on a grindstone. One backing off is sufficient to allow for the drill being sharpened four or five times.

When a drill has been backed off, it is placed in the sharpening machine, as shown in Fig. 222, the shank end centre resting on centre point. The twisted portion of the drill is supported by a thin vee plate, placed near the drill nose. The two edges of the flute are placed on the left-hand side of vee, and the round portion rests on the right-hand side, as shown. The cutting lip of drill is indicated by dotted line D. This is made parallel, or nearly so, to line G on vee plate. By moving the plate

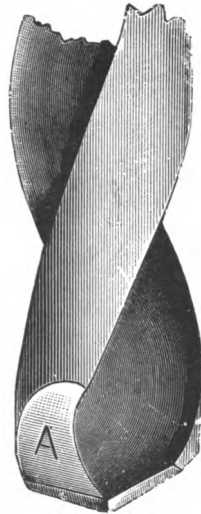

FIG. 221.

holder upwards or downwards with the hand wheel, the slide may then be moved up until the lip of drill is touching the under side of grinding wheel. The machine is then started while the drill is firmly gripped with the right hand, as shown in Fig. 223.

With the assistance of left hand, the lip of drill is then passed several times backwards and forwards under the grinding wheel, which should take a very light cut. Before giving another feed, the drill is moved half a turn, and the opposite lip treated in the same manner as the first. Then, by slight movement of hand wheel, a light feed can be given, and so on, taking each lip alternately until the drill is sharpened. The machine with its accessories is shown in Fig. 224. The accompanying illustrations, Figs. 225 to 237, show some of the uses to which the machine may be put, and the applications are obvious.

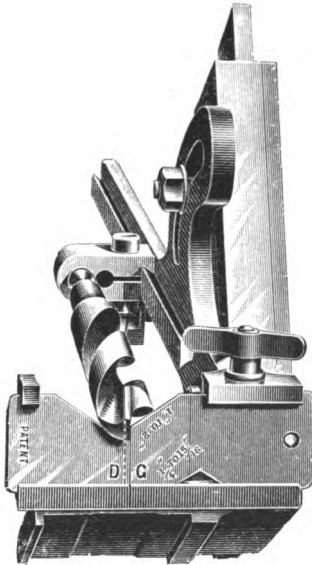
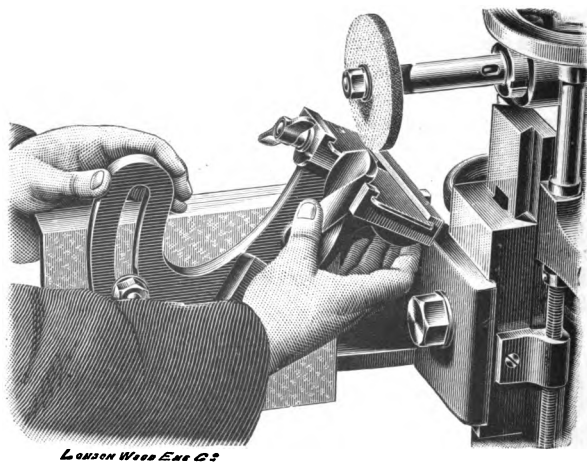

FIG. 222.—Method of fixing drill.



London Works Eng Co.

FIG. 223.—Grinding twist drill.

Commutator Grinder.—Fig. 238 is a portable apparatus for grinding the commutators of dynamos in place. The emery wheel is carried on

a compound slide rest with swivelling arrangement for bringing the grinding wheel into position.

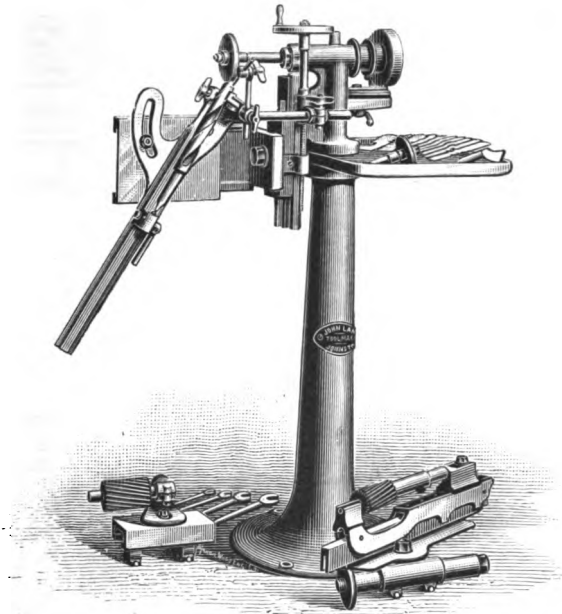

FIG. 224.—Lang's grinding machine.

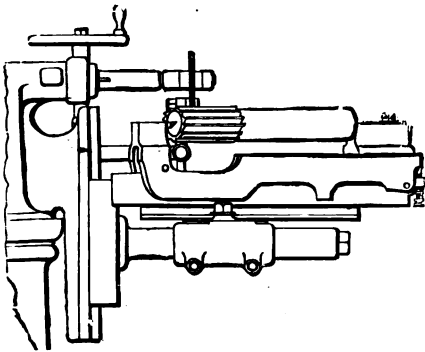

FIG. 225.—Sharpening reamer.

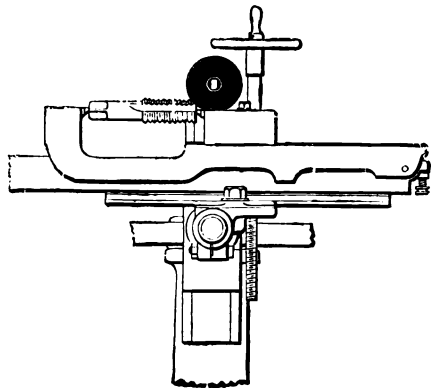

FIG. 226.—Feuling tap.

Beyer, Peacock & Co.'s Patent Universal Lapping and Grinding Machine (Fig. 239).—To render the following particulars clear, it may

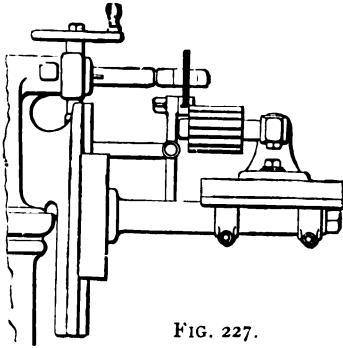

FIG. 227.

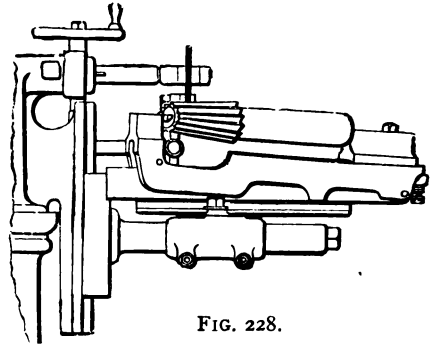

FIG. 228.

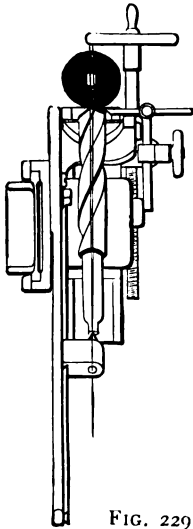

FIG. 229.

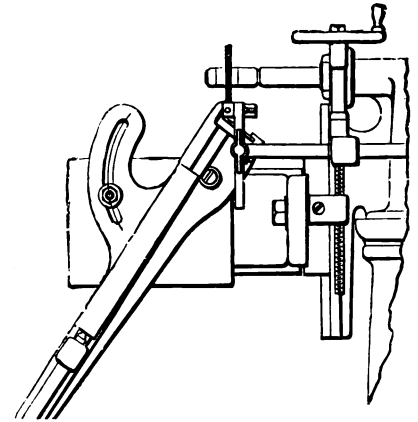

FIG. 230.

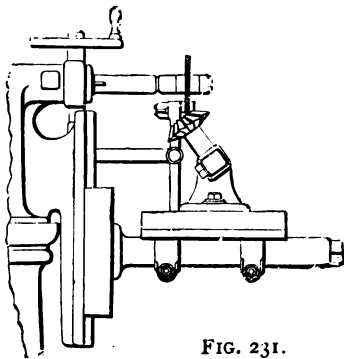

FIG. 231.

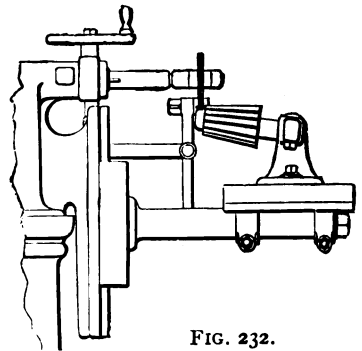

FIG. 232.

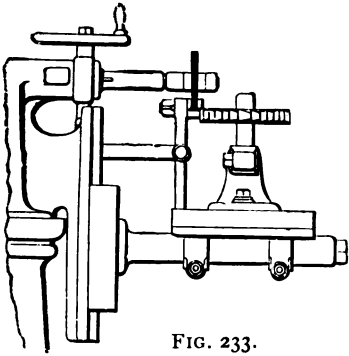

FIG. 233.

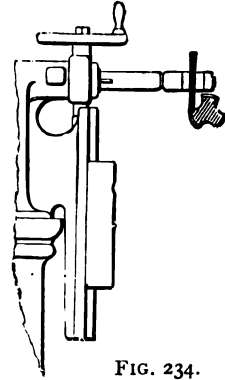

FIG. 234.

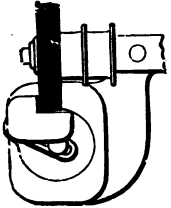

FIG. 235.

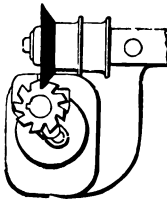

FIG. 236.

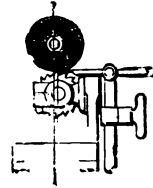

FIG. 237.

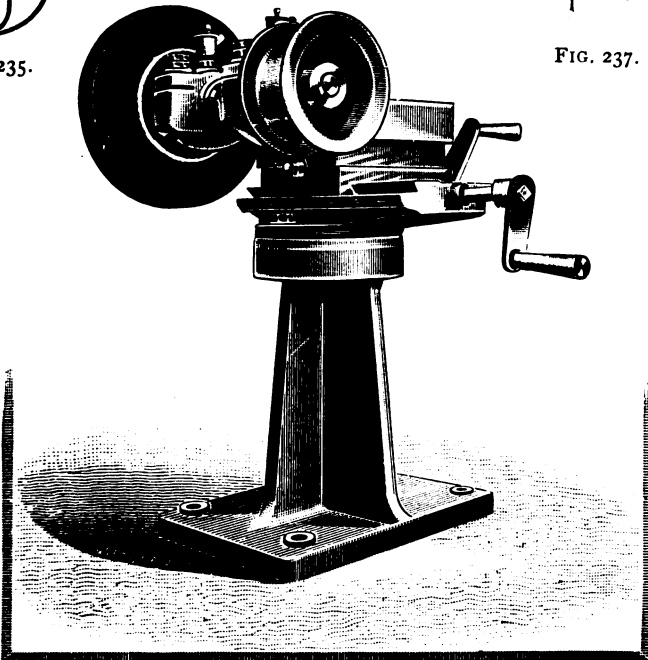

FIG. 238.—Luke and Spencer's commutator grinder.

be stated that the principle on which this machine depends in the lapping out of holes is the use of a series of eccentric spindles. The

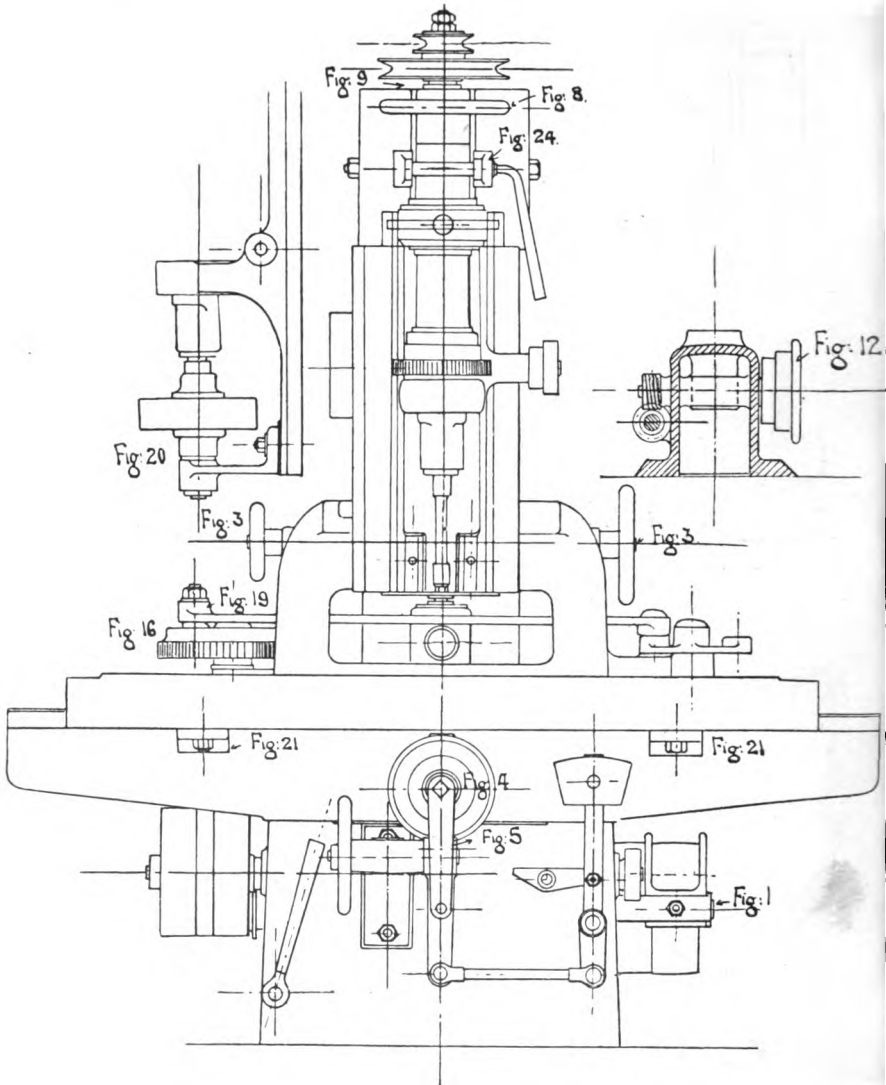
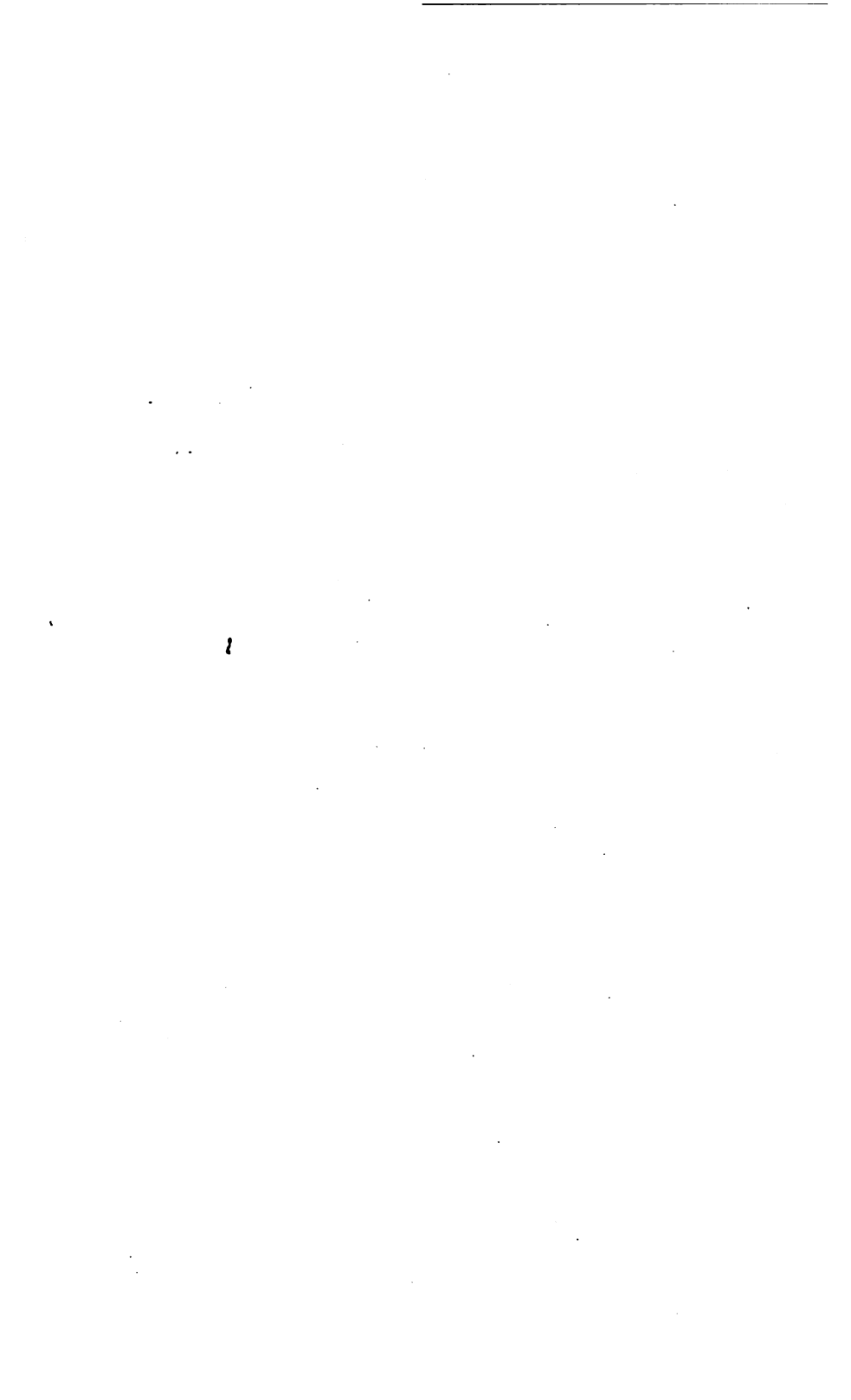
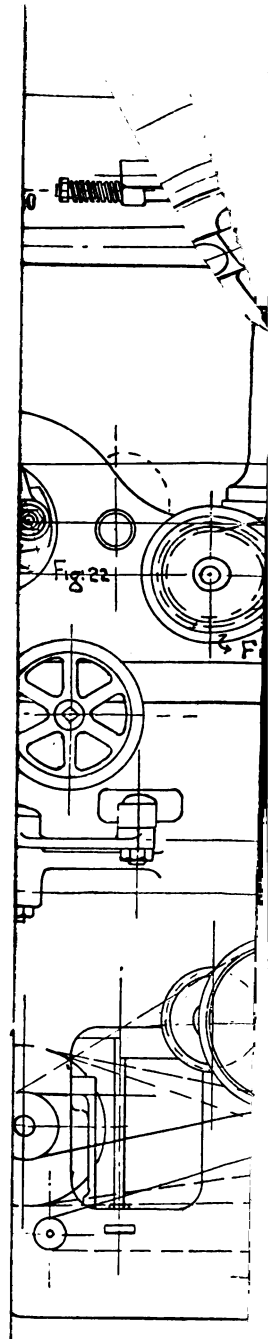

FIG. 239.—Universal lapping and grinding machine.

inner one carrying the grinding wheel is somewhat less in diameter than the hole to be ground, and revolves at a high velocity. This grinding





AND GRINDING MACHINE
O., MANCHESTER.

wheel is brought in contact with the surface of the hole to be ground by adjusting the orbit (in which it revolves, and which orbit revolves) to the necessary extent, which is accomplished by increasing the eccentricity of the spindles, by means of the hand wheel shown on the drawing as Fig. 8. These movements are combined with an adjustable vertical reciprocating motion of the whole system of spindles, actuated by the crank, rod, and levers (Figs. 10, 22, and 24) for the purpose of traversing holes of various depths. When lapping out holes, a grinding wheel should be used of such a diameter as will enable it to pass freely through the holes about to be ground.

The eccentric orbit, in which revolves the emery wheel, is adjusted centrally with the hole by means of the transverse adjustment on the headstock (Fig. 3), and longitudinal adjustment on the main table (Fig. 4), this table having a fine adjustment with worm and wheel (Fig. 5), which is actuated by a clutch (Fig. 6). The correct position is found by inserting the grinding wheel in the hole and revolving the main spindle (Fig. 7), while at the same time throwing the internal spindle (Fig. 2) sufficiently out of centre to bring the emery wheel in contact with the sides of the hole all round.

The feed is obtained by carefully increasing the eccentricity of the grinder spindle by turning the hand wheel (Fig. 8) at the top of the main spindle, which should be then fixed in position by means of the lock nut (Fig. 9). When gauging work is fixed on the machine table, the emery wheel can be raised out of the hole by liberating the connecting rod (Fig. 10 on drawing).

Grinding Expansion Links and Blocks.—To grind expansion links and blocks, the grinder spindle is set concentric with the main spindle, and is locked in that position by means of a set-screw Fig. 13, the mandrel used for lapping holes being replaced by one having an adjustable lower bearing (Fig. 14). The main table remaining stationary, the supplementary table is guided between vee strips which fit into the grooves of the main table.

In grinding radial links and blocks, the above-mentioned strips are removed, and the table is bolted to the radius arm (Fig. 18), which must be set to the exact radius required.

In either case the stroke of the table must be accurately adjusted to suit the length of the link or block by means of the horizontal disc and connecting rod (Fig. 19).

In grinding slide-bars, &c., the large emery wheel is used (Fig. 20), the work being fixed on suitable chucks mounted to the main table, the longitudinal traverse being adjusted by means of the spring stops (Fig. 21), to suit the work being ground. The axle boxes are fixed on a chuck which swivels on a centre, bolted to the table, and is set square to the same by taper blocks sliding in the table grooves, and fitting into recesses in the end of the chuck. When grinding, a constant stream of clean water should be forced on to the emery wheel by means of the pump attached to the machine.

Grinding Shafts of Steel.—Grinding is superseding lathe work in some cases by removing a small amount from steel shafts, axles,

spindles, etc. Although the roughing has previously been done in an ordinary slide lathe with a cutting tool, it is found an advantage to use a grinding machine to get a more accurate finish on the work. There are occasionally small chilled portions in castings of iron, especially when the work has cores (which have been held in their place in the mould with nails). These small, hard points resist ordinary turning or boring tools, and are a source of trouble and delay if they cannot be cut out with hammer and chisel. If, however, an emery wheel is used, the obstructions can be removed in a few minutes.

Circular-saw Sharpening Machines.—There are two kinds of saw teeth (Figs. 241, 242). The former has teeth cut at equal distance apart around its periphery with a saw file. An improved form is shown in the latter case, being spaced and cut with a coarser pitch. This leaves the teeth much stronger, and at the same time gives ample space for the cuttings to fall away. The makers, Messrs. Spear & Jackson, state that

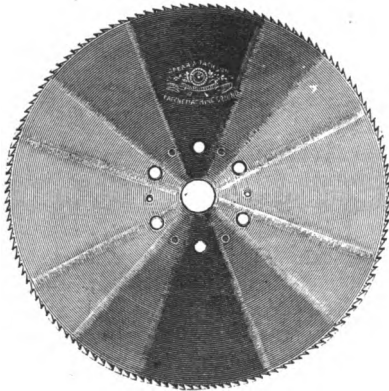

FIG. 241.

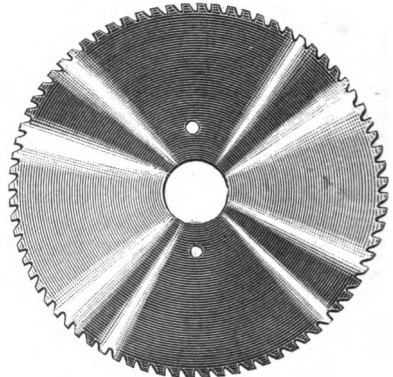

FIG. 242.

the improved form of teeth gives very satisfactory results, as no clogging occurs. The teeth are too hard to be sharpened by filing, but are easily and quickly ground by an emery wheel.

An automatic sharpening machine is shown in Fig. 243 with circular saw under treatment. This is provided with an emery wheel which has a uniform reciprocating motion, the saw being thus moved one tooth at a time, which movement is identical with that of the wheel. Therefore the grinding is regular, as each tooth is equally treated. In this respect automatic sharpening is valuable, because each tooth cuts with the same pressure.

Swing-frame Grinding Machine (Fig. 244).—This machine is suspended from overhead, and is fitted with universal joints and telescopic rods, so that the wheel may be twisted to any angle, or swung into range to work on the surfaces of machine beds and other heavy castings in the fettling shop, instead of chipping and filing them. In some cases a circular wire-scratch brush is used in place of the grinding wheel,

which quickly cleans the sand away and shows any projections to be smoothed down.

It is the practice to prevent as far as possible any loose portions of emery doing damage by covering the discs with suitable covering. This is seen to the full extent on an emery tool grinder, as in Fig. 190A, where only a small niche is left for the rest on which to place the tool while it is being ground. It should be pointed out that the percentage of flying wheels is very small, but when they do burst, owing to their

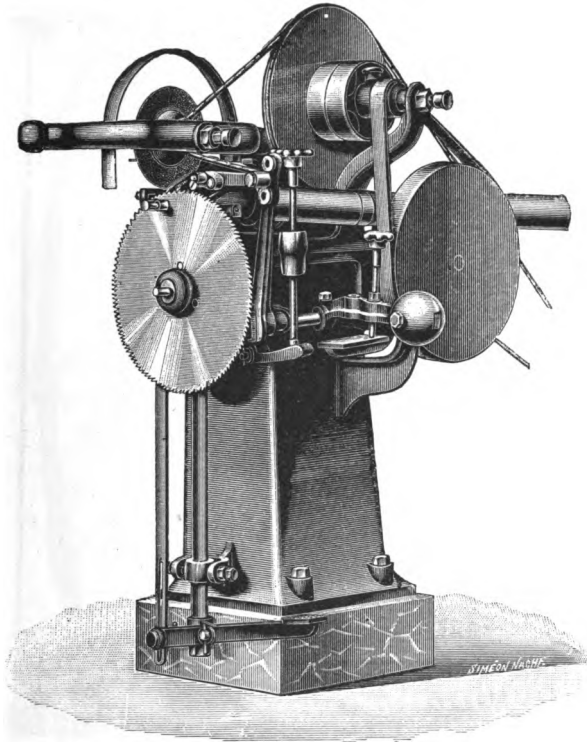

FIG. 243.—Circular-saw sharpening machine.

centrifugal force, they may do considerable damage if allowed to get away.

Keeping wheels in true condition is another and an important help against breakage. A systematic overhaul of each disc is adopted in many shops. There is much to be said in favour of this practice, which will perhaps be better understood if the faults of an untrue wheel are considered. A dull wheel has little bite. An eccentric wheel does not cut evenly; it is more likely to burst, and destroys the evenness of the spindle bearings, causing it to vibrate, and therefore unduly wear away.

Polishing and Buffing.—Small work, such as cycle and sewing-machine parts, are sometimes ground and polished on an emery band machine, such as is shown in Fig. 245. The belt or band is emery

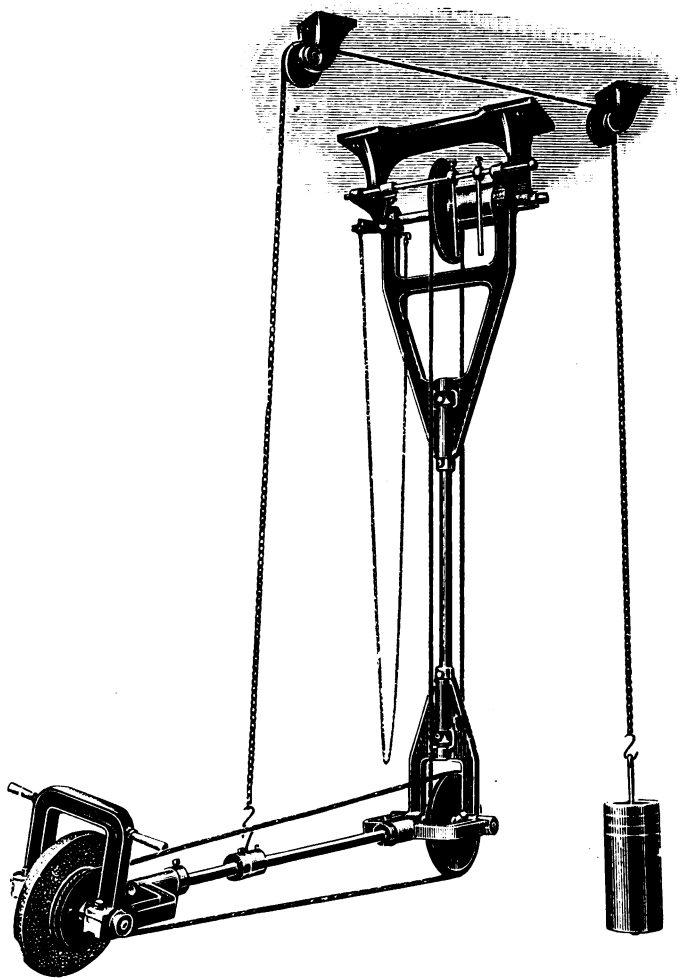

FIG. 244.—Swing-frame grinding machine.

covered, and is kept uniformly apart by passing over guide pulleys. Several operatives may be working at the same time at this machine.

After the articles are polished they are finally finished on "mops" and brushes. A mop or "bob" is made by securing a number of sheets of calico between two small washers of leather. The calico sheets are

6 in. to 8 in. diameter, and form a wheel about $1\frac{1}{2}$ in. wide. The centrifugal speed of the mop enables the workmen to hold the articles to be polished against the rim with a considerable pressure. Rudge, lime,

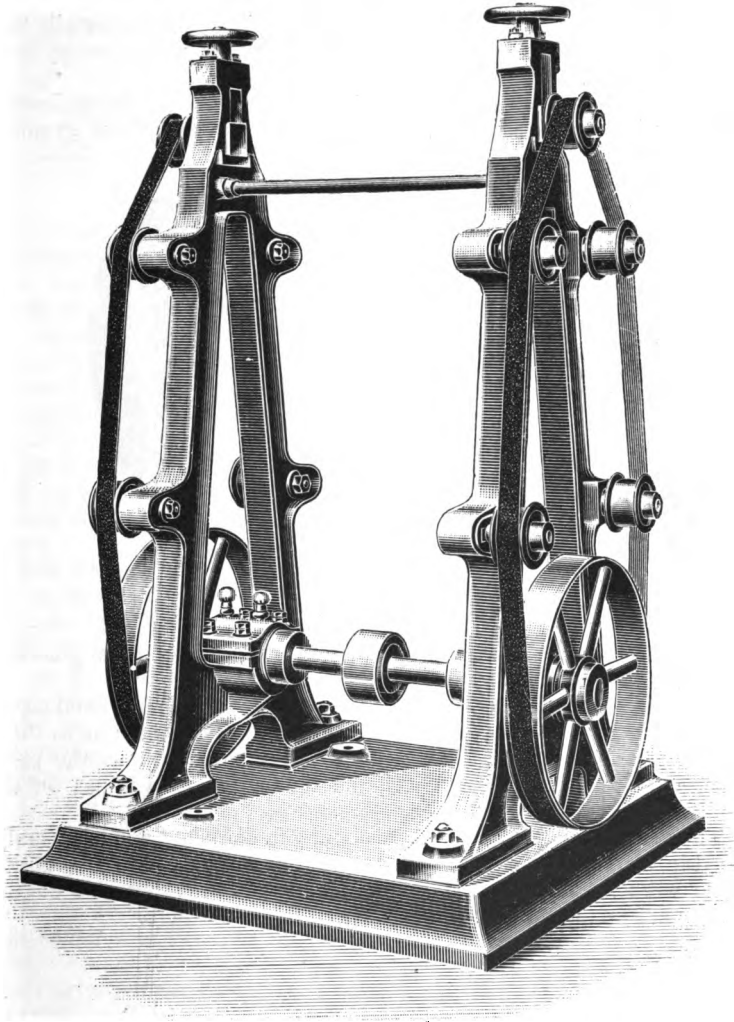

FIG. 245.—Emery band machine.

and crocus powder are used on the mops, according to the material worked upon. These mops and brushes are fixed at intervals on a shaft running the whole length of a bench, and small machine parts in brass and plated goods are quickly polished to a high degree.

Polishing is much better done with revolving discs than by hand. The wheels used are sometimes made of porpoise hide when for small work, or built up with wood and covered with porpoise or leather strips for larger work.

There are other wheels made of felt; these, however, are usually thin discs, and are first given a coating of glue and then fine emery flour sprinkled over it.

The machine illustrated (Fig. 246) has two wooden wheels leather covered, which are each 3 ft. diameter. As the process of grinding

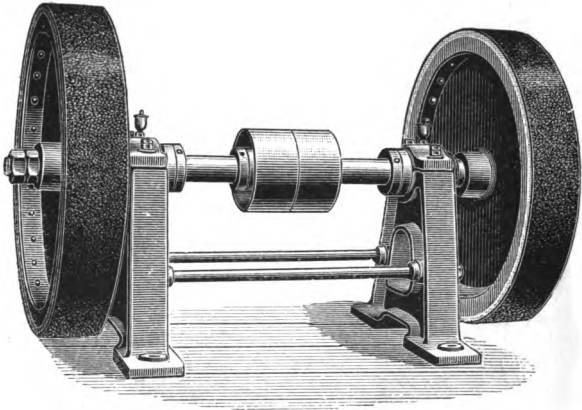

FIG. 246.—Polishing wheels.

destroys the cutting capacity of the wheels, a further supply of glue and emery makes them new again.

Polishing or Glazing.—This machine spindle has a right-hand taper-cut screw at one extremity, and a left-hand one at the other; on to these the discs are screwed in the direction of the rotation, thus, the more pressure on the rim of the wheel, the tighter the grip it has on the spindle.

The wheels called “glazers” are about 3 ft. diameter, and are usually placed in the grinding shop. They serve a good purpose in locomotive engine works, where the flat parts of the hardened portions of the motions are first ground and finally glazed to polish them.

CHAPTER XI.

COLD IRON AND STEEL SAWING AND PLANING MACHINES.

MANY small studs and axles which were either forged hot or cut from cold bars at the anvil, and subsequently tooled between the centres of a lathe, are now made directly from the bar in an automatic machine, known as a turret lathe, made expressly for such work. The bars, however, are of limited sectional area, because, if heavy bars or shafts of considerable length were carried in a turret lathe, their fixing and centrally supporting would not be economical, as the space required beyond the headstock would be equal to three or four times the whole length of the lathe. Besides this, an undue amount of weight would be put on the machine bearings, causing a waste of power in rotating the shaft, as well as increased wear in important parts. It is therefore the practice to first cut the shafts and bars into the required lengths by sawing.

The Automatic Sawing Machine—illustrated in Fig. 247, by Messrs. Lee & Hunt, Nottingham—is designed to carry a circular saw, which will take a clean and straight cut through a bar of iron or steel, making it to a dead length, which for duplicate work is absolutely necessary. The cut surfaces are smooth, and therefore need no subsequent dressing, as is the case with hot iron saws, which usually leave a flash on the bar end, while the length is necessarily in excess of that required. A further disadvantage is the additional cost in heating the bars to be sawn.

Cutting off bars of cold iron or steel at the anvil is obviously slow at the best; the ends have to be centred, turned, or shaped, then re-centred, and frequently the best brands are either badly bent or the fracture badly torn, especially in Lowmoor or Swedish iron.

In the above type of machine the driving spindle is forged with a large flange at one end, to which the saw is bolted; this ensures a positive drive. An automatic traversing motion is given to the saddle through a clutch arrangement on the feed screw, and when reversed the saddle is traversed back by a quick return through a system of gears. A stout shaft of steel extends through the machine bed at each end, and on this shaft a worm is carried; this also is attached to the under part of the saddle by trunnion bearings. On the driving side, between the housing and a collar forged on the worm, an antifriction race carrying steel balls is located, which greatly reduces the power required to drive the machine. The phosphor bronze wheel which gives motion to the saw spindle is

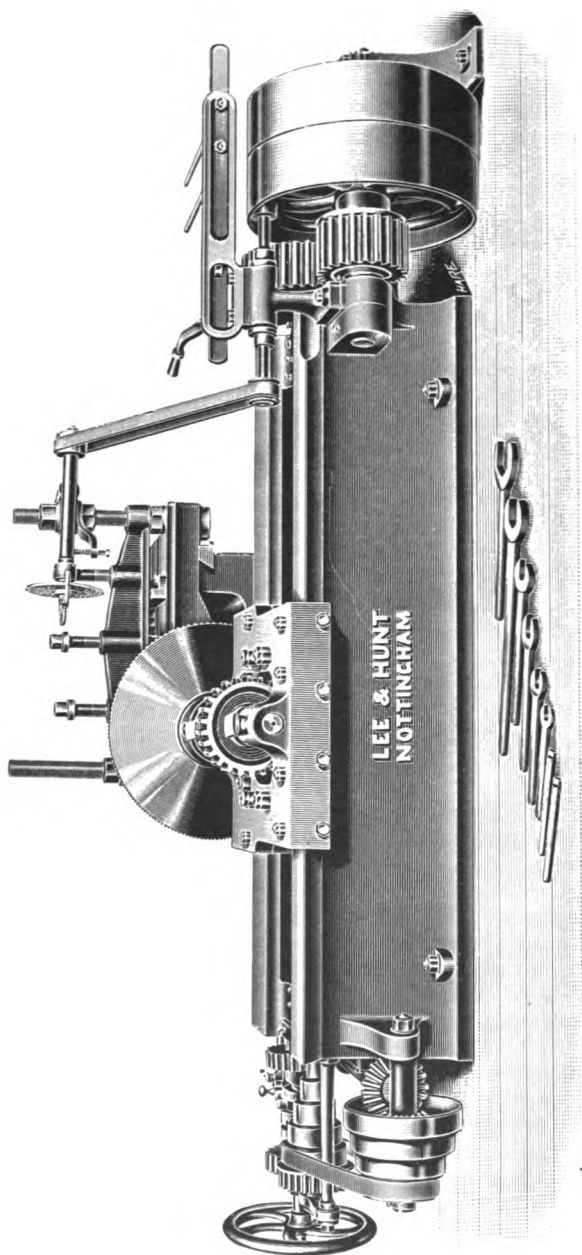

FIG. 247. — Automatic sawing machine.

provided with an ingenious patented arrangement which disconnects it, thereby allowing the saw and spindle to be revolved by hand, and the sharpening of the saw teeth to be done while in place by the emery wheel shown.

Sawing machines of the larger types are fitted with a clutch arrangement for the above purpose, while the smaller machines carry their bronze wheels on conical bushes. Both types are kept in place by lock-nuts, but the tension once removed, the spindles are instantly free, as is obviously seen from Fig. 247. These machines are frequently made with self-contained engine.

A circular saw of 36-in. diameter will traverse at $\frac{3}{4}$ in. per minute along the bed with a peripheral speed of about 40 ft. Thus, a solid steel shaft of 6 in. diameter can be cut through in $8\frac{1}{2}$ minutes, or a steel girder, 12 x 5 in. in 20 minutes. Saws made of high speed steel (as now used) may have their speed considerably increased.

Instead of a circular saw, a milling disc with a number of cutters may be fixed to the driving spindle, which at once converts the machine into a powerful mill for plain surface work, such as facing the ends of huge castings or forgings of steel which would otherwise be difficult to dress.

Power Hack-saw.—The small machine given in Fig. 248 is by A. Herbert, Limited, Coventry. This is a simple arrangement; the saw is a hardened steel blade, called a hack saw, and is rigidly held between clamping plates at each end of the saw frame. The saw has a reciprocating motion, and is guided in a straight line by means of a slide. The pressure of the blade on the work is regulated by a sliding weight, so that a feed suited to the material can be obtained. The angle of the connecting rod is such as to relieve the pressure on the saw on its return stroke. The saw blades are 10 in. to 12 in. long, and are not re-sharpened when dull, it being more economical to insert new ones.

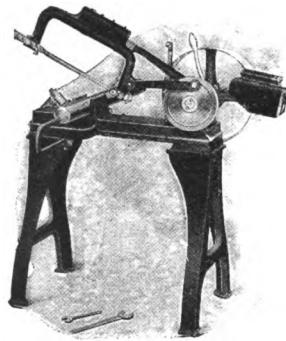

FIG. 248.—Power hack-saw.

Saws for cutting Metal.—Circular saws for cutting through bars of wrought iron or steel are of two principal kinds, those having vee-shaped teeth and those with stout teeth of a coarse pitch. The vee teeth are suitable for light work with fine feeds; if used in cutting through thick shafts the chips are apt to clog on wedge, and the teeth may be broken off. The saws having the coarse-pitched teeth are preferable for coarse traverses. The pitch varies considerably, but the following may be taken as generally adopted for ordinary purposes:—

Diameter of saw :	10" to 16"	18" to 24"	26" to 32"	34" to 40"	42" to 48"
Pitch :	$\frac{3}{8}$ "	$\frac{1}{4}$ "	$\frac{5}{16}$ "	$\frac{3}{8}$ "	$\frac{7}{16}$ " to $\frac{1}{2}$ "

The usual periphery speed is about 45 ft. per minute for sawing very

hard materials, such as armour plate, but for the soft metals and alloys this must be considerably increased.

Band Sawing Machines for Cold Metal.—Another type of machine is one in which a steel band is employed as the saw. These machines are specially adapted for curved cutting on plates of wrought iron or mild steel, and for sawing out the central blocks to form the webs in crank shafts.

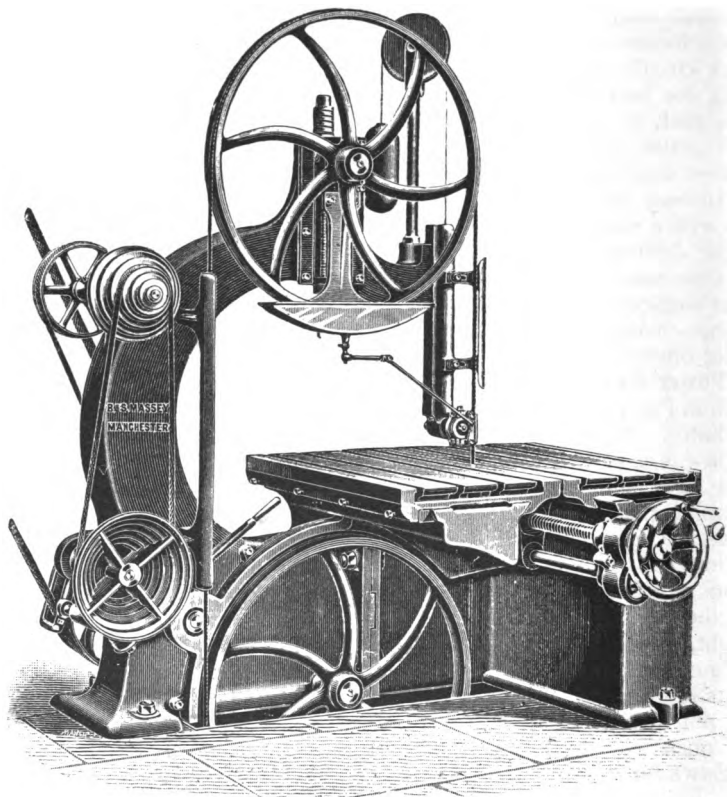

FIG. 249.—Metal band saw.

Dovetails can also be formed under the action of the band saw, and the fins removed from large stampings of intricate shape. Fig. 249 shows a band sawing machine which is fitted with an automatic slide for straight cutting, and is also capable of sawing the larger pieces of work either of angular or of curved form (the latter of course being fed by hand). The cutting speeds for wrought iron and mild steel up to 3 in. or 4 in. thick is at the rate of 1·3 sq. in. per minute, greater thicknesses at

about 1 sq. in. per minute. The saw blades are from $\frac{3}{4}$ in. to $1\frac{1}{4}$ in. wide, according to the kind of work to be cut. The narrow blades, after repeated sharpening, are retained for work having sharp curves.

To obtain a uniformly straight saw-cut through the metal, great care has to be exercised in *forming*, *brazing*, and *finishing* the joint of the blade. A small "forge" is usually employed for brazing broken saws. The ends of the saw are tapered with a file, and a lap joint is made by binding the ends together with fine iron wire and then with fine brass wire. The joint is next wetted with a strong solution of borax and water. To hold the blade perfectly straight, a clamp is used having one face truly planed; against this the back edge of the saw is fixed.

A jet of gas and air is then brought to play directly over the joint until the brass melts. The gas is then turned off, the blade, cooled with the air blast, and the joint filed down until it is the same thickness as the rest of the saw. The blade is finally set and sharpened in a saw-sharpening machine.

Rotary Planing Machine.—Fig. 250 shows a rotary planing machine by John Tangye, Manchester, in which the cutting tools are carried by a large head or disc. It is claimed that this method of cutting is superior to "reciprocating" tools, while the time occupied over a given piece of work is said to be less. Unlike the shaping machine, the slide carrying the driving spindle is made to travel longitudinally, and the cutters to rotate past the object to be dressed.

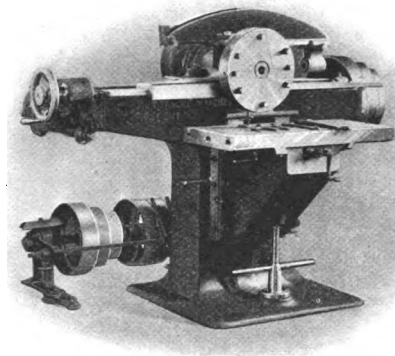

FIG. 250.—Rotary planing machine.

Shaping Machines.—When short pieces of work are to be planed, shaping machines are used in preference to planing machines. These are made in a variety of forms: *single-gear*ed, in which the motion is direct from the driving shaft to the connecting rod and ram; *double-gear*ed, in which the motion is transmitted through gear wheels to increase the power of the machine. Single-gear shapers are usually of small dimensions suitable for running at high speeds for light work. In these machines the *cutting tool travels*, while the work to be operated upon is fixed to a table which is stationary or is supported in a machine vice, as the case may be. Single-gear machines have one uniform travel to the ram and cutting tool in the forward and backward stroke.

Double-gear Shapers are fitted with a link or other quick return

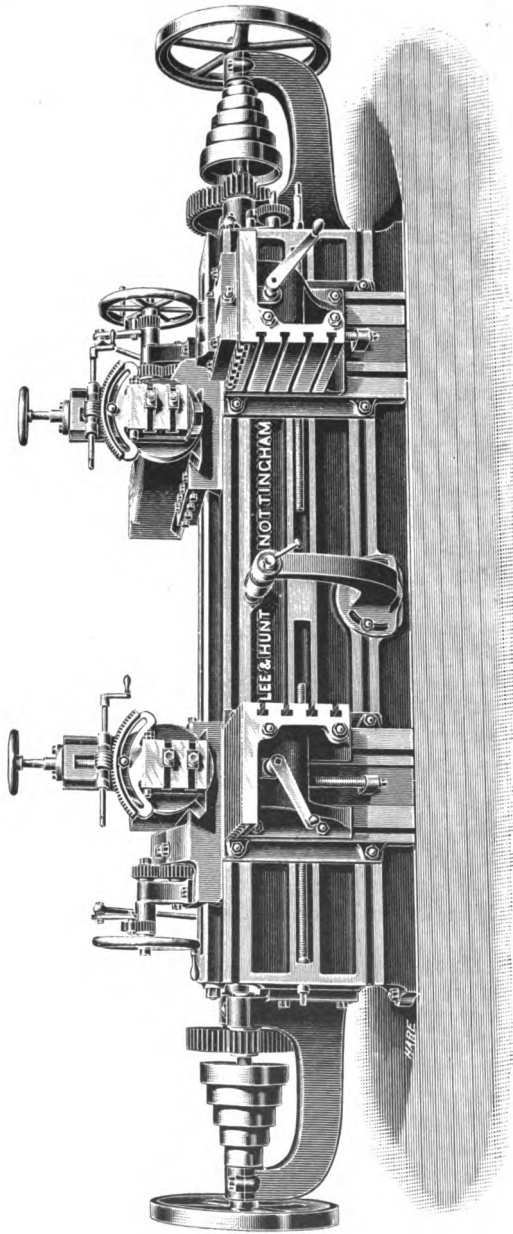

FIG. 251.—24-in. stroke shaping machine.

motion to the ram; the larger type of machines are frequently constructed with two heads or saddles which are independent in every movement (Fig. 251). In machines of the latter class, two cutting tools may be operating simultaneously on the same piece of work. Generally, however, one piece is being tooled while another is being set, unless the surfaces are large. The down-feed is by hand wheel, or made automatic by means of a ratchet and paul worked directly from a disc on the driving shaft. There are two distinct forms of transverse feed.

(a) By means of a system of levers located at the end of the machine bed to gears and feed screw, which rotates in a nut carried by the saddle.

There is no objection to be found in the above arrangement when the machine has a short bed, but when the saddle is working at the opposite end of a long bed, say, taking a finishing cut near a shoulder, then the arrangement is defective, as the operative has to leave his post to manipulate the feeding screw or paul without being able to see how the tool is progressing.

(b) By means of a set of gears, actuated by a ratchet motion which

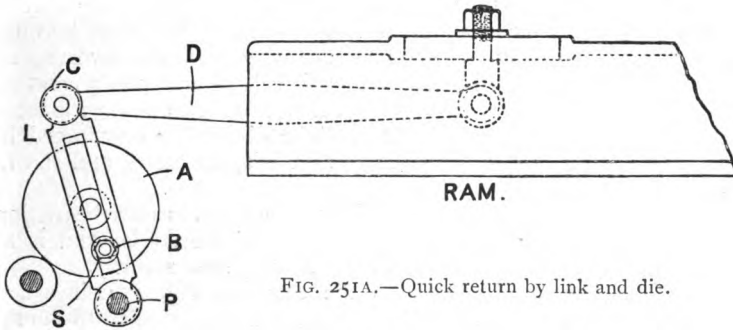

FIG. 251A.—Quick return by link and die.

is attached to one side of the saddle, and which traverses it along the bed of the machine.

This motion shown in Fig. 251 is very compact, and since the hand-wheel is near the ram and the cutting-tool, there is much to be said in favour of this arrangement.

Quick Return by Link and Die.—There are several methods of producing a quick-return motion for the ram of a shaping machine, one of which is given in detail in Fig. 251A. The link L is pivoted at P, and is attached at C to a connecting rod D; the opposite end of D is secured directly to the ram carrying the cutting tool. A pinion on the driving shaft engages with a spur-wheel having a tee-slot projecting from its face on one side, the slot running from the wheel-boss to an aperture near the teeth. When the bolt B is inserted in wheel A, a socket S is fitted upon it, then on to this the die is passed, and lastly the link is slid over the die and secured by means of a large washer and nut, and the hinge-pin at the lower end fixes the mechanism ready for use.

Hendey Shaping Machine.—The machine shown in Figs. 252-3 is a shaping machine made by the Hendey Norton Machine Co., of America. The arrangement of the reversing, and the feed motions are entirely different in character to the machines above described.

Friction Clutch Drive.—The movement of the ram in this case is 15 in., and any *intermediate distance* can be obtained while the machine is running. Referring to drawing No. 3, it will be seen that the ram is fitted with two stops which are adjustable by means of the gripping handles attached to them.

Micrometer Adjustment.—There is, in addition to the stops, a Micrometer Adjustment attached to the handle of the reversing lever which permits the stroke of the ram to travel with great exactness. The regulation is effected by means of a screw with a thumb-nut attached to a wedge-shaped piece on the handle of the reversing lever.

Reversing Mechanism.—There are two gear wheels engaging with a rack beneath the ram, the gears being driven directly from a wheel on the pulley shaft. When the stop on the ram strikes the reversing lever, the movement is communicated to the reversing rod which actuates the friction disc, and thus makes contact between the disc and the driving pulley. As soon as this occurs the friction is locked by means of a spring operating on a point near the bottom of the reversing rod. This is, therefore, converted into a positive drive until the second stop on the ram strikes the lever, whereon the position of the lever is moved and the whole mechanism liberated. The disc being now forced into the other driving pulley, frictional contact is again made, and the ram moves in an opposite direction.

Use of Locking Spring.—The locking arrangement insures the frictional contact remaining in place the full length of the stroke, and it also enables the machine to run and reverse on very slow speed.

Fixity of Ram.—Referring to the drawing, Fig. 252, it will be observed that in these machines there is not a moving slide to the ram, but to the table slide, which is fitted with a longitudinal traverse.

Hinged Table.—The table to which the work is secured is provided with a hinge joint at the top; this is useful when taper work has to be planed, the inclination being obtained by means of a screw at the bottom.

Locking Lever to Vice.—The parallel vice is not held down with bolts, but by means of a lever which works within the box-table.

Quick Return.—On the overhead shaft there are two pulleys to the machine; the larger one carries a crossed belt which gives the quick return motion to the ram. The other is a cone pulley with two steps to vary the speed of the cutting stroke.

Slotting Machines.—Slotting machines are made to cut in three different ways; slotting grooves in wheels, called keyways; "machining" plane surfaces, and "tooling" circular work, such as the ends of knuckle joints or connecting rods.

There are three feed motions, viz. longitudinal, transverse, and circular, each of which may be worked automatically or by hand (Fig. 253).

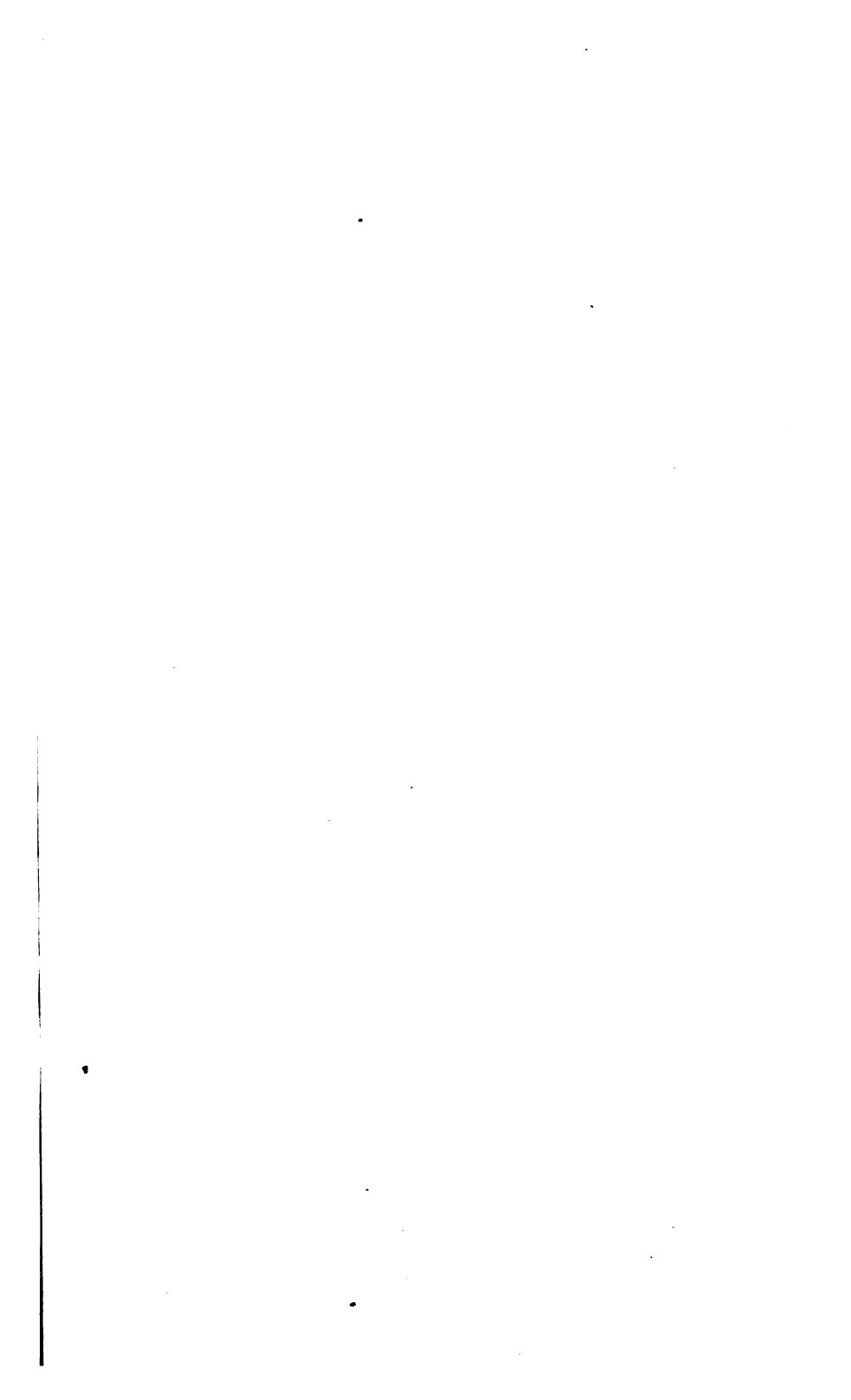

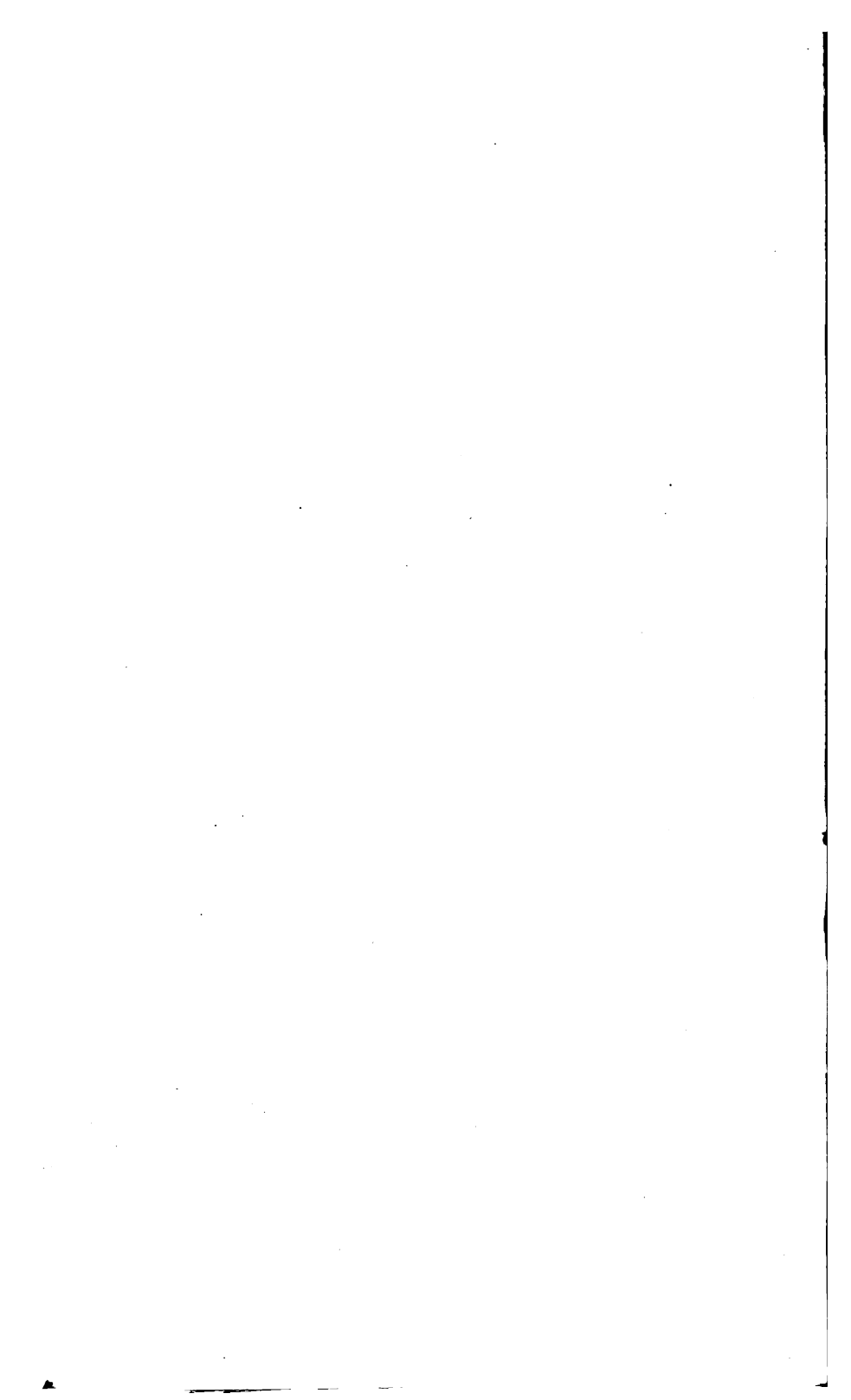

The ram carrying the cutting tool works in two vertical slides, and has a reciprocating motion, in which it is directly driven with a connecting rod by a crank pin, carried on a slotted disc at the end of the driving shaft in an ungeared machine, or by a link in a geared machine, which gives a quick return motion to the cutting tool

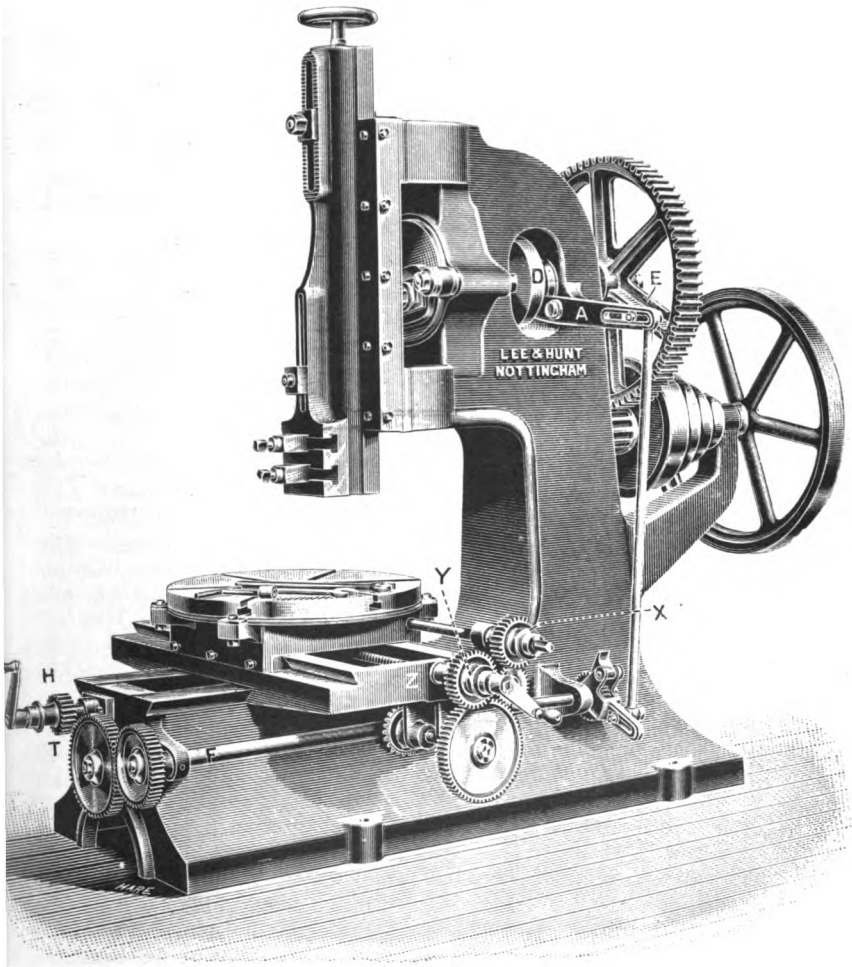

FIG. 254.—Slotting machine.

(251A). On the driving shaft a cam disc, D, is keyed. At the side of the main body of the casting an axle, A, is secured by a nut. On axle A rides a double-ended lever, at one end of which a steel roller is pivoted, which, by passing into the cam-groove on disc D, actuates the

Q

lever. At E a connecting rod is fixed, which operates at its other end; a bell-crank lever, carrying a paul or catch, which gives motion to a wheel keyed on shaft F. The cam-disc, D, is keyed on the driving shaft in such a position that when the ram is raised to its extreme limit preparatory to its return stroke, the cam operates the roller, and gives a short and sharp motion to the lever which communicates with the connecting rod, and ratchet wheel, *w*, is moved forward one or two teeth. The cut is thus "put on" alternately with the fall of the ram, and the tool cuts uniformly in a straight line. Each of the feed motions is obtained from the same ratchet-wheel shaft, G, and they may be operated either separately or in combination.

The longitudinal motion is actuated by gripping the wheel H to the coned bearing on the end of the traverse screw T, on which it rides; the "circular" by similarly gripping the wheel X, and the transverse by gripping the wheel Y to the traverse screw Z.

The circular motion is directly obtained through a worm carried by a bracket which is attached to the bottom slide; and the worm, carrying within its bore a small key, is traversed along the shaft as well as being rotated by it. Thus when the wheel is caused to grip the shaft the worm gives a slow movement to the table on which the work is secured. In machines of a larger type the worm and wheel are sometimes placed below the slide, out of the way of cuttings.

Circular-ended connecting rods and rounded joints are familiar examples showing the advantage of slotting in the above manner. "For plane surfaces, however, slotting machines will not compare with milling, shaping, or planing machines. The reason is partly because the increased distance between the tool nose and the slides in which the ram works gives more or less leverage to the ram. Another cause is that as the cut descends the leverage is greater, and the tendency is to leave the surfaces somewhat rounded instead of flat—well shown in slotting deep holes. In the last-named respect a shaping machine is another of this class.

Planing Machines.—A planing machine consists of two upright standards or cheeks bridged at the top by a cross rail or tie bar and secured at each side of the machine bed on which the table rides. The faces of each upright are scraped to a true plane, and down the centre of each face a groove is made, into which groove a square-threaded screw is placed vertically. At the top of these screws bevel wheels are geared with similar wheels on a horizontal shaft (see Fig. 255). Beneath the cross rail a horizontal slide is fixed which is capable of a rising and falling motion according to the work, whether it be a deep casting or a flat bar of iron to be "planed." The slide carries at the back two square-thread nuts which are fitted to the vertical screws, and at its front a bevel-wheel shaft which gives motion to the vertical slide carrying the tool-box and tool. Running parallel with the bevel-wheel shaft, and also taking bearing in the cross-slide, is a square-threaded screw engaging with a nut on the transverse slide or saddle; the tool-box can be moved evenly across the work at any distance from the table beneath it. Thus

the cutting tool may be moved vertically and horizontally by means of the slide and saddle respectively.

Each movement may be actuated by hand or automatically fed by a system of gear-wheels. By carrying the motion shafts through the slide, as in Fig. 255, the operator has the opportunity of working his machine from either side; this is an advantage, especially in deep cutting. These machines are not unfrequently engaged in "dressing up" surfaces which must be straight, but which do not have to act in any way as slides do. In work of this character the "dead" smoothness and the absolute evenness is not so much desired as a general flat appearance.

In machine-tool building, planing machines are most generally fully occupied in high-class work. It is in this work especially that the surfaces produced must be even, smooth, and truly parallel. Therefore, on the accuracy of the planing the subsequent quality of the machine construction greatly depends, whether the manufacture of the tools is of a heavy, medium, or light class. Remembering this, it is obvious that the principal moving parts of the machine should slide with as smooth a motion as possible, so that the surfaces after tooling will be such as to require a minimum amount of alteration or dressing.

The late Sir Joseph Whitworth of Manchester designed his planing machines with a powerful screw running the full length of the machine bed, and a nut engaging with this was secured to the underside of a long table. The table was thus traversed along the machine bed, and by means of a "reversing motion" the direction of movement was changed. At this instant, by a novel device, the tool-box in which the cutting tool was secured was also turned about, with the result that there was almost a constant cutting action, while the machine, of course, moved at one uniform rate during the backward and the forward stroke.

The screw-driven planing machine embodies all that can be desired in evenness of running, but the reversible tool holder is not now made, owing to the amount of wear, at a part which of all is the most vital, viz. the joints about the tool-box.

In many planing machines the gearing which transmits the power of the driving belt to the table produces more or less vibration in the machine, which is communicated to the cutting tool, the effect of which is exhibited upon the work in the form of *wave lines*, called "chatters," at right angles to the motion of the table, and of greater or less intensity, dependent upon the character of the vibrations, but always visible to the naked eye. So that planing thus produced, if intended for the high-class "machine tools," will need an amount of scraping and fitting to bring it to a true surface.

In the above type of plane the reciprocating table, being operated directly or indirectly through spur or bevel gearing, the speed of the return stroke is limited by the capacity of this gearing to resist the shocks which a high velocity imparts.

Chatter Marks.—Perhaps the greatest defects in planing machines have been the shock created by the reversal of the driving mechanism operating the table when running at a high velocity, and the difficulty

in stopping the table at either extremity of its movement by manipulating the reversing apparatus. If the workman desired to reverse the motion of the table while "under cut," he had first to throw the feed paul out of gear to avoid doubling the feed on the unfinished cut when automatic action was resumed. If he threw the paul out of gear, it could not be replaced so as to continue the original cut, and a mark upon the work was sure to occur.

Spiral-geared Plane.—A planing machine by Messrs. William Sellers & Co., Philadelphia, is illustrated in Fig. 255. This machine, "The

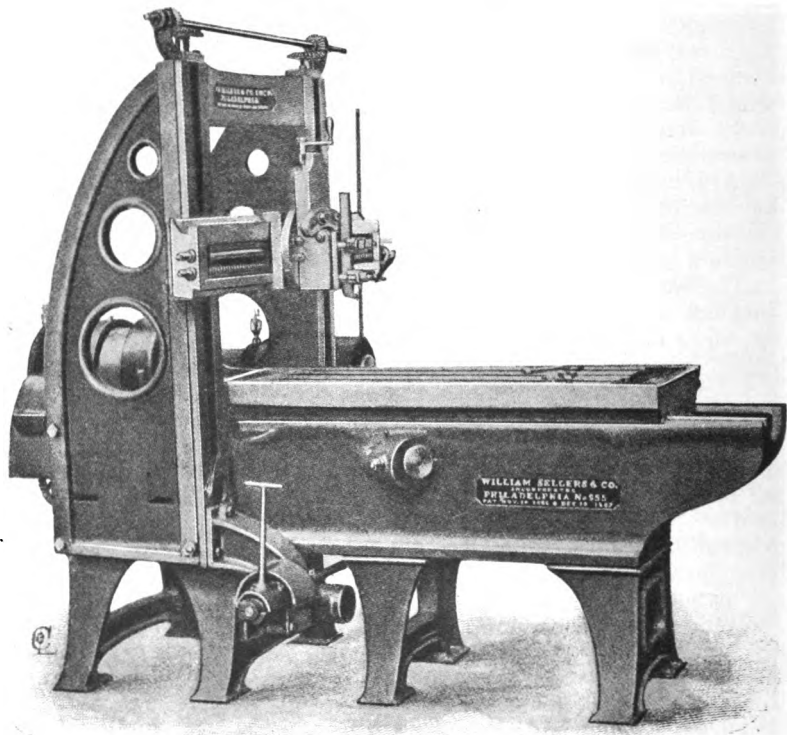

FIG. 255.—Spiral-geared plane.

Patent Spiral-Geared Plane," is now in general use, where chatter and some of the defects above referred to were felt to be serious.

It will be gathered from this that the objections referred to have been eliminated by this different type of machine. However that may be, there is a novelty in the idea and arrangement which has been to some extent imitated.

Briefly the changes are these : The gears are boxed and sheathed.

A spiral pinion engages with an inclined rack on the under side of the table, instead of the straight-toothed rack and pinion. The reversing mechanism is actuated by friction clutches driven from a belt or belts running in the same direction. When the stop on the table strikes the lever at one end of the stroke, it draws one clutch out of engagement, and presses lightly against the other, which is running in the opposite direction. Owing to this frictional escapement mechanism, *which is operated at a uniform rate of speed independent of the velocity of the machine table*, the rate of the return movement is safely increased from 54 ft. to 72 ft. per minute, and this without shock to the cutting tools. The shifting lever is connected with the feed motion by a clutch which may be disengaged by a half turn of the handle on the end of the lever, and the planer table reversed as desired without taking up additional feeds. When a straight toothed rack and pinion, however well constructed and geared, are subjected to great stress, they cannot move with absolute precision. That is to say, when this form of gearing is employed, as in a planing machine, to traverse the table and work with sufficient force to overcome the resistance of the cutting tools, each fresh tooth of the rack as it is drawn into gear with the rotating pinion imparts to the table a movement more or less irregular.

Securing Work to be planed.—The work to be planed is firmly secured with bolts and clips to the machine table, which is provided with T slots. The surface of the table is truly flat, and is usually finished by taking a very fine cut over it after the machine is finally fitted up in place.

There are many pieces much more conveniently secured in the parallel machine vice described on p. 327, Fig. 363. Such work as engine cylinders and lathe headstocks, which have to be machined on their base, and which cannot be bolted directly to the table or held in the machine vice, are secured to angle plates. The angle plates greatly facilitate the setting, since they stand truly vertical when secured to the table of the planing machine. Angle plates also serve well as stops to heavy castings and forgings by being fixed in front of them whilst they are tooled over.

Crank and Elliptical Gear Wheels.—For work of small dimensions planing machines are sometimes constructed with elliptical gearing and a connecting rod to give movement to the table, as in Fig. 256, by William Muir & Co., Limited, Manchester. The wheels are located at the back of the bed, and the connecting rod or crank is attached to one of these by one end, while the other end is secured to the machine table. The elliptical gears are so arranged that a uniform longitudinal traverse can be obtained for cutting and a treble speed for the return stroke. Machines of this character, like those which are "screw-driven," run very evenly, and are superior to the rack-and-pinion machines for producing smooth surfaces on the work.

Limit of Speed Cone.—The driving is by speed cone, which is an advantage in light running, as variable rates of travel are required where a variety of metals are to be cut. There is, however, a limit to this form of drive, owing to the rapid speed at which the table would travel during the return stroke when the forward traverse is at a maximum. (This

does not refer to those machines which are fitted with a separate mechanism to actuate the return travel of the table.)

Large Planing Machine.—A few particulars of a planing machine designed for the heaviest class of work in armour plate and steel forgings may not be without interest. This machine, built by Messrs. William Sellers & Co, will plane a piece of work 25 ft. long by 12 ft. wide. It is provided with two saddles 45 in. long on the cross rail, which is 42 in. deep. The swivel-tooth slides on the saddle are 6 ft. long by 20 in. wide,

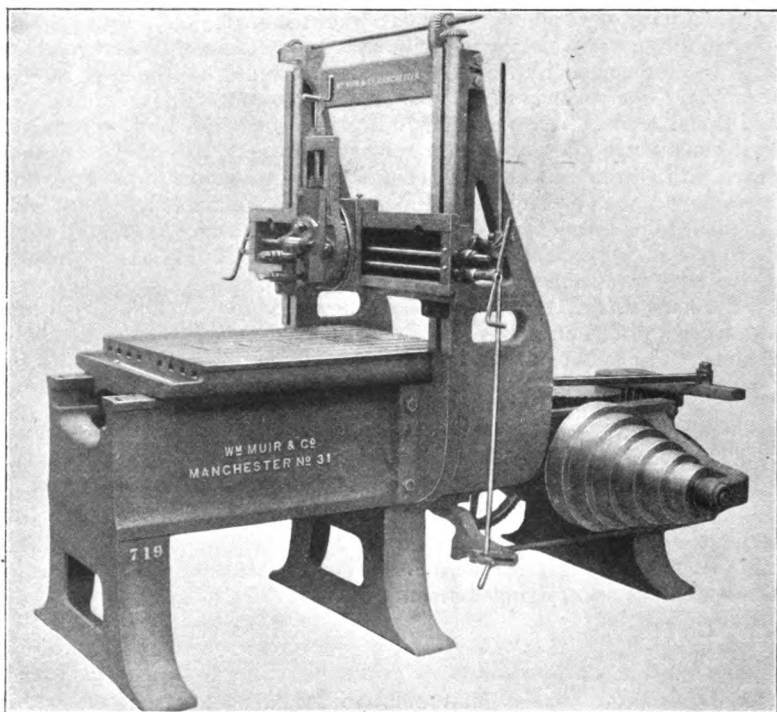

FIG. 256.—Crank-driven planing machine.

and have a stroke of 3 ft., while the tool apron and clamps are proportioned for cutter bar 6 in. square. Each saddle has its own screw and rod actuated by an independent feed motion. At the end of the cross rail, which is 22 ft. 8 in. long, each has its own electric motor for rapid traverse, while another motor is employed to raise and lower the cross rail. The housings or uprights, of box form, are 30 in. wide on the face, 8 ft. 6 in. deep, and each is provided with a slide rest having 30-in. stroke and carrying a tool apron adapted for a 4-in. square cutter bar. The table is 10 ft. wide, and has a cut steel rack, 3-in. pitch, 18-in. face. The rack is driven by a pinion having six teeth, which are cut spirally; the pinion is carried by a steel shaft 9 in. diameter, the shaft

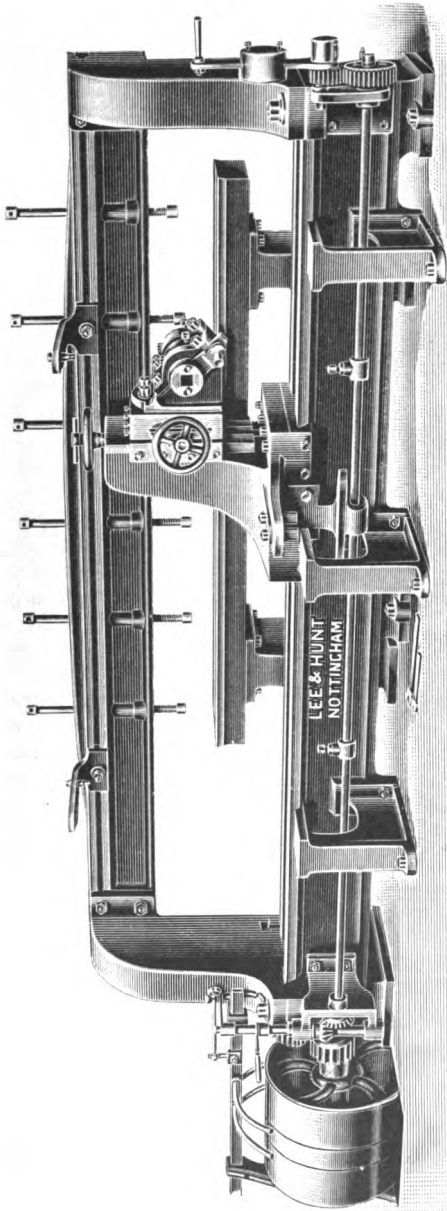

FIG. 257.—Plate-edge planing machine.

being fixed diagonally. The bearings in the bed for the table and the thrust bearings of the shaft are lubricated by oil supplied by a small pump and circulating system with tank pipes and filter for the oil on its return. The driving gear is operated by a 12-in. belt from a counter shaft or electric motor, and drives through reversing clutches operated by compressed air. Cutting power on four tools = 100,000 lbs.

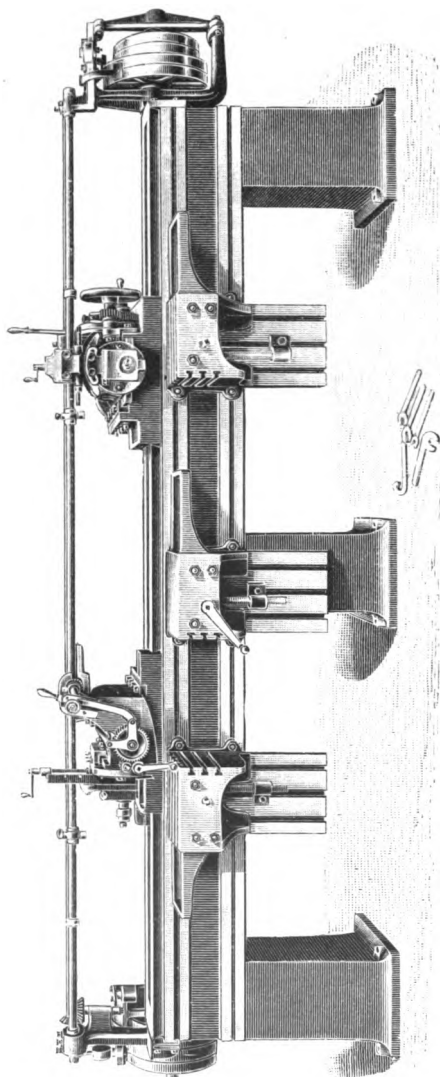

FIG. 258.—Open side plane, with two saddles and three tables.

Plate-edge Planing Machine.

Fig. 257 represents a machine for planing the edges of ship plates, boiler plates, etc. The work is placed upon the long table, and is clamped down by the six thimble screws carried in the massive beam above the saddle. The latter is traversed by a central screw running the whole length of the machine bed. The tool box is of the turnover type; that is to say, when the saddle has reached the adjustable stop shown in the front of machine, the motion to the saddle is automatically reversed. Then the workman turns over the tool box, causing it to operate in the opposite direction. There is a vertical and transverse slide to the saddle actuated by the

hand wheels shown. The clamping beam is arranged with open ends, so that plates of any length can be easily manipulated. Curved plates are planed by the aid of a "former," which is fixed when required to the brackets seen in front of the machine.

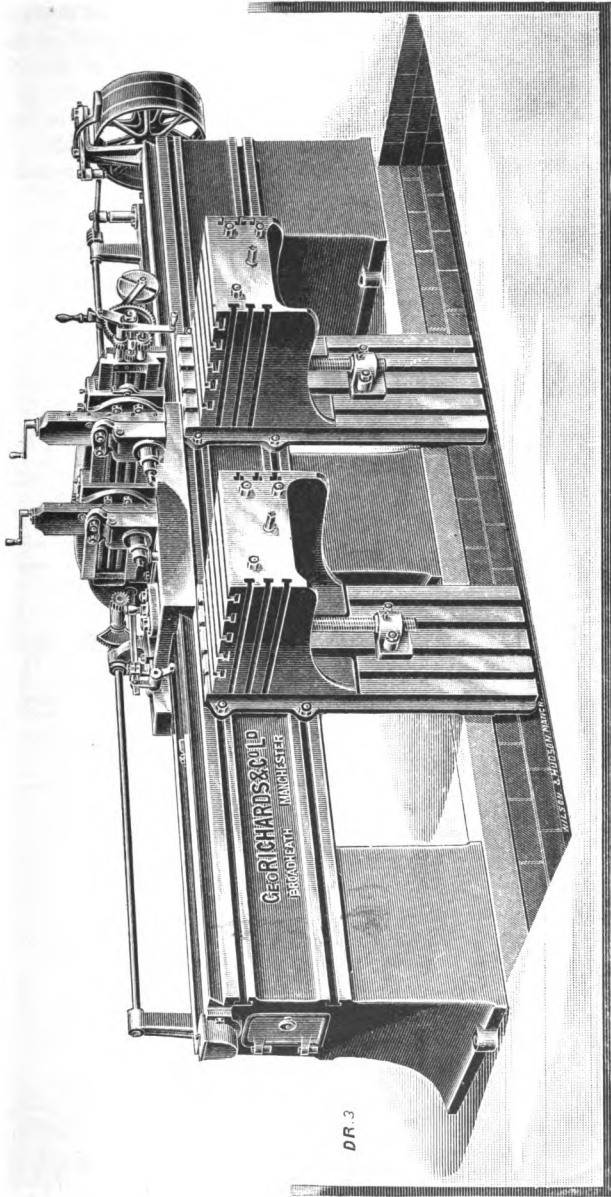

FIG. 259.—Open side planing machine, with two tool boxes.

This machine has a down-feed of 9 in., so that a number of plates may be planed together. Huge masses of metal may thus be secured to

a fixed table while the cutting tool is traversed past. In this respect a machine of this class has advantage over the ordinary type of plane, as the power to drive is less where there is not the weight of the table and work to move.

Open-side Planing Machine.—The machines illustrated in Figs. 258, 259 are made with an open side, and are constructed by Messrs. George Richards, of Broadheath, Manchester. Iron castings of irregular shape

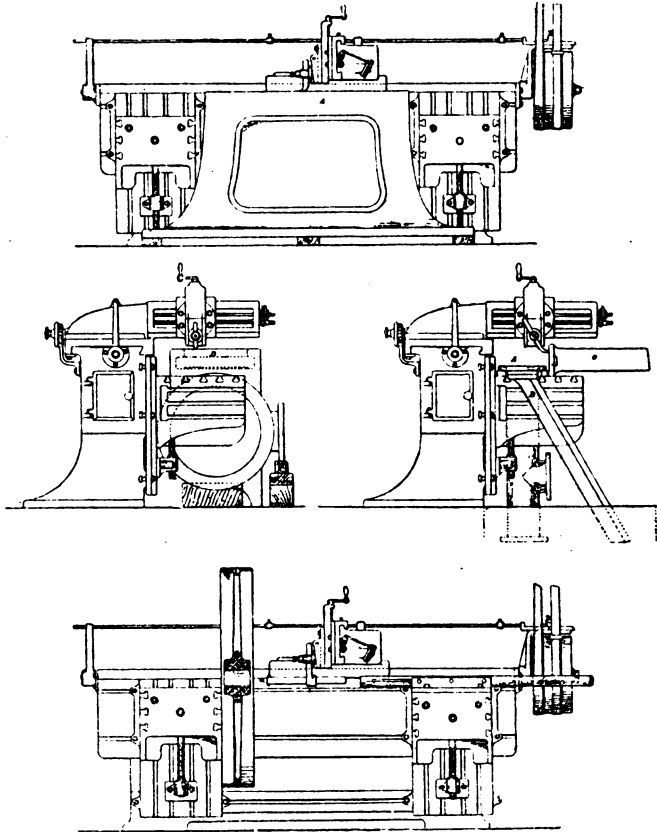

FIG. 260.—Examples of open side planing.

and other pieces of work can be conveniently tool over in these machines, but which in an ordinary planing machine would necessitate the tool box being packed off from its proper seating, and then made to carry an overhanging tool bar, a system always to be avoided, if practicable, on account of the increased vibration given to the cutting tool, and the extra time in preparing for the work and removing the packings.

In some machines of this class a bed plate is supplied. The plate

is let in flush with the ground floor, which is levelled to lie evenly, and is thus found useful to support the work, also to facilitate the setting.

Referring to Fig. 259, it will be observed that the bed is somewhat similar to that of a shaping machine, but the slides carrying the cutting tools traverse both longitudinally and transversely with the bed. This machine has capacity to "tool up" iron castings 30 ft. long by 40 in. wide, or by turning the position of the work, 80 in. wide can be surfaced over.

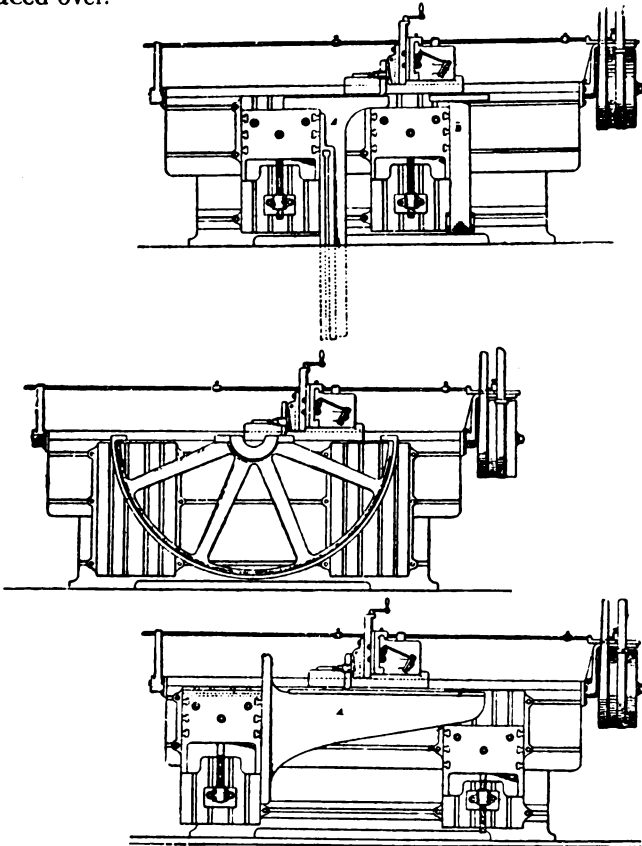

FIG. 260A.—Examples of open side planing.

There are some points of advantage in this type of planing machine, viz: heavy castings are quickly set; there is less friction of the moving slides, since the table and the work do not travel; and finally, there is much less area required for the machine.

Further comment is not necessary, as Fig. 260 gives examples of the application of the open-side plane on general work. The machines usually have a pit near the front face for the convenience of deep castings (see Fig. 259).

CHAPTER XII.

MILLING MACHINES.

“MILLING” is the process of cutting metal by the use of revolving cutters. Milling machines are of two principal kinds, viz. vertical and horizontal.

The vertical milling machine is a development of the drilling machine in which a revolving spindle carrying at its extremity a circular cutter with serrated teeth is made to operate on its end, or periphery, or both, as required, while the work is fixed to the machine table. These machines frequently have two spindles, one of which may be fitted with a “dummy,” *i.e.* a short shaft without teeth, or cutting edges, but which, by pressing against the outer or inner surface of a finished piece of work or templet, can be made to travel automatically or by hand, and by so doing cause the cutter spindle to follow the same path over a piece of work to be milled, the cutter being kept in action while any material remains over and above the size or shape of the templet. It will thus be seen that the two spindles, being carried by the same saddle, move together to the right or left according to the direction of traverse, and produce on the object to be milled the exact contour of the templet.

Vertical machines of this class are called “profiling” machines, and are much used in cycle, small-arm, and similar manufacture, where the parts are interchangeable. The milling machine is by no means modern, for some kinds of work have been milled for a considerable number of years, such, for instance, as wheel cutting and the facing on the “flats” of machine screws and nuts, also in the brass finishing trade. It was, however, not until recently that the milling machine has become universally adopted as an *absolute necessity* in all branches of engine construction and machine-building trades.

There were two principal reasons why milling as a process was not formerly more generally practised. In the first place, milling cutters, being home-made (by hand) were very expensive, and secondly, only comparatively few attempted the task, owing to their want of knowledge of the advantages of milling.

Where milling cutters were used, they were made as follows: Discs of crucible cast steel were forged, and annealed. Afterwards these were bored, turned, and division lines (very close) marked on their sides and circumference. Then commenced the slow and tedious task of filing out the spaces between the cutting edges, and with a

light hand hammer and small chisel to chip away the metal at the back of each cutting edge, so as to give clearance or relief to the teeth of the cutter, this part of the process being finished with the point of a file. The cutters were then hardened and tempered, and tested for truth by rotating them on their own mandrel or spindle between the centres of a lathe. If satisfactorily true, they were very carefully used on such work as the making of small gear wheels, fluting taps, and reamers, etc.

As the cutters became dull, and required re-sharpening, they had to be re-heated and annealed, and the face of each cutting edge filed, and again hardened and tempered as before. Thus the cutting capacity of the steel was deteriorated: added to this, the risk of cracking and warping was increased by repeatedly heating and quenching.

From the foregoing it will, I think, be easily understood that milling cutters were used only on such work as could not be well treated otherwise. This being so, it was not until milling as a good system had been well tested by a few British and some American firms that the practice became at all general.

"Universal" Milling Machine.—A milling machine to be "Universal," is one possessing the capacity of cutting the teeth of spur or bevel wheels, spiral drills, or any kind of taper or parallel work, automatically. A machine of this description is shown in Fig. 261, made by Messrs. Brown and Sharpe, of America.

Referring to the section of the headstock, it will be seen that the front bearing is provided with a nut, A, by tightening which the shoulder of the collar is brought against washers on front of the frame. The tail bearing is adjusted by the nut C.

It may be pointed out that these bearings in which the spindle revolves, although adjustable, are very seldom adjusted. When once properly set, they are best let alone, as the spindle is very sensitive.

The spindle nose is screw-cut to receive a chuck or face plate, but when not in use, a guard nut, D, is screwed on to protect the thread.

The speed cone has three steps, the largest being 10 in. diameter, and will take a 3-in. belt, and by using back gear six changes of speed may be obtained.

The spindle, which is of steel, is hardened and ground to fit its bearings. It is hollow, and at the front a taper hole is made to a standard taper gauge; by this arrangement standard tools may be used, the fit of which is reliable without trial.

Above the spindle, and running parallel with it, is a sleeve, in which the overhanging arm rides. The arm may be reversed, turned out of the way, or removed to receive an attachment.

The centre is adjustable by the screw shown at its extremity; but in some machines the end of the cutter mandrel is turned down to pass into a bushing carried by the overhanging arm, in addition to the adjustable centre referred to.

The machine table may be fed automatically in either direction, and can be changed by a simple movement of a lever on the front of the saddle, while the saddle which carries the table pivots in a clamp bed,

and is kept in position by three bolts, which are, when required, allowed to move in a circular path, in a similar manner to the compound slide of a lathe. This permits of the table being set at any angle up to 45° each way from zero.

Instead of wrenches being necessary, there are fixed handles to

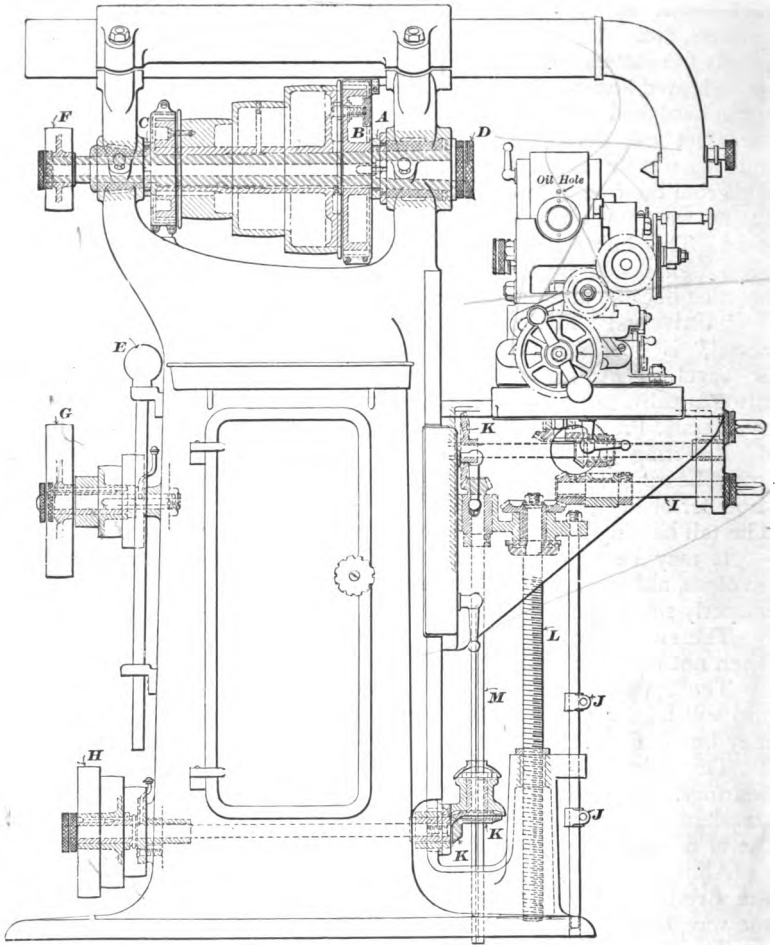

FIG. 261.—Universal milling machine.

clamp the knee or saddle as required. There are ball bearings to the knee seating which allow it to be easily moved. This is an improvement on some types of machines which are easily moved downwards (owing to the weight), but are difficult to raise. Beneath the knee

is the stop rod, carrying two sliding collars JJ, which are set when it is desirable to limit the movement of the knee.

By reference to Fig. 262, which is a section through the knee, saddle, and table, it will be seen that the feed is driven from the feed cones, through the bevel gears by the shaft A through the bevel gear B to the shaft carrying the bevel gear p , then through bevel gear E on lower end, of vertical shaft. The clutch G is operated by lever F.

An automatic stop is provided to release the feed at any point when running in either direction. The auxiliary lever O allows the feed to be released by hand. The table may be moved by hand from either end, as a handle is provided at each end for this purpose. Twelve changes of feed may be obtained by transposing the feed-cone pulleys

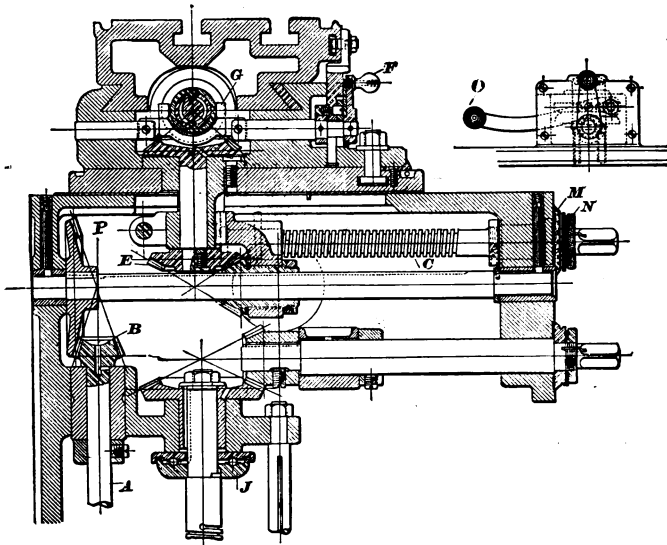

FIG. 262.—Section through saddle of universal milling machine.

F, G, H, Fig. 261, giving a variation of feeds from 0.005 to 0.12 in. to one revolution of the spindle. Fig. 263 is a longitudinal section.

Spiral Headstocks.—When it is desired to mill the grooves in reamers, taps, twist drills, and other work on mandrels, it is the practice to place the article between the centres of two movable headstocks, which are provided with dividing mechanism.

There are many different kinds of dividing or spiral headstocks, one of which is given in Fig. 264 as furnished with the "Universal Milling Machine." The special features in this type are, that the form admits of the bodies being clamped as solidly in one position as in another by two bolts which are placed in a convenient position on one side, and also that when the spindle is at an angle of 90° with the bed, the end of the spindle is comparatively low, thus making it very rigid in this position.

In doing many kinds of work, as in cutting the flutes in reamers, end mills, etc., the use of the worm and worm wheel can be dispensed with, and indexing done by revolving the spindle by hand. The motion is transmitted from the feed screw through change gears to two spiral gears. By this arrangement the spindle can be automatically rotated at whatever angle it may be set.

Tables are used with each machine giving the change gears for cutting 68 spirals, the arrangement being similar to fixing change wheels on a lathe. Thus a gear on the worm meshes with a gear on the socket, and a second gear on the socket meshes with the gear on the screw.

When it is desired to rotate the spindle independently of the worm and worm wheel, the worm A, Fig. 265, is arranged so that it may be thrown out of gear with the worm wheel B, when the spindle may be

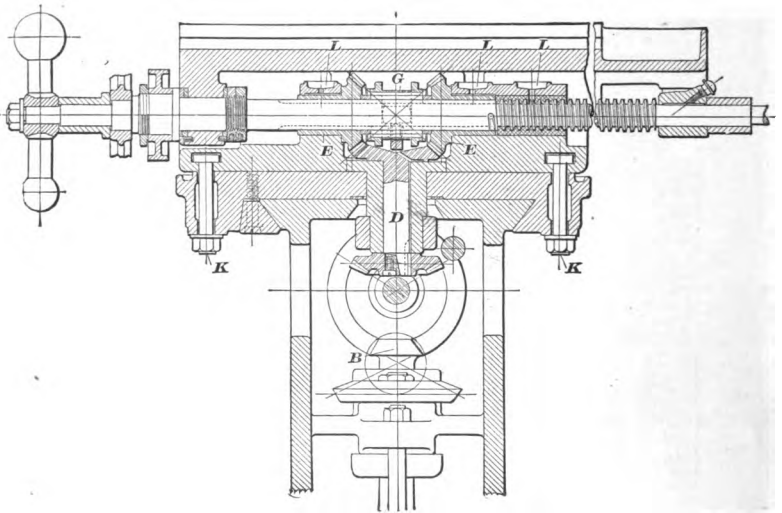

FIG. 263.—Longitudinal section of universal milling machine.

turned by hand and locked by the index plate C and pin D. An additional clamp is provided to hold the spindle, so that the strain will not come on the index pin and plate.

To throw the worm out of gear, the knob E is turned about a quarter of a revolution, and the nut G will be released, which holds the eccentric bush H. Then by moving E and F, the eccentric bush H will be revolved, and the worm disengaged from the worm wheel.

The footstock (Fig. 264A) has an adjustable centre. Two taper pins are used (one of which is shown at Z) to accurately locate this centre in line with the headstock centre. When it is desirable to set at an angle out of parallel with the base, as in cutting taper reamers, drills, etc., the centre can be elevated or depressed by means of a rack and pinion actuated by the nut U. The centre is firmly held in position by the

nuts W, X, and Y. There is an advantage in this, as centres which cannot be adjusted are apt to cramp the work during portions of its

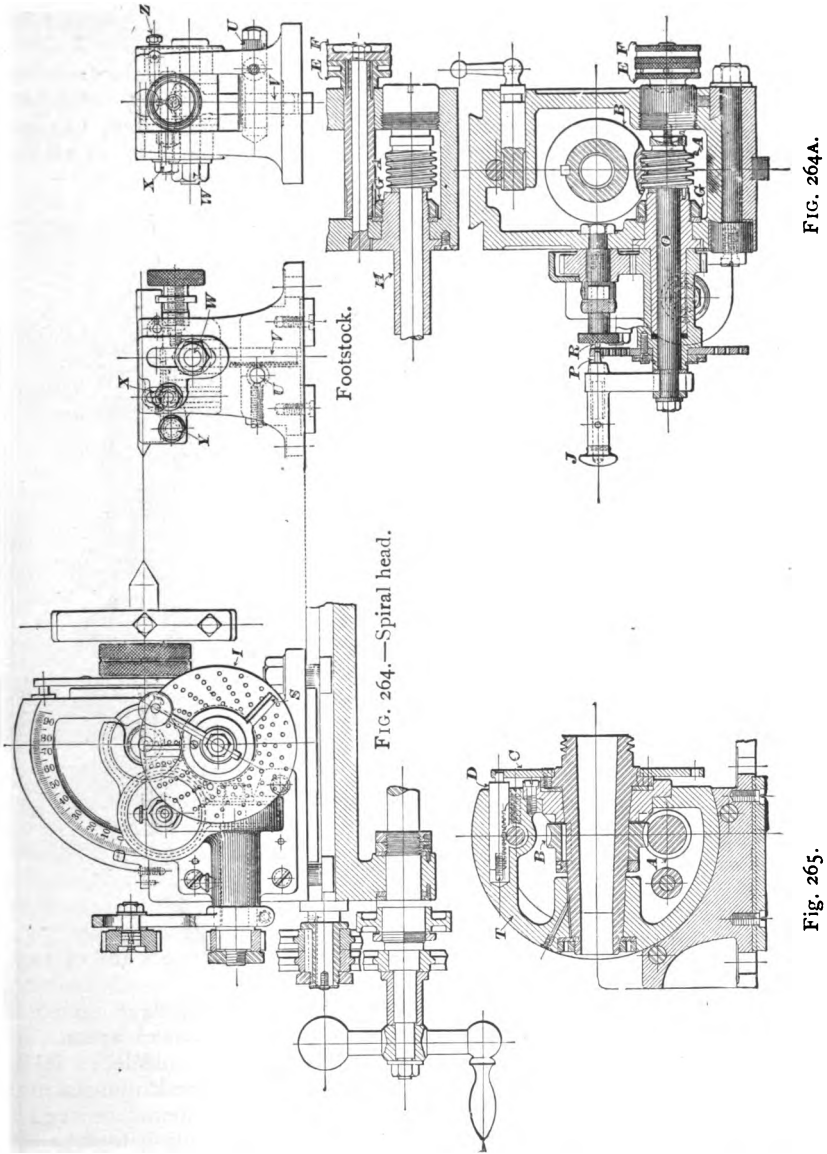

revolution, with the result that even spacing cannot always be obtained.
Duplex Milling Machine.—A milling machine is shown in Fig. 266,

R

having two spindles carried on a cross slide which is balanced and arranged to rise and fall by power upon the face of the uprights. The saddles carrying the tools may be traversed independently by hand or self-acting feed, which is variable, and which also may be reversed in direction.

As will be seen, the machine is provided with a broad table resting on a bed, having slides of large surface area, and is obviously intended for the heavier classes of work. The machine is treble geared, 144 in. long, 18 in. broad by 5 in. deep. The cutters are from 2 in. to 18 in. diameter, while the feeds are from $\frac{1}{2}$ in. to 3 in. per minute.

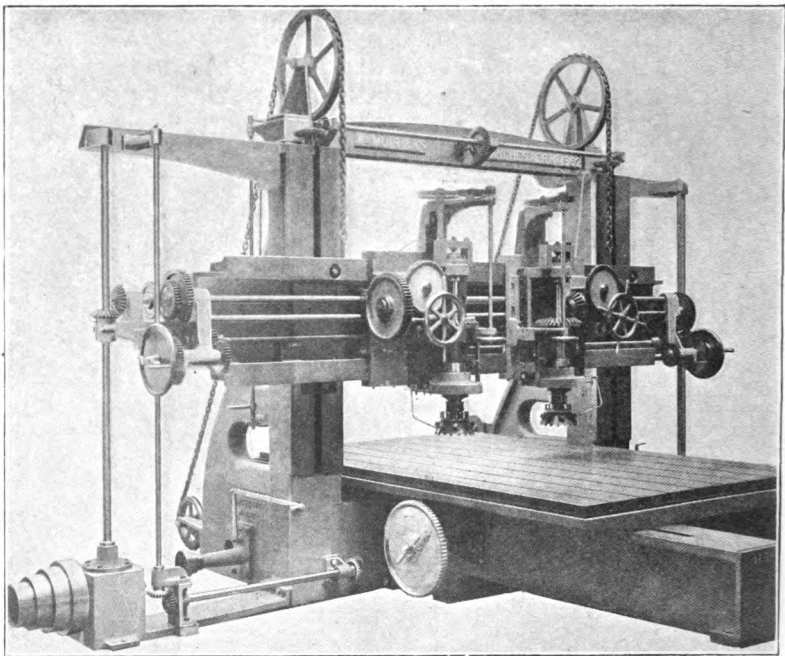

FIG. 266.—Duplex milling machine (by Muir).

Milling Cutters, and how to use them.—Milling cutters are of two principal kinds: (a) solid; (b) built up.

Making a Cutter.—Solid cutters are serrated discs of steel having a number of cutting edges called teeth at equal distances apart. A cylindrical disc of crucible cast steel is forged and annealed. It is afterwards bored and turned to the required shape and dimensions. The teeth are formed in a milling machine, and are then “relieved” or backed off by a special device at the lathe, the cutting tool being actuated by an eccentric. (See Fig. 267.) The milling cutter is hardened and tempered, and finally ground by emery wheels. The

Cutter is fixed for the purpose in a lathe chuck, and set practically true, while a small emery wheel is used to grind out the hole to standard size. The teeth are also ground, and the cutter is ready for use. Solid cutters

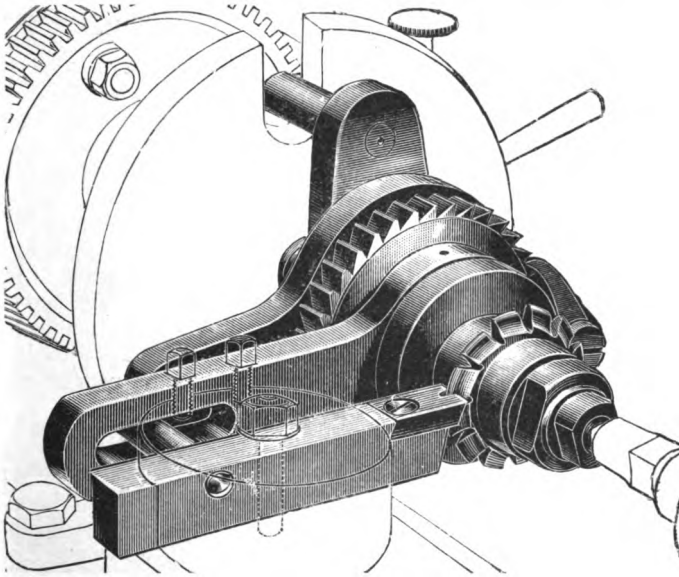

FIG. 267.—“Backing-off” milling cutter, by Selig Sonenthal.

are made in all sizes up to 6 in. diameter. Above 6 in. diameter, “built up” cutters are used.

A core of cast iron or mild steel is bored, turned, and grooved, and the teeth are inserted. These cutters are hardened and tempered separately, but are usually ground to truth after all have been assembled.

The term “formed” cutters applies to the cutters with teeth so relieved that they can be sharpened by grinding without changing their form, while “form cutter” can be applied to any cutter cutting a “form,” regardless of the manner in which the teeth may be relieved. Figs. 268, 269, 270, 270A, 270B are “formed cutters,” while Fig. 271 represents a “form” cutter. The advantage of a “formed” cutter is that it may be re-sharpened so long as the teeth will stand, without the original shape of its cutting edges being disturbed. An example of this is given.

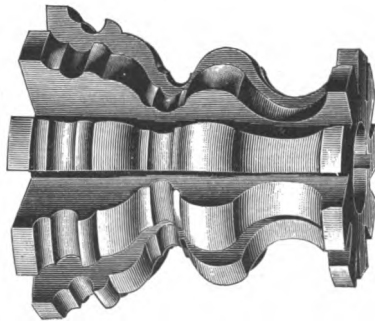

FIG. 268. —“Formed” cutter.

Fig. 272 represents a gear cutter when new. Fig. 273 shows the same cutter after cutting 467 cast-iron wheels, each having 64 teeth 3 in. on the face. This represents 29,888 teeth, or a total length cut of 7,472 feet. The teeth of the gears were cut from solid blanks and finished in one cut. This also illustrates the advantage gained by keeping the cutters sharp. (Figs. 274A, 274B).

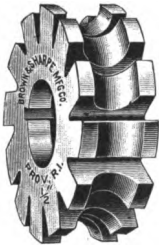

FIG. 269.—"Formed" cutter.

A plain slab milling cutter is given in Fig. 274 having spiral teeth; this enables each tooth to commence cutting gradually; there being several teeth operating at a given instant tends to reduce the vibration between the cutter and the work.

Another cutter of the spiral form is seen in Fig. 275, which is made solid to fit the main spindle of the machine. This "end mill" is used both as a surfacing tool and a facing tool.

Work may be placed on the

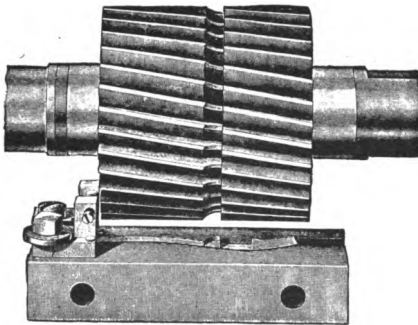

FIG. 270.—"Formed" cutter.

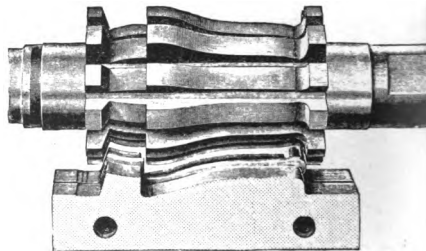

FIG. 270A.—"Formed" cutter.

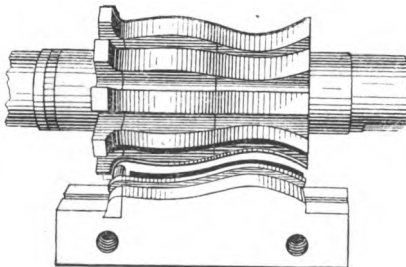

FIG. 270B.—"Formed" cutter.

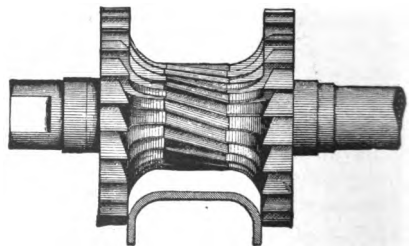

FIG. 271.—"Form" cutter.

machine table and milled at different facings with the above type of cutter, which could not be treated by a "mill" carried by an arbor. There are three kinds of teeth (*a*), (*b*), and (*c*), for milling on cast iron, wrought iron, or mild steel, and brass respectively (Fig. 274).

Figs. 276, 277 give in outline a tap and reamer as cut by milling

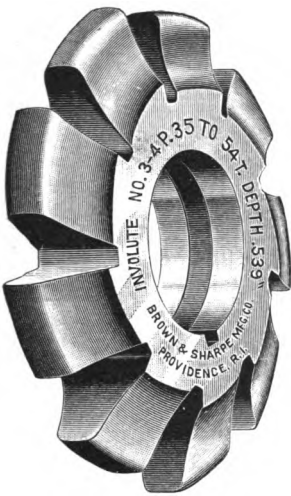

FIG. 272.—Gear cutter.

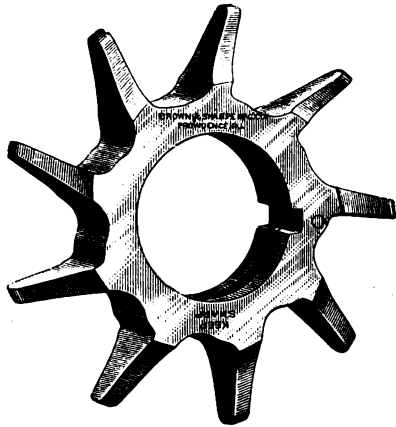

FIG. 273.—Gear cutter worn out.

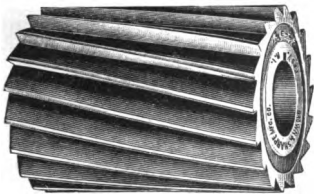

FIG. 274.—Plain slab milling cutter.



FIG. 275.—End mill.



FIG. 274A.—Side milling cutter, with inserted teeth.

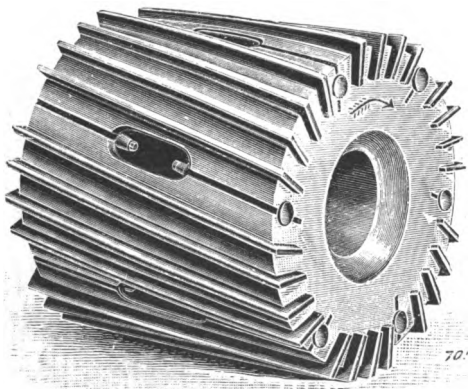

FIG. 274B.—Plain slab milling cutter, with inserted teeth.

cutters. Figs. 278, 279 are metal slitting saws, one of which is shown at work in Fig. 280.

Diameter of Mills.—It is well to have mills or cutters as small in

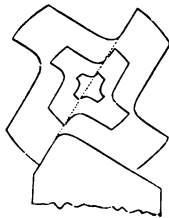

FIG. 276.—Fluting a tap.



FIG. 276A.—Cutter for grooving tap.

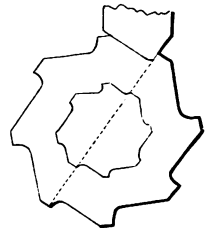

FIG. 277.—Fluting a reamer.



FIG. 278.—Metal slitting saw.



FIG. 279.—Metal slitting saw.

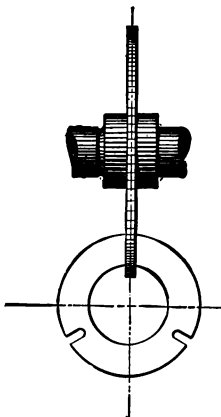

FIG. 280.—Metal slitting saw.

diameter as the work or their strength will admit. The reason is shown in Fig. 281.

Suppose the piece IDCJE is to be cut from IJ to DE. If the large mill A is used it will strike the piece first at I when its centre is at K, and will finish its cut when its centre is at M. The line G shows how far the mill must travel to cut off the stock IJDE. If the small mill B is used, however, it travels only the length of the line H. It can also be seen that a tooth of B travels through a shorter distance between the lines DE and IJ than a tooth of A. This is true of all ordinary work, or where the depth of cut ID is not more than half the diameter of the small mill. In short, small mills do more and better work, cut more easily, keep sharp longer, and cost less than large mills.

A mill is not necessarily too soft because it can be scratched with a file, for sometimes when cutters are too hard or brittle, and trouble is

caused by pieces breaking out of the teeth, they can be made to stand well and do good work by starting the temper.

Of late years mills have been made with coarser teeth than formerly, the advantages being more room for the chips, and less friction between the teeth and the work. When the teeth are so fine that the mill drags or the stock is powdered, the mill heats quickly, and does not cut freely. The friction may also be reduced, especially in large mills taking heavy

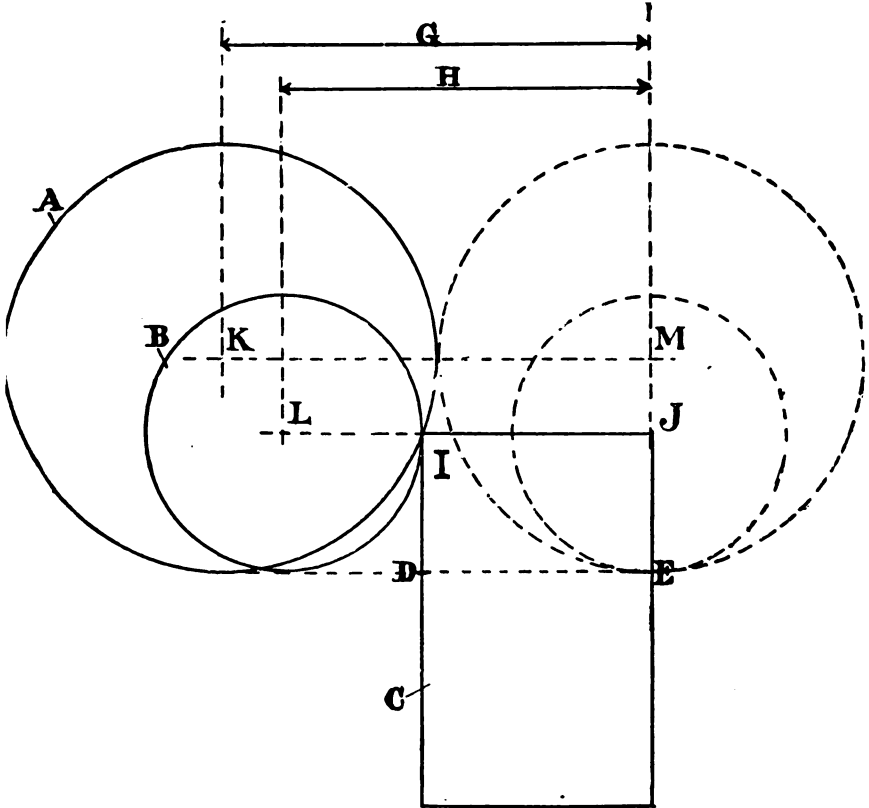

FIG. 281.—Correct diameter of milling cutter.

cuts, by nicking or cutting away parts of the teeth, which break up the chips and allow heavier feeds and cuts to be taken.

Mr. George Addy, of Sheffield, an authority on milling cutters, estimates the pitch of teeth of cutters from 4 in. to 15 in. diameter by the following rule :

$$\text{Pitch in inches} = \sqrt{(\text{diameter in inches} \times 8) \times 0.0625}$$

With reference to the cutting angle, the same gentleman states : "The adoption of the most suitable cutting angle should receive the same close

attention that is now universally bestowed upon the ordinary tools for turning and planing."

As a result of considerable research and experience, Mr. Addy gives as his opinion that the front of the teeth, instead of being truly radial, should have a backward inclination of 10° from the radius, the cutting angle being in this way 70° and the clearance 10° .

Messrs. Brown & Sharpe state the relief to be about 3° , and the

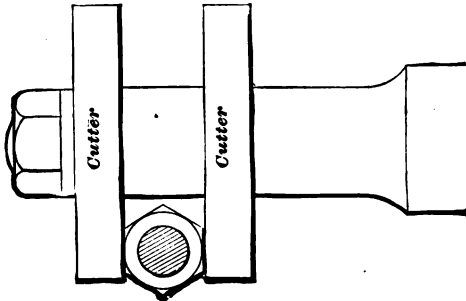

FIG. 282.—Straddle mills.

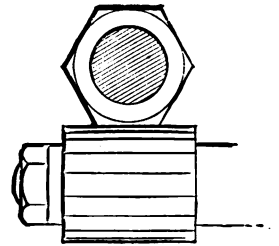

FIG. 283.—Milling nut and bolt.

"land," *i.e.* metal, at the top of the teeth from 0.02 in. to 0.04 in. wide before the clearance is cut or ground. Mills to cut grooves should be hollowing about $\frac{5}{100}$ in. for clearance; that is, a grooving mill (Fig. 280) should be about $\frac{1}{100}$ in. thinner at 1 in. from its edge or circumference than it is at its edge. Grooving mills are given a limit of $\frac{2}{1000}$ in. thickness.

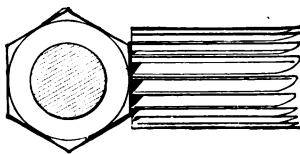

FIG. 284.—Milling nut and bolt.

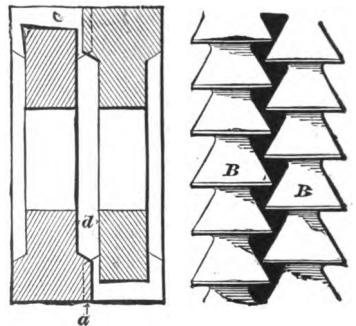

FIG. 285.—Milling cutters interlocked.

"Twin" or "straddle mills," cutting a bolt head or nut, are shown in Fig. 282. When these mills are not to hand, the work can be done by a milling cutter, as in Fig. 283, or by an end mill (Fig. 284). In either case when nuts are milled they are usually strung on a mandrel.

Two mills can be put together as in Fig. 285 with the teeth interlocked and used in cutting slots; the advantage of this arrangement is

that the mills can be blocked apart to keep the width of the cut always the same. (See Fig. 300.)

The end mill can also be used in cutting slots as in Fig. 286, the width of the slot being the same as the diameter of the mill. In this case it is better to feed the work back and forth than to drill holes at A and B.

For many kinds of work the fixture (Fig. 287) is convenient. It consists of a square piece of cast iron, several inches in length, bored to receive a shaft or spindle to be split at one end or both ends as shown, or to have a series of holes or flat places made at right angles with or directly opposite to each other. The slot runs the entire length of the casting, and a small screw is inserted at S to hold the work and prevent it from turning while in the shell. This appliance is held in the vice, but after each cut is taken the sleeve is given a quarter of a turn, and thus each of the four sides of the bolt head or other work is brought to the mill.

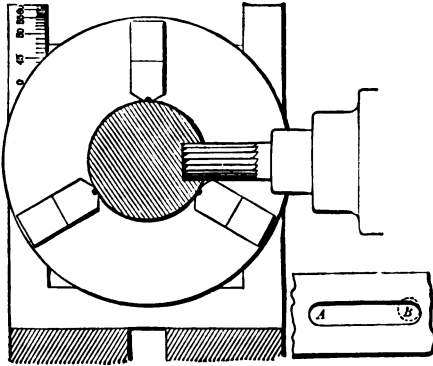

FIG. 286.—Milling slots.

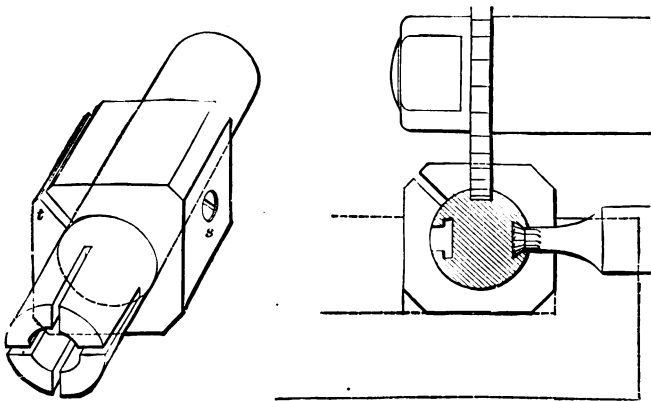

FIG. 287.—Milling fixture.

Fig. 287A is a tee-slot cutter.

A method of milling a surface and squaring one side of a projection on the surface is shown in Fig. 288. To save time in setting and to securely hold the work special vice jaws are used.

Fig. 289 illustrates the use of formed cutters in milling rack teeth.

The cutter shown is made in three parts, and each part cuts six teeth in the rack.

When a few pieces are to have round ends they may be milled as in Fig. 290, the piece R being rotated about S against the mill C.



FIG. 287A.—Tee-slot cutter.

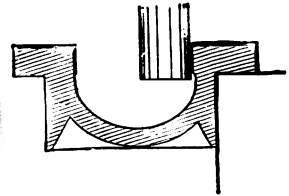

FIG. 288.—Milling a surface, and squaring one side.

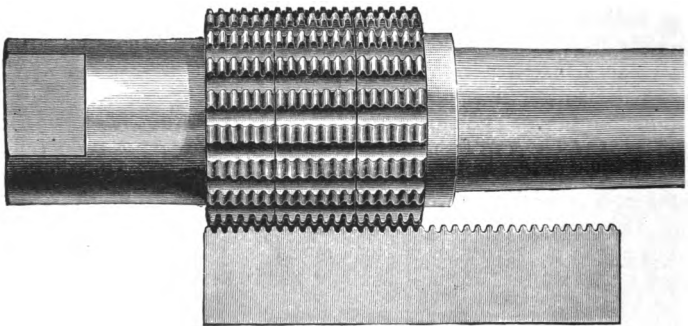

FIG. 289.—Milling rack teeth.

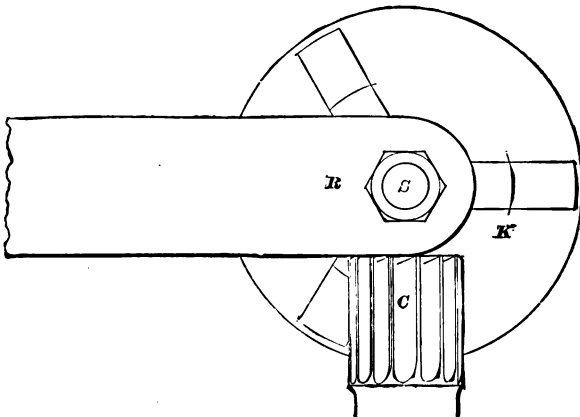

FIG. 290.—Rounding ends of work.

Fig. 291 shows the milling of two sides of a slot. A neat arrangement for holding and milling the keyways in two shafts is illustrated in Fig. 292.

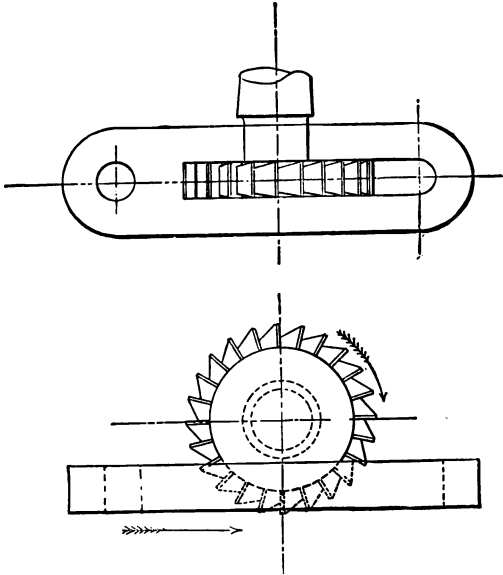

FIG. 291.—Milling two sides of a slot.

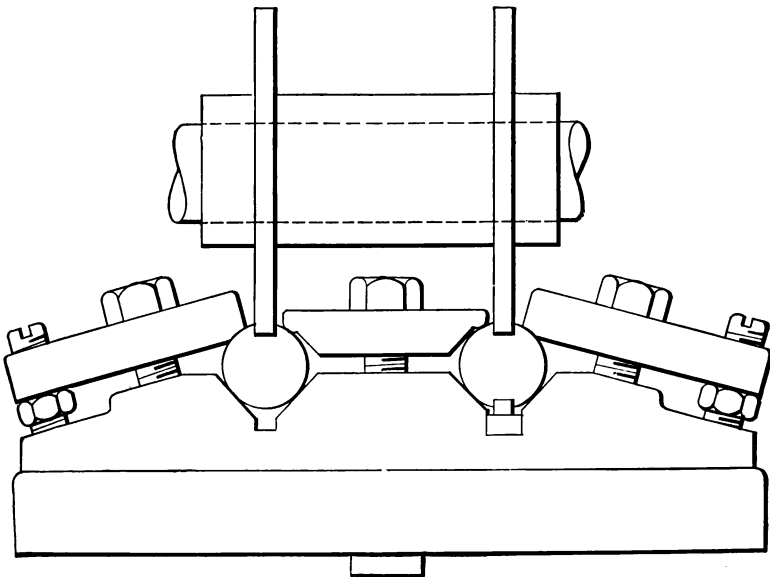

FIG. 292.—Milling the keyways in two shafts.

The above illustrations serve to show some of the uses to which cutters may be put; there are, however, special forms of mills arranged very frequently in groups, or, as they are better known, in gangs, by the aid of which a piece of work can be milled in one instead of several successive operations.

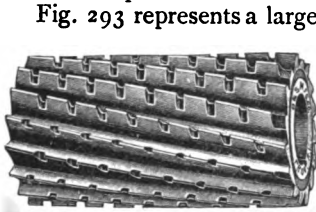

FIG. 293.—Cutter with notched teeth.

Fig. 293 represents a large mill with its teeth notched at intervals, in order to break up the metal as it is being cut, and to reduce the friction on the cutter. The mills at each end face the casting at the same time. The piece of work is the knee of a milling machine.

The machine at work is shown with cutters in operation in Fig. 294, and enlarged in Fig. 295. Further gang mills are represented in section in Figs. 296, 297, and 298, which show the tooling of other portions of the machine parts.

There is a difference of opinion as to whether the work should be

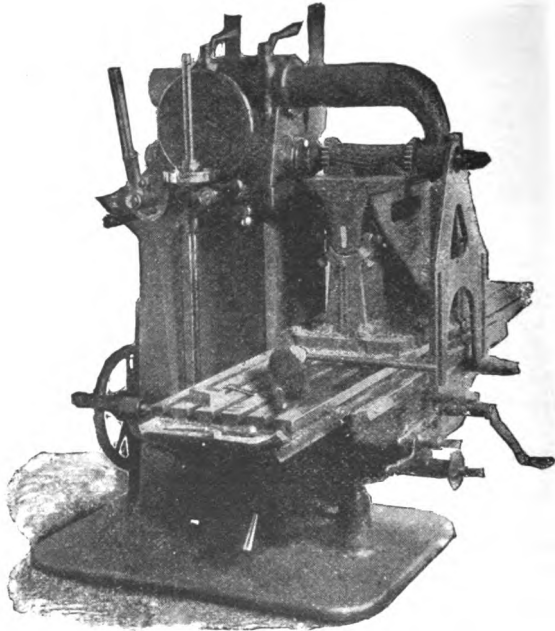

FIG. 294.—Large mill with notched teeth operating.

moved towards the cutter or with it. It is best for the work to move against the mill (see Fig. 299). When it moves in this way the teeth of the cutter in commencing their work, as soon as the hard scale is once broken, are immediately brought in contact with the softer material,

and when the scale is reached it is pried or broken off. Also when a piece moves in this way the cutter cannot dig into the work, as it is liable to do when the bed is moved in the same direction as the cutter.

When a piece is on the side of the cutter that is moving downwards, the piece should, as a rule, have a rigid support, and be fed by raising the knee of the machine.

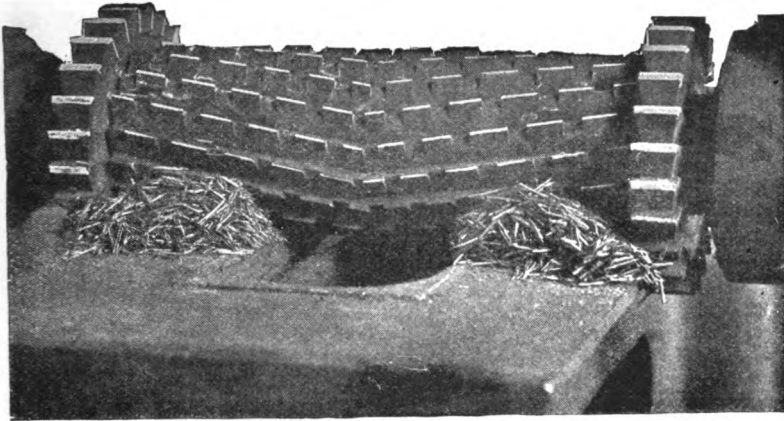
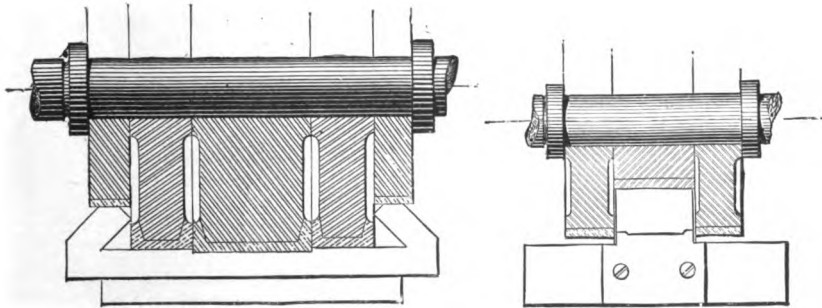

FIG. 295.—Milling face and sides at one cut.

Some work, however, is better milled by moving the cutter. For example, to dress both sides of a thick piece, *D*, with a pair of large straddle mills, it might be well to move the piece towards the left, as the mills then tend to keep it down in place instead of lifting it.



FIGS. 296, 297.—Straddle and gang mills in section.

Again, in milling deep slots or in cutting off stock with a thin cutter or saw it may be better to move the work with the cutter, as the cutter is then less likely to crowd sidewise and make a crooked slot.

When the work is moving with the cutter, the table grip-screws must be set up rather hard, for if the work moves too easily the cutter may

catch, and the cutter or work be injured. A counter weight to hold back the table is excellent in such milling.

For the purpose of making a comparative test of the two methods,

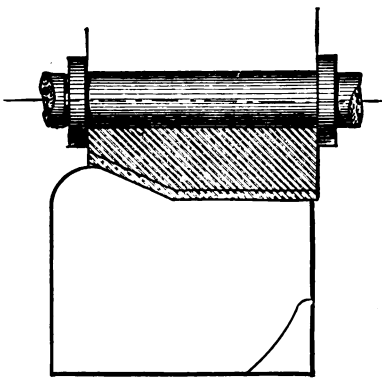

FIG. 298.—Straddle and gang mills in section.

Messrs. B. & S. made the following four experiments on their No. 5 machine. This machine had been provided with a take-up attachment for backlash of the table, two cutters of the same diameter and width were used, and suitable castings were provided, each being 3 in. square, and 3 ft. long (pickled).

First experiment with No. 1 cutter was with the cut cutting down on scale and feeding 6 in. per minute. Cutting one surface 3 ft. long, the cutter was found to be dull.

Second experiment with No. 2 cutter was against the cut. Cutting under the scale and feeding 6 in. per minute, eight castings 3 ft. long

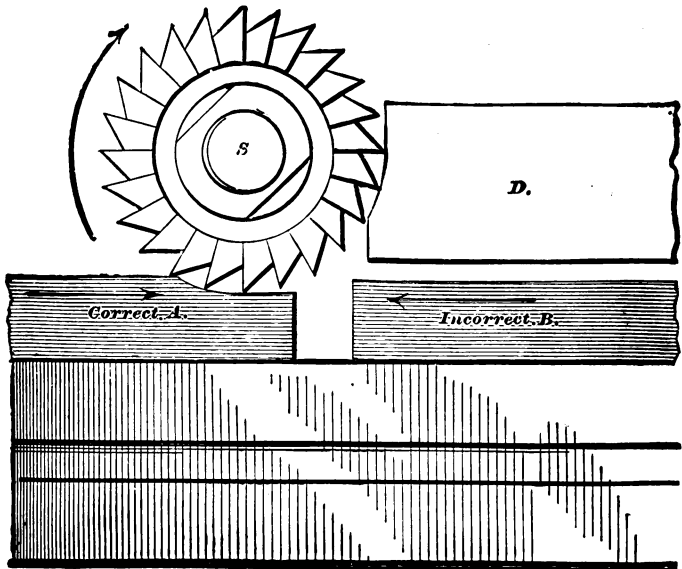

FIG. 299.—Correct position of cutter and work.

were milled before the cutter had shown the wear of No. 1. In order to prove the tempering of the cutters both were reground.

Third experiment was with No. 1 cutter working in same manner as

No. 2 cutter had been, viz. against the cut, cutting under the scale, and feeding 6 in. per minute. Eleven castings 3 ft. long were milled before the cutter had shown the wear of No. 2.

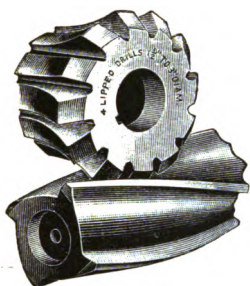

FIG. 300.—Fluting a reamer.



FIG. 301.—Milling cutters interlocked.

Fourth was with No. 2 cutter working in the same manner as No. 1 as described in first experiment. This cutter failed on first cut.

Fig. 300 is a mill for a four-flute reamer of the twisted pattern.

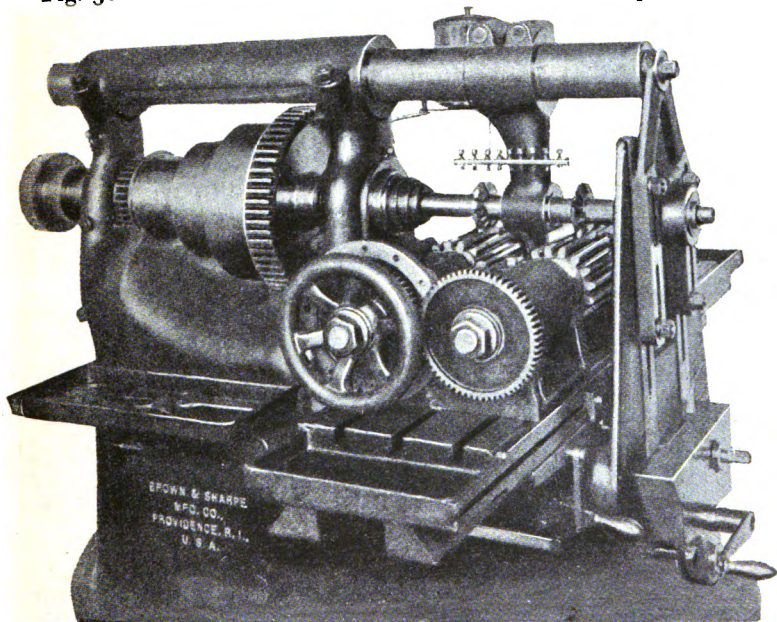

FIG. 302.—Milling motor pinions.

Duplex cutting with twin mills (Fig. 301) is an every day practice on repetitious work, and plainly shows the advantages of milling machines for both accuracy and interchangeability.

Fig. 302 represents the milling of two steel motor pinions.

In Fig. 303 straddle mills are engaged in cutting (from the solid metal) two slots in a machine table. Originally machine tables were cast with slots, but these were often difficult to clean out and expensive to plane, owing to irregularities on both sides and root, especially in long tables, which were more or less warped in their length. An advantage of "cut out" slots is that a bolt head filling one slot comfortably may be easily slid into every other slot, and will stand vertically wherever it is located.

The plain milling machine which is represented in Fig. 304 is *without*

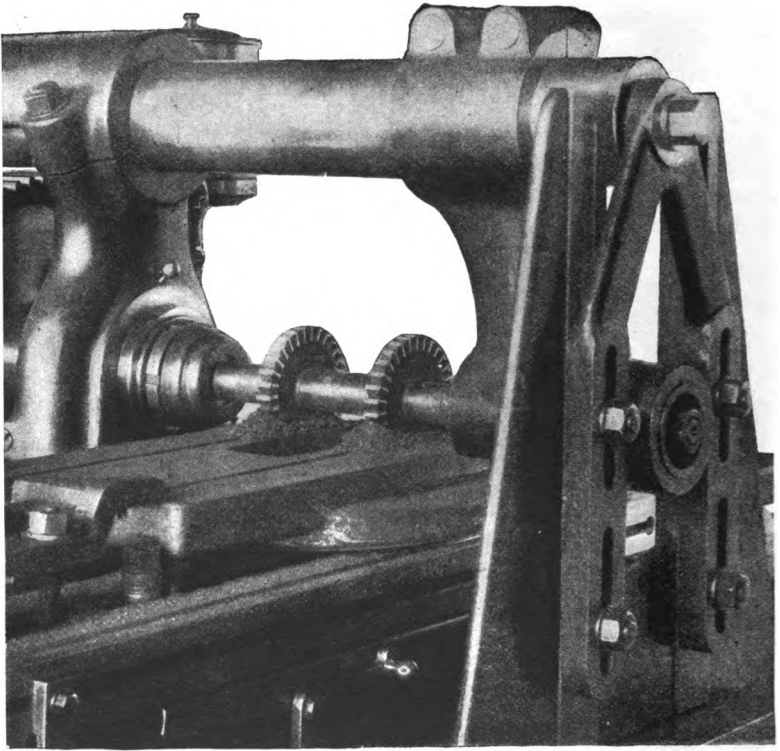

FIG. 303.—Straddle mills at work.

the aid of an arm brace, engaged by means of straddle mills in surfacing the two similar "ways" of a machine-bed on which the table will slide. This clearly shows the stiffness and accurate fitting of the important moving parts of the machine.

It will be observed that the overhanging arm is extended to a considerable distance from its point of support in order to carry the long spindle and mills upon it. Any vibration in the bearings would be reproduced upon the mills, and surfaces cut.

To guard against vibration, arm braces are rigged up as in Figs. 302, 303, to support both the overhanging arm and the end of the cutter mandrel. Acting as a further support, a sliding bracket is sometimes used which is hinged on the overhanging arm, and at its opposite end provided with a bush which fits the cutter mandrel. This arrangement assures stability, and is also well illustrated in Figs. 301 and 302.

A machine slide, secured in a powerful manner by clips, bolts, and stops, to the milling machine table, is shown in Fig. 305. Here five separate cutters are assembled on the mandrel, all milling at once.

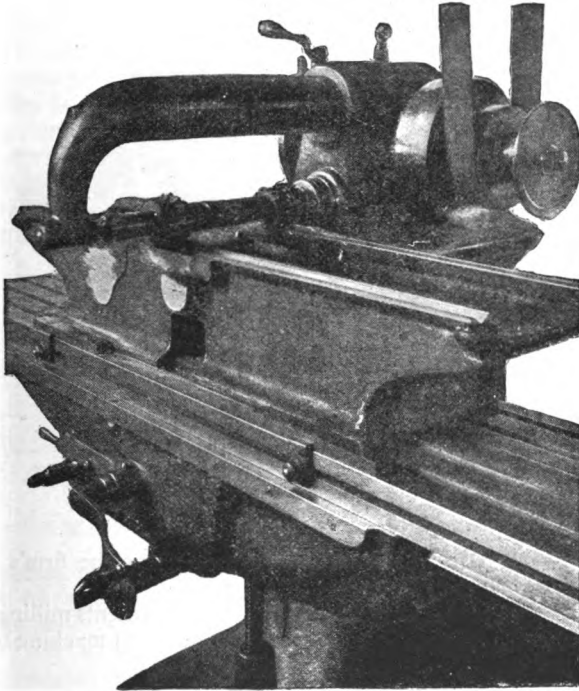

FIG. 304.—Plain milling machine surfacing machine bed.

It will be noticed that the three largest mills could have been made all of one piece, but this is not advisable, for the following reasons:—

1. Narrow cutters are the cheapest to produce.
2. They are easier renewed or sharpened.
3. The spiral form of tooth can be put in any order, which is an advantage, causing a proportionally less stress.
4. A narrow cutter can be more frequently used than a wide one.

Since, in the above example of gang cutting the transverse slide prevents the arm brace being secured to the machine bed, it will be seen that studs are used instead; the brace is provided with suitable slots for the purpose of attachment.

It would need much more space than can be given here to give a full description of milling machines, and the many uses to which the various cutters can be put. Every firm which makes a speciality is almost certain to require a special form of milling cutter adapted to its particular requirements. These cutters may be made to specification,

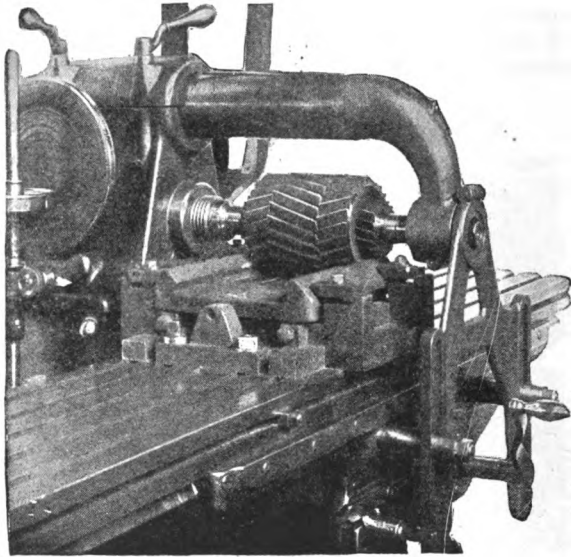

FIG. 305.—Gang cutters milling a slide.

or, as is generally the case in large works, made on the firm's premises by expert tool makers.

Reference may be made to Fig. 306, which represents milling between the arms of a wheel in order to balance it. Another machine tool could

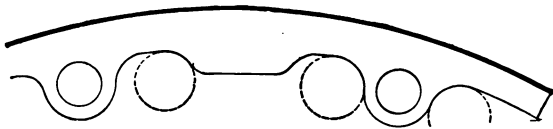

FIG. 306.—Milling between the arms of a wheel.

do this work, but the finish would be poor in comparison, while the cost would be very much higher.

Fig. 307 shows a cylinder being bored and faced internally with one milling cutter.

An angular shank mill similar to an end mill is represented in Fig. 308 for cutting out a keyway widest at the bottom. Such keyways

are frequently used, for instance, where change gears are to be kept from slipping by a key. If made by a single cut, and the mill be a delicate one, it is preferable to feed by hand, as the resistance and progress can easily be felt, and the liability to break the tool obviated.

Milling Jigs.—Milling jigs are of two kinds: those in which the work is secured by its outer edges and sides, and those to which the work to be milled is bolted.

In the former class the jig is a counterpart of the piece to be milled. A plaster cast is first obtained from the pattern, and from this a cradle is made, into which any casting from the original pattern will rest while milling. Articles are thus easily secured and removed; both these are important features in repetitious works. Cradles are best adapted to vertical machines, especially where angular surfaces have to be milled.

A cradle, D, is shown in section in Fig. 309, having a saddle with a projecting portion, E, comfortably housed in D. The gripping is done by the set-screws, which, owing to their angular position, force the casting hard down into its seating. Bolts, clips, and adjusting are not necessary when a cradle of this type is used. There is also less strain, and therefore less springing back after the machining has been performed.

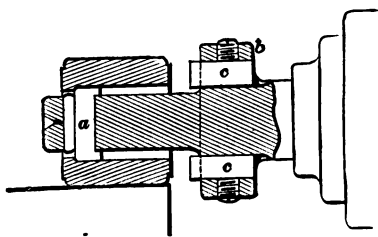

FIG. 307.—Boring and facing cylinder.

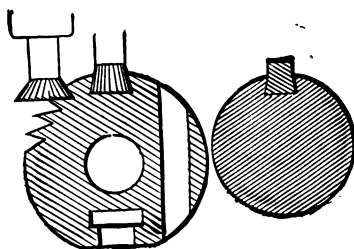

FIG. 308.—Milling angular keyway.

The vertical cutter is made wide enough to cut the surfaces AA and BB at one traverse of the table, while the surfaces CC can be milled with a large cutter with inserted teeth. The ends of the casting project from the cradle so as to permit their surfaces being tooled over. This leaves the remaining two sides and under surface for the next operation, when the casting is removed from the cradle.

Use of Milling Machines. Examples of Operations.—Oil is used in milling to obtain smoother work, to make the mills last longer, and where the nature of the work requires it, to wash the chips from the work or from the teeth of the cutters. It is generally used in milling a large number of pieces of steel, wrought iron, malleable iron, or tough bronze. When only a few pieces are to be milled it frequently is not used, and some steel castings are milled without oil; also in cutting cast iron it is not used. For light flat cuts it is put on the cutter with a brush, giving the work a thin covering like a varnish; for heavy cuts it should be led to the mill from the drip-can, or it should be pumped upon or across the mill in cutting deep grooves, in milling several grooves at one time, or indeed in milling any work where if the chips should stick

they might catch between the teeth and sides of the grooves, and scratch or bend the work.

Lard oil is generally used in milling, but any animal or fish oils may be used. The oil may be separated from the chips by means of a centrifugal separator, so that a large amount may be used with but little waste.

An excellent lubricant to use with a pump is made by mixing together and boiling for half-an-hour $\frac{1}{4}$ lb. sal soda, $\frac{1}{2}$ pint lard oil, $\frac{1}{2}$ pint soft soap, and water enough to make ten quarts.

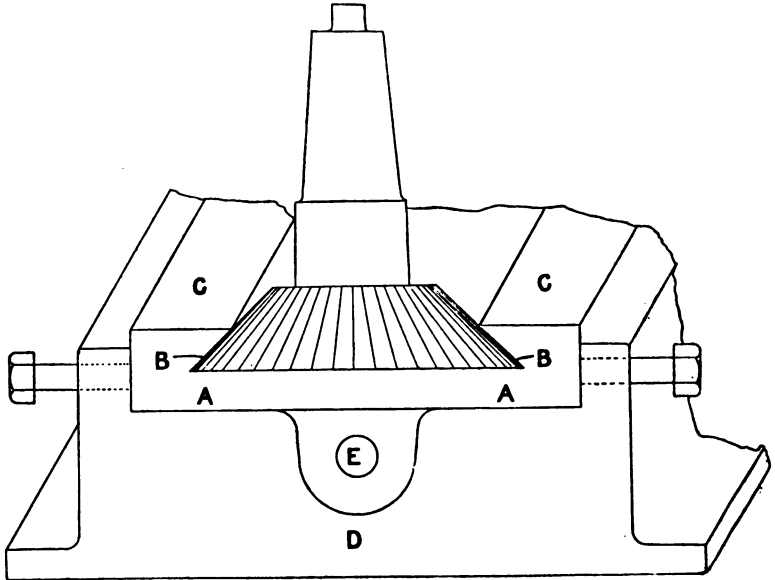

FIG. 309.—Cradle jig for milling.

It is impossible to give definite rules for the speed and feed of milling cutters, and what is here said is only in the way of suggestion. Sometimes the speed must be reduced, and yet the feed need not be changed. The judgment of the foreman or man in charge of the machine should determine what is best in each instance.

Average Speed.—The average speed on wrought iron and annealed steel is perhaps 40 ft. per minute, which gives about sixty turns per minute with cutters $2\frac{1}{2}$ in. diameter. The feed of the work for this surface speed of the cutter can be about $1\frac{1}{2}$ in. per minute, and the cut $\frac{3}{16}$ of an inch deep, and in tough brass the speed may be 80 ft., the feed as before, and the chip $\frac{3}{32}$ of an inch.

As a small cutter cuts faster than a large one, an end mill, for example $\frac{1}{2}$ in. diameter, can be run about 400 revolutions with a feed 4 in. a minute.

As examples showing what may regularly be done under suitable

conditions, we may mention that cutters $2\frac{1}{2}$ in. in diameter used in cutting annealed cast iron may be run at more than 200 turns, or at a surface speed of more than 125 ft., while the work is fed more than 8 in. a minute, the cuts are light, not more than $\frac{1}{32}$ of an inch deep, and the work is short, from $\frac{1}{2}$ in. to 1 in. long.

Two side mills 5 in. diameter, running 50 turns a minute, dress both edges of cast iron bars $\frac{3}{4}$ in. thick with a feed of more than 4 in. per minute.

Mr. George Addy, of Waverly works, Sheffield, gives as safe speeds for cutters of 6 in. diameter and upwards—

Steel	36 ft. per minute with a feed of $1\frac{1}{2}$ in. per minute.
Wrought iron	48 " " " " " " "
Cast iron	60 " " " " " " "
Brass	120 " " " " " " "

And he gives as a simple rule for obtaining the speed: "Number of revolutions which the cutter spindle should make when working on cast iron equals 240 divided by the diameter of cutter in inches."

Slotting cutters may often be run at a higher speed than other cutters of the same diameter, but with a wider face.

Angular cutters must in some instances be used with a fine feed to prevent breaking the points of the teeth (Figs. 310, 310A).

Messrs. Brown & Sharpe suggest a table of speeds for their machines, but not to be considered as an absolute guide, at the same time stating that the judgment of the foreman must determine what is best in each instance.

In considering the table it must be borne in mind that rapid progress is being made in milling, and that all figures are submitted with the certainty that improvements in machines, cutters, and fixtures will soon render them obsolete. Air-hardening steel cutters, now largely used, can be speeded and fed much more rapidly than those above referred to. An ordinary limit is $\frac{1}{4000}$ of an inch. This is allowable for bolt heads, nuts, and the squares at the ends of shafts where crank or hand wheels are used; also for some kinds of gibs, and many parts that are milled for a finish.

In most sewing-machine pieces, electrical and scientific instruments, typewriters, and fine machinery the limit is $\frac{2}{1000}$. Thus a slot that is called $\frac{1}{2}$ in. wide may be any size between $\frac{1}{2}$ in. and $\frac{502}{1000}$ of an inch (0.500 in. to 0.502 in.); while the tongue, or piece that goes into the $\frac{1}{2}$ -in. slot, may be of any size between $\frac{2}{1000}$ less than $\frac{1}{2}$ in. and $\frac{1}{2}$ in. (0.498 to 0.500). On many pieces, for instance usually on those milled for a finish, the limit may be either above or below the standard size.

Some work should be milled as close as possible to exact size; and when close fits are required it is often cheaper and better to do the fitting by the milling machine than by filing or other handwork.

The most accurate results in milling to a given thickness or size are ordinarily obtained by straddle mills or side-milling cutters; for when only one side is milled at a time, and the piece has to be changed from



FIG. 310.

side to side it is hardly practicable to work to a smaller limit than $\frac{2}{1000}$ inch. Side milling frequently requires more attention to keep the work smooth than ordinary surface milling; but very accurate milling may be done and excellent surfaces obtained by end mills running at high speeds.

Castings that are to be milled should be free from sand, they should

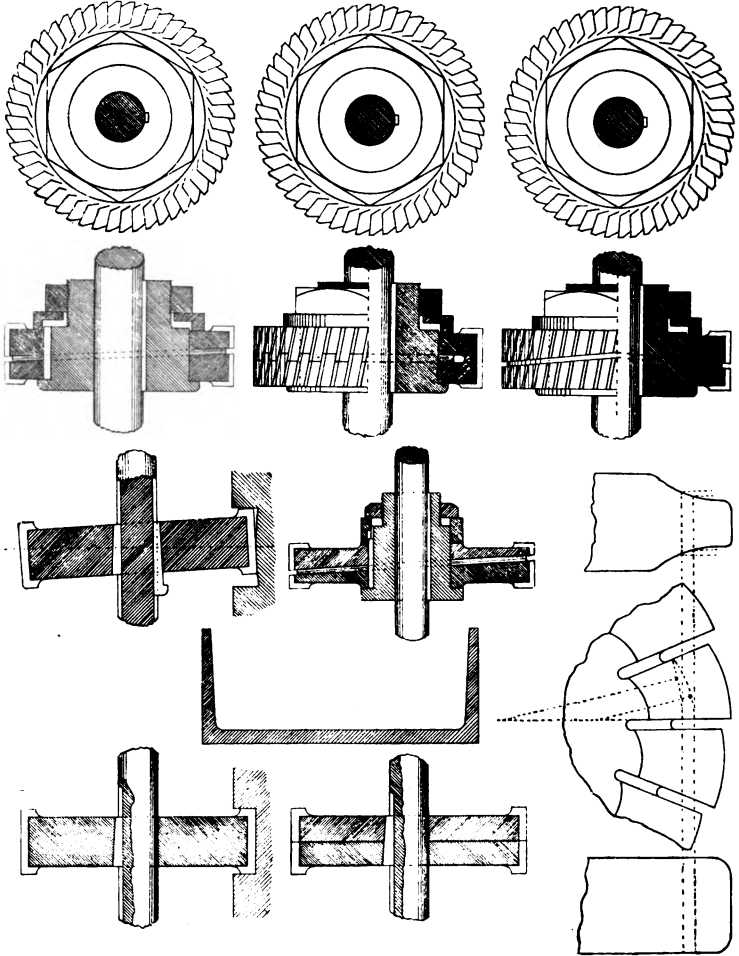

FIG. 310A.—Addy's patent expandable cutter.

be well pickled, and in some cases it is an advantage to have them rattled after being pickled. Where they are small and are to be finished rapidly, it is also well to have them annealed

Forgings should be free from scale. They can be pickled in ten minutes in one part sulphuric acid, and twenty-five parts boiling water,

and if then rinsed in boiling water they will dry before becoming rusty.

Adjustment of Cutters.—Collars are used to adjust the cutters in position on the cutter mandrel, and should be made of steel. Lead hammers are frequently used in fixing and releasing milling cutters. In practice this is established, that finished work must be struck only when absolutely necessary, and then either hard wood blocks or lead, or copper hammers are used, but in forcing hardened bushes or cutters the blows must be light because of the danger to fracture.

Cutting off stock can be conveniently done in a milling machine with a slitting saw, but better still by a broad-gauged toothed circular saw, 12 in. diameter. In the use of the latter there is no danger of the saw teeth becoming choked and galled by cuttings. It is necessary to secure the saw to the spindle flange in addition to keying it, owing to the strain set up in cutting. A further strength is given by screwing a flange to the saw, thereby increasing the length of the driving key.

Hand-feed Milling Machines.—For some classes of work milling machines constructed with "hand feed" are found more suitable than those having power feed to the table. Types of these machines are given in A, B, and C, Fig. 311, by the Anglo-American Machine Tool Co. The machines are made with the feed of the table arranged in two methods; one with a screw-and-crank handle at the end of the table, while the other has the table fed by a pinion and rack, moved by a hand lever.

Designed for Light Work.—The ordinary milling machine, with the table overhanging from the front of the frame and held to it by sliding surfaces, is not adapted to suit all the work a horizontal milling machine is capable of performing. In this type all the light milling can be satisfactorily done without much vibration.

Use of Arm Braces.—The "arm braces" are very useful to connect the table with the overhanging arm, and certainly give an increased support to the cutter mandrel, but when heavy work is fixed on the machine table, and several cutters are operating at the same time, it is often difficult to maintain a proper feed and speed without causing a visible vibration or "chatter marks."

Table supported on Rigid Box Casting.—There can be no doubt as to the increased rigidity of a machine in which the table is fixed on a box casting which has a large base extending to the floor.

Vertical Milling Machine.—The vertical milling machine shown in Fig. 312 is capable of a variety of operations. (A. Herbert, Coventry.)

Surfacing, i.e. plain milling on flat surfaces or on the sides or edges of an object by means of the longitudinal or transverse feeds.

Circular work, by means of the rotating table.

Profiling, i.e. irregularly shaped forgings or castings may be machined true on their exterior by means of a controlling object used as a pattern. For example, *cams* may be conveniently machined to proper shape or dimension and correct in appearance to the templet cam which is fixed on the machine table as a guide.

Recessing, undercutting, or milling out *tee slots*, also for dealing with work having a number of facings on different levels.

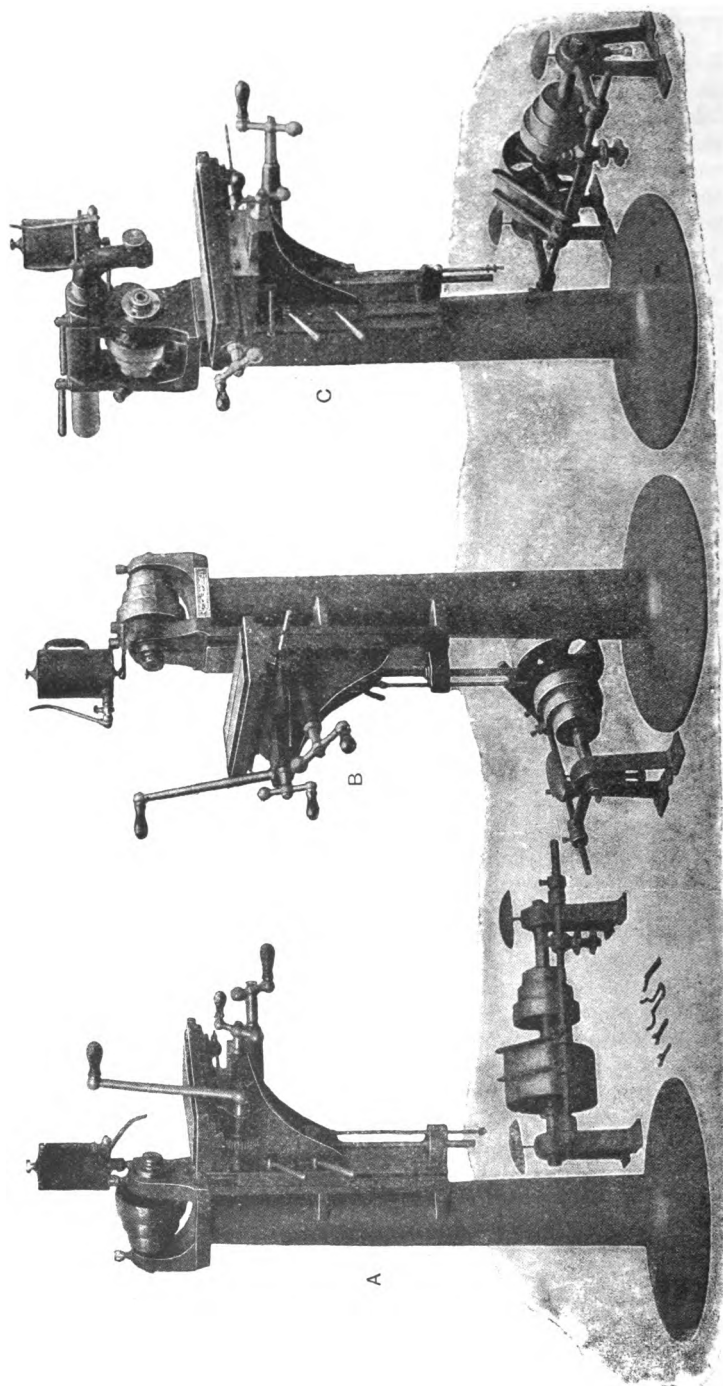

FIG. 311.—Hand-feed milling machines.

When high speeds are required for light milling, and where a smooth drive is important for small cutters the drive is directly by belt. The gearing, which is mounted directly upon the spindle, is used for heavy work.

Two Tables, each of which is provided with automatic feeds and stops, are used interchangeably. The *circular table*, used for rotary work, is made with a tray on its rim to catch the cuttings and lubricant. When long objects are to be milled the *rectangular table* is used, or it is useful for setting a gang of objects in line when doing repetition work.

A further advantage is that one piece can be set while another piece is being milled, thus saving the greater part of the time required for setting. The spindle head is balanced, can be raised and lowered by a hand wheel which gives motion to a worm and wheel and a rack and pinion. Vertical measurements are obtained by means of a graduated disc and a dead stop.

This machine has twelve speeds, varying in geometrical progression from 13.5 to 333 turns per minute. The feeds are sixteen in number, varying from 0.334 up to 8.5 in. per minute. All the gear wheels are enclosed, and the adjustments are made with handles, without the use of spanners.

Accurate Milling.—In milling work which has to be accurate to dimensions, dead stops are used. By this arrangement the automatic feed is used as in ordinary practice, then the final cutting is effected by hand for a short distance after the automatic stop is released.

Slab Milling Machine.—Slab milling, or plain-surface milling, is now extended to the longest surface in both engine and machine construction.

Fig. 313 represents a slab milling machine designed for any heavy work having long surfaces, such as the coupling and connecting rods

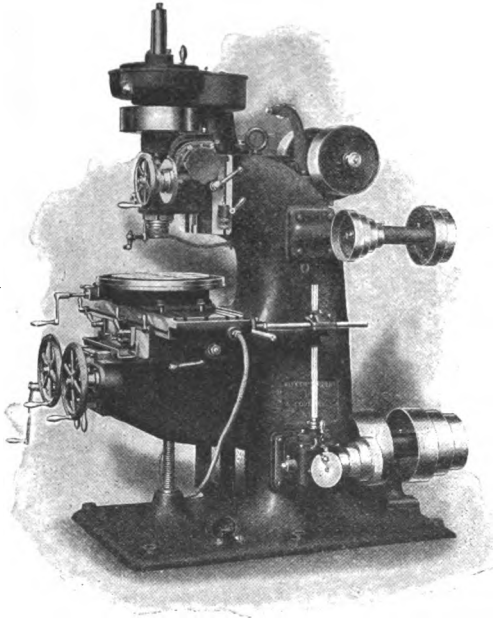

FIG. 312.—Vertical milling machine.

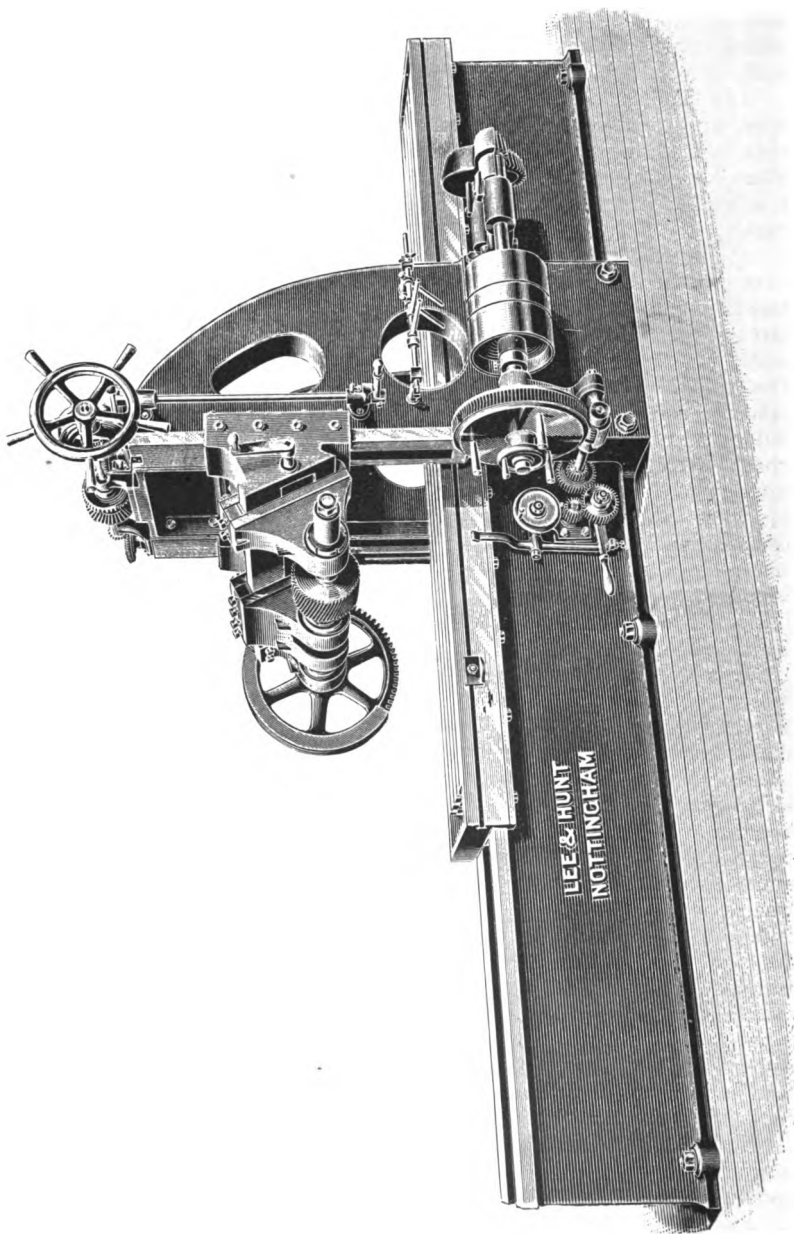

FIG. 313.—Slab milling machine.

for locomotives, slide bars, etc., while in the machine-building trades these machines do much of the work which was formerly planed. The machine, bed, table, standards, and cross slide are very similar in appearance to a planing machine.

Referring to Fig. 313, it will be seen that the cutter spindle is carried by two adjustable bearings, which will open out to receive a cutter up to 24 in. wide, or a gang of cutters to the same width. The cross slide is made with an inclination so that the periphery of the cutters will just allow the surface of the work to comfortably clear the cross rail. This being so, a cutter of much smaller dimension is available than would be the case were the faces of the cross slide vertical.

To obtain a uniformly smooth surface on the work, spiral-cut gearing is employed to drive the table, while all other gears are machine cut. The feed, which is variable, ranges from $\frac{3}{16}$ in. to 10 in. per minute. Provision is also made for pumping a copious supply of oil or soapy water upon the mills, which keeps the cutting edges cool, and also prevents the cuttings from clogging the teeth. The lubricant is drained into a tank, and used again.

A somewhat recent development is the screw milling machine. This applies the principle of the milling cutter to the formation of screw threads, and will cut screws of any section from $\frac{3}{8}$ in. to $1\frac{7}{8}$ in. diameter, and a pitch of from 2 to 10 threads per inch. The headstock carrying the cutter is situated at the right-hand end of the bed. The spindle and bearings are of hardened steel, and the machine is driven through a train of gears. The headstock may be moved vertically and transversely, and the spindle may be swung to any desired angle up to 25 degrees with the screw which is being milled, either right or left hand to suit the different dies and pitches being cut.

An index is provided by which the spindle may be set to the angle required, and a table is sent out with each machine, from which the correct angles may be ascertained.

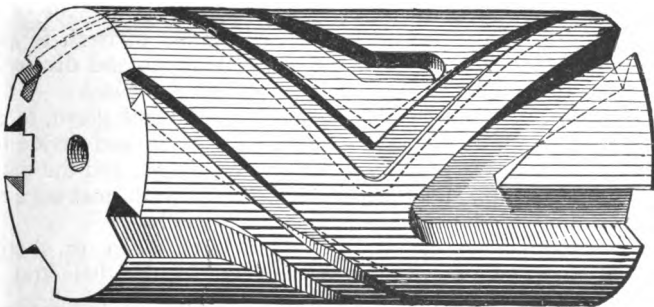

FIG. 314.—Example of milling cutter work.

CHAPTER XIII.

GEARING AND GEAR CUTTERS.

THE "diameter," when applied to gears, is always understood to mean the pitch diameter.

Diametral pitch of the gear is the number of teeth to each inch of its pitch diameter. If a gear has 40 teeth, and the pitch diameter is 4 in., there are 10 teeth to each inch of the pitch diameter, and the diametral pitch is 10, or, in other words, the gear is 10 diametral pitch.

Circular pitch is the distance from the centre of one tooth to the centre of the next tooth, measured along the pitch circle. If the distance from the centre of one tooth to the centre of the next tooth, measured along the pitch circle, is $\frac{1}{2}$ in., the gear is $\frac{1}{2}$ in. circular pitch.

The diametral pitch given, to obtain the circular pitch, divide 3.1416 by the diametral pitch. If the diametral pitch is 4, divide 3.1416 by 4, and the quotient 0.7854 is the circular pitch.

The circular pitch given, to obtain the diametral pitch, divide 3.1416 by the circular pitch. If the circular pitch is 2 in., divide 3.1416 by 2, and the quotient 1.5708 is the diametral pitch.

The number of teeth and the diametral pitch given to obtain the pitch diameter, divide the number of teeth by the diametral pitch. If the number of teeth is 40 and the diametral pitch is 4, divide 40 by 4, and the quotient 10 is the pitch diameter.

The number of teeth and the diametral pitch given, to obtain the whole diameter or size of blank of gear, add 2 to the number of teeth, and divide by the diametral pitch. If the number of teeth is 40, and the diametral pitch is 4, add 2 to the 40, making 42, and divide by 4; the quotient $10\frac{1}{2}$ is the whole diameter of the gear or blank.

The number of teeth and the diameter of the blank given, to obtain the diametral pitch, add 2 to the number of teeth, and divide by the diameter of the blank. If the number of teeth is 40, and the diameter of the blank is $10\frac{1}{2}$ in., add 2 to the number of teeth, making 42, and divide by $10\frac{1}{2}$; the quotient 4 is the diametral pitch.

The pitch diameter and the diametral pitch given, to obtain the number of teeth, multiply the pitch diameter by the diametral pitch. If the diameter of the pitch circle is 10 in., and the diametral pitch is 4, multiply 10 by 4, and the product, 40, will be the number of teeth in the gear.

The whole diameter of the blank and the diametral pitch given, to obtain the number of teeth in the gear, multiply the diameter by the

diametral pitch and subtract 2. If the whole diameter is $10\frac{1}{2}$, and the diametral pitch is 4, multiply $10\frac{1}{2}$ by 4, and the product 42, less 2, or 40 is the number of teeth.

The thickness of a tooth at the pitch line is found by dividing the

CUT GEARING (BY BROWN AND SHARPE).

CIRCULAR PITCH.			DIAMETRAL PITCH.		
Circular pitch.	Depth to pitch line.	Total depth of tooth.	Diametral pitch.	Depth to pitch line.	Total depth of tooth.
$\frac{1}{8}$	0'0398	0'0858	1	1'0000	2'1571
$\frac{3}{16}$	0'0597	0'1287	$1\frac{1}{4}$	0'8000	1'7257
$\frac{1}{4}$	0'0796	0'1716	$1\frac{1}{2}$	0'6666	1'4381
$\frac{5}{16}$	0'0995	0'2146	$1\frac{3}{4}$	0'5714	1'2326
$\frac{3}{8}$	0'1194	0'2575	2	0'5000	1'0785
$\frac{7}{16}$	0'1393	0'3003	$2\frac{1}{4}$	0'4444	0'9587
$\frac{1}{2}$	0'1592	0'3433	$2\frac{1}{2}$	0'4000	0'8628
$\frac{9}{16}$	0'1790	0'3862	$2\frac{3}{4}$	0'3636	0'7844
$\frac{5}{8}$	0'1989	0'4291	3	0'3333	0'7190
$\frac{11}{16}$	0'2189	0'4720	$3\frac{1}{4}$	0'2857	0'6163
$\frac{3}{4}$	0'2387	0'5150	4	0'2500	0'5393
$\frac{13}{16}$	0'2586	0'5579	5	0'2000	0'4314
$\frac{7}{8}$	0'2785	0'6007	6	0'1666	0'3595
$\frac{15}{16}$	0'2984	0'6437	7	0'1429	0'3081
1	0'3183	0'6866	8	0'1250	0'2696
			9	0'1111	0'2397
			10	0'1000	0'2157
			11	0'0909	0'1961
			12	0'0833	0'1798
			13	0'0769	0'1659
			14	0'0714	0'1541
			15	0'0666	0'1438
			16	0'0625	0'1348
			17	0'0588	0'1269
			18	0'0555	0'1198
			19	0'0526	0'1135
			20	0'0500	0'1079
			21	0'0476	0'1026
			22	0'0454	0'0980
			23	0'0434	0'0936
			24	0'0417	0'0898

circular pitch by 2, or dividing 1'57 by the diametral pitch. If the circular pitch is 1'047 in., or the diametral pitch is 3, divide 1'047 by 2, or 1'57 by 3, and the quotient, 0'523 in., is the thickness of tooth.

The whole depth of a tooth is found by dividing 2'157 by the diametral pitch. If the diametral pitch of a gear is 6, the whole depth is 2'157 divided by 6, or 0'3595.

The whole depth of a tooth is about $\frac{1}{8}$, or, more precisely, 0·6866 of the circular pitch. If the circular pitch is 2, the whole depth of tooth is about $\frac{1}{8}$ of 2 in., or nearly $1\frac{3}{8}$ in.

The distance between the centres of two gears is found by adding the number of teeth together, and divide half the sum by the diametral pitch. If two gears have 50 and 30 teeth respectively, and are 5 pitch, add 50 and 30, making 80; divide by 2, and then divide this quotient, 40, by the diametral pitch, 5; and the result, 8 in. is the centre distance.¹

CIRCULAR PITCH (BY SMITH AND COVENTRY).

Total depth of tooth = $\frac{12}{15}$ of pitch. Depth above pitch line = $\frac{5\frac{1}{2}}{15}$ " " " below " " = $\frac{6\frac{1}{2}}{15}$ " "			Total depth of tooth = $\frac{10}{15}$ of pitch. Depth above pitch line = $\frac{4\frac{1}{2}}{15}$ " " " below " " = $\frac{5\frac{1}{2}}{15}$ " "		
Circular pitch.	Depth to pitch line.	Total depth of tooth.	Circular pitch.	Depth to pitch line.	Total depth of tooth.
$\frac{1}{4}$	0·0916	0·2000	$1\frac{1}{8}$	0·3375	0·7500
$\frac{5}{16}$	0·1146	0·2500	$1\frac{1}{4}$	0·3750	0·8333
$\frac{3}{8}$	0·1375	0·3000	$1\frac{3}{8}$	0·4125	0·9166
$\frac{7}{16}$	0·1604	0·3500	$1\frac{1}{2}$	0·4500	1·0000
$\frac{1}{2}$	0·1833	0·4000	$1\frac{5}{8}$	0·4875	1·0833
$\frac{9}{16}$	0·2063	0·4500	$1\frac{3}{4}$	0·5250	1·1666
$\frac{5}{8}$	0·2291	0·5000	$1\frac{7}{8}$	0·5625	1·2500
$\frac{11}{16}$	0·2521	0·5500	2	0·6000	1·3333
$\frac{3}{4}$	0·2750	0·6000	$2\frac{1}{4}$	0·6750	1·5000
$\frac{13}{16}$	0·2979	0·6500	$2\frac{1}{2}$	0·7500	1·6666
$\frac{7}{8}$	0·3208	0·7000	3	0·9000	2·0000
$\frac{15}{16}$	0·3438	0·7500			
1	0·3666	0·8000			

Fully Automatic Gear-Cutting Machine.—The entirely automatic gear-cutting machine illustrated in Fig. 316 is by Messrs. G. Birch & Co., Manchester. In this machine the mandrel which supports the work is carried by a hollow spindle, the mouth of which is bored conical to give additional bearing, also to ensure perfect contact, which is so essential in all fitting parts, to keep them from vibrating when the cutting tools are in operation.

The mandrel is kept in place by a nut at the back. The bed of the machine is cast with an extension at one end, and is mounted on two standards, the one at the right hand is made wider to give support to the cutter head.

The skeleton or webbed leg supports are giving place to much wider

¹ Brown and Sharpe's "Gearing."

and stouter forms of castings called box legs, which extend to the floor similarly to the one above; by this arrangement springiness is considerably reduced.

The driving head is traversed along the bed by a screw to suit the size of the blank to be cut.

When setting the depth of tooth to be cut, an adjustable micrometer reading to $\frac{1}{1000}$ in. is used.

A bracket which serves as a stay to support the rim of the blank against the pressure of the cut is shown at the front of the machine, at the top of this a small headstock is located which gives additional support to the extremity of the mandrel. The bracket will swing the entire capacity of the machine.

The "master" wheel seen at the back is essentially an extremely

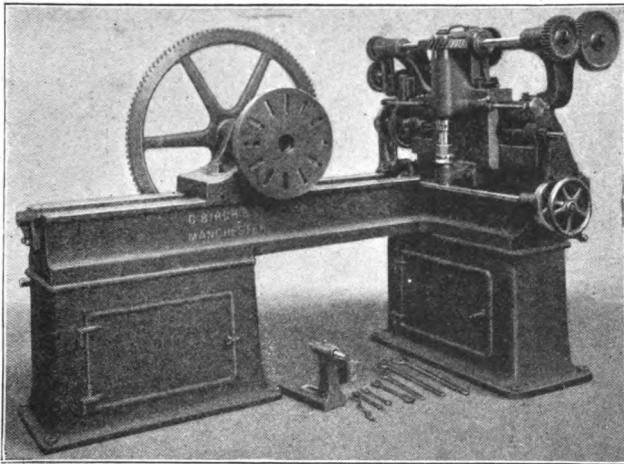

FIG. 316.—Automatic gear-cutting machine.

accurate one, as it gives the divisions of the wheel to be cut, hence its name "dividing wheel." The worm which imparts motion to this wheel can be dropped out of gear if required to allow the blank to be rotated by hand without throwing the change wheels out of gear, thus enabling the blank to be returned to its correct position.

The change wheels are used to cut gears ranging from 6 to 100 teeth, and all numbers from 100 to 600, except the prime numbers and their multiples.

The dividing arrangement which is automatic is positively driven by a clutch, and the dividing plate always turns one complete revolution, thus avoiding the mistakes by imperfect dividing.

The cutter spindle (which is vertical) is driven by spiral gearing, which is found to be specially adapted to smooth running. Beneath the

spiral gear wheel an exceedingly long bearing is provided which further adds to the rigidity of the cutter spindle.

The lower bearing is removed whenever a change of cutters is required, and the cutters are adjusted to the centre of the blanks by means of screw lock nuts, which does away with "packing." The cutters are fed by means of change gears.



FIG. 317.—Double helical steel gears.

Gears of Cast Iron and Cast Steel.—The form of tooth adopted generally is the epicycloid for large gears having cast teeth, but for rolling mill work and for punching, shearing, and similar machines, wheels with double helical teeth are largely used with quite satisfactory results. They can be, and indeed are, used for all classes of gearing,

but some discrimination is required to decide in general work whether these or straight toothed wheels are most suitable.

Some interesting examples of mild steel castings having double helical teeth are given in Figs. 317 and 318.

Fig. 317 shows a massive pair of steel gears 11 ft. 3 in. and 5 ft. 9 in. diameter respectively, 9 in. pitch and 36 in. wide on face. It will be noticed that the smaller wheel of the pair has a self-contained boss

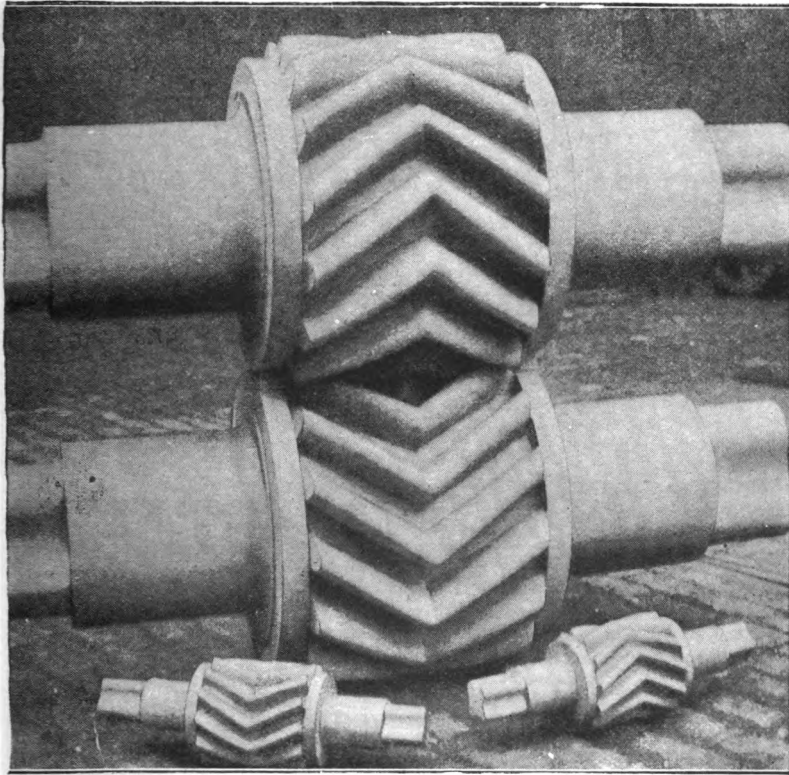
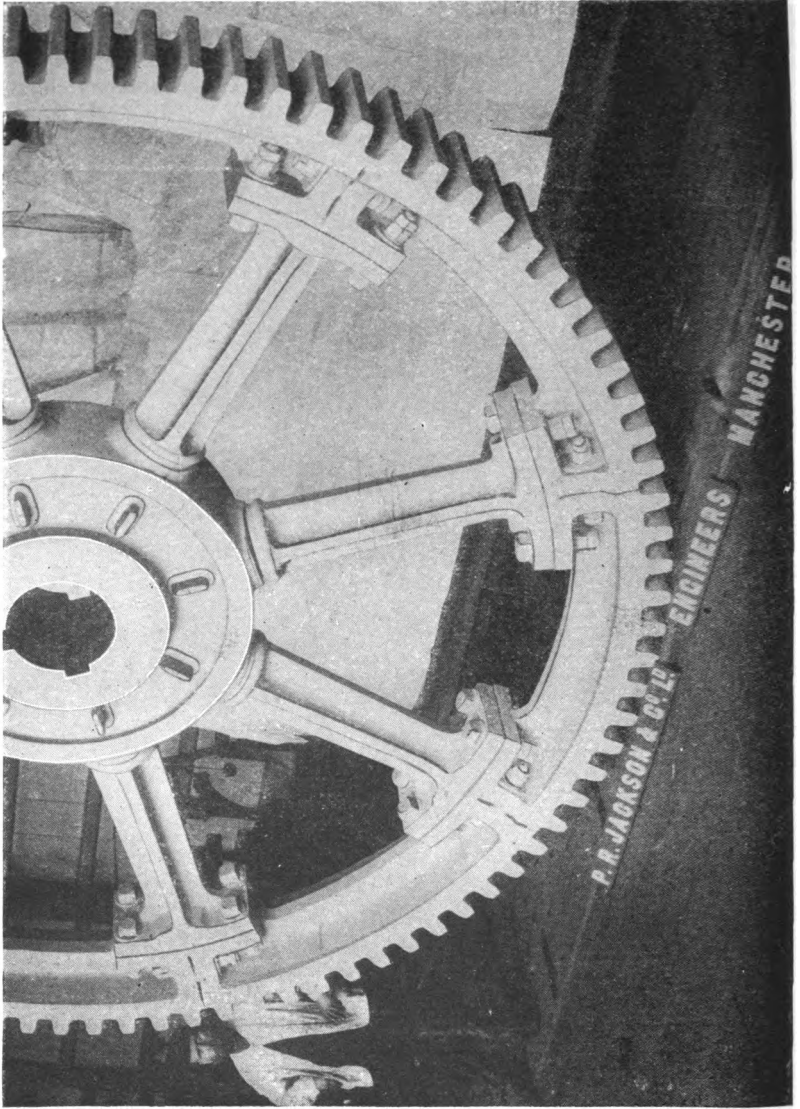

FIG. 318.—Double helical steel gears.

connected by seven webs or arms to the rim making it a solid casting, *i.e.* a single piece of metal. The larger wheel of the pair is one single casting, but the arms and boss have yet to be fitted or "built up." The six dovetailed slots are to receive the arms, the curved portions between are simply to reduce the weight which, although thus cored, is 16 $\frac{1}{4}$ tons.

In Fig. 318 the gear wheels and trunnions are made in one piece. The teeth are shrouded to the pitch line, which has the effect of considerably strengthening them, and at the same time prevents the gears

crowding closer to one another. Expansion and contraction in the shafts, or weak shafts and fixings, probably affect the working of helical



toothed wheels more injuriously than would be the case with straight toothed wheels.

Where the conditions are suitable, and care is taken to obtain proper accuracy in the teeth, helical wheels are found to work with remarkable smoothness and quietness.

Helical toothed wheels are generally made with cast teeth in this country. There are, however, one or two Continental firms who machine-cut these teeth.

Wheel Gears.—The most accurate gear wheels are machine cut, the most accurate cast gears are machine moulded.

It is not intended here to describe in detail the operations of making machine moulded toothed wheels. The teeth patterns are cut on machines of the same construction as those on which the wheels are moulded. This eliminates errors which might arise owing to differences in the cutting and moulding machines. The moulding-machine table carries a strong circular moulding box in which the mould for the wheel is formed. The patterns when finished are transferred to the moulding machines, and the teeth formed in the mould by the aid of a segment. The centre part of the wheel is built up by cores.

For steel wheels provision is made for a large rising head or feeder to give solidity to the casting, and for steel wheels the cores are all dried. The molten steel is run in the moulds from ladles of ordinary construction, except that the metal flows from a hole in the bottom of the ladle, getting the best metal this way, instead of over the side as with cast iron.

The rising heads which carry off any impurities there may be in the metal are either "parted off" in the lathe or cut asunder with circular or band sawing machines specially made for the purpose. The castings are either smoothly "fettled" by hand or by pneumatic tools. It is not the practice to cast wheels of considerable dimensions in one piece, but to make them in segments, or at least in halves.

The various parts are fitted by cotters, and bolts and nuts, as in Fig. 319, which shows a massive driving wheel, the rim of which is composed of eight segments. Each segment has to be tooled so as to form a joint to the next and so on round the wheel, and also tooled to fit the arms. The hub is shown with the arms secured by cotters.

This obviously requires careful and skilful manipulation of the various parts, and necessitates the measurements of each part to be taken and transferred with precision. There is no "allowance," *i.e.* "give and take" in the construction of a toothed wheel, the pitch must be uniform, and the rim concentric with the bore when the construction is complete. Any deviation would be sufficient to cause the teeth to crowd or jam.

Figs. 320 and 321 illustrate other forms of built-up gear wheels.

Bevel Gears.—The use of bevel-gear wheels is to transmit motion from one shaft to another at an angle to it, when the centre lines intersect.

The speed obtained is according to the ratio of diameters or numbers of teeth in a given pair of wheels.

The power to be transmitted decides the pitch of the teeth. When the speed transmitted to the driven shaft is the same as that of

the driving shaft, the gears are essentially alike in angle, diameter, and number of teeth.

When the shafts are at 90 degrees, and the wheels are alike, such wheels are called mitres. When there is a difference in the numbers of teeth as in Fig. 322, the wheels are not called mitres, but bevel gears.

The final adjustment of these mitre or bevel gears is important, and is properly termed "gearing the wheels." Especially is this the case, where the bearings for the respective shafts are in close proximity to each other.

For gears having cast teeth, the practice is to turn and finish each wheel, except the boss faces, which are simply tooled flat. Each wheel is placed in turn on its respective shaft in position, and measurement taken from the points of the teeth to the face of the bearing of the other shaft. The measurement thus obtained is transferred to the second of the pair of wheels, and is taken from the roots of the teeth

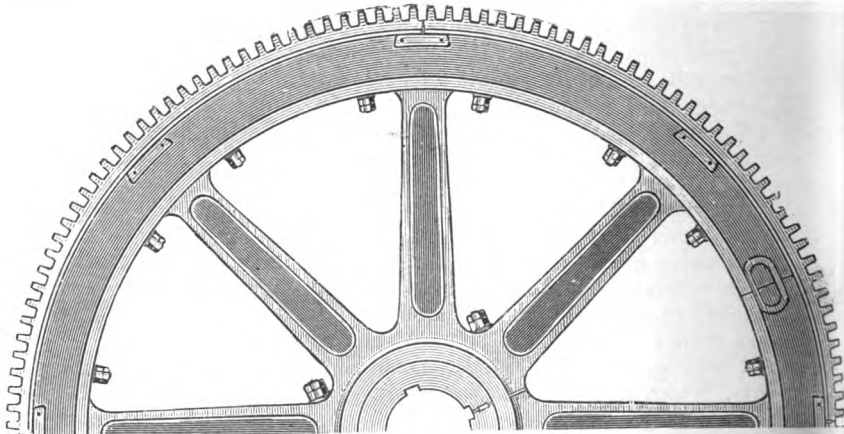

FIG. 320.—Built-up gear wheel.

to the face of the boss; any excess of metal is then turned off the boss face. This process is repeated for the other wheel, and the gears are then temporarily put in position where they are finally to ride.

Where the original patterns are in good condition, very little adjustment will be required. Mild steel cast gears are less reliable owing to the annealing process, which generally warps or buckles articles of an irregular form. When "meshing" wheels of mild steel a few teeth are "gearing" and any uneven places subsequently dressed by filing. This, however, is not done until each wheel has been keyed to its own respective shaft.

Many gears are now machine cut in cast iron, mild steel, gun metal, and phosphor bronze, Fig. 322A. This obviously reduces the task of "gearing" to a minimum, so that by the system of duplication and interchangeability of parts the gear blanks can be turned and machine cut to gauges without trial.

The Principal Forms of teeth in use are the Epicycloid and the Involute.

Involute Teeth.—The involute form is largely used for machine-cut teeth. They offer a greater facility in forming the cutters, as there is a single curve only, which forms both face and flank of the tooth sides.

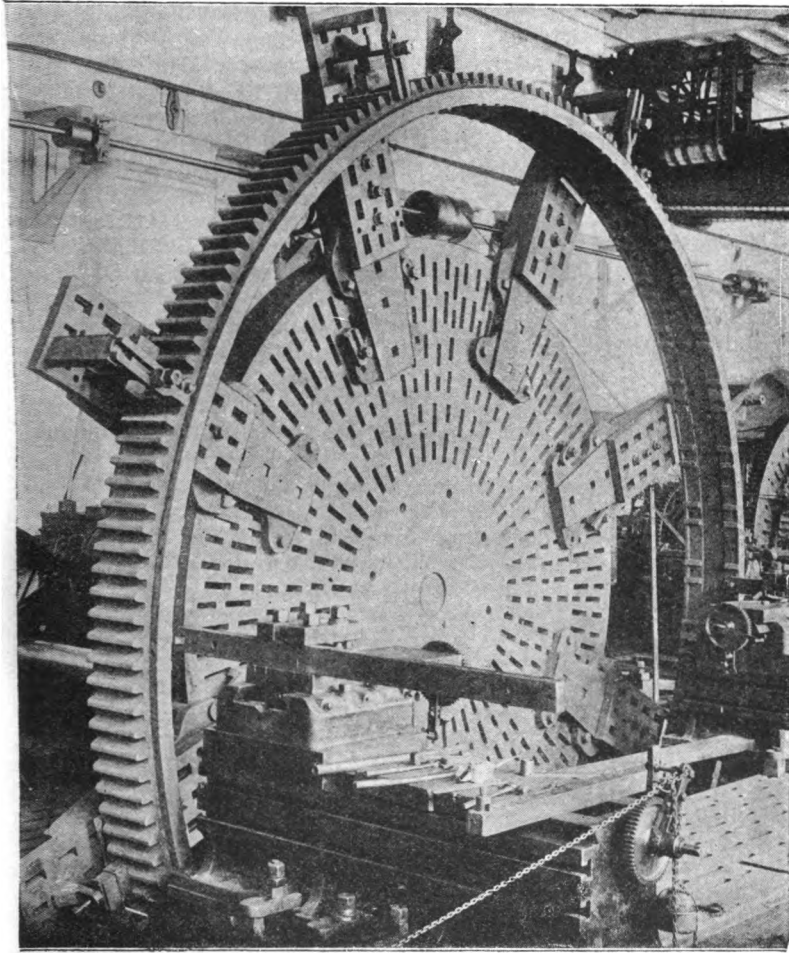

FIG. 321.—Turning the rim of a cast-steel gear.

In gears having thirty teeth and more, this curve can be a single arc of a circle whose radius is one-fourth the radius of the pitch circle, and a fillet equal in radius to one-sixth the widest part of the tooth space is added at bottom of the tooth to make it stronger. Cutters formed

to leave this fillet have the advantage of wearing longer than when brought up to a corner. Single curve or involute gears are, it is stated, the only gears that can be run at varying distances of axes, and transmit unvarying angular velocity. This peculiarity makes involute gears specially valuable for driving rolls, etc., the distance of whose axes is likely to be changed.

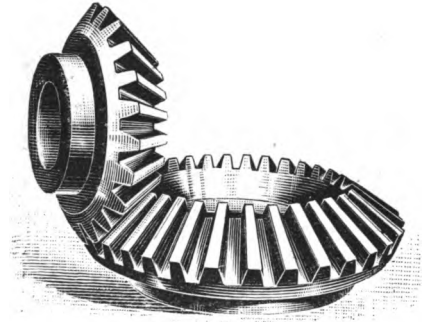

FIG. 322.—Bevel gears.

If, in any bevel gear, the teeth were sufficiently prolonged toward the apex, they would become infinitely small; that is, the teeth would all end in a point, or vanish at O .

We can also consider a bevel gear as beginning at the apex, and becoming larger and larger as we go away from the apex. Hence, as the bevel-gear teeth are tapering from end to end, we may say, that a bevel gear has a number of pitches, and pitch circles, or diameters.

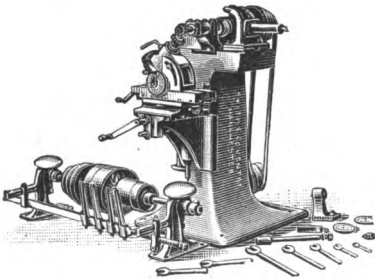

FIG. 322A.—Bevel gear-cutting machine.

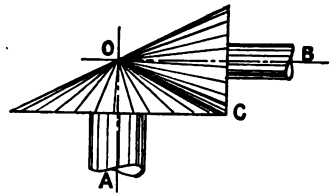

FIG. 323.—Setting out bevel wheels.

In speaking of the pitch of a bevel gear, we mean always the pitch at the largest pitch circle, or at the largest pitch diameter as at BD , Fig. 324.

Fig. 324 is a section of three bevel gears, the gear OBQ , being twice as large as the two others. The outer surface of a tooth as at mm' is called the face of the tooth. The distance mm' is usually called the length of the face of the tooth, though the real length is the distance

it occupies upon the line Oi . The outer part of a tooth at mn is called its large end, and the inner part $m' n'$ the small end.

Having decided upon the pitch and the numbers of teeth—

1. Draw centre lines of shafts AOB and COD at right angles.

2. Parallel to AOB , draw lines ab , and cd , each distant from AOB equal to half the largest pitch diameter of one gear. For 24 teeth 4 pitch, this half largest pitch diameter is 3 in.

3. Parallel to COD , draw lines ef and gh distant from COD equal to half the largest pitch diameter of the other gear. For a gear 12 teeth 4 pitch, this half largest pitch diameter is $1\frac{1}{2}$ in.

4. At the intersection of these four lines, draw Oi , Oj , Ok , and Ol ; these lines give the size and shape of the pitch cones. We call them "Cone pitch lines."

5. Perpendicular to the cone pitch lines and through the intersection

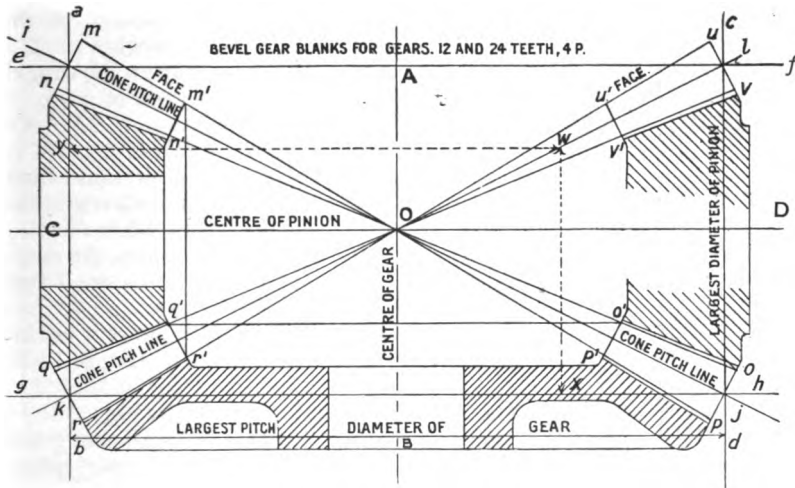

FIG. 324.—Section of 3 bevel wheels.

of lines ab , cd , ef , and gh , draw lines mn , op , qr . The lines uv are drawn to show that another gear can be drawn from the same diagram.

6 Upon the lines mn , op , qr , the addenda and depth of the teeth are laid off, these lines passing through the largest pitch circles of the gears. Lay off the addendum, it being in these gears $\frac{1}{4}$ in. This gives distance mn , op , qr , and uv equal to the working depth of the teeth, which in these gears is $\frac{1}{2}$ in.

The addendum is measured perpendicularly from the cone pitch lines at kr .

7. Draw lines Om , On , Oo , Op , Oq , Or . These lines give the height of teeth above the cone pitch lines as they approach O , and would vanish entirely at O .

It is quite as well never to have the length of teeth, or face mm' ,

longer than one-third the apex distance mO , nor more than two and one-half times the circular pitch.

8. Having decided upon the length of face, draw limiting lines $m'n'$ perpendicular to iO , $q'r'$ perpendicular to kO , and so on.

The distance between the cone pitch lines at the inner ends of the teeth $m'n'$ and $q'r'$, is called the inner or smaller pitch diameter; and the circle at these points is called the smallest pitch circle. We now have the outline of a section of the gears through their axes.

The distance mr is the whole diameter of the pinion. The distance go is the whole diameter of the gear.

In practice these diameters can be obtained by measuring the drawing. The diameter of the pinion is 3.45 in., and of the gear 6.22 in. We can find the angles also by measuring the drawing with a protractor. In the absence of a protractor, templates can be cut to the drawing.

In turning the blanks to the correct angle, place one arm of the protractor or templet against the wheel boss and test the angle.

Bevel Gears (Cutting).—When axes are at right angles, the sum of angles of edge in the two gears equals 90° , and the sums of angle of edge and face in each gear are alike.

The angles of axes remaining the same, all pairs of bevel gears of the same ratio have the same angle of edge; all pairs of same ratio and of same numbers of teeth, have the same angles of both edges and faces independent of the pitch. Thus, in all pairs of bevel gears having one gear twice as large as the other, with axes at right angles, the angle of edge of large gear is $63^\circ 26'$, and the angle of edge of the small gear $26^\circ 34'$.

In all pairs of bevel gears with axes at right angles, one gear having 24 teeth, and the other gear having 12 teeth, the angle of face of small gear is $59^\circ 11'$.

Data for Cutting Bevel Gears—(see table of data, p. 289).

1. The pitch and the numbers of the teeth the same as for spur gears.
2. The data for the cutter, as to its form: sometimes two cutters are needed for a pair of bevel gears.
3. The whole depth of the tooth spaces both at the outside and inside ends; $D'' + f$ at the outside, and $D''' + f$ at the inside.
4. The thickness of the teeth at the outside, and at the inside; t and t' .
5. The height of the teeth above the pitch lines at the outside and inside s and s' .

6. The cutting angles, or the angles that the path of the cutter makes with the axes of the gears. In Fig. 325 the cutting angle for the gear CD is $AO\phi$, and the cutting angle for the pinion is $BO\phi$.

The form of the teeth in one of these gears differs so much from that in the other gear that two cutters are required. In determining these cutters, we do not have to develop the forms of the gear teeth, we need merely measure the lines Ac and Bc , Fig. 325, and calculate the cutter forms, as if these distances were the radii of the pitch circles of the gears to be cut.

Twice the length Ac in inches multiplied by the diametral pitch equals the number of teeth for which to select a cutter for the 24-tooth gear; this number is about 54, which calls for a No. 3 bevel-gear cutter in the list of bevel-gear cutters (see p. 283).

Twice Bc multiplied by 8 equals about 13 which indicates a No. 8 bevel-gear cutter for the pinion.

This method of selecting cutters is based upon the idea of shaping the teeth as nearly right as practicable at the large end, and then filing the small ends where the cutter has not rounded them over enough. There are several things that affect the shape of the teeth, so that the choice of cutters is not always so simple a matter as the taking the lines Ac and Bc as radii.

In cutting a bevel gear in the ordinary gear-cutting machine, the finished spaces are not always of the same form as the cutter might be expected to make, because of the changes in the positions of the cutter and of the gear blank in order to cut the teeth of the right thickness at both ends.

The cutter must be thin enough to pass through the small end of the spaces so that the large end has to be cut to the right width by adjusting either the cutter or the blank sideways, then rotating the blank and cutting twice around. Thus, in Fig. 326, a gear and a cutter are set to have a space widened at the large end e' , and the last chip to be cut off by the right side of the cutter, the cutter having been moved to the left and the blank rotated in the direction of the arrow. In a universal milling machine the same result would be attained by moving the blank to the right and rotating it in the direction of the arrow. It should be remembered that, in setting to finish the side of a tooth, the tooth and the cutter are first separated sideways, and the blank is then rotated by indexing the spindle to bring the large end of the tooth up against the cutter.

This tends not only to cut the spaces wider at the large pitch circle, but also to cut off still more at the face of the tooth; that is, the teeth may be cut rather thin at the face and left rather thick at the root.

This tendency is greater as a cutting angle, BOo , Fig. 325, is smaller,

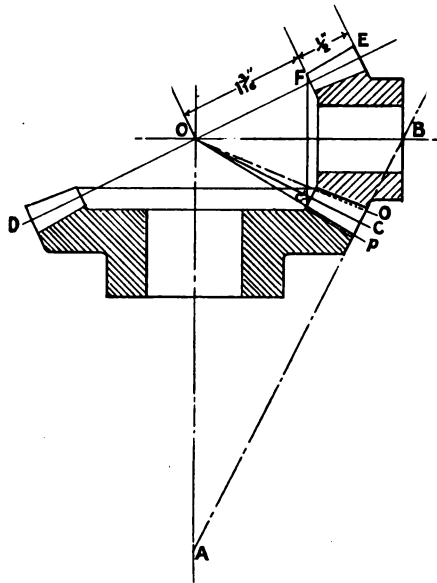

FIG. 325.—Bevel gear. Diagram for dimensions.

or as a bevel gear approaches a spur gear, because when the cutting angle is small the blank must be rotated through a greater arc in order to set to cut the right thickness at the outer pitch circle. Different workmen prefer different ways to compromise in the cutting of a bevel gear. When a blank is rotated in adjusting to finish the large end of the teeth there need not be much filing of the small end, if the cutter is right, for a pitch circle of the radius B_c , Fig. 325, which for our example is a No. 8 cutter, but the tooth faces may be rather thin at the large ends. This compromise is preferred by nearly all workmen; because it does not require much filing of the teeth.

A second approximation in cutting with a rotary cutter is to widen the spaces at the large end by swinging either the index spindle or the cutter-slide carriage, so as to pass the cutter through on an angle with the blank sideways, called the "side-angle," and not rotate the blank at all to widen the spaces. This side-angle method is employed in automatic mitre gear-cutting machines, and is available in the manufacture of mitre gears in large quantities, because with the proper relative thickness of cutter the tooth thickness comes right by merely adjusting for the side angle, but for cutting a few gears it is not so much liked, because in adjusting for the side angle the central setting for the cutter is usually lost, and has to be found by guiding into the central slot already cut.

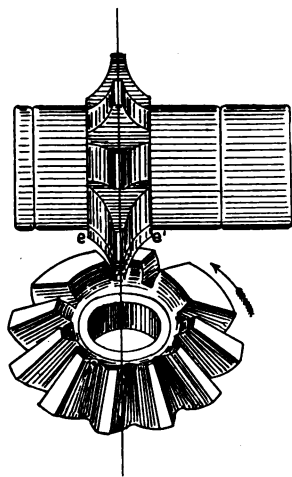

FIG. 326.—Setting bevel-gear cutter out of centre.

If the side-angle mechanism pivots about a line that passes very near the small end of the tooth to be cut, the central setting of the cutter may not be lost. With this method a gear must be cut at least twice round. In widening the spaces at the large end, the teeth are narrowed practically the same amount at the root as at the face, so that this side-angle method requires a wider cutter at $e e'$, Fig. 326, than the first or rotative method. The amount of filing required to correct the form of the teeth at the small end is about the same as in the first method.

A third approximate method consists in cutting the teeth right at the large end by going round at least twice, and then to trim the teeth at the small end and towards the large end with another cutter, going round at least four times in all. This method requires skill, and is necessarily a little slow, but it contains possibilities for considerable accuracy.

A fourth method is to have a cutter fully as thick as the spaces at the small end, cut rather deeper than the regular depth at the large end, and go only once round. This is a quick method, but more inaccurate

than the three preceding; it is available in the manufacture of large numbers of gears, when the tooth face is short compared with the apex distance; it is, however, seldom employed in cutting a few gears, and may require some experimenting to determine the form of cutter.

Sometimes the teeth are not cut to the regular depth at the small end, in order to have them thick enough, which may necessitate reducing the addendum of the teeth at the small end by turning the blank down. This method is extensively employed by chuck manufacturers.

A machine that cuts bevel gears with a reciprocating motion, and using a tool similar to a planing tool, is called a "gear planer," and the gears so cut are said to be planed.

CUTTERS FOR MITRE AND BEVEL GEARS.

Diametrical pitch.	Diameter of cutter.	Hole in cutter.
4	$3\frac{3}{8}$ "	$1\frac{1}{4}$ "
5	$3\frac{1}{8}$ "	$1\frac{1}{4}$ "
6	$2\frac{3}{4}$ "	$1\frac{1}{8}$ "
8	$2\frac{1}{2}$ "	$1\frac{1}{8}$ "
10	$2\frac{1}{4}$ "	$\frac{7}{8}$ "
12	2"	$\frac{7}{8}$ "
14	2"	$\frac{7}{8}$ "
16	$1\frac{15}{8}$ "	$\frac{7}{8}$ "
20	$1\frac{7}{8}$ "	$\frac{7}{8}$ "
24	$1\frac{3}{4}$ "	$\frac{7}{8}$ "

Worm and Worm Wheel.—A worm is a screw cut so as to gear with the teeth of a wheel called a worm wheel. A section of a worm through its axis is in outline the same as a rack of corresponding pitch. This outline can be made either to mesh with single or double curve gear teeth; but worms are usually made for single curve, because, the sides of involute rack teeth being straight, the tool for cutting a worm thread is more easily made. The thread tool is not usually rounded for giving the fillets at the bottom of worm threads. The rules for circular pitch apply in the size of tooth parts and diameter of pitch circle of worm wheel.

The pitch of a worm or screw is usually given in a way different from the pitch of a gear, viz. in number of threads to 1 in. of the length of the worm or screw. Thus, if we say a worm is two-pitch, we mean two threads to the inch, or the worm makes two turns to advance the thread 1 in. But a worm may be double-threaded, triple-threaded, and so on.

It is much better to call the advance of the worm thread the lead. Thus, a worm thread that advances 1 in. in one turn we call 1-in. lead in one turn.

A single-thread worm 4 threads to 1 in. is $\frac{1}{4}$ in. lead. We apply the

term "pitch" to the actual distance between the threads or teeth. In single-thread worms the lead and the pitch are alike. If we have to make a worm and wheel so many threads to 1 in., we first divide 1 in. by the number of threads to 1 in., and the quotient gives us the circular pitch.

The term "linear pitch" expresses exactly what is meant by circular pitch. Linear pitch has the advantage of being an exact use of language when applied to worms and racks.

The number of threads to 1 in. linear is the reciprocal of the linear pitch. Multiply 3.1416 by the number of threads to 1 in., and the product will be the diametral pitch of the worm wheel. Thus, we would say

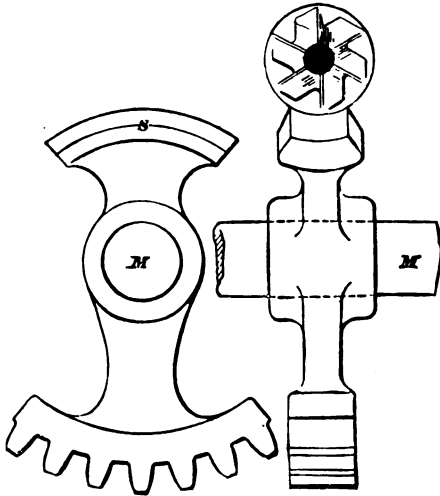

FIG. 327.—Milling faces of worm wheel.

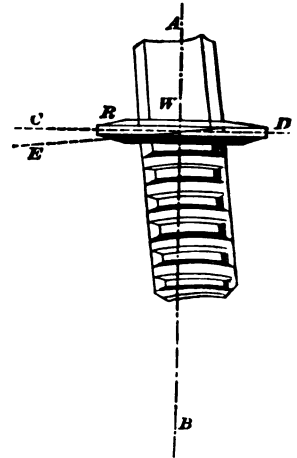

FIG. 328.—Cutting worm-wheel teeth.

of a double-thread worm advancing 1 in. in $1\frac{1}{3}$ turns, that lead = $\frac{3}{4}$ in. or 0.75 in.

Linear pitch, or $p' = \frac{3}{8}$ in. or 0.375 in.

Diametral pitch, or $P = 8.377$ in.

The system adopted by The Messrs. Brown & Sharpe is to mill the faces of worm wheels instead of turning them. The operation will be understood from Fig. 327, one part of which shows a section of a spur wheel and the other, S, a segment of a worm-wheel blank.

The practice involved in cutting worm wheels is seen in Fig. 328. The index centres are set central with the cutter on the line CD, as in cutting spur wheels. The mandrel holding the worm-wheel blank is put on the centres, and by moving the table lengthwise the centre of the face of the worm wheel is set under the centre of the cutter spindle AB. The table stop is put on so that the table will not move, then the saddle is set to the angles of the teeth as seen by the lines E and CD, and the vertical feed is used in cutting the work.

Hobs.—A hob is a worm of cast steel (Fig. 329) cut with the same screw-cutting tool that is used to cut the worm ; it is then grooved to make teeth for cutting. The diameter of the hob is a little in excess of the diameter of the worm, to give a suitable clearance. The outer corners of the hob threads can be rounded off as far as the clearance distance. The threads are relieved between the cut grooves, to form a side clearance ; provision for this relief is provided for in a universal milling machine. The hob is finally hardened and tempered.

The teeth of a worm wheel are first cut as nearly to the finished form as practicable, and then the worm wheel is mounted to mesh with the hob. There are two ways of doing this part of the work ; the best way is to make the spindle carrying the worm wheel to rotate by a direct mechanism, the other method is to cause the worm cutter to drive the worm wheel. The object of hobbing a wheel is to get more bearing surface of the teeth upon the threads of the worm. By hobbing we produce outline of teeth, something like the thread of a nut."

"Hindley" Worm.—The "Hindley" worm differs from the ordinary worm in being cut with a tool which travels in a circle, whereas the tool which cuts the ordinary worm travels in a straight line parallel to the axis of the worm mandrel.

A single tool for cutting a Hindley worm would be a representation in outline of a section of a tooth from the wheel intended to engage with the worm, and would turn on a centre lying at the same distance from the tip of the tool as the centre of the wheel is from the tip of the teeth. In other words, this tool would represent in sectional dimensions and situation relative to its centre of rotation a tooth of the worm wheel. In cutting the worm, it might be imagined that such a tool were a tooth of the wheel cutting its own circular path.

In actual manufacturing practice an exact duplicate of the wheel is made to cut the worm, and an exact duplicate of the worm cuts the wheel ; the theory of this gear being that the worm, cut by a cutter-head which truly represents the wheel, and the wheel being cut by a hob truly representative of the worm, the two will gear together perfectly. This is found to be nearly true, an allowance having to be made in cutting the worm for the thickness of the wheel. This will be readily understood when it is considered that the cutting edges of the cutters act as a thin sheet of metal might do upon a soft substance, and represent a section only of the wheel teeth, whereas the wheel itself is of a considerable thickness.

It will be seen that the distance from top to top of the worm threads is less than the distance from root to root (if a section be imagined),



FIG. 329.—Worm hob with relieved teeth.

because the centre line of the worm are radii of the wheel which diverge from the wheel centre. The pitch of the worm is therefore a variable quantity (see Fig. 329a).

"Gearing." Single-curve Gear having less than 30 Teeth (Fig. 330). Fig. 1 is a single-curve gear of 20 teeth, $\frac{1}{16}$ pitch.

Having calculated data for this, we proceed as follows:—

$$N = \text{number of teeth, } P = \text{pitch } \frac{N \times P}{3.1416} = \text{pitch circle}$$

Draw the pitch circle, and lay off in parts equal to one-half of the pitch. From one of these points, as B, draw a line to the centre C of the pitch circle and draw semicircle upon radius of pitch circle. The diameter of this semicircle is equal to the radius of the pitch circle. Draw addendum and whole-depth circles (see table, p. 289). From the point I on the addendum circle where the outer end of radius to pitch circle and semicircle meet, lay off upon the semicircle a distance equal to one-half radius of



Fig. 1. Single-curve gear having less than 30 teeth.

... and off as a chord. Through this chord draw a circle concentric to pitch circle. This circle is used as the basis for the teeth.

... are from addendum circle to the base circle and letting the base circle be the pitch circle. Thus an

... diameter to DE. From this diameter draw parallel lines to the base circle. Draw parallel lines to the base circle. Divide the space between the base circle and the pitch circle with dividers set as to the pitch circle for strengthening teeth.

These fillet arcs should be drawn on the bases of the teeth already drawn.

... Single-curve teeth. By theory, this curve

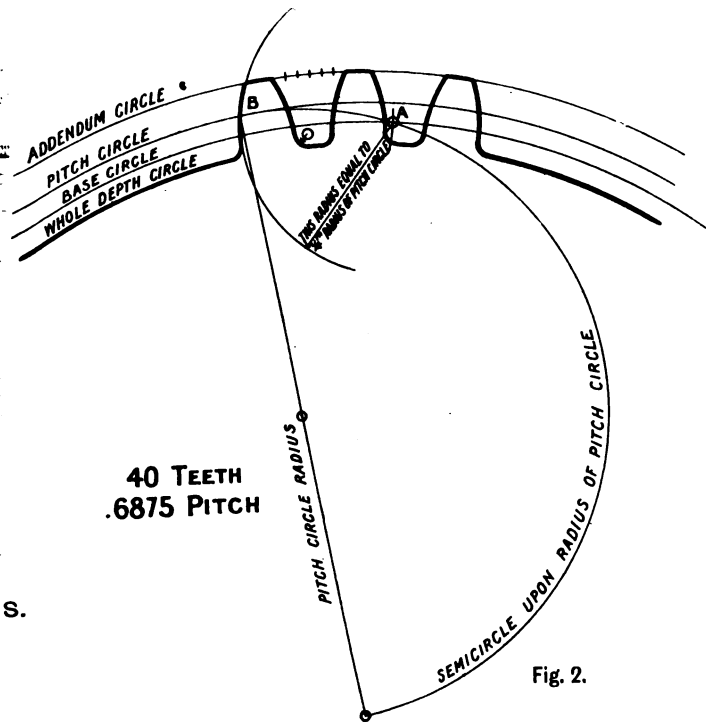

Fig. 2.

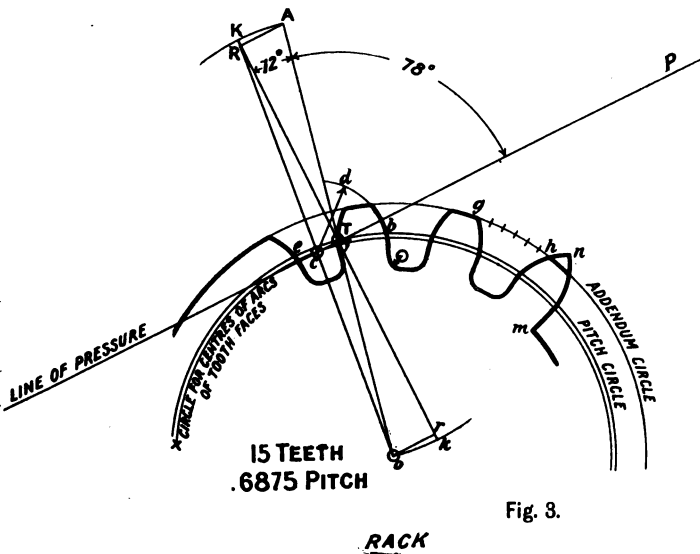

Fig. 3.

ES.

EIGHT-TOOTHED WHEELS.

[To face p. 286.]

because the centre line of the worm are radii of the wheel which diverge from the wheel centre. The pitch of the worm is therefore a variable quantity (see Fig. 329a).

"Gearing." Single-curve Gear having less than 30 Teeth (Fig. 330). Fig. 1 is a single-curve gear of 20 teeth, $\frac{1}{16}$ pitch.

Having calculated data for this, we proceed as follows:—

$$N = \text{number of teeth, } P = \text{pitch } \frac{N \times P}{3.1416} = \text{pitch circle}$$

Draw the pitch circle, and lay off in parts equal to one-half of the pitch. From one of these points, as B, draw a line to the centre C, bisect it, and draw semicircle upon radius of pitch circle. The diameter of this semicircle is equal to the radius of the pitch circle. Draw addendum and whole-depth circles (see table, p. 289). From the point B in pitch circle, where the outer end of radius to pitch circle and semicircle meet, lay off upon the semicircle a distance equal to one-half radius of

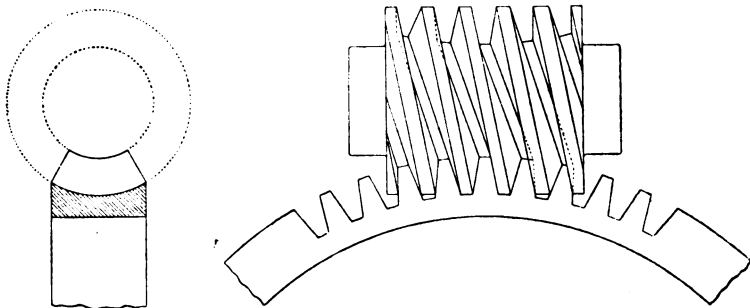

FIG. 329A.—"Hindley" worm.

semicircle, as shown at BA, this is laid off as a chord. Through this point, A, upon the semicircle draw a circle concentric to pitch circle. This circle is called "the base circle," and is used as the basis for describing the tooth arcs.

With dividers set at same radius draw arc from addendum circle to base circle, placing one leg of dividers in the base circle and letting the other leg pass through the point laid off in the pitch circle. Thus an arc is drawn about A as centre through B.

Describe a circle about C equal in diameter to DE. From this circle we obtain the sides of spaces inside of base circle. Draw parallel lines from DE touching the circle round C. Divide the space between the teeth on addendum circle into six equal parts; with dividers set as to radius to one-sixth of tooth space, draw the fillets for strengthening teeth at their roots. (This rule applies to all gears.) These fillet arcs should just touch the whole depth circle and the sides of the teeth already formed.

Single-curve Gears having 30 Teeth and over.—Single-curve teeth are so called because they have but one curve by theory, this curve

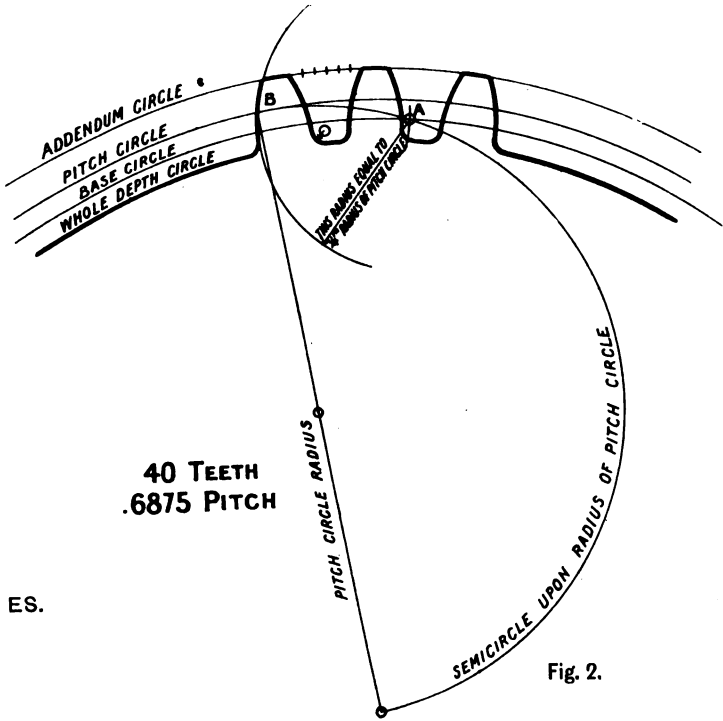

Fig. 2.

ES.

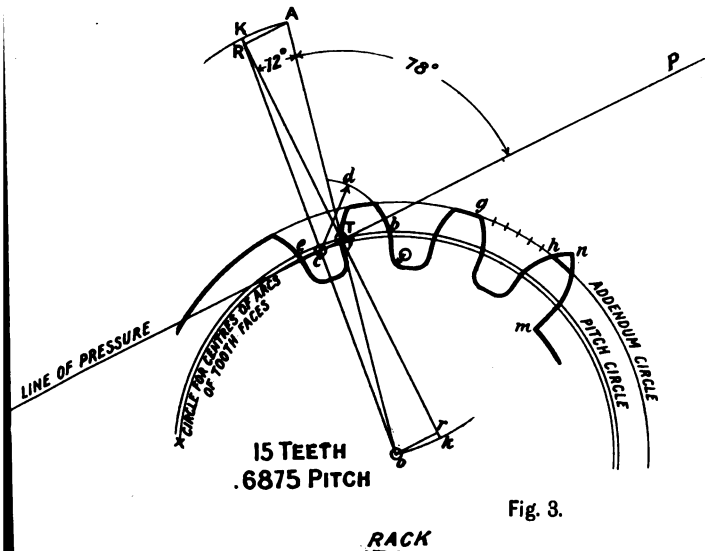
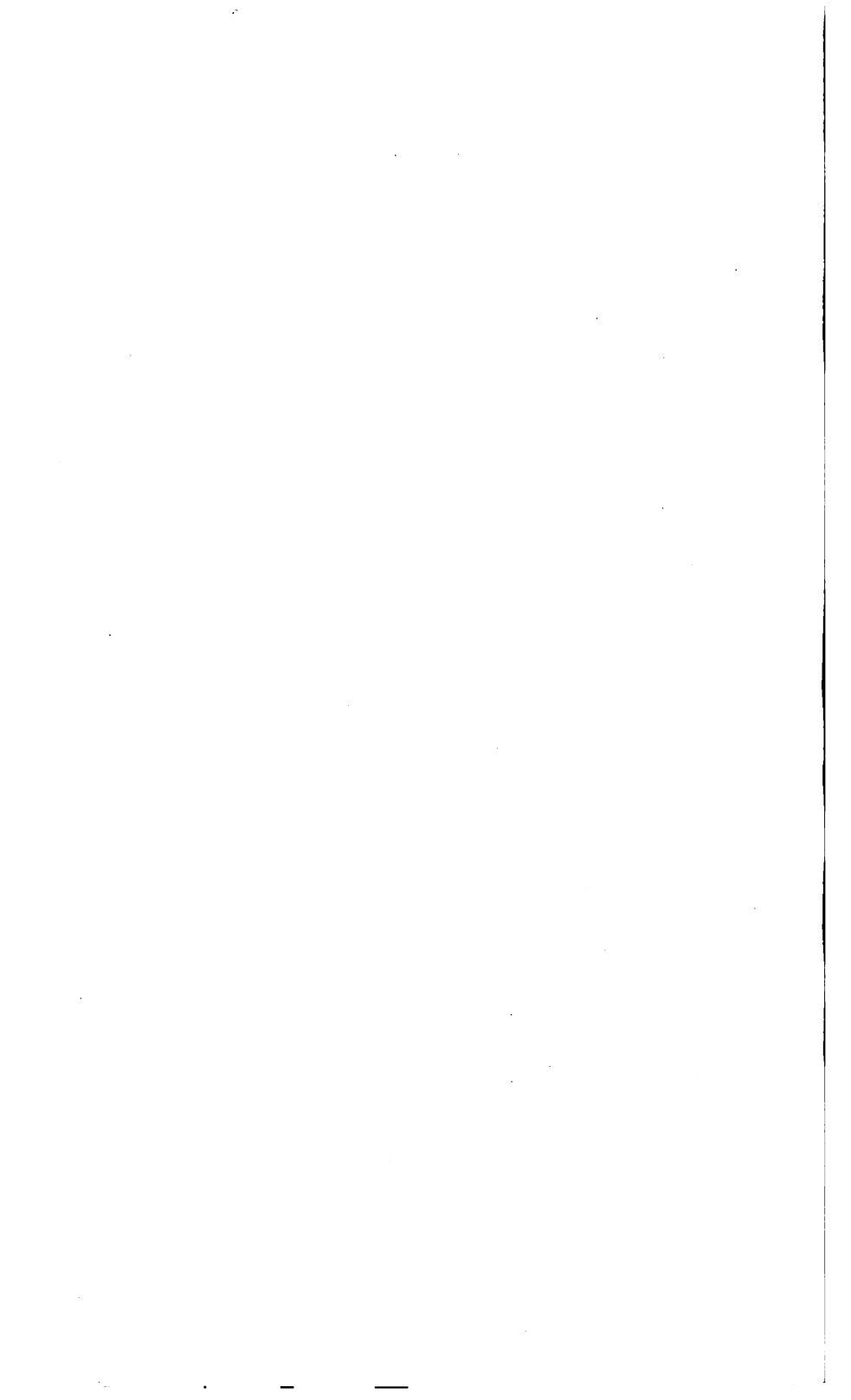

Fig. 3.

ES.

EIGHT-TOOTHED WHEELS.

[To face p. 286.



forming both face and flank of tooth sides. The curve in any gear of 30 or more teeth can be a single arc of a circle, whose radius is one-fourth the radius of the pitch circle.

Fig. 2 is a single-curve gear of 40 teeth $\frac{11}{16}$ pitch. Having calculated data for this, we proceed as with Fig. 1.

Describe pitch circle, addendum circle, and whole-depth circle, and base circle by the same method as previously described. With dividers set to one quarter of the radius of the pitch circle, draw arcs forming face and flanks of teeth, placing one leg of dividers on base circle, and letting the other pass through the point laid off on the pitch circle. Divide tooth space or addendum circle into six equal parts; with one of these as radius describe an arc connecting tooth flank and touching the whole-depth circle. A cutter has the advantage of lasting considerably longer that is made to form these fillets, than it would have if it was brought up to a corner.

Single-curve or involute gears are the only gears that can run at varying distance of axes and transmit unvarying angular velocity. This peculiarity makes involute gears specially valuable for driving rolls or any rotating pieces, the distance of whose axes is likely to be changed. The assertion that gears crowd harder on bearings when of involute than when of other forms of teeth has not been proved in actual practice.

In high-numbered gears, when they are to interchange with low numbered gears, it is necessary to round off the points of involute teeth. A good way of ascertaining how much to round off is by making thin metal templets of a few teeth and fitting addenda of teeth to clear the flanks.

"Double-curve Teeth."—Fig. 3 is a double-curve gear of 15 teeth, $\frac{11}{16}$ pitch. Fifteen teeth is taken as the "base" of this system. Until within a few years the base of a system of double-curve interchangeable gears was 12 teeth. It is now considered as the best practice to take 15 teeth. The reason for this change was, the 15-teeth base gave less angle of pressure and larger arc of contact, and hence longer lifetime of gears.

In double-curve teeth the formation of tooth sides change at the pitch line. In all gears the part of teeth outside of pitch line is convex, in some gears the sides of teeth inside pitch line are convex, in some radial, and in others concave. Convex faces and concave flanks are the most familiar. In interchangeable sets of gears, one gear in each set, or of each pitch, has radial flanks.

Gears with more than 15 teeth have concave flanks, gears with less than 15 teeth have convex flanks. This 15-tooth construction enters into gears of any number of teeth, and also into racks.

Having obtained data for 15 teeth $\frac{11}{16}$ pitch, we proceed as follows: Draw the pitch circle, and point it off into parts equal to thickness of tooth (*i.e.* $\frac{11}{32}$). From the centre, through one of these points, as T, draw line OIA. Draw addendum and whole-depth circles. About this point, T, with same radius as pitch circle, describe the arcs AK and O \dot{k} . For any other double-curve gear of this pitch the radius of arcs AK and O \dot{k} will be the same as this.

In a 15-tooth gear the arc O_k passes through the centre O , but for a gear of any other number of teeth this construction arc does not pass through the gear centre. The arcs AK and O_k are always taken from the pitch we are working with. Upon these arcs, on opposite sides of lines OTA , lay off tooth thickness AK and O_k , and draw line KT_k . Perpendicular to KT_k draw line of pressure LTP , also through O and A draw lines AR and Or perpendicular to KT_k .

The line of pressure is at an angle of 78° with the radius of gear. From O draw a line OR to intersection of AR with KT_k . Through point c , where OR intersects LP , describe a circle about the centre O . It is in this circle that leg of dividers is placed to describe tooth faces.

The radius cd of arc of tooth faces is the straight distance from c to tooth-thickness point b on the other side of radius OT . With this radius, cb , describe both sides of tooth faces. Draw flanks of all teeth radial as Oe and Of . This base gear of 15 teeth has radial flanks. With radius to one-sixth of widest part of tooth-space, gh , draw fillets at bottom of teeth as in previous figures.

The foregoing is a close approximation to epicycloidal teeth. To get the teeth exact, make two 15-tooth gears of sheet metal. Make addenda long enough to come to a point as at n . Make radial flanks as at m deep enough to clear addenda when gears are in mesh. First finish the flanks, then fit the long addenda to the flanks when gears are in mesh. When these two templet gears are alike, the centres are the right distance apart, and the teeth interlock without backlash, they are exact.

One of these templet gears can now be used to test any other templet gear of the same pitch. Gears and racks will be right when they run correctly with one of these 15-tooth templet gears. Five or six teeth are enough to make in a gear templet.

Double-curve Gears having more and less than 15 Teeth.—Fig. 4 is two gears in mesh, 12 and 24 teeth respectively, $\frac{1}{16}$ pitch. Having calculated data, describe the two-pitch circles, whole-depth circles, and addendum circles. Lay off the arcs AK and O_k as described for the previous figure. Draw line of pressure LP perpendicular to KT_k . This line will serve for both gears. Measure off the tooth thickness, or these arcs AK and O_k . The line KT_k is obtained in the same manner as in previous figure for all double-curve gears, the distances only varying according to the pitch. Perpendicular to KT_k draw the lines AR and Or .

From centre C through r draw line intersecting line of pressure in m . From C draw line to R , crossing line of pressure at c . Through m on line of pressure describe a circle concentric with pitch circle about C . It is from this circle, by placing one leg of the dividers on it, that we describe the flanks of the teeth.

The radius mn of flanks is the straight distance from m to the first tooth-thickness point on other side of line of centres CC' at v . To show how it is constructed, the arc is continued to n . This method of obtaining radius of double-curve tooth flanks applies to all gears with more than 15 teeth.

The tooth faces are constructed in the same manner as described for previous figure, viz. : Draw a circle through c concentric to pitch circle. Place one leg of dividers on this circle with radius cb , and draw tooth faces. The arc is continued to d to show method of construction. The radius of fillets at roots of teeth is one-sixth of tooth space on addendum circle.

The construction for flanks of 12, 13 and 14 teeth are similar to each other, and as follows : Through the centre C' draw a line from R , intersecting line of pressure in u . Through u draw a circle about C' . On this circle one leg of dividers is placed for drawing flanks. The arc is continued to V to show how constructed. The radius of flanks is the distance from u to the first tooth-thickness point e on the same side of CTC' . This will give convex flanks. The faces are similar to those in Fig. 3, the radius being wy . The arc is continued to x to show method of construction.

The circle for the centres of these tooth faces is constructed as follows : From C' draw a line to r , intersecting line of pressure at w . Through w draw a circle about C' concentric to pitch circle.

In speaking of different-sized gears the smallest ones are often called "pinions." The angle of pressure in all gears, except involute, constantly changes. 78° is the pressure angle in double-curve or epicycloidal gears for an instant only. In this system it is 78° when one side of a tooth reaches the line of centres, and the pressure against teeth is applied in the direction of the arrows.

The pressure angle of involute gears does not change.¹

DATA FOR GEAR TEETH.

Let D = diameter of addendum circle.

„ D' = „ „ pitch circle.

„ P' = circular pitch.

„ t = thickness of tooth at pitch line.

„ s = addendum or face, also length of working part of tooth below pitch line.

„ $2s = D''$, or twice the addendum, equals the working depth of teeth of two gears in mesh.

„ f = clearance or extra depth of space below working depth.

„ $s + f$ = depth of space below pitch line.

„ $D'' + f$ = whole depth of space.

„ N = number of teeth in one gear.

„ $n = 3.1416$, or the circumference when the diameter is 1.

¹ Brown and Sharpe's "Gearing."

CHAPTER XIV.

CUTTING TOOLS, AND HOW TO USE THEM.

"CUTTING Tools" are all intended to remove shavings or chips. (There are other tools used in "press working of metal," "punching and shearing," but these tools have a somewhat different action.) Tools used in the slide lathe are all provided with a clearance angle of at least 3° , whatever the "top rake" or cutting angle may be.

The most suitable angle for turning wrought iron is from 55° to 65° . Tools used in cutting wrought iron to a great depth below the surface are sometimes made with a more obtuse angle when the feed or traverse is coarse.

The best results are obtained in all cutting tools by observing the following points:—

1. The cutting edges must be kept keen.

2. There must be as much metal supporting the cutting edges as can be allowed, which is decided by the depth of the cut and thickness of shaving removed.

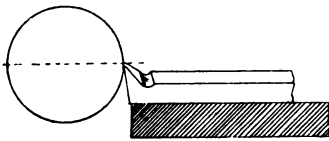

FIG. 331.—Correct position of tool.

3. The clearance should be as little as possible, just enough to allow simply the edge of the tool to touch the metal.

4. The "slope," "top rake," or "angle" the tool must have is always as little from the vertical as the nature of the metal to be cut will admit of.

5. The softer the metal, the keener the tool; and, conversely, the harder the metal, the more obtusely it must be ground (compare Figs. 332 with 340).

6. The nearer to its cutting edge a tool is supported, the keener it may be made, and the more even the surface produced. (Example, see Fig. 331.)

Tools used on mild steel are ground 65° ; this is extended to 70° for deep cuts. Cast iron is best cut with tools made at 75° , and for hard metal, such as chilled rolls, the angle reaches as much as 87° . The foregoing points apply to both circular and straight work, *i.e.* to turning and planing alike.

Turning tools used in the slide rest are placed level and with the point of the tools at the exact height of the centres. This is important in turning work of small diameter, as illustrated in Fig. 332A, B, C.

When the work is of a large diameter, there is no appreciable difference whether the tool is a little above or below the centre line; this is obvious, since the fractional part of a large circle makes but a small angle. But in the former case the tool nose begins to rub the surface of the work, and prevents the edge from cutting properly when placed above the centre line, while the cutting capacity is diminished when the tool is fixed below it. There is also a tendency for the work to lift and spring out of the lathe. It is wise, therefore, to set the height of the tools to a gauge (see Fig. 333). There should be a "leading side" to every traversing tool, commonly called "side rake," also a sloping away from the cutting edge on the upper surface or angle of the tool. The side and front rakes are constant, but the slope from the cutting edge on the upper surface varies according to the nature of the metal operated upon, also upon the depth of the cut and the rate of feed given to the tool.

When turning tools for hard cast iron and phosphor bronze, or other hard alloys, are first ground (the angle being almost a right angle), it is *not* intended to obtain a shaving with the tool, so much as to separate the particles, and thus get them to fall or fly off from the tool point, thereby carrying away the heat as fast as it is generated. Indeed, a tool can be set deeply into a revolving casting of hard iron, and caused to traverse at a coarse feed, making the chips fly to a considerable distance, yet leaving the casting almost as cool as before cutting.

In grinding tools for wrought iron and mild steel, a definite attempt *is* made to obtain a shaving cut.

This is done principally to reduce the power absorbed in driving; and since the tools and work may be kept cool by lubrication, the best results are obtained with hollow-ground tools. It will therefore be seen that heat must be either carried away or quenched as fast as it is generated, or the cutting capacity of the tools will be destroyed.

Reference has been made to "side rake," as given to traversing tools. It is well to point out here that a sliding lathe may carry a "reversing motion," which causes the saddle to travel either from right to left or left to right as the case may require, but the tools must be changed at the

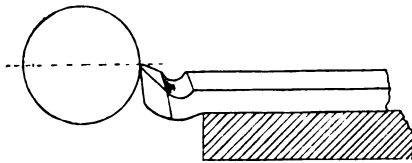

A.—Tool on centre line.

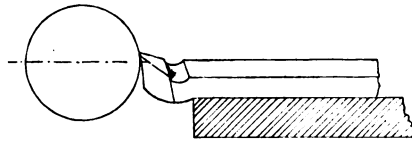

B.—Tool above centre line.

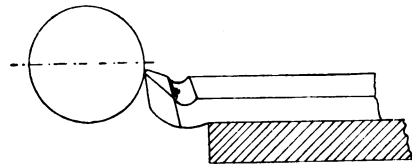

C.—Tool below centre line.

FIG. 332.—Various positions of sliding tools.

same time as the direction of the traverse. A tool cutting from right to left has a right-hand side rake only, and on no account should it be used to cut from left to right. From this it may be gathered that there are two divisions in a set of cutting tools, right and left hand roughing and finishing respectively.

Fig. 331 represents a surfacing tool for wrought iron, to be used on a general class of work.

Fig. 334 is a somewhat similar tool used on heavy forgings. It will be observed that this tool is forged without a hook, which is to give it strength; but such tools are soon weakened when repeatedly ground, which is not the case with hook tools, as there is provision made for grinding until the hollow itself is reached. An advantage for heavy cutting is found when using tools having a flat underside which are clamped in the rest, leaving little more than the cutting portion extending. This prevents any possible spring, and if every "slide" is properly adjusted, the surface cut is uniformly true and free from jar marks.

Reference has been made to the difference in the angle given to a tool for hard cast iron and soft wrought iron, viz. 80° for cast iron, and 60° for wrought iron, an actual difference of 20° . Now for illustration. Let us reverse the tools for each metal; we shall find a

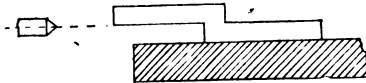
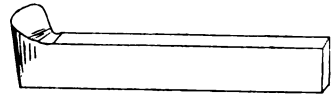

FIG. 333.—Height gauge.



ROUGHING TOOL.

FIG. 334.—(When broad-nosed), tool for finishing.

tool of 80° will refuse to make a shaving cut, and instead will lurch into the soft wrought iron, producing irregularly shaped chips, more like nuggets than shavings, and moreover will generate an abnormal amount of heat, requiring a copious supply of lubricant. In addition to this, the lathe is subjected to severe stresses, which may cause the belts to skid on the pulleys or to break the teeth of some of the gearing.

Again, to use a tool made to an angle of 60° on hard cast iron with a deep cut and a suitable traverse means disaster; there not being enough metal on the tool nose to support the cutting edges, they either snip or heat up and soften. This obviously shows that the nature of the metal to be operated upon has much to do with the correct form a cutting tool should possess, and that a tool giving satisfactory results when used in turning one kind of material is quite unsuitable for another.

It will be observed that when deep cuts are taken the brunt of the work is done by the leading side of the tool, and for this reason the front of the tool may be somewhat flattened, so as to scrape along the surface of the work, and thus leave it smooth.

A tool presented to the work having more front than side will not cut so deeply into the work as a tool with more lead. Indeed, front tools are for finishing, and usually are preceded by deep-cutting tools.

Side or crank tools are used both in the lathe and in the planing machine; they are forged somewhat similar to a roughing tool, and then bent over to the right or left hand as required. These tools are mostly employed in the lathe to remove a limited amount of metal, and for that reason they are ground to an acute angle (Fig. 335).

When engaged in planing or turning work of the heavier classes a more obtuse angle is given, and therefore deeper cuts are taken. To make the surface even, and to obtain a sharp corner, a knife tool similar to Fig. 336 is used; also to shorten any shaft the crank and side or knife tool are employed. A knife tool should cut freely on the blade, and should not be used to act on the extreme point. When correctly made and carefully manipulated, it is the best of all cutting tools. This tool, made with a slightly rounded point, answers equally well as a

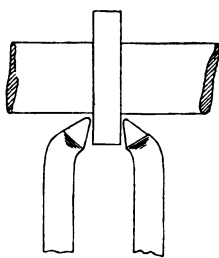

FIG. 335.—Tooling sides of collar.

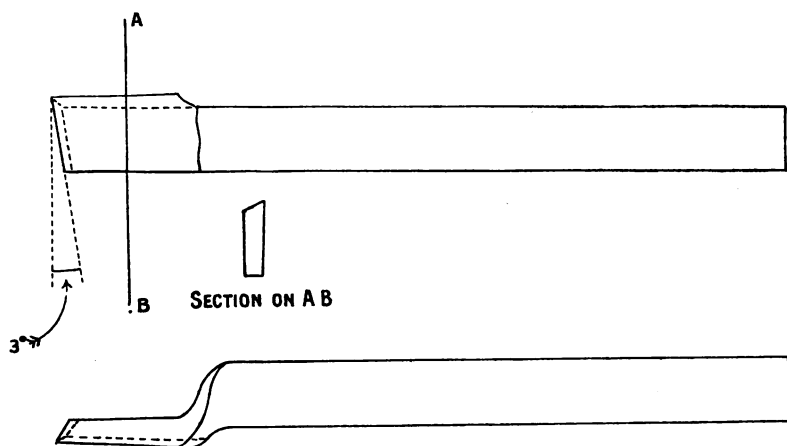

FIG. 336.—Knife tools.

surfacing or sliding tool, and when forged similar to Fig. 337, is one of the stoutest cutting tools employed on either mild steel or cast iron. There should be a slight bend immediately at the root of the blade, so that when presented to the work the point does not operate until after the leading side has well commenced to cut.

It will be noticed that this is an easy example to forge, the angle being obtained by simply cutting away the upper face, say, for $1\frac{1}{4}$ in. long, and from the centre of the steel, *i.e.* $\frac{1}{2}$ in. terminating the cut near the top edge, or cutting edge, of the tool, the clearance angle being formed by the use of the flattener.

Side tools are not always forged with a hook, especially in roughing

out small articles, such as cast-iron blanks for gear wheels, where the rim of the wheel is not far in excess of the dimensions of the boss. A pair of tools for this class of work are forged much the same as Fig. 343A, and are made in the first instance by drawing down the steel taper. These side tools are ground so as to cut on both sides and front, and by altering their position in the rest, they will do as much work as a stronger-looking tool. They are made to an angle of about 80° . They are much used as "necking" tools, and in turning up the throws of

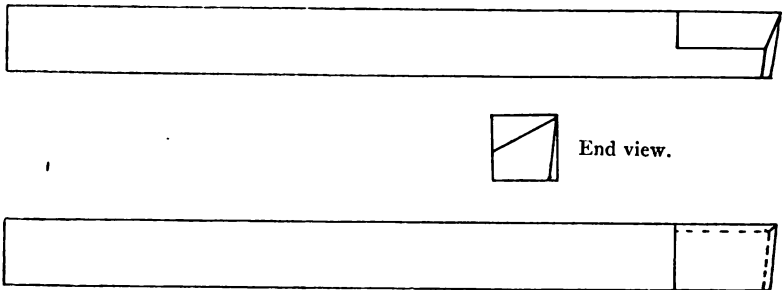
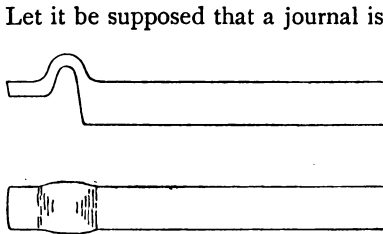

FIG. 337.—Stiff knife tool.

crank shafts, where, owing to the limited space, a broad tool could not be used. A good finish is afterwards given to the work by the use of a spring tool (see Fig. 338), which is also provided with a rounded corner, made in the first place by filing the tool to accurately fit a radius gauge or some other curvature.



SPRING TOOL.

FIG. 338.

Let it be supposed that a journal is to be turned in a shaft with $\frac{3}{8}$ -in. radius at each end of the bearing: a pair of gauges would be employed. These gauges, being accurately $\frac{3}{8}$ -in. radius, will fit each other precisely, and the spring tools are carefully filed to coincide with them, so that when the "brasses" are brought into their respective places, there is perfect agreement over all the surfaces in contact. These tools are used sometimes for finishing "plate" gear wheels in both radius work and on the flat. A spring tool should never be used on a surface of cast iron until all the scale has been removed by the other tools; any deep cutting attempted may at once destroy the keen cutting edges, or cause the tool to dig into the work and spoil it.

Parting tools are used to divide shafts or similar work into two parts while revolving in the lathe, and therefore require a good clearance on both sides (see Fig. 339, AB, C). Very large shafts, however, are not

usually divided asunder, but are cut to a small diameter, and finally broken off. Slender shafts may be cut through with a parting tool, but the practice is to support the work with stays during the process.

When cutting a surplus piece of iron or steel from a huge casting or forging, and the waste piece has to be broken off, there is a possibility of the fracture being irregular, and for it to enter the face of the finished portion. This tendency, however, can be considerably reduced by gently hammering the end face of the piece to be broken, the usual result being that a portion sometimes equal to the width of the parting tool is left for subsequent dressing. The more brittle the metal, the straighter the fracture when the above method is adopted.

Parting tools used on face plate work have to be specially made with a clearance greater on one side than the other, and the depth of the tool much less than is generally used on work riding between the lathe centres. The smaller the diameter of the work, the shallower the tool has to be made. This is obvious, as is seen in Fig. 341. It is a good plan to strike two circles on a board, and make the tool clearance accordingly. There should be *no doubt* as to the tool's correct shape when presented to the work, as error in this respect is likely to cause it to jam or break off. A parting tool vibrates more than any other, and

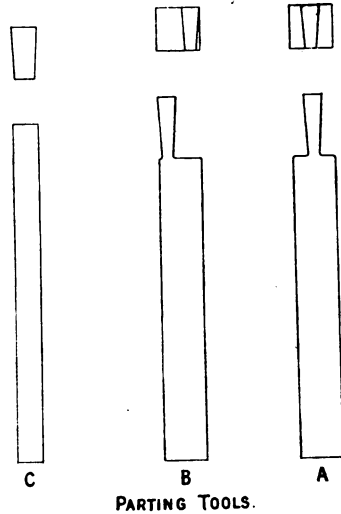

FIG. 339.

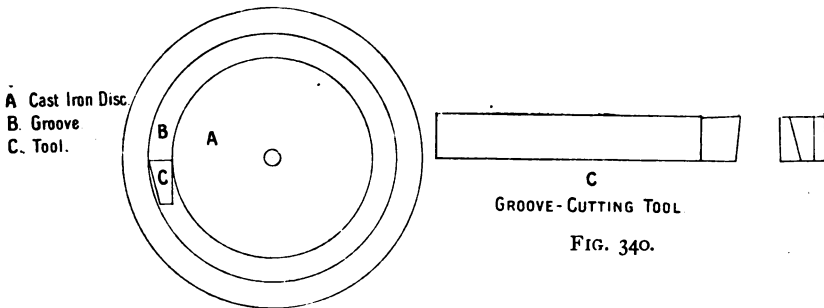

FIG. 341.

therefore must have a suitable clearance at each side and at the front. A 14-in. smooth, flat file, with the tang removed and the end upset, makes a capital parting tool for work of 8 in. or 10 in. diameter. The

file must be annealed throughout, the cutting nose alone being hardened and tempered. A support may be given to the extended portion of the tool by placing a slender bolt with nut between the under surface of the tool and the upper surface of the cross slide.

Parting tools are also used when planing out grooves in machine beds or tables; these also require to be made with plenty of side clearance, to enable the operative to lift the tool clear of the groove during each return stroke of the table.

Following these are undercutting tools, made in pairs—right and left hand—shown in Fig. 342. Since the total width of A and B must be fractionally less than the groove, it is necessary to divide the metal forming the tool very carefully; because the tool is used with a side thrust, there is a tendency for it to spring away from

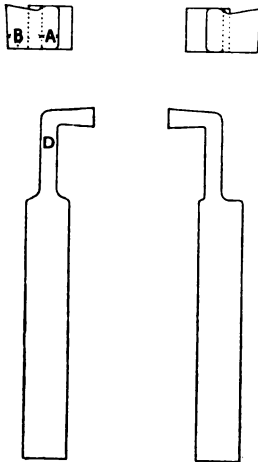

UNDERCUTTING.

FIG. 342.

its cut, causing D to collide with the walls of the groove. This will be clearly understood by an example. Suppose a tee slot is to be made in a machine-table casting, into which a $\frac{3}{4}$ -in. bolt head must pass. The bolt, measuring $1\frac{1}{2}$ in. across, will need a groove cutting $1\frac{9}{16}$ in. wide over all, that is, $\frac{3}{8}$ in. full each side the central groove. It is therefore obvious that any excess of metal on A or B will cause the tool to jam and break, since it has to be lifted at every stroke.

Undercutting tools used in the lathe have to be made specially for lathe use, for the reason explained in making tools for face plate work. The smaller the diameter of the job to be undercut, the greater the clearance the tool must have, and the greater the care in making and in using the tool. The process is slow, and not an easy task if the metal proves hard, for since the tool cuts equal to its breadth, there is considerable vibration, which is

intensified by the unavoidable distance from the cutting edge to the point of support. It is very important not to have these tools extending from the tool support any more than is absolutely necessary. Instead of tee slots, dovetail slots are frequently put in circular work, there being less metal cut away. There is a decided advantage in this, where there is a limited amount of metal to carry the bolts. An additional strength is therefore obtained by this means, and the bolts move much easier when made in this way than is the case where tee slots are used. A straight parting tool is first inserted, then a pair of tools are required similar to Fig. 343A.

In making these tools it is advisable to first describe two circles equal to the smallest diameter, and the one on the upper side of the

parting tool respectively. This will at once show the minimum amount of clearance the tools must have ; or, taken the other way, it shows us when too much clearance is given to the tools. A tool with too much clearance is liable to dig and jar. This is because the cutting edges are too keen, *i.e.* not backed up with a suitable amount of metal.

A recessing tool is one having square end and sides, that is, a portion standing at right angles to the body of the tool, the width being made suitable to the requirements. In appearance it is very similar to an undercutting tool, though usually much narrower, and not so strong. It is used to make a recess at the end of a blank hole, into which an inside screw-cutting tool may be run when commencing to cut or to finish cutting an internal screw. This type of tool is also used to part

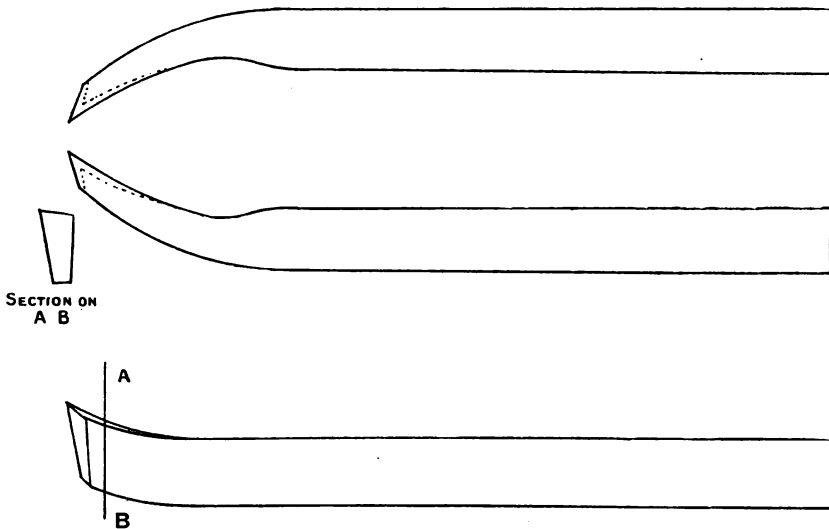

FIG. 343A.—Dovetail cutting tools.

off piston rings from a cast-iron hoop after they have been bored and turned to the sizes of small cylinders, etc. A recessing tool is made with clearance the same as a straight parting tool, being a little narrower at the shoulders than at the cutting end of the tool (Fig. 340).

Screw-cutting Tools.—The tools used for cutting square-thread screws are forged roughly to the required shape, and then finally dressed to the proper dimensions by grinding or filing. Square-thread screws have an inclination towards the right hand or left hand, which is decided by the use of a right-hand or left-hand cutting tool, also by the direction of the movement of the lathe saddle, whether caused to travel to the right or left along the bed. The motion given to the lathe spindle which drives the work is thus in one direction only, *viz.* towards the workman. A right-hand screw thread has the threads leaning towards

the left, and conversely a left-hand screw thread has threads leaning towards the right. (Fig. 344.)

The amount of obliquity is governed by two factors, the *diameter of the screw*, and by the *pitch*. Let us take an example in a Whitworth screw of 1-in. diameter made with a square thread. Here there are four threads per inch, or, as it is commonly called, a screw of $\frac{1}{4}$ in. pitch. Now, a pitch of a screw always includes a thread and a space, therefore the width of the cutting tool must be $\frac{1}{8}$ in., while the side rake is obtained by taking a point on a vertical line at a height from the base equal to

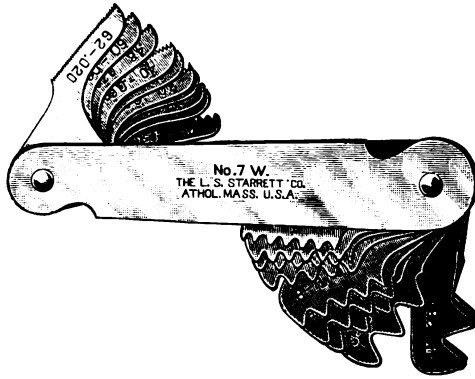
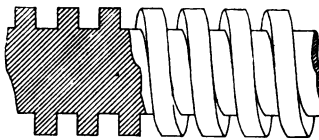
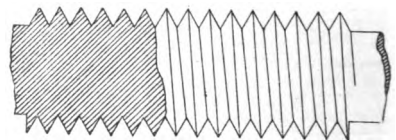

FIG. 343B.—Whitworth standard screw-pitch gauge.



Square thread.



Sharp V thread, angle 60°.

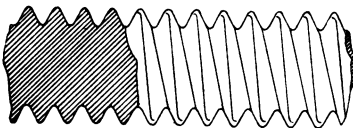

Whitworth thread, angle 55°.

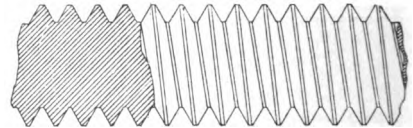

Sellers or U.S.A. standard thread, angle 60°.

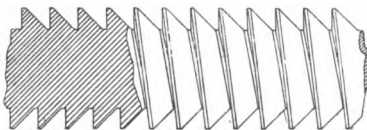

Buttress thread, angle 45°.

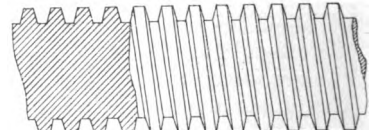

Acme thread, angle 29°.

FIG. 344.—Various forms of screw threads.

$1\frac{1}{2}$ times the diameter of the work. Then by marking the distance equal to half the pitch on a horizontal line, a line is then drawn

joining these points, which at once gives the inclination or side rake the tool must have. The angle thus obtained applies to the making of both right and left-hand screw-cutting tools, but it should be noted that only one side of the tool is treated, viz. the leading side; the following side is simply made to clear.

This point is not always understood in tool making, and consequently more clearance is given to the following side than is necessary,

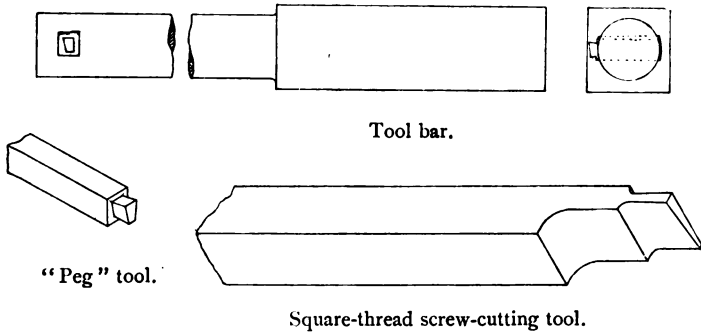

FIG. 344A.—Screw-cutting tools.

thereby weakening the tool. A tool should not be given so much side rake as to enable it to cut both right- and left-hand screws.

The tools illustrated in Fig. 344A have been made to cut a screw and nut, $\frac{1}{2}$ in. pitch, with two starting places. The diameter of the screw is $1\frac{1}{2}$ in. It will be observed that the extended portion of the tool is on the leading side; this is for convenience when cutting a thread which extends close to a shoulder. Referring, again, to the angle or side rake of a screw-cutting tool. Another method is to take the circumference of shaft and the pitch and make a diagram as in Fig. 345.

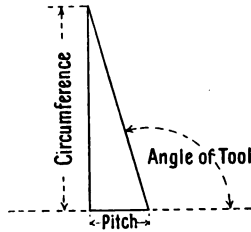

FIG. 345.—Screw-cutting gauge.

For coarse threads, the best plan is to make a gauge, then forge and twist the tool to suit it. This gives satisfactory results, as there is less subsequent dressing. The internal tool is made from a short piece of steel, which is fitted in the slot of a tool bar; the slot, being a little taper, secures the tool. A further security is effected by gripping the tool side by a set screw placed at the end of the bar. By having the slot made obliquely, the tool may be made to cut up to a shoulder. When this is not done the tools must be forged from bar steel.

Screw-cutting Gauge.—A very useful form of gauge is shown in

Fig. 346, which is convenient at the lathe in setting the tools for cutting internal and external screws, and for a number of other purposes illustrated in the diagrams.

When making screw-cutting tools the gauge is used as shown in

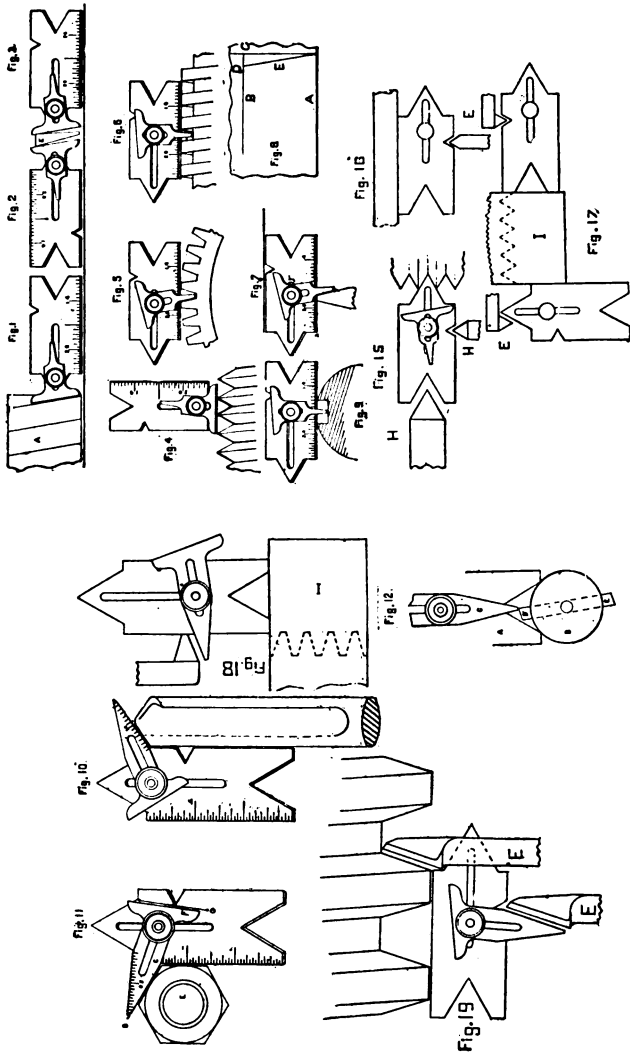

FIG. 346.—Examples illustrating the various uses of gauges.

Fig. 8. Take a piece of sheet metal with one edge, A, true. Then lay off line B, the same distance from the edge A as the diameter of the screws to be cut, then draw line C at right angles to A, and from line

C on line A measure off half the pitch D, and draw line E, which will be the angle or rake required for the tool. The gauge is set as shown in Fig. 1, and applied as shown in Figs. 2 and 3. When the gauge is set to suit any right-hand thread, by simply turning it over it is suitable for left-hand threads. When cutting vee threads the gauge may be used to test the grinding, and for setting the tool properly in the lathe.

Fig. 4 shows a screw thread being tested for accuracy by means of the 60° point of the gauge. Screws having odd pitches may also be tested for depth and angle of thread, also for correct setting of the tool in the lathe (see Figs. 5 and 7). Square threads are gauged by means of the tongue and scale (Fig. 6).

Machining Copper.—Copper may be cut at a much higher rate of both speed and feed than any of the alloys, as brass, gun-metal, etc., providing the tool is so formed as to get rid of the chips easily, and that a copious supply of lubricant is used, preferably soap and water. The tool best suited for the purpose is well fluted or hollowed out so as to give a decided lead to the cutting edge, and at the same time be so formed as to give ample room for the chips to get away from the tool nose. "Copper stays" treated in the above manner may be turned in a hollow spindle lathe, the thread cut and finished, and parted off in a few minutes.

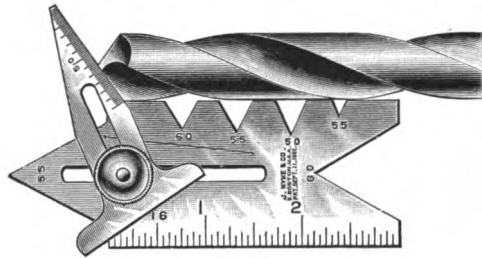

FIG. 346A.—Screw-cutting gauge testing drill (Wyke's patent).

Tool Holders.—For a general class of work, that is, straightforward cutting, tool holders are more economical than tools forged from the bar. The cutting tools, *i.e.* the short pieces of steel, are frequently ground into shape without any smithing being necessary. Steels of a high grade, and those of the air-hardening class, are used preferably to carbon or tempering steels. A very useful kind is "Novo steel." This air-hardening steel is extremely hard, and since it has the property of carbon steels, which may be annealed, tools can be formed and filed into any required shape before hardening.

The greatest advantage of a tool holder is the rigidity it affords to the cutting edges of the tool. This admits of higher speeds and coarser feeds than could be obtained from bar-steel tools, unless of specially large sections.

Turning and planing tools by Messrs. Smith and Coventry are shown in Figs. 347 and 348. The tool shanks are of mild steel, slightly cranked at the end, with a hole bored at a suitable angle to give the proper clearance. A piece of round steel, with the end ground obliquely, forms the tool; the amount of this obliquity is decided by means of a gauge.

Fig. 333 is a gauge used in setting the tool to the height of the

lathe centre, instead of running down the cross slide and actually setting the tool to the centre point.

Examples of vertical, horizontal, and angular planing are shown in Fig. 348.

Fig. 349 ("Allen's" patent) consists of a similar holder to the above,

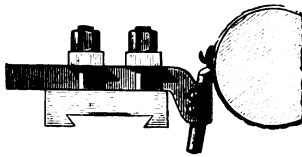

FIG. 347.—Tool holder.

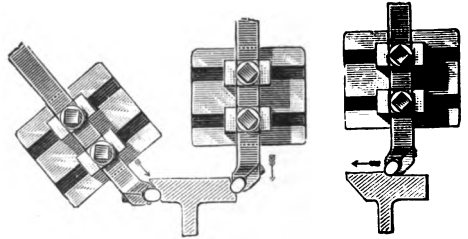

FIG. 348.—Tool holder at work.

but in this the tools are serrated at the back, and secured by means of a serrated wedge instead of the set screws.

A holder in which the tools may be swivelled to an angle is shown in Fig. 350, by the same makers.

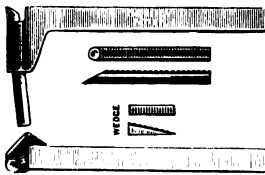

FIG. 349.—Tool holder.

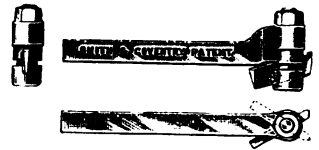

FIG. 350.—Swivel tool holder.

"Sundale" Tool Holder.—The tool holder shown in Fig. 351 is by Messrs. Selig-Sonnenthal. The tools are made of ordinary square steel, and can be swivelled (as shown by the dotted circle) to suit the



FIG. 351.—Swivel tool holder.

work. When adjusted, the tool is locked by means of the serrated teeth engaging with the forward part of the holder, the grip being obtained by the large nut beneath.

Cutting Tools for Planing Machines.—Tools used in planing metal are made with a minimum amount of clearance beneath the cutting edges. They are much simpler to set than lathe tools, and are generally much more bulky (Fig. 352). There are several reasons why planing tools are forged and ground differently to turning tools. Firstly, the planing tool must be strong, with the cutting edges well backed up with a substantial body of metal. This body may be above the bar, so that heat may be carried away as it is generated. Greater depths of cut and greater distances from the tool box are further causes why planing tools must be stouter than turning tools. Long cast-iron beds and heavy forgings in wrought iron and mild steel are frequently made with surfaces so uneven as to need a depth of cut considerably in excess of those suitable for works of a shorter length.

In planing the work is "under cut" for a longer period than most lathe work, which is a further reason for stiffness of the cutting tool. In the second place, there is a tendency for the shavings to "crowd" about the tool nose. This is due to the compression of the metal in the direction of the cut. To reduce this compression (and its consequent

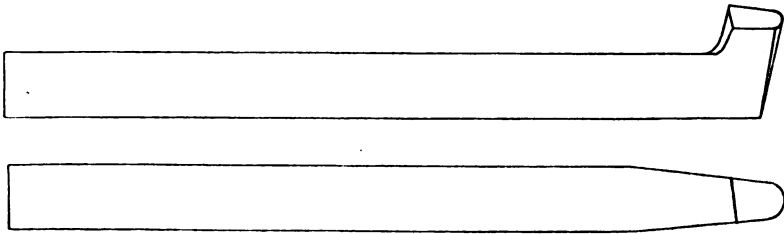

FIG. 352.—Planing tools.

friction) to a minimum, the cutting tools must be formed with a proper cutting angle, *i.e.* top rake and side rake. What is really necessary is to curl the shavings from wrought iron and mild steel to one side of the tool, so that the strain on the machine and the friction on the tool shall be as little as possible.

The amount of top rake for planing tools is very little, but this can be made up by an increased side rake in the direction of the cut. The tools are also governed by the fitting of the horizontal and vertical slides; these cannot be too good a job. When horizontal planing is being done, there should be an increased tension put on the set screws of the vertical slide "strip," and *vice versa*. This will tend to reduce the vibration, and give a better finish to the surface of metal cut.

Profile Tool Steel.—The various tools illustrated in Fig. 353 are made from profile steel. In order to reduce the weight of the cutting tools, special rolls and dies are employed in the manufacture of this steel, and it is further claimed that tools forged from these bars are more quickly made than those forged from bars of rectangular steel. By thus giving to the bars a similar contour of the cutting tool required,

twist drills, reamers, fluted borers, and tools which have to be dressed, can be milled into the correct shape in *less* time than is usually the case, because the amount of material to be cut away is less. The profile steel is the invention of J. Beardmore and Son, Sheffield.

Reamers.—A reamer is a cylindrical cutting tool, and is used to make

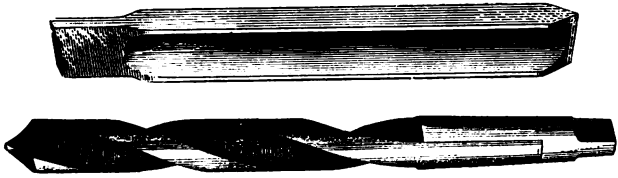

FIG. 353.—“Profile” steel tools.



FIG. 353A.—Hand reamer.



FIG. 353B.—Reamer.

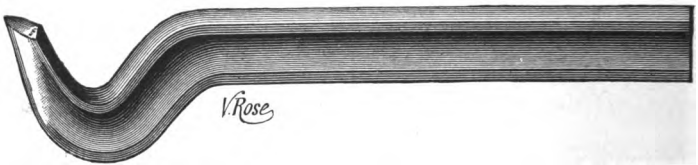

FIG. 353C.—Profile steel turning tool.



FIG. 353D.—Forged drill.



FIG. 353E.—Expanding reamer.

drilled holes smooth, true, and up to standard size. There are two kinds—parallel and taper.

Parallel or “standard” reamers are stocked in all sizes from $\frac{1}{4}$ in. to 2 in. diameter.

“Taper reamers” are stocked when “turned” to the “Morse taper,” but otherwise they are made to specification.

Making a Reamer.—A suitable length is cut from a bar of high-grade tool steel and thoroughly annealed.

Taper Shank.—The shank is turned to a "Morse gauge," and the parallel portion made a little in excess of the finished size required.

Cutting Edges.—The cutting edges are formed by milling a series of grooves at regular intervals (see "Milling Reamer," Chap. XII.), running lengthwise, each groove being backed by a cutter, to give a suitable clearance in the larger reamers. Those of the smaller sizes are backed off by an emery wheel.

Hardened and tempered.—The reamer is then hardened and tempered, and finally the teeth or cutting edges are sharpened on an emery grinding machine. This grinding is continued until the standard size has been obtained, and the tool will cut the walls of a hole smoothly to admit the gauge.

Efficiency.—A good reamer, having its cutting edges properly fluted and spaced apart, will admit of re-sharpening many times without losing its efficiency.

Hints.—To maintain this efficiency, these tools must be kept sharp and clean, allowed a minimum amount of metal to be removed, and inserted into holes which have been drilled or bored thoroughly. The converse of these three rules is disastrous to good reamers. A dull and dirty reamer clogs and heats. An undue amount of metal to be removed causes end-wear, and therefore much friction, and consequently reduction of speed.

Cored Holes.—A hole only partially tooled may have sand or scale left from the "core," either of which at once destroys the finely sharpened cutting edges of the reamer.

Hand Reamers.—Reamers which are for hand use are made with a square on end of shank to receive a tap wrench. These, however, are not much used, owing to the improved facilities of drilling and reamering out work either by the aid of pneumatic or electric power drills, which may be taken and located anywhere near the work.

Portable Appliance.—See "Portable Drills," p. 68.

Expansible Reamers.—Expansible reamers are convenient inasmuch as they are capable of enlargement. They are therefore useful in jobbing workshops, where holes may be required other than precise standard size.

Construction.—After a solid reamer has been made, it is then divided and slit through to the centre in three places by a thin saw in the milling machine, a hole is drilled and tapped down the end of the reamer, and a slender screw having a conical head in inserted. The adjustment is effected by regulating this screw. It should be noted that in this class of reamer there are some cutting edges more prominent than others, and these get the brunt of the work, which is a defect.

Hardening and tempering Steel. Cutting Tools and Springs.—The proper steel for cutting tools, saws, and springs is a refined quality, called crucible cast steel, or "tool" steel. There are lower grades of

steel, that is, steel containing a less percentage of carbon, called mild steel. These, however, form a distinct class, not intended to make cutting tools. It is important for a student or apprentice to note this, because, to a beginner, there is little difference noticeable from external appearance. However, if we cut a piece from a bar of refined tool steel, and another piece from a bar of mild steel, and examine both fractures, we see a dense close-grained leaden appearance on the tool steel (see Fig. 57, p. 47), while the mild steel is considerably coarser and open-grained.

Another distinctive feature in tool steel is the sharp corners of the square or rectangular sections, and the almost perfect roundness of the circular sections, although there are some brands of mild steel used in turret lathes which leave nothing to be desired either in truth or smoothness. A further test may be made by striking the steel a sharp blow. When it is tool steel a clear ringing sound is emitted.

There are two distinct processes in hardening and tempering. A piece of tool steel, heated to a blood-red heat and quickly plunged into a trough of cold water, will be found, when cold, to be very hard—too hard for use as a cutting tool; that is to say, a properly shaped cutting tool, treated in the above fashion, and ground to the angle most suited to the work, will not retain the cutting edges, especially in heavy classes of work. The same tool, again heated and quickly quenched, may be subsequently tempered to any desirable degree of hardness in one of the following ways :—

The best plan, after the tool has been hardened, is to brighten one or more of the tool facets, usually the part below the cutting edge, with a piece of sandstone; or, better still, a fitter's polishing stick, quickly rubbed, will make a cleaner polish (this is done so that the temper may be detected easily). A short length of flat or square iron is heated and laid on the anvil, with the cutting portion of the tool above it; the heat is soon absorbed by the steel, and colours begin to run down towards the tool nose. These prismatic colours indicate the various degrees of hardness, and as they rapidly travel there is no time to lose when the proper colour has arrived. The tool is instantly quenched, and not removed from the water until it is cold. Another plan is to heat up the tool nose and then hold the steel vertically, with the heated portion just immersed in the bath, for eight seconds, then brighten one facet very quickly and look for the colours. This time they will be more compact; hence there is more need to be alert, or they will be gone before the steel is quenched.

The second method is much quicker than the first, but it is not so good. There are two important reasons for this—

1. In partially quenching steel the outer section alone is affected, and there is contraction of the cooled parts, but the internal molecules are in a state of expansion, and thus there is a struggle between them, with the result that the tool cracks to settle matters.

2. The tempered part is too local, and a tool in daily use requires hardening and tempering more frequently, which is detrimental to the quality of the steel.

It is important to note that steel, after heating and quenching, should not be removed from the cooling liquid, whether water or oil, until it is of the same temperature as the atmosphere.

A pair of ball bearings of large diameter were hardened, and placed upon the bed of a machine in which they were to be polished. There was a considerable distance between the smithy and turnery, and after the bearings had lain for several minutes, one of them exploded, bursting uniformly at a weak section. This proves what has been already stated, and also shows us that steel changes its form during hardening; and, further, that when a thin section is attached to two thick sections, the cooling of the thin section seems to be too rapid for the thick parts, and the result is either a fracture or buckling.

There are internal stresses in the material which are set up during the process of forging, hence all forgings are finally annealed. This removes these stresses to some extent, but never fully. The worst cases are those where there is considerable difference in the dimensions of the object. To make hardening and tempering quite clear, let us take a few familiar examples.

1. To harden a scriber, the point should be heated to a blood-red heat and quickly quenched.

2. To harden a scraper for cast iron it should be heated to a bright red and slaked off.

3. To harden and temper a chipping chisel it must be heated to a blood-red heat, about 1 in. from the cutting edge, and then $\frac{1}{2}$ in. of its length slaked and quickly brought to the anvil and rubbed with sandstone until a light purple colour appears, when it is instantly quenched.

4. To harden and temper an elastic coil spring it must be uniformly heated over the fire to redness and slaked in oil, then held high above the fire until the oil flashes, and finally slaked in water or oil.

5. To harden and temper a boring cutter it is heated to cherry red and slaked out; when cold, it is removed and one side polished. If small, a pair of tongs heated will draw the temper, which should be a dark straw colour. Cutters of larger sizes are placed in the fire so that only one end will get hot. This may be hardened similarly to No. 3, with this exception, the chisel is held vertically while quenching, but the cutting edges of the boring cutter should be at an equal angle to the surface of the water, viz. 45° . This will harden the tool just where it is wanted to be hard, and only there. If this is done, the cutter will "stand" better, because the heels are soft; and, further, when roughing heavy and irregular cuts, there is considerable stress on the cutter in two opposite directions, each tending to break it off near the bar, therefore the central portion is best left soft. (Fig. 354.)

6. To harden and temper a "master tap." Before hardening fill the vee grooves and between the threads with soft soap; this will protect the threads and cutting edges from the fierceness of the fire. Heat up to blood red and quench in oil, then, when quite cold, thoroughly clean the tap and polish each groove. A wrought-iron tube, well heated, is

best for the purpose of tempering. This is obvious, because the heat from the tube pours in all directions over the tap; thus a uniform colour is obtained. The proper colour is dark straw. Oil hardening increases the strength, but reduces the hardness. Articles heated and hardened in oil take much longer in cooling, hence the slower the hardening the more elastic the steel becomes.

EXAMPLE.—A steel coil spring heated and slaked in water becomes quite brittle, and may be crushed to fragments instantly. A similar spring slaked in oil will last for years.

In some experiments made by M. Levat, a French engineer, in the practice of tool hardening, it was found that, comparing tools hardened in water and carbolic acid respectively, the results were in favour of carbolic hardening.

Contact with the air quickly causes hot iron and steel to oxidize, and,

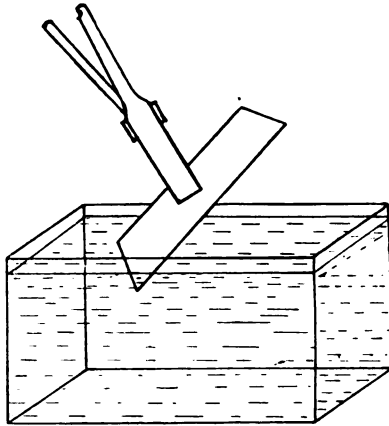

FIG. 354.—Hardening cutter.

therefore should, as far as possible, be prevented. Small articles may be placed in a tube along with charcoal, and after plugging the ends the tube is uniformly heated to bright redness. By unscrewing one plug the articles can quickly be dropped into a trough of water, and if properly done there will not be time for scales to form, with a result that there is little polishing necessary.

Another way to harden steel tools is to place them in heated lead, and afterwards quickly quenched in oil or water, according to the degree of hardness required. There is much to be said in favour of this plan. The temperature of the heated lead can be raised to that degree best suited for the purpose, and uniformly kept at that heat, a thermometer being used to test with. That is where the gas and air hardening apparatus proves useful. The articles cannot be overheated, as is the case in a coal or coke fire; even when not placed in hot lead, but under the influence of the flames, the supply is quite under control.

Tempering Tests for Tools.—

1	Light straw	430° Fahr.
2	Straw	450° "
3	Dark straw	470° "
4	Light brown	490° "
5	Dark brown	510° "
6	Light purple	520° "
7	Dark purple	530° "
8	Bright blue	550° "
9	Blue	560° "
10	Dark blue	600° "

1, 2, 3, 4, are suitable tempers for machine-cutting tools, much depending upon the quality of the tool steel used, and upon the nature of the metal to be cut.

5, 6, 7, are for saws, sets, chisels, and other percussion tools.

8, 9, 10, are for screw-drivers and some kinds of springs. Short flat springs and coil springs are heated and slaked in oil, afterwards "flashed," *i.e.* heated until the oil on their surface blazes, then finally slaked in oil.

The above remarks are to be considered in a general sense, as much depends upon the quality of steel from which the springs are formed.

Many engineers prefer to purchase springs from spring makers instead of making them, for the reason above stated.

CHAPTER XV.

FITTING, ERECTING, VICE WORK, AND TOOLS.

Hammers and their Uses.—In this section we shall enumerate the various kinds of hand hammers in common use, and give a few notes on the fitting of hammer shafts. These hammers are forged from crucible cast steel. Their names denote the uses to which they are to be put.

Fitting Hammers.—Fitting hammers (Fig. 355) are similar in form to those used in the machine and forge shops. The heads weigh from $1\frac{1}{4}$ to 2 lbs. The shafts are from 13 in. to 18 in. in length.

Hand Chipping Hammers.—Chipping hammers are of two kinds. One type is illustrated in Fig. 355. The other type is similar, save that one end is drawn out flat so as to form what is termed a "straight pane."

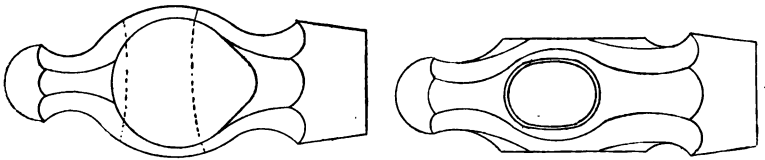

FIG. 355.—Hand chipping hammers.

Riveting Hammers.—Riveting hammers usually have round panes, though for certain kinds of work they are made with flat panes. Those used for small work are much smaller and lighter than fitting hammers.

Planishing Hammers.—These have large flat faces. They are used when flattening or straightening steel bars, strips, plates, or saws that have become buckled or bent during the machining process. To "planish" smoothly without bruising the material is a most difficult art. In many establishments special men, called "planishers," are employed to do such work. Large pieces of work which have been buckled are usually straightened in a planishing press.

File Forgers' Hammers.—File forgers' hammers have heavy heads and short shafts.

Hand File Cutters' Hammers.—These vary in weight from a few ounces to more than two pounds, according to the size and grade of file to be cut. The shafts are fitted obliquely into the heads, so that the file cutter may hit the head of the small chisel, which he holds at an

inclination to the work, by means of a small wrist movement instead of a more tiring and less accurate arm movement.

Sledge or Striking Hammers.—The weight of the head varies from 7 to 20 lbs. The faces are either both flat or one is rounded and one is flat. The shafts, which are of hickory or ash, are about 3 ft. long. These hammers are forged from steel bars in a smithy having power hammers.

Fitting Hammer Shafts.—This appears to be a very simple job until one has tried it. To securely fix a hammer shaft at right angles to the head requires a considerable amount of care. The axis of the oval eye in the hammer head into which the shaft is to be fitted is parallel to the faces. Its section is least at the centre and slightly greater at one extremity than the other. With a pair of inside calipers find which (see Fig. 355) is the narrowest end of the hole, insert the shaft through that, so that the wedge when driven in shall expand the shaft as much as possible, and so make the head very secure.

Before the shaft is inserted it will have to be pared down. Great care must be taken that both sides are pared equally. It is best to gauge the work as it is progressing; after the shaft has been made to enter the eye in the hammer head it may be driven in by a series of steady blows from a wooden mallet delivered upon the handle end of the shaft as it is held vertically in the left hand with the hammer head nearest to the ground. This is the only proper way of driving a shaft into a hammer head.

When the shaft has entered as far as it will go, place it horizontally in the vice and test the position of the head. The shaft may be too tight, or the head may not be on quite straight. If so, after chalking the side to be altered, drive out the shaft, take off what is required with a rasp, and again drive in the shaft. Repeat this operation until the aft end of the shaft is level with the far side of the hammer head. Then, having again removed the head, place the shaft in the vice and saw the V slot for the wedge. This should be nearly as long as the hole in the hammer head. Then insert the shaft for the last time, and drive home the wedge while the shaft is held in the left hand. It is far better to drive home the wedge while the shaft is thus held than to drive it while either the shaft or head are supported in the vice. Iron wedges are not so good as wooden ones, as they do not so readily fit the saw slots, and for this reason sooner become loose.

Tapping.—Tapping, although a seemingly simple operation, is of importance to the correct fitting of screws, studs, or bolts.

Set of Taps.—A full set of taps (Fig. 356) should always be considered as essential to make a full threaded nut, *i.e.* a taper or leading tap (Fig. E) to start with should enter the hole without pressure or being used as a reamer.

Taper Tap.—Taper taps are not passed through holes, but cut out a way for the second tap called an intermediate.

Intermediate.—Referring to Fig. A it will be noticed that the leading threads are partially cut away, this being done to ensure the tap entering the hole previously tapped with the taper one. Intermediate

taps should on no account be used singly, as they are not constructed to remove all the metal necessary for a full thread. Small taps especially are frequently fractured by the extra strain caused by this abuse.

Plug or Finishing Tap.—Plug taps (D) do very little work, they are made to a gauge exactly standard size, and are parallel from end to end. Their function is simply to gauge more than to cut the holes previously tapped.

How to use Taps.—To tap a hole truly straight requires more care

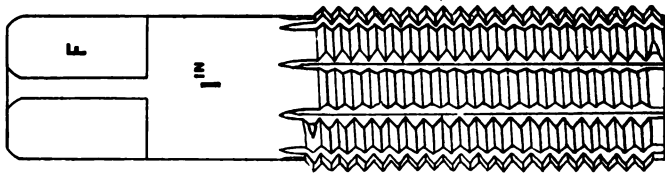

Master tap.

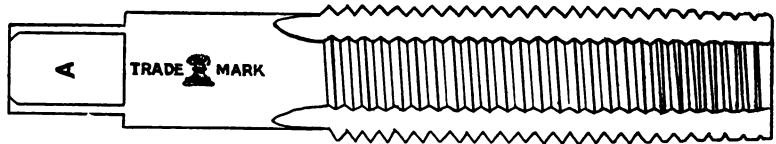
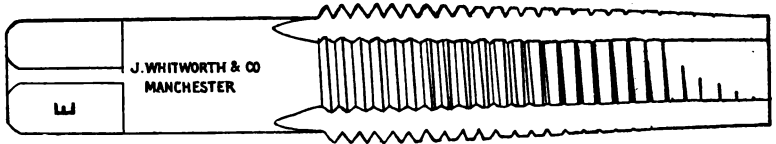
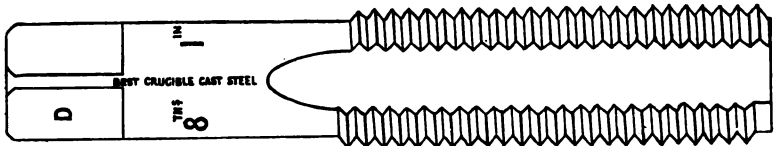

FIG. 356.—Set of hand taps.

than some imagine. When the surface around the hole has been machined, or otherwise dressed over, the task is less difficult.

How to start.—First place the leading tap in the hole and lubricate the threads; then, with a double ended wrench, turn the tap until it has sufficient grip to hold itself upright.

Gauge.—Now, by placing a square on the surface of the hole and allowing the blade to enter each flute of the tap, the parallel portion

above the threads will at once show when the tap is standing perpendicularly. After this has been done, the tap wrench is moved about one-third of a circle at once alternating with a slight movement backward to reduce the friction. Further tests are made by the aid of the square until the tap will stand erect in any position. When a tap commences to go in a crooked path a slight amount of pressure given to the wrench handles will usually alter this, but if allowed to make a few threads wrongly there is little chance of altering the course of the tap, especially where it is important for the nut to be a correct fit on the screw.

Horizontal tapping is more difficult still, because it frequently occurs on work having some projecting parts which prevent the use of a double-ended tap wrench. A single-ended tap wrench has therefore to be used, which acts much as a crank and is frequently the cause of taps breaking. Fig. F is a master tap used *only* when cutting *dies* or *chasers*.

Screwing with Stocks and Dies.—To produce a good thread so that there shall be no ragged or torn parts from end to end of a screw requires considerable care especially as the screwing nears completion.

Diameter increases.—The dies cause the metal to “flow” or expand, so that if tested with a micrometer gauge, both before and after the threads have been produced, there is a decided expansion noticeable. At this stage, although the threads are fully formed, the nut will not pass, it is here that the danger of stripping presents itself the most. It is much the best plan to put small cuts on and to work the dies always in one direction, rather than to make the dies act more quickly by giving an extra grip to the set screw, and so making the friction on the screw threads greater than the screw will take, when either the tops of the threads are torn off or whole threads are pulled out and the screw spoilt.

Use of Oil in Screwing, Tapping, and Reaming.—When screwing, a lubricant is indispensable to wrought iron, mild steel, crucible cast steel, copper, vulcanite, etc. Cast iron, brass, gun metal, phosphor bronze are usually screwed without lubricants. Tapping is much the same as screwing, although a better finish is obtained in cast nuts when a lubricant is used; there is, however, a division of opinion as to the economic value of lubricating either taps or reamers when working in cast iron. Holes which are tapped or reamed without a lubricant are larger in diameter than similar holes tapped or reamed with the full use of a lubricant. It therefore follows that there must be more friction and an increase of wear in the latter case.

Polishing.—To polish is to give a final dressing with emery cloth, emery wheels, “polishing buffs,” bobs, etc., to articles made of iron, steel, or brass. The work is generally “fitted” and finished before any polishing is done and polished after stripping. Long bars and other flat surfaces are first “draw-filed” and then a flat stick covered with emery cloth is used in the same direction and manner as the draw file.

The degree of smoothness required decides the grade or number of emery cloth used. Work requiring an ordinary finish is polished with “No. 2” emery cloth and afterwards with “No. 1.” Engine work is

sometimes polished with cloth No. 2 only, or it is filed and finished with second cut files. Surfaces thus treated are not brilliant, a close observation reveals the file cuts even while the work is new. Small work is not conveniently polished by hand. Hand polishing is also much slower than polishing by the aid of polishing wheels and buffs. Surfaces required bright, and which do not carry any fitted attachment, are ground and glazed. Polishing and glazing by power are treated in Chapter X. on "Grinding Machinery."

Use of the Scraper.—The only method at the present found successful to make a perfect contact between two surfaces of metal is by the use of a scraper. The surfaces to be "scraped" are tooled over first, as it is impossible to scrape any surface which has not been thoroughly faced or bored, as the case may be. It has already been stated that files are at once deprived of their keenness by passing them over any work upon the surface of which the scale has not been entirely removed.

Now, the cutting edges of a scraper, though very hard and made

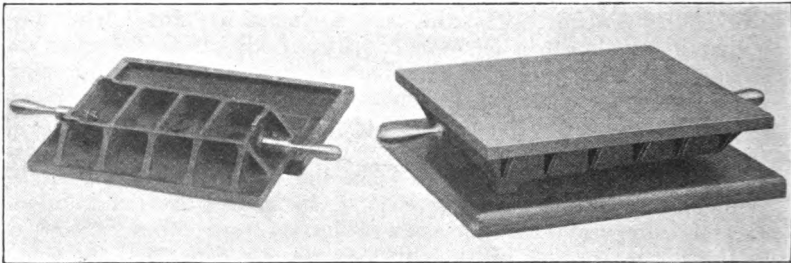

FIG. 357.—Surface plate.

sharp by the use of an oil-stone, if brought in contact with any "scabby part" are at once spoiled. (This instruction is particularly intended for apprentices and others who may be interested.) A practical workman knows this, and therefore would not attempt an impossibility.

Scraping is written and spoken of as being "easy to do." It is not the case by any means, and for proof of this an examination of a "standard surface plate," such as Fig. 357, is recommended, or, better still, attempt to make a small one. A uniformly even plane can be at once spoiled by a few unnecessary strokes of the scraping tool; this, therefore, explains the need of careful working. Again, scraping requires an amount of skill and good judgment to properly manipulate the tool, it is not a "shovel" and must not be used as such.

As the binding points appear in little groups closer and closer together the care and skill increase, that is to say, a greater attention is given as the work nears completion. Each little elevation has to be aimed at and taken off with the scraper without lowering the surrounding metal; to maintain an even pressure therefore, on the cutting edge, the tool has to be entirely under control, and given a certain amount of

wrist movement together with a forward movement. To do this properly the arms should be held close to the body so far as the elbows when it is possible, as is the case when the work is supported in the vice, also when scraping many other surfaces that are narrow.

Large surface plates are examples illustrating the highest skill, because the above method of holding the tool can only be applied partially. As the workman scrapes further and further away from him he leans over the work more and more, but the central portion, in very large plates, cannot be reached conveniently unless the arms are extended, then it is that the full mastery of the tool is called into play.

In the manufacture of these surface plates a reference plate or "standard" true plate (Fig. 357) has to be finally used. The standard plate is balanced evenly and held over the plate to be tested, then slowly lowered by the crane and worked over the lower surface. It cannot be lifted vertically without taking the lower one with it, such is the evenness of the two planes. When the standard plate is removed it has to be drawn across the lower plate; this requires care, or the standard may be put out of balance, with the result that it may make impressions on the plate to be scraped, which of course would be disastrous if removed by the scraper.

When the late Sir J. Whitworth introduced surface plates three plates were used interchangeably, by which means error in each plate was at once detected.

Use of Surface Plates.—The custom is to place a number of them about the Fitter's bench, more or fewer according to the class of work done. "Machined" cast iron and soft alloys are finally scraped and tested on a surface plate. Wrought iron and steel parts are not so easily scraped and are usually finished on their surfaces with smooth files.

In scraping up metal to a true plane the practice is slow and tedious. The scraping tools are usually forged from old smooth files by hammering them to a thin edge. They are not hardened and tempered like other cutting tools, but are simply heated to a bright red heat and are slacked out quickly; this makes them very hard. The cutting edges make an angle of about 90° . They are first ground quite smooth on both sides, and the end has a slight curvature. Afterwards an oil-stone is used until all traces of marks by grinding has disappeared leaving the faces smooth and the cutting edges keen.

These tools, when once properly made, will last *without reforging* for a considerable time. A thin edge cuts better than a thick one, and the scraper is also much easier to manipulate, especially when only small binding points are to be removed. Some workmen prefer to use triangular files from which to forge the scrapers, in which case the tool has three facets. These are used in finishing only.

After a satisfactory plane has been produced on machine beds, tables, and slides, they are generally "frosted" over. This "dappling" is produced by expert workmen who scrape the surfaces uniformly in one direction, and then start another course in an opposite direction. Frosting is done to give a good appearance, but in *no* other way does it improve the work.

Ground Joints.—Ground joints are the best to withstand pressure, but these are generally limited to cylindrical objects. The parts are first scraped to coincide as nearly as practicable, and then finished by grinding one surface on the other with a thin film of oil and powdered (flour) emery or crocus powder between the joint. It is necessary to keep the film on the highest parts, as the work proceeds, otherwise the joint will be a defective one—the shallow parts being ground without actually touching. Valves, cocks, taps, and similar work, where the areas of the joints are small compared with the diameters, require to be carefully handled and cannot be well done without experience. Very fine, and small parts in brass fittings are finished with crocus powder.

Files and File Manufacture.—Small files are forged into shape at the anvil from crucible cast-steel bars of suitable section. Large files are hammered into shape under power hammers. The tangs are drawn at a small fire by operatives who do nothing else. The blanks are afterwards ground into shape on large coarse grit grindstones which are rotated at a high speed. The grinder sits astride a “horse” with a board immediately beneath him and after placing a file blank in position he can, if necessary, give the whole weight of his body to the board. And thus the object is quickly reduced to the required form. In grinding angular files a nick is made at the end of the board into which the file may lodge. To keep the stone even, and at the same time prevent the work being ground more in one place than another, the grinder gives a swinging motion to the board. A straight edge and movable or fixed calipers are used to test with as the grinding proceeds. The blanks are next dried, cleaned, and greased, ready for the teeth to be cut.

There are two ways of doing the work—either by hand hammer and flat chisel or by a file-cutting machine. In cutting files by hand considerable experience is necessary, because the spacing of the cut to form the teeth has to be decided by the judgment of the workman. In addition to this, he must know the proper size of hammer to use, the weight of the blow required, and the correct inclination at which the chisel is to be held when struck. File cutters’ hammers vary from a few ounces to $1\frac{1}{2}$ lb. weight, according to the depth of cut required; this also governs the weight of the blows which cause the chisel to penetrate to a greater or less degree. The inclination of the chisel edges are ground to form an angle of about 35° for small and “smooth” files, and for coarse or “rough cut” files 50° . The lengths of the chisels are from two to three inches, and the width from half an inch to two and a half inches. Their edges are ground straight and are always wider than the file to be cut.

Before commencing to cut the teeth, a block of lead is first put on the bench and the file is secured to it by a leather strap which passes over each end of it, and then through holes in the bench over the feet of the workman in the form of stirrups. The chisel is held in the left hand at an angle of about 55° and inclined from the vertical away from the workman from 4° to 15° according to the character of the file. Commencing at the point of the file the first cut is made by one blow,

and the metal is banked up in a ridge against which the chisel is placed for the next cut. The blows follow each other in rapid succession from 60 to 80 per minute. When one course has been completed the second course is cut obliquely, but with less depth. These are double cut, sometimes called second-cut files. It is obvious that the weight of the hammer blows must be uniformly given or the distance between the teeth would be irregular and in such case the file would be spoiled. When about to harden, and before placing in the fire, the files are smeared over with beer grounds or some other sticky fluid which prevents the sharp edges of the teeth being injured. When at a bright and uniform heat the file is quickly plunged into a bath containing salt and water which has the effect of at once hardening the teeth, but before the internal portion of the file has been acted upon, it is withdrawn and tested; if correct, it is immediately "slaked off." If,

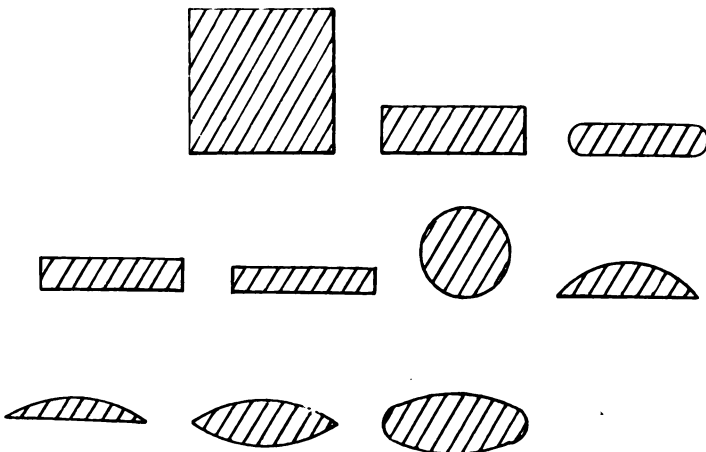

FIG. 358.—Sections of files.

however, the file has been warped in the process, it is placed between two fixed parallel rods and sprung back to "truth." This is only the work of a few seconds, or the heated part of the file would have influence over the hardened teeth and spoil them. After the files are hardened they are rinsed and brushed. When dry they are oiled and packed ready for shipment.

From the illustration it will be seen that files are graded by their shape and form of teeth, also by their purpose and length. As to their shape, we need only refer to those used in general workshop practice, although it may be said, that there is a large variety of each class made for special work. (See sections of files, Fig. 358.)

All the files used are made from one or other of the following sections. Square, round, or angular. Those from the square. 1, square file; 2, flat; 3, wheel; 4, slotting; 5, slitting file (each of the

above are sometimes provided with one safe edge); 6, round file; 7, frame saw file; 8, half-round; 9, double half-round; 10, oval file; 11, triangular, called 3-square, or, when small, saw file.

The illustrations of the various cuts of files and rasps are shown in Fig. 359. Nos. 1, 2, 3, 4, 5, and 6 have double-cut teeth. Nos. 7 to 12 are float or single cut; 13 to 18 rasp cut. The lengths of the files in general use are from 4 in. to 14 in. The file is measured from the shoulder to the point.

EXAMPLES.—A $\frac{3}{8}$ in. square safe edge = a file made from $\frac{3}{8}$ in. square steel; a 14 in. rough cut, indicates that a file 14 in. long is desired; a $\frac{1}{2}$ in. cotter or slotting file = one to pass in a slot $\frac{1}{2}$ in. wide; a 6 in. half-round smooth = a file 6 in. long; a 4 in. saw file = a triangular file 4 in. long.

Use of Files.—Files are less in demand now than formerly; this is owing to machine tools doing the work more perfectly; for instance, many articles which were formerly machined in a shaping machine and finished at the bench with files are now “milled” or “profiled” in such a manner as to dispense with any subsequent dressing. Grinding machinery has also done much to reduce the costly labour of filing. See Chapters X., Grinding, and XII., Milling. However, files are still used, and always will be used at the bench on some kinds of work, and the following hints are given as to their proper use. The teeth must be kept clean by a frequent use of a file, or scratch brush; if this is overlooked, the work will not be evenly dressed, and will have a bad finish, however much labour may have been bestowed. The work which “pins” the files the most, are copper, steel, lead, and wrought iron; all other metals are easily brushed off.

Files for brass work have their teeth cut almost horizontally, and do their work with less labour than those used for general work in iron and steel. It is absolutely necessary to keep the files separate. Files used on brass and phosphor bronze; must be used *exclusively* on these alloys, while they will cut. Afterwards they may be used on cast iron and mild steel. On no account use a file on the latter metals and afterwards attempt to file up gun metal or phosphor bronze; the teeth are not keen enough for the purpose.

Again, rough files are unfit for tool steel, as, owing to the increased depth of the teeth, they will not stand, but crumble under each stroke. A “second cut” or “float” will do better work, and a file 12 in. long is preferable to one 14 in. long. This is chiefly because tool steel, being very hard, resists the progress of the file and refuses to be cut at all, if forced past a certain limit. Therefore, since it must be filed slowly, a short file is much better under control than a long one. And another reason for preferring a short file is that the surfaces to be filed are usually of small area when made of cast steel.

The manner of holding a file is of importance to a beginner. Since the file cuts only during the forward stroke, there must be a full control of it, so that an amount of pressure can be given to it during its forward journey, and the pressure reduced during the return. To obtain the best results, the right foot should be two feet back, with the

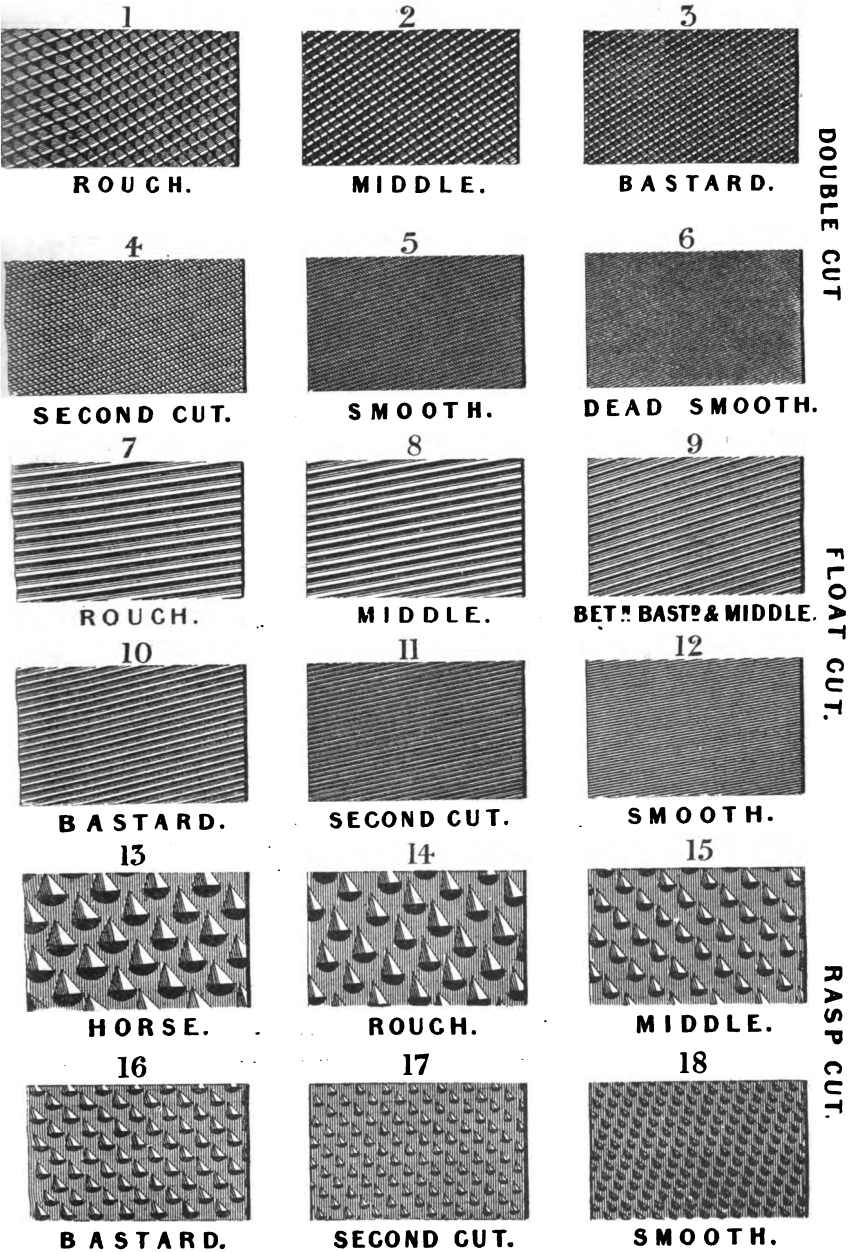

FIG. 359.—Grade of files.

heel and toe parallel with the vice jaws, while the left foot is at right angles and extended up to the vice. Each stroke forward takes the file its full length and requires the body to go a portion of the way, while the arms are extended horizontally when the stroke has reached its limit. At this instant the left knee is bent and takes a considerable part in the movement. When the return is made the pressure on the file is somewhat slackened (on small surfaces), but when filing large surfaces, the tension is almost all released.

It is impossible to use a file properly while the feet touch, and the workman stands erect; all control of the file is lost, with the result that the filed surface is "round" instead of flat. This does not refer to extremely small work, so much as that of a general character. It is obvious that a coarse file used on a broad surface will be pushed differently to that of a smooth file on a small surface. In the former case the file should have all the pressure the workman can put on it to make it cut freely, and move at a suitable speed. To obtain the best results the workman's body moves with each forward stroke, necessitating that his feet should be spread so that an increased weight can be given to the hands grasping the file. "Cross-filing" is generally done on broad surfaces to keep the work flat. The deeper the cut in iron or steel, the more liable is the file to pin, so that there is a limit to the amount of pressure actually required. When engaged in smooth filing steel, the workman stands more erect, the pressure being considerably less, and not requiring much more than hand pressure. It is only after considerable practice, that smooth files can be successfully used without much clogging. The best plan to obtain a good finish by filing, is to remove "pins" as they come, and to try to control the pressure exerted, so that no more pinning occurs. (This only refers to fibrous metals.) It is customary to chalk a new file to prevent "pins," and a further precaution taken by some is to add a few drops of oil.

Files are not flat from end to end, but are made with a slight curve. It would be impossible to file flat with a 14 in. rough file, if it were perfectly straight, because an even pressure cannot be put (vertically on the file during the whole length of stroke. Cross-filing is often productive of good results. Another reason is because, strictly speaking, files are warped to some degree in the hardening process.

Files are cut with "one safe edge" *i.e.* one edge left uncut, this is to ensure that a face not intended to be filed, may be protected, even when it is necessary to file close up to the corner. The safe edge of a file, will, if carefully examined shows burrs, these have been produced in the process of cutting the teeth on the flat sides. It is therefore the practice to grind the burrs down until the safe edge is flat. This is especially necessary for very accurate work.

Round files, and half-round files, are considerably more curved in their length than flat ones. The reason for this is to enable their use to be brought to bear upon small elevations in hollow work without interfering with other parts. Suppose, for instance, that it is necessary to file down an elevation in a bored hole, without enlarging

the aperture at the mouth. This may be done, if great care is exercised, but if the files were made with less curve, it would not be practicable.

To enable these files to cut freely without forming ridges, it is advisable to give a twist to the wrist during the forward stroke.

Better results are obtained by finishing hollow surfaces with a half-round scraper (made by grinding off the teeth on both face and sides of an old half-round smooth file, and sharpening up the cutting edges with an oil-stone). These scrapers are in general use in engine shops and machine tool works, but in machine building, where the various parts are of less dimensions, half-round scrapers are not much used.

Chipping Chisels.—The chisels used for chipping and cutting metal are made from bars of crucible cast steel, called tool steel. The bars are octagonal or oval in section. The latter may be produced from round bars by flattening two sides. Much depends upon the quality of the steel, which should be good, close-grained, and tough.

Forging a Chisel.—To make a chisel, a piece is first cut off about $6\frac{1}{2}$ in. long. One end is heated to a blood-red heat, while the other end is gripped by a pair of hollow bit tongs. The chisel head is first formed by holding the heated portion over towards the opposite edge of the anvil in an inclined position, then by slowly rotating the tongs and hammering down the steel until the end becomes circular for a distance of $\frac{2}{8}$ in.; finish with a little trimming.

The steel is now reversed in the tongs, and, after a heat about $1\frac{1}{2}$ in. long has been taken, the steel is drawn down to a wedge shape, care being taken to keep the edges from spreading. The steel must be repeatedly given half a turn to effect this. It should occasionally be turned over so as to get the taper uniform with the sides—Fig. 360 (1).

It is important to note that the under side of the chisel lies flat on the anvil, and a flattener should be used towards the end to smoothen the work. The chisel should measure $8\frac{3}{4}$ in. to 9 in. over all; *i.e.* assuming that a bar of octagonal steel measures $\frac{7}{8}$ in. across the flats, the width of the taper portion must not exceed 1 in. and that parallel for $2\frac{1}{2}$ in. in length. It is wrong to forge chisels tapering as in Fig. (2), or spreading as in Fig. (3). Tapering chisels are likely to wedge, and probably break off when used, and spreading considerably weakens a chisel at the outer-edge corners.

Fig. (3) shows a chisel hollow ground, and here again the corners get the brunt of the work, and will easily break off under heavy blows. Chipping chisels are best ground a little convex; by this means the force of the blow is received more at the centre of the chisel edge, and the corners are preserved, with the result that the tool is kept longer in proper condition.

When grinding a flat chisel, an equal amount should be removed from both facets, so that when the head is struck the work is cut straight. A plan of a chisel edge is shown properly ground in Fig. (8). It is, however, a common thing to see a beginner grind a chisel similar to Fig. (8A).

Cast iron and brass are cut or chipped without any lubrication, but wrought iron and mild steel yield better when the chisel edge is first rubbed on a piece of oily waste. The cutting edge must be kept sharp, and as thin as the nature of the work will admit of. It is a custom to do rough slogging with stout chisels kept for the purpose, but for a smooth finishing cut a light chisel drawn out thin is used. When a considerable amount of metal has to be chipped away, a "cross cut"—Fig. (5) chisel is used to make a series of grooves over the surface of the

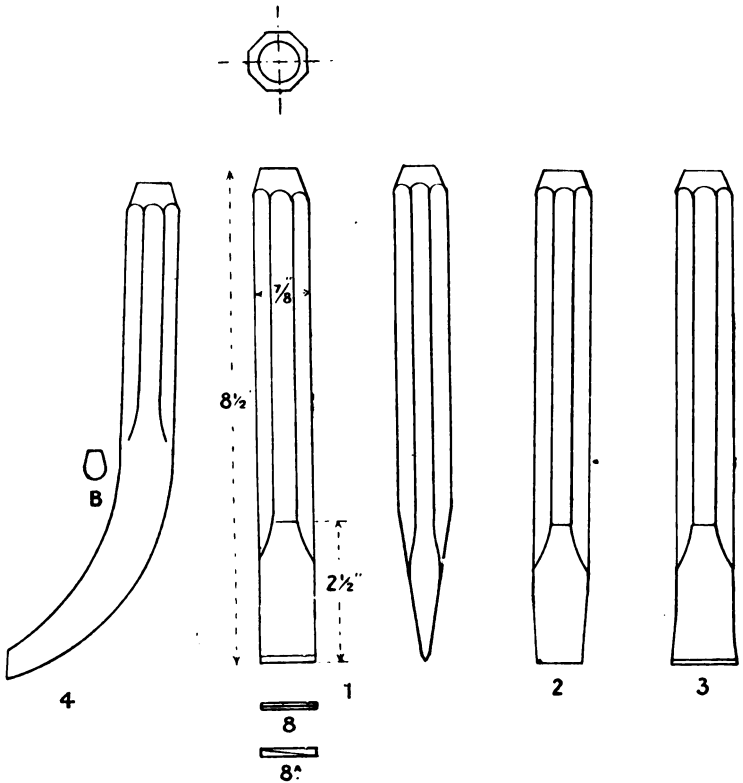

FIG. 360.—Chipping chisels.

work, the distance between the grooves being about $\frac{1}{8}$ in. less than the breadth of the flat chisel to be used along with it. Cutting out channels greatly expedites the work, especially in cast iron, because by so doing the metal is broken up much more easily. The cross-cut chisel is widest at the cutting edge, having a "clearance" for an inch above it so as to give it freedom when cutting keyways.

A useful chisel for cutting sheet metal is shown in Fig. (9). With the flat side of the chisel resting evenly on the top of the vice in which the

work is gripped, the chisel will shear off the upper portion, leaving a clean, even cut almost free from any burr or fracture. This side chisel is also used to finish the face of a hole-side, where it would be difficult to get an ordinary flat chisel in. The angle is about 45° for wrought iron or mild steel, and for soft material, such as copper, 30° or 35° . The angle of an ordinary flat chisel is about 65° for hard steel, and 60° for cast iron. The softer the material, the more acute the angle.

The round-nosed or oil-grooving chisel, Fig. (4), is forged much the same as a cross-cut: broadened at B to give strength to the cutting nose, which is necessarily small; but, however small the area of the cutting portion, the metal immediately above it must be less so, to give clearance.

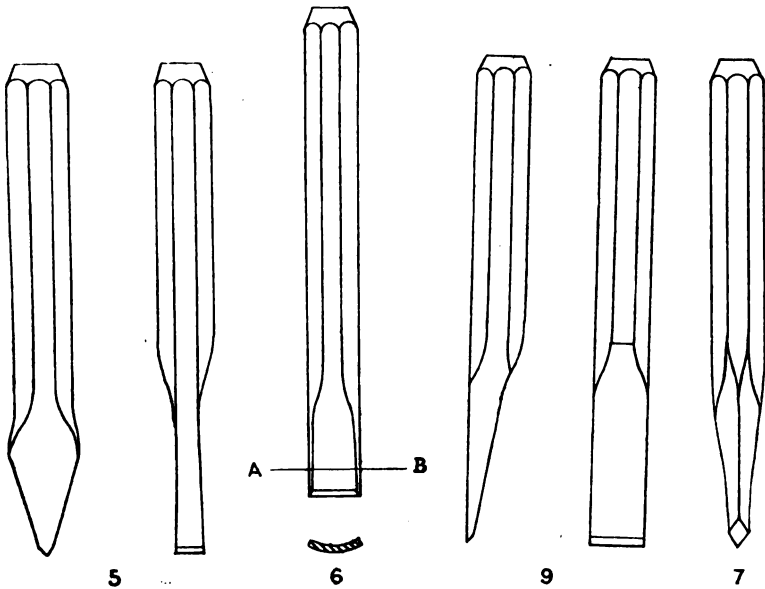

FIG. 360 (continued).—Chipping chisels.

Thinning a chisel thus must be done carefully, so as to keep an equal amount of metal each side of the centre. A chisel forged or formed out of line cannot be used with any degree of satisfaction, as there will be an undue amount of springing. When using a chisel on an even surface, the inclination at which it must be held is decided for us by the angle at which the chisel has been ground. The under face of the chisel should lie on the face of the work, and for this reason it is best to note the inclination before a blow is struck on the chisel head. It is obvious that the angle when once found must be kept, as any raising or lowering of the wrist will at once produce an effect upon the surface of the work more or less corrugated.

The art of chipping cannot be attained without much practice, but with a light hammer ($1\frac{1}{4}$ lb.) and steady blows, delivered uniformly on a chisel held rigidly, some approximation to evenness may be acquired.

Another chisel for cutting out a clearance in hollow or radial work is given in Fig. (6). This is a rounded chisel, sometimes called a "cow mouth."

Fig. (7) represents a "diamond-point" chisel, used in both deep and shallow slots; it is also useful to get in a sharp corner or to cut out a vee-shaped groove. The proper temper to give to chipping chisels is explained under "Hardening and Tempering," p. 307.

Templets.—Templets are also used as "measuring rods" to work to; of course, then they should be properly termed "gauges," or measuring rods.

EXAMPLE.—A pulley is sometimes ordered of a certain diameter and face, and bored to a "templet," *i.e.* wire rod, sent with order. This is generally done to obtain an accurate fit, the "templet" really being a piece of steel wire to represent in its extreme length the diameter of the shaft on to which the pulley must ride; it is, however, only resorted to as an *actual gauge* when the work in question is not a "standard dimension." These rod templets or gauges are occasionally used as a means of testing and also transferring measurements (see End Measuring Rods, Chapter I.) It is not always practicable nor expedient that each piece of work passing into the fitter's hands should have been first tooled over in a machine.

Let us suppose, for example, that a rectangular plate is cast with "facing strips" which are to be "dressed" with hammer and chisel and file sufficiently to make it "fit" and "finish" flush with the upper surface of a frame which is also cast with facing strips, ends, and sides, and base to receive it; assuming both castings are straight, and that a difference of $\frac{1}{4}$ in. prevents the plates from dropping into position. This will mean $\frac{1}{16}$ in. to be chipped and filed off each strip, and will require careful treatment by an experienced workman. A straight-edge must be used on the seatings of both plate and frame, the latter also tested with a spirit-level, which will at once show the highest and lowest parts.

The relative sides of the frame can now be tested with a square, also of the plate; if satisfactorily rectangular, two end measuring rods must be prepared, one equal to the finished width, the other equal to the finished length. These may be easily and quickly made from a $\frac{5}{16}$ in. rod of round steel, and the frame and plate carefully gauged over before commencing. Each strip should now be chalked over and a straight-edge laid on; then with a fine-pointed scribe, scribe the four sides of the frame, the distance between the lines to be equal to the plate to be fitted (giving a few pops with a centre punch). After the rough skin has been removed by chipping, the progress should at once be examined and compared with a straight edge. The chisels should be kept sharp, or the fracture of some edge or corner will result.

As a further guide, some workmen prefer to chamfer away the metal up to the line before commencing to chip. This is a safe plan, especially if any doubt exists as to ability to wield the tools accurately. Each

right-angle face is thus followed and tested with straight-edge and square (and here again some prefer to use a movable mete, which will show how near the work is to the finished sizes). Then the two rods are used, which, of course, will not enter until the work is practically finished. As the work approaches completion, the square and rods are more frequently used until the two rods will enter.

We next give attention to the plate, and mark off as before, taking care that the lines scribed are at the proper distance apart in both directions. Now, there are two methods of doing this work ; one is to "fit and try," the other is to work to the straight-edge, square, and rods. The former, the oldest, and until recently the most general, is to work the under edge down to the line, and then to dress off the remainder as the judgment directs with oft-repeated "tries." The latter plan would be to work as above stated to the tools and the templet rods. In this way trial fitting is reduced to a minimum, while the accuracy of the sense of touch is increased. The work is done with increased confidence, the actual cost in time is much less, and the risk of failure more remote.

Vices. — There are three kinds of vices, bench, hand, and machine.

Bench vices include staple, parallel, and swivel vices.

Staple Vices. — Staple vices are self-opening, having a spring between the two legs above the pivot. Their disadvantage is that the jaws are only truly parallel when they are closed. This renders this type of vice unfit for gripping large surfaces. When, however, the jaws have to be opened very wide the work is made secure by the insertion of wedges. These vices are very useful in loco-engine shops ; they will stand a great deal of hard usage.

Parallel Vices.—Parallel vices are now in general use in machining shops. There are several different forms of these. The one in Fig. 361 is known as Parkinson's perfect instantaneous grip vice. The screw is made with a buttress thread, and the nut is controlled by a lever and spring which may be used to open the vice instantly, in which case the vice block is drawn bodily forward or closed by compressing the spring, and finally the (vice pin) screw is used to put on the grip.

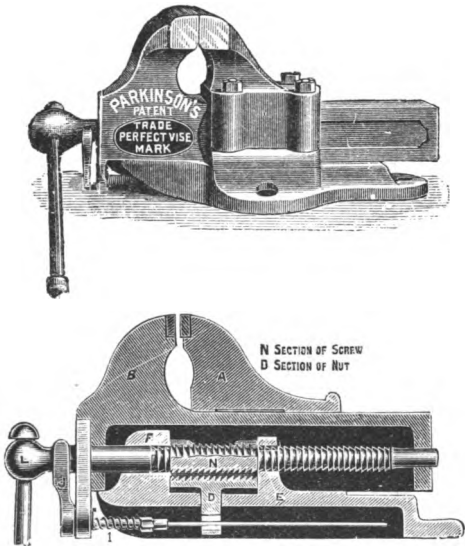

FIG. 361.—Parallel vice.

Another type of parallel bench vice is known as the "fast grip." In this arrangement there are two screws, one to move the vice quickly, and which serves to grip work for filing; the other, a finer pitched screw, which serves to give an additional grip on the work by means of a long lever. This is an ingenious device, and with the parallel jaws a considerable grip can be obtained.

Taylor's Novel Machine Vice.—Fig. 362 represents a novel device for holding articles to be machined. The fixed and movable "jaws" are both fitted with a number of thin rods, or tubes, which are acted

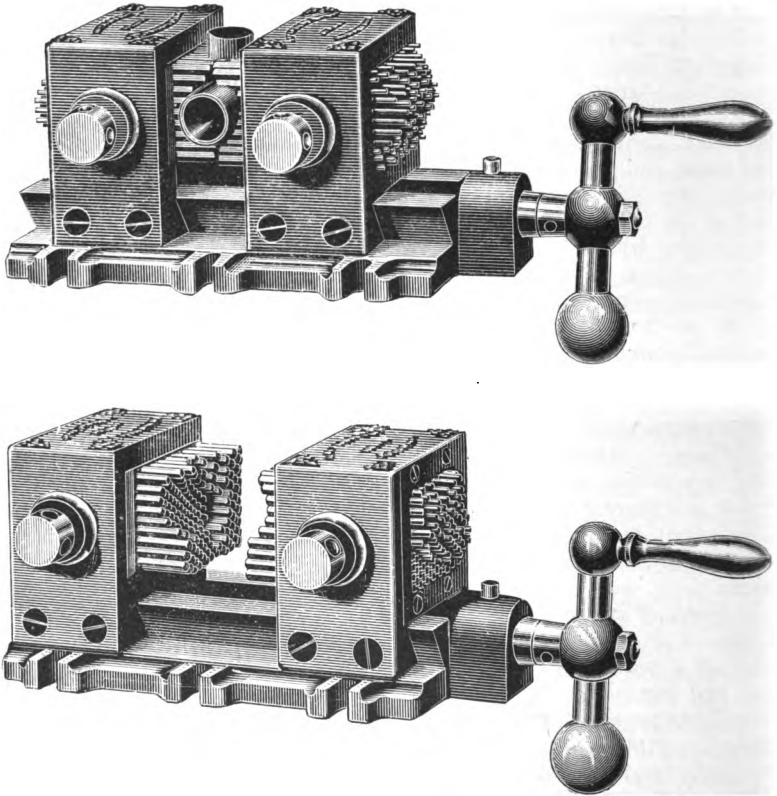

FIG. 362.—Novel vice.

upon by internal springs, but which can be instantly and firmly locked by the controlling screws shown.

The irregularly shaped article is placed between the jaws, both controlling screws are released of their grip, and as the vice is closed by the usual vice screw the article is pressed upon lightly by the movable rods. The controlling screws are then turned, which fixes the rods, and

by tightening the vice screw the work is held securely. After one piece has been operated upon, and the sliding jaw opened, a similar piece can be inserted in the jig, and by simply tightening the screws as before machining can be proceeded with, "setting" being unnecessary. In this way work of a repetitious character—such, for instance, as cycle, sewing-machine, or small-arm parts—can be satisfactorily treated.

The machine vice is the invention of Taylor, of London.

The machine vice illustrated in Figs. 363 and 363A, B, is used on the

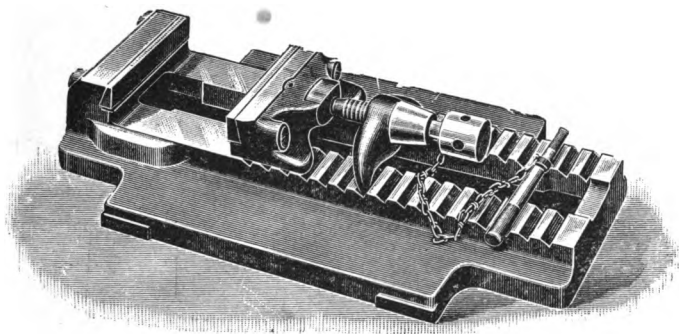

FIG. 363.—Machine vice.

tables of milling, shaping, and drilling machines, for holding down the work instead of clamping it directly to the tables. In working with these vices the "setting" of the work is made easy. The loose jaw is fitted

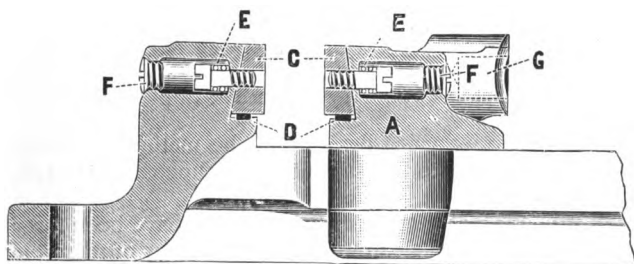

FIG. 363A.—Parallel vice.

anywhere along the notched surface of the bed (as the work requires), the final adjustment being made by tightening up the "grip pin" with the "lever" shown. The bevelled jaws have a sliding movement, which is an advantage in holding the work down; that is to say, the more a piece is gripped, the more firmly is it pulled downward by means of the jaws (see detail view of "Jaw Plate and Springs.") The loose jaw has a cylindrical base which enables it to be swivelled when angular

shaped pieces are to be secured. This vice is the invention of C. Taylor, Birmingham.

Vice Work.—Under this head is included work done by workmen as distinguished from work done by a machine. Vice work can be divided into two principal classes—fitting and assembling. The workmen engaged at the vice or similar work involving skill in the use of the hammer and chisel and file are classed as “fitters,” “assemblers,” or “erectors,” according to the particular class of work upon which they are engaged.

Fitters.—This particular class of workmen must have the highest skill in handicraft work, and an intelligent knowledge of machine drawing. As an illustration of this we may consider the fitting up of a knuckle joint, which, in a simple form, consists of a double eye, *a*, and a single eye, *b*, these parts being free to turn on the adjacent faces *CC* and *DD* round the joint pin *E*.

Fig. 364 illustrates the kind of drawing usually supplied to the

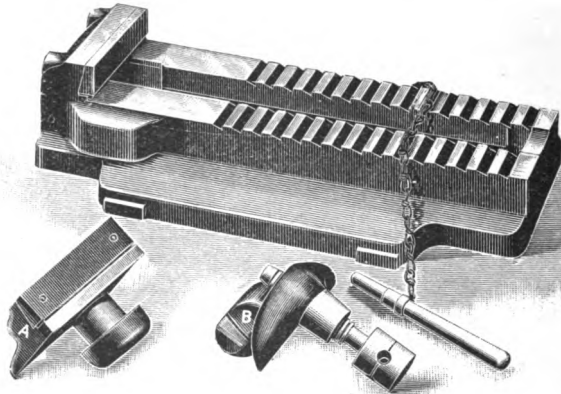

FIG. 363B.—Taylor's machine vice.

workmen, and in the following description the method of fitting up the joint is given. The various measurements are supposed to be taken from such a drawing.

We will suppose that the pieces for this joint have been forged solid (as is usually the case with small work). The shanks of these pieces are first turned, and the forgings are then delivered to the fitter to be set out. The end *j* (with the centre in) should also be faced in the lathe, and one of the faces, *h* or *g*, shaped parallel with the shank; but if these parts have not been machined they must be filed square to the fork and parallel to the shank. The surfaces should be tested with a square and scribing block, the shank being placed in vee blocks on a true surface.

The width *kl* of the inside of the jaw and, *gh*, of the outside are then marked off on the flat surface *j* by means of a pair of dividers, and the centre line *p* and parallel lines through *kl* and *gh* are traced by a

scribing block, and the depth U of the slot is measured from the turned edge S , after which the faces h and g are turned to the scribed lines, and the slot kul cut out by the shaping or slotting machine or by hand. The jaw is afterwards placed in the vee block with the squared faces h and g perpendicular.

The centre line p is traced by the scribing block; the centre q is then set out from the drawing, or is fixed upon according to the finished size

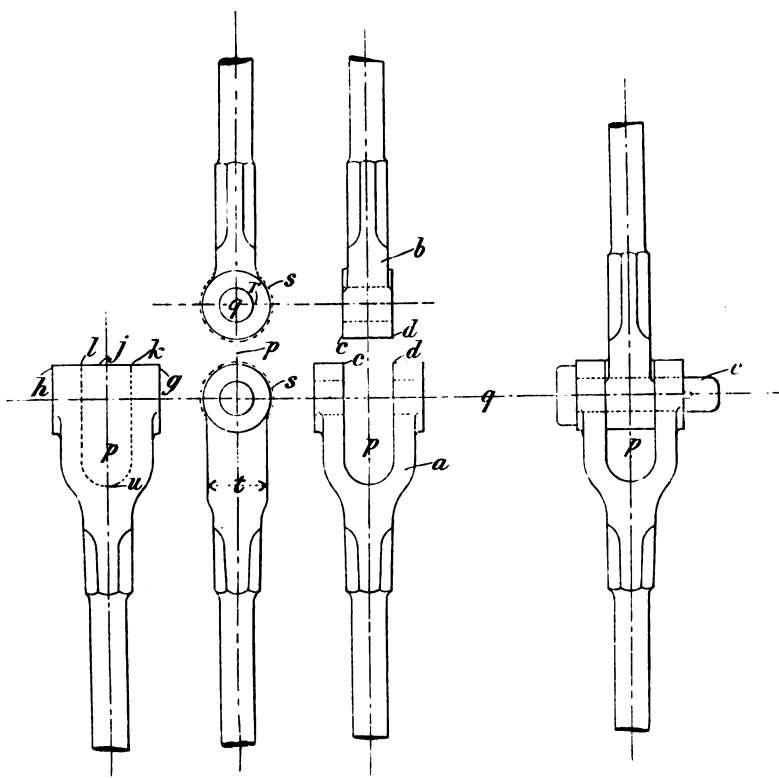

FIG. 364.—Knuckle joint.

of the "jaw," or "shaping," or other incidental circumstances, and from this centre the circles r and s for the joint pin and size of the jaw are described. The width at t is then set off, and lines parallel to the centre line p are drawn and joined to the centre q by arcs of circles which may be of the same radius as the circle S . The hole for the joint can then be drilled.

The shank is firmly secured in vee blocks, and the trued face set parallel with the machine table. A packing is inserted between the

jaws to ensure the hole being drilled square with the shank, and to prevent the jaws being closed by the pressure of the drill.

The single-eye jaw is set out, its surfaces machined, and its hole drilled in a similar manner. The two parts of the jaws have now to be fitted together, and the edges filed up true. One face of the single-eye jaw and one of the inner faces of the double-eye jaw are filed and scraped to a surface plate square with the drilled hole, after which the second inner face of the double-eyed jaw is filed and scraped parallel to the inner face already trued.

The second face of the single-eye jaw is then filed and scraped parallel with the trued face, and by means of calipers or similar gauges is made exactly the same width as that of the space between the inside of the double-eyed jaw, so that the two parts are a very tight fit. The hole in both jaws is then reamed out to the standard size. The parts of the jaws are then separated, the burrs from the reaming removed, and the tight places on the surfaces of the jaw scraped until the parts fit together freely, but without shake. The outside faces of the double-eyed jaw can then be filed parallel to the inner faces and the joint-pin turned and fitted to the hole. The two parts of the joint are then put together with a temporary joint pin which does not project beyond the outer faces of the jaw.

A flat is filed across the jaw parallel with the joint pin. The single eye is then rotated on the pin, and another flat is filed on the double eye down to the level of the single eye, and in this manner about one half of the double-eye jaw is filed to the level of the flat on the single eye. The parts are then separated and the single eye turned over so that the second half of the double eye can be filed in the same manner as the first half, and since the edge of the double eye will then be filed to a flat on the single eye it must be circular. The single eye can then be filed to the shaped form of the double eye, and in a well-finished joint the edges of the jaws should be flush with each other in whatever position they may be turned to.

The portion between the lines t of the double jaw are then filed square with the faces g and h , and care must be taken in filing between the lines t and the circle to prevent the formation of humps and hollows. The jaw can then be draw-filed and polished in the usual manner.

This example of a knuckle joint has been given as an illustration of the high-class skill of a modern fitter. It demands a knowledge of setting out work and the manipulation of the file and scraper. In an up-to-date machine shop, however, many of the operations described, with reference to the filing-up of the knuckle joint, would be performed by modern machinery, or aided by the use of templates. Thus, the inner and outer surfaces would be milled, and little or no hand labour would be required to fit the parts together; while the outline of the joints would be shaped or tooled in a profiling machine, or ground or filed to a template, and polished by the emery wheel and buff.

For knuckle joints which require to be hardened, the parts are milled nearly to the finished sizes, and then hardened, after which they are machine ground to the finished sizes.

Assemblers or Erectors.—The duty of these workmen consists principally in the fixing together of parts of mechanisms that have been previously machined and fitted. In many cases the work of the erector is closely allied to that of the fitter, and may even require a greater experience, although very rarely the same amount of handicraft skill.

The assembler proper is more generally engaged in the putting together and in the adjustment of sewing machines, linotype machines, calculating machines, typewriters, and other machines of which a large number of exactly the same kind are required; while the erector proper is engaged in the fixing together of engines and machines which may be of the same type, but which vary in gauge, size, and other particulars.

In the case of the assembler proper the work can be said to consist solely in the putting together of a number of finished parts, and adjusting the relative position of such parts, and while this work demands a knowledge of the machine and its method of working, it may not need a skilful mechanic to do it. It does not call for the same amount of manual skill which is necessary to the fitter.

The erector, on the other hand, has not only to put together and adjust the relative positions of finished parts, but in many cases has to fit together rough castings, such as the bearings for a shaft which extends across a machine, the said bearings having to be padded to a "tie" bar. Again, the variation in the contraction of a large casting, such as an engine-bed, and the different positions in such a bed of machined facings demand considerable experience on the part of the erector to enable the various parts of the engine to be corrected, fixed, and fitted relatively to the centre line of the gauge and to each other.

Example of Filing-up Calipers.—An interesting example for a beginner, involving the use of both lathe and drilling machine, is to make a pair of calipers. An even piece of cast steel (preferably saw blade) should be chosen and secured in the vice. After smearing the surface with chalk, make a small centre pop, and scribe a line the full length the calipers are to be made, with a centre pop at opposite end. Then with a pair of compasses set to the radius of the washer, describe a circle bounded by the dot first made, and at the other end mark on each side of the centre a distance equal to half the width of the caliper points to be made. Join these with the circle, and we have the outline of one leg of the calipers. After similarly "scribing out" a second piece, the material may be "cut away," or "drilled out." This may be too brittle and "risky" to be chiselled, in which case a series of holes, as near the edge of the line and as close together as is convenient, should be drilled. If both pieces of steel are first clamped fast together better results are obtained, and whilst thus clamped the hole to receive the rivet may be made and reamed.

After drilling there should be a temporary rivet put in, the edges dressed, and the material around the circle filed away. The calipers are now ready to be bent. If they are made blood red they may be suitably bent over the beak of the anvil at one heat. It is the best plan to use a wooden mallet to hammer with. After bending remove the temporary rivet and dress up the sides.

The *rivet* should be a perfectly cylindrical piece of steel with a head turned at one end, and should be used to test the accuracy of the finished faces of both legs, *i.e.* so far as the diameter of the rivet head will show. It is preferable that the rivet should be kept as part of the stock, so that a carrier can be fixed on to the opposite end until perfect coincidence between the inside face of the rivet head and each side of both legs of the calipers has been obtained. Any inaccuracy in this respect can usually soon be reduced by scraping. After this is finished the edges should be rounded a little and the points trimmed ready for hardening. The points of calipers are not required sharp and straight, but slightly rounded with a smooth file, or by grinding on an emery wheel.

It is erroneous to suppose measurements can be transferred by extremely sharp-pointed, *i.e.* sharp-edged calipers. The straight ends prevent actual contact between the internal walls of the holes, and the extreme sharp end makes it difficult to lodge the leg of an inside caliper on an outside caliper when dimensions are to be transferred. The faces having once been true, very little dressing will be required.

A block of wood fixed in the vice serves well as a "jig" rest on to which the flat side of the caliper leg may be laid. A small clamp, or a few joiner's brads will secure it whilst it is dressed and polished. There should be a smear of oil on the rivet before it is inserted, and some prefer to rub the washer faces with a little beeswax immediately before riveting. As the rivet tightens the legs, they should be opened wide and closed repeatedly. Steel rivets and washer should be used. Not a single blow must be given after a satisfactory tightening has been effected. Good work in calipers is nowhere more important than at the rivet.

To test: open them to their widest, and close slowly. If properly done there will be a uniform tension throughout; while, on the other hand, calipers improperly made will be tighter at one place than another, and others will have a rocking movement wherever the jaws may be set at. Both the defects above referred to are irremediable. The former proves the faces of the calipers or washers, or both, are uneven, and the latter proves that the hole or the rivet is not perfectly cylindrical. The heads of the rivet and washer are trimmed and polished with a brace and a wooden stock, cupped slightly to receive the head of the rivet; a strip of emery cloth is, of course, inserted between. Calipers thus made are not usually hardened, but steels of a lower grade are always hardened at the caliper points.

Holding Work in the Vice.—The grip necessary to firmly secure articles which are to be chipped, filed, or fitted while held in the vice jaws is sometimes considerable. The jaw faces next the work have been cut and hardened like a file; and the projecting teeth would therefore penetrate the smooth surfaces of machined work, and damage it. Clamps are therefore inserted between the hard jaws and the work to prevent any bruising. Those in general use are made by casting lead in a suitable mould. The castings are about $\frac{3}{8}$ in. thick of L-shaped section, but are finally adapted to fit the vice by hammering. For heavy work, a little tin is melted with the lead, which hardens the product, otherwise the clamps soon lose their shape by repeated squeezing.

Copper clamps are harder, and give a firmer grip than lead, but better still are those made of sheet steel; these are first cut out, and then heated and bent to the shape of the vice jaws. Light work is conveniently held between clamps of hard wood, except when hammering has to be done. Small screws and pins are best held in a pair of spring clamps, which remain in correct position after the work has been released, the bow of the spring serving as a tray to catch any small pins, etc., as they may fall (see Fig. 365).

When it is necessary to grip a screw by the thread, a hexagon nut sawn through on one side is used to hold the screwed portion without any possibility of damaging it, or a strip of flat iron or steel bar may be drilled and tapped to various-sized screws, and afterwards sawn asunder longitudinally; such a pair of screw clamps is further improved by fixing a bow-shaped piece of steel at one end, thus keeping the clamps together,

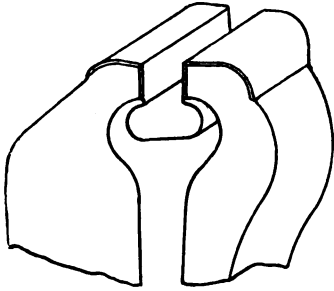

FIG. 365.—Vice clamps.

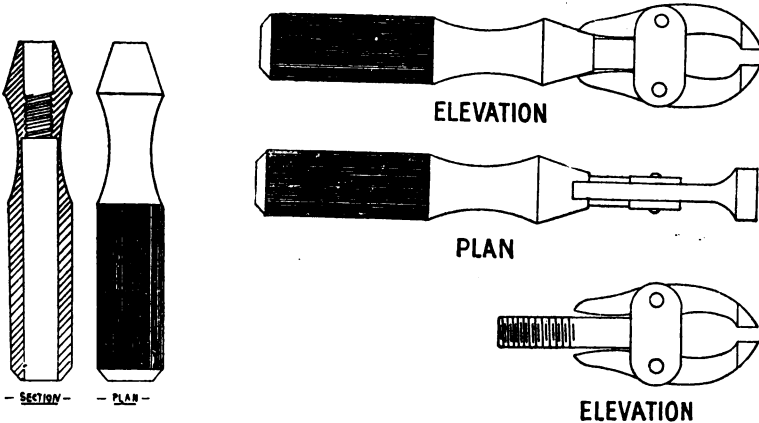

FIG. 366.—Hand vice.

and open to admit the screws. Small hand vice are also useful to hold pins (Fig. 366).

Keys and Key Fitting.—Keys are made of wrought iron, mild steel, or tool steel. Those forged from mild steel bars or from tool steel are generally used, their shapes varying according as they are fixed or movable. (Fig. 367.)

Fixed Keys.—A fixed key, commonly called a “sunk” or “feather” key, lies in a key bed made in a shaft or spindle to receive it.

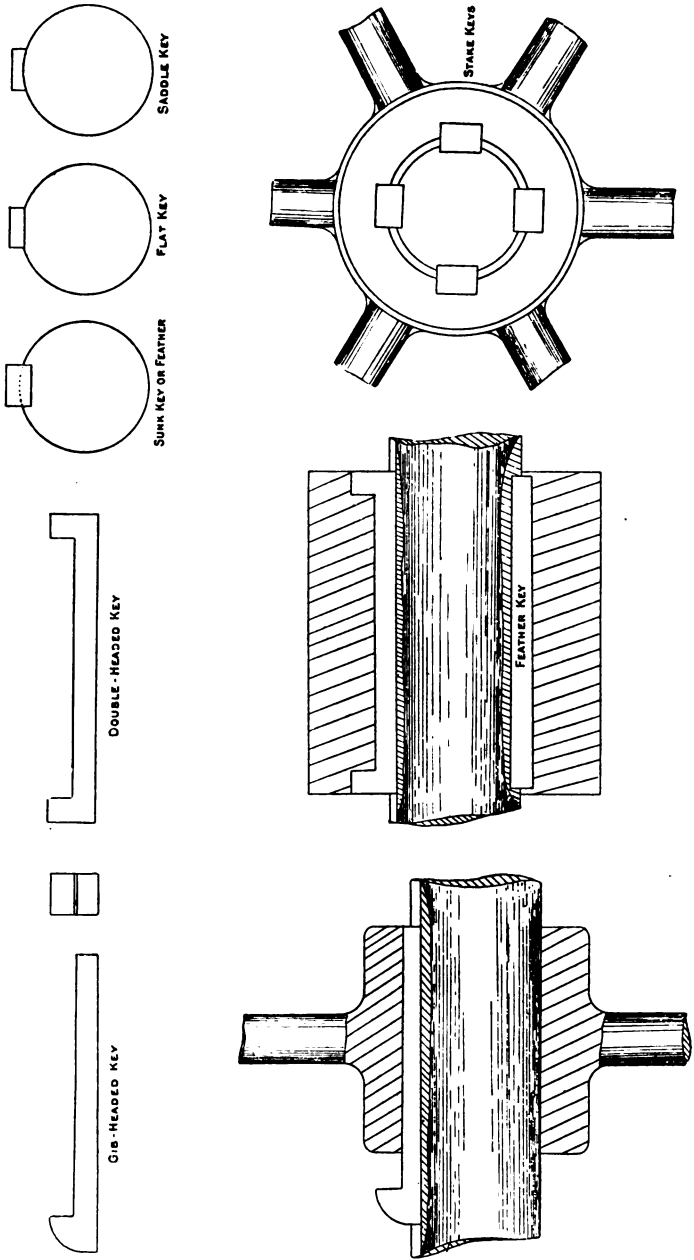

FIG. 367.—Various methods of fitting keys.

Gib-headed Keys.—A gib-headed key is one which may be driven into its place by hammering the head, or withdrawn by inserting a lever between the face of the work and the inner face of the key head, or driven out with a key drift.

Headless Keys.—Keys without heads are fitted into their place in the same manner as gib-headed ones, but in such cases a “key drift” is used to remove them. When it is impracticable for a drift to be used, a headed key is fitted; and when finally driven in, the head is sawn off. The latter method is adopted where a headed key would be dangerous.

Saddle Keys.—A saddle key is frequently used for light work, such, for instance, as in fixing small pulleys to shafts. Used in conjunction with a sunk key, and placed at right angles to it, a saddle key will prevent a badly fitting wheel from rocking on its shaft.

Headless keys, although safe, are troublesome to remove; in some cases they have to be destroyed, by drilling a hole through them, before the wheels can be removed from their shafts. Sometimes it is necessary for a wheel to slide for a short distance along its shaft, and still rotate with it at any interval of its travel; in this case a sunk key is secured to the shaft on which the wheel slides.

Sunk keys are retained in place either by caulking or by screws passing into the shafts. In heavy work, where large keys are used, it is a good plan to first make a piece of wood fit the keyways. It is then used as a templet, from which the forger, grinder, miller, or fitter may work. The above method is a sure one, and greatly expedites the work of the fitter, leaving him just a little finishing to be done with the file.

In cases where a wheel has to travel for a considerable distance along its shaft, the key is let into the wheel, and held in place by one or two projecting pins, by screws, or by riveting up the ends of the key.

The same methods are adopted in opposite cases, *i.e.* when the shaft or spindle has end movement, and the wheels or worms are fixed, only being able to rotate with their respective shafts or spindles (see Illustrations of Various Methods of Keying).

Another method of keying is to file a flat surface on the shaft, and then use a gib-headed or other flat form of key. The latter method is adopted in such cases as cannot be conveniently treated until other mechanisms are properly located, or when the shafts are too slender to permit hollow keyways or beds being cut in them.

“Staking” is a term applied to the securing of heavy wheels to their shafts by a number of keys. An example of this is illustrated in Fig. 367. The shaft may be 6 in. diameter, and the hole in the boss of the wheel (which is cored only) 8 in. diameter. The keyways may be chipped and filed out, and the shaft planed or milled with a number of flats; the keys are then driven in place, and the wheel rim set to revolve truly, by driving the keys more or less on one side. The setting is quite as well done by this means as in the lathe, and without any fear of springing the wheel, which always has to be risked when large but slender wheels are fastened on to a face plate.

An improvement in the system of keying is given in a patented arrangement by Messrs. Geo. Richards, Broadheath, Manchester, the distinctive features of which are that the keys are made of a hard grade of cast steel, which admits of them being made much thinner, and

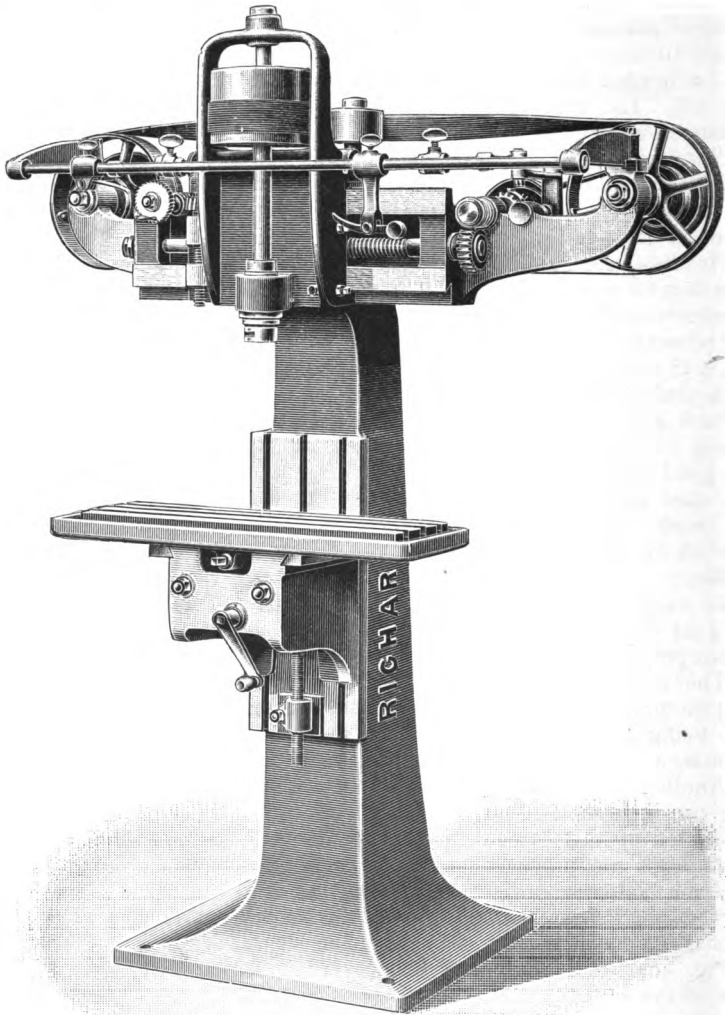

FIG. 368.—Slot-drilling machine.

inserted in their shafts to a greater depth, than is usual, thus giving them a firm hold. The same makers have also an automatic keyway cutting machine to cut the key beds (see Fig. 368).

When the shafts are cut, the keys are simply forced into their place, without filing or any subsequent alteration. Thus the work is of a much higher grade of finish, and is more accurate than the "hit-and-miss practice" of trial fitting.

Trial fitting, which must now be explained, is the system of working more by good judgment than by measurement, is fast becoming obsolete. It is, perhaps, surviving longer in key fitting than in any other branch of workshop practice. The method of fitting a key to a wheel and shaft has been to select a key as near as possible to the measured key bed, and then to file it down just where it binds the hardest. This process of "fit and try" is most unsatisfactory, for two reasons: In the first place, the thin end of the key, being repeatedly filed, may be too thin at the finish; and in the second, the time taken to repeatedly try the key is excessive. Especially is this the case in fitting wheels to their spindles having sunk keys, and in work which needs a crane or pulley blocks to lift the spindle into its place. It should be thoroughly understood that a key should fit the whole of its surface within the wheel, and not more in one place than another. Too much emphasis cannot be laid upon this, as the subsequent true running of both wheels and shafts are dependent upon good-fitting keys.

The beds for keys are tooled out in one of the following ways. Very long shafts are "keyway cut" on a planing machine. Other shafts or spindles are milled or cut in a slot drilling machine. Whichever machine is used, the bed of the keyway must be cut exactly true, and flat in the seating. This will require careful setting to lines marked previously, but will well repay when the wheel is placed in position on the shaft.

Wheels are slotted with a tool equal in width to the bed in the shaft. It is also the practice to set out the keyway in the wheel, and slot a groove to a template used for the purpose. Machines carrying special tools and shafts to fit any standard hole are now in use; by this means wheels may be slotted centrally (which is not always the case in a keyway cut in a slotting machine, and it should be here pointed out that the relation between the slotted wheel and the key bed in the shaft must be ascertained at the outset, so that any slight difference when the wheel is in position may be corrected by filing).

Key fitting is important work in several respects. In the first place the work should be gauged over in every detail, and in the second place carefully made to the measurements obtained by the calipers at both ends of the keyway.

Vice—Jigs.—"Jigs" are of two principal kinds—"template jigs" and "holding jigs."

Template jigs are by no means a modern introduction, especially in small repetition work. These jigs are made use of at the vice and bench work, being used as guides or gauges in filing up thin pieces of flat sheet metal, and also when the shape of the piece is irregular and will not hold in the vice in the ordinary way. Especially is this the case in small-arm and similar small mechanisms which are finished by filing. In some cases a piece of steel is carefully prepared and

accurately finished and hardened, the shape of this "template" being identically the same as the required work is to be. Then a piece of work is put alongside the template, and both are secured in the vice together, the filing being continued until the work's surface is reduced to the same contour as the template.

A much more accurate method is to use two hardened templates with the piece to be "filed up" sandwiched between them; the work cannot be irregularly filed, nor yet reduced too much by this plan, while with but one template error is obviously possible to occur.

There are also other appliances used to hold the work, such as blocks of wood on the upper surfaces, of which shallow beds or prints for the articles to be filed are made; these blocks are also to be classed among filing jigs.

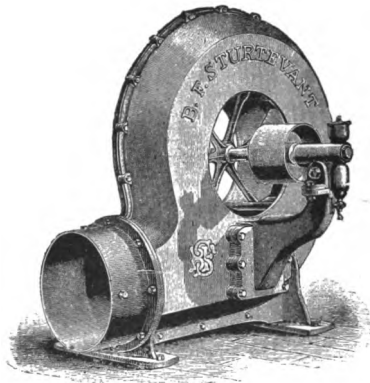



FIG. 368A.—Smith's fan or blower.

CHAPTER XVI.

FORGING PROCESSES.

“FORGING” is the shaping of wrought iron or steel whilst it is hot by hammering, or by squeezing (see Chap. III., on Manufacture of Iron and Steel). Besides iron and steel there are a few copper alloys which can be forged, but these are special mixtures for specific work. Forging, like other branches of engineering workshop practice, has undergone considerable change, and can now be divided into several distinct departments.

Heavy Forging Shop.—The heavier class of work is wrought under powerful steam hammers, hydraulic forming presses, bending rolls, cogging mills, and tilt hammers (which are not so much in use as formerly). In the same shop fixed and portable riveting machines and multiple drilling machines are also generally found.

Angle-iron Smithy.—Another special shop is devoted to the treatment of angle-iron bars of the various sections  (Fig. 369). Here the fires are open all round, so as to allow the smith facility when heating up the bars for bending, forming, or welding, as the case may be. Angle smiths are very skilful, but are restricted to this work alone, and are not accustomed to general forging.

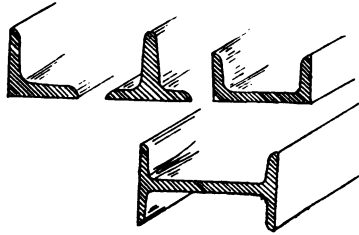

FIG. 369.—Sections of angle iron.

“Forming” Shop.—The “forming” shop is a modern development, and is unique, inasmuch as the workmen are generally unskilled, the work being done by special machines. The forgings produced are of the highest class, and are made as follows: The bars to be bent are uniformly heated in a furnace, from whence they are removed separately to the table of a forming machine (“Bulldozer”), which in its motion and appearance somewhat resembles an ordinary planing machine (see Figs. 370, 371). A pair of dies having the exact form the bar is intended to assume are cast in iron. One of the dies is rigidly secured to the machine table, and another fixed in perfect alignment to a vertical column located at the end of the machine bed. The heated bar is then squeezed between the dies, and thus receives an impression

of their particular shape. Dies of other forms are sometimes used at the opposite end of the machine table, enabling a forging to be produced by both the forward and backward stroke of the table. The dies are frequently changed and others substituted for different work.

The under framework for tramcars is an example illustrating this method of working. The peculiar bends given to some of these bars

necessitated the use of gauges and templates, and the skill of a first-class workman to direct the hammermen where to strike when the work was entirely done by hand at the anvil. In addition to this, the forgings had to be overhauled and twisted to suit (which is obviously necessary in all forged work which has not to be machined, *i.e.* planed or shaped).

Compared with this, each forging made in the above machine is exactly true to pattern, and is much more quickly produced since it is formed in one operation only. These machines are used in "gang" punching plates, also for straightening purposes.

Fig. 370 represents a single-gear "Bulldozer" for light running where speed is more important than power. These machines make from 35 to 50 strokes per minute.

Two examples of bent work are given in Fig. 372. These are too well known to need description.

The Smith's Hearth.—A smith's hearth was formerly a brick structure; it is now generally constructed of iron, in two principal forms, those of a stationary character (Figs. 374, 374A), and those made to run on wheels, called portable forges (Fig. 375).

Tuyere.—In the smithy the hearth is usually fitted with a tuyere,

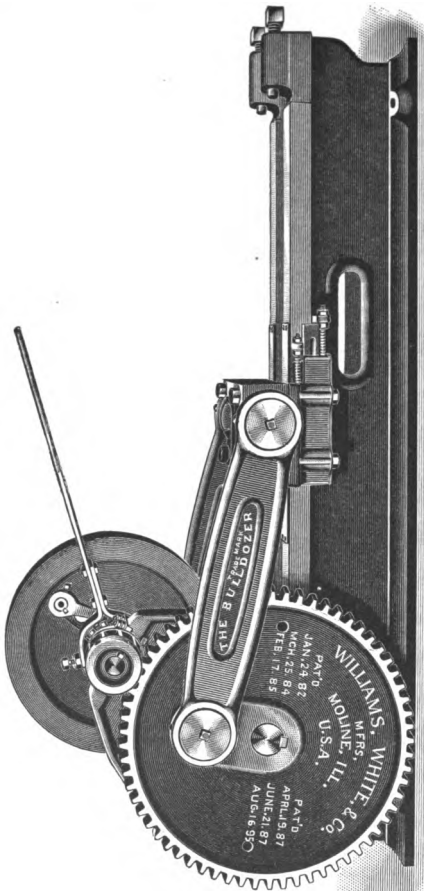

FIG. 370.—Single-gear "Bulldozer."

through which the air passes direct to the fire from the fan or blower. The tuyere B is made of wrought iron or mild steel, shown in Fig. 373; the air pipe and the nozzle are surrounded with water supplied from a

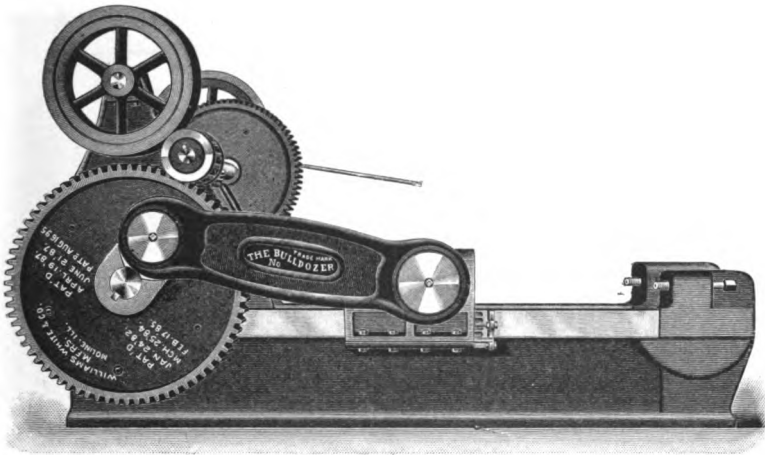
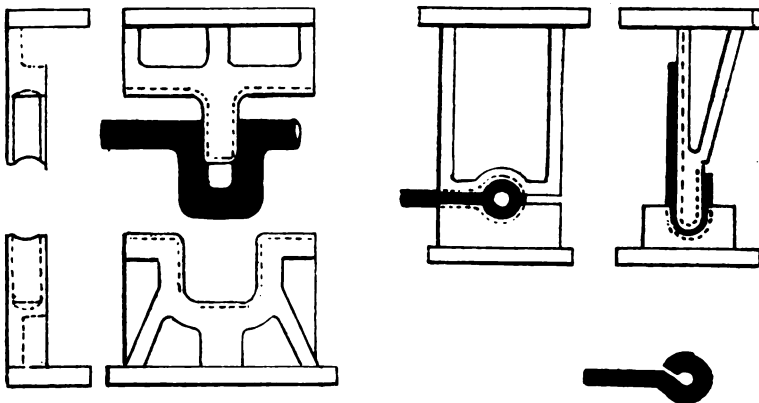

FIG. 371.—Double-geared "Bulldozer."

tank, A, at the back of the hearth. This water is to keep the tuyere from being injured by the heat of the fire. Waterless tuyeres of cast iron are sometimes used, but these are not so good or reliable as the above.



Bent crank and dies.

Eye bolt and dies.

FIG. 372.—Bent work by above.

The Air Blast.—The air to blow up a smithy fire is obtained by means of revolving vanes, as contained in a "fan" or "blower," or, for very small hearths, by means of a bellows. Whichever form is used, the

air is drawn into a receiver and forced through a pipe leading directly to the heart of the fire.

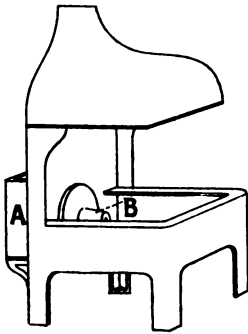

FIG. 374.—Iron hearth.

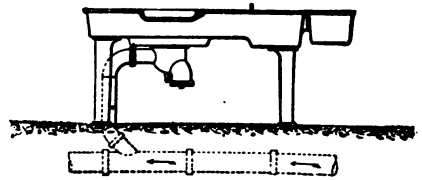
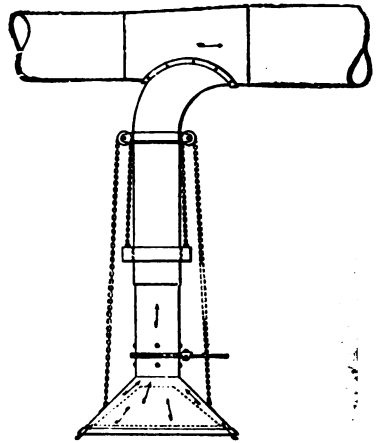

FIG. 374A.—Modern hearth.

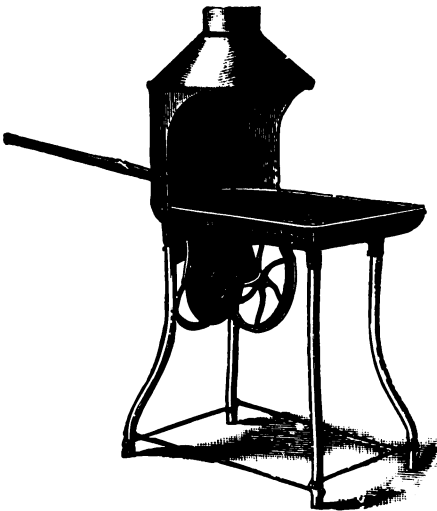

FIG. 375.—Portable hearth.

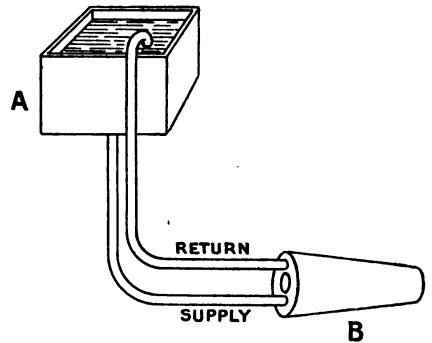

FIG. 373.—Water tuyere.

Of the former class, Fig. 376 is an illustration of a "blower." This is considered one of the most economical, as the power required

to run this machine is very little, while the speed of revolution is about 300 per minute. In this machine there are two "revolvers," which are connected in such a manner as to permit of no backward escapement of air. B shows a "blower" of a large size, with engine attached, suitable for a large number of forge fires invented by "Root."

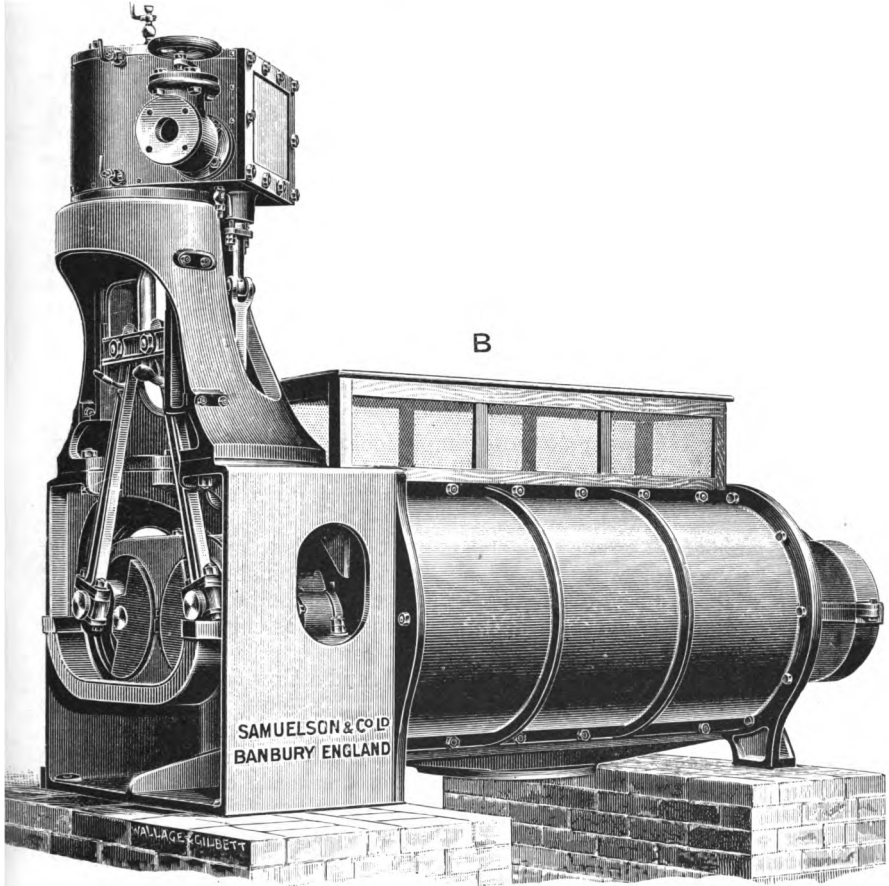

FIG. 376.--Root's blower.

Fire.—On the bed of the hearth a layer of spent or burnt fuel is laid, to prevent the fire from spreading. Immediately below the air nozzle a hollow is made, into which the fire is placed. In ordinary working a small, nut-sized coke, called "breeze," is preferred, which is obtained by passing coke in its usual form through a crushing mill. For welding purposes this breeze is "floated," *i.e.* only that portion which will float is used.

Slag.—Any impurities the coke may contain will accumulate and form a slag which is injurious to the iron, but owing to its weight it sinks below the nozzle and solidifies into dross, in which form it is removed from the fire.

Flux.—As the slag sometimes adheres to the iron, a little sand is sprinkled on this immediately before it reaches a welding heat, and the iron then put back into the fire for a few minutes. When it is ready the sand will have melted and formed a coating over the hottest portion, which is either knocked off or brushed off, according to the size and weight of the bar.

To prevent the slag from sticking to the iron whilst in the fire is not an easy task for a beginner, and all traces of this should therefore be avoided or removed as soon as it is noticed. It may be avoided to a considerable extent if care is taken when "taking a heat."

The slag, being much heavier than the coke, sinks below the tuyere nose, so that when putting a rod or bar into the fire (unless freshly made) it should, at the least, lie horizontally, and in a low fire the heated portion of the iron is best preserved by keeping its extremity inclined a little upwards. As the fire sinks a little coke is lightly drawn from the heap on opposite side of the hearth; when this is done the temperature quickly rises, and the care to keep the iron from burning increases, necessitating more frequent withdrawals to examine the progress.

When withdrawing a heat to simply look at it, do the work steadily, otherwise the black coke will fall and take the place occupied by the iron, which practically means, when getting up a welding heat, recommencing the operation.

Another hint on the care and use of the fire is to avoid placing cast-steel cutting tools in a "green fire," for the reason above stated. The heat of the fire is at a white heat, and therefore too hot for crucible cast tool steel, and more especially thin sections, such as chipping chisels and keen-edged cutting tools.

To heat steel thoroughly is important, and a slow fire is necessary to thoroughly "soak" the metal.

Forging a Pair of Tongs (Anvil Work).—To forge and put together a pair of "flat bitted" tongs of the most usual pattern, select a bar of good 1-in. square iron; lay about 3 in. on the inside edge of the anvil and "take down" the thickness to $\frac{1}{2}$ in., at the same time "drawing" it edgeways to maintain the width at 1 in. This is done rapidly, so as to have enough heat in the bar for the next step, which consists in turning it at right angles and hanging the "bit," or part just taken down, over the front edge of the anvil and flattening the bar just behind it. The third step is performed by placing the work about 3 in. farther forward on the anvil, and again turning at right angles, slightly raising the back end, and striking the iron fairly over the front edge of the anvil, alternating the blows by turning and returning the bar. Cut off the "bit" 3 or 4 in. behind the part last heated. Prepare a second bit in exactly the same manner, and scarf down one end of each.

For the handles or "reins" choose a piece of $\frac{1}{2}$ -in. rod, upset one end, scarf it, and weld it to one of the bits. Serve the other bit the

same. Punch a $\frac{3}{8}$ -in. hole through each, and connect them by riveting.

Reheat the finished tongs and dress them parallel; then cool by immersion and constant motion in cold water.

The other forms are made in a similar manner, dressing the bits in each case around pieces of metal of suitable shape and size.¹

Fig. 377, A, B, and C, are flat bit tongs, hollow bits, and pliers.

Processes and Terms used in the Smithy.—"To draw down" is to reduce a shaft or bar of iron or steel from one dimension to another. The work may be done by gradually hammering the end of the metal as in pointing a thin rod. To do this successfully the end of the rod is made white hot and lightly hammered, which closes the fibres of the iron

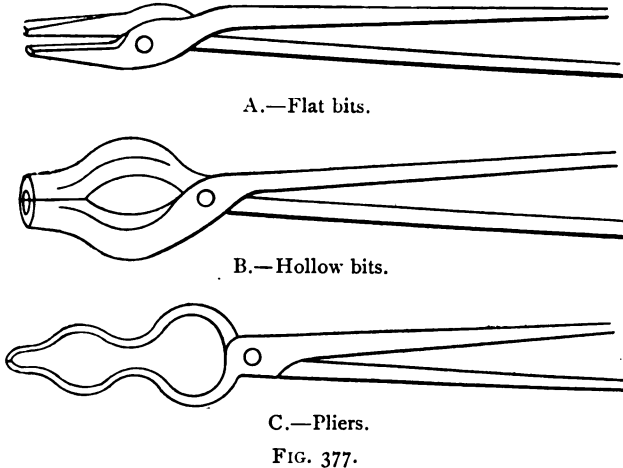

and prevents it from splitting, quarter turning and alternating the iron on the anvil with each blow.

To draw down from a shoulder we use "necking" tools or "fullers" (see Fig. 380A). Suppose a swell on a shaft is to be 2 in. diameter by 4 in. long, and reduced on each side to $\frac{7}{8}$ in. diameter (the dimensions being forging sizes). The necking tools would be used to roughly form the shoulders, the upper tool being struck makes a groove in the bar or shaft, and at the same time the force of the blow drives the shaft on to the lower fuller. The shafting is then turned round a little, and the blows repeated until the grooves are finished.

There are several ways of reducing the 2-in. bar to $\frac{7}{8}$ in. In general practice a steam or power hammer would be employed to reduce the work roughly to size, or the shaft could be swaged down directly under the swaging tools of a forging machine.

One of these forging machines is illustrated in Fig. 378 by W. Ryder. The dies are made to vibrate very rapidly, and quickly reduce a bar to

¹ Spon's "Mechanics Own Book."

any desired diameter by passing it through and through the various dies. The dies are adjustable. Heavy bars are upset in different ways according to their length and shape. When short enough to pass vertically under the steam hammer, the iron is quickly upset by first slacking those parts not required to be thickened.

Making Iron.—This practice is often more expedient when a few heavy forgings are to be made, and is called "making iron." A short stiff bar is selected and increased in dimensions by "upsetting," until the mass is sufficiently thickened to make the required forging from.

Piling.—When such a bar is not to be obtained, several bars of less dimensions are bound together, heated and welded, and then forged into the required shape. This process is called "piling," and improves the quality of the iron by thus compressing it.

Smithing.—This is somewhat distinct from forging, in the general meaning of the term. A smith's work may include the use of a steam or power hammer in addition to his assistant, the striker, but if his work is of small dimensions, then the forgings are entirely wrought at the anvil.

Forging.—A forger's work is usually wrought, partly at the steam hammer and partly at the anvil and swage block (see Fig. 379).

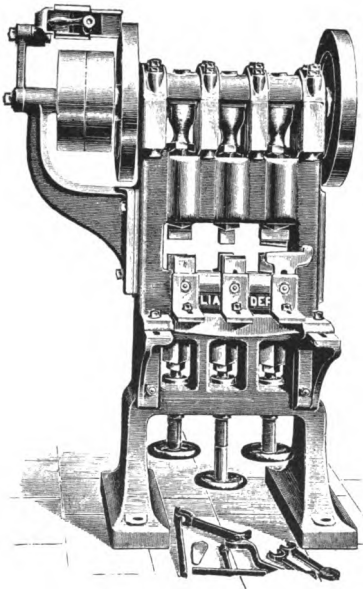

FIG. 378.—"Ryder" forging machine.

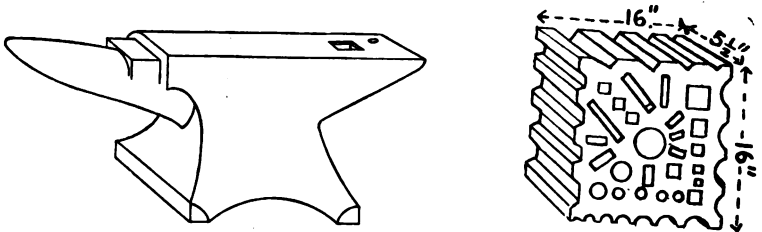

FIG. 379.—Anvil and swage block.

Striker.—If the smith is to turn out good work expeditiously, he must have the help of a good striker. Striking is a matter requiring more skill than one might gather from a casual glance. The following

points have to be attended to. The heated iron must be struck at the proper time and in the right place; the proper hammer must be used with a suitable rate of blows; and, lastly, with just the necessary amount of force for the work undergoing operation.

Experience in discharging this duty takes a considerable time to acquire, as the striker should be accustomed to the *smith's method of working* on a job, hence it is not an uncommon thing to find a smith and his assistant who have worked together at the same fire for years.

Forging an Axle by Hand.—To forge an axle which is to be turned subsequently to the dimensions given in Fig. 380. It is the practice to make the forging $\frac{1}{8}$ in. larger every way. From a bar of $\frac{7}{8}$ -in. round steel cut off a piece $6\frac{1}{2}$ in. long, heat it in the fire, and after slaking both ends, "upset" it by striking the steel fairly while it is held vertically. The position of the swell is decided by the amount of heated portion left after slaking both ends.

A heat is next taken on a $\frac{3}{4}$ -in. square bar, which is bent and cut off to form the collar; it is placed on the axle, and with a sharp blow

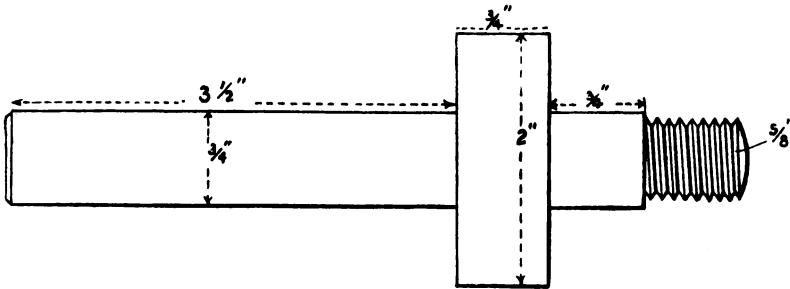

FIG. 380.—Forged axle.

secured in place. Reheat and weld with rapid blows, the collar resting in the bottom swage. The next step is to use the top swage and flattener, the weight of the hammer blows increasing as the steel gets cooler.

To facilitate flattening the collar, a hole is provided either in the anvil or swage block, into which the axle is quickly put. The flattening tool is made with one hollow side, which is brought close up to the axle (Fig. 380A, Anvil Tools). The work is then trimmed and cut off, say, $6\frac{1}{4}$ in. long.

In this, as in all welded steel work, the metal has to be well "soaked," that is, thoroughly heated, so that the collar unites with the axle to form one complete mass. In mild steel especially, great care has to be taken not to heat the work too much, and to give light blows at first when welding, otherwise the metal loses its power of cohesion, and crumbles under the hammer.

Hardening and Tempering of Steel.—A piece of steel is "hardened" by heating it to a cherry red, and then quickly slaking it. This, however, leaves the steel too brittle for ordinary purposes, and in order to give it the necessary strength, it requires to be "let down" or slightly

softened, which consists of reheating to a much lower temperature, and then cooling as before.

In the case of a chisel the edge is heated to a cherry red for a considerable length, and then dipped about 1 in. in cold water. If the hardened part is now roughly polished, say, with a piece of broken grindstone, a film of oxide will form on the polished surface. As the heat is gradually transmitted from the unslaked portion of the chisel to the cutting edge this film will change in colour. First a pale yellow will be observed, then brown yellow, yellow with purple spots, purple, dark blue, and finally black (the first colour corresponding with the hardest temper). As soon as the dark purple reaches the cutting edge the chisel should be at once dipped in water, to cool it throughout, which completes the tempering.

The tempering colour for metal turning tools is a dark straw yellow,

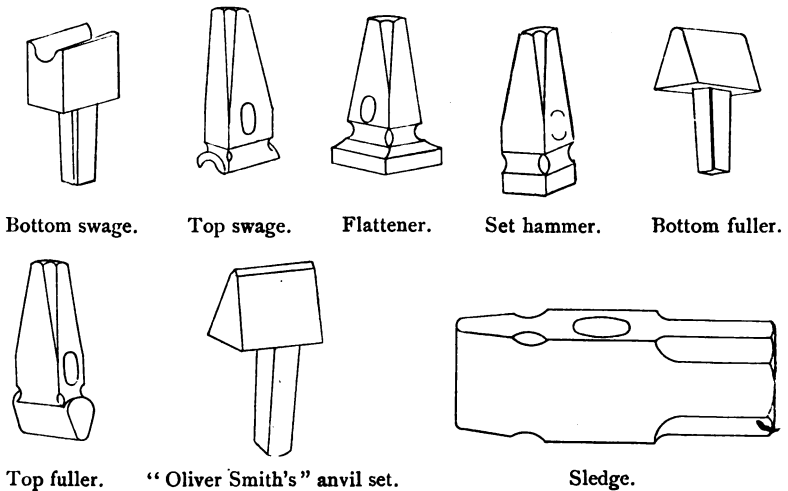

FIG. 380A.—Tools used at anvil.

approximating brown, corresponding to 470° to 490° F. For chipping chisels and other percussive tools it is a brown yellow, representing about 500° F.; and for springs and saws, purple and dark blue, indicating a temperature of 550° to 600° F.

Casehardening.—Casehardening consists of heating wrought iron in contact with carbonaceous substances, as yellow prussiate of potash, bone dust, horn-shavings, etc., and then quenching it in water. This process converts the surface of the iron into steel, and is often employed in the hardening of dies and other working parts of machines.

Punching.—Holes may be made in hot iron or steel bars by driving a steel punch through them. The bars to be punched are made as hot as is practicable without burning the edges or surface of the work. The smith's punch is a little taper, so that it may easily be withdrawn

from the hole after punching. Cold work is differently treated; the punches are slightly taper, but in an opposite direction to those used on hot work. The largest diameter is at the extremity, the result being that a hole punched in this way is parallel, and the punch itself, by cutting on its end face, is used without wedging, owing to the clearance given at the back of the cutting edge.

Drifting.—Drifts are tools used to enlarge holes which have previously been punched or made by drilling, or by "coring" as is frequently the case in castings of malleable iron and mild steel.

Drifts.—The smith's drift for hot work is much similar to the punch he uses, *i.e.* smaller at the entering end, and here again the taper is in a converse position in drifts used in making holes to a larger diameter (except the fitter's serrated drift, which is provided with a series of cutting edges at a regular distance apart, each cutting edge being a little in excess of the preceding one).

Boiler-maker's Drifts.—When boiler plates which have been punched are put together, the holes are not always in alignment; a drift is then hammered through the holes until the rivet can be passed through. This practice, however, is not good, and drilled plates are used in boiler work to obviate the use of drifts in this particular.

"*Soaking*" signifies thoroughly heating, and is a term used more especially in heating heavy forgings. To do this effectually the forger carefully regulates the amount of air passing to the fire, until the mass is heated generally. To allow a full blast of air, the temperature of the fire would quickly increase, and would be sufficient to burn the exterior of the iron before the interior could be hot enough to be worked. This exterior burning happens to some extent when the "heat" is about ready to be withdrawn. It will thus be seen that experience is very necessary for the forger to give him correct judgment as to when a huge mass, or even one of smaller dimensions, has been thoroughly "soaked" with a minimum amount of burning.

Welding heat.—This for wrought iron is indicated by the fizzing sparks given off, and by the white appearance of the iron when withdrawn from the fire. Mild steel welds at a less intense heat than does wrought iron, and therefore needs more care in heating. Tool steel soon becomes plastic, and loses its properties if once heated. For these reasons it is seldom welded; scarcely ever is it welded to another piece of similar steel. The higher the grade of steel the greater the difficulty. This steel is spoilt for the manufacture of cutting instruments if overheated. Steel of a lower grade, as shear steel, double shear, etc., may be satisfactorily welded to good wrought iron for facing purposes, such as hammers, and similar tools. This is owing to the fact that it possesses less carbon.

Forms of Welds.—*Welding* (Fig. 381).—Welding is the joining together of two pieces of iron or steel when at a high temperature. There are two distinct ways of doing the work—(1) by heating the parts to be welded in a coal, coke, or other fire, and afterwards hammering them together while in a plastic condition; (2) by electric welding process.

The latter is not a general practice, but by it joints may be united

in very awkward places, in some of which the former method would be altogether impracticable. Besides this, electric welding is successfully carried out on works that are far advanced in construction; the unions thus made are perfectly sound and thorough. The parts to be joined are brought closely together and heated and joined or welded so quickly as to leave no time for oxide to form.

The former process requires care and experience to make reliable welds. The following points should be observed: A clean fire is essential. Coke free from sulphur—preferably those which are first “floated.” No. 1 “Breeze” is considered good. Good iron or steel are necessary to get satisfactory results. Impure iron will not weld, and is therefore outside consideration for the purpose. The pieces to be united are both “upset” and scarfed; this spreading is to obtain an

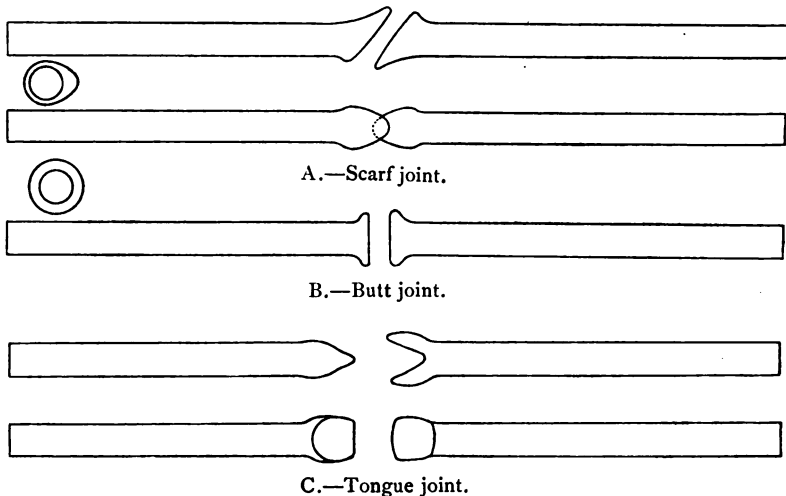

FIG. 381A, B, C.—Forms of welds.

enlargement at the joint, which is afterwards hammered down to the dimensions at other parts of the bar. (There is always a wasting away of the iron, and unless well upset, a reduction would be noticed when the weld was finished.)

The smith bends the surface outwards to ensure the joint being internally sound (see forms of welds, Fig. 381A). It is obvious when the rounded faces touch first a sure contact is obtained by hammering the outer edges down as the work is rotated, thus any impurities, together with the air, are driven out. Very much, however, depends upon the temperature at which the pieces are heated to, and to the length of time they remain in the fire at that temperature. It is most important to heat both pieces alike by allowing them to reach welding heat at the same time, and withdrawing them instantly. In heavy work two fires are employed to enable the smith to do this.

Scale or oxide must be quickly brushed or knocked off, and the joint made in the least possible time. In heavy bars the faces to be joined are brushed with a wire brush immediately before contact is made. Should any scale remain on the jointed surfaces, the weld at those parts will be insecure.

There is no indication of unsoundness by the outside appearance, nor can a faulty weld always be detected by the sound when the forging is struck a sharp blow; it is not until the outer surface has been tooled that defects should be searched for, but then a sharp blow near the joint should be given, and if defective, by appearance or otherwise, repeated blows will eventually open out the defect.

A "butt" weld is formed by first upsetting the two ends and welding without scarfing, as in Fig. 381B, D. This form of weld is adopted when a shaft needs to be lengthened but a little, or in the case of joining flat bars at a right angle, *i.e.* where the weld is made at a considerable distance from both ends of a bar. Another welded joint is the tongue weld, represented in Fig. 381C. It is important to notice that the wedge goes to the root of the split to ensure a sound weld.

Nut and Bolt Machinery (Forge).—

Nuts and bolts are made in both iron and mild steel, and for the trade special machinery is employed. Where, however, it is the practice for an engineering firm to make their own forgings throughout, then nuts and bolts are made by "Oliver" smiths.

An "Oliver" is a hammer with an iron shaft, which is hinged, and suspended over the anvil by a spring. The smith works without an assistant, which makes it impossible for large bolts and nuts to be made in this way; but small bolts and nuts are quickly produced, and the quality of the work is of the highest class. All the tools are made to fit the anvil, so that there is no holding required. The suspended hammer is worked by the foot.

Where large quantities are made by machinery the iron is heated in a special furnace, which in some cases is fed automatically by a thin stream of oil, which has the advantage of keeping the temperature of the furnace uniform, and at the same time is perfectly clean and compact, there being neither chimney nor flues for the smoke or fumes necessary. Several bars or rods are heated simultaneously, and when the bolt-making machines are worked to their full capacity, the output is enormous. The machines are simple and effective. The punches are so made as to leave but a small punching. The burr being forced into the body of the nut, the iron is thereby compressed, and the nut reliably sound.

The bolt-forging machine has a rising and falling motion; the bolt,

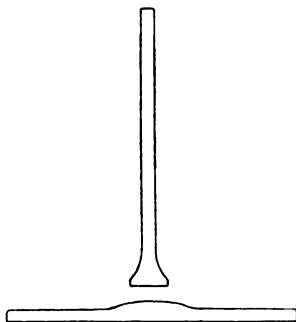

FIG. 381D.—Pump joint prepared for welding.

a rod of suitable length, is inserted, and the machine presses it roughly into the shape of a bolt by one stroke, and the second operation finishes it. By this arrangement several tons of bolts are forged in a week by a man and boy.

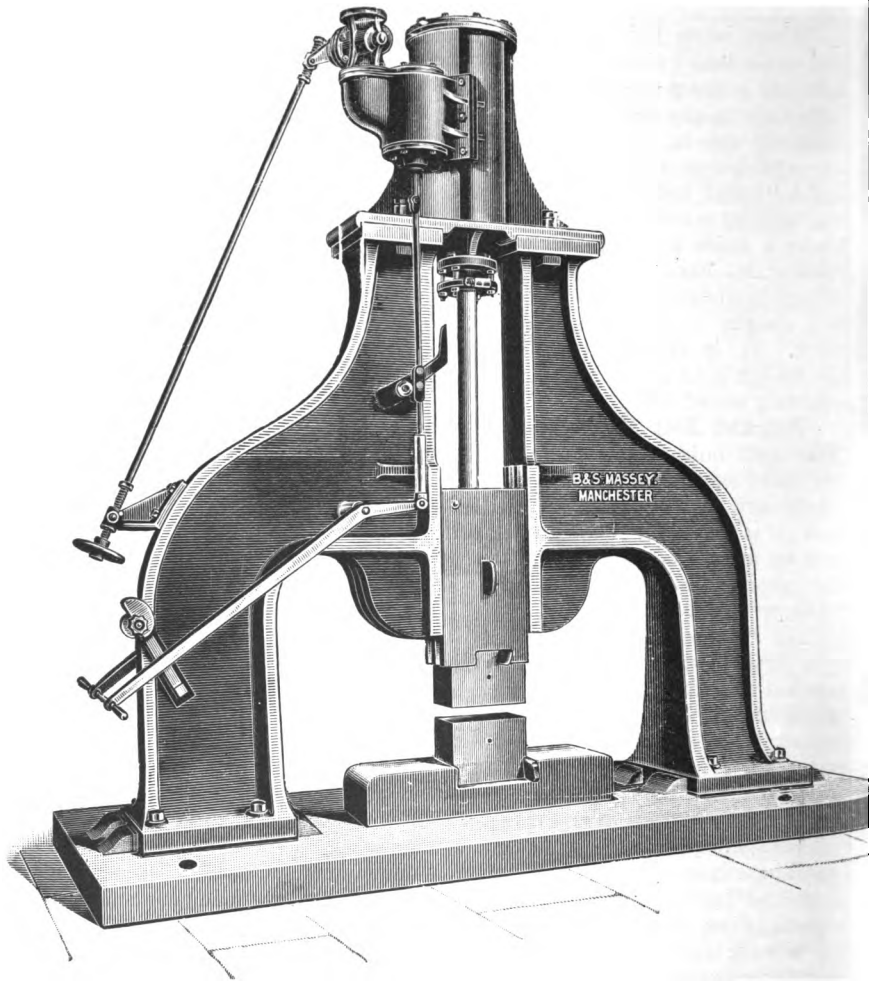

FIG. 382.—Steam hammer (30 cwt.).

Mushroom-headed bolts have a thin fin or flash left as they proceed from the dies; this, however, is quickly removed by holding them against a serrated disc of steel, which revolves at a very high speed.

Forging Hammer.—Fig. 382 illustrates a steam hammer of 30 cwt. size, the representative type for general and locomotive work. The

Longest stroke is 39 in.; the space between the arch of the standards, 8 ft. 1 in.; diameter of cylinder, 17 in. These hammers are in constant use in iron and steel works where large masses of metal can be hammered direct from the furnace, as in shingling, or huge lumps forged into shape without the standards in any way obstructing the progress. In this, as in the other types, the anvil block passes through the base plate on to a foundation, as illustrated in Fig. 383. Massey's patent valve gear is fitted for single and double acting, thus rendering the hammer under perfect control at any point on its way up to give a light or heavy blow.

Steam Hammers.—The energy of the blow of a hammer is expressed in foot-pounds, and may be ascertained by the following formula:—

a = area of piston in square inches.

p = average pressure of steam on piston during downward stroke in pounds per square inch.

S = stroke of piston in feet.

w = falling weight in pounds.

E = energy of blow after full stroke and before striking in foot-pounds.

$$E = (ap + w) S$$

The velocity of the tup the instant before striking may be calculated by the following formula:—

P = total pressure on piston = pa .

F = total force causing downward acceleration = $P + w = pa + w$.

g = acceleration due to gravity = 32.2 .

v = velocity after full stroke and before striking in feet per second.

$$V^2 = \frac{2FgS}{w}$$

The question is sometimes asked, "What weight of blow does the hammer strike?" The force of a blow cannot be stated in terms of weight, because the pressure of a weight is continuous, whereas the force of a blow is expended in a moment. It has, however, been ascertained by careful experiments that the maximum blow of a 5 cwt. double-acting steam hammer, with moderate steam pressure, produces a crushing effect upon a piece of hot iron as great as that produced by a load of about 30 tons. A $\frac{1}{2}$ -cwt. double-acting steam hammer, with moderate steam pressure, produces a crushing effect equal to that produced by a load of about $2\frac{1}{2}$ tons.

In old-fashioned single-acting steam hammers the steam could only act on the under side of the piston, the tup falling merely by its own weight.

In double-acting steam hammers the steam is also allowed to press on the top of the piston during the fall, to increase its speed. This, of course, enables many more blows to be struck in a given time and more work done at one heat.

When fixing steam hammers it is important to have them securely bedded on good foundations. By referring to Fig. 383 it will be observed that three or four courses of brick are first laid, next a bed of

stone or concrete, and above this pitchpine is laid plankwise. The anvil block passes through the base plate, and rests on this. The base plate securing the standards is also supported on pitchpine blocks ; by thus cushioning the hammer the vibration is considerably reduced.

Combined Valve Gear.—Combined self-acting and hand-worked valve gear is shown in Fig. 384. By the use of this arrangement the hammer works automatically, strikes lightly or heavily, quickly or slowly, with long or short strokes as desired, the change being made instantaneously without stopping the hammer. Dead blows can also be given by hand at any moment without adjustment of the gear. When work requires to be bent, it may be firmly held between the pallets.

The letters refer to the more important working parts.

D is a piston valve.

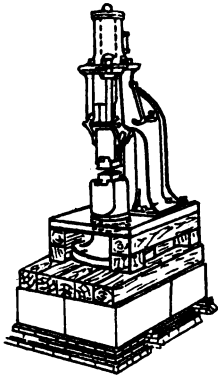

FIG. 383.—Method of fixing steam hammer.

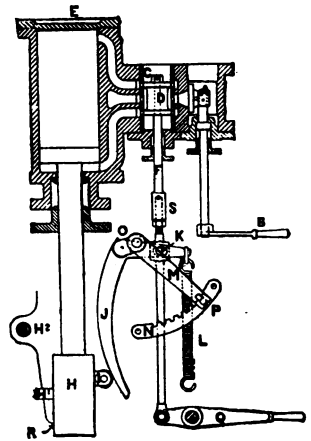

FIG. 384.—Combined valve gear.

F is a piston-valve spindle. This should be kept fairly well screwed up, otherwise the hammer will work irregularly.

L is a spiral spring. This should be kept tight enough to hold the curved lever J always in contact with the roller I, but not tighter than it is necessary to do this.

N = position for short strokes.

P = position for long strokes.

O = hand-working lever, not used when hammer is working self-acting ; but when a dead blow is required this lever is pressed downwards.

There is a screw adjustment, S, in valve-spindle F which must be adjusted till the piston makes a full stroke without striking the cylinder cover E, with lever M in position P, and full pressure of steam from the boiler.

Hand Valve Gear.—In the hand-worked valve gear (Fig. 385) the hand lever requires to be worked for each stroke, while a tripper lever automatically cuts off the steam from below the piston, thus making

it almost impossible for the piston to strike the cylinder cover. The admission of steam below the piston is regulated by a cam adjustment. The valve spindle is furnished with a spring socket to reduce the shock felt by the hammerman when the tup strikes the tripper lever.

D = the piston valve.

FF = screw adjustment in piston-valve spindle.

S = hand-working lever. This lever controls piston-valve D; when it is raised, the tup rises; when it is lowered, the tup falls.

W is the tripper lever. When the tup strikes this lever it turns off the steam from underneath the piston so as to check the rise of the tup.

If lever S be moved too suddenly the piston might strike the cylinder cover; but means for preventing this are provided (see VV).

VV is the cam for regulating steam admission below the piston. This cam may be turned into any position so as to limit the upward travel of

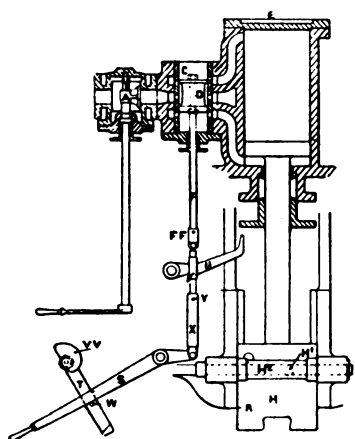

FIG. 385.—Hand-worked valve gear.

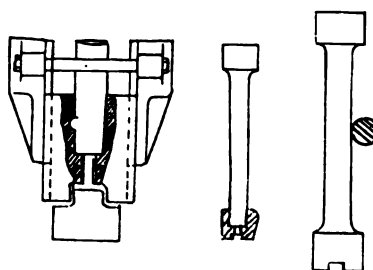

FIG. 386.—Steam hammer tups.

the lever S to any required extent and prevent admission of too much steam below the piston. It is the practice when first starting the hammer to set the cam in its lowest position, and then gradually turn it round until the best working position is found.

W is the pin for making the hammer single-acting. When this is allowed to limit the downward movement of the lever S no steam is admitted to the top of the piston, therefore the hammer works single-acting.

X is a spring socket previously referred to.

Sometimes in starting the hammer the piston valve sticks fast, and has to be forcibly moved up and down a few times before it works freely. In this case it is necessary to put a small pin into the hole V in order to pull the valve down by means of lever S.

Tups.—The tups of steam hammers are made of mild steel or hammered scrap iron. When it is necessary to loosen the trip from the piston rod the front stay H² (Fig. 386) is removed, and the tup-pin H¹

is driven out ; then by inserting a steel punch, Z, a heavy dead blow is given.

The tups are of two kinds ; for small hammers they are usually made separate from the piston. Hammers over 12 cwt. size are supplied with tups forged solid with the piston rod. In the latter case the cylinder stuffing boxes are necessarily made loose and in halves.

Smithwork.—The value of a steam hammer is greatly increased by the addition of useful tools suited to it, for cutting off, necking down, swaging, etc., some of which are illustrated below (Fig. 387).

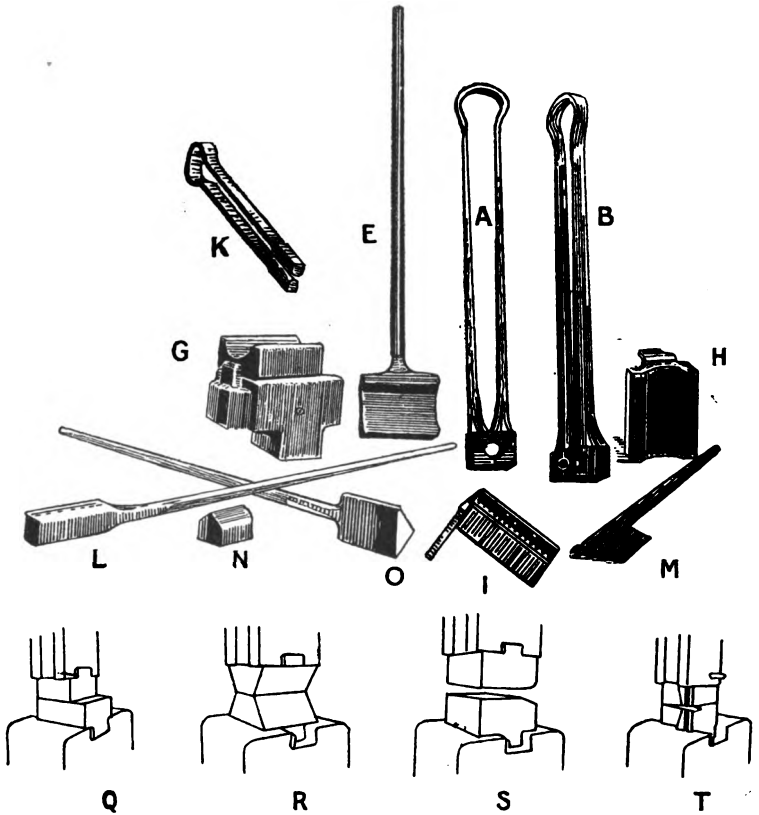

FIG. 387.—Tools used at steam hammer.

AB are plain spring swages used in reducing round iron or steel.

EF are single top swages.

GHI are single-bottom swages.

J = special anvil pallet for single-bottom swages.

K = spring necking-tools used when locating the amount and distance the swaging is to be done along a shaft of iron or steel.

L = a flattening tool or "nobbler."

M = hot cutter or knives.

N = cold cutters.

O = vee tools for shouldering.

P = round necking tools.

Q = scarfing pallets.

R = drawing pallets.

S = hammer-making pallets.

T = file-making pallets.

The hammer shown in Fig. 388 is a 1 cwt. size, in general use for light smithing. In this type, with overhanging slides, there is room for long bars to be placed between the standards.

Steam Stamp.—Another form is shown in Fig. 389, in which the tup is guided by round adjustable pillars. This hammer is used for stamping. The illustration represents a 10-cwt. size with a massive base block, on the top of which the lower die may be secured and adjusted by the bolster screws. The piston has a stroke of 30 in., and has at the top a spring buffer arrangement to prevent it striking the cylinder cover, as the piston returns to the top of stroke directly hand lever is released. Provision is, however, made for regulating the force of the blow, and the speed at which the tup rises off the work after the blow has been given.

Stamping Dies.—Ordinary dies may be fixed somewhat similarly to the fixing of a bolster in a punching machine. For ordinary methods see A and B, Fig. 390. Special methods of fixing dies for exceptional cases are shown at C, D, E, F and G. The dies should be so placed in the stamp that the centre of pressure upon the forging shall be as nearly as possible on the vertical centre line of the tup. This greatly relieves the strain upon the slides or piston rod of the stamp. A blast pipe is used to blow the scale out of the bottom die.

It is customary in using steam hammers and steam stamps to drain all the water from the steam pipes, so as to supply dry steam to the cylinder.

Player's Patent Pneumatic Hammer.—The hammer shown in Fig. 391 is driven by belt. The driving pulley is fixed to a steel shaft which works a "banjo" (better known as "cross slide") by means of a slipper block, which causes the banjo attached to the cylinder to vibrate in a vertical direction. Inside the cylinder there is a piston which is kept air-tight in the usual way. The "tup" fixed to the piston rod carries the hammer which gives the blow. When the hammer is started the piston rises in the cylinder to its highest position, then, by means of a valve attached to the back of the cylinder, the tup can be gradually brought down with at first light blows, then heavier blows, as required according to the will of the operator, and is controlled by a foot or hand lever according to the size of the hammer.

The variation of the blow is caused as follows: Supposing the piston to be at its highest position, on pressing the treadle down or altering the

handle, as the case may be, the air is allowed to escape from underneath the piston, and as it is being drawn in both above and below the piston by the shifting valves, seen in front of the cylinder, it can be readily understood that by alteration of the controlling valve at the back of the

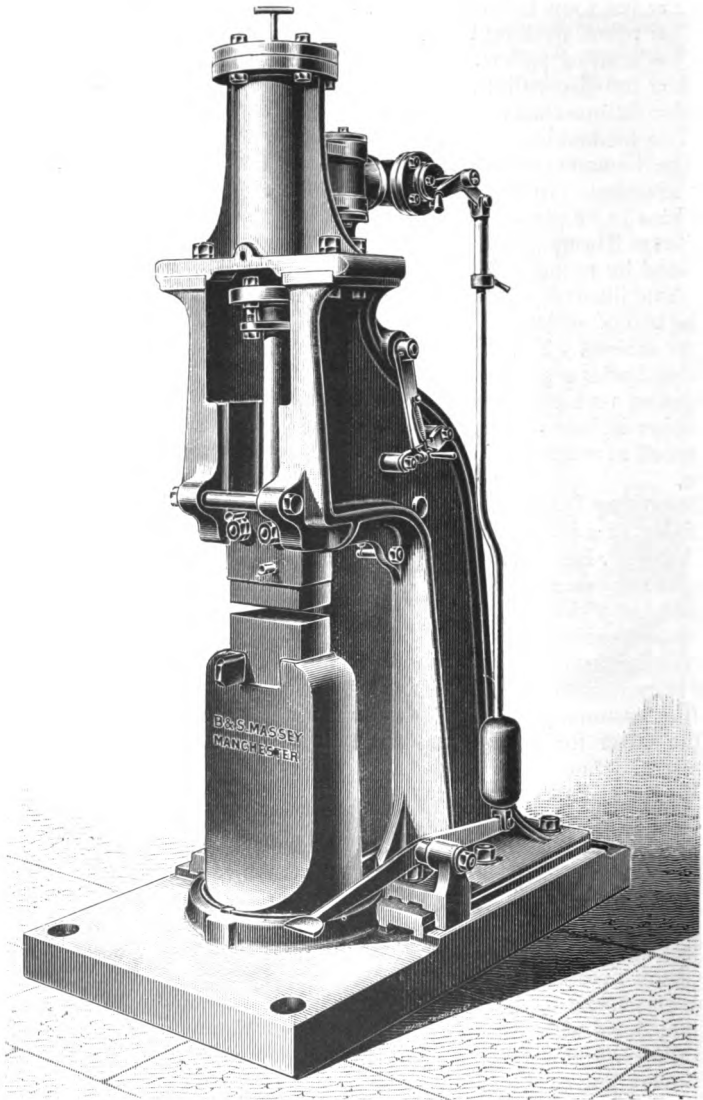

FIG. 388.—Steam hammer (1 cwt.).

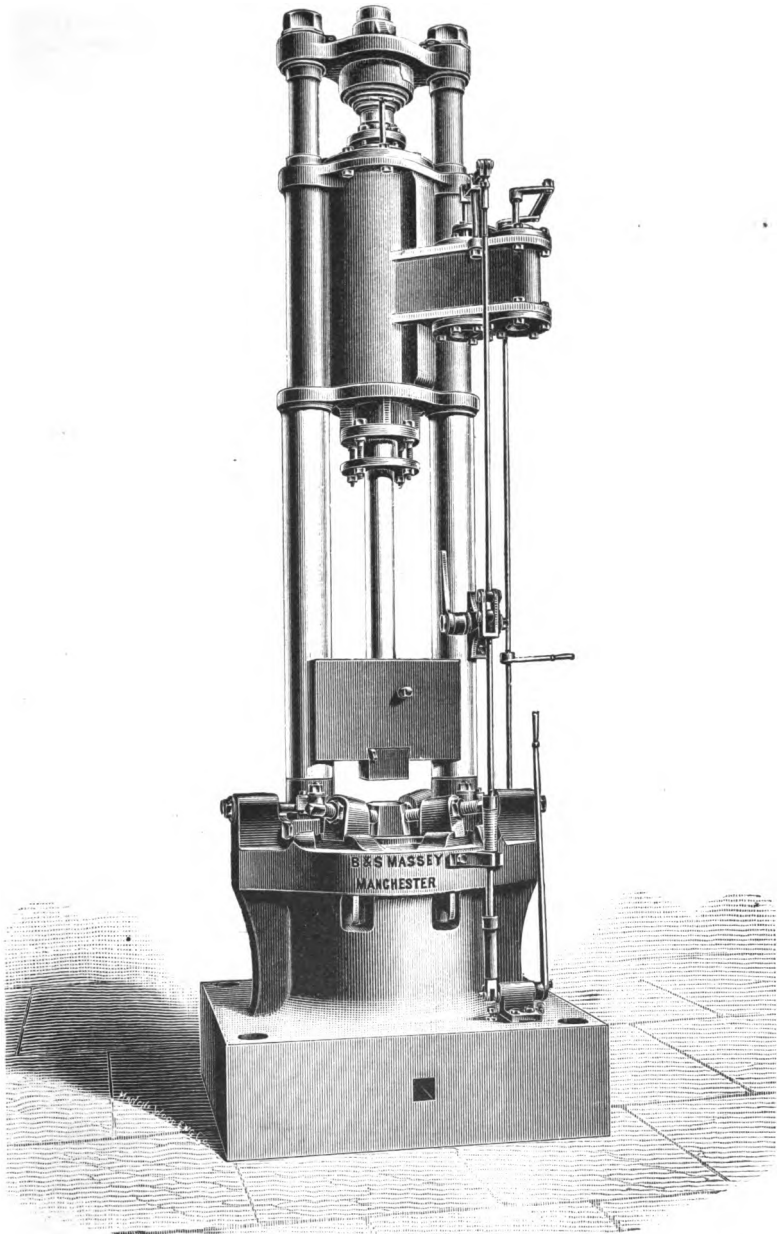

FIG. 389.—Steam hammer (10 cwt.).

cylinder an instant alteration of the position of the piston in the cylinder is obtained. On releasing the foot or hand lever the cylinder draws in air below the piston, and forces the piston again to its highest position.

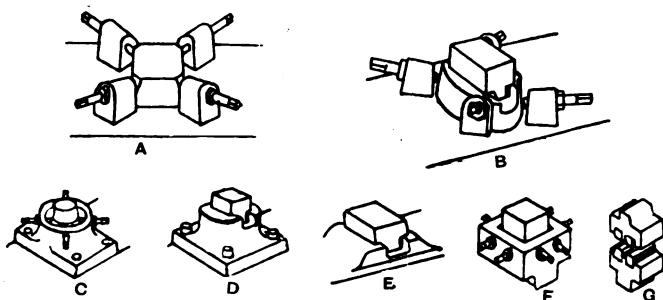

FIG. 390.—Stamping dies.

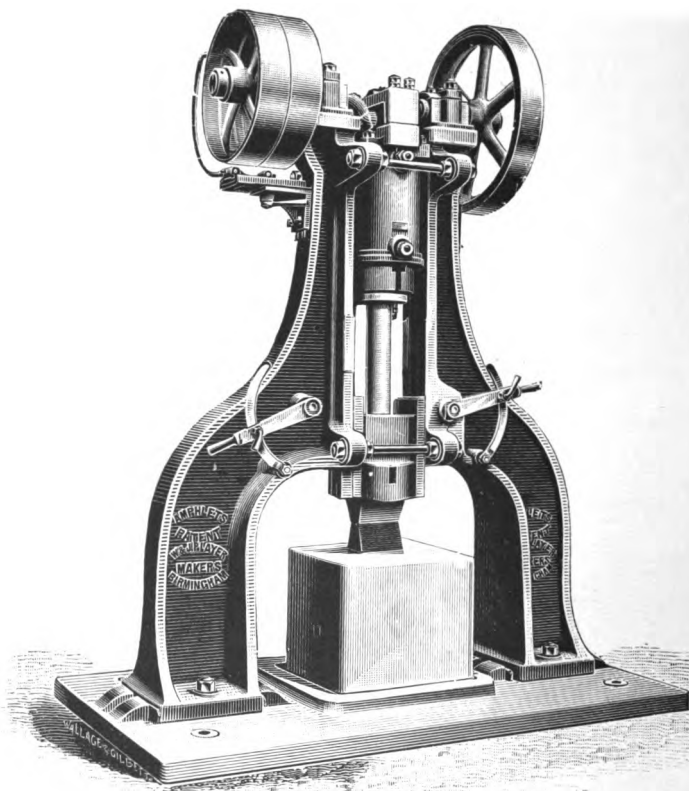

FIG. 391.—Pneumatic belt-driver hammer.

While the hammer is running, the piston is cushioning up and down in the cylinder ready to give an instantaneous blow.

The $\frac{3}{4}$ cwt. hammer (Fig. 392) gives 350 blows per minute, and the 7 cwt. hammer runs at 150 to 200 blows per minute. The brake, worked by hand lever, is used for stopping the hammer at any point of the stroke whilst running.

Pneumatic Tools.—

The "Boyer" riveter is used for riveting shell plates with rivets up to $1\frac{1}{2}$ in. diameter. The riveting hammer is mounted, and has a travel of $3\frac{7}{8}$ in. in an outer cylinder, to which air is admitted when the hammer trigger is depressed. The pressure, acting on a collar surrounding the hammer barrel, shoots the tool forward on to the rivet head, the notched bar at the other end of the rigging being adjusted to provide the reaction necessary for the snap to be continuously pressed on to the rivet, while the percussive riveting action is performed by the hammer.

The hammer with its casing is mounted in a spherical bearing which enables it to be turned about through any desired angle within the requisite limits. In a more recent type the air is admitted through a throttle valve.

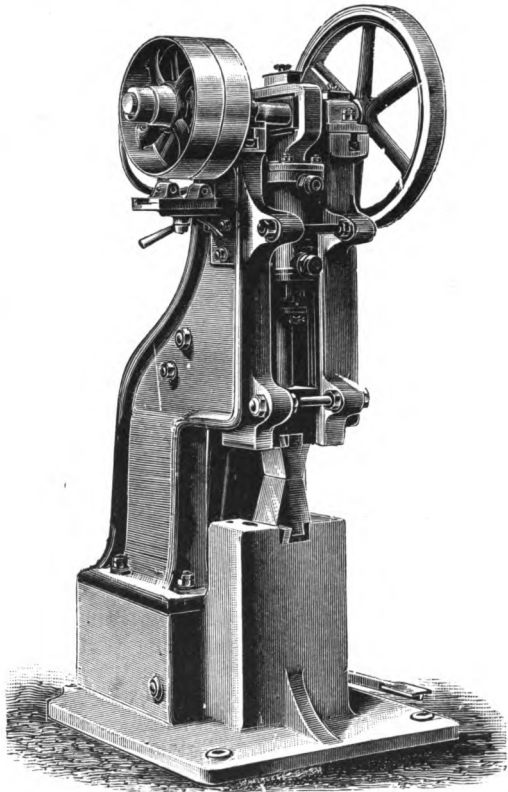

FIG. 392.—Pneumatic belt-driven hammer.

CHAPTER XVII.

HYDRAULIC MACHINE TOOLS AND RIVETING.

Rivets and Riveting.—Rivets are generally used in permanent structures, as built-up girders, bridges, roof-principals, pit-head frames, and so forth. For constructional or boiler-work the rivets are made either of steel or the best wrought iron. Rivets for this class of work are preferable to bolts, as they are hammered home whilst hot, the contraction during cooling tending to bind the plates, or whatever is being riveted, together very rigidly.

Riveting is done by hand or by a machine worked by hydraulic or other power (see Hydraulic Riveting of Various Joints, Fig. 393). Most of the rivets used now are machine made. In the manufacture of these the rod-iron is fed into a forging machine, and whilst hot the required length is cut off. On this length of rod a head of the desired shape is then formed (see Figs. A, B, and C).

In hand-riveting the holes in the plates to be secured together are first brought in line, the hot rivet is passed through, and one workman holds a lever on the head of the rivet on one side of the plates whilst another hammers the protruding portion of the rivet on the opposite side, thus forming the other "head." The most common form of rivet is the "cup-head" shown at A, Fig. 393. The rounded appearance is given it whilst hot by means of a "snap" or die. B C illustrate "conical" and "pan-head" rivets. The diameter of the rivet, of course, depends upon the thickness of the plates through which it passes. A rough rule is to make the rivet diameter twice the thickness of one of the plates, a better one is $D = T \frac{5}{8} + \frac{3}{8}$ in., where D represents diameter of rivet and T the thickness of plate. The "snap," as it is sometimes termed, or the length of the rivet required to form the head after it is in position, is generally taken as $1\frac{1}{4}$ times the diameter.

In cases where the projection of rivet heads would be objectionable, as one girder resting upon another, the practice is to countersink the rivets; this will be understood from a glance at C, Fig. 393. The outside plate of the girder is countersunk about two-thirds of its thickness, and the rivet hammered down till flush with the plate. The allowance for "snap" in the countersunk rivet is from $\frac{3}{4}$ D to D, D representing rivet diameter.

Rivet holes are either punched or drilled. For the better class of work, however, as boilers, drilling is much to be preferred. Punching, it was found, had a serious effect on the plates, especially if these were

of second-class quality. This, to some extent, was remedied by the process of "annealing," which consists of heating the plates to redness over a wood fire for some time, which allows the iron to resume its original fibrous condition. Of course, if in being punched the plates

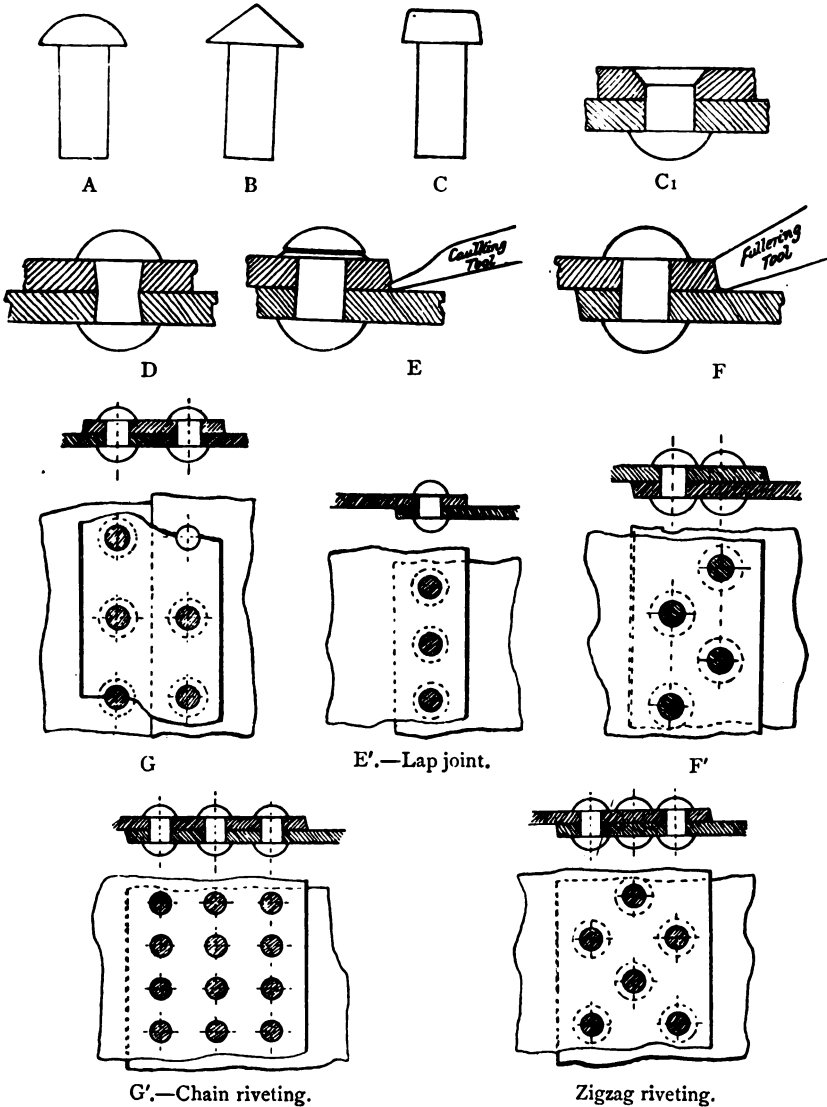

FIG. 393.—Rivets and riveting.

cracked, say across the line of holes, annealing was of no avail. Another method resorted to with punched plates is to reamer the holes about $\frac{3}{16}$ in. larger. Where drills are employed, the holes are more accurately spaced, necessitating less labour in drifting; but if the plates have to pass through the bending rolls the burrs left by the drills must first be removed, which is unnecessary with punched plates. In good boilerwork it is customary to bend the plates first and drill them when in position, which provides against the holes being out of truth with each other. Drilling holes is rather more expensive than punching, but where multiple drills are employed the difference in cost is little.

Whilst discussing the merits of punching and drilling, we might draw the reader's attention to a detail in connection with punching. Owing to the fact that the hole in the bolster or die is slightly larger than the punch, punched holes are found to be taper. Advantage can be taken of this by placing the plates to be riveted so that the larger diameter of the hole is outside, as shown in D, Fig. 393. When the rivet is hammered in position it acts somewhat to the purpose of a countersunk rivet, the contraction whilst hot binding the plates very securely together, at the same time taking some of the load off the head. In a shearing stress, however, no advantage is gained, as the rivet at the point of shear is only its original diameter.

Caulking and Fullering.—To ensure a steam or air-tight joint after riveting, "caulking" or "fullering" is resorted to. This perhaps will best be understood by a glance at Figs. E, F. The edge of the outside plate at the joint is planed to a slight bevel, and the caulking tool, which resembles a blunt-nosed chisel, hammered against this, at the point shown. The fullering tool is generally the same thickness at the point as the plates. By the application of this tool any space left between the rivet and plate is closed up. Rivet heads are only caulked when they are found to leak.

Forms of Joints.—The simplest and, by the way, weakest form of joint is known as the "single-riveted lap-joint" illustrated at E', Fig. 393. The distance of the rivet holes from the edge of the plate should not be less than the diameter of rivet. The "lap," *i.e.* the amount one plate overlaps the other, is usually a little more than three times this, whilst the pitch may be taken from 2 to $2\frac{1}{4}$ times rivet diameter.

A stiffer joint for boilerwork is the "butt joint" G. Fig. 393 represents this joint with one cover-plate only. In this case the thickness of the cover or strap, to comply with the Board of Trade rule, should be $1\frac{1}{8}$ times the thickness of the boiler plate. If double-cover straps are used, the thickness of *each* of these should equal that of the single strap. A joint may be either single, double, or treble riveted, as will be seen from Figs. E', F', G'. In some cases of girder-work even more rows of rivets may be found necessary. The spacing of the rivets may be either "chain" or "zigzag."

Chain riveting on the whole is stronger than zigzag riveting, but in the latter method, owing to the lap required not being so great, a lighter joint is formed. In zigzag riveting the diagonal pitch should never be less than that for chain riveting; that is, 2 to $2\frac{1}{4}$ times diameter of rivet used.

In any form of joint the rivets should be so pitched that the resistance to shear equals that of the plates to tearing. The student will notice that the transverse, or vertical, seams in a horizontal boiler are generally single riveted, whilst the longitudinal seams are double riveted. This is on account of the stress being much greater on the longitudinal joints than transverse joints.

However well a joint may be secured, it is always found to be weaker than the plate. The strength of the joint compared to that of the solid plate is termed the "efficiency of the joint."

Hydraulic Power.—Water, to all intents and purposes of the engineer, is an inelastic fluid. The molecules of which it is composed are displaced by the slightest force, whether this force consists of the weight of the water itself or the application of an external pressure. This is evident from the ready manner in which water, or any liquid, adapts itself to the shape of any vessel in which it may be contained.

Pascal's Law.—It is owing to the above fact that water possesses the property of transmitting pressure equally in every direction. This is

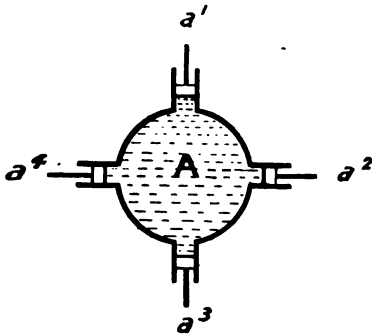

FIG. 394.—Pascal's law (1).

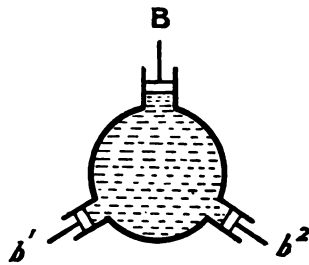

FIG. 395.—Vessel in illustration of Pascal's law (2).

generally known as "Pascal's law." Suppose we take a metal globe A, filled with water and provided with outlets arranged horizontally, as shown in Fig. 394. Let a_1, a_2, a_3, a_4 represent four pistons of equal area, and fitted sufficiently tight as just to overcome the tendency of the water to escape. Now, if we push piston a^1 inwards with a force of, say, 1 lb., pistons a_2, a_3, a_4 will be pushed outwards with just the same force, viz. 1 lb. each. Had we chosen any of the four pistons, exactly the same thing would have occurred, in accordance with the law just enunciated.

Suppose, now, that we take a vessel as in Fig. 395, pistons b^1 and b^2 being each 1 sq. in. in area, and piston B having an area of 2 sq. in. If at piston b^1 , say, a force of 5 lbs. is applied, b^2 will be pushed outwards with a force of 5 lbs., and B with a force of 10 lbs., by virtue of this piston being twice the area of either b^1 or b^2 . Or if we exert a force of 20 lbs. at B, a pressure of 10 lbs. will be exerted on each of the pistons b^1 and b^2 . From this the student will see that the pressure

sustained by the pistons is in direct proportion to their areas. This fact is observed in calculations for safety or relief valves on hydraulic cylinders, air receivers, steam boilers, etc.

Hydraulic Press.—From experiments similar to those we have just alluded to, Pascal realized that if he had water contained in a vessel of small sectional area, and he subjected it to a pressure, this pressure would be magnified in a much larger vessel if the two were placed in communication. Hence he conceived the idea of the hydrostatic, or hydraulic, press.

F, Fig. 396, is a force pump (see diagram) having plunger of small diameter, and supplied with a suction pipe *S*, and delivery pipe *d*. The delivery is placed in connection with the hydraulic cylinder *C*. Non-return valves governing the supply and delivery are shown at *V*₁ and *V*₂. A lever, *l*, is fitted to the pump to increase the purchase when working this. *f* acts as a fulcrum, *R* is the ram, and also serves as the

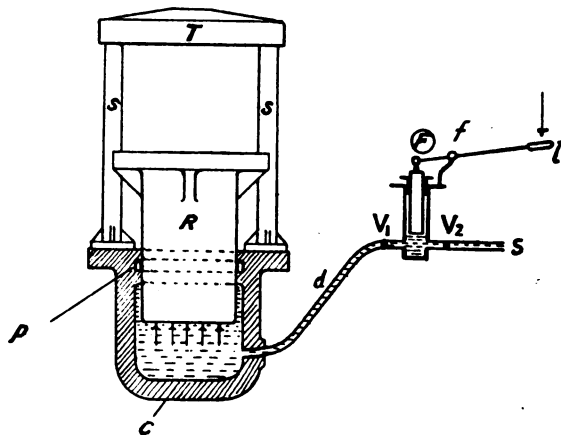

FIG. 396.—Hydraulic press.

bottom plate of the press. The top plate *T* is secured to the standards *ss*, which act as guides for the ram. Suitable means of preventing the escape of water from the cylinder are provided at *p*.

Let us now see what work we can get out of this machine. Suppose, in the press we have briefly described, the pump plunger has an area of 1 sq. in., and that of the ram 60 sq. in. The leverage of the handle is 10 to 1 (that is, the distance from the point where the force is applied to the fulcrum *f* is 10 times the distance from the fulcrum to the centre of the plunger). If we exert a pressure of 40 lbs. at the end of the lever, what will be the total pressure on any object we may place between the top and bottom plates of the press? The factors which increase the force of the machine are: 10, the purchase of the lever; 40 lbs., the force applied at end of lever; and 60 sq. in., the sectional area of ram. Those factors which counterbalance these are: 1 sq. in., the sectional area of plunger; and 1 sq. in., the distance of plunger from fulcrum; and

if we divide the product of these latter into the product of the former we shall obtain the total pressure exerted by the ram.

Thus, $\frac{10 \times 40 \times 60}{1 \times 1} = 24,000$ lbs., and if we assume the efficiency of the press is 0.75 (*i.e.* 25 per cent. of the theoretical work is lost in friction), then the total pressure = $\frac{24,000 \times 3}{4} = 18,000$ lbs.

Head of Water.—The force exerted by a liquid on any surface with which it is in contact is always perpendicular to that surface. In other words, if we have a vessel, of any shape, containing water, the pressure exerted by the water against the surface of the sides or bottom of the vessel will act at right angles to the surface under consideration, so long as the liquid remains at rest. From this it follows that the total pressure on the horizontal base of a tank due to the water it contained would be found by multiplying the area of the base, say in square feet by the depth of the water, also taken in feet, and then the product by 62.5, or the weight of a cubic foot of water in pounds. For example, suppose we have a rectangular tank, 10 ft. long by 5 ft. wide by 4 ft. deep. Required the total pressure on the plates composing the base when the tank contained 3 ft. of water, $10 \times 5 \times 3 \times 62.5 = 9375$ lbs.

Again, in a vertical pipe containing a liquid there is a pressure at its base depending upon the area of this and the height at which the liquid stands. This pressure is technically termed "head;" thus we speak of so many feet head of water, meaning that we have a column of water so many feet, as the circumstances may be, high. It is obvious, then, that the pressure varies directly as the head, *i.e.* a head of 20 ft. will exert twice as much pressure per square inch or square foot as a head of 10 ft.

Accumulator.—The student will now see that if we had water at an elevation which would supply us with a pressure of several hundred pounds per square inch, much useful work could be done by this. As this, however, is impracticable on account of the height to which the reservoir would have to be raised in order to supply us with a suitable water pressure, resource is had to an hydraulic accumulator, which is an arrangement for storing an artificial head of water. For machines requiring an intermittent supply of hydraulic power, as lifts, presses, cranes, riveters, etc., which one moment may require full pressure, and the next be standing idle perhaps, the accumulator is especially adapted.

Fig. 397 illustrates, in elevation, a short-stroke accumulator of the "inverted" type; *i.e.* instead of the ram which carries the load being forced out of the hydraulic cylinder, as is customary, the reverse obtains, *viz.* the ram remains stationary, and the cylinder with the stuffing box is made to slide over it. The diagram will make this clear to the student.

a is the cylinder provided with gland *b*, *c* is the ram which has a hole bored down the centre for admitting the water under pressure to the cylinder. This water, which is supplied by the pump charging the accumulator, passes through the relief valve (see Figs. 397); *d* is the ballast-chamber made up of sheet-iron plates, and attached to the sliding cylinder by means of the bottom plate *e*, and crossbridge *f*. Into this

chamber is placed sand or earth until the necessary load is obtained which will produce the working pressure desired. Here we may observe that to find this we avail ourselves of the principle explained under "Head of Water." Thus, suppose we have a ram 4 in. diameter, and we require a working pressure of 2000 lbs. per square inch to ascertain the weight of ballast we shall have to place in the chamber. Area of 4 in. = 12.5 sq. in. multiplied by 2000 lbs. gives 25,000 lbs., and if we deduct from this the weight of the ballast chamber and hydraulic cylinder, we shall then have the net weight of the material required.

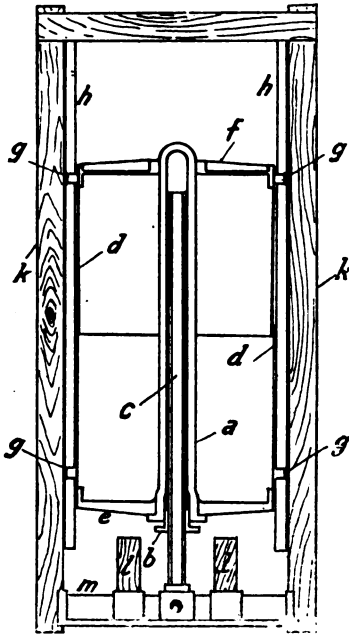

FIG. 397.—Hydraulic accumulator (diagram).

supply from pump by the coupling *b*. The water is forced past valve V_1 to valve V_2 , causing this to lift, and thus entering the accumulator, or if the accumulator is charged into the main for supplying the machines, which is arranged in the chamber just above valve V_2 and at right angles to the inlet to accumulator, as shown at C in Fig. 399 (the student will notice that Fig. 399 represents an end elevation); *l* is a lever turning round the fulcrum *f*, and connected at the other end to the tappet rod of the accumulator; *g* is a guard for keeping this lever in its proper position. If the supply to the hydraulic machines is shut off, as the accumulator approaches the end of its stroke the lever *l* is lifted by means of the tappet rod just referred to. Immediately this

gggg are four brackets which work in the T-iron guide *hh* fastened to the timber framing *kk*; *ll* are blocks of wood for the ballast chamber to rest on when in its lowest position, *m* is a cast-iron base plate supporting the ram, and serving to stiffen the wooden framing.

The action of the accumulator is simple in the extreme. Water is forced by the pump or pumps through the hole in the centre of the ram into the hydraulic cylinder, causing this to lift, at the same time to raise the ballast chamber with it; *n* is a tappet rod communicating with the supply and relief valve, which, as the accumulator nears the end of its stroke, is struck by the tappet *o*, thus governing the admission of water from the pump.

Supply and Relief Valve.—The supply and relief valve just alluded to is also worthy of notice, and we here give a sketch of one. The valve is attached to the accumulator at *a* (Fig. 398) and to the

takes place, the valve V_1 , being released of its load, lifts and puts the supply from pump in communication with overflow pipe o . This over-

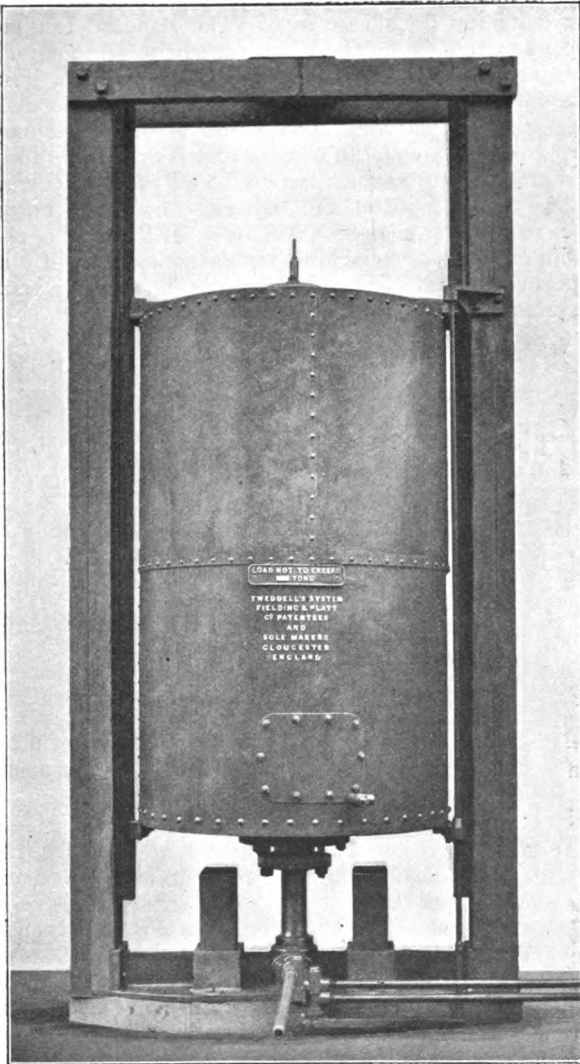

FIG. 397A.—Accumulator.

flow pipe, it will be noticed, is also arranged just above valve V_1 and at right angles to supply from pump, as shown in Fig. 399. m and n are

arrangement for packing. Branch pipes are led from the supply main c to the starting valves on the machines.

The standard working pressure for hydraulic machine tools is 1500 lbs. per square inch, equal to 105 kilog. per square centimetre (approximately), or 0.669 ton per square inch. The standard test pressure is 3500 lbs. per square inch, or 250 kilog. per square centimetre.

When using a pressure of 1500 lbs. per square inch, if we let w represent total pressure required on ram in tons; d , the diameter of ram in inches; and a , the area of ram, also in inches, we may take it that w is approximately equal to $0.5d^2w$, to $0.6695a$, and a to $1.494w$.

At this pressure (1500 lbs.), with a speed of 5 ft. per second, a pipe of $\frac{1}{2}$ -in. internal diameter will transmit 2.67 actual horse-power; a 1-in. pipe, 10.7 H.P.; a $1\frac{1}{4}$ -in. pipe, 16.73 H.P.; and a $1\frac{1}{2}$ -in. pipe, 24 H.P., with only an appreciable loss of efficiency. Or, if a represent area of pipe in inches, $13.63a$ will equal the horse-power transmitted, with a pressure and velocity mentioned above.

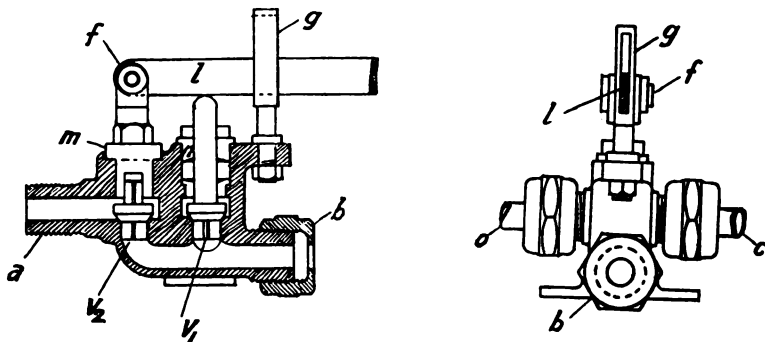

FIGS. 398, 399.—Supply and relief valve.

If D = diameter of ram of hydraulic cylinder in inches, then contents in gallons per foot of cylinder length will approximately be $\frac{D^2}{30}$ or $0.033 D^2$.

Each gallon pumped into the accumulator at 1500 lbs. per square inch represents, very nearly, one horse-power actual. Accumulator efficiency is about 99 per cent.

The Hydraulic Jack.—The hydraulic jack (Fig. 400) consists of a hydraulic cylinder having an upper and lower jaw to suit various work, this cylinder being carried on a stationary ram which forms the lower part of the jack. Water or oil is contained in the upper part of the cylinder, and by the motion of the outside lever, which works the inner plunger, it is forced through first the suction valve and then the delivery valve into the lower part of the cylinder. Pressure is thus exerted on the ram, and so the cylinder, and any load placed upon it, is raised. When required to lower the jack, the screw-down valve shown on the right-hand side of the diagram is released, and the liquid runs back into the upper

reservoir. The power obtained by the jack depends on the leverage and on the ratio of the areas of the plunger and ram.

Hydraulic Machine Tools.—The subject of hydraulic machine tools has now widened to such an extent that it would be almost impossible in a work of this size to explain all the uses to which hydraulic power can be applied in a general engineering workshop. We therefore propose to limit ourselves to those tools used in a boiler shop, and this limitation, though allowing us to include for the most part machines in constant use, excludes many machines of importance which are not so frequently used. Our field will therefore include hydraulic riveters, punching and shearing machines, flanging presses, boiler-plate bending-machines, accumulators, jacks, etc. We may here say that the machines described are those on the Tweddell system by Messrs. Fielding and Platt of Gloucester.

The hydraulic method of operating machines does away with belting and its attendant disadvantages, permitting the machines to be placed in any convenient position in the shop. When a belt-driven machine is too heavily or suddenly loaded, as is often the case in punching or shearing thick plates of steel, either the belt slips or the machine breaks down. When, however, hydraulic power is the medium, the stresses that can be brought to bear on the machine tools are strictly limited by the area of the cylinder and the pressure of the water carried. Thus with a constant pressure, and a machine tool designed to cope with the work it is called upon to do, it is practically impossible for the machine to break down.

Punching and Shearing.—In this type of machine (Fig. 401) it will be noticed that the cylinder is separate from the main body, which is an advantage in case anything breaks down. The cylinder and all working parts being placed at the back are out of the way of the workmen whilst manipulating the plates to be dealt with. No water can drop on the plate or get in the way of the men. An increase of bearing surface to the ram and an automatic tappet gear for economising the water (by adjusting the stroke to suit thicknesses of plates) are improvements. The ram or vertical slide of the machine is actuated by a powerful lever, and in some machines an automatic gear is placed

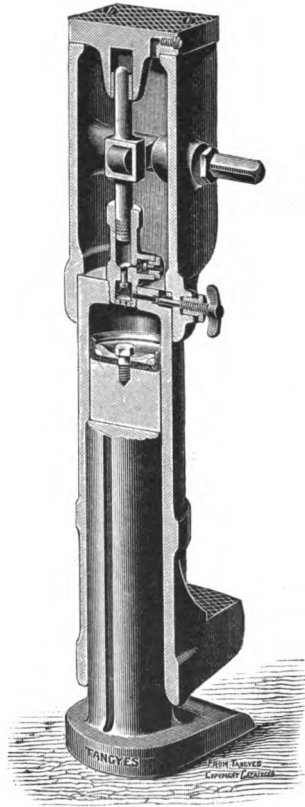

FIG. 400.—Tangye's Hydraulic jack.

which enables it to run continuously at any desired speed. The machines are made with 36-in. and 24-in. gaps, and will punch holes from $\frac{1}{4}$ -in. to $1\frac{1}{2}$ -in. diameter.

Shearing machines are somewhat similar in construction, only that they are made to carry the shear-blades directly in the centre line of the ram.

Punching and shearing machines are made in a combined form if desired, but it is not the general practice. Since two separate cylinders

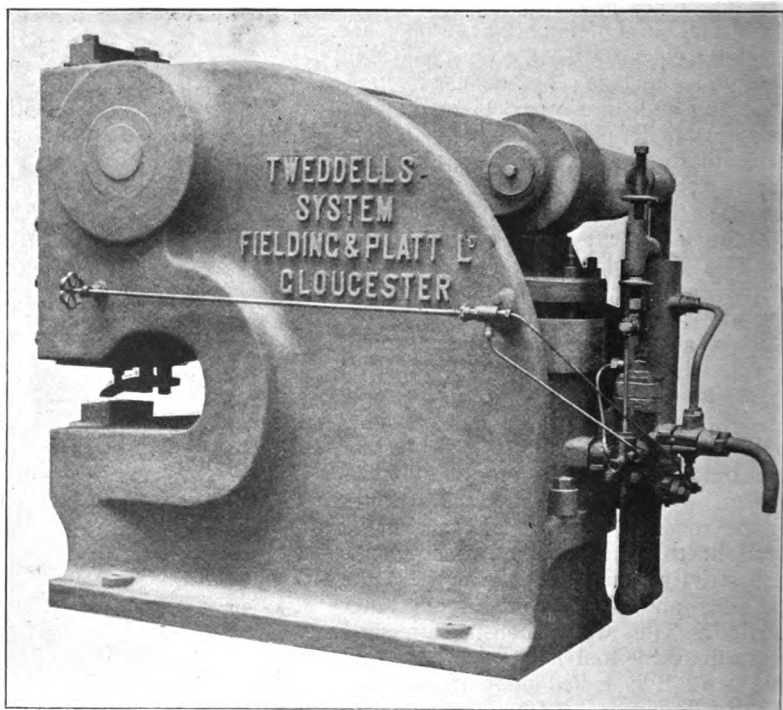

FIG. 401.—Hydraulic punching machine.

are essential, there is no advantage in a duplex machine, while, on the other hand, independent machines can be located where most suitable.

Hydraulic Flanging Press.—Hydraulic machinery is extensively used in flanging plates used in boiler construction. The machine illustrated in Fig. 402 has been designed to do the work step by step, thus following as nearly as possible the hand process. It will be noticed in this machine that there are three hydraulic cylinders, two of which are vertical and one horizontal. The outer vertical ram grips the plate on the segmental block, representing a portion of the circumferential flange, while the inner ram in its descent turns down the plate. After 8 to 9 ft.

of the flanging is thus done, the inner ram is raised out of the way, and the ram of the horizontal cylinder is advanced to square the flange up. Dome ends and furnace mouths may be flanged in the same machine by dies of the usual type. In this case the two vertical rams of the same machine are coupled together by the top block, thus utilizing their combined power (see Fig. 402).

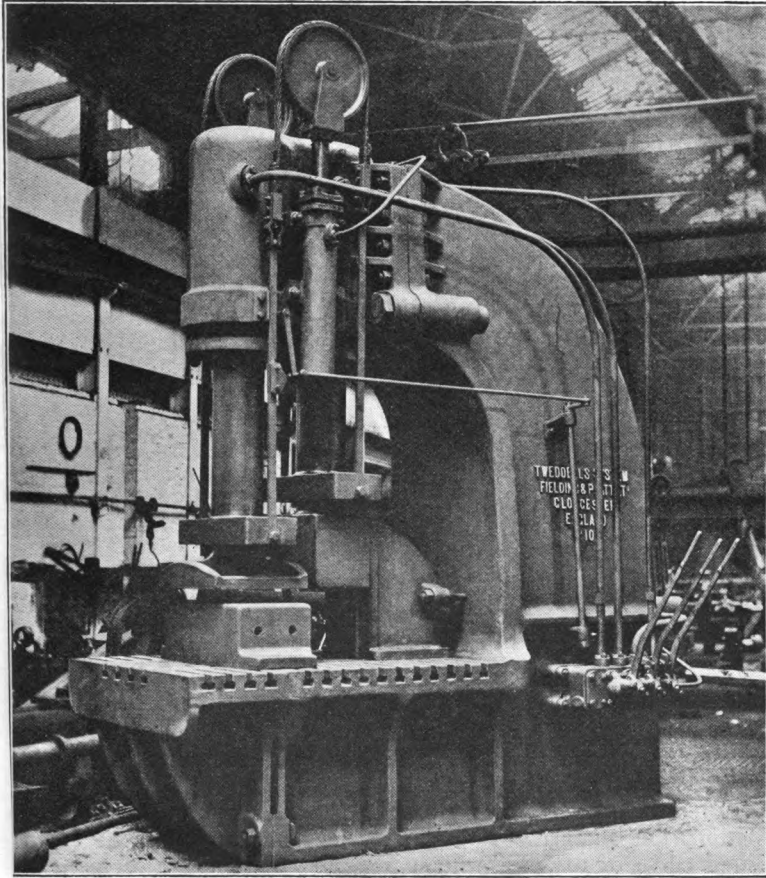

FIG. 402.—Hydraulic flanging press.

These machines will flange the shell-plates instead of the front and back plates when this mode of construction is preferred. They may also be used for flanging furnace flue-rings, for thickening or staving the ends of tubes for tubulous boilers, for stamping and other work.

Hydraulic Boiler Shell-plate Bender.—The machine illustrated in

Fig. 403 is a new type of bender which supersedes the old-fashioned bending rolls, especially for heavy work. It consists of three vertical girders resting upon a strong bed-plate, the two outer ones being bolted securely down and firmly connected together by the tie at the top, the middle one being fastened by a hinged bolt to allow of the removal of plates which have been bent to a complete circle.

The central girder is moved by means of a vertical ram acting upon rollers and inclined planes, forming a perfect parallel motion towards the fixed vertical girder at the right hand. The adjacent faces of these girders are curved, the moving one being concave, whilst the fixed ones are convex. By this arrangement the plate is bent to any desired curve without the need of special dies. The plates, having been placed edge-

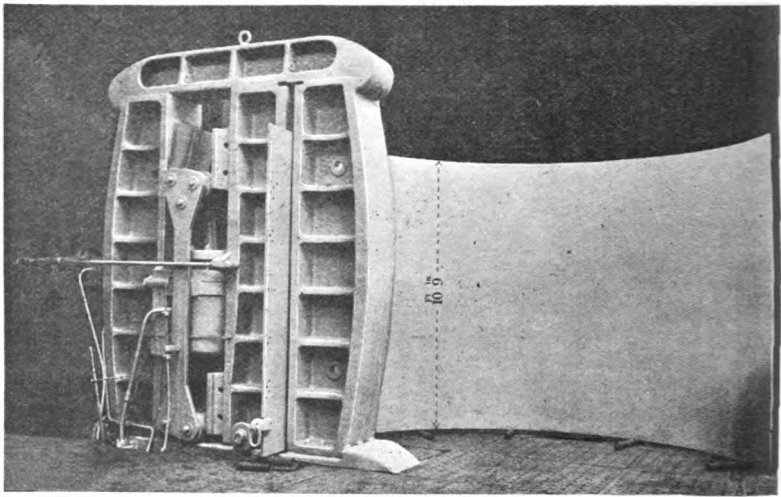

FIG. 403.—Boiler shell-plate bender.

wise up on small rollers on a cast-iron floor, are hauled through the machine in short steps of about 3 in. each by an automatic feed gear at every stroke of the bending girder.

Plates of every thickness are bent by one operation, and by previously adjusting the automatic stop, a plate may be correctly bent to any desired curve or thickness without repeated trials with a templet. A plate $1\frac{5}{8}$ in. thick, 13 ft. wide, can be bent to any desired curve at a rate of from 2 to 3 ft. per minute.

Large Stationary Hydraulic Riveter.—The machine described (Fig. 404) is on the Tweddells system, and is of the “built up” type. The two main castings, A and B, are connected securely together by two main bolts at D, which are of sufficient strength to withs and the stresses produced when closing and forming the rivet. The part A supports the cylinders. The tail cup G for forming the rivet is carried

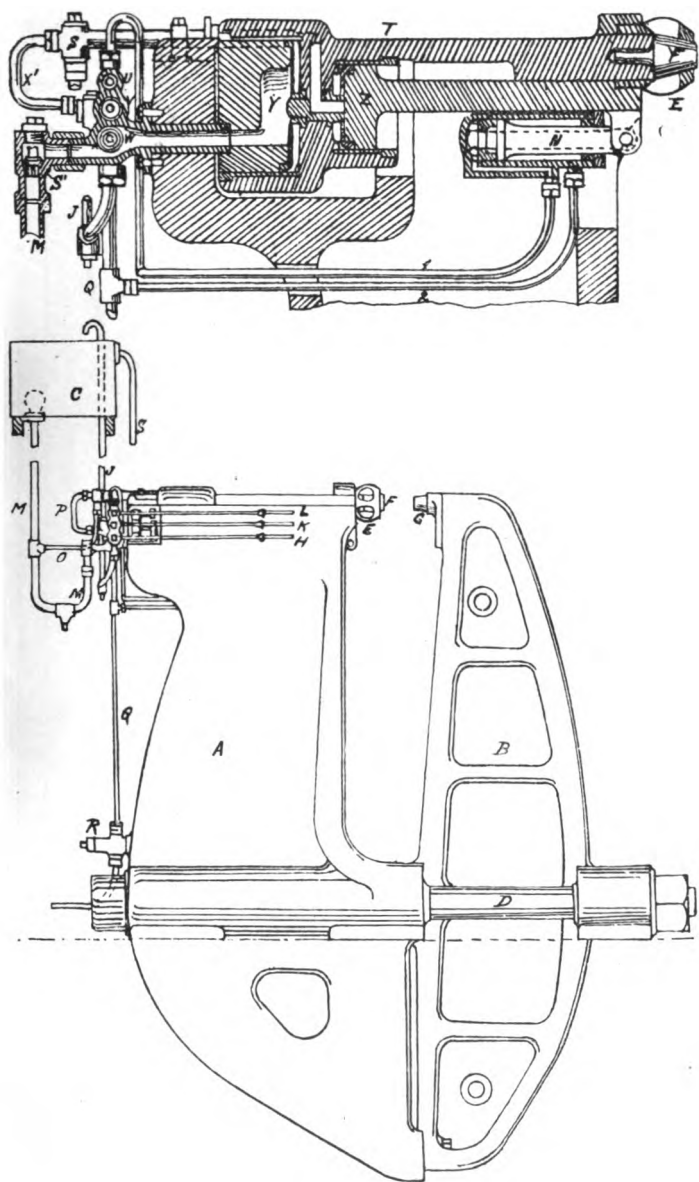

FIG. 404. —Hydraulic riveter (details of arrangement.)

by the part B, the edge of the cup being brought up to the level of the top of the casting, so as to form a "flush top," as it is termed. This is necessary for getting into corners of various pieces of work.

The heading cup is carried by the riveting cylinder T. The cylinder rides upon the fixed ram, Y, and within T is placed the ram Z, which in operating advances the plate-closing tool E. The ram N is of piston form, and is capable of receiving pressure on either face, that is for advance or return.

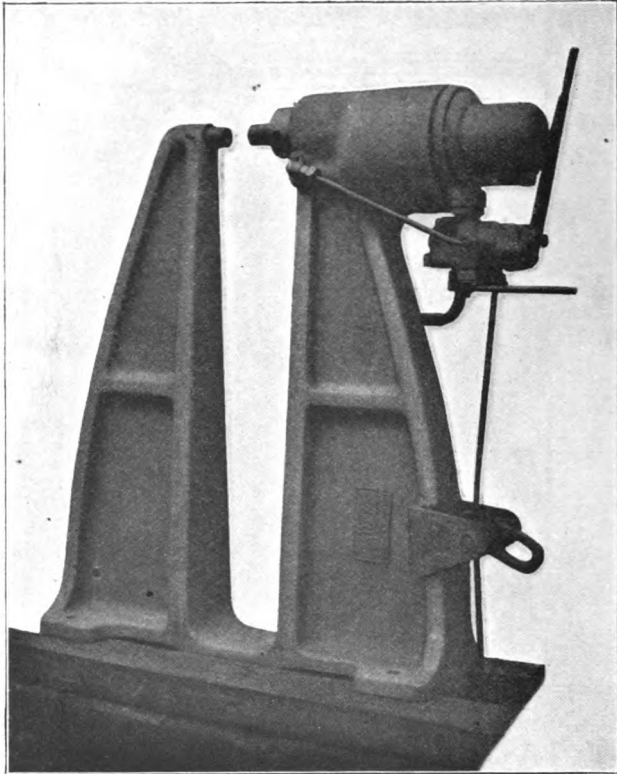

FIG. 405.—Stationary hydraulic riveter.

A tank, C, placed about 20 ft. above the top of the machine, supplies the cylinders at Z and Y with low-pressure water. The pipe M conveys this water to the cylinder Y, and the pipe O is connected to Z. By means of the check valves S and S¹ the water is prevented from returning, except through the exhaust pipe J. The pressure pipe Q, and the exhaust pipe J both communicate with the piston valves U, V, and W. U is connected to the back end of the cylinder N through the

pipe 1. V is connected with the cylinder Z by means of the pipe X', and W with the cylinder Y. 2 is a constant-pressure pipe connecting the pipe Q and the front end of N. A stop valve R is connected to the pipe Q. The action and principle of working of the machine is as follows:—

The boiler seam or other work is first placed in position between the cups F and G. The rivet is heated, and put in from the side G. The valve U is opened to pressure by the lever L, and the ram N is thus caused to advance to the right, due to the difference in area of its faces, the new pressure being applied on the left. This

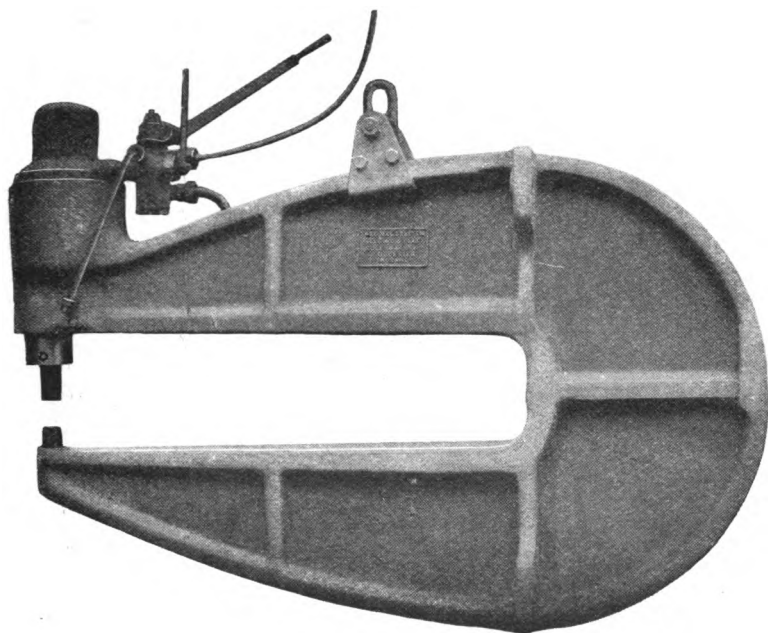

FIG. 405A.—Solid type, portable.

pressure, together with the pressure due to the head of water in the tank, which passes through the check valves S and S', carries the parts Z and T forward. When the rivet and plate are reached respectively by F and E, pressure water is admitted at V by the movement of the lever K. The pressure water passes through the pipe X', and the ram Z is caused to advance, thus pressing the plates together firmly between the tools E and G.

The valve W is now opened by means of the lever H, and the pressure is communicated to the ram Y, causing the cylinder T to be advanced and the cupping tool F to close the rivet. The pressure obtained is due to the difference in areas of the rams Z and Y.

After the rivet has cooled considerably, the pressure would be released, the valves being opened to exhaust by the levers L, K, and H, and water would be able to pass from Z into Y by the pipe Q.

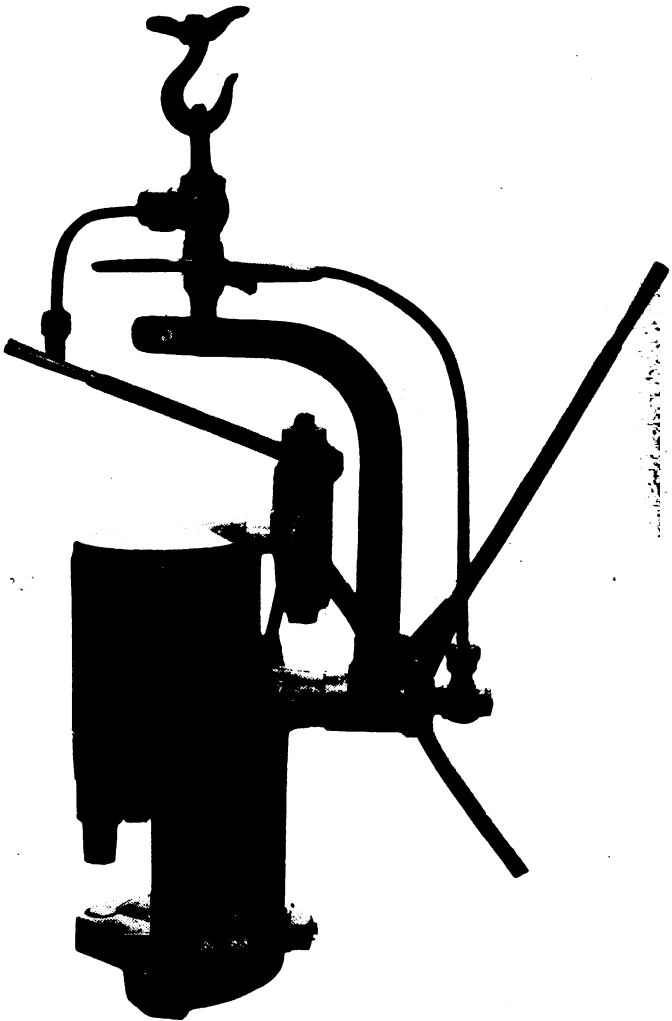

Fig. 406.—Portable hydraulic riveter for furnace mouths.

The pressure in *z* has, however, not been released, so with exhausting *i* the ram *N* is brought back to its first position, also the cylinder *T* and ram *Z*, thus causing the water to rise in the tank *C*.

The plate-closing tool causes the plates to be pressed tightly together before the rivet is compressed, thus preventing collars being formed on the rivet between the plates. The use of the low-pressure water to fill the cylinders before the pressure is applied greatly economizes the high-pressure water.

"Fulding" Type Patent Portable Riveter (Figs. 405 to 409).—The

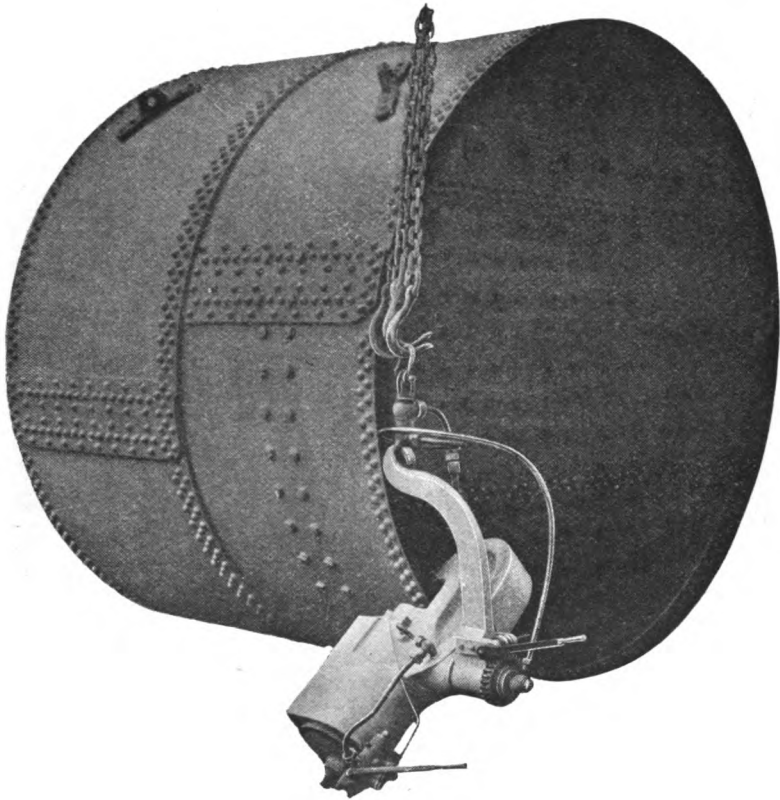

FIG. 406A.—Special form of portable riveter at work.

great advantage of this machine is that both the riveting dies are clear of the hydraulic cylinder; the long arms or levers carrying them oscillate on a strong steel centre pin. The hydraulic cylinder and ram are placed at the other end of these levers. Connecting rods between the two levers are avoided by making the centre line of the cylinder follow the radial path of the arms, of which the cylinder forms the outer end. The design of this machine makes it specially suitable for getting into corner work, and riveting angle irons on to flat plates.

The following gives a brief description of some of the hydraulic

machine tools on the Tweddells system as applied to locomotive engine and boiler work. (See folding plate, Fig. 407):—

A Stationary Hydraulic Riveter Crane.—A is the fixed riveter, similar to that shown in Fig. 408, which is described more in detail, but without the plate-closing tool. The crane is controlled by means of the handles at *h*, and so the boiler can be lifted and adjusted in position as required; *c* being the traversing cylinder, *b* the lifting cylinder, and *a* the slewing cylinder, each being supplied with multiplying gear.

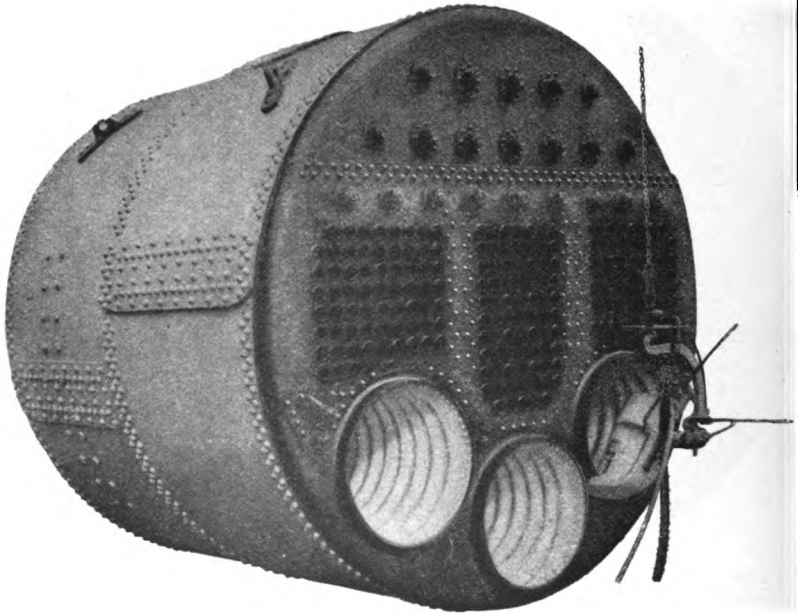

FIG. 408.—Portable riveter at work.

Q is a smaller crane worked by hydraulic means, in which case the jib is raised directly from the cylinder.

E and H are portable riveters of the "bear" type, E being specially suitable for the riveting of the smoke-box tube plate; H is used for the riveting of the loco. frames.

F and G show special applications of this type of portable riveter for dome and manhole riveting.

A small "bear" portable riveter, shown at C, has been devised for foundation ring and firehole-door riveting.

A₂ shows a stationary riveter adapted for loco. fire-boxes.

D is a portable riveter crane. The riveter is adjusted vertically by means of the ram on the trolley *d*. The pressure pipe on the arm

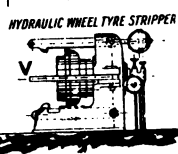
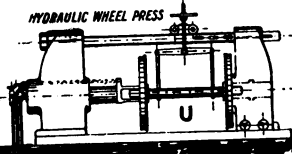
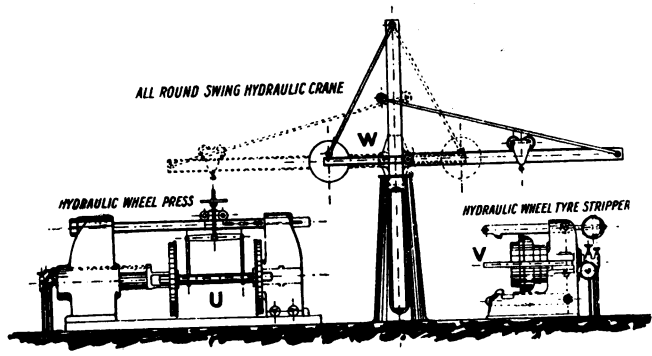
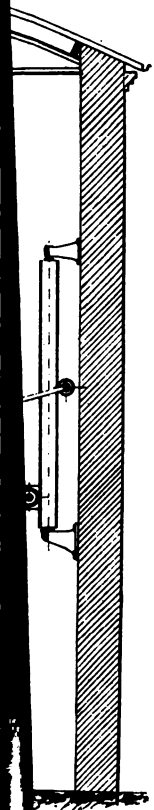
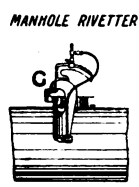
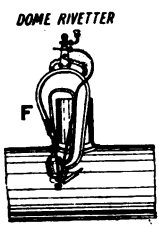

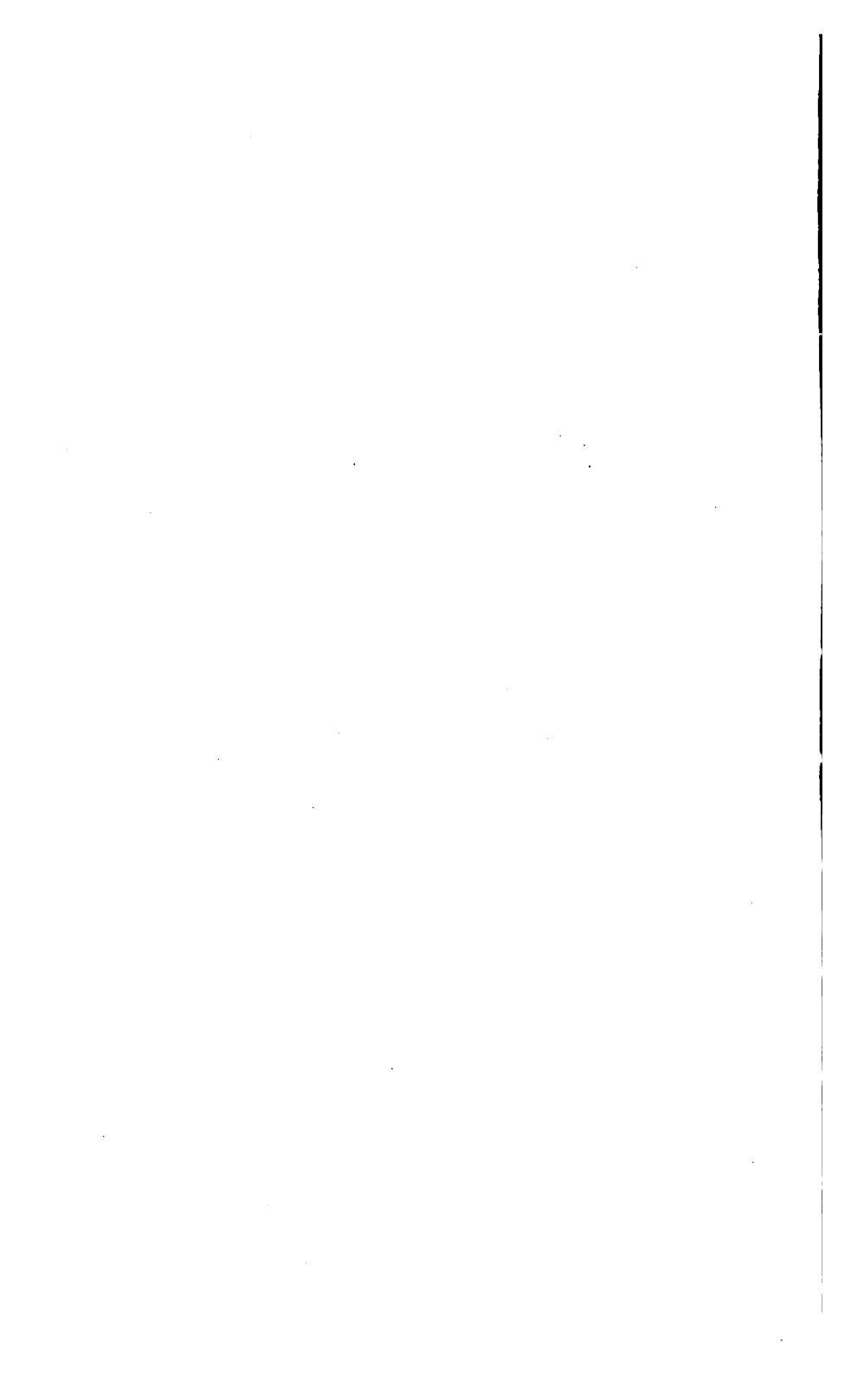

of D, at position *e*, is jointed for the horizontal movement of the trolley, and the pipe leading to the riveter is coiled to allow springing during vertical movement.

L represents a travelling riveter crane with portable riveter, K.

K is an example of the "lever" form of portable riveter, having long arms. It is shown in the operation of riveting part of a tender.

M is a forging press suitable for stamping purposes.

N shows the flanging press.

The table *b*, on which is fixed the lower die *c*, is raised by the central ram on the admission of water pressure to the hydraulic cylinder *a*.

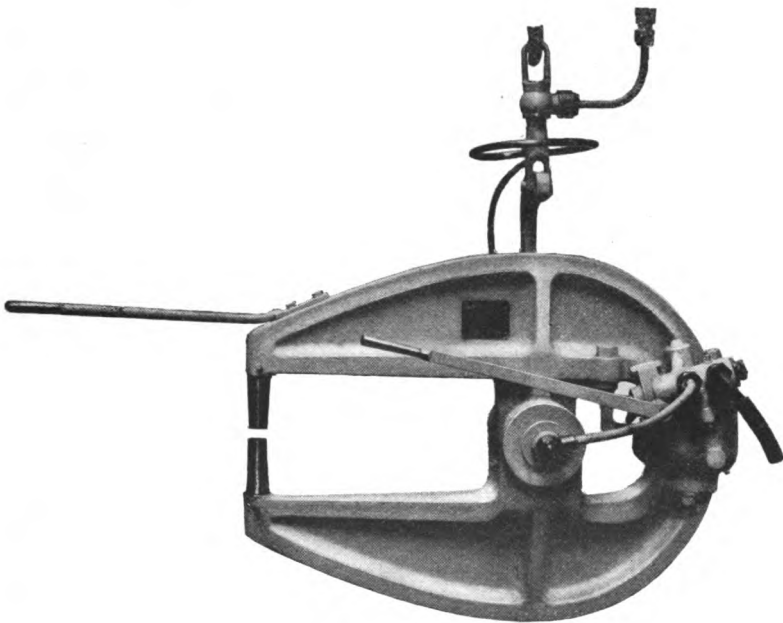

FIG. 409.--Fielding type pat portable riveter.

The upper die *d* is carried by the girder or block *e*. The guides *f* are provided with nuts, by means of which the position of *e* can be adjusted. There are four cylinders, *g*, containing the rams *h*, which are used for holding up the plate, which has previously been made red hot, against the upper die, while the bottom die is slowly raised by the central ram. The valve box *v* has two levers, one for controlling the "vice" rams, and the other for the central or flanging ram, the vice rams being first operated until the plate is held against the upper die.

After flanging a plate the levers are reversed, thus exhausting the cylinders and lowering the rams, and the plate may be withdrawn.

HYDRAULIC NOTES.

1 imperial gallon	= 277'274 cubic inches.
1 imperial gallon	= 0'016045 cubic foot.
1 imperial gallon	= 10 lbs.
A cubic foot of sea water	= 64'00 lbs.
A cubic inch of sea water	= 0'037037 lb.
A cubic foot of water	= 62'32 lbs.
A cubic inch of water	= 0'03616 lb.
A cylindrical foot of water	= 48'96 lbs.
A cylindrical inch of water	= 0'0284 lb.
A column of water 12 in. long 1 in. square	= 0'434 lb.
The capacity of a 12-in. cube	= 6'232 gallons.
The capacity of a 1-in. square 1 ft. long	= 0'0434 gallon.
The capacity of a 1-ft. diameter 1 ft. long	= 4'896 gallons.
The capacity of a cylinder in gallons 1 yard long	= 0'1 diameter squared.
The capacity of a 1-in. diameter 1 ft. long	= 0'034 gallon.
The capacity of a cylindrical inch	= 0'009832 gallon.
The capacity of a cubic inch	= 0'023606 gallon.
The capacity of a sphere 12 in. diameter	= 3'263 gallons.
The capacity of a sphere 1 in. diameter	= 0'00188 gallon.
1 imperial gallon	= 1'2 United States gallon.
1 imperial gallon	= 4'543 litres of water.
1 United States gallon	= 231'0 cubic inches.
1 United States gallon	= 0'83 imperial gallon.
1 United States gallon	= 3'8 litres of water.
1 cubic foot of water	= 6'232 imperial gallons.
1 cubic foot of water	= 7'476 United States gallons.
1 cubic foot of water	= 28'375 litres of water.
1 litre of water	= 0'22 imperial gallon.
1 litre of water	= 0'264 United States gallons.
1 litre of water	= 61'0 cubic inches.
1 litre of water	= 0'0353 cubic foot.

CHAPTER XVIII.

TRANSMISSION OF POWER.

It is a common practice to transmit motion by the aid of pulleys and belts, or bands. The general forms are flat or slightly curved pulleys of wrought or cast iron, and leather belting (oak-tanned, raw hide, or link). The cast-iron pulleys are made in various diameters and widths of face, and may be one single casting or built up of halves. Pulleys of the former class are used in machine building and all purposes where it is not difficult to get the pulleys in place. Those of the latter class are called "split" pulleys, and are portable; they can be located anywhere as required (see Fig 410). A familiar instance is given in the machine shop of a general engineer. When a new machine is introduced, a driving pulley is required on the main shaft. Now, a pulley cast all of a piece would necessitate a portion of the shafting to be released from its coupling, and probably several pulleys removed to get the new one in position, causing much trouble and delay. On the other hand, a split pulley can be secured in a few minutes (generally).

A great stress is found to exist between the pulley rim and hub or boss, viz. in the arms, rendering them weak when subjected to shock. This tension is caused by unequal cooling after the operation of casting the pulley in the mould. It is not uncommon to see pulleys fractured before any "tooling" operations are commenced, and frequently during the machining stage arm fractures have been discovered. Large pulleys with wrought-iron arms have been designed to overcome the above defect; the arms are placed in the mould, and the rim and hub formed respectively by the molten metal. An example of this type of pulley is seen in the large driving wheels or rope pulleys used at collieries, *i.e.* the pit-head gear.

Wrought-iron Pulleys.—A further development is the wrought-iron pulley (Fig. 411). In this case the pulley is constructed or built up by hand. There is much to be said in favour of this class of pulley for high-speed work and heavy drives. Being of wrought iron, it is stronger to resist tensional strain than cast iron, and may therefore be run at higher speeds without risk of breaking, while the weight is from 30 to 50 per cent. less. The rim being of a uniform thickness, the pulley is practically evenly balanced. This feature is a very

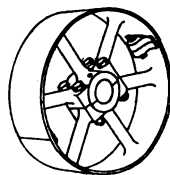

FIG. 410.—Split pulley.

important one in high-speed running, and gives wrought-iron pulleys a preference to those of cast iron, which have to be balanced after turning, which is a costly item.

There are many ways of fixing a pulley to a shaft. The simplest way is to use a split pulley and bore it to be a tight fit on the shaft; then, when the bolts are screwed up, the pulley will grip the shaft tight enough for any ordinary driving for small powers. This plan has also the advantage that a pulley may be located at any point on the shaft without special preparation, and it does not damage the shaft's surface. Another plan is to use set-screws.

Saddle or hollow keys are useful for small pulleys, as they do not

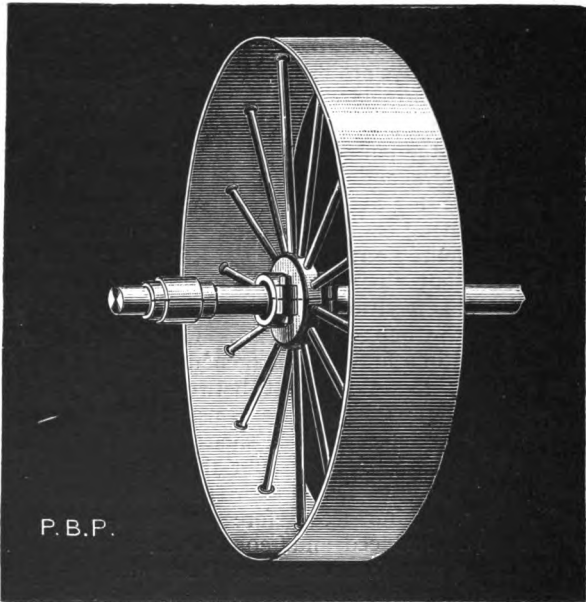

FIG. 411.—Wrought-iron pulley.

damage the shaft, but they have no great holding power, and throw a great strain on the pulley boss.

If a pulley has to transmit any considerable power, and especially if it be of large diameter, the only really satisfactory way to fix them is by means of sunk keys; gib-headed keys are dangerous, and taper keys have a tendency to burst the boss; they are also expensive to fit and troublesome to remove. Besides this, the key bed is necessarily twice the length of the key, while with a sunk or feather key one length is enough.

Plain and Screwed Cone Bushes.—There are several plans whereby one pulley can be made to fit any size of shaft within certain limits. This result has been obtained by the use of loose bushes. The bosses

of all pulleys of certain sizes are bored to one diameter, and the loose bushes are used to fit the pulley for any particular shaft.

Two principal kinds of loose bushes are made, one a plain one which is held in position by set-screws, and the other a taper bush screwed on the outside. The boss of the pulley is screw-cut internally, so that when the bush is put on the shaft and the pulley screwed on to it, the tighter the belt pulls, the tighter the bush grips the shaft (see Fig. 412).

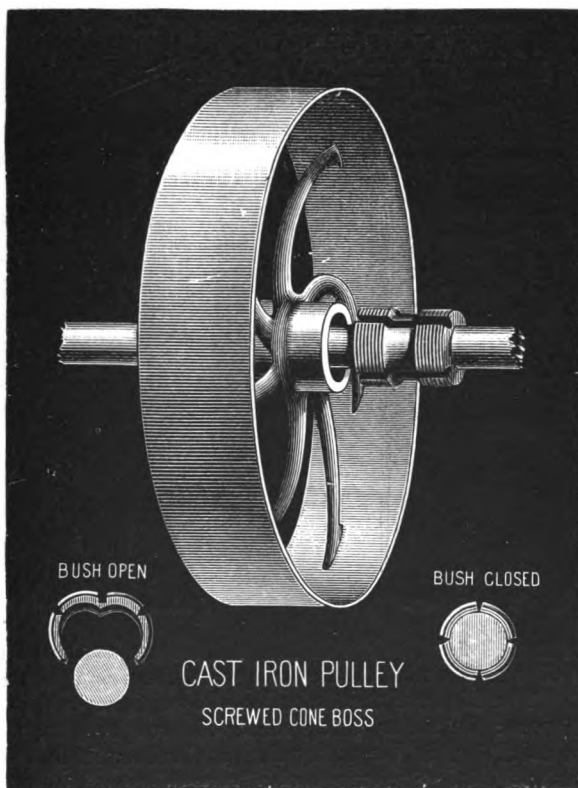

FIG. 412.

Pulleys built up entirely of wood are much used for driving small machines. These are also made in halves, and are bored to standard sizes to receive bushes which are also stocked to suit the various driving shafts. The pulleys are secured by bolts in a similar way to the iron pulleys described. The rims are built up of several strips which are lagged, to prevent warping. The weight on the main shaft being thus reduced, there is obviously considerably less friction on the bearings, and, of course, less power absorbed. (Fig. 413).

Balancing Pulleys.—It is essential for pulleys which are to run at high speeds that they should be truly turned and balanced. The centrifugal force generated by the pulley when revolving at a high speed must be uniformly distributed; this, however, can only be obtained by carefully testing the pulley and placing an adequate balance inside the pulley's rim. One method adopted is to have two parallel bars planed to knife edges and laid perfectly horizontally and at equal distance apart throughout their length. A short shaft is driven lightly into the bore of the pulley, which is then mounted on the knife edges of the bars and the pulley slowly rotated, the heaviest part coming to rest at the bottom, at which position a centre dot is placed on the pulley's rim. This process is repeated slowly two or three times to ascertain the correct position.

The balancing may be effected in two or three ways. In the first place, if the error is slight, some of the metal between the arms on the

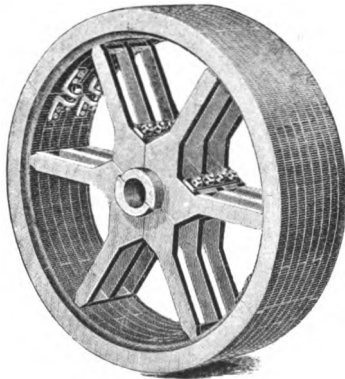

FIG. 413.—Wood pulley.

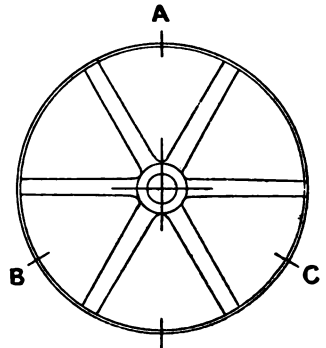

FIG. 414.—Balancing a pulley.

portion not tooled may be chipped away. Another method is to secure temporary clips to the edge of the pulley rim, the weight of the clips to be known. The clips are then substituted by weights cast in the form of a mushroom; the stems, being made of wrought iron, are passed through holes drilled in the pulley face, and subsequently riveted and dressed flush with it. Sometimes clay is used instead of metal clips, each piece of clay being weighed and the amount made up by a corresponding weight of iron or lead, and rivets.

Instead of placing a large weight all in one place, as in the above example, the weight required may be placed at two points, A and B, as in Fig. 414.

Let us suppose a pulley gravitates at C. Then by using a pair of trammels, and taking C as a centre, mark off equal divisions as at A and B; by thus dividing the pulley and the weights a much neater finish can be obtained. When high-speed pulleys are in perfect balance there will be an absence of all tremor, but this can only be effected by

revolving the pulleys at the speed they are finally to be run at. In other words, balancing by the knife-edge process and rotating

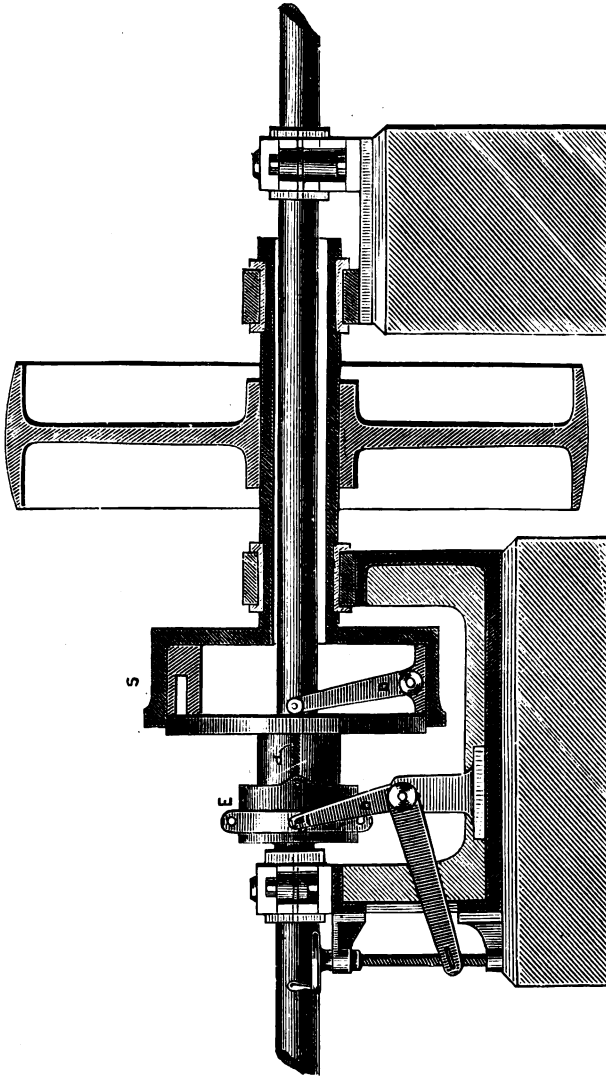

FIG. 415.—Friction clutch with hollow sleeve.

by hand is only approximate. The actual test must be applied by rotating the pulleys at their proper speeds.

Friction Clutches.—Friction clutches are used instead of fast and loose pulleys to connect running shafts or wheels with shafts or wheels

which are standing. They are equally useful for purposes of disconnection, and thus become economizers of power, because, where one portion only of a workshop is at times requiring power, and sometimes only a few machines to be run, there it is that one of the advantages of friction clutches is clearly seen, and thus the original practice of fast-and-loose pulleys are dispensed with. The friction clutch, unlike the claw clutch, may be put in or out of gear slowly, which is a decided advantage where sudden shocks would be objectionable; and further, a friction clutch may be connected at any point while both shafts are at rest.

An arrangement showing a hollow sleeve clutch is given in Fig. 415. It will be noticed that the large pulley is not riding on the shaft, but is supported by a sleeve which is also part of the clutch S. Since the sleeve is carried in independent bearings, the weight of the pulley and tension of the belt are taken off the shaft. This is an important

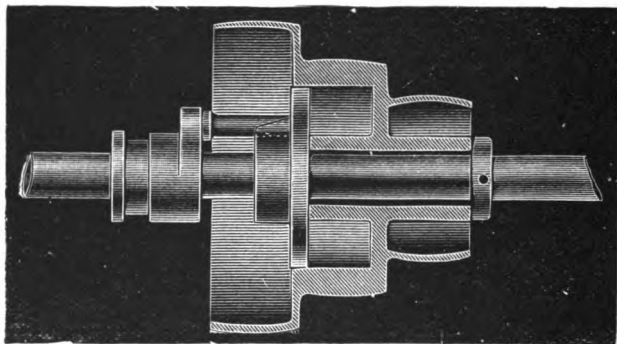

FIG. 416.—Friction clutch to speed cone.

feature in heavy transmission, as by its use there is no wear and tear of the shaft when the clutch is out of gear.

Applications of friction clutches are very numerous, but a few examples are selected from ordinary practice. Figs. 416 and 417 illustrate the method applied to a speed cone and reversing pulleys respectively, as used in turret and other lathes; one pulley is, of course, rotated by a crossed belt. A further example (Fig. 418), the clutch being attached to a bevel wheel, similarly in Fig. 419, which is a double-armed pulley; in the latter cases there is a bushing of phosphor bronze to further reduce friction.

Fig. 420 is a friction coupling (Bagshaw-Addyman's patent). This type is used in place of an ordinary flange coupling on the line shaft.

Referring to Fig. 420, the general arrangement needs little description. Fig. 2 is a section. The power is exerted by the insertion of a wedge A, which opens out the leaves BB, and thereby expanding the ring C, which grips the shell D, over its whole inner surface. The application to wheels or pulleys is shown in Fig. 3. Instead of the

hand wheel shown, which is for general purposes, the lever may be worked by hand when frequent disconnection is required, as in small-power transmission. The above are by J. Bagshaw & Sons, Limited,

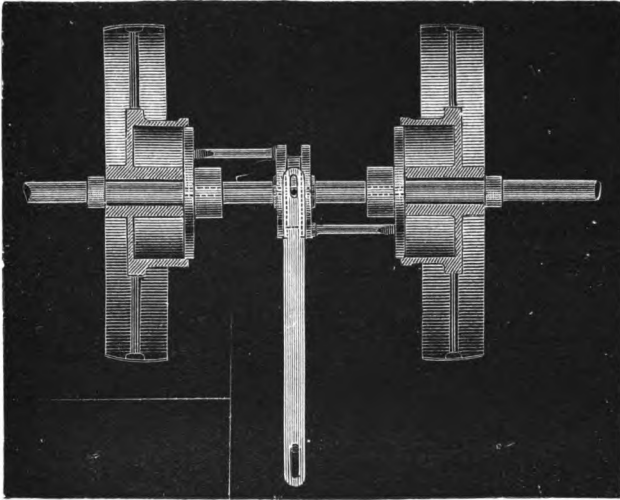

FIG. 417.—Friction clutch to reversing pulleys.

Batley. There are many other kinds of friction clutches, one of which is known as the elastic clutch.

Couplings.—A coupling is a cast-iron sleeve into which the ends of

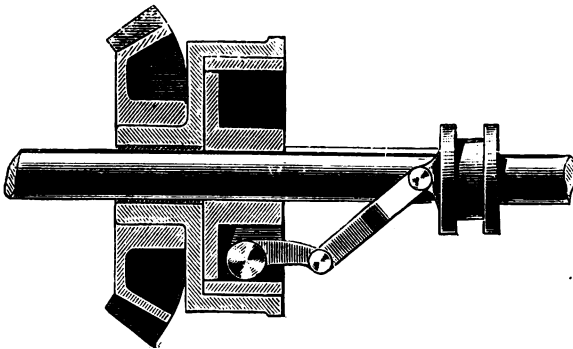

FIG. 418.—Friction clutch to bevel wheels.

two shafts may be placed and secured. The simplest form is the "muff" coupling, which is now almost obsolete, owing to the difficulty of its removal from the shafts.

The "flange" coupling consists of a coupling in two parts which

are secured together by turned bolts, the heads of which are recessed flush with the flange. (Fig. 421.) The shafts are key-bedded, as are the couplings, the latter being secured in place by tightly fitted

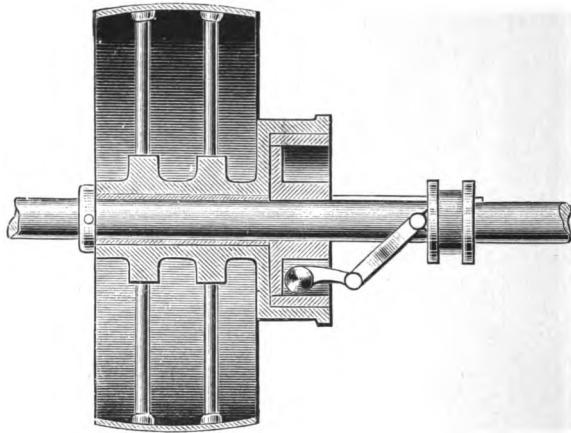

FIG. 419.—Friction clutch to double-armed pulley.

keys. To get the couplings absolutely true, they are turned on their internal faces after keying on to their respective shafts. This is both

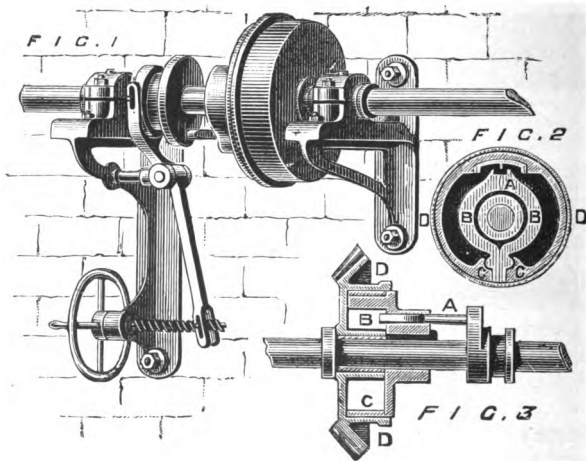

FIG. 420.—Friction coupling.

costly and inconvenient, especially if the coupling has to be disconnected to pass on a solid pulley.

The Compression Coupling (Fig. 422)—sometimes called "Sellers'"

coupling (after the inventor)—although built up of several parts, is undoubtedly the best. It embodies all the essential points, viz.—

It is easy to put on or remove; it is bored to slide on the shaft (without hammering); it fits the shaft, and cannot slip, has no projecting bolts, and is always true on any shaft of a similar diameter, *i.e.* it is interchangeable.

The coupling proper consists of three pieces, an outer sleeve, A, and two cones, BB. The two cones are first bored to fit a shaft of standard size; they are then placed on a mandrel and turned to a taper of one in four. The outer shell is first bored to the same taper, and turned on a special mandrel. Round the inside of the shell and the outside of the cones are cast three equidistant grooves, D_1, D_2, D_3 (Fig. 423). The cones are completely cut through, as shown in Fig. 423, so as to make them slightly elastic. When the coupling and shafts are put together as shown, and three bolts passed through the grooves and screwed up, the coupling is ready for work. It will be understood that, the several parts

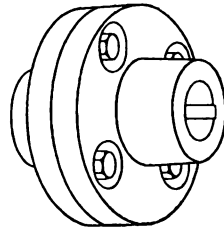

FIG. 421.—Flange coupling.

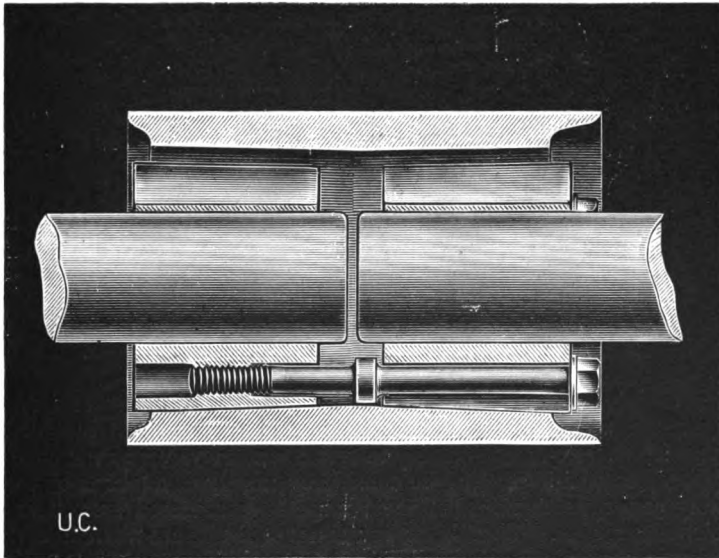

FIG. 422.—Sellers' compression couplings.

being accurately turned and bored, it is obvious that the coupling will be true on any shaft of the same size. The above description is for a friction drive, but for very large shafts a sliding feather is let into the shaft to act as a stop.

Figs. 424, 425, are exaggerations, but are intended to show what takes place when trying to couple together two shafts that vary in size, be it ever so little, with a rigid coupling.

Shafting and Bearings.—Shafting for the transmission of power to the various machines may be of wrought iron or mild steel, and, independently of the machines driven by it, absorbs power (when once set in motion) in consequence of the friction in the bearings, and the resistance of the air to the pulleys.

The friction of the bearings is proportional to the weight of the shaft and the diameter, fitting, and lubrication of the journals. When shafting is at work it is subjected to two different kinds of strains, viz. a torsional strain owing to rotative power exerted by the engine in



FIG. 423.—Sellers' compression coupling.

order to drive the machines, and a bending strain, owing to its own weight, the weight of the pulleys on it, and the resultant pull of the belts. The strength of shafting to resist torsion varies as the cube of the diameter, and if shafting be considered merely as a means of transmitting power, its torsional stiffness must be considered as well as its torsional strength. That is, it must not twist more than a certain amount in a certain length, or else the speed of revolution at the far end of the shaft will be so jerky and irregular that it will be sure to spoil work done by machines driven from it at that point. The maximum of twisting allowable in good practice is 1 degree, or $\frac{1}{360}$ of a revolution for each 20 diameters in length of the shaft. The strength of shafts, so far as torsional stiffness is concerned, is proportional to the square of the area of their cross section.

In calculating the size of shafting, it may be taken as a safe rule that wrought iron will stand a working stress of 9000 lbs. per square inch of cross section, and steel 13,500 lbs. The following formulæ for calculating the dimensions of shafting as used in ordinary mill work have been

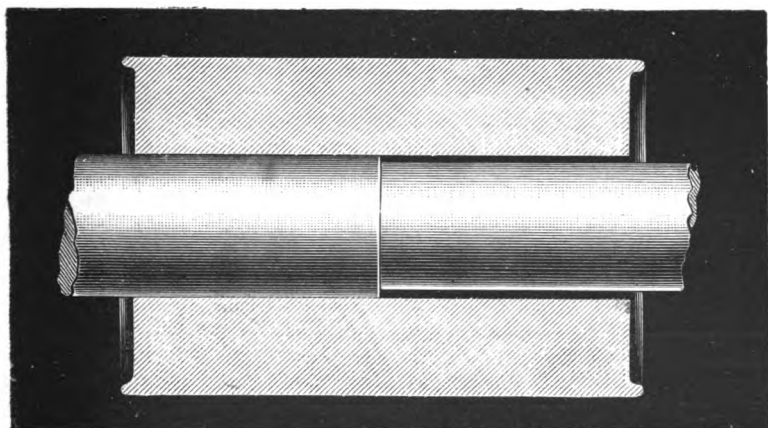
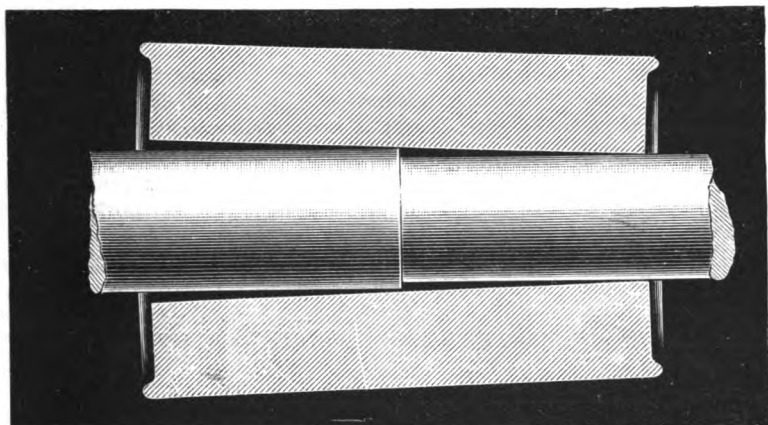

FIGS. 424, 425.—Shafts coupled out of line.

decided on after carefully comparing the best text-books with the best practice; they are reduced to their simplest forms:—

Diameter of wrought-iron shaft to transmit a given horse-power, taking into consideration the twisting moment only—

$$= 3.294 \sqrt[3]{\frac{\text{horse-power to be transmitted}}{\text{number of revolutions per minute}}}$$

Diameter of wrought-iron shaft to transmit a given horse-power, allowing for the bending strain of pulleys and belts—

$$= 4.2 \sqrt[3]{\frac{\text{horse-power to be transmitted}}{\text{number of revolutions per minute}}}$$

If the shaft be of steel, multiply the diameter as found for wrought iron by 0.874.

Therefore, a 3-in. diameter steel shaft will transmit 80 horse-power at 150 revolutions per minute, while a wrought-iron shaft will be $3\frac{1}{2}$ in. diameter to transmit 80 horse-power at 150 revolutions per minute.

The next point to be considered is the distance between the bearings by which the shaft is supported. A safe rule for this is: the distance in feet between the bearing of a shaft carrying the usual proportion of pulleys should be $5\sqrt[3]{\text{the diameter of shaft in inches}^2}$.

The following table is calculated from this formula, and shows at a glance either how far apart the bearings may be when a given size of shaft is to be used, or if it is only possible to put bearings in certain places, then what size the shaft must be to work properly:—

Diameter of shaft.		Distance of bearings.		Diameter of shaft.		Distance of bearings.		Diameter of shaft.		Distance of bearings.	
in.	ft.	in.	ft.	in.	ft.	in.	ft.	in.	ft.	in.	ft.
1	5 0	$3\frac{1}{4}$	11 0	6	16 6						
$1\frac{1}{4}$	5 9	$3\frac{1}{2}$	11 6	$6\frac{1}{2}$	17 6						
$1\frac{1}{2}$	6 6	$3\frac{3}{4}$	12 0	7	18 3						
$1\frac{3}{4}$	7 3	4	12 6	$7\frac{1}{2}$	19 0						
2	8 0	$4\frac{1}{4}$	13 0	8	20 0						
$2\frac{1}{4}$	8 6	$4\frac{1}{2}$	13 6	$8\frac{1}{2}$	20 9						
$2\frac{1}{2}$	9 3	$4\frac{3}{4}$	14 0	9	21 6						
$2\frac{3}{4}$	9 9	5	14 6	10	23 3						
3	10 3	$5\frac{1}{2}$	15 6	11	24 9						
				12	26 3						

TABLE OF WEIGHT OF TURNED WROUGHT-IRON SHAFTING.

Diameter of shaft.		Weight per foot.		Diameter of shaft.		Weight per foot.	
in.	lbs.	in.	lbs.	in.	lbs.	in.	lbs.
1	2.62	$3\frac{3}{4}$	33.5	8	168.0		
$1\frac{1}{4}$	4.09	4	41.9	$8\frac{1}{2}$	189.0		
$1\frac{1}{2}$	5.89	$4\frac{1}{4}$	47.3	9	212.0		
$1\frac{3}{4}$	8.02	$4\frac{1}{2}$	53.0	$9\frac{1}{2}$	236.0		
2	10.5	$4\frac{3}{4}$	59.1	10	262.0		
$2\frac{1}{4}$	13.3	5	65.5	$10\frac{1}{2}$	289.0		
$2\frac{1}{2}$	16.4	$5\frac{1}{2}$	79.2	11	317.0		
$2\frac{3}{4}$	19.8	6	94.2	$11\frac{1}{2}$	347.0		
3	23.6	$6\frac{1}{2}$	111.0	12	377.0		
$3\frac{1}{4}$	27.7	7	128.0	14	462.0		
$3\frac{1}{2}$	32.1	$7\frac{1}{2}$	147.0				

The weight of steel shafting may be found by multiplying these weights by 1.02, but the difference is small, amounting to only $6\frac{1}{2}$ ounces per foot of 3-in. shafting.

As an example, we will assume that a shaft of wrought iron is to be used, $2\frac{1}{2}$ in. diameter, and making 150 revolutions per minute. It is, perhaps, the commonest size and speed, and so represents every-day work. For a shaft of this diameter the bearings should be spaced apart, $5\sqrt[3]{2.5^3} = 5\sqrt[3]{6.25}$,

$$= 5 \times 1.842 = 9.210 \text{ ft.} = 9 \text{ ft. } 3 \text{ in.}$$

The weight of 9 ft. 3 in. of $2\frac{1}{2}$ -in. shafting is 151 lbs. The friction on each bearing, or the power required to overcome it expressed in foot-pounds per minute will be—

$$= 0.0157 \times 150 \times 2.5 \times 151 = 889$$

Now, if a $2\frac{1}{8}$ -in. steel shaft be substituted for the $2\frac{1}{2}$ wrought iron one, the distance apart of the bearings should be 8 ft. The weight of 8 ft. of $2\frac{1}{8}$ in. shafting is 95 lbs., therefore the friction of each bearing will be—

$$= 0.0157 \times 150 \times 2 \times 95 = 447 \text{ ft. lbs. per minute}$$

as against 889 for $2\frac{1}{2}$ -in. shafting, but there will be more bearings in a given length of 2-in. shafting in the proportion of 9.25 to 8. Therefore, to compare them we must increase the 447 proportionately, which makes 520 as against 889, or, in other words, the power required to drive an iron shaft is 70 per cent. more than that required to drive a steel one to do the same work.

Going now to the economical question involved in first cost, we may assume that steel shafting, weight for weight, costs 50 per cent. more than iron. Let us, then, assume the cost of iron shafting at $1\frac{1}{2}d.$ per lb., and steel at $2\frac{1}{4}d.$ 1 ft. of $2\frac{1}{2}$ -in. iron shafting weighs 16.4 lbs., and at $1\frac{1}{2}d.$ costs 2s. $0\frac{1}{2}d.$ 1 ft. of $2\frac{1}{8}$ -in. shafting weighs 10.5 lbs., and at $2\frac{1}{4}d.$ costs 1s. $11\frac{1}{2}d.$, showing that in first cost steel is practically the same as iron, while the daily cost of driving the iron shaft is 70 per cent. more than the steel one.

Bearings.—Bearings for shafting have undergone considerable change; the shafting has been produced under improved conditions at the rolls, and with superior straightening appliances shafts have been more truly set before and after turning. Special lathes, too, have been designed for shafting, which has resulted in the work produced being more cylindrical and truer to gauge.

Shafting bearings were formerly plumper blocks worked out in dimensions to the old rule—diameters = $2\frac{1}{2}d.$ This formulæ is now obsolete, and instead of a bearing with a top and bottom brass, we have no brass at all, but simply cast-iron bearings. This is stated to be the best material for the purpose, and undoubtedly under proper conditions cast iron will wear as smooth as any of the alloys of more expensive metals. The proper conditions are, shafting straight, round, and true to gauge from end to end.

Bearings designed of such a form that the length may be made as great as necessary to keep the pressure per square inch very low, and also to automatically adjust themselves to give a full support to the shaft without any possibility of binding. It is therefore contended that under these circumstances cast iron is the proper and best material. It is harder than brass, and will therefore last longer, and will wear the shaft less.

It is almost impossible to set a series of rigid bearings so truly that the shaft will bear on each of them throughout its whole length and without straining, nor if by chance so set will they last long in that state, for settlement, or warping, or something is sure to happen to throw them out of line. Thus the very first thing that happens when a new shaft is put to work is that it wears itself a bed, *i.e.* it wears away its bearings; the result is that a space is left into which dust and grit can get. These bed themselves in the brass, and wear the shaft, and so mutual self-destruction goes on.

The operation thus involuntarily performed is exactly what we do when we desire to grind down a shaft, *viz.* "lapping." Referring to the design of the old-fashioned bearings, they are considered faulty in two important points; first, they are rigid and immovable in any direction when once they have been set; and second, because they are rigid they must be made narrow, or otherwise they would bind the shaft to too great an extent for practical use. Even when narrow, owing to almost inevitable errors in alignment, they bind the shaft to a certain extent, and the merit of the combined brass and narrowness is that they are the more readily worn away.

This, therefore, proves that a long bearing is better than a narrow one. The weight is distributed over a larger area, and therefore both shaft and bearing are less worn. In fact, with liberally proportioned bearings the wear is inappreciable after several years of use. Although the bearing is made longer, the friction is theoretically not altered (provided the fit be perfect in each case) but actually it is decreased, and for this reason: perfect lubrication consists in keeping a film of oil at all times between the shaft and the bearing, so that the shaft does not actually touch the bearing, but floats on a film of oil, the particles of which roll on one another when the shaft revolves, forming, in fact, a roller bearing. But it is difficult to keep the film intact if the pressure per square inch of bearing surface becomes great. It is hard to say the exact pressure that may be applied with safety, but there is no doubt that with bearings of only $1\frac{1}{2}$ or 2 diameters in length, the point when the oil would be squeezed out becomes dangerously near, and, in fact, is often passed; while with bearings of 4 diameters there is an ample margin of safety, and, the film of oil being thicker, more perfect, and under less pressure, the shaft will actually in daily practice revolve more freely in such an one than in a narrow bearing. Only, as before stated, the use of long bearings makes it absolutely necessary that they should be free to adjust themselves to the shaft, and it is just the invention of a form of bearing which will allow of this that has made long bearings a success.

Setting Bearings.—In this form of bearing the setting has been considered in the design, and what was originally a slow and awkward matter is now comparatively easy. The plan adopted is briefly this: to set one point in every bearing in line, such point to be the exact centre of the bearing, using this point as a centre of a ball formed outside the bearing. Two cups are so located in the frame to carry the bearing, one above and the other below it; these cups may be raised or lowered by the screws. (See Fig. 426.)

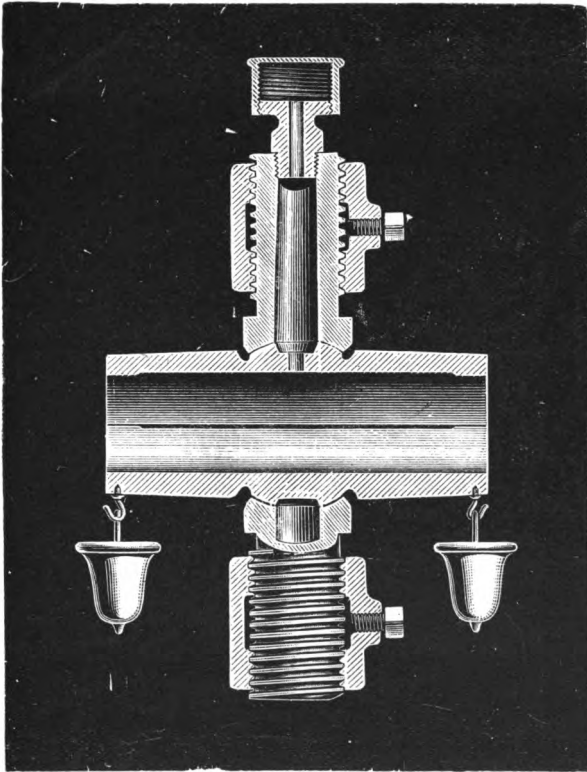
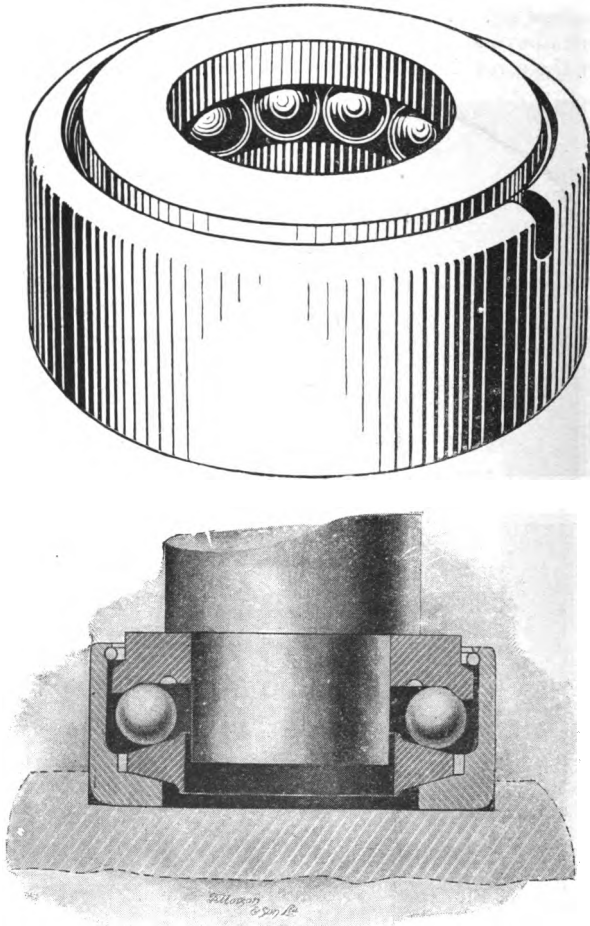

FIG. 426.—Swivel bearing, in section.

Setting Bearings in Alignment.—It is difficult and almost impossible to set a series of bearings in perfect alignment, both vertically and horizontally throughout their whole length. Much, however, depends upon the type of bearing and the method adopted in setting. It is suggested that we set one point in every bearing in line, and that we select for such point the exact centre of the bearing. Now, if we form on the outside of the bearing a ball having that point for its centre, and if we arrange two cups in the frame that carries the bearing, one to go below

the ball and the other above it, and if, further, we provide an arrangement by which these cups can be raised and lowered, it is clear that we have a satisfactory bearing. Such a bearing is shown in Fig. 426, which is a sectional elevation of a swivel bearing. The ball and cups form a



FIGS. 427, 428.—Ball thrust bearings.

ball joint, in which the shaft is free to move in any direction sufficiently to accommodate itself to the shaft.

Another feature is that in case the main shaft should get slightly bent, the bearing will roll in its seat to the same amount, and so save

additional friction. The use of the adjusting screws, combined with the ball and socket, renders the erection of shafting very simple.

Ball Bearings.—The Hoffman Manufacturing Company, Ltd., Chelmsford, patented a ball thrust bearing, which is illustrated in Fig. 427. The bearing is made either to support the end of a vertical shaft, or to act between a fixed abutment and a collar, or a shaft working horizontally. As will be seen in the sectional view (Fig. 428), the balls are located between two discs, which are partially enveloped by an annular ring. This ring is bored and coned on its inner face to the same inclination as the ring next to it, while the upper disc has a ball-race near its outer edge, the rest part being left flat. Referring to the figure, it will also be seen that the lower disc is bored considerably larger than the diameter of the shaft, which gives room for it to travel, as well as rotate; it also gives an increase of freedom to the balls. Thus, when the shaft revolves, the bearing receives the thrust, and the upper disc, the balls, and the lower disc either revolve unitedly or

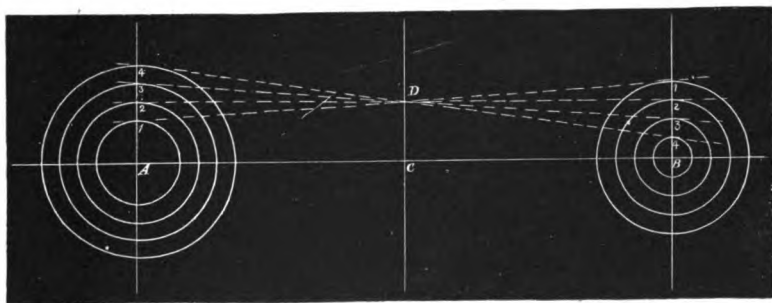

FIG. 429.—Speeding cone pulleys.

separately, as the case may be. A steel wire coil is inserted above the upper disc, which keeps the bearing compact, and at once makes it self-contained. These bearings are made for all shafts between $\frac{3}{4}$ -in. and 3-in. diameter.

Rule for Cone Pulleys.—A convenient rule for finding the diameter of cone pulleys so that a belt may run equally tight on all of them is as follows. Draw a line AB (see Fig. 429) making AB equal distance between centres of cones. Bisect AB in C, and erect perpendicular CD. The diameters of one cone are known, and one step of the other cone. From A as a centre describe four circles (1, 2, 3, 4) to represent the steps of the cone whose diameters are known. Draw a straight line tangent to the one circle on B and the circle on A with which it corresponds. This line will cut CD in D. If, now, tangents be drawn to the other circles on A and passing through the point D, and if circles be drawn from B as a centre touching these several lines, then the circles on B will be the diameters of pulleys that will work with those on A, so that the belt will always be equally tight.

Wall Box and Bearings.—Main shafts are frequently carried through two or more shops. Fig. 430 shows a type of wall box, with swivel bearing bolted inside it. Fig. 431 represents a wall bracket with swivel and adjustable bearing. The same type of bearing is sometimes fitted to a hanger, and suspended from an upper floor or beam.

A further type (Fig. 432) is used when pillars are available; in this case the bracket is short and compact compared with the wall bracket, but in the latter allowance for pulleys and belts has to be considered in the design.

Counter Shaft.—Fig. 433 represents a counter shaft and hangers.

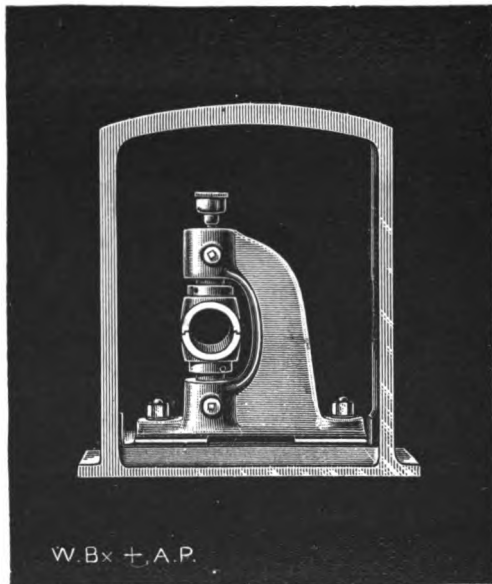

FIG. 430.—Wall box and bearing.

The arm at the back has an adjustable sling to carry the rod for shifting the belt. It will be seen that the bar is moved by means of a pin fixed in a disc and connected with it by means of a bent rod. Motion is given in either direction by pulling a cord or chain lying in the groove of the disc.

Speed of Shafts and Pulleys.—To find the size of pulley required on a shaft which is to be driven at a certain rate from a given pulley on a shaft of fixed rate: Multiply the speed of shaft 1 (revolutions per minute) by the diameter of given pulley 1, and divide by speed (revolutions per minute) re-

quired for shaft 2. This gives the diameter of pulley 2 in same units as diameter of pulley 1 was taken. If the diameter of pulley 2 is known, and speed of shaft 2 is required, divide by diameter of pulley 2, and get speed of shaft 2 (revolutions per minute).

EXAMPLE 1.—What speed (revolutions per minute) will a shaft B (Fig. 1) with a pulley 6 in. diameter run at when driven from a pulley 24 in. diameter on a shaft A running at 150 revolutions per minute?

$$\frac{24 \times 150}{6} = 600 \text{ revolutions per minute (Fig. 434).}$$

EXAMPLE 2.—A dynamo running at 600 revolutions per minute has to be driven from a pulley P on a shaft which is running at 100

revolutions per minute. The dynamo has a pulley, D, 8 in. diameter. Find size of pulley P on the shaft (see Fig. 435).

$$\frac{600 \times 8}{100} = 48 \text{ in. diameter}$$

EXAMPLE 3.—A polishing-machine is to be driven at 1800 revolutions per minute from a pulley, A, 30 in. diameter on a shaft running at 120 revolutions per minute. Diameter of pulley P on polishing-machine 3 in. Find suitable-sized pulleys B and C on a countershaft, so that machine is driven at the rate required.

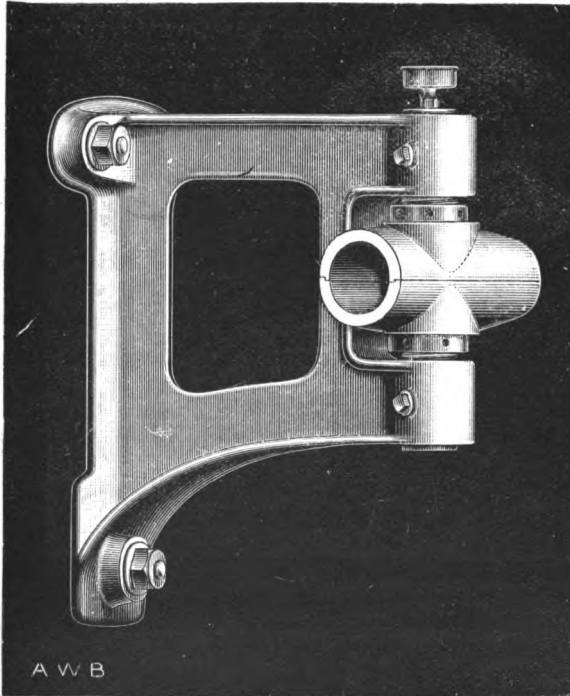

FIG. 431.—Swivel bearing supported by beam.

Suppose the countershaft revolves at x revolutions per minute (see Fig. 436).

$$\begin{aligned} \text{Then } \frac{30 \times 120}{B \times x} \times \frac{C \times x}{3} &= 1800 \\ \text{or } 12 C &= 18 B \\ \therefore C &= \frac{3}{2} B \end{aligned}$$

We have only to fix on a convenient size for one pulley, and we know the other.

Suppose $B = 10$ in. diameter.

Then $C = 15$ in. diameter.

These pulleys, put on countershaft as shown in Example 3, Fig. 436, would effect the desired result.

Roller Bearings.—Although the advantages claimed as arising from the use of roller bearings have long been acknowledged as theoretically sound, it is only within the last few years that roller bearings have come into commercial use. The principal advantages claimed for roller bearings are—

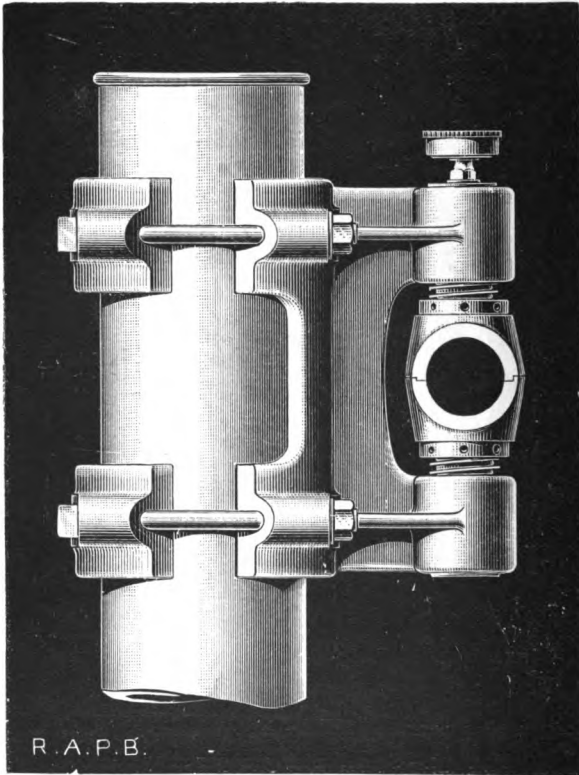

FIG. 432.—Swivel bearing on pillars.

1. Reduction in starting effort.
2. Reduced tractive effort.
3. Decreased revolving effort.
4. Economy in lubrication.

For many years the only successful application of rolling motion to bearings was the well-known "ball bearing" so universally adopted for cycles; and although these bearings have proved very satisfactory for

light loads, they are not suited for heavy loads, as the balls indent the path or race upon which they run. As soon as this takes place, the balls begin to lose their friction-reducing properties. If a semi-circular trough be constructed which accurately fits a ball, and after the ball is placed therein one end of the trough is lifted until movement of the ball takes place, it will be found that the ball moves by sliding, not by rolling. This is indentation carried to its extreme limit. Another defect in ball bearings is that the balls are allowed to touch each other, and as the touching points of any two balls are revolving in opposite directions, there must be a certain amount of scrubbing friction.

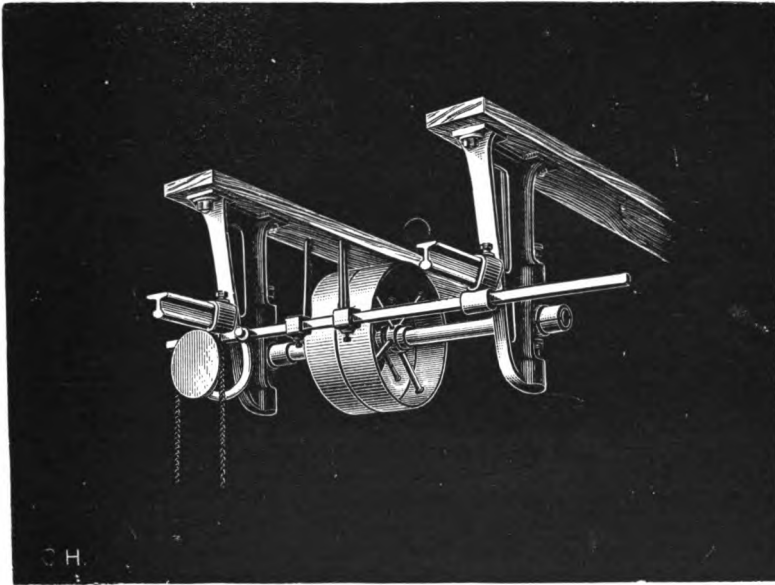

FIG. 433.—Counter shaft and hanger.

The roller bearing suited for heavy work is one made by the Roller-Bearings Co., Ltd., of London. This particular form of bearing has been arrived at after many trials of various kinds of bearings. It consists of a floating cage, which, though not theoretically perfect, has been found to give better results in practice than other forms which are more theoretically perfect. The construction of this bearing is clearly shown in Figs. 437, 438.

The following figures are the results of experiments made to ascertain the relative starting effort of tramcars fitted with ordinary bearings and those with roller bearings.

On a gradient of 1 in 20 : ordinary bearings, 100 ; roller bearings, 77. Saving, 23 per cent.

On a gradient of 1 in 80: ordinary bearings, 100; roller bearings, 50. Saving, 50 per cent.

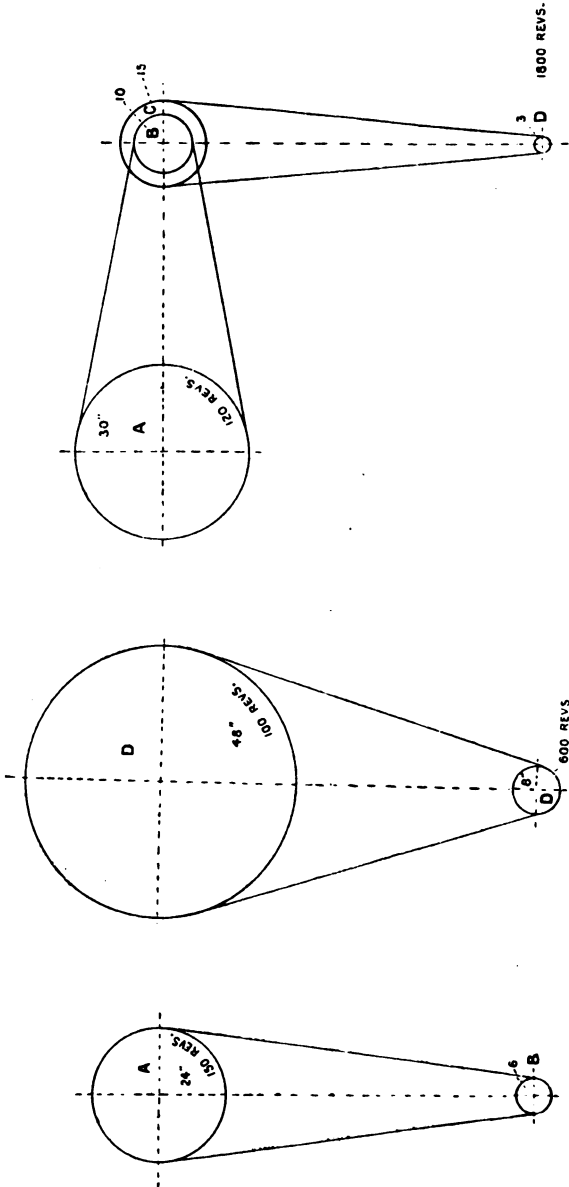

FIGS. 434, 435, 436.—Examples of speeding.

On a gradient of 1 in 140 : ordinary bearings, 100 ; roller bearings, 39·6. Saving, 60·4 per cent.

Patent Rolled Shafting.—Mild steel shafts, direct from the rolling

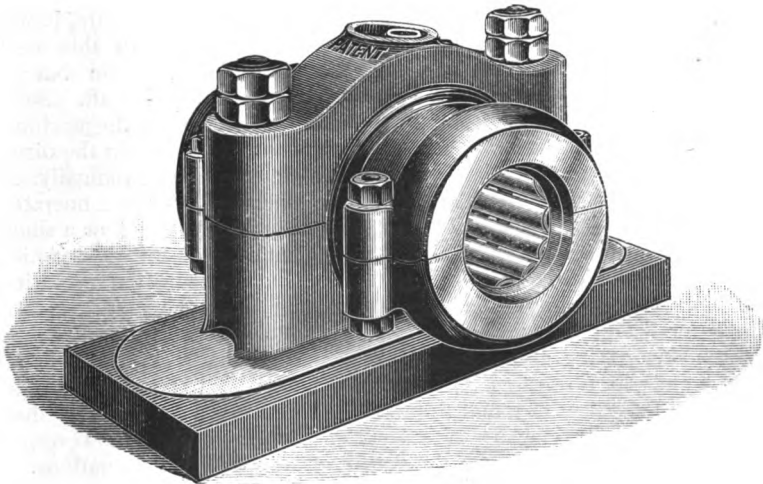
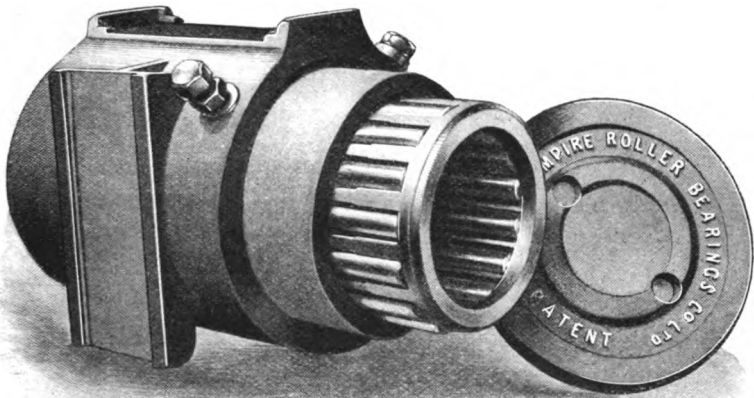

FIGS. 437, 438.—Roller bearings.

mills, are first straightened either in a special machine made for the purpose or with a "crambo" used in a lathe.

The shafting, however, known as the "Patent Rolled Shafting" is a superior article to that which is prepared for turning, inasmuch as it is

subjected to a special treatment, which leaves little to be desired either for diametrical accuracy or uniform straightness. So far as the manufacture of the steel into a shaft, the process is identical with the usual practice, that is by "piling" and "rolling," as is the case when ordinary round steel bars are being produced. In the patented process, however, when the bar leaves the "rolls," it is a trifle larger in diameter than the proper size. The bar after being rolled is a good red heat; it is therefore allowed to cool down to a dull red heat (in daylight), which is found by practice to be the best heat for "planishing," as the operation which makes it true and straight is called.

The planishing machine is a massive structure, and stands well down on the floor to avoid lifting the bars to be operated upon. The machine consists of a pair of vertical discs, which rapidly revolve on horizontal shafts. They are nearly equal in diameter, and are placed face to face, but not with their centres opposite, there being a horizontal distance of about 9 in. between the centre lines of the discs. Supposing the faces to be three inches apart, and the discs to be revolving in the same direction, then if a bar slightly larger than three inches is placed between them, the bar will revolve on its own axis, and will be reduced in diameter to exactly three inches.

The bar is horizontal, and when it is at the same level as the centres of the discs it will simply revolve between them, and will have no other motion; if, however, it be lifted above the centres, say about $\frac{1}{2}$ in., it will, besides revolving, travel lengthwise between the discs. Should it be $\frac{1}{4}$ in. or so below the level of the centre, it will also travel lengthwise, but in the reverse direction. In this way, then, works the machine at the Kirkstall Forge. The bar is brought from the rolls slightly larger than the intended shaft. After cooling to the right temperature, it is placed on the table of the machine, which is level with the floor, and one end is inserted between the discs. It immediately commences to revolve and to travel longitudinally, so that after a little time the whole length of the bar has been operated upon or planished. When it leaves the discs, the bar is now a shaft, comparatively round and straight. The surfaces of the discs which perform the planishing are perfectly smooth, and during the operation a copious supply of water falls upon them and upon the shaft. Hence the latter leaves the machinery perfectly free from scale, and with a smooth skin having a dark-blue polish. These shafts are made in all sizes, from 7-in. down to $\frac{1}{2}$ -in. diameter. According to tests made, these rolled steel shafts were found to be one-fifth stronger (in tension) than the ordinary rolled shafts of the same diameter. This, however, is what might be expected from the nature of the planishing operations.

A recent test as to diametrical accuracy was made, and a maximum error of $\frac{1}{3000}$ of an inch was found.

The writer saw a machine under construction in which the shafts were of the above type; each shaft, after passing through several bearings, was quite free to rotate, requiring no adjustment.

Belts.—To ensure steady driving, a belt must be of uniform thickness and quality throughout. Leather belting is therefore generally made

from the choicest portions of the hide. Owing to the want of uniformity in quality of even the best belts, double belts are usually employed to drive large machine tools. "Raw-hide" belts give the most uniform drive with high speeds; these being strong and flexible, parallel in length, and even in thickness. Belt-joints are made by cementing, sewing, or riveting. Canvas, rubber, and gutta-percher are also made up into belts. Those made of canvas are apt to get frayed on the edges when controlled by a belt fork. This fraying may be obviated by fixing rollers on the fork ends, which revolve as the belt travels past them.

"*Crossed Belts.*"—A crossed or "full twist" belt gives a reverse motion to the driven shaft. (Fig. 439).



FIG. 439.—Crossed belt.

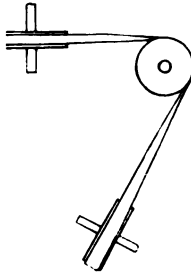

FIG. 440.—Driving at an angle.

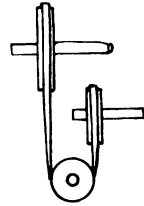
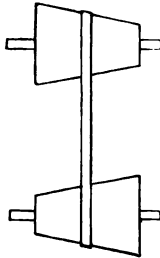
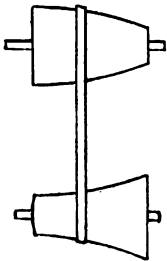

FIG. 441.—Quarter twist return.



FIGS. 442, 443.—Tapering cones.

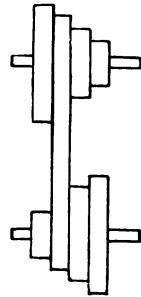
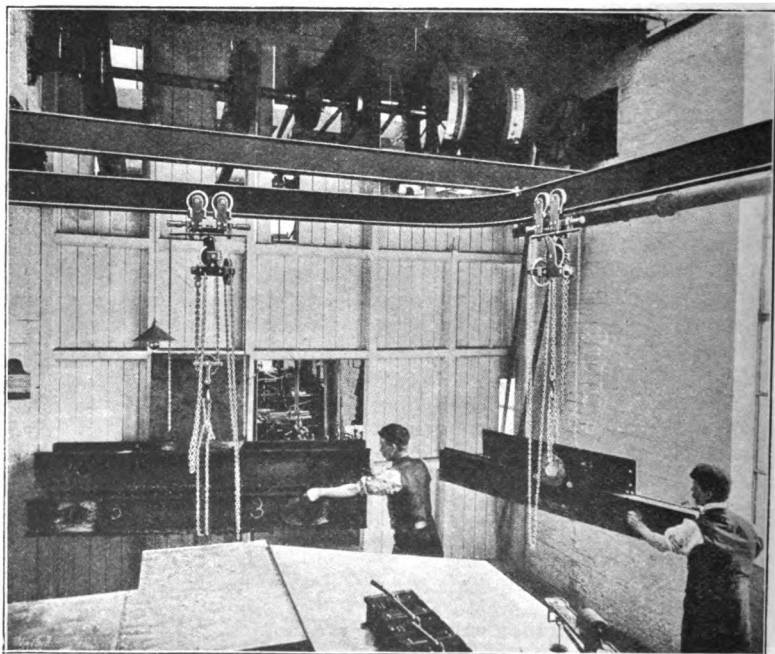
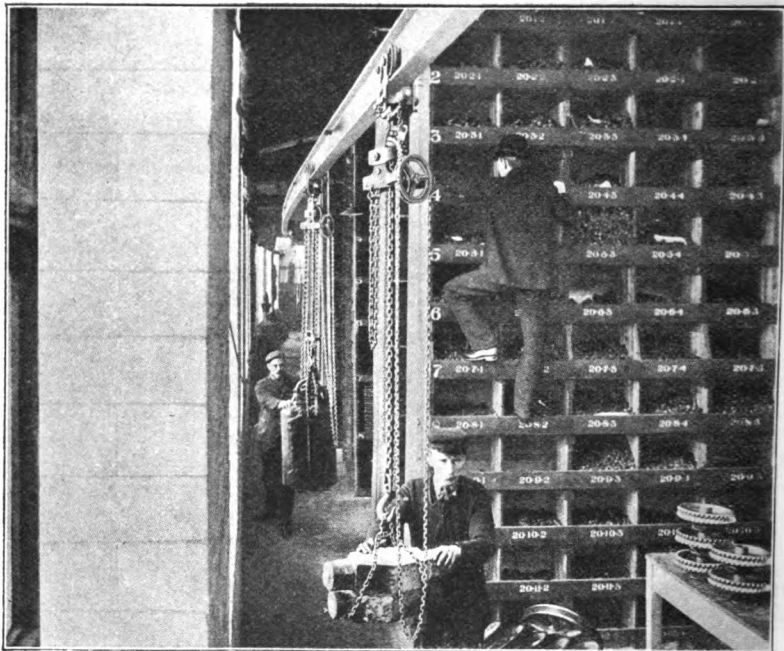

FIG. 444.—Stepped cones.

NOTE.—It is important in fixing a belt to note that it is properly twisted. The following hints may be useful :—

1. Note the direction of driving and driven shafts
2. Place belt on driving shaft so that "splices" are all in one direction, and that the end of splice leaves pulley last.
3. Take both ends of belt, and make *one* twist, taking care that the insides rub together.
4. According to the direction of drive required, let belt on forward



FIGS. 445, 446.—Tackle for lifting and shifting material.

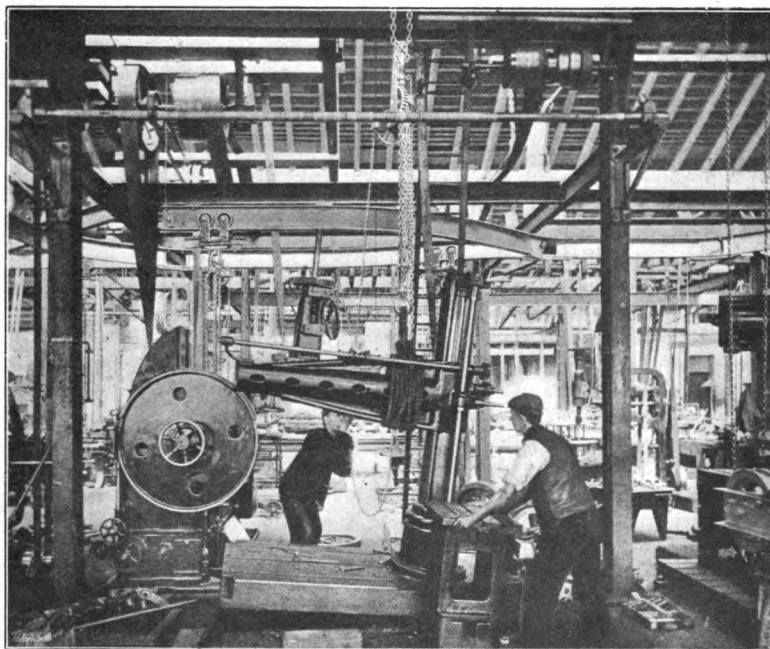
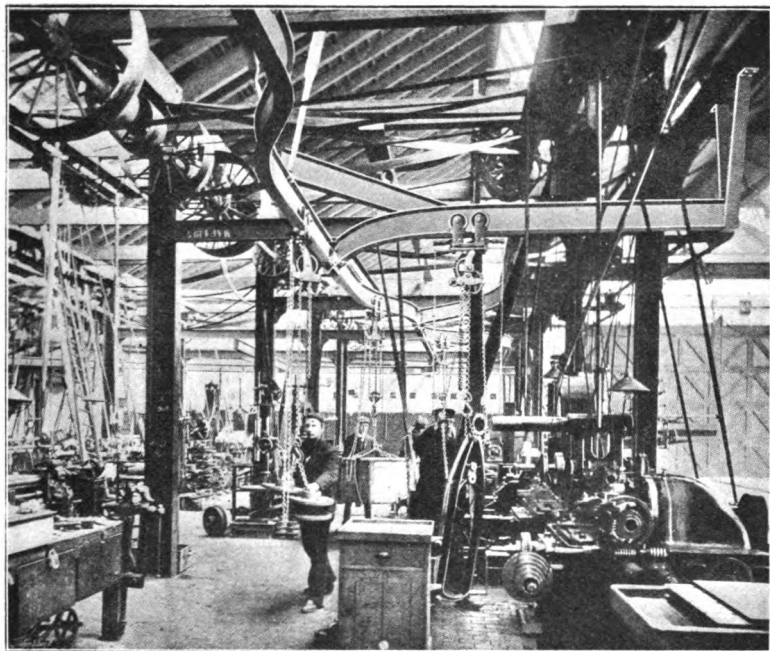

FIGS. 447, 448.—Tackle for lifting and shifting material.

side go to *driven* pulley and pass *over* it, that is, assuming the driving pulley parts with the belt *beneath* it.

Crossed belts are frequently used side by side, with "open," *i.e.* not crossed, belts, to reverse the direction of rotation of counter shafts to lathes and screwing machines when engaged in using dies or taps.

There are two distinct sets of pulleys required on the countershaft when the reversing motion is to be faster than the other one; this is obtained by pulleys of different diameters. When the speed of rotation is to be the same in both directions, three pulleys only are required, the two outer ones carry the open and crossed belts respectively, and are called idle or loose pulleys. The counter shaft can be instantly thrown into action by transferring one or other of the belts to the fast pulley between them.

Referring to the foregoing it will be understood that the belt forks are in opposite directions; these are to guide the belt on to the fast pulleys as required. Another way of doing this is to employ two pulleys with a clutch between them. The clutch actuates a cone disc which has its counterpart in the internal part of the pulley's rim. This is a very effective and smooth form of drive, there being no belt forks required.



FIG. 448A.—
"Blackwall"
hitch.

Transmitting Motion by Belts.—Fig. 440 shows the method of driving by belt a shaft placed at an angle. The two idle pulleys being placed on a shaft at right angles to the driving and driven shafts. When two parallel shafts lying in the same plane are too close for a direct drive, the arrangement shown in Fig. 441 is found satisfactory, called a Quarter Twist return belt.

Figs. 442 and 443 show two forms of tapering cones for altering the relative speeds of the driving and the driven shafts. These pulleys allow of a minute and continual change of the speed by traversing the belt.

The stepped speed cone shown in Fig. 444 may be considered as a modification of these taper cones.

"Slinging" a Piece of Work.—In fixing a rope sling on the hook of a crane or pulley block a secure way is to first twist a loop in the rope, as shown in Fig. 448A; the more pull there is on the rope, the tighter the loop grips the hook. This method is an improvement on the single loop, especially when the work has to be carried for a distance, high above the machinery in the shop. For the above purpose two slings are better than one; and by first placing a piece of canvas on the bright parts the possibility of the work slipping is diminished. Bright shafts are carried more securely by two slings than by one; the slings should be of an equal length. Rope slings are more reliable than iron chains. The former show fracture some time before severance, while the latter break without warning; this defect is greatly overcome by using a suitably strong chain, and further by periodically annealing every link.

Tackle for lifting and shifting Material.—One of the most important factors in the economic working of an engineering workshop is the facility with which the various iron castings and forgings are moved

from place to place, or to the machine tools. In modern and well-equipped shops one or two travelling cranes, worked either electrically, or by steam, or hand power, run the whole length and breadth of the shop. To such machines which cannot be conveniently reached by the traveller, *i.e.* those situated beneath the balcony, provision is made by having a single rail (with junctions and side tracks as required), upon which trolleys carrying pulley-blocks are located. There is by this arrangement a complete service of blocks always ready to the workmen's hands, so that waiting for a "crane" or a "lift" is not known. This is decidedly an advantage. We have seen men frequently wait for the crane and pulley-blocks too from ten to thirty minutes, and while they were being served *others had to wait*.

Figs. 445, 446, show material being run from the stores to the shops for either machining or fitting there.

Fig. 447 shows a view of a modern machine shop fitted complete with Herbert Morris and Bastert's system of Overhead Runways. The lifting gears and trolleys in this picture are engaged in taking material to and fixing same in the various machines it has to be operated on.

Fig. 448 shows this system being used for shifting a radial drilling machine from one place to another. Loads with this system are travelled with marvellous ease. The trolleys run on ball-bearings, and, owing to the high-class manner in which they are made, it is practically impossible for them to get out of order.

CHAPTER XIX.

METHODS OF WORKING.

THERE are three distinct systems of working in this country. The first may be called "time work," where each operative is paid at a pre-determined rate of wage per hour according to the agreement made when engaged either by the principal manager or the foreman, as the case may be. The amount may be the "standard rate," or less or more, according to personal ability or merit. In many establishments each order has a working number, and all work for that particular order is booked daily by every operative engaged on it. From this the actual cost of production may be ascertained, and for similar work comparison can be made from time to time.

In such establishments as make machines to a standard pattern a closer application of the "time system" is frequently observed. The quantity of pieces are given out to be "machined," and a record is made of the fact, and the time is also noted, both then and after the completion of the work, so that by a daily perusal of the storekeeper's book by the manager or foreman the eye soon becomes familiar; and since each operative is engaged usually in his special work, any great difference in the time booked is quickly detected, and inquiries are made. These investigations are very helpful to the managing staff, inasmuch as they make it familiar with all the reasons for delay or improvement, as the case may be. It is a wonderful and orderly system, because by it the exact stage of the work in progress can be ascertained not only to a day but to an hour.

Another system is that of piece work. One of the first essentials of a successful piece-work system is the establishment of a proper method of arriving at piece-work prices. The usual method pursued hitherto when prices have to be settled for a new machine is to either guess at the price from the nearest parallel case in the cost-book, or else to put one machine through the shop on "time work," and take the piece-work prices from the booked cost of the time work. Both these methods are inaccurate and unsatisfactory, especially the latter, for in this a distinct temptation is held out to the men to make the time job last as long as possible so as to get high piece-work prices, after which they take care to do the piece work itself at a slow rate, only making such profit as will not result in the price being "cut."

A more satisfactory system is that in which the price of each process is obtained by tabulating and pricing each of the elementary operations

into which it is sub-divided. To carry this system into effect it is necessary that speed and feed tables should be prepared for all the machine tools and appliances, and that notes should be taken continuously of the time taken on all elementary hand processes, such as the time taken to put the change wheels on a given lathe, the time taken to remove a face plate and put on a chuck, the time taken to remove a given weight from one part of the shop to another, and so on.

A continuous record of these matters taken day by day will not only be useful in settling piece-work prices, but it will also enable the manager to know where time is being wasted and where economy may be effected by improved methods.

The speed and feed tables having been prepared, the calculation of the cutting time of the tools may be effected by very simple formulæ; and if this were all that is necessary the piece-work prices would be a matter of a very simple calculation, and could be got out by the draughtsman when getting out his list of quantities and weights.

The point of real difficulty is the determination of the idle time; that is to say, the time lost in getting the stuff out of the stores, setting it in the machine, changing tools and chucks and so forth, all of which will take greater or less time according to the efficiency of the management.

The percentage of idle time is a good criterion of managerial ability, for upon it depend to a large extent the commercial success of the concern.

Before calculating the time which will be taken to do any given job, we must decide upon the cutting speed and rate of feed. These can only be determined either by experiment or from previous experience, as they depend upon many conditions. The job itself may be of such form as to spring or even break under the strain of a heavy cut, or its shape may be such that it cannot be held in the machine with sufficient firmness. The strength and stiffness of the machine tool, the chuck or vice, the slide-rest, and the cutting tool itself must all be considered. Then, again, the speed and feed are governed by the degree of accuracy required.

In jobs requiring no great accuracy a slight spring does not matter, and a heavy cut may be used; but where accuracy is needed, spring is not permissible, and light cuts are essential.

In connection with the following formulæ a few figures as to cutting speeds and feeds are given. These, however, must not be regarded as rigid figures, applicable to all cases, but rather as bases to commence from when experimenting to determine the right speeds for new jobs.

Lathe Work.—The number of revolutions per minute for a given cutting speed is obtained by formula No 1 :—

$$R = \frac{3.8 \times C}{D}$$

when R = revolutions.

C = cutting speed in feet per minute.

D = diameter of the job in inches.

The speed so found will probably not coincide with any of those on

the speed and feed tables, but, of course, the nearest is taken. The time required for each traverse is then found by formula No. 2 :—

$$T = \frac{L}{R \times F}$$

when T = time in minutes.

L = length of traverse in inches (whether sliding or surfacing.)

F = feed in inches per revolution.

EXAMPLE.—A shaft 2 in. in diameter to have a cut taken along 36 in. of its length.

C = 22 ft. per minute

F = 0.032 per revolution

$$R = \frac{3.8 \times 22}{2} = 41\frac{1}{2} \text{ revolutions, nearest} = 40$$

$$\text{Time} = \frac{36}{40 \times 0.032} = 28 \text{ minutes}$$

Cutting Speeds.—Cast iron, 30 ft. to 36 ft. per minute ; steel, 16 ft. to 26 ft. ; hardened steel and chilled iron, 13 ft.

Drilling formulæ Nos. 1 and 2 apply to drilling, C being the cutting speed at the periphery of the drill, R being the revolutions per minute of the drill, and L the depth of the hole.

Diameter of drill.	Wrought iron.		Cast iron.	
	C	F	C	F
$\frac{1}{8}$ in. to $\frac{1}{4}$ in. .	20	0.0035	16	0.0045
$\frac{1}{4}$ in.	20	0.005	16	0.00625
$\frac{1}{4}$ in. to $\frac{1}{2}$ in. .	20	0.0075	16	0.00875
$\frac{1}{2}$ in. and over .	20	0.010	16	0.0125

EXAMPLE.—Hole, $\frac{7}{8}$ in. diameter ; $3\frac{1}{4}$ through in wrought iron.

$$R = \frac{3.8 \times 20}{0.875} = 87, \text{ nearest } 90$$

$$T = \frac{3.25}{90 \times 0.01} = 3\frac{3}{4} \text{ minutes}$$

Milling.—The speed of the cutter in revolutions per minute for a given cutting speed is given by formula No. 1, in which C = the cutting speed at the periphery of the cutter, and D the diameter of the cutter. In preparing the speed and feed list the feed of the table in inches per minute, with the belt on the different cones, should be taken. The time taken for a given traverse is that given by the formula No. 3 :—

$$T = \frac{L}{F}$$

in which F is the feed of the table in inches per minute. (See Brown & Sharpe's Treatise on Milling.)

Planing.—As planing machines are set to run at one speed only, the preparation of their speed and feed table is a simple matter.

The time taken for a traverse is given by formula No. 4 :—

$$T = \frac{0.083 \times W \times L \times (1 + R)}{C \times F} \times x$$

in which W = width in inches of the surface ; L = the length of the stroke ; R = ratio of the quick return ; C = cutting speed in feet per minute ; F = feed in inches per cut, and x a constant depending on the loss of time at each reversal, and which must be determined by experiment for each machine.

EXAMPLE.—

(a) Surface 72 in. \times 36 in. wide.

$C = 20$ ft.

$F = 0.0625$, no quick return.

$x = \text{say } 1.05$.

$$T = \frac{0.083 \times 73 \times 36.25 \times (1 + 1)}{20 \times 0.0625} \times 1.05 = 369 \text{ mins.}$$

(b) Same job, but with quick return having a ratio of 1 to 4.

$$T = \frac{0.083 \times 73 \times 36.25 \times (1 + \frac{1}{4})}{20 \times 0.0625} \times 1.05 = 230 \text{ mins.}$$

Here we see the advantage of the quick return.

Slotting and Shaping.—There are two methods of driving the rams of slotters and shapers. In one the ram is driven by a screw with a reversing motion similar to that of a planer. This offers the advantage of a uniform speed of the tool throughout the stroke, but as the reversal is dependent upon momentum, it does not take place at exactly the same point at every stroke, so that clearance must be left for the tool at both ends, and this renders this class of machine unsuitable in those cases where the tool has to move within definite limits. For these machines formula No. 4 applies, the same as the planers.

In the other class of slotters and shapers the ram is driven by a crank and connecting rod, a quick return being generally obtained by driving the connecting rod through a link instead of attaching it directly to the crank pin. These machines have cone pulleys, and the stroke of the connecting rod can be varied so that a number of cutting speeds can be obtained. In preparing the speed and feed table the number of revolutions per minute of the crank shaft with the belt on different cones should be taken, and the revolutions per minute required for a given cutting speed and stroke are then found by the formula No. 5 :—

$$R = \frac{C \times 12}{L \times (1 + R)}$$

in which C = the cutting speed in feet per minute ; L = the stroke in inches ; and R = the ratio of the quick return. It should be borne in mind that in these machines the cutting speed is not uniform throughout the stroke, so that C represents the average cutting speed.

The time required for a complete traverse is given as before, by the formula No. 4, but omitting the constant x , as there is practically no loss of time at reversal.

In addition to the tools enumerated there are in every shop others of a special or subsidiary nature, the speeds and feeds of which also require to be obtained.

The foregoing formulæ will enable us to calculate very quickly the actual tooling time on the different jobs, but this is only one item among the number which go to make up the total time of the job.

When a man is given a new piece of work he usually has to go to the stores to fetch it, and when he arrives there a stores man not well acquainted with the work may bring him half a dozen articles before he hits upon the right one ; and perhaps the workman may stand neglected at the counter waiting till the storemen finish telling each other fairy-tales before condescending to give him their attention. When he gets back to his machine the work has to be chucked or cramped, the tools set, and measurements taken. The time of none of these things can be determined by calculation, but can be determined by a manager who has full power over the drawing office, works, and stores. He can order the work in such a way that the men do not have to go to the stores for their work, but have it laid beside their machines by the labourers in good time. He can also see that only men are employed in the stores who have been through the shops, and know the names and appearance of all the goods used, and he can also suppress gossip.

A tool room and regular supply of tools to the men, without the necessity of their taking them to be ground or dressed, is a natural accompaniment to piecework. The provision of time-saving chucks, tool-setting arrangements, and measuring instruments lies entirely with the manager. For these reasons the true determination of the piecework rates must lie with the manager and his staff, with whom will also lie the work of recording continuous observations of the time taken on the work as it proceeds.

When preparing the schedule of piecework prices it is desirable to prepare, at the same time, a complete list of the materials, with their weight and cost, so that the total cost of the contemplated work may be obtained, and alterations made if it is found excessive. The particulars should be entered into a book.

Lifting Tackle.—Each machine should have a handy jib or girder, a light-block or compressed-air cylinder to lift the work, so leaving the shop-traveller to have to deal with heavy jobs only.

Boring Mill.—This should have jaws (perfectly self-centering) on the face plate, and a turret to take the tools so as to save time in tool changing.

Lathe.—In order to save time in tool changing this should have

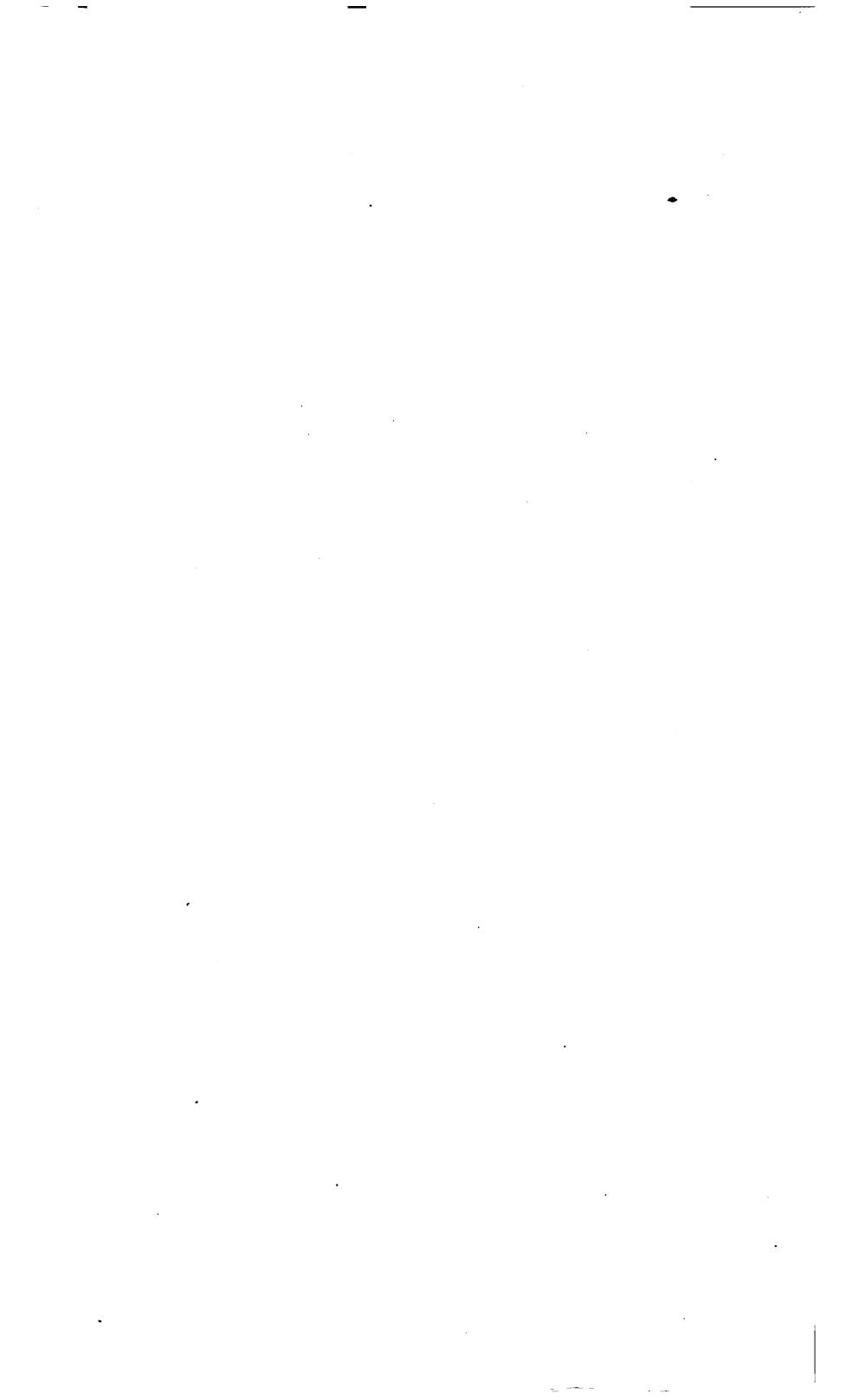

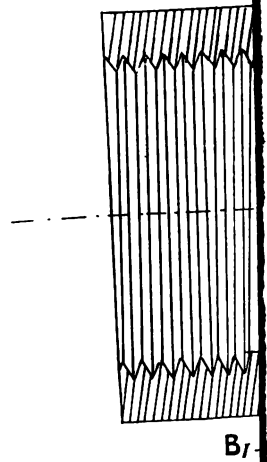
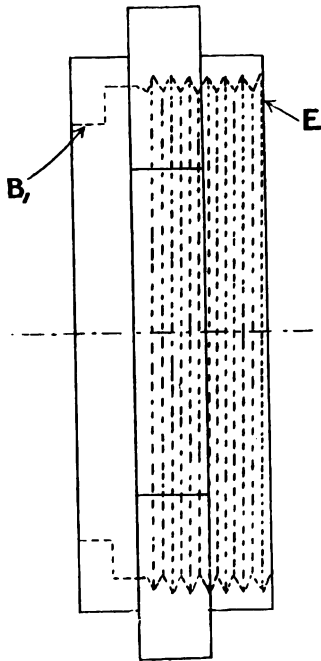
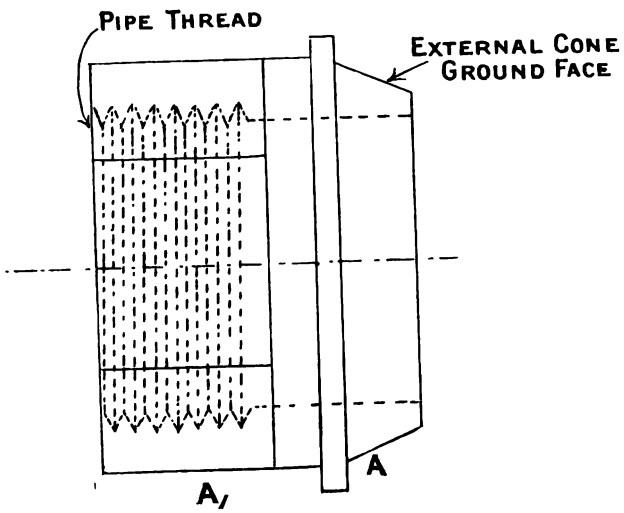

FIG. 449.—SECTIONS OF UN

turret, preferably square, so that the tools can be brought close up to the job, so avoiding spring. For the turning 45° corners and recesses the top should be set over by the tool-maker accurately, and then steady-pin hole drilled and reamed through the top and bottom wivel plates, so that the top can in future be set to 45° accurately without loss of time.

Drilling and Tapping.—In this work it is desirable to tap the holes immediately after they have been drilled, and before the job has been moved, so as to ensure the taper being concentric with the holes. The tapping chuck should therefore be arranged so that the drills and taps can be changed in it simultaneously. It should also have a reversing motion within itself, so that the tap can be run out without having to reverse the machine, and it should also have a friction clutch to prevent breakage of taps. The machine should be fitted with speed-changing gear, by means of which the speed can be changed instantly from tapping to drilling and *vice versa* without having to change the traps.

Stores.—Orders for various material required should be handed to the foreman labourer, and it should be his duty to see that they are obtained from the stores and laid by the machines in good time, so that the machine men may go straight on from job to job without loss of time. For the same reason their price notes should be given to them in advance, so they will see what jobs they have before them, and if they do not see the material coming round they can speak to the foreman about it in good time.

It should be noted on the schedule of piecework prices that for each process the name of the tool is entered on the same line as the number of hours which the process will take. From these entries a summary is prepared, which shows at a glance the total amount of work for the shop in any given job. With summaries for all the work in the shop, the manager can see at once what work he has before him, and how many hours it will take to finish; and bearing in mind the dates given for delivery, he can see whether any (and if so which) portion of the shop will have to work overtime to keep to promises.

Union Joint.—The union joint (Fig. 449) is a ground fit between the two coned surfaces A and B, and when held in contact by the retaining nut E, which is screwed on to the part B, a thoroughly steam-tight joint is made. When fixing the pieces together, the rim of B₁ is slipped over A₁, D is then screwed into the internal nut E until the faces of A and B make a joint. This is an easy joint to connect and disconnect, and when worn can be reground with emery powder and oil. The screwed portions are fitted to various sizes of steam piping; such, for instance, as a " $1\frac{1}{4}$ -in. union" means that the pipe is $1\frac{1}{4}$ -in. bore, but the outer diameter is 1.65, and the union is threaded to suit it. There are in this case eleven threads per inch. A table showing the number of threads per inch on each size of pipe is given on page 424.

Sometimes it is more convenient to have a flange on the union fastened together with bolts; in this case the faces form a steam-tight



joint. When it is desired to couple up a pipe of smaller size, a "bushing" is used; this screws over the small pipe with its internal threading and into the large pipe by its external threading. Two parallel pipes may be connected by a "fitting" called a return bend, made semicircular; or pipes may be joined by a Y-branch: this is where two pipes are rooted into one. The fitting called an elbow is to conduct a pipe in an angle of 90° or a right angle.

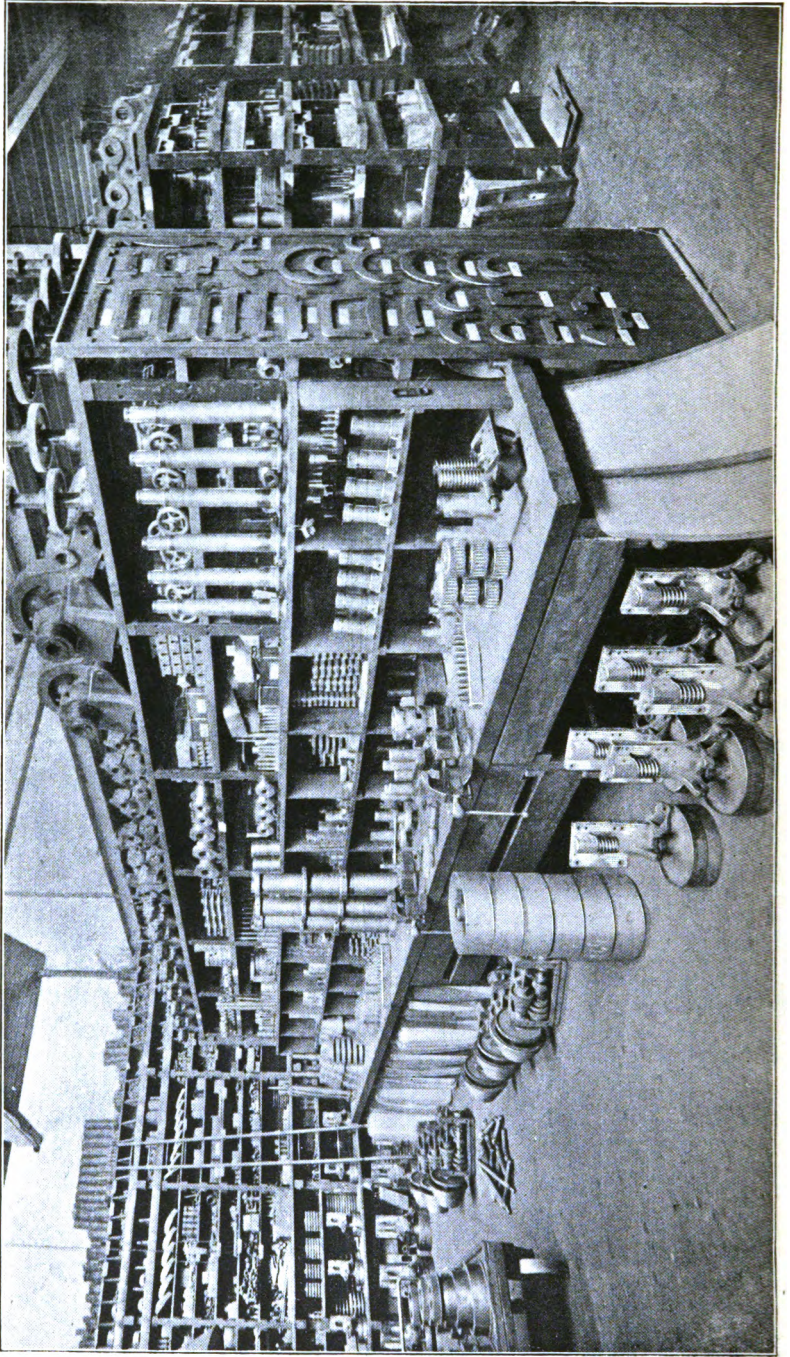

FIG. 49A.—MODERN STORE ROOM—FINISHED WORK.

APPENDIX

Shaw's Electrical Measuring Machine.—The foregoing measuring machines depend on the principle of compression, *i.e.* a feeler or "gravity piece" is directly or indirectly gripped between the head and the gauge; when the head is made to recede the "gravity piece" falls, and the reading on the machine is then taken.

But another principle, that of electric touch, has recently been proved by Dr. Shaw, Nottingham, to be much more sensitive than that

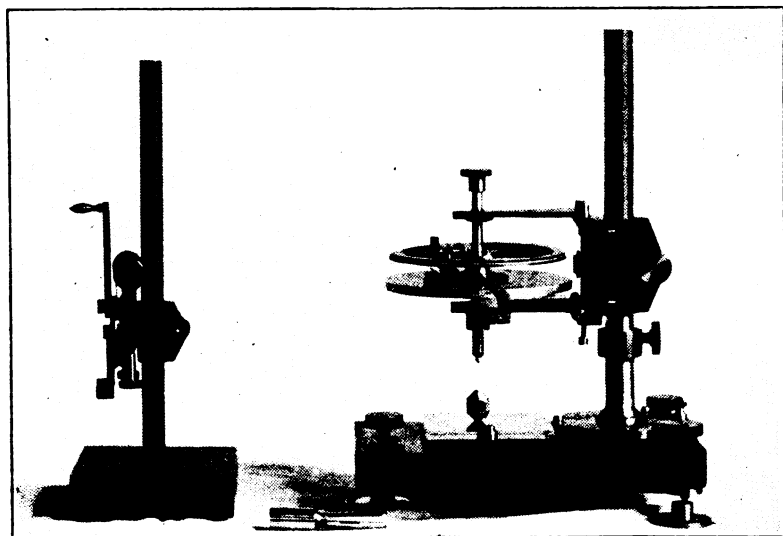

FIG 450.—Shaw's electrical measuring machine.

of compression. When the head touches the gauge an electric circuit is completed through a telephone carried by the observer. Instead of using heads which are plain or slightly convex, as in the compression machines, one or both heads are rounded points or beads. The screw has a pitch of $\frac{1}{50}$ in., the wheel has 500 divisions, and the vernier shows tenths—so the unit is $\frac{1}{250000}$ in. It is as easy to read a difference of this amount as $\frac{1}{25000}$ in. on a compression machine.

This great gain in sensitiveness is not due to any improvement in the mechanism, but to the totally different principle of detecting touch.

In the form of instrument shown there is a fixed base which is rendered optically plain; on this the gauge is placed, and the screw is lowered until electric contact is made. The electrical accessories are simple and easily arranged.

WHITWORTH STANDARD SCREW THREADS. (FIG. 451.)

$$\text{Formula } \begin{cases} p = \text{pitch} = \frac{1}{\text{No. of threads per inch}} \\ d = \text{depth} = p \times 0.64033. \\ r = \text{radius} = p \times 0.1373. \end{cases}$$

Diameter.	No. of threads per inch.	Diameter.	No. of threads per inch.	Diameter.	No. of threads per inch.	Diameter.	No. of threads per inch.
$\frac{1}{4}$	20	$\frac{7}{8}$	9	2	$4\frac{1}{2}$	$3\frac{1}{4}$	$3\frac{1}{4}$
$\frac{5}{16}$	18	$\frac{1}{2}$	9	$2\frac{1}{8}$	$4\frac{1}{2}$	$3\frac{3}{8}$	$3\frac{1}{4}$
$\frac{3}{8}$	16	1	8	$2\frac{1}{4}$	4	$3\frac{1}{2}$	$3\frac{1}{4}$
$\frac{17}{16}$	14	$1\frac{1}{8}$	7	$2\frac{3}{8}$	4	$3\frac{3}{8}$	$3\frac{1}{4}$
$\frac{1}{2}$	12	$1\frac{1}{4}$	7	$2\frac{1}{2}$	4	$3\frac{3}{4}$	3
$\frac{9}{16}$	12	$1\frac{3}{8}$	6	$2\frac{3}{8}$	4	$3\frac{3}{8}$	3
$\frac{7}{8}$	11	$1\frac{1}{2}$	6	$2\frac{1}{4}$	$3\frac{1}{2}$	4	3
$\frac{11}{16}$	11	$1\frac{5}{8}$	5	$2\frac{7}{8}$	$3\frac{1}{2}$		
$\frac{3}{4}$	10	$1\frac{3}{4}$	5	3	$3\frac{1}{2}$		
$\frac{13}{16}$	10	$1\frac{7}{8}$	$4\frac{1}{2}$	$3\frac{1}{8}$	$3\frac{1}{4}$		

AMERICAN STANDARD THREAD. (FIG. 452.)

$$\text{Formula } \begin{cases} p = \text{pitch} = \frac{1}{\text{No. of threads per inch}} \\ d = \text{depth} = p \times 0.6495. \\ f = \text{flat} = \frac{p}{8}. \end{cases}$$

Diameter.	No. of threads per inch.	Diameter.	No. of threads per inch.	Diameter.	No. of threads per inch.	Diameter.	No. of threads per inch.
$\frac{1}{4}$	20	1	8	$2\frac{1}{8}$	$4\frac{1}{2}$	$3\frac{1}{4}$	$3\frac{1}{2}$
$\frac{5}{16}$	18	$1\frac{1}{8}$	7	$2\frac{1}{4}$	$4\frac{1}{2}$	$3\frac{3}{8}$	$3\frac{1}{4}$
$\frac{3}{8}$	16	$1\frac{1}{4}$	7	$2\frac{3}{8}$	4	$3\frac{1}{2}$	$3\frac{1}{4}$
$\frac{7}{16}$	14	$1\frac{3}{8}$	6	$2\frac{1}{2}$	4	$3\frac{5}{8}$	$3\frac{1}{4}$
$\frac{1}{2}$	13	$1\frac{1}{2}$	6	$2\frac{3}{8}$	4	$3\frac{3}{4}$	3
$\frac{9}{16}$	12	$1\frac{5}{8}$	$5\frac{1}{2}$	$2\frac{1}{4}$	4	$3\frac{7}{8}$	3
$\frac{5}{8}$	11	$1\frac{3}{4}$	5	$2\frac{7}{8}$	$3\frac{1}{2}$	4	3
$\frac{3}{4}$	10	$1\frac{7}{8}$	5	3	$3\frac{1}{2}$		
$\frac{7}{8}$	9	2	$4\frac{1}{2}$	$3\frac{1}{8}$	$3\frac{1}{4}$		

ACME STANDARD SCREW THREAD. (FIG. 453.)

$$\text{Formula } \begin{cases} p = \text{pitch} = \frac{1}{\text{No. of threads per inch}} \\ d = \text{depth} = \frac{1}{2}p + 0.010. \\ f = \text{flat} = p \times 0.3707. \end{cases}$$

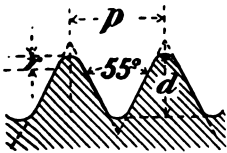

FIG. 451.

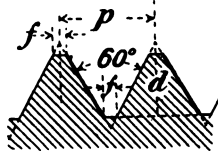

FIG. 452.

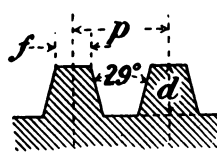

FIG. 453.

BRITISH ASSOCIATION STANDARD THREAD. (FIG. 454.)

$$\text{Formula } \begin{cases} p = \text{pitch} = \frac{1}{\text{No. of threads per inch}} \\ d = \text{depth} = p \times 0.06. \\ r = \text{radius} = \frac{2 \times p}{11}. \end{cases}$$

No.	Nominal dimensions in thousandths of an inch.			Absolute dimensions in millimetres.	
	Diameter.	Pitch.	Threads per inch.	Diameter.	Pitch.
25	10	2.8	353.0	0.25	0.072
24	11	3.1	317.0	0.29	0.080
23	13	3.5	285.0	0.33	0.089
22	15	3.9	259.0	0.37	0.098
21	17	4.3	231.0	0.42	0.11
20	19	4.7	212.0	0.48	0.12
19	21	5.5	181.0	0.54	0.14
18	24	5.9	169.0	0.62	0.15
17	27	6.7	149.0	0.70	0.17
16	31	7.5	134.0	0.79	0.19
15	35	8.3	121.0	0.90	0.21
14	39	9.1	110.0	1.0	0.23
13	44	9.8	101.0	1.2	0.25
12	51	11.0	90.7	1.3	0.28
11	59	12.2	81.9	1.5	0.31
10	67	13.8	72.6	1.7	0.35
9	75	15.4	65.1	1.9	0.39
8	86	16.9	59.1	2.2	0.43
7	98	18.9	52.9	2.5	0.48
6	110	20.9	47.9	2.8	0.53
5	126	23.2	43.0	3.2	0.59
4	142	26.0	38.5	3.6	0.66
3	161	28.7	34.8	4.1	0.73
2	185	31.9	31.4	4.7	0.81
1	209	35.4	28.2	5.3	0.90
0	236	39.4	25.4	6.0	1.00

SHARP "V" THREAD. (FIG. 455.)

$$\text{Formula } \begin{cases} p = \text{pitch} = \frac{1}{\text{No. of threads per inch}} \\ d = \text{depth} = p \times 0.8660. \end{cases}$$

Diameter.	No. of threads per inch.	Diameter.	No. of threads per inch.	Diameter.	No. of threads per inch.	Diameter.	No. of threads per inch.
$\frac{1}{4}$	20	$\frac{7}{8}$	9	2	$4\frac{1}{2}$	$3\frac{1}{4}$	$3\frac{1}{2}$
$\frac{5}{16}$	18	$\frac{3}{4}$	9	$2\frac{1}{8}$	$4\frac{1}{2}$	$3\frac{3}{8}$	$3\frac{1}{4}$
$\frac{3}{8}$	16	1	8	$2\frac{1}{4}$	$4\frac{1}{2}$	$3\frac{1}{2}$	$3\frac{1}{4}$
$\frac{7}{16}$	14	$1\frac{1}{8}$	7	$2\frac{1}{2}$	$4\frac{1}{2}$	$3\frac{5}{8}$	$3\frac{1}{4}$
$\frac{1}{2}$	12	$1\frac{1}{4}$	7	$2\frac{1}{2}$	4	$3\frac{7}{8}$	3
$\frac{9}{16}$	12	$1\frac{3}{8}$	6	$2\frac{3}{8}$	4	$3\frac{7}{8}$	3
$\frac{5}{8}$	11	$1\frac{1}{2}$	6	$2\frac{3}{4}$	4	4	3
$\frac{11}{16}$	11	$1\frac{5}{8}$	5	$2\frac{7}{8}$	4		
$\frac{3}{4}$	10	$1\frac{3}{4}$	5	3	$3\frac{1}{2}$		
$\frac{13}{16}$	10	$1\frac{7}{8}$	$4\frac{1}{2}$	$3\frac{1}{2}$	$3\frac{1}{2}$		

INTERNATIONAL AND FRENCH STANDARD THREAD (*Metric System*).

(FIG. 456.)

$$\text{Formula } \begin{cases} p = \text{pitch} = \frac{1}{\text{No. of threads per inch}} \\ d = \text{depth} = p \times 0.6495. \\ f = \text{flat} = \frac{p}{8}. \end{cases}$$

INTERNATIONAL STANDARD. TAPS AND DIES.

Diameter. Millimetres.	Pitch. Millimetres.	Diameter. Millimetres.	Pitch. Millimetres.	Diameter. Millimetres.	Pitch. Millimetres.
6	1.0	20	2.5	48	5.0
7	1.0	22	2.5	52	5.0
8	1.25	24	3.0	56	5.5
9	1.25	27	3.0	60	5.5
10	1.5	30	3.5	64	6.0
11	1.5	33	3.5	68	6.5
12	1.75	36	4.0	72	6.5
14	2.0	39	4.0	76	6.5
16	2.0	42	4.5	80	7.0
18	2.5	45	4.5		

FRENCH STANDARD. TAPS AND DIES.

Diameter. Millimetres.	Pitch. Millimetres.	Diameter. Millimetres.	Pitch. Millimetres.	Diameter. Millimetres.	Pitch. Millimetres.
3	0.5	16	2.0	36	4.0
4	0.75	18	2.5	38	4.0
5	0.75	20	2.5	40	4.0
6	1.0	22	3.0	42	4.5
7	1.0	24	3.0	44	4.5
8	1.0	26	3.0	46	4.5
9	1.0	28	3.0	48	5.0
10	1.5	30	3.5	50	5.0
12	1.5	32	3.5		
14	2.0	34	3.5		



FIG. 454.

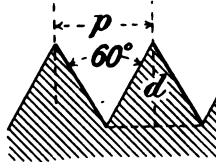

FIG. 455.



FIG. 456.

WHITWORTH GAS THREADS.

Size.	Diameter.	Diameter at bottom of thread.	Number of threads per inch.	Size.	Diameter.	Diameter at bottom of thread.
in. 1/8	0.3825	0.3367	28	in. 1 3/8	2.021	1.905
1/4	0.518	0.4506	19	1 1/2	2.16	2.042
3/8	0.6563	0.5889	19	1 3/4	2.245	2.1285
1/2	0.8257	0.7342	14	2	2.347	2.2305
5/8	0.9022	0.8107	14	2 1/4	2.5875	2.471
3/4	1.041	0.9495	14	2 1/2	3.0013	2.8848
7/8	1.189	1.0975	14	2 3/4	3.247	3.1305
1	1.309	1.1925	11	3	3.485	3.3685
1 1/8	1.492	1.3755	11	3 1/4	3.6985	3.582
1 1/4	1.65	1.5335	11	3 1/2	3.912	3.7955
1 3/8	1.745	1.6285	11	3 3/4	4.1255	4.009
1 1/2	1.8825	1.765	11	4	4.339	4.223

NOTE.—All piping above 1 in. has 11 threads per inch.

THICKNESSES OF PIPES.

Gas and water piping.			Hydraulic piping. Wrought iron.			Hydraulic piping. Cast iron 700 lbs.	
Internal diameter of pipe.	External diameter of pipe.	Number of threads per inch.	Internal diameter of pipe to stand 4000 lbs. per square inch.	External diameter of pipe.	Number of threads per inch.	Internal diameter of pipe.	External diameter of pipe.
in.	0'656	19	in.	in.	14	in.	in.
$\frac{1}{8}$	0'825	14	$\frac{1}{8}$	$\frac{1}{8}$	14	$\frac{1}{8}$	$1\frac{1}{8}$
$\frac{1}{4}$	1'041	14	$\frac{1}{4}$	$\frac{1}{4}$	14	2	$2\frac{3}{8}$
$\frac{3}{8}$	1'309	11	$\frac{3}{8}$	$\frac{3}{8}$	11	$2\frac{1}{2}$	$2\frac{1}{2}$
$\frac{1}{2}$	1'492	11	$\frac{1}{2}$	$\frac{1}{2}$	11	$2\frac{1}{2}$	$2\frac{3}{8}$
$\frac{5}{8}$	1'650	11	$\frac{5}{8}$	$\frac{5}{8}$	11	3	$3\frac{3}{8}$
1	1'745	11	1	1	11	$3\frac{1}{2}$	$3\frac{3}{8}$
$1\frac{1}{8}$	1'882	11	$1\frac{1}{8}$	$1\frac{1}{8}$	11	4	$4\frac{3}{8}$
$1\frac{1}{4}$	2'021	11	$1\frac{1}{4}$	$1\frac{1}{4}$	11	5	$5\frac{7}{8}$
$1\frac{3}{8}$	2'158	11	$1\frac{3}{8}$	2	11	6	7
$1\frac{1}{2}$	2'245	11	$1\frac{1}{2}$	2	11		
$1\frac{3}{4}$	2'347	11	$1\frac{3}{4}$	$2\frac{1}{4}$	11		
2	2'467	11	2	$2\frac{3}{8}$	11		
$2\frac{1}{8}$	2'587	11		2	11		
$2\frac{1}{4}$	2'794	11					
$2\frac{3}{8}$	3'001	11					

HORSE-POWER REQUIRED TO DRIVE MACHINERY (*Flather*).

Machine.	H.P.
Small screw-cutting lathe, $13\frac{1}{2}$ -in. swing (back-geared)	0'41
Screw-cutting lathe, 20 in.	0'47
Large facing lathe, treble-geared, will swing 68 in.	0'91
Shaper, 15-in. stroke	0'63
Planing machine, 36 in. \times 36 in. \times 11 ft.	0'84
Large plane, 76 in. \times 76 in. \times 57 ft.	1'47
Large drilling machine	1'24
Radial drill, 6-ft. swing	0'53
Slotting machine, 8-in. stroke	0'28
Slotting machine, 15-in. stroke	0'95
Universal milling machine (Brown & Sharpe, No. 1)	0'28
Gear-cutting machine, to cut 20 in. diameter	0'28
Horizontal boring machine (for iron), 22-in. swing	0'93
Hydraulic shearing machine	1'52
Large plate shears, knives 28 in. long, 3-in. stroke, to punch plates $1\frac{1}{4}$ in. thick	7'12

Grindstone for tools, 31 in. diameter, 6-in. face (velocity, 680 ft. per minute) 1'55
 Grindstone for stock, 42 in. diameter, 12-in. face (velocity, 1680 ft. per minute) 3'11

DECIMAL EQUIVALENTS OF PARTS OF AN INCH.

$\frac{1}{8}$	$\frac{1}{16}$	$\frac{1}{32}$	$\frac{1}{64}$	$\frac{1}{128}$	$\frac{1}{256}$	$\frac{1}{512}$	$\frac{1}{1024}$
0'01563	0'03125	0'04688	0'0625	0'07813	0'09375	0'10938	0'125
$\frac{1}{4}$	$\frac{1}{8}$	$\frac{1}{16}$	$\frac{1}{32}$	$\frac{1}{64}$	$\frac{1}{128}$	$\frac{1}{256}$	$\frac{1}{512}$
0'26563	0'28125	0'29688	0'3125	0'32813	0'34375	0'35938	0'375
$\frac{3}{8}$	$\frac{1}{2}$	$\frac{5}{8}$	$\frac{3}{4}$	$\frac{7}{8}$	$\frac{1}{1}$	$\frac{1}{1}$	$\frac{1}{1}$
0'51563	0'53125	0'54688	0'5625	0'57813	0'59375	0'60938	0'625
$\frac{1}{2}$	$\frac{3}{4}$	$\frac{5}{8}$	$\frac{3}{4}$	$\frac{7}{8}$	$\frac{1}{1}$	$\frac{1}{1}$	$\frac{1}{1}$
0'76563	0'78125	0'79688	0'8125	0'82813	0'84375	0'85938	0'875
$\frac{1}{2}$	$\frac{3}{4}$	$\frac{5}{8}$	$\frac{3}{4}$	$\frac{7}{8}$	$\frac{1}{1}$	$\frac{1}{1}$	$\frac{1}{1}$
0'82813	0'84375	0'85938	0'875	0'89063	0'90625	0'92188	0'9375
$\frac{1}{2}$	$\frac{3}{4}$	$\frac{5}{8}$	$\frac{3}{4}$	$\frac{7}{8}$	$\frac{1}{1}$	$\frac{1}{1}$	$\frac{1}{1}$
0'90625	0'92188	0'9375	0'95313	0'96875	0'98438	0'99999	1'00000
$\frac{1}{2}$	$\frac{3}{4}$	$\frac{5}{8}$	$\frac{3}{4}$	$\frac{7}{8}$	$\frac{1}{1}$	$\frac{1}{1}$	$\frac{1}{1}$
0'95313	0'96875	0'98438	0'99999	1'00000	1'00000	1'00000	1'00000
$\frac{1}{2}$	$\frac{3}{4}$	$\frac{5}{8}$	$\frac{3}{4}$	$\frac{7}{8}$	$\frac{1}{1}$	$\frac{1}{1}$	$\frac{1}{1}$
0'99999	1'00000	1'00000	1'00000	1'00000	1'00000	1'00000	1'00000

FRENCH OR METRIC MEASURES.

The metric unit of length is the metre = 39'37 inches.

The metric unit of weight is the kilogram = 2'2046 pounds.

The following prefixes are used for subdivisions and multiples.

Milli = $\frac{1}{1000}$, centi = $\frac{1}{100}$, deci = $\frac{1}{10}$, deca = 10, hecto = 100, kilo = 1000, myria = 10,000.

FRENCH AND BRITISH (AND AMERICAN) EQUIVALENT MEASURES.

Measures of Length.

French.	British and U.S.
1 metre	= 39'37 inches, or 3'2808 feet, 1'00 yards.
0'3048 metre	= 1 foot.
1 centimetre	= 0'3937 inch.
2'54 centimetres	= 1 inch.
1 millimetre	= 0'03937 inch.
25'4 millimetres	= 1 inch.
1 kilometre	= 1093'6 yards, or 0'62137 mile.

Measures of Weight

French.	British and U.S.
1 gramme	= 15'432 grains.
0'0648 gramme	= 1 grain.
28'35 gramme	= 1 ounce avoirdupois.
1 kilogramme	= 2'2046 pounds.

Measures of Weight.—continued.

French.		British and U.S.
0·4536 kilogramme	=	1 pound.
1 tonne or metric ton	}	0·9842 ton of 2240 pounds.
1000 kilogrammes		19·68 cwts.
1·016 metric tons	}	2204·6 pounds.
1016 kilogrammes		= 1 ton of 2240 pounds.

Measures of Capacity.

French.		British and U.S.
1 litre (1 cubic decimetre)	=	61·023 cubic inches.
		0·03532 cubic foot.
		0·2642 gallon (American).
		2·202 pounds of water at 62° F.
28·316 litres	=	1 cubic foot.
4·543 litres	=	1 gallon (British).
3·785 litres	=	1 gallon (American).

MEASUREMENTS.

Linear Measure.

12 inches = 1 foot.	1 kilometre = 1000 metres.
3 feet = 1 yard.	1 decimetre = 0·1 metre.
5½ yards = 1 pole.	1 centimetre = 0·01 metre.
40 poles = 1 furlong.	1 millimetre = 0·001 metre.
8 furlongs = 1 mile.	1 metre = 3 feet 3¼ inches.

Measures of Area.

144 sq. inches = 1 sq. foot.	1 arc = 100 sq. metres.
9 sq. yards = 1 sq. yard.	1 centi-arc = 1 sq. metre.
4840 sq. yards = 1 acre.	

Measures of Volume.

1728 cubic inches = 1 cubic foot.	1 stere = 1 cubic metre.
27 cubic feet = 1 cubic yard.	

Measures of Capacity.

4 gills = 1 pint.	1 kilolitre = 1000 litres.
2 pints = 1 quart.	1 hectolitre = 100 litres.
4 quarts = 1 gallon.	1 decalitre = 10 litres.
2 gallons = 1 peck.	1 litre
4 pecks = 1 bushel.	1 decilitre = 0·1 litre.
1 gallon of pure water weighs	1 centilitre = 0·01 litre.
10 pounds avoirdupois.	1 millilitre = 0·001 of a litre.
	1 litre of pure water weighs 1 kilo-
	gram.

<i>Imperial System.</i>	<i>Metric System.</i>
16 drams = 1 ounce.	1 kilogram = 1000 grams.
16 ounces = 1 pound.	1 hectogram = 100 grams.
14 pounds = 1 stone.	1 decagram = 10 grams.
8 stones = 1 hundredweight (cwt.)	1 gram
20 cwt. = 1 ton.	1 decigram = 0'1 gram.
	1 centigram = 0'01 gram.
	1 milligram = 0'001 gram.
	1 kilogram = 2 $\frac{1}{10}$ or 2'2 pounds avoirdupois nearly.

Abbreviated Equivalents.

1 millimetre = $\frac{1}{100}$ of an inch.
1 metre = $3\frac{1}{3}$ feet.
1 kilometre = $\frac{5}{16}$ of a mile.
1 sq. metre = $1\frac{2}{10}$ sq. yard.

TABLE OF DECIMAL EQUIVALENTS OF STUBS' STEEL WIRE GAUGE.

Letter.	Size of letter in decimals.	No. of wire gauge.	Size of number in decimals.	No. of wire gauge.	Size of number in decimals.	No. of wire gauge.	Size of number in decimals.
Z	0'413	1	0'227	28	0'139	55	0'050
Y	0'404	2	0'219	29	0'134	56	0'045
X	0'397	3	0'212	30	0'127	57	0'042
W	0'386	4	0'207	31	0'120	58	0'041
V	0'377	5	0'204	32	0'115	59	0'040
U	0'368	6	0'201	33	0'112	60	0'039
T	0'358	7	0'199	34	0'110	61	0'038
S	0'348	8	0'197	35	0'108	62	0'037
R	0'339	9	0'194	36	0'106	63	0'036
Q	0'332	10	0'191	37	0'103	64	0'035
P	0'323	11	0'188	38	0'101	65	0'033
O	0'316	12	0'185	39	0'099	66	0'032
N	0'302	13	0'182	40	0'097	67	0'031
M	0'295	14	0'180	41	0'095	68	0'030
L	0'290	15	0'178	42	0'092	69	0'029
K	0'281	16	0'175	43	0'088	70	0'027
J	0'277	17	0'172	44	0'085	71	0'026
I	0'272	18	0'168	45	0'081	72	0'024
H	0'266	19	0'164	46	0'079	73	0'023
G	0'261	20	0'161	47	0'077	74	0'022
F	0'257	21	0'157	48	0'075	75	0'020
E	0'250	22	0'155	49	0'072	76	0'018
D	0'246	23	0'153	50	0'069	77	0'016
C	0'242	24	0'151	51	0'066	78	0'015
B	0'238	25	0'148	52	0'063	79	0'014
A	0'234	26	0'146	53	0'058	80	0'013
		27	0'143	54	0'055		

STUBS' GAUGES.

In using the gauges known as Stubs' Gauges, there should be constantly borne in mind the difference between the Stubs' Iron Wire Gauge and the Stubs' Steel Wire Gauge. The Stubs' Iron Wire Gauge is the one commonly known as the English Standard Wire, or Birmingham Gauge, and designates the Stubs' *soft* wire sizes.

The Stubs' Steel Wire Gauge is the one that is used in measuring drawn steel wire or drill rods of Stubs' make, and is also used by many makers of American drill rods.

DIMENSIONS OF SIZES IN DECIMAL PARTS OF AN INCH.

Number of wire gauge.	American, or Brown and Sharpe.	Birmingham, or Stubs' wire.	Washburn & Moen Manufacturing Co., Worcester, Mass.	Imperial wire gauge.	Stubs' steel wire.	U. S. standard for plate.	Number of wire gauge.
000000	—	—	—	0'464	—	0'46875	000000
00000	—	—	—	0'432	—	0'4375	00000
0000	0'46	0'454	0'3938	0'400	—	0'40625	0000
000	0'40964	0'425	0'3625	0'372	—	0'375	000
00	0'3648	0'38	0'3310	0'348	—	0'34375	00
0	0'32486	0'34	0'3065	0'324	—	0'3125	0
1	0'2893	0'3	0'2830	0'300	0'227	0'28125	1
2	0'25763	0'284	0'2625	0'276	0'219	0'265625	2
3	0'22942	0'259	0'2437	0'252	0'212	0'25	3
4	0'20431	0'238	0'2253	0'232	0'207	0'234375	4
5	0'18194	0'22	0'2070	0'212	0'204	0'21875	5
6	0'16202	0'203	0'1920	0'192	0'201	0'203125	6
7	0'14428	0'18	0'1770	0'176	0'199	0'1875	7
8	0'12849	0'165	0'1620	0'160	0'197	0'171875	8
9	0'11443	0'148	0'1483	0'144	0'194	0'15625	9
10	0'10189	0'134	0'1350	0'128	0'191	0'140625	10
11	0'090742	0'12	0'1205	0'116	0'188	0'125	11
12	0'080808	0'109	0'1055	0'104	0'185	0'109375	12
13	0'071961	0'095	0'0915	0'092	0'182	0'09375	13
14	0'064084	0'083	0'0800	0'080	0'180	0'078125	14
15	0'057068	0'072	0'0720	0'072	0'178	0'0703125	15
16	0'05082	0'065	0'0625	0'064	0'175	0'0625	16
17	0'045257	0'058	0'0540	0'056	0'172	0'05625	17
18	0'040303	0'049	0'0475	0'048	0'168	0'05	18
19	0'03589	0'042	0'0410	0'040	0'164	0'04375	19
20	0'031961	0'035	0'0348	0'036	0'161	0'0375	20
21	0'028462	0'032	0'03175	0'032	0'157	0'034375	21
22	0'025347	0'028	0'0286	0'028	0'155	0'03125	22
23	0'022571	0'025	0'0258	0'024	0'153	0'028125	23
24	0'0201	0'022	0'0230	0'022	0'151	0'025	24
25	0'0179	0'02	0'0204	0'020	0'148	0'021875	25
26	0'01594	0'018	0'0181	0'018	0'146	0'01875	26
27	0'014195	0'016	0'0173	0'0164	0'143	0'0171875	27
28	0'012641	0'014	0'0162	0'0149	0'139	0'015625	28
29	0'011257	0'013	0'0150	0'0136	0'134	0'0140625	29
30	0'010025	0'012	0'0140	0'0124	0'127	0'0125	30
31	0'008928	0'01	0'0132	0'0116	0'120	0'0109375	31
32	0'00795	0'009	0'0128	0'0108	0'115	0'01015625	32
33	0'00708	0'008	0'0118	0'0100	0'112	0'009375	33
34	0'006304	0'007	0'0104	0'0092	0'110	0'00859375	34
35	0'005614	0'005	0'0095	0'0084	0'108	0'0078125	35
36	0'005	0'004	0'0090	0'0076	0'106	0'00703125	36
37	0'004453	—	—	0'0068	0'103	0'006040625	37
38	0'003965	—	—	0'0060	0'101	0'00625	38
39	0'003531	—	—	0'0052	0'099	—	39
40	0'003144	—	—	0'0048	0'097	—	40

WEIGHTS OF SQUARE AND ROUND BARS OF WROUGHT IRON
IN POUNDS PER LINEAL FOOT.—*Kent.*

IRON WEIGHING 480 LBS. PER CUBIC FOOT. FOR STEEL, ADD 2 PER CENT.

Thickness or diameter in inches.	Weight of square bar one foot long.	Weight of round bar one foot long.	Thickness or diameter in inches.	Weight of square bar one foot long.	Weight of round bar one foot long.
0					
1-16	0'013	0'010	1-2	20'83	16'36
1-8	0'052	0'041	9-16	21'89	17'19
3-16	0'117	0'092	5-8	22'97	18'04
1-4	0'208	0'164	11-16	24'08	18'91
5-16	0'326	0'256	3-4	25'21	19'80
3-8	0'469	0'368	13-16	26'37	20'71
7-16	0'638	0'501	7-8	27'55	21'64
1-2	0'833	0'654	15-16	28'76	22'59
9-16	1'055	0'828	3	30'00	23'56
5-8	1'302	1'023	1-16	31'26	24'55
11-16	1'576	1'237	1-8	32'55	25'57
3-4	1'875	1'473	3-16	33'87	26'60
13-16	2'201	1'728	1-4	35'21	27'65
7-8	2'552	2'004	5-16	36'58	28'73
15-16	2'930	2'301	3-8	37'97	29'82
1			7-16	39'39	30'94
1-16	3'333	2'618	1-2	40'83	32'07
1-8	3'763	2'955	9-16	42'30	33'23
3-16	4'219	3'313	5-8	43'80	34'40
1-4	5'208	4'091	11-16	45'33	35'60
5-16	5'742	4'510	3-4	46'88	36'82
3-8	6'302	4'950	13-16	48'45	38'05
7-16	6'888	5'410	7-8	50'05	39'31
1-2	7'500	5'890	15-16	51'68	40'59
9-16	8'138	6'392	4	53'33	41'89
5-8	8'802	6'913	1-16	55'01	43'21
11-16	9'492	7'455	1-8	56'72	44'55
3-4	10'21	8'018	3-16	58'45	45'91
13-16	10'95	8'601	1-4	60'21	47'29
7-8	11'72	9'204	5-16	61'99	48'69
15-16	12'51	9'828	3-8	63'80	50'11
2			7-16	65'64	51'55
1-16	13'33	10'47	1-2	67'50	53'01
1-8	14'18	11'14	9-16	69'39	54'50
3-16	15'05	11'82	5-8	71'30	56'00
1-4	15'95	12'53	11-16	73'24	57'52
5-16	16'88	13'25	3-4	75'21	59'07
3-8	17'83	14'00	13-16	77'20	60'63
7-16	18'80	14'77	7-8	79'22	62'22
	19'80	15'55	15-16	81'26	63'82

“Renolds” Driving Chains and Wheels.—Chain-gear is a positive method of driving, combining the advantages of wheel gearing, with the



FIG. 457.—“Renold” patent silent chain.

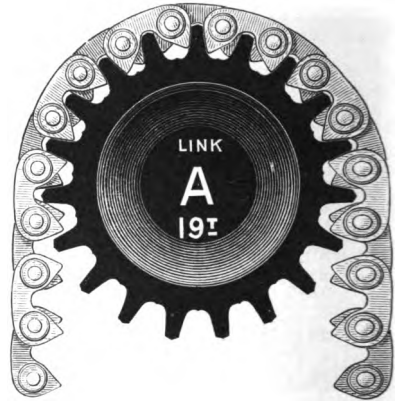

FIG. 458.

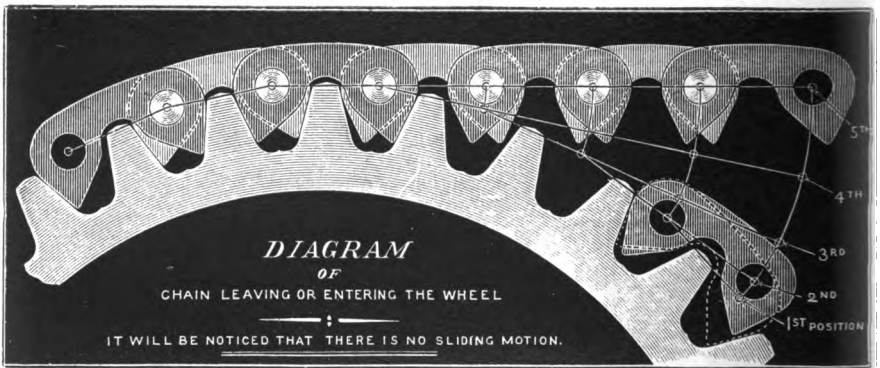

FIG. 459.—Silent chain-tooth form.

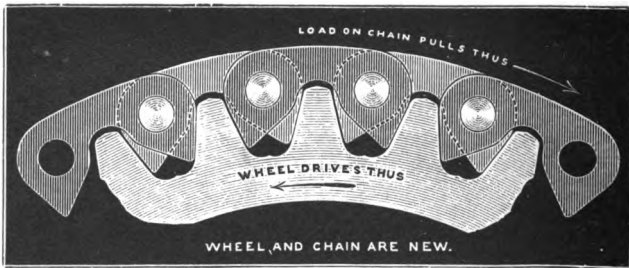

FIG. 460.—New wheel and chain.

simplicity of belt driving. The illustrations Figs. 457, 458 show forms of chain teeth of different diameter, these having fifteen and nineteen teeth



FIG. 461.—Worn and lengthened chain.

respectively. A special feature in this form of drive in the construction of the chain (see Fig. 459). As there is no sliding, the chain transmits

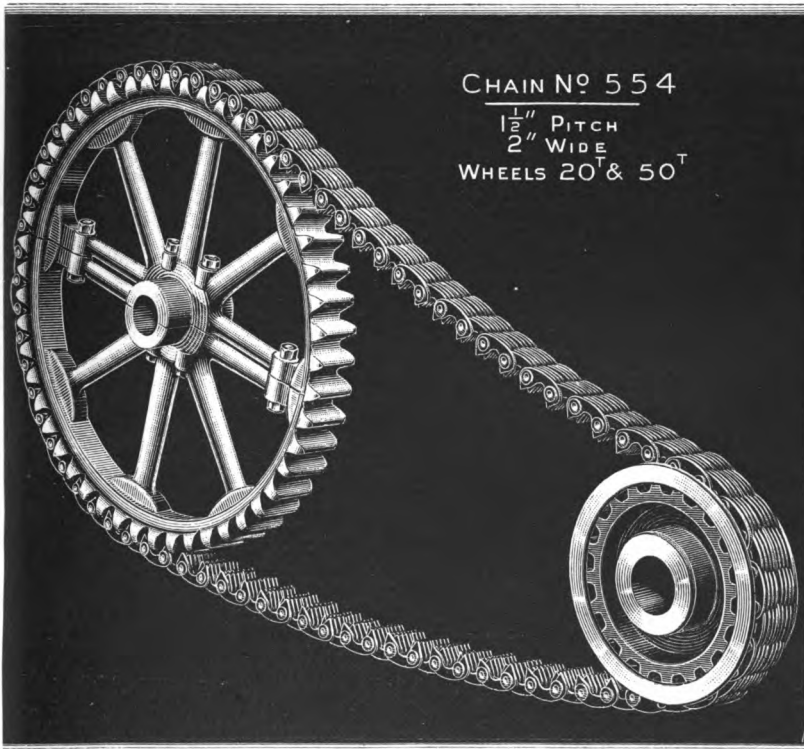

FIG. 462.—Driving a counter shaft.

the motion from one shaft to another with a uniformly smooth drive. This has been effected by having, as a basis of construction, the wheels and chains geometrically set out, and the gears cut with a special cutter for each diameter of wheels. There is a further advantage in this arrangement, viz., that just as the chain lengthens, the links adapt themselves to suit the pitch of the wheel, even when the chain has worn and lengthened $\frac{9}{10}$ inch per foot (Fig. 461).

Fig. 460 shows a wheel and chain when new. Besides this form of drive being adopted for cycle and motor cars, it is also much used in the machine shops to connect the driving spindles with the feed shafts in both horizontal and vertical milling machines; and in cases where electric motors are used to drive the tools the above chains and wheels are employed instead of belts and pulleys. A further case is to use the chain drive from main shafts to counter shafts, when these are unavoidably very close together; an example of this is given in Fig. 462.

INDEX

A

Abrupt taper, grinding of, 197
 Accumulator, hydraulic, 368, 369
 —, valves of, 370
 Accuracy of "standards," 5
 Acme screw threads, 298
 Addy's expansible cutter, 262
 Adjustable micrometer, 19
 Advantages of conical bearings, 106
 Air-hardening steel, 48
 Alignment of lathe headstocks, 163
 Allen's patent tool holder, 263
 Alloys. *See* BRASS.
 Aluminium melting-point, 54
 —, shrinkage of, 54
 —, bronze, 53
 Amateur's lathe, 104
 American standard screws, 298-420
 — wire gauge, 428
 Analysis of cast iron, 43
 Ancient bolts and nuts, 39
 Anderson's patent facing tool, 64
 Angle, clearance, for tools, 290
 —, cutting, for tools, 290
 —, relief, for tools, 290
 — of British Association screws, 421
 — of U. S. Association screws, 420
 —, screw-cutting gauge for, 300
 —, iron sections, 339
 —, iron smith, 339
 —, plate work, 35
 —, pressure on gear teeth, 289
 Angular milling cutters, 261
 — drive by belts, 407
 — for keyways, 259
 Anvil tools, 346
 Arms of wheels, milling between, 306
 Arrangement, centre-truing, 128
 — for centering shafts, 129
 — of hydraulic riveter, 375
 — of wheels and flanges (emery), 258
 Art of chipping, 324
 — of filing, 318
 Assembling room, modern, 92
 Attachment for cutting gears, lathe, 110
 — for cutting slots, 112

Automatic die, "Hartness," 87
 — keyway cutting machine, 336
 — saw sharpener, 217, 218
 — screw machine, 96
 — wheel cutting, 270
 Average speed for milling, 260
 Axial pressure in spindle, 106
 Axle, forging, 347
 —, lathe, duplex, 119

B

Babbitt's metal, 53
 Back-geared lathe, 112
 Back-stay, 112
 Bad iron, 45
 Balancing pulleys, 336
 Ball bearings, thrust, 398
 — to lathe centre, 129
 — turning-rest, 162
 Band machine (emery), 215
 Bearings, cone and journal, 106
 —, oval, 118
 —, pillar, 402
 —, roller, 405
 — supported by beam, 401
 —, swivel, 397
 —, wall-box, 400
 Bed, gap lathe, 122
 —, setting out for machine, 30
 —, straight, 115
 Belt-driven hammer, 361
 Belt driving at an angle, 407
 — on stepped cones, 407
 —, quarter twist, 407
 Belts, crossed, 407
 Bending, machine forge, 341
 — machine, hydraulic, 374
 — wrought iron, 45
 Bessemer steel, 48
 Bethlehem's steel, 48
 Bevel gear, cutting, 280
 — drawing, 281
 — diagram, 281
 —, setting out of centre, 282
 —, table of cutters for, 283
 — square, 23

- Bevel gear, universal protractor, 22
 — wheel, frictional drive to, 389
 Beyer and Peacock's patent grinding machine, 210
 Birmingham wire gauge, 428
 Black diamond, 187
 Blade of knife tool, 293
 Blanks for bevel gears, 21
 Blast air, smithy, 343
 — furnace, 42
 Blister steel, 46
 Block swage, 346
 Blow, energy of hammer, 353
 Blower, "Root's," 342
 Birch's front-slide lathe, 107
 Bits, flat and hollow (tongs), 345
 Boiler-maker's drifts, 349
 Bolts, ancient, 39
 —, annealed, 38
 —, standard, 40
 —, without heads, 40
 Boring bar (Muir), 144
 — cutter, hardening, 307
 — crank-shaft bearings, 165
 — cylinder, 165
 — and facing cylinder, 259
 — machine, duplex, 141
 — —, floor, 145, 146
 — —, heavy, 146
 — and milling machine, 148
 — plumber blocks, 166
 — shaper body, 29
 — and turning taper, 163
 Boshes' smelting furnace, 42
 Box, wall, bearing, 400
 Boxwood scales, 2
 Brackets to be bored, 28-33
 Brass burnishing, 159
 —, files for, 318
 — finisher's lathe, 93
 — finishing machine, 159
 —, hand tools for, 158
 —, hard, 53
 —, —, grinding, 205
 —, rolled and cast, 156
 — screws, large and small, 159
 —, yellow, 53
 Break lathe, 124
 Breast drill, 67
 Breeze, 350
 Bronze, aluminium, 53
 —, gun metal, 53
 —, phosphor, 52
 British Association standard screws, 421
 Brush for files, 318
 Built-up gear wheels, 274-276
 Bush, grinding ends of, 201
 Burnishing brass, 159
 Butt joint, 250
 Buttress threads, 298
- C
- Calipers, adjustable, 7
 —, final test for, 8
 — for gear teeth, 17
 —, interchangeable, 19
 —, micrometer, 16
 —, setting odd leg, 8
 —, — two pairs of, 6
 —, sliding vernier, 21
 —, spring bows, 8
 Capstan lathe, 93, 94
 Carriers, "Clements'" driver for, 112
 —, duplex, 112
 Casehardening, 348
 Cast brass, 53
 — iron, malleable, 46
 — — pulleys, 385
 — —, smelting, 42
 — —, tools for, 290
 — mild steel, Bessemer, 48
 — — —, Siemens Martin's, 48
 — tool-steel crucible, 46
 — — —, self-hardening, 48
 — steel wheel, turning a, 277
 Castings, shrinkage of, 44
 Caulking tools, 363
 Centre cup, 127
 —, extended, 127
 —, half, 127
 —, line and ball turning, 162
 —, oil groove, 127
 — points, angle for, 126
 — —, combined drill and, 127
 — —, coned, 127
 —, portable, drilling appliance, 129
 —, reduced, 127
 —, square, 127
 — stay for shafts, 112-138
 —, Taylor's patent ball, 130
 — truing machine, 128
 Chain, annealed, 410
 — and wheel driving, 430-432
 Change wheels, calculations for, 77
 — —, examples, 173
 Chasers, inside and outside, 154
 —, form of teeth, 177
 Chasing long screws, 88
 — screws by hand, 153
 Chisels, various, 323
 Chuck, bell, lathe, 110
 —, collet, lathe, 85
 —, combination, lathe, 131
 —, dog, lathe, 110
 —, drill, lathe, 134
 —, four-jaw, lathe, 131
 —, three-jaw, lathe, 157
 —, two-jaw, lathe, 133
 —, universal, lathe, 131
 —, valve-turning, lathe, 94

- Chucking clip, 40
 Circular pitch, 270
 — slotting, 226
 — saw sharpener, 213
 — teeth, 212
 Clam-nut for lathe guide screw, 114
 Clams for vice, lead and iron, 332, 333
 — for vice, vulcanite, 161
 Cleanliness and lubrication, 76
 Clearance angle in lathe tools, 299
 — in milling cutters, 248
 Clips, uses of, 39
 Closed spiral spring, 161
 Clutch claw, 388
 —, friction and elastic, 388
 Coarse spiral spring, 161
 Cold iron and steel sawing machine, 217
 — twisted and bent, 45
 Collar stay, 112
 —, side tools for, 293
 — thrust, 113
 Collet chuck, 89
 Combination chuck, 89
 Combined valve gear, 131
 Commercial value of a standard, 5
 Common iron, 45
 Commutator grinding appliance, 209
 Compact steel springs, 161
 Complete self-acting, etc., lathe, 110
 — lathe for tool-room, 109
 Cone clutch, 388
 Cone pulley, speeding by, 399
 — in turret lathe, 101
 Conical bearings, 106
 Connecting rod to shaper machine, 223
 — to slotting machine, 225
 Copies of British standard yard, 1
 Copper, depositing (Elmores), 52
 —, machining, 301
 —, smelting, 51
 Core box, 34
 Corect diameter of milling cutter, 247
 Cored holes bad for drilling, 58
 — work, 30
 Coupling flange, 391
 — rod, grinding machine, 210
 —, Sellers' compression, 391
 — shafts out of line, 393
 Cradle jig for milling, 20
 Crank-driven plane (Muir), 229
 Crank-pin, fitting a, 167
 — shaft bearing, 165, 166
 —, cast and wrought-iron and steel,
 167
 Cross-cut chisel, 322
 Crucible cast steel, 47
 Cupola, 42
 Cutter for boring, 308
 —, hardening a, 308
 —, Addy's expansible milling, 262
 —, adjustment of, 263
 Cutter, grinding machine, 207
 Cutters, angle of milling, 248
 —, angular milling, 261
 —, bevel gear milling, 282
 —, duplex milling, 255
 —, end milling, 245
 —, fluting milling, 246
 —, gang milling, 254
 —, gear milling, 244
 —, interlocked milling, 248
 —, notched tooth milling, 252
 —, safe speed for milling, 261
 —, straddle milling, 248
 —, twin milling, 255
 —, twist drill milling, 61
 — with form teeth, 244
 — formed teeth, 243
 — inserted teeth, 246
 — straight teeth, 246
 — spiral teeth, 246
 Cutting angles, hand tools for brass, 158
 —, hand tools for iron and steel,
 156
 —, slide lathe, 209
 — bevel gears, 282
 — gears on milling machine, 255
 — on automatic machine, 271
 — screws, tools for, 297-299
 —, tools for and gauge, 299
 —, wheels for, 177
 — tools, How to Use, 290-305
 —, high-speed lathe for, 121
 Curve for gear teeth, 286, 287
 Cylinder boring machine, 143
 — and facing machine, 259
 — portable machine, 149
 Cylindrical standard gauges, 2
- D
- Dappling a scraped surface, 315
 Data for bevel gears, 280
 Depth gauges, 25, 26
 — screw threads, Sharp V, 20
 — of U.S. standard, 20
 — Whitworth, 20
 Description of Whitworth lathe, 110-113
 Diameter of milling cutter, 247
 Diamond tools, 187
 —, pointed, 155
 Die, Hartness', automatic, 87
 Differences, immeasurable, 12
 Disc crank, 168
 —, standard reference, 11
 Dividing heads (milling), 239
 Division plate (lathe), 108
 Dog chuck (lathe), 110
 Double acting steam hammer, 353
 — armed pulleys, 390
 — curved teeth (gear), 287

Double screw threads, 175
 Drift, boiler-maker's, 349
 — flitters, 349
 — forgers, 349
 Drill, breast, 67
 —, effect of bad grinding, 59
 —, grinding twist, 59
 —, — machine, 207
 —, high-speed attachment, 62
 —, holder and rest, 161
 —, how to sharpen, 206
 —, making a twist, 60
 —, method of driving, 59
 —, oil-tube attachment, 63
 —, parallel and taper shanks, 58
 —, sensitive attachment, 62
 —, speed and feed for, 60
 —, Tapper Payton's patent, 64
 —, testing new, 60
 Drilled holes for screw cutting, 175
 Drilling at an angle, 76
 — cored holes, 58
 — in the lathe, 160
 — jigs, 75, 76
 — machine, belt-driven, 74
 —, geared, 72
 —, radial, 74
 —, rotary, portable appliances,
 69
 —, ratchet brace for, 68
 —, sensitive pillar, 71
 —, universal, 75
 Driver, Clements', 112
 Driving pulleys, 114
 Drop-forging dies, 357
 Double driver, 112
 — screw threads, 153
 Duplex axle lathe, 119
 — boring machine, 141
 — milling machine, 242
 — shaping machine, 222
 — tool grinder, 204
 — wheel lathe, 118

E

Eccentric shaft, setting out, 31
 Elastic coil-spring, hardening, 307
 Electric welding, 349
 Electrical measuring machine, Dr.
 Shaw's, 419
 Electricians' non-magnetic level, 24
 Emery wheels, 179
 —, mounted, 184, 185
 "End" and "line" measure, 2
 — measuring rods, 11
 — and squaring, grinding bush on,
 201
 Ends of work rounded, 250
 Engine-cylinder, boring, 165

Energy of a hammer-blow, 353
 Example of filing-up calipers, 331, 332
 — of fitting knuckle-joint, 328-331
 — of milling, 267
 — of cold iron twisted and bent, 45
 — of cutter sharpening, 208, 209
 — of gearing change-wheels, 177
 — of key fitting, 335, 336
 — of open side planing, 234, 235
 Expanding reamer, 304
 Expansion link and block grinding
 machine, 211
 Explanation of graduations, 17
 — of micrometer, 17
 External gauges, 11
 — tapers being ground, 196
 — slight tapers being ground, 197
 Eye bolt and dies, 341

F

Faces and sides milled at one cut, 254
 Facing and boring machine, 144
 Feed milling-machine, hand, 263, 264
 Fielding type of hydraulic rivetter, 381
 File brush, 318
 — manufacture, 316
 Files for brass, 318
 —, grade of, 319
 —, pinning of, 320
 —, section of, 317
 —, uses of, 318
 Finger travelling stay, 139
 Finisher's lathe, brass, 93
 Finishing machine, brass, 159
 "Fit and try" system, 337
 Fit, method of obtaining, a, 12
 Fitting keys, 335-337
 Fixing steam-hammer, 353, 354
 Flange coupling, 391
 Flanging press, hydraulic, 373
 Flattener, Smith's, 348
 Floor boring machine, 145, 146
 Fluting a tap, 246
 — a reamer, 255
 Flux, 341
 Fly-wheel and facing lathe, 123, 124
 — and pulley lathe, 117
 Follow rest, 194
 Forging a chisel, 321
 — machine, 345
 — tongs, 341
 Form cutters, 244
 Formed cutters, 243, 244
 Former plate lathe, 162
 Forming-shop (forging), 339-341
 Form of chaser, 88
 Forms of centres, 127
 — of rivet joints, 363, 364
 Frame, swing, sharpening machine, 214

Friction cone clutch, 388
 ——— to bevel wheels, 389
 ——— clutch coupling, 390
 ——— to pulleys, 389
 Front slide lathe, 108
 Frosting a plane surface, 315
 Fullering tools, 364
 Function of thrust pin, 118
 Furnace, reverberatory, 41

G

Gang mills, 253
 Gap lathes, 163
 Gas-engine cylinder boring machine, 141
 ——— threads, Whitworth, 423
 Gauge, American wire, 427, 428
 ———, British wire, 417
 ———, Stubs' wire, 417
 ———, depth, 26
 ———, Imperial wire, 428
 ———, "thickness" or "feeler," 24
 Gauges, boring and turning taper, 163
 ———, cylindrical standard, 2
 ———, height of tool, 292
 ———, limit, 9
 Gear cutters, 245
 ——— cutting attachment, 106
 ——— machine, automatic, 270
 ——— of cast iron and steel, 272
 ——— teeth, curve for double, 287, 288
 ———, ——— for single, 286
 ———, turning rim of a steel, 277
 ——— wheels, built-up, 274
 Gears, double helical, 272, 273
 Gearing change wheels, 177
 Gisholt lathe, 99, 100, 101, 102
 Glazing, 268
 Graduations of micrometer, 17
 Grinder, duplex, 204
 ——— for commutators, 209
 Grinding chisels, 321
 ——— expansion links and blocks, 211
 ——— external tapers, 196
 ——— head, section of, 193
 ——— and lapping machine, 210
 ——— room, modern (*see* Frontispiece)
 ——— shafts of steel, 211
 Grip socket drill, 66
 Groove cutting tools, 295
 Grooving chisels, 322
 Ground joints, 316
 Guide in chipping, 324
 Gun metal, 53
 ——— shell, turning, 14

H

Hack-sawing machine, 219
 Hammer, energy of blow, 353

Hammer, double acting, 353
 ———, file cutter's, 310
 ———, hand chipping, 310
 ———, sledge, 348
 ———, single acting, 353
 ———, planishing, 310
 ———, 30-cwt. steam, 359
 ———, 10-cwt. steam, 359
 ———, 1 cwt. steam, 358
 ———, Player's pneumatic, 360, 361
 Hand chasers, 154
 ——— chased screws, 153
 ——— feed, 263, 264
 ——— turning tools, brass, 158
 ———, ———, iron, 155
 Hard brass, 53
 Hardening and tempering cutters, 308
 ——— ——— tools, 305
 Hartness' turret lathe, 78
 Headed keys "gib," 335
 Headless keys, 335
 Head of grinding machine, 193
 ——— of water (hydraulics), 367
 Hearth, angle-iron smith's, 339
 ———, iron, 342
 ———, modern, 342
 ———, portable, 342
 Heavy boring machine, 146
 ——— face-plate lathe, 122
 Hendy Norton lathe, 125
 ——— pillar shaper, 224
 High-speed drill, 62
 ——— lathe, 120
 ——— steel, 301
 Hinged table to shaper, 224
 Holder and rest for tools, 161
 Holders, tool, 301, 302
 Holding-down clips, 40
 Holding work in vice, 332
 Holes cored for drilling, 58
 Hollow "bits," tongs, 345
 ——— spindle lathe, 78-103
 Horizontal boring machines, 141-146
 How to gear change wheels, 177
 ——— to originate a taper, 163
 ——— to use cutting tools, 290
 Hydraulic accumulator, 368-369
 ——— boiler shell-plate bender, 374
 ——— flanging press, 373
 ——— jack, Tangyes', 371
 ——— machine tools, 371
 ——— notes, 382
 ——— riveter, drawing of, 375
 ———, Fielding type, 381
 ——— for furnace mouths, 378
 ———, portable, at work, 378-380
 ———, ———, solid type, 377
 ——— stationary, 376
 ——— power, 365
 ——— punching machine, 372
 ——— valves, 370

I

- Immeasurable differences, 14
 Imperial wire gauge, 428
 Indicator, lathe test, 15
 Inserted teeth milling cutter, 245
 Inside calipers, 7
 — chasers, 154
 Interchangeable micrometer, 19
 — system, the, 75
 Interlocked milling cutters, 255
 Internal gauges, 11
 — grinding appliance, 198
 Involute gear cutter, 245
 — — —, pressure angle of, 289
 Iron, bent and twisted, cold, 45
 —, cast, analysis of, 43
 —, chipping chisels, 321
 —, blast furnace, 42
 —, hearth, 340
 —, pig, smelting, 43
 —, piling, 346
 —, pulleys, balancing, 386
 —, cast, solid, 385
 —, split, 383
 —, wrought, 384
 —, quality of, 45
 —, reverberatory furnace, 44
 —, turning tools, hand, 155
 —, —, slide rest, 290
 —, weight of iron and steel, 304
 —, welding, 349
 —, joints for, 350
 Irregular work, setting and machinery, 33

J

- Jaw chuck for brass, 157
 — — —, combination, 131
 — — —, four-jaw, 131
 — — —, three-jaw, 157
 — — —, two-jaw, 133
 — — —, universal, 131
 Jig drilling, 337
 — filing, 337
 — milling cradle, 259, 260
 Joint, butt, weld, 350
 —, scarf, weld, 350
 —, tongue, weld, 350
 —, ground, 316
 —, knuckle, fitting a, 329
 —, union, 417
 Journal bearings, 107
 Junk rings, 169

K

- Keys, double-headed, 334
 —, flat, 334

Keys, fixed, 344

- , gib, 335
 —, headless, 335
 —, saddle, 335
 —, staking, 335
 —, sunk, 335
 Keyway cutting machine, 336
 —, milling angular, 259
 — — — in two shafts, 255
 Kilogram weight, 4
 Knife tools, 293, 294

L

- Lang's sharpening machine, 205
 Lapping and grinding machine, 211
 Large brass screws, 159
 —, milling cutters, 253
 —, steel gears, 272-277
 Lathe, alignment of heads, 104
 —, amateur's, 104
 —, angle-plate work, 36
 —, arrangement of, 113
 —, back gear (Plate), 119
 —, bell chuck, 119
 —, break, 124
 —, capstan, 93
 —, carriers, double (*see* Plate, Fig. 119)
 —, centres, various forms of, 129
 —, —, grinding, 128
 —, centering machine, 129
 —, — and straightening, 137
 —, change wheels (*see* Fig. 188)
 —, — — — worked out, 173-177
 —, dog chuck, } (*see* Plate, Fig. 119)
 —, dogs double }
 —, drill chuck, }
 —, driver, Clements', 112
 —, driving work in, 118
 —, face and boring, 122, 123
 —, former plate for, 162
 —, front slide, 108
 —, gap, 122
 —, gear cutting attachment, 110
 —, Gisholt turret, 98
 —, Hartness' turret, 78-80
 —, Herbert turret, 90
 —, — — —, hexagon, 91
 —, leading screw, 173
 —, loose headstock, 114
 —, mandrels for, 172
 —, saddle work, 116
 —, spindle ground with emery wheels,
 183
 —, — — — bearings, 106, 107
 —, strength of plates, 134
 —, tools for brass, hand, 158
 —, — — — for iron and steel, hand, 155
 —, — — — for slide rest, 290
 —, stay for sliding or back, 139

- Lathe, stay for portable plate (*see* Fig. 119)
 —, — three jaw centre, 138
 —, straight bed, 115
 — test indicator, 15
 —, tool-room, 111
 — turning-taper, 163
 —, wheel, double railway, 118
 —, — and pulley, 117
 Leaden pipe manufacture, 56
 Length, British standard of, 1
 —, French standard of, 3
 Lifting and shifting material, 411
 Limit gauges, 10
 "Line and end" measure, 2
 Lining-out table and tools, 227
 Link, quick return by, 223
 Lubrication and cleanliness, 76
 — for chipping chisels, 322
- M
- Machine, band sawing, 220
 — bed, setting out, 30
 — bolts and nuts, 38
 — for boring and facing, 144
 — for boring oil-engine cylinders, 143
 — for boring stationary engine cylinders, 146
 — for boring and tapping, 147
 — for gear cutting, automatic, 270
 — for screw making, automatic, 96
 — for slotting, automatic, 224
 — for sawing metal, automatic, 217, 218, 219
 — for tapping, automatic, 65, 66
 — for truing centres, 128
 — tool grinder, 205
 — tools, hydraulic, 371
 —, universal milling, 238-241
 Machining copper, 301
 — irregular work, 33
 Magazine, overhead, 102
 Making iron, 346
 — tools, 176
 Malleable iron castings, 46
 Mandrel to expand, 136
 —, how to make a, 135
 —, screw, 137
 —, spring-making on, 161
 —, press, 137
 Manganese or white bronze, 53
 Manufacture of iron, cast, malleable, and wrought, 42-46
 — of lead pipe, 56
 — of mild steel, 48
 — of tool steel, 46
 — of tool steel, air-hardening, 48
 Marking-out table and tools, 28
 Master tap, uses of, 313
- Materials, tackle for lifting and shifting, 411
 Measure, British unit of, 1
 —, metric unit of, 3
 —, "end and line," 2
 Measurement, uses of, 6
 Measuring machine, Sir W. A. Armstrong, Whitworth & Co.'s, 15
 —, Dr. Shaw's electrical, 419
 —, G. Richards & Co.'s, 15
 — rods, standard, 11
 Method of fixing a steam hammer, 353
 — of obtaining a "working fit," 12
 Micrometer calipers, 16-20
 Mill for vertical turning and boring, 151, 152
 Milling and boring machine, 150-152
 — cutters, Addy's patent, 262
 —, angle for, 248
 —, backing off a, 243
 —, Brown and Sharps' patent, 245
 —, form, 244
 —, formed, 244
 —, gang, 258
 —, gear, 245
 —, grooving, 246
 —, interlocked, 248
 —, operating, 253
 —, slab, 245
 —, slitting, 246
 —, solid, 245
 —, tee slot, 250
 —, teeth inserted, 245
 —, work, example of, 267
 — flutes in taps, 246
 — fixture, 249
 — gear teeth, 255
 — jig, 260
 — machine bed, 257
 — table, 256
 — teeth in rack, 250
 — two sides of a slot, 249-251
 — and profiling, 263
 Modern assembling room, 92
 — grinding room (*see* Frontispiece)
 — store room, 419
 — smith's hearth, 342
 Motion, lathe, reversing, 113, 176
 Movable or centre stay, 138
- N
- Narrow milling cutters, 257
 New standard metre, 3
 Notched milling cutter, 252
 Notes on hydraulics, 382
 Number of wire gauge, 428
 Nut and bolt milling, 248
 — — — — — machinery, 351

Nut to guide screw, 114
 — set on angle plate, 37

O

Obliquity of screw threads, 298
 Obtaining a working fit, 12
 Odd legs, calipers, 8
 Oil-engine cylinder boring machine, 141
 — tube socket, 64
 — — twist drill, 63
 Oliver's smith's forge, 351
 — — set, 348
 Open hearth steel process, 49
 Operating notched mill, 253
 Ore, iron, 42
 Originating a taper lathe, 163
 Outside chasing tools, 154
 Oval bearings, 118
 — turning "loco" crank shafts, 172
 Overhanging head lathe, 107
 — — tools, 290
 Overhead magazine, 102

P

Packed-up lathe for boring, 165
 Parallel vice, 325-328
 Parting tools, 295
 Payton's universal tapper, 64
 Peacock and Beyer's grinding machine, 210
 Pearn's universal tapper, 65, 66
 Pig iron, 43
 Piling iron, 346
 Pin, crank, 167
 Pin, thrust, lathe, 118
 Pinion, milling teeth of, 255
 Piston rings, 168
 Plain grinding, 196-201
 — milling machine, 257
 Planing machine, crank-driven, 229
 — — described, 226
 — —, "open side," 232
 — —, "plate edge" 231
 — —, "spiral geared," 228
 — — tools, 203
 Plan of turret lathe, 100
 Plate, angle-work on, 35
 — bending machine, 374
 — divided for lathe, 106
 — former for lathe, 162
 — moulding, 156
 Plummer block boring, 166
 Pneumatic hammers, 360, 361
 Pocket spirit-level, 25
 Portable hearth, 342
 Position of cutter and work, 254
 — of cutting tools, 290

Position of tooth rest, 203
 — of workmen when filing, 320
 Power hack-saw, 219
 —, transmission of, 383-411
 Press, mandrel, 137
 Press, straightening, 137
 Processes of forging, 339
 Production of metallic bars, 54
 Profile steel, 303
 Profiling machine, 263
 Protractor, universal bevel, 22
 Pulley, balancing a, 385
 —, cast iron solid, 385
 —, double armed, 390
 —, reversing, 389
 —, speeding of, 404
 —, — of cone, 399
 —, split, 383
 —, wood, 386
 — and fly-wheel lathe, 117
 Pulleys, two sets of lathe, 114
 Pump weld, 351
 Punching, 348
 Punching machine, 372
 — — shafts, 32

Q

Quality of iron, 46
 Quick return shaper, 223

R

Rack teeth cutting, 250
 Ram of shaping machine, 223
 Ramsbottom rings, 168
 Reamer, grinding a, 203
 —, making a, 305
 Recessing tool, 297
 Reducing chatter in plane, 193
 Reference discs, standard, 11
 Rest, use of centre, 202
 Rest, — of drill and stay, 110
 —, — of drill holder, 161
 —, — of follow, 194
 —, — of grinding, 194
 —, — of spring, 194
 —, — of tool, 205
 —, — of in turning balls, 162
 Return motion, quick, 223
 Reverberatory furnace, 44
 Reversing motion traverse, 113
 — pulleys by friction, 389
 Revolving valve chuck, 94
 Riveter, details of hydraulic, 375
 —, Fielding type, 381
 —, furnace mouth, 378
 —, portable solid, 377
 —, stationary, 376

Rivets and riveting, 362, 363
 Rods, end measuring, 11
 —, wire treatment of, 51
 Rolled and cast brass, 156
 Roller feed turret, 86
 Root's blower (forge), 343
 Rotary planing machine, 221
 Rounding ends of work, milling, 250
 Round-nosed chisel, 323, 324
 ——— hand turning tool, 158
 Rules, ivory, paper, and steel, 2
 ——— for screw cutting, 173
 Runways, overhead, 411
 Ryder forging machine, 346

S

Saddle for lathe, 113
 ——— keys, 335,
 ———, work bored on, 166
 Safe speed for milling cutters, 261
 Saw, power, hack, 219
 ——— sharpening machines, 213
 Sowing machines, automatic, 217, 218
 ———, hand, 220
 Scrapers, use of, 314
 Screw cutting, diagram of wheels, 175
 ———, double threads, 175
 ——— gauge, Wyke's, 300
 ———, multiple threads, 175
 ——— treadle lathe, 104
 ———, wheels for, 173
 ——— with stocks and dies, 313
 ——— machine, automatic, 96
 ——— mandrel, 137
 ——— micrometer, gauging a, 90
 ——— thread micrometer, 19
 ——— threads, various forms of, 298
 ———, Acme, 421
 ———, American standard, 420
 ———, British Association, 421
 ———, International, 422
 ———, sharp vee, 422
 ———, Whitworth gas, 423
 ———, Whitworth standard, 420
 Scriber, to harden, 307
 Scribing irregular work, 133
 ——— out eccentric shafts, 31
 ——— barrel to be bored, 34
 Section of angle iron, 339
 ——— of chuck for grinding, 202
 ——— of grinding head, 193
 ——— of mild steel casting, 55
 ——— of files, 387
 ——— through saddle of milling machine, 239
 Self-centering jaw chuck, 160
 Sellers' coupling, 391
 ——— lathe, 115
 Sensitive high-speed drilling, 62

Set of taps, 311
 Setting calipers, 6
 ——— lathe to turn taper, 162
 Shaft, crank, bearings bored, 165
 ———, turning rest, 140
 Shafting, spirit level to test, 24
 Shafts, hammer, 311
 Shaper plate, oval turning, 172
 Shaping machine, duplex, 222
 ———, Hendey, 223
 ———, template for, 29
 Sharpening machine, Lang's, 205
 Shaw's, Dr., electrical measuring machine, 419
 Sheet metal, chisel for, 322
 Shifting and lifting material, runways for, 408, 409
 Shoe for grinding, 195
 Showing effect of heat, 190
 Shrinkage of aluminium, 54
 ——— of castings, 44
 Side and face milling, 253
 Side milling cutter, 251
 Siemens' steel, 49
 Single-acting steam hammer, 353
 ——— curve gear teeth, 286
 Slab milling machine, 265, 266
 Slag, 344
 Sledge, 348
 Sleeved pinion setting, 34
 Slides milled with gang cutters, 257
 Sliding micrometer caliper, 21
 ——— tools, various positions of, 290
 Slinging a piece of work, 410
 Slitting saws, metal, 246
 Slot-drilling machine, 336
 Slot, milling a, 251
 Slots for bolts, 40
 Slotting machine, 224
 Small lathe work (drilling), 160
 Smelting iron, 42
 Smith and Coventry's tool holder, 301,
 302
 Smith's work, 356
 Soaking (iron), 349
 Solid pulley (cast), 385
 Speeding of cone pulleys, 399
 ——— of pulleys, 404
 Speed of shafts and pulleys, 400
 Spiral form of teeth, 257
 ——— headstock, milling machine, 241
 ——— springs, closed, 161
 ———, coarse, 162
 ———, making, 161
 ——— with sure pitch, 162
 Spirit levels, 24
 Split pulley, 383
 Spring collet chuck, 85
 ——— making, 161
 ——— tools, 294
 Square bevel, 23

- Squaring end of bush, 201
 Staking keys, 335
 Standard, commercial value of, 5
 — gauges, cylindrical, 2
 — metre, 4
 — reference discs, 11
 — screw pitch gauge, 298
 — surface plate, 315
 — yard, 1
 Starting taps, 312
 Stay, centre, for shafts, 112-138
 — collar and drill rest, 110
 —, travelling finger, 139
 Steam hammer, 352
 —, double acting, 353
 —, method of fixing, 354
 —, stamping, 357
 —, dies, 357-360
 —, tools, 356
 —, tups, 355
 —, 1-cwt., 358
 —, 10-cwt., 359
 —, 30-cwt., 352
 —, valve gear, combined, 354
 —, —, hand, 355
 Steel, Bessemer, 48
 —, cementation process, 46
 —, correct treatment of, 51
 —, gear, turning rim of a, 277
 —, hardening and tempering, 305
 —, high-speed cutting, 121
 —, manufacture, 49
 —, rules, 2
 Stiff knife tool, 293
 Store room, modern (Plate), 419
 Straightening and centering press, 137
 Stubs' wire gauge, 427
 — steel wire gauge, 427
 Stud chasing by hand, 153
 Sunk keys, 325
 Surface grinding, 202
 — plate, testing a, 315
 —, uses of, 315
 Surfacing bed in plain milling machine, 257
 Swivel bearing, 397
 — supported by beams, 401
 — by columns, 402
 — to lathe side rest, 162
 — tool holder, 302
- T
- Table of decimal equivalents, 427
 — for "marking out" work, 27
 — rotating for circular work, 263
 Tackle for lifting and shifting material, 411
 Tail or thrust pin, 104
 Tangye's hydraulic jack, 371
 Taper turning, different ways of, 162
 —, originating a T for, 163
 — work, grinding abrupt, 197
 —, external, 199
 —, internal, 200
 —, special pieces of, 195
 Tapper, universal, machine, 65, 66
 Tapping and boring machine, 147
 — hole, furnace, 43
 — horizontally, 313
 — with and without oil, 313
 Taps and dies, French, 423
 —, how to use, 312
 —, master, 313
 —, testing pitch of, 89
 —, Whitworth, set of, 311
 —, gas threads, 423
 Taylor's machine vice, 327, 328
 — novel machine vice, 326
 Tee-slot milling cutter, 250
 Teeth curve for double gear, 286
 — for single gear, 286
 — of gear wheels, 286-288
 — of motor pinions, 255
 — of rack milling, 250
 — gear, vernier caliper for, 17
 Tempering steel, 305-9
 —. See Chapter XVI., 347
 — tools, examples of, 307-9
 Templet, marking out, 29
 Ten-cwt. steam hammer, 359
 Test indicator for lathe, 5
 Testing pitch of tap, 86
 — truth of an angle plate, 36
 — of a surface plate, 315
 Thickness gauge, 24
 — of pipes, 424
 Thinning a chisel, 323
 Thread, acme screw, 420
 —, American standard, 420
 —, British Association, 421
 —, chasing screw, 153
 —, drunken screw, 154
 —, double screw, cutting a, 154
 —, gas, Whitworth, 423
 —, gauge for, Whitworth, 423
 —, for setting tool for, 300
 —, International, 422
 —, metric standard, 422
 —, sharp V screw, 422
 —, screw, micrometer, 20
 Threads, Whitworth standard, 420
 Threading tools, 299
 Throw of eccentric shafts, 31, 32
 Tongs, forging a pair, 341
 Tongue-joint, welding a, 350
 Tool caulking, 363
 — fullering, 363
 — grinder, 179
 —, duplex, 204
 — holders, 302

Tool making, 176
 — room, 176
 — —, lathe for, 111
 — steel, air-hardening, 48
 — —, double shear, 46
 — —, crucible cast, 46
 — —, hardening, 307
 — —, tempering, 307
 Tools, angle for cutting, 290
 — bar, peg, 299
 —, boring, 299
 —, chasing, how to use, 153, 154
 —, cutting, how to use, 290
 — for cutting dovetails, 297
 — for cutting grooves, 295
 — for turning brass, 158
 — for turning iron and steel, 155
 — for turning and cutting screws, 297-
 299
 —, knife, blade, 293
 —, planing machine, 293
 —, sliding and surfacing lathe, 293
 —, spring radius, 294
 —, undercutting slot, 296
 Top and bottom anvil tools, 348
 Transmission of power, 383
 Travelling stay, 139
 Treadle screw-cutting lathe, 104
 Trial fitting, 337
 True alignment of headstocks, 163
 Truing, centre, arrangement, 127, 201
 Tups for steam hammer, 355
 Turner and stay combined, 83
 Turning rest, ball, 162
 — —, duplex, 162
 — rim of a steel gear, 277
 —, taper, guns, 14
 — —, by headstocks, 162
 — —, by slide, 162
 — —, by template, 162
 Turret lathe, "Hartness" flat, 78
 — —, Herbert A., 92
 — —, Gisholt's motor-driven, 99
 — —, roller feed for, 86
 — —, turning small fly-wheels in, 101
 — —, turning speed cone in, 101
 — —, turning valves in, 102
 Twist drill, grinding a, 59
 — —, making a, 60
 — —, oil tube, 63
 — —, parallel shank, 58
 — —, taper shank, 58
 — —, speeds and feeds for, 59, 60
 — —, testing a new, 58
 Twisted and bent iron, 45
 Two keyways milled together, 251
 — slots milled together, 256

U

Undercutting tools, 296

Union joint, 417
 Unit of measure, British, 1
 — —, metric, 3
 Universal bevel protractor, 22
 — grinding machine, 178, 179
 — lapping and grinding machine, 211
 — milling machine, 237
 — tapping appliance, 65, 66
 Use of clips, proper, 40
 — of files, proper, 318
 — of measurement, proper, 6
 — of scrapers, proper, 314
 — of screw cutting gauge, proper, 300
 — of tooth rest, 203
 — of washers, proper, 39

V

Value of a standard, commercial, 5
 Valve gear, steam hammer, 354
 — —, combined and hand, 354
 —, hydraulic accumulator, 370
 —, revolving chuck, 94
 — turning in turret lathe, 102
 Various forms of bearings, 106
 — of keys, 334
 — positions for cutting tools, 209
 — uses of screw-cutting gauge, 300
 V blocks, uses of, 27
 —, "Acme" threads, 421
 —, American standard threads, 420
 —, British Association threads, 421
 —, International (metric) threads, 422
 —, sharp threads, 422
 —, Whitworth standard, threads, 420
 Vernier, calipers for gear teeth, 17
 — explained, 17
 — sliding gauge, 19
 Vertical milling machine, 263
 — turning and boring mill, 150, 152
 Vessel showing "Pascal's" law, 365
 Vice clams, lead, 332
 — —, iron, 332
 — —, vulcanite, 161
 — —, hand, 333
 — —, holding work in, 332
 — —, jigs, 337
 — —, novel machine, 326
 — —, parallel, 325
 — —, perfect, 327
 — —, section of, 327
 — —, staple, 325
 — — work, examples of, 328-331

W

Wall box, 400
 Washers, use of, 39
 Welding, electric, 349

- Welding heat, 349, 350
 Welds, forms of, 349
 Weight of iron (Kent), 429
 — of kilogram, 426
 Wire gauges, 427
 — rods, 51
 — spring making, 161
 Wheel, "built-up," 271
 —, driven by chain, 430-432
 —, emery, 179
 —, mitre, 276
 — teeth, construction of, 286
 —, double helical, 272
 —, frustum of cones for, 278
 —, single and double curve, 286
 —, polishing, 246
 Whitworth-Armstrong lathe, details of,
 110-113
 — measuring machine, 15
 — screw threads, 298-420
 — standard gauges, 11
 — surface plates, 314
 Whitworth taps, 312
 Wood pulleys, 386
 Work bored on lathe saddle, 165, 166
 —, cored, 30
 —, ground, 195
 —, milling round ends of, 250
 —, relative position of cutter and, 254
 Working, methods of, 412-417
 Wrought iron, production of, 44
 —, weldable, 45
 Worm, Hindley, 286
 — wheel, cutting teeth in a, 284
 —, hob for, 285
 —, milling faces of a, 284
 — and worm wheels, 286
 Wyke's screw-cutting gauge, 300

Y

Yard, British standard, 1

THE END.

