

MACHINERY'S REFERENCE SERIES

EACH NUMBER IS ONE UNIT IN A COMPLETE LIBRARY OF
MACHINE DESIGN AND SHOP PRACTICE REVISED AND
REPUBLISHED FROM MACHINERY

NUMBER 108

DIE-CASTING MACHINES

CONTENTS

The Design of Die-casting Machines, by E. F. LAKE	-	3
Automatic Die-casting Machines, by E. F. LAKE	-	24
Modern Type Hand-operated Die-casting Machine, by A. W. CHRISTIANSON	- - - - -	33

1965
1966
89

MIS
MIS
WIDE

1965
1966
89

CHAPTER I

THE DESIGN OF DIE-CASTING MACHINES

Die-castings have become fairly well known in the past few years, but the machines, metals and methods employed in their manufacture are as yet very little known. This is due no doubt to the fact that the apparatus and methods employed have been zealously guarded as secrets by those engaged in this manufacture. It may be surprising to many to learn that the commercially successful manufacture of castings from alloys in metal die-molds has not been accomplished through any recent invention, nor been the result of any one individual's efforts. Like most other industries, it has been of a gradual growth, through a

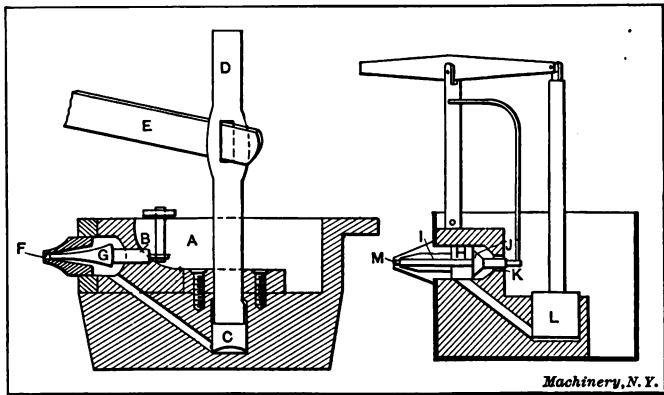

Fig. 1. Type-casting Machine built in 1849. Fig. 2. Improvement in the Type-casting Machine, made in 1856

period covering more than sixty years. The machines have been slowly perfected, and the alloys for the castings have been continually improved. Thus it is now possible to make dense, sound die-castings from alloys nearly as strong as brass, and a process by which a very strong bronze can be cast in die-molds is being developed.

Historical Development of Die-casting Machines

The first machines or methods along this line were used to manufacture bullets and type. Many inventions for casting bullets were made and several patents taken out in the years preceding and following the American rebellion and the Mexican war.

Of the type-casting machines, the first one of which we can obtain an illustration was patented on March 27, 1849, by J. J. Sturgiss. A sectional view of this machine is shown in Fig. 1. This illustrates the basic principle on which most of the die-casting machines in use to-day are built. In this machine the molten metal flows from the pot A which

is surrounded with heat, through the opening *B* into the cylinder *C*. Plunger *D* is then forced down by the lever *E*, which is operated by a cam and connecting-rods, and forces the metal out of nipple *F* into the type-mold. Piston valve *G* is then forced forward to squeeze the metal into the mold and also cut off the liquid stream, so it will flow back into the pot.

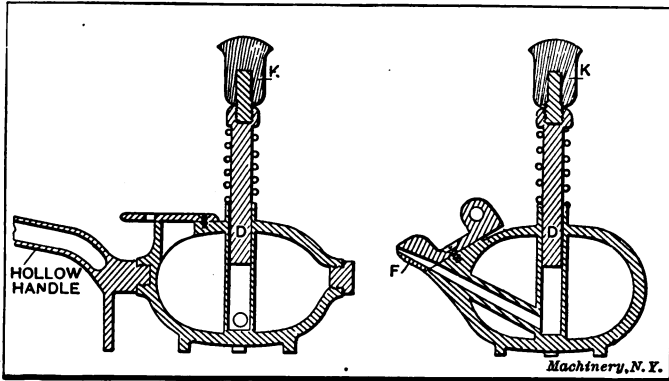

Fig. 3. Small Hand-operated Machine built in 1872

This was followed in 1852 by another patent by W. P. Barr covering other points on a machine which worked in practically the same manner as that shown in Fig. 1. As shown in Fig. 2, E. Peluze patented an apparatus on similar lines in 1856. His improvement over the two former machines was in the piston valve *H*. In this, valve *I* was

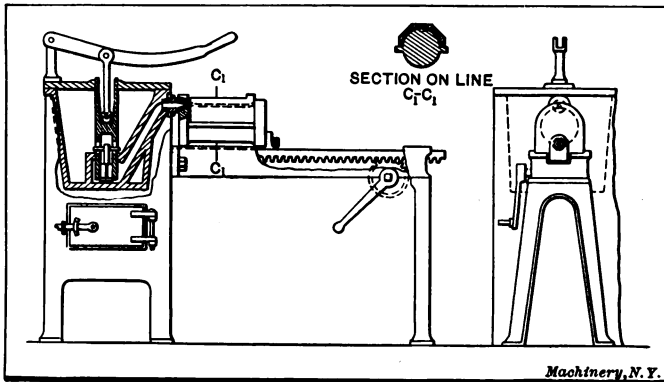

Fig. 4. First Die-casting Machine built for Miscellaneous Work (1877) set up for Casting Bearings

moved back until beveled surface *J* closed opening *K*, through which the molten metal flowed. Plunger *L* was then forced down, and this made the metal flow through nipple *M* into the type-mold. After this, piston valve *I* was forced forward, the same as in Fig. 1, and for the same reasons.

In 1872 a small hand machine was patented, as shown in Fig. 3. This was filled with molten metal from a melting pot, and when set on the bench, the palm of the hand was brought down forcibly on the wooden knob *K*. This forced down piston *D* and squeezed the metal out through nipple *F*. Other machines were invented in the following years for making medals, sewing machine bobbins and various other small articles. The type-metal apparatus was also improved by such inventions as that shown in Fig. 6, in which a much better design and arrangement were made of heating chamber, melting pot, cylinder, plunger, etc.

The first attempt to apply these principles to a more universal manufacture of castings was made by C. and B. H. Dusenbury in the

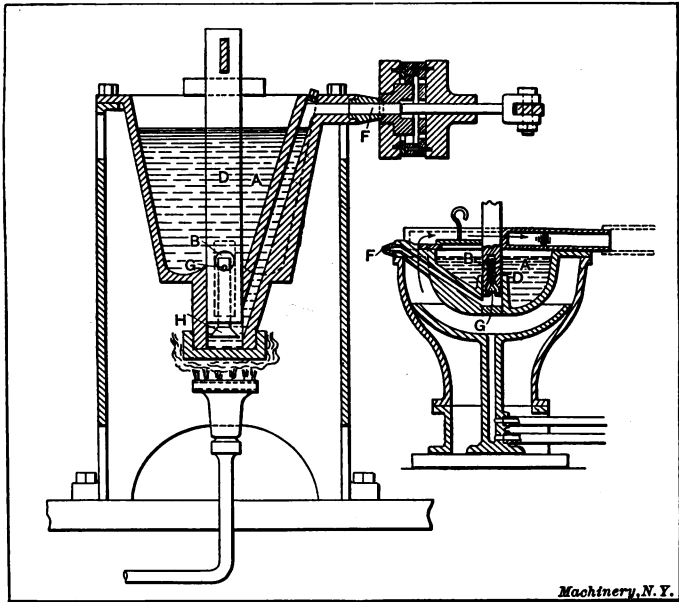

Fig. 5. Die-casting Machine patented in 1892. Fig. 6. Improvement made in 1888 on Machine shown in Figs. 1 and 2

machine shown in Fig. 4, which they patented in 1877. In this, the same principles as used on former machines were adopted for the melting pot, cylinder, plunger, outlet passage and nipple. In addition thereto, arrangements were made by which the die-molds, that contained impressions for journal bearings, were located on the machine, and exchanged for others when desired. Thus a wide range was given to the machine. The method of moving the mold away from the nipple so it could be opened and closed was accomplished by the gear and rack.

Little was done with this method of casting until after C. W. Weiss was allowed some claims, on March 8, 1892, on practically the same machine that was patented by the Dusenburys in 1877. This is shown

in Fig. 5. From this time on the die-casting business has steadily grown until it is now quite an important factor in the manufacture of many products. The many improvements have given us automatic machines that insert wires, bushings, clock wheels, etc., of steel, bronze or other strong metals, into the molds; and close them, cast the alloy and eject the finished casting out of the mold. Between this and the simple hand-operated machine there are belt-driven, motor-driven and semi-automatic machines used in the manufacture of die castings.

Hand-operated Machines

The strictly hand-operated machines have been perfected to an extent that enables one man to turn out a large number of castings with an alloy that is not very high-priced. Thus a machine may be placed in a room or in any part of a shop where there is no power. The only thing required to operate it is a supply of gas to heat the melting pot

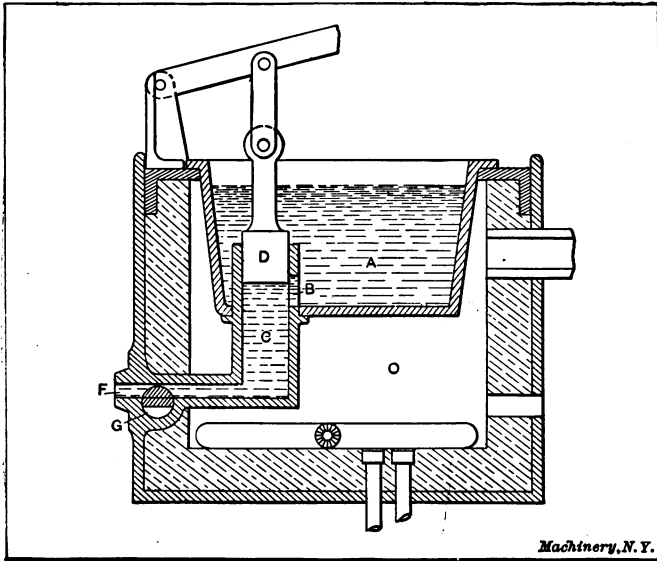

Fig. 7. Melting Pot with Side Outlet

and melt the metal, and a man. The output of these hand-operated machines is so large that it is only under very special conditions that the automatic machines can be economically operated. These conditions would require a very large number of castings from the same mold, and the castings could not be very intricate. With the hand-operated machines, however, very intricate castings can be made from the white-metal alloys generally used.

The modern hand-operated machine with its melting pot and method of forcing the metal into the molds has undergone many changes and has been the subject of a great deal of designing. In connection with it, valves and sprue-cutters have been made in several different ways.

The ways and means of holding the molds for the cast and then opening, or parting them to eject the casting have also been improved in various ways. From the melting pot the metal has been forced through the sides, top and bottom, and then into the molds. A cylinder and plunger has been the favorite method used, and this has been designed in various styles and sizes. Some have used air for forcing the metal into the mold, but with no success.

Melting Pots and Plungers

In Fig. 7 is shown one of the latest styles of machines with the outlet from the melting pot in the side. In this the burning gas in chamber *O* keeps the metal molten in pot *A* and it flows through passage *B* into pressure chamber *C*. From here it is forced by plunger *D*

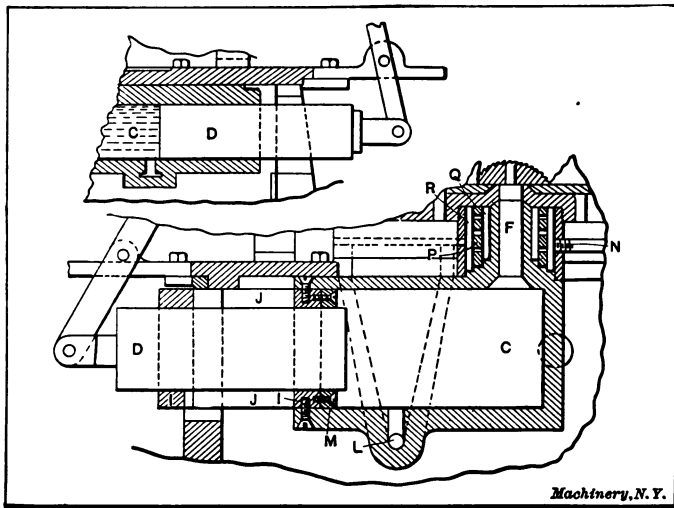

Fig. 8. Long Type of Plunger. Fig. 9. Plunger smaller than Cylinder—
Auxiliary Heating Chamber for Outlet Passage

through nozzle *F* into the mold. Valve *G* is then turned over to stop up the passage and thus cut off the flow of metal. This style of machine brings the pressure chamber *C* down into the gas chamber, where it is easily heated to the right temperature for casting. The metal that lies between valve *G* and the end of nozzle *F*, however, has to be removed before it freezes and before the mold is opened. It is therefore necessary each time a casting is made to move the entire mold away from nozzle *F*, while the sprue-cutter is in position for keeping the metal away from the casting. This extra metal then falls to the floor. This has been overcome in some machines, and hence one cause of trouble is removed. Another fault is that while plunger *D* is traveling past port *B* it forces the metal out into melting pot *A* and thus keeps it continually churned. This causes the dross and slag that should rise to the top to mix with the molten metal and enter the castings.

The plungers used with this type of machine differ considerably. The one shown in Fig. 7 has a bearing surface as long as the diameter of the plunger. This "square" plunger gives very good satisfaction where it is covered with molten metal, as it is in this case. An extremely long plunger is shown in Fig. 8. The construction of the machine is such that one end of the plunger comes out into the gas chamber and therefore it was extended into the open air in order to overcome the excessive heat of the gas flames. Much trouble has been experienced with this type, from the metal freezing around the surface between it and the cylinder, thus causing the plunger to stick. This is largely due to the great difference in temperature between the two ends, and consequently plungers of this type have to be continually cleaned.

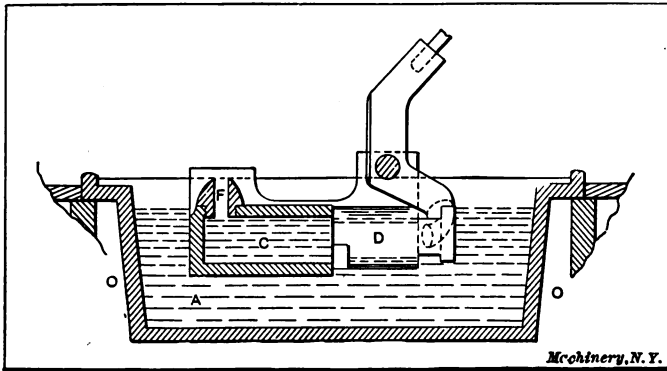

Fig. 10. Pressure Chamber submerged in Melting Pot

To overcome this, the type of plunger shown in Fig. 9 was invented. It is smaller in diameter than the cylinder or pressure chamber and travels in a rack composed of the two rings *I*, which are held together by ribs *J*. One of these rings fits into the end of the cylinder, and holds the rack in position. The molten metal flows into the pressure chamber through port *L*, and a valve closes this port when the plunger is brought forward to force the metal up into the mold. In the cylinder is located an asbestos washer *M* for preventing any leakage of molten metal that might occur. This type of plunger largely overcomes the tendency of metal to freeze on the bearing surface, as its area is greatly reduced. Dross also is not as liable to clog and stick the plunger in the cylinder. This design has, however, added the troubles encountered with an asbestos washer, which, owing to its non-cohesiveness, is continually crumbling away and flaking off.

Around the outlet or nozzle of this machine has been placed an auxiliary heating chamber. Gas enters through pipe *N*, surrounds the nozzle in passage *R*, passes through the perforated ring *P* and fills the inner chamber *Q*; after which the burnt gases pass out. This keeps the molten metal that fills nozzle *F* from chilling when a casting is

being made. This is one of the troubles often met with in this style of die-casting machine. Of course, when the sprue-cutter has severed the metal between the mold and the pressure chamber *C*, this passage empties when plunger *D* is pulled back. Passage *F*, however, is filled a large part of the time, as in making a casting it is necessary to bring the plunger forward as hard as possible, and hold it there while the mold is filling with metal and the sprue-cutter is being operated. Metal freezing in this passage causes a great deal of trouble which a heating chamber might abolish.

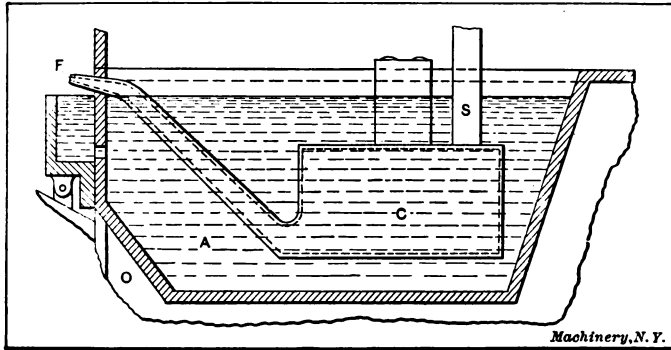

Fig. 11. Melting Pot with Air Pressure Chamber

In Fig. 10 is shown another style of melting pot. This has a pressure chamber submerged in the molten bath, and the plunger is operated by a lever which passes out through the top of the bath. The nozzle also carries the metal through the top of the bath to the mold. In this type the melting pot *A* is surrounded with gas flames at *O*, and the metal in the pressure chamber has to be heated through the mass of metal in the melting pot *A*. It is therefore difficult to keep the

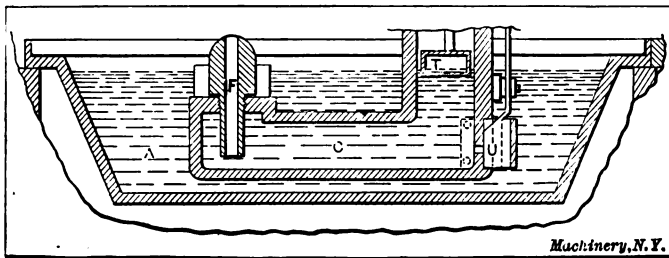

Fig. 12. Another Type of Air Pressure Chamber in the Melting Pot

metal in pressure chamber *C* as hot as that in melting pot *A*. The opposite condition should exist, *i. e.*, the metal should be hottest at the point where it is being forced into the mold. While several die-casting firms have used this type of machine, it has been the cause of much trouble.

Application of Compressed Air to Die casting Machines

In Fig. 11 is shown a pressure chamber submerged in a melting pot, but instead of using a plunger, compressed air is driven into the pressure chamber through pipe *S*, and this forces the molten metal out through nozzle *F* and into the mold. This application of compressed air has appealed to many builders of die-casting machines owing to its simplicity of operation, its positiveness, and the fact that operating troubles, such as the plunger sticking to the cylinder, were overcome in the machine. All those who attempted it, however, were men who understood nothing of metallurgy or the nature of metals. With the exception of a few very rare elements, oxygen unites with every known substance. It has a special affinity for metals when heated, and the

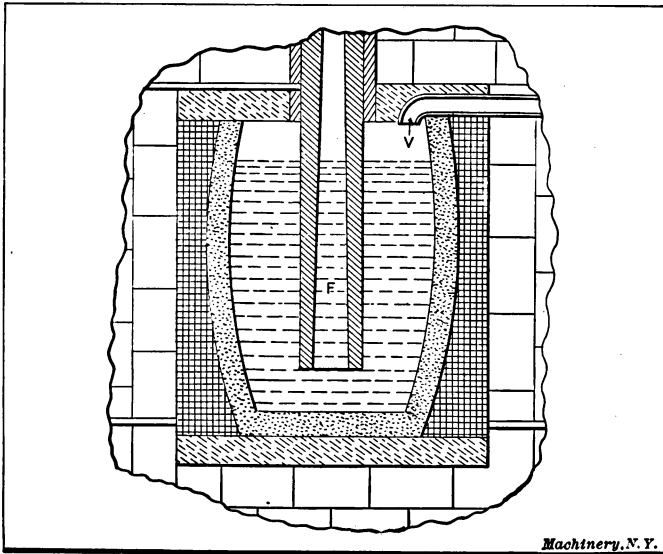

Fig. 13. Electrically Heated Crucible for Melting Pot

higher the temperature, the greater will be this affinity. It is one of the most injurious elements that can be injected into metals. By forcing air under pressure into pressure chamber *C* as is done in this case, it is impinged directly upon the surface of the metal with considerable force, and thus greatly increases the amount of oxygen that the metal will absorb from this air. After the first few castings are made, the metal becomes full of small bubbles which increase in size with the number of castings made, and in a short time there is nothing to the casting but a shell of metal that is filled with bubbles. Many times such castings are marketed because the spongy formation of the center does not show on the outer surface, but the instant they are broken, their worthlessness is apparent.

In Fig. 12 is another type of the pressure chamber that is submerged in the melting pot, and thus has the coldest part of the molten

metal passing through nozzle *F*, as in the case in Figs. 10 and 11. In this, air pressure has been used to force the metal up through nozzle *F*, but an attempt has been made to overcome the defects always encountered when using air. Float *T* has been placed in a compartment by itself, and the air is blown into this so that it will impinge upon

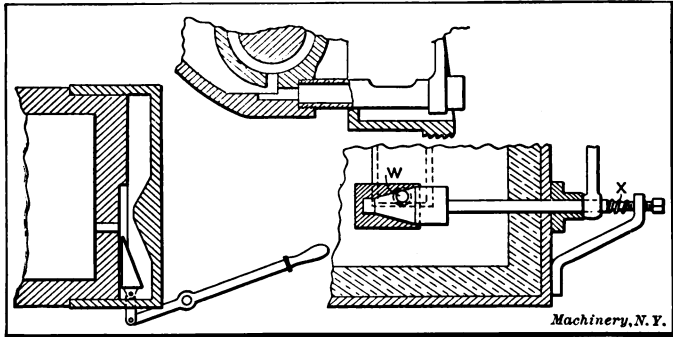

Fig. 14. Three Styles of Valves used

the surface of the float, and only have a small surface of metal around the float to absorb the oxygen. Nozzle *F* was also made of a casting that projected close to the bottom of the bath in order to let out any bubbles and get only the densest metal in the pressure chamber. It

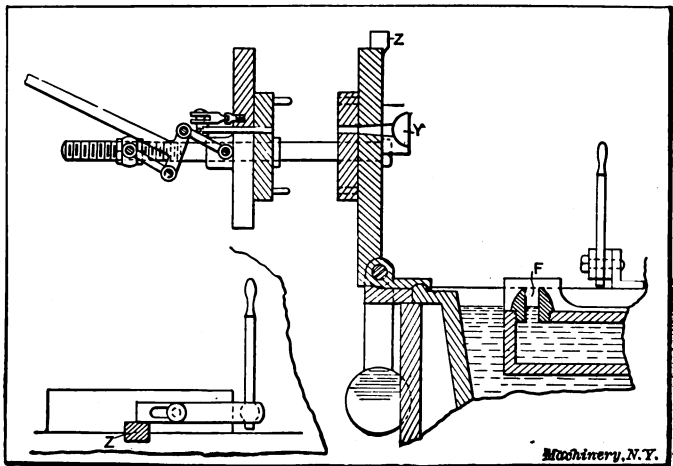

Fig. 15. Tilting Mold Table and Method of Parting the Mold

was thought that the bad effects of air, or the oxygen in the air, would be overcome by causing it to travel downward and then across the pressure chamber to the nozzle *F*. While the bad features of air pressure were overcome to a certain extent, they could not be entirely avoided as long as any part of the surface of the metal was left free to be attacked by the oxygen in the atmosphere. Thus, while this

machine will make quite a number of castings before the metal becomes charged with oxygen, it is still only a question of time when that will occur, and then the castings will be weakened and probably spongy and porous. An automatically operating valve was placed at *U*, so that pressure chamber *C* would take metal in as fast as it was injected into the molds.

Electrically Heating the Melting Pot

Another type of melting pot is shown in Fig. 13. In this design an ordinary graphite crucible is surrounded with a resistance coil, and placed in a brick-lined receptacle. An electric current is then turned on to heat the crucible and metal. The top of the crucible is sealed,

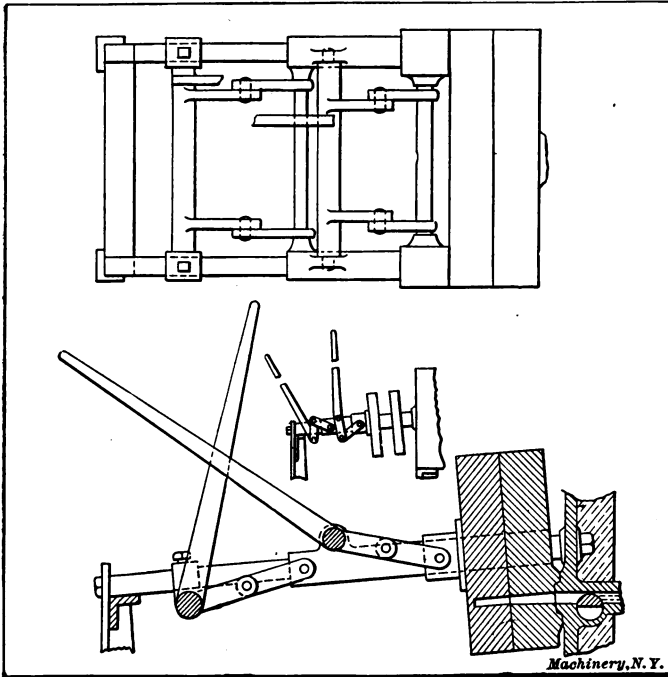

Fig. 16. Toggle-joint Arrangement for Parting the Mold and Drawing it away from the Spout

and air is injected through pipe *V* to force the metal up through the nozzle. While the electric heating arrangement is a good feature, the air pressure attacking the surface of the molten metal makes this type a complete failure.

Valves

In Fig. 14 are shown three styles of valves which are used on die-casting machines. The one to the right, as can be seen, is cone-shaped and opens and closes the hole *W*. A sectional view through this hole is shown in Fig. 7 where the valve is marked *G*, and hole *W* represents

outlet passage *F*. This valve is kept a tight fit by a spring located at *X*. It is easy to operate by connecting it to some of the other levers on the machine. The valve shown in the center of the illustration is operated automatically by chain and sprocket wheels, and closes its opening by turning half-way around. The bad feature of this valve is the large amount of surface which the molten metal comes in contact with, thus causing the valve to stick. The valve shown to the left is much more simple and has practically no wearing surface, it being merely a wedge-shaped block that is forced into place by a beveled projection on a frame. This, however, can not be used in all places, and though its design is doubtless the best, its use is limited to the places where it can be operated.

Opening and Closing the Molds

The methods of holding the die-molds vary with the different styles of machines, and a large part of this variation is due to the different constructions previously shown. In the machines that eject the metal

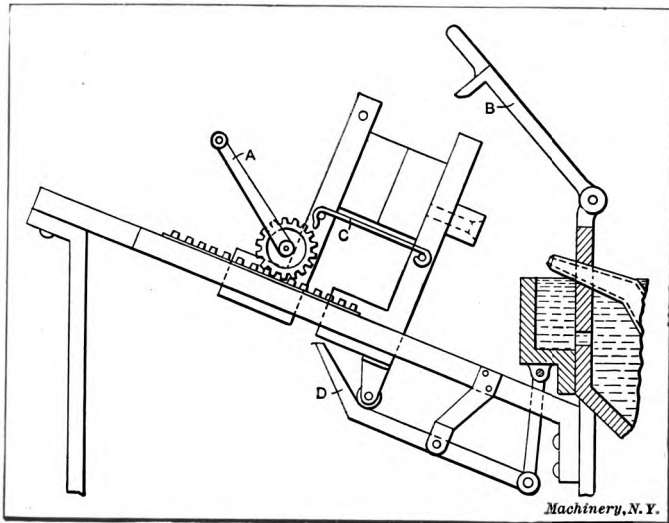

Fig. 17. Back and Pinion used to part the Mold and draw it away from the Spout

through the top of the bath, platens are used on which to rest the mold, and these are usually fitted with tilting arrangements similar to the one shown in Fig. 15. In this machine, nozzle *F* is ball-shaped, and socket *Y* fits down over it when the table, with its die-mold, is in position for casting. The platen is clamped down by projection *Z* fitting under a piece that is moved by the upright lever, as shown by the sketch in the lower left-hand corner. The mold is divided into two parts. One part is fitted to a plate located on two rods that are bolted to the platen. A toggle-joint is then used to pull the two parts of the mold apart, so that the casting may be removed. This toggle-joint is operated by the lever shown in the inclined position, and as will be seen,

arrangements are made to take up any wear that might occur in this joint. The mold will thus be a perfectly tight fit at all times. This is a very important point in making die-castings, as the metal is squeezed into the mold under pressure, and if the joint were not a tight fit, this metal would squeeze out through the sides.

In Fig. 16 is shown a method of holding the mold in position for casting on a machine that takes the metal out through the side. One

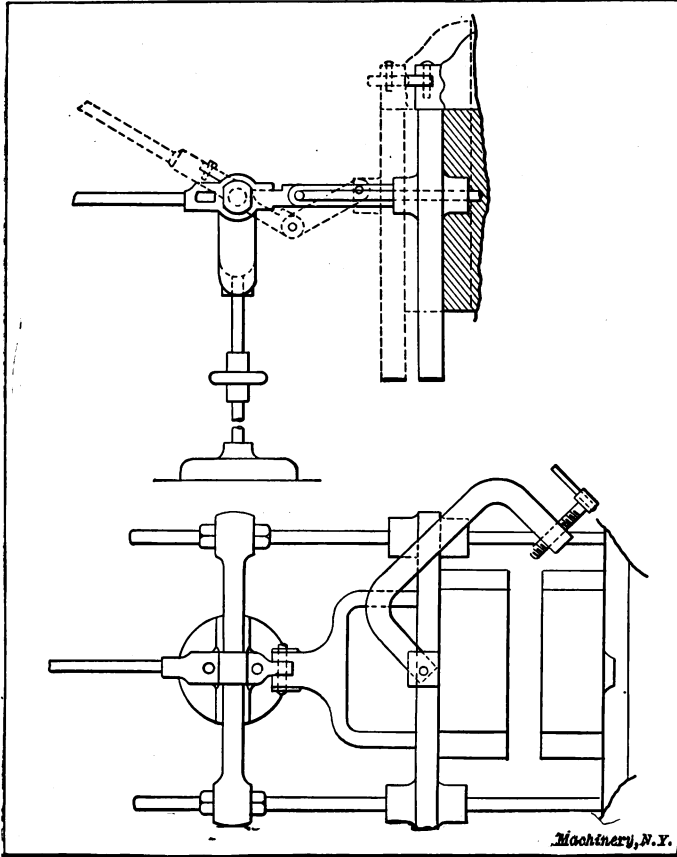

Fig. 18. Another Method of Opening and Closing the Mold

toggle-joint is used to close the two halves of the mold, while a second one is used to force the entire mold up against the nozzle. Why the toggle-joint, with all its faults, is used so much on die-casting machines is really a mystery, and yet it is probably due to the fact that the first machines invented were equipped with toggle-joints, and consequently nearly all designers followed this principle.

In Fig. 17 is shown a rack and pinion which is used for moving the mold away from the nozzle and also for parting it. In this illustra-

tion, lever *A* is used to operate the pinion which pulls the mold away from the spout. Hook *B* is then dropped down over the mold to hold it in position, while hook *C* is released and the two halves of the mold are pulled apart by the same gear and rack. In pulling the mold back, lever *D* is tripped and opens a valve that allows enough metal to flow into the pressure chamber to take the place of that which has been

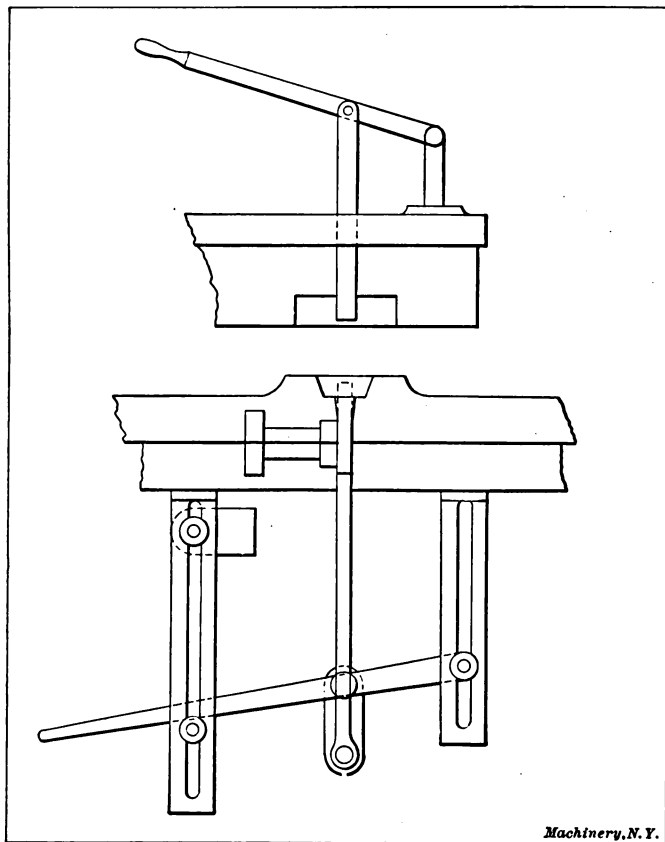

Fig. 19. Two Forms of Sprue-cutters

forced into the mold. While this tripping arrangement is good, and the gear, rack and pinion work successfully, the rest of the design is very crude, and it would mean very slow work in making castings. This machine, however, has not been commercially operated, and probably would not be without considerable re-designing. One of its worst features is the teapot form of pressure chamber with its air pressure. In Fig. 18 is shown still another method of opening and closing the mold, and clamping the two halves together. This also is crude and too slow in its operation.

Sprue-cutters and Ejectors

One of the necessary features on all die-casting machines that turn out perfect castings is the sprue-cutter. Two forms of these are shown in Fig. 19. The upper one is simply a rod that is pushed through the center of the casting. It implies that the casting has a center hole, and is very simple to construct and operate. If this hole is straight, it is

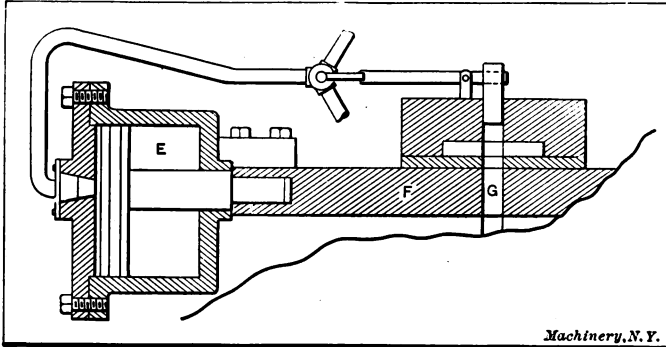

Fig. 20. Moving Platen to cut off the Sprue

immaterial whether it be round, square or any other shape. After the mold is filled, the sprue-cutter is pushed through it to separate the casting from the metal in the melting pot.

When castings have no center hole, the sprue-cutter can be placed at the end of the casting, as shown in the lower view. This mechanism

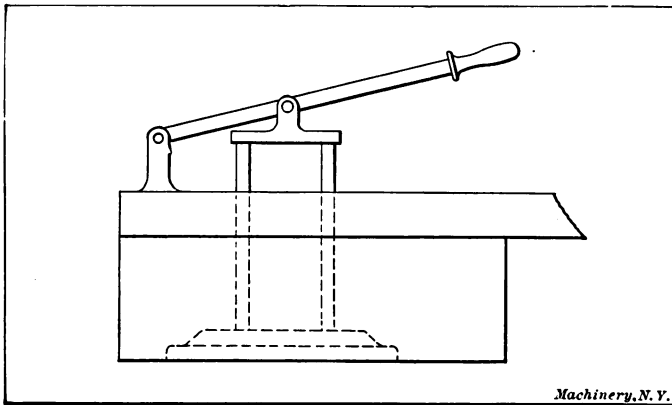

Fig. 21. Casting Ejector

makes it possible to stop the sprue-cutter at both ends of its stroke, the stops being adjustable to any position. The lever also gives the sprue-cutter, which must be a tight fit in the hole in which it operates, a straight push.

In another style of machine the sprue is cut with the platen, as shown in Fig. 20. In this, a piston working in the air cylinder *E*

pushes platen *F* over far enough for outlet passage *G* to be out of alignment with the sprue hole in the mold, or the outlet in the lower part of the machine. This cuts off the metal, and leaves a pocket of metal in passage *G* which will equal the thickness of the platen. When it is held long enough for the casting to freeze in the mold, the metal in this passage will freeze and thus put the machine out of commission.

The principle of using air to operate different parts of die-casting machines, such as pressure levers, sprue-cutters, casting ejectors, etc.,

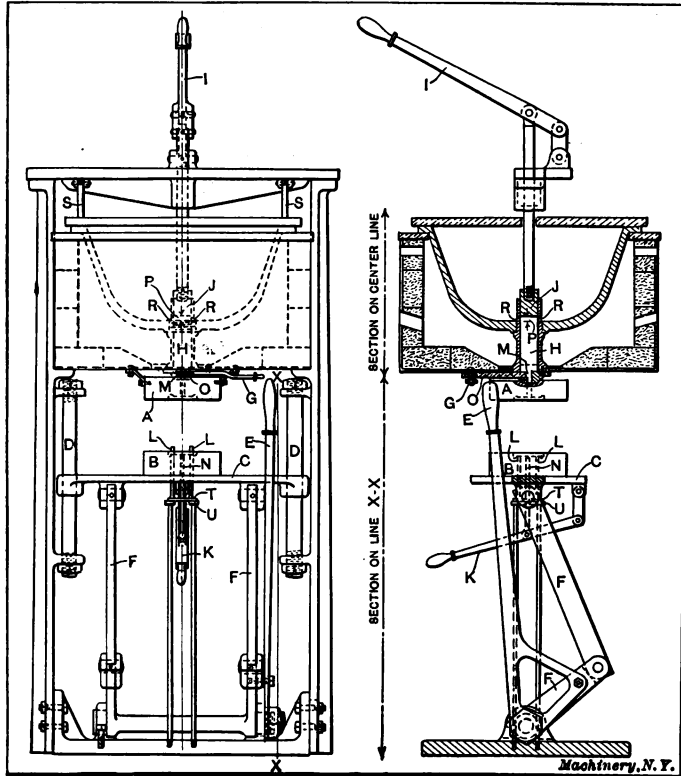

Fig. 22. Upright Machine for Making Die-castings

is very good; but considerable care in designing must be exercised to insure that no metal will be trapped in any part of the machine, and become solid. When this occurs it means that the machine must be taken apart and cleaned before it can be further operated.

In Fig. 21 is shown a casting ejector. This is fastened to one-half of the die-mold, and when the casting is complete and the mold open, the lever is brought down so that the small rods will push the casting out of the mold. The rods, of course, can be placed in any position desired, made of any size or shape, and are a very simple part of the

die-casting machine. The casting ejector and the sprue-cutter must occupy positions very close to each other, and the levers that operate each one of these are placed in easy reach of the operator.

Upright Die-casting Machine

In Fig. 22 is shown a complete upright machine that differs quite materially from the others shown. In this, the heating chamber, with its melting pot and pressure chamber, is supported on a cast-steel frame, and the molds are held directly underneath its center. The upper half *A* of the mold is fastened to the bottom of the heating chamber, and the lower half *B* is lowered away from it to get the casting out. The lower half of the mold rides on a cast-iron plate *C* which moves up and down on rods *D*. Lever *E* raises plate *C* with its half-mold, by means of the toggle-joints *F*.

In operating the machine, the two halves of the mold are brought together tightly by pulling lever *E* outward. Lever *G* is then moved out to open outlet *M* of pressure chamber *H*, so that the metal will enter the mold. The lever *I*, which is above the machine, is pulled down to force plunger *J* downward, and thus squeeze the metal filling the cylinder or pressure chamber *H* into the mold. Lever *K* is then pulled up and forces the sprue-cutter *N* entirely through the upper half of the mold *A* and into the nozzle. Lever *G* is now pushed in to close the opening from pressure chamber *H*, sprue-cutter *N* pulled out with lever *K*, and the bottom half of the mold lowered by pushing in lever *E*. As this is done, small plate *T* beneath plate *C*, strikes plate *U*, which is supported from the base of the machine, and this causes casting-ejector *L* to push the casting out of the lower half of the mold. Hinged pieces *S* hold down the cover of the melting pot, so that when the two half-molds are brought together they will not raise the melting pot. One difficulty encountered with this type of machine is that of keeping outlet *M* free from molten metal, so that it will not drop on the casting and spoil it when the mold is opened for its removal. By making sprue-cutter *N* come up close to the metal cut-off *O*, this can be accomplished, but to make a tight fit of these two parts and keep it tight with the continued movements of the machine, while making castings, is not as easy as it looks. A very small drop of metal will often spoil the casting that is being made.

Another bad feature is that the plunger must move the distance shown by *P* before it forces the metal into the mold. While moving this distance it is squirting the molten metal out through ports *R*, and thus churning up the metal in the melting pot. This metal should be kept as quiet as possible. Another bad feature is that four levers must be moved independently for each casting that is made, and this makes the operation of the machine rather slow. These levers should be connected in such a way that the pulling of the two levers would be all that is required.

A machine of this type, however, could very easily be belt- or motor-driven, and thus make its operation a boy's work. The work would consist of removing the castings and starting and stopping the machine.

It could also very easily be made to operate automatically, and thus do away with even that much hand labor. The upright machine appeals to many on account of having the natural phenomena of gravity to assist in getting the metal from the melting pot into the mold. If the liability of molten metal dripping on the finished casting is overcome, this style of machine is very handy and easy to operate.

While many die-casting machines are made for belt or electric drive and semi-automatic or completely automatic, it requires an enormous output to make such a machine a paying proposition, for by gating the castings in molds, a very large output can be obtained with one man's labor on a hand-operated machine, but where thousands of pieces are to be made per day, the automatic machine will save this one man's labor, and can thus be made to pay.

Alloys for Die-castings

Many different alloys are used for die-castings. It is necessary to have an alloy with a fine, close grain that is free from porosity and low in shrinkage. Castings used for some purposes must have a high tensile strength and great hardness, and these can only be obtained at a sacrifice of ductility. Castings with a high ductility can easily be made, but the tensile strength and hardness must be sacrificed. This is also a general rule that applies to the manufacture and production of alloys and metals for all other purposes as well as die-castings.

Zinc, tin, copper, antimony, lead, aluminum, nickel, bismuth, magnesium and silver have been compounded in many different percentages to form alloys from which castings for a variety of purposes are made. The first five, namely, zinc, tin, copper, lead and antimony are those most commonly used. Nearly any degree of strength, hardness, toughness, ductility, etc., can be obtained up to those inherent in the combinations that can be made. As yet, no one has marketed castings of the yellow metals or successfully made die-castings, on a commercial scale, from alloys or metals that have a melting temperature much above 1200 degrees F., or that have a strength equal to the bronzes. Considerable experimenting has been done and success is nearer than it was some years ago, even though the right method may not yet have been discovered.

Aluminum in small percentages is used in many of the die-castings. It acts as a purifier of the alloy, and causes it to flow more freely in the mold. To cast pure aluminum in die-molds or aluminum alloyed with small percentages of zinc or copper, or both, is very difficult. These alloys cannot be cast at all in very thin sections or with very fine detail in figured work, such as is produced in art castings. The lighter aluminum-magnesium alloys have also been experimented with, but these experiments have not met with much success as yet.

Much time and money has been spent by the different die-casting firms to die-cast manganese bronze, but this has been a failure, owing to the zinc oxide which forms on its surface when the alloy strikes the colder metal from which the die-mold is made. It is very doubtful if this feature can be overcome. One of the great difficulties encountered

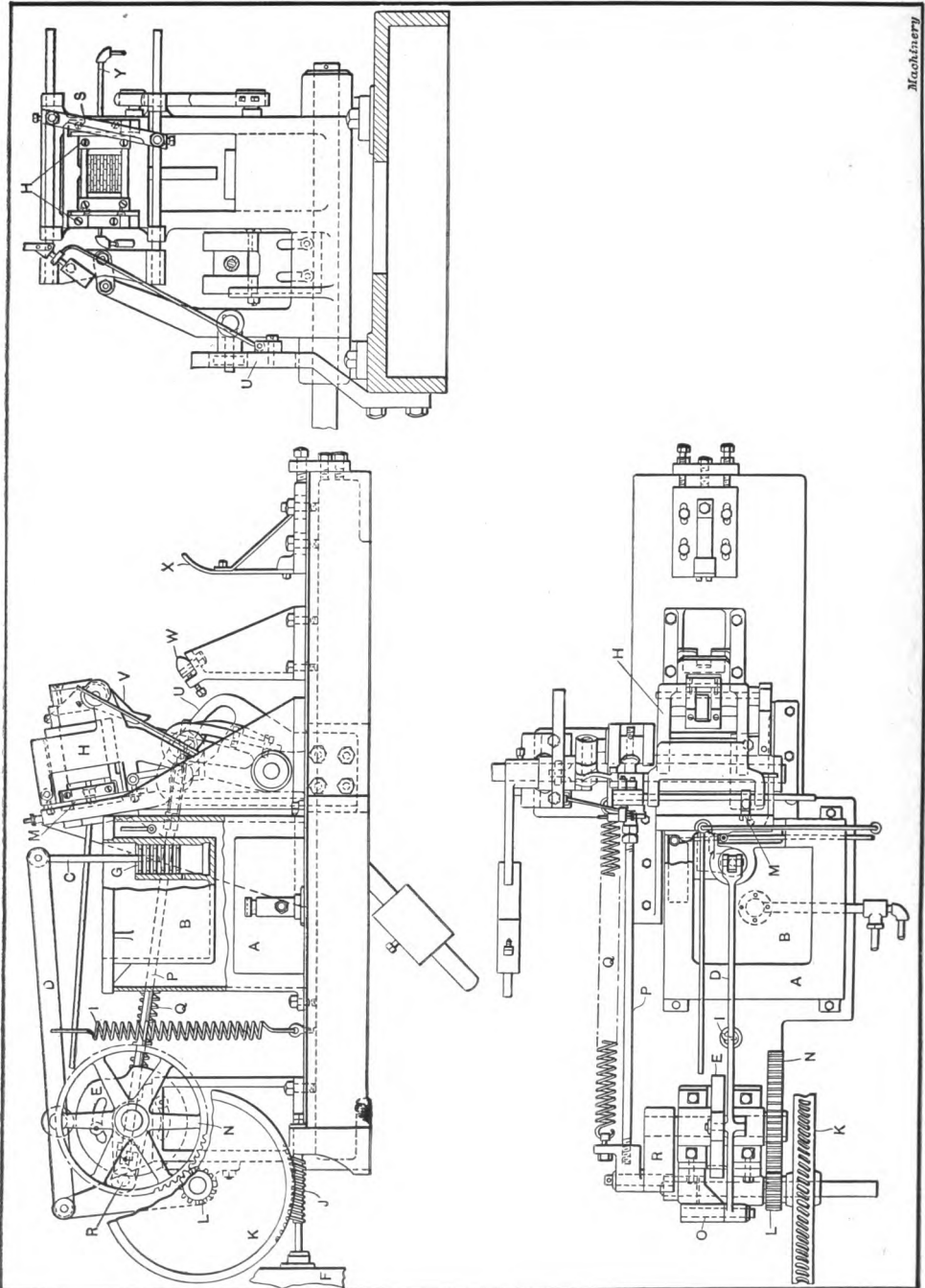

Fig. 23. Modern Type of Automatic Die-casting Machine

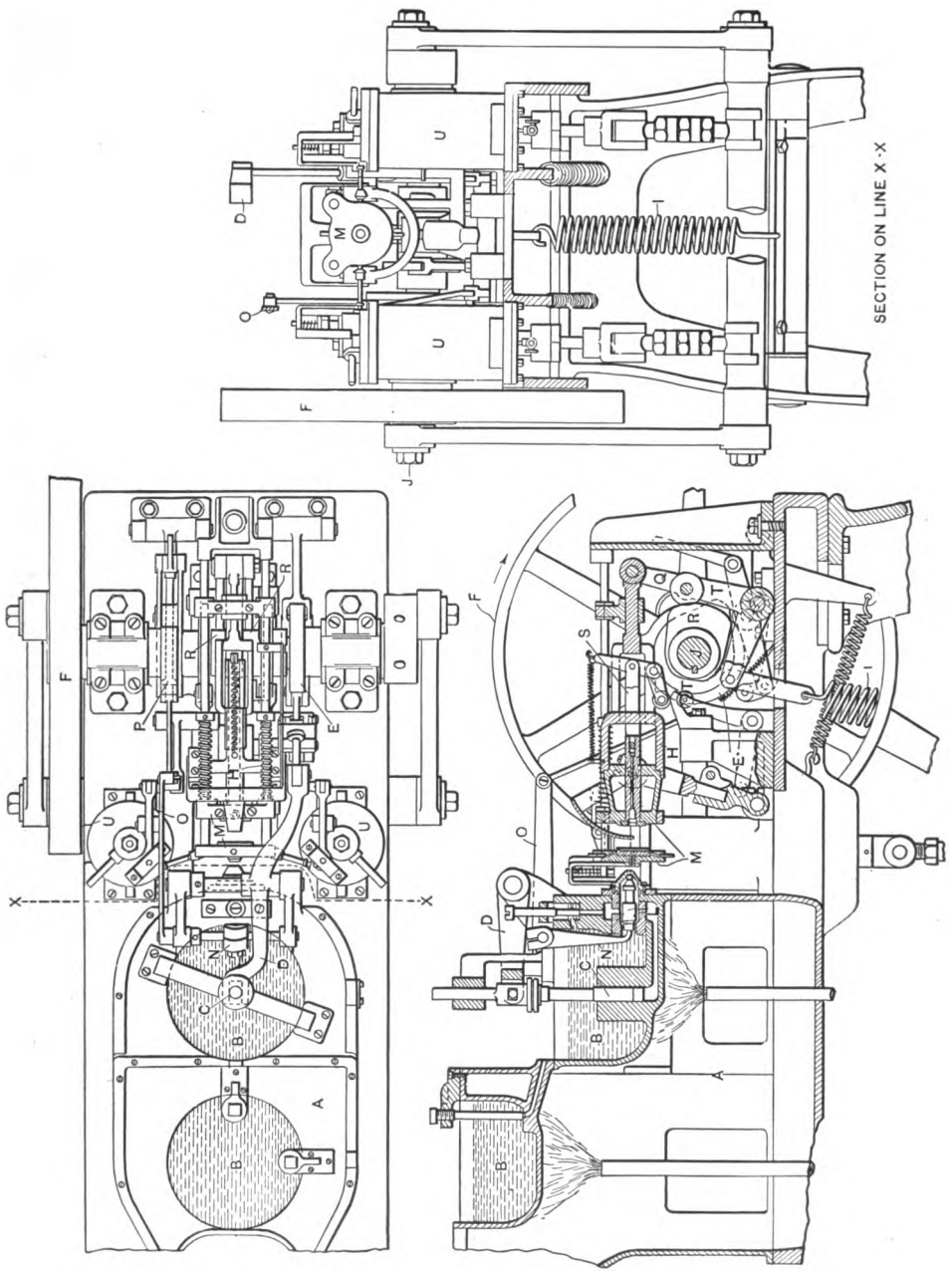

Fig. 24. The Latest Type of Automatic Die-casting Machine

Machinery

in casting metals of these comparatively high melting temperatures is the oxidization that the casting surface of the steel mold undergoes when its temperature is raised by the molten metal coming in contact therewith. This causes the mold to alter in size and shape, and thus destroys the accuracy of the castings. As this is an expensive way of producing castings, it is only by making them accurate as regards size and shape, and thus saving all machine work, that they can be made a commercial success. When this is done, however, the saving effected is so great that the die-casting machine and its products have become a necessity in manufacturing many parts of machines, instruments, etc., in the modern shop.

Aside from the die-castings made for bearings, zinc is the principal metal in die-casting alloys. An analysis of one of the most prominent makes of die-castings for use where no great strength or hardness was required shows 73.75 per cent of zinc; 14.75 per cent of tin; 5.25 per cent of copper, and 6.25 per cent of aluminum. Another prominent make that is used for similar purposes showed 72.70 per cent of zinc; 19.00 per cent of tin; 5.00 per cent of copper; 2.00 per cent of lead; 1.00 per cent of aluminum, and 0.30 per cent of antimony.

A die-casting that is somewhat harder than the two before given shows on analysis that the alloy is composed of 73.80 per cent zinc; 12.00 per cent tin; 10.80 per cent copper; 3.40 per cent aluminum, and 0.20 per cent iron, the iron being an impurity. Some very hard die-castings analyze as follows: 46.20 per cent zinc; 30.80 per cent tin; 20.40 per cent copper; and 2.60 per cent aluminum. An alloy that is very high in zinc contains 93.00 per cent of zinc; 3.50 per cent tin; 2.00 per cent copper; 1.50 per cent antimony, and 0.40 per cent aluminum.

[The sum of the percentages is 100.40. This anomaly is explained by the fact that after melting 93 pounds zinc, 3.5 pounds tin, 2 pounds copper, and 1.5 pound antimony, 6.5 ounces of aluminum is added as a deoxidizer.]

Another alloy is composed of 90.00 per cent zinc, 6.00 per cent copper, 1.00 per cent tin, and 3.00 per cent aluminum.

While zinc and aluminum in certain percentages and under some conditions might make good die-castings, the aluminum cannot be very high or the alloy shows a tendency to disintegrate. An alloy composed of 50.00 per cent zinc and 50.00 per cent aluminum will disintegrate into a granular mass inside of a year. Such a mixture, even though possessing considerable strength at the time of casting, would very soon lose its strength and crumble up. Some of the die-castings made at present disintegrate, so that their strength is greatly weakened in the course of two or three years. This, however, is due to improper mixtures, as they can easily be made so that practically no disintegration will take place at all.

Zinc and tin mixtures also show an inclination to disintegrate, and hence some other material has to be alloyed with them to act as a binder. They are also inclined to be very brittle unless copper is added, and the molten metal thus given a greater ductility. The zinc and tin mixtures that contain a small percentage of copper are good for wearing parts and also for plating and japanning.

Antimony and bismuth have frequently been used in combination with lead to give the lead a greater hardness. Where no particular strength is desired, such an alloy can be used. The type metals that contain approximately 83 per cent lead and 17 per cent antimony have been cast in machines using steel molds for a number of decades. Practically all of the type metals such as standard, electrotypes, linotype, etc., are easily manufactured by die-casting. These contain from 58 to 80 per cent lead, from 4 to 25 per cent antimony, and from 3 to 15 per cent tin. This gives a metal that is fairly hard and has considerable weight, but it is comparatively weak.

Alloys with high percentages of zinc, and a comparatively high copper content are very brittle, with little ductility and strength, while an alloy that is high in zinc and low in copper, *i. e.*, containing 90 to 92 per cent zinc and 8 to 10 per cent copper, shows a good resiliency and strength but no ductility.

Tin alloyed with lead and zinc casts freely and clean, and hence can be made to fill delicate parts of a mold. The zinc in die-castings usually runs from 70 to 90 per cent; the tin from 5 to 30 per cent; the copper from 2 to 20 per cent; the antimony from 1 to 5 per cent; and aluminum as high as 6 per cent has been used. While other metals have been used for making alloys for special castings, the ordinary casting can be produced from alloys made from these metals.

CHAPTER II

AUTOMATIC DIE-CASTING MACHINES

Nearly all die-casting machines in use at the present time are operated by hand, that is, a number of levers are pulled back and forth to perform the different operations of closing the mold, moving the plunger to force the metal into the mold, cutting off the sprue, opening the mold, and ejecting the castings. Nearly all of these machines require two men to operate them, and in some cases it requires five men to operate two machines. With these hand-operated machines a large quantity of castings can be manufactured in a day, and many have not considered it necessary to design and build more expensive machines. Some manufacturers, however, have built completely automatic machines for their own use, in order to save the labor cost of the hand-operated machines. These automatic machines are very successful, and are producing die-castings at a very low cost.

Automatic machines for casting type have been in use for more than sixty years, and these are, in reality, die-casting machines, although only used for the particular purpose of manufacturing type. Like all other die-casting machines, the automatics were devised from ideas and principles adopted in the type-casting machines, and are, in fact, largely improvements of these. The first attempt at applying such machines to the manufacture of castings, other than type, is shown in Figs. 25 and 26. This machine was patented by M. Dimock in 1875 for the manufacture of sewing machine bobbins. By turning crank *F*, all movements were produced that were necessary for the casting of a bobbin and throwing it out of the machine. By putting a pulley in place of the crank, it could be belt-driven and thus made completely automatic. In this machine, *A* is the furnace and *B* the melting pot located over the furnace, in which the metal is melted and held, ready for casting; *C* is the upper end of the pump or plunger that forces the metal into the mold. This plunger is raised and lowered by levers *D*, which in turn are moved by cam *E* located on the driving shaft, which passes through the machine from crank *F* to the flywheel *G*. The mold and the apparatus for opening and closing it and ejecting the casting are located on a framework just above this shaft. The die-mold receives its metal from a nozzle in the side of the melting pot.

The cross-section of the die-mold, with shank *H* on which it is pivoted, is shown enlarged in Fig. 27; the bobbin which is cast in it is shown above the mold. Shank *H* fits into cross-head *I*, and is, by means of this cross-head, pulled back from the spout so that it can be opened. The two halves of mold *M* are opened like an alligator's jaw by turning bar *J*, which is long enough for this purpose and is located on the end of shaft *U* that passes through shank *H* and carriage *I*. The cast bobbin is then thrown out and the mold closed, ready for another casting. The

cross-head and mold are moved back and forth by lever *K*, one end of which is pivoted to the frame at the bottom of the machine, while the other end works in a slot in the cross-head. Lever *K* is operated by

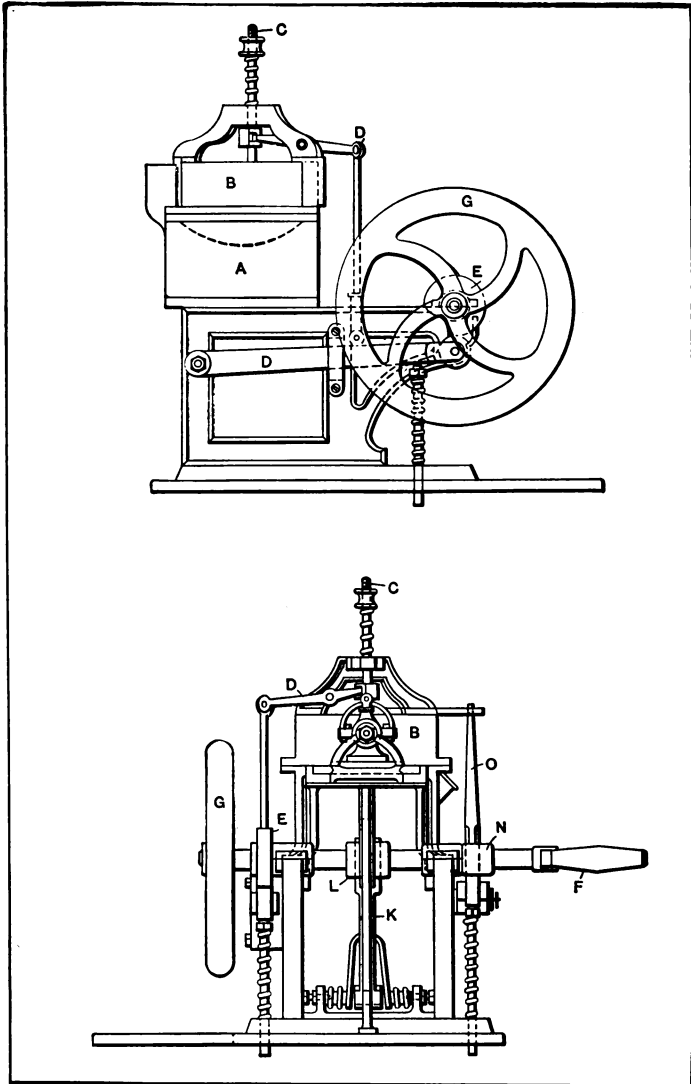

Fig. 25. Side View and End Elevation of First Automatic Die-casting Machine

cam *L* which is located at the center of the main shaft. When mold *M* is moved up to the nozzle of the machine, the tapered end at *V* enters a socket, thus holding the mold firmly closed. As soon as the mold

assumes this position, a cam located on the main shaft at *N* operates hinged lever *O*, and this, in turn, moves lever *P*, which opens a valve that allows the molten metal to be injected into the die-mold. This

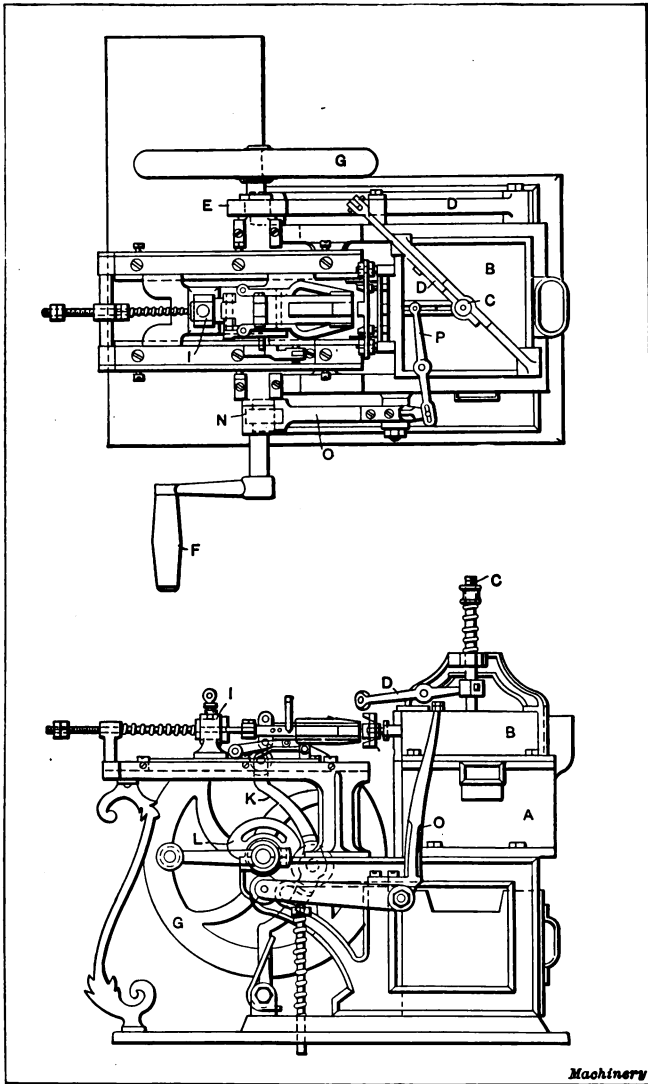

Fig. 26. Plan View and Side Elevation of First Automatic Die-casting Machine

valve operates in practically the same manner as valve *T* in Fig. 23 and valve *L* in Fig. 24, to be described later. In the meantime, plunger *C* has been raised to the top and as soon as the metal cut-off valve opens, the plunger is forced down and fills the mold with metal.

While this machine was simple in design, it worked fairly well, and many castings were made with it. The springs which gave the levers their return motion, however, were not positive enough, and on later machines cams were added for this work. A sprue-cutter, such as is now used, was not provided, and hence the sprue had to be broken off from each casting. These were about the only faults that could be found, and the principles here adopted were developed to a point that enabled automatic die-casting machines to cast pieces very intricate in shape. Movements were devised for pulling out pins, located in the die-molds, as well as other loose pieces that might form any size or shape of hole in the casting.

In 1902, Mr. C. H. Veeder patented the machine shown in Fig. 28. On this he was granted patents on nineteen combinations claims, but it will be seen that, although the machine is greatly improved in its design, the basic principles on which it operates are practically the same as those of the machine patented in 1875. The furnace is located at *A*, the melting pot at *B*, and the upper end of the plunger at *C*, as in the former machine. Lever *D* is operated by cam *E* and moves rod *Q* and lever *R*, which latter causes plunger *S* to travel up and down and squirt

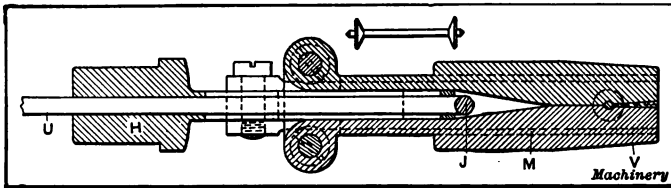
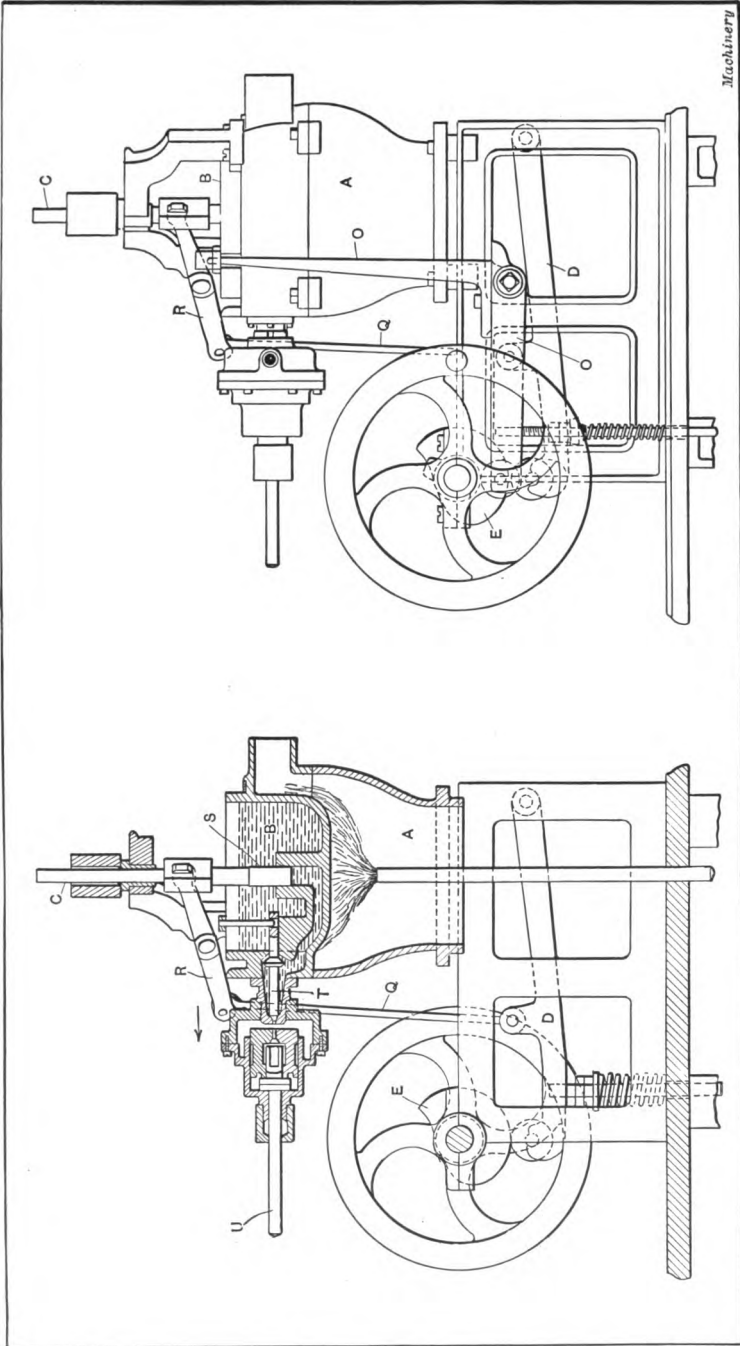

Fig. 27. Die-mold and the Bobbin cast

the molten metal into the die-mold. Another cam moves pivoted lever *O*, which is connected with the valve rod, and opens and closes valve *T* in identically the same manner as did the earlier machine; in fact, the shape of lever *O* is almost the same. This, however, is a design that has been successfully used for years on type-casting machines and is difficult to improve upon.

The manner of parting the mold to remove the casting is altogether different. Instead of opening it like an alligator's jaw, as in the earlier type of machine, a part of the mold is moved back, away from the machine, and the casting is thus allowed to fall out. The mechanism that opens and closes the mold is not shown in Fig. 28, but it is done with a very similar supporting frame and cross-head to that which draws the mold away from the nozzle in the Dimock machine in Figs. 25 and 26; but instead of using rod *U* to turn bar *J* and thus open the mold, as in the Dimock machine, rod *U* is used to form a core in the casting and after the casting has been made, rod *U* is pulled back to free the casting from the mold. This machine has been used for several years, but has also been improved upon. It has been made entirely automatic by putting a pulley in place of the crank wheel.

While in most automatic machines cams have been used to control nearly all of the movements, in others springs and gears have been



Machinery

Fig. 28. Modern Die-casting Machine

used in combination with cams. Such a machine is shown in Fig. 23. In this a cam *E* is used to control the motion of the pump plunger and a large spring is used to hold the lever against this cam. The mold is moved up to the spout and away from it by a crank on the end of the shaft that holds the cam. This shaft is driven by a gear *N* that meshes with a pinion *L* driven by a worm-wheel *K* and worm *J*; the worm, in turn, is driven by a pulley *F* and belt. A stationary cam is used to control the motion of a knife which cuts off the sprues and a brush that brushes off the knife. With the exception of the spring for holding the lever that operates the plunger against the cam, this machine works successfully. A spring in this location is liable to fail, owing to the plunger's sticking in the cylinder, due to dross in the molten metal; no metal would then be forced into the mold.

This machine was especially designed for casting electric storage battery grids, but can well be used for making many shapes of castings for machine parts. These grids are thin strips of metal, crossing each other at right angles, the strips being joined together at each intersection; they thus contain a number of square openings, and resemble wire netting, except that the strips are not round. As in the other die-casting machines, *A* is the furnace, *B* the melting pot over the furnace, *C* the plunger rod, and *D* the lever that operates the plunger. A roller attached to lever *D* rides on cam *E*, to guide the up and down motion of plunger *G*; spring *I* holds lever *D* against cam *E*. It would doubtless be better to use another cam to perform the work of this spring and thus make the upward motion of the plunger as positive as is the downward motion. Cam *E* is so shaped and timed in its motion as to cause the plunger *G* to move down only when the mold is closed tightly against the nozzle and ready to receive the metal. To reduce the air pressure in the mold against the action of the plunger, so that all parts are filled with the incoming metal, an air pipe *Y*, with pump, is often connected to the mold. This automatically pumps out the air and creates a vacuum in the cavity of the mold that shapes the casting, just before the molten metal is injected into it by the plunger.

The mold is operated by a mechanism that is as simple, positive and handy as that of any die-casting machine made. Mold *M* is located on rocker arm *H*, which is connected by rod *P* and spring *Q* to crank *R*. Thus, while cam *E* is controlling the operation of plunger *G*, crank *R* is controlling the movements of the mold. Mold *M* is thus brought up to the nozzle and held there while plunger *G* descends and squirts the metal into it. Plunger *G* is then raised for another stroke, while mold *M* is rocking back away from the nozzle. For the grid casting made in this machine many gates are used, and while the rocker is carrying the mold back to the end of its stroke, knife *S* travels across the face of the mold and cuts off the sprues. A brush then travels across the face of knife *S* and brushes off any chips that may have accumulated. These motions are controlled by cam *U*, which is bolted to the side of the frame.

On many kinds of castings for machines or instruments, the shape is such that this knife and brush could not be used for the sprue cutter,

but it is easy to take off this mechanism and attach others that would perform the necessary operations, and which might be even simpler in design. The distance through which rocker arm *H* travels can be adjusted by shortening or lengthening rod *P* by the nuts provided. The mold can thus always be kept tightly against the nozzle, and also go back far enough to eject any casting. When rocker arm *H* reaches the end of its backward stroke, arm *V* strikes block *W* and this operates the mechanism that ejects the casting from the mold. To insure no jar, flat spring *X* is provided for rocker arm *H* to strike against.

One of the most complete automatic die-casting machines built is shown in Fig. 24. This machine was patented by Mr. C. H. Veeder and is a vast improvement on the machine shown in Fig. 28. It is supplied with two melting pots and is completely automatic. All that the attendant has to do is to keep the secondary melting pot filled with metal and carry away the finished castings. With each casting that is made, the metal lowers in the melting pot and the secondary melting pot is used for the purpose of keeping the primary melting pot filled. In this machine the air is exhausted from the mold with an air pump before forcing the metal into it, thus insuring the filling of every crevice. The machine differs from nearly all other types in that it has provision for a powerful, positive pressure for forcing the metal into the mold, in addition to the vacuum. Thus, the formation of gas bubbles or air pockets in the cavity that forms the castings is overcome and deformed castings are not produced. The percentage of bad castings has, therefore, been reduced to a minimum.

In this machine also, *A* is the furnace; *B* the melting pots; *C* the plunger; *D* the lever that moves the plunger up and down; *E* the cam that causes the movements of this lever; *F* the pulley that drives the machines; *H* the carriage that holds and operates the mold; and *M* the mold.

A single shaft *J*, driven by pulley *F*, controls all the movements. Cams are located on the central portion of this shaft and cranks on the two ends to give the machine all of its movements. No gears are used. A double-action valve is used to control the injection of the metal into the mold, and to cut off the sprue. This valve is shown at *L*. Before plunger *C* starts moving downward, arm *N* is moved away from valve *L* and the flow of metal due to the downward motion of plunger *C* causes valve *L* to move to the left and close the opening between the passage in which this valve is located and the melting pot. Thus, all of the pressure exerted by the plunger is used to force the molten metal from this valve chamber into the mold. When the die-mold has been filled, arm *N* pushes against valve *L* and causes it to close up the nozzle opening through which the metal flows into the die-mold, and, at the same time, valve *L* cuts off the sprue of the casting. Arm *N* is moved by lever *O*, which, in turn, derives its motion from cam *P*.

Carriage *H*, which holds the mold and controls its movements, is operated by a series of levers that are moved by two cams. Lever *Q*, with its connection levers, is moved by cam *R*, and this pulls carriage *H* to the right to open the die-mold as shown in the lower left-hand

view of Fig. 24. By the action of cam *R*, lever *Q* afterwards moves carriage *H* to the left, thus closing the mold and holding it tightly against the nozzle while it is being filled with the casting metal. Spring *I* holds the roller of lever *Q* against cam *R*. This is a weak point of the machine, as the pressure that forces the molten metal into the mold is exerted against this spring; unless a locking device is attached to the mold, and this requires additional mechanism. Another cam could more easily be used to close the mold and hold it against the pressure of plunger *C*. While the mold is opening, bar *S* is moving to the left through carriage *H* to eject the casting from the mold. The movement of bar *S* is controlled by a series of levers moved by cam *T*. While the mold is closed, vacuum tanks *U* are automatically connected with it and draw out all of the air. A vacuum is constantly maintained in these tanks by an air pump.

With all of these movements properly timed, die castings are made as fast as the metal will solidify, and can be ejected from the mold without deforming the castings. Most die-casting machines do not apply much pressure to the plunger, but depend on the suction created by the vacuum to draw the metal into the mold. This does not produce castings with as fine and dense a grain as when a high pressure is applied, and they are more liable to have porous and spongy places. The high pressure, combined with the vacuum in the mold, also makes the casting correspond exactly to the contour of the cavity cut in the mold. One die-mold can be taken out and another, for a different casting, inserted in its place with very little labor. Thus the machine can be made to operate on several kinds of castings in a day's run.

These and other reasons make it one of the most economical machines built, as the cost of the castings has been reduced to little more than the cost of the metals for making the alloys, the gas that keeps the metal molten, interest on original investment, and the expense necessary to keep the machine in repair. Automatic type-casting machines cast one type at a time, at the rate of 240 per minute. This speed is largely due to the fact that cold water is forced through a water-jacket that surrounds the type cavity in the mold; as many as 240 per hour would be a high figure for die-castings for machine or instrument parts, as these are nearly always more intricate in design and have a larger volume of metal to be cooled. Many times, however, more than one casting can be made in a mold. When the mold is water-jacketed, and the machine completely automatic, the output of perfect castings will be many times that of hand-operated machines, and at a very low labor cost.

The formation of coarse crystals is an inherent trait of all metals when they are slowly cooled from the liquid state. This coarse crystallization is more pronounced in some metals than in others, and the alloys from which die-castings are made are composed of the metals that form the coarsest crystals, when so cooled. The most notable example of this crystalline formation is antimony, while zinc is another metal that has a very flaky crystalline structure. This formation of

coarse crystals can be overcome to a large extent if the metals are chilled and suddenly solidified from the molten state, when casting them into shape. This is done in the machine shown in Fig. 24, by circulating a stream of cold water through a water jacket formed around the cavity in the mold that forms the casting. While the vacuum created in the cavity of the mold and the pressure used to force the metal in have a tendency to reduce the coarse grain and crystallization, the rapid cooling and solidification that is caused by the current of cold water still further aids in refining the grain.

The action is similar to that which takes place when hardening steel. In this case, the grain is refined by heating cold metal to the desired temperature, and the fine grain is retained by instantly quenching in a liquid, and thus suddenly cooling the metal. If it were allowed to cool slowly, the grain crystals would return to the coarse size of the unheated steel; or if heated to too high a temperature, a coarse grain would be formed that could only be refined by the pressure or hammering applied during forging operations. In the die-casting alloys, this fine grain is produced by melting, and the quicker it can be cooled down from the molten state, the finer will be the grain of the metal in the castings. It is not a difficult matter to surround the casting cavity in all die-molds with a water-jacket. This, of course, will not only give the metal a more dense, homogeneous grain, but will also solidify the castings much more quickly and enable many more castings to be made per hour than can be made in a machine where the mold is not water-jacketed.

CHAPTER III

MODERN HAND-OPERATED DIE-CASTING MACHINE

In the present chapter a simple method for making die-castings is explained, and one of the best machines for casting white metal, or for making "pressure castings," as they are often called, is described. The accompanying illustration, Fig. 29, shows cross-sectional elevations of the machine, which is one of the latest designs of die-casting machines in practical use. No skill is required to operate it; an ordinary laborer can learn how to do it in a very satisfactory way in a short time. When the dies are small and there are only two or three levers to be handled, one man can operate the machine advantageously. But when larger dies are used and a number of levers must be handled, it is more economical to employ two men at the machine. It is important, however, that only one man control the injection of the metal into the dies. This is a very essential point, because two men cannot produce exactly the same results for every pouring. Uniformity in the control of the injection of the metal is one of the basic points in white metal die-casting.

In designing a die-casting machine, it is necessary to so arrange it that the metal will be handled as little as possible, as otherwise part of the metal would oxidize and be wasted. The molten metal should be covered so that the air will not strike it more than is absolutely necessary. In the machine shown in the accompanying illustration, the metal comes into contact with the air only at the nozzle, where it is injected into the die. It may be argued that this would have a detrimental effect on the casting, but experience has shown that it does not; the reason for this is that the surface which comes in contact with the air is so small in comparison to the amount of metal that is pressed out each time, that the few seconds during which the air comes into contact with the surface is not enough to have any serious effect. This is particularly true in the case of large castings. In the case of small castings the metal is poured so much oftener that the surface of the metal at the nozzle is not in contact with the air long enough to injure the casting.

The design of the die-casting machine is, briefly, as follows: In the accompanying illustration *A* is a gas furnace made by the American Gas Furnace Co., this furnace being one of the standard sizes. At *E* are shown the gas burners, four being placed on each side of the furnace. The metal is melted in the pot *B*, and the gas burners can be so controlled that the heat can be directed toward any part of the melting pot. This pot is made of cast iron, and it can be replaced by one of the standard sizes made by the American Gas Furnace Co., at very little cost, when burnt out. The life of the pot depends upon the

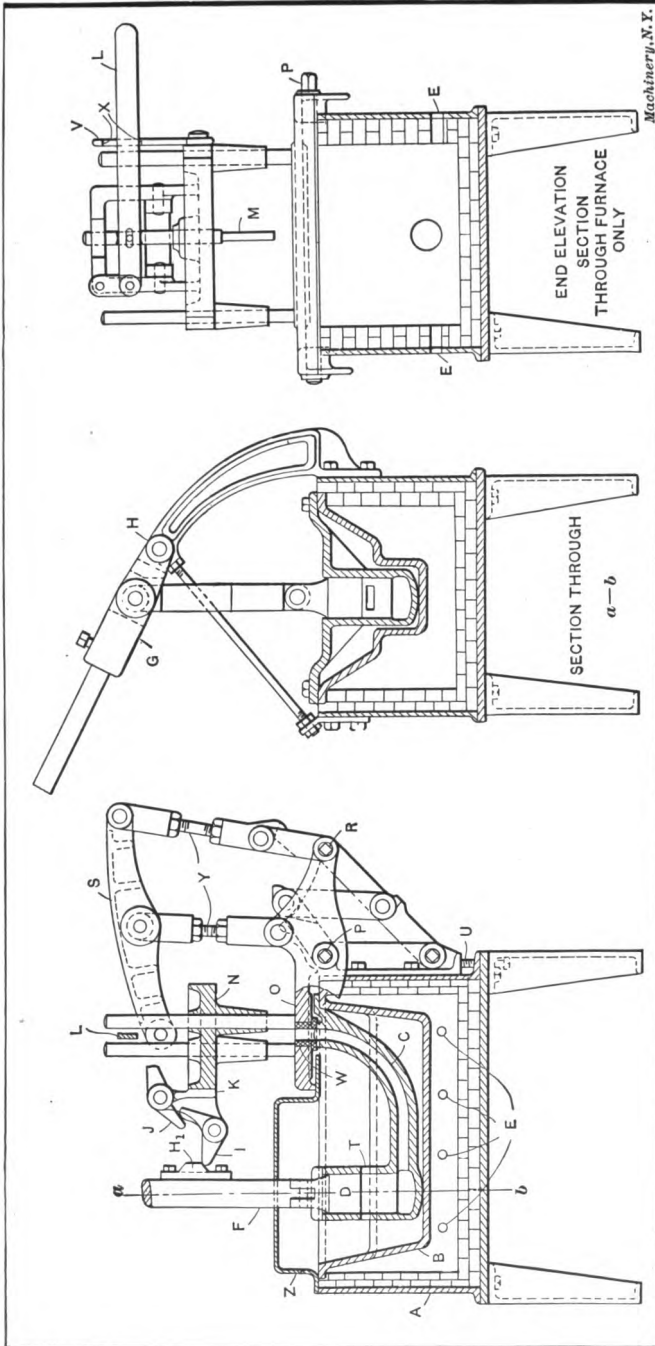

Fig. 29. Die-casting Machine of Recent Design

metal used for making the die-castings. If the metal requires a high degree of heat for melting, the receptacle naturally will not last so long as when less heat is required.

At *C* is shown the part forming the nozzle which is connected to a cylinder in which the metal is compressed by means of the plunger *D*. When the plunger descends, the metal is pressed or pushed out through the nozzle *C*, which is tube-shaped as shown in the illustration. At *F* is shown a connecting-rod which is operated by means of the handle *G* having its fulcrum at *H*. A dog or trip *H*₁, fastened to the connecting-rod *F*, operates the lever *I* which, in turn, moves the lever *J*, both of these levers being mounted on bracket *K*. The lever *J*, in turn, operates the handle *L*. To the handle *L* is attached a rod *M*, called a "sprue cutter." The part *V* acts as a stop for the motion of lever *L*, this motion being limited between the points *X*. The stop *V* swings out of the way for lever *L*, when the core is being pushed out of the casting.

The dies are fastened between the plates *N* and *O*. The plate *O* is hinged at *P*, and the shaft passing through the lever at *P* is squared on the end as shown, so that a handle may be put on the shaft. In this way plate *O* can be swung away from the nozzle, thus allowing the die to swing away from the furnace through an angle of about 45 degrees. This uncovers nozzle *C*, permitting the pushing out of the so-called "core," which is formed at every pouring. It is advisable to have the core as small as possible, but, of course, the size of the core depends very largely on the size of the casting. When the die-plates are swung away from the nozzle, the operator chills the core by means of compressed air blown through a rubber tube, and when this is done the core is forced out by a forward push of the handle *L*, which at that moment operates the sprue cutter *M*. This action releases the core which is slightly tapered in order that it may be easily removed.

The next operation is to separate the two plates *O* and *N*, thus opening the die, one-half of which is held on the plate *N* and the other on the plate *O*. The die-plates *N* and *O* are separated by operating a handle placed on shaft *R*, which through a set of connecting links and the arm *S* separates the two plates. At *Y* adjustment is provided for setting the two plates properly for any size of die. The top of the furnace is covered by a sheet-iron lid *Z*, lined with asbestos. This cover is left on all the time when the heat is on or when the metal is melted, so as to prevent the latter from coming in contact with the air.

At *T* is a slot in the pressure cylinder through which the metal runs into the cylinder before being pressed into the die. The screw *U* serves the purpose of adjusting the nozzle, so as to get it perfectly tight. This is an important factor, as is also the cleaning of the nozzle, which should be done by the operator after every pouring. This takes but a moment's time and makes it possible to obtain good results. Many times the neglect of this precaution has made it difficult to obtain good castings.

When the die is open, ready to eject the casting, the operator takes the air hose and chills off the casting for a moment. Then he grasps the handle connected to the ejecting pins in the die, and puts one hand under the edge of the die, when a push of the handle makes the piece or pieces fall into the hand of the operator. The air hose is again used for cleaning the die. The reason for this is that after every pouring there is, due to the pressure, a small fin formed on the face of the die, and this must be removed before casting another piece. Blowing the air over the face of the die removes it easily. After the die is cleaned and again closed, plate *O* is closed down over the nozzle and everything is ready for the next pouring. All the operations described require but a part of a minute, especially when the machine and dies are small and light. When a larger machine and larger dies are used, the work cannot be done so rapidly, but will be in proportion to the size and design of the pieces to be cast.

Many experiments have been made to obtain a strong and durable metal for die-castings. When making small parts for machines which require high tensile strength, great care must be exercised to obtain a strong metal and one that flows easily, because when the metal flows easily it is possible to obtain a solid casting. The mixing of the metal must be done in a careful manner, because white metal is very treacherous, and carelessness at this time makes it difficult to obtain good castings. The metal must be carefully handled, and care taken to see that it is not too hot when casting. If it is too hot, the operator will have difficulty in obtaining good sound castings.

The dies should be heated slightly before beginning the casting. This is done by closing the die and also closing the plate *O* lightly against the nozzle while the metal is melting. The die will then be of the right temperature for starting the work when the metal is melted. Care should also be taken to keep an even heat in the furnace, so that the temperature of the metal is the proper one for obtaining solid castings. This can be done only by a man experienced in white-metal casting. The metal should not be put into the pot in "pigs," as this chills the melted metal in the pot and causes difficulties. Instead a small furnace should be used alongside of the machine for melting the metal. This melting can be done at a slow heat which is, in itself, a good thing for white metal. When more than one man works the machine it is difficult to obtain castings without blow-holes. A casting may look dense on the outside, and when broken may show such defects as to make it useless for the purposes for which it is intended.

Making Dies for Pressure Castings

When making a die for a pressure casting, the piece to be made should first be considered, as the shape of the piece will govern the point at which the dies should be parted. If the dies are not made and parted correctly, and the sprue not put in the proper place, it will be difficult to obtain good castings. It is therefore desirable to take these points into consideration before attempting to lay out a pair of dies for making pressure castings. Care should also be taken when making the

dies to have them fit together closely, so that there will be no fin left on the casting; this, however, in some cases is unavoidable.

The next point to take into consideration is the weight and character of the castings. If the casting is a thin shell of an odd shape, particular attention should be given to the position of the sprue-cutter, which should be placed so that it will be possible to insure the mold being filled. When the sprue-cutter is not located in the proper position, it will be found that the mold will not fill up properly, which will result in poor castings. It is impossible to lay down any hard and fast rule for the shape or position of the sprue, as the work under consideration is the determining factor. It is well, however, to fill the mold from the bottom, as is the rule in iron molding.

Another factor which enters into the problem for making successful pressure castings is the position in which the dies are set in the machine, the design of the machine, and the conditions under which it works. If the machine has a good pressure, the sprue can be made small, but if the pressure is reduced, which results from various causes,

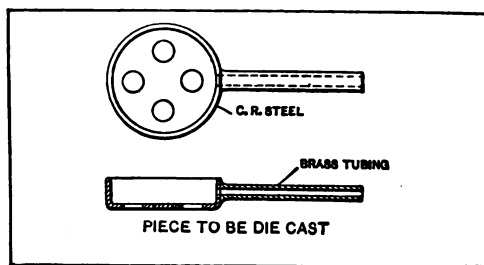

Fig. 30. Work produced on Die shown in Fig. 31

the sprue should be designed to compensate for the loss in pressure. The pressure is sometimes decreased by overheating the metal, which expands the cylinder in the machine, so that the metal squirts out around the sides of the plunger.

The piece shown in Fig. 30 is made from sheet steel and has a brass tube inserted in it. The cost of making this part was so high that it was decided to make the body from white metal and cast the brass tube in it. The end of the brass tube which fits in the body or cap is knurled, so that the tube is held tightly by the metal when cast around it. The die for casting this piece from white metal was made to cast one piece at a time. Of course, if a large quantity had been required it would have been possible to make the dies to cast more than one piece.

The die shown in Fig. 31 consists mainly of a cast-iron frame *A* of box-shape construction. On the top face of the box is fastened the lower die *C*, the other half of the impression being formed in the plate or die *D*. *E* is a circular plug which pushes the brass tube up against the core *F*, forming the inside of the casting. A handle *G*, pivoted on the bracket *H* actuates this plunger *E*, and the coil spring *J* connected to the handle *G* keeps the brass tube tightly up against the core *F*, while

the piece is being cast. *K* is a gate through which the metal passes into the dies, while the hole *L* is made to fit the sprue-cutter *B*, the latter removing the metal passing from the pot to the sprue, after the piece is cast. The gate is broken off after the piece is removed from the

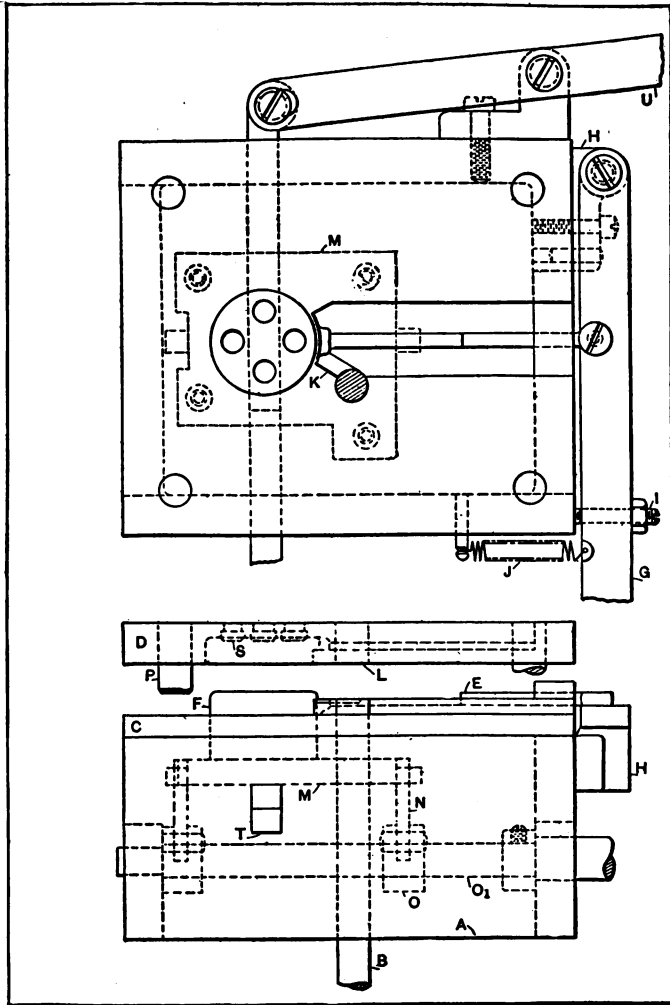

Fig. 31. Die used for producing Work shown in Fig. 30

dies, which can be accomplished with a slight pressure of the hand. The gate should not be made more than 0.010 to 0.015 inch thick, but the width should be made to suit the piece. A plate *M* is held to the lower die by four studs, and acts as a bearing for the links *N*. The studs in the plate *M* are used for guides as well as stops for the up and down

movement of the plate, as is shown in the separate view Fig. 32. *O* is an arm which is mounted on a squared portion on the shaft *O*₁, the arm being bent at one end to form a handle. This arm *O*, through the links *N*, raises and lowers the plate *M*, which, in turn, actuates the core *F*. Dowels *P* are used for lining up the two dies in their relative positions. The dowels should be driven into the thickest die, so that they will be held rigidly.

The holes in the casting are formed by the four core-pins *S*, which

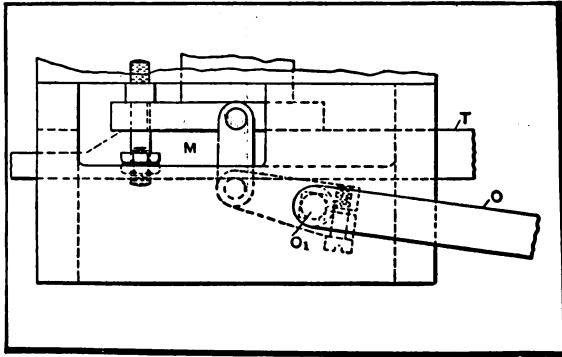
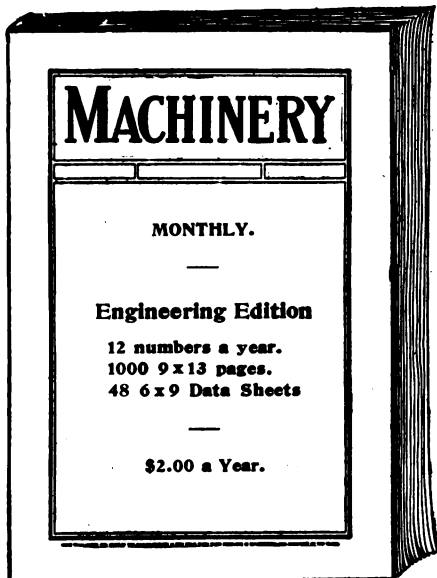

Fig. 32. Side Elevation of Die shown in Fig. 31

are fastened to the upper plate *D*. A slide *T* is pushed in under the plate *M* by means of the lower lever *U*, and is used to prevent the core from blowing out when the pressure is applied for forcing the metal into the dies. The die *D* is held in the die-casting machine on the plate nearest the nozzle, while the other half of the die is fastened to the rear plate. After the plates are separated the piece is ejected by means of a handle, which is pushed forward, allowing the core *F* to go back flush with the plate *C*, when the piece will fall into the hand if placed under the die.



MACHINERY is the leading journal in the machine-building field and meets the requirements of the mechanical engineer, superintendent, designer, tool-maker and machinist, as no other journal does. MACHINERY is a monthly and deals with machine design, tool design, machine construction, shop practice, shop systems and shop management. The reading matter in MACHINERY is written by practical men and edited by mechanical men of long practical training. The twelve numbers a year contain a thousand

pages of carefully selected and edited mechanical information.

Each number of MACHINERY contains a variety of articles on machine shop practice. These articles include carefully prepared descriptions of manufacturing methods and current mechanical developments. Shop systems and shop management are ably handled by the foremost writers. Every number contains the most extensive and complete monthly record published by any journal, or in any form, of new machinery and tools and accessories for the machine shop. A special department is devoted to "Letters on Practical Subjects," to which practical mechanics contribute their experiences. There is a department of Shop Kinks—brief, concise little contributions which contain ideas of value to the man in the shop or at the drafting table.

The mechanical engineer, machine designer and draftsman are also well provided for in MACHINERY. Every number contains articles on the theory and practice of machine design, on the properties of materials, and on labor-saving methods and systems. There are reviews of research work in the mechanical field, valuable results of carefully made experiments are recorded, and the world's progress in every field of mechanical endeavor is closely watched.

One of the most valuable features is the four-page monthly Data Sheet Supplement printed on strong manila paper. These Data Sheets contain high-grade, condensed mechanical data, covering machine design, machine operation and kindred subjects. They are the cream of mechanical information.

