

UC-NRLF



B 3 018 838

25 CENTS

TJ

7

M3

V128

BORING, RECESSING AND MULTIPLE TURNING TOOLS

BY ALBERT A. DOWD

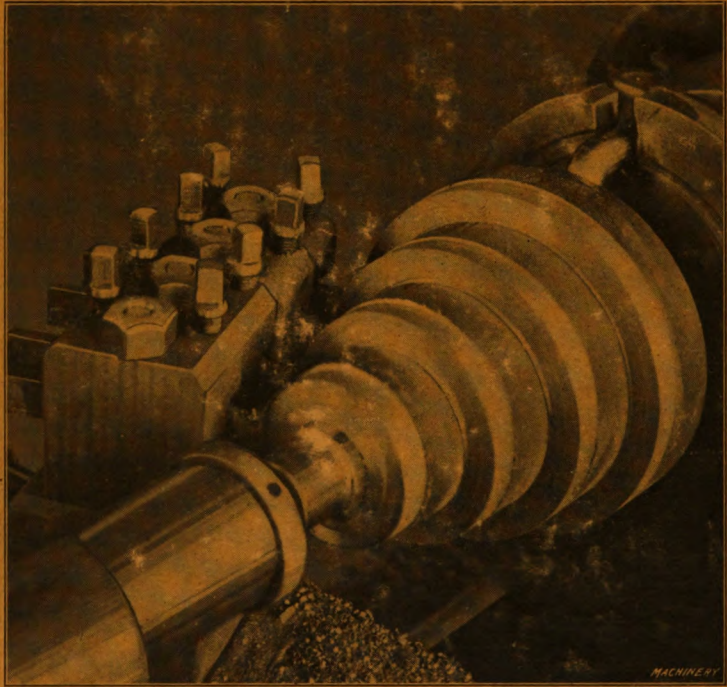

MACHINERY'S REFERENCE BOOK NO. 128
PUBLISHED BY MACHINERY, NEW YORK



MACHINERY'S REFERENCE SERIES

EACH NUMBER IS ONE UNIT IN A COMPLETE LIBRARY OF
MACHINE DESIGN AND SHOP PRACTICE REVISED AND
REPUBLISHED FROM MACHINERY

NUMBER 128

BORING, RECESSING AND MULTIPLE TURNING TOOLS

By ALBERT A. DOWD

CONTENTS

Design and Construction of Boring Tools - - - -	3
Recessing Tools - - - - -	16
Adjustable and Multiple Turning Tools - - - -	32

71 JM

M3

v. 128

71 JM
M3
v. 128

CHAPTER I

DESIGN AND CONSTRUCTION OF BORING TOOLS

A boring tool or boring-bar is, in itself, a very simple tool and yet, in its various applications, it may require considerable forethought in order to obtain a tool which will be exactly the right one for the job. In order to properly design any kind of a cutting tool, an intimate knowledge of the actual working conditions which are met with in using the tool is a valuable asset. There are a number of factors which influence the design of boring tools and there are also many types of machinery to which boring tools may be applied. In some cases the bar revolves with the spindle of the machine, while in others it is held rigidly and the work revolves around it. These things affect the design and must be considered. The work naturally controls the size of the bar and also its shape, while the material which is to be cut makes a difference in the shape of the tool and determines the amount of "chip clearance" necessary.

The tools described and illustrated in this chapter must be considered as representative types of the many varieties to be met with in the general course of manufacturing. Points in design and construction will be noted and faulty tools will be discussed and criticised.

General Points in Boring Tool Design

Some of the important points in the design and construction of tools for single-point boring are here given, and while some of these may seem obvious, they may be of assistance in calling attention to matters which would otherwise be overlooked.

1. Chip clearance must be very carefully looked after when the tool is to be used for cutting steel, as an accumulation of chips caused by insufficient clearance is very annoying to the operator and also injures the work by tearing or scratching it, and finally ruins the bar itself unless it is hardened. The amount of clearance between the bar and the work should be as great as possible without sacrificing strength, and in this connection it should be noted that in addition to the necessary chip clearance at the point where the cutting action takes place, provision must also be made to get rid of the chips themselves. For this reason the portion of the bar beyond the cutting tool should be so proportioned that chips will not wedge. In cutting materials other than steel the clearance is not so important, as the chips are short and do not curl up or cling to the bar, so that they practically take care of themselves.

2. The method of holding or clamping the tool in position should be such that the thrust of the cut comes against the solid body of the bar and not against the set-screws or clamps. It is advisable to use square-head set-screws instead of the headless type whenever possible.

3. Boring-bars should be provided with some means of adjusting the tools for diameters, by the use of "backing-up" screws or wedges. The so-called "sledge hammer adjustment" type of bar should never be used when there is room enough to put in adjusting screws.

4. Boring-bar tools should be made as large as the diameter of the bar will permit without sacrificing strength, in order to assist in carrying away the heat generated by the cutting action, and to permit the use of heavier feeds without burning the tool. The rake of the tool should be such that it will turn the chips to the best advantage.

5. The bar should be so designed that micrometers can be used over the bar and tool in order that the operator may be able to set his diameters closely without resorting to the usual "cut-and-try" method used by our forefathers.

6. In the design of multiple boring-bars which are to be used to bore up to a shoulder, it is not good practice to set the tools in the bar at an angle. They should be located in a plane perpendicular to the axis of the bar. If set at an angle it will be found a very difficult matter to grind the tools so that diameters and shoulder distances will remain constant.

7. Bars designed for use on turret lathes should have the tools set in a plane perpendicular to the rotation of the turret. By this means variations in the indexing of the turret are minimized in their relation to the cutting tools, so that diameters can be held much closer to size than if the tools are arranged in a plane parallel to the turret rotation.

8. When the work is of such a nature that a cutting lubricant is required, provision should be made so that an ample supply of the fluid can be carried directly onto the face of the cutting tool. This result can be accomplished either by means of a hole in the bar with outlets at the proper places, or oil grooves covered with a strip of sheet brass. In either case a good connection must be made with the cutting lubricant system on the machine. This may be arranged by a distributing collar on the turret or by means of a special oiling device through the spindle.

Boring Tools for the Engine Lathe

Boring tools which are designed for use in the engine lathe are generally of a very simple kind, adapted only to light cutting and seldom used for more than one or two pieces of work of the same size at the same time. Several varieties are to be found in the average tool-room, although forged tools will be noted in greater numbers than any of the others. Tools of this kind of almost every conceivable shape and size, from a small round "hook tool" for cutting an inside recess, to a large bar of tool steel bent over at the end for boring some long pieces of work, will be found in abundance. There are square bars and round bars with inserted tools, and, in addition to these, each toolmaker has a special boring tool of his own make which he uses for jig work. These special tools occasionally show consider-

able ingenuity in their construction, and are usually made in such a way that very fine adjustments can be attained.

The upper part of Fig. 1 shows a piece of work *A* held by the outside in chuck jaws, the machine on which the work is to be done being an engine lathe. A plain forged tool *B* is held in the toolpost *C* on the cross-slide of the lathe. This type of tool is the simplest of all tools used for boring and consists of a rectangular piece of tool steel of suitable size to fit the toolpost. The tool is drawn out and bent

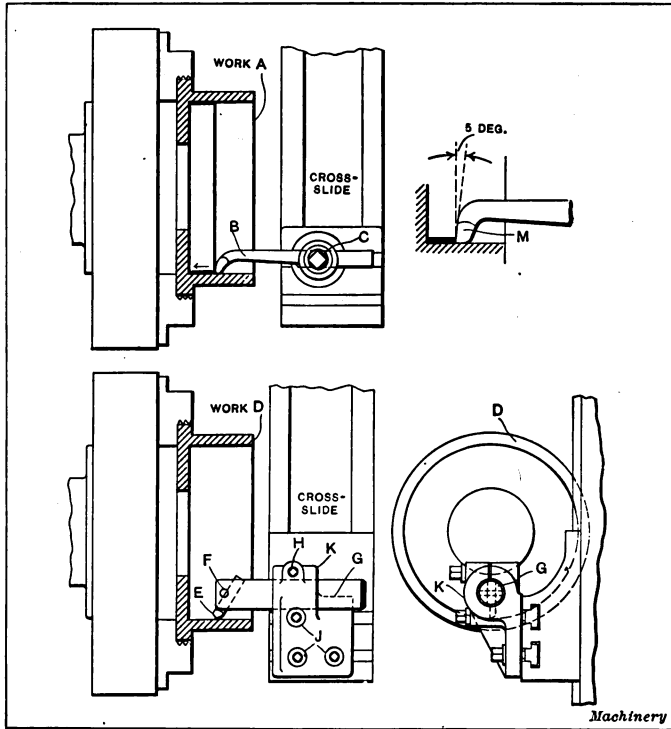

Fig. 1. (Upper View) Forged Type of Boring Tool; (Lower View) Boring Tool with Inserted Cutter

over at the cutting end by the blacksmith and is then ground to a cutting edge by the workman using it. Hundreds of tools of this variety can be found in every machine shop and factory in this country. They are suitable only for light cutting and there is a tendency toward "chatter" even when the cut is light; this is due partly to the shape of the cutting end and partly to the overhang of the entire tool. It will be found that less chatter will result if a slight land or flat is stoned on the tool immediately below the cutting edge. The tool should also be set slightly above the center. For casting work where scale is encountered, there is a decided tendency for the tool to ride up on the scale and ruin very rapidly if it is ground

Adjustable Boring Tools for Jig Work

Fig. 2 represents two styles of adjustable boring tools used mostly for boring small shallow holes or jig bushings. These tools are capable of fine adjustments but are not suited for any kind of heavy cutting. The upper part of the illustration shows how tool *B* is used for boring a part of the bushing *A*, which is held in chuck jaws. The body of the tool-holder *H* is made of steel and is turned down and tapered at *J* to fit the tailstock spindle. The adjustable swivel *D* is pivoted on the shouldered screw *E*, and is adjusted by the two headless set-screws *F* and *G*. The tool *B* is of round section and fits the end of the swivel, where it is held in place by the two screws *C*. The end of the tool is bent over for the purpose of clearance. A tool of this kind is very convenient and is easily adjusted for diameters within its capacity. It is not adapted to deep holes, but can be made up in several sizes so that it will handle fairly large work.

The lower part of the illustration shows another tool of somewhat similar construction, which is designed for the same purpose as the other. The body is of steel and the shank *T* is turned taper to fit the tailstock spindle. The forward portion of the body *R* is cut out to receive the swivel *N*, which pivots on the screw *S*. The tool *M* is of round section, bent over at the end, and it is held in place by the two screws *O*. One adjusting screw *Q* is all that is required in this tool, as the coil spring *P* takes up lost motion and prevents drawing in. This tool is not as rigid as the one previously referred to, but the spring makes adjusting much quicker, as only one screw is needed. A number of tools of this type, and of various sizes, were made for tool-room use in a large automobile factory and were used on the greater part of the jig work.

Boring Tools for the Horizontal Turret Lathe

Boring tools which are required for use on the horizontal turret lathe are of many forms and their design is somewhat dependent on the type of machine to which they are to be attached. On machines having no transverse movement to the turret slide, the tools are nearly always designed for straight boring, while on the other types of machines, *i. e.*, those having transverse movement, the design is frequently made in such a way that the tools can also be used for facing operations. The form of the turret itself also influences the design to a certain extent, for it is evident that a flat turret would require a different type of tool-holder than one of the vertical face variety.

Single-point Starting Tool for Taper Holes

The work *A* shown in Fig. 3 is a malleable iron automobile hub with a cored taper hole which runs out of truth very badly. Therefore it was necessary to design a starting tool of the single-point variety in order to generate a true running hole, so that the subsequent tool would start properly without being influenced by the wobble of the core. This tool and tool-holder are very simple, the tool itself

being a piece of round high-speed steel bent over on the end and ground to cut a diameter a trifle smaller than the large end of the tapered hole. The holder *E* is a piece of machine steel of cylindrical shape, which is ground on the outside to fit the turret hole and on the inside to fit the shank of the tool *B*. Two set-screws *D* are used to hold the tool in position. It will be noted that the end of the cutting point is ground very nearly square so that it will not ride up on the scale. The tool is not made for continuous boring but is merely used

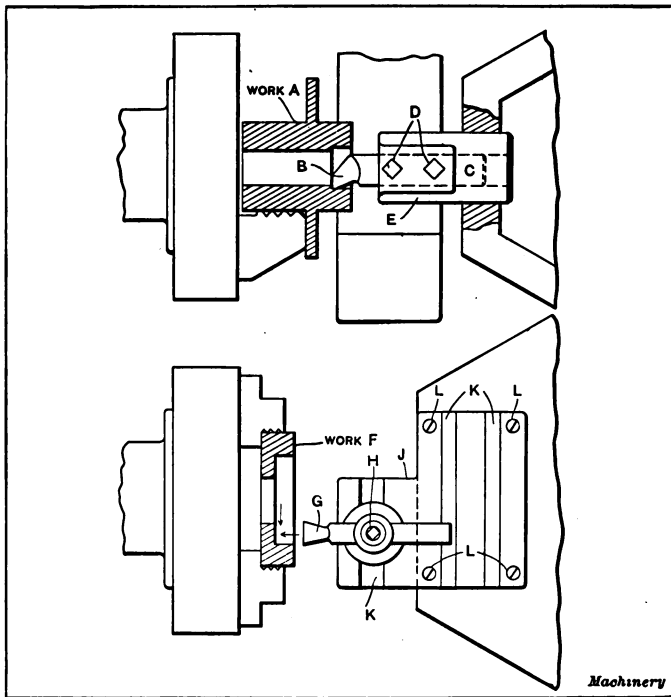

Fig. 3. (Upper View) Single-point Starting Tool; (Lower View) Boring and Facing Tool

to generate a true hole for a short distance into the cored portion of the hub.

Boring and Facing Tool for a Flat Turret

An example of a boring tool which is also used for facing out a pocket on a turret lathe having a flat turret is shown in the lower part of Fig. 3. This tool is of the "shovel nose" type and its cutting action is rather hard on account of the bluntness of the nose and the amount of stock which is removed. The work *F* is a machine steel forging and the shoulder is not recessed at all in the blank. The tool *G* is of rectangular section and it is forged and ground on the cutting end to the shape shown. The tool-holder *H* is supported by the steel bracket *J* which is fastened down on the turret face by screws *L*. The slots

K are T-shaped and permit various settings and combinations of tools to be made.

Fig. 4 shows a very simple type of single-point adjustable boring-bar for machining the bushing *A* (see upper part of the illustration). Although this bar is simple in its construction, there are several important points in design which should be carefully noted. The bar *E* is of a low grade of tool steel and is hardened and ground to fit the turret hole. The reason for making the bar of tool steel is simply to

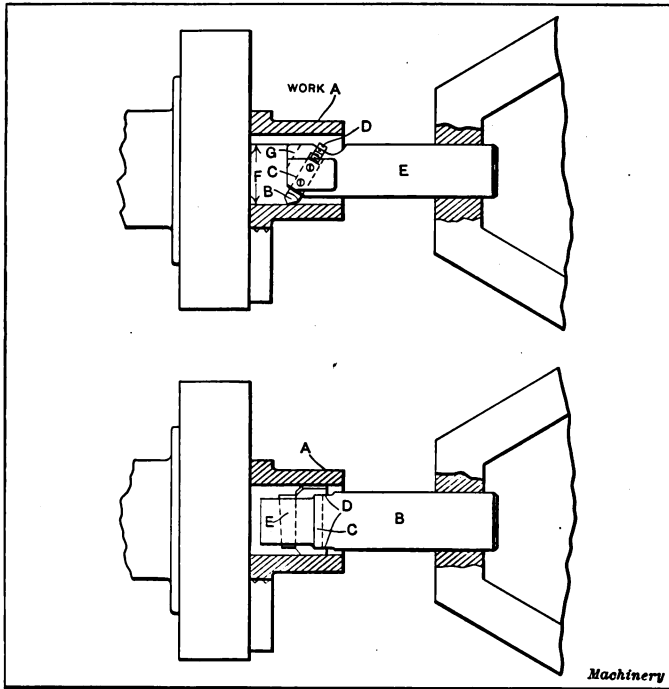

Fig. 4. (Upper View) Boring-bar with Adjustable Cutter; (Lower View) Boring-bar with Double-ended Cutter

obtain all the rigidity possible and thereby obviate chatter. The tool *B* is of round section and is put through the bar at a slight angle, being held in position by the two screws *C*. A backing-up screw *D* permits careful adjustment to be made. The bar is cut away where the tool comes through to provide chip clearance, but it is cylindrical on the end except in this one place. By making it this way, it is found an easy matter to use micrometer calipers across the bar and tool as indicated at *F*, so that accurate settings may be readily made without resorting to "cut-and-try" methods. It is very bad practice to bevel the end of the bar at *G* and put the holding screws through at this point, because a caliper point is sacrificed by so doing. *A*

simple formula is here given for setting tools of this type for turning a given diameter:

Let F = required calipering distance for a given size hole;
 X = diameter of the bar at the end where the tool is;
 Y = diameter of the hole to be bored.

Then

$$F = \frac{X + Y}{2}$$

This formula will be found useful for setting tools very close to the desired diameter, although the spring of the bar will cause slight variations and the amount of stock which is to be removed also makes some difference.

The lower part of Fig. 4 shows a boring tool of an entirely different type. The cutter is double-ended, and a bar of this sort is often used for removing stock rapidly. Although it is a faster cutting tool than a bar having only a single tool or cutting point, it cannot be depended upon to produce a hole which is absolutely concentric with other surfaces machined at the same setting. The work A is the same as in the upper part of the illustration, and the bar B fits the turret hole. It is flattened slightly on two sides at points D , and a rectangular slot contains the cutter C and the wedge E . It will be noted that the cutter is shouldered so that it is a close fit at the points D . Tools of this type cannot be ground radially without changing their diameters, but this is seldom necessary as the cutting edge is at the forward end. A land of about $\frac{1}{8}$ inch is usually left just back of the bevel, and the cutter can be ground back to this point without changing the diameter. Beyond this, however, there is a slight back taper for the sake of clearance, so that the life of the cutter does not extend beyond it.

Boring-bar with Provision for Cutting Lubricant

On certain classes of work it is very difficult to supply the cutting points of the tools with sufficient lubrication to make them thoroughly efficient, when the regular supply system is used. Some method must be devised, therefore, to direct the flow to the point or points where the cutting action takes place. An example of a bar arranged to carry the lubricant to inaccessible tools is shown in the upper part of Fig. 5. The work A in the chuck jaws is an automobile hub of malleable iron. It will be noted that the portion bored by the forward tool C is in such a position that it cannot be reached for lubricating purposes in the ordinary way, but the rear tool D can easily be taken care of. The boring-bar B is of a low grade of tool steel and fits the turret hole at the rear end; the forward end J is a running fit in the chuck bushing L . A telescoping oil supply tube K enters this end of the bar and is supplied with lubricant from the rear end of the spindle. The hole in the bar at H leads the fluid directly onto the face of the cutting tool C , thus insuring constant lubrication at this

point. The two tools are held in place by the screws *E* and *F*, and they are provided with means of adjustment in the backing-up screws *G*. The writer has used bars of this type in a number of cases with very gratifying results.

Fig. 5 (lower illustration) shows a very different condition, in a multi-cutting boring-bar for generating a series of true holes in the bronze artillery hub *A*. The finished hole is tapered but a starting bar was used in order to prepare the hole properly for the taper tools

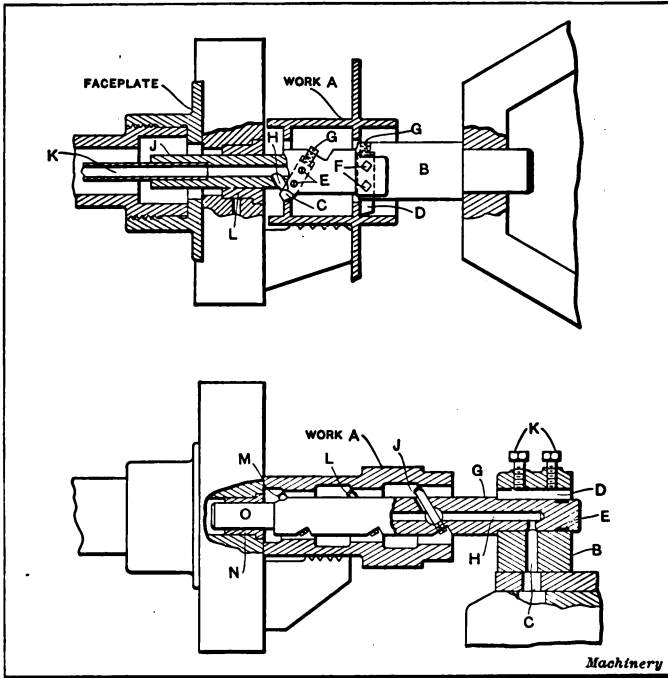

Fig. 5. Boring-bars arranged for lubricating Cutters

which followed it, so that they would not be influenced by the irregularities of the cored hole. In this case the turret lathe was one of the flat-turret variety, and provision was made for lubrication through the hole *C* in the turret face. As the turret indexed to the proper position, this hole came directly over another in the slide, which, in turn, was connected with the lubricant pressure supply system, thus allowing the liquid to pass up into the body of the tool-holder. The boring-bar *G* is turned down at the rear end to fit the tool-holder *B*, and has an annular groove *E* which is packed with felt to prevent the escape of lubricant. A shoe *D* is forced down on the bar by the two screws *K* and prevents the bar from turning. The hole *H* in the bar is drilled from the forward end and is tightly plugged so that this end remains closed to prevent the lubricant from passing through. A groove is

cut in front of the tools *J*, *M* and *L*, as shown at *J*, and this allows the fluid to flow directly onto the faces of the tools. The end of the bar is piloted at *O* in the bushing *N* which is fixed in the chuck body. An arrangement of this sort has also proved successful in a number of instances.

Bar for Undercutting, Facing and Boring in the Vertical Turret Lathe

A very difficult condition for which to design tools is shown in Fig. 6, as the work itself requires rapidity of handling and is a steel casting weighing about 300 pounds. Only a part of the piece is shown at *A*, but it will readily be seen that it is necessary to make the bar in such a way that the tools can be used to do all the cutting indicated by the arrows; *i. e.*, undercut the upper flange, double-bore the interior, and face the lower shoulder. As the fixture on which the work was held was of the indexing variety and was very much off center, it was not expedient to run at high speed. Therefore, the double boring was of assistance in increasing the production. It will be noted that the hole through which the tools pass is of small diameter, which makes the problem still more difficult. The shank of the bar *B* fits the turret hole at its upper end and is slotted so that the pin *F* in the turret will act as a driver. (This feature is patented by the Bullard Machine Tool Co.) The lower part of the bar is eccentric to the shank in order to obtain the necessary clearance when the tools are in action. Even the tools themselves are considerably out of the ordinary in that they will cut in two directions. The upper tool *D* is used for undercutting the flange and also for boring, while the lower tool *E* is used for facing the lower shoulder and partially boring the interior. Both these tools have backing-up screws *G* and are held in place by the headless set-screws.

As it was necessary to set these two tools so that they would cut approximately the same diameter, the gage shown at the right of the figure was made to assist in the setting. The V-block *K* was slotted to receive the steel strip *J* so that distance *L* would measure the correct distance from the bar shown in section at *M*. It is obvious that the gage could be placed against the bar so that tools could be set out the right amount by means of the backing-up screws. This bar gave fairly satisfactory results although some trouble was experienced with chips, as there was considerable stock to remove. There was likewise a slight tendency to chatter when using a heavy feed, but this was remedied by careful grinding to make the cut as easy as possible. It must be remembered that the conditions were about as awkward as they could be, and the lack of room made it necessary to cut down the bar to such an extent that it was hardly heavy enough for the work. Taken as a whole, however, the action was satisfactory for a roughing tool. It was not used for finishing cuts.

Slip-cutter Bar for the Vertical Turret Lathe

The steel hub shown at *A* in Fig. 7 is held on a special fixture, located by the previously bored and reamed hole which fits the stud

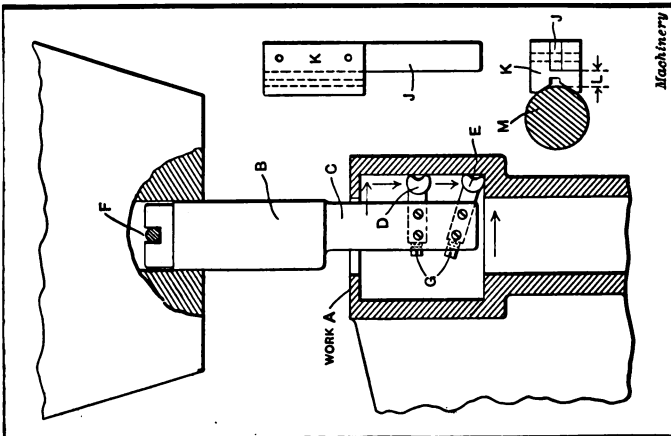

Fig. 6. Bar for Undercutting, Facing and Boring in the Vertical Turret Lathe and Gauge used in setting Tools

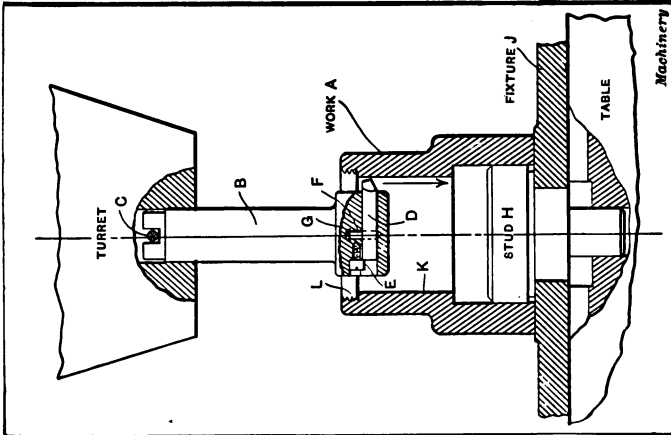

Fig. 7. Bar equipped with a Set of Interchangeable Cutters for Boring and Reaming

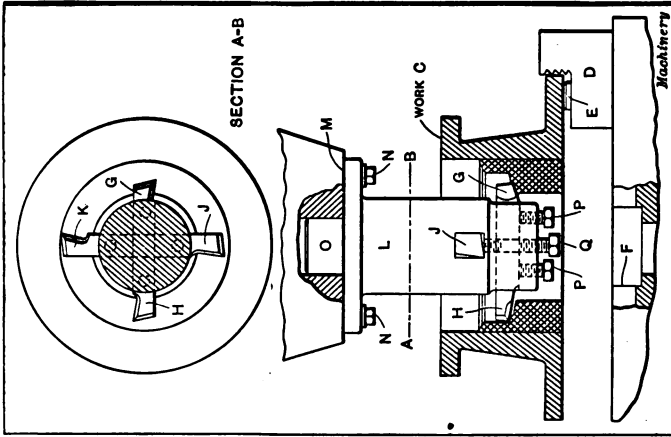

Fig. 8. Bar with Four Cutters set at Different Radii for removing Considerable Stock in One Cut

H. The hole *K* has been rough-bored in the first operation, but enough stock has been left for the final finishing so that it may be finish-bored and reamed and part *L* threaded at the same setting. This type of bar is the product of the Bullard Machine Tool Co., and is designed especially for use in their machines. It is a combination boring- and reaming-bar, and the cutters are of the "slip" variety. One bar can be furnished with a set of cutters for the various sizes of holes within its capacity. A full set of cutters for any one size of hole consists of chamfering, rough-boring, finish-boring, rough-reaming and finish-reaming tools. The first three of these are of square section, carefully ground to fit the broached hole *D*. The rear ends of these tools bring up against the shoulder of the screw *E*, which acts as a stop. The fit in the hole is such that tools can easily be put in and taken out with the fingers.

The two reaming cutters are used in the rectangular hole *F* which is at right angles to the other hole; these tools are allowed to float so that they follow the hole generated by the boring tools. The action against the reaming cutters is in an upward direction, and comes against the hardened steel plug *G* which is inserted in the bar. The bar *B* is of special steel and is slotted at the upper end to fit the driving pin *C* which is located in the turret. Bars of this type have a number of advantages, one of which is that only one turret hole is occupied; other advantages are the cost of maintenance, and the adaptability of the bar with its series of cutters to handle a number of different sized holes. The cost of large sizes of reamers of the fluted type is considerable, while a flat reamer such as that used in this bar is inexpensive. It may be noted that the pressure or thrust of the cut is all that holds the boring tools in place, so that trouble would be experienced if a cored pocket were to be encountered. This is provided for by a detent screw in the end of the bar, which prevents the tools from coming out. This screw can be put in any time if it is found necessary.

Multi-cutting Bar for the Vertical Turret Lathe

An example of a bar designed to remove a large amount of stock in a very short time is given in Fig. 8. The work shown at *C* is a steel boiler nozzle which is forged, and a 5-inch hole punch in it before it is machined by the vertical turret lathe. The finished hole is 8 inches in diameter and it was desired to remove the surplus stock as rapidly as possible. Accuracy in the diameter of the hole was not essential. The bar *L* is a steel forging which fits the turret face at *M* and is held to it by the screws *N*. The stem *O* is used to center the bar in the turret. Two rectangular holes are broached through the body of the bar, at right angles to each other, and these receive the high-speed steel cutters shown. It will be noted that these cutters are so proportioned that they remove the stock in a series of steps, each tool extending beyond the preceding one and also above it about $\frac{1}{8}$ inch.

The section taken at *A—B* shows the manner in which the tools extend beyond each other, and the lower view illustrates the cutting action of the tools. One end of the first tool *G* makes the first step, while the other end *H* makes the second. In like manner one end of the upper tool *J* makes the third step while the other end *K* takes out the remainder. The two screws *P* hold the first tool in place, while the other is secured by the screws *Q*. It will be noted that the work is held in jaws *D* and is supported on buttons at *E*; the height above the table is great enough to allow the end of the bar and the set-screws to go through far enough to finish the cut. Regarding the upkeep of these tools, attention is called to the fact that they may be pushed backward or forward to compensate for wear and distribute the cut. For roughing purposes requiring rapid removal of stock and rapid cutting, a bar of this sort has proved very successful, but it is not recommended for work requiring great accuracy.

Other Types of Boring-bars

There are several bars on the market which are adjustable for various diameters by means of micrometer screws and taper wedges. These are useful for many purposes but space will not permit a detailed description nor has it been the writer's purpose to deal with the many varieties but rather with representative types. Special bars for many purposes, porcupine bars and cutter heads of various kinds, have not been described, because these are not single-point boring tools. Neither has mention been made of boring tools such as are used in fixture work on the horizontal boring machine, for these are found in every tool-room, in all shapes and sizes.

In several of the illustrations it may be noted that the tools are shown in a plane parallel with the rotation of the turret. This has been done simply because the details are more clearly apparent when shown in this way. Greater accuracy is obtained by setting the tools in a plane perpendicular to the turret rotation, as previously stated.

CHAPTER II

RECESSING TOOLS

Many varieties of cylindrical work call for the machining of an annular recess or groove in a place which may be inaccessible to the cutting tools. The form of recess varies greatly and the accuracy required is likewise variable. The form may be either narrow or wide, deep or shallow, while the accuracy called for may be either within narrow or liberal limits, as for instance, when the recess is for clearance only. In fact, in the majority of cases the purpose of the relief or recess is merely to obtain clearance for some moving part or for tools when machining an adjacent surface. Very frequently a groove is cut to serve as an oil-pocket or to provide a space which can be filled with packing to act as a gland. It is evident that great accuracy is not essential when the work is of this nature. There are occasionally conditions which require more accurate work, as for instance when another piece is to be sprung into place, such as a spring ring or something of a similar nature, but even in a case of this kind a certain amount of inaccuracy is permissible. The machines to which recessing tools are most frequently fitted are the engine lathe, the horizontal turret lathe, the vertical turret lathe, the vertical drilling machine and the horizontal boring mill. Other machines are occasionally equipped with tools for the same purpose, but those mentioned are most frequently used.

In many cases the position of the relief or groove is such that it cannot be readily seen by the operator, nor can it be easily calipered. The workman, therefore, must tell how the tool is cutting by the "feeling" of it and by the character of the chips. He is really "working in the dark," and for that very reason every precaution must be taken in regard to position of tools, diameter and shoulder stops, etc., so that the machining can be done without withdrawing the tool to note the progress of the work. In this connection it is well to bear in mind that the action of any kind of grooving tool is much the same as a cutting-off tool. It must be kept very sharp and set so that the cutting edge is slightly above center, when it is used for internal work. It will be seen that if the tool is slightly above center the springing down of the cutting edge (due to the pressure of the cut) will have a tendency to keep it from "digging in", and will therefore assist in the prevention of chatter. Some of the important points in the design of recessing tools are given herewith.

Points in Design of Recessing Tools

1. Rigidity is of the greatest importance and every precaution should be taken to insure as substantial a holder as possible. The

tool itself should be of as great a section as the conditions and the space will permit. Some method of supporting the overhanging end should be provided, either by means of a pilot or in some other way which may suggest itself. Moving parts should have a means of adjustment for wear, and gibs should be set up as snugly as possible and still allow free movement.

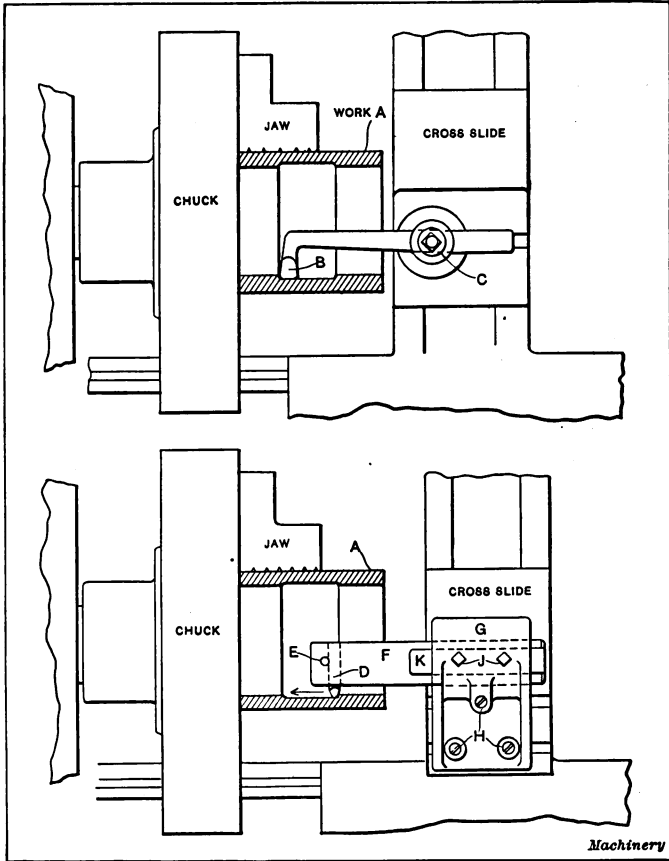

Fig. 1. Two Simple Types of Recessing Tools for the Engine Lathe

2. The feed motion should be carefully considered. Screw feed is best, and may be contained in the tool itself or may be operated by the cut-off slide. Lever feed is uncertain and produces uneven cutting unless the work upon which it is used runs at high speed. When this is the case and if the cut is not too heavy, it can be used with satisfactory results. The work to be done is a factor in determining the method most satisfactory for the feed motion.

3. Means are needed for determining the depth of the cut. There are several ways in which the depth of the cut can be positively de-

terminated; a positive stop can be provided; the dial on the cut-off slide can be used when the feed motion of the slide is the operating force; an indicator or a graduated dial on the tool-holder itself may be provided.

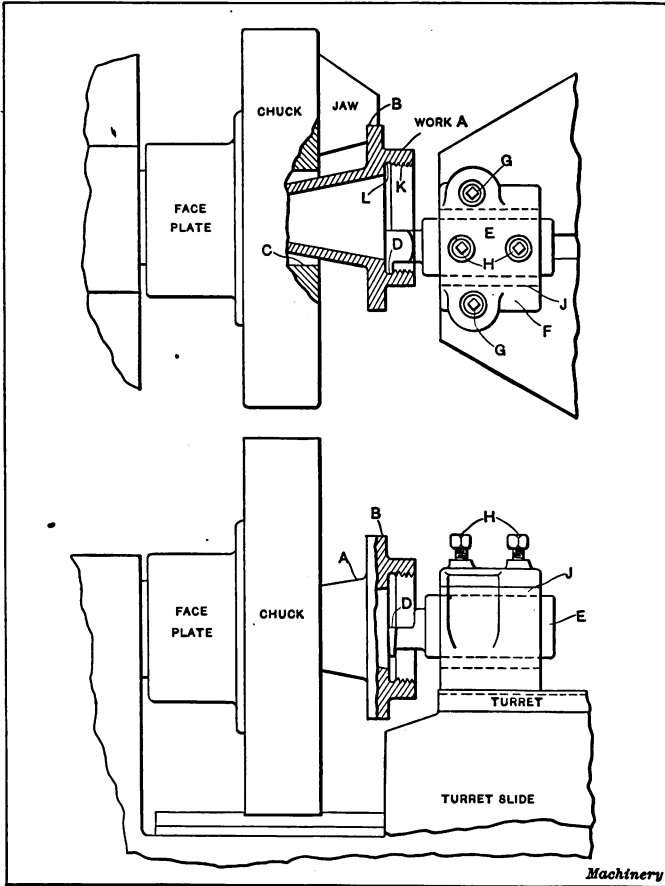

Fig. 2. Recessing Tool used in a Turret Lathe

4. Rapidity of operation is essential.

5. Adjustment for the cutting tool should be provided. This adjustment may be made either by manipulating the tool by hand or by means of a backing-up screw. The latter method is the better one and should be used whenever practicable. The upkeep of the tool is important, and for that reason inserted tools are preferable to those which form a part of the mechanism itself. In confined situations it is occasionally necessary to make the tool of special shape. This should be done only as a last resort, when necessitated by the conditions

governing the work. In cases of this kind several tools should be made to provide for emergencies.

Recessing Tools for the Engine Lathe

The upper illustration in Fig. 1 shows a bushing *A* which is held by the outside in regular chuck jaws. This work is to be done on the engine lathe, and the recess is to be cut at the same setting. A forged tool *B* is held in the regular tool-post *C* on the cross-slide of the lathe, and is forced into the required depth by hand. After this the longitudinal feed is started and the remainder of the recess cut. This type of tool is much used for lathe work when only one or two pieces are to be machined. Its advantages are that it can be easily made and quickly adjusted. Its disadvantage is that it has a tendency to chatter, and is, therefore, suitable only for very light cutting.

The device shown in the lower portion of the same illustration is much more rigid, but is not nearly as adaptable to various conditions. In this arrangement the tool *D* is of round section and is held in place by taper pin *E*. The bar *F* is of steel and is secured in the holder *G* by the two screws *J* which bear against a flat *K* on the bar. Three screws *H* enter shoes in the cross slide T-slots and secure the holder firmly to the slide.

Recessing Tool for a Horizontal Turret Lathe

The work *A* shown in Fig. 2 is a steel forging of an automobile hub which is held in a three-jawed chuck by the flange *B*, the tapered portion entering the hole *C* in the chuck body. The inside of the hub is to be threaded at *K* with a collapsing tap. A recess is therefore needed at *L* in order to obtain a clean thread. The machine selected for the work is a Pratt & Whitney turret lathe having a cross-sliding turret of the flat type. The recessing tool is of high-speed steel, with the shank turned and ground cylindrical at *E*. The front end is also turned to form the flange *D*, and is afterward cut away and finished to the shape required, as clearly shown in the lower part of the illustration. The tool-holder *F* is of cast iron and contains a steel split bushing *J* which is compressed by two screws *H* in the top of the holder. The action of this tool was satisfactory, but the upkeep is obviously rather expensive.

Eccentric Recessing Tool for a Horizontal Turret Lathe

The work *A* shown in Fig. 3 is a steel flange which is to be recessed at *B* in order to provide the necessary clearance for the threaded portion *C*. In this instance the cut-off slide was used during the progress of the work, so that a considerable overhang from the turret was required. Strictly speaking this is not an eccentric tool, for the various parts of the body are concentric, but by a reference to the upper part of the illustration it will be seen that the center-line *VW* of the recessing tool does not coincide with the center-line *TU* of the spindle. Now as the tool-holder *F* revolves on the center line *VW*, it

is evident that the path of the tool *D*, as it swings, will be eccentric to the center line of the spindle. The body *L* is of cast iron and is mounted on the dovetailed turret face, being securely held in position by the gib *M* and the screws *N*. The tool-holder *F* is of tool steel and is turned down at *K* to a running fit in the body. The end *Q* with the

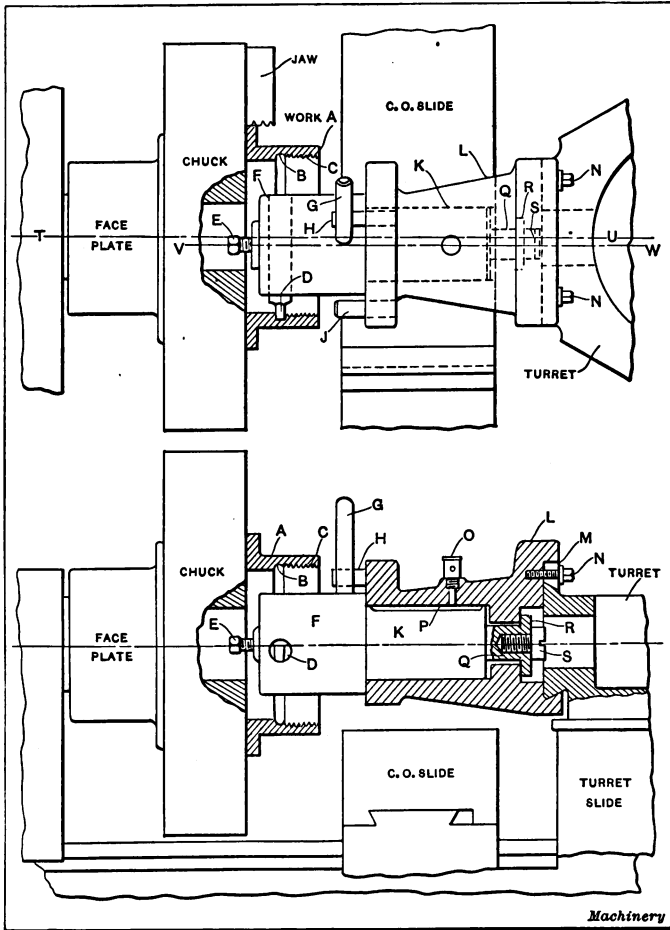

Fig. 3. An Eccentric Recessing Tool for the Turret Lathe

screw and washer *S* and *R* acts as a retainer to keep the tool-holder in position. The tool *D* is of round section with the cutting end so shaped that it will cut the recess properly. A set-screw *E* holds it in position. An oiler *O* is located in the body and distributes the oil to the bearing through the oil groove *P*. An operating handle *G* is driven into the holder, and is located between the pins *H* and *J* which act as stops. As the lever *G* is operated, the tool *D*, starting with

slight clearance at the bottom of the hole, moves gradually upward and outward until the full depth of cut has been reached. At the completion of the cut the tool stands in the position shown in the

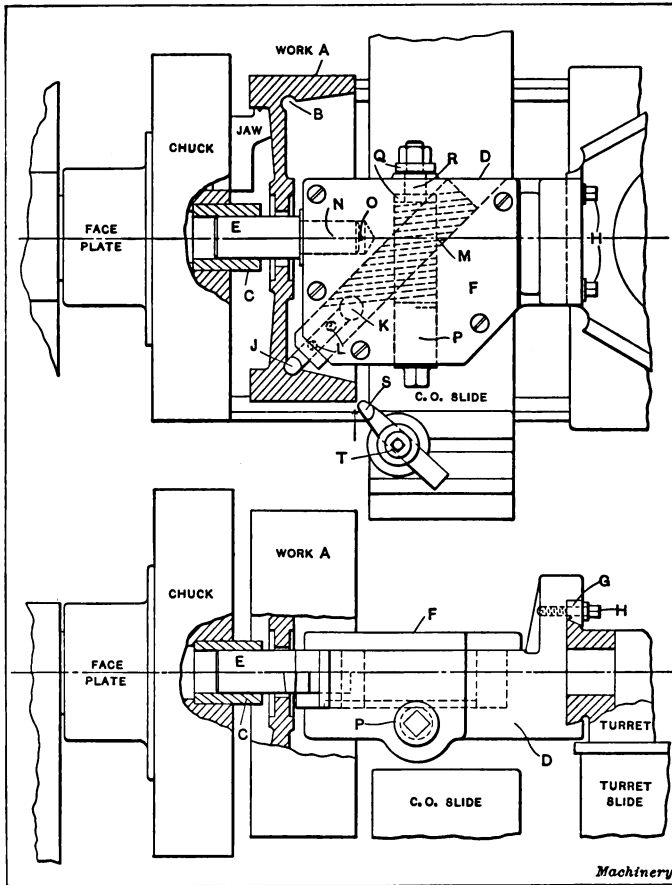

Fig. 4. A Recessing Tool used in machining an Automobile Flywheel

illustration. The action of this tool was perfectly satisfactory, and as it is comparatively simple in construction, the cost of building was not excessive.

Piloted Recessing Tool for an Automobile Flywheel

A rather peculiar condition is shown in Fig. 4, the work A being an automobile flywheel having a semi-circular recess at B. Attention is called to the fact that this recess is put in at an angle of 45 degrees with the center line. It is evidently only a clearance groove for the

male clutch member and it is not known to the writer why some other style of groove would not have answered the purpose just as well.

The work *A* is held by the inside of the rim in special jaws. The body of tool *D* is made of cast steel and is fitted to the dovetailed face of the turret, the gib *G* securing it firmly by means of the collar-head screws *H*. A tool-steel pilot *E* enters the bushing *C* in the chuck and assists in supporting the body against the pressure of the cut. This pilot *E* is shouldered and forced into the body at *N*. A small hole *O* is drilled to avoid air compression when forcing in the pilot. If this is not done the fitter may be deceived into thinking that he has secured a good fit at this point when in reality it is the air compression which causes the stem to fit tightly. A cover plate *F* tends to strengthen the body and overcome the weakening effect caused by the cutting of the angular slot, and also assists in preventing the entrance of dirt and chips. Tool *J* is of square section and is held in the sliding block *M* by two screws *L*. Hole *K* is for machining purposes only. The operating screw *P* is squared up on one end to receive a wrench, while the other end is shouldered at *R* and threaded to receive a hexagon nut. There are two thrust washers shown at *Q*. The screw has four Acme threads per inch, right-hand, and meshes with the angular rack cut on the under side of the tool-carrying slide *M*. It is evident that the rotary motion of screw *P* will cause movement of the block, in its longitudinal direction, thus feeding the tool into the work at the desired angle. The forged tool *S*, held in the tool-holder *T* on the cut-off slide, is slowly fed across the rim while the recessing operation is taking place.

Double Recessing Bar for a Rear Axle Housing

The work *A* shown in Fig. 5 is a bronze rear axle housing for an automobile, and the recessing bar is only one of a group of tools used at the same setting of the work. Previous to this setting the finished annular rings at the two ends *D* and *E* of the casting were machined so that they might be used as locating points in this setting. The ring *D* slips into the split bushing in the holding device *B*. The other end *E* revolves in a roller back-rest *F* which is placed on the ways of the turret lathe. This back-rest is not shown in detail, as its construction is not essential in connection with the recessing tool. The two grooves in the work at *S* were to be spaced an exact distance part and it was partly to insure accurate spacing that this bar was designed, although rapidity of operation was also a factor. A cast-iron bracket *K* is fastened to the dovetailed face of the turret by means of gib *Y* shown in the lower view. The handwheel *W* is connected to a shaft which drives the pinion *M*. A steel pointer *X* is fastened to the bracket and acts as an indicator on the graduated rim of the wheel. It will be seen that this arrangement makes it very easy to determine the depth of the cut.

The pinion *M* meshes with a rack cut upon the enlarged end *N*

of the operating rod *L*. This rod is considerably below the center of the bar and is flattened at *O* and *P*. The tongues *Q* and *R* are angularly cut on these surfaces, and they engage with grooves on the under side of the tool-carrying blocks *T*, so that any longitudinal movement of the rod *L* is transformed into a radial movement of the blocks. The

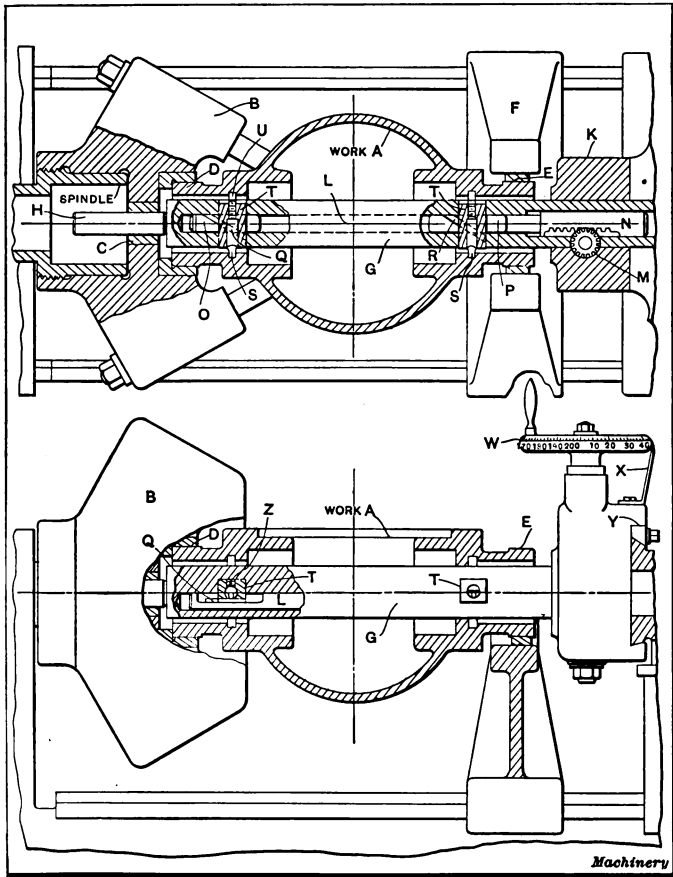

Fig. 5. A Double Recessing Tool Arrangement for a Rear Axle Housing

grooving tools *S* are of round section and are held in position by the headless screws *Z*. The backing-up screws *U* permit accurate adjustments to be made with ease. The pilot *H* enters the steel bushing *C* in the body of the holding device and assists in preventing chatter. An added refinement to this tool was an oil-groove from which oil was lead directly to the cutting tools. This was supplied with oil through a special piping system and a distributing collar on

the turret. In order to avoid confusion in the drawing, this has not been shown. This device gave very satisfactory results.

Recessing Tool for an Automobile Bearing Retainer

The work shown at *A* in Fig. 6 is a malleable iron bearing retainer for an automobile. The casting is held by the outside in a

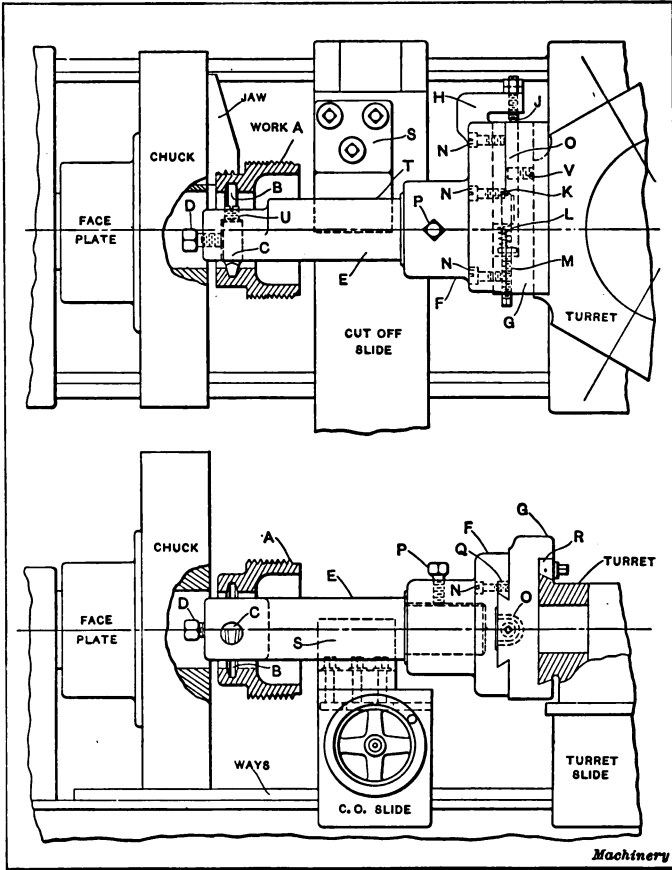

Fig. 6. A Recessing Tool for an Automobile Bearing Retainer

three-jawed chuck; the machine on which the operations are performed is a horizontal turret lathe. The piece is completely finished in one setting. As the cut-off slide front tool carrier was used during the progress of the work, it was found necessary to design the recessing tool so that it extended out over the slide. It is evident that an overhang as great as this would cause trouble unless some means of intermediate support were provided. The bracket *S* was therefore used on the rear of the cut-off slide, the portion *T* being cut out to the

radius of the bar so as to act as a support and at the same time provide the feed motion necessary (through the reverse feed of the slide) to force the tool into the work. The cutting tool *C* is of round section properly shaped at the end to form the required groove *B*. It is secured in place in the bar *E* by the set-screw *D*; radial adjustment is

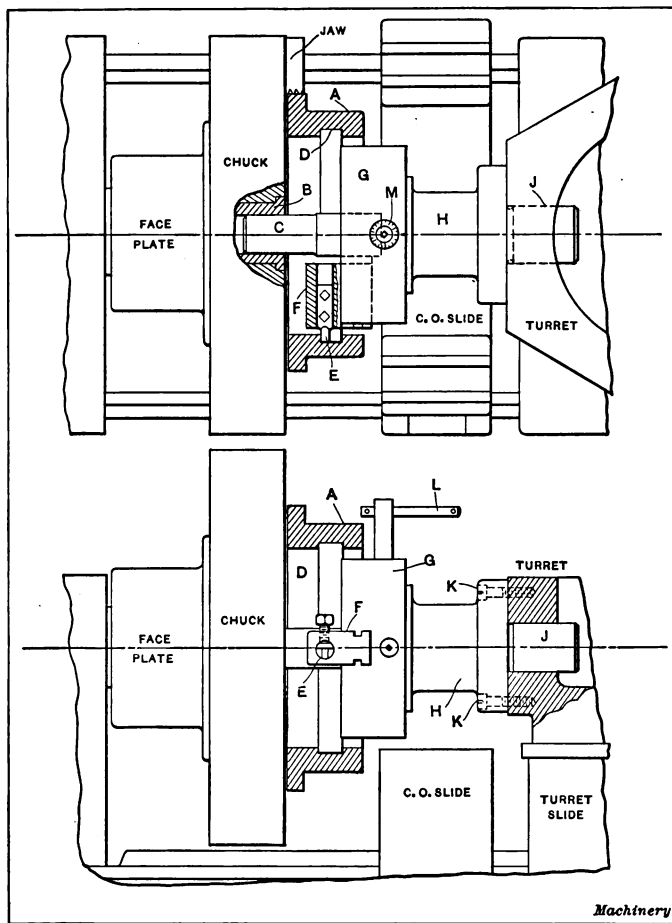

Fig. 7. A Recessing Tool for a Large Collar, used in a Turret Lathe

secured through screw *U*. The rear end of the bar is shouldered and fitted to the sliding bracket *F*; the set-screw *P* holds it in place. The slide *F* is dovetailed and is gibbed to the fixed bracket *G* by the gib *Q* which is adjusted for wear by the screws *N*. The lug *H* at the end of the slide is provided with a stop-screw *J* which permits close adjustments to be made for the depth of cut. This lug is not shown in the lower view but it is set slightly to one side of the cored groove *O*

so that the screw will bear against the solid portion. The bracket *G* is mounted on the dovetail of the turret and is held in place by the gib *R*. The special screw *M* is shouldered to receive the coil spring *L* which thrusts against it and against lug *K* on the slide. The strength of the spring may be easily adjusted by the screw to the desired compression. The screw *V* is simply used to limit the reverse movement of the slide, so that it will not move back too far before or after the work has been done. This device was used for three different pieces by simply changing the tool and regulating the stop-screw. Its performance was thoroughly satisfactory.

Recessing Tool for a Large Collar

The large collar *A* in Fig. 7 was held by the outside of the flange in a three-jawed chuck on a horizontal turret lathe. The internal groove *D* was to be cut during this setting of the work, and as a small geared scroll chuck was conveniently available, it was arranged as a recessing device for this casting. The cast-iron bracket *H* was fitted to the faceplate recess at the rear of the chuck body. The stem *J* was turned down to fit the hole in the turret face, and the four screws *K* secured it thereto. One of the standard chuck jaws *F* was annealed and shaped up as shown. It was then drilled to receive the tool *E*, and tapped out so that two set screws could be used to hold the tool. The jaw was then re-hardened and a small amount of fitting done so that it worked smoothly. A graduated collar was applied at *M*, and a special wrench *L*, having a slip handle, served to operate the scroll and thereby caused the tool to move radially as required. A tool-steel pilot *C* was forced into the center hole in the chuck body *G*, and a bushing *B* in the spindle chuck body served as a guide and support for it, thereby greatly increasing the efficiency of the tool and doing away with the chance for chatter.

Recessing Bar for a Triple Groove

In all of the examples which have so far been given, the work has been done in a horizontal plane, but we shall describe a few cases which are handled in a vertical plane on the vertical turret lathe. As this machine has a turret slide which can be traversed horizontally, it is evident that no special attachments are required for plain recessing or grooving, but there are conditions which may be decidedly out of the ordinary, under which a special arrangement for recessing may be used to advantage, for example, any sort of groove which is deep down in a hole, multiple grooving at a considerable depth, or any other condition of a similar nature. When the groove is very deep, there is naturally a considerable overhang of any tool which may be used for the work. If the overhang is excessive, it follows that there is apt to be more or less vibration, and vibration means chatter. If, however, a tool or bar having an excessive overhang from the turret is supported at its lower end, the tendency to chatter is at once overcome; but, if support is provided at this point, the horizontal move-

ment of the turret slide cannot be used. Therefore, some method which will give a radial movement to the grooving tool must be used when the bar is to be supported at its lower end.

Fig. 8 shows a piece of work at *A* which is set up so that it can be machined complete in one setting. The casting is held by the in-

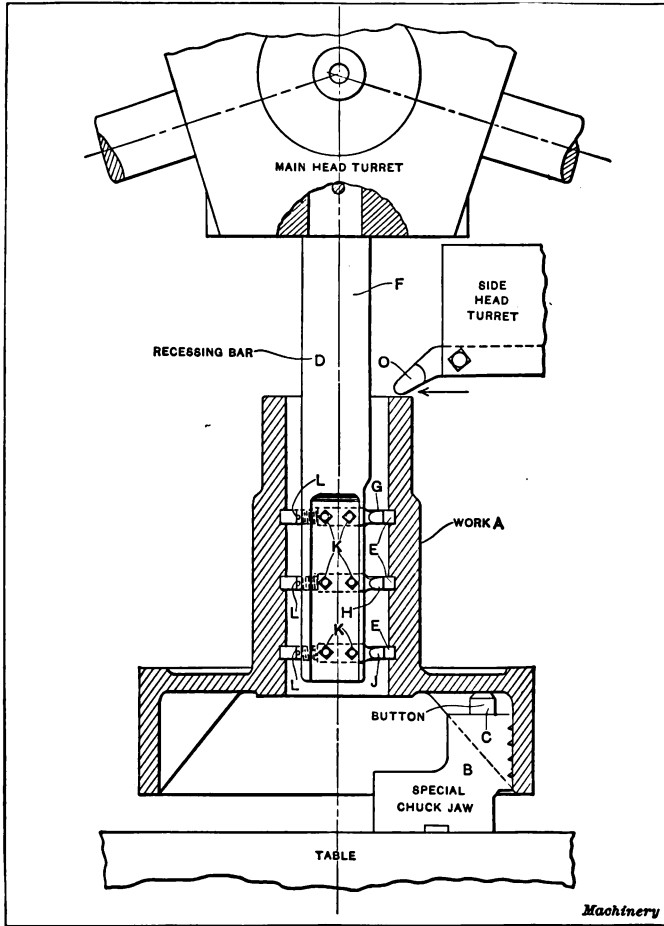

Fig. 8. A Multiple Recessing Tool used in a Vertical Turret Lathe

side of the rim in special chuck jaws *B*, and is supported at three points on the steel buttons *C* which rest in pockets in the jaws. The inner ribs of the casting act as drivers against the sides of the jaws. The three grooves *E* are to be machined and the tools *G*, *H*, and *J* are correctly spaced to perform the work. These are secured in the bar *D* by means of the set-screws *K*, and accurate adjustment is pro-

vided by screws *L*. The bar *D* is shouldered at the turret face and is driven by a pin in the turret in the usual manner. The tool *O* in the side head turret is used for facing while the inside work is being

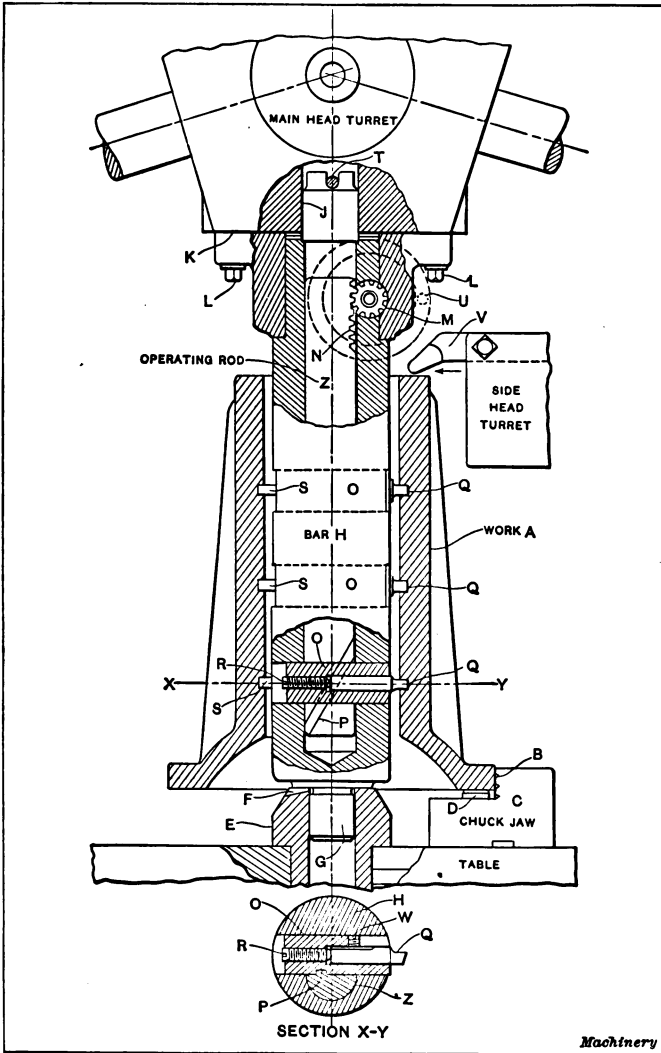

Fig. 9. Another Multiple Recessing Tool used in a Vertical Turret Lathe

done, as this brings the cutting action of the outside and inside tools in opposition and therefore tends to overcome vibration. If very fine feed is used on the turret traverse, good results may be obtained with this method, although there is a tendency to chatter due to the ex-

cessive overhang. Slight variations in the depth of the grooves may also be found on account of the spring of the bar.

Piloted Recessing Bar for a Triple Internal Groove

The cast-iron valve cap shown in Fig. 9 is another example of a piece of work having three grooves equally spaced, and in which the lower groove is at a considerable distance from the turret. This piece is finished complete in one setting and is held by the outside of the flange in the standard chuck jaws *C*, being supported at three points by the buttons *D*. This tool is somewhat similar in its operation to that shown in Fig. 5, except that it is arranged in a vertical instead of in a horizontal plane. A heavy cast-iron bracket is bolted against the turret face *K* by screws *L*, and a locating plug *J* centers the device in the turret. The bar *H* is of steel and has a pilot *G* at its lower end. This pilot is hardened and ground to fit the bushing *E* which is inserted in the center of the table. The top of the bushing is milled out to leave three projecting pads *F*. These pads form a positive stop to insure the correct height; it will be noted that the tendency when in action would be to keep these pads clean and free from chips or dirt. The upper end of the bar is shouldered and is fastened to the bracket. As in the former instance the operating rod *Z* is flattened at certain places and angular tongues *P* are provided. These tongues mesh with corresponding grooves in the tool carrying blocks *O*. The section *X-Y* gives a good idea of the construction.

The tools *Q* are held in place by the short set-screws *W* in the square steel blocks *O*. The backing-up screws *R* permit of rapid and easy adjustment. At the upper end of the operating rod the rack *N* is cut and the pinion *M* meshes with it and operates the rod. The handwheel through which the pinion is operated is indicated at *U* by the dotted lines. This portion of the mechanism is identical with that described in Fig. 5. The tool *V* in the side-head turret is used for facing the end of the casting during the progress of the recessing operation.

Recessing Tool operated by Bevel Gears

A somewhat unusual condition is shown in Fig. 10, this arrangement having been suggested for the work *A* in order to rapidly perform the grooving operation deep down in the interior of the casting at *V*. It was desired to machine this casting complete at one setting. The chuck jaws *B* were of special form, having a slight angle on the inside of the jaw which drew the casting down onto the three points *C*. A cast-iron pot *E* was fastened to the table by screws *K*, and cored openings *J* were left at the points where the jaws gripped the work. Midway between the jaws, the pot casting took the form as shown at *D* and the dogs *F* were sunk into the edges of the flange by means of the hollow set-screws *G*. The bar *M* is a steel casting which bolts against the turret face at its upper end; it is located by the plug *L*. The operating sleeve *T* is of tool steel, hardened and ground, and having an angular slot *X* at its lower end, which bears

against the tool *V*. It is well to make up several of these tools, so that replacements can be quickly made in case of breakage. A steel plate *W* is let into the casting at this point to form a cover plate for

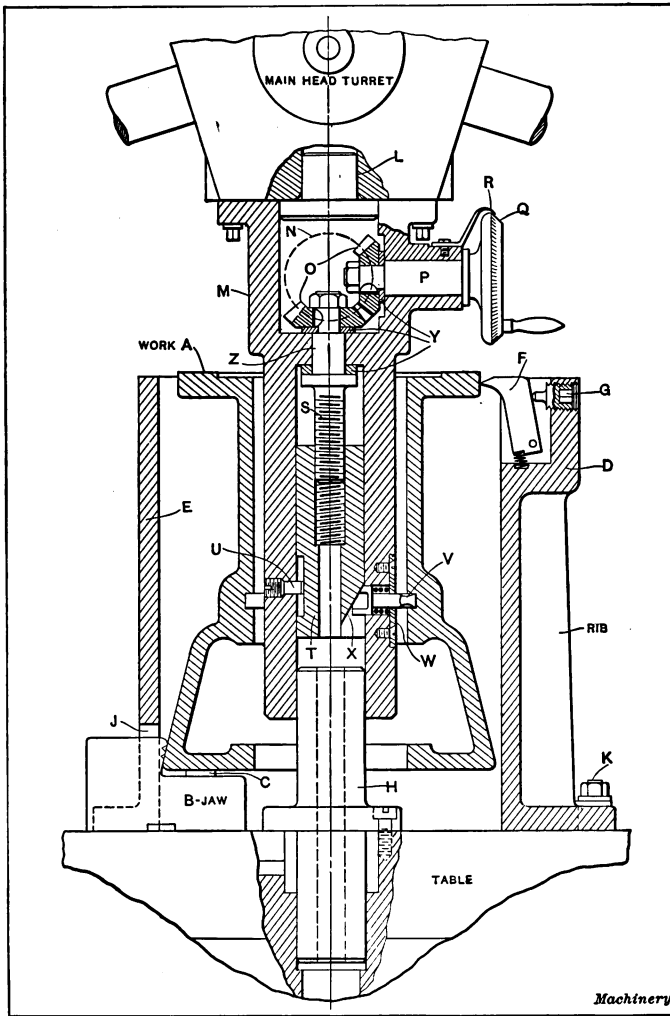

Fig. 10. A Tool for recessing in a Difficult Position, in Use in a Vertical Turret Lathe

the tool and spring pocket. A test-screw *U* fits a slot in the operating sleeve and prevents it from turning.

The left-hand threaded shaft *S* is journaled at its upper end *Z* and the miter gear *O* is keyed in place. The shaft *P* carries another gear which meshes with the former, and the entire mechanism is operated

by the handwheel *Q*. (This handwheel in reality is located 45 degrees toward the front of the machine from the position shown). A pointer *R* assists in making accurate readings from the graduated bevel on the handwheel. Steel thrust collars *Y* are provided for wear. The tool-steel pintle *H* is fitted to the center of the table and is held down by the screws shown. This pintle acts as a guide upon

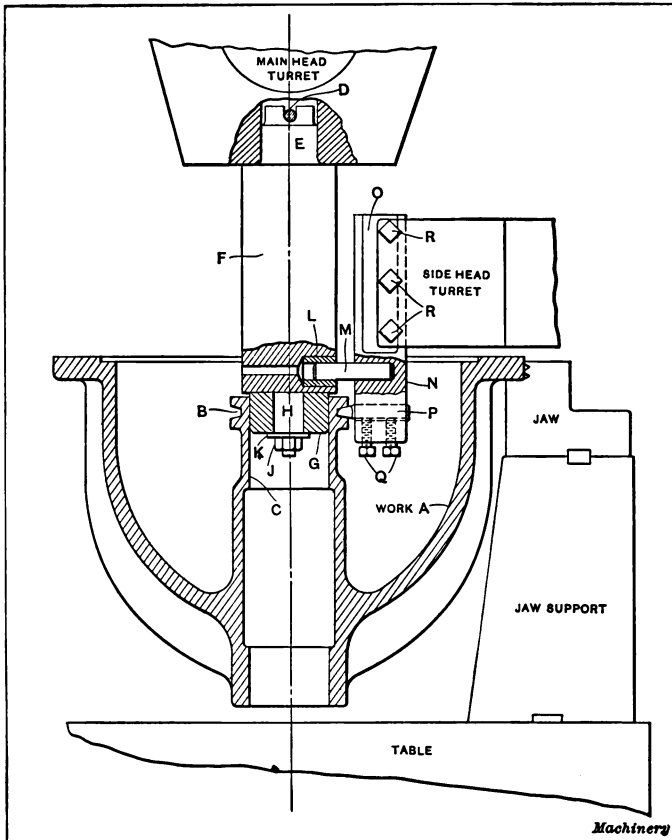

Fig. 11. An Arrangement for cutting a Groove on the Outside of a Sleeve

which the mechanism is located and greatly assists in making it rigid.

Arrangement for External Grooving

A thin piece of work for electrical machinery, shown at *A* in Fig. 11, has been completely machined with the exception of the groove *B*. At the time when the operation of grooving takes place, a revolving steel pilot *G* fits the previously reamed hole *C* and is held in its position on *H* by the nut and washer *J* and *K*. The upper portion of

the bar *F* is shouldered at *E* and fits the turret hole, being kept from turning by pin *D*. A round bar *N* is flatted on two sides at *O* and is held in the side-head turret by the three screws *R*. The lower portion of the bar carries the grooving tool *P* which is held in place by the two screws *Q*. A tool-steel pin *M* is forced into the bar *N* and forms a sliding tie between the pilot bar *F* and the side-head bar *N*. The bushing *L* is inserted in the pilot bar to receive the pin. It will be readily seen that this method overcomes the vibration which would naturally be caused by the grooving tool acting on the thin and unsupported hub.

CHAPTER III

ADJUSTABLE AND MULTI-CUTTING TURNING TOOLS

The cost of tool equipment for the manufacture of interchangeable work is an item which should be proportionate to the number of pieces to be machined. The saving in time which can be made by the use of special tools should also be carefully considered, as there are many cases where special equipments are designed for work which could be handled to advantage by the judicious use of standard tools. In order to obtain the greatest possible production from their machines, there have been instances where machine tool builders have sold tool equipments of expensive design, when a standard equipment would have done the work very nearly as well. Undoubtedly there was some gain in production, but it is doubtful whether the saving in time would pay for the special tools. The upkeep of special tools is also a factor which must be taken into consideration. It is interesting to note that the present aim of machine tool builders is to so design standard tool equipments that they can be adapted readily to a great variety of working conditions. A great deal of time is spent by manufacturers in devising and experimenting with various tools in order to perfect them to such an extent that they will conform to these conditions.

The rapid growth of the automobile industry in the past ten years is largely responsible for the broader development of our machine tools. The enormous quantities of interchangeable parts which are required in this industry and the manufacturers' desire for increased production have brought into existence a great variety of multi-cutting tools. Tools of this kind may be designed for a variety of uses, and tool-holders capable of containing several tools can also be designed to handle a considerable range of work.

Adjustable tools and those having cutters for turning several diameters are sometimes combined with boring-bars, drills, or cutter

heads, these being applied to some one of the various types of turret lathes. They are also occasionally designed for use on a vertical boring mill.

When used on the turret lathe, the cut-off slide is frequently equipped with a gang of tools so that the operations of turning, boring and facing can be carried on at the same time. Quite frequently the tools are so arranged that from nine to twelve are working at the same time, with the result that there is a considerable gain in production. There are a great many varieties of so-called "box-tools" on the market, and these are principally used for bar work on turret lathes or screw machines having a collet mechanism. Tools of this type are usually a part of the standard equipment furnished with screw machines adapted to bar work, and they will not be discussed in the present chapter.

The design of multi-cutting turning tools for castings and forgings which have several diameters to be machined is a subject well worth considering, for it is safe to say that nearly an manufacturer who uses horizontal or vertical turret lathes can greatly increase the productive efficiency of his machines by the judicious use of multi-cutting tools. The several designs of turning tools illustrated in this chapter have been built for various purposes, and a careful study of the types shown may be of assistance in suggesting methods which can be used to perform some piece of work requiring tools of a similar kind. Some of the important points in the design of tools of this nature are given herewith.

General Points in Design

1. **Rigidity:** Avoid overhang as much as possible unless some sort of outboard support can be used. Pilot the tool if practicable.
2. **Arrangement of tools:** They should be perpendicular to the plane in which the turret rotates when indexing, because variations in diameters are less likely to take place when tools are arranged in this way. Unequal indexing of the turret has very little effect on the radial position of the tools under these conditions, so that sizes can be held much closer than if they are placed in a plane parallel to the turret rotation. Use standard rectangular stock for the cutting tools so that the upkeep will be inexpensive and reforging be avoided.
3. Try to make the block containing the tools removable so that it can be replaced easily by another block with tools arranged differently to handle other work.
4. Make the tool-block adjustable if possible.
5. Back up the tools with adjusting screws.
6. See that provision is made so that cutting lubricant can be directed on the faces of the tools when forgings or steel castings are to be machined.
7. Arrange the tool-block in such a way that the thrust of the cut does not come against it; it is much better to have the thrust come on the body of the tool.

Multi-turning Tool for Electric Motor Shafts

One example shown in Fig. 1 is given of a multi-turning tool for bar work. This tool was designed for use on the electric motor shaft shown at *A* in the illustration. The work was handled in short lengths although the stock is a regular commercial product. Roughing and finishing operations were performed with the same type of tools. The work was held in collet jaws. Something like twenty

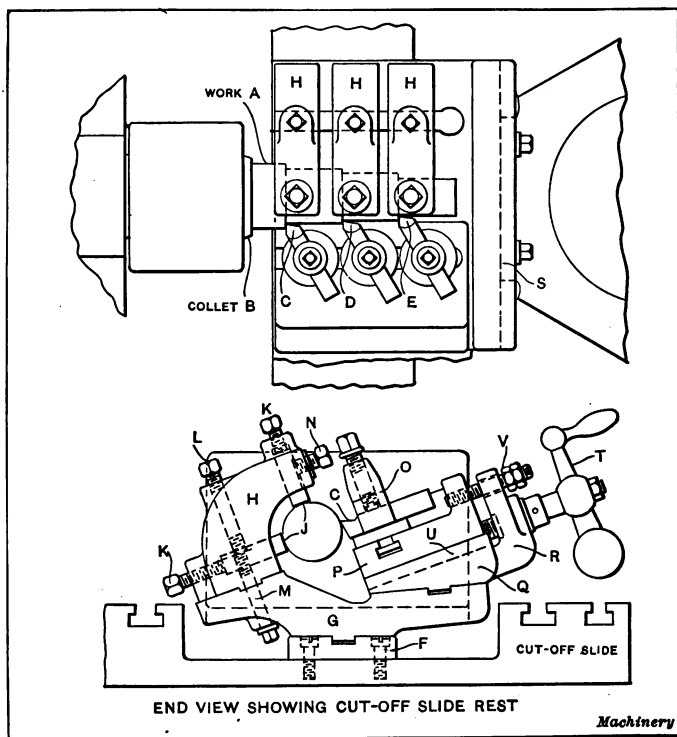

Fig. 1. Special Multi-turning Tool for Bar Work

varieties of shafts having different diameters and shoulder lengths were handled by these tools.

A Pratt & Whitney turret lathe with collet mechanism was used for this work; as this type of machine has a turret with dovetail faces, the body of the tool *G* was arranged to fit the dovetail and the gib *S* held it in place. The cut-off slide was planed off at the center and the hardened steel block *F* was secured to it. It will be noted that this block acts as a support for the tool, and the tongue assists in preventing lateral movement. The cast-iron block *Q* is fastened to the body of the tool and it is dovetailed at *U* to receive the tool-slide *P*. This is of steel and it is T-slotted so that standard toolposts *O* can be used. It will be seen that the tools *C*, *D*, and *E* are held in such a way that

they can be adjusted readily both for different diameters and for shoulders of varying lengths. The slide is screw controlled and is operated by the handle *T*. A positive adjustable stop is provided by the check-nuts *V*. The back-rests *J* are of tool steel and are contained in the brackets *H*. The screws *K*, *L*, and *N* are used for binding and adjusting, while those at *M* pass down through slots in the body of the

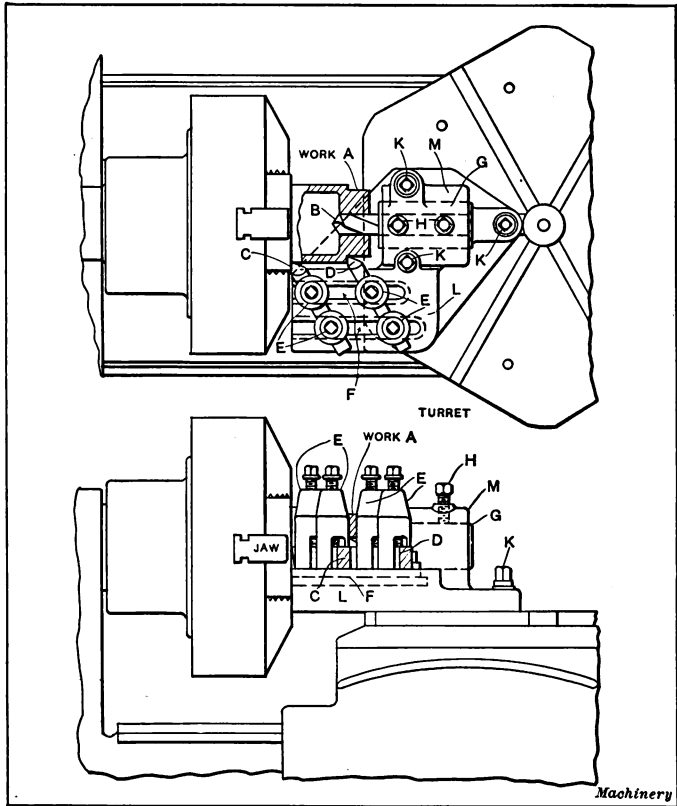

Fig. 2. Multiple Tool-holder for the Turntable Type of Lathe

tool and permit adjustment of the back-rests in a longitudinal direction.

Points worthy of notice in this tool are the method of supporting the body by means of the block on the cut-off slide, the flexibility of the tool adjustments, and the ease with which any tool may be replaced if broken or used up. The tools are of standard section and therefore require no machining except cutting off and grinding.

Multiple Tool-holder for the Turntable-type of Lathe

The bronze nut shown at *A* in Fig. 2 is an example of a piece of work which is to be drilled and turned on two diameters at the same

time. There were six pieces of this kind varying slightly in size, which had to be machined in lots of twenty-five. Two tool-holders were used to do the work, one tool being arranged as shown in the illustration, while the other contained a boring tool in place of the drill *B*. The holder *L* was made of cast steel and was T-slotted in two places at *F*, so that tool-holders *E* of the standard type could be used. These carry the tools *C* and *D*, and attention is called to the

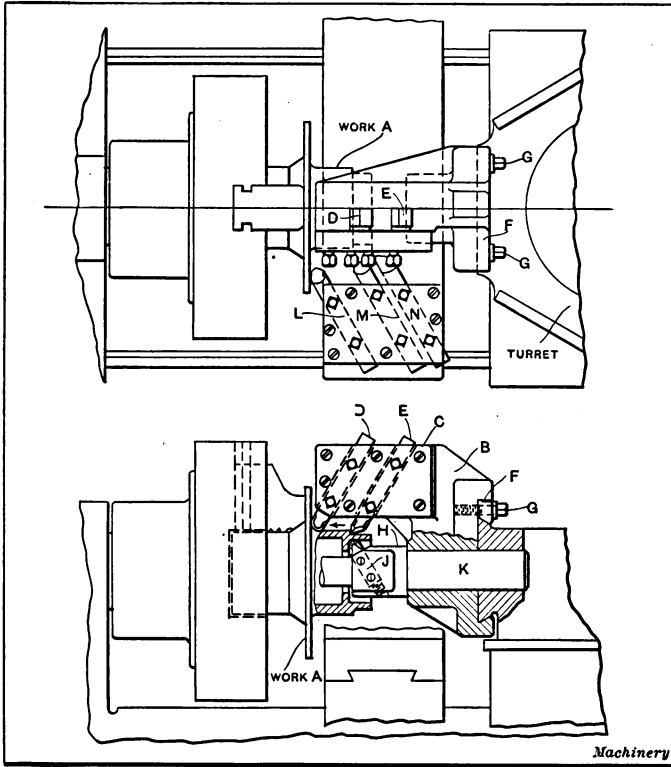

Fig. 3. Multiple Tool-holder for machining Automobile Hubs

way in which two posts are used for each tool to insure the maximum rigidity. The body of the holder is fastened to the turret face by the screws *K*, and is tongued on its under side to fit the slot. A semi-cylindrical boss *M* contains the split bushing *G* which holds the drill *B*. Two screws *H* are employed to clamp the bushing. This holder is simple, easily made and quite adaptable for work within its capacity. There are likely to be slight variations in the diameters turned due to imperfect indexing of the turret, but for general commercial work these usually are not great enough to cause any serious trouble.

Multiple Tool-holder for an Automobile Hub

The piece of work shown at A in Fig. 3 is an automobile hub, and the tool-holder is arranged so that the operations of turning and boring can be carried on simultaneously with the facing. The tools L, M and N are secured in a special block on the cut-off slide. The tool-holder B is of cast iron and well ribbed; it fits the dovetailed face of the turret, being secured in position by the screws G and the gib F. The turning tools D and E are mounted vertically, and the steel cap-plate C contains the necessary holding screws. The boring-bar H is

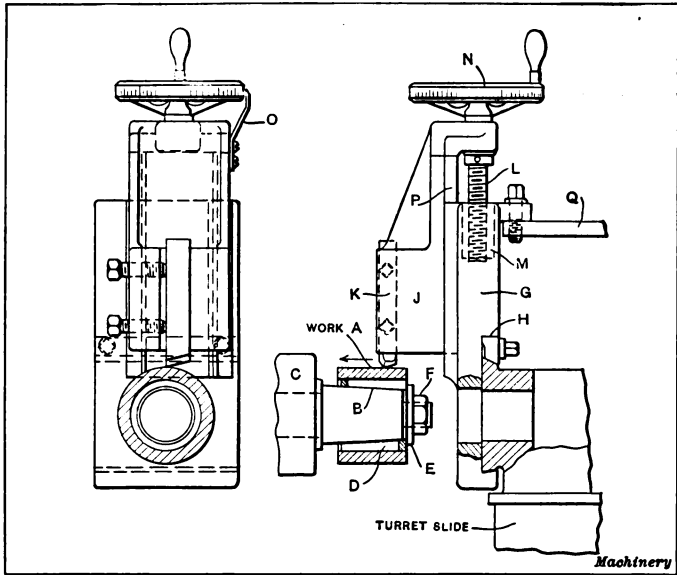

Fig. 4. Adjustable Turning Tool for finishing the Outside of Short Bushings

piloted in a chuck bushing at its forward end and contains the tool J, which stands in a vertical plane like the turning tools. The shank of the bar K is secured by the turret binding screw and an additional set-screw in the holder itself. A tool of this type will produce more accurate work than the type shown in the preceding illustration, on account of the position of the cutting tools with reference to the turret indexing. A feature of some importance is the piloting of the boring-bar, as this assists in the prevention of vibration. Care should be taken in the design of tool-holders of this type, that the overhang from the turret face is not too great, for if this is excessive, a certain amount of chatter is inevitable.

Adjustable Turning Tool for Short Bushings

A number of short bushings such as that shown at A in Fig. 4 were to be refinished on the outside. The bushings were of various di-

ameters ranging from $2\frac{1}{4}$ to 4 inches, while the lengths varied from $1\frac{1}{2}$ to 3 inches. The pieces were held on arbors *B*, in collet jaws *C*. A split sleeve *D* was expanded inside the work by the action of collar *E* and nut *F*. The body of the tool *G* was secured to the dovetailed face of the turret by gib *H*. The tool-slide *J* is a steel casting dovetailed at *P* and fitted with an adjustable taper gib to take up the

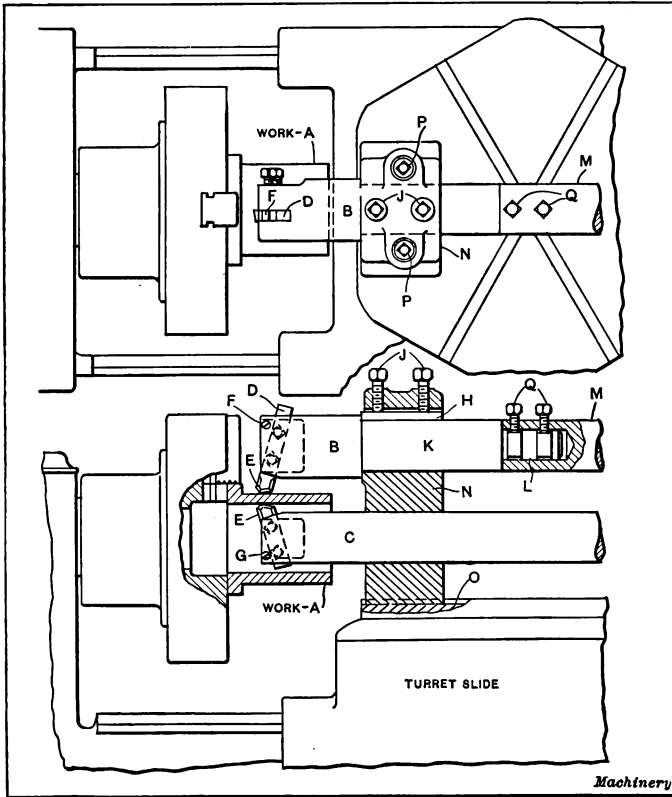

Fig. 5. Boring-bars for turning Concentric Packing Rings

wear. The cutting tool *K* is placed in a slot in the slide and is secured by the screws shown. The screw *L* is journaled in a lug at the upper end of the slide and enters a steel nut *M* in the body of the tool. Radial adjustment is obtained through this screw by means of the handwheel *N*. The rim of the wheel is graduated and the pointer *O* permits accurate readings to be made. This tool is very good indeed for light work, and accurate results can be obtained by its use. When two tools are used, a tie-rod *Q* assists in making the combination more rigid.

Holder for Adjustable Boring- and Turning-bars

The work shown at *A* in Fig. 5 is a cast-iron pot from which concentric packing rings are to be cut, and the boring and turning are done at the same time. Two cast-iron holders *N* are tongued at *O* and secured to opposite sides of the turret by the screws *P*. The turning- and boring-bars *B* and *C* pass through the holders and extend entirely across the turret. The boring-bar *C* is of the same diameter

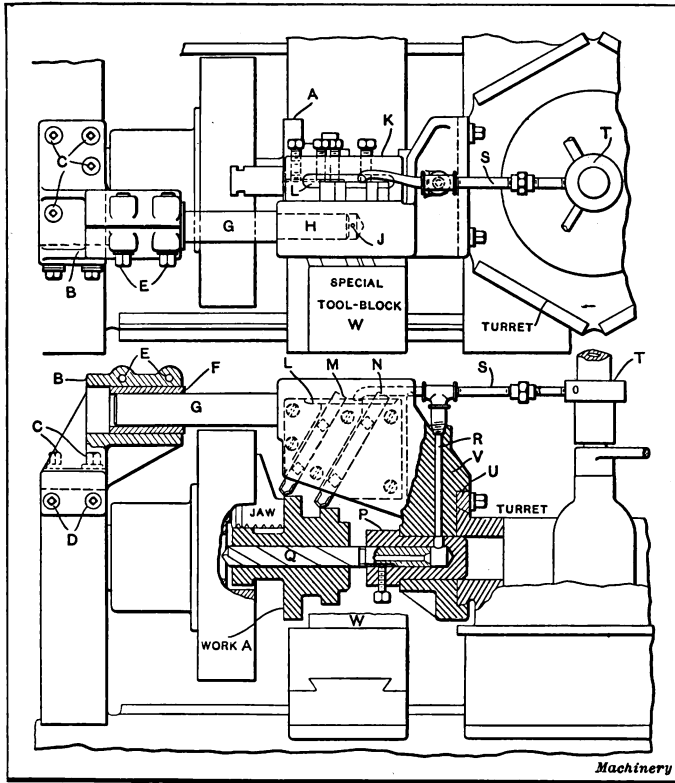

Fig. 6. Piloted Multiple Turning Tool for Gear Blanks

along its entire length, and it is secured in the holders by shoe binders similar to that shown at *H* but located in the sides of the holders. The boring tools *E* are of rectangular section and secured by set-screws in the slots at the ends of the bar. The screws *F* and *G* help to stiffen the ends of the bars where they are slotted. The upper or turning-bar is made in two sections *K* and *M* so that the tools may be swung radially to bring them into their proper position when the turret is set off center for turning larger diameters. The end of one bar is turned down at *L* to fit the hole in the other bar and the screws *Q* make a firm joint. A set of bars and holders of this kind is a very

useful adjunct to a turret lathe equipment, and it may be adapted to a variety of uses. The double tie feature across the turret gives exceptional rigidity.

Piloted Multiple Turning Tool for Steel Gear Blanks

The automobile jack-shaft gear blank shown at *A* in Fig. 6 is of alloy steel and it is held in special chuck jaws so that it can be

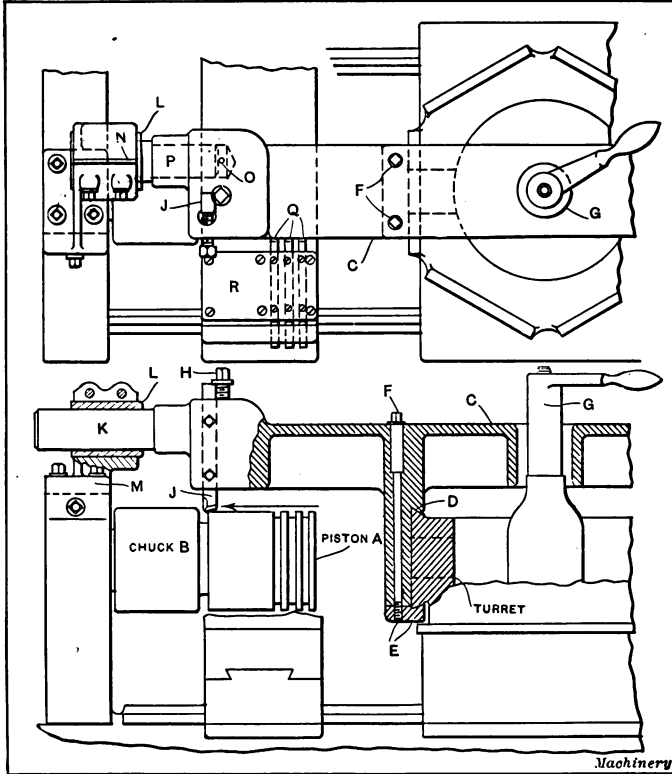

Fig. 7. Double-end Piloted Turning Tool for Pistons

drilled, turned and faced simultaneously. A special tool-block on the cut-off slide performs the latter operation, while the turning and drilling tools are carried by the turret. The body of the turning tool *V* is made of cast iron and is fastened to the dovetail turret face by the gib shown at *U*. The tool-block *K* is of steel and is slotted to receive tools *M* and *N*. An oil groove is cut at *L* along the top of the block and it is supplied with oil from the special piping system shown. The pipe *S* leads to the distributing collar *T* which, in turn, is connected with the cutting lubricant piping system on the machine. The slots in the tool-block are of sufficient width to permit an ample supply of fluid to run down and reach the cutting ends of the tools, thus as-

sisting greatly in prolonging the life of the tools and also allowing higher cutting speeds. The oil-drill *Q* is held in a steel supporting bushing *P* which fits the body of the tool-holder. It is supplied with lubricant through the hole *R* which is connected to the piping system. The steel pilot *G* is shouldered at *H* and is forced into the body of the holder. The small hole *J* is put in so that air pressure will not be generated when the pilot is pressed into place, as this would tend to

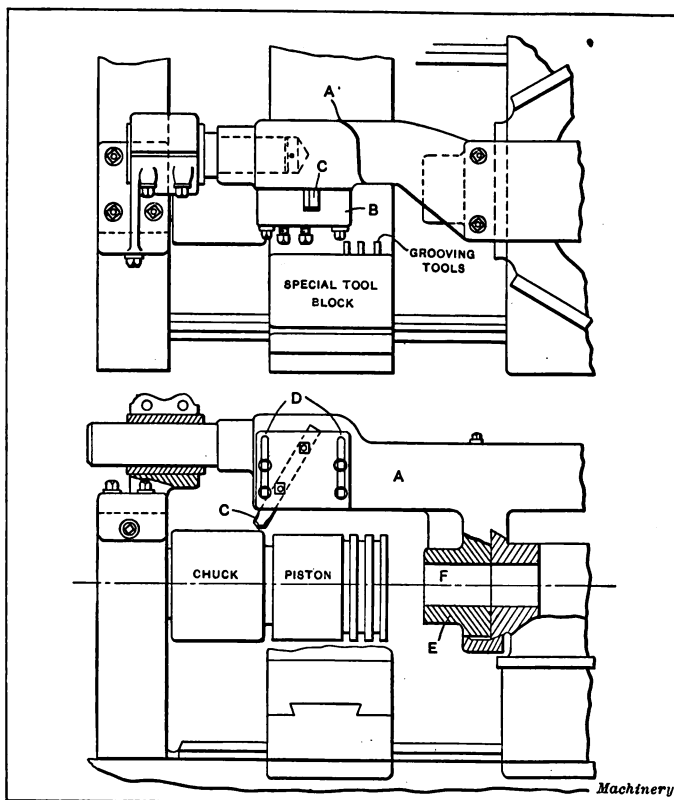

Fig. 8. Piston Turning Tool having Adjustable Tool-block

deceive the fitter by making him think he had a good fit when, in reality, it was compressed air that made the pilot hard to force in. Pilots are sometimes fitted so that they were apparently all right at the time when the work was done, and yet when the time came for the tools to be used, it was found that they were loose enough to cause trouble. The air hole will prevent trouble of this kind.

A special bracket is shown at *B* and it is screwed to the spindle cap by the screws *C* and *D*. The bronze bushing *F* receives the end of pilot *G*, and it is clamped by the binding screws *E*. This method of supporting a turning tool is very successful and assists greatly in per-

mitting heavy cutting without chatter. Another feature of this tool is the manner in which oil is conveyed to the cutting tools. Attention is also called to the position of the tool-block, this being at the rear of the body so that the thrust of the cut is brought directly against the heavier part of the casting. The method of mounting the tools is also a little out of the ordinary, in that the block and tools form a

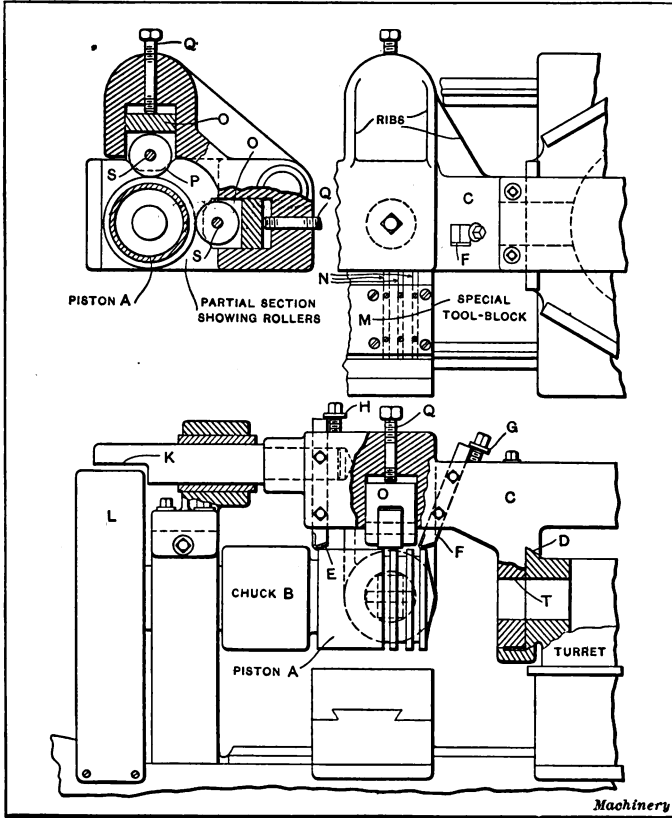

Fig. 9. Multiple Turning Tool equipped with Pilot and Roller Back-rest

unit which can readily be removed, permitting the substitution of another block with tools arranged differently, to handle other work requiring different spacing. Two turning tools on opposite sides of the turret were used for this particular piece, one being used for roughing and the other for finishing.

Double-end Piloted Turning Tool for Pistons

The piston A shown in Fig. 7 is held by the inside on a special expanding pin chuck B. The arrangement of tools is that recommended by the Pratt & Whitney Co., for turning automobile pistons on

their horizontal turret lathe. The turning tool-holder *C* is of cast iron and is double ended, reaching entirely across the turret, and the two ends are exactly the same. The body or arm is of U-section and it is cored out at the center so that the turret binder-lever can pass through it, as shown at *G*. A careful fit is made on the dovetail at *D*, and two special bolts *F* pass down through the body of the tool and pull up the gib *E* against the lower dovetail, thus clamping the tool securely. The tool *J* is backed up by the collar-head screw *H* and is secured by means of two screws. The steel pilot *K* fits the bushing *L* in the spindle cap bracket *M*, as in a previous instance. It will be noted that an air hole *O* is provided where the shank *P* enters the end of the tool body. In connection with the turning tools a special block on the cut-off slide is used to cut the ring groove in the piston. This block and tools are shown at *R* and *Q* in the upper view. This style of equipment is very well known and has given universal satisfaction.

Piston Turning Tool having Adjustable Tool-block

A development of the preceding tool is shown in Fig. 8. It will be noted that although the general construction is about the same, in this instance the tool-block is made separate so that other blocks may be substituted having more than one tool. Considerable adjustment is also permissible by means of slots shown at *D*. It is obvious that this method of construction requires the tool-block *B* to be of steel and somewhat heavy, so that it will properly resist the thrust of the cut. The screws which hold the block in position must also be of ample size. As this particular tool was designed for use in turning and boring ring pots, in addition to piston work, the boss *E* was supplied and bored at *F* to receive a boring-bar.

Special Multiple Turning Tool with Roller Back-rest

In a great many instances the design of an automobile piston is such that it is permissible to center the solid end, and this gives a chance to support the end by a conical rest. While the ring grooves are being cut some support is essential, and in the case of the piston shown in Fig. 9 the use of roller supports in place of a center rest was found necessary for the reason that centering was not permitted. The piston *A* is held on the special chuck *B* and the two tools *E* and *F* are held in a double-end tool-holder. Adjustment is obtained by means of the collar-head screws *H* and *G*. The turning tool body *C* fits the turret dovetail at *D* and it is clamped, as previously stated. The end of the pilot *K* is cut away on its under side in order to clear the gear guard *L*. The steel supports *O* are backed up by the screws *Q*, which are also used for adjusting purposes. The hardened and ground steel rollers *P* are hung on the pins *S*. (See detail view.) A special tool-block *M* contains the grooving tools *N*. This equipment also was very successful.

Adjustable Piloted Turning Tool for Large Diameters

A somewhat different type of tool is shown in Fig. 10, this being adjustable for various diameters from the 12-inch casting *A* down to a

diameter of 6 inches or a trifle under that size if necessary. This tool was rather heavy and cumbersome and not entirely successful on heavy cuts. On the lighter variety of work, however, it proved satisfactory and adaptable. Two tools were used on opposite sides of the turret; the flat steel tie-bar *L* helped to prevent sagging.

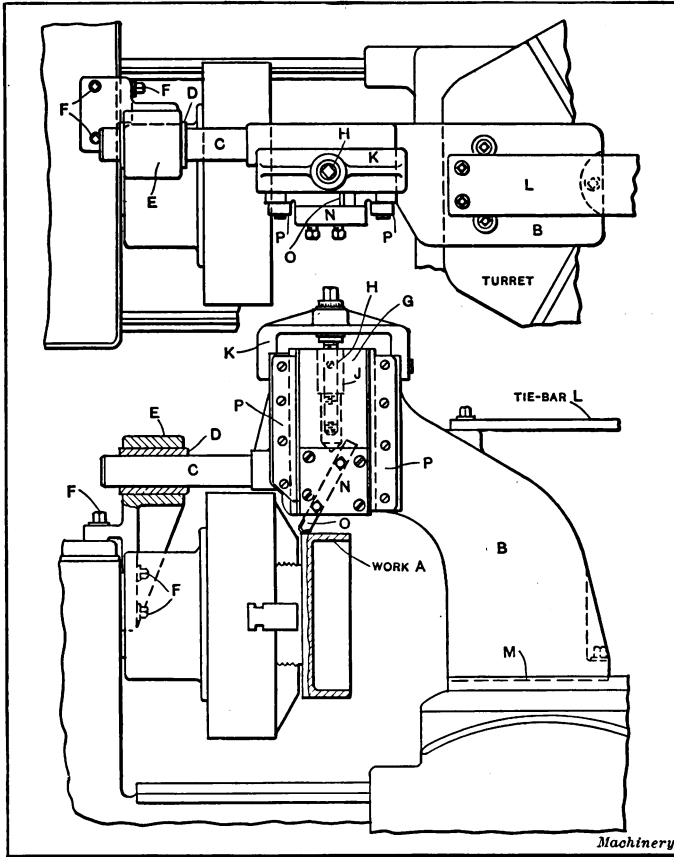

Fig. 10. Adjustable Piloted Turning Tool for Large Work

The body of the holder *B* is of cast iron cored out so that the walls are $\frac{1}{2}$ inch section, and it is tongued along its lower face to fit the turret at *M*. The forward end holds the steel pilot *C*, which is supported and guided by the bushing *D*. The bracket *E* is fastened to the head of the machine by the screws *F*, thus insuring a rigid support for the end of the pilot. The tool-slide *N* contains the tool *O* and it is securely gibbed by the two steel straps *P*. A taper gib (not shown) provides adjustment for wear on the sides. The bracket *K* is screwed to the top of the tool body and journals the operating screw *H*. A gradu-

ated collar permits accurate settings to be made without trouble. A bronze nut in the body of the slide at *J* receives the operating screw.

Multiple Turning Tool for the Vertical Turret Lathe

The vertical turret lathe is less frequently supplied with multiple tools than the horizontal type of machine, for the reason that the regular equipment supplied by the manufacturers is adapted to a wide range of conditions without very much special tooling, and, in addition, the class of work for which this machine is more likely to be used is of such a nature that multiple turning tools are less likely to be re-

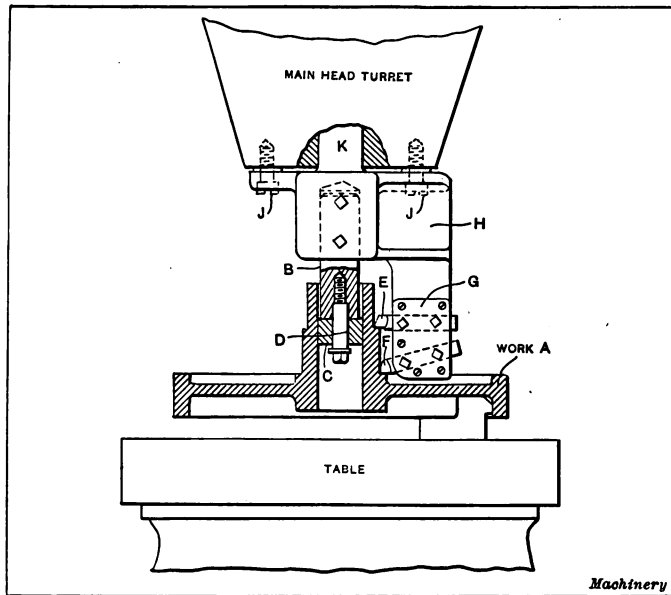

Fig. 11. Multiple Turning Tool for Vertical Turret Lathe

quired. There are instances, however, when a considerable increase in production may be made by the use of the multiple type of tools. Take for example the special gear shown at *A* in Fig. 11. This piece of work is held by the inside of the rim in special jaws, and the tools in the side-head turret are used to face and turn the gear portion while the special multiple tools are at work on the hub. Before the operation illustrated takes place, the work has been bored, reamed and faced on the other side.

The body of the tool *H* is of cast iron and it is fastened to the turret face by the screws *J*, while the plug *K* centers it in the turret hole. The turning tools *E* and *F* are secured in the slots and a steel cover-plate *G* gives support for the set-screws which hold the tools in place. A steel shank *B* has a revolving roll *C* fastened to its lower end by the shouldered screw *D*; this roll acts as a pilot in the finished hole.

The construction of this device is simple and the results obtained by its use are excellent.

Piloted Multiple Turning Tool for Triple Gear Blank

A radical departure from regular methods is shown in Fig. 12. The work *A* for which the equipment was designed is a cast-iron triple gear blank. Attention is called to the fact that in this illustration the side-head is shown in a false position in order to show the cutting action more clearly. The body *H* of the multiple turning tool is fitted

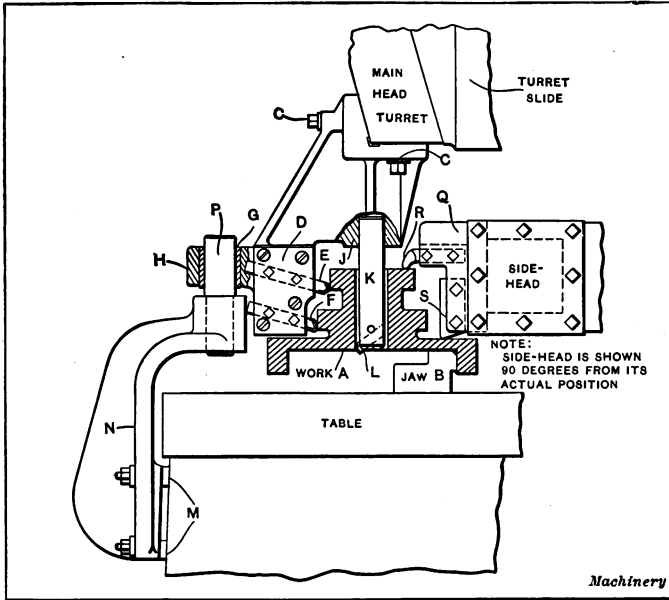

Fig. 12. Piloted Multiple Turning Tool for Triple Gear Blank

to the turret and held in position by the screws *C*. A steel bushing *G* acts as an outboard support for the tool, and it is a sliding fit on the pilot *P* which is shouldered in the supporting bracket *N*. This bracket is heavily ribbed and is fastened to the bed of the machine. The adjustable washers at *M* are used to align the bracket properly. A tool-block *D* contains the two turning tools *E* and *F*, and the boring-bar *K* is held in the hub *J*. The arrangement of the side-head, in this instance, is a little out of the ordinary. A special tool-block *Q* contains the two facing tools *R* and *S*, and these work simultaneously with the turning tools, thereby making production very rapid.

Multiple Toolpost Turret for the Side-head

The cone pulley shown at *A* in Fig. 13 was machined in one setting. The casting was held by the inside of the lower or largest step of the cone and a driver (not shown) was placed against the interior ribbing,

as the jaws were not sufficient to hold the work securely against the cutting action of the four turning tools. A special side-head turret toolholder was designed for this piece of work, and the facing and turning tools *D*, *E*, *F* and *G* were held in it as shown in the illustration. One set of tools was used for roughing and a duplicate set on the other side of the turret post was used for finishing. The entire group of tools pivoted on the stud *H*. While these cutters were operating on the outside of the pulley, the boring-bar *B* (held in the main head turret and driven by the pin *C*) was slowly boring out the hole. A forming plate was used to give the desired crown to the steps. The production could have been improved if a special turning tool had been used in the main head for turning the four steps of the cone, and the side-

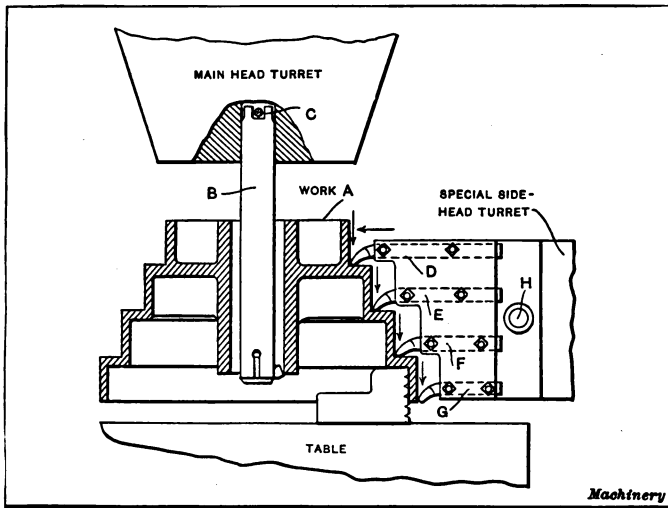

Fig. 13. Multiple Toolpost Turret for the Side-head

head used for facing only. These operations could have taken place at the same time, and the speeds would have been more nearly correct. The boring could have been done at a higher rate of speed. However, the results obtained with the arrangement shown in the illustration were satisfactory.

Multiple Turning Tool for the Vertical Boring Mill

The vertical boring mill is seldom equipped with multiple turning tools, but there are cases where production can be increased considerably by their use. One example only is given of the use of an equipment of this kind. Fig. 14 shows a large pulley at *A*, and this is held by the inside of the larger step in the special jaws *B*. The buttons *C* give a three-point support to the work. A special tool-holder *D* is slotted out to receive the tools *E*, *F* and *G* which are used for the turning and boring. The plate *H* is fastened over one end of the tool-

holder in order to tie it together, and the filler-block *J* gives additional strength while its upper end engages the right-hand ram and acts as a driver. Another block *K* ties the lower end of the tool-holder together. The left-hand head contains the toolpost *L* which supports the tool *M*. This tool is used for facing while the other tools are turning.

Other instances of multiple turning might be given, and illustrations

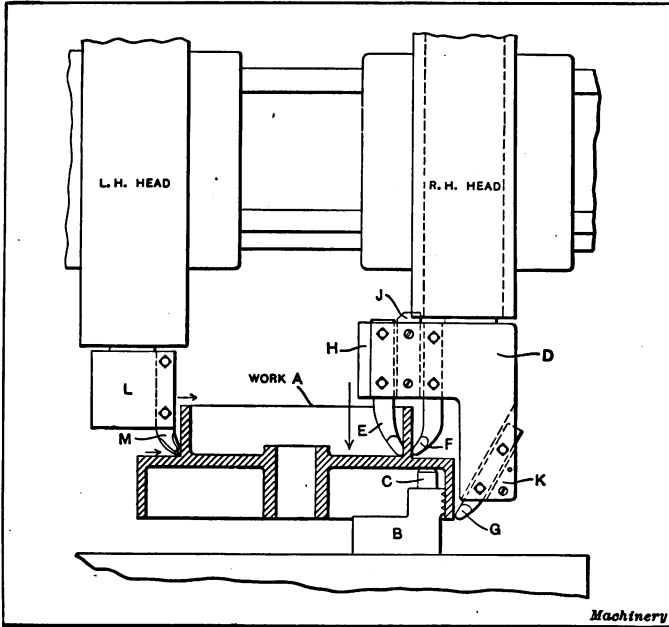
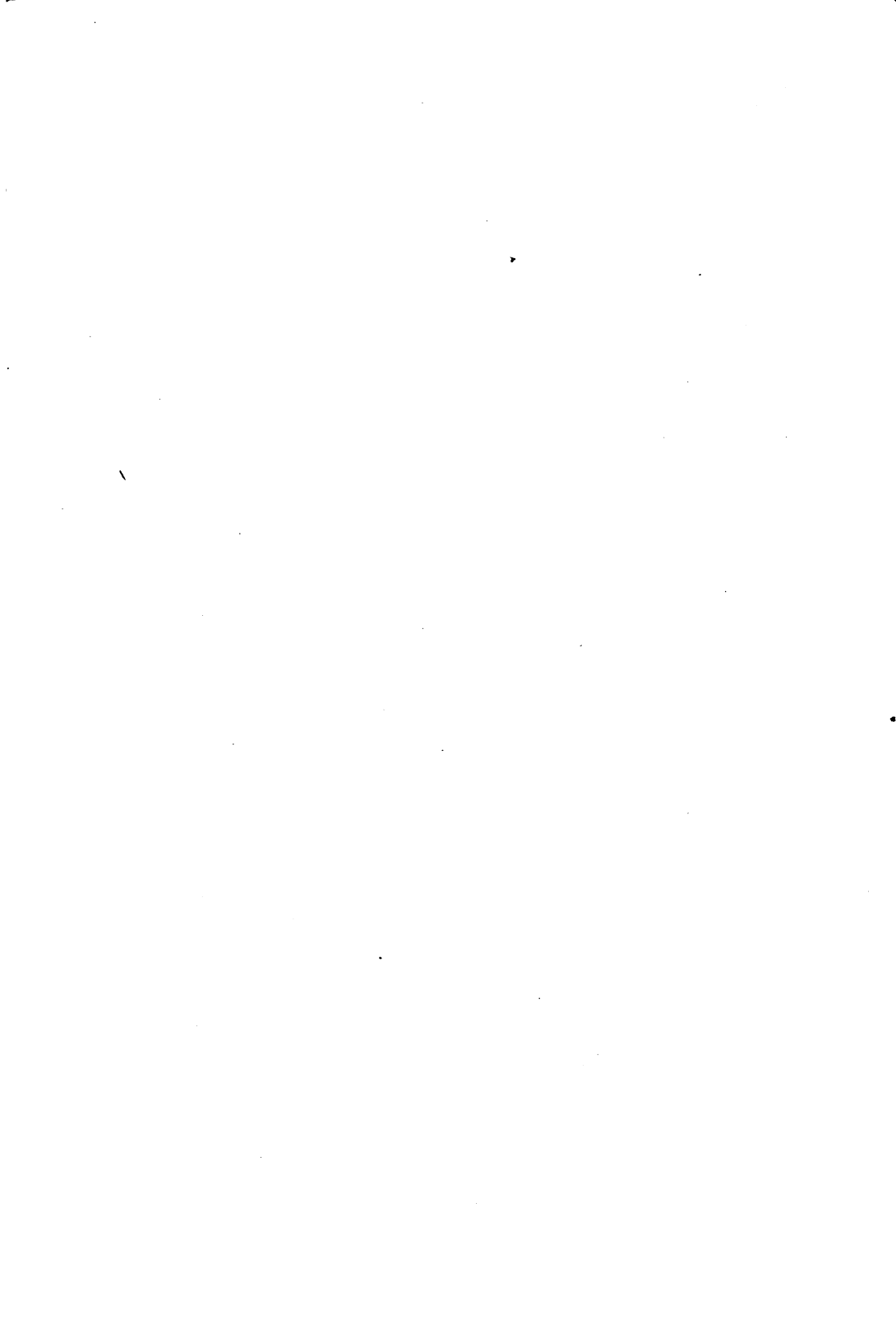
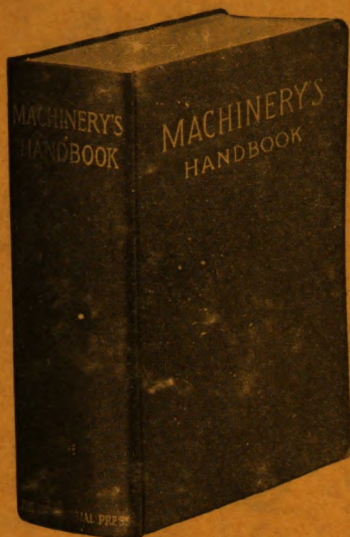

Fig. 14. Application of Multiple Turning Tool to Vertical Boring Mill

shown, but these would be much on the same order as those which have been mentioned and would be of no particular value as representative types. Tools have been selected for this chapter which seem to best illustrate the principles of design required in the various types.





MACHINERY'S HANDBOOK

For MACHINE SHOP
AND DRAFTING-ROOM

A REFERENCE BOOK ON MACHINE
DESIGN AND SHOP PRACTICE FOR
THE MECHANICAL ENGINEER,
DRAFTSMAN, TOOLMAKER AND
MACHINIST.

MACHINERY'S Handbook comprises nearly 100 pages of carefully edited and condensed data relating to the theory and practice of the machine-building industries. It is the first and only complete handbook devoted exclusively to the metal-working field, and contains in compact and condensed form the information and data collected by MACHINERY during the past twenty years. It is the one essential book in a library of mechanical literature, because it contains all that is of importance in the text-books and treatises on mechanical engineering practice. Price \$5.00. (1£).

GENERAL CONTENTS

Mathematical tables—Principal methods and formulas in arithmetic and algebra—Logarithms and logarithmic tables—Areas and volumes—Solution of triangles and trigonometrical tables—Geometrical propositions and problems—Mechanics—Strength of materials—Riveting and riveted joints—Strength and properties of steel wire—Strength and properties of wire rope—Formulas and tables for spring design—Torsional strength—Shafting—Friction—Plain, roller and ball bearings—Keys and keyways—Clutches and couplings—Friction brakes—Cams, cam design and cam milling—Spur gearing—Bevel gearing—Spiral gearing—Herringbone gearing—Worm gearing—Epicyclic gearing—Belted and rope drives—Transmission chain and chain drives—Crane chain—Dimensions of small machine details—Speeds and feeds of machine tools—Shrinkage and force fit allowances—Measuring tools and gaging methods—Change gears for spiral milling—Milling machine indexing—Jigs and fixtures—Grinding and grinding wheels—Screw thread systems and thread gages—Taps and threading dies—Milling cutters—Reamers, counterbores and twist drills—Heat-treatment of steel—Hardening, casehardening, annealing—Testing the hardness of metals—Foundry and pattern shop information—The welding of metals—Autogenous welding—Thermit welding—Machine welding—Blacksmith shop information—Die casting—Extrusion process—Soldering and brazing—Etching and etching fluids—Coloring metals—Machinery foundations—Application of motors to machine tools—Dynamo and motor troubles—Weights and measures—Metric system—Conversion tables—Specific gravity—Weights of materials—Heat—Pneumatics—Water pressure and flow of water—Pipes and piping—Lutes and cements—Patents.

MACHINERY, the leading journal in the machine-building field, the originator of the 25-cent Reference and Data Books. Published monthly. Subscription, \$2.00 yearly. Foreign subscription, \$3.00.

THE INDUSTRIAL PRESS, Publishers of MACHINERY

140-148 LAFAYETTE STREET

NEW YORK CITY, U. S. A.

