

ECCLECTIC SYSTEM OF INDUSTRIAL DRAWING

ELEMENTS OF MECHANICAL DRAWING

BY
CHRISTINE SULLIVAN, Ph.D.

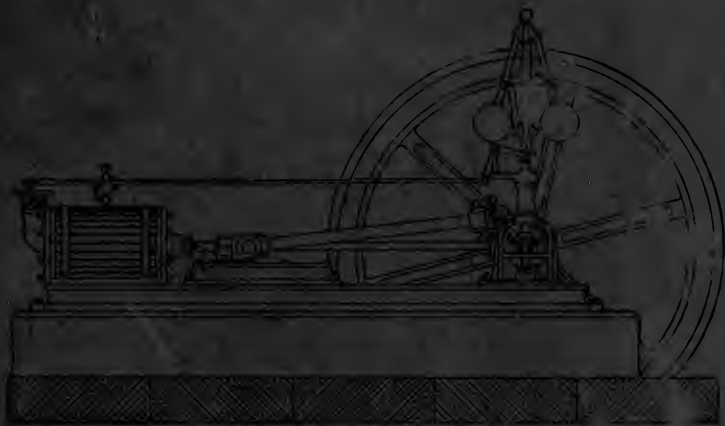

NEW YORK ... CINCINNATI ... CHICAGO
AMERICAN BOOK COMPANY

1893

T
353
S94

LIBRARY OF CONGRESS.

Chap. Copyright No.

Shelf T 353

..... S 94
UNITED STATES OF AMERICA.





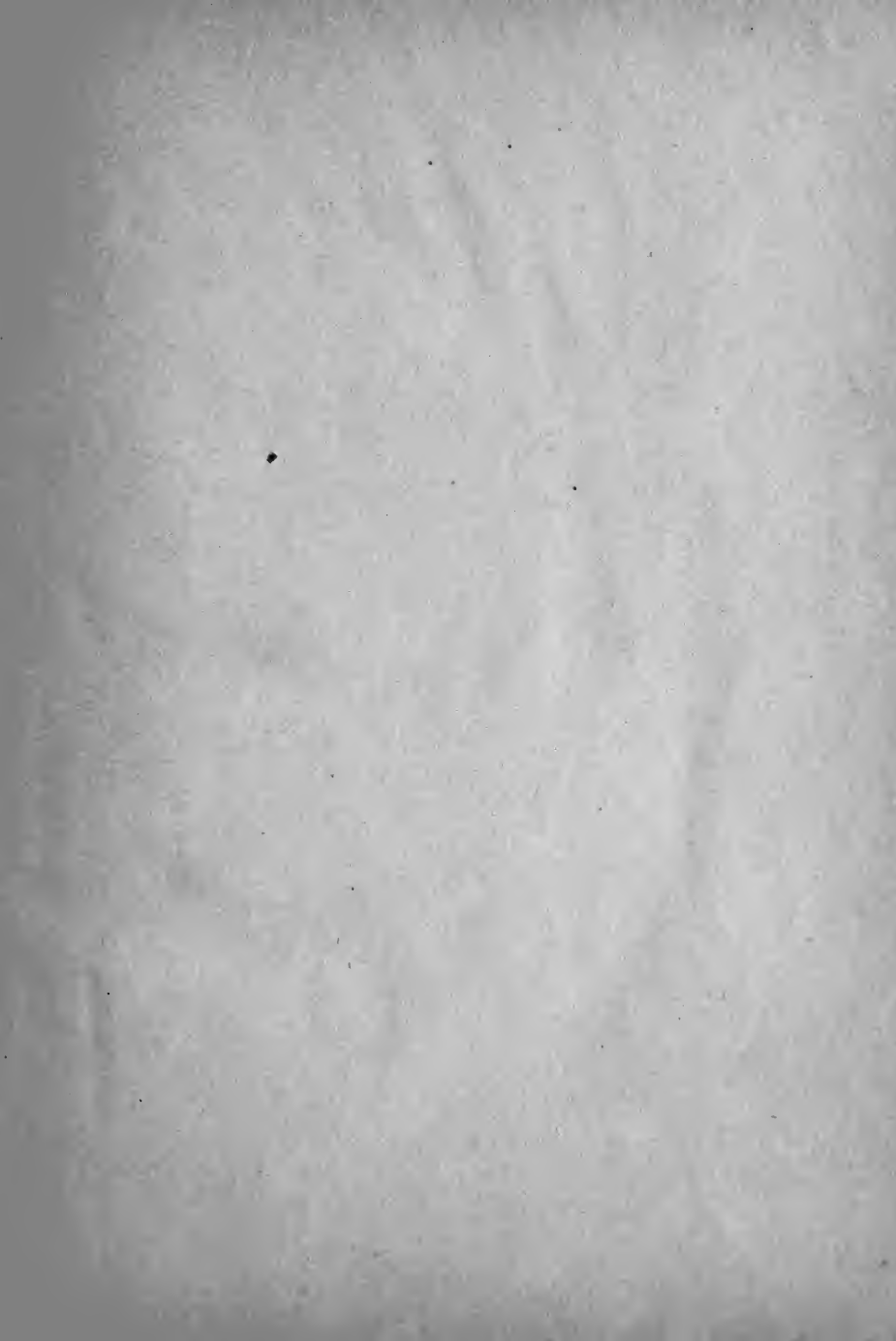



ECLECTIC SYSTEM OF INDUSTRIAL DRAWING

ELEMENTS OF MECHANICAL DRAWING

FOR USE IN THE SCHOOLROOM AND THE WORKSHOP

BY

CHRISTINE SULLIVAN, Ph.D.



NEW YORK ·· CINCINNATI ·· CHICAGO
AMERICAN BOOK COMPANY

1893

22830Y1



COPYRIGHT, 1893, BY
AMERICAN BOOK COMPANY

Ele. Mech. Dr.

T 353
.S 94

CONTENTS.

LESSON	PAGE
I. MATERIALS NECESSARY, AND HOW TO USE THEM	5
II. DEFINITIONS	7
III. DEFINITIONS, <i>Continued</i>	10
IV. DEFINITIONS, <i>Concluded</i>	12
V. GEOMETRIC PROBLEMS	16
VI. EXERCISE WITH RULER AND COMPASSES	20
VII. EXERCISE WITH RULER AND COMPASSES, <i>Continued</i>	21
VIII. EXERCISE WITH RULER AND COMPASSES, <i>Continued</i>	22
IX. EXERCISE WITH RULER AND COMPASSES, <i>Concluded</i>	22
X. GEOMETRIC PROBLEMS	24
XI. GEOMETRIC PROBLEMS, <i>Concluded</i>	26
XII. GEOMETRICAL SOLIDS UNFOLDED	28
XIII. PERSPECTIVE	33
XIV. SCALE	35
XV. WORKING DRAWINGS	36
XVI. MECHANICAL POWERS	38
XVII. GEOMETRIC SOLIDS. — PLANS AND ELEVATIONS	39
XVIII. JOINTS	47
XIX. MASONRY	50
XX. MECHANICAL DEVICES	51
XXI. MECHANICAL DEVICES, <i>Concluded</i>	53

LESSON	PAGE
XXII. ARCHITECTURE	56
XXIII. ARCHITECTURE, <i>Concluded</i>	57
XXIV. TRACING AND BLUE PRINTING	58
XXV. MACHINERY	58
XXVI. MACHINERY, <i>Concluded</i>	60
XXVII. WHEELS	61
XXVIII. GEOMETRIC CONSTRUCTION	65
XXIX. COLOR	66
XXX. ISOMETRIC PROJECTION	68

ELEMENTS OF MECHANICAL DRAWING.

LESSON I.

MATERIALS NECESSARY, AND HOW TO USE THEM.

1. *Drawing Board.* — This must be of well-seasoned lumber, have a smooth surface, and be not less than 18 by 24 inches.
2. *Paper.* — The paper must be smaller than the board, so that it will not project over the edges. If the drawing is to remain on the board but a short time, it may be fastened down with *thumb tacks*. If it is to be some time on the board, it is advisable to dampen the paper with a sponge, and paste the edges to the board, stretching the paper equally in all directions from the center.
3. *T Square.* — This should be held against the left side of the board, and should be used for horizontal lines only. Use a triangle (90°) for vertical lines.
4. *Pencils.* — These must be of good quality; the lead sharpened to a round point for sketching, and to a flat edge for ruling.

NOTE. — If the drawings are to be finished in ink, the penciling must be very light.

5. *Ink.* — The pupil must never use writing fluid, which rusts and destroys the instruments.

NOTE 1. — A small quantity of indigo added to the India ink will prevent the lines in the drawing from turning brown.

NOTE 2. — To make ink waterproof, drop a piece of bichromate of potassium about the size of a bean into the bottle of ink. After using this solution, clean the ink foot of the compasses and pen thoroughly.

6. *Dividers.* — These are employed when distances are to be accurately measured.

7. *Protractor.* — This instrument is used in measuring and constructing angles. It is semicircular in shape, and the arc is divided into 180° .

8. *Horn Center.* — It is used to prevent the compass foot from enlarging any center.

9. *A Pair of Compasses.* — They consist of the body of the compasses and three adjustable parts: the steel for measuring; the pencil leg, used for drawing arcs, circles, etc.; and the ink leg, which is used to repeat the pencil work in ink.

10. *Ruling Pen.* — This is used for inking straight lines.

HINTS IN USING THE COMPASSES.

(a) In describing a circle keep the ink leg perpendicular to the surface of the paper by means of a joint in the ink leg.

(b) In describing circles do not bear weight on the compasses sufficient to force the steel point through the paper.

(c) If many concentric circles or arcs are required, the pupil should use a horn center.

(d) Use compasses with round, not too sharp steel point.

(e) Hold compasses very loosely between the thumb and forefinger only.

(f) Allow the instrument to rest with equal weight on all points of a curve.

(g) When lengthening rod is used to describe circles of a long radius, the pupil must remember to keep the ink leg bent, and perpendicular to the surface of the paper.

($\frac{1}{2}$) Bow pen and pencil and spring bows are used for drawing small circles.

NOTE 1. — Ruling pen and compasses may be supplied with ink by means of a camel's-hair brush.

NOTE 2. — Always test pen and compasses before inking in the drawing.

NOTE 3. — Always thoroughly dry and clean inking leg and drawing pen before putting away.

LESSON II.

DEFINITIONS.

As almost all forms in machinery are geometrical, and as it is necessary for the pupil to have a knowledge of the names of the different geometrical forms, and also to know how to construct the same, the following definitions must be learned by the class. The pupil should draw on paper and on the blackboard all exercises illustrating these definitions.

LINES AND SURFACES.

NOTE. — For exercises see p. 24.

1. A *straight* line is the shortest distance between two points.
2. Straight lines are *horizontal*, *vertical*, and *oblique*.

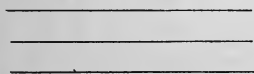

FIG. 1. — HORIZONTAL LINES.

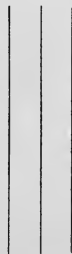

FIG. 2. — VERTICAL LINES.

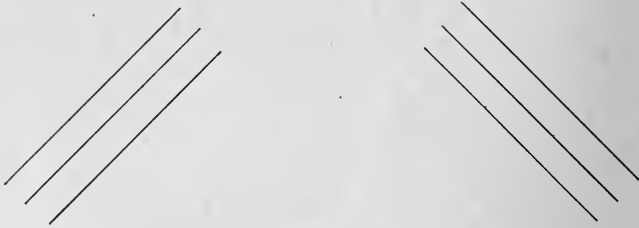

FIG. 3. — OBLIQUE LINES.

3. A *curved* line is a line that changes its direction at every point.
4. Curves are *regular* and *irregular*.



FIG. 4. — REGULAR CURVE.

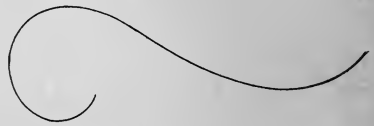

FIG. 5. — IRREGULAR CURVE.

5. *Surface* has length and breadth without thickness.
6. A *plane* surface is a flat, even surface.
7. *Parallel* lines are lines that will not meet, no matter how far produced. They lie in the same plane.

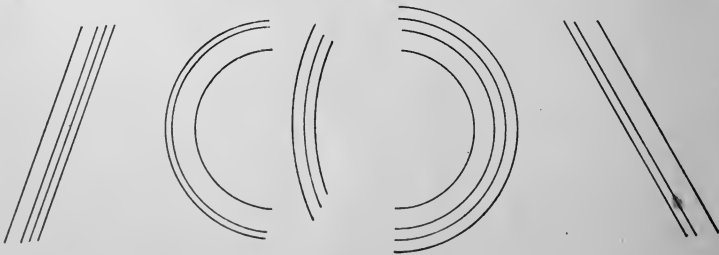

FIG. 6. — PARALLEL LINES.

ANGLES.

8. An *angle* is the amount of divergence between two lines that meet in any plane.

9. An angle is designated by naming its sides, or by naming the vertex only.

10. There are three kinds of angles.

11. A *right* angle is formed by one straight line meeting another straight line, making the adjacent angles equal. It measures 90° (marked R. A.).

12. An *obtuse* angle is greater than a right angle.

13. An *acute* angle is less than a right angle.

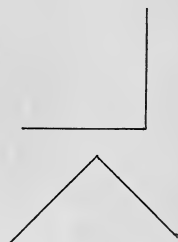

FIG. 7. — RIGHT ANGLES.

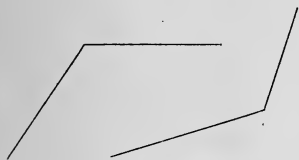

FIG. 8. — OBTUSE ANGLES.

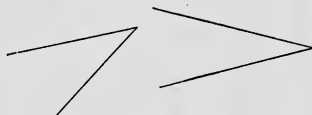

FIG. 9. — ACUTE ANGLES.

14. A *curvilinear* angle is formed by two curves.

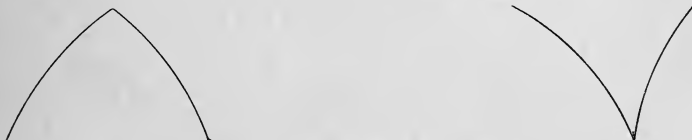

FIG. 10. — CURVILINEAR ANGLES.

15. A *mixilinear* angle is formed by a curve and a straight line.



FIG. 11. — MIXILINEAR ANGLES.

LESSON III.

DEFINITIONS. — *Continued.*

POLYGONS.

16. A *polygon* is a surface bounded by straight lines.
17. A polygon of three sides is called a *triangle*.
18. A polygon of four sides is called a *quadrilateral* (Fig. 12).
19. A polygon of five sides is called a *pentagon*.
20. A polygon of six sides is called a *hexagon*.
21. A polygon of seven sides is called a *heptagon*.
22. A polygon of eight sides is called an *octagon*.
23. A polygon of nine sides is called a *nonagon*.
24. A polygon of ten sides is called a *decagon*.
25. A polygon of twelve sides is called a *dodecagon*.

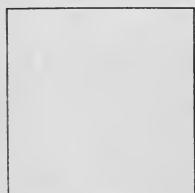

Square.

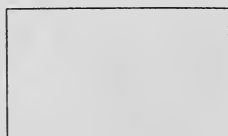

Rectangle.



Rhomboid.



Rhombus.

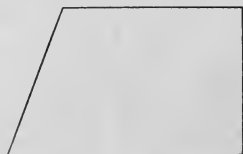

Trapezoid.



Trapezium.

FIG. 12. — QUADRILATERALS.

26. An *equilateral* polygon is one whose sides are equal.
 27. An *equiangular* polygon is one whose angles are equal.

TRIANGLES.

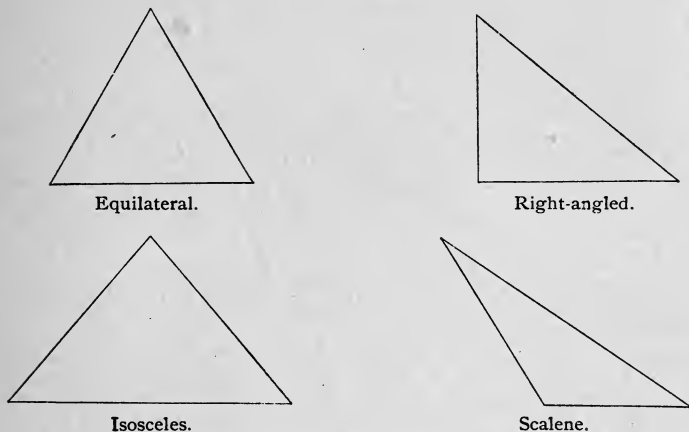

FIG. 13. — TRIANGLES.

28. An *equilateral* triangle has all sides equal.
 29. A *right-angled* triangle is one that has a right angle.
 30. An *isosceles* triangle has two sides equal.
 31. A *scalene* triangle has no two sides equal.
 32. An *equiangular* triangle is called a *trigon*.
 33. Triangles are sometimes *trilaterals*.

TECHNICAL TERMS USED IN GEOMETRY.

34. A *point* indicates position without magnitude, as the center of a circle or the intersection of two lines (Fig. 14). The point of intersection is where two lines cross (Fig. 15).



FIG. 14.



FIG. 15.



FIG. 16.

35. A *line* has length. It indicates direction (Fig. 16).
36. A *given line* is a fixed or known line, the length of which is given.
37. To *produce* or *prolong* a line is to lengthen it in the same straight line or direction.
38. *Lines of construction* are the lines used in the solution of a problem.
39. To *describe a figure* is to draw it on a sheet of paper or any other plane surface.



FIG. 17.

40. To *set off a distance* is to mark on the drawing a given distance.
41. The *area of a surface* is the space which it contains.
42. *Altitude* is a straight line drawn from the vertex of any figure perpendicular to its base (Fig. 17).
43. *Equal figures* are those having the same area.
44. A *perimeter* is the outer boundary of a figure, the sum of all the sides.
45. A *periphery* is the circumference of a circle, ellipse, or other regular curvilinear figure.
46. To *bisect* is to divide into two equal parts.
47. To *coincide* is to agree in every respect, — position, length, etc.
48. A *problem* is something proposed which requires solution.
49. An *axiom* is a self-evident truth.
50. A *tangent* is a straight line that touches a curve at but one point.
51. A *regular polygon* is both equilateral and equiangular.
52. The *diagonal* of a polygon is a straight line joining the vertices of any two angles not consecutive.

LESSON IV.

DEFINITIONS. — *Concluded.*

THE CIRCLE.

53. A *circle* is a plane figure bounded by a curved line every point of which is equally distant from a point within called the *center*.

54. A *circumference* is the curved line that bounds the circle.

55. A *diameter* is a straight line that passes through the center, and terminates in the circumference.

NOTE. — A circumference is $3\frac{1}{7}$ times its own diameter.

56. A *radius* is a straight line that extends from the center to the circumference.

57. An *arc* is a part of the circumference.

58. A *sector* is the space included between the radii and arc.

59. A *chord* is a straight line connecting the extremities of an arc.

60. A *segment* is the space included between the chord and its arc.

61. An angle at the center is measured by an arc at the circumference between the sides of the angle. This arc is said to *subtend* the angle.

62. An angle whose vertex is in the circumference is measured by one half the arc which subtends it.

63. A *secant* is a line which meets the circumference of a circle in two points, and lies partly within and partly without the circumference (Fig. 19).

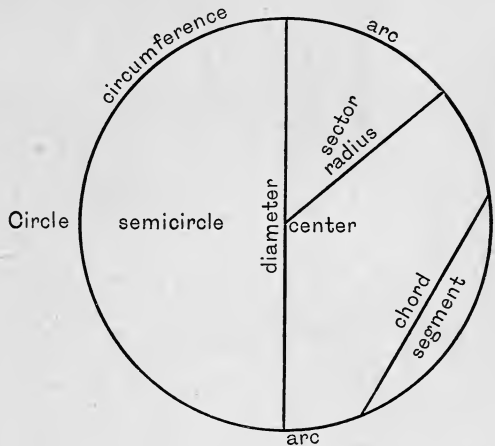

FIG. 18.

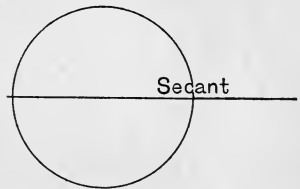

FIG. 19.

QUESTIONS FOR CLASS EXERCISES.

It is advisable to have a number of pupils, six or eight, at work at the blackboard; the remainder of the class preparing the exercises at their desks.

Exercises in Drawing Horizontal Lines.

1. Define the term *horizontal*.
2. Draw five 3-inch lines one fourth of an inch apart.
3. Draw four 5-inch lines one eighth of an inch apart.
4. Draw six 4-inch lines one sixteenth of an inch apart.

Exercises in Drawing Vertical Lines.

5. Draw five 4-inch lines one eighth of an inch apart.
6. Draw six 3-inch lines one sixteenth of an inch apart.
7. Draw three 5-inch lines one fourth of an inch apart.

Exercises in Drawing Oblique Lines.

8. Draw five 4-inch lines one eighth of an inch apart.
9. Draw six 3-inch lines one sixteenth of an inch apart.
10. Draw four 5-inch lines one fourth of an inch apart.

NOTE. — Draw these oblique lines from right to left, and then repeat the exercise in the direction of left to right.

Miscellaneous Exercises.

11. What is a simple curve? Draw one; radius, 2 inches.
12. What is a concave surface? Draw one; radius, $1\frac{1}{2}$ inches.
13. What is a curvilinear figure? Illustrate by a drawing.
14. Make a mixed figure with one curve and a straight line.
15. Make a mixed figure having one line and two curves.
16. Make a mixed figure having one curve and two lines.
17. Place two circles to touch each other, centers on a straight line; radii, 1 inch and $\frac{3}{4}$ of an inch.
18. Place three tangent circles, centers in a vertical line; radii, $\frac{3}{8}$ of an inch, $\frac{3}{4}$ of an inch, and 1 inch.
19. What are great arcs; less arcs? Illustrate by drawing; radius, 1 inch.

20. What does the term *segment* mean? Illustrate by drawing segments of circles, lines, and spheres.
21. Make a greater segment ; less segment.
22. Can you cut more than one greater segment from a circle ?
23. Place two circles so that the circumference of each passes through the center of each ; radii, 1 inch and $1\frac{1}{4}$ inches. The curved portion is a *double segment*.
24. In how many ways can you divide a double segment into two equal and similar parts? Illustrate.
25. Divide a double segment into four equal and similar parts.
26. Make two angles with two lines.
27. What are adjacent angles? Illustrate.
28. What is a perpendicular line? Illustrate.
29. Can you make three angles with two lines? Illustrate.
30. Can you make four angles with two lines? More than four angles with two lines?
31. What is a quadrant? Illustrate with radius of $1\frac{1}{4}$ inches.
32. What is a degree of a circle ($^{\circ}$)?
33. Make a right angle ; an acute angle ; an obtuse angle.
34. A sector which has an arc greater than a semicircle is said to have a *reëntrant angle*. Illustrate.
35. Concentric circles have a common center. Illustrate with radii of $1\frac{1}{2}$ inches and less.
36. Eccentric circles have in part a common circumference but different centers. Illustrate.
37. Divide a sector into two parts that shall be equal and similar to each other.
38. How would you determine the ratio a circumference bears to its diameter ?
39. Make three concentric circles, the largest circle being $1\frac{1}{2}$ inches in diameter.
40. Make two eccentric circles, largest $1\frac{1}{4}$ inches in diameter.
41. Describe a circle having a radius of 1 inch, and draw a tangent to the same.

42. Give an example of a tangent to an arc; radius of arc, $\frac{3}{4}$ of an inch.

43. Compare angle at center (B , Fig. 20) and angle at circumference (A , Fig. 20) with reference to size.

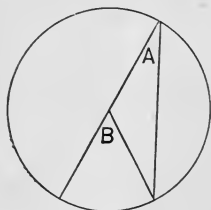

FIG. 20.

44. Are arcs intersected by parallel chords equal, or unequal? Illustrate.

45. What does the term *coincide* mean?

46. Place two triangles so that one side of one may coincide with one side of the other.

47. Divide an equilateral triangle so that the two parts may be equal and similar.

48. What is a sector?

49. Make an acute-angled sector; an obtuse-angled sector.

50. Make three sectors, each containing 180° , and write in each a different and appropriate name; radii, $1\frac{1}{4}$ inches.

51. What does the term *periphery* mean? Illustrate by drawing peripheries of circles, ellipses, and other figures.

LESSON V.

GEOMETRIC PROBLEMS.

PROBLEM I. — *To bisect a given line.*

Let AB (Fig. 21) be the given line. From A and B as centers, and with a radius greater than one half the line, describe the arcs 1 and 2. Connect the points of intersection by the line 1 2, which passes through the point C , the center of the line, dividing it into two equal parts.

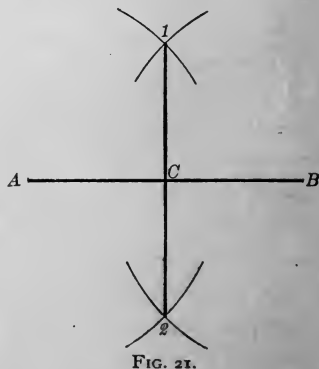

FIG. 21.

PROBLEM 2.—*To construct an angle equal to a given angle.*

Let ABC (Fig. 22) be the given angle. Draw the line MP . With M as a center, and a radius MO equal to BC , describe arcs. Measure the arc CA by a chord, and with the same chord lay off an equal arc OS , and draw the line MS , which gives the angle at 2 equal to ABC .

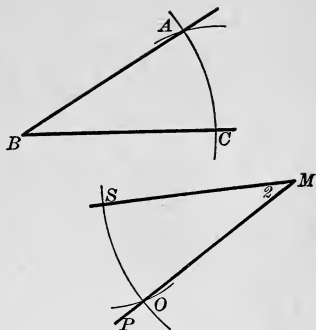

FIG. 22.

PROBLEM 3.—*To construct a triangle, two angles and the included side given.*

Let 1 and 2 (Fig. 23) be the angles, and AB the included line. Draw the line OM , and on it lay off a distance equal to the given line AB , and mark it CD . At C and D make angles equal to 1 and 2 . Produce the sides of the angles until they meet in E . CDE is the triangle.

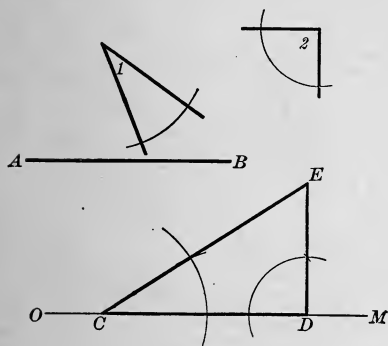

FIG. 23.

PROBLEM 4.—*To construct a square on its diagonal.*

Let AB (Fig. 24) be the given diagonal. Bisect the diagonal AB by CD , and mark the center point O . On the line CD , with O as a center and OA as a radius, lay off OM and OS equal to OA . Join the points A, S, B, M , which gives the required square.

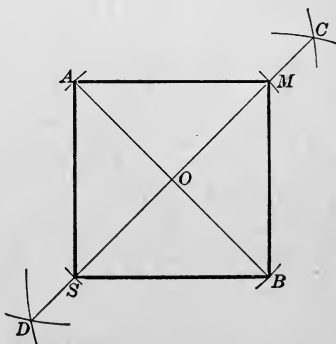

FIG. 24.

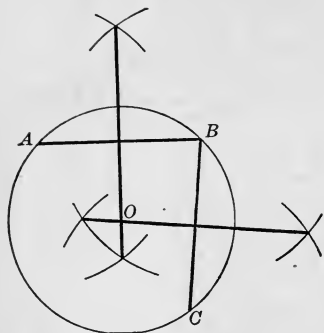

FIG. 25.

PROBLEM 5. — *To find the center of a given circle.*

Draw any two chords AB and BC (Fig. 25). Bisect these chords, and prolong the bisecting lines. Where these meet, locate the required center.

PROBLEM 6. — *To erect a perpendicular from a point without a given line.*

Let AB (Fig. 26) be the given line, and O the point. From O as a center, with a line extending above AB , describe an arc cutting AB in 1 and 2. With these as centers, describe arcs intersecting in F . Connect F and O , producing the required perpendicular.

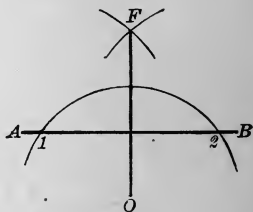

FIG. 26.

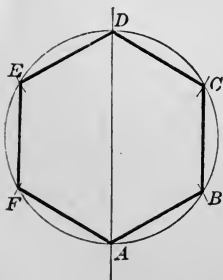

FIG. 27.

PROBLEM 7. — *To construct a hexagon.*

Describe a circle. With the radius of the circle as a chord, lay off on the circumference the points A, B, C, D, E, F (Fig. 27). Connect these points by straight lines, which construction gives the required hexagon.

PROBLEM 8. — *To bisect any angle.*

Let ABC (Fig. 28) be the required angle. With B as a center, and BA as a radius, describe the arc AC , and draw the chord AC . Bisect this chord (Prob. 1). This line also bisects the arc and the angle B at the center.

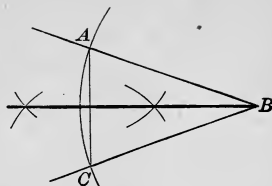

FIG. 28.

PROBLEM 9. — *To trisect any angle.*

Let ABC (Fig. 29) be the angle. From B as a center, describe an arc EF . With the same radius, and F as a center, describe an arc cutting the arc EF in O . From E as a center, and the same radius, describe an arc, and locate the point S . Through the points O and S draw lines from B , dividing the angle as required.

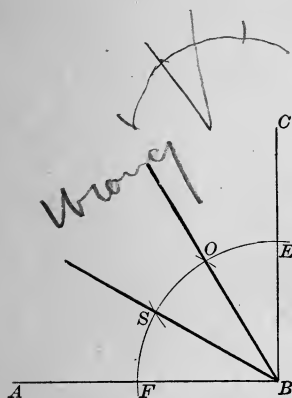

FIG. 29.

PROBLEM 10. — *To construct a rectangle whose sides shall be equal to two given lines.*

Let AB and CD (Fig. 30) be the given lines. Draw the straight line EF equal to CD , and from E draw EH perpendicular to EF and equal to AB . From F and H as centers, with radii equal to AB and CD , describe arcs, and mark their point of intersection M . Draw HM and FM . $EFHM$ is the required rectangle.

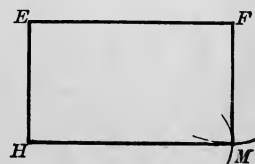
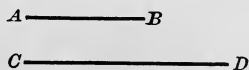

FIG. 30.

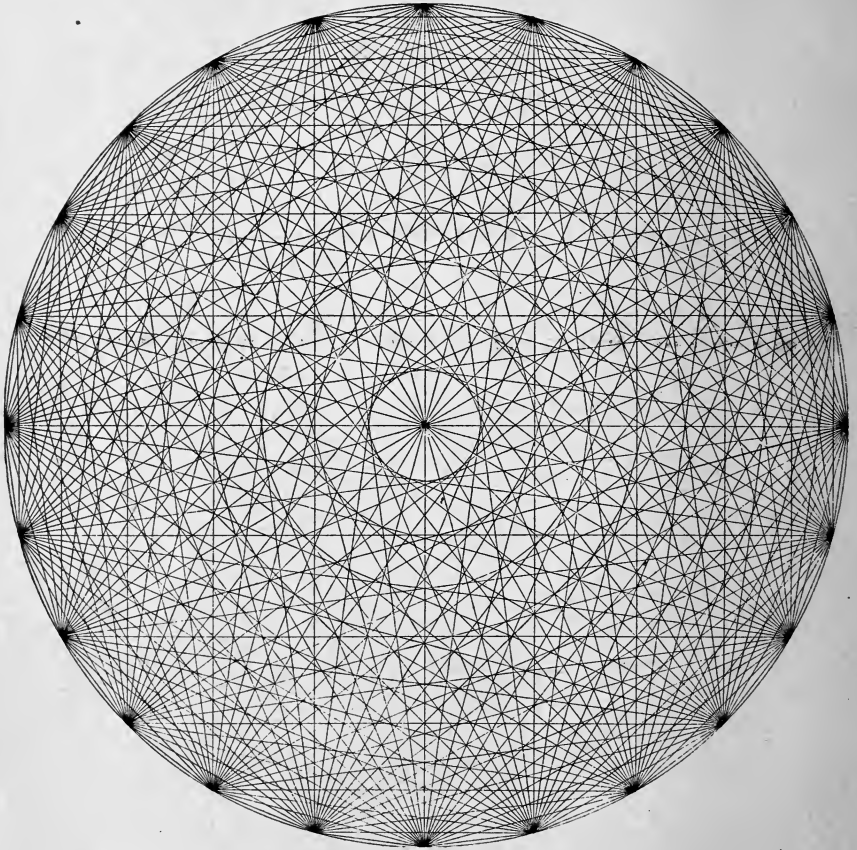

FIG. 31.

LESSON VI.

EXERCISE WITH RULER AND COMPASSES.

EXERCISE I. — Describe a circle (Fig. 31). Divide the circumference into six equal parts. Each chord will be equal in length to the radius of the circle. Divide each sixth into four equal parts. Connect each point with every point in the circumference.

LESSON VII.

EXERCISE WITH RULER AND COMPASSES. — *Continued.*

EXERCISE 2. — Draw 144 circles in a one-foot square. The square (Fig. 32) is divided into one-inch squares, diagonals are drawn, and circles are tangent to each side of the small square.

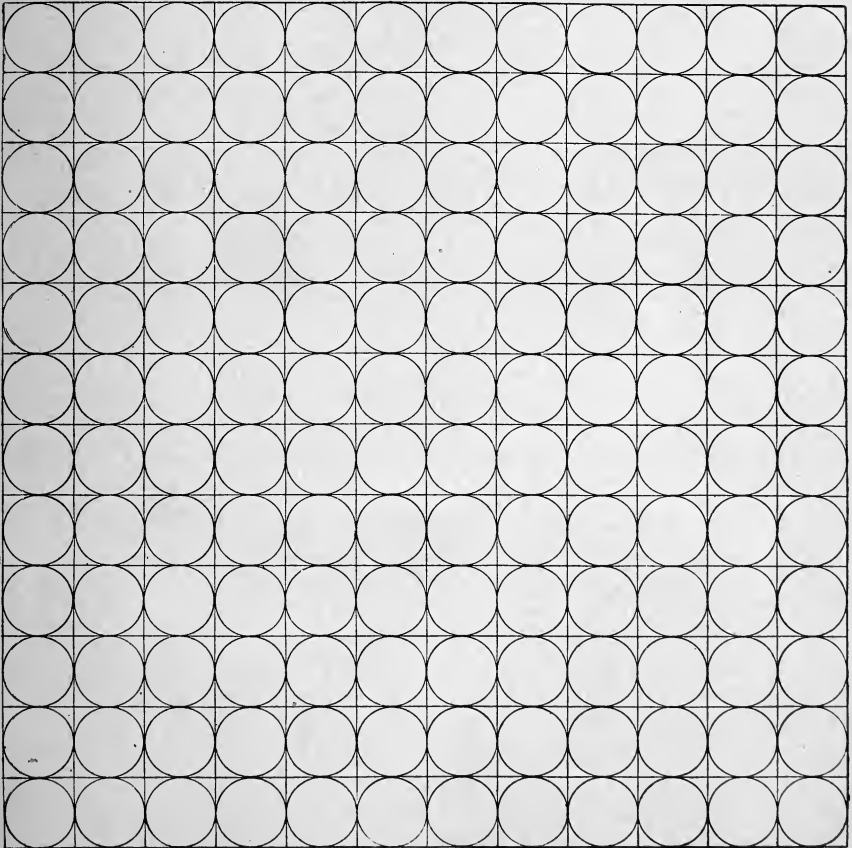

FIG. 32.

LESSON VIII.

EXERCISE WITH RULER AND COMPASSES. — *Continued.*

NOTE. — These exercises are not given in the form of or as problems in geometry, but as exercises with ruler and compasses. They should be drawn on six-inch horizontal lines.

EXERCISE 3. — Draw several concentric circles on a horizontal diameter that shall pass through one end of the diameter (Fig. 33). A line drawn perpendicular to this end will be tangent to all the circles.

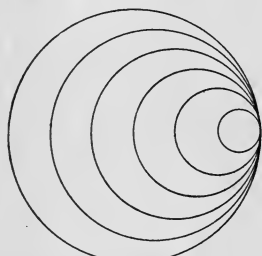

FIG. 33.

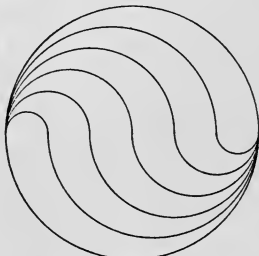

FIG. 34.

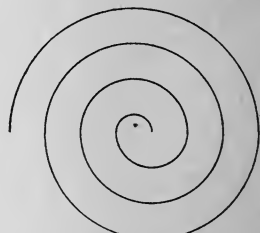

FIG. 35.

EXERCISE 4. — Divide a circle into any number of parts which shall be equal to each other in area and perimeter (Fig. 34). The curves in this exercise are all half circles drawn on opposite sides of the line.

EXERCISE 5. — Produce a spiral on a horizontal diameter by drawing half circles on both sides of the diameter (Fig. 35). Those above the line have one center, and those below the line another center on the same line.

LESSON IX.

EXERCISE WITH RULER AND COMPASSES. — *Concluded.*

EXERCISE 6. — Draw a three-inch square, $ABCD$ (Fig. 36). With I as a center, and IC as the first radius, describe half circles an eighth of an inch apart.

NOTE. — Care must be taken not to show joining of curves and vertical lines.

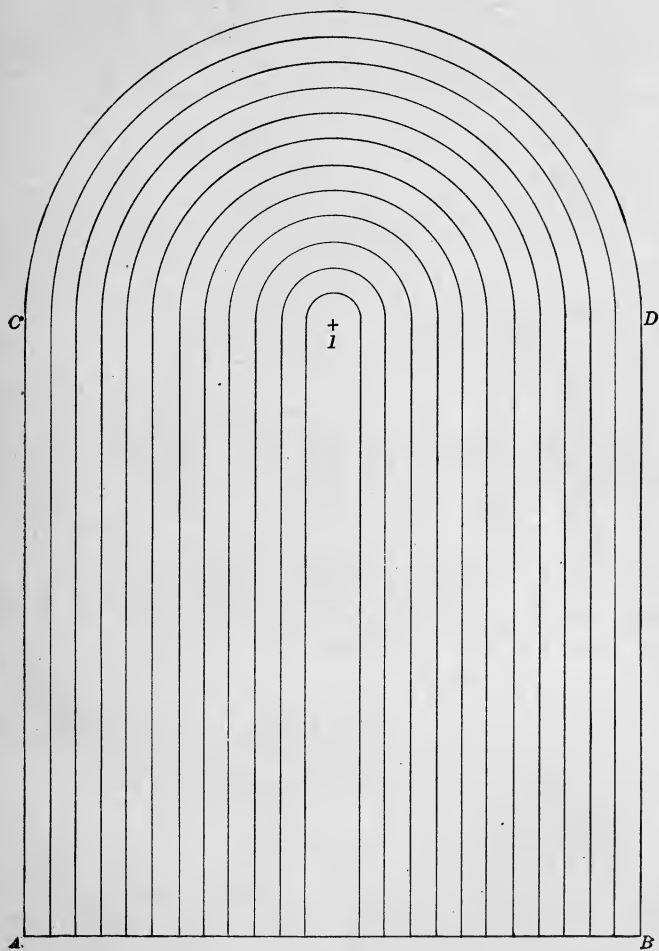

FIG. 36.

LESSON X.

GEOMETRIC PROBLEMS.

PROBLEM 1. — *To construct a regular pentagon.*

Produce AB to C (Fig. 37), making BC equal to AB . From B as a center, with BA as a radius, describe the arc ADC , and divide the half circumference into five equal parts. From the point B draw through the point 2 the line BD . Bisect BD and BA by perpendicular lines meeting in O . From O as a center, and with OB as a radius, describe a circle. From B draw lines BE and BF through the points 3 and 4 in the semicircle. Join the points $A, F,$

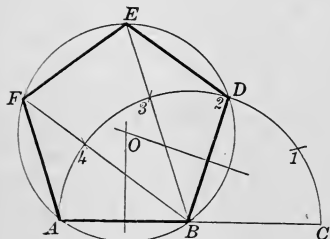

FIG. 37.

$E, D,$ and B , which gives the required pentagon, $ABDEF$.

PROBLEM 2. — *In a given square to inscribe a regular octagon.*

Let $ABCD$ (Fig. 38) be the given square. Draw the diagonals intersecting in the point E . From the corners of the square $ABCD$ as centers, with a radius equal to AE , describe arcs cutting the sides of the square in the points $MG, FI, HL,$ and KN . Join these points, and the required octagon will be completed.

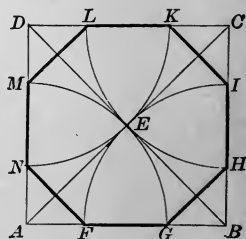

FIG. 38.

PROBLEM 3. — *To divide a circle into three concentric parts bearing the proportions of 1, 2, 3 from the center.*

Let ABC (Fig. 39) be the given circle. Mark the center D , and

draw AD , and in this radius describe a semicircle. Divide the radius AD into six equal parts. From 4 and 6 draw perpendiculars meeting the semicircle in E and F . From D as a center, and DE and DF as radii, describe the circles which will divide the first circle into three parts.

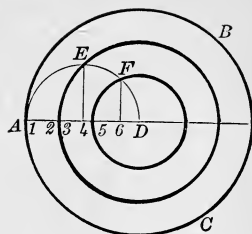

FIG. 39.

PROBLEM 4. — *To divide a circle into any number of equal or proportional parts by concentric divisions.*

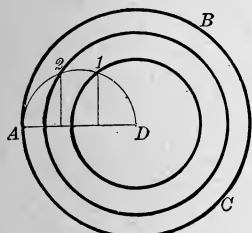

FIG. 40.

Let ABC (Fig. 40) be the circle to be divided into three parts. Draw the radius AD , and divide it into as many equal parts as the circle is to be divided into. Upon the radius describe a semicircle, and erect vertical lines from the points dividing the radius, locating the points 1 and 2. From D as a center, and $D1$ and $D2$ as radii, describe circles dividing the first circle into three parts.

PROBLEM 5. — *To draw a straight line equal to any given arc of a circle.*

Let AB (Fig. 41) be the given arc. Find the center of the arc, O , and complete the circle ABC . Draw the diameter BOD , and produce it to M , making DM equal OD . Draw a tangent at B . Draw a line from M to A , and produce it to meet the tangent B in the point X . This will give BX equal (nearly) to the arc AB .

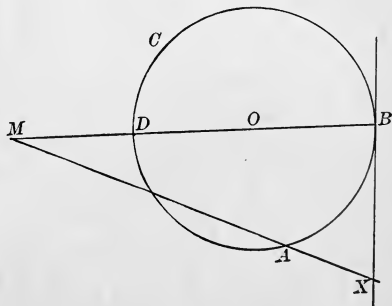

FIG. 41.

NOTE. — There is no exact method of working this problem.

LESSON XI.

GEOMETRIC PROBLEMS. — *Concluded.*

FIG. 42.

PROBLEM 6. — *To construct a square which shall be equal to a given circle.*

Describe the circle, and draw the diameters at right angles to each other. Through the point D (Fig. 42) draw the line MDP tangent, and equal to the diameter AB . Draw the lines CM and CP , cutting the circumference in S and X . Bisect SM and XP , and join the points 1 and 2. On this line construct the square, which will be equal to the given circle.

PROBLEM 7. — *To locate the axes of a given ellipse.*

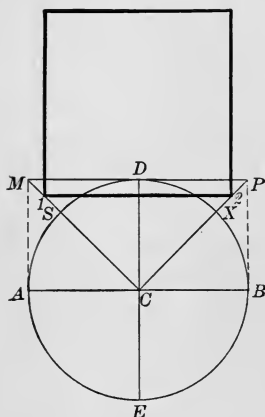
Draw AB and CD (Fig. 43) across the given ellipse, parallel to each other. Bisect each of these lines in E and F . Join E and F , and continue until line meets ellipse in G and H . Bisect the line GH , and from the center O draw an arc cutting the ellipse in C and M . Draw the line CM . Through O draw PS parallel to CM . Draw TW at right angles to PS through the point O . PS is the conjugate axis, and TW the transverse.

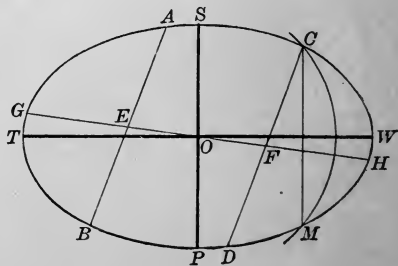

FIG. 43.

PROBLEM 8. — *To construct an egg-shaped oval.*

Draw the diameter AB (Fig. 44). Describe the circle $AOBM$. Draw the radius CO at right angles to AB , meeting the circumference in the point O . Join AO and BO , and produce them indefinitely beyond O . With A and B as centers, and AB as a radius, describe the arcs AD and BE , terminated by the straight lines AE and BD in the points D and E . With O as a center, and OD as a radius, describe the arc DXE . $AMBEXD$ is the required oval.

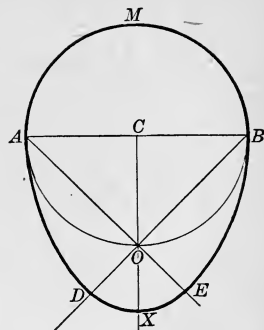

FIG. 44.

PROBLEM 9. — *To draw tangents to an ellipse from a given point without the curve.*

Let A (Fig. 45) be the given point. From A as a center, with a radius equal to its distance from F' , the nearest focus, describe an arc. From the other focus, F , with the transverse axis BC as a radius, cut the arc in P and S , and join PF and SF , cutting the curve in O and M . From A , through these points O and M , draw the tangents.

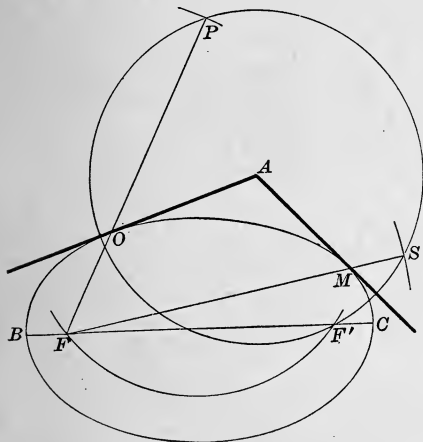

FIG. 45.

PROBLEM 10. — *To draw a tangent to an ellipse through a given point in the curve.*

Let A (Fig. 46) be the given point. Find the foci of the ellipse FF' by describing arcs with a radius equal to BO with D as a center, and mark the

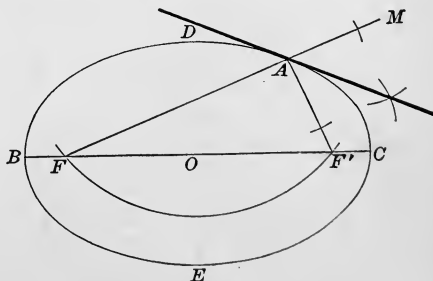

FIG. 46.

points F and F' . From the given point A , draw straight lines to the foci F and F' , and produce FA beyond the curve to the point M . Bisect the angle MAF' . This bisecting line is the required tangent.

LESSON XII.

GEOMETRICAL SOLIDS UNFOLDED.

THE pupil will draw the following geometrical solids (Exercise 1), and the same unfolded (Exercise 2). He will also draw Exercise 2 on cardboard, and cut through the outlines. This will give a diagram whose outline will coincide with the outline of Exercise 2. Cut the other lines half through. Fold up the parts and glue the edges, and the desired outlines will be formed.

The object of this lesson is to give the pupil a series of exercises that will enable him to understand working drawings clearly and thoroughly. To do this he must be able (1) to read a working drawing, (2) to make a working drawing, (3) to make the model from the working drawing.

I. ALL FACES EQUAL.

1. A regular *tetrahedron*, or equilateral pyramid, is a solid bounded by four equal triangles (Fig. 47).

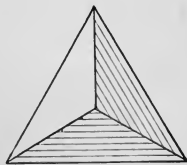

Exercise 1.

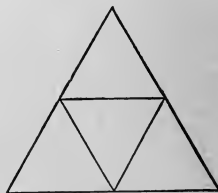

Exercise 2.

FIG. 47.

2. A regular *hexahedron*, or cube, is a solid bounded by six equal squares (Fig. 48).

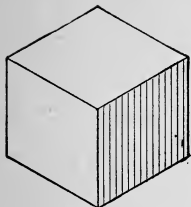

Exercise 1.

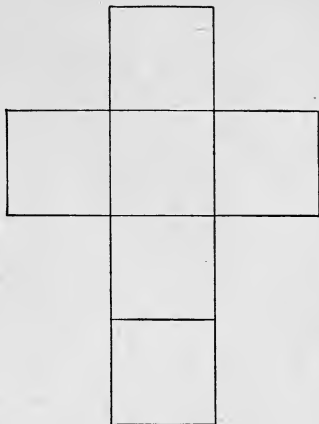

Exercise 2.

FIG. 48.

3. A regular *octahedron* is a solid bounded by eight equal triangles (Fig. 49).

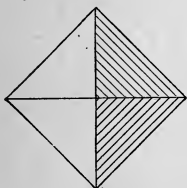

Exercise 1.

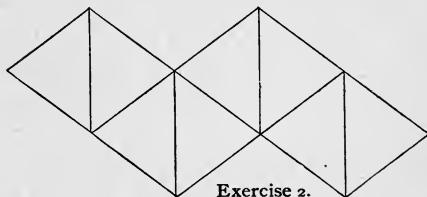

Exercise 2.

FIG. 49.

4. A regular *dodecahedron* is a solid bounded by twelve equal pentagons (Fig. 50).

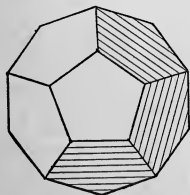

Exercise 1.

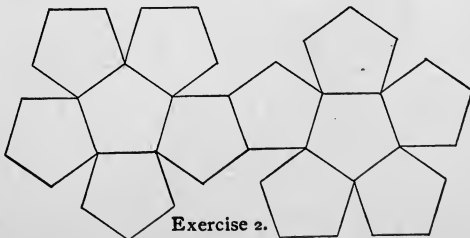

Exercise 2.

FIG. 50.

5. A regular *icosahedron* is a solid bounded by twenty equal triangles (Fig. 51).

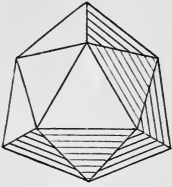

Exercise 1.

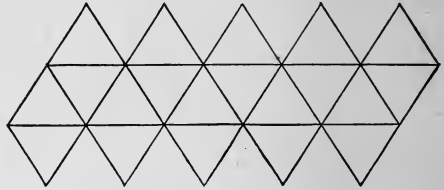

Exercise 2.

FIG. 51.

II. FACES NOT ALL EQUAL.

6. A *prism* has three or more longitudinal faces and parallel edges, and is terminated by two parallel planes of equal size and shape.

7. A *pyramid* has three or more faces radiating from a common point called a *vertex*: they inclose a regular polygon, which is called the *base*.

8. A *triangular prism* has an equilateral triangle for a base (Fig. 52).



Exercise 1.

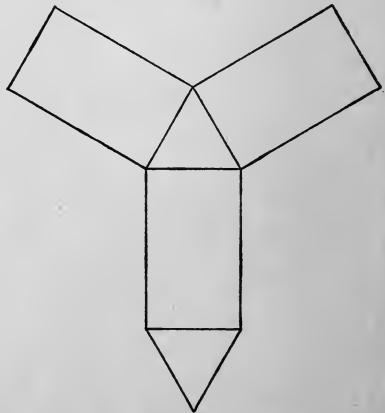

Exercise 2.

FIG. 52.

9. A *triangular pyramid* has a three-sided base (Fig. 53).

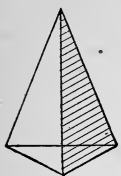

Exercise 1.

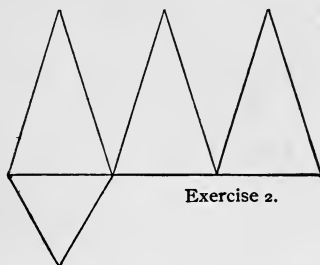

Exercise 2.

FIG. 53.

10. A *quadrangular prism* has a square for a base (Fig. 54).

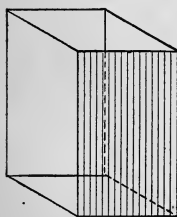

Exercise 1.

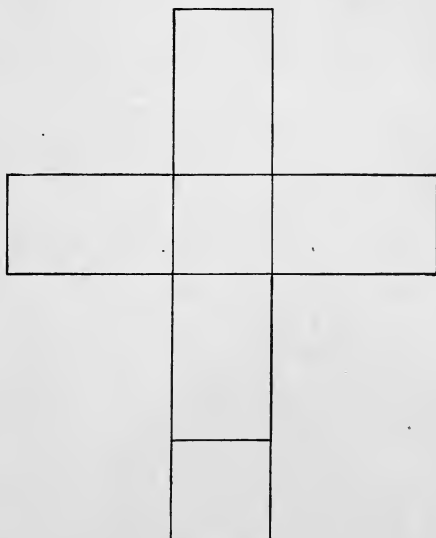

Exercise 2.

FIG. 54.

11. A *quadrangular pyramid* has a square for a base (Fig. 55).

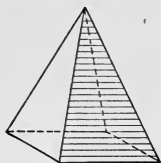

Exercise 1.

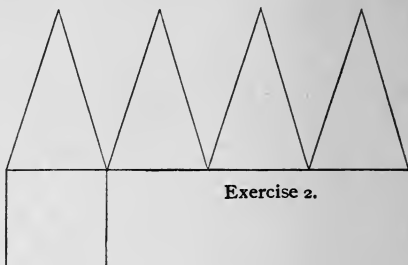

Exercise 2.

FIG. 55.

12. An *hexagonal prism* has a hexagon for a base (Fig. 56).

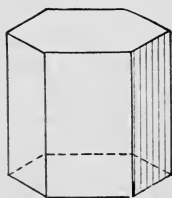

Exercise 1.

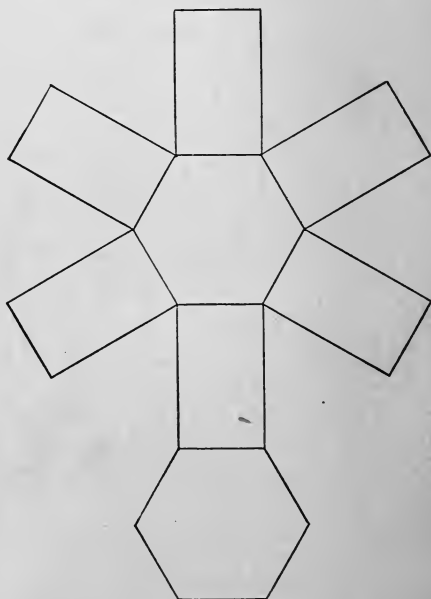

Exercise 2.

FIG. 56.

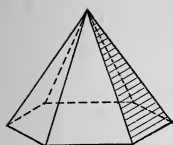

Exercise 1.

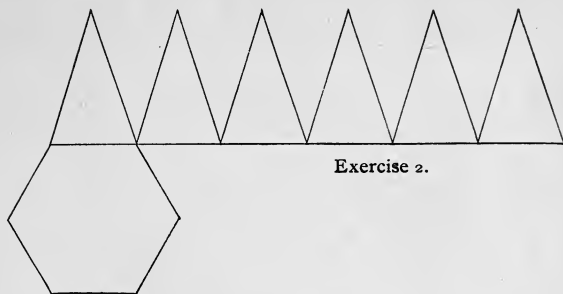

Exercise 2.

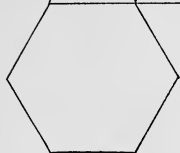

FIG. 57.

13. An *hexagonal pyramid* has a six-sided polygon for a base (Fig. 57).

LESSON XIII.

PERSPECTIVE.

A FAIR knowledge of perspective is of the utmost importance to the draughtsman. The knowledge and power gained by drawing the geometric type forms will enable him to delineate objects that are more complicated in construction. He is advised to select these rigid forms for models, in order to acquire a knowledge of forms, and a power of delineation, that are so necessary. The production of pictures will avail little to the pupil studying to become a draughtsman, because he will permit little inaccuracies to escape uncorrected that can be readily detected in a drawing from a cube, cone, prism, or other forms with exact outlines.

The differences between perspective and projection are, that perspective represents an object as it *appears* to the eye, and but one *drawing* is required to give a representation of it; while in a projection we have the object represented as it *is*, and at least two drawings are necessary to give a complete idea of it.

SUGGESTIONS.

1. A cube is the type form for rectilinear objects.
2. A cylinder is the type form for curvilinear objects.
3. Appearances of objects depend on two conditions, — distance and position. Distance produces perspective ; position, fore-shortening.

4. *Rectilinear objects* in *parallel* perspective have one face represented by an actual drawing, and one vanishing point.

5. In *angular* perspective no face is represented by an actual view, and there are two vanishing points.

6. The circle, when in full view, is represented by a circle ; when viewed obliquely, by an ellipse ; and when viewed edgewise, by a line.

7. The point of station where the observer stands is the base of an upright plane, which the observer is supposed to occupy. All objects below his eye are said to be below the level of the eye ; all above, above the level of the eye.

8. Vertical lines are always represented by vertical lines.

9. Horizontal lines or edges are represented by horizontal and oblique lines, — by horizontal lines when the edges are parallel to the plane of the observer ; by oblique lines when the edges make an angle with this plane.

10. Retreating lines above the eye seem to run down to a point on a level with the eye, and opposite to it ; those below the eye seem to run up to the same point.

11. The apparent width of foreshortened surface may be ascertained by pencil measuring in space, and the drawing tested by rules of perspective.

12. Lines that are at an angle to the observer, and *parallel* in the object, vanish to one point in the drawing.

EXERCISE FOR PRACTICE.—Make perspective sketches of cube, prisms, cylinder, cone, and pyramids.

NOTE 1. — Make three drawings of each object : first view, directly in front of the observer ; second view, to the left ; and third view, to the right.

NOTE 2. — See “ Elements of Perspective for Schoolroom and Workshop.”

LESSON XIV.

SCALE.

As objects to be manufactured are generally so large that it is not convenient to draw them the actual size, they are represented by drawings many times smaller.

The proportions between these objects and the drawings are called *scales*. If the object is ten feet high, and the drawing is made ten inches high, the scale is one inch to the foot ($1''$ to $1'$); if this same object is represented by a drawing twenty inches high, the scale is two inches to the foot; if by a drawing only five inches high, half an inch to the foot; if by a two-and-a-half-inch drawing, a quarter of an inch to the foot. This last, a quarter of an inch to the foot, is the scale most commonly used by draughtsmen.

In making drawings, the pupil works first from measurements from plates and models, reducing or enlarging as directed.

This practice gives facility in copying ready-made drawings, and is indispensable in the first lessons.

Later the pupil will take rough sketches, using the pencil and two-foot rule only. A rough sketch of the object is made, and accurate measurements of every part jotted down. From these drawings and figures the mechanical drawings are made by means of the instruments. All lines and parts are drawn according to the accepted scale.

EXERCISES FOR PRACTICE.

EXERCISE 1. — Draw a line $8'$ high, scale $\frac{1}{4}''$ to $1'$.

EXERCISE 2. — Draw a rectangle $9'$ by $4'$, scale $\frac{1}{2}''$ to $1'$.

EXERCISE 3. — Draw a $10'$ square, scale $\frac{1}{8}''$ to $1'$.

EXERCISE 4. — Draw a circle, diameter $15'$, scale $\frac{3}{8}''$ to $1'$.

EXERCISE 5. — Measure with two-foot rule, and represent with lines the following: front line of platform, side wall of room, rear wall of room, horizontal length of window sill, height and width of door. Use the following scales for each measurement: $\frac{1}{4}''$, $\frac{3}{8}''$, $\frac{1}{2}''$.

LESSON XV.

WORKING DRAWINGS.

A *working* drawing of any object is one that gives the shape of the parts. The sizes of the different parts are indicated by figures. Perspective represents the objects as they *appear*.

Working drawings, or projections, represent the objects as they *are*. Fig. 48, p. 29, shows perspective and working drawings of a cube.

In making working drawings, certain lines and conventions or signs are made

use of. These are: 1. Full or visible line (Fig. 58, *a*); 2. Center line (*b*); 3. Working line (*c*); 4.

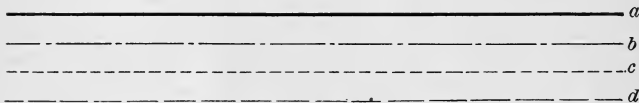

FIG. 58.

Invisible line (*d*); 5. Half tint (*e*); 6. Figuring (8' = 8 feet, 10" = 10 inches).

1. *Full or visible* lines are continuous lines that represent visible edges or profiles.

2. *Center lines* represent no part of a drawing. They are vertical lines of indefinite length. They indicate where the middle of the working drawing will fall on the paper.

3. *Working lines* are used to carry one point or distance to another.

4. *Invisible lines* are those which represent invisible edges or profiles.

On working drawings, feet and inches are marked thus: feet, ' ; inches, ". Arrow lines are made in connection with the figures indicating proportions or sizes. These lines are called *dimension lines*.

Working drawings are not made freehand, but with instruments, and are often called *instrumental drawings*.

EXERCISES FOR PRACTICE.

EXERCISE 1. — Make several drawings (Fig. 59), using dimensions

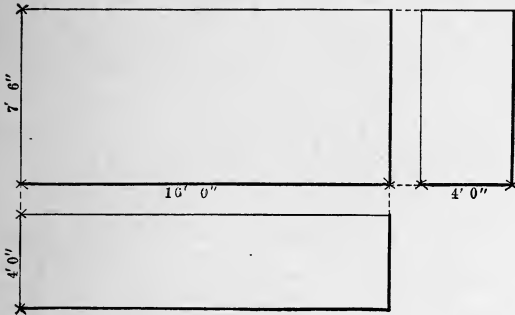

Exercise 1.

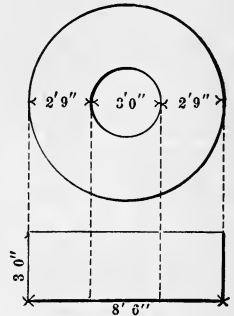

Exercise 2.

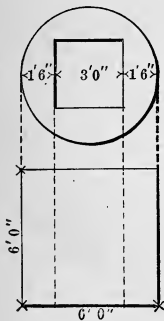

Exercise 3.

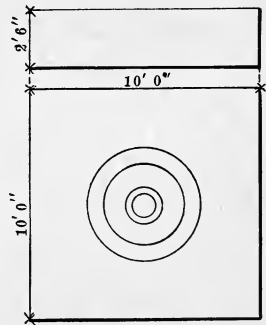

Exercise 4.

FIG. 59.

of your own selection, introducing all the lines explained in this lesson.

EXERCISE 2. — Write out an explanation of each exercise, and make perspective sketches after the following suggestion: "Exercise 1, Fig. 59, shows working drawings of a box, 7½' high, 16' long, and 4' wide."

LESSON XVI.

MECHANICAL POWERS.

ALL machines and mechanical devices, numerous and varied as they are, are combinations of the six simple mechanical powers :
 1. Lever ; 2. Pulley ; 3. Inclined plane ; 4. Wedge ; 5. Screw ; 6. Wheel and axle.

1. A *lever* is an inflexible bar that can be moved about a fulcrum ; as, a crowbar, steelyard, balance, hand-truck, poker, scissors, pincers, nutcracker, tongs, door on hinges, etc.

NOTE. — The nearer the fulcrum is to the weight, the greater the power gained. The pupil will make drawings illustrating the definition.

2. A *pulley* is a wheel with a grooved circumference, over which a rope passes. It is fixed to the frame by means of an axis on which the wheel turns.

NOTE. — Pulleys are used to change the direction of motion. Illustrate.

3. An *inclined plane* is a plane at an angle to the ground plane.

NOTE. — It is used to facilitate motion or movement over an uneven surface. Illustrate.

4. *Wedges* are of two kinds : 1. Those having one inclined surface ;
 2. Those having two inclined surfaces.

NOTE — The first class are used for raising weights ; the second class, for splitting wood timbers, rending rocks, etc. Illustrate.

5. A *screw* consists of a cylinder with threads wrapped around it. The hollow cylinder, grooved on the inside, that receives this, is called a *nut*.

NOTE. — Screws are used when continued pressure is required in a small space. Illustrate.

6. A *wheel and axle* is a lever of the first kind, giving uninterrupted motion. It is called the *endless lever, capstan and windlass*, etc. Illustrate.

LESSON XVII.

GEOMETRIC SOLIDS.—PLANS AND ELEVATIONS.

ALL objects have three dimensions,—length, breadth, and thickness.

Perspective is the art of representing them as they appear.

Projection is the representation as they exist or really are.

Projections are also termed *constructive* or *working* drawings. They represent the real forms of objects and their dimensions according to a given scale. They represent plans and elevations, and are used

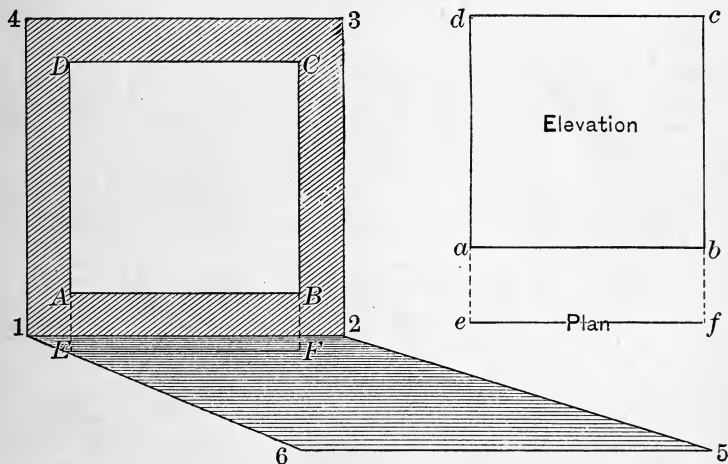

FIG. 60.

by machinists, architects, builders, and inventors. In making projections, the outlines of the object and its parts are supposed to be projected, or thrown on a vertical and on a horizontal plane. These planes or surfaces are at right angles to each other, like the floor and the wall of a room. The floor is termed the *horizontal* plane, and the wall the *vertical* plane. When the object is located, and its vertical features projected on the vertical plane, we have the *vertical projection*, or *elevation*. When the horizontal features are projected on the horizontal plane, we have the *horizontal projection*, or the *plan*.

EXERCISES FOR PRACTICE.

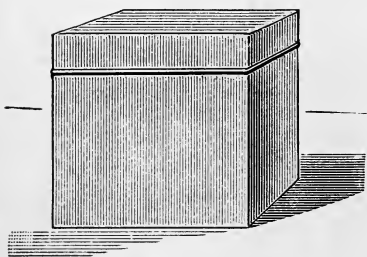
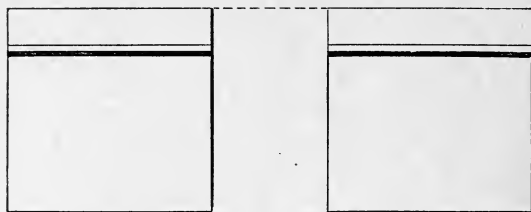

FIG. 61.

EXERCISE
1. — Draw plan
and elevation
of a square
(Fig. 60).

EXERCISE
2. — Draw plan,
elevations, and
perspective of
a cubical box
(Fig. 61).

NOTE 1. — The
pupil will draw on
blackboard and on
paper the geometri-
cal solids and
their vertical and
horizontal projec-

tions (scales, $\frac{1}{4}''$ to 1', and $\frac{1}{2}''$ to 1').

NOTE 2. — In blackboard drawings allow 3 inches to each inch actual measurement.

EXERCISE 3. — Draw a cylinder 6 feet high,
diameter of base
being 4 feet (Fig.
62); also plan
and elevation
(Fig. 63).

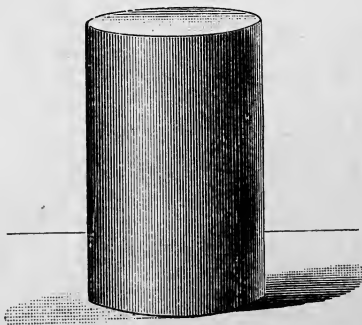

FIG. 62.

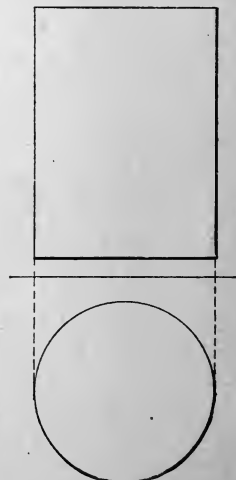

FIG. 63.

EXERCISE 4. — Draw a cone 4 feet high, diameter of base 4 feet (Fig. 64); also plan and elevation (Fig. 65).

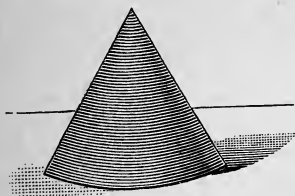

FIG. 64.
Projections.

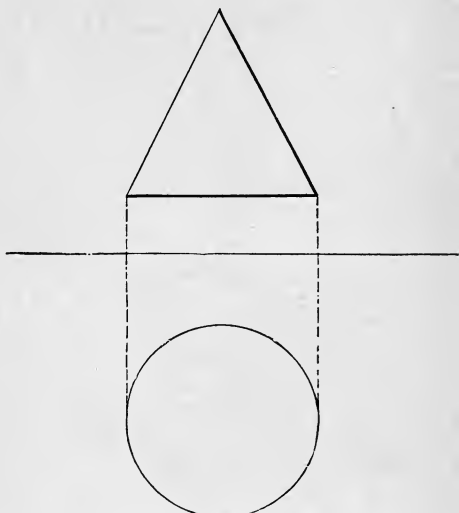

FIG. 65.

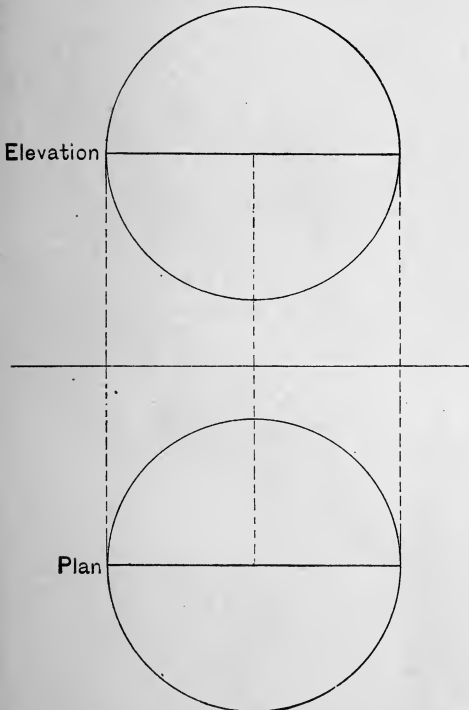

FIG. 66.

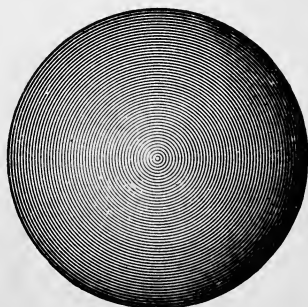

FIG. 67.

EXERCISE 5. — Draw a sphere having diameter of 6 feet (Fig. 67); also plan and elevation (Fig. 66).

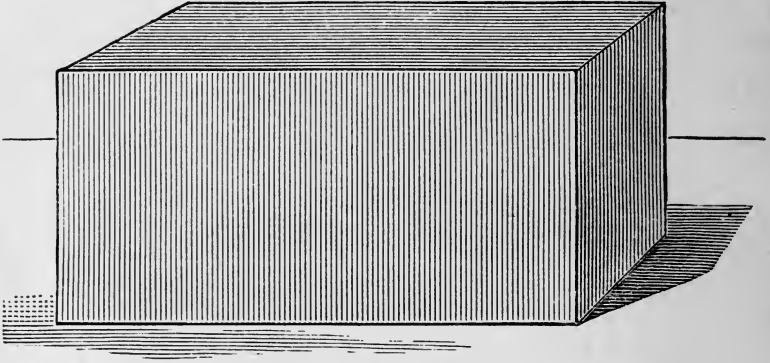

FIG. 68.

Projections.

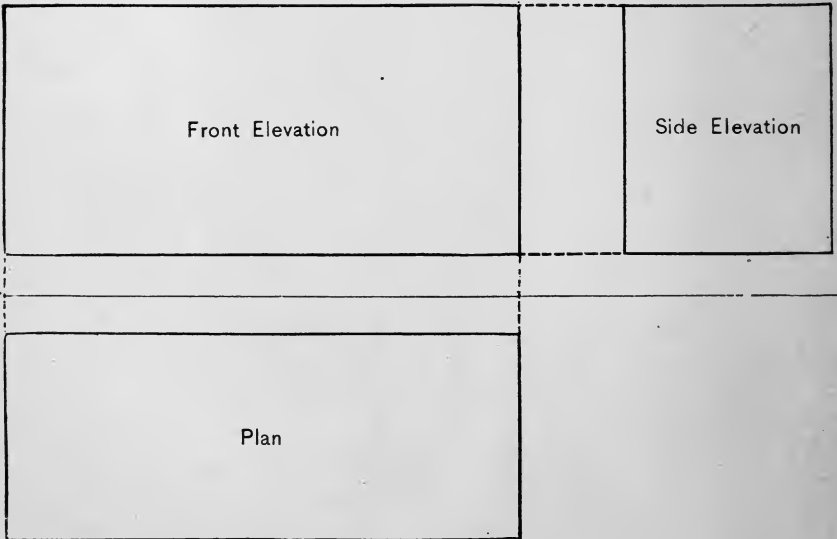

FIG. 69.

EXERCISE 6. — Draw a box 10 feet long, 5 feet high, and 4 feet wide (Fig. 68) ; also plan and elevations (Fig. 69).

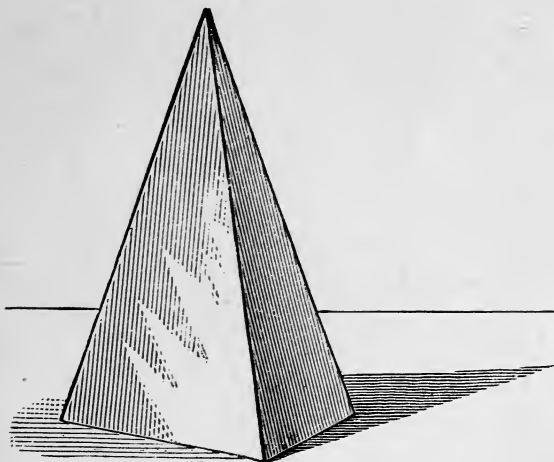

FIG. 70.

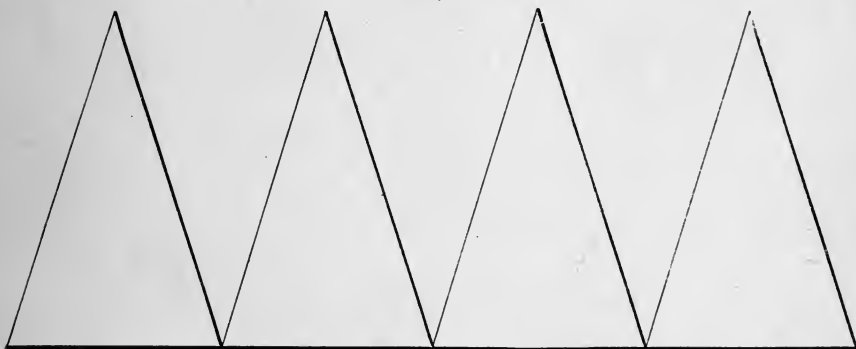
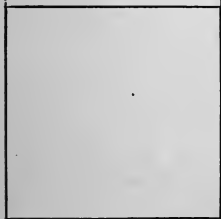

FIG. 71.

EXERCISE 7.— Draw a pyramid 8 feet high, having a base 5 feet square (Fig. 70); also plan and elevations (Fig. 71).



EXERCISE 8. — Draw a truncated cone 7 feet high, diameter of base 8 feet, diameter of top 2 feet (Fig. 72); also plan and elevation (Fig. 73).

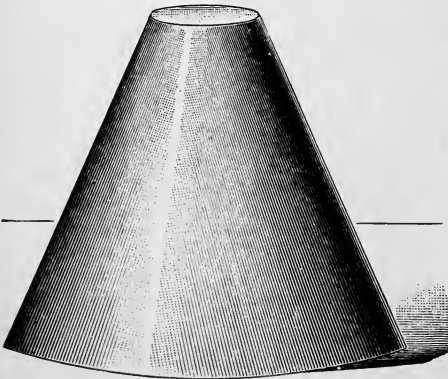

FIG. 72.

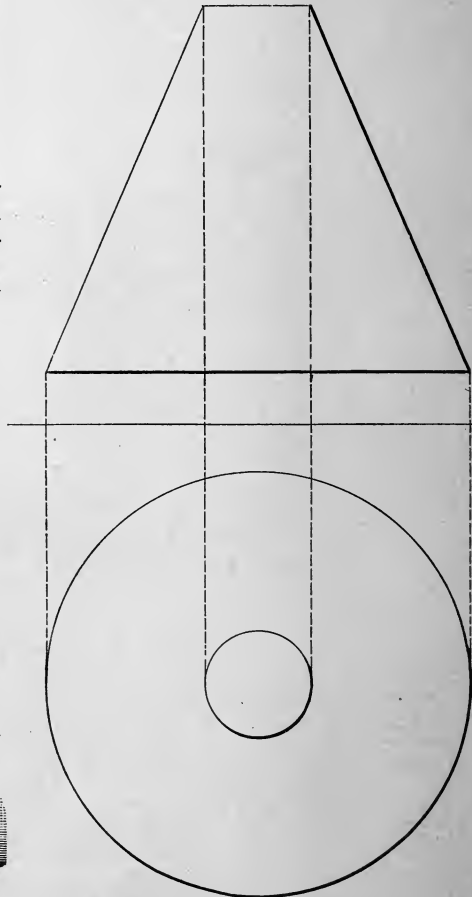

FIG. 73.

EXERCISE 9.—Draw a hollow cylinder 7 feet high, diameter $4\frac{1}{2}$ feet, diameter of opening $2\frac{1}{2}$ feet (Fig. 74); also plan and elevation (Fig. 75).

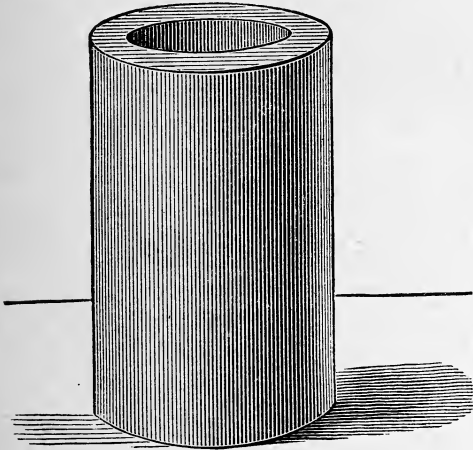

FIG. 74.

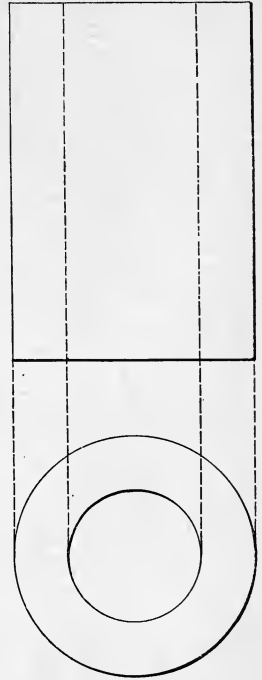

FIG. 75.

EXERCISE 10.—Draw a hemisphere with diameter of 4 feet (Fig. 76); also plan and elevation (Fig. 77).



FIG. 76.

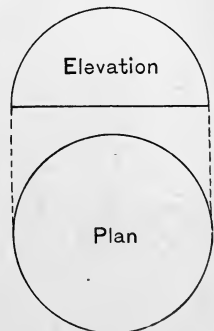

FIG. 77.

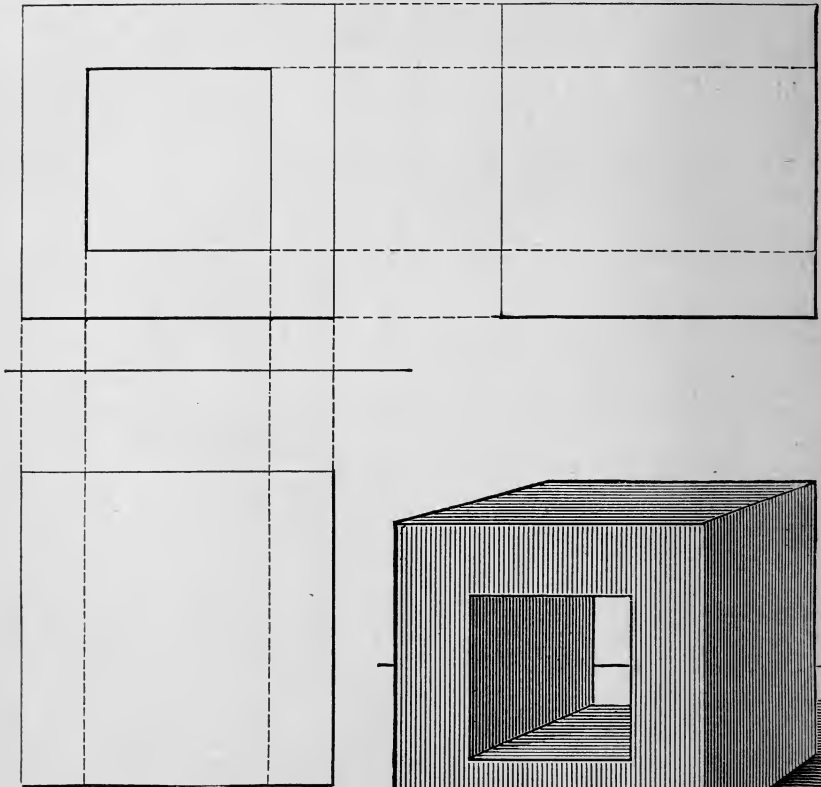

FIG. 78.

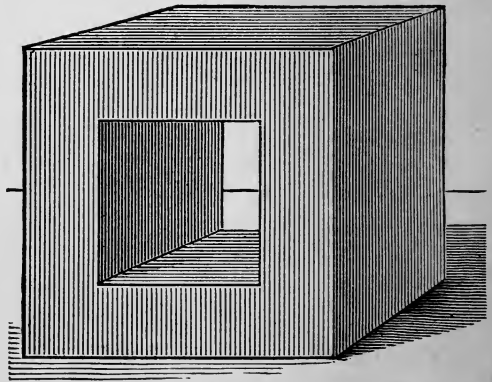

FIG. 79.

EXERCISE II.— Draw a cubical box 6 feet each way, opening $3\frac{1}{2}$ feet (Fig. 79); also plan and elevations (Fig. 78).

LESSON XVIII.

JOINTS.

EXERCISES FOR PRACTICE.

EXERCISE 1. — Draw a corner joint (Fig. 80).

EXERCISE 2. — Draw a notched joint (Fig. 81).

EXERCISES 3, 4, and 5. — Draw a mortise and tenon (Figs. 82, 83, 84).

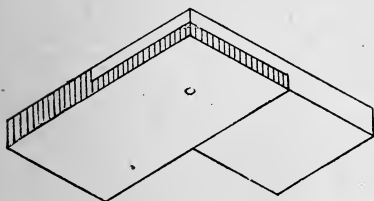

FIG. 80.

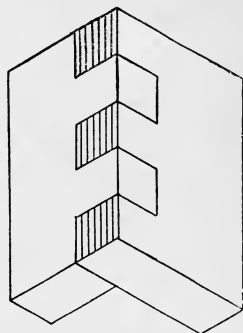

FIG. 81.

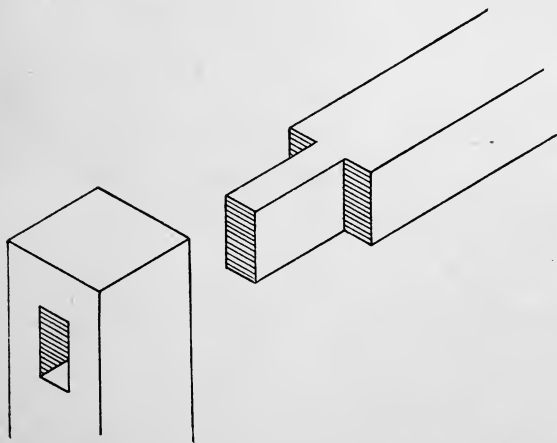

FIG. 82.

EXERCISE 6. — Draw a joist and flooring (Fig. 85).

EXERCISE 7. — Draw a beam and stirrup (Fig. 86).

NOTE. — The pupil will make sketches of the following, tongue and groove and dovetail, from objects, not from drawings, and make working drawings of the same to scale.

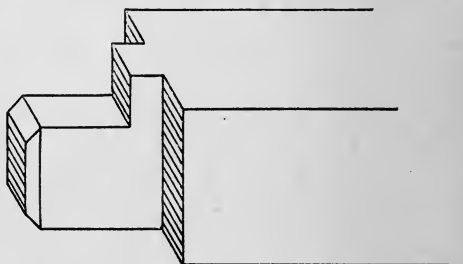
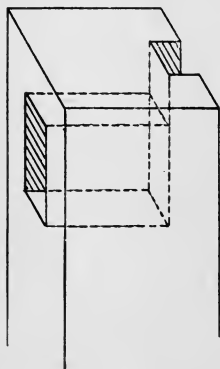

FIG. 83.

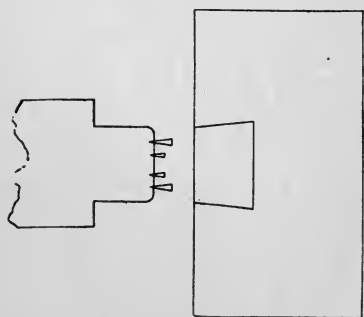

FIG. 84.

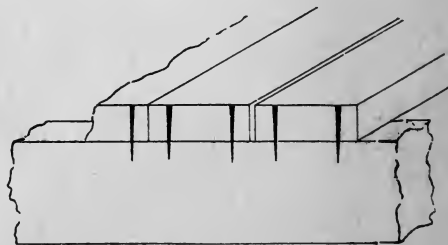

FIG. 85.

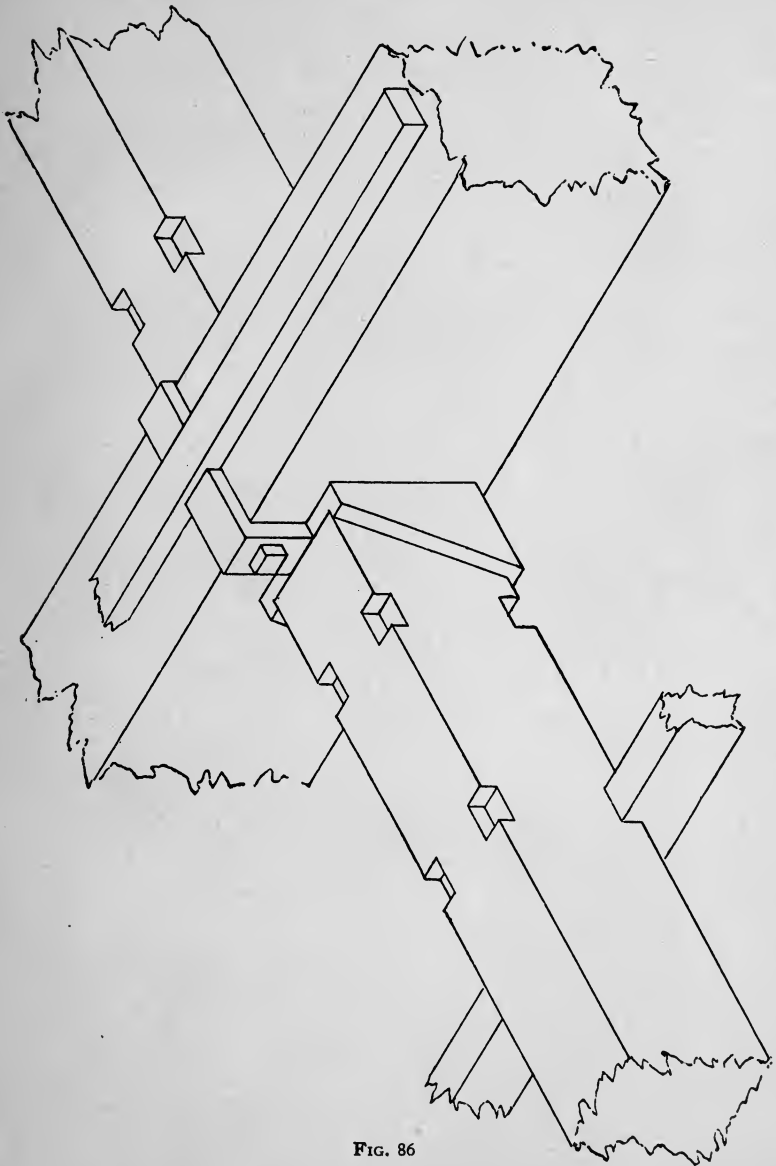

FIG. 86

LESSON XIX.

MASONRY.

EXERCISE 1. — Stone work (Fig. 87, *a*).

EXERCISE 2. — Stone joint (Fig. 87, *b*).

EXERCISES 3 and 4. — Brick footings (Fig. 87, *c, d*).

EXERCISE 5. — Draw plan and elevations of a chimney (Fig. 87, *e*).

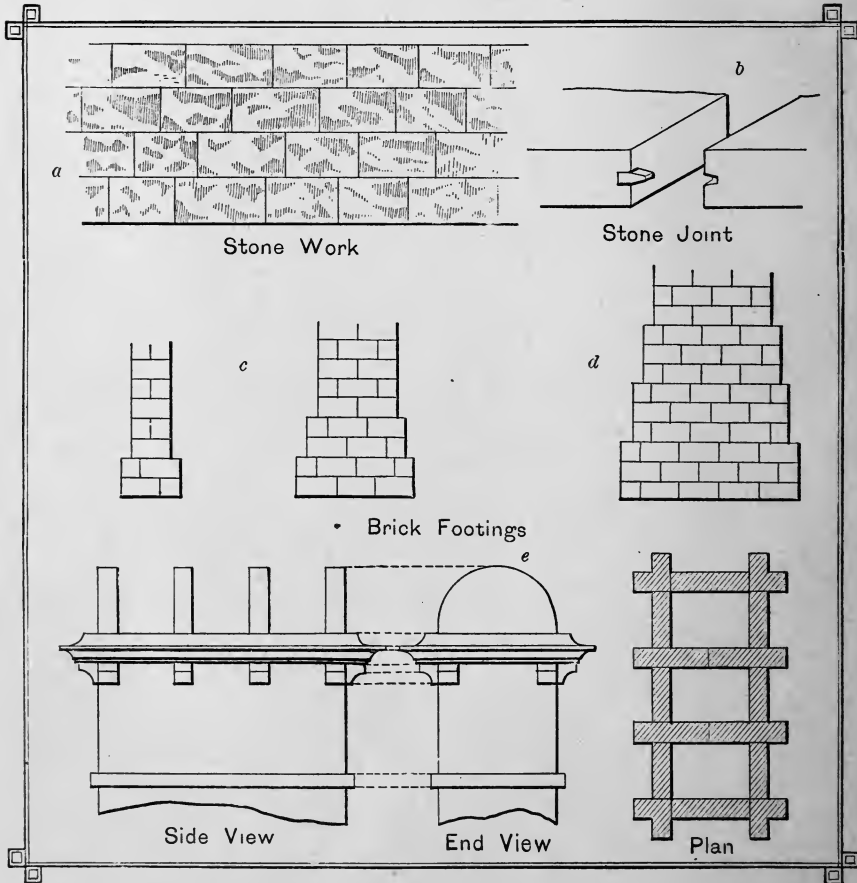
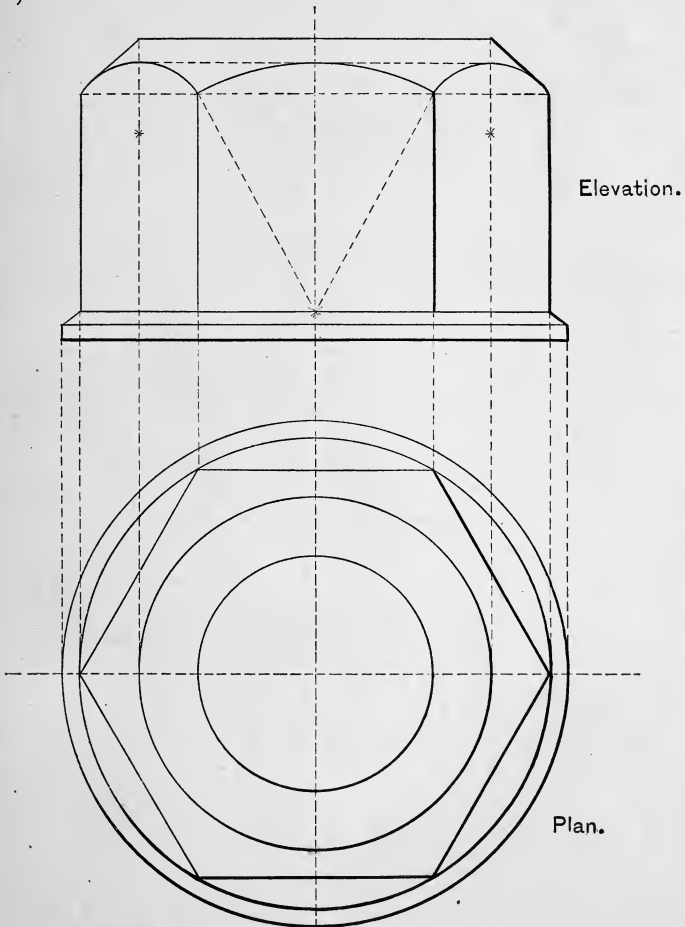

FIG. 87.

LESSON XX.

MECHANICAL DEVICES.

EXERCISE I. — Elevation and plan of hexagonal nut and washer (Fig. 88).



Elevation.

Plan.

FIG. 88.

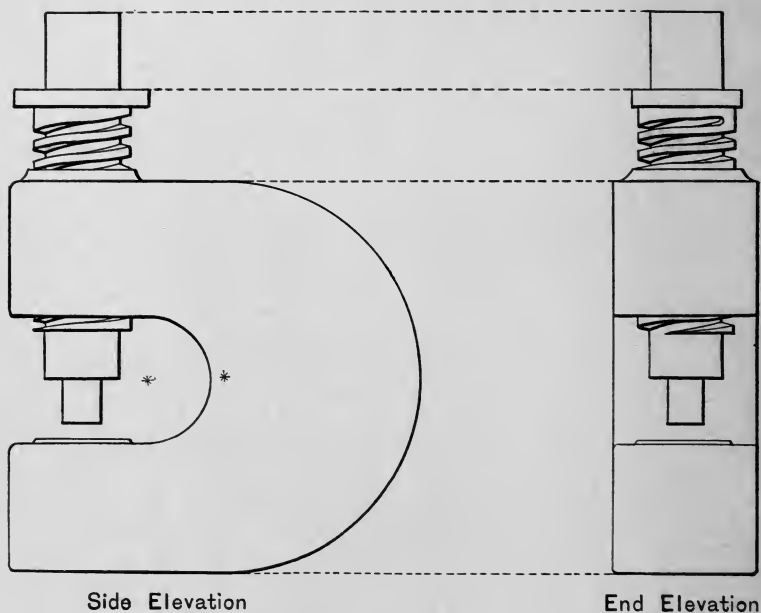

FIG. 89.

EXERCISE 2. — Side and end elevation of screw punch (Fig. 89).

NOTE. — Pupils will make sketches of faucet, wrench, and pulley, and from these sketches make working drawings to scales.

LESSON XXI.

MECHANICAL DEVICES. — *Concluded.*

EXERCISE 3. — Screw chuck, full size (Figs. 90, 91).

NOTE.—The pupil will make sketches of the washer, bolt and nut, coupling, and rivets, and from these sketches make working drawings to scales.

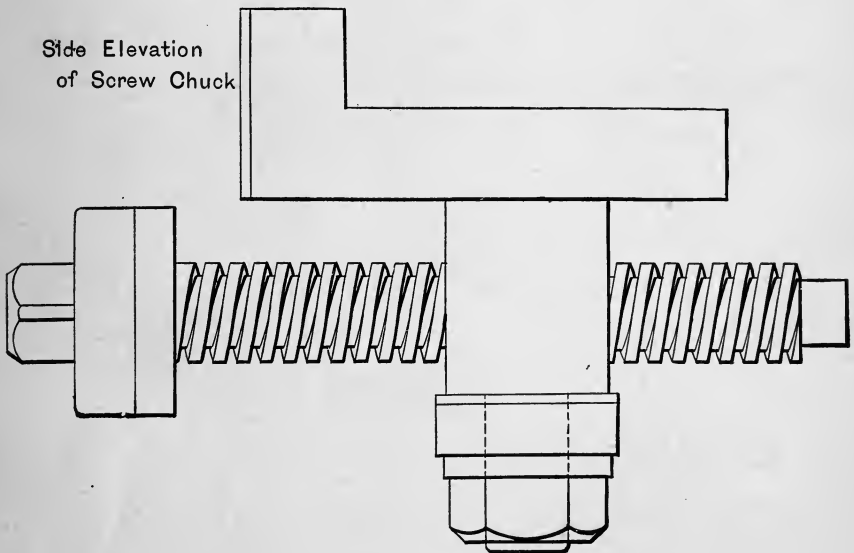

FIG. 90.

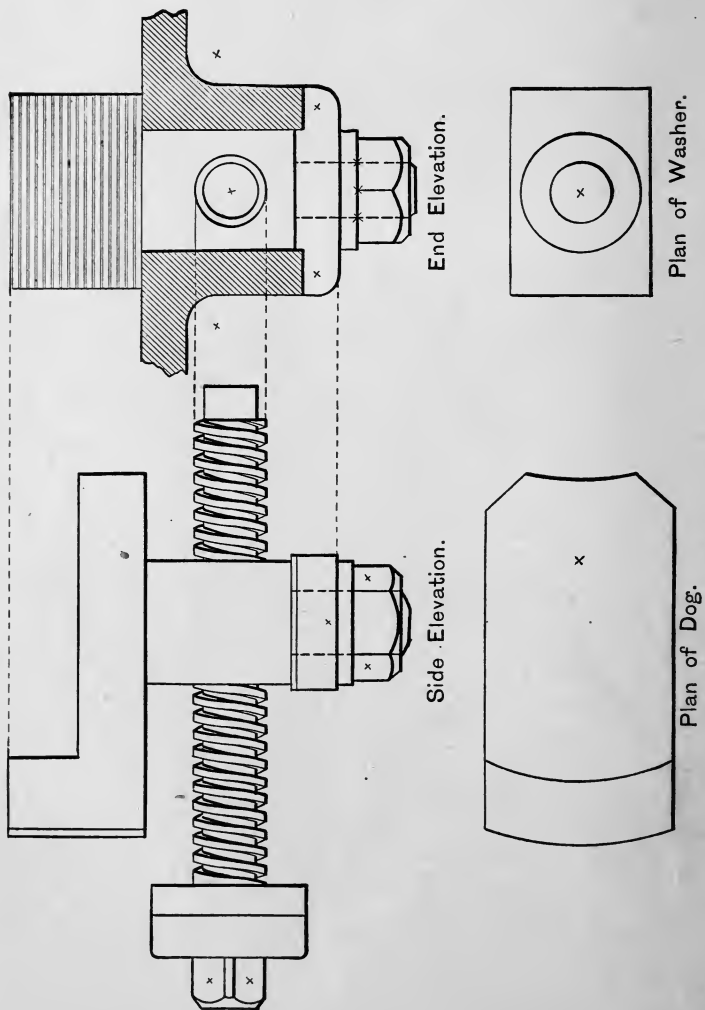

FIG. 91.

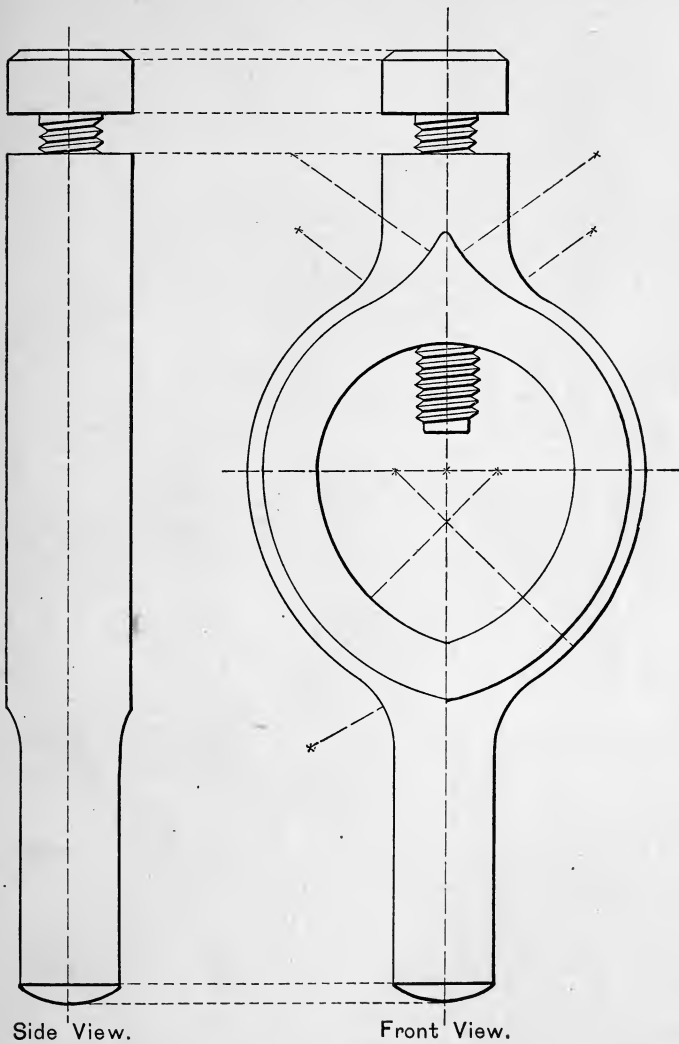
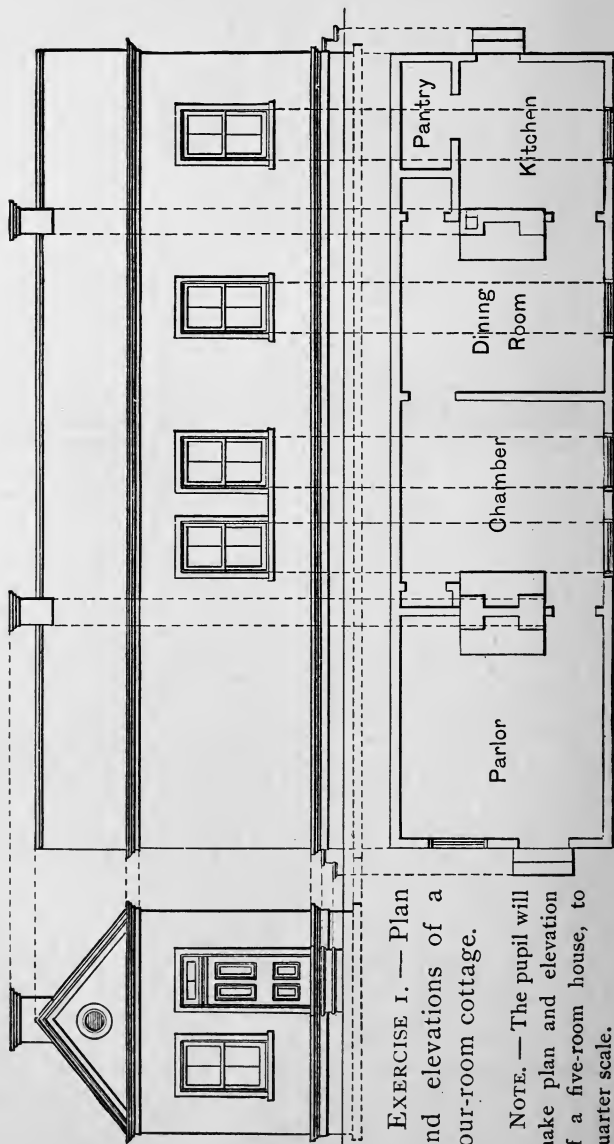

FIG. 92.

EXERCISE 4. — Lathe carrier (Fig. 92).

LESSON XXII. — ARCHITECTURE.



EXERCISE I. — Plan and elevations of a four-room cottage.

NOTE. — The pupil will make plan and elevation of a five-room house, to quarter scale.

FIG. 93.

LESSON XXIII.

ARCHITECTURE. — *Concluded.*

EXERCISE 2. — Draw detail of window, interior and exterior ; scale, $\frac{7}{16}$ " to 1' (Fig. 94).

NOTE. — The pupil will take measurements of a door, and make working drawings of the same (scale, 1" to 1').

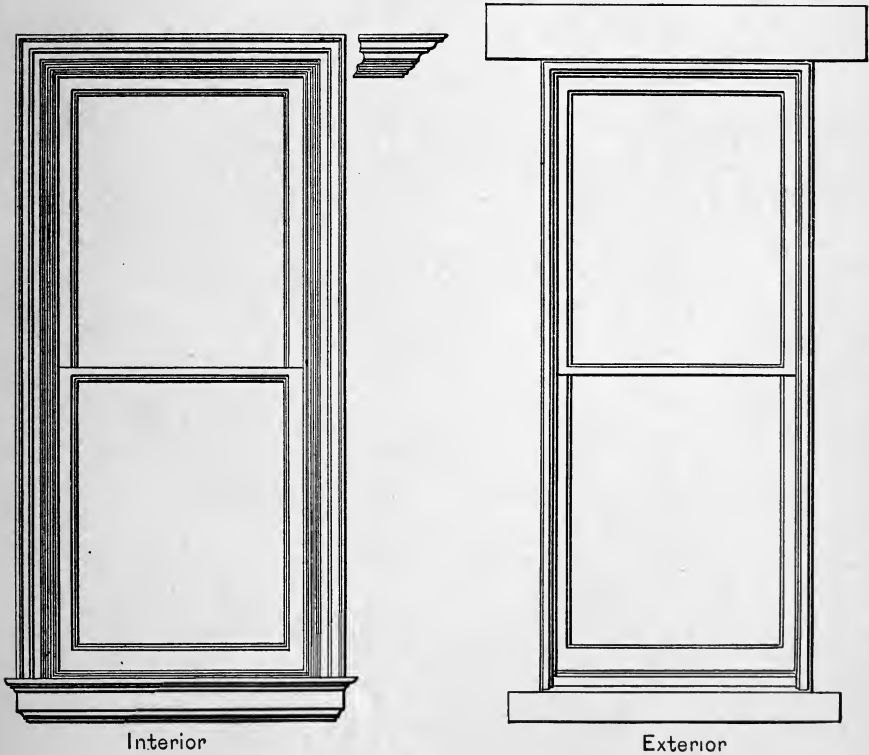

FIG. 94.

LESSON XXIV.

TRACING AND BLUE PRINTING.

AFTER the pupil has made a working drawing in lead pencil, he will "ink in" the same with compasses and ruling pen, and with soft rubber or bread eraser all traces of pencil and finger marks. He will then cut a piece of "tracing linen" the same size as the paper on which he has just finished a drawing, and fasten it on his drawing board, *over* his finished drawing, with thumb tacks (unglazed side of tracing linen up), and trace on it all the lines in the finished drawing.

When all the lines have been reproduced on the linen, place the tracing just made over a similar-sized chemically prepared blue-print paper, and place them under a sheet of clear glass on a drawing board. Expose this to the direct rays of the sun for four minutes. When the sun is not bright, it will be necessary to expose the tracing (over the blue-print paper and under the glass) from eight to ten minutes. At the end of the time, remove the glass and the tracing, and pass the blue-print paper through a large flat pan of water until all the lines of the tracing and drawing appear in lines of white on a blue ground. Let the water drain off the paper. Put the tracings and blue prints away for safe keeping with the drawings.

LESSON XXV.

MACHINERY.

FIG. 95 represents a side elevation of a steam engine (scale 3" to 1'), showing the steam ports, cylinder, valve box, and other details. The pupil will take rough sketches of stationary or locomotive engines (out of school hours), and make working drawings or draughtings of the different parts and of the whole.

NOTE. — The pupil will make rough sketches of the following: cylinder, piston, steam ports, valves, crank pin, cotter, connecting rod, motion block, valve rod, piston rod, pedestal, plummer block, eccentric, and other details, and, according to scale, reproduce them in finished drawings, making tracings and blue prints of same.

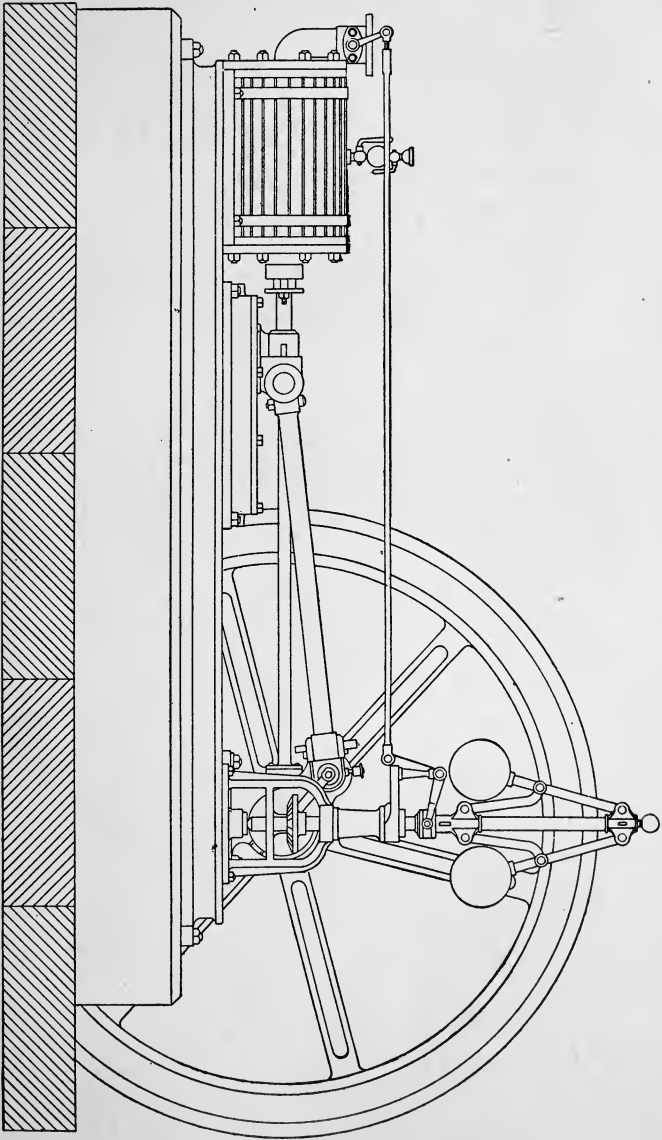

FIG. 95.

LESSON XXVI.

MACHINERY. — *Concluded.*

EXERCISE 1. — Draw a piston (Fig. 96).

EXERCISE 2. — Draw a crank (Fig. 97).

EXERCISE 3. — Draw an eccentric (Fig. 98).

EXERCISE 4. — Draw governors (Fig. 99).

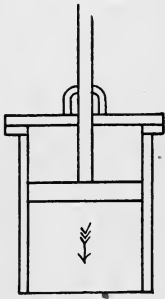

FIG. 96.

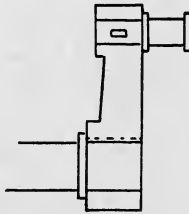

FIG. 97.

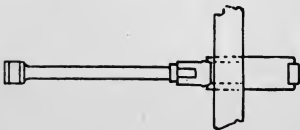
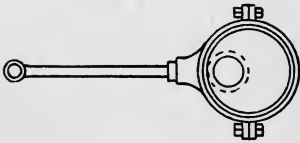

FIG. 98.

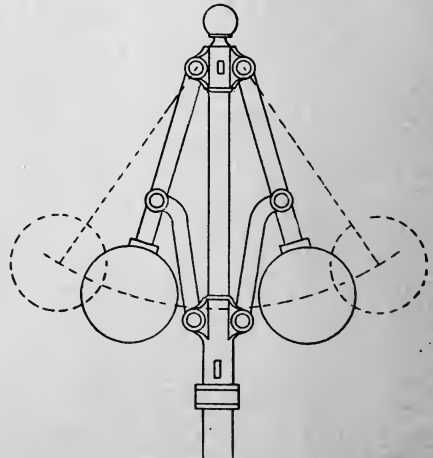

FIG. 99.

EXERCISE 5. — *To produce a given straight line beyond a given obstacle.*

Let AB (Fig. 100) be the straight line, and X be the obstacle.

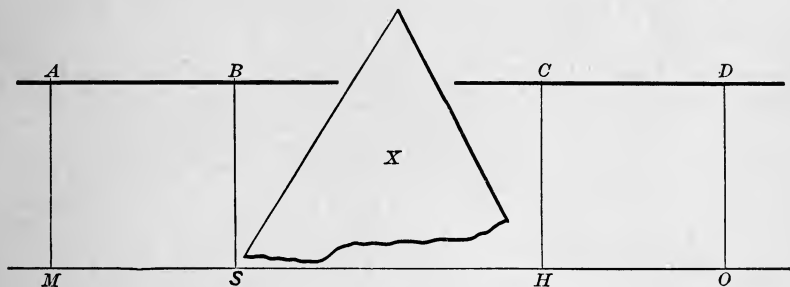

FIG. 100.

Continue a straight line beyond the obstacle. From A and B , or any other points in this line, draw two perpendiculars of equal length, AM and BS (let them fall beyond the obstacle). Draw MS , and produce it indefinitely. At any two points beyond the obstacle locate H and O , and from these draw the perpendiculars HC and OD , equal in length to AM . Draw the line CD , which is the required prolongation of AB .

LESSON XXVII.

WHEELS.

IN order to transfer motion or force from one axis to another, wheels furnished with teeth are employed.

There are various kinds of wheels, — spur wheels, cog wheels, face

wheels, crown wheels, annular wheels, bevel wheels, miter wheels, and skew bevels.

The curves described, or used for the form of the teeth, are :
 1. The *cycloid* ; 2. The *epicycloid* ; 3. The *hypocycloid*. These curves are traced on the following lines : —

1. The *cycloid* is traced by any point in a circle while rolling along a straight line (Fig. 101).

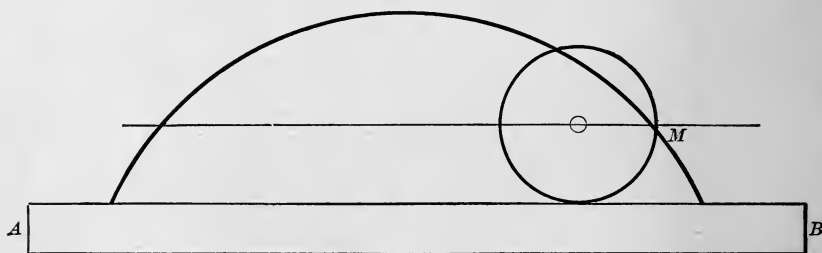

FIG. 101.

2. The *epicycloid* is traced by any point in a circle rolling on another circumference or arc.

3. The *hypocycloid* is traced by any point in a circle rolling on the inner side of the circumference.

NOTE. — Although these wheels are designed and the patterns for them made on scientific principles, still, by considering the curves as portions of circles, they may be made sufficiently accurate for general purposes of drawing.

The cycloid is a curve described by a point in the circumference of a circle during one revolution. The line upon which the circle rolls is called the *director*. The circle is called the *generating* circle, and the point in it is called the *generator*.

The cycloid was invented by the famous mathematician Galileo of Pisa, toward the close of the sixteenth century.

To trace a cycloid by mechanical means, fasten a straightedge to any board. Take a circular piece of wood and fix a small knob in the center *O* (Fig. 101), and cut a small notch in the circumference

M. Roll the disk along the straightedge by means of the knob at *O*, keeping the point of a pencil in the notch at *M*. The line described by the pencil is a cycloid.

If instead of a straightedge a circle or arc be employed, the curve traced by the pencil will be an epicycloid.

PROBLEM. — *To draw a cycloid, the generating circle being given.*

Let *C* (Fig. 102) be the center of the generating circle, and *AB* the

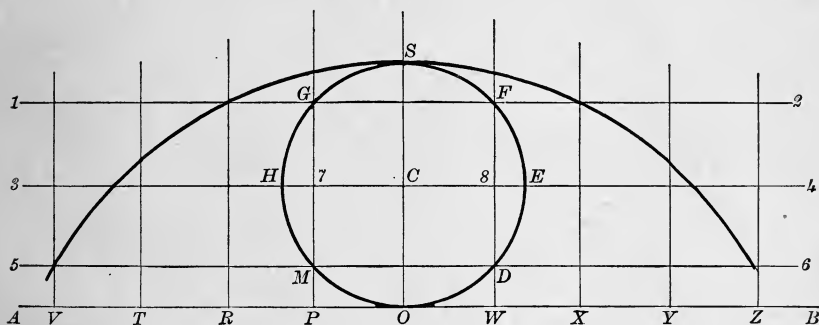

FIG. 102.

director. Divide each half of this circle into four equal parts (each half may be divided into any number of equal parts), and through each point, *D*, *E*, *F*, *G*, *H*, *M*, draw lines indefinitely, parallel to *AB*. Draw the diameter *OS*, and from *O* lay off each way on the line *AB* the same number and sized spaces as we have on the half circle. From each of these points, *P*, *R*, *T*, *V*, *W*, *X*, *Y*, *Z*, erect perpendiculars to meet the line 1 2. With a radius *CO*, and a center in the next point to the right or left, 7 or 8, describe an arc, cutting the *third* parallel; from the next point to the right or left as center, and the same radius, describe an arc cutting the *second* parallel; and so on. The points thus located on the parallels are the points on the curve through which the cycloid will pass.

EXERCISE. — Draw projections of cog wheel 3' in diameter (scale $\frac{1}{2}$ " to 1').

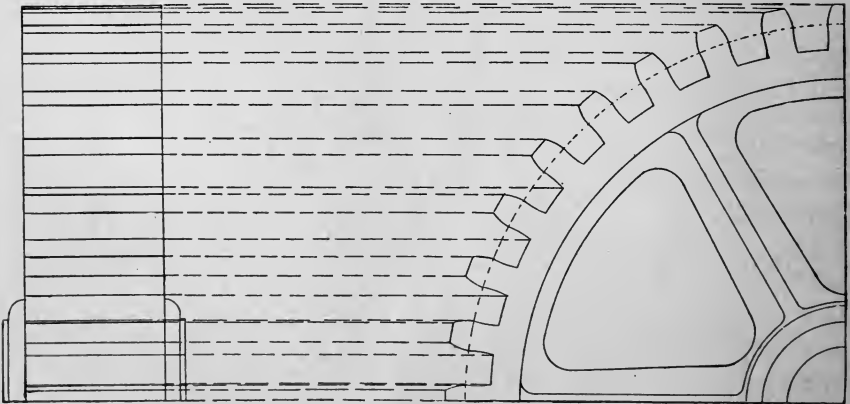
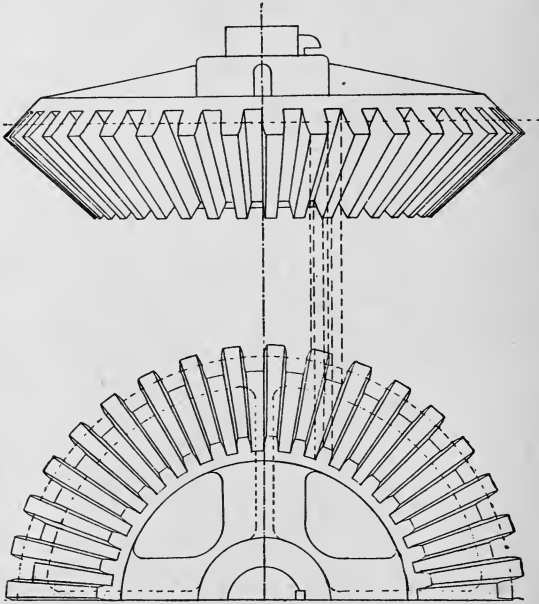

FIG. 103.

LESSON XXVIII.

GEOMETRIC CONSTRUCTION.

EXERCISE 1.—In an equilateral triangle inscribe three equal circles tangent to each side and to each other (Fig. 104).

EXERCISE 2.—In a square inscribe four equal circles tangent to each side and to each other (Fig. 105).

EXERCISE 3.—In a pentagon inscribe five equal circles tangent to each side and to each other (Fig. 106).

EXERCISE 4.—In a hexagon inscribe six equal circles tangent to each other and to each side of the polygon (Fig. 107).

EXERCISE 5.—In an octagon inscribe eight equal circles tangent to each other and to each side (Fig. 108).

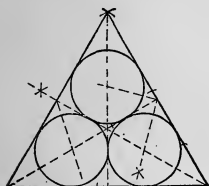

FIG. 104.

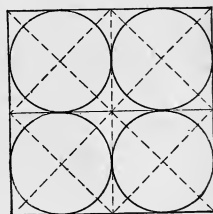

FIG. 105.

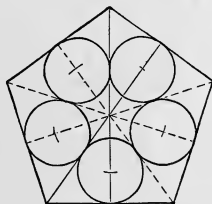

FIG. 106.

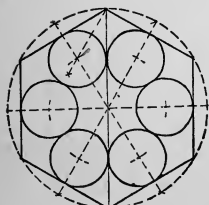

FIG. 107.

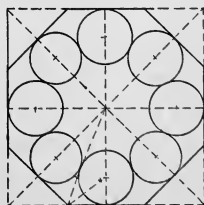

FIG. 108.

LESSON XXIX.

COLOR.

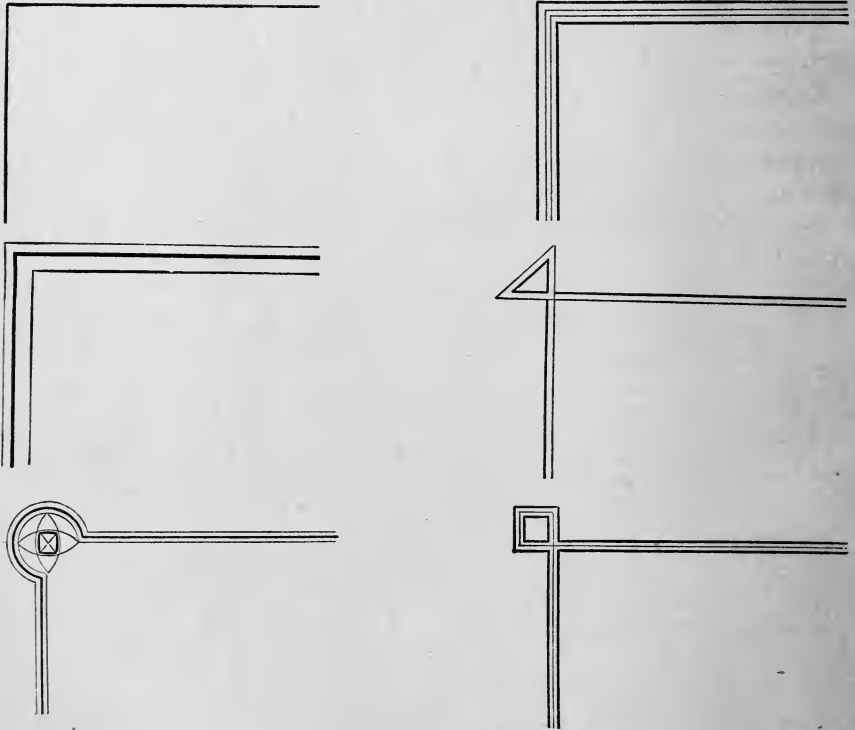

FIG. 109.—BORDERS FOR PAPERS.

It is advisable to color working drawings in order to show at a glance the materials of which the different parts are to be made.

A correct outline drawing is the first requisite, as no amount of coloring, no matter how acceptably it may be finished, will improve a poor or faulty outline.

SUGGESTIONS.

1. Stretch paper as suggested in Lesson I. Never use "hot-pressed" paper.

2. Fasten a camel's-hair pencil, or brush, at each end of the brush handle, — one brush for color, the other for clear water. *Caution:* Do not have too much liquid in the brushes, as it will run on the hand or paper.

3. Select the color to be used on the drawing, and rub one corner of it in a small pan or dish, and add water until the paint is ready for use. If tube colors are used, screw off the top of the tube and squeeze out a very small quantity into the pan. Add water. In order that a color should flow easily and cover a surface evenly, it should be thin.

4. When ready to color the drawing, fill the brush with the color prepared, and, holding it nearly upright, pass quickly over the upper part of the drawing, washing from upper left to lower right as rapidly as possible, so that the whole surface may be covered before any part dries.

5. In order to obtain the practice to lay a flat wash of color evenly, fill in triangles, squares, circles, etc., with color washes. Color small surfaces at first.

6. Use a large brush in preference to a small one, as a small one is likely to streak the wash. In using a large brush, great care must be exercised to prevent the color wash from passing over the outlines.

7. When the color has been washed on, do not touch it until it is dry.

The following substances are generally represented by draughtsmen as here indicated: —

1. Brass. — Gamboge or Roman ocher, shaded by sepia.
2. Brickwork (in elevations). — Lake, mixed with burnt sienna or Venetian red.
Brickwork (in plans and sections). — Vermilion and crimson.

3. Clay or earth. — Vandyke brown or burnt umber.
4. Concrete work. — Sepia, or neutral tint.
5. Copper. — Orange.
6. Granite. — Pale India ink.
Red granite. — Lake and sepia.
7. Iron

{	cast iron (in plan and elevation). — Neutral tint.	}	Or Prussian blue.
	cast iron (in section). — Very light wash of gray.		
	wrought iron (in plan and elevation). — Indigo.		
	wrought iron (in section). — Indigo, very light.		
8. Woods. — Pale washes of burnt sienna.
9. Lead. — Pale indigo, tinged with India ink.
10. Oak. — Vandyke brown.
11. Steel. — Pale indigo, tinged with lake.
12. Stone. — Pale sepia.
13. Slate. — Indigo and lake, or Payne's gray.
14. Limestone. — Indigo.
15. Tin. — Pale Prussian.

LESSON XXX.

ISOMETRIC PROJECTION.

ISOMETRIC projection differs from perspective and orthographic projection, inasmuch as it shows the view of the entire object, and all the lines in the drawing may be measured by a uniform scale. It is called the perspective of the workshop. This style of representing objects was first used by Professor Farish of Cambridge, in 1820.

In perspective drawings objects diminish in size as they appear more distant, according to optical laws, and it is impossible to measure their sizes. In orthographic projection two drawings are required, and the lengths of the lines are altered according to the angle at which the object may be placed. The whole system of isometric projection — meaning projections with equal measurements — is based on a cube so situated with relation to the horizontal

plane that its projection on the vertical plane will be a hexagon $BCDHFE$ (Fig. 110). The three visible faces of the cube are equal in the representation. The angles are not right angles, as in the actual cube, but are acute and oblique, — two acute angles 60° , and two oblique angles 120° .

The line BC leaves the horizontal line MO at an angle of 30° , making the representation of the right angle an acute, ABC , measuring 60° . The lengths of the lines are established by a scale. Vertical lines are represented by vertical lines. The angle at A measures 120° . The line AD , and all other lines of the object parallel to BC , are made parallel to BC in the representation. The faces $ABEF$ and $ADHF$ are drawn in the same manner as the face $ABCD$.

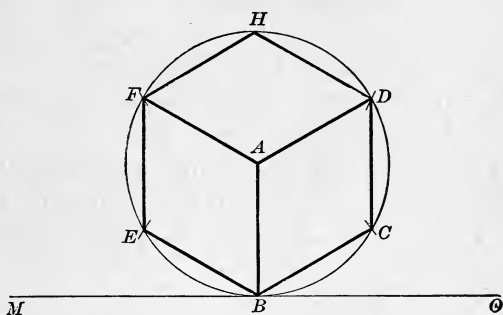

FIG. 110.

An isometric drawing unites plan, elevation, and projected view in one.

To construct an isometric scale so that the object to be drawn may be one twelfth of the real size, proceed as follows (as the scale is one inch to the foot, and as an inch is one twelfth of a foot, each of the twelfths

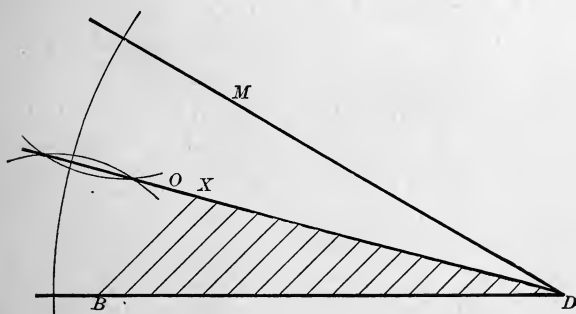

FIG. 111.

will represent an inch): —

Draw the line BD (Fig. 111) an inch and a half long, representing

the *real* length of an object one foot and a half. Mark on BD the twelfths of inches which are to represent inches on the scale.

Make the angle BDM 30° , with the set square, and bisect it. This gives the angle BDO , 15° . From the point B draw an angle of 45° to DX . From each point marked off on the line draw lines parallel to the line BX . The divisions on DX will represent inches, and the line DX is an isometrical scale of $\frac{1}{1\frac{1}{2}}$. Or, instead of making a scale, lay off on the lines which will represent the figure when completed, in isometric projection, the exact measurements. Thus, to draw a cube of $4' 0''$ in isometric projection, lay off the line AB (Fig. 110) vertical, $4' 0''$ long. From the point B project the lines BC and BE at angles of 30° each with the base line, measuring $4' 0''$ along the lines to points C and E . At these points establish verticals $4' 0''$ long. Connect the point A with F and D by lines parallel to BE and BC . From D and F project lines parallel to AF and AD , until they meet in H . Represent bottom of cube by dotted lines from E and C , parallel to FH and DH respectively.

EXERCISES FOR PRACTICE.

EXERCISE 1. — Draw an isometric view of a cube (Fig. 110).

EXERCISE 2. — Draw an isometric scale (Fig. 111).

EXERCISE 3. — Draw plan (Fig. 112) and isometric projection (Fig. 113) of a flight of steps.

EXERCISE 4. — Draw plan (Fig. 114) and isometric projection (Fig. 115) of dovetailed joint.

EXERCISE 5. — Draw plan (Fig. 116) and isometric projection (Fig. 117) of a summerhouse.

EXERCISE 6. — Draw plan (Fig. 118) and front elevation (Fig. 119) and isometric projection of a summerhouse.

EXERCISE 7. — Draw front elevation and isometric projection (Fig. 120) of an arch.

NOTE. — The plan of Exercise 5 is here given, and the pupils will make at least two elevations of the summerhouse.

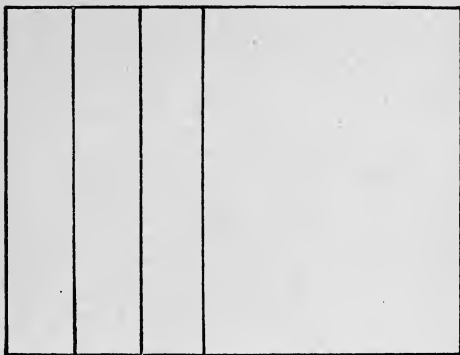

FIG. 112.

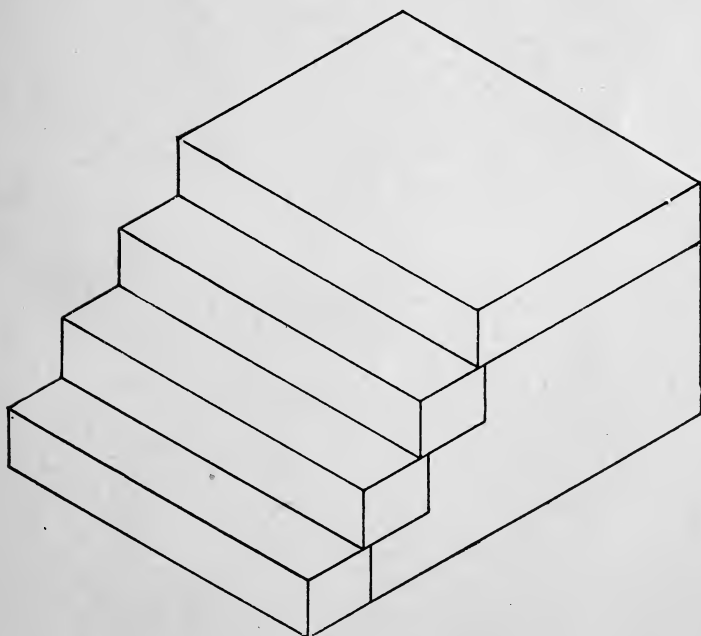

FIG. 113.

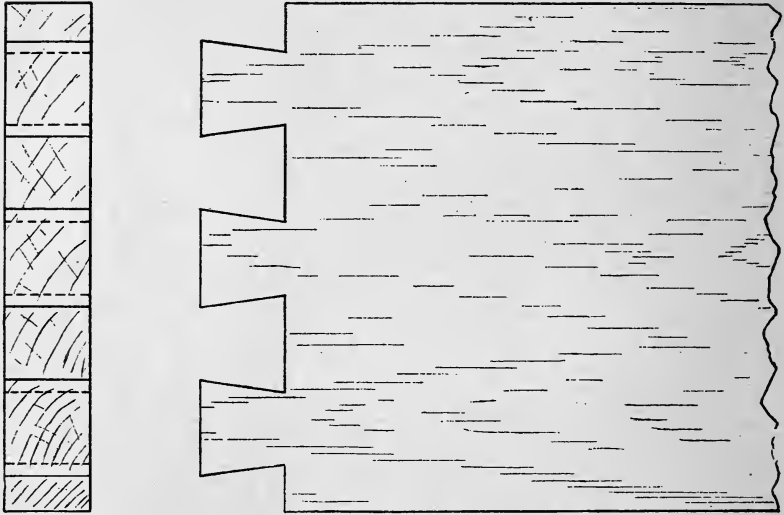

FIG. 114.

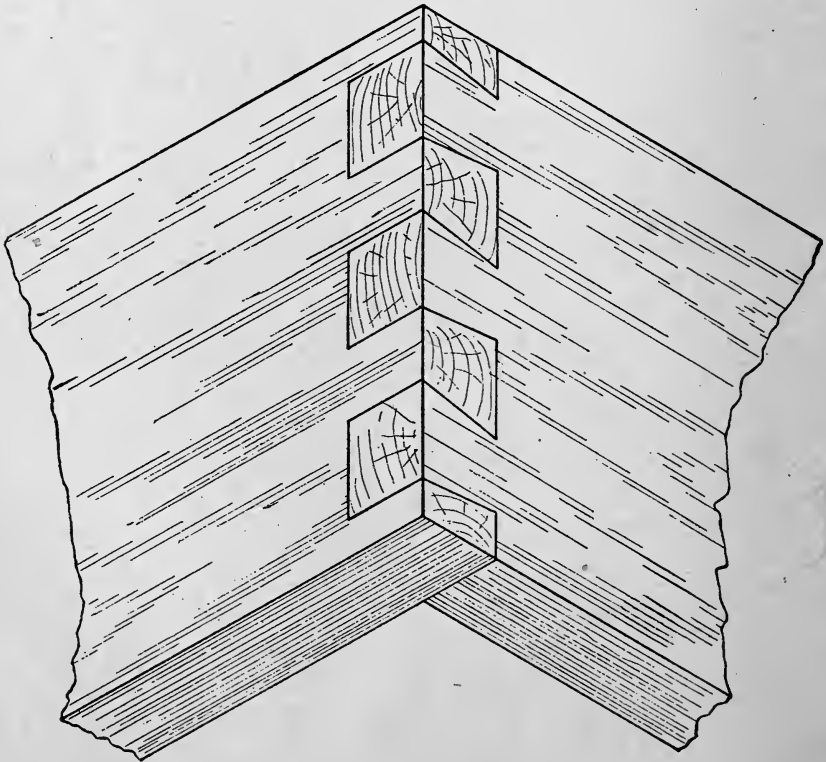

FIG. 115.



FIG. 116.

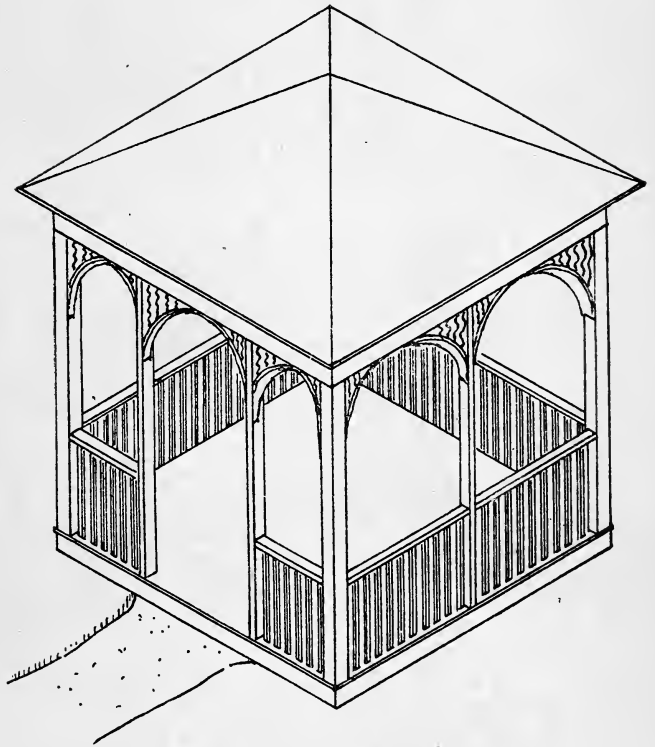

FIG. 117.

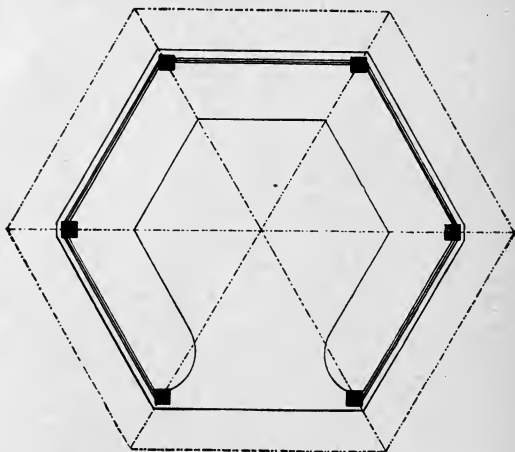

FIG. 118.

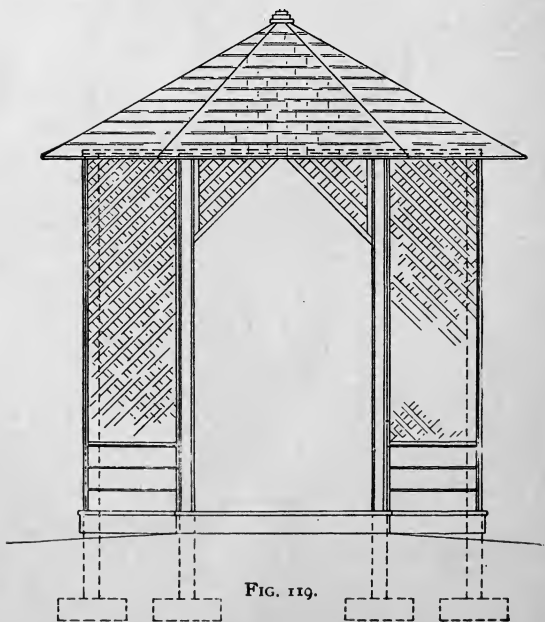

FIG. 119.

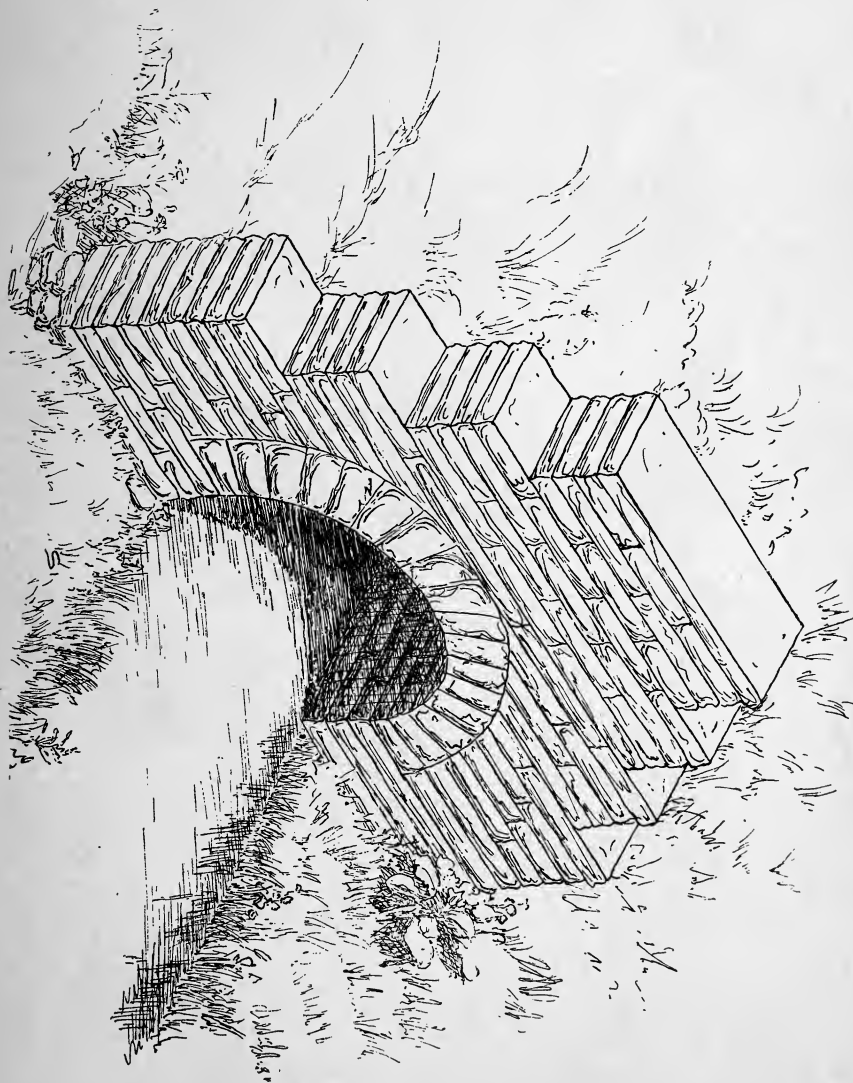

FIG. 120.



LIBRARY OF CONGRESS



0 019 973 578 0