



THE RESEARCH LABORATORY, SCHENECTADY

o

X-RAY STUDIES



GENERAL ELECTRIC COMPANY
SCHENECTADY, N. Y.

OCTOBER, 1919

Y-1368

Page 3942.11.0



T. W. Wood

This volume is a collection of papers describing original researches which have been made by various members of the staff of the Research Laboratory, of the General Electric Company, relating to the subject of X-rays. They have appeared from time to time in scientific periodicals, as separately indicated. It has seemed wise to collect and republish them because of the interest they might have to Roentgenologists.

Permission to reprint them has been duly received, and we herewith express our thanks to the original publishers.

INDEX

	PAGE
Metallic Tungsten and Some of Its Applications (1912)	5
W. D. COOLIDGE	
The Effect of Space Charge and Residual Gases on Thermionic Currents in High Vacuum (1913)	11
I. LANGMUIR	
A Powerful Roentgen-ray Tube with a Pure Electron Discharge (1913)	39
W. D. COOLIDGE	
Physical Investigation Work in Progress on Tubes and Accessories (1915)	55
W. D. COOLIDGE	
A New Device for Rectifying High Tension Alternating Currents (1915)	63
SAUL DUSHMAN	
A Model X-Ray Dark-Room (1915)	79
W. P. DAVEY	
A Summary of Physical Investigation Work in Progress on Tubes and Accessories (1915)	83
W. D. COOLIDGE	
Roentgen-rays from Sources Other Than the Focal Spot in Tubes of the Pure Electron Discharge Type (1917)	95
W. D. COOLIDGE and C. N. MOORE	
A Portable Roentgen-ray Generating Outfit (1918)	107
W. D. COOLIDGE and C. N. MOORE	
A New Radiator Type of Hot Cathode Roentgen-ray Tube (1919)	117
W. D. COOLIDGE	
The Use and Abuse of Roentgen-ray Tubes (1918)	123
C. N. MOORE	
The Radiator Type of Tube (1918)	127
W. D. COOLIDGE	
Apparatus for Portable Radiography (1919)	133
W. D. COOLIDGE	

Roentgen-ray Spectra (1915)	153
A. W. HULL	
The High Frequency Spectrum of Tungsten (1916)	161
A. W. HULL and MARION RICE	

INDEX—Continued

	PAGE
The Maximum Frequency of X-Rays at Constant Voltages Between 30,000 and 100,000 (1916)	165
A. W. HULL	
The Law of Absorption of X-Rays at High Frequencies (1916)	167
A. W. HULL and MARION RICE	
The X-Ray Spectrum of Tungsten (1916)	169
A. W. HULL	
A New Method of X-Ray Crystal Analysis (1917)	179
A. W. HULL	
A New Method of Chemical Analysis (1919)	207
A. W. HULL	
Positions of Atoms in Metals (1919)	213
A. W. HULL	

Some Interesting Applications of the Coolidge X-Ray Tube (1914)	231
W. P. DAVEY	
Radiography of Metals (1915)	239
W. P. DAVEY	
X-Ray Examination of Built-up Mica (1915)	247
C. N. MOORE	
Application of the Coolidge Tube to Metallurgical Research (1915)	251
W. P. DAVEY	
The Effect of X-Rays on the Length of Life of Tribolium Confusum (1917)	255
W. P. DAVEY	
Prolongation of Life of Tribolium Confusum Apparently Due to Small Doses of X-Rays (1919)	267
W. P. DAVEY	

X-Rays (1915)	273
W. P. DAVEY	

X-RAY STUDIES



METALLIC TUNGSTEN AND SOME OF ITS APPLICATIONS*

BY W. D. COOLIDGE

Tungsten does not occur as such in nature; but in the form of compounds it is pretty well distributed. The most important ores are sheelite or calcium tungstate and wolframite or iron-manganese tungstate. The principal source of the ore at this time in this country is Boulder County, Colorado.

From the ore it is a simple matter to get the yellow oxide (trioxide) of tungsten. And the trioxide may be reduced in various ways, as with hydrogen, zinc and carbon, to metallic tungsten. The product so obtained is in the shape of a powder ranging in color from gray to black depending upon the fineness of its state of subdivision.

Owing to its very high melting point, it was for a long time impossible to get the pure powdered metal into the form of a dense coherent homogeneous mass. Two Austrians, Messrs. Just and Hanaman¹, working in Vienna, finally succeeded, however, in producing the pure metal in this condition and in filamentary form, and by using it as an incandescent filament became the inventors of the tungsten lamp.

One of their processes consisted in first mixing the finely divided tungsten powder with a carbonaceous binding agent. The plastic mass so obtained was then extruded through a small orifice. The resulting thread was heated in the absence of air, to carbonize the binder. The fragile body so produced consisted of tungsten powder and carbon and was electrically conducting. If it had been used in this condition it would have been worthless owing to the presence of carbon which lowers the melting point and besides this, slowly distills out in a vacuum, causing a blackening of the lamp globe. But Just and Hanaman found that the carbon could be removed by heating the filament to a high temperature, by passing current through it, in an atmosphere of hydrogen and water vapor. This high temperature treatment not only removes carbon but also causes the filament, under the action of capillary forces, to shrink to a dense homogeneous body.

Various other processes were subsequently devised for making small filaments of pure tungsten. But these were all alike in this, that they started with the finely divided metal or oxide or some other compound of the metal. By the help of some agglomerant, the finely divided material was then worked into a plastic mass. This was then brought into filamentary form by extrusion through a die, and was then raised to a high temperature under such conditions that nothing but pure tungsten remained, the filament sintering under the application of the high temperature to a dense coherent body.

Filaments produced in this way showed the melting point of pure tungsten (about 3000 deg. C.) And they were very satisfactory as lamp filaments except in one respect—they were weak mechanically. They were, like spun glass, highly elastic but absolutely brittle; that is, they could not, by cold bending, be given the slightest permanent deformation.

In the above mentioned brittle condition, metallic tungsten had, as such, but one single commercial application, namely as a lamp filament. This application was however extremely important—so much so that a vast amount of the most painstaking investigation work was carried out both in this country and abroad in the endeavor to produce a ductile form of tungsten. Without some such enormous commercial interest at stake, it seems extremely doubtful whether the product sought for would ever have

*Copyright, 1912, by American Institute of Electrical Engineers.

1. U. S. Patent No. 1,018,502.

been produced. For no one knew but what metallic tungsten, like the silicon of today, was, at room temperature, inherently brittle. And the evidence in support of the theory that it was inherently brittle was almost overwhelming.

At a meeting of the Institute in May, 1910², the author presented a paper telling of the successful reaching of the goal—the production of ductile tungsten. At that time samples of drawn wire were shown and the hope was expressed that within a short time laboratory processes could be brought to a point where the public could profit by the new invention. This development has taken place so rapidly that today the bulk of the world's supply of tungsten lamps is made from drawn wire.

As has been said above, so long as tungsten was a brittle metal it found but one single technical application. But with the advent of ductile tungsten, the whole situation is changed, and the metal has now, apart from its use as a lamp filament, assumed a very considerable degree of technical importance.

Before proceeding to a discussion of some of the new applications it may be well to summarize here some of the most important properties of wrought tungsten. Most of these data have already been published.³

Physical Properties. Wrought tungsten is a bright steel-colored metal having the same density as gold, 19.3. (This varies somewhat with the amount of mechanical working which the specimen has had.)

The strength and pliability both increase with the amount of mechanical working. The fracture may be very coarsely crystalline, or it may resemble that of a very fine grained tool steel or it may be fibrous and silky in appearance, or it may lie anywhere between these extremes, the appearance in each case depending upon the chemical purity and upon the preceding thermal and mechanical treatment. The tensile strengths measured have ranged from 460,000 lb. (208,652 kg.) per sq. in. (6.45 sq. cm.) for a wire 0.005 in. (0.127 mm.) in diameter to 610,000 lb. (276,691 kg.) for a 0.0012-in. (0.0305 mm) wire.

Tungsten is hardened by working but not by heating and quenching. Similarly tungsten containing carbon is not appreciably affected by quenching. The hardness imparted by working may be entirely removed by carrying the metal to white heat.

The ductility is extreme, as is shown by the fact that wire only 0.0006 in. (0.0152 mm.) in diameter is now produced in large quantity.

Tungsten is non-magnetic.

The electrical resistivity at 25 deg. C., expressed in microhms per centimeter cube is 6.2 for the hard drawn wire and 5.0 for the same annealed. The corresponding data for annealed copper and annealed platinum are 1.87 and 11.1 respectively.

The temperature coefficient of electrical resistivity per degree between 0 deg. and 170 deg. C. is 0.0051.

Assuming the Franz-Wiedemann law to hold for the relation of heat to electrical conductivity, we may calculate the heat conductivity of annealed wrought tungsten to be 0.37 times that of copper and 2.2 times that of platinum.

The coefficient of heat expansion per degree from 20 deg. to 100 deg. C., is 336×10^{-8} , which is about 0.26 that of platinum.

Chemical Properties. Wrought tungsten does not tarnish upon standing in the air. Upon heating it to a temperature of three or four hundred degrees, however, it oxidizes superficially and turns blue just as steel does. At bright red heat the oxide volatilizes and the metal wastes away more or less rapidly, depending upon the temperature.

2. Transactions A.I.E.E. Vol. 29, Part II, pp. 961 to 965.

3. C. G. Fink, *Transactions Am. Electrochem. Soc.*, Vol. 17, pp. 229 to 234 (1910).
W. E. Ruder, *Jour. Amer. Chem. Soc.*, April, 1912.

It is quite resistant to the action of most acids, being entirely unaffected at room temperature by either dilute or concentrated hydrofluoric, hydrochloric, nitric, and sulphuric acids. With aqua regia at room temperature the action is very slight. At a higher temperature, 110 deg. C., there is no action in the case of hydrofluoric, concentrated nitric and dilute sulphuric acids, while the action is but slight in the case of dilute and concentrated hydrochloric, concentrated sulphuric, dilute nitric, and aqua regia. There is no action in the case of a mixture of sulphuric and chromic acids, but the metal dissolves rapidly in a mixture of hydrofluoric and nitric acids.

An aqueous solution of caustic potash has no effect on wrought tungsten, but the fused salt does attack the metal slowly.

In aqueous solutions of sodium or potassium carbonate or mixtures of the two, tungsten dissolves slowly, the action being considerably hastened by the addition of potassium nitrate.

ELECTRICAL CONTACTS OF WROUGHT TUNGSTEN

Under the conditions pertaining in many electrical make and break devices, as in magnetos, spark coils, voltage regulators, railway signal relays, telegraph and telephone relays, telegraph sending keys, etc., wrought tungsten has proved to be far superior to platinum or platinum-iridium for the contact points.

This was not in any sense an obvious application, for tungsten is not, like platinum, a difficultly oxidizable metal. It might well have been assumed that under the heat of the minute arcs which form when the contacts are separated, the tungsten would oxidize at the points where arcing has taken place, and that non-conducting layers would thus be formed which would produce a high and variable contact resistance. In fact, our first experiments bore out this theory. But subsequent work showed that the difficulty in these early experiments came from the fact that, at the time, we were unable to make a good thermal and electrical joint between the tungsten and the contact carrying members. With the attainment of a good conducting joint, our results changed completely. The contacts no longer rose to the same high temperature and the oxidation decreased to little or nothing. Moreover, in case there was any oxidation, it was to the lower and electrically conducting oxides.

Tungsten contacts wear longer than those of platinum or platinum-iridium. This is doubtless due largely to the lower vapor pressure. At temperatures at which platinum volatilizes badly, tungsten has a very low vapor pressure. Besides this the heat conductivity of tungsten is more than twice that of platinum and as a result, the contact faces do not rise to the same high temperature. (In comparison with platinum-iridium alloys, the ratio of heat conductivities is still more favorable to tungsten.) In connection with the life of contacts, another important consideration is that of hardness. Tungsten is so hard that it does not batter down at all under the continual hammering which the contacts get in service.

Tungsten contacts show less tendency to stick than do contacts of platinum or platinum-iridium. This is to be attributed in part to the higher melting point of tungsten. There seems to be another factor here, however, for while we are able, by proper manipulation, to securely weld together two pieces of platinum at a temperature considerably below the melting point, it has not as yet been possible, except by actual fusion, to produce anything more than a very weak adhesion between two pieces of tungsten.

One minor and unexpected advantage connected with the use of tungsten contacts consists in the fact that they seem less sensitive to the accidental presence of oil than do platinum contacts.

Allusion has already been made to the difficulty at first experienced in producing satisfactory thermal contact between tungsten and the metal comprising the contact carrying member. This was due to the fact that tungsten cannot be satisfactorily soldered by any of the ordinary processes. This difficulty has been overcome in the following way: The little disc of tungsten, which is to serve as contact point, is attached by means of copper to the head of an iron tack. Copper does not alloy with tungsten, but under suitable conditions, it wets it, and then adheres firmly. This gives a joint of high thermal and electrical conductivity between the tungsten and the head of the iron tack. The shank of the tack is then either pressed in, or brazed, or riveted to the contact carrying member.

WROUGHT TUNGSTEN AS TARGET IN A ROENTGEN (X-RAY) TUBE

This has proved to be, both from the scientific and practical points of view, an exceptionally interesting application.

Until recently platinum has been almost universally regarded as the best target material, and it has so long held undisputed sway in this field that the Roentgen ray worker has come to look upon its limitations as inherent in the Roentgen tube.

With the advent of dense, forged pieces of pure malleable tungsten the possibilities of the Roentgen tube are greatly extended.

The desiderata in a material to be used as the anticathode or target are the following:

1. High specific gravity.
2. High melting point.
3. High heat conductivity.
4. Low vapor pressure at high temperature.

The reasons why the above qualities are desirable follow readily from a brief consideration of the theory of Roentgen-ray production.

From the concave cathode, electrically charged particles, the electrons, are shot out at high velocity in a direction normal to the surface. The paths of these particles converge and the target is placed at or near the point of strongest convergence, the focus point. When the electron meets an obstruction, as the target, its velocity is reduced, and the denser the target the more rapid is the deceleration. The more rapid the deceleration the greater is the amplitude of the electromagnetic pulse, the Roentgen-ray sent out. Here then is a need for high specific gravity; that of forged tungsten is but little less than that of platinum.

In modern Roentgen-ray practice, powerful apparatus, running sometimes to a capacity of 10 and even 15 kilowatts, is used to excite the tube. The greater part of the energy delivered to the tube is transformed into heat at the point where the cathode rays bombard the target. Where platinum is used it has been found necessary, to prevent melting, to place the target beyond the focus of the cathode so as to spread the bombardment over a larger area. As a radiograph is a shadow picture, and as the source of the Roentgen-ray is the bombarded area of the target, this enlarging of that area is clearly an undesirable thing to do, as the larger area will mean more overlapping and less definition in the resulting picture. In this way, the melting point of platinum has been the limiting feature of the Roentgen tube. The capacity of the tube has been increased by water cooling the platinum or by using as a target a large mass of copper having a very thin platinum face. But the limit, although raised by these artifices, has still been the melting point of the platinum.

Tungsten has a much higher melting point (3000 deg. C. as against 1755 deg. for platinum), and so, even with sharp focusing of the cathode rays on the target,

permits the use of more energy than has hitherto been possible; for the high temperature to which it can run enables it to radiate more heat, and its better heat conductivity permits a more rapid flow of heat from the focus spot to the surrounding metal.

Stability of vacuum in a Roentgen tube is of the utmost importance, as the character of the rays is so largely determined by the vacuum. Metal, which under the influence of the high temperature vaporizes from the target, condenses on the glass in finely divided form and absorbs relatively large amounts of gas, thus changing the vacuum. At high temperatures tungsten vaporizes least of all the metals.

Two distinct types of tungsten target are being tried out experimentally in competition with one another.

The first of these consists of a heavy copper block with a disc of wrought tungsten attached to the face. This is similar to the platinum targets which have been in use for some years. The function of the copper is simply to conduct heat away from the tungsten and to act as a heat storage reservoir. In this latter capacity it is much more effective than would at first seem possible, owing to the fact that while the rate of energy input is high the time is correspondingly short, a single excitation of the tube lasting for perhaps only a half second. It is interesting to note that it would take an energy input of over 60 kilowatts acting for a second to raise the temperature of a half pound mass of copper by 700 deg. C.

The second type is for the first time made possible by the advent of wrought tungsten. In this type the target consists entirely of refractory metal, and this is allowed to heat up to such temperatures that it is capable of radiating relatively large quantities of energy. Tungsten at its melting point, is capable of radiating about 375 watts per sq. cm. This means that a tungsten disc 3 cm. in diameter and 0.2 cm. thick would, if its entire mass were at the melting point, be radiating energy at the rate of over 5 kilowatts. (The same cylinder, if made of platinum and run at 1750 deg., the melting point of platinum, would radiate only about one twentieth as much.) It would not of course be practicable to run the entire tungsten mass at the melting point, and, owing to the resistance to heat flow, the focal spot would of course come to the melting point while the periphery was at a considerably lower temperature. But such a target would at least be able to radiate continuously relatively large amounts of energy

The target has, for a long time, been the most vulnerable point in the tube, but this is no longer true. For either of the above types of tungsten target can be made so good that failure of the tubes as they are now built will be due to other causes.

THE TUNGSTEN OR MOLYBDENUM-WOUND ELECTRIC FURNACE

This has been fully described in an article by Winne and Dantsizen⁴. This is not only a useful adjunct to scientific investigation work; but has already become a very important factory tool. When wound upon a body of alundum, either of these metals makes possible the attainment of higher temperatures than can be obtained with a platinum-wound furnace. And as higher and higher melting refractories are produced the temperature range of this furnace will be extended.

TUNGSTEN PROJECTILES

The use of wrought tungsten as a projectile is being carefully investigated. It offers, in this field, possibilities not possessed by any other metal.

The present small arm service projectile is made of lead with a jacket of copper-nickel alloy. The principal advantage of lead over iron, which would of course be

4. R. Winne & C. Dantsizen, *Transactions Am. Electrochem. Soc.* Vol. 20, pp. 287 to 290 (1911).

cheaper, is that it has a higher specific gravity. Because of this fact a lead bullet will have a smaller cross-section, and will therefore encounter less air resistance to its flight, than will an iron bullet of the same weight, and will therefore give a flatter trajectory and longer range. An iron bullet of the same diameter as the lead bullet could of course be given the same weight by increasing its length. But this would at once necessitate giving it a higher rotational velocity to keep its axis tangential to its flight. To impart this added rotational velocity calls for the expenditure of energy and so leaves less for velocity of translation. The lead bullet then with its higher density makes possible a flatter trajectory and longer range. With the exception of tungsten, lead is the densest metal which can be considered for this purpose, for gold is the cheapest of the other elements having a higher specific gravity than lead. The density of wrought tungsten is 19.3 while that of lead is 11.5.

For military purposes, the softness of lead is not an advantage, a soft nosed bullet being tabooed in civilized warfare. For this reason and because of the fact that it is too weak to hold the rifling, it has to be jacketed with the copper-nickel alloy. To take the rifling and to act as a gas check, the tungsten bullet will require a copper band or its equivalent at the base.

The hardness and high tensile strength of wrought tungsten will give high penetrating power.

The high melting point of tungsten will prevent it from being harmfully upset at the base by the combined action of the high temperature and rapid impact due to the combustion of the powder charge. (An unsymmetrical upsetting of the base of a projectile is very prejudicial to accuracy.)

It would be a very simple matter to calculate the constants of the trajectory of a tungsten projectile were it not for the fact that the high density removes it too far from the present base line. For such calculations one quantity is lacking, the so-called "form factor." This factor could itself be calculated if it contained, as the name would seem to imply, only the dimensions and the specific gravity, but there are also involved in it all of the errors due to simplifying assumptions which have been made in connection with the mathematical derivation of formulæ. It therefore becomes necessary to experimentally determine the constants of the trajectory of tungsten bullets, and this work is now being carried out.

CHEMICAL WARE OF TUNGSTEN

Because of its inertness to many chemical agents wrought tungsten in the form of dishes is certain to find many industrial applications. Small dishes have already been made successfully, and work is already under way looking to the production of larger sizes.

[Reprinted from the *PHYSICAL REVIEW*, N. S., Vol. II, No. 6, December, 1913.]

THE EFFECT OF SPACE CHARGE AND RESIDUAL GASES ON THERMIONIC CURRENTS IN HIGH VACUUM *

BY IRVING LANGMUIR

When a carbon or metal filament is heated in a vacuum and surrounded by a positively charged metal cylinder, it is well known that electrons are given off by the hot solid. This effect in lamps has been commonly known as the Edison effect and has been rather fully described in the case of carbon lamps by Fleming.¹

Richardson and others have studied quantitatively the ionization produced by hot solids, especially from heated platinum, and have collected a large amount of data. It has generally been found that the saturation current is independent of the pressure of the gas and increases rapidly with increasing temperature of the filament. However, certain gases were found to have very marked effects; for example, traces of hydrogen were found to increase enormously the saturation current obtained from hot platinum.² Recent investigations have shown³ that at least in some cases the current is due to secondary chemical effects.

Pring and Parker⁴ showed that the current obtained from incandescent carbon could be cut down to very small values by progressive purification of the carbon and improvement of the vacuum. They conclude that "the large currents hitherto obtained with heated carbon cannot be ascribed to the emission of electrons from carbon itself, but that they are probably due to some reaction at high temperatures between the carbon, or contained impurities, and the surrounding gases, which involves the emission of electrons." Pring and Parker observed also that the ionization (or rather thermionic current) "increased only very slightly with the temperature above 1800 degrees."

The effect of these publications, together with that of Soddy,⁵ who noticed similar effects with a Wehnelt cathode, has been to cast doubt on the existence of a thermionic current in a perfect vacuum and from pure metals. The opinion seems to be gaining ground, especially in Germany, that the emission of electrons from incandescent solids is a secondary effect produced by chemical reactions, or at least is caused by the presence of gas.

With the above-mentioned exceptions, it has generally been found that the thermionic current increased with the temperature at a very high rate. The relation be-

* Copyright, 1913, by American Physical Society.

¹ *Phil. Mag.*, 42, P. 52 (1896).

² H. A. Wilson, *Phil. Trans.*, 202, 243 (1903).

³ Fredenhagen, *Ver. d. phys. Ges.*, 14, 384 (1912).

⁴ *Phil. Mag.*, 23, 192 (1912).

⁵ *Nature*, 77, 53 (1907).

tween current and temperature was usually accurately represented by Richardson's equation

$$(1) \quad i = a\sqrt{T}e^{-\frac{b}{T}},$$

where a and b are constants and i is the saturation current at the absolute temperature T .

If the older values of a and b as found, for example, for carbon, are substituted in the above equation and the currents for very high temperatures (above 2500 deg.) are calculated, values of many amperes or even thousands of amperes per square cm. are usually obtained. This raises the question why in ordinary incandescent lamps very large thermionic currents do not occur.

There is every reason to think that the thermionic current from tungsten should be fairly large. When we run a tungsten lamp up to 2 or even 2.5 times its normal voltage (filament temperature 2900–3400 deg. K.) we should, therefore, expect to get thermionic currents of several amperes between the two ends of the filament. Simple observation of a lamp run under such conditions indicates that this is not the case. For example, consider a lamp which takes 110 volts and 0.3 ampere when running at normal specific consumption (1.25 watts per candle). By raising the voltage to 250, the temperature of the filament will be brought to about 3000 deg. K. and the current is then about 0.45 ampere. The resistance of the filament has thus increased from 366 ohms up to 555. The total surface of the filament is nearly half a square cm., yet it is evident that if there is any thermionic current between the two ends of the filament, it cannot exceed a few hundredths of an ampere. This apparent discrepancy between the results of calculation by Richardson's equation and the facts observed with a tungsten lamp seemed at first to confirm the growing opinion that in a very high vacuum the thermionic current is very small, if not entirely absent.

Experiments on the Edison effect in tungsten lamps, made some time ago by the writer, throw a great deal of light on the cause of the apparent failure of Richardson's equation at high temperatures. The observations, therefore, seem of sufficient interest to warrant their publication.

EXPERIMENTS ON EDISON EFFECT IN TUNGSTEN LAMPS

Some lamps were made containing two single loop (hairpin) tungsten filaments with separate leading-in wires. Each loop could thus be run separately. The lamps were given a specially good lamp exhaust, which involved heating them to 360 deg. for an hour while being exhausted with a mercury pump. A trap immersed in liquid air was placed between the pump and the lamp to condense out water vapor, carbon dioxide and mercury vapor. The filaments were then connected in series and the lamps run at a specific consumption of about 1 watt per candle for fifteen minutes, to drive the gas from the filaments. The lamps were then sealed off from the pump and the filaments were again heated, this time being run at 0.4 watt per candle for a few minutes, to age the filaments and improve the vacuum (clean-up effects).

Experiments were then undertaken to measure the thermionic currents that flowed across the space between the two filaments when one was heated to various temperatures while the other was connected to a constant source of positive potential of about 125 volts. A milliammeter was connected in series with the cold filament.

When the temperature of the cathode filament was raised to about 2000 deg. K. a current of about 0.0001 ampere was observed to flow between the two filaments. As this temperature was raised the thermionic current rose very rapidly, until at about 2200 deg. K. it was about 0.0006 ampere. As the temperature was raised above 2200

deg. K., *no further increase in the thermionic current occurred*, even when the filament was heated nearly to the melting-point (3540 deg. K.). By raising the voltage on the anode to about 250 volts, the thermionic current increased to about 0.0015 ampere. It required, however, a temperature about 200 deg. higher to reach this current than had been found necessary to reach the maximum current at the lower voltage. At temperatures below 2200 deg. K., the current was practically the same with 125 as with 250 volts.

The results of a later and more accurate experiment are given in Fig. 1. The filament used for these measurements consisted of a single loop of drawn tungsten wire, of diameter 0.0069 cm. and total length of 10.84 cm. and area of 0.234 sq. cm. A similar filament, at a distance of about 1.2 cm., served as anode. Both filaments had been aged a couple of hours at high temperature and the vacuum thus obtained was certainly better than 10^{-6} mm.¹

The temperatures of the filament were determined from the relation

$$T = \frac{11,230}{7.029 - \log_{10} H'}$$

where H is the intrinsic brilliancy of the filament in international candles per sq. cm. of projected area.²

The points indicated by small circles (Fig. 1) are experimentally determined. Two different anode voltages were used: 240 and 120 volts, with respect to the negative terminal of the filament which served as hot cathode. The voltage used to heat the cathode varied from about 7 to 15 volts, so the *average* potential difference between anode and cathode was somewhat less than 240 and 120 volts. The curve given for 60 volts was determined from other experiments devised especially to determine the effect of voltage variations.

It is seen from these curves that at low temperatures the current for all three voltages is the same, but that as the temperature is raised the currents at the lower voltages fall below those for higher voltages and finally each in turn reaches a constant value.

By plotting $(\log i - \frac{1}{2} \log T)$ against $1/T$ it was found that all the points on the 240-volt curve up to a temperature of about 2150 deg. lay very close to a straight line. This indicates that these results can be expressed by Richardson's equation. From the slope and position of the line, the values of a and b of Richardson's equation were found to be

$$\begin{aligned} a &= 27 \times 10^6 \text{ (amperes per sq. cm.)}, \\ b &= 55,600 \text{ (degrees)}. \end{aligned}$$

The heavy black curve of Fig. 1 was calculated by plotting Richardson's equation, using these values of a and b . The agreement between this curve and the experiments at low temperature is nearly perfect; in fact, much better than can be seen from Fig. 1.

It is seen that each experimentally determined curve can be divided into three parts:

1. A part which follows Richardson's equation accurately.
2. A part which consists of a horizontal straight line; that is, a part in which the current is independent of the temperature of the filament.
3. A transition curve between these.

The horizontal part of the curve was of particular interest. The current being independent of the temperature of the filament is probably independent of the nature of

¹ Judging from measurements on similar lamps made by means of the "molecular" gage described by the writer, *PHYS. REV.*, 1(2), 337 (1913).

² The derivation of this formula will soon be published, probably in the *PHYSICAL REVIEW*.

the cathode. It seemed possible, however, that it might be dependent on the anode. Several experiments were undertaken to determine the factors which governed the value of this new kind of "temperature" saturation current. It was found that it was very largely affected by any one of the four factors:

1. Voltage of anode.
2. Presence of magnetic field.
3. Area of anode.
4. Distance from anode to cathode.

It is especially noteworthy that none of these factors had any influence on the thermionic current over the first part of the curve; *i.e.*, that part which follows Richardson's equation. That is, the constants a and b were not affected by voltage, or magnetic field, or distance, or area of anode.

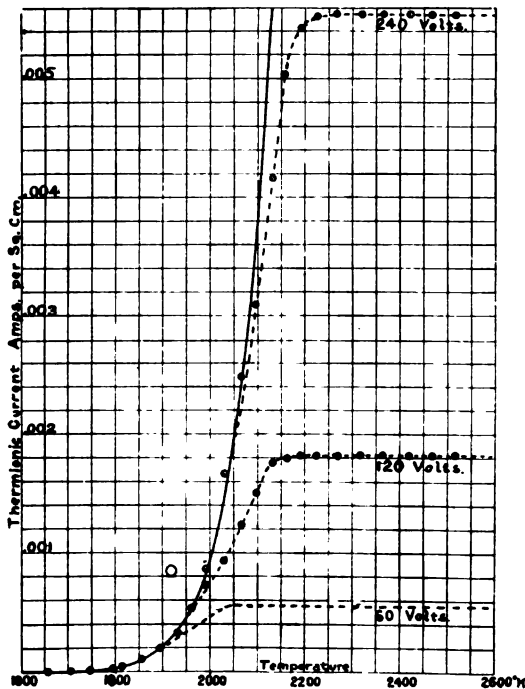

Fig. 1

After trying out several hypotheses which suggested themselves, it finally occurred to the writer that this temperature saturation might be due to a space charge produced by the electrons between the cathode and anode. The theory of electronic conduction in a space devoid of all positive charges or gas molecules seems to have been strangely neglected. It has apparently always been taken for granted that positive ions are present, or at least a sufficient amount of gas, so that the motion of the electrons follows the laws of diffusion. J. J. Thomson¹ gives the differential equations that apply to the calculation of electron conduction through space, and suggests that a method for the determination of e/m could be worked out in this way. He apparently does not fully integrate the equations or realize their application to ordinary thermionic currents.

THEORY OF ELECTRONIC CONDUCTION IN A SPACE DEVOID OF MOLECULES OR POSITIVE IONS

In order to form a clear conception of the problem before us, let us consider (see Fig. 2) two infinite parallel planes, A and B , one of which, A , has the properties of an incandescent solid; that is, we assume that it emits low velocity electrons spontaneously. The other, plane B , we consider to be positively charged.

Now if the temperature of the plate A is so low that few or no electrons are emitted, then the potential between the two plates will vary linearly between the two, as indicated by the line PT .

As the temperature of A is raised, electrons are emitted. Under the influence of the field these pass across the space from A to B and thus constitute a current of magnitude i (per sq. cm.).

¹ Conduction of Electricity through Gases, 2d edition, p. 223.

These electrons move with a velocity which depends on the potential drop through which they have passed. Let us assume, as a first rough approximation, that they move with constant velocity across the space. Then there will be in the unit volume a space charge ρ equal to i/v , where v is the velocity of the electrons. If the velocities are uniform, the space charge will be uniform and it follows from Poisson's equation.

$$(2) \quad \Delta V = \frac{\delta^2 V}{\delta x^2} + \frac{\delta^2 V}{\delta y^2} + \frac{\delta^2 V}{\delta z^2} = -4\pi\rho$$

that

$$(3) \quad \frac{d^2 V}{dx^2} = -4\pi\rho$$

If we consider ρ constant and negative (for electrons), we see from this equation that the potential distribution between the two plates takes the form of a parabola, as indicated by the curve *PST*.

If the temperature of the plate *A* be increased still further, the electron current increases so that the potential curve finally becomes a parabola with a horizontal tangent at *P*.

If we assume that the electrons are given off from the plate *A* with practically no initial velocity, we see that the current cannot increase beyond the point where the potential curve becomes horizontal at *P*, for any further increase of current would make the potential curve at *P* slope downwards and the electrons would be unable to move against this unfavorable potential gradient.

In other words, we see that the effect of the space charge is to limit the current. A further increase in the temperature of the plate *A* would then not cause an increase of current.

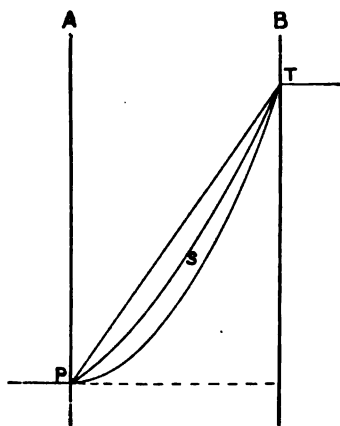

Fig. 2.

Electron Current between Parallel Planes.—Let us now attempt a more rigorous solution of the problem.

It has been shown by Richardson and others that the mean kinetic energy of the thermions is closely equal to that of gas molecules at the same temperature. This indicates that they have velocities so low that very few of them are capable of moving against a negative potential of more than a couple of volts. Since the voltages applied to the anode are much larger than this, we may assume, for convenience, that the electrons are given off by the plate *A* without initial velocity.

Now let V be the potential at a distance x from the plate *A*. The kinetic energy of an electron when it has traveled the distance x from the plate will thus be

$$(4) \quad \frac{1}{2}mv^2 = Ve.$$

The current (per unit area) carried by the electrons at any place will be

$$(5) \quad i = \rho v$$

For convenience, we take e and ρ positive even for electrons. Equation (3) thus becomes (in electrostatic units).

$$(6) \quad \frac{d^2 V}{dx^2} = 4\pi\rho.$$

These three equations enable us to express V as a function of x and i . By eliminating ρ and v from (4), (5) and (6), we obtain

$$(7) \quad \frac{d^2 V}{dx^2} = 2\pi\sqrt{2} \sqrt{\frac{m}{e}} \frac{i}{\sqrt{V}}.$$

Multiply this by $2 \cdot dV/dx$ and integrate

$$(8) \quad \left(\frac{dV}{dx}\right)^2 - \left(\frac{dV}{dx}\right)_0^2 = 8\pi i \sqrt{\frac{2mV}{e}}.$$

Now if there is an opposing (negative) potential gradient at the surface of the plate A , *no current* will flow. If there is a positive potential gradient all the electrons that are given off from the plate A will reach B , so that the current that flows will be determined by Richardson's equation. The case that we are interested in is that in which the current is less than the saturation current and is determined by the voltage of the anode. Evidently for this case the potential gradient at the plate A is zero; that is,

$$\left(\frac{dV}{dx}\right)_0 = 0,$$

whence from (8) by extracting the square root:

$$(9) \quad \frac{dV}{dx} = \sqrt{8\pi i} \sqrt{\frac{2mV}{e}}.$$

Integrating and solving for i , we obtain:

$$(10) \quad i = \frac{\sqrt{2}}{9\pi} \sqrt{\frac{e}{m}} \frac{V^{\frac{3}{2}}}{x^2}.$$

This equation¹ gives the maximum electron current density between two infinite parallel plates with the distance x between them and with a potential difference V . This equation holds only where the initial velocity of the electrons at the plate A is negligible compared to that produced by the potential V . It does not hold at such high voltages that the electrons move with velocities approaching that of light.

Taking $e/m = 1.77 \times 10^7$ E.M. units, reducing to E.S. units and substituting in (10) and then reducing to volt, ampere units, we obtain from equation (10):

$$(11) \quad i = 2.33 \times 10^{-6} \frac{V^{\frac{3}{2}}}{x^2},$$

where i is the maximum current density in amperes per sq. cm., x is the distance between the plates in centimeters, and V is the potential difference in volts.

Electron Current between Concentric Cylinders.—Let us consider a wire of radius a placed in the axis of a cylinder of radius r . Let i be the thermionic current per unit of length from the wire.

For the case of symmetrical cylindrical coordinates, Poisson's equation becomes²

$$\Delta V = \frac{1}{r} \frac{d}{dr} \left(r \frac{dV}{dr} \right) = 4\pi\rho$$

or

$$(12) \quad \frac{d}{dr} \left(r \frac{dV}{dr} \right) = 4\pi\rho r.$$

¹ Since submitting this paper for publication the attention of the writer has been called to the fact that C. D. Child (Phys. Rev., 32, 492, 1911), has already derived this equation. He has, however, applied it only to the case where the conduction takes place solely by positive ions.

² Weber's Differential Gleichungen, 1900, Vol. 1, p. 98.

The equation corresponding to (5) is

$$(13) \quad i = 2\pi r \rho v.$$

These two equations, together with equation (4), which also applies to this case, give us

$$(14) \quad r \frac{d^2 V}{dr^2} + \frac{dV}{dr} = i \sqrt{\frac{2m}{eV}}.$$

This equation probably cannot be directly integrated, but it is possible to obtain a result in terms of a series. The final solution takes the form

$$(15) \quad i = \frac{2\sqrt{2}}{9} \sqrt{\frac{e}{m}} \frac{V^{\frac{3}{2}}}{r\beta^2},$$

where β is a quantity which varies from 0 to 1. The value of β can be obtained by substituting equation (15) in (14) and placing

$$(16) \quad r = ae^\gamma.$$

Equation (14) is thus reduced to

$$(17) \quad 3\beta \frac{d^2 \beta}{d\gamma^2} + \left(\frac{d\beta}{d\gamma}\right)^2 + 4\beta \frac{d\beta}{d\gamma} + \beta^2 - 1 = 0.$$

The solution of this equation gives

$$(18) \quad \beta = \gamma - \frac{1}{3}\gamma^2 + \frac{1}{120}\gamma^3 - \frac{1}{3360}\gamma^4 + \dots,$$

where

$$\gamma = \ln \frac{r}{a}.$$

Mr. E. Q. Adams, of this laboratory, has calculated the values of β for various values of r/a and has shown that the value of β rapidly approaches unity and that for all values of r/a greater than 10, β may for most purposes be taken equal to unity. The following table was prepared from Mr. Adams' data:

TABLE I

r/a	β^2	r/a	β^2
1.00	0.000	5.0	0.755
1.25	0.045	6.0	0.818
1.50	0.116	7.0	0.867
1.75	0.200	8.0	0.902
2.00	0.275	9.0	0.925
2.50	0.405	10.0	0.940
3.00	0.512	15.0	0.978
4.00	0.665	∞	1.000

Since in practical cases the diameter of the cylinder around the wire is usually much more than ten times that of the wire, the formula (1) may usually be written

$$(19) \quad i = \frac{2\sqrt{2}}{9} \sqrt{\frac{e}{m}} \frac{V^{\frac{3}{2}}}{r}.$$

That is, the maximum electron current from a small wire is independent of the diameter of the wire, inversely proportional to the radius of the enclosing cylinder and proportional to $V^{\frac{3}{2}}$.

Substituting numerical values for e/m and reducing to ordinary electrical units (volts, amperes, cm.) equation (19) becomes

$$(20) \quad i = 14.65 \times 10^{-6} \frac{V^{3/2}}{r}.$$

Electron Current between Electrodes of Other Shapes.—It can be shown that between electrodes of any shape the maximum electron current varies with $V^{3/2}$. Let us consider a system in which we have the maximum electron current with the potential difference V . Then Poisson's equation

$$(2) \quad \Delta V = 4\pi\rho$$

holds for such a space, as well as the two equations

$$(5) \quad i = \rho v$$

and

$$(4) \quad \frac{1}{2}mv^2 = Ve.$$

Now let us increase the voltage in the ratio $1:n$ and increase the current in the ratio $1:n^{3/2}$. Equations (5) and (4) thus become

$$\begin{aligned} n^{3/2}i &= \rho v \\ \frac{1}{2}mv^2 &= nVe. \end{aligned}$$

Eliminating v from these, and solving for ρ , we get

$$\rho = ni \sqrt{\frac{m}{2Ve}}.$$

From this we see that ρ has been increased n fold. However, since V has been increased also n fold, Poisson's equation (2) still holds. Hence we see that increasing the current by a factor $n^{3/2}$ and increasing the voltage by the factor n , leads to a condition which still satisfies the three equations (2), (4), and (5). This is, however, equivalent to increasing the current proportionally to $V^{3/2}$. We thus see that whatever the configuration of the electrodes, the *maximum* electron current varies with $V^{3/2}$.

DISCUSSION OF THE THEORY

The foregoing theoretical considerations have indicated that in a space devoid of positive ions, or gas molecules, the space charge caused by the electrons limits the current that flows between a hot cathode and cold anode under a given difference of potential. It now remains to compare the maximum currents obtained in the experiments, with those calculated from the equations that have been derived.

Let us consider the data given in Fig. 1. The maximum electron current at 120 volts was 0.000426 ampere from the hot filament, or 0.00182 ampere per sq. cm. At 240 volts the total current was 0.00130 ampere, or 0.00556 ampere per sq. cm. Since we are not dealing with parallel plane electrodes, nor with concentric cylinders, neither equation (11) nor (20) will apply rigorously. We are, however, mainly concerned in determining whether the space charge is an adequate explanation of the observed limitation of the thermionic current, and therefore can test out the two equations by calculating the distances which would have to exist between plane or cylindrical electrodes in order to give the observed thermionic currents.

We will first test out equation (11), which should apply to parallel plane electrodes. Let us take the observed values of V and i and calculate x . We thus obtain:

$$\begin{aligned} \text{For } V = 120 \text{ volts and } i = 0.00182, \text{ we find } x &= 1.30 \text{ cm.;} \\ V = 240 \text{ volts } \quad i = 0.00556, \text{ we find } x &= 1.25 \text{ cm.} \end{aligned}$$

Our formula thus indicates that the current density between parallel plane electrodes about 1.3 cm. apart would be the same as that observed. This is, however, very close to the actual distance between the electrodes. The very close agreement is probably due to the counter-balancing of two factors: first, the weakening of the electrostatic field, due to the flare of the lines of force around the wires, and second, the reduction of the intensity of the space charge owing to this same flare.

Let us now test the equation (20), which should apply to concentric cylinders. Since the wire was 10.8 cm. long, the values of i (amperes per cm.) were 0.0000394 at 120 volts and 0.000120 at 240 volts. Substituting these values in (20) and solving for r we obtain

$$\begin{aligned} \text{at 120 volts } r &= 490. \text{ cm.}, \\ \text{240 volts } r &= 450. \text{ cm.} \end{aligned}$$

We see that the radius of a cylindrical anode would have to be very large (470 cm.), in order to give only the observed thermionic current. This result, however, appears perfectly reasonable, for the field produced by a small wire anode is naturally much weaker than that produced by a cylindrical anode surrounding the cathode.

The numerical values obtained from these equations are certainly of the right order of magnitude and agree as well with the experimental results as could be expected when the shape of the electrodes departs so far from those assumed in the calculations.

We have seen that the theory leads us to the conclusion that for electrodes of any shape the maximum thermionic current should vary with $V^{2/3}$. This can be readily tested out from the experiment. The ratio of the currents at the two voltages is 3.05. Taking the 2/3 power of this ratio, the voltage ratio should be 2.10, whereas actually it was 2.0. However, it must be remembered that the voltage of the anode was measured from the negative end of the filament, so that the average voltage drop from anode to cathode was about seven or eight volts less than those given. This would give for the voltage ratio 232:112, or 2.07, as against the 2.10 calculated by the three-halves power law.

Several experiments have been undertaken to study the relation of maximum current to voltage over a wide range of voltage. Voltages from 10 volts up to 800 volts have been tried and the results plotted on logarithmic paper. From the slopes of the resulting lines the exponent of the voltage was calculated. Values varying from 1.5 to 1.7 have been obtained. Under certain conditions, to be described in more detail later, values much higher than these are sometimes obtained.

The above considerations indicate that the space charge produced by the electrons is a sufficient cause for the limitation of current observed in the experiments.

EFFECT OF RESIDUAL GASES ON CONSTANTS OF RICHARDSON'S EQUATION

In some of the early experiments on the thermionic current between two tungsten filaments, extremely variable results were obtained for the constants of Richardson's equation. In many cases, however, when anode potentials as high as 150 or 250 volts were applied, a blue glow appeared in the lamp, indicating ionization of the residual gas. To get rid of this, the two filaments were connected in series and both heated to a very high temperature (2900 deg. K.) for a few minutes. This "cleans up" the vacuum to an extremely high degree. The writer is publishing a series of articles in the Journal of the American Chemical Society on the clean up of various gases in a tungsten lamp. It has been found that with a very high temperature of the filament, all gases except the inert ones may be removed practically quantitatively. This treatment of the lamp to improve the vacuum resulted in a marked change in the constants of Richardson's equation and also changed the maximum thermionic currents.

To improve the vacuum still further, in some cases the entire bulb was immersed in liquid air and the filaments were again heated to high temperature for a short time. This sometimes resulted in a further change in the thermionic current.

These effects were clearly due to traces of residual gas. To study them in more detail, some experiments were carried out in which lamp bulbs containing two filaments (or sometimes three) were connected to a vacuum system consisting of Töpler pump, sensitive McLeod gage and trap immersed in liquid air, placed directly below the lamp. The lamps were exhausted to less than 0.0001 mm. and heated for one hour to 360 deg. C., to drive water vapor and carbon dioxide into the liquid air trap. No stop-cocks were used in the entire system, so that vapors of vaseline, etc., were avoided. The liquid air trap prevented the entrance of mercury vapor into the lamp. Care was taken to keep liquid air on the trap day and night during the whole experiment.

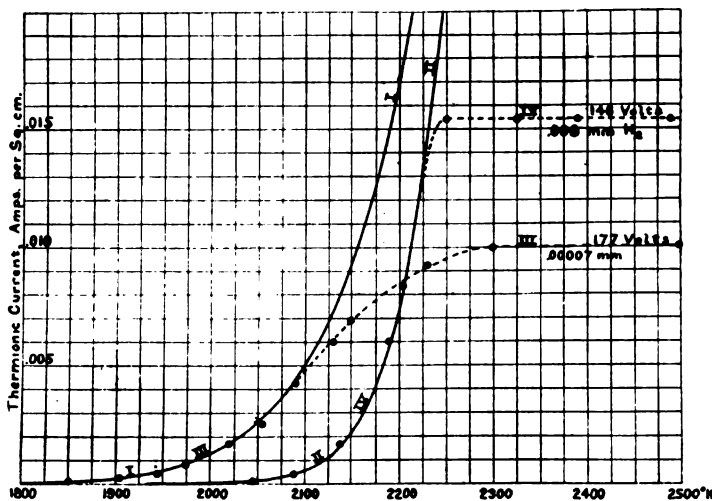

Fig. 3

The constants of Richardson's equation were found to be

$$a = 22.10^6 \text{ amps. per sq. cm.},$$

$$b = 55,800 \text{ degrees.}$$

Liquid air was now placed around the lamp bulb, and the thermionic current again determined. During this run the pressure was constant at 0.00007 mm.

The constants were then found to be:

$$a = 34 \times 10^6,$$

$$b = 55,500.$$

A plot of the curve, calculated from these data by Richardson's equation, is given in Curve I., Fig. 3, together with the experimentally determined points (Curve III).

The effect of cooling the bulb in liquid air was thus to increase the thermionic current considerably (about 60 per cent. at 2000 deg. K.). The filament was now run at 2130 deg. K., at which temperature a thermionic current of 0.00214 amp. was observed. The liquid air was then removed from the bulb. The thermionic current fell rapidly to 0.00049 and then rose to 0.00184, at which it remained steady.

Hydrogen.—Pure hydrogen to a pressure of 0.012 mm. was now admitted. The thermionic current was rather variable, changing gradually with the time, but by

running the temperature up and down several times, fairly consistent results were obtained. The average values of Richardson's constants were

$$a = 5.4 \times 10^{11},$$
$$b = 82,500.$$

The hydrogen had gradually cleaned up during these runs from 0.012 mm. to 0.006 mm.¹ The remainder of the hydrogen was now pumped out (down to 0.00011 mm.) and another run was made to determine the thermionic current in good vacuum. The results were

$$a = 4.3 \times 10^{12},$$
$$b = 85,000.$$

The pressure rose during this run from 0.00011 to 0.00052 mm.

The removal of the hydrogen thus produced relatively little effect, and certainly did not tend to cause a and b to return to the original values in a good vacuum.

More hydrogen (0.007mm.) was now let in, and the constants were found to be

$$a = 7.6 \times 10^{13},$$
$$b = 115,000.$$

During this run the hydrogen cleaned up from 0.007 to 0.004 mm.

A plot of the curve calculated from Richardson's equation is given in Fig. 3 (Curve II), together with the experimentally determined points (Curve IV).

The general effect of the hydrogen had apparently been to lower permanently² the thermionic current, especially at low temperature. It had at the same time increased the value of the constant b to more than double its original value.

Effect of Bulb Temperature.—At this stage in the experiments it was found that touching the bulb with the fingers had a marked effect on the thermionic current. This was due to a temperature effect. With the filament at 2190 deg. K. the current was 0.0011 amp. Warming the bulb slightly lowered the current to 0.0003. Placing ice water around the bulb raised the current to 0.0038. Liquid air, however, gave the same result as ice water. A run with the bulb in liquid air, with a pressure of 0.00025 mm. of hydrogen in the bulb, gave

$$a = 20.4 \times 10^6,$$
$$b = 55,600.$$

These values are very close to those previously obtained with liquid air before any hydrogen had been let into the bulb.

Immediately after this run a beaker containing water at 62 deg. C. was placed around the bulb. The pressure rose to 0.0017 mm. and the values of a and b became

$$a = 7.7 \times 10^{16},$$
$$b = 105,000.$$

A large number of runs were now made at different bulb temperatures. The results were similar to those already given, except that gradually the effect of heating the bulb became less marked and after a couple of days practically the same results were obtained with the bulb at 50 deg. as at 0 deg. For example, two consecutive runs gave

$$\text{at } 0^\circ \quad a = 54.10^6, \quad b = 58,500;$$
$$\text{at } 53^\circ \quad a = 60.10^6, \quad b = 58,500.$$

¹ See paper on Active Modification of Hydrogen, Langmuir, J. Amer. Chem. Soc., 34, 1310 (1912).

² The increase in the value of b in Richardson's equation much more than offsets the increase in a , so that at temperatures in the neighborhood of 2000 deg., the currents in hydrogen are very much smaller than the original currents in vacuum.

Before this condition of insensitiveness to bulb temperature had been reached, tests were made to see if the changes in the thermionic current were due to vacuum changes or absorption of gas by the filament. The effect of interchanging the two filaments was tried many times. That is, the filament which had previously been used as anode was made cathode and vice versa. In no case did this change make any material difference in the magnitude of the thermionic current. The heating of the bulb produced exactly the same effect, regardless of the previous history of the filament. The changes that did occur could clearly all be ascribed to vacuum changes caused by the absorption or evolution of gas by the bulb.

Water Vapor.—The fact that the temperature of the bulb was in some cases so much more important than the pressure of hydrogen indicated that it was the presence of water vapor that caused the decrease in the thermionic current and the increase in *b*. To test this out, the liquid air was removed for a couple of minutes from the liquid air trap below the lamp and then replaced. The effect of thus allowing water vapor to enter the lamp was to make the thermionic current extremely sensitive to the temperature of the bulb. This sensitiveness could be destroyed again by heating the bulb to 360 deg. and cooling.

The conclusion to be drawn from these facts is that the decrease in the thermionic current is due to the presence of traces of water vapor. The McLeod gage gives no indication of such small amounts of water vapor, but the fact that little or no hydrogen is evolved by the action of the filament on the water vapor, together with the fact that the water vapor can remain days in the lamp before diffusing down into the liquid air trap, indicate that the pressure must be extremely low—probably not over 10^{-6} mm. Yet the evidence is strong that such pressures of water vapor have an enormous effect on the saturation thermionic current from tungsten.

Oxygen.—It had been known that water vapor in contact with a hot tungsten filament oxidizes the filament with the liberation of atomic hydrogen. It was, therefore, of interest to know whether the marked effect produced on the thermionic current by water vapor is due to this particular reaction or whether the same effect will not be produced by dry oxygen.

To test this out, the system was exhausted to a pressure of 0.00012 mm. The mercury in the Töpler pump bulb was raised so as to seal off the bulb and pure dry oxygen was admitted to the bulb. The quantity was chosen so that it would give a pressure of 0.005 mm. when allowed to flow out into the whole system by lowering the mercury in the pump bulb.

The filament (*A*) was now run at 2190 deg. K., and the other filament (*B*) was charged 250 volts positively with respect to the cathode. The thermionic current was 0.0031 amp.

On lowering the mercury in the pump bulb and allowing the oxygen to enter the lamp bulb, the thermionic current dropped immediately to 0.00013; that is, to 4 per cent of its original value. As the oxygen gradually disappeared, the current steadily rose in value, as follows:

	Pressure, Mm.	Thermionic Current.
On admitting oxygen.....	0.005	0.00013
After 5 minutes.....	0.0003	0.00030
After 10 minutes.....	0.00016	0.00090
After 15 minutes.....	0.00014	0.00164
After 20 minutes.....	0.00010	0.00230
After 28 minutes.....	0.00007	0.00270

After letting in another supply of oxygen, the thermionic current was determined at various temperatures and gave

$$a = 6.8 \times 10^{13}$$

$$b = 94,300.$$

The effect of oxygen is thus found to be quite similar to that of water vapor.

Nitrogen.—Experiments with nitrogen showed that this gas also usually decreased the thermionic current, although not so strongly as oxygen. Since nitrogen does not clean up as rapidly as oxygen, this gas was chosen for a series of experiments to determine whether other factors, such as anode voltage, had an influence on the Richardson constants in the presence of gas.

Effect of Anode Potential.—In one experiment a pressure of about 0.001 to 0.002 mm. of nitrogen was present in the bulb. A run was made with a potential of 220 volts on the anode, then a run with 100 volts, and then another run at 220 volts. The thermionic currents (milliamperes per sq. cm.) in the three runs were as follows:

TABLE II

Temp.	220 Volts.	100 Volts.	220 Volts.
2045	0.34	0.29
2090	0.70	0.63
2140	1.54	1.29
2190	2.7	4.0	2.9
2250	6.3	4.9	7.0
2325	16.2	5.0	19.3
2390	21.0	5.0	20.0
Pressure of $N_2 =$	0.0015 mm.	0.0012 mm.	0.0012 mm.

These results show that under certain conditions (low temperature and proper pressure of nitrogen) less current is obtained with 220 volts than with 100 volts. In this connection it may be said that these thermionic currents were reproducible and accurately measurable. The values changed gradually, however, as the nitrogen cleaned up.¹

The following are typical runs (Table III) selected from many that were made while the nitrogen was gradually disappearing:

TABLE III

Temp.	PRESSURE 0.00067 MM.		PRESSURE 0.00011 MM.	
	100 Volts.	220 Volts.	100 Volts.	220 Volts.
2045	0.53	0.36	1.58	1.50
2090	1.02	0.86	2.9	2.90
2140	2.50	1.90	3.8	6.2
2190	4.2	4.50	4.4	9.8
2250	4.6	11.8	4.6	11.4
2325	4.8	13.8	11.8
2390	13.9	42.1

Thus, as the nitrogen cleans up, the thermionic current increases and tends to return to its original value. At the same time the peculiar effect of the anode voltage in causing less current to flow at high voltage also practically disappears.

¹ This is the electrochemical clean-up of nitrogen referred to by the writer in a paper on "The Clean-up of Nitrogen in Tungsten Lamps," *Jour. Amer. Chem. Soc.*, 35, 931 (1913).

All the experiments with nitrogen were made with the bulb surrounded with ice. This precaution, however, did not seem necessary in these runs, for at various times the ice was removed, but the thermionic current remained unchanged.

In order to investigate in more detail the effect of the anode potential at various pressures of nitrogen and different filament temperatures, a special experiment was undertaken. A lamp containing two single loop filaments in a large bulb was sealed to the same vacuum system and exhausted as before. The filaments were of 0.0124 cm. diameter and each 8.9 cm. long.

After ageing the filament, the thermionic current was measured at 120 and 230 volts; the constants a and b were:

$$\begin{aligned} \text{at 120 volts } a &= 1.2 \times 10^{13}, & b &= 83,000; \\ \text{230 volts } a &= 4.7 \times 10^{12}, & b &= 80,500. \end{aligned}$$

On the average, even with currents so low that the space charge should have no effect, the thermionic current was about 20 per cent. less with 120 than with 230 volts. This effect, which is just the opposite of that noted in the preceding experiment, is of fairly common occurrence when very special precautions are not taken to avoid traces of certain gases.

The effect of oxygen on the thermionic current with different anode potentials was next tried. In every case the current was greatly reduced by the presence of this gas. The currents obtained with 120 volts and with 230 volts were always practically identical.

Another measurement of the thermionic current in good vacuum (0.0001 mm.) at 120 and 240 volts gave

$$\begin{aligned} a &= 1.1 \times 10^{11}, \\ b &= 74,000. \end{aligned}$$

The curve obtained by Richardson's equation with these constants is given in Curve I, Fig. 4, while Curves II and III are drawn through the experimentally determined points.

A pressure of 0.0021 mm. of nitrogen was now introduced and the following measurements made at 120 and 235 volts. The results are expressed in milliamperes per sq. cm.

TABLE IV

Filament Temp.	PRESSURE 0.0021 MM. NITROGEN	
	Anode 120 Volts	Anode 235 Volts
2000	0.132	0.130
2050	0.278	0.283
2100	0.515	0.552
2150	1.07	1.42
2200	2.90	3.90
2250	6.4	8.0
2300	12.9	16.6
2350	>26	>26.
$a =$	1.66×10^9	2.2×10^9
$b =$	68200	73200

These results are plotted (Curves IV, V, Fig. 4) for comparison with the preceding run in a vacuum. It is to be noted that at temperatures up to 2050 deg. the thermionic current, even with such a high pressure of gas, is not as much affected by the anode voltage as it had previously been found to be in a "good" vacuum. The presence of the

nitrogen has, however, entirely removed all limitation of the current by space charge at the higher filament temperatures.

Some runs were now made with the filament at fixed temperatures while the anode voltage was varied over a wide range. In most cases the pressure of nitrogen was kept as nearly constant as possible at 0.0025 mm.; in some runs, however, the effects produced by a pressure of 0.0010 mm. were studied.

The data from three runs with the filament at 2100 deg. are given in Fig. 5. The points along Curves I and II were obtained with 0.0025 and 0.0010 mm. pressure of nitrogen. The nitrogen was then pumped out to a pressure of 0.00016 mm., and the points along Curve III were then obtained.

These curves help clear up several points that had been left very indefinite by the previous data. At anode potentials below 80 or 90 volts the effect of nitrogen is evidently to increase the thermionic current materially. But above a certain critical potential, which is higher the lower the pressure of nitrogen, the thermionic current decreases as the anode potential is raised. By comparison of the data on these curves with the curves of Fig. 4, it is seen that they are entirely consistent with the latter.

In looking for an explanation of the shape of these curves, it is important to bear in mind that the lower parts of the curves are determined primarily by the space charge. When the thermionic current is plotted against *temperature*, as in Figs. 1 and 3, the lower part of the curve gives the saturation thermionic current (Richardson), while the upper part gives the part which is limited by the space charge. On the other hand,

when we plot the current against the *anode potential*, as in this case, the two parts are interchanged in position; thus the lower part of the curve gives the current as limited by space charge and the upper horizontal part gives the saturation current.

The lower part of Curve III, if obtained in a perfect vacuum, should, therefore, follow equation (11): in other words, the current should increase with $V^{\frac{3}{2}}$. By plotting the first six points of this curve on logarithmic paper, a straight line was obtained, but the slope, instead of giving $3/2$ as the exponent of V , gave 1.71. This difference is certainly due to residual gas. Curve IV, Fig. 5, was obtained by continuing the curve

$$i = \text{constant} \times V^{1.71}.$$

The Curve III separates from IV above 125 volts because the current gradually reaches saturation for the filament at 2100 deg.

We are now in a position to discuss the Curve I and II. At anode potentials below 20 volts the curves seem to coincide fairly well, but the current rapidly increases at

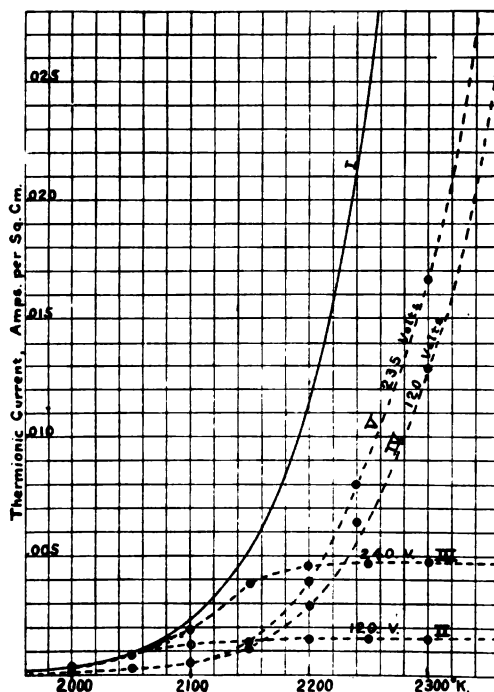

Fig. 4

higher potentials. Plotting the first six points of Curve I on logarithmic paper does not give a straight line, but the exponent of V is found to increase from about 2 to over 6. The cause of this rise in current is probably that positive ions are formed by the collisions of the electrons with nitrogen molecules. The positive ions moving slowly carry only a very minute fraction of the current, yet by their mere presence they materially reduce the space charge and therefore allow a larger current to flow.

If this were the only factor, one would expect with increasing voltage that the current would rise to the normal saturation current and then remain constant until the voltage reaches a point where additional electrons are liberated from the cathode by the impact of positive ions against it. But before this point is reached, some other factor begins to make itself felt. This is

evidently a limitation of the current, not by space charge, but by some phenomenon which prevents the emission of electrons from the cathode. It is, however, not due to a simple alteration of the properties of the material of the cathode, for its magnitude depends on the anode potential.

The following theory seems to be consistent with all the observed facts and may prove to be the correct explanation of the phenomenon.

Theory of the Effect of Nitrogen on the Thermionic Current.—The writer has shown¹ that nitrogen does not react perceptibly with solid tungsten at any temperature, but does react completely with all the tungsten that evaporates from the filament to form the compound WN_2 . The evidence indicated that this compound is unstable at temperatures above 2400 deg. Now although ordinary nitrogen does not react with solid tungsten to form a compound, it is not improbable that nitrogen ions possessing enormously high kinetic energy as compared with the ordinary molecules, will do so. The compound formed, however, being unstable, does not permanently remain on the surface, but either decomposes or volatilizes. Any such process, however, requires a certain amount of time, so that the molecules would remain on or in the surface during perhaps a perceptible fraction of a second. The higher the temperature of the filament the shorter the average time that would elapse between the formation of a molecule of the compound and its elimination from the surface.

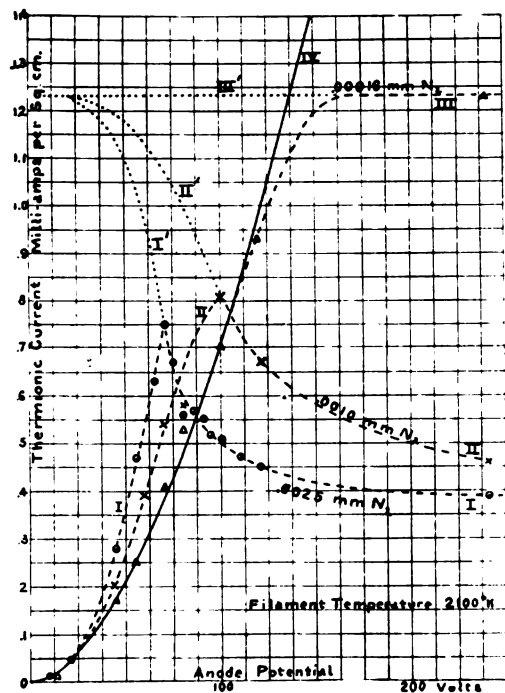

Fig. 5

Let us now apply this theory to the data presented in Fig. 5. At an anode potential below 20 volts, no positive ions are formed, so the surface of the tungsten is not exposed to bombardment. At higher voltages the positive ions are produced in increasing numbers and strike the cathode with increasing velocity. As a result the surface becomes more or less completely covered by a layer of molecules of the compound. Since as a rule a compound would be expected to emit electrons less freely than a metal,

¹ Jour. Amer. Chem. Soc., 35, p. 943 (1913).

it is not unreasonable to imagine this surface layer as being the cause of the decreased electron emission.

In a perfect vacuum the actual *electron emission* from the tungsten is independent of the anode voltage as indicated in Curve III', Fig. 5. However, at low anode voltages the space charge causes most of the electrons to return to the filament, so that the actual *current* obtained is as shown in Curve III. On the other hand, in low pressures of nitrogen the actual electron emission decreases as the anode potential increases, as illustrated by the hypothetical Curve I' and II'. As in the case of the vacuum, however, at low voltages the space charge causes the return of most of the electrons to the cathode, so that the actual curves (I and II) show a current which rises rapidly with increasing potentials. When the potential becomes sufficient to prevent the return of any electrons to the cathode, then the current becomes limited solely by the electron emission from the metal. At high voltages, therefore, the current decreases with increased anode potential because of the increasing proportion of the cathode surface covered with the compound.

The theory thus accounts for the shape of the curves in Fig. 5 in a satisfactory way. It also gives a reason for the shape of the curves obtained with nitrogen, given in Fig. 4.

The effect of nitrogen has invariably been to decrease greatly the saturation current at 240 volts. At low temperatures this effect is much more pronounced than at high. This is indicated by the fact that the introduction of nitrogen (or oxygen) always increases the value of Richardson's constant b from 55,000 up to 80,000 or more. These facts are in complete accord with the theory, for, as has been pointed out, the length of time that the molecules of the compound will remain on the metal would be much less at high temperatures. Therefore, the higher the temperature, the smaller the proportion of the surface covered by molecules of the compound, and the nearer the observed thermionic current approaches the normal saturation current.

Whatever the nature of change in the surface of the tungsten which decreases the electron emission, it is one which does not persist for more than a few seconds after the removal of the nitrogen. In the course of all these experiments, except before ageing the filaments, there were never any effects which could not be immediately duplicated after interchanging the functions of the two electrodes. There is, therefore, no reason to call upon any "inexhaustible supply of gas" in the filament to account for any of the phenomena observed.¹

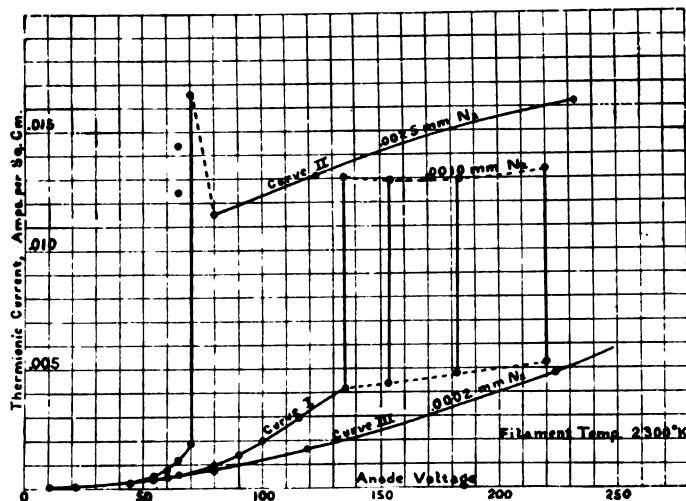

¹ The writer feels strongly that the majority of the cases cited in the literature where fine platinum wires, etc., apparently continue to give off gas after prolonged heating, are caused not by gas from the wire, but by water vapor or other gases liberated from the walls (or vapors from stopcock grease or sealing-wax) which are changed chemically by the hot wire or by electrical discharges.

Effect of Anode Potential at Higher Filament Temperature.—The data on the effect of anode potential obtained with the filament at a higher temperature, 2300 deg. K., is given in Fig. 6. With 0.0010 mm. of nitrogen, the current rose steadily (Curve I) until a potential of about 135 volts was reached. With potentials higher than this, the current would rise to a high value, 0.013 amp. per sq. cm. or more, immediately on lighting the filament, and the discharge was accompanied by a strong purple glow filling the bulb. Suddenly the current fell to 0.005 amp. per sq. cm. or less, and at the same time the purple glow vanished. Every time that this happened the pressure in the system would fall from about 0.0012 to 0.0006 or less, so that fresh nitrogen had to be admitted after each trial.

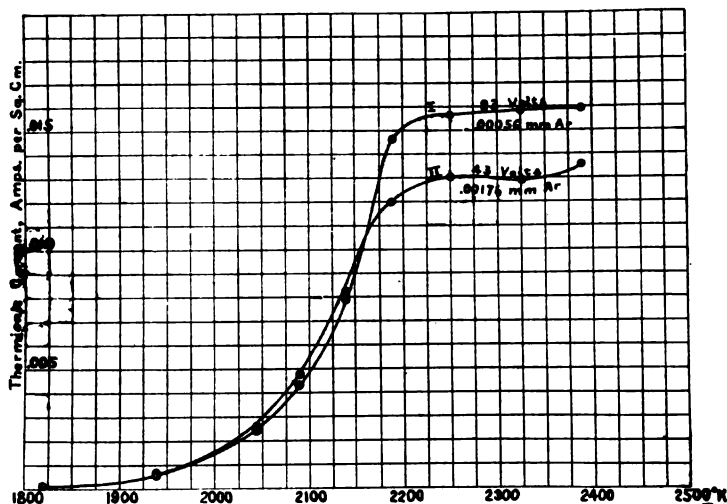

Fig. 7

With a pressure of about 0.0025 mm. of nitrogen (Curve II) a discontinuity occurred in the current values at an anode potential of 70 volts. Above this, however, the current was again steady. These unstable conditions are probably due to ionization reaching such a value that the bombardment of the cathode by the positive ions gives rise to additional electrons. These in turn cause the formation of fresh positive ions. The effect is thus one which can readily become unstable. It is interesting to note, however, that even with this additional electron emission, the current is still less than the *saturation* current in a perfect vacuum, which from Curve I', Fig. 4, would be about 0.050 ampere per sq. cm. Undoubtedly at higher pressures and voltages than those used the currents caused by ionization would ultimately greatly exceed the saturation current from the filament.

Curve III gives the current obtained with a much better vacuum and probably represents very closely the normal current as limited by space charge. The effect of the nitrogen is thus mainly to produce positive ions and neutralize the space charge.

Argon.—A series of experiments was made to determine the thermionic current in low pressures of argon. The surprising result was obtained that the saturation currents were in every case (pressures up to 0.002 mm.) identical with the results previously obtained in the best vacuum. That the argon had the further effect of neutralizing the space charge is shown by the relatively large currents obtained with anode voltages of only 40–100 volts.

In all, about thirty runs were made, and with two exceptions they all gave values of the Richardson constant b between 50,500 and 58,000. The Curves I and II, Fig. 7, are examples of typical runs. It is seen by comparison with Fig. 3 that the maximum currents obtained are considerably larger than those to be had in vacuum with similar

voltages, but these larger currents are due solely to the removal of the limitation imposed by the space charge. At lower temperatures the currents obtained are practically identical with those in vacuum.

Another remarkable fact about the effect of argon on the thermionic current is that considerable admixtures of nitrogen or even oxygen have little or no effect. Thus, while the filament was running at 2190 deg. in argon at 0.0016 mm. pressure, an amount of nitrogen was let in, which raised the pressure to 0.0035, yet the current at 240 volts changed only about 5 per cent.

In another case, while the filament was running under similar conditions as in the test with nitrogen, an amount of oxygen was suddenly admitted sufficient to raise the total pressure from 0.0016 to 0.0035 mm. In this case the current was decreased by about 10 per cent for a few seconds, but rapidly returned within a couple of per cent of the original value. Upon lowering the temperature to 2045 deg., the thermionic current was found to be only 7 per cent of its value in argon, while at 2140 deg. it was 20 per cent of its original value. If these results are compared with those cited previously on the effect of oxygen on the thermionic current, it will be seen that the argon has enormously weakened the effect produced by oxygen, especially at higher temperatures.

Argon acted remarkably in another respect. The thermionic current in argon caused very marked disintegration of the hot cathode; whereas this effect is entirely absent in a good vacuum with a pure electron current, and only present to a very slight degree in pressures of nitrogen as low as 0.002 mm. With the argon the filament rapidly increased in resistance by loss of material which deposited on the bulb in the form of black bands, principally behind the *anode*. These bands had more or less the shape of the anode filament and had a white strip down their centers—evidently the shadow cast by the anode. This proves that the tungsten which was sputtered from the cathode was or became *negatively* charged. It is surprising that the thermionic current was identical with that in a high vacuum, notwithstanding this marked disintegration of the cathode. This experiment certainly proves that there is no necessary relation between cathode disintegration and thermionic current.

These results with argon are strong support for the theory that the positive ions of nitrogen or ordinary molecules of oxygen form unstable compounds with the tungsten which prevent the normal electron emission. Argon not being capable of reacting chemically with the tungsten does not reduce the thermionic currents.

The explanation of the action of argon in preventing oxygen and nitrogen from having their normal effect is probably that the bombardment of the cathode by the positive argon ions, which is undoubtedly (in accordance with Stark's theory) the cause of the sputtering of the cathode, also sputters away any compound formed and thus keeps the surface of the tungsten clean. At lower temperatures and hence lower currents, the sputtering is less marked and therefore the argon interferes less with the normal action of the oxygen.

EXPERIMENTS WITH PLATES AND CYLINDERS AS ANODES

In all the experiments mentioned thus far, the anode has been a tungsten filament which has been freed from gas by heating to 2500 deg. Several experiments, however, were also made with anodes of thin sheet metal, in the form of plates or cylinders. In general, in these experiments, unless very special methods of treating the electrodes are adopted, the evidences of the presence of gas are much more marked than in the experiments with filaments as anodes. A great variety of erratic effects occur, such as

gradual changes in the thermionic current, and various kinds of fatigue effects. Some of these effects are particularly pronounced at low temperatures of the filament. A large amount of data has been obtained in studying these effects, and much of it is of such interest that the results will be published in detail in subsequent papers. For the present it will suffice to consider the results of a few runs at various filament temperatures and anode voltages, in a lamp containing a cylindrical anode.

The anode in this experiment consisted of a cylinder of platinum foil, 3.5 cm. diameter and 6 cm. long. Inside of this, about 1 cm. apart, were placed two single loop tungsten filaments of wire 0.0127 cm. diameter and each 9.9 cm. long. The surface of each was thus 0.40 sq. cm. A cylindrical glass bulb fitted closely about the platinum cylinder.

The platinum cylinder, before placing in the lamp bulb, was ignited for a few minutes over a blast lamp to a white heat and washed with nitric acid, but, other than this, purposely not subjected to special treatment.

This lamp was sealed to the same system as before and the same care was used in exhausting it as in the other experiments. That is, after exhausting to 0.001 mm., the bulb was heated to 370 deg. C. for an hour and a half. From the beginning to the end of the experiment the trap directly below the lamp was kept in liquid air.

During the first few days the results were extremely erratic and were characterized especially by lag or fatigue effects. The results showed clearly, however, that these were not due to gas contained in the filament, but were rather caused by gas from the anode liberated by electron bombardment. The quantities of gas liberated, however, were very small so that even with the Töpler pump no great difficulty was experienced in keeping the pressure continually below 0.001 mm.

The runs about to be described were made on the tenth day after the beginning of the experiment. By this time most of the erratic effects had disappeared and the results obtained were beautifully reproducible.

A series of runs was made with the following anode voltages, and in the following order: 240, 124, 30, 50, 70, 90, 70, 50, 30, 20, 110, 124. At each voltage the thermionic currents were measured at temperatures from 1850 deg. to 2350 deg. or 2500 deg., in steps of 50 deg. The pressure during all these runs varied within the limits 0.00007 to 0.00023 mm. In every case different runs at the same anode voltage gave practically identical results. Furthermore, at temperatures so low that saturation current was obtained, the thermionic currents at different voltages were the same. The results of these runs are given in Fig. 8. All the experimentally determined points are given, except where the curves run together, and then the points for the curve made at 110 volts are given.

For comparison with these results, the Curve I, of Fig. 3, has been replotted in Fig. 8 (continuous heavy line). This curve gives the results that were obtained under good conditions in a vacuum and in a case in which temperatures were determined in the same manner as in the present experiment.

The upper portion of the curve (not given in Fig. 3) was calculated by Richardson's equation, using the constants

$$a = 34 \times 10^6,$$
$$b = 55,500.$$

It will be seen, from Fig. 8, that the currents obtained with the cylindrical anode are much larger than any recorded previously in this paper. Thus with 110 volts or more, currents up to 0.350 ampere per sq. cm. (actual current measured was 0.139 amp.) were obtained. But the curves show plainly that at the *same temperature* of the fila-

ment, the currents are always less than those obtained under the best vacuum conditions. The shape of the anode reduces the effect of space charge and thus allows much more current to flow with the same voltage than in the previous experiments.

This experiment offers the most convincing evidence possible of the correctness of the general theory of the effects of gas outlined previously.

According to this theory, the effect of certain gases (probably most gases except the inert gases) is to *cut down* the normal electron emission from the heated metal, by the formation of an unstable compound on the surface. At higher temperatures the rate of decomposition or evaporation of the compound is greater and hence fewer molecules of the compound remain on the surface. At sufficiently high temperatures the compound should completely disappear and thus allow the electron emission to become normal.

The present experiment is in full accord with this theory. At low temperatures the electron emission (saturation current) is much less than the normal, but at higher temperatures it increases rapidly up to the normal value, but the current *never exceeds the normal current*.

These facts are made much clearer by plotting $\log i/\sqrt{\tau}$ against $1/T$ (Fig. 9). With these functions as coördinates, the points should lie on a straight line if the current follows Richardson's equation. Curve I is the normal vacuum curve shown in Figs. 3 and 8, and Curve II is that

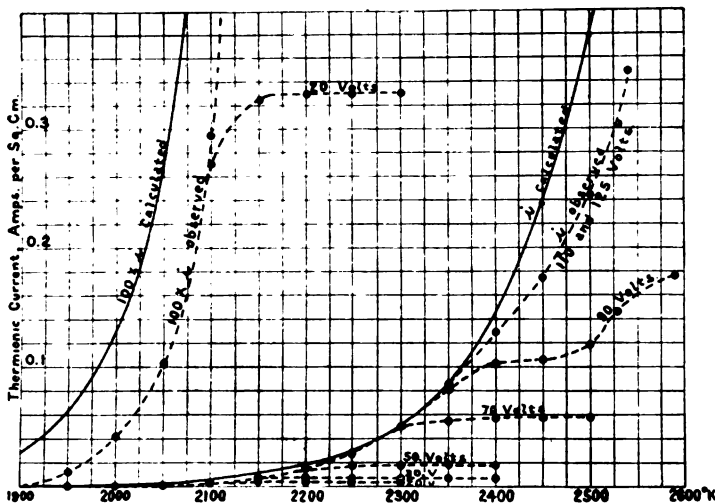

Fig. 8

obtained from the experiment with the cylindrical anode at a potential of 110 volts. It is seen that the second line is not straight. The lower part is practically straight, but the upper part *does not cross* the normal vacuum curve, but instead bends over and joins it. The reason that it does not follow it at higher temperatures, is probably that space charge is having some effect, as in the run with 90 volts (see Fig. 8). The *extremely close* coincidence between the observed, and calculated curves over the short range of contact is undoubtedly partly accidental.

The fact that the curves obtained at low anode voltages (20–30 volts) coincide at lower temperatures with the curves obtained with high potentials, shows in this case that the compound on the surface is not formed from positive ions, but is formed directly by a reaction between the gas and the metal. The gas in this case is probably carbon monoxide or hydrogen, and can easily be supposed to react in this way to form unstable compounds. With nitrogen, on the other hand, the evidence is good that the compound forms only when positive nitrogen ions strike the filament.

The effect of the gas in eliminating the space charge is strikingly shown in this experiment. At higher potentials the thermionic current increases much more rapidly than the three halves power of the voltage. This shows that positive ions are formed

which reduce or eliminate the space charge produced by the electrons, yet themselves do not carry a perceptible portion of current.

Some other experiments, to be described in detail in a subsequent paper, have shown that the bombardment of the cathode, even by positive ions of a velocity corresponding to only 110 volts, causes the cathode to emit electrons having a velocity corresponding to 6-12 volts. Thus a third filament in a bulb in which a thermionic current is flowing often charges up rapidly to a potential of 10 volts *negative* with respect to the *negative* end of the cathode filament. This observation is entirely in line with previous observations on delta rays and electron emission caused by canal rays.

GENERAL DISCUSSION

The evidence presented in this paper and the theories that have been advanced are

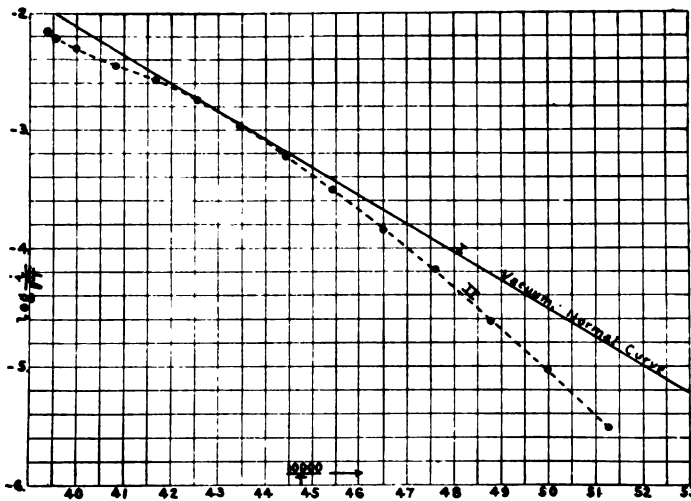

Fig. 9

thought to throw a rather new light on the electron emission from incandescent solids in high vacuum.

In the first place, the work indicates that the experimental conditions that have commonly been employed in the investigation of thermionic currents in vacuo have not been well adapted to eliminate important secondary effects. The proper conditions seem to be:

1. Extremely high vacuum; that is, a pressure below 0.0001 mm. should be obtained.

The presence of certain gases is much more injurious than others. Gases such as oxygen, water vapor, carbon dioxide, and hydro-carbons, which are very active chemically at high temperatures, should be especially avoided. This means that all stopcocks and sealing-wax must be eliminated and all glass parts not to be cooled by liquid air must be heated for at least an hour to 360 deg. or more. Even with the Gaede molecular pump these precautions are necessary.

2. Avoidance of large anodes, except those that have been especially treated by heating in a vacuum to 2000 deg. or have been exposed to powerful electron bombardment in a very high vacuum. Treating the metal by making it an electrode in an ordinary glow discharge, except when the inert gases are used, is about the worst thing that could be done to it. Preferably, the anode should consist of tungsten wire which is freed from gas by heating to 2500 deg. for ten minutes. This should be done in the apparatus itself.

3. The relative position and size of the electrodes should be such that space charge does not limit the current to an undesirable degree.

If proper precautions are taken to obtain an extremely high vacuum, and if the anode consists of molybdenum or tungsten and is given a preliminary treatment by exposing to very powerful electron bombardment, it is possible to use cylindrical anodes without obtaining the slightest evidence of positive ionization. For this purpose the

anode should be charged to several thousand volts and the filaments raised to such temperatures that 50–200 milliamperes thermionic current are obtained. Under these conditions the anode becomes heated to a bright red or white heat, and the combined effect of the electron bombardment and the high temperature is to free the anode from gas. After such treatment pure electron currents of several tenths of an ampere may be obtained without positive ionization. Dr. Dushman has found that under these conditions the space charge equation (20) holds with a high degree of accuracy.¹ In this way, by using three cylindrical anodes on the guard-ring principle, it should be possible to use equation (20) to determine the value of e/m with a degree of precision greater than that obtainable by any other method. Neither the writer nor Dr. Dushman intends to make such precision measurements and, therefore, we should like to suggest that this method be seriously considered by those who plan to make such determinations.

Failure to observe the conditions given above has, it is feared by the writer, very seriously vitiated most of the quantitative results obtained in the past on thermionic current in a vacuum. It is also undoubtedly the principal cause of the opinion which is so prevalent today that the electron emission from hot solids is a secondary effect, probably usually produced by chemical reactions, which would disappear if a perfect vacuum could be obtained.

The evidence presented in this paper will, it is hoped, counteract these unfortunate tendencies and help place the Richardson theory of electron emission on a firm footing or at least stimulate the critical study of the theory. The thermionic effect is of at least as great intrinsic interest as the photoelectric effect, and should receive as much, if not more, attention on the part of physicists.

Let us now examine more closely some of the experiments which have led to the common knowledge of thermionic currents in vacuo.

With platinum wires extremely variable results have been obtained. H. A. Wilson found that by heating the wire in oxygen or by previously boiling it for 24 hours in nitric acid, the thermionic current would be reduced to the 100,000th part of its original value. This lower value, however, he considers the normal value in a vacuum, and believes the increase observed when hydrogen is admitted to be due to some secondary effect.

The effect of oxygen on the thermionic current from platinum is so strikingly similar to that observed with tungsten that the writer can not help but feel that the cause in both cases is similar. The writer has found², and will soon publish his results in detail, that when a platinum wire is heated in oxygen at low pressure, the platinum evaporates at the *same rate* as in a vacuum and that the platinum *vapor* combines quantitatively with the oxygen after it leaves the surface of the wire to form the compound PtO_2 . This is identically the same type of reaction that has been observed with tungsten and nitrogen. This suggests strongly that oxygen would have a similar effect on the thermionic current from platinum that nitrogen has on tungsten. In other words, the oxygen would cut the thermionic current down to a value *lower* than the normal vacuum current. Hydrogen would reduce the oxide and allow the normal current to flow. Of course it is quite possible, although not probable, that some gases may increase the thermionic current instead of decreasing it.

PRING AND PARKER'S EXPERIMENTS³

The excellent experiments of these investigators have been perhaps the most convincing evidence that the thermionic electron emission is a secondary effect. Let us, therefore, criticize the experiment in the light of the new theory.

¹ These results will soon be published by Dr. Dushman.

² Jour. Amer. Chem. Soc., 35, p. 944 (1913).

³ Phil. Mag., 25, 192 (1912).

In the first place, carbon is a substance which at high temperatures is particularly active chemically, so that it probably reacts with every gas present in the system. The residual gases may, therefore, be expected to have a particularly strong action in reducing (or possibly increasing) the thermionic current. Although Pring and Parker have attempted to obtain a high vacuum, and have measured the pressures, yet the best vacuum they claim to have attained, while heating the cathode, is 0.001 mm. Actually, however, the pressure must have been at least several times this amount, for mercury vapor (0.002 mm.) had free access to the apparatus and they used "soft wax" in several places, which gives off large quantities of various vapors, all of which are readily condensable and therefore not indicated by the McLeod gauge.

In the second place, the distance between anode and cathode in their experiments varied from 4.8 to 11 cm., so that in a perfect vacuum, with only 330 volts on the anode they could have obtained only very little current because of the space charge. For example, if we calculate from equation (11) the total current that could be carried at 330 volts between two electrodes 8.0 cm. in area at a distance of 4.8 cm., we obtain only 0.0048 ampere. Whereas Pring and Parker obtained currents as high as 40 amperes, with only 40 to 60 volts in the beginning; later on, after the carbon had ceased giving off large quantities of gas, the currents fell to as low as 0.000016, with the temperature of the carbon rod at 2050 deg.

The reason that the currents in their experiments went down to values so much below that which we have calculated above from the "space charge" equation may possibly be that the electron emission was actually decreased to that low value by the presence of gas. A much more probable explanation suggests itself by referring to the diagram of their apparatus (Fig. 1, Pring and Parker's paper). Apparently they have placed a glass cylinder, *F*, around the anode, in order to protect the walls of the tube from the radiation from the hot anode. In discharges at high pressures this cylinder would have little or no effect on the discharge, but at low pressures, where the free path of the electrons from the cathode becomes commensurate with the distance (apparently about 2 cm.) from the cathode to this cylinder, the effect is very important. At very low pressures these electrons charge up the cylinder to the potential of the anode and therefore practically destroy the potential gradient close to the cathode, where it is especially needed to remove the space charge. The writer has often observed effects of this kind in connection with his work; in fact, in very high vacuum the charging up of the glass sometimes becomes very troublesome. Thus, in some cases, after measuring a thermionic current with 240 volts on the anode, no current at all will be obtained when the anode potential is changed to 120 volts. By touching the bulb with the hand and then with the other hand touching the positive terminal of the direct current supply line, the current instantly starts up again.

In Pring and Parker's experiments, therefore, as the vacuum improved, the potential available for the removal of the space charge decreased very rapidly, and this effect is probably responsible for the extremely small currents obtained by them in some cases.¹

LILIENFELD'S EXPERIMENTS²

Lilienfeld has concluded from the results of very careful and elaborate experiments in which he took precautions to obtain a particularly high vacuum, that positive ions play an essential role in conduction of electricity, even through the highest vacuum.

¹ Ann. Phys., **32**, 673 (1910).

² In still more recent work Pring (Proc. Roy. Soc., **89**, 344, 1913) again finds the electron emission from carbon to be due entirely to secondary effects. Undoubtedly the large currents that have often been obtained are due to these cause but some measurements we have made show clearly the existence of a true electron emission. (See Appendix.)

He finds that beyond a certain point these effects are entirely independent of the degree of vacuum. He finds also that the potential gradient is uniform in the space between the electrodes and that the current varies almost exactly proportional to the *square* of the potential gradient. He shows from these results that there is no space charge (except at extremely low currents), but that there must be equal numbers of positive and negative ions in every unit of volume.

Lilienfeld used a Wehnelt cathode as a source of electrons, and anodes of platinum foil, which were kept cold by liquid air while the discharge passed.

These results are so radically different from those that have been described in the present paper that they call for comment. The effects observed by Lilienfeld are certainly real, and prove that the kind of discharge that he was studying is totally distinct from the pure electron currents that have been obtained with hot tungsten cathodes.

The essential difference in the conditions is undoubtedly the use of the Wehnelt cathode.

From some experiments made in this laboratory with Wehnelt cathodes, and judging from the experiments of Child,¹ the writer is strongly of the opinion that the Wehnelt cathode is not a primary source of electrons at all, but is simply a cathode which is particularly sensitive to bombardment by positive ions and under the influence of such bombardment emits electrons copiously.

In Lilienfeld's experiments, with the long and crooked path between anode and cathode, the space charge would have prevented a pure electron discharge from taking place. The Wehnelt cathode, however, probably liberates quantities of gas sufficient to furnish the positive ions necessary. It is also possible that Lilienfeld obtained a steady evolution of sufficient gas by the electron bombardment of the anodes which had never been properly freed from gas.

APPENDIX²

Since the foregoing paper was written, a large amount of data on thermionic currents from various metals has been obtained under conditions of still better vacuum. The measurements thus far made are of a preliminary nature, but seem to indicate that the normal thermionic current from tungsten is even larger than that previously given. Much more accurate determinations of the thermionic currents from tungsten, tantalum, molybdenum, platinum and carbon are in progress, and will be published. The results thus far show that with all these substances, the effect of residual gases is always to decrease the thermionic current. Often the current obtained after the best vacuum conditions have been attained is 100-1,000 times as great as that observed when only the usual means of obtaining so-called high vacuum are employed.

The following preliminary results, giving the observed thermionic currents in milliamperes per sq. cm. from various filaments at 2000 deg. K., may be of interest, but should be considered merely as lower limits to the normal electron emission in a perfect vacuum:

Metal.	Thermionic Current at 2000 deg. K. Milliamps. per Sq. Cm.	Richardson's Constant <i>b</i>
Tungsten.....	3	55,000
Tantalum.....	7	50,000
Molybdenum.....	13	50,000
Platinum.....	0.6	80,000
Carbon.....	1.0	32,000

¹ *Phys. Rev.*, 32, 492 (1911).

Added during correction of proof.

The values of b given in the last column are probably all slightly too high. With platinum it is extremely difficult to get concordant results, probably because the surface film is fairly stable, even close to the melting-point of the metal. Fredenhagen¹ has recently given reasons for concluding that none of the measurements thus far made of thermionic currents from platinum have really given anything more than secondary effects. He suggests that the presence of an oxide film may seriously affect the results. Our experience has fully confirmed his conclusions.

SUMMARY

It is shown both theoretically and experimentally that the mutual repulsion of electrons (space charge) in a space devoid of positive ions, limits the current that flows from a hot cathode to a cold anode. For parallel plane electrodes of infinite extent, separated by the distance x , and with a potential difference V between them, the maximum current (per unit area) that can flow if no positive ions are present is

$$i = \frac{\sqrt{2}}{9\pi} \sqrt{\frac{e}{m}} \frac{V^{\frac{3}{2}}}{x^2}.$$

For the analogous case of an infinitely long, hot wire, placed concentrically within a cylindrical anode, of radius r , the maximum current per unit length is

$$i = \frac{2\sqrt{2}}{9} \sqrt{\frac{e}{m}} \frac{V^{\frac{3}{2}}}{r\beta^2},$$

where β varies from 0 to 1, according to the diameter of the wire, but for all wires less than 1/20 the diameter of the anode, β is a quantity extremely close to unity.

2. In the presence of gas at pressures above 0.001 mm., and at voltages above 40 volts, there is usually sufficient production of positive ions to reduce greatly the space charge and thus allow more current to flow than indicated by the above equations.

3. It is shown, contrary to the ordinary opinion, that the general effect of very low pressures of gas is to *reduce* greatly the electron emission from an incandescent metal.

4. This effect is especially marked at low temperatures. In most cases it probably disappears at very high temperatures.

5. The constant b of Richardson's equation

$$i = a\sqrt{T}e^{-\frac{b}{T}}$$

is always increased, in the case of tungsten, by the introduction of oxygen, nitrogen, water vapor, carbon monoxide or dioxide. Argon, however, has no effect on either constant.

6. The normal thermionic current from tungsten in a "perfect" vacuum follows Richardson's equation accurately. The constants are approximately:

$$a = 34 \times 10^6 \text{ amps. per sq. cm.,}$$

$$b = 55,500.$$

7. Preliminary data are given for the electron emission from tantalum, molybdenum, platinum and carbon. With these substances also the effect of gases is to decrease greatly the electron emission.

8. The effect of nitrogen in decreasing the thermionic current from tungsten depends on the voltage of the anode. In many cases less current is obtained with 240 volts than with 120 volts. With oxygen, the effect seems independent of the anode voltage.

¹ Leipziger Berichte, math. phys. Kl., 65, 42, 1913.

9. The following theory seems to account for most of the observed phenomena and is apparently not inconsistent with any:

The effect of gases in changing the saturation current is due to the formation of unstable compounds on the surface of the wire. In the cases observed the presence of the compound decreases the electron emission. It is possible, however, that in some cases it might cause an increase. The extent to which the surface is covered by the compound depends on the rate of formation of the compound and on its rate of removal from the surface. The compound may be *formed* on the surface directly by reaction with the gas (for example, oxygen), or by reacting principally with positive ions which strike the surface (nitrogen). The compound may be *removed* from the surface by decomposition, evaporation, or cathode sputtering (*i. e.*, being driven off by bombardment of positive ions).

10. The experimental conditions which should be met, in order to study most easily the thermionic currents in high vacuum, are discussed. It is pointed out that failure to observe these conditions is probably the cause of other investigators having found that the thermionic currents tend to decrease with increasing purity of the cathode and progressive improvement of the vacuum.

11. It is concluded that with proper precautions the emission of electrons from an incandescent solid in a very high vacuum (pressures below 0.10^{-6} mm.) is an important specific property of the substance and is not due to secondary causes.

In conclusion, the writer wishes to express his appreciation of the valuable assistance of Mr. S. P. Sweetser, and Mr. William Rogers who have carried out most of the experimental part of this investigation.

RESEARCH LABORATORY,
GENERAL ELECTRIC COMPANY,
SCHENECTADY, N. Y.



A POWERFUL ROENTGEN RAY TUBE WITH A PURE ELECTRON DISCHARGE*

By W. D. COOLIDGE

RESEARCH LABORATORY OF THE GENERAL ELECTRIC COMPANY, SCHENECTADY, N. Y.

§ 1. INTRODUCTION

In an earlier publication attention has been called¹ to the use of wrought tungsten for the anticathode, or target, of a Roentgen tube of the ordinary type. In the development of this target many different designs were made and mounted in tubes, and these tubes were operated on what was then the most powerful Roentgen apparatus on the market, a 10-kw. transformer coupled to a mechanical rectifying device. The operation of tubes in this manner, to see how much energy it took to ruin the target, gave perhaps an unusual viewpoint. When, as a result of these experiments, a satisfactory form of target had been developed, the writer became interested in studying the remaining limitations in the tube. Some of these limitations are the following:

1. With low discharge currents the vacuum gradually improves, with a consequent increase in the penetrating power of the rays produced.

2. With high discharge currents there are very rapid vacuum changes, sometimes in one direction and sometimes in the other.

3. If a heavy discharge current is continued for more than a few seconds the target is heated to redness and then gives off so much gas that the tube may have to be re-exhausted.

4. If the temperature of the standard copper-backed target is allowed to get up to bright redness, a rapid deposition of metallic copper begins to take place on the bulb, continuing for some time after the cutting off of the current, owing to the very slow rate of cooling from such temperatures in the evacuated space.

5. Of the tubes tested, very many have failed from cracking of the glass, and this, with one exception, always at the same point; that is, in the zone around the cathode. In many cases there has first been chipping-out of the glass from the inner surface of the tube at this point.

6. The focal spot on the target in many tubes wanders about very rapidly.² In many cases where it does not show a tendency to wander, it will be found after a heavy discharge to have permanently changed its location.

7. While it is relatively easy to lower the tube resistance by means of the various gas regulators, it is a relatively slow matter to raise it much.

8. With very heavy discharges, the central portion of the usual massive aluminum cathode melts, and the molten globules so formed are shot right across the tube, flattening themselves out on the glass and sticking to it. When the melted area is small, no harm is done except that the curvature of the cathode at this point may be changed, and the focal spot may, in consequence, be moved.

* Copyright, 1913, by the American Physical Society.

From the *Phys. Rev.*, Vol. II, 409-430 (1913).

¹ Coolidge, *Trans. Am. Inst. E. E.*, June, 1912, pp. 870-872.

² In radiographic work, movement of the focal spot during an exposure is of course detrimental to good definition.

9. No two tubes are exactly alike in their electrical characteristics.

10. The characteristics are in general far from ideal, in that the penetrating power of the Roentgen rays produced changes with the magnitude of the discharge current.

It was found that limitations 3 and 4 could be removed by the use of a massive all-tungsten (in place of the usual copper-backed) target. Such a target can be run continuously at intense white heat. Aside from eliminating the troubles incident to the use of copper, the all-tungsten target does not change the general characteristics of the tube.

An attempt was made to remove limitation 8, imposed by the low melting point of aluminum, by substituting for it a tungsten cathode of the same dimensions. Tubes made up in this way showed a behavior entirely different from that of the ordinary tube. They would have been absolutely hopeless from the standpoint of a practical radiographer. They were like the ordinary Roentgen tube which is in the condition which the radiographer describes as "cranky." Upon passing a discharge current of any magnitude through the tube, the resistance would quickly rise to a point where, even with an impressed potential difference of 100,000 volts, no further discharge would pass. The tube could be restored to its original condition by the liberation of gas from the vacuum regulator. The phenomena would repeat themselves as often as one cared to make the experiment. Continuous operation for even a few seconds seemed out of the question. It finally developed, however, that with the adoption of the following expedient, the situation changed. Gas was admitted from the regulator and a discharge passed through the tube. As soon as the resistance had risen, more gas was admitted and the tube was again excited. These operations were repeated as rapidly as possible. With each excitation of the tube, the cathode became hotter. There was evidently the same focusing of the positive ions bombarding the cathode as there was of the electrons at the anticathode, for there was a similar localization of heat at the two electrodes. A little conical depression which formed at the center of the cathode showed that, with the vacuum range employed, the positive ion bombardment was, at least mainly, confined to an area only about 2 mm. in diameter. As soon as the cathode had become heated to bright incandescence,¹ the behavior of the tube changed, and it could then be operated continuously for at least several minutes. Upon interrupting the discharge for a short time, and so allowing the cathode to cool, the "cranky" condition returned, and the tube could again be operated continuously only after repeating the procedure outlined above.

Tubes like the above with tungsten cathodes showed, upon operation, a rapid blackening of the bulb. The deposit proved to be metallic tungsten. The conical depression which invariably formed at the center of the cathode seemed to indicate that this was the source of the deposit, the disintegration of the metal at this point being doubtless due to the mechanical action of the positive ions which bombard it.

The extreme instability of vacuum attendant upon the use of a tungsten cathode in what was otherwise a standard Roentgen tube called attention very forcibly to the part which is played by gases in the ordinary aluminum cathode. (The tungsten cathodes used must have been, from their method of manufacture, relatively very free from gas.)

A consideration of the above-mentioned limitations showed that they were for the most part incident to the use of gas and that they could therefore be made to dis-

¹ The magnitude of the heating effect at the cathode was much greater with tungsten than it is with aluminum cathodes. In one case the cathode and the anode, which functioned also as anticathode, were both made of tungsten, exactly alike in size and shape and symmetrically placed in the tube (concave faces towards each other). On continuous operation, both ran at white heat, and, as nearly as the eye could judge, at the same temperature. Where aluminum is used as the cathode material, much less heat is developed in the cathode than in the target. Willey (Vernon J. Willey, Archives of the Roentgen Ray, XII, p. 250, 1908) finds in tubes of the ordinary type that 75 to 85 per cent of the total heat evolution in the tube, inclusive of the glass walls, takes place at the target.

appear if a tube could be operated with a very much higher vacuum. In this case the electrons would have to be supplied in some other way than by bombardment of the cathode by positive ions.

Richardson¹ and others had shown that electrons might be produced by simply heating the cathode. But the values of the thermionic currents obtained by different observers had varied between wide limits, so much so as to suggest that a Roentgen tube based upon this principle might be as unstable in resistance as is the standard tube. Moreover, the fact that the substances usually worked with, platinum and carbon, are so difficult to completely free from gas, suggested strongly that with the cleaner conditions (greater freedom from gas) that could be realized by the use of tungsten, the thermionic currents might cease altogether.² Some experiments of Dr. Irving Langmuir,³ however, on the thermionic currents between two tungsten filaments in a highly evacuated space, were very reassuring. According to his observations, after a certain high degree of exhaustion had been reached, the thermionic currents increased, up to a certain limiting value, as the tube became freer and freer from gas.

The idea of using a hot cathode in a Roentgen tube was not new, but, so far as the writer could learn, the principle had never been successfully applied in a vacuum good enough so that positive ions did not play an essential rôle.

Wehnelt and Trenkle⁴ had used a hot lime cathode for the production of very soft Roentgen rays, working with voltages from 400 to 1000. Wehnelt, in another article, describes the use of his lime cathode in a Braun tube, and here he says that it is not advisable to employ more than 1000 volts, as otherwise cathode rays come off from that part of the platinum which is bare, giving bad disintegration.

The Roentgen rays produced by voltages as low as 1000 are, of course, too "soft" for the ordinary applications.

Lilienfeld and Rosenthal⁵ had described a Roentgen tube whose penetrating power is, they say, independent of vacuum. Their main aluminum cathode and their platinum anticathode are shaped and located like the electrodes in the ordinary Roentgen tube. Besides these they have an anode and an auxiliary hot cathode. Current from a low voltage source passes from the hot cathode to the anode and this current furnishes the positive ions which by their bombardment of the main cathode liberate electrons from it. Their tube is dependent for its operation on the presence of positive ions, for without these there is no means provided for getting electrons out from the main, aluminum, cathode. Lilienfeld concludes from his extended experiments in tube exhaustion that the complete removal of all gas from tube and electrodes would not do away with positive ions. There would according to this view be no such thing as a pure electron discharge. Lilienfeld's work in exhausting the gas from the tube itself and from the glass seems to have been excellent, but according to the experience of the writer, his electrodes were not sufficiently freed from gas to justify the conclusions drawn. Working even with tungsten electrodes in a tube so designed that the electrodes could be heated in place to very high temperatures, the writer has had the positive ion effects persist for hours, disappearing completely however as the electrodes become sufficiently freed from gas.

¹ Proc. Camb. Phil. Soc., XI, 286 (1902); Proc. Roy. Soc., LXXI, pp. 415-418 (1903).

² See Goldstein, *Ann. der Physik*, 24, p. 91, 1885. He finds that platinum must be heated almost to its melting point to give an appreciable thermionic current. Also see H. A. Wilson, *Proc., Roy. Soc.*, 78, pp. 272-276 (1903). He concludes with the following statement: "It is probable that a pure platinum wire heated in a perfect vacuum would not discharge any electricity at all, either positive or negative, to an extent appreciable on a galvanometer."

³ This work is just being published.

⁴ A. Wehnelt and W. Trenkle, *Sitzungsber. d. Phys.-Medic. Soc. in Erlangen*, 37, 312-315 (1905).

⁵ J. E. Lilienfeld and W. J. Rosenthal, *Fortschritte auf dem Gebiete der Röntgenstrahlen*, 18, 256-263 (1912).

The work of Dr. Langmuir had shown that a hot tungsten cathode in a very high vacuum could be made to yield continuously a supply of electrons at a rate determined by the temperature.

Further work showed that very high voltages, up to at least 100,000, in no wise affect this rate of emission. For application to the fields of radiography and fluoroscopy, it was necessary to develop a satisfactory method of focusing. And, finally, the large amounts of energy transformed into heat in a Roentgen tube render imperative the use of a very heavy target, and this made it necessary to develop methods for sufficiently freeing from gas large masses of metal.

The result of efforts in this direction has been entirely successful, and tubes have been made, based upon this principle, which are free from all of the above-mentioned limitations. This is of particular physical interest because it brings all of the peculiarities of the Roentgen ray tube into accord with the modern conception of electronic conduction and gas molecule decomposition. In the following, it will be sufficient to describe one type (a focusing tube) and its characteristics, leaving for later papers the description of other types.

§ 2. GENERAL DESCRIPTION OF THE NEW TYPE OF TUBE

The structural features of the new tube which differ from those of the ordinary type are the following:

The pressure, instead of being, as in the ordinary tube, a few microns, is as low as it has been possible to make it, that is, not more than a few hundredths of a micron.

The cathode consists of a body which can be electrically heated (such as a tungsten or tantalum filament) and, suitably located with reference to this portion, an electrically conducting ring or cylinder, consisting preferably of molybdenum or tungsten or other refractory metal. The ring or cylinder is connected either to the heated portion of the cathode, or to an external source of current by means of which its potential may be brought to any desired value with respect to the heated portion. The heated portion of the cathode serves as the source of electrons, while the ring or cylinder assists in so shaping the electrical field in the neighborhood of the cathode that the desired degree of focusing of the cathode-ray stream upon the target shall result.

The anticathode, or target, functions at the same time as anode.

The operation is satisfactory only when the vacuum is exceedingly high, so high that the ordinary tube would carry no current even on 100,000 volts.

§ 3. THEORY OF OPERATION

As will be seen from the characteristics of the tube, in § 5, it gives, in operation, no evidence of positive ions. This makes the theory of its operation exceedingly simple.

The discharge appears to be purely thermionic in character.

The rate of emission of electrons from the filament appears to be in accord with Richardson's Law, which says that the maximum thermionic current, which can be drawn from a hot filament is

$$i = a\sqrt{T}e^{-\frac{b}{T}}$$

where T is the absolute temperature, e is the base of the natural system of logarithms, and a and b are constants.

In the particular tube described in detail in this paper, over the range of temperatures and voltages included in the data of Table I, this simple law accounts perfectly for the conductivity of the tube. With still higher temperatures, however, the discharge currents would be found to increase at a much slower rate than that required

by the above law. And the same applies, even in the temperature range of Table I, to a different tube design in which the distance between cathode and anode is greater. In these cases the failure to follow Richardson's Law at the higher temperatures has been accounted for by Dr. Larmuir¹ by the spacial density of negative electricity in the neighborhood of the cathode.

§ 4. DETAILED DESCRIPTION OF TUBE NO. 147

This description relates to tube No. 147, which was used in getting the data for the following tables. Fig. 1 shows a complete assembly, while Fig. 2 shows an enlarged detail of the cathode and of the front end of the target

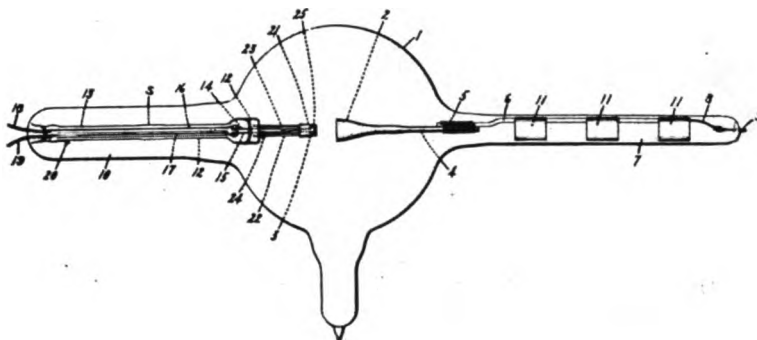

Fig. 1

The Cathode

In the diagrams, 25 is a tungsten filament in the shape of a flat, closely wound spiral. It consists of a wire 0.216 mm. in diameter and 33.4 mm. long with $5\frac{1}{2}$ convolutions, the outermost of which has a diameter of 3.5 mm. It is electrically welded to the ends of two heavy molybdenum wires 14 and 15, to the other extremities of which are welded the two copper wires 16 and 17. These in turn are welded to the platinum wires 18 and 19. The molybdenum wires are sealed directly into a piece of special glass, 12, which has essentially the same temperature coefficient of expansion as molybdenum. This first seal is simply to insure a rigid support for the hot filament, the outer seal being the one relied upon for vacuum tightness. The outer end, 13, of the support tube is of German glass like the bulb itself, and it is, therefore, necessary to interpose at S a series of intermediate glasses to take care of the difference in expansion coefficients between 12 and 13. The small glass tube, 20, prevents short-circuiting of the copper wires, 16 and 17.

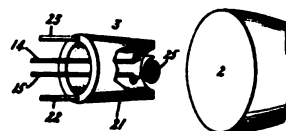

Fig. 2

The filament is heated by current from a small storage battery which is, electrically, well insulated from the ground.

In the circuit are placed an ammeter and an adjustable rheostat and, by means of the latter, the filament current can be regulated, by very fine steps, from 3 to 5 amperes. Over this current range, the potential drop through the filament varies from 1.8 to 4.6 volts and the filament temperature from 1890 to 2540 degrees absolute.

The Focusing Device

This consists of a cylindrical tube of molybdenum, 21. It is 6.3 mm. inside diameter and is mounted so as to be concentric with the tungsten filament, and so that its inner

¹L. c.

end projects 1.0 mm. beyond the plane of the latter. It is supported by the two stout molybdenum wires, 22 and 23, which are sealed into the end of the glass tube, 12. It is metallically connected to one of the filament leads, at 24.

Besides acting as a focusing device, it also prevents any discharge from the back of the heated portion of the cathode.

The Anticathode or Target

The anticathode or target, 2, which also serves as anode, consists of a single piece of wrought tungsten, having at the end facing the cathode a diameter of 1.9 cm. (Its weight is about 100 gm.) By means of a molybdenum wire, 5, it is firmly bound to the molybdenum support, 6. This support is made up of a rectangular strip and, riveted to this, three split rings, 11, 11, 11, all of molybdenum. The split rings fit snugly in the glass anode arm, 7. They serve the double purpose of properly supporting the anode and of conducting heat away from the rectangular strip and so preventing too much heat flow to the seal of the lead-in-wire, 9.

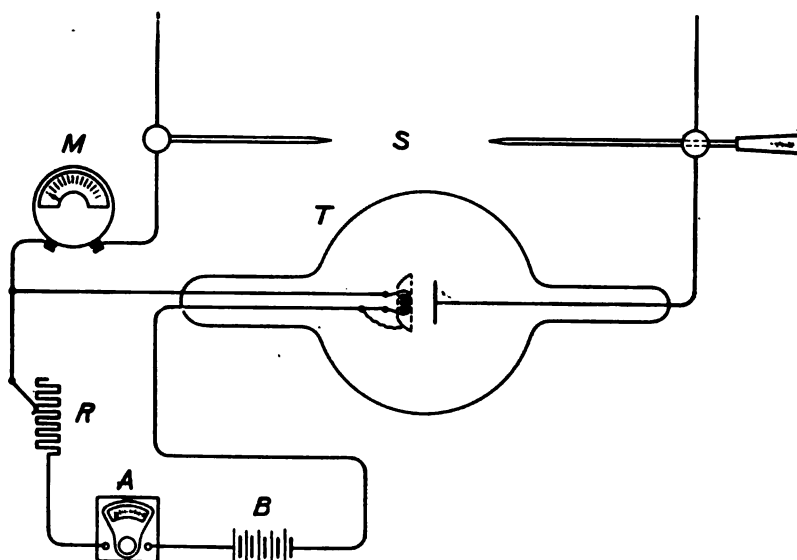

Fig. 3

The Bulb

This is of German glass and about 18 cm. in diameter.

The Exhaust

This is as thorough as possible.

For the earlier tubes, mercury pumps were used, with a liquid-air trap between tube and pump to eliminate mercury vapor. The whole tube, while connected to the pump, was in an oven and was heated at intervals to 470 deg. C. Between heating operations the tube was operated with as heavy discharge currents as the condition of its vacuum would permit. For hours the tube would show the characteristics of an ordinary Roentgen tube, and in many cases a several days' application of the above treatment was required to entirely eliminate these characteristics and to realize an essentially pure electron discharge.

The exhaust time has been greatly reduced in two ways. The massive tungsten anode is given a preliminary firing to a very high temperature in a tungsten-tube

vacuum furnace.¹ The molybdenum support is also fired, to a somewhat lower temperature, in the same manner. In the second place, a Gaede molecular pump has been substituted for the mercury pumps and, at the same time, a very large and short connection has been adopted between tube and pump.

In the later stages of the exhaust a very heavy discharge current is maintained continuously on the tube for perhaps an hour, the temperature of the bulb being kept from rising too high by the use of a fan.

The pressure in the finished tube is very low, certainly not more than a few hundredths of a micron and probably much less than this.

Connections and Method of Operating

The tube was connected as shown in the diagram, Fig. 3, in which, *T* is the tube; *B* is a small storage battery; *A* is an ammeter; *R* is an adjustable rheostat which can be controlled from behind the lead screen which shields the operator from the Roentgen rays; *S* is an adjustable spark gap with pointed electrodes, which can also be operated from behind the lead screen; and *M* is a milliamperemeter which can be read from behind the screen.

As the high potential is connected to the battery circuit it is necessary that the latter shall be thoroughly insulated from the ground.

As a high potential source, a 10-kw. Snook machine, made by the Roentgen Apparatus Co., was used. This consists of a rotary converter driven from the direct current end and delivering alternating current at 150 volts and 60 cycles per second to a closed magnetic circuit step-up transformer with oil insulation. From the secondary of this transformer the high voltage current is passed through a mechanical rectifying switch (which is direct-connected to the shaft of the rotary) and the milliamperemeter, *M*, to the tube. The output of the transformer is controlled by a variable resistance in the primary.

Throughout these experiments a fan was kept blowing on the tube. Without this fan, the gas pressures in the tube would be slightly higher, and the discharge currents would be in consequence slightly lower.

§ 5. CHARACTERISTICS

A. No Discharge Current Unless Filament is Heated

Unless the filament is heated, the tube shows no conductivity in either direction, even with voltages as high as 100,000.

B. Tube Allows Current to Pass in Only One Direction

The tube suppresses any current in the direction which does not make the hot filament cathode. It is therefore capable of rectifying its own current when supplied from an alternating source.

In the case of a focusing tube, however, the use of alternating current will very considerably lower the maximum allowable energy input. For as soon as the target becomes heated at the focal spot to a temperature approximating that of the filament, the tube will cease to completely rectify, and, as the temperature of the focal spot rises, will allow more and more current to pass in the wrong direction. This, to be sure, will not cause either a harmful vacuum change or a metallic deposit on the bulb, as it would in the case of the ordinary tube, but it will give rise to needless heating of the bulb where it is bombarded by the cathode rays from the target, and to disturbing Roentgen rays emanating from the glass at this point. In the case of a tube which does

¹ A description of this furnace will be published in the near future. The heating element consists of a tungsten tube 2.5 cm. inside diameter and 30 cm. long. This is fastened in an upright position and, by means of suitable terminals, is connected to a 100-kw. transformer. The heating element is placed in a water-cooled metal cylinder and the space within connected to a pump which maintains, with the furnace at its highest temperature, a vacuum of a few microns.

not focus, but in which the cathode rays bombard the entire surface of the anode, the allowable energy input which the tube will completely rectify can be increased to any desired amount by simply increasing the surface of the anode.

C. Discharge Current Determined Primarily by Filament Temperature

With a given design, the amount of discharge current which can be passed through the tube is determined primarily by the temperature of the filament, and responds instantly to changes in the same in either direction.

The effect of both temperature and voltage on the discharge current, in the case of tube No. 147, illustrated in Fig. 1, may be seen by referring to Table I, which gives the data on the finished tube after it had been sealed off from the pump. The focal spot was 3 mm. in diameter.

In the table, Column I gives the length in centimeters of the equivalent spark gap. Column II gives the heating current (C) in the filament, expressed in amperes.

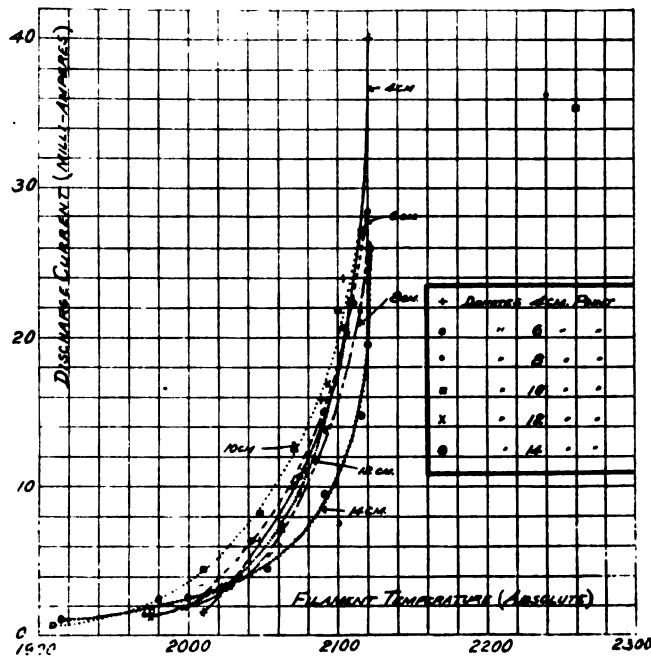

Fig. 4

Column III gives the filament temperature (T), expressed in degrees absolute, corresponding to the values of C in Column II. The temperature values were obtained by comparison with a previously calibrated tungsten lamp.

Column IV gives the discharge current (i) through the tube, in milliamperes.

Column V gives the calculated values of $(-\log i \sqrt{T})$ to the base 10.

Column VI gives calculated values of $(0.434, T \times 10^6)$.

To obtain the data in the table, the experimental procedure was as follows: The filament current was first set at a predetermined point. The spark gap was next set, also at a predetermined point. The tube was then excited and the voltage across the tube terminals adjusted (by varying the resistance in the primary circuit of the transformer) until sparks were occasionally jumping across the parallel spark gap. The discharge current value was then read off from the milliammeter.

The filament current was then raised to a second predetermined value. This increased the discharge current and lowered the potential across the tube terminals

The latter was then raised to its original value and the new discharge current reading was obtained.

In this way the discharge current value, for a given voltage, was brought up by steps to the point where the tube finally began to show signs of instability. The temperature-current series was then repeated with a different voltage.

The values of discharge current and temperature for each voltage are plotted in Fig. 4. The different curves are seen to lie very close together, showing that over the range of voltages employed, the magnitude of the discharge current is practically independent of voltage. This shows that the current in these experiments was always the saturation value.¹

TABLE I

I	II	III	IV	V	VI
Equivalent Spark Gap (Cm.)	Filament Current i (Amps.)	Filament Temp. T (Degs. Abs.)	Discharge Current i (Milliamps.)	$-\text{Log} \frac{i}{\sqrt{T}}$	$\frac{.434}{T} \times 10^6$
4	3.40	2010	1.7	1.4212	216.1
	3.45	2028	3.5	1.1094	214.1
	3.51	2049	6.4	.4985	212.0
	3.60	2077	11.3	.6056	209.1
	3.66	2088	15.8	.4611	208.0
	3.67	2104	24.0	.2813	206.4
	3.71	2116	27.0	.2313	205.3
	3.73	2121	40.0	.0611	204.8
6	3.29	1976	1.6	1.4438	219.8
	3.43	2020	3.3	1.1341	215.0
	3.52	2053	6.5	.8433	211.5
	3.59	2074	10.6	.6331	209.4
	3.64	2090	15.3	.4753	207.8
	3.70	2110	22.3	.3138	205.8
	3.72	2120	28.3	.2113	204.9
8	3.27	1970	1.6	1.4431	220.4
	3.43	2020	2.9	1.1902	215.0
	3.53	2055	5.7	.9005	211.3
	3.59	2074	9.7	.6716	209.4
	3.64	2090	13.8	.5201	207.8
	3.71	2116	21.8	.3242	205.3
	3.73	2121	26.2	.2449	204.8
	4.07	2240	36.2	.1164	193.9
10	3.09	1909	0.6	1.8411	227.5
	3.31	1980	2.5	1.2504	219.4
	3.40	2010	4.4	1.0081	216.1
	3.50	2046	8.2	.7416	212.3
	3.57	2070	12.6	.5576	209.8
	3.67	2104	20.7	.3455	206.4
	3.65	2096	21.8	.3222	207.2
	3.71	2116	27.0	.2313	205.2
	4.13	2259	35.4	.1279	192.3
12	3.28	1973	1.7	1.4171	220.2
	3.44	2023	3.4	1.1215	214.7
	3.55	2061	7.3	.7937	210.7
	3.57	2070	10.1	.6537	209.8
	3.65	2093	16.9	.4325	207.5
	3.68	2107	22.4	.3116	206.1
	3.68	2107	20.1	.3586	206.1
	3.73	2121	26.0	.2482	204.8
14	3.11	1917	1.0	1.6413	226.6
	3.36	1998	2.5	1.2624	217.4
	3.52	2053	4.5	1.0030	211.5
	3.64	2090	8.6	.7255	207.8
	3.71	2116	14.7	.4954	205.3
	3.72	2120	19.6	.3708	204.9
3.73	2121	26.0	.2482	204.8	

¹ The two points to the extreme right of the curves correspond to an unstable condition of the tube. The instability disappears instantly upon lowering the filament temperature.

According to Richardson, the relation between the saturation current flowing from a hot filament and the absolute temperature of the filament is expressed by the equation $i = a\sqrt{T}e^{-\frac{b}{T}}$, in which i is the current, T is the temperature, and a and b are constants of which the first has to do with the concentration of electrons within the hot body, and the second represents the amount of work required to get the electron through the surface of the metal. e is the base of the Napierian system of logarithms.

Richardson¹ applies this equation to his data by first taking the logarithm, to the base 10, of both sides of the equation, which gives

$$\log i = \log a + \frac{1}{2} \log T - \frac{b}{T} (0.434)$$

or

$$-\log \frac{i}{\sqrt{T}} = b \frac{.434}{T} - \log a,$$

which is the equation of a straight line.

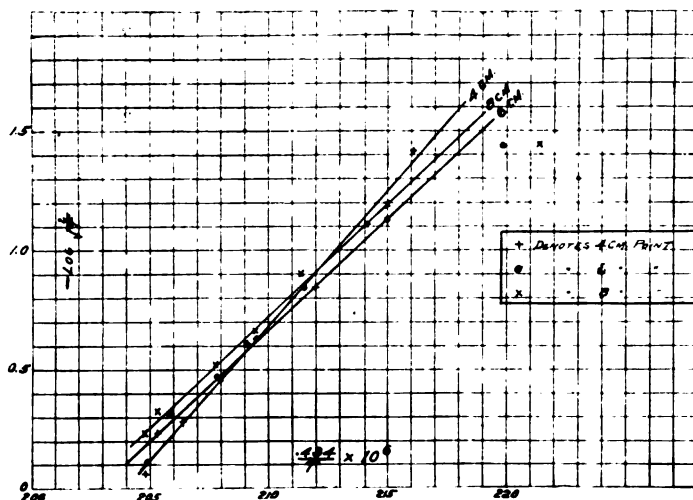

Fig. 5

If then the values of Columns IV and V are plotted, they should lie along straight lines, provided conduction in the tube, between the voltage limits used, follows Richardson's Law.

Reference to the plots, Figs. 5 and 6, will show that the points are closely represented by straight lines. By reading off the tangents of the angles which the lines make with the horizontal axis we get the following values of the constant b :

Voltage Corresponding to Spark Gap of	Value of b
4 cm.....	115,000
6 cm.....	93,000
8 cm.....	94,000
10 cm.....	71,000
12 cm.....	76,000
14 cm.....	60,000
Average.....	85,000

¹ O. W. Richardson, Proc. Camb. Phil. Soc., 11, p. 293 (1901).

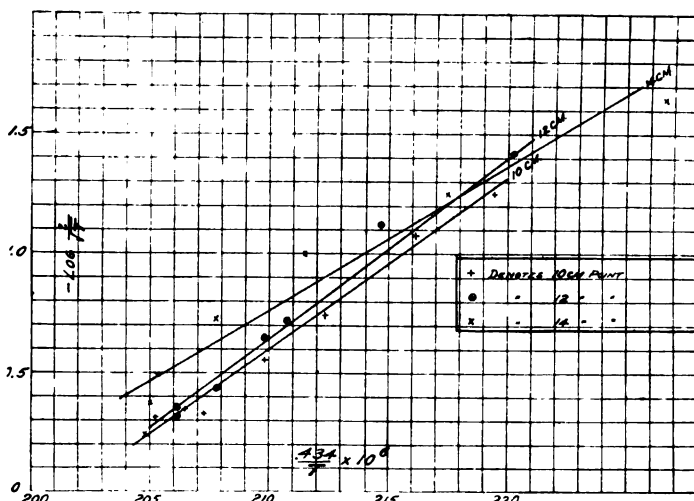

Fig. 6

These values of b are interesting in that they all fall within the range of the values which are just being published by Dr. Langmuir. His values were obtained from an apparatus in which the electrodes were fine tungsten filaments having a total mass perhaps 1/100,000 of that of the target in the above tube. His results show the enormous effect of gas on the value of b , and the conclusion can, therefore, be drawn that very large tungsten masses can be used in a tube without, to any appreciable extent, impairing the vacuum, even though these masses may be heated close to their melting point.

If the temperature of the filament is low, only a small number of electrons escape from it and, consequently, only a small discharge current (the saturation current) can be sent through the tube. Increasing the impressed voltage above that needed for this current value causes no further increase in current. It simply increases the velocity of the cathode rays and hence the penetrating power of the Roentgen rays.

At higher filament temperatures there is a current-limiting factor, other than the number of electrons emitted by the hot filament, which plays a dominating part. This factor is the spacial density of negative electricity in front of the cathode, which amounts, in effect, to a back electromotive force. This factor would play a very important role at lower voltages; but in the case of the Roentgen ray tube the voltages involved are so high that, in case a suitable design is used, its influence can be entirely avoided, as is shown by the data of Table I.

D. Penetrating Power of Roentgen Rays Determined by Voltage Across Tube Terminals

The penetrating power of the Roentgen rays coming from the tube increases with the potential difference between tube terminals.

With the tube excited from a variable potential source, such as the transformer, it did not seem safe to predict that, with the same equivalent spark gap, the rays would show, photographically, the same penetrating power as those from a standard tube. But upon making the experiment, using a Benoist penetrometer,¹ it was found that they did.

The experiment was interesting from another point of view in that it showed how readily the new tube could be adapted to a given set of conditions.

An exposure was made first with a standard tube of the ordinary type, and the discharge current and equivalent spark gap were noted. A tube of the new type was

¹ M. L. Benoist, C. R., 134, 225 (1902).

then set up in place of the standard. It was but the work of a moment to adjust the new tube to the point where it showed the same discharge current and equivalent spark gap as the standard tube. The radiographs of the penetrometer, made with the two tubes, showed the same penetration number.

E. Capable of Continuous Operation Without Change of Characteristics

That the tube may be operated continuously without showing an appreciable change in characteristics is shown by the following experiment on Tube No. 147, illustrated in Fig. 1.

The filament current was set at 4.1 amperes. This gave a discharge current of 25 milliamperes. The impressed voltage was then set at a point where the tube showed a 7-cm. equivalent spark gap.

The tube was then run continuously, with no adjustment of any kind, for 50 minutes. The readings of discharge current and equivalent spark gap, taken every two minutes, are given in Table II.

F. Sharpness of Focus

Sharpness of focus is determined mainly by the design of the tube. If the filament temperature is such that, with the voltage employed, the discharge current does not represent the saturation value, the size of the focal spot will vary with the impressed voltage. But in the tube shown in Fig. 1, over the range of voltages corresponding to an equivalent spark gap ranging from 4 to 14 cm., the focal spot does not vary appreciably in size.

The tube may be made to focus more sharply by increasing the distance between the filament and the front (end facing the target) of the molybdenum tube. This change in design will also affect the temperature-current characteristics of the tube in the direction that a higher filament temperature will be needed for a given discharge current value.

Similarly it may be made to focus less sharply by decreasing the distance between the filament and the front of the focusing device.

All of the observations made are consistent with the idea that focusing is determined by the shape of the equipotential surfaces which may be drawn in the space between cathode and anode, and that the surfaces close to the cathode have the strongly preponderating influence.

TABLE II

Time	Discharge Current (Milliamps.)	Equivalent Spark Gap (Cm.)
11:48 a.m.	25	7.0
:50	25	7.0
:52	25	6.9
:54	25	6.5
:56	25	6.5
12:00 p.m.	25	6.7
:02	25	6.9
:04	25	6.5
:06	24	6.4
:08	24	6.5
:10	24	6.5
:12	23	6.6
:14	25	7.0
:16	25	6.8
:18	24	6.8
:20	25	6.9
:23 1/2	23	6.7
:26	23	6.9
:28	25	6.9
:30	25	6.9
:32	25	7.0
:34	24	6.9
:36	25	7.0
:38	24	7.1

Near the cathode, the velocity of the electrons is relatively small, and the direction of their motion will therefore conform closely to the direction of the strong electric force. Near the anode, on the other hand, the velocity of the electrons is so high that the same force acting over the same length of path will produce but little deflection.

G. Fixity of Position of Focal Spot

The focal spot on the anode does not wander, but remains perfectly fixed in position. This is in sharp contrast to the ordinary Röntgen tube in which the focal spot does move about, and often so rapidly as to be noticeable even during the shortest radiographic exposures.¹ The effect of movement of the focal spot is, of course, to cause in the radiograph or on the screen, a blurring of all lines except those parallel to the direction of motion. In the earlier stages of exhaustion, while the new tube is being operated with a relatively poor vacuum, the focal spot may dance about, but as the electrodes and the glass become freer from gas the motility of the focal spot decreases and finally disappears completely. Its disappearance goes hand in hand with the disappearance of fluorescence of the glass, discussed in Section *J*. Movement of the focal spot appears to be due to the action of positive ions in disturbing the distribution of static charge on the glass walls of the tube.

H. Tube Not Sensitive to Considerable Changes in Gas Pressure

The gas pressure within the tube is so low that it can increase several-fold, and apparently decrease without limit, without appreciably affecting the other characteristics.

The slight effect of pressure change may be seen from the following experiment:

While one of the tubes was being continuously operated on the pump, the pressure as indicated by a McLeod gauge, decreased from 0.113 to 0.035 micron.² The discharge current passing through the tube remained constant at 3.1 milliamperes, while the parallel spark gap backed up by the tube changed only from 7.9 to 8.6 cm. A corresponding pressure change in the case of an ordinary Roentgen tube would bring about an enormous change in current and voltage.

I. Capable of Continuous Operation with High Energy Input

Owing to the fact that the tungsten target can run at such a high temperature, large amounts of energy can be continuously radiated.

J. No Fluorescence of Glass

When operating properly the tube shows no fluorescence of the glass at any point. Corresponding to this, there is an absence of the usual strong local heating of the anterior hemisphere. The absence of fluorescence and of local heating seem to point to the fact that there is no bombardment of the glass by secondary cathode rays sent out from the target. This is in striking contradistinction to what takes place in an ordinary Roentgen tube, where, in the case of a platinum target, it has been found that there are about three fourths as many electrons leaving the target and going to the glass as secondary cathode rays, as there are bombarding it in the form of primary cathode rays. This elimination of secondary cathode ray bombardment prevents the production of a large part of the useless and disturbing Roentgen rays which emanate from the glass in the case of the ordinary tube.

The absence of bombardment of the glass is of interest both theoretically and practically. Other explanations of the lack of fluorescence suggested themselves at first. A plausible hypothesis was that bombardment took place, but that the surface of the glass was much freer from gas than it is in the ordinary tube and that this

¹ See Dr. Pfähler, *Fortschritte auf dem Gebiete der Röntgenstrahlen*, 18, pp. 340-343 (1911-1912).

² In the light of later experiments it seems doubtful whether a further pressure decrease, no matter how great, would have appreciably affected the tube characteristics.

accounted for the lack of fluorescence. But the fact that fluorescence appears so suddenly when a trace of gas is evolved, coupled with the fact that such fluorescence may appear in streaks and that these may rapidly change their location, seems to disprove the hypothesis. It also seemed possible at first that the fluorescence might be there, but that it could not be seen because of the strong light emission from both filament and target. But this hypothesis is disproved by the fact that with filament and target at their highest temperatures, fluorescence becomes suddenly strongly visible whenever gas is liberated.

The simple explanation appears to be based upon the fact that the large number of positive ions present in an ordinary Roentgen tube is here lacking. The inner surface of the glass becomes strongly negatively charged, when the tube is first operated, and not being able to attract an appreciable number of positive ions, remains so. The presence of this negative charge upon the glass prevents further electrons, either in the shape of primary or secondary cathode rays, from going there.

K. Identity of Starting and Running Voltage

The starting, or break-down voltage of the tube is the same as the running voltage. This is very different from the state of affairs in the ordinary tube in which the break-down voltage is much higher than the running voltage.¹ The difference is to be explained as follows: In the ordinary tube the number of ions present when the circuit is closed is exceedingly small, being only that due to natural ionization causes, such as radioactive matter in the surroundings. After the discharge circuit is closed, the number of ions increases, by collision, very rapidly, and the voltage across the tube terminals falls in consequence. In the case of the new tube, on the other hand, the full supply of electrons is there the instant the discharge circuit is closed, and even before this, and the available number is not changed by the discharge current.

L. No Heating of Cathode by Discharge Current and no Evidence of Cathodic Disintegration

An earlier experiment showed that when a tube is made up with two similar concave tungsten electrodes, symmetrically located in the tube, and operated on direct current at an ordinary Roentgen tube vacuum, the heating effect at the cathode is as strong as that at the anode. Furthermore, the heat evolution at the cathode is as strongly localized as it is at the anode. In fact, it is impossible, when the tube is operating, to tell, by looking at it, which of the white hot electrodes is functioning as anode and which as cathode. There is a very rapid blackening of the bulb in such a tube, the material of the deposit coming evidently from the cathode, which shows a deep and sharply defined cavity at the point of local heating. The simple explanation seems to be that the cathode is bombarded by positive ions and that the emission of the electrons which constitute the cathode ray stream is due to this bombardment. So, also, the heating effect and the cathodic disintegration.

At the higher vacuum and with the relatively gas-free electrodes of the new tube there is no evidence of any bombardment of the cathode. In the earlier stages of gas removal, when a discharge can be made to pass through the tube without the heating current in the filament, the latter is seen to be strongly locally heated by the discharge current, as from bombardment by positive ions. But when the exhaustion has been completed and the tube is operated with the cathode hot, a voltmeter and ammeter in the filament circuit show no change even when a very heavy discharge is sent through the tube. Positive ion bombardment, if it existed to an appreciable extent, would raise the temperature and, hence, the resistance of the tungsten filament and would therefore be indicated by the instruments. If it were very local and considerable, it

¹ See Dessauer, l. c.

would be further indicated by a melting through of the filament at the point in question. The resistance change and local disintegration of the filament have been observed in only those cases where the vacuum, as shown by other effects, such as fluorescence of the glass, has been poor.

Disintegration of the cathode would also manifest itself in blackening of the bulb. Even after running for several hours, the deposit on the bulb is very slight, and what there is may well be entirely accounted for by vaporization of tungsten at the focal spot on the target.

M. The Target the Factor Limiting Allowable Energy Input

There is one limitation with the new tube. With a sharp focusing tube and above a certain energy input the tube resistance is unstable, dropping suddenly to perhaps a small fraction of its original value, returning instantly to the old value however upon stopping the discharge or upon lowering it to the limiting value. The cause of this phenomenon appears to be as follows:

With a very high energy input and sharp focusing, the surface of the target melts at the focal spot and volatilizes. Owing to the fact that this tungsten vapor is produced at the focal spot, all of the primary cathode rays pass through it and, by collision, ionize it. This of course decreases the tube resistance. The larger the focal spot the greater is the limiting current. The design of the target also has a great deal to do with the limiting current value, as the face of a thin target is vaporized with a much lower energy input than a relatively thick one. For very short excitation of the tube, the limiting energy input is somewhat larger than for longer periods; but an input which can be carried for a few seconds can be carried indefinitely.

The effect of substituting any other single refractory metal for the tungsten of the target will be to lower the maximum allowable energy input. For the essential properties of a target material are: high density, high melting point, high heat conductivity, and low vapor pressure. Tungsten has a higher melting point and lower vapor pressure than any other metal. Its nearest competitor in point of refractoriness, tantalum, has only about one third of the heat conductivity. Molybdenum and iridium have vapor pressures altogether too high to entitle them to consideration, even if their melting points made them otherwise competitors. Osmium has only about one half of the heat conductivity of tungsten.

The ordinary copper-backed tungsten target would be very difficult to exhaust sufficiently. Otherwise its use might be desirable for certain classes of work, as it would raise the maximum allowable instantaneous energy input.

§ 6. DANGER CONNECTED WITH USE OF TUBE

There has been in the old tube a certain element of safety in that it could not be run continuously with a very heavy energy input. The new tube, even when focusing sharply, can be operated, for example, on a 7-cm. parallel spark gap with currents as high as 25 milliamperes for hours at a time, and without the slightest attention.

For most purposes, other than diagnostic or radiographic work, there is no advantage in having the tube focus. In case it does not, the above-mentioned energy input limitation falls away and the tube can apparently be designed for any energy input whatsoever. This will permit, in this field, of the use of much greater Roentgen ray intensities than have heretofore been realized.

In the light of the above, it will be seen that the precautions which have been shown by years of experience to be sufficient for work with the old tube are not necessarily sufficient for the user of the new one.

§ 7. SUMMARY

In the foregoing, a new and powerful Roentgen ray tube has been described. It differs in principle from the ordinary type in that the discharge current is purely thermionic in character. Both the tube and the electrodes are as thoroughly freed from gas as possible, and all of the characteristics seem to indicate that positive ions play no appreciable rôle.

The tube allows current to pass in only one direction and can therefore be operated from either direct or alternating current.

The intensity and the penetrating power of the Roentgen rays produced are both under the complete control of the operator, and each can be instantly increased or decreased independently of the other.

The tube can be operated continuously for hours, with either high or low discharge currents, without showing an appreciable change in either the intensity or the penetrating power of the resulting radiations.

The tube in operation shows no fluorescence of the glass and no local heating of the anterior hemisphere.

The starting and running voltage are the same.

An article bearing especially upon the application of the new tube to radiographic and diagnostic and to therapeutic purposes will appear shortly in one of the Roentgen ray journals.

It is a pleasure to me, in closing, to express my appreciation of the services of Mr. Leonard Dempster, who has assisted me throughout this work.

PHYSICAL INVESTIGATION WORK IN PROGRESS ON TUBES AND ACCESSORIES*

BY W. D. COOLIDGE, PH.D.

The following is a continuation of a paper¹ given last year and is in the main, a report of unfinished work.

THE PRODUCTION AND MAINTENANCE OF VERY HIGH VACUA

The evolution of the vacuum pump has been very rapid in the last few years. An enormous stride was taken by Gaede who, in 1912, published the story of the so-called Molecular Pump.² Ever since it became available, this has been an extremely useful tool, but because of the high speed at which it runs the difficulty of keeping it in good condition for continuous operation has been very considerable. Furthermore, there was a limit to the degree of exhaustion which could be attained with it. For these reasons a great deal of interest was aroused by Gaede's announcement, in 1915, of his so-called Diffusion Pump.³ With this device it was possible, theoretically at least, to remove the very last molecule from the space to be exhausted. There were, furthermore, no moving parts in the device. By the application of heat, mercury was caused to boil and the column of mercury vapor, upon rising, passed by a narrow slit in the wall of the container. This slit was in communication with the space to be exhausted, and any gas molecules coming from this space, and diffusing through the slit, were carried along by the ascending column of mercury vapor. The mercury vapor being condensed in the upper part of the device, ran back as liquid mercury. The gas carried up by the mercury vapor was removed by an ordinary air pump. The one serious limitation in the device was the speed of operation, which was considerably less than that of the "molecular" pump.

Dr. Langmuir, of our laboratory, has developed a new form of mercury-vapor pump—the so-called Condensation Pump.⁴ It produces the same high vacuum as the "Diffusion Pump," operates more rapidly and is easier to construct. Its mode of operation may be seen by referring to Fig. 1 in which *A* represents a glass bulb containing mercury; *B* a glass tube leading into a larger glass tube, *C*; *D* a tube leading to the vessel to be evacuated, and *E* a water jacket.

The mercury in *A* is heated and kept boiling by a small electric stove underneath. Waste of heat is reduced by lagging *A* and *B* with asbestos. Between *D* and the vessel to be exhausted is a liquid-air trap which serves to condense any mercury vapor coming from the pump.

In operation, a vigorous blast of mercury vapor is maintained down through the open end of *B* into *C*. Gas molecules, coming through *D* from the vessel to be exhausted, diffusing into the mercury blast are carried downward by it to the lower end of *C*, from which point they are removed by an ordinary air pump. The tube *C* is cooled by the water jacket, the mercury vapor condenses on its sides and flows back to *A*.

With the help of the condensation pump, the evacuation of the space in an X-ray tube becomes a simple matter.

¹ *Am. Journ. of Roentgenology*, December, 1915.

² W. Gaede, *Ber. d. d. phys. Ges.*, 15, 775-787 (1912).

³ *Ann. d. Physik*, 46, 357-392 (1915).

⁴ *Phys. Rev.*, 8, p. 48, July (1916).

*Read at the Seventeenth Annual Meeting of the American Roentgen Ray Society, Chicago, Sept. 27-30, 1916.

Copyright by the American Journal of Roentgenology, 1917.

The manner in which gas is removed from the metal parts has already been described.⁵

The glass is, under certain conditions, a much more troublesome source of gas. Whenever a tube is heated to a higher temperature than it had while connected to the pump, water vapor and carbon dioxide are given up to the space from the inner surface of the glass. This situation is helped by heating the tube almost to the collapsing point while it is connected to the pump. That this does not completely take care of the problem, however, is shown by the experience we have had in attempting to greatly reduce the size of tubes.

With a 9.5-cm. ($3\frac{3}{4}$ -inch) bulb we have found that it takes an energy input of 1200 watts, continuously applied, to cause the glass to collapse. (The tube in this experi-

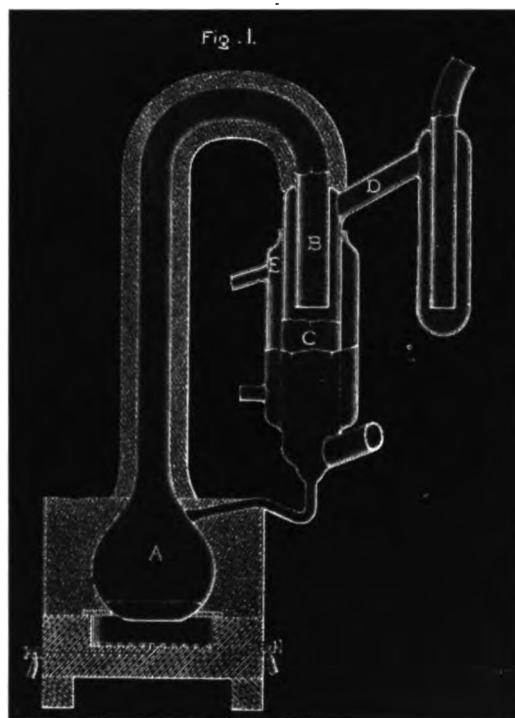

Drawing of Langmuir's New Form of Mercury-vapor Pump—the So-called Condensation Pump

ment had a regular solid tungsten target. The tube was freely exposed to the air, and was in a metal box 112 cm. high, 56 cm. wide and 114 cm. long. There was no forced circulation of air.) When this tube was exhausted in the same manner as the 17.8-cm. (7-inch) tube now on the market, we found that an energy input of 360 watts, when continuously applied for $1\frac{1}{2}$ to 2 minutes, would cause the evolution of sufficient gas from the glass to render the tube useless until re-exhausted. After re-exhaustion, upon again testing the tube, it was found that the 360 watts, continuously applied for a couple of minutes, would once more render re-exhaustion necessary. (For ordinary roentgenographic work, the tube was all right, as this did not heat the glass to too high a temperature.)

Greatly extending the exhaust time on the pump did not help materially, and the long continued operation of the tube, with continuous evolution of gas, resulted in a very considerable metallic deposit on the bulb.

⁵ *Ibid.* 6, 416-417 (1913).

In the water-cooled tube, we had found that the use in the electrode construction of some metal which undergoes strong cathodic disintegration, such as copper for example, was very helpful. When the vacuum became sufficiently impaired, the copper was subjected to positive ion bombardment and was thereby spattered on to the glass walls of the tube. By this process, gas molecules were removed chemically and mechanically from the space and the vacuum was in this manner automatically improved by the electrical operation of the tube. The experiment was, therefore, tried with the 9.5-cm. tube, of introducing copper into the cathode structure (as a major portion of the focusing device). This did not appear to help the situation at all. The reason is probably to be found in the fact that in the air-cooled tube the bulb gets very hot, while it does not in the water-cooled tube. Much of the gas which is trapped by the copper deposited on the bulb is doubtless released again, if the bulb is allowed to get hot.

Thinking that we might possibly get help from it, we introduced some metallic thorium powder into the bulb of one of the small tubes. The experiment was successful and we find that the bulb of such a tube can be heated to the collapsing point without troublesome impairment of the vacuum. Metallic zirconium powder can also be used. Several other metals were tried, such as calcium, titanium and tantalum, but none of these proved helpful. (Calcium apparently has too high a vapor pressure.) It seems most probable that the rare earth metals, thorium and zirconium, help in maintaining a vacuum by reacting with the gases given off from the glass, and that the solid compounds so formed have an exceedingly low decomposition pressure, even at the temperature at which lime glass softens.

We see, then, in the use of these metals one way of increasing the allowable energy input of a tube of a given size.

Another method which suggested itself was to make the tube entirely of fused quartz. This has been tried and found successful. Such a tube, only 6 centimeters in diameter, has been successfully operated continuously with 2000 watts and this without the help of forced air circulation.

At the moment, another method which does not involve the use of the rare earth metals or of fused quartz is being tried out. It consists in first heating the tube almost to the collapsing point, while connected to the pump, and then letting in specially purified nitrogen gas so as to have the same pressure within and without. The temperature is then raised to just short of the point at which the glass will sag under its own weight. This is nearly 200 deg. C. higher than the bulb will stand when evacuated. By the alternate application of the high temperature treatment, with and without vacuum, several times, we find that the inner surface of the glass is greatly improved. By this method we have already succeeded in producing a glass tube with a 9.5-cm. bulb which can be continuously operated with as much as 600 watts, and this without forced air circulation. More experimental work is to be done on this method to see if it cannot be so modified as to enable us to safely let the tube get still hotter. (This tube in which we are now able to use 600 watts continuously without forced air circulation will not collapse with less than 1200 watts.)

CATHODE DESIGN

To get the greatest possible X-ray intensity from a focal spot of given size (and this must always be the desideratum in diagnostic work), the energy delivered to the focal spot must be as uniformly distributed over it as possible. The size of the focal spot and the energy distribution are determined by the cathode design, the size and shape of anode, the distance between anode and cathode, and the size of bulb.

Widely different focal spots can be produced with the same design of filament spiral, the same design of anode, the same size of bulb and the same distance between filament spiral and anode, by merely changing the design of the focusing device. This may be seen by referring to Fig. 2, which shows three different cathode assemblies. The filament spirals are exactly alike in all three, but the focusing devices are radically different. To the right of each cathode diagram is a Roentgen ray pinhole camera picture of the focal spot, made with that cathode. The anode used was in all cases the standard 45 deg. angle type and the distance from anode to filament spiral was in all cases the same.

Fig. 3 shows how the focal spot changes when, all other factors remaining the same, the location of the focusing device with respect to the filament spiral is changed. The

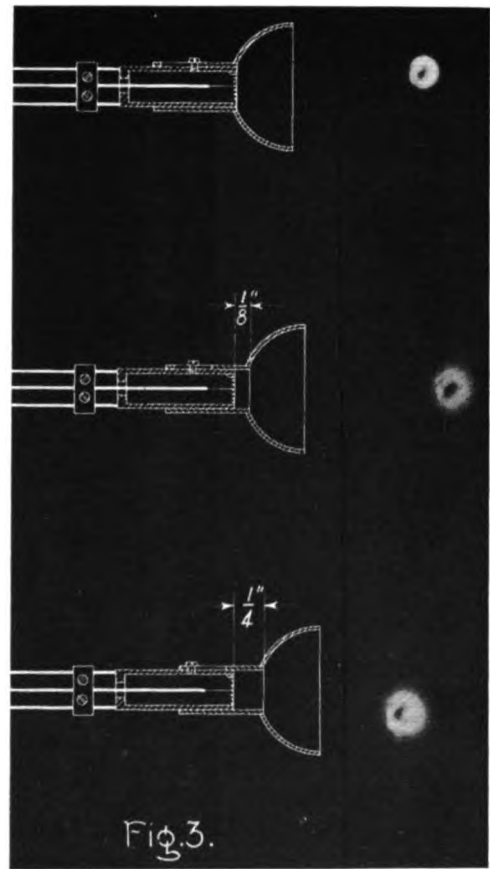
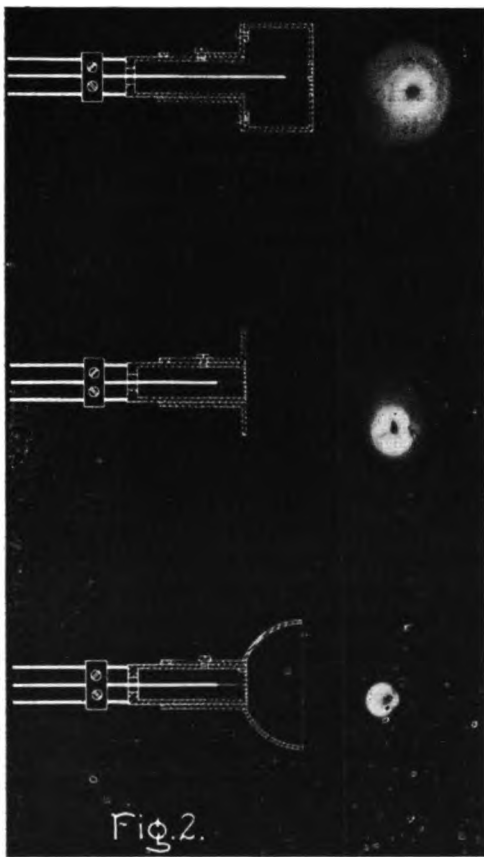

diagram shows three different settings of an adjustable cathode (these settings were made by merely tapping the tube while it was held in an inclined position) and, to the right of each, a pinhole camera picture of the focal spot, made with that setting.

Finally, Fig. 4 shows how the focal spot changes with the distance between filament spiral and anode. In this case, the setting of the adjustable cathode was held constant and the position of the movable anode was changed.

The problem of getting the best focal spot of a given size for a given size of bulb has finally resolved itself into making up an experimental tube in which the distance between anode and filament spiral can be varied at will and in which the location of the

filament with respect to the focusing device can also be varied at will. The construction of such a tube is shown in Fig. 5.

The focusing device, *d*, which is in this case a hemispherical bowl, is attached to a sleeve which, by tapping, can be made to slide on *f*, the molybdenum tube in which the filament spiral is fastened.

The anode also can be moved by holding the tube in a vertical position and rapping the lower end smartly against a firmly supported piece of soft wood. This causes the iron support-tube to slide in the glass tube, *b*.

Focal spot pictures are made as each variable is changed separately, and an inspection of these shows which setting of focusing device and which distance from filament spiral to anode gives the best focal spot.

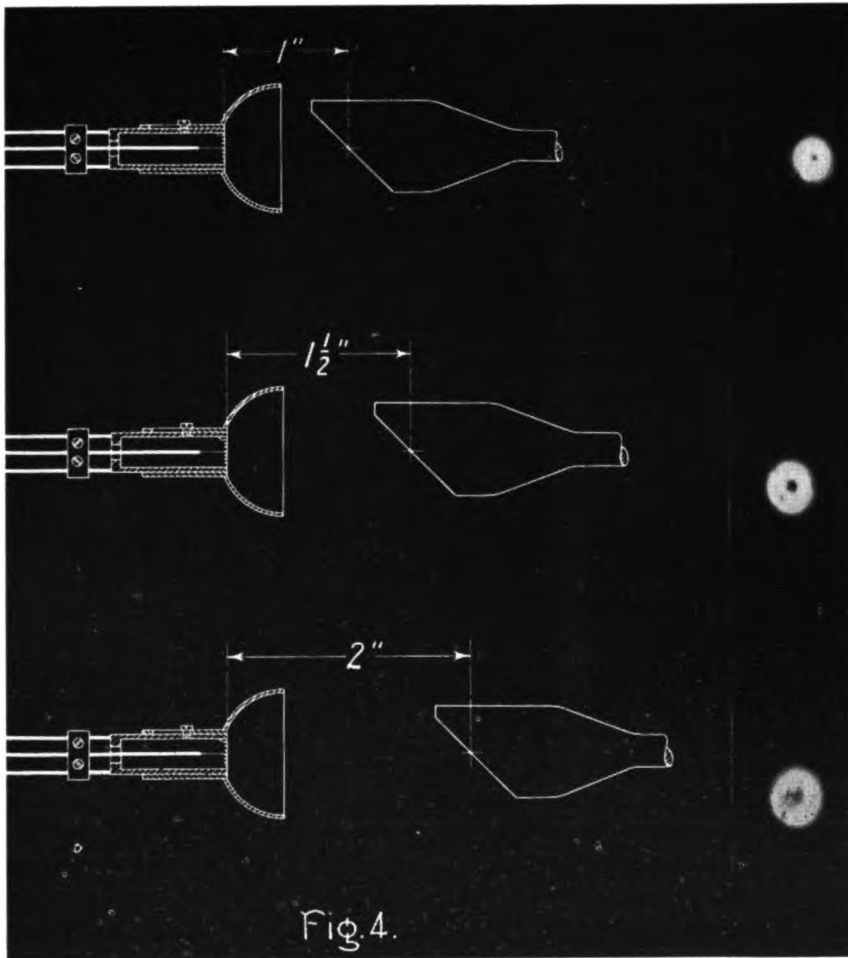

METAL TUBE

In February of last year, Prof. Zehnder⁶ published an article entitled "Eine gefahrlose metallische Röntgenröhre" (A Safe Metallic Roentgen Ray Tube). A somewhat similar metal tube has also been used, while connected to the pump, by Siegbahn.⁷

⁶ L. Zehnder, *Electrotech. Ztschr.*, Heft 5, pp. 49-50, Feb. 4 (1915).

⁷ For a description of this tube, see the Inaugural Dissertation of Ivar Malmer entitled "Untersuchungen über die Hochfrequenzspectra der Elemente," Lund (1915).

There seem to be many reasons why such a tube as that described by Zehnder may be impracticable, but he has, at least, stated a good problem. There are some very great advantages which might be derived from a metal tube, if it can be so constructed that it can be successfully operated.

Until we had developed a tube with a water-cooled anode,⁸ we had doubts as to whether it would ever be possible to secure and maintain in a metal tube a vacuum sufficiently high for a tube with a pure electron discharge. Our experience with the water-cooled tube, however, encouraged us to try the metal tube. The first attempts were not at all promising, as we seemed to have, in the large amount of metal, a never-failing source of gas, too much for satisfactory operation even while the tube was connected to the pump. Thinking that the difficulty might possibly be due to oxidation of the metal, we filled the tube with purified hydrogen and heated it. The hydrogen, containing water-vapor from the reaction which had taken place, was then pumped out and fresh hydrogen admitted. This cycle of operations was repeated several times. After such treatment, it was found that the tube could be satisfactorily exhausted and that it would maintain its vacuum upon being sealed off from the pump.

Another very serious difficulty which we experienced was the puncturing and tearing of the glass, even at low operating voltages, in the neighborhood of where the glass,

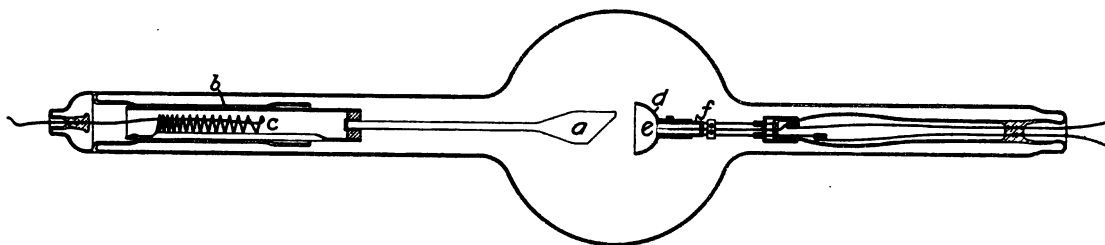

Fig. 5.

used to insulate the cathode, is sealed on to the metal portion of the tube. This difficulty was finally obviated by the use of an inner metal sleeve which is attached to the metal body of the tube and extends for some distance beyond the glass seal. The helpful action of this sleeve is probably due to the fact that it electrostatically prevents electrons from getting to the inner surface of the glass near the seal.

Fig. 6 shows a cut of such a tube. In the figure, *a*, the body of the tube, is of copper. The cathode, *f*, projects into *a* and is supported and insulated from it by the glass tube *c*. *b* is a flaring piece of thin-walled platinum tubing which is silver-soldered at the small end to the copper tube and sealed at the large end to *c*. The hot cathode, *f*, is supported by means of the copper tube *e*, which at the outer end is enlarged and fitted tightly on to the glass tube *d*. Of the two copper wires carrying current in to the filament, the one marked *h* is metallically connected to *e*, while the other is insulated. *g* is a window of thin platinum which also serves as target. It is so thin that a considerable fraction of the Roentgen rays produced on the side next to the cathode pass through it and are available for use on the other side.

In operation, the metal body of the tube is connected to the positive terminal of the generator.

⁸ This Journal for December, 1915, pp. 7-10.

In most of the experimental work which has been done on the tube up to this time, there has been no window put in for the exit of the X-rays. In the absence of a window, and with a current of 200 milli-amperes and a 4-inch spark gap, there was no visible illumination of an "Astral" screen held close to the tube.

Rays may be taken out of such a tube in two ways, either through a target of thin foil in the end of the tube or from a massive 45 deg. angle target and out through a window in the side. The tube has been cooled by means of a metal jacket, slipped over *a*, through which water was kept flowing.

If it can be brought to a satisfactory state of development, such a tube would have, among others, the following advantages:

(1) It can be so designed that no direct rays, other than the narrow pencil desired, can leave it. The walls would either be made so thick that no appreciable amount of radiation could get through them, or a protecting jacket of lead or some other metal of high atomic weight would be slipped on the outside. This means that the present combination of a seven-inch tube and protective holder, weighing perhaps 25 or 30 lbs., could be replaced by a metal tube of higher power and more complete protection, weighing perhaps not more than half a pound. This would make it possible to simplify fluoroscopic apparatus. The small size of the metal tube would also be a convenience in therapeutic work.

(2) The tube can be built with a diaphragm, in the form of a metal cone, projecting in almost to the focal spot, so as to effectively keep within the tube all rays except those emanating from the focal spot.

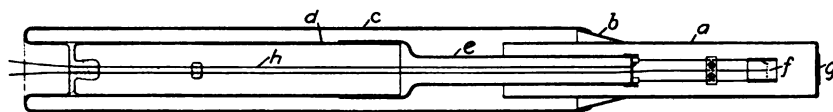

Fig. 6.

Diagram One Third Natural Size of New Tube with Inner Metal Sleeve. (See text)

(3) It lends itself to very effective cooling of the anode and, hence, to high power work.

(4) The type in which the rays are taken through a thin metal foil acting as a target in the end of the tube should be capable of development for insertion into body cavities for internal therapy. The source of X-rays would be in the extreme end of the tube and the portion inserted would be all metal and connected to earth. There would therefore be no danger to the patient from either breaking glass or electric shock.

HIGH-POWER, HIGH-VOLTAGE OUTFIT FOR EXPERIMENTAL THERAPY

A special transformer has been developed for use with a water-cooled tube. In this outfit the tube rectifies its own current and there is no mechanical rectifying switch. The transformer is designed to supply continuously (by the hour if necessary) a maximum current of 60 milliamperes at a maximum voltage of 150,000 (effective).

The installation of such an outfit brings new problems with it. The most vital of these is the protection of both operator and patient from both X-rays and electric shock. Mr. Perkins has worked out all of the details of the installation and will give a full description of the outfit in the near future in the *General Electric Review*.

With this outfit it should be possible to test out the effect of higher voltage than is now being used, and, at the same time, to resort to much heavier filtering than is now practicable.

A NEW DEVICE FOR RECTIFYING HIGH TENSION ALTERNATING CURRENTS*

THE KENOTRON

BY DR. SAUL DUSHMAN

INTRODUCTION

The emission of negatively charged corpuscles or electrons from heated metals may be illustrated by the following arrangement: In an ordinary lamp bulb containing a tungsten or carbon filament there is also sealed-in a metal plate. After the lamp is well exhausted it is observed, on charging the filament negatively (making it cathode) with respect to the plate, that a current passes across the vacuous space. If the filament is charged positively this current disappears. Furthermore, the magnitude of this electron emission (thermionic current) from the heated cathode increases with increase in the temperature of the filament.

This effect had been observed by Edison and was more fully investigated in the case of carbon lamps by Fleming.¹ In view of the unilateral conductivity possessed by such an arrangement as that described above, Fleming applied it as an "electric valve" to rectify electric oscillations such as are obtained from a "wireless" antenna, and, therefore, render it possible for these oscillations to affect a galvanometer or telephone.²

That the current from a hot cathode in an exhausted bulb is due to a convection of electrons, that is of negatively charged corpuscles having a mass which is about 1/1800th of that of a hydrogen atom, may be shown by deflecting the current in magnetic and electrostatic fields and determining the ratio e/m . Another method is that described below and which depends upon the space charge produced by the electrons under certain conditions.

The relation between thermionic current and temperature of cathode was further investigated by Richardson and he found that in all cases the relation could be accurately represented by an equation of the form,
$$i = a\sqrt{T} \epsilon^{-\frac{b}{T}} \quad (1)$$

where a and b are constants for the particular metal and i is the saturation thermionic current per unit area at the absolute temperature T .

Subsequent experiments, however, by other investigators tended to throw much doubt upon the actual existence of a pure electron emission from a heated metal in a good vacuum. It was found that different gases affected the values of the constants a and b to an immense extent, so that at the same temperature the thermionic current obtained varied over a very wide range. Furthermore, it seemed that the greater the precaution taken to attain a high vacuum, the smaller the thermionic currents obtained, and the conclusion was drawn that in a "perfect" vacuum the thermionic currents would disappear altogether. In fact, the view generally held until the past year by the German physicists and by quite a few English physicists was that the thermionic currents were due to chemical reactions in a gas layer at the surface of the heated metal, and that, therefore, there was no justification for believing in the existence of a pure electron emission *per ipse* from a heated metal.

¹ Proc. Roy. Soc., London., 47, 122 (1890).

² Proc. Roy. Soc., Lond., 74, 476 (1905). See also J. A. Fleming, "Principles of Electric Wave Telegraphy and Telephony," pp. 477-482 (second edition).

*Copyright, 1915, by *General Electric Review*.

This subject was taken up in the Research Laboratory of the General Electric Company, by Dr. Irving Langmuir, and he found that in the case of heated tungsten filaments the electron emission at constant temperature *increased* as the vacuum improved until a constant value was attained which varied with the temperature in accordance with Richardson's equation. Dr. W. D. Coolidge applied this fact to the construction of a hot cathode Roentgen ray tube¹ in which electrons are produced from a heated filament in a highly exhausted bulb. A tungsten target is used as anode and by applying very high voltages (50,000 to 100,000) the electrons are given velocities great enough to produce very penetrating X-rays when they strike the target.

During the last few years Dr. Langmuir has carried out a detailed investigation of the whole subject of electron emission from heated metals and the results obtained have led to a large number of interesting and highly important applications.

While a complete summary of these applications will be presented by Dr. Langmuir at a future meeting of the Institute of Radio Engineers, it has been considered advisable to publish a preliminary account of one important application of hot cathode tubes in the development of which the writer has been interested. This concerns the application to the rectification of high tension alternating currents.

THE HOT CATHODE RECTIFIER

As mentioned above, the fact that an exhausted tube, containing two electrodes, one of which is heated by some external source, acts as a rectifier, has been known for a number of years. But difficulties were met with in the way of applying this practically. The magnitude of the current obtained was apt to vary quite erratically, especially with slight variations in degree of vacuum. Furthermore, in the types of hot cathode rectifiers exhausted by ordinary methods, the electron emission is accompanied by a blue glow. This glow becomes more and more pronounced the higher the voltage at which the rectifier is operated, and it is found that under these conditions the cathode gradually disintegrates so that the rectifier becomes inoperative.

An explanation of these phenomena gradually developed as a result of the above mentioned investigations on thermionic currents in high vacua. It was perceived that the blue glow is due to the presence of positively charged gas molecules (ions), and that the disintegration of the cathode is due to bombardment by these positive ions moving with high velocity. But when the vacuum is made as perfect as possible, the conduction occurs only by means of electrons emitted from the hot cathode, and there is no evidence whatever of any blue glow or other forms of gaseous discharge. Thus, while it had previously been considered that a certain amount of gas is absolutely essential to obtain conduction from a hot cathode, and the presence of blue glow was taken to be a necessary accompaniment of conduction in such cases, it was found that by adopting certain methods of treatment and the use of high vacua, a hot cathode rectifier could be constructed in which all of the difficulties discussed above are avoided.

Special methods have been developed for treating all metal parts and glass walls so that they are made as free of gas as possible. A Gaede molecular pump in series with two other pumps is used to evacuate the tubes. It has been shown by the writer² that by using this arrangement together with a liquid air trap inserted between rectifier and molecular pump, it is possible to attain a vacuum as high as 5×10^{-7} mm. of mercury. At this pressure the mean free path of an electron is so great that the chance of its colliding with any gas molecules and thus forming ions by collision is reduced to a minimum.

In the Coolidge X-ray tube there is no difficulty in obtaining such a good vacuum that no gaseous discharge occurs even when 150,000 volts is applied across the elec-

¹ W. D. Coolidge, *Phys. Rev.*, Dec., 1913.

² S. Dushman, *Phys. Rev.*, April, 1914. The complete paper will appear very shortly in the same journal.

trodes. There appears to be no limit to the voltage for which the tube may be constructed except that due to electrostatic strains. A further discussion of this point is, however, reserved for a subsequent section.

ELECTRON EMISSION IN HIGH VACUUM

Regarding the difficulty of obtaining constant values for the thermionic currents at given temperatures, it has already been mentioned that in a sufficiently good vacuum the results obtained are perfectly definite and reproducible. In the case of tungsten in a "perfect" vacuum the value of the constants a and b in the Richardson equation are 23.6×10^{-9} and 52500 respectively, where i is measured in milliamperes per square centimeter.¹

Using these constants, the values of i calculated for different values of T are as given in the following table:

TABLE I

T	i/cm^2
2000	4.2 milliamps.
2100	15.1
2200	48.3
2300	137.7
2400	364.8
2500	891.0
2600	2044.0

In Fig. 1 these results have been plotted on semi-logarithmic paper. Plotting directly values of i against those of T one obtains a curve of the form shown in Fig. 2.²

SPACE CHARGE EFFECT

It was observed by Langmuir that in addition to this temperature limitation the electron current may be also limited by *space charge*. With a low potential difference between the electrodes the phenomena observed are as follows:

As the temperature of the cathode increases, the electron emission increases at first in accordance with the equation of Richardson. However, above a certain temperature this current becomes constant; further increase in temperature does not cause any corresponding increase in thermionic current. The temperature at which this limitation occurs increases with increase in anode potential. The curves shown in Fig. 2 illustrate this very well. They represent the results observed when the thermionic current was measured from a 10-mil tungsten filament situated along the axis of a cylindrical anode 7.62 cm. long and 1.27 cm. in radius. Thus, with a potential difference of 55.5 volts, the electron emission increased according to the equation of Richardson until a temperature of about 2300 deg. K was attained. With further increase in temperature, the thermionic current remained absolutely constant. But when the voltage was increased to 87.5, the thermionic current continued to increase up to 2350 deg. K. With a voltage of 129, the increase in thermionic current was observed up to 2400 deg. K.

This effect (which is observed *only in extremely good vacua*) is due to the existence of a space charge produced by the emitted electrons. In other words, the electrons emitted from the hot cathode produce an electrostatic field which tends to prevent the

¹ I. Langmuir, *Physikal. Zeit.*, 15, 516 (1914).

² S. Dushman, *Phys. Rev.*, 4, 121 (1914). The area of the hot filament used was 0.61 cm^2 . The experiments from which this curve was plotted were performed some time ago. Both the degree of vacuum attained and the accuracy of temperature determination were not as good as that obtained in measuring the values of a and b given above. When it is considered that an error of 25 degrees in the determination of the temperature at 2400 deg. K. is sufficient to account for the difference between these values of the constants and those given in the curve, the discrepancy does not appear so great.

motion of any more electrons toward the anode. As the positive potential on the latter increases, more and more electrons are permitted to reach the anode.

From theoretical considerations it was deduced by Langmuir that the thermionic current ought to increase with the three-halves power of the voltage (until the saturation current as defined by the Richardson equation is attained), that is, for electrodes of *any shape*, the space charge current

$$i_s = k \cdot V^{3/2} \quad (2)$$

Where V denotes the potential difference and k is a constant depending on the shape of the electrodes, their area and the distance apart.

For the case of a heated filament in a concentric cylindrical anode (infinite length)

$$i_s = \frac{2\sqrt{2}}{9} \sqrt{\frac{\epsilon}{m}} \frac{V^{3/2}}{r} \quad (3)$$

Where i_s is the thermionic current per unit length and r is the radius of the anode.

Converting into ordinary units (milliamperes and volts) this equation becomes

$$i_s = \frac{14.6}{r} \times V^{3/2} \times 10^{-3} \quad (4)$$

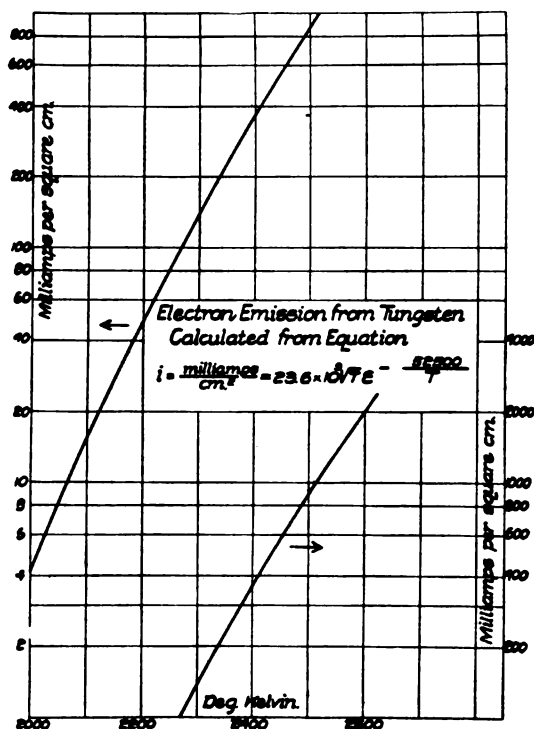

Fig. 1. Electron Emission from Tungsten in a "Perfect" Vacuum

The data shown in Fig. 2, which were obtained in the course of an investigation carried out by the writer, are in full accord with the results calculated from this equation. Substituting for r the value 1.27 cm., and noting that the actual length of cylinder used was 7.62 cm., the values of the constant factor as obtained from the observed space charge currents for different voltages do not differ by more than 2 per cent from 14.6.¹

In the case of a heated tungsten plate parallel to another plate, the space charge current per sq. cm., in milliamperes, is

$$i_s = 2.32 \times 10^{-3} \times \frac{V^{3/2}}{x^2} \quad (5)$$

where x is the distance between the plates in centimeters.

It ought to be observed that up to a point at which the diameter of the filament amounts to about five per cent of the diameter of the anode cylinder, or of the distance between the plates,

the space charge voltage is independent of the actual diameter of the filament.

The thermionic current from a hot cathode may, therefore, be limited either by temperature or by space charge. With a given temperature of the cathode, the thermionic current will increase at first as the positive potential on the anode is increased, and for each voltage V , there will be a corresponding value of i_s according to equation (2). When i_s ,

¹ It is evident that equation (3) may be used as a method for the determination of ϵ/m . The results obtained, therefore, serve to confirm once more the conclusion that the negative current from the hot cathode is due to electrons.

has attained the value i which corresponds to saturation thermionic current from the filament at the given temperature, further increase in voltage has no effect.

On the other hand, with a given voltage drop, the current increases with the temperature until i is equal to i_s , and further increase in temperature leads to no corresponding increase in thermionic current. This is the case illustrated in Fig. 2.

The existence of this space charge effect is evidence of the absence of any positive ionization, and serves, therefore, as additional confirmation of the conclusion that the currents obtained from a hot cathode in a very high vacuum are due to a pure electron emission, and are not dependent upon the presence of any small amounts of gas.

In this respect the behavior of a hot filament in a good vacuum differs radically from the exhibited by a Wehnelt cathode. In the case of the latter the currents obtained are due largely to the presence of positive ions, as is shown by the absence of space charge effects. The result is that the cathode disintegrates under the action of positive ion bombardment, and a rectifier containing such a cathode, therefore, cannot be used with potentials higher than a few hundred volts at most. On the other hand, in the case of a rectifier containing a hot filament as cathode and exhausted to as high a degree of vacuum as possible, there is no conduction except by electrons. In order to distinguish the latter type of hot cathode rectifier from other forms in which positive ions play an essential role, the designation, *kenotron*, has been specially coined. This word is derived from the Greek adjective *kenos*, meaning "empty" and the suffix *tron* signifying an instrument or appliance. The applicability of the name is self-evident.

Having indicated the possibility of the construction of a high voltage hot cathode rectifier, we shall now proceed to discuss the principles underlying the designing of such rectifiers.

PRINCIPLES OF DESIGN OF KENOTRONS

The question as to the proper design of a kenotron may be treated under three headings:

1. The amount of current to be rectified.
2. The maximum permissible voltage loss in the rectifier.
3. The proper form of electrodes to prevent electrostatic strains on the filament.

(1) CURRENT CARRYING CAPACITY OF THE KENOTRON

The current carrying capacity of a kenotron when given sufficiently high voltage between the electrodes, is limited only by the area of the surface emitting electrons (that is, length and diameter of filament) and its temperature. The data given in Table I and the curve shown in Fig. 1 are, therefore, of fundamental importance in this connection. The next consideration is, of course, the "life"¹ of the filament at

¹ The "life" of a filament is usually taken in this laboratory as the time required to evaporate 10 per cent of the diameter. For data on the rate of evaporation of tungsten filaments the reader is referred to the paper by Langmuir, *Phys. Rev.*, 2, 329 (1913).

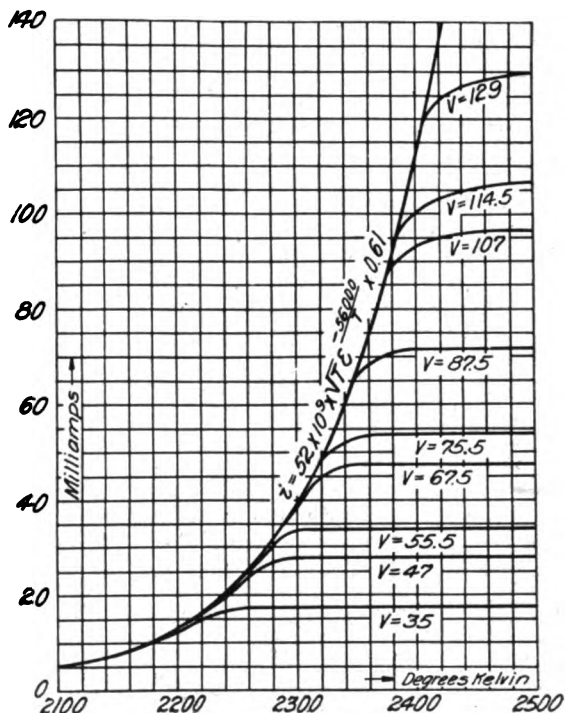

Fig. 2. The Effect of Space Charge on the Thermionic Currents

any temperature, and normally the maximum temperature at which the filament is maintained should be such that the "life" of the filament is over 1000 hours at least.

Thus, a 5-mil filament at 2400 deg. K. (corresponding to 1 watt per candle) has a life of about 4000 hours. The electron emission per 1 cm. length of 5-mil filament at this temperature, as calculated from Table I is 15 milliamperes. The energy required to maintain the filament at this temperature is about 4.5 watts per cm. length.

Where the kenotron is required for currents of 100 milliamperes or more, it is better to use a 7 or 10-mil filament. This is of advantage in two respects. Not only is there an increase in area per unit length, but also the life is much longer at the same temperature. On the other hand, the temperature can be increased and the life of the filament still be maintained at over 1000 hours. Thus, in the case of a 10-mil filament at 2500 deg. K., the life is pretty nearly 3000 hours, while the electron emission is 70 milliamperes per cm. length.

The data shown in Table II are of great interest in this connection. As "safe" temperature we consider that at which the life of the filament is over 2000 hours. The last column also gives the watts per cm. length of filament, a figure which is of importance in calculating the losses in the rectifier itself.¹

TABLE II

Diam. of Filament in Mils	"Safe" Temperature	Electron Emission per Cm. Length	Watts per Cm. Length ²
5	2475	30	3.1
7	2500	50	4.6
10	2550	100	7.2
15	2575	200	11.3

(2) VOLTAGE DROP IN KENOTRON

Owing to the existence of the space charge effect it is evident that for any given current carrying capacity i of a kenotron there will exist a voltage drop V in the rectifier itself and the relation between these will be of the form indicated in equation (2).

We can now consider the manner in which the kenotron operates when placed in series with a resistance across a source of high voltage.

Let E denote the value of this voltage at any instant, and i_s the current rectified. If V denotes the voltage drop through the kenotron, and R , the resistance of the load, it follows from equation (2) that

$$i_s = kV^{\frac{3}{2}} = k(E - i_s R)^{\frac{3}{2}} \quad (2a)$$

With constant value of E , the current rectified increases as R is decreased until i has attained the value i corresponding to saturation thermionic current at the temperature at which the cathode is maintained. If now R is decreased still further, i remains constant, and consequently the *voltage over the kenotron increases beyond that given by equation (2)*. That is, this equation gives the *minimum voltage* drop through the kenotron when rectifying a given current i_s ; but when operating in series with a resistance, the *voltage drop in the kenotron is that available above the $i_s R$ drop in load*. In case of a short-circuit on the latter, where R decreases indefinitely, the total voltage of the source is taken up by the kenotron, thus liberating the whole of the energy, Ei , as heat at the anode, and the latter may be raised to a temperature at which it will melt or volatilize and ruin the tube.

¹ The current necessary to heat the filament varies from 2 to 10 amperes, according to the diameter of the filament and the temperature, and may be obtained either from a storage battery or small transformer.

² These figures are based upon data published by Langmuir. Phys. Rev., 34, 401 (1913).

It is necessary to emphasize this characteristic behavior of the kenotron, and in practice care should be taken to provide against short-circuiting of the load, or some form of protective device should be used.

The watts lost in the kenotron owing to the space charge effect is

$$W_R = Vi = kV^{\frac{3}{2}} \quad (6)$$

Because of the high degree of vacuum, none of the electrons lose energy by collision with gas molecules. The whole of their kinetic energy is, therefore, liberated as heat at the anode, just as the energy of rifle bullets traveling through a comparatively frictionless medium is converted into heat at the target. Denoting the number of electrons emitted per unit area and per unit time by n , and their velocity by v , it follows that the energy converted into heat at the anode is

$$W_R = n (\frac{1}{2} m v^2) = n e V = i V \quad (6a)$$

If to this be added the watts w_H used in heating the filament, then the total loss in energy becomes

$$W_L = W_H + W_R \quad (7)$$

Of this energy loss, the whole of W_R and a large fraction of W_H are used up in heating the anode.

It is evident that if the anode becomes too hot the rectification will tend to become imperfect. The rectifier must, therefore, be so designed that the space charge voltage is not great enough to cause heating of the anode when the requisite current is being carried by the tube. The amount of energy (in watts per square centimeter) required to maintain tungsten at a temperature T is given by the equation.¹

$$W_s = 12.54 \left(\frac{T}{1703} \right)^{4.74} \quad (8)$$

Table III gives the values of W_s for different temperatures. The last column gives the corresponding values of the electron emission per unit area in milliamperes.

TABLE III

T	W_s	i
1000	0.96	1.2×10^{-11}
1500	6.9	6×10^{-4}
1800	16.4	0.3
2000	28.9	4.2
2500	77.5	890

From these data it may be concluded that about 10 watts per sq. cm. of anode area is quite permissible. This would correspond to a temperature of about 1600 deg. K., that is a very bright red heat. At this temperature the electron emission is still less than 0.02 milli-ampere per sq. cm.

(3) ELECTRODE DESIGN

There remains only one other point to consider in the design of kenotrons and that is the prevention of electrostatic strains on the filament. As is well known, the electrostatic force between two charged surfaces increases as the square of the voltage difference. At voltages of 25,000 and over, this force becomes quite appreciable and unless special precautions are taken in the design of electrodes, it is possible at such voltages to actually pull the heated filament over towards the anode. When the keno-

¹ I. Langmuir, Phys. Rev., 34, 401 (1912). The same equation is also approximately true for molybdenum.

tron is used in series with a load on a high tension alternating current circuit, there is a very low potential difference between the electrode during the half cycle that rectification occurs, while during the other half cycle the whole of the voltage drop generated by the transformer or other source of alternating current occurs in the rectifier itself. It is, therefore, necessary to design the kenotron so that the electrostatic forces acting on the filament are reduced to a minimum.

Various types of construction have been adopted to take care of this difficulty. A straight filament in the axis of a cylindrical anode; a V- or W-shaped filament placed symmetrically between two parallel plates; or a headlight filament inside a molybdenum cap; each of these types of construction has been found practicable up to certain voltages.

Of course, electrostatic forces can be overcome by placing the filament at quite a distance from the anode and shielding the former in the same manner as is done by Coolidge in his Roentgen ray tube. But under these conditions the "space charge" voltage (which increases with the first or second power of the distance, see equations 4 and 5) becomes excessively high and the energy loss in such a rectifier would be altogether too large.

DIFFERENT TYPES OF KENOTRONS

The different types of kenotrons mentioned in the previous section are illustrated in Figs. 3, 4 and 5. In the following section it is intended to discuss briefly the characteristics of rectifiers that have been constructed along these lines and to point out the relative advantages and disadvantages of each type.

Fig. 3 shows a molybdenum cylinder *A* with a coaxial filament *F*. For direct current voltages up to 15,000 the diameter of the cylinder need not exceed one-half inch (1.27 cm.), while the length may be made as much as four inches (10 cm.) A. 10-mil filament is used as cathode.

At a temperature of 2550 deg. K. (see Table II) the maximum current obtainable from such a kenotron is about 400 milli-amperes, and the voltage drop necessary to produce this current as calculated from equation (4), and actually observed, is

$$V = \left(\frac{400}{14.6} \times \frac{1.27}{2} \times \frac{10^{-3}}{10} \right)^{\frac{2}{3}}$$

$$= 145.$$

The space charge equation for this kenotron is

$$i_s = 230 \times 10^{-3} \times V^{\frac{3}{2}} \text{ milli-amperes.}$$

At 145 volts, $W_R = 145 \times 0.400 = 58$ watts. Also $w_H = 72$ (Table II). The total energy used up in the rectifier is, therefore, 130 watts. As the radiating area of anode surface is about 80 sq. cm., this energy loss corresponds to slightly over 1.5 watts per sq. cm., which is just sufficient to maintain the anode at a dull red heat (1100 deg. K.). Since the kenotron is capable of rectifying $0.400 \times 15,000 = 6$ kw., the energy loss in the tube corresponds to about 2 per cent of the total amount of energy rectified.

For direct current voltages up to 75,000 or 100,000, the diameter of the cylinder is increased to about 5 cm. For mechanical reasons it has been found necessary, in this case, to attach the filament to a molybdenum rod framework, which serves to increase the space charge voltage above that calculated from equation (4). In a tube intended to rectify 10 kw. at 100,000 volts the current carrying capacity required is 100 milli-amperes. This electron emission is easily obtained from about 4 cm. of 7-mil filament at a temperature around 2400 deg. K.

The space charge data of Table IV were obtained with one kenotron (No. 72) of this type:

These observations are in accord with the equation

$$i_s = 6 \times 10^{-3} \times V^{\frac{3}{2}}$$

The energy loss in the tube owing to this space charge voltage amounts to 65 watts for 100 milli-amperes. Adding to this about 50 watts consumed by the filament, the total energy lost in the kenotron is about 125 watts which represents only 1.25 per cent of the total energy which the tube is capable of rectifying.

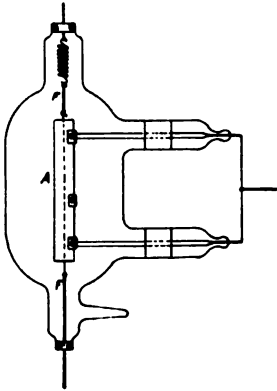

Fig. 3. Kenotron Containing Cylindrical Anode

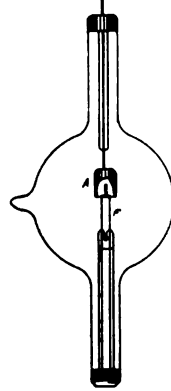

Fig. 4. Molybdenum Cap Type of Kenotron

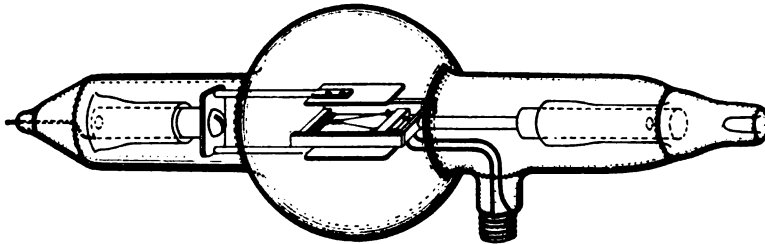

Fig. 5. Kenotron with Filament Between Two Parallel Plates

A form of kenotron which is suitable for voltages not over 10,000 and currents ranging up to 100 milli-amperes is that shown in Fig. 4. It consists of a small filament, such as is used in automobile headlights inserted in a molybdenum cap about 1.6 cm. ($\frac{5}{8}$ inch) in diameter.

TABLE IV

V	i_s
310	33 milli-amperes
260	25
130	9

The following table gives the currents actually obtained with different voltages in the case of kenotrons containing a 7-mil headlight filament (No. 50), and 5-mil headlight respectively (No. 51).

TABLE V

KENOTRON NO. 50		KENOTRON NO. 51	
V	i_s	V	i_s
20	2.7	100	19
40	7.6	150	36
80	25.0	200	55
120	46.0		
160	70.0		
200	96.0		
240	115.0		

In the case of No. 50, the observations are very accurately represented by the equation

$$i_s = 34 \times 10^{-3} \times V$$

While in that of No. 51, the corresponding equation is

$$i_s = 34 \times 10^{-3} \times V^{\frac{1}{2}}$$

In neither case is it necessary to heat the filament to a temperature above 2400 deg. K. The radiating surface of the anode is about 4 sq. cm. and the total energy loss for 100 milli-amperes is about 50 watts.

The case of a V-shaped filament between two tungsten plates is illustrated in Fig. 5.

In one case (kenotron No. 66) the plates were about 2 cm. apart, while in another (kenotron No. 70) the plates were twice as far apart. Table VI gives the characteristics for each kenotron.

TABLE VI

KENOTRON NO. 66			KENOTRON NO. 70		
Fil. Temp.	V	i	Fil. Temp.	V	i
2340	260	25	2320	340	28
2370	260	35	2370	340	50
2410	260	90	2400	340	54
2450	260	100	2500	340	60
2500	260	100	2500	260	42
2500	130	35	2500	130	14

$i_s = 24 \times 10^{-3} \times V^{\frac{1}{2}}$			$i_s = 9.9 \times 10^{-3} \times V^{\frac{1}{2}}$		
--	--	--	---	--	--

The filament in kenotron No. 70 was about 7, while that in No. 66 was about 6 cm. long.¹ Each tungsten plate was about 2.5 × 5 cm.; so that the total radiating surface was about 25 sq. cm. Kenotron No. 66 could be used up to about 40,000 volts, while No. 70 showed no sparking or straining of filament up to 60,000 volts.

By using a W-shaped 7-mil filament (total length about 20 cm.) between two tungsten plates 5 cm. square and situated 1.25 cm. apart (kenotron No. 54), the space charge voltage for given current carrying capacity was considerably reduced. The space charge equation for this kenotron was found to be

$$i_s = 103 \times 10^{-3} \times V^{\frac{1}{2}}$$

Owing to the small distance between the plates, the filament was not situated exactly symmetrically with respect to them, and it was, therefore, not thought advisable to use the kenotron with direct current voltages higher than 25,000.

¹ Owing to lead losses only the central portion of the filament was at the temperature indicated.

Here again, the energy loss in the kenotron for a 10-kw. unit, (current carrying capacity of 400 milli-amperes) is well below 2 per cent.

A comparison of the different types of kenotrons illustrated above leads to the following conclusions:

(1) For current carrying capacities up to 500 milli-amperes, either a cylindrical anode with a filament down the axis, or a W-shaped filament placed between two parallel plates may be used. The first named type can apparently be made much more efficient as regards losses due to space charge effect.

(2) Where currents of the order of 100 milli-amperes or less have to be rectified, and the maximum direct current voltage is not over 15,000, the molybdenum cap type is one that is simpler mechanically and also quite efficient.

(3) For voltages up to 100,000, the cylindrical anode type has proven itself to be very practicable and efficient.

OSCILLOGRAMS OF PERFORMANCE OF KENOTRONS WITH ALTERNATING CURRENT VOLTAGES

In order to illustrate the characteristics of a kenotron when used with a-c. sources, a number of oscillograms were taken. Film Fig. 6 was obtained with kenotron No. 54 placed directly across the 60-cycle, 122-volt terminals. The upper curve represents the voltage of the generator, while the lower curve gives the current through the

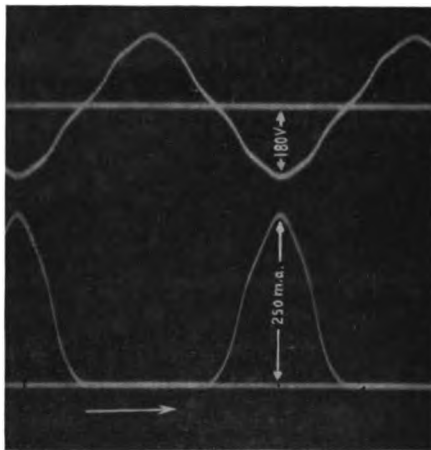

Fig. 6. Half-wave Rectification, Upper Curve Gives Voltage Over Kenotron; Lower Curve Gives Current Rectified. Note the Effect of Voltage Limitation

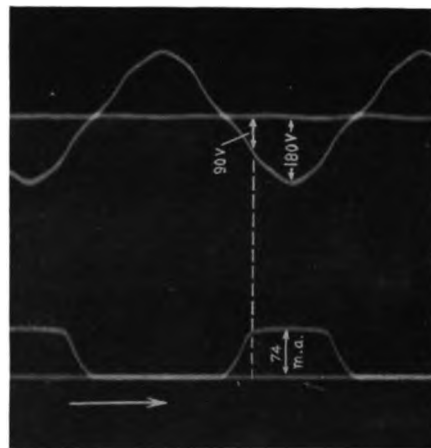

Fig. 7. Same as Fig. 6. Note the Effect of Temperature Limitation

kenotron. The effective a-c. voltage was 122 and the maximum voltage 180. The lower curve shows that the rectification obtained was absolutely perfect; also the peaked nature of the current wave shows that it was limited by space charge throughout the whole cycle.

It will be remembered that for this kenotron the space charge equation as obtained from direct current measurement, was

$$i_s = 103 \times 10^{-3} \times V^{\frac{1}{2}}$$

It was, therefore, expected that this relation ought to hold quantitatively for simultaneous values of voltage and current as measured on the oscillogram. The results obtained confirm this expectation splendidly.

The following table gives the values of i_s as observed and calculated for values of V corresponding to different intervals of a second t after the beginning of the cycle:

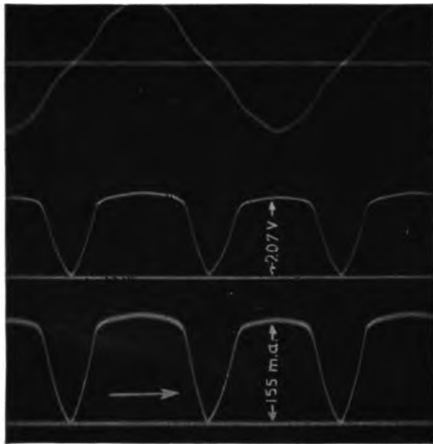

Fig. 8. Full Rectification, Using Arrangement Shown in Fig. 10. Upper Curve—Voltage Over Primary of Transformer; Middle Curve—Voltage Overload; Lower Curve—Current Rectified. The Latter was Limited by Temperature of Cathode in Each Case



Fig. 9. Same as Fig. 8. The Current Rectified was Limited on One Half Cycle by Temperature and on the Other Half by Voltage

TABLE VII

t	V (upper curve)	i_s (lower curve)	i_s (calculated)
0.0015	64	55	53
0.0022	130	150	153
0.0031	165	207	212
0.0042	180	250	251

A direct current milli-ammeter in series with the oscillograph read 68 m.a.

Film Fig. 7 was obtained with the same arrangement of apparatus, but the filament temperature was made so low that the maximum current obtainable was well below the space charge current for 180 volts. The current curve begins to flatten at a point for which $V=90$. The corresponding space charge current as calculated from the above equation is 88 milli-amperes, while the oscillogram indicates 74 milli-amperes. The direct current milli-ammeter showed a current of 28 m.a.

The oscillograms shown in films Figs. 8 and 9 were obtained with an arrangement of apparatus similar to that shown in Fig. 10. The low tension side of a potential transformer TT , ratio of coils 20 to 1, was connected to the 122-volt alternating current generator, while the high tension coils were connected to two kenotrons AF and $A'F'$ as shown in the diagram. (The condenser C shown in the diagram was omitted.) The direct current was taken from the middle point of the transformer and the filaments. A load of two 250-volt carbon lamps (60-watt type) was connected in series with a milli-ammeter and the current strip of the oscillograph to the terminals BB' . The kenotrons used were not of the same construction, with the result that the space charge voltages for the same current were quite different.

The upper curve in each film gives the voltage over the primary of the transformer, the middle curve gives the voltage over BB' , while the lower curve gives the current through the load. In taking film Fig. 8, the temperature of the filaments was maintained very low, with the result that both current and voltage waves were flattened con-

siderably. The slight irregularity in the amplitudes of the two half cycles was due to the fact that it was almost impossible to adjust the temperatures of the two filaments so that they would possess the same electron emission. The direct current milliammeter read 100 milli-amperes.

Film Fig. 9 shows an interesting case in which the thermionic current from one kenotron was limited by space charge, while that from the other was limited by temperature. The d-c. ammeter indicated 140 m.a. When taking the oscillogram of the current through the load, the voltmeter strip was opened, and when photographing the wave of voltage over load, the current indicating strip of the oscillograph was short-circuited.

SUMMARY

Summarizing briefly what has been stated regarding the hot cathode rectifier (kenotron) it has been shown that:

(1) The current rectification is due to the emission of electrons from a heated filament in as good a vacuum as can be obtained. The current carrying capacity of the kenotron depends *only* upon the area and temperature of the filament, and increases with the latter according to an equation of the form:

$$i = a\sqrt{T} \epsilon^{-\frac{b}{T}} \quad (1)$$

where i denotes the saturation thermionic current.

(2) The voltage drop in the kenotron depends upon the area, shape and distance apart of the electrodes, and increases with the current actually rectified according to an equation of the form

$$i_s = k.V^{\frac{1}{2}} \quad (2)$$

where i_s denotes the space charge current.

When i is measured in milli-amperes, the magnitude of k varies in ordinary cases from 5×10^{-3} for very high voltage kenotrons, to 250×10^{-3} for lower voltage kenotrons. In other words, for a potential drop in the kenotron of 100 volts, the rectified current varies from 5 to 250 milli-amperes.

As has been mentioned on page 160, equation (2) gives the minimum voltage drop over the kenotron when it is operated in series with a resistance under most efficient conditions. Owing, however, to the fact that the filament temperature limits the maximum current which the kenotron can rectify, it is possible for the voltage over the latter to exceed the value given by equation (2) as the *rectifier takes the difference between the maximum voltage available and that consumed in the load*. Care should, therefore, be taken in using the kenotron to avoid short circuits of the load; or some form of protective device should be used.

(3) The actual energy losses in the kenotron may be reduced to less than two per cent of the total energy rectified when the tube is operated to its full voltage limit.

(4) Up to the present, kenotrons have been constructed for direct current voltages as high as 100,000; but there is every expectation of being able to extend the field of application to 150,000 and even 200,000 volts.

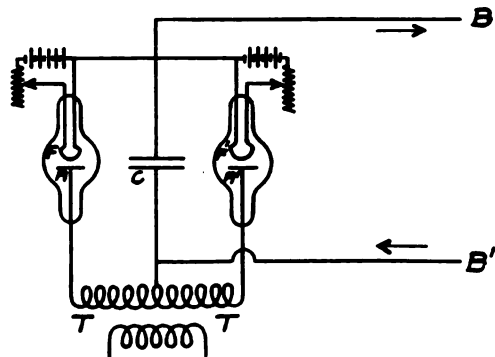

Fig. 10. Arrangement for Rectifying Both Half-waves, Using Middle Point Connection on Transformer

The maximum current rectified has been as much as 1500 milli-amperes (1.5 amperes); but it is much more convenient to construct these rectifiers in the form of 10-kw. units where the voltages required exceed 25,000. For lower voltages, smaller units are advisable.

(5) A great advantage possessed by the kenotron is that two or more of them can be operated in parallel. From the remarks made above in connection with equation (2-a), it is evident that when a number of kenotrons connected in parallel are placed in series with a resistance, the current through the latter will control the voltage drop and current through each kenotron so that in each case an equation of the form (2-a) is satisfied.

The kenotron thus possesses at least two advantages over the mercury arc rectifier; firstly, because it may be operated at higher voltages, and secondly in the fact that several kenotrons can be operated in parallel.

APPLICATIONS OF THE KENOTRON

No doubt a number of applications of this device will suggest themselves to electrical engineers and physicists. A few words, indicating the possible fields of application that have already been suggested, will probably not be out of place.

In the *physical laboratory* where *small direct currents* of a few milli-amperes at *very high voltages* are required, as for spectroscopic work, operating small discharge tubes, etc., the kenotron ought to prove exceptionally useful. An arrangement similar to that shown in Fig. 10, and consisting of two kenotrons of the headlight filament type with a 60:1 potential transformer will act as a satisfactory source of direct current voltages up to 4500 or 5000.

Fig. 11. Arrangement of Four Kenotrons for Making Use of Full Voltage of Transformer

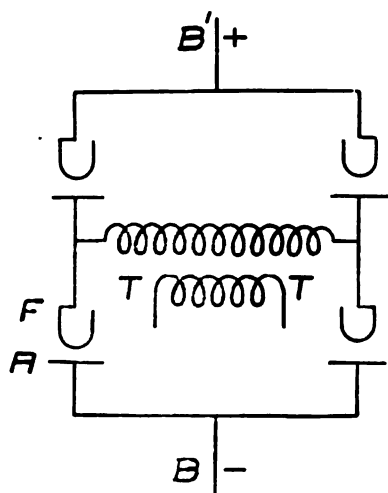

By inserting a condenser *C* of sufficiently high capacity between the terminals *BB'* the direct current obtained may be made as free from pulsations as desired. The kenotron could also be used for testing the dielectric strength of insulation with high voltage direct currents.

The writer has obtained as much as 400 milli-amperes direct current at 6000 to 7000 volts by using in the same manner a 500-cycle generator and a 100 to 10,000-volt transformer.¹ By inserting capacity between the high tension direct current terminals, it was found possible to reduce fluctuations in the resulting direct current to less than five per cent when 100 milli-amperes was being used at 6000 volts.

Fig. 11 shows an arrangement of four kenotrons in which the whole of the voltage generated by the transformer is utilized. *BB'* are the direct current leads.

The combination of kenotrons and transformer could be used to replace the cumbersome static machines and the still more complicated mechanical rectifiers that are at present used to produce high voltage direct current for *X-ray tubes* and the *precipitation of dust, smoke, etc.*

Another field of application that appears to be very much within the limits of possibility is that of *high voltage direct current transmission*. While this system has not been used to any extent in this country, it is a well known fact that the Thury system

¹The kenotron operates just as satisfactorily on 100,000 cycles as on ordinary frequencies.

has met with great success in Europe.¹ To transmit 1000 kw. by 100 kenotrons, working in parallel at a voltage of 50,000 to 75,000 is quite a feasible proposition.

In conclusion the writer wishes to express his indebtedness to Dr. Langmuir and Mr. W. C. White of the Research Laboratory for valuable suggestions and kind co-operation during the work on the development of the above device.

¹ J. S. Highfield, Journ. Inst. Elec. Eng., London, 38, 471; 49, 848; 51, 640. In these papers the advantages of high voltage direct current transmission are discussed very fully.

A MODEL X-RAY DARK-ROOM*

BY WHEELER P. DAVEY

Anyone visiting the offices of a large number of X-ray practitioners is impressed by the small number of first-class dark-rooms. Men enjoying a large practice as X-ray specialists have had occasion to fit up rooms very well adapted to the purpose, but those with smaller practice, or those who use X-rays as an aid to diagnosis in their own general practice do not seem to have been so fortunate. It is with the hope of aiding such men in planning an efficient and convenient dark-room, that this article is written.

In planning a dark-room for X-ray work, space must be provided for the following:

(1) Stock solution of developer; (2) Developing shelf; (3) Sink; (4) Hypo bath; (5) Wash-tank; (6) Drying rack; (7) Racks for holding envelopes; (8) Interval timer; (9) Ventilating fan; and (10) Necessary lights and switches.

In addition to the above it is usually desirable to provide room for a moderate supply of plates and for a stock of chemicals. A small viewing screen in the dark-room is a great convenience but not a necessity. If frames are used for fixing, washing and drying the plates (and the author believes that they should be), then space should be provided for them on the walls of the room.

The room should be planned so as to make everything as compact as possible, and so that it is never necessary to allow a plate, wet with hypo, to drip on the floor. The two dark-rooms described in this article have been found satisfactory enough to warrant them being called "Model" dark-rooms. One is in the Research Laboratory of the General Electric Company. Space was at a premium and the room was built out like a closet in one of the rooms. The other is in the office of a well-known surgeon whose X-ray practice is large enough to require the constant services of a trained Roentgenologist. In this case compactness was not as essential as the ability to handle a large number of plates quickly.

Both dark-rooms were planned with the idea of developing plates entirely by time. With the Coolidge tube the penetration and exposure can be made so definite that this method is by far to be preferred. Tank development was considered, but was thought not to be economical enough of developer because of the large size of plates used in stomach and chest work. It is possible, however, to combine the convenience of the tank-method with the economy of the tray-method if the following technique is followed.

(1) Fill the tray quarter-full of *fresh* developer at some standard temperature (say 65 deg. F.).

(2) Insert plate.

(3) Shake tray vigorously from end to end and from side to side to remove air bubbles.

(4) Cover tray with a *light-tight* cover and leave undisturbed for ten minutes, as shown by the interval-timer. (Adjust the exposure so that this is the proper time of development.)

(5) After using, pour developer at once into an air-tight bottle just large enough to hold it, and put in water bath to keep cool. If care is taken not to use stale, discolored developer, this method has been found to be quite as satisfactory as tank development.

* Copyright, 1915, by *General Electric Review*.

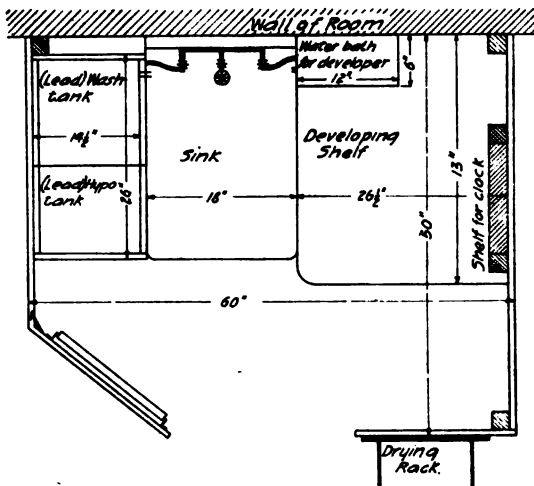

Fig. 1. Ground Plan, Dark Room No. 1

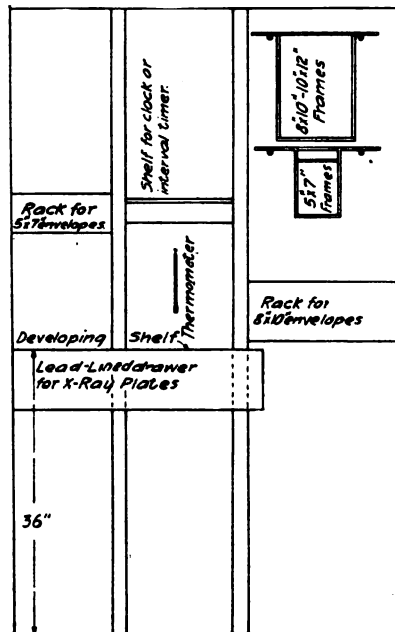

Fig. 3. Right Wall, Dark Room No. 1

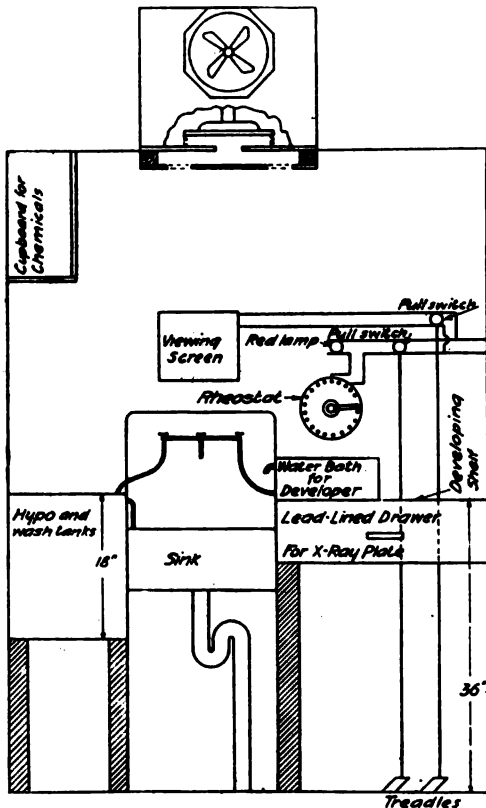

Fig. 2. Back Wall, Dark Room No. 1

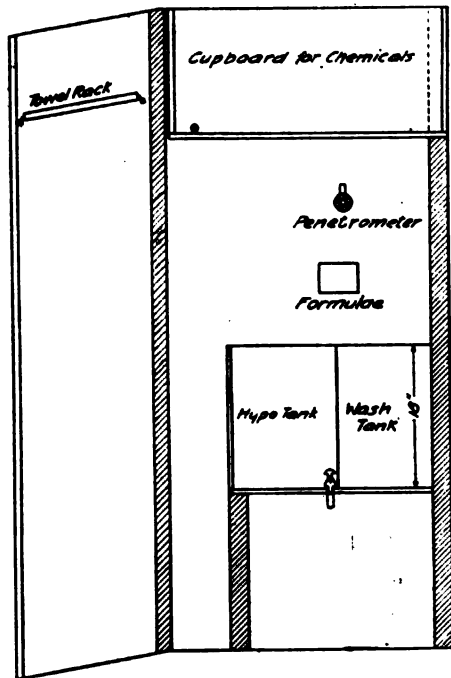

Fig. 4. Left Wall, Dark Room No. 1

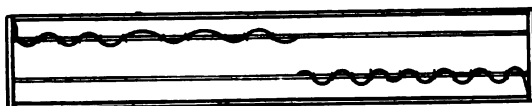

Fig. 5

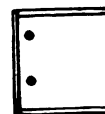

Fig. 5a

Method of Hanging Curtains in Doorway of Dark Room No. 1

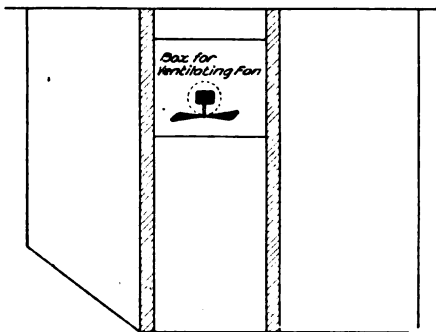

Fig. 6. Roof Plan, Dark Room No. 1

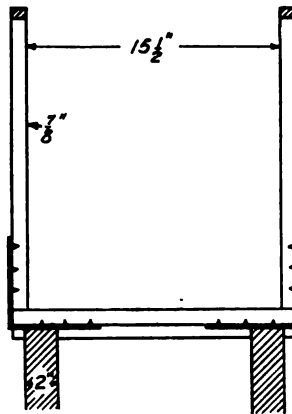

Fig. 9. End View of Drying Rack, Dark Room No. 2

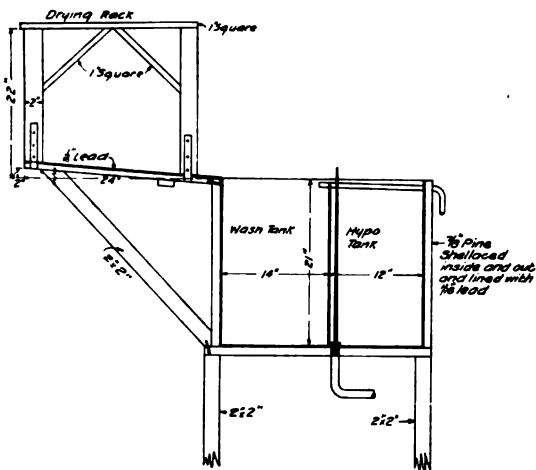

Fig. 7. Side View of Hypo and Wash Tanks and Drying Racks, Dark Room No. 2

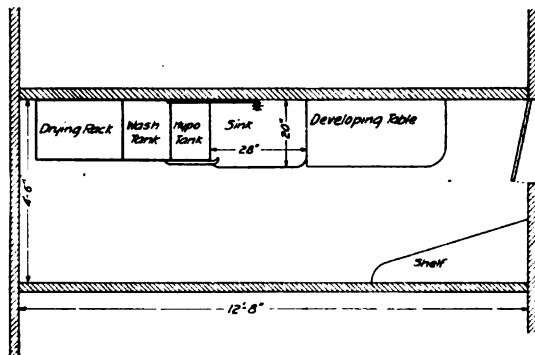

Fig. 10. Ground Plan, Dark Room No. 2

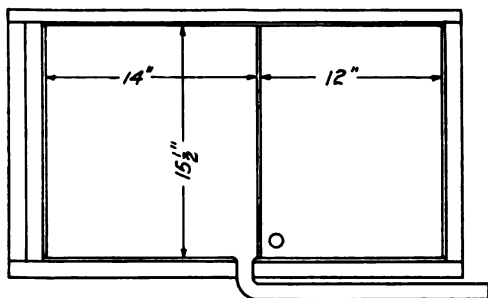

Fig. 8. Top View of Hypo and Wash Tanks, Dark Room No. 2

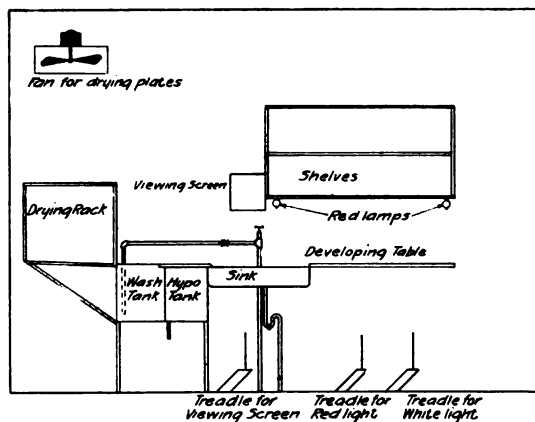

Fig. 11. Wall of Dark Room No. 2

As soon as the plate comes from the developer it is put in a frame, washed in the sink and at once put in the hypo tank. After fixing it is washed in the wash-tank and hung on the rack to dry. The use of the frames will be found to keep the gelatin from being marred by finger prints.

A glance at the plan of either dark-room will show that (1) a plate is never brought near the developer after having once left it; (2) lights are turned on and off from the floor,—there are no switches covered with hypo to spread hypo-dust into the developer; (3) the sink is between the hypo and the developer so that in passing from one to the other the hands may be washed; (4) the running water of the wash-tank is in contact with the hypo tank, thus insuring cold hypo; (5) a plate can never drip hypo on the floor, even when being viewed on the viewing screen.

In planning the viewing screen, a great deal of experimental work was done to find the best possible source of illumination for negatives. Every style of incandescent lamp known has been tried and compared with north-sky and with the mercury arc.

As a result, it was found that the "Blue Photographic Mazda" is by far the best source of illumination for viewing X-ray negatives. The viewing screens were, therefore, designed to be used with these lamps.

Plans of the smaller of the two dark-rooms are given in Figs. 1 to 6. This room was designed for use with plates not to exceed 10 by 12 inches in size. There is no reason why it could not have been designed for use with plates of any size. The walls were built of dry matched sheeting. The developing shelf was covered with lead partly to make it water-proof and partly to better protect the plates in the drawer from X-rays. Care must be taken to have plenty of overlapping of lead so that the rays may find no open crack through which to enter. The rheostat (Fig. 2) is a 300-ohm rheostat, and has all the range needed for dimming a 50-watt red light. The use of light during development is, however, not as necessary with "time development" as with the ordinary method. It is the practice of the author to dim the lamp as much as possible, using it merely as a point of reference in locating things in the room.

Attention is called to the use of curtains in the doorways as a means of economizing space. Two curtains are hung on separate rods as shown in Fig. 5. The outside edges are fastened permanently to the doorway. The inside edges are fastened to sticks about one inch square. These sticks act as weights and prevent the curtains from blowing in and causing light-leaks. Each curtain is wide enough to stretch completely across the doorway. A suitable housing (see Fig. 5a) painted black on the inside prevents light-leaking over the top of the curtains. The curtains are made of double thickness of galatea.

Plans of the larger dark-room are shown in Figs. 7 to 11. Attention is called to the method of drying the plates with the fan. The arrangement of the red lights is also worthy of notice. Instead of using a rheostat, two 10-watt red lamps were connected in series. This made them both burn dimly. In accordance with the suggestion made above, they are used, not as a source of light for watching the development of the plates, but merely as marks to guide the operator in his movements about the room. One lamp is placed at the extreme end of the developing table, the other is placed over the sink. The dimensions of the hypo and wash tanks and of the drying rack are given in Figs. 7 to 9 in some detail as a guide to any who care to have similar work done. In Fig. 11 the switches governing the various lamps are not shown. The treadles will, however, indicate where these switches should be placed.

A SUMMARY OF PHYSICAL INVESTIGATION WORK IN PROGRESS ON TUBES AND ACCESSORIES*

BY W. D. COOLIDGE

The following is a résumé of some of the X-ray investigation work which is in progress in our laboratory.

RADIOGRAPHIC WORK REQUIRING THE SHARPEST POSSIBLE DEFINITION

Conditions to be Met in the Tube—For this purpose, the first and most important desideratum in a tube is that it shall give the greatest possible X-ray intensity from a given sized small focal spot, for the use of a small focal spot imposes upon the tube a correspondingly small energy-input limitation, and this extends the time during which immobility of the part to be radiographed must be maintained.

To get the largest allowable energy input from a given sized focal spot the following conditions must be met:

- (a) The distribution of energy over the focal spot must be uniform.
- (b) Heat must be removed from the focal spot as rapidly as possible.

The Cathode—So far as (a) is concerned, the design of the cathode is all-important. Its effect is best studied experimentally by making X-ray pinhole camera pictures of the focal spot with various types of cathode.

A convenient method of making such pinhole camera focal-spot pictures is as follows: Take a square sheet of lead, say a sixteenth of an inch thick and of the right size to take the place usually occupied by the diaphragm in the tube stand. Make a conical depression in the center with a machinist's prick-punch, or other suitable tool. With a knife remove the tiny prominence produced in this way on the back of the lead plate, and then, with a pin or small drill open the hole to the desired size, say 0.02 inches in diameter. (If the hole is too large the focal spot picture will lack sharpness, and if it is too small, the required time of exposure will be needlessly long.) Put the lead plate and the tube in place in the holder and lay the photographic plate on a table below. The size of the focal spot picture can be varied at will by raising or lowering the tube holder. If it is to be of natural size, the distance from plate to pin-hole should be equal to that from pin-hole to focal spot. If it is desired to study the focal spot in greater detail, it is well to make the former distance twice the latter, which will give a twofold magnification.

It is a good plan to make two exposures, one of which is much longer than the other. The long exposure will then show the full extent of the focal spot, and the shorter one will show the distribution of energy over it. (In the case of gas-filled tubes, one should use the same current and voltage as are to be employed in regular work, for with this type of tube the size of focal spot varies greatly with the vacuum, being smaller the harder the tube is. With a hot-cathode tube, on the other hand, the size of focal spot is always the same regardless of the current and voltage employed.)

No conclusion concerning uniformity of distribution of energy can be drawn from the focal spot picture, unless care is taken to guard against over-exposure, for otherwise

* Copyright, 1915, by American Journal of Roentgenology.

even a very bad distribution will appear uniform. This is shown by the upper pair of focal spot pictures in Fig. 1. The right-hand one was exposed 3 seconds and the other 25. These are twice natural size.

One interesting type of cathode is shown in Fig. 2. The focusing device is a hemispherical bowl, and the filament spiral, instead of being convex outward, is concave, with the same radius of curvature as the bowl, and is located in the center and in the surface of the latter. Except for a small hole in the center, this gives a focal spot which shows a very nearly uniform distribution of energy and which is also very sharp and clean-cut at the edges. It is reproduced (again in twice natural size) in Fig. 1, the lower pair.

Target Design.—In connection with (b), various modifications of the target have been tried. The most obvious experiment was perhaps to try the copper-backed tungsten target such as is used in the gas-filled tube, for this brings copper, which has three times the heat conductivity of tungsten, close to the focal spot.

For a long time we were not able to make this experiment with the hot-cathode tube for the reason that we did not know how to exhaust it, to the required high degree of vacuum, with anything but tungsten or molybdenum electrodes. We finally learned how to do this and then made up two tubes, one with a copper-backed and the other with our regular all-tungsten target, taking care that the focal spot should have the

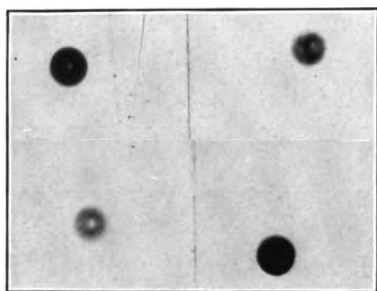

Fig. 1

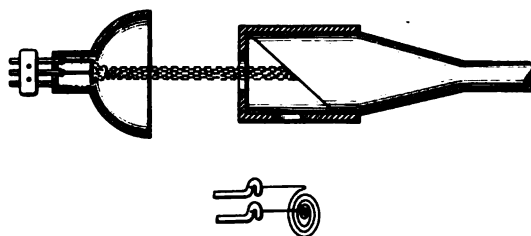

Fig. 2

same size in both. (This was subsequently checked by the X-ray pinhole-camera picture method.) The tubes were run on a definite voltage for a definite time, with a definite current. The focal spot was then inspected to make sure that melting had not taken place. The current was then raised successively to higher values until the focal spot was finally melted, sufficient time being allowed between experiments for the target to cool.

For exposures of 3 seconds or less, starting cold, there appeared to be no difference in the two targets, or at any rate not more than the experimental error. The experiment is of course a little crude, but not so much so as one might at first think; for it can be repeated as many times as desired. (This is made possible by the fact that the bright shiny area which has been melted at the focal spot may be made to take on a dulled or frosted appearance by operating the tube even for as short a time as a minute with an energy input which is safely below that sufficient to cause melting. Having frosted the surface in this way, there is of course no trouble in again finding how much it takes, starting cold, to melt the focal spot.)

For 30-second exposures the copper-backed target was able to carry about twice as much energy as the all-tungsten target. This difference was due merely to the greater heat capacity of the heavy copper-backed target, and could have been eliminated by the use of a larger tungsten target.

For still longer exposures the tables were turned, and the advantage was all with the all-tungsten target. This was of course due to the fact that it is not permissible to let a copper target get above a dull red heat, as otherwise it volatilizes badly and deposits on the bulb.

The experiment showed that a sufficiently large all-tungsten target would do anything that could be done with the present standard copper-backed target. (It was moreover free from the above mentioned limitation of the latter.)

The question naturally arises as to why copper with its three-fold greater heat conductivity does not assist more in getting heat away from the focal spot. The reason is this, that the tungsten disc in the standard copper-backed target is so thick (about 2.5 millimeters). The only place where high heat conductivity is important is in the immediate neighborhood of the focal spot and this position is in either case occupied by tungsten. Copper could be made to help if the thickness of the tungsten button could safely be considerably reduced. But if this is done the copper back of the focal spot melts. This melting of the copper is accompanied by expansion and this bulges out

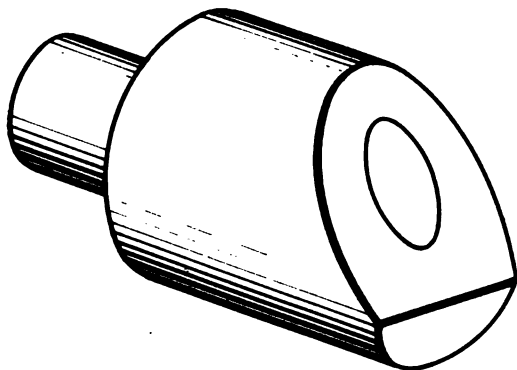

Fig. 3

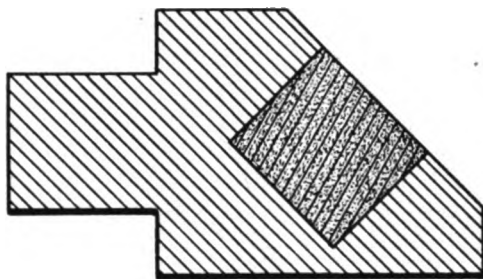

Fig. 4

the tungsten at this point. Upon cooling, contraction of the copper takes place and an empty space is left between the tungsten and the copper at the focal spot. When the tube is again used, the tungsten at the focal spot, not being in contact with the copper behind it, melts right through, thus ruining the target.

If exposures were made in rapid succession with a very fine focus tube, there would be an advantage in increasing the present size of the all-tungsten target so as to give it more heat capacity and more radiating surface. The same increase in heat capacity and radiating surface can be secured with less weight by such a construction as is shown in Fig. 3 and again, in section, in Fig. 4. In this case the target consists of a very thick tungsten cylinder pressed into a block of molybdenum. The latter metal helps in this way, that it is lighter than tungsten, which means more radiating surface for a given weight, and that it has about twice the heat capacity for a given weight.

But, in the way in which the very fine focus tube now seems to be used in practice, the exposure would always start with a relatively cool target. For this and the above reasons there appears to be no advantage in increasing the heat capacity and radiating surface of the present all-tungsten target in the fine focus tube.

The above relations may be seen at a glance by an inspection of the following incomplete table. It shows current values just insufficient to cause melting, starting with the target cold and with the tube always backing up the same spark gap ($1\frac{1}{2}$ in.). The focal spots were all of the same size.

Type of Target	Milli-amperes			
	3 sec.	10 sec.	30 sec.	Equilibrium
Copper-backed tungsten.....	38	35	30	..
Molybdenum-backed tungsten.....	35	25	15
Regular tungsten.....	30	15	12.5

Water Cooling of the Target.—This will help the sharp focus tube, at least to this extent, that the exposure will then always start with a cold target. It will, furthermore, make it possible for the tube to carry almost as much energy for an indefinite period as it does for a very short one. This subject has yet to be quantitatively investigated for the actual conditions met in practice.

Direct Current Excitation.—Considerable help may also come from the use of a constant potential continuous current source. Some preliminary experiments by Dr. Hull seem to indicate that, working with the proper voltages to give the same mixture of rays (having the same proportions of the different wave-lengths), the X-ray intensity for the same heating of the target is about one third greater with constant potential than it is with the usual sine wave. This gain would not seem to justify the increased

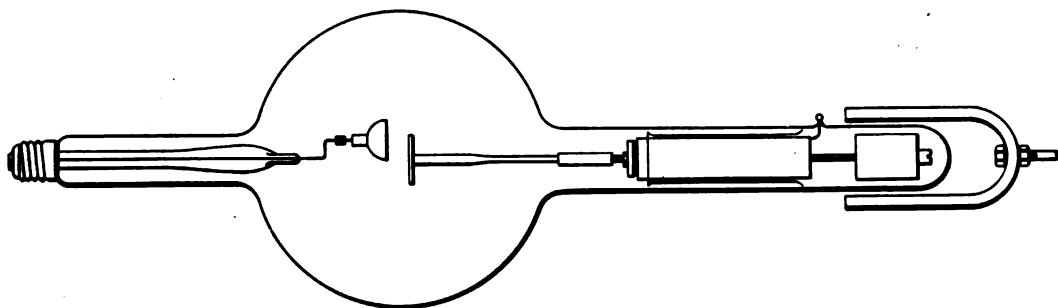

Fig. 5

complications in such a generator, but careful investigation may show that the advantage is really much greater and for the following reasons: When a tube is run hard on the ordinary sources of current supply, the focal spot always gets very rough and often cracks. The sharp points and edges so formed are in a very poor position to give up their heat to the heavy metal mass behind and, to this extent, the limiting energy input must suffer. The roughening action appears to be due to the forces of heat expansion and contraction brought into play by the intermittent character of the bombardment (usually 60 cycles per second) and is lacking in the case of continuous current at constant potential. This subject merits careful quantitative investigation.

Rotation of the Target.—As an entirely different method of increasing the allowable energy input for a given size of focal spot, we are trying Prof. Elihu Thomson's scheme of rotating the target. This rotation leaves the size, and position in space, of the focal spot unchanged, but results in spreading the energy over a much larger area. We have already had such tubes in operation with the target running at 750 r.p.m., and with the focal spot describing a circle $\frac{3}{4}$ in. in diameter. One of them is shown in Fig. 5. The target in this instance was rotated by means of an externally placed permanent horseshoe magnet acting on the soft iron armature within.

The crude experiments which we have already made seem to indicate that, with the above mentioned speed of 750 r.p.m., and with the focal spot describing a circle

$\frac{3}{4}$ in. in diameter, we can carry two or three times as much energy for the size of focal spot used, as we can with the target stationary.

It seems as though, to justify the complications inherent in the use of a rotating target, we need something more like a 10-fold increase over the stationary target. If bearing troubles can be eliminated, this should be attainable, and more work is to be done along this line.

A HOODED TARGET

For best definition in radiographic work, the rays should all come from the focal spot. With the type of hot-cathode tube now on the market, there is a very considerable emanation of X-rays from all over the target. By means of the ionization method, we have investigated this quantitatively, and have found that the integrated value of the rays from $\frac{1}{2}$ of the target surface exclusive of the focal spot (this is of course all that counts, as those coming from the side which is turned away from the plate do not affect it) is about $\frac{1}{6}$ of the intensity from the focal spot.

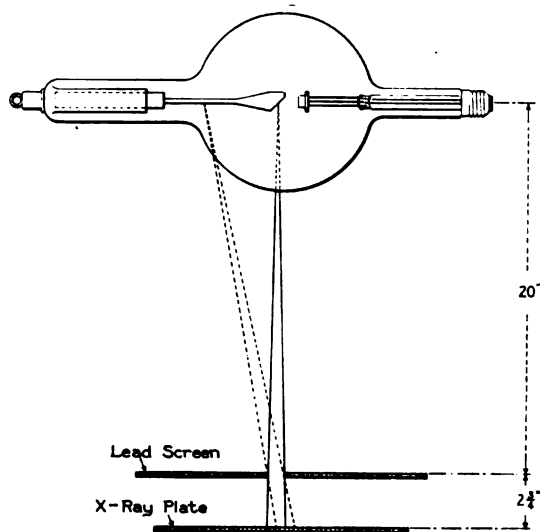

Fig. 6

All of our experimental evidence at present points to the fact that these disturbing X-rays from the body of the target are caused by secondary cathode rays coming from the focal spot and prevented from going to the glass as they do in the ordinary gas-filled tube, by a negative electrification of the bulb.

To reduce the intensity of this disturbing factor, a cylindrical cap or hood of molybdenum has been attached to the front of the target (see Fig. 2). The cathode rays enter this hood through a small hole in the front, and the X-rays emerge through a second hole in the side.

The hood offers the following advantages: (a) It reduces the radiation from the surface of the target exclusive of the focal spot to about $\frac{1}{6}$ (in the present design) of what it is without the hood. Its effect in this direction is well shown by the following experiment: A lead plate with several small holes was placed about $2\frac{3}{4}$ inches above a photographic plate and 20 inches away from the focal spot (see Fig. 6). To have the effect as pronounced as possible, no cone or other diaphragm was used. Two equally timed exposures were made on the same plate, one with a hooded tube and the other with an unhooded one having the same sized focal spot. The same voltage and milli-

amperage were used in both cases (see Fig. 7). The black, sharply defined circles were produced by the rays coming from the focal spot, while the balance of the picture is due to the rays coming from the surface of the target other than the focal spot. The fact that the same intensity of rays was emitted from the focal spot in both tubes was confirmed by the equal density of the circular areas in the two pictures. It is clear that the halos in the right-hand picture, made with the hooded target, are much less intense than they are in the other one.

The fact that the intensity of radiation from the back of the target has been in this way reduced to $\frac{1}{6}$ of its value, might well lead the roentgenologist to hope for much better definition in radiograms of human beings, from the use of the hood. Experience teaches, however, that the gain is very slight. It can be seen by the direct comparison of two plates, but could with difficulty be confirmed without making the direct comparison. The reason for this doubtless lies in the fact that in those cases where one could possibly hope to see it, namely, with thick objects such as the head, it is almost

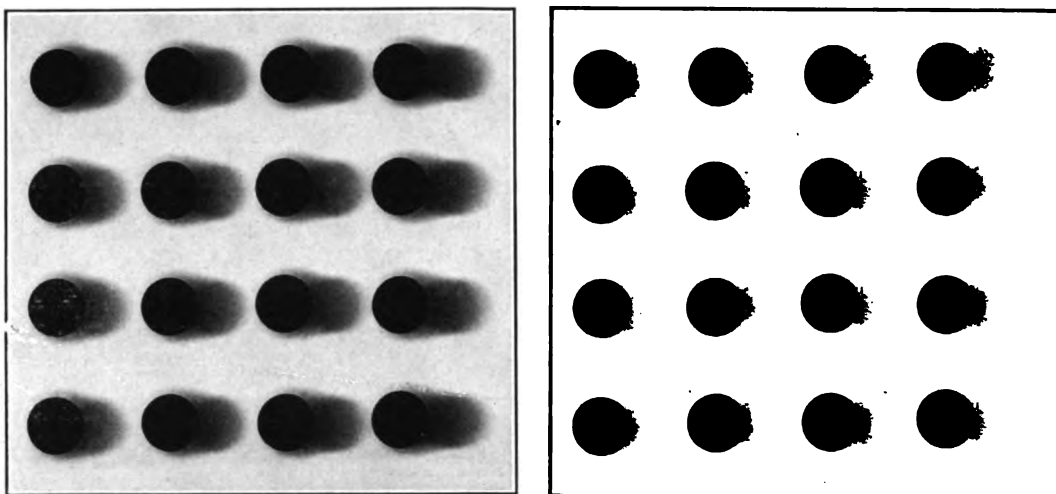

Fig. 7

masked by the much more disturbing effect of the secondary rays coming from the object itself.

(b) The hood reduces the danger to the operator as it, together with the cathode, cuts off all but the narrow cone of direct rays which is actually desired.

(c) It greatly reduces the amount of inverse current which can pass through the tube when the latter is run on alternating current and with sufficient energy to heat the focal spot to temperatures approximating that of the cathode spiral.

(d) It reduces the blackening of the bulb which results if a tube is run so hard that the focal spot is melted and volatilized.

(e) It reduces the danger from putting excessive currents through the tube, for a melted globule of tungsten, which might otherwise strike the glass bulb and crack it, is now very likely to be intercepted by the hood.

For certain purposes, the hood promises to be very useful. In the light of experiments, to be described later, however, on the use of much smaller bulbs and on the use of water-cooled targets, it may not have as much importance as would otherwise attach to it.

SIZE OF BULB

This can be very greatly reduced, probably to 4 inches for most work.

The chief advantages to be derived from the adoption of a smaller bulb are the following:

(1) For the same amount of X-ray protection, it permits of a great reduction in the size and weight of the tube holder.

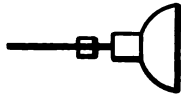
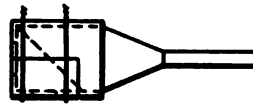

Fig. 8



(2) It permits a closer approach of the diaphragms to the focal spot and hence gives better definition.

(3) It permits a closer approach of the focal spot to the object to be rayed. This is in some cases desirable

(4) It decreases the danger of tube-breakage in handling.

TIPLESS BULB

We find that the seal-off tip can be removed from the bulb to the end of one of the side arms, so that it is later covered by the terminal cap. This seems to considerably simplify the design of a satisfactory tube holder, and it also reduces the danger of tube breakage.

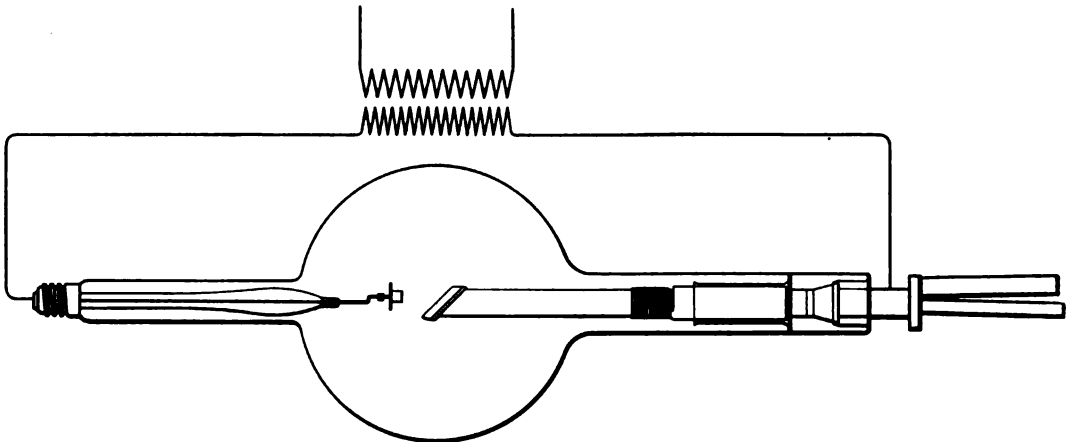

Fig. 9

HIGH POTENTIAL TUBE WITH HOODED TARGET AND INTERNAL FILTER

At the Cleveland meeting of the Society last year, I reported on some experimental work on tubes which could be operated backing up a 15- or even a 20-inch spark. It seemed at the time that it might be interesting to have such high potentials tried out for therapeutic work. Upon studying the situation, however, it developed that with the very thick aluminum filters which it seemed desirable to use, the problem of protecting the patient, with the cross-fire technique and many ports of entry, was more difficult than anything which had been met before. It could of course be taken care of by the development of a suitable tube holder. The problem is greatly simplified by the use of a hooded target with a piece of tungsten foil or other filtering material covering the opening in the hood (see Fig. 8). With this arrangement, no direct unfiltered rays can leave the tube.

HIGH POWER TUBE WITH WATER-COOLED TARGET

The experimental development of this tube has had, so far, for its objective, continuous service at very high power, for industrial applications. But it is already clear that there are certain advantages connected with this tube which must be taken very seriously by the roentgenologist. The most striking differences between it and the present hot-cathode tube are the following: Owing to the effective cooling of the target, very large amounts of energy can be carried, without heating the focal spot to the point where inverse current can pass. The tube is, therefore, capable of rectifying its own

current even for heavy loads. The cooling of the target also prevents the strong heating of the glass, due to radiation from the target, which takes place in the present tube on continuous operation.

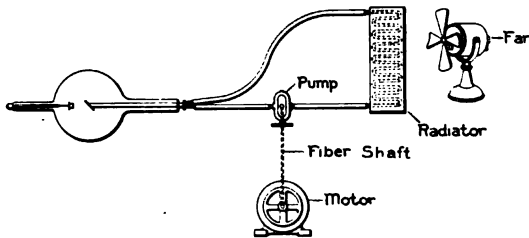

Fig. 10

Description.—The general design may be seen in Fig. 9. The cathode is the same as has been used in the regular Coolidge tube. The target consists of a copper-backed piece of tungsten which is silver-soldered to the end of a thin-walled copper tube. Inside this copper tube is another smaller one through which water is brought to the back of the target, from which point it escapes through the space between the two tubes.

As shown in the diagram, the tube is connected directly to the terminals of a high-tension transformer, without any auxiliary rectifying device.

Performance.—A good idea of the exceedingly regular operation of the water-cooled tube is given by the performance of tube X-179, which was run continuously for 42 hours, carrying a current of 100 milli-amperes and supporting a potential of 70,000 volts (peak value). During the whole test, the filament current necessary to make the tube draw 100 milli-amperes varied only from 4.58 amperes to 4.50 amperes. These values represent the extreme change observed during 42 hours. It was, furthermore, a perfectly regular progressive change, taking place in the direction of a lowering of the filament current with the time of operation. The change was not only small, but was clearly due not to any change in vacuum but to a gradual pulling out of the cathode spiral which can be entirely obviated by a suitable cathode design. At the end of the test, the target had sprung a leak. In the next design of target the water was brought closer to the face. This one ran 68 hours continuously at 100 milli-amperes and 70,000 volts, and then failed just as the first one had. A later target design appears to eliminate the trouble experienced in the above mentioned models.

Capacity.—Our life-tests, as stated above, have been run at 100 milli-amperes and 70,000 volts. But the same tubes have been run continuously at 200 milli-amperes and 70,000 volts and at 100 milli-amperes and 100,000 volts. There is no apparent reason why, by increasing the size of target and focal spot, the allowable energy input should not be raised to at least 25 or 50 kilowatts for continuous operation.

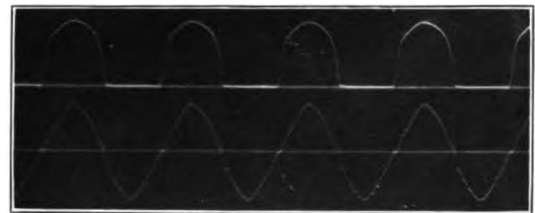

Fig. 11. 25-kw. G-E Transformer. Tube load: 100 M. A., 70 Kv.
Upper curve: tube current. Lower curve: useful voltage
above zero line and inverse voltage below

Capacity.—Our life-tests, as stated above, have been run at 100 milli-amperes and 70,000 volts. But the same tubes have been run continuously at 200 milli-amperes and 70,000 volts and at 100 milli-amperes and 100,000 volts. There is no apparent reason why, by increasing the size of target and focal spot, the allowable energy input should not be raised to at least 25 or 50 kilowatts for continuous operation.

Different Water Cooling Systems.—Over 99 per cent of the energy supplied to such a tube is delivered to the water used in cooling the anode. A simple calculation shows that an energy input of 200.0 milli-amperes at 70,000 volts is sufficient to raise the temperature of a liter of water from 20 deg. centigrade to the boiling point in 33 seconds. This shows that, for continuous operation at this high power, it is necessary, if boiling is to be prevented, to pass through the target at least 2 liters of cold water per minute. There are two easy ways of doing this. The first consists in connecting the tube right to the faucet and using tap water. To do this necessitates grounding one side of the X-ray transformer. This appears to be unobjectionable for work calling for voltages not to exceed, say, 70,000, and this system when applied to the above combination appears to make the simplest conceivable high power X-ray outfit. It seems admirably adapted to the industrial applications at least, such as sterilization, insecticide, metal radiography, and the coloring of glass, porcelain, etc.

The second method of handling the cooling problem involves the use of a radiator (the automobile types are admirably suited to the purpose), a water-circulating pump, and a fan (see Fig. 10). With this method the whole water system is insulated, and the middle point of the transformer secondary is grounded. As a result, corona troubles are reduced, and in so far as this effect is concerned, it becomes possible to go to twice the voltage that could be used with the other system. It is, therefore, the method which recommends itself for therapeutic work. The ordinary Ford radiator with a 12-in. desk fan and a small water pump takes care of at least 7 kw. continuously. By using a more powerful fan or a cellular (instead of a tubular) radiator, the effectiveness of this cooling system could readily be doubled.

A small desk fan or Sirocco blower is also necessary for cooling the bulb.

Suitable Source of Current Supply.—The water-cooled tube, when rectifying its own current, places new demands on a transformer. Only one half-wave passes through



Fig. 13. W. & B. Transformer. Tube load: 100 M. A., 41 K. Useful voltage above zero line and inverse voltage below

the tube, with the result that, unless the transformer is suited to the work, the voltage on this half-wave may be much lower than on the other half. This would introduce a difficulty in the measurement of voltage. A spark-gap, for example, when used in the ordinary way, would measure the inverse voltage and not that corresponding to the X-rays produced. Furthermore, if the inverse voltage was much higher than that in the right direction, there would be a needless strain on the insulation of the transformer, and increased corona from the wires leading to the tube.

The oscillograms, Figs. 11 and 12, show the behavior of the tube under heavy load on a suitable transformer. The upper curves show that the tube completely rectifies its own current, as there is nothing below the zero line. The lower curves, indicating voltage, were obtained by the use of a very sensitive vibrator in series with a high resistance water column which was connected in parallel with the tube.

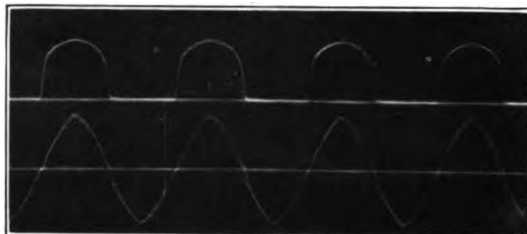

Fig. 12. 25-kw. G-E Transformer. Tube load: 200 M. A., 70 Kv. Upper curve: tube current. Lower curve: useful voltage above zero line and inverse voltage below

The potential curves show but little departure from a sine wave. The application of a millimeter scale to the curves shows that in the case of the 100 milli-ampere load the peak value of the inverse voltage is only 2.5 per cent greater than that of the direct voltage, and that even in the case of the 200 milli-ampere load, it is only 4 per cent greater.

Fig. 13 shows the voltage curve obtained with the same tube excited from one of the regular X-ray transformers now on the market. (It happened to be a Waite & Bartlett. The mechanical rectifier was not used.) Inspection of the curve shows that the inverse voltage is much higher than the direct voltage. Measurement of the peak values made on the oscillogram shows them to be in the ratio of 31.5 to 14.8; or, in other words, the inverse voltage is 113 per cent higher than the direct or useful voltage.

It is obvious from the above that the high power water-cooled tube can be used with perfect satisfaction on a large transformer of suitable design, with no auxiliary rectifying device. It is equally clear that it must not be used as a self-rectifying tube on such transformers as those now on the market, which were designed with a view to utilizing both half-waves

In these experiments, furthermore, the resistance of the mains supplying the transformers was kept very low and the voltage was controlled through the field excitation of the alternator. Even with a suitable transformer, the scheme does not lend itself to resistance control, for the effect of resistance in series with the primary is to lower the useful secondary voltage but not the inverse. In practice the simplest method for controlling voltage would be by means of an auto-transformer or by the use of a number of taps on the primary.

The above considerations will apply with equal force to the use of a kenotron for the rectification of current for the ordinary Coolidge tube. The combination, to be satisfactory for work where heavy tube currents are ever to be employed, necessitates the use of a relatively large transformer, that is unless some special method is employed for the reduction of inverse voltage.

ADVANTAGES OF WATER COOLED TUBE EXCITED DIRECTLY FROM TRANSFORMER WITHOUT AUXILIARY RECTIFYING DEVICE

They may be summarized as follows:

- (1) High power for continuous operation—there is no power limit in sight.
- (2) Noiseless operation.
- (3) Simplicity and reliability.
- (4) This system will make it possible to go without difficulty to voltages much higher than 100,000.
- (5) It is perfectly adapted to the operation of any desired number of tubes running in parallel.
- (6) Owing to the high power which can be employed and to the fact that the target is cooled, the system is well adapted to the production of homogeneous rays. The target facing can be made of any one of a large number of the metals and the rays can then be passed through a filter of the same material.
- (7) The water-cooled target permits of the use of a much smaller bulb than would otherwise be necessary for the same power.
- (8) The close voltage regulation which is necessary for the satisfactory operation of the above system is also helpful in the exact duplication of results, for a considerable degree of inaccuracy in the adjustment of filament temperature has no appreciable effect on voltage, and hence on penetration.

THE USE OF A KENOTRON FOR RECTIFYING CURRENT WITH THE PRESENT COOLIDGE TUBE

Provided a suitable transformer is used a kenotron* may be substituted for the mechanical rectifier, for the operation of the ordinary Coolidge tube.

As has been pointed out in the preceding section, the transformer requirements are, for this purpose, exactly the same as for the self-rectifying water-cooled tube.

There is much to be said in favor of the use of the kenotron, and the advantages (2), (3), (4) and (8) which have been cited for the water-cooled tube operated directly from a transformer, apply equally here.

THE CONTROL OF FILAMENT TEMPERATURE

To simplify and render more accurate the technique of the Coolidge tube, some source of filament current supply which is much better than the storage battery or the simple transformer is needed. The desideratum is a source of perfectly constant potential. This would allow the filament temperature to be controlled by means of a dial switch, each point of which, with the same tube, would always mean the same temperature, and hence the same milliamperage.

After working with magnetos, boosters, Nernst iron wire ballasts, etc., we have finally found what appears to be a perfectly satisfactory solution of the problem. It consists in the use of a specially designed transformer in conjunction with the usual filament current transformer. It is the function of the former to make it possible to deliver to the filament constant current, even though the line voltage may fluctuate greatly and suddenly. The regular filament current transformer is retained merely to provide the necessary insulation between the filament circuit and the supply mains. This combination draws its energy directly from the mains in the case of alternating current installations, and from the alternating current side of the rotary in the case of direct current installations. For induction coils run from direct current, where there is no alternating current supply, it will be necessary to add to the above combination a small rotary.

The special constant potential transformer referred to above has no moving parts and no time lag. The present model allows the filament current to fluctuate less than one per cent when the supply voltage varies 25 per cent. This means that it completely takes care of the ordinary fluctuations in the supply voltage, due to causes external to the X-ray installations and of the sudden drop caused by the closing of the X-ray switch as well.

Change in filament temperature may be effected by means of a dial switch which controls a resistance connected in series with the primary of the ordinary filament current transformer.

The above method does away with the need of any accurate adjustment of either a resistance or an impedance and with the need of the accurate reading of an ammeter or milliammeter. Each point on the dial means always the same filament temperature and the same milli-ampere.

It will mean a great simplification in the use of the tube. In those cases, for example, where it is used for radiographic work exclusively and where the operator prefers to use the same penetration and the same milliamperage for everything, he will never need to think of anything but his main switch and his watch. It will also be a great convenience in those cases where the technique of the operator combines in the same case fluoroscopy and radiography. For the filament temperature will be carried from that requisite for fluoroscopy to that required for radiography by moving the dial

* Saul Duschmann, *General Electric Review*, 1915.

switch from one button to another, and these two buttons can be adjacent to one another.

ACCURATE MEASUREMENT OF TUBE VOLTAGE

The best method by far would appear to be the one which is generally used by the electrical engineer in high potential work. It consists in the use of a voltmeter and a special potential coil properly located in the transformer. If there is sufficient iron and copper in the transformer, this method is very simple and should be exceedingly satisfactory. If, on the other hand, a small transformer is made to do heavy work, there will be a large correction to be applied to the voltmeter reading and this correction will be a variable quantity dependent on the load. This last applies, and with greater force, to the use of a voltmeter across the primary. In either of the two latter cases,

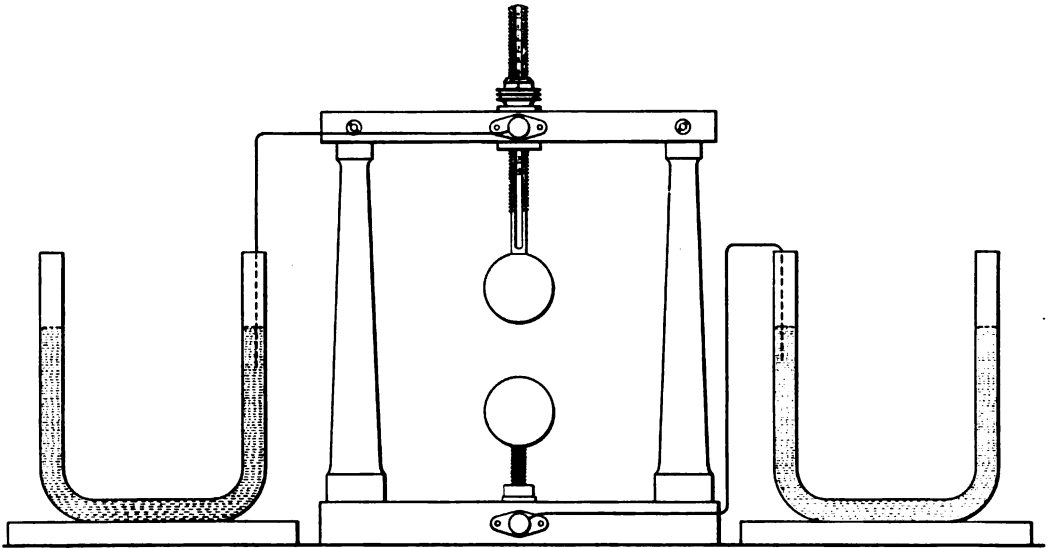

Fig. 14

however, there should be no trouble in making an accurate voltage calibration, for the different loads actually employed, by means of a sphere gap.

This instrument (see Fig. 14) has been standardized by the American Institute of Electrical Engineers. A table of spark lengths, and the precautions necessary in using the instrument and the corrections to be applied, are given in their Standardization Rules (Edition of July 1, 1915). For the voltages now used in X-ray work, the 62.5 mm. spheres will be found most satisfactory. The distance between them is adjustable by means of the milled nut at the top, as shown in the diagram, and can be read on the micrometer head connected with it. The glass U-tubes on either side of the gap are filled with distilled water. Their purpose is to interpose sufficient resistance in the circuit to prevent destructive arcing on the surface of the spheres. The tubes may well be about $\frac{3}{4}$ inches internal diameter and of such length that there shall be in each of them about 15 inches of water column.

In X-ray work, the usefulness of the sphere gap will doubtless be confined exclusively to calibrating the combination of voltmeter and transformer.

ROENTGEN RAYS FROM SOURCES OTHER THAN THE FOCAL SPOT IN TUBES OF THE PURE ELECTRON DISCHARGE TYPE *

BY W. D. COOLIDGE AND C. N. MOORE

Early in the history of the hot cathode type of roentgen tube, and before any other roentgenograms had been made with it, the pinhole-camera-picture method was applied in a preliminary study of the source of the roentgen rays from the tube. This work showed that the entire surface of the target was active in producing roentgen rays. In spite of this fact, however, experiments showed that good roentgenographs of the various parts of the human body could be produced with the tube.

Since that time, various workers have felt that still better roentgenographic results might be obtained if all rays other than those coming from the focal spot could be eliminated.

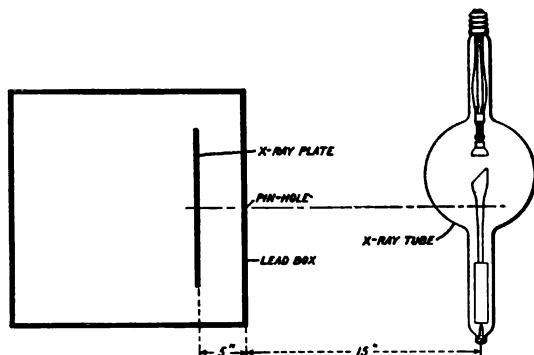

Fig. 1. Arrangement of Apparatus for making Pinhole-Camera Roentgenograms shown in this Article

It seemed desirable to investigate the subject pretty thoroughly to learn, first, how the effect of roentgen rays other than those coming from the focal spot could best be minimized and, second, whether the elimination of this effect would result in roentgenographic images of greater diagnostic value. The investigation also seemed worth while for the light which it would throw on the *modus operandi* of the hot cathode type of roentgen tube and for the use to which such information could be put in the development of new forms of this tube. The investigation consisted mainly in a pinhole-camera-picture study of various forms of the tube.

The following pinhole-camera roentgenograms were all made under the same general conditions: The same diaphragm, with a hole 0.020 inches in diameter, was used throughout; the distance from the length axis of the tube to the pinhole was always the same, 15-in., and the distance from the pinhole to the photographic plate was 5-in.; and in all length-views of the target the tube was so placed that the neck of the target was directly opposite the pinhole (see Fig. 1). The plate was in a closed box made of lead $\frac{1}{8}$ -in. thick. Unless otherwise noted, the same voltage, that corresponding to a 7-in. spark gap between points, was used throughout, and the same current, 4 milli-amperes,

* From *General Electric Review*, April, 1917, pp. 272-281.

and the same time, 10 minutes. Time development for 4 minutes at the same definite temperature and with fresh developer was used on all of the plates. To still further guard against the possibility of unequal development, as well as to make comparison easier, a pinhole camera roentgenogram of the standard tube has in many cases been put on the same plate with the particular type which was being investigated. No protection of any kind, not even the usual lead glass bowl, was used around the tube and no cone or diaphragm.

PINHOLE-CAMERA ROENTGENOGRAMS MADE WITH THE STANDARD HOT-CATHODE TUBE

Fig. 2 was made with a standard medium focus tube, operating with the voltage corresponding to a 7-in. spark gap between points and with 4 milliamperes of current for

40 minutes. The image of the focal spot is greatly overexposed, so that the roentgenogram gives a very exaggerated impression of the amount of radiation coming from the remainder of the target. The overexposure was intentional, the idea being to show the relative intensities of the radiation coming from those portions of the target other than the focal spot. The roentgenogram shows that the entire target, including the molybdenum stem and the adjacent end of the iron support-tube, gives off roentgen rays and must, therefore, be bombarded by cathode rays from some source or other. The circle described about the middle

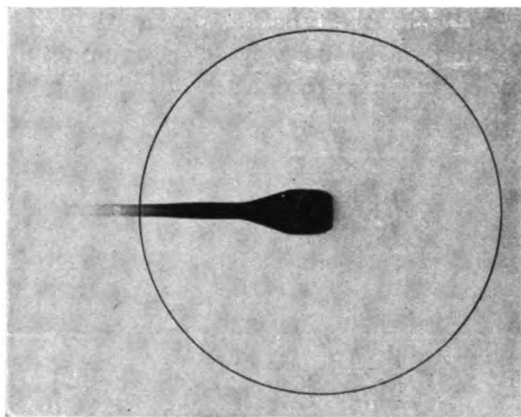

Fig. 2. Roentgenogram made with Standard Medium-Focus Tube

of the focal spot as a center indicates the location of the glass bulb. As will be pointed out in connection with some of the later plates, the production of roentgen rays from the entire surface of the target must be accounted for by the reflection* of cathode rays from the focal spot. These reflected rays, consisting as they do of negatively charged particles, electrons, cannot go to the cathode, as it is negatively charged. Nor can they go to the glass bulb, as it is charged to the potential of the cathode. They come away from the focal spot, as will be shown later, with almost as high a velocity as that with which they approached it; but, by the repulsion of the charges on the cathode and on the glass, they are forced to go



Fig. 3. Roentgenograms of Front and Back of Target. Note that, except for Working Face, Intensity is Practically the same Front and Back

* The term reflection has been used throughout this paper to include both true reflection and secondary emission.

back and strike the target again, and many of them are doubtless again reflected and again forced to return to the target. Roentgen rays must be produced with each collision with the target. It is clear from Fig. 2 that relatively few electrons are able to get into the anode arm, because of the repulsion of the negative charge on the bulb back of the anode and on the walls of the anode arm. The intensity of the rays coming from the stem will be seen to fall off very rapidly at the point where the circle crosses the stem.

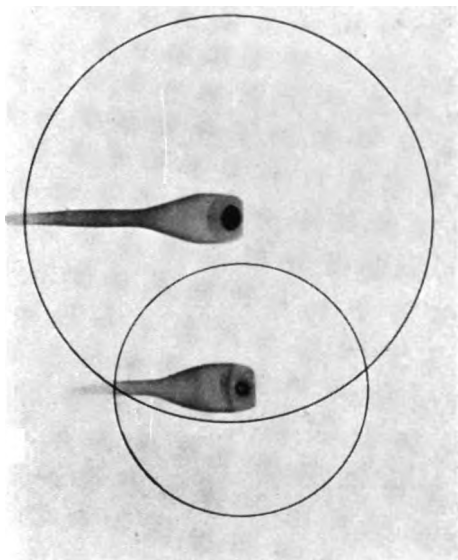

Fig. 4. Roentgenograms made with 7-in. and 3 $\frac{3}{4}$ -in. Tubes

Those surfaces of the cathode structure which face the anode are also seen to give off roentgen rays. The origin of these is entirely different in its nature. They are secondary roentgen rays produced by the primary roentgen rays coming from the target.

Fig. 3 shows the front and back of a target. Except for the working face, the intensity is seen to be essentially the same both front and back. The intensity of radiation appears greater at the peripheral than it does in the central portion of the picture, and, in general, the greater the angle of inclination of the surface with reference to the plane of the photographic plate, the greater is the apparent intensity of radiation.

This is simply due to the fact that the roentgen rays are emitted with equal intensity in all directions from each and every point in the surface.

In Fig. 4 the roentgenogram at the top was made with a 7-in. tube and that at the bottom with a 3 $\frac{3}{4}$ -in. tube. The circle described about the middle of each focal spot as a center gives the location of the glass bulb in each case. The figure brings out strikingly the effect of the negative charge on the glass in determining the extent of the target to be bombarded by the reflected cathode rays. The total production of roentgen rays outside of the focal spot is doubtless the same in both cases. (No attempt has been made to confirm this quantitatively.) But there is very little coming from that portion of the stem which is within the anode arm and, therefore, there is, of necessity, a greater intensity of radiation from the body of the target in the small tube than there is in the large one.

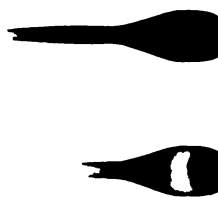

Fig. 5. Roentgenograms showing the effect of voltage. Upper, 10-in. Spark Gap; Lower, 2-in. Spark Gap

Fig. 5 shows the effect of voltage. Both roentgenograms were made with the same tube, the lower one with a 2-in. spark gap (between points) and the upper one with a 10-in. spark gap. The exposures were so chosen, by means of a preliminary set of experiments, that the photographic effect of the rays from the focal spot should be the

same in both cases. This meant an exposure of 30000 milliampere seconds for the 2-in. spark gap and 3500 for the 10-in. spark gap. The body of the target, which is of tungsten, shows a somewhat different distribution of radiation in the two cases, the working face and the entire forward portion showing less radiation at the 2-in. spark gap, and the rear portion more. The molybdenum stem radiates very feebly at the 2-in. spark gap, so that there is no trouble in seeing where it is attached to the tungsten head of the target. The explanation for the feebler radiation of molybdenum is, as will be seen later, to be found in its lower atomic weight. At the 10-in. spark gap the molybdenum stem is seen to radiate even more strongly than the tungsten. This is due to the fact that, at this higher voltage, there is added to the general radiation of the molybdenum the characteristic radiation of that element.

To give an idea of the relative intensity and penetrating power of the radiation from the focal spot and from the balance of the target, two roentgenograms of a Benoist penetrometer were made, one with the rays from the front and the other with the rays from the back of the target. These are shown in Fig. 6. Both were made with a 2-in. spark gap. The one to the right was made by rays coming from the front of the target and was given, as measured in milliampere seconds, $1/10$ the exposure of the other. The central circular areas show very nearly the same photographic action, indicating that the total radiation from the back of the target is, photographically measured, about $1/10$ of that from the front. This means that in the ordinary roentgenogram, made from the front of the target, there will be, photographically measured, about $1/9$ as much radiation from the body and stem of the target as there is from the focal spot. This fraction would, in ordinary work, be reduced a little by the use of a diaphragm and cone. The penetration is seen to be about $4\frac{1}{2}$ Benoist from the back and 5 Benoist from the front.

With a 10-in. spark gap, as shown by Fig. 7, the conditions are seen to be much the same. As before, the right-hand roentgenogram was made from the front, and the other from the back of the target. The exposure from the front, as measured in milliampere seconds, was $1/9$ of that from the back and was apparently a little too much. The factor of $1/10$ used in the preceding figure would have been better. The penetration from the front was 9 Benoist, and from the back 8 Benoist.

Photographically measured then, there appears to be from the front of the target, over this wide range of voltage, approximately $1/9$ as much radiation coming from the balance of the surface as there is from the focal spot, and of but slightly less penetrating power.

METHODS FOR MINIMIZING THE EFFECT

Hooded Target

One of the different methods which has suggested itself for reducing the effect of the radiation from outside of the focal spot is the use of a metal hood attached to the working end of the target. This is illustrated in Fig. 8 and has been described in an earlier paper.* The cathode rays enter through a hole in the end of the hood and the roentgen rays emerge through a hole in the side. Fig. 9 shows the roentgenogram from such a hooded target, and above it, for comparison, that of the target in a standard tube. Fig. 10 shows the same thing except that the targets are turned sidewise. The position of the focal spot has, in the case of the hooded target, been indicated by those roentgen rays from the focal spot which penetrated the molybdenum hood, which in this case was only $\frac{1}{32}$ in. thick. A comparison of the two roentgenograms shows that the amount of radiation from the body and stem of the target is greatly reduced by the use of the hood.

* W. D. Coolidge, *Am. Journal of Roentgenology*, Vol. II, p. 882 (1915).

(Quantitative measurements with the ionization chamber show that with the design of hood used in this experiment, the reduction is to about 1/6 of what it would be without the hood.)

The roentgenograms of the hooded target are, of themselves, sufficient to prove that at least all of that radiation from outside the focal spot which is eliminated by the use of a hood must be due to cathode rays reflected from the focal spot. Without such proof, one might think that much of this might be due to failure on the part of the cathode focusing device to bring to the focal spot all of the primary bundle of cathode rays. An inspection of the hooded target roentgenogram in Fig. 10 shows the true explanation. Through the hole in the side of the hood can be seen a small

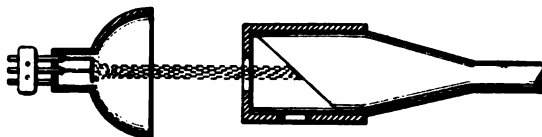

Fig. 8. Metal Hood on Working End of Target

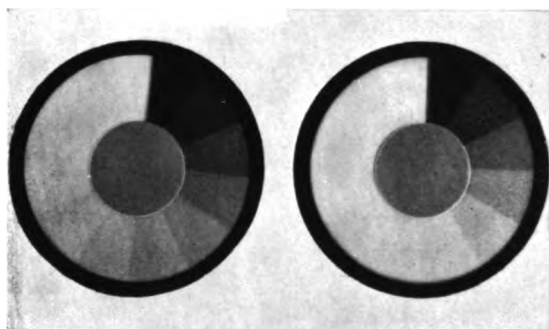

Fig. 6. Roentgenograms of a Benoist Penetrometer. Right, Rays from Front of Target; Left, Rays from Back of Target. Exposure for Front of Target 1/10 that for Back of Target. 2-in. Spark Gap

portion of the inner surface of the hood, and this area shows a very vigorous roentgen ray production. The hood is in good metallic contact with the target, and is, therefore, of necessity at the same potential as the latter. There is then no force to deflect any of the rapidly moving cathode ray stream out of its course and to bring it to the inner surface of the hood. The only possible explanation remaining then, is that the vigorous bombardment of the inner surface of the hood, which manifests itself not only through

roentgen ray production but also by a very rapid heating of the hood (upon starting to excite the tube with a cold target the hood comes to incandescence before the body of the target does), is due to cathode rays reflected from the focal spot. The reflection is not prevented by the hood, but the roentgen rays resulting from the reflected cathode rays are produced on the inner surface of the hood instead of being produced on the outer surface of the target. The fact that the roentgenogram shows more intensity on the lower side of the target is easily accounted for by assuming that a few of the reflected rays come out through the hole in the side of the hood and then bombard the body and stem of the target on that same side.

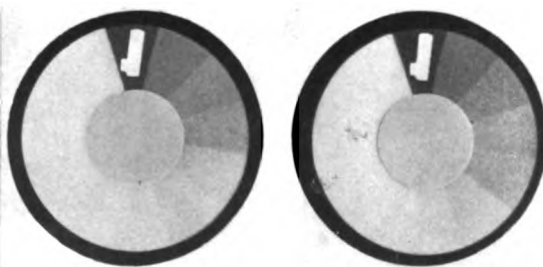

Fig. 7. Roentgenograms for Front and Back of Target as in Fig. 6, but with 10-in. Spark Gap. Exposure 1 to 9

Fig. 11 shows two hooded targets differing only in this respect, that in the lower one a piece of thin tungsten foil (0.0008 in. thick) has been bound over the hole in the side of

the hood. This would necessarily prevent any of the reflected cathode rays from escaping at this point. An inspection of the roentgenogram shows that the use of the foil

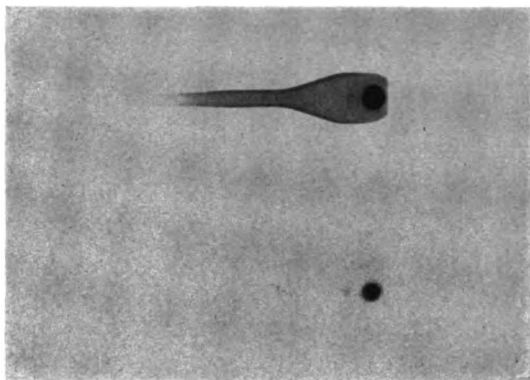

Fig. 9. Upper, Roentgenogram of Hooded Target; Lower, Roentgenogram of Target of Standard Tube

has prevented the difference in intensity on the two sides of the target which is noticeable in the case of the hooded target without the foil. It seems most probable, especially in the light of Fig. 14, which will be described later, that the small amount of radiation remaining on the surface and stem in the case of the hooded target with the foil is due to reflected cathode rays coming from the focal spot and emerging through the hole in the end of the hood, through which the primary cathode rays enter. The number of electrons escaping in this way would naturally be relatively

Cathode Placed Very Close to Anode

small, owing to the fact that the angle subtended by the hole is small, and to the further fact that these electrons have to move out against the electrostatic repulsion of the cathode. Another method which has presented itself for reducing the intensity of the roentgen radiation from the body and stem of the target consists in bringing the cathode so close to the anode that the reflected cathode rays are driven almost straight back to the focal spot by the electrostatic repulsion of the cathode.

In Fig. 12 the front end of the

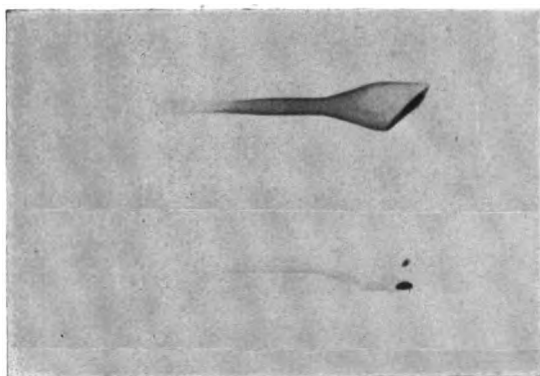

Fig. 10. Same as Fig. 9, except that Targets are turned Sidewise

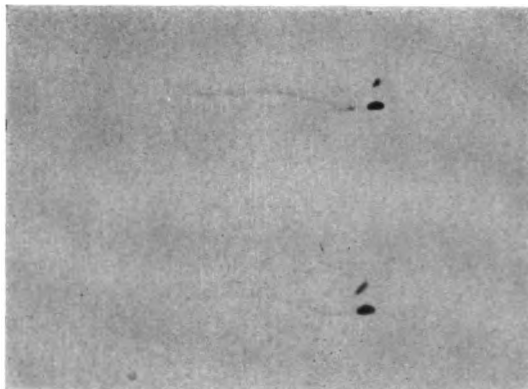

Fig. 11. Upper, Roentgenogram of Hooded Target; Lower, Roentgenogram of Hooded Target with Tungsten Foil

molybdenum focusing tube of the cathode was only 2.5 mm. from the anode at its nearest point. (This front end of the focusing tube is clearly visible in the figure, due to the secondary roentgen rays emitted by it.) The



Fig. 12. Roentgenogram of Target of Tube in which Cathode is placed Very Close to Anode

roentgenogram shows that the reflected electrons which started out in this direction were forced, by electrostatic repulsion, to again bombard the target on its face, close to the focal spot. Those leaving in other directions, where the distance between the end of the cathode and the inclined face of the anode was greater, were able to get much further away from the focal spot.

Fig. 13 is the diagram of a tube representing a more radical experiment. In this tube the working face of the target was at right angles to the axis of the tube and the distance between the end of the focusing device and the face of the anode was only 2.3 mm. (In this tube, the filament spiral, to prevent its being pulled out under the strong electrostatic attraction, was set much further back than usual in the focusing device.)

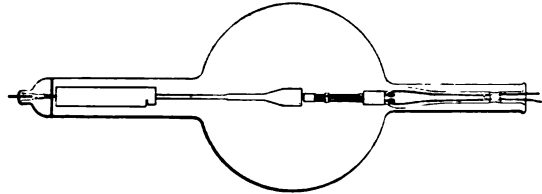

Fig. 13. Tube in which Working Face of Target is at Right Angles to Axis of Tube. Distance between focusing device and face of anode, 2.3 millimeters

At the bottom of Fig. 14 is seen the roentgenogram of this tube, the rays being taken from the face of the target in a direction making a very small angle with the face.

The small round spot in the center of the target face is the focal spot, seen through the molybdenum focusing tube. The concentric circular ring around this is due to the reflected cathode rays which, instead of being allowed to bombard the target all over its surface, have been forced to return to points close to the focal spot. Comparison of this roentgenogram

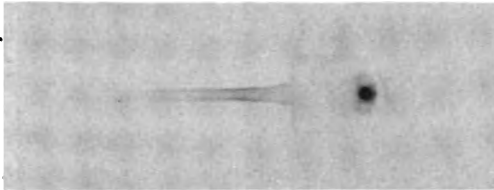

Fig. 15. Roentgenogram of Target Consisting of Tungsten Button set in Block of Copper

ogram with that of the standard tube above it shows how very effective this method has been.

Influence of the Atomic Number of the Metal on Which the Reflected Cathode Rays Fall

Fig. 15 is the roentgenogram of a target consisting of a tungsten button, 19 mm. in diameter, set in a block of copper 32 mm. in diameter, the latter being supported by a stem of molybdenum screwed into it. The line between the tungsten and the copper is quite marked in the roentgenogram, and the roentgen ray production is clearly less from the copper than it is from the tungsten. This is in accordance with data published by Kaye on the efficiency of different metals in producing general roentgen radiation (not including characteristic) under a given cathode ray bombardment. His measurements were made with 25,000 volts on the tube.

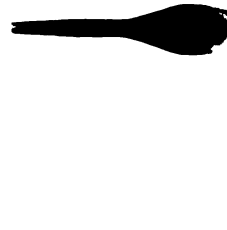

Fig. 14. Lower, Roentgenogram of Target of Tube shown in Fig. 13; Upper, Roentgenogram of Target of Standard Tube

"INDEPENDENT" RADIATION

Metal	Atomic Weight	Intensity of Radiation
Platinum	195.2	100
Tungsten.....	184.0	91
Molybdenum.....	96.0	51
Copper.....	63.6	33
Aluminum.....	27.	10

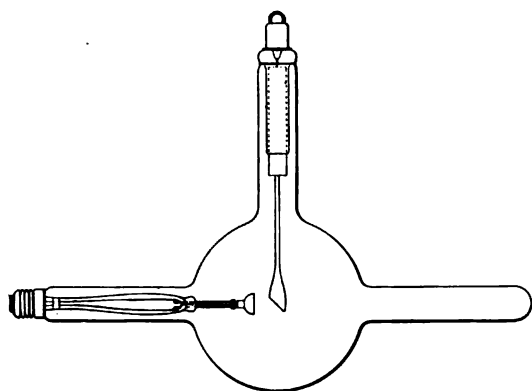

Fig. 16. Tube in which Target is placed at Right Angles to Length-axis of Tube

intensity of bombardment of the surface by the reflected cathode rays, but rather reduces the efficiency of the roentgen-ray production resulting from this bombardment.

Target Placed at Right Angles to the Length-axis of the Tube

In this method no attempt is made to influence the production of roentgen rays on the surface of the target. The target is merely inserted in the side of the bulb as shown in Fig. 16, instead of in the usual position, and the rays are then taken from the end instead of the side of the target. As a result, the rays from the body and stem of the target do not affect the roentgenogram, as they are

He found, as the table shows, that the efficiency decreases as the atomic weight decreases, and is approximately proportional to it. By calorizing the copper on the surface, or by otherwise covering it with aluminum, or by replacing the copper with magnesium or some metal of still lower atomic weight, it would be possible to still further reduce the roentgen-ray production from the surface of the target outside of the focal spot. The method is different in principle from either of the preceding in that it involves no attempt to reduce the

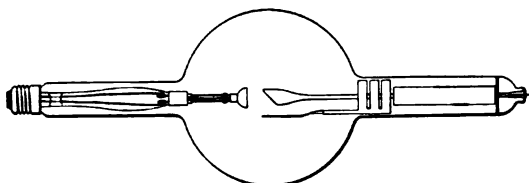

Fig. 18. Tube having Diaphragm Parallel to Target and Insulated from it



Fig. 17. Right, Roentgenogram of Target of Tube shown in Fig. 16; Left, Broadside View of Target for Comparison

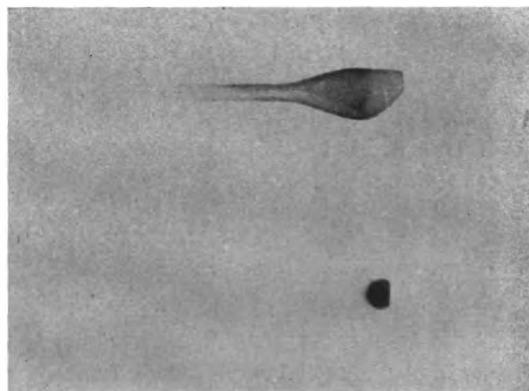

Fig. 19. Two Roentgenograms of Target of Tube shown in Fig. 18

intercepted by the face. This is shown in the roentgenogram (Fig. 17), in which the broadside view of the target is also given for comparison. In this simple form this method would be very effective for work calling for a narrow angle of rays; it would not be effective when the angle is wide enough so that the face of the target no longer intercepts the rays coming from the body and stem.

Diaphragm Within the Tube, Parallel to the Target and Insulated from It

This construction is illustrated in Fig. 18. The diaphragm is made of some metal opaque to the roentgen rays, such as molybdenum or tungsten. It may be attached to the cathode, or it may be supported by the glass of the anode arm. In either case the diaphragm will be at cathode potential when the tube is operating, and hence will not be bombarded by the reflected cathode beam. Therefore, it will not of itself be a source of roentgen rays. Fig. 19 shows two roentgenograms of such a target. The lower one is a face view. The diaphragm itself does not show at all in this view, indicating that it undergoes no cathode ray bombardment. The body and stem of the target show through the diaphragm a little, owing to the fact that it consisted of molybdenum only 0.010 in. thick. The upper roentgenogram was made after rotating the tube through an angle of about 120 degrees. It shows that from the inner surface of the diaphragm there is a small amount of roentgen radiation, but this is seen to take place only from that portion of the end of the diaphragm which is in the path of the roentgen rays from the focal spot, and is hence secondary roentgen radiation. The roentgenogram shows that the molybdenum piece not only serves as a diaphragm, but that, by being at cathode potential as it is, it causes some of the reflected cathode ray bombardment to be transferred by electrostatic repulsion from the front to the back of the anode.

Limitations of the Various Methods

Each of these methods, as applied to the present standard tube, interferes in some way with its general usefulness. The hood, to be very effective, should have a small window for the emergence of the roentgen rays, and this limits the size of plate which can be covered with the tube. The same consideration applies, although with less force, to the internal diaphragm which is insulated from the anode.

The placing of the target at right angles to the length axis of the tube makes the tube awkward to handle. In the simple form, it is, furthermore, effective in only the narrow central cone of rays. The tube can, of course, be used to cover a wide angle, but it is only the central portion of the resulting roentgenograph which can profit appreciably by the method.

The placing of the cathode very close to the anode (as close as 2.5 mm., for example) limits the potential which can be used on the tube, at least with present exhaust methods. It would, furthermore, make it necessary to take the roentgen rays out

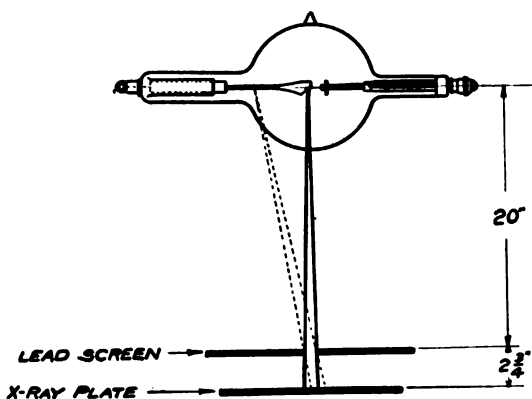

Fig. 20. Diagram showing Arrangement of Apparatus for Determining Effectiveness of Different Methods

through the cathode structure. The placing of the cathode too close to the anode would also make it difficult to maintain a constant filament temperature, that is, if the target were allowed to become incandescent.

The use of a metal of low atomic weight for the surface of the entire target (exclusive of that needed for the focal spot) and stem, is practicable only in case the target is not to be allowed to become very hot, for the reason that there is no metal of low atomic weight which is sufficiently refractory. (Among the non-metallic elements, carbon might possibly be used, but it would render the exhaust more difficult, and at high temperature it furthermore alloys readily with tungsten.)

Relative Test of Effectiveness of the Various Methods

Of course, the pinhole-camera roentgenograms themselves give some idea of the effectiveness of the various methods. Nevertheless, it is difficult to say from an inspection of them which method would give a tube that would make of a given object the best roentgenogram. For this reason a test method, which has been described before* and which is illustrated in Fig. 20, was resorted to. The test object is a lead plate with nine small round holes in it, and is placed at a distance

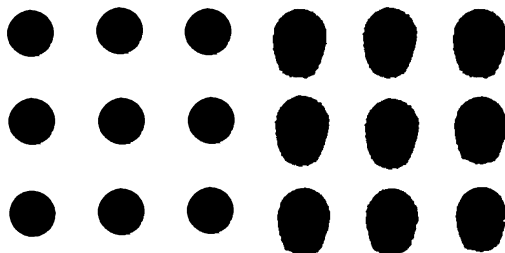

Fig. 21. Left, Roentgenogram through Holes in Lead Plate with Hooded Target (Fig. 8); Right, Standard Tube.

of $2\frac{3}{4}$ in. from the photographic plate. The tube is placed with its focal spot 20 in. from the X-ray plate. No external diaphragm or cone is used. All exposures are made with the same voltage, current and time, and the same development is used throughout. If all of the roentgen rays came from the focal spot, the radiogram would, in each case, be a series of sharply defined circular areas. Any rays coming from the body and stem of the target tend to produce a halo on one side of each of these circles.

The roentgenogram to the right in Fig. 21 was made with the standard tube and that to the left with the tube having a hooded target.

Fig. 22 shows a similar comparison between the standard tube and the one with the target set into the side of the bulb, as in Fig. 16.

Fig. 23 is a test of the standard tube versus the one with the internal diaphragm, as in Fig. 18.

It will be seen that, according to this test, the tube with the internal diaphragm is the best of those tried. The tube with the copper-backed target was not included. The

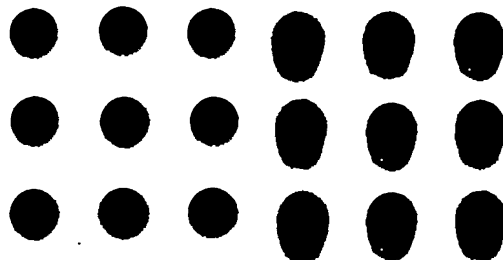

Fig. 22. Left, Tube with Target placed at Right Angles to Length-Axis (Fig. 16); Right, Standard Tube

* W. D. Coolidge, Am. Journal of Roentgenology, Vol. II, p. 885 (1915).

one with the cathode placed very close to the anode, as in Fig. 13, was not included for the reason that, while from the body and stem of the target it gave the least radiation of any of the tubes, the design of this particular tube was not adapted to the test.

Comparative Test of the Tube with Internal Diaphragm Against the Standard Tube in Medical Roentgenography

The test with the lead plate with the holes was recognized in the beginning as an artificial one, the results of which might be difficult to interpret in terms of medical work. It seemed to be a safe guide, however, as to the relative effectiveness of the different methods.

Having determined in this manner that, of the various experimental tubes made, the one with the internal diaphragm should be looked to for the best definition in roentgenography, the next problem was to show by actual tests whether roentgenographs of medical subjects made with the internally diaphragmed tube were appreciably better than those made with the standard tube.

A pair of tubes was chosen, one with and the other without the diaphragm, with the same size of focal spot (as determined by the pinhole-camera method).

The difference found in the pairs of plates made with these tubes of various parts of the body, was so small that it proved very difficult to show beyond reasonable doubt that there was really *any* perceptible difference. Failure to get absolute immobilization of the part in question with either roentgenogram was enough to bring a decision in favor of the other plate. It was finally found that whatever difference there is could better be shown by roentgenograms of a dried skull. This test appears to be more searching than that with a live subject, for the reason that the smaller amount of secondary radiation from the dried skull gives better definition and hence puts the observer in a favorable position to notice differences ascribable to the cause in question. To further this same end, a very small size of focal spot was chosen for the test. The most important thing of all was to use exactly the same voltage on both tubes. This was accomplished by the use of auto-transformer control of the high-voltage transformer and by the use of a stabilizer in the filament circuit.

The difference between such a pair of plates is so small that it at first escaped detection. It would be lost in reproduction. Such a pair of plates has been submitted to quite a number of prominent roentgenologists, and some of these have chosen the right plate and some the wrong one as the work of the tube with the internal diaphragm.

Explanation of the Smallness of the Gain Made in the Quality of the Roentgenogram by Reducing the Effect of the Radiation from the Target Outside of the Focal Spot.

The explanation lies in the sensitiveness curve of the photographic plate and in the narrow range of plate densities involved in roentgenograms of the human body. This is easily proved by going back and making further roentgenograms of the lead plate

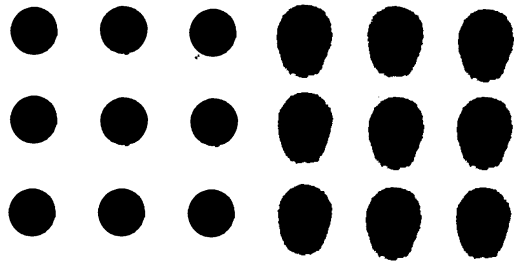

Fig. 23. Left, Tube with Internal Diaphragm (Fig. 18). Right, Standard Tube

with the holes. If, instead of greatly over-exposing the area of the plate under the holes, so as to bring out the halos strongly, the exposure is so timed as

to bring the density of this part of the developed plate only to the maximum density found in actual roentgenograms of the human body, it becomes difficult to see the halos. This is illustrated by Figs. 24 and 25. These were made with the pair of tubes in question, one with and one without an internal diaphragm, and with the same technique employed in Figs. 21, 22, and 23, except that the exposure, instead of being 37.5 milliamperere seconds, was 10 in Fig. 24 and 1 in Fig. 25.

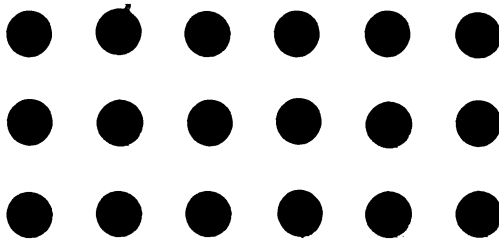

Fig. 24. Left, Tube with Internal Diaphragm; Right, Standard Tube. Exposure, 10 Milliamperere Seconds

Conclusions Concerning the Importance of the Role Played by the Rays from the Target Outside of the Focal Spot, in Medical Diagnosis

With the present roentgenographic technique, the part played by these rays seems to the writers to be too small to warrant the use of any one of the methods described for minimizing it, that is, with the present standard type of tube.

In fluoroscopy, comparative tests have not yet been made between the standard and the internally diaphragmed tube; but it seems most probable that the situation is not essentially different here from what it is in roentgenography.

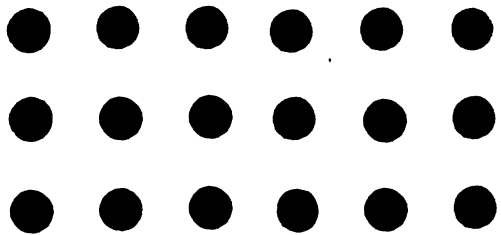

Fig. 25. Left, Tube with Internal Diaphragm; Right, Standard Tube. Exposure, 1 Milliamperere Second

A PORTABLE ROENTGEN-RAY GENERATING OUTFIT*

BY W. D. COOLIDGE AND C. N. MOORE

INTRODUCTION

When it appeared that this country might become involved in the European war various Red Cross Units were formed, and some of these instituted inquiries concerning Roentgen-ray apparatus suitable for war needs. It was through such inquiries that the authors became interested in the problem of a portable Roentgen-ray generating outfit.

The problem as it first presented itself appeared rather indefinite, as but little was generally known concerning the degree of portability required, the current and voltage needed to operate the tube, the amount of service which would be required of the apparatus, the question as to whether power could usually be had from existing electric circuits, etc.† Existing outfits apparently left much to be desired. The best way of attacking the problem seemed to be to investigate the various possible systems, so as to determine which was best adapted for development into a generating outfit of considerable portability and sufficient output.

SYSTEMS INVESTIGATED

The various systems which the authors seriously considered for the purpose were:

- (1) A gasolene-electric set furnishing low voltage direct current to a rotary converter, with a step-up transformer and a mechanical rectifier attached to the shaft of the rotary.
- (2) A gasolene-electric set furnishing alternating current to a step-up transformer and with a mechanical rectifier driven from a small synchronous motor.
- (3) The same as (2), except for the substitution of a kenotron for the synchronous motor and mechanical rectifier.
- (4) A gasolene-electric set furnishing alternating current to a step-up transformer, with a self-rectifying Roentgen-ray tube operating directly from the latter.
- (5) A storage battery operating an induction coil through a mechanical interrupter or a mercury-turbine interrupter with suitable gas dielectric.
- (6) A storage battery operating a motor-generator and so producing alternating current to be fed to a step-up transformer and thence to a self-rectifying Roentgen-ray tube.

An investigation of these separate methods led to the elimination of all but (4) for the following reasons:

With (1), to avoid the use of long high-tension leads, it appeared necessary to locate the gasolene-electric set close to the Roentgen-ray table, and hence to make the operating room noisy. Furthermore, the efficiency of a small rotary is very low for the size in question, perhaps 25 per cent, and this would necessitate the use of a relatively large and heavy gasolene-electric set.

* From *General Electric Review*, XXI, January, 1918, pp. 60-67. Since this article was published there have been some changes made in the portable table and transformer box, so that the present form of these devices does not conform with those shown in Fig. 4 and Fig. 5 of this article.

† Among others, the following excellent papers bearing on the subject were read with great interest:

"The X-ray Equipment and Work in the Army at the Present Time," by Capt. William A. Duncan, *American Journal of Roentgenology*, 268-275 (1914).

"The Electrotechnical Problem of the Production of Roentgen Rays in the Present War," by Dr. Umberto Magini, *L'Electrotecnica*, Vol. III, No. 7, March 5, pp. 126-133 (1916).

Copyright, 1918, by *General Electric Review*.

There were numerous objections to (2). It practically necessitated placing the rectifier near the operating table where the noise was undesirable; the use of the synchronously driven mechanical rectifier involved the loss of a considerable amount of energy (the small one which we tried consumed 350 watts); the behavior of this rectifier on the current supplied by a dynamo driven by a small single-cylinder, 4-cycle engine was not good; and finally, the rectifier looked like a serious complication provided it could be dispensed with.

While (3) was good, it was clearly not as simple as (4).

It developed that the electrical efficiency of both (5) and (6) was very low, probably less than 25 per cent. This meant that, for the production of any reasonable Roentgen-ray intensity for any considerable length of time, either of these systems would lead to a relatively heavy outfit.

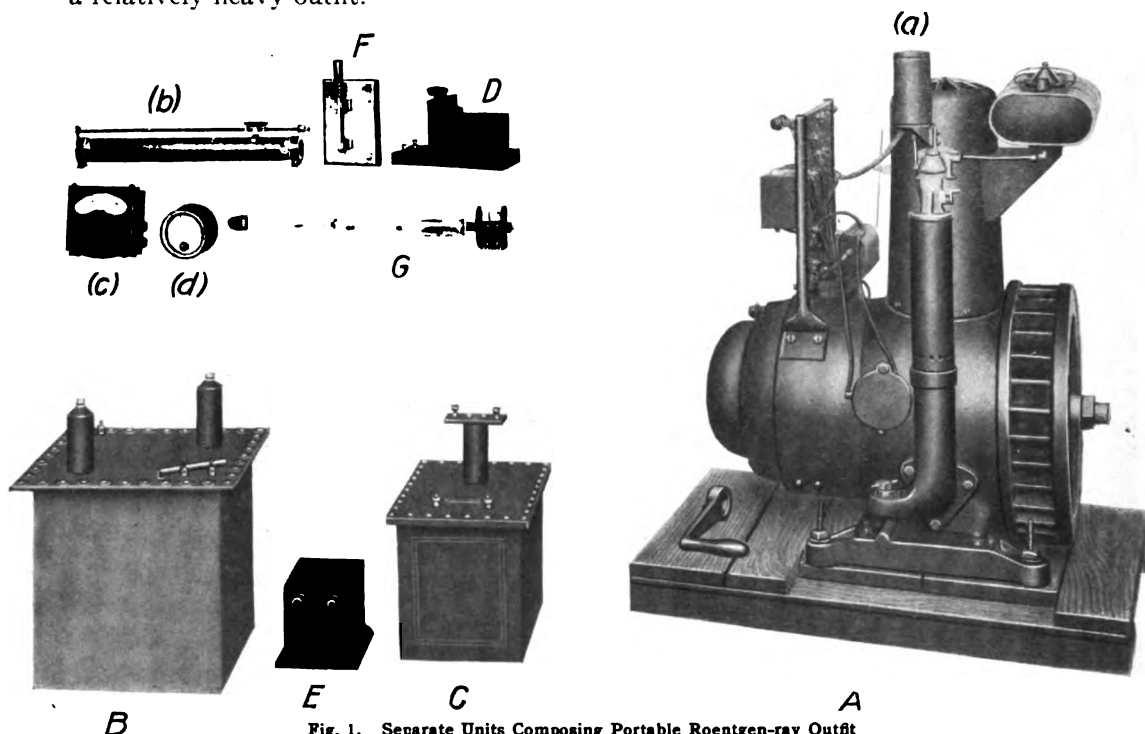

Fig. 1. Separate Units Composing Portable Roentgen-ray Outfit

THE SYSTEM CHOSEN

System (4), consisting of a gasolene-electric set furnishing alternating current to a step-up transformer, and with a special self-rectifying Roentgen-ray tube operating directly from the latter, was finally chosen. The advantages of this system when compared with the others may be briefly summarized as follows:

It is simpler.

It is more efficient electrically.

It is lighter in weight for a given output, and hence more portable.

It does not involve the care of a storage battery.

It involves the use of no moving parts other than the gasolene-electric set.

The outfit is self-contained, requiring merely gasolene to run it, and hence can be operated anywhere at any time regardless of the presence or absence of electric supply circuits.

The one member having moving parts, namely the gasolene-electric set, can be located at any desired distance from the Roentgen-ray room.

THE OUTFIT AS DEVELOPED

Separate Elements Comprising the Outfit

Having settled upon the system, it became necessary to get the component parts. The exigency of the case made it desirable to use, in so far as possible, apparatus which was already in production and hence readily available. For this reason, apparatus was borrowed from many different manufacturers and tested for its fitness for the particular purpose in question. The elements which were finally chosen are shown in Fig. 1. A description of each of these elements, together with the reasons for choosing it, is given in the following:

(A) Gasolene-electric Set

Various single- and multiple-cylinder engines of the 2-cycle and 4-cycle type were tried out, and the conclusion was reached that the one which was best adapted to the purpose was the Delco-light engine made by the Domestic Engineering Company of Dayton, Ohio. This engine was already direct-connected to a dynamo.

The Delco-light set was originally built for direct current at 40 volts, but by a change in armature- and field-windings and by the addition of a pair of slip rings and brushes it was adapted to furnish alternating current at the desired voltage. The engine was also provided with a special throttle-governor for regulating the generator voltage. This governor consists of a solenoid (a) mounted above the carburetor, the movable core of the solenoid being connected to the butterfly valve of the throttle. The solenoid is operated by direct current taken from the commutator of the generator. A



Fig. 2. Special Self-rectifying Roentgen-ray Tube

variable resistance (b) is placed in series with the solenoid, and by means of this resistance any throttle opening and hence any desired engine speed and alternating current voltage may be obtained. The alternating-current voltage is indicated by the voltmeter (c).

The reasons for choosing the Delco-light outfit in preference to others were:

It has a single cylinder engine with corresponding mechanical simplicity.

The engine is of the 4-cycle type and hence easy to start and flexible in operation.

The engine is air-cooled, and this does away with the possibility of having water freeze in the jackets in cold weather.

The armature of the dynamo is mounted directly on the crankshaft of the engine and the crankshaft has but two main bearings. This effectively does away with coupling troubles and with lack of alignment.

It is self-lubricating.

It is self-excited.

It is of suitable capacity.

It has been developed for long continued service with a minimum of attention.

At great expense, it has been thoroughly standardized, and this means interchangeability of parts, and that all sets will have essentially the same characteristics.

The workmanship is excellent.

It is available in any desired quantity on very short notice.

(B) Roentgen-ray Transformer

A small transformer, made by the Victor Electric Company of Chicago, for their dental radiographic outfit, was chosen for the following reasons:

It is an oil-insulated closed-magnetic circuit transformer of the proper capacity.

It is oil-tight.

Its design is such that, with the load in question, the "inverse" voltage is not prohibitively high.

It was available on short notice, as only two minor changes were required. These changes consisted in adapting the primary winding to the voltage of the generator and in bringing out leads for the milliammeter (d) from the grounded middle point of the secondary (this makes the milliammeter a low-tension instrument).

(C) Filament-current Transformer

Here again it seemed imperative that an oil insulated transformer should be used, and that this should be electrically efficient, of light weight, and oil tight.

The Victor filament-current transformer appeared to fulfill these conditions better than any other which was available at the time.

(D) Filament-current Control

That manufactured by the Wappler Electric Company was chosen for this outfit because of its small size, fineness of regulation, and the fact that the setting, once made, was not easily disturbed.

(E) Booster

The line voltage drops considerably when the full load is thrown on the generator. To prevent the lowering of the filament-current which would result from this, a small transformer was designed, the primary of which is inserted in the primary circuit of the X-ray transformer and the secondary in the primary circuit of the filament-transformer, as shown in the wiring diagram (Fig. 3).

(F) Operating Switch

A single-pole single-throw switch of substantial construction was chosen.

(G) Special Self-rectifying Tube

There was no tube suitable for diagnostic work and capable of rectifying its own current, for frequent long exposures, with as much energy as that available from the Delcolight set. It, therefore, became necessary to undertake its development, and the result is seen in Fig. 2. This tube is fully discussed in a separate paper published in the current number of the *Review* by one of the authors. Briefly, it is a hot-cathode tube with a 9.5 cm. ($3\frac{3}{4}$ in.) bulb. The cathode has been especially designed to give a focal spot 3.2 mm. ($\frac{1}{8}$ in.) in diameter and with a very uniform distribution of energy. The target consists of a small wrought-tungsten button set in a solid block of copper, and this block is electrically welded to a solid copper stem 1.6 cm. ($\frac{5}{8}$ in.) in diameter which extends out through the anode arm to an external radiator. A platinum sleeve is silver-soldered at one end to the copper stem and attached at the other end to the glass of the anode arm. The target, complete with stem and radiator, weight 860 gms. and has a heat capacity of 81 calories per degree centigrade. The present standard solid tungsten target, complete with molybdenum stem and iron supporting tube, has a heat capacity of less than 10 calories. Because of its greater heat capacity, it takes much longer to heat the radiator type of target to redness than it does the solid tungsten target. Unlike the latter, the target in the new tube, even at relatively low temperatures, cools rapidly in the interval between radiographic exposures, and, therefore, permits of starting each exposure with an essentially cold target. As a result, the focal spot, even though small, is kept from reaching a temperature high enough to allow "inverse" current to pass

through the tube. Furthermore (and this serves as an additional safeguard), this type of tube does not allow an appreciable amount of inverse current to pass even though it is so badly overloaded that the focal spot becomes heated to the melting point. A probable explanation of this striking fact is given in the companion article on the tube.

COMPLETE WIRING DIAGRAM

This is shown in Fig. 3 and needs no further explanation.

COMPLETE OUTFIT

The complete outfit is shown in Fig. 4, in which the gasoline-electric set is seen at the left. The Roentgen-ray and filament-current transformers, the filament current control, and the booster are in the lower part of the box at the end of the table (see Fig. 5, which shows the inside of this box). On a shelf in the top of this box are a voltmeter for showing line voltage, the adjustable rheostat for controlling line voltage, a milliammeter for indicating the tube current, and the operating switch. (There is a cover for this box which is screwed on for shipment.) The X-ray tube is permanently located in the movable tube-box under the table.*

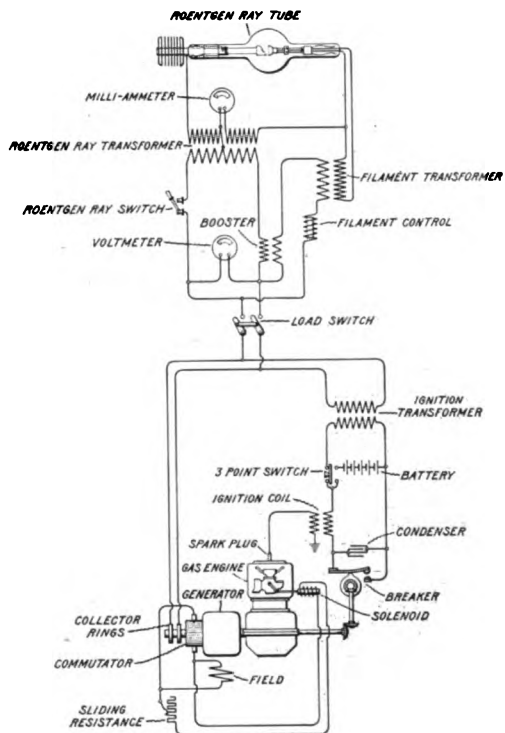

Fig. 3. Complete Wiring Diagram 7

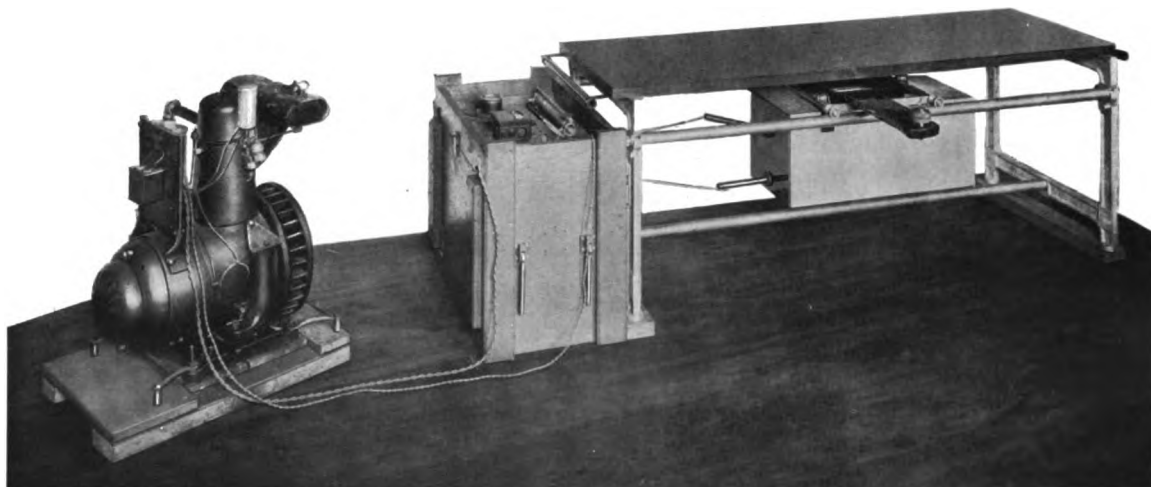

Fig. 4. Complete Portable Roentgen-ray Outfit

TECHNIQUE

The outfit as described lends itself readily to a very simple technique. Experience extending over several years has convinced the writers that it is very convenient, for

* The table, tube box, and shutter were all developed by the co-operative work of others, including Major Shearer, Major Geo. Johnston, and the Kelley-Koett Company.

experimental work, to have extreme flexibility in a Roentgen-ray generating outfit, so that the penetrating power of the rays can be varied at will between wide limits. It has also convinced them, however, that Roentgenologists would get better average results in diagnostic work if their outfits were made much less flexible, so that the Roentgen-ray tube could be used more, for example, as the ordinary incandescent lamp is. When such a lamp is lighted on the ordinary constant-potential circuit, it gives always the same kind and the same amount of light. It is entirely practicable to operate a Roentgen-ray tube in this same manner. It is merely necessary to see that the filament current is always the same and that the high-tension voltage impressed upon the tube terminals is always the same. Under these circumstances the tube always gives out Roentgen-rays of the same penetrating power* and of the same intensity. More artistic radiographs can be made by adapting the penetrating power of the rays to the thickness of the part to be radiographed, but experience shows that with a suitable compromise voltage (we have adopted that corresponding to a 5-in. spark between pointed electrodes which is equal to 57,500 volts effective, as actually measured by a sphere gap)

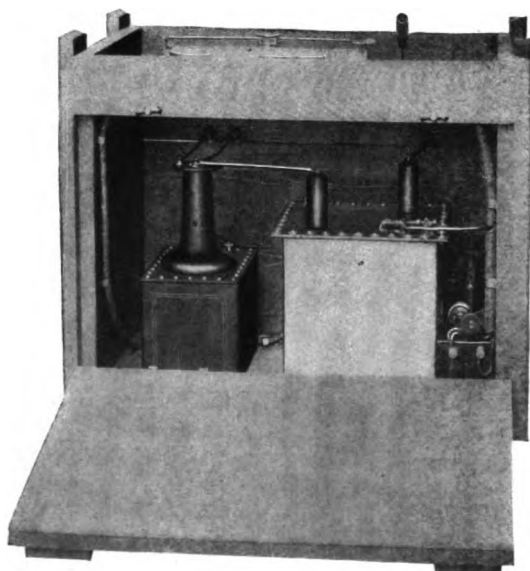

Fig. 5. Transformer and Instrument Box

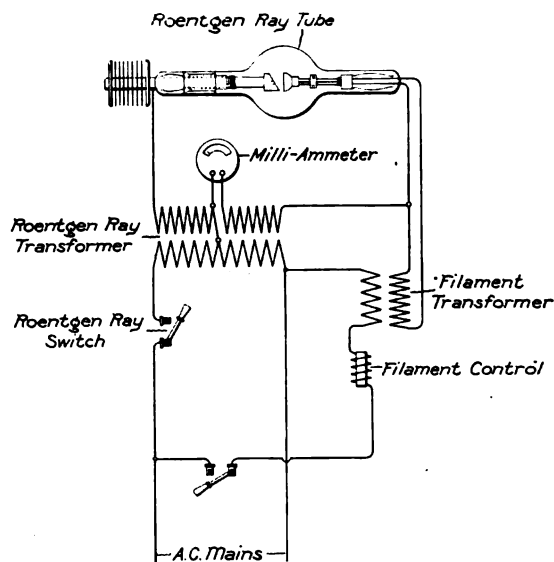

Fig. 6. Wiring Diagram for Outfit Operated Directly from Existing Alternating Current Mains (when Gasolene Electric Set is not needed)

excellent radiographs can be made of all parts of the human body, and with a great simplification in apparatus and technique. The time factor becomes the only variable and this is adapted to the thickness of the part to be radiographed.

With 57,500 volts (effective) and 10 milliamperes and a distance of 45.7 cm. (18 in.) from focal spot to plate, the writers have found that for Seed plates and the average adult subject, the following table of exposures gives good results:

Exposures 18 in. distance			
Hand.....	1	Shoulder.....	8
Elbow.....	2	Hip.....	20
Knee.....	4	Frontal sinus.....	50

Too much weight should not be attached to this table, as it is based on a relatively small amount of work. It is merely given to show in a general way how the time of ex-

* These rays are not homogeneous, but the mixture is always the same.

posure varies for different parts of the body when the intensity and penetrating power of the rays are held constant.

The compromise voltage used for radiography appears well suited to fluoroscopy, and at this voltage a current of 5 ma. appears to give sufficient illumination.

The reason for adopting for radiography the amount of energy corresponding to 10 ma. at a 5-in. spark was that it was the maximum amount available in the tube when operating from the Delco-light generator.

This energy could, of course, have been taken at any desired potential, as this was merely a matter of transformer design. The reasons for choosing the potential corresponding to a 5-in. spark were: Given a certain amount of energy to work with, the Roentgen-ray intensity, as measured by the illumination of the fluorescent screen or the action on the photographic plate, goes up rapidly with the voltage. This is obvious from the well known fact that Roentgen-ray intensity, measured as above, increases with the first power of the milliamperage and with the square of the voltage while the energy delivered to the tube is proportional to the product of the first power of the current and the voltage. This, then, was an argument in favor of high voltage. On the other hand, contrast, in both radiography and fluoroscopy, decreases with increasing voltage. This is an argument against the use of too high voltage. The voltage corresponding to a 5-in. spark between points appeared to be a good compromise.

The authors have adopted the following general method of using the outfit.

After starting the engine, the resistance (b) is all cut out. This causes the engine to idle at its lowest speed.

For radiographic work, the resistance of (b) is raised until the line voltage indicated by (c) is about 160. The filament current is then adjusted once for all* by means of the control (D) until, upon closing the X-ray switch, the milliamperemeter registers 10. As the X-ray switch is closed the line voltage is seen to drop. The resistance of (b) should be changed until the line voltage with the 10 ma. load, is 122. The line voltage is now observed when the load is taken off, and is in future work brought to this point before closing the Roentgen-ray switch. The important point is that the voltmeter reading when the 10 milliampere load is on shall always be 122. If this condition is fulfilled, all radiographic work will be done with a tube voltage corresponding to a 5-in. spark between points.

For fluoroscopic work, it is not necessary to touch the filament current control. This should be left just as it was for radiographic work. After closing the Roentgen-ray switch, the rheostat (b) is so adjusted that the tube carries 5 milliamperes. The tube voltage will then be the same as it is with the 10-ma. setting for radiographic work.

ENGINEERING DATA

(1) *Electrical Efficiency*

Wattmeter measurements taken at various points in the circuit showed that, with the radiographic load of 10 ma. at 57,500 volts (effective), the alternating-current generator was delivering 820 watts, and that this energy was consumed in various parts of the outfit as follows:

	Watts
Main line loss.	10
Booster loss.	12
Filament-current control loss.	14
Filament-current transformer loss.	5
Energy consumed in filament.	43
Energy delivered to Roentgen-ray transformer.	694
<hr/>	
Total.	778

* It should subsequently need to be changed only when tubes are changed.

The difference of 5 per cent between this total and the 820 watts measured directly at the brushes of the generator is doubtless to be explained in part by experimental error and in part by distortion of wave-form.

From the above, it is seen that 85 per cent (694 watts) of the energy from the generator is delivered to the Roentgen-ray transformer.

The energy in the high-tension discharge passing through the tube was not measured directly. (If time had permitted, it would have been determined by thermal measurements of the heat generated in the target.) It should be approximately equal to 575 watts (the product of tube current and voltage, or 0.010 by 57,500.) *According to this, the Roentgen-ray tube gets, in the form of high-tension discharge, 83 per cent of the energy delivered to the Roentgen-ray transformer and 70 per cent of the total energy delivered by the alternating-current generator.*

(2) Gasolene Economy

This was determined for various Roentgen-ray loads. In the following table, the first column gives the number of the experiment, the second the load, the third the engine speed in revolutions per minute, the fourth the dynamo voltage, and the last the economy expressed in hours of operation per gallon of gasolene consumed.

Expt. No.	Roentgen-ray Load	R.p.m.	Dynamo Voltage	Hours per Gallon
1	0	900	90	5 ¹ / ₂
2	0	1440	160	4
3	Radiographic	1382	122	3 ¹ / ₂
4	Fluoroscopic	1320	114	3 ³ / ₄

In Experiment 1, the engine was idling at its lowest speed and the Roentgen-ray switch was open. In Experiment 2, the engine speed was that required for radiographic work, but the Roentgen-ray switch was open. In Experiment 3, the radiographic load is on for 15 seconds and then off for the remaining 45 seconds of each minute. (This particular schedule was chosen as representing the severest radiographic service which was likely to be required of the outfit.) The fourth experiment was with a fluoroscopic load kept on continuously.

(3) Weights

The weight in pounds of the different parts of the outfit is given in the following table:

Engine and generator, with wooden base	377 lbs.
Tube-box, and shutter	110 lbs.
Table	164 lbs.
Transformer and instrument box with contents	244 lbs.
Total	895 lbs.

ADVANTAGES OF THE OUTFIT

The advantages of the complete outfit, as described above, may be summarized as follows:

- (1) Simplicity of apparatus.
- (2) High efficiency with consequent light weight and portability.
- (3) No moving parts other than the gasolene-electric set.
- (4) Control of line voltage, making it possible to duplicate electrical conditions and X-ray results very accurately.
- (5) The tube has been designed to carry all of the energy that the generator can deliver. For this reason no harm can be done to the tube by raising the

filament current too high. Under such conditions the milliamperage will go up, but the voltage will decrease so that the energy delivered to the tube will not go up appreciably.

- (6) The gasolene-electric set can be placed at any desired distance from the high tension part of the outfit, so as to avoid noise in the operating room.
- (7) No storage battery to get out of order.
- (8) Engine can be made to idle at very low speed, conducive to long life. This advantage comes from the use of the voltage governor instead of a speed governor.
- (9) An accidental short circuit of the generator does no harm; it simply lowers the line voltage to such an extent that the field excitation goes down, the ignition fails, and the engine stops.

IMPROVEMENTS WHICH COULD BE MADE BY SPECIAL DESIGN

The outfit described was developed primarily for army use, and the exigency of the case made it necessary, in so far as possible, to make use of parts which were already in production and hence readily available. It could be further simplified and improved by special design.

The greatest improvement would come from a reduction in the "inverse" voltage. By proper electrical design of the dynamo and the high-voltage transformer, this "inverse" voltage could readily be reduced to a point where it would be but slightly in excess of the "useful" voltage.

This would make it practicable and easy to work with a high-tension system grounded on one side. The cathode of the tube would then be connected to the lead covering of the tube box, and through this and the supporting mechanisms to the grounded metal frame of the table. There would then be only one high-tension terminal to the transformer and only one high-tension wire going to the tube (to the anode). The grounding of the cathode end of the tube would make it possible to dispense with the relatively bulky filament-current transformer insulated for high potential and to replace it with a very small ordinary low-voltage transformer. It would also, for the following reasons, increase the allowable tube travel: first, the grounded end of the tube could safely be moved to the extreme end of the table; and, second, owing to the reduction in inverse voltage, the length of tube and tube-box could be materially reduced.

The set described is intended to be used as a unit; but it would be a simple matter to so modify it that it could be operated from existing electric circuits without running the gasolene-electric set. The wiring diagram (Fig. 6) shows the simplicity of such a system. Where different line voltages are to be encountered, the Roentgen-ray and filament-current transformers would have special primary windings with several taps, or with several sections which could be connected in series or in multiple. Another method of accomplishing the same result would consist in using an auto-transformer provided with suitable taps to take in current of any commercial voltage and deliver it at the 122 volts given by the Delco-light set. There is already sufficient iron in the transformers to take care of a wide range of frequencies. For operation from direct-current mains, a rotary converter would be needed. When operating from existing electric mains, with either alternating or direct current, the booster would not be needed.

In closing, the authors wish to express their thanks to the many different manufacturers who loaned the apparatus used in the investigation of the different systems referred to in this article.

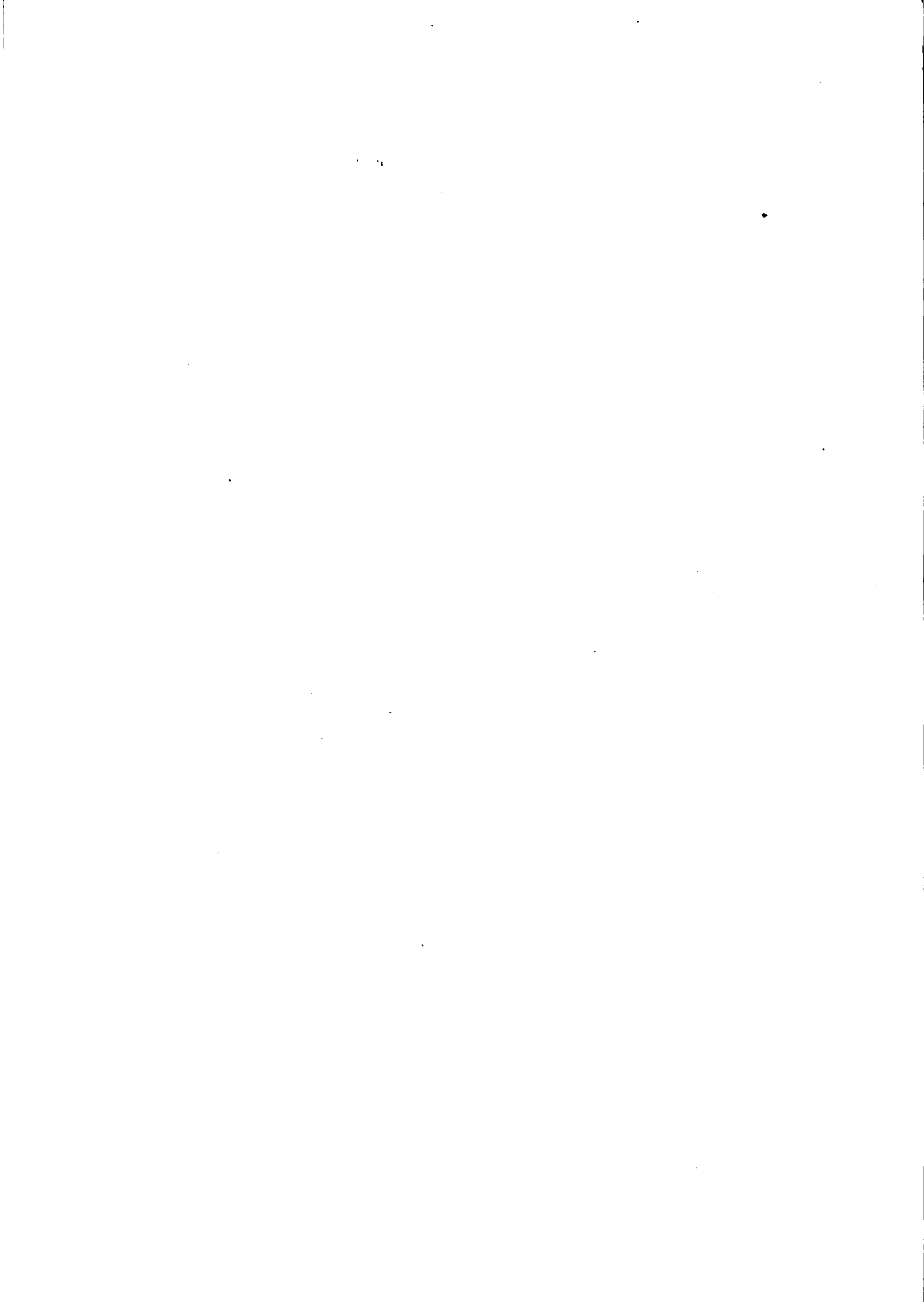

A NEW RADIATOR TYPE OF HOT-CATHODE ROENTGEN-RAY TUBE*

BY DR. W. D. COOLIDGE

INTRODUCTION

The type of tube described in this article was developed specifically for military use in the portable Roentgen-ray outfits at the Front. Its characteristics are such, however, that it seems ultimately destined to supplant the earlier type of hot-cathode tube for all diagnostic work.

THE PROBLEM

A study of the situation had shown that the electrical efficiency of existing portable Roentgen-ray generating outfits was low,¹ and that it could be very greatly increased if a suitable tube could be developed for operation directly from the secondary of a high-tension transformer, without the use of any auxiliary rectifying device. As the portable apparatus was intended for diagnostic work, it was highly desirable that the focal spot in such a tube should be as small as possible for handling the required amount of energy.

THE STATUS OF THE PRIOR ART

The earlier form of hot-cathode tube having a solid tungsten target is capable of rectifying its own current; but only for such amounts of energy as do not heat the focal spot to a temperature approximating that of the cathode spiral. As soon, however, as any part of the focal spot is heated to a sufficiently high temperature, it emits electrons copiously, and, therefore, when supplied from a source of alternating potential, it permits so-called "inverse" current to pass. The "inverse" cathode-ray stream comes out from the focal spot in a direction perpendicular to the face of the target and proceeds, in the form of a narrow pencil, straight to the glass wall of the bulb close to and slightly behind the cathode. The glass at this spot fluoresces vigorously, becomes locally heated, and usually cracks. As air enters the bulb, a spark discharge passes through the opening and it is then easy, for one who has not studied the phenomenon, to conclude that the tube failed by puncturing under electrostatic strain.

The local heating of the glass, attendant upon overloading a tube which is running on alternating current, can be prevented by making the cathode focusing device of some refractory metal, such as molybdenum or tungsten, and so locating this in the tube that it intercepts the "inverse" cathode-ray stream.²

While this method has proved exceedingly useful as a safety device, when such a tube is to be used on alternating current, it does not appreciably increase its capacity, for it would obviously be undesirable to have the cathode focusing-device giving off Roentgen-rays under such bombardment.

* From *General Electric Review*, Jan., 1918, pp. 56-60.

¹ The electrical efficiency of Roentgen-ray apparatus has usually been comparatively unimportant, but as efficiency determines the weight and bulk of the entire generating outfit, it is obviously a very important factor in the design of portable outfits.

² Under these circumstances, the fact that the tubes being overloaded is shown by a sudden vigorous local heating of the focusing device. In case the area heated in this way becomes sufficiently hot, it becomes a third source of cathode rays. These last cathode rays focus on the target at a point somewhat removed from the original and legitimate focal spot. This can be very easily observed and confirmed by the pinhole-camera method.

Copyright, 1919, by *General Electric Review*.

The essential condition to be fulfilled was that heat should be more rapidly withdrawn from the focal spot. This could have been accomplished by water-cooling,¹ but this method clearly involved undesirable complications for portable work. Experiment showed that the most effective simple method consisted in providing a target having a large heat capacity and high heat conductivity, and then in arranging to effectively cool this mass of metal during the interval between radiographic exposures. The importance of having the target cold at the start is shown by the following experience with a tube having a 3.2 mm. focal spot and a solid tungsten target: With the maximum allowable energy input, it was possible when beginning with the target at room temperature to run four times as long before "inverse" current appeared as when the experiment was started with the target at dull red heat.

Now, in the case of the ordinary Roentgen-ray tube, the cooling of the target from dull red heat to room temperature is an exceedingly slow operation. The heat can get out only (1) by radiation, which, with small differences in temperature between the hot body and its surroundings, takes place at a very low rate, and (2) by conduction through the small lead-in wire and through the glass.

DESCRIPTION OF THE RADIATOR TYPE OF TUBE

The Anode

The considerations which have been described finally led to the anode design shown in Fig. 1. The anode stem consists of a solid bar of copper 1.6 cm. ($\frac{5}{8}$ in.) in diameter



Fig. 1. Special Self-rectifying Roentgen-ray Tube

which is brought out through the glass of the anode arm to a copper radiator. The head of the anode consists of a mass of specially purified copper which is first cast in vacuum onto a tungsten button and is then electrically welded to the stem. The tungsten button, which is destined to receive the cathode ray bombardment is 2.5 mm. (0.1 in.) thick and 9.5 mm. ($\frac{3}{8}$ in.) in diameter.

The complete target, with radiator, weighs 860 gm. and has a heat capacity of 81 calories per degree centigrade; while the present standard solid tungsten target, complete with molybdenum stem and iron supporting tube, has a heat capacity of less than 10 calories. Because of its greater heat capacity, it takes much longer to heat the radiator type of target to a given temperature than it does the solid tungsten target. What is much more important, however, is the fact that between radiographic exposures the target in the new tube cools comparatively rapidly owing to the large copper stem and the radiator.

The Cathode

The cathode in this tube has been designed to give a focal spot 3.2 mm. ($\frac{1}{8}$ in.) in diameter with a very uniform energy distribution.²

¹ Coolidge, Am. J., of Roentgenology, pp. 7-8 (1915).

² For the method of developing a suitable cathode design, see American Journal of Roentgenology, pp. 5-6 (1917).

Size of Bulb

In the standard hot-cathode tube with the solid tungsten target, the target gets very hot and radiates through the glass walls of the tube the greater part of the energy it receives. As a result, the glass becomes strongly heated. In the new radiator type of tube, by far the greatest part of the energy imparted to the target is conducted to the radiator. It, therefore, becomes possible to make the glass bulb very small. For portable work, a diameter of 9.5 cm. ($3\frac{3}{4}$ in.) has been standardized.

The Exhausting of the Tube

The exhausting of a hot-cathode tube, containing the anode which has been described, to such a point that the tube could be sealed off from the pump appeared at first to be an impossibility. A point was finally reached where after sealing the tube off and allowing it to stand over night, the vacuum was good. Upon operating such a tube for a few seconds, however, the vacuum rapidly deteriorated until the tube showed a Geissler glow. After a second exhausting, covering a period of several hours, the experience mentioned was duplicated with this difference: the tube operated successfully for a somewhat longer time. A third exhausting, again extending over a period of several hours, finally resulted in a good tube. Since that time it has developed that the exhaust is made much easier by first filling the tube with purified hydrogen and then heat-



Fig. 2. Tube in Lead-Glass Shell

ing it strongly. It is still a very serious operation, however, when compared with even the exhausting of the hot-cathode tubes of the earlier type.

THEORY OF OPERATION

In the radiator type of tube, the passage of "inverse" current is avoided by a construction which removes heat from the focal spot so rapidly that, in normal use, it never reaches the temperature at which an appreciable thermionic emission of electrons can take place. In testing the first tubes of this type, it was found that some other very powerful cause was acting to prevent electron emission from the focal spot. It developed that, in this tube, the temperature of the focal spot could be raised to that of the cathode spiral and even brought to the melting point, while the tube was operating on alternating current, without having the tube allow any appreciable "inverse" current to pass.

The most probable explanation of this phenomenon appears to be as follows: The thermionic emission of electrons from a heated tungsten surface is very greatly reduced by traces of oxygen.¹ Now, in the case of the solid tungsten target, the oxygen which is originally present in the metal is removed during the exhausting of the tube by maintaining the target for a considerable time at intense white heat while the tube is connected to the pump. Under these conditions oxide of tungsten dissociates, and the

¹ I. Langmuir, *Phys. Rev.*, pp. 465-466 (1913).

oxygen is removed from the tube by the pump. In the radiator type of tube the conditions are very different. There is, at the beginning of the exhausting process, a large amount of oxygen both in the tungsten button and in the copper of the target. During the exhausting, the temperature of the target must at all times be kept below the melting point of copper. As a result, there is probably sufficient oxygen left in the target to account for the observed phenomenon. The oxygen in the tungsten at the focal spot would be liberated by the heat produced by cathode ray bombardment. This oxygen would then be chemically removed from the surrounding space by the hot copper of the target. Other oxygen in the metal layers just behind the focal spot would then diffuse to the focal spot; and this cycle of operations would go on indefinitely, the trace of oxygen in the tungsten at the focal spot always greatly reducing the electron emission.

With a tube containing such a target, heat is conducted away from the focal spot so rapidly that the tube could satisfactorily be used to do the work for which it was intended without the help of the phenomenon mentioned. The latter furnishes a factor, however, which strongly safeguards this type of tube when rectifying its own current.

OVERLOAD LIMITATIONS AND BEHAVIOR OF THIS FIRST MODEL OF THE RADIATOR TYPE TUBE

The first model of the radiator type tube was designed to carry 10 milliamperes at a 5-in. parallel spark between pointed electrodes for the time required for making the most difficult radiographs, and to carry a fluoroscopic load of 5 milliamperes at a 5-in. parallel spark continuously for an indefinite period.

Under abuse, its behavior is as follows: When operated continuously with 10 milliamperes at a 5-in. parallel spark and with a constant heating current in the filament spiral, the milliamperage may gradually drop. If the experiment is continued until the anode is red hot, and this will take about $2\frac{1}{2}$ minutes, the current may drop to as low as 6 milliamperes. (The amount of this drop depends upon the degree of the exhaustion, being greater the poorer this is.) Upon cooling the anode, the vacuum immediately returns to its original condition, as shown by the fact that, with the same filament current, the milliamperage returns to 10. It is surprising to see how quick this recovery is; it has been found to take place even in the short time that it takes to cool the anode by holding the radiator under a cold-water faucet. This recovery is doubtlessly due to gas absorption by the anode.

MEASUREMENT OF VOLTAGE WITH TUBE RECTIFYING ITS OWN CURRENT

Upon operating a tube, which rectifies its own current, directly from the secondary of a transformer, the "inverse" voltage is always higher than the "useful" voltage. Consequently, the measurement of tube voltage by a parallel spark-gap used in the ordinary way would, in general, be very misleading, for the observed spark length corresponds to the "inverse" voltage and not to that which produces the Roentgen-rays and hence determines their nature. A simple and very satisfactory method of dealing with this difficulty consists in connecting an alternating-current voltmeter across the primary of the transformer and then calibrating once for all this combination of transformer and voltmeter. The calibration can be conveniently made with the help of a kenotron connected in series with the Roentgen-ray tube. The two tubes should be so connected that current can pass through the Roentgen-ray tube in the right direction. If now a spark-gap is connected across the Roentgen-ray tube terminals, it measures the useful voltage (and this is essentially what it would be if the kenotron were not in the circuit, for the voltage drop in a suitable kenotron is not more than one or two hundred volts and can hence be neglected). If the spark-gap were connected directly across the trans-

former terminals it would measure the "inverse" voltage. The difference between the two will depend upon the load and hence it is necessary that the calibration should be made for every load which it is desired to use with the tube. Unless appreciable changes take place in the wave form of the current supply, a single calibration suffices, and this can be made by the manufacturer of the transformer. Unless otherwise specified, the voltage referred to in this article is always the "useful" and not the "inverse" voltage.

ATTACHMENT OF RADIATOR TO TARGET STEM

In the first radiator type tubes made, the radiator was soft-soldered to the copper stem of the target. It was later found that the tube would stand almost as hard abuse if the solder was omitted and the radiator was simply slipped on over the stem and held in place by a thumb-screw. This has made it possible, for some applications, to adapt a simple, close-fitting, two-part, lead-glass shield to the tube.

LEAD-GLASS PROTECTIVE SHIELD

As such a shield is, in some cases, a matter of considerable importance, it is perhaps well to discuss briefly a form which seems very satisfactory. It is evident that there will be some applications where the tube shield ought, for a given amount of protection, to be as light as possible. In these cases, it should obviously have the same form as the tube and should fit closely to the latter. Furthermore, it should let the heat energy of the cathode-spiral radiate through it, as otherwise both the shield and the tube would, with prolonged filament excitation, get very hot. The ideal light-weight shield will then be a non-conductor of electricity, to permit of its being closely fitted to the tube, and will be transparent to ordinary light radiations. Glass containing sufficient lead would be a satisfactory material from which to make such a shield. The ordinary X-ray protective glass with which the author is familiar does not have as high a lead content as seems desirable. The best samples which he has tested have to be used in layers 10 to 12 times as thick as metallic lead to give the same protection as the latter. Experiments made by Dr. G. Stanley Meikle, of this laboratory showed that glass could be made experimentally which contained so much lead that, for the same protective effect, the glass layer had to be only 1.4 times as thick as sheet lead. Such glass when melted attacks the glass-pot quite readily and may, therefore, be difficult to manufacture. However, the author has recently been able to obtain glass* containing enough lead so that, for the same protective effect, the glass layer has to be but 4 times as thick as sheet lead.

The properties of this glass are such that it cannot be readily blown into thick-walled bulbs, but it can be pressed in moulds. Fig. 2 shows a picture of a tube surrounded by such a shield which is made in two parts bolted together in the middle. A hole in one side permits egress to the desired bundle of Roentgen rays.

APPLICATIONS OF THE TUBE

Two portable Roentgen-ray generating units have already been built around the first model of this tube. These are the "U.S. Army Portable Unit" and the "U.S. Army Bedside Unit." In both of these outfits the tube is operated directly from a high-voltage transformer with no auxiliary rectifying device.

This model of the tube should also be useful for general fluoroscopic work and for all radiographic work which can be done with a focal spot as small as 3.2 mm. ($\frac{1}{8}$ -in.) in

* From the Corning Glass Works.

diameter. (This means an amount of energy not in excess of that corresponding to 10 m.a. at a 5-in. parallel spark between pointed electrodes.)

For more rapid radiography, other models will be developed with larger focal spots, but probably with the same external tube dimensions.

ADVANTAGES OF THE RADIATOR TYPE TUBE

The advantages which the new type of tube possesses over the earlier type for diagnostic work are the following:

1. It can be used to rectify its own current under conditions of service which are much severer than would be permissible with the earlier type of hot-cathode tube having the same size of focal spot.

2. The bulb can be smaller than is permissible with the earlier type handling the same amount of energy.

3. On either alternating- or rectified-current it will carry the maximum allowable energy for a much longer time.

4. It can have, even for heavy duty, a close-fitting tube shield.

The author desires to express his thanks to George Hotaling, C. N. Moore, and Leonard Dempster for their assistance in carrying out the work which has been described.

USE AND ABUSE OF ROENTGEN-RAY TUBES *

BY C. N. MOORE

I feel rather as though an apology were due for appearing before a body of trained roentgenologists to speak upon the subject of the use and abuse of roentgen-ray tubes. My only excuse for doing so, is the belief that experience gained in the development, manufacture and testing of tubes, together with the examination of tubes returned for repairs, may enable me to be of some service by pointing out the conditions under which tubes were designed to operate. I will mention some of their limitations, and by means of sample tubes and a few simple experiments show some of the results of abuse. In the present emergency, it is highly desirable to conserve and utilize to the utmost degree the tubes which must be transported under such difficulties and for such distances. I hope that nothing I shall say will conflict with what you are being taught in the various schools for military roentgenology. My remarks will apply specifically to the hot cathode type of tube, but will apply in the main to all types.

Turning first to the all-tungsten target tube in the seven-inch bulb—a tube designed for diagnostic work, both roentgenographic and fluoroscopic, and for roentgenotherapy. It is intended to be operated under the following conditions: (1) With voltages as high as that corresponding to a ten-inch parallel spark gap between points, and with currents depending upon conditions to be explained later, and (2) upon apparatus delivering rectified current to the tube. You are all perfectly familiar with the operation of this tube, but I wish to say a few words regarding the conditions just mentioned.

First, in regard to the question of the amount of energy that a tube will carry. In this case, energy may be considered as the product of the milliamperage times the potential (spark gap). Once the target design is fixed, the allowable energy input is determined principally by four things: (1) The target material, (2) the area of the focal spot, (3) the time during which the energy is applied, and (4) the temperature of the target at the time the energy is applied. Of the energy applied to the focal spot, approximately 99.8 per cent is converted into heat, so that the question of the allowable energy input is really a question of the rapidity with which heat can be removed from the focal spot and of the melting point of the target material. The metal tungsten is used today for the target face in practically all tubes. It has a melting point of 3300 deg. C. If this temperature is exceeded, tungsten will melt. The filament in this incandescent lamp is made of tungsten. I am going to raise its temperature above 3300 deg. C. by operating it at a voltage considerably in excess of that for which it was built. As I cut out resistance in series with the lamp, the tungsten becomes hotter and hotter, until finally at this point where it is white hot, it melts. Probably the worst abuse of the roentgen-ray tube is due to a lack of consideration of the fact that tungsten has this definite melting point. Present practice is resulting in repeated melting of the focal spot in many tubes. The molten tungsten vaporizes rapidly in an evacuated space, and deposits in a thin film over the active hemisphere, as is shown by this tube. This mirror-like metal deposit on the inside of the glass should not be confused with the violet coloration which always results when the particular kinds of glass used in these bulbs are subjected to prolonged exposure to roentgen rays. This violet color is due to some change taking place within the glass itself and is perfectly harmless. The thin film of tungsten exerts no appreciable filtering effect upon the roentgen ray, but it does disturb

* Read before the Nineteenth Annual Meeting of the American Roentgen Ray Society, Chattanooga, Tenn., September, 1918. Reprinted from the American Journal of Roentgenology, November, 1918, Vol. V, No. II, pp. 529-531. Copyright, 1918.

the electrical conditions within the tube. Experiments in the laboratory have shown that a grounded metal wire can be brought up into contact with a clear bulb when the tube is operating, whereas with a tube having a metal deposit inside, such a wire must be moved away a number of inches to avoid puncturing the tube. The metal of the tube stand is usually grounded and the large number of punctured bulbs similar to the one which I am showing you, would be greatly reduced if the practice of blackening bulbs were discontinued. Furthermore, I want to call your attention to the fact that this practice results in no appreciable gain. You may succeed in increasing your roentgen ray production a few per cent thereby, but this is hardly of interest. At the same time you have probably greatly reduced the life of your tube. Properly used, a tube will gradually acquire the deep violet color shown in this tube, which was returned for a trifling mechanical defect after two and a half years of constant use. If used in the same conservative manner, this tube should last many years more.

Just a few words in regard to the other factors involved in the question of allowable energy input. It is obvious that more energy may be applied to a large focal spot than to a small one without exceeding the allowable temperature. For a given size of focal spot, more energy may be applied for a short time than would be possible if the time of application were longer. And finally, for a given size of focal spot, more energy may be applied to a cold target without melting the focal spot than to one that is already hot, because in the case of the cold target, heat will flow away from the focal spot more rapidly.

What I have said so far has applied mainly to roentgenographic work. For continuous operations in roentgenotherapy, the limiting feature is not so much the target as the glass of the bulb. It is possible to get the body of the target so hot that heat radiated from it may cause gas to be driven out of the glass or may even melt the glass. Adequate cooling of the bulb is necessary to prevent this.

I have already stated that the present seven-inch tube with the solid tungsten target was designed to operate upon apparatus delivering rectified current to the tube. It is not designed to operate directly from the terminals of a high tension transformer without the interposition of a suitable rectifying device, or from the terminals of a coil without the use of valve tubes. Operation under these conditions constitutes one of the worst abuses with which we are familiar. Again it is a question of the temperature of the focal spot. Tungsten at a temperature of about 2000 deg. C. begins to emit electrons at an appreciable rate. As a consequence, if a source of alternating potential is applied to the terminals of a tube with the focal spot or any point in the focal spot, at or above this temperature, inverse current will pass through the tube. This inverse current may focus on the glass in the cathode stem, causing cracking and the emission of gas, or it may focus on the glass of the bulb directly below the cathode. It is customary to speak of a tube being punctured by inverse at this point. What really happens is that the inverse current heats the glass locally so that it actually melts, or else sets up strains so that the glass cracks during this or some subsequent operation. After cracking, air rushes in and the electric current traveling along the air current gives the impression that a spark was the cause of the puncture. The presence of inverse is always indicated by green fluorescence at the cathode end of the tube. I am now going to do something which should never be done. I am going to run this tube directly from the terminals of a transformer with no other rectifying device. Within a few seconds from the start you will see green fluorescence appearing in the cathode arm. Now that the target is at a dull red temperature, the focal spot is hotter and you see the green fluorescence immediately upon closing the switch. The tube has not yet been injured

but if I should continue as I am about to do now, I shall undoubtedly ruin the tube. You see the inverse current focusing now on the glass below the cathode and a moment later so much gas has been evolved that I shall have to discontinue operation of the tube. Subsequent examination of the tube shows that, while cooling, the glass has cracked at the point where the inverse current focused upon it. The same thing would happen on an induction coil. It will also occur on the regular interrupterless machines if the rectifying switch is not set properly.

Turning now to the radiator type of tube which was developed for use in connection with the portable army outfits. This tube is adapted to diagnostic use only, and the allowable energy input is limited to that corresponding to 10 ma. at a five-inch parallel spark gap. For continuous operation in fluoroscopy, the current is limited to 5 ma. It is not suitable for therapy for the reason that it has not been designed to operate at the voltages used in such work and because it will not carry continuously more than one quarter of a kilowatt. The seven-inch tube with no copper in the anode will carry continuously about one kilowatt.

The radiator type tube is so designed that it will rectify its own current and can therefore be operated directly from the terminals of a high tension transformer or a coil. You are all familiar with the manner in which it is used on the portable outfits. It will operate equally well on outfits delivering rectified current if the limits mentioned above are not exceeded.

I am now going to run a radiator tube on this apparatus taken from a portable outfit, with a current of 10 ma. to demonstrate the behavior of this tube under abuse. The longest roentgenographic exposure is probably not over forty seconds. You will observe from the milliammeter that the tube has remained fairly constant during this time. If, now, I continue running longer without adjusting the filament current, the milliamperage will gradually drop until at the end of two minutes it has reached 8 ma. This falling off in the milliamperage is due to the presence of gas driven out of the copper in the anode by heat. If I set the tube aside, the copper as it cools will reabsorb the gas and the tube will return to its original condition. Because of lack of time, however, I shall have to omit this part of the experiment. I am now going to abuse this tube. I will operate it at 10 ma. until it shows signs of distress. At the end of about four minutes the copper of the target has reached such a temperature that I shall have to discontinue to avoid melting it. Frequently before this point is reached, the tube will show green fluorescence throughout the bulb, owing to the fact that so much gas will have been evolved that further operation is unsafe.

THE RADIATOR TYPE OF TUBE*

BY W. D. COOLIDGE

Research Laboratory, General Electric Company
SCHENECTADY, N. Y.

The radiator type of tube has already been described.¹ Up to the present time, its use has been confined exclusively to the army and in this service it has been used as a self-rectifying tube in the Portable and Bedside outfits. Owing to the fact that the tube has recently become generally available for use on existing standard generating outfits, the following amplification of what has been published will perhaps be useful.

The leading motive in the development of this type was originally to get, in the form of a small simple and rugged structure, a tube which would operate satisfactorily when alternating current was supplied to its terminals. As will be seen from the following, however, the use of the tube should not be limited to such service,² for it will do better diagnostic work on any generating outfit than will the earlier form of hot-cathode tube with the solid tungsten target.

FIELD OF USEFULNESS OF THE RADIATOR TUBE

This type of tube makes possible the use of a simple transformer³ as a current generating outfit (for direct current circuits a converter must be added). It has been found that a little transformer of suitable design and weighing but slightly over 50 pounds is adequate for supplying a current of 50 milliamperes at a useful gap of 5-in. to a self-rectifying tube. This, of course, means that a very small and relatively inexpensive outfit of this type can be made to do even very rapid diagnostic work. The freedom from mechanical and electrical complications and from noise and the diminution in the odors attendant upon high tension discharges in air seem very much in favor of this system.

The tube operates satisfactorily on the transformer, the interrupterless outfit, and the induction coil, and is hence generally applicable to diagnostic work. With the induction coil it renders a valve tube unnecessary. With the interrupterless machine, it offers the advantage that it is not injured by a faulty setting of the mechanical rectifier. With every current source it permits of the intermittent use of more energy than could in practice safely be carried by a tube with a solid tungsten target and the same size of focal spot.

It is not, in its present form, adapted to therapeutic work, for, with continuous operation, it will carry less than one fourth as much energy as the 7-inch hot-cathode tube with solid tungsten target.

CURRENT-CARRYING CAPACITY OF THE RADIATOR TUBE

For a given voltage, the current-carrying capacity of the radiator type of tube is a very definite quantity. This is due to the fact that the target of the radiator tube cools so rapidly, between exposures, that every exposure is started with a relatively cold target. What can be done with the tube then, in radiographic work, depends but little on its past history.

This will perhaps be made clearer by the following consideration: The target, with its heat-storage capacity, is like a reservoir used for the storage of water. It is capable

* Copyright 1919 by American Journal of Roentgenology.

¹ *Gen. Elec. Rev.*, 21, pp. 55-60 (1918).

² It is, perhaps, necessary to place additional emphasis on this point for the reason that one is instructed in the *U. S. Army X-ray Manual* not to use this tube on large installations or interrupterless machines. This was doubtless, under the circumstances existing at the time, a wise regulation. To apply this regulation to civil practice, however, would be equivalent to saying that no 10-ma. X-ray tube should be operated from a large machine.

³ This word, transformer, is so generally incorrectly used by the roentgenologist that a definition will not be out of place. A transformer is a device for transforming an alternating current of one voltage to that of another. In its simplest form, it consists of two coils of wire placed around a common iron core. It is *not* an "Interrupterless Machine"—the latter consists essentially of a transformer, a synchronous motor, and a mechanical rectifying switch.

of absorbing and storing up an amount of heat energy, which is determined by the size of the target and by the amount of heat already in it, just as the reservoir is capable of taking up an amount of water determined by its size and by the amount of water already in it. The capacity of the target to take up heat is always the same provided it is always at the same temperature at the beginning of the exposure.

It is then a simple matter for the manufacturer to specify the capacity of tubes of the radiator type.⁴

In the particular service for which the radiator tube was first developed, the amount of electrical energy available at the tube terminals was strictly limited and corresponded to 10 ma. at a 5-inch useful gap. The focal spot in the first model was then made as small as could be conservatively used with this amount of energy ($\frac{1}{8}$ -inch in diameter). In this connection, the writer wishes to lay emphasis on the word *conservatively*. He has seen one of these tubes which had been in almost constant radiographic service in a base hospital for a period of several months. It had been operated on an interrupterless machine with a load of 10 ma. at a 5-inch gap. Inspection showed that the focal-spot had never even been frosted and could not be identified without operating the tube. Under such circumstances and with such consistent use, there is, of course, a temptation on the part of the operator to increase the load and to exceed the current specified by the manufacturer. The writer, however, cannot see a justification for doing this. If, without serious damage, a current of say 30 milliamperes could occasionally be used with a tube marked 10 ma., it might seem worth while; but it can't be done. It will ruin the tube. With the tube, in the base hospital in question, the current could undoubtedly have been raised 50 per cent and this would have reduced the time of exposure to two thirds of what it had been. The point which the writer wishes to make, however, is that the gain derived from attempting to operate a radiator tube, or any other roentgen ray tube of any kind, or a jack-knife, or any other device, at the breakdown point is out of all proportion to the cost.

Later in the war it was felt by some that there was need, in the army service, of a limited number of mobile outfits having a higher current capacity than the standard U. S. Army Portable outfit. For this reason, experimental work was undertaken on a larger size, 3 kw., Delco-light set. It developed that, with certain minor changes, this set, when connected to the small X-ray transformer used in the standard Portable outfit, was capable of delivering 30 ma. at a 5-inch useful gap to a self-rectifying tube.

It was found that a radiator type of tube with a $\frac{3}{16}$ -inch focal spot behaved nicely with the 30 milliamperes load. Except for the larger focal spot, this tube was identical with the 10 milliamperes radiator tube.

There is every reason to think that, with a still larger focal spot, this same design of radiator tube will be found equally satisfactory for 100 milliamperes or more, and that it will still operate just as well on alternating as on rectified current.

The current-carrying capacity is the same for alternating as it is for rectified current, as the tube will safely rectify any current which does not damage the focal spot.

OPERATION ON TRANSFORMER (WITHOUT MECHANICAL OR OTHER RECTIFIER)

When used where it has to rectify its own current, the radiator type of tube shows its greatest superiority over the hot cathode tube with the solid tungsten target,⁵ used under the same conditions. This is illustrated by the following experimental data:

⁴ In the case of the earlier type of tube with the solid tungsten target, the specification of current-carrying capacity was always rather unsatisfactory for the reason that the cooling of the target in this tube, between exposures, was relatively very slow. Because of this latter fact, the target temperature, at the beginning of an exposure might be anything between room temperature and intense white heat. The amount of heat which the solid tungsten target was capable of storing up and, hence, the current-carrying capacity, was then a very variable quantity, depending on the temperature of the target at the beginning of the exposure.

⁵ The latter should never be used to rectify its own current. The reasons will be obvious from the following data.

30-MILLIAMPERE RADIATOR TUBE, OPERATED FROM TRANSFORMER (WITHOUT RECTIFIER)

With the target at room temperature, a current of 30 milliamperes at a 5-inch useful gap was applied continuously for 35 seconds. At the end of this time, there was a slight flash of green fluorescence in the tube and evidence of a slight high voltage surge on the line. The target was bright red. No harm had been done to the tube, but it would have been unsafe to continue without interruption.

With intermittent operation, it was found that a 6-second exposure with 30 milliamperes at a 5-inch useful gap could be repeated indefinitely with 40 second intervals between exposures.

With suitable intervals between, exposures with 30 ma. ranging in time from 0 to 35 seconds could then be made.

MEDIUM FOCUS 7-INCH TUBE WITH SOLID TUNGSTEN TARGET, OPERATED FROM TRANSFORMER (WITHOUT RECTIFIER)

Starting with the target at room temperature, this tube was operated with 30 milliamperes at a 5-inch useful gap for 10 seconds. At the end of this time it showed green fluorescence at the cathode end, indicating that it was beginning to pass inverse current. The target was red hot. Experience has shown that had the operation of this tube been continued further without interruption, it would have been put permanently out of commission, either from cracking the bulb back of the cathode or from deterioration of vacuum.

After waiting 15 minutes for the target to cool, it was found that the tube would carry the 30 ma. load for $5\frac{1}{2}$ seconds, at the end of which time, inverse again appeared. After a further wait of 21 minutes, it was possible to operate it for 7 seconds

This tube then would have stood from a cold start, a single 30 ma. exposure of 10 seconds, and repeated exposures of 6 seconds duration with intervals of about 20 minutes between.

BROAD-FOCUS 7-INCH TUBE WITH SOLID TUNGSTEN TARGET, OPERATED FROM TRANSFORMER (WITHOUT RECTIFIER)

Experiment showed that this tube could be run with 30 milliamperes at a 5-inch gap for 6-second exposures at intervals of 15 minutes

FURTHER CONSIDERATIONS

With the present design, the 7-inch tubes with solid tungsten target show considerable differences in the evenness of distribution of energy over the focal spot. The two 7-inch tubes tested were taken at random and for this reason they do not represent the worst conditions. Other tubes will be found which will behave even worse than these when operating on alternating current.

It is also a fact that commercial experience with this type of tube operating directly from a transformer (without a rectifying device) has resulted in the rapid destruction of tubes and has been thoroughly unsatisfactory

The 30 milliampere radiator tube was designed to rectify its own current. It was, in the above mentioned experiments, always much further from the actual breakdown point than were the other tubes. A load much higher than that used would have been necessary to produce inverse with the radiator tube (the fluorescence referred to in the test was due to gas given off from the hot copper and was not a manifestation of inverse current), and, had inverse been produced, it would have been intercepted by the hemispherical cathode and so kept from hitting the glass.

The above tests can then be summarized as follows: Running directly from a transformer (without a mechanical rectifying switch), the 30-milliamper radiator tube was operated for single periods of 35 seconds duration, while the limiting time of operation with the medium focus solid tungsten target tube was 10 seconds. Six-second periods of operation could be repeated indefinitely with 40-second intervals with the radiator tube, while intervals of 15 and 20 minutes were needed with the other two tubes. Furthermore, the radiator tube was not endangered by the above tests, while the others were being operated very close to the breakdown point.

Attention should be called to the fact that the above tests were forced tests. They are given merely to show the radically different behavior of the two types of tube when operating on alternating current. At the present time, there is certainly no occasion in diagnostic work to use 30 ma. at a 5-inch useful gap for a period of anything like 35 seconds or to make any considerable number of consecutive 6-second exposures with a time interval of only 40 seconds between them.

OPERATION ON INTERRUPTERLESS MACHINE

For satisfactory diagnostic work, it is imperative that a voltage control of the auto-transformer type rather than the resistance type be employed. The use of auto-transformer control will ensure constant voltage and will hence greatly facilitate the duplication of results.

The results obtained should be better than with the tube having a solid tungsten target; for in general, for a given amount of energy, a smaller focal spot can be used in the radiator tube.

The tube also offers this additional advantage, for use on the above outfit, that a faulty setting of the rectifying device, resulting perhaps in sufficient inverse to ruin the tube with the solid tungsten target, will not injure the radiator tube.

OPERATION ON INDUCTION COIL

The radiator tube is well adapted to induction coil use and renders a valve tube unnecessary. The cathode filament may be supplied with current from an insulated storage battery or from a small converter and special step-down transformer. For diagnostic work, however, the induction coil outfit, because of its complications, does not seem competitive with the simple transformer.

USE OF LOW MILLIAMPERAGE

Some enthusiastic users of a 10 ma. tube seem to feel that there is some mysterious advantage derived from the use of low milliamperage per se. In some cases they have gone so far as to take tubes adapted to operation with say 40 ma. and run them at 10 ma.

There is no harm in doing this; but it is easy to show by actual experiment that, provided the same voltage and the same exposure time, reckoned in milliamper seconds, are used, radiographs made with a 40-ma. tube at 10 ma. cannot be distinguished from those made at 40 ma.

It is true that, unless the operator is equipped with a time switch adapted to the measurement of short time intervals, he will time his exposures more accurately when using low milliamperage and longer intervals.

The main advantage, however, to be derived from the use of low milliamperage comes from the fact that it makes possible the use of a tube with a small focal spot. It is easy to demonstrate that, with satisfactory immobilization of the subject, and the same focal-spot-plate distance, the same voltage and the same exposure in milliamper seconds, the definition is always better the smaller the focal spot.

SHIELD FOR THE RADIATOR TUBE

The main advantage of the split glass shield which has been developed for the radiator tube, consists in the fact that it completely surrounds the tube and is made of thick glass having a high lead content.

In case the focal spot happens to be exactly in the plane of separation of the two halves of this shield, there is seen to be a very thin beam of roentgen rays escaping through the joint. This leakage is so slight, however, that it would seem to be unimportant. It can, moreover, be completely stopped by seeing that the focal spot is not in the plane of separation. One of the advantages of the present design lies in the fact that it makes possible the condition that each half shield shall fit together with every other half shield to make a pair.

The method of supporting the tube in the shield has come in for deserved criticism. An experimental model has been made in which the outer ends of the glass are threaded to take hard-rubber screw caps. These caps force tapered split bushings of some resilient material, such as cork, in between the arms of the X-ray tube and the shield. This holds the tube securely in position in the shield and prevents rotation.

EFFECT OF THE RADIATOR TUBE ON THE DESIGN OF GENERATING APPARATUS

While it is early to make many predictions concerning the new generating apparatus which will be developed for operating this tube, the following statements seem to the writer to be conservative.

Much fluoroscopic work and much radiographic work will be done with a simple transformer outfit operated from a lamp socket. Such small outfits will be very simple and can be made almost fool-proof.

There is a splendid field of usefulness for a small light-weight hand-portable outfit operating on this system, to use in the home of the patient who cannot be moved to a roentgen ray laboratory. Preliminary experiments seem to indicate that a suitable small transformer weighing not more than 40 or 50 pounds can be made for this service.

In the field of dental radiography, it seems certain that the outfits of this type which have already been developed by different manufacturers will find a wide field of usefulness.

CONSTRUCTION OF THE TUBE

The forced large-scale production of the tube, incident to its war use and certain war-time conditions, brought about several radical changes in tube construction.

The fact that an insufficient number of skilled glass-blowers was available made it necessary to develop special machines with which most of the glass-working could be done by girl operators. Help was also obtained by getting from the glass works mold-blown parts, such as the cathode side-arm, and the anode- and cathode-support tubes, instead of making these by hand from glass tubing.

About twelve dollars worth of platinum was needed in every anode and at one time the radiator tube enjoyed the unenviable reputation of being the biggest war-time consumer of platinum that there was. Research work which had been carried on for several years finally resulted in the production of an entirely satisfactory substitute for platinum in this field, consisting of an alloy of iron and nickel covered with copper.

The early exhaust work called for one skilled operator for each tube on the pumps, to control the current supplied to the tube. Experimental work in this field, however, finally resulted in the development of a very simple exhaust system which automatically accomplishes what the best operator had done. The system consists of a small high-tension transformer connected to the tube terminals. In series with the primary of

this transformer is a large ballast resistance, the function of which is to lower the amount of energy supplied to the tube as gas is liberated from the glass and the electrodes. The filament-current transformer is operated in parallel with the primary of the high-tension transformer and, as a result of this connection, and the presence of the ballast resistance, the filament temperature is automatically lowered whenever gas is liberated during the exhaust. The entire operation is carried out without adjustment of either the ballast resistance or the filament current control.

APPARATUS FOR PORTABLE RADIOGRAPHY*

By W. D. COOLIDGE

INTRODUCTION

For cases which cannot safely or conveniently be moved to an X-ray laboratory, the need has long been felt, by the medical profession, of X-ray apparatus suitable to conveniently transport to, and operate in, the home of the patient.

In hospital work, also, there is a need for portable X-ray apparatus which can be conveniently taken to, and operated at, the bedside in any private room or ward.

The extent to which such apparatus will be used in the future will depend upon the state of development of the apparatus at the time in question. It will depend upon such factors as the electrical and X-ray efficiency, ease of portability, convenience in handling, controllability and reliability.

The problem is not new, but its importance seems to justify a great deal of careful and extended consideration and research. Although the work of the author and his associates, in this field, is not yet completed and is in many ways imperfect, the following general discussion of the problem and the description of an experimental portable apparatus, together with the considerations which have led to its present form, may be helpful to the advancement of the art.

GENERAL CONSIDERATIONS

The presence or absence of an existing electric lighting or power circuit has, of course, nothing to do with the desirability of having X-ray diagnosis, but it has much to do with the form of apparatus required. For this reason, this section will be treated under two headings:

(a) *Where there is no Existing Electrical Supply Circuit.* In this case, recourse may, at the present time, be had to the "U. S. Army Portable Outfit."¹

For civilian practice, it is clearly desirable to have something of easier portability than this, and for this reason, apparatus similar to that described below could well be used to replace the instrument box, tube, and tube holding mechanism of the "U. S. Army Portable Outfit."

(b) *Where an Existing Electric Supply Circuit is Available.* This is the condition which has been predicated throughout the following discussion.

1. *Weight and Size Limitations.* It seems desirable that there shall be no single piece of the apparatus which cannot be conveniently carried by one man. Experience shows that a package weighing 43 pounds and having a thickness of 7 inches and a depth of 15 inches and a length of 14 inches can, when provided with a suitable handle, be conveniently carried for short distances (say a couple of hundred feet) and up and down stairs. With a given weight, an increase in thickness is always troublesome and, for going up and down stairs, length and depth also deserve serious consideration, as they determine whether the arm of the person carrying the package can or cannot be fully extended. It seems undesirable to have any single package appreciably exceed 45 pounds in weight.

* From The Journal of Roentgenology, II, pp. 149-176 (1919).

¹ W. D. Coolidge and C. N. Moore, *General Electric Review*, Vol. 21, pp. 60-67 (1918).

As the outfit must be readily transportable in an automobile, it seems desirable to limit the length of the longest package to the width of the tonneau of a small car, that is, to about 36 inches.

2. *Capability of Standing Mechanical Abuse.* As a portable outfit is necessarily subjected to a great deal of mechanical vibration during use and transportation, it should be as rugged in construction as is possibly consistent with the required light weight. Provision must, of course, be made in suitable carrying cases for any necessarily fragile parts.

3. *Water-proofness.* As the outfit must, obviously, often be taken out in the rain, it is desirable that every part shall either be rainproof or provided with some waterproof cover.

4. *Amount of Electrical Energy Available.* The operating electric current will, in general, be taken from a lighting circuit and the connection will be made to the nearest lamp-socket or base-board receptacle. This will usually mean a 110-volt circuit fused for either 6 or 10 amperes. The total amount of energy available will then be about 660 watts (the amount used in the electric flat-iron). For radiographic exposures of one second or less, about twice this amount of energy can be used without blowing 6 ampere fuses. Longer exposures with this larger amount of energy can, of course, be made by replacing the usual 6 or 10 ampere house fuses with some of larger capacity.

5. *High Efficiency Desirable.* As the amount of electrical energy available is so definitely limited, the questions of electrical and X-ray efficiency are clearly matters of prime importance.

6. *Best Voltage for X-ray Tube.* As, with a given amount of energy supplied to the tube, the photographic action of the X-rays produced increases directly with the voltage, it is clearly desirable to use as high a voltage on the tube as is consistent with the production of satisfactory radiographs. This appears to be about 60,000 volts.

7. *Size of Focal Spot in X-ray Tube.* For best definition in radiography, the size of the focal spot in the tube should always be as small as can be used with the amount of energy to be employed. As, for portable work, not more than 10 milli-amperes at 60,000 volts is available, this will mean a focal spot diameter of about $\frac{1}{8}$ inch (3 mm.).

8. *Rigid Tube-support.* It will be possible to get, in portable work, the fine definition which comes from the use of such a small focal spot. To realize on this possible gain, however, it will be necessary to take adequate precautions to guard against too much mechanical vibration of the tube. (An amplitude of vibration of as little as $\frac{1}{16}$ inch would, for example, reduce the sharpness of definition from that obtainable with a 10-milliamper tube to that of a 30-milliamper tube. This calls then, for a very rigid tube-support.

9. *Low Tension Winding of Transformer or Coil should be Insulated from Ground.* This is made desirable by the fact that, in most cases, one side of the lighting circuit is already connected to the earth. If such a circuit were connected to a transformer primary, one of whose terminals was already connected to earth, it would cause a short-circuit on the line unless it happened that the grounded side of the line was connected to the grounded side of the transformer. The necessity of finding out, by suitable test, which side of the line is grounded is obviated if the transformer primary is itself not connected to earth.

10. *Sufficient Range of Electrical Control to Adapt Outfit to Operation on All Lighting Circuits.* The voltage of lighting circuits varies somewhat in different cities, and in

different parts of the same city and is also different in a given place at different times. Furthermore, the voltage which must be supplied to the primary of a transformer or coil for a given secondary voltage is not independent of the load, but increases with it. It is desirable that one should always be able to supply to the tube terminals the same high tension voltage regardless of what the line voltage at that particular place happens to be at that particular time and regardless of the milliamperage which he chooses to use. For this reason, there should be a control apparatus, and its range should be adequate.

11. *Quietness of Both Mechanical and Electrical Operation.* This seems especially desirable in portable work; for those patients who cannot safely be taken to an X-ray laboratory are in general in poor condition to stand noises caused either by the mechanism of an X-ray outfit or by high-tension discharges. This condition is further intensified by the fact that, owing to the small size of the average bedroom, the whole outfit is very close to the patient.

12. *Sufficient Mechanical Flexibility in the Tube-holding Mechanism.* The tube-holding mechanism should have ample flexibility so that the tube can quickly and readily be brought to any desired position, in order that the patient may be disturbed as little as possible.

13. *Ship-shape Condition of High Tension Circuit.* The condition and surroundings attending portable work are certain to be very varied. To safeguard both patient and operator from accidental electrical shock, it is, therefore, even more than usually desirable that all parts of the high tension circuit should be in as ship-shape a condition as possible.

14. *Current Limiting Device.* To further safeguard patient and operator from the high tension, some form of overload circuit-breaking device should be used in the low-tension circuit. In case a human body were accidentally interposed between the high tension conductors, the house fuses might eventually blow, but a good mechanical circuit-breaker would operate much more rapidly and hence give better protection.

The overload circuit-breaker also affords a good deal of electrical protection to the X-ray apparatus itself.

15. *X-ray Protection.* In the past, portable work has often been done with entirely inadequate protection for the operator, and this appears to be one of the reasons why so little portable work has been done. It is clearly desirable to have as good X-ray protection in the home of the patient or in the hospital as in the X-ray laboratory.

16. *Stereoscopic Tube-shift.* In many portable cases it will be difficult to move the patient so as to get the customary right angle projection. Provision, therefore, should be made for stereo-radiography.

17. *Connections for Low Tension Circuit.* The terminals of the connecting cables should be so designed that the apparatus cannot be connected up wrong. The terminals should also be sufficiently rugged so that they can be stepped on without being injured.

18. *Precautions Necessary to Guard Against Tube Breakage.* Experience teaches that even in the X-ray laboratory many more tubes are broken in handling than in use. In portable work, the amount of handling which the tube will receive will be much greater than in laboratory work, and as a result, breakage will be greater unless careful consideration is given to the design of the tube, the tube-holder and the tube-carrying case.

DESCRIPTION OF AN EXPERIMENTAL PORTABLE OUTFIT

The experimental apparatus described below is the result of an attempt to comply with the requirements laid down in the preceding section.

1. *General Description.* The complete alternating current outfit, as it stands, ready to be taken out, is shown in Fig. 1, and again set up ready for use, in Fig. 2. In Fig. 2, the lamp socket which serves as the source of current is at the right and above the picture. A cable is seen leading from the lamp socket down to the instrument box on the chair. From the left side of the instrument or control box, another cable is seen leading to the transformer which stands on the base of the wooden tube stand. From the transformer, insulated conductors (a single one at the anode end and a double one at the cathode end) carry the high tension current to a new self-rectifying radiator type of X-ray tube. On the top of the instrument box the single control handle is seen at the front left-hand corner and the push-button X-ray switch at the front right-hand corner.

2. *The Tube.* The regular type of hot-cathode tube, together with the special lead-glass shield which goes with it, weighs about 7 pounds. Experiments with this combination showed that, because of its heavy weight, a relatively heavy and bulky tube-stand was required for a sufficiently rigid support. For this reason, the development of the special small tube, shown in Fig. 3, was undertaken. This tube has an overall length of 14 inches. The bulb has an inside diameter of 2 inches and an outside diameter of $2\frac{1}{2}$ inches. Except for the transparent window, the whole tube is made of glass having a very high lead content (55 per cent by weight of element lead, equal in protective power to one-fourth its thickness of sheet lead). The bulb is $\frac{1}{4}$ inch thick and therefore offers the same X-ray protection as $\frac{1}{8}$ inch of sheet lead.

This tube then requires no external X-ray shield and offers the same protection as does the regular $3\frac{3}{4}$ inch radiator tube when the latter is equipped with its special heavy shield.

It had been the original plan to use a small tube made of the ordinary thin-walled lime glass and to surround this with a close-fitting thick-walled lead-glass shield. The experiment was tried, however, of making the bulb of the X-ray tube of the thick-walled lead-glass intended for the shield, putting in a thin-walled lead-free window for the passage of the desired bundle of rays.

There was a great deal of difficulty encountered in making the first experiment. The lead-glass used was a quarter of an inch thick and was, for this reason, very hard for the glass blower to handle. Unless heated very slowly and uniformly, it cracked. It was, furthermore, because of its high lead content, unlike ordinary glass, in that as it was heated it suddenly became very soft instead of having a long temperature range through which it was plastic. To make matters still worse, the available lead-free glass for windows has a considerably higher melting point. Such tubes were finally successfully produced, however. Upon operating them, it was found that, quite contrary to expectations, they were much better than tubes of the same size made of thin lime glass. They ran with less crackling noise than any of the many tubes with which they were compared. It at first seemed possible that this might be due to these first thick-walled tubes having, for some unknown reason, a better vacuum than the tubes with which they were compared. Later experiments, however, showed that the better result could not well be ascribed to this cause. It was also not due to the substitution of lead-glass for lime-glass, for tubes made of thin-walled lead-glass were no better than those made of the customary thin-walled lime-glass. It was then due to the use of *thick-walled* glass, and this conclusion was experimentally confirmed by making some

tubes from lime-glass bulbs having a quarter-inch wall thickness. They behaved as well as the thick-walled lead-glass bulbs.

The effect of the bulb thickness on the quietness of operation of a tube is probably to be ascribed either to the leakage of electricity through the glass or to the electrostatic condenser action of the negatively charged inner surface of the bulb and the slightly conducting outer surface. Further experiments will be undertaken to clear up this point.

The cathode of the new tube is the same as that of the regular 10-milliamperere radiator tube. The anode is also the same except that it is shorter. The path which the heat has to travel from the focal spot to the radiator is $5\frac{1}{2}$ inches in the new, and $8\frac{1}{4}$ inches in the earlier tube. For continuous operation, then, the capacity of the smaller tube should be somewhat greater than that of the larger one.

The window has essentially the same X-ray transparency as does the wall of the bulb in the earlier types of tube.

The new tube, complete with radiator, weighs 2 pounds, that is, less than one-third as much as the earlier type fitted with a shield giving the same amount of X-ray protection.

3. *The Transformer.* The transformer is shown completely assembled with cover in Fig. 1 and uncovered in Fig. 2. Inside views are shown in Figs. 4 and 5.

It is an oil insulated transformer and delivers 10 milliamperes at 60,000 volts (useful). Complete with wooden base and carrying cover, it weighs 43 pounds. It is especially designed with reference to the operation of a self-rectifying tube, or, in other words, to have for a given weight, a minimum inverse voltage.

When the development work on this transformer was started, the lightest oil-insulated transformer available for this service weighed, without any protecting cover or base, 72 pounds.

Of the various steps taken to reduce weight, the most effective consisted in so shaping the transformer case as to make it conform, as closely as possible, to the high tension coils. This very considerably reduced the required amount of oil.

With this reduction in the volume of the transformer, the safe bringing out of the low tension leads, in such a manner that they cannot get too close to the high tension parts of the system, becomes an important problem. This was solved in the following manner:

A U-shaped metal piece (25 in Fig. 6), was introduced into each end of the transformer case. The tongue, 26, of this U-shaped piece fits tightly in the space between the end of the core and the end wall of the transformer case and holds the U-shaped member in the position shown in Fig. 4, which is an elevation of the transformer (with cover removed). This is also shown in the plan view given in Fig. 5. The U-shaped pieces, together with the side walls of the case, thus form rectangular metal enclosures, completely walled off from the other, or high-tension, compartment. The primary leads, 28, are brought up through the right-hand compartment, which they enter through an opening, 27, in one of the lower corners. The other two low tension leads, 29, are connected to the inner ends of the two high tension coils and lead out through the left-hand compartment to a milliammeter in the instrument box. The diagram of transformer connections is shown in Fig. 7, in which 28 is the low tension coil and 13, 13 are the two high tension coils.

Besides serving to keep the low tension leads away from the high tension part of the transformer, the U-shaped members, 25, serve two other important functions. Extending as they do from the core to the cover, they help to hold the core down. Placed in

position, they electrostatically shield the high tension coils from the sharp edges of the case, 21, 22, 23 and 24, for the outer surfaces of the inner legs of these members lie flush with the surfaces 17 and 18 of the transformer case. They, therefore, reduce the danger of electrical breakdown at these points.

The low-tension coil is wound on a treated paper tube and is made integral with this by subsequent treatment with a special black varnish which is baked until it is hard. This tube slips tightly over the core. The high tension coils are likewise impregnated with black varnish and baked. As a result of this treatment, it becomes impossible for these coils to suffer from mechanical vibration. To keep them from moving laterally on the primary, the treated paper support-tubes on which they are wound, and with which they are made integral by the black-varnish treatment, are left long enough to completely fill the core window. Rotation of the secondaries is also prevented by the support tubes. They are so shaped at their outer ends that the core prevents their rotation.

Current for heating the cathode spiral is derived from a separate coil wound over one of the high tension secondaries.

As a safety spark gap, to protect the transformer from high-voltage surges, a sphere gap, set to spark over at 90,000 volts, is used for the transformer terminals.

The sphere-gap has been used in preference to a point-gap for the following reasons:

(1) A sphere-gap is quicker in action than a point-gap and its use, therefore, imposes less electrical strain on the insulation of the transformer.

(2) It avoids the corona attendant on the use of pointed electrodes.

(3) It saves space (the electrodes of a point-gap would have to be about 9 inches apart, while the corresponding spacing of the 2-inch spheres is $3\frac{1}{2}$ inches).

To prevent warping of the cover of the transformer, which would cause a change in the spacing of the terminals of the safety-gap, the cover is made of bakelite.

The removable cover, to which the carrying handle is attached, is made to extend below the bakelite cover, to shed rain. In use, it is clamped in place by four wing-nuts which screw on pivoted bolts attached to the upper corners of the transformer case.

The base of the transformer is made of wood, to better withstand mechanical abuse. It is made large (7×14 inches) for stability.

4. *The Control of Tube Voltage and Current.* Auto-transformer control is used. The auto-transformer, together with a special auto-transformer switch, is located in the instrument box (see Fig. 8). By means of this combination, operated from the handle at the left side of the box, it is possible to always deliver a definite voltage, say 100 volts, to the transformer primary even though the line voltage may be as much as 15 per cent above or below this value.

The voltmeter, shown at the left rear corner of the instrument box indicates the voltage delivered by the auto-transformer.

The milliammeter is connected in to the middle point of the secondary of the X-ray transformer.

Nothing further would be needed for the control of voltage and milliamperage, were it not for the fact that the cathodes in different tubes are not exactly alike and that the voltage of the filament heating circuit will not be exactly the same for all transformers. To take care of this complication, a little rheostat, diagrammatically shown at 9 in Fig. 7, is built into the reel used on the cathode side. As this is in the high tension circuit, it is desirable for the safety of the operator, that it should be used as seldom as possible. For this reason and also to prevent the setting, once made, from being accidentally disturbed, a perforated metal cover is provided which is kept locked

securely in place over the rheostat by means of a thumb screw. See Fig. 9, which shows one face of the cathode reel with rheostat uncovered.

The X-ray transformer is calibrated¹ by means of a suitable sphere-gap and kenotron. The calibration of a certain experimental transformer was, for example, as follows:

For 5 m.a. at 60,000 volts (effective), use 100 volts on the primary.

In using a tube for the first time on this transformer, the rheostat in the filament circuit would be adjusted until with a voltmeter reading of 100, the tube is carrying 5 milliamperes. The cover is then fastened over the rheostat and it should never be necessary to remove it as long as the same tube and transformer are used.

In subsequent work, and regardless of what the *line* voltage may be, the desired milliamperage is secured by merely setting the auto-transformer switch. With this method of operation, it will always be found that the primary voltage is near enough to the figure given in the calibration. (If the milliamperage is correct and there is an error of 5 per cent, for example, in voltage, the error in exposure will amount to only 10 per cent, an amount which in ordinary work will be negligible.)

This simple method of control is made possible by the fact that the electron emission from the hot-cathode changes so very rapidly with temperature and, hence, in this case, with the voltage applied to the primary of the X-ray transformer. This is illustrated by the following table which shows how the milliamperage changed, in an actual experiment, as the applied voltage was changed by means of the auto-transformer switch. The rheostat in the filament circuit was not touched during the experiment. The third column gives the values of the high tension voltage (effective).

PORTABLE TRANSFORMER NO. 11

Primary Volts	Tube Current (Milliamperes)	Tube Voltage (Useful)
100	2.8	60,000
102	5.0	61,000
104	6.0	61,500
107	7.4	62,000
110	8.5	63,000
111	9.5	64,300
112	10.0	65,000

An increase of 12 per cent in primary voltage has here caused an increase of 200 per cent in milliamperage and an increase of only 8.3 per cent in secondary voltage.

5. *Circuit Breaker.* This is shown in Fig. 10. It is placed inside of the instrument box and is connected in series with the main low-voltage circuit. When tripped, it can be reset by means of the vertical rod which leads up through the cover and is surmounted by a large button.

This circuit breaker is a very important part of a portable or any other X-ray outfit. It reduces the danger to patient and operator from accidental electric shock. Furthermore, even with the best hot cathode tubes so far produced, it will occasionally happen that there is a high voltage surge which causes a flame discharge to take place across the safety gap on the transformer. This amounts to a practical short circuit on the line and, in the absence of a circuit breaker, the current drawn from the lamp socket would suddenly jump from, say, 6 amperes to perhaps 50. As a result, some fuse or fuses in the garret or the basement, as the case may be, would burn out. The

¹ See *General Electric Review*, XXI, page 58 (1918).

circuit breaker, which operates at about 20 amperes will, with an overload, act quickly enough to save a 6 ampere fuse. Its use will save the operator much time which would otherwise be spent in locating house fuses.

6. *Switches.* The main circuit is closed by means of a push-button switch located in the right front corner of the instrument box and opened later by a motor-driven adjustable relay (time-switch) which is seen at the front of the instrument box. The push-button switch is a three leaved one, with a 6-ohm resistance between the middle and lowest leaves. Upon pressing it, the upper and middle leaves first make contact, thus closing the low tension circuit through the resistance which is then short-circuited as the middle and lowest leads come together. Unless the circuit is closed through resistance, in this way, there will be a very high voltage surge whenever it happens that the circuit is closed at or near the peak of the voltage wave.

7. *The Tube-stand.* Before taking up the development of the stand described below, a good deal of consideration was given to the method which has been most frequently used in the portable work of the past. This method consists in using an adjustable arm carrying the tube-holder at one end and attached at the other to the case of the coil or other high potential source. The method necessitates placing the coil on the edge of a chair or table. This gives a rather precarious support. Furthermore, the chair or table presumably has four legs. If the joints are good and strong, this is bad, as the support will then rock until a wedge is put under the leg which is off of the floor. If the table or chair is sufficiently weak in the joints it will, under the weight of the coil, stand on four legs, but such a weak piece of furniture does not give a good firm support either. Besides the question of the bearing on the floor, there is also the question of having the coil properly supported on the chair which may have a seat of almost any shape. Besides the above objections, the chair or table support is clumsy to move around.

The stand which was finally developed is made of wood. It is shown in Fig. 2 and again, disassembled, in Fig. 11. Wood was chosen rather than metal because of its being an electrical insulator and because it stands mechanical abuse better than a thin-walled metal structure of equal weight.

The triangular base has a 3-point support and is made as large as can be accommodated in the special suitcase designed to carry the photographic material and some of the detachable parts of the outfit.

The upright post has a metal casting attached to the bottom and this is securely clamped to the base by means of two machine-screws with wing-shaped heads. The considerations which determine the position of the upright on the base are the following:

(1) In position for use at the bedside, the wooden upright should come between the metal of the bed and the transformer terminals. This definitely places the upright essentially in the middle of the base.

(2) For maximum stability, the upright should be so located on the base as to bring the transformer, as it is in Fig. 2, over two of the base supports.

As there is no brace extending from the upright to the front point of the base, the latter can be pushed forward, under even the lowest bed, until the upright almost touches the side of the bed. In this way the overhang required of the extension arm is reduced to a minimum.

The upright is made of large section for torsional rigidity.

The extension arm is secured by two clamp-screws. It pivots about and can be slid through the one in the upright. The second clamp-screw, with the short arm to which

it is attached, makes it unnecessary to set the first clamp-screw up very tight and, furthermore, it sets a safe limit to the downward travel of the tube.

Motion of the tube about three different axes, at right angles to one another, is secured through three clamp-screws. In addition to this, the tube may be easily rotated about its own length axis.

For the stereoscopic shift, a small clamp-screw which attaches the U-shaped tube-holder to the balance of the tube-holding mechanism is loosened and the tube may then be easily moved on the arc of a circle, of 24-inch radius, whose center is the center of the photographic plate when the latter is in position. To prevent possible movement of the whole stand, during the operation of making the tube-shift and changing plates, a little fiber cup, attached to the base, is brought, by rotation of the steel member which carries it, under the front caster.

As a mechanical safeguard for the tube and to render manipulation easier, a helical spring is used at the point where the tube-carrying mechanism is attached to the end of the extension arm. This spring counteracts the effect of gravity in tending to cause rotation about the clamp screw at this point. Without this spring, the tube-carrying mechanism can, when the thumb-screw in question is loosened, swing down, under the influence of gravity, so far that the tube strikes against either the extension arm or the upright post.

Heavily insulated cable is used for the high tension leads. This is to prevent corona with its attendant noise and odor. It also helps greatly, by its weight, in reducing tube-vibration, cutting it down to less than half of what it would otherwise be.

The use of large cable necessitates large special reels. To keep the high tension leads away from the bed and the patient, these reels are placed high upon the stand. They are supported at the ends of a wooden cross-arm and are widely spaced to allow much freedom of movement of the tube without having the leads come too close together. The cable used on the cathode side is a two conductor cable and two separate circuits have to be provided through the reel on this side. One circuit leads through the spring of the reel to the fixed axis and the other leads through a metal brush, and a slip-ring shown in Fig. 2, on the inner face of the reel.

The cross-arm and tube-holder must be kept dry, as they have to support the full electrical potential of the high tension circuit. They are carried in the suitcase. For use in places where the humidity is very high, it may prove desirable to make them of bakelite.

The type of caster used for the base is very important. The casters must work nicely on polished floors and on thick rugs. Of many different types which have been tried, the "A. B. C. Ball" casters have proved to be by far the best. Equipped with these, the tube-stand may be readily moved by taking hold of it anywhere. With any other type of caster which has been tried, it would be necessary to use a larger base as, otherwise, the stand could be too easily overturned in attempting to push it about. Contrary to what might have been predicted, the easy mobility which these casters give, also greatly reduces the trouble from tube vibration. This may readily be seen by striking the side of the tube-holder with the hand. When this is done, it will be found that, with the other casters which have been tried, the upright post is given a torsional deflection and then continues to execute a series of torsional vibrations. While these may be of small angular magnitude, they produce a considerable linear movement of the tube at the end of its long support-arm. When the experiment is tried with "A. B. C." casters, the result is entirely different. The mobility of the

system is then so great that, under the force of a sidewise blow, the whole stand moves, thus eliminating the torsional vibration of the upright post.

The greater mobility of the "A. B. C. Ball" caster appears to be due partly to the fact that it is a ball-bearing device, but mainly to the fact that it permits free movement in any direction without first having to be forced into a certain definite position with respect to this direction.

8. *Special Hospital Base for Tube-stand.* For hospital work, a different base, mounted on three light and relatively large rubber-tired wheels, is used for the stand. A fourth wheel, smaller than the others, is mounted a short distance back of the main rear wheels. It is so placed that it is normally about a half inch above the floor. With the transformer in position, the center of gravity of the stand is only slightly in front of the axis of the main rear wheels. By a slight downward pressure, exerted on the rear end of the extension arm, the front wheel may be lifted from the floor. The stand is then on two wheels and can readily be turned sharply to either side. The small rear wheel merely serves to keep the stand from being tipped over backwards. In this way the axes of all four wheels can be rigidly mounted instead of having to be pivoted and steered.

9. *A Special Alternative Tube-holder.* A special tube-holder has been developed which must be tested out in competition with the simpler one shown in Fig. 11. It is made of bakelite and is shown in Fig. 12. The X-ray tube is flexibly mounted inside of the holder, by means of the two disks of sponge rubber seen in the figure on the side arms of the tube. It may be accurately centered in the holder and then fixed in place by a single clamp-nut, attached to a bakelite strip which is carried by a thin bakelite ring which surrounds the sponge rubber disk used on the cathode side-arm. The bakelite tube of the holder is rotatable in two brass rings.

The total weight of the holder is $1\frac{1}{4}$ pounds. The advantages which it offers are the following:

- (1) It serves as a carrying case for the tube which can be put as it is, without special packing precautions, in the suit-case.
- (2) It can be used for special work where it is desirable to intercept the light coming from the tube.
- (3) It serves for the ready attachment of filters and diaphragms and, if desired, of a pointer for indicating the direction of the central beam of X-rays.

The disadvantage, if it has one, is that it conceals the glass X-ray tube and may hence lead to more mechanical abuse than the latter would otherwise get.

As shown, it is not adapted to stereo-work, but it can readily be made so.

10. *Operation on Direct Current Circuits.* For direct current work, a converter (rotary) has to be used. This is shown in its carrying case in Fig. 13. Unless a starting box, or its equivalent, is employed, the starting of this rotary will blow 6-ampere fuses. To obviate the need of using a regular starting box, which is needlessly large and heavy, a two point switch and a single small resistance unit are employed. Upon turning this switch to the first point, the converter is connected to the line through the resistance unit and on the second point the resistance is cut out.

The connections are so arranged that the use of the converter does not in any way affect the calibration of the balance of the electrical part of the outfit.

The converter weighs about 35 pounds.

The direct current taken from the line, for 60,000 volts (useful) at the tube, will be about 6 amperes for 5 milliamperes and 10 amperes for 10 milliamperes of high tension current.

11. *The Suit-case.* This is divided up into compartments and, with its contents, will weigh about 40 pounds.

12. *Technique.* This will be the same as that of any other tube operating with the same current and voltage.

In this connection, attention should be called to the fact that the capabilities of such an outfit may be tremendously increased by the use of screens and especially so by the use of the Duplitized film and double screens. With this last combination, for example, with 10 milliamperes, chest radiographs may be made at a distance of 28 inches, in one-half second; mastoids at a distance of 20 inches, in two and one-half seconds; and frontal sinuses at a distance of $18\frac{1}{2}$ inches in nine seconds.

With double screens having a speed factor of say 6, a 10-milliamperere tube is made to do work which, for the same speed, would require without screens a 60-milliamperere tube. The result is the vastly improved definition which goes with the 10-milliamperere focal spot, which is less than half as large as that required for the 60-milliamperere tube. Furthermore, the radiograph made with the double screens will, if the same voltage is employed in both cases, show markedly greater contrast.

In closing, the author wishes to acknowledge his indebtedness to the many members of the laboratory staff and to the many factory engineers who have contributed to the development work described in the paper.

It is also a pleasure to thank Mr. C. N. Moore for his helpful efforts in testing the outfit in the laboratory, in the home of the patient and in the hospital.

He also wishes to express his appreciation of the many courtesies received from Dr. Charles G. McMullen, whose sympathetic co-operation has been of the greatest assistance.

Research Laboratory, General Electric Company, Schenectady, N. Y.

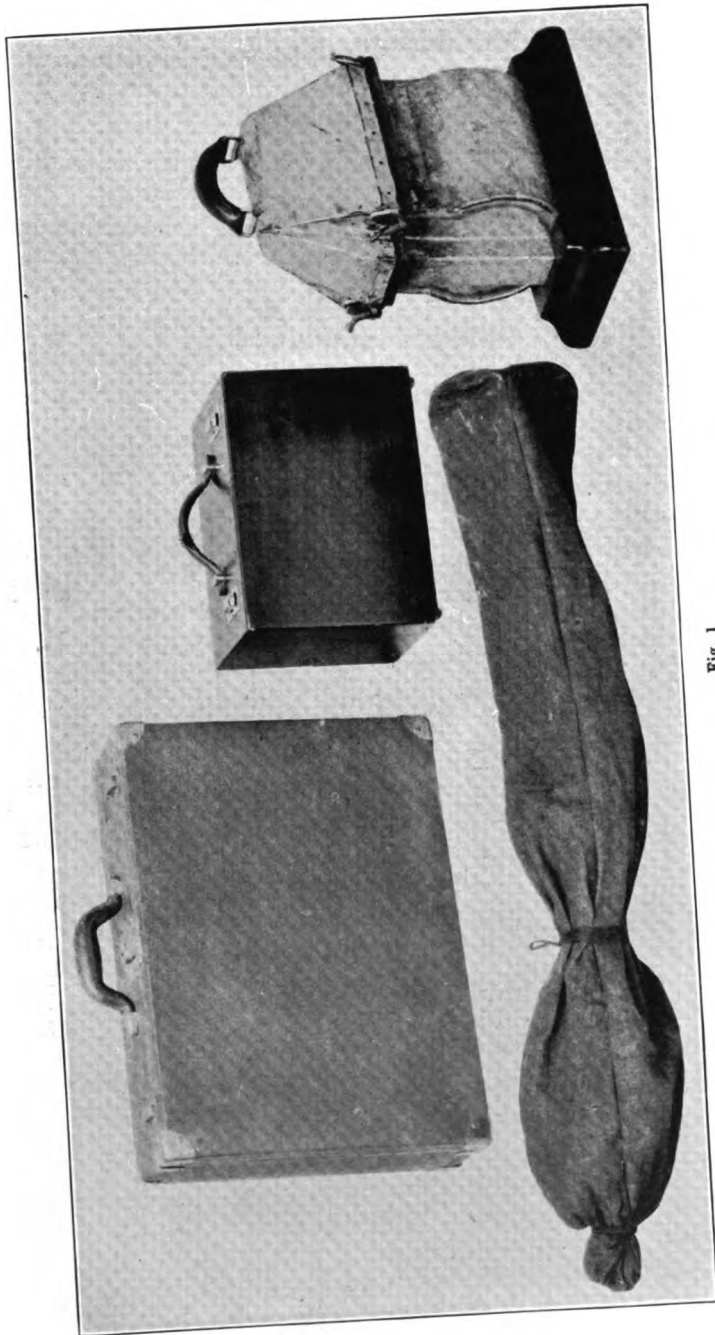

FIG. 1

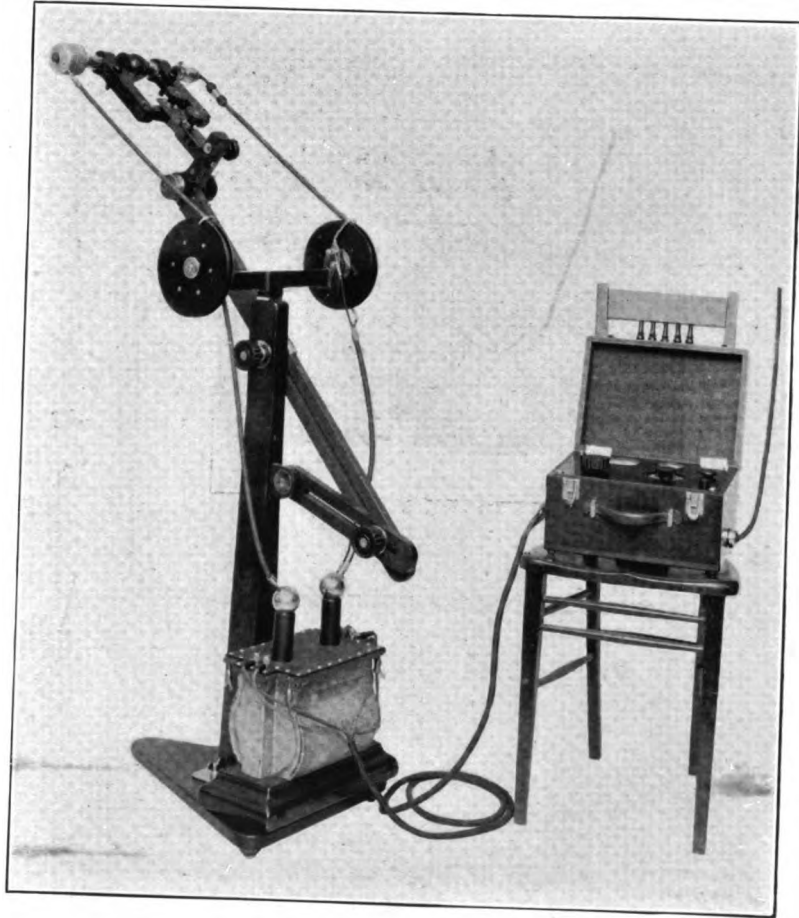

Fig. 2



Fig. 3

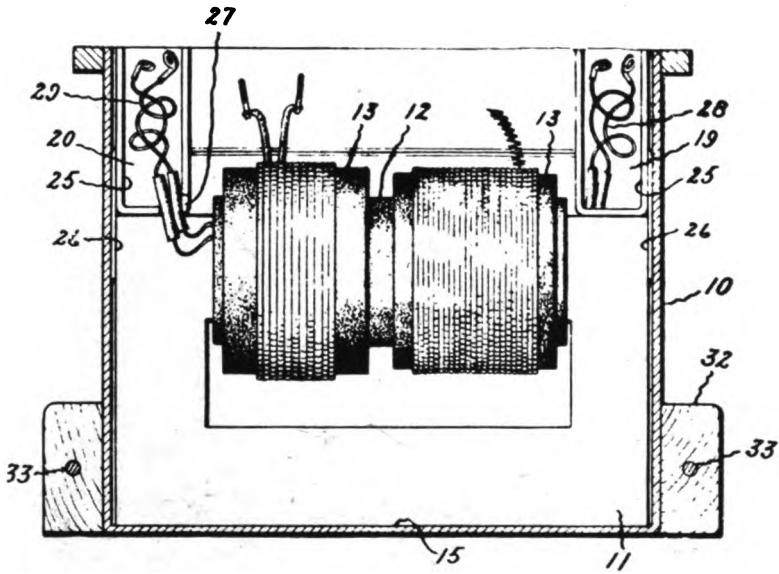

Fig. 4

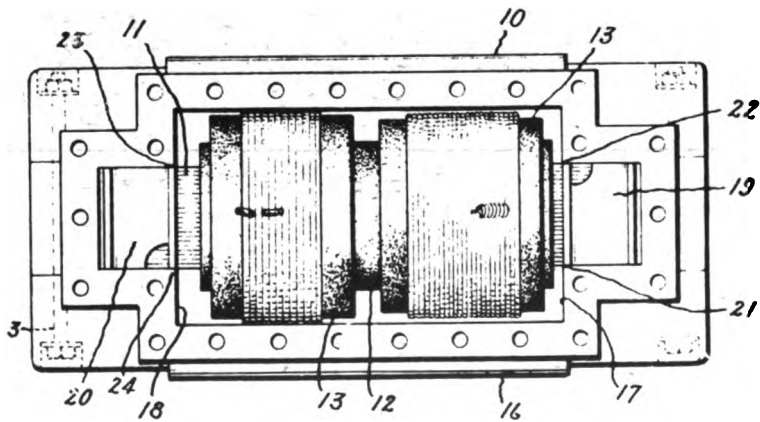

Fig. 5

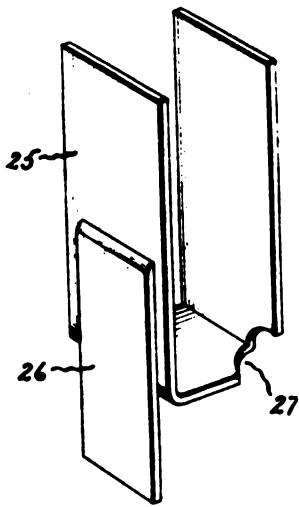

Fig. 6

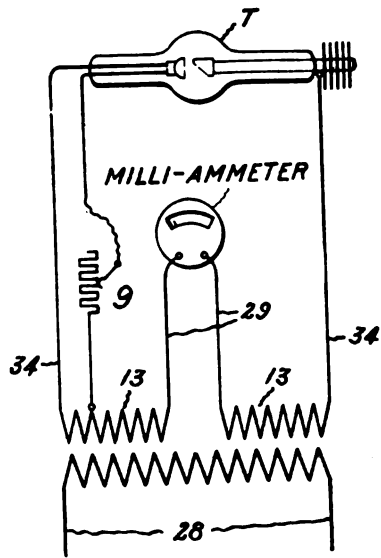

Fig. 7

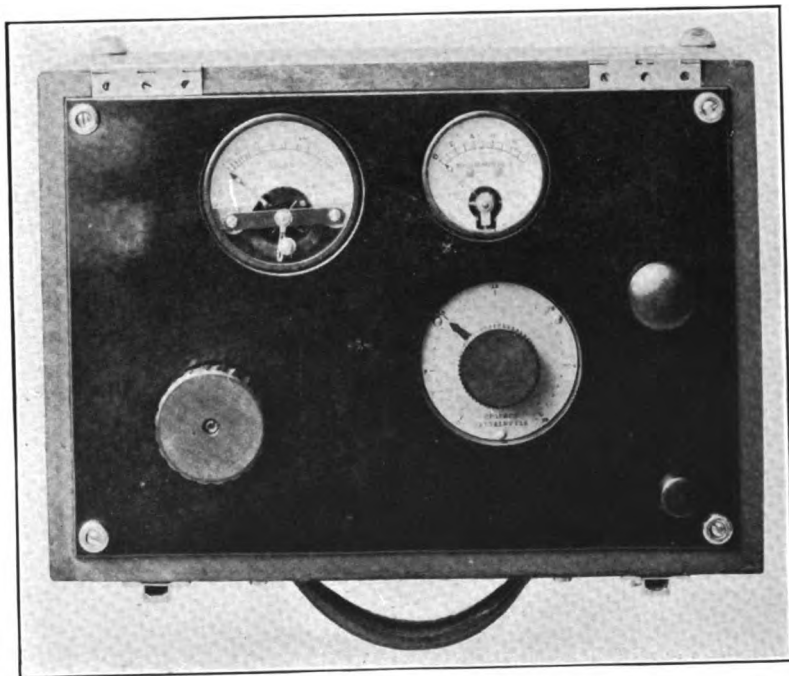

Fig. 8

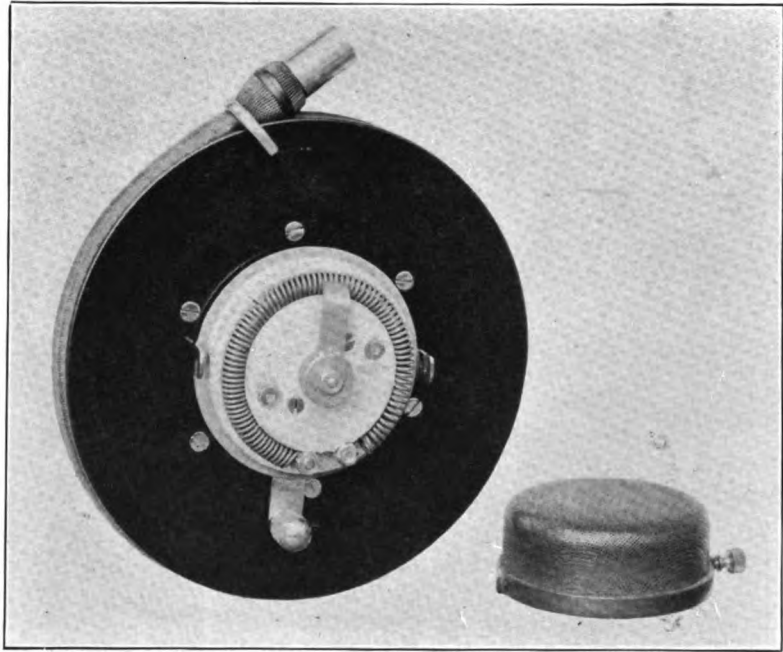

Fig. 9

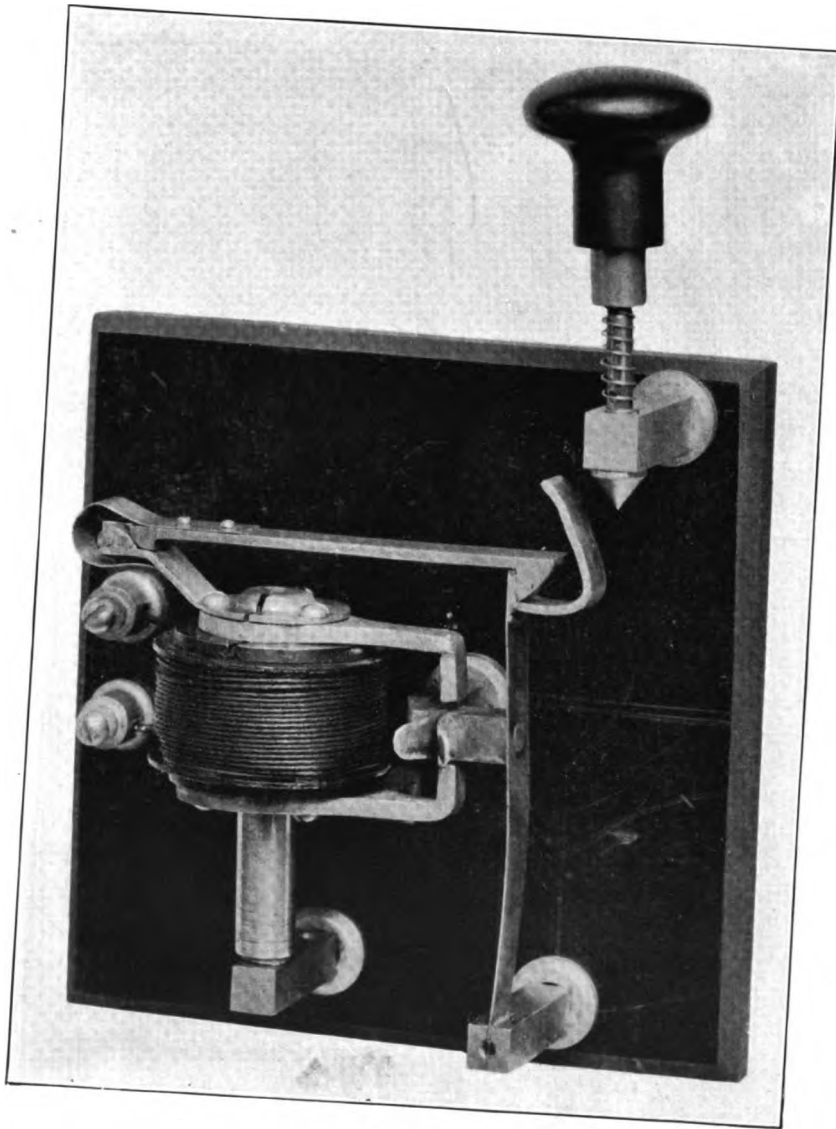

Fig. 10

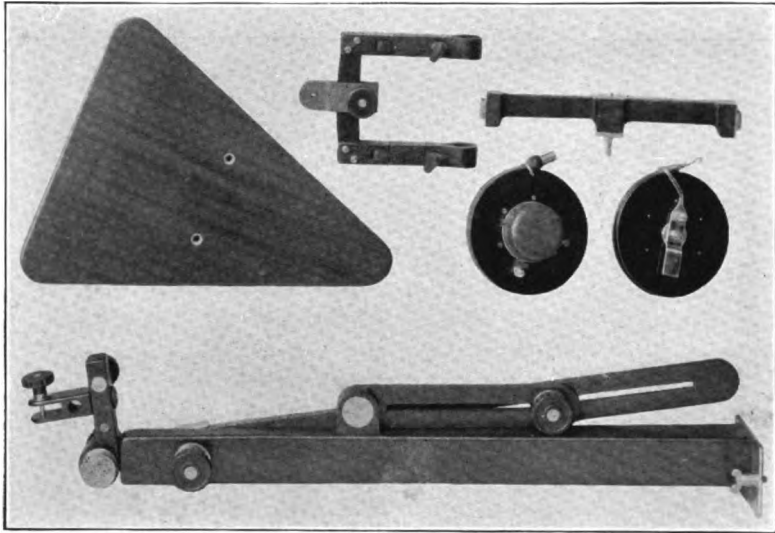

Fig. 11

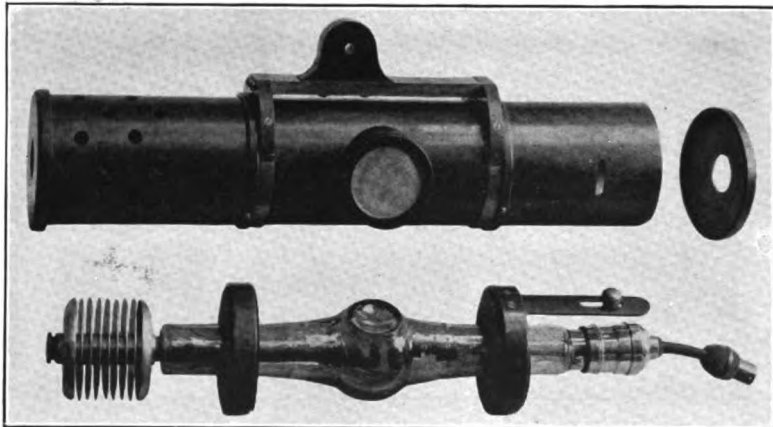

Fig 12

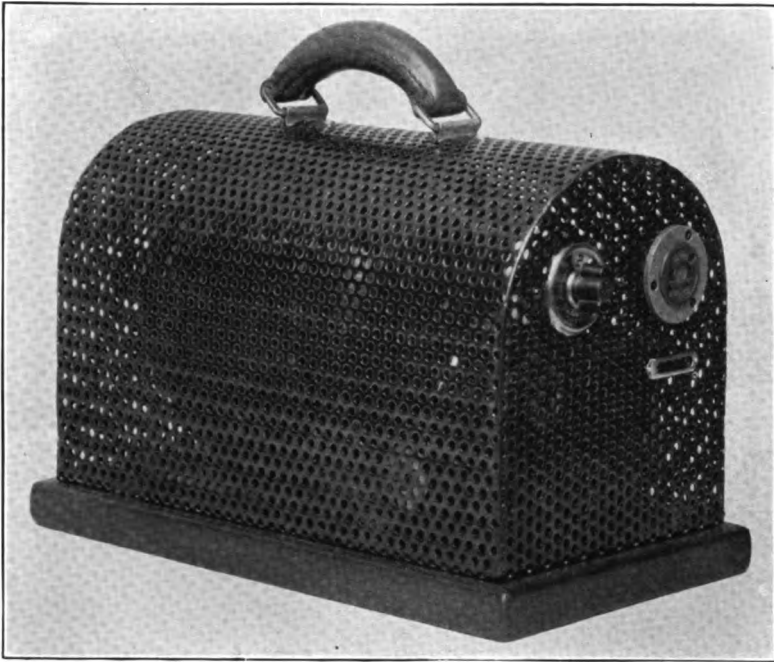
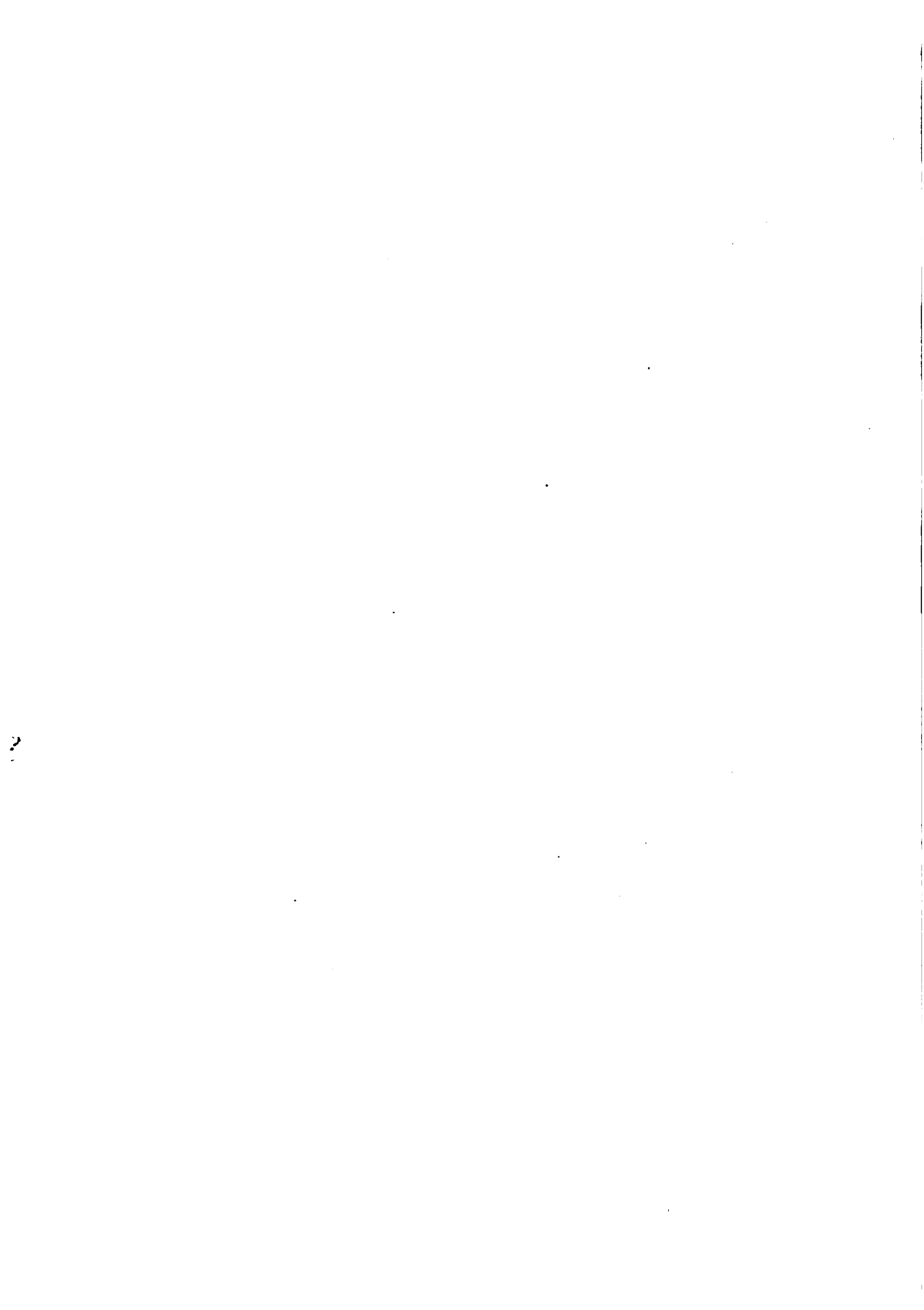

Fig. 13



ROENTGEN-RAY SPECTRA*

BY ALBERT W. HULL

The following is a preliminary report of measurements of roentgen ray spectra. It is presented as a first contribution to exact roentgenology and an example of what can be done in the way of accurate measurement of the quality and intensity of roentgen rays produced by a standard tube

Our ability to make these exact measurements of roentgen ray quality is due to five great discoveries of the last three years.

The first, by Professor Laue and his colleagues, is the proof that roentgen rays are the same in nature as ordinary light; that is, electric waves of definite wave-length. In light, the quality,—that is, color, absorbability, actinic and chemical effect—depends only upon wave-length, and recent experiments have shown the same to be true of roentgen rays. This gives us a standard of quality—the wave-length.

The second great discovery is a tube that behaves the same yesterday, to-day and forever, and every tube exactly like every other one—by Dr. Coolidge.

Third, the discovery of a source of constant high voltage of unlimited power, by means of the kenotron—by Dr. Langmuir and his associates. These last two, the standard tube and standard power to run it, give us something definite to measure.

Fourth, a roentgen ray spectrometer which enables us to break up a beam of

Regarding the first and last of these discoveries, namely, the proof that roentgen rays are identical with light except in wave-lengths, and that a large ionization chamber can measure intensity, I need only say that the evidence is so good that it is accepted by all roentgen ray physicists.

The reproducibility of the hot cathode tube can be verified directly by any roentgenologist, but it is worth mentioning that any lack of reproducibility is a theoretical impossibility in a well exhausted hot cathode tube. At the same voltage and current it *must* give the same rays, both in quality and quantity, at all times.

The other two “implements,” the high voltage apparatus and the spectrometer, will be described in detail.

roentgen rays into its constituent wave-lengths, in the same way as a beam of light is broken up into its constituent colors by a prism—by Professor Bragg and his son.

Fifth, the proof by Professor Barkla, of London, and his associates, that a reliable measure of the intensity of a beam of roentgen rays is the ionization it produces in a chamber large enough to completely absorb it.

These last two, the spectrometer and ionization chamber, give us the means of resolving the roentgen ray beam into its constituent wave-lengths and measuring the intensity of each wave-length.

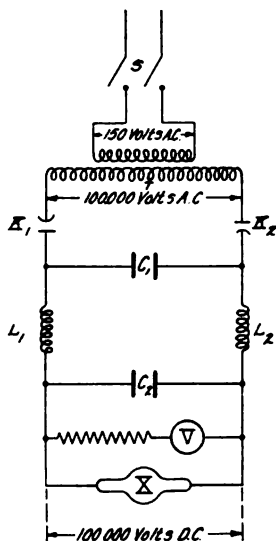

Fig. 1

* Copyright, 1915, by American Journal of Roentgenology.

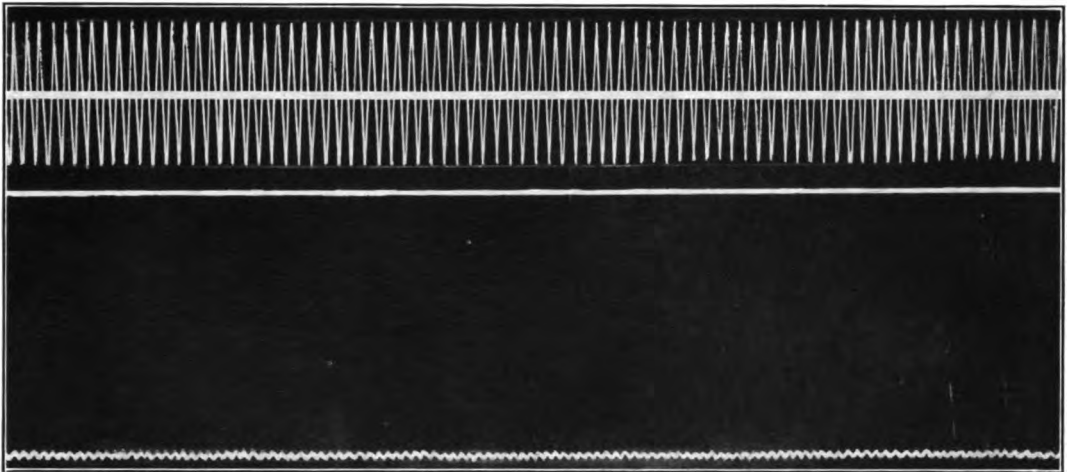

Fig. 2. 92,000 Volts, 55 Milliamperes. Lower Curve Primary A. C. Wave, Upper Curve D. C. Voltage

THE HIGH VOLTAGE APPARATUS

The arrangement of apparatus for obtaining high constant voltage with large power is shown in Fig. 1.

Alternating current of 2,000 cycles and 150 volts flows through the operating switch *S* to transformer *T*, which boosts the voltage to 100,000 volts. This 100,000 volt current flows through the kenotrons *K*₁ and *K*₂, which rectify it, through the choking coils *L*₁ and *L*₂, to the roentgen ray tube *X*. The small condensers *C*₁ and *C*₂ (capacity $\frac{1}{1000}$ microfarad each), together with the choking coils *L*₁ and *L*₂ (inductance about 200 henries each) smooth out the voltage oscillations that remain after rectifying, so that the voltage at the terminals of the roentgen ray tube is constant within less than 1% (for 5 kw. or less) and this constant voltage is measured by an ordinary voltmeter *V* of very high resistance.

The constancy of the voltage is shown in the oscillograms* of Figs. 2 and 3, which were taken with a water resistance in parallel with the tube. The lower curve in each is the 2,000 cycle primary voltage, the upper curve the voltage at the terminals of

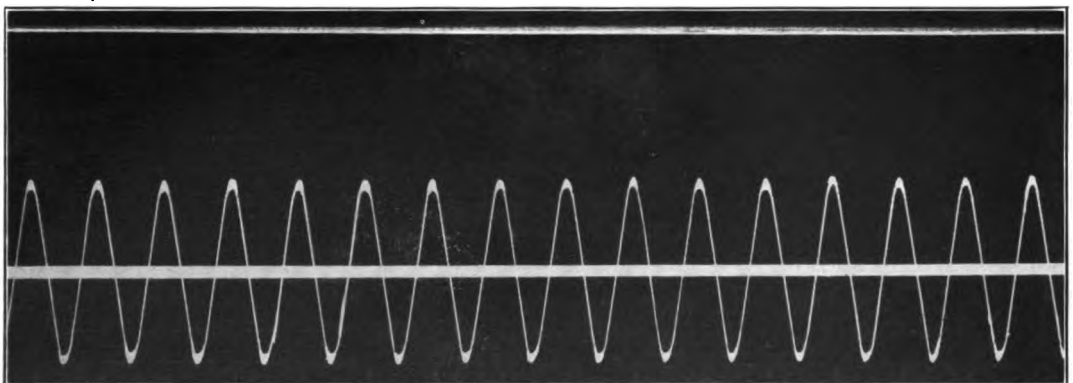

Fig. 3. 50,000 Volts, 65 Milliamperes. Lower Curve Primary A. C. Wave, Upper Curve D. C. Voltage

* It was found necessary to retouch these oscillograms in order to get plates for publication.

the tube. In Fig. 2 the voltage is 92,000 and the current 55 milliamperes, making a load of 5 kw. Under these conditions it can be seen that the voltage fluctuates about 1%. The fluctuations are much smaller for lighter loads, and can be still further reduced at voltages below 50,000 by connecting the two kenotrons in parallel and using the middle point of the transformer. Fig. 3 shows the result. Here the voltage is 50,000 and the current 65 milliamperes, making 3.2 kw. The base line for the constant voltage has been made coincident with that of the primary 2,000 cycle wave. The fluctuations probably do not show in the reproduction. They are about 1/10 of 1%.

These tests prove that we have a source of voltage sufficiently constant for our purpose. In fact, it is as constant as that of any low voltage direct current generator, and is read with the same precision on the same kind of voltmeter.

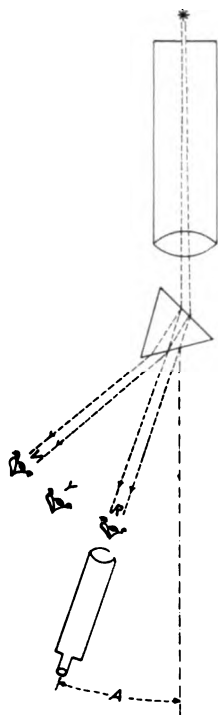

Fig. 4 (a)

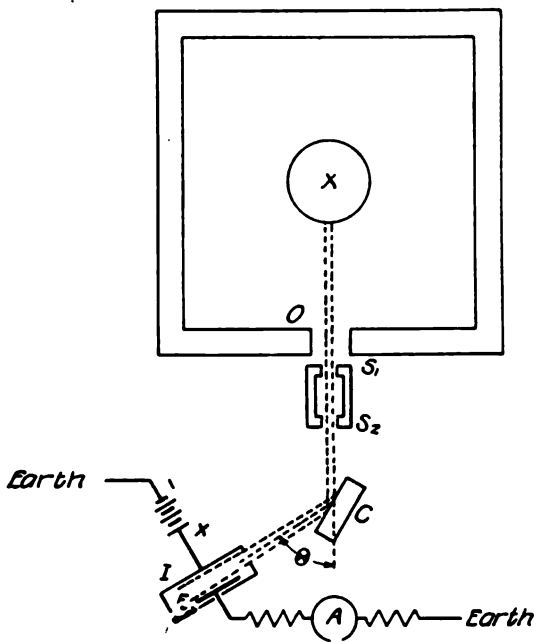

Fig. 4 (b)

THE ROENTGEN RAY SPECTROMETER

The principle of the spectrometer can best be understood by comparison with the ordinary light spectrometer. If one wishes to analyze a beam of visible light into its constituent colors one lets it fall on a prism, as in Fig. 4 (a). By placing the eye at *R*, *Y* or *V* one will then see red, yellow, or green, respectively, provided these colors are present in the beam, and one can estimate by the eye the relative intensity of the different colors. Thus, if the beam of light came from an incandescent carbon filament the yellow would be most intense; if from a mercury arc the green would predominate.

For accurate work, such as is done in our lamp factories, the eye is not a sufficiently reliable judge either of color or intensity. It is therefore replaced by a telescope. The color of each constituent of the light is recorded in terms of its wave-length, which can be calculated from the angle *A* of the telescope, and the intensity is measured by a photometer.

A record is thus obtained of the intensity of each wave-length (that is, each color, wave-length being a more precise definition of color) in the beam of light. The results are generally shown graphically, by plotting the wave-lengths as abscissas (horizontal) and the intensities as ordinates (vertically). Fig. 5 shows the spectrum, as it is called, of a tungsten Mazda lamp measured and plotted in this way. The shaded portion is the visible part, that to the right being the so-called infra red; that is, wave lengths too long to affect the eye.

The roentgen ray spectrometer operates on exactly the same principle. Since the wave-lengths are much shorter than those of visible light, the glass prism has to be replaced by a crystal of rock salt or iceland spar, and the photometer by something that is sensitive to short wave-lengths, such as a photographic plate or an ionization chamber. We use the later because it is the more accurate.

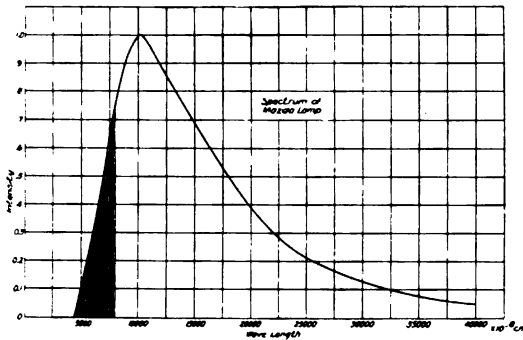

Fig. 5

The spectrometer is shown in Fig. 4 (b). The roentgen ray tube is completely enclosed in a lead box $\frac{1}{2}$ inch thick. The rays emerge from the box through the small hole *O*, pass through narrow slits *S*, and *S*₂, and fall on the crystal *C*.

This crystal reflects each wave-length in a different direction. The reflected rays enter the ionization chamber *I*, where they make the gas electrically conducting and cause a current to flow from the outside of the chamber, which is highly charged, to the central electrode *E*, and thence through the sensitive ammeter *A* to earth. This current is proportional to the intensity of the rays entering the chamber. The angle θ at which the chamber is set tells which wave-length is entering the chamber. Thus, by moving the chamber around gradually from small to large angles, and recording the current for each angle, we have a record of the intensity of each wave-length in the spectrum which we are examining.

The Roentgen Ray Spectra.—Fig. 6 shows the spectrum thus obtained of a tungsten target at 40,000 volts and 1 milliamper, plotted in the same way as that of the hot tungsten filament, Fig. 5. The scale of wave-length, which is laid off horizontally, is measured in the same units as for the visible spectrum, the so-called Ångström unit, which is a hundred-millionth of a centimeter.

Thus the wave-lengths given by a roentgen ray tube can be compared directly with those of an incandescent lamp. The intensity of each wave-length is equal to the vertical distance from the corresponding point on the horizontal axis up to the curve. For example, the intensity of the rays of length .3 is zero; that is, no rays of this length are produced by the tube at 40,000 volts. The rays of length .35 have an intensity 55, those of length .42 have the greatest intensity of all, namely, 97. The units in which intensity is measured are chosen arbitrarily, since only *relative* intensity is desired here. They will later be referred to some standard.

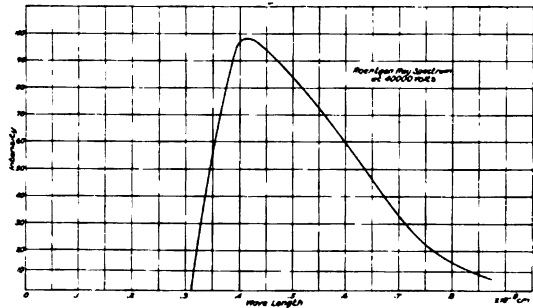

Fig. 6

Fig. 7 shows the spectra obtained at five different voltages, from 20,000 to 40,000. Two things are very striking. As voltage increases, the average wave-length decreases very rapidly, which means increased penetrating power a fact already well known. And at the higher voltages the intensity is greater for *all wave lengths*.

Thus an increase of voltage increases not only the penetrating radiation but the soft radiation also, and it is only by the use of some selective filter, such as aluminium, which absorbs the long wave-lengths more than the short ones, that one can hope to obtain penetrating radiation without soft radiation. Even so, the amount of aluminium necessary is very large, much larger than has commonly been supposed. Fig. 8 shows

the spectrum at 70,000 volts, first without any filter (curve 1) and then with 3 mm. of aluminium (curve 2). It can be seen that the aluminium has reduced the intensity of the soft radiation (long wave-lengths) much more than that of the penetrating, but there is still an enormous amount of soft radiation left. This could, of course, be much further reduced by the use of still more aluminium, but not without cutting down the intensity of the useful penetrating rays

to a small fraction of its original value. With the new powerful water-cooled tube described elsewhere in this issue it will be possible to use this method and still have left sufficient intensity for practical work. This will open up a new field in deep therapy and roentgenography. In addition, it is hoped by the use of particular target materials which give a very powerful characteristic radiation for some particular wave-length,

to obtain still purer "monochromatic" rays of high penetration. Experiments in this line will be reported in the near future.

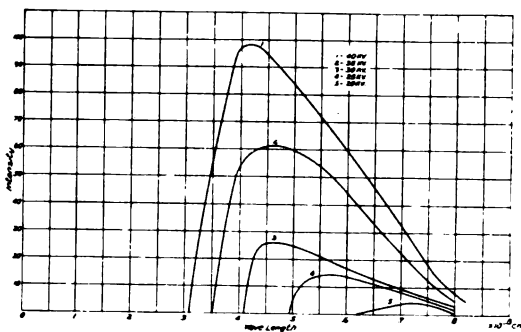

Fig. 7

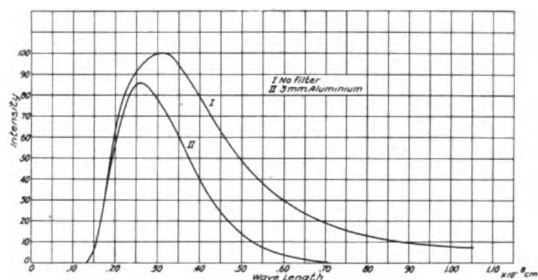

Fig. 8

COMPARISON OF ALTERNATING AND DIRECT VOLTAGE SPECTRA

The work described above was all done with constant potential. It is important to know whether the same results can be obtained with an alternating potential (rectified, either by

the tube itself or by some reliable rectifier), and whether the spectra obtained by the two methods (constant and fluctuating potential respectively) are sufficiently alike so that work done with one can be compared with work done with the other. In answering "Yes" to this question, I want to be very careful to be clearly understood. There are a great many kinds of alternating potential, which are very different from each other. Fig. 9 shows two typical voltage curves. Curve 1 is the voltage given by an induction coil with mercury interrupter; Curve 2 that of a standard 25-kw. transformer.

It is probable that the spectra given by these two machines at the same maximum voltage and same current would not be the same, or even approximately so. I think, though as yet I have tried it only for the sine wave and constant potential, that I

could find a *voltage* and a *current* for the one, at which it would give a spectrum nearly the same as that given by the other at a *different (definite) voltage and current*. For example, the one machine might require 70,000 maximum volts and 2 milliamperes to give the same spectrum as the other machine at 60,000 volts and 1 milliampere. Knowing this conversion factor, it would be possible to reproduce with machine (2) work done on machine (1).

But I wish to emphasize that the conversion factor is likely to be *big*, for machines differing greatly in wave form, and can by no means be neglected. In order to use the conversion factor it is of course necessary to be able to measure the true maximum voltage, a question fully discussed by Dr. Coolidge elsewhere in this issue.

The simplest form of alternating potential, and at the same time the most reproducible and most easily measured, is the simple sine wave (curve 2, Fig. 9). This is the

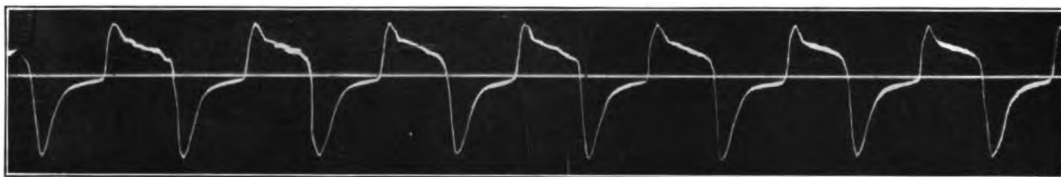

Curve 1. Oscillogram of Induction Coil Voltage

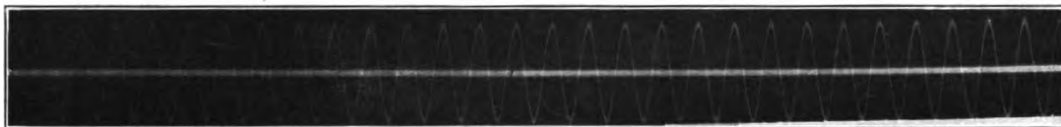

Fig. 9

Curve 2. Voltage Wave of Standard Transformer

kind of voltage wave that is always obtained from a good transformer when not overloaded. If, in addition, we use as rectifier a kenotron, which simply suppresses the lower half of the wave without changing the upper (useful) half, or, in case of the hot cathode tube, we make the tube act as its own rectifier, then we have a fluctuating potential of definite form for which the "conversion factor" can be obtained. This has been done for the voltage of 70,000, and Fig. 10 shows the results. The voltage factor is unity; that is, the maximum A. C. voltage is the same as the D. C. voltage.* The current factor is $\frac{2}{3}$; that is, 3 milliamperes A. C. at 70,000 volts maximum are required to give the same spectrum as 2 milliamperes D. C. at 70,000 volts. Further data regarding the factor of conversion from sine wave to constant potential will be published soon, in connection with the constant potential spectra.

In conclusion, I wish to emphasize the fact that it is the *wave-length* of the rays used, and not voltage or spark gap, that determines penetration, therapeutic action, and all other effects. In order to duplicate work it is necessary to use a beam containing *the same wave-lengths in the same relative intensity*, that is, the same *spectrum*. With constant potential, or fluctuating potential of definite wave-form, it is probable that the unfiltered spectrum depends only upon voltage. If this proves to be so, the only measurements which an operator will have to make under these conditions are voltage, thickness

* The exact equality of the voltages cannot be affirmed without further experiment, as the transformer used was not fitted with a special voltage coil. The difference, if any, is certainly very small.

of filter, and milliampere-minutes. This question is being carefully investigated, and will be reported on in the near future. The one thing that can be stated with absolute certainty at present, and which is of fundamental importance, is *that if one works always with rays having the same spectrum, the only variable is milliampere-minutes.*

It will probably never be possible to compare completely by any simple numerical ratio the effects of roentgen ray beams that have different spectra. For they differ not in magnitude but in kind. It is, therefore, desirable to devise means for obtaining always the same spectrum, or one of two or three standard spectra, and doing all work under one of these standard conditions. It is to be hoped that the recently appointed committee on standardization will take up at an early date the problem of standardizing roentgen technique, so that all work done by members of this Society will be done with one of two, or at most three, spectra—*spectra*, not voltages.

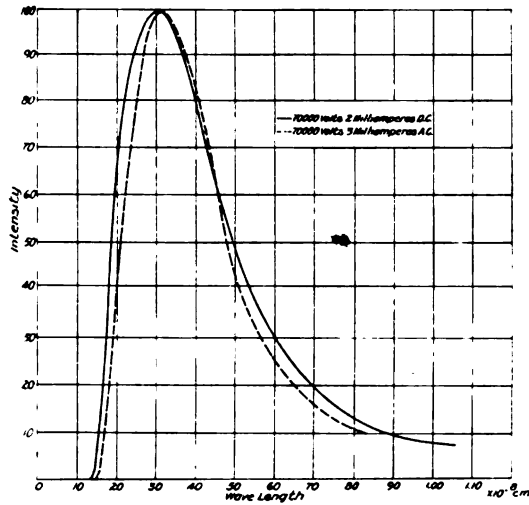

Fig. 10

THE HIGH FREQUENCY SPECTRUM OF TUNGSTEN*

BY ALBERT W. HULL AND MARION RICE

Moseley¹ has shown that the high frequency spectrum given out by the target of an X-ray tube consists of two series of lines superimposed upon a continuous spectrum. The lines, which are known as the *K* and *L* series, respectively, are characteristic of the material of the target. Moseley measured the wave lengths of most of the *K* lines for elements having atomic weights between aluminum and silver, and of the *L* lines for elements from calcium to gold, and showed that for all the lines measured the square roots of the frequencies of corresponding lines are proportional to the atomic numbers of the elements emitting them. Malmer² has added to this list the *K* lines of six more elements between silver and lanthanum, and W. H. Bragg³ and others have studied in great detail the lines of a few of these elements, especially rhodium and platinum.

The continuous or band spectrum was observed qualitatively by Moseley (l.c.), and its short wave-length limit at different voltages measured by Duane and Hunt⁴ who found this limiting frequency, ν_{\max} , to be exactly proportional to the voltage on the tube, and given accurately by the quantum relation $h\nu_{\max} = eV$, where V is the voltage on the tube, e the charge of an electron, and h Planck's constant.

The spectrum of tungsten is of special interest on account of its use as target material in X-ray tubes, and it has been the subject of several recent investigations. Barnes⁵ measured the *L* lines, but was unable to find any *K* lines, although his voltage, 96,000, was sufficiently high for their excitation. Gorton⁶ also measured the *L* lines. Rutherford, Barnes and Richardson,⁷ using the coefficient of absorption method, measured the effective wave-length of the "end radiation," i.e., the short wave-length limit of the continuous spectrum, for different voltages up to 180,000, and found that this minimum wave-length did not decrease continuously with increase of voltage, but approached asymptotically a limiting value of 0.172 Ångström units. As will be shown below, the wave-lengths found by the spectrometer are much shorter, and do not appear to approach any limiting value.

The spectrum shown in Fig. 1 was taken in the usual manner with a rock salt crystal in continuous slow rotation, photographic plate stationary at 19.13 cm. distance from the crystal, collimating slits 0.2 mm. wide and 20 cm. apart, with a Coolidge tube running at 1 millipmere and 100,000 volts constant potential. The horizontal band

L	Designation of line, $D =$ Distance from C in cm., $\lambda =$ Wave-length in Angström										
	λ_0	β_1	α_1	β_2	α_2		Ag_1	β_3	α_3		Br
D	0.964	1.332	1.496	2.614	2.932	2.994	3.332	3.948	4.386	4.494	6.524
λ	0.142	0.196	0.219	0.192	0.215	0.220	0.488	0.192	0.212	0.217	0.463
L	Ag_2	k	h		g	d	c	b	b'	a	a'
D	6.886	7.368	7.604	7.662	7.884	9.074	9.224	9.382	9.558	11.10	11.19
λ	0.487	1.033	1.065	1.073	1.100	1.242	1.260	1.280	1.300	1.468	1.480

gives the reflection from the cubic (100) planes of the crystal, those at 45 deg. from the dodecahedral (110) planes, and those between from the tetrahedral (210) planes, etc.

* Copyright, 1916, by National Academy of Sciences.

¹ Moseley, *Phil. Mag.*, 26, 210 and 1024 (1913); 27, 710 (1914).

² I. Malmer, *Phil. Mag.*, 28, 787 (1914).

³ W. H. Bragg, *Phil. Mag.*, 29, 407 (1915).

⁴ Duane & Hunt, *Physic. Rev.*, 6, 166 (1915).

⁵ Barnes, *Phil. Mag.*, 30, 368 (1915).

⁶ Gorton, *Physic Rev.*, 7, 203 (1916).

⁷ Rutherford, Barnes and Richardson, *Phil. Mag.*, 30, 339 (1915).

The wave-lengths of the lines and bands in the horizontal strip are given in the accompanying table. C , in the photograph, is the undeviated central beam, diminished in intensity by passage through a lead strip 2 mm. thick and 5 mm. wide, placed in front of the plate. The shadow of this strip extends only one fourth of the distance from C to λ_0 and is not visible on the plate.

The short wave-length limit of the spectrum, marked λ_0 , is the shortest wave-length that is produced by electrons of velocity corresponding to the operating voltage (100,000) and its value, 0.142 Ångström units, agrees very closely with the value given by Duane and Hunt's formula $eV = h\nu_{\max} = hc/\lambda_{\min}$. I have already shown¹ that the

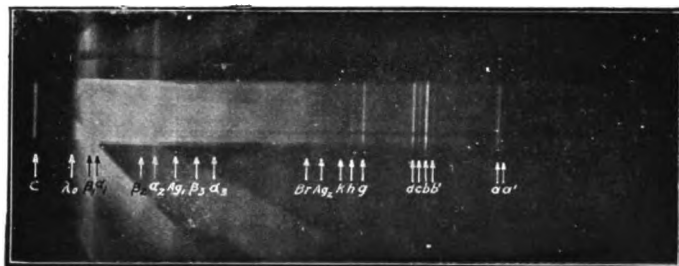

Fig. 1

proportionality between frequency and voltage holds accurately up to 100,000 volts, and these measurements have since been extended, with less accuracy, up to 150,000 volts. The shortest wave-length so far observed is 8×10^{-10} cm., or 0.08 Å.U.

The lines marked $\alpha_1\beta_1$, $\alpha_2\beta_2$, and $\alpha_3\beta_3$ are the first, second, and third order reflections respectively of the K_α and K_β lines of tungsten, the α line being a doublet. They are more clearly shown in Fig. 2, which was taken with narrower slits and greater distance of photographic plate from crystal, so that the doublet is clearly resolved. In

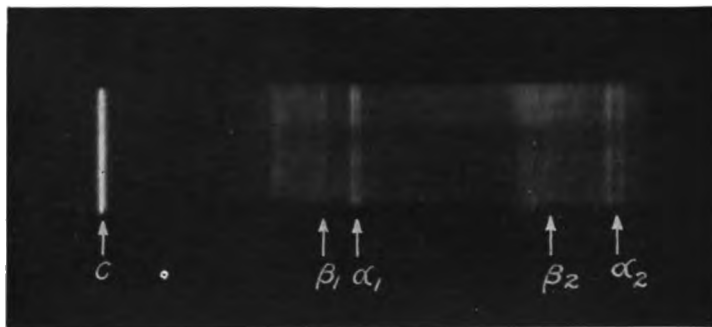

Fig. 2

this photograph the second order was given an extra exposure, which accounts for the apparent band in the middle. In the photograph of Fig. 1, all parts were given the same exposure. The wave-lengths of the lines are about 6% less than would be required by Moseley's formula. Slight deviations from the formula have already been noted for the K lines measured by Moseley and Malmer. All these lines, including tungsten, can, however, be correctly represented by the empirical formulae

$$\nu_\alpha = 1.64 \times 10^{15} N^{2.10} \text{ for the } \alpha \text{ lines,}$$

and

$$\nu_\beta = 1.56 \times 10^{15} N^{2.15} \text{ for the } \beta \text{ lines,}$$

¹ Hull, *Physic. Rev.*, 7, 156 (1916).

where ν is the frequency and N the atomic number. These formulae, while they have no theoretical significance, may be useful for interpolation.

The bands which terminate on the long wave-length side at Ag_1 and Ag_2 are due to the silver in the photographic plate and are produced by the reflection, in the first and second order respectively, of those wave-lengths which are capable of stimulating the characteristic radiation of silver, that is, those which are shorter than the gamma line of silver. The edge of the band therefore marks the position of the γ line of silver,

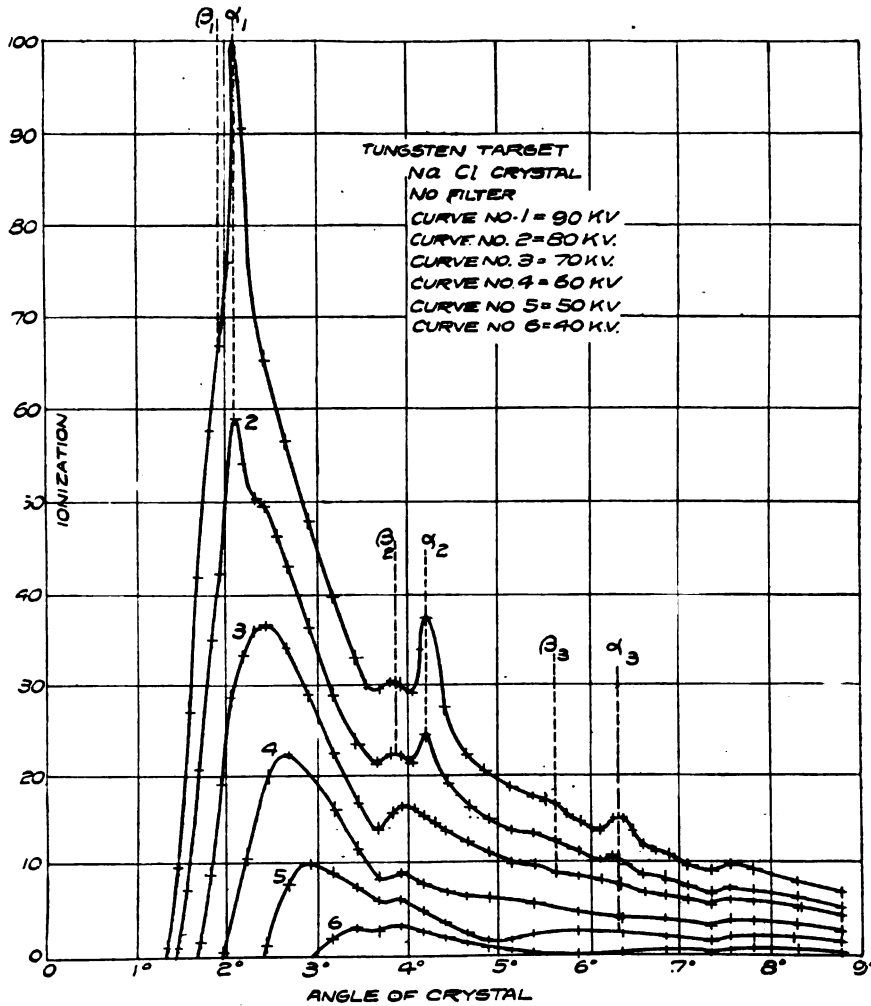

Fig. 3

0.488 Å.U. In the same way the band terminated at Br is due to the bromine in the photographic plate, and marks the position of the γ line of bromine.

The remaining nine lines, $a \dots \dots k$, belong to the L spectrum of tungsten, and agree with those found by Barnes,¹ with the inclusion of two faint lines not observed by Barnes. The line marked h appears to be a doublet. Gorton's² values are all about 2% smaller.

¹ Barnes, *Phil. Mag.*, 30, 368 (1915).
Gorton, *Physic Rev.*, 7, 203 (1916).

The position of the K lines, and their relation to the general radiation at different voltages, has been studied by means of the ionization chamber also. Fig. 3 shows the ionization current as a function of the angle of incidence of the rays on the crystal, for five different voltages, and Fig. 4 a part of the same in the second order. The position of the K lines, in the first, second and third order respectively, is shown by the dotted lines marked $\alpha_1, \beta_1, \alpha_2, \beta_2$, etc. There is no trace of the lines at 70,000 volts, but at 80,000 they are clearly visible, and increase in intensity as the voltage increases. It is

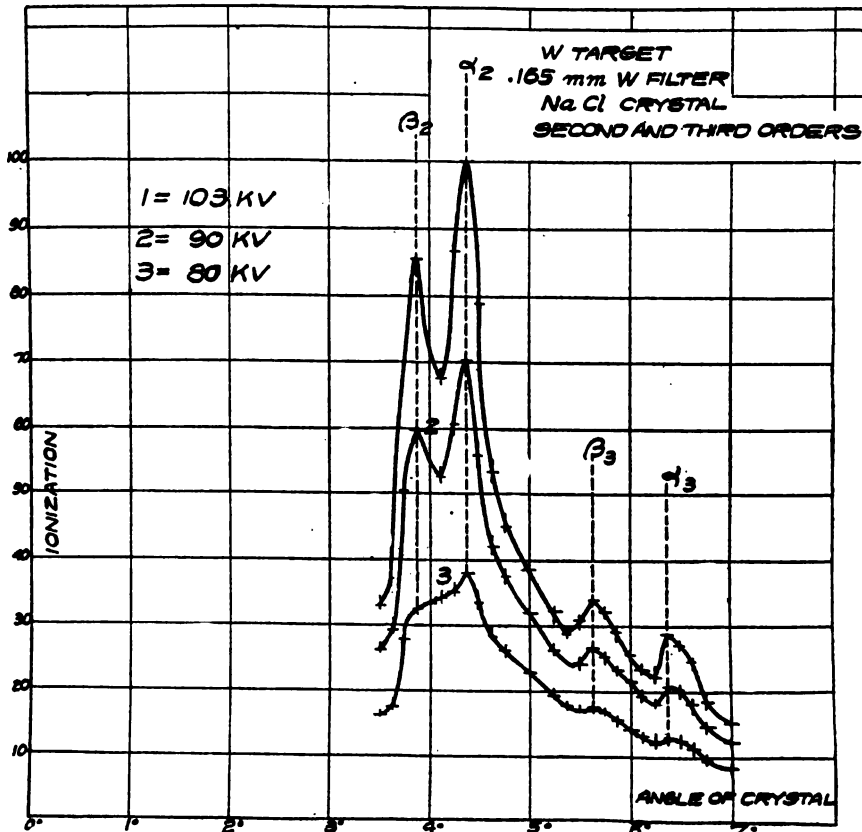

Fig. 4

probable that the lowest voltage at which the lines appear is the "quantum" voltage¹ i.e., that given by Duane and Hunt's equation, for the γ line, about 70,000 volts for tungsten. This would be in harmony with the mechanism of radiation suggested by Kossel¹ and has already been found by Webster² to hold for rhodium. It may be mentioned that the quantum relations established by Kossel between the frequencies of the K and L lines hold true for the tungsten lines.

A more detailed account of these and other experiments on the tungsten spectrum, including the distribution of energy in the continuous spectrum, will be published shortly in the *Physical Review*.

¹ Kossel, *Ber. D. Physik. Ges.* 16, 953 (1914).

² Webster, these Proceedings, 2, 80 (1916).

THE MAXIMUM FREQUENCY OF X-RAYS AT CONSTANT VOLTAGES BETWEEN 30,000 AND 100,000.^{1*}

BY ALBERT W. HULL

RESEARCH LABORATORY, GENERAL ELECTRIC COMPANY, SCHENECTADY, N. Y.

In the *Philosophical Magazine* for September, 1915, Professor Rutherford has reported experiments in which the maximum frequency of X-rays at different voltages was calculated from the absorption coefficients of the total radiation after a sufficient part of it has been absorbed to make the absorption coefficient nearly constant. He found that the maximum frequencies determined in this way did not increase linearly with the voltage, but less rapidly, and reached a maximum at 140,000 volts.

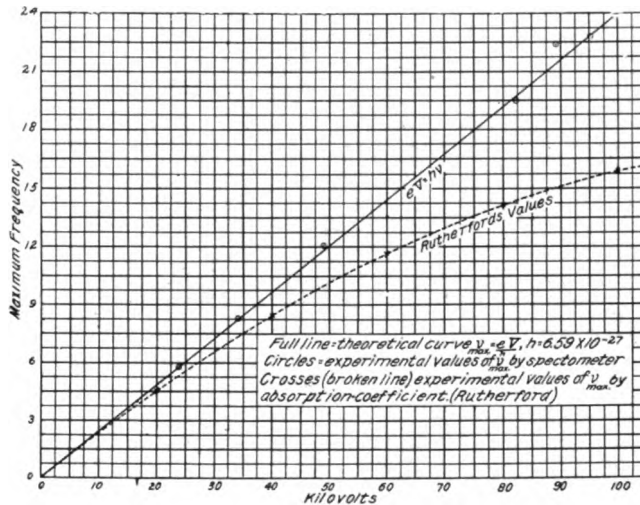

Fig. 1

The measurements given below are taken from the curves of energy distribution in the X-ray spectra at constant potentials,² which the author has been investigating. They were taken with the spectrometer, with an accuracy of about three or four per cent. Within this limit of error the maximum frequencies are proportional to voltage and are given by the quantum relation³ $eV = h\nu_{\max}$, where ν_{\max} is the maximum frequency of X-rays produced at constant potential V , e is the charge of an electron, and h Planck's constant, which is taken as 6.59×10^{-27} . It is evident from the graph that there is no tendency to fall below this value at higher voltages, as Rutherford found. For convenience of comparison, Rutherford's values are reproduced on the dotted curve.

* Copyright, 1916, by American Physical Society.

¹ Abstract of a paper presented at the Chicago meeting of the Physical Society, November 26, 1915.

² To be published soon.

³ Duane (*Phys. Rev.*, 8, 166, Aug., 1915) has already shown this to be true for voltages up to 40,000.

Volts $\times 10^3$	MAXIMUM FREQUENCY $\times 10^{13}$	
	Theoretical	Experimental
24.0	5.8	5.78
34.1	8.21	8.27
48.8	11.78	12.14
82.0	19.8	19.5
89.0	21.4	22.4
95.0	22.9	22.8

The cause of the difference between Rutherford's values and the author's is due to the fact, which Duane (*l. c.*) has already pointed out, that the absorption method does not give the maximum frequency. It can be shown from the energy distribution curves that the absorption coefficient method leads to values of ν_{\max} which fall below the true values more and more as the voltage is raised. In fact, Rutherford's values can be calculated directly from the energy distribution curves and the law of absorption. This question will be more fully discussed in a future publication. The fact which it is desired to point out here is that the maximum frequency for voltages up to 100,000 is given accurately by the quantum relation, and that there is no reason to believe that it should not continue to increase with voltage indefinitely.

THE LAW OF ABSORPTION OF X-RAYS AT HIGH FREQUENCIES^{1*}

BY ALBERT W. HULL AND MARION RICE

It has been shown, from Barkla's absorption data and Moseley's table of wave-lengths, that the coefficient of absorption of all metals varies approximately as the cube of the wave-length, except in the immediate vicinity of one of the characteristic wave-lengths of the metal. The experimental data extends over a range of wave-lengths from 4 to 0.5 Å.U. approximately, but the law has frequently been extrapolated to very short wave-lengths and used as a measure of wave-length. It is important to know how far such extrapolation is justified.

The measurements given below were made on narrow portions of a beam of "white" radiation from a tungsten target, dispersed by a rock-salt crystal and isolated by a very narrow slit in the lead face of the ionization chamber. The absorbing sheets were 15 cm. from this slit, so that the amount of fluorescent and scattered radiation entering the chamber was negligible.

The energy taken from the beam by the absorbing sheets consisted, therefore, of two parts:

1. That which was transformed into energy of a different form or different wave-length, such as heat, fluorescent radiation, corpuscular radiation.
2. That which was re-emitted as radiation of the same wave-length, viz., the scattered radiation. The observed absorption coefficient μ/ρ may therefore be written

$$\frac{\mu}{\rho} = \frac{\tau}{\rho} + \frac{\sigma}{\rho},$$

where τ is what may be called the transformation coefficient and σ the coefficient of scattering.

On the simple electromagnetic theory we should expect σ to be independent of wave-length and proportional to the number of scattering electrons per unit volume, *i.e.*, to the density approx., so that σ/ρ should be a universal constant. This hypothesis is substantiated, within the limit of experimental error, by Barkla's measurements. If we assume that the other part of the absorption, the "transformation coefficient," varies as the cube of the wave-length, eq. 1 becomes $\mu/\rho = a\lambda^3 + b$, where a is constant for a given absorber between its absorption bands, and b is the same for all substances and all wave-lengths.

Taking a from Barkla's data on long wave-length radiations, and $b = 0.12$, the observed absorption coefficients for aluminum and copper should be given by

$$\left(\frac{\mu}{\rho}\right)_{\text{Al}} = 14.9\lambda^3 + 0.12,$$

$$\left(\frac{\mu}{\rho}\right)_{\text{Cu}} = 150.\lambda^3 + 0.12,$$

where λ is in Ångströms.

These equations are plotted in the figure (full lines), and agree with the experimental values within experimental error (the errors were rather large for the shortest and longest wave-lengths measured, on account of small deflections). Rutherford's value for the absorption in aluminum of the shortest γ -rays from radium B, viz., $(\mu/\rho)_{\text{Al}} = 0.19$ for $\lambda = 0.164$ Å.U., is also shown in the figure. It falls satisfactorily on the curve.

* Copyright, 1916, by American Physical Society.

¹ Abstract of a paper presented at the Washington meeting of the Physical Society, April 20-21, 1916.

For lead, the region investigated includes one of the characteristic absorption bands of lead. Photographs of the spectrum through a lead sheet showed that this band, which is due to the excitation of the *K* fluorescent radiation of lead, begins at $\lambda = 0.149$ Å.U. For wave-lengths longer than this, the absorption obeys the equation $(\mu/\rho)_{Pb} = 430\lambda^3 + 0.12$ (full curve). The value of $a = 430$ is subject to some error on account of the difficulty of measuring the thickness of the lead sheet. For wave-lengths shorter than 0.149 the data is not sufficient to determine the law, but it is evident that extrapolation of the above equation is not justified.

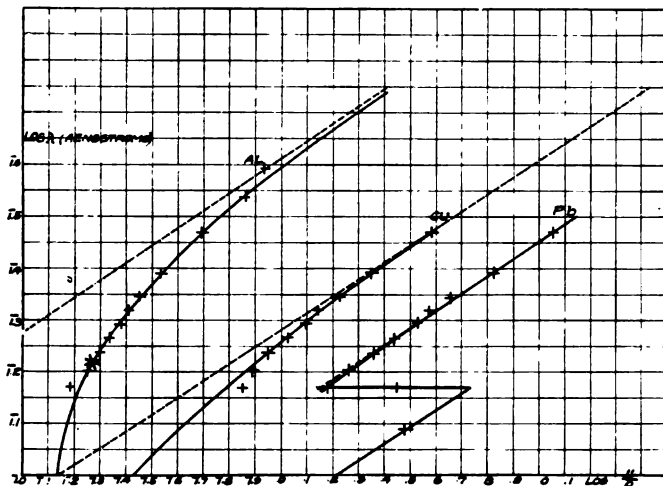

Mass Absorption Coefficient (μ/ρ) for Al, Cu, and Pb, between $\lambda = 0.12$ and $\lambda = 0.39$ Ångstroms. Full lines = theoretical curves for complete absorption coefficient. Broken " " = theoretical curves for "corrected absorption" or "transformation" coefficient. * = Rutherford's value for γ rays.

Fig. 1

If, instead of dealing with the coefficient of total absorption, as above, we calculate the "corrected absorption coefficient" or "transformation coefficient," by subtracting $\sigma/\rho = 0.12$ from the observed value of μ/ρ , we have for all substances and all wave-lengths thus far investigated the very simple law

$$\frac{T}{\rho} = a\lambda^3,$$

where a is a constant for each substance over the entire range between its absorption bands. This law is shown graphically for aluminum and copper (broken lines) in the figure.

Wave-length Ångstroms	MASS ABSORPTION COEFFICIENT					
	Al.		Cu.		Pb.	
	Obs.	Calc.	Obs.	Calc.	Obs.	Calc.
0.392	0.860	1.02				
0.343	0.726	0.721				
0.294	0.493	0.499	3.84	3.94	11.1	11.04
0.245	0.342	0.339	2.24	2.33	6.7	6.44
0.221	0.283	0.281	1.70	1.74	4.63	4.76
0.208	0.255	0.254	1.39	1.47	3.70	3.99
0.196	0.243	0.232	1.27	1.25	3.40	3.36
0.184	0.218	0.213	1.07	1.06	2.71	2.80
0.172	0.199	0.196	0.91	0.88	2.32	2.31
0.160	0.178	0.181	0.79	0.74	1.82	1.88
0.147	0.154	0.167	0.71	0.60	1.50	
					2.80	
0.122					3.00	

THE X-RAY SPECTRUM OF TUNGSTEN

BY A. W. HULL

THE NATURE OF X-RAYS

Ever since the discovery of X-rays, in 1896, scholars have been divided in opinion regarding their nature. One school, lead by Prof. W. H. Bragg, held that the rays consisted of high speed particles, so small and so fast that they could penetrate solid bodies. Their arguments were based mainly on the energy changes between the X-rays and the cathode rays that produce them. The other school considered the X-rays to be the same in nature as ordinary light, i. e., electromagnetic waves, and the principal evidence in favor of this view was the fact that X-rays cannot be bent or deflected by the strongest electric and magnetic fields. The question has now been settled in favor of the wave theory, and it is a beautiful example of scientific open-mindedness that Prof. Bragg, the champion of the corpuscular theory, was one of the first to accept the decisive evidence, and has become the chief exponent of the wave theory which he so long opposed. It is interesting to note that exactly the same difference of opinion existed in Sir Isaac Newton's time regarding the nature of ordinary light, and that Newton, during his whole life, believed in the corpuscular theory. We may be sure that he, too, would have been prompt to change to the now-accepted wave theory, if the decisive evidence had appeared in his life-time. ✓

It is not the purpose of the present article to describe the beautiful experiments which led to the solution of this problem—this has been ably done by Prof. Bragg himself¹— but rather to present as vivid a picture as possible of the present theory and its interesting consequences.

DEFINITION OF SPECTRUM

Since light consists of waves of electric and magnetic force traveling through space, its quality must depend on the lengths of these waves, and, if there is more than one wave-length, on their relative intensities. The *spectrum* of the light is the sum total of these wave-lengths, weighted according to their intensities. The commonest form of spectrum is a photograph of the beam after it has passed through a prism or grating. The prism or grating separates the wave-lengths and sends each to a different point on the photographic plate, where it produces a blackening proportional to its intensity. The distance measured horizontally along the spectrum (c.f. Fig. 3) gives, therefore, the wave-length, and the blackness* at that point the intensity, of each constituent of the beam. If the intensity of any particular wave-length is greater than that of its neighbors it stands out as a black line, thus producing the so-called "line spectrum" that is characteristic of gases and vapors. Fig. 3 is an example. (The black lines print as white lines.) In the light from an incandescent solid body, on the other hand, the intensity of neighboring wave-lengths differs but little, so that its spectrum is a continuous band,

Copyright, 1916, by *General Electric Review*.

¹ "X-rays and Crystal Structure," by W. H. and W. L. Bragg, G. Bell & Sons, London, 1915.

* Fig. 3 is made from a *positive* print, so that blackness is printed as whiteness.

shading off gradually on each end. In this case the photograph is less satisfactory for expressing the intensity relation than a curve like Fig. 4, which represents the spectrum of incandescent tungsten at 2200 deg. C. Here the distances measured horizontally represent wave-lengths, the same as in the photograph, but the intensity of each wave-length is represented by the vertical height of the corresponding point on the curve, instead of by the blackness.

The spectrum of X-rays, which are given out by a solid metal when it is struck by high speed electrons, is, in appearance, a combination of incandescent solid and vapor, that is, it has both the strong continuous spectrum and strong lines. The wave-lengths are, of course, much shorter than those of ordinary light.

THE MECHANISM OF RADIATION AND REFLECTION

A ray of light consists of trains of waves sent out by the vibrating electrons in the luminous body, one train from each electron, just as a train of water waves is sent out by any vibrating object in water, or sound waves by a vibrating tuning-fork in the air.

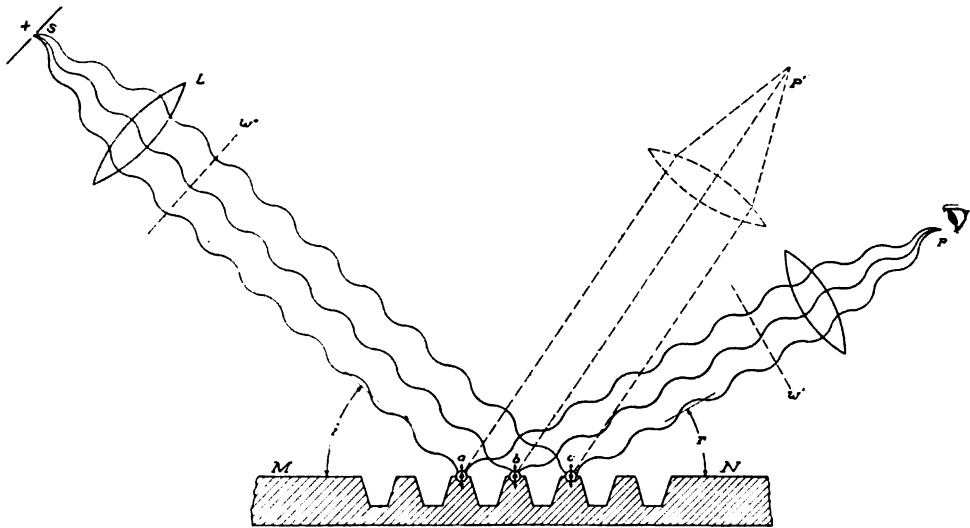

Fig. 1. Diffraction Grating Spectrometer

In the case of light the waves consist of electric force instead of water or air, but in all other respects they resemble water waves very closely. Picture an electron endowed with eyes standing at a point in the path of the ray of light. The electron will observe that the electric force at the point where he is standing is now upward, that is, in such a direction that an electrically charged body would be pulled upward by it, now downward, now up, now down, etc., in regular sequence, with a periodicity which is called the "frequency" of the light; and if, at the instant when a crest is passing him, that is, when the electric force is upward and at maximum intensity, he looks backward to the next approaching crest, the distance to this crest is a wave-length of the light. The electron will also report that the electric force, instead of being alternately up and down, may be to the right and left respectively, or in any other direction at right angles to that in which the rays are travelling; and that the electric force is always accompanied by a magnetic force at right angles to it. But being electrical, he will be chiefly concerned with the electric force, and since reflection depends on electrons, our interests are identical with his.

We may now give a picture of reflection. The observing electron of the preceding paragraph will experience the pull of the electric force, and, unless he is very firmly anchored,—and we have good evidence that most of the electrons in matter are only loosely held to their positions in the atoms—will soon find himself riding on the wave, moving up and down in synchronism with it. And being electrical, he cannot oscillate in this way without sending out waves of electric force, like the electrons in hot bodies. These secondary waves constitute reflected light. The reflected rays are to be looked upon as new rays, not the primary ones turned back, although it is, of course, the same energy, slightly diminished, that appears in these reflected rays. A good analogy is a motor-generator generating alternating current of the same frequency as the primary current.

THE FORMATION OF SPECTRA

The picture of reflection just given can now be applied to explain the separation of different wave lengths of either X-rays or ordinary light into a spectrum. To obtain

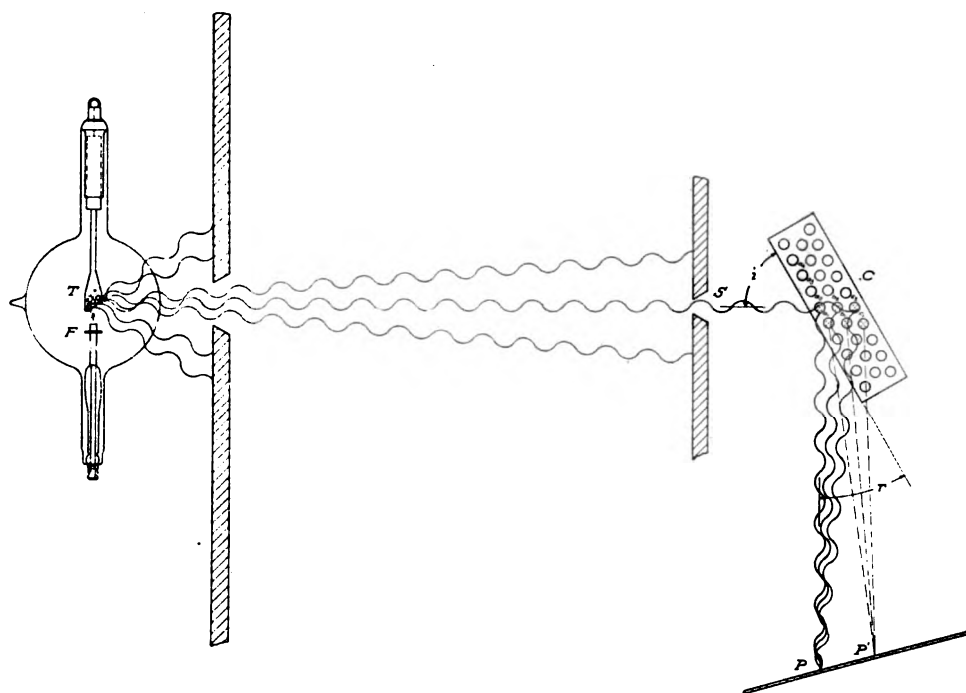

Fig. 2. The Crystal X-ray Spectrometer

the spectrum of a beam of ordinary light we select a small portion of it by means of a narrow slit *S*, Fig. 1, make its ray travel in parallel lines by a lens *L*, and let them fall on a grating *M-N*. The grating consists of a plate of glass or metal ruled with a large number of fine, parallel grooves. Those electrons in the grating surface upon which the light falls are set into oscillation by it and each one becomes a new source of light waves which it sends out in all directions.

In order to obtain the spectrum of our source of light we have only to add up these secondary wavelets, each with its proper phase. If the wavelets sent out by two electrons, *a* and *b*, Fig. 1, arrive at a point *P* in exactly opposite phase, the electric force due to one will always be downward when that due to the other is upward, and of the same magnitude, i.e., we shall have at every instant two equal and opposite electric

forces at that point. The resultant electric force will therefore be zero continuously, and if the eye be placed there the electrons in the retina that cause the sensation of sight will not be set into vibration. If, however, the waves arrive at P in the same phase, their electric forces add, and the light is doubled.

The wavelets from the grooved portions need not be considered, as their phase relations are so irregular that their resultant is always small. The locus of points at which the wavelets from the plane areas a , b , c , etc., arrive in the same phase may be found from geometry as follows:

The forced oscillation of the electrons in the metal surface follows exactly the exciting wave, so that the secondary wavelets, at the moment of starting out, are in phase with the primary. The relative phase of the different rays at P depends, therefore, only on the distances that the rays have to travel from S to P . A part of the distance, that from S and P to planes W_0 and W_1 , perpendicular to the direction of the rays respectively, we know to be the same for all rays on account of the action of the lens, so that the distances to be compared are from W_0 to W_1 . It is evident at once from the figure that this distance is exactly the same for all rays provided the "angle of incidence," SbM is equal to the "angle of reflection" PbN . This gives the law of ordinary reflection, and is true for all wave-lengths, and independently of whether the surface MN is continuous or broken by scratches. If the surface is continuous this is the *only* direction in which the secondary waves are all in phase, that is, this is the only direction in which light is reflected. But if the surface is broken by grooves equally spaced, there is another direction P' in which the optical distance $S-P'$ for rays from consecutive plane areas (a , b , etc.) differs by just one wave-length, so that the wavelets from a arrive just one wave-length ahead of those from b , those from b one wave-length ahead of those from c , etc. They will thus be in phase at P' and light of this wave-length will be intense at P' . For a different wave-length the wavelets will not be in phase at P' , but will be at some other point P'' . Thus the different wave-lengths will be separated and form a spectrum.

It is also possible for the wavelets from a to arrive at some point exactly two, three, or four wave-lengths ahead of those from b , and so be in phase. The spectra thus formed are called spectra of the "second order," "third order," etc. A photograph of the complete spectrum will generally contain several orders, some of them overlapping each other.

In the case of X-rays the picture is still simpler; for the wave-lengths are so short that we are able to use for a grating a natural crystal such as rock salt, in which the individual atoms take the place of the little faces a , b , c , of Fig. 1. Crystallography teaches that the atoms in crystals are arranged in regular, equidistant planes, and Prof. Bragg and his son have been able, by means of X-ray spectra, not only to confirm this hypothesis but to find the exact positions of the atoms. They find that the atoms in each plane are equally spaced in parallel rows. These rows of atoms correspond to the narrow plane surfaces between grooves in the diffraction grating. The only difference between the crystal and the grating is that the X-rays penetrate several thousand planes deep, so that the crystal is like a pile of semi-transparent gratings, all equidistant and with their lines parallel.

The use of the crystal as a grating is shown graphically in Fig. 2, where F represents the hot filament cathode of the X-ray tube, T the target, C the crystal, and P the photographic plate. The electrons of the "cathode ray" stream fall upon the target and set the electrons of the atoms in its surface into violent vibration. It is easy to conceive how the frequency of vibration caused by one of these blows, from an electron moving with half the velocity of light, should be much higher than that caused by a bump from another atom, such as gives rise to the visible light of a hot body.

These vibrating electrons of the target send out the high frequency electric waves which we call X-rays. They travel out in all directions, and a portion of them, passing through the narrow slit S , fall on the crystal C , and cause the electrons in its atoms to vibrate and radiate secondary wavelets. These secondary wavelets then travel to the photographic plate P and there reinforce or annul each other according to their phase relations, as in the case of the visible spectrum already discussed.

To find the proper phase relations it is best to proceed in two steps, first considering the atoms in a single plane, and then the relation of the planes to each other. For a single plane the phase relations are exactly the same as for the grating, since the plane with its rows of atoms acts just like a grating. We need, for the present purpose, only the first relation deduced above, namely, that the wavelets from all the atoms in the plane will be in phase with each other, provided the "angle of incidence" of the rays on the plane is equal to the so called "angle of reflection," the angle at which that part of the secondary rays which we are considering leaves the crystal. Any one atom in the plane may therefore represent the phase of all of them, provided we keep the angles of incidence and reflection equal.

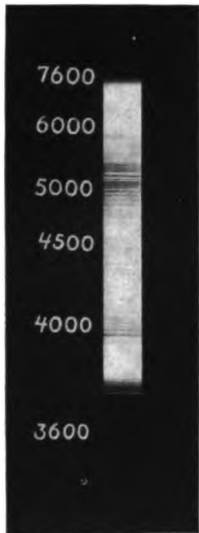

Fig. 3. Visible Spectrum of Tungsten Vapor. (Wave Lengths in Angstrom Units)

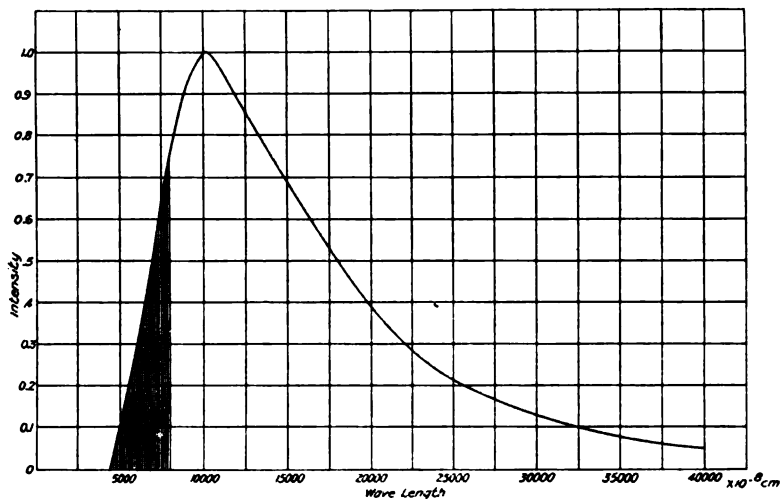

Fig. 4. Spectrum of Incandescent Solid Tungsten

The second part of the problem is to find under what conditions the wavelets from the atoms in the first plane are in phase with those from the second, etc. Let us take as representative atoms from the different planes, those which lie in a straight line parallel to the primary beam, as a_1, b_1, c_1 , etc., Fig. 2. (If necessary the planes may be imagined to slide over each other until these atoms are in line.) The primary wave $s a b c$ reaches b later than a , so that the phase of oscillation of the electrons of b , and hence of the wavelets which they send out, will be behind those of a . The wavelets from b also have a greater distance to travel to P than those from a , so that they will be still more behind in phase when they arrive at P . If, however, they are a whole wave-length, or any whole number of wave-lengths behind, they will be in phase, and the electric forces of the two will add. Exactly the same relation will exist between the wavelets from c and b , d and c , etc., since the planes are equidistant. Hence the wavelets from all the atoms in the crystal will be in phase at P when two conditions are ful-

filled: (1) the angle of incidence must be equal to the angle of reflection; (2) this angle must be such that the wavelets from successive planes differ in phase by some integral number of wave-lengths. We then obtain a registration on the photographic plate at P , of one wave-length of the primary beam. For a different wave-length the wavelets will be in phase at some adjacent point P' on the photographic plate, provided we rotate the crystal until the angles of incidence and reflection are again equal, and of the proper value for this new wave length. Thus by continuous rotation of the crystal, which is accomplished by a motor and worm gear, all the wave-lengths in the beam are successively registered.

According to the second condition given above, the same wave-length may be registered at several different positions on the plate, corresponding to phase differences of one, two, three, etc., wave-lengths between wavelets from consecutive planes. Hence if the crystal is rotated far enough, several complete spectra will be obtained, called respectively the first, second, third, etc., order spectra. The intensity of the

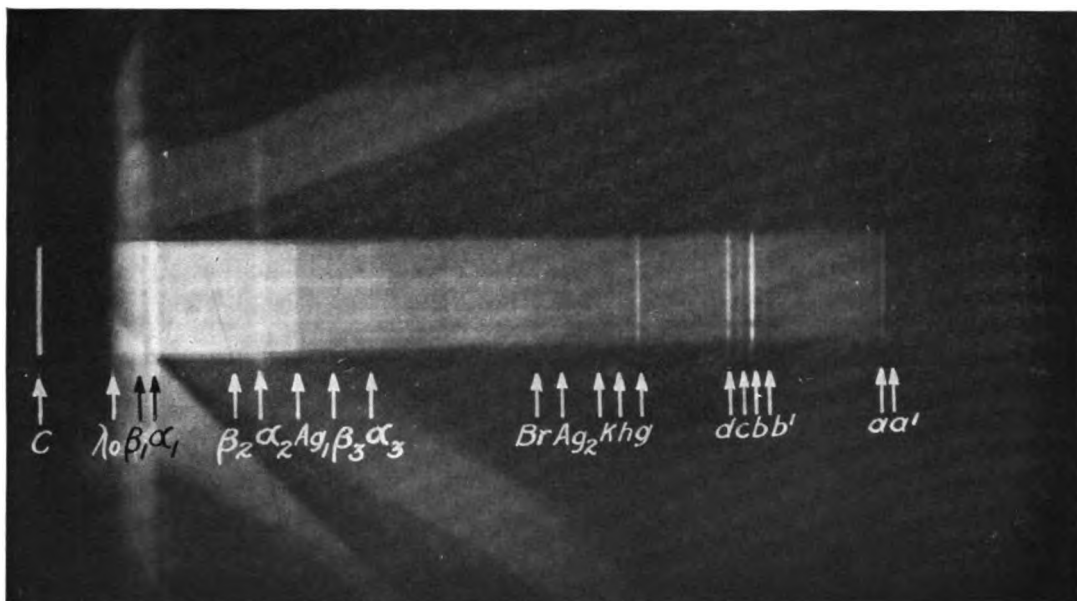

Fig. 5. Complete X-ray Spectrum of Tungsten at 100,000 Volts

higher orders is very small, so that usually not more than three orders are visible. Fig. 6 shows the so-called "K" lines of tungsten in two orders, and Fig. 5 in three orders.

The photographic plate gives the correct values of the wave-lengths present in the beam, but not the intensity. In order to obtain this we make use of the fact that when X-rays pass through a gas they make it electrically conducting. Hence if the rays are allowed to enter an "ionization chamber," which consists simply of two oppositely charged plates, a current will flow through the gas between the plates. This current can be measured by a sensitive electrometer and is proportional, if the gas is dense enough to absorb nearly all the rays, to the intensity of the rays. Thus by putting the ionization chamber in place of the photographic plate, and reading the electrometer at regular intervals while the crystal is being rotated, one obtains the intensities of all the wave-lengths in the spectrum. The spectrum shown in Fig. 7 was obtained in this way.

DESCRIPTION OF THE SPECTRUM

The X-ray spectrum of tungsten, obtained as described above, is shown in Figs. 5, 6 and 7. It consists of a "continuous spectrum" extending over four octaves (from the wave-length $\lambda = 0.12 \times 10^{-8}$ cm. to $\lambda = 2 \times 10^{-8}$ cm.), and 16 lines. Four of these lines, on the short wave-length end of the spectrum, are very close together and are known as the *K* series. They are usually designated as α^1 , α , β and γ . In Fig. 5, these four lines appear as only two, the " α doublet" appearing as a single line, and the β and γ lines being likewise too close to appear separately. The other 12 lines form another group, with wave-lengths nearly ten times those of the *K* series, and are known as the *L* series.

Fig. 6 shows a photograph taken in the manner described above, with a Coolidge tube having a tungsten target, running at 100,000 volts and 1.2 milliamperes. The rock salt crystal (*C*, Fig. 2), was 40 cm. from the target *T* and 56 cm. from the photographic plate, and was kept in continuous rotation during the four-hour exposure.

The photograph shows three of the four "*K*" lines of tungsten, the α doublet and the strong β line, in the first and second orders (marked with subscripts 1 and 2 respectively). The γ line, which is just to the left of the β line, is too weak to show. The wave-lengths of these lines are 0.212, 0.208, and 0.185 Ångström units* for the two α lines and the β line respectively. The wave-length of the β line, which is the shortest line that has been observed in the tungsten X-ray spectrum, is a little less than $\frac{1}{10,000}$ of the wave-length of the shortest ultraviolet line ($\lambda = 2700$ Ångströms) that has been found in the spark spectrum of tungsten vapor.

Fig. 5 is taken under the same conditions of current and voltage as Fig. 6, but the photographic plate was only one-third as far, 19 cm., from the crystal and the crystal was rotated through a larger angle so as to obtain a larger portion of the spectrum. The time of exposure was six hours. On this photograph *C* is the undeviated primary beam of rays which has passed straight through the crystal, and marks the zero line from which to measure the lines on the spectrum. The wave-lengths of these lines are approximately proportional to their distance from this zero line, except for the lines of 2nd and 3rd order, whose distances must be divided by 2 and 3 respectively.

The wave-length marked λ_0 at the extreme left of the photograph, the shortest wave-length present in the spectrum, is connected in a very interesting way with the velocity of the electrons which impinge upon the target in the X-ray tube, and produce the rays. If we speak in terms of frequency instead of wave-length, the frequency of this limiting wave-length multiplied by Planck's universal constant "*h*," the so-called "quantum," is exactly equal to the kinetic energy of the impinging electron. This relation has been checked over the whole range of voltage from 20,000 to 100,000 volts, and is more than a coincidence. It is another of the striking mathematical relations which the "quantum theory" † has brought to light, and which, though not at present understood, must have an extremely intimate connection with the mechanism of atomic structure.

The lines marked $\alpha_1, \alpha_2, \alpha_3$, and $\beta_1, \beta_2, \beta_3$ are the first, second and third orders respectively of the α and β lines of the "*K*" series. The two α lines show separately in the second order, but not in the first. The γ line is not visible.

The band whose edge is marked A_{g_1} is an absorption band of the silver in the photographic plate. For all wave-lengths shorter than this wave-length A_{g_1} (0.485 Ångströms), silver has an especially strong absorption. Since photographic action depends

* The Ångström unit $\frac{1}{100,000,000}$ cm., is the standard unit for expressing the wave-lengths of visible light, and is used here for the sake of comparison. The wave-length of ordinary green light is 5000 Ångström units.

† For a brief review of the quantum theory see Dushman, *G. E. Rev.*, Sept., 1914.

upon the amount of light which the sensitive film absorbs, and since about 99 per cent of the energy of X light goes through the plate without absorption, it is evident that an increase in the absorbing power of the silver will cause a large increase in blackening.

The band Ag_2 is also due to the silver, and is caused by the "second order" reflection of these same wave-lengths, striking the plate this time at a point twice as far from the

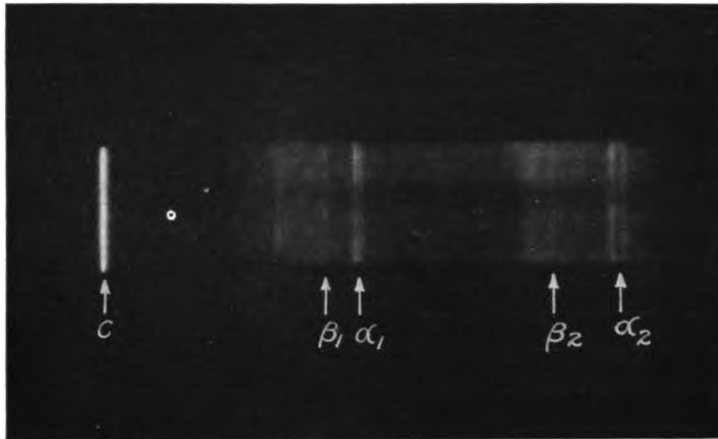

Fig. 6. X-ray Spectrum of Tungsten—The "K" Lines

central line C . In the same way the band Br is due to the special absorption, by the bromine atoms in the silver bromide of the photographic plate, of all wave-lengths shorter than 0.918 Ångströms.

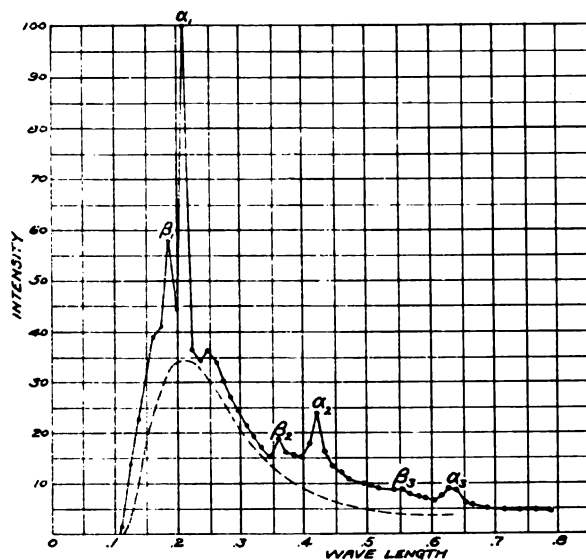

Fig. 7. X-ray Spectrum of Tungsten at 100,000 Volts, Obtained by the Ionization Chamber

There is one other absorption band, which shows clearly on the original photograph, just to the left of Br . It is due to the special absorption, by the minute trace of rubidium in the glass of the X-ray bulb, of all wave-lengths shorter than 0.814 Ångströms. In this case special absorption means a loss of light to the photographic plate, hence the spectrum to the left of Rb is less black than that to the right. The absorption

bands due to the other constituents of the glass fall too far to the right to show on the photograph.

All known elements have these X-ray absorption bands, and their positions are much more regular and more simply related to the material than are the bands in the visible spectrum. As far as known every element has two absorption bands for X-rays, one beginning at a wave-length just beyond its *K* series on the short wave-length side, the other just beyond its *L* series. The wave-lengths at which each of these bands begin, for the different elements, are very nearly proportional, inversely, to the squares of the "atomic numbers" of the respective elements.* The physical meaning of this relation also, like the quantum, is not yet known. Its simplicity and exactness give it significance.

The rest of the lines, those to the right of Ag_2 , all belong to the "*L*" series. For convenience of identification they are lettered *a-k*. Their wave-lengths range from 1.47 Ångströms for "*a*" to 1.033 for "*k*." They are all in the first order.

For the purpose of comparison the spectrum of tungsten vapor, made luminous by an electric spark, is shown in Fig. 3. The lines do not show very clearly because they are so numerous. Compared with the complexity of these visible spectra, some of which contain as many as 60,000 lines, the X-ray spectra are strikingly simple. This simplicity makes the X-ray spectra especially useful, both for scientific investigation and as a means of chemical analysis.

The continuous spectrum, which appears as a continuous background in Figs. 5 and 6, is shown graphically in Fig. 7. This was obtained by the use of an ionization chamber and electrometer, in place of the photographic plate, as explained above. The current and voltage were the same as for Figs. 5 and 6, viz., 100,000 volts and 1.2 milliamperes. The ordinates of points on the curve give the intensity of the corresponding wave-lengths, whose values, in Ångströms, are given by the abscissas. The circles mark the experimental measurements as read from the electrometer.

The curve shows clearly the repetition in the first, second and third orders of the α and β lines shown in the photographs of Figs. 5 and 6. It also shows the relative intensity of the lines as compared with the continuous spectrum upon which they are superimposed. The continuous spectrum is, like the lines, present in all three orders, so that to obtain the true relative intensity of the different wave-lengths in the beam it is necessary to separate these different orders. This has been done for a lower voltage, 70,000, and the resulting values are shown in the dotted curve, Fig. 4. Here the *K* lines are absent, as the voltage, 70,000, was not high enough to excite them. For comparison the visible and infra-red spectrum of incandescent tungsten at 2200 deg. C., which is approximately the temperature of the filament of a Mazda lamp, is given in Fig. 4. The shaded portion represents the visible part. If the wave-lengths in Fig. 4 were all reduced ten thousand fold, it would coincide very nearly with the dotted curve in Fig. 7.

* The atomic number of an element is the number of its position in a table arranged according to atomic weight, beginning with hydrogen equal to one, helium two, etc. It has been found to be more intimately connected with the chemical properties of the atom than the atomic weight, and is probably very closely related to the number of electrons in the atom.



A NEW METHOD OF X-RAY CRYSTAL ANALYSIS*

BY A. W. HULL

The beautiful methods of crystal analysis that have been developed by Laue and the Braggs are applicable only to individual crystals of appreciable size, reasonably free from twinning and distortion, and sufficiently developed to allow the determination of the direction of their axes. For the majority of substances, especially the elementary ones, such crystals cannot be found in nature or in ordinary technical products, and their growth is difficult and time-consuming.

The method described below is a modification of the Bragg method, and is applicable to all crystalline substances. The quantity of material required is preferably 0.005 c.c., but one tenth of this amount is sufficient. Extreme purity of material is not required, and a large admixture of (uncombined) foreign material, twenty or even fifty per cent, is allowable provided it is amorphous or of known crystalline structure.

OUTLINE OF METHOD

The method consists in sending a narrow beam of monochromatic X-rays (Fig. 2) through a disordered mass of small crystals of the substance to be investigated, and photographing the diffraction pattern produced. Disorder, as regards orientation of the small crystals, is essential. It is attained by reducing the substance to as finely divided form as practicable, placing it in a thin-walled tube of glass or other amorphous material, and keeping it in continuous rotation during the exposure.² If the particles are too large, or are needle-shaped or lamellar, so that they tend to assume a definite orientation, they are frequently stirred. In this way it is assured that the average orientation of the little crystals during the long exposure is a random one. At any given instant there will be a certain number of crystals whose 100 planes make the proper angle with the X-ray beam to reflect the particular wave-length used, a certain number of others whose 111 planes are at the angle appropriate for reflection by these planes, and so for every possible plane that belongs to the crystal system represented. Each of these little groups will contain the same number of little crystals, provided the distribution is truly random, and the total number of crystals sufficiently large. This condition is very nearly realized in the case of fine powders, and may, by sufficient rotation and stirring, always be realized for the *average orientation* during the whole

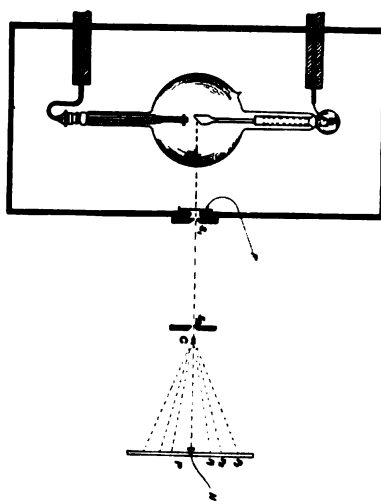

Fig. 2

* Copyright, 1917, by the American Physical Society.

¹ A brief description of this method was given before the American Physical Society in October, 1916, and published in this journal for January, 1917.

² If the powder is fine, rotation is not necessary unless great precision is desired. With crystal grains 0.01 cm. in diameter, or less, the pattern generally appears quite uniform without rotation.

exposure; that is, there will be, *on the average*, as many cubic centimeters of crystals reflecting from their 100 planes as there are cubic centimeters reflecting from 111, 210, or any other plane. This is true for every possible plane in the crystal.

The diffraction pattern should contain, therefore, reflections from every possible plane in the crystal, or as many of these as fall within the limits of the photographic plate. Fig. 1, Plate 1, shows the pattern given by aluminium when illuminated by a small circular beam of nearly monochromatic rays from a molybdenum tube. The exposure was nine hours, with 37 milliamperes at 30,000 volts, and crystal powder 15 cm. from the target and 5.9 cm. from photographic plate. The faintness of the vertical portions of the circles is due to the cylindrical form in which the powder was mounted, causing greater absorption of rays scattered in the vertical plane. Patterns containing many more lines are shown in Figs. 6–10, where the diaphragm limiting the beam was a slit instead of a circular aperture, and the pattern was received on a photographic film bent in the arc of a circle.

The number of possible planes in any crystal system is infinite. Hence if equal reflecting opportunity meant equal reflected energy, it would follow that the energy reflected by each system of planes must be an infinitesimal fraction of the primary beam, and hence could produce no individual photographic effect. It is easily seen, however, that only those planes whose distance apart is greater than $\lambda/2$, where λ is the wavelength of the incident rays, can reflect any energy at all. Planes whose distance apart is less than this cannot have, in any direction, except that of the incident beam, equality of phase of the wavelets diffracted by electrons in consecutive planes. Hence the resultant amplitude associated with any such plane is very small, and would be identically zero for a perfect lattice and sufficiently large number of planes. The total scattered energy is, therefore, divided among a finite number of planes, each of which produces upon the photographic plate a linear image of the source (cf. Fig. 1). The total possible number of these lines depends upon the crystal structure and the wavelength. For diamond, with the wavelength of the K_α doublet of molybdenum, $\lambda = 0.712$, the total number of lines is 27. All of these are present in the photograph shown in Fig. 12. For the rhodium doublet, $\lambda = 0.617$, the total number is 30; for the tungsten doublet, $\lambda = 0.212$, it is more than 100; while the iron doublet, $\lambda = 1.93$, can be reflected by only three sets of diamond planes, the octahedral (111), rhombic dodecahedral (110), and the trapezohedral (311). The diffraction pattern in this case would consist, therefore, of but three lines.

The positions of these lines, in terms of their angular deviation from the central beam, are completely determined by the spacing of the corresponding planes, according to the classic equation $n\lambda = 2d \sin \theta$, where θ is the angle between the incident ray and the plane, hence 2θ is the angular deviation, d the distance between consecutive planes, λ the wavelength of the incident rays, and n the order of the reflection. The calculation of these positions is discussed in detail below.

The relative intensity of the lines, when corrected for temperature, angle, and the number of co-operating planes, depends only upon the space distribution of the electrons of which the atoms are composed. Most of these electrons are so strongly bound to their atoms that their positions can probably be completely specified by the positions of the atomic nuclei and the characteristic *structure* of the atom. Experiments are in progress to determine such a structure for some of the simpler atoms. A few of the electrons, however, are so influenced by the proximity of other atoms, that their position will depend much on the crystal structure and state of combination of the substance. There is also good reason to believe that certain electrons are really *free*, in

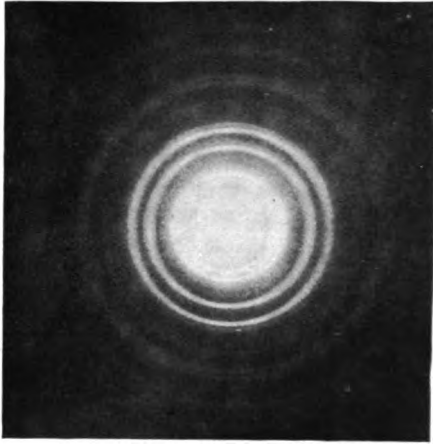

Fig. 1. Aluminium

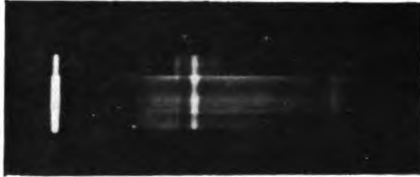

Fig. 5. Tungsten X-Ray Spectrum

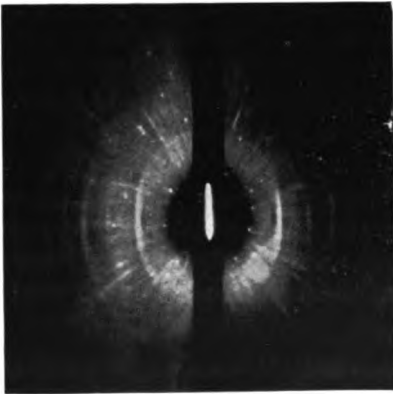

Fig. 6. Iron



Fig. 7a. Silicon Steel

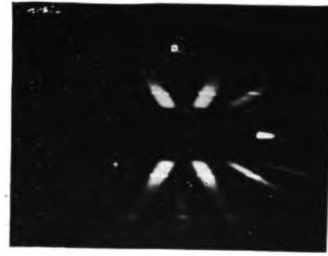

Fig. 7b. Silicon Steel



Fig. 8. Silicon



Fig. 9. Aluminium



Fig. 10. Magnesium



Fig. 11. Graphite



Fig. 12. Diamond

that they belong to no atom, but occupy definite spaces in the lattice, as though they were atoms.

With elements of high atomic weight, where each atom contains a large number of electrons, the majority of these electrons must be quite close to the nucleus, so that the intensity of the lines will depend primarily upon the position of the nuclei relative to their planes, and only slightly upon the characteristic structure of the atom and the position of valence and free electrons. With these substances, therefore, the relative intensity of the lines gives direct evidence regarding the positions of the atoms, and may be used, in the manner described by the Braggs,¹ for the determination of crystal structure. The powder photographs have an advantage, in this respect, over ionization-chamber measurements, in that the intensities of reflection from different planes, as well as different orders, are directly comparable, which is not true of ionization-chamber measurements unless the crystal is very large and may be ground for each plane.

In the case of light substances, on the other hand, the intensities depend very much on the internal structure of the atoms, and unless this structure is known or postulated, but little weight should be given to intensity in determining the crystal structure. Much evidence for the structure of these elements may be obtained, however, from the observation of the *position* of a large number of lines, and this evidence will generally be found sufficient. The examples given at the end of this paper are all elements of low atomic weight, and the analysis given is based entirely on the position of the lines. The photographs used for the analysis are preliminary ones, taken with very crude experimental arrangements, and yet in every case, except one, the evidence is sufficient.

The method of measuring and interpreting intensity will form the subject of a future paper.

EXPERIMENTAL ARRANGEMENT

The arrangement of apparatus is shown in Fig. 2. The X-ray tube is completely enclosed in a very tightly built lead box. If a tungsten target is to be used this box should be of $\frac{1}{4}$ -inch lead, with an extra $\frac{1}{4}$ -inch on the side facing the photographic plate. If a rhodium or molybdenum target is used $\frac{1}{8}$ inch on the side toward the photographic plate, and $\frac{1}{8}$ inch for the rest of the box, is sufficient. The rays pass through the filter F and slits S_1 and S_2 , and fall upon the crystal substance C , by which they are diffracted to points p_1 , p_2 , etc., on the photographic plate P . The direct beam is stopped by a narrow lead strip H , of such thickness that the photographic image produced by this beam is within the range of normal exposure. For a tungsten target, the thickness of this strip should be $\frac{1}{8}$ inch; for a molybdenum target about $1/100$ inch.

THE X-RAY TUBE

In order to produce monochromatic rays, it is necessary to use a target which gives a characteristic radiation of the desired wave-length, and to run the tube at such a voltage that the radiation of this wave-length will be both intense and capable of isolation by filtering.

The relation between general and characteristic radiation at different voltages has been investigated, for tungsten and molybdenum, by the author,² and, in more detail, for rhodium by Webster, and platinum by Webster and Clark.³ The results may be summarized as follows: The characteristic *line spectra* are excited only when the voltage across the tube is equal to or greater than the value $V = \frac{h\nu}{e}$, where h is Planck's constant, e the charge of an electron, and ν the frequency corresponding to the short wave-length limit of the series to which the line belongs.

¹ X-Rays and Crystal Structure, pp. 120 ff.

² Nat. Acad. Proc., 2, 268, 1916.

³ Phys. Rev., 7, 599, 1916; Nat. Acad. Proc., 5, 185, 1917.

With increase of voltage above this limiting voltage, the intensity of the lines increases rapidly, approximately proportional to the $3/2$ power of the excess of voltage above the limiting value.¹ The following table will show the rate of increase for the α line of the K series of molybdenum, as used in the experiments described below.²

TABLE I
Increase of Intensity of the K_{α} Line of Mo with Voltage

	KILOVOLTS									
	20.	22.	24.	26.	28.	30.	32.	34.	36.	40.
Intensity.....	0	1.25	2.75	4.80	7.30	9.60	12.65	15.2	18.5	23.4

The rapid increase of characteristic radiation with voltage makes it desirable to use as high voltage as possible. If the voltage is too high, however, a part of the general radiation, whose maximum frequency is directly proportional to the voltage,³ becomes so short that it is impossible to separate it from the characteristic by a selective filter. With a molybdenum target the best working voltage is about 30,000 volts, with tungsten about 100,000 volts.

FILTERS

Although it is impossible to produce truly monochromatic radiation by filtering, it is easy to obtain a spectrum containing only *one line*, and in which the intensity of this line is more than thirty times that of any part of the general radiation. To accomplish this, use is made of the sudden increase in absorption of the filter at the wave-length corresponding to the limit of one of its characteristic series; that is, at the wave-length which is just short enough to excite in the filter one of its characteristic radiations. A filter is chosen whose K series limit⁴ lies as close as possible to the desired wave-length *on its short wave-length side*. For example, to isolate the K line of molybdenum whose wave-length is 0.712 \AA ., the most appropriate filter is zirconium, the limit of whose K series is at $\lambda = 0.690 \text{ \AA}$.. The absorption coefficient of the filter is then a minimum for the wave-length in question, and increases rapidly with wave-length *in both directions*; on the left, toward shorter wave-lengths, it jumps suddenly by about 8-fold; on the right it increases more slowly, viz., as the cube of the wave-length.⁵

If the longest wave-length in the series, which, fortunately, in the case of the K series, is the most intense, is chosen for the monochromatic ray, the eight-fold increase in absorption coefficient will completely eliminate the other lines of the series, while reducing the chosen line by only one half. To eliminate the general radiation is not so easy. Webster has shown⁶ that the intensity of the characteristic radiation increases more rapidly with voltage than that of the neighboring general radiation, so that the higher the voltage the more prominently the line stands out above adjacent wave-lengths, and this is the only way in which it can be sharply separated *from longer wave-lengths*. If the voltage is too high, however, the shortest wave-length end of the general spectrum becomes transmissible by the filter, and while its wave-length is far removed from that of the line which is to be isolated, and it can itself produce no line image, yet its integral effect produces a general blackening of the plate that obscures the lines. Sharp limitation on the *short* wave-length side is obtained by the selective action of the filter.

It is necessary, therefore to choose filter material, filter thickness, and voltage, to correspond to the target used. For a molybdenum target, the filter should be zir-

¹ Webster and Clark, Proc. Nat. Acad., 3, 185, 1917.

² The general radiation of the same wave-length as the α line is included in these values.

³ See Duane and Hunt, Phys. Rev., 6, 619, and Hull Phys. Rev., 7, 156.

⁴ A complete table of wave-lengths of series lines for all elements thus far investigated is given by Siegbahn, Jahrb. Radioact. u. Electronik, 13, 300, 1916.

⁵ Hull and Rice, Phys. Rev., 3, 326, 1916.

⁶ L. c.

conium, and a thickness of about 0.35 mm. of powdered zircon is sufficient¹ (see Fig. 3). The optimum voltage is between 28,000 and 30,000 volts. For a tungsten target the filter should be ytterbium, of a thickness of about 0.15 mm., but this has not yet been tested. A filter of this thickness of metallic tungsten or tantalum eliminates most of the general spectrum, but leaves the β doublet as well as the α doublet, which is very

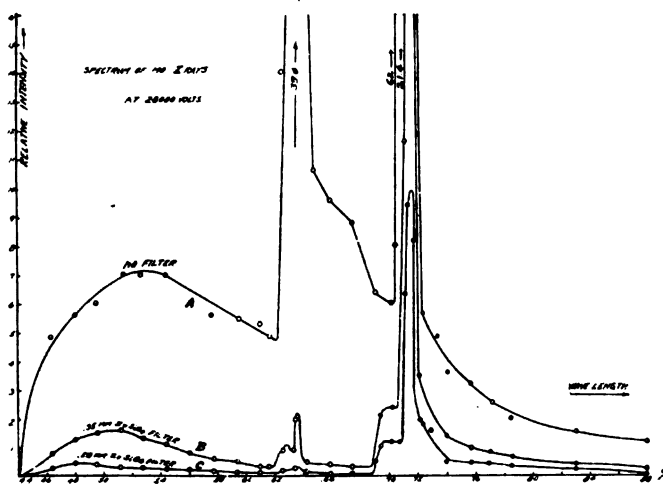

Fig. 3

undesirable (cf. Figs. 4 and 5). The optimum voltage is about 100,000 volts. The effect of filtering on the spectrum of a molybdenum target at 28,000 volts is shown in Fig. 3, which gives the intensity of the different wave-lengths as measured with an ionization chamber, so constructed as to eliminate, nearly, errors due to incomplete absorption.² No correction has been made for coefficient of reflection of the (rock salt) crystal. The intensities of the K lines are too great to be shown on the figure, the α line being four times and the line β two and one half times the height of the diagram. A filter of 0.35 mm. of zircon reduces the intensity of the α line from 62 to 21.4; while reducing the β line from 39 to 2.2. The general radiation to the left is still quite prominent. An increase in filter thickness from 0.35 mm. to 0.58 mm. (Curve C) reduces it but little more than it reduces the α line, so that very little is gained by additional filtering. The sudden increase in absorption of the zirconium is seen at $\lambda_0 = 0.690 \text{ \AA.}$, which is exactly the short wave-length limit of its K series, as extrapolated from Malmer's values of the β_1 and β_2 lines of yttrium and the β_1 line of zirconium.

The effect of a tungsten filter upon the spectrum of tungsten at 110,000 volts is shown in Figs. 4 and 5. Here the critical wave-length of the filter is at the short wave-length edge of the whole series, so that all the lines are present. A filter of ytterbium would eliminate all but the α doublet. Fig. 4 gives the ionization chamber

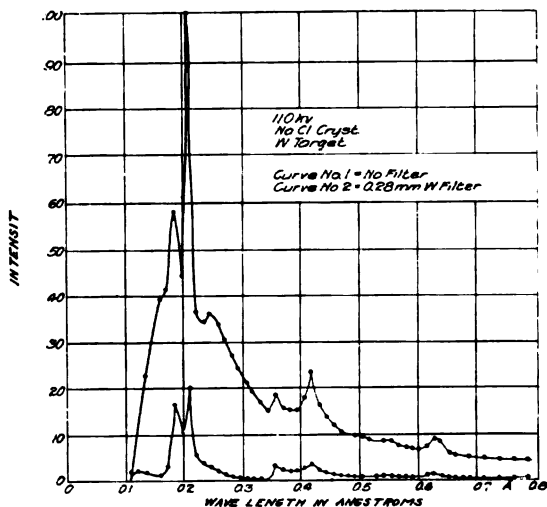

Fig. 4

¹ The absorption of the Si and O in zircon is negligible compared to that of the zirconium, so that crystal zircon is as efficient as metallic zirconium.

² The ionization chamber contains two electrodes of equal length. The second electrode, the one farther from the crystal, was connected to the electrometer, and the pressure of methyl iodide in the chamber was such that the wave-lengths in the middle of the range investigated suffered 50 per cent absorption in passing through the first half of the chamber. The electrometer deflection is proportional to $I_0 e^{-\mu l} (1 - e^{-\mu l})$, where I_0 is the intensity on entering the chamber, l the length of either electrode and μ the coefficient of absorption of the methyl iodide. This expression has a very flat maximum for $e^{-\mu l} = \frac{1}{2}$, so that for a considerable range on either side, the readings are proportional to I_0 .

measurements, uncorrected, of the tungsten spectrum at 110,000 volts, as reflected by a rock salt crystal. The upper curve is the unfiltered spectrum, the lower that which has passed through a filter of 0.15 mm. of metallic tungsten. The K lines are much more prominent in the filtered than in the unfiltered spectrum, but the general radiation, especially the short wave-length end, is much too prominent, showing that the voltage is too high. In Fig. 5 the effect of the tungsten filter (above) is compared with that of 1 cm. of aluminium (below), in order to show more clearly the selective effect of the tungsten filter. The wide middle portion of the spectrum is unfiltered.

THE CRYSTALLINE MATERIAL

The Bragg method of X-ray crystal analysis is by far the simplest whenever single crystals of sufficient perfection are available. If, however, perfect order of crystalline arrangement cannot be had, the next simplest condition is perfect chaos, that is, a random grouping of small crystals, such that there is equi-partition of reflecting opportunity among all the crystal planes. This has two disadvantages, viz., that the opportunity of any one plane to reflect is very small, so that long exposures are necessary; and the images from all planes appear on the same plate, so that it is impossible, without calculation, to tell which image belongs to which plane. It has the advantages, on the other hand, of allowing a definite numerical calculation of the position and intensity of each line, and of being free from uncertainties due to imperfection and twinning of crystals. In the latter respect it serves as a valuable check on the direct Bragg method.

The crystalline material is, wherever possible, procured in the form of a fine powder of 0.01 cm. diameter or less. This may be accomplished by filing, crushing, or by chemical or electro-chemical precipitation, or by distillation. In the case of the metals like alkalis, to which none of these methods can be applied, satisfactory results have been obtained by squirting the metal through a die in the form of a very fine wire, which is packed, with random folding, into a small glass tube, and kept in continuous rotation, with frequent vertical displacements, during exposure.

The method of mounting the crystalline substance depends on the wave-length used. If tungsten rays ($\lambda = 0.212$) are used, so that the angles of reflection, for all visible lines, are small, it is most convenient to press the powder into a flat sheet, or between plane glass plates, and place this sheet at right angles to the beam. In this case the correction for the difference in absorption of the different diffracted rays is negligible. If a molybdenum tube is used, on the other hand, diffracted rays can be observed at angles up to 180 deg. (cf. Fig. 10), so that the substance must be mounted in a cylindrical tube. In this case also, the correction for absorption is unnecessary, provided the diameter of the tube is properly chosen and the beam of rays is wide enough to illuminate the whole tube.

The optimum thickness of crystalline material, for a given wave-length, may be calculated approximately as follows:

Let k represent the scattering coefficient and μ the absorption coefficient of the substance for the wave-length used, and I_0 the intensity of the incident rays. The intensity scattered by a thin layer dx at a distance x below the surface will be

$$dR = kI_0e^{-\mu x}dx.$$

This radiation will suffer further absorption in passing through a thickness $t-x$, approximately, where t is the thickness of the sheet. Hence the total intensity of the scattered radiation that emerges will be

$$R = \int_0^t kI_0e^{-\mu}dx \\ = kI_0te^{-\mu}.$$

This will be a maximum when

$$\frac{dR}{dt} = kI_0(e^{-\mu t} - \mu t e^{-\mu t}) = 0$$

or

$$t = \frac{1}{\mu},$$

where t is the thickness of the crystalline sheet in centimeters and μ the linear absorption coefficient.

If the material is in cylindrical form, the optimum diameter is slightly greater than the above value.

EXPOSURE

Very long exposures, as remarked above, are necessary if a large number of lines is desired, and it is important to increase the speed by the use of an intensifying screen, and by bringing the crystal as close as practicable to the tube. With rays as absorbable as those from a molybdenum tube, it is necessary to use films, not plates, with the intensifying screen. Under reasonable conditions, an exposure of ten to twenty hours will produce a general blackening of the plate well within the limit of normal exposure. Since a greater density than this cannot increase the contrast, nothing is to be gained by longer exposure. Further detail can be hoped for only by using more nearly monochromatic rays, screening the plate more perfectly from stray and secondary rays in the room, and decreasing the ratio of amorphous to crystalline material in the specimen under examination.

ANALYSIS OF THE PHOTOGRAPHS

A. Cubic Crystals

The method of deducing the crystal structure from the experimental data is very similar to that used by the Braggs, with this difference: In the Bragg method reflections from three or four known planes are observed, and a structure is sought which gives the spacings and intensities observed for these planes. In the method described above a single photograph is taken, containing reflections from a large number of unknown planes, and a structure is sought whose *whole pattern* of planes, arranged in the order of decreasing spacing and omitting none, fits the observed pattern. In both cases the method is one of trial and error, namely, to try one arrangement after another, beginning with the simplest, until one is found which fits.

CALCULATION OF THEORETICAL CRYSTAL SPACINGS

The process of calculating the spacings of the planes in any assumed crystal structure is as follows: The positions of the atoms are specified by their co-ordinates with respect to the crystallographic axes. For example, a centered cubic lattice is represented by a system of atoms whose co-ordinates (x, y, z) are $\begin{cases} m, n, p, \\ m + \frac{1}{2}, n + \frac{1}{2}, p + \frac{1}{2}, \end{cases}$ where $m, n,$ and p assume all possible integral values, and the unit is the side of the elementary cube. The distance from any atom x_1, y_1, z_1 , to a plane whose (Miller) indices are h, k, l is, for rectangular axes,

$$d = \frac{hx_1 + ky_1 + lz_1 - 1}{\sqrt{h^2 + k^2 + l^2}}. \quad (1)$$

Since the family of planes parallel to h, k, l , contains all the atoms in the crystal, one of these planes must pass through the atom x_1, y_1, z_1 , so that d is the distance from the plane h, k, l to a plane parallel to it through x_1, y_1, z_1 . The "spacing" of the planes h, k, l , which is the smallest value of d that repeats itself, is found by substituting different

TABLE II

Indices of Form	Smallest Distance Between Planes d .	SPACING OF PLANES AND SUBMULTIPLES d/n .		
		$n = 1$.	2.	3.
100	$\frac{1}{\sqrt{1}}$.50	.25	.167
110	$\frac{1}{\sqrt{2}}$.354	.177	.118
111	$\frac{1}{\sqrt{3}}$.577	.289	.192
210	$\frac{1}{\sqrt{5}}$.224	.112	.075
310	$\frac{1}{\sqrt{10}}$.158	.079	.053
410	$\frac{1}{\sqrt{17}}$.121	.061	.040
320	$\frac{1}{\sqrt{13}}$.139	.070	.046
311	$\frac{1}{\sqrt{11}}$.302	.151	.101
411	$\frac{1}{\sqrt{18}}$.118	.059	.039
511	$\frac{1}{\sqrt{27}}$.192	.096	.064
711	$\frac{1}{\sqrt{51}}$.140	.070	.047
911	$\frac{1}{\sqrt{83}}$.110	.055	.037
322	$\frac{1}{\sqrt{17}}$.121	.016	.040
533	$\frac{1}{\sqrt{43}}$.152	.076	.051
733	$\frac{1}{\sqrt{67}}$.122	.061	.041
221	$\frac{1}{\sqrt{9}}$.167	.084	.056
331	$\frac{1}{\sqrt{19}}$.115	.058	.038
551	$\frac{1}{\sqrt{51}}$.140	.070	.047
553	$\frac{1}{\sqrt{59}}$.130	.065	.043
321	$\frac{1}{\sqrt{14}}$.134	.067	.045
531	$\frac{1}{\sqrt{35}}$.168	.084	.056
731	$\frac{1}{\sqrt{59}}$.130	.065	.043
751	$\frac{1}{\sqrt{75}}$.115	.058	.038
753	$\frac{1}{\sqrt{83}}$.110	.055	.037

values of the co-ordinates m, n, p for x_1, y_1, z_1 in equation (1), and observing the smallest value and periodicity of d . For example, to find the spacing of the 111 planes of the centered cubic lattice, place h, k, l each equal to 1, assume for m, n and p the values 0, 1, 2, 3, etc., and substitute in equation (1). All the atoms in the group m, n, p are found to lie in planes at distances $\frac{1}{\sqrt{3}}, \frac{2}{\sqrt{3}}, \frac{3}{\sqrt{3}}$, etc., from h, k, l , and those of the group $m + \frac{1}{2}, n + \frac{1}{2}, p + \frac{1}{2}$, at distances $\frac{1/2}{\sqrt{3}}, \frac{1\frac{1}{2}}{\sqrt{3}}, \frac{2\frac{1}{2}}{\sqrt{3}}$, etc. Since both groups contain the same number of atoms, the spacing is regular and is equal to $\frac{1/2}{\sqrt{3}}$ times the side of the elementary cube. If the structure is one of the fourteen regular lattices, as the centered cube, all parallel planes are equally spaced, and only the minimum value of d need be found.

In this way the spacings of all the principal planes, that is, those whose indices are small numbers, are calculated and tabulated; and it is easy, by systematic procedure, to be sure that no plane has been skipped whose spacing is within the limits of the table.

As an example, the calculation of the spacings of a face-centered lattice is given in full below (Table II).

The co-ordinates of the atoms are

$$\begin{array}{ccc} m, & n, & p, \\ m + \frac{1}{2}, & n + \frac{1}{2}, & p, \\ m + \frac{1}{2}, & n, & p + \frac{1}{2}, \\ m, & n + \frac{1}{2}, & p + \frac{1}{2}, \end{array}$$

where m, n , and p assume all possible integral values.

The first column gives the indices of the form, the second the smallest values of d for that form, obtained by substituting the co-ordinates of the atoms in equation (1), and the third the same value of d expressed as a fraction of the lattice-constant, together with its submultiples $d/2, d/3, d/4$, etc., corresponding to reflections of second, third, etc., order. The unit is the "lattice constant," the side of the elementary face-centered cube. The table contains all planes having values of d/n greater than 0.12. These values are collected in Table III, arranged in order of decreasing d/n .

For convenience of reference, the spacings, *i.e.*, the distance between consecutive parallel planes, of the most important forms in the four most common cubic lattices are tabulated in Table III, together with such submultiples, d/n , of these spacings as come within the range of the tables. The order is that of decreasing d/n , and the table contains all values of d/n greater than 0.12.¹ The table also contains the number of different sets of planes in each of the given forms. For example, the hexahedral form (100) consists of three families of parallel planes, parallel respectively to 100, 010, and 001.

To test whether any new crystal belongs to one of the lattices represented in Table III, it is only necessary to calculate the values of d/n from the lines of its powder photograph, tabulate them in order, and compare this table with Table III.

The unit of d/n in Table III is the "lattice constant," *i.e.*, the side of the elementary cube whose successive translations can generate the whole lattice. To find the spacing of any set of planes in a crystal having one of these lattices it is only necessary to multiply the value of d given in the table by the "lattice constant" of the given crystal.

The first three lattices in the table are the regular cubic space lattices, in which every atom is equivalent in position to every other. In all other possible cubic lattices the atoms must be divided into two or more classes, whose positions in the lattice are not equivalent.

¹ In order to shorten the table the simple cube spacings, which are much more numerous than the others, have not been tabulated beyond $d/n = .1766$.

TABLE III

Indices of Form	Plane Families Belonging to Form	SPACING OF PLANES, INCLUDING SUBMULTIPLE d/n			
		Simple Cube	Centered Cube	Face-centered Cube	Diamond
100	3	1.00			
110	6	.707	.707		
111	4	.577		.577	.577
100	3	($n=2$) .500	.500	.500	
210	12	.447			
211	12	.408	.408		
110	6	($n=2$) .354	($n=2$) .354	.354	.354
{ 221	{ 12	{ .3333			
{ 100	{ 3	{ ($n=3$) .3333			
310	12	.3160	.3160		
311	12	.3014		.301	.301
111	4	($n=2$) .2885	.2885	($n=2$) .2885	($n=2$) .2885
320	12	.2774			
321	24	.2672	.2672		
100	3	($n=4$) .2500	($n=2$) .2500	($n=2$) .2500	.2500
{ 410	{ 12	{ .2423			
{ 322	{ 12	{ .2423			
{ 411	{ 12	{ .2358			
{ 110	{ 6	{ ($n=3$) .2358	($n=3$) .2358		
331	12	.2292		.2292	.2292
210	12	($n=2$) .2234	.2234	.2234	
421	24	.2180			
332	12	.2132	.2132		
211	12	($n=2$) .2040	($n=2$) .2040	.2040	.2040
{ 430	{ 12	{ .200			
100	3	($n=5$) .200			
{ 431	{ 24	{ .1960	.1960		
{ 510	{ 12	{ .1960	.1960		
{ 511	{ 12	{ .1923		.1923	.1923
{ 111	{ 4	{ ($n=3$) .1923		($n=3$) .1923	($n=3$) .1923
{ 520	{ 12	{ .1856			
{ 432	{ 24	{ .1856			
521	24	.1826			
110	6	($n=4$) .1766	($n=4$) .1766	($n=2$) .1766	($n=2$) .1766
{ 530	{ 12	{ .1714	.1714		
{ 433	{ 12	{ .1714	.1714		
531	24			.169	.169
{ 100	{ 3	{ .167	($n=3$) .167	($n=3$) .167	
{ 221	{ 12	{ .167	.167	.167	
{ 611	{ 12	{ .1621			
{ 532	{ 24	{ .1621			
310	12	($n=2$) .1580	.1580	.1580	.1580
533	12			.1525	.1525
311	12		.1507	($n=2$) .1507	($n=2$) .1507
631	24		.1474		
111	4		($n=2$) .1442	($n=4$) .1442	($n=4$) .1442
{ 110	{ 6	{ .1414	($n=5$) .1414		
{ 710	{ 12	{ .1414	.1414		
543	24				
{ 711	{ 12	{ .1400		.1400	.1400
{ 551	{ 12	{ .1400		.1400	.1400
320	12		.1387	.1387	
{ 211	{ 12	{ .1360	($n=3$) .1360		
{ 552	{ 12	{ .1360	.1360		
{ 721	{ 24	{ .1360			
321	24	($n=2$) .1336	.1336	.1336	.1336
730	12	.1312			
{ 553	{ 12	{ .1301		.1301	.1301
{ 731	{ 24	{ .1301		.1301	.1301
732	24	.1270			
{ 651	{ 24	{ .1270			
100	3	($n=4$) .1250	($n=4$) .1250	($n=4$) .1250	($n=2$) .1250
741	24	.1230			
{ 811	{ 12	{ .1230			
{ 554	{ 12	{ .1230			
733	12			.1222	.1222
{ 410	{ 12	{ .1212		.1212	
322	12	.1212		.1212	

The first lattice is the *simple cubic lattice*, the unit of whose structure is a cube with atoms at each corner. The positions of the atoms are specified by giving to each of the co-ordinates m, n, p all possible integral values within the limits of the size of the crystal. Each atom in the lattice has as nearest neighbors six symmetrically placed atoms, which form an octahedron about it. This arrangement of atoms is exemplified by rock salt, except that in rock salt the atoms are alternately sodium and chlorine. No elementary substance with simple cubic structure has yet been found.

The second lattice is a *centered cubic lattice*, whose unit is a cube with an atom in each corner, and one at the center of the cube. It may be formed by superimposing two simple cubic lattices in such manner that the atoms of the one are at the centers of the cubes of the other. The co-ordinates of the atoms are therefore given by

$$\left. \begin{array}{l} m, n, p, \\ m + \frac{1}{2}, n + \frac{1}{2}, p + \frac{1}{2}, \end{array} \right\}$$

where m, n , and p have all possible integral values. Each atom in this lattice has eight equidistant nearest neighbors, which form a cube about it. Examples of this structure are iron and sodium.

The third lattice is the *face-centered cubic lattice*. Its unit of structure is a cube with an atom at each corner and one in the center of each face. It may be formed by the superposition of four simple cubic lattices with construction points¹ $0, 0, 0$; $\frac{1}{2}, \frac{1}{2}, 0$; $\frac{1}{2}, 0, \frac{1}{2}$; $0, \frac{1}{2}, \frac{1}{2}$, respectively. The co-ordinates of the atoms are therefore

$$\begin{array}{l} m, n, p, \\ m + \frac{1}{2}, n + \frac{1}{2}, p, \\ m + \frac{1}{2}, n, p + \frac{1}{2}, \\ m, n + \frac{1}{2}, p + \frac{1}{2}, \end{array}$$

where m, n , and p have all possible integral values. Each atom in this lattice is surrounded by twelve equidistant atoms which form a regular dodecahedron about it. Examples of this structure are aluminium, copper, silver, gold and lead.

The fourth lattice is known as the *diamond type* of lattice, and is exemplified by diamond and silicon. It may be formed by the superposition of two face-centered lattices, with construction points $0, 0, 0$, and $\frac{1}{4}, \frac{1}{4}, \frac{1}{4}$ respectively. The co-ordinates of the atoms are therefore

$$\begin{array}{l} m, n, p, \\ m + \frac{1}{2}, n + \frac{1}{2}, p, \\ m + \frac{1}{2}, n, p + \frac{1}{2}, \\ m, n + \frac{1}{2}, p + \frac{1}{2}, \\ m + \frac{1}{4}, n + \frac{1}{4}, p + \frac{1}{4}, \\ m + \frac{3}{4}, n + \frac{3}{4}, p + \frac{1}{4}, \\ m + \frac{3}{4}, n + \frac{1}{4}, p + \frac{3}{4}, \\ m + \frac{1}{4}, n + \frac{3}{4}, p + \frac{3}{4}, \end{array}$$

where m, n , and p have all possible integral values.

Each atom in this lattice is surrounded by four equidistant atoms, which form a tetrahedron about it. The tetrahedra, however, are not all similarly situated, half of the atoms being surrounded by positive tetrahedra, and the other half by negative tetrahedra. In this lattice successive parallel planes are not all equidistant. In those forms whose indices are all odd numbers, as (751), (533), the planes are arranged in regularly spaced pairs, the distance between members of a pair being one fourth the distance between consecutive pairs. In all other forms, that is, those whose indices are not all odd, the spacing is regular.

¹ The term "construction point" is used to denote the position of some definite point, which may be looked upon as the starting point of each lattice, with respect to the co-ordinate axes.

B. Crystals Other Than Cubic

In the case of crystals belonging to systems other than the cubic, the procedure is not so simple. It is necessary to make a separate calculation, not only for every kind of atomic grouping, but for every different ratio of the axes or angle between axes. When these axes are not known from crystallographic data, as in the case of graphite, for example, a great many trials have to be made before the correct one is found. Also, in the case of oblique axes the formula for the distance between planes is less simple. However, when the crystallographic data is reliable the process is not difficult. A few examples will be given below for illustration and reference.

The general formula for the distance from a plane h, k, l (Miller indices) to a parallel plane through the point x_1, y_1, z_1 , referred to any system of axes X, Y, Z , having angles λ, μ, ν between the axes YZ, XZ , and XY respectively, is¹

$$d = \frac{hx_1 + ky_1 + lz_1 - 1}{\begin{vmatrix} h \cos \nu & \cos \mu & 1 & h \cos \mu & 1 & \cos \nu & h \\ h & k & 1 & \cos \lambda & +k & \cos \nu & k \cos \lambda & +l & \cos \nu & 1 & k \\ l & \cos \lambda & 1 & \cos \mu & l & 1 & \cos \mu & \cos \lambda & l \\ 1 & \cos \nu & \cos \mu & \cos \nu & 1 & \cos \lambda & \cos \mu & \cos \lambda & 1 \end{vmatrix}}{2}$$

For the three rectangular systems, the cubic, tetragonal and orthorhombic, λ, μ , and ν are each 90 deg. and equation (2) reduces to equation (1). For the tetragonal and orthorhombic systems, however, and in all the other systems except the cubic and trigonal, the co-ordinates x_1, y_1, z_1 , and the indices h, k , and l are not all measured in the same units. The products hx_1, ky_1, lz_1 , of the numerator are of zero dimensions, but the values of h, k , and l in the denominator contain the units, and must be replaced by $h/a, k/b, l/c$, where a, b , and c are the unit axes of the crystal in the X, Y , and Z directions respectively. This gives:

For the tetragonal system

$$d = \frac{hx_1 + ky_1 + lz_1 - 1}{\sqrt{h^2 + k^2 + (l/c)^2}}, \quad (3)$$

where c is the axial ratio of the crystal; and for the orthorhombic system

$$d = \frac{hx_1 + ky_1 + lz_1 - 1}{\sqrt{(h/a)^2 + k^2 + (l/c)^2}}, \quad (4)$$

where a and c are the lengths of the shorter lateral axis and vertical axis respectively.

For the hexagonal system, if two of the horizontal axes, 120 deg. apart, are taken as X and Y , and the vertical axis as Z , λ and μ are each 90 deg. and ν 120 deg., and equation (2) reduces to

$$d = \frac{hx_1 + ky_1 + lz_1 - 1}{\sqrt{4/3(h^2 + hk + k^2) + (l/c)^2}}, \quad (5)$$

where c is the "axial ratio" for the particular crystal species.

¹ This formula is easily obtained from the fundamental equation

$$d = x_1 \cos \alpha + y_1 \cos \beta + z_1 \cos \gamma - p,$$

by substituting for $\cos \alpha, \cos \beta, \cos \gamma$, and ν their values in terms of h, k, l, λ, μ , and ν given by the equations:

$$\begin{aligned} \cos \alpha &= l' + m \cos \nu + n \cos \mu = hp \\ \cos \beta &= l' \cos \nu + m + n \cos \lambda = kp \\ \cos \gamma &= l' \cos \mu + m \cos \lambda + n = lp \\ l' \cos \alpha + m \cos \beta + n \cos \gamma &= 1 \end{aligned}$$

where $\cos \alpha, \cos \beta, \cos \gamma$ are the direction cosines, and l', m, n the direction ratios of the perpendicular p from the origin to the plane hkl .

For the trigonal system, in which $\lambda = \mu = \nu$, equation 2 reduces to

$$d = \frac{(hx_1 + ky_1 + lz_1 - 1)\sqrt{1 + 2\cos^3\lambda - 3\cos^2\lambda}}{\sqrt{(h^2 + k^2 + l^2)\sin^2\lambda + 2(hk + hl + kl)(\cos^2\lambda - \cos\lambda)}} \quad (6)$$

For the monoclinic system λ and ν are each 90 deg. and equation (2) becomes

$$d = \frac{hx_1 + ky_1 + lz_1 - 1}{\sqrt{\frac{\left(\frac{h}{a}\right)^2 + \left(\frac{l}{c}\right)^2 - 2\frac{hl}{ac}\cos\mu}{\sin^2\mu} + k^2}}, \quad (7)$$

where a and c refer to the lengths of the clinodiagonal and vertical axes respectively, the orthodiagonal axis b being taken as unity.

Finally, for the triclinic system, for which the general equation (2) must be used, it should be noted that in order to use the equation for numerical calculation, the quantities h , k , and l in the denominator should be divided by the corresponding axial lengths a , b , c .

Standard tables of calculated spacings, like Table III above, cannot be given for crystal systems other than the isometric, since the axial ratios and angles are different for each crystal. By way of example, however, the spacings of three hexagonal lattices having the axial ratio 1.624, which is the accepted value for magnesium, are given in Table IV. The first is a simple lattice of triangular prisms, the length of whose side is taken as unity and whose height is therefore 1.624. It is one of the regular space lattices. The positions of the atoms in this lattice are given, in hexagonal co-ordinates (see equation (5) above) by $(x, y, z) = m, n, pc$ where each of the co-ordinates m , n , and p assumes all possible integral values, and c is the axial ratio. The second lattice in Table IV is composed of two of the above triangular lattices intermeshed in such a way that the atoms of the first are in the centers of the prisms of the second and vice versa. It differs but very little from the so-called hexagonal close-packing, which is one of the two alternative arrangements which the atoms would assume if they were hard spheres and were forced by pressure into the closest possible packing. The positions of the atoms

are given by $\left\{ \begin{array}{l} m, n, pc \\ m + \frac{1}{3}, n + \frac{2}{3}, (p + \frac{1}{2})c \end{array} \right.$ where the co-ordinates refer to hexagonal axes,

and m , n , p , have all possible integral values. The third lattice in Table IV is composed of three of the above simple triangular lattices, the atoms of the second and third being directly above the centers of the alternate triangles of the first lattice, at distances of $\frac{1}{3}$ and $\frac{2}{3}$ respectively of the height of the prism. It is the regular rhombohedral lattice. The positions of the atoms in this lattice may be most simply specified with reference to trigonal axes, but for convenience of comparison with the first two lattices, they are given in terms of hexagonal axes. The hexagonal co-ordinates are

$$\left\{ \begin{array}{l} m, n, pc \\ m + \frac{1}{3}, n + \frac{2}{3}, (p + \frac{1}{3})c \\ m + \frac{2}{3}, n + \frac{1}{3}, (p + \frac{2}{3})c \end{array} \right.$$

where m , n , and p have all possible integral values, and c is the axial ratio 1.624.

The first column in Table IV gives the indices of the form, the second, fourth and sixth the number of different families of planes belonging to the form, and the third, fifth and seventh the spacing of these planes in the respective lattices, found by substituting the co-ordinates of the atoms in equation (5). The unit is the side of the elementary triangular prism. The eighth column gives, for comparison, the indices of the

TABLE IV

Indices of Form	SIMPLE TRIANGULAR LATTICE		CLOSE PACKED LATTICE		RHOMBOHEDRAL LATTICE		
	Number of Co-operating Planes	Spacing of Planes	Number of Co-operating Planes	Spacing of Planes	Number of Co-operating Planes	Spacing of Planes	Trigonal Indices of Form
0001	1	1.624					
10 $\bar{1}$ 0	3	.866	3	.866			
0001	1	($n=2$) .812	1	.812			
10 $\bar{1}$ 1	6	.764	6	.764	3	.764	100
10 $\bar{1}$ 2	6	.592	6	.592	3	.592	110
0001	1	($n=3$) .541			1	.541	111
11 $\bar{2}$ 0	3	.500	3	.500	3	.500	$\bar{1}$ 10
11 $\bar{2}$ 1	6	.477					
10 $\bar{1}$ 3	6	.458	6	.458			
10 $\bar{1}$ 0	3	($n=2$) .433	3	($n=2$) .433			
11 $\bar{2}$ 2	6	.426	6	.426			
20 $\bar{2}$ 1	6	.418	6	.418	3	.418	$\bar{1}$ 11
0001	1	($n=4$) .406	1	($n=2$) .406			
10 $\bar{1}$ 1	6	($n=2$) .382	6	($n=2$) .382	3	($n=2$) .382	100
10 $\bar{1}$ 4	6	.368	6	.368	3	.368	211
11 $\bar{2}$ 3	6	.367			6	.367	210
20 $\bar{2}$ 3	6	.338	6	.338			
21 $\bar{3}$ 0	6	.327	6	.327			
0001	1	($n=5$) .325					
21 $\bar{3}$ 1	12	.321	12	.321	6	.321	$\bar{2}$ 10
11 $\bar{2}$ 4	6	.315	6	.315			
{ 10 $\bar{1}$ 5	6	.304	6	.304	3	.304	221
{ 21 $\bar{3}$ 2	12	.304	12	.304	6	.304	$\bar{2}$ 11
10 $\bar{1}$ 2	6	($n=2$) .296	6	($n=2$) .296	3	($n=2$) .296	110
10 $\bar{1}$ 0	3	($n=3$) .289	3	($n=3$) .289	3	.289	$\bar{2}$ 11

planes of the rhombohedral lattice in trigonal (Miller) co-ordinates. The atoms are in this case referred to three equal axes, making equal angles of 78.4 deg. with each other, and their co-ordinates are m , n , p , where each of these numbers has all possible integral values.

EXAMPLES

As examples of the application of the method of analysis described above, the analysis of ten elementary crystalline substances is given below. Three of these analyses are incomplete, but are of such importance as to warrant their inclusion. Four others have already been briefly described elsewhere, and are given here in more detail. The last, diamond, which has been completely analyzed by the Braggs, is added as a check upon the method, and as an example of the immense amount of information which can be obtained from a single photograph.

The experimental data is collected in Tables V to XIV. The first column in each table gives the estimated intensity of each line. The estimate is necessarily very rough, but photometric measurements have little value unless care is taken to make control exposures to determine the characteristic curve of the plate under the actual conditions of exposure and development. In the photographs here described, this was not done. The second column gives the distance, x , of each line on the photograph from the central undeviated image of the slit. The third column gives the angular deviation 2θ , of the ray that produced the line, calculated from x and the distance between crystalline material and photographic plate. The fourth and fifth columns give the experimental

and theoretical values of d/n , where d is the distance in Ångströms between consecutive planes, and n the order of reflection. The experimental values of d/n are calculated from the angular deviation 2θ by means of the equation $n\lambda = 2d \sin \theta$. The theoretical values are obtained by multiplying the values in Table III and IV by the lattice constants of the respective crystals. The sixth column gives the indices of the forms to which the reflecting planes belong, and the last column the number of families of planes belonging to the given form and having the same spacing, so that their reflections are superimposed. The number of these co-operating planes is a measure of the intensity of the line to be expected if the atoms are symmetrical and equally distributed in successive planes.

IRON

The iron investigated was obtained from two sources, viz., fine filings of pure electrolytic iron, and fine iron powder obtained by the reduction of Fe_2O_3 in hydrogen. The filings were mounted in a thin-walled glass tube 2 mm. in diameter, which was kept in rotation during the exposure. The reduced oxide was pressed into a sheet 2 mm. thick, which was mounted firmly at right angles to the beam of X-rays. Both specimens gave the same lines.

A fine-focus Coolidge X-ray tube with tungsten target was used for all the iron photographs. It was operated by the constant potential equipment which has been in use for two years in the Research Laboratory,¹ at 110,000 volts and 1 milliamperere.

Fig. 6 shows one of the photographs of the iron powder (reduced oxide). For all lines beyond the first three, the α doublet is resolved into two very narrow, sharp lines. The β line of the K radiation is visible on the plate for some of the stronger reflections, but is easily distinguishable from the double α line. In this exposure both slits were very narrow, about 0.2 mm. wide. The distance from X-ray tube to first slit was 20 cm., from first to second slit 15 cm., and from crystal to photographic plate 18.15 cm. Seed X-ray plate was used, with calcium tungstate intensifying screen. The exposure was 20 hours.

The lines in this photograph are tabulated in Table V, together with the calculated spacings, as described above. The observed spacings (column 4) agree with the theoretical spacings for a centered cube of side 2.86 Å. (column 5) within the limit of ac-

TABLE V

Iron

Intensity of Line	Distance of Line from Center	Angular Deviation of Line 2θ	SPACING OF PLANES IN ÅNGSTRÖMS		Indices of Form	Number of Co-operating Planes
			Experimental	Theoretical		
1.00	1.87	5.90	2.05	2.06	110	6
.46	2.67	8.40	1.43	1.43	100	3
.54	3.40	10.30	1.16	1.16	211	12
.24	3.85	11.96	1.005	1.01	110 ($n=2$)	3
.18	4.32	13.40	.910	.905	310	12
.16	4.75	14.67	.823	.826	111	4
.22	5.17	15.90	.757	.765	321	24
				.715	100 ($n=2$)	3
.12	5.92	18.06	.665	.675	{ 110 ($n=3$)	18
					{ 411	12
.03	6.27	19.06	.633	.638	210	12
.02	6.62	20.06	.600	.610	332	12
.02	7.00	21.10	.572	.584	211 ($n=2$)	
					{ 510	
.10	7.25	21.78	.555	.560	{ 431	36
.02	7.95	23.16	.522	.522	521	24

¹ Phys. Rev., 7, 405, 1916. For a fuller description see G. E. Review, 19, 173, March, 1916.

curacy of measurement of the lines. The intensities also vary in the manner to be expected, except that the second order 110 line is too intense and the second order 100 too weak. The bearing of this fact on the question of the arrangement of electrons in the iron atom has been discussed elsewhere.¹

A centered cubic lattice should have two atoms associated with each elementary cube. By equating the mass of the n atoms in an elementary cube to the mass of the cube, *i. e.*, its volume \times density of the metal, we obtain

$$n = \frac{\rho d^3}{M} = \frac{7.86 \times 2.86^3 \times 10^{-24}}{55.4 \times 1.663 \times 10^{-24}} = 2.00$$

As a check upon this analysis, photographs were taken of single crystals of silicon steel, containing about 3.5 per cent silicon, which were mounted on the spectrometer table and rotated about definite axes. Two of these photographs are reproduced in Fig. 7. The first, Fig. 7*a*, is the photograph of a thin crystal about 5 mm. square, cut parallel to 100. It was mounted 12 cm. from the photographic plate, with its 100 face normal to a beam of tungsten rays, and rotated slowly, about an axis perpendicular to 001, for a few degrees on each side of the center. It shows, in the horizontal plane, the spectrum of the tungsten target reflected from 010, and at 45 deg. and 135 deg. the same reflected from 011 and 0 $\bar{1}1$ respectively. The two K lines in tungsten, the unresolved α doublet and the β line, show plainly in each of these spectra, and the distance between the α doublets of the right and left spectra, *viz.*, 3.56 cm. for 010, and 2.50 cm. for 011, give for the spacings of these planes:

$$\begin{aligned} d_{010} &= 1.43 \text{ \AA.}, \\ d_{011} &= 2.04 \text{ \AA.} \end{aligned}$$

The second photograph, Fig. 7*b*, shows the result of rotating a thin crystal cut parallel to 111, and mounted normal to the rays, about an axis perpendicular to 110, for a few degrees on each side. It shows, in the horizontal plane, the reflection from $\bar{1}12$ and at 30, 60 and 71 deg. to the horizontal the reflections from $\bar{1}01$, $\bar{2}11$, $\bar{3}21$, with corresponding reflection from $\bar{2}31$, $\bar{1}21$ and $\bar{0}11$ at angles of 109, 120 and 150 deg. respectively to the horizontal. The planes $\bar{1}01$ and $\bar{0}11$ show both first and second order spectra. The distances between α lines of these spectra agree excellently for planes belonging to the same form, and give for the spacing of the planes in the three forms represented:

$$\begin{aligned} d_{\bar{2}11} &= 1.15 \text{ \AA.}, \\ d_{\bar{1}10} &= 2.02 \text{ \AA.}, \\ d_{\bar{3}21} &= 0.75 \text{ \AA.} \end{aligned}$$

The agreement of these angles and spacings with the theoretical values for a centered cubic lattice indicates that the position of the atoms in iron is not greatly affected by the presence of 3½ per cent Si.

A series of photographs of one of these crystals at liquid air temperature, room temperature, and 1000 deg. C. respectively showed no observable change, even in intensities. It is necessary to photograph more forms, however, before definite conclusions can be drawn regarding the relation of α to β iron. Several photographs of iron powder at different temperatures between 700 deg. C. and 900 deg. C. were spoiled, either by chemical fog due to the heating of the photographic plate, or by the growth of the crystals during exposure, thus giving only a few large spots on the photograph.

SILICON

Small crystals of metallic silicon were crushed in a mortar and sifted through a gauze of 200 meshes to the inch. The fine powder was mounted in a very thin-walled

¹ Phys. Rev., *9*, 84, 1917.

tube of lime glass, and kept in continuous rotation during a four-hour exposure to rays from a molybdenum target, running at 32 kv. constant potential and 8 milliamperes. A filter of zircon powder .037 cm. thick reduced the spectrum essentially to a single line, the unresolved α doublet, $\lambda = .712$, of molybdenum, as shown in Fig. 3. The crystal was 15 cm. from the X-ray target and 11.3 cm. from the photographic film, which was bent in the arc of a circle, with the crystal at the center. Both slits were quite wide, about 1 mm., and about 5 cm. apart. Eastman X-ray film was used, with calcium tungstate intensifying screen.

The photograph obtained is reproduced in Fig. 8, and the measurements are given in Table VI. The spacings tabulated as "theoretical" are those of a lattice of the diamond type, *i. e.*, two intermeshed face-centered lattices, each of side 5.43 Å., one lattice being displaced, with reference to the other, along the cube diagonal a distance one fourth the length of the diagonal. The agreement is perfect. The estimates of intensity are not accurate enough to warrant discussion.

The number of atoms associated with each unit cube is

$$n = \frac{\rho d^3}{M} = \frac{2.34 \times 5.43^3}{28.1 \times 1.663} = 8.00,$$

which is the correct number for this type of lattice.

TABLE VI
Silicon

Intensity of Line	Distance of Line from Center	Angular Deviation of Line 2θ	SPACING OF PLANES IN ANGSTROMS		Indices of Form	Number of Cooperating Planes
			Experimental	Theoretical		
Estimated	Cm.	Degrees				
1.00	2.58	13.56	3.13	3.14	111	4
.80	4.21	23.0	1.93	1.93	110	6
.75	4.97	26.16	1.64	1.64	311	12
0				1.57	111 ($n=2$)	4
.25	6.00	31.58	1.36	1.356	100	3
.45	6.54	34.42	1.25	1.25	331	12
.50	7.39	38.92	1.11	1.11	211	12
.40	7.84	40.78	1.05	1.04	{ 511	16
.20	8.59	45.20	.96	.96	{ 111 ($n=3$)	16
.30	8.98	47.22	.92	.92	{ 110 ($n=2$)	6
.25	9.66	50.44	.86	.86	531	24
.10	10.01	52.44	.83	.83	310	12
0				.82	533	12
.05	10.62	55.70	.79	.79	311 ($n=2$)	12
.10	11.00	59.76	.76	.76	{ 111 ($n=4$)	4
.20	11.58	60.36	.73	.73	{ 711	24
.15	11.90	62.56	.71	.71	{ 551	24
0				.68	{ 321	36
0				.66	{ 731	3
.05	13.33	70.0	.64	.64	{ 553	12
.05	13.60	71.44	.63	.63	{ 100 ($n=2$)	12
					{ 733	12
					{ 411	12
					{ 751	28
					{ 111 ($n=5$)	28

ALUMINIUM

Fine filings of pure sheet aluminium were mounted in exactly the same manner as silicon, and exposed for 3 hours to molybdenum rays, produced at 40,000 volts, 9 milliamperes, and filtered by .037 cm. of zircon powder. The photograph obtained is shown in Fig. 9, and the measurements are given in Table VII.

TABLE VII
Aluminium

Intensity of Line	Distance of Line from Centre	Angular Deviation of Line 2θ	SPACING OF PLANES IN ANGSTROMS		Indices of Form	Cooperating Planes
			Experimental	Theoretical		
Estimated	Cm.	Degrees				
1.00	3.45	17.80	2.33	2.33	111	4
.60	3.99	20.60	2.025	2.025	100	3
.50	5.67	29.26	1.43	1.43	110	6
.60	6.68	34.5	1.21	1.22	311	12
.20	6.95	35.8	1.17	1.17	111 ($n=2$)	4
.05	8.09	41.8	1.01	1.01	100 ($n=2$)	3
.25	8.86	45.6	.93	.93	331	12
.25	9.11	47.0	.90	.90	210	12
.10	10.05	51.8	.82	.83	211	12
.15	10.66	55.0	.78	.78	{ 511	
.02	11.75	60.6	.71	.72	{ 111 ($n=3$)	16
.04	12.30	63.4	.68	.68	{ 110 ($n=2$)	6
					531	24

TABLE VIII
Magnesium

Intensity of Line	Distance of Line from Centre	Angle of Reflection	SPACING OF PLANES IN ANGSTROMS		Indices of Form	Number of Cooperating Planes
			Experimental	Theoretical		
Estimated	Cm.	Degrees				
.40	2.92	14.80	2.75	2.75	1010	3
				2.59	0001	1
1.00	3.30	16.66	2.44	2.44	10 $\bar{1}$ 1	6
.30	4.23	21.48	1.91	1.90	1012	6
.40	5.03	25.50	1.61	1.60	11 $\bar{2}$ 0	3
.35	5.50	27.8	1.48	1.48	10 $\bar{1}$ 3	6
				1.38	1010 (2)	3
.35	5.95	30.00	1.36	1.36	11 $\bar{3}$ 2	6
.12	6.05	30.6	1.34	1.34	20 $\bar{2}$ 1	6
				1.30	0001 (2)	1
.06	6.65	33.6	1.23	1.23	10 $\bar{1}$ 1 (2)	6
.02	6.9	34.8	1.18	1.18	10 $\bar{1}$ 4	6
.10	7.52	38.0	1.09	1.08	20 $\bar{2}$ 3	6
.18	7.96	40.2	1.04	1.05	21 $\bar{3}$ 0	6
.02	8.1	41.0	1.02	1.03	21 $\bar{3}$ 1	12
				1.01	11 $\bar{2}$ 4	6
.12	8.41	42.6	.98	.97	{ 21 $\bar{3}$ 2	
					{ 10 $\bar{1}$ 5	18
				.94	1012 (2)	6
.01	8.83	44.8	.93	.92	1010 (3)	3
.10	9.15	46.2	.90	.89	21 $\bar{3}$ 3	12
.06	9.48	48.0	.87	.87	{ 3032	
					{ 0001 (3)	7
.02	9.90	50.2	.83	.83	{ 10 $\bar{1}$ 6	
				.82	{ 20 $\bar{2}$ 5	12
					{ 10 $\bar{1}$ 1 (3)	
					{ 21 $\bar{3}$ 4	18
				.80	11 $\bar{2}$ 0 (2)	3
.06	10.95	55.4	.77	.77	31 $\bar{4}$ 0	6

The "theoretical" spacings in Table VII are those of a face-centered cubic lattice. Their agreement with the "experimental" values obtained from the lines on the photograph is satisfactory.

The number of atoms per unit elementary cube is

$$n = \frac{\rho a^3}{M} = \frac{2.70 \times (4.05)^3}{2.69 \times 1.663} = 4.00.$$

This is the correct number for a face-centered lattice.

The unit of structure of the aluminium crystal is, therefore, a face-centered cube, of side 4.05 Å., with one atom of aluminium at each corner and one at the center of each face.

MAGNESIUM

The magnesium used in these experiments was the commercial electrolytic product made in the research laboratory. Several photographs were taken, some with fine filings from cast rods of this metal, and some with filings from large crystals formed by vacuum distillation. Both kinds of powder gave the same results.

The powder was mounted in a 2-mm. tube of thin glass, and exposed under exactly the same conditions as silicon and aluminium. Fig. 10 shows a photograph obtained from a 6-hour exposure at 32,000 volts and 9 milliamperes, and Table VIII gives the numerical data.

The "theoretical spacings" in Table VIII are those of a hexagonal lattice composed of two sets of triangular prisms, each of side 3.22 Å. and axial ratio 1.624, with construction points 000 and $\frac{1}{3}$, $\frac{2}{3}$, $\frac{1}{2}$ respectively. This is the lattice whose spacings are given in column 5 of Table IV, under "Close-Packed Lattice." It is slightly distorted, however, from true hexagonal close packing, which requires an axial ratio of 1.633. This variation from theoretical close packing is to be attributed to a slight asymmetry in the structure of the magnesium atoms.

The agreement between calculated and experimental spacings is satisfactory, except that several lines which were to be expected do not show in the photograph. In particular, the reflection from the basal plane, 0001, is absent in all the photographs.

It seemed desirable, therefore, to supplement the evidence furnished by the powder photographs by photographs of single crystals, mounted with definite orientations. Several such photographs were taken, the measurements of three of which are given in Table IX. The crystals were formed by vacuum distillation, and were about 2 mm. in diameter. The first was mounted with its basal plane (0001) parallel to the rays, and rotated slowly about an axis normal to $1\bar{2}10$, for about 30 deg. on each side of the center.¹

The second crystal was mounted so as to rotate about the same axis as the first, but with $10\bar{1}0$ parallel to the rays at the start. The third was mounted with $11\bar{2}0$ parallel

TABLE IX

CRYSTAL 1			CRYSTAL 2			CRYSTAL 3		
Position of Line	Spacing of Plane	Indices of Plane	Position of Line	Spacing of Plane	Indices of Plane	Position of Line	Spacing of Plane	Indices of Plane
3.10	2.59	0001	2.90	2.75	$10\bar{1}0$	5.02	1.60	$11\bar{2}0$
2.90	2.75	$10\bar{1}0$	3.10	2.59	0001	5.50	1.48	$10\bar{2}1$
3.30	2.44	$10\bar{1}1$	3.30	2.44	$10\bar{1}1$	6.0	1.36	$11\bar{2}2$
4.20	1.90	$10\bar{1}2$	6.05	1.34	$20\bar{2}1$			
5.50	1.48	$10\bar{1}3$	8.92	0.92	$10\bar{1}0(3)$			
6.27	1.30	0001(2)	5.9	1.38	$10\bar{1}0(2)$			

¹ The reflection from $10\bar{1}0$ should not have appeared on this plate. It was very faint, but clearly visible on both sides, and was probably due to a twin upon $10\bar{1}1$, a small portion of which was included in cutting the crystal from the mass of other crystals upon which it grew. A second specimen mounted and photographed in the same manner did not show this line. Similar twinning must account for the 0001 reflection shown by crystal 2, and $10\bar{1}3$ by crystal 3.

to the rays, and rotated about an axis normal to $10\bar{1}0$. The patterns obtained in these photographs differed from those of the single iron crystals in containing reflections from many more planes, corresponding to the greater complexity of the hexagonal system. Molybdenum rays were used, filtered through .037 cm. of zircon, so that the spectrum consisted of a single line.

The lines reflected in the horizontal plane, which appeared on the three photographs, are given in Table IX. The 0001 reflection was very strong on the first photograph, and on three additional photographs which were taken to make certain its identity. Its absence in all the powder photographs must be due, therefore, to the much greater relative intensity of the reflections from other forms, containing many more planes. These forms reflect not only the lines but the unabsorbed part of the general spectrum, causing a fog over the plate that obscures weak lines.

The lines tabulated in Table IX, and all the others which appeared on these photographs, are the ones which should appear, with the exceptions mentioned in the above note.

The evidence seems sufficient that the assumed structure is correct, viz., that the atoms of magnesium are arranged on two interpenetrating lattices of triangular prisms, each of side 3.22 Å. and height 5.23 Å., with one atom at each corner, the atoms of one set being in the center of the prisms of the other.

SODIUM

The first photographs of sodium were of rods, about 1 mm. in diameter and 1 cm. long, cut from an old sample that had been in the laboratory several years. These rods were placed in sealed glass tubes, and exposed to molybdenum rays. They gave intense reflections, of a pattern which indicated that the lump from which the samples were cut was a single large crystal.

Several unsuccessful attempts were then made to obtain finely divided crystals of sodium. Distillation in vacuum into the thin-walled tube which was to be photographed was found impossible. Several different glasses and pure silica tubing were tried. The sodium always ate through the tube wall before it could be coaxed into the narrow tube. Melting the distilled sodium so that it flowed into the tube resulted in an amorphous condition, which gave no lines at all. It is probable that distillation, had it succeeded, would have given the same result, for potassium distilled in this way was found to be completely amorphous. Shaking in hot xylol gave a beautiful collection of tiny spheres, but these too were amorphous, and annealing for 16 hours at 90 deg. C. failed to produce any appreciable crystallization. Crystallization from ammonia solution gave a black mass, from which it was difficult to separate the pure sodium. Fairly good photographs were obtained with fine shreds, scraped from the lump, with a knife, under dry xylol, and packed in a small glass tube.

A satisfactory sample was finally prepared by squirting the cold metal through a 0.01 cm. die, and packing the fine thread, with random folding, into a 1 mm. glass tube, which was immediately sealed. The sample from which this was taken was about two months old, and was apparently only slightly crystallized, so that only a few lines were visible, on the dense continuous background due to the amorphous part. Two photographs, taken under the same conditions as the preceding, with exposures of 4 and 14 hours respectively at 30 kv. 27 milliamperes, gave identical lines, which are tabulated in Table X.

TABLE X
Sodium

Intensity of Line	Distance of Line from Center	Angular Deviation of Line 2θ	SPACING OF PLANES IN ANGSTROMS		Indices of Form	Number of Cooperating Planes
			Experimental	Theoretical (Centered Cube)		
Estimated	Cm.	Degrees				
1.00	2.66	13.38	3.05	3.04	110	6
.10	3.78	19.06	2.15	2.15	100	3
.40	4.66	23.36	1.76	1.76	211	12
.10	5.38	27.04	1.52	1.52	110(2)	6
.08	6.03	30.26	1.36	1.36	310	12
.02	6.57	33.40	1.24	1.24	111	4
.05	7.18	36.0	1.15	1.15	321	24

These seven lines, which are the only ones that appeared on any of the sodium photographs, agree perfectly with the theoretical spacings of a centered cubic lattice, of side 4.30 Å., and cannot be made to fit any other simple type of lattice.

The number of atoms per elementary cube is

$$n = \frac{0.970 \times 4.30^3}{22.8 \times 1.663} = 2.03,$$

which is as close to the required number, two, as the data would warrant.

The evidence is sufficient, I think, in spite of the limited number of lines, to show that the atoms of sodium, when in its crystalline form, are arranged on a lattice whose unit of structure is a centered cube, of side 4.30 Å., with one atom at each corner and one in the center of the cube. The tendency to form this regular arrangement is, however, very slight, corresponding to a small difference between the potential energies of the crystalline and amorphous states. This fact is important for the determination of the structure of the sodium atom.

The structures of the elements thus far described have been determined with considerable certainty. The three following have been only partially determined, but are included as examples of the possibilities, as well as the difficulties, of the analysis.

LITHIUM

The structure of lithium is of special interest because, on account of the small number of electrons associated with each atom, it may be expected to yield valuable information regarding the arrangement of these electrons around the nucleus. The analysis is difficult, however, on account of the complete lack of crystallographic data, the slowness of crystallization, and the difficulty of obtaining pure metal.

It was first attempted to distill lithium in vacuum, for the double purpose of purification and of obtaining small crystals. Various methods of heating the metal were tried, such as a tungsten spiral with the lithium ribbon lying in its axis, a molybdenum cup heated externally by electron bombardment, etc., but without success. The metal reacts violently with glass and silica at temperatures far below those at which its vapor pressure is appreciable.

Two samples were used. The first was prepared by electrolysis of pure lithium chloride, in a graphite crucible, and probably contains little impurity except carbon. A small lump was rolled, between steel surfaces, into a cylinder 2 mm. in diameter, and sealed in a glass tube. It was exposed, in the same manner as the previous crystals, for 7 hours to molybdenum rays at 40 kv. and 6 milliamperes, and gave the lines tabulated in Table XI.

TABLE XI
Lithium

Intensity of Line	Distance of Line from	Angle of Reflection	SPACING OF PLANES IN ANGSTROMS		Indices of Form	Number of Cooperating Planes
			Experimental	Theoretical (Simple Cube)		
Estimated	Cm	Degrees				
				3.50	100	3
.70	3.20	16.50	2.50	2.48	110	6
1.00	3.96	20.44	2.02	2.02	111	4
.05	4.61	23.4	1.75	1.75	100(2)	3
				1.56	210	12
.40	5.62	29.0	1.43	1.43	211	12
.02	6.5	33.6	1.24	1.24	110(2)	6
.60	6.95	35.9	1.17	1.17	{ 221	
					{ 100(3)	15
				1.10	310	12
				1.05	311	12
.10	8.07	41.6	1.01	1.01	111(2)	4
				.97	320	12
				.87	100(4)	3
				.85	{ 410	
					{ 322	24
.05	9.99	51.6	.83	.83	{ 411	
					{ 110(3)	18
				.80	331	12
.20	10.82	56.0	.77	.78	210(2)	12

The spacings calculated are those of a simple cubic lattice, of side 3.50 Å., and the density of lithium requires that 2 atoms be associated with each point of the lattice, viz.:

$$n = \frac{\rho d^3}{M} = \frac{0.53 \times 3.50^3}{6.89 \times 1.663} = 2.00$$

A centered cubic lattice in which half of the atoms, those belonging to one of the two component simple cubic lattices, are oriented oppositely to the other half, could probably be made to fit the observations by assuming a suitable arrangement of the electrons in the atoms. It is more probable, however, in view of the next photograph, that the strong lines at 3.96 cm. and 6.95 cm. are due either to an impurity or to the admixture of a second form of lithium. All the other lines in Table XI are consistent with a centered cubic lattice, of side 3.50 Å., with one atom of lithium at each cube corner and one in the center of each cube.

The second sample was taken from a very old stock of supposedly very pure lithium, origin not known. A fine thread was squirted through a die and packed into a glass tube, in the same manner as sodium. A five-hour exposure to molybdenum rays, at 30 kv. 27 milliamperes, gave only 3 lines, viz., a strong line at 3.22 cm., and two weaker lines at 4.60 cm., and 5.46 cm. These are exactly the positions of the first three lines of the centered cubic lattice described above, and it is especially noteworthy that the line at 4.60 is relatively much stronger than on the preceding photograph, and the strong lines at 3.96 cm. and 6.95 cm. are entirely lacking. One is tempted to consider this last photograph as that of pure lithium, since its interpretation is simpler than the preceding, and it gives to lithium the same structure as sodium. The number of lines is too small, however, to justify this conclusion, and further experiments with purer metal are needed.

NICKEL

Specially purified nickel wire was melted in vacuum and cast in a lump. Filings from this lump were placed in a small cell 2.5 mm. thick, and exposed 4 hours to tung-

sten rays, produced at 110,000 volts, 1 milliamper, filtered through 0.015 cm. of tantalum. The photographic plate was placed 15.7 cm. from the crystal, at right angles to the beam of X-rays. The lines obtained are tabulated in Table XII.

TABLE XII
Nickel

Intensity of Line	Distance of Line from Centre	Angular Deviation of Line	SPACING OF PLANES IN ÅNGSTRÖMS		Indices of Form	Number of Cooperating Planes
			Experimental	Theoretical (Centered Cube)		
Estimated	Cm.	Degrees				
Very strong.....	1.70	6.17	1.95	1.95	110	6
Faint.....	2.42	8.75	1.38	1.38	100	3
Strong.....	2.97	10.70	1.13	1.13	211	12
Medium.....	3.42	12.25	.98	.98	110(2)	6
Faint.....	3.80	13.60	.89	.87	310	12
				.79	111	4
Strong.....	4.58	16.28	.74	.74	321	24

The spacings agree perfectly with those of a centered cubic lattice, of side 2.76 Å. with one atom of nickel at each cube corner and one in the center of the cube. Taking the density of pure nickel as 9.00, which is probably too low, the number of atoms associated with each elementary cube is

$$n = \frac{\rho d^3}{M} = \frac{9.00 \times 2.76^3}{58.2 \times 1.663} = 1.95$$

which is as close to the required value, 2, as the data will warrant.

Three other photographs, one of a thick electrolytic deposit on very thin nickel foil, the other two of a 2 mm. nickel rod of unknown origin, gave quite different lines. The electrolytic deposit was exposed but a short time, and gave 4 lines, at 1.64, 1.89, 2.70 and 3.14 cm. corresponding to spacings of 2.10, 1.76, 1.25, 1.07 respectively, *which are exactly the spacings of the first four lines of a face-centered cube, of side 4.52 Å.* The number of atoms associated with the elementary cube is

$$\frac{9 \times 3.52^3}{58.2 \times 1.663} = 4.02$$

which is correct for a face-centered cubic lattice containing one atom of nickel at each corner and one in the center of each face.

The other two photographs, of the nickel rod of unknown origin, contained the lines of both the preceding ones, but only these lines. It was presumably a mixture of the two crystalline forms of nickel, represented by the two preceding specimens respectively.

The evidence is very strong, therefore, that nickel crystallizes in two different forms, one a centered cubic lattice, like iron, and the other a face-centered cubic lattice, like copper. The relation of the magnetic and mechanical properties to these crystalline changes has not been studied, and the above analysis is to be regarded as only preliminary.

GRAPHITE

Several photographs of both natural and artificial graphite have been taken. The natural graphite was in large flakes, obtained from the Dixon Crucible Company. The artificial graphite was a very fine powder, furnished by the Acheson Company. Both had been heated to 3500 deg. C. in a special graphite furnace to remove impurities and ash.

The natural graphite, either in large flakes or where pressed into a glass tube, gave very unsymmetrical photographs, showing the predominance of certain orientations of the crystals. By forcing it through a copper gauze of 100 meshes to the inch, a power was obtained which, when packed in a glass tube and kept in rotation, gave very regular

TABLE XIII

Graphite

Intensity of Line	Distance of Center	Angular Deviation of Line	SPACING OF PLANES IN ANGSTROMS		Indices of Form	Number of Cooperating Planes
			Experimental	Theoretical		
Estimated	Cm.	Degrees				
100	2.40	12.16	3.37	3.37	0001	1
30	3.84	19.46	2.11	2.12	1010	3
60	3.99	20.20	2.03	2.02	1011	3
1	4.47	22.60	1.81	1.80	1012	6
3	4.81	24.34	1.690	1.685	0001(2)	1
2	5.21	26.38	1.560	1.544	1013	6
				1.318	1014	6
35	6.65	33.70	1.227	1.227	1120	3
50	7.09	35.90	1.155	1.152	1122	6
				1.138	1015	6
				1.124	0001(3)	1
				1.062	1010(2)	3
3	7.82	39.60	1.050	1.048	2021	6
				1.008	1011(2)	6
15	8.31	42.10	.990	.994	1016	6
				.990	1124	6
				.960	2023	6
				.897	1012(2)	6
				.877	1017	6
				.842	0001(4)	1
				.833	2025	6
2	10.06	51.0	.827	.829	1126	6
5	10.41	52.8	.800	.802	2130	6
				.797	2131	12
				.783	1018	6
				.780	2132	12
				.773	1013(2)	6
				.756	2133	12
				.725	2134	12
				.715	2027	6
7	11.85	60.0	.712	.708	1010(3)	3
				.708	1019	6
15	12.11	31.4	.697	.696	1128	6
				.693	3032	6
				.690	2135	12
1	12.61	64.0	.672	.674	1011(3)	6
				.674	0001(5)	1
				.660	1014(2)	6
9	12.94	65.6	.656	.654	3034	6
				.654	2136	12
				.644	10110	6
1	13.79	69.8	.621	.616	2137	12
				.616	1120(2)	3
3	14.11	71.50	.609	.612	2029	6
				.612	2241	6
				.603	1121(2)	6
				.598	1012(3)	6
2	14.57	73.8	.592	.592	2243	6
				.592	11210	6

and symmetrical photographs. *The lines in these photographs were identical with those in the photographs of artificial graphite*, showing that the two are identical in crystalline structure. One of these photographs, obtained from a 16-hour exposure to Mo rays at

34,000 volts and 16 milliamperes, is reproduced in Fig. 11, and the lines, together with the calculated spacings, are tabulated in Table XIII.

The crystallographic data regarding graphite is very meager and uncertain, and in attempting to guess its crystalline structure one has an embarrassing freedom of choice, both of crystal systems and of axial ratios and angles. The only guiding principles, apart from the lines in the photograph are, first, that the true structure is probably very simple and symmetrical, since all its atoms are alike, and second, that the nearest approach of adjacent atoms cannot be very different from that in diamond.

The structure whose spacings are tabulated in Table XIII, fits the experimental data best of all that have been tried, and seems capable, when account is taken of the internal structure of the atoms, of explaining all the observed intensities of the lines. It is a hexagonal structure, composed of four simple lattices of triangular prisms, each of side 2.47 Å. and height 6.80 Å., the atoms of the third lattice being directly above those of the first at a distance of one half the height of the prism, those of the 2d and 4th lattices being above the centers of alternate triangles of the first, at distances 1/14 and 8/14 respectively of the height of the prism. The co-ordinates of the atoms are:

$$\begin{array}{lll}
 m, & n, & pc, \\
 m + \frac{1}{3}, & n + \frac{2}{3}, & (p + \frac{1}{14})c, \\
 m, & n, & (p + \frac{1}{2})c, \\
 m + \frac{2}{3}, & n + \frac{1}{3}, & (p + \frac{8}{14})c,
 \end{array}$$

where m , n , and p have all possible values and c , the axial ratio, is 2.75. The 0001 planes are thus arranged in pairs, similar to the 111 planes in diamond. The distance between nearest consecutive planes, and between atoms in each plane, .48 Å. and 2.47 Å. respectively, are slightly less than their values .51 and 2.52 for diamond, and the nearest approach of atoms is 1.50 Å. as compared to 1.54 for diamond. This closer approach of the atoms in graphite would indicate chemical stability. The distance between consecutive pairs of planes, however, is much greater, viz., 3.40 Å. in graphite, than its value 2.06 Å. in diamond, which accounts for the extreme ease of basal cleavage and gliding in graphite.

The agreement between experimental and calculated spacings in Table XIII is well within the limit of the experimental error, which is about 1 per cent. Every experimental spacing is accounted for, the first 12 with certainty, the last 7 with some ambiguity on account of the large number of theoretical spacings. The absence of reflection from planes such as $10\bar{1}4$, $10\bar{1}5$, the second orders of $10\bar{1}0$ and $10\bar{1}1$, and the third and fourth orders of 0001, is dependent not only on the positions, but on the internal structure of the atoms, and cannot be interpreted except in conjunction with a study of this internal structure, which will be undertaken as soon as accurate photographic measurements can be obtained.

The structure given above has the lowest symmetry of any elementary substance yet studied. It may be that the essential elements of the hexagonal lattice can be more simply represented by a monoclinic or triclinic, or possibly an orthorhombic lattice, though efforts in this direction have so far been unsuccessful.

DIAMOND

The crystal structure of diamond has been completely determined by the Braggs,¹ and confirmed by numerous observers. Comparison of the results of these investigators with those obtained from a powder photograph will therefore serve as an excellent check upon the latter. In addition, the powder photograph of diamond has a merit of its own, for it furnishes evidence not hitherto available regarding the internal structure

¹ X-Rays and Crystal Structure, p. 102 ff., Proc. Roy. Soc. A., 89, 277.

of the most interesting of all atoms. The photographs taken thus far are not suitable for photomentering, but arrangements are complete for taking such photographs, and for measuring the intensity of the lines.

Several photographs of diamond have been taken, under varying conditions, with identical results, as regards position and relative intensity of lines. Fig. 12 shows the result of a fifteen-hour exposure to Mo rays at 30,000 volts, 35 milliamperes, with zircon filter of 0.37 mm. A very thin wall glass tube of special lithium boro-silicate glass, 2 mm. in diameter, was filled with diamond powder, obtained by crushing some old dies in a steel mortar. This powder was mounted on the spectrometer table, concentric with a wooden disc 10.27 cm. in diameter, upon which Eastmen X-ray film was fastened *in a complete circle*, except for a 5 mm. hole where the rays entered. The collimator slits were about 1.5 mm. wide, and the distance from X-ray target to powder was approximately 35 cm. Only one half of this film, corresponding to angles of diffraction from 0 deg. to 180 deg., is shown in Fig. 12. Twenty-five of the possible 27 lines are visible in the photograph, the last two being obscured by the dense fog.

TABLE XIV

Intensity of Line	Distance of Line from Center x	Angular Deviation of Line 2θ	SPACING OF PLANES IN ÅNGSTROMS		Indices of Form	Number of Cooperating Planes
			Experimental	Theoretical		
Estimated	Cm.	Degrees				
1.00	1.80	20.06	2.05	2.06	111	4
.50	2.96	33.0	1.26	1.26	110	6
.40	3.49	39.92	1.072	1.075	311	12
.10	4.26	47.4	.885	.890	100	3
.25	4.66	52.0	.813	.817	331	12
.40	5.31	59.2	.721	.728	211	12
.20	5.66	63.0	.680	.683	{ 111(3)	
					511	16
.10	6.22	69.4	.625	.630	110(2)	6
.20	6.54	73.0	.597	.602	531	24
.15	7.10	79.2	.558	.563	310	12
.06	7.43	82.8	.538	.543	533	12
.03	7.98	89.0	.507	.513	111(4)	4
.08	8.24	91.8	.496	.498	{ 711	
					551	24
.20	8.76	97.6	.473	.476	321	24
.15	9.06	101.0	.462	.463	{ 731	
					553	36
.005	9.70	107.6	.442	.445	100(4)	3
.003	10.00	113.2	.432	.435	733	12
.12	10.52	116.8	.417	.420	{ 411	
					110(3)	18
.08	10.84	120.8	.409	.411	{ 751	
					111(5)	28
.05	11.50	127.6	.397	.397	210	12
{ .08	11.84	132.0	.389	.391	{ 753	36
.02	11.93	132.8				
.05	12.54	139.8				
.01	12.70	141.4	.378	.379	332	12
.05	13.00	145.0	.372	.373	931	24
.01	13.23	147.2				
.07	14.00	156.0	.363	.363	211(2)	12
.02	14.27	159.0				
{ .20	14.83	165.4	.358	.358	{ 933	48
.06	15.35	171.2				

The lines and the corresponding spacings are tabulated in Table XIV, and compared with those required for the lattice which has been assigned to diamond by the Braggs. The agreement is absolute. It will be noted that for the larger deviations the doublet of the molybdenum radiation is clearly resolved.

[CONTRIBUTION FROM THE RESEARCH LABORATORY OF THE GENERAL ELECTRIC CO.]

A NEW METHOD OF CHEMICAL ANALYSIS*

BY A. W. HULL

Received April 16, 1919

Two methods of X-ray chemical analysis are already fairly well known.

The first, which may be called X-ray spectrum analysis, is the result of the classical experiments of Moseley,¹ and consists in attaching the substance to be investigated to the target of an X-ray tube and photographing its X-ray line spectrum. The X lines belonging to each element are very few in number as compared with the very large number in the visible spectrum, and they bear a simple relation to the atomic numbers of the elements, so that they can be identified quickly and absolutely by comparison with standard tables. Moseley's measurements have been extended by Siegbahn² and his collaborators to practically all known elements of atomic weight greater than sodium, and the lines have been collected in a table for convenient reference.³ This method is applicable to all substances which can be attached to the target of an X-ray tube, except those in the first row of the periodic table.³ It thus supplements visible spectrum analysis in being most easily applicable where the latter is least so, *viz.*, to substances not easily volatilized.

The second method, which may be called the X-ray absorption band method, is due to the discovery of Barkla⁴ of the X-ray absorption bands of the chemical elements. The position of the edges of these bands have now been measured accurately and tabulated for practically all the elements above zinc⁵ by Duane and Blake. The method of analysis consists in placing the substance to be examined, in the form of an absorbing layer, either liquid or solid, in front of an X-ray tube, photographing the spectrum, and comparing the absorption bands in the photograph with the tabulated values. It is applicable to all chemical elements except those in the first row of the periodic table.

Both of these methods give evidence only of the chemical elements present, and not of their state of chemical combination. Both are capable of quantitative as well as qualitative application. They have the advantage over older methods that their results are absolutely unambiguous, since they depend only on the atomic numbers of the elements in question, and not upon any of their chemical properties or states of combination. The fact that these methods have not as yet come into common use is due not so much to any difficulty in their application, as to the fact that they are new, and that no problem of sufficient importance has presented itself to warrant their rapid development.

* Copyright, 1919, American Chemical Society.

¹ Moseley, *Phil. Mag.*, 26, 1024 (1913); 27, 703 (1914).

² Siegbahn, *Jahrb. Radioact. Electronik*, 15, 336 (1916).

³ The limitation is due to the fact that no crystal is known with atoms far enough apart to act as a grating for the relatively long wave lengths characteristic of these first row elements.

⁴ *Phil. Mag.*, 17, 739 (1909).

⁵ *Phys. Rev.*, 10, 697 (1917).

The purpose of this paper is to describe a third and fundamentally different method of X-ray chemical analysis. It is simpler than the other two in that it does not require a spectrometer, and it supplements them in that it gives evidence which they do not supply, namely, the state of chemical combination for each of the elements present.

The method consists in reducing to powder form the substance to be examined, placing it in a small glass tube, sending a beam of monochromatic X-rays through it, and photographing the diffraction pattern produced. The only apparatus required is a source of voltage, an X-ray tube, and a photographic plate or film. The amount of material necessary for a determination is one cubic millimeter. The method is applicable to all chemical elements and compounds which are crystalline in structure.¹

The arrangement of apparatus is shown in Fig. 1. T is a transformer furnished with an extra coil for lighting the filament of the X-ray tube; X a Coolidge X-ray tube; F a sheet of metal, properly chosen,² serving as a filter; S₁ and S₂ slits in thin sheets of lead; T a thin-walled tube, about one mm. in diameter, of some light amorphous material, such as glass, celluloid, or collodion, containing the powdered substance to be tested; and F a narrow strip of photographic film bent over a semicircular strip of brass or wood, concentric with T.³

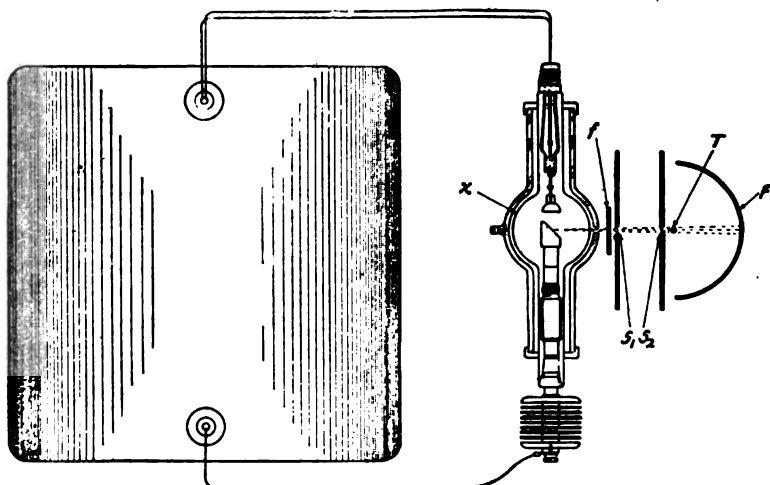

Fig. 1

The rays from the X-ray tube pass first through the filter, which absorbs all but a single wave length; then through the two slits, which confine them to a narrow beam (about one mm. wide); then through the powdered material, which scatters or "reflects" a very small fraction of them; and thence to the center of the photographic film. An exposure of one hour will generally give all the information desired.

When the film is developed it shows, in addition to the over-exposed line in the center where the direct beam strikes, a series of other lines on each side of the center. These lines are caused by the "reflections" of the X-rays from the tiny crystals in the powder. Their distance from the center of the film depends on the distance between

¹ The number of non-crystalline solid substances is probably very small. All the solids thus far examined, including many that have been considered amorphous, have been found crystalline with the single exception of glass.

² The filter is chosen of such material that it specially absorbs all wave lengths shorter than the desired one, leaving practically nothing but a single intense line, the α line of the K series of the anode material. The proper material for the filter depends upon the material of the X-ray tube anode. For a molybdenum X-ray tube the proper material is zirconium. For details see *Phys. Rev.*, 10, 665 (1917).

³ For rapid work it is desirable to use *Dupli-Tized* X-ray film, and place on each side of it a thin strip of calcium tungstate intensifying screen.



Fig. 2

the planes of atoms in the crystal, and there is one line for every important set of planes in the crystal. It is evident, therefore, that substances with different crystalline structure will give entirely different patterns of lines (compare, for example, silicon, magnesium carbonate, lithium fluoride, Fig. 4). Substances of similar chemical nature, on the other hand, will in general have similar crystal structure, and give similar patterns, so that it is often possible to identify a photograph at a glance as belonging to a certain type of element or compound. Thus, lithium, sodium and potassium fluorides, sodium and potassium chlorides, and magnesium oxide (Fig. 3) all have the same arrangement of atoms in their crystals, and all give precisely similar patterns of lines, the one being simply a magnified image of the other. The magnification or spread of the pattern is different for each one, being inversely proportional to the cube root of the molecular volume. Since no two similar substances have *exactly* the same molecular volume, it is easy to distinguish them, as the difference is cumulative for lines far from the center.¹

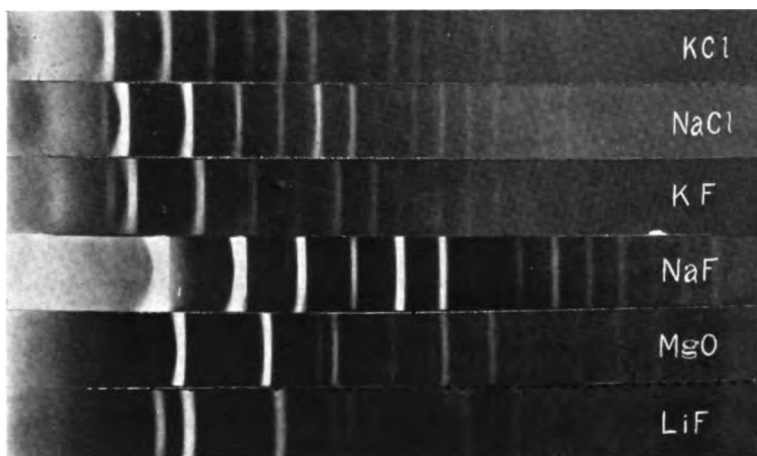

Fig. 3

As an example, the photographs of potassium and sodium chlorides, which are the nearest together of any of the patterns thus far investigated, have been placed side by side in Fig. 3 for comparison. A further distinguishing mark is the relative intensity of the different lines, which differs greatly even in the most closely related compounds, depending on the relative shapes and sizes of the atoms in the compound. Thus lithium fluoride, magnesium oxide, sodium fluoride and potassium chloride have precisely similar patterns (Fig. 3), but certain lines, as the first and fourth, are very strong in lithium fluoride, fairly strong in magnesium oxide, barely visible in sodium fluoride, and entirely lacking in potassium chloride.

¹ The lines farthest from the center diverge even more than the difference in molecular volume, since the cube root of molecular volume is strictly proportional, inversely, to the *sine* of the angles of reflection, whereas the distances of the lines from the center are proportional to the angles themselves. The difference is negligible for lines near the center (small angles), but for large angles the dispersion thus produced is very large, so that two exactly similar substances differing in molecular volume by less than 1 per cent could easily be distinguished.

Further details concerning the theory of the production of these lines, and their relation to the crystalline structure of the substance, will be found in the *Physical Review*.¹ This theory will not be reproduced here, as is it not essential to chemical analysis, beyond establishing the facts that every crystalline substance gives a pattern; that the same substance always gives the same pattern; and that in a mixture of substances each produces its pattern independently of the others, so that the photograph obtained with a mixture is the superimposed sum of the photographs that would be obtained by exposing each of the components separately for the same length of time. This law applies quantitatively to the intensities of the lines, as well as to their positions, so that the method is capable of development as a quantitative analysis.

As illustrations of the general type of photographs obtained with simple compounds and elements, Fig. 2 shows two typical photographs, of silicon and sodium fluoride, respectively; Fig. 3 a series of isomorphous alkali halogens, illustrating their similarity of pattern and their differences in spacing and intensity; and Fig. 4 gives a series of dissimilar substances, illustrating their different types of pattern.

As practical examples, two actual analyses will be described. They are only roughly quantitative, but could easily be refined to any required accuracy. In addition, they give information which no other method of analysis can furnish.

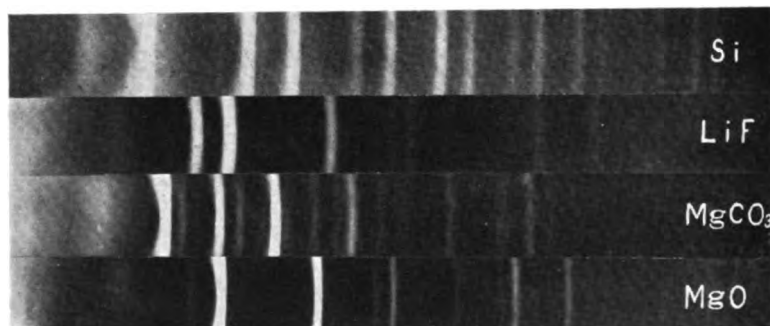

Fig. 4

The first analysis was of a sample of sodium fluoride, taken from stock, labelled "c. p." It was photographed in the manner described and gave the pattern shown in the middle section of Fig. 5. A sample of very pure sodium fluoride was then prepared and photographed, with the results shown in the lower section of Fig. 5. It is evident from the correspondence of the lines that the unknown sample was sodium fluoride, but that it contained a large amount of impurity, which one would estimate, from the relative intensity of the lines, at 30 or 40 per cent.² In order to determine the nature of the impurity, a series of photographs was taken of substances which were considered the most probable constituents, such as sodium carbonate, sodium chloride, sodium hydrogen fluoride, etc. The pattern of sodium hydrogen fluoride is shown in the upper section of Fig. 5. It is evident at a glance that it corresponds to the impurity in the test sample of sodium fluoride, and a careful examination shows that all the lines not common to the two lower photographs are common to the two upper ones. In other words, sodium hydrogen fluoride is the only impurity that is present in appreciable quantity. The amount present can be roughly estimated from the relative intensity of the lines, and this could be made into a quantitative method by preparing for comparison a series of photographs of mixtures of known composition.

¹ *Phys. Rev.*, 10, 661-696 (1917).

² This sample was later titrated and found to contain 19.2 per cent F, which corresponds to 60 per cent NaHF₂.

The fact to be emphasized, however, is that this analysis shows that the sample consisted of a simple mixture of separate crystals of sodium fluoride and sodium hydrogen fluoride, and not a mixture of these with a hydrate, or some more complex compound. Information of this kind might, in some cases, be of considerable value, and it can always be obtained by this method.

The second example is the analysis of two samples of identical chemical content, viz., 33.5 per cent potassium, 19.7 per cent sodium, 16.3 per cent fluorine, and 30.5 per cent chlorine. The photographs given by these two samples are shown together, for comparison, in Fig. 6. It is evident that the two samples are far from being identical, in fact, that they contain nothing in common.

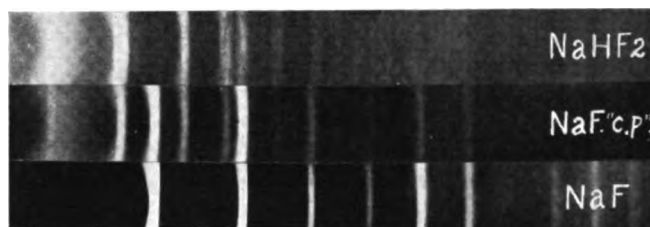

Fig. 5

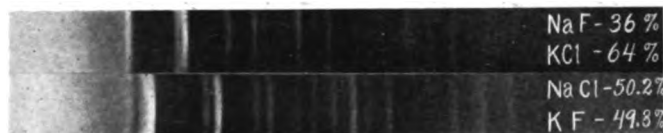

Fig. 6

The first of these photographs is shown again in Fig. 7, in comparison with sodium fluoride and potassium chloride, and is seen to contain all the lines of both of them, and no other lines. Hence this sample consists of a mixture of sodium fluoride and potassium chloride (36 per cent sodium fluoride, 64 per cent potassium chloride) and nothing else. To show how conclusive the test is, this same sample is shown again in Fig. 8 in comparison with sodium chloride and potassium fluoride. It is evident that neither of these patterns is present in the sample. The chance correspondence of individual lines has no meaning. If a substance is present, *its whole pattern* must be present in the photograph, and the relative intensities in this pattern must be the same as in the comparison standard. Thus the absence in the test photograph of a *single* intense line of comparison substance proves that *none* of this substance is present, and that any other correspondences between the two are mere chance.

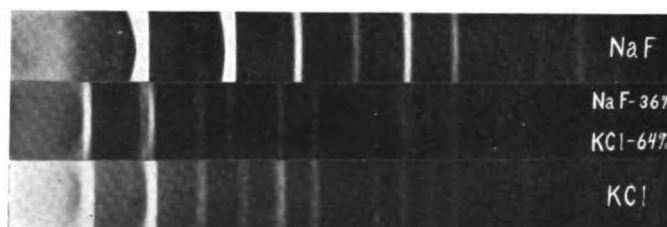

Fig. 7

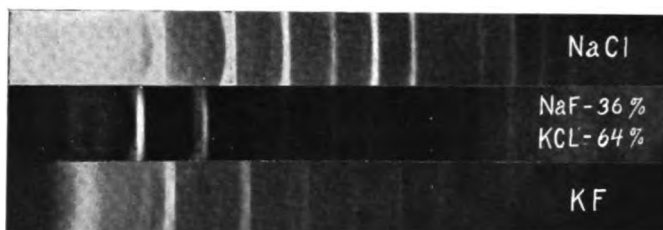

Fig. 8

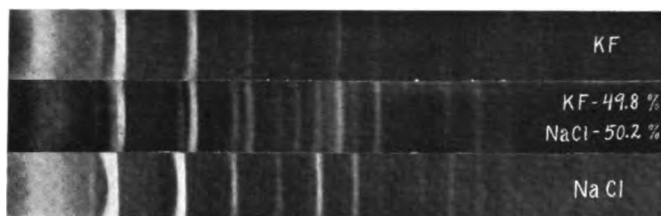

Fig. 9

The second sample is shown in Fig. 9, in comparison with sodium chloride and potassium fluoride, and it is evident that it consists of a mixture of these two salts (50.2 per cent sodium chloride, 49.8 per cent potassium fluoride) and *nothing else*.

These examples are very simple ones. It is possible to go much further. By narrowing the slits and using a smaller tube of test material very sharp, narrow lines can be obtained, and a mixture of several substances analyzed without ambiguity. Furthermore, by long exposures, so as to greatly overexpose the principal components of a mixture, substances present only in very small amounts can be made to show.

THE POSITIONS OF ATOMS IN METALS*

BY A. W. HULL

The determination of the exact positions of atoms in solid bodies is the next to last of a series of discoveries, that have made atoms as real as the bricks of which houses are built.

The atom of 20 years ago was the "hypothetical smallest sub-division of matter." The atom of today is a real object of definite shape and size. We know what it is made of. We know its weight in grams. We can see its splash when it impinges on a plate of fluorescent material. We know its exact speed when it flies about as gas. And, lastly, we know its exact position when it forms part of a solid body.

A brief enumeration of these discoveries is a necessary introduction to the following discussion.

First came the discovery of *dancing molecules*. Heat had been considered a substance. The "Kinetic Theory of Gases" proved that it is a condition, *viz.*, the motion of the molecules, which fly about like frenzied bees, bumping against each other and the walls of their enclosure. Through this discovery, all the store of facts and laws about gases can be correlated by the single picture of these dancing molecules. We believe in these dancing molecules as firmly as in the law of gravitation. Whenever we think of gas we see dancing molecules.

The next discovery was J. J. Thomson's *streaming electrons*. Our text-books taught, and some still do, that electricity is not a fluid, though it behaves in many ways like one. Thomson proved that electricity is a fluid, that its atoms are the electrons which constitute the atoms of matter, and that it flows through wires just as water flows through pipes.

Next came the *weighing of the atom*. Faraday showed long ago how to determine the weight of an atom in terms of the charge it carries in electrolysis. There remained, therefore, only the measurement of this "unit charge," *viz.*, the charge of a single electron, by Millikan, to give the exact weight in grams of any atom that can be deposited electrolytically. As soon as the weight of any one atom is known, the weights of all the others can at once be calculated from the known relative atomic weights.

Then came the *counting of individual atoms*. This began with Sir William Crookes' "spinharscope," and culminated in the beautiful experiments of Rutherford and Geiger, in which they counted one by one the helium atoms (the so-called " α particles") as they emerged from the surface of disintegrating radium; and then allowed them to pass, one by one, into a thin-walled glass tube, until enough had accumulated to form a gas whose pressure could be measured and spectrum analyzed.

These counting experiments led directly to the determination of the *composition of the atom*. J. J. Thomson had proved that every atom contains electrons. Rutherford proved that it also contains a positively charged kernel or nucleus, very small compared to the whole atom, but so dense that it contributes nearly the whole weight of the atom. The hypothetical atom thus became a concrete thing that can be visualized; a tiny (but large enough to be studied) solar system, with nucleus sun and electron planets. The only respect in which one kind of atom differs from another is the magnitude of the

* Copyright, 1919, by the American Institute of Electrical Engineers.

positive charge of the nucleus, which determines how many electrons it can hold in its planetary system, and hence all its physical and chemical properties.

Finally came the discovery, by the Braggs, of the method of determining the positions of the atoms in solid bodies. The beautiful "point lattices" of the crystallographers were hypothetical. They enumerated possibilities, but could not point out the reality. The Bragg measurements of atomic distances give the actual arrangements. They are as accurate and reliable as those of the surveyor or astronomer. The only assumption made is that the arrangement of atoms is a regular one which repeats itself, and this assumption can be checked by experiment. The method consists simply in the measurement, by means of a special "measuring rod" which will be described, of the distance between atoms in three or more different directions. From these measurements a model can be constructed, which can then be checked by further measurements. The model must also agree with known physical properties of the substance, such as density, atomic weight, and crystal habit. A model which contains but one kind of atoms and satisfies all these tests may be regarded as very reliable. The reliability is still further increased by the fact that all the models investigated thus far have turned out to be very simple. In cases

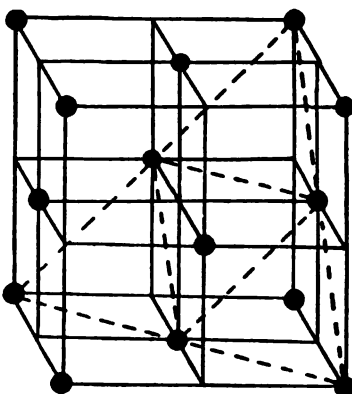

Fig. 1a. Face Centered Cubic Arrangement (Cubic Close Packing)

where there is more than one kind of atom, *i.e.*, compounds or alloys, an additional factor, *viz.*, the size and shape of the atoms, must be taken account of. There is one type of compound, containing only two kinds of atoms, whose structure is so simple that it cannot be misunderstood. Examples of this type will be included in the following discussion. Compounds containing more than two kinds of atoms have not yet been sufficiently studied to warrant their discussion, but there is every reason to believe that their analysis will be equally simple and reliable.

In the following pages, there will be given, first, a general survey of the results obtained, then a brief description of the method of measurement, and lastly, a more complete discussion of the individual models and some of their properties.

I have referred to the location of atoms as next to last in the series of atomic discoveries. For in order to complete the picture, one more discovery is necessary, *viz.*, the shape and size of the atom. An excellent beginning in this direction has already been made by Langmuir¹ whose theory of atomic structure predicts the shapes and relative sizes of all the atoms, and gives strong chemical evidence in favor of these predictions. The author hopes soon to be able to add the evidence of X-ray measurements, which will determine not only the shape but the exact size of the atoms, that is, the positions of the electrons in the atoms.

¹ Langmuir, *J. Amer. Chem. Soc.* 41, 868, June, 1919.

Summary of Results. The most striking result of these investigations is the extreme simplicity of arrangement of atoms in common metals. Among the metals thus far examined only three types of atomic arrangement are found, and these are, with one exception, the three simplest geometrical arrangements known. The simplest arrangement of all is not found among metals, but is characteristic of salts, which are composed of equal numbers of positive and negative ions. This type and a fifth type, also very simple, which is characteristic of non-metallic elements, will be included in the discussion for the purpose of comparison.

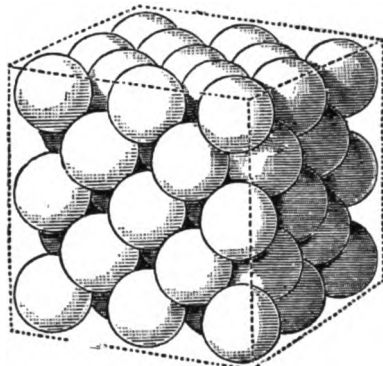

Fig. 1b. Face Centered Cubic Arrangement (Cubic Close Packing)

The most common arrangement in metals is the *face centered cubic* arrangement, shown in Fig. 1. This is also the most important since most of the useful metals,—*e. g.*, aluminium, nickel, cobalt, copper, silver, platinum, gold,—have this arrangement of atoms. Perhaps it would be better to say that those substances are most useful as metals which have this arrangement, since, as will be shown later, their ductility is due largely to this arrangement.

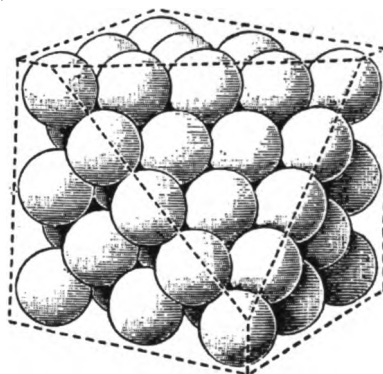

Fig. 1c. Face Centered Cubic Arrangement (Cubic Close Packing)

The face-centered cubic arrangement is obtained by dividing the space occupied by a single crystal or "grain" of metal up into a system of equal, closely packed cubes (Fig. 1a) and placing an atom at each cube corner and at the center of each cube face. All the atoms in this arrangement, both corner and face atoms, are similarly situated as regards symmetry and relation to neighbors. Each atom is surrounded by twelve others, all equidistant and exactly similarly situated for every atom. It is this high degree of symmetry, combined with the close packing, that makes substances of this type so ductile. This arrangement is known as "cubic close-packing" and is one of the two alternative arrangements that equal hard spheres assume (Fig. 1b) when pressed tightly

together, with sufficient shaking to allow them to find their places. This suggests, and the other evidence at hand points to the same conclusion,¹ that the atoms of the substances which have this arrangement are fairly spherical in shape. The necessary shaking corresponds to the temperature required for "annealing." The only difference between the packing of balls and that of atoms of this kind is the ability of the atoms to hold on to each other after they have found their places.

There is one important exception to the rule that the most ductile, and, therefore, the most generally useful substances are those whose atoms are in face-centered cubic arrangement, *viz.*, iron. The atoms of iron, and also of chromium, molybdenum, tungsten, and the alkali metals, are in *centered cubic* arrangement (Fig. 2). This arrangement is obtained by dividing the space occupied by a single crystal or grain into equal close-packed cubes, and placing an atom at each cube corner and each cube center. The two sets of atoms, the "corner-atoms" and the "center atoms," are interchangeable, so that if the system of lines in Fig. 2 had started with one of the center atoms, all the corner atoms in Fig. 2 would become center atoms and vice versa. Each atom, whether center or corner atom, is surrounded by eight others in perfect cubic arrangement about it, situated always in the same direction and at the same distances. Hence this

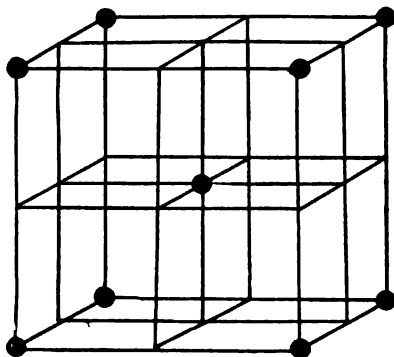

Fig. 2. Centered Cubic Arrangement

arrangement has the same high degree of symmetry as the face-centered cubic arrangement. It is not, however, as closely packed. Smooth, hard spheres cannot be packed in centered cubic arrangement except by the use of constraints, and when so packed are in unstable equilibrium. A slight jar causes them to reassemble in one of the close-packed arrangements. (Figs. 1 and 3). It is evident, then, that the atoms of these elements are either not spherical or that they possess some special forces of attraction localized at cube corners (see Fig. 15).

The third type of arrangement found in metals is the *hexagonal close-packed* arrangement (Fig. 3). It is the second of the two alternative arrangements which equal hard spheres assume when closely packed by pressure and shaking. It is less symmetrical than the cubic close packed arrangement, but equally close packed. The two are closely related, and each can be produced from the other by a simple gliding, as will be shown later. This is the arrangement taken by the atoms of magnesium, zinc, cadmium electrolytic cobalt, and probably to some extent by all cubic close-packed metals when strained (so as to cause gliding.) This arrangement is formed by dividing the space occupied by a single crystal of the substance into a series of equal closely packed right triangular prisms, the bases of which are equilateral triangles, and the altitudes equal to 1.633 times the length of the sides of the triangles. (Fig. 3.) An atom is

¹ cf. Langmuir, l. c. p. 878.

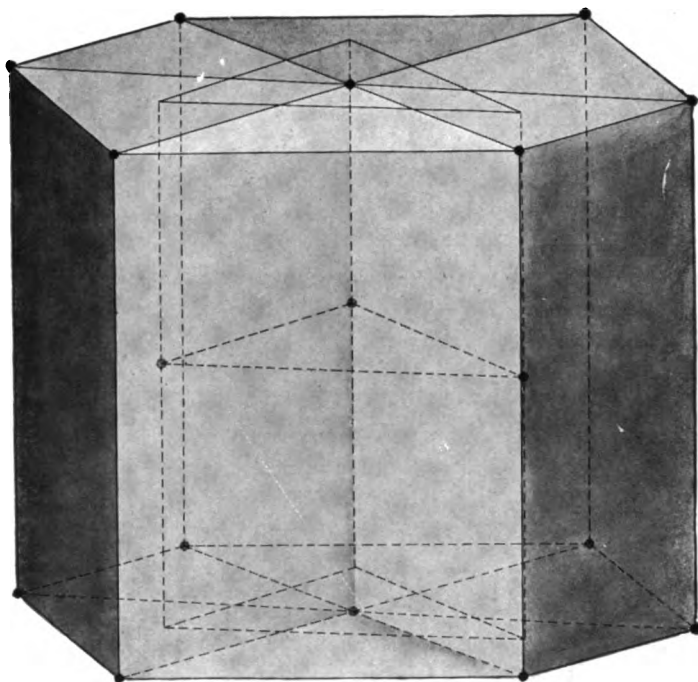

Fig. 3. Hexagonal Close Packed Arrangement

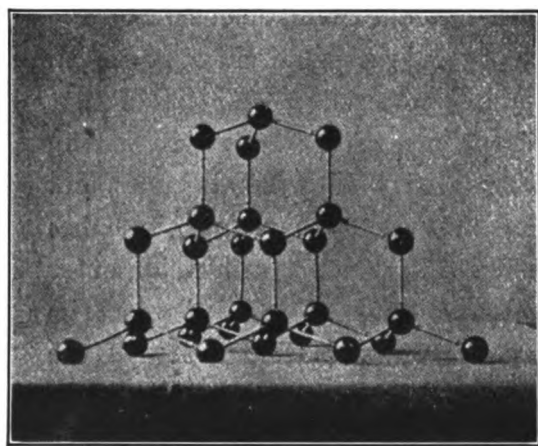

Fig. 5. Tetrahedral Arrangement

located at each prism corner and at half of the prism centers. This arrangement is simpler and more symmetrical than it appears. Each atom is surrounded by twelve others, all equidistant and uniformly spaced about it in dodecahedral arrangement. These dodecahedra are of exactly the same dimensions as in the cubic close-packed arrangement, but are not quite regular, the upper half being rotated 60 deg. from the position corresponding to a regular dodecahedron.

There are two other simple types of arrangement, which, though they do not occur among metals, are important for comparison, and their description will make clearer the distinguishing features of metals.

The first is the *simple cubic* arrangement (Fig. 4). It is formed by dividing the space occupied by a crystal into a series of equal, closely-packed cubes, and placing an atom at each cube corner. All the atoms are similarly situated, each being surrounded by six others, all equidistant, in the direction of the cube faces. In spite of its great simplicity, it has only the same degree of symmetry as the two cubic arrangements already described. It is an extremely "loose packed" arrangement for hard spheres, and would

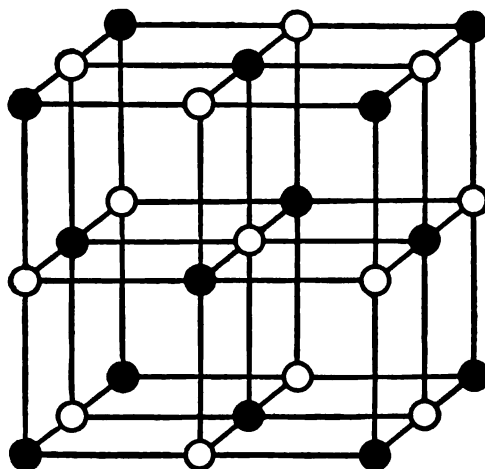

Fig. 4. Simple Cubic Arrangement

be very unstable. A system of equal cubes, however, if packed in this manner would fill all space.

No elementary solid has yet been found whose atoms arrange themselves in this manner. This fact might be interpreted as evidence that none of the atoms are cubical in shape. There is strong evidence, however, that many of the atoms, especially those of low atomic weight, are approximately cubical in shape.¹ The fact that when these substances crystallize, their atoms do not pack together in simple cubic arrangement, is due rather to the nature of the forces holding them together (see discussion of iron, tungsten, etc., above). It may be taken as evidence that these forces, in the case of cubical atoms, are not localized at the centers of cube faces, but at cube corners.

The substances which have this simple cubic arrangement of atoms are composed of equal numbers of positive and negative ions. The positive and negative ions alternate in every direction as shown in Figs. 4 and 16, so that each positive ion is completely surrounded by six negative ions and vice versa. The forces holding these atoms together are different from any of those thus far considered. In the cases described above, and in the great majority of compounds, the cohesion is due to the "stray fields"

¹ (See Langmuir, 1. c., p. 892 ff.)

of the atoms. In these *ion compounds* it is due to the electrostatic attraction between the oppositely charged ions. This is stronger than the stray fields, and causes the atoms to pack together as closely as their shape will allow. The fact that they choose to pack in simple cubic arrangement is additional evidence that they are cubic in shape. No ion compounds of this kind (*i.e.* containing equal numbers of positive and negative ions of approximately the same size) between spherical atoms have yet been examined, but it is to be expected that they will show one of the "close packed" arrangements (face-centered cubic or hexagonal) described above.

The fifth simple type of atomic arrangement is the *tetrahedral* arrangement. (Fig. 5.) Each atom is surrounded by four others, arranged in a regular tetrahedron about it. It is not as symmetrical as the three cubic arrangements described above (Figs. 1, 2 and 4) for while each atom is at the center of a tetrahedron of neighboring atoms, half of these tetrahedra are positive and half negative; *i.e.*, upside down with respect to the first.

The only substances thus far found with the tetrahedral arrangement of atoms are diamond, silicon, and the "ion compound" $\text{NH}_4 \text{Cl}$. There is strong chemical evidence that in each of these substances the unit of structure (*viz.*, the *C* and *Si* atom, and the NH_4 ion) is really tetrahedral in shape.

The Measuring Machine. The determination of these atomic arrangements requires the measurement, in as many different directions as possible, of the distance between consecutive *planes of atoms*. The arrangement of atoms, whatever it may be, is assumed to be a regular one which repeats itself throughout the crystal.¹ This assumption can be checked by the result. Through such an arrangement a system of equidistant parallel planes can be drawn in any direction whatever so as to pass through all the atoms. In most directions, these planes will be very close together and sparsely settled with atoms. In a few particular directions, however, they will be far apart and densely populated. These are the directions of easy cleavage and gliding. It is these densely populated planes whose distances apart are measured.

The original measuring machine, by which the pioneer measurements were made, was a special form of "spectrometer." It has been simply and charmingly described by its inventors in a book² worth reading. The measurements described in this paper were made with a modified form of Bragg machine. The original machine was applicable only to large, perfect crystals, required careful manipulation, and was subject to serious error unless the crystals were very perfect and the number of observations large. The author's modification is free from these errors, requires but one simple observation, and is applicable to all substances which are crystalline, *i.e.*, all in which there is any arrangement to measure.

The complete machine is shown in Fig. 6. It consists of a small transformer (or other source of high potential) capable of supplying 1 kw. at about 30,000 peak volts; a Coolidge X-ray tube, *X*; a thin sheet of properly chosen material, *f*, serving as filter; a pair of slits, s_1 and s_2 , in metal sheets, to limit the beam of X-rays; a tiny glass tube, *T*, containing the powdered substance to be measured; and a photographic plate or strip of film bent in arc of circle, *F*. The operation consists in filling the glass tube with a few milligrams of the substance to be analyzed, powdered as finely as possible; "loading" the photographic film holder; exposing over night to X-rays at 30,000 peak volts and as many milliamperes as the tube will carry safely without watching, (a maximum exposure of 300 milliamperes hours); and developing the film.

¹ If the arrangement is not regular, there is nothing to be measured. Such "amorphous" solids are very few in number, much fewer than was previously believed.

² W. H. and W. L. Bragg, "X-rays, and Crystal Structure" G. Bell & Sons, London.

Typical photographs are shown in Fig. 7a, and 7b. Fig. 7a is a photograph of aluminium filings, taken with a plate and very short slits, so that the trace of the direct beam in the center of the plate is a circular spot. Fig. 7b is a photograph of molybdenum powder, taken with circular film and slits as shown in Fig. 6.¹ In this case the traces of the circles on the film show as nearly straight lines. The circles and lines are due to the "reflection" of the X-rays by the tiny crystals of molybdenum in the tube, as will be described later. The distances of these circles or lines from the central line on the film are nearly proportional, inversely, to the distances between the planes of atoms, and from them these atomic distances can be easily and quickly calculated. Some examples of calculation are given below.

The Measuring Rod. The measuring rod by which these atomic distances are measured is the wave-length of a particular X-ray.

The possibility of measuring the dimensions of any physical body depends, primarily, upon the possession of a measuring rod of length comparable with the dimensions to be measured. Thus, the discovery and calibration of wave-lengths of visible light opened

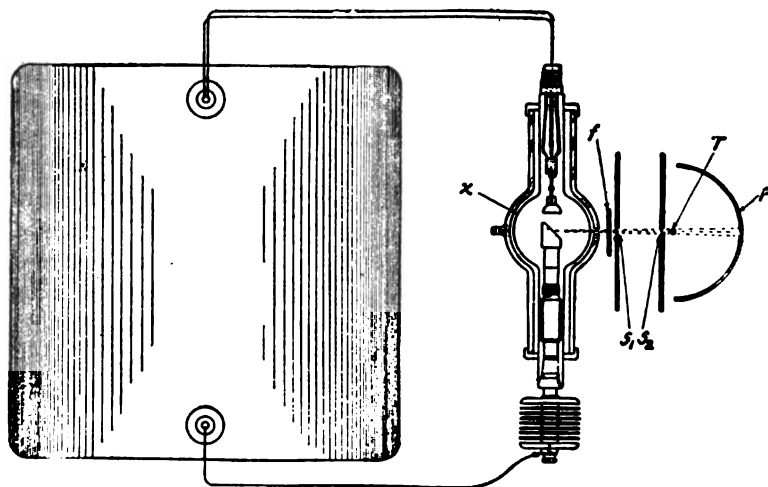

Fig. 6. Powder Photograph Apparatus

up a whole new field of measurements, comparable in length with the new measuring rod, such as the thickness of films, imperfection of polished surfaces, displacement of vibrating membranes, increase in length due to thermal expansion, etc. In the same way, the discovery that X-rays are of the same nature as light, and the isolation and calibration of X-ray wave-lengths, opened up a vast new field of measurements of dimensions comparable with the wave-length of X-rays, *viz.*, atomic dimensions.

We are accustomed to think of the measurement of things too large or too small to see and touch as necessarily very rough and approximate. It is somewhat of a surprise, therefore, to note that the only measurements accurate enough to justify the use of eight-place logarithm tables are those of astronomy; that wave-lengths of light are measured to 1 part in 10,000,000; and that the wave-length of X-rays, and by means of it, the distances between atoms, can easily be measured to 1 part in 100,000.

The spectrum of X-rays is exactly like that of visible light, except that the wave-lengths are shorter. It consists (Fig. 8) of bright lines superimposed upon a continuous spectrum. The wave-lengths in the X-ray spectrum depend upon anode material and voltage (Figs. 9 and 10) in exactly the same way that the wave lengths in the visible spectrum depend upon incandescent material and temperature. And just as it is

¹ The central line and first "reflected" line in Fig. 7b have been partially absorbed by a "stepped" filter, placed directly in front of the film, for the purpose of measuring the intensity of the lines.



Fig. 7b. Molybdenum

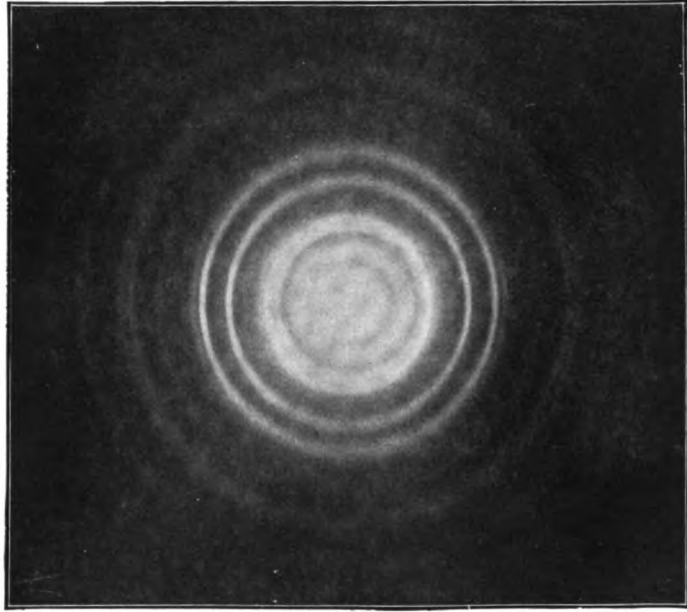

Fig. 7a. Aluminum

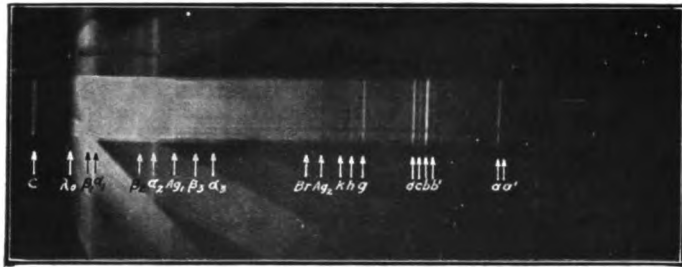

Fig. 8. X-ray Spectrum of Tungsten

possible to obtain nearly monochromatic yellow light by putting salt in a flame under proper conditions, so by running an X-ray tube with proper anode at the right voltage, it is possible to produce a single wave length (line) of such great intensity that practically all the rest of the spectrum can be absorbed by a properly chosen filter, leaving nearly monochromatic X-rays.¹ (Fig. 10.) It is in this way that the monochromatic X-rays used in these measurements are produced. The measurements described in this paper were made with X-rays from a molybdenum target operated at 28,000 volts constant potential, and the filter was powdered crystal zircon, pressed,

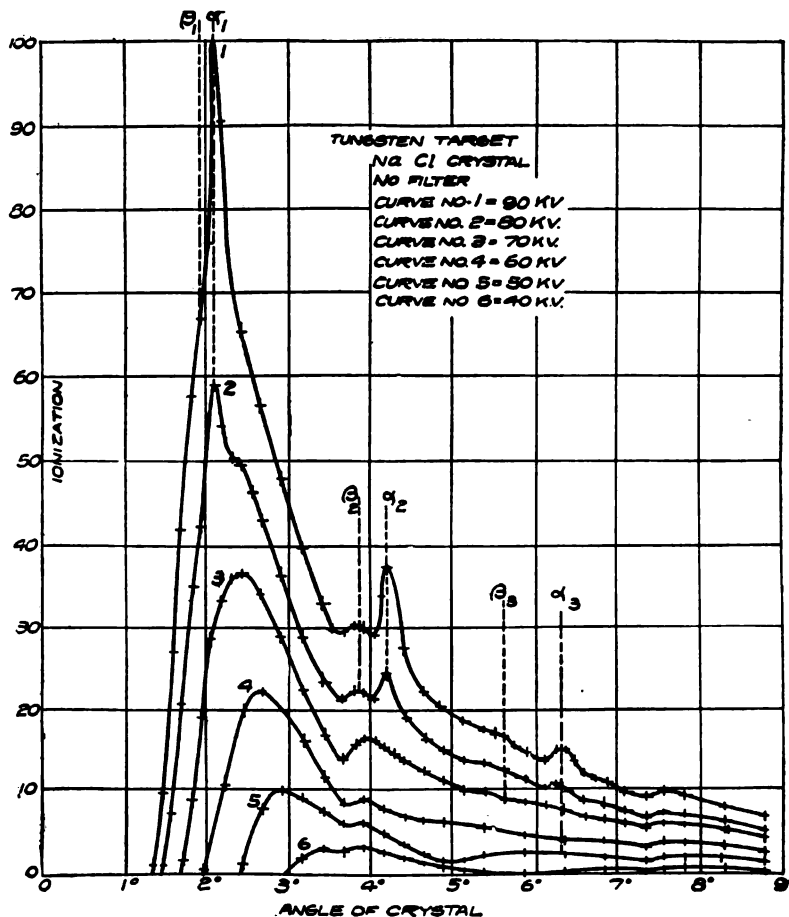

Fig. 9. Effect of Voltage on X-ray Spectrum of Tungsten

with a small amount of organic binder, into a sheet $\frac{1}{4}$ mm. thick. The resulting spectrum, before and after filtering, is shown in Fig. 10.

Calibration of Measuring Rod. The measurement of the wave-length of X-rays in centimeters was part of the pioneer work of the Braggs,² and was accomplished in the same way as the measurement of visible wave-lengths, *viz.* by the use of a "grating" of known dimensions. It is interlocked with the determination of crystal structure, since the grating used was a crystal, and it was necessary, before using it, to determine its dimensions, *i.e.* the arrangement of atoms in it. The procedure was that of experiment and trial. Preliminary experiments indicated that the atoms of rock salt were in simple cubic arrangement, as shown in Fig. 4. Assuming this to be so,

¹ For a more detailed description, see Hull, *Phys., Rev.* 10, 666, 1917.

² X-rays and Crystal Structure, p. 110.

a rock salt crystal was used as a grating to measure tentatively the wave-lengths of X-rays. These wave-lengths were then used for further investigation of the arrangement of atoms in rock salt and other crystals, and were checked and corrected by successive trials.

The method of using the rock-salt grating is shown in Fig. 11. The crystal *C*, with its planes of atoms perpendicular to the paper, is placed in the path of a narrow beam of X-rays. Each plane of atoms acts like a mirror and reflects a small fraction of the rays. The reflection is a maximum when the reflected waves from all the planes (many million, except in the case of very long wave-lengths) are in phase, that is, when each is an exact wave-length or some whole number of wave-lengths behind the next. It is easy to show that this is true only when

$$n \lambda = 2 d \sin \theta \quad (1)$$

where *n* is an integer, usually 1 or 2, λ the wave-length, *d* the distance between planes of atoms, and θ the angle of incidence (*i* in Fig. 11) of the rays on the crystal.¹

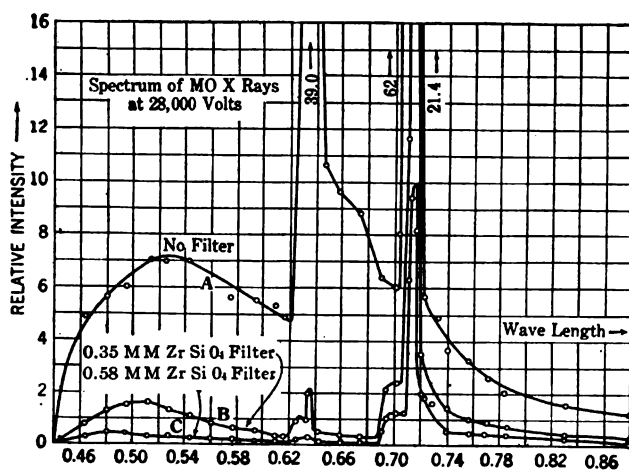

Fig. 10. Effect of Filtering on Molybdenum X-ray Spectrum

The determination of λ requires, therefore, the knowledge of *n*, *d*, and θ . θ can be observed, and the orders, *n*, counted. *d* must be determined initially from the physical properties of the crystal, *viz.* its density, atomic weights, and arrangement of atoms. This can best be explained by an example:

The atoms of rock salt are in simple cubic arrangement, as shown in Fig. 4. There is one atom to each cube, as can be seen by displacing all the atoms in Fig. 4 in the direction of a cube diagonal to the cube centers. Half of the cubes contain sodium atoms and half chlorine atoms. The average weight per cube is the mean of the weights of one sodium and one chlorine atom, *viz.* $\frac{1}{2} (38.00 \times 10^{-24}g + 58.50 \times 10^{-24}g) = 48.25 \times 10^{-24}g$.

Hence the density, which is the weight per unit volume, must be equal to $\frac{48.25 \times 10^{-24}}{d^3}$

where *d* is the side of one of the small cubes (Fig. 4,) *i.e.*, the distance between planes of atoms parallel to the cube faces. This value of density must be the same as that obtained by measuring and weighing a large crystal, *viz.* 2.174. This gives

$$d = \sqrt[3]{\frac{48.25 \times 10^{-24}}{2.174}} = 2.814 \times 10^{-8} \text{cm.} = 2.814 \text{\AA}$$

¹ It will be observed that in order to measure different wave-lengths the crystal must be rotated. This is the only essential difference between the crystal grating and the ordinary diffraction grating.

² The Angstrom unit or \AA ($=10^{-8}$ cm.) which is the standard unit for expressing wave-lengths of visible light, is even better suited to atomic and X-ray measurements. It will be used or assumed in all the following discussions.

The wave-length of the “ α doublet” of molybdenum determined in this way is 0.712 \AA .¹ This is the “measuring rod” with which the following measurements were made.

Interpretation of Powder Photographs. The X-ray wave length thus calibrated can now be used to measure atomic distances. If, in the arrangement shown in Fig. 11, the X-rays are made monochromatic by proper voltage and filtering, then as the crystal is rotated a series of intense reflections will be observed at angles whose sines are in the ratio 1 : 2 : 3, etc., corresponding to successive integral values of n in Eq. 1. If a new face is ground on the crystal at an angle to the first, and exposed to the rays in the same way, another similar series of reflections will be observed, at different angles, corresponding to the different distance (d , Eq. 1) between the planes parallel to this new face. The process of analyzing a crystal consists in observing these reflections from as many faces as possible, and calculating, from Eq. 1, the distance between the planes parallel to them. When a single crystal is used this requires many observations. The work is greatly simplified by using a powder, in which all possible orientations are represented

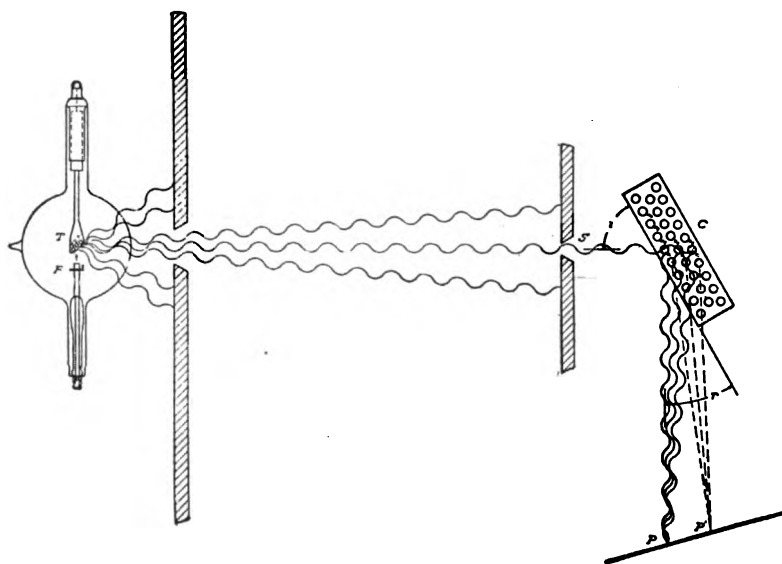

Fig. 11. X-ray Spectrometer

at the same time by one or more of the tiny crystals, and photographing simultaneously the reflections from all these little crystals. This is the method sketched in Fig. 6, and gives patterns of lines like Figs. 7, 12 and 13. It might be expected that the number of lines in these patterns would be infinite, since there is an infinite number of different possible planes in any crystal. The reflections from most of the planes, however, come at angles whose sines are greater than 1 (as is evident from equation [1] when d is small) and which, therefore, do not exist.²

The analysis of these photographs is very simple in the case of simple substances, like pure metals. It consists in finding, by successive trials, an arrangement of atoms whose planar spacings, beginning with the planes farthest apart and skipping none, exactly fit the observed pattern of lines. The calculation of the planar spacings for all the important planes is not difficult, and with simple substances but few trials are necessary.

¹ The best measurements of X-ray wave-lengths are those of Siegbahn, *Verh. Deut. Phys. Ges.* 13,300, 1917.

² This means physically that there is no angle of incidence large enough to make the reflection from one plane a whole wave-length behind that from the one in front.

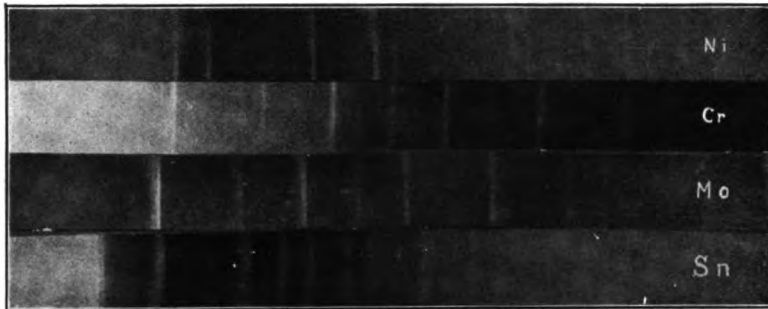

Fig. 12. Typical X-ray Powder Photographs of Metals

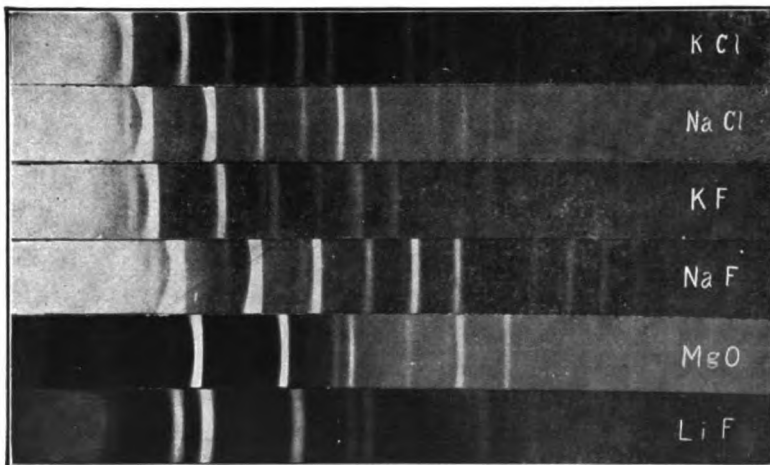

Fig. 13. Typical X-ray Powder Photographs of Salts

The method of calculation can best be shown by an example. Potassium chloride (Fig. 13) gives the simplest pattern of lines yet observed. It consists of 6 regularly spaced lines, then a slight gap, then 7 more lines. (these may not all show in the reproduction), then another gap, etc. The best first guess is that a simple pattern like this corresponds to a simple cubic arrangement. The equation of solid geometry for the distance between planes in a simple cubic arrangement is

$$d = \frac{d_0}{\sqrt{h^2 + k^2 + l^2}} \quad (2)$$

where h , k , and l are any whole numbers, and d_0 is the side of the cube. The numbers h , k , l , are called the "indices" of the planes. They are the reciprocals of the intercepts of the planes on the X , Y and Z axes respectively.

The largest distance is $\frac{d_0}{\sqrt{1}}$, corresponding to the "indices" 1, 0, 0. This gives the line nearest the center (see equation 1). The next line is $\frac{d_0}{\sqrt{2}}$, given by the planes whose indices are 1, 1, 0. Then follow $\frac{d_0}{\sqrt{3}}$ (1, 1, 1), $\frac{d_0}{\sqrt{4}}$ (2, 0, 0), $\frac{d_0}{\sqrt{5}}$ (2, 1, 0), and $\frac{d_0}{\sqrt{6}}$ (2, 1, 1). The next line, corresponding to $\frac{d_0}{\sqrt{7}}$, should be lacking, as there are no three numbers the sum of whose squares is 7. Fig. 13 shows that it is actually lacking. Then follow, in regular order, $\frac{d_0}{\sqrt{8}}$ (2, 2, 0), $\frac{d_0}{\sqrt{9}}$ (2, 2, 1 and 3, 0, 0), $\frac{d_0}{\sqrt{10}}$ (3, 1, 0), $\frac{d_0}{\sqrt{11}}$ (3, 1, 1), $\frac{d_0}{\sqrt{12}}$ (2, 2, 2), $\frac{d_0}{\sqrt{13}}$ (3, 2, 0) and $\frac{d_0}{\sqrt{14}}$ (3, 2, 1). Then should come another gap, corresponding to $\frac{d_0}{\sqrt{15}}$, which cannot be formed from the squares of three integers. These regularities can be better seen in some of the other patterns in Fig. 13, which are exactly similar to that of KCl, except that there are extra lines just in front of the first, third and fifth regular lines, due to the difference in weight and size of the two atoms of which these salts are composed. The calculation of the positions of these extra lines is also simple, but will not be given here.

Returning to KCl, the positions of the lines calculated from the above series of inverse square roots are found to coincide exactly with the observed pattern. This proves that the first guess was correct, that the atoms of KCl are in simple cubic arrangement. The result can be independently checked, however, by the density. For the average mass in each of the small cubes, divided by the volume of the cube, must equal the known density of the substance. The value of d_0 calculated from equation 1 is 3.13Å. The average weight of potassium and chlorine atoms is $\frac{1}{2} (64.5 + 58.5) \times 10^{-24}$ g = 61.5×10^{-24} g. This gives for the density $\frac{61.5 \times 10^{-24}}{(3.13 \times 10^{-8})^3} = 2.01$ which checks with the standard value within experimental error¹.

One more example may be briefly cited, *viz.* molybdenum. Its pattern is shown in Fig. 7b. It is found that the series of lines which corresponds to a simple cubic arrangement does not fit this pattern. We therefore try a centered cubic arrangement.

¹ These X-ray determinations of density are, in general, much more accurate than the standard ones.

The distance between planes in this arrangement is calculated in the same way as for the simple cubic arrangement, except that half the lines, *viz.* those due to planes the sum of whose indices are odd, are lacking¹. Hence the relative spacings, beginning with the largest, should be proportional to $\frac{1}{\sqrt{2}}, \frac{1}{\sqrt{4}}, \frac{1}{\sqrt{6}}$, etc. The series of lines calculated from these values is found to fit the pattern of Fig. 10 exactly. The length d_0 of the side of the small cube is 3.15\AA . As check, the density of molybdenum should be equal to the weight of two molybdenum atoms divided by the volume of the cube, *i.e.* $\frac{318 \times 10^{-24}}{(3.15 \times 10^{-8})^3} = 10.0$ which is the correct value.

DISCUSSION OF RESULTS

The results of the measurements that have been made thus far are summarized in the following table. The list includes most of the metals that are easily obtainable in

Substance	Arrangement of Atoms	Length of side of Elementary Cube In Ångstroms	Distance between Nearest Atoms (Between Centers) In Ångstroms
Aluminum	Face-Centered Cubic	4.05	2.86
Cobalt	(Cubic close packed)	3.57	2.52
Nickel	(Cubic close packed)	3.54	2.50
Copper	(Cubic close packed)	3.60	2.54
Rhodium	(Cubic close packed)	3.82	2.70
Silver	(Cubic close packed)	4.06	2.87
Platinum	(Cubic close packed)	4.02	2.85
Gold	(Cubic close packed)	4.08	2.88
Lead	(Cubic close packed)	4.92	3.48
Lithium	Centered Cubic	3.50	3.03
Sodium	Centered Cubic	4.30	3.72
Chromium	Centered Cubic	2.91	2.52
Iron	Centered Cubic	2.86	2.48
Molybdenum	Centered Cubic	3.15	2.73
Tunsten	Centered Cubic	3.15	2.73
Magnesium	Hexagonal (close packed)	..	3.22
Zinc	Hexagonal (close packed)	..	2.84
Cadmium	Hexagonal (close packed)	..	3.15
Cobalt	Hexagonal (close packed)	..	2.53
Diamond	Tetrahedral	3.56	1.54
Silicon	Tetrahedral	5.43	2.35
Lithium Fluoride	Simple Cubic	2.01	2.01
Sodium Fluoride	Simple Cubic	2.31	2.31
Sodium Chloride	Simple Cubic	2.81	2.81
Potassium Fluoride	Simple Cubic	2.69	2.69
Potassium Chloride	Simple Cubic	3.13	3.13
Potassium Iodide	Simple Cubic	3.55	3.55
Magnesium Oxide	Simple Cubic	2.11	2.11

pure form, a few simple salts, as examples, and the non-metallic elements carbon (diamond) and silicon. The structure of graphite is less simple, and will not be discussed here. It apparently contains a mixture of forms, produced by gliding, like cobalt.

The case of cobalt is exceptional. A finely powdered sample produced by rapid electrolysis showed a mixture of cubic and hexagonal close-packing in nearly equal ratio. After annealing in hydrogen at 600 deg. this sample showed only the cubic form. Another sample, composed of filings from pure cast metal, showed slight traces of hexagonal packing, due presumably to straining. It is probable that the other cubic close-packed metals will behave in a similar manner, but this question has not been studied.

¹ For details and theory see Hull, *Phys. Rev.* 10,673, 1917.

PHYSICAL PROPERTIES

Many of the physical properties of these substances are evident from an inspection of their atomic models. Thus it is clear why metals with face-centered cubic arrangement are soft and ductile. For in the planes parallel to the octahedral faces (the bevelled face in Fig. 1c) the atoms are so closely packed that one plane can slip over the one beneath it without appreciable elevation, and without the atoms getting away from each other's attractive influence. There are 4 sets of planes parallel to which this easy gliding can take place, *viz.* those parallel to the 4 pairs of octahedral faces, and in each of these planes there are three equally easy directions. There is no direction, therefore, in which a shearing force can be applied to a crystal of this kind which would not be nearly parallel to one of these directions of easy gliding.

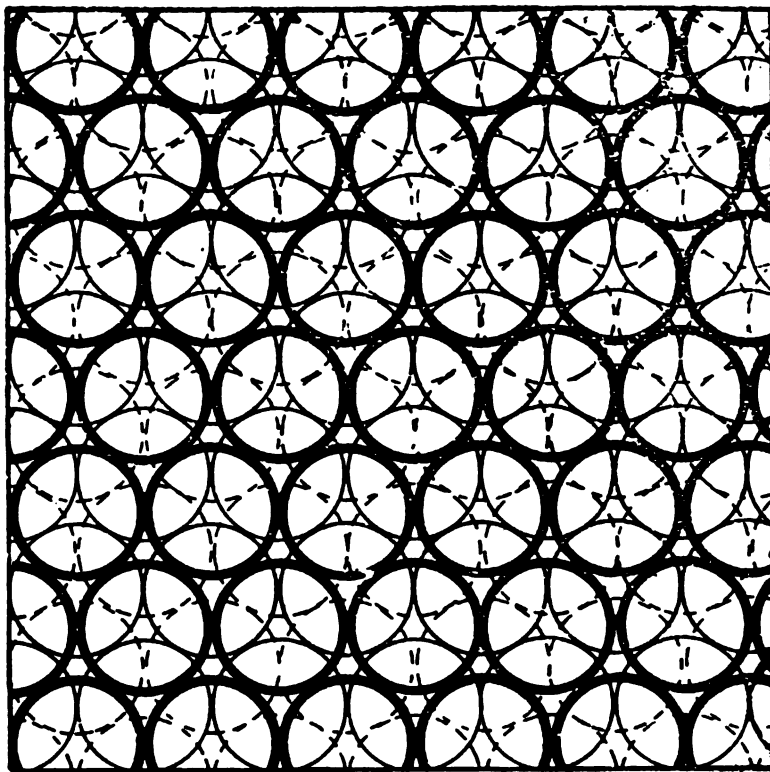

Fig. 14a. Arrangement of Atoms in Successive Planes in Cubic Close Packing

If the shear takes place in such uniform manner that each plane moves over the one beneath it by the same amount, the original arrangement is reproduced and no strain results. If only the alternate planes move, however, the arrangement becomes hexagonal close packing. This is evident from Figs. 14a and 14b, which give the arrangement of atoms in successive close-packed planes (dotted and heavy lines respectively) in the cubic and hexagonal arrangements respectively. In the cubic arrangement there are three different positions of the planes, and these alternate 1, 2, 3, 1, 2, 3, etc. In the hexagonal arrangement there are only two positions, which alternate, 1, 2, 1, 2, etc.

In the hexagonal close-packed arrangement there is only one set of planes parallel to which this easy gliding can take place. Hence a strained metal becomes less ductile

to the extent to which its arrangement becomes hexagonal, and it is evident that mechanical working should produce hardening.

The centered cubic metals should be somewhat less ductile than the face-centered, for the atoms hold on to each other at only 8 points (Fig. 15) instead of 12, and are more likely to move out of each other's influence during gliding.

In the tetrahedral arrangement gliding is impossible. The atoms touch at only 4 points, and in jumping from one stable position to the next would entirely lose hold of each other. This firm interlocking also accounts for the hardness of these substances.

In the case of the simple cubic salts (Fig. 16) gliding is impossible for a different reason. The atoms are held together by electrostatic attraction, each ion being surrounded by six oppositely charged ions. The process of gliding would bring ions of like charge opposite each other, with resulting repulsion and cleavage.

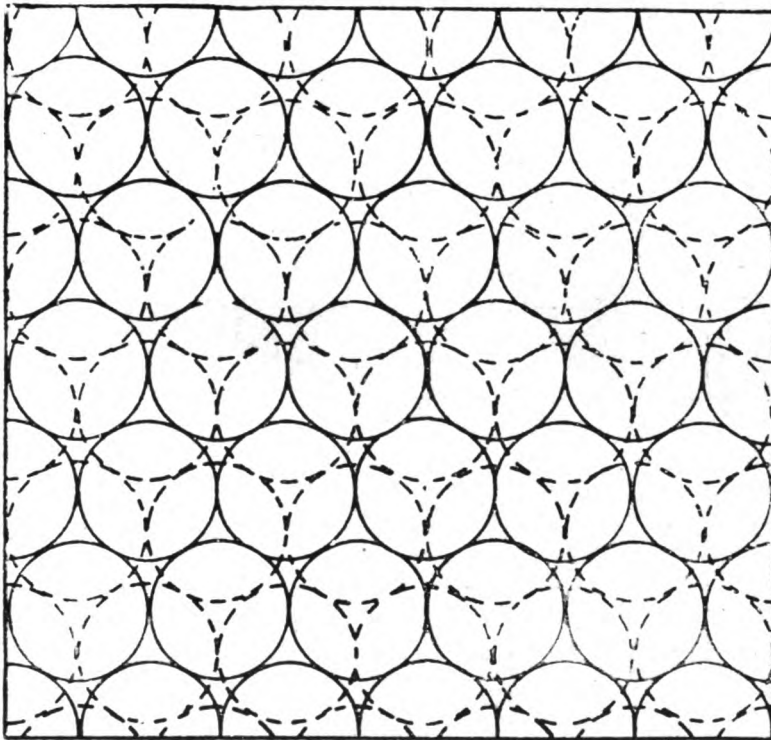

Fig. 14b. Arrangement of Atoms in Successive Planes in Hexagonal Close Packing

The electrical conductivity of metals depends on the ability of electrons to move between the atoms. A discussion of this without a better knowledge of the shape and size of atoms would be premature. It can be seen at once, however, why "ions salts" and crystals like diamond are nonconductors. In each of these arrangements the electrons in the atoms are in complete groups of eight, which is such a stable arrangement¹ that large forces (corresponding to the dielectric strength of the substance) are required to remove them. The atoms of metals, on the other hand, have extra electrons which cannot find places in these stable shells, and are therefore "free" to move from atom to atom.

¹ Langmuir, l. c. p. 873.

MAGNETIC PROPERTIES

It is well known that the ferro-magnetism of iron is not a specific property of the iron atom, since iron in solution and in compounds is in general not ferro-magnetic. The ferro-magnetism must depend, not only on the nature of the atoms, but on the way in which they are grouped together. It might have been anticipated, therefore, that

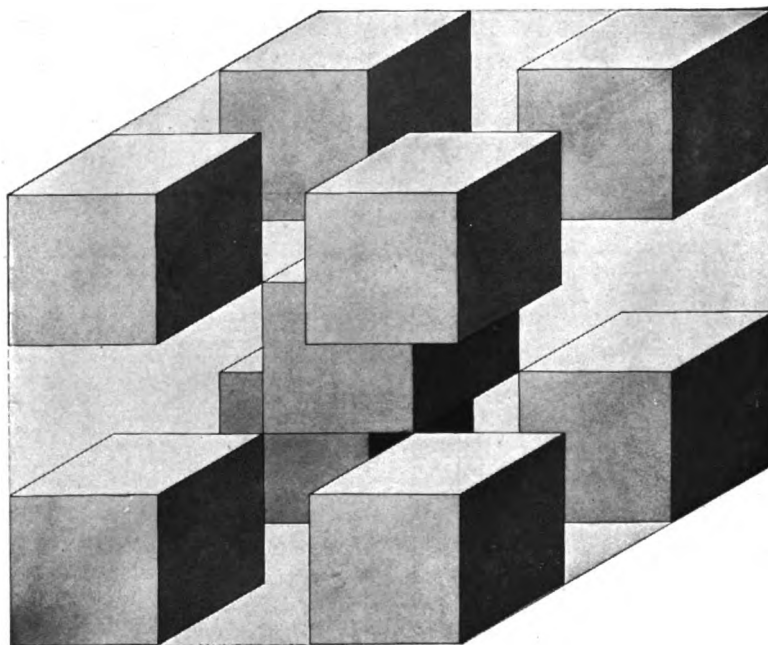

Fig. 15. Packing of Atoms in Centered Cubic Arrangement

the cause of ferro-magnetism was the *centered cubic arrangement* which is characteristic of iron. A glance at Table I shows that this is not the case. Nickel, which is ferro-magnetic, has a face-centered cubic arrangement, like copper. Cobalt is sometimes like copper, sometimes like magnesium. Neither is like iron. Chromium, on the other

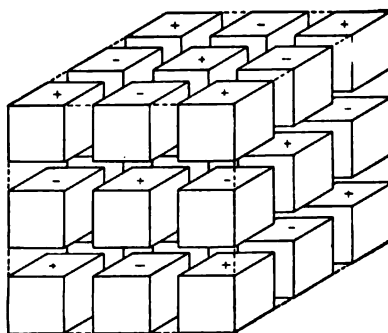

Fig. 16. Packing of Atoms in Simple Cubic Arrangement

hand, which is not ferro-magnetic, has a centered cubic arrangement like iron. Manganese has not yet been obtained sufficiently pure to determine its arrangement. It is evident, therefore, that while the centered cubic arrangement may be favorable to ferro-magnetism, and may make iron more magnetic than cobalt and nickel, it is not the principal or even an essential factor.

SOME INTERESTING APPLICATIONS OF THE COOLIDGE X-RAY TUBE

BY DR. WHEELER P. DAVEY

There have lately been published many very interesting radiographs of flowers, leaves and insects. Typical instances are shown by Pierre Goby, Hall-Edwards and others. These men have found it desirable in such work to use tubes in which the vacuum was widely different from that employed in ordinary radiographic work. For instance, in referring to a splendid radiograph of tulip blossoms, Hall-Edwards (*Archives of the Roentgen Ray*, June, 1914), who is using tubes of the ordinary type (in this case a "Muller" with a Bauer regulator) notes that "it is rather dangerous to use new tubes for this purpose (although the best results can undoubtedly be obtained by them), for the reason that it is very easy to pass the boundary line and get a vacuum so low that it cannot be raised without re-exhausting the tube." Such difficulties, though they have not prevented securing beautiful radiographs, have doubtless kept this method of internal and structural photography from advancing as rapidly as it might otherwise have done.

The Coolidge X-Ray Tube (see *Physical Review*, December, 1913, or *General Electric Review*, February, 1914), has proved itself to be an efficient tool in the hand of the medical profession, and it occurred to the writer that it would prove equally valuable to botanists and biologists in connection with the study of plant and animal life.

The main advantages in the use of the Coolidge tube are (1) the independence of the quantity and the penetrating ability of the rays produced (2) the ease and rapidity with which the quantity and penetration of the rays may be regulated, and (3) the fact that when the tube is once adjusted to the requirements of the operator it needs no further attention. To bring the tube to any desired adjustment, the operator pulls a handle which regulates the current through the tube, thus determining definitely the quantity of X-rays produced. He then adjusts the voltage across the tube until the penetration is of the desired degree. These adjustments are rapid and require the minimum of technical skill.

To illustrate this, the writer took a tube at random (it happened to be No. 280) from the rack and took a number of radiographs of various botanical specimens. It was at once found that, when the proper penetration and exposure had been determined, the radiographs could be duplicated time after time with absolute precision. Then biological specimens were tried, and finally radiographs were taken of dense objects, such as fuse plugs and Ingersoll watches. As in the case of the botanical specimens, all of these radiographs could be accurately reproduced as often as desired.

About this time tube No. 280 was accidentally broken. Another tube (No. 297) was picked at random from the rack and much of the former work was repeated with it. There was no difference noticeable between the two sets of pictures.

It was the original intention to publish only those radiographs taken with tube No. 280, but it was later decided to add such of those taken with No. 297 as seemed to be of peculiar interest. The radiographs reproduced here were not chosen from the total number taken because of any novelty or excellence in the pictures themselves, but rather because they show what a wide range of work can be done with a single Coolidge tube, and because they suggest that the Coolidge tube is destined to become a precision-instrument of value to the botanist, biologist and mineralogist as well as to the physicist and the physician.

None of the pictures shown here has been re-touched or altered in any way.

Copyright, 1914, by General Electric Company.

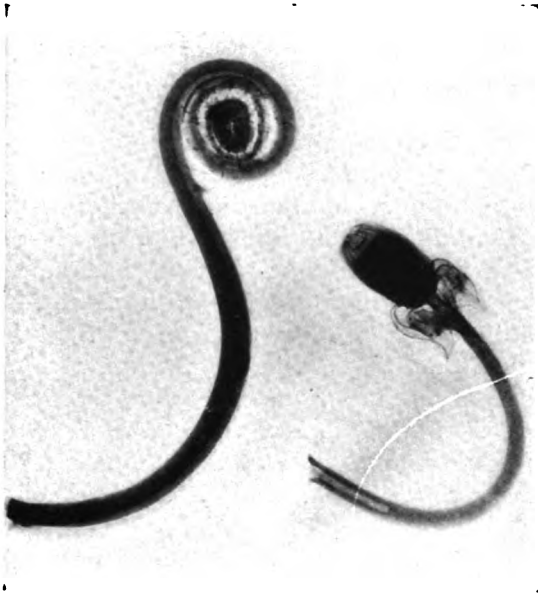

Fig. 1. Fern Bud and Dandelion Bud. Tube 280

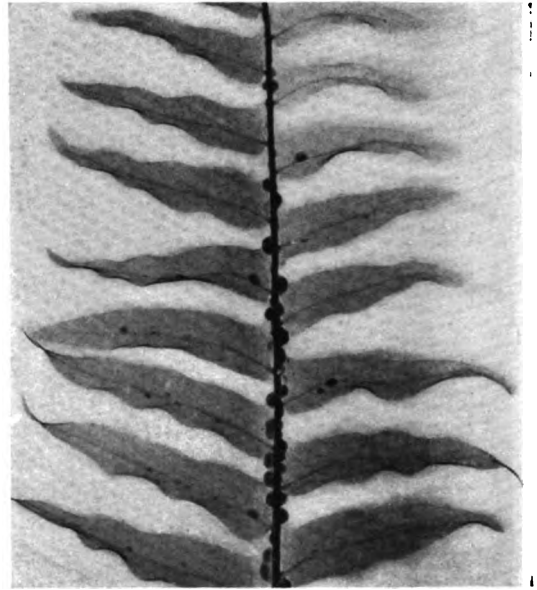

Fig. 2. Fern Leaf with Colonies of Bugs. Tube 280



Fig. 3. Cherry Twigs, with Young Leaves, Buds and Freshly Opened Flower. Tube 280



Fig. 4. Cherry Twigs with Mature Blossoms. A Couple of the Blossoms have already lost their Petals. Tube 28

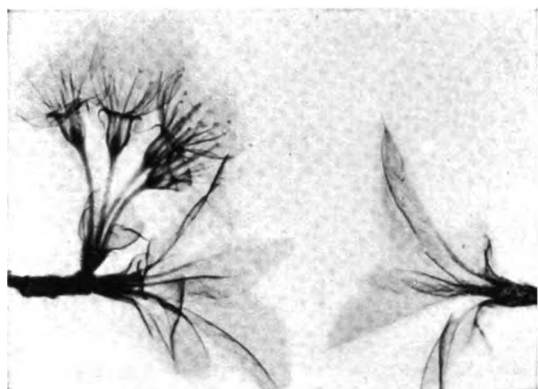

Fig 5. Another Branch of Mature Cherry Blossoms and a Spray of Leaves. Tube 280

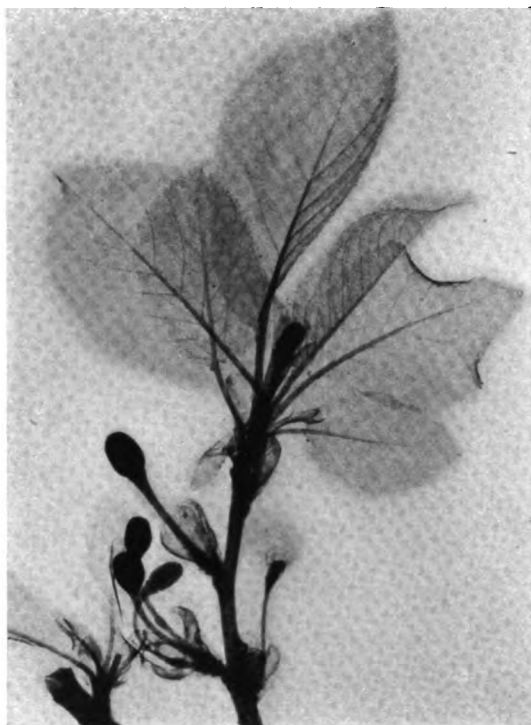

Fig. 7. Cherry Twig. The Cherry is started to form around the Pit. Tube 280



Fig. 6. Cherry Twig. All the Blossoms have lost their Petals. The Cherry Pits have started to form. Tube 280

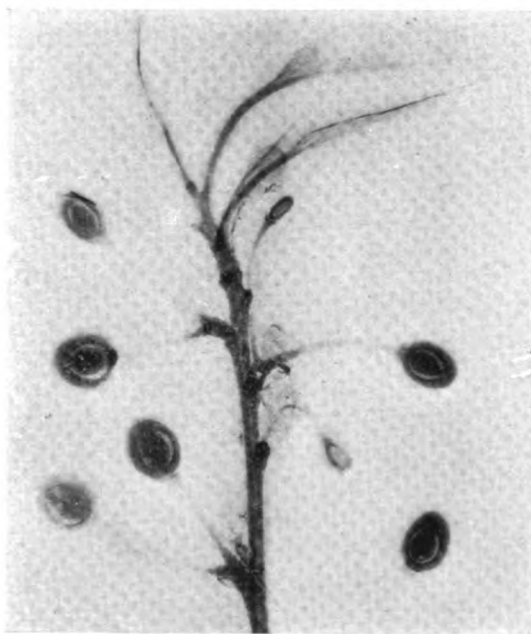

Fig. 8. Cherry Twig. The Cherries are about half developed. Tube 297

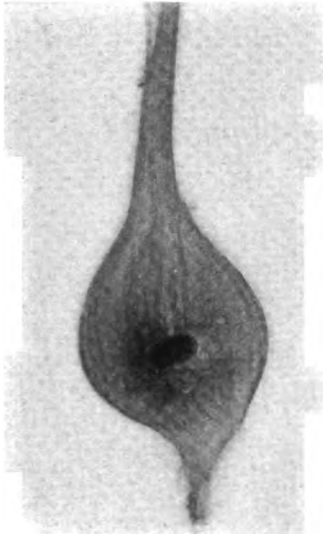

Fig. 9. Golden-Rod Gall. The worm inside is alive. After this picture was taken, the worm finished its metamorphosis and the resulting fly "*Eurosta (Trypeta) solidaginis*," made its way out into the laboratory. Tube 280

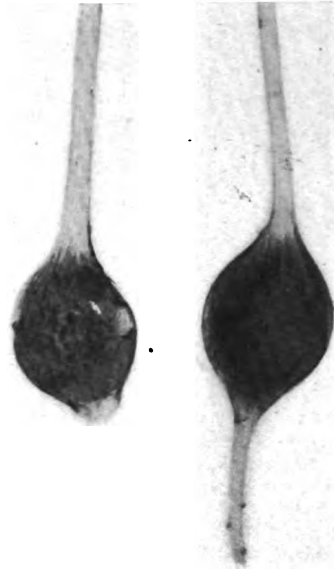

Fig. 10. Golden-Rod Galls. The Worm inside is dead. Tube 280



Fig. 11. Grayfish. This subject differs from the tadpoles, which follow, in that the bony structure is on the outside. Tube 297



Fig. 12. Young Tadpoles. Note the shape of the intestines, and the beginning of ossification of the first vertebra. The intestines show up strongly in contrast to the surrounding flesh because the natural food with which they have gorged themselves is rather opaque to the X-rays. Tube 297



Fig. 13. Still Older Tadpoles. In the oldest of the three the vertebra show considerable ossification. Tube 297



Fig. 15. Still Older Tadpoles. Note growth of the intestines, and further ossification of vertebra. The neck is beginning to form. Tube 297



Fig. 14. Tadpole, Size of Largest One of Fig. 13. Magnified three and one-half diameters. Note articles of food in the intestines. Tube 280

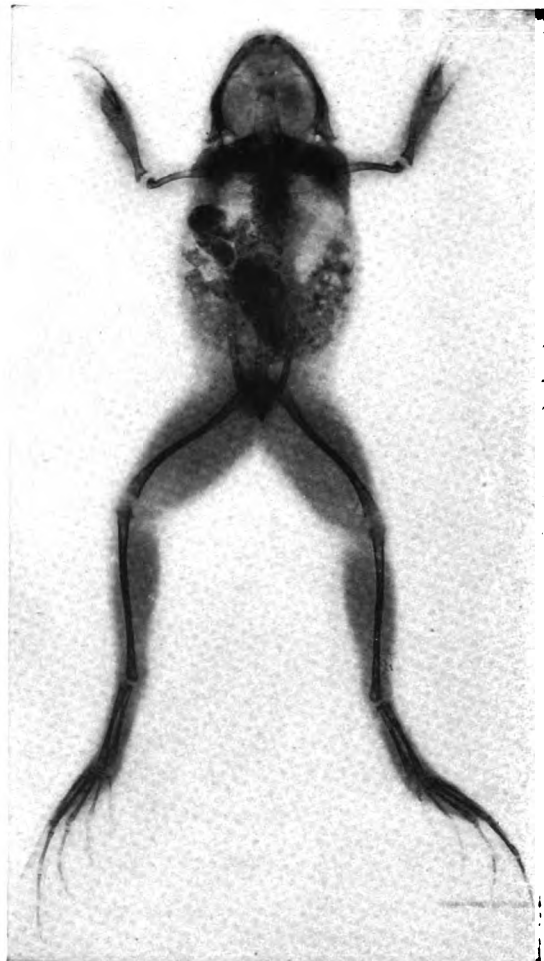

Fig. 16. A Young Frog. The intestines are taking their final shape. Ossification of bones is nearly complete. Tube 297

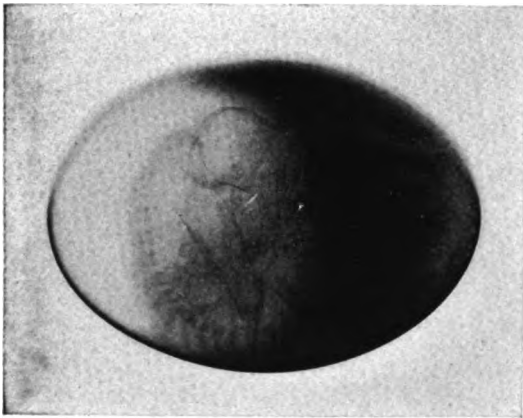

Fig. 17. Partly Hatched Egg. Tube 280

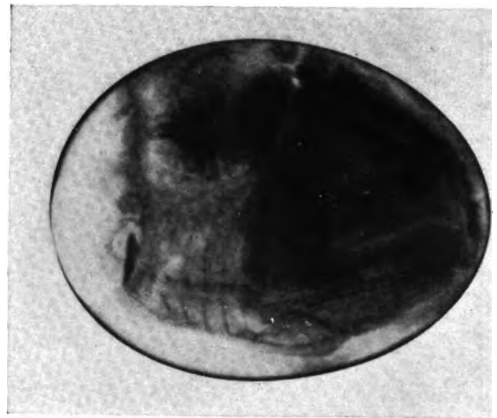

Fig. 18. Egg Nearly Hatched. Tube 280

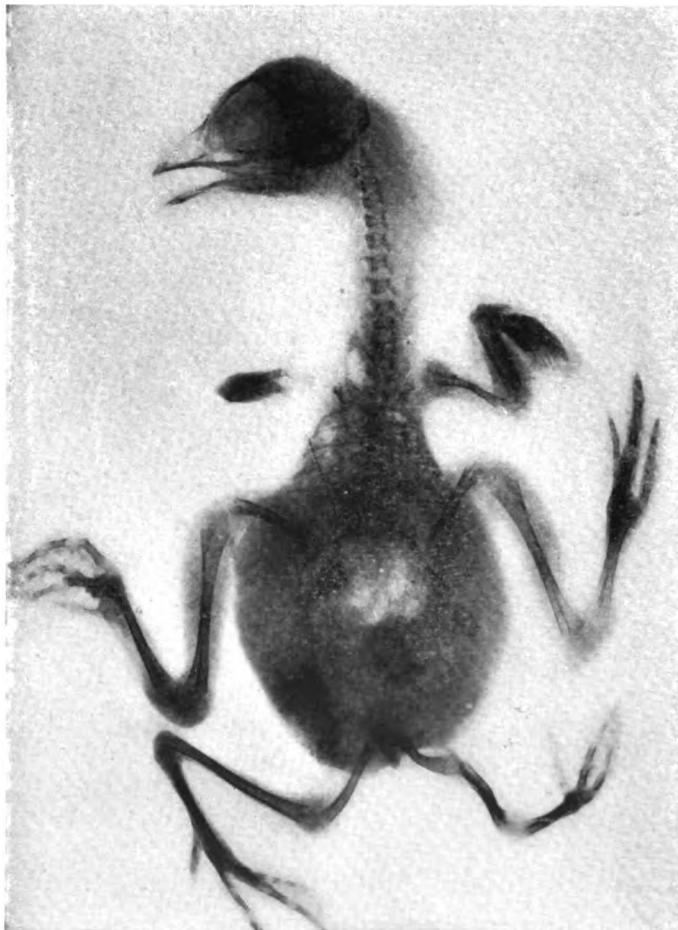

Fig. 19. Four-legged Chicken, Five Hours Old. Tube 297

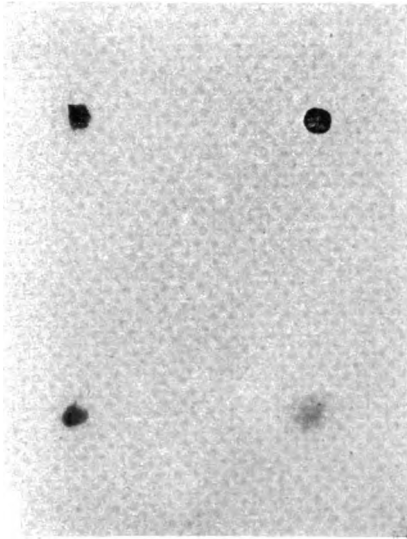

Fig. 20. The substances most commonly used to imitate diamonds are fused oxide of aluminum, quartz, and lead glass. The figure shows a radiograph of these three as contrasted with a diamond of the same size. In the order of transparency to X-rays they are: diamond, fused oxide of aluminum, quartz, lead glass.
 Tube 21

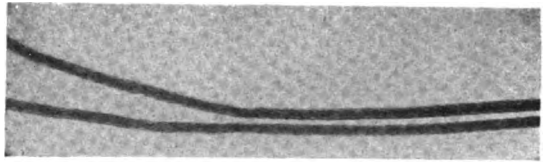

Fig. 22. Cabled Copper Wire. Radiograph taken through the insulation. Tube 280

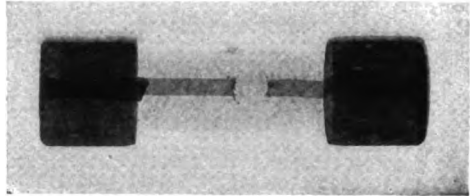

Fig. 23. Cartridge Fuse. Tube 280

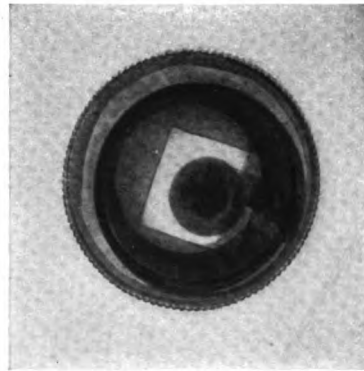

Fig. 24. Fuse Plug. Tube 280



Fig. 21. Ingersoll Watch. Tube 280

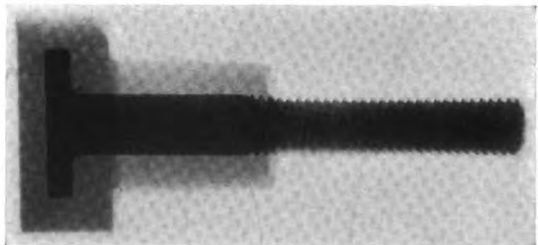

Fig. 25. "Moulded Compound" insulation around a steel bolt. Tube 280



RADIOGRAPHY OF METALS*

BY DR. WHEELER P. DAVEY

RESEARCH LABORATORY, GENERAL ELECTRIC COMPANY

In an article in the *General Electric Review*, January, 1915, reference was made to the X-ray examination of a steel casting $\frac{9}{16}$ of an inch thick. Fig. 1 shows one of the radiographs thus obtained. All these radiographs showed plainly the tool marks on the surface of the casting. *All but one* showed peculiar markings which were of such shape as to strongly suggest that they were indeed the pictures of holes in the interior. A cylindrical piece, one inch in diameter, was punched from the casting at a point where the radiograph, shown in Fig. 1, indicated that a blow-hole should be found. (The location of the sample punched out is indicated by a circle.) Fig. 2 is a photograph of the side of the punching and it shows the hole that was found.

Since that article was written it has seemed desirable (1) to obtain data from which the exposure necessary for any thickness of steel could be at once calculated, (2) to find the thickness of the smallest air inclusion which could be radiographed in a given thickness of steel, (3) to find the direction from which to hope for further progress, and (4) to find the technique of radiographing metals.

In order to gain some preliminary data, several pieces of $\frac{1}{2}$ in. boiler plate were obtained, five by seven inches in size. In one of these, holes were drilled in such a way that the axis of each hole was midway between the faces of the steel and parallel to those faces. The diameters of these holes are listed in Table I.

TABLE I

Hole Number	Diameter
1	$\frac{1}{4}$ inch
2	$\frac{1}{8}$ inch
3	$\frac{1}{16}$ inch
4	$\frac{1}{32}$ inch
5	$\frac{1}{64}$ inch

Exposures were made on Seed X-ray plates at a distance of 20 inches with Coolidge tube X-117 which was operated on a Scheidel-Western induction coil having a mercury turbine break. The X-ray plate was placed on a sheet of $\frac{1}{8}$ in lead. The steel plate was laid on this and a lead cover was placed over the whole in such a manner that the cover and backing made a complete lead shield for the X-ray plate. (See Fig. 3.) A rectangular hole in the cover allowed such X-rays as were able to penetrate the steel to reach the X-ray plate. This afforded complete protection against secondary rays. Without such precautions, the effect of secondary rays on the X-ray plate would have been greater than that of the rays used to take the picture. If the steel had been two or three feet square, such precautions would have been unnecessary. By placing the

* Copyright, 1915, by *General Electric Review*.

pieces of boiler plate on top of each other any thickness of steel desired could be obtained. Exposures were made at 11-, 13- and 15-in. parallel spark-gap between points. An attempt was made to use a 17-in. spark gap, but was abandoned due to flashing in the tube. The results are tabulated in Table II.

TABLE II

Thickness of Steel in In.	Plate	Spark Gap	Exposure in Milliampere-minutes	Holes Visible
$\frac{1}{2}$	D	11	7	1-2-3-4-5
	A	13	4	1-2-3-4-5
	B	15	2	1-2-3-4-5
1	E	11	45	1-2-3-4-5
	F	13	19	1-2-3-4-5
	G	15	10	1-2-3-4-5
$1\frac{1}{2}$	H	11	45	1-2-3 very faint
	I	13	30	1-2-3 very faint
	K	13	90	1-2-3 faint
	J	15	30	1-2-3-4-5 very faint
	L	15	60	1-2-3-4-5 faint



Fig. 1. Radiograph of a Steel Casting Showing Flaw Within Casting. The Circle Shows where a Piece was Later Punched Out

This really means, of course, that at 13-in. spark-gap 90 milliampere-minutes is sufficient to enable one to notice the difference in blackening between exposures through $1\frac{7}{8}$ in. and $1\frac{1}{2}$ in. of steel, but is not sufficient to enable one to detect the difference in blackening between exposures through $1\frac{1}{2}$ in. and $1\frac{1}{2}$ in.

These results were necessarily incomplete, since the plates were by no means all of the same density. They served, however, to demonstrate two facts.

1. With the voltages which can now be used, it is impracticable to radiograph through more than $1\frac{1}{2}$ in. of steel with tungsten target tubes because of the time required.

2. The use of high voltages does not seem to appreciably reduce the clearness of the picture obtained. (It was to have been expected from published data on scattering in aluminum that enough scattered radiation would have been produced to blur the pictures, but plate *B* apparently shows as good detail as does plate *D*.)

It remained to verify these conclusions by data of a quantitative nature. Seed X-ray plates were, therefore, exposed under the same conditions as before except that none of the slabs of steel used had been drilled. For each thickness of steel, all the exposures at a given spark-gap were made on the same plate. Each plate, then, showed a series of steps which increased in density from one end of the plate to the other. Thickness of steel, spark-gap, and milliamperere-minutes were recorded on each plate by means of lead numbers. Data regarding these plates is listed in Table III.



Fig. 2. Ordinary Photograph of One Edge of the Punching from the Plate Shown in Fig. 2. Note Flaw

TABLE III

Plate No.	Thickness of Steel	Spark-gap
216	$\frac{1}{2}$	11 inches
217	$\frac{1}{2}$	13 inches
218	$\frac{1}{2}$	15 inches
221	1	11 inches
220	1	13 inches
219	1	15 inches
222	$1\frac{1}{2}$	15 inches

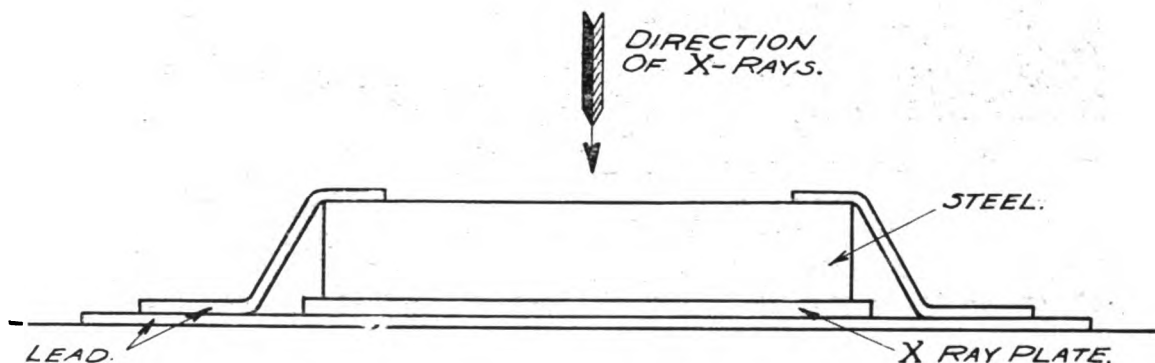

Fig. 3. Diagram of the Method of Preparing Steel Sample, X-ray Plate, Lead Mask and Lead Backing for Taking Radiograph

A study of these plates showed the following facts: Let $E_{\frac{1}{2}}$ be the exposure in milliamperere-minutes necessary to produce a given darkening of the plate through $\frac{1}{2}$ inch of steel, and let E_1 and $E_{1\frac{1}{2}}$ be the exposures necessary to produce the same darkening through 1 inch and $1\frac{1}{2}$ inch respectively.

Then at 11 in. gap

$$E_{\frac{1}{2}}:E_1=1:11$$

At 13 in. gap

$$E_{\frac{1}{2}}:E_1=1:8$$

At 15 in. gap

$$E_{\frac{1}{2}}:E_1=E_1:E_{1\frac{1}{2}}=1:8$$

Also, through both $\frac{1}{2}$ inch and 1 inch of steel

$$E_{13 \text{ in. gap}}:E_{11 \text{ in. gap}}=1:4$$

$$\text{and } E_{15 \text{ in. gap}}:E_{13 \text{ in. gap}}=2:3$$

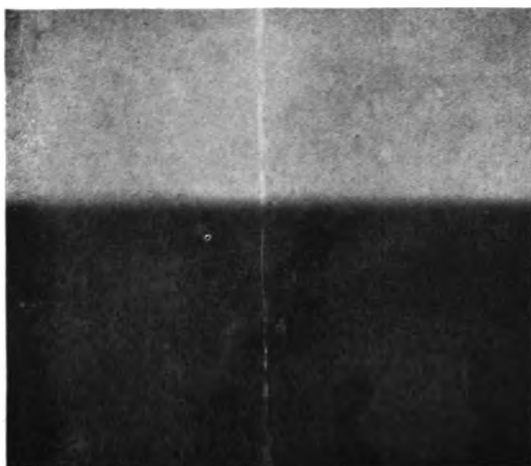

Fig. 4a. Radiograph of Autogenous Weld in Steel. Sample No. 1. Only the Surfaces Have Been Welded



Fig. 5a. Radiograph of Autogenous Weld in Steel. Sample No. 2. Holes in Center Due to Metal not Being Thoroughly Fused

It is at once evident that *either* X-rays from a tungsten target at 13 in. gap are more penetrating than when produced at 11 in. gap, *or* the X-ray plates used are more sensitive to the rays produced at 13 in. gap. There is other evidence to show that the first of these conclusions is the more probable, but it is the *effect of the X-rays on the plate* which is of prime importance in this work, so that from a radiographic standpoint we may say that in any case the *effective penetration* of the rays is a little greater at 13 in. gap than at 11 in. gap.

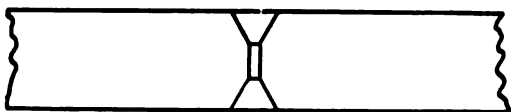

Fig. 4b. Diagram of Section of Weld in Sample No. 1



Fig. 5b. Diagram of Section of Weld of Sample No. 2

In the same way we may conclude that the effective penetration at 15 in. gap is the same as at 13 in. gap. There is, however, a marked decrease in the amount of exposure required as the voltage across the tube (as measured by the spark-gap) is increased. This may be due to one of two causes, *either* the efficiency of transformation from the kinetic energy of the cathode stream into the energy of the X-rays may be greater at high voltages, *or* there may be some peculiarity in the wave-form produced by the induction coil such that a great deal of energy is given off at a voltage corresponding to 13 in. gap when the coil is operated so as to give a maximum voltage corresponding to a

15 in. gap. Investigation work on crystal-reflection of X-rays will serve to decide between the two hypotheses.

From the data at hand, it is easily possible by well known means to construct formulae for computing the exposure necessary for radiographing steel at various spark gaps.

Let Q_0 be the quantity of X-rays impinging on the steel during the exposure.

Let Q be the quantity of the rays which pass through the steel.

Let x be the thickness of the steel.

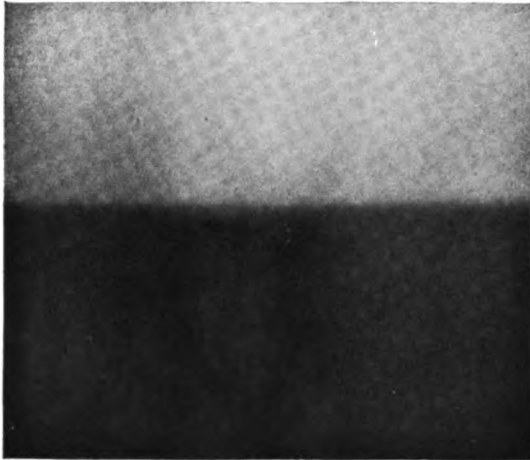

Fig. 6a. Radiograph of Autogenous Weld in Steel.
Sample No. 3. Weld is Porous



Fig. 7a. Radiograph of Autogenous Weld in Steel.
Sample No. 4. A Good Weld

Let λ be the coefficient of absorption of the steel. Then, if the X-rays are homogeneous,

$$Q = Q_0 \epsilon^{-\lambda x}$$

Where ϵ is the base of natural logarithms.

Now at 15-in. gap we know that $\frac{E_{1/2}}{E_1} = \frac{E_1}{E_{1/4}} = 1/8$

The rays given off at 15 in. gap are, therefore, practically homogeneous. Since $\frac{E_{1/2}}{E_1} = 1/8$



Fig. 6b. Diagram of Section of Weld in Sample No. 3

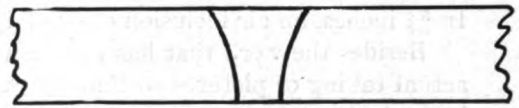

Fig. 7b. Diagram of Section of Weld in Sample No. 4

at 13 in. gap, we may assume that these rays are also practically homogeneous. Rays given off at 11 in. gap are still sufficiently homogeneous, after having passed through the first few hundredths of an inch of steel, to allow of being treated as though they were actually homogeneous. Calculations for exposures at 11 in. gap are to be considered as being only good approximations.

$$Q/Q_0 = 1/8 = \epsilon^{-x\lambda} = \epsilon^{-1/2\lambda}$$

$$\log 8 = 1/2\lambda = 2.079$$

$$\lambda = 4.16 \text{ inches}^{-1} = 1.64 \text{ centimeters}^{-1}$$

Likewise for 15 in. gap

$$\lambda = 4.16 \text{ inches}^{-1} = 1.64 \text{ centimeters}^{-1}$$

Applying the same method for 11 in. gap

$$\lambda = 4.80 \text{ inches}^{-1} = 1.89 \text{ centimeters}^{-1}$$

Now at 15 in. gap and 20 in. distance, 0.8 milliampere-minutes gives a good exposure through $\frac{1}{2}$ inch of steel. A corresponding darkening would have been produced on a bare (unobstructed) plate by an exposure of 0.1 milliampere-minutes. This corresponds to Q in the formula. We may therefore write, since $Q_0 = E$,

$$\begin{aligned} 0.1 &= E e^{-4.16 x} \\ 10 E &= e^{4.16 x} \\ \log_e 10 E &= 4.16 x \\ \log_{10} 10 E &= 1.80 x \\ E &= 1/10 \log_{10}^{-1} 1.80 x \end{aligned}$$

where x is the thickness of the steel in inches or

$$E = 1/10 \log_{10}^{-1} 0.71 x$$

where x is the thickness of the steel in centimeters.

The corresponding formulae for 13 in. gap are

$$\begin{aligned} E &= 3/20 \log_{10}^{-1} 1.80 x \quad (x \text{ in inches}) \\ E &= 3/20 \log_{10}^{-1} 0.71 x \quad (x \text{ in centimeters}) \end{aligned}$$

The approximate formulae for 11 in. gap are

$$\begin{aligned} E &= 3/5 \log_{10}^{-1} 2.09 x \quad (x \text{ in inches}) \\ E &= 3/5 \log_{10}^{-1} 0.82 x \quad (x \text{ in centimeters}) \end{aligned}$$

It remained to find the thickness of the smallest air-inclusion which could be radiographed in steel at 15-in. gap. For this purpose two plates of steel were taken. The faces were machined flat and in one of them a slot was cut, thus giving a *wedge* of air. The slot and the faces of the steel plates were then ground smooth. When completed, each plate was $\frac{5}{8}$ in. thick. The air wedge was 10 inches long, 1 inch wide, and $\frac{9}{64}$ inch thick at its thick end. When the two plates were bolted together, the air wedge simulated a blow-hole in a casting. The wedge was then radiographed at 15 in. gap. When the X-ray plates were dry the place was noted at which the outline of the wedge was barely visible. In order to avoid error, only a small portion of the wedge image was viewed at one time, the remainder being blocked off with cardboard. It was found that an air inclusion 0.021 inch thick could be detected in $1\frac{1}{4}$ inches of steel. In $\frac{5}{8}$ inches, an air inclusion of 0.007 inch could be detected.

Besides the work that has been outlined herein much more has been done in the actual taking of pictures so that the technique of radiography through metals might be worked out.

A record of a single example will suffice. Four samples of autogenous welds in steel were obtained. The welding had been done with an oxy-acetylene flame. The samples were $\frac{1}{2}$ inch thick and about 4 inches square, and their faces were fairly rough. Sample No. 1 had only been welded on the surfaces. (See Fig. 4b.) Sample No. 2 had been insufficiently heated so that there was incomplete fusion of the metal at the center. (See Fig. 5b.) In welding sample No. 3 an excess of oxygen had been used in the flame which caused the presence of oxide on the surface. (See Fig. 6b.) Sample No. 4 was considered to be a good weld. (See Fig. 7b.) One-half of each face of the samples was machined off, so that half the length of the weld was between flat, parallel faces; the other half was left under the original rough surfaces. As a result, one-half of each sample

was $\frac{1}{2}$ inch thick and the other half was about $\frac{3}{8}$ inch thick. Radiographs were taken at 15-in. gap under the conditions described above. Reference to the formula for exposure at 15-in. gap shows that the exposures through the $\frac{1}{2}$ inch and $\frac{3}{8}$ inch portions were in the ratio of 1 to 1.7. The resulting radiographs are shown in Fig. 4a, 5a, 6a, and 7a.

Fig. 4a shows clearly the unwelded center of sample No. 1 in both portions of the picture. Fig. 5a shows, in both portions of sample No. 2, the holes caused by the metal not having been thoroughly fused at the center. That portion of Fig. 6a which was taken through the machined end of the weld of sample No. 3 would seem to indicate a porous structure. Such a structure was evident during the machining. The portion of the picture taken through the unmachined end of the weld did not show such a structure with certainty. This was to have been expected, as the inequalities in thickness due to the uneven surface were at least as great as those due to porous or frothy structure. Fig. 7a shows that, as far as gross structure is concerned, sample No. 4 was a good weld.

It is, of course, self-evident that a radiograph gives only the gross structure of the metal, and gives no information as to the "grain," crystal interlocking at the edge of the weld, etc. A radiograph does, however, give valuable information as to the presence of blow-holes, slag inclusions, porous spots, and defects of like nature which could not be found otherwise except by cutting into the metal. Unfortunately, no fluoroscopic screen now known is sensitive enough for this work; therefore, all work in metals must be done radiographically. An inspection of the formulae that have just been derived demonstrates that, for the present at least, radiography of steel is a commercial possibility only up to thicknesses of $\frac{1}{2}$ inch. For greater thicknesses, the time required is rather great. The big saving in time which is gained by the use of a 15-in. spark-gap instead of a 13-in. gap makes it seem probable that a further increase in the voltage across the tube would allow one to radiograph still greater thicknesses of steel.



Fig. 8. A Radiograph of a Steel Casting Revealing a Flaw in the Interior of the Plate

X-RAY EXAMINATION OF "BUILT-UP" MICA*

BY C. N. MOORE

The process of manufacturing "built-up" mica for use as an insulating material in electrical machinery consists essentially in pasting together, at an elevated temperature under pressure, thin flakes of mica with a suitable binder, planing down the resulting product to the required thickness, and cutting it into sheets of the required size. In this process, certain defects which would affect insulating qualities of the finished product have to be guarded against. Among these are the presence of foreign materials of a metallic nature, and of areas not of the required thickness. In practice, these defects are detected by subjecting the material to very careful visual inspection and gauging with a micrometer. This, however, entails considerable labor. The successful application of X-rays to the detecting of defects in such materials as steel and copper cast-

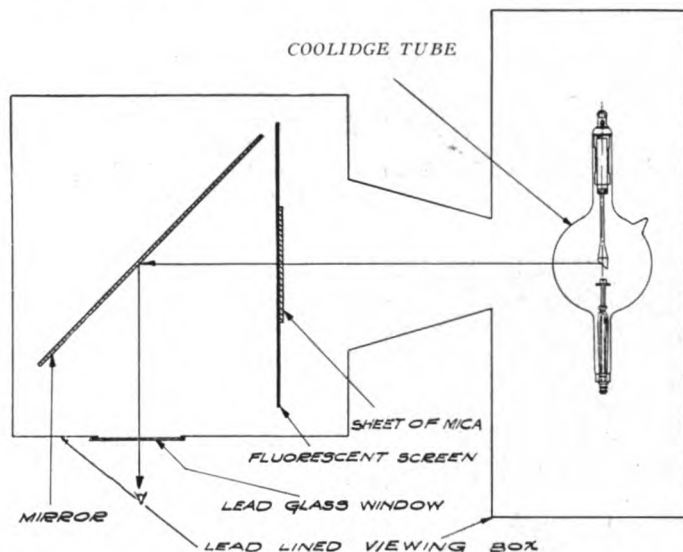

Fig. 1. Arrangement of Coolidge Tube and Viewing Box for Inspection of Built-up Mica

ings, already described in earlier issues of this publication, suggested the possibility of utilizing X-rays as a means of increasing the efficiency of the regular inspection of mica.

With this end in view, Dr. Davey and the writer obtained micas (some known to be good and others known to be defective) for examination in the Research Laboratory. These samples were about 0.032 of an inch in thickness and had been cut into small sheets of the required size for placing in the commutators. These pieces were placed upon a fluorescent screen in a specially designed viewing box (Fig. 1) at a distance of 20 inches from a Coolidge X-ray tube. When the tube was operating with a current of about 6 milliamperes and a parallel spark gap of six inches, the structure of the mica, as shown on the fluorescent screen, could be viewed from the outside of the box by means of a mirror set at an angle of 45 deg. to the screen.

* Published in *General Electric Review*, March, 1915.

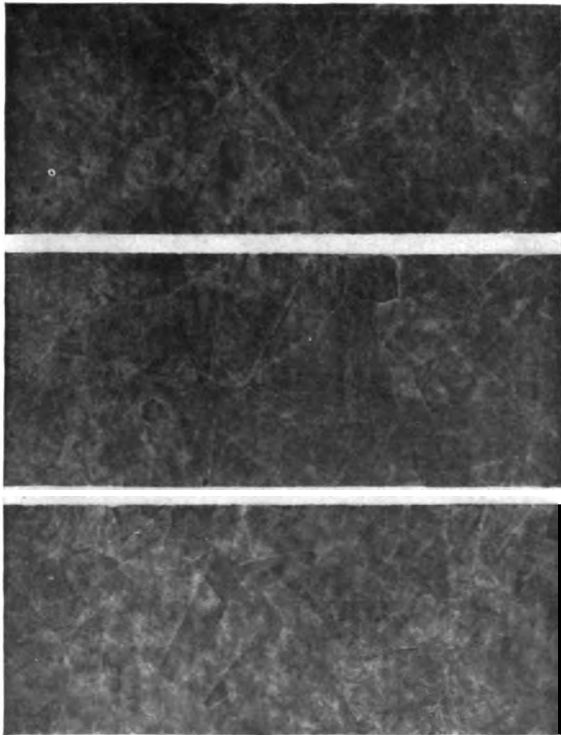

Fig. 2. Radiograph of Three Sheets of Built-up Mica of Fairly Uniform Thickness

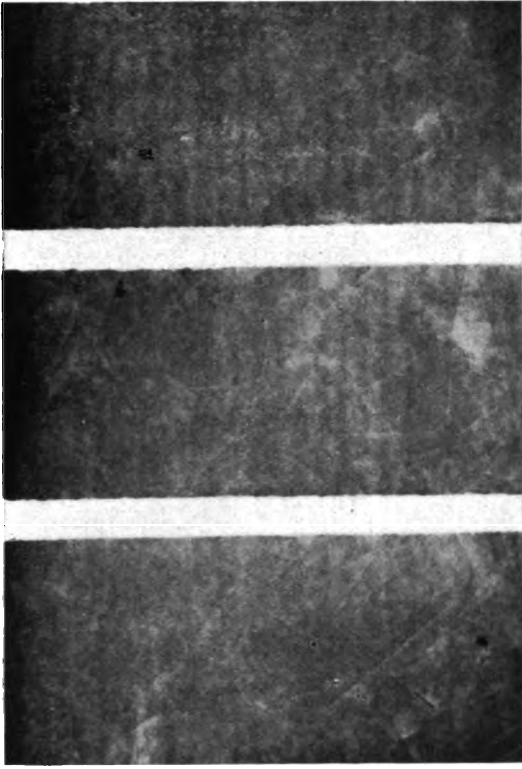

Fig. 4. Radiograph of Mica showing Presence of Particles of Foreign Material

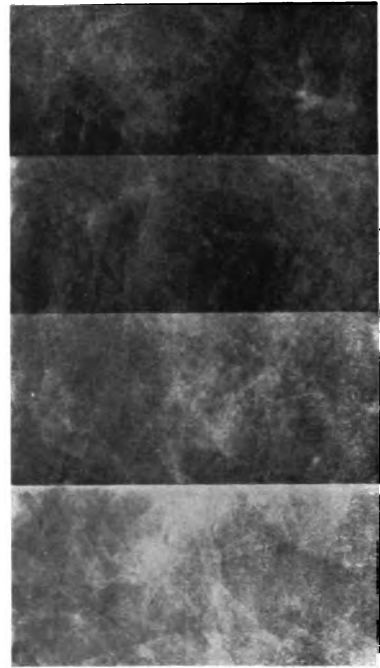

Fig. 3. Radiograph of Sections of Built-up Mica showing a Difference of Thickness of 0.005 in.

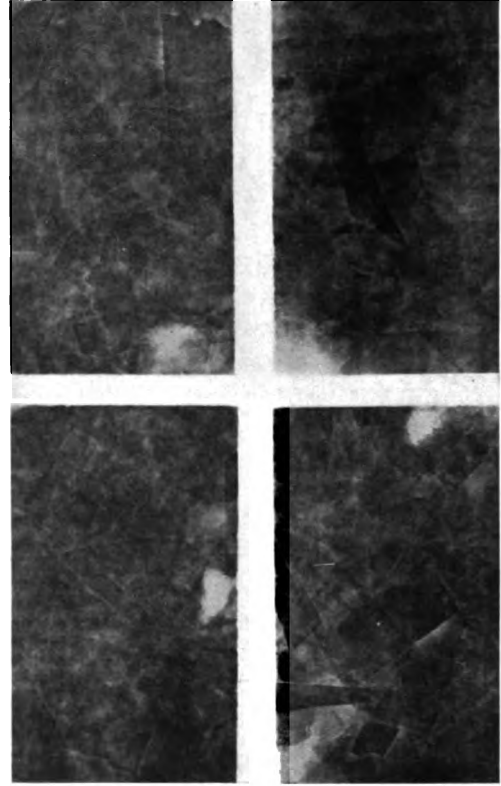

Fig. 5. Radiograph of Four Sheets of Mica 0.032 in. Thick with Small Areas of Thinner and Thicker Sections which show up respectively as Light and Dark Spots

Some of the samples examined contained small particles of iron oxide not visible to the eye on the surface of the sheet of mica. As iron oxide is much more opaque than mica to X-rays, this material showed up as black spots in the image of the mica on the fluorescent screen. Other samples examined contained small sections not as thick as the main portion of the sheet. These sections, being more transparent to X-rays, showed up as light spots in the image on the screen. Samples of uniform thickness which contained no foreign material gave images of uniform density upon the screen. It was found that the examination could be made very accurately and rapidly, one glance at the image on the screen being sufficient to detect the presence of any defects.

The nature of the images on the fluorescent screen is shown in the radiographs. These were taken on Seed X-ray plates, with an exposure of five minutes at a distance of 30 inches from a Coolidge tube. The tube was operated from an induction coil on 10 milliamperes with a parallel spark gap of four inches. Fig. 2 shows the radiograph of three sheets of fairly uniform thickness. The various flakes of mica which go together to make up the finished sheet are plainly visible. As these flakes are in most cases only a few thousandths of an inch in thickness, this radiograph shows what small differences of thickness may be detected by means of the X-rays and the fluorescent screen. Fig. 3 illustrates this more clearly. In this case a sheet of mica 0.050 of an inch thick was planed down so that successive sections were 0.045, 0.035 and 0.020 inch thick. The radiograph of this sheet shows that a difference in thickness of 0.005 of an inch may readily be detected.

The ease with which foreign material may be detected is shown by Fig. 4. The particles of iron oxide present in this particular case were not visible on the surface, but they are plainly visible as black spots in the radiograph taken of the sheets of mica.

Fig. 5 shows a radiograph of four sheets of mica 0.032 of an inch thick with small areas considerably thinner than the main portion of the sheet. These thinner areas show up as light spots in the radiograph.

The results obtained on an experimental scale in the laboratory have demonstrated the adaptability of the X-ray apparatus as a factory tool for the inspection not only of "built-up" mica but of any similar material of not too great a thickness.

APPLICATION OF THE COOLIDGE TUBE TO METALLURGICAL RESEARCH*

BY DR. WHEELER P. DAVEY

Dr. Weintraub in the February, 1913, number of the *Journal of Industrial and Engineering Chemistry* describing boron and its compounds says:

"Boron suboxide, a by-product obtained in the manufacture of boron, can be used for obtaining high conductivity cast copper. Copper cast without additions is full of pores and blowholes, and, therefore, mechanically unfit and of very low electric conductivity; the removal of the gases from copper by the known deoxidizers is liable to give an alloy containing a small amount of deoxidizer, an amount sufficient, however, to lower the conductivity of the copper very considerably. Boron suboxide, however, has the property of deoxidizing copper without combining with it, as boron suboxide has no affinity for copper. Tons of copper are cast now by this process, improving the quality of the product and at the same time cheapening it."

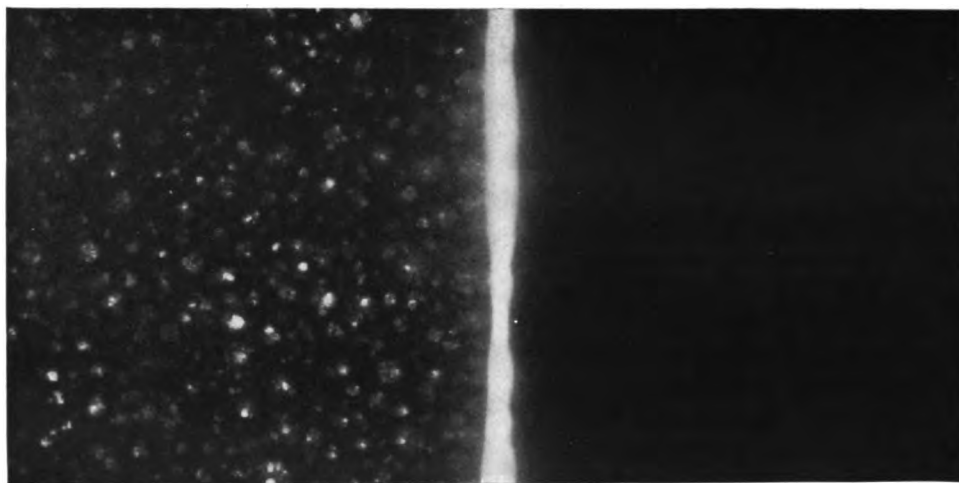

Fig. 1. Radiograph of a Block of "Unboronized" (Pure) Copper side by side with a Block of "Boronized" (Pure) Copper. Note difference of internal structure.

In the refining of copper for electrical purposes, the electrically deposited metal is melted in a reverberatory furnace. A world of delicate chemical control is connected with this furnace refining. When ready to pour, the metal is cast into open iron moulds which give a copper pig or bar of about 75 lb. in weight.

If the metal were merely melted and then poured the casting would be full of blowholes and would be of low electrical conductivity. The molten copper is allowed to oxidize in the furnace and the oxidation is augmented by air blown into the metal. When the melt contains five or six per cent of oxide, the major part of the other impurities have been burned away and the work of reduction is started. As ordinarily done, this consists in the so-called "poling." Green sticks are submerged in the molten

* Copyright, 1915, by *General Electric Review*.

copper and the gases and carbon reduce the oxide, and such harmful products as sulphur dioxide are driven out of the metal. The proper time for pouring is not that representing complete reduction of all oxide, as it has been determined by experience that over-poling also gives a porous inferior ingot.

It was once believed that the copper absorbed carbon which in over-poled copper caused the rising in the mold and the porous condition when cast. Hampe corrected this idea and attributed the porous state of over-poled copper to the effect of absorbed hydrogen and carbon monoxide. In any case the fact remains that if we merely melt copper and cast it we get a porous casting, and if we thoroughly remove dissolved oxygen by carbon or similar reducing agents, we also get a porous casting.

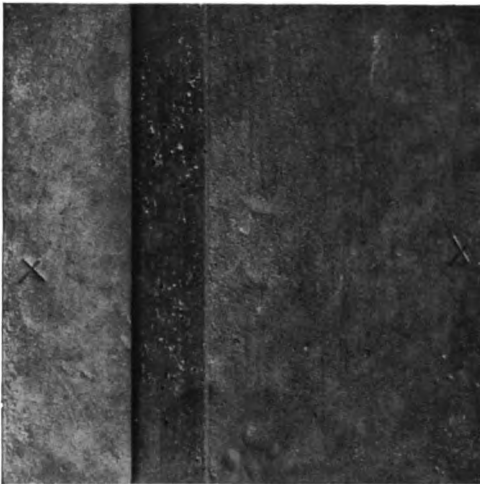

Fig. 2. Ordinary Photograph of the Block of "Unboronized" Copper

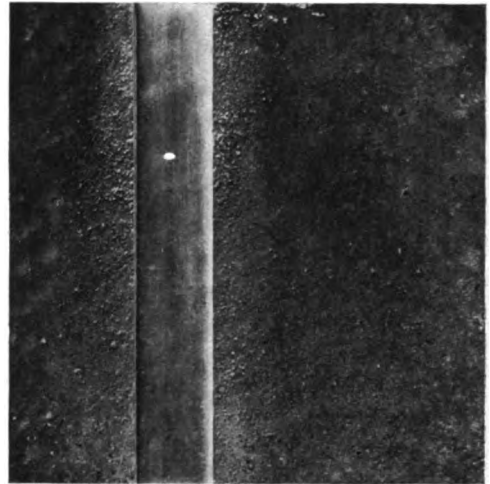

Fig. 3. Ordinary Photograph of the Block of "Boronized" Copper.

The use of the boron flux of Weintraub has done away entirely with the difficulty of obtaining sound castings of high electrical conductivity. It seemed interesting to illustrate the effect on the porosity by an investigation, using X-rays. For this purpose some high grade copper was melted in the usual way and poured into a sand mold to give a block 10 by 10 by $\frac{3}{4}$ inches. Another portion was treated with one per cent of the boron flux at the time of pouring and was cast in a similar mold. These two castings were then placed side by side on an 8 by 10-inch Seed X-ray plate, 22 inches from the focal spot of a Coolidge X-ray tube and exposed for two minutes. The current through the tube was 2.8 milliamperes and the potential difference across the tube corresponded to a 10-inch parallel spark gap between points. The resulting radiograph is shown in Fig. 1. The copper cast in the ordinary way is seen to be full of pores. The cast with the boron flux is so perfect that no holes are visible. The two castings were then taken to the machine shop and a portion of the surface of each was machined as smooth as possible. Ordinary photographs were then taken, see Figs. 2 and 3. As was to have been expected from the radiograph, Fig. 1, the holes were clearly visible in the common copper. In the "boronized" copper the holes are either entirely absent or are microscopic.

The advantage of the radiograph in experimental work is obvious. Without the use of X-rays it is necessary to machine off layer after layer of the sample in order to expose

to view any hidden defects. Even when this is done it remains for the experimenter to build up a mental picture of the defects in his casting on the basis of what he has seen on each of the exposed layers. From the radiograph it is possible to see *all of these defects at once* without destroying the casting. If it seems desirable, it is easily possible to make stereoscopic radiographs whereby the defects may be seen in their entirety and their depths easily estimated. Such a stereoscopic radiograph of a portion of the pure copper casting is shown in Fig. 4. This figure should be viewed through an ordinary stereoscope.

In view of the results shown, the X-ray examination of metals as a means of metallurgical research seems to have certain attractive and desirable features not found in other methods and to open a wide field for further work.

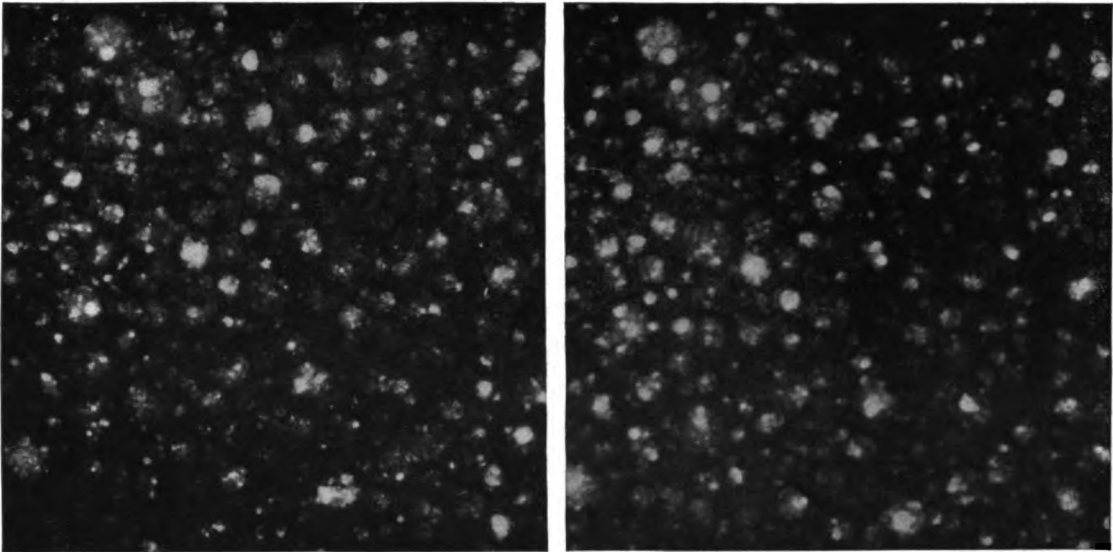

Fig. 4. Stereoscopic Radiograph of a Portion of the Block of Unboronized Copper (Actual Size).
When viewed through a hand-stereoscope this shows the size and relative depth of the pores



THE EFFECT OF X-RAYS ON THE LENGTH OF LIFE OF TRIBOLIUM CONFUSUM

BY WHEELER P. DAVEY

Introduction

A great deal of work is reported in the literature on the effect of X-rays on various forms of animal life. A study of this literature shows that, interesting though the results may be, it is with few exceptions difficult to duplicate the experiments because the physical data relating to the dosage have been so incompletely given. Excluding work on human beings, the following work may be mentioned.

Hastings, Beckton and Wedd¹ found that the hatching of silkworm eggs was accelerated by X-rays (dose not given) and that the second generation was less fertile. Bordier² X-rayed six silkworms, giving them a dose of 7 to 8 H†, at some unknown penetration. He found an increased restlessness and smaller size. The cocoon was only half size, and the moth did not emerge. Hasebroeck³ was able to kill caterpillars of *Charaxes* (dose not given), but those of *Vanessa urticae*, after being X-rayed an unknown amount, developed into butterflies which were unable to fly. Lopriori⁴ found a destructive action on *Vallisneria spiralis*, *Genista* and *Darlingtonia* (dose not given).

Perthes⁵ X-rayed the ova of *Ascaris megalocephala*, giving them a dose of 24 H at a voltage corresponding to 6.5 cm. spark gap. Cell-division was so much retarded that although the control specimens were in the 4-cell stage at the end of 36 hours, the rayed specimens were still in the 1-cell and 2-cell stage. Hastings⁶ rayed eggs of the same species, using an unknown quantity of characteristic X-rays from copper. He found a retardation in growth. Runner⁷ X-rayed the eggs of the cigarette beetle (*Lasioderma serricornis*) using a Coolidge tube and giving a dose of 150 milliamperes-minutes at 65 kilovolts at a distance of 7.5 inches. He found that eggs less than 3 days old failed to hatch, and became shrunken in about 10 days. Eggs over 3 days old hatched but the larvae never reached the pupa stage. Larvae similarly rayed refused to eat, and although they lived a long time after raying, they never reached the pupa stage.

Gilman and Baetjer⁸ found that X-rays (amount not given) accelerated the development of eggs of *Amblystoma* for about 10 days, but produced monsters. They also rayed hen's eggs (dose not given) and found an accelerated development for 36 hours with the final production of monsters. Bordier and Galimard⁹ gave incubating hen's eggs daily doses of X-rays of 15 H each (penetration not given) for 20 days. The eggs contained no embryos. In specimens which had been allowed to develop some-

† Holzknicht units are measured by means of the change in color produced by X-rays in a pastille of barium platino-cyanide. The reading of these pastilles varies considerably with the wave-length of X-rays used, so that X-ray measurements made by such pastilles are meaningless except when the voltage across the tube is given, or when the "penetration" of the rays is given in some other reliable way. A better method of measuring X-rays is given later in this article.

- (1) Hastings, Beckton and Wedd, Arch. Middlesex Hosp. 11th Cancer Report, 1912.
- (2) Bordier, Le Radium, II, p. 410, 1905.
- (3) Hasebroeck, Fortschr. a.d. Geb. der Roent. XI, p. 53.
- (4) Lopriori, cit. Schaudin in Pflueger's Arch. 77, p. 31, 1899.
- (5) Perthes, Deut. med. Woch. 30, 1904.
- (6) Hastings, Arch. Middlesex Hosp. 11th Cancer Report, 1912.
- (7) Runner, Jour. of Agr. Research, June 12, 1916.
- (8) Gilman and Baetjer, Am. Jour. Physiol. X, p. 222, 1904.
- (9) Bordier and Galimard, Jour. d' Elect. Med. p. 491, 1905.

what before raying, growth was arrested at the first dose. These results were confirmed by Gaskell¹⁰, but he makes no record of the dose.

Lengfellner¹¹ X-rayed three pregnant guinea pigs, three days before term (dose not given). Two of the mothers were at once killed. Their young died in 10 minutes. The third mother had a miscarriage in 5 hours; the young were all dead. He also rayed one hind leg of an 8 days old puppy (dose not given). Seven and one-half months later this leg was 8 cm. shorter than the other. Cohn¹² rayed the *heads* of pregnant rabbits (dose not given) enclosing the rest of the rabbit in a lead box. Pregnancy continued to full term. For 14 days after birth the young seemed normal, but afterward they became stunted so that after 7 weeks they were only one-third the size of the controls. Forsterling¹³ found that if he rayed the heads of 40-hour old rabbits (dose not given) the whole animal was stunted, but if any other part of the animal were rayed, only that part was stunted. Krukenberg¹⁴ found that if the pelvis of a young dog or goat is X-rayed (dose not given) the growth of the hind legs is retarded. Raying the shoulders caused ataxia and nervousness, affected the eyesight and made the animal more irritable.

The work showing the possibility of a stimulating effect on eggs is confirmed in an interesting way by studies on single types of cells in animals. Menetrier and Mallet¹⁵, and Rowntree¹⁶ have shown by raying the ears and tails of rats that somewhere between zero dose and that dose necessary to produce dermatitis, there is a dose which stimulates the growth of epithelial tissue. Benjamin, Ruess, Sleuka and Schwartz¹⁷, Aubertin and Beaujard¹⁸ and Murphy and Norton¹⁹ have shown that X-rays in the proper amount may increase the number of leukocytes.

All the above work may be summarized as follows: X-rays may act upon an organism (or on a single type of cell in that organism) in one of three ways: (1) to produce a stimulation; (2) to produce a destructive effect which takes place only after a certain latent interval; (3) to produce an instant destructive effect.

By analogy with the action of various drugs, one would expect that the rays could be made to act in any one of these three ways at will by merely varying the size of the dose. Not enough of the authors cited above have adequately recorded the dose to enable one to verify this analogy without further experimentation. It is the purpose of this article to record the results of experiments made toward this end.

About a year ago the writer was engaged in some preliminary work on the lethal effect of X-rays on *tribolium confusum*. These little beetles are ordinarily called "flour weevils" and are said by Chittenden²⁰ to be the most injurious enemy to prepared cereal foods. In two years from the time of their recognition as a distinct species, they had spread to nearly every state in the Union, and even as early as 1895 are said to have cost the millers of the United States over \$100,000 in manufactured products alone. It was found possible to destroy the eggs of these beetles with X-rays, thus giving hope of a new technical use for X-rays, but the most interesting results from a scientific point of view were obtained from the beetles themselves.

It was found that these beetles could be killed with X-rays if a sufficiently large dose were given, but it was noticed that the beetles did not die for several days after they

(¹⁰) Gaskell, Proc. Roy. Soc. B 83, Feb. 28, 1911.

(¹¹) Lengfellner, Munch. med. Woch. p. 44, 1906.

(¹²) Cohn, Verh. d. deutsch. Roent. Gesel. Bd III, 0.128.

(¹³) Forsterling, Verh. d. deutsch. Roent. Gesel. Bd III, p. 126.

(¹⁴) Krukenberg, Verh. d. deutsch. Roent. Gesel. Bd V, p. 68.

(¹⁵) Menetrier and Mallet, Bull. de l'Ass. fran. pour l'etude du Cancer II, p. 150, 1907.

(¹⁶) Rowntree, Arch. Middlesex Hosp. Cancer Reports 1908-1909.

(¹⁷) Benjamin, Reuss, Sleuka, and Schwartz, Wien klin. Woch. 19, p. 788, 1906.

(¹⁸) Aubertin and Beaujard, Arch. de Med. Exper. et d'Anat. Path. 2, p. 273, 1908.

(¹⁹) Murphy and Norton, Science, Dec. 10, 1915.

(²⁰) Chittenden, Bull. No. 4, New Series, Revised Ed. U.S. Dept. of Agr. p. 113, 1902.

were rayed. Further experiments indicated that the length of this latent interval depended upon the amount of the X-ray dose, and there seemed to be some evidence that this relation was approximately logarithmic. It was, therefore, decided to repeat these experiments more carefully, first making sure that the effect was really due to X-rays and not some attendant circumstance, and then to investigate the relation between the latent-interval and the X-ray dosage. This required a large number of beetles and it was necessary to determine their life history and how best to propagate them. It was found that they grow and propagate best in oatmeal or whole wheat flour, but they will live in corn meal, white flour or any of the prepared cereal products. Propagation takes place best at a temperature of 35-36 deg. C. and at high humidity. Temperatures of 45 deg. C. or over are fatal. The eggs are white and from 0.3 to 0.6 mm. in diameter. They are usually associated with pieces of grain. Larvae grow to a length of 5 or 6 mm. and shed their skins six times. Pupae are white. Young beetles are a light straw color which later darkens to a russet. The beetles are about 4 mm. longer. They are especially adapted to such work as is reported here because they are small, harmless, easy to handle and count in large numbers; they propagate readily, cannot crawl out of glass beakers or small porcelain crucibles, and show little tendency to fly.

In the preliminary experiments mentioned above, the beetles were packed in small wooden pill boxes with some food. There were 25 beetles in each box. There was a possibility that death was not due to any action of X-rays on the beetles, but might have occurred from any of the following causes:

1. Lack of air and food.
2. High temperature due to over-crowding.
3. Injury due to over-crowding.
4. NO_2 caused by the high voltage connections of the X-ray tube.
5. Ionized air.
6. Excessive humidity.
7. Effect of X-rays on the food in the boxes or even on the boxes alone.

The following seven experiments were therefore made:

Experiment I

To Show that the Beetles were not Killed by Lack of Air and Food Rather than by X-rays

- A. 10 beetles were sealed up in a glass tube with a rubber stopper, without food, in a space 0.05 cubic inch. They were all alive at the end of 76 hours.
- B. 20 beetles were sealed up, without food, in a space 0.05 cubic inch. They were all alive at the end of 3 weeks, but some of them seemed to be stuck together by a film of moisture. At the end of 4 weeks, 8 were still alive.
- C. 10 beetles were sealed up in a space 0.05 cubic inch together with a pinch of white flour. They were all alive at the end of 8 weeks. Evidently the flour had taken care of the body moisture noted in B.

Therefore, Tribolium confusum are not easily killed by lack of air, provided they are kept dry and have food.

Experiment II

To Show that the Beetles were not Killed by some Effect of Temperature, Rather than by X-rays

20 beetles were placed in a round-bottom test tube, $\frac{3}{8}$ of an inch in diameter, well heat-insulated. Temperature was measured from time to time by means of a delicate thermocouple. The highest temperature reached was $27\frac{1}{4}$ deg. C.

Therefore, the beetles cannot by over-crowding in a heat-insulated space raise their temperature high enough to produce death.

Experiment III

To Show that the Beetles were not Killed by Mechanical Injury Rather than by X-rays

- A. 5 beetles were placed in a tapered test tube. Diameter of test tube was $\frac{3}{8}$ inch. Length of taper was $1\frac{1}{8}$ inch. A small hole in the bottom gave ventilation. The beetles were, therefore, crowded together, and repeatedly crawled over one another in their efforts to escape. All were alive at the end of 97 hours.
- B. 5 beetles were shaken violently in a glass beaker 50 times a day. At the end of two days, 4 were still alive. At the end of a week, 3 were still alive.
- C. In addition, it may be stated that beetles used as "controls" in the main body of this work do not seem to be at all affected by being dropped through a funnel several times daily during the process of counting.

Therefore, the beetles are not easily given fatal injuries.

Experiment IV

To Show that the Beetles were not Killed by NO_2 Rather than by X-rays

- A. 20 beetles were put in a test tube $\frac{3}{8}$ inch in diameter with a little corn meal. The test tube was connected to a source of NO_2 . All beetles were alive after having been in an atmosphere of NO_2 for 25 hours. At the end of 64 hours, 5 were alive.
- B. 25 beetles were put in a vial and exposed to dilute NO_2 for 5 minutes. The concentration of NO_2 was such as to distinctly color starch-KI paper in $1\frac{1}{2}$ minutes. 23 beetles were found alive after the 20th day. But there is not enough ozone and NO_2 together in the lead box where the beetles are X-rayed to color starch-KI paper during an exposure of $14,000 \frac{MAM}{25^2}$ at 50 kv.

Therefore, there is not enough NO_2 produced while the beetles are being X-rayed to affect them.

Experiment V

To Show that the Beetles were not Killed by Ionized Air Rather than by X-rays

25 beetles were carefully shielded from X-rays. Ionized air, together with what little ozone and NO_2 might be present was drawn past the beetles during an exposure of $19,600 \frac{MAM}{25^2}$ at 50 kv. Even if only 10 per cent of the ions remained uncombined when they reached the beetles, still this would be equal to that caused directly by $1960 \frac{MAM}{25^2}$ at 50 kv. This dose of X-rays, acting directly on the beetles, would have killed them all in less than 2 weeks if death were produced by ionized air rather than by X-rays directly. But at the end of 21 days, only 1 beetle was dead.

Therefore, the beetles are not killed by ionized air.

Experiment VI

To Show that the Beetles were not Killed by too High Humidity Rather than by X-rays

- A. 10 beetles were put, without food, in a flat bottomed test tube $\frac{3}{8}$ inch in diameter, which was kept dry by a side tube filled with P_2O_5 . All but one were alive after 6 days.
- B. 60 beetles were gathered in such a way that each beetle was slightly moistened on the back. They were all put, without food, in a test tube 1 inch in diameter. As they crawled over each other, the moisture was spread over their whole bodies. In 6 hours most of the beetles were dead. Those alive were so weak that they could not turn over, even when lying on their sides. 60 other beetles put in a similar test tube with a cloth bottom, lived. The cloth bottom could only have acted as a ventilator and an absorber of water.
- C. Beetles are grown in an almost water-saturated atmosphere in the brooders and seem to thrive well.

Therefore, the beetles are not harmed by either extreme dryness or by high humidity, but may be killed by strangulation when water is condensed on them.

Experiment VII

To Find Effect of X-rays on the Food of the Beetles

A box similar to those used in the preliminary experiments was filled with corn meal and X-rayed 15,000 milliamperes-minutes at 25 cm. distance at 50 kilovolts. 25 beetles were then put in this box with the cornmeal. They lived lives of normal length. But beetles rayed this amount die almost instantly.

Therefore, X-raying the boxes and the food has no effect upon the length of life of the beetles.

In the light of the above experiments, it seems safe to conclude that the death of the beetles recorded below was due to X-rays, rather than to some accidental circumstance.

APPARATUS

X-rays were produced by a water-cooled Coolidge tube (tungsten target) operating directly from a high-tension 60-cycle transformer. Such tubes will rectify their own current up to 50–100 milliamperes, at 50 kilovolts (r.m.s.). Oscillograph tests showed that the transformer was of such a type that when operated under the above conditions the wave-form of the secondary (high voltage) resembled that of the primary (low voltage), and the inverse voltage did not exceed the direct voltage (i.e. operating voltage of the tube) by 5 per cent. Further tests with the oscillograph showed that the r.m.s. voltage of the secondary differed from that shown by a voltmeter coil by not more than 3 per cent. Tube voltage was, therefore, measured in terms of r.m.s. kilovolts, as shown by the meter.

The voltage impressed upon the primary was controlled by means of an auto-transformer of such size as to cause no appreciable change in wave-form. The wave-form used was very nearly sinusoidal.

The filament of the X-ray tube was heated by current from a small transformer. This was connected through a ballast transformer to the terminals of the circuit supplying the auto-transformer. Connections are shown in Fig. 1.

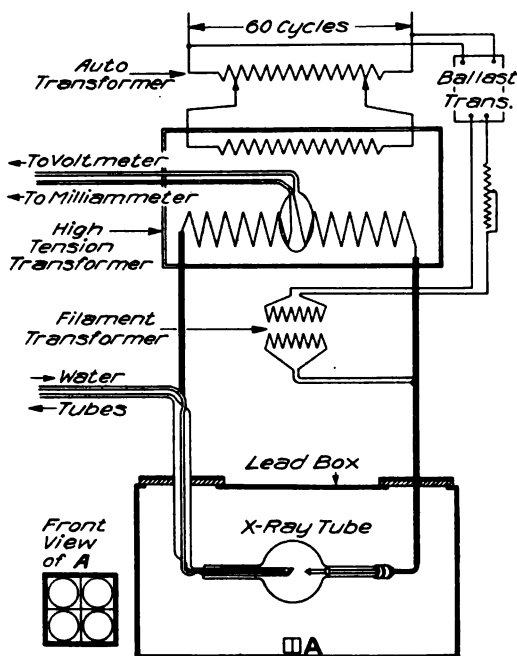

Fig. 1. Diagram of Connections of X-ray Outfit

Tube current was measured with a direct-current milliammeter. Since this current was pulsating (half of every wave being suppressed by the rectifying action of the X-ray tube), oscillograph records were taken to compare the meter-reading with the instantaneous value of the current. It was found in all cases that the value of the mean current as shown on the meter was almost exactly half the value of the peak of the wave. The current through the tube was, therefore, read in mean milliamperes on the meter. The wave form of this current was similar in every way to that of other Coolidge tubes.

The X-ray tube was in a lead box whose walls were $\frac{1}{4}$ inch thick. This provided a safe protection from X-rays at the voltages used. The tube was connected to the transformer by $\frac{1}{2}$ inch rods, to prevent corona. Where these rods entered the lead box, the lead was replaced by lead glass 1 inch thick, which acted both as insulation and as X-ray protection.

A chamber of lead (see A, Fig. 1) 7 cm. square and 5 cm. long was placed in the wall of this lead box, directly opposite the focal spot of the X-ray tube. A sheet of aluminum

0.025 mm. thick was fastened across the end of the chamber nearest the X-ray tube. This protected the interior of the chamber from electrostatic effects, and prevented any NO_2 , ozone, etc., from the interior of the lead box, and any radiant heat from the X-ray tube from entering the chamber. The lead sides of the chamber protected the interior from any secondary X-rays which might be produced on the walls of the lead box. The only rays which could enter the chamber were those sent out directly from the X-ray tube itself.

Into this chamber were placed, four at a time, the boxes of beetles to be rayed. These boxes were of wood, cylindrical in shape, $1\frac{1}{8}$ inches in diameter and $\frac{5}{8}$ of an inch high. The wood was $\frac{1}{8}$ of an inch thick. Each box contained 25 beetles and a little cornmeal, and was kept closed during the raying. The X-rays, therefore, after leaving the X-ray tube, passed through 0.025 mm. of Al and 3 mm. of wood before reaching the beetles and cornmeal. At the voltage employed in this work (50 kv.r.m.s.), the error due to absorption of X-rays by the small thickness of Al and wood was very small.

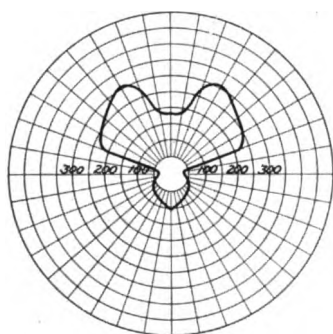

Fig. 2-A. Curves Showing Per Cent Beetles Dead at Different Intervals after Raying. Doses Vary from 500 to 8000 $\frac{MAM}{25^2}$ at 50 Kv.

kept in incubators at 35-36 deg. C. and at saturated humidity, except while being X-rayed or while being counted. Every box was opened daily, the beetles separated from the cornmeal and a record made of the number of live and dead beetles. The assistants who did this counting has no way of knowing the dose of X-rays which had been given.

After all the beetles in a given group of boxes were dead, the data sheets were collected and the data combined as shown in Table I. From 4 to 8 control boxes were used with each experiment to make sure that the beetles were in every way normal. The normal death rate at the end of the first 15 days was never more than 4 per cent.

Beetles rayed 500 $\frac{MAM}{25^2}$ at 50 kv. were practically all dead in 15 days. Beetles rayed larger doses were all dead in less than 15 days. Therefore, no correction for normal death rate of the X-rayed beetles was considered necessary.

It was found that, while all the beetles in a given box did not die at the same moment, there was a very narrow range of time during which most of them died, thus suggesting that we were dealing with a quantitative effect which could be studied to some good. For example, the results given more in detail in Table I and II and in Fig. 2-A

show that if the dose was 15,000 $\frac{MAM}{25^2}$ at 50 kv., all the beetles were dead at the end of the raying; if the dose was 2000 $\frac{MAM}{25^2}$ at 50 kv. practically all the beetles died

EXPERIMENTAL

Two or three thousand beetles were gathered from the same brooder on the same day and put into a large granite-ware pail. The next morning they were packed with a little sterile cornmeal in the wooden boxes mentioned above, 25 in each box. In this way the distribution of age, susceptibility to X-rays, etc., was as nearly uniform as possible.

From this time on the tightly closed boxes were kept in incubators at 35-36 deg. C. and at saturated humidity, except while being X-rayed or while being counted. Every box was opened daily, the beetles separated from the cornmeal and a record made of the number of live and dead beetles. The assistants who did this counting has no way of knowing the dose of X-rays which had been given.

After all the beetles in a given group of boxes were dead, the data sheets were collected and the data combined as shown in Table I. From 4 to 8 control boxes were used with each experiment to make sure that the beetles were in every way normal. The normal death rate at the end of the first 15 days was never more than 4 per cent.

Beetles rayed 500 $\frac{MAM}{25^2}$ at 50 kv. were practically all dead in 15 days. Beetles rayed larger doses were all dead in less than 15 days. Therefore, no correction for normal death rate of the X-rayed beetles was considered necessary.

It was found that, while all the beetles in a given box did not die at the same moment, there was a very narrow range of time during which most of them died, thus suggesting that we were dealing with a quantitative effect which could be studied to some good. For example, the results given more in detail in Table I and II and in Fig. 2-A

show that if the dose was 15,000 $\frac{MAM}{25^2}$ at 50 kv., all the beetles were dead at the end of the raying; if the dose was 2000 $\frac{MAM}{25^2}$ at 50 kv. practically all the beetles died

between the 3rd and the 6th days after raying, while half of them died between the 4th and 5th days; if the dose was $500 \frac{MAM}{25^2}$ at 50 kv., death took place between the 4th and the 9th days, while half of them died between the 6th and 8th days. Doses less than $500 \frac{MAM}{25^2}$ at 50 kv. were not fatal to all the beetles.

Now if the percentage of dead beetles is plotted against the time which has elapsed since they were X-rayed, it is evident that the points follow a smooth curve, which is the integral of a probability curve. If now the slope of this curve is plotted against its abscissae, a probability curve may be obtained. If the beetles represented by two such curves have been gathered from the same brooder at the same time, the corresponding points on the two curves may be compared, for they represent beetles of corresponding resistance to the action of the X-rays. It will be noticed that the curve approaches the zero and the 100 per cent lines asymptotically. This is in agreement with the well-known fact in toxicology that some individuals are especially susceptible to a given harmful agent, so that a very small dose causes death, while other individuals are especially resistant to the same agent so that they continue to live for a comparatively long time, even when given large doses. The steepness of the curves as plotted in Fig. 2-A is a measure of the idiosyncrasy.

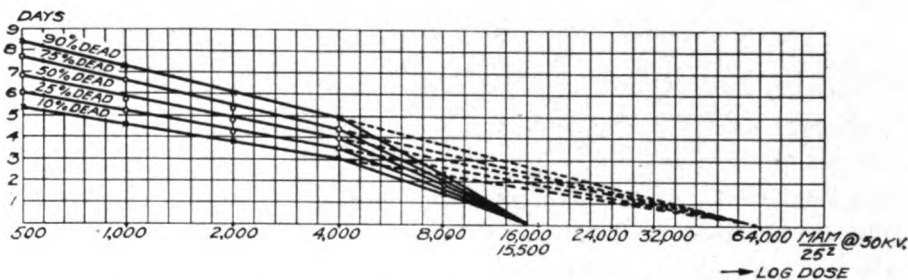

Fig. 2-B. Curves Showing Length of Life, after Raying, of 10, 25, 50, 75 and 90 Per Cent of Beetles. "Days Life" is Plotted against the X-Ray Dose.

This gives a method of handling the data which not only eliminates errors due to idiosyncrasy, but which even gives a measure of idiosyncrasy which is accurate enough between the limits of "25 per cent dead" and "75 per cent dead." Fig. 2-A shows a series of results obtained in this way in which even the 10 per cent and 90 per cent points could be used. Before discussing Fig. 2-B, it will be necessary to explain the methods of recording X-ray dosage.

In order to define the quantity of X-rays and the bundle of wave-lengths used in a given experiment, it is necessary to record explicitly,

1. The material used as a target in the X-ray tube.
2. The thickness and kind of filters (if any).
3. The form of the voltage wave.
4. The form of the current wave.

TABLE I

Beetles Rayed 2000 $\frac{MAM}{25^2}$ @ 50 Kv_{rms}

Box	Days	0	1	2	3.2	4.2	4.8	5.2	6	7	7.2
36.....		0	0	1	1	5	14	17	22	24	25
37.....		0	0	0	0	6	15	19	24	25	25
38.....		0	0	0	0	5	16	18	24	25	25
39.....		0	0	1	1	9	15	18	24	25	25
Total dead.....		0	0	2	2	25	60	72	94	99	100
Per cent dead.....		0	0	2	2	25	60	72	94	99	100

TABLE II

Beetles Rayed 500 $\frac{MAM}{25^2}$ @ 50 Kv_{rms}

Box	Days	0	1	2	3	4	5	6	7	8	8.3	9	10	11
23.....		0	0	1	1	1	2	11	18	24	24	24	25	25
24.....		0	0	0	0	0	1	5	9	17	20	23	24	25
25.....		0	0	0	0	1	3	6	19	22	24	25	25	25
26.....		0	0	1	1	1	1	6	11	20	23	25	25	25
Total dead.....		0	0	2	2	3	7	28	57	83	91	97	99	100
Per cent dead.....		0	0	2	2	3	7	28	57	83	91	97	99	100

The following must be recorded either explicitly or implicitly:

5. Voltage across the X-ray tube.
6. Current through the tube.
7. The length of time the X-rays were employed.
8. The distance from the focal spot of the X-ray tube to the point to be rayed.

If 1, 2, 3, 4 are kept constant throughout the experiment, they may be stated once for all (as was done in this report under the head of "apparatus"), and the dose of X-rays may then be defined by either of two methods:

- a. The voltage may be expressed directly, or an approximation may be given in terms of the readings of a Benoist penetrometer or in terms of the Christen "half value layer." The other factors may be given in terms of the reading of a Kienböck strip or a Holz-knecht pastille, etc., or better.
- b. The voltage and distance are given directly and the product of the current and time is given, thus,

"100 milliamper-minute at 25 cm. distance at 50 kilovolts." This is usually contracted to read

$$100 \frac{MAM}{25^2} \text{ at } 50 \text{ kv.}$$

It will be noticed that the distance is expressed in terms of its square. This is because the intensity of X-rays varies inversely as the square of the distance. Too much stress cannot be laid upon the necessity for recording the voltage, and for keeping the voltage reading constant; for not only does the penetrating power of the X-rays depend upon the voltage, but even the quantity of rays given off by the tube per milliamper depends very largely upon the voltage.

In Fig. 2-B, *days life* is plotted against the *logarithm* of the X-ray dose. The 10, 25, 50, 75 and 90 per cent points of the curves for 500, 1000, 2000 and 4000 kv. lie on a

family of straight lines $Y = A - B \log X$, where X is the X-ray dose and Y is the number of days life after raying. All these lines meet the zero line at the point 64,000. The points for 8,000 and 15,500 $\frac{MAM}{25^2}$ at 50 kv. do not lie on these lines, but when taken along with the points for 4000 $\frac{MAM}{25^2}$ at 50 kv., they are found to form a new family of curves of the same type as the first, but with a steeper slope. The interpretation of this is given later. It should be noted here, however, that beetles rayed more than 4000 $\frac{MAM}{25^2}$ at 50 kv. were unable to move their legs and antennae easily, but that this effect was not noticed in beetles rayed less than this amount. For this reason it was difficult at the higher dosages to obtain data as accurate as that obtained at the lower dosages. Curves like Fig. 2 have been obtained time after time, the only difference being in

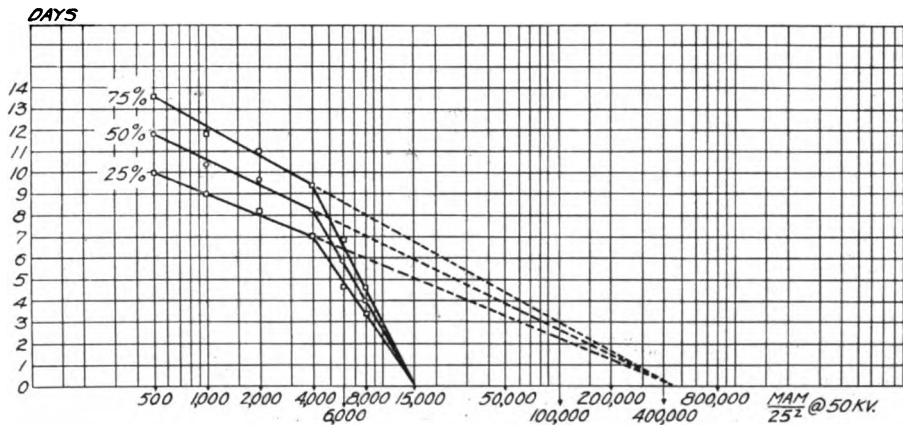

Fig. 3. Curves Similar to those of Fig. 2-B. "Days Life" is Plotted against the Logarithm of the X-Ray Dose

the height of the ordinates and the slope of the family of curves. Fig. 3 shows a typical curve of this sort. It will be noticed that in spite of the difference in the ordinates, the sharp break in the curve occurs at the same dosage.

At 50 kilovolts the lowest dose of X-rays which is fatal to all the beetles is 500 $\frac{MAM}{25^2}$. In order to explore the field below this dose, 1100 beetles were gathered from the same brooder at the same time and packed into boxes of 25 each with sterile corn-meal, and these boxes were divided into 7 groups of 8 boxes each, and one group of 4 boxes.

One group of 8 was kept as a control. The others were rayed 100, 200, 250, 300 $\frac{MAM}{25^2}$ at 50 kv. respectively. The group of 4 was rayed 500 $\frac{MAM}{25^2}$ at 50 kv. The results are plotted in Fig. 4, curves A, B, C, D, E, F, G.

It will be noticed that there is very little difference between curves A and B. Except for a small hump between 0 and 10 days, there is no essential difference between curves A and C. This is brought out in curve G, which is the same as curve C, except that the calculations are based on the supposition that there were no beetles dead on the tenth day. This similarity is still more marked between curves B and G. Except for a similar hump between 0 and 12 days, curve D resembles curves A and B. The hump

is, however, much higher than in C. In curve E the hump is still of the same shape as in curves C and D (it is the integral of a probability curve) and covers a period of 12 days, but is considerably higher. In curve F the "hump" is the whole curve, except for a very flat portion which represents a *single* very resistance beetle.

These curves have been duplicated several times, and although beetles gathered from different brooders at different times give curves of slightly different shape, still all the curves agree very closely with the typical ones shown in Fig. 4, especially with regard to the "hump."

This would make it seem that at 50 kilovolts, $200 \frac{MAM}{25^2}$ is the minimum lethal dose of X-rays for the least resistant beetles, and that $500 \frac{MAM}{25^2}$ is the minimum lethal dose for the most resistant beetles. The fact that the "hump" is always of the same form suggests that these beetles which would live 9 days with a dose of $200 \frac{MAM}{25^2}$ at 50 kv. would live a shorter time if rayed $250 \frac{MAM}{25^2}$ at 50 kv. and that some more slightly resistant beetles which would be unaffected by a dose of 200 are killed off at the end of 9 days by a dose of 250. But when a dose of $500 \frac{MAM}{25^2}$ at 50 kv. is reached, the most resistant beetles are also affected by the rays, so that the whole graph then approximates the probability integral.

Due to a breakdown of the transformer, the data to date at any other voltage than 50 kv. is fragmentary. Fig. 5 shows the data obtained at 68 KV_{RMS} just before the transformer broke down. The beetles were gathered at the same time as those of Fig. 3 and the raying was done within 3 days of that of Fig. 3. The two graphs may, therefore, be compared for what they are worth. It is hoped later to determine more accurately the effect of voltage.

THEORETICAL

It has been shown above that if the dosage of X-rays is sufficiently large, the experimental relation between length of life (Y) and X-ray dosage (X) is of the form

$$Y = A - B \log X$$

This formula may be easily derived from an extension of the Psycho-physic Law, which states that a change in response to an external stimulus is directly proportional to

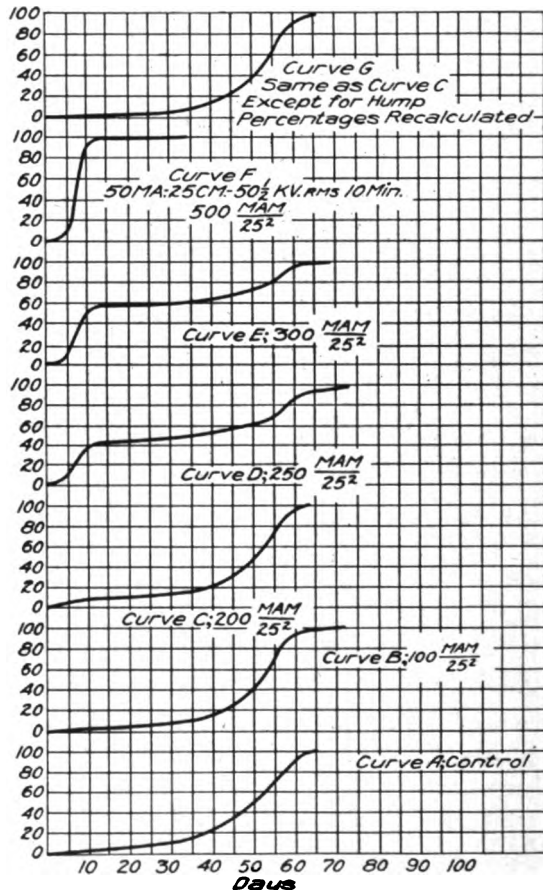

Fig. 4. Curves showing per cent beetles dead at different intervals after raying. Doses vary from 0 to $500 \frac{MAM}{25^2}$ at 50 kv.

the change in the stimulus, but inversely proportional to the amount of the stimulus. Thus the flicker-sensation caused by suddenly dimming a light is directly proportional to the amount of dimming, but inversely proportional to the total intensity of the light. Now let us suppose that the same principle applies to the action of X-rays on living cells.

Let Y = the number of days a beetle will live after being X-rayed.

Let X = the amount of the X-ray dose.

Then dY is directly proportional to dX and inversely proportional to X . Moreover, an increase in X produces a decrease in Y .

Therefore,

$$dY = -B \frac{dX}{X}$$

Integrating, $Y = A - B (\log X)$ which is the same as the equation of the experimental graph.

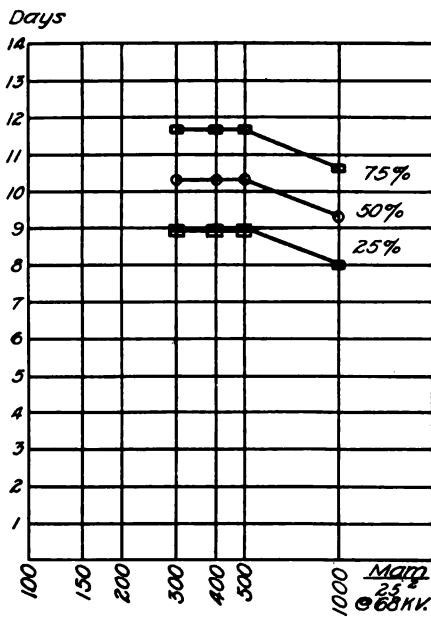

Fig. 5. Curves giving fragmentary data of "Days Life" plotted against the logarithm of the X-rays dose at 68 kv.

The constant of integration A has at present only a theoretical meaning, for it represents the number of days a beetle would live if it were X-rayed only $1 \frac{MAM}{25^2}$ at 50 kv. and if no process of repair went on inside the beetle, and if there were no other cause of death present.

It will be noticed that this formula takes no account of any cause of death other than X-rays, nor of any process of repair which may go on inside the beetle. It, therefore, applies only when the X-ray dose has been large enough to completely destroy the protective mechanism of the beetle, and when the damage caused by the X-rays is large enough so that all other causes of death may be neglected.

It should be noted that length of life after raying is a measure of the *resistance* of an organism to X-rays, not of its *susceptibility*. If X-rays are able to kill the organism in two different ways, as by attacking two different

kinds of cells, or two different organs, then the experimental graph should be the resultant of two straight lines, but in such a case it must be remembered that *susceptibilities* not *resistances* are to be added.

The graphs shown above seem to indicate that *Tribolium Confusum* are affected in two ways by the X-rays; the threshold dose being, for the first way, $500 \frac{MAM}{25^2}$ at 50 kv. and for the second way about $4000 \frac{MAM}{25^2}$ at 50 kv. These graphs would also seem to indicate that the cause of death for dosages between 500 and 4000 is negligible in the presence of that for dosages above $4000 \frac{MAM}{25^2}$ at 50 kv.

SUMMARY

1. It has been shown that the lethal effect noticed on *tribolium confusum* beetles after X-raying is really due to X-rays and not to some accidental circumstance.

2. A method has been developed which eliminates the error due to idiosyncrasy, thus making it possible to obtain bio-physical data of a considerable degree of precision.

3. It has been shown that the lethal effect of X-rays on *tribolium confusum* bears a definite mathematical relation to the logarithm of the total X-ray dose.

4. An extension of the Psycho-physic Law gives a theoretical explanation of the experimental data, if the *resistance* rather than the *susceptibility* of the organism to the X-rays is considered.

The effects produced by small doses, by changes in voltage, and by dividing the dose of X-rays into small parts, will be taken up in a later article.

A full bibliography of work done up to 1912 may be found in *Fortschr. a.d. Gebiete der Roent.* XIX, p. 123, 1912, in an article by Walter.

A complete bibliography of all X-ray work since 1912 has been published by Gocht.

PROLONGATION OF LIFE OF TRIBOLIUM CONFUSUM APPARENTLY DUE TO SMALL DOSES OF X-RAYS

BY WHEELER P. DAVEY

In a previous article* by the author experiments were described which showed: first, that X-rays when given in sufficient quantity were able to shorten the life of tribolium confusum; and second, that the length of life after X-raying could be expressed by a mathematical formula, the theoretical derivation of which was given. It is the purpose of this article to give the results of further experiments showing that it is apparently possible to materially lengthen the life of these same organisms by giving sufficiently small doses of X-rays.

In the article referred to, curves were given showing that the minimum dose necessary to kill *all* the beetles was $500 \frac{MAM}{25^2}$ at 50 kv.† Some of the less resistant beetles could be killed by smaller doses, but the curves for 100 and $200 \frac{MAM}{25^2}$ at 50 kv. had portions in which the death rate was lower than that of the controls. Comment on this was reserved until it could be confirmed by further experiments. Ample confirmation has now been obtained.

The experiments undertaken fall into two groups: *A*, those in which very small doses of X-rays were given daily throughout the life of the beetles; *B*, those in which the X-ray dose was given all at one time, as in the work previously published. In each of these groups of experiments it has been shown possible to duplicate results time after time, subject only to those general limitations which are inseparable from biological work. Typical experiments in each group will be described in the following. The apparatus and technique were the same as in the work previously reported.

EXPERIMENT A: PROLONGATION OF LIFE DUE TO SMALL DAILY DOSES OF X-RAYS

Six groups of approximately 950 individuals each were taken. These were known as groups *IV*, *IW*, *IX*, *IY*, *IZ*, and *JA*.

Group *IV* was the control.

Group *IW* was given $6\frac{1}{4} \frac{MAM}{25^2}$ at 50 kv., 25 ma. daily.

“ *IX* was given $12\frac{1}{2} \frac{MAM}{25^2}$ at 50 kv., 25 ma. daily.

“ *IY* was given $25 \frac{MAM}{25^2}$ at 50 kv., 25 ma. daily.

“ *IZ* was given $50 \frac{MAM}{25^2}$ at 50 kv., 25 ma. daily.

“ *JA* was given $100 \frac{MAM}{25^2}$ at 50 kv., 25 ma. daily.

After 159 days the beetles were practically all dead. The data on the death rates were then collected and plotted as shown in Fig. 1. These graphs furnish ample proof that it is possible to reduce the death rate of tribolium confusum by small daily doses of X-rays.

* "Effect of X-rays on the Length of Life of Tribolium Confusum," Journal of Experimental Zoology, Vol. 22, No. 3, April, 1917. See also p. 255, this book.

† i.e., 500 milliampere-minutes at 25 cm. distance at 50 "rootmean-square" kilovolts.
Copyright, 1919, by General Electric Review.

Table I gives readings from these graphs to the nearest whole number. These readings, taken from the smooth curves of the graphs, do not differ from the actual experimental data by more than one per cent.

Except while being X-rayed or counted, the beetles were kept in an incubator at 34-35 deg. C. In order to make sure that the results were not affected by some possible "temperature co-efficient of life," † the controls were taken out of the incubator while group JA was being rayed, and were kept out during the whole raying. Since group JA was rayed the longest time each day, this meant that the controls were cooled off for a longer time than groups IW, IX, IY, IZ. Therefore, if cooling off for a few minutes each day happened to tend to increase the length of life, then the controls were made to live longer than they otherwise would. The actual increase in length of life observed in groups IW, IX and IY is, therefore, not due to any possible effect of temperature, but occurs in spite of it. After so many boxes of beetles in JA were dead that the time of raying group IZ was greater than the time of raying JA, the controls were kept out of the incubator while group IZ was being rayed.

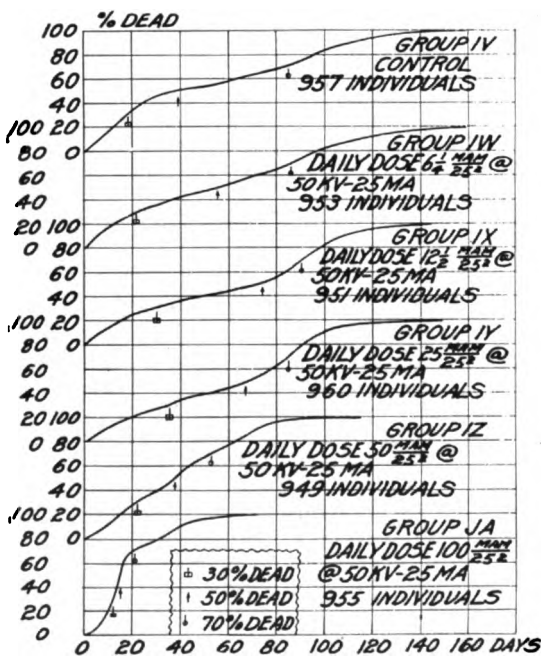

Fig. 1

Some data not given in the graphs may be of additional interest. Each group was divided into two sub-groups of about the same number of individuals each. It was found that the idiosyncrasy was great enough that the curves of the corresponding sub-groups could not be exactly superimposed. However, it was found that this idiosyncrasy was always less than the changes in death rate caused by X-rays. By way of illustration, Table II shows the percentage of beetles dead in each sub-group: on the day when 50 per cent of the controls were dead, and on the day when 50 per cent of the X-rayed group were dead. This table shows that the lowest death rate among the controls (group IV) was higher than the highest death rate among the beetles of groups IW, IX, IY.

It is interesting to note in this connection that the total dose received by these beetles was greatly in excess of that minimum dose which, when given all at once, would have caused premature death.

TABLE I

Number Days after Raying	Per Cent Dead Group IY Control	Per Cent Dead Group IW 6 1/4 M.A.M. at 50 kv. Daily	Per Cent Dead Group IX 12 1/2 M.A.M. at 50 kv. Daily	Per Cent Dead Group IY 25 M.A.M. at 50 kv. Daily	Per Cent Dead Group IZ 50 M.A.M. at 50 kv. Daily	Per Cent Dead Group JA 100 M.A.M. at 50 kv. Daily
10	17	17	14	11	12	20
20	34	29	25	21	28	69
30	46	35	30	28	39	79
40	51	42	36	34	55	90
50	54	47	40	39	67	96
60	58	53	44	44	77	99
70	63	59	48	52	88	100
80	67	65	56	63	96	
90	74	74	69	79	98	
100	84	83	84	91	99	

† Loeb & Northrup, Proc. Nat. Acad. Sci., Aug. 1916.

A further analysis of the data of groups *IV* to *JA* will be of interest. The curves shown in Fig. 1 when re-plotted on probability paper* appear as shown in Fig. 2. It was found that each curve was composed of portions of three accurate probability curves joined end to end. It is as though there were three causes of death, or perhaps three definite groups of ages. These three portions of the death-rate curve will be termed *A*, *B*, and *C*. Portion *C* represents those beetles which lived the longest in their group.

Table III gives the death rate per 100 in each group for *A*, *B*, and *C*.

TABLE II

Group	APPROX. 50 PER CENT CONTROLS DEAD		APPROX. 50 PER CENT X-RAYED BEETLES DEAD	
	Sub-group (1)	Sub-group (2)	Sub-group (1)	Sub-group (2)
	39th day		56th day	
<i>IV</i>	47.7	54.2	52.8	60.0
<i>IW</i>	41.6	42.1	48.1	52.3
	39th day		74th day	
<i>IV</i>	47.7	54.2	59.9	70.3
<i>IX</i>	32.4	38.3	44.7	54.1
	39th day		67th day	
<i>IV</i>	47.7	54.2	58.6	68.2
<i>IY</i>	31.7	36.7	48.5	50.2
	39th day		38th day	
<i>IV</i>	47.7	54.2	46.8	53.4
<i>IZ</i>	52.9	54.5	50.1	52.4
	39th day		14th day	
<i>IV</i>	47.7	54.2	22.1	24.9
<i>JA</i>	88.5	91.7	43.7	46.8

TABLE III

Group	Daily Dose	Per Cent Which Died of "A"	Per Cent Which Died of "B"	Per Cent Which Died of "C"
<i>IV</i>	Control	44	26	30
<i>IW</i>	6¼	32	36	32
<i>IX</i>	12½	26	26	48
<i>IY</i>	25	21	35	44
<i>IZ</i>	50	23	61	16
<i>JA</i>	100	64	17	19

* The ordinates of probability paper are so spaced that the ordinary curve of the probability integral is represented by a straight line.

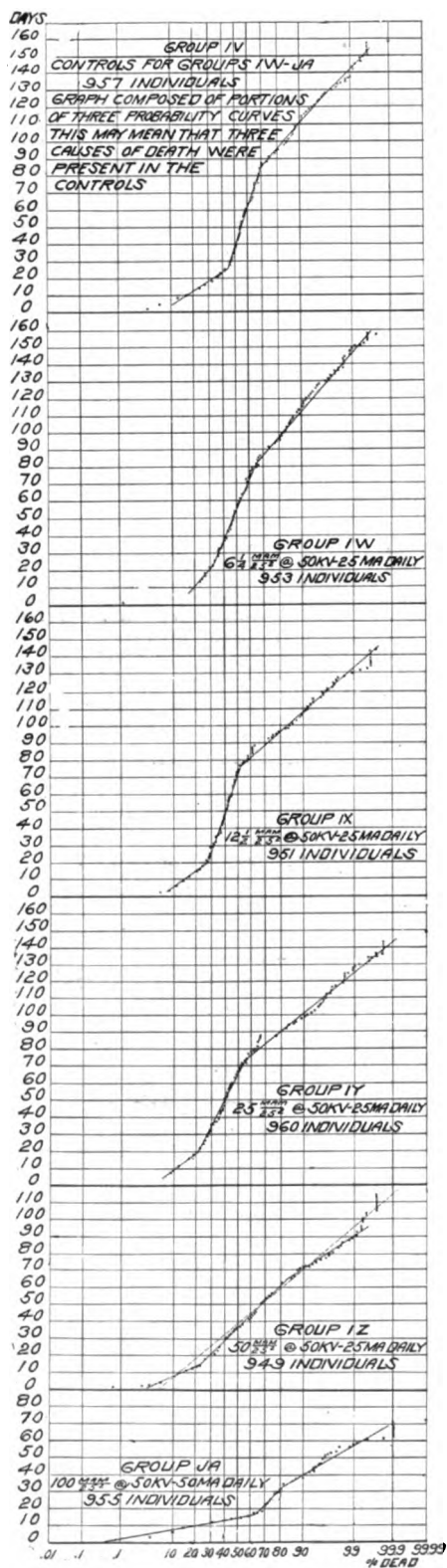

Fig. 2

It is evident that the smallest daily dose (group *IIV*) decreases the death rate of "A" and that those beetles which are kept from dying of "A," die of "B." Deaths from cause "C" are practically unaltered. A larger daily dose (group *IX*) causes about half of those which would normally die of "A" to die of "C." A still larger daily dose (group *IY*) causes half of those which would have died of "A" to die of "B" and "C." A still larger daily dose (group *IZ*) acts much like the previous dose in causing almost half of those which would have died of "A" to die of "B," but it differs from it in that some of those which would have died of "C" are prematurely killed. The largest daily dose employed (group *JA*) caused about a third of those which would have died of "B" and "C" to die of "A."

It is hard to interpret all this. It may be that life cannot exist except in the presence of a small amount of radioactivity. The radioactivity of the earth may not have been of the optimum value, so that some benefit was derived from the X-rays received each day. The following is an effort at an alternative explanation. The evidence given by group *JA* shows that the lethal action of X-rays is tied up in some way with cause of death "A." It is well known that the lethal action of X-rays is more marked on cells in the process of division than on those in the resting state. Therefore, small daily doses (larger than a certain minimal value) can kill off those few cells which happen to be in a state of division at the time of raying. The death of these few cells stimulates the production of more to take their places between the periods of raying. Therefore, small daily doses, instead of increasing the death rate from cause "A," actually decrease it by stimulating the processes of repair. The whole individual beetle, therefore, has a smaller chance of dying from "A" and is compelled to die of either "B" or "C." When the daily dose is increased to such a value that the daily destruction of cells is equal to or greater than the production of new cells, premature death occurs, from causes "B" or "A" (see groups *IZ* and *JA*).

EXPERIMENT B: PROLONGATION OF LIFE DUE TO SMALL SINGLE DOSES OF X-RAYS

Five groups of approximately 850 individuals each were taken. These were known as groups *JB*, *JC*, *JD*, *JE* and *JF*.

Group *JB* was the control.

Group *JC* was given $100 \frac{MAM}{25^2}$ at 50 kv., 50 ma.

“ *JD* was given $200 \frac{MAM}{25^2}$ at 50 kv., 50 ma.

“ *JE* was given $300 \frac{MAM}{25^2}$ at 50 kv., 50 ma.

“ *JF* was given $400 \frac{MAM}{25^2}$ at 50 kv., 50 ma.

The beetles were rather old, so that the controls were all dead on the 40th day of the experiment. There were so few beetles still alive after the 35th day that the results of the last five days are not of the same order of accuracy as those of the first 35 days.

During the first 10 days of the experiment, group *JC* ($100 \frac{MAM}{25^2}$ at 50 kv.) had the same death rate as the controls. After the tenth day the death rate was considerably less than that of the controls. The two groups were divided into two equal sub-groups and although it was found that the idiosyncrasy was such that the sub-groups were not exactly alike, still, after the tenth day, the highest death rate of group *JC* was lower than the lowest death rate of the controls.

During the first 17 days of the experiment, group *JD* ($200 \frac{MAM}{25^2}$ at 50 kv.)

had a higher death rate than the controls. After the 17th day, the death rate of groups *JD* was less than that of the controls. After the 20th day, the death rate of *JD* was identical with that of *JC*. When divided into two equal sub-groups as described above, it was found that after the 22nd day the highest death rate of group *JD* was less than the lowest death rate of the controls.

During the first 29 days of the experiment, the death rate of group *JE* ($300 \frac{MAM}{25^2}$ at 50 kv.) was greater than that of the controls. After the 29th day, the death rate of *JE* was less than that of the controls.

The death rate of group *JF* ($400 \frac{MAM}{25^2}$ at 50 kv.) was at all times greater than that of the controls.

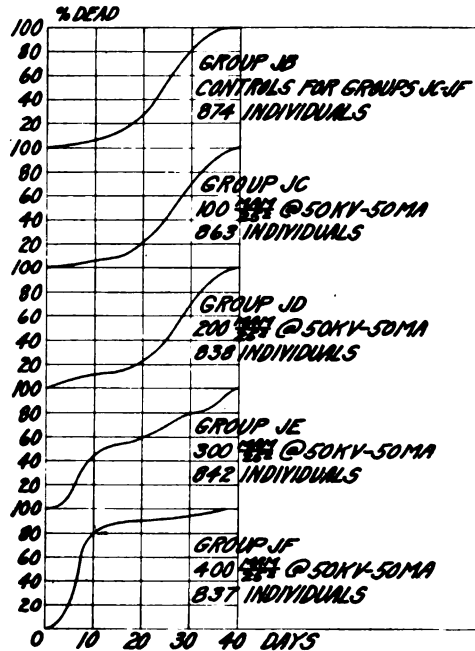

Fig. 3

These results are shown graphically in Fig. 3. Fig. 4 contains an analysis of these same curves by means of probability paper, showing that, as in the case of experiment A, the curves are composed of accurate portions of probability curves placed end to end.

All of the foregoing results seem to be a direct confirmation of the curves given in the previous paper (*loc. cit.*). The effect of concentrated single doses is not nearly so

marked as the effect of a series of small "homeopathic" doses. This seems to be much the same law as is already well known in serum therapy and in the action of certain drugs. In the case of serum therapy, this law has been shown to be identical with the law of absorption. If it could be rigorously shown that the effects of exposure to X-rays follow the same general law, we should conclude that the X-rays are responsible for the production of some substance, perhaps in the blood, which is later absorbed.

Summary

(1) It has been shown that the life of *tribolium confusum* may be prolonged by the use of a purely physical agent; i.e., X-rays.

(2) The prolongation of life due to a series of small daily doses is greater than that of larger doses given all at once.

(3) The lethal effect of an X-ray dose is less if it is split up into a series of small daily doses, than if it is given all at once.

(4) A method of graphical analysis of results has been described by which the number of causes of death may be determined from the death rate, and by which the effect of an external agent upon each of these causes may be studied.

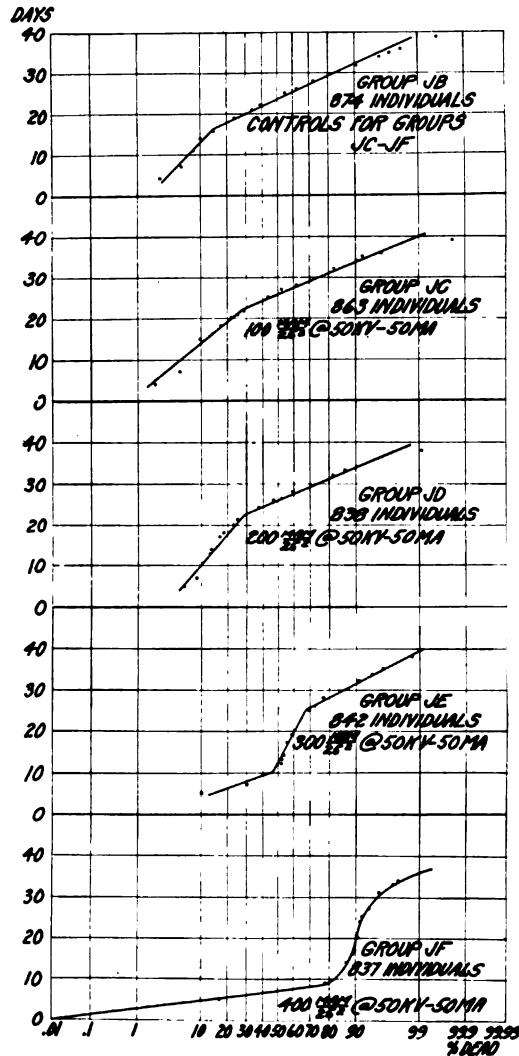

Fig. 4

(5) Using the same kind of organism throughout the whole experiment, the work reported in this and the previous paper (*loc. cit.*) has shown that, by merely varying the size of the dose, a purely physical agent (X-rays) may be made to produce at will (a) a stimulation, (b) a destructive effect which occurs only after a latent interval, and (c) an instant destructive effect.

X-RAYS

BY DR. WHEELER P. DAVEY

PART I

Of all the theories so far proposed as to the nature of X-rays, the Electromagnetic Theory seems to be the most useful.¹ This theory seeks to account for X-rays in terms of the properties of the electrostatic and magnetic fields of electrically charged moving particles. It is found that such a theory is capable of giving a rational basis for correlating the facts known at present about X-rays and is also able to suggest fruitful topics for further research.

It is well known that if a stationary body, A , is given an electric charge, the region around A becomes altered in such a manner that a force of repulsion is exerted upon any other body similarly charged. For simplicity let A be spherical in shape and not situated near any other charged body; then, the electric force extends from it radially in all directions. If the location of A or the amount of charge upon it is changed, there is a corresponding change in the electric force, and this *change in the electric force* is propagated from A with the velocity of light (3×10^{10} cm. per sec.)

Now suppose that A is moving with uniform velocity and that this motion has already been kept up for so long a time that the whole electric field of force is in motion with it. This condition of the electric field is represented diagrammatically in Fig. 1. If A is suddenly stopped, the condition of the electric field is as represented in Fig. 2a. The direction of motion is represented by XX' . If A had continued in uniform motion for a time, t , it would have reached A' , and would have had a field such as is shown by the lines $A'DE$, $A'HI$, $A'X'$, $A'JK$, etc. But, since A has been stopped, it will finally have a field such as is shown by the lines ABC , AFG , AX' , ALM , etc. The intermediate stage is shown by the full lines $ABDE$, $AFHI$, AX' , $ALJK$, etc., where BD , FH , LJ , etc., constitute the *changing portion* of the electric field, which, as has been stated before, moves out from A in all directions with the velocity of light. BD has the same relation to $ABDE$ as the "crack of a whip" has to the whip itself.

The movement of a line of electric force calls into existence a magnetic field, and this holds true independently of whether the movement is caused as previously described or is caused by electric charges passing through a wire. Now, when a current passes through a wire, the direction of the magnetic field is mutually perpendicular to the direction of the electric field and to the direction of the current. Since the electric field of each elementary charge of electricity moves with that charge, we may make this more general statement—*The direction of the magnetic field due to a moving electric field is mutually perpendicular to the direction of that electric field and to the direction in which that field is moving.* We should therefore expect to find that as BD , FH , LJ , etc., move outward from A they would be accompanied by a magnetic field perpendicular to the paper. The pulse sent out by A upon stopping is therefore partly electric and partly magnetic in its nature and is called an "electromagnetic" pulse.

¹ The word "useful" is used here purposely. No theory is to be regarded as a statement of absolute fact. A theory may be *disproved*, but it can never be *completely proved*. Of two or more theories, all of which are equally consistent with the known experimental data, the one to be preferred is that which proves to be of greatest use in *producing results*.

Copyright, 1915, by *General Electric Review*.

According to the electromagnetic theory, primary X-rays consist of such pulses as have just been described. If negatively charged particles of matter (variously called corpuscles, β particles, cathode rays, and electrons) are shot out at high velocities toward the target of an X-ray tube, they will experience a great decrease in velocity upon entering the face of the target; and during the time that this retardation occurs.

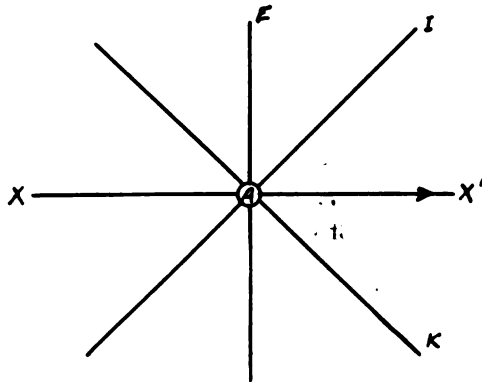

Fig. 1

X-rays are produced. Their properties seem to depend only upon the rate of retardation which the cathode rays experience at the target, and this in turn depends only upon the voltage across the terminals of the X-ray tube and upon the material used as a target.

If OH (see Fig. 2) is drawn parallel to XX , so as to represent the path taken by H , then FO is called the "thickness" of the pulse FH . We will call this thickness d . The electric force along FH may be considered as being the resultant of two forces, P_1 along FO , and P_2 along OH . Since the dielectric

constant of empty space is unity, we have at once.

$$P_1 = \frac{\epsilon}{(AF)^2} \text{ or } \frac{\epsilon}{r^2},$$

where ϵ is the amount of the charge on A , and

$$P_2 = P_1 \frac{OH}{FO} = \frac{\epsilon}{r^2} \times \frac{OH}{d}$$

Now let

u = the velocity of A just before being suddenly stopped.

V = the velocity of propagation of the pulse FH (equal to the velocity of light).

T = the time A would have required to have reached A' .

Then

$$OH = AA' = uT$$

and since

$$r = VT$$

it follows that

$$OH = \frac{ur}{V}$$

and

$$P_2 = \frac{\epsilon}{r^2} \times \frac{ur}{dV} = \frac{\epsilon u}{rdV}$$

Since the pulse FH is moving in a direction parallel to AF , we are only interested in that component of P_2 which is parallel to AF , viz., P_2' , where

$$P_2' = \frac{\epsilon u}{rdV} \sin \theta$$

Now the energy of the pulse is partly electrostatic, and partly magnetic. That portion which is electrostatic is equal to $\frac{1}{8\pi}$ times the square of the electric force.

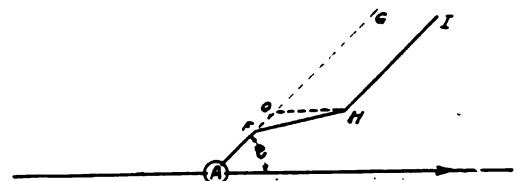
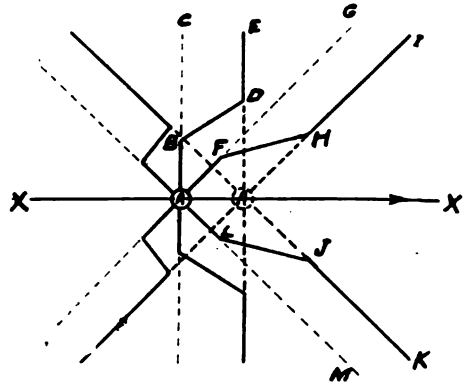

Fig. 2

$$E_E = \frac{\epsilon^2 u^2 \sin^2 \theta}{8\pi r^2 d^2 V^2}$$

The magnetic portion is $\frac{1}{8\pi V^2}$ times the square of the magnetic intensity. But the magnetic intensity is V times the electric force which produces it.

$$E_M = \frac{\epsilon^2 u^2 \sin^2 \theta}{8\pi r^2 d^2 V^2}$$

The total energy of the pulse FH is therefore

$$E_{FO} = \frac{\epsilon^2 u^2 \sin^2 \theta}{4\pi r^2 d^2 V^2}$$

The energy of the whole spherical pulse is obviously obtained by integrating E_{FO} , thus giving

$$E = \frac{2}{3} \frac{\epsilon^2 u^2}{d V}$$

where d depends for its value upon the values of θ and u and upon the atomic weight of the material used as a target.

It will be useful to gain an idea of how u depends upon the voltage across an X-ray tube. If the charge on a cathode partical is ϵ then a voltage E will represent an energy of $E\epsilon$. The mechanical energy of the electron is $\frac{1}{2}mu^2$. By the law of conservation of energy

$$E\epsilon = \frac{1}{2}mu^2$$

$$E = \frac{1}{2} \frac{m}{\epsilon} u^2$$

For purposes of convenience this is often written

$$E = \frac{1}{2} \frac{u^2}{\epsilon/m}$$

Now the value of ϵ/m is not a constant but depends in a complicated way upon the value of u . Table I has been calculated from data given by Bucherer (1909), Steinmetz (1898), and Algermissen (1906). Spark gap lengths are to be considered only as approximate measurements of voltage under ordinary working conditions.

When the cathode rays strike the target they are not stopped instantaneously at the surface, but merely suffer retardation so that they penetrate for some distance into the body of the target.¹ After once entering the target, the particles no longer all move in the same general direction, but travel more or less radially. If, for a given velocity of cathode rays, we imagine the target to be made thicker and thicker, a thickness will be reached at last for which there are as many particles emerging in one direction as in any other. This thickness is called "The depth of complete scattering."²

In aluminum it is 0.015 cm.; in copper, 0.001 cm.; in silver, 0.001 cm.; in gold, 0.00020 cm.; and in lead, 0.00025 cm. at 90,000 volts. It varies directly as the voltage employed across the tube.

Those primary rays which are able to overcome the absorbing effect of the target reach the surface and emerge into the vacuum space of the tube. Measurements have

¹ W. R. Ham, Phys. Rev. xxx, Jan., 1910.

W. P. Davey, Jour. Franklin Inst., Mar., 1911.

L. G. Davey, Phys. Rev., Sept., 1914.

² J. A. Crowther, Roy. Soc. Proc., 80, A, pp. 186-206, Mar. 5, 1908.

W. R. Ham, Phys. Rev. xxx, 1, pp. 119-121, Jan., 1910.

TABLE I

μ in Miles per Sec.	μ in Cm. per Sec.	E in Volts	E in Cm. Spark Gap Between Needle Points (A-C.)	E in Cm. Spark Gap Between Balls 5 Cm. in Diameter (D-C.)
	$\times 10^9$			
11,800	1.88	1,000	0.1	
18,900	3.00	2,330	0.2	
37,900	6.00	10,300	0.8	0.2
	7.50	16,200	1.3	0.4
56,800	9.00	23,770	2.0	0.7
	9.60	27,200	2.3	0.8
63,000	10.2	30,900	2.7	0.9
	10.8	34,800	3.1	1.0
	11.4	39,300	3.6	1.2
74,400	12.0	44,000	4.3	1.4
	12.6	49,100	5.0	1.6
	13.2	54,300	5.9	1.8
	13.8	59,900	6.9	2.1
	14.4	66,100	7.9	2.4
93,000	15.0	72,800	9.3	2.7
	15.6	79,700	10.6	3.1
	16.2	87,200	12.0	3.6
	16.8	95,400	13.6	4.2
	17.4	104,200	15.5	4.9
111,600	18.0	113,400	19.6	5.6
	18.6	123,500	20.0	6.8
	19.2	134,100		8.1
	19.8	146,100		10.1
	20.4	158,900		13.0
130,200	21.0	172,900	30.00	16.2
	21.6	188,100		19.5
	22.2	205,300		
	22.8	224,000	45.0	
	23.4	245,200		
142,600	24.0	268,900		
	24.6	296,000		
	25.2	327,700		

shown¹ that if the voltage across the tube is made very small, then the primary rays at the moment of generation, have their maximum of intensity in a direction perpendicular to the cathode stream, and a minimum of intensity in a direction parallel to the cathode stream. This effect is called "polarization." As the voltage across the tube is increased, the polarization is decreased, until finally it becomes immeasurable. This is explained by assuming that at the higher potentials the rays formed by the initial retardation of the cathode stream are negligible in their effects, when compared with those rays which come out in all directions from the depth of complete scattering.

SECONDARY RAYS

When X-rays are made to impinge upon a substance, that substance itself becomes a source of X-rays, which are called "secondary rays." Two distinct types of secondary rays are recognized, viz., "scattered" and "characteristic". When X-rays pass through a substance, the emergent beam is found to act in the same way that light acts on passing through a fog. The rays retain all the peculiarities of the incident beam, but have suffered a diffuse reflection or "scattering." Scattered rays emerge from both the in-

¹ R. Blondlot, *Comptes Rendus*, 136, pp. 284-286, Feb. 2, 1903. *Nature*, 69, p. 463, March 17, 1904.
 C. G. Barkla, *Roy. Soc. Phil. Trans.*, 204, pp. 467-479, May 31, 1905. *Roy. Soc. Proc.*, 74, pp. 474-475, March 16, 1905.
 H. Haga, *Konink. Akad. Wetensch. Amsterdam Versl.*, 15, pp. 64-68, July 20, 1906.
 J. Herwig, *Ann. d. Phys.*, 29, 2, pp. 398-400, May 21, 1909.
 E. Basseler, *Ann. d. Phys.*, 28, 4, pp. 808-884, Mar. 16, 1909.
 L. Vegard, *Roy. Soc. Proc.*, Ser. A., 83, pp. 379-393, Mar. 22, 1910.
 W. R. Ham, *Phys. Rev.*, xxx, pp. 96-121, Jan., 1910.
 F. C. Miller, *Franklin Inst. Jour.*, 171, pp. 457-461, May, 1911.

idence and the emergence faces, and the radiation in the emergence direction is much greater in intensity than that in the incidence direction.¹

Scattering increases with the thickness and with the atomic weight of the scattering substance, and, within the limits ordinarily used, is greater, the greater the penetrating ability of the incident rays.

If X-rays of very low penetrating ability are allowed to fall on a substance (called a "radiator"), the emergent beam contains only two components (a) that portion of the primary beam which has been unaltered and, (b) the scattered rays. If, now, the penetrating ability of the incident beam is gradually increased, a point is at last reached at which a new type of radiation appears, which is characteristic of the substance used as the radiator.²

Barkla and Sadler³ have shown that if the incident primary rays are less penetrating than are the secondary rays which are characteristic of the radiator used, then no secondary rays are produced; but if the incident primary rays are more penetrating than the characteristic secondary radiation, then "characteristic" rays are produced.

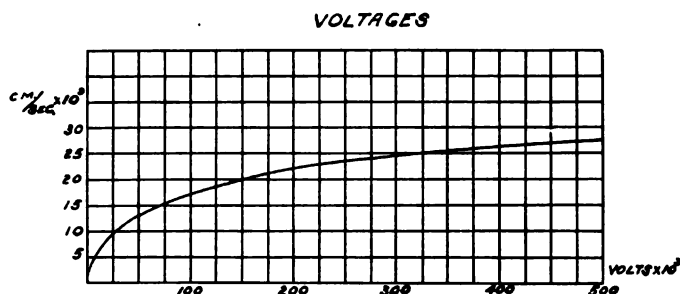

Fig. 3

The production of characteristic X-rays is very analogous to the production of fluorescent light. In fact, the analogy is so close that some writers are adopting the term "Fluorescence Roentgen Radiation."

Chapman and Piper⁴ tried to detect a continuance of secondary radiation after excitation from the primary rays had ceased, but were unable to detect even 1/250 of the original radiation 1/3000 of a second after the exciting primary rays had been removed.

Radiators may be classified into four groups in the order of their atomic weights. The radiations given out by the members of each group are very much alike.

Group 1 (1-32).-H-S. When excited by a beam from a "soft" tube the members of this group give off little, if any, characteristic radiation; almost the entire radiation being of the scattered type and this is polarized in a plane perpendicular to the direction of the parent cathode stream. If the tube is made moderately "hard" (i.e., if it gives off rays of moderate penetrating power), a slight amount of characteristic radiation will be displayed, and if the tube is very "hard," a well-defined characteristic beam is given off, having a penetrating ability much different from that of the exciting rays.

Group 2 (52-65).-Cr-Zn. This group gives off a beam composed almost entirely of a true characteristic radiation, even when excited by rays from a "soft" tube, but this radiation has little penetrating ability. With a given excitation, the ionization produced by it is almost 100 times that produced by an equal mass belonging to Group 1.

¹ Barkla and Ayers, *Phil. Mag.*, pp. 270-280, Feb., 1911.

Owen, *Proc. Camb. Phil. Soc.*, vol. 18, p. 161, 1911.

Crowther, *Proc. Roy. Soc.*, pp. 478-494, Feb., 1912.

² C. J. Barkla and C. A. Sadler, *Nature*, 77, pp. 343-344, Feb. 13, 1908, *Nature*, 80, p. 37, March 11, 1919.

³ Barkla and Sadler, *Nature*, 80, p. 37, March 11, 1909.

⁴ Chapman and Piper, *Phil. Mag.*, 19, pp. 897-903, June, 1910.

Group 3 (107-125).-Ag-I. If the exciting beam is only of moderate penetrating ability, this group gives off mostly a scattered radiation, but, unlike that from Group 1, it is unpolarized, and there is a noticeable amount of characteristic radiation present. The relative amounts of scattered and characteristic radiation vary greatly with small changes in the character of the exciting rays.

TABLE II
WAVE-LENGTHS OF VARIOUS CHARACTERISTIC X-RAYS

NOTE.—The most important line in each series is called α . The next most important is called β .

Elements	K SERIES		L SERIES	
	$\frac{\alpha}{\times 10^{-8} \text{ Cm.}}$	$\frac{\beta}{\times 10^{-8} \text{ Cm.}}$	$\frac{\alpha}{\times 10^{-8} \text{ Cm.}}$	$\frac{\beta}{\times 10^{-8} \text{ Cm.}}$
Al	8.364	7.912		
Si	7.142	6.729		
Ci	4.750		
K	3.759	3.463		
Ca	3.368	3.094		
Ti	2.758	2.524		
V	2.519	2.297		
Cr	2.301	2.093		
Mn	2.111	1.818		
Fe	1.946	1.765		
Co	1.798	1.629		
Ni	1.662	1.506		
Cu	1.549	1.402		
Zn	1.445	1.306		
Y	0.838		
Zr	0.794	6.091
Nb	0.750	5.749	5.507
Mo	0.721	5.423	5.187
Ru	0.638	4.861	4.660
Rh			4.622
Pd	0.584	4.385	4.168
Ag	0.560	4.170
Sn			3.619
Sb			3.458	3.245
La			2.676	2.471
Ce			2.567	2.360
Pr			2.471	2.265
Nd			2.382	2.175
Sa			2.208	2.008
Eu			2.130	1.925
Gd			2.057	1.853
Ho			1.914	1.711
Er			1.790	1.591
Ta			1.525	1.330
W			1.486
Os			1.397	1.201
Ir			1.354	1.155
Pt			1.316	1.121
Au			1.287	1.092

Group 4 (183-206).W-Bi. These substances resemble Group 2 in their action.

For all these elements the penetrating ability of the characteristic rays is independent of the intensity or of the penetrating ability of the exciting beam, but is a periodic function of the atomic weights of the radiating elements.¹

If the radiator is a chemical compound, the component atoms and radicals determine the character of the secondary rays produced.²

¹ C. G. Barkla and C. A. Sadler, *Phil. Mag.*, 16, pp. 550-584, Oct., 1908.

² J. A. Crowther, *Phil. Mag.*, 14, pp. 653-675, Nov., 1907.

The rays coming from salts are composed of (1), a homogeneous radiation having the same penetrating ability as that from the metal itself, and, (2), a scattered primary radiation considerably more penetrating than that of (1) due to the acid radical. If a metal occurs in the acid radical it has no individual effect, but merely acts with the remainder of the radical.¹

There seems to be a real physical difference between primary X-rays and characteristic X-rays. From the electromagnetic theory, primary rays seem to consist of an irregular succession of "splashes." Experimental evidence (which will be taken up in a latter article) seems to show that characteristic rays consist of trains of waves resembling light waves, except for the fact that the wave length is about 1/1000 that of ordinary light. Each element is able to emit characteristic rays whose wave lengths fall into certain well defined groups. Two of these (called *K* and *L* respectively) are of great importance. For any given radiator, rays of the *K* group are about 300 times as penetrating as those of the *L* group. Table II shows the wave lengths of the two most intense members of each group for 39 elements. It will be noticed that, to date, there

TABLE III
MINIMUM SPEED OF CATHODE RAYS REQUIRED TO EXCITE CHARACTERISTIC RADIATIONS

Radiator	Atomic Weight (<i>A</i> = 16)	Critical Velocity of Cathode Rays to Excite <i>K</i> Radiation	Voltage Necessary to Give Critical Velocity to Cathode Rays
		cm./sec.	volts
Aluminum.....	27.1	2.06×10^9	1200
Chromium.....	52.0	5.09×10^9	7320
Iron.....	55.8	5.83×10^9	9600
Nickel.....	58.7	6.17×10^9	10750
Copper.....	63.6	6.26×10^9	11080
Zinc.....	65.4	6.32×10^9	11280
Selenium.....	79.2	7.38×10^9	15400

are many gaps still to be filled in the list. The values given in the table were published by Mosely in the *Philosophical Magazine*, April, 1914.

Chapman has shown² that if the *L* radiation of one element is of nearly the same wave-length as the *K* radiation of another element, then their atomic weights (A_L and A_K respectively) are related by the formula

$$A_K = \frac{1}{2} (A_L - 48).$$

Whiddington has shown³ that when any given substance is used as the target of an X-ray tube, it will give off characteristic *K* rays if the speed in cm. per sec. of the cathode rays is greater than 10^8 times the atomic weight of that substance. From Chapman's formula it follows that the characteristic *L* rays would be obtained at a speed of $\frac{1}{2} (A - 48) \times 10^8$ cm. per sec., where *A* is the atomic weight. Table III shows Whiddington's experimental values.

The subject of electromagnetic disturbances was discussed at the beginning of this article from the standpoint of a single retardation of the electron. It is evident that, if the electron had been considered as having a regular to-and-fro motion, the resulting electromagnetic disturbance would have consisted of a *train of waves* of a definite wave length. It is, therefore, natural to assume that characteristic X-rays are produced when certain electrons in an atom are made to vibrate at some natural frequency. Such

¹ J. L. Glasson, Camb. Phil. Soc., pp. 437-441, June 14, 1910.

² Chapman, Proc., Roy. Soc., 1912.

³ Whiddington, Proc. Roy. Soc., 1911.

vibrations could be set up by giving the electron a *single impulse*, provided that the time consumed in communicating the impulse is not more than half the time of one natural vibration of the electron. We thus have a theoretical basis for the experimental facts that secondary rays may be produced both by sufficiently "thin" primary rays, and also by cathode rays of sufficiently high velocity. It is plain *why* the wave-length of characteristic rays remains the same when the breadth of the primary rays is decreased or when the speed of the cathode stream is increased beyond the critical value, and *why* no characteristic rays are produced until these critical values are reached. In short, the electromagnetic theory gives us a rational basis upon which we may correlate the facts known at present about the nature of X-rays.

PART II

There are certain general properties which are common to all X-rays. Among these are:

1. The fluorescent effect
2. The photographic effect
3. The ionizing effect
4. The chemical effect
5. The dehydrating effect
6. The photo-electric effect
7. The action on a selenium cell
8. The penetrating effect
9. The physiological effect

(1) *The Fluorescent Effect*

Certain uranium compounds and certain salts of the alkali and alkali-earth metals have the property of fluorescing, i.e., of giving off visible light when exposed to the action of X-rays. Many of these compounds phosphoresce, i.e., continue to give off light, for a short time after the X-rays have been cut off. In order to be of great use in X-ray work, a fluorescent screen should possess the following characteristics: (a) the color of the light should be such as to give good visual acuity; (b) the intensity of light per unit intensity of X-rays should be as great as possible, and should not decrease with continuous operation of the screen; (c) there should be as little phosphorescence as possible, and (d) the crystals of the fluorescent salt must be so small that the "grain" of the screen is not visible when the screen is in use.

The selection of a material possessing these qualifications is a long tedious task, for the fluorescent properties of a given salt are greatly changed by the addition of minute amounts of impurities. A salt showing almost no fluorescence when pure may fluoresce brightly when mixed with but a fraction of one per cent of some other salt. In spite of the fact that each formula for fluorescent material is entirely empirical, there are three or four varieties of screens on the market which meet the requirements given in the preceding paragraph. All of these give off light whose intensity is determined by the current through the X-ray tube, the voltage across the tube, and by the distance from the target of the tube. If the intensity of the fluorescent light is plotted against either the current or the voltage, the resulting curve is a straight line or a succession of straight lines.¹ As would be expected, the intensity varies inversely as the square of the distance between the fluorescent screen and the target of the tube.

¹ J. S. Shearer, Am. Journal Roentgenology, Nov., 1914.

(2) The Photographic Effect

X-rays have much the same effect on a photographic plate as ordinary light. Just as photographic plates are more sensitive to certain wave-lengths of light than to others; in the same way they are found to be more sensitive to certain wave-lengths of X-rays than to others. This is usually explained by assuming that the plate is most sensitive when exposed to X-rays of such wave-length as will excite characteristic secondary rays from one or more of the elements in the emulsion. Since all manufacturers do not necessarily use the same chemicals in making their X-ray plates, it follows that (a) all brands of plates do not have the same speed when excited by X-rays of the same wave length, (b) a plate which is exceptionally "slow" when excited by rays of long wave length (i.e., little penetrating ability) may be quite "fast" when used with rays of short wave length (i.e., great penetrating ability).

It is impossible to focus X-rays as one would focus visible light in ordinary photography. Radiographs are merely *shadow pictures*. If all parts of the object to be radiographed were of the same transparency to the rays,¹ all that one could possibly obtain would be a uniform blackening of the photographic plate. But, if one part of the object is more opaque to X-rays than some other part, then the radiograph will show a corresponding change in density. Thus we are able to obtain radiographs of the human body because of the different opacities of various tissues, and it is possible to show holes in metal castings because of the differences caused in the thickness of the metal.

In ordinary photography the chief variables to be considered are *exposure* and *development*. In radiography there is an additional variable, namely, *penetration*. In choosing the proper penetration, the radiographer must constantly bear in mind that as the penetrating ability of the X-rays is increased there is an increased tendency to blur the picture, because of scattered rays. It is also necessary to remember that a radiograph taken with very penetrating rays is less "contrasty" than one taken with rays of moderate penetration. For any given amount of exposure, the optimum penetration is, therefore, that penetration at which the most opaque part of the object permits only a very slight darkening of the photographic plate.

Radiographs are always examined as *negatives*. A radiograph is, therefore, of proper density when it can be easily viewed against a clear north sky. This is, as a rule, much denser than is advisable for making the best positive prints.

(3) The Ionizing Effect

If a charged body is exposed to X-rays, it will be found to lose its charge. This is explained by assuming that the air in the path of the X-rays becomes broken up into *ions*, or electrically charged atoms. The air thus becomes a conductor of electricity and causes the charge to leak away. While the quantity of charge carried by different ions is not always the same, still it is always some exact whole number times 4.9016×10^{-10} electrostatic units of charge.²

Fig. 1 shows an ordinary form of ionization chamber. Two thin sheets of aluminum foil form the ends of a metal cylinder. Midway between them and insulated from them is another thin piece of aluminum foil. This middle sheet is connected to a quadrant

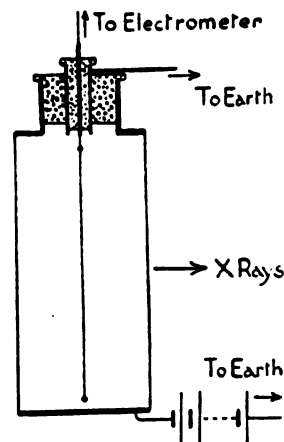

Fig. 1. An Ionizing Chamber

¹ Transparency to X-rays has no relation to transparency to ordinary light. An object may be quite opaque to ordinary light and yet be very transparent to X-rays and vice versa.

² R. A. Millikan, *Science*, 23, pp. 436-448, Sept. 30, 1910. This is the strongest evidence we have that electricity has an atomic structure. The charge on an electron is 4.9016×10^{-10} e.s. units.

electrometer, or to an electroscope. In some cases it is possible to obtain a current large enough to measure with a galvanometer connected between the inner and outer plates. This type of ionization chamber has many advantages. (Some of its objectionable features will be taken up later.)

Suppose such an ionization chamber to be exposed to the action of X-rays of constant intensity and wave-lengths. If the difference of potential between the inner and outer sheets is small, the ionization current will be small. As this difference in potential is increased, the ionization current increases, but at last a condition of "saturation" is

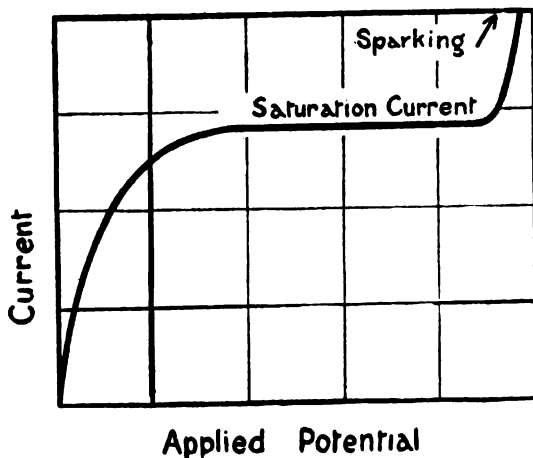

Fig. 2. Voltage-Current Curve of an Ionization Chamber

reached in which the current is independent of the voltage. At very high potential differences the current once more increases and sparking soon occurs. Fig. 2 shows the form of the voltage-current curve of an ionizing chamber.

In scientific work *quantity of X-rays* is measured in terms of the amount of electricity which the rays are able to cause to flow from one terminal of the ionizing chamber to the other. In such measurements it is absolutely necessary to have a saturation current through the ionizing chamber, otherwise the amount of electricity carried across will depend largely upon

the potential difference between the plates of the chamber. It is also necessary to make sure that the chamber is of proper design and of suitable material.

Owen,¹ and Barkla and Philpot² have shown that, except when characteristic rays of the gas were strongly excited, ionization in that gas was practically independent of the wave-length of the X-rays employed. Their results are collected in Table I. Methyl Iodide appears to be an exception to this rule.

In a previous article it was stated that when X-rays of sufficient penetrating ability fell upon a body, that body became a source of characteristic X-rays. Under such conditions the body also gives off a large number of electrons (secondary corpuscular radiation). These electrons have the ability to ionize any gas in which they find themselves. It is at once evident that there are serious limitations imposed upon an ionizing chamber. Before the amount of electricity transferred from one terminal to the other may be taken as a measure of the *quantity of X-rays*, it is necessary to make sure that the material used in its construction is not giving off secondary corpuscular radiation. It is equally necessary to make sure that the gas used in the chamber is not itself giving off secondary corpuscular radiation. An ideally designed chamber is so constructed that it is impossible for the direct X-ray beam, or the secondary X-rays scattered by the gas, or the secondary rays characteristic of the gas to strike its walls. It is almost impossible to design a chamber such that all these conditions will be fully met under all circumstances. Usually the design is made such as to be quite satisfactory for use with the wave-lengths of rays that are to be measured.

¹ E. A. Owen. Proc. Roy. Soc. A., 86, pp. 426-439, 1912.

² Barkla and Philpot, Phil. Mag., xxv, pp. 832-836, 1913.

In many cases it is necessary to measure the total amount of energy in the X-ray beam. This may be done by using an ionization chamber long enough to completely absorb all the rays.

C. T. R. Wilson has shown¹ that it is possible to condense water-vapor upon ions, thus making the path of the ions visible. Fig. 3 shows the arrangement of his apparatus. A steel ball was fastened to a very heavy ball by a thread. The heavy ball was hung by a stout cord. When the cord was suddenly loosened the ball dropped a short distance, opening a valve. This caused the bottom of the expansion chamber to be quickly lowered and produced a condition of supersaturation of the moisture in the expansion chamber. The stopping of the large ball broke the thread, thus allowing the

TABLE I
RELATIVE IONIZATION PRODUCED IN VARIOUS GASES BY HOMOGENEOUS X-RAYS

Element Emitting Characteristic K Radiation	IONIZATION RELATIVE TO AIR = 1					
	H ₂ (Beatty)	O ₂ (B.&P.)	CO ₂ (Owen)	SO ₂ (Owen)	C ₂ H ₅ Br (B.&P.)	CH ₂ I (B.&P.)
Fe	0.00571	1.37	1.58	11.3	41.2	
Ni		1.35	1.55	11.6		162
Cu	0.00573	1.38	1.55	11.8	42	152
Zn	0.00570	1.42	1.54	11.5	41.6	
As	0.00573	1.27	1.51	11.7	42.2	158
Se		1.31	1.53	11.8	41.7	
Sr		1.28	1.53	11.8	153	
Mo		1.28	1.54	11.5	213	188
Ag		1.32			272	198
Sn	0.04	1.29			335	205
Sb		1.28				
I						211
Ba						251

smaller steel ball to fall freely. In its descent it closed a spark-gap, allowing a condenser discharge to pass through the X-ray tube. After a predetermined interval it closed a second spark-gap which allowed another condenser discharge to pass through a mercury vapor lamp. This illuminated the cloud in the expansion chamber, and enabled the paths of the ions to be photographed. A characteristic photograph is shown in Fig. 4. As a result of his work Wilson could find no direct action of the X-ray upon the gas. The only role of the X-rays seemed to be that of causing the gas to give off electrons (i.e., ionize the gas). These electrons, by impact upon the molecules of the gas, cause further ionization.

(4) The Chemical Effect

Except for the action of X-rays upon the materials in the film of a photographic plate, the only chemical actions so far noticed seem to be a precipitating effect, and a hydrolytic effect. Iodine is precipitated from its solution in chloroform by exposure to the rays.²

Schwartz has found an ammonium oxalate-mercury bichloride mixture which precipitates calomel under the action of X-rays.³

When starch is exposed to the rays, it is changed into soluble starch and then into dextrin.⁴

¹ Proc. Roy. Soc., A., 85, p. 285, 1911.

Proc. Roy. Soc., A., 87, pp. 277-299, 1912.

² H. Bordier and J. Galimard, Arch. d'Elect. Med. 14, Aug. 10, Sept. 10, 1906.

³ G. Schwartz, Wein Med. Presse. xlvii, 2092, 1906.

⁴ Colwell and Russ, Arch. Middlesex Hosp. xxvii, p. 63.

(5) *The Dehydrating Effect*

Ammonium, potassium, barium, and magnesium platinocyanides change color when exposed to X-rays, due to dehydration.¹

(6) *The Photo-Electric Effect*

As was stated in the discussion of ionization, when a body gives off characteristic X-rays it also gives off electrons. These electrons leave the body with the same velocity that a cathode stream would need in order to produce the X-rays characteristic of that body. This is true no matter what the intensity or wave-length of the exciting X-rays may be. This effect corresponds in every way to the well known photo-electric effect in which a clean metal surface gives off electrons when illuminated by ordinary light.

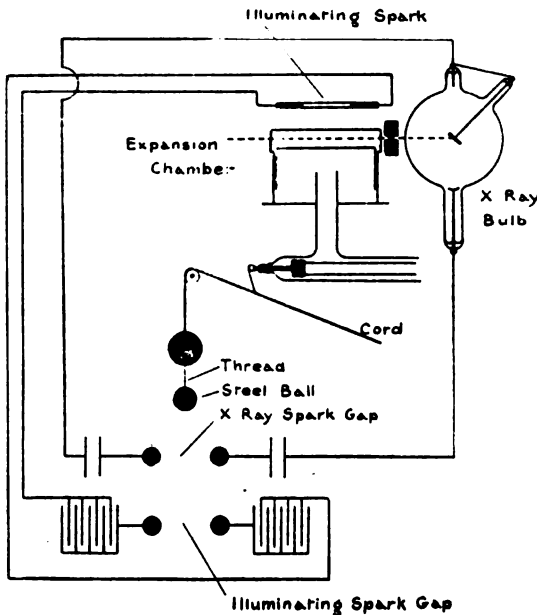

Fig. 3. Diagram of Wilson's Apparatus for Photographing the Paths of Ions

(7) *The Action Selenium Cell*

X-rays affect the electric resistance of a selenium cell in the same manner as light.²

(8) *The Penetrating Effect*

All substances exert more or less of an absorbing effect on X-rays. In general, the absorbing effect of any given substance for a given bundle of rays depends upon the material used as a target in the tube, the nature and thickness of the absorbing substance, the history of the radiation after leaving the target, and the potential drop across the tube at the instant the given bundle of rays is given off. Ordinarily, if the target in the tube is a substance of high atomic weight, then rays from that tube will be less readily absorbed than if the target had been of low atomic weight.

When rays from an ordinary X-ray tube pass through a substance some of the radiation is absorbed, so that the emergent beam acts more feebly on a fluorescent screen, photographic plate, selenium cell, or ionizing chamber. If rays from a platinum-target tube, operating under ordinary working conditions, are made to pass through silver, the intensity of the emergent beam may be calculated from the formula,

$$I = I_0 \epsilon^{-\lambda x}$$

in which

I_0 = intensity of the incident beam.

I = intensity of the emergent beam.

ϵ = base of natural logarithms = 2.7182.

x = thickness of the absorber.

λ = coefficient of absorption of the substance used as absorber.

¹ Bordier and Galimard, Arch. d'Elect. Medical, May 10, 1905.

G. Holzknicht, Arch. d'Elect. Med., Oct. 10, 1910.

² Perreau, Comtes Rendus 129, pp. 956-957, Dec. 4, 1899.

Athanasiadis, Ann d. Phys., 27, 4, pp. 890-996, Nov. 26, 1908.

λ is very approximately independent of the thickness of the silver.¹

All substances for which the above law holds true are said to be "aradiochroic." If, however, the rays are made to pass through sheets of aluminum, tin, etc., the above law does not hold. The value of λ as calculated by the formula is different for different thicknesses of the absorbing sheet; but, as the thickness is increased, λ approaches more and more nearly to a constant value, and the law holds approximately if the sheet is thick enough. The formula may also be made to apply approximately if the difference in thickness between two absorbing sheets is so small that the value of λ has not changed appreciably, due to the change in thickness. Absorbers which act in this way are said to be "radiochroic," and are often called "filters."

These facts may be explained by assuming that an X-ray tube sends out a complex radiation ("heterogeneous beam") composed of primary rays and secondary rays characteristic of the target. In aradiochroic substances the coefficients of absorption for the component beams are approximately the same. In radiochroic substances the beams are unequally absorbed. If the filter is thick enough to completely absorb all but one of the components, the emergent beam is said to be "homogeneous," and the absorption law will hold accurately for any absorber through which the beam may subsequently pass, provided no secondary rays characteristic of the absorber are produced. It is to be noticed that no substance is absolutely aradiochroic. Silver is probably the most nearly aradiochroic metal for the rays given off by a tube with a platinum target; but it is quite radiochroic for the rays given off by a lead target,² because of being more opaque to the "secondary" component than to the "primary" component of the beam. If the absorber is of the same material as the target, it is more opaque to the "primary" component than to the "secondary" component; but the two absorption coefficients may be so nearly equal as to cause the absorber to appear under some conditions to be almost completely aradiochroic.³

If the absorber is of the same material as the target, then λ decreases as the potential difference across the tube is increased, and the decrease of λ with the increase of the potential difference is much more marked the higher the potential difference employed.⁴

If the absorber is a chemical compound, the total absorption under any specified conditions is the sum of the various absorptions caused under those conditions by the various atoms and radicals of which the absorber is composed.⁵

As a rough-and-ready means of determining the penetrating ability of X-rays, physicians use what they call "penetrometers." Of these the Benoist and the Whenelt are the most accurate. In both of these instruments the opacity of a standard sheet of

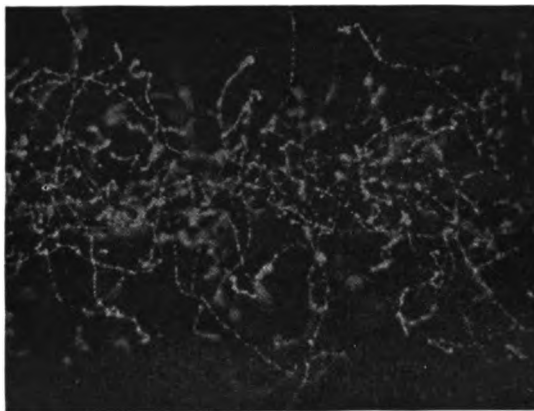

Fig. 4. Photograph of Paths of Ions Taken by C. T. R. Wilson

¹ L. Benoit, *Journal de Physique*, 1901.

J. Beloit, *Arch d'Elect. Med.*, Aug. 10, 1910.

² W. R. Ham, *Phys. Rev.* xxx, 1, Jan. 1910, pp. 104-105, 118-120.

³ G. W. C. Kaye, *Camb. Phil. Soc. Proc.* 14, pp. 236-245, Oct. 15, 1907.

Roy. Soc. Phil. Trans. A, 209, pp. 123-151, Nov. 19, 1908.

⁴ W. R. Ham, *Phys. Rev.* xxx, 1, pp. 108, 111-113, Jan., 1910.

⁵ W. Seitz, *Phys. Zeitschr.* 13, pp. 476-480, June 1, 1912.

Blennard and Labesse, *Comptes Rendus*, 1896, cxxii, pp. 723-725.

silver is matched against the opacity of aluminum of various thicknesses. In the case of the Whenelt penetrometer, a standard piece of silver is fastened to a fluorescent screen. A specially shaped wedge is slid past the screen until a thickness is at last reached such that the illumination of the screen under the aluminum is the same as that under the silver. The penetrating ability or "hardness" of the rays is read on an arbitrary scale.

The Benoist penetrometer consists of a disk of silver 0.11 mm. thick. Around this disk, arranged like a circular staircase, are steps of aluminum, each step being one millimeter higher than the one preceding. A radiograph of the penetrometer is taken and the "hardness" is defined as the number of millimeters of aluminum which are as opaque as the disk of silver. Care must be taken not to over-expose the radiograph, otherwise the whole negative will be blurred and a correct reading will be found impossible.

(9) *The Physiological Effect*

When X-rays are directed toward a given layer of flesh, in general, some of them pass though while others are absorbed and give up their energy to the flesh. If sufficient energy is thus delivered to the flesh, serious pathological changes result which are of great importance from the viewpoint of the physician, but which do not concern the physical investigator, aside from the question of his own self-protection. A person in good health may have several radiographs taken (sufficient for ordinary diagnostic work) by a well-informed operator, without any danger of an X-ray burn; but the operator, or research-physicist, must, because of the possibility of long-continued exposure or more often because of frequent repetition of short exposures, protect himself most carefully. The German Roentgen Society recommends that for work such as is ordinarily done by physicians the protection should consist of at least two millimeters of sheet lead, eight millimeters of X-ray proof rubber impregnated with lead, or lead glass from ten to twenty millimeters thick.¹

¹ Archives of the Roentgen Ray, July, 1913.

PART III

In Part I of this series it was shown that the electromagnetic theory of X-rays considers characteristic X-rays as being light of very short wave length. It would be reasonable to expect that, if this were so, characteristic X-rays would obey the same laws of diffraction as light waves. The experimental verification of this expectation is one of the most signal vindications of the electromagnetic theory.

Before considering the experiments themselves it will be well to consider the diffraction of ordinary light. Let XX^1 (Figs. 1, 2 and 3) be a surface opaque to ordinary light, and let B and E be narrow slits. If the two rays of light AB and DE come originally from the the same portion of the same source by paths of equal length, then the light-wave at B will be in phase with the light-wave at E . Therefore, B and E will act as exactly similar sources of light. A lens placed at CF will cause the light to appear at the focus as a luminous spot, for the two beams of light will meet in the same phase having traveled equal paths from B and E . If the lens is moved slightly to one side the intensity of the light will be much diminished, for the light from B and E will travel over paths of different lengths. If the lens is moved further to one side, no light will be seen at the focal spot. But if the lens is moved to a position GH (Fig. 1) such that the difference in path-length is one wave-length, then the two beams once more meet in phase and light is seen. In the same way light may be observed at IJ and KV (Figs. 2 and 3) where the difference in path-length is two and three wave-lengths respectively.

The light appearing at CF is usually called an image of the "zero order," that at GH an image of the "first order," etc. The intensity of the light falls off rapidly as the "order" of the image increases, so that only the first few "orders" can be made use of.

An inspection of Figs. 1, 2 and 3 will make it at once evident that, if the angles separating the various orders of images are to be large enough to be measurable with accuracy, the distance d must be comparable with the wave-length of the light used. Thus diffraction gratings intended for use

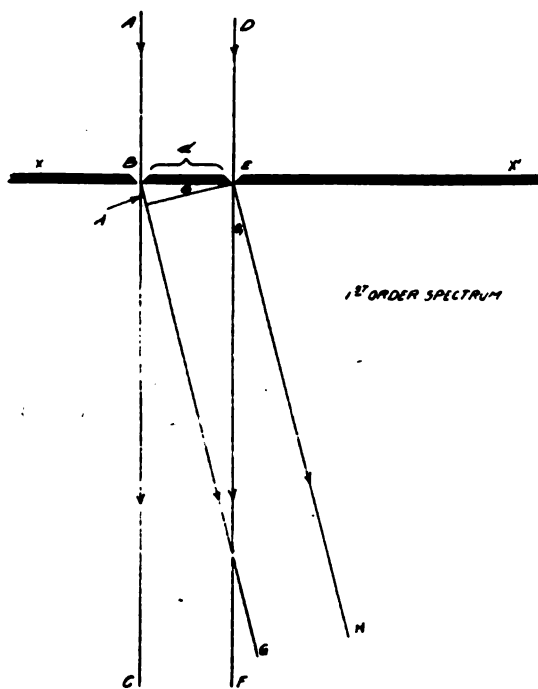

Fig. 1. Diagram Showing Production of a Spectrum of the 1st Order

hope of overcoming this difficulty but they did not achieve much success.

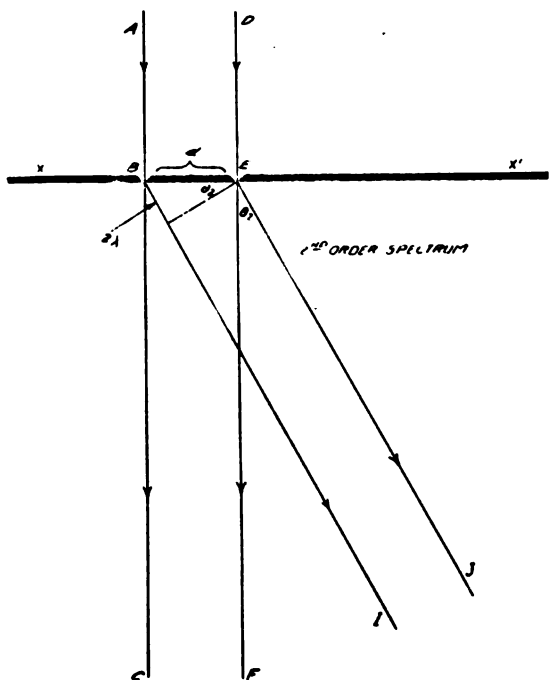

Fig. 2. Diagram Showing Production of a Spectrum of the 2nd Order

with visible light (wave-lengths in the neighborhood of 10^{-5} centimeters) usually have a grating space d of from 0.002 cm. to 0.0005 cm. Now the wave-length of X-rays is in the neighborhood of 10^{-6} centimeters. It is evidently hopeless to attempt to rule a grating so fine that the lines are only one hundred-millionth of a centimeter apart.

Haga and Wind¹ and Walter and Pohl² tried to use a single narrow wedge in the

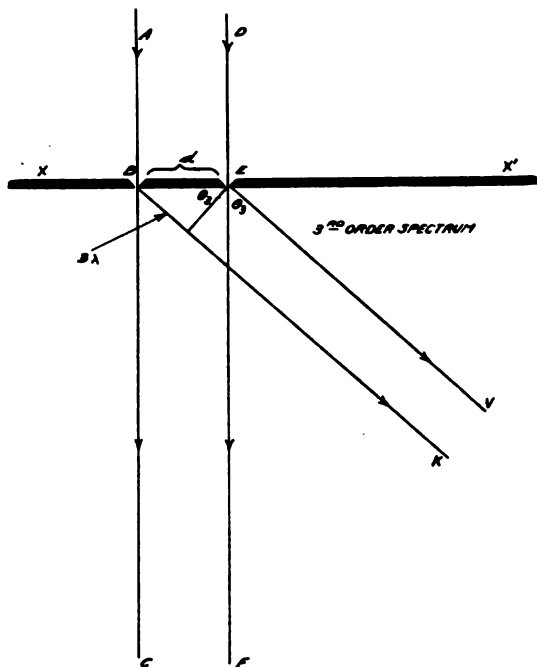

Fig. 3. Diagram Showing Production of a Spectrum of the 3rd Order

¹ Haga and Wind, Wied, Ann., pp. 884-895, 1899.

² Walter and Pohl, Ann. d. Phys., pp. 715-724, 1908.

To Prof. Laue of Munich belongs the credit for the next great step in the diffraction of X-rays. The atoms in a crystal are arranged in a definite systematic formation and their inter-atomic distances are of the same general order of magnitude as the wave-lengths of X-rays, as calculated from theory. Laue, therefore, was led to regard a crystal as a ready-made natural diffraction grating for use with X-rays. Such gratings are much more complicated than those used with ordinary light because of their three-dimensional nature. Friedrich and Knipping¹ verified experimentally Laues' conjecture. Their apparatus is shown diagrammatically in Fig. 4, and Fig. 5 shows diffraction patterns which they obtained.

It will be noticed from Fig. 4 that Friedrich and Knipping used the crystal as a *transmission* grating. The method was capable of showing that X-rays could be diffracted, but was not well adapted to measuring the wave-length of X-rays nor to a study of crystal structure. W. L. Bragg conceived the idea of using a crystal as a *reflection* grating (see Fig. 6). This method possesses the advantage that the results are very easy of interpretation, which is evident at once by an inspection of Fig. 7.

The distance MNP is the difference in path-length of the two X-ray beams A_1 and A_2 . If this distance is an exact whole number of wave-lengths, the two reflected waves are in phase and the wave actually exists. Otherwise, the waves are out of phase and interfere destructively. There are thus only two conditions to be met, (a) the angle of reflection must equal the angle of incidence, (b) the wave-length of the X-rays must be such that it is an exact divisor of the difference in the path-length caused by reflection from the various crystal planes. If the inter-atomic distances and the angles between crystal planes are known, the wave-length of any X-ray beam may be calculated from the angle at which it will reflect. Conversely, if the wave-length of the rays and the angle at which they

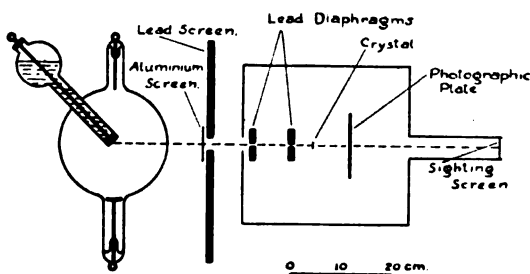

Fig. 4. Diagram of Apparatus Used by Friedrich Knipping and Laue

reflect from a given crystal face are known, then from the angles between the crystal planes the inter-atomic distances may be calculated.

An attempt has been made in Fig. 7 to show by lines drawn through the atoms that there are many crystal-planes possible in different directions in a single crystal. An inspection of the diagram shows at once that the inter-atomic distance is different for different planes. By examining the various orders of spectra from the various crystal planes, Prof. Bragg has been able to assign a definite arrangement to the atoms of a crystal. Fig. 8 shows two spectra obtained by reflection. Fig. 9 shows the structure of a crystal of a halogen salt of a monovalent metal. The black spots represent metallic atoms, (Na , K , etc.). The white spots represent the halogen (F , Cl , Br , I).

As a result of the work in X-ray spectra, the Mendelejeff table of elements is to be largely replaced by the Rutherford system of atomic numbers (Table I) which is based on the fact that, if the elements are arranged in the order of their atomic weights, the *atomic numbers* are proportional to the reciprocal of the square roots of the wave-lengths of the characteristic X-rays.

¹ Friedrich, Knipping and Laue, *Ann. d. Phys.*, pp. 971-1002, 1913.

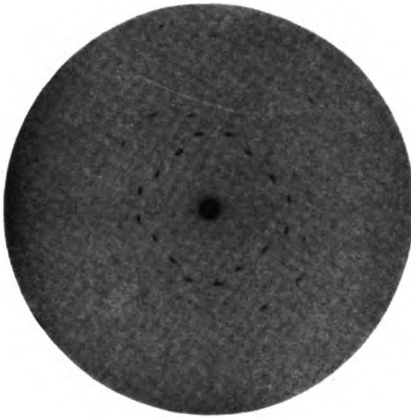

Fig. 5a. Through Crystal of Zinc Blend.
Rays Passed Through Crystal
Perpendicular to 100 Plane

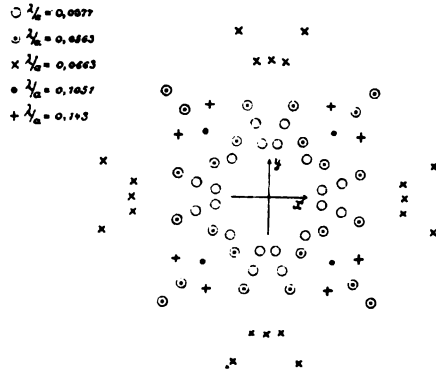

Fig. 5b. Theoretical Diagram Showing
Position of Possible Spots on Fig. 5a

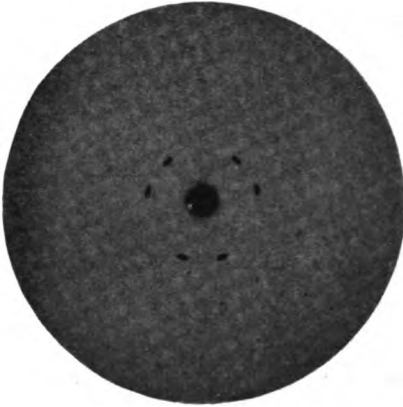

Fig. 5c. Through Crystal of Zinc Blend.
Rays Passed Through Crystal
Perpendicular to 111 Plane



Fig. 5d. Same as Fig. 5c Except that the
Crystal has been Slightly Rotated

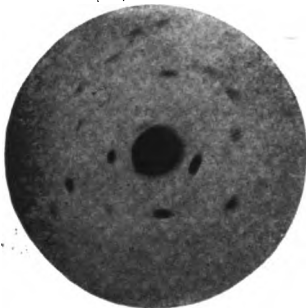

Fig. 5e. Through Copper Sulphate.
Rays Passed Perpendicular
to 110 Plane

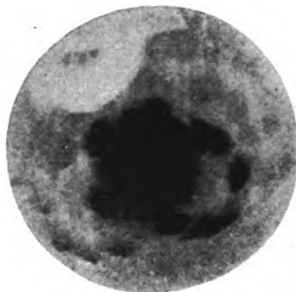

Fig. 5f. Same as Fig. 5e, except that
Photographic Plate is Farther
from Crystal

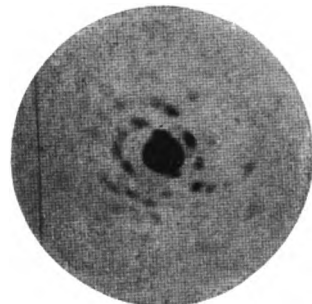

Fig. 5g. Rays Passed Through
Powdered Copper Sulphate

Fig. 5. Spectra Obtained by Knipping and Laue

A striking instance of the interrelation of the various branches of science is furnished by the work of the physicist in X-rays which has been found useful not only in physics



Fig. 6. Arrangement of Apparatus Used by Bragg

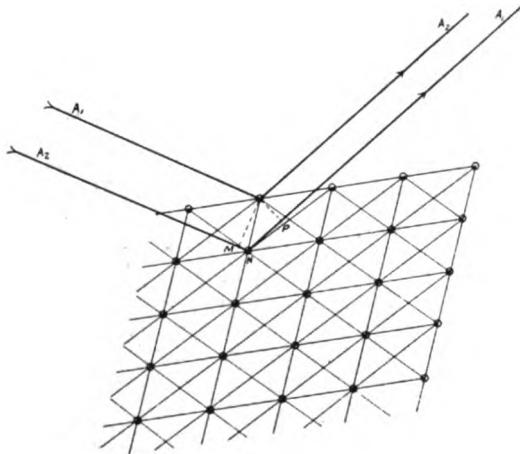
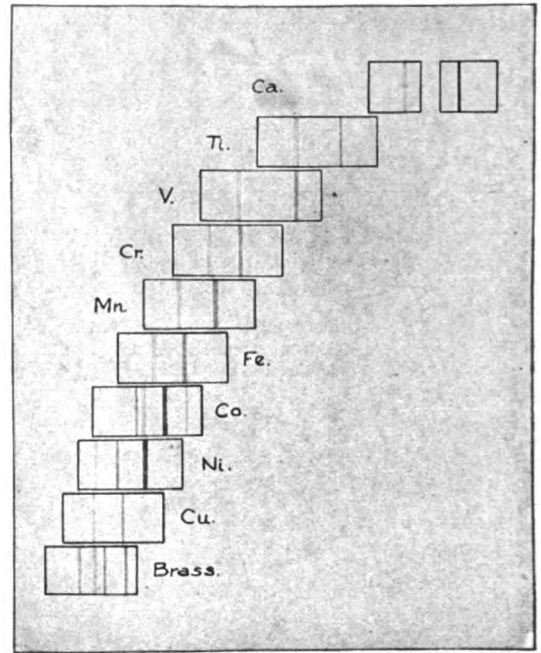

Fig. 7. Diagram Showing Reflection by Atoms in a Crystal



→ Increasing Wave Length.

Fig. 10. Spectra Obtained Using Various Metals as Reflectors

but also in crystallography and chemistry. The crystallographer is now able to measure in centimeters the distances between the molecules in crystals and is able in many

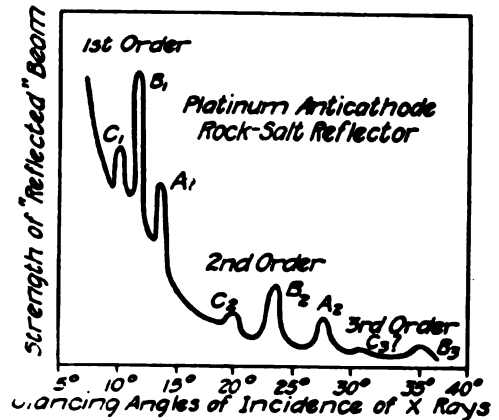
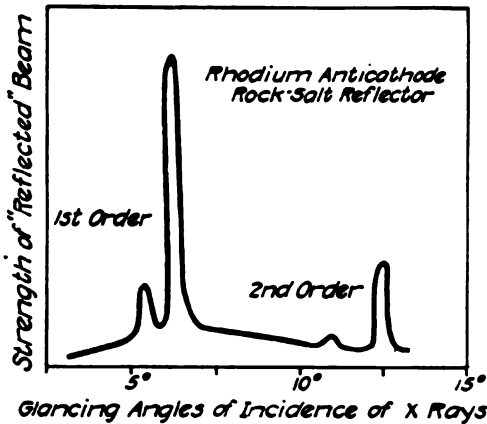

Fig. 8. Spectra Obtained by Bragg

cases to assign a definite structure to them. The chemist now knows that, at least as far as crystals are concerned, there are no such things as molecules in the sense in which

TABLE I
THE RUTHERFORD SYSTEM OF ATOMIC NUMBERS

Atomic Numbers	Symbol	Atomic Weight	Atomic Numbers	Symbol	Atomic Weight
1	<i>H</i>	1.008	57	<i>La</i>	139.
2	<i>He</i>	3.99	58	<i>Ce</i>	140.25
3	<i>Li</i>	6.94	59	<i>Pr</i>	140.6
4	<i>Gl</i>	9.1	60	<i>Nd</i>	144.3
5	<i>B</i>	11.	61		
6	<i>C</i>	12.	62	<i>Sa</i>	150.4
7	<i>N</i>	14.01	63	<i>Eu</i>	152.
8	<i>O</i>	16.	64	<i>Gd</i>	157.3
9	<i>F</i>	19.	65	<i>Tb</i>	159.2
10	<i>Ne</i>	20.2	66	<i>Ho</i>	163.5
11	<i>Na</i>	23.	67	<i>Dy</i>	162.5
12	<i>Mg</i>	24.32	68	<i>Er</i>	167.7
13	<i>Al</i>	27.1	69	<i>Tm_i</i>	
14	<i>Si</i>	28.3	70	<i>Tm_{ii}</i>	
15	<i>P</i>	31.04	71	<i>Yb</i>	172.
16	<i>S</i>	32.07	72	<i>Lu</i>	174.
17	<i>Cl</i>	35.46	73	<i>Ta</i>	181.5
18	<i>A</i>	39.88	74	<i>W</i>	184.
19	<i>K</i>	39.1	75		
20	<i>Ca</i>	40.07	76	<i>Os</i>	190.9
21	<i>Sc</i>	44.1	77	<i>Ir</i>	193.1
22	<i>Ti</i>	48.1	78	<i>Pt</i>	195.2
23	<i>V</i>	51.	79	<i>Au</i>	197.2
24	<i>Cr</i>	52.	80	<i>Hg</i>	200.6
25	<i>Mn</i>	54.93	81	<i>Tl</i>	204.
26	<i>Fe</i>	55.84	81	<i>RaC₂</i>	210.
27	<i>Co</i>	58.97	81	<i>AcD</i>	
28	<i>Ni</i>	58.68	81	<i>ThD</i>	208.
29	<i>Cu</i>	63.57	82	<i>Pb</i>	207.1
30	<i>Zn</i>	65.37	82	<i>RaB</i>	214.
31	<i>Ga</i>	69.9	82	<i>RaD</i>	210.
32	<i>Ge</i>	72.5	82	<i>ThB</i>	212.
33	<i>As</i>	74.96	82	<i>AcB</i>	
34	<i>Se</i>	79.2	83	<i>Bi</i>	208.
35	<i>Br</i>	79.92	83	<i>RaC</i>	214.
36	<i>Kr</i>	82.92	83	<i>RaE</i>	210.
37	<i>Rb</i>	85.45	83	<i>AcC</i>	
38	<i>Sr</i>	87.63	83	<i>ThC</i>	212.
39	<i>Yt</i>	89.	84	<i>RaA</i>	218.
40	<i>Zr</i>	90.6	84	<i>RF</i>	210.
41	<i>Nb</i>	93.5	85		
42	<i>Mo</i>	96.	86	<i>Nt</i>	222.
43			87		
44	<i>Ru</i>	101.7	88	<i>Ra</i>	226.
45	<i>Rh</i>	102.9	88	<i>Mes. Thi</i>	228.
46	<i>Pd</i>	106.7	88	<i>AcX</i>	
47	<i>Ag</i>	107.88	88	<i>ThX</i>	224.
48	<i>Cd</i>	112.4	89	<i>Ac</i>	
49	<i>In</i>	114.8	89	<i>Mes. Thii</i>	228.
50	<i>Sn</i>	119.	90	<i>Th</i>	232.
51	<i>Sb</i>	120.2	90	<i>Ux</i>	230.5
52	<i>Te</i>	127.5	90	<i>Io</i>	230.5
53	<i>I</i>	126.92	90	<i>RaAc</i>	
54	<i>Xe</i>	130.2	90	<i>Rath</i>	228.
55	<i>Cs</i>	132.81	91	<i>Ux₂</i>	
56	<i>Ba</i>	137.37	92	<i>U</i>	238.5

the word is ordinarily used in chemistry. The *whole crystal* is a big complex molecule, and the chemical formula only shows the relative amounts of each element present. It

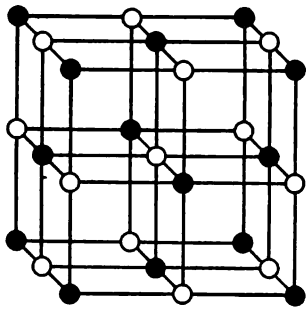

Fig. 9. Arrangement of Atoms in a Crystal of Sodium Chloride

is reasonable to assume that in metals the *crystal* (not the "molecule") is, next to the atom, the unit to be considered. It has even been suggested that it might be possible to use the characteristic X-rays as a means of identifying the various elements, so that a measurement of the wave-length of the characteristic X-rays from a substance would serve as a qualitative analysis of the substance. Fig. 10 shows in diagram, spectra of the third order obtained by Mosley.* They are so arranged that the scale of wave-lengths of each plate registers with the scale of the plates above and below

it. Table II which is of approximate wave-lengths is given for reference.

* Mosley, Phil. Mag., Dec., pp. 1024-1034, 1913.

TABLE II

VARIOUS ELEMENTS, THEIR ATOMIC WEIGHTS, AND WAVE-LENGTHS OF THEIR CHARACTERISTIC X-RAYS

Element	Atomic Weight	Wave-Length	Remarks
Calcium.....	40.1	3.36×10^{-8} cm. 3.09×10^{-8} cm.	Strong K radiation Weak radiation
Titanium.....	48.1	2.76×10^{-8} cm. 2.525×10^{-8} cm.	Strong K radiation Weak radiation
Vanadium.....	51.1	2.52×10^{-8} cm. 2.30×10^{-8} cm.	Strong K radiation Weak radiation
Chromium.....	52.0	2.30×10^{-8} cm. 2.09×10^{-8} cm.	Strong K radiation Weak radiation
Manganesec.....	54.9	2.11×10^{-8} cm. 1.92×10^{-8} cm.	Strong K radiation Weak radiation
Iron.....	55.9	1.945×10^{-8} cm. 1.765×10^{-8} cm.	Strong K radiation Weak radiation
Cobalt.....	59.0	1.80×10^{-8} cm. 1.63×10^{-8} cm.	Strong K radiation Weak radiation
Nickel.....	58.7	1.66×10^{-8} cm. 1.505×10^{-8} cm.	Strong K radiation Weak radiation
Copper.....	63.6	1.55×10^{-8} cm. 1.40×10^{-8} cm.	Strong K radiation Weak radiation

