



VOLUME I.

TOPOGRAPHICAL DRAWING AND SKETCHING.



# TOPOGRAPHICAL DRAWING

AND

# SKETCHING,

*Including Applications of Photography.*

IN TWO VOLUMES.

BY

LIEUT. HENRY A. REED. U. S. ARMY,

*Assistant Professor of Drawing, U. S. Military Academy, West Point, N. Y.*

FOURTH EDITION—REVISED AND ENLARGED.

SECOND THOUSAND.

NEW YORK:

JOHN WILEY & SONS.

LONDON: CHAPMAN & HALL, LIMITED.

1897.

COPYRIGHT, 1888.  
By JOHN WILEY & SONS.

ROBERT DRUMMOND, ELECTROTYPYER AND PRINTER, NEW YORK.

56455

JAN 10 1901

SQH  
· E25  
· 2

## PREFACE.

---

THE writing of this book was first suggested by the fact that there was no native work which fully treated of and illustrated rapid methods of hill-shading; and it is now written not only to explain these and other methods now used either separately or in conjunction with them, but also to present the subject of topographical sketching in a form suited to a beginner.

The methods of both drawing and sketching as now practised in the principal topographical schools, and there considered the best, are described in detail.

The writer has searched every available source, both foreign and native, for new information, and desires especially to acknowledge that gained from the publications of the U. S. Coast Survey, the "Mémorial de l'Officier du Génie," and from the recent works of Lehagre, Maes and Bertrand of the French schools, and of Colonels Richards and Roberts of the British Army; and also to express his indebtedness for valuable advice, assistance, and opportunities afforded by his friend, Professor Charles W. Larned, Department of Drawing, U. S. M. A.

WEST POINT, N. Y., June 23, 1886.

---

## PREFACE TO THE SECOND EDITION.

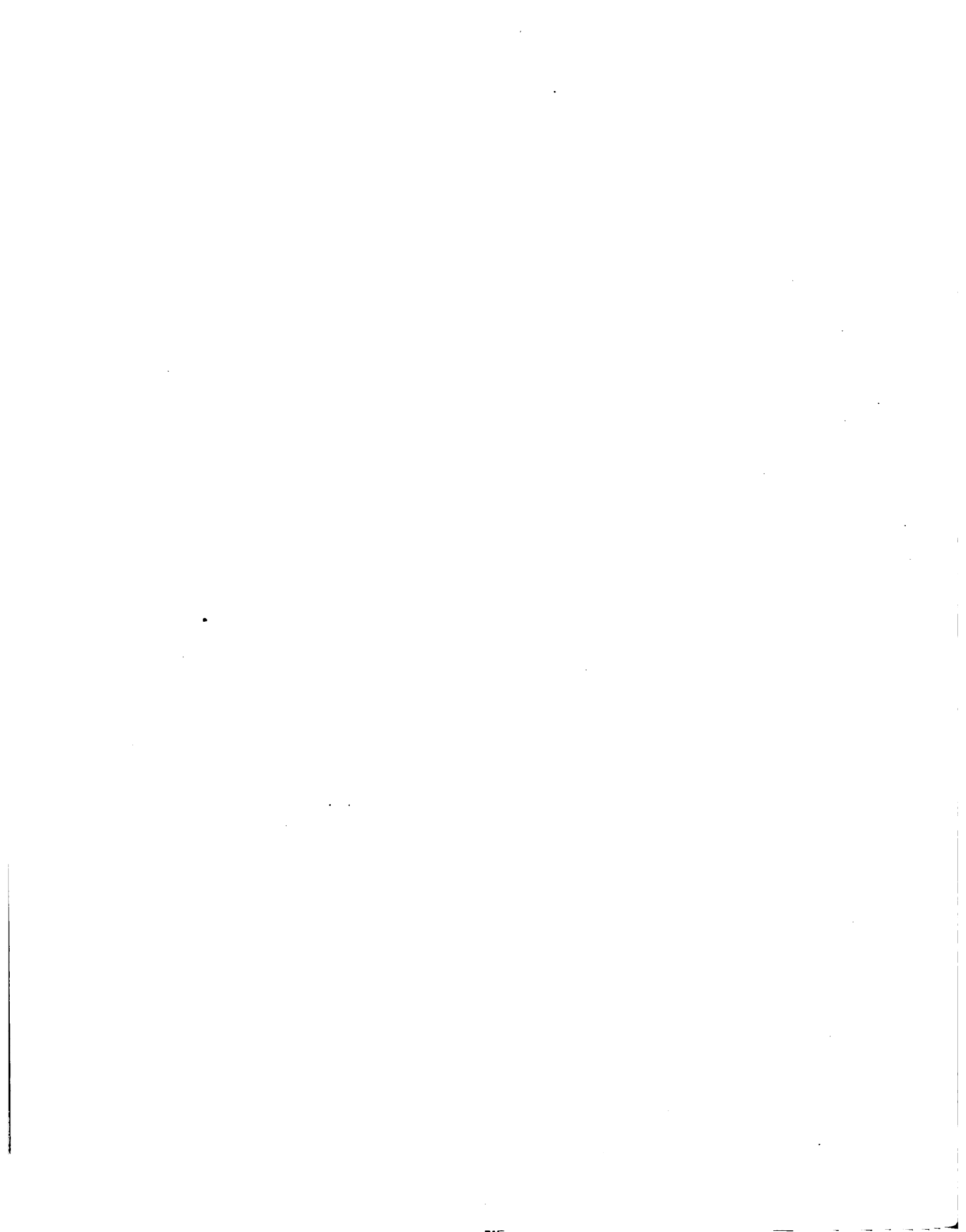
---

SOON after the issue of the First Edition, this manual was adopted for the use of Cadets at the U. S. Military Academy; an opportunity was thus afforded to the writer of personally testing its merits as a guide to the student, and, having made such changes and additions as seemed advisable, it is now believed to be well suited to purposes of instruction.

The present enlarged edition consists of two volumes bound in one; Vol. I. contains the subject-matter of the First Edition, except that part pertaining to Photographic Sketching; but with the addition of Methods of Plotting when the Earth's Sphericity is Considered, and of more information on the subjects of Conventional Signs, Modelling and Sketching; while Vol. II., "Photography applied to Surveying," which has its own Preface and Index, not only contains the information omitted as above stated from Vol. I., but is intended to be a fairly complete presentation of this subject in its various forms and applications.

A "Contents," and an "Index" alphabetically arranged, are prefixed to each volume; and Vol. II. is also published separately.

WEST POINT, N. Y., March 17, 1888.



# CONTENTS.

## *TOPOGRAPHICAL DRAWING.*

### PART I.

|  | PAGE |
|--|------|
| INTRODUCTORY—INSTRUMENTS AND MATERIALS—PRACTICAL RULES AND SUGGESTIONS—SCALES<br>AND PLOTTING, . . . . . | 1    |

### PART II.

|  |    |
|--|----|
| PLAIN TOPOGRAPHICAL DRAWING, . . . . . | 29 |
|--|----|

### PART III.

|  |    |
|--|----|
| TOPOGRAPHICAL DRAWING IN COLORS, . . . . . | 70 |
|--|----|

### PART IV.

|   |    |
|---|----|
| COPYING, REDUCTION AND ENLARGEMENT OF MAPS AND MODELLING, . . . . . | 79 |
|---|----|

### PART V.

|  |    |
|--|----|
| PROJECTIONS FOR MAPS OF LARGE AREAS, . . . . . | 93 |
|--|----|

## *TOPOGRAPHICAL SKETCHING.*

### PART VI.

|  |    |
|--|----|
| SKETCHING—INSTRUMENTS, METHODS AND EXAMPLES, . . . . . | 97 |
|--|----|

## *APPENDIX.*

|   |     |
|---|-----|
| PLOTTING THE TRIANGULATION WITH THE EARTH'S SPHERICITY CONSIDERED, PROFESSIONAL WORK<br>IN PLASTER MODELLING, ETC., . . . . . | 119 |
|---|-----|

|                   |         |
|-------------------|---------|
| TABLES, . . . . . | 129-133 |
|-------------------|---------|

(List of Tables at End of Index to Vol. I.)

|                  |         |
|------------------|---------|
| INDEX, . . . . . | 135-140 |
|------------------|---------|

|                   |                 |
|-------------------|-----------------|
| PLATES, . . . . . | End of Vol. II. |
|-------------------|-----------------|

(List of "Illustrations" follows p. ix.)





# ILLUSTRATIONS.

---

## TOPOGRAPHICAL DRAWING.

### PLATE I.—INSTRUMENTS AND SCALES.

Figure 1. *a*, Straight-edges; *b*, T-square; *c*, Triangles; *d*, Parallel Rulers—Rolling and Sliding.

2. *e* and *f*, Dividers; *g*, Pencil-point; *h*, Pen-point; *i*, Extension-bar; *k*, Spring Dividers and Bow-pen; *m*, Beam-compass; *n*, Points for same.

3. Curve Pen.

4. Dotting-pen.

5. Border and Road Pen.

6. Dotting-pen.

7. Protractor, Semicircular.

8. Triangular Scale of Equal Parts.

9. Protractor, Rectangular.

10. Sector.

11. Protractor, Vernier.

12. Scales of Distance.

13. Diagonal Scale.

14. Division of a Line into Equal Parts.

15, 16, and 17. Verniers—Direct, Retrograde and Circular.

### PLATE II.—PLOTING.

18 and 19. Angles, Construction of, with Sines, etc.

20, 21, 22, and 23. Plotting by Rectangular Coordinates.

24. Plotting by Single Meridian Line and Protractor Sheets.

25. Plotting by Several Meridian Lines.

26. Closing a Plot.

27. Plotting of a Vertical Section.

### PLATE III.—CONVENTIONAL SIGNS—LAND.

### PLATE IV.—CONVENTIONAL SIGNS—LAND AND WATER.

### PLATE V.—CONVENTIONAL SIGNS—MISCELLANEOUS, INCLUDING MILITARY SIGNS. SIGNS FOR DECIPHERING MAPS AND FOR VERTICAL SECTIONS.

### PLATE VI.—CONVENTIONAL SIGNS EMPLOYED IN MAPS OF U. S. COAST SURVEY.

### PLATE VII.—CONTOURS, AND PLOTTING OF SAME.

28. Contours, Equidistances and References.

29, 30, and 35. Scales of Inclination.

PLATE VII—*Continued.*

- 31. Reduction of Surface-measurements to the Horizon.
- 32. Goulier's Scale for same.
- 33 and 34. Plotting of Contours—Surface-line of Uniform Inclination.
- 36. Same.—Surface-line not of Uniform Inclination.
- 37 and 38. Same, Scale of Slopes for.

## PLATE VIII.—CHARACTERISTIC SURFACE LINES AND FORMS.

- 39. Study of Contours, etc.
- 40. Section from Contoured Map.
- 41. The Sectograph and its Application.
- 42 and 43. Cols, Geometrical and Natural.
- 44 and 45. Normals.
- 46, 47, 48 and 49. Lines of Greatest Descent.

## PLATE IX.—EXAMPLES OF HACHURE HILL-SHADING.—HORIZONTAL AND VERTICAL SYSTEMS, VERTICAL AND OBLIQUE ILLUMINATION.

## PLATE X.—SCALES OF SHADE AND WORKING-SCALES.

- 50. Lehmann's Scale of Shade.
- 51. Same, Austrian Modification of.
- 52. Working-Scale for same.
- 53. U. S. Coast Survey Scale of Shade.
- 54. English Scale of Shade (for standard, see Fig. 59).
- 55. Danish Scale of Shade.
- 56. General Müffling's Scale of Shade.
- 57. Colonel Bonne's Scale of Shade.
- 58. French War Department Scale of Shade.

## PLATE XI.—HACHURE HILL-SHADING.

- 59. English Standard Scale of Shade for  $\frac{1}{10000}$ , and an equidistance of 25 feet.
- 60 and 61. Hachuring, Horizontal System.
- 62 and 63. Hachuring, Vertical System.

## PLATE XII.—EXAMPLES OF HILL-SHADING AND ROCK REPRESENTATION.—U. S. COAST SURVEY AND FRENCH SYSTEMS.

## PLATE XIII.—BRUSH HILL-SHADING.

- 64. Scale of Shade, French System.
- 65, 66 and 67. Curves of Shade, Tracing of.

## PLATE XIV.—MAP LETTERING.—U. S. COAST SURVEY.

## PLATE XV.—CONVENTIONAL TINTS.

## PLATE XVI.—EXAMPLES IN THE USE OF COLOR—MAP AND SKETCH.

## PLATE XVII.—EXAMPLE IN THE USE OF COLOR—FRENCH SYSTEM, PART OF ALGERIA.

## PLATE XVIII.—COPYING, REDUCTION AND ENLARGEMENT OF MAPS.

- 68. Three legged Dividers.
- 69 and 69a. Copying by Squares.
- 70. Construction of Similar Rectangles.
- 71 and 72. Construction of Proportional Squares.

## ILLUSTRATIONS.

x!

### PLATE XVIII.—Continued.

- 73. Proportional Dividers.
- 74. Angle of Reduction.
- 75. Pantograph.
- 76 and 77. Pantograph, Principle of Construction of.
- 78 and 79. Pantograph, another Form, and Principle of Construction of.
- 80. Micrograph.
- 81. Eidograph.

### PLATE XIX.—PROJECTIONS FOR MAPS OF LARGE AREAS.

- 82. Rectangular Projection.
- 83. Projection with Converging Meridians
- 84. Simple Conic Projection.
- 85 and 86. Simple Conic Projection, Application of Rectangular Coordinates to.
- 87. Equidistant Polyconic Projection—Graphical Construction of.

## TOPOGRAPHICAL SKETCHING.

### PLATE XX. SKETCHING-INSTRUMENTS.

- 88. Rectangular Box-compass.
- 89. Prismatic Compass.
- 90. Hand-level.
- 91. Abney's Reflecting Level and Clinometer.
- 92 and 92a. Pedometer
- 93. Odometer.
- 94 and 94a. Aneroid Barometer.

### PLATE XXI.—TOPOGRAPHICAL SKETCHING, METHODS OF.

- 95. Subject of Sketch, with Skeleton and Traverses.
- 96. Note-book—Form I., for Plotting in the Field.
- 97. Note-book—Form II., for Subsequent Plotting.
- 98. Triangulation Notes, Record for.
- 99 and 100. Extending the Triangulation from the Base.
- 101. Traverse.
- 102. Alignments and Prolongations.

### PLATE XXII.—TOPOGRAPHICAL SKETCHING, METHODS AND EXAMPLES OF.

- 103, 104, 105, 106 and 107. Contour Sketching.
- 108. Profile Sketch.
- 109. Horizontal Sketch.

### PLATE XXIII.—EYE AND LANDSCAPE SKETCHING.

- 110. Rapid Eye Sketch.
- 111 and 112. Landscape Sketches.

## DIAGRAMS IN TEXT.

|  | PAGE               |
|--|--------------------|
| Pencil-points and Pen-holder, . . . . .                | 1                  |
| Drawing or Right-line Pen, . . . . .                   | 2                  |
| Grading of Intervals, . . . . .                        | 4                  |
| Irregular Curves, . . . . .                            | 5                  |
| Interpolation of Heights with Sector, . . . . .        | 9                  |
| Drawing-boards, . . . . .                              | 12                 |
| Oblique Intersections, . . . . .                       | 15                 |
| Trigonometer, . . . . .                                | 27                 |
| Elevations, . . . . .                                  | 44                 |
| Title, Arrangement of, . . . . .                       | 66                 |
| Names of Features, Position of, . . . . .              | 67                 |
| Brushes, Sizes used, . . . . .                         | 70                 |
| Flat Tints, Laying of, . . . . .                       | 72                 |
| Tints, Grading of, . . . . .                           | 73                 |
| Tints, Blending of, . . . . .                          | 73                 |
| Dragging, Manipulation of Brush in, . . . . .          | 74                 |
| Graphical Measurement of Heights, . . . . .            | 103                |
| Plotting of a Triangulation of Great Extent, . . . . . | 119 <i>et seq.</i> |

# TOPOGRAPHICAL DRAWING.

## PART I.

### INSTRUMENTS AND MATERIALS—PRACTICAL RULES AND SUGGESTIONS— SCALES AND PLOTTING.

1. *Introductory.*—Topographical Drawing is the art of representing graphically the natural and artificial features of a limited portion of the earth's surface. The positions and dimensions of these features are determined by topographical surveying and sketching, and the drawing is made from the records and notes of these operations.

The principal characteristic of this kind of drawing is the representation of the relief of forms. While in other maps, horizontal distances and dimensions only are given, in a topographical map heights also are represented, and conventional methods are employed to produce an effect similar to that which the features themselves would present to the eye if viewed from points vertically above them.

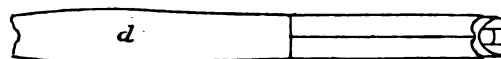
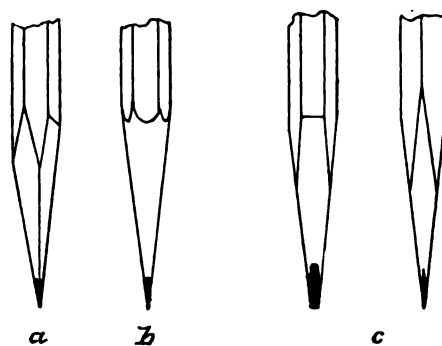
Topographical Signs are conventional symbols, or figures, employed to represent the different features. In Plain Topographical Drawing (Part II.) these signs are in black and white, while in Colored Topographical Drawing (Part III.) various colors and tints are used to express them.

#### SECTION I.—INSTRUMENTS AND MATERIALS.

The increased cost of the best instruments is fully repaid by the time and labor saved in their use.

2. *Pencil.*—Lead-pencils corresponding to Faber's Siberian Graphite, of H B, H, 4 H, and 6 H grades, are suitable for the purpose: the two latter grades for plotting, marking points of division of lines, and other fine work; and the former for sketching purposes, and for drawing some of the signs, such as trees and stone walls,

which require a certain degree of emphasis, especially on maps drawn to a large scale. Lead of good quality will produce a smooth, even line without requiring pressure sufficient to indent the paper. A sharp well-shaped point is required for good work. The accompany-



ing figure shows the "cone" and "chisel" points; the latter being used, on account of its durability, for drawing straight lines, and the former for all other purposes. To form the conical point, the pyramidal point *a* is formed first, and then trimmed to the shape *b*. The side and end view of the chisel-shaped point is given at *c*.

Emery-paper or fine sand-paper, tacked to a flat surface, is very handy for keeping a pencil sharp; but after its use the point should be made smooth by rubbing it flatwise on paper, before applying it to the drawing.

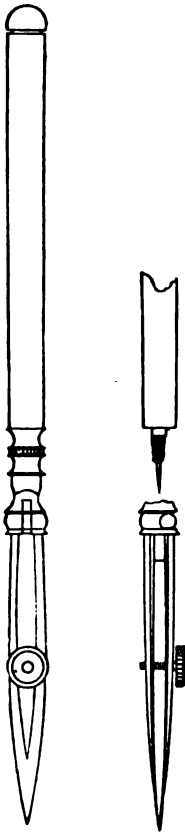
3. *Common and Crow-quill Pens.*—The common pen is used for all free-hand ink-drawing with exceptions, that for long smooth curves the curve-pen (par. 17), and for the finest lines the crow-quill, are substituted. It should be smooth-pointed and elastic. Gillott's "303" and "404" are good standards for general use—the latter for the coarser work. The crow-quill is a much smaller pen, with a very fine point.

To promote steadiness, the lower part of the pen-holder should be reinforced, or enlarged, as shown at *d* in the preceding figure, and the pen inserted about half its length. It is held as in ordinary writing. Even with the best of ink, the pen must be wiped very often to prevent clogging. A fine-pointed pen is in good condition when with the pressure due to the weight of the pen and holder, the latter being held at the tip, or resting in the hollow of the thumb and forefinger, the point will describe a continuous hair-line.

4. *Drawing or Right-line Pen.*—The different parts of this instrument are shown in the accompanying figure. Convenient sizes are 6 and 4½ inches respectively—the smaller for fine lines.

A drawing-pen consists of two steel points, called "nibs," attached to an ivory or ebony handle; one nib is hinged at its base to facilitate cleaning the inner surfaces: a small block at the base tends to spread the nibs, which can be adjusted for lines of different breadth by means of the milled-head screw shown in the figure. In the larger sizes, the handle, which may be unscrewed, is provided at its lower extremity with a needle-point, of use in marking points, erasing and transferring. German silver nibs are best for colored inks and water-colors.

In use, it is filled by holding it vertically, nibs uppermost, and inserting near the points a common pen or a piece of paper charged with ink; the ink will usually be drawn upward to the points by capillary action, otherwise the pen or paper is passed between the points. The quantity of ink required is soon observed in practice, and there should be none on the outer surfaces of the nibs. A straight-edge or a curve is always used in connection with it. In drawing a line, the pen is held perpendicularly to the surface of the paper, with the exception of a slight and uniform inclination in the direction of the movement, the points pressing equally upon the surface, and the nib opposite the milled head very lightly against the guiding edge. The line is drawn by a continuous movement, and as rapidly as the flow of the ink and the formation of an even line will permit. If the points become clogged, a piece of paper or a pen-point is passed between them; and if this does not clear them, the nibs should be opened, cleaned and refilled. The pen should be cleaned when put away.



The points become dulled by use, and require resetting by an instrument-maker; but, lacking this resource, they may be put in order as follows:—First, make the nibs of equal length and of a rounded shape by drawing lines, so to speak, on a fine-grained whetstone; then, holding the pen at an angle of about  $20^\circ$  with the surface of the stone, and applying the outer surface of each nib in succession, sharpen each point until, by reflected light, the dulled edge is no longer perceptible, and at the same time the nibs are of equal length and the points are not so sharp as to cut or scratch the drawing.

5. *Instruments for Drawing Straight Lines.*—The principal instruments used with pen or pencil for drawing straight lines, are the straight-edge or ruler, triangle and T-square. These are of steel, rubber, or hard fine-grained wood; and should have straight, carefully finished edges, and lie flat upon the paper.

Those of wood or rubber are liable to warp; the edges should be frequently tested for accuracy, which is readily done by placing the edge to be tested in contact with a steel straight-edge, and holding the instruments between the eye and the light.

Another method is to rule a fine line and prolong it with the same edge about half its length; this edge, applied to different parts of the line, and on each side of it, should coincide with it.

For fine work, these instruments should not exceed one tenth of an inch in thickness. Although metal rulers and triangles retain their shape and edges, they are more liable to soil the paper than those of wood.

6. Two straight-edges (*a*, Fig. 1, Plate I.), of fifteen and thirty inches in length respectively, are enough for ordinary purposes. As a precaution against blotting, to keep the points of the pen from contact with the straight-edge, it is desirable to have one edge bevelled; this edge, in inking, to be next to the drawing. A right line of greater length than the straight-edge may be defined by placing two straight-edges together flat on the paper, with their edges overlapping; or by marking points exactly underneath a thread stretched the required distance, and then joining the points with the straight-edge.

7. *Triangle (c*, Fig. 1).—The triangle is used in conjunction with the straight-edge for drawing parallels and perpendiculars. The open or “frame-pattern,” shown in the figure, does not cover up so much of the work as the solid one, is handier, and if of wood or rubber, is less liable to warp. The smaller angles are usually either  $45^\circ$  and  $45^\circ$ , or  $30^\circ$  and  $60^\circ$ . To test the accuracy of the right angle, place either side, as *ab*, coincident with a fine right line, and draw a line along *ac*; revolve the triangle about the side *ac*, make *ab* again coincide with the right line and draw another line along *ac*: the two lines thus drawn should be parallel.

To draw Parallels: Place a side against a straight-edge, and draw a line along either of the other sides; without moving the straight-edge, slide the triangle along the desired distance, and draw another line along the same edge as before: the two lines thus drawn will be parallels.

It is apparent that to draw lines perpendicular to each other the longest side is placed against the straight-edge,—the other two sides serving as the guiding-edges.

8. T-Square (*b*, Fig. 1).—This instrument in its handiest shape consists of a thin “blade” and a thicker adjustable “head.” The upper half of the head is firmly fastened to the blade, with its inner edge perpendicular to the edges of the latter, and its lower surface flush with

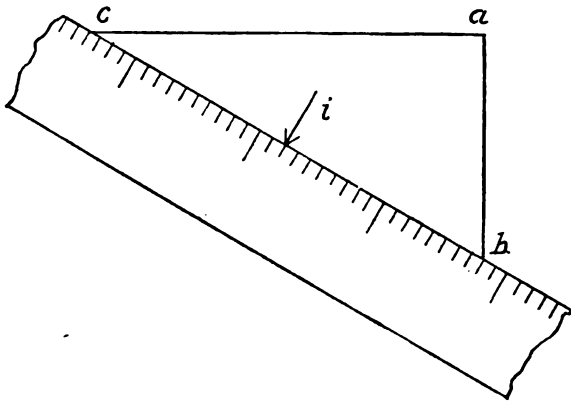


that of the blade. The lower half is the duplicate of the upper, and by means of the clamp-screw, shown in the figure, its inner edge can be fixed at any desired angle with the edges of the blade. In using it, this inner edge, adjusted as required, is pressed against the edge of the drawing-board, while the blade lies flat upon the drawing. Under these conditions the square is moved over the drawing, and any number of sets of parallels can be drawn along its edges, or those of a triangle used in conjunction with it. If the edge of the drawing-board is not straight, a thin straight-edge can be fastened to it. The right angles between the edges of the upper head and blade are tested as described for the triangle.

9. *Parallel Rulers* (*d*, Fig. 1).—Of these there are two kinds—the sliding and the rolling. The former consists of two straight-edges joined near their extremities by two metal strips of equal length, which are pivoted at the points of attachment, so that when the straight-edges are separated they remain parallel.

The other ruler is a straight-edge of considerable weight provided, near its extremities, with rollers of equal diameter, movable about the same axis. The manner of using them is apparent. On account of the play at the joints, and of the axle, these instruments are not suitable for accurate work. They serve well, however, for section-lining and like purposes.

10. *To grade Intervals*.—The following is a simple method of drawing parallels with equal or regularly graded intervals, such as are required in section-lining and in filling in out-



lines of buildings, etc. Using a triangle and straight-edge of the same thickness, the latter graduated along one of its edges into, say tenths of inches, place them as shown in the figure, with the index *i* coincident with one of the divisions of the straight-edge. If now the triangle be moved along the latter, and lines be drawn along *ac* when the index reaches each of the divisions in succession, it is apparent that the parallels will be equally spaced. If *cab* is  $90^\circ$  and *acb*  $30^\circ$ : since  $\sin 30^\circ = \frac{1}{2}$ ,  $ab = \frac{1}{2}bc$ ; therefore

with the above divisions the intervals are each  $\frac{1}{20}$  of an inch: or if *ab* is  $\frac{1}{8}, \frac{1}{4}, \dots$  of *bc*, each interval will be  $\frac{1}{80}, \frac{1}{40}, \dots$  of an inch; and if the divisions are reduced to twentieths, these intervals become  $\frac{1}{80}, \frac{1}{80}, \dots$  of an inch. It is readily seen that a regular gradation is obtained by increasing the distance passed over by the index, by one division for each parallel.

11. *Section-Liners*.—These are instruments devised for the purposes stated in the foregoing paragraph. A straight-edge is made to move over successive regular distances by means of springs and adjustable stops, the distances being gauged by attached scales and indices. The best forms would serve to produce an even gradation with little trouble; but practice soon trains the eye to this kind of work, and for ordinary topographical purposes a triangle and a straight-edge will prove sufficient.

12. The *necessary instruments for drawing curved lines* are dividers, bow-pen and pencil, and an irregular curve. To these may be added beam-compasses for describing arcs of large radii, and the curve-pen.

13. *Dividers*.—This instrument (Fig. 2), shown at *f* with needle-point inserted, is fur-

nished, in addition to the customary steel-points (*e*), with pencil and pen points, and an extension-bar, shown at *g*, *h*, and *i*, respectively, which are inserted as needed and securely held in place by set-screws.

The best instruments are of German silver, and have a steel friction-plate interposed between the branches or legs at the pivot, to prevent wear and secure smoothness of motion: the necessary amount of friction being obtained by means of the horizontal adjusting-screws shown in the figure—the vertical adjusting-screws serving to bind the handle to the heads of the former. With the exception of the steel-points, used principally for spacing and for setting off distances, the different points are hinge-jointed, to admit of their being set perpendicularly to the paper in describing arcs, which is particularly necessary in using the pen-point.

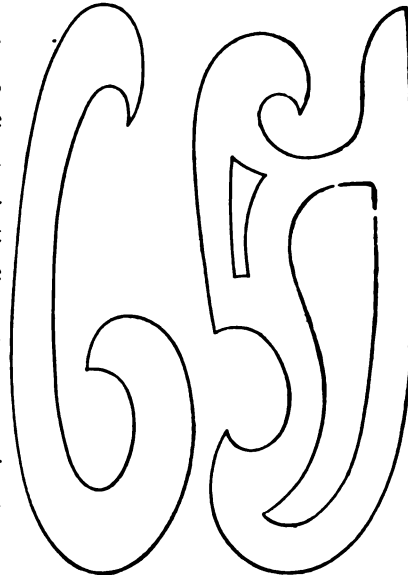
In the absence of leads made especially for the pencil-point, serviceable ones can be cut from a hard-lead pencil. The “shouldered” needle, shown inserted, is more rigid and convenient than a plain needle. A large radius is obtained with the extension-bar.

In describing arcs, the handle is held between the thumb and forefinger, the point of the needle is kept in place with very light pressure, and the curve is described with a continuous movement. To prevent wearing large holes in the paper, when several arcs are described from the same centre, a “horn-centre”—a thin transparent piece of horn, with points on its under surface to keep it in place—is interposed between the point and the paper.

14. *Spring-Dividors* (*k*, Fig. 2).—This instrument, also called a *bow-pen* or *pencil*, is used for describing arcs of very small radii. In the kind shown at the top of the figure the legs are formed of one piece of steel, bent until the points are about an inch apart, and are adjusted by means of the screw and nut. Of the other two, in the form shown on the left, the pen or pencil point revolves about a steel rod, which serves both as a handle and needle-point; and as the rod is always kept perpendicular to the paper, and stationary, it is the handier form for describing very small arcs.

15. *Irregular Curve*.—This instrument has a variety of forms, two of which are shown in the accompanying figure. It is very useful as a guide to the pen or pencil point in drawing bends of roads and other accidental curves, giving a smoothness to the drawing not otherwise easily attainable. The only difficulty attending its use is to avoid making angular junctions in the prolongation of a line. This is obviated by being careful to make the edge of the curve, at the beginning of the prolongation, tangent to the latter part of the line already drawn.

16. *Beam-Compass* (*m*, Fig. 2).—This instrument is used for describing arcs of greater radii than can be described with the dividers and extension-bar. As shown in the figure, it consists of two metal clamps which can be attached to a straight-edge or bar, and at any required distance apart. The clamps have sockets for pen, pencil, or needle points. Some kinds require special bars to fit the clamps, while in others, termed “portable beam-compasses,” the clamps can be attached to any straight-edge. The pattern (McCord’s) shown in



the figure is substantial, and has exact means of adjustment afforded by the form of clamp, the part carrying the point being made to traverse the slide by means of the milled-head screw, while the points remain perpendicular to the paper.

It is best used with a graduated bar made to fit it. A support furnished with casters is often used with a beam-compass to support the bar at its middle point.

17. *The Curve-Pen* (Fig. 3).—This differs from the right-line pen in having curved nibs attached to a rod which turns freely within the handle. It is particularly useful in drawing curves free-hand; the pen for this purpose being held with the handle perpendicular to the surface of the paper, and moved in the direction of the required curve—the point following the pencilled tracing. By means of a nut at the upper extremity of the handle, the latter may be clamped to the rod, and the instrument used as a right-line pen.

18. *Dotting, Border, and Road Pens*.—These may be termed labor-saving instruments, since by their use regular spacing and even width of line are attained by a single stroke, while the eye and hand are only engaged in following the right direction.

The Dotting-Pen (Figs. 4 and 6) has a set of interchangeable wheels, with teeth or cogs corresponding to the arrangements of dots and dashes required.

In the form (Fig. 6), the teeth act as cogs upon a lever which carries a pen-point at its outer extremity; and motion is given to the cog-wheel by rolling the outer wheel, fastened to the same arbor with the latter, along the edge of a ruler.

In the other form, the wheel is supplied with ink from a reservoir above, the teeth being applied directly to the paper. This instrument is also called a *roulette*.

The Border and Road Pen (Fig. 5) is used for drawing either heavy or parallel lines. For the former, the space between the branches is filled with ink, and adjusted by means of the large milled-head screw; for roads, the branches only are filled, and can be independently adjusted to different widths of line. It is useful in drawing any features represented by parallels. Some draughtsmen prefer the branches bent in the same direction, to facilitate following the edge of a ruler closely.

19. The *principal instruments for measuring lines and angles*, or for setting off horizontal distances, azimuths and bearings, are the scale of equal parts and the protractor. To a description of these is added that of the sector, mainly on account of its usefulness in finding proportional parts. These instruments are made of boxwood, ivory, hard rubber, or metal. Horn and paper are also used for protractors and scales.

20. *Scale of Equal Parts*.—A convenient form of this instrument is the “triangular scale of equal parts” (Fig. 8), so called from the shape of its cross-section. Its different edges are graduated to show 10, 20, 30, 40, 50, and 60 parts of an inch, and for finer work 80 and 100 parts. Those graduated the entire length of the edges are most convenient. Distances are laid off directly with this scale. The “scale-guard” is a sliding attachment used with the scale to save time in finding the particular edge in use, and in repeating a measurement. In the use of paper scales, which are accurately engraved or machine divided, and similarly graduated, the variations in length due to heat and moisture, are sensibly equal to corresponding changes in the drawing; besides, they are not so liable to soil the latter as scales made from other material.

Scales of equal parts, graduated to other convenient units, as chains, metres, etc., are likewise readily obtainable. When much time is required for the completion of a drawing,

greater accuracy is probably attained by the use of a scale constructed upon the drawing itself.

21. *Spacing-Dividers*.—The steel points of dividers are of frequent use in comparing distances, and in transferring them from a scale; but when great nicety is required and successive small distances are to be laid off, the spacing-dividers, which differ from the spring-dividers (*k*, Fig. 2) only in having two steel points instead of one, are very useful.

22. *Protractors*.—These instruments, in general use in plotting, are for the direct measurement of angles. The usual forms are the rectangular, semicircular, full circle, and vernier.

The rectangular protractor is graduated on both faces, the front face (Fig. 9) having three edges graduated into degrees or half-degrees, the third edge being the *diameter* of the circle of graduation, with its centre marked as shown.

The divisions are commonly numbered from  $0^\circ$  at the left, around to  $180^\circ$  on the outer edge, and repeated in the reverse direction on an inner line. This face also contains scales of equal parts of an inch, and a scale of chords marked "*CHO*" or "*C*."

The other face contains like scales, with the addition of a diagonal scale of equal parts.

The *Abbot Protractor*, of rectangular shape, has the edges of each face graduated to half-degrees, numbered from left to right; on one face from  $0^\circ$  to  $180^\circ$ , and on the other from  $180^\circ$  to  $360^\circ$ . It contains a scale of tenths of inches, and one of hundredths of a foot. It is particularly handy in field-sketching.

23. *The Semicircular Protractor* is of two forms—either with the graduation extending a few degrees beyond the diameter, or with the diameter and outer edge coincident. In the latter case a straight-edge can be utilized in securing exact coincidence of the diameter with a given line, by first adjusting the straight-edge to the line, and then placing the diameter against it.

The circular protractor is simply an extension of the graduation to  $360^\circ$ , covering an entire circle.

24. *To protract an Angle* with either of the above forms: The instrument is laid flat upon the paper, and held securely in position; a line is drawn along the diameter, and points are marked upon the paper exactly beneath the centre, and the degree-division corresponding to the required angle; then a right line joining these points will make the required angle with the first line drawn. To draw a line through any point of a given line, which shall make a required angle with the line: the diameter and centre are first placed coincident with the line and point respectively, and the operation is then as above described; or the centre and degree-division corresponding to the angle may be placed coincident with the line, and a line drawn along the diameter.

To protract an angle with the scale *CHO*: From a given point of a right line as a centre, with the distance *o-60* as a radius, describe an arc intersecting the line; from this point of intersection as a centre, with a radius equal to the distance from *o* to that division of *CHO* corresponding to the number of degrees in the required angle, describe an arc intersecting the first arc; the right line joining the point of intersection of the arcs with the given point will make the required angle with the given line.

25. *To Plot a Bearing*.—In plotting bearings taken with the "surveyor's compass," the quadrant in which a course lies is apparent from the designation of the bearing: this is also the case with the improved prismatic compass (*a*, par. 154); but a little difficulty arises at

first with other methods of graduation used in the prismatic compass, which the following simple rule is intended to obviate.

With the compass-card graduated from  $0^\circ$  at the N. around to the right  $360^\circ$ : I. Denote the difference between the reading and  $180^\circ$  by  $+R$  or  $-R$ , according as the reading is less or greater than  $180^\circ$ . II. For  $+R$ , use the direct graduation of the protractor, placing it so that its centre and the degree division  $R$  shall be on a meridian line passing through or near the plotted station, and the diameter shall pass through it; a line drawn along the diameter from the station to the W. of the meridian will coincide with the required course. For  $-R$ , use the reverse graduation and draw the line to the E.

It is apparent that, with a compass-card graduated from  $0^\circ$  at the N. around to the right  $180^\circ$ , repeated in the same direction on the other semi-circumference, the only modification in this rule is that the W. readings themselves are the  $-R$  values.

With the second protractor described in par. 22, and the above  $0^\circ$ - $360^\circ$  graduated card, the rule applies to readings less than  $180^\circ$ ; but owing to the direct graduation of this protractor from  $180^\circ$  to  $360^\circ$ , readings greater than  $180^\circ$  are subtracted from  $540^\circ$ .

26. *Vernier Protractor*.—With protractors already described it is difficult to estimate as closely as one fourth of a degree; consequently for accurate work the instrument represented in Fig. 11 is used. The arm, movable about the centre, carries a vernier, reading in some instruments to minutes. The beveled edge of the arm is in the prolongation of the radius passing through the 0 of the vernier, and the exact centre is indicated by the intersection of two fine lines marked on a piece of horn let into the instrument. In protracting an angle, the arm is set by means of the vernier, the  $180^\circ$  diameter is placed coincident with the given line, with the centre at the given point; and using a sharp-edged pencil, the required line is drawn along the beveled edge. In some instruments the graduation extends over a full circle.

27. Among other forms of vernier protractors are Crozet's and Tabarant's. In the former the scale is let into a flat rectangular metal frame. By turning the scale about its centre, the diameter may be set at any required angle with an edge of the frame, which edge is then placed against a straight-edge coincident with the meridian or other line of direction, and the protractor is moved along it until the diameter passes through the desired point.

The special feature of Tabarant's protractor is a metal parallelogram, articulated at the corners, hinged at one corner to an extremity of the diameter and connected at an adjacent corner with the other extremity of the diameter by an arc, of which the length can be made equal to the magnetic declination. The parallelogram, of which the edge joining the other two corners is placed against a straight-edge, serves to enlarge the area of plotting for any position of the latter.

28. In a semicircular protractor, the diameter and outer edge when not coincident, should be parallel.

To test this: Draw a line along the diameter, also a radial line to any degree-division; then slide the protractor along the radial, the centre and this division remaining upon it: the outer edge should coincide with the first line drawn.

29. *Sector* (Fig. 10).—This is of about the form and size of the single-folding foot-rule. Radials, termed sectoral lines, arranged in pairs, one of a pair on each arm, and variously divided, are engraved on each face.

The sectoral lines on one face are a pair of scales of equal parts termed the "line of lines," a pair of scales of chords, of secants, and of polygons, marked respectively *L*, *C*, *S* and *POL*. A scale of tenths of inches is marked along the edge, and one of hundredths of a foot on the outer edge. On the other face are sectoral lines of sines, of tangents up to  $45^\circ$ , and another of tangents from  $45^\circ$  to  $75^\circ$  to a lesser radius, marked respectively *S* and *T*; together with "Gunter's lines" of logarithmic numbers, sines and tangents, marked respectively *N*, *S*, and *T*.

The solution of problems with the sector depends upon the principle that homologous sides of similar triangles are proportional, and a solution is termed simple or compound according as it involves the use of one or two pairs of lines.

In the latter case, from the above principle, the two pairs used should make equal angles at the centre; but in some instruments the angles formed by the line *T*, from  $45^\circ$  to  $75^\circ$ , and of secants, are equal to each other, but unequal to those formed by the other sectoral lines; therefore when one of these circular functions is used in a compound solution, it must be expressed in terms of some other function.

A distance measured from the centre on a sectoral line is termed *lateral* (*l*); and from a point on one of a pair to the corresponding point on the other, *transverse* (*t*). The divisions of a sectoral line are contained between three parallels, and the points of the dividers are always applied to the inner parallel, or to the one that passes through the centre.

To use the line *L*: 1. To find a fourth proportional, as *x*, in the proportion  $a : b :: c : x$ ; set off  $l = a$ ; open the sector until, at the extremity of *l*,  $t = b$ ; prolong *l* until it is equal to *c*; then at the extremity of this prolongation,  $t = x$ .

2. To bisect a right line, as *A*: Make  $t_{10} - 10 = A$ , then  $t_5 - 5 = \frac{A}{2}$ , which for the sake of verification is laid off from each extremity of *A*.

3. A line is divided into an even number of equal parts by first bisecting it as above, then bisecting each half, and so on; and into an uneven number by a simple application of the same principle; e.g., to subdivide *A* into five equal parts: make  $t_5 - 5 = A$ , lay off  $t_3 - 3$  from each extremity, and then bisect the extreme parts.

4. To obtain a scale of  $\frac{1}{10}$ , or 1 inch = 10 feet, for measurements of feet and tenths of a foot: Make  $t_{10} - 10 = 1$  inch; then  $t_{3.4} - 3.4 = 3.4$  feet; and so on.

5. For copying drawings to a scale differing from the original; e.g., to reduce a drawing, lineally, one fifth: Make  $t_5 - 5 = a$  a line of the original; then  $t_4 - 4$  is its reduced length, and points are found in a similar way by intersecting arcs described with reduced radii from the extremities of this line as centres, and so on throughout the drawing. The lines *L* may be used for interpolating heights. Thus, in the figure, the heights or references of the plotted points *a* and *b* are 20 and 25 feet respectively, and the line *ab* is of uniform declivity; to interpolate the (23') point. On the lines *L* make  $t_5 - 5 = ab$ ; then  $t_3 - 3 = ac$ , which laid off from *a* gives the required point.



The lines *C* are used to protract angles to any radius,  $t_{60} - 60$ . For any angle of  $60^\circ$  or less, say  $20^\circ$ : With  $t_{60} - 60$  describe an arc; subtend any portion of it by a chord =  $t_{20} - 20$ ; the radials drawn to the extremities of the chord include the required angle. If the angle is very small, say  $2^\circ$ , with  $t_{60} - 60$  describe an arc as before; then from any point of it set off

two chords, as  $t_{40} - 40$  and  $t_{42} - 42$ , differing numerically by the number of degrees in the required arc: the radials drawn to the other extremities of these chords will include the required angle.

For an angle greater than  $60^\circ$ : Divide the given number of degrees into parts of  $60^\circ$  and less; with  $t_{60} - 60$  describe an arc as before, and on it lay off consecutively as chords the values of  $t$  corresponding to the parts into which the angle is divided: the radials drawn to the points of beginning and ending of the series will include the required angle. The lines *POL* are used to inscribe a regular polygon, the radius of the circle being  $t_6 - 6$ ; the sides of the polygon are  $t_4 - 4$  for a square,  $t_5 - 5$  for a pentagon . . . . The lines *C* may be used in a similar manner by taking  $t_{60} - 60$  as a radius and  $t = \frac{360}{n}$  as a chord,  $n$  being the number of sides required, and an exact divisor of 360.

The sine of an angle corresponding to a given radius is found by making  $t_{90} - 90$ , on the lines *S*, equal to this radius; the sine required is then  $t$ , between the numbers corresponding to the number of degrees in the given angle. A tangent is similarly found by first making  $t_{45} - 45 =$  to the given radius, and using the upper lines *T* for angles greater than  $45^\circ$ . For secants,  $t_0 - 0$  is first made equal to the given radius.

Any other circular function may be found by using its equivalent in terms of those above given. This instrument is not much used, but is very handy for the above purposes. The use of "Gunter's lines" can be found in treatises on mathematical instruments.

30. *Drawing-Paper*.—Whatman's paper is generally used for topographical purposes. There are three kinds: the "hot-pressed" (H), which has a smooth surface, mostly used for fine-lined drawing; the "not hot-pressed" (N), which has a finely grained surface, and is in general use for map-work; and the "rough" (R), which has a coarsely grained surface adapted to strongly lined work and drawings made to a large scale. The last two kinds, known also as "cold-pressed," are suitable for colored maps, and generally for brush-work drawing.

The following table gives the names of the different brands of Whatman's paper, sizes in inches of whole sheets, and the kinds of each brand usually obtainable.

| BRANDS.                   | Sizes.    | Kinds. |   |    | BRANDS.               | Sizes.    | Kinds. |   |    |
|---------------------------|-----------|--------|---|----|-----------------------|-----------|--------|---|----|
| Emperor . . . . .         | 68 X 48   | ..     | N | R  | Elephant . . . . .    | 28 X 23   | H      | N | .. |
| Antiquarian . . . . .     | 53 X 31   | H      | N | .. | Super Royal . . . . . | 27½ X 19½ | H      | N | .. |
| Double Elephant . . . . . | 40 X 26½  | H      | N | R  | Royal . . . . .       | 24 X 19½  | H      | N | R  |
| Atlas . . . . .           | 34 X 26   | H      | N | .. | Medium . . . . .      | 22 X 17   | H      | N | .. |
| Columbier . . . . .       | 34½ X 23½ | H      | N | .. | Demy . . . . .        | 20 X 15   | H      | N | .. |
| Imperial . . . . .        | 30 X 21   | H      | N | R  | Cap . . . . .         | 17 X 13   | H      | N | .. |

It is also graded according to quality into "selected best," which is without imperfections, and "common;" but there is little difference in these either in cost or texture. The most imperfect sheets are found in the outside quires of a bundle. There is also a very fine, expensive grade of Double Elephant and Imperial known as "extra weight." The Double Elephant, Imperial and Demy are the brands mostly in use for ordinary map-work. The water-mark "Whatman," or "Whatman Turkey Mills," with date of manufacture, is readily seen by holding the paper between the eye and the light; and the face nearest the eye when the name reads aright, is that on which the drawing is usually made; but there is little difference practically, a good rule being to choose the smoother face.

It improves with age, since the seasoning process diminishes its liability to vary in size. It may be obtained for long maps in continuous rolls varying from 36 to 62 inches in width, and either muslin-backed to make it less liable to tear, or plain.

A point to note in the use of roll-paper for valuable maps is that it expands four or five times more in the direction of its breadth than that of its length.

31. *Tracing-Paper and Cloth.*—These are very thin and semi-transparent, and are used principally for copying purposes. Tracing-paper is obtained in sheets from 13×17 to 30×40 inches in size, or in continuous rolls from 37 to 54 inches in width. It can be made by applying a mixture of one part of boiled linseed-oil and five parts of turpentine, thinly, with a sponge, to one face of common tissue-paper, the paper resting upon a flat smooth surface: the paper is then hung up to dry, and when the more transparent oil-streaks disappear, is ready for use.

Tracing-cloth is to be had in continuous rolls, from 18 to 42 inches in width.

32. *Transfer-Paper.*—This is thin paper having for drawing purposes one face covered with black-lead or other similar material, so that by laying this face on a sheet of ordinary paper and passing a sharp point over the reverse face, the mark thus made will be duplicated on the other paper. It should be very thin for transferring fine lines. The manner of using it is described under "Copying." It can be made by sifting pulverized black-lead over a stretched piece of strong tissue-paper, dusting off the larger particles, and then rubbing the surface with cotton until smooth, or until it will not easily soil the surface on which it is to be used. The different-colored ochre-powders may be utilized in the same way.

33. *Cross-section and Profile Papers.*—These are used for drawing directly to scale, and for sketching purposes. The former, in sheets from 14×17 to 16×22 inches in size, or in rolls 20 inches wide, is ruled in squares of one sixteenth to one fourth of an inch, or according to the metric system, of 1 mm. or greater; each fifth, tenth, or other convenient line being ruled heavier, to facilitate reading the distances.

Profile paper is similarly ruled, except that the vertical are usually one tenth of the corresponding horizontal intervals.

34. *India Ink* in sticks or in liquid form is always used in topographical drawing. The stick variety is the best and is the only kind suitable for brush-work. It varies much in quality; the best kind having a smooth surface, and showing a brownish hue after rubbing on a wet surface, and a bright, iridescent surface of fracture.

Although any small clean dish will serve for preparing the ink, it is more convenient to use an ink-saucer, provided with a cover to exclude the dust, and a deep cavity to hold the ink and retard evaporation.

To prepare it, a very little water is poured into the saucer and the stick is rubbed in it, the end being pressed firmly on the bottom of the dish, until a jet-black liquid results. The degree of blackness is readily determined by observing the shade produced in drawing a line on white paper and blurring it by rubbing while wet; a magnifying-glass is very handy in this connection.

The ink is best freshly prepared for each day's work. A few drops of ox-gall will make it flow freely.

The fluid variety has the merit of being always ready for use, only requiring the addition of a few drops of water, alcohol, or ammonia, when too thick, and to be shaken occasionally;



but unless of the best quality, it is liable to "run" when the lines made with it are washed, and should therefore be tested before using it in connection with brush-work. It frequently varies in intensity. The few colors used in plain topographical drawing are described in Part III.

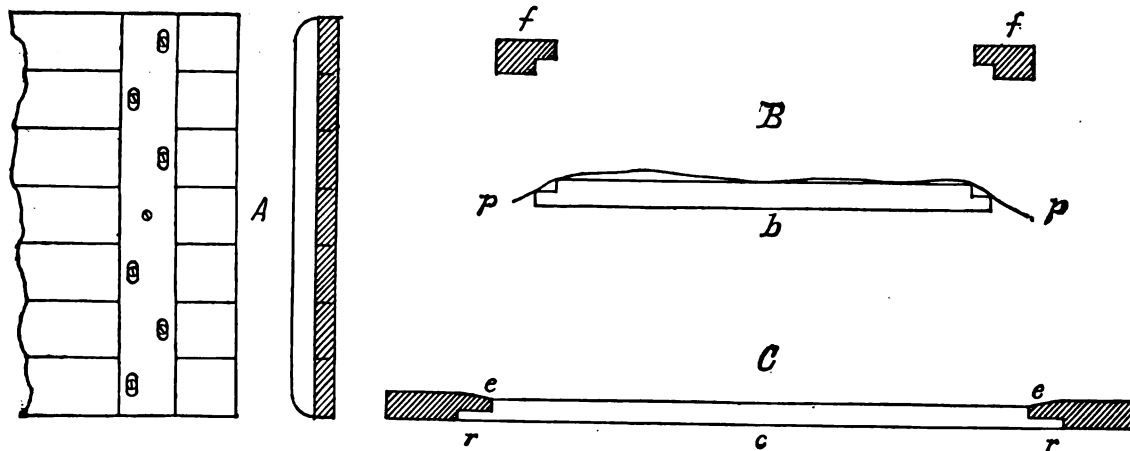
35. The *other necessary materials and instruments* are: drawing-pins, commonly called "thumb-tacks," sharp pointed, and provided with flat, thin heads so as not to obstruct the movements of other instruments over the surface of the drawing; horn-centres (par. 13); a penknife, a fine, flat file and emery or fine sand-paper for sharpening pencils; a finely grained stone for sharpening pen- and needle-points; a magnifying-glass for ascertaining the condition of pen-points, the exact intersections of lines, etc.; two or three sponges, the largest about 6 inches in diameter; blotting-paper, a rubber and an ink-eraser, and a drawing-board which is described in the following paragraph.

Materials specially required for colored drawing are described in Part III.

## SECTION II.—PREPARATION OF THE PAPER, DRAWING-BOARDS, AND PRACTICAL RULES AND SUGGESTIONS.

36. *Preparation of the Paper and the Plain Drawing-Board.*—For some purposes the paper might be simply fastened along its edges with thumb-tacks to a flat smooth board or table; but for an elaborate drawing with pen or brush, and for the sake of accuracy and ease in working, it is stretched smoothly upon and firmly fastened to a drawing-board.

The latter is of well-seasoned wood, from three quarters to one inch in thickness, and at least half an inch larger each way than the paper for the drawing, and to prevent warping,



strips of the same thickness are tongued and grooved to the edges, perpendicularly to the fibre; or, if but one face for use is desired, a strip may be screwed to the back near each end.

For use with the T-square, the board should be rectangular. Straight smooth strips of hard-wood, against which the head rests, are sometimes fastened along the edges, but an ordinary straight-edge may be used for this purpose.

A substantial single-surface drawing-board is shown at A in the accompanying figure.—Longitudinal cuts about one eighth of an inch wide and two inches apart extending half-way through the board, are made along the back, and a hard-wood strip is then screwed to the

back near each end; all the screws except the centre ones passing through slots in the strip which are furnished with metal washers. By this arrangement the warping takes place mainly in the different sections separated by the cuts; the play of the screw-heads in the slots permits of a general expansion or contraction without bending the strip, which could be of metal, and the drawing surface is practically unimpaired.

37. *Stretching the Paper.*—This operation so often proves a source of annoyance on account of the edges loosening in drying, that the following invariably successful plan is given in detail:

- a. Prepare some hot glue in the usual way; light-colored or clarified glue is the best.
- b. Expand the paper by soaking it in water until it is limp, or will not spring back when bent.
- c. Let it drain till the water drops slowly from it; then place it back up on a clean flat surface, and dry the edges a little more by applying blotting-paper along them.
- d. With a stiff brush—a “sash-tool” is the best—apply the hot glue rapidly along the edge for a space one half to one inch in breadth, according to the size of the sheet.
- e. Take the paper by its diagonally opposite corners, and place it, face up, evenly on the drawing-board, which should be dry and free from dust; and with the finger-tips press each edge rapidly and firmly to the board, passing them from the middle point of the edges outward to the extremities.
- f. Place the board in a horizontal position, face up, to dry exposed to the ordinary temperature of the room.

Some draughtsmen prefer to expand the paper by laying it on a flat, clean surface, and applying a wet sponge to the back; and this plan would be more convenient with very large sheets.

In using cold glue or paste, it is necessary in drying to secure the edges with thumb-tacks or by tacking a strip of wood along them, and safer to keep the central portion of the sheet damp until the edges adhere firmly. In expanding with a sponge the edges may be turned up to keep them dry.

38. *Stretching-Frames.*—A very expeditious way of stretching paper is to use the frame shown in section at *B* in the preceding figure. The expanded paper *p* is laid upon the solid back *b*, the hard-wood frame *f* is then pressed down over the edges of *b* and secured in place by buttons attached to the lower surface of *f*. The rabbets should be so proportioned that the paper may be flush with the upper surface of *f* when the frame is closed.

For a brush-work drawing not exceeding about  $2 \times 3$  feet in size, the most convenient form is a stiff, rectangular, open frame, on which the paper is stretched as described in par. 37. The open space permits the paper to be dampened on the back, so that in extending the shades or tints the edges of the latter will not dry too rapidly. To prevent indenting the surface of the larger sheets, the hand should rest upon a support extending across the frame. With a support for the back of the paper while working, sheets much larger than  $2 \times 3$  feet may be used with this frame.

39. *Mounting Paper on Cloth.*—The cloth used is bleached muslin, which is first attached to a stretcher, and the paper then pasted to it. A stretcher for small drawings, not exceeding about  $20 \times 30$  inches, is a flat, rectangular, wooden frame (*C*, preceding fig.), the sides and ends of which are about four inches wide and three eighths of an inch in thickness. For large

drawings these dimensions are increased and cross-pieces are necessary to give sufficient strength and stiffness to resist the tension of the paper in drying.

The inner upper edges  $e, e$ , of the frame are rounded to prevent creasing the paper; and the cross-pieces  $c$  are let into the back at suitable intervals, so as to just reach the rounded edges, the rabbets  $r, r$ , not extending more than one third across the sides.

To stretch the cloth, it is laid upon a smooth, flat surface, the stretcher is placed face down upon it, and the cloth is drawn tightly over the ends and tacked to the back of the frame. The middle points are tacked first; the tacks are placed opposite each other and not more than three inches apart, and it is best to fold the edges of the cloth in tacking them; the sides are then fastened in the same way.

The paper is now placed face down on a cloth-covered table and expanded with sponge and water; the surplus water, or little pools, are then removed and cold flour-paste is thoroughly applied with a large brush, the stretched cloth is then placed upon the pasted surface and the back of the cloth is well rubbed to make it adhere closely. The stretcher is then reversed, the edges of the paper are rubbed down, and any air-bubbles are pricked with a fine needle. In order to use the T-square, straight strips are fastened to the rough cloth edges. Drawings on tracing-paper or tracing-cloth should be mounted on paper before mounting them on cloth.

40. *To Join Sheets of Paper.*—Each of the meeting edges is first beveled by placing it along the edge of a table and rubbing it down with fine sand or glass paper, making it very thin at the extremity. The edges are then glued together, rubbed down, and placed between straight-edges or flat surfaces, and under pressure, to dry. For additional security, a paper strip may be glued to the back of the joint.

If joined sheets are to be stretched, it is best done before the joints are quite dry; a sponge is used in dampening and the joints are carefully avoided. The joints in tracing-paper are made very narrow, and after being secured, a strip of paper is laid over them on each face, and they are left to dry, either rolled tightly, or upon a flat surface and under pressure.

41. *The room* used for drawing purposes should be well lighted. In an upper story the light is less liable to obstruction, and besides, the paper is less exposed to moisture. If it has a southern exposure, white window-shades are needed. The drawing-table, arranged for a sitting or a standing position, according to the size of the drawing and the convenience of the draughtsman, is placed near the window, and the board is so arranged upon it as to receive the best light available. A light from the left and front, striking the paper at an angle of about  $45^\circ$  with the horizontal, and an inclination of the board, when not very large, of about  $5^\circ$  downward toward the draughtsman, are favorable conditions. When gas-light, which is very objectionable, is used, the burners should be about two or three feet above the table, furnished with reflectors, and project horizontally so as not to cast a shadow upon the paper. For extensive work, running water, or a good supply of this very necessary article, with large receptacles for expanding paper and other uses, should be available.

The paper must be kept as clean as possible, and for this purpose should be dusted each time before beginning work, and the straight-edges and triangles wiped clean; while at work, white paper should be interposed between the hand and the drawing, and the latter covered with white paper or cloth when the day's work is done.

It is advisable, in filling in the details, to expose only so much of the drawing as is needed for the time being.

42. *Erasures* must be carefully made. To erase pencil-lines: Remove as much lead as possible by rubbing bread-crumbs on the paper; then use an edge of the rubber eraser—a sharp wedge-shaped piece cut from the rubber is very handy for this purpose. To remove ink-lines: Apply blotting-paper and wait till dry; then, if fine, use a needle-point, otherwise glass-paper or a very sharp knife or ink-eraser, keeping the blade perpendicular to the paper and moving it in different directions, the paper resting on glass or other smooth surface; the rubber eraser is then applied, and the abraded surface afterwards rubbed smooth with the thumb-nail or with an ivory handle. An ink line or blot can be covered with Chinese white. If the drawing is to be shaded or tinted with the brush, neither the knife nor rubber is used for erasing; pencil-lines are removed with bread or, like ink-lines, are washed out with sponge and water.

As precautions against blotting, the ink-saucer is kept at the side of the drawing, the quantity of ink in the pen should not be more than is retained when the latter is lifted suddenly over the saucer, and the outside of the nibs must be free from ink.

43. *Rules for Line Drawing*.—Lines are classed as dotted, broken, and full. A dotted line is a succession of equally sized dots with equal spaces; a broken line, a series of dashes of equal length, equally spaced; and a full line is simply a continuous line.

For convenience of description, lines are graded as fine, medium, and heavy; the first grade are as fine as can be drawn and be clearly visible; the second are twice the breadth of the first; and the third, twice the breadth of the second.

In large maps drawn to a large scale these breadths are increased, while still retaining their relative values.

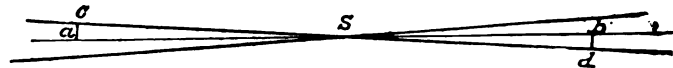
1. All construction-lines are fine, are drawn with as little pressure as possible; and to show points of intersection distinctly, are prolonged a little beyond them.

2. All straight lines should be drawn with the straight-edge and right-line pen; the latter being moved along the upper or farther edge of the former, and in a direction from left to right. If drawn free-hand, the direction is the same or towards the draughtsman. In prolonging a line, a slight interval is left between the original and the added portion, which, though hardly noticeable, can be afterwards filled with a common pen.

3. In laying off consecutive distances, to prevent cumulative errors, each point of division is located by measurement from the initial point; or the total distance is laid off, and then subdivided.

4. Right angles are preferably determined geometrically with dividers and intersecting arcs; but if with other means, the accuracy of the latter should be carefully tested.

5. Intersections of lines meeting at a very oblique angle can be determined, as shown in the figure, by assuming a point *a* on the bisecting line *ab*, and locating *b* so that *bd*, perpendicular to *cd*, shall be equal to *ac*, also perpendicular to *cd*; then *s*, the middle point of *ab*, is the required point.



6. When practicable, lines are drawn from, rather than to a given point; tangents are drawn to arcs rather than the reverse, and the points of tangency are geometrically con-

structed. A point is marked when determined, by enclosing it in a very small circle, or, if a triangulation point, in a triangle; a square figure is used to enclose a stadia survey point.

7. To prevent making ragged lines with the pen, it should be tried on a separate piece of paper or on the margin of the drawing each time it is refilled, or after any delay in the work, before applying it to the drawing.

8. Uniformity of line for like details in any map is necessary for clearness and to produce a pleasing effect; and this is obtained by using a pen of such capacity that with light, even pressure, the ink will flow freely from it, and by pressing the nibs equally upon the paper.

### SECTION III.—SCALES AND PLOTTING.

44. *Scale of the Map.*—The representations on a map or plan bear a constant relation or ratio to the actual forms, dimensions and distances; and this constant ratio is termed the *scale of the map*. This ratio could be assumed arbitrarily; but for convenience in calculation, and to accord with the decimal division of scales of equal parts used in plotting, it is represented by a fraction of the form  $\frac{1}{m}$ , termed the *representative fraction (r. f.)*, having unity for its numerator, and for its denominator some multiple of 10. If  $d$  and  $D$  represent respectively corresponding plotted and actual distances, expressed in units of the same denomination, the ratio is  $\frac{d}{D}$ ; dividing each term by  $d$ ,  $\frac{d}{D} = \frac{1}{m}$ ; from which  $d = \frac{D}{m}$ , and  $D = d \times m$ : from which expressions, either the actual or plotted distance being given, the other is obtained; therefore, *to convert an actual into a plotted distance, multiply it by the representative fraction; and to convert a plotted into an actual distance, divide it by the representative fraction*. For example:  $D$ , measured on the ground, is 375 feet, and  $r. f. = \frac{1}{1500}$ ; then  $d = \frac{375}{1500}$  feet = 3 inches: or, in the other case,  $d$  being given, then  $D = 3 \times 1500 = 4500$  inches = 375 feet.

To ascertain the scale of a map, it is only necessary to place any plotted distance  $d$  with its corresponding actual distance  $D$  expressed in units of the same denomination, under the form of the fraction  $\frac{d}{D}$ , and reduce this fraction to the form  $\frac{1}{m}$ , or one having unity for its numerator.

45. *The Scale of Distances* is used for mutually converting actual and plotted distances without calculation, and is constructed as follows: The data required are the scale of the map, or  $r. f.$ ; the units of measure, whether feet, yards, metres . . . . .; and the "reading" desired, whether thousands, hundreds, tens, or single units. Assuming  $r. f. = \frac{1}{1200}$ , units of feet, and the reading, hundreds and tens of feet: Draw a right line—the fine upper line shown in Fig. 12—and, since 1 inch on the map represents an actual distance of 1200 inches = 100 feet, divide this line into inches, subdivide the left-hand interval into tenths of inches, and mark and number the different points as shown.

The part to the left of 0 is termed the "extension" of the scale, and its subdivisions secondary, or minor, in contradistinction to the primary or main divisions of the scale. The unit employed should always be shown, and is usually placed after the last or right-hand number, or as shown in the figure.

The scale is completed by adding a heavy line below and the  $r. f.$  above, as shown.

This scale might be designated a "scale of 1 inch to 100 feet," written in place of or in addition to the *r. f.* If a map is to be reproduced by a photographic process, it is safer to omit the *r. f.*—using instead of it the unit employed, as shown in Fig. 12.

A corresponding scale of metres is also shown in the figure. Two or more scales having the same *r. f.*, but different units, placed upon the same map, are termed "comparative scales;" and as the early general adoption of the metric system is possible, it is advisable to have scales of English units and metres on all important maps.

Owing to changes in the size of a drawing, due to heat and moisture, and to shrinkage when cut from a stretcher, a scale of distances should be constructed upon the map when the drawing is begun. This is more particularly necessary in important maps requiring considerable time for their completion. (See also par. 128.)

46. *Diagonal Scales.*—In using the scale just described, distances less than those given by the secondary divisions have to be estimated, and some means for their exact measurement are necessary. This is afforded by the diagonal scale, which is constructed as follows: Using the same data as in Fig. 12, construct the scale of distances represented by the lower line in Fig. 13. At the 0 point erect a perpendicular of convenient length, and divide it into ten equal parts; through the points of division draw parallels to the line of the scale of distances, and erect perpendiculars at the 100, 200, . . . . 500 points. In the rectangle thus formed on the "extension," subdivide the side opposite the extension into ten equal parts, and join its points of division with the alternate points of division of the extension, by the diagonals, as shown. It is evident from inspection that each diagonal in its ascent gains a total distance of  $\frac{1}{10}$  of an inch, or 10 feet, to the left of a vertical, and therefore a distance of 1 foot to the left, between each two consecutive horizontals.

For convenience of application, the horizontals are numbered from below upward as shown. To set off 308 feet: The diagonal through 0 of the scale of distances having gained a distance of eight feet to the left, at the horizontal numbered eight, extend the points of the dividers on this horizontal, from the 300 vertical to the first or nearest diagonal; for 347 feet, extend them on the seventh horizontal, from the 300 vertical to the fourth diagonal; and so on.

To show furlongs with an extension reading to single miles, only eight horizontals would be necessary; and similarly, the diagonal construction can be applied to any other unit. This scale and the scale of distances used in the construction of the map are sometimes called "Scales of Construction."

47. A *vernier* is a small scale of equal parts used for reading fractional parts of the divisions of the scale to which it is attached. Referring to Fig. 15, the vernier *V* is equal in length to 9 divisions of the scale *S*, and is divided into 10 equal parts.

Suppose *S* to be a scale of tenths of inches; then the difference in length between a division of *S*, or  $\frac{1}{10}$  of an inch, and a division of *V*, or  $\frac{9}{10}$  of  $\frac{1}{10}$  of an inch, is  $\frac{1}{10} - \frac{9}{100} = \frac{1}{100}$  inch, which is called the "least count of the vernier," and is the smallest fractional part that can be read by it. The least count is numerically equal to the value of one division of the scale divided by the number of divisions of the vernier.

Algebraically considered, let *s* = length of one division of *S*, *v* = length of one division of *V*, and let *m* of the former divisions equal in length *m* + 1 of the latter: then *ms* = (*m* + 1) *v*;  $v = \frac{m}{m+1}s$ ; and *s* - *v*, or the least count, =  $s - \frac{m}{m+1}s = \frac{s}{m+1}$ , as above.

The 0 of the vernier is the index of the scale: referring to the figure, if  $V, 0$  and  $S, 7$  coincided, the reading would be 7 inches; but in its present position the fractional part between 0 and 7 must be added to seven inches. If  $V, 1$  coincided with  $S, 7.1$ , the addition would be just equal to the least count, or  $\frac{1}{100}$  inch; if  $V, 2$  coincided with  $S, 7.2$ , it would be  $\frac{2}{100}$ ; but, as shown,  $V, 7$  coincides with  $S, 7.7$ , and the reading is  $7. + \frac{7}{100}$  or 7.07 inches; therefore to read the vernier: If its 0 division coincides with a division of  $S$ , the latter gives the required reading; if not, read the next preceding division of  $S$ ; find the  $V$  division that coincides with any  $S$  division, multiply its number by the least count, and add the product to the  $S$  reading. If several divisions of  $S$  and  $V$  appear coincident, use the middle one; if none are coincident, and a division of  $S$  is midway between two of  $V$ , the true reading corresponds to the point midway between them.

Verniers are classed as direct, to which class the one just described belongs, and retrograde. The number of divisions of a direct vernier is greater by one, and of a retrograde vernier less by one, than the number of divisions of the line or arc which they respectively cover. The divisions of the former are numbered in the same order, that is to say, the numbers increase in the same direction, as those of the scale to which it is attached; and the reverse usually obtains in the latter class.

The retrograde form is used for convenience when the vernier cannot be moved a distance, at least equal to its length, beyond the extremity of the scale. Thus in Fig. 16, readings are obtained up to 12 inches, without the index passing that division; the reading as shown is 11.97 inches; the index having passed the 11.9 division of  $S$ , and  $V, 7$  coinciding with an  $S$  division.

Fig. 17 represents a vernier for reading fractions of a degree. The limb is graduated to  $\frac{1}{4}^\circ$ , as in the common vernier protractor, and since 15  $V$  divisions cover 14  $S$  divisions, the least count is  $\frac{\frac{1}{4}^\circ}{15} = 1$  minute. For convenience in reading in either direction, the vernier is made of double length, the graduation is extended in each direction from the index, and it is called a double vernier, in contradistinction to those already described.

The reading as shown is  $22^\circ 37'$ , the index being between the  $22\frac{1}{2}^\circ$  and  $22\frac{3}{4}^\circ$  divisions of  $S$ , and  $V, 7$ , to the right of the index, coinciding with an  $S$  division. Considering 20 and 25 of  $S$  interchanged, the left-hand vernier is used, and the reading is  $22^\circ 23'$ .

48. *Vertical and Time Scales.*—The vertical scale, or scale of heights, is generally greater than the scale of distances, and the proportional increase is termed “the exaggeration of the scale.” This is made necessary because differences of elevation are less apparent than horizontal distances; and besides, in levelling, very minute differences of elevation are often required. The usual exaggeration is 10; e.g., with a scale of distances of  $\frac{1}{1000}$ , the scale of heights would be  $\frac{1}{100}$ .

Time-scales are used to measure distances by the time required to traverse them; the *r.f.*, rate of motion, and the desired reading are the data required. They are used in rapid sketching, and for plotting maps from itineraries, the intervals of time required in passing from point to point being noted (see *g*, par. 50).

49. *To Divide a Line into Equal Parts.*—Fig. 14 illustrates a convenient method of dividing a line into equal parts. To divide  $AB$  into five equal parts: Draw  $AC$ , and beginning

at *A*, set off with dividers or measuring-scale the five consecutive equal distances *Aa*, *ab* . . . . . *de*; join the last point of division *e* with *B*, and draw *dd'*, *cc'*, . . . . . parallel to *CB*: the points of intersection of these lines with *AB* are the required points of division. *CAB* should be of such a size as to prevent very oblique intersections with *AB*. This construction depends upon the principle that like parts of similar triangles are proportional to each other.

In a like manner, to subdivide an interval between two parallel lines into equal parts, other than those marked on the scale: Place the scale obliquely, so that the required number of divisions will be included between the lines; mark the points of division and draw lines through them parallel to the given lines.

50. *Examples of Scale-Construction.*—*a.* Required a scale of 6 inches to one mile to read thousands, with subdivisions of hundreds of feet:

$$\frac{6}{\text{No. of inches in one mile}} = \frac{6}{63360} = \frac{1}{10560} = r.f.;$$

and for a total representation of 5000 feet,  $6000 \times \frac{1}{10560} = 5.68$  inches; a sufficiently close approximation is obtained by using 5.68 (see par. 51). A right line 5.68 inches in length is then subdivided into five equal parts, each part thus representing 1000 feet, and the extension subdivided into ten equal parts will show hundreds of feet. The total length could also be obtained from the proportion, 5280 (No. feet in one mile): 5000::6: total length of the scale.

*b.* Required a scale of four inches to one mile to read thousands and hundreds of yards,  $r.f. = \frac{1}{15840}$ . For a total representation of 3000 yards, 1760 (No. yards in one mile): 3000::4: total length = 6.82 inches, very nearly. Divided into three equal parts, each part will represent 1000 yards, and each of the ten subdivisions of the extension will represent 100 yards.

*c.* Given  $r.f. = \frac{1}{8000}$ ; to construct a scale with primary divisions of 100 feet each: 100 feet = 1200 inches, and  $1200 \times \frac{1}{8000} = .15$  inches = length of a primary division. 1000 feet is represented by 4.166 inches, which is laid off and divided as already described to show hundreds and tens of feet.

*d.* Given a map with no scale or  $r.f.$  upon it; to find the  $r.f.$ : Measure an actual distance, and its representation on the map; and place these measurements, reduced to the same denomination, in the form of a fraction with the plotted distance as the numerator, and reduce to the form  $\frac{1}{m}$ : a scale can then be constructed as already described.

If the superficial area only of the surface represented is known: Let the map be 12 inches square and represent 10 acres; to find  $r.f.$ :  $10A = 48400$  square yards; 12 inches therefore represents  $\sqrt{48400} = 220$  yards = 660 feet;  $\therefore r.f. = \frac{1}{800}$ , from which the desired scale may be constructed. If this map were  $8 \times 12$  inches in dimensions, then one square inch would represent 504 square yards, and  $r.f. = \frac{1}{808}$ , approximately.

*e.* As already indicated, comparative scales have the same  $r.f.$ , and different units of measurement. A French map has a scale of French leagues attached, and the  $r.f.$  is omitted. By measurement, the distance 0 — 30, or 30 leagues, on the scale = 2.5 inches. A French league = 4262.84 yards. To construct a comparative scale of English or statute miles: 30 French leagues = 127885.2 yards, 100 miles = 176000 yards; therefore 127885.2 : 176000 :: 2.5 : the number of inches representing 100 miles = 3.44 inches very nearly; and a right line of this length is divided and subdivided as already explained.



f. Having subdivisions of sixths of degrees, to construct a direct vernier to read minutes:

$s - v = \frac{1}{60} = \frac{s}{m + 1} = \frac{1}{m + 1}$ ; therefore  $m + 1 = \frac{1}{60} \times 60 = 10$ , or 10 *V* divisions cover 9 *S* divisions. For a retrograde vernier,  $v - s = \frac{s}{m - 1}$ ;  $m - 1 = 10$ ; and 10 *V* divisions cover 11 *S* divisions. For a direct vernier reading to 20 seconds,  $s - v = 20'' = \frac{10'}{m + 1}$ ; therefore  $m + 1 = \frac{600}{20} = 30$ ; and 30 *V* divisions cover 29 *S* divisions.

g. The rate of motion is three miles per hour; to construct a scale of five miles to one inch (*r. f.* =  $\frac{1}{316800}$ ), to show distances traversed in five minutes: Let *x* inches represent the distance travelled in one hour; then  $316800 : 1 :: 3 \times 5280 \times 12 : x = \frac{6}{10}$  inch; therefore the distance traversed in five minutes is  $\frac{1}{12}$  of  $\frac{6}{10} = \frac{1}{20}$  inch, and the scale is constructed accordingly.

h. Given a scale of 500 paces to the inch, the average pace being 29.63 inches, to construct a scale of yards; *r. f.* is  $\frac{1}{14118}$ , and to read 500 yards the length of the scale is  $500 \times 36 \times \frac{1}{14118} = 1.21$  inches,  $\frac{1}{8}$  of which represents 100 yards.

i. To construct a scale of paces reading to 1000 paces, and showing 10 paces; the average pace being 31 inches, and *r. f.*  $\frac{1}{10180}$ . Its total length is  $\frac{31000}{10180} = 2.935$  inches, which is subdivided into ten equal parts representing 100 paces each, etc.

51. *Inferior Limit of Scale Measurement.*—The smallest distance that can be estimated by the eye, or that can be measured with dividers, may be assumed as 0.01 of an inch; and this distance is the probable error which would be made in plotting, or in measuring distances on the map. Denoting this by  $\epsilon$ , the scale of the map being  $\frac{1}{m}$ , the approximation to the true distance is  $\epsilon \times m$ ; and in plotting with the instruments ordinarily used, distances less than this cannot be exactly represented. e.g. If *r. f.* =  $\frac{1}{30100}$ ,  $\epsilon \times m = 50$  inches; if *r. f.* =  $\frac{1}{30100}$ ,  $\epsilon \times m = 50$  feet; which distances are therefore the inferior limits of their respective scales.

52. *The principal conditions governing the choice of a scale are—*

The smallest measured detail required upon the map should be clearly represented.

To economize time, the smallest scale consistent with the above condition should be chosen.

The actual and plotted distances should be readily convertible.

As to the first condition, since an application of the formula  $\epsilon \times m$  (par. 51) determines the least dimension that can be clearly represented according to any given scale, it is a simple matter to conform to it. The second condition is particularly applicable to maps of large extent, or those covering large tracts containing much detail. The third condition would be perfectly fulfilled by the adoption of the metric system of measurement; but since English units are in general use in the United States for surveying purposes, the best alternative is to apply the decimal system to them. The scale might then be represented by either one of the following fractions:  $\frac{1}{10}$ ,  $\frac{1}{20}$ ,  $\frac{1}{30}$ ;  $\frac{1}{100}$ ,  $\frac{1}{200}$ ,  $\frac{1}{300}$ ;  $\frac{1}{1000}$ ,  $\frac{1}{2000}$ ,  $\frac{1}{3000}$ , affording an ample range for all purposes. Actual measurements could be made with the 50 or 100 feet chain, with tape or rod graduated into feet and decimals of feet, making reductions to feet for plotting unnecessary; and the plotting would be done with a scale of equal parts of one foot, decimally divided. Some of the advantages of a simple system like this are saving of time, and less liability to error in calculation, a tendency to uniformity of scale in maps made for like purposes, and the facility in reading maps which this uniformity would give.

53. The following scales are used in different countries for topographical purposes :

IN GREAT BRITAIN.

| REPRESENTATIVE FRACTION.                 | FOR WHAT USED.  |
|--|---|
| $\frac{1}{62500}$ (1 in. to 1 mile)....  | The smaller Ordnance maps, surveys of provinces for both civil and military purposes; suited to maps of explorations.   |
| $\frac{1}{25000}$ (4 in. to 1 mile)....  | Smallest scale permitted for deposited plans of proposed works for military road reconnaissances.   |
| $\frac{1}{10000}$ (6 in. to 1 mile)....  | Larger Ordnance maps. Just large enough to show roads, buildings, and other important objects distinctly in their true proportions, and at the same time embrace a plan of a considerable extent of country. Best adapted for selection of lines for engineering works, for parliamentary plans and preliminary estimates. Suitable for military positions. |
| $\frac{1}{10000}$ .....                  | Decimal scale suited to same constructions.   |
| $\frac{1}{4000}$ (400 ft. to 1 in.)....  | Smallest scale permitted for "enlarged plans" of buildings, and of land within the curtilage.   |
| $\frac{1}{2000}$ .....                   | Suited to working surveys and land plans of great engineering works.  |
| $\frac{1}{1000}$ .....                   | For plans of part of the Ordnance Survey from which above Ordnance maps are reduced. Suited to land plans of engineering works and of estates.  |
| $\frac{1}{4000}$ (200 ft. to 1 in.)....  | Smallest scale prescribed for land or contract plans in Ireland.  |
| $\frac{1}{1000}$ (100 ft. to 1 in.)....  | Suited to plans of towns when not very intricate.   |
| $\frac{1}{6250}$ (60 in. to 1 mile)....  | Ordnance plans of same.   |
| $\frac{1}{1000}$ .....                   | Decimal scale suited to same.   |
| $\frac{1}{1200}$ (120 in. to 1 mile).... | Ordnance plans of the more intricately built towns.   |
| $\frac{1}{1000}$ .....                   | Decimal scale suited to same.   |
| FOR PLANS OF RAILWAYS.                   |   |
| $\frac{1}{10000}$ .....                  | Minimum scale for plans and sections.   |
| $\frac{1}{1000}$ .....                   | Minimum vertical scale for sections.  |
| $\frac{1}{1000}$ .....                   | Minimum scale for cross-sections and sections of road alterations.  |

IN FRANCE.

| REPRESENTATIVE FRACTION. | FOR WHAT USED.   |
|--------------------------|--|
| $\frac{1}{25000}$ .....  | For the new engraved map of France.  |
| $\frac{1}{10000}$ .....  | For the surveys from which the above map was made.   |
| $\frac{1}{5000}$ .....   | For surveys of large extent, military reconnaissances of frontiers, and the encampment of an army. |
| $\frac{1}{10000}$ .....  | Plan of a place with its environs, of a canton, special reconnaissances.                           |
| $\frac{1}{5000}$ .....   | Surveys of a town with a large extent of the surrounding country, plans of battlefields.           |
| $\frac{1}{2500}$ .....   | Surveys of cities, routes, and defensible positions.   |
| $\frac{1}{1000}$ .....   | For the front of a fortification, with its outworks.   |

IN THE UNITED STATES.

| REPRESENTATIVE FRACTION.  | FOR WHAT USED.                               |
|---|--|
| $\frac{1}{2500}$ to $\frac{1}{10000}$ .....                     | For small areas, such as farm surveys.       |
| $\frac{1}{10000}$ , $\frac{1}{12500}$ , $\frac{1}{15000}$ ..... | For topographical surveys in general.        |
| $\frac{1}{25000}$ , $\frac{1}{30000}$ , $\frac{1}{35000}$ ..... | For topographical surveys of large areas.    |
| $\frac{1}{50000}$ to $\frac{1}{100000}$ .....                   | For general maps covering a large territory. |

## IN BELGIUM.

| REPRESENTATIVE FRACTION.                        | FOR WHAT USED.   |
|---|--|
| $\frac{1}{10000}$ .....                         | For mineral concessions. } These are also used for farm surveys. |
| $\frac{1}{20000}$ .....                         | For projected railways. }  |
| $\frac{1}{100000}$ .....                        | For topographical plans.   |
| $\frac{1}{250000}$ to $\frac{1}{1000000}$ ..... | For topographical maps.  |

54. *Plotting* consists in locating on paper and in their true relative positions, the points, lines and angles determined in the field. Topographical maps are usually confined to the representations of areas of the earth's surface so small that in their construction the earth's sphericity may be neglected; therefore the methods of plotting used in plane-surveying are appropriate. The methods employed for representations of larger areas are described in Part V.

The usual sequence observed is to first define the limits of the map and the proper direction of a meridian line, then to plot the triangulation, traversing and levelling, in the order given.

55. *Plotting of Points, Lines and Angles.*—A point is plotted by assuming its position, by determining its direction and distance from a given point, or by the intersection of given lines. Its position is indicated as described in 6, par. 43.

A right line of known length and unknown position is plotted by assuming a point for one extremity, and, with a straight-edge as a guide for the pencil-point, drawing a fine line accurately through the point; the other extremity is then determined by the application of the scale of distances; or the exact length may be laid off from the assumed point with the scale, and the line drawn afterwards. In either case the extremities must be indicated exactly opposite the proper scale-divisions.

The manner of plotting or protracting angles with the protractor and with the scale of chords has been described in pars. 24 and 25. A table of natural sines, cosines and tangents (see Table III., Appendix) is frequently used for this purpose. e.g., To plot an angle  $A$ : Make  $AB$  (Fig. 18, Plate II.) =  $\cos A$  to any convenient radius; at  $B$  erect the perpendicular  $BC = \sin A$  to the same scale; draw  $AC$ : then  $BAC$  is the required angle. Or make  $AB = \cos A$  as before, then from  $B$  and  $A$  as centres, and with radii corresponding respectively to the  $\sin$  and radius reduced to the same scale, describe arcs intersecting at  $C$ .

The natural sines can be used as a scale of chords, since the chord of an arc which measures an angle as  $@ = 2 \sin \frac{1}{2}@$ . Thus, in Fig. 19, with  $D$  on  $DE$  as a centre, and a convenient radius  $R$ , describe the arc  $Ea$ ; find from the table the sine of  $\frac{1}{2}@$ , multiply it by  $2R$ , and with the product as a radius, and  $E$  as a centre, describe an arc intersecting the first at  $F$ .  $FDE$  is the angle required.

To use the natural tangents: Set off  $AB$  (Fig. 18) any convenient number  $n$  of inches in length; erect the perpendicular  $BC = n \times \text{tang } A$ , and join  $A$  and  $C$ .  $CAB$  is the angle required.

56. *Defining the Limits of the Map and the Direction of a Meridian Line.*—The total length and breadth of the map can be determined from the record by calculation: e.g., as a rule the sum of the Eastings or Westings is the horizontal, and of the Northings or Southings

the vertical dimensions; then assuming, when practicable, the top of the paper as N., the rectangle to enclose the plot, and of which the sides are the inner lines of the border, is constructed as follows:

Through the middle point of the paper, determined by its intersecting diagonals, draw two right lines perpendicular to each other, one of them at least parallel to an edge of the drawing-board. From the middle point set off half the length of the map in each direction on one of these lines, and half the breadth in each direction on the other, using the longer line for the greater dimension; then right lines through the extremities of these distances and parallel to those already drawn will be the limiting lines required. A marginal space, as broad as may be desired, between them and the cutting-out line, may then be defined, and the part outside of this used for trying the pen, etc.

Until after considerable practice in plotting, it is best to plot the triangulation, and at least the courses of the traversing, on paper other than that intended for the map. The limits of the map are at once shown, the inner lines of the border are drawn, or their positions with reference to a meridian line marked, and the work is properly adjusted upon the map-paper and transferred, usually by pricking through the angular points (II., par. 140). By this plan the surface of the map-paper is to a great extent kept unimpaired, and there is no liability to an unfavorable disposition of the plot.

As already indicated, the vertical edges of the border are usually parallel to a true meridian line, with their upper extremities toward the N. This disposition may be found inconvenient, especially on very large maps which for convenience in reading always require their greater dimensions to be placed horizontally; but if practicable N. should be either toward the upper or the right-hand edges of the map. In any case the N. point should be in the upper quadrants.

57. *Plotting the Triangulation.*—Since the triangulation is the most important part of the field-work, the more exact methods are used in plotting it; and of these a system of rectangular coordinates is the best, because each survey-point is independently fixed, and cumulative errors are thus avoided. In Fig. 20, the right lines  $XX'$  and  $YY'$  perpendicular to each other are termed the coordinate axes, and distances from either axis measured on the other, or on lines parallel to it, are the coordinates. Coordinates parallel to  $XX'$  are designated by the letters  $x, x', \dots$  or  $x^a, x^b, \dots$ ; and those parallel to  $YY'$  by  $y, y', \dots$  or  $y^a, y^b, \dots$ . Coordinates measured in opposite directions from either axis are distinguished by contrary signs: e.g., if the coordinates of  $P$  are  $+x$  and  $+y$ , those of  $P'$  are  $+x$  and  $-y$ ; of  $P''$ ,  $-x$  and  $+y, \dots$

The field record gives at least the length of the base, its azimuth, or direction with reference to the meridian,—usually measured from S. around through W.,—and at least two angles of each of the different triangles. The base being reduced to the horizon, and the sides of the triangles computed, the triangulation may then be plotted as follows:

The axes  $NS$  and  $WE$  (Fig. 22), meridian and east and west lines respectively, are drawn through the plotted extremity  $A$  of the base  $AB$ .  $x, x'$  coordinates are measured parallel to  $WE$ ;  $+$  in the direction  $AW$ , and  $-$  in the direction  $AE$ .  $y, y'$  coordinates are measured parallel to  $NS$ ;  $+$  in the direction  $AS$ , and  $-$  in the direction  $AN$ . The origin, or initial point of arcs, is taken in  $AS$ , so that the measurement of azimuths will be in the direction S.W.N.E., to agree with field-azimuthal observations. Since the length of the base and its

azimuth  $z$  ( $90^\circ + @$ ; see accompanying table) are given, the coordinates of  $B$  are  $x = Ab = AB \cos @$ ,  $y = Ab' = -AB \sin @$ ; and by laying off these distances from  $A$  on the corresponding axes, and drawing lines parallel to the axes through the extremities  $b$  and  $b'$  as shown, the intersection of these lines fixes  $B$ . Instead of drawing parallels, any point as  $B$  is usually fixed by the intersection of two arcs; one described from  $b$  as a centre and a radius  $= y$ , and the other from  $b'$  and radius  $= x$ .

TABLE GIVING THE TRIGONOMETRICAL FUNCTIONS OF ANY ARC OR ANGLE IN TERMS OF THOSE OF AN ARC OR ANGLE LESS THAN  $90^\circ$ .

| ANGLE.                | sin.    | cos.    | tan.    | cot.    | sec.      | cosec.    |
|-----------------------|---------|---------|---------|---------|-----------|-----------|
| $90^\circ + @$ .....  | cos @   | - sin @ | - cot @ | - tan @ | - cosec @ | sec @     |
| $180^\circ - @$ ..... | sin @   | - cos @ | - tan @ | - cot @ | - sec @   | cosec @   |
| $180^\circ + @$ ..... | - sin @ | - cos @ | tan @   | cot @   | - sec @   | - cosec @ |
| $270^\circ - @$ ..... | - cos @ | - sin @ | cot @   | tan @   | - cosec @ | - sec @   |
| $270^\circ + @$ ..... | - sin @ | sin @   | - cot @ | - tan @ | cosec @   | - sec @   |
| $360^\circ - @$ ..... | - sin @ | cos @   | - tan @ | - cot @ | sec @     | - cosec @ |

To find  $C$ :  $AC$  is given;  $z'$ , the azimuth of  $AC$  is  $z + CAB$ ; and the coordinates of  $C$  are  $x' = Ac = AC \cos @$ ;  $y' = Ac' = -AC \sin @$ ; and  $C$  is fixed as before by intersecting lines through  $c$  and  $c'$ . If through any point as  $C$ , right lines  $l' Cc, \dots$  are drawn parallel to the axes, the sides of the triangles meeting at this point form the hypotenuses of right-angled triangles, of which the angles can be deduced from the azimuths, and the coordinates determined: e.g.;  $z''$ , the azimuth of  $CB$ , is  $z' - (ABC + CAB)$ ;  $z'''$ , the azimuth of  $CD$ , is  $z'' + BCD \dots$

The coordinates of  $D$  are  $x'' = Ad = x' + Cl$ ,  $y'' = dD = dl + lD = y' + lD$ ; and since, in the right-angled triangle  $DCI$ ,  $CD$  is known, and  $DCI = z''' - 90^\circ = s$  (see figure),  $Cl = CD \cos s$ , and  $lD = CD \sin s$ ; therefore  $x'' = x' + CD \cos s$ , and  $y'' = -(y' + CD \sin s) \dots$

To facilitate the plotting, the coordinates may be previously calculated and arranged in tabular form as shown below, the preliminary plotting affording an opportunity for this purpose; and if either axis is intermediate in a chain of triangles, the accuracy of this computa-

| STATIONS. | COORDINATES (in feet). |      |      |      |
|-----------|------------------------|------|------|------|
|           | + x.                   | - x. | + y. | - y. |
| A.....    | 0                      | .... | 0    | .... |
| B.....    | ....                   | 500  | 1175 | .... |
| C.....    | ....                   | 1385 | 370  | .... |
| D.....    | ....                   | 1680 | 1740 | .... |
| G.....    | ....                   | 1760 | .... | 1300 |
| H.....    | 450                    | .... | 900  | .... |

tion can be verified for the coordinates measured in the direction of this axis, by first computing the coordinates of the points on one side of the axis, and then of those on the other; the sums of these separate values should be equal.

Thus, in Fig. 23, measuring from  $A$  in the direction  $AF$ , the sum of the coordinates of

$C$ ,  $E$  and  $F$  is evidently equal to the sum of the coordinates of  $B$ ,  $D$  and  $F$ . This would find its application in plotting secondary triangles, the line  $AF$  representing a side of one of the primary triangles.

In the foregoing description the coordinates are deduced from the azimuths and the lengths of the sides. To reverse the operation, which is sometimes found necessary, the following formulæ from analytical geometry are used :

$$d = \sqrt{(x' - x)^2 + (y' - y)^2}, \text{ and } \text{tang } @ = \frac{x' - x}{y' - y};$$

in which  $d$  is the distance between two points of which the coordinates are  $x, y$ , and  $x', y'$ , respectively, and  $@$  is the angle included between the right line joining these points and the meridian. (For Plotting the Triangulation, see also Appendix, page 127 *et seq.*)

58. Simple and rapid methods of plotting a triangulation when great accuracy is not required, are either by intersecting arcs described with the calculated sides as radii, and thus consecutively locating the different vertices ; or having given the different angles, by protracting them in their relative positions at the extremities of the sides thus consecutively determined—in either case beginning with the plotted base, or a plotted side of one of the triangles.

The latter method would generally be used in plotting a sketch in which the principal points were located by a system of triangles. The former method could best be applied in the case of well-conditioned triangles, of which none of the angles are less than  $30^\circ$ , since the points of intersection could then be clearly determined.

59. The plotting of the courses of compass-traverse surveys by rect. coordinates is a simple operation. Thus in Fig. 21 the meridian line  $NS$  drawn through the plotted starting-point  $A$ , and the line  $WE$  perpendicular to it, are the axes ; and to conform to the usual order, + values of  $x$  are measured from  $NS$  to the right, and - values to the left ; + values of  $y$  from  $WE$  upward, and - values downward. The letters of a bearing determine the algebraic signs of the coordinates of either extremity of a course referred to axes parallel to the principal axes  $NS$  and  $WE$ , drawn through the other extremity. Thus the bearing of  $AB$  is  $N\beta^\circ W$ , and for  $B$ ,  $x$  is -, and  $y$  + ; for  $C$ ,  $x'$  is -, and  $y'$  + ; for  $D$ ,  $x''$  is +, and  $y''$  + ; and generally,

for  $NE$  bearings,  $x$  and  $y$  are + ;  
 for  $SW$  bearings,  $x$  and  $y$  are - ;  
 for  $NW$  bearings,  $x$  is -, and  $y$  + ;  
 for  $SE$  bearings,  $x$  is +, and  $y$  - .

The coordinates required are  $x, x^a, x^b \dots y, y^a, y^b \dots$

For  $B$ ,  $x = -AB \sin \beta$ , and  $y = AB \cos \beta$  ; denoting by  $\beta'$  and  $\beta''$  the respective bearings of  $BC$  and  $CD$ , then

for  $C$ ,  $x^a = -(x + x') = -(x + BC \sin \beta')$ ,  $y^a = y + y' = y + BC \cos \beta'$  ;

for  $D$ ,  $x^b = -x - x' + x'' = -(x^a - CD \sin \beta'')$ ,  $y^b = y + y' + y'' = y^a + CD \cos \beta''$  :

and in general, the principal coordinate of any point is that of the next preceding point  $\pm$  the coordinate of the required point referred to the latter as an origin.

For convenience in plotting, the coordinates of the different points are first computed and arranged in tabular form (par. 57); and in a closed survey the accuracy of the computation is verified when the final values of  $x$  and  $y$ , the coordinates of the starting-point, are each 0.

60. The courses of compass-traverses, or of other traverses in which the angles are measured from a fixed line of direction, may be plotted as in Fig. 24. The protractor is placed in a central position on the sheet, with its  $0^\circ$  and  $180^\circ$  divisions coincident with a meridian line. The angles made by the different courses with the meridian are then marked on the sheet opposite the corresponding divisions of the protractor. If radii  $Ob$ ,  $Oc$  are drawn to these points they will make angles with  $NS$  equal to the corresponding bearings; thus,  $NOb =$  bearing of  $AB$ ,  $SOc =$  bearing of  $BC$  . . . . . Therefore  $A$  is first fixed; then, with ruler and triangle, a line is drawn through  $A$  parallel to  $Ob$ , and  $B$  is fixed by limiting the course  $AB$  to its proper length.

In the same manner a line is drawn through  $B$  parallel to  $Oc$ , and limited to its proper length, fixing  $C$ ; and similarly for the rest of the courses. The last course plotted should end at  $A$ .

A central position for the protractor is preferable, because then no parallels are transferred to a very great distance from the radii.

Paper protractors of large size are much used for this purpose, being temporarily fastened in the required position; also "protractor-sheets,"—full sheets of paper with protractors printed on them.

A handy means of protracting angles and setting off distances at the same time, as in the plotting of stadia-measurements, when a paper scale is not used, is to glue a piece of paper to the lower surface of the scale of equal parts, and fasten the 0 point of the scale-edge used to the vertex by a fine needle. This edge can then be turned about the needle at pleasure, and much time saved that would otherwise be spent in adjusting it.

61. The courses may be plotted as shown in Fig. 25. At  $G$ , the starting-point, the bearing  $NGH$  is plotted; the point  $H$  is then fixed by measurement, and a second meridian line is drawn through it as shown, and used to plot  $HI$ , and so on to the end of the traverse. This method is preferable to the last in a map of large extent, where it is difficult to transfer the bearings from a single meridian line. The  $\top$ -square is handy for the purpose, since in its different parallel positions its edges show the direction of the meridian lines; and the semi-circular or rectangular protractor, with its diameter resting against the edges, is readily used to plot the bearings at the different points.

In this, and in the method described in the preceding paragraph, an error committed in plotting a bearing affects all the following courses. This method involves an additional chance of error in drawing the several meridian lines; and neither of the methods should be used, except for the location of minor details, or when frequent checks can be had upon the work. Either, however, is well adapted to the plotting of sketches where an approximation only to the truth is desired.

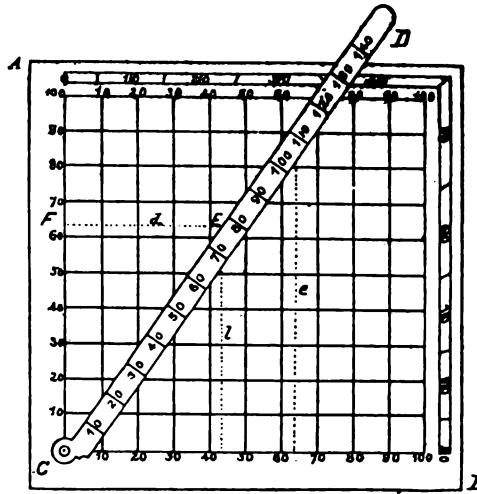
62. *The Trigonometer* is an instrument, illustrated in the accompanying figure, used for the mechanical solution of trigonometrical problems.

*AB* is a thin metal plate 15 inches square, containing 100 small equal squares arranged and numbered as shown, each being subdivided into 100 others, omitted in the figure.

The unit of graduation of the arm *CD*, pivoted at *C*, is a side of one of the small squares, and is also subdivided into 10 equal parts. The outer scale in the original shows quarter degrees.

To find the latitude and departure for any course as *CE*, indicated by the arm-graduation, turn the arm until its edge cuts the degree-division of the bearing; then *l* and *d* are the latitude and departure respectively.

For the radius *CF*, *d* and *e* are respectively the tangent and cot. of the arc given by the outer scale, and similarly for the other circular functions.



63. *Closing a Plot.*—A traverse should close either upon its starting point or upon some other determined point of the survey, according to the plan adopted in the field-work.

If it does not close, the plotting should be gone over; and if still in error, the fault evidently rests with the field-work, and a new survey is required. If the error is inconsiderable as referred to the purpose of the map, it can be distributed among the courses in proportion to their lengths, or by the method illustrated in Fig. 26. In plotting the traverse *ABC . . . .* the last course ends at *G* instead of at *A*, showing the error *GA*. To close the plot, join *A* and *G*, and through the other stations draw parallels to *AG*, as shown. The correction for each course is then obtained as follows: For *AB*, the sum of the courses : *AB* :: *GA* : *a* = *Bb*, which is laid off from *B* in the direction *GA*. *Ab* is then the corrected position of the first course. For *BC*, the sum of the courses : *AB* + *BC* :: *GA* : *x* = *Cc*, and *bc* is the corrected position of the second course; and similarly for the rest of the courses. The first term of the proportion is the sum of all the courses; the second term is the sum of the course under consideration and the preceding courses; and the third is the total error. A graphical construction is to set off the courses consecutively on a right line; erect perpendiculars at the extremity of each course; set off the total error on the perpendicular at the farther extremity of the last course, and join its outer extremity with the initial point by a right line. From the similar triangles thus formed the corrections for the different courses will evidently be the corresponding perpendiculars included between the two right lines.

When it is found necessary to resurvey a line on account of an error evidently in the field-work, an *error sheet* is used. It is of various forms, but should show clearly the location of the line in error, its recorded and scale lengths, and where the record of its survey can be found. Some indication of the source of error should if possible be furnished the surveyor.

64. *Plotting a Vertical Section.*—The levelling record is given below. The references, or heights of the stations above the datum-plane, are obtained by adding a rise or subtracting a fall from the next preceding reference. On the right line *MN* (Fig. 27) set off from *M* the “distances” as given in the record. Erect the perpendiculars as shown, and set off from *MN*, on these lines, distances corresponding to the “references.”



## TOPOGRAPHICAL DRAWING.

| STATIONS. | Bearings. | Distances.<br>Feet. | Readings. |       | Differences. |         | Refer-<br>ences.<br>Feet. | REMARKS.          |
|-----------|-----------|---------------------|-----------|-------|--------------|---------|---------------------------|-------------------|
|           |           |                     | B. S.     | F. S. | Rise +.      | Fall -. |                           |                   |
| A.....    | ....      | ....                | 9.28      | ....  | ....         | ....    | 100.00                    | Datum-plane.      |
| B.....    | ....      | 508.6               | ....      | 7.92  | 1.36         | ....    | 101.36                    | 100 feet below A. |
| B.....    | ....      | ....                | 6.54      | ....  | ....         | ....    | ....                      | .....             |
| C.....    | ....      | 694.3               | ....      | 11.43 | ....         | 4.89    | 96.47                     | .....             |
| C.....    | ....      | ....                | 12.65     | ....  | ....         | ....    | ....                      | .....             |
| D.....    | ....      | 427.5               | ....      | 5.25  | 7.40         | ....    | 103.87                    | .....             |
| D.....    | ....      | ....                | 10.37     | ....  | ....         | ....    | ....                      | .....             |
| E.....    | ....      | 486.4               | ....      | 3.58  | 6.79         | ....    | 110.66                    | .....             |
|           |           | 2116.8              | 38.84     | 28.18 | 15.55        | 4.89    | ....                      |                   |
|           |           |                     | 28.18     |       | 4.89         |         | 100.00                    |                   |
|           |           |                     | 10.66     |       | 10.66        |         | 10.66                     |                   |

The line  $AB \dots E$ , through the outer extremities of these distances, is the required section or profile of the surface.

It is more exact to set off all distances from  $M$ , adding each to the sum of those preceding. The vertical scale is ten times as large as that for the horizontal distances, for reasons already given; and it is apparent in this case that the differences of elevation would be barely visible if it were not so increased. The T-square is convenient for erecting the perpendiculars; but the use of section or profile paper (par. 33) obviates the necessity of drawing them, and it is generally used for this work.

The plotting of contours, and the construction of sections and elevations from contoured maps, are described in Part II.

## PART II.

## PLAIN TOPOGRAPHICAL DRAWING.

65. AS may be inferred from the heading, Part II. is a description of the construction of a plain or uncolored topographical map.

The triangulation and traverses, together with such other reference lines and points as may be necessary to locate the different features having been plotted, topographical drawing properly begins; and the subject is naturally divided into—

- I. A Description of the Conventional Signs.
- II. Representing the Details.
- III. Representing the Configuration or Surface Forms of Ground.
- IV. Finishing the Map, including Lettering and Ornamentation.

## SECTION I.—CONVENTIONAL SIGNS.

66. The signs or symbols used to represent the different features are intended to be of such forms as to be easily and rapidly made and readily understood. Those used for the commonest features, such as cleared land, forests and streams, are practically identical in all schools of map-drawing; while other signs for special features vary in different countries and with the taste or skill of different draughtsmen.

It would be very advantageous to have the same sign for the same feature on all occasions, so as to prevent the possibility of mistake—a condition which is well appreciated in the military service, where a commander's knowledge of the country in which a campaign is to be conducted, or of the ground where a decisive battle may be fought, may depend upon sketches hastily made, and in which the signs are necessarily roughly drawn.

The signs are made to resemble approximately the features or objects themselves, as the latter would appear from a point of observation located above them, or in some cases as if viewed in elevation.

67. *Shading of the Signs.*—In most topographical drawings, the effect of light and shade is added to produce relief. The source of light is regarded as above and to the left of objects; or, more definitely, the rays of light are parallel to a ray making an angle of  $45^\circ$  with the horizontal plane, and of which the projection upon the drawing bisects the lower right or upper left angle of the border. Objects extending above or below the general surface are shaded correspondingly; the former by a heavier outline on the side remote from the source of light, and the latter on the side nearest it. The positions of shadows when represented are similarly determined.

The present tendency toward simplifying the signs is to omit both shades and shadows unless, as in the case of a colored drawing, the latter may be needed to distinguish certain features.

68. A multiplicity of signs tends to confusion, and taxes the memory unnecessarily; names or verbal descriptions being much better suited to the purpose.

It may be remarked that a strict adherence to the forms given is not necessary for the production of an intelligible map. Still the aim should be to make a map that shall also please the eye: clearness should be combined with tasteful execution, evenness, regularity, and uniformity in repetition; and to assist in attaining this end, a detailed description of the manner of making the signs accompanies the plates, and the faults most frequently committed in drawing them are pointed out.

No exact rule can be laid down as to the sizes of the signs. In maps drawn to a small scale, some which individually represent objects measured in the field are, for the sake of clearness, necessarily much exaggerated above their scale dimensions. They are usually drawn too large. As a general rule, they should be just large enough to be easily read; but if the scale is very large, they may be increased in size proportionately, to lessen the number of repetitions and thus diminish the amount of work.

69. For convenience of reference, the important signs are represented in the different Plates in the following order:

Plate III. Conventional Signs—Land.

Plate IV. Conventional Signs—Land and Water.

Plate V. Conventional Signs—Miscellaneous, including Military Signs, Signs for Deciphering Maps and for Vertical Sections.

Plate VI. Conventional Signs employed in Maps of the U. S. Coast Survey.

#### PLATE III.

##### 70. *Conventional Signs—Land.*

*Cleared Land.*—Groups of fine dots and dashes, 5 to 7 in each group or tuft, are distributed over the tract evenly, but not in rows; the base of each tuft parallel to the lower edge of the border of the map. As shown at *a*, each tuft begins and ends with a dot; while the intermediate dashes, increasing in length to the middle one, which is vertical, radiate from a point below the middle of the base at a distance from the latter of about half its length. The effect desired, viewed at a short distance, is that of a flat tint; and when the lack of this is due to uneven distribution, the fault may be remedied by filling the larger spaces with groups of dots. The effect is more pleasing when the vertical dimensions of the tufts are slight, and the dashes are curved outward from the middle one as shown at *b*.

The usual faults consist in making the signs too large, in giving the bases an upward inclination, and in placing the tufts in rows. If the straight edge of the paper used under the hand for protecting the drawing is kept parallel to the lower border of the map, it will serve as a guide for the direction of the bases; and by first placing the tufts here and there irregularly, at wide intervals apart, and then filling the intervals in a similar way, the making of rows can be avoided.

*Cultivated Land.*—Alternate parallel rows of dots and dashes corresponding to furrows are used. The dots and dashes are evenly spaced, of uniform size, and close together. The spaces of any row of dashes are opposite the dashes of adjacent rows, and the rows of adjoining fields are oblique to each other. The rows are drawn with a ruler and triangle, the paper being so disposed that the lines may be drawn from left to right along the edge of the triangle.

If more convenient, the rows of dashes may be drawn first, and the rows of dots interlined.

The principal fault is irregularity in lengths of dashes and in spacing, which, for a beginner, makes the use of a scale of equal parts necessary.

*Sand, Gravel and Mud.*—For isolated sand-tracts, the dots are close together and evenly distributed, as at *c*. Along shores a good effect is produced by diminishing the sizes of the dots and increasing the intervals as the distance from the shore-line increases, as at *d*. In tidal waters, for the portion of the shore uncovered by the ebb, rows of dots are drawn parallel to the shore-line, as at *e*. Sand-dunes are represented as at *f*. Gravelly tracts are represented by the sign for sand, with coarse dots, and very small, curved and angular outlines, representing stones, distributed throughout, as at *g*; and mud, by short strokes parallel to the lower edge of the border and in sets, as at *h*.

*Orchard.*—Small, curved outlines, representing the trees in plan, are regularly distributed within the enclosure. These are first located by pencil-dots placed at equal intervals. Each tree is shaded by slightly emphasizing the outline and adding a few interior curves on the side remote from the source of light. The shadow beginning at the outline is of an oval shape, with the longer axis parallel to the projection of a ray of light, and is made up of parallel straight lines close together and perpendicular to this projection, as at *i*.

The faults consist in making the signs too large, angularity of outline, uneven shadows and in extending the latter beyond the projections of rays tangent to the outline.

At *i* in the figure, is shown the order, indicated by the numbers, in which the curves of the outline are conveniently drawn—1 and 2 from right to left, and 3 and 4 from left to right; and at *k*, a method of spacing the trees and assuring the direction of the shadow: the horizontal lines are drawn first, at equal intervals apart, one set at least being parallel to a side of the enclosure; the oblique lines are then drawn through the points of intersection, and parallel to the projection of a ray. In making the shadows, if a straight edge of the paper used to protect the hand is kept parallel to the projection of a ray, and so that the shadow-lines may be drawn toward the draughtsman, the proper direction of these lines is readily observed; and by preserving equal intervals and using the same number of lines for each of the shadows, the latter will be of uniform length. On maps drawn to a small scale, the shadows are frequently omitted.

*Woods.*—But two signs are generally used, representing respectively deciduous and evergreen trees. The former sign is similar to that for orchards, except that the sizes and distribution of the signs are irregular. Projecting boughs of isolated trees, and portions of clumps or large masses, should have rounded forms. Angularity of outline, and regularity in size and distribution, are to be avoided. The strokes should not cross each other, nor loops be formed. Shadows are not necessary, especially in a close growth such as a forest; but it is best to shade the outlines as already described. At *l*, are various forms of clumps; at *m*, evergreens; at *n*, is a special sign for oak; and at the lower right-hand corner, these signs with that for underbrush interspersed, are shown.

*Alkaline Flat and Saline Bed.*—The former is represented at *p*, the heaviest dots forming the outline, and defining a space which is left white.

The latter, *q*, is represented by its outline filled with rows of short dashes perpendicular to the lower edge of the map-border.

*Vegetable-Garden.*—The enclosure is divided into rectangular or triangular figures, separated by narrow spaces representing paths; and the figures are then filled with the sign

for cultivated land drawn to a small scale. For flower-gardens, the sign for cleared land and woods, drawn to a very small scale, are used instead of that for cultivated land.

*Park and Cemetery.*—The enclosure is divided into regular and irregular figures, with narrow spaces bounded by parallel lines for the roads and paths; the figures are then filled in with the signs for cleared land and woods. The distinguishing features for a cemetery are the headstones, as shown. Signs for different *field-products*, suited to maps drawn to a large scale, are also given.

## PLATE IV.

71. *Conventional Signs—Land and Water.*—*Survey points and lines* are represented by the signs numbered from 1 to 11 inclusive.

|                         |                    |                      |
|-------------------------|--------------------|----------------------|
| 1. Triangulation point. | 5. Stone landmark. | 9. Monument.         |
| 2. Plane-table “        | 6. Wooden “        | 10. County boundary. |
| 3. Common survey “      | 7. Mound “         | 11. State “          |
| 4. Signal-tower.        | 8. Tree “          |                      |

In addition to these, a rectangle containing a dot is used for a stadia survey point. The signs for boundaries should be of such weight and form as to be readily distinguished from the others.

*Enclosures :*

|                           |                              |                        |
|---------------------------|------------------------------|------------------------|
| 12. Rail or “worm” fence. | 14. Board fence.             | 16. Stone wall, rough. |
| 13. Picket fence.         | 15. Stone wall, with coping. | 17. Hedge.             |

For 12, the angles should be obtuse and the panels of equal length. The large dots of 13 and 14 represent the posts, and are equally spaced; 15 is shaded according to the general rule (par. 67); and 15, 16 and 17 are more clearly distinguished when the shadows are drawn: the shadow-lines should be perpendicular to the projection of a ray.

*Communications :*

|                      |                             |                 |
|----------------------|-----------------------------|-----------------|
| 18. Path, foot.      | 22. Road, main.             | 26. Telegraph.  |
| 19. “ mounted.       | 23. “ paved.                | 27. Embankment. |
| 20. Road, undefined. | 24. Railroad, single track. | 28. Cutting.    |
| 21. “ minor.         | 25. “ double “              | 29. Tunnel.     |

The distinction made between 21 and 22 is that the former consists of fine lines, and the latter of medium lines with a greater interval. In maps to large scales, these lines are replaced by signs for the features which enclose the road. The English convention is to represent fenced roads by full lines, and unfenced roads by broken lines.

In the sign for railroads, the number of lines is increased correspondingly for a greater number of tracks. Horse-railroads, tramways, etc., are represented by medium lines, single or double, through the middle of the street. In 26, the posts, or longer lines, are perpendicular to the edge of the road; and if no road exists, the bases should be connected by a fine line.

An embankment is represented by hachures alone; while a cutting has an outline drawn along its outer edges.

The direction of the road in 29 is indicated by a heavy dotted line, and other subterranean passages are indicated in like manner.

Parts of communications, the positions of which are not fully determined, are represented by dotted or broken lines.

*Buildings :*

- |                       |                  |              |
|-----------------------|------------------|--------------|
| 30. Building, wooden. | 33. Light-house. | 36. Village. |
| 31. " masonry.        | 34. Windmill.    | 37. Town.    |
| 32. Church.           | 35. Settlement.  | 38. City.    |

The main distinction observed in representing buildings is as to the material used in their construction. In Plain Topographical Drawing, wooden buildings are represented by fine, and buildings of masonry by heavy, outlines; and in either case the interior space is usually filled with fine, parallel lines, close together. These filling-in lines should be parallel throughout the map, and at the same time diagonals of the figures. Therefore, when the buildings face different points of the compass, a direction for these lines is chosen that will make them diagonals of the greatest number of buildings. If it is desired to make a distinction between brick and stone buildings, use very heavy outlines for the latter.

The outlines may be shaded, but in black and white maps shadows are not usually drawn.

In maps drawn to a very small scale, no distinction can well be made as to material; and to make them clearly visible, all buildings are represented by solid black figures.

*Signs pertaining to Water :*

- |                               |                           |                           |
|-------------------------------|---------------------------|---------------------------|
| 39. Well.                     | 54. Aqueduct.             | 69. Direction of current. |
| 40. Spring.                   | 55. Head of navigation.   | 70. Ford, foot.           |
| 41. Pond.                     | 56. Buoy.                 | 71. " wagon.              |
| 42. Marsh, fresh.             | 57. Rocks, bare.          | 72. Bridge, foot.         |
| 43. " salt.                   | 58. " sometimes bare.     | 73. " wooden.             |
| 44. Brook.                    | 59. " sunken.             | 74. " draw.               |
| 45. Creek.                    | 60. " dangerous.          | 75. " truss.              |
| 46. Practicable for all arms. | 61. " position uncertain. | 76. " stone.              |
| 47. " " inf'y and cavalry.    | 62. Bar.                  | 77. " pontoon.            |
| 48. Impracticable.            | 63. Shoal.                | 78. " suspension.         |
| 49. River.                    | 64. Fog-bell.             | 79. Ferry, rowboat.       |
| 50. High and low water.       | 65. Light-ship.           | 80. " steam.              |
| 51. Dam.                      | 66. Anchorage.            | 81. " rope.               |
| 52. Falls.                    | 67. Wreck.                | 82. " flying.             |
| 53. Canal, with locks.        | 68. Surf.                 |                           |

*Pond.*—The outline properly shaded is filled with fine lines, with small equal intervals and parallel to the lower edge of the border of the map. Any unevenness in the lines or irregularity in the spaces is particularly noticeable, and must be carefully avoided.

*Marsh.*—This is a combination of the signs for pond and cleared land. The former is drawn first. For fresh-water marshes, irregular spaces are left in the ruling, and these spaces are afterwards filled in with the sign for cleared land: the latter sign is also drawn here and there at irregular intervals, between the ruled lines. The proper outline of each space is produced by not having consecutive lines terminate in the same vertical.

For salt-water marsh, no spaces are left in the ruling.

Reclaimed marshes are indicated by the addition of confined streams or ditches.

If it is desired to distinguish between a marsh, which may be sometimes dry, and a swamp, for the former use rows of dots here and there in place of the full lines.

*Brook or Rivulet.*—An irregular line following its course, fine at the source, and increas-

ing slightly in breadth to the mouth. Frequent curves near the source are characteristic of small streams, especially in rugged tracts; and whip-lash, snaky-looking lines should always be avoided.

An important consideration in regard to streams, particularly in a military point of view, is the practicability of crossing them; and a conventional sign to express this condition, used for sketching-purposes in the English military schools, is shown.

*River, or Large Body of Water.*—The space between the shore-lines is filled with parallels termed “water-lines.” The shore-lines are drawn first, then a water-line next to *each* shore-line, carefully conforming in its direction to the various projections and indentations of the latter. Another water-line is then drawn parallel to the first, and so on. The final line or lines will thus be in the middle or axis of the stream, and proper junctions corresponding to the varying widths will be formed.

To produce the best effect, the water-lines and intervals are both graded so that the finest line and broadest interval shall be in the axis of the stream; but, as it is very difficult, especially for a beginner, to preserve both gradations, the lines are usually all made fine. The irregularities are lessened in consecutive lines, so that in a broad stream the curves of the central lines are quite smooth.

In drawing a water-line, the preceding one should be at the left hand, the line drawn towards the body, and the paper so disposed as to facilitate this operation. To preserve the proper interval, it is better to keep the eye on the interval rather than on the line.

The general rule for shading is sometimes applied to shore-lines. The direction of the current is indicated by an arrow, as shown.

In tidal waters, two sets of shore- and water-lines may be used as shown, one set corresponding to high- and the other to low-water mark. The high-water shore-line is made the heaviest.

For *Rapids and Torrents* (XII. Plate VI.), the water-lines are broken into short, curved lengths; and for *Whirlpools* they are given spiral shapes, still preserving the local gradation of the intervals.

For *Canal-locks*, the V-shaped figures have their vertices up-stream.

The anchor for *anchorage* is pointed up-stream.

*Sand-shoals and Bars.*—A dotted contour-line defining the boundary. If permanent, the depth of this line is noted upon it.

*Mud banks.*—As at *h* in Plate; or by two sets of dotted lines crossing each other obliquely.

For *sunken rocks*, the depth in feet is noted in the attached circle. Rock-formations of considerable extent are drawn as described in Section III.

*Soundings* are represented by numbers giving the depth in feet, as shown near the bottom of the plate. The 1-, 2-, and 3-fathom curves may be indicated by dotted lines, the dots being respectively continuous, in pairs and in groups of three.

The direction of the current should always be indicated at fords.

The flared ends of the sign for a bridge indicate the approaches or abutments. The bases of the piers are usually pointed at the up-stream extremities.

PLATE V.

72. *Conventional Signs—Miscellaneous.*—As to the *military signs*, the side on which the blackened portions of those for infantry and cavalry, in line, is placed, indicates the front or

direction of the movement; and in the sign for artillery, the short arm of the figure projects towards the target. The direction, in march, is usually indicated by an arrow-head placed at the head of the column.

The heavy line in the signs for fortifications represents the interior crest; and the width of the interval between it and the adjacent fine line on the exterior, the thickness of the parapet.

On maps to a very small scale, fortifications are represented by a single heavy line, giving the position of the interior crest. The hachured slopes of trenches, etc., are on the right, left and front.

The 40 signs "*For Deciphering Maps*" in the plate, are introduced for the service they may afford in reading old maps (see par. 68). At least 800 others have been in use within a comparatively recent date, but those given are more commonly seen. Their names are:

- |                       |                        |                             |
|-----------------------|------------------------|-----------------------------|
| 1. Mill, water-power. | 15. Rope-walk.         | 29. Sentinels.              |
| 2. " steam-power.     | 16. Quarry.            | 30. Vedettes.               |
| 3. Saw-mill.          | 17. Chapel and church. | 31. Indians, with firearms. |
| 4. Ship-mill.         | 18. Custom house.      | 32. " without "             |
| 5. Powder-mill.       | 19. Post-office.       | 33. Gold.                   |
| 6. Cotton factory.    | 20. Hotel.             | 34. Silver.                 |
| 7. Woollen "          | 21. Inn.               | 35. Copper.                 |
| 8. Sugar "            | 22. Railroad station.  | 36. Mercury.                |
| 9. Silk "             | 23. Telegraph "        | 37. Lead.                   |
| 10. Indigo "          | 24. Mineral spring.    | 38. Tin.                    |
| 11. Iron-works.       | 25. Gate, turnstile.   | 39. Iron.                   |
| 12. Glass-works.      | 26. Weir.              | 40. Coal.                   |
| 13. Brick kiln.       | 27. Buoys.             |                             |
| 14. Lime-kiln.        | 28. " mooring.         |                             |

The right-hand half of Plate V. contains signs used for *Vertical Sections*.

PLATE VI.

73. *Conventional Signs—U. S. Coast Survey.*—The signs in this plate are typical examples photo-engraved from the present standard topographical drawings of the U. S. Coast Survey.

The different features represented in the rectangles are as follows:

- |  |  |
|--|--|
| I. Oak woods and orchards.                         | VII. Arroyos.  |
| II. Rice-dikes.                                    | VIII. Soft stratified rocks and gulches.                     |
| III. Abraded rock-faces, granite.                  | IX. Railroad, mid-river sands and common rock escarpments.   |
| IV. Granite cliff—crest, face and talus.           | X. Railroad, tunnel, mid-river drift, canal and dam.         |
| V. Town and pine woods.                            | XI. Eroded drift-banks, with boulders set free.              |
| VI. City, villas, salt and fresh marsh, and docks. | XII. River-torrent, eruptive rocks and basaltic escarpments. |

74. An ingenious and rapid method of printing the signs by hand, due to J. A. Ocker-son, Am. Soc. C.E., is described in the Report of the Mississippi River Commission. It consists in electrotyping a tasteful arrangement of signs for any feature on a very thin copper plate, about 3×14 inches in size, backing the plate with rubber, and wrapping it around a wooden cylinder of corresponding dimensions.

The cylinder revolves about a handle passing through its centre and projecting at the ends. The plate is inked at each revolution by means of an ink-roller—the best quality of German printing-ink being used. Due pressure is applied to the handles, and the cylinder is rolled slowly over the map. Impressions are readily joined by placing a strip of paper along the edge of the part already printed, thus permitting the cylinder to overlap as much as may be desired.

To prevent any sign or name upon the map from receiving an impression, a pencil made



of common starch is drawn over it once ; and after the printing is finished, the starch is easily brushed off.

Electrotypes are made for the different signs to be used in a map of any particular tract. The time required for printing is at most one tenth of that spent in drawing by hand, and the process is exceedingly well adapted to maps of large extent, and to all which do not require a fine grade of lines.

This process is also extended to include the lettering, as described in par. 127.

#### SECTION II.—REPRESENTING THE DETAILS.

75. *Pencilling the Details.*—The positions of the details are first carefully determined by lines or dots in pencil, lightly drawn ; the shading, shadows and filling-in of outlines being omitted. Thus the edges of roads, the shore-lines of streams, are accurately represented by fine lines drawn through the plotted points, and following their various bends and curves, as given in the field-notes ; buildings, fields, forests and all features of which the boundaries are given, by outlines ; orchards, by outlines with properly spaced dots indicating the positions of the different trees ; and so on, until all the features are so completely located that no doubt or delay can arise, nor liability to erasure be incurred, in the subsequent inking.

The following order to be observed in the pencilling is found from experience to facilitate the work :

1. The communications ; 2, the streams, beginning with the principal one ; 3, the cities, towns, villages and detached buildings ; 4, the enclosures ; 5, the marshes, woods and remaining features ; 6, the contours (par. 86).

To avoid mistakes, it is well to indicate verbally, or by a few hastily drawn signs, the kinds of wood, field productions, material, etc., within the various outlines as soon as drawn. The location of rocks should be shown, so that the contours in ink may not be drawn through them.

A space may also be outlined for the scale, compass and legend.

76. *Inking the Details.*—The construction-lines, and all lines not needed to fix the positions of the features or in finishing the map, are then erased by means already described ; and those left should be reduced as much as possible consistent with visibility. The drawing is then ready for inking ; and in this operation it will be found convenient to preserve the same order as prescribed for the pencilling.

It is advisable to begin with such a part of the drawing that, in the progress of the work, lines already inked may not be defaced by rubbing, or by leaning upon the drawing.

#### SECTION III.—REPRESENTING THE CONFIGURATION OR SURFACE-FORMS OF GROUND.

77. There are two general methods of representing hills or mountains and surface-undulations, viz. :

I. By contours.

II. By contours and hill-shading.

Surface-forms are also represented by hill-shading alone ; but the contours are first surveyed and plotted in pencil, so that, although the contours may not appear in the finished map, this operation virtually resolves itself into Method II. It may be remarked, however,

that in the representations of slight changes of form and in field-sketching, hill-shading alone is frequently used.

Method I. has the advantage of simplicity, and the topographical signs are never obscured. In Method II., the elevations and depressions are more forcibly presented to the eye; and if the shading is so light as not to obscure the signs, the addition of the relief thus obtained is evidently an advantage.

#### METHOD I.—BY CONTOURS.

78. *Contours, Equidistances and References* (Plate VII.).—The intersection of the surface of the ground by a horizontal plane is a contour (the term is also applied to its projection upon a map). Shore-lines of still water are familiar illustrations of contours; and if they should be determined for an elevation, by survey at each considerable rise of water, and all projected vertically upon a horizontal plane, it is obvious that by giving to each of the projections a number representing its vertical distance from this plane, the general shape or configuration of the surface would be at once shown.

It is also apparent that the less the rise of water between consecutive measurements, the greater would be the number of shore-lines, and consequently of projections, and the more complete would be the representation.

In Fig. 28, the hill, of which  $DSP$  is a profile, is cut by the horizontal planes, of which  $aa'$ ,  $bb'$ , and  $cc'$  are the traces, and  $a''$ ,  $b''$ , and  $c''$  are the projections of the contours thus determined, upon the horizontal plane  $D'CP'$ ; the numbers 40, 80 and 120 giving the heights of  $a''$ ,  $b''$  and  $c''$  above  $D'CP'$ .

Contours are determined at equal vertical distances apart. Their heights are all referred to a single horizontal plane called the *datum plane*. These heights are indicated by numbers, called *references*, placed upon the contours, and the equal vertical distances are called *equidistances*. Thus, in the figure,  $D'CP'$  is the datum plane, its reference is 0, and the equidistance is 40. If the datum plane is intermediate in a system of contours, the — sign is prefixed to the references of contours below it.

It is apparent that the greater the degree of declivity, the closer are the projections,—compare  $D'a''$  and  $b''c''$ , the projections of  $Da$  and  $bc$  respectively,—which condition enables the observer to see at once upon the map the relative steepness of different slopes.

79. The slope between consecutive contours, along a normal or line perpendicular to both, is considered uniform; therefore the degree of declivity can readily be determined from the projections upon the map—e.g., in the figure (drawn to a scale of  $\frac{1}{1800}$ ), the degree of declivity of  $a''D'$  is the angle  $aDd$  of the right-angled triangle, of which  $Dd = 80$  feet, as determined by the scale, is the base; and the altitude  $ad = 40$  feet, is the equidistance. This angle may be constructed and measured with a protractor; or determined trigonometrically from the relation  $\text{tang. } aDd = \frac{ad}{Dd} = \frac{40}{80} = \frac{1}{2}, \therefore aDd = 27^\circ$ , very nearly; but the simplest means is a scale of inclination described in the following paragraph.

80. The *Scale of Inclination* (Fig. 29), also called a scale of horizontal equivalents, is constructed as follows:—Draw  $AB$  and  $AC$  perpendicular to each other; through  $A$  draw the radials making with  $AB$  angles of  $5^\circ$ ,  $10^\circ$ ,  $15^\circ$ , . . . . .  $45^\circ$ , as shown; set off  $Ag$  equal to the equidistance according to the scale of the map, and draw  $gf$  parallel to  $AB$ . The parts of

$gf$  intercepted between  $g$  and the points of intersection of the different radials are the cotangents of the angles to the radius  $Ag$ —e.g., in Fig. 35, the tang. and cot. of  $25^\circ$  are  $Bd$  and  $Ce$  respectively; and of  $30^\circ$ ,  $Bd'$  and  $Ce'$ ; and these are the projections of the inclined lines  $Ae$  and  $Ae'$  respectively. Similarly, in Fig 28,  $D'a'' = Dd$  is the cot. of  $VaD$  (the angle of depression of  $aD$ ), to a radius corresponding to the equidistance  $ad$ , and it is also the projection of  $Da$ . The application of the scale is thus apparent; e.g., to ascertain the angle of inclination, or the degree of declivity along a normal as  $D'a''$ , between two consecutive contours;—with the dividers, set off from  $g$ , (Fig. 29),  $gd = D'a''$ ; the position of  $d$  between the  $25^\circ$  and  $30^\circ$  radials indicates a slope of  $27^\circ$ , as in par. 79.

To ascertain intermediate slopes and those exceeding  $45^\circ$ , it is only necessary to add the corresponding radials. By cutting it out along  $fg$ , the scale can be applied directly to the map.

For another form of this scale see close of par. 81.

81. Since  $Ce, Ce', \dots$  (Fig. 35), the horizontal projections of  $Ae, Ae', \dots$ , are the cotangents of the vertical angles  $25^\circ, 30^\circ, \dots$ ; a table of cotangents gives at once the ratio of the height to the base, corresponding to a unit of distance and to any angle of inclination; and the following table thus obtained is of general use:

RATIO OF HEIGHT TO BASE, AND LENGTH OF BASE CORRESPONDING TO THE EQUIDISTANCE, FOR SLOPES FROM  $1^\circ$  TO  $60^\circ$ .

| Slopes. | Ratio of height to base (approximate). | Base for 1 unit of height (cot of slope). | Base for 5 units of height. | Base for 10 units of height. | Slopes. | Ratio of height to base (approximate). | Base for 1 unit of height (cot of slope). | Base for 5 units of height. | Base for 10 units of height. |
|---------|--|---|-----------------------------|------------------------------|---------|--|---|-----------------------------|------------------------------|
| 1°      | 1 to 57                                | 57.29                                     | 286.45                      | 572.9                        | 15°     | 1 to 3.7                               | 3.73                                      | 18.6                        | 37.3                         |
| 2       | 1 to 29                                | 28.64                                     | 143.2                       | 286.4                        | 16      | 1 to 3.5                               | 3.49                                      | 17.5                        | 34.9                         |
| 3       | 1 to 19                                | 19.08                                     | 90.4                        | 190.8                        | 17      | 1 to 3.2                               | 3.27                                      | 16.3                        | 32.7                         |
| 4       | 1 to 14                                | 14.30                                     | 71.5                        | 143                          | 18      | 1 to 3                                 | 3.08                                      | 15.4                        | 30.8                         |
| 5       | 1 to 11                                | 11.43                                     | 57.2                        | 114.3                        | 19      | 1 to 3                                 | 2.9                                       | 14.5                        | 29                           |
| 6       | 1 to 10                                | 9.51                                      | 47.5                        | 95.1                         | 20      | 1 to 2.7                               | 2.75                                      | 13.7                        | 27.5                         |
| 7       | 1 to 8                                 | 8.14                                      | 40.7                        | 81.4                         | 25      | 1 to 2                                 | 2.14                                      | 10.7                        | 21.4                         |
| 8       | 1 to 7                                 | 7.12                                      | 35.6                        | 71.2                         | 30      | 1 to 1.7                               | 1.73                                      | 8.6                         | 17.3                         |
| 9       | 1 to 6                                 | 6.31                                      | 31.5                        | 63.1                         | 35      | 1 to 1.4                               | 1.43                                      | 7.2                         | 14.3                         |
| 10      | 1 to 6                                 | 5.67                                      | 28.3                        | 56.7                         | 40      | 1 to 1.2                               | 1.19                                      | 6                           | 11.9                         |
| 11      | 1 to 5                                 | 5.14                                      | 25.7                        | 51.4                         | 45      | 1 to 1                                 | 1   | 5                           | 10                           |
| 12      | 1 to 4.7                               | 4.7                                       | 23.5                        | 47                           | 50      | 1 to 0.8                               | 0.84                                      | 4.2                         | 8.4                          |
| 13      | 1 to 4.3                               | 4.33                                      | 21.6                        | 43.3                         | 55      | 1 to 0.7                               | 0.7                                       | 3.5                         | 7                            |
| 14      | 1 to 4                                 | 4.01                                      | 20                          | 40.1                         | 60      | 1 to 0.6                               | 0.58                                      | 2.9                         | 5.8                          |

Lengths of base corresponding to heights or equidistances not given in the table, are readily found by multiplication. Thus, for an equidistance of 15 feet and a slope of  $6^\circ$ , the base is  $3 \times 47.5 = 142.5$ , or three times the base for 5 feet; for an equidistance of 50 feet and a slope of  $19^\circ$ , the base is 145.0, or 5 times the base for 10 feet, etc.

The length of base corresponding to a unit of height is roughly obtained by dividing 60 by the number of degrees representing the slope; e.g., the base for  $10^\circ = \frac{60}{10} = 6$ ; for  $15^\circ$  it is 4, for  $20^\circ$ , 3 . . . . . A scale of inclination for any equidistance can also be constructed by use of this table, as follows:—From  $G$  on the right line  $GF$  (Fig. 30), set off, according to the scale of the map,  $Ga, Gb, \dots Gk$ , corresponding respectively to the bases for the different slopes and the given equidistance, and mark the points of division as shown.

82. The *reduction of surface-measurements to the horizon* is of frequent application in the plotting of contours. A case often presented is: given the angle of elevation  $CAB$  (Fig. 31), or of depression  $VCA$ , (or  $VaD$ , Fig. 28), and the distance  $AC$ ; to find  $AB$ . Let @ repre-

sent the vertical angle, and  $h$ ,  $a$  and  $b$  the distances  $AC$ ,  $BC$  and  $AB$  respectively; then  $b = h \cos @$ —e.g.,  $@ = 15^\circ$ , of which the cosine is 0.9659, and  $h$  is 320 feet; then the horizontal equivalent  $b = 320 \times 0.9659 = 309$  feet.

If the vertical angles are very small, say less than  $10^\circ$ , it is better, for great exactness, to use the sine of the angle in the computation, since the cosines of small angles differ but little from each other in value. Thus, referring to the figure,  $h - b = h - h \cos @ = h (1 - \cos @)$ ; and since  $1 - \cos @ = 2 \sin^2 \frac{@}{2}$ ,  $b = h \left(1 - 2 \sin^2 \frac{@}{2}\right)$ .

This reduction may be made graphically by constructing a right-angled triangle in accordance with the given conditions. Taking the foregoing example; at  $A$ , on the right line  $AB$ , construct the angle  $@ = 15^\circ$ , and make  $AC = 320$  feet, according to the scale; from  $C$ , let fall the perpendicular  $CB$ , and find the length of  $AB$  from the same scale.

83. The handiest means, however, for making this reduction is *Goulier's scale*, which is constructed as follows: Let  $AB$  (Fig. 32) be the scale of the map; from  $C$ , distant from  $AB$  at least  $\frac{3AB}{2}$ , as a centre, describe the arc of a circle tangent to the scale, as shown; and beginning at the tangent point, subdivide the arc into degrees. Join  $C$  and the points of division of the scale by right lines, and through the degree divisions of the arc draw parallels to the line of the scale, terminating and marking them by numbers, as shown. Each of these parallels is a scale of reduction for the slope indicated by the number of degrees at its extremity—e.g., the scale being  $\frac{1}{1800}$ ,  $EF$  is the reduction of 120 feet measured on a slope of  $15^\circ$ ; for from the similar triangles  $CEF$  and  $CDG$ ,  $EF : DG :: CE : CD$ ; denoting the radius  $CD$  by  $R$ ,  $CE = R \cos 15^\circ$ ,  $\therefore EF = DG \cos 15^\circ = 120 \text{ ft.} \times \cos 15^\circ$ .

Therefore, in the use of this scale, the reduction is obtained at once from the parallel corresponding to the degree of declivity.

This scale, like others of frequent use, can be engraved with great exactness on metal.

84. A similar scale is adapted to the reduction of distances obtained by stadia measurements to their horizontal values. The rod being vertical, the angle of inclination of the optical axis to the horizon represented by  $\phi$ , and the reading by  $L$ ; then the horizontal distance  $H = L \cos^2 \phi$ . To construct the scale, draw  $CD$  as in Fig. 32, perpendicular to and equal in length to at least  $\frac{3AB}{2}$ . With the middle point of  $CD$  as a centre, describe an arc tangent to  $AB$ ; beginning at  $D$ , mark every second degree up to  $72^\circ$ ; draw the parallels and radius, as in Fig. 32, through the second degree divisions, and from  $C$  respectively; and mark each of the parallels at its extremity, by a number representing one half the number of degrees corresponding to the division of the arc through which it passes. Denoting the radius  $\frac{CD}{12}$  by  $R$ , any distance, as  $EF : DG :: R + R \cos^2 \phi : 2R$ ; or  $EF = DG \times \frac{1 + \cos^2 \phi}{2} = DG \cos^2 \phi$ . Then, as in the preceding case, the horizontal distance required is obtained at once from the parallel marked at its extremity with the number corresponding to the degree of inclination.

85. When the difference of level  $a$  and the surface-measurement  $h$  only are given, the reduction or base  $b$  may be obtained from the expression  $b^2 = h^2 - a^2$ ; or for rough approximations, since  $a^2 = h^2 - b^2 = (h - b)(h + b)$ ,  $h - b = \frac{a^2}{h + b}$ , from which  $b = h - \frac{a^2}{h + b}$ ; sub-

stituting  $2h$  for  $h + b$ ,  $b = h - \frac{a^2}{2h}$ . Or trigonometrically,  $b$  may be obtained by first ascertaining the angle  $@$  at the base, from the expression  $\sin @ = \frac{a}{h}$ ; then  $b = a \cot @$ .

86. *Plotting the Contours.*—The method employed in the field-work decides the way in which the contours shall be plotted. By the “regular method” of contouring, the equidistant points are determined in sufficient number to require but the plotting of these points, and the tracing or drawing of the contours through them, while at the same time carefully considering the accidental forms of ground between adjacent points, as noted in the field record or sketches. By the “irregular method,” the heights of prominent points are determined either separately, or by profiles along characteristic surface-lines, such as those of greatest and least declivity; or again, by levelling the intersections of lines traced upon the ground. These points are then plotted, and the contours are drawn through the equidistant points, which are fixed by interpolation as follows:

87. Case I.—*When the surface line joining any two of the determined points is regarded as of uniform inclination.*

In Fig. 33,  $A$ ,  $B$ ,  $C$  and  $D$ , with references as shown, are plotted; required the equidistant points for the 120', 140' . . . . . 200' contours.

Join the different points by right lines as shown. Each line, the length of which is obtained by referring it to the scale of distances, ( $\frac{1}{1800}$ ), is the base of a right-angled triangle, of which the difference of the references of its extremities is the altitude. Beginning with the line  $AB$ , the distance from  $A$  to  $p$ , the 200' equidistant point, may be obtained from the following proportion.

The difference of the references of  $A$  and  $B$ : the difference of the references of  $A$  and  $p$  ::  $AB$  :  $Ap$  = the distance required; or directly,  $98' : 12' :: 250' : Ap = 30'.6$ , which laid off from  $A$  on  $AB$ , according to the scale of distances, fixes  $p$ .

It is advisable, however, to use the shortest methods and preserve uniformity in making the computations. Thus,  $\frac{250}{98} = 2.551$  is the cotangent of the angle of inclination of  $AB$ ; therefore  $Ap = 12' \times 2.55 = 30'.6$ , and  $Bp' = 6' \times 2.55 = 15'.3$ ; which laid off on  $AB$ , from  $A$  and  $B$  respectively, fix the 200' and 120' equidistant points.

The interval  $pp'$  is then subdivided into four equal parts, and the points of subdivision are the required points of the other contours. Similarly,  $\frac{120}{78} = 2.0$ , is the cotangent of the angle of inclination of  $AC$ ; the 200' point is  $12' \times 2.0 = 24'$ , distant from  $A$  on  $AC$ ; and the 140' point is  $3' \times 2.0 = 6'$ , distant from  $C$ ;—the 120' contour evidently passing below  $C$ , and cutting the line  $BC$  at a point 44'.4 from  $B$ . The equidistant points on  $AD$  are fixed in like manner.

If the angle of inclination of  $AB$  is also given in the record, the cotangent is obtained at once from the table, and the operation is still further simplified.

88. Fig. 34 illustrates a *method of fixing the equidistant points graphically.*

The references of the plotted points  $A$  and  $B$  are respectively 62' and 93'. To interpolate the five-foot contours from 65' to 90': join  $A$  and  $B$  by a right line; then draw  $AC$ , making a convenient angle with  $AB$ , and subdivide it with a scale of equal parts, according to the equidistances desired. Thus, using the tenths of inch-divisions, place the scale along  $AC$ , the 6'.2 division coincident with  $A$ , and mark the 6''.5, 7''.0, 7''.5 . . . . . 9''.0, and 9''.3 points as

shown; join *C* and *B* by a right line, and through the marked points draw lines parallel to *CB*. Their intersections with *AB* are the equidistant points required.

In most cases the line *AC* may be dispensed with—the required points being dotted along the edge of the scale of equal parts placed at a convenient angle.

When the heights of the different points are obtained by levelling the intersections of lines traced upon the ground, the slope between adjacent points is considered uniform, and the operation of plotting the equidistant points is similar to that just described.

89. Case II.—When the surface line is not regarded as of uniform inclination.

Thus, in Fig. 36, the profile *Kk* is obtained by section-levelling. To fix the equidistant points of the 50, 40 . . . . . contours: set off from *K*, on *KA*, *Ka*, *Kb* . . . . ., respectively equal to 2', 12', 22' and 32', according to the vertical scale; and through the points *a*, *b*, . . . . . draw *aa'*, *bb'*, . . . . . parallel to *AB*. From the points of intersection of these parallels with *Kk*, let fall the perpendiculars intersecting *AB* at *m*, *n*, *o* and *p*; then the distances *Am*, *An* . . . . ., set off from *A* on the plotted profile, will fix the required points.

The positions of the equidistant points are frequently estimated by eye in the field-work; and the plotting is simply a copy of the field sketch, according to the scale of the map (see Topographical Sketching).

90. Scale of Slopes.—If the references of the extremities, or at least of one extremity, and the angle of inclination of a line, are given, the scale of slopes affords a ready means for fixing the equidistant points. It is constructed as follows: From *A*, Fig. 37, set off on *AB* the distances *A* 45°, *A* 40°, . . . . . *A* 15°, proportional to the cotangents of 45°, 40°, . . . . . 15°, and draw horizontals through the extremities. Subdivide the 15° horizontal into equal parts, each representing the cot. 15° to a radius of 0".05, or  $3.7320 \times 0".05 = 0".186$ , which represents the horizontal distance between two points, having a difference of level of 5', 10', 20', 50', or 100', according as the scale of the map is  $\frac{1}{2500}$ ,  $\frac{1}{4000}$ ,  $\frac{1}{8000}$ ,  $\frac{1}{16000}$ , or  $\frac{1}{32000}$ .

Join these points of division with *A*; then each of the upper horizontals will also be subdivided into equal parts in length proportional to their distance from *A*, and which represent the horizontal distances, corresponding to the degree of inclination marked at the left-hand extremity. Horizontal distances corresponding to smaller equidistances may be represented by a further subdivision, as shown in the left-hand intervals, below the 15° horizontal.

Choosing another point *A'* at pleasure, the distances *A'* 10°, *A'* 9°, *A'* 8°, proportional to the cotangents of 10°, 9° and 8°, are set off from *A'*; the 8° horizontal is divided into equal parts, each representing the cot. 8° to the same radius as before, or  $7.1154 \times 0".05 = 0".355$ , and lines are drawn from the points of division converging at *A'*, as shown.

In like manner, proportional distances are set off from *A''* and from *A'''*; the 4° and 2° horizontals are similarly divided into equal parts, and lines are drawn as before, converging at *A''* and *A'''*.

Horizontals for the intermediate degrees are readily drawn; and a scale of tangents is added on the right, for use in plotting when the measurements are taken with instruments which give the tangents of inclinations only.

This scale is of very simple application. Thus, in Fig. 38, to interpolate the 70', 80', . . . . . 110' equidistant points in the line *AB*, the angle of inclination being 4° and the scale  $\frac{1}{4000}$  (diminished in the Fig.). Presuming the scale to be on tracing-linen, place *a*, the subdivision

of the  $4^\circ$  horizontal, coincident with  $A$ , of which the reference is (62'), and prick through the required points  $b, c, d \dots$

If the scale is on metal, transfer the points with a paper slip.

91. *Drawing of Contours*.—The equidistant points having been plotted, and the contours completely represented in pencil, the contours are then drawn, usually in red ink or crimson lake. Burnt sienna is sometimes used for this purpose,—(See Plate VI.)

The lines should be of the medium grade (I. par. 43), even and distinct, and are best drawn with a curve-pen (par. 17), carefully following the pencilled contours. After considerable practice, a less stiff and consequently more pleasing effect may be produced by using the common pen for this purpose. They are never drawn through the sign for rocks or buildings, and, except on maps to a very small scale, they should not cross the signs for communications.

The references, in small, distinct figures, are sometimes placed in breaks left in the contours, but it is just as well to place them immediately above the corresponding contours, with their bases resting upon the latter; and it makes them more conspicuous to place them along a line, normal to all the contours included between the summit and base of each slope—the tops of the figures, as above implied, being toward the summit. For convenience in reading the map, the references may be repeated in different parts of it, more particularly where the contours make marked changes of direction.

The value of the equidistance, "Equidistance (so many) feet or yards," is noted on the map, either in the vicinity of the scale of distances, or immediately below the left-hand extremity of the lower edge of the border.

For convenience in reading the map, every fifth or tenth contour, counting from the datum plane, is made a trifle heavier than the others: e.g., if the equidistance is 5 feet, the 25', 50' . . . . ., or the 50', 100' . . . . . are emphasized; if 2', the 10', 20' . . . . . A contour of doubtful position is represented by a dotted line.

92. *Intermediate contours*, represented by dotted lines, are sometimes necessary to define the outline of a summit, or to represent intervening or accidental slopes, when the equidistance is relatively great. Thus, in Fig. 39, the summits  $S$  and  $S'$  . . . . . and the configuration of the ground about them are thus defined. The reference of a summit is placed within this upper contour.

*Auxiliary contours*, as applied in the text, are those used especially for determining the directions of hachures, and are described in the appropriate place.

93. *Study of a Contoured Map*.—Fig. 39, Plate VIII., shows various surface-forms of ground as represented by contours, and also the positions of certain surface-lines and other details, preparatory to a description of Method II. The references are purposely omitted, but relative heights are readily ascertained by assuming the datum level at pleasure, say 50 feet below the lowest contour, and applying the equidistance. Watercourses naturally indicate the lower surface-lines of a tract; and the main stream or body of water, the lowest surface-line; therefore when these are contained in a contoured map, no difficulty usually arises in determining the general configuration, even without the references. Thus in the plate, the general slope from  $S'$  (near village) is to the right, left and front down to the main stream, and is interrupted on the right by the plateau containing the village. An exceptional case however, is presented SW from  $S$ . With no streams or references it is impossible to decide

whether  $D$  is a summit, or the base of a depression; in the plate it represents the latter feature, and is marked with the letter  $D$ . All depressions situated in tracts generally level, or where any ambiguity might exist, should be marked with the letter  $D$  in red or black.

The irregular forms marked  $r$  indicate rock-surfaces; and it is observed, as heretofore described, that the contours terminate abruptly at their outlines.

The ridges  $SCS'''$  and  $S'C''S''$  are called *water-partings*, because at these lines the surface water parts and begins to flow down the slopes on either side. The position of a water-parting is determined, as in the case of the ridge  $SCS'''$ , by joining the points  $S$ ,  $C$  and  $S'''$  by a line which intersects the intervening contours at their points of greatest curvature (see also  $d$ , par. 100).

The lines  $S'P$  and  $S^{1v}P'$  are also water-partings, and are similarly drawn. A water-parting of great extent is termed a *divide*. The slopes extending from a water-parting in either direction are called *water-sheds*. The lines  $BW$ ,  $B'W'$  and  $CD$  are termed *watercourses*, because the water from the adjoining slopes unites along this line and follows it to the outlet. Watercourses, like water-partings, cut the contours at their points of greatest curvature. The watercourse or axial line of a valley is termed the *thalweg*: it is the line of meeting of the slopes on either side.

It is observed in the case of a water-parting that the contours are concave, and in the case of a watercourse convex, toward the summit of the slope which they immediately define. Adjacent descending normals (par. 100) diverge from a water-parting and converge toward a watercourse, as shown at  $S^{1v}P'$  and  $BW$  respectively. (See also lines of greatest descent, par. 100.)

The depressions  $C$ ,  $C'$  and  $C''$  between adjacent summits are termed *Cols*, necks or saddles, and are important details in regard to hill-shading.

Geometrically considered, a col is the highest point of the line of intersection of two adjoining slopes. As in Fig. 42,  $AB$  is the line of intersection of two slopes or spurs, determined by joining the points of intersection of contours having like references; and  $C$ , the highest point of this line, is the col. It is the lowest point of the ridge  $SS'$ . The general surface between the summits  $S$  and  $S'$  is therefore of double curvature, ascending from  $C$  to  $S$  and  $S'$ , and descending from  $C$  to  $A$  and  $B$ .

The natural surface is more like that shown in Fig. 43. The col  $C$  is ordinarily a small plateau sloping as above described, and limited as shown by the dotted lines, which are the intersections of the surface by a horizontal plane intermediate between the "20" and "30" contours. Other forms of cols are shown in the plate.

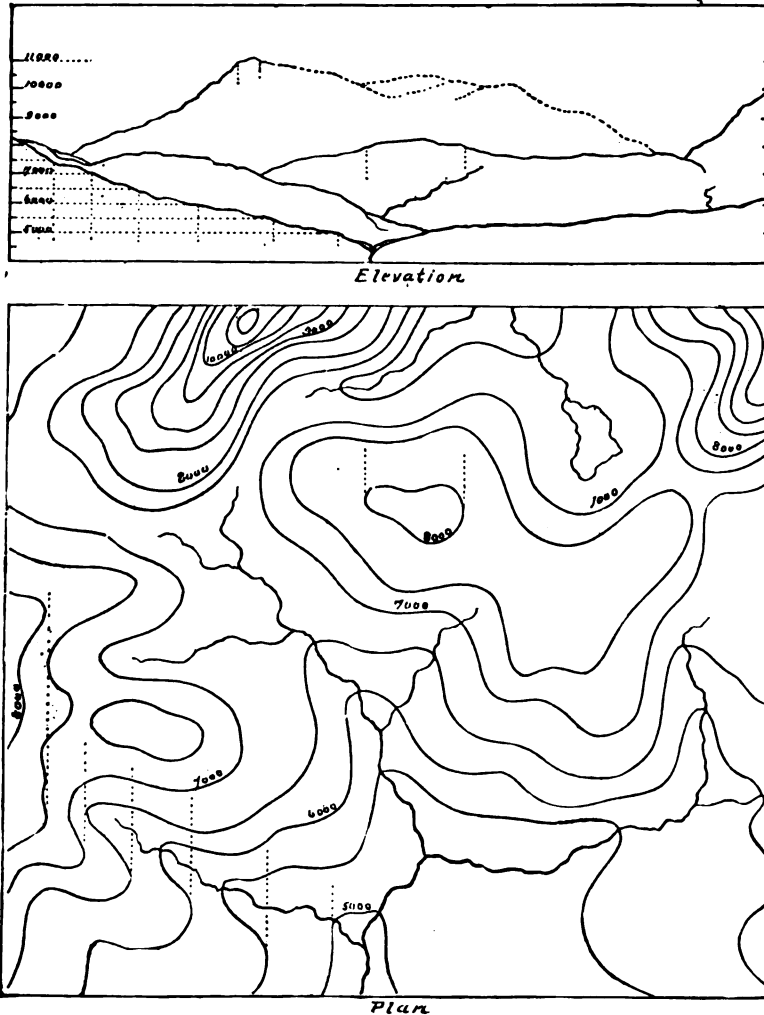
94. *To Construct a Vertical Section from a Contoured Map*, as through  $AA$  (Fig. 39).—Draw  $AA$ , and at a convenient distance below,  $A'A'$  parallel to it.

Set off from  $o$ , near  $A'A'$ , the equal vertical distances  $o-1$ ,  $1-2$ , . . . ., according to the vertical scale and corresponding to the equidistance, and through the extremities draw lines parallel to  $A'A'$ ; the latter are the traces of contour planes. From the points  $v$ ,  $v'$ ,  $v''$ , . . . ., in which  $AA$  intersects the contours, let fall perpendiculars  $vv$ ,  $v'v'$ , . . . .; then the line  $VV$ , through the intersections of the latter with the corresponding traces, is the section required. Various intersected details, such as roads, streams, rocks and buildings, are represented in a similar manner by projecting the extreme points of their outlines and filling the space by characteristic lines, as shown.



The *Sectograph* (Fig. 41) is a convenient instrument for this purpose. It consists of a rectangular piece of cardboard on which lines, parallel to the longer edge  $MN$ , are ruled with intervals corresponding to the equidistance and the scale of the map; and lines perpendicular to  $MN$  are drawn at convenient intervals to assist the eye in determining vertical directions.

In use, it is so placed upon the map that the edge  $MN$  coincides with the line, as  $HH'$ , along which the section is required.



From the points in which  $MN$  intersects the contours, verticals are then drawn to the corresponding parallels as shown, and a line  $EGF$  through the points thus determined is the section required. The sectograph is particularly convenient when several sections are required from the same map. It is also handy for ascertaining if any point is visible from another. Thus, to determine the intervisibility of  $H$  and  $H'$ , construct the section as above and apply a straight-edge from  $E$  to  $F$ , if it intersects the section, the points are not intervisible, otherwise they are. Only such portions of the section need be drawn as will contain the doubtful points.

The simpler plan, however, would be to join the

points by a right line; then, at the only points of it which from inspection could obscure the view, erect perpendiculars to this line; lay off on each its corresponding height as given by the contours, and apply a straight-edge, as above, to the outer extremities.

An *Elevation* is the orthographic projection upon a vertical plane of the visible outlines of all the features, both near and distant, which it may be desired to represent, and gives at a glance a comprehensive idea of relative heights. The above figure illustrates the method of construction from a contoured map.

No explanation is considered necessary. The projecting lines are simply tangent to the contours; and because the nearer outlines obscure those beyond, the former are constructed first.

95. To lay out a Road of a Given Grade, say of  $6^\circ$ .—Referring to the table, par. 81; for a

“rise” of 50 feet, the base is  $9.51 \times 50 = 475.5$  feet; therefore, with this distance reduced to the scale of the map (Fig. 39) as a radius, and the starting-point *a* (at right of bridge) as a centre, describe an arc intersecting the next higher contour; from *b*, the point thus determined, as a new centre, and with the same radius, find *c*, and so on. A line through these points, conforming to the general configuration of the surface, gives the direction of the road. Strictly, it defines the edge nearest the summit of the different slopes.

#### METHOD II.—BY CONTOURS COMBINED WITH HILL-SHADING.

96. Three different systems are in use :

I. The *Horizontal System*, in which the spaces between the contours are filled with strokes parallel to the contours.

II. The *Vertical System*, in which these spaces are filled with strokes normal to the contours.

III. Contours and brush-shading, which may be termed the *Brush System*.

Various methods, named after the inventors or the countries in which they are generally used, are employed in the different systems.

The first two systems have been in general use up to the present time. A knowledge of them is therefore necessary to understand maps constructed in accordance with them. For the engraver to accurately represent a tract in relief, a hachured map (*c. par. 100*) is necessary as a model to work from. Practice in hachuring cultivates accuracy of observation, and an appreciation of forms of ground, and also gives a manual skill not otherwise readily obtainable. These systems are therefore fully described in the text. The principal objections to their employment, at least for the manuscript maps usually required, are the obscuration of details, particularly upon the steeper slopes, and the great amount of time consumed in the work of hachuring.

System III., or the “brush system,” combines the elements of exactness and rapidity of execution, which are most desirable in the production of manuscript maps; and since the art of engraving by “crayon-lithography” is being rapidly perfected, it is reasonable to conclude that this system will soon be generally adopted for all purposes of hill-representation where relief additional to that given by the contours may be desired.

A description of hill-shading naturally comes first in the explanation of Method II.

#### HILL-SHADING.

97. The object of hill-shading is to produce a relief more pronounced than that afforded by detached contours.

The surface to be represented is considered as illuminated by either vertical or oblique rays of light, and different kinds of relief are thus produced. Rules are deduced governing the application of the shading in these two general cases, and are modified to suit each particular method or system of shading. As in the representation of other features, the visual rays are considered as vertical. With *vertical illumination*, the angle of incidence increases, and the quantity of light received upon a unit of surface diminishes, as the different surfaces are more inclined to the horizon; therefore slopes appear darker as the angle of inclination is greater. A horizontal surface thus appears white, and is so represented. The angle of inclination, corresponding to which a slope shall be represented by black, is not rigidly fixed. It is

usually considered as either  $45^\circ$  or  $50^\circ$ —the angle of stability of common earth. But if it be represented by  $n^\circ$ , then with vertical illumination there results the following general rule to be observed in shading:

*Horizontal surfaces are represented by white; slopes of  $n^\circ$  and upward, by black; and intermediate slopes by an intensity of shade varying directly with the angle of inclination.*

98. With *oblique illumination*, the effect is to make slopes on the side of the source of light appear lighter, and on the reverse side darker, irrespective of their relative steepness. In 1874, previous to which purely arbitrary methods existed, M. le Colonel Goulier, professor of topography at the French School of Application, deduced a general rule applicable to this case. With vertical illumination, a right cone with a circular base would be represented by a shade of uniform intensity; but with oblique illumination, and assuming the top of the paper as N, the shading is graded as follows: the NW element of the cone is shaded with an intensity represented by 1, the NE and SW elements receive the intensity 2, and the SE element, the intensity 4; therefore with oblique illumination the general rule for shading is:

*The element in full light receives a certain intensity of shade; this is doubled for the half-lighted elements, and quadrupled for the element most remote from the source of light. The spaces between these elements receive the corresponding intermediate shades.*

The relief thus obtained is very striking; but contours cannot be dispensed with in the finished map, if a correct representation of relative heights and steepness is desired.

99. The oblique illumination is very useful in depicting rock-surfaces, and in general for rugged tracts, in which high peaks, sharp ridges and deep ravines predominate; while for an undulating or moderately hilly country the vertical illumination produces sufficient relief.

The present tendency is to employ the latter for the general hill-shading, and the former in the representation of rock-surfaces.

100. Before describing the different systems of hill-shading, certain *elementary definitions* are necessary.

*a.* A *normal* is a line perpendicular to the tangent to a curve at the point of contact: *aa* and *bb*, Fig. 44 (Plate VIII.), are normals to the given curve.

Two curves are normal to each other when their tangents at the point of intersection are perpendicular; thus, in Fig. 45 *n'n'* is normal to *nn*.

*b.* A *zone* is the inclined surface bounded by adjacent contours; and which would be generated by a right line moved along these contours, while at the same time it is normal to both. In projection, it is the space bounded by adjacent contours.

*c.* *Hachures* are the pen- or pencil strokes which make up the shading. The perpendicular distance between the central or axial lines of adjacent hachures is termed the *space*, and the white space between adjacent hachures the *interval*. The proper distribution of hachures is described under the different systems and methods of hill-shading.

*d.* A *line of greatest descent*, also termed an *orthogonal*, is a surface-line, usually curved, which at any of its points has a greater inclination to the horizon than any other intersecting surface-line has at that point.

It is normal to the contours, both on the surface and in projection. Thus, in Fig. 46, let *cc* and *c'c'* represent two adjacent surface contours so close together that the part *AB* of the line of greatest descent may be regarded as rectilinear: *dd* is the projection of *cc* upon the plane of *c'c'*, *A'* is the projection of *A*, and *A'B* of *AB*, upon this plane. Let *BC* be so small as to be

considered rectilinear, and draw  $CA'$  and  $CA$ ; then from the right-angled triangles  $AA'B$  and  $AA'C$ ,

$$\text{tang } B = \frac{AA'}{A'B}, \quad \text{tang } C = \frac{AA'}{A'C}.$$

From the definition of the line of greatest descent, angle  $B >$  angle  $C$ ,  $\therefore$  tang  $B >$  tang  $C$ , and  $A'B$  must be less than  $A'C$ ; therefore  $A'B$  is perpendicular to  $BC$ , and consequently to  $c'c'$ ; and from a well-known proposition of geometry,  $AB$  is also perpendicular to  $c'c'$ .

Therefore in projection, as well as upon the natural surface, a line of greatest descent meets or cuts the contours perpendicularly, and is consequently normal to them. Since water-partings and watercourses are also normal to the contours, they are included in this class, being lines of greatest descent having a less inclination than others in their vicinity.

In the horizontal and vertical systems, lines of greatest descent determine the directions of the hachures; it is therefore essential that they should be correctly drawn, and the water-partings and watercourses described in par. 93, together with auxiliary contours, are used for this purpose. No difficulty usually attends the drawing of a water-parting or a watercourse, since it is simply necessary to begin it at the summit of a salient or re-entrant, as the case may be, and produce the line so it shall cut the contours at their points of greatest curvature, and at the same time be normal to them. Thus, in Fig. 47, the water-parting  $SP$  is so drawn; but when the contours are widely separated and oblique to each other, it is difficult at first sight to determine the directions of lines of greatest descent, as from  $a, a', \dots$ ; therefore lines called *auxiliary contours* are interpolated, as shown in Fig. 48. Since the sections of the water-parting  $SP$ , included in the different zones, increase in length progressively from the summit to the base of the slope, they should be correspondingly subdivided to obtain the required equidistant points for the auxiliary contours. The lines  $S'P'$  and  $S''P''$ , separating the more rounded portion of the salient from the slopes represented by contours sensibly parallel, are first drawn and their sections are subdivided, as in the case of  $SP$ : the auxiliary contours are then drawn through the corresponding points of subdivision, as shown in the figure.

The smaller zones thus formed may be further subdivided if desired, until no doubt can exist as to the direction of the lines of greatest descent, which are then drawn as required. After some practice, the operation may be simplified by subdividing the water-parting or watercourse only as above described, and then drawing the auxiliary contours by eye, so they shall pass through these points. In the case of a re-entrant or ravine these lines are drawn in a similar manner.

A col, Fig. 49, presents the only case where the drawing of these lines appears difficult.

Suppose the lowest point  $C$  of the ridge  $SS'$ , and also of the col itself, to be an equidistant point; then the contours with the same reference as this equidistant point, of all the slopes, will meet at this point, and these contours will conform sensibly to the lines  $cc$  and  $c'c'$ . If  $C$  is not an equidistant point, the directions of the adjacent contours will conform closely to the directions of  $cc$  and  $c'c'$ , and their distance from these lines can be readily estimated. Therefore, these lines are drawn first in their approximately true position; the water-partings  $SC, S'C$ , and the watercourses  $CB, CA$ , are then drawn; and the sections of the latter contained in the different zones, and between  $C$  and the nearest contours, are subdivided as described in the cases of spurs and ravines. Auxiliary contours are

drawn through the points of subdivision, as shown in the figure, and the directions of the lines of greatest descent are at once determined. It may be observed that when  $C$  is an equidistant point, the solitary case of contours meeting upon a natural surface is presented; and this case and that of a vertical surface are the only instances of contours meeting or apparently intersecting in projection.

*e.* Lines of greatest descent and auxiliary contours are called *guiding-lines*, because, as heretofore stated, they determine the directions of the hachures.

*f.* A *scale of shade* is a means for determining the intensity of shade appropriate to a given slope; and a *working-scale* is a guide to the proper distribution of the shade, in the form of hachures or with the brush, in accordance with the scale of shade.

Since these scales differ in the different systems, they are separately described in connection with these systems.

101. *Preliminary Work required in the Application of the Different Systems.*—The contours having been plotted in pencil—

I. Construct a scale of inclination (par. 80) for the given equidistance.

II. Construct a working-scale (described with each system) suited to the scale of the map.

III. Draw the guiding-lines (*e*, par. 100), if the map is to be hachured, so that no doubt can exist as to the proper directions of the hachures. These may be drawn as the work of shading progresses, and are in pencil.

102. An example of the *Horizontal System with Vertical Illumination* is given in Plate IX. This is commonly known as the English system, and is now in use in the English schools of topography (see also par. 109).

The standard scale of shade and a working-scale, used in the English government surveys, are represented in Plate XI., Fig. 59. The former is in the column headed "Scale of Shade for Angle given;" each set of hachures, with its intervals, showing the relative amount of black and white for the slope designated below it, as well as the exact breadth of hachure and interval to be used in representing this slope upon a map drawn to any scale and with any equidistance.

The working-scale, in the two outer columns, shows the *number* of these hachures, with their intervals, to be used in the different zones for a map drawn to a scale of  $\frac{1}{100000}$ , or 6 inches to 1 mile, and an equidistance of 25 feet.

For an equi-distance of 50 feet and the same representative fraction ( $\frac{1}{100000}$ ) the number of hachures for a  $35^\circ$  zone would be 4, instead of 2 as in the figure; for a  $20^\circ$  zone, 6 . . . . . To find the *number* of hachures for the different slopes for any representative fraction and equidistance, apply the corresponding scale of inclination (par. 80) to the edge of the scale of shade; and the number of hachures in the  $35^\circ$ ,  $30^\circ$ . . . . . sets, covered by the  $35^\circ$ ,  $30^\circ$ . . . . . divisions of the scale of inclination, is the number required. For slopes between  $35^\circ$  and  $45^\circ$ , the hachures given for  $35^\circ$  are used, the breadths being increased, while the number remains the same; and beyond  $45^\circ$ , vertical hachures or dashes irregularly placed are used.

The inner column, headed "Approximate Gradients," gives the tangents approximately, instead of the degrees of inclination.

The *lengths of hachures* are not fixed, varying between  $\frac{1}{80}$  and  $\frac{1}{2}$  of an inch, the finer hachures being made the longer.

The *operation of shading*, following the preliminary work (par. 101), is governed by the following rules:

The working-scale is applied to the different zones where the slope changes, and a few strokes of the proper breadth and in the right direction are made—preferably with the pencil at first—to serve as guides in the hachuring.

The hachures conform in direction to the auxiliary contours, and are invariably drawn perpendicularly to the lines of greatest descent; as at *mm*, Fig. 60, and not as at *nn*.

Beginning at the summits and working downwards, the hachures are drawn in sets which are blended into each other, and which break intervals so as to prevent the existence of white streaks, as at *oo*.

The sets should not be drawn in bands around the elevation.

The hachures are drawn towards the draughtsman, the work extending toward the right, so the pen will not hide the last hachure drawn, and the space can be readily estimated—the paper being so disposed as to facilitate this operation.

Each hachure is of the same breadth throughout, and should be drawn freely and firmly. Much care and deliberation are required at first, but freedom of execution will come from practice.

If the contours are to be in the finished map, they are drawn in red, as described in par. 91; or if in black, in broken and dotted lines, to distinguish them from the hachures.

103. *Despres' System* is the same as the English system, except that the contours are always required in the finished map.

In *Mandrot's System*, employed in Switzerland, no hachures are used, the shading being effected by increasing the breadths of the contours in direct proportion to the angles of inclination; and where a brown color, instead of India ink, is used for the contours, the details are not obscured, and a pleasing effect is produced. Some of the fine Russian maps of Sebastopol were constructed, under the direction of General Todleben, according to this system.

104. The *Horizontal System with Oblique Illumination* is also illustrated in Plate IX. The method of procedure is the same as with vertical illumination, except that the gradation of the hachures is in accordance with the principles given in par. 98. As before stated, this kind of representation produces a very striking effect when the surface is very rugged.

105. *The Vertical System with Vertical Illumination* is illustrated in Plates IX. and XII.

There are several varieties of this system of shading, the most important being Lehmann's, commonly known as the "German System," and its modifications, and the French System; in all of which the hachures are drawn coincident with lines of greatest descent (par. 100). Except in the French System, and for slopes from  $1^{\circ}$  to  $5^{\circ}$  in the use of Lehmann's scale, the hachures are drawn a certain number to an inch, measured perpendicularly to the lines of greatest descent throughout the same map; while their lengths are not fixed, but are generally, as in the horizontal system, increased for the gentler slopes.

The mechanical operation of drawing hachures, including curving, blending, etc., is the same for all, and is described in par. 115; but their distribution is in accordance with the different scales of shade and working-scales.

#### SCALES OF SHADE AND WORKING-SCALES.—PLATE X.

106. *Lehmann's Scale of Shade and Working scale*.—Referring to the general rule for shading with vertical illumination (par. 97),  $n^{\circ}$  in this scale is  $45^{\circ}$ , and the intensities of shade

for the different slopes from  $0^\circ$  to  $45^\circ$ , may be denoted by the numbers 0, 1, 2, 3, . . . . . 45,—0 representing white, and 45 black.

Considering only the slopes of  $5^\circ$ ,  $10^\circ$ ,  $15^\circ$ , . . . . .  $40^\circ$ , differing by  $5^\circ$ , the intensities of the corresponding shades are then 1, 2, 3, . . . . . 8; therefore, to construct the scale of shade, the space between the parallels  $AB$  and  $CD$ , Fig. 50, is divided into ten equal rectangles marked  $0^\circ$ ,  $5^\circ$ , . . . . .  $45^\circ$ , each of which is subdivided into nine others by vertical lines as shown. One subdivision of the  $5^\circ$  rectangle is then blackened, 2 of the  $10^\circ$ , 3 of the  $15^\circ$ , . . . . . 9 of the  $45^\circ$ . The ratio of black to white is thus shown to be :

|   |   |
|---|---|
| For a $5^\circ$ slope, 1 : 8, or $\frac{1}{8}$ ;  | for a $25^\circ$ slope, 5 : 4, or $\frac{5}{4}$ ; |
| for a $10^\circ$ slope, 2 : 7, or $\frac{2}{7}$ ; | for a $30^\circ$ slope, 6 : 3, or $\frac{6}{3}$ ; |
| for a $15^\circ$ slope, 3 : 6, or $\frac{3}{6}$ ; | for a $35^\circ$ slope, 7 : 2, or $\frac{7}{2}$ ; |
| for a $20^\circ$ slope, 4 : 5, or $\frac{4}{5}$ ; | for a $40^\circ$ slope, 8 : 1, or $\frac{8}{1}$ ; |

and this ratio for any slope is obtained from the expression  $\frac{@}{45^\circ - @}$ , @ representing the angle of inclination ; e.g., the ratio for  $15^\circ$  is  $\frac{15}{45 - 15} = \frac{3}{6}$ .

An exception is made for slopes less than  $5^\circ$ , the number of hachures being diminished as follows: For the same map-space which for a slope of  $5^\circ$  is covered by five hachures, four hachures only are used for a  $4^\circ$  slope, 3 for  $3^\circ$ , 2 for  $2^\circ$ , and 1 for  $1^\circ$ .

To construct a *working-scale*, it is usually necessary to first decide upon the number of hachures required per inch. This number varies generally with the scale of the map, as many as 75 being used for maps drawn to very small scales, while 40 to 60 is the usual number.

In Lehmann's standard working-scale, however, this number is fixed by making the breadth of the hachure for a  $5^\circ$  slope  $\frac{1}{4}$  of a millimetre (Maes); and the breadth of hachure for any slope exceeding  $5^\circ$  is readily deduced from the proportion  $H : S :: @ : 45^\circ$ ; in which  $H$  is the breadth required,  $S$  is the space between the axes of the hachures—in other words, a unit of the number per inch—and @ is the angle of inclination. A method of constructing the standard working-scale is shown in the lower part of the figure (50). The main divisions of the scale of shade are made 16 mm. (about  $\frac{3}{4}$  inch) in length, four parallels are drawn below  $CD$ , as shown, and the verticals defining the main divisions of the scale of shade are produced to  $EF$ . In the first row of rectangles thus formed below  $CD$ , the black corresponding to the different slopes is subdivided into two equal parts and distributed as shown; these parts are again subdivided and distributed in the following row; and so on to  $EF$ , in which the black and white is in the form of hachures with spaces of 1 mm.

In following this method of construction, to obtain any required number per inch, make the main divisions of the scale of shade of corresponding length, and, if necessary, change the number of rows used to distribute the black; e.g., for 20 per inch, the main divisions should be 0.8 inch in length; for 30,  $\frac{1}{3}$  . . . . . In practice, the breadths of hachures and intervals intermediate to those given in the working-scale are estimated by eye.

To make use of this scale, it is cut off along the line  $EF$ , the scale of inclination (par. 80) is applied to the contours, and the hachures corresponding to the slope thus determined are copied from it—the edge  $EF$  being placed just above the contour for this purpose. The  $40^\circ$  hachures, increased in breadth, are used instead of solid black for the  $45^\circ$  slopes.

It may be observed that contours in Lehmann's original system simply gave the general outline of the configuration, without indicating absolute heights, and thus merely served as guiding-lines for the hachures.

107. *The Austrian Scale of Shade and Working-scale.*—On account of the total obscuration of details frequently produced in the representation of mountainous tracts by the use of Lehmann's scale, the Austrian school increased its range by making  $n = 50$  (par. 97), for slopes from  $5^\circ$  to  $45^\circ$  inclusive. The intensities of shade for the different slopes,  $5^\circ, 10^\circ, 15^\circ, \dots, 45^\circ$ , are thus represented by the numbers 1, 2, 3, . . . . . 9, and the scale of shade could be constructed in a manner similar to that adopted in the construction of Lehmann's; but this school chose to represent in the different rectangles the relative amount of black and white, for the different slopes, in spaces corresponding to intervals between consecutive contours, and the scale (Fig. 51) is thus constructed.

From  $G$  on  $GH$ , lay off consecutively, and to any convenient radius, the cotangents of  $5^\circ, 10^\circ, 15^\circ, \dots, 45^\circ$ , which is readily done by use of the scale of inclination (par. 80), and erect perpendiculars at the extremities of these distances; divide one of these perpendiculars, as  $Gg$ , into ten equal parts, and through the points of division draw lines parallel to  $GH$ , as shown. The main divisions of the scale, marked  $5^\circ, 10^\circ, \dots, 45^\circ$ , will thus be divided into ten equal parts. One part of the  $5^\circ$  division is then blackened, two parts of the  $10^\circ, \dots, 9$  of the  $45^\circ$ .

The ratio of black to white is thus shown to be:

|                                |                                |
|--------------------------------|--------------------------------|
| For a $5^\circ$ slope, 1 : 9;  | for a $25^\circ$ slope, 5 : 5; |
| for a $10^\circ$ slope, 2 : 8; | for a $30^\circ$ slope, 6 : 4; |
| for a $15^\circ$ slope, 3 : 7; | for a $35^\circ$ slope, 7 : 3; |
| for a $20^\circ$ slope, 4 : 6; | for a $40^\circ$ slope, 8 : 2; |

and for slopes of  $45^\circ$  and upwards, 9 : 1.

This ratio for any slope between  $5^\circ$  and  $45^\circ$  is obtained from the expression  $\frac{50 - @}{@}$ , @ representing the angle of inclination. In the plates issued by the Polytechnic School at Karlsruhe, @ = 50.

The same exception as in Lehmann's scale is made for slopes between  $1^\circ$  and  $5^\circ$ .

These ratios and the consideration that the lengths of hachures are purely arbitrary, render the construction of the *working-scale* a very simple matter. For clearness of illustration 20 hachures per inch are assumed, and the working-scale is constructed as shown in Fig. 52. Five hachures for each slope are a sufficient number to serve as guides in the distribution of the shade; therefore on  $IK$ ,  $2\frac{1}{4}$  inches in length, construct 9 equal rectangles and mark them  $5^\circ, 10^\circ, \dots, 45^\circ$ , as shown; subdivide each rectangle by fine vertical lines into five equal parts, and blacken each part in accordance with the scale of shade. The last operation is conveniently performed as follows: Since the breadth of the black for  $5^\circ$  in the scale of shade is  $\frac{1}{10}$  of the breadth of the  $5^\circ$  rectangle, the hachure for this slope is  $\frac{1}{10}$  of  $\frac{1}{5} = \frac{1}{50}$  of an inch; therefore the fine vertical lines already drawn in the  $5^\circ$  rectangle of the working-scale represent the hachures for this slope. Similarly, the intervals between the hachures of the  $45^\circ$  rectangle are made as narrow as possible. The hachures of the  $25^\circ$  rectangle are then



constructed by blackening  $\frac{1}{2}$  of each vertical subdivision; those of the  $35^\circ$ , by blackening  $\frac{3}{4}$ ; of the  $15^\circ$ ,  $\frac{1}{4}$ ; and the breadths of the hachures for the other rectangles are then proportioned between those already drawn. The blackening in each case should begin at the vertical lines of subdivision and extend in the same direction throughout the scale.

The breadths of hachures for slopes intermediate to those given in the scale are estimated by eye.

The scale is completed by producing the main lines of subdivision downwards, a distance from  $IK$  equal to the lengths of the horizontal equivalents for the corresponding slope (par. 80), and cutting it out along the lines  $IK$  and  $LM$ ; or a separate scale of inclination may be used. It is applied as described at the close of par. 106.

108. *The U. S. Coast Survey Scale of Shade and Working scale.*—A modification of Lehmann's scale, by which its range was increased to include a slope of  $75^\circ$ , was adopted by the U. S. Coast Survey in 1860.

For Coast Survey maps, the ratios of black to white for the different slopes are as given in the first two columns of the adjoining table. Lehmann's ratios from  $5^\circ$  to  $25^\circ$  inclusive are

| Slope.    | Ratio of black to white | No. of hachures per in. |
|-----------|-------------------------|-------------------------|
| $1^\circ$ | 1 : 21                  | 50                      |
| 2         | 1 : 18                  | 57.1                    |
| 3         | 1 : $15\frac{1}{2}$     | $66\frac{2}{3}$         |
| 4         | 1 : $12\frac{3}{4}$     | 80                      |
| 5         | 1 : 8                   |                         |
| 10        | 2 : 7                   |                         |
| 15        | 3 : 6                   |                         |
| 20        | 4 : 5                   | 100                     |
| 25        | 5 : 4                   |                         |
| 30        | 3 : 2                   |                         |
| 35        | 7 : 3                   |                         |
| 40        | 4 : 1                   |                         |
| 45        | $5\frac{1}{2}$ : 1      | 80                      |
| 55        | $6\frac{1}{2}$ : 1      | $66\frac{2}{3}$         |
| 65        | $7\frac{1}{2}$ : 1      | 57.1                    |
| 75        | 9 : 1                   | 50                      |

thus retained; from  $25^\circ$  to  $40^\circ$ , the scale follows the curve of natural sines; but beyond this, the required intensity of shade is produced in hachuring by retaining the same interval as for  $40^\circ$ , while increasing the  $40^\circ$  space 25 per cent for  $45^\circ$ , 50 per cent for  $55^\circ$ , 75 per cent for  $65^\circ$  and 100 per cent for  $75^\circ$ . For slopes less than  $5^\circ$ , the breadth of hachures is the same as for  $5^\circ$ ; but the  $5^\circ$  space is increased 25 per cent for  $4^\circ$ , 50 per cent for  $3^\circ$ , 75 per cent for  $2^\circ$ , and 100 per cent for  $1^\circ$ .

The last column of the table gives the number of hachures per inch employed by the engraver for the published maps of  $\frac{1}{80000}$ . The number per inch for manuscript maps is:

For the scale of  $\frac{1}{10000}$ , 40;  
for the scale of  $\frac{1}{20000}$ , 50;

for the scale of  $\frac{1}{40000}$ , 65; and  
for the scale of  $\frac{1}{80000}$ , 80.

The model of  $\frac{1}{80000}$ , and of other maps to very small scales, are reduced for the engraver from the manuscript maps, by the processes of photography (par. 147).

From the above data a working-scale is thus constructed. For illustration, for the slopes from  $5^\circ$  to  $40^\circ$  inclusive, 5 hachures only are represented and 20 per inch instead of 100.

On  $NO$  (Fig. 58), 2 inches in length, construct 8 equal rectangles, marking them  $5^\circ, 10^\circ, \dots, 40^\circ$ , and subdividing each by fine vertical lines into 5 smaller equal rectangles, as shown. Blacken the latter in accordance with the corresponding ratios of the scale of shade, the black extending from the vertical lines in the same direction throughout the scale. From  $O$  toward the left, and from  $N$  toward the right, the breadths of the smaller rectangles corresponding to the other slopes—in other words, the spaces—are increased in regular order 25, 50, 75 and 100 per cent, in accordance with the above table. The lines of subdivision from  $N$  to  $Q$ , and the intervals from  $O$  to  $P$ , are therefore made very narrow; the former, for a working scale constructed in accordance with the table, being  $\frac{1}{100}$  (the breadth of hachure for  $5^\circ$ ), and the

latter  $\frac{1}{800}$  of an inch (the interval for  $40^\circ$ ). The proportionate widths for the scale (Fig. 53), are  $\frac{1}{320}$  and  $\frac{1}{110}$  of an inch respectively.

109. A modification of Lehmann's scale of shade, in use in England for ordinary purposes, has the advantage of simplicity and is very easily applied.

The ratios of black to white are:

For a slope of  $15^\circ$ , 1 : 2;  
for a slope of  $22\frac{1}{2}^\circ$ , 1 : 1;

for a slope of  $30^\circ$ , 2 : 1;  
for  $0^\circ$  white; and  $45^\circ$ , black.

According to this convention, the working-scale is constructed by assuming for the medium slope of  $22\frac{1}{2}^\circ$  a breadth of hachure best suited to the work in hand; the breadths for  $15^\circ$  and  $30^\circ$  are then fixed by the above ratios, and those for intermediate slopes are estimated by eye.

Fig. 54 is a working-scale of 20 hachures to the inch, constructed in accordance with these ratios.

110. The *Danish method of hill-shading*, as illustrated in a portion of the "Map of Denmark and Schleswig-Holstein," resembles Lehmann's to some extent. This map is constructed to a scale of  $\frac{1}{80000}$  and reduced to  $\frac{1}{80000}$ . The principal feature of its construction consists in varying the equidistances according to the steepness of the slopes; so that the equidistance employed for slopes of  $14^\circ$ , or  $\frac{1}{4}$ , and less, is doubled for slopes from  $14^\circ$  to  $27^\circ$ , or  $\frac{1}{2}$ , and quadrupled for slopes from  $27^\circ$  to  $45^\circ$ , or  $\frac{1}{1}$ . No shading is used on slopes less than  $14^\circ$ , while the intensity of shade increases regularly from  $14^\circ$  upward.

Fig. 55 is a working-scale for a map of  $\frac{1}{100000}$ , with equidistances as shown. In each of the rectangles marked  $1^\circ$ ,  $5^\circ$ ,  $10^\circ$  and  $14^\circ$ , four 10-ft. equidistances are given; from  $14^\circ$  again to  $27^\circ$ , two 20-ft. equidistances; and from  $27^\circ$  again to  $45^\circ$ , one 40-ft. equidistance. The finest hachures are used for the  $14^\circ$  slope. The breadths of the hachures increase regularly up to  $45^\circ$ , and the same number of hachures per inch is employed for all the rectangles of each group, as shown in the figure.

111. General Müffling, of the Prussian army, modified Lehmann's scale conformably to the Austrian system (par. 107), and in addition introduced the style of hachuring shown in Fig. 56. Slopes of  $45^\circ$  and upward are represented by the hachures for  $45^\circ$ ; slopes of  $40^\circ$  to  $45^\circ$ , by those for  $40^\circ$ , and so on down the scale; the slopes intermediate to those given in the scale being represented by corresponding gradations.

The advantages claimed are that no previous practice in hachuring is necessary to produce an intelligible map, and that a notable error in reading the map is impossible.

112. *The French System of Hill-shading*.—The main difference between this and the other forms of the vertical system just described, is in the method of separating the hachures.

Two varieties of this system are in use in the French School, viz., Colonel Bonne's and that adopted by the Commission of 1828.

113. Colonel Bonne's system, now employed in the French War Department, comprises scales of shade for maps of  $\frac{1}{100000}$ ,  $\frac{1}{200000}$ ,  $\frac{1}{400000}$ , and  $\frac{1}{800000}$ . The ratio of black to white for any slope is  $\frac{1}{2} \times \text{tang. of the inclination}$ ; therefore the ratios for the different slopes are as follows:

|                                      |                                       |
|--------------------------------------|---------------------------------------|
| For a slope of $1^\circ$ , 1 : 38.0; | for a slope of $25^\circ$ , 1 : 1.3;  |
| for a slope of $5^\circ$ , 1 : 7.6;  | for a slope of $30^\circ$ , 1 : 1.15; |
| for a slope of $10^\circ$ , 1 : 3.8; | for a slope of $35^\circ$ , 1 : 0.95; |
| for a slope of $15^\circ$ , 1 : 2.5; | for a slope of $40^\circ$ , 1 : 0.8;  |
| for a slope of $20^\circ$ , 1 : 1.8; | for a slope of $45^\circ$ , 3 : 2.    |

The intensities of shade for the different slopes are uniform in the same map, but the breadths of the hachures diminish directly with the scale of the map. As to the intervals between hachures, Colonel Bonne appears to have imposed the condition that, for the same map, the hachures for all the slopes should become indistinct at the same distance from the eye (Lehagre).

A working-scale constructed in accordance with the scale of shade is shown in Fig. 53. The slopes are designated by their tangents, and the horizontal equivalents (par. 80) are given upon the slips projecting below the groups of hachures. Thus *ab* is the hor. equiv. for an equidistance of 2.5 m., *ac* for 5 m., and correspondingly for the other slopes.

To apply it, the scale, cut out along its outline, is so placed that the right-hand edges of the slips shall be normal to two consecutive contours; and the hor. equiv. being thus determined, the hachures immediately above the corresponding slip are copied upon the map. A proportional scale may readily be constructed for any equidistance or degree-graduation.

114. The Commission of 1828 adopted the following method of hill-shading (Lehagre):

The contours are plotted in pencil, and must have a constant equidistance for the same map.

The hachures follow the lines of greatest descent and, as a rule, are continuous in each zone—that is to say, they extend entirely across a zone from one contour to the other; they also break intervals, so as to mark the positions of the contours when the latter are erased. They do not extend across roads, but are so drawn on either side of them as to give the roads the appearance of being cut out or erased from the general shaded surface. They are drawn across paths of gardens and parks.

Slopes less than  $\frac{1}{4}$  (corresponding to the French “grade”) are left white, except in cases where it is desirable to preserve the continuity of shade. Slopes exceeding  $45^\circ$  are expressed by special signs: if rock-surfaces, by figures resembling outlines of rocks; if simply rugged with ledges here and there, by hachures with white spaces irregularly distributed between the zones, which are subsequently filled with horizontal and oblique strokes termed rock-markings. (See par. 119.)

Between the limits of  $\frac{1}{4}$  and  $\frac{1}{2}$  the relative breadths and intervals of the hachures are fixed by the following rules:

1. For hachures which upon a uniform slope are more than 2 mm. (0.078 in.) in length, the breadth is constant, and the interval is equal to  $\frac{1}{4}$  the length.
2. For hachures less than 2 mm. in length, the space =  $\frac{1}{2}$  mm., and the breadth of hachure increases as the length diminishes.

To preserve a certain degree of uniformity in hachuring by different draughtsmen, the following conventions have been recently adopted (Lehagre, 1876).

For the gentler slopes, the hachures for maps of  $\frac{1}{20000}$  and less are made very fine, and a little heavier for  $\frac{1}{10000}$ . For the slope of  $\frac{1}{2}$ , the hachures and intervals are of equal breadth;



3. Shades of different intensities are blended into each other, and the limiting hachures of a slope are blended into the level surface. Thus, as in Fig. 62, the hachures for the slopes at *b* and *c* having been determined by the scale of shade, they are gradually increased in breadth in working between these points. Similarly, in working down the slopes, the rows corresponding to different degrees of declivity are blended by tapering the extremities of the hachures as along *dd* or *ee*. The upper and lower rows are also blended with the level surfaces, as at *f* and *g*. The shading is sometimes blended at the bases of slopes by shortening alternate hachures, as shown at *g'*; but an irregular outline produces the best effect.

4. The hachures of any row should begin at an imaginary line joining the lower extremities of the preceding row, as at *h*—neither below it, as at *i*, nor above it, as at *k*; and as a general rule they should break intervals, although no special effort should be made to this effect.

5. To avoid too much splaying of hachures, a free use of guiding-lines (par. 100) is necessary in hachuring the parts of slopes defined by sharply curved contours. As shown in Fig. 63, the hachures in the vicinity of *mm'* and *lo'*, are made quite short as compared with the breadth of zone, and the numerous guiding-lines assure their direction.

At *p* and *q* is shown the manner of rounding sharp curves by occasionally shortening the hachures; and at *r*, an application of the foregoing rules to the hachuring of a col,—see also *d*, par. 100.

In rounding sharp curves, hachures for steep slopes are also tapered, as at *s*.

In the French system, in order to obtain the proper shade when the hachures diverge considerably, the spaces are measured on an auxiliary contour midway between the principal contours, as at *t*.

For regular spacing of hachures, a roulette or small toothed wheel, the intervals between the teeth corresponding to the number of hachures per inch, is very convenient for marking off the spaces.

The requisites for good work are a steady hand, good instruments and material, facility in drawing guiding-lines, in blending the different grades of shade along as well as across the zones and in preserving uniformity of shade for like slopes throughout the map; all of which necessitates a careful observance of the rules and considerable practice.

116. A rigid adherence to the scales of shade in hachuring would evidently result in representing slopes strictly in accordance with their steepness; and with the working-scale attached to the map, it would be simply necessary to refer to it, to ascertain the exact inclination at any point; but, aside from the great labor and skill required for such precise work, the reference itself requires a practised eye; and for practical purposes and general use, maps so constructed, with hachures only to represent the slopes, may be said to be inappropriate.

If, however, the contours are in the finished map, and hachuring is employed simply as an accessory to give relief to the forms of ground, exactness of representation is afforded by the contours, much latitude is permitted in hachuring, whereby the labor and skill required are very much lessened, and a map is produced which is not only correct in the delineation of forms, but also attractive in its nicety of detail.

117. Plate IX. affords an example of *Hill-shading by the Vertical System, with Oblique Illumination*. The operation of shading is similar to that described in par. 115, with a further gradation of the hachures in conformance with the general rule given in par. 98.

118. The relative merits of the horizontal and vertical systems are difficult to determine.

It may be said that the former is harder to learn, for fine work it is slower of execution, and it has the disadvantage that communications, which usually follow the general level, are liable to be confounded with the hachures. In the latter, the hachures, as a rule, break intervals throughout the map; therefore no continuous lines exist to cause confusion of detail, besides, the vertical system appears best suited to engraving, since the finest maps of recent date are engraved in accordance with it.

119. *Representation of Rock-surfaces.*—The outlines of rock-surfaces and rugged localities are indicated in pencil during the plotting of the contours; and in order that the particular formations may be approximately represented, sketches or verbal descriptions of them should be found in the field-notes. Characteristic lines, extending in the general directions of the main combs and crevices, give an idea of the formation and furnish a basis or frame-work for the shading. Vertical or oblique illumination is used with either system of hill-shading. The latter is simpler, more effective, and when well executed is much more pleasing to the eye, the former requiring so much black on the steep surfaces as to rob other details of their values. The regular hachuring ends at the pencilled outlines above described, abruptly, if the hachured slope is steep, or with fine hachures touching the outlines here and there if this slope is gentle. The rock-shading is effected by groups of hachures, adjacent groups having different directions; and while these are being applied, a variety of harmonious forms, as well as the proper intensity of shade to bring them out, will suggest themselves.

Fig. 39, Plate VIII., contains outline rock-formations. Plate VI., examples of rock-shading with vertical illumination; and Plate XII., examples with both vertical and oblique illumination.

It mars a map very much to employ criss-cross lines, or regular blocks of lines oblique to each other, to represent this feature. The study and copying of good examples, or a little practice in sketching rock-forms in outline, and in constructing a rough plan of such outlines, would soon give facility in drawing pleasing signs for them. Variety of shape and a careful consideration of the direction of the light are essentials to good work.

120. *Contours Combined with Brush Hill-shading* (Plate XIII.).—This system, as employed at the French School of Application, is as follows:

The same principle applies as in the horizontal and vertical systems,—viz., that the intensity of shade is proportioned to the degree of declivity; it is therefore necessary to establish a corresponding law of gradation.

*Vertical Illumination* is first considered.

a. Six elementary shades are used, having the intensities or values represented by the fractions  $\frac{6}{4}$ ,  $\frac{5}{4}$ ,  $\frac{4}{4}$ ,  $\frac{3}{4}$ ,  $\frac{2}{4}$  and  $\frac{1}{4}$ , corresponding to the slopes  $\frac{1}{2}$ ,  $\frac{1}{4}$ ,  $\frac{1}{8}$ ,  $\frac{1}{16}$ ,  $\frac{1}{32}$  and  $\frac{1}{64}$ , which they respectively represent. These values taken in the above order are also designated by the numbers 6, 5, 4, 3, 2, and 1. No. 6 is termed the normal tone or shade, and its value corresponds to that of a series of parallel lines and spaces of equal breadth, as shown in Fig. 64. This figure also shows the order of arrangement of the different shades. The normal shade is obtained by trial with India ink, or other shading material used, and brush,—the correct shade being produced, when, at a short distance from the eye, it appears of the same intensity as the above series of parallel lines. No. 5 is obtained by adding to 6 a quantity of water equal to that it already contains, 4 is obtained from 5 in a similar manner, and so on to number 1; in each case doubling the quantity of water used in the next preceding shade.

b. A working-scale could be formed by filling these rectangles with the elementary shades prepared as already described; but to conform to the method in practice, it is constructed by superposed shades as indicated in "Superposition of Shades,"—see figure. The rectangles from 1 to 6 inclusive are shaded with No. 1; those from 2 to 6 inclusive, again with No. 1; from 3 to 6, with No. 2; from 4 to 6, with No. 3; and so on, sensibly doubling the intensity for each increase in the degree of declivity.

Although the shades for but few slopes are given in the scale, it is readily seen that by the addition of more or less water to the elementary shades, any intermediate shade required can be produced.

c. The application of the working-scale is thus illustrated: Let a plane be moved tangent to the surface of the ground while preserving a constant inclination to the horizon, of say  $\frac{1}{8}$ . The line of contact, termed a curve of equal shade, thus formed, would be represented by shade No. 3, corresponding to the inclination of  $\frac{1}{8}$ ; while the inclination on one side of this curve would be greater and on the other less than  $\frac{1}{8}$ . The curve of equal shade  $\frac{1}{2}$ , being similarly determined, and represented by No. 2, a zone is defined bounded by these two curves; and it is apparent that in shading this zone, the shade should be graded from one curve to the other.

Supposing that all the curves of equal shade,  $\frac{1}{4}$ ,  $\frac{1}{2}$ , . . . . .  $\frac{1}{8}$  are traced upon the map; then, conforming to the working-scale, all slopes steeper than  $\frac{1}{4}$  would be covered with shade No. 1, graded to zero at the edges of level ground; shade No. 1 would then again be applied to slopes steeper than  $\frac{1}{2}$ , and graded to zero at curve  $\frac{1}{4}$ ; No. 3, to slopes steeper than  $\frac{1}{8}$ , and graded to  $\frac{1}{2}$ , and so on for the rest of the slopes. (See pars. 133 and 134.)

The intensities of shade so produced conform to the scale, and a true representation of the configuration can thus be obtained.

If irregular slopes intervene between these curves of equal shade, the shades corresponding to them are capable of exact determination as follows:

Let  $\frac{7}{8}$  be such a slope; the shade value required is  $\frac{4}{8} + \frac{2}{8} + \frac{1}{8}$ , and shades 3, 2 and 1 are correspondingly superposed. As a ready means of obtaining these different values the following table is prepared:

| Slopes.       | Superposed Shades. |               |               |               |               |                |                | Shade Values.  |
|---------------|--------------------|---------------|---------------|---------------|---------------|----------------|----------------|----------------|
|               | 1                  | 1             | 2             | 3             | 4             | 5              | 6              |                |
| $\frac{1}{8}$ | $\frac{1}{8}$      | ..            | ..            | ..            | ..            | ..             | ..             | $\frac{1}{8}$  |
| $\frac{1}{4}$ | $\frac{1}{8}$      | $\frac{1}{8}$ | ..            | ..            | ..            | ..             | ..             | $\frac{2}{8}$  |
| $\frac{1}{6}$ | $\frac{1}{8}$      | $\frac{1}{8}$ | $\frac{2}{8}$ | ..            | ..            | ..             | ..             | $\frac{4}{8}$  |
| $\frac{1}{8}$ | $\frac{1}{8}$      | $\frac{1}{8}$ | $\frac{2}{8}$ | $\frac{4}{8}$ | ..            | ..             | ..             | $\frac{8}{8}$  |
| $\frac{1}{2}$ | $\frac{1}{8}$      | $\frac{1}{8}$ | $\frac{2}{8}$ | $\frac{4}{8}$ | $\frac{8}{8}$ | ..             | ..             | $\frac{16}{8}$ |
| $\frac{1}{2}$ | $\frac{1}{8}$      | $\frac{1}{8}$ | $\frac{2}{8}$ | $\frac{4}{8}$ | $\frac{8}{8}$ | $\frac{16}{8}$ | ..             | $\frac{32}{8}$ |
| $\frac{1}{1}$ | $\frac{1}{8}$      | $\frac{1}{8}$ | $\frac{2}{8}$ | $\frac{4}{8}$ | $\frac{8}{8}$ | $\frac{16}{8}$ | $\frac{32}{8}$ | $\frac{64}{8}$ |

To find the shade value for a slope of  $\frac{33}{8}$ , look under "shade values" for next higher scale value =  $\frac{32}{8}$ , and add together the least number of "superposed shades," on the same

horizontal line, that will produce  $\frac{23}{64} = \frac{16 + 4 + 2 + 1}{64}$ ; or the required shade is produced by the superposition of 5, 3, 2, and 1.

It is observed that a slope of  $45^\circ$  is represented by the superposition of all the shades. The result, although darker than No. 6, is by no means black; in fact, all the shades produced form simply a parallel series having certain relative values, as in many other forms of scales of shade.

*d.* The next step is to trace the curves of equal shade upon the contoured map, which is readily effected from the consideration that the slope along a normal between adjacent contours is uniform, and that normals of equal length between adjacent contours indicate equal degrees of declivity. Thus, in Fig. 65 the normals  $n, n, \dots$  being of equal length mark slopes of equal declivity about the watercourse  $ab$ , and the dotted line drawn through their middle points is a curve of equal shade. The points  $n'$  and  $n''$  are located approximately as follows:  $n'$  is evidently between  $c$  and  $d$ ; and since the inclination is less rapid from the middle point of  $cd$  towards  $c$  than toward  $d$ ,  $n'$  will be nearer the lower contour; and, similarly,  $n''$  is nearer  $e$  than  $f$ . The points  $n, n, \dots$  can be located by measurement upon the map; e.g., to find the curve of equal shade  $\frac{7}{84}$ ,—this ratio representing practically the tangent of  $7^\circ$ ,—take in the dividers the horizontal equivalent of  $7^\circ$  from the scale of inclination (par. 80), and mark by dots, as in the figure, the different points where adjacent contours are separated by this distance. No sensible error arises from considering the normals as straight where they may be slightly curved.

*e.* In par. *d* above, an undulating surface is assumed; but where the forms of ground are more pronounced, they are considered geometrically.

Thus the spur (Fig. 66) may be regarded as a conoidal surface. Draw the parallels  $gh$  and  $ik$  tangent respectively to the 40 and 20 contours; the line  $lm$  joining the points of tangency is sensibly the line of contact of the plane of these tangents, with the surface, and the line  $op$  drawn through the middle point of  $lm$ , and perpendicular to the tangents, will have the same inclination as the plane.

In practice an opening,  $qporst$ , is made in paper or cardboard, the parallel edges  $qp$  and  $or$  being separated by the perpendicular edge  $op$  = horizontal equivalent, according to the scale of the map, of the slope for which the curve of shade is desired; and the middle point  $u$  of  $op$  is marked.

This instrument is so applied to adjacent contours that  $qp$  and  $or$  are tangent to them, and  $ol$  appears equal to  $pm$ ; a point is marked immediately below  $u$  for one point of the required curve; and so on for the other points.

Curves are similarly determined for ravines or re-entrants, the instrument in any case being so placed that the convexity of the contours within the opening shall be towards the edges  $qp$  and  $or$ .

*f.* The hill-features requiring no shade are a summit, the base of a cup-shaped depression or hollow, and a col. The white spaces marking them are slightly exaggerated to make them more conspicuous; and the shades beginning here are gradually increased to their proper values at the nearest curves.

*g.* In practice the curves of equal shade, which are represented by light pencil-dots, are not traced with mathematical accuracy; and after considerable experience in reading con-



toured maps, their location may be estimated by eye, or at least with the occasional use of a scale of inclination.

The forms of ground should be previously carefully studied and the levels particularly noted. The shading corresponding to a given slope is not stopped abruptly at the extreme curves; but since slopes, except in rugged tracts, change their inclinations gradually, it is made to conform to this condition, and is carried beyond and blended into the local shade.

Any of the elementary shades required for the relief may be used first; but it is better to begin with one of the lighter, bearing in mind that a darker shade is never used until the one next preceding has been superposed once upon itself. The roads being left white separate the map into parts for shading, which is a great convenience on account of the rapidity with which the shading dries, and the consequent difficulty in large areas of properly blending the different shades.

Intermediate shades are used as required. During the progress of the work the effect of the relief already obtained should be carefully studied, and the subsequent shades be increased or diminished in value accordingly.

To avoid spotting, the paper should be neither worn nor scratched; but if so injured, a light wash of size is applied before the shading is begun. If the paper has been submitted to strong pressure, light friction with a damp sponge will usually restore the grain, and it should be kept a trifle damp to prevent the washes from drying too rapidly. If, nevertheless, spots appear, they may, if dark, be removed with a sponge, or by careful rubbing with soft linen;—a paper with a hole just exposing the spot being used to protect the map;—if light, by stippling (par. 135) with a brush nearly dry, or with a pencil.

For shading, sepia may be used instead of India ink; but the latter with a little indigo or cobalt added gives a better effect, particularly if colors are to be employed in representing the other features.

121. *For Oblique Illumination*, M. Goulier's law of gradation (par. 98) is applied.

The relief is first given as described for vertical illumination (par. 120), but much lighter shades are employed; e.g., the elementary shades 1, 2, . . . . are used for slopes of  $\frac{1}{3}$ ,  $\frac{1}{4}$  . . . . respectively, instead of for  $\frac{1}{4}$ ,  $\frac{1}{3}$ , . . . . The slopes extending toward N. E., S. E. and S. W. are again shaded as in the first operation, and the shade is blended with the N. W. portions. The "normal tone" is then applied as with vertical illumination, to the S. E. slopes, and blended with the N. E. and S. W. portions.

The time required is about twice as long, and the maps have about the same intensity as with vertical illumination.

Either India ink or sepia is used, but a brighter effect is produced by using the latter for the first shading, and the former for the other two.

Certain colors may be used in the first shading,—sepia for tillable land, neutral tint (a mixture of red, blue and yellow) for rocky surfaces, neutral tint and burnt sienna for rocks, and Prussian blue for glaciers—the rest of this shading to be in India ink. Glacier shades are reduced to half values.

Whether the illumination be vertical or oblique, the effect of aerial perspective is increased by treating the higher elevations with a light wash of burnt sienna, and the depressions with a light tint of cobalt,—the former at its lower edge, and the latter at its upper

edge, being blended into the slopes. This effect is intensified in the valleys by a very light wash of Chinese white tinted with cobalt.

Finally, the contours are represented either in black or red.

122. *Brush-shading as ordinarily practised.*—In the details just given is observed a careful adherence to the principles forming the basis of all art-representation, viz., working from the whole to a part and following a well-prearranged system; and whatever method may be adopted, these principles should underlie it. The details are very valuable in affording correct ideas of relief and of the exact means for producing it, and should be carefully studied.

In view of the fact, however, that shading is now employed as an accessory to contours (see also par. 116), the operation becomes very simple.

The materials required are stick India ink of good quality, dishes for mixing the shades, the brushes described in par. 129, water and blotting-paper.

The open frame described in par. 38 is best adapted to the work.

The outlines of all the details, as well as the contours, should be plotted in order to define the limits of the shade. For the best results the plotting should be in pencil only; in lines fine as a rule, but sufficiently strong on the steeper slopes to be visible after the shade is applied.

All superfluous lead is removed with bread, as described in par. 42, or by the application of water with a large soft brush or sponge.

If it is desired to ink the contours and outlines of the details first, the drawing must be washed, before shading, with water and a large soft brush, until the ink ceases to run, the frame being held in an inclined position, face up, for this purpose, and the drawing finally flowed with clean water. It is then placed in a horizontal position and permitted to dry at the ordinary temperature of the room.

In case the ink runs, the drawing should be washed again. Heavy lining must be deferred till the shading is finished.

The ink, prepared as described in par. 34, is then diluted to produce the first shade, which should be dark enough when applied to be distinctly visible at a short distance from the map.

When dry, the drawing is moistened on the back and disposed as described for laying a flat tint (par. 132), and is ready for the shading.

The steepest and gentlest slopes are observed and their relative shade values decided upon, the number of intermediate values depending upon the differences of slope and the degree or strength of relief desired. Ordinarily from three to five shades are sufficient, mountainous tracts requiring the greater number.

The first shade, prepared as above, is then thoroughly stirred with the brush and applied as described in par. 132, to all the slopes, beginning at the upper part of the map and working across and downwards; and, as the work proceeds, is blended (par. 134) into the levels, which are left white. Roads and buildings, except in small scaled maps, are also left white.

The drawing is then dried, artificial heat may be used to expedite the work, and any lack of flatness may be remedied by washing with soft brush and water; but washing should never be attempted until the drawing is thoroughly dry.

The back of the drawing is again moistened, and the second shade, of the same value as the first or of a slightly increased value, is applied to all but the gentlest slopes, working in

each case from the summit around and downward toward the base—the brush following the general direction of the contours,—and blending it at the edges into the first shade.

The rest of the shades are then applied, in each case omitting the slopes corresponding to the preceding values, the intensity of each being judged of by eye, and so related to the others that the shade value decided upon at first for the steepest slope shall not be exceeded.

In general a light relief, requiring the use of light shades throughout, is sufficient, and also prevents any obscuration of the other features.

The quantity of liquid used in the brush is lessened for the smaller areas. The amount of moisture required in the paper to make the shade flow freely, and to facilitate blending by preventing too rapid drying at the edges, is soon learned from practice. It will also be found unnecessary in laying successive shades to wait each time until the paper itself is dry; but a good rule to follow at first is not to apply a shade, or, in colors, a tint, until the preceding one is thoroughly dry; and if the area to be covered is of considerable extent, to always moisten the paper as above described before applying it.

If the open frame is not used, the front surface of the drawing is moistened with a soft brush, and the surplus moisture may be absorbed with blotting-paper.

The tendency at first is to use too strong shades.

If greater precision is desired, the curves of equal shade (*d*, par. 120) may be lightly dotted in pencil upon the map, as shown in Fig. 67, Plate XIII. Three shade values are here employed to produce the relief. The first shade extends from summit to base; the second, from near the summit to the curve *bb*; and the third, from near the upper limit of the second to *aa*. The first shade is blended into the summit and the general level at the base, and the others into the zones outside of their limiting curves.

With a little practice, however, the different slopes are readily separated according to steepness, into three or more groups, and the corresponding shades are applied as already described.

A little Payne's gray, sufficient to produce a slightly bluish tint, causes the India ink to work well and produces a very pleasing effect. Indigo or cobalt may be used instead of Payne's gray.

When the hill-shading is finished, the outlines already drawn are filled with the proper signs, as heretofore described (par. 76).

Rocky surfaces are represented with the tint used for the shading, strengthened when necessary, and applied as described in par. 135, and illustrated in colors in Plate XV., the characteristic pen-markings (par. 119) being added if desired.

It is apparent that this method of hill-shading has two very important recommendations, viz., great saving of time and clearness of representation. It is therefore particularly well adapted to the production of manuscript maps.

For reproduction by photo-engraving, it is only necessary to make a fair copy with wax crayon on grained paper for the engraver; or, if by lithography, substitute lithographic chalk for the wax crayon. This preparation, however, is usually made by the engraver from the models furnished him.

123. *Pencil Hill-shading*.—A very rapid method of hill-shading, well suited to sketching purposes, is now used for all English military maps and sketches. It resembles charcoal drawing, and is effected as follows:

The contours are plotted in crimson lake and the streams in Prussian blue,—in sketching, these features are drawn with a red and blue pencil,—the shading is then applied in accordance with the standard scale of shade (par. 102).

A smooth, hard surface should be underneath the drawing. A soft pencil is applied to the steepest slopes; the shade thus produced is then rubbed with a piece of chamois leather, folded into a pad, and is extended to the gentler slopes. The depth of shade is increased as required, by the use of the pencil, and diminished by the application of a rubber eraser,—sharp lights produced by the latter can be blended at the edges with the pad.

The general relief is produced broadly at first, and the details are brought out afterwards as above described.

To bring out any particular form sharply, a hole of the corresponding shape is cut in a piece of paper used to protect the rest of the drawing, and the rubber eraser is applied as above.

To shade a minute feature, a pointed shape is given to the folded chamois leather. Rough patches of shade and pencil-marks can usually be smoothed by hard rubbing with the leather; but in case the pencil is too hard, scrapings from it are used rather than the pencil itself.

Low levels receive a light shade, summits are left white, and spurs are shaded lighter than ravines.

The shades should be so firmly rubbed in as to bear handling; but can be fixed by spraying with shellac and alcohol, or by floating upon a thin solution of isinglass or gum-arabic.

Any coloring desired is deferred until the shading is finished.

A variation of this method of shading consists in first plotting the contours very lightly in pencil, then indenting them with a sharp style, and applying the shade as just described. In this case the contours are left nearly white.

#### SECTION IV.—FINISHING THE MAP, INCLUDING LETTERING AND ORNAMENTATION.

124. To complete the map, after the shading and signs are finished, there are required. 1. The lettering, including the title; 2. The scale of distances; 3. The "compass," or indications of the directions of the true and magnetic meridians; and 4. The border: all of which are usually added in the order given.

The equidistance (par. 91) and the height of the datum-plane above some permanent bench-mark should also be noted; and if the map is in relief, a scale of shade is usually attached, the latter being indispensable if the contours are not drawn.

125. *The Lettering.*—Roman letters and italics are now in general use for all topographical drawings.

*Forms of Letters.*—The general rule is to employ upright Roman capitals for names of the most important features; inclined Roman or italic capitals for those next in importance; Roman upright with initial capitals for the third in rank; Roman inclined, or italics with initial capitals, for the fourth; and small italics for the fifth, or for the least important purposes and designations.

The French convention is to assign these forms in the above order respectively to cities, towns, villages, hamlets and farms, or isolated buildings.

The general rule is modified in the construction of the U. S. Coast Survey maps, by always using inclined letters for water features; and since inclined letters are more easily read and produce a more pleasing effect when names are placed obliquely with reference to the map-borders, as is generally the case for water features, it seems best to adhere to this modification.

*Sizes of Letters.*—The largest letters are used in the title for the name of the tract or object represented, the smallest for explanatory notes; and between these dimensions, the sizes are proportioned to the importance of the different features designated.

According to the last condition, the largest of these intermediate sizes are used for the principal mountain-ranges and main divisions of the tract; for the larger bodies of water,—oceans, bays and great lakes; the next in size for the minor mountain-ranges and ranges of hills, the minor divisions of the tract and for the smaller bodies of water,—coves, small lakes, . . . .; the third in size for detached mountains, peaks, passes, ravines and other important hill features, cities, the larger towns, the principal communications and streams; and the fourth for hills and hill features of minor importance, villages, settlements, farms, important buildings and constructions, including the minor roads, and for rivulets, brooks and ponds.

Since a pond in one map may rank in importance with an ocean in another, it is evidently impossible to prescribe exact sizes of letters for the different features; but the foregoing list will give a pretty clear idea of proper gradation. For the scale of  $\frac{1}{10000}$  a good practical rule is to make the largest letters of the title—

For a map of about  $2 \times 3$  feet in dimensions — 0.3 in. in height;  
 “ “ “ “ “  $1 \times 1.5$  “ “ “ — 0.2 in. “ “ ;

and proportionately for maps of other dimensions; and since explanatory notes are always very small letters, the intermediate grades are readily assigned.

Small letters, called “lower-case,” are practically  $\frac{2}{3}$  the height of the corresponding capitals.

The following table (from Maes) gives the forms and height of letters used in the Belgian School for maps of ordinary size drawn to scales as given. The heights are in decimillimetres; In the column headed “Form,” RU, RI, ru, ri and i represent, respectively, Roman capitals upright, the same inclined, Roman small upright, the same inclined, and italics. It is presented for the assistance it may afford in determining suitable relative heights of letters for the different features, when much precision is required.

## MAP LETTERS—BELGIAN SYSTEM.

| FEATURES.                   | Heights for Scales of |         |           | FORM.   | FEATURES.                   | Heights for Scales of |         |           | FORM.     |
|-----------------------------|-----------------------|---------|-----------|---|-----------------------------|-----------------------|---------|-----------|-----------|
|                             | 1:5000                | 1:10000 | 1:20000   |   |                             | 1:5000                | 1:10000 | 1:20000   |           |
| Abbeys.....                 | 20                    | 15      | 12        | <i>ri</i>   | Levels (references).....    | 15                    | 10      | 10        | <i>i</i>  |
| Aqueducts.....              | 20                    | 18      | 12        | <i>ru</i>   | Light-houses.....           | 15                    | 10      | 10        | <i>i</i>  |
| Avenues.....                | 20                    | 15      | 12        | <i>ru</i>   | Manufactories.....          | 15                    | 10      | 10        | <i>i</i>  |
| Barracks.....               | 20                    | 15      | 12        | <i>ri</i>   | Marshes.....                | 30                    | 25      | 20        | <i>ri</i> |
| Batteries.....              | 15                    | 10      | 10        | <i>i</i>  | Meadows.....                | 30                    | 20      | 15        | <i>ri</i> |
| Battle-fields.....          | 25                    | 20      | 15        | <i>ru</i>   | Milestones.....             | 10                    | 10      | 10        | <i>i</i>  |
| Bays.....                   | 45                    | 40      | 35        | <i>RU</i>   | Mines.....                  | 15                    | 10      | 10        | <i>i</i>  |
| Brickyards.....             | 15                    | 10      | 10        | <i>i</i>  | Mountains, { chain.....     | 65                    | 60      | 50        | <i>RU</i> |
| Brooks.....                 | 18                    | 15      | 12        | <i>i</i>  | { secondary... 55           | 50                    | 40      | <i>RI</i> |           |
| Camps.....                  | 30                    | 20      | 15        | <i>ru</i>   | { isolated..... 35          | 30                    | 25      | <i>RI</i> |           |
| Canals, { large.....        | 35                    | 30      | 25        | <i>RI</i>   | Parks.....                  | 30                    | 25      | 20        | <i>ri</i> |
| { small.....                | 25                    | 20      | 18        | <i>ru</i>   | Paths.....                  | 15                    | 15      | 12        | <i>i</i>  |
| Capes, { large.....         | 40                    | 35      | 30        | <i>RI</i>   | Plantations.....            | 30                    | 25      | 20        | <i>ri</i> |
| { small.....                | 30                    | 20      | 15        | <i>ru</i>   | Posts, military.....        | 15                    | 10      | 10        | <i>i</i>  |
| Cemeteries.....             | 18                    | 15      | 12        | <i>i</i>  | Race-course.....            | 15                    | 10      | 10        | <i>i</i>  |
| Churches.....               | 15                    | 10      | 10        | <i>i</i>  | Kavines.....                | 15                    | 10      | 10        | <i>i</i>  |
| Cities, { 1st order.....    | 80                    | 70      | 55        | <i>RU</i>   | Redoubts.....               | 25                    | 20      | 15        | <i>ru</i> |
| { 2d order.....             | 65                    | 60      | 50        | <i>RU</i>   | Rivers, { large.....        | 40                    | 30      | 25        | <i>RI</i> |
| { 3d order.....             | 50                    | 45      | 35        | <i>RU</i>   | { small.....                | 30                    | 25      | 20        | <i>ru</i> |
| Creeks.....                 | 30                    | 25      | 20        | <i>ru</i>   | Roads (main), { 1st class.. | 30                    | 20      | 18        | <i>ru</i> |
| Cross roads.....            | 15                    | 10      | 10        | <i>i</i>  | { 2d class..                | 25                    | 15      | 12        | <i>ri</i> |
| Defiles.....                | 15                    | 10      | 10        | <i>i</i>  | { 3d class..                | 20                    | 15      | 12        | <i>i</i>  |
| Embankments.....            | 15                    | 10      | 10        | <i>i</i>  | Roads (minor), { large..    | 28                    | 18      | 15        | <i>ru</i> |
| Farms.....                  | 15                    | 10      | 10        | <i>i</i>  | { small..                   | 18                    | 15      | 12        | <i>i</i>  |
| Fences.....                 | 15                    | 10      | 10        | <i>i</i>  | Roadsteads.....             | 40                    | 35      | 30        | <i>RI</i> |
| Ferries and Fords.....      | 15                    | 10      | 10        | <i>i</i>  | Sand-banks, { large.....    | 35                    | 25      | 20        | <i>ru</i> |
| Forests, { large.....       | 65                    | 60      | 50        | <i>RU</i>   | { small.....                | 25                    | 20      | 15        | <i>ri</i> |
| { small.....                | 55                    | 50      | 40        | <i>RU</i>   | Suburbs.....                | 40                    | 30      | 25        | <i>RI</i> |
| Forts.....                  | 30                    | 25      | 20        | <i>ru</i>   | Towns.....                  | 45                    | 35      | 25        | <i>RI</i> |
| Fountains.....              | 10                    | 10      | 10        | <i>i</i>  | Trenches.....               | 15                    | 10      | 10        | <i>i</i>  |
| Gulfs, { large.....         | 65                    | 60      | 50        | <i>RU</i>   | Valleys, { large.....       | 45                    | 40      | 30        | <i>RI</i> |
| { medium.....               | 50                    | 40      | 30        | <i>RI</i>   | { small.....                | 30                    | 25      | 20        | <i>ru</i> |
| { ordinary.....             | 30                    | 20      | 15        | <i>ru</i>   | Villages, { large.....      | 35                    | 30      | 25        | <i>ru</i> |
| Hamlets.....                | 25                    | 20      | 15        | <i>ri</i>   | { ordinary... 30            | 25                    | 20      | <i>ru</i> |           |
| Harbors.....                | 20                    | 15      | 12        | <i>ru</i>   | Villas, { large.....        | 30                    | 20      | 15        | <i>ru</i> |
| Heaths.....                 | 30                    | 25      | 20        | <i>ri</i>   | { small.....                | 20                    | 15      | 12        | <i>ru</i> |
| Hills.....                  | 25                    | 20      | 18        | <i>ru</i>   | Woods, { large.....         | 40                    | 35      | 25        | <i>RI</i> |
| Islands (sea), { large..... | 70                    | 60      | 50        | <i>RU</i>   | { small... 30               | 25                    | 20      | <i>ru</i> |           |
| { medium... 50              | 45                    | 40      | <i>RI</i> | Small isolated objects in<br>general, bridges, tun-<br>nels, houses, etc..... | 15                          | 10                    | 10      | <i>i</i>  |           |
| { small... 30               | 20                    | 15      | <i>ru</i> |   |                             |                       |         |           |           |
| Islands (river).....        | 25                    | 20      | 18        | <i>ri</i>   |                             |                       |         |           |           |
| Lakes, { large.....         | 40                    | 35      | 30        | <i>RU</i>   |                             |                       |         |           |           |
| { medium.....               | 35                    | 30      | 25        | <i>RI</i>   |                             |                       |         |           |           |
| { small.....                | 25                    | 15      | 12        | <i>ru</i>   |                             |                       |         |           |           |

*Disposition of the Letters.*—Names should be so placed as to be easily read, show clearly the object designated and not obscure the signs.

For *Isolated Features*, the names are placed, when possible, at the right or left of, and close to, the different objects designated, and parallel to the lower edge of the border, the spaces between the letters and words conforming to those of ordinary print.

For *Communications*, the names are placed parallel and close to the edges or boundaries; the spaces between letters remaining the same as in ordinary print, while the words are separated by intervals, which, for uniformity in the same map, may be taken equal to the length of the longest word there used for these designations. The bases of the letters are best turned toward the communication, and such part of the latter should be selected for the name that when the drawing is held in its proper position the letters will not be reversed; e.g., if the road extends upward to the right or downward to the left, or in a vertical direction, the name is placed on the left of it; if horizontally, above; otherwise, to the right. If a terminus of a road is within the drawing, its name may be omitted in the designation,—the word “from” or “to,” preceding the name of the other terminus, being sufficient.

3 [
2
2 [
3
1 [
2
1 [
2
1 [

SOUTHAMPTON,
NEW YORK.

Surveyed by James Atkinson, C.E.

Scale 1:1000.

1886.

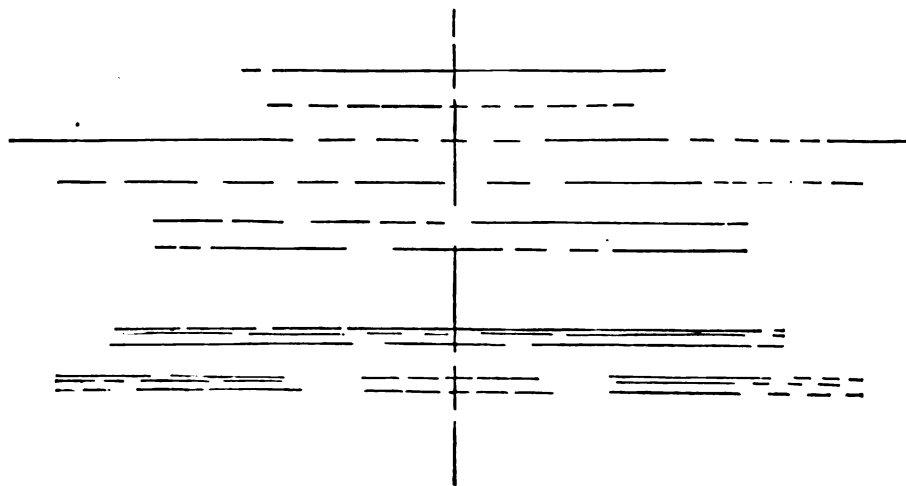
5 [
5
6 [
5
4 [
10
2 [
4
2 [

Scale 1:1000.

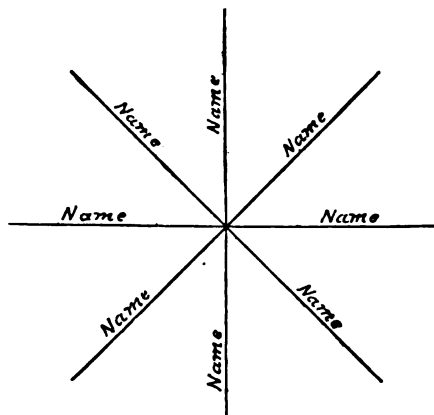
Surveyed by Samuel Green, C.E.

1877-8.

Equidistance 20 ft.



*For Streams*, the same rules apply as for communications, except when their widths are at least twice the height of the letters, in which case the names are placed along the axes of the streams, independently of the direction of the current which is indicated by an arrow. The accompanying figure shows the proper position of names relative to lines of features having various directions.



*For Elongated Outlines*, as in the cases of forests, marshes and bodies of water, the names are extended in the direction of the greater dimension and along straight or smoothly curved lines midway between the boundaries. The letters are not "extended;" but, with the words, are so spaced that the name in each case will occupy nearly the entire length of the feature,—the spaces being proportional to those used in ordinary print. In certain cases, when names placed on the features would obscure them, or the scale of the map is very small, a *legend*, or list of the names, is placed in an unimportant part of the map, or outside of the border; and corresponding letters or numerals attached to the different names and features serve as mutual references. These names should be horizontal, and arranged in one or more vertical rows.

126. *The Title*, as shown on the opposite page, consists of the name of the tract or locality represented, called the principal name, the location of the tract, the surveyor's name, date of survey and the scale of the map expressed by its representative fraction. The equidistance between contours may also be stated, and any explanatory notes it may be desirable to give may be arranged with the title or placed elsewhere upon the map.

*The Position of the Title* is next to the border, usually in a corner of the map where it will interfere least with the details. A central position next to the upper or lower border may be selected, in which case the title is not enclosed in a rectangle.

In maps where the entire space within the border is desired for the details, the title is placed outside of the border, the principal name at the top, midway, and the rest at the bottom of the map.

The largest letters used in the map are reserved for the principal name, the next in size for any modification of this name, as "PART OF," "AND VICINITY," etc.; the name of the county or State in which the tract is located may be about  $\frac{2}{3}$  the height of the principal name: all of which are capitals. The words "Surveyed by —," "Scale —" and the date are about  $\frac{1}{2}$  the height of the principal name, and in Roman capitals and small letters; while the explanatory notes are in italics, and of less size.

The title should be symmetrically arranged with reference to a vertical line through the middle point of the space assigned to it; which is readily done by sketching each line first on a separate paper, and then assigning its middle point to the vertical line, and working outwards from it in the construction of the letters.

A simple arrangement of plain letters is more effective, pleases the eye for a greater length of time, and is easier of execution than elaborate lettering.

The figures at the left in the diagram give relative heights of letters and spaces suitable



for titles, and the arrangement of broken lines at the bottom of the plate shows the manner of gauging them.

127. *The Construction of Letters.*—Nothing mars a map more than poor lettering, and if the skill necessary to draw Roman or italic letters free-hand well is desired, it must be acquired through long and patient practice in copying from the best models.

Two ways are therefore suggested to avoid the difficulty; one is to trace and transfer the outlines of the letters by the means described in pars. 31-2, then ink and fill them in; and the other, by far the easier, is to obtain the alphabets required in type metal (which can be done at a very small cost), "set them up" as desired, and, clamping them firmly in some simple device, or between flat surfaces with the hand, press the letters on a cloth covered with powdered black-lead, stamp the name in its proper place indicated by a pencil-line, and ink the impression with a common pen.

Where many maps are made, it is of course preferable to obtain the clamps, rollers and ink necessary for regularly printing the names.

Ockerson's devices (par. 74) are extended as follows to the printing of letters and figures.

For letters, a stamp, working like an ordinary office-stamp, is used. The type composing any desired name is "set up" and clamped in a typeholder at the base of the piston, and, after inking, is impressed upon the paper through an opening in the base of the frame. The outer edges of this base being rectangular, with two of them parallel to the line of type, serve as guides in locating the names.

For numbers, three concentric revolving disks are used, each disk containing the ten numerals in type, so that any combination of three figures is readily formed. This is particularly valuable for representing soundings.

Plate XIV. gives specimens of lettering used in maps of the U. S. Coast Survey.

For colored maps, a more pleasing effect is produced by the use of either "light-faced" or "open" capitals (see Plate XVI.) for the principal name.

Although the spaces between letters and words may be ascertained by measurement of common print, the general rule for letters may be found useful; which is to make the spaces between capitals and small letters the breadths of the intervals between the uprights of the letters H and n respectively.

128. *Scales, Compass, Border and Framing.*—In addition to the representative fraction given in the title, the scale of distances (par. 45) is placed in the vicinity of, or immediately below the title. For important maps a scale of metres, in addition to one of English units, should be constructed, the relative positions being shown in Plate I. The scale of shade for maps in relief may be placed in the vicinity of the scale of distances, or immediately below a lower corner of the border.

The direction of true N., and the magnetic declination, or variation of the compass, should always be indicated. This is usually done by means of a figure called a "compass" conspicuously placed in some convenient part of the map, usually over the sign for water, where a large body of water is represented. A simple form is the most pleasing and useful; and may consist of two intersecting lines of medium breadth, showing the directions of the cardinal points, the N. point being marked with the letter N, and of two or more finer lines indicating the intermediate points.

A still simpler form (see Plates VIII. and XVI.) is an arrow several inches in length, say

10 inches for a map 2×3 feet in dimensions, pointing true N.; with the variation of the compass indicated by a second shaft diverging, in the direction of the variation, from a point near the middle of the first, and terminated by a half arrow-head placed without the angle thus formed. The arrow-heads should be equidistant from this point of divergence, and be of light, curved lines rather than solid. The amount of variation may be noted along the shaft, or within the angle in the direction of an arc described from the point of divergence of the shafts as a centre—the usual wording being “Variation—° E,” or “W,” as the case may be. A compass is of course unnecessary with parallels of latitude and meridians.

The border should be rectangular in shape, and also of some simple combination of right lines. Some varieties are shown in the diagram of titles facing page 67. A general rule is to make its total breadth =  $\frac{1}{10}$  of the shorter inner edge already drawn (par. 56); and when composed of a fine, inner line and a heavy, outer one, to make the breadth of the latter  $\frac{1}{2}$  the total breadth.

If the meridians and parallels of latitude are represented, an inner space is required for the degree-numbers; and may be defined by a fine line, distant from the above about three times the total breadth above given.

In the absence of meridians and parallels, it is advisable, in order to detect subsequent distortions of any part of the map, to construct a set of rectangles of fine lines parallel to the border lines, 100, 1000 feet, or 1 mile . . . . on a side, according to the scale of the map.

The margin should be sufficiently broad to give a good relief to the border.

Narrow flat mouldings of plain wood, varnished to show the grain, and with bevelled black-enamelled edges, make very pleasing frames for plain topographical drawings.

## PART III.

## TOPOGRAPHICAL DRAWING IN COLORS.

## SECTION I.—MATERIALS, RULES FOR WORKING IN COLORS AND PREPARATION AND LAYING OF TINTS.

129. *Materials and Instruments.*—For topographical drawing in colors, the materials and instruments required, in addition to those prescribed in Part I., Section II., are water-colors, brushes, plates or saucers and tumblers for mixing tints and cleansing brushes. A right-line pen with plated or German silver nibs, on account of its freedom from corrosion, is superior to the steel pen for line-work in colors.

The best stick India ink should be used.

Paper suited to this work is described in par. 30.

Moist water-colors in "pans" or "half-pans" are handiest, and Winsor & Newton's are always of good quality.

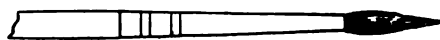
The colors necessary are: Yellow Ochre (Y. O.), Indigo (I.), Crimson Lake (C. L.), Gamboge (G.), Prussian Blue (P. B.), Payne's Gray (P. G.), Sepia (S.) and Burnt Sienna (B. S.); to which may be added Brown Madder and Vandyke Brown. A tube of Chinese White will prove useful for touching up ragged edges of lines and for covering blemishes that cannot be erased.

The colors should be kept in a covered tin box to retain their moisture, and so separated from each other that, in supplying the brush, they will not be mixed.

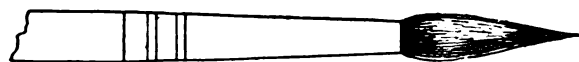
When too hard, a drop of glycerine will soften them.

Four sable brushes are necessary—three small ones for applying the tints, and a larger one for washing and toning purposes.

The accompanying figure shows the sizes for the small brushes, two of the larger size being used for general work, and the smaller for covering small areas, buildings, rock-markings,



etc. A good brush after a thorough wetting should preserve its elasticity, and show a fine point when the water is thrown out of it by a quick motion of the hand. A compartment in the tin box should be provided for them.



They must be washed in clean water before and after using them, never left standing in water, and they should be put away "pointed" by the quick motion above described.

A flat sable brush, 2 to 3 inches in width, is best for washing and toning, and should be treated with the same care as the others.

130. The following rules should be carefully observed in working with colors:

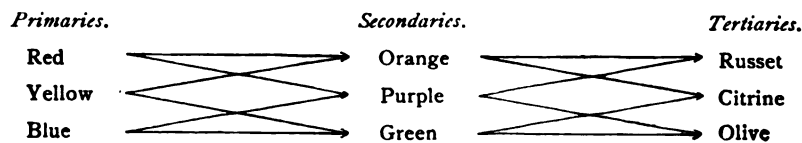
- I. The materials must be kept clean and free from dust.
- II. In preparing tints, the colors must be thoroughly mixed with the water, and the mixture well stirred with the brush at first, and each time the latter is refilled.
- III. Surfaces greater than 2 or 3 square inches in extent are best dampened before tinting, as described in "Laying of Flat Tints" (par. 132).
- IV. The surface to be tinted should be inclined at a small angle, 5° to 10°, so that the tint will flow freely along it and in the direction of its greatest dimension. The drawing should be left or placed to dry in the same position.
- V. The base of the brush or part next to the handle must not touch the surface of the paper in the operation of laying a tint.
- VI. A tint must not be retouched in any way until dry, either while laying it, or to correct errors afterwards. When dry, small spots lighter than the general tint may be stippled (par. 135) with the point of the brush and a small quantity of color; and small spots darker than the general tint, by repeated alternating applications of water with the point of the brush, and of blotting-paper. Large inequalities must be removed by washing the entire tinted surface with the large brush, and deep markings require the use of the sponge.
- VII. Light tints must be used at first, at least until practice is had in estimating values.
- VIII. Repetitions of the same sign must be of a uniform tint throughout the map, and tints of different color should have like values.
- IX. Except as described in par. 122, all ink markings or lining must be deferred till the coloring is finished.

131. *Preparation of Tints.*—A *single tint* is prepared by rubbing the wet brush on the surface of the color and stirring it in a quantity of water somewhat greater than would be required to cover the surface to be tinted.

The colors prescribed are transparent; and since the white of the paper corresponds in effect to the white pigment used in oil-colors, a tint is made strong or light by the use of more or less of the color, or by varying the quantity of water.

In preparing a *double tint*, or one made of two colors (connected by the sign + in the text), the lighter color is mixed first with the water, and the other then added until the required tint is produced. Tints are sometimes superposed singly to produce a double tint, and when properly done the effect is more brilliant than if previously mixed.

The following table may prove useful in showing how different colors are produced:



Thus red + yellow = orange; purple + green = olive, etc.

A neutral tint is a mixture of red, yellow and blue. Blue is a cold color, red and yellow are warm colors, and are correspondingly added or used in greater quantity in a mixture, to produce cold and warm tints.

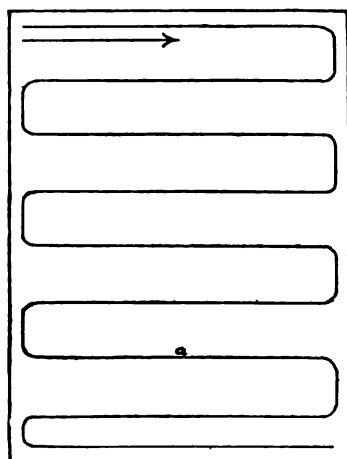
Each of the primaries harmonizes with the combination of the other two; yellow with purple, etc.; and the same is true of the secondaries—purple with citrine, etc.

A transparent color is made opaque by the addition of Chinese white; so unless this effect is desired, the brush must be carefully washed after using this pigment.

If hard or cake colors only are available, the tints are prepared by rubbing, as described for India ink (par. 34).

132. *Laying of Flat Tints.*—Since laying a flat or even tint is quite difficult for the beginner and is the most frequent operation in colored drawing, it is minutely described. Pure color, clean water, a soft and elastic sable brush and a good paper surface are the requisites. Presuming the open frame (par. 38) in use, the paper is moistened on the back, and when the front surface feels cold to the touch or the paper begins to warp, it is disposed at an angle of from  $5^{\circ}$  to  $10^{\circ}$ , sloping towards the draughtsman.

The tint prepared as above described is then thoroughly stirred with the brush; the latter is then well filled, and, with the handle pointing toward the right shoulder, the operation is begun at the upper left-hand corner of the surface to be tinted. With light pressure and a motion just slow enough to permit covering, the tint is laid on in bands, as shown in the



accompanying figure, from left to right along the upper edge, as indicated by the arrow, the point of the brush extending to the edge; then down the right-hand edge a distance of about half the length of the brush; then back to the left-hand edge, overlapping the first band enough to cause the tint to flow freely from the latter into the second band, and so on to the lower edge of the surface. The pressure should be even throughout, and the motion continuous. The brush should be kept well filled until reaching a point as at *a* near the lower edge, when the quantity of liquid in it should be a little more than enough to finish. When the lower band is completed, the quantity remaining is thrown out of the brush, as heretofore described, and the superfluous tint is removed from the drawing through

capillary action, by moving the point of the brush back and forth along the lower edge; or a straight edge of blotting-paper may be used for the purpose.

It may be found easier at first to lay the upper band as described; and the others by successive pats with the brush, following each other back and forth across the surface in the order shown in the figure, the tip of the brush remaining in contact with the surface.

The result, when the paper is dry, should be a perfectly uniform tint without streaks or spots.

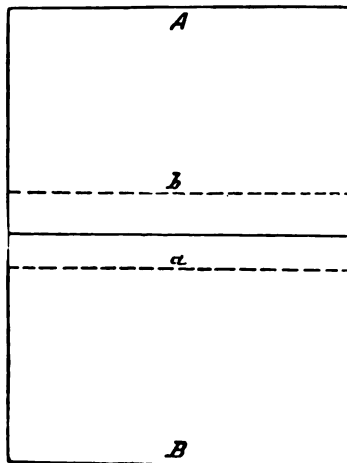
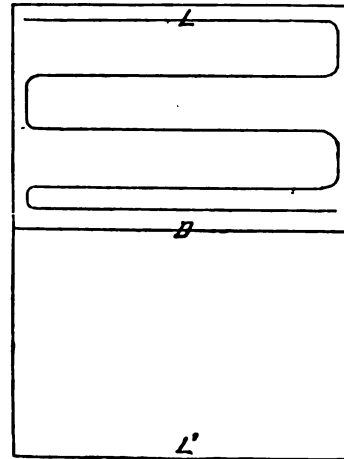
If the open frame is not used, the front surface may be dampened with a sponge or brush and the tint applied when the surface ceases to glisten in observing it obliquely. In this case blotting-paper can be used to expedite the drying before the application of the first tint, but not afterwards. Artificial heat of a moderate temperature, or exposure to the sun's rays, may be resorted to.

133. *To Lay a Graded Tint.*—Having decided upon the relative values required at the two extremities of the surface, as at *L* and *D* in the accompanying figure, prepare the corresponding tints. For a single gradation, as from light at *L* to dark at *D*, lay a band of the lighter tint along the upper edge; then, adding some of the darker to the lighter tint, lay the next band with the mixture slightly overlapping the first, and so on, adding the darker tint

for each successive band until *D* is reached. The relative quantities required of each tint are easily found from practice. The result should be a tint increasing uniformly in intensity from *L* to *D*. If the gradation is not sufficiently rapid, when dry begin with a band of water at the upper end, add the tint as required, and re-grade.

For a double gradation, as from dark at *D* to light at both *L* and *L'*, proceed as above from *L* to *D* and continue to *L'*, reversing the process by adding water for the successive bands.

134. *To Blend Tints.*—If a single tint is to be blended into a white or colored surface, as at the extremities of a slope; first, take up most of the superfluous tint at the edge to be blended, by passing the point of the brush back and forth once or twice; then, working rapidly, lay a narrow band of water slightly overlapping this edge, and treat it the same as the final band of color; apply water as before, and so on until the color fades into the white or colored surface.



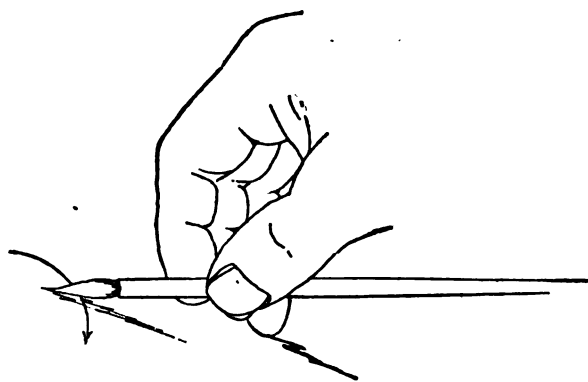
To blend tints of different colors, as in the sign for “brush-wood” (Plate XV.), suppose that the upper and lower halves of the rectangle in the accompanying figure are to contain different tints so applied that their line of junction shall be invisible. Beginning at *A*, lay one tint as far as the dotted line *a*, and, working rapidly, take up most of the superfluous color along this line; then cleanse the brush quickly, fill it with the other tint, and beginning at the dotted line *b*, lay this tint to the bottom of the rectangle. It is more convenient to have a separate brush for each tint.

135. *Stippling and “Dragging.”*—Stippling is the operation of laying a tint by dots placed close together, and is of use in covering spots or blemishes. The point of the brush and very little of the required tint are used.

It is best to cover the space gradually with several sets of dots, waiting each time for the preceding set to dry before filling the intervals with another.

“Dragging” consists in laying a ragged tint, by which irregular forms and “accidental lights” are produced. It is of much use in expressing rugged surfaces, rock-markings and shadows. The side of the brush and very little color are used, and the handle of the brush is so held as to make a very small angle with the surface of the drawing.

Thus, as in the following figure, for “dragging” rugged or rock surfaces, the handle is held between the thumb and forefinger, while the hand is supported by the tip of the second finger. With gentle pressure, the brush is moved back and forth, or in one direction only, as indicated by the arrow, until the desired degree of ruggedness is expressed. The effect is heightened by a second or third application. (See Rule VI., par. 130.)



As to their *Durability*, all water-colors undergo more or less change from exposure to light and atmospheric impurities. The most sensitive and therefore unreliable of the list given in par. 129 are Prussian blue and crimson lake, for which cobalt and light red may be advantageously substituted. Indigo, Payne's gray and sepia are affected to a much less degree; but, to insure their retention, should be applied with greater force than would otherwise be required. The other colors, although becoming somewhat darker from exposure, may be regarded as permanent. As a rule, the colors known as "earths" are the most stable.

#### SECTION II.—THE CONVENTIONAL TINTS (PLATE XV.).

136. The different features are represented by colors, alone or in combination with the signs employed in plain topographical drawing. A color-resemblance in some cases assists the eye in recognizing them. Thus, water, trees and sand are represented by blue, green and yellow respectively. Except for slopes, the illumination is oblique (par. 98). The conventional tints are as follows:

For *Sand*—Yellow ochre, a flat tint. Gravel may be shown by dots of burnt sienna.

For *Water*—Prussian blue, a flat tint. If a lower tone is desired for the map, use indigo instead of Prussian blue. Another form is given in the plate, and also in Plate XVII.

For *Cultivated Land*.—Burnt Sienna, a flat tint, which, when dry, is ruled with parallel lines, as shown in the figure; a right-line pen, ruler and triangle, and the same tint, or one a trifle stronger, being used for this purpose. For greater variety, alternate fields may be tinted, as shown, with P. G. + Cr. L., or B. S. + Cr. L., each ruled with tints of the same; and all three may be used, care being taken to so arrange the different tints (see par. 131) as to produce a pleasing effect. If the ruled lines are omitted, B. S. alone must be used.

For *Cleared Land*—Indigo + gamboge, or P. B. + G., a warm flat tint (par. 131).

For *Underbrush*—The tints for cleared and cultivated land, alternating in irregularly shaped patches, and blended as described in par. 134. To produce the best effect, observe the law of harmonious contrast (par. 131) as to which of these tints to place next to the feature already represented. This feature is designated "Brushwood" in the Plate.

For *Marsh*—Prussian blue, "dragged," as described in par. 135. The strokes of the brush should be made parallel to the lower edge of the map-border. The lower edges of the strips of land are then shaded with a strong tint of P. G. + Cr. L., applied with the tip of the brush, and invariably in the direction above stated. These shade-lines may be ruled in.

In the figure, the marsh is in a tract of underbrush, and, as in all cases, is superposed upon the sign for the latter.

For *Mud*—The same horizontal strokes as in plain drawing, except that sepia is used instead of India ink.

For *Trees*—Trees and clumps of trees are first outlined distinctly in pencil; and, for maps drawn to a large scale, a flat tint of gamboge is then laid over the entire surface within these

outlines (see "Trees, Analysis"). The shading is then effected with a green tint, stronger and warmer than that used for cleared land, and composed of Ind. + G., or Pr. B. + G., according as Ind. or Pr. B. is used for water. The shading-strokes are applied on the side remote from the source of light, and in a curvilinear direction, so as to bring out the rounded forms by properly defining the lines of shade. The addition of a little S. improves this tint.

For the shadows, a tint of P. G. + Cr. L. is used, and applied as described for the shade, a rounded outline being given to the forms.

The accidental lights produced by the operation of dragging (par. 135), applied to both shades and shadows, prevent a harsh effect. The pencilled outlines may be strengthened, if necessary, particularly on the shaded side.

For maps drawn to a smaller scale, a flat tint of Pr. B. + G., warmed with a little sepia, is recommended for the entire surface within the carefully pencilled outlines (see "Trees, Masses"), the shadows and shading being omitted. This is well adapted to forests, when the trees are represented in large masses.

This sign is always superposed upon that for the general surface.

For *Orchards*—The outlines, regularly distributed, as shown in Plate III., are tinted as above described.

For *Evergreens*—The tints of green are cooler and darker:—use P. B. + S.; laying in the masses first, then adding the spinal touches, and finally cross-hatching for the shades.

*Buildings*—If of wood, sepia; for masonry, Cr. L. The outlines of wooden buildings are drawn and shaded with India ink; and of masonry with Cr. L., a very strong tint being used. To distinguish brick from stone, make the outlines of the latter the heavier. If desired, P. G. may be used for stone, and light red for brick.

For *Roads*—The pencilled outlines are filled with a flat tint of Y. O.; the edges being subsequently traced in India ink, as described for plain drawings.

For a *Path, Trail, or Ford*—India ink, the same as in plain drawing. When paths are in outline, the latter is filled with Y. O.

For *Bridges*—The outline is filled with Y. O., and the same distinction as to wood and masonry is observed as in "Buildings."

*Fences* are represented with India ink, as in plain drawing; *Stone Walls* by their outlines filled with Cr. L., and *Hedges* by the sign for "Trees." The shadows for the last two features are in P. G. + Cr. L. For *Troops*, the "front" is indicated by the full colored side or end.

For *Slopes* (Plates XV. and XVI.)—Graded tints of P. G. + Cr. L., or cobalt + ivory black, enough of the first ingredient to produce a bluish tint, are applied as described for brush-shading (par. 122). The contours, in distinct medium lines, are drawn with strong Cr. L. and the references with red or India ink, small fine-lined figures being employed.

The shading should be a little darker than for plain drawings, on account of its obscuration to some extent by the superposed tints which represent the other features. The necessity of having the details to be left white clearly outlined in pencil, previous to the shading, is apparent.

The clearest drawing is obtained by making use of the pencilled contours for defining the forms of ground, and deferring the drawing of the contours in color until the shading is finished and the other features are tinted. Brown ochre, or sepia + B. S., is suited to any hachuring that may be required.

For maps of very large areas (see Plate XVII.), the shading is sometimes omitted,



For *Rocks*—Sepia warmed with a little B. S. This is first “dragged” (par. 135) over the shaded slope, thus producing the general forms or outlines shown in the middle rectangle at the right of the plate; a second application, and a third if necessary, with a few touches of strong color here and there, will produce the effect shown in the lower rectangle. The three rectangles fully illustrate the different stages of the operation.

Hachures in sepia are sometimes added, as for “slopes.”

Other features not above enumerated are represented by their outlines tinted, or filled with tints corresponding to the material of which they are composed. Iron, the only other element which may be required, as in the case of bridges, is represented by P. G. + Ind. + a little India ink. Features not otherwise clearly expressed are designated by name.

Plate XVI. shows a combination of these signs in the shape of a map, and also the use of color in sketching, described in Part VI. For colors for *Vertical Sections*, see Plate V.

137. The following sequence is observed in the different operations:

I. Plotting the triangulation and traverses (pars. 57 to 61), the contours (par. 86 *et seq.*), outlining the details (par. 75) and the place for the title and legend (par. 126). If the plotting involves the use of many lines, it is advisable to use a separate sheet for this work and transfer it (see “Copying,” par. 140) to the stretched paper, thus saving the surface of the latter just so much wear.

As a rule, this work should be done in pencil, and upon its accuracy the reliability of the map will depend.

II. Cleaning the surface (par. 42) preparatory to laying the tints. In this great care is required to prevent injuring the surface, and thus avoid the blemishes that would otherwise result in the tinting.

III. The tinting, in the following order: The streams, roads, hill-shading, including rock-surfaces, finishing the contours in Cr. L.; the different kinds of land, buildings, and the enclosures. Note that on washed surfaces use weak or light tints.

IV. The inking of such details as require it.

V. Finishing the map as described in section IV (pars. 124 to 128). Since India ink of an intense black is used, and the effect of black by juxtaposition is to subdue colors, the different ink lines are made lighter than in plain drawing, and the letters are preferably of the light-faced, open, or skeleton type.

138. The French system.—*The Conventional Tints* are as follows:

For *Water*—A light tint of Prussian blue; the shore-lines are bands of a darker blue, graded outward to the general tint; or the space is filled with regular water-lines, as shown in Plate XVII.

For *Ditches*—When the scale is small, a single line of Prussian blue or sepia, according as the ditch is wet or dry; for large scales, the same as for “water.”

*Marshes* are represented by outlines filled with light blue; the edges of the land are shaded with a darker tint of the kind used to represent the land, or with blue.

For *Cultivated Land*—When the relief is not expressed, by white; otherwise, by a flat tint of red ochre (“ocre de ru”)—burnt sienna corresponds to this tint.

For *Cleared Land* (meadows, etc.)—A bluish or cool green.

For *Trees*—If isolated, by small rounded forms of warm green, for scales of  $\frac{1}{8000}$  or greater; and for smaller scales, dots of this tint sufficiently large and varied in shape to not be mistaken for dotted lines.

For *Orchards*—These signs are regularly distributed in rows, parallel to the longer sides of the enclosures.

Shade-trees along roads, for scales of  $\frac{1}{8000}$  and less, are placed just outside of the edges, at regular intervals and opposite each other; but along streams, the trees on one bank are opposite the intervals on the other.

The tints for brushwood and evergreens are as in Plate XV.

For *Slopes*—If the drawing is orometric (the configuration being expressed by contours only), the contours and references are in burnt sienna (see Plate XVII). If in relief, hachured, the hachures are in brown ochre, the contours and references being as above. Rocky ledges are expressed by horizontal strokes of B. S. or neutral tint, or both.

Artificial slopes, such as in terraces, fortifications, etc., receive a tint of India ink, graded from dark to light, from summit to base, and superposed with a tint of green or B. S., for embankments or cuttings respectively. The upper outlines are made heavier than the lower.

With scales of  $\frac{1}{8000}$  or less, canal and banquette slopes are not expressed; and with scales of  $\frac{1}{10000}$  or less, levee and exterior slopes, of which the height is less than 2 metres, are represented by single lines.

For *Buildings*—If of masonry, outlines of Cr. L. or carmine, filled with a flat tint of the same. For wooden buildings, the outlines and interior flat tint are in India ink, the outlines being shaded to make the material of construction more apparent and to give relief.

For arched walls, or walls supported by columns, dotted outlines are used; and for ruins, the dotted outlines, omitting the interior tint.

For masses of buildings (city blocks, etc.), the general masses only, without interior detail. An exception is made in the large-scale drawings for the gardens, etc., belonging to important houses, and for those which abut against the roadway.

For public buildings, the outlines are made very heavy; and with scales of  $\frac{1}{10000}$  or greater, the ridges of roofs are represented, and the slopes of the roofs are shaded with India ink, the illumination being oblique.

Certain flat tints within the outlines show the special use of buildings. Thus, those belonging to a particular administration are tinted with deep carmine; those belonging to the State, to parishes or departments, with vermilion or orange red; to the engineer service, with grayish blue; and to the artillery, with violet. Grayish blue alone is prescribed when the special use is not designated.

For *Communications*—The outlines in India ink, with the interior left white. With scales greater than  $\frac{1}{8000}$ , true breadths are represented; with  $\frac{1}{8000}$ , except in villages, the breadths are increased about  $\frac{1}{8}$  of an inch. With  $\frac{1}{10000}$ , each of the edges of a principal route or highway is represented by a heavy inner and fine outer line: for departmental routes only one of these interior lines is made heavy; and in each case the breadth between the interior lines is  $\frac{1}{8}$  inch. For a main road one heavy and one fine line are used; the breadth is  $\frac{1}{8}$  inch: fine lines with the same interval are used for its regularly travelled branches. A paved road but little used is represented by a full and a dotted line with an interval of  $\frac{1}{8}$  in.; a wood-road not paved, by two dotted lines, with same interval; and a path, by a single heavy line, full if used for beasts of burden, and dotted if a simple footpath. For parks and gardens, the paths and carriage-ways are in green.

These breadths are reduced proportionally for smaller scales.

For *Enclosures*—Fences, by full or dotted lines in India ink, with large dots to represent

the posts; walls, by a heavy red line; hedges, by a row of small, shaded trees in green, for scales up to  $\frac{1}{8000}$ ; for smaller scales, small, rounded forms at short intervals, with dots between. Wells and springs, by red and blue outlines respectively, filled with blue; boundaries, by square red dots.

*Rules as to Lines and Tints.*—With scales of  $\frac{1}{8000}$  or greater, full lines are used except in the following cases: For undetermined features, heavy dotted lines; for subterranean features, the same with the dots close together—red for dry masonry, blue for aqueducts, and black for mine-galleries. For continuous intermediate contours, fine broken lines, the dashes long; but when portions only are represented, fine dotted lines are used.

For the smaller scales, broken, dotted and full lines are used for communications, as conventional signs to indicate their nature, importance and degree of practicability.

A general rule for clearness of expression is to have the breadths of lines proportioned to the importance of the object represented, and three grades are thus prescribed for the larger scale,—the finest, for limits of cultivated land and for contours (the latter a trifle heavier than the former); the second or medium grade, for paths, common roads, outlines of buildings and shore-lines, and the heaviest for the inner lines of highways.

The details must be accurately represented in outlines before tinting,—the outline of masonry in red; of water, in blue; of trees, isolated or in masses, hedges and paths of parks and gardens, in green; and of other features, in black.

The tints should be of such relative intensities as to make any of them readily distinguishable from the others; therefore surfaces of small extent receive the darker or stronger tints. The green for trees and cleared land is made quite strong and of a bluish tint; light blue is used for streams and bodies of water of sufficient breadth to be clearly defined by their outlines.

The lighter tints are laid first, as the proper gradations and relative intensities are thus better determined.

As a precaution against the fading of any tint, and to avoid any uncertainty as to the object represented, the initials in India ink of the names of the different kinds of land are placed within the enclosures.

Before tinting, the drawing is washed by causing water to flow rapidly over it; and since red “runs” more easily than the other colors, the red outlines are drawn first to give them a longer time to dry.

Plate XVII. (from Capt. Wheeler’s Report upon the Third Int. Geog. Congress and Exhibition, published by the U. S. Corps of Engineers) illustrates the French system of coloring as applied to maps of large areas. As may be observed, but six colors are employed, and with very pleasing results.

The following systems of coloring are now employed for this purpose by the countries designated (from same report):

*Spain.*—Black for arable ground and lettering; blue for water; red for buildings, constructions, and ordinary routes; green for forests, horticultural tracts and grazing-lands; sienna for contours.

*Switzerland.*—Blue for water; bronze for contours; brown hachures for surfaces which cannot be easily represented by contours; black for other details.

*Prussia.*—Relief is expressed by Müffling’s system (par. 111) for slopes of  $5^\circ$  and  $10^\circ$ , and by Lehmann’s (par. 106) for more abrupt ground, 34 hachures per inch being used.

## PART IV.

## COPYING, REDUCTION AND ENLARGEMENT OF MAPS AND MODELLING.

## SECTION I.—COPYING, REDUCTION AND ENLARGEMENT OF MAPS (PLATE XVIII.).

139. In important topographical surveys, and especially those covering a tract with much detail, the first complete plot is usually made to a larger scale than that required for the finished map, and, with the field notes and sketches, is preserved for future reference.

This plot is then copied with great care to the required scale, the details and relief are refined as much as possible, and the map is finished; and, if desired, is ready for reproduction.

If, however, it is to be reproduced by any of the photographic processes, either the original plot or an exact copy of it is carefully finished throughout, and then reduced to the required scale by this process; or a copy of it is made to an intermediate scale, in which those details which would become indistinct in the reduction are "generalized" (see par. 141), and this is used for the purpose. Photographic copies on glass—transparencies—on account of their freedom from changes due to atmospheric influences, are very useful as models for the engraver.

This branch of drawing is therefore an important element in map-construction, and the different methods are described in detail.

In any of the methods used, some means of testing the accuracy of the work are required, of which the simplest consists in having the original drawing and the sheet for the copy subdivided into sets of squares:—of equal size in both, if the copy is to be to the same scale as the original; or correspondingly increased or diminished in the copy, for an enlargement or a reduction.

The test then consists in ascertaining by measurement if the lines of both drawings cut corresponding points of the sides of the squares.

In photographic reductions, the presence of the squares serves to detect any local distortion (see also I., par. 140). Meridian lines and parallels of latitude may serve this purpose in maps drawn to a very small scale. If the squares prescribed in par. 128 are on the original drawing, and it is found by measurement that no correction for distortion due to atmospheric influences is necessary, then for a copy to the same scale, the vertices may be transferred to the sheet for the copy as prescribed in II., par. 140; otherwise, the squares for the copy are accurately constructed; and in copying the details, corrections either by eye or by measurement are effected proportional to the changes in dimension or position that have taken place in different directions.

If it is undesirable to draw the squares upon the original, tracing-paper securely fastened to the latter may be used for the purpose.

As in all other topographical drawing, construction-lines are in pencil.

140. *Copying to the Original Scale.*—I. *Geometrically.*—The sides of the squares serve as

lines of reference, distances are transferred with the dividers or by measurement, and the different points of any detail are thus accurately located. Right lines are located by fixing their extremities; and circles and other regular curves, by fixing the extremities of their radii or axes. Right lines, intersecting details already copied, may be drawn on both sheets, and intermediate details located by means of co-ordinates from corresponding points.

Contours are located by their intersections with lines already drawn; and if a sufficient number of the latter does not exist for their complete determination, others favorably placed can readily be added.

This process is very slow, but susceptible of great accuracy.

The three-legged dividers (Fig. 68) are very useful in fixing a point by its distances from any two already determined.

II. *By Pricking.*—A very accurate means of copying points (extremities of right lines, radii of circles, etc.) consists in fastening the original drawing, face up, upon the sheet for the copy, and then with a fine needle pricking through the required points to the surface beneath. It is particularly useful in copying triangulation and traverse-lines. Any difficulty in recognizing the different points is obviated by raising a corner of the original—the other corners being securely fastened—and marking the points as soon as determined. A fine needle does not injure the surface, and the holes may be closed entirely by placing the drawing on a smooth surface and rubbing the reverse side with an ivory handle.

III. *By Tracing.*—To copy a drawing on tracing-paper or linen (par. 31), this material, glossy side up, is securely fastened along its edges to the original, by drawing-pins or other means; and as every detail is distinctly visible through it, it is simply necessary to follow the lines with the pen.

If the sheet is not large enough to cover the drawing, it may be held in place, and pin-holes thus avoided, by fastening strips of paper along its edges and to those of the drawing.

On account of the warping produced by the wetting required if the copy is to be tinted or shaded, it is best to first stretch the sheet, the water being applied with a sponge to white paper laid over the tracing-paper which soon becomes sufficiently limp to attach to the stretcher (par. 38). Tints appear well applied to the back of tracing-linen.

In copying from a tracing, the original should lie upon a white surface to make the lines distinct.

Vegetable tracing-paper can be made more pliable, will lie closer to the drawing and work better, by soaking it for about an hour in a solution of 4 parts of water to 1 of glycerine, and then drying it on a line in the open air. For pencil-work, paper thus prepared requires a light rubbing with talc or sandarach. The "Blue Process" (par. 147) is much used in connection with tracings, for copying to the original scale.

IV. *Copying on Glass.*—A pane of glass of suitable size is disposed within or near a window, and at an angle of 20° to 30° inclining downwards toward the draughtsman, so that by means of white paper placed a short distance beneath, or by an arrangement of mirrors, the light may be reflected upward through it to the eye.

The original drawing, face up, is then fastened to its upper surface, the sheet for the copy is superposed, and if the paper is not too thick, the lines will appear sufficiently distinct to trace with pen or pencil. The best result obtains by excluding all light except that which is reflected through the glass.

If the paper of the original is too thick, a tracing may be substituted for it; and if the fair sheet is so thick that the lines appear confused, the extremities of the latter may be first pricked through with a fine needle, so that when the fair sheet is superposed, the lines are readily determined by the brilliant points at their extremities. The squares prescribed in par. 139 prove of great assistance in adjusting the sheet when the size of the drawing makes it necessary to copy it by sections.

V. *By Transfer.*—The sheet for the copy is fastened to a flat, smooth surface, transfer-paper (par. 32) is laid over it, and the original, face up, is superposed and secured in place. A steel or agate point, sharp enough to make a fine line, and at the same time not cut the paper, is then drawn over the lines to be copied, which are thus duplicated on the fair sheet. To avoid omissions, squares are drawn upon the original, or it is otherwise divided into sections which are finished separately.

Any displacement is readily detected during the progress of the work by retransferring any of the lines, and observing if the two transfers coincide.

#### REDUCING AND ENLARGING.

141. *Generalization of Detail.*—In making reductions, as indicated in par. 139, certain changes in the representation of details, as compared with the original, are required. Distances, breadths of line and interval, which in the latter are clearly shown, would, if faithfully copied, often become indistinct.

Thus, in reducing by photography from  $\frac{1}{10000}$  to  $\frac{1}{80000}$ , distances which are considerable quantities according to the former scale disappear, and outlines of buildings distinctly separated unite and appear as black dots.

A certain generalization is therefore necessary; outlines of isolated details are made larger than their proportional scale-dimensions, groups of individual signs are massed into a less number or into a single sign; communications and enclosures are reduced to single lines, if necessary; and slopes, narrow in plan, such as banks of canals and ditches, are represented in like manner.

In regard to contours, it is evident that in order to preserve the same minuteness of detail as to forms of ground, the contours must all be copied; but if this would result in bringing them so close as to produce complexity, or obscure other details, the number of contours must be diminished; e.g., for a reduction from  $\frac{1}{80000}$  with an equidistance of 50 feet, to  $\frac{1}{100000}$ , copy alternate contours and mark the equidistance "100 feet;" if to  $\frac{1}{200000}$ , copy every fourth contour, and mark the equidistance "200 feet." In reducing to scales much smaller than the original, the general configuration is preserved, while many minor features—the smaller spurs, ravines, cols, etc.—which would become indistinct, are omitted.

If an equidistance, not a multiple of that given, is required, the contours to be copied are so interpolated in the original as to preserve the continuity of surface, and at the same time conform to the new scale.

In large establishments, these changes are made according to a system of scales, as may be observed in Appendix 20, U. S. Coast Survey Report for 1860-1. The system prescribed in the text (par. 138) will serve as a general guide; but as no rigid rules can apply to all cases, much is left in this matter to the judgment of the draughtsman.

142. *Different Methods.*—Geometrical and mechanical methods are used in reducing and enlarging drawings.

The former include the “Method by Squares” and other geometrical means, and the latter the use of the proportional dividers, pantograph, eidograph and photography.

For the *Method by Squares.*—To prepare the original, let  $AB$  and  $AC$  (Fig. 69) be adjacent inner edges of the border. From  $A$  set off the equal distances  $A-1, 1-2 \dots 4-5$ , and through their extremities draw lines respectively parallel to the edges, as shown.

The greater the amount of detail, the greater will be the number of squares required.

The fractional parts which remain, as in the upper and right-hand portions of the figure, when an edge is not exactly divisible by  $A-1$ , serve the same purpose as the squares.

The fair sheet (paper for the copy) is then prepared by constructing first the rectangle of the inner edges of the border, corresponding to the proportions fixed upon for the reduction or enlargement. For a simple lineal reduction, e.g., a dimension of the copy to be  $\frac{1}{2}, \frac{1}{3} \dots$  that of the original, make  $ab$  and  $ac$  (Fig. 69a)  $\frac{1}{2}, \frac{1}{3} \dots$  the length of  $AB$  and  $AC$  respectively, and correspondingly for the equal distances  $a-1', 1'-2' \dots 4'-5'$ : and similarly for an enlargement. The squares are then drawn as before.

For a reduction by areas, proportional squares or rectangles may be constructed either arithmetically or geometrically.

Arithmetically; since similar figures are to each other as the squares of lines like placed; let  $a$  represent the area of the copy;  $b$ , the area of the original;  $c$ , the required line of the copy; and  $o$  the given line of the original; then  $a : b :: c^2 : o^2$ ; or  $c = \sqrt{\frac{a}{b}} o$ ; e.g., suppose  $AB$  and  $AC$  (Fig. 69) respectively 35 and 24 inches in length; then for a reduction to  $\frac{3}{8}$ ,  $ab$  (Fig. 69a)  $= \sqrt{\frac{3}{8}} 35^2 = 28''.6$ , and  $ac = 19''.6$ . For an enlargement,  $c = \sqrt{\frac{b}{a}} o$ .

Or one side only of a rectangle need be calculated; the adjacent side is then obtained as shown in Fig. 70: For a reduction: by setting off from  $A'$  on the original  $A'B'C'D'$ , the distance  $A'b'$  equal to the calculated side; then erecting the perpendicular at  $b'$ , and drawing through the intersection  $y$  of the latter with the diagonal  $A'D'$ ,  $c'y$  parallel to  $A'B'$ .  $A'b'c'y$  is the rectangle required. All rectangles having their diagonals in the same line are similar, and their corresponding sides are therefore proportional.

The copying-squares are then located by subdividing adjacent sides of the rectangles into parts like placed, and proportional to those of the original (see par 49).

The geometrical reduction depends upon the familiar principles that the square described on the hypotenuse of a right-angled triangle is equal to the sum of the squares described on the other two sides; and that if a perpendicular be let fall from the vertex of the right angle to the hypotenuse, the squares of the sides about the right angle will be to each other as the adjacent segments of the hypotenuse.

Thus, given the square  $CG$  (Fig. 71); to construct another that shall be in any required proportion to it, as 2 : 3. Describe the semi-circumference  $CED$ ; subdivide  $CD$  into 3 equal parts; erect the perpendicular  $FE$ , and draw  $CE$ : then will  $\overline{CE}^2 = \frac{2}{3} \overline{CD}^2$ .  $\overline{ED}^2$  is evidently  $\frac{1}{3} \overline{CE}^2$  or  $\frac{1}{9} \overline{CD}^2$ .

For an enlargement: To construct a square that shall be a multiple of any given square, as  $KI$  (Fig. 72). Draw the diagonal  $HL$ ; make  $Hd$  equal to  $HL$ ; then  $\overline{Hd}^2 = 2KI$ . Produce  $IL$ ;

make  $IM = Hd$ , and  $He = Hm$ ; then  $\overline{He} = 3KI$ ; and similarly for any other multiple of  $KI$ .

If the rectangle of the border is not copied first, it is advisable as a check to first copy the square outline of the greatest number of squares, and then subdivide it into smaller squares corresponding to the original.

The squares having been constructed, the points in which lines of detail cut the sides of the squares of the original are noted, and the required lines are made to cut corresponding points marked on the fair sheet. The details are either drawn in by eye, or more accurate means are used—proportional dividers being very handy in this connection for exact work.

143. *Proportional Dividers* (Fig. 73).—This instrument is very convenient for copying to any scale. When the legs are closed, the slide which bears the pivot can be moved along the slots, and clamped with its index at any desired division of the scale. When opened, the distances between the points at the two extremities bear a ratio to each other, indicated by the number marked on this division.  $\frac{1}{2}, \frac{1}{3}, \dots$  on the scale of “lines” indicate distances bearing the ratios of 1 : 2, 1 : 3 . . . . . ; if on the scale of “circles,” that the areas of circles described with these distances as radii, or of similar plane figures having these distances as homologous lines, are as 1 : 2, 1 : 3 . . . . . Scales of “solids” are found on some instruments.

An arc is also sometimes attached, by which the legs may be clamped at any angle.

Even with careful handling, the points soon wear off; and the scales then serve only as a means of approximate adjustment, which, however, is readily perfected by trial—using a scale of equal parts.

144. *The Angle of Reduction* is used in connection with ordinary dividers, and is constructed as follows: Make  $NO$  (Fig. 74) equal to a side of a square on the original map; from  $O$ , as a centre, with  $OP =$  to a side of a square of the copy as a radius, describe an arc as shown, and from  $N$  draw the tangent  $NP$ ; then  $PNO$  is the angle of reduction. To use it; let  $No$  be a dimension taken with the dividers from the original map; with one point at  $o$ , extend the dividers until an arc described with the other point would be tangent to  $NP$ , then  $op$  is the reduced dimension required.

Reductions may be made with great accuracy if this angle is traced in fine lines on metal.

An allowance may be made for alterations or changes in the squares of the original, due to atmospheric influences, by using the mean length of two adjacent sides for  $NO$ ; or the squares may be subdivided into 4, 8, . . . . . others, and the smaller squares then copied separately.

145. *The Pantograph*.—This instrument, having a variety of forms, consists essentially of four straight bars of wood or metal forming an articulated parallelogram. Fig. 75 represents a common form. The bars  $AW$ ,  $AF$ , and  $BE$  are of equal length, and the pivots at  $A$  and  $B$  are stationary; the fourth bar,  $CD$ , equal in length to  $AB$ , is pivoted at its extremities to sliding plates, which can be clamped at any of the divisions marked on  $AW$  and  $BE$ , and is always made parallel to  $AB$ . The entire instrument is pivoted to a piece of metal,  $W$ , sufficiently heavy to remain immovable while copying. Projecting points on its lower surface are sometimes provided to keep  $W$  in place. At  $T$   $AT$  being equal to  $AW$ —is a tracing-point with which to follow the lines of the original drawing. At  $P$  is a pencil-point which may be clamped at any desired division of  $CD$ , and which copies the lines traced at  $T$ . As may be observed, the instrument is arranged in the figure for reducing.



It is in adjustment when (Fig. 76)  $AW : DW :: AT : DP$ , or as  $m : n$ ,— $m$  and  $n$  representing respectively the scales of the original and of the copy. For, let  $TT'$  be a right line described by the tracer, then will  $PP'$ , described by the pencil, be a right line parallel to  $TT'$ , and  $TT' : PP' :: m : n$ . From the two positions of the instrument,  $AW : DW :: AT : DP$ , and  $A'W : D'W :: A'T' : D'P'$ ; and since during the movement,  $D'P'$  remains parallel to  $A'B'$ , it follows that  $W, P$ , and  $T$  are in a right line as at first. Then, since  $TW : PW :: AT : DP$ , and  $T'W : P'W :: A'B' : D'P' :: AT : DP$ ; therefore  $TW : PW :: T'W : P'W$ , and the triangles  $WTT'$  and  $WPP'$  are similar; whence it follows that  $TT'$  and  $PP'$  are parallel, and also that they are in the desired ratio; because  $TT' : PP' :: TW : PW$ , or as  $AW : DW = m : n$ . Consequently, the figures described by the pencil and tracer are similar.

From the foregoing, the instrument is not in adjustment unless  $ABCD$  is an exact parallelogram; and  $T, P$  and  $W$  are in a right line. The test of the former condition is made by measurement, and of the latter by means of a stretched thread.

The adjustment for reduction to any required scale needs no further explanation; the pivot at  $W$  and the tracing-point are simply placed at the 0 divisions of the bars to which they are attached; and the bar  $CD$  and the pencil-point, are so adjusted as to fulfil the condition  $AW : DW :: AT : DP :: m : n$ .

The graduation of the bars assists in making this adjustment, and, with a fine instrument, serves to make it directly.

For a copy,  $m = n$ ,  $W$  and  $P$  are interchanged, and a copy in reverse results.

If  $\frac{n}{m}$  is greater than  $\frac{1}{2}$ , a more rigid system is obtained, as shown in Fig. 77, by interchanging  $T$  and  $W$ , moving  $CD$  to  $C'D'$ , and adjusting the pencil-point at  $P'$  as already described.

For an enlargement, the tracer and pencil are interchanged; but on account of the multiplication of errors due to inaccurate tracing, the pantograph is not recommended for this purpose, except when rough copies only are required.

For accurate work the instrument should be of metal; to insure freedom of movement, it should be supported on casters at such points as  $A, B, C$  and  $D$ ; or, as in some of the expensive forms, guyed to an upright fixed in  $W$ , and about which it freely turns; the work should be performed upon a smooth, level table. It is convenient to have the pencil-holder hinged so that the pencil-point may be raised, to prevent false lines being made in passing over blank portions of the original. The pencil may be weighted to make a heavy line, and a cup is sometimes provided in which shot are placed for this purpose.

For right lines, a straight-edge is used to guide the tracer; and for curved lines, a curve. The open triangle is convenient for copying rectangular outlines. To check the motion of the instrument when its inertia tends to carry the tracing-point beyond a desired limit, or move tangentially to a curve, an ivory friction-roller which runs along the paper, is in some instruments attached near the tracer, and is manipulated by the left hand, while the right guides the tracing-point. To secure steadiness in working, both elbows should rest upon the table.

The only difficulty arising in properly placing the instrument at first is in making the field swept by it, on both original and fair sheets, as wide as possible. The squares prescribed in par. 139 should be drawn, so that when it becomes necessary to move the instrument, the

correctness of its new position may be tested by retracing the sides of the squares on the original, and observing that the pencil-point follows the copy.

Another form of the pantograph, in which the pivots at all the vertices of the parallelogram are fixed in position, is shown in Fig. 78. The tracer  $T$  is fixed to  $BF$ , but the pencil  $P$ , and the weight  $W$ , can be clamped at any desired division of  $DE$  and  $DC$ . With  $T$  and  $P$  placed as shown, the copy is in reverse; the proper or "erect" copy being obtained by interchanging  $P$  and  $W$ . The placing, adjustment and manipulation of this form of the pantograph are, in general, as described for the other.

That the copy is similar to the original is shown in Fig. 79. For let  $TT'$  and  $PP'$  represent respectively right lines of the original and copy; from the first position of the instrument, shown by the heavy lines,  $AT : DW :: AP : DP$ ; from the second position,  $A'T' : D'W' :: A'P' : D'P'$ ; and since  $A'T'$  and  $D'W'$  are parallel, the second proportion shows that  $P', W'$  and  $T'$  are in a right line; therefore  $T'W' : W'P' :: AD : DP$ , and  $T'W' : W'P' :: A'D' : D'P'$ ; consequently  $T'W' : T'W' :: W'P' : W'P'$ . The triangles  $TWT'$  and  $PWP'$  have the angles at  $W$  equal; they are therefore similar; and it results that  $PP'$  and  $TT'$  are parallel, and that for any position of  $P$ , the ratio  $\frac{TT'}{PP'} = \frac{TW}{WP} = \frac{AD}{DP} = \frac{m}{n}$  is constant.

In another form of pantograph called the *micrograph* (Maes), (Fig. 80), the articulations at  $A$  and  $C$  only are stationary, the bars are usually of equal length, and the adjustment for any desired ratio of reduction is effected by increasing or diminishing the lengths of the sides of the parallelogram by an arrangement of holes and pins, or by means of sliding-boxes and clamps at  $B$  and  $D$ . This form is unsuited to accurate work.

To adjust the pantograph to any desired ratio of reduction, when the bars are not graduated: First, see that  $T, P$  and  $W$  are in a right line; and with  $T$  trace a long right line, which denote by  $L$ . On the line described by  $P$ , set off a distance  $L'$ , such that  $\frac{L}{L'} = \frac{m}{n}$ ; then change the alignment of  $T, P$  and  $W$ , until  $P$  traces  $L'$  while  $T$  traces  $L$ .

146. *The Eidograph* (Fig. 81) is a very exact and convenient instrument for the reduction of drawings between the limits of  $\frac{1}{2}$  and full size. It revolves about a vertical pin which projects from the heavy weight  $W$  and enters the box  $B$ , through which the centre beam has a transversal motion, and to which it can be clamped.

The two pulleys,  $p$ , fitted to the ends of the beam are of the same diameter, and have a simultaneous movement by means of the two steel bands,  $b$ , which can be adjusted to that degree of tension which will make the bars  $AP$  and  $TD$  exactly parallel, and at the same time secure steadiness of motion. These bars slide through, and can be clamped to, boxes attached to the under-surfaces of the pulleys. The tracer and pencil are attached to sockets at  $T$  and  $P$  respectively. A cord extending from  $T$  to  $P$  serves to raise the pencil-point when necessary in the operation of tracing. The beam and bars are metal tubes graduated into equal parts, reading from 0 to 100 each way from their middle points, while readings to thousandths are effected by means of verniers attached to the boxes.

A weight which fits the beam is used to preserve the equilibrium, when  $W$  is not at the centre of gravity of the instrument.

To adjust the instrument; make the vernier-indices coincide with the zero-points on

beam and bars, and mark points with both tracing- and pencil-points; revolve the instrument until the pencil-point coincides with mark made by tracer. Tracing-point should then coincide with pencil-mark: if not; mark the new position of tracing-point, bisect the interval between it and the pencil-mark, and by means of the adjusting-screws of the bands, make the tracing-point coincide with the bisection. The bars should now be parallel and the two points and the vertical pin of *W* in a right line; and if the graduations are correct, these conditions should also obtain when the indices of all the verniers are set to like readings. It is evident from inspection of the figure, that when the adjustments are properly made, similar figures must be described by the tracer and pencil.

To set the instrument for reduction in any desired proportion, as copy : original ::  $n : m$ ;—Let  $x$  represent the required reading; since there are 200 divisions of each scale, the fulcrums of the beam and of each bar, when the verniers are adjusted to this reading, divide the scale into two parts, one part containing  $100 - x = n$  divisions, and the other  $100 + x = m$  divisions; consequently  $n : m :: 100 - x : 100 + x$ , from which  $x = 100 \frac{m - n}{m + n}$ . E.g., suppose the copy is to be  $\frac{1}{4}$  (lineally) of the original, then  $x = 100 \frac{4 - 1}{4 + 1} = 60$ , and the vernier indices are set on this division of the scales. For reducing, the indices of the beam and of *AP* are placed on the halves toward *P*, and those of *TD* on the half next to *D*; for an enlargement, this arrangement is reversed.

147. *Copying by Photography.*—This method has the advantages of accuracy and rapidity, and is generally used when a number of copies of the same map is required.

The two processes commonly used are the “wet plate” and dry plate,” in each of which a negative on glass is first made, and from this the copies are printed. Aside from the chemical preparations and their general application, which can be learned from a photographer or from some of the many manuals of photography, there are certain special rules to be observed in order to obtain a good negative.

In the *preparation of the subject* (the map to be copied), the lines must be very black and on a white surface.

Stick India ink of good quality is reliable, and with a magnifying-glass to examine as to variability in intensity, no error need be committed in this respect. The addition of a little red or yellow coloring-matter—carmine, crimson lake, burnt sienna, or bichromate of potassa—to the water used in preparing the ink is advisable, as the lines thus “take” blacker.

Since red and yellow “take” nearly black, and blue nearly white, bluish white paper is to be preferred. The paper should also be smooth, like the “Plain Saxe” much used for photographic purposes.

The subject should be drawn to a scale at least  $\frac{1}{3}$  larger than required for the copy, in order that slight irregularities may disappear in the reduction. If a greater reduction is required, the subject must be generalized as described in par. 141, and allowances made for the diminished sizes of scales, letters, etc.; e. g., in reducing from  $\frac{1}{100000}$  to  $\frac{1}{200000}$ , the representative fraction must be changed to  $\frac{1}{200000}$  on the subject, and the letters and lines made respectively larger and broader than are appropriate to the former scale.

A very fine line in the subject is liable in any case to become indistinct. The *lens* used should be of the “rectilinear” type, so that right lines on the extreme boundaries of the sub-

ject will not be curved or distorted. Any fault in this respect is readily detected by examination, or, if necessary, by measurement of the image on the ground glass. To produce sharply defined lines, very small stops should be used, so that the rays which act upon the plate may be confined to those which enter near the optical centre of the objective or front lens. Rules are prescribed for determining the relative distances of subject and ground glass from the optical centre in order to obtain the desired reduction; but to ensure an exact copy, the safest plan is to construct the outline of the subject on the ground glass, according to the scale required, and then focus so that the image of the outline of the original shall coincide with it. The subject and ground glass should be parallel, and the optical axis, or axis of the lens tube produced, should intersect the middle point of the subject, at least very nearly.

It is more convenient for adjustment to have the subject and ground glass vertical. To fulfil these conditions, rigid and adjustable stands are used for both camera and subject; but for want of better means, a level table for the camera, with a vertical support to which the subject may be fastened, will serve.

The *subject should be strongly and equally lighted*; and, as much as possible, all light except that proceeding from the subject should be excluded from the lens.

To obtain a fair negative is by no means a difficult operation; but, in addition to the information acquired from experts, considerable practice is required to make a perfect one. The following is a brief description of a process successfully used by the writer for obtaining a negative suited to map-work:

**With Wet Plates:**

For albumenizing; white of 1 egg + 2 qts. water, thoroughly shaken with broken glass and flowed on the glass, which should be perfectly clean, and dripping from a fresh application of clear running water. Dry under cover at least 24 hours before using.

For collodionizing; a thin collodion of a sherry color,—made so, if necessary, by the addition of a little iodine (scales dissolved in 95% alcohol).

For sensitizing; a silver bath, having a strength of 42 gr. to 1 oz. of water, the latter being first cleansed by adding to it an ounce or so of silver nitrate and placing it in the sun till the impurities are precipitated, and then filtering it through cotton. When perfectly transparent, add a few drops of nitric acid (C. P.), sufficient to make the bath redden blue litmus paper; then suspend in it a plate, coated with collodion on both sides, for about 24 hours.

To sensitize a plate, two or three minutes' suspension in this bath is sufficient.

For the exposure, use direct sunlight illumination if practicable; if not, use reflected sunlight and place black-paper cone on lens-tube.

Time, with smallest stop, about 30 seconds,—soon ascertained in practice.

For developing: a saturated solution of sulphate of iron 2 parts + double sulphate of iron and ammonia 1 part; to 2 quarts of which add sulphate of copper  $\frac{1}{2}$  oz. To 1 oz. of this add 8 oz. water + 1 oz. of acetic acid. Flow and develop until light parts just begin to turn dark, then wash. For fixing, use a bath of  $\frac{1}{2}$  oz. cyanide potassium + 16 oz. water; time, about 10 seconds, or until light parts disappear.

Wash about half a minute in clear, running water, and dry on edge in rack.

If intensification is needed, use sat. sol. bichloride mercury, in which leave plate until film

turns white; then wash, and place it in sol. of ammonia 1 oz. + water 10 oz., and leave till film is blackened. Wash and dry.

To produce very dense negatives, use a bath of 1 oz. sulphate of copper + 2 oz. bromide potassium + 6 oz. water; wash, and flow with a weak solution (say 20 gr.) of nitrate of silver. Wash and dry in rack.

With Dry Plates ("Rapid" brands):

A printed circular giving the process best suited to each of the many kinds of dry plates manufactured usually accompanies each box of plates; but for map-work the following process is a simple and good one:

Use same illumination of subject as above described for "wet plate." Time of exposure with smallest stop; begin with 3 seconds.

Wash one minute under the tap, then develop with the following solutions:

No. 1, a filtered sat. sol. of oxalate of potassa + a few drops of oxalic acid.

No. 2, a filtered " " " sulphate of iron + " " " sulph. " (C. P.)

To four parts of No. 1 add one part of No. 2, first diluting each separately with half its bulk of water.

For the bath, use enough to cover the entire plate, and develop until lines are visible on glass side; wash, and fix in bath of hyposulphite soda 1 part + water 5 parts; when clear, wash at least 1 hour in running water.

These plates may be intensified as described for wet plates; but will seldom need it, unless for lithographic work.

For the printing:

1. Albumenized paper is lightly rubbed smooth with a canton-flannel pad, then sensitized by floating on a silver bath of 50 gr. to the oz.
2. Fumed with strong ammonia 30 minutes.
3. Exposed in printing frames in the usual manner until the lines are slightly bronzed.
4. Washed in running water, two changes, ten minutes altogether.
5. Put in bath of salt one part + water 50 parts, until lines turn red.
6. Toned in chloride gold solution which contains one grain to a sheet of paper, and consists of 8 oz. of borax (1 part) and water (80 parts), to 1 gr. of chloride of gold. Time, until red lines turn black.
7. Fixed in fresh hypo-solution as for plates—time, 10 minutes; then placed in strong solution of salt and water for 10 minutes, and finally washed in running water for about 5 hours.

Clear hydrant-water is used in all of these operations.

Transparencies, or positives on glass, are valuable for retaining the lines of an original map in their true dimensions and relative positions, unchanged by atmospheric influences during the slow process of engraving, and also for copying from directly, as described in IV., par. 140. The negative itself may be used for the latter purpose; but if so intended, the film side of the plate should be placed to the rear in the plate-holder, so that the fair sheet may be placed in contact with the image.

The "*Blue Process*" is a ready means for copying. A tracing of the original is first made (III., par. 140), using very black ink and no very fine lines. Smooth, white, sensitized paper is then exposed underneath the tracing to the action of light, and the result, after washing in water, is a duplicate of the tracing, in white lines on a blue ground.

Paper already sensitized is usually obtainable, but may be prepared as follows:

Dissolve

|        |  | Parts. |
|--------|--|--------|
| No. 1. | Potassic ferri cyanide (red Prussiate potash)..... | 1      |
|        | in water .....                                     | 4      |
| No. 2. | Ammonio ferric citrate .....                       | 1      |
|        | in water.....                                      | 4      |

and filter separately.

In a room dimly lighted, or under gas-light, place the paper flat on a table, mix two parts of No. 1 and three of No. 2 in a saucer, and with a broad soft brush apply this mixture to one side of the paper, being careful to cover it well, and avoiding streaks by going over it a second time with oblique strokes: hang the paper up to dry, and keep in a dark place till used. The paper, and solutions also, are best freshly prepared.

A convenient printing-apparatus consists of a rectangular wooden frame, large enough to hold the tracing, and about three inches deep, in the top of which is fixed a strong plate of clear glass; a smooth flat board which fits inside the frame; and two or three pieces of felt or blanket of the size of the board.

To use it, place the frame glass down, lay the tracing face down on the glass, and on this the sensitized paper also face down.

The pads are then laid evenly on the paper and pressed firmly with the board, which is secured in place. The latter should be hinged in the middle, or in smaller sections, to admit of examining the progress of the printing.

In direct sunlight, with fresh material, an exposure of from 5 to 8 minutes is sufficient; but with a subdued light, an hour or more is sometimes required. Warm weather requires less time than cold. A strong metallic gray color indicates sufficient exposure.

When long enough exposed, the print is placed in water for 2 or 3 minutes, or until the drip shows no yellow tinge, and is then hung up or placed between folds of blotting-paper to dry.

The following formula is from Lieut. Harris' "Instruction in Photography:"

Dissolve

|        |                                   | Parts. |
|--------|-----------------------------------|--------|
| No. 1. | Potassic ferri cyanide.....       | 1      |
|        | in water.....                     | 6      |
| No. 2. | Ammonio ferric citrate .....      | 1½     |
|        | in water.....                     | 6      |
| No. 3. | Ammonia liquor, concentrated..... | 1½     |

When needed, mix 1 and 2, and add 3.

To write upon a blue print, use a saturated solution of sal soda and a clean pen.

To obtain *blue lines on a white ground*, use a negative of the subject in lieu of the tracing.

A negative may be extemporized by placing the subject face down on a copying-glass (IV., par. 140), and, with a sharp point, tracing the lines on the surface of a plate of glass covered with any smoothly laid material not so opaque as to render the subject invisible in

copying. Or, to dispense with the latter condition, make a tracing and transfer it by carbon paper, so it will be reversed on the prepared glass; then cut out the lines with a sharp point.

For *black lines on a white ground*, Colas' process may be used.

A hard well-sized paper is coated as described for the blue process, with the following preparation:

|                          | Parts. |
|--------------------------|--------|
| Persulphate of iron..... | 1      |
| Perchloride of iron..... | 2      |
| Tartaric acid .....      | 1      |
| Gelatine .....           | 1      |
| Water .....              | 30     |

When dry, expose under the tracing until the greenish-yellow tint of the paper disappears, except where covered by the opaque lines; then develop in a bath composed of

|                  | Parts. |
|------------------|--------|
| Gallic acid..... | 1      |
| Alcohol.....     | 10     |
| Water.....       | 50     |

Fix in water as in blue process.

The following formula is for *red lines on a white ground*:

|          |                             |                 |
|----------|-----------------------------|-----------------|
| No. 1. { | Uranic nitrate.....         | 40 to 50 grains |
|          | Water.....                  | 1 oz.           |
| No. 2. { | Potassic ferri cyanide..... | 15 grains       |
|          | Water.....                  | 1 oz.           |

Float Saxe or any other equally smooth paper 2 or 3 minutes on 1 and dry; after exposure, develop by floating on 2 until details are brought out (30 to 60 seconds), then wash 5 minutes in water.

148. *Modelling*.—A topographical model or relief-representation of a tract, in plaster or other suitable material, certainly presents the different features with greater clearness and force than can be done by any other means. The configuration of the surface, mountains, hills, surface-undulations and the streams and buildings are shown in miniature; and, with the appropriate colors, so distinctly, that a thorough knowledge of the tract is obtained at a glance. From a military point of view, models are excellent references in the study of campaigns and battles, affording a most thorough appreciation of important positions; and for geological purposes, particular formations may be clearly represented in colors on the faces of different vertical sections.

The *Details of Construction* include the preparation of a topographical map of the tract to be represented, a suitable vertical scale, the model, the mould, the cast, the representation of minor details, and the coloring.

The map having been completed, a *vertical scale* suited to the configuration is selected. For a map scale of 6 inches to 1 mile, the following exaggerations of height afford pleasing reliefs:

For a mountainous tract,  $\frac{1}{8}$ ; if only hilly,  $\frac{1}{4}$ ; if gently undulating,  $\frac{3}{8}$ . For smaller scales except for very rugged tracts, the exaggeration should be correspondingly increased. For a tract consisting wholly of mountains, no exaggeration is necessary.

There are several ways of *forming the model*; the two generally in use are:

I. *With Clay*.—Fasten a duplicate of the map to a flat, well-seasoned board, or, better, to a slab of plaster; drive pieces of strong wire vertically into the board and through points of the characteristic surface-lines, such as the highest and lowest points of water partings and courses, and where marked changes in their direction occur; also through the peaks and the lowest points of depressions, the junctions and principal bends of rivers, etc.; nip off the wires, so that their lengths measured by the vertical scale will correspond to the heights, as given by the contours, of the points through which they are driven. Then fill the spaces with fine clay to the tops of the wires, and mould the surface with the fingers, or suitable tools, to conform to the map. In case of any delay in the work, the clay may be kept moist by the application of a wet cloth.

Another plan, due to Henry Brooks, and by which a very exact representation may be effected, is as follows:

First trace the contours on, or transfer them to, waxed or oiled paper, which fasten to a board sufficiently thin to be cut with a jig-saw; saw through the contours, leaving small portions of the board uncut so that the zones will be held together, and fasten this board, by its outer edges only, to another, which should be flat and rigid, and which may be called the base. Then, from sheet-brass, or other pliable and sufficiently stiff material, cut strips in lengths and widths corresponding respectively to the portions of the different contours represented, and their heights above the datum-plane, or "base." These strips are then bent and thrust into the corresponding saw-cuts until their lower edges are in contact with the base,—portions of these lower edges being first cut away where the contours are not sawed through. A set of vertical cylinders is thus formed of which the upper edges represent the contours in true position.

The intervals between the cylinders are now filled with moist clay, the surface being moulded to conform to the contours or upper edges of the cylinders, and to any intermediate irregularity of the tract it may be desirable to represent. It is advisable to treat the entire surface with a coating of hot wax before filling in with clay, in order to prevent any warping that might otherwise result from moisture.

II. *By Successive Horizontal Layers*.—The base of the model should be a flat, rigid surface, representing the horizontal plane through the lowest point of the tract.

Select cardboard or other plane-surfaced material that may be easily cut, of a thickness corresponding to the equidistance measured by the vertical scale; transfer the lowest contour of the map to a piece of cardboard (V., par. 140) of sufficient size, cut the latter along this contour, and with glue or otherwise fasten the layer thus formed to the base of the model. A jig-saw is very handy for cutting out the material.

The next higher layer is then formed in a similar manner and superposed in its true position on the first, and so on to the highest summit of the tract. Where depressions occur, corresponding cuts are made in the different layers.

The layers need not be continuous pieces, particularly in large models, but the annular breadth should be sufficient to enable them to be firmly fastened in place. To aid in properly



superposing them, corresponding marks should be made, or holes punched in consecutive layers.

The terraced surface thus produced is then rounded out and made to conform to the natural surface, either with wax softened in warm water, putty, or other plastic material ; and when this is firm the model is ready for use.

Another plan consists in first transferring the lowest contour to the base, prepared as above described, and levelled ; then a flat strip of soft metal, as lead, is bent so that its inner edge shall coincide with the contour, and the strip resting upon the base thus form a mould for the lowest zone. This is then filled with plaster, as hereafter described for the mould, and to a height corresponding to the equidistance ; when dry, the next higher contour is transferred to it ; the second zone is formed in a similar manner, and so on to the summits. The terraced formation may then be rounded as above described, or by cutting.

To make the *Mould*: construct a strong wooden frame that will exactly enclose the model and extend an inch above it ; place it tightly around the model, and with a camel's hair brush, cover the surface of the latter with sweet oil, leaving the sides of the frame dry. Then pour over the model plaster-of-Paris, mixed to a proper consistency with water, filling the frame.

After 15 or 20 minutes the mould is removed, dried in the sun or by gentle artificial heat, then given two or three coats of drying-oil, and in about two days is ready for use.

For large representations, the model is cut into sections not exceeding 3 or 4 feet square, the frames are made very strong, and each section is moulded separately.

To make the *Cast*, oil the inner surfaces of mould and frame, and pour plaster into it, as for the model. When set, the cast is taken out—a few gentle raps with a hammer near the base of the frame expediting the matter, if necessary—and dried, as above described. It is then given one or two coats of a very thin, hot solution of isinglass preparatory to coloring it. Pieces broken off may be fastened in place with glue, or, when this is impracticable, *papier-maché* may be shaped to fit and glued in.

For the *Representation of Details*, the method of copying by squares (I., par. 140) is resorted to. A frame is fitted to the outer edges of the cast as prescribed for moulding ; squares are ruled upon the map, and the points of intersections of the dividing-lines are transferred to the upper edges of the frame. By means of a straight-edge and pencil, the latter being held vertically, the corresponding lines may then be drawn upon the cast, and serve as references for filling in such of the details as may be suited to the scale employed.

Water-colors, thoroughly mixed, and to which a little mucilage is added, are used for the coloring, which should conform to nature as closely as possible.

Glass may be used to represent the large bodies of water—a greenish-blue tint serving to heighten the effect.

Streams are colored with Prussian blue ; buildings, moulded or cut out of some light material, are fastened in place and colored to represent the material of construction.

For drawing-models, the contours should be represented. This may be effected as above described ; or, before the details are drawn, by placing the cast on the level bottom of a small tank of water, and marking each shore-line as the water is reduced in depth an amount corresponding to the equidistance. (For details of professional work in plaster, see Appendix, par. 177.)

## PART V.

## PROJECTIONS FOR MAPS OF LARGE AREAS.

149. For a large tract several hundreds of miles in extent, it is necessary to plot the lines, angles and points, so they may have as nearly as possible their relative positions, as if projected upon the spheroidal surface represented by the mean sea-level.

For this purpose, in the survey, the tract is divided for topographical representation into zones so small that they do not differ sensibly from their projections upon horizontal planes tangent at their middle points; and since a meridional arc of  $1^\circ$  in length differs from its projection on such a plane by but  $6\frac{1}{2}$  feet, or  $\frac{1}{800}$  of an inch to a scale of 1 inch to 1 mile, it follows that with the scales ordinarily used any zone may contain right lines considerably greater than  $1^\circ$ , or  $69\frac{1}{2}$  miles, in length (par. 52).

The separate plots of these partial areas are then assembled on a *projection* of meridians and parallels. Since a sphere or spheroid is not developable upon a plane surface, in other words cannot be so spread out as to exactly coincide with it, this projection cannot represent the meridians and parallels in their true relative positions; therefore, although the primary triangulation fixes the geodetic positions (determines their latitude and longitude) of two or more points of each zone, there must be discrepancies between actual distances and their representations upon the assembled plot, and these will vary principally with the extent of territory and the kind of projection employed.

For topographical maps, the cylindrical and conical projections are generally used.

150. *Cylindrical Projections*.—Suppose a cylinder tangent along the equator, and the meridians and parallels projected upon it by their planes produced. If this cylinder be now rolled out upon any of its tangent planes, these projections will be developed into right lines at right angles to each other. Arcs of the equator will be represented in their true length, while arcs of the meridians and parallels will be respectively diminished and increased as their distances from the equator increase, the difference being small near the equator, but rapidly increasing toward the poles.

If, instead of this, a right cylinder be passed through a parallel, say of  $30^\circ$  N., a similar result obtains, except that the arcs of the parallels between  $30^\circ$  and  $0^\circ$  are diminished, the arcs of the given parallel only being faithfully represented.

Of the modifications of the cylindrical projection commonly used there are:

I. *The Rectangular Projection*.—To construct it, draw  $PP$  (Fig. 82, Plate XIX.) to represent the middle parallel of the tract to be projected, and graduate it, according to the scale of the map, into degrees, minutes, or parts or multiples thereof (Table VI., Appendix), as may be desired, corresponding to their true lengths on this parallel; and through the points  $m . . . . .$ , thus determined, draw right lines perpendicular to  $PP$ ; they represent the required meridians. The parallels are fixed in a similar manner by setting off from  $PP$ , on any meridian, the consecutive distances  $Mp'$ ,  $Mp . . . . .$ , respectively equal to the reduced length of a de-

gree or part thereof (Table IV., Appendix), for the corresponding intervals between the parallels.

II. *The Projection with Converging Meridians.*—Draw  $CC$  (Fig. 83) to represent the central meridian, and graduate it into degrees or parts thereof (Table IV.). Through the determined points,  $p, \dots$ , near the upper and lower edges of the sheet, draw the parallels  $P'P'$ ,  $P''P''$ ; and, beginning at  $CC$ , subdivide each into parts corresponding to the length of a degree or part thereof (Table VI.) of longitude, measured on this parallel; the right lines  $mm'$ ,  $\dots$ , through the points thus determined, are the required meridians. Intermediate parallels  $p'p'$ ,  $\dots$  are drawn as desired.

This projection is suited to larger areas than (I.). The adaptability of either projection to the required purpose depends upon the extent of territory to be represented and the scale of the map (par. 52).

151. *Conical Projections.*—Suppose a cone tangent to the earth's surface along a parallel of latitude, and the planes of the meridians and parallels produced to intersect it; the meridians will be projected into right lines passing through the vertex—elements of the cone—and the parallels into circumferences of circles intersecting the projected meridians at right angles. If the cone be now cut along an element, and rolled out upon any of its tangent planes, the projections will appear as in Fig. 84,—the meridians all converging to the vertex,  $V$ , and the parallels as arcs of circles described from  $V$  as a centre. The parallels still intersect the meridians perpendicularly, but arcs of meridians are diminished toward the poles and increased toward the equator, while arcs of the parallels are all increased, except those of the parallel of tangency, which are represented in their true dimensions.

Arcs of the meridians may be correctly represented by laying off from the parallel of tangency and along the central meridian (the element of contact of the plane of development) consecutive distances corresponding to the length of a degree of latitude, or part thereof, and with  $V$  as a centre describing arcs of circles through the points of divisions.

Of the conical projections, those most in use are:

I. *The Simple Conic Projection*, in which the parallel of tangency is the central parallel of the tract to be represented, and is made the central parallel of the map sheet. Its radius is

$$r = R \cot l, \quad (1.)$$

in which  $l$  is the latitude of this parallel, and  $R$  the mean radius of the earth's surface.

To construct it; draw the right line  $VC$  (Fig. 84) to represent the central meridian, and let  $M$  be assumed as its intersection with the central parallel. On  $VC$  set off  $Mp, \dots$ , each equal to the length, reduced to the scale of the map, of a degree of latitude or part thereof, (Table IV.); also  $MV = r$  (Eq. 1): then from  $V$  as a centre, describe the arcs  $p'p'$ ,  $P'P'$ ,  $\dots$  through  $M, p, \dots$ , and they will be the required parallels.

On  $PP$  set off  $Mm, \dots, mP$ , each equal to a degree, or part thereof, of this parallel (Table VI.), and the right lines  $Vm, VP, \dots$  will be the required meridians.

When the value of  $r$  places  $V$  at an inconvenient distance, as is usually the case with small areas, points of the central parallel may be determined by rectangular coordinates as follows:

Let  $VC$  (Fig. 85) represent the central meridian; through  $M$ , its assumed intersection with the required parallel, draw  $AB$  perpendicular to  $VC$ , and use  $VC$  and  $AB$  as the axes of  $X$  and  $Y$  respectively (par. 57),  $M$  being the origin.

The coordinates of any required point, as  $P$ , are  $x = mP$  and  $y = pP$ .

Denote by  $v$  the angle  $MVP$  made with  $VC$  by the meridian through  $P$ ; then  $x$  is the  $\sin v$ ; and  $y$  is the  $\text{ver sin } v$ ; and since the radius of the required parallel is  $r$ , the corresponding values of the coordinates are

$$x = r \sin v, \text{ and } y = r \text{ ver sin } v. \quad (2.)$$

To find  $v$  measured on  $MP$ , let  $d$  represent the difference of longitude of  $VC$  and the meridian through  $P$ . Referring to  $a$  and  $b$  (Fig. 86), in which  $R'$  is evidently equal to  $R \cos l$ ,

$$90^\circ : dR' :: d : M'p';$$

and similarly,  $90^\circ : dr :: v : M'p';$

therefore  $d'R' = drv$ ; substituting for  $R'$  and  $r$  their values and reducing,

$$V = d \frac{R \cos l}{R \cot l} = d \sin l;$$

and by substituting this value for  $v$  in (Eq. 2),

$$x = r \sin (d \sin l), \text{ and } y = r \text{ ver sin } (d \sin l). \quad (3.)$$

For a point  $1^\circ$  distant from  $M$ ,  $d = 1$ ;

For a point  $1'$  distant from  $M$ ,  $d = \frac{1}{60}$ ;

and similarly for other differences of longitude.

Three or more points having been fixed, a curve drawn through them will be the parallel required. The meridians will be represented by normals to this parallel at the desired points of subdivision; and additional parallels, concentric with  $PP$ , may be described through corresponding points of subdivision of the normals.

II. *Bonne's Projection*.—In this, the line representing the central meridian is first subdivided into the required number of intervals, and the parallels are then constructed through the points of subdivision. Each parallel is then subdivided into degrees, or parts thereof, corresponding to the intervals required between the meridians, which are then drawn through the points of subdivision. The latter are thus curved lines intersecting the central parallel only at right angles.

Distances measured on the central meridian and on any parallel are faithfully represented, and the zones between parallels are in their true relations to each other and to the central meridian. Distances along other meridians are increased in the same ratio that the cosines of the angles between the radius of a parallel and the tangent to a meridian, at their point of intersection, are diminished; and the result is, that while the areas of the different quadrilaterals are unchanged, their diagonals become unequal, and this inequality increases toward the polar corners of the map.

The construction of the parallels by points is as described for the central parallel in (I.)

III. *The Polyconic Projection*.—In this projection, each parallel is the line of contact of a tangent cone; therefore, in the development, the parallels are arcs of circles described from different points of the central meridian as centres, and with radii equal to the cotangents of their latitudes. The meridians are curves intersecting the parallels nearly perpendicularly, the arcs of the meridians being exaggerated in proportion to the increase of longitude from the central meridian. This is termed the *rectangular polyconic projection*: and is constructed by setting off, upon the central meridian, distances corresponding to rectified arcs (Table IV.) of

one degree, or parts thereof, and with the different radii  $R \cot l$ , the centres evidently being on the central meridian, describing the parallels through the points of division: the meridians are then curved lines drawn normal to the different parallels.

For narrow belts of country the *ordinary polyconic projection* is used. The central meridian alone is normal to the parallels, and is developed in its true length. The parallels are constructed as above described, and the meridians are curved lines drawn through the extremities of the arcs of the different parallels, corresponding to equal differences of longitude measured upon them.

For the smaller areas usually represented in topographical maps a graphic construction termed the *equidistant polyconic projection* is used.

The limiting meridians and parallels, and the scale being given, draw a meridian line  $VV$ , (Fig. 87), as nearly through the middle point of the sheet as the proper spacing of the meridians and parallels will permit. Beginning at  $A$ , near the top of the sheet, set off on  $VV$ ,  $AM$ , and  $MN$  respectively equal to the lengths of the degrees, or parts thereof (Table IV., Appendix) of the central meridian, corresponding to the given latitudes; and draw  $BC$ ,  $DE$ , and  $FL$  exactly perpendicular to  $VV$ , and extending across the sheet. Set off on these perpendiculars, from  $A$ ,  $M$  and  $N$ , the distances  $Ac$ ,  $Ab$ ,  $Me$ , . . . . .  $Nf$  equal to the corresponding values of  $x$  (Table V., Appendix) for the extreme meridians of the survey; and at the extremities  $b$ ,  $c$ ,  $d$  . . . . .  $f$  of these distances, set off, parallel to  $VV$ ,  $bb'$ ,  $cc'$ , . . . . .  $ff'$ , equal to the corresponding values of  $y$  in the same table.

Through  $b'$ ,  $d'$  and  $f'$ , and through  $c'$ ,  $e'$  and  $g'$  draw the meridians  $HI$  and  $KL$ , which for areas not exceeding about 200 miles square will be sensibly straight lines. Other meridians  $kk'$ ,  $lh'$  . . . . . are drawn as required. Then subdivide the sections  $b'd'$ ,  $c'e'$  . . . . . into the desired number of equal parts  $b'b''$ ,  $b''b'''$ , . . . . . of the same value as the intervals between the meridians (i.e., if the latter are minutes, make the former minutes, etc.); and the curves  $pp$  . . . . . through the corresponding points of division will be the required parallels.

For very small areas, the points  $b'$ ,  $c'$ , . . . . .  $g'$  may be joined to  $A$ ,  $M$  and  $N$  by right lines.

The accuracy of the construction is verified in the usual manner by comparing any plotted interval, as  $s$ , with its actual length reduced to the scale of the map, and by the measurement of diagonals as  $tt$ ,  $t't'$ , symmetrically disposed as to  $VV$ , and which should be of equal length.

152. *Plotting the Triangulation.*—The meridians and parallels plotted, and the latitudes and longitudes of the triangulation-points given, any intersection as  $o$  of the former lines is an origin of co-ordinates for any point as  $r$ ,— $x$  and  $y$  being the number of seconds of longitude and latitude respectively from  $o$ .

To verify the accuracy of the plot, compare the actual distances, reduced to the scale of the map, between triangulation-points, with their plotted distances.

To plot meridians and parallels upon a map already filled in with the topographical details, needs no further explanation; the latitude and longitude of any point and the direction of the meridian through it being known, the construction is simply the reverse of that just described.

Tables for the values in minutes and seconds of  $x$  and  $y$  for differences of longitude, to include  $30^\circ$  on each side of the central meridian, are given in the U. S. Coast and Geodetic Survey Report for 1884.

For methods of Plotting the Triangulation when the earth's sphericity is considered, see Appendix, pars. 174 and 175.

# TOPOGRAPHICAL SKETCHING.

---

## PART VI.

---

### SKETCHING-INSTRUMENTS, METHODS AND EXAMPLES.

#### SECTION I.—GENERAL CONSIDERATIONS, INSTRUMENTS, LOCATING POINTS, MEASUREMENT OF DISTANCES AND HEIGHTS, THE SKELETON.

153. *General Considerations.*—The aim in the following pages is to show how with simple means to represent a route and the important features bordering it, a military position, or a tract of small or large extent, in an intelligible manner and with a degree of accuracy suited to the special purpose for which the sketch is made.

The mode adopted in treating this subject is to first describe a method of working with the presumption that suitable hand-instruments and plenty of time are at command, and then vary the details to suit less favorable conditions.

The operations performed are based upon the general principles of topographical surveying and drawing, and their degree of accuracy depends upon the kind of instruments used, the method of working, and the time devoted to it. Facility in plotting is a prime requisite, and a theoretical knowledge of the manipulation and use of the more exact topographical instruments is of great assistance; but it is only after much practice in the measurement of angles and distances, both instrumentally and by eye-estimation, that the ability is finally acquired of intelligibly representing a tract of country, or a route, while passing rapidly over it.

Whether done in haste or at leisure, it embraces the following operations:

- I. Constructing the skeleton or outline of the sketch;
- II. Filling in the details;
- III. Representing the configuration of the surface, or hill-sketching.

These are performed either in the order given, or the first two together and the last then added, or all three are carried on at once as the work progresses; the method adopted depending mainly upon facility in sketching and the time at command. A beginner is obliged to perform them in the order given, until enough experience is gained to combine them, and thereafter the advantage obtains that no part of the ground need be revisited.

154. *Sketching-Instruments* (Plate XX).—The instruments ordinarily used are a hand-compass, hand-level, clinometer, protractor, lead-pencil, rubber eraser and note-book; or in place of the last, the required number of sheets of paper, secured to a light, smooth, rectangular board or cardboard of convenient size. A red pencil for contours and a blue one for

streams are particularly useful in preventing confusion of lines when much detail is required. With water-colors, some of the features, such as woods, cleared and cultivated land, bodies of water, etc., can be represented with great rapidity.

The above are the essential instruments; others of importance, suited to special purposes, are described in their appropriate places.

*a. Hand-compasses.*—Two kinds are in general use, the “rectangular box-compass” and the “prismatic compass.” Each consists of a cylindrical *compass-box*, usually of brass, three or four inches in diameter and from one to one-half an inch in depth; containing a magnetic needle, with its N. end marked, and a *compass-card* having its edge graduated into 360 degrees, numbered toward the right, or in the same direction as the hour-divisions of a dial. The needle is free to move horizontally upon a pivot attached to the centre of the bottom; but to prevent wear of the pivot when the compass is not in use, a lever is so arranged that one end lifts the needle off the pivot when the other is pressed down. A glass cover protects the needle and card. These two kinds differ essentially in the attachment of the card and devices for sighting.

In the *rectangular box-compass* (Fig. 88), the compass-box is sunken its depth into a square piece or case of hard wood provided with a hinged lid, and the  $0^\circ$  and  $180^\circ$  line is parallel to the hinged edge.

*To take a Bearing;* open the lid to the right at right angles to the case; hold the case horizontally, and in such a position near the eye that the distant object can be seen along one of the faces of the lid, and the vibrations of the needle watched at the same time; check the vibrations with the lever; and when the needle is at rest, hold it in place and read and record the number of the division next to its N. end. With a little practice the mean of two or more successive delicate vibrations can be observed, and more accurate work ensured.

A form of this instrument has the lines of sight at right angles to the lid, a vertical slit in the middle of the latter, and a sight-vane diametrically opposite which can be turned down when not in use.

In the *prismatic compass* (Fig. 89) the card is attached to the needle, and the  $180^\circ$  division is usually at the N. end. The four “cardinal points” are also marked on the card. The adjustable sights, *s* and *s'*, with slits in them, are hinged to the upper edge of the box, at points diametrically opposite each other. The sight *s*, held next to the observer's eye, contains a lens, and a glass prism which reflects the number immediately below on the card to the eye, at the same time an observation is taken through the slits at the distant object. The front sight, when folded down for the purpose of placing the box in its case, lifts the needle off the pivot, in the manner already described (see Fig. 88). By pressing a knob which projects from the side of the box, usually under the front sight, a spring bears on the rim of the card and the needle-vibrations are checked. In the instrument shown, the cam *c* serves to retain the card free of the pivot when the box is closed.

*To take a Bearing;* adjust the prism so that the numbers on the card can be easily read; hold the box steadily in a horizontal position so that the distant object, of which the bearing is required, may be clearly seen through the slits in both sights; check the needle, and record the number which appears to be cut by the hair in the slit of the front sight.

If the card is graduated from  $0^\circ$  to  $180^\circ$  on each semicircumference, care must be taken to record the semicircumference on which the number is read, as E.  $90^\circ$ , or W.  $90^\circ$ , etc.

A mirror, shown attached to  $s'$ , is used for taking bearings of the sun or of very elevated points, the colored glasses attached to  $s$  serving in the former case as a protection to the eye. It is not, however, of much practical value, since by use of a plumb-line a point vertically beneath that of which the bearing is desired may readily be found.

The common pocket-compass, graduated with the "points of the compass" only, may be made serviceable by notching its rim directly over the N. and S. points and using these notches for sighting. By carefully tipping the box in the direction of the needle, the latter will be held in place for reading (the S. notch should be held next to the eye, and the "point" under N. end of needle recorded); or the card may be easily graduated into degrees, the box encased, and the compass used as already described.

The protractor, and its use in plotting bearings taken with differently graduated compasses, are described in Topographical Drawing, pars. 22 *et seq.*

*b. Hand-levels and Clinometers.*—A *Hand-level* is shown in Fig. 90. It consists of a metal tube 5 to 7 inches in length, and closed at each end with plane glass. When held horizontally, the rays from the bubble  $b$  pass through an opening beneath to the mirror  $m$ , which usually occupies the left half of the tube and is inclined at an angle of  $45^\circ$  with the axis of the latter, and are reflected to the eye at  $e$ ; in this position of the instrument a horizontal cross-wire within the tube bisects the image of the bubble and any distant point on a level with the eye.

In the improved form, the eye-piece is telescopic and contains a semicircular lens which magnifies the image of the bubble.

*To measure differences of level;* locate a point of the slope on a level with the eye; proceed to that point and locate another, and so on, to the height desired. The number of observations, multiplied by the height of the eye above the ground, will be the required difference.

Its most important use is to ascertain from the sketcher's position the points of intersection of a contour with distant objects.

There is also a great variety of *clinometers*,—instruments for measuring angles of elevation or depression. One of the best is "*Abney's Reflecting Level*" (Fig. 91), which is a combination of the hand-level and clinometer.

A rectangular metal tube,  $T$ , about  $4\frac{1}{2}$  inches long, is furnished with mirror, eye-aperture and cross-hair, as in the hand-level; the limb,  $A$ , fixed to the tube, is graduated to degrees, while the index-arm,  $i$ , which carries the level,  $L$ , is provided with a vernier which reads to 10 minutes.

To make  $L$  horizontal, the milled head,  $h$ , is turned with the left hand while the instrument is held with the right.

To use it as a hand-level, set the index at  $0^\circ$ .

To measure the angle of elevation or depression of a point, sight the point, make  $L$  horizontal as above described, and read the arc passed over by the index of the vernier.

A scale of slopes from  $\frac{1}{4}$  to  $\frac{1}{10}$  is also marked on the limb; but in using it, the front edge of the arm is the index.

To test the adjustment, set the index at  $0^\circ$ ; sight at a distant object and move the entire instrument until a point of the object and the bubble are bisected by the lower edge of the mirror; then revolve the instrument  $180^\circ$  about its axis and bisect the bubble as before. If



in adjustment, the same point will again be bisected: if not, correct half the error by means of the screws which fasten the level to its support.

For lack of better means, a protractor and plumb line may be used for both hand-level and clinometer;—the plumb-line being suspended from the “centre” of the former; and the diameter edge, held uppermost, used as the line of sight.

In measuring angles of inclination, the line of sight is directed parallel to the general surface of the slope; but if the slope is seen in profile, the clinometer is held at arm's-length, with its axis or longer edge parallel to the profile line.

The lead-pencil should be of medium grade, and the note-book or paper ruled in accordance with the special method adopted in making the sketch (par. 160).

155. As to scales and plotting, these subjects are fully described in Topographical Drawing, Part I., Section III.

The particular scale to be used depends upon the purpose of the sketch and the area to be covered by it. For a route-sketch, it is ordinarily 4 or 6 inches to a mile.

The conventional signs are used in sketching: they are necessarily roughly and rapidly drawn, but no ambiguity should exist as to their exact meaning. In cases where a doubt might arise, it is best to describe the particular feature by its name written upon it, or by a marginal reference.

156. *Locating Points, and Measurement of Distances and Heights.*—Points are located by offsets from a given line, by intersections of compass-bearings, or by estimating their positions.

As in surveying, offsets are measured perpendicularly to a course.

If by compass-bearings, these should be taken from such known points that the intersections will not be at a very acute angle.

A check-bearing from a third point serves as a verification.

A point is also located by interpolation, i.e., by taking bearings from it of two or more given points, and then plotting these bearings at the latter points, and producing the lines until they intersect, which necessarily locates the required point.

To promote accuracy, when time permits, both direct and reverse bearings of a course are taken and the mean is used in plotting.

If the reverse bearing is less than  $180^\circ$ , then  $\frac{\text{sum of the bearings} + 180^\circ}{2} = \text{mean bearing.}$

If the reverse bearing is greater than  $180^\circ$ , then  $\frac{\text{sum of the bearings} - 180^\circ}{2} = \text{mean bearing.}$

157. Distances are measured by pacing, by the odometer, by the time required to pass over them, or they are estimated.

*a. By Pacing.*—The ordinary gait, or customary step, and rate of walking are best suited to this purpose, and a regular swing of the arms tends to make the steps of equal length.

The steps are counted singly, or each double step only is noted.

For plotting, the *average pace* is the unit of measurement. This is found by pacing a known distance with an easy, even step, and dividing the distance by the number of steps. By repeating the operation several times, a final average is obtained which will be more accurate.

The *Pedometer* (Fig. 92) is of great assistance, since by recording the number of paces automatically it permits the entire attention to be devoted to other parts of the work.

It is of metal, of the size and shape of a watch, and is carried suspended by the hook *h* from a button-hole, or pocket-edge of the coat or vest. Its interior mechanism (Fig. 92*a*) consists of a weight, *W*, attached to an arm pivoted on the same arbor as the ratchet-wheel, *C*. When at rest, *W* is kept at the highest point of the slot in which it plays (indicated by the dotted line) by the tension of the spring *s''*. In the motion due to walking, the spring *s* advances one notch for each descent of *W*, — *s'* retaining *C* in place during this downward movement.

The screw, *s'''*, serves to limit the play of *W* to any desired extent.

The large hand (Fig. 92) advances 1 division at each step, and registers 100 paces each entire revolution. The hand on the right advances 1 division for each 100 paces, and the one on the left 1 division for each 1000 paces. The hands may be set at 0, care being taken to turn them in a backward direction.

*b. The Odometer* is an instrument for registering automatically the number of revolutions of the carriage-wheel to which it is attached, the distance passed over being the product of number of revolutions  $\times$  circumference of the wheel.

Its usual form is shown in Fig. 93. The bob, *B*, is suspended by its lugs, *l*, to the arbor, *a*, fixed to the stirrup, *S*. On the front face of *B* are two dials of equal diameter which revolve upon the same pivot, *b*, the teeth of each engaging in the thread of *a*, as shown. It is contained in a leather case, and so attached to the carriage-wheel that the dials are to the front. It is seen from inspection of the figure that the dials are advanced one tooth for each revolution of the carriage-wheel; and since the outer or front dial contains 100 teeth, and the other 99, the latter gains 1 tooth, or dial division, for each of its own entire revolutions.

The manner of registering is seen in the figure, the motion of the dials being in the opposite direction of the hands of a watch, the hook index, *i*, (attached to the back of *B*), serving for the outer dial, and the 0 of the latter for the inner one—the former dial evidently recording the number of single revolutions up to 100, and the latter the number of hundreds of revolutions up to 99.

The zeros may be made to coincide if desired, by first removing the screw at *b*. The present reading is 3483.

The distance between any two points is the difference of the readings at these points  $\times$  the circumference of the carriage-wheel; but owing to the slip of the latter and other irregularities of motion, a special wheel, either trundled by hand or separately harnessed, is sometimes used for the more precise measurements. In the ordinary application of it, a little practice will serve to determine the corrections, or the percentage of reduction, necessary to be made for the particular vehicle to which it is attached.

*c.* In sketching from the saddle, the length of the horse's pace, ascertained for the different gaits, may be taken as the unit; or, in very rapid work, the distance passed over in one minute (see also par 48).

*d.* The correct *estimation of distances by eye* is of great importance, and especially so when, as is often the case in the military service, but little time for making the sketch is available.

The values ascribed to both distances and angles vary with the locality, atmospheric conditions and time of day.

Distances appear too small or too great according as the sun is respectively in front or in rear of the observer. They are usually underestimated in a fog or in rainy weather, after a storm, and when the ground is covered with snow. Distances observed down a slope appear shorter than in a contrary direction, and sharp undulations of the surface make the different ridges appear nearer.

Angles of depression of slopes appear too great when observed from the bases, or in profile; and in estimating differences of elevation of points, not far removed, of an irregular surface, the tendency is to diminish them, frequently as much as one-half their actual value; also in trying to find a point of equal elevation on the opposite side of a valley, it almost invariably happens that a higher one is selected.

It is only by much practice in observing known angles and distances, and under the conditions above enumerated, that the eye is trained to avoid these illusions.

The following general indications of distances from Lehagre and the "Feld-Taschenbuch" may be of use. Ordinary powers of vision and a clear atmosphere are assumed. Church spires are visible from 7 to 9 miles; windmills and large buildings, from 5 to 6 miles; ordinary buildings, if isolated and white, from  $3\frac{1}{2}$  to  $4\frac{1}{2}$  miles; windows, from  $1\frac{3}{4}$  to  $2\frac{1}{4}$  miles; large trunks of trees, from  $1\frac{1}{4}$  to  $1\frac{1}{2}$  miles; and small trunks and telegraph-poles, from 1000 to 1200 yards.

As regards military observations;—At a distance of 1600 yards, a column of infantry presents the appearance of a heavy line of uniform thickness; in the case of cavalry, the line is thicker, and indented along its upper edges. The rifles are distinctly visible if the day is bright.

At 1300 yards, infantry files are distinguishable; also whether cavalry is mounted or dismounted; and guns are distinguished from their carriages.

At 750 yards, the movements of arms and legs, white parts of the uniform, and the horses' heads are observable.

At 600 yards, the movements of horses' legs; and the front of a squadron may be estimated by the number of files.

At 450 yards, men's heads, kind of head-covering; mounted men are readily distinguished from their horses, and dark colors become visible.

At 300 yards, cap ornaments and light-colored facings.

At 200 yards, the faces, brass belt-plates, and the intervals between the limbs and the body at rest.

At 150 yards, the hands, buttons, and hair of a light color.

At 100 yards, the position of the eyes may be seen.

*e.* A distance measured on a slope is reduced to its horizontal value; therefore the angle of inclination is required, and the first method, prescribed in par. 82, is applicable.

Or, roughly, to obtain the horizontal distance: on a slope of  $5^\circ$ , the average pace being 30 inches, an actual distance of 120 paces is diminished by very nearly half a pace; on a slope of  $10^\circ$ , by 2 paces; on a slope of  $15^\circ$ , by 4 paces; on a slope of  $20^\circ$ , by 7 paces; on a slope of  $25^\circ$ , by 11 paces, etc.: these values being obtained by multiplying 120 by the  $\text{ver. sin}$  (or  $1 - \cos$ ) of the different angles of inclination.

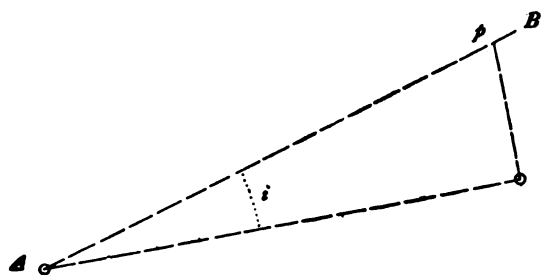
A similar table, on a basis of 100 paces, may be constructed, suited to any other average pace, and to the different degrees of declivity.

As a rule, intersections of compass-bearings are used to determine points, the distances to which are in any way difficult to measure directly.

On slopes exceeding 15° of inclination, paced distances are in general unreliable.

158. *Measurement of Heights.*—*a.* Heights may be measured as described in the use of the hand-level (*b*, par. 154).

The clinometer in conjunction with the table (par. 81) serves to find the difference of level between points already plotted; e.g., the distance between the plotted points, measured by the scale of distances, is 1134 ft.; the vertical angle, as determined at one of the points by the clinometer, is 10°: from the table, 5.67 ft. horizontal distance corresponds to 1 ft. of elevation, therefore the difference of level is  $\frac{1134}{5.67} = 200$  ft.



A *Graphical Method* is illustrated in the accompanying figure. The summit *S* having been located by compass-intersections and plotted, and the vertical angle *i* measured from any plotted point as *A*; join *A* and *S* by a right line, and draw *AB*, making *BAS* equal to *i*; then *Sp*, perpendicular to *AS*, will represent the required height, and may be measured with a scale of equal parts.

Or measure *AS* by the scale, then  $Sp = AS \text{ tang. } i$ .

The following table is convenient in sketching in mountainous tracts.

The first column gives the angle of elevation or depression; and the second, the corresponding differences of level for distances of 1 mile.

| °  | Feet. | °  | Feet. | °   | Feet. | °   | Feet. |
|----|-------|----|-------|-----|-------|-----|-------|
| ½  | 46    | 4½ | 415   | 8½  | 789   | 12½ | 1170  |
| 1  | 92    | 5  | 462   | 9   | 836   | 13  | 1218  |
| 1½ | 138   | 5½ | 508   | 9½  | 883   | 13½ | 1267  |
| 2  | 184   | 6  | 554   | 10  | 931   | 14  | 1316  |
| 2½ | 230   | 6½ | 601   | 10½ | 978   | 14½ | 1365  |
| 3  | 276   | 7  | 648   | 11  | 1026  | 15  | 1414  |
| 3½ | 322   | 7½ | 695   | 11½ | 1074  | 15½ | 1464  |
| 4  | 369   | 8  | 742   | 12  | 1122  | 16  | 1514  |

Differences of level for other distances are found by multiplying the tabular difference by the given distance expressed in miles.

*b.* The *Aneroid Barometer* (Fig. 94) is very useful for this purpose in hilly or mountainous districts. It is of metal, and, like the pedometer, is usually of the shape and size of a watch. Its interior mechanism is shown in Fig. 94*a*.

The cylindrical box, *B*, is of very thin metal, has a corrugated upper surface, and is nearly exhausted of air. It is connected with the spring *S*, (of which the tension is adjustable,) by means of the pillar *p*; and the rise and fall of its upper surface, due to changes of atmospheric pressure, are thus confined within narrow limits. The motion of *S* due to these changes is

communicated to the index hand  $h$ , by the levers  $l$  and  $l'$ , shaft  $b$ , and chain  $c$ ,—the latter being kept tense by the hair-spring  $t$ .

For an increase of atmospheric pressure, the lever-arms are evidently drawn towards  $S$ , the chain is wound about the arbor by the hair-spring, and the index moves to the right; the reverse obtains with a decrease of pressure.

Aneroids are usually compensated for temperature by making the lever  $l$  of strips of brass and steel soldered together; and if properly effected, the same reading would exist inside and outside of a room, at the same level, with differences of  $30^\circ$  or  $40^\circ$  F.—time being allowed in each case for the instrument to acquire the temperature of the surrounding air.

A common form of graduation is shown in Fig. 94: the outer or altitude scale being movable, so that its 0 point may be set at the barometric reading of any desired point of the tract, and the height of any other point, as referred to the latter, be read directly from it.

In another handy form of the instrument, a pin projecting from the inner edge of the lid can be adjusted to indicate the bar. reading at the starting-point, and the index-hand also can be set at any desired reading.

The usual method is to set the 0 of the altitude-scale at the bar. reading of 31 inches; then if the temperature is about  $50^\circ$  F., the difference of the readings for any two points is the difference of altitude. At other temperatures the following correction is applied:

If the sum of the temperatures at the two stations is greater than  $100^\circ$  F., add  $\frac{1}{1000}$  of the height for every degree in excess of  $100^\circ$ ; if the sum is less than  $100^\circ$  F., subtract  $\frac{1}{1000}$  of the height for every degree less than  $100^\circ$  F.

The formula is,

$$\text{Difference of level} = (h - h') \left[ 1 + \frac{t + t' - 100}{1000} \right];$$

$h$  and  $h'$  being the readings of the altitude-scale at the respective stations, and  $t$  and  $t'$  the corresponding temperatures.

Table VII. (Appendix) is a copy of Airy's table, to which the correction for temperature is applied as above described.

The following method is prescribed in the U. S. Coast and Geodetic Survey Reports:

The index and scale errors, if any, of the aneroid should be determined and entered in the record. If of small value, they may be neglected, as differences and not absolute heights are required.

The following formula will give the difference in height between two stations at which the aneroid and thermometer have been read within a few hours' interval of time,—the shorter the interval the better.

$$\text{Difference} \dots\dots\dots = 60345 \text{ feet } (\log B - \log b)$$

$$\text{Mean temperature} \dots\dots\dots = \frac{T + t}{2}.$$

This factor varies with the mean temperature. For every degree above  $32^\circ$  F. add 134 to 60345.

*Example.*

$$\begin{array}{r}
 B = 28.72 \quad \log B = 1.4581844 \\
 b = 27.14 \quad \log b = 1.4336098 \\
 \hline
 \phantom{b = 27.14} \phantom{\log b = 1.4336098} \phantom{=} 0.0245746 \\
 \hline
 \phantom{b = 27.14} \phantom{\log b = 1.4336098} \phantom{=} \phantom{=} \phantom{=} \text{logs.} \\
 \phantom{b = 27.14} \phantom{\log b = 1.4336098} \phantom{=} \phantom{=} \phantom{=} \phantom{=} 8.3904865 \\
 \\
 \frac{T+t}{2} = 62^\circ.5, \text{ and, hence, } 64432 \quad 4.8091016 \\
 \hline
 \text{Difference} = 1583.4 \text{ feet} \quad 3.1995881
 \end{array}$$

Or the difference in height may be taken from the following table, by interpolation of tenths; e.g.:

$$\begin{array}{r}
 28.72 \text{ at } 62^\circ.5 \text{ for } 1220.0 \text{ feet} \\
 27.14 \text{ at } 62^\circ.5 \text{ for } 2803.6 \text{ feet} \\
 \hline
 \text{Difference} \dots 1583.6 \text{ feet}
 \end{array}$$

TABLE GIVING THE DIFFERENCE IN HEIGHT, IN FEET, BETWEEN TWO STATIONS, AT THE MEAN OF THE TWO OBSERVED TEMPERATURES.

| BAROMETER. | MEAN OF OBSERVED TEMPERATURES IN DEGREES FAHRENHEIT. |        |        |        |        |        |        |
|------------|--|--------|--------|--------|--------|--------|--------|
|            | 32°  | 42°    | 52°    | 62°    | 72°    | 82°    | 92°    |
| 30.0       |  |        |        |        |        |        |        |
| 29.9       | 87.5   | 89.4   | 91.4   | 93.3   | 95.3   | 97.2   | 99.2   |
| 29.8       | 175.3  | 179.2  | 183.1  | 187.0  | 190.9  | 194.8  | 198.7  |
| 29.7       | 263.4  | 269.3  | 275.1  | 280.9  | 286.8  | 292.7  | 298.5  |
| 29.6       | 351.8  | 359.6  | 367.4  | 375.2  | 383.0  | 390.9  | 398.7  |
| 29.5       | 440.5  | 450.3  | 460.0  | 469.8  | 479.6  | 489.4  | 499.2  |
| 29.4       | 529.5  | 541.3  | 553.0  | 564.7  | 576.5  | 588.2  | 600.1  |
| 29.3       | 618.8  | 632.6  | 646.3  | 659.9  | 673.7  | 687.4  | 701.3  |
| 29.2       | 708.4  | 724.2  | 739.9  | 755.4  | 771.3  | 787.0  | 802.8  |
| 29.1       | 798.3  | 816.1  | 833.8  | 851.3  | 869.2  | 886.9  | 904.7  |
| 29.0       | 888.5  | 908.2  | 927.9  | 947.6  | 967.4  | 987.2  | 1007.0 |
| 28.9       | 979.0  | 1000.7 | 1022.4 | 1044.2 | 1065.9 | 1087.8 | 1109.6 |
| 28.8       | 1069.9   | 1093.5 | 1117.3 | 1141.1 | 1164.8 | 1188.8 | 1212.6 |
| 28.7       | 1161.1   | 1186.7 | 1212.5 | 1238.3 | 1264.1 | 1290.0 | 1315.9 |
| 28.6       | 1252.5   | 1280.3 | 1308.1 | 1335.9 | 1363.8 | 1391.6 | 1419.5 |
| 28.5       | 1344.3   | 1374.2 | 1404.0 | 1433.8 | 1463.7 | 1493.6 | 1523.5 |
| 28.4       | 1436.4   | 1468.4 | 1500.2 | 1532.1 | 1563.9 | 1595.9 | 1627.9 |
| 28.3       | 1528.5   | 1562.9 | 1596.8 | 1630.7 | 1664.5 | 1698.6 | 1732.7 |
| 28.2       | 1621.5   | 1657.7 | 1693.7 | 1729.6 | 1765.6 | 1801.7 | 1837.9 |
| 28.1       | 1714.6   | 1752.8 | 1790.9 | 1828.9 | 1867.0 | 1905.2 | 1943.4 |
| 28.0       | 1808.1   | 1848.3 | 1888.5 | 1928.6 | 1968.8 | 2009.0 | 2049.3 |
| 27.9       | 1901.9   | 1944.2 | 1986.4 | 2028.6 | 2071.0 | 2113.2 | 2155.6 |
| 27.8       | 1996.0   | 2040.4 | 2084.7 | 2128.9 | 2173.5 | 2217.8 | 2262.3 |
| 27.7       | 2090.5   | 2136.9 | 2183.4 | 2229.6 | 2276.3 | 2322.7 | 2369.3 |
| 27.6       | 2185.2   | 2233.8 | 2282.4 | 2330.7 | 2379.4 | 2428.0 | 2476.7 |
| 27.5       | 2280.3   | 2331.1 | 2381.7 | 2432.2 | 2482.9 | 2533.6 | 2584.5 |
| 27.4       | 2375.8   | 2428.7 | 2481.4 | 2534.1 | 2586.8 | 2639.6 | 2692.7 |
| 27.3       | 2471.6   | 2526.7 | 2581.3 | 2636.2 | 2691.1 | 2746.0 | 2801.3 |
| 27.2       | 2567.8   | 2625.0 | 2681.9 | 2738.9 | 2795.9 | 2852.9 | 2910.7 |
| 27.1       | 2664.3   | 2723.6 | 2782.6 | 2841.8 | 2901.0 | 2960.2 | 3019.7 |
| 27.0       | 2761.2   | 2822.6 | 2883.9 | 2945.1 | 3006.5 | 3067.9 | 3129.5 |

A fair approximation suited to rough work is obtained from the formula

$$D = 9 (h - h')$$

If  $h$  is less than 26, or the temperature exceeds  $70^\circ$  F., use 10 instead of 9 for the multiplier.\*

\* The following formula gives very close approximations, and is easily remembered. Divide the difference of readings of barometer by their sum, and multiply quotient by 55,000 feet. To correct for temperature, add to or subtract from this result  $\frac{1}{10}$  of itself for each degree F. above or below  $55^\circ$ .

The readings of an aneroid should correspond to those of a standard mercurial barometer reduced to 32° F.; and frequent comparisons on several successive days will determine the difference, if any, which should be constant, at least for the time occupied in any single sketch, and is applied as an index error to the readings.

In a series of observations, the aneroid should be held in the same position for reading; slightly tapped, or swung back and forth before reading, to overcome any friction in the parts; and sufficient time allowed for it to acquire the temperature of the surrounding air. The usual plan is to suspend it by the ring in such a position that, in observing it, the index shall be projected at right angles to the dial-face; and, if a thermometer is attached, as in Fig. 94, to read the latter first, before it becomes affected by the heat of the hand.

The readings of a good aneroid may be relied upon when taken at intervals so short that they are not affected by changes of pressure due to other causes than changes of level or temperature. If the reading at the first of any two stations is subsequently found to differ from that first observed, a mean of these may be taken as the true reading.

After being subjected to sudden changes of pressure, the position of the 0 point changes and a new comparison with a standard is required.

A large aneroid is in general more accurate than a small one.

In ascending, good results are obtained until the readings decrease 6 inches. In descending, the limit is 8 inches.

Its usefulness in obtaining extended profiles of mountainous tracts is apparent.

The following form of record is suited to this purpose (see also par. 166):

| Station. | Distance<br>by —<br>Reading. | Percentage<br>of<br>Reduction. | Bearing. | Aneroid No. — |       |
|----------|------------------------------|--------------------------------|----------|---------------|-------|
|          |                              |                                |          | Inches.       | Feet. |
|          |                              |                                |          |               |       |

159. *Constructing the Skeleton.*—I. The general principle of working from the whole to a part requires that reference lines and points should first be established, and the loss of time due to hesitancy in working, on account of uncertainty as to position, and spent in making corrections, thus avoided.

With the scale usually employed, 4 or 6 inches to a mile, but a comparatively few reference lines and points are required, and these may be obtainable from a general map containing the principal features of the tract; if not, the skeleton is constructed by one of the following methods. In this as in other parts of the work, the plotting may be done in the field, or the measurements recorded and afterwards plotted.

II. *By Triangulation.*—Fig. 95, Plate XXI., represents a tract in which the principal points *C, D, E, . . . .* were established by a system of triangulation based on *AB*, as shown. Most of the principal points were selected on account of their favorable location for hill-sketching. The traversing, for filling in the details, began at *E*, and, following the roads, was frequently checked upon the  $\Delta$ s. The traverse stations are marked  $\odot$ . Fig. 98 is a record of part of the triangulation, and Figs. 96 and 97 show different forms of keeping the traverse notes as applied to the first few courses.

For clearness of illustration, a small tract is chosen ; but it is evident that for one of great extent the operations would be similar.

The conditions governing the selection of a position for the base are that it should be centrally located, free from marked irregularities of ground, in open ground, its extremities intervisible, and that several of the principal points shall be visible from both extremities.

Its length will depend upon the extent of the area to be represented. The present tendency in surveying, to save time, is to use comparatively short bases measured with great accuracy ; and, applying this to sketching, a base of from 500 to 1000 yards would serve for a tract of from 5 to 10 miles square.

Its bearing is taken from each extremity, and its length is carefully paced,—a mean of at least two measurements being required for this most important line. It is also advisable to use a rigid support for the compass here and at all the principal points.

The base is then plotted, approximately in its relative position on the paper with reference to other lines of the tract ; and, if practicable, so that the N. shall be toward the top of the sheet.

In extending the triangulation from the base  $AB$  (Fig. 99, Plate XXI.), the principal points  $C, D, \dots$  should be selected so that the angles  $ACB, ADB, \dots$  shall not be much less than  $30^\circ$ . If the location is unfavorable to this condition, a point as  $E$  (Fig. 100) is first fixed, then a point as  $D'$  can be located by bearings from  $B'$  and  $E$  ; or  $D'$  may be subsequently fixed by intersections from other points.

At least one check-bearing is required for each of the principal points ; and if the latter are not conspicuously marked upon the ground by natural or artificial objects, a signal of some description should be set up.

Generally in taking a bearing, such a point of the distant object should be selected as may be visible and easily recognized at points from which it is to be subsequently observed.

As a test of the accuracy of the skeleton, in addition to that given by check-bearings ; measure in the field the distance between any two stations independently plotted, and compare with the plotted distance.

Instead of writing on the plot the names of objects sighted upon, the form shown in Fig. 98 may be used.

Each station is given a distinguishing letter or numeral, which should be marked upon the plot. It is advisable to observe a larger number of points than is really needed to form the skeleton, so as to admit of a selection of those best suited to this purpose, and also to furnish others that might prove useful in filling in the details.

III. *By Traversing*.—A polygonal figure, enclosing the main portion of the tract, is determined by following as much as possible the lines of roads and streams.

While traversing and following this route, the intersections of the courses by roads, paths, edges of woods and fields and other prominent features, are determined, as are also the positions of commanding summits.

As a rule, the polygon thus obtained will not close. If its angles are all salient, the error due to angular measurement is the difference between their sum, and  $180^\circ \times$  number of courses less two ; if there are  $n$  re-entrant angles, subtract their sum from  $n \times 360^\circ$ , add the remainder to the sum of the salient angles, and proceed as above, as if the angles were all salient. The difference thus obtained is distributed equally among all the angles. If



the polygon still remains unclosed on account of errors of distance, the total error in distance is distributed among the different sides in proportion to their lengths. (See also par. 63.)

The skeleton is then completed by determining the interior lines, of which the points of intersections with the different courses have been fixed, as above prescribed.

IV. *By Traversing Combined with Radiation and Intersection.*—A route, as *G, H, I, . . . .* (Fig. 101), is chosen, from which the commanding points *a, b, c, . . . .*, to the right and left, are visible; it is then traversed and these points are determined by any of the various methods heretofore described. The lines *Ha, Hb, . . . .* form so many traverse routes for obtaining the interior details. *a, b, . . . .* should be so situated and numerous as to conjointly command a view of the entire tract. If a height is available from which a greater portion of the tract is visible, a commanding point of it is marked, and radial lines are determined, in direction, to all the principal points. These lines are then traversed, and suitable points are established from which to begin the minor traverses. If the distance between any two of the principal points is known, all the others visible from them may be located by intersections, and this part of the skeleton determined at once. (See also Appendix, par. 176.)

V. *By Parallels and Perpendiculars.*—The principal points are first determined by any of the methods already described. If the tract is open and not much intersected by streams or other obstacles, it is then divided into four parts by right lines intersecting at right angles at a central point. One of these lines is then traversed and suitable points of it determined, through which, perpendiculars being established, the tract is thus subdivided into parallel zones of convenient width, of which the details to the right and left of alternate perpendiculars are sketched by traversing the latter.

VI. Figure 102 illustrates the use of *alignments and prolongations* in determining the outline of a fortification. *h, e, e', f, i* and *g* are points already determined. At *h*, it is observed that *h* and *i* are aligned on the face *MN*; at *e*, that *e* and *f* are aligned on *MO*; at *e'*, that *e'* and *g* are in the prolongation of *NP*: and it is evident that by joining these points, as shown in the figure, their intersections will fix *M* and *N*; and that the entire outline can be determined in a similar manner.

This method, in its general application, has a very wide range, and in eye-sketching is often of great value. In experienced hands it serves not only for determining the skeleton, but also, by reference to the principal lines, for filling in the details. (See also pars. 163 and 167.)

160. *Filling in the Details.*—The skeleton having been determined and plotted, the details are obtained by traversing in such directions as may be best adapted to representing the character of the surface, and also afford opportunities for checking the measurements by closing upon, or referring to, the principal or other points of lines already established.

As previously stated, this part of the sketch may be completed in the field, in which case errors are immediately detected and corrected; or it may be more convenient, as in unfavorable weather, or when secrecy is required as is sometimes the case in the military service, to record the measurements and plot them afterwards.

The entire skeleton, or, if too large, a tracing of part of it of convenient size, might be taken into the field, and the details plotted directly upon it; otherwise, a note-book of suitable size, say 6x8 inches, ruled according to one of the following forms, is generally used:

I. *Form of Note-book for Plotting the Sketch in the Field.*—This is illustrated by Fig. 96. Three vertical columns are ruled on each left-hand page, as shown; the central column is for

the stations, bearings of and distances between the different points of the traversed route ; the side columns are for the lengths of offsets to the right and left respectively ; and the side spaces are for descriptive remarks.

Each right-hand page is prepared for the plotting by ruling it into inch-squares, a side representing 1 mile, 1000 yards or feet, etc., which may be subdivided at pleasure, and which assist in setting off distances. A protracting circle is described in the central part of the page, as shown, and its divisions are numbered to correspond to those of the particular compass in use. (See par. 60.)

Instead of using a circle, the edges of the sheet may be graduated into degrees and parts thereof, thus forming a rectangular protractor sheet.

It is used as follows: Begin at the bottom of the central column, note the date and minute of starting; and immediately above it, represent the first station, or starting-point, by its proper sign. Use the letters of the alphabet, or numerals, in regular order, to designate the stations. Select some well-defined object in advance—the farther off the better, provided the distance to it can be conveniently measured—take its bearing and record it immediately above the station. Mark the station and plot the bearing (in direction only) on the right-hand page, assuming that set of lines for meridians, and starting from such a point on the page as will ensure getting as much of the route on it as possible; e.g., if the route runs northeasterly, mark the top of the page N and begin near the lower left-hand corner. Then proceed to sketch the route to the second station.

In locating objects from intermediate points of a course, record at the instant of halting the total distance from the preceding station. Sketch an object as soon as located, holding the note-book in its true position with reference to lines upon the ground.

On leaving a course to measure an offset, mark the point left, so that the course may be resumed at its proper place.

Descriptive remarks are made in their appropriate column and opposite the sketch of the objects to which they apply.

For obvious reasons, avoid using the compass in the immediate vicinity of iron, such as a bridle-bit or wagon-tire.

II. *Form of Note-book used when the Plotting is not done in the Field.*—As illustrated in Fig. 97, each right-hand page is ruled with two vertical lines, forming a central column for the stations, bearings and distances of the route traversed.

The side spaces are for rough sketches of objects on the right and left of the courses, and which are shown approximately in their relative positions.

The left-hand pages are for descriptive remarks.

In its use, the date, time of starting, stations, bearings and distances of the route are noted as prescribed for Form I. The central column, however, represents the successive courses; and, to prevent the confusion of lines which would otherwise occur in changing direction, is interrupted at the extremities of each course by double lines drawn across the page.

Intermediate bearings and offsets are noted by drawing lines free-hand, from the point of observation, in the direction of the object observed, and writing the bearing or distance, and if necessary, "to house," "to wood," etc., upon them. The central column is regarded as without breadth in representing objects which cross it; e.g., a road is terminated at one side of the column and resumed in its proper direction at the point horizontally opposite.

A point from which a cross-traverse is run is indicated by enclosing its distance, marked on the course, by a line.

In any mode of sketching that may be adopted, the direction of the meridian and the unit of measurement must be recorded; and if the sketch itself conveys but a part of the required information, the verbal description must furnish the rest.

161. *Features to be sketched or otherwise described.*—The purpose of the sketch of course determines the nature and amount of detail to be included; but for practice, it is best to note all details of any prominence.

For military purposes those features only are noted which affect the movements, dispositions and accommodation of troops, either in march or battle.

The following are some of the most important:

*Roads.*—Their width, of what made, condition, grade, cuttings and embankments, and whether fenced or not; if railroads, whether single or double track, and the gauge; the directions of paths and trails if in a mountainous or difficult country.

*Bridges.*—The length, width, material, form of construction, and condition.

*Streams.*—Their width, depth, nature of bottom and banks; whether fordable, and if so, where, and whether on foot or mounted; direction and rapidity of current (observe time required for floating object to pass a distance measured on the bank); if subject to overflow, note the heights of high-water marks, and ascertain, if possible, from the inhabitants of adjacent points, during what season of the year it occurs; whether fit for drinking purposes.

*Ponds.*—Depth, width of bed, nature and kind of approaches.

*Springs and Wells.*—Depth, quantity and quality of water.

*Marshes.*—Outline; whether arising from springs or overflow; depth; whether practicable for foot, mounted troops, artillery or wagons; kind of vegetation; if wooded, kind and density of growth.

*Cultivated Land.*—Outlines, enclosures, kind of soil and nature of product.

*Cleared Land.*—Kind of soil and nature of surface.

*Woods.*—Outlines; kinds of trees, density of growth; location of roads traversing them; kind of soil, containing undergrowth or not.

*Villages.*—Outlines, main roads leading to them, population, general dimensions and kinds of houses and streets, shade-trees or open, water-supply, manufactures and general resources, directions and distances to adjacent villages. The production of the surrounding country in kind and quantity should be ascertained here, or *en route*, from the inhabitants. The kind of stock should include draught animals and those used for food.

*Slopes.*—Nature of surface and their accessibility. The following current data are given, but should not be too rigidly construed: A slope of  $60^\circ$  is inaccessible to infantry;  $45^\circ$ , difficult for infantry;  $30^\circ$ , inaccessible to cavalry;  $15^\circ$ , inaccessible to artillery;  $5^\circ$ , accessible to loaded wagons.

Information not afforded by the sketch is arranged methodically in an accompanying report.

Dividing-lines between parts of the same features are of less importance than the extreme boundaries.

In case a feature would obscure other details, or a minute representation of it is required, either a separate sketch or a verbal description is necessary.

## HILL-SKETCHING.

## SECTION II.—REPRESENTING THE CONFIGURATION OF THE SURFACE (PLATE XXII.).

162. The other features required having been represented, the final, and, to a beginner, the most difficult operation, is to sketch the forms of ground.

If streams exist, they are of great assistance in this work, since by their various ramifications the general outlines of the bases of the different elevations are at once obtained, and the positions of the water partings and courses, required for the full representation of the slopes, can be more easily determined.

The method by contours is generally adopted. No rigid rule can be laid down as to the best starting-point; but it is usual to begin at the higher ground and work downwards, because the initial contour can then be run at whatever level will best show the configuration, and the directions of the water partings and courses can be more readily observed.

163. *A Detached Hill.*—From the summit the sketcher's position is fixed by interpolation (par. 156) from two or more known points; the general directions of the water partings and courses radiating from it are found with the hand-compass, or by reference to points already plotted (see VI., par. 159); the angles of depression of these lines, to the nearest points where marked changes of inclination take place, are then measured by the clinometer, the distances to the latter are ascertained, and the horizontal equivalents, corresponding to the equidistance adopted, are laid off on each of them respectively, thus affording reference-points through which to draw the contours. Fig. 103 illustrates the operation.

Beginning at *S*, having the reference of say 350 feet, the part *SA* of the water-parting *SAA'* is plotted from measurements taken as above described. Suppose its inclination to be  $9^\circ$ , its length 1000 feet (400 30-inch paces), and that 50-foot contours are required.

From the table (par. 81), the h. e. for three equidistances is 946.5 feet, which is laid off from *S* on *SA*; and its subdivision into 3 equal parts gives the reference-points of the (300), (250) and (200) contours. The other points of *SA'* are found in a similar manner. Returning to *S*, *SB* is then traversed (or the traverse may be in the direction *BS*); and as the required points are successively determined, the corresponding portions of the contours are drawn by eye through them and the points of *SAA'*. The rest of the hill is sketched in a similar manner.

By means of a scale of horizontal equivalents (Fig. 30, Plate VII.), constructed for the given scale and equidistance, the reference-points may be spaced off with great rapidity.

It is usual to determine but a few reference-points near the summit, on each of the principal lines, and sketch these contours; then to obtain the form of the lower portion in a similar manner, and, finally, to interpolate contours for the intermediate slopes.

To represent the deflections of a contour with accuracy, a rule ordinarily observed is to determine its reference on three adjacent profiles, the intermediate one being preferably along a re-entrant, before sketching it.

In the interpolation of contours it frequently occurs that some portions of the surface are not represented with much accuracy. Thus in the profile, Fig. 104, *C* and *D* being plotted and the angle *CDF* measured, the points between *C* and *E* are fixed with reasonable accuracy, owing to the uniform slope, while those of *ED* are wholly estimated.

The following method of sketching a hill is also used. The other features having been plotted, the equidistant points on a direct line from a given point to the summit are fixed and plotted (*b*, par. 154); the summit is then located by interpolation, if not already fixed, and, from a commanding position, the contours are sketched through the equidistant points thus determined.

The use of the method of Alignments and Prolongations (VI., par. 159) is illustrated in Fig. 105. The other details plotted, the direction of the principal line *GHI* is determined by observing from the starting-point *G* that, prolonged, it intersects the angle of the road at *g*; from *H* it intersects the house *h*, and from *I* the fence-corner *i*.

An under-feature, such as a detached knoll, is usually represented by determining its highest point, and the contour which passes through, or nearest to, the lowest point of the col.

In the sketching of contours as well as of other details, the plot should be held so that its lines shall have relatively the same directions as those upon the ground.

As soon as an equidistant point is determined, its reference should be marked upon it.

164. In the case of a *Number of Elevations and Depressions*, either continuous or separate sets of contours are employed, the former plan being preferred when practicable, as it saves subsequent reduction to a common datum plane. Therefore the surrounding country is carefully examined from the starting-point, and, with the aid of the hand-level, conspicuous objects of equal height with this point are observed and noted for use as reference-points, when the forms of ground in their vicinity are sketched. The use of an aneroid would of course render this operation unnecessary.

The sketcher must judge for himself, from information gained in the preceding parts of the work, as to the best starting-point.

If there is a natural level, such as an extensive plateau or large body of water suitably located, this may be chosen as a datum for the equidistances, and as containing the initial points from which to measure the principal lines.

If an extended valley traverses the tract, the work may be begun at its lowest point; and, in ascending it, the direction and inclination of the principal lines are measured. The highest equidistant point of the valley having been determined, the adjacent hills are sketched and the work proceeds in a reverse direction back to the starting-point.

If the usual method is adopted—i.e., working downwards from the summits—the crest-lines, or highest contours, are determined for the different elevations as the work progresses, and furnish starting points for measuring equidistances on the principal lines of the slopes. As opportunities occur, the heights of objects on adjacent hills, at the level of the eye, are noted as at the starting point, especially of those which fix the positions of crest-lines, so that the work may be readily begun on reaching the summits.

165. *Parts of Contours may be Sketched from Distant Points.*

I. From Profile Views.—Thus, in Fig. 106, *K* and the summit *S* having been plotted; from *K* the points *L* and *M* are observed with the hand-level; the part *LfM* of the 80-ft. contour is then drawn, as closely as may be estimated, in its true position.

The angles of inclination of the profile lines on either side are then measured with the clinometer held at arm's length (*b*, par. 154); and by means of the table (par. 81) the positions

of the other equidistant points are approximately determined, and the contours are drawn through the corresponding points.

II. From the point *N* (Fig. 107), the respective angles of depression of the plotted summit *O*, and point *P* of the valley, are observed.

From these angles, and the distances *NO* and *NP* measured on the plot, the heights are found to be 110 ft. and 20 ft. respectively. *OP* is then drawn and subdivided accordingly and the intermediate contours are drawn through the corresponding points of subdivision.

166. In *Mountainous Districts* the equidistance is seldom less than 100 ft., often 250 to 500 feet, and the representation of the general configuration only is attempted.

The sketch can be based upon a system of triangulation, the base being measured in a valley, or along a plateau or water-shed, or the skeleton can be obtained by any of the other methods described in par. 159. The principal points are the summits of the different elevations, and marked features of the lower levels such as the junctions or bends of streams and detached clumps of trees.

Differences of level of occupied points are usually obtained with the aneroid barometer (*b*, par. 158).

The peaks and summits of the principal under-features, and the directions of the main water partings and courses, are fixed with considerable accuracy, while the different slopes are expressed by contours drawn in from the sketcher's positions on commanding points, as follows:

*Horizontal Sketches* of the configuration are made from each occupied point, and should contain more or less of the surrounding forms, according to the number and proximity of the different stations and their favorable disposition as to range of view and extent of command.

The accuracy of the result is verified when the sketches are assembled upon the skeleton, by corresponding contours of points of the same features, sketched from different stations, being superposed. This degree of accuracy would of course seldom obtain, an adjustment is therefore required; and this operation is governed by the knowledge due to careful observation, and by a true appreciation of forms of ground. (See also Appendix, par. 176.)

Fig. 109 is an illustration of a horizontal sketch, and also represents a convenient form of note-book for plotting and recording the bearings of surrounding points. The top of the page is *N* in the figure, and the radii of circles described from the sketcher's position represent distances suited to the scale employed.

*Profile Sketches* of different parts of the range should be taken from commanding peaks, for the assistance they may afford in the ready recognition of the different points during the progress of the work, as well as in representing the particular formation.

Fig. 108 shows a sketch of this nature.

For ready reference, the profile may be drawn opposite to or on a line with the record of the bearing, and the bearings of the different summits written immediately above the latter, as shown.

A profile sketch is often useful in the representation of ground of which the irregularities are less marked.

## SECTION III.—SKETCHING WITHOUT INSTRUMENTS.

167. When the instruments commonly used are not available, the angles, most of the distances, and the forms of ground must be estimated by eye. Much previous practice with instruments is required before common errors (*e*, par. 157) can be avoided.

A thorough knowledge of the principles of topographical surveying will naturally enable each individual to form his own method of working; but a good one is to group the details within simple geometrical figures, and follow the general method of plane-table surveying as follows:

*Plane-table Method.*—The page of the note-book, or the sketching-paper, held horizontally, is the plane table, and a straight-edge serves for the alidade.

As an illustration; from a position, as *A*, commanding a view of some of the important points, the sketch is begun by plotting *A* so it shall have relatively the same position on the page or sheet that the point has in the tract.

One of the distant points, as *B*, is then plotted in its relative position approximately; and, without reference to a scale of distances, *a* and *b* (using the small letters to designate points of the plot) are joined by a right line.

The sheet is then held horizontally, or for convenience placed upon the ground, and “oriented” (so placed that *ab* and *AB* have the same direction); and by means of the straight-edge, right lines are drawn from *a* in the directions of other points, *C*, *D*, . . . . which are marked respectively *c*, *d* . . . . The straight edge may be accurately aligned upon a distant point, by adjusting it so that from a position in rear of the sheet, the edge and the distant point are observed to be covered by a plumb-line.

Proceeding to *B*, the sheet is oriented on *A*,—*ba* lying in the direction *BA*; right lines are drawn from *b* in the directions of the points *C*, *D*, . . . ; and their intersections with the corresponding lines from *A* fix the points *c*, *d* . . . . in their true positions.

The distance *AB* may be measured in passing over it, and *ab* increased or diminished so it shall conform to any desired scale; or, during the entire sketching, the relative positions only of points may be considered, and from the measurement of any long line, made at a convenient opportunity, the scale may be afterwards constructed.

The operation is extended in a similar manner to embrace the entire tract; and the right lines joining the different points, are lines of reference for filling in the details, which with the configuration are sketched by eye in passing between these points.

A check upon the work is obtained at any time by orienting the table at any point, and observing if a line drawn from this point toward any other already plotted intersects the latter.

A true meridian line is obtained, approximately, by orienting the table and tracing the shadow of a plumb-line upon it at noon.

A compass may be used for orienting by fixing it to the board and holding the latter so that the needle shall point to the same division of the card at all the stations.

Another plan is to construct a dial on a corner of the sheet, and mark the shadows of a pin, placed vertically at the centre, for the different hours of the day. A timepiece then serves to place the sheet in its proper position at any hour.

In the English military service, a convenient pocket arrangement, called the *Cavalry Sketching-case*, is used for rapid work.

It consists of a small board which, by means of rollers at its opposite extremities, will hold a paper about  $7 \times 36$  inches in size—a shape suited to the representation of routes; and when in use it is strapped to the left wrist.

A ruler is attached at one of its extremities to a button, which traverses a slot in the edge of the board, so that it can be turned in any direction on the surface of the paper.

It is oriented by means of a compass, having a “meridian-line,” with an index at one extremity, engraved on its glass cover.

In beginning the sketch, the board is held so that the longer edge of the paper shall lie in the general direction of the route; the compass-box is turned in its receptacle until the “meridian-line” has the same direction as the needle, the index being over the N. end, and a parallel line to represent the magnetic meridian is ruled on the paper, and its N. end marked.

To use it, the sketcher being mounted; face the distant extremity of the first course to be represented; hold the board in front of the waist, the wrist against the body; orient it; turn the ruler in the direction of the course, and draw the latter, taking care that the needle and “meridian-line” lie in the same direction. The course is then traversed and the details are sketched.

When the sketch tends to run off, draw a line across the paper to limit the part already represented, adjust the board to the new part of the route as at first, and continue as above described.

These partial sketches are combined by first cutting them out along their limiting lines; they are then placed on a table relatively in the same position as the corresponding lines on the ground,—which is effected by driving a pin through the terminal point of the first partial sketch and the starting-point of the second, and turning them until the meridian-lines are parallel; the other partial sketches are then added, and are all cut through along lateral lines drawn through the pin-holes, and are united by pasting strips on the back, or by fastening them to a single sheet.

Distances may be laid off with greater accuracy by means of suitable scales marked on the edges of the ruler; and, when desired, objects may be located by intersections, as with the plane-table.

The following instructive example of “*Eye-sketching*” is from the “Aide-Mémoire.”

The sketch (see Fig. 110, Plate XXIII.) was made by Lieut. Bainbrigg during the Peninsular War; the area covered was about 9 square miles, and the time occupied  $2\frac{1}{2}$  hours.

“DUBLIN, 5th January 1846.

“Having been requested by the Editors of the ‘Aide-Mémoire’ to give a specimen of the sort of sketch of a position required during the Peninsular War, with an account of the mode of performing the work; the annexed, which I was required to make by his Grace the Duke of Wellington in Spain, is supplied accordingly; and the following is a statement of the circumstances under which that sketch was ordered, and the way I took to perform it.

“In 1812, when the French army, under Marshal Marmont, was crossing the Tormes, at Huerta, above Salamanca, before the forts of that place were taken, the Duke—at that time standing on the high ground in front of Cabrerizos, observing the enemy—desired me to cross the river, and see what sort of a position there was in a certain assigned direction, for stopping the advance of the French, and to make a sketch of it as quickly as possible.



"There were about two miles to ride to the ford of Sta. Martha, and perceiving at once that that point would be the left of the position, on having crossed, I began at the point *A*.

*A*. "The lines of direction to *B, C, D, E, F, G*, were first laid down, sketching in the river, the roads, the village, and particularly the church of Sta. Martha. These lines of direction were, in fact, so many angles laid down and protracted on the sketch, but no instrument was used, as there was no time: everything was done by the eye. I did not dismount, and galloped from station to station.

*C*. "Having finished at *A*, I went along the road to Huerta (*C*), a farm of only two or three buildings, which was the only point to be seen in that direction from *A*; judging, then, this distance galloped over, the line from the church of Sta. Martha to *C* was assumed as the base.

"It was desirable that this front of the sketch towards Huerta should be done first, as the enemy's skirmishers were exchanging shots with ours between *C* and Pelobravo (*M*), when I reached that ground.

"*C* being fixed, the lines to *H, I, J, K, L, M*, were laid off; the line *H* intersecting the line *B*, showed where the rivulet joined the Tormes. The line *J*, intersecting *AE*, showed nearly where the steep fall of ground at *J* would come. The line *L* pointed out where the road to Calvarosa Abajo crossed the rivulet, and to that point (*N*) I went.

*N*. "Here the angle between Sta. Martha and *C* was laid off, which fixed *N*, and then intersecting the lines *I* and *K* (taken from *C*), those two farms were fixed. The direction (*O*) of the stream was noted, and also the line to *J* was intersected; also a fresh object (*P*), a remarkable tree, was taken, as it was the only object between *J* and *P*, along the crest of what would obviously be the position.

*Q*. "The village (*M*) could not be seen; I therefore went to the rising ground (*Q*) from whence it was visible: at this point it was observable that I was in a line with the farm (*K*) and Sta. Martha church; then, assuming that line to be correct, the angle between Sta. Martha and *C* was laid down, which thus fixed *Q*. The next angle was that between *C* and *M*, by which the village *M* was fixed.

*P*. "Proceeding from *Q*, up the hill, to *P*, the angle was taken formed by *N* and Sta. Martha, which fixed *P*; it was also noticed that the line to the farm (*I*) passed to the right of the farm (*K*), which observation helped to correct the sketch: also it could be seen that the line to *H* passed over *K*. The direction (*J*) was next taken, showing the fall of ground and the direction of the road (*D*). There were no other points that could be fixed between *D* and the skirt of the wood (*R*).

*R*. "I then galloped to the top of the hill, and placing myself in a line with the two farms (*I* and *K*), that line was assumed to be correct; and then observing the angles between *K* and Sta. Martha, between *K* and *C*, and *K* and *P*, *R* was fixed.

"At *R*, I could see (over the trees) the village of Calvarosa Ariba, and also a chapel (called an Hermita) on this side of it, the directions to which were taken; also to the remarkable hill (*S*), and the abrupt slopes of the ground to the rear (*U* and *V*).

"A line was drawn to the fall, or gap, in the ground (*T*), taking great care that this, as well as those to *S*, Calvarosa, and the chapel, were as correct as possible in regard to the line from *P*, because the connection of the right of the position rested on this

point, and the accuracy of the winding up of the sketch would depend on the correctness with which those angles were taken.

- T.* "Next to *T*; and as, on reaching it, it was clear that none of the points on the left of the position could be seen, except *R*, it became necessary that the distance from *R* to *T* should be judged as accurately as possible—which distance became a fresh base. At *T*, thus fixed, all the right could be seen, and the Hermita could be intersected, as well as the ground to the rear (*U*, *V*, and *E*). The direction (*X*) of the smaller hill was taken, and the line over its summit, it was observed, passed to the abrupt right-hand slope of the ground (*W*), to the rear of the position. A farm also, in a hollow of some wood to the front, was also noted.
- X.* "I then went to the smaller hill, intending to go to the top, but the rocks were so rugged I could not ride up; so, standing on a line between it and *T*, at *X*, that station was fixed by observing the direction to *E* and to the Hermita.
- "The line to Calvarosa from *R* was next intersected, which fixed that place. The direction to the houses (*Z*) was also laid down, and this place turned out to be the village of Arapiles; and the two remarkable hills were the celebrated hills of the same name.
- "The line *W* being intersected, gave the boundary of the ground (*Y*): the farm in front, observed from *T*, could no longer be seen.
- "Passing, then, down by the right and along the hollow between the two great hills, I went to the Hermita, and this point having been before fixed, from thence the direction of the further fall of the great hill (*S*) and two slopes of the hill on the further side of the Calvarosa valley were secured, as well as the direction of the water-course above and below. I then passed down the valley, and wound up the sketch at *O*.
- "Going back from thence to *C*, I proceeded along the main road to *D* and *E*, putting in, on judgment, the village of Carvajosa, as well as the point *F*, where was a house, and where the great Salamanca road passed.
- "I returned to Cabrerizos, finding the Duke where I had left him, and handed him the sketch, having been absent about two hours and a half. I made a verbal report to his Grace, pointing out the high hill (*S*), which we could plainly see from the spot where we then stood, observing that it was doubtful how far guns could be brought there, not having had time to ride thither. The Duke gave me back the sketch, to put it in ink, which I did, sitting down on the ground, and returned it to his Grace.
- "In the afternoon of that day the position just sketched was occupied by part of our army; and the enemy having, by signal, communicated with the forts of Salamanca, re-crossed the Tormes at Huerta, and retired on the Douro.
- "Some weeks after (July 21, 1812), this position was again occupied, but being too strong to be attacked in front, the French marched round it, and the battle of Salamanca took place next day, to the right of the ground here sketched—viz., to the right of the village (*Z*) of Arapiles. In making this, the sort of sketch-book was used given in the note below.—P. B."

The "sketch-book" referred to consisted simply of a pasteboard 6x9 inches, with black parchment cover and flap; and furnished with a loop on each side to which a string was attached, and by means of which it could be suspended from the neck and in front of the waist.

168. *Landscape-sketching* (Figs. 111 and 112, Plate XXIII).—For topographical purposes, a landscape-sketch is a free-hand drawing of the outlines of important features. It affords a good general idea of a tract, particularly if the ground is much diversified and the sketch is made from a favorable position, and is at times the only available method of representation.

True sizes and relative positions should be given as nearly as possible; the outlines of nearer objects made heavier than those more remote, a regular gradation according to distance being preserved if possible; and the point of the compass from which the sketch is made and the estimated distance of the sketcher's position from a central object are noted.

Facility is acquired by practice, but to those who find it "impossible" to sketch, the following suggestions may be of value.

Draw a horizontal line to represent the horizon of the point of view, placing it at its proper height on the sheet relative to the field of view, and through its middle point draw a vertical line. Observe a prominent object centrally located, and placing the sheet suddenly in a vertical position in front of the eye so that the horizontal line shall be projected in the horizon, and the vertical pass through the object, mark the position of the latter on the vertical. The retention of an image upon the retina makes this an easy matter.

Points near the extreme right and left of the field may then be fixed in a similar manner, taking care each time to hold the sheet in its original position. These with a few other prominent points being thus fixed, it is a simple matter to fill in intermediate lines and objects by eye. The usual method is to measure the distances between objects and differences of level by means of the pencil, held at arm's-length and perpendicularly to the line of sight.

169. *Itineraries*, or verbal descriptions of features, with a record of the measurements necessary to plot them, are at times the only data available for making the sketch. The following form is a convenient one, and fully explains itself:

| Names of places, and their distances from the starting-point. | Consecutive distances between important points of the route. | Designations of important points.—<br>These are determined by changes in the direction or construction of the roads traversed, in the nature of the soil; the entrance to a defile, terminals of steep slopes, obstacles, a bridge, ford or building; forks of the road, paths, etc. | Lengths, measured on the road traversed, of its different features; declivities, levels, etc. | Breadth of the road traversed, where changes in this occur. | Sketches or profiles of defiles, bridges, fords or other important objects. | Detailed descriptions of the condition and practicability of the road traversed, of the terrene it passes through; of villages, dwellings, streams; of important positions on the right and left; nature and dimensions of bridges; fords, periods of overflow; capacities of ferries as to number of men, horses or carriages, and time required for round trip. Available material and means for the repair of road and bridges. | Remarks. |
|---|--|--|---|---|---|--|----------|
|   |  |  |   |   |   |  |          |

The notes would of course conform to the purpose for which the itinerary is made.

## APPENDIX.

170. When the triangulation is of such extent that the earth's sphericity must be considered in the plotting, the order of procedure may be as follows:

*a. Reduction of the Base to the Mean Sea-Level.*—In the accompanying figure the base  $AB$  is made up of measured sections (see broken lines) of arcs of great circles at unequal distances from  $C$ , the earth's centre, and the altitude of the arc  $AB$  is the mean of the altitudes of the extremities of these sections. Assume  $ab$  as the mean sea-level; denote by  $L$  and  $l$  the lengths of  $AB$  and  $ab$  respectively, by  $R$  the radius of  $ab$ , and by  $h$  the altitude of  $AB$  referred to  $ab$ ; then

$$\frac{L}{l} = \frac{R+h}{R}; \quad \therefore l = L \frac{R}{R+h} = L \frac{1}{1 + \frac{h}{R}};$$

by development,

$$l = L \left( 1 - \frac{h}{R} + \frac{h^2}{R^2} - \dots \right);$$

or, by neglecting the terms following the second, which may be done without appreciable error,

$$l = L - L \frac{h}{R}.$$

E.g.,  $AB = 2000$  yds.,  
 $h = 100$  yds.,

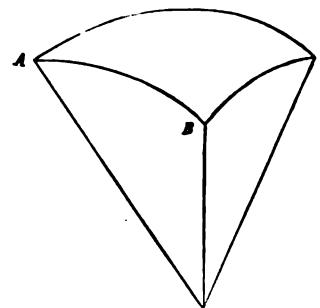
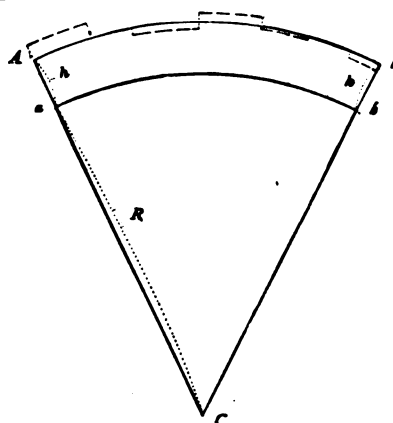
Mean value of  $R = 6963529.74$  yds.; then  $l = 2000 - 2000 \frac{100}{6963529.74} = 1999.9719$  yds.

*b. Modifications of the Triangles.*—Since a spherical triangle is not developable in its exact dimensions upon a plane surface, certain modifications of these dimensions are necessary before plotting.

It is a well-known fact that the sum of the three angles  $A$ ,  $B$  and  $C$  (accompanying figure) exceeds  $180^\circ$  by a certain quantity termed the spherical excess, which call  $E$ . From geometry,

$E : 8 \text{ right-angles} :: \text{area of the triangle} : \text{surface of the sphere};$

whence for a triangular area of about 0.386 sq. miles, or for a triangle with a base of 0.62138 and height of 1.24276 miles, it is  $0''.005$ ; and for a triangular area of about 77.223 sq. miles, or for a triangle with base and height each of 12.4276 miles, it is  $1''.0$ .  $E$  may therefore be graphically determined in



seconds by constructing a plane triangle according to the field-measurements, computing its area and then dividing by the above area corresponding to 1".0. The necessity of "correcting for spherical excess" to keep within the limit of error of scale-measurement (par. 51) can thus be readily ascertained.

The spherical excess is usually denoted by the expression

$$E = A + B + C - 180^\circ;$$

and the *first modification* for development of the spherical triangle is made by subtracting  $\frac{E}{3}$  from each of the angles. The resulting angles are termed *mean-angles*, which denote by  $A'$ ,  $B'$  and  $C'$ .

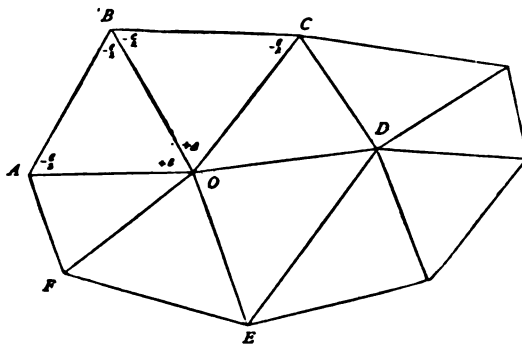
If but two angles,  $A$  and  $B$ , of the triangle are measured, the third angle,  $C$ , is evidently obtained from the formula

$$C = 180^\circ - (A + B);$$

and in this case, to correct for  $E$ : Compute  $E$  graphically as already described, then

$$A' = A - \frac{E}{3}; \quad B' = B - \frac{E}{3}; \quad \text{and } C' = 180^\circ - (A' + B').$$

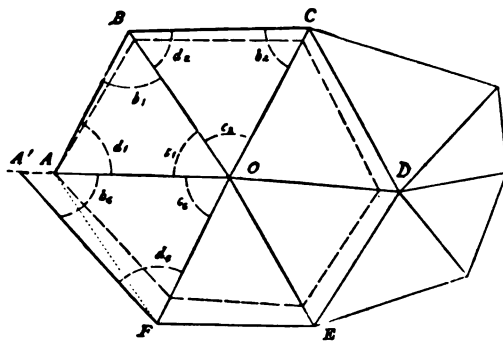
The mean-angles computed, two conditions must be fulfilled, viz.: the sum of the angles



about a central point, as  $O$  (see accompanying figure), must be  $360^\circ$ ; and, having used a side, as  $AO$ , measured or computed, as a basis for computing the sides of the triangles about  $O$ , the final computation should give  $AO$  exactly in its original length.

The *second modification* consists, therefore, in:

I. Dividing or distributing the difference between  $360^\circ$  and the sum of the angles about  $O$  equally among these angles, and then changing the other angles of each triangle correspondingly; e.g., let this difference for each angle about  $O$  be  $+\epsilon$ ; then, in each triangle, the sum of the angles exceeds  $180^\circ$  by  $+\epsilon$ , and the two outer angles must be diminished each by  $\frac{\epsilon}{2}$ . A like modification is made in the other poly-



gons, care being taken to change such angles only as are exterior to the polygon already modified.

II. In the polygon  $AB \dots F$  (see accompanying figure), let  $A'O$ , instead of  $AO$ , result from the final computation;  $AO$  and  $A'O$  will evidently coincide in direction as a result of (I.); but they should be of equal length.

In any triangle of the polygon, denote by  $b$  the angle opposite the known side; by  $d$  the angle opposite the side to be determined; and by  $c$  the remaining angle. In the modification proposed, the angles  $c$  remain unchanged, while the angles  $b$  and  $d$  are changed

and in an inverse sense; e.g., to arrive at  $A$  instead of at  $A'$ , it is necessary to diminish all the angles  $d$  and increase the angles  $b$  by the same quantity  $x$ . To determine  $x$ : From trigonometry,

$$\frac{BO}{AO} = \frac{\sin d_1}{\sin b_1}; \quad \frac{CO}{BO} = \frac{\sin d_2}{\sin b_2}; \quad \dots \quad \frac{AO}{FO} = \frac{\sin d_n}{\sin b_n};$$

multiplying these equations member by member, and since the numerator and denominator of the first member consist of the same factors,

$$\frac{BO \times CO \dots AO}{AO \times BO \dots FO} = \frac{\text{product of the sines } d}{\text{product of the sines } b} = 1; \quad (a)$$

using logarithms,

$$\Sigma \log \sin d - \Sigma \log \sin b = 0, \quad (b)$$

the equation of condition which the angles must satisfy. Presuming that the angles  $d$  are to be diminished and the angles  $b$  increased by  $x$  seconds; then, performing the operation for each of the angles and adding like equations,

$$\Sigma \log \sin (d - x) = \Sigma \log \sin d - \Sigma \Delta_d \times \frac{x}{10};$$

$$\Sigma \log \sin (b + x) = \Sigma \log \sin b + \Sigma \Delta_b \times \frac{x}{10};$$

in which  $\Delta$  = tabular difference for  $10''$ , corresponding to the angle  $d$ . By substitution, equation (b) becomes

$$\Sigma \log \sin d - \Sigma \Delta_d \times \frac{x}{10} - \Sigma \log \sin b - \Sigma \Delta_b \times \frac{x}{10} = 0;$$

whence

$$x = 10 \left[ \frac{\Sigma \log \sin d - \Sigma \log \sin b}{\Sigma \Delta_d + \Sigma \Delta_b} \right].$$

The terms of the second member are known, and  $x$  being thus determined it is algebraically subtracted and added respectively to the angles  $d$  and  $b$ ,—the proper sign of  $x$  being that of the difference of the two sums of logarithms.

In the case of a chain of triangles, when the closing is effected on a distant measured base,—e.g., beginning at  $CD$  and ending at  $DE$ ,—equation (a), using the same notation, becomes

$$\frac{\text{Product of the sin } d}{\text{Product of the sin } b} = \frac{DE}{CD};$$

or

$$\log DE - \log CD = D = \Sigma \log \sin d - \Sigma \log \sin b,$$

and

$$x = 10 \left[ \frac{\Sigma \log \sin d - \Sigma \log \sin b - D}{\Sigma \Delta_d + \Sigma \Delta_b} \right].$$

A similar compensation is made for each of the other parts of the triangulation; *compensated mean-angles* are thus obtained with which the final computation of the triangles and the determination of their sides preparatory to plotting are made; and the triangles may then be developed without lacunes (intervals between sides of adjacent triangles) around the central point  $O$  of the triangulation.

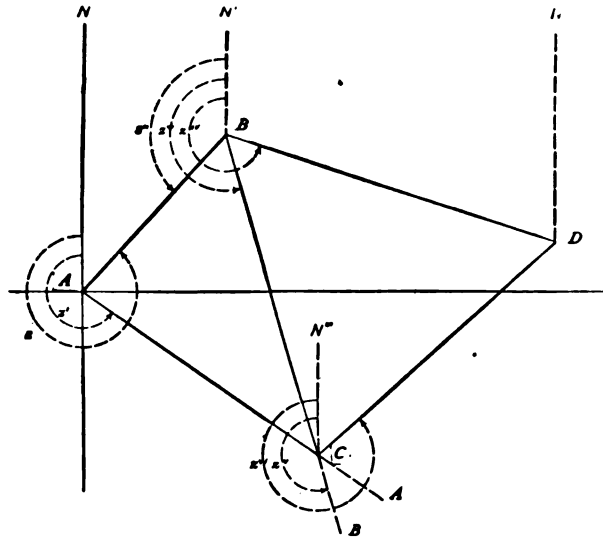
Designating the distance from the middle point of the map to either of its corners as the radius, and the corresponding actual distance by  $R$ ; then the maximum errors resulting from this mode of development are as follows:

|                |      |      |       |       |       |        |
|----------------|------|------|-------|-------|-------|--------|
| Scale,         | 1000 | 5000 | 10000 | 20000 | 30000 | 100000 |
| Error, inches, | 3.9  | 19.7 | 39.4  | 79.7  | 196.7 | 393.7  |
| $R$ , miles,   | 18.0 | 23.0 | 31.0  | 42.0  | 49.0  | 84.0;  |

the basis of calculation being a limit of permissible error in plotting of 0.004 of an inch. With the inferior limit of scale-measurement (par. 51)  $R$  could be increased for these different scales to at least double the above lengths.

*c. Plotting the Triangles.*—The following method of plotting the triangles by rectangular coordinates is described in addition to that given in par. 57, because of the complete system of checking afforded in the computations. If it is desired that the direction of measurement shall be S. W. N. E., the change may be readily made.

I. *To Determine the Azimuths.*—In the triangle  $BAC$  of the accompanying figure,  $z$ , the azimuth of  $AB$ , is given; to determine the azimuths of  $AC$  and  $BC$ . The azimuths are assumed



as measured from the meridian around through W., or in the direction N. W. S. E. A convention used for determining them is to consider a side of a triangle as a right hand or a left-hand side, according as it lies to the right or left of the side used in determining the azimuth,—the observer in each case looking toward the outer extremity, or the point indicated in the text by the second of the two letters designating it.

For  $AC$ , a right-hand side with reference to  $AB$ , the azimuth,  $z'$ , is  $z - BAC$ ,  $-BAC$  being known. Transferring the

origin to  $B$ ;  $z''$ , the azimuth of  $BA$ , is  $z - 180^\circ$ ; and since the measurement may be made from either extremity, the general expression is  $z'' = z \pm 180^\circ$ .

For  $BC$ , a left-hand side with reference to  $BA$ :  $z''' = z'' + ABC$ ,  $-ABC$  being known.

Transferring the origin to  $C$  and producing the sides  $AC$  and  $BC$  in  $CA'$  and  $CB'$  respectively, there results  $z' - z''' = B'CA' = BCA$ ; and since  $BCA$  is known, a check upon the preceding calculations obtains.

For the triangle  $BCD$ : the azimuth of  $BD$ , a left-hand side with reference to  $BC$ , is  $z^v = z''' + CBD$ . Transferring the origin to  $C$ , the azimuth of  $CB$  is  $z^v = z''' \pm 180^\circ$ ; and for the right-hand side  $CD$ ,  $z^v = z^v - BCD + 360^\circ$ ,—the addition of  $360^\circ$  here being neces-

sary to make the azimuth positive. The check upon this calculation consists in satisfying the equation  $z^v - z^v = BDC$ . And similarly for the rest of the triangles.

The following rules therefore serve for determining the azimuths:

The azimuth of either given side, considered as the base of the triangle, being known, the azimuth of a right-hand side is obtained by *subtracting* the corresponding angle of the triangle from the azimuth of this base, and adding, if necessary,  $360^\circ$  to make the result positive.

The azimuth of a left-hand side is similarly obtained by the *addition* of this angle of the triangle.

The difference between the azimuths of a right- and a left-hand side of a triangle should be the included angle.

II. *To Determine the Rectangular Coordinates.*—Let  $O$  in the accompanying figure be a central point of the triangulation and the origin of the coordinate axes  $ON$  and  $OE$ , meridian and E. and W. lines respectively. Represent by  $X$  and  $Y$  the principal coordinates, and by  $x$  and  $y$  the minor co-ordinates pertaining to sets of minor axes parallel to  $ON$  and  $OE$ .

In the triangle  $OBC$ , which has a vertex at the origin; for the vertex  $B$ ,  $BP$  or  $X = OB \sin POB$ ; but  $\sin POB = -\sin z$ ; from which

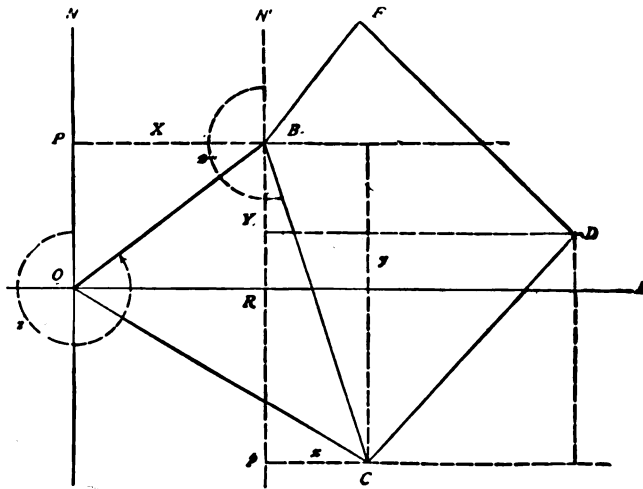
$$X = -OB \sin z.$$

In the triangle  $OBR$ ,  $OP = BR$  or  $Y = OB \cos POB$ ; and since  $\cos POB = \cos z$ ,

$$Y = OB \cos z.$$

Similarly for the vertex  $C$ ,

$$X' = -OC \sin z' \quad \text{and} \quad Y' = OC \cos z'.$$



These formulæ are general, provided the azimuths are measured as above described, and the trigonometrical functions are given their proper signs.

For a check upon these calculations consider  $B$  as an origin of coordinates. Then, by applying the formulæ, the results for the vertex  $B$  are the minor coordinates

$$x = -BC \sin z'''; \quad y = BC \cos z''';$$

and the principal coordinates of  $C$  referred to  $O$  are

$$X' = X + x; \quad Y' = Y + y.$$

Thus the principal coordinates of  $C$  are obtained in two ways, and like values should obtain. This check is to be applied in each triangle before proceeding farther in the work.

For  $D$  the minor coordinates are similarly determined, considering the origin first at  $B$ , then at  $C$ ; its principal coordinates are then determined under these two conditions, and, as above, like values should obtain.



For convenience in plotting, the principal coordinates should be tabulated as described in par. 57.

171. The following form for the approximate adjustment of a tertiary system of triangulation is in use in the Lake Survey service. For the general solution see "Lake Survey Report, 1872."

I. *Spherical Excess*.—When the sides of the triangles do not exceed three miles in length, and an error of one tenth of a second is permissible, the spherical excess may be neglected.

II. *Local Adjustment*.—For a sum angle, find the discrepancy between the sum angle and the separate measured single angles of which it is made up; then, if the number of single angles is  $n$ ,

$$\text{Correction for each single angle} = + \frac{\text{discrepancy}}{n + 1};$$

$$\text{Correction for sum angle} = - \frac{\text{discrepancy}}{n + 1}.$$

When the horizon is closed,

$$\text{Correction for each angle} = \frac{1}{n} (360^\circ \sim \text{sum of the angles}).$$

III. *General Adjustment*.—The local adjustments made, the single angles at each station are subject to a further correction as follows: In this operation, whether the chain consists of triangles or quadrilaterals or both combined, each polygon is assumed to be independent of the others; and there result, first—

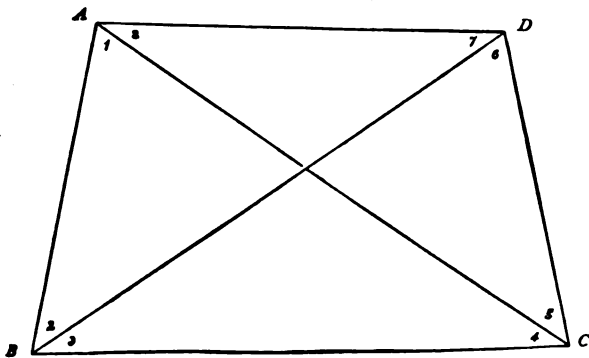
*For the General Adjustment of a Triangle*.—Correct each of its angles by  $\frac{1}{3} (180^\circ \sim \text{sum of the angles})$ ; e.g.,

Measured Angles (locally adjusted).

| °             | '  | "    |
|---------------|----|------|
| 49            | 17 | 23.0 |
| 66            | 34 | 09.0 |
| 64            | 08 | 34.0 |
|               |    |      |
| Excess = 06.0 |    |      |

Final Angles.

| °   | '  | "    |
|-----|----|------|
| 49  | 17 | 21.0 |
| 66  | 34 | 07.0 |
| 64  | 08 | 32.0 |
|     |    |      |
| 180 |    |      |



*For a Quadrilateral*.—If the sum of the angles of each of the three triangles of a quadrilateral is made  $180^\circ$ , the sum of the angles of the fourth triangle must be  $180^\circ$ . In the accompanying figure assume each of the measured angles  $A_1, B_1, C_1, \dots$ , of the quadrilateral  $ABCD$  as locally adjusted; then if  $a_1, b_1, c_1, \dots$ , denote the corrections for these angles respectively,

$$\left. \begin{aligned} A_1 + a_1 + B_1 + b_1 + C_1 + c_1 - 180^\circ &= 0; \\ A_1 + a_1 + B_1 + b_1 + D_1 + d_1 - 180^\circ &= 0; \\ A_1 + a_1 + D_1 + d_1 + C_1 + c_1 - 180^\circ &= 0; \end{aligned} \right\} \quad (1)$$

or, denoting the differences between the sums of the measured angles and  $180^\circ$  by  $v_1, v_2, v_3$ , respectively, these equations may be written:

$$\left. \begin{aligned} a_1 + b_1 + b_2 + c_1 + v_1 &= 0; \\ a_1 + b_2 + a_2 + d_1 + v_2 &= 0; \\ a_2 + d_1 + d_2 + d_3 + v_3 &= 0; \end{aligned} \right\} \quad (2)$$

also assume that

$$a_1^2 + a_2^2 + b_1^2 + b_2^2 + c_1^2 + c_2^2 + d_1^2 + d_2^2 = \text{a minimum.} \quad (3)$$

From these four equations the eight corrections are to be found. Solving, there result

$$\left. \begin{aligned} a_1 = b_1 &= \frac{-v_1 - 2v_2 + v_3}{8}; & c_1 = d_1 &= \frac{-v_1 + 2v_2 - 3v_3}{8}; \\ b_2 = c_1 &= \frac{-3v_1 + 2v_2 - v_3}{8}; & d_2 = a_2 &= \frac{+v_1 - 2v_2 - v_3}{8}. \end{aligned} \right\} \quad (4)$$

These final corrections added to the locally-adjusted angles give the final angles.

Therefore for the general adjustment of a quadrilateral apply the following

*Rule.*—Select any three triangles  $ABC, ABD, ADC$ ; call the differences of the sums of the measured angles (locally adjusted) and  $180^\circ$ ,  $v_1, v_2, v_3$ , respectively, and substitute these values,  $v_1, v_2, v_3$ , in formulas (4) to obtain the required corrections.

*Check.*—The sum of the angles of each of the four triangles of the quadrilateral should be  $180^\circ$ .

#### EXAMPLE.

##### Triangle $ABC$ .

|               | Measured Angles. |    |    | Correction. | Final Angles. |    |      |
|---------------|------------------|----|----|-------------|---------------|----|------|
|               | °                | '  | "  | "           | °             | '  | "    |
| $A_1 + a_1 =$ | 53               | 53 | 50 | - 0.4       | 53            | 53 | 49.6 |
| $B_1 + b_1 =$ | 46               | 49 | 06 | - 0.4       | 46            | 49 | 05.6 |
| $B_2 + b_2 =$ | 37               | 18 | 12 | + 2.9       | 37            | 18 | 14.9 |
| $C_1 + c_1 =$ | 41               | 58 | 47 | + 2.9       | 41            | 68 | 49.9 |
|               | <hr/>            |    |    |             | <hr/>         |    |      |
|               | 179              | 59 | 55 |             | 180           | 0  | 0    |

$$v_1 = - 5''.0$$

##### Triangle $ADC$ .

|               |       |    |    |       |       |    |      |
|---------------|-------|----|----|-------|-------|----|------|
| $A_2 + a_2 =$ | 49    | 17 | 23 | - 3.1 | 49    | 17 | 19.9 |
| $D_1 + d_1 =$ | 29    | 59 | 48 | - 3.1 | 29    | 59 | 44.9 |
| $D_2 + d_2 =$ | 36    | 34 | 21 | + 0.1 | 36    | 34 | 21.1 |
| $C_2 + c_2 =$ | 64    | 08 | 34 | + 0.1 | 64    | 08 | 34.1 |
|               | <hr/> |    |    |       | <hr/> |    |      |
|               | 180   | 00 | 06 |       | 180   | 0  | 0    |

$$v_2 = + 6''.0$$

Triangle *ABD*.

|               | Measured Angles. |    |    | Correction. | Final Angles. |    |      |
|---------------|------------------|----|----|-------------|---------------|----|------|
|               | °                | '  | "  | "           | °             | '  | "    |
| $A_1 + a_1 =$ | 53               | 53 | 50 | - 0.4       | 53            | 53 | 49.6 |
| $A_2 + a_2 =$ | 49               | 17 | 23 | - 3.1       | 49            | 17 | 19.9 |
| $B_1 + b_1 =$ | 46               | 49 | 06 | - 0.4       | 46            | 49 | 05.6 |
| $D_1 + d_1 =$ | 29               | 59 | 48 | - 3.1       | 29            | 59 | 44.9 |
|               | <hr/>            |    |    |             | <hr/>         |    |      |
|               | 180              | 00 | 07 |             | 180           |    |      |

$$v_1 = + 7''.0$$

Triangle *BCD*—Check.

|               |       |    |      |
|---------------|-------|----|------|
| $B_1 + b_1 =$ | 37    | 18 | 14.9 |
| $C_1 + c_1 =$ | 41    | 58 | 49.9 |
| $C_2 + c_2 =$ | 64    | 08 | 34.1 |
| $D_1 + d_1 =$ | 36    | 34 | 21.1 |
|               | <hr/> |    |      |
|               | 180   | 0  | 0    |

172. *Assemblage of Partial Sketches*.—In the case of a very large tract, when haste is required, the work is divided by assigning separate parts bounded by prominent features, or by established lines, to different persons; and, to insure greater accuracy in the result, a sufficient number of principal points, so located as to have at least two or three which may be readily recognized on each part, are first fixed by a general triangulation of the whole, and plotted upon a single sheet. At least one line of reference is thus obtained for each partial sketch, and is first plotted in its true position, and according to the scale adopted, on the fair sheet. It is advisable that each sketcher should also know the positions of a few stations outside of his tract, so that he may when necessary fix points of the latter by interpolation (par. 156).

The partial sketches finished, they are then, with the aid afforded by the triangulation-sheet, adjusted and fastened in their true positions upon a flat surface, and are carefully cut through along their respective boundaries. They are now placed face down in their true positions; fastened together temporarily with thin strips of paper at intervals of a few inches; and are then reversed and marginal corrections are indicated where the roads, streams, etc., do not meet accurately. They are then separated, the marginal corrections are carefully made, and the partial sketches are ready for assembling, which is effected as desired,—by pasting them in their true positions to stiff paper, card-board or cloth, or by simply joining the edges by narrow strips of paper or cloth pasted along the back.

Without a general triangulation, the true or magnetic meridian-lines of the different sketches serve for uniting them; since the partial sketches are then so adjusted that these lines shall be parallel and the N. points shall lie in the same direction. The errors, or failures in meeting, however, are generally considerable, and much judgment is required in the arrangement. To facilitate an accurate assemblage in this case, a practical method is as follows:

A general route through the entire tract is selected, and parts on the right and left of it are assigned to the different sketchers. The inner boundaries of the partial sketches are in the route itself; the outer ones are in the outer limits of the tract; while the lateral

boundaries are right-lines determined by the bearings of prominent objects which are as nearly as may be in a direction at right-angles to the route. Each sketcher as he arrives at his lateral boundary traverses it so far as to represent the important details cutting it; and it is apparent that in the preparatory assemblage of the partial sketches as above described, no difficulty will arise in properly adjusting the margins.

173. The following are the details of the operation of making a large topographical plaster cast as recently performed at the U. S. M. A. by a professional, and will be found useful. The model,—about  $5 \times 6$  feet in dimensions, representing a rugged tract,—having been constructed as first described under “II. By Successive Horizontal Layers,”—was thoroughly oiled (sweet-oil and a sash-tool were used for this purpose); it was then placed on the floor, and strong boards, extending about one inch above its edges, were nailed to the sides of the model, thus forming a receptacle for the plaster; the inner surfaces of the boards above the model were also oiled.

Plaster, the “Casting” grade, was then mixed in tubs with cold water—in bulk about 1 : 5 or 6—to the consistency of cream, the plaster carefully sprinkled in by hand, and a light blue color produced by the addition of washing-blue to the water, so that parts which might break off in casting could be readily distinguished. As soon as mixed, the plaster was thoroughly applied to the model,—thrown on by hand thinly over the finer detail, and then over the entire surface to a thickness of about an inch. This and the other applications of plaster had to be rapidly made.

Six pieces of old gas-pipe were then laid over the plaster, one piece near each edge, and the remaining two at a right angle across the middle; these pieces projected a few inches, except along one edge. The pipes were then bound together at the angles with wire.

Tepid water was then sprinkled over the plaster layer, and the little pools thus formed were absorbed with a sponge. Another layer of plaster mixed as before, leaving out the blue, was then applied thickly along the pipes and the edges; and supports, a few inches in height, upon which the mould was to rest when reversed, were formed and levelled with a straight-edge.

After an hour's interval, the construction was placed on edge,—the edge along which the gas-pipe did not project; the mould was separated very slightly from the model along the upper edge by gently pushing on the pipe projections; and hot water was poured into the crevice thus formed, until the mould and model were found to be detached from each other. The model was then pried and entirely removed from the mould along the lower edge; and the latter was then firmly braced in a slightly inclined position for convenience in repairing damages. The wax buildings were broken from the model, but were readily dug out of the mould; and the very few pieces which broke from the plaster were readily replaced and fastened with shellac and alcohol.

The following day the mould was first thoroughly saturated with water, applied with a sponge to the back, until the face glistened with moisture, (required about  $2\frac{1}{2}$  hours; a steady stream from a hose is generally used for this purpose). It was then placed on its supports on the floor, board edges were attached, and a mixture of plaster (the “Superfine” grade) and water, of the same consistency as the other mixture, was then applied as before by hand and poured over the entire surface to a thickness of about 1 inch. Pieces of burlap were then pressed into the surface and covered with plaster; a piece of gas-pipe was laid along and just

within each edge, and another piece placed diagonally; pieces of burlap dipped in a tub of "Casting" plaster mixture were laid along and over the pipes and thoroughly pressed into the general surface; and the latter mixture was added until the pipes were well covered at their intersections, while the cast was left as light as possible consistent with sufficient strength. Supports were then built up as for the mould.

After a few minutes' interval the construction was placed on edge as before,—lifted evenly to prevent cross-strains; the side boards were knocked off, and, with chisel and mallet, the mould was detached in fragments from the cast; first by removing the pipes, then the heavier lumps of plaster until the blue stratum was reached, and finally the latter by very delicate strokes. Pieces broken off were replaced and fastened with putty consisting of saturated "Superfine" plaster. The cast was then placèd conveniently upon a table, and the details requiring it were cut and trimmed to proper shape.

# TABLES.

## TABLE I.

### MEASURES OF DIFFERENT COUNTRIES IN METRES AND ENGLISH UNITS.

| MEASURES OF LENGTH. |              |               |               | ITINERARY MEASURES. |                 |               |                   |
|---------------------|--------------|---------------|---------------|---------------------|-----------------|---------------|-------------------|
| COUNTRY.            | DESIGNATION. | EQUIVALENT IN |               | COUNTRY.            | DESIGNATION.    | EQUIVALENT IN |                   |
|                     |              | Metres.       | English Feet. |                     |                 | Metres.       | Eng. Stat. Miles. |
| England             | Foot         | 0.3048        | ....          | England             | Statute mile    | 1609.3        | ...               |
| France              | Metre        | ....          | 3.2809        | France              | Myriametre      | 10000.0       | 6.2138            |
| "                   | Paris foot   | 0.3248        | 1.0658        | Russia              | Verst           | 1066.8        | 0.6629            |
| Russia              | Foot         | 0.3048        | 1.0000        | Prussia             | Mile            | 7532.5        | 4.6806            |
| Prussia             | "            | 0.3139        | 1.0297        | Denmark             | "               | 7532.5        | 4.6806            |
| Denmark             | "            | 0.3139        | 1.0297        | Sweden              | "               | 10699.0       | 6.6480            |
| Bavaria             | "            | 0.2919        | 0.9576        | Germany             | Geog. mile      | 7420.2        | 4.6108            |
| Saxony              | "            | 0.2832        | 0.9291        | Austria             | Mile            | 7586.7        | 4.7142            |
| Baden               | "            | 0.3000        | 0.9843        | Spain               | Judicial league | 4239.8        | 2.6346            |
| Switzerland         | "            | 0.3000        | 0.9843        | Mexico              | " "             | 4239.8        | 2.6346            |
| Austria             | Vienna foot  | 0.3161        | 1.0371        | Portugal            | League          | 6181.4        | 3.8410            |
| Spain               | Foot         | 0.2827        | 0.9274        | Hungary             | Mile            | 8333.0        | 5.1780            |
| Mexico              | "            | 0.2827        | 0.9274        | Tuscany             | "               | 1652.8        | 1.0270            |

## TABLE II.

### FOR MUTUAL CONVERSION OF METRES AND ENGLISH UNITS.

| METRES TO YARDS. |        | METRES TO MILES. |                |                 | YARDS TO METRES. |         | MILES TO METRES. |                         |                           |
|------------------|--------|------------------|----------------|-----------------|------------------|---------|------------------|-------------------------|---------------------------|
| Metres.          | Yards. | Metres.          | Statute Miles. | Nautical Miles. | Yards.           | Metres. | Miles.           | Metres in Statute Miles | Metres in Nautical Miles. |
| 1                | 1.094  | 10               | 0.006          | 0.005           | 1                | 0.914   | 1                | 1609.33                 | 1853.25                   |
| 2                | 2.187  | 20               | 0.012          | 0.011           | 2                | 1.829   | 2                | 3218.66                 | 3706.50                   |
| 3                | 3.281  | 30               | 0.019          | 0.016           | 3                | 2.743   | 3                | 4827.99                 | 5559.74                   |
| 4                | 4.374  | 40               | 0.025          | 0.022           | 4                | 3.658   | 4                | 6437.32                 | 7412.99                   |
| 5                | 5.468  | 50               | 0.031          | 0.027           | 5                | 4.572   | 5                | 8046.65                 | 9266.24                   |
| 6                | 6.562  | 60               | 0.037          | 0.032           | 6                | 5.486   | 6                | 9655.98                 | 11119.49                  |
| 7                | 7.655  | 70               | 0.043          | 0.038           | 7                | 6.401   | 7                | 11265.31                | 12972.74                  |
| 8                | 8.749  | 80               | 0.050          | 0.043           | 8                | 7.315   | 8                | 12874.64                | 14825.98                  |
| 9                | 9.843  | 90               | 0.056          | 0.049           | 9                | 8.230   | 9                | 14483.97                | 16679.23                  |
| 10               | 10.936 | 100              | 0.062          | 0.054           | 10               | 9.144   | 10               | 16093.3                 | 18532.50                  |

1 metre = 1.093623 yards.

= 0.00062138 statute mile.

= 0.00053959 nautical mile.

1 yard = 0.914392 metre.

1 statute mile = 1609.330 metres.

1 nautical " = 1853.248 "

NOTE.—Tables II., IV., V. and VI. are based upon Clarke's Determinations, the present accepted standards.

TABLE III.  
NATURAL SINES, COSINES, TANGENTS AND COTANGENTS.

| °  | Sine   | D.  | Tang.   | D.  | Cotang.  | D. | Cosine | D.  | °  |
|----|--------|-----|---------|-----|----------|----|--------|-----|----|
| 0  | 0.0000 |     | 0.0000  |     | ∞        |    | 1.0000 |     | 90 |
| 30 | 0.0087 |     | 0.0087  |     | 114.5887 |    | 1.0000 |     | 30 |
| 1  | 0.0175 |     | 0.0175  |     | 57.2900  |    | 0.9998 | 0.1 | 89 |
| 30 | 0.0262 |     | 0.0262  |     | 38.1885  |    | 0.9997 |     | 30 |
| 2  | 0.0349 |     | 0.0349  | 2.9 | 28.6363  |    | 0.9994 |     | 88 |
| 30 | 0.0436 |     | 0.0437  |     | 22.9038  |    | 0.9990 |     | 30 |
| 3  | 0.0523 |     | 0.0524  |     | 19.0811  |    | 0.9986 |     | 87 |
| 30 | 0.0610 |     | 0.0612  |     | 16.3499  |    | 0.9981 | 0.2 | 30 |
| 4  | 0.0698 |     | 0.0699  |     | 14.3007  |    | 0.9976 |     | 86 |
| 30 | 0.0785 | 2.9 | 0.0787  |     | 12.7062  |    | 0.9969 |     | 30 |
| 5  | 0.0872 |     | 0.0875  |     | 11.4301  |    | 0.9962 |     | 85 |
| 30 | 0.0958 |     | 0.0963  |     | 10.3854  |    | 0.9954 |     | 30 |
| 6  | 0.1045 |     | 0.1051  |     | 9.5144   |    | 0.9945 | 0.3 | 84 |
| 30 | 0.1132 |     | 0.1139  |     | 8.7769   |    | 0.9936 |     | 30 |
| 7  | 0.1219 |     | 0.1228  |     | 8.1443   |    | 0.9925 |     | 83 |
| 30 | 0.1305 |     | 0.1317  |     | 7.5958   |    | 0.9914 |     | 30 |
| 8  | 0.1392 |     | 0.1405  | 3.0 | 7.1154   |    | 0.9903 | 0.4 | 82 |
| 30 | 0.1478 |     | 0.1495  |     | 6.6912   |    | 0.9890 |     | 30 |
| 9  | 0.1564 |     | 0.1584  |     | 6.3138   |    | 0.9877 |     | 81 |
| 30 | 0.1650 |     | 0.1673  |     | 5.7958   |    | 0.9863 |     | 30 |
| 10 | 0.1736 |     | 0.1763  |     | 5.6713   |    | 0.9848 | 0.5 | 80 |
| 30 | 0.1822 |     | 0.1853  |     | 5.3955   |    | 0.9833 |     | 30 |
| 11 | 0.1908 |     | 0.1944  |     | 5.1446   |    | 0.9816 |     | 79 |
| 30 | 0.1994 |     | 0.2035  |     | 4.9152   |    | 0.9799 | 0.6 | 30 |
| 12 | 0.2079 |     | 0.2126  |     | 4.7046   |    | 0.9781 |     | 78 |
| 30 | 0.2164 |     | 0.2217  |     | 4.5107   |    | 0.9763 |     | 30 |
| 13 | 0.2250 |     | 0.2309  |     | 4.3315   |    | 0.9744 |     | 77 |
| 30 | 0.2334 |     | 0.2401  | 3.1 | 4.1653   |    | 0.9724 | 0.7 | 30 |
| 14 | 0.2419 |     | 0.2493  |     | 4.0108   |    | 0.9703 |     | 76 |
| 30 | 0.2504 | 2.8 | 0.2586  |     | 3.8667   |    | 0.9681 |     | 30 |
| 15 | 0.2588 |     | 0.2679  |     | 3.7321   |    | 0.9659 |     | 75 |
| 30 | 0.2672 |     | 0.2773  |     | 3.6059   |    | 0.9636 |     | 30 |
| 16 | 0.2756 |     | 0.2867  |     | 3.4874   |    | 0.9613 | 0.8 | 74 |
| 30 | 0.2840 |     | 0.2962  |     | 3.3759   |    | 0.9588 |     | 30 |
| 17 | 0.2924 |     | 0.3057  | 3.2 | 3.2709   |    | 0.9563 |     | 73 |
| 30 | 0.3007 |     | 0.3153  |     | 3.1716   |    | 0.9537 |     | 30 |
| 18 | 0.3090 |     | 0.3249  |     | 3.0777   |    | 0.9511 | 0.9 | 72 |
| 30 | 0.3173 |     | 0.3346  |     | 2.9887   |    | 0.9483 |     | 30 |
| 19 | 0.3256 |     | 0.3443  |     | 2.9042   |    | 0.9455 |     | 71 |
| 30 | 0.3338 |     | 0.3541  |     | 2.8239   |    | 0.9426 |     | 30 |
| 20 | 0.3420 |     | 0.3640  | 3.3 | 2.7475   |    | 0.9397 | 1.0 | 70 |
| 30 | 0.3502 |     | 0.3739  |     | 2.6746   |    | 0.9367 |     | 30 |
| 21 | 0.3584 |     | 0.3839  |     | 2.6051   |    | 0.9336 |     | 69 |
| 30 | 0.3665 |     | 0.3939  |     | 2.5386   |    | 0.9304 | 1.1 | 30 |
| 22 | 0.3746 |     | 0.4040  |     | 2.4751   |    | 0.9272 |     | 68 |
| 30 | 0.3827 | 2.7 | 0.4142  | 3.4 | 2.4142   |    | 0.9239 |     | 30 |
| 23 | 0.3907 |     | 0.4245  |     | 2.3559   |    | 0.9205 |     | 67 |
| 30 | 0.3987 |     | 0.4348  |     | 2.2998   |    | 0.9171 |     | 30 |
| 24 | 0.4067 |     | 0.4452  |     | 2.2460   |    | 0.9135 | 1.2 | 66 |
| 30 | 0.4147 |     | 0.4557  | 3.5 | 2.1943   |    | 0.9100 |     | 30 |
|    | Cosine | D.  | Cotang. | D.  | Tang.    | D. | Sine   | D.  |    |

For intermediate values  $\cot = \frac{\cos}{\sin}$  or  $\frac{1}{\text{tang}}$ .

TABLE III.—Continued.  
NATURAL SINES, COSINES, TANGENTS AND COTANGENTS.

| ° ' / | Sine   | D.  | Tang.   | D.  | Cotang. | D. | Cosine | D.  | ° ' / |
|-------|--------|-----|---------|-----|---------|----|--------|-----|-------|
| 25    | 0.4226 |     | 0.4663  |     | 2.1445  |    | 0.9063 |     | 65    |
| 30    | 0.4305 |     | 0.4770  | 3.6 | 2.0965  |    | 0.9026 |     | 30    |
| 26    | 0.4384 |     | 0.4877  |     | 2.0503  |    | 0.8988 | 1.3 | 64    |
| 30    | 0.4462 |     | 0.4986  |     | 2.0057  |    | 0.8949 |     | 30    |
| 27    | 0.4540 | 2.6 | 0.5095  |     | 1.9626  |    | 0.8910 |     | 63    |
| 30    | 0.4617 |     | 0.5206  | 3.7 | 1.9210  |    | 0.8870 |     | 30    |
| 28    | 0.4695 |     | 0.5317  |     | 1.8807  |    | 0.8829 |     | 62    |
| 30    | 0.4772 |     | 0.5430  |     | 1.8418  |    | 0.8788 | 1.4 | 30    |
| 29    | 0.4848 |     | 0.5543  | 3.8 | 1.8040  |    | 0.8746 |     | 61    |
| 30    | 0.4924 |     | 0.5658  |     | 1.7675  |    | 0.8704 |     | 30    |
| 30    | 0.5000 |     | 0.5774  | 3.9 | 1.7321  |    | 0.8660 |     | 60    |
| 30    | 0.5075 |     | 0.5890  |     | 1.6977  |    | 0.8616 | 1.5 | 30    |
| 31    | 0.5150 |     | 0.6000  | 4.0 | 1.6643  |    | 0.8572 |     | 59    |
| 30    | 0.5225 | 2.5 | 0.6128  |     | 1.6319  |    | 0.8526 |     | 30    |
| 32    | 0.5299 |     | 0.6249  | 4.1 | 1.6003  |    | 0.8480 |     | 58    |
| 30    | 0.5373 |     | 0.6371  |     | 1.5697  |    | 0.8434 |     | 30    |
| 33    | 0.5446 |     | 0.6494  |     | 1.5399  |    | 0.8387 | 1.6 | 57    |
| 30    | 0.5519 |     | 0.6619  | 4.2 | 1.5108  |    | 0.8339 |     | 30    |
| 34    | 0.5592 |     | 0.6742  |     | 1.4826  |    | 0.8290 |     | 56    |
| 30    | 0.5664 |     | 0.6873  | 4.3 | 1.4550  |    | 0.8241 |     | 30    |
| 35    | 0.5736 | 2.4 | 0.7002  | 4.3 | 1.4281  |    | 0.8192 |     | 55    |
| 30    | 0.5807 |     | 0.7133  | 4.4 | 1.4019  |    | 0.8141 | 1.7 | 30    |
| 36    | 0.5878 |     | 0.7265  | 4.4 | 1.3764  |    | 0.8090 |     | 54    |
| 30    | 0.5948 |     | 0.7400  | 4.5 | 1.3514  |    | 0.8039 |     | 30    |
| 37    | 0.6018 |     | 0.7536  | 4.5 | 1.3270  |    | 0.7986 |     | 53    |
| 30    | 0.6088 |     | 0.7673  | 4.6 | 1.3032  |    | 0.7934 |     | 30    |
| 38    | 0.6157 | 2.3 | 0.7813  | 4.7 | 1.2799  |    | 0.7880 |     | 52    |
| 30    | 0.6225 |     | 0.7954  | 4.7 | 1.2572  |    | 0.7826 | 1.8 | 30    |
| 39    | 0.6293 |     | 0.8098  | 4.8 | 1.2349  |    | 0.7771 |     | 51    |
| 30    | 0.6361 |     | 0.8243  | 4.9 | 1.2131  |    | 0.7716 |     | 30    |
| 40    | 0.6428 |     | 0.8391  | 5.0 | 1.1918  |    | 0.7660 |     | 50    |
| 30    | 0.6494 |     | 0.8541  | 5.0 | 1.1708  |    | 0.7604 | 1.9 | 30    |
| 41    | 0.6561 | 2.2 | 0.8693  | 5.1 | 1.1504  |    | 0.7547 |     | 49    |
| 30    | 0.6626 |     | 0.8847  | 5.2 | 1.1303  |    | 0.7490 |     | 30    |
| 42    | 0.6691 |     | 0.9004  | 5.3 | 1.1106  |    | 0.7431 |     | 48    |
| 30    | 0.6756 |     | 0.9136  | 5.4 | 1.0913  |    | 0.7373 |     | 30    |
| 43    | 0.6820 |     | 0.9325  | 5.5 | 1.0724  |    | 0.7314 | 2.0 | 47    |
| 30    | 0.6884 |     | 0.9490  | 5.5 | 1.0538  |    | 0.7254 |     | 30    |
| 44    | 0.6947 | 2.1 | 0.9657  | 5.6 | 1.0355  |    | 0.7193 |     | 46    |
| 30    | 0.7009 |     | 0.9872  | 5.7 | 1.0176  |    | 0.7133 | 2.1 | 30    |
| 45    | 0.7071 |     | 1.0000  | 5.8 | 1.0000  |    | 0.7071 |     | 45    |
|       | Cosine | D.  | Cotang. | D.  | Tang.   | D. | Sine   | D.  |       |

For intermediate values  $\cot = \frac{1}{\tan}$  or  $\frac{\cos}{\sin}$ .

Columns "D" give the differences corresponding to arcs of 1'; e.g., the  $\sin 23^{\circ}20' = \sin 23^{\circ} +$  the difference for 1' (or  $2.7 \times 20 = 0.3907 + 54 = 0.3961 \dots$



TABLE IV.  
MERIDIONAL ARCS.

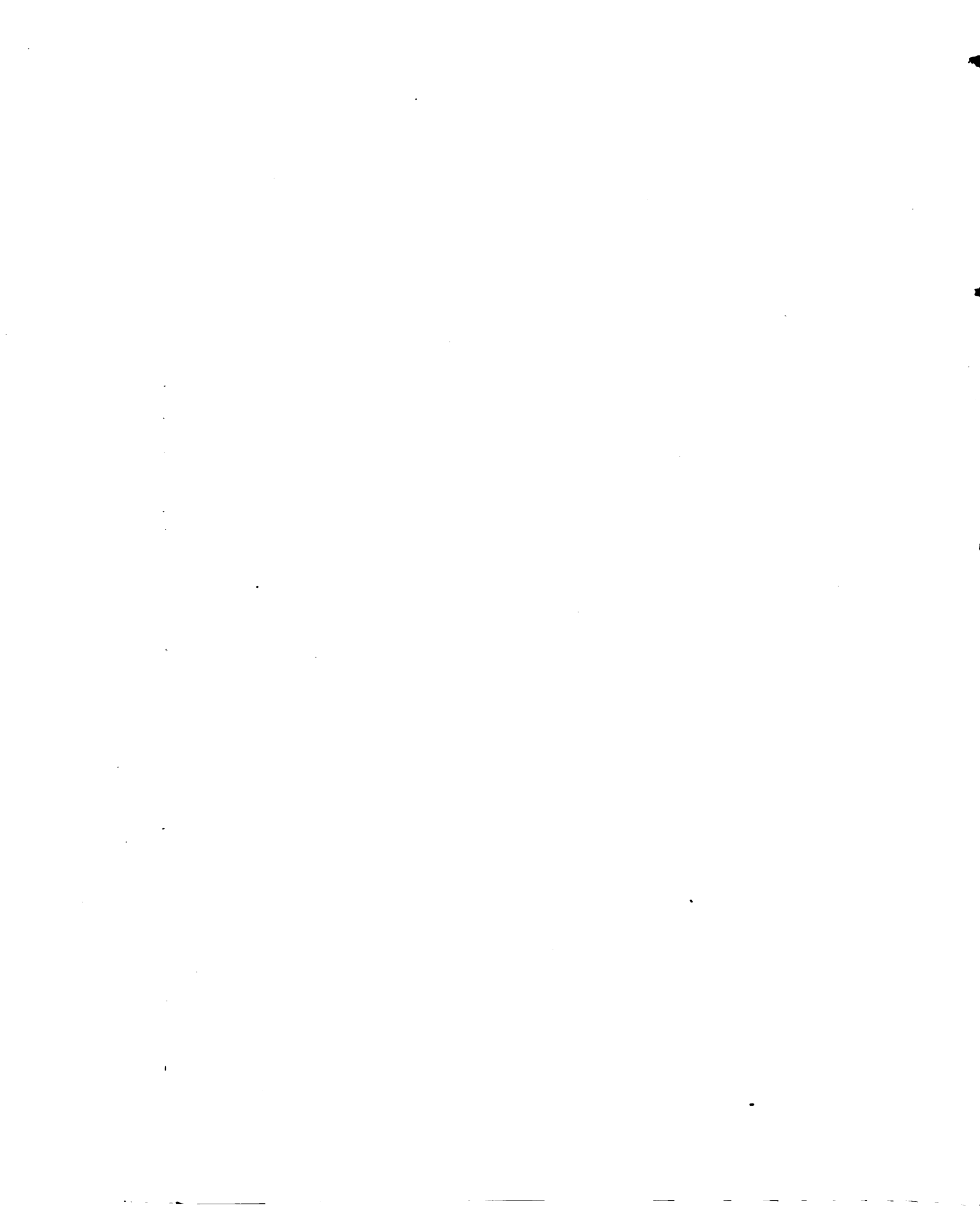
| From Lat. | To Lat. | Length in Metres. | From Lat. | To Lat. | Length in Metres. | From Lat. | To Lat. | Length in Metres. |
|-----------|---------|-------------------|-----------|---------|-------------------|-----------|---------|-------------------|
| 20        | 21      | 110705.1          | 30        | 31      | 110857.0          | 40        | 41      | 111042.4          |
| 21        | 22      | 110718.2          | 31        | 32      | 110874.4          | 41        | 42      | 111061.9          |
| 22        | 23      | 110731.8          | 32        | 33      | 110892.1          | 42        | 43      | 111081.6          |
| 23        | 24      | 110746.0          | 33        | 34      | 110910.1          | 43        | 44      | 111101.3          |
| 24        | 25      | 110760.6          | 34        | 35      | 110928.3          | 44        | 45      | 111121.0          |
| 25        | 26      | 110775.6          | 35        | 36      | 110946.9          | 45        | 46      | 111140.8          |
| 26        | 27      | 110791.1          | 36        | 37      | 110965.6          | 46        | 47      | 111160.5          |
| 27        | 28      | 110807.0          | 37        | 38      | 110984.5          | 47        | 48      | 111180.2          |
| 28        | 29      | 110823.3          | 38        | 39      | 111003.7          | 48        | 49      | 111199.9          |
| 29        | 30      | 110840.0          | 39        | 40      | 111023.0          | 49        | 50      | 111219.5          |

For arcs of 1', divide by 60; for arcs of 1'', by 3600.

TABLE V.  
POLYCONIC PROJECTION.

| For the Latitude of | COORDINATES IN METRES, FOR DIFFERENCES OF LONGITUDE OF |     |            |     |             |      |             |       |           |       |
|---------------------|--|-----|------------|-----|-------------|------|-------------|-------|-----------|-------|
|                     | 1 minute.  |     | 5 minutes. |     | 10 minutes. |      | 30 minutes. |       | 1 degree. |       |
|                     | x.   | y.  | x.         | y.  | x.          | y.   | x.          | y.    | x.        | y.    |
| 20°                 | 1744.1   | 0.1 | 8720.7     | 2.2 | 17441.4     | 8.7  | 52324.2     | 78.1  | 104648.0  | 312.3 |
| 21                  | 1732.9   | 0.1 | 8664.3     | 2.2 | 17328.6     | 9.0  | 51985.9     | 81.3  | 103971.3  | 325.2 |
| 22                  | 1721.1   | 0.1 | 8605.4     | 2.3 | 17210.7     | 9.4  | 51631.8     | 84.4  | 103263.1  | 337.6 |
| 23                  | 1708.7   | 0.1 | 8543.7     | 2.4 | 17087.4     | 9.7  | 51262.0     | 87.4  | 102523.4  | 349.6 |
| 24                  | 1695.9   | 0.1 | 8479.5     | 2.5 | 16958.9     | 10.0 | 50876.6     | 90.3  | 101752.7  | 361.2 |
| 25                  | 1682.5   | 0.1 | 8412.7     | 2.6 | 16825.3     | 10.3 | 50475.8     | 93.1  | 100950.9  | 372.3 |
| 26                  | 1668.7   | 0.1 | 8343.3     | 2.7 | 16686.6     | 10.6 | 50059.6     | 95.8  | 100118.5  | 383.0 |
| 27                  | 1654.3   | 0.1 | 8271.4     | 2.7 | 16542.8     | 10.9 | 49628.2     | 98.3  | 99255.7   | 393.2 |
| 28                  | 1639.4   | 0.1 | 8197.0     | 2.8 | 16393.9     | 11.2 | 49181.7     | 100.7 | 98362.6   | 403.0 |
| 29                  | 1624.0   | 0.1 | 8120.1     | 2.9 | 16240.1     | 11.5 | 48720.3     | 103.1 | 97439.6   | 412.2 |
| 30                  | 1608.1   | 0.1 | 8040.7     | 2.9 | 16081.4     | 11.7 | 48244.0     | 105.3 | 96487.0   | 421.0 |
| 31                  | 1591.8   | 0.1 | 7958.9     | 3.0 | 15917.7     | 11.9 | 47753.0     | 107.3 | 95505.0   | 429.3 |
| 32                  | 1574.9   | 0.1 | 7874.6     | 3.0 | 15749.2     | 12.1 | 47247.4     | 109.3 | 94493.8   | 437.0 |
| 33                  | 1557.6   | 0.1 | 7787.9     | 3.1 | 15575.9     | 12.3 | 46727.4     | 111.0 | 93453.8   | 444.2 |
| 34                  | 1539.8   | 0.1 | 7698.9     | 3.1 | 15397.9     | 12.5 | 46193.2     | 112.7 | 92385.4   | 450.8 |
| 35                  | 1521.5   | 0.1 | 7607.5     | 3.2 | 15215.0     | 12.7 | 45645.0     | 114.2 | 91288.8   | 456.9 |
| 36                  | 1502.8   | 0.1 | 7513.8     | 3.2 | 15027.6     | 12.8 | 45082.7     | 115.6 | 90164.3   | 462.5 |
| 37                  | 1483.6   | 0.1 | 7417.8     | 3.3 | 14835.6     | 13.0 | 44506.7     | 116.9 | 89012.2   | 467.5 |
| 38                  | 1463.9   | 0.1 | 7319.6     | 3.3 | 14639.1     | 13.1 | 43917.1     | 118.0 | 87833.0   | 471.9 |
| 39                  | 1443.8   | 0.1 | 7219.0     | 3.3 | 14438.1     | 13.2 | 43314.1     | 118.9 | 86626.9   | 475.8 |
| 40                  | 1423.3   | 0.1 | 7116.3     | 3.3 | 14232.6     | 13.3 | 42697.8     | 119.8 | 85394.3   | 479.0 |
| 41                  | 1402.3   | 0.1 | 7011.5     | 3.3 | 14022.9     | 13.4 | 42068.5     | 120.4 | 84135.6   | 481.7 |
| 42                  | 1380.9   | 0.1 | 6904.4     | 3.4 | 13808.8     | 13.4 | 41426.3     | 120.9 | 82851.2   | 483.8 |
| 43                  | 1359.1   | 0.1 | 6795.3     | 3.4 | 13590.5     | 13.5 | 40771.4     | 121.3 | 81541.3   | 485.3 |
| 44                  | 1336.8   | 0.1 | 6684.0     | 3.4 | 13368.1     | 13.5 | 40104.0     | 121.5 | 80206.5   | 486.2 |
| 45                  | 1314.1   | 0.1 | 6570.8     | 3.4 | 13141.5     | 13.5 | 39424.3     | 121.6 | 78847.1   | 486.5 |
| 46                  | 1291.1   | 0.1 | 6455.5     | 3.4 | 12910.9     | 13.5 | 38732.6     | 121.6 | 77463.6   | 486.3 |
| 47                  | 1267.6   | 0.1 | 6338.2     | 3.4 | 12676.4     | 13.5 | 38028.9     | 121.4 | 76056.3   | 485.4 |
| 48                  | 1243.8   | 0.1 | 6219.0     | 3.3 | 12437.9     | 13.4 | 37313.6     | 121.0 | 74625.6   | 484.0 |
| 49                  | 1219.6   | 0.1 | 6097.9     | 3.3 | 12195.8     | 13.4 | 36586.8     | 120.5 | 73172.0   | 481.9 |
| 50                  | 1195.0   | 0.1 | 5974.8     | 3.3 | 11949.7     | 13.3 | 35848.8     | 119.8 | 71696.0   | 479.3 |





# INDEX OF VOLUME I.

| PAR.   | PAGE   | PAR.  | PAGE |
|--|--------|---|------|
| 171. Adjustment of a Tertiary System of Triangulation (Lake Survey), . . . . . | 124    | 16. Compass, Beam-, . . . . .   | 5    |
| Airy's Table for Aneroid Measurements, . . . . .                               | 133    | 154. " , Hand-, for Sketching Purposes, . . . . .   | 98   |
| 159. Alignments and Prolongations, in Sketching, . . . . .                     | 108    | 128. " Compass," of Map, Construction of, . . . . .   | 68   |
| 158. Aneroid Barometer, . . . . .  | 103    | " Compasses," <i>see</i> " Dividers."   |      |
| 144. Angle of Reduction, in Copying, . . . . .                                 | 83     | CONFIGURATION OF GROUND, REPRESENTING THE,  | 36   |
| 19. Angles, Instruments for Measuring, . . . . .                               | 6      | 151. Conical Projections, for Maps, . . . . .   | 94   |
| 24. " , To Protract with Protractor and by Chords, . . . . .                   | 7      | 43. Construction Lines, How to Draw, . . . . .  | 15   |
| 55. " , To Protract by Sines, Cosines, etc., . . . . .                         | 22     | 94. Contoured Map, To Construct Vertical Section and Elevation from, . . . . .  | 43   |
| 57. " , or Arcs, Trigonometrical Functions of (Table), . . . . .               | 24     | 93. " " , Study of a, . . . . .   | 42   |
| 165. " , Vertical, Sketching of Contours by, . . . . .                         | 113    | 95. " " , To Lay Out a Road on a, . . . . .   | 44   |
| Arcs, Meridional (Table IV.), . . . . .  | 132    | CONTOURS :  |      |
| 172. Assemblage of Partial Sketches, . . . . .                                 | 126    | 78. Definition of, Equidistances and References, . . . . .  | 37   |
| 107. Austrian Scale of Shade and Working-scale, . . . . .                      | 51     | 79. Plotting of, . . . . .  | 37   |
| Auxiliary Contours, . . . . .  | 42, 47 | 86. To Determine Degree of Declivity from, . . . . .  | 40   |
| 170. Base, Reduction of, to Mean Sea-level, . . . . .                          | 119    | 91. Drawing of, Marking References of, . . . . .  | 42   |
| 16. Beam-compass, . . . . .  | 5      | 92. Intermediate and Auxiliary, . . . . .   | 42   |
| 25. Bearing, To Plot a, . . . . .  | 7      | 96. Combined with Hill-shading,—the Three Systems, . . . . .  | 45   |
| 154. " , To Take with Hand-compass, . . . . .                                  | 98     | 116. Necessity for, in Hachured Maps, . . . . .   | 56   |
| 134. Blending of Tints, . . . . .  | 73     | 165. Sketching of, from Distant Points;—from Profile Views, by Vertical Angles, . . . . .   | 112  |
| 147. Blue Process, Blue Lines on White, and Conversely, . . . . .              | 88     | CONVENTIONAL SIGNS:   |      |
| 151. Bonne's Projection for Maps, . . . . .                                    | 95     | 66. General Description, . . . . .  | 29   |
| 113. " Scale of Shade and Working-scale, . . . . .                             | 53     | 67. Shading of the Signs, . . . . .   | 29   |
| 18. Border-pen, . . . . .  | 6      | 68. General Remarks, Number and Sizes of the Signs, etc., . . . . .   | 29   |
| 128. Borders, Map, Construction of, . . . . .                                  | 68     | 69. Arrangement of, in the Different Plates, . . . . .  | 30   |
| " " , Diagram of, . . . . .  | 66     | 70. For Land, . . . . .   | 30   |
| 71. Boundaries, Signs for, . . . . .   | 32     | 71. For Land and Water-Survey-points and Lines, Boundaries, Enclosures, Communications and Buildings, Marsh, Water, Soundings, etc.; Artificial Features pertaining to Streams, . . . . . | 32   |
| 14. Bow-pens and Bow-pencils, . . . . .  | 5      | 72. Military Signs, Signs for Deciphering Maps and for Vertical Sections, . . . . .   | 34   |
| 30. Brands of Drawing-paper, . . . . .   | 10     | 73. U. S. Coast Survey, . . . . .   | 35   |
| BRUSH HILL-SHADING, <i>see</i> " Hill-shading."                                |        | 74. Rapid Method of Making, . . . . .   | 35   |
| Brushes, <i>see</i> " Materials."  |        | 155. Used in Sketching, . . . . .   | 100  |
| 167. Cavalry Sketching-case, . . . . .   | 114    | CONVENTIONAL TINTS AND THEIR APPLICATION:   |      |
| 99. Choice of Illumination, . . . . .  | 46     | 129. Materials and Instruments, . . . . .   | 70   |
| 52. " of Scale, Conditions Governing, . . . . .                                | 20     | 130. Rules for Working in Colors, . . . . .   | 71   |
| 154. Clinometers, in Sketching, . . . . .                                      | 97     | 131. Preparation of Tints, . . . . .  | 71   |
| 63. Closing a Plot, and Error-sheets, . . . . .                                | 27     | 132. Laying of Flat Tints, . . . . .  | 72   |
| 108. Coast Survey, U. S., Scale of Shade and Working-scale, . . . . .          | 52     | 133. Laying of Graded Tints, . . . . .  | 72   |
| 73. " " , Signs employed by, . . . . .   | 35     | 134. To Blend Tints, . . . . .  | 73   |
| 127. " " , System of Lettering, . . . . .                                      | 68     | 135. Stippling, Dragging and Durability of Colors, . . . . .  | 74   |
| 158. " " , Table of Heights, Aneroid, . . . . .                                | 105    | 136. Employed for the Different Features, . . . . .   | 74   |
| 130. Colors, Rules for Working in, . . . . .                                   | 71     | 137. Operation of Tinting, . . . . .  | 76   |
| 131. " , Harmonious Contrast of, . . . . .                                     | 71     | 138. French System, Conventional Tints, and Rules Observed in Color-drawing, Other Systems, . . . . .   | 76   |
| 135. " , Stippling and Dragging of, . . . . .                                  | 73     |   |      |
| 135. " , Durability of, . . . . .  | 74     |   |      |
| " , for Different Features, <i>see</i> " Conventional Tints."                  |        |   |      |
| " , for Vertical Sections, <i>see</i> Plate V.                                 |        |   |      |

| PAR.   | PAGE | PAR.  | PAGE |
|--|------|---|------|
| 44.  | 16   | 4.  | 2    |
| "    of Metres and English Units (Table II.), . . . . .  | 129  | 35.   | 12   |
| COPYING, REDUCTION AND ENLARGEMENT OF MAPS:  |      |   |      |
| 139.   | 79   | 135.  | 73   |
| 140.   | 79   | 146.  | 85   |
| <i>Reducing and Enlarging:</i>   |      |   |      |
| 141.   | 81   | 94.   | 44   |
| 142.   | 82   | 109.  | 53   |
| 143.   | 83   | 102.  | 48   |
| 144.   | 83   | 141-7.  | 81-6 |
| 145.   | 83   | 20.   | 6    |
| 146.   | 85   | 49.   | 18   |
| 147.   | 86   | 78.   | 37   |
| Generalization of Detail, . . . . .  |      | 81.   | 38   |
| Different Methods—Method by Squares, . . . . .   |      | 42.   | 15   |
| Proportional Dividers, Description and Use, . . . . .  |      | 63.   | 27   |
| The Angle of Reduction, Description and Use of, . . . . .  |      | 157.  | 101  |
| The Pantograph, Description and Use of, . . . . .  |      | 50.   | 19   |
| The Eidograph, Description and Use of, . . . . .   |      | 147.  | 87-8 |
| Copying by Photography, Preparation of the Subject to be Copied, The Lens, Relative Positions of Ground-glass and Subject, Lighting the Subject, General Considerations, Blue Process, Black or Red Lines on White Ground, . . . . . |      | 167.  | 114  |
| 33.  | 11   | 75.   | 36   |
| Cross-section and Profile Paper, Description and Use of, . . . . .   |      | 160.  | 108  |
| 3.   | 2    | FINISHING THE MAP, INCLUDING LETTERING AND ORNAMENTATION: |      |
| 27.  | 8    | 124.  | 63   |
| 17.  | 6    | 125.  | 63   |
| 15.  | 5    | 126.  | 67   |
| "    of Equal Shade, Tracing of, . . . . .   |      | 127.  | 68   |
| 150.   | 93   | 128.  | 68   |
| 110.   | 53   | 132.  | 72   |
| 78.  | 37   | FORMS OF GROUND, SURFACE, REPRESENTING THE, . . . . .     |      |
| 79.  | 37   | 128.  | 68   |
| 100.   | 46   | 114.  | 54   |
| 100.   | 46   | 138.  | 76   |
| 103.   | 49   | 120.  | 57   |
| DETAILS, REPRESENTING THE:   |      |   |      |
| 75.  | 36   | 112.  | 53   |
| 141.   | 81   | 141.  | 81   |
| 160.   | 108  | 140.  | 80   |
| 147.   | 87   | 83.   | 39   |
| 46.  | 17   | 133.  | 72   |
| Distances, Measurement of, in Sketching, <i>see</i> "Sketching."   |      |   |      |
| 13.  | 5    | 10.   | 4    |
| 14.  | 5    | 100.  | 46   |
| 21.  | 7    | 100.  | 48   |
| 143.   | 83   | 116.  | 56   |
| 18.  | 6    | 100.  | 46   |
| 135.   | 73   | 154.  | 97-8 |
| 36.  | 12   | 103.  | 103  |
| DRAWING-PAPER:   |      |   |      |
| 30.  | 10   | HILL-SHADING:   |      |
| 36.  | 12   | 96.   | 45   |
| 37.  | 13   | 100.  | 46   |
| 39.  | 13   | 101.  | 48   |
| 40.  | 14   | 102.  | 48   |
|  |      | 103.  | 49   |
|  |      | 104.  | 49   |
|  |      | 105.  | 49   |
|  |      | 112.  | 53   |
|  |      | 115.  | 55   |
|  |      | 117.  | 56   |
|  |      | 118.  | 56   |

| PAR.  |  | PAGE  | PAR.   |  | PAGE   |
|-------|--|-------|--------|--|--------|
| 120.  | Contours Combined with Brush Hill-shading. French System with V. Illumination: <i>a.</i> Scale of Shade; <i>b.</i> Working-scale; <i>c.</i> Application of the Working-scale; <i>d.</i> Tracing of Curves of Equal Shade; <i>e.</i> Case of Strongly-marked Irregularities of Surface; <i>f.</i> Features Requiring no Shade; <i>g.</i> Practical Operation, . . . . . | 57    | 51.    | Limit, Inferior, of Scale Measurement, . . . . .   | 20     |
| 121.  | Same. Oblique Illumination, . . . . .  | 60    | 56.    | Limits of the Map, and Direction of Meridian Line, . . . . .   | 22     |
| 122.  | Brush-shading, Ordinary Practice of—Materials Required, Preparation and Operation, . . . . .   | 61    | 43.    | Line-drawing, Rules for, . . . . .   | 15     |
| 123.  | With Pencil, in Sketching, . . . . .   | 62    | 43.    | Lines, Classification and Grades of, How to Draw Construction Lines, . . . . .   | 15     |
| 136.  | " Colors ( <i>see also</i> "Slopes"), . . . . .  | 75    | 100.   | " of Greatest Descent, and Guiding Lines, . . . . .  | 46     |
|       | HILL-SKETCHING, <i>see</i> "Sketching."  |       | 55.    | " , Plotting of, . . . . .   | 22     |
| 81.   | Horizontal Equivalents, Table giving Ratio of Height to Base for Slopes from 1° to 60°, . . . . .  | 38    | 156.   | Locating Points, in Sketching, . . . . .   | 100    |
|       | Illumination, <i>see</i> "Hill-shading."   |       | 35.    | Magnifying-glass, Use of, in Drawing, . . . . .  | 2      |
| 80.   | Inclination, Scale of, . . . . .   | 37    | 103.   | Mandrot's System of Hill-shading, . . . . .  | 49     |
| 34.   | India Ink, Qualities and Preparation of, . . . . .   | 11    | 56.    | Map, Defining Limits of, . . . . .   | 22     |
| 51.   | Inferior Limit of Scale-measurement, . . . . .   | 20    |        | " , Finishing the, <i>see</i> "Finishing."   |        |
| 34.   | Ink for Drawing Purposes, . . . . .  | 11    | 44.    | " , Scale of the, . . . . .  | 16     |
| 76.   | Inking the Details, . . . . .  | 36    |        | MAP PROJECTIONS:   |        |
|       | INSTRUMENTS, FOR DRAWING:  |       | 149.   | General Considerations, . . . . .  | 93     |
| 2, 3. | Pencils and Pens, . . . . .  | 1, 2  | 150.   | Cylindrical Projections—I. Rectangular Projection; II. Projection with Converging Meridians, . . . . .                       | 93     |
| 5.    | Instruments for Drawing Straight Lines, . . . . .  | 3     | 151.   | Conical Projections—I. Simple Conic; II. Bonne's; III. Polyconic, including Rectangular, Ordinary and Equidistant, . . . . . | 94     |
| 12.   | Instruments Necessary for Drawing Curved Lines, . . . . .  | 4     | 152.   | Plotting the Triangulation on, . . . . .   | 96     |
| 19.   | Instruments for Measuring Lines and Angles, . . . . .  | 6     | 91.    | Marking the References, . . . . .  | 42     |
| 35.   | Other Necessary Instruments (not classified), . . . . .  | 12    |        | MATERIALS FOR DRAWING:   |        |
| 62.   | Trigonometer, . . . . .  | 26    | 30.    | Drawing-paper, . . . . .   | 10     |
| 129.  | For Use with Colors, . . . . .   | 70    | 31-2.  | Tracing-paper and Cloth and Transfer Paper, . . . . .  | 11     |
|       | For Copying, . . . . .   | 79-90 | 33.    | Cross-section and Profile Paper, . . . . .   | 11     |
|       | INSTRUMENTS, FOR SKETCHING:  |       | 34.    | India Ink, . . . . .   | 11     |
| 154.  | Hand-compasses, Levels, Clinometers, etc., . . . . .   | 97    | 35.    | Other Materials (Not Classified), . . . . .  | 12     |
| 157.  | Pedometer, Odometer, . . . . .   | 101   | 36.    | Drawing-boards, . . . . .  | 12     |
| 158.  | Aneroid Barometer, . . . . .   | 103   | 38.    | Stretching-frames, . . . . .   | 13     |
| 167.  | Cavalry Sketching-case, . . . . .  | 114   | 122.   | For Brush Hill-shading, . . . . .  | 61     |
| 92.   | Intermediate Contours, . . . . .   | 42    | 129.   | " Color-drawing, . . . . .   | 70     |
| 159.  | Intersections, Sketching by, . . . . .   | 106   | 147.   | " Photography, Blue Process, etc., . . . . .   | 86     |
| 10.   | Intervals, To Grade, . . . . .   | 4     | 148.   | " Modelling, . . . . .   | 90     |
| 94.   | Intervisibility of Stations, To Determine, from a Contoured Map, . . . . .   | 44    | 154-9. | " Sketching, . . . . .   | 97-108 |
| 15.   | Irregular Curves, Description and Use of, . . . . .  | 5     | 157.   | Measurement of Distances, in Sketching, . . . . .  | 100    |
| 169.  | Itinerary, Form of, . . . . .  | 118   | 158.   | " of Heights and Differences of Level, in Sketching, . . . . .   | 103    |
| 40.   | Joining Sheets of Paper, . . . . .   | 14    | 158.   | " of Heights, Coast Survey Method, . . . . .   | 104    |
| 70.   | Land, Conventional Signs for, . . . . .  | 30    |        | " " " , Aneroid (Airy's Tab.), . . . . .   | 135    |
| 71.   | " and Water, Conventional Signs for, . . . . .   | 32    |        | Measures of Different Countries in Metres and English Units (Table), . . . . .   | 129    |
| 168.  | Landscape Sketching, . . . . .   | 118   | 56.    | Meridian Line on Map, Direction of, . . . . .  | 22     |
|       | LARGE AREAS, MAP PROJECTIONS FOR, . . . . .  | 93-6  |        | " " " , Form of, <i>see</i> "Finishing."   |        |
| 132.  | Laying of Flat Tints, . . . . .  | 72    |        | Meridional Arcs (Table of), . . . . .  | 132    |
| 133.  | " of Graded Tints, . . . . .   | 72    | 145.   | Micrograph, . . . . .  | 85     |
| 2.    | Lead-pencils, Kinds Used, To Sharpen, . . . . .  | 1     | 72.    | Military Signs, . . . . .  | 34     |
| 106.  | Lehmann's Scale of Shade and Working-scale, . . . . .  | 49    |        | MODELLING:   |        |
| 109.  | English Modification of, . . . . .   | 53    | 148.   | Purposes of Models and Details of Construction, . . . . .  | 90     |
| 111.  | Müffling's " , . . . . .   | 53    | 148.   | With Clay, by Successive Horizontal Layers, . . . . .  | 91     |
|       | Lengths of Degrees of the Parallel (Table VI.), . . . . .  | 133   | 173.   | Professional Work in Plaster, . . . . .  | 127    |
| 147.  | Lens for Photographic Copying, . . . . .   | 86    | 166.   | Mountainous Tracts, Sketching in, . . . . .  | 113    |
|       | LETTERING, MAP:  |       | 39.    | Mounting of Paper on Cloth, . . . . .  | 13     |
| 125.  | Forms, Sizes, Dispositions, . . . . .  | 63    | 111.   | Müffling's Scale of Shade and Working-scale, . . . . .   | 53     |
| 125.  | Forms and Heights, Belgian School (Table), . . . . .   | 65    |        | Mutual Conversion of Metres and English Units (Table), . . . . .   | 129    |
| 127.  | U. S. Coast Survey System, . . . . .   | 68    |        | Natural Sines, Cosines, Tangents and Cotangents (Table), . . . . .   | 130    |
| 154.  | Levels, Hand-, for Sketching Purposes, . . . . .   | 98    | 100.   | Normals, Definition of, . . . . .  | 46     |
| 41.   | Light, Arrangement of, in Drawing, . . . . .   | 14    |        |  |        |

| PAR.  | PAGE | PAR.  | PAGE |
|---|------|---|------|
| 160.  | 108  | 43.   | 15   |
| 98.   | 46   | PRACTICAL RULES AND SUGGESTIONS, FOR  |      |
| 157.  | 100  | DRAWING, . . . . .  |      |
| Operations of Shading and Tinting, <i>see</i> "Hill-shading and Tinting."   |      | 101.  | 48   |
| Ornamentation of Maps, <i>see</i> "Finishing . . ."   |      | 36.   | 12   |
| 156.  | 100  | 131.  | 71   |
| 145.  | 83   | 140.  | 80   |
| PAPER, DRAWING:   |      | 147.  | 88   |
| 30.   | 10   | 154.  | 98   |
| 31-3.   | 11   | 173.  | 127  |
| 36.   | 12   | 33.   | 11   |
| 37, 39.   | 13   | 166.  | 113  |
| 40.   | 14   | 165.  | 112  |
| Parallel, Lengths of Degrees of the (Table), . . . . .  |      | PROJECTIONS, MAP, <i>see</i> "Map Projections."   |      |
| 9.  | 4    | 159.  | 108  |
| 159.  | 108  | 143.  | 83   |
| 157.  | 101  | 24.   | 7    |
| 123.  | 62   | 60.   | 26   |
| 75.   | 36   | PROTRACTORS:  |      |
| 2.  | 1    | 22-3.   | 7    |
| 3.  | 2    | Rectangular, the "Abbot," Semicircular and  |      |
| 4.  | 2    | Circular, . . . . .   |      |
| and How to Repair Points of, . . . . .  |      | 26.   | 8    |
| 17, 18.   | 6    | 27.   | 8    |
| 147.  | 86   | 28.   | 8    |
| 167.  | 114  | 60.   | 26   |
| PLOTTING:   |      | 159.  | 108  |
| 25.   | 7    | 167.  | 115  |
| 54.   | 22   | 122-3.  | 61   |
| 55.   | 22   | 74.   | 35   |
| 57.   | 23   | " " of Making the Conventional  |      |
| the Triangulation ( <i>see also</i> Appendix, page 119 <i>et seq.</i> ), . . . . .  |      | 58.   | 25   |
| 58.   | 25   | " " of Plotting, . . . . .  |      |
| 59.   | 25   | 81.   | 38   |
| of Traverse Courses by Rectangular Coordinates, . . . . .   |      | Ratios of Height to Base, for Slopes 1° to 60°  |      |
| 60.   | 26   | (Table), . . . . .  |      |
| Meridian Line, of Stadia Measurements, . . . . .  |      | 59.   | 25   |
| 61.   | 26   | Rectangular Coordinates, Plotting of Traverse   |      |
| of Traverse Courses by the Use of Several Meridian Lines, . . . . .   |      | Courses by, . . . . .   |      |
| 62.   | 26   | 150.  | 93   |
| 63.   | 27   | 151.  | 95   |
| 64.   | 27   | 22.   | 7    |
| 86.   | 40   | REDUCTION AND ENLARGEMENT OF MAPS, . . . . .  |      |
| 87.   | 40   | 170.  | 119  |
| Same. Case I.—When the Surface-line is of Uniform Inclination, . . . . .  |      | 82.   | 38   |
| 88.   | 40   | REDUCTION OF SURFACE-MEASUREMENTS TO THE  |      |
| 89.   | 41   | HORIZON, . . . . .  |      |
| Same. Graphical Method, . . . . .   |      | 83.   | 39   |
| 90.   | 41   | 84.   | 39   |
| Same. Scale of Slopes for, . . . . .  |      | 85.   | 39   |
| 152.  | 96   | 78.   | 37   |
| 160.  | 108  | 42.   | 42   |
| 170.  | 119  | " , How to Mark the, . . . . .  |      |
| of the Triangulation, when the Earth's Sphericity is Considered— <i>a.</i> Reduction of the Base to the Mean Sea-level; <i>b.</i> Modifications of the Triangles; <i>c.</i> Plotting the Triangles. . . . . |      | 154.  | 99   |
| 171.  | 124  | 118.  | 56   |
| 172.  | 126  | Relative Merits of H. and V. Systems of Hill-shading, . . . . .                             |      |
| 151.  | 95   | 4.  | 3    |
| Polyconic Projection, Rectangular, Ordinary and Equidistant, . . . . .  |      | 119.  | 57   |
| "   | 134  | REPRESENTING THE CONFIGURATION OR SURFACE-FORMS OF GROUND, . . . . .                        |      |
| "   | 134  | FACE-FORMS OF GROUND, . . . . . 36 <i>et seq.</i>   |      |
|   |      | REPRESENTING THE CONFIGURATION OR SURFACE-FORMS OF GROUND, in Sketching, 111 <i>et seq.</i> |      |
|   |      | REPRESENTING THE DETAILS, . . . . . 36  |      |
|   |      | 2.  | 2    |
|   |      | 95.   | 44   |
|   |      | 18.   | 6    |
|   |      | 119.  | 57   |
|   |      | 41.   | 14   |

| PAR.   | PAGE  | PAR.   | PAGE |
|--|---|--------|------|
| <b>RULES:</b>  |   |        |      |
| 44.  | for Conversion of Distances, . . . . .  | 16     |      |
| 71.  | for Line Drawing, . . . . .   | 15     |      |
| 130.   | for Working in Colors, . . . . .  | 71     |      |
| Rulers, <i>see</i> "Straight-edges."   |   |        |      |
| 9.   | " , Parallel, . . . . .   | 4      |      |
| <b>SCALES:</b>   |   |        |      |
| 20.  | of Equal Parts, Description and Use of, . . . . .   | 6      |      |
| 44.  | of the Map, Definition of, . . . . .  | 16     |      |
| 45.  | of Distances, Construction and Use of, . . . . .  | 16     |      |
| 46.  | Diagonal, . . . . .   | 17     |      |
| 47.  | Vernier, . . . . .  | 17     |      |
| 48.  | Vertical and Time, . . . . .  | 18     |      |
| 50.  | Examples of Scale-construction, . . . . .   | 19     |      |
| 51.  | Inferior Limit of Scale-measurement, . . . . .  | 20     |      |
| 52.  | Conditions Governing Choice of, . . . . .   | 20     |      |
| 53.  | Used in Different Countries, . . . . .  | 21     |      |
| <i>In Contouring:</i>  |   |        |      |
| 80.  | of Inclination, Construction and Use of, . . . . .  | 37     |      |
| 83.  | for Reduction of Surface-measurements to the Horizon, . . . . .   | 39     |      |
| 84.  | Same. In Case of Stadia, . . . . .  | 39     |      |
| 90.  | of Slopes, . . . . .  | 41     |      |
| <i>In Hill-shading, Scales of Shade and Working-scales:</i>                              |   |        |      |
| 100.   | of Shade, and Working-. Definitions of, . . . . .   | 48     |      |
| 102.   | English Standard, . . . . .   | 48     |      |
| 106.   | Lehmann's, . . . . .  | 49     |      |
| 107.   | Austrian, . . . . .   | 51     |      |
| 108.   | U. S. Coast Survey, . . . . .   | 52     |      |
| 109.   | Lehmann's, English Modification of, . . . . .   | 53     |      |
| 110.   | Danish, . . . . .   | 53     |      |
| 111.   | Muffling's, . . . . .   | 53     |      |
| 113.   | Bonne's (French System), V. System, . . . . .   | 53     |      |
| 114.   | French Commission, . . . . .  | 54     |      |
| 120.   | for Brush Hill-shading, . . . . .   | 57     |      |
| 128.   | Position of, on Maps, . . . . .   | 68     |      |
| 147.   | in Photographic Reduction, . . . . .  | 86     |      |
| 155.   | Used in Sketching, . . . . .  | 100    |      |
| 11.  | Section-liners, General Description of, . . . . .   | 4      |      |
| 94.  | Sectograph, and Intervisibility of Stations, . . . . .  | 44     |      |
| 29.  | Sector, Description and Use of, . . . . .   | 8      |      |
| 23.  | Semicircular Protractor, . . . . .  | 7      |      |
|  | " " , Test for, . . . . .   | 8      |      |
| 67.  | Shading of the Conventional Signs, . . . . .  | 29     |      |
| Signs for Features, <i>see</i> "Conventional Signs."                                     |   |        |      |
| <b>SKETCHING:</b>  |   |        |      |
| <i>Instruments, Locating Points, Measurement of Distances and Heights, the Skeleton:</i> |   |        |      |
| 153.   | General Considerations, . . . . .   | 97     |      |
| 154.   | Sketching-instruments— <i>a.</i> Hand-compasses; <i>b.</i> Hand-levels and Clinometers; <i>c.</i> Pencils, etc., . . . . .  | 97     |      |
| 155.   | Scales, Plotting and Signs, . . . . .   | 100    |      |
| 156.   | Locating Points, . . . . .  | 100    |      |
| 157.   | Measurement of Distances— <i>a.</i> By Pacing. the Pedometer; <i>b.</i> By the Odometer; <i>c.</i> When Mounted; <i>d.</i> By Eye Estimation; <i>e.</i> On Slopes, . . . . .  | 100    |      |
| 158.   | Measurement of Heights— <i>a.</i> Graphical and Trigonometrical; <i>b.</i> By the Aneroid Barometer, . . . . .  | 103    |      |
| 159.   | Constructing the Skeleton—I. General Considerations; II. By Triangulation; III. By Traversing; IV. By Traversing Combined with Radiation and Intersection; V. By Parallels and Perpendiculars; VI. By Alignments and Prolongations, . . . . . | 106    |      |
| 160.   | Filling in the Details—General Considerations; Form (I.) of Note-book for Plotting the Sketch in the Field; Form (II.) of Note-book Used when the Plotting is not Done in the Field, . . . . .  | 108    |      |
| 161.   | Features to be Sketched or Otherwise Described, . . . . .   | 110    |      |
| <i>Representing the Configuration of the Surface (or Hill-sketching):</i>                |   |        |      |
| 162.   | General Considerations, . . . . .   | 111    |      |
| 163.   | Case of a Detached Hill, . . . . .  | 111    |      |
| 164.   | Case of a Number of Elevations and Depressions, . . . . .   | 112    |      |
| 165.   | Parts of Contours, Sketching of, from Distant Points—I. From Profile Views; II. By Vertical Angles, . . . . .   | 112    |      |
| 166.   | In Mountainous Districts, Horizontal and Profile Sketches, . . . . .  | 113    |      |
| <i>Sketching Without Instruments:</i>  |   |        |      |
| 167.   | General Considerations and the Plane-table Method; the Cavalry Sketching-case; Example of Rapid Eye Sketching, . . . . .  | 114    |      |
| 168.   | Landscape Sketching, . . . . .  | 118    |      |
| 169.   | Itinerary, Form of, . . . . .   | 118    |      |
| 172.   | Partial Sketches, Assemblage of, . . . . .  | 126    |      |
| Slopes, Representation of, <i>see</i> "Hill-shading" and "Conventional Tints."           |   |        |      |
| 90.  | Slopes, Scale of, . . . . .   | 41     |      |
| 21.  | Spacing-dividers, Description and Use of, . . . . .   | 7      |      |
| 14.  | Spring Dividers, . . . . .  | 5      |      |
| 142.   | Squares, Copying by, . . . . .  | 82     |      |
| 60, 84.  | Stadia Measurements, Plotting of, . . . . .   | 26, 39 |      |
| 135.   | Stippling and Dragging, and the Durability of Colors, . . . . .   | 73     |      |
| 6.   | Straight-edges, Kinds Required, and Use of, . . . . .   | 3      |      |
| 37.  | Stretching the Paper, . . . . .   | 13     |      |
| 38.  | Stretching-frames, or "Stretchers," . . . . .   | 13     |      |
| 93.  | Study of a Contoured Map, . . . . .   | 42     |      |
| <b>SURFACE-FORMS OF GROUND, REPRESENTING THE,</b> . . . . . 36 <i>et seq.</i>            |   |        |      |
| 82.  | Surface-measurements, Reduction of, to the Horizon, . . . . .   | 38     |      |
| 71.  | Survey Points and Lines, Signs for, . . . . .   | 32     |      |
| 96.  | Systems of Hill-shading, . . . . .  | 45     |      |
| TABLES, <i>see</i> List of, at End of Index.   |   |        |      |
| Thumb-tacks, <i>see</i> "Drawing-pins."  |   |        |      |
| 48.  | Time-scales, . . . . .  | 18     |      |
| Tints, <i>see</i> "Conventional Tints."  |   |        |      |
| 126.   | Title, Arrangement and Disposition of, . . . . .  | 67     |      |
| 31.  | Tracing-paper and Tracing-cloth, Description, Use and Manufacture of, . . . . .   | 11     |      |
| 140.   | Tracing, Copying by, . . . . .  | 80     |      |
| 140.   | Transfer, " . . . . .   | 81     |      |
| 32.  | Transfer-paper, Description, Use and Manufacture of, . . . . .  | 11     |      |
| 59.  | Traverse Courses, Plotting of, . . . . .  | 25-6   |      |



| PAR.   | PAGE | PAR.   | PAGE |
|--|------|--|------|
| 159. Traversing, in Sketching, . . . . .                         | 107  | 165. Vertical Angles, Sketching of Contours by, . . .            | 112  |
| 7. Triangles, Kinds and Use of, . . . . .                        | 3    | 48. " and Time Scales, Construction and Use of, . . . . .        | 18   |
| TRIANGULATION:   |      |  |      |
| 57. Plotting of the, . . . . .                                   | 23   | 97. " Illumination, . . . . .                                    | 45   |
| 58. " , Rapid Methods of, . . . . .                              | 25   | VERTICAL SECTIONS:   |      |
| 152. " , on Map Projections, . . . . .                           | 96   | 64. Plotting of, . . . . .                                       | 27   |
| 159. In Sketching, . . . . .                                     | 106  | 94. Construction of, from Contoured Map, . . . . .               | 43   |
| 170. Plotting of the, Earth's Sphericity Considered, . . . . .   | 119  | Signs and Colors for ( <i>see</i> Plate V.), . . . . .           | 34   |
| 171. Adjustment of a Tertiary System of (Lake Survey), . . . . . | 124  | Vertical Systems of Hill-shading, <i>see</i> " Hill-shading."    |      |
| 62. Trigonometer, Description and Use of, . . . . .              | 26   | 165. Views, Profile, Use of, in Sketching Contours, . . . . .    | 112  |
| 57. Trigonometrical Functions, Table of, . . . . .               | 24   | Water, Signs for, <i>see</i> " Conventional Signs" and " Tints." |      |
| 8. T-Square, . . . . .   | 3    | Working-scales, <i>see</i> " Scales."                            |      |
| 26. Vernier Protractor, Description and Use of, . . . . .        | 8    | 100. Zones, Definition of, . . . . .                             | 46   |
| 47. " Scale, Construction and Use of, . . . . .                  | 17   |  |      |

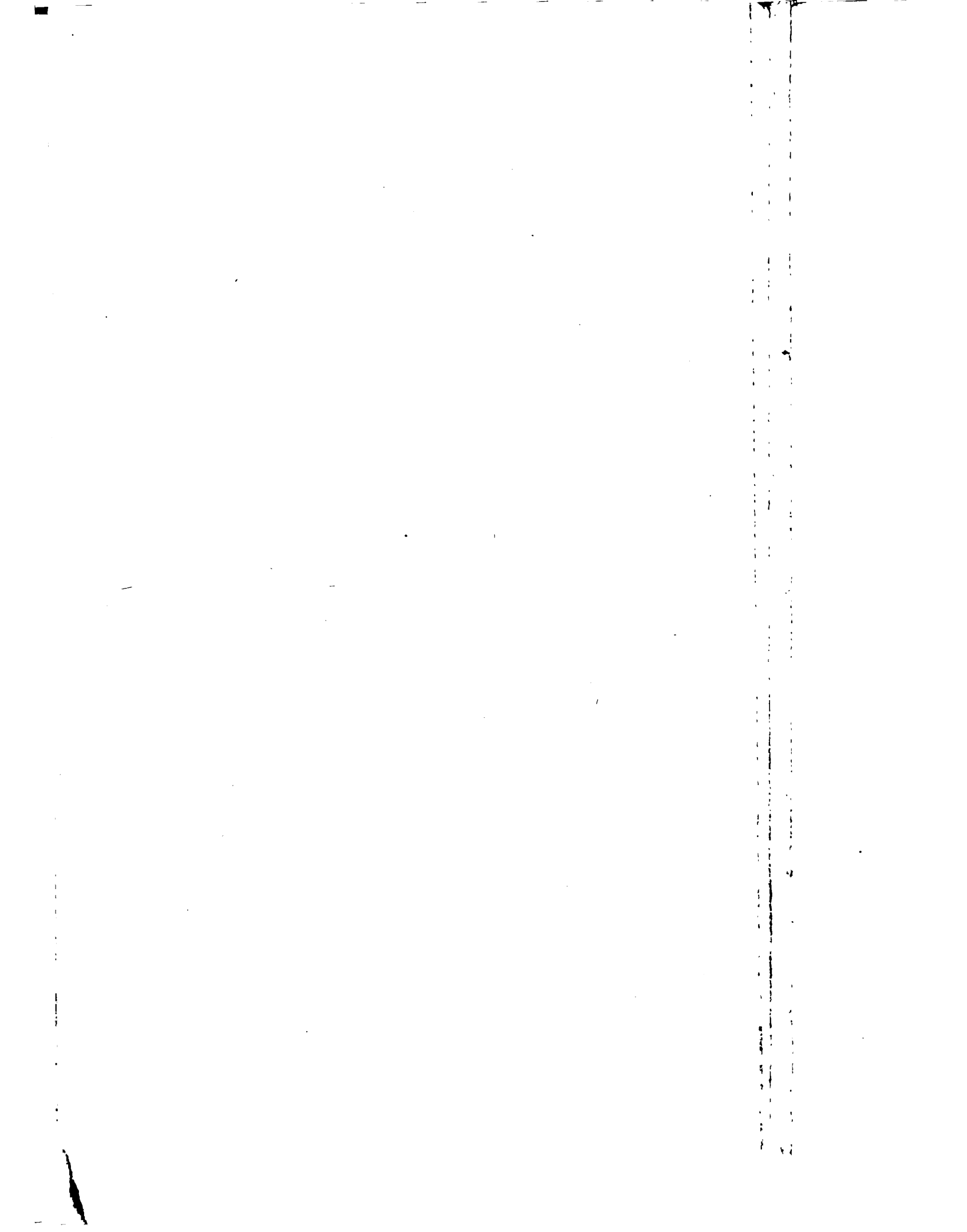
TABLES.

|   | PAGE |  | PAGE |
|---|------|--|------|
| Drawing-paper, Brands, Kinds and Sizes of, . . . . .  | 10   | Table I. Measures of Different Countries in Metres and English Units, . . . . .      | 129  |
| Topographical Scales Used in Different Countries, . . . . .   | 21   | " II. For Mutual Conversion of Metres and English Units, . . . . .                   | 129  |
| Trigonometrical Functions of any Arc or Angle in Terms of those of an Arc or Angle less than 90°, . . . . . | 24   | " III. Natural Sines, Cosines, Tangents and Cotangents, . . . . .                    | 130  |
| Horizontal Equivalents—Ratios of Height to Base for Slopes from 1° to 60°, . . . . .                        | 38   | " IV. Meridional Arcs, . . . . .   | 132  |
| Letters—Forms and Heights (Belgian School), . . . . .   | 65   | " V. Coordinates for Polyconic Projection, . . . . .                                 | 132  |
| Differences of Level, Measurement of, in Mountainous Tracts, . . . . .                                      | 103  | " VI. Length of Degrees of the Parallel, . . . . .                                   | 133  |
| Differences of Level, Measurement of, with Aneroid (U. S. C. Survey), . . . . .                             | 105  | " VII. Airy's Table for Measurement of Heights with the Aneroid Barometer, . . . . . | 133  |

PLA

PAR.  
159. Tr  
7. Tri  
TR  
57. I  
58.  
152.  
159. !  
170. !  
171. !  
  
62. Tr  
57. Tr  
8. T-  
26. V  
47.

Drawn  
Topog  
Trigon  
T  
Horiz  
fo  
Letter  
Differ  
or  
Differ  
(



140

PAR.

159. ]

7. ]

]

57.

58.

152.

159.

170.

171.

62.

57.

8.

26.

47.

Draw

Topo

Trigg

Hori:

f

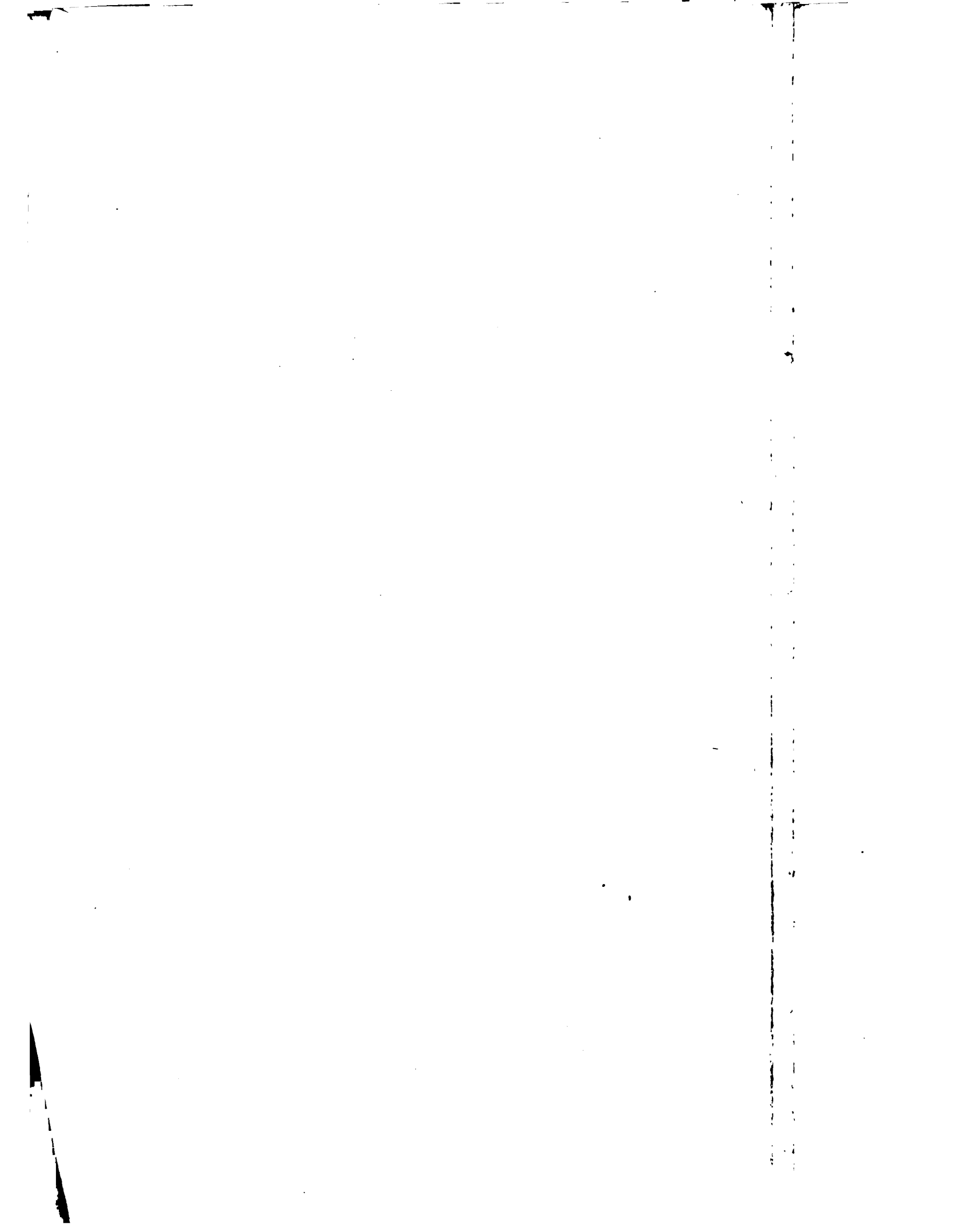
Lette

Diffe

(

Diffe

(



140

PAR.

159. T

7. T

T

57.

58.

152.

159.

170.

171.

62. T

57. T

8. T

26. T

47.

Draw

Topo.

Trigo

T

Horiz

f

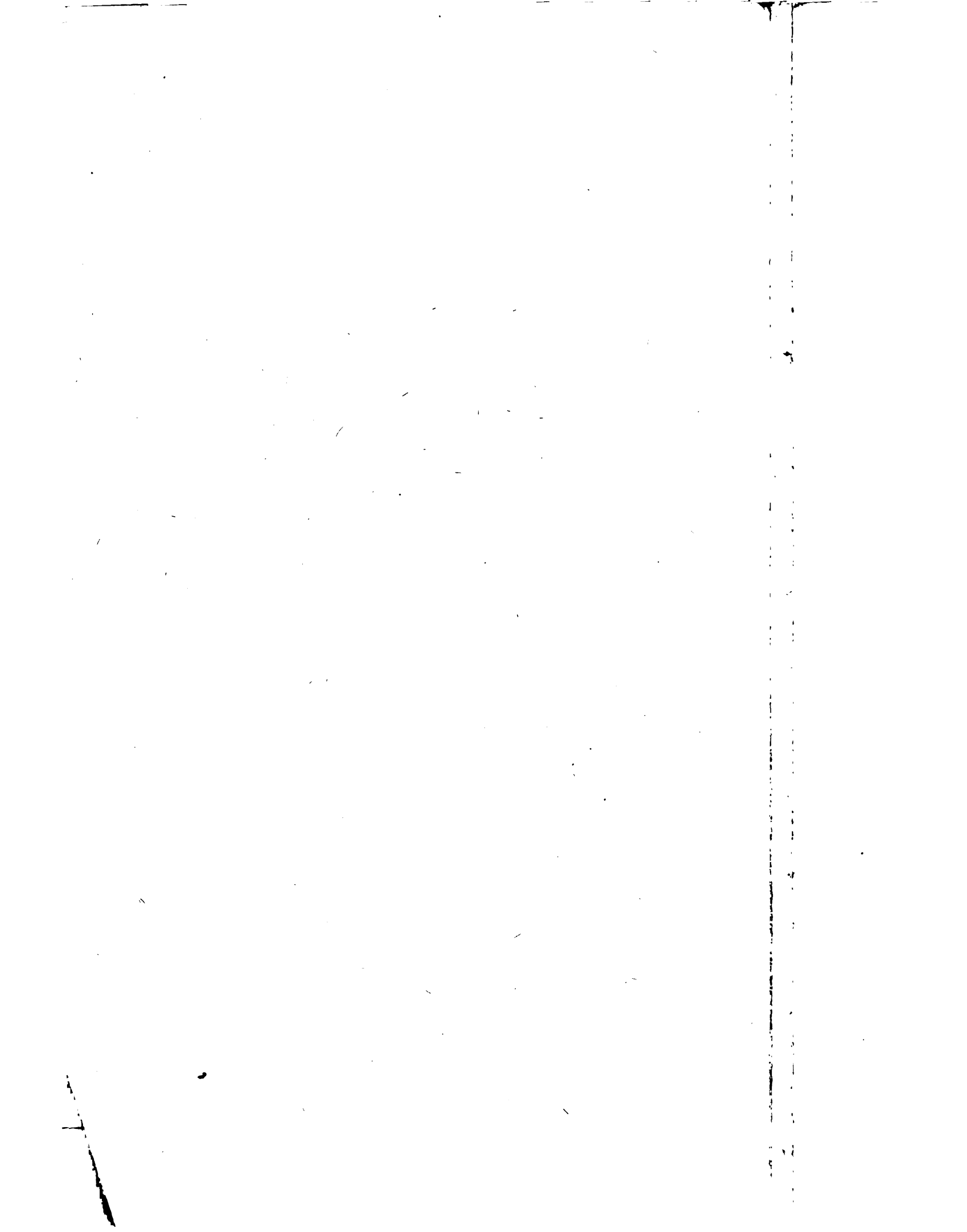
Lette

Diffe

c

Diffe

(





140

PAR.

159. 7

7. 7

7

57.

58.

152.

159.

170.

171.

62.

57.

8.

26.

47.

Draw

Topo

Trigg

Hori

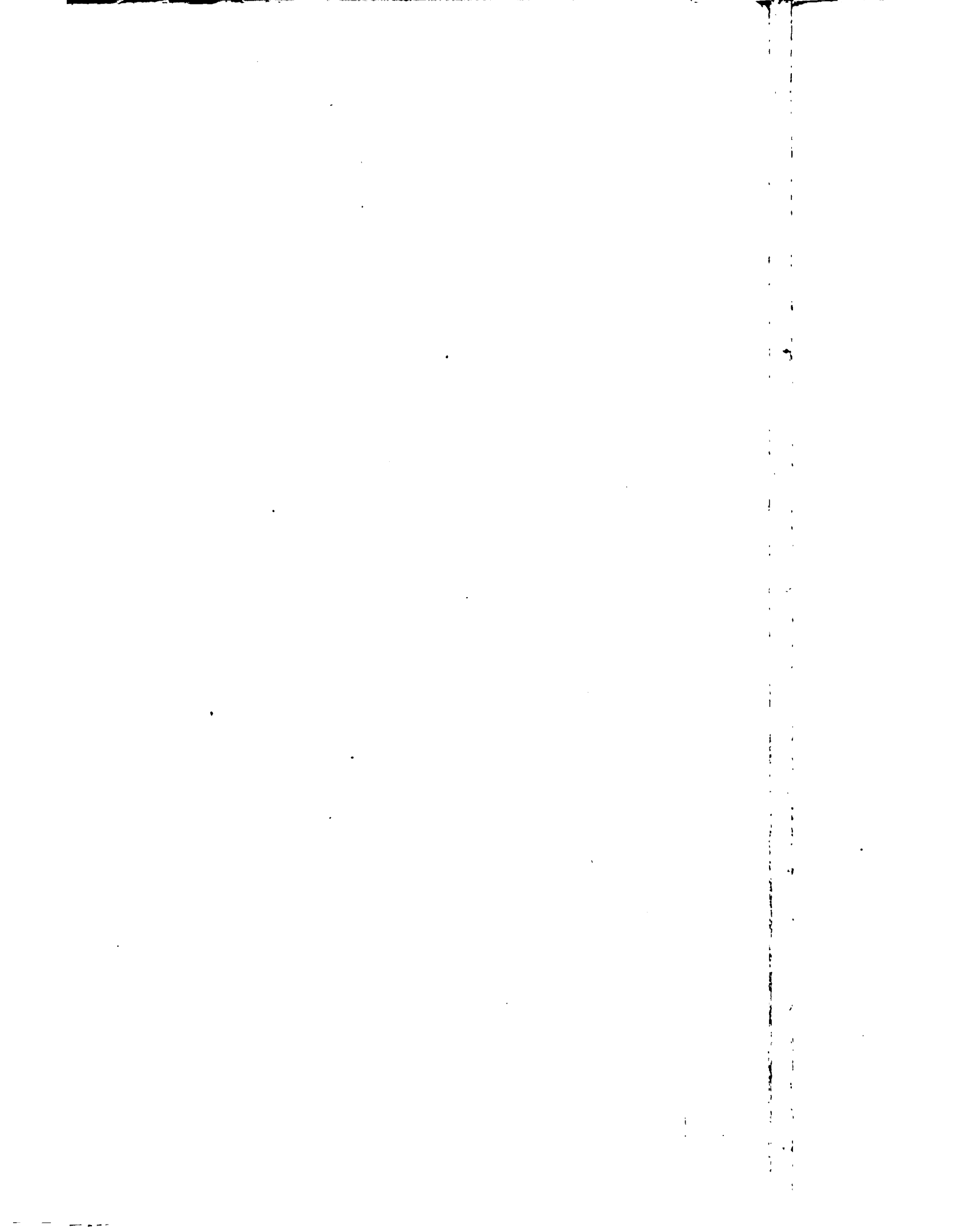
1

Lette

Diffe

Diffe

1



140

PAR.

159.

7.

57.

58.

152.

159.

170.

171.

62.

57.

8.

26.

47.

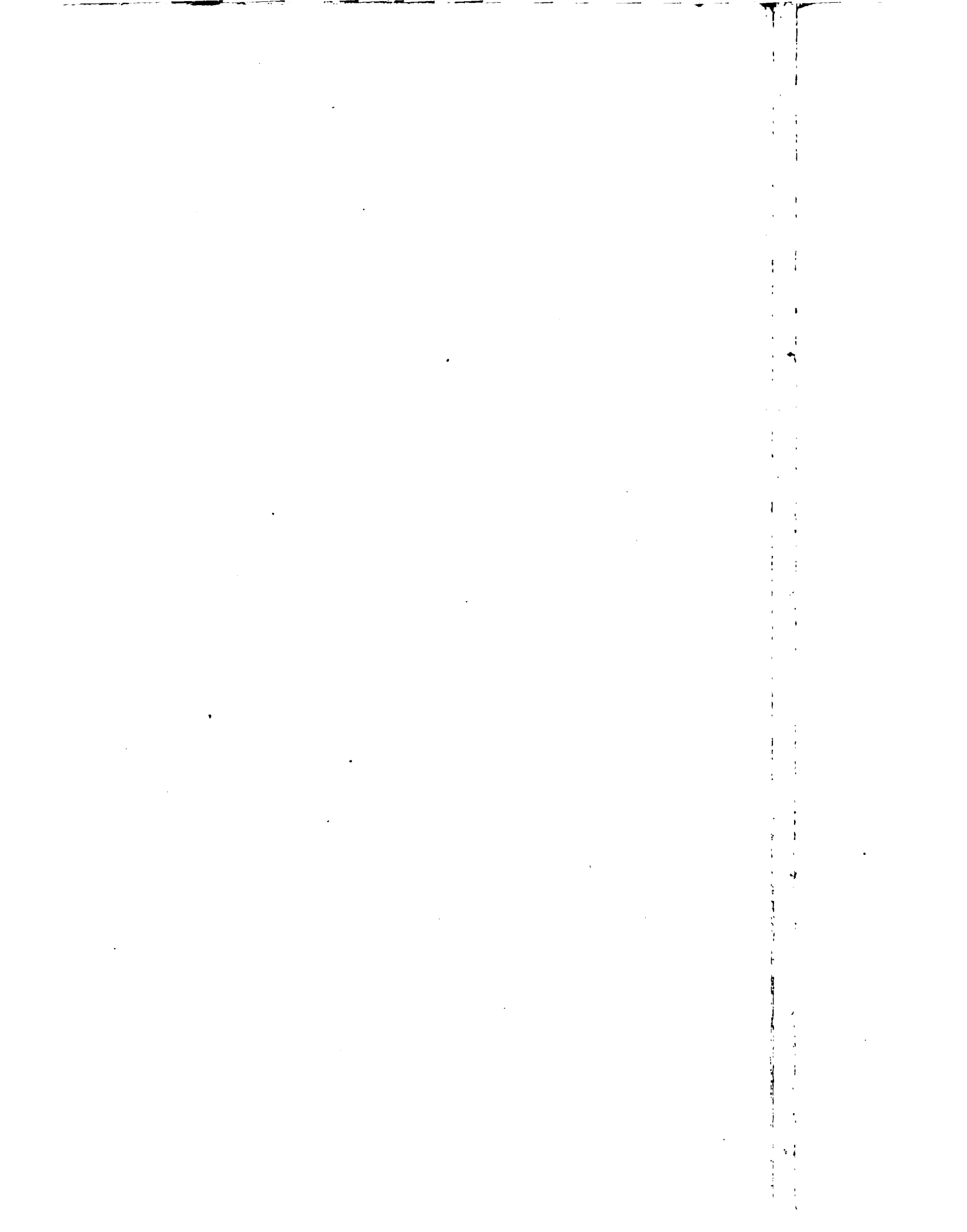
Draw  
Topo  
Trigo

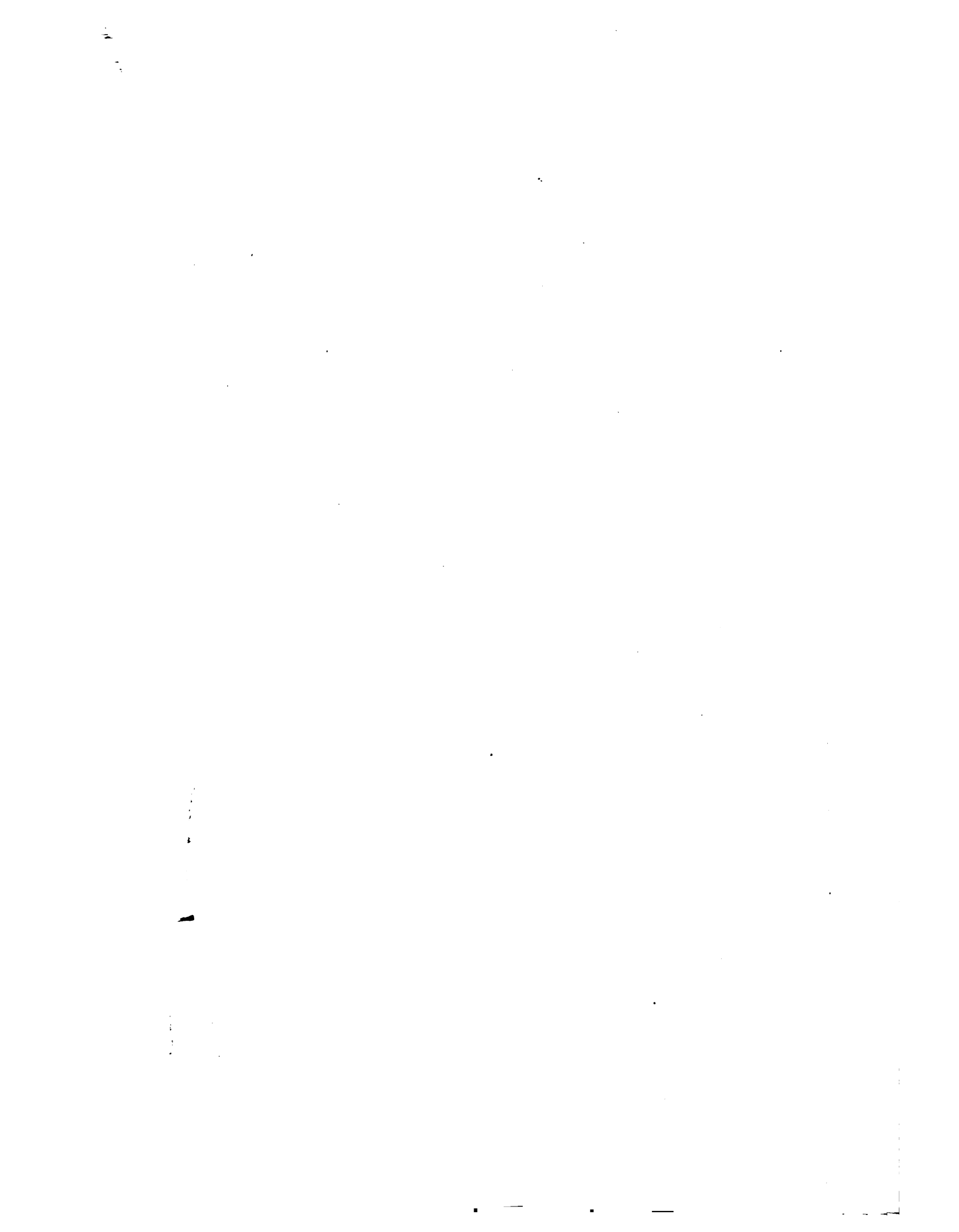
Hori

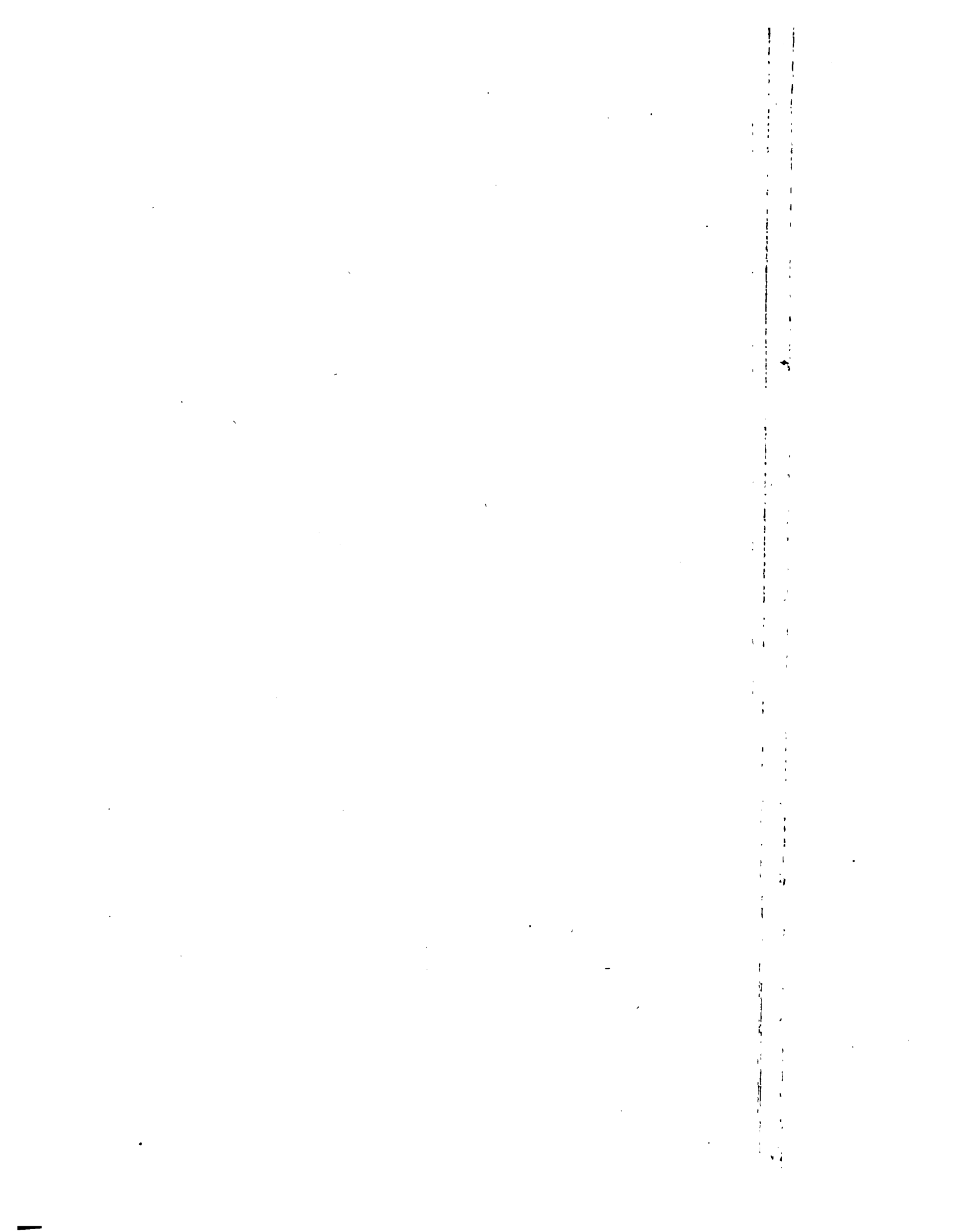
Lette

Diffe

Diffe







140

PAR.

159.

7.

57.

58.

152.

159.

170.

171.

62.

57.

8.

26.

47.

Draw

Topo

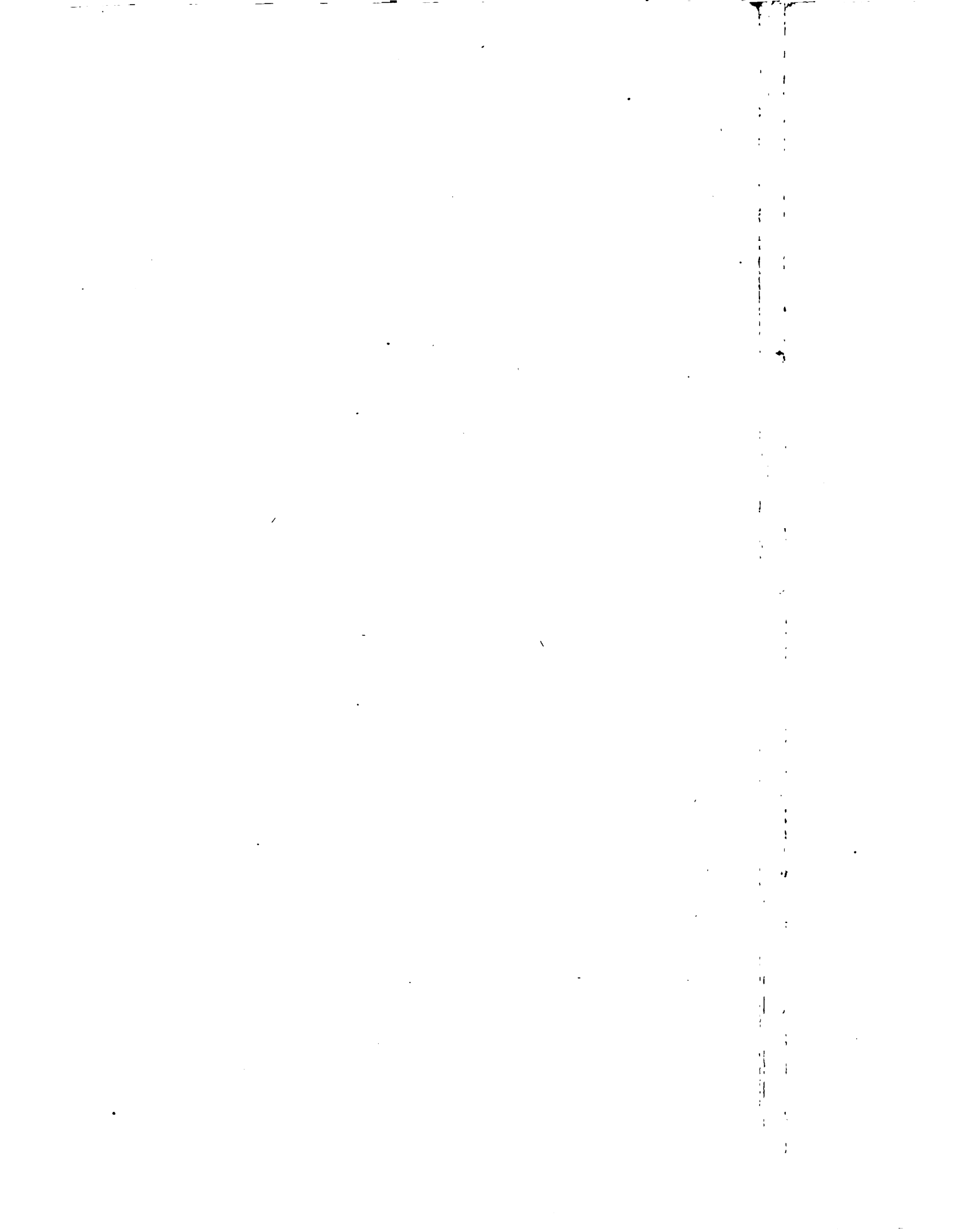
Trig

Hori

Lette

Diffe

Diffe





140

PAR.

159.

7.

57.

58.

152.

159.

170.

171.

62.

57.

8.

26.

47.

Draw

Top

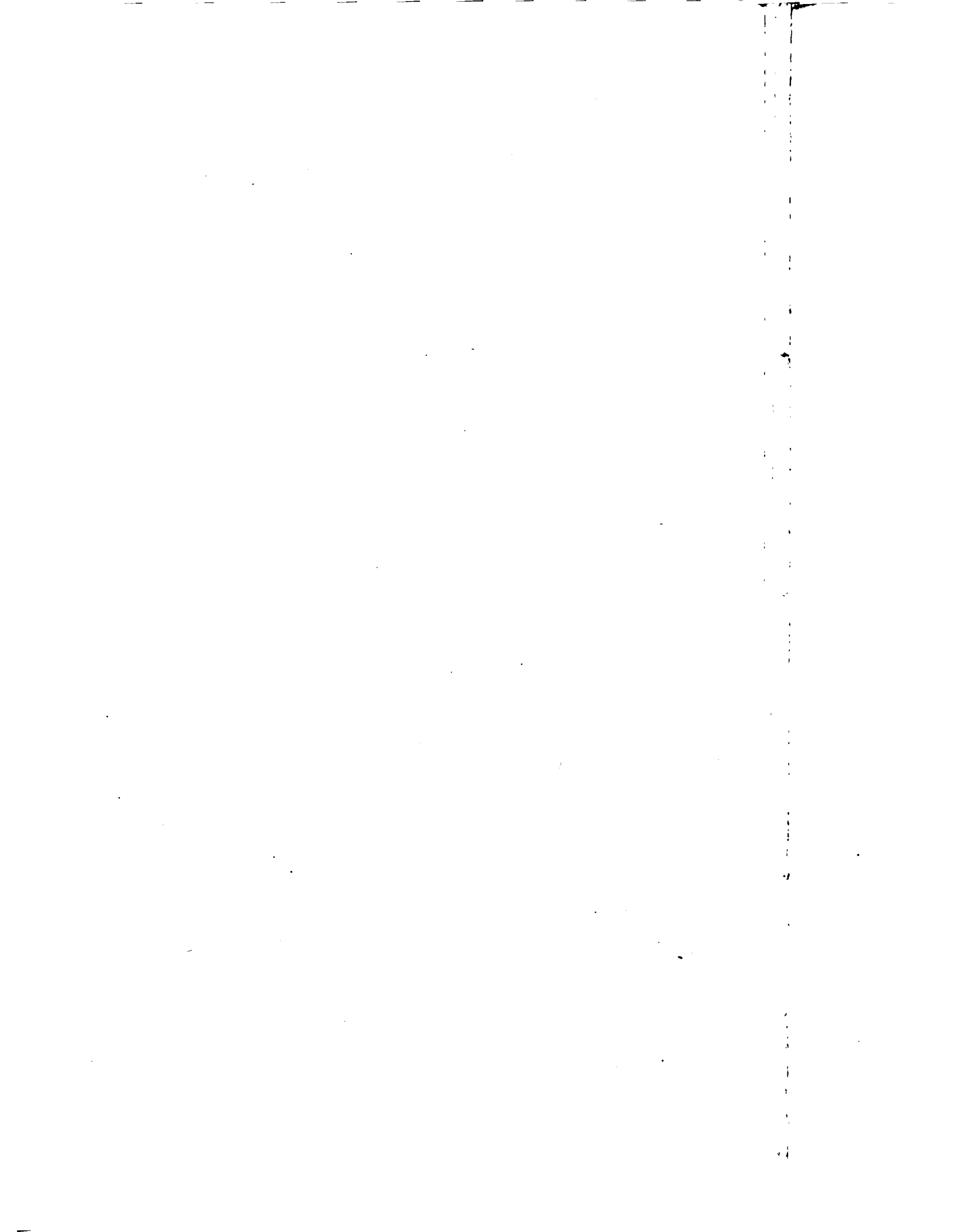
Trig

Hor

Let

Diff

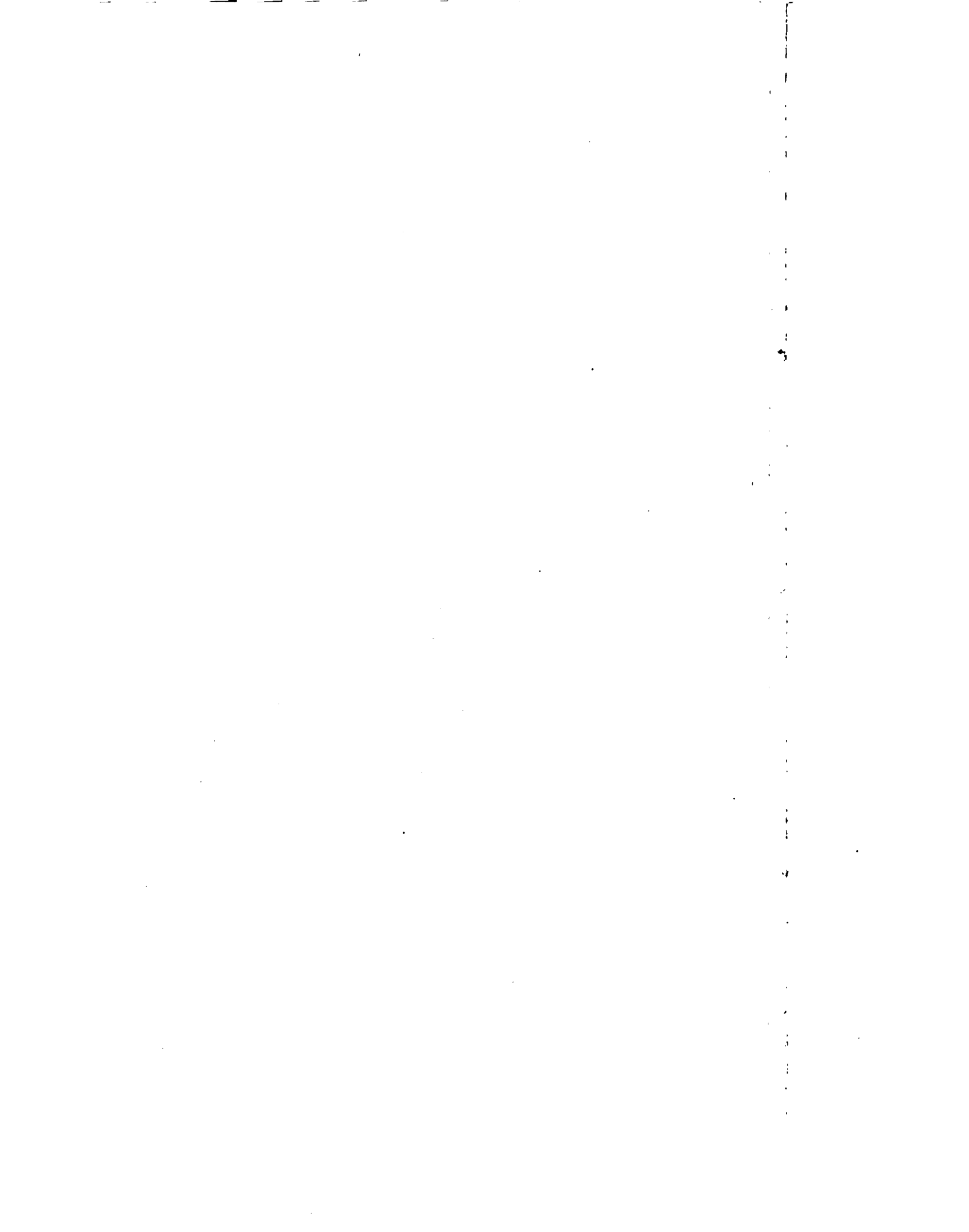
Diff





PL





140

PAR.

159-

7-

57-

58-

152-

159-

170-

171-

62.

57-

8.

26.

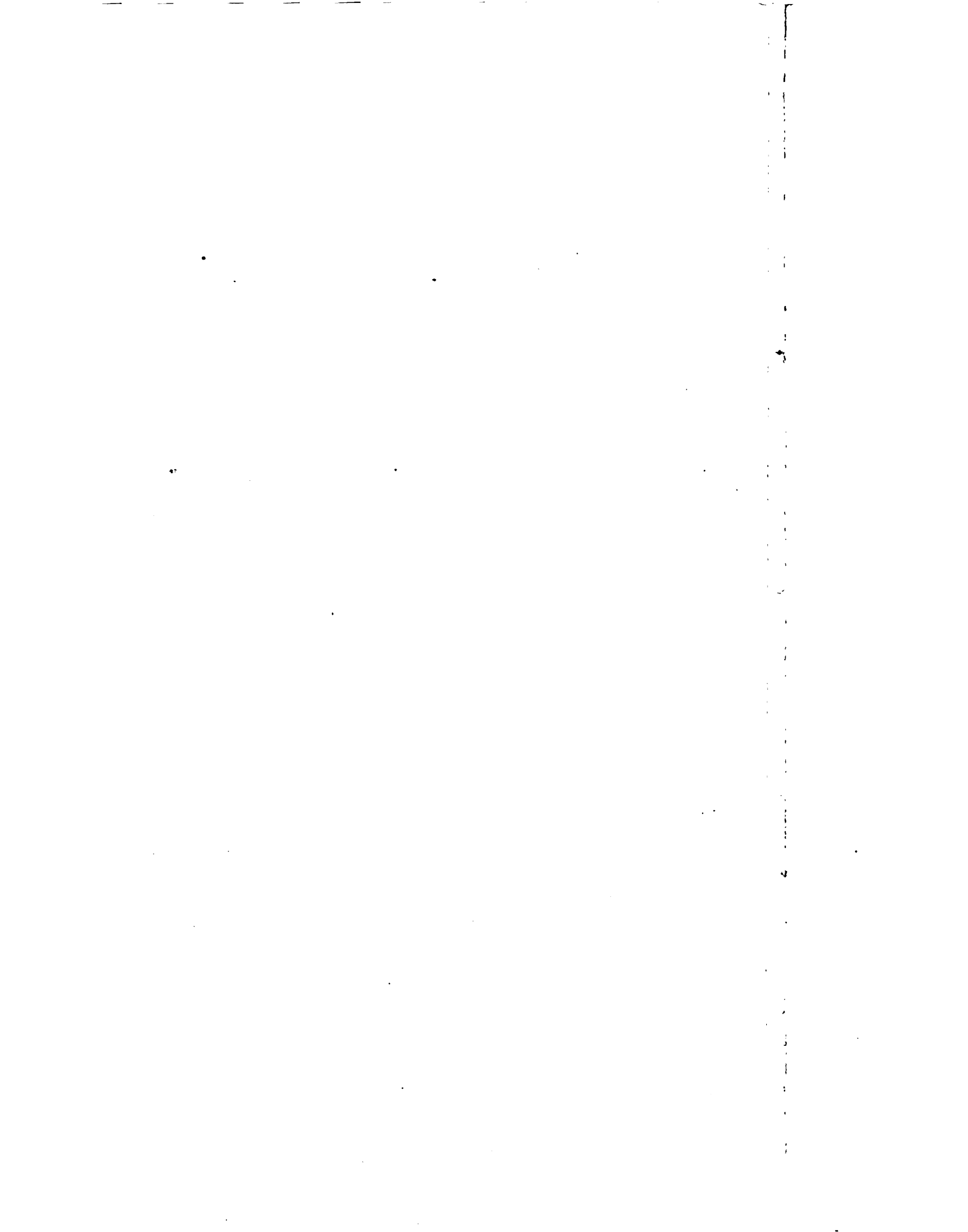
47.

Dra  
Top  
Trig

Hor

Lett  
Diff

Diff





140

PAR.

159.

7-

57-

58-

152-

159-

170-

171-

62.

57.

8.

26.

47.

Dra  
Top  
Trig

Hor

Let  
Diff

Diff

PI

Height of Letters

4

3

2

1

0

0

0

140

PAR.

159.

7.

57.

58.

152.

159.

170.

171.

62.

57.

8.

263

47.

Dr

To

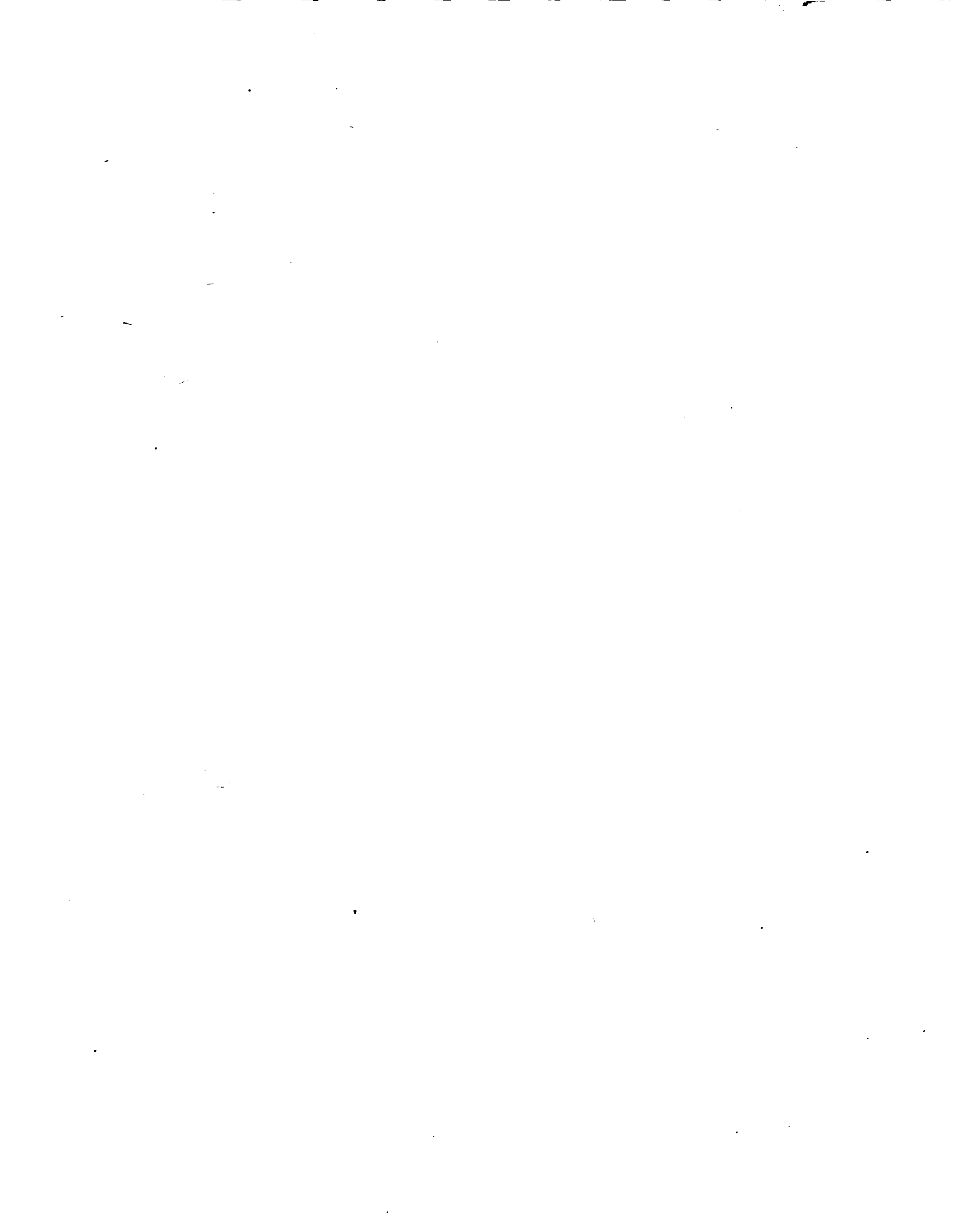
Tri

Ho

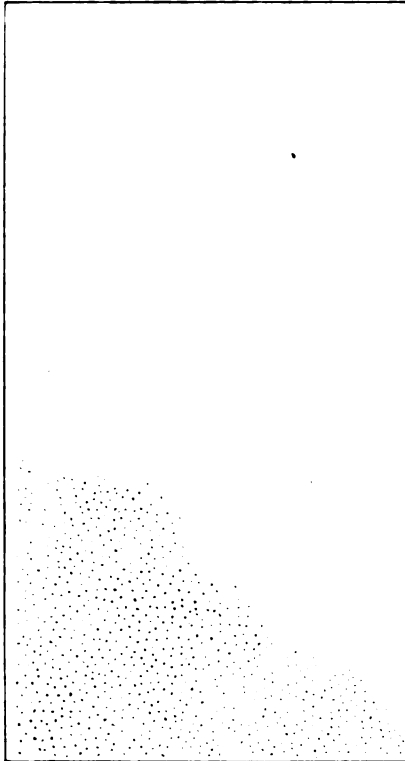
Let

Di

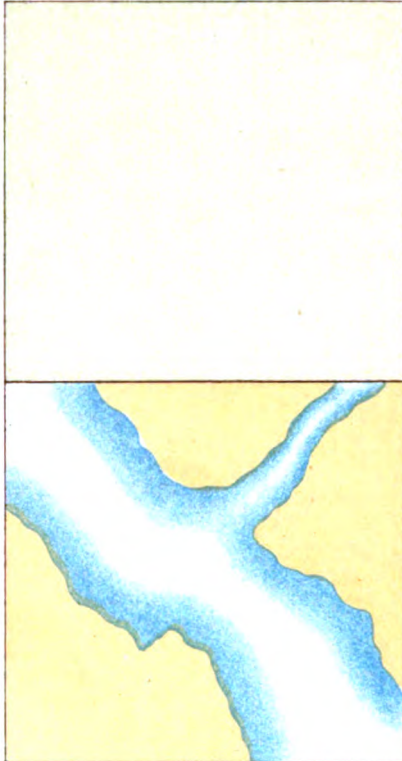
Di



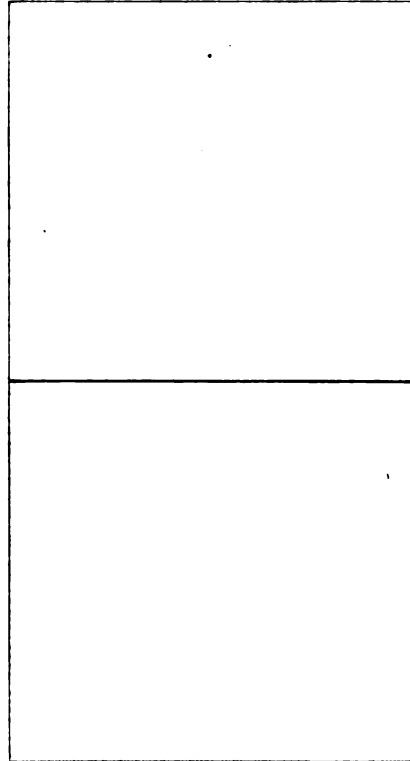
SAND AND GRAVEL



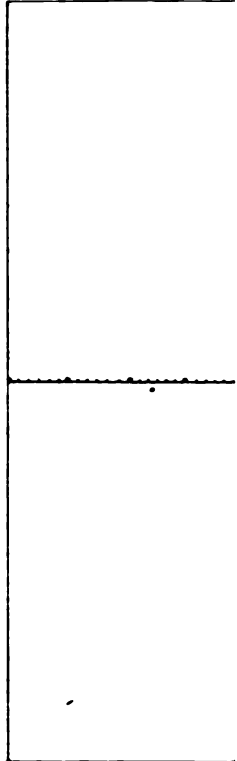
WATER



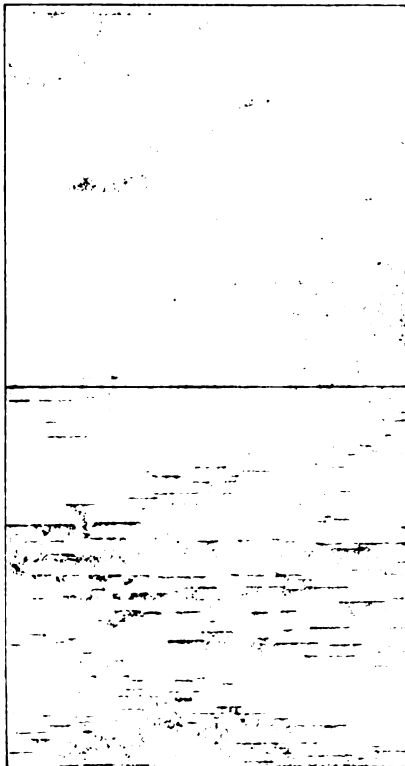
CULTIVATED LAND



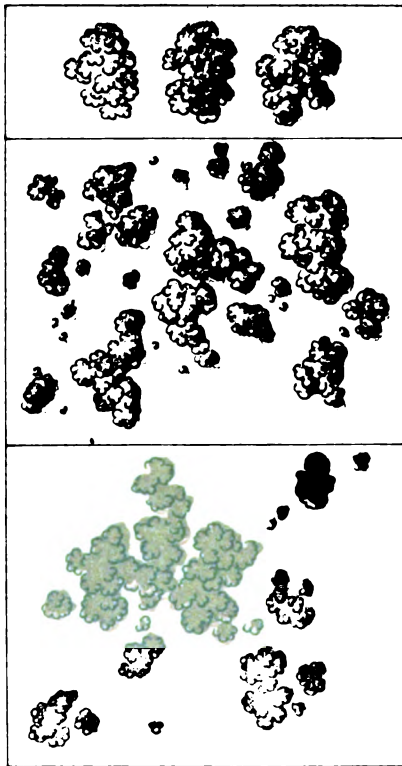
CLEAPED



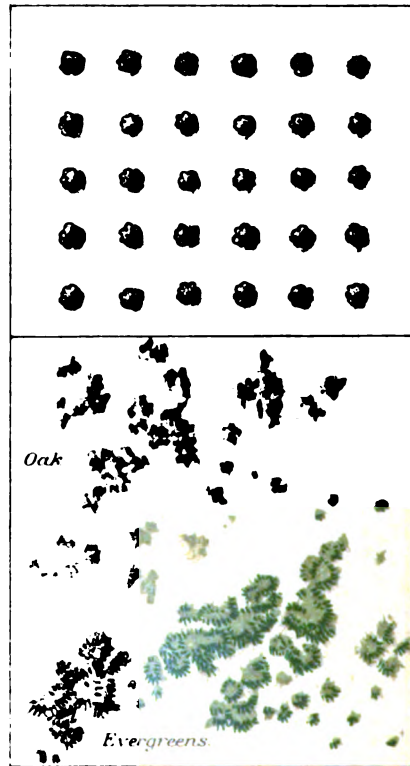
MARSH



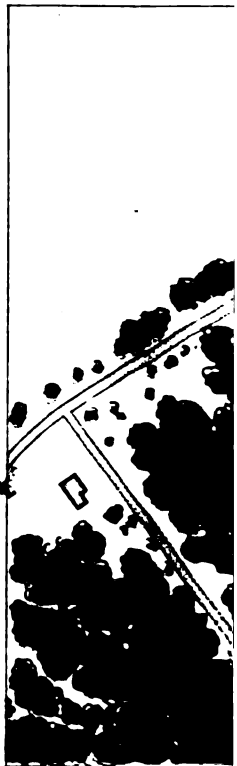
TREES-ANALYSIS



TREES-KINDS

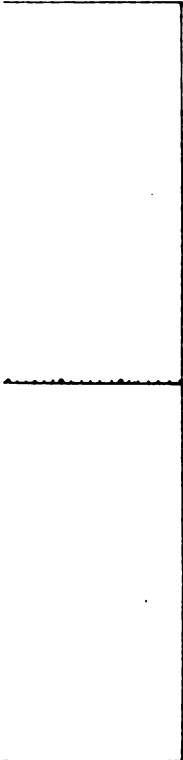


TREES-N

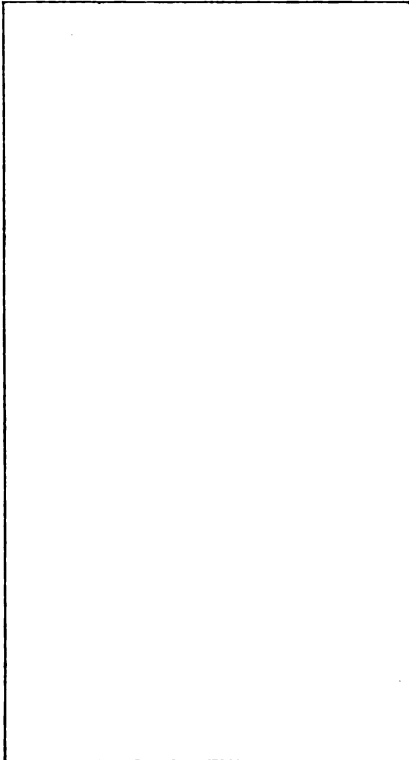


# VAL TINTS

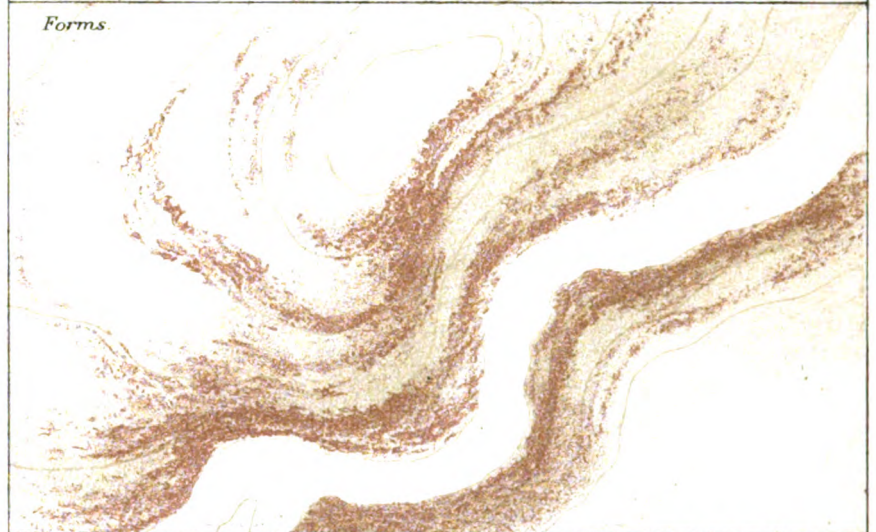
## LAND



## BRUSHWOOD



## ROCKY SURFACES



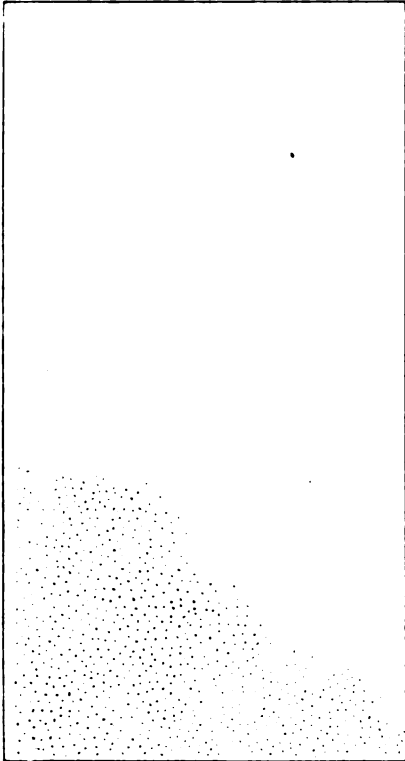
## ASSES



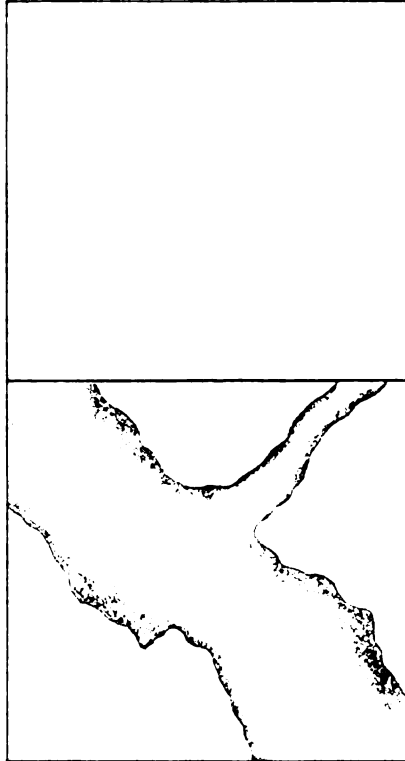
## MISCELLANEOUS

|                        |                    |
|------------------------|--------------------|
| <i>Wooden Building</i> |                    |
| <i>Brick do</i>        |                    |
| <i>Stone do</i>        |                    |
| <i>Road</i>            |                    |
| <i>Bridge, Wooden</i>  |                    |
| <i>do Masonry</i>      |                    |
| <i>Walls</i>           | <i>with coping</i> |
|                        | <i>without do</i>  |
| <i>Hedge</i>           |                    |
| <i>Cavalry</i>         |                    |
| <i>Artillery</i>       |                    |
| <i>Infantry</i>        |                    |

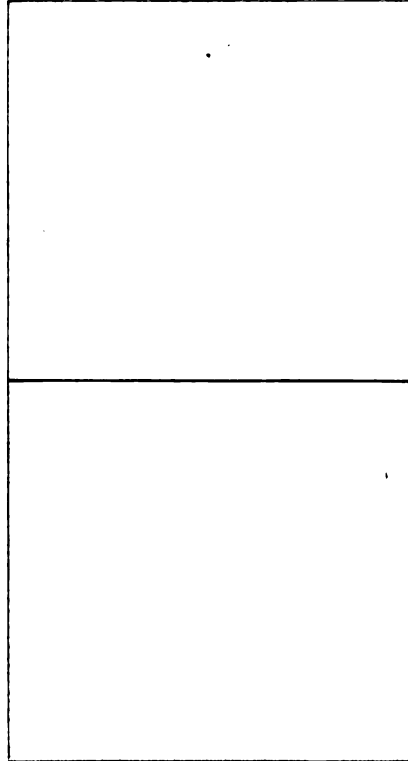
SAND AND GRAVEL



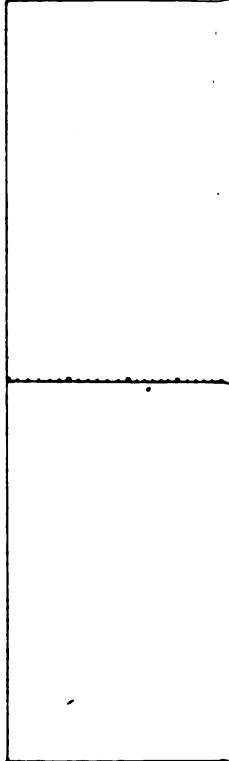
WATER



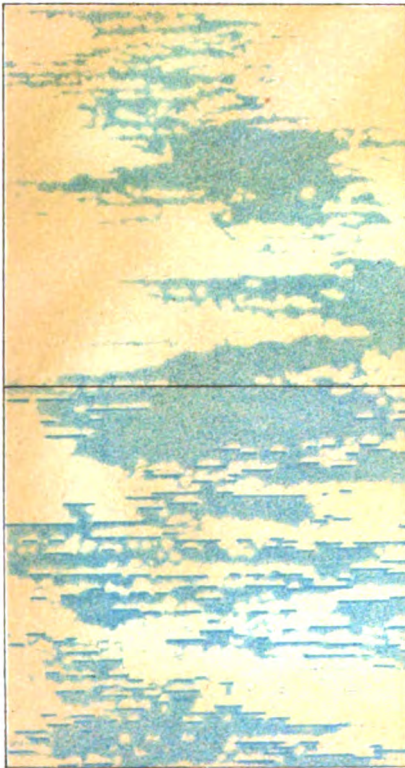
CULTIVATED LAND



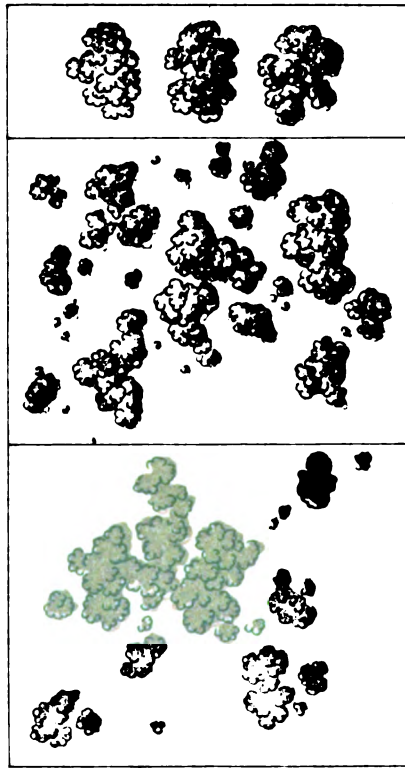
CLEARED



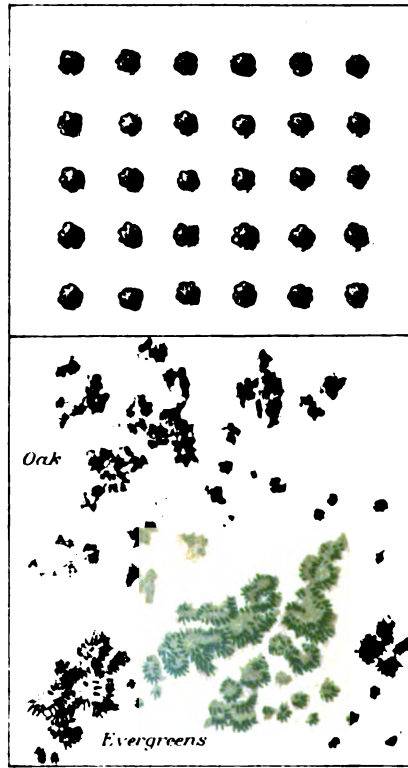
MARSH



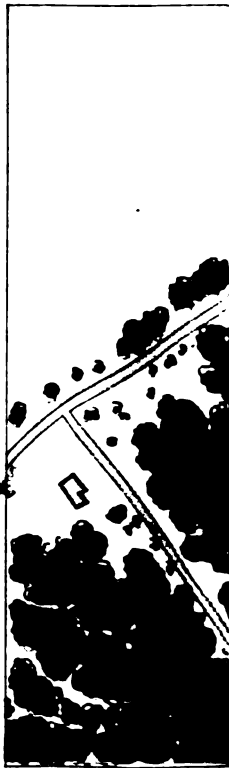
TREES - ANALYSIS



TREES - KINDS



TREES - M

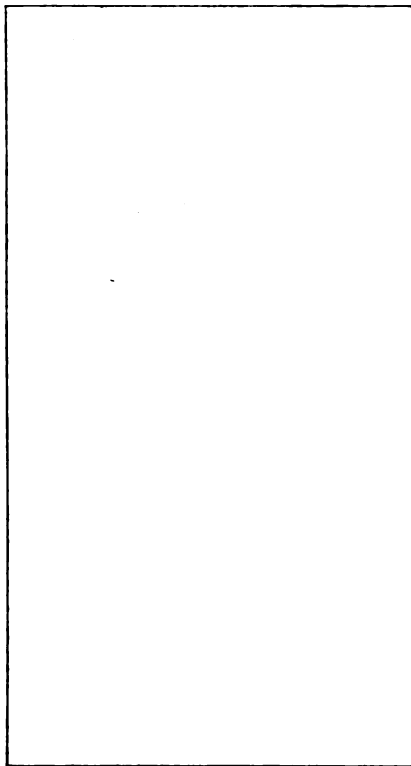


# AL TINTS

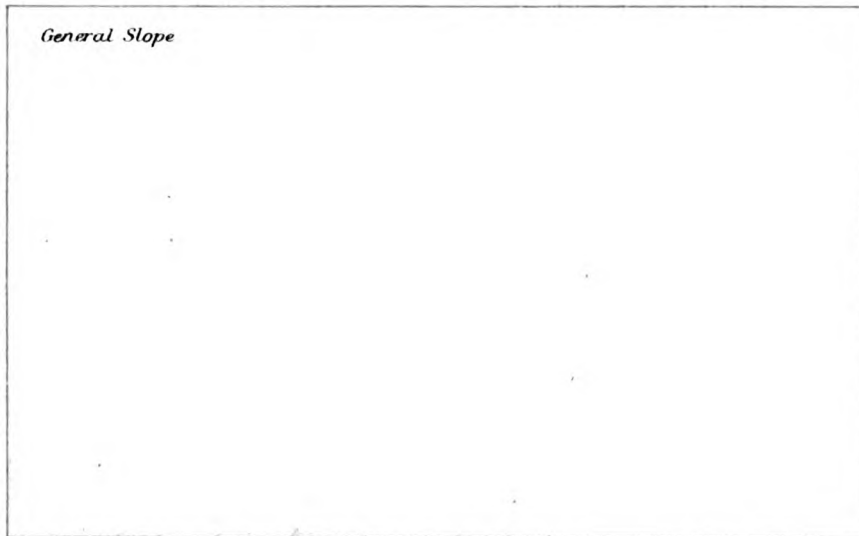
## LAND



## BRUSHWOOD



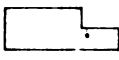

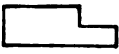
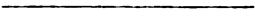
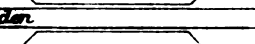
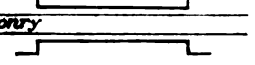



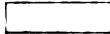
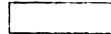
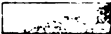
## ROCKY SURFACES

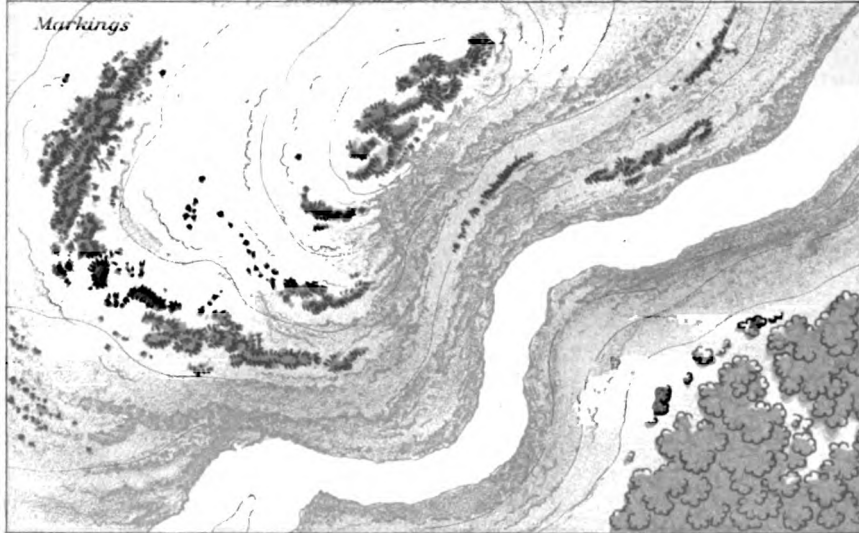


## SSES



## MISCELLANEOUS

*Wooden Building*   
*Brick do*   
*Stone do*   
*Road*   
*Bridge, Wooden*   
*do Masonry*   
*Walls* { *with coping*   
*without do*   
*Hedge*   
*Cavalry*    
 *Artillery*    
 *Infantry* 

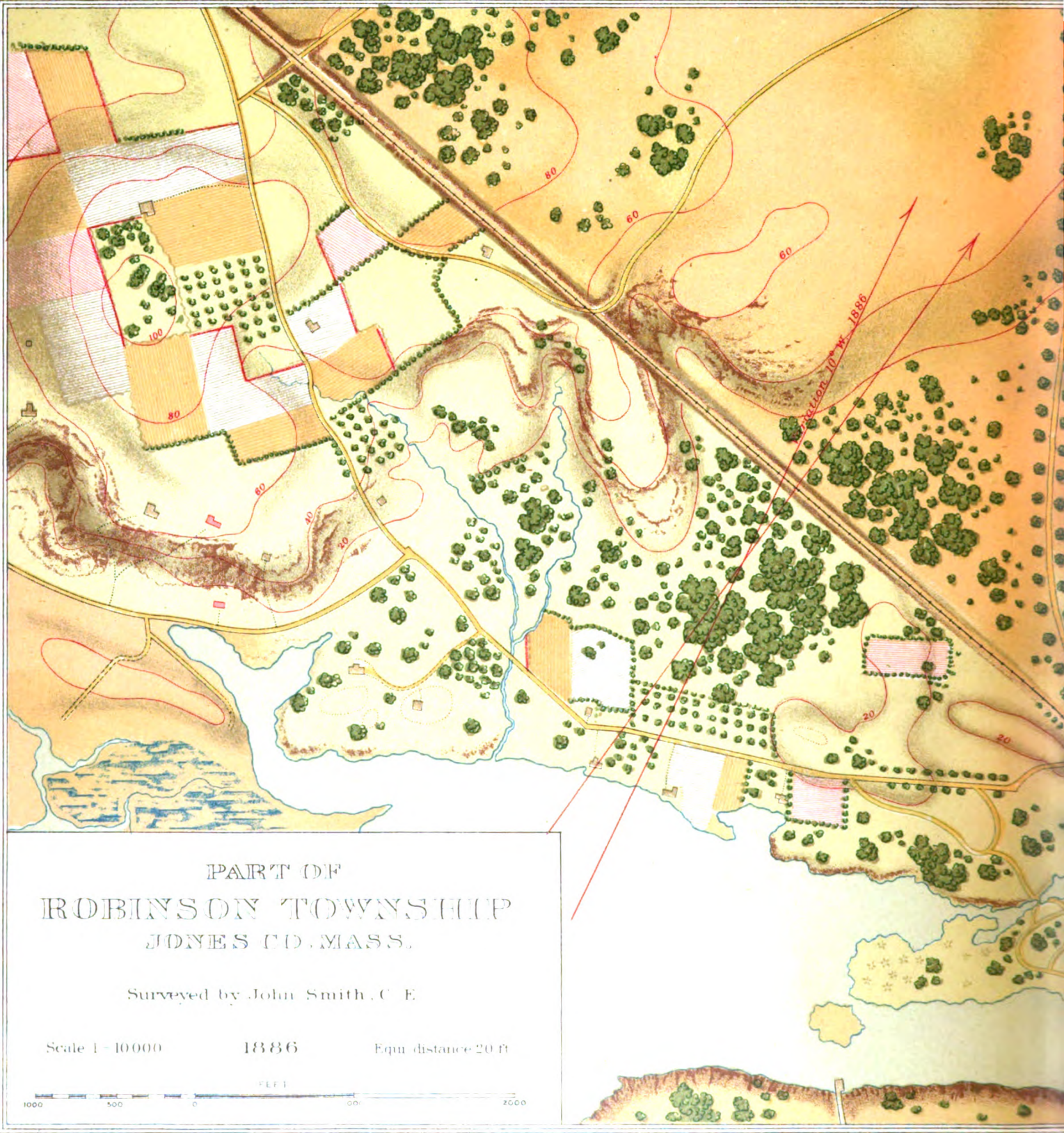




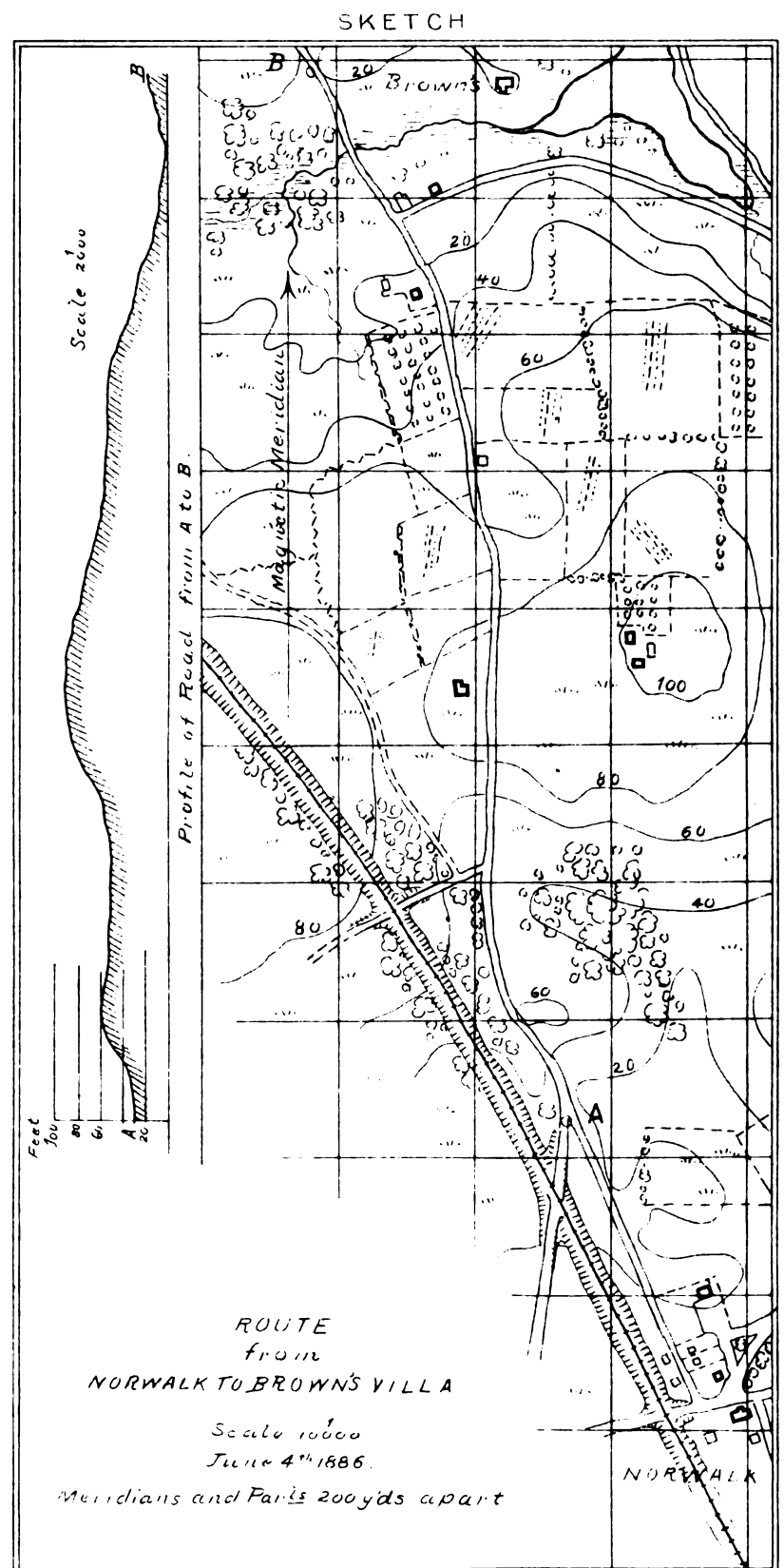
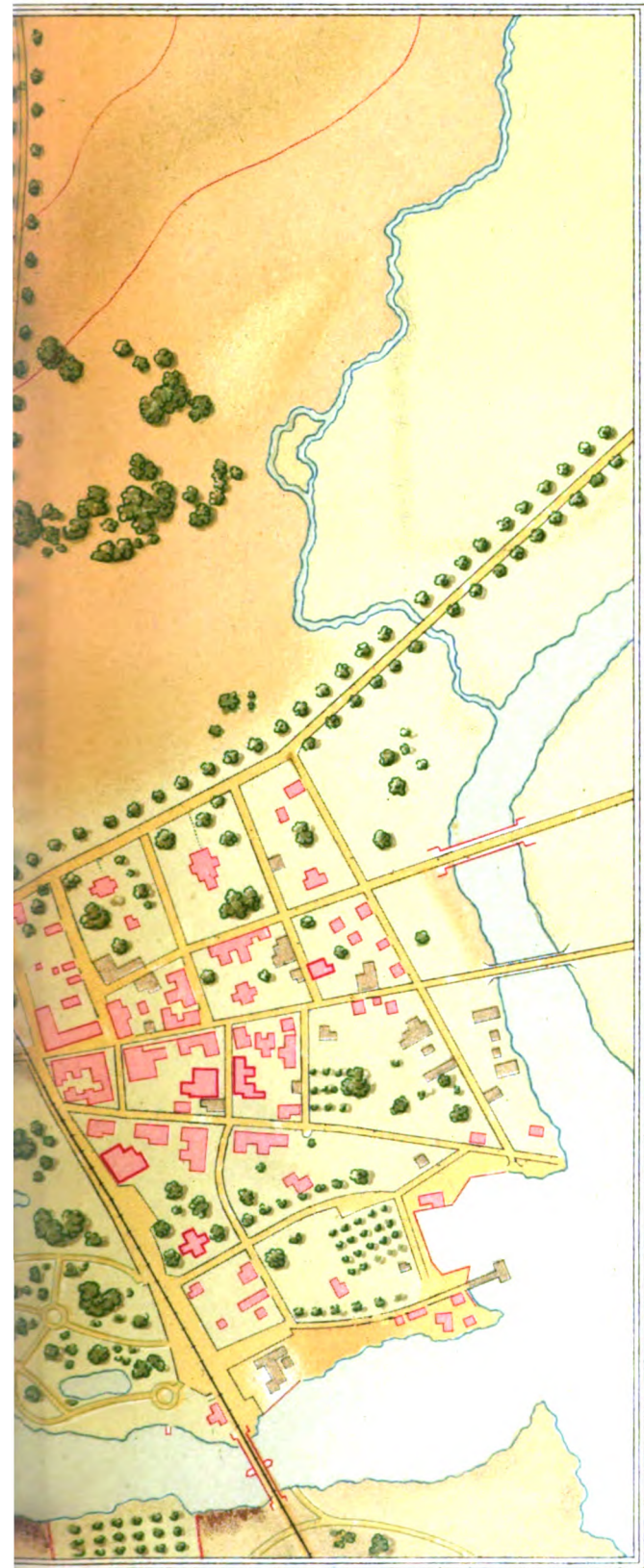


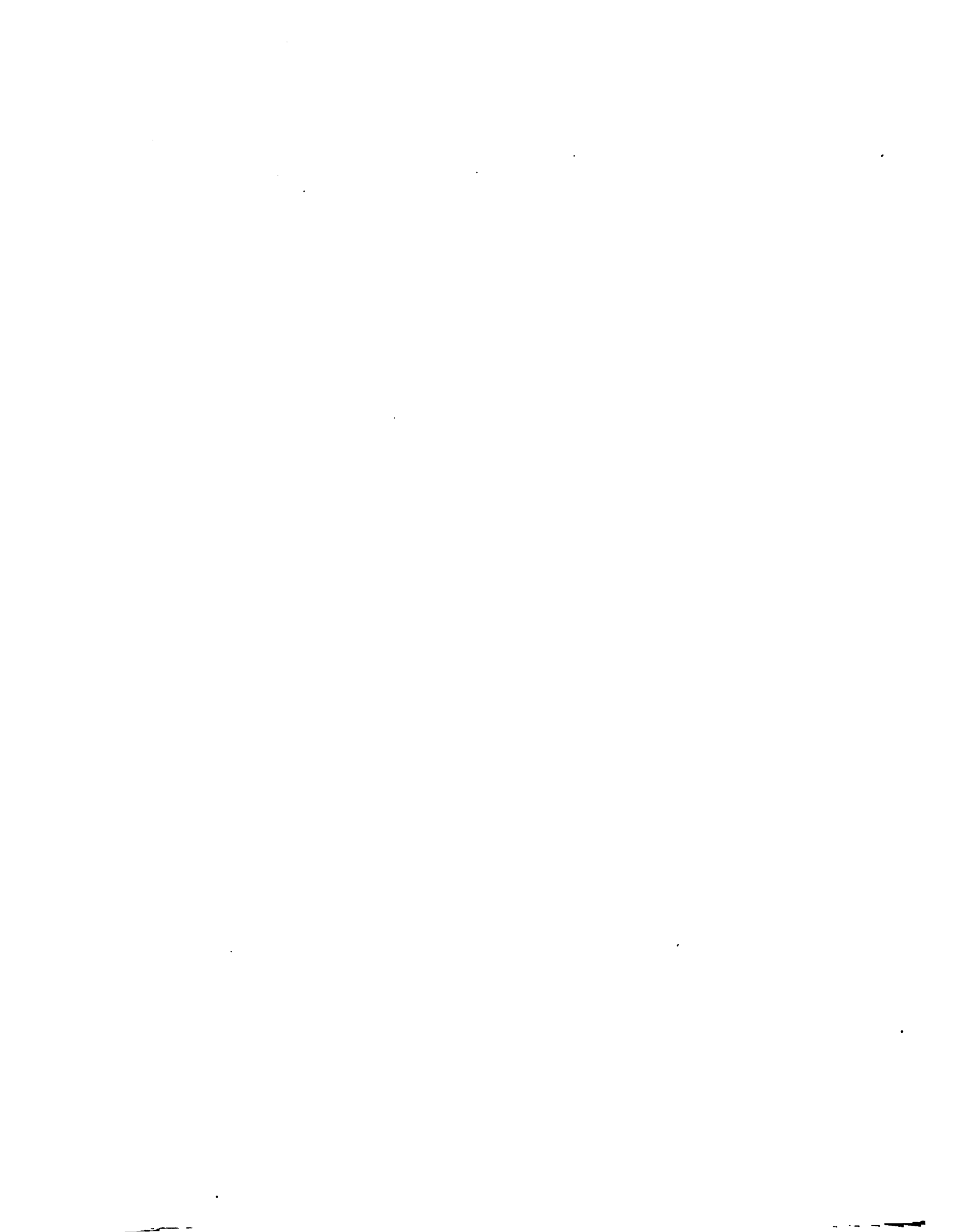


M A P



THE USE OF COLOR.





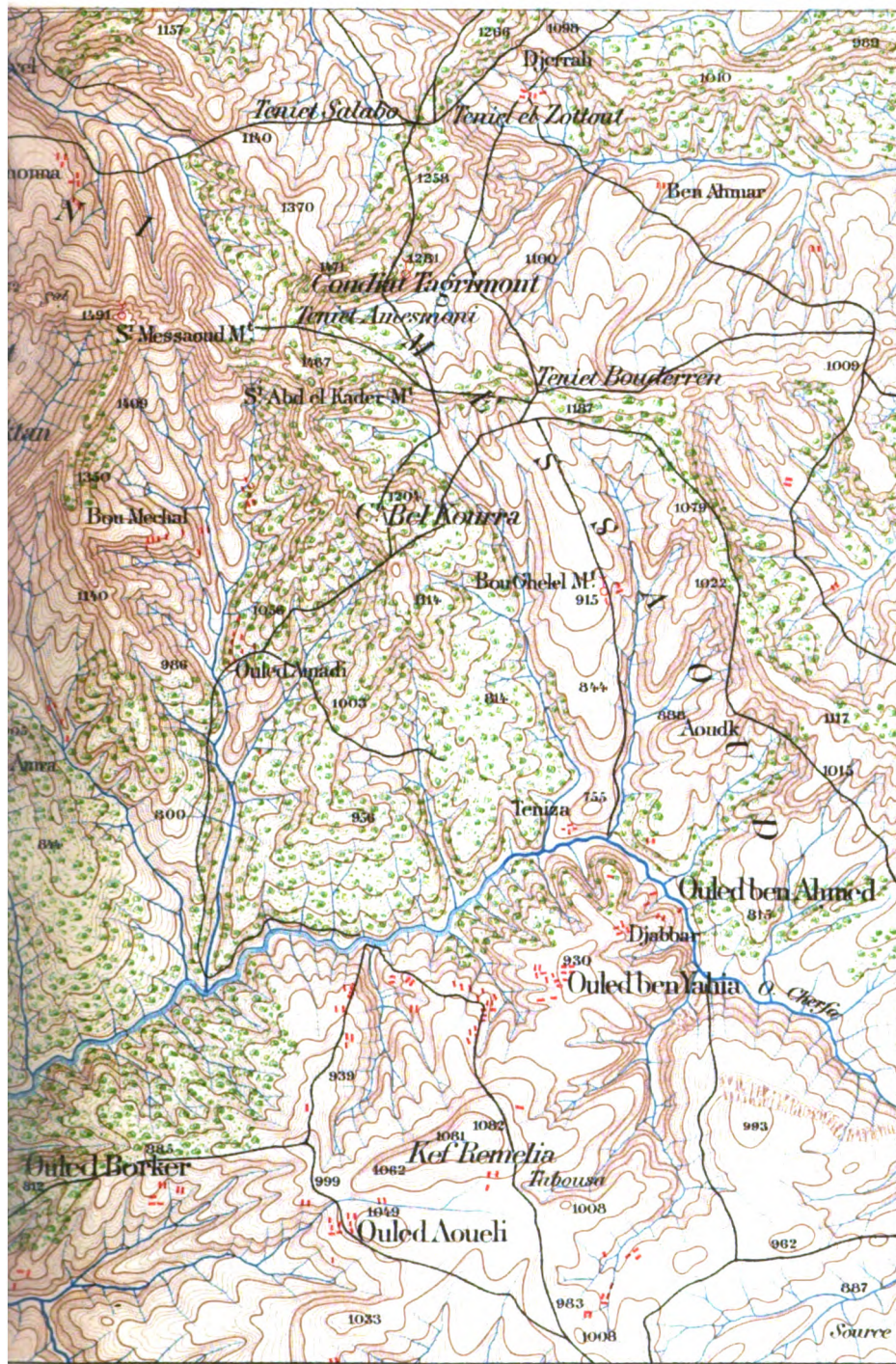




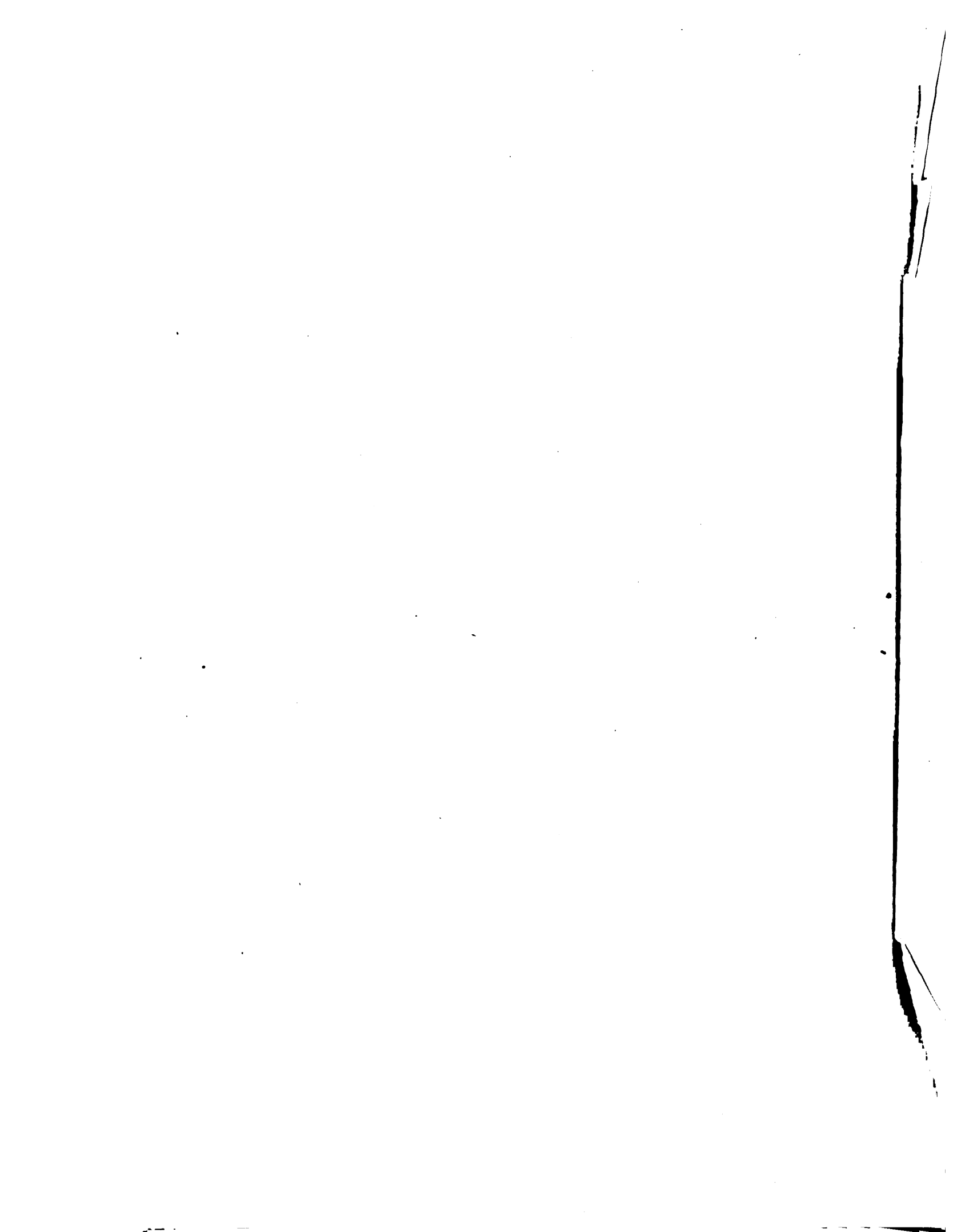
Initial Meridian - Paris

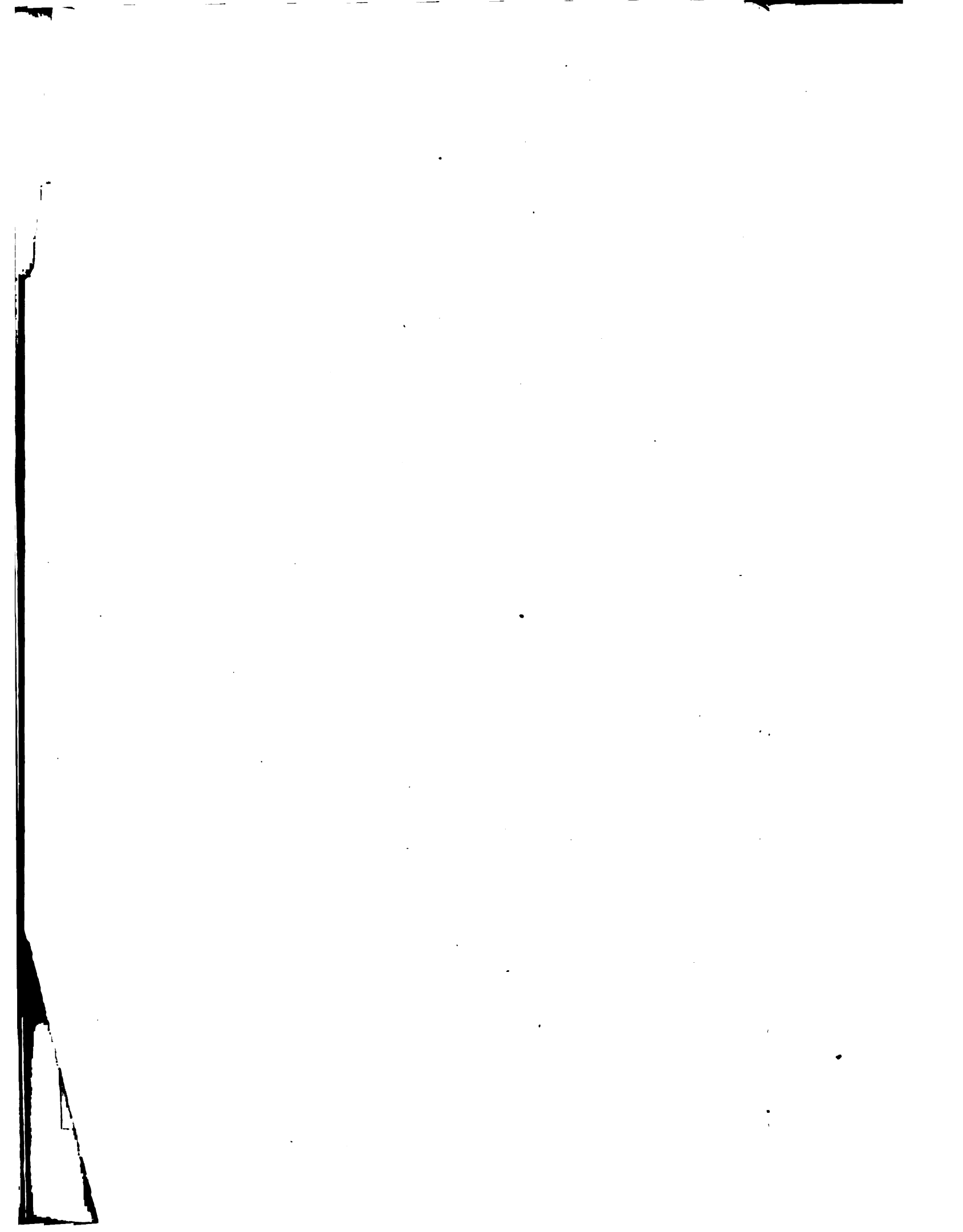
Meters 1000 0 500 1000 1500 2000

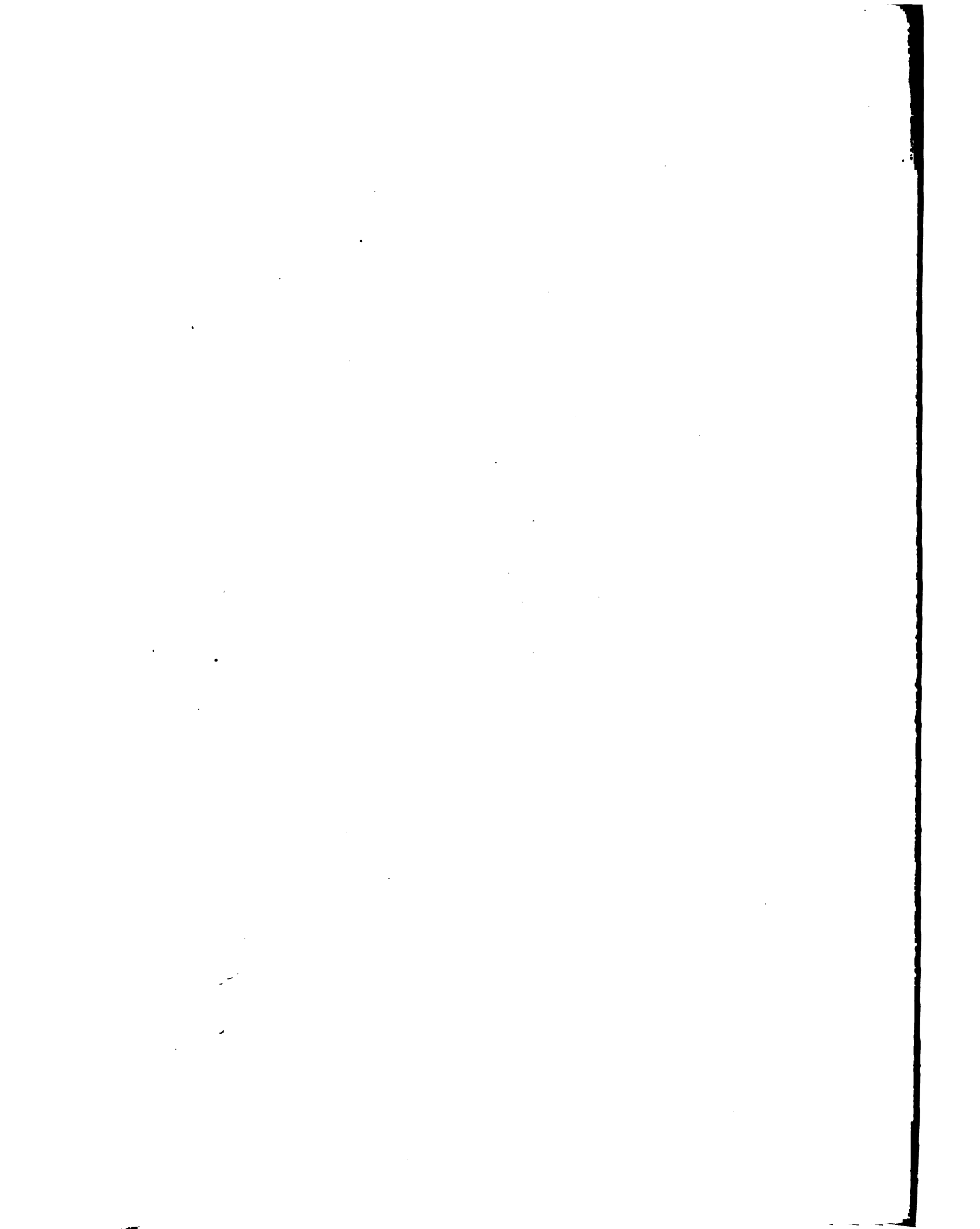
RIA.)

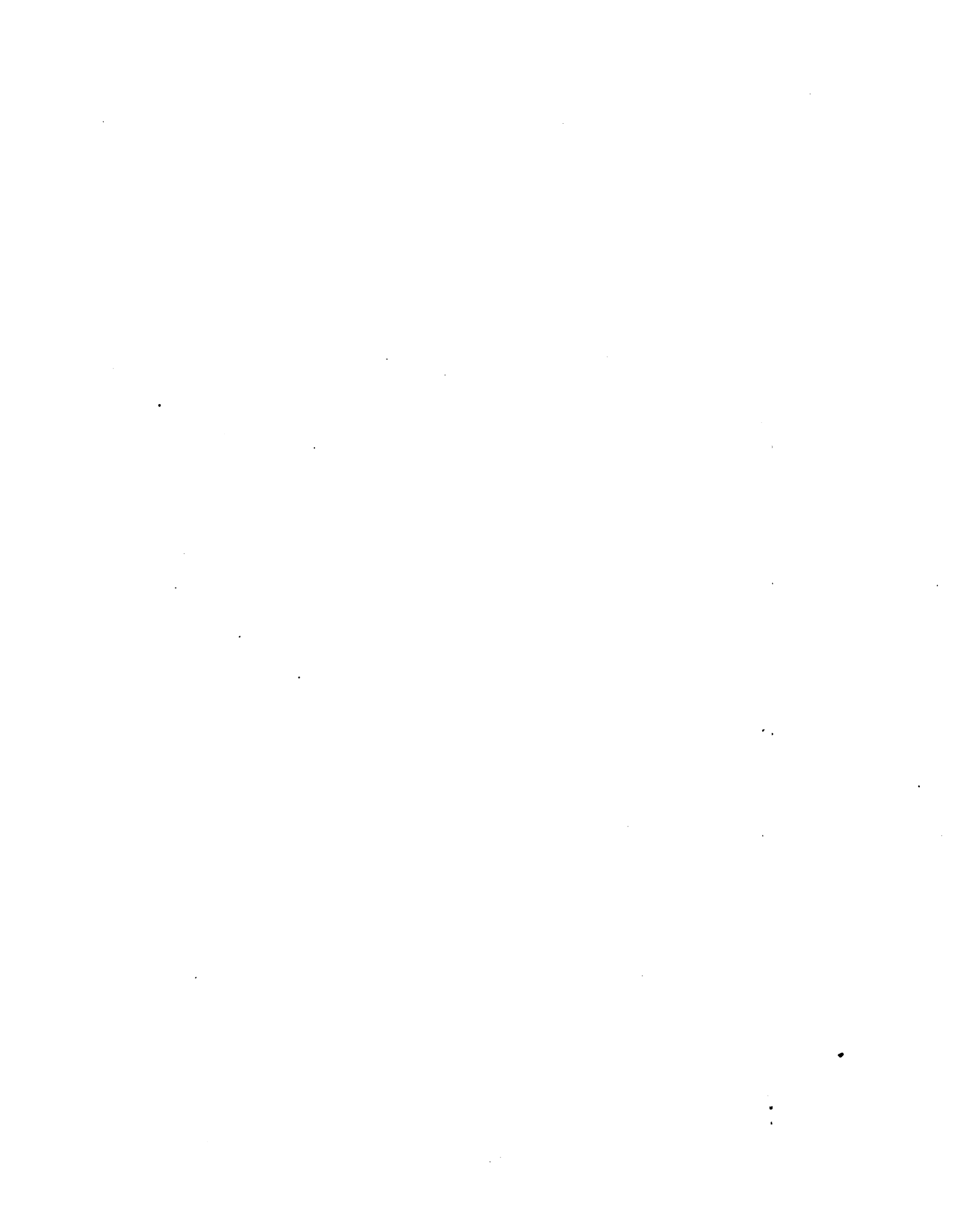


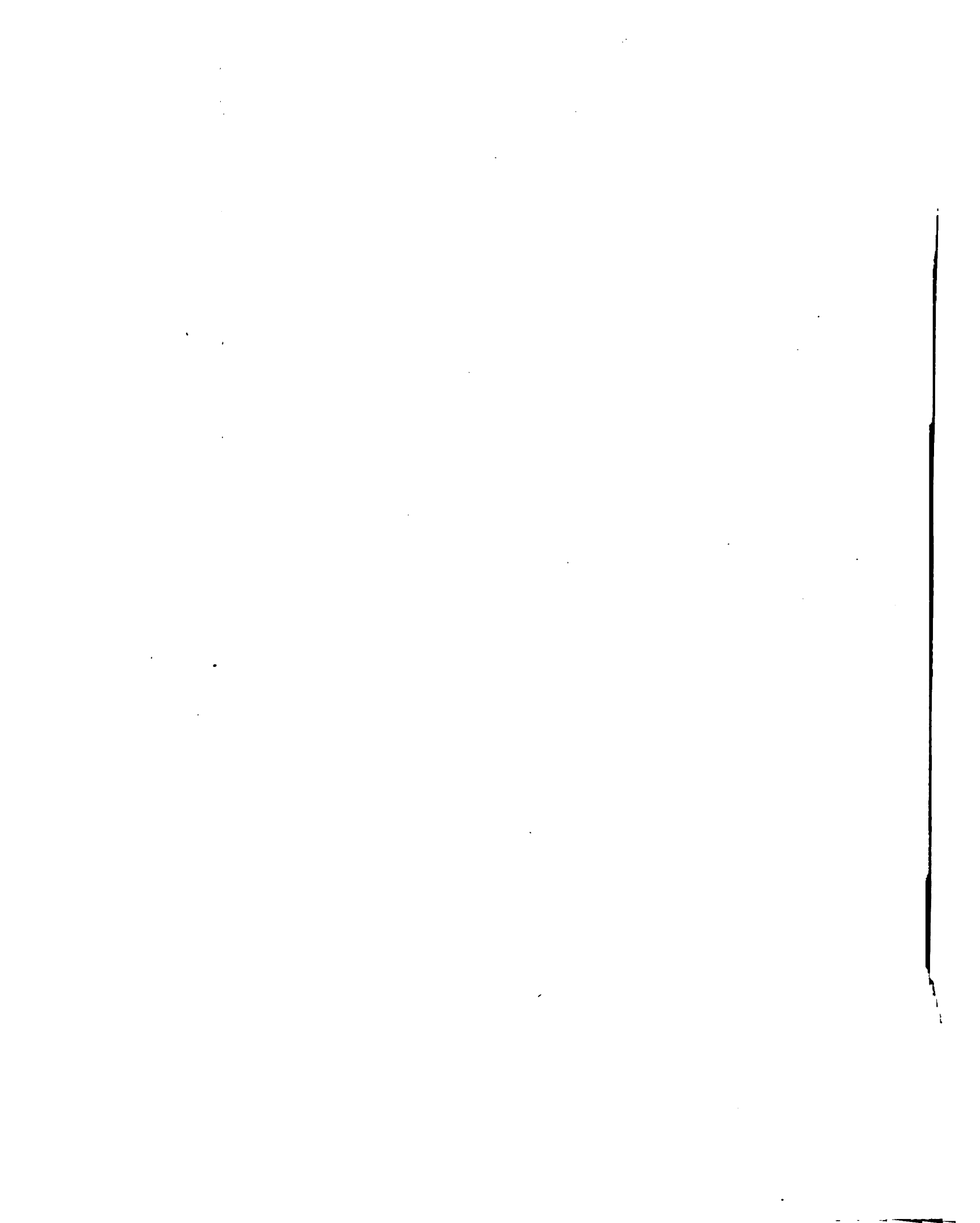


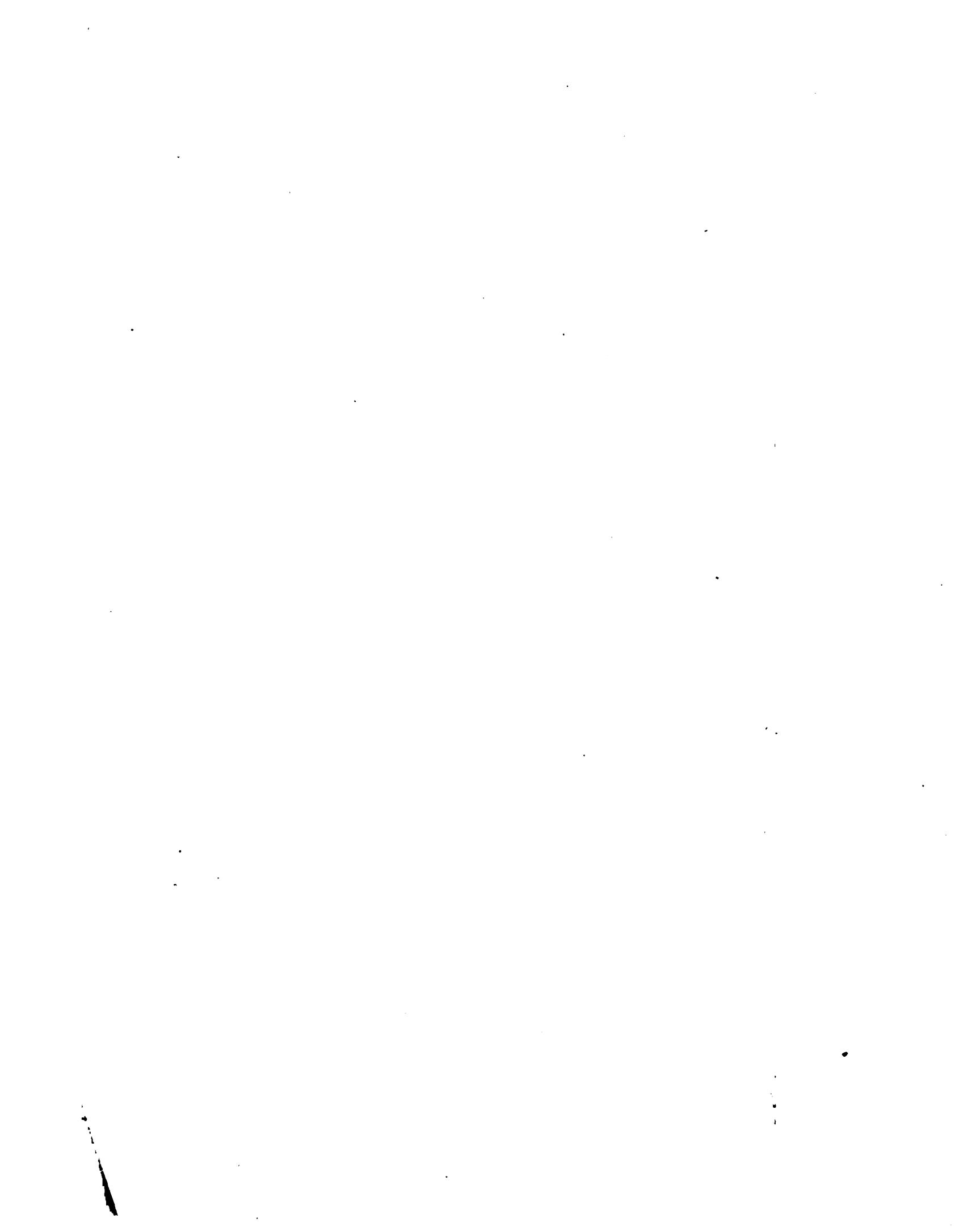




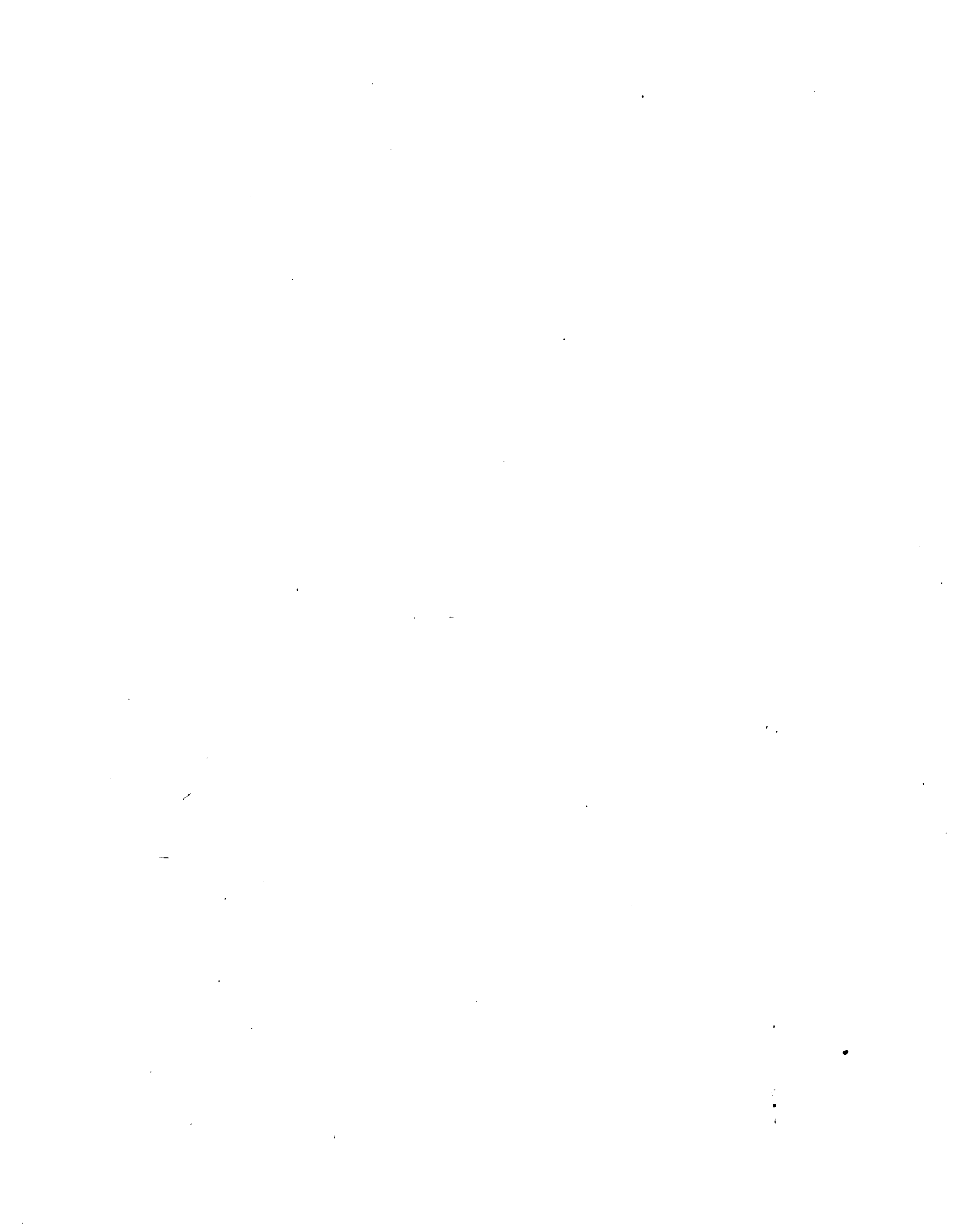




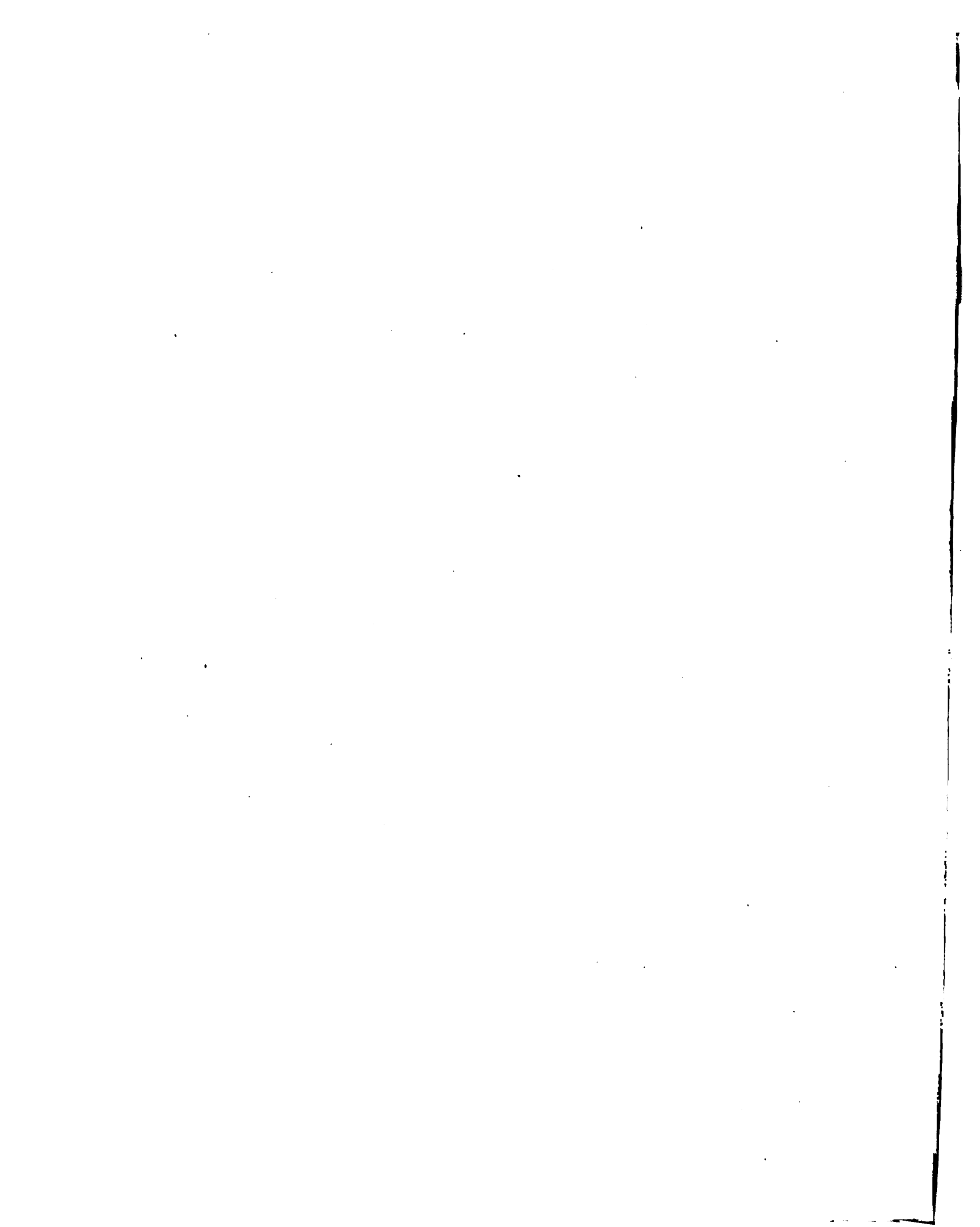


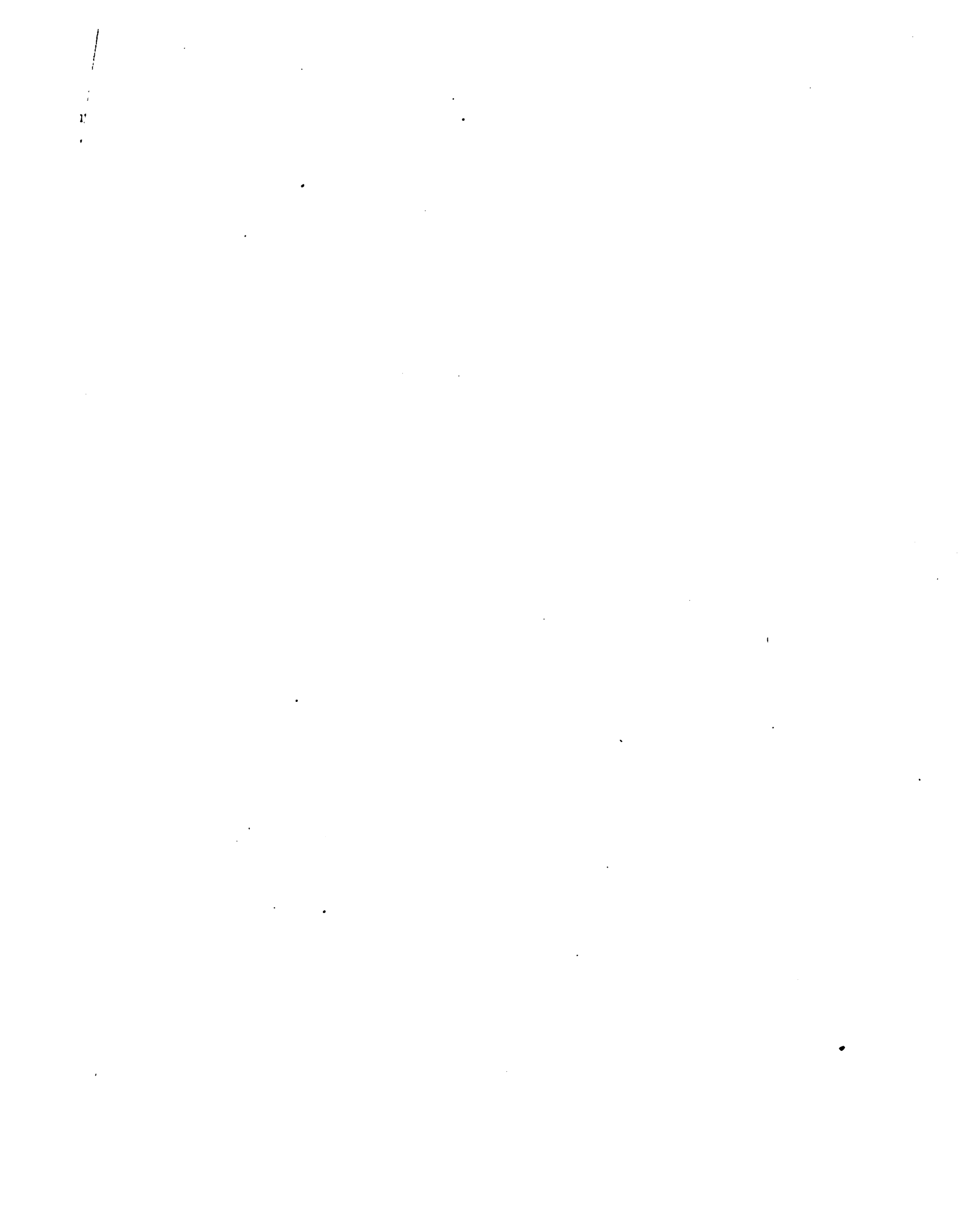


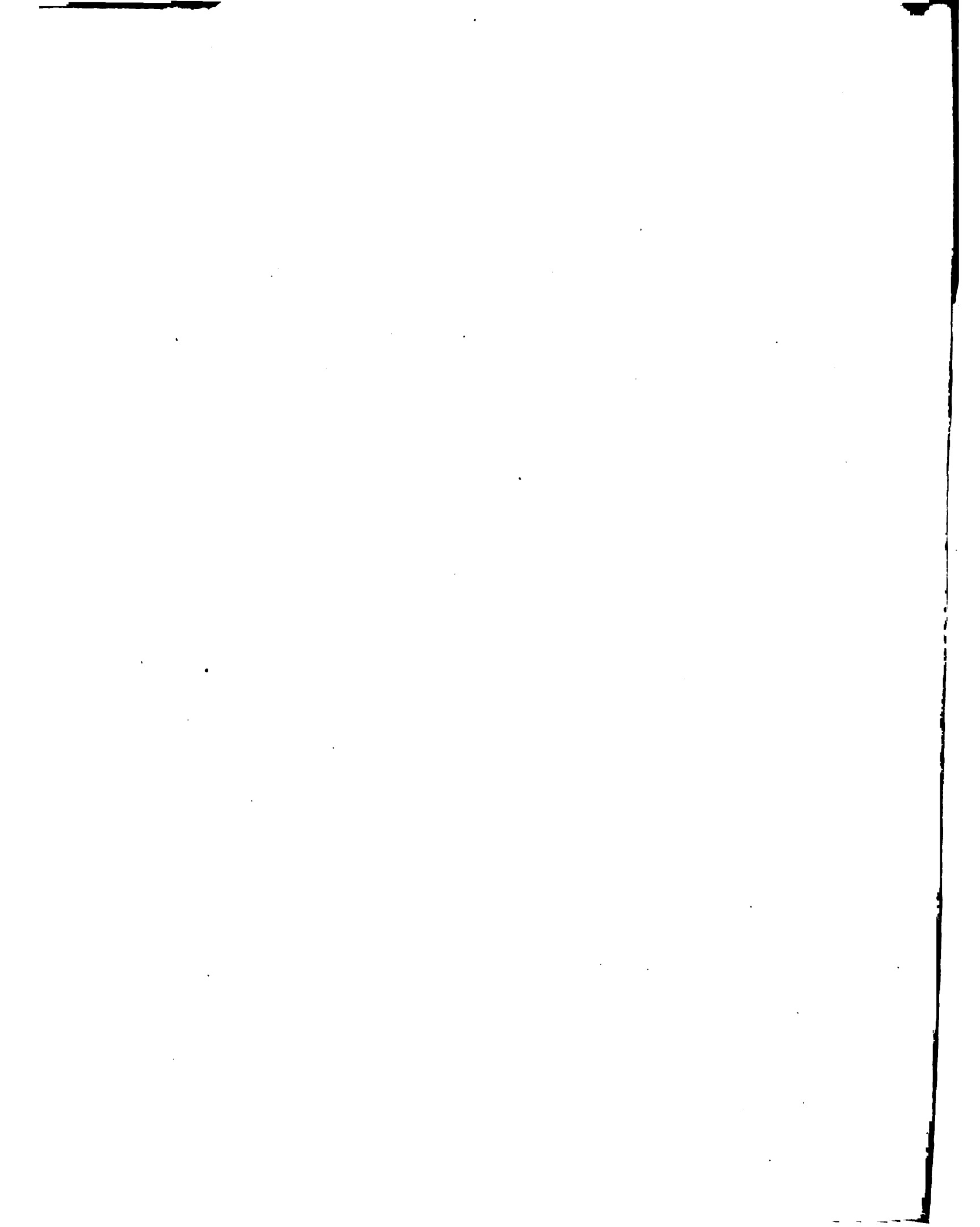












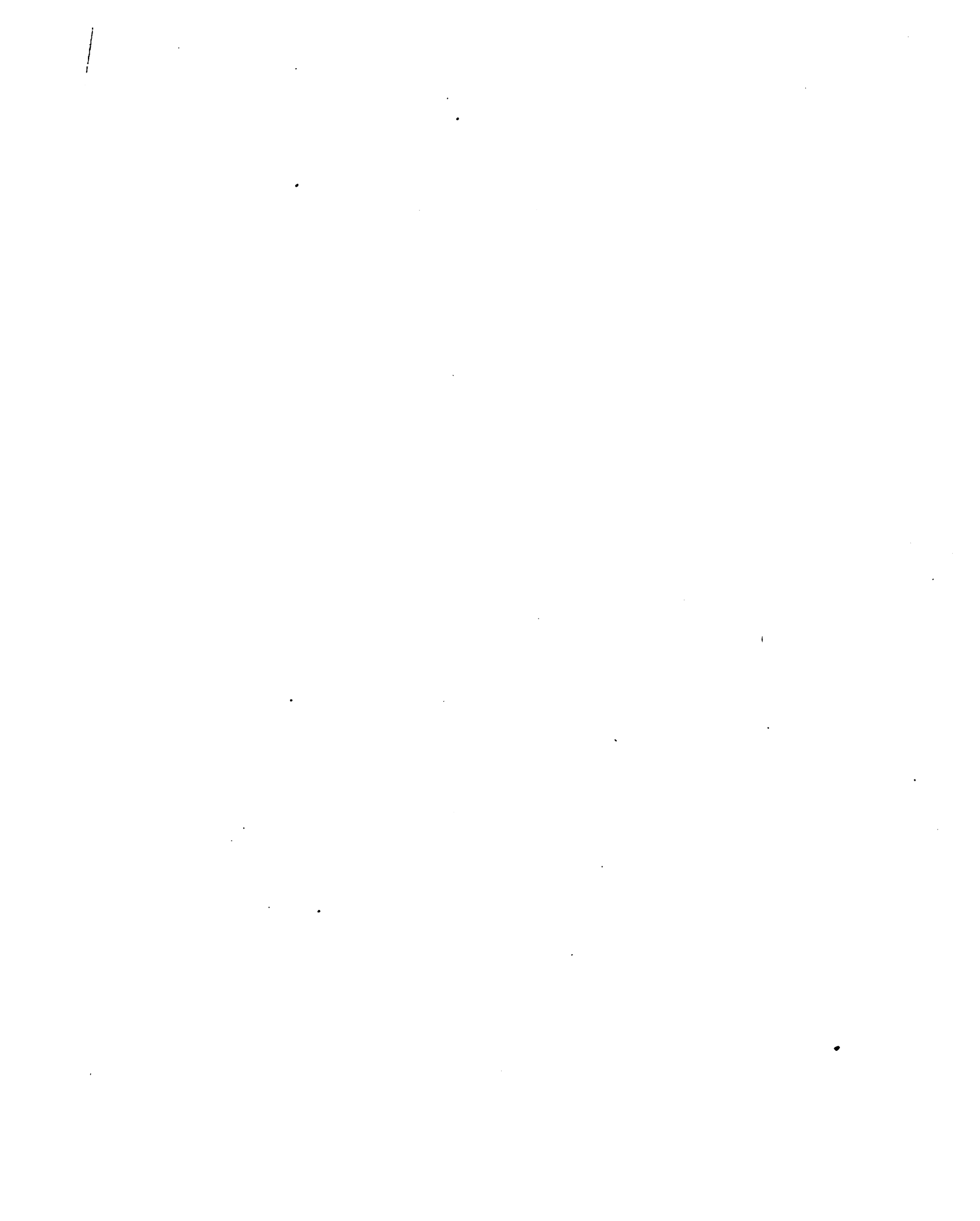






Fig 110

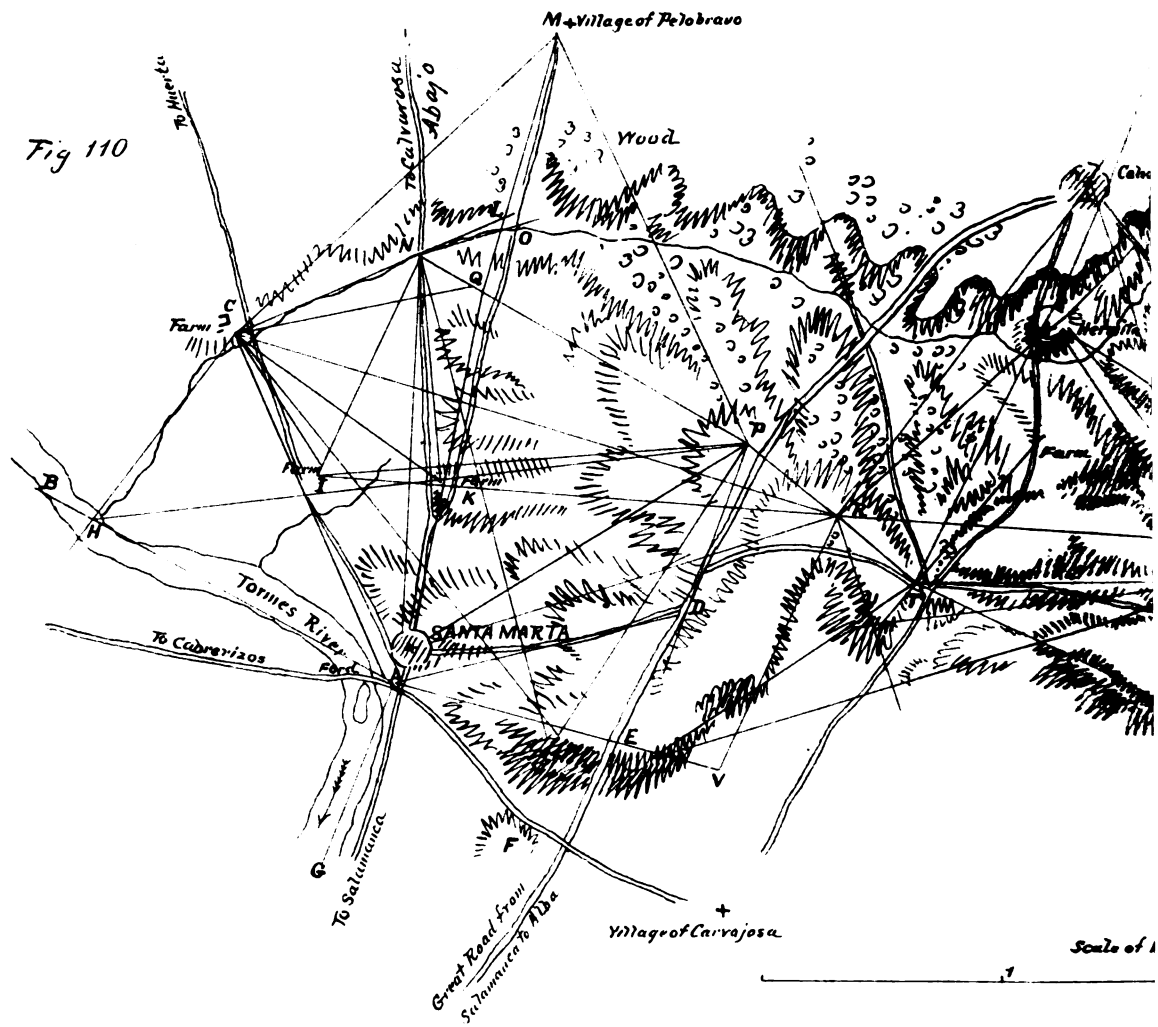
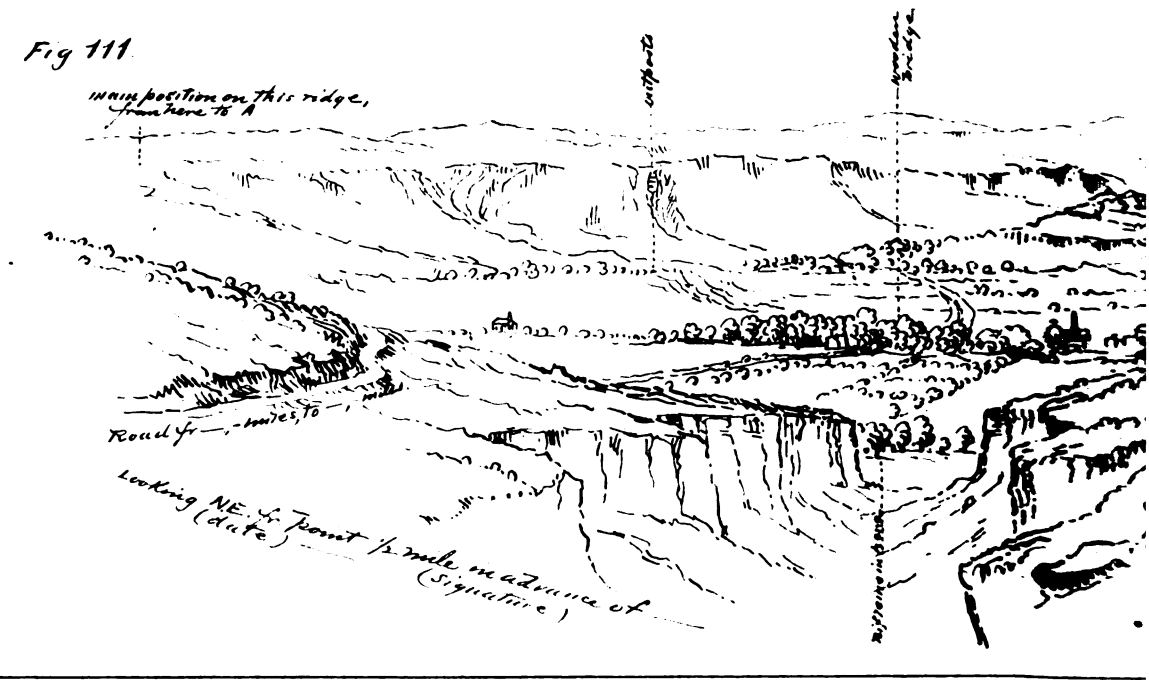


Fig 111

main position on this ridge,  
from here to A

Road 4 1/2 miles to

Looking NE. 1/4 Point 1/2 mile in advance of  
(date) (Signature)



# APE SKETCHING

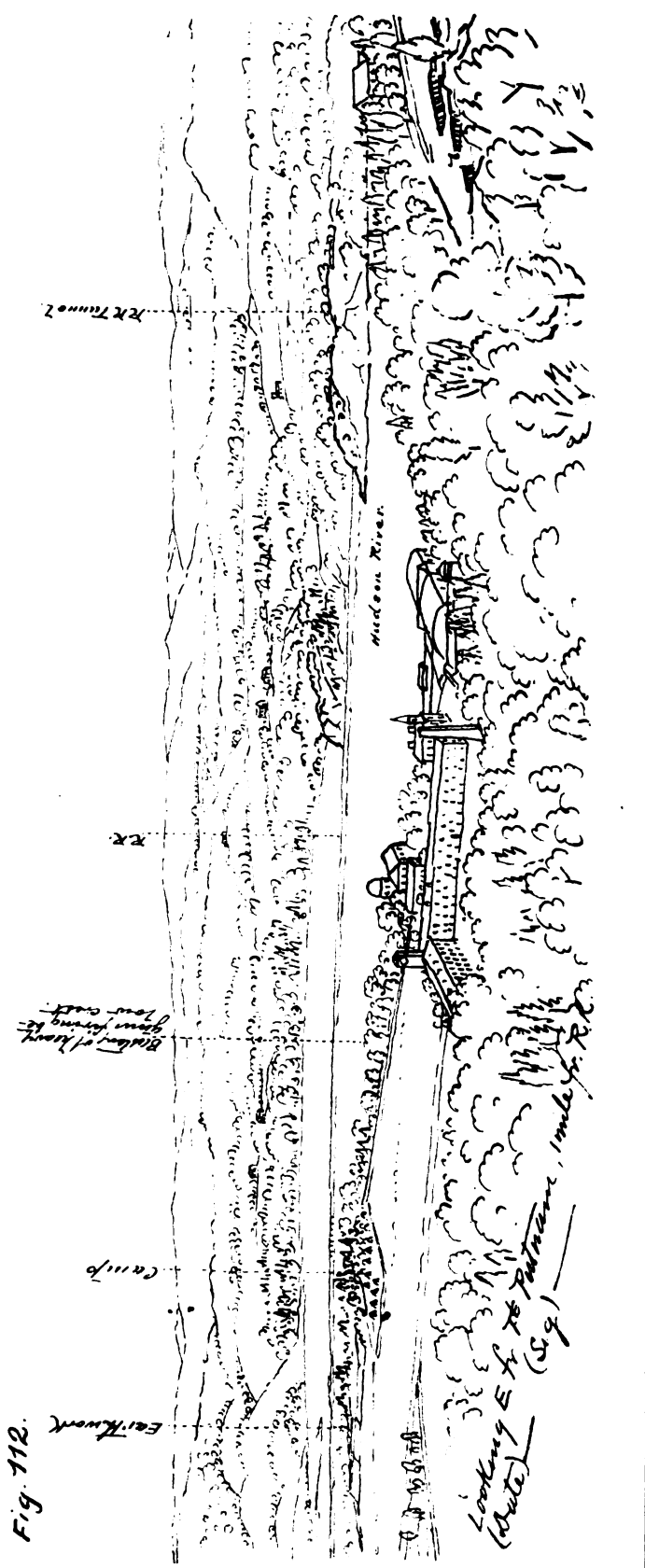
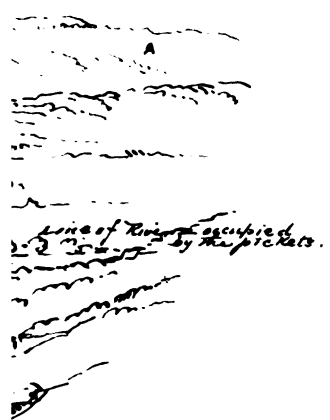
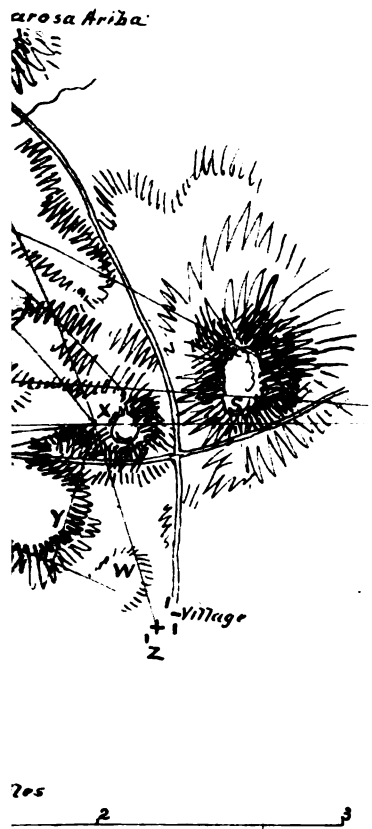


Fig. 112.



Fig 110

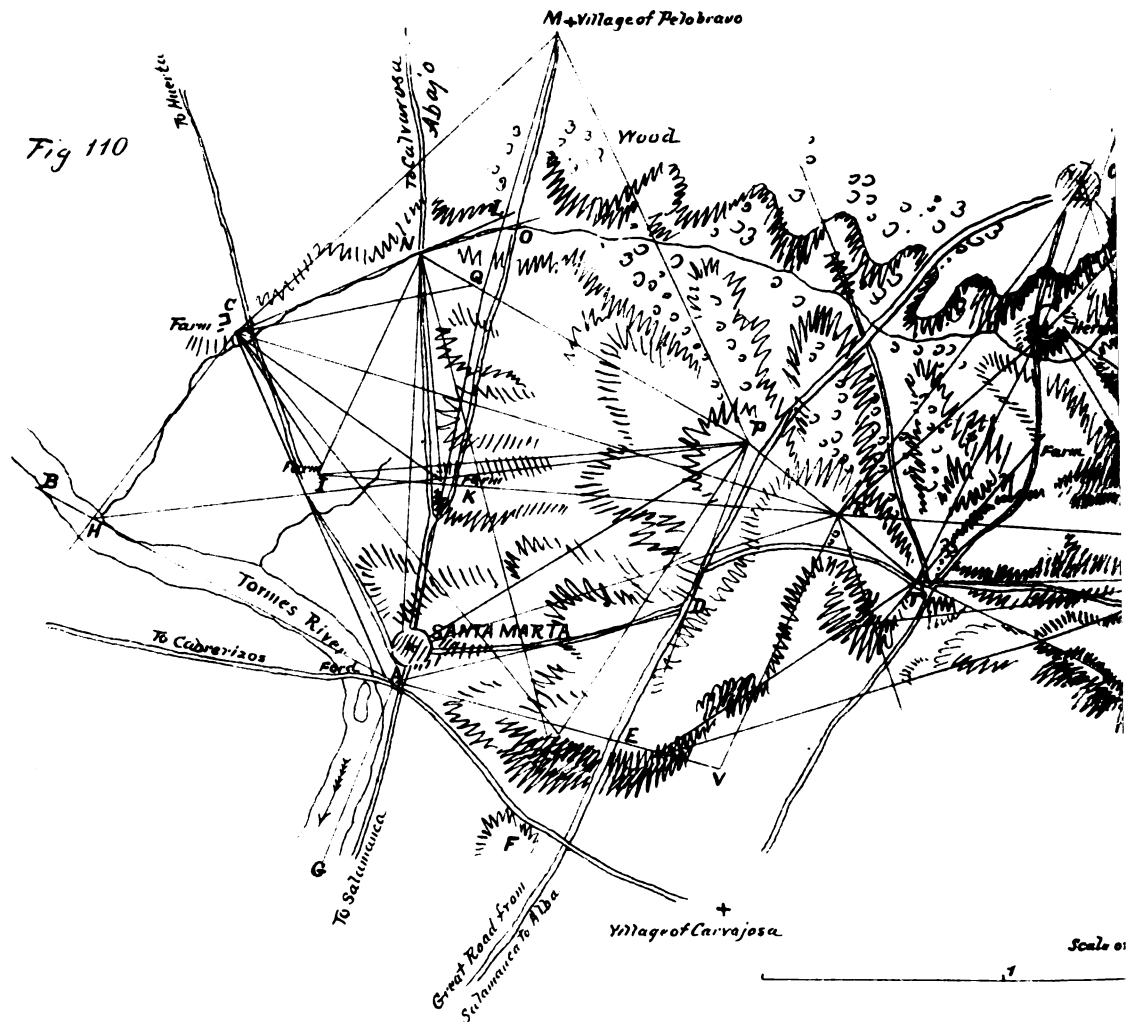
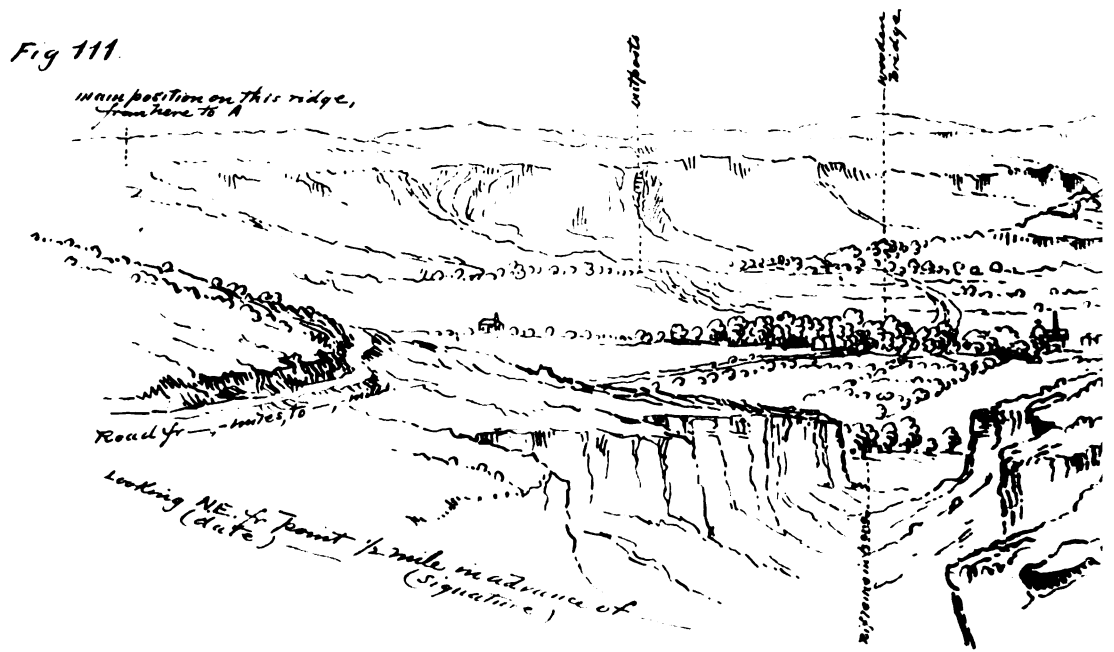


Fig 111



# APE SKETCHING

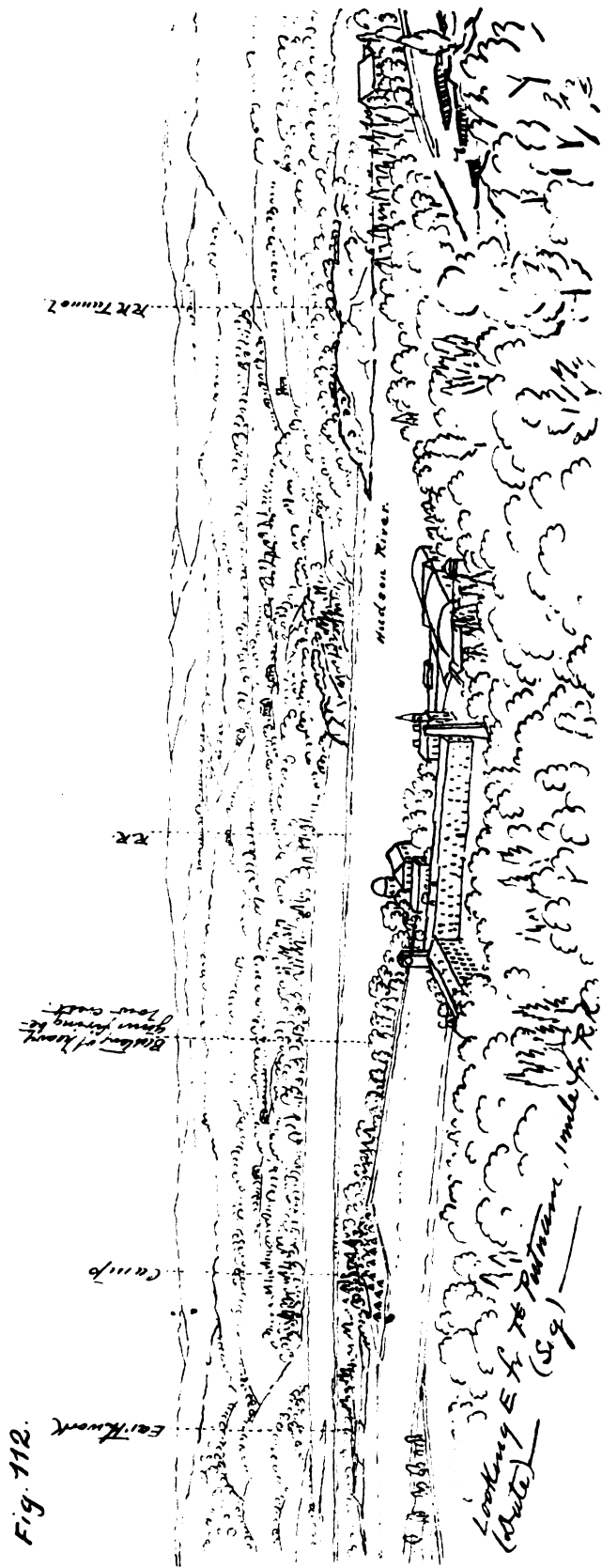
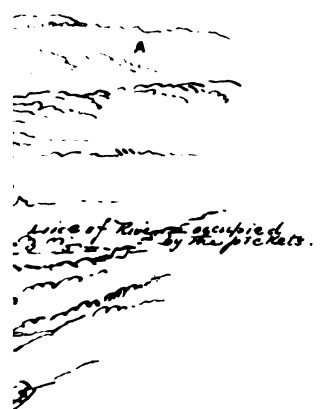
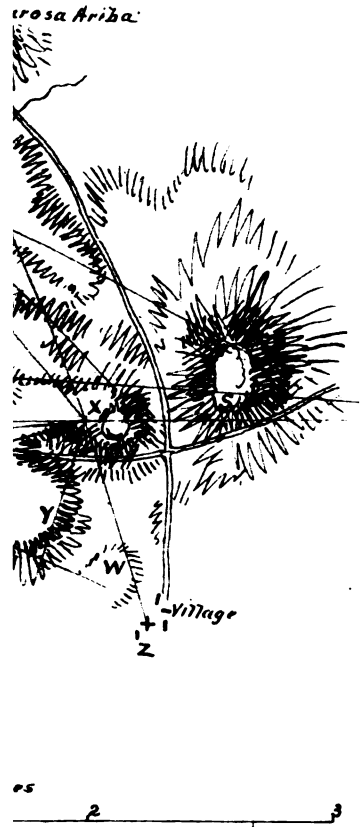
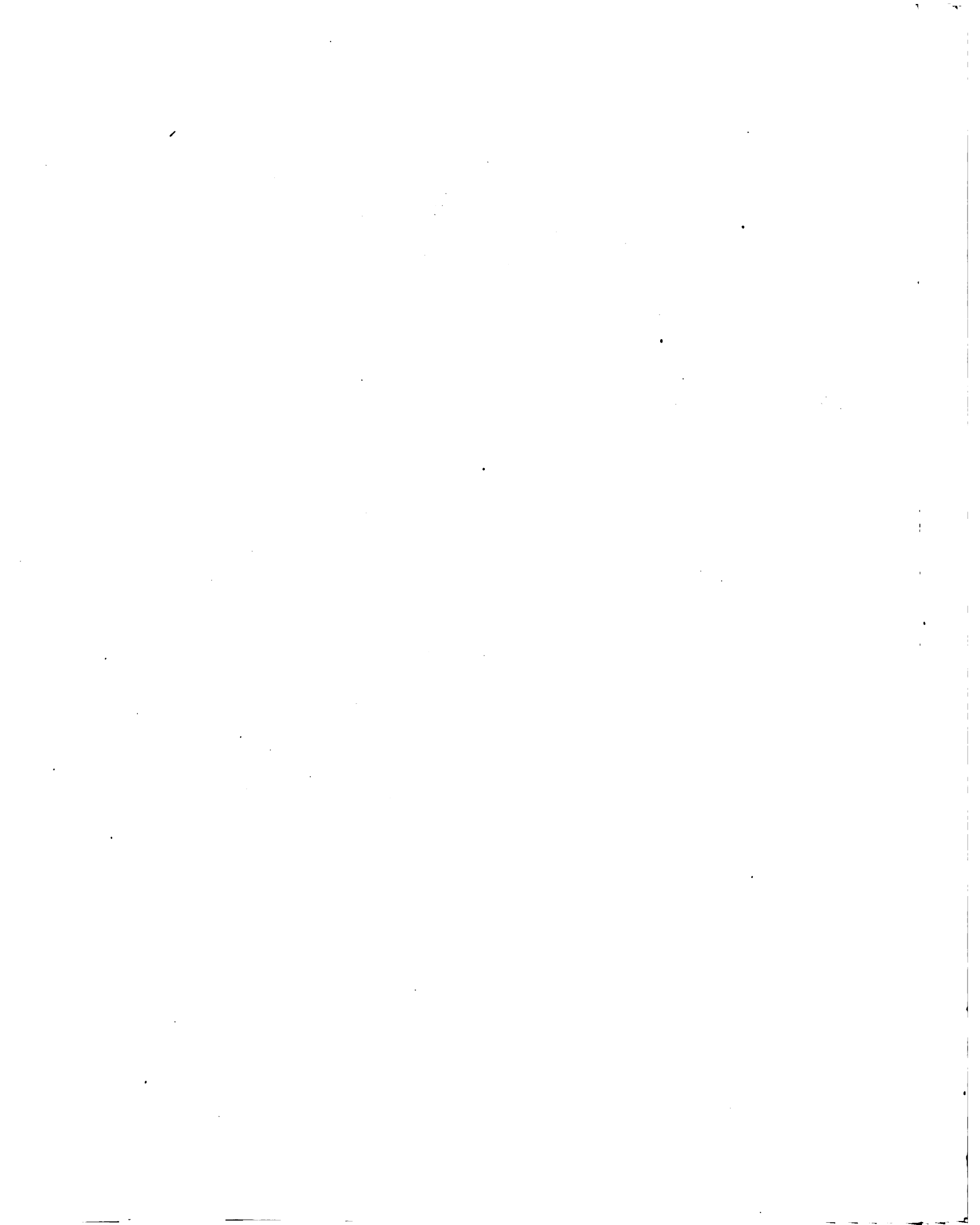


Fig. 112.



VOLUME II.

PHOTOGRAPHY APPLIED TO SURVEYING.



PHOTOGRAPHY  
APPLIED TO SURVEYING.

BY

LIEUT. HENRY A. REED, U. S. ARMY,  
*Assistant Professor of Drawing, U. S. Military Academy, West Point, N. Y.*

*FOURTH EDITION.*  
SECOND THOUSAND.

NEW YORK:  
JOHN WILEY & SONS.  
LONDON: CHAPMAN & HALL, LIMITED.  
1897.

**COPYRIGHT, 1886,**  
**By JOHN WILEY & SONS**

**ROBERT DRUMMOND, ELECTROTYPYPER AND PRINTER, NEW YORK.**

## PREFACE.

---

IT would seem from the scarcity of published information on the subject of this treatise, that its practical value has not been justly appreciated. In foreign countries, and particularly in France, photography has been for a considerable period applied to surveying; and the results show a saving of time and labor that cannot be attained by any other known means; and, as in ordinary surveying, an accuracy that is directly proportioned to the quality of the instruments employed and to the care exercised in the field-work. In the United States, photographs are sometimes used as addenda to an important map, because they are recognized as conveying information to be otherwise gained only by actual inspection of the tract or subject represented; and when it is considered that in themselves they present all the data necessary for the construction of a map, thus rendering field-work other than that required for their production unnecessary, then certainly this method needs but to be better known to be appreciated.

In his own practice its value is so strongly impressed, that the author feels it a duty to try and present the subject in a plain and concise manner, trusting that others may so improve and enlarge upon it, that this method of surveying will not fail to become more generally understood and practised.

Of the numerous foreign authors whose recent works have been referred to for information may be mentioned Laussedat, Girard, Gossin, Hannot, Bornecque, Javary, Tisandier, Dufaux, Pizzighelli, Keucker, and Colson. Acknowledgment is also due for information obtained from the periodicals *La Revue d'Artillerie*, *La Nature*, and the *Bulletin de la Société Française de Photographie*.

WEST POINT, N. Y., January 23, 1888.





# CONTENTS.

---

|   | PAGE |
|---|------|
| SECTION I.  |      |
| INTRODUCTORY.—HISTORICAL SKETCH AND GENERAL PRINCIPLES, . . . . .                 | 1    |
| SECTION II.   |      |
| METHOD BY PLANE PERSPECTIVES.—INSTRUMENTS AND MATERIALS, FIELD-WORK AND PLOTTING, | 9    |
| SECTION III.  |      |
| METHOD BY CYLINDRIC PERSPECTIVES.—INSTRUMENTS, FIELD-WORK AND PLOTTING, . . .     | 36   |
| SECTION IV.   |      |
| METHOD BY RADIAL PERSPECTIVES.—INSTRUMENTS, FIELD-WORK AND PLOTTING, . . .        | 42   |
| SECTION V.  |      |
| THE CAMERA WITHOUT A LENS, . . . . .  | 50   |
| SECTION VI.   |      |
| TELESCOPIC AND BALLOON PHOTOGRAPHY, . . . . .                                     | 52   |
| SECTION VII.  |      |
| VARIOUS APPLICATIONS OF PHOTOGRAPHIC SURVEYING, AND SOME OF ITS ADVANTAGES, .     | 62   |
| INDEX, . . . . .  |      |

---

| PLATES.   |             |
|---|-------------|
| XXIV. PHOTOGRAPHIC MAP, . . . . .                 | End of Vol. |
| XXV. PHOTOGRAPHS PREPARED FOR PLOTTING, . . . . . | "           |
| XXVI. OUTLINE PHOTOGRAPHIC MAP, . . . . .         | "           |



# PHOTOGRAPHY APPLIED TO SURVEYING.

---

## SECTION I.

### INTRODUCTORY.—HISTORICAL SKETCH AND GENERAL PRINCIPLES.

#### HISTORICAL SKETCH.

1. PERSPECTIVE drawings were used as data for the construction of plans long before the practical application of photography. Near the beginning of the present century, Beautemps-Beaupré called attention to their use in topographical surveying. The instructions prepared by him for the officers of the frigate *Bonite*, preceding a voyage around the earth, recommended them for the survey of the surroundings of places visited, and of the coasts which were either passed by or could not be reached. His method was simply to make drawings or careful sketches of the subject from any two stations, of which the distance apart was determined; then, by measuring with a sextant or other means, at each station, the angle included by a visual ray to any point and the right line joining the stations, data were afforded for orienting the sketches on the plot; and a simple geometrical construction, the reverse problem of perspective drawing, then sufficed to locate the details in plan. The accuracy of the result evidently depended upon skill in sketching. Colonel Leblanc subsequently endeavored to apply this method to military topography; but found, even under the most favorable circumstances, that the results were only approximately exact; and, having but few advocates, it was no longer employed. The result of these attempts induced Colonel Laussedat, professor of geodesy at the polytechnic school, to try and find some means whereby ordinary skill in drawing would suffice for the production of accurate maps; and, in 1854, his efforts ended successfully in his well-known adaptation to the purpose of Wollaston's camera lucida; and later in the telemetrograph,—a combination of the camera lucida and telescope.

In 1839, when Arago presented Daguerre's famous discovery to the French Chamber of Deputies, he said, "That the subjection of photographic images in their formation to geometrical rules will enable us with very few data to determine from these images the exact dimensions of the highest objects, of the most inaccessible structures. . . . We could give some ideas we have entertained of rapid means of investigation that the topographer will be enabled to borrow from photography. . . ."

In 1847, Martens, a French engraver, constructed a panoramic apparatus consisting of a camera with a cylindrical daguerreotype plate vertically disposed; the plate remained stationary, while the part containing the objective revolved; the light acted upon the plate through a small vertical slit in a diaphragm placed opposite the objective. Sharply-

defined images were thus produced; but the preparation of the curved plate, and sensitizing it by the collodion process, were attended with too much difficulty to make the apparatus useful.

Martens' instrument was modified by Garella, L. Schuller, and also by Brandon, so that the image was received upon a flat plate. The camera, by means of clock-work, was made to revolve about a vertical axis through the optic centre of the objective, carrying with it, and in rear of the objective, a screen which contained a vertical slit; a narrow sector of light was thus admitted; at the same time the plate was made to move and occupy positions such as to be continuously tangent to the cylinder described by the base of the sector. Vertical lines were faithfully represented, but horizontals, not contained in the horizon of the instrument, were represented by curves.

Similar modifications were made by J. Martens and by Koch; and Silvy substituted for the glass and metal plates a sensitized paper which was made to roll from one cylinder to another.

In 1856, M. Chevallier made his first researches in this direction, and succeeded in forming upon a single plate, horizontally disposed, an entire tour of the horizon. As the camera he employed belongs to a class having certain special merits, a detailed description of it in its present improved condition is given in the text, par. 46. Mangin's camera also belongs to this class, and its description follows that of the former instrument.

In 1858, M. Porro, a maker of instruments of precision, proposed an ingenious apparatus intended especially for topographical purposes; but the transformation of the images necessary to the construction of the plan was so tedious and complicated, that it was never brought into use.

Other modifications or improvements in panoramic cameras were made in 1857 by Ross and Brooman, in 1861 by Sutton, in 1864 by Johnson, about 1865 by Busch, and quite recently by Liesegang of Dusseldorf; these instruments receiving various names, such as the "pantoscopic camera," "metoscopic camera," and the "camera of rotation."

About 1858, M. Carette invented a camera giving views about two inches square, and insured the verticality of his plates by means of a circular level. While he made the exposures, an assistant measured with a pocket sextant the angles necessary to fix the photographic stations. The negatives were used directly to obtain the coordinates of different points of the perspective. This camera was employed simply as an accessory to the ordinary topographical instruments to fix some of the points upon the sketch.

In 1864, Colonel Laussedat, now Director of the National Conservatory of Arts and Trades in Paris, published in the *Mémorial de l'Officier du Génie* a very thorough description of photographic surveying, in fact so exhaustive that at the present date no treatise upon this subject can be complete without making use of the results of his researches, and no practice perfect without applying the principles that he established. He may be called the inventor of practical photographic surveying. Two of his most extensive undertakings were a partial survey of Paris in 1861, and of Grenoble and its suburbs in 1864, the latter in charge of Captain Javary. In each case the topographical maps were characterized by great accuracy; in the former, agreeing precisely with the regular survey made by the engineer in charge of roads and bridges, and in the latter the

differences of level as compared with the regular survey nowhere exceeding 19 inches, which for ordinary scales is of course within the limit of permissible error.

During this period, and while Col. Laussedat's method was practised in France, experiments were made in Germany by Meydenbauer, the counsellor in charge of public buildings, with a view to applying photography to land and architectural surveying. Apparently unaware of the researches of Beautemps-Beaupré and Laussedat, he first resorted to photography for the construction of plans and elevations of certain structures, difficult of access; and like that of Beautemps-Beaupré, his method consisted in determining the orthographic projection from the photograph by reversing the direct perspective problem. In land-surveying, his method was based upon the same principles as Laussedat's; but on account of the very narrow field of view which, in the objectives then employed, corresponded to a true image, he would soon have abandoned his very costly experiments had it not been for the optician Busch of Rathenow, who at this juncture invented the pantoscope. This instrument, presumably similar to the modification of Martens' heretofore described, gave a true image for a field of view of  $105^\circ$ ; the only fault consisting in an unequal brilliancy of the centre and edges, which however could be avoided by securing a favorable illumination of the subject. (Steinheil's apparatus, now in use, is exempt from this fault.) Meydenbauer's work now began to attract much attention, and "photogrammetry," as the method with both the pantoscope and the ordinary camera was termed, was more extensively applied. One of his trial surveys was that of Fribourg and its suburbs, covering an area about half a mile square, which was plotted to a scale of  $\frac{1}{10000}$ , with 10 feet contours, by himself and a draughtsman who had not taken part in the field-work. The field-work required 2 days; there were 6 stations and 21 plates; the office-work was performed in 3 weeks: and the resulting map was accurate in every respect. Elevations of buildings were also obtained with like success.

During later years, several different instruments for the purpose have been invented, of which the most important appear to be Duboscq's Polyconograph, Bertsch's Automatic Camera, and Dubroni's Apparatus. In the first mentioned, the inner surface of the shield of the plate-holder was subdivided by raised strips into fifteen equal squares, and the strips being of such thickness as to touch the sensitive plate, the latter was practically subdivided in a like manner. A metal part of the camera containing the lens could be fastened at pleasure opposite any one of these squares, and an exposure made by means of a corresponding opening in the shield. The focussing was effected with the aid of a ground glass placed in the prolongation of the sensitive plate, the lens part being attached to it for this purpose. This instrument was of very small dimensions, the tripods when folded serving as a cane.

The term "automatic" was applied to Bertsch's camera because it was focussed permanently for distant views. The camera consisted of a four-inch metal cube, a lens of four-inch focal distance, and the sensitive plates were two and one half inches square. The proper direction for any view was given by means of an alidade with attached level, having at one extremity an open rectangle which, with the other extremity of the alidade as the point of observation, exactly limited the field. The negatives produced were so sharply defined as to admit of a useful enlargement of from 100 to 500 times their super-

ficial area. A field laboratory, contained in a box fifteen inches square, accompanied the camera.

The main features of Dubroni's Apparatus were its easy manipulation, and the use of the camera itself for developing the plates. The camera was a box with yellow glass sides, enclosed in another box of wood; openings were provided as usual for the lens and for introducing the plate. The latter having been collodionized and introduced, the box was inverted, lens upward, and the silver solution was poured in through a tube. The plate being thus sensitized, the instrument was then pointed and the exposure made; the box was again inverted and the plate developed by introducing the required solution; the fixing was delayed till the day's survey was finished. Since the focal distance was adjusted by the instrument-maker, and rules for the manipulation accompanied each instrument, the work could be performed by those not at all skilled in photography.

Doubtless other important inventions of this nature exist; but those mentioned give an idea of the progress made in the past, and, together with the instruments described in the text, will serve to give a fair knowledge of the development of this very important aid to surveying.

#### GENERAL PRINCIPLES.

2. *Range and Object of the Method.*—Although the range of Photographic Surveying extends to geodetic measurements, it is limited in the present treatise to ordinary plane and topographical work.

As in surveying with compass or transit, this method has for its object the measurement of angles and distances necessary to the location of points, for a graphical representation of the important features of a limited portion of the earth's surface. Like an ordinary topographical map this representation is a horizontal projection with added references for heights; but beyond this, the means employed furnishes, without additional labor, a complete view of the tract surveyed, with its details as they would be naturally presented to the eye, which

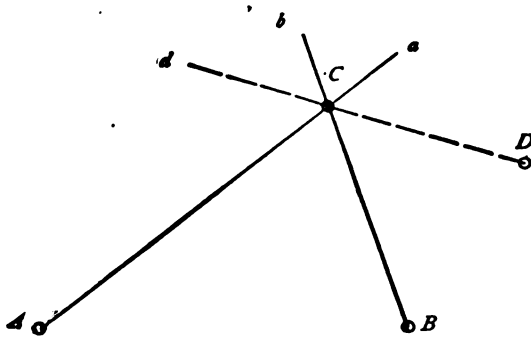


FIG. 1.

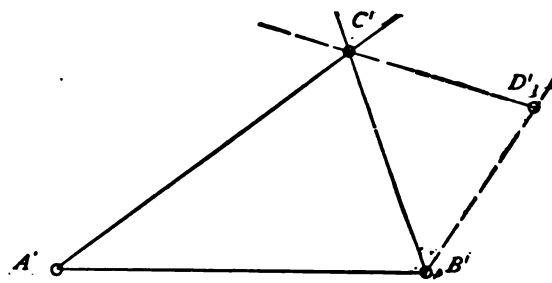


FIG. 2.

addition evidently increases the value of the result. Its accuracy, as will hereafter be shown, may be said to be sufficient for the purposes above stated.

3. *Location of Points.*—Two ways of locating points are used.

I. By the intersection of two or more right lines through given points;—thus, *C* (Fig. 1) is fixed in position if from two given points, *A* and *B*, the directions *Aa* and *Bb* are known; and if from a third point, *D*, *Dd* is also given, and *Dd* intersects *C*, a

check upon the work is afforded. It is evident that curved lines serve the same purpose if their positions are known.

$C$  may also be fixed if, as shown in Fig. 2, the distance  $A'B'$  and the angles  $C'A'B'$  and  $C'B'A'$  are given; and, as before, a third point  $D'$ , being fixed, and the angle  $C'D'B'$  given, a check is also afforded.

II. By an Azimuth and a Distance.—Thus, in Fig. 3, the point  $E$ , of the right line  $EF$ , given;  $G$  is fixed, if the azimuth  $\varepsilon$  and the distance  $EG$  are known. A check is had either by another azimuth and distance, or by the application of (I), using other known points and lines.

The foregoing constructions apply to plane-photographic surveying. To locate a point completely requires that not only shall its position in plan, or its projection upon a horizontal plane, be determined; but also that its elevation or depression with reference to this plane shall be known. Thus, in Fig. 4, let  $K$  be the required point; its projection  $k$  in plan may be found by (I) or (II), e.g., as indicated, by the azimuth  $\varepsilon$  and distance  $Hk$ ; but its complete determination requires the elevation or distance  $h$  above this plane. This is ordinarily found in photographic surveying, by measuring the angle of elevation

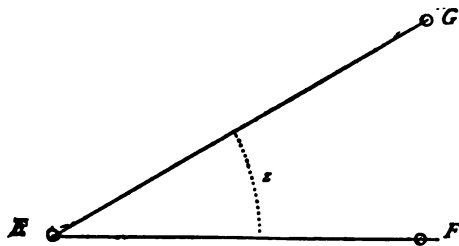


FIG. 3.

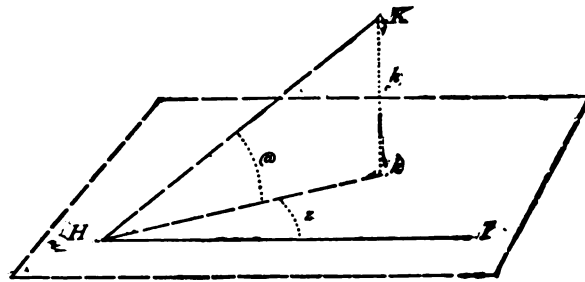


FIG. 4.

@ by means hereinafter explained; then  $h = Hk \text{ tang. } @$ . The position of a point below the horizontal plane is similarly determined by measuring the angle of depression.

4. *Relation of Photographs to Perspective Drawings: Definitions of Terms.*—The ready application of photography to surveying requires that the photographs taken in the field shall be accurate representations of the features included in the field of view; in other words, that they shall be true perspectives. The definitions of certain terms used in perspective drawing may here be found appropriate. In Fig. 5, the picture  $V$  represents the distant topographical features as shown, and  $O$  the eye of the observer.  $V$  is called the *plane of the picture*, and, for convenience in the application of geometric rules, is taken in a vertical position;  $O$  is the *point of sight*;  $P$ , the point in which a visual ray perpendicular to  $V$  pierces it, is called the *principal point*; the horizontal line  $HH'$  through  $P$  is the *horizon of the picture*, or simply the *horizon*,—it is evidently the intersection with  $V$  of the observer's horizon; and the points in which visual rays, or right lines from distant points to  $O$ , pierce  $V$ , are the *perspectives of these points*; thus  $a, b, \dots$  are the perspectives of  $A, B, \dots$ . These elements will be frequently designated hereafter by their distinguishing letters as above given.

5. *To Determine the Direction of a Point from a Perspective Representation.*—If the different points of a landscape and the visual rays intersecting them be vertically pro-



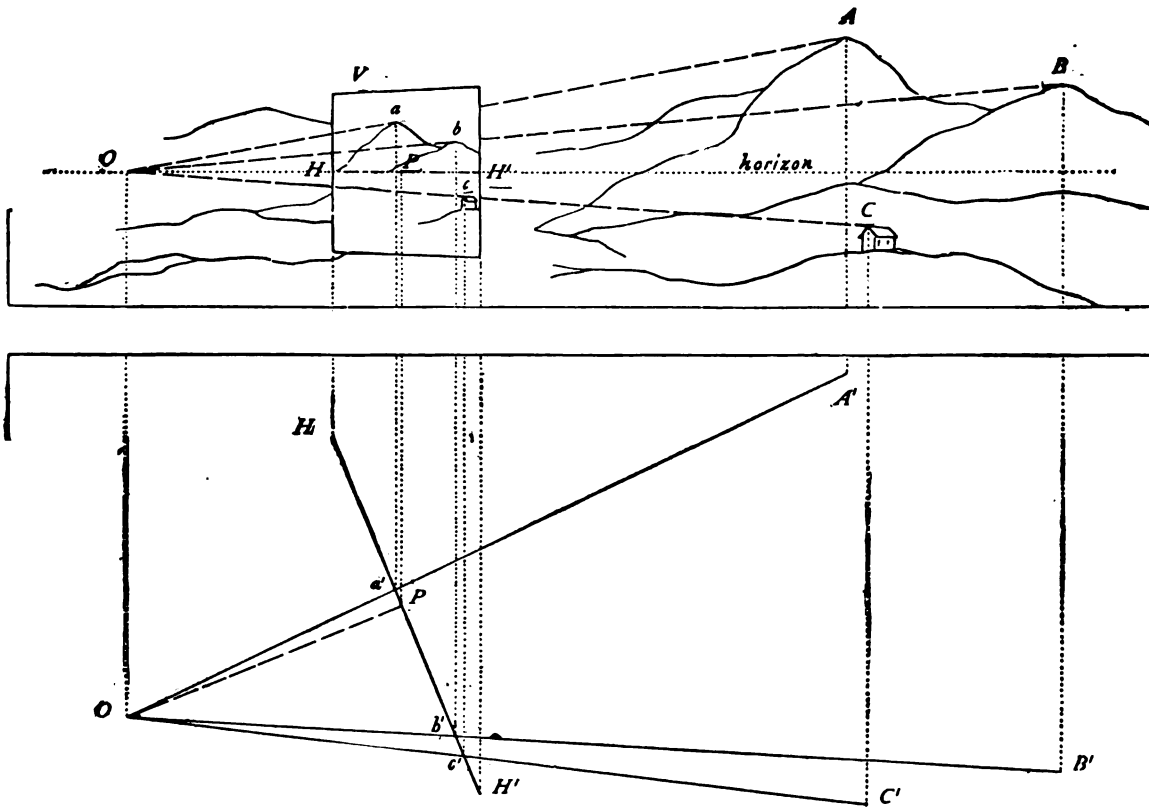


FIG. 5.

jected into the plane of the horizon, the angles included by the projections of the visual rays are the true horizontal angles; the same that would be measured with a theodolite or any other horizontal angle-measurer:—Thus, in Fig. 5,  $OP$  and  $HH'$ , since they are in this plane, are their own projections;  $OA$  and  $OB$  are horizontally projected in  $OA'$  and  $OB'$  . . . . ; and  $a'Ob'$  is evidently the horizontal angle included by  $OA'$  and  $OB'$ ;  $a'Oc'$  the angle included by  $OA'$  and  $OC'$  . . . .

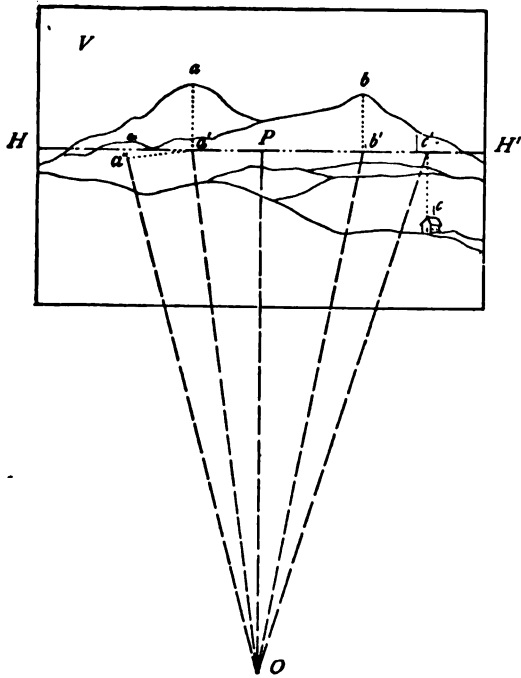


FIG. 6.

Now let  $V$ , Fig. 6, represent a perspective, as in Fig. 5;—Since the positions of  $HH'$  and  $P$ , and the distance  $OP$ , are always known; if  $V$  be laid upon a flat surface,  $PO$  can be set off perpendicularly to  $HH'$ , the different points  $a$ ,  $b$ , . . . . may be projected vertically into  $HH'$ ,—see  $a'$ ,  $b'$ , . . . . in the figure,—and the horizontal angle between any two points will then be included by the right lines joining their projections with  $O$ . Thus  $a'Ob'$  is the true horizontal angle of the points  $A$  and  $B$ ,— $a$  and  $b$ , in the figure. Hence the direction from  $O$  of the projection of any point on the horizontal plane may be determined from the perspective.

These angles may be measured with a protractor; or, since  $Pa'$ ,  $Pb'$  . . . . are the tangents, to the radius  $OP$ , of the angles which they respectively subtend, any angle may be determined by first measuring its tangent with a scale of equal parts; then the distance thus obtained, divided by  $OP$ , is the natural tangent of the angle, and the angle is given in a table of natural tangents:—Thus,  $\text{tang. } a'Ob' = \frac{Pa' + Pb'}{OP}$  . . .;  $b'Oc'$  is obtained by determining  $POc'$  and  $POb'$  separately, then  $b'Oc' = POc' - POb'$ .

The vertical angles are similarly determined; e.g., to find the angle of elevation of  $A$  ( $a$  in the figure); set off  $a'a''$  perpendicular to  $Oa'$  and equal to  $a'a$ , then measure  $a''Oa'$  with a protractor; or, since  $a'a''$  is the tan.  $a''Oa'$  to the radius  $Oa'$ , measure  $Oa'$  with a scale of equal parts, then  $\text{tan. } a''Oa' = \frac{a'a''}{Oa'}$ .

Therefore, since its azimuth and vertical angle (see also Fig. 4) are given, the *true direction* of any point with reference to  $O$  may be determined from a perspective representation.

6. To Determine the Position of a Point from a Perspective Representation.—The other

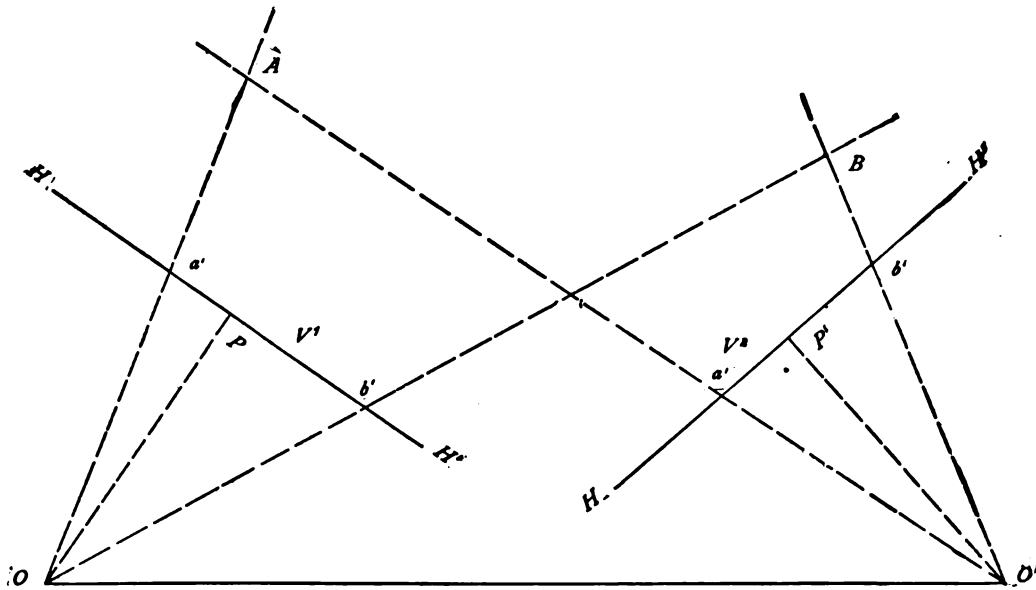


FIG. 7.

element required to fix a point completely is its distance from  $O$ , or, which is equivalent, its direction from some other point of which the position with reference to  $O$  is known. The latter method is generally used in photographic surveying; in other words, in this process, points are fixed by intersections from known points.

This method requires that the points of observation  $O$  and  $O'$ , Fig. 7, of two views,  $V'$  and  $V''$ , shall be fixed, and the directions of  $OP$  and  $O'P'$  known: if the positions of the horizons  $HH'$  are then given, it is only necessary to draw right lines from  $O$  and  $O'$  through the projections of any point on these horizons and produce them to intersection:—Thus, to fix  $A$  in plan; produce  $Oa'$  till it intersects  $O'a''$ , and similarly for any other point represented on both views. The view from a third known point,

embracing points on the other two views, would serve to check the accuracy of the plot.

To avoid repetition, the orientation of the views, or the determination of the required directions of  $OP$  and the consequent positions of  $HH'$  for the different views, is deferred to Plotting, par. 24 *et seq.*

The remaining element to determine is the reference, or the distance of any point above or below the horizontal or datum plane. Referring to Fig. 8; the distances  $Oa'$

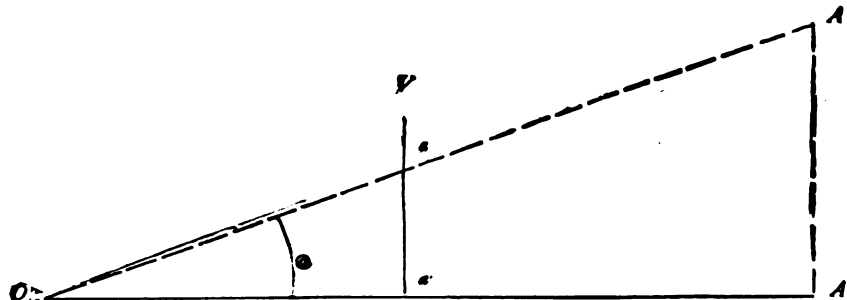


FIG. 8.

and  $a'a$  being measured on the view, and  $OA'$  measured on the plot; then  $Oa' : OA' :: a'a : A'A$ , whence  $A'A = \frac{OA' \times a'a}{Oa'}$ ; denoting  $A'A$  by  $H$ , and  $OA'$  by  $D$ , and since  $\frac{a'a}{Oa'}$  is the tang. @ (see figure) to the radius  $Oa'$ , there results the general expression for the reference of a point

$$H = \pm D \text{ tang. @};$$

the  $+$  and  $-$  signs referring respectively to distances above or below the datum plane.

Since the position of a point may thus be found, any point may be *completely determined* from a perspective representation.

The next step is to describe the instruments and means employed in the Field-work.

## SECTION II.

### METHOD BY PLANE PERSPECTIVES.—INSTRUMENTS AND MATERIALS, FIELD-WORK AND PLOTTING.

#### INSTRUMENTS AND MATERIALS.

THE instruments and material required to obtain a photographic perspective are the camera with its objective, a compass, level, certain other appliances which will be described in their appropriate places, and the sensitive plates.

7. *Camera for Plane Perspectives.*—Fig. 9 represents the kind of camera used for this purpose; it is the kind generally used for photographic work. Its principal parts are the

back *B*, front *F*, bellows *b*, objective *O*, objective-slide *D*, ground-glass *G*, rails *R*, and tripod *T*. *H* is the plate-holder, *s* its shield, and *p* the needle-points, of which the use is hereinafter described. Any carefully-constructed camera of this type can be used with good results. The special requirements are that the different parts shall be so fitted to each other as to admit of rigid and uniform adjustment. The tripod legs should be quite stiff, and when of the ordinary telescopic pattern, as in the figure, the levelling of the instrument is very quickly effected; the binding screw which secures the camera to the tripod-head should be large and strong. In focussing with the special pattern shown in the figure, the back is fixed to the rails, while the front is made

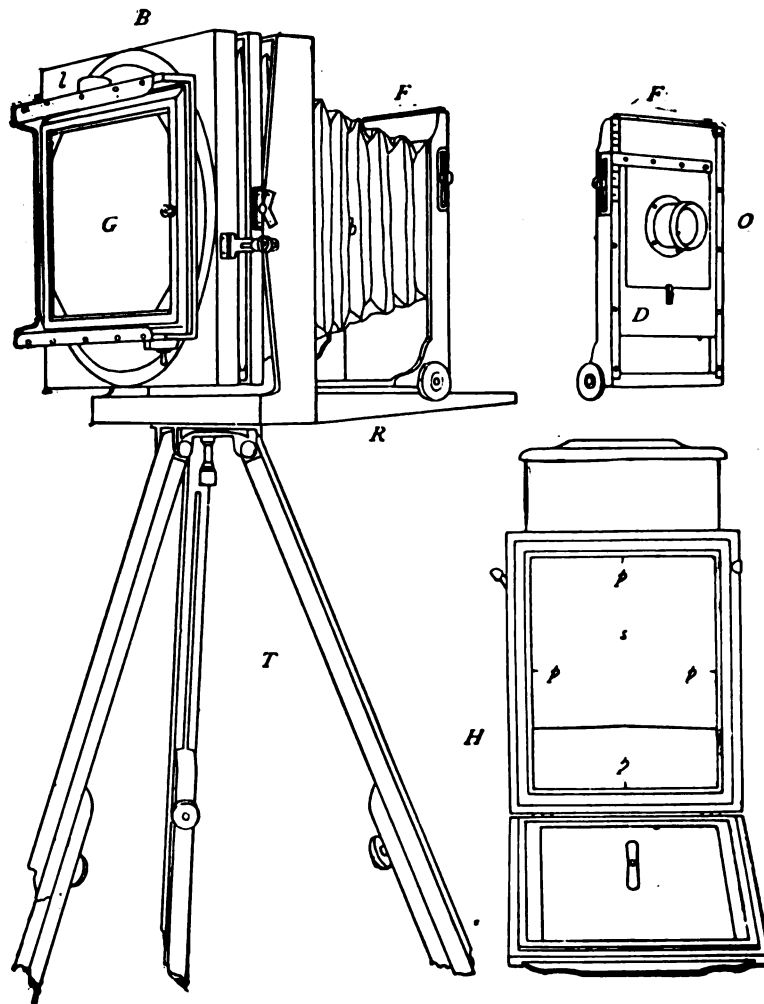


FIG. 9.

to traverse by means of the milled head shown at the base of the front; but the ordinary pattern, in which the back is made to traverse, evidently serves the same purpose.

When adjusted for taking a view for surveying purposes, the optic axis of the objective should be horizontal, and the film surface of the sensitive plate—the plane of the picture (par. 4)—perpendicular to it. This condition is generally assured by levelling the camera when the ground-glass and objective-slide are parallel; and it also requires that the plate-holder should so fit the back, that the sensitive plate when inserted shall exactly replace the ground-glass. In a well-constructed camera these conditions either exist permanently, or are capable of adjustment as will be hereinafter explained. The form shown in Fig. 9 is called a "double swing-back," because the back can be turned a few degrees about either a horizontal or a vertical axis, and the plate may thus be placed and clamped in positions oblique to the optic axis; this appliance is very convenient for ordinary photographic work, but unnecessary for the present purpose; in fact, with a swing-back, an additional adjustment is required to make the ground-glass and objective-slide parallel; a plain, rectangular, bellows camera, firmly constructed, is the simplest and best for surveying purposes. (See also close of pars. 20 and 24.)

8. *The Objective.*—An objective is required that will produce upon a plane surface a true perspective of a landscape, or at least one sufficiently exact for the present purpose. There are doubtless other suitable forms, but those known to the author are Dallmeyer's Rapid Rectilinear, his Wide-angle Rectilinear, Steinheil's Aplanatic, and the Hermagis  $90^\circ$  Angle objectives; they are respectively English, German, and French patterns adapted to surveying purposes; and the accuracy of representation resulting from their use is directly proportioned to the care exercised in the field- and office-work. Each consists of a double combination of lenses; each combination being made

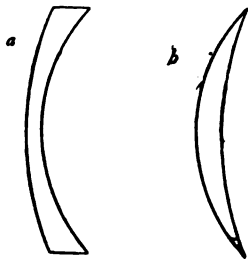


FIG. 10.

by joining a concavo-convex lens, *a*, Fig. 10, of which the concave face has the greater curvature, and a meniscus, *b*, Fig. 10, of which the convex face has the greater curvature. In the Dallmeyer combinations, the former is of flint, and the latter of crown-glass; while in the Steinheil they are of flint-glass, but of different density.

Fig. 11 shows the manner in which the lenses are arranged in the objective-tube, thus forming a symmetrical double combination. By this construction and the use of proper diaphragms, or "stops," one of which, *s*, is shown inserted, these objectives are corrected for spherical and chromatic aberration and are free from distortion; therefore by accurately focussing, the images formed are true and distinct throughout.

Fig. 12 represents the Rapid Rectilinear  $10 \times 12$ , the greater number indicating in inches a side of the largest square plate which may be effectively covered by the image: the dimensions  $10 \times 12$  are the trade size of the plate. The lens-tube *T* is attached by means of a screw-thread to the flange *F*, which is fastened by screws to the objective-slide; the cover or cap fitting the extremity *E* of the tube, and used in making ordinary exposures, is usually of leather lined with velvet; it should fit closely, and at the same time permit of removal without jarring the camera,—a pneumatic shutter, adjustable for either time or instantaneous exposures, is much to be preferred.

9. *Compass and Level.*—A convenient form of an attached *compass* is that in which the degree graduations are numbered from  $0^\circ$  to  $360^\circ$ , from right to left, or in the inverse order of the numbers on a watch-dial, and the  $0^\circ$ - $180^\circ$  line is in the vertical

plane of the optic axis of the objective, or in a plane parallel to it, the  $0^\circ$  being to the front; for in this case, when the camera is pointed toward the N.E. quadrant, the indications will be in the natural order from  $0^\circ$  to  $90^\circ$ , and so on throughout a revolution, thus requiring no computation, and that the numbers only of the graduation be recorded.

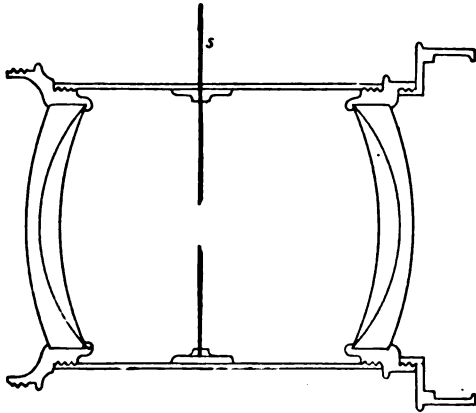


FIG. 11.

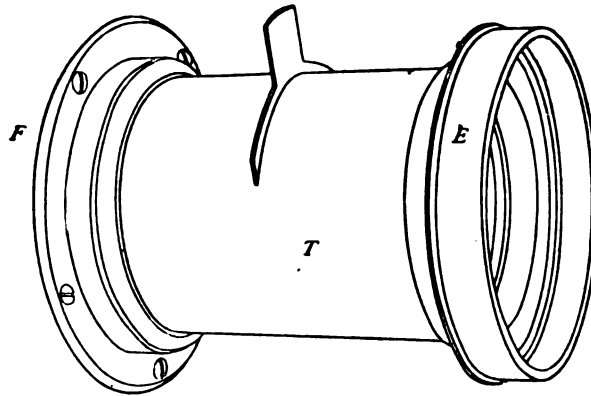


FIG. 12.

In the absence of an attached compass, a hand-compass will serve the purpose, and for convenience while reading may be rested upon the top or on the rails of the camera.

The *level* may be fixed to the camera by the instrument-maker or detached, and in either case the circular form, Fig. 13, is very convenient. If attached, it is desirable to have two of this form, one on the back and the other on the front of the camera: one is shown in position at *l*, Fig. 9.

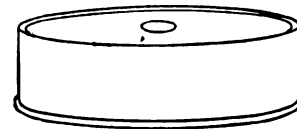


FIG. 13.

10. *Sensitive Plates and Changing-boxes.*—During most of the period considered in par. 1, rapid dry plates were unknown, consequently the work was obstructed by cumbersome apparatus and the delay incident to long exposures and field development. At the present time, not only have dry plates been brought to a state of great perfection; but, where very light outfits and great rapidity of manipulation (as instanced in the roller plate-holder) are elements of prime importance, paper has replaced glass. It is well to state, however, in this connection, that for exact work in surveying, glass negatives have not yet been equalled; they retain their shape, and the images are thus undistorted by chemical manipulation;—(see also par. 32.)

Any of the standard dry plates are suitable; but with reference to detailed representation, a  $5 \times 8$  (inches) is the smallest that can be used to advantage. They are taken into the field in their original packing-boxes,—the plate-holders, of which six double ones are a convenient number, having first been filled in the dark-room. A negative-box for exposed plates is necessary; also a “field-tent,” or a thick orange or ruby-colored cloth, underneath which the plates may be transferred as needed from the plate-holders to the negative-box, and from the packages to the plate-holders. A changing-box is also used for this purpose; the plates sliding directly from it to the holder, and the converse, making the tent or cloth unnecessary.

A recent invention, due to Capt. de Torres of the Spanish army, consists of a wooden box of sufficient dimensions to contain 24 plates, which are held parallel and at a small distance apart by lateral grooves. One of its sides, double the length of the box, slides in longitudinal grooves and contains a central vertical slit, large enough to permit a plate to pass freely through it; and an indexed scale and button on one of the edges serve to place and fasten the slit opposite any plate. A corresponding slit is in one extremity of the plate-holder, and each slit is furnished with a stiff cloth screen which opens and closes automatically. To transfer a plate: the end of the plate-holder is placed against the side of the box, so that the slits are opposite each other; the box is tilted, and the plate slides into the holder, where it rests upon four small triangular pieces of steel placed midway of the sides of the latter, and which also serve the same purpose as the needle-points (par. 7): the plate is held firmly in place by a clamp-screw of which the milled head projects at the back of the holder. As an additional safeguard against the admission of light during the transfer, the end of the holder is made to fit grooves on either side of the slit in the box. A plate after exposure is transferred back in a similar manner.

Another and very simple device consists in making the camera-back of metal and of sufficient size to contain, say, a dozen plates, each plate contained in the thin flexible holder which is in common use. The plates in place, a leaf-spring attached to the rear inner face of the box or back, and which bends downward, forces the plates to the front. The cover of the box consists, in addition to the lid, which is closed for transportation, of a rubber cloth, large enough to admit of the shield being withdrawn within it from any holder, and also to permit a holder, after exposure of its contained plate, to be transferred from the front to the rear of the series. The last plate-holder of the series is readily distinguished by a notch cut in its shield.

11. *Tests and Measurements Required.*—It has been observed that for good work the different parts of a camera should be susceptible of rigid and uniform adjustment; appliances are also needed in the field operation of levelling, to determine the horizon of a view; certain preliminary tests and measurements are therefore necessary, and these taken in their appropriate order are:

- I. The Test for Register.
  - II. The Measurement of  $OP$ , or the Focal Distance.
  - III. The Determination of  $HH'$  for any View.
  - IV. The Measurement of the Field of View.
- To these is added a Test for Distortion.

Since the accuracy attained in field-work and plotting will depend almost entirely upon the result of these operations, hardly too much care can be exercised in their performance.

12. *Test for Register.*—When the plate-holder is inserted, the camera should “register;” that is to say, the film surface of the sensitive plate should exactly replace the rough surface of the ground-glass. To test for this: focus an object, a few yards distant, accurately on the latter, using a large stop; then substitute for the sensitive plate a plate of ground-glass, or of other glass covered with a thin translucent film, the film to the front; withdraw the shield and observe if the image is as distinct as before; if not,

note and mark on the rails the distance the back has to be moved to the front or rear, to make it so, and adjust accordingly in making exposures. As in cases of other faults of construction, when this test is made at first and the defect discovered, the instrument-maker should remedy it.

13. *Measurement of the Focal Distance, or OP.*—For general work in photography, the focal distance of an objective, the distance of the focus from the optic centre, is variable, depending upon the distance of the subject from the optic centre; but, in surveying, since the nearest points of the features to be represented are usually so far distant that the rays of an incident pencil from any point may be regarded as parallel, the focal distance for parallel rays is required. This for a combination of lenses is called the equivalent focal distance, but for the sake of brevity the term “equivalent” is hereinafter omitted.

All objectives of the same name and size are supposed to have the same focal distance, which is usually stated by the maker; but slight variations in their manufacture give different values for it, and it is therefore best to measure it for each one.

For a simple convex lens, double or plano-convex, the position of the optic centre

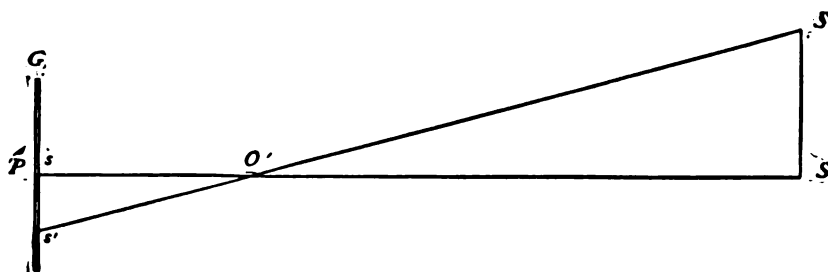


FIG. 14.

is easily observed, and it is only necessary to measure, with a scale of equal parts, the perpendicular distance from it to the rough surface of the ground-glass; but for a double combination lens this operation is evidently impracticable and any of the following methods may be employed:

I. Set up and level the camera; place a staff, *S*, Fig. 14 (a horizontal projection), vertical and about 75 yards from *G*, the rough surface of the ground-glass; and another staff, *S'*, also vertical about 10 yards from *S*, and so that *SS'* shall be perpendicular to *PS*. Having drawn a vertical line through the middle point of *G*, focus *S* upon it; measure *PS*,—the horizontal distance between *G* and *S*,—*SS'* and *ss'*: then from the similar triangles thus formed, *Os* or *OP* : *ss'* :: *OS* : *SS'*; *OP* : *ss'* :: *OP* : *ss'*; whence  $2OP : 2ss' :: OS + OP : SS' + ss'$ ; by substitution,  $OP : ss' :: PS : SS' + ss'$ ; therefore

$$OP = \frac{PS \times ss'}{SS' + ss'}$$

e.g.:  $PS = 75$  yards,  $SS' = 10$  yards, and  $ss' = 2$  inches; then  $OP = \frac{75 \times 36 \times 2}{10 \times 36 + 2} = 14.92$  inches, very nearly, near enough for practical purposes.  $ss'$  can be measured either by exposing a sensitive plate and applying a scale of equal parts to it after development; or on the rear surface of the ground-glass, by carefully marking off on the edge of a



strip of white paper, the distance  $ss'$ , and applying the scale; in any case,  $ss'$  and  $SS'$  should be measured in the same direction.

II. Having set up and levelled the camera, focus two points, as  $S$  and  $S'$ , Fig. 14, 75 or 100 yards distant, and so disposed that their images on the ground-glass will be separated horizontally by a distance of about one third of its breadth. Make one image, as  $s$ , coincide with the middle vertical of  $G$ ; and measure the distance  $ss'$ . Remove the camera; set up a transit or other angle-measurer at  $O$ , and measure the angle  $SOS' = sOs'$ , which denote by  $a$ ; then

$$OP = \frac{ss'}{\text{tang. } a} = ss' \cot. a.$$

III. It is a well-known principle of optics that when the sizes of image and object are equal, the distance between them is four times the equivalent focal distance of the lens. Therefore, to measure  $OP$ : construct upon a sheet of white paper two right lines at right angles to each other; from the point of intersection as a centre, and with a radius of about one third of the shorter side of the ground-glass, describe the circumference of a circle, and fasten the sheet to a vertical wall or board; set up and level the camera in such a position that the image of the centre of the circle shall be in the optic axis,—the middle point of the ground-glass when the objective-slide is in its normal position (see par. 14); and focus so that the construction on the paper, and its image, shall be of equal size, which condition can be ascertained by the application of a pair of dividers. Remove the objective and measure the distance from the ground-glass to the paper: one fourth of this distance is the required value of  $OP$ . This method usually requires a long camera, or an extension piece in front to hold the lens.

Whenever the focal distance is determined by Method I. or II., the positions of the parts of the camera, especially that of the back or front according to which one of these is made to traverse, should be indicated by marks carefully made upon the metal mountings, so that this adjustment can be readily made at any time.

By Method III., the position of the optic centre can be indicated upon the objective-tube by first replacing the latter, and then setting off from the paper one half the distance between paper and ground-glass, or  $2OP$ . It can also be indicated in Methods I. and II. by means which will suggest themselves.

14. *The Determination of the Horizon, or  $HH'$ .*—First find the middle point of the ground-glass,—which is readily done by drawing its two diagonals,—and through it draw two right lines parallel to a horizontal and a vertical edge respectively of the ground-glass frame. These edges should be perpendicular to each other; but if, through faulty construction of the frame, they are not so, then set up the camera and level it, and, with the aid of a carpenter's level, locate the horizontal line which passes through this middle point, and draw it; and also draw a vertical line through the same point.

The camera being set up and levelled, focus on a distant point, previously ascertained with a surveyor's level to be on a level with this horizontal line, and move the objective-slide up or down until the image of the distant point is cut by the horizontal. The objective, or objective-slide, is now in its *normal position*, and  $HH'$  will evidently pass through the middle point of a view taken under these conditions.

It is apparent that the amount of sky or of foreground in the view can be changed by raising or lowering the objective, and that this condition usually enables the surveyor to adjust his camera so as to include all the features required, whether the station be elevated or depressed with reference to the surrounding features; but in moving the objective-slide from its normal position,  $HH'$  will no longer pass through the middle point of the view, and some means are necessary for determining its true position.

A simple device for determining  $HH'$  under these conditions is as follows: The right-hand part of Fig. 15 represents a vertical section through the optic axis,  $G$  the

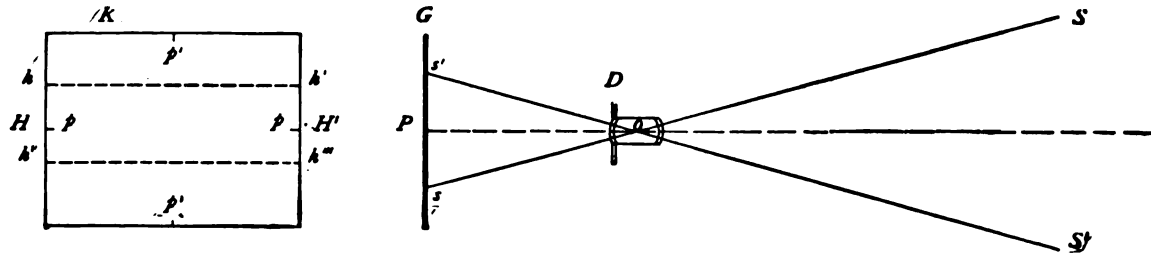


FIG. 15.

ground-glass,  $D$  the objective-slide; and  $K$  represents the plate-holder, or, in case of a small plate, the kit (a frame fitting within the plate-holder) used to hold it. (See also  $H$ , Fig. 9.) When  $D$  is in its normal position and an exposure made,  $HH'$  is imaged upon the negative, and therefore upon the print taken from it, by means of the needle-points  $p$  projecting from the middle points of the vertical edges of the holder or kit, and immediately in front of the sensitive plate.

The points  $p'$  similarly mark the position of the middle vertical. The author has made use of fine cambric needles, reduced to about one third of their length, and heated, before insertion, to prevent breaking when the plate was pressed against them. For needles, metal triangular pieces might be substituted, the plate resting upon them. The true positions for the needle-points may evidently be found in a manner similar to that described for drawing the horizontal and vertical upon the ground-glass, or by other simple means. It is apparent that when  $D$  is raised or lowered,  $HH'$  will rise or fall an equal distance, and will be found at, say,  $hh'$  or  $h'h''$ . To measure this vertical interval,  $Hh$  or  $Hh''$ , construct on the front of the camera a scale of equal parts, as shown at  $c$  in Fig. 16, and an index, which may be an edge of the strap  $r$ , on the slide will then mark the division denoting the required interval.

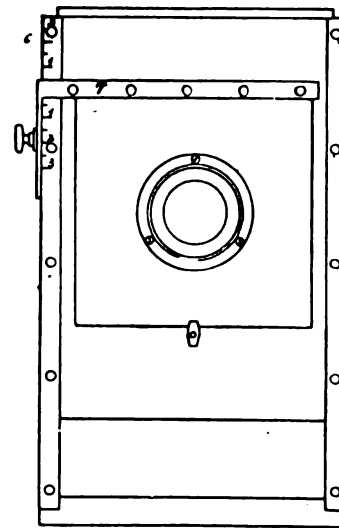


FIG. 16.

The index should mark 0 when the slide is in its normal position, and the divisions above and below be considered as positive and negative respectively. By this construction  $HH'$  may be fixed upon any negative or print by setting off vertically in the proper direction, from each of the marks produced by the needle-points  $p$ , the distance measured by this scale, and joining the outer extremities by a right line.

It is apparent that any truly-horizontal line of a print or negative may serve for the measurement of horizontal angles; but the needle-points usually mark  $HH'$  through the middle point, and since paper prints are subject to distortion by chemical manipulation (see also par. 32), this position is likely to give more exact measurements. (For another method of determining  $HH'$ , see close of par. 20.)

15. *Measurement of the Field of View.*—The extent of the field of view of the camera is an important element in surveying, since it determines the amount of the visible landscape that can be included in the photograph. It is measured, horizontally, by the angle included by right lines drawn from the optic centre to the extremities of  $HH'$ ; and, vertically, by right lines from the optic centre to the extremities of the middle vertical of the ground-glass. The horizontal field of view is therefore twice the angle of which the tangent is  $\frac{1}{2} \frac{HH'}{OP}$ , and the vertical field is twice the angle of which the tangent is  $\frac{1}{2} \frac{\text{middle vertical}}{OP}$ ; e.g., if  $HH' = 9.6$  inches and  $OP = 16$  inches, then

$$\frac{1}{2} \frac{9''.6}{16''} = \frac{9''.6}{32''} = 0''.3,$$

which practically is the tangent of  $17^\circ$ ;  $\therefore$  the horizontal field of view =  $34^\circ$ .

This element may be determined graphically by constructing the angle on paper, and then measuring it with a protractor.

This is evidently the field of view for the particular camera to which the objective is attached, and a like construction gives it for any sized plate. To measure the field of view of the objective; use, instead of  $\frac{1}{2}HH'$ , a radius of the circle of light formed on the ground-glass, when the objective is attached to a camera larger than that to which it is suited.

Owing to the defects, due to development, nearly always existing along the edges of a plate, it is advisable in the above measurement to make an allowance of  $2^\circ$  or  $3^\circ$  for any plate. It is seldom that the vertical field is insufficient.

When haste is an important element, a wide-angle objective, of which the focal distance is much less and the field therefore much wider, may be used to great advantage. In Dallmeyer's  $8 \times 10$  rapid rectilinear,  $OP$  is  $13''$ , affording a field of about  $38^\circ$ ; while in his  $8 \times 10$  wide-angle rectilinear,  $OP$  is  $7''$ , and the field is about  $54^\circ$ ; therefore with the former, 10 plates would be required for a complete tour of the horizon; but with the latter, only 7 plates are needed.

16. *Test of an Objective for Distortion.*—To ascertain beyond a doubt that the objective is free from distortion throughout the entire field of view assigned to it, a modification or extension of the method used for measuring  $OP$  (par. 13) may be employed. Thus, in Fig. 17, a horizontal projection, place additional vertical staves at  $S''$ ,  $S''' \dots$  in  $SS'$  prolonged, the number and location being such that their images  $s''$ ,  $s''' \dots$  are well distributed along any line of  $G$ , one of them being near each of the vertical edges of the latter, and  $s$  being on the middle vertical.

Measure, horizontally, the distance from  $S$  to each staff; expose a plate, and, on the developed negative, project  $s$ ,  $s' \dots$  into  $HH'$ ; from  $OP$  and the tangents  $ss''$ ,  $ss'' \dots$  determine the angles  $sOs''$ ,  $sOs'' \dots$ ; then compare these angles with  $SOS''$ ,  $SOS'' \dots$ ,

computed from the radius  $OS$  and tangents  $SS'''$ ,  $SS''$  . . . . The corresponding angles of the two sets should be equal. Or simple proportions may be used; thus,  $ss'''$  should be to  $SS''' :: Os$ , or  $OP, : OS$  . . . .; or an angle-measurer may be substituted as in measuring  $OP$ .

To be very accurate, revolve the objective  $90^\circ$  and repeat the operation.

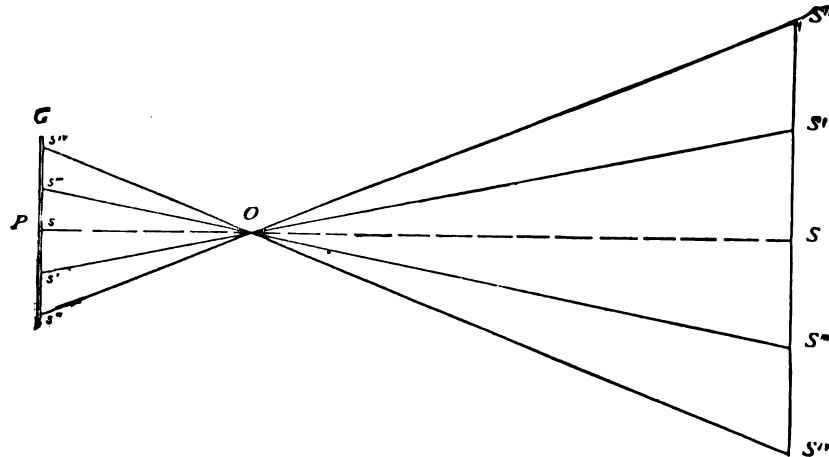


FIG. 17.

Another method is as follows: Subdivide a rectangle, constructed on a flat surface, into equal squares; make the dispositions prescribed in III., par. 13, for paper and camera; and compare the different sides of the squares with their images. When a value for  $OP$ , less than that given in III., par. 13, is employed, it is only necessary that these images should be proportional reductions of the original squares. For convenience, the sides of the rectangle should be proportioned to the edges of the ground-glass; and, in focussing, their images should lie near these edges.

17. *Exposure, Development and Printing.*—Before proceeding to the Field-work, a brief description of the operations which result in a “view” photograph suited to surveying purposes may be found serviceable. For fuller details of manipulation, reference may be made to Manuals of Photography.

(a) *The Exposure.*—The camera is placed firmly upon its tripod, levelled, and pointed toward the subject; the back or front, according to which of these is made to traverse, is then adjusted to the mark corresponding to the focal distance (see close of par. 13); the objective-slide is so disposed that the image will occupy the most favorable position upon the ground-glass, and the index number of the slide is noted. The proper stop is then placed in the objective; the latter is capped to exclude the light, and the plate-holder, containing the sensitive plate, is inserted. The levelling should now be verified. The shield is then withdrawn, the cap is removed for a period corresponding to the sensitiveness of the plate, and atmospheric and various other influences soon observed in practice; the shield is now replaced. With a particularly rapid dry plate (sensitiveness 25) and a bright day, try the use of the smallest stop and an exposure of about half a second. (See also par. 23.)

(b) *The Development.*—A printed circular, giving the process of development best suited to each of the many kinds of dry plates manufactured, usually accompanies each box of plates; but the following is a simple and good one:

In the dark-room, remove the plate from the holder and wash it for half a minute under the tap; then develop with the following solutions:

No. 1,—a filtered sat. sol. of oxalate of potassa + a few drops of oxalic acid.

No. 2,—a filtered sat. sol. of sulphate of iron + a few drops of sulphuric acid (C. P.).

To four parts of No. 1 add one part of No. 2, first diluting each separately with half its bulk of water; place the plate, film up, in a shallow porcelain or japanned tray, and cover it quickly with this developer; keep the liquid in motion by gentle rocking, and develop until some of the details are visible on the glass side; then wash the plate a minute under the tap, and place it, film up, in the fixing-bath, composed of hyposulphite of soda 1 part + alum  $\frac{1}{8}$  part + water 5 parts; when clear, that is when the white film has disappeared, leave it a few minutes longer in this bath, and then place it in running water, where it should remain at least one hour (five hours are better). The resulting negative is then permitted to dry spontaneously. A few drops of a 15-gr. solution of bromide of potassium in water, added to the developer, will sometimes result in giving more of the finer details; and distant mountains may be brought out with greater clearness by brushing them once or twice, using a camel's-hair brush, with a 5-gr. solution of this bromide during the development. A clearing solution is sometimes needed after fixing; but is oftener needed with pyro than with iron developers.

(c) *The Printing.*—Albumenized paper is lightly rubbed smooth with a Canton flannel pad; then sensitized by floating it about 2 minutes on a silver bath of 50 gr. to the oz.,—care being taken not to let the solution touch the back of the paper. It is then, after thorough drying, exposed in a wooden box to the fumes of strong ammonia, for from 30 to 40 minutes—the shorter period in warm weather. The negative having been placed, glass face outward, in a printing-frame, Fig. 18, a piece of sensitized paper of suitable size is laid carefully

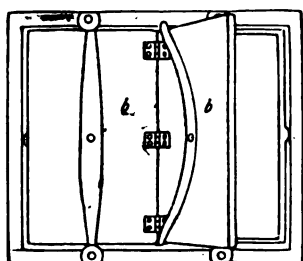


FIG. 18.

on the film; the back, *b*, is pressed down and secured, and the frame is exposed facing the sun, or bright sky, until the lines of the print are slightly bronzed, which condition may be observed by means of the hinged sections of the back. When a sufficient number of prints have been made, they are washed in running water for about 5 minutes; then put in a bath of salt 1 part + water 50 parts, until the lines turn red; they are then "toned" with chloride of gold, 1 gr. to each sheet of paper, made by adding this to a solution

of borax 1 part + water 80 parts—a sufficient quantity to contain the prints; they are left in this bath and kept continually in motion until the red lines turn black; then washed a few minutes, and placed in the fixing-bath, same as for plates, and left 10 minutes. They are then placed in a strong solution of salt and water for 10 minutes, and finally are washed for about 5 hours in running water. After drying, trimming and mounting, they become the ordinary landscape photographs.

Other and simpler processes for printing, such as the "blue-process," using a negative to print from, may be resorted to; and in most cases afford results sufficiently good for the plotting.

## THE FIELD-WORK.

18. *General Considerations.*—The general principles of ordinary surveying apply in the field-work; the main conditions to be fulfilled in order to ensure satisfactory results being the selection of suitable points of observation, or stations, and the proper distribution of the stations to obtain favorable intersections and to economize time.

The three following methods of working are described:

- I. With the Camera, when the triangulation has been established.
- II. With the Camera and Hand-compass.
- III. With the Camera alone.

19. *Selection and Distribution of Stations.*—The photographs obtained should embrace, as far as possible, all of the features to be represented upon the finished map. This is of easy accomplishment when commanding points exist, and easier than might at first be supposed when the tract to be represented is comparatively level. What is considered covered ground in ordinary surveying presents no greater difficulty here; e.g., in the case of a heavily wooded section of the tract, in working with transit or compass, salient points only of the outlines are usually exactly located from the commanding stations, the rest being filled in by eye; while in photographic work, with usually no additional labor in the field, every visible curve and detail of these outlines may be plotted from the photographs should it be desirable so to do.

As in ordinary surveying, meanders with prismatic compass and note-book are occasionally needed, more especially to prevent multiplication of photographs in cases of views being obscured by the interposition of abrupt salients or spurs; and, as in the case above given, to represent roads or paths through the covered ground.

The intersection of lines very oblique to each other does not fix a point with clearness;

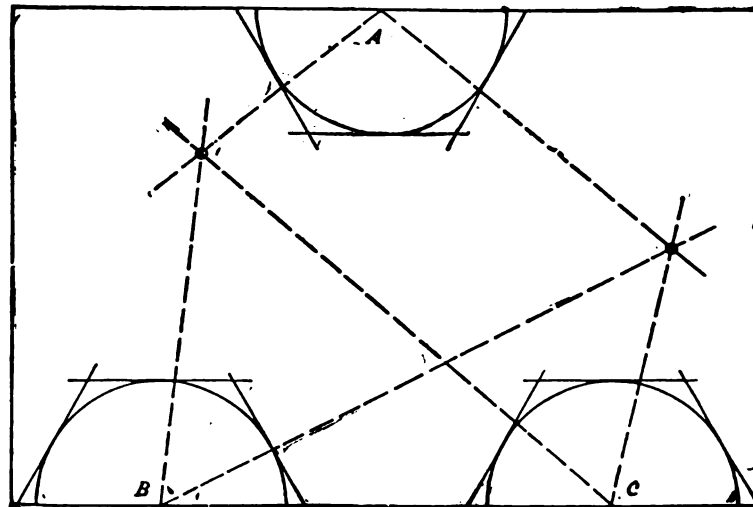


FIG. 19.

the most favorable intersections, in the case of two photographs of the same section, will be afforded when the photographs are taken from stations, so disposed with reference to each other, that, in the exposures, the optic axes produced would intersect at a right angle; between these limits there is a wide range for selection, and on this selection, or choice of stations, the successful result greatly depends. For an ordinary tract of, say,  $3 \times 4$  miles in extent, three stations disposed, as shown in Fig. 19, at the vertices *A*, *B* and *C*

of an approximately equilateral triangle, would doubtless give the best result. If the borders do not contain commanding points, three interior stations similarly disposed might prove equally good; but, on account of the resulting wider field at the different stations, more plates would usually be needed.

An important element in this selection, when exact work is required, is that check-lines shall be afforded for all important points; in other words, and as above illustrated, that each of these points shall be found upon one photograph from each of at least three stations.

As to economy of time, and that of plates also may be added, this rests principally upon the judgment exercised in the grouping of the stations. It is unnecessary that any point to be represented should appear oftener than as above stated; and practice shows that the best arrangement of the stations is in groups of three, each one of a group facing, and the exposures at that station being confined to, the same section of the tract. An application of this principle is afforded in selecting for stations the vertices of triangles in a triangulation system; a complete tour of the horizon would then usually embrace several triangles.

20. *First Method—With the Triangulation Previously Established.*—The method of development, from a measured base, of a system of triangles or quadrilaterals, of which the vertices are exact positions of prominent points, is too well known to require a description here; it is only necessary that this system should be adapted to the present purpose,—that the positions of the stations should meet the requirements stated in par. 19.

The stations having been established, and the photographer furnished with a tracing of the triangulation sheet in which they are alphabetically marked, the work is begun preferably at one which has an exceptionally good command; for this may lessen the number of exposures which might otherwise be required from one or more adjacent stations, without diminishing the number of checks required for good work. A tour of the horizon, or so much of it as may be needed, is then made, working systematically here, as at all other stations, from left to right. The exposures are recorded in their order of completion  $V_a^1, V_a^2, V_a^3, \dots$ , the sub-letter referring to the station. Since the plate-holder shields are numbered in the natural order 1, 2, 3,  $\dots$ ; if the contained plates are exposed accordingly, mistakes will be obviated, means will be afforded in the plotting, as will be hereinafter shown, for properly locating the different views, and the work can be plotted by those not present at the field-operations.

The following-described method of working and form of record were employed with good results by the author:

The camera is set up, pointing in the general direction of the left-hand view; adjusted to the focal distance; levelled approximately; then carefully pointed so as to include the objects on the extreme left; the objective-slide is then adjusted so that the vertical field shall include the important features, and its index number is recorded. The plate-holder is now inserted; the camera levelled accurately; the exposure is made, and the bearing of the optic axis as indicated by the compass is also recorded.

The camera is then turned to the right for the next view, and in this operation care is taken to include in the second view the objects on the extreme right of the field in the first; this is necessary for reasons given in par. 15, and because this double representation serves a purpose in the plotting (see par. 26); a second exposure is then made with the same precautions as before observed, and so on for the remaining views.

The form of record employed is here given.

| STATION. | VIEW. |               |          | REMARKS. |
|----------|-------|---------------|----------|----------|
|          | No.   | Index Number. | Bearing. |          |
| A        | 1     | 0             | 195½     |          |
|          | 2     | 0             | 227      |          |
| ..       | ..    | ..            | ..       |          |
| B        | 1     | - 2           | 84       |          |

The index number of the objective-slide is frequently the same for all views taken at any one station.

In this instance, a detached hand-compass was used; as soon as the plate-holder was withdrawn, the bearing of a point of the image of any prominent object, cut by the middle vertical of the ground-glass, was taken, and a description of the point was recorded either verbally or by a rough sketch (see Fig. 20), sufficiently intelligible to be recognized in the developed negative. Since this vertical extended throughout the field, no difficulty arose in finding some object projected upon it and well disposed for the purpose. It is apparent that the bearing indicated by an attached compass immediately after the exposure, and before the camera is disturbed by withdrawing the plate-holder, is likely to be more exact.

From a consideration of the foregoing, it is seen that with suitable appliances the camera could be auto-

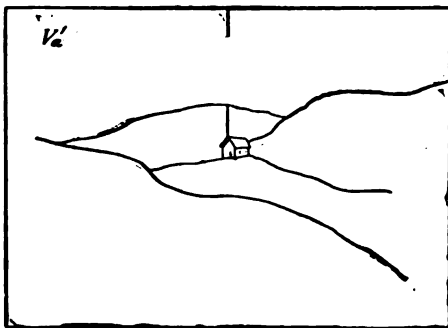


FIG. 20.

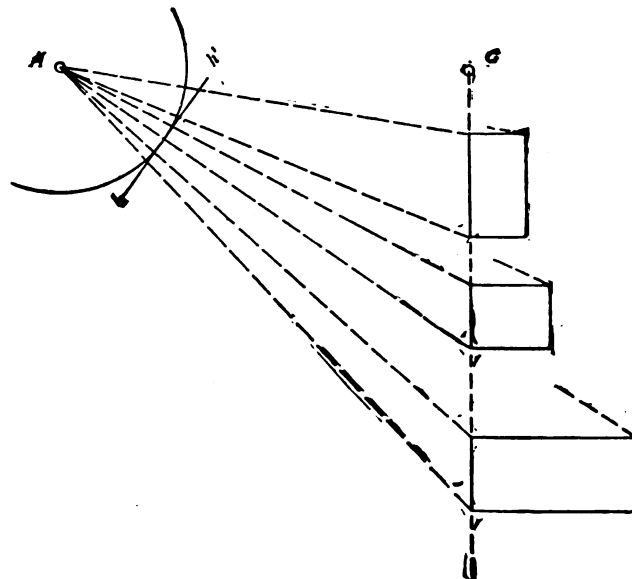


FIG. 21.

matically checked in its revolutions, for the different fields in succession; or, a horizontal limb might be added and the arc of revolution measured by it, thus requiring but one bearing for a set of views from any station.

A judicious use of the hand-compass may frequently serve to diminish the number of views otherwise required. Thus, in Fig. 21, the buildings are located by means of the view from station A, supplemented by the compass bearing of the front line taken from any point of it, as C, which has been fixed by interpolation, or otherwise, from stations



already determined. This line evidently intersects the lines of direction from  $A$  in required points of the buildings; similar applications of the compass will suggest themselves.

The needle-points  $pp'$ , Fig. 15, could be dispensed with and the horizon, or  $HH'$  of a print, be otherwise determined as follows: At the station from which any view is taken, measure with a hand-clinometer the angle of elevation or depression of a prominent point, situated near the right and left vertical, respectively, of the field of view—a third point would serve as a check, and its vertical angle should therefore be measured; take also from this station and from at least one other station the compass-bearings of these three points, so that their plan may be constructed. Set off, in the proper direction from the image of each point on the print, a vertical equal in length to the natural tangent of the corresponding angle  $\times$  distance from station to its horizontal projection; then the right line joining the outer extremities of the verticals will be the required horizon. It is apparent that, by a simple graphical application of the "three-point problem," the three compass-bearings taken as here described might also serve to orient the projected horizons on the plot.

21. *Second Method—With Camera and Hand-compass.*—There being no previous tri-

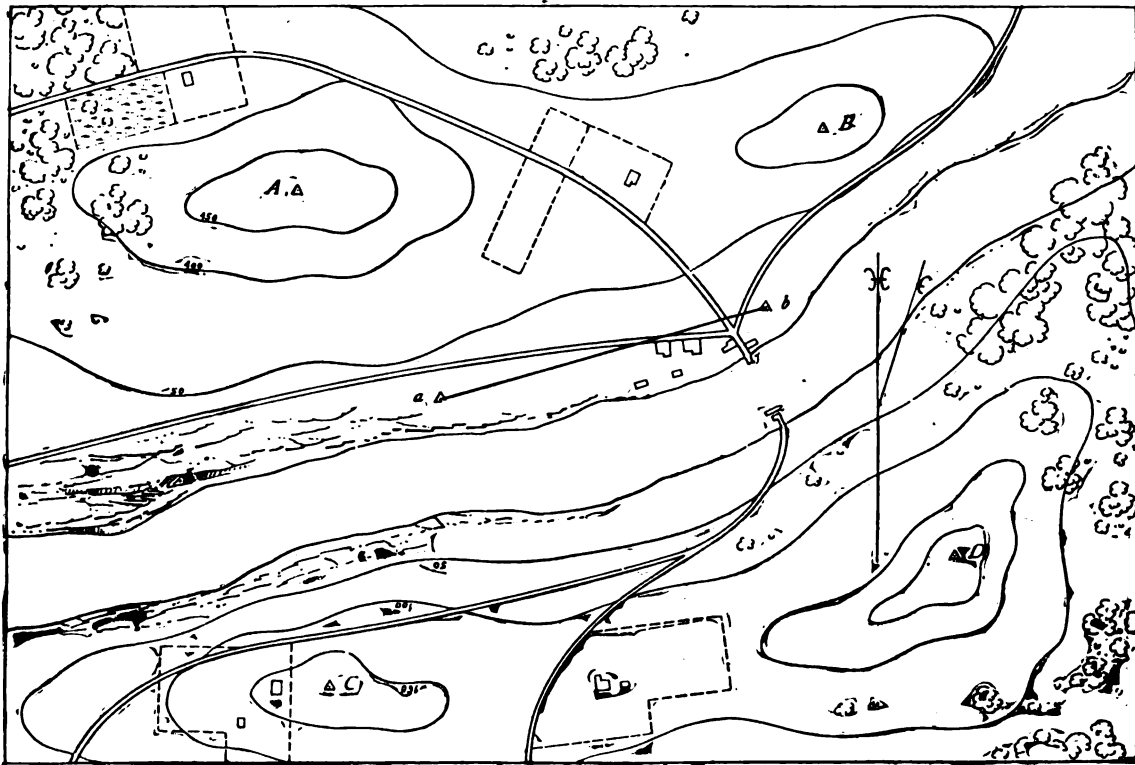


FIG. 22.

angulation in this case, the stations are determined by intersecting compass bearings taken as the work progresses, the details of the photographic work conforming to those of Method I.

Thus, as illustrated in Fig. 22, beginning at  $A$ , a tour of the horizon, or so much thereof as may be needed, is made; and, if no natural signal exists by means of which the camera's position at  $A$  may be subsequently recognized from at least one other station, as  $B$

or *C*, an artificial signal is set up; this may be a white or black flag according to the nature of the background as viewed from the second station, whether earth or sky respectively. Proceeding to *B*, another tour is made and the bearing of *A* taken. If a suitable position for the camera at *C* or *D* can be discerned from *B*, its bearing is also taken; and, as a rule, *on reaching any station, the bearing of every other station to be subsequently occupied, or which has already been occupied, when its position can be discerned, should be taken and recorded.*

Interpolation by compass-bearings is of much use here; e.g., referring to the preceding figure, *C* is fixed if from it the bearings of *A* and *B* are taken, since these bearings if plotted at *A* and *B* and produced must intersect at *C*.

The bearings evidently serve to locate the stations in their proper relative positions, the only element lacking to plot to any required scale being the exact length of some line represented in the view. This element may be supplied, as in ordinary triangulation, by the measurement of a side as *AB*; or a shorter distance as *ab* may be measured and the points *A* and *B* fixed by intersections; in either case the measured distance is plotted according to the desired scale, and is the base of development for the plotting.

Plotting to scale may also be effected as illustrated in Fig. 23. Assume two points, as *A* and *B*, in their true directions with reference to each other, but with the intervening distance taken at pleasure; then, starting from these points, plot the extremities *a* and *b* of a distance which has been measured on the ground; also plot some contained point, as *C*, used as a station. Construct the triangle *ABC*; and from *a* set off toward *b*, *ab'* = the measured distance reduced to the required scale; then from *A* set off

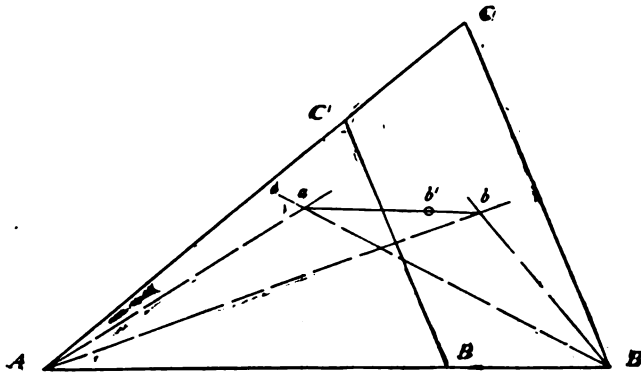


FIG. 23.

$AB' = \frac{ab' \times AB}{ab}$  and through *B'* draw a line parallel to *BC*; *B'* and *C'* thus determined are the required positions of *B* and *C* for the given scale, and the triangle *AB'C'* forms a basis of development for the plotting.

22. *Third Method—With Camera only.*—In this case, it is best to start from a measured base. With an attached compass, the bearings of *OP* for the different views serve to orient the views on the plotting sheet. The case in which a compass is used for orienting only, and that in which it is dispensed with altogether, require no further description than that given for the plotting in "Special Cases of Orientation," par. 26. In regard to the stations, careful attention should be paid to occupying those points only which may be clearly recognized in the views taken from adjacent stations; and in this respect it is best to have at all stations visible signals, natural or artificial, which present a strong contrast to their surroundings. With ordinary care this method is quite accurate, and may often prove the only one available; but, on account of the independent data afforded, the addition of compass-bearings, of at least the stations, is advisable.

23. *Best Time for the Field-work.*—As to the season of year: for wooded tracts, the best time is undoubtedly the Spring or Fall, when the leaves are off the trees and the range of view is thereby very much increased; the Winter season also often affords favorable opportunities. For tracts not wooded, or with scattered trees only, there is but little choice. The dry plates now made can be used in all seasons with equally good effect.

As to the time of day: the main rule to follow in visiting the different stations is to so arrange the route, that at any station the camera may be pointed toward the sun as little as possible. The most favorable direction of the sun's rays is from the right or left, and rear, of the instrument; in some cases, however, as in that of hilly or undulating ground, it is of advantage to have them in a direction nearly perpendicular to the optic axis, thus giving the elevations and depressions greater prominence by the addition of their visible shades and shadows. In this respect, a little observation of the relative degrees of clearness with which various portions of a landscape are seen, under different degrees of inclination of the sun's rays, will prove of value. Bouguer's table of the intensities of solar rays corresponding to different altitudes of the sun is very instructive here, and is given below; 10,000 represents the intensity in a perfectly transparent atmosphere.

| SUN'S ALTITUDE. | INTENSITY. | SUN'S ALTITUDE. | INTENSITY. |
|-----------------|------------|-----------------|------------|
| 0°              | 6          | 20°             | 5474       |
| 1               | 7          | 25              | 6136       |
| 2               | 192        | 30              | 6613       |
| 3               | 454        | 40              | 7237       |
| 4               | 802        | 50              | 7624       |
| 5               | 1201       | 70              | 8016       |
| 10              | 3149       | 90              | 8123       |
| 15              | 4534       |                 |            |

Since the actinic effect of solar rays is directly proportioned to the length of time during which they act, the variations above given must be mainly due to the different distances traversed in the atmospheric envelope; for the same reason, and because of the less density of the atmosphere, exposures made in mountainous or elevated tracts should be of less duration than at the sea-level. According to this table, exposures made, for example, at 8 A.M. and 4 P.M. should be of the same duration; but, in practice, it is found that, owing to the comparatively greater amount of moisture at the latter hour and the consequent partial absorption of the ultra-violet rays, the second exposure should be of greater duration. It is also observed in landscape-photography that the actinic effect of light reflected from white clouds is even more powerful than that of a perfectly clear sky; bringing out the details of deep valleys with great clearness.

As to the weather: a very clear atmosphere frequently exists in Winter, and usually after a storm during all seasons.

On account of the extreme rapidity of the field-work as compared with that of any

of the other methods of surveying, it is seldom that the surveyor may not take advantage of the most favorable conditions and circumstances.

THE PLOTTING.

24. *General Considerations.*—The plotting of a survey consists of the two following distinct operations:

I. Constructing the plan, or the horizontal projections of the different points and lines;

II. Determining the heights of points with reference to the datum plane; and, as already described in par. 6, the result is the complete determination of these elements.

It seems hardly necessary to state here that the principles defined and illustrated in Section I., and there confined to a perspective drawing, apply directly to a photographic representation. Thus, in Fig. 24,  $V$  and  $V'$  represent respectively the relative positions, with reference to the point of sight, of a perspective drawing and a photographic representation; they are vertical and parallel, equidistant from  $O$ , and the right line  $POP'$  pierces each at its middle point; and since any point as  $D$  is projected

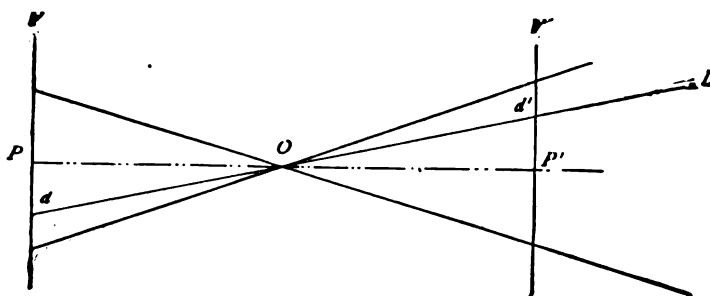


FIG. 24.

by the same visual ray in  $d$  and  $d'$ , which are equidistant from the middle points of  $V$  and  $V'$ , the two views are similar. Another consideration; since the maps are seldom constructed to a scale greater than  $\frac{1}{30000}$ , and because  $OP$  seldom exceeds 15 inches,  $\frac{1}{333}$  of an inch to this scale, it makes no sensible difference in the plotting whether in the field-measurements a station-point is directly beneath the optic centre of the lens, or beneath the ground-glass; to be strictly exact, however, it is apparent that the camera should be so constructed as to revolve about a vertical axis through the optic centre; and that in setting it up in the field the optic centre should be plumbed over the station-point.

25. *To Construct the Plan.*—Assume two views,  $V_a'$  and  $V_b'$ , Fig. 25, taken from the extremities of a given line,  $AB$ , and embracing the same objects. Having plotted  $AB$ ; from each extremity, with  $OP$  as a radius, describe circumferences as shown. Draw the radii  $AV_a'$  and  $BV_b'$ , making with the line of the magnetic meridian angles ( $20^\circ$  and  $280^\circ$  in the figure), equal respectively to the bearings of  $OP$  for the views; then the tangents  $hh'$ , at the extremities of these radii, are the required projections of  $HH'$ . This operation is termed the *Orientation of the views*.

All the points which are to appear in the plot having been projected on the respective horizons of the views (par. 5), and then transferred by means of dividers or otherwise, to the corresponding projections  $hh'$ , any point is plotted by simply drawing right lines from the plotted stations through the transferred projections, and producing them to intersection; thus  $c$ , the intersection of  $Ac'$  and  $Bc'$ ; and  $d$ , of  $Ad'$  and

$Bd'$ , are the required projections of the actual points  $C$  and  $D$ . If a view from a third station also contains these points, a check is afforded upon the accuracy of the plot.

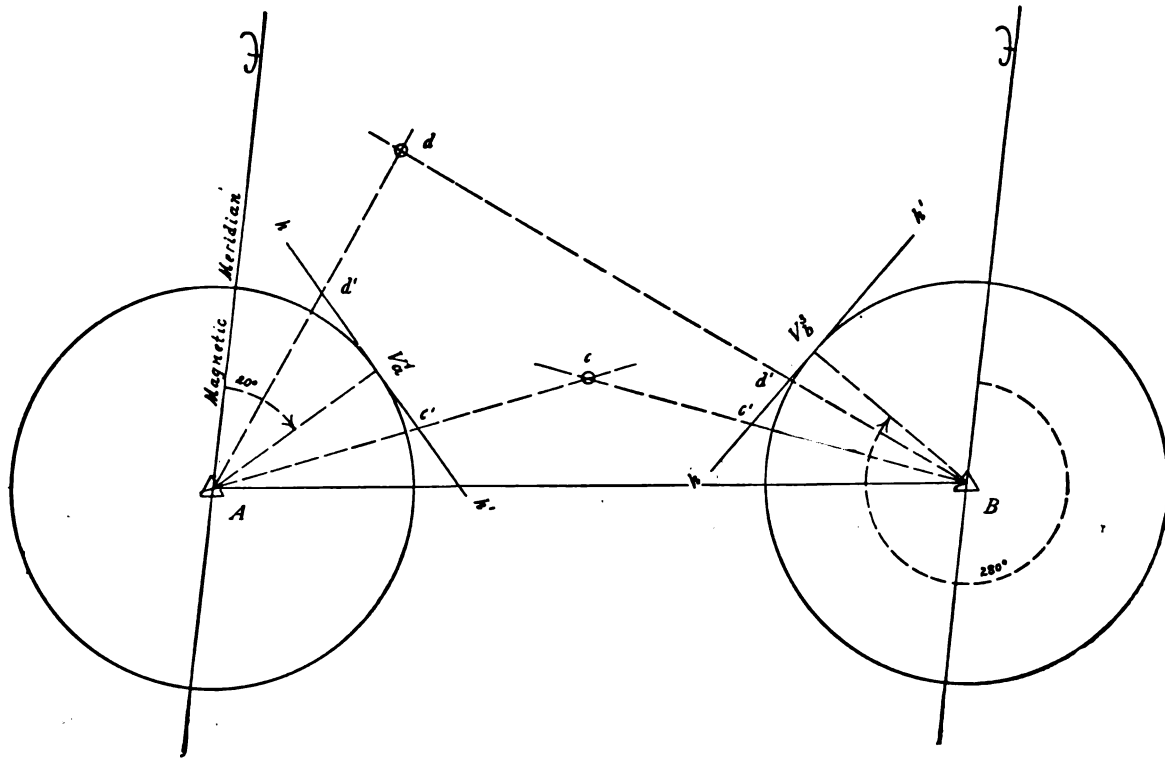


FIG. 25.

The plan of the entire survey is plotted in a similar manner; by first orienting all the views at their respective stations, and then fixing the required points by intersections as above.

26. *Special Cases of Orientation.*—I. Reference has been made to the necessity of

having the views overlap slightly. This condition may be utilized, not only as a check in the plotting, but also to orient the views when compass-bearings of  $OP$  have been omitted. Thus, in Fig. 26, let  $o'$  and  $o''$  be the representations of the same object on the consecutive views  $V_a^1$  and  $V_a^2$ , and suppose the compass-bearing of  $AV_a^2$  is unknown; to orient the second view, in other words to find the tangent-point of  $V_a^2$ : at  $d$  construct a tangent to the given arc, and on it set off  $dd'$  equal to the horizontal distance measured, on the second view, from the middle vertical to the image of  $O$ ; join  $d'$  and  $A$  by a right line; then will  $V_a^2$  be the tangent-point required.

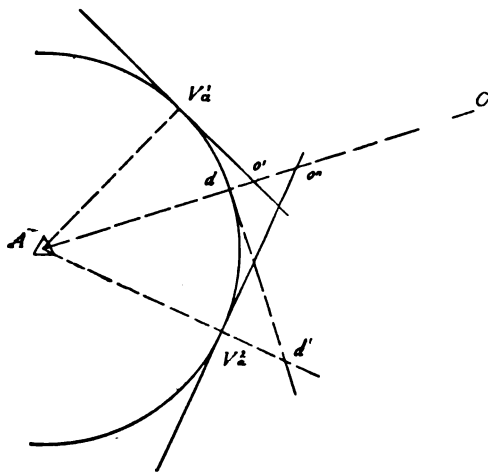


FIG. 26.

It is readily seen that in the other case, when the bearing  $AV_a^2$  is known, the check referred to is afforded by  $\sigma$  and  $o''$  being on the same line of direction.

II. When the compass-bearing of some line of direction other than the optic axis is given, as that of  $AO$ , Fig. 27;—*graphically*, plot at  $A$  the bearing of  $O$  as indicated; construct the tangent at  $p$ , and make  $pp'$  equal to the horizontal distance, measured on the print, from the projection of  $o$  to the middle vertical of the print; then  $Ap'$  will intersect the given arc at the tangent-point required: or, *trigonometrically*, since the horizontal distance  $pp'$ , or  $Vp'$ , is the tangent of  $V Ao'$  to the radius  $OP = AV$ ;  $\tan. VAo' = \frac{Vp'}{AV}$ , and  $V Ao'$  can then be obtained from a table of natural tangents; therefore first plot the bearing of  $O$ ; then protract  $V Ao$ , and the side  $AV$  will intersect the given arc at the tangent-point required.

III. In the case of confined space on the plotting-sheet: when the plotted station is near the border of the sheet, it may happen that the usual orientation would cause the work to fall outside of the sheet. This inconvenience can be avoided either by proportional reduction, or by reversing the position of the transferred horizon; thus, in Fig. 28,

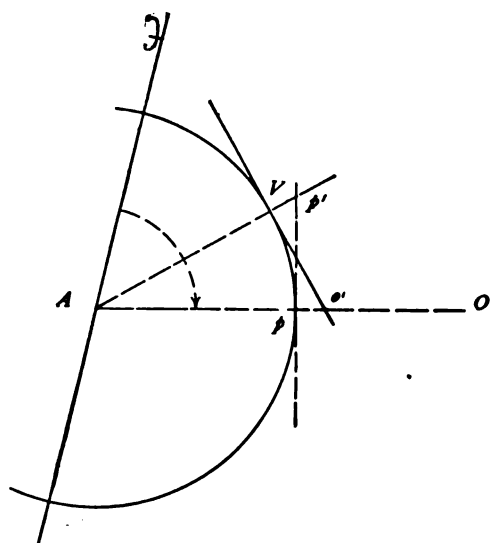


FIG. 27.

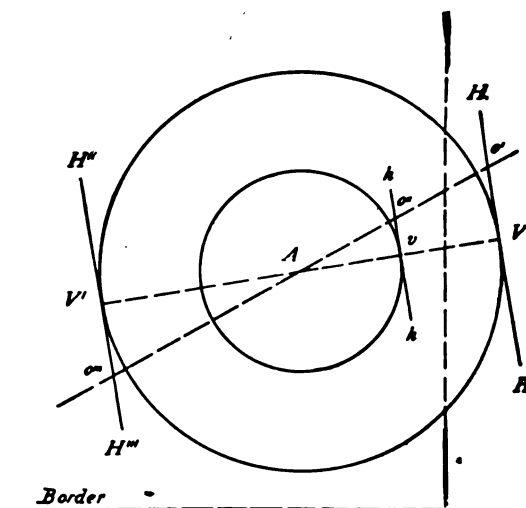


FIG. 28.

$AV$  is the direction of  $OP$ , and  $HH'$  falls without the border. With  $Av = \frac{1}{2}$  or  $\frac{2}{3} \dots$  of  $AV$ , as a radius, describe the interior concentric arc; at  $v$ , construct the tangent  $hh'$ ,—its length bearing the same ratio to  $HH'$  that  $Av$  does to  $AV$ : then with sector, proportional dividers, or otherwise, transfer the different horizontal distances, proportionally reduced, from the view to  $hh'$ : the required intersections are then found as heretofore described.

Or, by reversing the positions of the horizons; thus, at  $V'$ , the intersection of  $AV$  produced with the circumference, construct the tangent  $H''H'''$ . It is plain from inspection of the figure that in the transfer, the horizontal distances are now to be set off from  $V'$  in the reverse direction, e.g.,  $o'$  on the view falling at  $o'''$ —the line of direction remaining unchanged. When necessary, the horizon can be both reduced proportionally and oriented in reverse on an inner circumference.

IV. Suppose the camera to have been used independently of the compass. Thus,

in Fig. 29, if the view from  $A$  contains both  $B$  and  $C$ , and that from  $B$  both  $A$  and  $C$ : draw a right line  $AB$  representing the horizontal distance from  $A$  to  $B$  according to the scale of the map. With radius  $OP$  describe arcs as shown. Project the images  $a$ ,  $b$  and  $c$  on the horizons of their respective views. To orient the views:  $A$ ,  $b'$ ,  $a'$  and  $B$  must be contained in  $AB$ ; and  $C$  should serve as a check for accuracy. At  $t$ , the intersection of one of the arcs with  $AB$ , construct the tangent  $tg$ , in length = the horizontal distance from  $P$  (par. 4) to  $b'$ , measured on the print; draw  $Ag$ ; then will the tangent at  $p$  be the projected horizon,  $hh'$ , of the view from  $A$ .  $h''h'''$  is similarly constructed; and the subsequent plotting from these views is performed as already described for other cases.  $C$  being thus fixed, and the view from it embracing  $A$  or  $B$ , the plotting is extended as

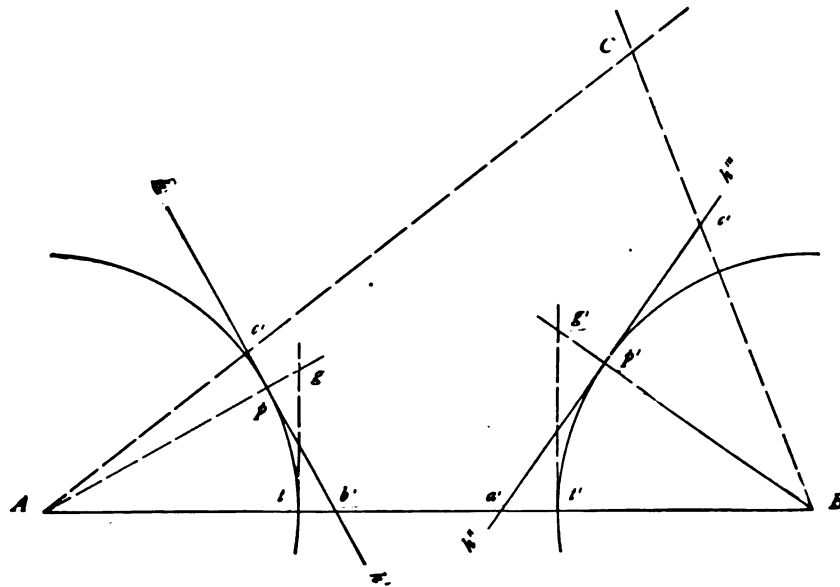


FIG. 29.

above described for the stations  $A$  and  $B$ ; and so on throughout the survey. It is observed that stations to be occupied must be so located as to be readily fixed by intersections from those already occupied. Numerous opportunities for checking will evidently be afforded. (See also par. 22.)

27. *To Determine the Heights, or References.*—The general expression for the vertical distances of points from a datum plane is (par. 6)  $H = \pm D \text{ tang. } @$ ; therefore, the plan having been constructed, in order to obtain the reference of any point from a view, it is only necessary to measure on the plot the distance from the station to the point and multiply it by  $\text{tan. } @$ .

A reference may be determined arithmetically, trigonometrically, or mechanically.

*Arithmetically:* Referring to par. 6 and Fig. 8,  $\text{tan. } @ = \frac{a'a}{Oa'}$ ; therefore measure  $a'a$ , or the vertical distance of the point from  $HH'$ ; divide this by  $Oa'$  and multiply the quotient by the plotted distance  $OA'$ ; the product is the required reference. *Trigonometrically:*  $a'a''$ , Fig. 6, being equal to  $a'a$  measured on the view, make the construction indicated in this figure; measure  $a'Oa'$  with a protractor; find the  $\text{tan.}$  of

this angle from a table of natural tangents, and multiply it by  $OA'$ . The *mechanical* determination is described in par. 29.

28. *Mechanical Measurement of Horizontal and Vertical Angles.*—To avoid linear constructions upon the negative or print, the author has devised a *tangent-glass*, which may be constructed as follows: select a flat, clear pane of glass, a trifle larger than the ground-glass of the camera; coat one face with white wax reduced by heat to a thin liquid; after the wax is poured on, it may be made to cover evenly by gently moving the glass back and forth over a lamp-flame. When cold, rule with a needle-point two right lines  $HH'$  and  $VV'$ , Fig. 30, exactly perpendicular to each other, intersecting at the

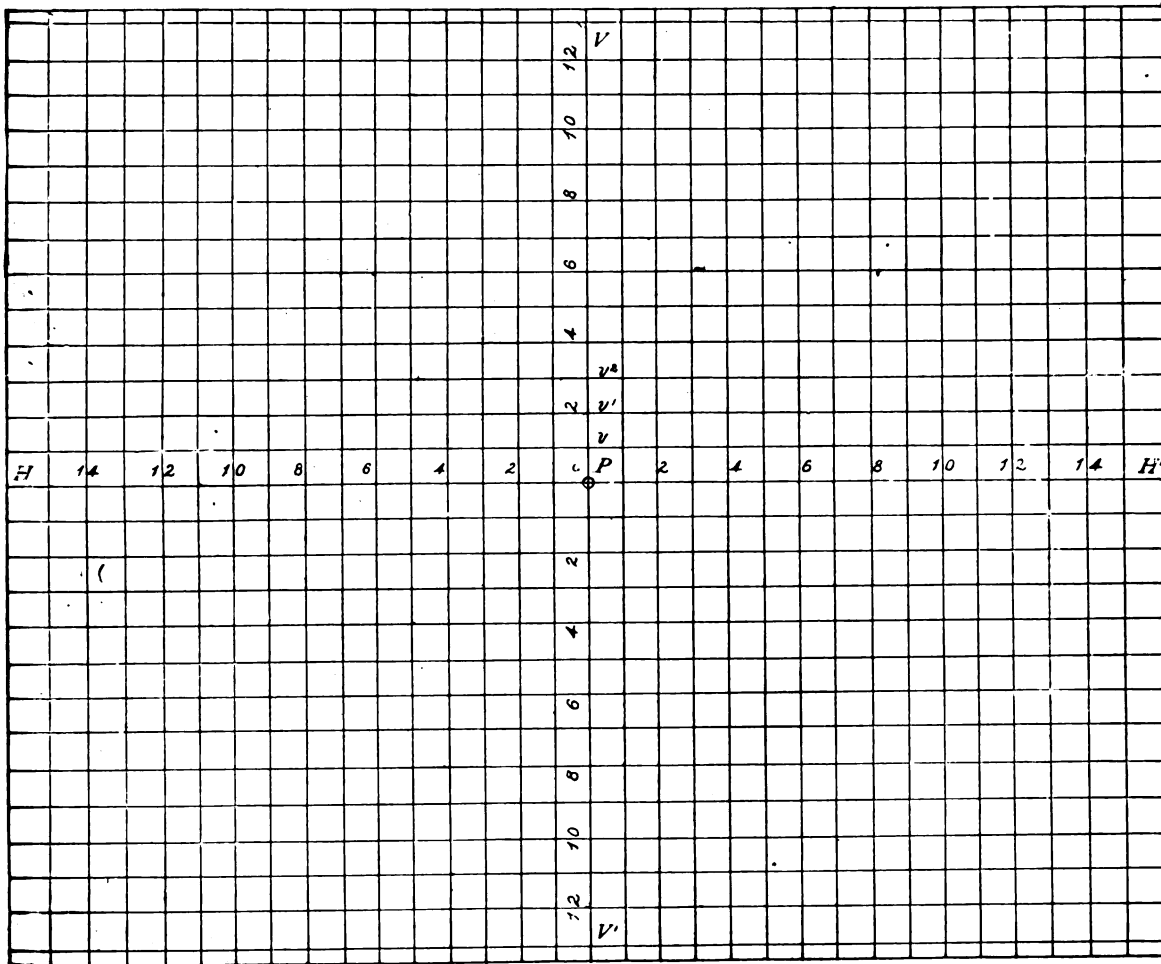


FIG. 30.

middle point  $P$ , and approximately parallel to the edges of the glass. From a table of nat. tangents, compute the tangents, to the radius  $OP$ , first of  $\frac{1}{2}^\circ$ , then of  $1^\circ$ ,  $1\frac{1}{2}^\circ$ , and so on, increasing by  $\frac{1}{2}^\circ$  for each computation, up to the number of degrees required to include half the vertical field of the camera,—full degrees only are shown in the figure. Set off these tangents,  $Pv$ ,  $Pv'$ ,  $Pv''$  . . . . , on  $VV'$  in each direction from  $P$ ; through their extremities,  $v$ ,  $v'$ ,  $v''$  . . . . , draw lines parallel to  $HH'$  and mark them as shown. Make a like construction of lines parallel to  $VV'$ . The ruled face is then exposed to the fumes of hydrofluoric acid, produced by adding sulphuric acid to fluor-spar in a leaden



dish. The dish may be made from sheet-lead, by bending up the edges to form sides about 1 inch in height, and should be a trifle smaller than the glass so that the latter may rest upon the edges and prevent escape of the fumes. When etched, the wax is removed and the tangent-glass is ready for use.

To ascertain a *horizontal angle*, it is only necessary to place the glass so that  $HH'$  shall cover the horizon of the print, and  $VV'$  the middle vertical; and then read off the required angle. This position of the glass is evidently assured by means of the images of the needle-points (par. 14);—also by location of a central point (par 20).

With the usual focal distance, the sides of the small rectangles are of sufficient length to admit of estimating to 6' of arc, which for a distance of 1 mile represents about 9 feet; but with the aid of a microscope, and a scale of hundredths of inches, angles of 1' are easily observed. For rough work, as in topographical sketching, the glass may be replaced by tracing-cloth,—the frame, Fig. 34, then coming in handily.

To ascertain a *vertical angle*: Referring to Fig. 31,  $HH'$  represents the middle hori-

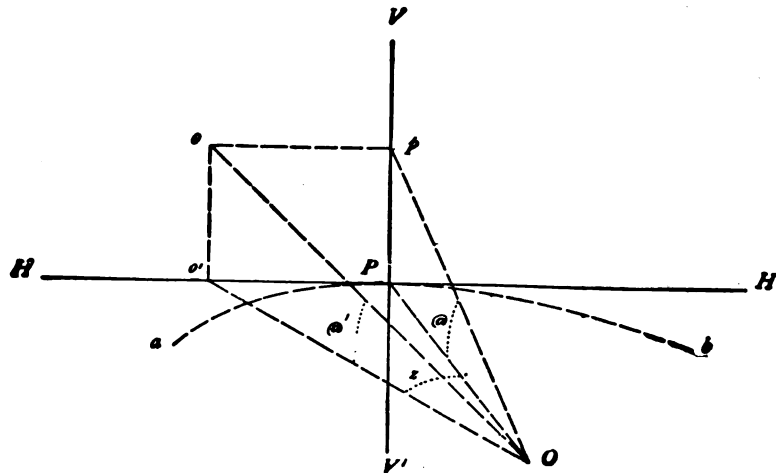


FIG. 31.

zontal, and  $VV'$  the middle vertical of the tangent-glass.  $ab$  is a circular arc in the plane  $HOH'$ ,—this arc evidently representing the intersection with this plane, of a cylinder of which the vertical axis passes through  $O$ , and of which  $VV'$  is the tangent element in the plane of the picture. From consideration of the figure, it is apparent that the only vertical angles which can be measured directly with the glass, on the view, are those of points contained in the plane of  $O$  and  $VV'$ ; and that to read the vertical angles of other points, it is first necessary to find their tangents, in terms of the radius  $OP$  and the azimuths; which may be effected as follows:

Suppose the tangent-glass laid upon the view as described for the measurement of horizontal angles, and  $o$  and  $p$  to be points of the view on the same horizontal. Denote the angle  $pOP$  by  $@$ , and the angle  $oOo'$ , which is evidently less than  $pOP$ , by  $@'$ ; also let  $z$  denote the azimuth  $POo'$ . Then to obtain the required value for  $\tan. @'$ :

$$\tan. @ = \frac{Pp}{OP}; \tan. @' = \frac{o'o}{Oo'} = \frac{Pp}{Oo'}; \text{ but } Oo' = \frac{OP}{\cos. z} = OP \sec. z; \therefore \tan. @' =$$

$$\frac{Pp}{OP \sec. z} = \frac{\tan. @}{\sec. z}; \text{ and since } \frac{1}{\sec.} = \cos., \tan. @' = \tan. @ \cos. z.$$

Therefore on stiff paper or card-board (or the glass might be of sufficient extent for the purpose) make the construction shown in Fig. 32, of which the part subdivided into rectangles is a duplicate of the upper half of Fig. 30. From  $P$ , on the middle vertical, set off  $PO =$  the focal distance; draw  $AB$  parallel to  $HH'$ ; and produce the verticals (not produced in figure) to meet  $AB$ . Let  $o$  be any point of the view, and  $o''$  the intersection with  $AB$  of the vertical passing through it: place a straight-edge, or scale of equal parts, on  $P$  and  $o''$ , and from  $P$  set off along the edge, indicated by the broken line,  $Po''' = o'o$ :

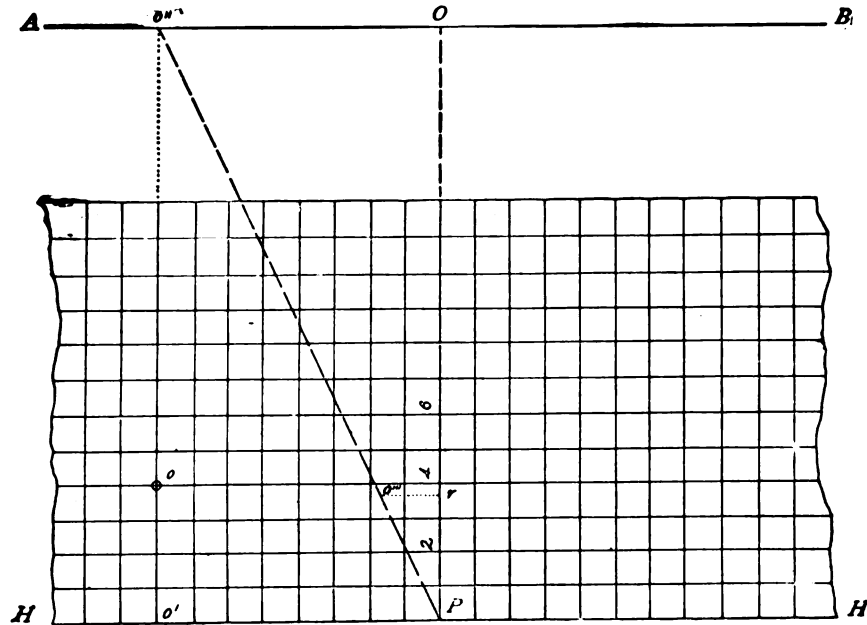


FIG. 32.

the required vertical angle of  $o$  will then be indicated by the horizontal passing through  $o''$ . For,  $Pr$  is the cos. of the angle  $o''Pr$ ; and, since  $\cos. = \frac{\text{base}}{\text{hypotenuse}}$ , the base or  $\tan. @' = \tan. @ \cos. z$ , as above. This scale may be termed the *vertical angle scale*; and, for a short focal distance, may be conveniently etched upon the same glass with, and as an extension of, the tangent scale.

29. *Mechanical Measurement of Heights.*—The vertical angles determined, another scale which may be called the *scale of heights* can be used for the lineal measurements. Let  $CD$ , Fig. 33, represent the scale of distances used in the construction of the plan. From the  $o$  extremity as a centre, and with a convenient radius, describe a circular arc, which subdivide into half degrees (whole degrees in the figure), and draw radials as shown. To measure the height of any point, as  $O$  in the preceding figure: measure its horizontal distance on the plot; suppose this to be 1765 feet; at  $d$ , the 1765' division of the scale, measure the vertical distance  $dd'$  to the radial indicating the vertical angle, in this case the  $3^{\circ}.60'$  radial; which distance, reduced to the scale of the map, is the height required. The map scale itself may be used for this purpose, or a scale of equal parts can be substituted. For a map scale of  $\frac{1}{80000}$ ,  $\frac{1}{80}$ -inch divi-

sions measure to within 9 feet, and estimation to half of this amount is easily had by eye; but the application of  $\frac{1}{100}$ -inch divisions, and the aid of a magnifying-glass, are advisable for more exact work.

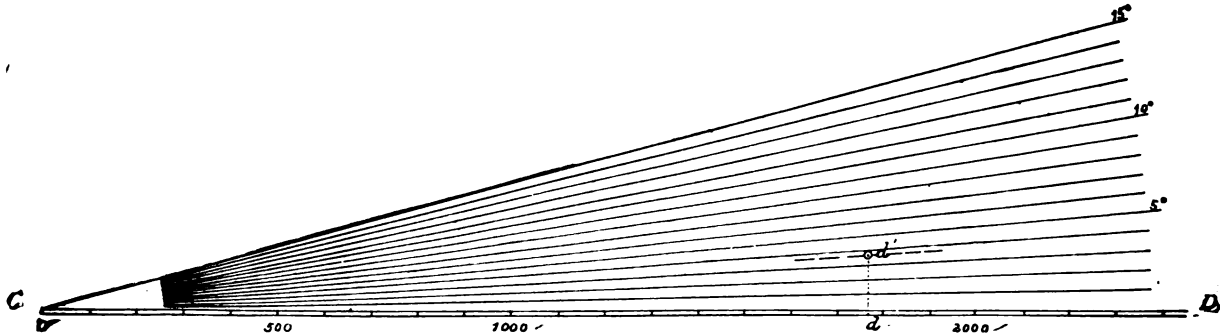


FIG. 33.

Great exactness may be obtained by doubling the length of the scale of heights, and using correspondingly double the distances measured on the plot.

When it is considered that, once made, these scales serve for all views taken with the same lens, the slight labor expended in their construction is certainly of little moment as compared with the facility afforded by their use. It would be advantageous to have the last one described engraved on metal.

30. *Reduction of References to a Datum Plane—The Contouring.*—In the determination of heights heretofore described, the plane of reference is the horizon of the station from which a view is taken; but, as in all topographical work, the measurements thus made for the different stations must all be reduced to a single or common datum plane. As previously stated, this is assumed as passing through or below the lowest point of the tract. The reduction is made in the usual manner, by adding to the measurements for any view the reference of the station at which that view was taken. To facilitate this operation, a form of record similar to the following will prove convenient:

FORM OF RECORD FOR REDUCTION OF HEIGHTS TO COMMON DATUM.

| VIEW.   | POINT. | REFERENCE. | REFERENCE OF STATION. | FINAL REFERENCE. | REMARKS. |
|---------|--------|------------|-----------------------|------------------|----------|
|         |        | Fect.      | Fect.                 | Fect.            |          |
| $V_a^1$ | 1      | + 102      | + 460                 | + 562            |          |
|         | 2      | + 90       |                       | 550              |          |
|         | 3      | - 25       |                       | 435              |          |
| *       | *      | *          | *                     | *                |          |

No difficulty arises in determining the reference in the fourth column; each station will appear on at least one of the views, and its reference is then obtained the same as for any other point; if it appear on two, a check is afforded. In the case of reciprocal views, the difference in elevation of the stations is readily ascertained from the

relative positions of the *HH*'s on them; and when the same point is represented on views from two stations, the difference of its references, as measured on them, is evidently the difference in height of the stations.

As to the *contouring*, or plotting of contours: the reduced or final references having been noted beside the plotted points, the views are examined, and the conformation of ground carefully observed; the equidistant points are then marked on the plot, and the contours can be drawn with nearly if not quite as much precision as is usually attained in the "irregular methods" of contouring with other instruments. Additional points are supplied where needed for this purpose, and aid is derived from the condition, that all points cut by *HH'* on any view, have the same reference as the station from which that view is taken. From the fact that lines of direction, from stations to points of profiles, are tangent in plan to the corresponding contours, additional aid is afforded, and is frequently made use of in this part of the plotting.

31. *Suggestions in Regard to Plotting.*—The plotting of a triangulation is fully described in text-books of topographical drawing. The triangulation is plotted first; then come the orientation of the views at plotted stations and the construction of the plan; and, finally, the determination of the heights and the contouring. It will be found advantageous to fasten together in their proper order a set of views taken from each station, as the general view of the tract thus afforded gives a better knowledge of the work in hand, and the different points are more readily recognized; blue-prints serve this purpose. Each view should be marked as already described,  $V_a^1, V_a^2 \dots V_b^1 \dots$  so as to be quickly identified; and, as soon as oriented, the transferred horizon is to be similarly marked. It is well to number, on the views, all the points to be plotted, using like numbers for the same points both on the different views and for their projections on the transferred horizons. In the plotting by intersections, silk threads may be used if desired, instead of a straight-edge: each thread is fastened at one extremity to a needle thrust into a plotted station; the threads are then stretched over corresponding transferred projections and by their intersections fix the points. The references of points should be marked as soon as determined, beside the plotted points; and also recorded for reduction to a common datum (par. 30); for marking the final references, it is best to use a colored pencil. If possible, all important points should be checked by a third intersection; in fact, to secure a faithful representation, all the precautions that are observed when other methods of surveying are employed, should be taken.

32. *Preparation of Prints—Advantage in Use of Negatives.*—When the plotting is to be done from prints, or regular photographs, these should be carefully and equally dampened between sheets of blotting-paper, and then pasted, without rubbing, to stiff cardboard. As already stated, if the tangent-glass is used, no lines need be drawn upon them; otherwise, the horizons are drawn; and the points to be plotted, numbered as described in par. 31, are projected by verticals into their respective horizons. The horizons and any other desired lines may be printed from the negatives, by previously marking them on the latter with a fine needle-point.

Owing to distortion of the paper, frequently produced in the chemical manipulations, prints are less reliable than the glass negatives; therefore for exact work the latter should

be used. Sometimes, owing to unfavorable conditions of weather, or to improperly timed exposures, negatives do not show details with sufficient clearness for plotting purposes. This fault can ordinarily be remedied by using transparencies made from these negatives, preferably by the wet-plate process, and which will usually give fine definition. Better prints are often obtained from obscure dry-plate negatives by first making transparencies as above, and then, from the latter, making wet-plate negatives to print from. If the plotting is rapidly done, the paper prints, if excluded from light when not in use, may be employed without subjecting them to the process of toning, etc., and the consequent liability to distortion. In any of these operations, increased clearness in definition of sky-lines, hill-profiles and of other features, may be obtained, to almost any degree, by employing the usual process of retouching. Enlargements or reductions to any desired scale are readily effected by the ordinary photographic process. In applying the tangent-glass, it is more convenient to place the negative, film down, upon its etched face, and to rest both upon a strong plate of glass secured to an open frame, so disposed that the light may be reflected from a white surface upward through the glass to the

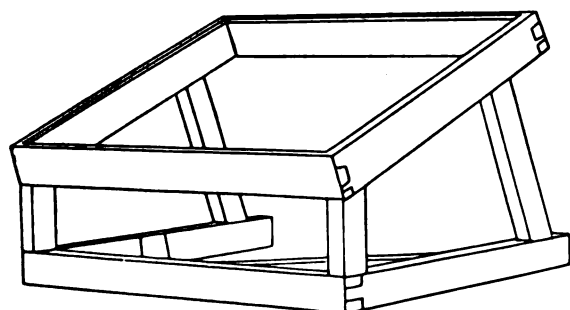


FIG. 34.

eye. Fig. 34 represents a frame of this kind; placed in front of a window, and tilted at any desired angle, a sheet of white paper beneath serves as a reflector, and all but the reflected light is easily excluded by an opaque curtain conveniently disposed about the frame and draughtsman. With this arrangement, the details are clearly visible, and ruler and triangle may be applied without inconvenience. The negatives

also should be labelled so as to be readily identified.

To prepare prints for accurate plotting, proceed as follows: Construct a duplicate of the tangent-glass lines on the film of an exposed, blank, developed and fixed dry plate, using a needle-point and marking prominently the extremities of  $HH'$  and  $VV'$ ; print these lines on the sheets of sensitized paper intended for the views; and, in the subsequent printing, be careful to adjust these sheets so that the extremities of  $HH'$  and  $VV'$  will rest exactly upon the images of the needle-points on the station negatives. A variation from this operation, and one which may possibly give better results, is to expose each dry plate, for an instant, beneath the ruled negative, before exposing for the landscape-views; the tangent-lines will then appear in the latter. Care should be taken to have both sensitive plate and ruled negative rest evenly on the base and against one end of the plate-holder; in ruling the negative,  $HH'$  should be at the exact height of the needle-points, and marks made on the sensitive plate, in its first exposure, to show which edges of it to place up and against the end for the view.

33. *Choice of Scale—Accuracy Attainable.*—As a result of experience it has been found that the scale of  $\frac{1}{8000}$ , or of  $\frac{1}{4800}$ , is the most convenient for photographic work. A smaller scale would naturally be used for reconnaissances, in which the observations are made with great rapidity and therefore as a rule with less precision.

As to the accuracy attainable: in regard to the plan; admitting an error of  $\frac{1}{810}$  of an inch in the observation with a magnifying-glass of points on prints, this on a circumference of 20-inch radius (corresponding to a focal distance of 20 inches) represents an angle of about 45'', and the maximum error in the location of a point 2700 yards distant would therefore be but 20 inches, which, reduced to the scale of  $\frac{1}{8000}$ , would of course be inappreciable. For the heights; assuming a point 1000 yards distant and the same focal distance, the error would be  $\frac{36000 \times .004}{20} = 7.2$  inches, which corresponds to an angular error of about 30'', and, in observing with ordinary instruments, this degree of accuracy would seldom be excelled.

The facts set forth in this paragraph are results of the observations made at a time when photographic instruments were in a less perfect condition than at present. In the author's experience during the past year, in the outline photographic survey of a tract of about 12 square miles, using the camera represented in Fig. 9, a Dallmeyer rapid rectilinear objective, with  $OP = 15''.68$ , and plotting from the negatives with the aid of the tangent glass, points of the plan checked exactly: and in plotting the levelling, the difference in heights of points at various distances corresponded to the measurements made by careful work with a surveyor's level. The scale of the plot in this case was  $\frac{1}{10000}$ , and the field-work for the entire tract required but half a day.

It may be said that the accuracy attainable is sufficient for all ordinary purposes.

34. *Explanation of Plate XXIV,—a Photographic Map (see end of book).*—Plate XXIV, from the Mémorial de l'Officier du Génie, represents a photographic map of an area of 4500 hectares,—in English units the rectangle is about 3.1 × 4.4 miles. The field-work was first plotted to the scale of  $\frac{1}{8000}$ , and afterwards reduced by photo-lithography to its present scale,  $\frac{1}{30000}$ . The small triangles,  $\Delta$ , mark the vertices of the triangulation; these and the other points marked by a small circle,  $\odot$ , are the photographic stations,—the minor triangulation, or traversing, by which the  $\odot$ s were fixed, is omitted. The base was measured in the valley E. of Sainte-Marie-aux-Mines, and served, as shown, to fix points 1 and 2, and the directions of points 4, 5, 16 and 17: the side 1-2 was then used to fix the points 3, 4, 10, . . . . The contours have an equidistance of 5 metres; the field-work occupied ten days; the number of photographic stations was 31; of prints, 52; and of points determined, 1400. This survey was conducted by M. Javary in 1869.

*Plates XXV and XXVI* are intended to illustrate the method of plotting from field-work with the ordinary camera. The map was first plotted to  $\frac{1}{10000}$  as described in par. 21, and then reduced by photography to present scale. Time consumed in field-work, 10 hours; with more experience, plotting could have been done in 24 hours. To include all details of the tract, at least 10 more stations would have been required. The following form of record proved very convenient in plotting the levelling:

| POINT No. | OBSERVED FROM STATION. | VERT. ANGLE, +, OR - | TANGENT. | DISTANCE. | ELEVATION, + DEPRESSION, - | FINAL REFERENCE. | REMARKS. |
|-----------|------------------------|----------------------|----------|-----------|----------------------------|------------------|----------|
|-----------|------------------------|----------------------|----------|-----------|----------------------------|------------------|----------|

The author is indebted to Prof. Larned for the sketches of Plate XXV.

In continuation of par. 32, the author desires to state that an excellent negative for plotting from may be produced by interposing the tangent-glass in front of the sensitive plate during the regular exposure made in taking the view.

### SECTION III.

#### CYLINDRIC PERSPECTIVES.—INSTRUMENTS, FIELD-WORK AND PLOTTING.

35. *The Topographic Cyliandrograph.*—This ingenious instrument, a type of the cylindro-perspective class of cameras, is the recent invention of M. Moëssard, formerly professor of topography at St. Cyr, now commandant of engineers and professor “à l’École Supérieure de Guerre.”

Views obtained with it are cylindric perspectives; the radius,—the focal distance,—is a constant quantity for vertical as well as horizontal angles; and the number of views required for a complete tour of the horizon is but two and a fraction ( $20^\circ$ ). Fig. 35 is a general view of the apparatus.

36. *The Camera.*—The camera consists of a semicircular wooden lid *A*, Fig. 36, and base *B*, which are horizontally disposed: and a vertical, rectangular, wooden frame *F*. These pieces are fastened together with hinges and hooks as shown, so that they may be readily folded for transportation. When opened, a brass standard *s*, attached to the lid in rear, rests upon the base, where it is fastened in position by a button, and thus serves to keep these parts rigidly parallel; this may also be folded against the lid

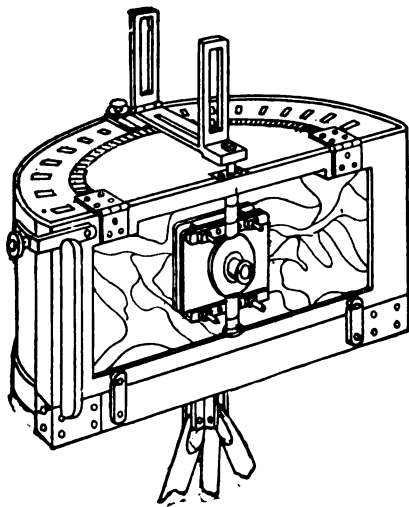


FIG. 35.

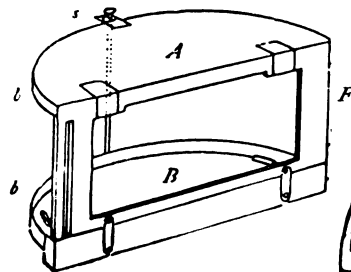


FIG. 36.

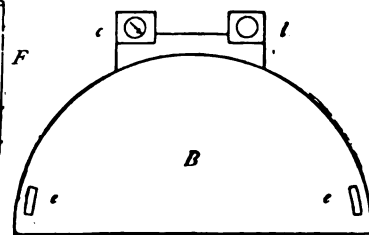


FIG. 37.

for transportation. Strips *b*, of brass, project vertically 0.4 of an inch beyond the edges. The projections, *e*, Fig. 37, on the upper surface of the base, are guards or guides for the flexible plate-holder (see Fig. 40), which, when in position for an exposure, forms the cylindrical part of the camera. Projecting pieces, *l* and *c*, in rear of the base, serve as supports for the circular level, and for the compass, which is graduated from  $0^\circ$  to  $360^\circ$  in the usual direction, N., E., S. and W., and which has its  $0^\circ$ - $180^\circ$  line parallel to the middle radius of the lid, with the  $0^\circ$  point to the front. In the latest form of the instrument, two tube levels at right angles, and the compass, 4.7 inches in diameter, are let into the

upper surface of the lid. A plate in the lower surface of the base serves to attach the camera to the tripod-head.

37. *The Objective.*—The objective-carrier, shown in Fig. 38, is so attached by a vertical spindle to the middle of the frame *F* (Fig. 36), that the optic axis of the objective is horizontal and the optic centre, or, in the case of a single lens, the rear nodal point, is in the axis of the camera. Fig. 38 shows the arrangement; the objective *o* is rigidly fastened to the rear plate *p*, and enters freely an opening in the front plate *f*, the plates being held together by adjusting screws and spiral springs as shown. Fig. 35 shows the manner in which the objective may be made to revolve horizontally,—the alidade, attached to the upper rectangular extremity of the spindle *t* (Fig. 38), serving as a handle. The other extremity of the alidade traverses a circular scale of degrees, which is attached to or engraved upon the lid, and which has its centre in the axis of rotation; the alidade is also furnished with a spring of slight tension, a click, projecting beneath and engaging in notches (Fig. 35) cut in the lid; which device serves to regulate the rate of motion of the alidade, by assigning so many clicks per second, and thereby to time the exposure. In front, light is excluded from the interior of the camera by a rubber cloth, attached to the rear plate of the objective and the inner edges of the vertical frame, and of such dimensions as to permit perfect freedom of motion to the objective.

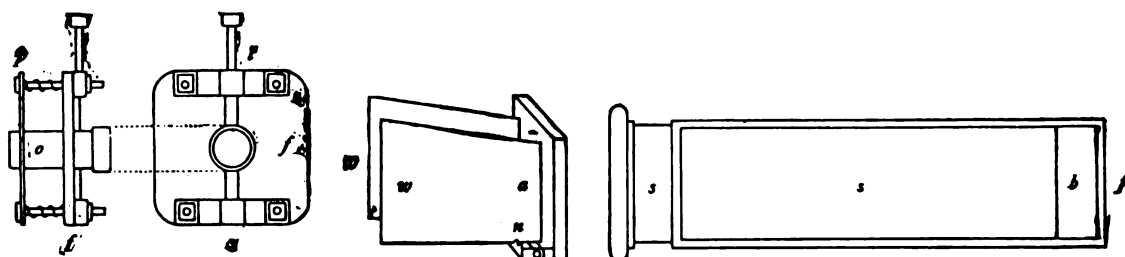


FIG. 38.

FIG. 39.

FIG. 40.

To confine the deviated rays to the area effectively covered by the objective, there are two wings or screens, *w*, Fig. 39, of tin blackened, attached to the rear plate of the objective-carrier and projecting into the camera; each turns freely about a vertical axis *a*, and, by means of the notches *n* in the rear projecting piece, may be made to occupy three different positions, thus increasing or diminishing the breadth of field: the projecting piece and screens may be folded against the plate for transportation. The screens should be of such size as to turn freely in the camera during the rotation of the objective. The folding vanes (Fig. 35) with cross-hairs, attached to the alidade, serve to determine at any instant that portion of the landscape which is being "taken" when the screens are parallel.

Any rectilinear objective, composed of either a single or double combination lens, will serve, provided its focal distance is equal to or a very little less than the radius of the camera.

38. *The Plate-holder.*—The plate-holder, Fig. 40, is a rectangular frame, *f*, of some solid, flexible material, backed with rubber cloth, *b*, stretched upon and glued to the frame,—the sensitized paper, which is used instead of glass plates, when in position, resting against it.



The shield *s*, of flexible card-board blackened, fits into grooves in the edges of the holder, and is manipulated in the usual manner. The milled head, shown at the left in Fig. 35, serves to release a hinged brass clamp, or cleat, when the holder is to be inserted, and to secure the holder after insertion, so as to entirely exclude the light. Several plate-holders are used, and are easily packed for transportation.

39. *Scale of Azimuths and Slopes.*—Fig. 41 represents the means by which a scale of azimuths and of slopes is impressed or marked upon the negative.

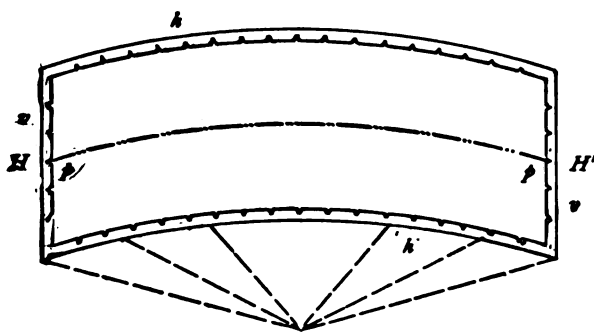


FIG. 41.

Two notched, curved brass strips, *h*, having their centres in the axis of rotation, are attached vertically to the lid and base respectively, and immediately in front of the plate-holder; they project slightly beyond the frame of the latter, so that the notches may be represented on the negative by the exposure. The strips *v* are similarly attached to the edges of the vertical frame. The notches in *h* correspond to divisions of 1 "grade," or of  $1^\circ$ , as the case may

be, to a radius = the distance from the plate-holder to the axis of rotation of the objective; and the notches in *v*, to  $\frac{1}{100}$  part of this distance. Projecting points at *p* mark the horizon, or *HH'*. (Note.—On account of the blurred images thus produced, it would seem better to attach these strips made of very thin metal to the inner edges of the holder, so that during exposure they would rest in contact with the paper.)

40. *Adjustment of the Optic Centre.*—In order that the image of every point should be clearly defined and immovable during rotation of the objective, it is necessary that the optic centre should be in the axis of rotation, in or near which line it is supposed to have been originally fixed by the instrument-maker. To test this condition: a narrow plate of ground-glass, ruled with fine vertical lines, is placed in the usual manner to receive the image of a distant point; if the image is displaced in the direction of the rotation, the rear plate of the objective-carrier must be advanced by means of the adjusting screws; if in a contrary direction, the plate is moved to the rear. In this adjustment, to preserve the parallelism of the plates, it is necessary that the screws should be turned equally, which condition is assured by means of indices on the screw-heads.

41. *The Manipulation.*—To make an exposure: the camera, with objective capped, is set up and approximately levelled; the lid is raised; the plate-holder, containing the sensitized paper, is inserted and clamped; the screens are favorably disposed, and the lid is closed. The camera is then levelled; the alidade is adjusted to the  $85^\circ$  division of the scale; the vanes are raised, and, by revolving the camera, the vertical cross-hairs are aligned upon the object to occupy the centre of the view. The shield is then withdrawn; the alidade is adjusted to the  $0^\circ$  of the scale; the objective is uncapped and revolved by means of the alidade, until the latter has reached the  $180^\circ$  division,—the velocity of rotation being determined as in ordinary landscape photography; and the cap and shield are then replaced. The time of exposure is also determined in some degree by the positions of the screens, being shorter when these are placed in the outer notches (Fig. 39).

42. *Device for Orienting the Views.*—A semicircular limb, having its centre in the axis of rotation and its radius less than that of the camera, is attached to the upper surface of the base, and is graduated into degrees or parts thereof, from  $90^\circ$  to  $270^\circ$ , corresponding in position to those on half the compass-limb. Two blocks are made to slide along this limb, each carrying a vertical spindle about  $1\frac{1}{4}$  inches in length; one spindle is terminated at its upper extremity by an arrow-head, and the other by a crescent. Just before closing the lid for an exposure, one of these spindles is adjusted to the division corresponding to that marked by the compass-needle; and the other, to the division differing from it by  $90^\circ$ . By this obstruction of the deviated rays, their positions are marked upon the negative, the arrow-head indicating the N. or S. point, and the crescent the E. or W. point, thus furnishing the basis for the scale of azimuths. The division indicated by the compass-needle is also recorded in the note-book.

To illustrate: For the first exposure (see Fig. 42), the compass indication is  $55^\circ$ ; the

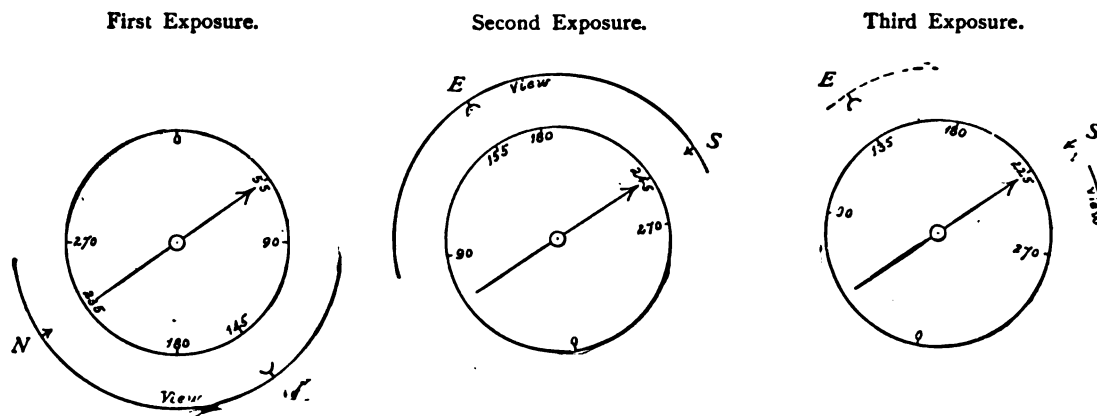


FIG. 42

$0^\circ$ - $180^\circ$  line being parallel to the optic axis, with the  $0^\circ$  to the front, the direction of the middle point of the view is N.  $55^\circ$  W.; consequently to mark the N. point, the arrow-head is adjusted to the  $55^\circ + 180^\circ = 235^\circ$  division, and the crescent to the  $235^\circ - 90^\circ = 145^\circ$  division of the scale to mark the W. point. For the second exposure; the field being  $170^\circ$ , and the order in which the views are taken being from left to right: when the camera is revolved  $170^\circ$ , the compass indication is  $245^\circ$ ; the arrow-head is adjusted to this division and will mark the S. point on the negative, while the crescent, at the  $245^\circ - 90^\circ = 155^\circ$  division, marks the E. point. The two views cover  $170^\circ \times 2 = 340^\circ$ ; a third view of  $20^\circ$  is therefore required to complete a tour of the horizon. The exact supplement is obtained by revolving the camera until the needle indicates  $245^\circ - 20^\circ = 225^\circ$ , when the adjusted arrow-head will mark the S. point; and by withdrawing the shield a sufficient extent, the E. point may be marked by the crescent placed at  $225^\circ - 90^\circ = 135^\circ$ . For reasons heretofore given, it is advisable to have the views overlap, say  $10^\circ$ , in which case the arcs of revolution of the camera would be correspondingly diminished. (*Note.*—The additions and subtractions above required could in great measure be avoided by reversing the order of the numbers on the base scale.)

43. *The Field-work and Plotting.*—The *field-work* corresponds in detail to that de-

scribed in paragraphs 18 to 23 for plane-perspective cameras; any exceptions due to the form of the instrument readily suggesting themselves.

Fig. 43 represents a print ready for plotting.  $HH'$  is the horizon;  $SS'$  and  $WW'$  are verticals drawn through the S. and W. points respectively; and  $z$  is the azimuth of a point  $o$ ,  $65^\circ$  from S., or  $115^\circ$  from N.,—S. being usually taken as the origin. The vertical angle of  $o$  is read off, as a slope-angle, on the side scale; and is  $\frac{1}{100}, \dots, \frac{3}{100}, \dots, \frac{4}{100}, \dots$ , according to the number of divisions from  $H'$  to  $h'$ .

In measuring the azimuths, use the mean of the distances  $SZ$  and  $S'Z'$ ; and similarly for the vertical angles, use the mean of  $Hh$  and  $H'h'$ .

The stations plotted, a circle is described with each plotted station as a centre, and with any convenient radius, the azimuths of the different points, determined as above, are protracted, and the points are located on the plot by intersections of right lines drawn

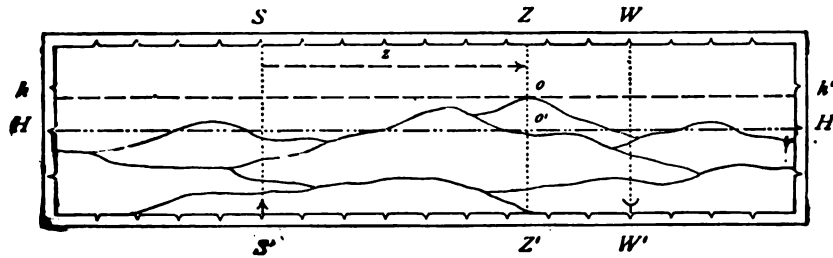


FIG. 43.

from the plotted stations through the corresponding azimuthal divisions. It is apparent that when chords, sines, tangents, or ordinary protractors are used in protracting the azimuths, the greater their radii the more accurate graphically will be the results.

As to the heights; the reference of any point is given by means of the side scale, e.g.: Suppose  $\frac{H'h' + Hh}{2} = 3.5$  divisions; then, the reference required is  $.035 \times$  the plotted horizontal distance from the station to the point.

44. The *advantages claimed* in the use of this instrument are:

I. Since the scales are already impressed in the exposure, measurements may be made directly upon either the negative or print; the only construction required being that of the right lines, as  $hh'$  and  $ZZ'$  (Fig. 43), through the images of the required points; but on account of distortions, which might take place in printing, it is advisable to draw these lines on the negatives.

II. No construction of the focal distance is required; nor is it necessary to consider it in the field-work, because the apparatus is effective only when the optic centre is in the axis of rotation; and, when adjusted, the focal distance is exactly equal to the radius of the cylinder.

III. No distortion exists if the objective is rectilinear, owing to the screens limiting the field to that effectively covered by the lens; if it does exist, the images will not be clearly defined, therefore when these are clearly defined there is positively no distortion. In vertical planes, however, there may be a slight distortion near the edges of the field; but this is of slight importance, since the higher points are in the sky portion of the

view, and the lower points are so near the station that any small error in a corresponding slope-angle may be neglected.

IV. Eccentricity of position in the plates during the exposures 1, 2 and 3 at any station presents no inconvenience, because each view is oriented independently of the others, on the cardinal points; and, when required, the compass-readings, which are always recorded, furnish the elements necessary to orient the three views at the plotted station. The three-point problem may also be utilized in locating a station on the plot. (See also close of par. 52.)

To give the photographic view a natural appearance, or to represent the details as they would appear at the station, the "cylindroscope" may be used. It is simply a wooden semi-cylinder, of dimensions equal to those of the cylindrical part of the camera; the photographs are placed on its interior surface and observed from the middle point of its axis.

## SECTION IV.

### RADIAL PERSPECTIVES.—INSTRUMENTS, FIELD-WORK AND PLOTTING.

45. *Photographic Plane-tables.*—If at any station a photographic view of the surrounding tract be represented upon a horizontal surface, every point of the representation occupying its true position; then will the horizontal angle of any two points be measured by the angle included by the right lines, or radii, drawn from the plotted station through the images of these

points. This is the principle of construction of the following-described instruments. As to relative heights of points, means for their determination similar to those described for plane and cylindric perspectives are employed.

46. *Chevallier's Camera.*—In 1858, this instrument was submitted by M. Auguste Chevallier to the consideration of the "Société d'Encouragement," and favorably received; and since that date the inventor has succeeded in bringing it to a still higher state of perfection. In its present improved form, and as manufactured by the optician Duboscq of Paris, it consists of a circular dark-chamber, *A*, Fig. 44, resting upon a triangular support, *B*, which is furnished with levelling-screws that bear upon the tripod-head, as shown. These attachments are similar in construction to those of a theodolite, thus admitting of a revolution of the chamber in azimuth,—a tangent-screw, *T*, serving for close adjustments. A

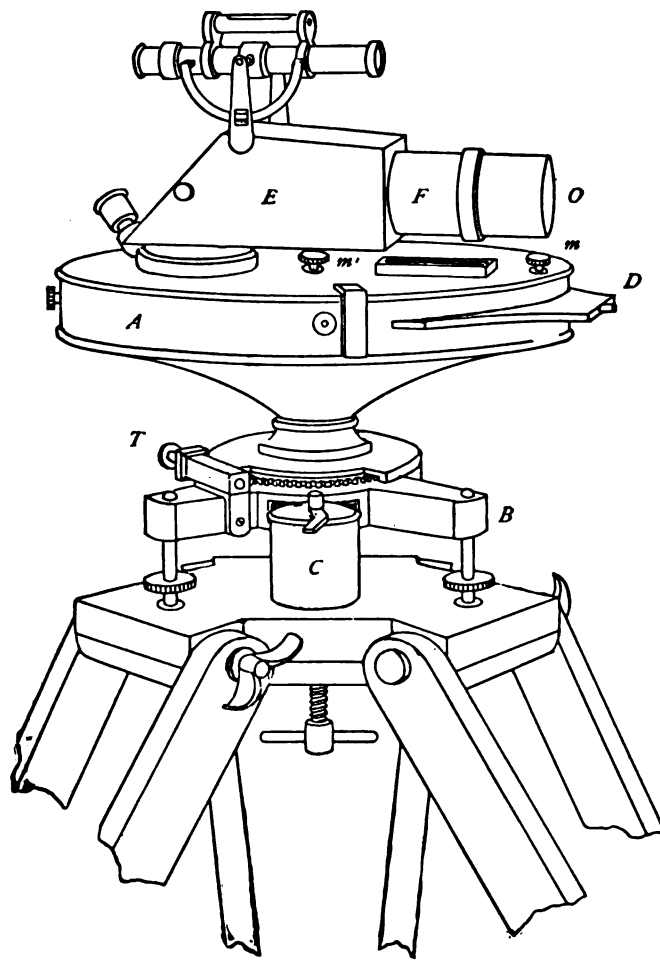


FIG. 44.

plate-holder, *D*, shown inserted, contains the sensitive plate. The cover, or upper plate of the chamber, which carries the objective system, is movable about its centre, its edge resting in double grooves in the upper edge of the cylindrical rim; its serrated edge is geared to two pinions, which may be engaged at pleasure; to one of these pinions motion

may be communicated by means of a simple clock-work movement, *C*, thus ensuring uniform rotation; while the other, furnished with a projecting milled head, *m*, serves to revolve the plate by hand to any desired position. A graduated circle is fastened to the edge of the chamber immediately below the edge of the plate, and diametrically opposite openings in the latter permit the reading of arcs or angles. A small circular level serves to ensure the horizontality of the plate; at the centre of rotation and projecting through the milled head *m'*, is a sharp metal point, furnished with a spiral spring, which is thrust downward to mark this centre on the sensitive plate,—an operation, however, which may be dispensed with, as will be shown; *m'* also serves another purpose, to be described.

The objective system consists of the box *E* and tube *F*, the axis of the latter and that of the dark-chamber being in the same plane; the tube contains the lens, and the box has at its rear extremity a triangular glass prism, with its edges horizontally disposed. Rays from external objects entering the tube at *O* are, after deviation by the lens, reflected vertically downwards through a circular opening in the plate, and are focussed on the sensitive plate; this opening, as shown in the figure, being between the centre and edge of the plate.

A circular disk with sectoral openings of different dimensions is suspended immediately above the sensitive plate, its centre being in the axis of rotation of the instrument; and, by means of indices on the milled

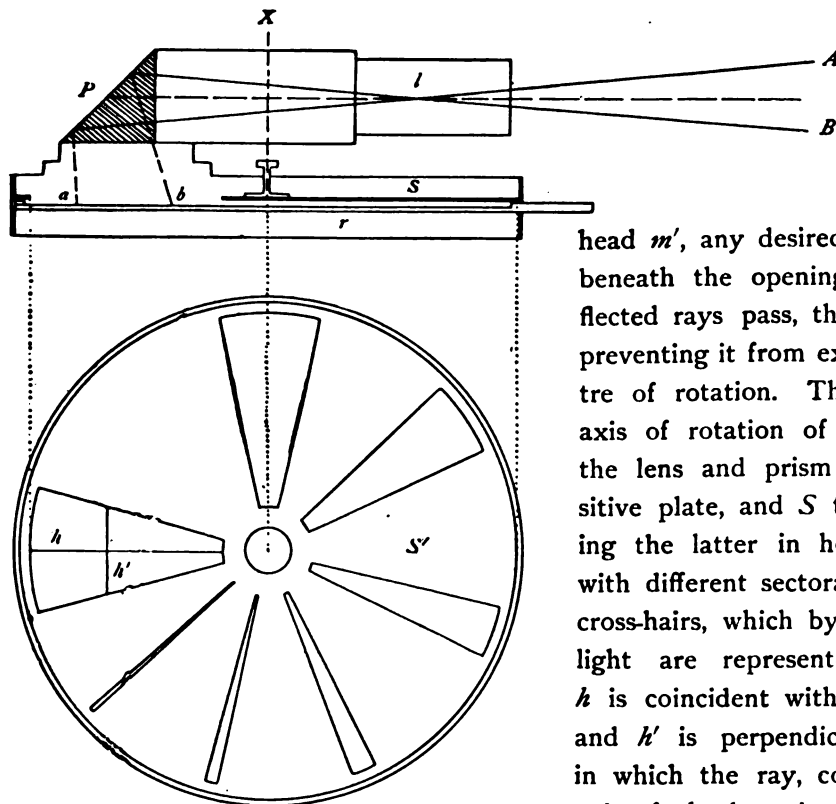


FIG. 45.

head *m'*, any desired sector may be brought beneath the opening through which the reflected rays pass, thus limiting the field and preventing it from extending beyond the centre of rotation. Thus, in Fig. 45, *X* is the axis of rotation of the instrument, *l* and *P* the lens and prism respectively, *r* the sensitive plate, and *S* the screen,—*S'* representing the latter in horizontal projection, and with different sectoral openings. *h* and *h'* are cross-hairs, which by their obstruction of the light are represented upon the negative; *h* is coincident with a radius of the screen; and *h'* is perpendicular to *h* at the point in which the ray, coincident with the optic axis of the lens, intersects it after reflection by the prism: therefore, when operating by

“fixed sectors” (par. 47), all points, of which the images are located on *h'*, are on a level with the optic axis at the station where the exposure is made. Simply to mark the trace of the “principal plane,”—that containing the axes of rotation and of the objective.—the smaller sectors are used; and the smallest, about 1°, in operating by “continuous movement” (par. 48), in which case *h* is suppressed.

It is apparent that to facilitate plotting, the distance of the image of  $h'$  from the centre of rotation of the sensitive plate, should be exactly equal to the focal distance of the objective, and this condition is assured by the instrument-maker.

In addition to the parts above enumerated, a small telescope with cross-hairs, and a vertical limb, are attached, as shown, to the upper surface of the box; and are used for pointing, and to measure vertical angles of points that may lie without the field of the objective,—the latter case however rarely occurring. When the instrument is set up, the optic axes of the telescope and of the camera-objective are in the same vertical plane. An attached compass affords the means for orienting the views in the subsequent plotting, and two methods for this purpose are prescribed;—one consists in rotating the plate, after an exposure is made, until a covered slit in the base of the compass-box, and which extends through the plate, is in the vertical plane of the needle; this cover is then removed for an instant, and an image of the needle is formed on the sensitive plate, thus giving the required meridian line: as the compass is located near the edge of the plate, the image of the needle will not interfere with other details. The other method consists in placing a staff vertical at some distance in front, and in the field of view; its image in the negative, and its bearing obtained by means of telescope and compass, afford the necessary data. The instrument is permanently focussed by the maker for distant views; and the usual form of cap is used in making exposures. In regard to size, it may be stated that excellent work has been done with a camera constructed for sensitive plates affording circles of but 4 inches in diameter.

47. *Operating by Fixed Sectors.*—This is its least important use. Suppose the camera set up at any station, pointed at a distant signal, and an exposure made; an image of the signal and its surrounding features is obtained, and the image of  $h$  will cut that of the signal. If now the plate be rotated, the chamber being clamped, and an exposure made toward a second signal, it is evident that the angle included by the two images of  $h$  on the developed negative, is the true horizontal angle of these signals as measured at the station. The image of  $h'$  will in each view intersect points of all objects having the same altitude as the optic axis. By using a sectoral opening of about  $10^\circ$ , a view is obtained in which the maximum error due to distortion falls within the limit permissible in the graphical construction of a plan. It is unnecessary to point exactly at any signal, because with rough pointing the image will always be found in the vicinity of  $h$ , and all the images of  $h$  in the different sectors must have their true relative positions; and in this property rests the value of the instrument for rapid work.

48. *Operating by Continuous Movement.*—In this mode of working lie the great advantages derived from its use, viz.: absolute accuracy in the measurement of horizontal angles, and the great rapidity with which the field-work may be performed.

In the preceding operation, a narrow sector had to be used to avoid distortion, and to complete a tour of the horizon many views were required. If with this sector a continuous movement were given to the plate, sector and plate revolving together, images of objects would be superposed and become indistinguishable; but by reducing it to a very narrow slit, coincident in position with  $h$ , the sensitive plate will receive at each instant the images of those points only that are situated in the principal plane (par. 46); there will be no superposition throughout a revolution; and, from a view thus obtained, the true horizontal angle of any two points is given by the radials that intersect the images of these points.

If, in reference to the required plan, certain sectors of the landscape are unimportant, it is only necessary to cap the objective while traversing them; but with the rapid plates now in use, no appreciable time is lost by making the entire tour.

As already stated, the cross-hair  $h$  is suppressed, while  $h'$ , reduced in length practically to a point, leaves its image upon the sensitive plate in the form of a circumference of a circle, described with the centre of rotation as a centre, thus indicating the true horizon of the station.

It is apparent that with an inverting objective, and the relative positions of objective and prism shown in Fig. 45, the sky will occupy the outer portion of the picture. Such a representation is called "nadiral," in contradistinction to one in which the sky

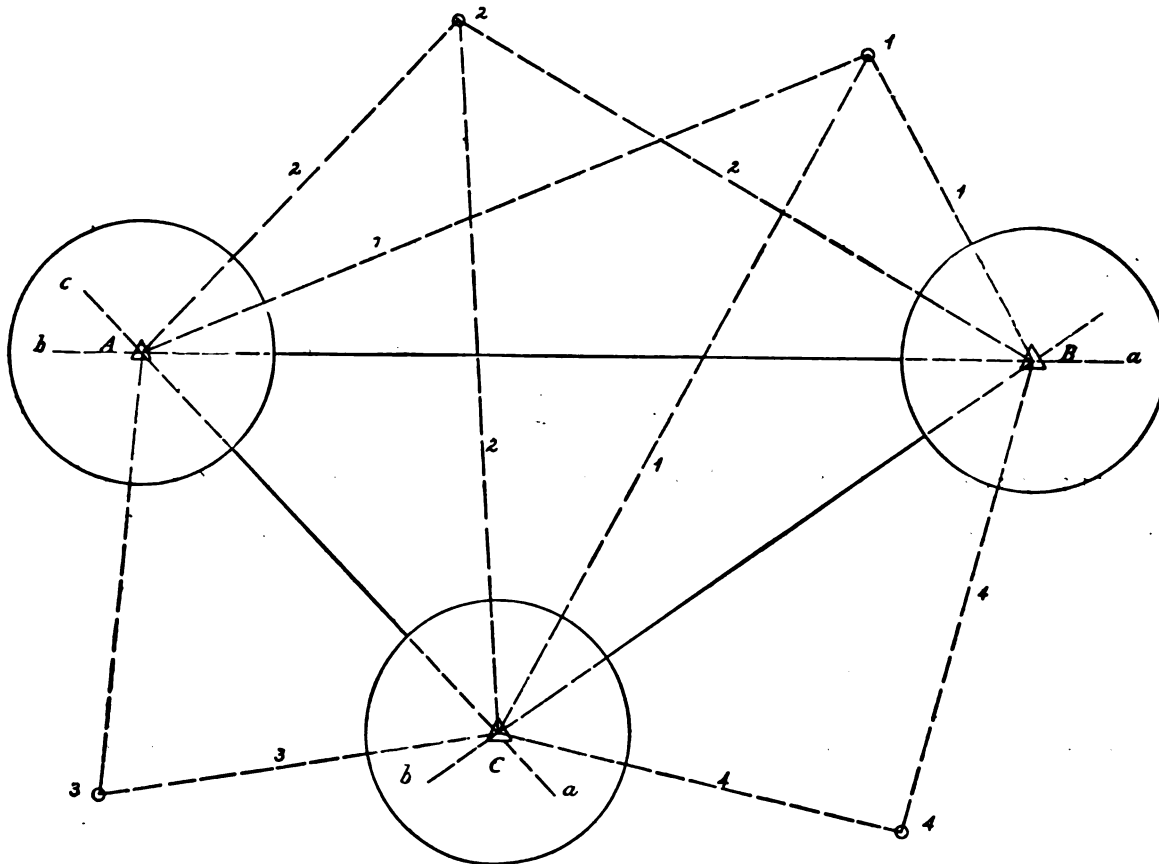


FIG. 46.

occupies a central position, which is termed "zenithal:" the latter is evidently produced by placing the inverting objective between the prism and sensitive plate, as in the other form of this instrument. Although these representations possess the same value for surveying purposes, the former presents the more natural appearance. In either case, a radial drawn upon the sensitive plate represents the vertical of any point, the image of which it intersects.

49. *The Field-work and Construction of the Plan.*—As in other methods of surveying, a base, as  $AB$ , Fig. 46, is measured, and from each extremity a tour of the horizon is made; this is repeated at a third station, as  $C$ , which is contained in views from  $A$  and  $B$ ; and so on throughout the tract. The selection of stations is governed by the conditions



already stated in par. 19. It is apparent, from the usual multiplication of representations of any point, that numerous opportunities for verification are afforded for the plotting. It is hardly necessary to state that, in setting up the instrument, the centre of rotation should be plumbed over the station-point, and the axis of rotation made truly vertical.

In constructing the plan, either negatives or prints may be used directly as projectors. On the negatives, the landscape is represented as if rotated horizontally  $180^\circ$ . due allowance should therefore be made for the position of the N. point. On the prints, in addition to this, when the sensitive plate is exposed film up, the positions of objects are reversed; and the remedy lies in either placing the film down, or in making the prints transparent with oil or other material.

Fig. 46 fully illustrates the construction of the plan; the base is plotted to the required scale; the views from the extremities are placed with their centres at these plotted points, and are rotated until their meridian lines are parallel to the direction assumed for the meridian upon the sheet; right lines are then drawn from the centres to corresponding points and produced to intersection, thus locating required points as in plane-table surveying. A third view is then similarly oriented and used, and so on throughout the work.

50. *Determination of the Heights.*—Since the image of the circumference described by the cross-hair  $h'$  is the horizon of the picture, it serves as a datum line to which all points are referred: the *reference* of any point is therefore given by the formula

$$x = md \frac{h}{f};$$

in which  $f$  is the focal distance,  $\frac{1}{m}$  the scale of the map,  $d$  the distance from the station to the point, measured on the plan, and  $h$  the vertical distance of the point from the horizon, measured on the view. Since the maps, or at least the first sheets of the respective maps, may all be plotted to the same scale,  $\frac{m}{f}$  may be considered as a constant quantity; a convenient coordinate table may therefore be prepared, giving the values of  $x$  for values of  $d$  and  $h$ , differing by, say, 100 feet and 10 feet respectively, thus facilitating the plotting. The references to a common datum plane are obtained in the usual manner.

51. *Instrumental Error, Advantages Claimed.*—The *errors* are those observed in all optical instruments employing lenses. Distortions in a horizontal direction are destroyed; while those in a vertical direction, if existing, may be detected by comparison of "fixed sector" views with those obtained by "continuous movement," and then corrected. The only cause of confusion is the slight angular deviation of a vertical ray after passing through a small sector, thus causing it to spread to the right and left of its true position a distance equal to half the breadth of the sector; but this lack of definition is obviated by using a sectoral opening not greater than  $1^\circ$ .

As illustrating its accuracy, M. Jouart states that, in his own practice with an instrument of this kind having a focal distance of 7.5 inches, and in plotting to a scale of  $\frac{1}{1000}$ , satisfactory results were obtained up to distances exceeding 1 mile. In a recent Parisian publication, M. Gossin also states that its use is attended with excellent results.

The range of the instrument evidently depends entirely upon the power of the objective used.

The main *advantages claimed* for it, as compared with ordinary surveying instruments, are the certainty with which a tour may be closed, and errors of arc-reading thus obviated; the great rapidity of execution; its simplicity of manipulation, which enables a novice to produce practically perfect views; and, as with all photographic surveying instruments, the production of complete views of the topographical features. Captain Han-not, chief of the photographic service of the Belgian war department, states, in regard to this instrument, that in its construction it embodies in a most happy manner all the improvements of which a camera is capable; and that, as compared with the ordinary plane-table, it possesses a great number of advantages in its favor. With the very sensitive dry plates now generally available, and the very narrow sectoral opening made permissible by their use, joined to careful construction and the employment of a good objective, this instrument must prove of valuable assistance in surveying, for both civil and military purposes.

52. *Mangin's Camera*.—This instrument, like that just described, is of French invention. It produces, without rotation of any part, an entire tour of the horizon upon a single plate. The theory of its construction is based upon the idea—due to Capt. Prudent—that virtual

images produced by a spherical convex reflector, might be photographed so as to represent the original objects in their true proportions.

I. *The Metallic Reflector*.—Col. Mangin solved the problem, by first constructing a reflector of which the form of the generating curve was dependent upon the condition that the virtual images should be rigorously exact for its median zone. This reflector, *R*, Fig. 47, is a silver-coated surface of revolution, having its axis, *X*, vertical, in order that it may receive the incident rays from all points of the horizon. By total reflection, the pencils are made to converge to a point, *O*, of this axis; where an objective, having its

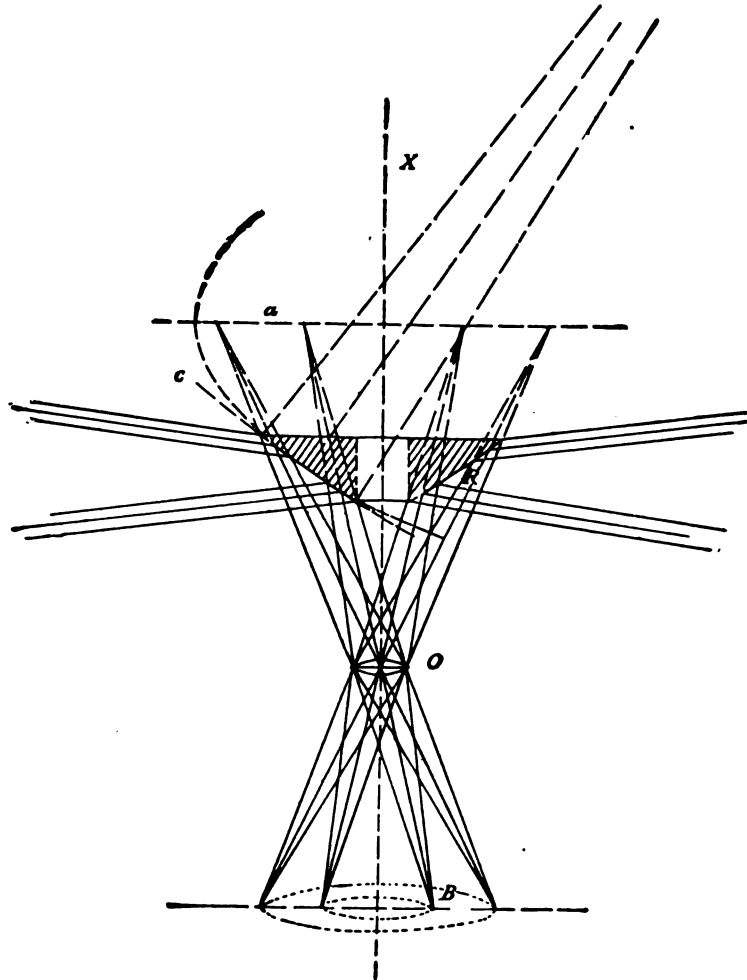


FIG. 47.

optic axis coincident with that of the reflector, serves to produce upon the sensitive plate placed on the base,  $B$ , of the chamber, the conjugate of an image formed by the reflector.

For photographic purposes, each point of the virtual image should be true and clearly defined, and the pencil of rays emanating from it rigorously conical, in order to produce on  $B$  a true image of the original point. Neither a spherical nor a conical reflector would serve this purpose, when the incident and reflected rays make considerable angles with each other; but, by making the generatrix an arc of a parabola, with its axis,  $a$ , horizontal, the incident rays in the horizon of the station are reflected to  $O$  as desired. In the manufacture of the reflector, the arc,  $c$ , of an osculatory circle, tangent at the middle point

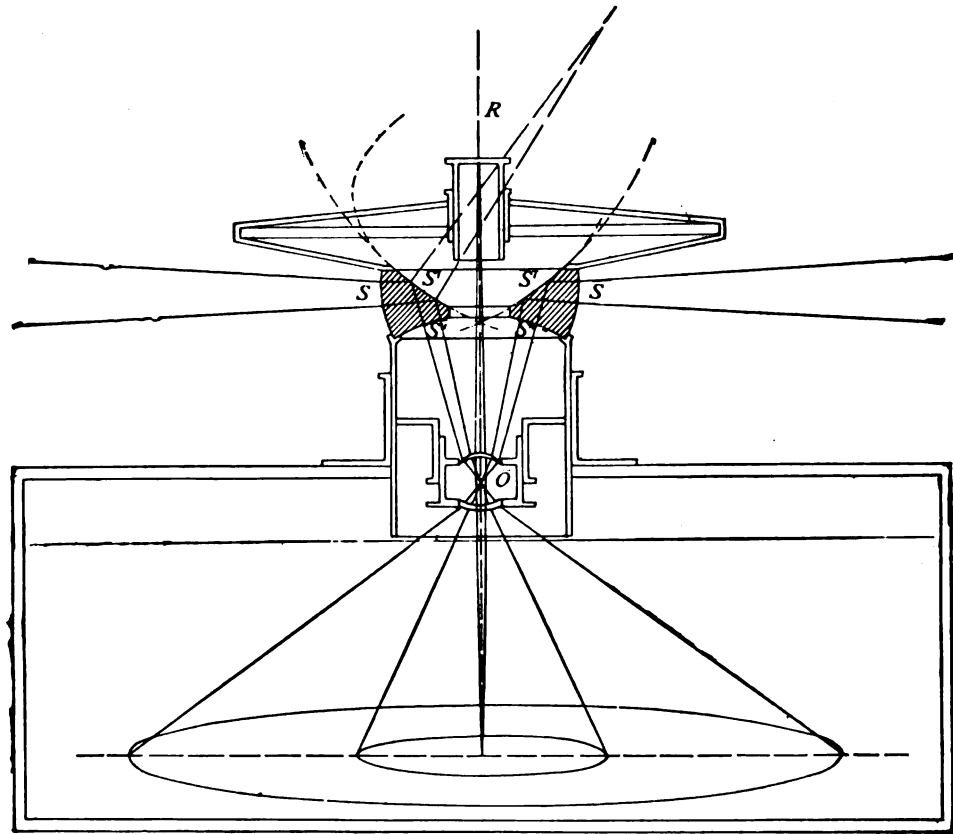


FIG. 48.

of the parabolic arc, was substituted for the latter, and the construction is allied to that of the annular light-house lens.

As the distance, measured on the reflector, from the median zone, or middle horizontal circle, increases, the definition decreases; but it is found by experiment that rays, incident upon any part, which make angles of  $15^\circ$  with the horizon, are sufficiently well defined for practical purposes; the vertical field of the instrument is therefore  $30^\circ$ .

The distance from  $O$  to  $B$ , and the selection of an objective to place at  $O$ , are governed by the rules observed in making enlargements by photography. For example: Let  $d$  denote the distance from  $O$  to the median plane of the reflector; then, to produce on

$B$  an image twice the diameter of the virtual image;  $OB$  must be equal to  $2d$ , and an objective is used of which the focal distance  $f$  is derived from the expression  $\frac{1}{f} = \frac{1}{d} + \frac{1}{2d}$ .

II. *The Glass Reflector.*—The metallic reflector is easily tarnished by chemical reaction, and is therefore hardly suited to photographic work; to remedy this, Col. Mangin constructed one of glass, of which the form is such as to correct the effect of refraction. The outer surface,  $S$ , Fig. 48, which receives the incident rays, is torus-shaped; the upper or reflecting surface,  $S'$ , is of the same form as the metallic reflector; and the lower surface,  $S''$ , is spherical, its centre,  $O$ , being the focus of the reflected rays: the objective at  $O$  is for the purpose described in (I). This reflector has another advantage, since reflected rays are not obstructed by the mountings which are required for the metallic reflector.

With this camera, the diedral angles formed by vertical planes intersecting the station and exterior points, are truly represented on the picture by the sectors included by radials drawn to the images of the points,—the centre being the image of a minute opening, which admits the vertical ray  $R$  in the axis of the reflector; and all points, in any vertical plane of the station, have their images in the same radius. The horizon of the picture,  $HH'$ , may be defined, either by the image of a circumference engraved on the reflector, and which is coincident with the line of contact of a vertical cylinder; or independently, in which case any distant point in the horizon of the station is noted, and, with the axial point as a centre, a circumference passing through the image of this point is then described on the negative or print,—checks are afforded by observing two or more points.

The operation of *plotting*, from the negatives or prints, is evidently similar to that described for Chevallier's camera.

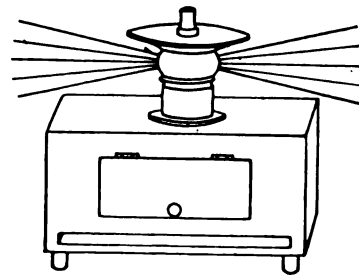


FIG. 49.

Fig. 49 represents the camera complete. In another form of this instrument, a triangular prism is employed to reflect the rays, after deviation by the objective, to the sensitive plate vertically disposed,—this arrangement making the camera more compact.

## SECTION V.

### THE CAMERA WITHOUT A LENS.

53. It is well known that, if rays of light from exterior objects enter a dark chamber through a very small aperture in one of its sides, images of these objects are formed on the side opposite the aperture, and that the images will be sharply defined if the aperture is circular and its edge is free from flaws.

The apparatus required is either an ordinary camera, or a box especially constructed for the purpose. For general purposes its length when extended should be at least 12 inches, and its lateral dimensions such as to admit an ordinary plate-holder containing plates of the required size. Means already described are resorted to for the setting up and levelling. The position of the aperture should correspond in every respect to that of the intersection of the optic axis of an objective with the front face of a camera; therefore, to make the arrangement complete, the aperture should be constructed in an ordinary objective-slide, of which the centre, or flange for a lens-tube, is filled with some opaque material. Apertures of different sizes, corresponding to different fields of view and sizes of images, are required; it is therefore more convenient for manipulation to construct them as hereinafter described, and attach the plates to a single metal strip which may be held and moved in grooves against or across a central opening in the slide, so that any desired aperture may be readily made to face the opening; or a revolving disk containing the apertures may replace the strip. A superposed sliding strip, or another revolving disk, will serve as a cap in making exposures.

To admit oblique rays, either the aperture must be conical, or else constructed in very thin metal. In the former case, a conical cavity, of which the angle at the vertex should be at least  $90^\circ$ , is drilled nearly through the metal, and the perforation is completed with a needle-point; in the latter, the thin metal, platinum, tin-foil, or gold leaf, is placed on a flat, smooth, hard-wood surface and pierced with a needle, care being taken in this as in the former case to make the aperture circular and of the required size; the latter is easily determined with the aid of a magnifying-glass and a finely divided scale of equal parts,—a needle gauged and suitably marked will prove useful in this operation. When thin or leaf metal is used, it is of course attached to annular pieces of thicker, or less pliable material, before being fastened to the strip or disk; and the latter is suitably pierced so as not to obstruct the rays. As a precaution against reflections in the camera, metal parts facing the interior should be blackened.

To obtain well-defined images the sizes of apertures, and the distances from apertures to the sensitive plate, which may be termed *aperture distances*, should vary according to the following rules derived from experiment:

For an aperture distance of 3.14 inches, the size of aperture is 0.012 of an inch;  
" " " 11.80 " , " " " 0.02 " " ;

and between these distances, the sizes vary proportionally from those given.

It is apparent from a consideration of the limiting rays of any field of view, or of any object, that the shorter the aperture distance, the wider will be the field embraced in a photograph, and the smaller will be the images. A short aperture distance entails less

exposure than a long one, because of the greater illumination; and a 90° field is found to be about the limit of equal illumination.

Assuming, for surveying purposes, 90° as the desired horizontal field or angle of view, then in order that any plate shall exactly contain the view, the aperture distance should be one half the horizontal dimensions of the plate; but for reasons heretofore stated a marginal allowance is advisable, therefore it is best to make the distance a trifle less—say 4.75 inches for an 8×10, and 3.75 inches for a 5×8.

In the use of this camera, images on a ground-glass are so faint as to be distinguished with difficulty, except in the brightest light; therefore, to dispose the camera for any view, the following simple device is employed: For the horizontal field; mark, by a projecting pin or otherwise, a point on the front upper edge of the camera and exactly in the vertical of the aperture; and mark two other points on the rear upper edge, one near and opposite to each extremity of the upper edge of the sensitive plate; then the prolongations of the sides of the angle, formed by joining the front point with the other two, will evidently serve, by sighting along them, to adjust the aperture distance so that any desired field will be contained by the plate. A similar device on a side of the camera serves to determine the vertical field.

A tour of the horizon requires but four separate views of 90° each; and each view may be limited to its proper quadrant as follows: At the first exposure, sight a distant point in the prolongation of one of the lateral faces of the camera; then, assuming the camera to be rectangular in plan, for the second disposition, revolve the camera until this point is intersected by the plane of a longitudinal face; and similarly for the two remaining views.

With sensitive dry plates, the period of exposure for landscapes is about 10 seconds in sunlight, and from 25 to 35 seconds on a cloudy day. With a Stanley dry plate, sensitiveness 25, aperture 0.013 of an inch in platinum leaf, aperture distance 4.5 inches, and exposure 10 seconds, the author obtained an excellent negative, which at ordinary visual range could hardly be distinguished from one sharply focussed with a lens. The following table from successful experiments will prove useful:

| SUBJECT.       | PLATE.                         | APERTURE. | AP. DISTANCE. | EXPOSURE.  | REMARKS.                              |
|----------------|--------------------------------|-----------|---------------|------------|---------------------------------------|
|                |                                | Inches.   | Inches.       |            |                                       |
| Landscape..... | Wet plate.....                 | 0.02      | 11.81         | 10' to 15' | Cloudy weather.                       |
| "              | Dry plates, sensitiveness 25.. | 0.12      | 3.14          | 10"        | In sunlight.                          |
| "              | " "                            | 0.12      | 3.14          | 25" to 35" | Cloudy weather.                       |
| In studio..... | " "                            | 0.02      | 12.0          | 1'         | Subject 10 ft. distant, well lighted. |

There are certain merits due to this method, viz.: that, when the camera is properly set up and levelled, the images formed are free from distortion, and it may be recommended for accuracy and simplicity. Its usefulness must of course be determined by local circumstances and conditions, such as the degree of definition required, sensitiveness of the plates, and the kind of lens available for other methods of working. The principle may be readily applied to the production of plane, cylindric, or radial perspectives.

## SECTION VI.

### TELESCOPIC AND BALLOON PHOTOGRAPHY.

54. *Telescopic or Long-range Photography.*—This has for an object the photographic representation of features beyond the range of the ordinary camera-objective. The means required consist of a telescope attached to the front of the camera, and which has its optic axis in the prolongation of that of the camera-objective;—the latter objective may be dispensed with. Fig. 50 shows an arrangement of camera and telescope for the purpose. Fig. 51 represents M. Lacombe's device for attaching the telescope; after inserting the eye-piece *a*, the tube-ring *b*, which has a thread cut on its projecting cylinder, is screwed into the outer extremity *c* of the objective-tube; a diaphragm, *d*,

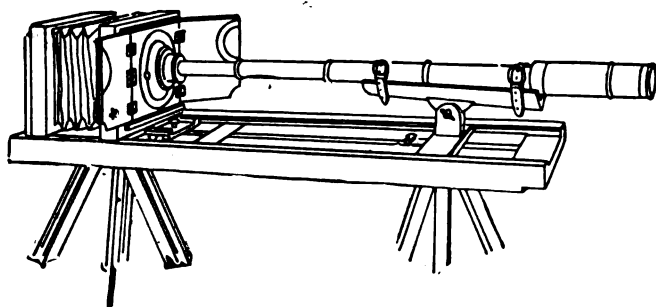


FIG. 50.

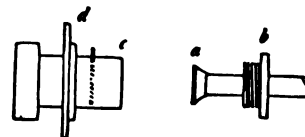


FIG. 51.

with large opening preventing the eye-piece from injuring the objective. Fig. 50 represents the other arrangements and the manner of focussing.

Another French operator, M. Mathieu, dispenses with the metal ring *b*, using instead a cylinder of stiff red cloth, which excludes actinic rays. While making the exposure, he envelopes the apparatus with a thick black cloth, in order to thoroughly exclude all light except that which enters through the telescope. There are two conditions indispensable to success: one, that all light, except that proceeding from the subject to be photographed, must be excluded from the apparatus; and the other, that the exposures must be timed with great care.

Figs. 52 and 53 are sketches from "La Nature" of M. Mathieu's work, the feature *C* in the former being magnified as shown in the latter, by the means just described. As to the details in this case: The camera used was a 5×7, and the lens a No. 2 Darlot. The time of exposure with an 0.08-inch stop, an ordinary dry plate, and a range of 0.75 mile, was 90 seconds. Good negatives were obtained at a distance of 3.75 miles.

This method is much like that practised in taking lunar photographs, and which is described in some astronomical treatises. Its application for surveying purposes would prove of value for representing inaccessible objects, such as the peaks and precipitous

slopes of mountains; and, in military operations, when the detailed description of a dis-

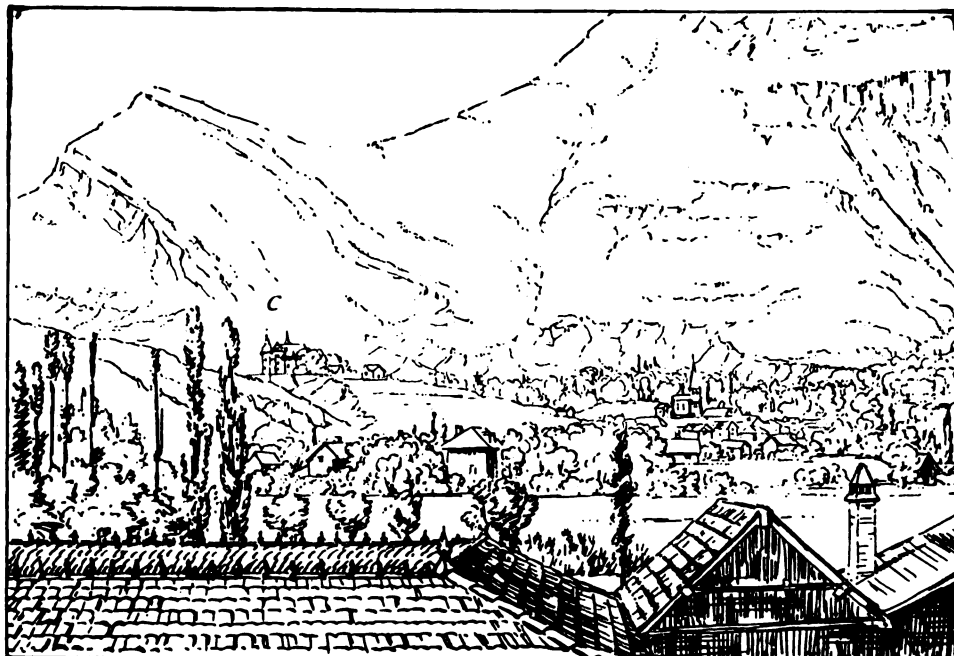


FIG. 52.

tant redoubt, or other fortification or position is needed.

55. *Balloon Photography—Sketch of Progress to 1880.*—Visual command afforded from great heights on a clear day is nowhere so perfectly attained, as from the cage or car of a balloon a few thousand feet above the earth's surface; there is no substructure to interfere, and the country is spread out like a map beneath. The idea of taking advantage of such favorable conditions for photographic surveying seems to have originated, in 1855, with M. Andraud; but it was not put into practical form until 1858, when M. Nadar, who, having no knowledge of a previous conception of the idea, resolved to do no less than make a survey of entire France, by means of photography and a captive balloon. His plan was to ascend to a height of 1000 metres above points previously determined; this height would command an area of 1,000,000 square metres, or 100 hectares (about 250 acres); and, since at least ten stations could be occupied daily, weather permitting, 1000 hectares would be the day's work. For military purposes, during a campaign, communication with headquarters was to be maintained by means of a box,

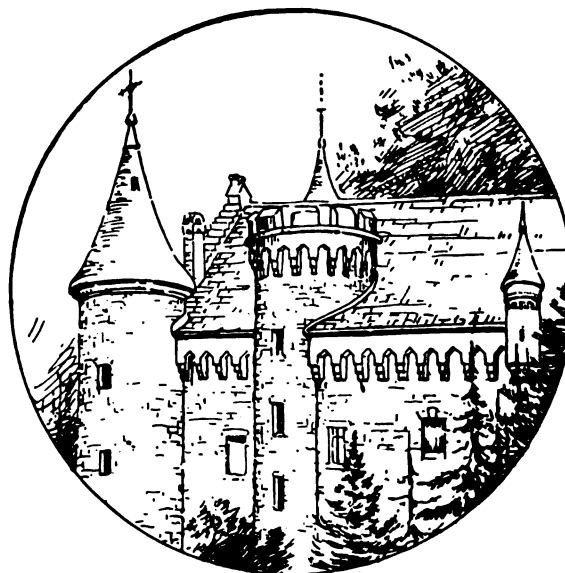


FIG. 53.



sliding along one of the cords which held the balloon, and by which the prints containing views of the enemy's position, etc., were to be dispatched every fifteen minutes. Patents were secured both in France and foreign countries, and he set to work developing his plan. The swaying of the balloon, lack of sufficiently rapid plates, and the escape of gas from the envelope, made the manipulation so difficult that the photographs obtained were of little value. Subsequently, however, in 1868, he succeeded in taking many useful balloon photographs which, considering the means then available, were as perfect as could be expected.

In the War of the Rebellion, captive balloons were frequently used to obtain information as to the surrounding country, the enemy's position, etc. In May, 1862, the Union army before Richmond employed one, and succeeded in photographing on a single plate all the country between Richmond and Manchester on the west, and the Chickahominy on the east; the rivers, smaller streams, railroads, marshes, pine-woods, etc., were all represented, as well as the dispositions of troops. Two prints were made from the negatives thus obtained; one of which was retained by the army commander, and the other by the aeronaut. Rectangles were ruled on them, the same number and disposition on each; reference-letters were attached; and, since in the subsequent ascents telegraphic communication was maintained between headquarters and the balloon, the prints enabled the aeronaut to give information of all important events that transpired in any rectangle; which information in several instances proved very valuable.

At this time, similar and successful use of balloons was made on the Mississippi near Cairo. These results, added to those attained during the war of 1866 in Bohemia, led to the formation in France of the French Society of Aerial Navigation, in existence at the present date, and including men of wealth and scientific attainment: the participation of its members in the Franco-Prussian War, particularly during the siege of Paris, when both free and captive balloons were employed, is well known. The faults of management and the failures that occasionally took place, and these were more especially noticeable on the German side, were mainly due to inexperience, imperfect apparatus and lack of instruction;—in this connection, it may be stated that the Germans, in 1887, added to their army an aeronautic section of fifty men.

The Meudon School of Aerostation was formed in 1871 for the purpose of instructing soldiers in the duties of aeronauts. A commission, of which Col. Laussedat was the most active member, was appointed the same date to study this subject, and it devoted especial attention to balloon photographic surveying.

In 1878, M. Dagron undertook to carry out the scheme proposed by M. Nadar; but the slow action of wet plates, joined to oscillations of the balloon, resulted in confused negatives; and it was only on a very calm day that he finally succeeded in obtaining a fair negative of part of the city of Paris, in which most of the prominent features could be recognized.

In the following year, dry plates and the instantaneous shutter were used by M. Triboulet; but after making an exposure in a free balloon at a favorable altitude of 500 metres, a storm caused a descent into the Seine, and custom-house officers opened his plate-holders to examine for contraband articles.

In 1879, on account of services rendered in Afghanistan and Zululand, the English

war department made ballooning apparatus part of their permanent military outfit, and provided for the instruction of troops in its use.

56. *Recent Experiments.*—In June, 1880, M. Desmarests, with rapid dry plates and an electric instantaneous shutter, obtained two good negatives. The first represented a portion of the village of Ménil-Esnard near Rouen, including an area 900 metres square, to a scale of about  $\frac{1}{4000}$ ; the altitude of the balloon was about 1100 metres, the velocity of ascent 6 to 8 metres, and the weather misty. Although lacking in clearness, buildings, roads, trees, and piles of stones intended for paving purposes, were defined. The camera was so disposed that the objective-tube projected through an opening in the base of the car. The other negative was made at an altitude of 1300 metres, and embraced the country between Rouen and Quillebœuf; unfortunately clouds intervened in many places; but, by an enlargement of the original, M. Carette unexpectedly brought out many details, which before were unobservable with a microscope. In the second operation, the camera was secured to the side of the car, altitudes were measured with a very sensitive aneroid barometer, and the objective used was a Derogy  $8\times 10$ , with a focal distance of 11.5 inches; and, since the time of exposure was about  $\frac{1}{30}$  of a second, and the velocity of translation of the balloon about 6 to 7 metres per second, the angle of displacement—about  $8''$ —was insensible. This experiment attracted much attention and therefore gave the subject greater prominence.

In 1883, Mr. Shadbolt of England succeeded in making with dry plates good negatives from exposures at altitudes varying from 500 to 1000 metres. In all the prints, the topographical features were distinguishable; but in one obtained at 650 metres above Stamford Hill, in the northern part of London, the features were particularly well defined; in fact, with the aid of a microscope, the smallest objects could be easily recognized. Experiments of this nature are now being made at the school of ballooning at Chatham.

57. *Special Apparatus for Balloon Photography.*—In the instances given, the aeronaut occupied the car and manipulated his camera in the usual way; but, in 1884, M. Triboulet devised another method of working. He constructed a hexagonal willow basket to contain the photographic apparatus, and suspended it beneath the car of a captive balloon. The latter was unaccompanied by an aeronaut,—electric communication with the earth, by means of a light cable, serving to make the exposures. As shown in Fig. 54,

the interior of the basket was subdivided into seven dark chambers; six of the objectives were disposed horizontally to obtain a tour of the horizon, while the seventh projected

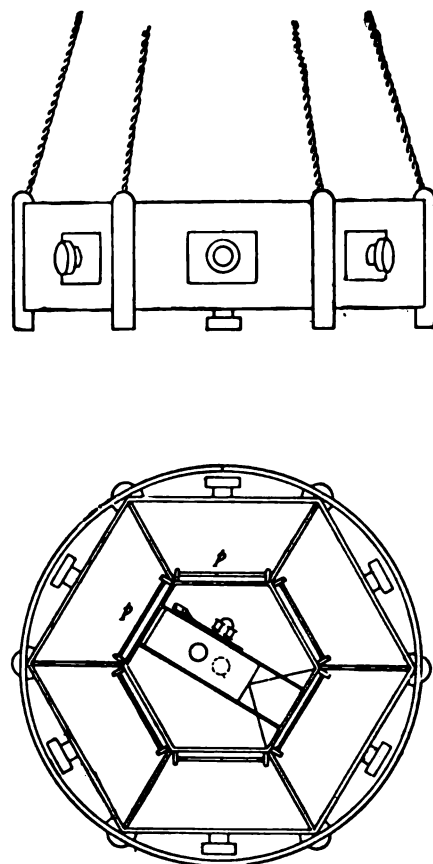


FIG. 54.

through the base of the basket and gave the view beneath. Sensitive dry plates about  $8 \times 10$  inches in dimension were used, the plate-holders occupying the positions  $p$ ; and the images on the plates overlapped 0.4 of an inch to facilitate joining the prints. The instantaneous shutter, drop-pattern, was arranged as shown in Fig. 55; the drop  $a$ , held in the grooved strips  $b$ , was retained in position by the stop  $c$  attached to a metal spring  $d$ ; on closing the circuit the electro-magnet  $e$  withdrew the stop, and the drop was quickly closed by means of the rubber bands  $f$ . The photographs obtained in this instance were fairly good.

At the close of 1884, M. Cassé made use of a very small captive balloon; and, to avoid the weight due to the use of an electric cable, substituted slow-match, which being of a length corresponding to the period of ascent, released the stop ( $c$ , Fig. 55) at the proper elevation. Clock-work has also been employed for this purpose. Experi-

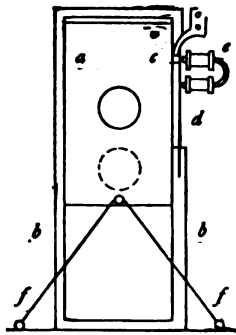


FIG. 55.

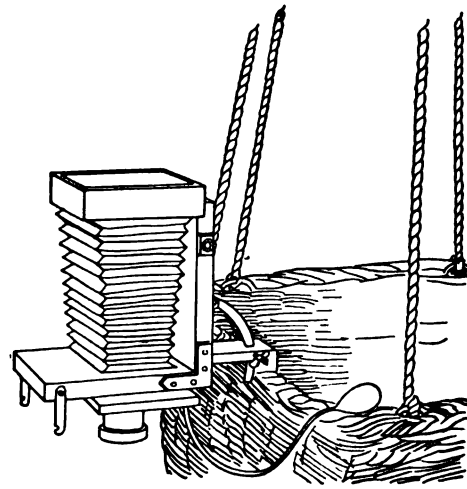


FIG. 56.

ments of this nature and attended with similar results were made at Chatham during the same year.

58. *Notably Successful Experiments.*—A notable instance is afforded in the experience of MM. Tissandier and Ducom at Paris in 1885. The ascent was made at 1.40 P.M., in a partially cloudy atmosphere, and with a wind-velocity of about 12 miles per hour. The photographic apparatus consisted of a  $5 \times 8$ -inch camera, Mackenstein tourist pattern, attached to the car as shown in Fig. 56; and a Français rapid rectilinear objective No. 4, having a 22-inch focus and an opening of 1.4 inches, stopped to 1 inch. The drop-shutter used gave an exposure of  $\frac{1}{80}$  of a second, and the gelatino-bromide plates were specially manufactured for the purpose. Exposures were made at altitudes varying from 600 to 1100 metres; several were very successful, the best appearing to be that at 600 metres above the isle of Saint-Louis, and in which, with the aid of a microscope, the coils of rope contained in the passing boats are plainly visible—a tracing from the photograph, in the author's possession, is given in Fig. 57. The most sharply-defined views were obtained when the sun's rays were so oblique that slight shadows were cast. The motion of translation did not affect the sharpness, but it was found best to spring the shutter near the beginning or end of an oscillation.

In July of the same year, M. Pinard, of Nantes, obtained good  $7\times 9$  negatives from exposures made at altitudes varying from 400 to 1700 metres. He used a 10-inch focus Steinheil antiplanat, with a stop of  $\frac{1}{16}$ , and the drop-shutter gave an exposure of  $\frac{1}{80}$  of a second.

The latest and best results appear to be from the experiments of Captains C. and P. Renard and M. Georget in 1885, and of MM. Tissandier and P. Nadar in 1886. Of the many good photographs made by the former party, that one obtained at 10.17 A.M., at an altitude of 720 metres, deserves especial mention for fineness of detail. The latter party of aeronauts made an ascent lasting 6 hours, and obtained 30 photographs, including some from an altitude of 1200 metres; various dispositions of the camera were

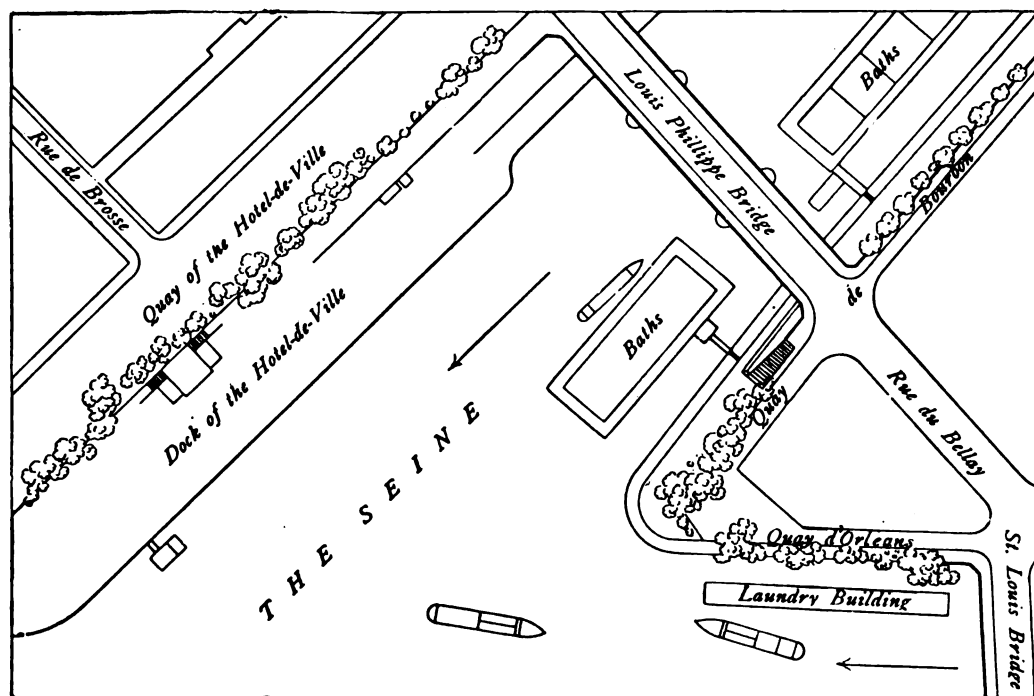


FIG. 57.

made in order to obtain both plan and oblique views. The time of exposure was  $\frac{1}{80}$  of a second.

59. *Photographic Outfit and Method of Working.*—The following is a brief description of Mr. Shadbolt's preparations for balloon photography: "My list of requisites comprises a  $5\times 7\frac{1}{2}$ -inch camera, a good supply of double plate-holders, lenses, shutters, etc., an aneroid barometer with altitude-scale registering up to 15,000 feet, a pocket-compass and maps of the country over which I am to travel, and a copy of Murray's threepenny time-tables, small edition, which comes in handily on landing. If circumstances permit, I prefer to fix my apparatus before starting;—the case containing the slides, etc., being attached to the side-ropes of the car by means of a strap, so as to be close at hand, and the camera fixed in its place on the edge of the basket by means of any simple device. . . . The barometer I fasten to the rigging close by the camera, so as to enable me to record the altitude as each exposure is made."

60. *Use of Small Balloons, Captive and Free.*—In 1881, Capt. Elesdale, R.E., proposed to use a small balloon, either captive or free, having sufficient lifting power to carry a very light camera to any desired height; the exposure to be made at the proper time either by electric apparatus controlled from the ground, or, automatically, by clock-work attachment. In his subsequent experiments, various devices were employed to ensure a proper direction of the optic axis; for plan views, the axis was kept vertical by attaching the camera, pointing downward, to a rectangular frame, suspended horizontally from a ring beneath the balloon by means of four cords or steel chains of equal length; for inclined views, the optic axis was to be pointed in any desired direction by attaching the camera to one end of a bamboo rod, the retaining or ground cord being secured to the other end, while the rod was suspended at the required angle by two cords of different lengths; a light sail, formed by filling in the triangle of the rod and cords with silk, was suggested as a means for keeping the camera steady in the direction of the wind. In case of no wind, a multiple camera similar to that used by M. Triboulet (see par. 57), was to be employed.

For military purposes, as in the case of an investment, the besieger could resort to either one of the two following processes for obtaining comprehensive views of the enemy's position:

*a.* A line of connected balloons is to be floated across the position, and the views are to be taken in transit as follows: Having selected a suitable point to windward, its location being accurately ascertained by the preliminary use of one or more pilot-balloons, balloon No. 1 with camera attached is sent up, its retaining-cord of silk, or best hemp, being paid out freely from a windlass running on friction-rollers, so as to offer as slight a resistance as possible. No. 1 having reached its equilibrium level, say 2000 feet, No. 2 is instantly toggled on and sent up; then No. 3, and so on throughout the series of five or more; the interval, or section of cord between balloons, evidently depending upon the lifting power. No check of ascent is to be permitted, or the series will tend to pivot around the starting-point and come to the ground. The automatic apparatus is set at the proper time for making an exposure, from observation of the rate of travel of the pilot-balloons; or, for the later balloons of the series, from information communicated by signals from an assistant, stationed in a direction perpendicular to the path, and who would observe the leading balloons.

The system is brought to the ground beyond the enemy's position by attaching a very light grapnel, with a suspension cord 50 to 100 feet in length, to the last balloon; and by cutting a small hole near the crown of the latter to permit the gradual escape of its gas, which will begin to be effective when the balloon has reached its equilibrium level.

*b.* In the other process, each balloon is to be sent up independently, the escape of gas being so provided for, as above, that the balloon shall descend at a suitable distance and be held by its grapnel.

In a special case, as in the close investment of a fortress when it is necessary to ascertain if an inner line of defence is being constructed by the besieged, two methods are prescribed, the choice depending upon the direction of the wind. First, when the

wind is favorable and blowing towards the enemy: the small balloon is inflated in the advanced trench, say at 200 yards from the work; it is sent up, with camera attached to a rod, as above described; the view is taken at, say, 80 yards from the work, when, by the release of a weight suspended from the balloon by a cord, which is automatically parted by the burning of a time-fuze, the balloon rapidly ascends out of reach of the enemy's bullets; the windlass is then quickly carried to the rear trenches, the cord being paid out freely, and the balloon is hauled down at a safe distance. Provided the camera is not hit, a few bullets through the envelope do no harm. In the second case, when the wind is from the opposite direction: a solid shot, to which a short length of chain connected with a fine hempen line is attached, is fired with the proper powder-charge to a point near the crest of the glacis; the balloon, fastened to the line and also to its retaining cord, is then sent up; the line is burned through at the proper time by a time-fuze, the balloon rises rapidly and is hauled down as before.

To ensure steadiness of ascent and to prevent oscillation of the captive balloons, Capt. Elesdale prescribes that "all vertical strain except that due to the dead weight of the cord itself should be removed; and all horizontal strain should be avoided if possible, and when this is not possible it should be changed into a small, steady and uniform retarding force, instead of an unyielding pull, until the picture is taken." In case of the balloon rising to still air above a wind-current, to keep it in position "the drifting lower portion of cord must be fed with more cord from the ground as fast as it will run out."

As a result of his experiments up to August, 1883, Capt. Elesdale remarks "that with a proper and thoroughly worked out apparatus, constructed by the aid of opticians and mathematical-instrument makers, so as to admit of instrumental accuracy in all the processes, and for pictures taken on ordinary ground (not representing any violent slopes or extreme differences of level) we may expect to attain by balloon photography more accurate plans than are usually obtainable by ordinary surveying."

61. *Observations on Balloon Photographic Surveying.*—The facts given in paragraphs 55 to 58 show that good photographs, giving either vertical, oblique or panoramic views of a country, may be obtained from balloons; and the first question now presented appears to be whether, aside from their value as pictorial representations, they may be used as data for the construction of exact or true maps.

I. *With Captive Balloons.*—Taking first the case of a single view: *When a balloon in mid-air is stationary*, as in the case of a captive balloon in still weather, a panoramic view obtained corresponds to cases described in the preceding sections; with a difference in its favor, however, that the point of observation is exceptionally commanding. The vertical or plan view—that obtained by pointing vertically through the base of the car—affords under favorable illumination a perfect means for the measurement of horizontal angles; the middle point of the view being the radial or angular point. A vertical view of a flat tract would be a most perfect and detailed map or plan of itself, and could be enlarged or reduced as desired to conform to any scale,—the plans of buildings, which, by their positions in the outer part of the view, would present one or more faces, being given by the bases; but in the case of a mountainous or hilly tract, neither the eleva-

tions nor horizontal distance would, as a rule, be truly represented. Thus, as shown in Fig. 58: at the altitude  $PB$ , the peak  $D$  is projected by a visual ray in  $D'$  instead of  $D''$ , representing an error of  $D''D'$  in its horizontal distance from  $P$ . Both the distance  $PD''$  and the elevation  $D''D$  may however be readily determined as follows: On the

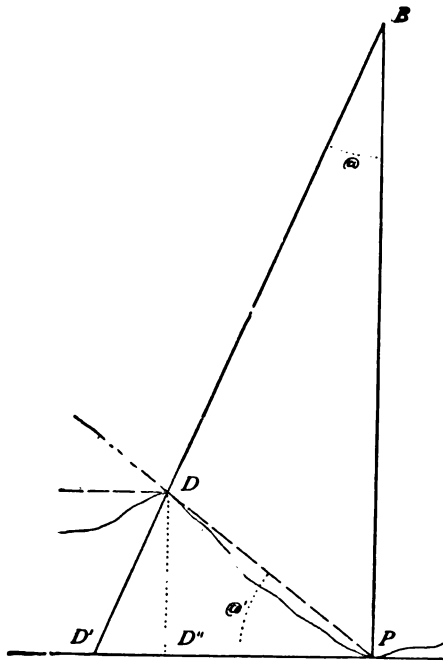


FIG. 58

print, measure the angle  $@$ , which is given by its tangent,  $PD'$ ,— $PB$  being measured by the aneroid; from the station  $P$  measure the angle of elevation  $@'$ ; plot the triangle  $PDB$ , in accordance with the scale of the map; then  $D''D$  and  $PD''$ , measured by this scale, are respectively the elevation and horizontal distance required. For oblique views, the plotting would be more complex—the measured angles requiring the correction due to the angular displacement of the optic axis from a vertical. It has been suggested that compensation for obliquity of the plane of the picture, due to either uniformly sloping ground, the optic axis being vertical; or to an oblique position of the axis, in the case of flat country; may be effected, as in copying by photography, by a simple adjustment of the original photograph, or of the sensitive plate, in a secondary photographic process.

*When the captive balloon is not stationary*, and even when oscillating under a strong wind, it is shown, from experiments made at Berlin in 1885, that the car itself can be maintained with its base horizontal. The cords of the net, instead of converging in the usual manner to a ring beneath, were attached at intervals to a horizontal bar. For the balloon used,—a sphere of 50,000 cu. ft. capacity, filled with hydrogen, and carrying eight persons,—the bar was 2 inches in diameter and 33 feet in length, and the car was suspended from its middle point; two light cables 0.4 inch in diameter were fastened one to each extremity of the bar, and were joined 65 feet beneath it to the main cable. Suppose the balloon to be moved out of the vertical of the station; then, if the sensitive plate is horizontal, the view itself will show the intersection of the optic axis with the earth; this point might also be fixed by bearings of known points taken from the car, or by transit measurements from the earth,—the instant of exposure in the latter case being communicated by signal.

If a series of views are thus taken above known points of an extensive tract, they may be used in plotting as so many protractors, by fastening their centres with needle-points to the plotted stations; then, by orienting them and conforming to the plane-table method of intersections, the required points are readily located. A scale for any single view is easily constructed from the ratio of any represented distance to the corresponding actual distance. For the general plot, since the method of intersections is independent of the diameters of the views, differences of altitude would not affect the construction of a plan, it being only necessary to fix the stations to scale.

From an altitude of 2000 feet excellent photographs have been obtained; and each

of these, taken with a Hermagis 90° lens, would represent an area about  $\frac{1}{4}$  of a mile square; while from a 3250-ft. altitude, at which good results are noted, the area would be about  $1\frac{1}{4}$  miles square.

II. *With Free Balloons.*—But few experiments in photographic surveying with free balloons have up to the present date been recorded; but the proposition seems by no means infeasible, since the dirigibility of balloons has become practicable. In the experiments of Captains Templar, Lee and Elesdale, at Woolwich in 1879, the differences in direction of the air-currents at different heights were utilized to travel in any desired direction; a small pilot-balloon of about 200 cu. ft. capacity being made to ascend or descend a distance of 2000 feet from the car, to show the directions of the air-currents. At Meudon, in 1884, Capt. Renard, with a balloon propelled by means of an electric motor, the screw being at the bow, and steered with a rudder-sail, travelled at will in a 9-mile wind, at the rate of 14 miles an hour, returning after a trip of 47 minutes to the point of departure. It is evident that, in either of these cases, vertical views taken at proper intervals would have furnished a map of the entire country passed over. More recently, Captains Renard and Krebs have perfected an electric motor which ensures a continuous voyage of four or five hours' duration.

For the purpose of measuring altitudes with precision in balloon surveying, M. Casella has recently constructed a very sensitive aneroid barometer which indicates differences in height of one foot.

With very sensitive plates and rapid shutters, the photographic operations are of easy performance, and photographs are obtained that lack nothing in clearness and accurate representation. Much assistance is afforded to military art in the rapidity and faithfulness with which the enemy's defences and positions may be depicted; and to the geographer the means are supplied for obtaining descriptions of isolated tracts and of those inaccessible by ordinary means. Panoramic and plan views well combined give results of great interest, and present to the aeronaut and photographer new and important applications of their arts.



## SECTION VII.

### VARIOUS APPLICATIONS OF PHOTOGRAPHIC SURVEYING, AND SOME OF ITS ADVANTAGES.

62. *General Considerations.*—It has been shown in the preceding pages that with the camera as a surveying instrument the field-work may be performed with great rapidity, and with an economy of men and material exceeding that due to other means; and that, in the plotting, the plan results from an application of the very simple method of intersections; while the representation of heights and surface-forms is accomplished either mechanically, or by the use of tabular values which may be easily and rapidly applied. As to the contouring, it is apparent that in some cases, owing to the surface-covering of trees and the interposition of projecting spurs or salients, the lesser inequalities are not given in the prints; but this deficiency can be supplied, as in other methods, by field-sketching; and, in respect to this part of the work, it may be said of this method, as of ordinary topographical surveying, that the production of a complete map requires a true appreciation of forms of ground. With carefully-constructed instruments, and most of the standard cameras and rectilinear lenses now made are suitable, the results exceed in precision those ordinarily obtained with either compass or plane-table; and as to thoroughness of detailed description, there is of course nothing to exceed a photographic representation.

63. *To Farm-surveys and Engineering Purposes.*—For farm-surveys, fields, and small tracts in general, a few exposures—in many cases three will suffice—from well-selected points furnish the data for a complete map.

For engineering purposes, aside from its adaptation to the topographical survey of projected routes of railroads, canals, and other subjects which have already been referred to, this means is especially useful for conveying information as to the condition of important constructions. Photographs obtained at different stages in the progress of the work in hand afford descriptions which, for thoroughness, written communications are inadequate to give; these faithful records, representing the site, foundations, intermediate conditions of the structure; with date, number of men at work, state of the weather, etc., noted on the back of each print, are very valuable for future reference.

64. *To Geographical and Archæological Descriptions.*—As an aid to the geographer this means is of great value. The difficulties due to optical illusion which, in ordinary topographical sketching, mountainous or hilly tracts present, are obviated; from the peaks, panoramic views are comprehensive and far-reaching; and exposures from the less elevated points furnish details of the deeper valleys, and of those tracts which from the peaks are either shut out or obscure. The choice of illumination, properly exercised, gives a definition to surface-lines and points, that actually appears sharper in a print than in nature:

therefore, as compared with ordinary observation, a more accurate map-delineation results. Both geological and botanical information are included in the print,—the rock-structure, peculiar formations, deposits, the forest and individual growths, and much else that assists to a thorough knowledge of the country.

Profile views of a range of mountains or hills, taken either from peaks or favorable points of a valley route, are excellent data for plotting. The directions of stations from each other are ascertained by compass-bearings; while the aneroid would prove of valuable assistance in the levelling, and the odometer would measure the distances between stations of the valley route. Coast-lines also may be accurately described from views taken off shore. For the representation of inaccessible objects, tracts, summits, declivities, morasses, or craters, the method is unrivalled.

To the archæologist its use is of inestimable value; intricate lines of figure of buildings, monuments, or earth constructions, are faithfully produced, and their measurement is thus made easy of accomplishment. The photographic survey of Persepolis and of the Mosque of Mesdjid-a-djunia, by Dr. Stolze, are recent instances of its successful application.

As addenda to plotted maps, the photographs, for minute information, will often serve the same purpose as actual inspection.

65. *To Military Purposes.*—The rapidity with which ground may be represented offers special advantages to the military service. As an instance of rapid work: In 1874, M. Javary made in one day, in the valley of l'Arly, a photographic reconnaissance extending 14 miles, and embracing the features within a distance of from one to two miles on either side of the route followed. This work was performed with two cameras of the ordinary type, a compass and a stadia. The two last instruments were kept on the route, while a photographer, with stadia-rod and camera, marched on each side. At a given signal, the distance to either photographic station was measured by the stadia, and its bearing taken; the photographer took the bearings necessary to orient his views; and means for checking the orientation were supplied by bearings, taken from the stadia-stations, of prominent points that would appear in the views.

On another occasion, M. Javary made, in six hours, a photographic survey of the ground included in a zone three fourths of a mile in width, in front of a fortified place; and, after 8 hours expended in the plotting, presented the commanding officer of the attacking force with an *exact and complete map, including the levelling; and this in rainy weather and with wet plates.* He states that, with four operators, the exact survey of any fortified place can be made and plotted within 24 hours.

As an instance of its value in defensive operations, views of the surrounding country may be taken from the different salients or other commanding points of a work; the distances to the enemy's batteries, etc., ascertained from the plotting, can then be noted on the representations of the objects, and the prints distributed to the chiefs of pieces, who are thus enabled in an instant to get the range of any contained point.

Aside from the merit of this method as a means of military surveying, the representation by photographs of all the details possesses a special advantage in camp or field; it may happen that a knowledge of some feature of ground, which in ordinary

topographical sketching might be omitted, would prove of great value; again, the naturalness of a photographic representation might convey to some the information not afforded them by a topographical map.

Since balloon photography claims such an important part in warfare; the element of danger to the aeronaut, from the enemy's fire, is of considerable moment. During the siege of Paris, the Germans made use of a large rifle so mounted, and furnished with stock and butt, that it could be fired from the shoulder; this was transported by wagon to points over which the French balloons chanced to pass, and some of the aeronauts testified to hearing the bullets whiz by them when at altitudes of from 800 to 1000 yards. In November, 1870, one balloon, "La Daguerre," lost so much gas from perforation by the balls from the ordinary infantry rifle, that it had to descend and was captured by the Prussians. From experiments subsequently made by the French war department it was found that, at an altitude of 1300 feet, a balloon 13 feet in diameter was unharmed by the best sharpshooters with a chassepot rifle; but from the testimony above given, their failure in attaining it must have been due to ignorance of the true form of the trajectory when the line of fire is inclined to the horizon. It is found, theoretically, that with a chassepot rifle, model of 1874, the extreme range in firing upward, at angles between  $80^{\circ}$  and  $90^{\circ}$  with the horizon, is nearly 2100 yards, while the effective range as against an ordinary balloon is about 800 yards; for angles between  $60^{\circ}$  and  $70^{\circ}$ , the effective range is increased to about 950 yards, and between  $40^{\circ}$  and  $50^{\circ}$  to about 1000 yards. (For an elaborate discussion of this subject, see "Tir Contre les Ballons," by Dufaux, 1886.)

The "Jahresberichte" enumerates the following conditions to be fulfilled, in order that balloons may be generally adaptable to military service:

- I. To be readily transportable, either inflated or empty.
- II. That the envelopes shall be resisting and impermeable to the contained gas, in order that they may lose as little as possible of their ascensional force.
- III. The means to be supplied for filling them rapidly, in any place whatever, and of replacing the gas lost.
- IV. For free balloons: power to move in any direction, of landing promptly and with security, also of rising promptly.
- V. For captive balloons: means for preventing rotation about a vertical axis, and for causing them to rise in good condition notwithstanding the wind.

Experiments very lately made in France and England have been successful as to the first three conditions; as may be observed in the preceding pages (Section VI.), the fourth and fifth are in a fair way of fulfillment; and it certainly seems, after having within a comparatively short period surmounted so many obstacles, that the efforts made to perfect this valuable aid to scientific investigation, for civil as well as military purposes, will soon meet with a favorable termination.

66. *Some of the Advantages Derived from its Use.*—In photographic surveying, an entire tour of the horizon, or any desired part thereof, is obtained in a few minutes by a series of very simple operations, involving no multiplied or fatiguing observations; no drawings, sketches, or lines of direction difficult to trace in the field; no delicate pointings or minute readings, and no prolonged computations. There is no fear of having forgotten, or omitted, some important point; because every visible detail is represented, and, when

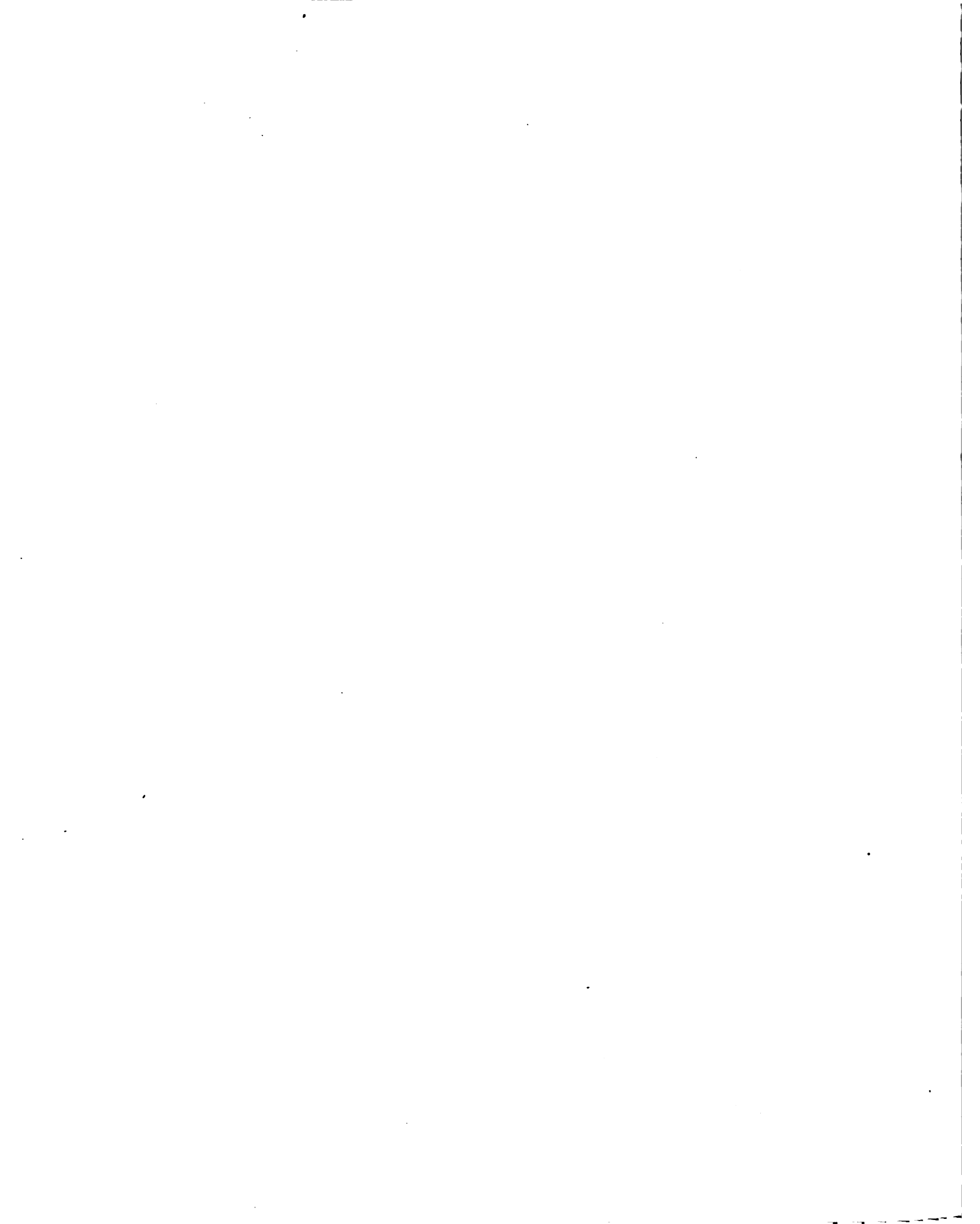
negatives are used in plotting, with a precision that is rarely exceeded; there is also no occasion, as in other methods, for rejecting erroneous or doubtful observations.

The office-work presents no difficulties; the constructions are simple and rational; and errors of destination, pointing or orientation, are made impossible by the numerous verifications which serve at each step to check results already attained. All the work done in the field is of value, and there are no regrets for not having made all useful observations at any station.

The map finished, the photographs, as addenda, present as already stated a view as perfect and comprehensive as if the observer had personally traversed and inspected the tract or region represented.

The only inconvenience that seems to present itself, is that of acquiring a certain degree of skill in the chemical manipulations; but this part of the work is now reduced to such simplicity that but little practice is necessary for the purpose; besides, in surveys of considerable extent, a professional photographer would usually be retained.

Finally, in the prosecution of a survey, the stations may often be so selected that in the views artistic effect and necessary data are joined, and the resulting photographs would thus be made as interesting in the former respect as they are useful in the latter.



## INDEX TO VOLUME II.

| PAR.   | PAGE | PAR.   | PAGE |
|--|------|--|------|
| 33. Accuracy Attainable (see also pars. 1, 51, 52, 61, 62, and 65), . . . . .        | 34   | 4. Drawings, Perspective, Relation of Photographs to,                                  | 5    |
| 64. Addenda to Maps, Use of Photographs as, . . . . .                                | 62   | 63. Engineering Purposes, Application to, . . . . .                                    | 62   |
| 40. Adjustment of the Optic Centre, Cylindrograph, . . . . .                         | 38   | 51. Error, Instrumental, of Cylindrograph, . . . . .                                   | 46   |
| 32. Advantage in the Use of Negatives, . . . . .                                     | 33   | 56-58. Experiments in Balloon Photography, . . . . .                                   | 55-6 |
| 44. Advantages claimed for Cylindrograph, . . . . .                                  | 40   | 17. "Exposure" of Photographic Plates, . . . . .                                       | 17   |
| 64. " derived from Applications of Photographic Surveying, . . . . .                 | 62   | 63. Farm-surveys, Application to, . . . . .  | 62   |
| 28. Angle Scale, Vertical, . . . . .   | 31   | 15. Field of View, Measurement of, . . . . .   | 16   |
| 57. Apparatus for Balloon Photography, Special, . . . . .                            | 55   | FIELD-WORK :   |      |
| APPLICATIONS OF PHOTOGRAPHIC SURVEYING, . . . . .                                    |      | 24. General, Conditions, Methods, . . . . .  | 25   |
| 63. To Farm-surveys and Civil Engineering, . . . . .                                 | 62   | 19. Selection and Distribution of Stations, . . . . .                                  | 19   |
| 64. To Geographical and Archæological Description, and as Addenda to Maps, . . . . . | 62   | 20. Method I.—With Triangulation Established, . . . . .                                | 20   |
| 65. To Military Purposes, . . . . .  | 63   | 21. " II.— " Camera and Hand-compass, . . . . .  | 22   |
| 66. Some of the Advantages derived from, . . . . .                                   | 64   | 22. " III.— " Camera only, . . . . .   | 23   |
| 3. Azimuth and a Distance, Location of Points by, . . . . .                          | 5    | 23. Best Time for, . . . . .   | 24   |
| 39. Azimuth and Slope Scale, for Cylindrograph, . . . . .                            | 38   | 43. In Case of Cylindric Perspectives, . . . . .                                       | 39   |
| BALLOON PHOTOGRAPHY, . . . . .   |      | 47. " of Radial " , . . . . .  | 44   |
| 55. Sketch of Progress in, to 1880, . . . . .  | 53   | 47. Fixed Sectors, Operating by, . . . . .   | 44   |
| 56. Recent Experiments in, . . . . .   | 55   | 17. " Fixing" of Photographic Plates, . . . . .  | 17   |
| 57. Special Apparatus for, . . . . .   | 55   | 13. Focal Distance, Measurement of, . . . . .  | 13   |
| 58. Notably Successful Experiments in, . . . . .                                     | 56   | 20. Form of Record Used in Field-work (Method I.), . . . . .                           | 21   |
| 59. Photographic Outfit for, and Method of Working, . . . . .                        | 57   | Free Balloons, <i>see</i> " Balloon Photography."                                      |      |
| 60. Use of Small Balloons, Captive and Free, . . . . .                               | 58   | GENERAL PRINCIPLES, . . . . .  |      |
| 61. Observations on Balloon Phot. Surveying, . . . . .                               | 59   | 2. Range and Object of the Method, . . . . .   | 4    |
| 61. Balloon Phot. Surveying, Observations on, . . . . .                              | 59   | 3. Location of Points, . . . . .   | 4    |
| 60. Balloons, Small, Captive and Free, Use of, . . . . .                             | 58   | 4. Relation of Photographs to Perspective Drawings, Definitions of Terms, . . . . .    | 5    |
| 23. Best Time for Field-work, . . . . .  | 24   | 5, 6. To Determine the Direction and Position of a Point from a Perspective, . . . . . | 5, 7 |
| Camera, Early Forms of, <i>see</i> " Historical Sketch."                             |      | 64. Geographical Description, Application to, . . . . .                                | 62   |
| 7. " , for Plane Perspectives, . . . . .   | 9    | 52. Glass Reflector, Mangin's, . . . . .   | 49   |
| 36. " , " Cylindric " , . . . . .  | 36   | 21. Hand-compass, Method with Camera and, . . . . .                                    | 22   |
| 46. " , " Radial " , . . . . .   | 42   | 27. Heights, or References, To Determine, . . . . .                                    | 28   |
| 52. " , " " , Mangin's, . . . . .  | 47   | 29. " , Mechanical Measurement and Scale of, . . . . .                                 | 31   |
| 53. CAMERA WITHOUT A LENS, . . . . .   | 50   | 50. " , To Determine, in Radial Perspectives, . . . . .                                | 46   |
| Captive Balloons, <i>see</i> " Balloon Photography."                                 |      | 43. " , " " , in Cylindric " , . . . . .   | 39   |
| 46. Chevallier's Camera, . . . . .   | 42   | 61. " , in Balloon Photography, . . . . .  | 59   |
| 10. Changing-boxes, . . . . .  | 11   | 14. HH',—the Horizon, To Determine, . . . . .  | 14   |
| 33. Choice of Scale, . . . . .   | 34   | I. HISTORICAL SKETCH, . . . . .  |      |
| 63. Civil Engineering, Application to, . . . . .                                     | 62   | 14. Horizon, or HH', To Determine, . . . . .   | 14   |
| 9. Compass and Level, for Use with Camera, . . . . .                                 | 10   | Lens, <i>see</i> " Objective."   |      |
| 30. Contouring from Photographs, . . . . .   | 32   | 9. Level, for Camera, . . . . .  | 10   |
| 35. Cylindrograph, Topographic-, . . . . .   | 36   | Levelling, <i>see</i> " Heights, or References."                                       |      |
| 30. Datum Plane, Reduction of References to, . . . . .                               | 32   | 3. Location of Points, . . . . .   | 4    |
| 4. Definitions of Terms used in Perspectives, . . . . .                              | 5    | 54. LONG RANGE PHOTOGRAPHY, . . . . .  | 52   |
| 17. Development of Photographic Plates, . . . . .                                    | 17   | 52. Mangin's Camera, . . . . .   | 47   |
| 5. Direction of a Point, To Determine from a Perspective Representation, . . . . .   | 5    | 34. Map, Photographic, Explanation of, . . . . .                                       | 35   |
| 13. Distance, Focal, Measurement of, . . . . .                                       | 13   | 64. Maps, Use of Photographs as Addenda to, . . . . .                                  | 62   |
| 16. Distortion, Test of an Objective for, . . . . .                                  | 16   | 15. Measurement of Field of View, . . . . .  | 16   |
| 19. Distribution, and Selection, of Stations, . . . . .                              | 19   | 13. " of Focal Distance, . . . . .   | 13   |
|  |      | 28. Mechanical Measurement of Angles, . . . . .  | 29   |
|  |      | 29. " " of Heights, . . . . .  | 31   |

| PAR.   | PAGE  | PAR.  | PAGE     |
|--|-------|---|----------|
| 52. Metallic Reflector, Mangin's, . . . . .                              | 47    | PLOTTING—(Continued:)   |          |
| 65. Military Purposes, Application to, . . . . .                         | 63    | 32. Preparation of Prints for, Advantage in Use of                |          |
| Minor Surveys, <i>see</i> "Farm-surveys."                                |       | Negatives, Transparencies, . . . . .                              | 33       |
| 35. Moëssard's Camera, . . . . .   | 36    | 33. Choice of Scale, Accuracy Attainable, . . . . .               | 34       |
| 48. Movement, Continuous, Operating by, . . . . .                        | 44    | 34. Example of a Photographic Map, . . . . .                      | 35       |
| 10. Negative-box, . . . . .  | 11    | 43. From Cylindric Perspectives, . . . . .                        | 40       |
| 32. Negatives, Advantage in Use of, . . . . .                            | 33    | 49. " Radial " . . . . .  | 46       |
| 17. " , Development of, . . . . .  | 17    | 61. " Balloon Photographs, . . . . .                              | 59       |
| 2. Object of the Method, . . . . .                                       | 4     | 8. Pneumatic Shutter, Reference to, . . . . .                     | 10       |
| 37. Objective, and its Carrier, Cylindrograph, . . . . .                 | 37    | 5. Point, To Determine Direction of, from Perspec-                |          |
| 8. " , Description of, Kind Required, . . . . .                          | 10    | tives, . . . . .  | 5        |
| 16. " , Test for Distortion, . . . . .                                   | 16    | 6. " , To Determine Position of, from Perspectives,               | 7        |
| " , For other Kinds of, <i>see</i> Text under                            |       | 3. Points, Location of, . . . . .                                 | 4        |
| " Camera."   |       | 27. " , To Determine References of, . . . . .                     | 28       |
| 14. Objective Slide, and Objective-slide Scale, . . . . .                | 14    | 32. Preparation of Prints for Plotting, . . . . .                 | 33       |
| 61. Observations on Balloon Photography, . . . . .                       | 59    | PRINCIPLES, GENERAL, . . . . .                                    | 4        |
| 13. <i>OP</i> —Focal Distance, Measurement of, . . . . .                 | 13    | 17. Printing Frame and Printing from Negatives, . . . . .         | 17       |
| 48. Operating by Continuous Movement, . . . . .                          | 44    | 32. Prints, Preparation of, for Plotting, . . . . .               | 33       |
| 47. " " Fixed Sectors, . . . . .   | 44    | RADIAL PERSPECTIVES, METHOD BY, . . . . .                         | 42       |
| 17. Operation of Taking a Photograph, . . . . .                          | 17    | 2. Range of the Method, . . . . .                                 | 4        |
| Optic Axis, <i>see</i> "Tests and Measurements."                         |       | 20. Record, Form of, for Field-work, . . . . .                    | 20       |
| 13. Optic Centre, To Find Position of, . . . . .                         | 13    | 30. " , " " Reduction of Heights to Com-                          |          |
| 25. Orientation of Views, Definition of, . . . . .                       | 25    | mon Datum, . . . . .  | 32       |
| 42. " " , Device for, Cylindrograph, . . . . .                           | 39    | 27. References of Points, Determination of, . . . . .             | 28       |
| 26. " " , Special Cases of, . . . . .                                    | 26    | 30. " , Reduction of, to Datum Plane, . . . . .                   | 32       |
| 59. Outfit, Photographic, for Balloon Photography, . . . . .             | 57    | 52. Reflectors, Glass and Metallic (Mangin's), . . . . .          | 47       |
| 7-10. " , " , General, . . . . .   | 9-11  | 12. Register, To Test for, . . . . .                              | 12       |
| 1. Panoramic Apparatus, Early Forms of, . . . . .                        | 1     | 4. Relation of Photographs to Perspective Drawings, . . . . .     | 5        |
| 4. Perspective Drawings, Definition of Terms, . . . . .                  | 6     | 10. Roller Plate-holder, Reference to, . . . . .                  | 11       |
| 1. " " , Early Use of, in Map Con-                                       |       | 28. Scale, Vertical Angle, . . . . .                              | 31       |
| struction, . . . . .   | 1     | 29. " of Heights, . . . . .                                       | 31       |
| 4. " " , Relation of Photographs to,                                     | 5     | 39. " , Azimuth- and Slope-, Cylindrograph, . . . . .             | 38       |
| PERSPECTIVES, CYLINDRIC, METHOD BY, . . . . .                            | 9     | 35. " , Choice of, . . . . .                                      | 36       |
| " , PLANE, " , . . . . .   | 36    | 47. Sectors, Fixed, Operating by, . . . . .                       | 44       |
| " , RADIAL, " , . . . . .  | 42    | 19. Selection and Distribution of Stations, . . . . .             | 19       |
| 17. Photographs for Surveying Purposes, How to Make, . . . . .           | 17    | 10. Sensitive Plates and Changing-boxes, . . . . .                | 11       |
| 34. Photographic Maps (Pl. XXIV <i>et seq.</i> ), Explanation, . . . . . | 35    | 60. Small Balloons, Captive and Free, Use of, . . . . .           | 58       |
| 4. Photographs, Relation of, to Perspective Drawings, . . . . .          | 5     | 66. Some of the Advantages, in Applications of Subject, . . . . . | 64       |
| 25. Plan, Construction of the, . . . . .                                 | 25    | 57. Special Apparatus for Balloon Photography, . . . . .          | 55       |
| PLANE PERSPECTIVES, METHOD BY, . . . . .                                 | 7     | 26. " Cases of Orientation, . . . . .                             | 26       |
| 45. Plane-tables, Photographic, . . . . .                                | 42    | 19. Stations, Selection and Distribution of, . . . . .            | 19       |
| 38. Plate-holder for Cylindrograph, . . . . .                            | 37    | 31. Suggestions in Regard to Plotting, . . . . .                  | 33       |
| 7. " , Ordinary, . . . . .   | 9     | 63. Surveys, Farm-, Application to, . . . . .                     | 62       |
| 10. Plates, Sensitive, or Photographic, . . . . .                        | 11    | 28. Tangent-glass, or -Scale, . . . . .                           | 29       |
| PLOTTING:  |       | 1. Telemetrograph, Reference to the, . . . . .                    | 1        |
| 24. General Considerations, . . . . .                                    | 25    | TELESCOPIC PHOTOGRAPHY, . . . . .                                 | 52       |
| 25. Construction of the Plan, . . . . .                                  | 25    | 4. Terms Used in Perspective, Definitions of, . . . . .           | 5        |
| 26. Special Cases of Orientation, . . . . .                              | 26    | 12. Test for Register, . . . . .                                  | 12       |
| 27. To Determine Heights or References of Points, . . . . .              | 28    | 16. Tests and Measurements Required, . . . . .                    | 16       |
| 28. Mechanical Measurement of Horizontal and Vertical                    |       | 23. Time for Field-work, The Best, . . . . .                      | 24       |
| Angles, Tangent-glass and Vertical Angle                                 |       | 17. Toning of Photographs, . . . . .                              | 17       |
| Scale, . . . . .   | 29-31 | 35. Topographic-Cylindrograph, . . . . .                          | 36       |
| 29. Mechanical Measurement of Heights, Scale of                          |       | 32. Transparencies, Use of, in Plotting, . . . . .                | 34       |
| Heights, . . . . .   | 31    | 20. Triangulation, Reference to, . . . . .                        | 20       |
| 30. Reduction of References to a Datum Plane, The                        |       | 28. Vertical Angle Scale, . . . . .                               | 31       |
| Contouring, . . . . .  | 32    | 6, 27-8. Vertical Angles, Measurement of, . . . . .               | 7, 28-31 |
| 31. Suggestions in Regard to, . . . . .                                  | 33    | 28. " , " , Mechanical, . . . . .                                 | 30       |

