



# SUPERVISION OF LOCOMOTIVES.

HOW EFFECTIVE SERVICE AND ECONOMY OF  
OPERATION MAY BE FURTHERED.

---

SUPPLEMENT TO

# THE SCIENCE OF RAILWAYS

---

BY

MARSHALL M. KIRKMAN.

---

PUBLISHED BY

THE WORLD RAILWAY PUBLISHING CO.

---

NEW YORK AND CHICAGO:  
THE WORLD RAILWAY PUBLISHING COMPANY.  
1904.

Transportation

Library

TF

7

.K59

1904

COPYRIGHT BY

THE WORLD RAILWAY PUBLISHING COMPANY,

1904.

ALSO ENTERED AT STATIONER'S HALL, LONDON, ENGLAND.

*All rights reserved.*

**TABLE OF CONTENTS.**

---

	<b>Page.</b>
Motive Power of Railroads, and Men, - - - - -	5
Chapter I, Supervisory Methods of the Motive Power Department, and their extent and usefulness, - - - - -	7
Chapter II, Details of the Arrangement and Administration of the Department of Motive Power and Machinery, - - -	15
Chapter III, Returns and Exhibits. Their use and great value,	34
Chapter IV, List of Returns and Exhibits. Specific Draft of each Return and Exhibit, made to or by those in charge of Motive Power and Machinery in regard to Location of Locomotives; Condition; Use of Locomotives; Repairs made; Supplies used in their working; Details of Break-downs and other defects; Comparative work done; Relative cost of Supplies and Repairs; Employes on Engines and at Shops; Wages thereof, and other important details connected with the Motive Power Department of a Railway,	41
Chapter V, Locomotive and Train Mileage, - - - - -	246
Index, - - - - -	255



## INTRODUCTION.

---

### MOTIVE POWER OF RAILROADS AND MEN.

---

The motive power of a railroad is like cash in hand or good credit in the case of an individual. It makes things go; and if wisely handled represents a great and potential force—Prosperity, in fact. The care and wisdom exercised, therefore, in Supervising and administering the locomotive department tends to the prosperity of railroads, or the reverse. Everything, then, that helps toward good government, adds knowledge and incentive in regard to the affairs of this great and little known department, is not only of value to the department but to owners and managers generally. Hence the writing of books like this and others relating to railway operations. To the widely experienced and responsible officials in charge of the power department, what is written, descriptive and otherwise, of their branch of the service seems superficial; of little or no value—primary in fact. And this is true so far as it personally concerns such officials. But technical books are not written for those already wise, but for those who seek wisdom; who wish to supplement their limited knowledge and experience with that of others. Hence such books, and hence writers in such fields need neither apologists nor advocates.

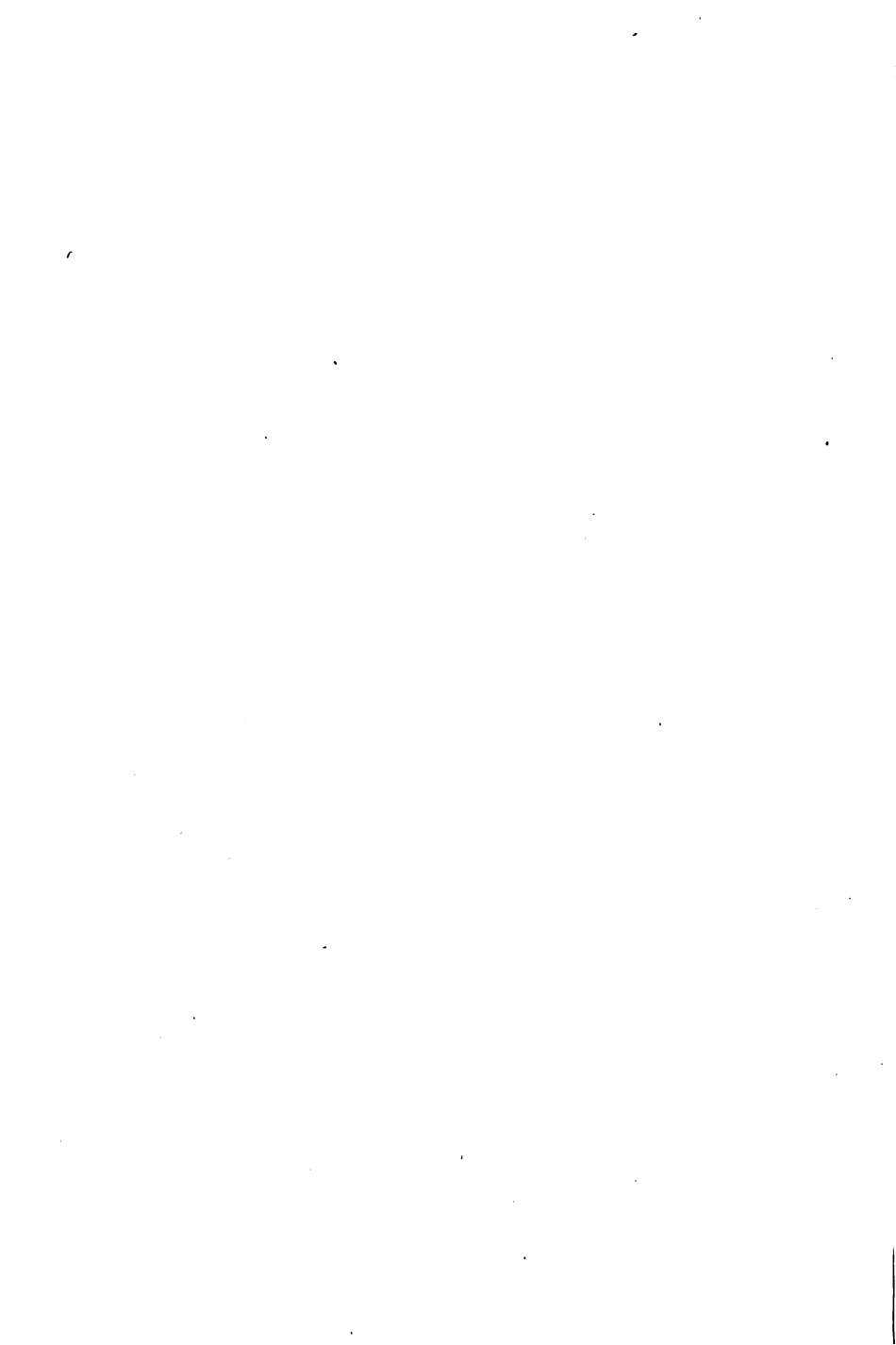

## CHAPTER I.

### SUPERVISORY METHODS AND THEIR EXTENT AND USEFULNESS.

In connection with the supervisory work of locomotives, it needs no argument with practical railway men to prove that, in order to secure the greatest possible economy and effectiveness of both engines and machinery, they should be maintained at the maximum efficiency. Not only is cost of repairs greatly increased with every hour of neglect, but effective service is correspondingly impaired. The exorbitant price that a railway company pays for shortage of equipment or lack of means to remove an engine from service and make repairs as needed, is out of all proportion to the saving effected in the number of locomotives or the momentary lightening of the expense account. It is with locomotives and machinery as it is with a leaky roof; not only is the immediate defect heightened, but it involves other and multiplied losses, so that the ultimate cost of repairs spreads and increases with every hour of neglect. "A stitch in time saves nine" is not a mere figure of speech but the dictate of a wise and thrifty housewife; and it is a maxim that applies with even greater force to the complex and costly machinery of a locomotive, the wear and tear of which is constant and destructive under the most favorable circumstances.

Every one immediately responsible for the use and care of the locomotives and machinery of a railroad fully appreciates this. But their wisdom and effectiveness is rendered nugatory if it is not equally well understood—and acted upon—by their superiors who are immediately responsible for operations as a whole.



A feature of locomotive supervision that the onlooker does not much regard if, indeed, he thinks of it at all, is the practical knowledge and acumen required to apportion locomotives to the various parts of a road with good judgment, according to the fitness of the machine to do the work, the urgency of the work, and its comparative value from the earnings point of view to the carrier. In the case of a widely extended railway—and all of our railways are widely extended—the distribution of engines to meet needed requirements when business is pressing, must at once tax and rack those in charge of motive power almost to the point of desperation. For it goes without saying that no railroad can possibly provide itself with sufficient engines to do, with ease, the maximum amount of service that may be required for a particular day, or week, or month in the year. The number necessary to meet ordinary conditions, with a margin for emergencies, is the most that any company can afford. When, therefore, a rush occurs as it will frequently, and often unexpectedly, the niceties, perplexities, and harassments of apportioning the engines judiciously to meet such emergencies, is too apparent to require comment. This is one feature of locomotive supervision and perhaps as important, if not more important, than any other single thing connected with the service. How to get the most out of the power, make it most productive of revenue and public utility, with the least incidental expense, wear and tear, and disarrangement of service, is the problem that ever confronts those in charge. For in order to utilize locomotives to the best advantage in emergencies (and at other times as well), it is not only necessary to know what particular engines are in service or available for service, but what each engine can do; what kind of service it is best adapted to. For in the economy of the department, machines are classed all the way from the light serviceable en-

gines to those capable of hauling a heavy train at the highest rate of speed. There is as much difference, it may be truly said, between locomotives as there is between men or women. Some will work cheerfully and to their fullest capacity in all kinds of weather and under all circumstances; while others must be coddled and petted and fussed over. One will be capable of hauling a great load at a high rate of speed; while another will haul a great load but only at the minimum rate. Some will be quick to move, others slow. The condition of the engine has also to be considered. And so it goes; each having peculiarities that require those in charge to be familiar with in order to use them to the best advantage.

In practical working it has been found to conserve both economy and effectiveness to keep expert engineers traveling on a line to scrutinize the workings of engines and give directions to engineers and firemen as circumstances require, or the improvements and changes in service, from time to time, suggest. Such supervisory work is found especially necessary and valuable in connection with the use of fuel. If the firing of an engine is carelessly or ignorantly performed, great waste of fuel and power occur in consequence. Both economy, the good of the machine and the load hauled, depend so much upon scientific firing that this feature of the service claims and receives the constant attention of those responsible for effective working of the motive power department.

Another supervisory feature of the service is the critical examinations firemen must pass, both before entering the service and at the end of the first, second and third years of their work; and, indeed, after they have been commissioned as engineers, up to the time they are admitted to the passenger service. Such examinations were unknown in early days as were many other features now thought indispensable. In-

deed, many roads now seek to correct the deficiency in former practice, as regards examination of firemen, by requiring engineers, who did not pass such an examination, to do so now. This on the theory that such examinations are not only necessary for the good of the company and the safety of the public, but for the well-being of the engineer himself. However, practical experience counts for much (is better than perfection in theory), and so the examinations in respect to old engineers are not, it may be said, as rigid as in the case of firemen progressing toward a higher position.

Of the intrinsic value of these examinations there can be no question and the writer has had many commendatory letters from engineers and firemen in regard to the value to them of certain parts of the "Science of Railways" that relate to such matters, as well as those of a more general nature in regard to the department of motive power and machinery.

It is perhaps true in regard to the supervision and needs of locomotives, that if all those that a railroad operates daily under the scrutiny of the official in charge of the department, his personal supervision over them, his knowledge of their needs in the way of repairs and betterments, would perhaps suffice—provided he was also able to look after the practical things connected therewith, such as the scrutiny of the parts affected, details of labor and machinery and tools. But this is impossible. He can only be at one place at a time while his engines are scattered over hundreds or thousands of miles of roads, some actively employed, others filling the round house and repair shops. Yet he must have definite knowledge of every locomotive, where it is, what service it is performing, and its condition.

Now, how are the Superintendent of Motive Power and Machinery and his assistants to know about loco-

motives that they never get more than a glimpse of, and in regard to the details of which they are necessarily ignorant. Manifestly, in order to know about these locomotives, their utility, usefulness, whether they fulfill the requirements of the service, what repairs and betterments, if any, are necessary, they must derive their information through returns sent them by subordinates and others. With these before them they know, with approximate accuracy, the condition of each particular locomotive and, summing up the whole, of the locomotives in the aggregate. Such being the case the immense value of returns furnishing specific intelligence in regard to every detail becomes apparent at a glance. Through them, those in charge of the department keep in touch with what is going on, and are able to meet all the varied and pressing needs of the service from day to day, and so meet the just expectation of the management and public requirements. The methods employed, indeed, in this respect, are not materially different from those found necessary in all the various departments of a railway. Thus, those in charge of traffic, through the returns they receive, are kept advised of the progress and needs of business. The same is true of the department of accounts; for, from the returns there centered, business is classified and earnings computed, and balances ascertained. And similarly, in the operating department, the reports that reach the head, and so on down the line, are such as to enable the management to wisely supervise operations, safeguard lives and property, and expedite business generally.

The returns of the locomotive department are, as in other departments, the eyes through which those in charge see what is going on. These returns are made by those conversant with the facts and are made to those whose duties require them to know the facts, or

such generalization of the same as the service demands. Operations and needs are thus focused. These returns portray every feature of activity and through them, from day to day, what is going on at far distant points, is distinctly and quickly focused, and such action taken as circumstances require. These necessary and invaluable forms will be found elsewhere herein. They contain full explanatory notes in regard to their purpose and how used. Through them officers know the number of men engaged in working, repairing, maintaining, cleaning, and looking after the equipment; how many engines are available, where engines are needed, how many are in the hospital, when they will be fit for service—information so full and specific that it has but to be studied for the officials to inform themselves effectively in regard to every needed requirement.

This is how Locomotive Supervision in its practical sense is utilized and applied. In this way those in charge of motive power watch the inspection of locomotives, and their general condition and special features, including boilers, fire-boxes, stay-bolts, steam-gauges, safety valves; the location of each locomotive; how each locomotive is employed; the condition of locomotives; those in working order; those needing repairs; those undergoing repairs; the nature of the repairs; when the repairs will be completed; the distribution of locomotives; the particulars and cost of repairs of locomotives; the boilers that have been cleaned; failures in performance of work; the nature (cause) of the failure of locomotives; valve motion; breaking down of particular parts of engines, such as wheels, tires, couplers, driving boxes, brasses, cylinder heads, eccentric fixtures, rods and straps, pistons and rods, valves, rocker shafts, crossheads, crank pins, stay bolts and other

miscellaneous (specified) parts of the locomotive; the mileage of wheels, steel tires, etc.; the wheels and tires that have been removed; the failure of guaranteed parts; the mileage of locomotives; train movements; the switching service; delays of engines; wrecks; accidents; stock killed; actual performance of locomotives; consumption of fuel and oil per unit of service; lubrication; the force employed on locomotives; the hours worked and the wages of engineers and firemen; the force employed in and about shops; their wages; material ordered, how used and quantity on hand; to what accounts labor and material are charged; the tools and machinery at shops; the condition of stationary boilers and shop fixtures; result of mechanical examinations of firemen and others; particulars regarding the employment of the force; its supervision; government; complaints, etc.

This enumeration of supervisory work, while far from complete, is yet sufficient to call attention to the vast number of specific things, every one of which is important, that require the attention of the Superintendent of Motive Power and his assistants; work all important to the economical and effective operation of a property.

Especial attention is called to the different returns—blanks—embodied herein. No one can be advised in regard to the workings of the locomotive department unless familiar with these interesting exhibits. From them he will get more than a glimpse of the practical details that attend the maintenance and operation of engines. He will be able to scan the vast and busy field and so make long and valuable strides toward a personal and practical understanding of its multitudinous affairs. This understanding will be of vast interest and importance to every one connected with the power service; and only less so to the officers and ambitious employes of the operating department,

whose usefulness depends so greatly on the efficiency and co-operation of the locomotive department. Every branch of the service is dependent in a measure, it may be said, on the way locomotives are handled. Much can be done toward securing efficiency in this respect by those engaged in other branches of the service, through co-operation, by aiding the power department where it needs strengthening. But to render such assistance the needs, embarrassments, and vast details of the department must be measurably understood and appreciated. It is the purpose of this book, it may be said, to aid in accomplishing this.

The extent of the motive power department and its many and varied perplexities have only been understood heretofore by those at its head. And this because of its obscure and unwritten features and the technical work of those employed. It is a busy, noisy, mysterious world, in fact, even to many who live within its fold. But here, as in other departments of railroad life, general and specific knowledge of its workings will be found to add greatly to its usefulness. For the more people who comprehend the work generally and in detail, the greater the number of men whose energy and ambition will be stimulated, and whose efforts, consequently, will give added force to the intellectual, moral and physical affairs of the department, and, in so far as they do, make out of it all that human ingenuity and effort can accomplish.

## CHAPTER II.

### DETAILS OF THE ARRANGEMENT AND ADMINISTRATION OF THE DEPARTMENT OF MOTIVE POWER AND MACHINERY.

Of the character, in general and particular, of the work connected with the locomotive plant and the administration of the department, no one who has not had immediate charge of its direction and responsibilities can speak advisedly, or have much to say of practical worth to students and searchers after knowledge in this mysterious and little known field of industry. The subject covers much of general and particular interest in regard to designing of engines, the kind of machines required; inspection thereof; the appliances of engines; location and arrangement of shops and tracks, and the facilities in other directions needed to secure the best results. The modus operandi of overhauling engines that require general repairs; the supervisory work of those in charge of the department; watching shop work; organizing and governing the force generally; discerning what is needed; eliminating extraneous and unnecessary things, form a part of the work of supervising locomotives on a road. For be it understood this book does not pretend in any way to refer to plans or work in the great locomotive manufacturing institutions of the country where these machines are built to sell to railway companies. It refers wholly to the use of locomotives. This feature comes within the particular interest and province of all railway men, but knowledge thereof is confined to so few, that the force as a whole may be said, practically, to know nothing about the organization and conduct of the locomotive department. Fully conscious



of this I have accordingly sought the advice and assistance of an expert in such matters, Mr. Robert Quayle, long a Superintendent of Motive Power and Machinery, and an authority everywhere recognized as pre-eminent, who for a life-time has been in charge of the motive power and machinery of an up-to-date railway. It is not too much to say that he is the peer of the most advanced, conscientious, honest and laborious thinkers and workers in perfecting and administering this great department of railway service. No one can have greater personal knowledge than he of the needs and practices and the economical and effective government of the forces employed. I have been fortunate in this, as I have been throughout all my labors in connection with the discussion of railway matters, in securing the enlightened, progressive and conscientious co-operation of an expert in railway operations.

With this brief and insufficient acknowledgment I will conclude the chapter with what Mr. Quayle has to say in regard to practical details connected with the location and arrangement of shops, and the daily administrative duties of the department of machinery and motive power. What he has written will be of interest and value to all connected with railways—no matter what their position or opportunities to acquire knowledge in this particular field may be.

The question of taking care of the motive power and machinery of a railroad is a problem that requires careful study and thought to maintain it at the standard the service requires; to secure the highest efficiency at the lowest possible cost. When we consider the amount of money paid out annually, that the Mechanical Department is responsible for, we realize that the strictest business methods must be employed to prevent possible waste. For, on a road properly equipped with locomotives, with a sufficient number of shops and

round-houses to take care of the same, nearly one-third of the total amount of money expended annually by a railroad company for operating expenses, comes under the jurisdiction of the Superintendent of Motive Power and Machinery and his assistants. This money is expended for the purchase, care and maintenance of locomotives and machinery; wages of enginemen, wipers, machinists, helpers; fuel, oil and waste. Of these, wages is the largest item. Next comes fuel. Therefore the greatest care must be exercised to see that no unnecessary expense is incurred and no more help employed than is absolutely required; and, further, to see that the greatest economy is practiced in the handling and use of fuel and other supplies.

In connection with the repairs of locomotives, the question comes up as to the proper way to locate shops so as to get the best results; *i. e.*, to make necessary repairs quickly so as to get the locomotives back into the service with the least possible delay, for an idle engine earns no money for its owner. We have to consider whether it is better to have a large central plant, properly located, where all the heavy work can be done; or whether it is best to have a number of smaller plants so located that engines in need of repairs will not have to be taken an unnecessary distance to the shop; for hauling a dead locomotive means that two or three cars less can be handled in a train, thus entailing a loss of revenue to the Company.

In the first place, concentration of shop work means less cost for supervision and therefore consequent lessening of expense. But for a road that extends, say, many miles in one direction, it certainly does not pay to run or haul an engine a long distance, to get it to the main shop. Therefore it is found more convenient to locate smaller shops, generally at division points, to take care of all but the heaviest work. At the headquarters of the road (or better still, at a centrally lo-

cated point) a large plant should be equipped with modern tools and machinery to take care of the repairs that cannot be handled advantageously by the smaller shops. This large plant will, of course, incidentally, receive and repair all engines working within an easy radius of its doors, the same as a local shop, without reference to the extent of repairs to be made.

It has occurred naturally, that with the enormous growth in the size of power, that the smaller shops have not as a rule kept apace with modern improvements in the way of tools and shop facilities; and so are precluded from handling repairs of the modern, large engines advantageously. This will of course be remedied in time, but meanwhile such locomotives must be taken to division shops, or the main central plant.

The organization of the Motive Power Department of a road, is a matter that requires thought and care to bring and keep up to the high standard required, for a road soon obtains an inevitable notoriety if its service is not good; and with competition in the business, other lines prosper through such neglect to provide prompt and adequate service.

In direct charge of the small army of men employed it is absolutely necessary that at the head of the Power Department should be a man who has had years experience and who knows just how everything should be done. He must be a natural leader of men, as the antagonizing of employes, consisting as they do of a variety of trades, nationalities and dispositions, is fatal to success. It is remarkable the discrimination possessed by men, and a superior who treats everybody with kindness, firmness and fairness, can be assured of the good will and services of his subordinates, a thing essential to his success.

The method of classifying Motive Power Department officials varies on different roads. In some cases

the Superintendent of Motive Power is equal only in power and authority to a master mechanic. Whereas, on other systems, where the mileage is great and under one management, a General Superintendent of Motive Power is usually employed, who reports direct to the General Manager or a Vice-President. In such cases the superintendents of motive power and machinery report to and take orders from the General Superintendent of Motive Power and Machinery. In this case the latter official is entirely independent of the ordinary operating officials. On other roads the Mechanical Department may be practically under the control of a General or Division Superintendent.

This arrangement, however, is not practically the best, for the expert in such cases has often to do business with and take orders from men who are not familiar with mechanical matters. The most satisfactory method of handling the department is shown where the officials generally rank according to the following order:

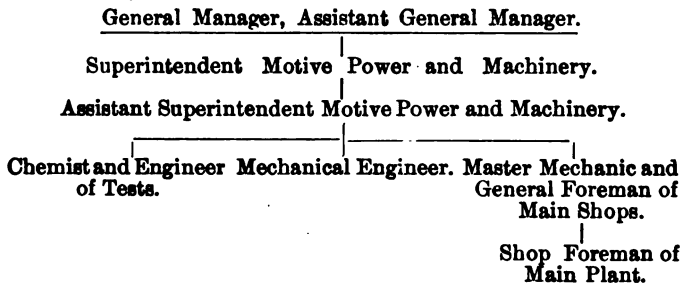

LINE ORGANIZATION.

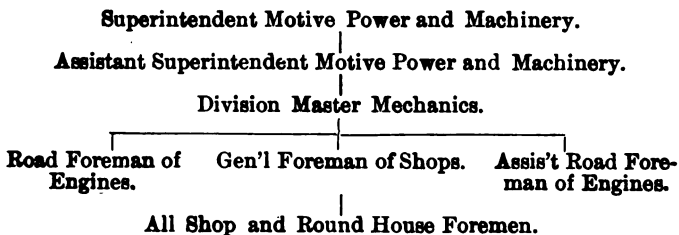

The question when to shop an engine is one that requires a good deal of attention on the part of the Superintendent of Motive Power and his assistants. Should an engine be taken in for General Repairs, which may cost from \$1,200.00 to \$1,800.00, when, by making light repairs and putting it into suitable service, much more work can be obtained from it? Or the reverse? It can never be best to keep an engine in service when it is doing work in an extravagant manner, causing failures, and not only delaying its own train, but others that may be on the road. Each particular case has to be decided, however, according to circumstances, and to obtain results at the least possible cost and embarrassment to the service; and when saying this, we have to consider all departments concerned. An engine can be kept in service for so long a time that the cost per mile run will apparently be low, but at the same time while getting over the road, it may not be hauling full tonnage, and the cost per ton mile will really be very high.

As already stated, engines requiring heavy boiler work, or those on divisions adjacent to the main shops are taken care of there, but a large number have to be given repairs at the smaller shops.

On divisions where the water used by engines is good, little or no boiler work is necessary and an engine can be kept in service for two or three years, by doing what small amount of work is needed to the machinery at intervals. The mileage in such cases often runs up to 150,000 or 200,000 miles; but on divisions where the water is strongly impregnated with scale forming matter, the department is kept busy trying to get mileage enough out of engines before shopping them, to satisfy the Superintendent of Motive Power and Machinery. On such divisions as these, it is nothing unusual for a new engine to require flues reset after four to six months' service, and at the expiration of eight to ten

months (or before the engine has made 50,000 miles) new half side sheets are often necessary. This work, done at a small shop, will keep the engine out of service for thirty days or more; while at the main shop such work, which comes under the head of general repairs, can be done in eighteen to twenty days by the aid of modern tools and machinery, thus cutting down the time the engine is out of service. This is a matter of great importance, especially at a time when business is heavy and engines are in demand to keep cars moving.

The question of purifying water that is laden with sulphate and carbonate of lime has been given much attention. The old-fashioned method of trying to make a locomotive boiler into a "water softener" has given way to the more common sense method of treating the water in suitable tanks prior to being put into the tender; and this with good results. In some cases, engines consigned to the shops, that have been using the untreated water, are kept in service 60 to 90 days longer by using treated water entirely.

The designing of locomotives so as to get the most satisfactory service out of them, is a matter that requires more than ordinary care and attention. In accomplishing this the Mechanical Engineer submits his ideas on paper, after finding out what is required, and this is carefully examined by the Superintendent of Motive Power, so as to see that the weight on drivers is not greater than the Engineering Department will allow on its structures; also that the heating surface is properly proportioned to the size of the cylinders, and that the power exerted by the cylinders is sufficient to utilize all the adhesion given by the weight of the locomotive on the driving wheels.

It is also a matter of great importance to utilize parts that are standard on a road so far as possible. The question of bearing surfaces must also be looked into carefully, as an engine that runs hot on account of ex-

cessive pressure per square inch on the journals, is obviously unsuited to the service. Again, if through faulty design, the engine does not make steam freely or cannot make time, the department is justly called to account. So it will be seen that each part has to be gone over on the drafting board, to be sure that it bears its proper relation to the other parts and to the whole machine.

An important part of the Draughtsman's business is to so design the locomotive that the parts that need renewal frequently are easily accessible. Bushings for brake rigging, rocker boxes, tumbling shafts, cylinders and so on, are a step in the right direction, as they enable repairs to be made at small cost. By their use the various parts are kept standard size much cheaper than they otherwise could be—bushings being kept in stock instead of the whole part.

Between engines of somewhat similar capacity, there should be as little difference as is consistent with the design. This means a large reduction of material in stock and a consequent reduction in the number of special tools for finishing same. Grates, small brackets, brake heads, driving boxes, springs, wheel centers, crank pins, etc., can, with very little planning in such cases, be used interchangeably to good advantage. By living up to the dimensions as shown on the working drawings, a standard can be maintained which will enable changes to be made at small expense. While it is a good plan to invite suggestions from the men handling the engine on the road and in the round house, a change of design in any part should not be made without getting authority from the person charged with this duty; for if a change is a good thing at one place it is good at another; and the drawing should be revised to show the improvement so that it may be generally embodied in any repairs that are to be made to the part or parts affected.

The Drawing Office plays an important part in the railroad world, for here the locomotive is born. The Mechanical Engineer is the head of this office, under him coming the Chief Draughtsman, and such assistants as are necessary to do the work. The duties of the Mechanical Engineer are varied. To-day he will be busy designing a locomotive—to-morrow engaged upon plans for new shops, and the next day figuring upon a proposed electrical installation. He is expected to keep in touch with all shop improvements, new designs of power, etc., and be able to answer any and every question that may arise, from the power required to move a turn-table to the amount needed to drive a shop with its various tools and machinery. The care of all drawings, blue prints, etc., is entrusted to the Chief Draughtsman, who must be methodical, filing everything so that it can be found at a minute's notice.

The patterns for cast and malleable iron, brass and steel, are under the jurisdiction and care of the drawing office; and it is the duty of the Mechanical Engineer and his assistants to so design their work in their patterns that the greatest strength necessary will be forthcoming without undue weight. Thus, an unfinished casting should only have enough stock in it to finish up properly with a minimum amount of machine work.

When there are many locomotives a dynamometer car will be found advantageous to determine some of the problems that cannot be got at any other way with any degree of accuracy. This car is usually fitted with properly designed and calibrated draft rigging, so that when connected to the rear tender draw-bar, the exact pull of the locomotive can be determined, and by a series of levers and pointers, this information is transferred and drawn on a paper, which is made to travel at a certain speed. A clock connected up electrically, makes a mark on the paper every ten seconds and a



push button operated by an assistant is used to move a pen which makes a mark on the paper at each mile post, so that at a glance the speed can be told. Air, steam and other gauges are used to determine the pressure carried, and generally in connection with this apparatus an indicator is applied to the engine, by which the performance of the steam in the cylinder is plainly shown.

This work is usually done under the direction of the Mechanical Engineer, apprentices being used to get the data, and work it up to show the efficiency or inefficiency of the locomotive.

Another important branch of the Mechanical Department is taken care of by the Chemist and Engineer of Tests, whose duty it is to test the various metals, etc., and see that they come up to specifications. Steel for boilers is closely inspected before being accepted for use; steel castings are examined to see that they are free from flaws, checks or blow holes; lenses for signal lamps of all kinds have to pass a rigid test; and torpedoes which are used as a danger signal are exploded (a few from each shipment taken hap-hazard), as a check on the manufacturer. Rubber goods and the other appliances in use on a railroad are also subjected to minute inspection before the Engineer of Tests will accept them. By this means poor material that might get into the locomotives and cars and cause trouble, is discovered and rejected to the great good of the service.

The visiting of shops along the line is something that the Superintendent of Motive Power and his Assistants must do to keep in touch with what is going on. On a large road, this will be a matter of considerable difficulty within reasonable time on ordinary train service. This difficulty is overcome through the business courtesy of the Operating officials who have to make trips that extend to all parts of the system, inviting

the official in charge of motive power to accompany them. They thus have opportunity of meeting the Master Mechanics, Foremen and Division Superintendents, and of observing the service and hearing any complaints about the motive power, or suggestions for improving it. The Road Foremen and their Assistants also come in for a share of attention, while inspecting the road, and thus many things come up which benefit all concerned.

When matters of general importance have to be transacted, a meeting of the Master Mechanics is called, who journey to headquarters, and there talk over the matters under consideration, and thus an understanding is obtained. Afterwards the Master Mechanic on his return home, will get his foremen together and give them instructions as may be necessary.

It is the general rule on roads to promote Firemen when competent, to the position of Engineer, and all new firemen when hired, are required to pass a physical examination, so that defective eyesight, color blindness or other defects may be detected. After satisfactorily passing the examination, the fireman is put to work and provided with a book containing information pertaining to his duties in the economical operation of an engine, which interrogatories he is required to answer after being in service twelve months. At the expiration of that time, he is given the second year's book which contains information of a more advanced form, and an examination is given him at the end of the second year. He then gets the third year's book, which covers more fully the points that he should understand.

Before becoming an engineer, at the end of the three years, he must pass a time card examination before the Division Superintendent and a medical examination before the Company's Surgeon. If he passes these successfully, he is sent to headquarters before an Examining Board, consisting of Road Foremen of

Engines, and the Air Brake Instructor, who put him through a written and oral examination. If he answers correctly eighty per cent of the questions (air brake and mechanical), he is reported to the Master Mechanic as a full-fledged Engineer. He is then used on Switch engines and unimportant freight trains for the first year, after which he is entitled to full pay; but even then is not allowed to handle a Passenger train. Three years' service as an engineer is required before this, the goal of all young engineers, is reached. Thus every safeguard is thrown around the service and the public, before the embryo engineer is allowed to handle an engine.

Let us now look at the main shops and the arrangement of them and the tools and machinery they require. From six to ten per cent. of the engines in use on a road will generally be undergoing repairs, so that with the help of the local shops, the principal plant should be able to handle from 35 to 45 engines per month, depending of course on the number of locomotives, the condition of the power, and whether the demand for it is great or not.\*

In deciding upon a location, the endeavor should be to pick one having clean and reputable surroundings, a level, high piece of ground where good drainage can be obtained, with perfect accessibility from all sides so as to be able to handle things more economically and quickly than otherwise would be the case.

In choosing land there should be taken into consideration the possibility of growth, which on many railways is very rapid, so that many Superintendents of Motive Power and Machinery have been cramped for lack of room, which could at first have been obtained cheaply. Having decided upon a location, the best layout of

---

\*This estimate is based on an equipment of 1,200 locomotives. It should, therefore, be lessened or enlarged according to the circumstances of the case.

shops must be secured so as to get an engine through them with as little delay as possible. Plenty of room inside and out, costs money in the first place, but pays on account of the increased facilities for getting about and not having one thing buried and perhaps lost by other things being put on top of it. The larger the shops the greater the possibility for good arrangement; and the better the arrangement the better will be the method of getting out the work, with a consequent reduction in cost.

Outside the shops should be a series of tracks connected with a transfer table, for the storing of engines that have been brought in for repairs. One track should be used for getting engines out of shop, putting the tenders behind; and another be available for pushing engines in, so that the two operations can be going on at the same time. Much controversy has taken place as to the best kind of erecting shop, and there are advocates of the two kinds generally used. The one with a large number of stalls at right angles to the main building, fed by a transfer table with an overhead crane for wheeling and unwheeling, having as many advocates as the one where from four to six engines stand on a single track, the tracks paralleling one another, each containing as many engines, traveling cranes of suitable capacity being used to get them from the in-going track to a vacant place, and after repairs have been made, lifting them on to the out-going track. We will use the former plan in the proposed shops, as it is the one most generally adopted in America.

With an output of thirty-five engines per month, there should be thirty stalls available, as it would be possible, providing the machines were capable of doing it, to increase the number of engines turned out to fifty per month, if occasion required it.

Plenty of room should be allowed on each side and in front and back of the largest locomotive so that men can do their work without interfering with each other, and the flues taken out and put in, without the necessity of having doors opened, as is sometimes necessary. The storage of parts taken from locomotives in shops, that do not need repairs, is a matter that should be given consideration. In some shops these parts are stored in pits each side of the engines, having heavy covers over them. Another plan is to have a lean-to (addition) outside of the shop where racks are provided between tracks. This latter method is probably the better one as the parts are always in view of the foreman and men, and are not so likely to accumulate as in a pit. A double track, electrically driven, high speed transfer table, of sufficient length to take an engine and tender on it, will provide ready means of quickly handling engines and supplies in and out of shops.

The erecting and machine shop should be combined and provided with a good system of electric cranes to move the parts taken from the engines, after having been boiled in a lye vat conveniently located, to the machine that is to do the work on it. The ideal way is to place all the tools so that an extra handling, or a backward movement, will not be necessary. The various parts when handled by more than one machine, should go in at one end rough, and come out at the the other end, finished.

The machine side should have a gallery in which all of the light work, such as air brake material, brass work, bolt making, etc., is done. The machine shop, proper, should be divided up, and in one half the heavy tools located, and direct motor driven, with high speed single track ten ton cranes over them to facilitate the handling of material. The blacksmith and forge shops should go together, and be so located that

heavy frames and forgings can be conveniently handled to and from the erecting shop and to the machines.

The complement of the blacksmith shop should consist among other things of a 1,500 pound steam hammer for general work, and a 3,500 pound hammer for frame work; while for axles and heavy forgings, one not less than 6,000 pounds should be provided. Forging machines for turning out standard work should be used whenever possible and grouped together. A blast fan in duplicate and direct driven either by motor or engine, and not connected with any other machine, should furnish a pressure of eight ounces for the fires.

The boiler shop should be combined with the tank shop, and suitable cranes for quickly moving boilers and tanks, will help to increase the output. The tin shop and pipe shop should also be together under one foreman, and should be a very large roomy shop on account of the material and work done in this building being bulky.

The gray iron and brass foundry should also be together. The paint shop should stand by itself as it is generally used for painting tenders only. The painting on the locomotive should be done in the shops while repairs are being made, to economize time.

The storehouse is one of the most important factors in getting power into service promptly. By locating it centrally, it can be readily reached from each of the shops, and thus a large amount of valuable time saved. A telfer system can be employed for handling medium heavy material with very good results.

As all of the shops and buildings mentioned use power, light and heat, it is very essential that an economical plant be installed to furnish these. With electrical power-transmission, cranes, etc., and a suitable lighting system such as would be necessary for a plant of this size, a large amount of current has to be furnished, and two generator units, each able separately

to run the plant should be provided so as to take care of repairs, emergencies, etc.; while for night loads, a smaller capacity unit could be used to good advantage. As a large number of pneumatic tools are used in most up-to-date shops, it is very necessary to have air compressors with a capacity amply large for every emergency. Probably the best results can be obtained by having two air compressors, each with a capacity of 1200 cubic feet of free air per minute. In case of a break down there would be something to fall back on, and still leave room for growth.

A high pressure water system for fire protection should be installed in the power plant, and pumps for taking care of accumulator in boiler shop, etc. The exhaust steam from engines, pumps and air compressors, should be used for heating the numerous buildings; which can thus be done economically.

To furnish steam, a battery of boilers, fitted with automatic stokers and chain grates, and coal and cinder handling machinery, will enable the plant to be run at a minimum cost for labor and fuel used, that could not be successfully done in a hand fired furnace.\*

We will now watch an engine in its progress through the shops. It has arrived on the "Hospital Track" and the Master Mechanic from whose division it came, has sent forward a report of work necessary to be done. This report is turned over to the General Foreman, who in turn gives it to each of the foremen so they may note the work they are called on to do, and so

---

\*What is said here derives added interest and importance from what is said in other parts of the "Science of Railways" in regard to matters relating to locomotives and the machinery and shops incident thereto. This brief treatise or resume, however, is of immediate interest, affording further insight into what is occurring in this great field of industry. It also affords an interesting exposition of results as to the growth and perfection of the appliances devised by those connected with the department of Motive Power, who have studied it to the great benefit of railways and to the great profit of those who own these properties.

get ready. We will suppose that the engine needs a new firebox and what is known as general repairs. The first move is to take the tank from engine and put it in the tank shop for repairs, the engine meanwhile being placed in stripping shed where all of the rods, links, eccentrics, air pump, driving brake, material, etc., are removed and placed in a lye vat to have the grease boiled off from them. The next move is to the transfer table, from which it is hauled by a windlass or drum with cable into a vacant stall, and immediately the overhead crane with double crab, lifts it bodily, so that the wheels may be rolled from under; after which it is lowered upon specially designed trucks, so that if necessary it can be moved along the track.

The boiler is lifted out and sent to the boiler shop, and the frames with cylinders left, for the mechanics to work on them; the parts from the locomotive are distributed to the various men or machines which work on them; the wheels are sent to the lathes for tires and journals to be turned up; the driving boxes to be fitted with new brasses, shoes and wedges, after being "laid off" are given to the planer hand; the eccentric straps and liners are turned up and closed; rocker boxes, valves, links, pistons, etc., etc., are taken to their respective place for repairs, the side and main rods being at the same time taken care of, and the brake rigging overhauled. As far as possible, all of this work is specialized, among men who have become experts in such matters.

On going to the boiler shop to look for the boiler of the engine, we will find that rivets have already been cut off back head, in readiness for the new firebox that has probably been made before the engine arrived in the shop. Flues are being taken out and all is hustle and noise, the pneumatic hammers making talk difficult and hearing impossible for an outsider. When the flues are removed, they are taken to a rattler,



which in causing them to revolve and drop against each other quickly breaks off the scale. From here they are taken to a machine which cuts off each end and then a piece is fitted in and welded up to the flue so as to make it the same length that it was before. After testing, they are ready to go back to the boiler, where the back boiler head has been removed, the stay bolts broken off and mud ring removed. After this is done the old firebox can come out and the new one take its place. When properly located, the holes to receive the stay bolts are tapped out, stay bolts run in, and mud ring and staybolts riveted up.

By this time the flues are going into the boiler, and after being fastened in flue sheet by expanding and beading, the boiler is ready to be tested, and if any defects exist they are remedied before it leaves the shop.

Let us now go back and see what is being done on the other part of the engine that was left in the erecting shop. We will find men facing up driving box jaws, prior to shoes and wedges being fitted, and other men will be boring out cylinders, and fitting up eccentrics and straps and driving boxes on the wheels that belong to the engine.

The spring rigging will be put in shape and everything moving, so as to be ready when its turn comes to be assembled. A glance into the tank shop will show that the tank is about ready to come out and go to the paint shop. We will find that the tender boxes and wheels have been put in good condition, and that the tank proper has been tested for leaks and the frame overhauled.

Meanwhile, the tender has been hauled on to the transfer table, and from there goes to the paint shop where it is cleaned, rubbed down and painted in readiness for the arrival of the engine from the shop. We will take another look into the erecting shop and will

find that the boiler has arrived from the boiler shop and the crane has picked it up and set it down upon the frames. Work now goes along very rapidly. The engine is raised and wheels run under it, after which the shoes and wedges are put in, binders applied, links and eccentric blades put up, guides hung, main rods applied and valves set. To do this rollers are placed under main driving wheels, or wheels having eccentrics on them and revolved, and with proper knowledge and the necessary tools, the valves are set so as to give the best results in the service.

The boiler is now filled with steam from the power plant, and again tested, after which the throttle valve is opened and as the front cylinder heads and pistons have not yet been put in place, the steam rushes from the boiler, through the dry and steam pipes and passages, out of the cylinders, carrying with it any foreign material that may have accidentally been dropped by the men while doing their work. During the time this work has been going on, painters have been busy and the engine begins to have a finished appearance. The side rods are put on, pistons and cylinder heads applied, pilot fastened in its proper place and the rest of the painting done. The engine is then taken out and tender put behind it. After getting coal and water we are now ready to break it in, *i. e.*, run it under steam to see that the various parts run smoothly and cool; after which it is ready for the particular service it has been assigned to.

Such briefly are the methods adopted with the engines that pass through the shop. Some, of course, will not require such extensive repairs as those mentioned, while others will require more. But whatever may be necessary, system and orderliness, it is apparent, will accomplish more satisfactory and economical results than can otherwise be attained.

## CHAPTER III.

### FORMS AND EXHIBITS, THEIR USE AND GREAT VALUE.

The value of these in connection with the motive power department cannot be overestimated, for through them those responsible for the conduct of business are not only able to direct operations over a wide territory, from hour to hour, intelligently, but afterwards to sum up the results secured. These results are judged according to attainable standards of work, through comparisons and otherwise, and commendation or reproof are based thereon. It will be seen, therefore, that they are of inestimable value and that, without them, there could be neither effective supervision nor intelligent co-operation. It is apparent, therefore, that they should be minute and exhaustive, and should be faithfully made and intelligently studied by those concerned. Through them every phase of the service is discerned, including the placing of locomotives and knowledge of their needs and performances.

No one can study the returns and exhibits of railway operations without being impressed with their necessity and great value in practical operations. To searchers after knowledge they not only afford insight into the workings of the great departments, but have additional value in the things they suggest.

The returns and exhibits embodied herein, measurably represent the needs of those in charge of locomotives. They have been of slow growth and portray the evolution of the service in this respect. For, at one time, there may be said to have been neither returns nor exhibits of any kind regarding the working of locomotives. That was in the beginning when chaos

reigned, compared to the systematic supervision and discharge of business exercised at the present moment.

It is probable that these forms and exhibits represent but a phase of growth; that with time and greater knowledge and experience they will be bettered and others added. This is the experience of every great and growing business. What seems perfect today is found to be deficient in some respect tomorrow. That is because men are wiser today than they were yesterday. However, so far as these forms go, they are intended to furnish those in charge such data as is esteemed necessary to enable them to judge quickly and intelligently of what is going on, and of what the service needs. Through them and by comparisons, waste, improvidence and ineffective service are discerned and remedied. And it is not too much to say that it is through them that economy in the use of fuel, oil, waste and the working and repair of engines are more clearly traced and waste corrected, than through any other medium of information or advice attainable by those in charge.

Specific knowledge is all important when we remember how imperfect the locomotive is and how complicated are its workings, notwithstanding all the improvements that have been made in its construction and working. Because of this and their extended and widely separated use, carefully organized supervision is necessary to their effective working. It is not only necessary when anything is wrong in connection with their operation that it should be known, but that it should be known quickly if ineffective service and extravagance are to be prevented.

The transfer of engines from one part of a road to another is of constant occurrence, and effective service from the standpoint of profit and public accommodation is secured, or otherwise, through the intelligent action and celerity exercised by those in charge. The

sources of information at the disposition of the motive power department are such as to secure such action; and, in making transfers, to do so at the least possible inconvenience and cost to the service. Thus, among the returns, will be found those stating the location of locomotives; their condition; locomotives in shops; when repairs on particular locomotives will be completed; those available for service, etc.

Another feature is the immediate information certified to those in charge, of engine failures, whereby trains are delayed or danger incurred or threatened. And as there are innumerable causes for such failures each must be carefully scrutinized. As aids in this direction, returns are required specifically stating the cause of failure; the engineers' report of delays; the causes thereof, and such attendant and supernumerary returns as a proper understanding of the subject requires. From the reports of engine failures, those in charge are able to determine with approximate accuracy whether failures are due to defects in the machine, or lack of skill or care upon the part of those in charge. If due to the machine the break-down is not only of interest in itself, but suggestive in regard to appliances of like nature in other machines; and so valuable knowledge is oftentimes gained through these returns of break-downs. If, on the other hand, they are due to neglect or ignorance upon the part of those in charge, knowledge of the fact is valuable because of the curative discipline necessary to prevent a recurrence of the accident.

Another exhibit of special importance recounts the performance of locomotives. Through these repairs made, amount of work done and cost thereof and the relative economy exercised, are ascertained. At one time—and, indeed, measurably so now—comparisons were based on the mileage of engines. This, however, has been supplemented by comparisons on

the load hauled, which more nearly portrays the work done and, therefore, more fairly represents value received. Statistics of the performance of locomotives (and consequently of trains), it may be said, tend more and more with the management of railroads, to comparisons based on the paying load hauled; what is termed the ton mile basis in the case of freight. Thus the management is kept advised as to whether cars are fully loaded and the full complement hauled in trains. However, from the standpoint of motive power officials, statistics showing the total weight hauled—dead and paying—is all important in judging of the relative cost of operating engines. The motive power department is not responsible for the number or frequency of trains, nor for neglect or inability of operating officials to fully load cars. Its objective point or basis of comparison is the gross load hauled, and on this basis judgment is formed. The motive power department, it may be said, not only knows the work each engine performs and items of cost, but how one division of the line compares with another in this respect, and so on. Thus, through these and similar exhibits, every one is stimulated to make the best showing possible; to get all out of the locomotive that can be achieved through intelligent effort in loading and handling cars, and finally, in the economical working of the power used in doing the business.

In order to further effective supervision of locomotives it is found useful to keep specific accounts with each engine, viz.: mileage, fuel, oil, waste, tallow, engine supplies (and tools), cost of material used in repairs, cost of labor including superintendence, time and mileage record of wheels under locomotives, time and mileage record of steel tires on engine truck wheels\*, and finally, the tonnage hauled. This last is

---

\*In many cases, manufacturers of locomotive wheels and steel tires (and other kinds of wheels in some cases), guarantee that they will make certain mileage. Record must therefore be kept in order to enforce terms of guarantee if wheels fail.

all important, for it forms to a certain extent, the basis of determining relative skill and economy exercised by engineers; and, to pursue the inquiry further, the relative expenses of engines—as specified above.

To particularize, the sources of information that the accompanying returns point out are not only explicit, but suggest other and special lines of inquiry. Mediums of information may be multiplied almost indefinitely; those in charge will ever wish to know the whys and wherefores concerning all things affecting cost or efficiency of service. Averages will not suffice; they will wish to analyze and multiply their sources of information to the utmost. Thus many will not only require to know the tonnage hauled and the cost thereof, but the expenditure of forces involved. They will require to know daily or periodically the number of locomotives of each class in service (passenger, freight, switching, etc.), the gross quantities of fuel consumed—as well as the cost thereof—by each class of service; the number of pounds of fuel consumed per engine mile; the number of pounds of fuel consumed per car mile; the gross quantities consumed—as well as the cost—of valve, engine and car oil used on locomotives, and the quantity and cost thereof per mile run; the total number of pounds—as well as the cost—of waste used, and the quantity and cost thereof per mile run; the cost of engine service (including enginemen, round house men and engine supplies) per mile run; similarly the cost of engine service per car mile; the cost of repairs of engines (separately for material and labor) per mile run; the cost of repairs of engines (separately for material and labor) per car mile; the gross tonnage moved by locomotives. Not only will those responsible for locomotives desire to know all this in regard to cost per mile run by locomotives and per car mile, but as I have already explained they will also wish to know what the expenditure of material and cost of

labor are on the basis of tons hauled one mile—for passenger and freight service separately.

Information of this nature, in addition to that referred to elsewhere herein, directly or indirectly, will suggest itself as being valuable—if not absolutely necessary—to many having charge of the supervisory work of locomotives. No two men—it is probable—will place the same value on data of this and similar nature. Each will enforce, for permanent use or temporary expediency, such means of enlightenment as he can use advantageously or as the temporary exigencies of the service point out. And in this connection they will always consider the cost of the information—the clerical labor and expense it involves—in connection with its value, when obtained.

Effort has been taken in arranging the forms and exhibits which follow, not only to explain the purpose that each is intended to conserve, but also every necessary particular in regard to how the exhibit should be made and what it should contain. These directions, in fact, are so explicit that in the majority of cases it will not need long or technical experience to understand and compile them. Like accounts generally, if properly compiled, they have only to be studied to be understood. This last cannot be too strongly impressed on those who would keep themselves advised in regard to details of railway operations. Men often complain that they cannot understand accounts. This does not arise from lack of intelligence but from indisposition to study the accounts attentively. For there is nothing done by man that is so clear as accounts when thus studied. Nor, indeed, that furnish more valuable and needed information in the case of great and widely extended properties.

In regard to the forms and returns of a statistical nature, or those used for other purposes of Locomotive Supervision, no two roads, it is probable, will con-



form exactly to each other, either in the number or character of the exhibits. Wherever thoroughness is observed, however, they will be generally similar. The number and complexity (and oftentimes general similarity) of the returns will confuse and perplex the novice; to him they will very likely have the appearance of exaggeration, or, it may be, duplication of work. This, however, is only apparent when the situation and its needs are considered. Everyone who is responsible for locomotives must be kept advised in regard to the same in order that he may perform his duties effectively; or, in the event he neglects to do so, that the omission may be noticed and corrected. Thus, the foreman of a shop must have certain information, we will say, in regard to a particular phase of locomotive business; the master mechanic of that group of shops must also have information of a like nature, but differing in some respect; then the Superintendent of Motive Power and Machinery must also be advised in regard to the matter, not only for that particular shop but for the division, and for the whole road. Moreover, the General Manager or other operating official, also, requires specific information in regard to many things in order that his supervision of affairs may be effective. Thus, there will be four, or more, officials to be advised of occurrences, but no two, perhaps, requiring exactly the same details. And so, returns and exhibits must always be multiplied to conform to the many and varied requirements of those responsible for operations. And it may be truly said that the greater the knowledge and means of enlightenment and supervisory methods, that responsible officials are acquainted with, the more efficient and economical will be the conduct of the service—provided they make use of their knowledge. And because this is so, grave interest and value attach to the accompanying exhibits, which may seem so multiplied and perplexing to the casual examiner.

## CHAPTER IV.

### LIST OF FORMS AND EXHIBITS. SPECIFIC BLANKS.

NOTE.—In estimating the usefulness of these forms the particular official directed herein to make the return or receive it is unimportant. The organization of no two roads will agree, throughout, in respect to such matters. Thus, returns that are made by the division superintendent on one road may be made by the train dispatcher, master mechanic, or foreman of another; and this is equally true of the officials to whom returns are rendered. Such matters conform to environment; to whatever form of organization is thought best. It is the return itself that is interesting and important.

No.

1. Foreman's weekly report to the Master Mechanic of locomotive boilers washed out.
2. Master Mechanic's weekly report to Superintendent of Motive Power and Machinery of the location of locomotives.
3. Weekly report by the Superintendent of Motive Power and Machinery to interested officials of the total number of locomotives of each class on the different divisions.
4. Weekly report by the Superintendent of Motive Power and Machinery of the location of each locomotive.
5. Master Mechanic's monthly report to the Superintendent of Motive Power and Machinery of the condition of each engine on his division.
6. Monthly record of the Superintendent of Motive Power and Machinery of condition of each engine on each division.
7. Monthly record of the Superintendent of Motive Power and Machinery of the condition of the different classes of engines on each division.
8. Master Mechanic's report of repairs made on particular engines.
- 9 10, 11. Shop Foreman's report to his superior of repairs on particular engines.
12. Master Mechanic's report of cost of repairs on particular engines.

No

13. Master Mechanic's monthly summary to the Superintendent of Motive Power and Machinery in regard to heavy repairs made on engines.
14. Foreman's weekly report of Locomotives in shop.
15. Definition of what constitutes engine failures.
16. Train Dispatcher's daily report of engine failures.
17. Engineer's report to Master Mechanic of delays on each trip.
18. Master Mechanic's ten days report to the Superintendent of Motive Power and Machinery of engine failures.
19. Monthly record of the Superintendent of Motive Power and Machinery of particulars (cause) of engine failures on each day of the month.
20. Monthly summary of the Superintendent of Motive Power and Machinery of cause of engine failures on each division.
21. Locomotive Engineer's trip report of time worked.
22. Train Dispatcher's daily record of train movements.
23. Engineer's daily report of switching time.
24. Agent's report of time worked by switch yard crews.
25. Engineer's monthly report of time worked.
26. Division time book of Locomotive Engineers giving particulars of the service of each.
27. Engine house register.
28. Storekeeper's monthly report to the Superintendent of Motive Power and Machinery of delayed and over time allowed engineers and firemen.
29. Monthly record of the Superintendent of Motive Power and Machinery of the gross cost of delayed and over time on each division.
30. Monthly statement of locomotive mileage on each division.
31. Monthly report of locomotive mileage (classified) of each engine.
32. Monthly record of the mileage of each engine.
33. Monthly report of particulars of cost of repairs of each locomotive.
34. Monthly record of repairs on each locomotive.
35. Monthly report for the Superintendent of Motive Power and Machinery of the miles run and cost of repairs of each engine.
36. Monthly report for Division Master Mechanic of mileage and cost of repairs of each locomotive on his division.
37. Record of mileage (classified) and cost of repairs of each locomotive.
38. Form of coal tickets used on engines.
39. Monthly report of fuel delivered at each point to locomotives.
40. Monthly summary of fuel delivered to locomotives.
41. Form of oil and waste tickets used on engines.
42. Monthly report of total amount of oil and waste delivered to locomotives on each division.
43. Round House Foreman's monthly report of the number of engines wiped daily.

- No.
44. Monthly summary of charges to various operating accounts for material and labor account of engines on each division.
  45. Locomotive Report—particulars of service and cost for repairs, supplies and labor.
  46. Foreman's monthly report to Master Mechanic of cast iron truck and tender wheels applied to and removed from locomotives.
  47. Monthly record of Superintendent of Motive Power and Machinery of particulars of each defective cast iron engine and tender wheel removed.
  48. Monthly summary of the Superintendent of Motive Power and Machinery of the gross number of defective cast iron locomotive wheels removed, made by different manufacturers.
  49. Monthly report of the Superintendent of Motive Power and Machinery to the Purchasing Agent of defective cast iron wheels removed from locomotives and by whom made.
  50. Monthly report of the Superintendent of Motive Power and Machinery of wheels that have failed to meet guarantees of makers.
  51. Record of the Superintendent of Motive Power and Machinery of engine truck and tender wheels applied to and removed from each locomotive.
  52. Shop Foreman's monthly report to the Master Mechanic of particulars of steel tired engine truck and tender wheels applied to or removed from locomotives.
  53. Index to record of steel tired engine truck wheels.
  54. Record of Superintendent of Motive Power and Machinery of steel tires on engine truck wheels.
  55. Monthly report to the Superintendent of Motive Power and Machinery of engine driving wheel tires applied and removed.
  56. Index to driving wheel tire record.
  57. Record of Superintendent of Motive Power and Machinery of driving wheel tires.
  58. Daily report of distribution of shop labor of each man.
  59. Master Mechanic's monthly statement to Superintendent of Motive Power and Machinery of comparative cost of labor.
  60. Shop Foreman's monthly report to Master Mechanic of number of men of each class of labor employed during the month and wages paid.
  61. Master Mechanic's monthly report to Superintendent of Motive Power and Machinery of the total number of men of each class of labor employed on his division during the month and wages paid.

- No.
62. Summary made by Superintendent of Motive Power and Machinery for the General Manager of the total number of men of each class of labor and wages paid on whole road.  
Inspector's reports (as per diagrams) of locomotive break-ages of different parts as specified in Returns 63 to 78.
  63. Pilot coupler.
  64. Plate coupler.
  65. Master car builder's coupler. (M. C. B.)
  66. Axle.
  67. Driving box and brass.
  68. Cylinder heads.
  69. Equalizer. Equalizer Stand. Spring Hangers.
  70. Eccentric, eccentric strap, eccentric rod.
  71. Side rod, main rod and rod strap.
  72. Piston and piston rods.
  73. Valves, valve yokes and rocker shaft.
  74. Cross heads.
  75. Crank pins.
  76. Broken stay-bolts.
  77. Miscellaneous, used where diagram return is not provided.
  78. Condition of locomotive boiler.
  79. Inspector's record of inspection of stationary and locomotive fire-box stay-bolts.
  80. Inspector's monthly report of inspection of stationary and locomotive fire-box stay-bolts.
  81. Inspector's report of periodical inspection of stationary boilers.
  82. Inspector's report of inspection of air and steam gauges and safety valves.
  83. Inspector's report of changes and repairs of stationary boilers.
  84. Shop Foreman's report to Master Mechanic of valve motion of engines.
  85. Monthly report of each engineer's service, viz.: Total miles run by locomotives under his charge, tons hauled and fuel consumed.
  86. Statement of mileage made by each engineer to pint of lubricating oil.
  87. Master Mechanic's report to Superintendent of Motive Power and Machinery of condition of tools and machinery.
  88. Form of application made by those seeking employment on engines.
  89. Master Mechanic's notice of vacancies in runs and service.
  90. Notice of Superintendent of Motive Power and Machinery of those authorized to operate locomotives.
  91. Form of release to be signed by minors and their legal guardians.
  92. Certificate given on completion of apprenticeship.
  93. Master Mechanic's weekly report to Superintendent of Motive Power and Machinery of average terminal delays of freight engines and the cause therefor.

- No.
94. Engineer's requisition for supplies.
  95. Engineer's report to Round House Foreman of condition of engines at end of each trip.
  96. Engineer's report to Master Mechanic of particulars of stock killed or injured.
  97. Particulars of mechanical examinations of firemen at the end of the first, second and third years of service.
  98. General time book of particulars of hours worked by each man, rate of pay, wages and on what labor was expended.
  99. Requisition for and invoice of material.
  100. Notice of material ordered.
  101. Record of material ordered.
  102. Shop order for material.
  103. Report of piece work performed by each employe.
  104. Form of application for employment in shop.
  105. Daily distribution of labor for manufactured material work.
  106. Distribution blank for material used.
  107. Distribution blank for labor performed.
  108. Monthly Statement of the tonnage haul of engineers and average of number of tons hauled per train.

M. P. FORM 1.

**FOREMAN'S WEEKLY REPORT TO THE MASTER MECHANIC OF LOCOMOTIVE BOILERS WASHED OUT.**

The purpose of this report is to ascertain whether boilers are washed out regularly as required. In pursuance of this records are kept by the Master Mechanic and in the office of the Superintendent of Motive Power and Machinery of each boiler washed.





M. P. FORM 2.

**MASTER MECHANIC'S WEEKLY REPORT TO SUPERIN-  
TENDENT OF MOTIVE POWER AND MACHINERY OF  
THE LOCATION OF LOCOMOTIVES.**

This report is used to obtain information weekly of each engine belonging to the company, as to how and where it is engaged, the nature of repairs which each engine may be receiving, if any, and when it will be ready for service.

**MASTER MECHANIC'S WEEKLY REPORT TO SUPERINTENDENT OF MOTIVE  
POWER AND MACHINERY OF THE LOCATION OF LOCOMOTIVES.**

On ..... Division. For the week ending ..... 19.....

NOTE—This report is to be made by each Master Mechanic of all engines on his division. It must be sent to the Superintendent of Motive Power and Machinery on Saturday of each week.  
 In the column headed "How and where employed" should be shown the kind of service the engines are engaged in and the points between which they run.  
 In the case of engines engaged in switching service the points where the work is performed should be given.  
 The report should also show the engines on each division that are in the shop for repairs; also what repairs are needed to put each engine in running order.

Nos. of En- gines in Work- ing Order	How and Where Employed	Nos. of En- gines in Shop for Repairs	Date sent into Shop	Repairs and Alterations Necessary to put each Engine named in Running Order	Date Engine is expected to be Ready for Service

M. P. FORM 3.

WEEKLY REPORT BY THE SUPERINTENDENT OF MOTIVE POWER AND MACHINERY TO INTERESTED OFFICIALS OF THE TOTAL NUMBER OF LOCOMOTIVES OF EACH CLASS ON THE DIFFERENT DIVISIONS.

This report is used to obtain information in regard to the number of locomotives in the different classes of service on the several divisions of the road; also the number out of service for various reasons as stated in the report.



M. P. FORM 4.

WEEKLY REPORT BY THE SUPERINTENDENT OF MOTIVE POWER AND MACHINERY OF THE LOCATION OF EACH LOCOMOTIVE.

This interesting and somewhat complicated form is used by the Superintendent of Motive Power and Machinery for the purpose of ascertaining the location of each locomotive belonging to the company; also to see that none are omitted by Master Mechanics in their weekly reports, Form 2. The blank may also be used for the purpose of checking up other locomotive reports received from Master Mechanics, such as the monthly report of inspection of fire boxes, stay bolts, and so on.



M. P. FORM 5.

MASTER MECHANIC'S MONTHLY REPORT TO THE SUPER-  
INTENDENT OF MOTIVE POWER AND MACHINERY  
OF THE CONDITION OF EACH ENGINE ON HIS DIVI-  
SION.

The object of this extremely valuable report is to keep the Superintendent of Motive Power and Machinery advised as to the condition of the locomotives on each division; those in good order; those in fair or poor condition; and those in the shop for repairs. It also enables him to determine whether each engine in service makes reasonable mileage. In case engines are reported as being in poor condition after having been recently repaired, he is enabled to investigate the reason therefor.

**MASTER MECHANIC'S MONTHLY REPORT TO THE SUPERINTENDENT OF MOTIVE POWER AND MACHINERY OF THE CONDITION OF EACH ENGINE ON HIS DIVISION**

..... Division Date.....19.....

NOTE—This report is to be made on the first day of each month by the Master Mechanic for the Superintendent of Motive Power and Machinery. It must include all locomotives on division and show the condition and other particulars for each engine upon the date report is made.

Engine Number	Size of Cylinder	Date when General Repairs were Made	Mileage since last General Repairs (not incl. last month)	CONDITION OF			Number of months before repairs will be necessary. (Other remarks)
				Machinery	Flues	Fire Box and Boiler	



M. P. FORM 6.

MONTHLY RECORD OF THE SUPERINTENDENT OF MOTIVE POWER AND MACHINERY OF CONDITION OF EACH ENGINE ON EACH DIVISION.

The object of this exhibit is to aid the Superintendent of Motive Power and Machinery in obtaining knowledge of the condition of engines on each division; those in good, fair, or poor condition; those in shop; also vacant numbers of engines awaiting to be filled.



M. P. FORM 7.

MONTHLY RECORD OF THE SUPERINTENDENT OF MOTIVE POWER AND MACHINERY OF THE CONDITION OF THE DIFFERENT CLASSES OF ENGINES ON EACH DIVISION.

The purpose of this monthly report is to advise the General Manager of the condition of each class of locomotives on all the divisions; the number in active service; number in shops; number broken up or sold; number receiving general and heavy repairs; also percentage of locomotives of different classes and conditions.

**M. P. Form 7**  
**MONTHLY RECORD OF THE SUPERINTENDENT OF MOTIVE POWER AND MACHINERY OF**  
**THE CONDITION OF DIFFERENT CLASSES OF ENGINES ON EACH DIVISION.**

NOTE—This report is made in the office of the Superintendent of Motive Power and Machinery and forwarded to the General Manager on the fourth day of the following month. It is a summary of Form 6. It shows the condition of locomotives engaged actively in each kind of service on the different divisions; the number in shop for repairs; the number for which special disposition has been made; the number that has received general and heavy repairs; also percentage of engines in different conditions in each service and number in shop or disposed of.

DIVISIONS	NUMBER OF LOCOMOTIVES IN EACH SERVICE												TOTAL FOR ALL SERVICES			
	In Good Condition		In Fair Condition		In Poor Condition		In Shop		Sold or Cut Up		Total in each Service					
	Pass.	Fr.	Switch	Pass.	Fr.	Switch	Pass.	Fr.	Switch	Pass.	Fr.	Switch	Pass.	Fr.	Switch	
TOTAL																

**NUMBER OF ENGINES THAT RECEIVED GENERAL AND HEAVY REPAIRS.**

SHOP	ROAD		SWITCHING		TOTAL	CLASS OF SERVICE	No. of Engines	PERCENTAGE OF ENGINES					
	Gen'l	Heavy	Gen'l	Heavy				In Good Condit'n	In Fair Condit'n	In Poor Condit'n	Sold or Cut Up		
TOTAL						Passenger Freight. Switching.	TOTAL...						

**PERCENTAGE OF ENGINES IN DIFFERENT CONDITIONS IN EACH SERVICE**

M. P. FORM 8.

MASTER MECHANIC'S REPORT OF REPAIRS MADE ON  
PARTICULAR ENGINES.

This report shows in detail the repairs made on an engine, when such repairs amount to \$25.00 or more. It is scrutinized by the Superintendent of Motive Power and Machinery and is filed in his office.

MASTER MECHANIC'S REPORT OF REPAIRS MADE ON PARTICULAR ENGINES.

Shop Date 19

Engine No. Class

Note.—This form enumerates in detail the various parts of an engine. A report of this kind is to be made for each engine receiving repairs amounting to \$25.00 or more. When new parts are applied, such parts should be prefixed by the letter "X"; parts that are repaired by the letter "O." It should show the date the engine entered the shop, and the date when ready for service; also the total cost of material and labor expended in the repairs as shown at the end of the report.

When parts are repaired or renewed, of which there are two or more of the same name, the report will specify which parts they are; as right or left, front, middle or back, right front or left front.

When an engine is to be sent to the principal shop of the road for extensive repairs, the master mechanic should use this form to report all work necessary in repairing the engine. The report should be sent to the Superintendent of Motive Power and Machinery, who will, after approving such repairs, forward the report to the superintendent of the shop, thus enabling the latter to order material not in stock so as to guard against any delay in making the repairs. This will enable him to maintain a regular time schedule for repairing engines.

When the engine has been repaired the superintendent of the shop will make a report on this form showing in detail what repairs have been made. For engines repaired at local shops, the report will be made by the foreman in charge and forwarded to the master mechanic.

All reports of this form must be sent to the Superintendent of Motive Power and Machinery to be kept on file in his office.

BOILER AND FIRE BOX.		PISTONS.			
1. Boiler.		67. Spiders, Which.		131. Rocker Arms, Which.	
2. Boiler Braces.		68. Followers, Which.		132. Rocker Boxes, Which.	
3. First course from Arch.		69. Bull Rings, Which.		134. Straps, Which.	Mat'l.
4. Second course from Arch.		70. Packing, Which.	Kind.	135. Rods, Which.	
5. Third course from Arch.		71. Rods, Which.		136. Reverse Lever.	
6. Slope Sheet.		72. Glands, Which.		137. Quadrant.	
7. Roof Sheet.		73. Rod Packing, Which.	Kind.	138. Lead Rod.	
8. Right Side Sheet.		CROSS HEADS, Etc.		139. Valve Rod, Which.	
9. Left Side Sheet.		74. Cross Heads, Which.		140. Tumbling Shaft.	
10. Back Head Sheet.		75. Gibs.		STEAM PIPES, Etc.	
11. Throat Sheet.		76. Guides, Which.	Which.	141. Steam Pipes, Which.	
12. Front Flue Sheet.		77. Guides, Yokes, Which.	Which.	142. Exhaust Pipes, Which.	
13. Waist Sheet.		78. Guide Blocks, Which.	Which.	143. Ecc. Glands, Kind.	Spec.
14. Domes.		DRIVING WHEELS, Etc.		144. Tee Pipes.	
15. Dome Braces.		79. Wheels, Which.	Mat'l.	145. Dry Pipe.	
16. Dome Cap.		80. Axles, Which.	Mat'l.	146. Stand Pipe.	
17. Test Frames, lbs.		81. Boxes, Which.	Mat'l.	147. Throttle Valve.	
18. Pressure Allowed, lbs.		82. Brasses, Which.		148. Throttle Lever.	
19. Weight of Scale Removed, lbs.		83. Shoes, Which.		149. Throttle Shaft.	
20. Fire Box.		84. Wedges, Which.		MISCELLANEOUS.	
21. R. S. Sheet—Thickness, Make		85. Brasses, Which.		150. Air Signal and Piping.	
22. L. S. " " " " " "		86. Tire Thickness.	Diam.	151. Bell Stand.	Bell Ringer.
23. Door, " " " " " "		87. Tire Maker.		152. Brakes, Air.	Size of Pump.
24. Crown, " " " " " "		88. Crank Pins, Which.	Make	154. Bumper Girths, Beam.	
25. Flue, " " " " " "		89. Springs, Which.		155. Cab.	
26. Arch Tubes, Number new, Which		90. Hangers, Which.		156. Cab Brackets.	
27. Mud Ring.		91. Equalizers, Which.		157. Cab Deck Castings.	Wood Deck.
28. Stay Bolts, Number new.		ENGINE TRUCK.		158. Chasing Iron.	
29. Crown Bars, Number new.		92. Truck.		159. Horse Casting.	Frame Castings.
30. Crown Bar Braces.		93. B. C. Which.	Mat'l.	161. Frame Jaws and Braces.	
31. Crown Bolts.	No. reset	94. Brasses, Which.		162. Hand Railing.	
32. Flues, Number new.		95. Frames, Which.		163. Hand Rail Column.	
33. Combustion Tubes.		96. Pedestals, Which.		164. Head Light, Front, Back.	
34. Brick Arch.		97. Springs, Which.	Make.	165. Head Light Bracket.	
35. Grates.		98. Hanger, Which.		166. Jacket.	
BOILER ATTACHMENTS		99. Equalizers, Which.		167. Laggings.	Kind.
36. Ash Pan.		100. Top Center.		168. Packing.	
37. Ash Pan Dampers.		101. Bottom Center.		169. Pilot.	Front Back
38. Deflecting Plate.		102. Engine Truck Wheels, Number new.	Mat'l.	170. Pilot Coupler—Automatic.	
39. Extended Front.		FEED WATER.		171. Running Board.	
40. Fire Door and Frame.		103. Injectors, Which.		172. Running Board Brackets.	
41. Front End Ring.		104. Kind and Size—Right.	Left.	173. Sand Box.	
42. Front End Door.		105. Checks, Which.		174. Sand Box Casting.	
43. Netting.		106. Size and Make.		175. Sander—Kind.	
44. Petticoat Pipe.		107. Feed Pipes.		176. Steam Gauge.	
45. Safety Valve, No., Size and Make		108. Delivery Pipes.		177. Steam Heating Apparatus—Kind.	
46. Smoke Arch.		RODS.		178. Three Way Cool Air Pump Exhaust.	
47. Smoke Stack.		109. Main Rods, Which.	Mat'l.	179. Wheel Tender, Engine Truck.	
48. Smoke Burners, Kind.		110. Brasses, Which.		180. Tank, Capacity.	Gals.
49. Spark Hopper, Cinder Hopper.		111. Straps, Which.		181. Tank Braces.	
50. Whistle.		112. Balls, Which.	Keys.	182. Tank Valves.	
51. Wash-out Plugs.		113. Side Rods, Which.		183. Tank Hoop.	
COCKS.		114. Brasses, Which.		184. Tank Boxes.	
52. Blower.		115. Straps, Which.		185. Tender Frame, Iron or Wood.	
53. Cylinder.	Kind.	116. Bolts, Which.		186. Tender Frame Rods.	
54. Gauge.		STEAM CHESTS.		187. Tender Frame Draw Bar.	
55. Header.		117. Chests, Which.		188. Tender Draw Bar Coupler—Auto-	
56. Surface.		118. Covers, Which.		matic.	
57. Steam Heat.		119. Castings, Which.		189. Tender Trucks.	
58. Syphon.		120. Air Valves, Which.		190. Tender Truck Wheels, No. new.	Make.
59. Cab Oilers.		SLIDE VALVES.		191. Tender Springs.	
60. Right Feed Lubricator, No. Kind.		121. Valves, Which.		192. Tender Brakes.	
61. Cock Stand.		122. Kind.		193. Tender Draw Bar Coupler—Auto-	
62. Cock Stand.		123. Lap, Steam.	Exhaust.	matic.	
CYLINDERS.		124. Lead.		194. Tender Trucks, No. new.	Make.
63. Cylinders, Which, Bushed		125. Seats, Which.	Kind.	195. Tender Brakes.	
64. Cylinders, Which, Bored.		126. Yokes, Which.		196. Tender Springs.	
65. Cylinder Heads, Which.		127. Glands, Which.		197. Tender Brakes.	
66. Cylinder Castings, Which.		128. Stem Glands, Which.		198. Tender Draw Bar Coupler—Auto-	
67. Cylinder Jackets.		129. Stem Packing, Which.	Kind.	matic.	
		VALVE GEAR.		199. Tender Trucks.	
		130. Links, Which.		200. Tender Truck Wheels, No. new.	Make.
				201. Tender Springs.	
				202. Tender Brakes.	
				203. Tender Brakes.	
				204. Tender Springs.	
				205. Tender Brakes.	
				206. Tender Springs.	
				207. Tender Brakes.	
				208. Tender Springs.	
				209. Tender Brakes.	
				210. Tender Springs.	
				211. Tender Brakes.	
				212. Tender Springs.	
				213. Tender Brakes.	
				214. Tender Springs.	
				215. Tender Brakes.	
				216. Tender Springs.	
				217. Tender Brakes.	
				218. Tender Springs.	
				219. Tender Brakes.	
				220. Tender Springs.	
				221. Tender Brakes.	
				222. Tender Springs.	
				223. Tender Brakes.	
				224. Tender Springs.	
				225. Tender Brakes.	
				226. Tender Springs.	
				227. Tender Brakes.	
				228. Tender Springs.	
				229. Tender Brakes.	
				230. Tender Springs.	
				231. Tender Brakes.	
				232. Tender Springs.	
				233. Tender Brakes.	
				234. Tender Springs.	
				235. Tender Brakes.	
				236. Tender Springs.	
				237. Tender Brakes.	
				238. Tender Springs.	
				239. Tender Brakes.	
				240. Tender Springs.	
				241. Tender Brakes.	
				242. Tender Springs.	
				243. Tender Brakes.	
				244. Tender Springs.	
				245. Tender Brakes.	
				246. Tender Springs.	
				247. Tender Brakes.	
				248. Tender Springs.	
				249. Tender Brakes.	
				250. Tender Springs.	
				251. Tender Brakes.	
				252. Tender Springs.	
				253. Tender Brakes.	
				254. Tender Springs.	
				255. Tender Brakes.	
				256. Tender Springs.	
				257. Tender Brakes.	
				258. Tender Springs.	
				259. Tender Brakes.	
				260. Tender Springs.	
				261. Tender Brakes.	
				262. Tender Springs.	
				263. Tender Brakes.	
				264. Tender Springs.	
				265. Tender Brakes.	
				266. Tender Springs.	
				267. Tender Brakes.	
				268. Tender Springs.	
				269. Tender Brakes.	
				270. Tender Springs.	
				271. Tender Brakes.	
				272. Tender Springs.	
				273. Tender Brakes.	
				274. Tender Springs.	
				275. Tender Brakes.	
				276. Tender Springs.	
				277. Tender Brakes.	
				278. Tender Springs.	
				279. Tender Brakes.	
				280. Tender Springs.	
				281. Tender Brakes.	
				282. Tender Springs.	
				283. Tender Brakes.	
				284. Tender Springs.	
				285. Tender Brakes.	
				286. Tender Springs.	
				287. Tender Brakes.	
				288. Tender Springs.	
				289. Tender Brakes.	
				290. Tender Springs.	
				291. Tender Brakes.	
				292. Tender Springs.	
				293. Tender Brakes.	
				294. Tender Springs.	
				295. Tender Brakes.	
				296. Tender Springs.	
				297. Tender Brakes.	
				298. Tender Springs.	
				299. Tender Brakes.	
				300. Tender Springs.	
				301. Tender Brakes.	
				302. Tender Springs.	
				303. Tender Brakes.	
				304. Tender Springs.	
				305. Tender Brakes.	
				306. Tender Springs.	
				307. Tender Brakes.	
				308. Tender Springs.	
				309. Tender Brakes.	
				310. Tender Springs.	
				311. Tender Brakes.	
				312. Tender Springs.	
				313. Tender Brakes.	
				314. Tender Springs.	
				315. Tender Brakes.	
				316. Tender Springs.	
				317. Tender Brakes.	
				318. Tender Springs.	
				319. Tender Brakes.	
				320. Tender Springs.	
				321. Tender Brakes.	
				322. Tender Springs.	
				323. Tender Brakes.	
				324. Tender Springs.	
				325. Tender Brakes.	
				326. Tender Springs.	
				327. Tender Brakes.	
				328. Tender Springs.	
				329. Tender Brakes.	
				330. Tender Springs.	
				331. Tender Brakes.	
				332. Tender Springs.	
				333. Tender Brakes.	
				334. Tender Springs.	
				335. Tender Brakes.	
				336. Tender Springs.	
				337. Tender Brakes.	
				338. Tender Springs.	
				339. Tender Brakes.	
				340. Tender Springs.	
				341. Tender Brakes.	
				342. Tender Springs.	
				343. Tender Brakes.	
				344. Tender Springs.	
				345. Tender Brakes.	
				346. Tender Springs.	
				347. Tender Brakes.	
				348. Tender Springs.	
				349. Tender Brakes.	
				350. Tender Springs.	
				351. Tender Brakes.	
				352. Tender Springs.	
				353. Tender Brakes.	
				354. Tender Springs.	
				355. Tender Brakes.	
				356. Tender Springs.	
				357. Tender Brakes.	
				358. Tender Springs.	
				359. Tender Brakes.	
				360. Tender Springs.	

## M. P. FORMS 9, 10 AND 11.

## SHOP FOREMAN'S REPORT TO HIS SUPERIOR OF REPAIRS ON PARTICULAR ENGINES.

Forms 9, 10 and 11 are used by foremen at the general shops in connection with Form 8, the numbers on these blanks corresponding with the numbers used in designating the repairs as particularized on that form. Instead of itemizing (writing in) the repairs made on an engine, the foreman, to save clerical work, simply enters the letters "X" or "O" after the number which corresponds with the item of repairs as shown on Form 8.

Separate reports of this form (three in number) are provided for use in the different shops, the parts (numbers) listed on each report being such as will be repaired or renewed in the particular shop for which the form is designed.

M. P. Form 9

## SHOP FOREMAN'S REPORT TO HIS SUPERIOR OF REPAIRS ON PARTICULAR ENGINES

Engine No. ....

Date in .....

Date out .....

NOTE.—The numbers shown on this report correspond, so far as they go, to those shown on Form 8. For all repairs made to engines where new parts are applied the letter "X" should be entered opposite the number corresponding to the part replaced; for all parts that are repaired the letter "O" should be entered opposite the number.

This report will be sent to the general foreman, who will enter the several items shown herein, on Form 8.

1	23	79
2	24	80
3	25	86
4	26	87
5	27	88
6	28	109
7	29	110
8	30	111
9	31	112
10	32	113
11	33	114
12	39	115
13	46	116
14	67	128
15	68	129
17	69	130
19	70	136
20	71	137
21	72	
22	73	

Remarks: .....

.....

..... Foreman.



## SHOP FOREMAN'S REPORT TO HIS SUPERIOR OF RE-PAIRS ON PARTICULAR ENGINES

Engine No. ....

Date in .....

Date out .....

NOTE.—The numbers shown on this report correspond, so far as they go, to those shown on Form 8. For all repairs made to engines where new parts are applied the letter "X" should be entered opposite the number corresponding to the part replaced; for all parts that are repaired the letter "O" should be entered opposite the number.

This report will be sent to the general foreman, who will enter the several items shown herein, on Form 8.

16	62	94	125	151
26	63	95	126	152
34	64	96	127	156
35	65	97	131	157
40	66	98	132	158
41	74	99	133	159
42	75	100	134	160
47	76	101	135	161
48	77	102	138	162
49	78	105	139	163
51	81	107	140	165
52	82	108	141	173
53	83	117	142	174
54	84	118	143	175
55	85	119	144	176
56	89	120	145	177
57	90	121	146	178
58	91	122	147	
59	92	123	148	
60	93	124	149	

Remarks: .....

.....

..... Foreman.

M. P. Form 11

SHOP FOREMAN'S REPORT TO HIS SUPERIOR OF REPAIRS ON PARTICULAR ENGINES

Engine No.....

Date in.....

Date out.....

NOTE.—The numbers shown on this report correspond, so far as they go, to those shown on Form 8. For all repairs made to engines where new parts are applied, the letter "X" should be entered opposite the number corresponding to the part replaced; for all parts that are repaired the letter "O" should be entered opposite the number.

This report will be sent to the general foreman, who will enter the several items shown herein, on Form 8.

18		154		184	
36		Beam		185	
37		155		186	
38		157		187	
43		164		188	
44		166		189	
45		167		190	
49		169		191	
50		170		192	
61		171			
103		179			
104		180			
106		181			
150		182			
153		183			

Remarks: .....

..... Foreman.

M. P. FORM 12.

MASTER MECHANIC'S REPORT OF COST OF REPAIRS  
ON PARTICULAR ENGINES.

The purpose of this report is to show the gross cost of material and labor expended for repairs on a particular engine at a certain shop.

**MASTER MECHANIC'S REPORT OF COST OF REPAIRS ON PARTICULAR ENGINES**

.....Shop ..... Engine No.....

NOTE.—A report of this kind is made for each engine receiving repairs amounting to \$25.00 or more. The master mechanic will enter on this report the engine number, date in shop and date out of shop, and forward it to the storekeeper in whose office the distribution of material and labor is kept, who will enter the cost of material and labor expended in the repairs and return the report to the master mechanic, who will enter the cost of repairs in the space provided in Form 8 and keep this report on file in his office.

Date in shop..... Total Cost of Material .....

Date out of Shop..... Total Cost of Labor .....

Total Cost.....

Remarks:.....

.....

.....

.....  
*Master Mechanic.*

M. P. FORM 13.

MASTER MECHANIC'S MONTHLY SUMMARY TO THE  
SUPERINTENDENT OF MOTIVE POWER AND MA-  
CHINERY IN REGARD TO HEAVY REPAIRS MADE  
ON ENGINES.

This report is furnished the Superintendent of Motive Power and Machinery that he may have a check on the Master Mechanic's (Form 8), to see that the Master Mechanic does not fail to send in a detailed report of repairs on each engine.



**M. P. FORM 14.**

**FOREMAN'S WEEKLY REPORT OF LOCOMOTIVES IN SHOP.**

This report is designed to show the amount and division of work done on engine repairs at the general shops each week; also engines put in service and the number that await repairs.

FOREMAN'S WEEKLY REPORT OF LOCOMOTIVES IN SHOP.

For the week commencing.....19....

**NOTE.**—This report is compiled at the general shops on Monday of each week by the general foreman and a copy sent to each shop foreman, and to the Superintendent of Motive Power and Machinery. It shows the several shops through which an engine passes from the time of arrival on the hospital track until such engine has undergone repairs and left the shops.

The first section of this report represents the gangs into which the force of the erecting shop is divided. Under each gang should be shown the number and class of each engine undergoing repairs, also the division on which it was last in service, the date in shop, date expected out and the nature of the repairs to be given. In the "Miscellaneous" column of this section should be shown the dates on which engines will be out of the shops that have been delayed beyond, or that will be out previous to their scheduled dates.

The second section shows the output or the number of engines that have left the shop during the month, the number sent out each week being added to those previously reported for the same month.

The third section shows the engines receiving boiler-shop repairs in connection with other repairs, and also the output of engines from the boiler-shop during the month. The class of repairs given an engine in the boiler-shop should be indicated by the letters so shown in the note at the left of this section.

The fourth section shows the engines that will be limbered up and put in service the coming week, and also those put in service the previous week, the number and class of the engine, and the division on which it was last in service.

The fifth section shows the number and class of all engines on the hospital track awaiting repairs, the division on which each engine was last in service, the date received on hospital track and the nature of the repairs needed.

ENGINES IN THE SHOP.

GANG I				GANG II				GANG III				GANG IV				GANG V				MISCELLANEOUS			
Eng. No.	Class	Date in	Date out	Eng. No.	Class	Date in	Date out	Repairs	Eng. No.	Class	Date in	Date out	Repairs	Eng. No.	Class	Date in	Date out	Repairs	Eng. No.	Class	DATE		
																					Will be Out	Scheduled	

OUTPUT OF THE SHOP FOR MONTH OF..... UP TO.....

GANG I				GANG II				GANG III				GANG IV				GANG V							
Eng. No.	Class	Date in	Date out	Eng. No.	Class	Date in	Date out	Repairs	Eng. No.	Class	Date in	Date out	Repairs	Eng. No.	Class	Date in	Date out	Repairs	Eng. No.	Class	Date in	Date out	Repairs

ENGINES IN THE BOILER SHOP

OUTPUT OF THE BOILER SHOP FOR THE MONTH OF..... UP TO.....

NOTE—The following letters represent boiler repairs.	Eng. No.	Date in	Date out	Repair	Eng. No.	Date in	Date out	Repair	Eng. No.	Date in	Date out	Repair	Eng. No.	Date in	Date out	Repair
	A Fire Box B Half Sides C East Fire Sheet D Front Fire Sheet E Door Sheet F Crown Sheet G Smoke Arch H Wagon Top I Dome J Back Head K Extension L New Boiler															

ENGINES TO BE LIMBERED UP

ENGINES PUT IN SERVICE LAST WEEK

Engine No.	
Class	
Division	

ENGINES ON HOSPITAL TRACK

Engine No.	
Class	
Division	
Date on Track	
Repairs	

Engine No.	
Class	
Division	
Date on Track	
Repairs	

.....General Foreman.



M. P. FORM 15.

DEFINITION OF WHAT CONSTITUTES ENGINE FAILURES.

The purpose of this form is to advise employes of the operating and motive power departments as to what constitutes an engine failure; also causes by which trains are delayed, that are not to be considered or reported as engine failures.

**DEFINITION OF WHAT CONSTITUTES ENGINE FAILURES**

1. All delays occasioned by waiting for an engine at an initial terminal, except in cases where an engine must be turned, or does not arrive at initial point in time to be cared for and dispatched before leaving time.
2. All delays on account of engine breaking down; running hot; not steaming well or having to reduce tonnage on account of defective engine; causing a delay at a terminal; or meeting point; or junction connection; or delaying traffic.

**DELAYS FROM THE FOLLOWING CAUSES ARE NOT TO BE CONSIDERED AS ENGINE FAILURES.**

1. Whenever engines lose time and afterwards regain it without delay to connections or other traffic.
2. Whenever a passenger or scheduled freight train is delayed from other causes, and an engine (having a defect) makes up more time than it loses on its own account.
3. Delays to passenger trains when they are less than five minutes late at terminals or junction points.
4. Delays to scheduled freight trains when they are less than twenty minutes late at terminals or junction points.
5. Delays when an engine is given excess of tonnage and stalls on a hill, providing the engine is working and steaming well.
6. Delays on extra dead freight trains if the run is made in less hours than the miles divided by ten.
7. Whenever engines are steaming poorly, or flues leaking, on any run where the engine has been delayed on side tracks other than by defects of engine, or are on the road an unreasonable length of time: say fifteen hours or more per one hundred miles.
8. For reasonable delays in cleaning fires and ash-pans on the road.
9. When engines are coming from outside points to the shop for repairs.
10. Failure to provide a particular engine which is held in the roundhouse for needed repairs, and is called for by the Operating Department, before the stated time, of which latter the Operating Department has been informed.
11. Broken draft rigging on engines and tenders caused by air being set on train, account of bursted hose or breaking in two.
12. Delays to fast schedule trains when the weather conditions are such that it is impossible to make the time, providing the engine is working and steaming well.
13. Delays when an engine gets out of coal and water, caused by being held between coal and water stations an unreasonable length of time.

M. P. FORM 16.

TRAIN DISPATCHER'S DAILY REPORT OF ENGINE  
FAILURES.

The object of this report is to advise operating and mechanical officials of engine failures that occur on the different divisions daily; also as a check and to allow a comparison to be made of delays reported hereon as engine failures, with Form 17.

**TRAIN DISPATCHER'S DAILY REPORT OF  
ENGINE FAILURES**

.....Division.      Date .....19....

**NOTE.**—The Train Dispatcher will make four copies of this report, daily, and send one copy to each of the following officials: the General Superintendent, Division Superintendent, Superintendent of Motive Power and Machinery and Master Mechanic. The cause and particulars of delay as given in this report must be compared with Form 17.

Should the Master Mechanic consider an engine failure has been unjustly charged he will write to the Division Superintendent stating his reasons and send a copy of his letter to the Superintendent of Motive Power and Machinery. If, upon investigation, the Superintendent finds the failure has been unjustly charged, he will cancel same using this blank for that purpose, noting "cancelled" in the Remarks column, and send a copy of the cancellation report to the General Superintendent, Superintendent of Motive Power and Machinery and Master Mechanic.

Train No.	Conductor	Engineer	Engine No.	Cause	Time of Delay	REMARKS

M. P. FORM 17.

ENGINEER'S REPORT TO MASTER MECHANIC OF DELAYS ON EACH TRIP.

This report is to enable the Master Mechanic to obtain the engineer's version of delays on each trip; also to enable him to investigate the delays shown on Form 16.



**ENGINEER'S REPORT TO MASTER MECHANIC OF DELAYS ON EACH TRIP**

Date.....19..... at.....M.  
 Division..... Engine No..... Train No.....M.

Arrived at.....M.

**NOTE.**—This report is to be made by engineers, at the end of each trip in which delays of three minutes or more occur. The cause and full particulars of all such delays must be given. The report must be forwarded immediately to the master mechanic, who will compare it with Form 16, and investigate all discrepancies.

Whenever there is a delay in leaving or arriving at terminals, the exact time, in minutes, is to be shown, in order that the master mechanic may know how late a train is in leaving starting point or arriving at terminal without having to refer to the time card.

PLACE DELAYED	TIME DELAYED	CAUSE OF DELAY	TIME MADE UP	
			To Station	Minutes
Delayed Leaving.....				
Late Arriving.....				

.....Engineer.

M. P. FORM 18.

**MASTER MECHANIC'S TEN DAYS REPORT TO THE SUPERINTENDENT OF MOTIVE POWER AND MACHINERY OF ENGINE FAILURES.**

The object of this report is to enable a comparison to be made with Form 16 received by the Superintendent of Motive Power and Machinery; also for the information and enlightenment of mechanical officials, regarding particulars of failure, as explained by the Master Mechanic.





M. P. FORM 19.

**MONTHLY RECORD OF THE SUPERINTENDENT OF MOTIVE POWER AND MACHINERY OF PARTICULARS (CAUSE) OF ENGINE FAILURES ON EACH DAY OF THE MONTH.**

The object of this record is to ascertain at a glance the total number of engine failures from each cause daily, and finally for the whole month.



M. P. FORM 20.

MONTHLY SUMMARY OF THE SUPERINTENDENT OF MOTIVE POWER AND MACHINERY OF CAUSE OF ENGINE FAILURES ON EACH DIVISION.

The purpose of this exhibit, like those that precede it, is to afford the Superintendent of Motive Power and Machinery an accurate recapitulation of the total number of engine failures, from each cause, on the different divisions and on the whole road; and also to enable him to compare same with other months.

MONTHLY SUMMARY OF THE SUPERINTENDENT OF MOTIVE POWER AND MACHINERY OF CAUSE OF ENGINE FAILURES ON EACH DIVISION.

For the month of ..... 19.....

Note.—This monthly exhibit is compiled in the office of the Superintendent of Motive Power and Machinery on the twentieth day of the month succeeding that for which it is made. It is a summary of engine failures, and shows the number of failures from each cause on each division and for the whole road.  
In order that comparison may be made, the total number of failures, and miles run per engine failure is shown for the previous month and for the corresponding month of the previous year.

CAUSE OF FAILURE.	DIVISIONS	TOTALS	CAUSE OF FAILURE.	DIVISIONS	TOTALS
<b>HOT BEARINGS.</b>			64. Broken Driving Boxes		
1. Driving Boxes.			65. " Wedge Bolts		
2. Pins			66. " Driving Springs		
3. Engine Trucks.			67. " Engine Truck Springs		
4. Tender Trucks			68. " Tender Truck Springs		
5. Eccentrics			69. " Spring Hangers		
6. Wedges Stuck			70. " Reverse Levers		
7. Trailing Wheel Boxes			71. " Reverse Lever Latches		
<b>MACHINERY FAILURES.</b>			<b>BOILER FAILURES.</b>		
8. Broken Piston Rods			72. Leaking Pipes		
9. " Bent			73. " Fire Boxes		
10. " " Glands			74. " Arch Tubes		
11. " " Followers			75. " Steam Pipes		
12. " " Follower Bolts			76. " Exhaust Pipes		
13. Pistons, Loose			77. " Hand Hole Plates		
14. " Bent			78. Flues Burst		
15. Follower Bolts Loose			79. Arch Tubes Burst		
16. Broken Valve Stems			80. Hand Hole Plates Blown Out		
17. " Valve Stem Glands			81. Stay Bolts		
18. " " Yokes			82. Fire Box Studs		
19. " " Seats			83. Flue Plugs		
20. Balance Plates Loose			84. Blow-off Cook Stuck		
21. Broken Packing Rings			85. Blow-off Cook Leaking		
22. " Cross Heads			86. Broken Blow-off Cook Pipes		
23. " Cross Head Keys			87. Fouling		
24. " Cylinder Heads			88. Injectors Not Working		
25. " Cylinder Head Studs			89. Injector Cheeks Stuck		
26. " Cylinder Saddles			90. Broken Injector Pipes		
27. " Eccentrics			91. Broken Whistles		
28. " Eccentric Straps			92. Throttles Disconnected		
29. " " Blades			93. Throttles Leaking		
30. " " Strap Bolts			<b>AIR BRAKE FAILURES</b>		
31. " " Strap Bolts			94. Air Pumps		
32. Eccentric Blades Loose			95. Broken Air Pipes		
33. Eccentricity Slipped			96. Broken Air Hose		
34. Broken Frames			97. Air Pipes Loose		
35. " Pedestal Bolts			98. Air Pipes Leaking		
36. " Main Rods			99. Broken Brake Beams		
37. " Side Rods			100. " Brake Rods		
38. " Crank Pins			101. " Driver Brake Hangers		
39. " Rod Straps			102. " Driver Brakes		
40. " Rod Bolts			103. Driver Brakes Sticking		
41. Main Rods Bent			<b>MISCELLANEOUS FAILURES.</b>		
42. Rod Key Lost			104. Broken Drop Grates		
43. Rod Oil Cup Lost			105. Grates Burned		
44. Broken Guides			106. " Down		
45. " Guide Yokes			107. " Disconnected		
46. " Guide Poke Bolts			108. " Stuck		
47. " Rocker Arms			109. Broken Lubricator Glasses		
48. Rocker Arm Bolts Lost			110. " Water Glasses		
49. Broken Equalizers			111. " Tender Truss Rods		
50. " Equalizer Bolts			112. " Tender Draw Heads, F.		
51. " Links			113. " Tender Draw Heads, B.		
52. " Link Blocks			114. " Engine Draw Heads, F.		
53. " Link Block Pins			115. " Steam Heat Pipes		
54. " Link Lifters			116. Diaphragm Down		
55. " Driving Wheels			117. Fire Brick Arch Down.		
56. " Driving Axles			118. Poor Coal		
57. " Engine Truck Axles			119. Not Steaming (Other Causes)		
58. " Tender Truck Axles			120. Steam Hose		
59. " Tender Trucks			121. Lubricator		
60. " Tender Truck Brasses			122. Packing Blowing		
61. " Tires			123. Petticoat Pipes Misplaced		
62. Tires Loose			124. Blower Pipes B'k'n or Discon'd		
63. Cellar Bolts Lost			125. Tank Hose Disconnected		
			<b>TOTAL NUMBER OF FAILURES</b>		
			<b>TOTAL NUMBER OF FAILURES . . . 19 . . .</b>		
			<b>TOTAL NUMBER OF FAILURES . . . 19 . . .</b>		

RECAPITULATION

DIVISIONS						All Divisions
NUMBER OF FAILURES . . . . .						
TOTAL ENGINE MILES . . . . .						
MILES RUN PER ENGINE FAILURE . . . . .						
MILES RUN PER ENGINE FAILURE . . . . . 19						
MILES RUN PER ENGINE FAILURE . . . . . 19						

M. P. FORM 21.

LOCOMOTIVE ENGINEER'S TRIP REPORT OF TIME  
WORKED.

The purpose of this report is to obtain an accurate account of the time of engineers and firemen engaged in road work. It should be compared by the time-keeper with Form 22, and all discrepancies investigated. If delayed or overtime is claimed the time-keeper will forward the report to the division superintendent for verification and approval.

LOCOMOTIVE ENGINEER'S TRIP REPORT OF TIME WORKED.

Month of .....19.....

NOTE.—At the close of each day's service or trip, engineers will make a detailed report on this form and forward it to the roundhouse foreman, who will examine same and forward it to the timekeeper.  
Mileage made with light engines should be indicated by the letter "L"; with dead engine, hauled in train, by letter "D."

ENGINE NO.	TRAIN NO.	TIME CALLED FOR	DEPARTED		ARRIVED		MILES RUN AS PER TIME TABLE				HOURS WORKED IN ADDITION TO MILES RUN (Particulars must be given on back of this Report)			NAME OF FIREMAN	
			Time	From	At	Time	P	F	Gravel	M. Tr.	Work Switching Train	Over Time	Delayed Time		
		M	Day			Day									
		M	M			M									
		M	Day			Day									
		M	M			M									
		M	Day			Day									
		M	M			M									
		M	Day			Day									
		M	M			M									

.....Conductor

.....Engineer

M. P. FORM 22.

TRAIN DISPATCHER'S DAILY RECORD OF TRAIN MOVE-  
MENTS.

This report is used by the timekeeper in verifying Form 21. It is also a valuable record of what engines can do and what they are actually required to do.

**TRAIN DISPATCHER'S DAILY RECORD OF TRAIN MOVEMENTS.**

.....DIVISION.

Date..... 19.....

**NOTE**—The train dispatcher will enter hereon a record, daily, of train movements on his division and forward a copy to the engineers' and firemen's timekeeper. Entries for continuous trips should be made in succession.

Direction	Train No.	Engine No.	Engineers	Conductors	DEPARTING		ARRIVING		Actual Mileage	Hours on Duty	TONNAGE		Class Service	Remarks
					Term-inal	Time	Term-inal	Time			Capacity Engine	Hauled by Engine		

.....  
*Chief Train Dispatcher.*



M. P. FORM 23

**ENGINEER'S DAILY REPORT OF SWITCHING TIME.**

The object of this report is to obtain the time worked each day by crews of switch engines. It should be compared with Form 24 and all discrepancies investigated and corrected.

M. P. Form 23

**ENGINEER'S REPORT OF SWITCHING TIME.**

NOTE.—When an engine crew is engaged in switching, a report of this character must be made by the engineer at the close of the day's service and forwarded to the agent (or person in charge at the point where the work was performed), who, after approving same, will forward it to the timekeeper. If time is taken for meal, one hour should be deducted in allowing the time as shown by this report.

No. of Hours.....Engine No. } ..... .....	REMARKS. Did you work noon hour?
Switching at.....	
From.....o'clock.....M. To.....o'clock.....M.	
Date.....19.....	
..... <i>Engineer.</i> ..... <i>Fireman.</i>	

M. P. FORM 24.

AGENT'S REPORT OF TIME WORKED BY SWITCH YARD  
CREWS.

This report gives the names and time worked by switching crews. It is also used to verify the time reported by enginemen for switching work at stations and yards.

M. P. Form 24

**AGENT'S REPORT OF TIME WORKED BY SWITCH YARD CREWS.**

At..... for 24 hours ending..... o'clock M..... 19....

Signed.....

**INSTRUCTIONS:—**This report is to be made in triplicate (by the use of carbon sheets) by the agent, yard master or other person in charge of the station or yard where switching crews are engaged.  
A copy should be sent daily to the Division Superintendent and Storekeeper, and a copy retained as a record by the maker.

**TIME WORKED BY ENGINEMEN.**

Engine No.	Name of Engineer	Name of Fireman	Time Com- menced Work	Time Quit Work	Time Taken for Meals	Total Hours Worked

**TIME WORKED BY TRAINMEN.**

Engine No.	Name of Foreman	Name of Helpers	Time Com- menced Work	Time Quit Work	Time Taken for Meals	Total Hours Worked

M. P. FORM 25.

ENGINEER'S MONTHLY REPORT OF TIME WORKED.

This report of work done is used by timekeeper to verify the time allowed engineers and firemen during the month, as posted in the time book from the daily trip reports.

**ENGINEER'S MONTHLY REPORT OF TIME WORKED.**

.....Engineer.

For the month of.....19.... Division.

NOTE.—This report is made by each engineer and forwarded to the time-keeper not later than the second day after the close of the month.

Miscellaneous time is intended to include time attending law suits in-quests, dispatching, watching and trying engines, or other time not actually on road or engaged in switching services.

Delayed and overtime should be entered with running time.

NAME OF FIREMAN	Date	Engine Number	Miscellaneous Time	Switching Time	RUNNING TIME			
					Way-Frt. Eng.		Other Engines	
					Stand.	Large	Stand.	Large
	1							
	2							
	3							
	4							
	5							
	6							
	7							
	8							
	9							
	10							
	11							
	12							
	13							
	14							
	15							
	16							
	17							
	18							
	19							
	20							
	21							
	22							
	23							
	24							
	25							
	26							
	27							
	28							
	29							
	30							
	31							
TOTALS,								

Send Pay Check to.....

M. P. FORM 26.

DIVISION TIME BOOK OF LOCOMOTIVE ENGINEER'S  
GIVING PARTICULARS OF THE SERVICE OF EACH.

The loose leaves which go to make up the time book are bound together when the work is completed, in the office where the time is kept.

This form is used for keeping the time of both engineers and firemen, the positions being reversed in each case.

In the column headed "Miscellaneous Time," should be entered all time dispatching, trying engines, acting as witness in law cases, or other time not in actual service on road or switching work.

In column headed "Switching Time," should be entered time in which a crew is engaged in yard switching.

In column headed "Running Time," will be entered the total number of hours allowed each day for such service. When pay is based on the number of miles run, the total miles divided by ten will represent the hours, the term hour representing ten miles. The actual hours for which compensation is allowed, will be entered in these columns, according to the class of engine in service.\*

In the column headed "Engine Number," will be entered the number of the engine as shown on Form 21. In case an engine crew has more than one engine on a given date, the number of miles for each engine should be shown. If this cannot be entered in the proper column, it should be given in the "Remarks" column.

In the column headed "From and To," should be shown the name of the station from and to which the service has been rendered.

---

\*The accompanying formulas represent in part particular methods for determining wages and will require to be changed to meet different methods.

In the columns headed "Miles Run," will be entered the actual number of miles of each kind of service rendered on each division. All passenger and freight mileage shown should be the actual number of miles between the stations named, as indicated by the time tables.

The mileage for "Work" service should be computed at eight miles per hour when compensation is made on the basis of hours worked, and the mileage does not exceed this amount. If the actual miles run exceed eight miles per hour, they should be shown.

Switching mileage and pusher service should be computed at six miles per hour. Light mileage\*, which is also shown in switching column, is actual mileage as shown by the time table.

The location and kind of service entered in the "Work" column should be fully explained in the "Remarks" column, as all service of this nature must be charged to the account benefited thereby.

In the columns headed "Delayed Time" and "Overtime" should be entered amounts, which added to one-tenth of the miles run will equal the hours allowed for a run in which delayed or overtime occurred.

In the column headed "Constructive Mileage" should be entered the excess of the time allowed over the actual time worked, when under the terms of compensation the enginemen are entitled to pay for less than full work. For example, a freight crew on a certain date, makes a trip of 80 miles in less than eight hours, which is all the work they are called upon to do, and which is equivalent to eight hours' work, but as they are entitled to ten hours or a full day's pay, 20 miles is entered in the "Constructive Mileage" column, which added to the 80 miles actually run, equals 100 miles or ten hours' work.

---

\*Light mileage or a light engine is where an engine and tender passes over the road without any cars attached whatever.



At the close of the month each sheet should be footed and proved by comparing the total footings of the hours with those of the mileage.

The total footings of the hours at each separate rate should be shown in the column headed "Number of Hours Allowed," and the amount of wages at each separate rate computed and entered in the column headed "Amount." These amounts should be footed and the total entered on the pay roll.

DIVISION TIME BOOK OF LOCOMOTIVE ENGINEERS, GIVING PARTICULARS OF THE SERVICE OF EACH.

Month of ..... 19..... Page ..... Engineer.

Number of miles run must be based on distances as shown by Time Table.

NAME OF FIREMAN	DATE	TRAIN No.	RUNNING TIME				Miles Run on	Miles Run on	Miles Run on	Miles Run on	REMARKS
			Way Freight Eng. Class of Engine	Frt. and Construct'n Class of Engine	Passenger Class of Engine	Rate of Pay					
Short in previous month											
Total											

Description of Service	No. of Hrs. Allowed	Rate Per Hour	Amount
Road Service,			
Road Service,			
Road Service,			
Road Service,			
Pusher Service,			
Switching			
Dispatching,			
Total,			

M. P. FORM 27.

#### ENGINE HOUSE REGISTER.

This record book is kept in each round-house, and shows the arrival and departure of each engine, one page being used for arrivals and the opposite page for departures (the word, "Departures" being inserted in place of "Arrivals.")

It is carefully preserved as a record in case any question should arise regarding the time of arrival or departure of an engine or crew.

ENGINEHOUSE REGISTER.

.....Enginehouse.....19.....  
 DEPARTURES. (OR ARRIVALS.)

Number of Train	Number of Engine	Kind of Train	Destination	Engineer	Fireman	Time of Departures

NOTE—The page opposite this in the register is the same form as the above, and is used for "Arrivals." This book is useful for reference in keeping the switching time of engineers and firemen.

M. P. FORM 28.

STOREKEEPER'S MONTHLY REPORT TO THE SUPERINTENDENT OF MOTIVE POWER AND MACHINERY OF DELAYED AND OVERTIME ALLOWED ENGINEERS AND FIREMEN.

This record is made by the timekeeper, and, after being copied, is forwarded to the Superintendent of Motive Power and Machinery on or before the eighth day of the month.

It shows in detail the number of hours allowed each day to each engineer and fireman for delayed and overtime, as shown on Form 26. Like that form it is arranged to meet a particular method of computing the wages of enginemen.



M. P. FORM 29.

MONTHLY RECORD OF THE SUPERINTENDENT OF MOTIVE POWER AND MACHINERY OF THE GROSS COST OF DELAYED AND OVERTIME ON EACH DIVISION.

The purpose of this report is to keep motive power and operating officials advised of the cost each month of delayed and overtime on the different divisions and on the whole road.





M. P. FORM 30.

MONTHLY STATEMENT OF LOCOMOTIVE MILEAGE ON  
EACH DIVISION.

The purpose of this statement is to obtain the total mileage made in the different classes of service by each individual engine on the division.



M. P. FORM 31.

**MONTHLY REPORT OF LOCOMOTIVE MILEAGE (CLASSIFIED) OF EACH ENGINE.**

The purpose of this report made by the local time-keeper is to advise the general storekeeper of the mileage made by each engine on the division, in the different classes of service, and also the total mileage for the division.



M. P. FORM 32.

**MONTHLY RECORD OF THE MILEAGE OF EACH ENGINE.**

This form is used for summing up (and recording) the mileage made by each engine, monthly (and so for the year), in the different classes of service. It forms the basis of statistical statements, comparisons, etc.



M. P. FORM 33.

MONTHLY REPORT OF PARTICULARS OF COST OF RE-  
PAIRS OF EACH LOCOMOTIVE.

This report made for the general storekeeper is used by him in ascertaining the amount of material and labor expended in the repairs of engines at the different shops and thus by recapitulating the same to ascertain the total amount chargeable to each engine.





M. P. FORM 34.

MONTHLY RECORD OF REPAIRS ON EACH LOCOMO-  
TIVE.

This form is used for the purpose of recapitulating the cost of material and labor expended in the repairs of each engine during the month as reported from the several shops; and thus the general storekeeper ascertains the total amount chargeable to each engine.



M. P. FORM 35.

**MONTHLY REPORT FOR THE SUPERINTENDENT OF MOTIVE POWER AND MACHINERY OF THE MILES RUN AND COST OF REPAIRS OF EACH ENGINE.**

This report is used by the general storekeeper to ascertain the mileage made by the engines on each division in the different classes of service during the month; also the total amount of material and labor expended for repairs of the engines assigned to each division.



M. P. FORM 36.

MONTHLY REPORT FOR DIVISION MASTER MECHANIC  
OF MILEAGE AND COST OF REPAIRS OF EACH  
LOCOMOTIVE ON HIS DIVISION.

This form is used by the general storekeeper in reporting to the master mechanic of each division the total mileage and cost of repairs of the engines on his division during the month. Also the total mileage and cost of repairs.



M. P. FORM 37.

RECORD OF MILEAGE (CLASSIFIED) AND COST OF RE-  
PAIRS OF EACH LOCOMOTIVE.

This is a record book, kept in the office of the general storekeeper, and from which he may obtain, at any time, the mileage made by each engine in the different classes of service, during any month of the year on a particular division; also the cost of material and labor expended in repairing such engines.

## RECORD OF MILEAGE (CLASSIFIED) AND COST OF REPAIRS OF EACH LOCOMOTIVE.

**NOTE.**—This record book is written up by the general storekeeper. The number of the page corresponds to the engine number. The name of the division to which the engine is assigned, the mileage made in the different classes of service, and the amount of material and labor expended in the repairs as shown on Form 36 is entered each month. Mileage made by an engine on divisions other than the one to which it is assigned, should be entered in the space provided, giving the name of the division in each case.

ENGINE No. \_\_\_\_\_

	MILEAGE			COST OF REPAIRS		MILEAGE ON OTHER DIVISIONS										
	Div.	Pass.	Frts.	Work	Switch.	Total	Material	Labor	Total	Div.	Pass.	Frts.	Work	Switch.	Total	
July																
August																
September																
October																
November																
December																
January																
February																
March																
April																
May																
June																





**FORM OF COAL TICKETS USED ON ENGINES.**

NOTE—When coal is delivered to a locomotive, the engineer is required to give a ticket of this character for each ton received. Tickets should be given in numerical order, and of the class of service in which the engine is engaged.

<p>ONE TON COAL DELIVERED TO PASSENGER LOCOMOTIVE</p> <p>..... Division <b>3</b></p>	<p>ONE TON COAL DELIVERED TO FREIGHT LOCOMOTIVE</p> <p>..... Division <b>3</b></p>	<p>ONE TON COAL DELIVERED TO SWITCHING LOCOMOTIVE</p> <p>..... Division <b>3</b></p>
<p>ONE TON COAL DELIVERED TO PASSENGER LOCOMOTIVE</p> <p>..... Division <b>2</b></p>	<p>ONE TON COAL DELIVERED TO FREIGHT LOCOMOTIVE</p> <p>..... Division <b>2</b></p>	<p>ONE TON COAL DELIVERED TO SWITCHING LOCOMOTIVE</p> <p>..... Division <b>2</b></p>
<p>ONE TON COAL DELIVERED TO PASSENGER LOCOMOTIVE</p> <p>..... Division <b>1</b></p>	<p>ONE TON COAL DELIVERED TO FREIGHT LOCOMOTIVE</p> <p>..... Division <b>1</b></p>	<p>ONE TON COAL DELIVERED TO SWITCHING LOCOMOTIVE</p> <p>..... Division <b>1</b></p>
<p>ONE TON COAL DELIVERED TO PASSENGER LOCOMOTIVE</p> <p>..... Division <b>0</b></p>	<p>ONE TON COAL DELIVERED TO FREIGHT LOCOMOTIVE</p> <p>..... Division <b>0</b></p>	<p>ONE TON COAL DELIVERED TO SWITCHING LOCOMOTIVE</p> <p>..... Division <b>0</b></p>

NOTE—Upon some roads the number of the engine is printed on the ticket, the account being kept directly with the engine.

M. P. FORM 38.

## FORM OF COAL TICKETS USED ON ENGINES.

These tickets are used for purposes of accounting, for coal delivered to locomotives.

The tickets are in book form and perforated so that any number may be removed at one time. They are numbered consecutively, the first being numbered 0, the next 1, and so on.

A new book is given to each engineer at the beginning of the month. It has his name written on the cover, and his number and the name of the division to which he is assigned, stamped on each ticket. At the end of the month the book is returned to the Master Mechanic, with all unused tickets therein. Thus the number of the first unused ticket will represent the number of tons delivered to the engineer during the month.

To aid in determining the quantity of coal used in the different classes of service, it will be found advantageous to have the tickets printed on different colored paper, as say red for passenger service; white for freight, and blue for work trains and switching service.

**FORM OF COAL TICKETS USED ON ENGINES.**

NOTE—When coal is delivered to a locomotive, the engineer is required to give a ticket of this character for each ton received. Tickets should be given in numerical order, and of the class of service in which the engine is engaged.

<p>ONE TON COAL DELIVERED TO PASSENGER LOCOMOTIVE ..... Division <b>3</b></p>	<p>ONE TON COAL DELIVERED TO FREIGHT LOCOMOTIVE ..... Division <b>3</b></p>	<p>ONE TON COAL DELIVERED TO SWITCHING LOCOMOTIVE ..... Division <b>3</b></p>
<p>ONE TON COAL DELIVERED TO PASSENGER LOCOMOTIVE ..... Division <b>2</b></p>	<p>ONE TON COAL DELIVERED TO FREIGHT LOCOMOTIVE ..... Division <b>2</b></p>	<p>ONE TON COAL DELIVERED TO SWITCHING LOCOMOTIVE ..... Division <b>2</b></p>
<p>ONE TON COAL DELIVERED TO PASSENGER LOCOMOTIVE ..... Division <b>1</b></p>	<p>ONE TON COAL DELIVERED TO FREIGHT LOCOMOTIVE ..... Division <b>1</b></p>	<p>ONE TON COAL DELIVERED TO SWITCHING LOCOMOTIVE ..... Division <b>1</b></p>
<p>ONE TON COAL DELIVERED TO PASSENGER LOCOMOTIVE ..... Division <b>0</b></p>	<p>ONE TON COAL DELIVERED TO FREIGHT LOCOMOTIVE ..... Division <b>0</b></p>	<p>ONE TON COAL DELIVERED TO SWITCHING LOCOMOTIVE ..... Division <b>0</b></p>

NOTE—Upon some roads the number of the engine is printed on the ticket, the account being kept directly with the engine.

M. P. FORM 39.

MONTHLY REPORT OF FUEL DELIVERED AT EACH  
POINT TO LOCOMOTIVES.

The purpose of this monthly report is to enable the division storekeeper to ascertain (and account for) the amount of fuel delivered to locomotives engaged in the different classes of service on each division.

**MONTHLY REPORT OF FUEL DELIVERED AT EACH POINT TO LOCOMOTIVES.**

Daily record of Fuel delivered to ..... Station, during the month of ..... 19.....  
 At ..... Division Locomotives

**NOTE.**—Fuel tickets (in one ton or one cord quantities) are provided engineers for use as required. Agents and others in charge of fuel stations must collect tickets for all fuel delivered to locomotives. When collected they must be put in a box, which must be securely locked. Care must be exercised to see that the tickets received correspond with the fuel delivered. Also that the name of the division to which the engine is assigned is legible. In the event an engineer should refuse or neglect to deliver tickets for fuel received by him, report thereof must be made, forthwith, to the Division Master Mechanic, who will investigate the case and see that tickets are forwarded in accordance with the facts.

A report (of this form) is to be made for each division. The quantities, as per tickets, are to be entered on this report daily. At the close of the month it will be footed and an impression taken of it, after which it will be forwarded to the Storekeeper for the division, as may be directed. The tickets for fuel collected during the month must be arranged according to the order of service, viz: a—Passenger; b—Freight; c—Work, Switching, etc.

The tickets are colored red, white and blue (in the above order), so as to be easily distinguished. Before sending these tickets to headquarters, they must be arranged according to service, viz.: Passenger, Freight, etc.; also according to divisions; the packages for each class of service for each division being tied securely together.

It is the duty of the Agent or Storekeeper in charge of a fuel supply depot to see that those in immediate charge understand their duties and that they observe them. Fuel in store or in transit must be carefully guarded, and in the event of a shortage investigation must at once be set on foot and the proper official notified.

DATE	PASSENGER SERVICE.		FREIGHT SERVICE		WORK AND SWITCHING SERVICE		TOTAL	
	Tons Coal	Cords Wood	Tons Coal	Cords Wood	Tons Coal	Cords Wood	Tons Coal	Cords Wood
1								
2								
3								
4								
5								
6								
7								
8								
and so on to								
31								

.....AGENT.

M. P. FORM 40.

MONTHLY SUMMARY OF FUEL DELIVERED TO LOCOMOTIVES.

The purpose of this report is to furnish the general storekeeper with the amount of fuel (coal and wood) delivered to locomotives on each division, the amount for the different classes of service being given separately.

Reports and methods generally similar to those enumerated herein may be used to advantage when oil or other combustible is used for fuel.





M. P. FORM 41.

FORM OF OIL AND WASTE TICKETS USED ON  
ENGINES.

These tickets are used for purposes of accounting, for all oil and waste furnished locomotives.

The tickets are in book form and perforated so that any number may be removed at one time.

(They are also numbered in consecutive order, the first being numbered 0, the next 1, and so on.)

A new book is given to each engineer at the beginning of each month, with his name written on the cover, and his number and the name of the division to which he is assigned, stamped on each ticket.

At the end of the month the book is to be returned to the Master Mechanic with all unused tickets therein. The number shown on the first unused ticket, multiplied by the quantity designated on the ticket, represents the quantity of each kind of oil or waste delivered to each engineer during the month.

To aid in determining the quantities of the different kinds of oil and waste used, it will be found advantageous to have tickets printed on different colored paper, as blue for engine oil, red for valve oil, green for signal oil, white for car oil, yellow for cotton waste and brown for wool waste.

**FORM OF OIL AND WASTE TICKETS USED ON ENGINES.**

**NOTE.**—When oil or waste is delivered to an engineer he will give a ticket of this character for the number of pints of oil or pounds of waste received.  
 Tickets should be given in numerical order, and correspond to the kind of oil or waste received.  
 The engine number, class of service and date should be entered on each ticket by the engineer, before being given to the person delivering the oil or waste.

<p><b>4 PINTS ENGINE</b>                  OIL DELIVERED .....</p>	<p>IN .....</p>
<p>TO ENG. ....</p>	<p>SERVICE .....</p>
<p>DATE ..... 19 .....</p>	<p>ENGINEER .....</p>

<p><b>4 PINTS VALVE</b>                  OIL DELIVERED .....</p>	<p>IN .....</p>
<p>TO ENG. ....</p>	<p>SERVICE .....</p>
<p>DATE ..... 19 .....</p>	<p>ENGINEER .....</p>

<p><b>4 PINTS SIGNAL</b>                  OIL DELIVERED .....</p>	<p>IN .....</p>
<p>TO ENG. ....</p>	<p>SERVICE .....</p>
<p>DATE ..... 19 .....</p>	<p>ENGINEER .....</p>

<p><b>4 PTS. CAR</b>                  OIL DELIVERED .....</p>	<p>IN .....</p>
<p>TO ENG. ....</p>	<p>SERVICE .....</p>
<p>DATE ..... 19 .....</p>	<p>ENGINEER .....</p>

<p><b>¼ POUND COTTON</b>                  WASTE DELIVERED .....</p>	<p>IN .....</p>
<p>TO ENG. ....</p>	<p>SERVICE .....</p>
<p>DATE ..... 19 .....</p>	<p>ENGINEER .....</p>

<p><b>¼ POUND WOOL</b>                  WASTE DELIVERED .....</p>	<p>IN .....</p>
<p>TO ENG. ....</p>	<p>SERVICE .....</p>
<p>DATE ..... 19 .....</p>	<p>ENGINEER .....</p>

M. P. FORM 42.

MONTHLY REPORT OF TOTAL AMOUNT OF OIL AND  
WASTE DELIVERED TO LOCOMOTIVES  
ON EACH DIVISION.

From reports of this nature the general storekeeper ascertains the number of pints of oil and pounds of waste delivered to locomotives on each of the different divisions of a road.

M. P. Form 42

**MONTHLY REPORT OF TOTAL AMOUNT OF OIL  
AND WASTE DELIVERED TO LOCOMOTIVES  
ON EACH DIVISION.**

At.....During the month of.....19.....

NOTE.—This report is compiled by all disbursing storekeepers, and should be forwarded to the general storekeeper (after being copied), on or before the tenth day of each month. It should show the number of pints of each kind of oil, and pounds of waste delivered to locomotives on each division.

Pints of Oil	Division	Division	Division	Division	Division	Division
Engine						
Kerosene						
Signal						
Cylinder						
Car						
<b>Total</b>						
<b>Pounds of Waste</b>						
Cotton						
Wool						

M. P. FORM 43.

ROUND HOUSE FOREMAN'S MONTHLY REPORT OF  
THE NUMBER OF ENGINES WIPED DAILY.

This report furnishes the necessary information to the storekeeper to enable him to make a proper distribution of the labor of locomotive wipers and dispatchers and round house laborers, for the different classes of service in which the engines are engaged.



M. P. FORM 44.

MONTHLY SUMMARY OF CHARGES TO VARIOUS OPERATING ACCOUNTS FOR MATERIAL AND LABOR ACCOUNT OF ENGINES ON EACH DIVISION.

The purpose of this report is to advise the general storekeeper of the total amounts charged, by divisions, to the various operating accounts, according to the class of service in which the engines on each division are engaged.

M. P. Form 44

**MONTHLY SUMMARY OF CHARGES TO VARIOUS OPERATING  
ACCOUNTS FOR MATERIAL AND LABOR ACCOUNT  
OF ENGINES ON EACH DIVISION.**

At \_\_\_\_\_ For the month of \_\_\_\_\_ 19\_\_

NOTE.—This report is to be compiled by all storekeepers who keep distribution books. It should be forwarded to the general storekeeper (after being copied), on or before the twelfth day of each month.

Under the heading "Fuel Delivered to Locomotives," should be reported the number of tons of coal and cords of wood delivered to locomotives in the different classes of service, and showing the quantity chargeable to each division. These figures are compiled from Form 40, and any charges or credits shown in the material distribution book, on account of fuel furnished to locomotives in joint service, should be added to or subtracted from the fuel as shown on this report.

Charges to the accounts "Engineers and Firemen," "Oil, Waste and Tallow used on Locomotives," "Locomotive Wipers and Dispatchers," "Round House Laborers" and "Locomotive Supplies," should be reported in the spaces provided, and should show the amounts chargeable to each division on account of the different classes of service. The total of each account should agree with the amount charged such account in the material and labor distribution books before deducting the credits on account of work train invoices.

**FUEL DELIVERED TO LOCOMOTIVES**

DIVISIONS	PASSENGER		FREIGHT		WORK AND SWITCHING		TOTAL	
	Tons	Cords	Tons	Cords	Tons	Cords	Tons	Cords
	Coal	Wood	Coal	Wood	Coal	Wood	Coal	Wood
TOTAL								

**OIL, WASTE AND TALLOW USED ON LOCOMOTIVES.**

DIVISIONS	PASSENGER		FREIGHT		WORK AND SWITCHING		TOTAL	
	Material	Labor	Material	Labor	Material	Labor	Material	Labor
	TOTAL							

**ENGINEERS AND FIREMEN.**

DIVISIONS	PASSENGER		FREIGHT		WORK AND SWITCHING		TOTAL	
	Material	Labor	Material	Labor	Material	Labor	Material	Labor
	TOTAL							

**LOCOMOTIVE WIPERS AND DISPATCHERS.**

DIVISIONS	PASSENGER		FREIGHT		WORK AND SWITCHING		TOTAL	
	Material	Labor	Material	Labor	Material	Labor	Material	Labor
	TOTAL							

**ROUND HOUSE LABORERS.**

DIVISIONS	PASSENGER		FREIGHT		WORK AND SWITCHING		TOTAL	
	Material	Labor	Material	Labor	Material	Labor	Material	Labor
	TOTAL							

**LOCOMOTIVE SUPPLIES.**

DIVISIONS	PASSENGER		FREIGHT		WORK AND SWITCHING		TOTAL	
	Material	Labor	Material	Labor	Material	Labor	Material	Labor
	TOTAL							

STOREKEEPER.



M. P. FORM 45.

**LOCOMOTIVE REPORT—PARTICULARS OF SERVICE AND  
COST FOR REPAIRS, SUPPLIES AND LABOR.**

This valuable summary of locomotive operations is compiled in the office of the general storekeeper and a copy sent to the executive, operating, mechanical and accounting officials, on the twenty-fifth day of each month.

The object of this report is to inform the several officials monthly as to the amount of work (miles run and tons hauled) performed by locomotives on each division, and the cost of operations generally.

The comparison of the current month with the corresponding month of the previous year is interesting. The statistics for the different divisions of the road are exhibited separately, for the purpose of comparing one division with another.



M. P. FORM 46.

FOREMAN'S MONTHLY REPORT TO MASTER MECHANIC  
OF CAST IRON TRUCK AND TENDER WHEELS AP-  
PLIED TO AND REMOVED FROM LOCOMOTIVES.

The purpose of this report is to enable the Superintendent of Motive Power and Machinery to preserve a record of all cast iron truck and tender wheels applied to (put under) and removed from locomotives. This information is necessary to enable him to ascertain what wheels (if any) have failed to come up to maker's guarantee.

**FOREMAN'S MONTHLY REPORT TO MASTER MECHANIC OF CAST-IRON TRUCK AND TENDER WHEELS APPLIED TO AND REMOVED FROM LOCOMOTIVES.**

On Division..... During the month of.....19.....

*NOTE.*—At all points where cast iron truck and tender wheels are removed, a report of this character must be made by the foreman in charge, at the end of each month. After copying the same he should forward it to the Division Master Mechanic. The latter will make a summary (on this form), of all cast-iron truck and tender wheels removed on his division during the month, and after taking an impression of same, will forward it to the Superintendent of Motive Power and Machinery on or before the twelfth day of the following month.

Engine No.	Serial Letter and No. of Wheel	Size of Wheel	Truck or Tender Wheel	Maker's Name	Applied		Removed		Date Cast	Cause of Removal	Serial Letter and No. of Axle	Size of Axle	Remarks
					Place	Date	Place	Date					

M. P. FORM 47.

MONTHLY RECORD OF SUPERINTENDENT OF MOTIVE  
POWER AND MACHINERY OF EACH DEFECTIVE  
CAST IRON ENGINE AND TENDER WHEEL RE-  
MOVED.

The purpose of this report is to obtain the total mileage of wheels removed account being defective; and to ascertain what wheels, if any, have failed to make their guaranteed mileage.



M. P. FORM 48.

MONTHLY SUMMARY OF THE SUPERINTENDENT OF MOTIVE POWER AND MACHINERY OF THE GROSS NUMBER OF DEFECTIVE CAST IRON LOCOMOTIVE WHEELS REMOVED, MADE BY DIFFERENT MANUFACTURERS.

This is a record preserved in the office of the Superintendent of Motive Power and Machinery, of the number of wheels removed each month because of the various defects specified; also the average mileage made by such wheels, removed for cause.





M. P. FORM 49.

**MONTHLY REPORT OF THE SUPERINTENDENT OF MOTIVE POWER AND MACHINERY TO THE PURCHASING AGENT OF DEFECTIVE CAST IRON WHEELS REMOVED FROM LOCOMOTIVES AND BY WHOM MADE.**

Through this report the Purchasing Agent is advised as to the number of guaranteed wheels that have failed each month. The information is also valuable to him as indicating what make of wheels are giving the best service.

**MONTHLY REPORT OF THE SUPERINTENDENT OF  
MOTIVE POWER AND MACHINERY TO THE PUR-  
CHASING AGENT OF DEFECTIVE CAST IRON  
WHEELS REMOVED FROM LOCO-  
MOTIVES AND BY WHOM MADE.**

During the month of .....19....

NOTE.—This report is made by the Superintendent of Motive Power and Machinery to the Purchasing Agent.

It shows separately the total number of defective cast iron wheels manufactured by each firm, that have been removed from locomotives during the month; their average mileage; also number of wheels of each size failing to make good their guarantee.

MAKER'S NAME	Wheels Removed		Wheels Falling Under Guarantee			
	Number	Average Mileage	Number	Size	Average Mileage	Guarant'd Mileage

M. P. FORM 50.

MONTHLY REPORT OF THE SUPERINTENDENT OF MOTIVE POWER AND MACHINERY OF WHEELS THAT HAVE FAILED TO MEET GUARANTEES OF MAKERS.

This statement is used by the Superintendent of Motive Power and Machinery in reporting to the general storekeeper, each month, the number of cast iron locomotive wheels that have failed to make their guarantee, and which have also been accepted by the wheel company's inspector, to be returned for credit.

Claims for credit for all failed wheels should be made as follows: Bills will be rendered against the manufacturers of the wheels for the difference between the guarantee and the actual service. From the cost of the new wheel is deducted the value of same as scrap, which is computed on the basis of the value per gross ton.

The net value is divided by the guaranteed mileage, to obtain the cost per thousand miles, and the deficiency multiplied by the cost per thousand miles represents the amount due the railway company for service not received. To this amount is added the amount of 75c, covering the cost of labor for removing and replacing each wheel failing to make its guarantee.

The following example illustrates the method of computation. A wheel is guaranteed to run 70,000 miles, but it runs only 40,000 miles when it is necessary to remove it on account of some defect, leaving a deficiency of 30,000 miles.

Value of new wheel . . . . .	\$8.00
Value of wheel as scrap. . . . .	4.50
Net value. . . . .	<u>\$3.50</u>

\$3.50 divided by 70,000 miles equals 5c per thousand miles. The deficiency of 30,000 miles multiplied by 5c per thousand miles equals \$1.50, the amount allowed account of deficiency. Add for the labor of changing wheels 75c, making a total of \$2.25, which should be the amount of the bill against the maker.

**MONTHLY REPORT OF THE SUPERINTENDENT OF MOTIVE POWER AND MACHINERY OF  
WHEELS THAT HAVE FAILED TO MEET GUARANTEES OF MAKERS.**

Defective wheels removed from locomotives during the month of ..... 19....

Manufactured by .....

**NOTE.**—This report is made by the Superintendent of Motive Power and Machinery to the General Storekeeper as soon after the first of the month as the locomotive mileage can be obtained. All engine truck and tender wheels failing to make their guaranteed mileage (and which have been accepted by the wheel company's inspector) should be included in this report. A bill should be made against the makers for the deficiency as agreed upon.

Serial Letter and Number	Size	Weight	Kind	DATE				MILEAGE			Cause of Removal									
				CAST		APPLIED		REMOVED		Guaranteed		Actual	Deficiency							
				Month	Year	Month	Year	Month	Year											

M. P. FORM 51.

RECORD OF THE SUPERINTENDENT OF MOTIVE POWER  
AND MACHINERY OF ENGINE TRUCK AND TENDER  
WHEELS APPLIED TO, AND REMOVED FROM EACH  
LOCOMOTIVE.

This is the form of a record book kept in the office of the Superintendent of Motive Power and Machinery. Its purpose is to preserve a history of all cast iron wheels applied to and removed from locomotives.



M. P. FORM 52.

SHOP FOREMAN'S MONTHLY REPORT TO THE MASTER  
MECHANIC OF PARTICULARS OF STEEL TIRED EN-  
GINE TRUCK AND TENDER WHEELS APPLIED TO  
OR REMOVED FROM LOCOMOTIVES.

The purpose of this report is to enable the Superintendent of Motive Power and Machinery to preserve a record regarding the length of service of all steel tired engine truck and tender wheels, also the mileage made between the turnings of tires. This information is necessary to enable him to ascertain what makes of tires are giving the best service.





M. P. FORM 53.

INDEX TO RECORD OF STEEL-TIRED ENGINE TRUCK  
WHEELS.

This record book is kept in the office of the Superintendent of Motive Power and Machinery, each page number representing an engine number. The left hand side of each page is used for the index of the steel-tired engine truck wheels and the right hand side for cast iron wheels.

The object of this index is that the Superintendent of Motive Power and Machinery may know that the wheels are reported by the Master Mechanics as being under the proper engines, and to obtain information regarding the numbers of wheels or tires, and the dates they are applied to or removed from certain engines.



M. P. FORM 54.

**RECORD OF SUPERINTENDENT OF MOTIVE POWER AND  
MACHINERY OF STEEL TIRES ON ENGINE TRUCK  
WHEELS.**

*This record book is kept in the office of the Superintendent of Motive Power and Machinery.*

*The information called for hereon should be entered each month from Form 52, the numbers of tires being entered in numerical order. When wheels are applied, the numbers as shown on the tire, and place, and date applied are entered in the spaces provided. The place and date of removal should also be shown and the mileage computed between the date applied and date removed.*

*Its purpose is to obtain a record of all steel-tired truck wheels applied to locomotives and the mileage made by them under each engine.*



M. P. FORM 54.

RECORD OF SUPERINTENDENT OF MOTIVE POWER AND  
MACHINERY OF STEEL TIRES ON ENGINE TRUCK  
WHEELS.

This record book is kept in the office of the Superintendent of Motive Power and Machinery.

The information called for hereon should be entered each month from Form 52, the numbers of tires being entered in numerical order. When wheels are applied, the numbers as shown on the tire, and place, and date applied are entered in the spaces provided. The place and date of removal should also be shown and the mileage computed between the date applied and date removed.

Its purpose is to obtain a record of all steel-tired truck wheels applied to locomotives and the mileage made by them under each engine.



M. P. FORM 55.

MONTHLY REPORT TO THE SUPERINTENDENT OF MOTIVE POWER AND MACHINERY OF ENGINE DRIVING WHEEL TIRES APPLIED AND REMOVED.

The purpose of this report is to enable the Superintendent of Motive Power and Machinery to obtain a record of the life of engine driving wheel tires, and the mileage made by each between turnings, with a view of ascertaining which make of tires are giving the best service.





M. P. FORM 56.

INDEX TO DRIVING WHEEL TIRE RECORD.

This record book is kept in the office of the Superintendent of Motive Power and Machinery, each page representing an engine number.

The object of this index is to obtain a record of the driving wheel tires under each engine and the dates they are applied to or removed from the engines.



M. P. FORM 57.

**RECORD OF SUPERINTENDENT OF MOTIVE POWER AND  
MACHINERY OF DRIVING WHEEL TIRES.**

This record book is kept in the office of the Superintendent of Motive Power and Machinery.

The information called for hereon is entered each month from Form 55, the numbers of the tires being entered in numerical order. When a new tire is applied the thickness of same is entered in the column provided for that purpose and every time a tire is turned the thickness after turning is entered in the proper column. When the tire is reduced to  $1\frac{1}{2}$  inches in thickness it is scrapped. The mileage made by the tires between turnings should be shown hereon, and computed between the date applied and date removed.

Its purpose is to obtain a record of all tires applied to or removed from locomotives, and the mileage made by the tires between turnings,



M. P. FORM 58.

DAILY REPORT OF DISTRIBUTION OF SHOP LABOR OF  
EACH MAN.

The purpose of this report is to obtain the distribution to the different accounts of the time of each hourly employe in the Motive Power Department.

**DAILY REPORT OF DISTRIBUTION OF SHOP  
LABOR OF EACH MAN**

DATE.....19.....

Check No..... Name.....

NOTE.—This form is to be filled out by the employe each day, giving a detailed account of the work performed by him.

It should then be approved by the foreman and forwarded by him to the timekeeper for entry in the general time book.

Hours Worked	Engine or Other Account Worked On	REMARKS
		<p>EXAMINED</p> <p>_____</p> <p>FOREMAN</p>

M. P. FORM 59.

**MASTER MECHANIC'S MONTHLY STATEMENT TO SUPER-  
INTENDENT OF MOTIVE POWER AND MACHINERY  
OF COMPARATIVE COST OF LABOR.**

This report is made by the Master Mechanic and forwarded to the Superintendent of Motive Power and Machinery on the tenth day of the month succeeding that for which it is made. The amounts of the pay rolls for each sub-shop should be shown hereon for the current month, also for the previous month of the same year and the corresponding month of the previous year, and the amount of increase or decrease shown in the columns provided for that purpose.

The Superintendent of Motive Power and Machinery will use this form in making a summary of the several Master Mechanics' reports (showing the total amount of the pay rolls at each point) and forward a copy of same to the proper officials of the operating department.





M. P. FORM 60.

SHOP FOREMAN'S MONTHLY REPORT TO MASTER MECHANIC OF NUMBER OF MEN OF EACH CLASS OF LABOR EMPLOYED DURING THE MONTH AND WAGES PAID.

This report is to be made monthly, by all foremen in charge of shops and forwarded to the Master Mechanic on the sixth day of the month. It should show the classification of the employes according to their occupation, the rates per hour or per month, the total amount paid all employes, and the average amount paid per day to each class of employes.

The object of this report is to inform the Master Mechanic of the number of men employed, and the amount of the pay roll at each point.

SHOP FOREMAN'S MONTHLY REPORT TO MASTER  
MECHANIC OF NUMBER OF MEN OF EACH CLASS  
OF LABOR EMPLOYED DURING THE  
MONTH AND WAGES PAID.

FORCE EMPLOYED IN THE LOCOMOTIVE DEPARTMENT AT .....

ON THE LAST DAY OF.....19.....

OCCUPATION.	Rates			No. of Men	Total Am't	Per Day	Avg. Am't Per Day
	Per Hour	Per Month	Per Month				
Master Mechanics,							
General Foremen,							
Foremen,							
Draughtsmen,							
Clerks,							
Operators,							
Machinists,							
Machinists' Helpers,							
Machinists' Apprentices,							
Boiler Makers,							
Boiler Makers' Apprentices,							
Boiler Makers' Helpers,							
Blacksmiths,							
Blacksmiths' Helpers,							
Blacksmiths' Apprentices,							
Painters,							
Copper and Tinsmiths,							
Copper and Tinsmiths' Appren.							
Carpenters,							
Truck Repairers,							
Boiler Washers,							
Stationary Engineers,							
Stationary Firemen,							
Firing-up Locomotives,							
Wipers,							
Wipers at Outside Points,							
Turn-Table and Pitmen,							
Sandmen,							
Laborers and Sweepers,							
Callers,							
Switch-Tenders,							
Oilmen,							
Engine Inspectors,							
Watchmen,							
Dispatchers' Helpers,							
Pumpers,							
Telephone Boys,							
Coal-Heavers,							
Teamsters,							
Coal-Hoisters,							
Rail Mill Carriage Men,							
Rail Mill Straighteners,							
Sawyers,							
Totals,							

M. P. FORM 61.

**MASTER MECHANIC'S MONTHLY REPORT TO SUPERINTENDENT OF MOTIVE POWER AND MACHINERY OF THE TOTAL NUMBER OF MEN OF EACH CLASS OF LABOR EMPLOYED ON HIS DIVISION DURING THE MONTH AND WAGES PAID.**

This report is to be made by all Master Mechanics and forwarded to the Superintendent of Motive Power and Machinery on the eighth day of the month. It is a summary of Form 60 for the several shops, and should show the classification of the Motive Power Department employes at each point on the division according to their occupation, the rates per hour or per month, the total amount paid all employes at each point per day and the average amount paid per day to each class of employes.

**MASTER MECHANIC'S MONTHLY REPORT TO SUPERINTENDENT OF MOTIVE POWER AND MACHINERY OF THE TOTAL NUMBER OF MEN OF EACH CLASS OF LABOR EMPLOYED IN HIS DIVISION DURING THE MONTH AND WAGES PAID.**

FORCE EMPLOYED IN THE LOCOMOTIVE DEPARTMENT FOR THE MONTH ENDING \_\_\_\_\_ 19\_\_

LOCATION.	OCCUPATION	Rate Per Hour	Rate Per Month	No. of Men	Total Wages Per Mo.	Average Wages Per Mo.
	Mast. Mech. and Gen. Forem'n Foremen Clerks and Operators Machinists Machinists' Helpers Machinists' Apprentices Boiler Makers Boiler Makers' Helpers Boiler Makers' Apprentices Blacksmiths Blacksmiths' Helpers Blacksmiths' Apprentices Steam Fitters and Helpers Carpenters Painters and Helpers Coppermiths and Tinner Engine Inspectors Stationary Engineers Callers Boiler Washers Firing up Locomotives Watchmen Laborers and Sweepers Wipers Pitmen & F. Box Cleaners Oil and Sandmen Tinsmiths Telephone Boys Bolt Cutters Truck Repairers Drillers and Wheelmen Tool Boys Flue Cleaners TOTAL					
Shop						
Hours Worked						
Per Day						
Days per Week						
	Foremen Clerks and Operators Machinists Machinists' Helpers Machinists' Apprentices Boiler Makers Boiler Makers' Helpers Boiler Makers' Apprentices Blacksmiths Blacksmiths' Helpers Blacksmiths' Apprentices Painters and Helpers Tinner and Helpers Carpenters Truck Repairers Boiler Washers Stationary Engineers Stationary Firemen Firing up Locomotives Wipers Turn Table and Pitmen Sandmen Laborers and Sweepers Callers Chimney Engine Inspectors Flue Cleaners Firebox Cleaners Bolt Cutters Steam Fitters and Helpers Tool Room Men Drillers Watchmen Tool Boys TOTAL					
Shop						
Hours Worked						
Per Day						
Days per Week						
	Foremen Boiler Washers Wipers and Laborers Callers and Telephone Boys Machinists Machinists' Helpers Boiler Makers Boiler Makers' Helpers Blacksmiths Blacksmiths' Helpers Turn Table and Pitmen Stationary Engineers Flue Cleaners Firing up Men Oil and Sandmen TOTAL					
Shop						
Hours Worked						
Per Day						
Days per Week						
	Foremen Inspectors Boiler Makers Boiler Makers' Helpers Machinists Machinists' Helpers Wipers and Laborers Boiler Washers Turn Table and Pitmen Callers Oil and Sandmen TOTAL					
Shop						
Hours Worked						
Per Day						
Days per Week						
	Foremen Inspectors Boiler Makers Boiler Makers' Helpers Machinists Machinists' Helpers Firing up Men Wipers and Laborers Boiler Washers Turn Table and Pitmen Callers Oil and Sandmen TOTAL					
Shop						
Hours Worked						
Per Day						
Days per Week						
OUTSIDE POINTS	Wipers Laborers Stationary Engineers TOTAL Total for Division					

M. P. FORM 62.

SUMMARY MADE BY SUPERINTENDENT OF MOTIVE  
POWER AND MACHINERY FOR THE GENERAL MAN-  
AGER OF THE TOTAL NUMBER OF MEN OF EACH  
CLASS OF LABOR AND WAGES PAID ON WHOLE  
ROAD.

This report is to be made in the office of the Superintendent of Motive Power and Machinery on the tenth day of the month, showing the classification of all employes working in the Motive Power Department at the principal shop, and at the bottom of this report should be shown a summary of Form 61, and should be forwarded with them to the General Manager.

The object of this report is to obtain the number of employes, their average rate per day, according to their classification, and the amount of the pay rolls of each division.

# SUPERVISION OF LOCOMOTIVES.

169

M. P. Form 62

**SUMMARY MADE BY SUPERINTENDENT OF MOTIVE POWER AND MACHINERY FOR THE GENERAL MAN-  
AGES OF THE TOTAL NUMBER OF MEN OF EACH CLASS OF LABOR AND WAGES PAID ON WHOLE ROAD.**

**DETAILS OF FORCE EMPLOYED BY LOCOMOTIVE DEPARTMENT AT PRINCIPAL SHOP ON THE LAST DAY OF \_\_\_\_\_ 19\_\_\_\_**  
**SHOWN WORKED PER DAY**

DEPARTMENT	OCCUPATION	RATES PER HOUR	RATES PER MONTH	No. of Men	Total Amount	
					Per Day	Per Day
OFFICE	Supt. M. P. and M. and Asst. Supt. Motive and Locomotives					
	Superintendents of Mechanical Engineers					
	Superintendents of Electrical Engineers					
	Managers of heavy building inspectors					
	Blue Print Clerks					
	Total					
MACHINE SHOP - Tool Floor	Foreman and Gang Bosses					
	Machinists					
	Helpers and Handy Men					
	Apprentices					
	Watchmen					
	Toolmen					
	Boys Carters					
	Stationary Fireman					
	Piece Work Inspectors					
	Total					
TOOL ROOM	Foreman					
	Machinists					
	Total					
AIR BRAKE ROOM	Foreman					
	Total					
MANUFACTURING DEPARTMENT	Foreman					
	Machinists					
	Total					
MACHINE SHOP Erecting Floor	Foreman and Gang Bosses					
	Machinists					
	Helpers and Handy Men					
	Machinists' Apprentices					
	Laborers					
	Total					
BOILER SHOP	Foreman and Gang Bosses					
	Machinists					
	Boilermakers					
	Helpers and Holders On					
	Apprentices					
	Tool Erectors					
	Iron Welders					
	Total					
WHEEL SHOP	Foreman					
	Total					
TANK SHOP	Foreman and Gang Bosses					
	Machinists					
	Boilermakers					
	Helpers and Handy Men					
	Apprentices					
	Total					
BLACKSMITH SHOP	Foreman					
	Stationary Engineers					
	Curves Foremen					
	Spring Makers					
	Hammersmiths					
	Heaters					
	Hammerboys					
	Machinists					
	Laborers					
	Total					
PAINT SHOP	Foreman					
	Total					
CARPENTER SHOP	Foreman					
	Total					
FOUNDRY	Foreman					
	Heaters					
	Total					
TIN AND COPPER SHOP	Foreman					
	Total					
POWER HOUSE	Chief Engineer and Asst. Engrs.					
	Total					
SHOP AND YARD LABORERS	Foreman					
	Total					
	Total Principal Shop					
	Total Balance of Shop					
	Grand Total					

ACTUAL PAY ROLLS FOR THE MONTH OF _____ 19____										HOURLY MEN			MONTHLY MEN		WHOLE FORCE	
MONTH	Both of		SEMI	SEMI	Both of		SEMI	SEMI	WAGES	Days Worked Per Day	Number of Men	Amount Paid Per Day	Number of Men	Amount Paid Per Day	Number of Men	Amount Paid Per Day
	19	19			19	19										
<b>TOTALS</b>									<b>TOTALS</b>							

M. P. FORMS 63-78.

INSPECTOR'S REPORTS (AS PER DIAGRAMS) OF LOCOMOTIVE BREAKAGES OF DIFFERENT PARTS AS SPECIFIED BELOW, VIZ.: 63 TO 78.

Blanks 63 to 78, both inclusive, are to be used in reporting all breakages of the different locomotive parts named therein. Whenever a breakage occurs a report should be made on the proper blank by the inspector or round house foreman and forwarded at once to the Master Mechanic, who, after signing the report, and making any notations thereon which he may wish, will forward it to the Superintendent of Motive Power and Machinery, to be examined with a view of ascertaining what parts were broken through operation, or through carelessness, for which the Motive Power Department is responsible.

After the Superintendent of Motive Power and Machinery has completed his examination of these reports, he will forward them to the Mechanical Engineer, who will inspect them and ascertain whether the breakages were caused by parts being defective or through natural wear, and take any action which may be necessary to eliminate, as far as possible, any further breakages of such parts from the same causes.

REPORT OF BREAKAGES OF LOCOMOTIVE PARTS

PILOT COUPLER

Engine No. .... } Date found on inspection..... 19...  
 or  
 Class ..... } Date of failure..... 19... Reported at.....

NOTE.—The location of all fractures should be indicated with red ink lines and the dimensions given to some fixed point.

The questions relating to the fractures at the bottom of this form should be answered as explicitly as possible and the report sent to the master mechanic for his signature, and he will forward it immediately to the Superintendent of Motive Power and Machinery.

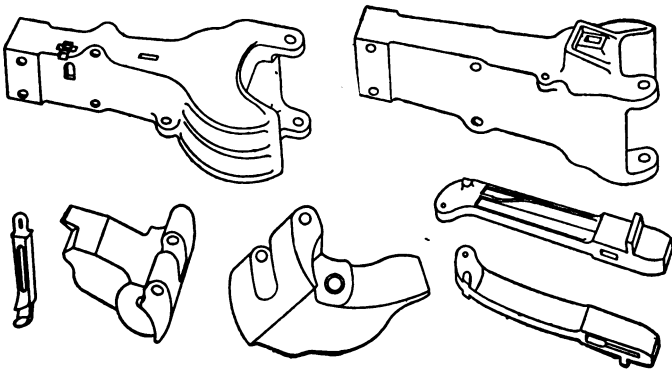

<p>Kind of metal.</p> <p>Was there flaw at point of fracture?</p> <p>Was there an old crack?</p> <p>Probable cause of failure.</p>	<p>REMARKS :</p> <p>.....</p> <p>.....</p> <p>.....</p> <p>..... Master Mechanic</p>
--	--



REPORT OF BREAKAGES OF LOCOMOTIVE PARTS.

PLATE COUPLER

Engine No. .... } Date found on inspection ..... 19...  
 or  
 Class ..... } Date of failure ..... 19... Reported at .....

The location of all fractures should be indicated with red ink lines, and the dimensions given to some fixed point.

The questions relating to the fractures at the bottom of this form should be answered as explicitly as possible and the report sent to the master mechanic for his signature, and he will forward it immediately to the Superintendent of Motive Power and Machinery.

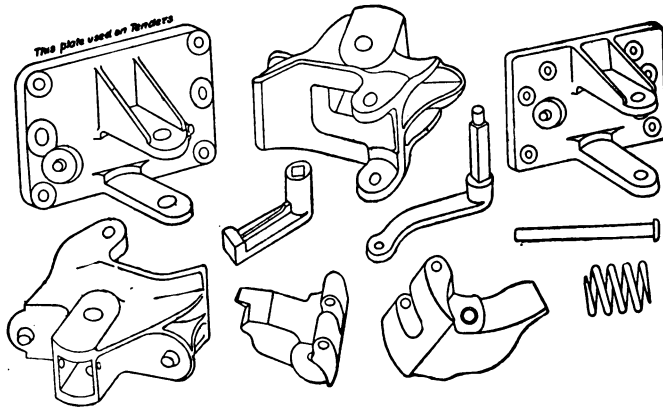

<p>Kind of metal.</p> <p>Was there flaw at point of fracture?</p> <p>Was there an old crack?</p> <p>Probable cause of failure.</p>	<p>REMARKS:</p> <p>.....</p> <p>.....</p> <p>.....</p> <p>.....</p> <p>..... Master Mechanic</p>
--	--

REPORT OF BREAKAGES OF LOCOMOTIVE PARTS

M. C. B. COUPLER

Engine No. .... } Date found on inspection ..... 19  
 Class ..... } <sup>OR</sup>  
 Date of failure ..... 19... Reported at .....

NOTE.—The location of all fractures should be indicated with red ink lines, and the dimensions given to some fixed point.  
 The questions relating to the fractures at the bottom of this form should be answered as explicitly as possible, and the report sent to the master mechanic for his signature, and he will forward it immediately to the Superintendent of Motive Power and Machinery.

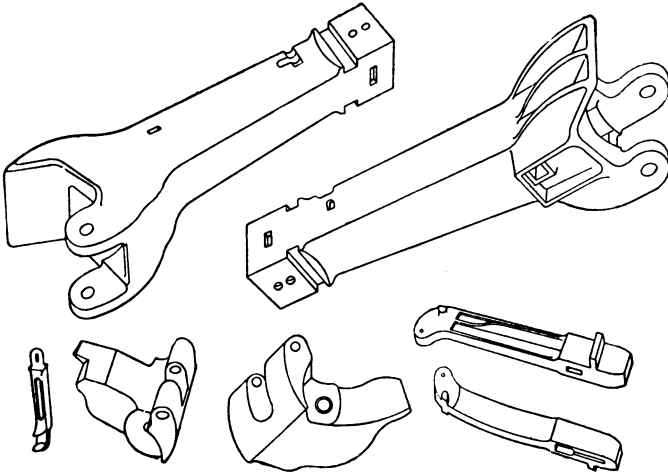

<p>Kind of metal.</p> <p>Was there flaw at point of fracture?</p> <p>Was there an old crack?</p> <p>Probable cause of failure.</p>	<p>REMARKS:</p> <p>.....</p> <p>.....</p> <p>.....</p> <p>.....</p> <p>..... Master Mechanic</p>
--	--



REPORT OF BREAKAGES OF LOCOMOTIVE PARTS.  
DRIVING BOX AND BRASS.

Engine No. .... } Date found on inspection ..... 19...  
 Class ..... } or  
 Date of failure ..... 19... Reported at .....

NOTE.—The location of all fractures should be indicated with red ink lines and the dimensions given to some fixed point.

The questions relating to the fractures at the bottom of this form should be answered as explicitly as possible and the report sent to the master mechanic for his signature, and he will forward it immediately to the Superintendent of Motive Power and Machinery.

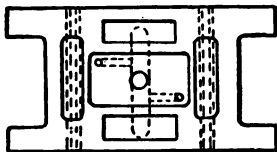

INSIDE FACE.

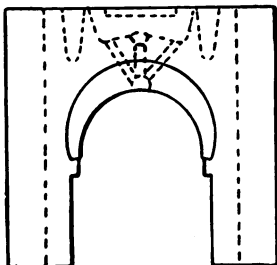

BOX

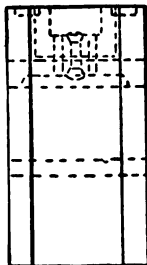

BRASS

Pattern No. ....

Dimension and, if possible, sketch of section at point of fracture :

Was it front, back or middle?  
.....

Kind of metal.....

Was there flaw at point of fracture?.....

Probable cause of failure?.....

Pattern No. ....

Dimension and, if possible, sketch of section at point of fracture :

Was it front, back or middle?  
.....

Kind of metal.....

Was there flaw at point of fracture?.....

Probable cause of failure?.....

Master Mechanic.

REPORT OF BREAKAGES OF LOCOMOTIVE PARTS.

CYLINDER HEADS.

Engine No. .... } Date found on inspection ..... 19...  
 or  
 Class ..... } Date of failure ..... 19 ... Reported at .....

NOTE.—The location of all fractures should be indicated with red ink lines and the dimensions given to some fixed point.

The questions relating to the fractures at the bottom of this form should be answered as explicitly as possible, and the report sent to the master mechanic for his signature, and he will forward it immediately to the Superintendent of Motive Power and Machinery.

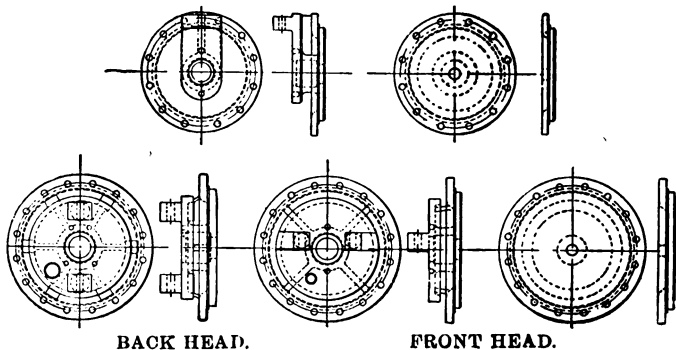

Pattern No. ....  
 Dimensions and, if possible,  
 sketch of section at point of  
 fracture.  
 Kind of metal .....  
 Was there flaw at point of  
 fracture? .....  
 Probable cause of failure.....

Pattern No. ....  
 Dimensions and, if possible,  
 sketch of section at point of  
 fracture.  
 Kind of metal .....  
 Was there flaw at point of  
 fracture? .....  
 Probable cause of failure.....

.....  
 Master Mechanic.

REPORT OF BREAKAGES OF LOCOMOTIVE PARTS.

**EQUALIZER.**                      **EQUALIZER STAND.**                      **SPRING HANGERS.**  
 Engine No. .... Date found on inspection ..... 19 ..  
 or  
 Class ..... } Date of failure ..... 19 ..... Reported at .....

NOTE.—The location of all fractures should be indicated with red ink lines and the dimensions given to some fixed point.

The questions relating to the fractures at the bottom of this form should be answered as explicitly as possible, and the report sent to the master mechanic for his signature, and he will forward it immediately to the Superintendent of Motive Power and Machinery.

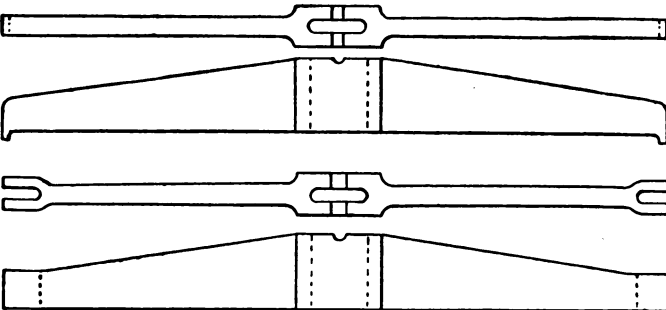
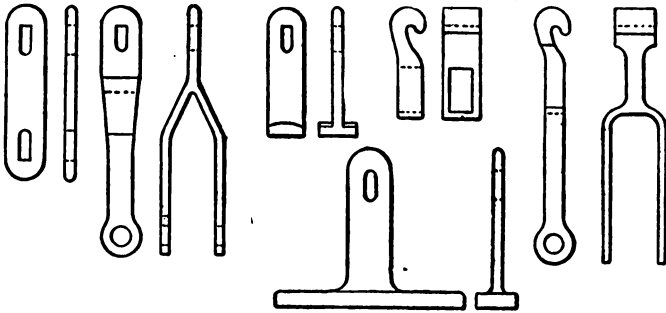

**EQUALIZER.**  
 Dimension and, if possible, sketch of section at point of fracture.  
 Kind of metal.  
 Was there flaw at point of fracture?  
 Probable cause of failure.

**EQUALIZER STAND.**  
 Dimension and, if possible, sketch of section at point of fracture.  
 Kind of metal.  
 Was there flaw at point of fracture?  
 Probable cause of failure.

**SPRING HANGERS.**  
 Dimension and, if possible, sketch of section at point of fracture.  
 Kind of metal.  
 Was there flaw at point of fracture?  
 Probable cause of failure?

.....  
 Master Mechanic.

REPORT OF BREAKAGES OF LOCOMOTIVE PARTS.

ECCENTRIC, ECCENTRIC STRAP, ECCENTRIC ROD.

Engine No. .... Date found on application.....19.....  
 Class..... or  
 Date of failure.....19.....Reported at.....

NOTE.—The location of all fractures should be indicated with red ink lines and the dimensions given to some fixed point.

The questions relating to the fractures at the bottom of this form should be answered as explicitly as possible and the report sent to the master mechanic for his signature, and he will forward it immediately to the Superintendent of Motive Power and Machinery.

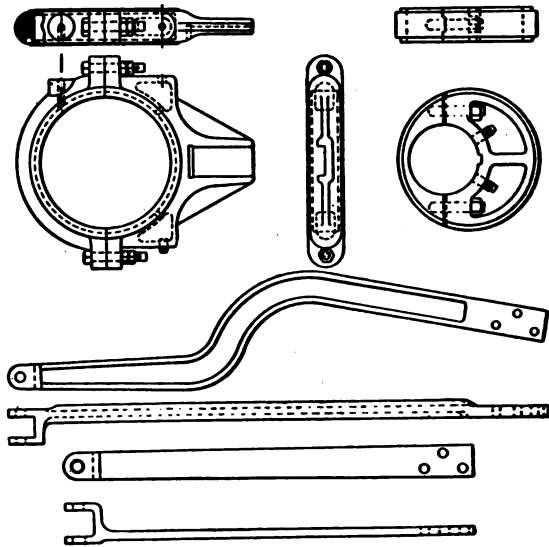

**ECCENTRIC**  
 Pattern No. ....  
 Forward..... Back.....  
 Dimensions, and if possible, sketch of section at point of fracture.  
 Kind of metal.....  
 Was there flaw at point of fracture?  
 Probable cause of failure.

**ECCENTRIC STRAP**  
 Pattern No. ....  
 Forward..... Back.....  
 Dimensions, and if possible, sketch of section at point of fracture.....  
 Kind of metal.....  
 Was there flaw at point of fracture?  
 Probable cause of failure.

**ECCENTRIC ROD**  
 Dimensions, and if possible, sketch of section at point of fracture.  
 Kind of metal.....  
 Was there flaw at point of fracture?  
 Probable cause of failure.

.....  
 MASTER MECHANIC.

M. P. Form 71

REPORT OF BREAKAGES OF LOCOMOTIVE PARTS.

SIDE ROD, MAIN ROD AND ROD STRAP.

Engine No. .... } Date found on inspection ..... 19...  
 or  
 Class ..... } Date of failure ..... 19... Reported at .....

NOTE.—The location of all fractures should be indicated with red ink lines and the dimensions given to some fixed point.

The questions relating to the fractures at the bottom of this form should be answered as explicitly as possible, and the report sent to the master mechanic for his signature, and he will forward it immediately to the Superintendent of Motive Power and Machinery.

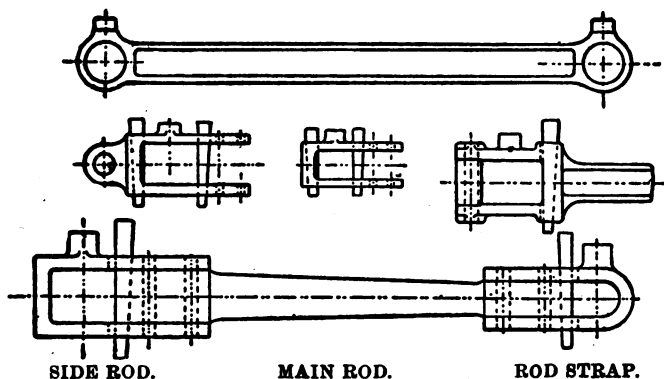

**SIDE ROD.**  
 Front end, .....  
 Back end, .....  
 Dimensions and if possible sketch of section at point of fracture.....

**MAIN ROD.**  
 Dimension, and if possible, sketch of section at point of fracture.....

**ROD STRAP.**  
 Front strap, .....  
 Back strap, .....  
 Dimension, and if possible, sketch of section at point of fracture.....

Kind of metal. ....  
 Was there flaw at point of fracture? .....  
 Probable cause of failure. ....

Kind of metal. ....  
 Was there flaw at point of fracture?.....  
 Probable cause of failure. ....

Kind of metal.....  
 Was there flaw at point of fracture?.....  
 Probable cause of failure. ....

Master Mechanic.



## REPORT OF BREAKAGES OF LOCOMOTIVE PARTS.

## PISTON AND PISTON RODS.

Engine No. .... } Date found on inspection ..... 19...  
 or  
 Class ..... } Date of failure ..... 19... Reported at .....

NOTE.—The location of all fractures should be indicated with red ink lines and the dimensions given to some fixed point.

The questions relating to the fractures at the bottom of this form should be answered as explicitly as possible, and the report sent to the master mechanic for his signature, and he will forward it immediately to the Superintendent of Motive Power and Machinery.

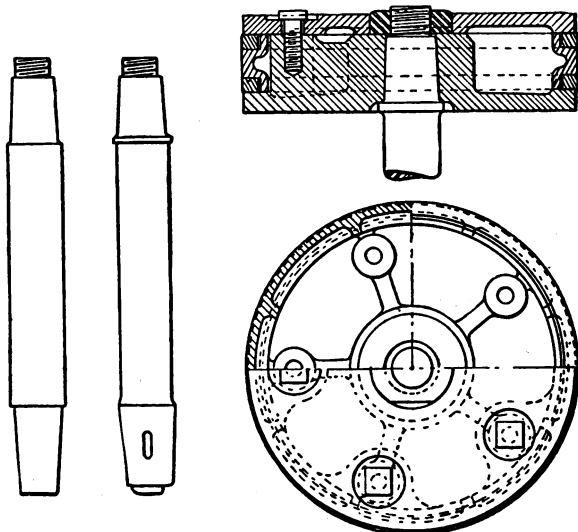

## PISTON.

Pattern No. } Bull-ring  
 } Spider  
 Dimensions and, if possible, sketch at point of fracture.  
 Kind of metal .....  
 Kind of packing .....  
 Front packing-ring....  
 Back packing-ring....  
 Was there blow-hole or flaw at point of fracture? .....  
 Probable cause of failure .....

## PISTON FOLLOWER.

Pattern No. ....  
 Dimensions and, if possible, sketch at point of fracture.  
 Kind of metal .....  
 Was there blow-hole or flaw at point of fracture? .....  
 Probable cause of failure .....

## PISTON ROD

Enlarged ends.....  
 Dimensions and, if possible, sketch at point of fracture.  
 Kind of metal .....  
 Was there flaw at point of fracture? .....  
 Did it show any old crack?.....  
 Shop letter and date put in .....  
 Probable cause of failure.....

.....  
 Master Mechanic.

REPORT OF BREAKAGES OF LOCOMOTIVE PARTS.

VALVES, VALVE YOKES AND ROCKER SHAFT.

Engine Number..... Date of failure.....  
 Reported at..... 19.....

NOTE.—The location of all fractures should be indicated with red ink lines and the dimensions given to some fixed point.

The questions relating to the fractures at the bottom of this form should be answered as explicitly as possible, and the report sent to the master mechanic for his signature, and he will forward it immediately to the Superintendent of Motive Power and Machinery.

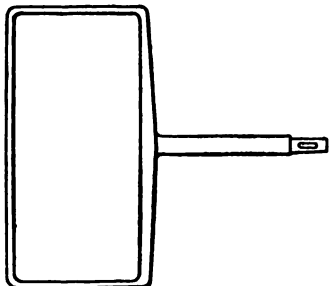
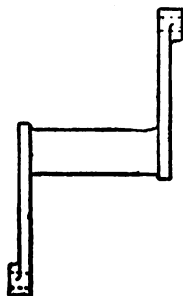
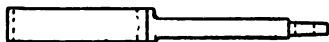
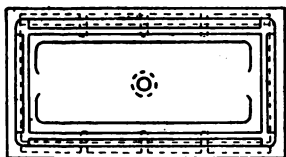
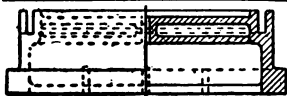

VALVE.

VALVE YOKE.

ROCKER SHAFT.

Pattern No. ....  
 Kind of metal.....  
 Dimensions and, if possible, sketch of section at point of fracture.  
 Kind of valve.....  
 Kind of balancing.....  
 Was there flaw at point of fracture?  
 Probable cause of failure.....

Kind of metal.....  
 Dimensions and, if possible, sketch of section at point of fracture.  
 Was there flaw at point of fracture?  
 Probable cause of failure.....

Pattern No. ....  
 Kind of metal.....  
 Dimensions and, if possible, sketch of section at point of fracture.  
 Was there flaw at point of fracture?  
 Probable cause of failure.....

Master Mechanic.

M. P. Form 74

## REPORT OF BREAKAGES OF LOCOMOTIVE PARTS

## CROSSHEADS.

FOUR-BAR CROSSHEAD. LAIRD CROSSHEAD. TWO-BAR CROSSHEAD.

Engine Number.....Date of failure.....

Reported at.....19.....

NOTE.—The location of all fractures should be indicated with red ink lines and the dimensions given to some fixed point.

The questions relating to the fractures at the bottom of this form should be answered as explicitly as possible, and the report sent to the master mechanic for his signature, and he will forward it immediately to the Superintendent of Motive Power and Machinery.

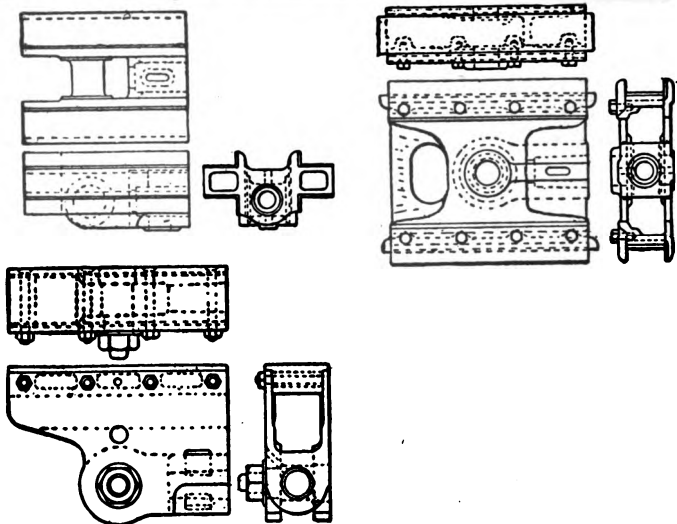

## FOUR-BAR CROSSHEAD.

Pattern No. ....

Kind of metal.....

Dimensions and, if possible, sketch of section at point of fracture.....

Was there flaw at point of fracture? .....

Probable cause of failure.....

## LAIRD CROSSHEAD.

Pattern No. ....

Kind of metal.....

Dimensions and, if possible, sketch of section at point of fracture.....

Was there flaw at point of fracture? .....

Probable cause of failure.....

## TWO-BAR CROSSHEAD.

Pattern No. ....

Kind of Metal.....

Dimensions and, if possible, sketch of section at point of fracture.....

Was there flaw at point of fracture? .....

Probable cause of failure.....

Master Mechanic.

REPORT OF BREAKAGES OF LOCOMOTIVE PARTS.

CRANK PINS.

Engine No. .... } Date found on inspection.....19....  
 or  
 Class..... } Date of failure.....19.... Reported at.....

NOTE.—The location of all fractures should be indicated with red ink lines and the dimensions given to some fixed point.

The questions relating to the fractures at the bottom of this form should be answered as explicitly as possible, and the report sent to the master mechanic for his signature, and he will forward it immediately to the Superintendent of Motive Power and Machinery.

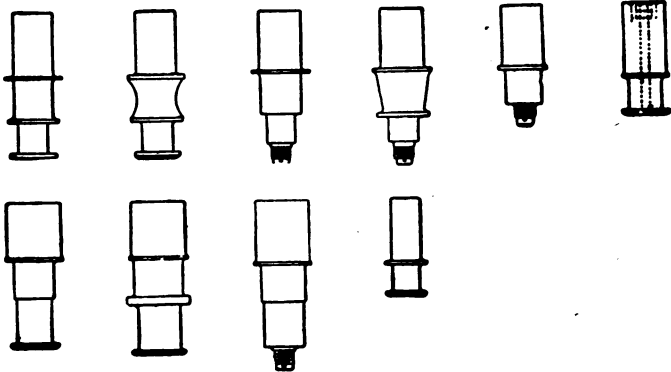

MAIN PIN.

BACK PIN.

FRONT PIN.

Dimensions and, if possible, sketch at point of fracture.

Dimensions and, if possible, sketch at point of fracture.

Dimensions and, if possible, sketch at point of fracture.

Kind of metal .....

Kind of metal .....

Kind of metal .....

Was there flaw at point of fracture? .....

Was there flaw at point of fracture? .....

Was there flaw at point of fracture? .....

Was there an old crack? .....

Was there an old crack? .....

Was there an old crack? .....

Did fracture show crystallisation? .....

Did fracture show crystallisation? .....

Did fracture show crystallisation? .....

About how long in service? .....

About how long in service? .....

About how long in service? .....

Probable cause of failure.....

Probable cause of failure.....

Probable cause of failure.....

Master Mechanic.

REPORT OF BREAKAGES OF LOCOMOTIVES PARTS  
STAY-BOLTS.

Engine No. .... at ..... Date ..... 19 .....

Inspected by .....

NOTE.—This report should show the condition of the fire-box sheets of each engine receiving boiler repairs and should be forwarded to the master mechanic for his signature, and he will forward it immediately to the Superintendent of Motive Power and Machinery.

All broken stay-bolts, cracks, patches or defects must be shown hereon as found at each inspection, and whenever repairs are made to fire-box sheets.

Each broken stay-bolt should be indicated by a circle drawn around it with red ink; those otherwise defective, by a red ink cross.

New patches should be shown on the diagrams given below by red ink lines; old patches, and size of sheets by black ink lines.

The laboratory number of all new sheets must be shown in the space provided.

Name of Sheet	Number Broken	Diameter of Bolts		Laboratory Number of New Sheets	REMARKS
		Removed	Applied		

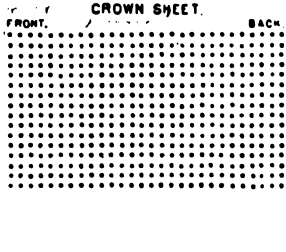
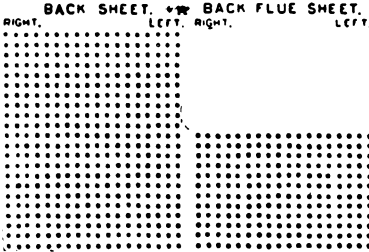
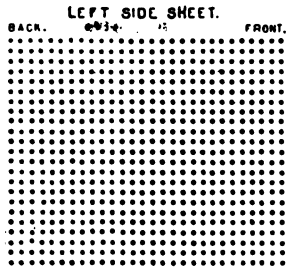
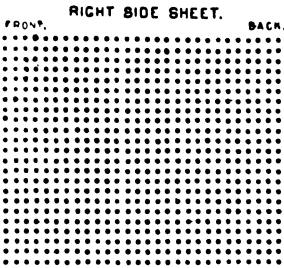

Master Mechanic

REPORT OF BREAKAGES OF LOCOMOTIVE PARTS

MISCELLANEOUS

Engine No. { Date found on inspection.....19....  
 or  
 Class ..... { Date of failure.....19.... Reported at.....  
 Hauling.....Section Train No.....

REMARKS : .....

.....  
 .....  
 .....  
 .....

Master Mechanic.

NOTE.—This report should be used in reporting all breakages of locomotive parts for which special forms are not provided.

A sketch should be made of the part broken and all fractures indicated thereon with red ink lines, and the dimensions given to some fixed point.

The report should be sent to the master mechanic for his signature, and he will forward it immediately to the Superintendent of Motive Power and Machinery.

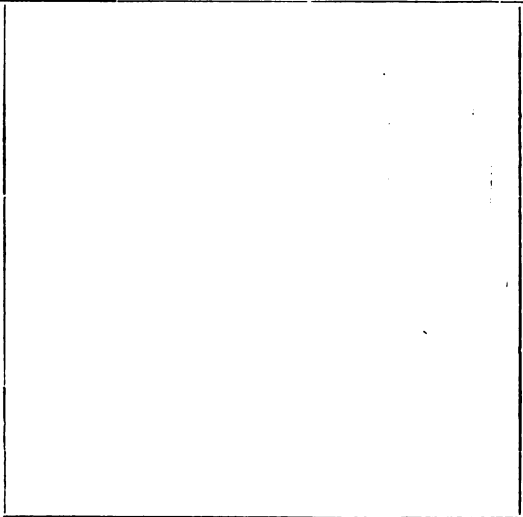

REPORT OF CONDITION OF LOCOMOTIVE BOILER  
 ENG. NO.....

INSPECTED AT.....DATE.....19...

TEST PRESSURE.....Lbs.

LABORATORY NOS. OF NEW PLATES	REMARKS.

NOTE.—This report should show the condition of the boiler of each engine receiving boiler repairs, and should be forwarded to the master mechanic for his signature, and he will forward it immediately to the Superintendent of Motive Power and Machinery.

The size of all new patches should be indicated on the diagrams given below, by red ink lines, and old patches by black ink lines.

The laboratory number of all new sheets must be shown in the space provided.

The condition of the fire-box sheets should be shown on Form 76.

Fig 3.



INSPECTED BY

Fig 1

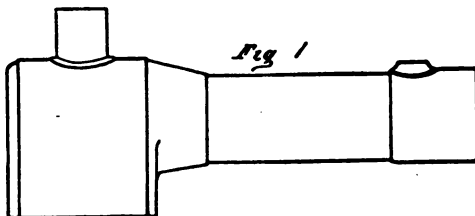
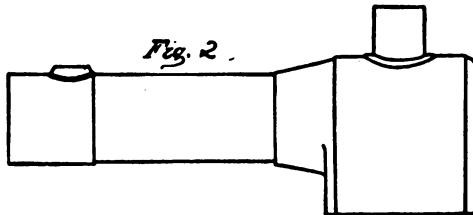

Fig 4



Fig. 2



.....  
 MASTER MECHANIC.





M. P. FORM 79.

INSPECTOR'S RECORD OF INSPECTION OF STATIONARY  
AND LOCOMOTIVE FIRE-BOX STAY-BOLTS.

This record book is kept by the inspector at each round house and shows the inspection of all fire-box stay-bolts made by him each month.



M. P. FORM 80.

**INSPECTOR'S MONTHLY REPORT OF INSPECTION OF  
STATIONARY AND LOCOMOTIVE FIRE-BOX STAY-  
BOLTS.**

The purpose of this report is that the Master Mechanic and Superintendent of Motive Power and Machinery may be advised that the stay-bolts in boilers are inspected monthly, according to the requirements of the Motive Power Department.



M. P. FORM 81.

INSPECTOR'S REPORT OF PERIODICAL INSPECTION OF  
STATIONARY BOILERS.

The purpose of this report is that the Superintendent of Motive Power and Machinery may be advised that all stationary boilers are inspected annually and that he may ascertain the condition they are in.

**INSPECTOR'S REPORT OF PERIODICAL INSPECTION OF STATIONARY BOILERS.**

At.....Shops.....Division. Date.....19.....

**NOTE.**—The annual inspection of stationary boilers should be made during the months of May and June. Two reports of this character must be filled out and signed by the person making the inspection at the time and place such inspection is made. One of the reports will be filed in the office of the master mechanic, and the other sent to the Superintendent of Motive Power and Machinery.

The inspection will include the application of hydrostatic pressure 25% above the working pressure carried. The water should be hot when pressure is applied. This should be followed by a close inspection of all plates, seams, braces, fittings, setting, etc., and any defects discovered must be remedied before the boiler is again put into service.

Boiler No.	Location	Working Pressure Carried	Test Pressure	Condition	Repairs Needed	Date Tested	Inspector's Signature

Signed.....

Master Mechanic.

M. P. FORM 82.

INSPECTOR'S REPORT OF INSPECTION OF AIR AND  
STEAM GAUGES AND SAFETY VALVES.

The purpose of this report is that the Superintendent of Motive Power and Machinery may be advised that all air and steam gauges and safety valves are inspected at regular intervals and that he may ascertain the condition they are in.





M. P. FORM 83.

**INSPECTOR'S REPORT OF CHANGES AND REPAIRS OF  
STATIONARY BOILERS.**

The purpose of this report is that the Superintendent of Motive Power and Machinery may obtain a complete record of details of stationary boilers, so as to keep an accurate check on the pressure carried by the boiler while in service.

INSPECTOR'S REPORT OF CHANGES AND REPAIRS OF STATIONARY BOILERS.

NOTE—This report is to be made at stated intervals or whenever any changes are made in stationary boilers, by the foreman or inspector and forwarded to the Superintendent of Motive Power and Machinery.

The items and dimensions should be given as called for on the diagram below.

All dimensions of the shell should be outside dimensions and those of the firebox inside dimensions. All seams should be located on the boiler diagrams by use of the seam diagrams and numbers on the opposite section of this form. If any other style of seam is used a sketch should be made in the blank space provided for that purpose.

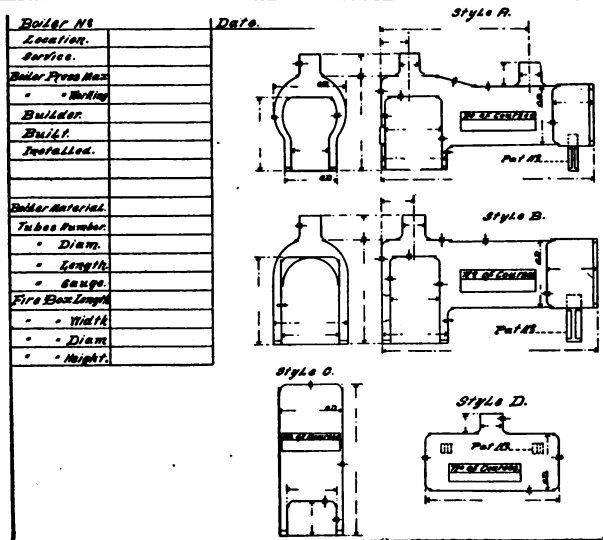

SEAM DIAGRAMS		DIMENSIONS OF SEAMS										
		*	A	B	C	D	E	F	G	H	I	K
		1										
		2										
		3										
		4										
		5										
		6										
		7										
		8										
		9										
		10										
		11										
		12										
		13										
		14										
		15										
		16										
		17										
		18										

\*Number of Seams as shown on Boiler Diagrams.

M. P. FORM 84.

SHOP FOREMAN'S REPORT TO MASTER MECHANIC OF  
VALVE MOTION OF ENGINES.

This report is used to obtain the dimensions of the parts of locomotives relating to the valve motion, when such locomotives have received repairs.

SHOP FOREMAN'S REPORT TO MASTER MECHANIC OF  
VALVE MOTION OF ENGINES.

Engine No. .... Class .....

..... Shops. Date..... 19.....

NOTE—This report should be made by the foreman of the shops where engines are repaired and sent to the master mechanic for his signature, and any notations which he may make, who will in turn forward same to the Superintendent of Motive Power and Machinery.

The report should show the dimensions of the parts enumerated below.

Cylinders .....	Throw of Eccentric .....
Steam Ports .....	Travel of Valve .....
Exhaust Port .....	Saddle Pin Back .....
Bridges .....	Lead Full Gear .....
Outside Lap .....	Valves Set by .....
Inside Clearance .....	

	STROKE LEAD FULL GEAR	STROKE OUT OF FULL GEAR	STROKE OUT OF FULL GEAR	DIFFERENCE IN STROKE	CLEARANCE OUT OF FULL GEAR	CLEARANCE OUT OF FULL GEAR	DIFFERENCE IN CLEARANCE	CLEARANCE FULL GEAR	DIFFERENCE IN CLEARANCE	LEAD FULL GEAR	LEAD OUT	DIFFERENCE FULL GEAR
FORWARD METHOD.												
BACK METHOD.												

REMARKS: .....

.....

.....

.....

.....

M. P. FORM 85.

MONTHLY REPORT OF EACH ENGINEER'S SERVICE,  
VIZ.: TOTAL MILES RUN BY LOCOMOTIVES UNDER  
HIS CHARGE, TONS HAULED AND FUEL CON-  
SUMED.

This is for the purpose of comparing the records of particular engineers in regard to economy practiced in the use of fuel each month—the record showing the locomotive mileage made per ton of coal used; also the average number of pounds of coal used to haul each 100 tons one mile. For purposes of comparison the engineers in each class of service (passenger, freight, etc.) are grouped together.

Another purpose of this report is to permit the management to ascertain and scrutinize what the relation of coal consumption is to the number of tons hauled. Afterwards, and in the "Performance of Locomotives" Form 45, the consumption of coal per ton mile is ascertained for all locomotives for the whole road.



M. P. FORM 86.

STATEMENT OF MILEAGE MADE BY EACH ENGINEER  
TO PINT OF LUBRICATING OIL.

The purpose of this report is that the Superintendent of Motive Power and Machinery may see that engineers are as economical as possible in the use of lubricating oils.

In connection with this form, it is the custom on some roads to place the engineers within certain limits per run. The effect of such precaution, if wisely determined, will heighten interest and enforce economy. This will be further insured, however, by comparing the operation of the engines—one with another—on the basis of the number of miles run to pint of oil.





M. P. FORM 87.

MASTER MECHANIC'S REPORT TO SUPERINTENDENT  
OF MOTIVE POWER AND MACHINERY OF CONDI-  
TION OF TOOLS AND MACHINERY.

This report is to be made by the Master Mechanic and forwarded to the Superintendent of Motive Power and Machinery whenever any changes are made, either by installing new or removing old tools and machinery.

A report of this character should also be made at the beginning of each year, covering all tools and machinery at the shops under the Master Mechanic's jurisdiction.

It is kept as a record in the office of the Superintendent of Motive Power and Machinery, and by it he is advised of the condition of all tools and machinery in the Motive Power Department.

**MASTER MECHANIC'S REPORT TO SUPERINTENDENT OF MOTIVE POWER AND  
MACHINERY OF CONDITION OF TOOLS AND MACHINERY.**

Shop..... Date..... 19.....

KIND	DESCRIPTION	MAKER'S		Location	Sub-Shop	Date Placed in Service	Cost When New	Estimated Value at Jan. 1, 19....	Present Condition	REMARKS
		Name	No.							

**M. P. FORM 88.****FORM OF APPLICATION MADE BY THOSE SEEKING EMPLOYMENT ON ENGINES.**

This form is to be used by all persons making application for employment as engineers, firemen, or engine dispatchers.



10. Give below the name, address and occupation of your parents and other relatives. If any are deceased, give other nearest relatives:

NAME	OCCUPATION	ADDRESS
Father:		
Mother:		
Nearest Male Relative		
On Father's Side:		
On Mother's Side:		

11. Have you ever been discharged or suspended from any situation? If so, state particulars, when and where.....
12. Have you ever been injured? If so, when..... where..... how..... and extent of injuries.....
13. Have you now or did you ever have any litigation with any railroad company?.....
14. Have you ever been in the employ of this company before? If so, state when, where, in what capacity, and cause of leaving.....
15. Do you drink malt or spirituous liquors?.....
16. Have you ever before made application for employment and been subjected to a physical examination? If so, when..... where..... and by what physician was examination made?.....
17. Were you accepted or rejected?.....

I hereby authorize this company and its officers, and the officers of any other company or firm by which I have been heretofore employed, to answer any or all inquiries as to my conduct and qualifications while in such service, and, so far as they may know, the cause of my leaving the same.

In consideration of my employment by said company, I further agree that whenever I shall sustain any personal injury while in the service of said company I will allow its surgeons and any medical examiners it may select to examine my person and body as often as the company may deem necessary in respect to the alleged injury, and I hereby waive all objections to such surgeons or medical examiners testifying whenever called upon by the company, and I further agree that my refusal to allow any such examination to be made or testimony to be given shall be a bar to the institution or prosecution of any action on account of such injuries; and any action pending at the time of such refusal shall at once abate in consequence thereof.

In further consideration of such employment I agree that if, while in the service of said company, I sustain any personal injury for which I shall or may make claim against the company for damages I will, within sixty days after receiving such injury, give notice in writing of such claim to the general claim agent of said company; which notice shall state the time, place, manner and cause of my being injured and the nature and extent of my injuries, and the claim made therefor, to the end that such claim may be fully, fairly and promptly investigated; and my failure to give written notice of such claim in the manner and within the time aforesaid, shall be a bar to the institution of any suit on account of such injuries.

Signature of Applicant.....

Address .....

Dated at.....this..... day of

.....19....

STATE OF ..... }  
COUNTY OF ..... } ss.

.....being first duly sworn, says that he is the applicant named in the foregoing application, that said application, is signed by him, and that the answers to questions in said application are made in his own hand-writing, and that each and all of the answers contained in said application are true.

Subscribed and sworn to before me this ..... day of ..... 19.....

Notary Public.

I hereby acknowledge receipt of a copy of the rules and regulations for the government of employes of the operating department of the ..... Railway Company, and all amendments thereto, and also a copy of the current time table, and agree to familiarize myself with and observe all the same, and to keep advised of such amendments to said rules as may be hereafter made, and have had explained to me the dangerous nature of the service in which I am about to engage. I have been notified that there are buildings, coal chutes, signal posts, switch stands, round house doors and other obstructions dangerously close to the tracks, and that I am required to look out for them and avoid danger, which I fully appreciate.

Dated at ..... this ..... day of ..... 19.....

SURGEON'S CERTIFICATE.

To be filled out and signed after a PERSONAL examination by any of the company's local surgeons.

The following is the report of the result of my examination of Mr.....

TO BE SIGNED BY APPLICANT IN PRESENCE OF EXAMINER.

- 1. When placed at a distance of twenty (20) feet from the test types, the last five (5) letters read correctly by the applicant are: Right eye ..... 20/..... Left eye ..... 20/..... Both eyes .....
2. A. The applicant selects skeins numbered as follows, as being of the same color as test skein A: B. The following as being of the same color as test skein B: C. The following as being of the same color as test skein C:
3. The applicant hears the tick of a watch with the right ear at ..... inches; with the left ear at ..... inches. For ordinary conversation at a distance of twenty (20) feet, the hearing is ..... (expressed in fractions).

I find that there is evidence of recent successful vaccination; that he is not suffering from any disease or disability other than noted, and that he does not manifest any evidence of an abuse of intoxicating liquors.

I hereby certify that, having examined him for defects of vision, color perception and hearing, and for other physical defects, I find him ) qualified ( ) disqualified ( to fill the position of.....

Disqualifying defects ..... Defects that do not disqualify ..... Remarks: .....

Examined by ..... Surgeon at.....

Date of Examination ..... 19.....

TO BE SIGNED BY SURGEON MAKING THE EXAMINATION.

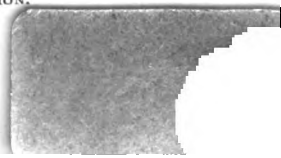

M. P. FORM 89.

**MASTER MECHANIC'S NOTICE OF VACANCIES IN RUNS  
AND SERVICE.**

The purpose of this notice is to advise enginemen of vacancies to be filled by a certain date, and to allow them to make application, if they so desire, for the vacant positions.

**MASTER MECHANIC'S NOTICE OF VACANCIES IN RUNS AND SERVICE.**

.....Division Date.....19.....

**NOTE.**—This notice is issued by the master mechanic whenever vacancies occur for engineers or firemen.

A copy should be sent to each round house foreman on the division and posted on the bulletin board or some other conspicuous place.

Applications should be made for the position desired and forwarded to the master mechanic on or before the date specified below.

<b>ENGINEER OR FIREMEN</b>	<b>TRAIN NO.</b>	<b>BETWEEN WHAT POINTS</b>

**All applications must be on file in the office of the master mechanic not later than.....19.....**



M. P. FORM 90.

NOTICE OF SUPERINTENDENT OF MOTIVE POWER AND  
MACHINERY OF THOSE AUTHORIZED TO OPERATE  
LOCOMOTIVES.

TO MASTER MECHANICS AND FOREMEN IN CHARGE OF  
ROUND HOUSES AND SHOPS.

This notice is used to furnish information to all employes of round-houses and shops as to what persons are permitted to move and operate the locomotive engines belonging to the company.

M. P. Form 90

NOTICE OF SUPERINTENDENT OF MOTIVE POWER AND MACHINERY OF THOSE AUTHORIZED TO OPERATE LOCOMOTIVES

TO MASTER MECHANICS AND FOREMEN IN CHARGE OF ROUND-HOUSES AND SHOPS:

No one other than Master Mechanics, Round-House Foremen, Engineers, Firemen or Hostlers are allowed to move or operate the locomotive engines of this Company All other employes are strictly forbidden to do so

Any employe disobeying this order will be liable to immediate discharge. Master Mechanics and Round-House Foremen are instructed to enforce the above order rigidly, and to provide all employes under them, who are not permitted to handle locomotives under the terms of this order, with a copy of this notice, to explain it carefully to them, to procure their acknowledgment thereof on this blank and forward the same immediately to the Superintendent of Motive Power and Machinery.

ACKNOWLEDGMENT OF EMPLOYEE.

The above notice has this day been read and explained to me by.....

and a copy thereof left in my possession. I agree to observe carefully the instructions contained therein.

Signed at.....this.....

day of.....19.....

Witness:

.....

**M. P. FORM 91.****FORM OF RELEASE TO BE SIGNED BY MINORS AND  
THEIR LEGAL GUARDIANS.**

This form is used in obtaining the consent of the parents or guardians of all minors to their employment in the Motive Power Department.

M. P. Form 91

**FORM OF RELEASE TO BE SIGNED BY MINORS  
AND THEIR LEGAL GUARDIANS**

**NOTE.**—This release must be furnished in duplicate by all minors before they are allowed to enter the service of the Company. It must be duly signed by the parents or guardian of the minor, witnessed by two disinterested persons and sworn to before a notary public.

One copy of the release should be kept on file in the office of the official under whom the minor is employed and the other forwarded to the Superintendent of Motive Power and Machinery.

**WHEREAS**, ..... who was  
..... years of age on the ..... day of .....  
19...., is about to enter the employment of the .....  
**RAILWAY COMPANY**; and

**WHEREAS**, the nature of such employment may from time to time be changed:

**THEREFORE**, IN CONSIDERATION of his being employed by that Company, in whatever capacity now or hereafter we, the undersigned, \*father and mother of said minor, do hereby agree with said Railway Company that we have given the said ..... his own time and earnings, and that he is of sufficient capacity to discharge the duties of his employment, now or hereafter, and that he may at all times himself collect and receipt for his wages from said Company in whatever position he may at any time be employed, and that we will make no claim against said Company at any time for any wages or earnings of said minor in the employment of said Railway Company, or for any injuries that he may receive during or in connection with said employment, or for any liability whatever on account of said minor or his employment.

**WITNESS** our hands and seals at ..... this ..... day of  
..... 19.....

**Witness:**

..... [SEAL]  
..... [SEAL]

\*If there is no father or mother and there is a guardian, the word "guardian" should be inserted instead of "father and mother," and the release executed by guardian.

I, ..... referred to in the above release, do hereby certify that I was ..... years of age on the ..... day of ..... 19...., and that the dangerous nature of the business in which I am about to engage has been explained to me by the agents of the Company, and that I fully understand the risks I am about to take in entering the employment of the ..... **RAILWAY COMPANY** as a .....

**Dated** at ..... this ..... day of  
..... 19.....

**WITNESS:**

.....

M. P. FORM 92.

CERTIFICATE GIVEN ON COMPLETION OF APPRENTICESHIP.

This certificate serves the purpose of a diploma, being given to all employes who have finished their apprenticeship in any line of work in the Motive Power Department.



M. P. FORM 93.

**MASTER MECHANIC'S WEEKLY REPORT TO SUPERIN-  
TENDENT OF MOTIVE POWER AND MACHINERY OF  
AVERAGE TERMINAL DELAYS OF FREIGHT ENGINES  
AND THE CAUSE THEREFOR.**

The purpose of this report is to furnish the Superintendent of Motive Power and Machinery with data regarding the total time freight engines are delayed at round-houses from various causes, and to enable him to take the necessary action to eliminate such delays.





M. P. FORM 94.

ENGINEER'S REQUISITION FOR SUPPLIES.

This form is a folio from the order book which is furnished each engineer by the Master Mechanic on the first day of the month. It is to be used only in ordering tools and supplies for locomotives, and at the end of the month the book, with all unused tickets, should be returned to the Master Mechanic.

It has been found advantageous to number the tickets in consecutive order in each book.



M. P. FORM 95.

ENGINEER'S REPORT TO ROUND HOUSE FOREMAN OF  
CONDITION OF ENGINES AT END OF EACH TRIP.

The purpose of this report is that the round-house foreman may ascertain the condition of each engine at the end of each trip, as reported by the engineer, and to see that all necessary repairs are made before the engine is allowed to go into service.

ENGINEER'S REPORT TO ROUNDHOUSE FOREMAN OF CONDITION OF ENGINES AT END OF EACH TRIP.

NOTE.—Engineers must carefully inspect their engines after each trip, whether needing repairs or not, and report their condition on this form, sending same to the round-house foreman. They will be held responsible for every defect not reported. No attention will be given to verbal reports or reports not signed by the engineer.

When repairs have been made to the engine, and the report signed by the person making the repairs and approved by the round-house foreman, it should be forwarded to the master mechanic, to be kept on file in his office.

Condition of Engine No. .... after careful inspection, on arrival at ....., Time ..... M., Date ..... 19....

Engine is in good condition, with the following exceptions:.....

.....
.....
.....
.....
.....

Condition of Right Injector .....

Condition of Left Injector .....

Condition of Blow-off Cock .....

Safety Valve lifts at ..... lbs.

Safety Valve seats at ..... lbs. .... Engineer.

(Reverse side of above.)

Repaired at .....
On ..... 19....
The following repairs were made on Engine No. ....
Repairs made by ..... Name of Workman in charge of work.
Approved by ..... Foreman Round-house.

M. P. FORM 96.

ENGINEER'S REPORT TO MASTER MECHANIC OF PARTICULARS OF STOCK KILLED OR INJURED.

The purpose of this report is that the officials may have a record of all stock killed or injured, in case a claim is made against the company by the owners of the stock.

M. P. Form 96

## ENGINEER'S REPORT TO MASTER MECHANIC OF PARTICULARS OF STOCK KILLED OR INJURED.

.....DIVISION.

**NOTE.**—This report must be made by engineers for all stock killed or injured by locomotives operated by them.

Each question must be answered fully and the report forwarded to the master mechanic, who will in turn forward it to the division superintendent.

- 
- 
1. Date.....19.....Train No. ....Passenger or Freight.....  
 No. of engine.....Conductor.....Brakeman.....  
 Time accident occurred.....M., Daylight or dark.....
  2. Number and kind of stock killed or injured.....
  3. Place of accident.....
  4. Was stock struck on a highway crossing?.....
  5. If so, was the proper crossing signal given?.....Was engine bell ringing?.....
  6. If accident happened on station grounds, was it between switches or between switch and cattle guard?.....
  7. Rate of speed when you first saw stock.....miles per hour.  
 Rate of speed when you struck stock.....
  8. Did accident happen at point where the track was straight? If so, for what distance before stock was struck?.....
  9. Was the alarm whistle sounded for stock?.....
  10. If so, at what distance from stock?.....
  11. What was the grade? Up or down? And for what distance from point of accident? .....
  12. How many cars did you have in train, loaded or empty?.....
  13. How far were you from stock when first discovered? .....
  14. Give reason why stock was not discovered by you or your fireman sooner?
  15. Was stock on track when you first discovered it?.....
  16. From which side of the engine did the stock come upon the track?.....
  17. State particularly what effort, if any, was made to avoid the accident?.....

### REMARKS.

18. Did you notice condition of Company's right of way fences, gates or bars, and give any information you think will be of value to Company, relative to same, and not above stated.....

.....

.....

.....

.....Engineer

U. S. FORM 97.

REGISTRATION OF TRADE UNIONS IN TRADE MAN, AND OF THE UNION ACT IN VARIOUS LABOR

WHEREAS there are many cases where there  
 is a discrepancy between the records of the company  
 and the records of the union in which the men worked  
 and the time of day in registering such time  
 as is necessary to be recorded. The sheets should be  
 prepared in such a manner that if pages may  
 be torn out of the book at the end of the month the  
 balance of the records should be correct for each man  
 and the balance of the records in the proper col-  
 umn of the book should be made in each of the  
 columns. It will be noted that the certified  
 records are forwarded monthly to the  
 Bureau of Labor Statistics and are in the pay roll  
 book of the Bureau of Labor Statistics.  
 It will be noted that the timekeeper  
 should be the person to prepare in the three  
 columns of the book in 115 and No. 105.





M. P. FORM 97.

**PARTICULARS OF HOURS WORKED BY EACH MAN,  
RATE OF PAY, WAGES, AND ON WHAT LABOR  
WAS EXPENDED.**

Foremen having charge of men at points where there is no separate timekeeper should use the accompanying blank in recording the number of hours worked by such men each day, and in distributing such time daily to the accounts benefited. The sheets should be eyeletted so that the necessary number of pages may be bound in one book. At the end of the month the total time worked during the month by each man should be summed up and entered in the proper column; also the total amounts chargeable to each of the accounts named. The book should then be certified to by the foreman and forwarded promptly to the proper official, who will enter the time on the pay roll and charge the labor in his distribution book.

At shops this form will be used by the timekeeper in entering the time claimed by employes on the three preceding forms, viz.: Nos. 58, 103 and No. 105.



## M. P. FORM 98.

## REQUISITION FOR AND INVOICE OF MATERIAL.

This form is to be used in ordering material, and serves the purpose of an invoice and requisition. It is one of three forms, namely: "Requisition for and Invoice of Material," "Notice of Material Ordered," (Form 99) and "Record of Material Ordered," (Form 100.) With the use of carbon sheets these forms are written simultaneously. The original is to be sent to the official to whom it is addressed; the second copy to the party who is to receive the material; and the third copy retained for the office record.

REQUISITION FOR AND INVOICE OF MATERIAL.

..... 19.....  
 Requisition No.....

Dear Sir:

REQUISITION is hereby made for MATERIAL called for below. Please send without delay to.....at.....

and send invoice to .....at.....

Certified to..... Date..... 19..... Signed:..... Date..... 19.....

Certified to..... Date..... 19..... Approved:..... Date..... 19.....

NOTE.—This blank should be used in ordering material—the quantity “Now on Hand,” “Due on Previous Requisitions” and “Additional Quantity Wanted,” and “Kind of Material” being entered in the proper places by the person making the requisition.

Upon receipt of this requisition, properly approved, the official upon whom it is drawn will forward the material in accordance with the directions given. Any items which cannot be supplied at once should be drawn off, to be shipped as soon as possible, and the person making the requisition promptly notified of the probable date of shipment.

All items shipped should be invoiced to the proper person, as directed, showing date and initials, and number of car in which shipped and quantity, price and amount in the spaces provided. Before forwarding, this invoice should be copied in the record book of “Material Forwarded.”

Before accepting this invoice, the person receiving it should forward it to the person to whom the material was shipped who should compare it with his record of the material received, and in the event of error or omission, or in case there is any variation or deficiency, either in quality or quantity, the subjoined account must be corrected accordingly.

Quantity of Material			KIND OF MATERIAL	MATERIAL SHIPPED		
Now on Hand	Due on Previous Requisitions	Additional Quantity Wanted		DATE..... Car.....		
			IN ORDERING MATERIAL PLEASE KEEP WITHIN SPACE BELOW			Quantity



**RECORD OF MATERIAL ORDERED.**

.....19...

No.....

Record of material ordered from above named official to be sent

to..... at.....

and to be invoiced to..... at.....

**NOTE**—This copy will be retained as a record by the person making the Requisition and must be filed in consecutive order according to the number.

.....Date.....19...

QUANTITY OF MATERIAL			KIND OF MATERIAL	INVOICE CHECKED		
Now on Hand	Due on Previous Requisitions	Additional Quantity Wanted		Invoice From	Date of Receipt	Date Checked

## M. P. FORM 101.

## SHOP ORDER FOR MATERIAL.

This form is to be used in ordering material from store to be used on all classes of work in shops. The order should be dated and specify in detail the articles required, quantity and the account to which the material is to be charged. The "Weight," "Price," and "Amount" columns should not be filled in by the person ordering the material, as this will be done by the storekeeper and the order will then furnish information for writing up the accounts. The stub should be filled out by the person ordering the material and retained as a record to be used in checking up the material when received. Orders for material to be used for articles manufactured at shops of the company, may be printed on colored paper to distinguish them from the orders for material to be used for other purposes if desired.





M. P. FORM 102.

**REPORT OF PIECE WORK PERFORMED BY EACH EMPLOYEE.**

This report is to be made by the foreman for each employe engaged on piece work. After being approved by the official in charge this report is to be sent to the timekeeper, who will make the proper allowance of time. A carbon sheet should be used and a copy retained by the foreman for his record. In view of the fact that these reports are all approved before being sent to the timekeeper, they may be printed on colored paper, thereby making it easier to designate them from the other labor forms.

SUPERVISION OF LOCOMOTIVES.

REPORT OF PIECE WORK PERFORMED BY EACH EMPLOYEE.

Check No.....  
Shop.....Shop,.....19.....

To.....  
.....

Please allow.....

occupation..... nature of work.....

number of pieces..... rate per.....

time engaged in above work from..... to.....

Charge to.....

Approved:.....

Foreman;

## M. P. FORM 103.

## FORM OF APPLICATION FOR EMPLOYMENT IN SHOP.

This form is to be used by all persons in making application for a position in the shops of the Motive Power Department. It furnishes information for an investigation of the record of the applicant as to his qualifications, and such investigation should always be made before a person is allowed to enter permanently into the employ of the company.

**FORM OF APPLICATION FOR EMPLOYMENT  
IN SHOP.**

**NOTE.**—Upon this application the applicant may be permitted to enter the service on probation, provided there is need for his services and he has passed a satisfactory examination, by the head of the department, but it must be distinctly understood that before he can enter permanently into the service or be regarded as a regular employe, the written approval of the head of the department must be obtained.

Full name and address of applicant. }  
 ..... }  
 ..... } Dated at..... 19..  
 ..... }  
 Place of birth..... Date of birth..... 18. Age.....  
 Nationality..... Married or single.....  
 What position do you desire?.....  
 What experience have you had in that line?.....  
 By whom are you employed at present?.....  
 No.....Street.....Town or City.....State of.....  
 In what capacity are you employed at present?.....  
 Is any one dependent on you for support? If so, give particulars.....  
 Give particulars and amount of any debt you owe or liability you are under...  
 Do you drink malt or spirituous liquors?.....  
 What is the condition of your general health?.....  
 Are you able-bodied?.....  
 Is your hearing good?.....  
 Is your eyesight good?.....  
 Are you able to distinguish colors?.....  
 Have you ever been injured? If so, when, where, how and extent of injury...  
 Name of last school attended.....  
 Did you graduate.....If not, how long did you attend?.....  
 State below where and how you have been employed during the last five years making no omission in the record: .

TIME OF SERVICE.			NAME OF EMPLOYER (If the employer was a corporation, give name of such corporation, also name and PRESENT address of official under whom you served.)	Place where Employed	Nature of Employment (How Employed.)	Why did you leave?
FROM		TO				
h th.	Year	Mth. Year				

Have you ever been discharged or suspended from any situation? If so, state when, where, and under what conditions?.....  
 Have you ever been in the employ of this Company before? If so, state when, where, in what capacity, and cause of leaving.....  
 Give below the name, address and occupation of your parents and other relatives. If any are deceased, give other nearest relatives: .

NAME.	OCCUPATION.	ADDRESS.
Father.....	.....	.....
Mother.....	.....	.....
NEAREST MALE RELATIVE:		
On Father's side.....	.....	.....
On Mother's side.....	.....	.....

Are any of your relatives in the employ of this Company? If so, state who they are, and in what capacity employed.....

Will you faithfully perform such duties as may be legally required of you by your superiors?.....

In consideration of my employment by said company, I agree that whenever I shall sustain any personal injury while in the service of said company I will allow its surgeon and any medical examiners it may select to examine my person and body as often as the company may deem necessary in respect to the alleged injury, and I hereby waive all objections to such surgeons or medical examiners testifying whenever called upon by the company, and I further agree that my refusal to allow any such examination to be made or testimony to be given shall be a bar to the institution or prosecution of any action on account of such injury; and any action pending at the time of such refusal shall at once abate in consequence thereof.

In further consideration of such employment I agree that if, while in the service of said company, I sustain any personal injury for which I shall or may make claim against the company for damages, I will, within thirty days after receiving such injury, give notice in writing of such claim to the General Claim Agent of said company; which notice shall state the time, place, manner and cause of my being injured and the nature and extent of my injuries, and the claim made therefor, to the end that such claim may be fully, fairly and promptly investigated; and my failure to give written notice of such claim in the manner and within the time aforesaid, shall be a bar to the institution of any suit on account of such injuries.

I certify that my answers to the above questions are true, and agree that they shall be the basis of my employment.

Signature of Applicant.....

(All applications for employment in this Department must be made on this blank in duplicate, and when party enters the service of this company the employing officer will send both copies to the head of the department.)

M. P. FORM 104.

**PARTICULARS OF MECHANICAL EXAMINATIONS OF FIRE-  
MEN AT THE END OF THE FIRST, SECOND AND  
THIRD YEARS OF SERVICE.**

The particulars of these examinations (so important in connection with the supervision of locomotives) are omitted here as they are given, with other matters relating to enginemen, elsewhere in the "Science of Railways."

It may be said, however, in connection with these examinations made by Master Mechanics, that one year is usually allowed each man who seeks to become an engineer, in which to prepare for the examination. At the end of that period he must pass with a percentage as high as 80. Should he fail to pass as high as this, he is given another opportunity to pass the same examination within six months; if he then fails to pass by a percentage equal to 80, he is dropped from the enginemen's list. The same rules are observed in regard to the second and third years' service and examinations.

M. P. FORM 105.

DAILY DISTRIBUTION OF LABOR FOR MANUFACTURED  
MATERIAL WORK.

This report is to be made out daily by each employe working upon material manufactured by the company. After being approved by the foreman it is to be forwarded to the timekeeper, who will make the proper allowance of time. It is then to be given to the cost clerk, to be used in obtaining the cost of the article under course of manufacture. This form may be printed on colored paper, in order that it may be distinguished readily from the other labor distribution slips.





M. P. FORM 106.

**DISTRIBUTION BLANK FOR MATERIAL USED.**

M. P. FORM 107.

**DISTRIBUTION BLANK FOR LABOR PERFORMED.**

Loose sheets of these forms are furnished to all employes who are required to make returns of material used (form 106) and labor performed (form 107). The object of furnishing the blanks in loose sheets is to enable the person who writes them up to take an impression copy before they leave his hands; thus the clerical work that would otherwise be required in making a written copy is avoided, the impression answering for local uses while the original is sent to headquarters.

It will be noticed that the sheets are eyeleted; these eyelets are to enable the person making the return to collect the sheets together and bind them in book form before they leave his hands. Covers for the books should be furnished with the blanks and similarly eyeleted.





M. P. Form 108

**MONTHLY STATEMENT OF THE TONNAGE HAUL OF ENGINEERS AND AVERAGE  
NUMBER OF TONS HAULED PER TRAIN.**

For month of ..... 19.....

NAME OF ENGINEER	Engine Number	Engine Mileage	NO. TONS HAULED ONE MILE	Average No. of Tons hauled per Train

**NOTE.**—The train reports of conductors show the engine mileage and train tonnage, and from these reports this exhibit is compiled. It is a summarization of an account kept with each engineer and shows his engine mileage and gross train ton-mileage. The information is of peculiar value in directions that need not be explained, to those concerned in the movement of equipment and traffic.

## CHAPTER V.

### LOCOMOTIVE AND TRAIN MILEAGE.

Information regarding locomotive mileage is of great value in many ways, but chiefly for ascertaining the relative economy exercised. For this purpose exhibits are prepared which show the average outlay per mile run by locomotives for wages of engineers, firemen, locomotive wipers, hostlers, and laborers at roundhouses; cost of repairs (material and labor being shown separately), supplies—such as tools and cab furniture—quantity and cost of fuel; quantities and cost of oil and waste, etc., etc. The statistics should show (as specified), the average number of pounds of coal, pints of lubricating oil, pounds of waste, and average train tonnage hauled, per mile run. These returns are commonly embraced in what is called the performance sheets of locomotives.

The use made of data regarding locomotive mileage varies on different roads; nor is uniformity observed in classifying the service. Because of this, and to facilitate comparisons, it has been suggested that the mileage of locomotives should be reported under the following specific heads:

- Passenger locomotive mileage.
- Freight locomotive mileage.
- Mixed train locomotive mileage.
- Helping locomotive mileage.
- Light locomotive mileage.
- Switching locomotive mileage.
- Work locomotive mileage.

There can be no objection to this classification being further subdivided to meet the preferences of par-

ticular roads—provided such subdivisions may finally be consolidated under the heads named above.

Passenger locomotive mileage embraces revenue passenger train mileage, as hereinafter defined, and the mileage of non-revenue trains of the passenger class, such as pay trains, official trains, complimentary trains, employes' trains, etc.

Freight locomotive mileage embraces revenue freight train mileage, not including the mileage of trains consisting of only a locomotive and caboose "running light." It also includes the mileage of non-revenue freight trains, such as trains hauling company material and supplies.

Mixed train locomotives mileage embraces revenue mixed train mileage.

Helping locomotive mileage embraces the mileage of locomotives while pushing, double-heading or otherwise assisting trains of all classes. It also includes the additional loaded mileage made in doubling hills. It is subdivided into four classes, according to the nature of the service, each of which should be separately reported, viz.: helping passenger trains, helping freight trains, helping mixed trains, and helping non-revenue trains.

Light locomotive mileage embraces that made by locomotives running "light," as when running for water or fuel; running to or from the roundhouse, shops, or trains; running light after pushing, double-heading, or in any similar way assisting passenger, freight, mixed or non-revenue trains; and light mileage made in doubling hills. It also includes the mileage of locomotives when running with only a caboose car attached.

Switching locomotive mileage embraces all loaded or light mileage made in switching cars, except shop or work switching.

Work locomotive mileage embraces the mileage of

locomotives engaged in hauling work trains, such as gravel, ballast, construction, wrecking and repair trains, snow plows and flangers; also the mileage of locomotives employed in shop or work switching.

---

The rules governing the computation of locomotive mileage are as generally follows:

The mileage of locomotives engaged in hauling trains—except helping mileage and work train mileage—should be based on the actual distance run between terminals, to be computed from the official time-table, as hereinafter prescribed for train mileage.

Helping and light mileage of locomotives should be based on the actual distance run while helping trains or running light, as the case may be.

Switching locomotive mileage is computed at an arbitrary rate of six miles per hour for the actual time while engaged in such service (or such other basis as may be determined from time to time.) Mileage for switching and other work done incidentally enroute at way stations is not generally allowed, except in the case of locomotives of local freight trains when employed in switching for one hour or more at a station—in which case they are allowed switching mileage at the rate of six miles per hour for the actual time so employed. No allowance is usually made when the time thus engaged is for less than one hour at any particular station.

Work locomotive mileage is arrived at in the same manner as prescribed for work train mileage.

To ascertain what percentage the helping passenger locomotive mileage is of the passenger train mileage, the total mileage of locomotives helping passenger trains should be divided by the total passenger train mileage.

---

To ascertain what percentage the helping freight

locomotive mileage is of the freight train mileage, the total mileage of locomotives helping freight trains should be divided by the total freight train mileage.

And similarly, to ascertain what percentage the helping mixed train locomotive mileage is of the mixed train mileage, the total mileage of locomotives helping mixed trains should be divided by the total mixed train mileage.

---

While usages differ in regard to the classification of locomotive mileage on different roads, nevertheless there is practical unanimity in reference to what constitutes the different classes of service, viz.: passenger, freight, switching and work. But there is nothing so fixed or necessarily arbitrary in connection with the matter as to enforce particular methods, whether or no.

If for any reason it is desired to consolidate the different classes of locomotive mileage so as to show only the four kinds of service as named above, the following classification has been suggested:

Passenger mileage to include passenger locomotive mileage; a proportion of the mixed train locomotive mileage, based on the work performed; the mileage of locomotives helping passenger trains; and, finally, the light mileage made by locomotives on account of passenger service.

Freight mileage to include freight locomotive mileage; a proportion of the mixed train locomotive mileage, based on the work performed; the mileage of locomotives engaged in helping freight trains; and, last, the light mileage made by locomotives on account of freight service.

Switching and work mileage should include the switching locomotive mileage and the work locomotive mileage as previously defined.



### TRAIN MILEAGE.

The following classification of train mileage, it is, of course, to be understood, may be further subdivided or extended to meet the preferences or special needs of a company; but no change is advisable that will prevent the ready compilation of the statistics required under the general heads prescribed by the government for the use of railroad companies in making their returns.

The subdivisions as given below represent the ideas of experts upon the subject, and will, generally, be found sufficient for all practical uses. For explanatory purposes here, a "train" may be defined as consisting of one or more cars coupled together, drawn by a locomotive, running between specified terminal points in accordance with an authorized schedule or time table, or under special orders from the operating officials of a company.

Each train and each section of a train operated by a separate train crew, is considered a separate train, whether hauled by one or more locomotives, either for the whole or only a part of the distance between the terminal stations.

Train mileage is divided into two general classes: revenue train mileage, which includes the mileage of all trains from the operation of which the company receives an income—directly or indirectly; and non-revenue train mileage, which includes the mileage of all trains operated by the company from which no income is derived.

Revenue train mileage is subdivided into passenger train mileage, freight train mileage, and mixed train mileage. These may be defined in detail as follows:

Passenger train mileage embraces the mileage of trains run to transport revenue-earning passengers, and to carry baggage, mail, express matter, and other traffic classed as passenger business—not including any trains which regularly include one or more cars

devoted exclusively or principally to carrying revenue-earning freight.

Freight train mileage embraces the mileage of trains run to transport revenue-earning freight—excluding all trains which regularly include one or more cars devoted exclusively or principally to revenue passenger business. It also includes the mileage of trains of empty freight cars, or of trains running light—*i. e.*, consisting of a locomotive and caboose.

NOTE.—When milk cars are hauled in a passenger train, the mileage of the train is, for convenience, generally embraced under the head of passenger train mileage. When milk or express cars are hauled in a freight train (and their earnings are classed as freight earnings) the mileage of the train is similarly included under the head of freight train mileage.

Mixed train mileage embraces that of trains carrying both revenue passengers and revenue freight—each car being exclusively or principally devoted to either passenger business or freight business. Freight trains that haul no passenger cars, but transport passengers in caboose or way cars, are not called mixed trains, but their mileage is included under the head of freight train mileage.

Non-revenue train mileage embraces the mileage of trains not directly connected with the earning of revenue, such as pay trains, official trains, complimentary special trans, trains run to convey employes; trains hauling the company's material and supplies gravel, ballast, construction, wrecking and repair trains, snow plows and flangers and so on. As a rule the mileage of non-revenue trains is not kept separate as to the classes named above, but given in gross under the general head of non-revenue train mileage.

NOTE.—Revenue passenger trains and revenue mixed trains may incidentally carry private or official cars, work or service cars, or cars of related classes, for which no charge is made; and similarly, revenue freight trains and revenue mixed trains may incidentally carry cars containing railway material and supplies, or other freight not earning revenue; but only whole trains of such non-paying cars should be regarded as non-revenue trains and classed accordingly.

The mileage made in switching trains and cars is not properly included under the head of train mileage. Such statistics should be reported under the head of "switching locomotive mileage," defined elsewhere.

---

In computing revenue train mileage the mileage allowed is based on the actual distance run between terminals, as shown by the official time table. There should be nothing added to this distance to cover switching or other work at way stations, or for service of helper or pusher engines, or extra engines on double or triple head trains, or for any distance run by the engine in excess of that run by the train, such as the distance from the round house to the train terminal, doubling hills, running for fuel or water, etc.

The same rule is observed in computing mileage of passengers and tons of freight, and car mileage.

The mileage of non-revenue trains should be based on the actual distance run between terminals, the same as directed for revenue trains. When work trains are run between terminals and do not work at some specified point or within specified limits, they are allowed the actual mileage made, the same as other trains. When run to a certain point for the purpose of working at that point or within specified limits, they should be allowed the actual mileage made under running orders, and in addition an arbitrary mileage of six miles per hour (or whatever may be agreed upon), for the time they actually work at the point designated or within the working limits specified.

From the foregoing it will be seen that train mileage takes no account of the gross work done, such as the number of cars moved, passengers carried, or tonnage hauled. A train is a train—whether long or short, heavy or light; and it is for this reason that train mileage figures alone are in themselves of no great value.

But when used in conjunction with other returns, operating efficiency may in a measure be determined; such statistics being of value to the officers of a company in the supervision of the movement of traffic, etc., etc.

For example, the expense of running a light train is proportionately greater than the expense of operating a heavier train—taking into consideration the relative tonnage moved—because many of the expenses incurred in connection with the movement of a train are practically the same, regardless of the gross tonnage handled. The expense for wages of engine-men and train crew, the cost of the supervision of a train's movement over the road, the expense of looking after and caring for the engine at terminal points, the maintenance of the roadway, and so on,—all large items of expense—are not increased in proportion with an increase in the load hauled by a train. If, therefore, the number of loaded freight cars hauled per train mile—the gross tonnage of revenue freight moved per train mile—can be increased, the earning power of the road is thereby heightened; and it is in determining; what has been accomplished along such lines that locomotive and train mileage statistics are of value.

NOTE.—In the volume on "Supervision of Cars," a classification is made of statistics found to be of practical value, such as the mileage of trains, the cars they haul, the loads they carry, etc.



# INDEX.

	PAGE
Agent's Report of Time Worked by Switch Yard Crews ( <i>Form</i> )	90, 91
Air Compressors—Necessity of	30
Blacksmith Shops—Arrangement of	29
Blanks—See Forms.	
Boiler Shops—Arrangement of	29
Boilers, Locomotive—Repairs to	20
Car Mileage	252
Certificate Given on Completion of Apprenticeship ( <i>Form</i> )	216, 217
Chemist, Place of in Organization	19
Computing Locomotive Mileage	248, 249
Daily Distribution of Labor for Manufactured Material Work ( <i>Form</i> )	240, 241
Daily Report of Distribution of Shop Labor of Each Man ( <i>Form</i> )	160, 161
Definition of What Constitutes Engine Failures ( <i>Form</i> )	72, 73
Department of Motive Power and Machinery; See "Motive Power Department."	
Distribution Blank for Labor Performed ( <i>Form</i> )	242, 244
Distribution Blank for Material Used ( <i>Form</i> )	242, 243
Division Time Book of Locomotive Engineer's Giving Particu- lars of the Service of Each ( <i>Form</i> )	94, 95, 96, 97
Division Master Mechanics—Place of in Organization	19
Draughtsmen, Chief—Duties of	23
Draughtsmen, Duties of	22
Drawing Office—Importance of	23
Dynamometer Car—Advantages of	23
Electricity, Use of in Shops and Buildings	29
Engineer, Mechanical—Place of in Organization	19
Engineer of Tests, Place of in Organization	19
Engineer's Daily Report of Switching Time ( <i>Form</i> )	88, 89
"    Examinations—Necessity of	9, 10
"    Monthly Report of Time Worked ( <i>Form</i> )	92, 93
"    Report to Master Mechanic of Delays on Each Trip ( <i>Form</i> )	76, 77
"    Report to Master Mechanic of Particulars of Stock Killed or Injured ( <i>Form</i> )	224, 225
"    Report to Round House Foreman of Condition of Engines at End of Each Trip ( <i>Form</i> )	222, 223
"    Requisition for Supplies ( <i>Form</i> )	220, 221
Engineers, Traveling—Usefulness of	9
Enginehouse Register ( <i>Form</i> )	98, 99

	PAGE
Engines, Road Foremen of—Place of in Organization	19
"    See also "Locomotives."	
Erecting Shops—Arrangement of	27, 28
Equipment, Shortage in—Effect of	7
Examinations, Engineers' and Firemen's—Necessity of	9, 10
Examiners, Firemen's	25, 26
Exhibits—See "Blanks," "Forms," "Returns."	
Firemen's Examinations—Necessity of	9, 10
Firemen, Examination of	25
"    Promotion of	25
Fire, Protection from—Arrangements for	30
Foreman, General—See "General Foremen."	
Foreman of Shops, General—Place of in Organization	19
Foreman's Monthly Report to Master Mechanic of Cast Iron Truck and Tender Wheels Applied to and Removed from Locomotives ( <i>Form</i> )	136, 137
Foreman's Weekly Report of Locomotives in Shop ( <i>Form</i> )	70, 71
"    Weekly Report to the Master Mechanic of Loco- motive Boilers Washed Out ( <i>Form</i> )	46, 47
Foremen, Roundhouse—Place of in Organization	19
"    Shop—Place of in Organization	19
Form of Application for Employment in Shop	236, 237, 238
"    of Application of those Seeking Employment on Engines	206, 207, 208, 209
"    of Coal Tickets used on Engines	120, 121
"    of Oil and Waste Tickets Used on Engines	126, 127
"    of Release to be Signed by Minors and Their Legal Guardians	214, 215
Forms Specific	41, 46, 245
"    Use of	34
"    Value of	34
"    What they Represent	35
Foundry, Arrangement of	29
Freight Locomotive Mileage	246, 247, 249
"    Mileage	252
"    Train Mileage	251
General Foremen, Place of in Organization	19
"    Manager, Place of in Organization	19
Helping Locomotive Mileage	246, 247
Hospital Track	30
Index to Driving Wheel Tire Record ( <i>Form</i> )	156, 157
"    to Record of Steel-Tired Engine Truck Wheels ( <i>Form</i> )	150, 151
Inspector's Monthly Report of Inspection of Stationary and Locomotive Fire-Box Stay-Bolts ( <i>Form</i> )	190, 191
"    Report (as per diagrams) of Locomotive Breakages of Different Parts ( <i>Form</i> )	170, 171, 172, 173, 174, 175, 176, 177, 178, 179, 180, 181, 182, 183, 184, 185, 186.
"    Report of Changes and Repairs of Stationary Boilers ( <i>Form</i> )	196, 197
"    Report of Inspection of Air and Steam Gauges and Safety Valves ( <i>Form</i> )	194, 195

INDEX.

257

	PAGE
Inspector's Record of Inspection of Stationary and Locomotive Fire-Box Stay-Bolts ( <i>Form</i> )	188, 189
"    Report of Periodical Inspection of Stationary Boilers ( <i>Form</i> )	192, 193
Light Locomotive Mileage	246, 247
Locomotive Engineer's Trip Report of Time Worked ( <i>Form</i> )	84, 85
"    Its Progress through the Shops	30
"    Mileage	246
"    Mileage—Classification of	249
"    Parts, Utilizing	21, 22
"    Report, Particulars of Service and Cost for Repairs, Supplies and Labor ( <i>Form</i> )	134, 135
Locomotives, Breaking in	33
"    Designing	21
"    Differences in	9
"    Distribution of Over Road	-
"    Faulty	21, 22
"    Keeping Specific Accounts with	37
"    Maintaining	6
"    Repairing	30
"    Statistics of Performance of	37
"    Supervising	7
"    Uniformity in Classes—Advantages of	22
"    Watching	12, 13
"    When to Shop	20
Machinery, maintaining	7
Machine Shops, Arrangement of	28
Master Mechanic, Place of in Organization	19
"    Mechanics, Division—Place of in Organization	19
"    Mechanics, Meetings of	25
"    Mechanic's Monthly Report to Superintendent of Motive Power and Machinery of the Total Number of Men of Each Class of Labor Employed on His Division During the Month and Wages Paid ( <i>Form</i> )	166, 167
"    Mechanic's Monthly Report to the Superintendent of Motive Power and Machinery of the Condition of Each Engine on His Division ( <i>Form</i> )	54, 55
"    Mechanic's Monthly Statement to Superintendent of Motive Power and Machinery of Comparative Cost of Labor ( <i>Form</i> )	162, 163
"    Mechanic's Notice of Vacancies in Runs and Service ( <i>Form</i> )	210, 211
"    Mechanic's Report to Superintendent of Motive Power and Machinery of Condition of Tools and Machinery ( <i>Form</i> )	204, 205
"    Mechanic's Report of Repairs made on Particular Engines ( <i>Form</i> )	60, 31
"    Mechanic's Report of Cost of Repairs on Particular Engines ( <i>Form</i> )	66, 67
"    Mechanic's Monthly Summary to the Superintendent of Motive Power and Machinery in Regard to Heavy Repairs Made on Engines ( <i>Form</i> )	68, 69



	PAGE
Master Mechanic's Ten Days Report to the Superintendent of Motive Power and Machinery of Engine Failures ( <i>Form</i> )	78, 79
“ Mechanic's Weekly Report to Superintendent of Motive Power and Machinery of Average Terminal Delays of Freight Engines and the Cause Therefor ( <i>Form</i> )	218, 219
“ Mechanic's Weekly Report to Superintendent of Motive Power and Machinery of the Location of Locomotives ( <i>Form</i> )	48, 49
Material, Testing	24
Mechanic, Master—See “Master Mechanic.”	
Mechanical Engineer, Duties of	21, 23
“ Engineer, Place of in Organization	19
Mileage Locomotive	246
“ Statistics	246
“ Train	246
Mixed Train Locomotive Mileage	246, 247
“ Train Mileage	251
Monthly Record of Repairs on Each Locomotive ( <i>Form</i> )	112, 113
“ Record of the Mileage of Each Engine ( <i>Form</i> )	108, 109
“ Record of the Superintendent of Motive Power and Machinery of Condition of Each Engine on Each Division ( <i>Form</i> )	56, 57
“ Record of the Superintendent of Motive Power and Machinery of Particulars (Cause) of Engine Failures on Each Day of the Month ( <i>Form</i> )	80, 81
“ Record of the Superintendent of Motive Power and Machinery of the Condition of the Different Classes of Engines on Each Division ( <i>Form</i> )	58, 59
“ Record of Superintendent of Motive Power and Machinery of Each Defective Cast Iron Engine and Tender Wheel Removed ( <i>Form</i> )	138, 139
“ Record of the Superintendent of Motive Power and Machinery of the Gross Cost of Delayed and Overtime on Each Division ( <i>Form</i> )	102, 103
“ Report for Division Master Mechanic of Mileage and Cost of Repairs of Each Locomotive on His Division ( <i>Form</i> )	116, 117
“ Report for the Superintendent of Motive Power and Machinery of the Miles Run and Cost of Repairs of Each Engine ( <i>Form</i> )	114, 115
“ Report of Each Engineer's Service, viz: Total Miles Run by Locomotive Under His Charge, Tons Hauled and Fuel Consumed ( <i>Form</i> )	200, 201
“ Report of Fuel Delivered at Each Point to Locomotives ( <i>Form</i> )	122, 123
“ Report of Locomotive Mileage (Classified) of Each Engine ( <i>Form</i> )	106, 107
“ Report of Particulars of Cost of Repairs of Each Locomotive ( <i>Form</i> )	110, 111

	PAGE
Monthly Report of the Superintendent of Motive Power and Machinery to the Purchasing Agent of Defective Cast Iron Wheels Removed from Locomotives and by Whom Made ( <i>Form</i> ).....	142, 143
“ Report of the Superintendent of Motive Power and Machinery of Wheels that have Failed to Meet Guarantee of Makers ( <i>Form</i> ).....	144, 145
“ Report of Total Amount of Oil and Waste Delivered to Locomotives on each Division ( <i>Form</i> ).....	128, 129
“ Report to the Superintendent of Motive Power and Machinery of Engine Driving Wheel Tires Applied and Removed ( <i>Form</i> ).....	154, 155
“ Statement of Locomotive Mileage on Each Division ( <i>Form</i> ).....	104, 105
“ Statement of the Tonnage Haul of Engineers and Average Number of Tons Hauled per Train ( <i>Form</i> )..	245
“ Summary of Charges to Various Operating Accounts for Material and Labor Account of Engines on Each Division ( <i>Form</i> ).....	132, 133
“ Summary of Fuel Delivered to Locomotives ( <i>Form</i> ).....	124, 125
“ Summary of the Superintendent of Motive Power and Machinery of Cause of Engine Failures on Each Division ( <i>Form</i> ).....	82, 83
“ Summary of the Superintendent of Motive Power and Machinery of the Gross Number of Defective Cast Iron Locomotive Wheels Removed, Made by Different Manufacturers ( <i>Form</i> ).....	140, 141
Motive Power Department, Administration of.....	15
“ Power Department, Details of.....	15
“ Power Department, Extent of.....	14
“ Power Department, Line Organization of.....	18, 19
“ Power Department, Organization of.....	18, 19
“ Power of Railroads.....	5
Non-Revenue Train Mileage.....	251, 252
Notice of Material Ordered ( <i>Form</i> ).....	230
Notice of Superintendent of Motive Power and Machinery of those authorized to Operate Locomotives ( <i>Form</i> ).....	212, 213
Office, Drawing—Importance of.....	23
Organization of Motive Power Department.....	19
Paint Shop, Arrangement of.....	29
Particulars of Hours Worked by Each Man, Rate of Pay, Wages, and on What Labor Was Expended ( <i>Form</i> ).....	226, 227
Particulars of Mechanical Examinations of Firemen at the end of the First Second and Third Years of Service.....	239
Passenger Locomotive Mileage.....	246, 247, 249
“ Mileage.....	252
“ Train Mileage.....	250
Patterns, Care of.....	23
“ Designing.....	23
Quayle, Robert.....	16

	PAGE
Record of Material Ordered ( <i>Form</i> )	231
“ of Mileage (Classified) and Cost of Repairs of Each Locomotive ( <i>Form</i> )	118, 119
“ of Superintendent of Motive Power and Machinery of Driving Wheel Tires ( <i>Form</i> )	158, 159
“ of the Superintendent of Motive Power and Machinery of Engine Truck and Tender Wheels Applied to and Removed from Each Locomotive ( <i>Form</i> )	146, 147
“ of Superintendent of Motive Power and Machinery of Steel Tires on Engine Truck Wheels ( <i>Form</i> )	152, 153
Repairs, Effect of Neglect on	7
Report of Piece Work Performed by Each Employe ( <i>Form</i> )	234, 235
Requisition for and Invoice of Material ( <i>Form</i> )	228, 229
Returns, Locomotive Department—Purpose of	11, 12
Returns—See “Forms.”	
Revenue Train Mileage	250, 252
Road Foremen of Engines, Place of in Organization	19
Round House Foreman’s Monthly Report of the Number of Engines Wiped Daily ( <i>Form</i> )	130, 131
“ House Foremen, Place of in Organization	19
Statistics, Mileage	246
Shops, Erecting—Arrangement of	27, 28
Shop Foreman’s Monthly Report to Master Mechanic of Number of Men of Each Class of Labor Employed During the Month and Wages Paid ( <i>Form</i> )	164, 165
“ Foreman’s Monthly Report to the Master Mechanic of Particulars of Steel Tired Engine Truck and Tender Wheels Applied to or Removed from Locomotives ( <i>Form</i> )	148, 149
“ Foreman’s Report to His Superior of Repairs on Particular Engines ( <i>Form</i> )	62, 63, 64, 65
“ Foreman’s Report to Master Mechanic of Valve Motion of Engines ( <i>Form</i> )	198, 199
“ Foremen, Place of in Organization	19
Shops, General—Equipment of	18
“ Main, Location of	26
“ Locomotive Repair—Locating	17
“ Main—Arrangement of	26
“ Main—General Foreman of	19
“ Main—Machinery Required In	26
“ Main—Tools Required In	26
“ Main—Tracks In	27
“ Small—Locating	17
“ Subordinate, Visiting	24
Shop Order for Material ( <i>Form</i> )	232, 233
Shopping Locomotives	20
Shop Work, Concentrating—Advantage of	17
Statement of Mileage Made by Each Engineer to Pint of Lubricating Oil ( <i>Form</i> )	202, 203
Steam, Supplying Shops With	30
Storehouse, Arrangement of	29

	PAGE
Storekeeper's Monthly Report to the Superintendent of Motive Power and Machinery of Delayed and Overtime Allowed Engineers and Firemen ( <i>Form</i> ) . . . . .	100, 101
Summary Made by Superintendent of Motive Power and Machinery for the General Manager of the Total Number of Men of Each Class of Labor and Wages Paid on Whole Road ( <i>Form</i> ) . . . . .	168, 169
Superintendent of Motive Power and Machinery, Extent of Expenditures of . . . . .	17
"    of Motive Power and Machinery—Methods of for Observing Equipment . . . . .	12, 13
"    of Motive Power and Machinery, Place of in Organization . . . . .	19
"    of Motive Power and Machinery—Sources of Information of . . . . .	10, 11
Switching Locomotive Mileage . . . . .	246, 247, 249
Tests, Engineer of—Place of in Organization . . . . .	19
Testing Material . . . . .	24
Train Dispatcher's Daily Report of Engine Failures ( <i>Form</i> ) . . . . .	74, 75
"    Dispatcher's Daily Record of Train Movements ( <i>Form</i> ) . . . . .	86, 87
"    Mileage . . . . .	246
"    Mileage, Classification of . . . . .	250
Waste, Preventing . . . . .	16
Water, Purifying—For Use by Locomotives . . . . .	21
Weekly Report by the Superintendent of Motive Power and Machinery to Interested Officials of the Total Number of Locomotives of Each Class on the Different Divisions ( <i>Form</i> ) . . . . .	50, 51
Weekly Report by the Superintendent of Motive Power and Machinery of the Location of Each Locomotive ( <i>Form</i> ) . . . . .	52, 53
Work Locomotive Mileage . . . . .	246, 247, 249

# Kirkman's Complete Works.

## THE SCIENCE OF RAILWAYS.

This great work is of inestimable value to those who look for advancement in railway work; also to those who by greater knowledge of railway affairs seek to become more useful to their employers. It is a library of Reference and Instruction; a recognized standard work on railways, at once concise, clear and comprehensive. It represents forty years of continuous effort on the part of the author, who has had nearly fifty years of practical experience as a railway officer. Thus, through his thorough acquaintance with the business, coupled with years of study, aided by the advice and co-operation of railway men of genius and vast experience in different departments of the service, he has been able to complete this great and lasting exposition of railway affairs.

## THE ROMANCE OF GILBERT HOLMES.

A romance of the Mississippi Valley in the early days, told with captivating power. Strong in plot, the most stirring adventures are interwoven with a love story which is idyllic and full of charm.

"Of the beauty and delicacy of the author's touch there can be no question."—Chicago Tribune.

"Each chapter contains something of interest. The love story gently and gracefully pervades the whole book."—Vanity Fair.

"A vivid and stirring picture of adventure, incident and romance that holds the interest of the reader from the start. A pretty love story runs through the book, told with so much delicacy and tenderness that it is a distinct charm."—Baltimore American.

"Wherever opened, something beautiful is found."—The Christian Nation, New York.

## ISKANDER.

A romance of the Court of Philip of Macedon and Alexander the Great. Full to the brim with stirring achievements. A page of history rewoven with the warp and woof of love and hate and intrigue and conflict.

"A delightful love story."—Philadelphia Inquirer.

"A swinging story of battle, intrigue, adventure, and that gentler thing, love."—Chicago Post.

"Well told. Full of tragic incident and stirring movement."—New Orleans Picayune.

"Replete with vivid description, entralling incident and soulful love passages."—New York Clubwomen.

"The love of Alexander and Roxana is described with great tenderness and the intrigue of the Macedonian Court is drawn with skill and historic precision."—Washington Star.

## PRIMITIVE CARRIERS.

In portfolio form, embracing fifteen hundred beautiful engravings, portraying the primitive peoples of the world and their methods of carriage in every age and quarter of the globe.

"A more interesting series of illustrations it would be difficult to imagine, or one that could give more clear and positive instruction in the history of humanity."—New York Sun.

"A superb volume, original in conception and unique in literature and art."—Chicago Tribune.

PUBLISHERS:

THE WORLD RAILWAY PUBLISHING COMPANY,  
CHICAGO.

