

# Scientific American.

THE ADVOCATE OF INDUSTRY, AND JOURNAL OF SCIENTIFIC, MECHANICAL, AND OTHER IMPROVEMENTS.

VOLUME X.]

NEW-YORK JUNE 16, 1855.

[NUMBER 40.]

THE  
**Scientific American,**  
PUBLISHED WEEKLY  
At 128 Fulton Street, N. Y. (Sun Buildings.)  
BY MUNN & COMPANY.

O. D. MUNN, S. H. WALKER, A. N. BRACE.

Agents:  
Federhen & Co., Boston. Dexter & Bro., New York.  
A. Winch, Philadelphia. E. G. Fuller, Halifax, N. S.  
S. G. Courtenay, Charleston. S. W. Pease, Cincinnati, O.  
Avery Bellford & Co., London. M. M. Gardisal & Co., Paris.  
Responsible Agents may also be found in all the principal cities and towns in the United States.  
Single copies of the paper are on sale at all the periodical stores in this city, Brooklyn, and Jersey City.

TERMS—\$2 a year:—\$1 in advance and the remainder in six months.

### Cement for the Outside Walls of Houses.

"The cement of Dihl," for coating the outside walls of buildings after they have received several coats of boiled oil, is composed of linseed oil boiled with litharge until it becomes a strong drier, then mixed with finely ground dry porcelain, or pipe clay, until it becomes of the consistency of thick mortar, in which state it is laid on.

Another kind is composed of dry sand, ten parts by measure, five of litharge, one of plaster of paris, or dry whiting, made moist with boiled linseed oil. In this state it has the appearance of dark brown wet sand. It is difficult to lay on, but soon becomes hard. The walls, in every case, should receive two coats of boiled oil, and be laid on in dry, but not hot weather.

### Administering Chloroform.

Edinburgh surgeons say that they are guided in avoiding danger to life from the use of chloroform in surgical cases, not by its effect on the pulse, but by the state of the breathing. They cease the administration of the vapor when the breathing becomes difficult, however favorable the pulse may appear to be. They also pay attention to the tongue, as a point of great importance. When the breathing becomes difficult, or ceases, they open the mouth, seize the tip of the tongue with artery forceps, and pull it well forward. Death, it is said, would have occurred in some cases but for the use of this expedient, which affords the external air free access to the lungs.

### Tasteless Infusion of Senna.

Dr. Brandeis recommends a cold infusion of senna for 12 hours in a covered vessel, as especially useful in infantile therapeutics. By this modification of the process usually employed, the water contains only the cathartic and the coloring matter, leaving the essential oil, the fatty matter, and the irritating resin, which are only soluble in hot water. Senna water thus prepared cold, is almost insipid, and its taste completely disappears when mixed with infusion of coffee or tea.—[Archives Generales de Medecine.]

### A Church Telegraph.

The Caledonian Mercury says, that a lady connected with one of the principal churches in the New Town, Edinburgh, having become enfeebled in health, and unable to leave her bed, rented a house adjoining the church, and had a gutta percha conductor actually led into her bed, and now, in the solitude of her sick chamber, she listens to the public ministrations of her spiritual adviser.

### A Natural Barometer.

They have in Germany a small green frog, termed by them the "leaf frog," which, when caught, is placed in a glass jar partly filled with water, and steps erected on which the little chap sits. If the weather is to be clear and fine, he reclines on the upper step, but if a storm is approaching he goes down part way, and if the storm is to be a severe one, he goes to the bottom. He is seldom more than an inch or an inch and a half long, and his rations consist of one fly per day.

## ADAMS' PATENT FIRE ENGINE.

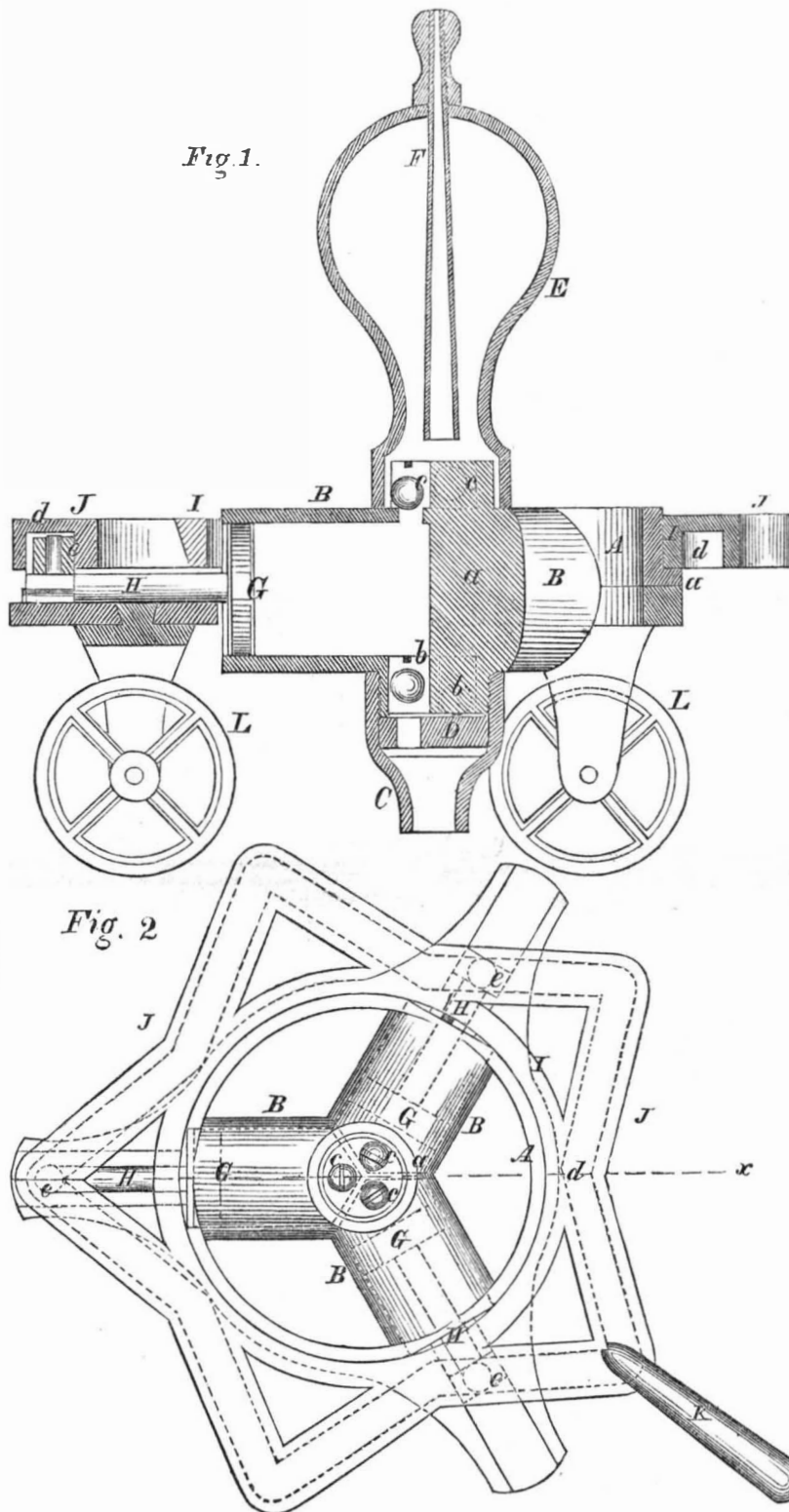

The accompanying engravings represent an improvement in fire engines, for which a patent was granted to John R. Adams, of Port Jervis, N. Y., on the first day of last month (May, 1855.)

Figure 1 is a vertical section of the fire engine, taken through *x x* of fig. 2, which is a top view with the air chamber removed. Similar letters refer to like parts. The nature of the invention consists in having a number of cylinders placed radially in a circular band or ring, and having said ring encompassed by a cam, which is allowed to work loosely around it. The cylinders are provided with the usual pistons and valves; the pistons are operated by the rotating cam, their rods have rollers on their outer ends, which work in a groove in the cam, which, owing to its form, gives them a reciprocating motion.

A represents a ring or band in which are cylinders, B B B, placed radially (three are represented, but more may be employed.)

The cylinders at their junction are kept separate by partitions, *a*, as shown in dotted lines, fig. 2. C, fig. 1, is the suction pipe, which is secured on the underside, at the junction of the cylinders. D is a valve seat above the suction pipe on which are three ball valves, *b b b*, one for each of the cylinders. At the central part, where the cylinders are joined above, there is an air chamber, E, with which the cylinders communicate by passages having ball valves, *c*. G G G are the piston heads of the cylinders, and H H H are the piston rods. The outer ends of the cylinders are not obstructed by the band, B, and they may all be formed in one casting. I is another ring or band encompassing the ring, A, the one (I) resting upon a flanch, (*a'*) on the periphery of A. On the periphery of ring, I, there is a zig-zag rim, J, which has a groove, *d*, on its under surface in which rollers, *e*, are confined; these are attached to the outer ends of the piston

rods, H. The rim, J, may have a suitable number of handles, K, connected to it (one only is shown.) The ring, I, rim, J, and sockets for the handles may be cast in one piece. The machine may be placed on wheels, as shown in fig. 1.

This water engine is operated by rotating the rim, J, which is really a cam. The piston rods, H, receive a reciprocating motion operating the pistons in consequence of the rollers, *e*, fitting in the eccentric groove, *d*. The water passes through the cylinders by successive strokes, and is ejected through the discharge pipe, F, in a continuous stream.—By this arrangement of cylinders, and the mode of operating the pistons, the power applied is uniform in its results. Horses may be attached to the levers, K, to work this pump like a gin.

This plan is applicable to ordinary pumps. Applied to ships pumps, a great number of persons could work on the levers, in the same manner as a capstan is operated, and the levers being made detachable, it will occupy but little room when not used.

More information may be obtained by letter addressed to Mr. Adams.

### Volcanic Phenomenon in Nova Scotia.

The St. Johns News states that there has been a great excitement among the inhabitants along the south-west shore of Nova Scotia, by a series of small earthquakes, which have taken place on the Granville mountains. Several months since the mountain quaked, and a deep fissure was opened in it, from whence smoke issued for about four weeks. About three weeks since, the ground was again violently agitated, a large chasm was opened, and forthwith a volume of smoke and stones were ejected. Eruptions of this mountain, since that time, have occurred almost daily, and many persons have moved from the immediate neighborhood, owing to the danger of being destroyed by the huge rocks thrown from the crater.

### Grateful Rains.

We perceive by some of our Southern contemporaries that many places in the South, which had suffered severely from long drouths, have been visited with refreshing rains. The Alabama river has once more become navigable, and boats loaded with cotton are moving forward to the sea board.

### Yacht Race.

The Annual Regatta of the New York Yacht Club took place on Thursday last week. Three classes of vessels contended for prizes; the first consisting of yachts over 50 tons; the second under fifty and over 25 tons, and the third under 25 tons. The *Julia* won the highest prize of the first class; the *Ray* the highest of the second class; and the *Twilight* the highest of the third.

### Remedy for Gapes in Chickens.

A correspondent says:—"Tell those of your readers who are interested in raising chickens, that a small pinch of gunpowder given to a chicken with the gapes, will effect a sure and complete cure in from one to three hours' time, and leave poor chick healthy and hearty. I speak from what I know, having tried the remedy with perfect satisfaction."

In deepening a well at Mobile, Ala., on the 15th ult., a cypress stump, which bore axe marks, was discovered at a depth of eighteen feet. Remains of trees are frequently found deeply imbedded, but no marks of cutting have ever been found in them before.

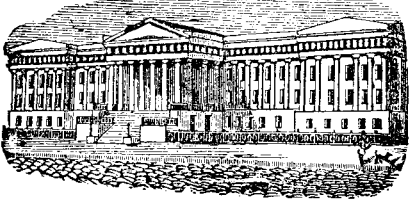

[Reported Officially for the Scientific American.]

## LIST OF PATENT CLAIMS

Issued from the United States Patent Office,  
FOR THE WEEK ENDING JUNE 5, 1855.

**REGISTERING BLOCKS FOR PRINTING OIL CLOTHS**—Jas. Albro, of Elizabethtown, N. J.: I do not claim a transverse bar or straight edge, C, applied to a printing table, A, separately, for it has been previously used, but what I claim is the bar or straight edge, C, with T shaped stops, E, attached permanently to it, in combination with the guide screws, d d e, in blocks, and the recess, c, in their right hand corners of the blocks, and smooth surface, b, on the faces of the blocks, as shown, and for the purpose as set forth.

[Adjustable hinged stops have been employed for registering blocks in oil cloth printing, but these require to be turned over to adjust the block for a succeeding impression. Various other devices have also been employed for the same purpose, more or less complicated, and therefore inferior to this one, which is exceedingly simple.]

**SEED PLANTERS**—Lucien A. Butts, of Cuba, N. Y.: I claim raising the seed to be planted up in a cup or cell, vertically or nearly so, above the height of the grain in the hopper, and then tripping a valve in the cup or cell, and allowing the seeds contained therein to drop through a tube towards the ground, substantially as described.

**BURNING BRICK**—Daniel and Geo. M. Blocher, of Cumberland, Md.: We claim the furnaces, F, entirely within the casement, and fed at the top, in combination with the close setting of the interior benches, as described, by which, placing the fuel within the arches is avoided, and the burning of the kiln improved, as set forth.

**SHIP VENTILATOR**—Ernest Bahr, of Rochester, Ind.: I claim the helical tube, A, provided with valves, i d n o p.

[The object of this improvement in ships' ventilators, is to allow a free current of air to pass down the tube into the ship, and to prevent any water from spray finding its way down the ventilator, even though the deck be swept with waves. The devices embraced in the claim effect this object.]

and guard plates, as shown. One end of the helix terminating above the deck, C, in two parts, D E the part, E, being provided with a wire wheel, g, and wire cloth covering, h, said part, E, being movable, so that it may be turned to face the wind at all times, for the purpose as set forth.

**FEEDING WATER TO STEAM BOILERS**—Thomas Champion, of Washington, D. C.: I claim supplying steam boilers with all their water through a sprinkler that is connected with the lower water space and feed pipe by a valve at their junction, which allows the water that passes up through the sprinkler to jet the plates when the pump is not acting, and so long as any water remains in the boiler above the feed or feed pipe, substantially in the manner and for the purpose set forth.

**DRAINS FOR SEWERS**—P. J. Coogan, of Charleston, S. C.: I claim the box or receiver, A, provided with syphons, I, J, and otherwise arranged as shown, for the purpose as set forth.

[The nature of this improvement in sewers consists in the employment of syphons placed within a box or receiver, so arranged that the sewer which extends from the box to the main sewer, is prevented from being choked up with sedimentary matter, and thus obviate effluvia arising therefrom. The object of the invention is good.]

**SEED PLANTERS**—C. H. Dana, of West Lebanon, N. H.: I claim the arrangement of the hinged vibratory mouth-piece, p s, at the lower end of the staff, B, with the projecting portion of the front side, b, of the seed box, and with the incision plate, f, descending therefrom, in such a manner that a downward sliding movement of the said staff upon the seed box will close the said mouth piece upon the incision plate, and form an incising planting receptacle for depositing the seeds in the ground, and an upward sliding movement of the said staff upon the seed box, will force open the said mouth piece, and leave the seeds in the extreme bottom of the incision formed by the said planting receptacle, substantially as set forth.

I also claim the arrangement by which I positively insure the opening of the mouth-piece, p s, of the planting receptacle, at each upward movement of the handle, B, viz., by means of the projecting portion, j, of the plate, i, which is secured to the seed box, or its equivalent, operating substantially as set forth.

**WASHING MACHINES**—J. W. Colver, of Louisville, Ky.: I am fully aware that clothes have been washed in machines by being put in a crate or basket and rotated in a tub, but in these the clothes scarcely ever change their positions, and there is no way of driving the water through them, (which really performs the washing,) I make no claims to such means or method.

But I claim the washing of clothes by placing them in a crate, basket, or creel, which has a reciprocating motion through the ends or back, and at the same time a rotary motion around its own axis, by which means the position of the clothes is constantly changing, whilst they are forced through the water, and are washed without being rubbed or injured, the motion of said crate, basket or creel being obtained by means substantially as described.

**SOAK PITS OF BRICK MACHINES**—Wm. H. Degges, of Washington, D. C.: I claim the revolving soak pit, or its equivalent, for uniformly soaking the clay when pulverized, and conveying it to a convenient position to be fed into the brick machine, substantially as specified.

**BRICK MACHINES**—Wm. H. Degges, of Washington, D. C.: I do not claim inserting the molds under the pug mill, on either side of the center, alternately to be moved thence under the apertures to be filled; neither do I claim dusting the parts of a brick machine generally for the single purpose of preventing the clay from adhering; nor do I claim mixing coal dust with the clay in any other manner than that described.

But I claim, first, causing the reciprocating bar, z, to rest at each end of its travel, whereby ample time is afforded for inserting the molds under the bottom of the pug mill, and for pressing the clay into them whilst in their rest position, substantially as set forth.

Second, inserting the molds immediately under the center of the pug mill, whence they are moved alternately to the right and left previous to being filled, whereby the size of the pug mill and the power required to work it are economized to the fullest extent.

Third, dusting the endless apron or other device, for conveying the clay to the pug mill, with a mixture of coal dust and sand, whereby the clay is prevented from adhering thereto, and at the same time the coal dust is evenly mixed with the clay during its preparation, for purposes specified.

Fourth, I claim the series of brushes, or other device, substantially the same, that will hold water, whereby the molds are both cleaned and dampened at the same time, as set forth.

**REAPING AND MOWING MACHINES**—Andrew Dietz and J. G. Dunham, of Ravenna, N. J.: We are aware that the cutter bar has been worked by the action of cams on the surface of the driving wheel, by means of rollers set in levers, when such rollers clamp the wheel between them, as in our former patent of March 27th, 1855 and also when the lever extends across the face of the wheel, but in the former case the mechanical arrangement is necessarily somewhat complicated, and in the latter case the great length of the levers from their points or center of oscillation renders them liable to vibration, and tends to spread the machine, and thus interferes with and prevents the proper and effectual transmission of motion to the cutter bar, and an additional lever is also necessary to connect the one extending across the face of the wheel with the cutter bar, thus complicating the whole arrangement; and we therefore do not now claim either of the above ways or modes of working the cutter bar.

But we claim the use for the purpose of transferring mo-

tion from the driving wheel to the cutter bar, of a short lever, B, the position of which is over the cam flange itself; the rollers being but a cam and a half apart, or its equivalent, the whole arranged substantially as described.

**SECURING WASHBOARD TO WALLS**—Thomas Estlack, of Philadelphia, Pa.: I claim securing washboards to the flooring, A, and to slides, D, which work in guides, C, attached to the walls, B, in the manner shown, or in an equivalent way, so that the washboards will, in case of the shrinking or settling of the flooring, fall or settle with it, thereby causing the lower edges of the washboards and flooring to be at all times in contact, as set forth.

[It too often happens, owing to the settling of floors in new buildings, that a wide gap soon appears between the base boards around rooms, and the floors. This improvement is to obviate this evil and make the base or washboard always lie close on the floor. The object of the improvement is an important one.]

**COMPOSING MUSIC**—William Fischer, of Philadelphia, Pa.: I claim so arranging a certain number of musical phrases, on each of a number of cards, that by selecting and combining one from each card, as described, a number of musical and perfectly melodious pieces can be composed, all of them differing from each other.

**BOOT JACKS**—F. J. French, of Whiteingham, Vt.: I claim the spring wedge, D, in combination with the lever, B, and spring, E, or their equivalents, and arranged substantially in the manner and for the purpose as set forth.

**SKIING BOOT AND SHOE COUNTERS**—Luther Hill, of Stoneham, Mass.: I claim combining with the rotary cylindrical bed or carrier, B, its face clamp, E, and arc cutter, M, the peripheral clamp, I, and its cutter, the whole being arranged and made to operate so as to perform the function of beveling along the arc of one counter, and the chord of another, during one revolution of the said cylinder bed, as specified.

I also claim combining the arc knife or cutter, M, the cylindrical bed or carrier, B, its face clamp, E, and arc cutter, M, the peripheral clamp, I, and its cutter, the whole being arranged and made to operate substantially as specified.

I also claim supporting the bifurcated frame, T, of the rocker frame, S, by means of a rotary journal and clamp, or the equivalent thereof, so that the angular position of the knife, M, with respect to the plane surface of the rotary carrier, B, may be changed as circumstances may require.

**GRAIN AND GRASS HARVESTERS**—M. G. Hubbard, of New York City: I claim the employment of two fingers, or each knife or sickle blade, for the purpose of dividing the cutting force expended at each stroke of the cutter bar, and also preserving more perfectly the cutters from injury by keeping stones, &c. from coming in contact therewith.

I do not claim the general device of making bars of angle iron, for the purpose of lightness and rigidity, but the making the cutter bar of angle iron for the purpose of attaining at the same time both the above advantages, and a shoulder against which to abut the knives, so that a single bolt to each will securely hold them, substantially as and for the purpose set forth.

**PROCESS OF MANUFACTURING HATS**—L. E. Hopkins, of Brooklyn, N. Y.: I do not claim the principle of manipulating while under water, for the purpose of working in the nap, or for the purpose of beating up the nap, as referred to and before patented.

But I claim the making a complete hat body by means of the manipulation of the nap, and the sticking, scalding in, and beating-up of nap, without regard to the peculiar machinery which may be used to produce the combined result of beating or otherwise manipulating in hot water, for the purpose of manufacturing a hat by a complete and continuous range of mechanical operations, as a substitute for the dipping and rubbing on a plank by hand, as described.

**FLOATING CABINS**—W. R. Jackson, of Baltimore, Md.: I claim the construction of a deck or saloon cabin of a steam or other vessel, substantially as described, so that it shall admit of being separated from the hull, and form in itself an escape or life boat, as set forth.

**DOUBLE ACTING PUMP**—E. A. Jeffery, of Corning, N. Y.: I do not claim merely substituting ball valves for other kinds of valves, in a tubular piston with valve seats at its ends.

I claim connecting the piston heads by a long tube, having a short valve chamber near its middle, with a single ball valve, the water passing alternately through each end of the tube, and out at the sides of said valve chamber, the valve chamber being so shaped that the ball will exclude the water from one end, by rolling it far enough to admit the water fairly at the other, while the piston heads are so far apart that the eduction port shall always be embraced between them, substantially as set forth.

[The single ball valve embraced in this claim acts as a substitute for a double valve, and simplifies the construction of this double pump, which discharges a continuous stream of water by taking in and forcing out the water at each stroke—up and down.]

**APPARATUS FOR BLEACHING RAGS**—Harrison Loring, of Boston, Mass.: I claim the manner of introducing steam to all parts of the revolving bleach at the same moment, by means of a perforated pipe attached to the interior of the bleach, the adjacent ends of which are connected by a socket joint to a stationary induction pipe, arranged as set forth, so as to allow of the expansion, contraction, and movement of the bleach without derangement; for the purpose and in the manner substantially as described.

I do not claim the revolving bleach, or bleaching by steam at a high temperature, as I am aware that it has been known and patented before.

**FASTENINGS FOR CARPETS**—Wm. S. Loughborough, of Rochester, N. Y.: I claim securing the edge of the carpet by means of a button fixed to the floor and tuning upon an inclined axis, so as to be self-clamping, as described.

**HYDRO-CARBON VAPOR APPARATUS**—S. T. McDougall, of Brooklyn, N. Y.: I claim the double gas pipe, C, for conveying hot air or steam around the pipes to prevent condensing, or any other substantially the same, and which will produce the intended effect.

**BRACE FOR SUPPORTING GARMENTS**—Daniel Minthorn, of New York City: I do not claim to have invented such braces or suspenders, for they have long been known and used.

But I claim, substantially as described, the arrangement of straps forming a suspender for the use of ladies or gentlemen, by which the hips are relieved of the weight of the lower garments, which are sustained by the shoulder straps, at the same time the regions of the lower ribs and viscera perfectly free in their action.

I claim also, in combination with the above suspender, the short corset by which the weight of the skirts is employed to raise and adjust the breasts and by tightening or loosening which, the said weight is more or less transferred from the shoulders to the breast.

I also claim the strap, F, attached to the boot or stockings, substantially as and for the purposes set forth and described.

**WAGON WHEELS**—Sylvanus Perkins, of Pittsburg, Pa.: I do not claim the male and female hub, or the nut on the inside of the tire; neither do I claim the hollow spoke, or the nut on the end of the male hub, as being new in themselves.

But I claim the combination and arrangement of the female hubs, F and I, the spokes, C, the rib, B, and the tire, A, the box, H, and the nuts, E and D, operated as and for the purposes set forth.

**MANUFACTURE OF HATS**—Andrew Rankin, of Newark, N. J.: I claim the employment of the rider for controlling the action of the hand, constructed and arranged substantially as specified, and in combination therewith the upright lever with movable fulcrum for operating the same.

I also claim uniting the hand and cradle by cords, whereby the bats are readily raised out of water to be handled, and the cradle is held in place to receive a new set of rollers.

**PORTFOLIO**—S. J. H. Smith, of Boston, Mass.: I do not claim a bill or paper file composed of two straight bars or plates, and elastic bands, uniting them together at their ends, when such bars or plates are so arranged that one may be parallel and above the other.

But I claim combining such with two covers, and a flexible elastic or extension back, so as to constitute the file portfolio, for the retention and protection of papers or letters, and protecting the mass or file of them on both sides and the back of the same.

**FURNACE FOR WARMING BUILDINGS**—G. S. G. Spence, of Boston, Mass.: I do not claim combining the dome of the

smoke chamber of an air heating furnace with one or more pipes so leading from the said dome or from the said smoke chamber, that the smoke and gases, in passing against such dome, shall be deflected in streams divergent from or with respect to the fire place.

Nor do I claim arranging an exit tube within the middle of a reverberatory chamber, and surrounding such tube by another tube or chamber which will prevent the volatile products of combustion, when descending towards the fuel from coming into contact with the flame thereof, before they pass into the receiving end of the tube.

But I claim so arranging and combining the exit tube, G, within the reverberating dome and smoke chamber, and with respect to the fire place thereof, as specified, that the smoke and gas reverberated from the dome, may not only pass towards the exit tube in convergent streams but be deflected towards and against the fuel or flame thereof, before they may escape into the lower end or mouth of the tube, my improvement being productive of a more perfect combination of the said volatile products, than takes place when the exit tube is surrounded by another tube or case, which separates the descending gaseous currents from the fire, before they escape into such tube.

And I claim so combining the valve, H, and the discharge tube, G, that the tube may be movable with the valve, and pass through the valve opening, as described, the valvethus serving to support the tube, and rendering unnecessary, any arms or such like devices, which would tend to collect soot, and otherwise obstruct the draft through the valve opening.

**BENCH REST**—J. D. Spiller, of Concord, N. H.: I claim combining with a bench rest, mechanism substantially as described, for not only elevating said rest with an intermittent rotary motion during successive pressure on a spring thumb slide, applied to said bench rest, as set forth, but for enabling said bench rest to be moved downward whenever necessary, in manner and for the purpose, as specified.

I also claim combining with the serrated top plate of the bench rest, a plain slide plate, combined and made to operate therewith, substantially as specified.

**MACHINES FOR KNEADING CLAY**—H. H. Thayer, of Sandwich, Mass.: I claim the employment of the inverted conical chamber, G, provided with a screen or perforated plate, K, which has its apertures of taper form, said chamber having a plunger or working in its upper cylindrical portion, for the purpose set forth.

I also claim the press chamber, G, constructed as described, in combination with the reciprocating fork, M, for cutting off the clay discharged from the press chamber, the fork being operated substantially as shown and described.

[The perforations in the screen are conical, and the piston which presses the clay, by forcing it through the conical perforations compresses it, and thus kneads it in a superior manner. The cutting off operation embraced in the second claim, allows of the clay being worked over and over again very rapidly. The improvement is a good one.]

**ORNAMENTAL FELT CLOTH**—O. B. Tomlinson, of Athens, Pa.: I do not claim the incorporation of rows of different colors in the manufacture of felt stripes, checks, or plaids.

But I claim the manufacturing of ornamental felt fabrics, by placing colored wool, fur, or any other shrinking substance, upon the surface of a sheet of batting, and shrinking the same colored wool, &c., into the body of the felt, in the manner substantially as described, to form an ornamental fabric of the character and quality described, for the purpose set forth.

[This claim explains this improvement very clearly; we have seen felt shoes and fancy patterns, ornamented with various flowers and figures, by this process, simply by properly disposing the colored wool on the sheet of batting, and then felting it; the patterns thus formed looked rich and beautiful.]

**STEAM ENGINE REGULATORS**—Henry Webster, of Beetown, Wis.: I claim, in this class of regulators, controlling the escape of water by the flap valve, f, and the rod, F, with its inclined piece, j, all applied and operating substantially as set forth.

[This invention is for governing the throttle valves of marine engines, by the rising and falling of a float in a water chamber, which is supplied by a pump, that will force in water according to the variable velocity of the engines, and thus regulate the supply of steam according as it is required. This invention deserves attention on account of its object and ingenuity.]

**GAS REGULATORS**—Hiram Wheelock, of Boston, Mass.: I claim the use of textile or fibrous substances for packing the chamber of a gas regulator, constructed and arranged as set forth.

**MELODEON**—W. C. Whipple and W. C. Bove, of Westfield, Conn.: We claim the use of two sets of levers, located in the wind chest, under the valves, and so connected as to enable us to play any desired note and its octave, when the whole is constructed, arranged, and made to operate substantially as described.

**LOOMS**—Wm. Whiteside and John Shinn, of Philadelphia, Pa.: We do not claim the controlling of the whole series of harness, or a part of them by one lever at the top of the loom, and a number of levers at the bottom of the loom.

But we claim the combination and arrangement of one lever at the bottom of the loom with one at the top, in such a manner as to control any number of leaves of harness that may be desirable, and open the warp shed evenly both ways, as described.

Second, we also claim the combination of the guides, traveling rods, the rollers, F F, and straps connecting the levers, b, for the purpose of bringing the hooks to their proper place, in time to be ready for the next movement of the pattern roller, as described.

Third, we do not claim the vertical levers for the purpose of opening the warp shed, but we claim them in combination with the wires, w, w, for the purpose of actuating the books, as described.

Fourth, we do not claim the swinging plates, K K, but we claim the combination of the swinging plates, K K, with the levers, L L, or the equivalent arrangement of the same, for the purpose of actuating the pickers, as described.

Fifth, we claim the rod, G, or its equivalent, so arranged with the rod, J, that when the shuttle is arrested in front of the reed, it cannot be brought to the reed, H, to strike the lever, P, and shift the driving strap, and immediately arrest the further advance of the lay, as described.

Sixth, the following we claim as an improvement on the machine of E. Burt, dated June 20, 1845, in which the said E. Burt claims the hanging welt protector on the race of the lay itself. The hanging of the loop on the race we do not claim, but that which we claim as our improvement is the balance catch, N, in combination with the loop, M, and operated by the swell, N, so that when the welt thread is broken or exhausted, it will immediately arrest the motion of the loom in the first forward motion of the lay, as described.

**BOOT CRIMPING MACHINES**—Geo. W. Zeigler, of Tiffin, Ohio: First, I claim the segment gear, M, and rack, J, or their equivalents, in combination with the slots, K K, or their equivalents, for the purpose of giving to the plate, H, the described motion, for the purposes set forth, substantially as described.

Second, I am aware that the jaws of boot crimping machines have been corrugated, and the ribs and grooves made parallel with their edges; therefore I make no claim to such corrugations.

But I claim corrugating them, substantially as described, for the purposes set forth.

[This machine crimps boots rapidly; the boot front is placed on the plate, H, and its edges placed between clamps and stretched; this plate, with the boot front, is then attached to the rack, S, and adjusted in the jaws, then by simply turning a shaft, the front is moved up and down between corrugated plates, and crimped expeditiously.]

**RING SPINNING FRAMES**—Wm. Darker Jr., (assignor to J. B. Thompson), of Philadelphia, Pa.: I claim, first, the method and means by which the bobbin is properly secured, to enable them to receive rotary motion, that is to say, attaching them to the top of metal sockets, E, which are large enough to receive the bobbins, and are secured to tubes, F, which revolve easily upon the spindles.

Second, the described method of attaching the bobbin to the spindle by a ball, f, which drops in a slot at the top of the spindle, whereby the bobbin is properly secured, and the tube is allowed to be of proper length to steady the ring, without interfering with the bobbin.

[This improvement is to enable the speed of the spindles to be increased without increasing the danger of breaking the threads. The great obstacle to the increase of speed in the common ring spinning frame, beyond a certain degree, is because the friction of the traveler upon the ring becomes so

great as to produce undue tension, and thus break the thread. To reduce this friction the ring is made to receive a rotary motion at a slower speed than the spindle, but in the same direction. The improvement accomplishes a desirable object.]

**WROUGHT IRON BEAMS AND GIRDERS**—Anthony Pollok, of Philadelphia, Pa.: I claim the combination in wrought or malleable iron beams or girders, of top and bottom T pieces, with flat or plane surfaced longitudinal plates, riveted upon both sides of the stems or vertical portions thereof, substantially as described, and for the purposes specified.

**RE-ISSUE.**  
**LOOMS**—B. H. Jenks, of Bridesburgh, Pa.: originally issued April 3, 1855 and ante-dated Jan. 8, 1855: I claim the yielding rest or support, K, for the picker arrangement, substantially as described, to break the sudden blow or concussion with which the shuttle impinges upon the picker, thereby preventing the filling of the cop from being jarred off and entangled and relieving the picker from danger of being broken.

I also claim separating or freeing the lever, K, and the picker from the end of the shuttle by the same movement which shifts the shuttle boxes operating through a combination of levers, cams, and springs, substantially as set forth, or through levers, cams, or treddies, worked from any part of the loom.

[Reader, do you ever stop and reflect upon what that class of our community called INVENTORS do for you individually as well as for the whole community? Think for a moment what would be the state of affairs in this and other civilized countries, if there had never existed inventors. We venture to assert, that from the Patents recorded in the above list, a half a million of dollars will not cover the benefit which the public (exclusive of the profit to the patentee) will derive from the inventions. It may seem a large amount of money for thirty-seven unpretending individuals to make in a single week, and if divided equally among them, would make a handsome competence for each, but when we consider the vast number of people who will patronize, directly and indirectly, and derive benefit from even the smallest improvement in any machine which comes into use, the vastness of the benefit derived from inventions begins to be realized.

Some of the patents in the above list are known to us to be valuable, for more than ONE-THIRD of the whole number of applications passed through our Agency, and the poorest of them, if they prove of no pecuniary benefit to themselves, will benefit the public—however imperceptibly—twenty times the cost of obtaining it.—[Ed.]

### Softening Horn.

The London *Artisan* mentions an invention for softening horn and rendering it elastic like whalebone. The horns are cleaned, split, opened out and flattened, and immersed for several days in a bath composed of 5 parts of glycerine and 100 parts of water. They are then placed in a second bath, consisting of 3 quarts of nitric acid, 2 quarts of pyroligneous acid, 12½ lbs. tannin, 5 lbs. bitartrate of potash, and 5 lbs. sulphate of zinc, with 25 gallons of water. After leaving this second bath it will have acquired a suitable degree of flexibility and elasticity to enable it to be used as a substitute for whalebone for certain purposes.

### A Salt Lake in Minnesota.

A salt lake has been discovered about 150 miles west from St. Cloud, in Minnesota, by W. H. Ingersoll, who was attached to the Pacific Railroad Survey. Mr. Ingersoll says that around the edges of the lake the salt can be gathered in baskets, and is of as good quality as ever he found in any other part of the United States. Mr. Ingersoll also says, that near the lake there are large beds of coal of the first quality.

### Meerschmum.

This is a mineral of a white earthy appearance; it is composed of silica and carbonic acid. It is found in many parts of the world—Piedmont in Italy, Wales in Great Britain, &c. When first dug up it is soft and greasy, and lathers like soap, and on that account is used by some Tartar tribes for washing their clothes in place of soap. The well-known Turkey tobacco pipes are made of it, by a process like that for making pottery ware. The bowls of these pipes are prepared for sale in Germany by soaking them first in tallow, then in wax, after which they are polished up.

### American Steel and Saw Works.

The *Railroad Record*, Cincinnati, O., gives an account of the stove and saw works of Lee & Leavitt, at Hamilton, Ohio, where excellent steel is made from Missouri, Lake Superior and Champlain iron. They use a great deal of their own steel in the manufacture of saws, &c. The factory was begun in 1853, and it does business amounting to \$125,000 per annum.

### Grape Vine Grubs.

A small white grub is very prevalent this season in grape vines. It makes its nest under a leaf which curls up and screens it from common observation. All those who have grape vines will do well to give them a thorough examination. A punctured or curled leaf is a sure sign of its presence. The only sure way to destroy them is to pick them off by hand.

(For the Scientific American.)  
Steam Boilers and Flues.

In the SCIENTIFIC AMERICAN of May 12, while speaking of the smoke-consuming furnaces of London, you remark, "We know that it is a mistaken notion entertained by many, that very long boilers and long tortuous flues save fuel."

Now I have no doubt that boilers and flues may be so long and tortuous as to check draft and combustion, but I think where the stack is sufficiently high to produce a good draft, that the heat and smoke may be made to pass to advantage around and within the boiler till they are nearly taken up or consumed. In arranging the power for the Newark Machine Works, I procured an engine of about 35 horse power (12 inch cylinder, 36 inch stroke,) of good construction, with double valves and extra cut-off. With this engine we drive 14 lathes for iron, 3 for wood work, 4 planers for iron, and one "Daniels" for wood; 4 drills and one boring and one tenoning machine, spliner and bolt cutters, two circular saws, punching and shearing machines, two trip hammers, a large blacking mill, and fan-blower for forges and foundry, with an average consumption of one tun of bituminous coal per day of 10 hours, including firing up.

Our boiler is 48 inches in diameter and 30 feet long, with two 17 inch flues. This boiler is set with four vertical bridge walls at about equal distances apart, the first is built within 4 inches of the boiler, the second 4½, the third 5, and the fourth 5½ inches. The heat passes under the boiler to the back end, thence forward through one of the flues, and back to a stack 34 inches square inside, and 85 feet high. This gives the heat a passage of 90 feet under and through the boiler. Our draft seems perfect, and it is one of the most controllable boilers I have ever seen. If any of your readers, using flue boilers, think they are doing as much work with less fuel, and who are not using a "Corliss engine," I shall be glad to test the actual amount of water evaporated and fuel consumed for six successive days of 10 hours, and if a greater economy is proven, the public should know the form of setting the boiler and the general arrangement.

We have not enough of fair and candid experiments in the mode of setting boilers and using steam. Nor is there enough published on these important subjects. The articles you have published, detailing Fairbairn's lecture, is of much interest, and I hope the subject will not rest till all those who read your important journal shall have an intelligent and practical standard to guide them in this most interesting branch of mechanical science.

We are building a series of portable engines of from 2 to 20 horse power, on the most substantial and compact plan, intending to test thoroughly the idea suggested by Fairbairn in the use of high steam worked expansively, and I will, at some future time, give you the details of some experiments. I am just applying one to a five foot veneering saw. The cylinder is 5 inches diameter and 12 inch stroke. The boiler is of heavy iron, and will safely carry 200 lbs. to the inch, though I do not expect to work it so high. It is expected to saw large walnut crotches and I shall be able to test its power, its evaporation, and its fuel exactly, and mean there shall be no guess-work in the matter.

JOSEPH E. HOLMES.

Newark, Ohio, May 30, 1855.

A Cold Place.

At Yakutsk, 62° North latitude, the Russian American Company bored for water in the courtyard of their establishment, to the depth of 380 feet, and found the ground frozen there. They could not obtain water and gave up the attempt. In that latitude the surface of the ground, a few feet deep, is thawed for a few weeks during summer, but all below is frost and ice. The inhabitants have cellars under all their dwellings, which are perpetual ice houses; in them, when the sun is intensely hot outside, they place their milk, fresh meat, &c., which soon become perfectly frozen.

History of Industrial Exhibitions.

The following is a brief yet interesting history of exhibitions taken from *Galvani's Messenger*:

"The first exhibition of the works of industry opened in Europe, dates back as far as 1798, and was held on the Champ-de-Mars. After that commencement, France had not less than eight or ten before her example was imitated by other countries. But at last the excellence of the idea struck other countries, and in succession, Italy, Spain, Belgium, Prussia, Russia, and Sweden entered on the same path. At last England also had her exhibition, but on so gigantic a scale, for it extended to every country of the globe, that all the preceding ones were of necessity far inferior to it. The exhibition of 1798, ordered in the midst of war, lasted but eight days, few branches of industry being represented there, and not more than about a dozen silver medals being awarded, and a score of honorable mentions made. The two exhibitions of 1801 and 1802 showed that an advance was taking place. There had been only 110 exhibitors in 1789, but there were 220 in 1801, and 540 in 1802. In the former of these years also, some celebrated men were awarded medals—Jacquart for his silk weaving machine, Carcel for his lamps, Ternaux for woolen stuffs, Montgolfier d'Annonay for paper, Fauler for morocco leather, and Utschneider for his porcelain and ceramic productions. It was in 1802 that appeared for the first time the French cashmere shawls which have since arrived at such extraordinary perfection. The fourth exhibition did not take place until 1806, as it soon became evident that too small a space of time ought not to be left between each two. That of 1806, the only one of the empire, had 1,122 exhibitors, and was remarkable for the excellent display of goods offered to public view. The war which followed momentarily suspended the vigorous impulse which had been imparted to the manufactures of the country; but though peace quickly brought back a certain amount of activity, the first three exhibitions of the Restoration, in 1819, 1823, and 1827, were not very remarkable for the aggregate excellence of the articles brought together. Still, at that of 1827, the articles manufactured at Paris showed a certain improvement, and the display of machinery was satisfactory. But dating from that period, the general improvement was as rapid as it was incontestable.—The three exhibitions of Louis Philippe's reign imparted to the institution somewhat of that character of general utility which will be one of the distinguishing characteristics of the universal Exhibition now about to open. The ascensional march of these three displays may be judged of by the number of exhibitors at each—namely, 2,447 in 1834, 3,381 in 1839, and 3,960 in 1844. A month was found no longer sufficient for keeping the exhibition open, and at last the time was increased to three. Each successive site also was found to be too restricted for the growing extent of the space required, and the exhibition of 1844 was held on the spot where the present Exhibition Palace has been erected. At last the display of 1849 took place; not open to the whole world, as at first intended, yet still containing the products of 4,500 exhibitors. But what France scarcely dared to venture on in 1849, when the political horizon was still so disturbed, England effected with immense success two years after. The Crystal Palace of London received upwards of 18,000 exhibitors, and received every day about 50,000 visitors to examine a mass of unheard of wealth, estimated at upwards of 500 million francs. Then followed those of Dublin and New-York, each meriting notice, though of a more restricted character, and now comes that of Paris, destined, many think, to exceed them all.

The value of American cotton exported in 1854, amounted to \$93,596,220; of this \$64,738,391, was exported to Great Britain, with the exception of a very small quantity to Ireland.

Water.

Pure sparkling cold water is not, as was anciently supposed, a simple element, but a compound of two gases—oxygen and hydrogen. If hydrogen be ignited in the open air it will burn with a pale blue flame, and if a bell glass be held over it, water will soon be seen trickling down its sides. The cause of this is, that the oxygen of the air combines with the hydrogen to produce combustion, and the result of their combination is water. In this state these two gases are bound together by some connection, which we call "chemical combination," which is but a name for something we do not understand. It is strange that water, which is the enemy of fire, should be composed of two gases, one of which burns readily, while the other is the great supporter of combustion. And it is equally strange that oxygen, so indispensable to animal life, should form nine-tenths by weight of a liquid (water) in which few terrestrial animals can live but for a few seconds. We cannot account for such properties in the elements of nature: we can only tell of their operations. We can conceive that they might have been endowed with different properties, but that is all. The properties of pure water are numerous: it has neither taste nor smell: it is neither sour, sweet, bitter, nor pungent; it does not irritate the most delicate nerve, nor does it disturb the most tender part of the frame. We cannot estimate it too highly: it soothes pain, it relieves thirst, it lubricates the tissues, it washes out the morbid humors from the system,—in short, but for the quality of these two gases, forming, in a mysterious manner, liquid water, no organism could exist on the earth. It is necessary to life in the animal and vegetable world. Countries without rains, (excepting they are fertilized by rivers like Egypt,) are dreary deserts, devoid of animal, plant, or flower.

It has been said by some philosophers that "gas is the natural condition of matter," but this is nothing better than scientific nonsense, for water is as much a natural condition of matter as gas; indeed, it is more so, hydrogen, although a gas, is not found in nature except combined with some other element, as a solid or fluid; never, at least in a state of pure gas. Upon such subtle laws as those developed in the combination of these two gases, forming water, hangs the existence of ten hundred millions of human beings, and that of countless myriads of the lesser creatures.

The Bible and the Discoveries of Science.

The following eloquent passages are from Lieut. Maury's late work, the "Physical Geography of the Sea":

"The Bible frequently makes allusion to the laws of nature, their operations and effects. But such allusions are often so wrapped in the fold of the peculiar and graceful drapery with which its language is occasionally clothed, that the meaning, though peeping out from its thin covering all the while, yet lives in some sense concealed, until the lights and revelations of science are thrown upon it; then it bursts out and strikes us with the more force and beauty.

As our knowledge of nature and her laws has increased, so has our understanding of many passages in the Bible been improved. The Bible called the earth 'the round world;' yet for ages it was the most damnable heresy for christian men to say the world is round; and finally, sailors circumnavigated the globe, proved the Bible to be right, and saved christian men of science from the stake. 'Canst thou tell the sweet influence of the Pleiades?'

Astronomers of the present day, if they have not answered the question, have thrown so much light upon it as to show that, if ever it be answered by man, he must consult the science of astronomy. It has recently been all but proved that the earth and sun, with their splendid retinue of comets, satellites, and planets, are all in motion around some point or center of attraction inconceivably remote, and that point is in the direction of the star Alion, one of the Pleiades! Who but the astronomer, then, could tell their sweet influences?

And as for the general system of atmospheric circulation which I have been so long endeavoring to describe, *the Bible tells it all in a single sentence*: 'The wind goeth toward the South and turneth about into the North; it whirleth about continually, and the wind returneth again according to his circuits.'—Ecl. i. 6."

Misdirected Industry.

The London correspondent of the *National Intelligencer* says:

One of the best things produced during the week is a lecture by Lord Ashburton, on "Common Things," which he has issued to the schoolmasters and schoolmistresses of Hants and Wilts. We give a short extract upon *misdirected intelligence*, which we think is particularly good. His Lordship says:

"If I had space, I would attempt to show you that it is not in the Crimea only, but that in our fields, in our towns, at our very thresholds, are to be found the same fatal results of misdirected intelligence. I would take you on that sea which we claim as our element, and show you the sails of our merchantmen cut against all rule of science, to hold the wind rather than to stand flat as a board; I would take you out amid the high priced stock of our farms and show you that the medical attendance to which their care is entrusted is as inferior to the instructed veterinary practitioner as was the surgeon-barber of Queen Elizabeth's time to Astley Cooper or Brodie of the present; I would show you our churches built without reference to acoustics, our palaces without regard to ventilation; I would show you our mechanics' institutes departing from the wise intention of Dr. Birbeck, their founder, and wasting noble aspirations after knowledge by *dilettanti* lectures upon useless frivolities. All this misdirected industry in manhood is the fruit of the misdirected bias imparted in childhood. You are answerable for that bias; may your efforts be successful."

Electro Magnetic Engines.

W. W. Bennett, of this city, informs us that a very neat electric engine, invented by Prof. Hall, is now in operation at No. 300 Broadway, this city. He says it is like that of H. M. Paine, which has been described in our columns, with the exception that the magnets of the wheel and those of the frame, are electro-magnets—none of them permanent—which makes it of greater power. In Hall's engine there are 32 electro-magnets secured on the rim of a brass wheel of about one foot in diameter, their poles outwards; and there is a corresponding number arranged around it on a brass frame, with their poles inward, so that the poles of all the magnets on the wheel pass near those on the frame. The poles of the magnets on the wheel are changed as they pass those on the frame, by a small wheel, or pole changer, on the axis of the large wheel. This engine, with suitable battery, is stated to be five or six horse power, and occupies a horizontal space not over two feet square. For economy and ingenuity, Mr. Bennett informs us, it will bear a favorable comparison with any electric motor yet made.

The steamer *Ben Franklin*, which left St. Thomas, W. I., on the 27th ult., had to put into Norfolk leaking very badly. All the male passengers had to work incessantly at the pumps for some days, to enable the vessel to reach port. At one time the water was some inches above the furnaces.

The street lamps in Boston are all being marked with the name of the street on which they are placed, to guide strangers at night—a plan already adopted in Philadelphia. We would be content in New York if the streets were all properly marked. The corners appear to be too numerous for the corporation painters.

BREEDING FISH.—The National Historic Society of New Jersey has appointed a committee to consider the feasibility of stocking the rivers with salmon. There seems to be no doubt that it can be done. The only question is if it can be made profitable.

## New Inventions.

## Railroad Ticket Register.

The accompanying figures represent a ticket register for railroad passengers in the cars, for which a patent was granted to William Apperly, of Louisville, Kentucky, on the 1st of last month (May, 1855.)

Fig. 1 is an external front view of the register, fig. 2 is a vertical section, and fig. 3 is a vertical section through the line, *x x*, fig. 2. Similar letters refer to like parts.

The object of the invention is to overcome the objections which are raised by railroad companies, and the traveling public, against the present methods of controlling that part of the business relating to the reception of fare from passengers by conductors after the cars have left the various stations. The nature of the improvement consists in providing in each of the cars a machine which shall hold a sufficient number of tickets for all the passengers in the same, and also discharge said tickets at the will of the conductor, and likewise register the same as fast as they are discharged or distributed. These machines to be under the control of the conductor as far as the distribution of the tickets is concerned, its internal arrangement being kept under lock and key by the directors, and only to be inspected by them or their accredited agent at the end of the trip. The tickets placed in the machines having the place where the passengers are going to, the different stopping places along the road, and the distance apart of one from the other marked upon them, and owing to their being thus marked, are desirable aids to the passengers, and consequently will be demanded by them at the time of paying their fare to the conductor, proper instructions for the passengers being posted in conspicuous places throughout the train. By this invention, every passenger that pays his fare, and demands and receives a ticket, which is registered, and consequently charged against the conductor, and as the machine is locked and cannot be turned back or interfered with, the number of fares received by the conductor will always be known by the directors at the end of the trip.

A represents a box with three compartments, *a b c*. The compartment, *a*, serving for the tickets, B, to be placed in as shown on the bottom of *a*; underneath the tickets there is a slide, C, which is capable of being moved in and out as illustrated by dotted lines, fig. 2. This slide is provided with a lip or flange on its upper side, said lip standing up just high enough to take hold of the last ticket, and at the same time be free from touching the ticket above it when drawn out to position shown in dotted lines. D is a spiral spring for keeping the tickets firmly down upon this slide, and thus ensuring their discharge separately when the slide is drawn out. E is an extension or small box provided on the box, A, at the opening through which the tickets pass in being carried to the discharge. E' is an inclined way, arranged in this extension or box, and passing up through a slit, *e*, formed in the slide so as not to interfere with the movement of said slide, for the tickets to move over. By providing this extension and way a person is prevented from inserting any instrument and drawing out a ticket, and the ticket will always be registered before coming in sight, and the forward end of the ticket is lifted from off the surface of the slide ready to be conveniently laid hold of by the conductor. H, I, J, K, L, represent cog wheels, arranged and geared together as shown in the compartment, *b*, and serving to give a slow motion to the index wheel, M, which is arranged in the compartment, *c*, which may have a window, *g*, to exhibit the number of tickets distributed. This index wheel is made fast on the axis of the wheel, L, and turns with it. K' is an elbow shaped arm or projection attached to the inner edge of the slide, the end, *f*, of this projection fits between the teeth of the cog wheel, H, and turns it the distance of one tooth every time the slide is drawn out and a ticket discharged, and thereby

causes it to give motion to the intermediate gearing, and turn the index wheel so far as to register the discharge of the ticket. As soon as one ticket is withdrawn another occupies its place ready to be carried out by the lip, it being caused to take its place by the pressure of a weighted follower, or a spiral spring, as shown. Instead of having a

separate machine in each car, a series of small portable ones connected together, containing tickets suitable for the various stations along the road, may be employed, these being carried from car to car by the conductor, and tickets supplied therefrom to the passengers, and registered.

This machine can be used for registering

## RAILROAD TICKET REGISTER.

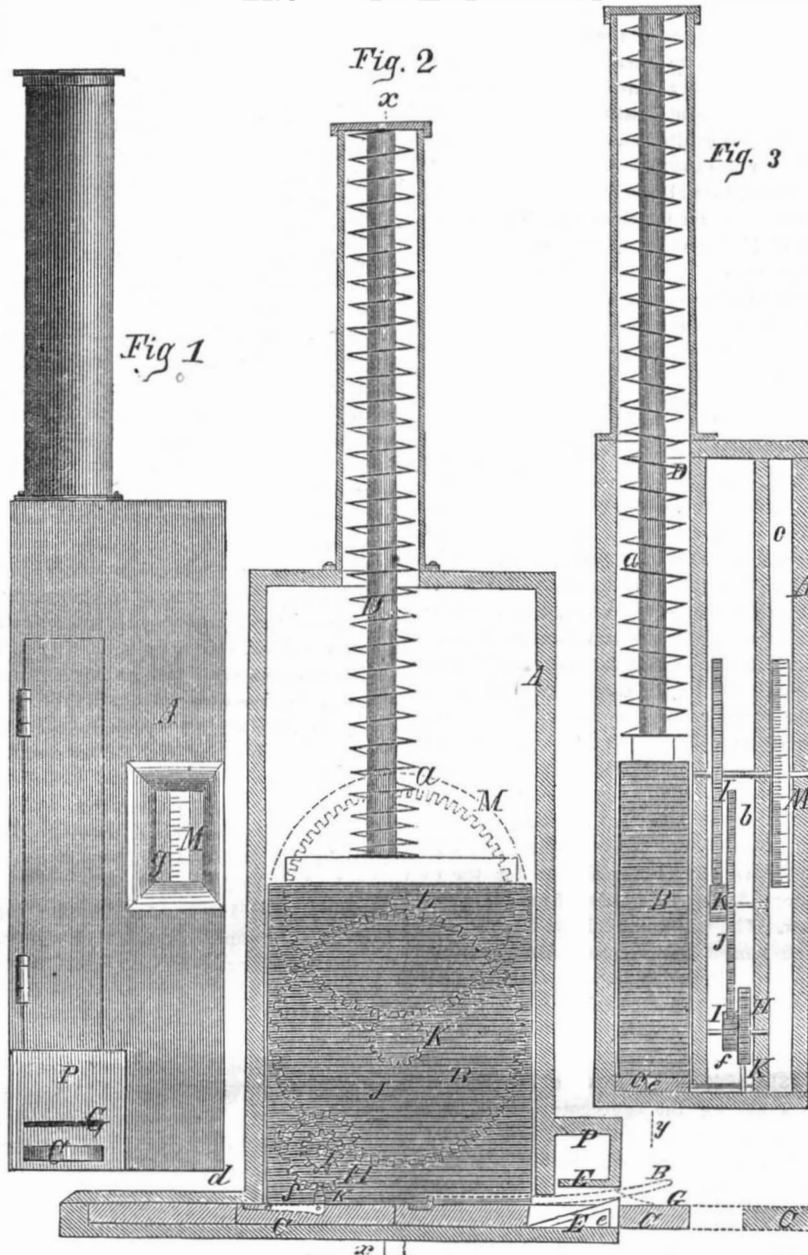

of tickets issued at the railway stations before the train starts as well as after, and may also be employed to advantage at all public places where money is collected in a similar manner.

A scale may be fixed in the front part of the register extending from top to bottom;

the divisions of it corresponding with the thickness of the tickets. A pointer fixed to the follower which keeps the tickets down, would indicate the number of tickets discharged.

More information may be obtained by letter addressed to the patentee.

## THOMAS'S ROTARY ENGINE.

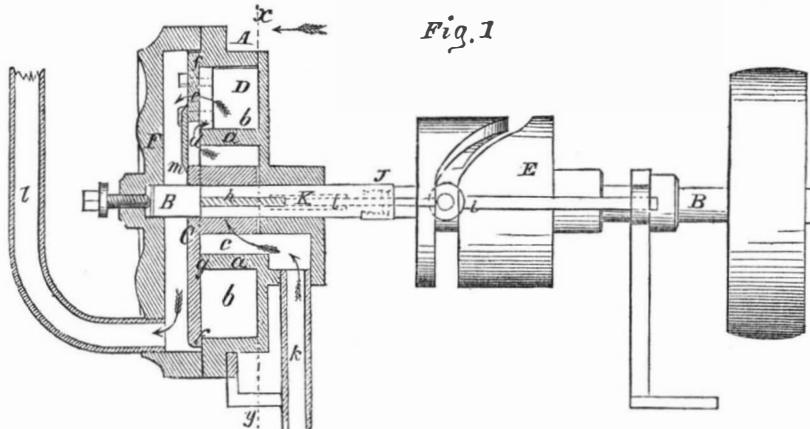

On the 17th of last April, a patent was granted to John J. Thomas, of Manayunk, Pa., for an improvement in rotary engines, represented in the accompanying engravings, fig. 1 being a longitudinal vertical section parallel with the axis, and fig. 2 is a transverse section in the line, *x y*, fig. 1 looking in the direction of the arrow. The same letters refer to like parts.

A is a cylinder which is or may be cast with one end solid or closed, and has its interior divided by an inner cylinder, *a*, which is cast with, or secured to it, into two cham-

bers, *b* and *c*. B is a shaft working through the end of the cylinder, and carrying a metal disk C, which is turned or otherwise faced to fit up to and work in contact with two faces, *f, g*, the former of which surrounds the open end of the bore of the cylinder, A, and the latter is on the end of the inner cylinder, *a*. This disk closes the two chambers, *b* and *c*, except where a communication is established between them through a passage, *d*, which consists simply of a recess in the face of the disk, C. The disk, C, has attached to its face a solid piston, D, which is fitted to revolve

around the annular chamber, *b*, between the cylinders, A *a*, and has also a passage, *e*, through it, the passage, *e*, being separated from the passage, *d*, by the piston, close to which both passages are arranged. The annular chamber, *b*, which may be considered the working cylinder, is, like some other rotary engines, fitted with two slides, *h h'*.— One of these slides is always in place to form a close partition or abutment within the chamber; but each is withdrawn in its turn, in a direction parallel with the shaft, B, to allow the piston, D, to pass in its revolution. The withdrawal and return of the slides, *h h'*, is effected by a grooved barrel cam, E, on the shaft, B, acting upon rods, *i*, which are attached to the slides, and work through stuffing boxes, *j*, at the ends of the hollow boxes, *k*, which are secured to the cylinder to receive the slides as they are withdrawn. The disk, C, is enclosed within a cap, F, which is bolted to the cylinder, A, and is deep enough to leave a chamber, *m*, at the back of the disk. The center of this cap receives a set screw, by which the shaft is adjusted to keep the disk, C, in close contact with the cylinder. The induction or suction pipe, *l*, is represented as connected with the chamber, *c*, and the eductor or discharge pipe, *l*, with the chamber, *m*.

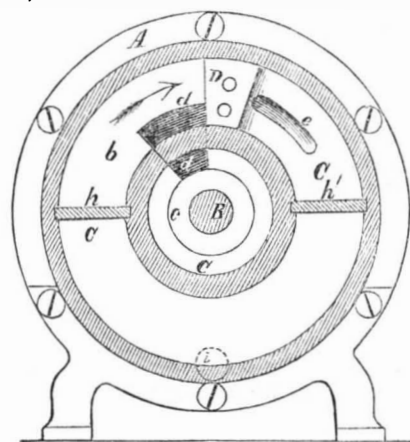

When the engine is employed as a motive agent, the steam or fluid passing through the induction pipe, enters the chamber, *c*, as indicated by the arrows in fig. 1, then passes through the passage, *d*, into the chamber, *b*, between the back of the piston, D, and the closed slider, or abutment, and gives motion to the piston and the disk in the direction of the arrow shown in fig. 2. It exhausts from between the front of the piston and the abutment through the passage, *e*, into the chamber, *m*, which is always in communication with the eduction pipe. When the engine is employed as a pump, motion is given to the shaft and disk, C, in the same direction as before described, by any suitable power, and the water rushes through the pipe, *h*, the chamber, *c*, and passage, *d*, to fill the vacuum formed in the chamber, *b*, behind the piston, and is forced out in front of the piston through the opening, *e*, into the eduction chamber, *m*. The action of the engine may be reversed either as a motor or a pump, as an engine, by simply making the pipe, *l*, the induction, and the pipe, *k*, the eduction,— and as a pump, by simply reversing the direction of the revolution of the shaft, which makes the pipe, *l*, the suction and the pipe, *k*, the discharge.

The advantage of this engine consists mainly in its simplicity. It requires no packing whatever, provided the piston, D, is made to enter the chamber, *b*, with a slight taper; any wear of the piston, or between the disk and the faces, *f g*, will be compensated for by turning the set screw, *n*, a little.

The engine may be so far modified as to make the disk, C, and its piston stationary, and to give the rotary motion to the cylinder, A, which will be the same in effect as when the cylinder is stationary and the disk rotates, as in either case the disk forms one side of the working cylinder or piston chamber, *b*.

More information may be obtained by letter addressed to Mr. Thomas, at Manayunk, Penn.

Scientific American.

NEW YORK, JUNE 16, 1855.

An Ocean Telegraph.

A few weeks since—on page 235—we directed attention to the great extent of ocean telegraph lines which had been constructed by British companies, and exhorted our telegraph engineers to look to their laurels, which some of them had claimed prospectively, in the construction of an "Atlantic Telegraph Line." Since the period mentioned, it has become a public fact that we are to have an "ocean telegraph," and as we hinted, Uncle John over the water is to have the largest share of the cost and labor in completing it. We are glad, however, that the ocean telegraph line is to be a joint stock work, or rather the work of two companies acting in concert—an American and a British one. The whole work has been contracted for, and it is expected that in three years, at furthest, from the present date, messages will be fleeting on lightning wings between New York and London. The American Company is formed of leading capitalists and gentlemen in this city. They have already secured grants—very liberal ones—of lands and charters from the provinces of Prince Edward's Island and Newfoundland, for carrying the telegraph through their territories and adjacent seas. In a few months, it is contemplated, there will be a continuous telegraph line between New York and Newfoundland, and arrangements have been made with the mail steamers to call there, homeward bound, and leave the news, which will at once be transmitted by the wires, and received three or four days before a steamer's arrival in port. A submarine cable of 70 miles long is now on its way from England, to connect Cape Breton with Newfoundland, and when this is done the American connections will be complete, and we shall then receive news from Europe in six days after the steamer has left Liverpool. But the great work will be the Atlantic submarine cable, which is designed to extend through the ocean from Ireland to Newfoundland, a distance of 1600 miles. The British Company has agreed to construct this, and to operate it, in connection with the American Company, for fifty years. The cable is to contain six wires, capable of transmitting seventy-two thousand words in twenty-four hours. It is estimated that its cost will amount to \$10,000,000, but it is calculated that the annual receipts will amount to \$60,000,000, and that the profits will be large. This is too high an estimate by a great deal, as the companies will certainly find out if they charge \$25 for ten words, as has been stated they intend to do. Such high charges will not lead to a very extensive business. The weight of the cable will amount to 13000 tons, and will employ a number of large steamships in carrying it. We hope the Company will meet with complete success in laying it down. Measures must be adopted and means employed to insure success, for a single mistake will involve consequences of the most serious and disastrous character. This project is a grand one in the highest sense of the term. The mind almost recoils upon itself in contemplating its effects.—Steamboats and railroads have effected social and commercial revolutions among the nations of the earth, but the telegraph is designed to accomplish as great, if not greater changes than any other invention of modern times. Its progress calls forth our admiration and excites us with astonishment. It is but a little over ten years since the first working telegraph line was erected in our country; now there are more than thirty thousand miles of wires in operation. They extend east, west, south, and north, and throb continually with the impulse of thought. In a few years more, the whole earth will be encircled with these electric nerves, and the American, Englishman, and Frenchman, will be conversing intelligently with one another, each with his foot on "his own native heath."

Nitrogen, Oxygen, and Carbonic Acid.

The atmosphere that surrounds us, and which at every breath enters and permeates our bodies, is composed of three subtle, elastic, and invisible fluids—those named above. In the first nothing can burn, and no life can exist; in the second, bodies burn, and animals live with great intensity of action; the third extinguishes both life and flame. Though they are very different in their properties singly, the admixture of them which forms our atmosphere is so beautifully adjusted to all things, animate and inanimate, on this earth, as to call forth the admiration of every man of science towards the Infinite Chemist. Did the air consist of nitrogen alone, there would be no heat felt on the earth excepting that of the sun's rays, consequently there would be no life on our planet, for neither animal nor plant could flourish. Were it formed of oxygen entirely, when once kindled it would produce a general conflagration, and would not be extinguished until everything combustible was consumed. If it were formed wholly of carbonic acid gas, the production of light and heat by combustion would be impossible, and there would be a reign of death. But the exact admixture of these three gases forming the genial air which we inhale, has rendered it possible for our planet to be the abode of life, activity, and beauty. Under their influence plants put forth their green leaves, and flowers put on their lovely colors; animals live and enjoy the abundance provided for them, and man calls forth light and heat as ministers of his comforts and pleasures. The inert nitrogen dilutes the too energetic oxygen, so as to make animal life continue longer; and the carbonic acid gas is rendered harmless to animal life by the very small quantity of it in the mixture. And while it does no injury to men, and no good as it respects inhalation, its presence is essential to the life and produce of vegetation, and thus by a secondary agency it is necessary to man's very existence—it is his poison and his aliment.

The Effects of Storms.

Those whose years have only been confined to the present century, and who have not read the wild and sublime history of ocean, earth, and air battles, may be ready to conclude that great physical revolutions have never taken place suddenly, and that all the operations of nature are exceedingly slow. But we find it stated in Maury's Physical Geography of the Sea, that in 1780 a hurricane took place in the West Indies which produced denuding effects during the short period which it lasted, of far greater magnitude than would be due to the operations of common storms during centuries.—The sea waves rose to a terrific height, and dashed down forts and castles, and flung huge rocks far inland. The wind swept down great forests, and leveled thousands of houses with the earth, and no less than twenty thousand persons lost their lives. We have no reason to conclude that such storms are hushed to sleep for ever; and yet, who knows but they are; it may be that nature is growing more uniform, and less violent in her operations. The earth affords evidence of its having undergone great changes in by-gone days. These changes may not have been so long in progress as the majority of geologists seem to suppose. The channel of the Niagara river below the Falls may have been scooped out in a few score instead of centuries of years, as has been calculated by some.

Pottsville Scientific Association.

We have received the bulletin of a scientific association formed in Pottsville, Pa., for the object of scientific research, especially in "natural science." To wish success to every such Institute accords with our feelings, and harmonizes with our principles. We find in this bulletin an able paper on the Falls of Niagara, being a translation from a French pamphlet by E. Desor. It also contains a paper by S. Lewis, C. E., on the height of Pottsville above tide water, in which we find it stated that the Court House is situated 713 feet above the sea. Another

paper by P. W. Sheaffer, on the paleontology of the coal measures, advances the idea "that certain beds of coal can be identified by their fossils." It is stated that this is true respecting the upper (red ash) and the lower (white ash) coal beds of Pottsville. The fossils of the upper are entirely different from those in the lower bed.

The Steel Plow.

One of the greatest improvements ever made in agricultural implements, especially for the Western States, was the adoption of the polished steel mold board for the plow, instead of the old cast and wrought-iron mold boards. The plowing of rich loam lands used to be a sad trial to the patience of the farmers of Illinois and Indiana, owing to the soil clogging on the mold boards of their plows. But plowing the rich prairie lands with the steel mold-board plow, instead of being one of the most trying and troublesome operations for the farmer, is one of the easiest and most pleasant. Such plows turn over the soil smoothly and freely, and with an ease to the cattle of about fifty per cent. We perceive, by a number of our Western exchanges, that there are quite a number of claimants for this improvement, but we have been given to understand that the inventor is H. H. May, of Galesburg, Ill., who first had such a plow made for his own use nearly twenty years ago, as an experiment. That experiment has saved millions of dollars to farmers, in lessening the expense and trouble of plowing.

The New Fire Steam Engine.

The new Steam Fire Engine, manufactured by Abel Shawk, of Cincinnati, for the city of Philadelphia, has been effectually tested with some of the hand engines of that city, and has come off victorious. In six minutes after the torch was applied to the kindling materials in the furnace, a pressure of 15 lbs. of steam was shown by the gauge, when the engine was set in motion. Under a pressure of 60 lbs. of steam, the pump made 80 strokes per minute, and threw the water 120 feet, using an inch nozzle. It has been estimated equal to eleven common fire engines manned by 575 men, estimating the quantity of water it is able to discharge in an hour.

Relief Arctic Expedition.

The Arctic and Relief, forming the expedition vessels for the search of Dr. Kane and his companions in the Arctic Seas, left the Bay of New York on the 4th inst., on their perilous voyage. We hope they will be successful; we also hope that this will be the last expedition ever fitted out by this or any other country for Arctic research. The North-west passage has been discovered, but what good has that done to navigation and commerce? No good at all,

Multiplying Gearing for Propellers.

The multiplying gearing of F. Dibben and L. Bollman, of this city, which was illustrated on page 409, Vol. 8, SCIENTIFIC AMERICAN, has been applied to the propeller shaft of the Sarah, one of Capt. Loper's vessels of the Thompson Line, plying between New York and Philadelphia. We have examined the gearing so applied, but did not witness it in operation; we were told, however, that during the trip (one only having been made yet) it gave great satisfaction.

Improvement in Pianofortes.

Messrs. Bennett & Co., 300 Broadway, N. Y., are now beginning to introduce their newly patented improvements in these instruments, the new pianos being known as Celestials. The effect of three different instruments may be separately produced by the same set of keys, to wit: the ordinary piano, the guitar, and a new combination of sound of exquisite sweetness which they term celestial. These excellent improvements we may hereafter illustrate.

Valuable Bequests.

The Toronto, C. W., Patriot says that William Maclure, a Scotchman, lately deceased, left the bulk of his property, valued at \$300,000, to be appropriated expressly for the purpose of the diffusion of useful knowledge and instruction amongst the institu-

tions, libraries, clubs, or meetings for useful instruction of the working classes or manual laborers in the United States of America.

[The above is from the Philadelphia Ledger, and is the first account we have seen of such a bequest for the benefit of our Mechanics' Institutes. Perhaps the Patriot referred to Wm. McClure, of Philadelphia, who did so much for science in our country a few years ago.

The Heat of Steam.

"From one volume of water of 212° there are formed 1700 volumes of steam of 212°, or a total of 360,400°."—[Colburn's Railroad Advocate.

[For more than a score of years we have been acquainted somewhat with steam and the steam engine, but have always entertained the idea that one volume of water converted into steam contained but 1202° of heat. We live and learn, however. If 1700 volumes of steam be condensed into one volume, then it will contain 360,400° according to the above conclusions. Now what is the fact? A cubic inch of water converted into steam, will only raise 5½ cubic inches of water from 32° to 212°, which with the cubic inch of the water of the steam will amount to 6½ cubic inches of water at 212°. We therefore have 32°—212°×5½+212°=1202—a degree of heat exceeding that of red hot iron. Men of science do not use the term "degrees of temperature" to indicate quantities like those of concrete substances—such as cubic inches of water—but simply to indicate intensity of action. A degree of heat and a unit of heat are altogether different things.

Beautiful Sawed Work.

We have examined some specimens of ornamental sawed work, in rosewood, by McLean, Kendall & Drake, of Boston, designers, manufacturers, and sawyers of pianoforte fret-work, &c., which does them high credit for ingenuity and skill. The specimen before us is intended for pianoforte fret-work, but the same principle of sawing is applicable to cutting out an endless number of patterns for block calico printing and other purposes. The lines are clear and gracefully curved,—a person never would imagine that such delicate, accurate, and beautiful workmanship was executed with a common gig saw, but Boston is a great city for ingenious craftsmen. The saw with which the specimen was executed was only 1-16th of an inch in width.

Progress of Reaping Machines.

We have been informed by a manufacturer of agricultural implements—one who is excellent authority—that between fifteen and sixteen thousand reaping machines will be manufactured and sold this year in our country. The demand is so great that manufacturers cannot make them fast enough for their orders. This affords evidence of agricultural prosperity, as the cost of these machines will amount to nearly two millions of dollars. Our farmers exhibit wisdom in using and patronizing machinery. A reaping machine will save the price of itself in one season.

Shower of Ice.

In a letter from John O. Diam, of Saint Mary's, Ohio, he informs us that a fierce storm of thunder and lightning visited that place on the 22nd of last month, and lasted for half an hour, during which period there fell large pieces of ice and huge hailstones. One piece which he picked up, three inches in circumference, was composed of three balls, one inside of the other. The inside one was clear and dense; the second appeared to be made up of wet snow, while the shell or outside one was dense and hard. The phenomenon of these hailstones—not an uncommon one in many parts of our country—may be attributed to great shocks of atmospheric electricity. If they were caused by warm and cold currents and clouds, as some suppose, how is it that they always accompany thunder storms?

The crops around New York, look very promising, although it may truly be said that no hot weather has yet been experienced.

Foreign Editorial Correspondence.—No. 3.

## Paris Exhibition, &amp;c.

PARIS, May 15, 1855.

The city of Paris, with its immense catalogue of stirring events, has never celebrated one equal in interest and importance to the opening of the Exhibition of Industry. In spite of the absorbing interest that hangs upon the war, France has not been indifferent to the claims of peace. To-day, amidst great pomp and ceremony, it has come to a splendid banquet of industry, to take notice of its ennobling trophies. Let us all hope that its influence will act as an antidote to the military spirit which has for ages prevailed among its people, smothering the genius of its inventors, and oppressing its laboring population. But it is clearly out of the question at present to direct public ceremonies of the military insignia, and therefore the claims of mechanics and inventors to places of distinction—as at the opening of the New York Exhibition—were entirely over-riden, while swords, cocked hats, epaulets, and stripes of the military and civic, eclipsed everything else. It is to the credit of the Commission, however, to acknowledge the act of recognition paid to many illustrious scientific men of the world, by having their names chiselled upon the outer walls of the building, as if this were their grand monument.

All the front seats of the galleries were reserved for ladies, and the whole ground space in front and at each side of the Emperor's throne were reserved for Foreign Commissioners and other dignitaries. These seats were upholstered with crimson velvet, edged with golden braid, and were fenced in by a strong railing, guarded by a formidable posse of armed police, to prevent the encroachment of barbarian exhibitors and the purchasers of season tickets. The published regulations permitted exhibitors to occupy any part except seats reserved for invited guests, therefore their accommodations were of the most uncomfortable kind, as they had no seats.

At a quarter to one the firing of the cannon at the Hotel des Invalides announced the starting of the Emperor and Empress from the Palace of the Tuilleries. They soon arrived, and as they entered the door of the Palace, and passed up the broad carpeted avenue to the throne, the cheering was considerable, but not deafening. However, they were well received, and after facing the vast auditory, Prince Napoleon, President of the Imperial Commission, cousin of the Emperor, read a statement of what had been done, and in a brief speech the Emperor acknowledged himself satisfied, and closed by saying, "I open, with great pleasure, this Temple of Peace, which invites all nations to concord." A very appropriate sentiment, and one to which I have no doubt the French and English especially, would just now respond to with much enthusiasm. Being a peace man myself, I felt its force. At the close of his speech he descended the throne, and in company with the Empress, passed under escort through various parts of the building, thus affording all present an opportunity of seeing them. They were well cheered at various points, especially the beautiful Empress. She seemed to be the favorite.

The scene in front of the throne was very imposing and brilliant, as it embraced Foreign Ministers in costume, many richly attired ladies, and officers of the army and navy, and Ministers of State, Justice, &c., besides Foreign Commissioners to the Exhibition, who were requested to appear in fashionable party dress. The United States were tolerably well represented, but none of its citizens assumed the military costume, except the American Minister and the Secretary of Legation. There were no religious ceremonies performed on the occasion.

Above the throne of the Emperor were suspended flags of the United States, also flags of the cities of New York, Boston, Philadelphia, and Baltimore. I notice two flags of our country with their stripes running the wrong way. I could not conjecture whether this was accidental, or designed to illustrate

the state of our Department in the Exhibition.

The price of admission to the Exhibition is fixed at five francs (94 cts) till the first of June.

There are many beautiful works of art already displayed, such as a large pyramid of artificial flowers from Berlin, a large fountain of several stages, filled in place of water with beautiful living flowers, a model of the meridian circle of Greenwich with the model of the instrument employed to raise and depress it an elegant aviary belonging to the Empress and well stocked with pretty little birds of very rich plumage, a colossal mirror 10 feet by 17, a very splendid affair, manufactured at St. Goban, a place in the west of France, celebrated for its manufactory of fine glass mirrors. Elkington & Mason, of Birmingham, Eng., make a fine exhibition of their electro-plated ware. England comes to France to contest for the prize of rich jewelry. This seems almost like taking coals to Newcastle; nevertheless the London jewellers make a grand display, one of them, it is said, will exhibit over \$600,000 worth.

In the Machinery Department, nothing is yet in readiness for exhibition, except an envelope folding machine, manufactured by Delarue. It operated to-day, and drew around it a perfect jam of visitors. It folds at the rate of 2000 per hour. Two stained glass windows, the largest paintings of the kind I have ever seen, attract much attention. The designs are allegorical, one representing France appealing to foreign nations to gather around her. The other represents Equity holding in one hand the scales of Justice, and in the other a seal. I was deeply impressed with the purposes of Equity in asking the producer to stamp his work with the seal of Justice.

I have lately made a visit to the celebrated Sevres Porcelain Works. I expected permission to pass through the workshops, but was advised by the Minister of State that this privilege was no longer extended to strangers, as their visits interfered with the labors of the workmen very much. It is well worth the visit to go through the Museum, however,—one picture, about two feet by eighteen inches, representing Music, I was informed, could not be purchased for less than \$10,000. I conclude not to speculate in Sevres Porcelain.

The season is very cold and backward for this country. S. H. W.

## European Inventions, Discoveries, &amp;c.

**SUCCESSFUL RIFLE-CANNON EXPERIMENT**—Following my successful experiment with an iron cylindro-conoidal shot, fired at Woolwich a few days ago, from a rifled musket of 11 bore, I this day fired a similarly formed iron shot from the rifle 9 pounder field gun, now at Woolwich, in presence of Col. Chalmer, Inspector of Artillery; Lieut. Carpenter, R. A.; several gentlemen visitors, and a number of non-commissioned officers of the Royal Artillery. The distance of the target was only 40 yards, that being quite sufficient for a first experiment; for if the shot did not revolve round its long axis, it would strike an object sideways in the first 6 ft. of its flight. The cannon had four broad grooves, about the tenth of an inch deep; the charge of powder was 1 lb. The shot struck the target point foremost, and the rifles of the gun were fully impressed on the expanding sabot, which was formed of twelve layers of sole leather, glued together with liquid glue; it required no particular force to ram it home. The rounded base of the shot was also shown on the face of the sabot, like the concave part of a dinner plate. The sabot also struck the target face foremost, it having parted from the shot on leaving the mouth of the gun. The cartridge, to be perfect, ought to have a wooden head, somewhat rounded, so as to impress the bottom of the sabot in the same manner as its front is impressed by the rounded base of the shot. These two highest pressures cause the sabot to expand laterally into the grooves of the cannon.—J. NORTON; May 15.

[This shot was illustrated and described on page 245, this Vol. SCIENTIFIC AMERICAN.

**PREVENTION OF RAILWAY ACCIDENTS**—The *Piedmontese Gazette* of the 5th May, gives some details concerning the experiments made with Chevalier Bonelli's new contrivance for communicating telegraphically with railway trains while in motion. A train was started on the Turin and Moncalieri line, and notwithstanding the unfavorable state of the weather, as it rained incessantly, questions and answers were exchanged between the Turin station and the train while the latter was at its fullest speed. Another experiment will shortly take place between Traffarello and Moncalieri, when the inventor promises to communicate despatches from a train in motion to another also in motion on the same line, and to the stations of Turin, Moncalieri, and Traffarello.

[This appears to be a useful invention. The idea has been suggested to us a number of times by various correspondents, but we are not aware of any one of them ever having made experiments like the above.

**WATER-POWER ENGINE**—A hydraulic power engine which works by the pressure of a column of water, simplified and originated by Mr. James Sinclair, engineer, Stirling, appears to be making its way successfully in Scotland. It has for some time been applied in several large printing offices in Stirling, Dundee, and other towns having the advantage of a high service of water from the hills. The proprietors of the *Scotsman*, published in Edinburgh, have recently adopted this mode of power with (as stated by them) perfect success. The whole machine weighs no more than 6 cwt., occupies a horizontal space of only 31 by 25 in., and but 37 inches high. It consists of two oscillating cylinders, working similarly to a high pressure steam engine, the water being admitted through the axis on which they vibrate. It works most smoothly, is perfectly safe, has great power for its size, and is perfectly manageable; there is no shock or recoil, and no danger of the pipes bursting. The column of water which the company allow is 150 ft. high, which gives sufficient power to work off 2000 impressions per hour. Wherever a supply of water of sufficient height can be obtained, these engines are well adapted to a great variety of purposes.

[A number of our correspondents having small supplies but high falls of water, have made inquiries of us respecting such engines, as being suitable and useful for various purposes. We are not acquainted with the peculiarities of their construction, but their economy and usefulness appear to be a settled matter.

**IMPROVEMENTS IN THE SCREW PROPELLER**—A brass screw propeller, embracing all the improvements recently patented by Mr. Griffiths, has been cast at the Vauxhall Foundry, Liverpool, 16 ft. 6 in. diameter, and weighing 8 tons, intended for the United States war frigate, *Princeton*. The principal peculiarity in Griffiths' propeller is that the blades are wider at the root than at the other extremity, and tapering gradually, quite different to the generally adopted principle. This form offers no obstruction to the vessel when under canvas, nor does it affect her steering properties, qualities which have been proved by numerous Admiralty experiments; it thus supersedes the necessity of raising the screw when not used, which involves considerable trouble and labor; and the unsightly and cumbersome well case passing through the chief cabin is not required, and the room saved, effecting a saving in first cost. Another great advantage consists in the facility of replacing a broken or injured blade, and of taking them out and altering the pitch. It also prevents all vibration, so destructive and unpleasant. We understand two other propellers on this principle are being constructed for the Royal Navy by R. Daglish, Jr.

[The above is from the *Liverpool Mercury*. It is the first we have heard of this affair,—our Government going to Liverpool for a propeller. We do not feel complimented by the act.

**ALCOHOL FROM COAL**—A young French chemist, of the name of Berthelot has made

the discovery that alcohol can be procured directly from olefant gas, which can be extracted in large quantities from coal.

**HEATING APPARATUS, BY MEANS OF FLUIDS** General Henry Dembinski, of Paris, has patented some novel and ingenious arrangements for obtaining heat, to be applied to heating or warming rooms and large buildings, hot-houses, and to cooking and other purposes. The general principle adopted by the patentee is such an arrangement of fluted or plain tubes, with tufts of wire passing through them, to be heated in any convenient manner, as, while hot, can have water continually to flow over or through them. The heated surface being extensive, in proportion to the water to be heated, keeps the latter in a constant state of ebullition, and by passing in that state through other pipes, so as to re-circulate over the heated surface, great economy of fuel is estimated by the patentee to be the result. A large square or circular flattened vessel is connected with a smaller one by a tube of small diameter at their upper part, and by one of larger caliber below; the steam and water, in a state of ebullition, pass along the upper pipe, and the water through the larger tube below, keeping up a constant circulation. In such case a single gas-burner only is employed, and the heated products of combustion so confined by a tube, as to heat the whole apparatus. There are various modifications of the arrangement, by which a whole suite of apartments can be heated with great facility. Ornamental vases, pillars, plinths, and other architectural and fanciful designs, may be made the heating medium in halls, staircases, single apartments, &c.

## Is the Center of the Earth a Mass of Fire?

We are gratified to find the following disquisition on the popular theory that the central parts of the earth are a mass of liquid fire, from a so closely scrutinizing writer as the editor of the SCIENTIFIC AMERICAN. To our mind this theory has ever been unsatisfactory, and the evidence adduced to support it very scanty and inconclusive. Not only have the arguments used by the editor against the soundness of the theory, often occurred to us, but many others, among which is the fact, that the ocean, and the air above it, is no warmer in those sections where it is deepest than in other places of the same latitude. The greatest known depth of the Atlantic, in any part, is, we believe, about nine miles, a depth at which, according to the theory in question, would be a red heat that would make that part of the sea lying over it boil like a pot; or, if it did not, on account of the diffusion of heat passing through the superincumbent mass of water, it must certainly greatly alter the temperature of the water and atmosphere in that part of the sea. But no such warmth of water or air is discovered any more at these six and nine miles depths than in the shallowest parts of the ocean.—[Freeman.

[The above is from the *Green Mountain Freeman*, Vt., as an introduction to an article copied from the SCIENTIFIC AMERICAN of the 26th ult., on the above subject. The argument presented is good, and will withstand many stout assaults. The editor, however, could not have been acquainted with the arguments we presented respecting some mines growing colder as they descended, for the facts on this point have only been brought to light within a very short period.

## Sawing Red-hot Iron.

Iron bars and shaftings are cut to length by a circular soft steel saw. The iron to be cut is presented red hot to the saw, which rotates at a high velocity, and is kept cool by its lower part passing through a trough containing cold water. A large bar of iron can thus be cut through in a few seconds.

## Bronze Statue of Washington.

The Ames Manufacturing Company, in Chicopee, Mass., are casting a colossal equestrian statue of Washington, to stand in Union Square, New York. It was modelled by H. K. Brown, and, as a work of art, is spoken of in the highest terms of praise.

TO CORRESPONDENTS.

E. B. K., of Texas—Your plan for an atmospheric bellows perpetual motion is a new idea, and we see no reason why it should not operate as well as any other known device for this purpose.

F. F., of Ohio—If your mechanical arrangement for scales is new you could get a patent. Such an invention would of course be of practical use—provided it worked well.

L. W., of Conn.—We think there is a combination in your projectile that is patentable, though there is more risk of rejections in applications for patents in inventions of this class than on many others, as there is no subject on which the ingenuity of the human race, in every part of the world and in all ages, has been more exercised than that of destructive projectiles.

L. A. T., of N. Y.—We have seen it stated in some of the Canada papers that the lake phenomenon was caused by a tornado.

G. M. H., of Va.—We would paint the tin roof with red lead, if it were ours. The paint will be all the better for being made up with boiled oil.

J. H. M., of Phila.—There is nothing new about Mr. Paine's engines that we can perceive. Your remarks are very good.

W. J. A. DeL., of Ct.—Your improvement in wire fences, to obviate the effects of expansion, &c., is new to us, and we think patentable. Our charge would be \$25.

E. G. W., of Ohio—A governor like yours, but employing water instead of air, has been employed, and there would be nothing patentable in substituting air for water—one fluid in place of another. \$1 received. Paper will be sent.

J. H. G.—We think it doubtful whether a patent can be had on your mill; apertures in the upper stone for cooling are well known; the dress is not patentable. If you have a new machine for cutting the dress perhaps that could be patented. You did not state your P. O. address.

L. A. T., of N. Y.—Your digger is not very well described. We do not discover anything patentable therein. Much obliged for the names. \$1 received. Paper will be sent. Patent Laws have been forwarded.

J. C., of N. J.—Your paddle wheel device is very old, and not patentable. On page 128, Vol. 5, Sci. Am. (1859), you will see a diagram similar to your sketch.

H. J., of Ala.—On pages 144 and 556, Vol. 5, of our paper, you will find engravings illustrative of your device for a propeller; therefore your invention is not patentable.

D. W. H., of Mo.—Your corn planter is new to us, and we think patentable.

J. S., of Ind.—Your churn gearing is not patentable.

J. S., of Mich.—We do not know the price of the Encyclopedia of Architecture; it is a foreign work and must be expensive. There is no particular work for draughting for carpenters and joiners; Appleton & Co., this city, no doubt, will give you the information respecting the work on architecture.

S. J. M., of Mass.—Your car brakes is not patentable; producing friction on the rails instead of on the wheels is not new.

W. B. G., of Iowa—Your device for changing rotary into reciprocating motion is very ancient, and will be found described in a table of mechanical movements published in Vol. 2, Sci. Am.

E. G., of Cal.—You can see an illustration of the principle of Morgan's wheel, on page 308 of Scott Russell's work on Steam Navigation. Yours, so far as you have explained it, is not new.

W. W. D., of Mass.—We think your mosquito fan bed would not be so cheap as a small portable fan operated by a spring; the idea, however, is new to us.

A. S., of N. H.—Alcohol is the only substance that we can recommend to dissolve the wax from your molds. Use it with a brush to clean out the mold after every impression.

R. H. C., of Vt.—We discover nothing patentable in your churn.

L. K., of Tenn.—You will be able to move machinery by your plan, but it would not be economical; it is not equal to that of Prof. Fage's Magnetic Engine, on page 65, Vol. 7, Sci. Am.

W. E. C., of Tenn.—Your rotary engine resembles some of the oldest engines of that character; we have models now in our office of some, containing all the features of yours. You will get some information on this subject in Vol. 4, Sci. Am., which contains a series of articles on rotary engines.

E. M. M., of ————Your washing machine appears to be a good one; if you desire to apply for a patent, send a model and Patent Office fee (\$3.3) to this office. Also give your address in full; your letter has no date or residence marked thereon.

A. N. W., of N. Y.—The cause of foaming in steamboats is impure water; we believe there is no sure cure for it but to use pure water. An upright boiler is generally more liable to foam than a horizontal one, as the water is more concentrated.

F. O. D., of N. Y.—We have never known of a whistle to be operated as described; but there has been such an endless variety of plans for boiler alarms, that it is impossible to speak with any degree of certainty as to the novelty of your plan.

Money received at the Scientific American Office on account of Patent Office business for the week ending Saturday, June 9—

- D. A. W., of Miss., \$25; M. L., of Mass., \$25; J. D. H., of Ill., \$25; S. M. B., of Mass., \$25; R. W. & D. D., of O., \$10; J. A. & Sons, of ———, \$30; H. H. M., of Ill., \$40; J. H., of N. Y., \$10; S. N. C., of Ill., \$25; J. L. I., of Ala., \$30; R. H., of Ill., \$30; J. H., Jr., of Wis., \$50; J. J. B., of Ind., \$25; L. M., of Mich., \$25; J. McG., of O., \$250; J. H. P. C., of Conn., \$25; C. M. H., of Ct., \$25; J. & E. A., of N. J., \$30; H. S., of O., \$50; S. & B., of Mich., \$30; S. & H., of N. Y., \$127; W. H. N., of N. Y., \$25; E. & M. H., of Va., \$25; S. C., of Ct., \$25; S. T. P., of N. J., \$30; T. E. C. B., of Ky., \$10; J. J. T., of Pa., \$35; C. F. B., of R. I., \$50; A. S., of N. Y., \$25; W. S., of N. Y., \$25; B. & D., of N. Y., \$25; J. S., of N. Y., \$25.

Specifications and drawings belonging to parties with the following initials have been forwarded to the Patent Office during the week ending Saturday, June 9—

- W. P., of N. Y.; J. J., of N. J.; J. D. H., of Ill.; M. L., of Mass.; A. S., of N. Y.; S. N. C., of Ill.; W. S., of N. Y.; J. H., Jr., of Wis.; J. H. P. C., of Ct.; L. M., of O.; B. & D., of N. Y.; J. J. B., of Ind.; C. M. H., of Ct.; J. S., of N. Y.; E. & M. H., of Va.; S. & H., of N. Y.; W. H. N., of N. Y.; D. C., of Ct.; S. C., of Ct.; J. J. T., of Pa.

Important Items.

TO NEW SUBSCRIBERS AND OTHERS—We are entirely out of Nos. 17, 25, 26, 27, Vol. 10.

MODELS—We are receiving almost daily, models of inventions which have not the names of their inventors marked upon them. This usually prevents us from taking any notice of them whatever. We shall esteem it a great favor if inventors will always attach their names to such models as they send us. It will save us much trouble, and sometimes prevent the model from being mislaid.

PATENT LAWS, AND GUIDE TO INVENTORS—Congress having adjourned without enacting any new laws pertaining to applications for patents, we have issued a new edition of the old laws, which may be had at our counter or sent by mail. This pamphlet contains not only the laws but all information touching the rules and regulations of the Patent Office Price 12 1/2 cents per copy.

PATENT CLAIMS—Persons desiring the claim of any invention which has been patented within fourteen years, can obtain a copy by addressing a letter to this office, stating the name of the patentee, and enclosing \$1 for fees for copying.

RECEIPTS—When money is paid at the office for subscription a receipt for it will always be given, but when subscribers remit their money by mail, they may consider the arrival of the first paper a bona fide acknowledgement of the receipt of their funds.

Terms of Advertising.

Table with 3 columns: Lines, Rate, Total. 4 lines for each insertion, \$1.00; 8 lines, \$2.00; 12 lines, \$3.00; 16 lines, \$4.00.

Advertisements exceeding 16 lines cannot be admitted, neither can engravings be inserted in the advertising columns at any price.

All advertisements must be paid for before inserting.

American and Foreign Patent Agency.

IMPORTANT TO INVENTORS—MESSRS. MUNN & CO., 128 Fulton street, New York, Publishers and Proprietors of the SCIENTIFIC AMERICAN, having for many years been extensively engaged in procuring Letters Patents for new mechanical and chemical inventions, offer their services upon the most reasonable terms. Patents promptly secured in the United States, Great Britain, France, Belgium, Holland, Austria, Russia, Spain, and in all countries where they are granted. All business entrusted to their charge is strictly confidential. Private consultations respecting the patentability of inventions are held free of charge, with inventors, at their office, from 9 A. M. until 4 P. M. Parties residing at a distance are informed that it is generally unnecessary for them to incur the expense of attending in person, as all the steps necessary to secure a patent can be arranged by letter. A rough sketch and description of the improvement should be first forwarded, which we will examine and give an opinion as to patentability, without charge. Models and fees can be sent with safety from any part of the country by express. In this respect New York is more accessible than any other city in our country. Circulars of information will be sent free of postage to any one wishing to learn the preliminary steps towards making an application. In addition to the advantages which the long experience and great success of our firm in obtaining patents present to inventors, they are informed that all inventions patented through our establishment, are noticed, at the proper time, in the SCIENTIFIC AMERICAN. This paper is read by not less than 100,000 persons every week, and enjoys a very wide-spread and substantial influence. Parties intrusting their business in our hands can rely upon prompt and faithful attention. Most of the patents obtained by Americans in foreign countries are secured through us; while it is well known that a very large proportion of all the patents applied for in the U. S., go through our agency. The offices of Messrs. Munn & Co.'s American and Foreign Patent Agency are at 128 Fulton Street, New York; London, No. 32 Essex st., Strand; Paris, No. 39 Boulevard St. Martin; Brussels, No. 6 Rue D'Or.

TO MANUFACTURERS—The advertiser, having experience in the general business and operations of cotton manufacture, and thoroughly understanding manufacturing and other accounts, offers his services to take charge of a small business, or as accountant, etc. to a manufacturing company. Satisfactory reference will be given to merchants and manufacturers in Boston. Address G. B., box 663, New York P. O. 402\*

TO IRON FOUNDERS—Scotch and American Pig Iron, Facing Dusts, Fire Clay, Fire Sand, Pig Iron, Bucking, Molding Sand, and other articles, for sale. O. ROBERTSON, 135 Water street. 404\*

\$6000 WORTH OF MACHINERY FOR sale consisting of Lathes Planers, Upright Drills, 2 sets of blacksmith's tools, complete; Lathes Tools, Drills, upper works, and Belting, Benches, and Drawers, etc., etc., all that could well fit up a shop to this extent for building light machinery, which will be sold on reasonable terms, by applying to JAS. HARRISON, Jr., Lovejoy's Hotel, or at room 10, Union Steam Works, corner 22nd street and Second avenue, New York. 404

THE DAILY SUN—Mail Subscribers.—The morning edition is forwarded by the early mails to country subscribers at \$1 per annum, or \$1 per quarter, payable in advance. The postage under the present law is as follows:—To any Post Office in the State of New York, 75 cents per year, payable quarterly, 19 1/2 cents in advance. To any Post Office out of New York State, but within the United States, \$1.86 per year, payable quarterly, 38 cents in advance.

Sole Proprietor of the Sun Establishment, Corner of Fulton and Nassau sts. 39

METALLIC OIL—CUMBERLAND BROTHERS Patent, and Yockey's Improved Lubricating Oils and Grease. These articles are adapted to the requirements of engineers and machinists, for every description of Machinery. The great economy of their use, both in their durability and entire freedom from gum, the lessening of wear on the journals, as also the saving of power by reducing friction, commend them to the attention of all parties using lubricating oils. May be had in packages containing from 1 to 200 gallons from the manufacturers. AUGUSTUS YOCKEY, 67 Exchange Place. 39 2\*

WROUGHT IRON PIPE—Boiler Flues Pumps Gauge Cocks, Oil Cups and every variety of fittings for steam, gas and water, manufactured and sold on the most favorable terms, by JAMES O. MORSE & CO., No. 79 John st., New York. 39 3\*

JACK SCREWS AND HYDRAULIC JACKS.—For sale at manufacturers' prices, by FOSTER & LEACH, 26 Broadway, N. Y. 37 13\*

ENGINEERING—The undersigned is prepared to furnish specifications, estimates, plans in general or detail of steamships, steamboats, propellers, high and low pressure engines, boilers and machinery of every description. Broker in steam vessels, machinery, boilers, &c. General Agent for Ashcroft's Steam and Vacuum Gauges, Allen & Noyes' Metallic Self-adjusting Non-leaking, Faber's Water Gauge, Sewell's Salinometer, Dudgeon's Hydraulic Lifting Press, Roebing's Patent Wire Rope for hoisting and d steering purposes, etc. CHARLES W. COPELAND, Consulting Engineer, 64 Broadway 14 13eov

UNITED STATES PATENT OFFICE.

Washington, May 19, 1855. ON THE PETITION of Emily C. Pullman, administratrix of the estate of Lewis Pullman, deceased, late of Albion, N. Y., praying for the extension of a patent granted to the said Lewis Pullman, on the 21st day of August, 1841, for an improvement in "machines for removing buildings," for seven years from the expiration of said patent, which takes place on the 21st day of August, 1855:

It is ordered that the said petition be heard at the Patent Office on Monday the 6th day of August next, at 12 o'clock, M.; and all persons are notified to appear and show cause, if any they have, why said petition ought not to be granted.

Persons opposing the extension are required to file in the Patent Office their objections, specially set forth in writing, at least twenty days before the day of hearing; all testimony filed by either party to be used at the said hearing must be taken and transmitted in accordance with the rules of the office, which will be furnished on application.

The testimony in the case will be closed on the 26th day of July, 1855; depositions and other papers relied upon as testimony must be filed in the office on or before the morning of that day; the arguments, if any, within ten days thereafter.

Ordered, also, that this notice be published in the Union Intelligencer, and Evening Star, Washington, D. C.; Pennsylvania, Philadelphia, Penn.; Scientific American, New York; Daily Baltimore Republican, and Post, Boston, Mass., once a week for three successive weeks previous to the 6th day of August next, the day of hearing.

P. S. Editors of the above papers will please copy and send their bills to the Patent Office, with a paper containing this notice. 38 3

LOWELL HYDRAULIC EXPERIMENTS—LITTLE BROWN & Co., Boston, have just published Lowell Hydraulic Experiments; being a selection from experiments on Hydraulic Motors, on the flow of water over weirs, and in canals of various rectangular section, and of short length. Made at Lowell, Mass., by J. B. FRANCIS, Civil Engineer, etc. 1 Vol. 4 to.; 15 plates, beautifully engraved. Price \$10. "The most original and important practical scientific treatise ever published in the country, and in its particular branch in any country, and which for reference must be standard among hydraulic engineers."—N. Y. Courier and Enquirer. 39 2

THE NEW YORK WEEKLY SUN is now sent to subscribers at the following very low rates, payable in advance:—One copy, 3 months, 25 cents; 6 mos, 50 cts.; 1 year, 75 cts.; 16 months, \$1; 3 copies, 1 year, \$2; 8 copies \$5; 13 copies, \$8; 25 copies, \$15. The postage within the State is only 13 cents a year—out of the State 26 cents a year. No traveling agents are employed. Specimen copies sent gratis. All letters should be post paid and directed to MOSES S. BEACH, Sun Office, New York. 39

MAMMOTH CATALOGUE OF BOOKS and Prints for 1855—sent gratis to all who apply for it. Address STEVENS & CO., publishers, corner Ann and Nassau sts., N. Y. 39 2\*

FOR SALE—Two patents (of late date) for improvements in Safe Locks; both locks are unbreakable and powder proof; simple to manufacture, and meet with a good sale. Address LINUS YALE, Newport, Herkimer Co., N. Y. 39 3\*

BALL AND BALLARD, (successors to Ball and Rice) Worcester, Mass., continue to manufacture the well known Daniels Planers; Gray and Wood, Patent Planers, being a combination of parts of the Daniels and Woodworth Planing Machines. This machine does the work fast and very nice; also Wright's Scroll Saws, Tenoning and Sash Molding Machines, warranted to be of a superior quality, and have recently been much improved; we also manufacture Mortising Machines, and a variety of other articles wanted to accompany the above named machines. 38 4\*

FOR SALE—A valuable Lumbering Establishment in full operation; a large new mill, a good stock of logs on hand, and a quantity of sawed lumber in the yard. Connected with the above is a large and desirable tract of timber land in Pennsylvania, near the Delaware River, and convenient to the N. Y. and Erie R. R. For particulars inquire of E. P. WHITMOR, office of the Plow, Loom and Anvil, No. 9 Spruce st., N. Y. 38 3

LUBRICATING OILS—We are prepared to furnish Cumberland's Patent Metallic Oil, and other superior lubricating materials; Railroad and Steamship Companies, and all parties using machinery, will find a decided advantage in using our oils, which are more economical than others in market. The Metallic Oil is favorably known for its ability, for saving power and for preventing the heating and wearing of machinery. The price of our No. 1 oil is only \$1.15 per gallon. Orders will receive prompt attention. WEED & CO., office 134 Pearl st., N. Y. 38 4\*

TREMPER'S PATENT REGULATOR and Fuel Economiser for Stationary or Marine Engines; will regulate better and with less fuel than any other known mode. Also will stop the engine, in case of accident.—The whole combined in one and warranted for governors or valves. Address JOHN TREMPER, 37 6\* No. 1 South Sixth st., Philadelphia, Pa.

STAFFORD'S HALF HUNDRED RECEIPTS—A pamphlet of 16 octavo pages, containing more than 50 new and valuable receipts. This book should be in the hands of every mechanic farmer, and thrifty housekeeper. Enclose two letter stamps in a letter directed to J. R. STAFFORD, Practical Chemist, No. 4 New street, New York, and the return mail will bring you the book with the postage paid thereon. 37 13

OIL! OIL! OIL!—For railroads, steamers, and for machinery and burning—Pease's Improved Machinery and Burning Oil will save fifty per cent., and will not gum. This oil possesses qualities vitally essential for lubricating and burning, and found in no other oil. It is offered to the public upon the most reliable, thorough and practical test. Our most skillful engineers and machinists pronounce it superior and cheaper than any other, and the only oil that is in all cases reliable and will not gum. The Scientific American, after several tests, pronounced it superior to any other they have ever used for machinery. For sale only by the inventor and manufacturer.

F. S. PEASE, 61 Main st., Buffalo, N. Y. N. B.—Relia le orders filled for any part of the United States and Europe. 19 eow13\*

J. P. MERRIAM'S MACHINERY DEPOT—No. 12 Platt st., N. Y., offers for sale these Engines, and furnishes to order Stationary and Portable Engines, Machinists' Tools, Slide Lathes, Drills, Planers, Chucks, Portable Grist, and Child's Circular Saw Mills, Fay's Sash Machines, Steam Gauges, &c. 31 5eov\*

MATHEMATICAL INSTRUMENTS—The undersigned furnishes, free of charge on application, to all parts of the United States, his new Illustrated Catalogue of Mathematical, Optical, and Philosophical Instruments. C. T. AMSLER, 31 eow 3m 211 Chest. ut. st., Philadelphia, Pa.

PORTABLE STEAM ENGINES.—S. C. HILLS, No. 12 Platt st., N. Y., offers for sale these Engines, with Boilers, Pumps, Heaters, etc., all complete, and very compact, from 2 to 10 horse power, suitable for printers, carpenters, farmers, planters, &c. A 2 1/2 horse can be seen in store. It occupies a space 5 by 3 feet, weighs 1500 lbs. price \$240; other sizes in proportion. 29 e3w

THE ARTISAN JOURNAL—A Monthly Record of the Process of Civil and Mechanical Engineering, Steam Navigation, Shipbuilding, and the Industrial Arts Chemistry, &c. Published in London, and sold in numbers and volumes by CHAS. H. HASELWEY, Consulting and Superintending Engineer, Bowling Green, New York. Drawings and specifications of Steam Machinery, in all its branches, furnished upon application. 14 lamf

THE CHEAPEST HORSE POWER KNOWN.

Patented April 1st, 1855.—Simpson's horse power has not a gear wheelabout it, and it can be constructed and kept in repair by an ordinary mechanic. It costs less and furnishes a larger percentage of power than any horse power known. For the purchase of rights for the District of Columbia, Maryland, Delaware, New Jersey, Pennsylvania, New York, Ohio, and the New England States, apply to Prof. CHAS. G. PAGE, Washington, D. C. 35tf

OFFICE OF THE HYDRAULIC WORKS—No. 28 Broadway, New York. Steam Pumping Engines, for steamers, wrecking purposes, irrigating and draining lands, deep mining shafts, quarries, and excavations, railroad stations, tanneries, factories, public institutions, hotels, gas works, &c. Also a large and improved class of Pumping Engines, for supplying cities, towns, and villages. Apply to H. R. WORTHINGTON, 33 3m

THE EUROPEAN MINING JOURNAL, RAILWAY and Commercial Gazette. A weekly newspaper, forming a complete history of the Commercial and Scientific Progress of Mines and Railways, and a carefully collated Synopsis, with numerous Illustrations, of all New Inventions and Improvements in Mechanics and Civil Engineering. Office 26 Fleet st., London. Price \$6.50 per annum. 36tf

GRAIN MILLS—EDWARD HARRISON, of New Haven, Conn., has on hand for sale, and is constantly manufacturing to order a great variety of his approved Flour and Grain Mills, including Bolting Machinery, Elevators, complete with Mills ready for use. Orders addressed as above to the patentee, who is the exclusive manufacturer, will be supplied with the latest improvements. Cut sent to applications, and all mills warranted to give satisfaction. 34tf

IMPORTANT INVENTION—Patented 7th June, 1855.—Falconer's Coupling for hose, hydrants, force pumps, etc., is the only coupling likely to supersede the screw coupling, and excels it in every respect, and after a public trial under the severest tests, it has been adopted under an Act of the Corporation of the City of Washington, for the Fire Department, in place of the screw coupling. For the purchase of rights, under the patent, apply to Prof. CHAS. G. PAGE, Washington, D. C. 35tf

JOHN PARSHLEY, NEW HAVEN, Conn. Manufacturer of Machinists Tools. Has on hand, and is finishing, all sizes of Engine and Hand Lathes, Iron Planers, Upright Drills, Bolt and Gear Cutters, Universal and Scroll Chucks of the best quality and latest style, at extremely low prices for approved paper, and still lower for cash.

N. B.—It is now admitted by all that New Haven is the best place to buy good machinists tools for 25 per cent less than any other place in the United States, as it was the first place and still is the only place where the tool business is pursued in a systematic way, which always gives good work and at a low price. And I know that I can sell (when quality and capacity is considered) ten or fifteen per cent. lower than any other tool builder in New Haven, as my business is large, and I make all of my own castings, and also 19-20ths of all the tool castings made in New Haven. Hence no one pretends to compete with me. Cuts of tools, with descriptions and prices, can be had by addressing me above. 40tf

POWER PLANERS—Persons wanting Iron Planers of superior workmanship, and that always give satisfaction, are recommended to the New Haven Manufacturing Co., New Haven, Ct. 40tf

TO LET—Light Rooms with steady power, on Canal, Elm, and Walker, streets, at very low rates. Situation central, buildings, and occupants, first class. Facilities for exhibiting new machines, by Mr. GAUDU, 102 Walker st. 31 3m\*

MACHINISTS' TOOLS—Meriden Machine Co. have on hand, at their New York Office, 15 Gold st., a great variety of Machinists' Tools, Hand and Power Punching Presses, Forcing Pumps, Machine Belting, &c., all of the best quality. Factory West Meriden, Conn. 31 13\*

T. B. RUSSELL, Manufacturer of Philosophical Apparatus and Inventors' Models, No. 7 Washington street, Salem, Mass. 33 12\*

ANDREWS & JESUP—Commission Merchants, Cotton and Woolen Machinery, Steam Engines, Machinists Tools, Belting, &c., Importers and Dealers in Manufacturer's Articles, No. 67 Pine st., N. Y. 33 1y

SMITH'S WATER-TUYERES—Prosser's Patent. These Tuyeres are made of wrought-iron, and are warranted not to crack by the most intense heat. Also Water-backs and Tables, for kitchen ranges, hotels, and restaurants, &c., requiring a constant supply of hot water. THOS. PROSSER & SON, 28 Platt st., New York. 27\*

MACHINISTS' TOOLS—Manufacturers, Mechanics and Railroad Supplies, Locomotive and Stationary Engines, Steam Boilers, Belting, Cotton and Woolen Machinery, Water Wheels, Pumps, Blowers, &c. FOSTER & LEACH, 26 Broadway, N. Y., Selling Agents of the Lawrence Machine Shop. 26 13\*

NEW HAVEN MFG CO—Machinists' Tools, Iron Planers, Engine and Hand Lathes, Drills, Bolt Cutters, Gear Cutters, Chucks, &c., on hand and finishing. These Tools are of superior quality, and are for sale low for cash or approved paper. For cuts giving full description and prices, Address, "New Haven Manufacturing Co." New Haven, Conn. 40tf

IRON PLANERS—Of various sizes and superior workmanship on hand and finishing, for sale low for cash. We confine ourselves solely to building Planers, and can warrant every machine, Lathes, Drills, Gear Cutters, Chucks, &c., of the best quality, furnished at very low prices. Address THOMPSON, SKINNER & CO., New Haven, Conn. 40tf

HARRISON'S GRAIN MILLS—Latest Patent.—\$1000 reward offered by the patentee for their equal. A supply constantly on hand. Liberal Commissions paid to agents. For further information address New Haven Manufacturing Co., New Haven, Conn., or to S. C. HILLS, our agent, 12 Platt Street, New York. 13 1f

1855—D. W. WHITING, Forwarding and Commission Merchant, Buffalo, N. Y.—Particular attention given to manufacturers' goods and wares, and shipped at the lowest rates by any line, as directed. Mark plainly, "care D. W. WHITING, Buffalo, N. Y." 29tf

NORCROSS ROTARY PLANING MACHINE—The Supreme Court of the U. S., at the Term of 1853 and 1854, having decided that the patent granted to Nicholas G. Norcross, of date Feb. 12, 1850, for a Rotary Planing Machine for Planing Boards and Planks, is not an infringement of the Woodworth Patent. Rights to use N. G. Norcross's patented machine can be purchased on application to N. G. NORCROSS, 208 Broadway, New York. Office for sale of rights at 208 Broadway, New York Boston, 27 State street, and Lowell, Mass. 16 6m\*

A. B. ELY Counselor at Law, 52 Washington st., Boston, will give particular attention to Patent Cases. Refers to Messrs. Munn & Co., Scientific American. 16 1y\*

VAIL'S CELEBRATED PORTABLE STEAM Engines and Saw Mills, Bogardus' Horsepower, Smut Machines, Saw and Grist Mill Irons and Gearing, Saw Gummers, Ratchet Drills, &c. Orders for light and heavy forging and castings executed with dispatch. 8 1y\* LOGAN VAIL & CO., 9 Gold st., N. Y.

## Science and Art.

## The Art of Dyeing.—No. 25.

**BROWN COLOR ON SILK**—The variety of shades of brown are legion, and yet these can all be produced by the same dye stuffs, and by pursuing the same process for each, except in proportioning the quantities of the dye stuffs. The principal quality required in the operator is the exact amount of each dye stuff to give, in order to match the shade or pattern desired. This relates to the skill of the eye. There is, however, a great amount of chemical knowledge required to make each dyestuff effect the proper object for which it is used. For want of such knowledge a person may unexpectedly find himself unable to match the required shade, simply because he has handled his goods too long in one liquor.

Brown colors are composed of the three primitive rays of light, yellow, red, and blue. These, when blended together in certain proportions, reflect the various shades of color known by the general name of "brown."—The simple and most common way to dye an unlimited number of shades on silk, is by preparing the goods by cleaning, in the common way, and giving them a mordant of alum. The alum tub should be of a strength from 2° to 3° in the hydrometer. An alum mordant tub is kept permanently standing in every dye house, but a temporary one may be made up in any farmer's family.—The silk is turned and handled in the liquor for about ten minutes, opened out freely, and then sunk under the liquor for one hour. The alum tub for silk should never be above milk warm, as hot alum tends to injure the luster of the goods. At the end of an hour the goods are lifted and rinsed in a tub of cold water, then lifted (if yarn wrung, if pieces dripped,) and opened loosely and evenly for the reception of the dye wood. The principal dye stuffs used are fustic, redwood (Brazil or hypernic,) and logwood. A brown color never looks well if it is deficient in yellow, therefore a tub of strong hot fustic liquor is made up, with the addition of the exact amount of redwood liquor to match the pattern. Into this the goods are entered and well handled, until they have acquired a rich red yellow color. They are then lifted, and the amount of logwood liquor is added to the tub which is judged will darken it down to the proper shade. The liquor is then stirred up, and the goods re-entered and handled rapidly, until they have become level and darkened to the proper tint. This should be the case in a few minutes, for silks prepared with an alum mordant, then dyed in fustic and redwood, will lose their foundation color if kept too long in the logwood liquor, and will acquire a dull watery appearance. The cause of this seems to be, that the alum parts with its fustic and redwood foundation, and unites more intimately with the logwood. All silk dyers, therefore, dye their brown colors a deep yellowish red first, and give the logwood afterwards, taking care to give the stuffs in large quantities, and handling rapidly. When the proper shade of brown is obtained the goods are washed well in cold water, and afterwards dried. All the great variety of brown colors can be dyed by the process described. For a very yellow shade of brown, give a great quantity of fustic, and very little red and logwood; for a redder shade give a little more redwood liquor. Logwood is given in quantity according to the darkness or lightness of shade desired. There can be no fear of spoiling this color with too much fustic. Fustic, redwood, and logwood, are boiled up into strong liquors, and kept standing in casks for use in all silk dye shops. Five pounds of fustic, two of common redwood, and one of logwood, are sufficient to dye ten pounds of silk a good brown color.

Farmers daughters might dye old silk ribbons a beautiful brown color by the process we have described. These ribbons should be boiled first in strong soap suds, then washed well, entered in the alum, and the rest of

the described process followed. Ribbons are dressed with a flat iron on the wrong side, in the same manner as linens. The iron should be pretty hot, for it injures the appearance of silk to rub over it more than twice during the time of dressing.

**ANOTTA BROWN**—The richest brown color on silk is dyed with a foundation of anotta. This should be given very strong. The goods are afterwards prepared with alum, and become of a deep orange color in this mordant. After they come out of the alum, they are dyed in the same way as that described above, excepting that a very small quantity of fustic and Brazil wood liquor are given, and these principally for leveling, as it has been found that the logwood is taken up more evenly by the goods than when it is given by itself.

A very beautiful brown color can be dyed on silk by dyeing it a purple color first, then preparing it in an alum mordant, and giving it a strong fustic liquor on the top.

There is one thing rather remarkable in dyeing a brown color on silk, viz: if the logwood be given first instead of the fustic, it will require twice as much of the latter dyewood to produce the same effect as it would if given first.

Improved Bit Fastening.

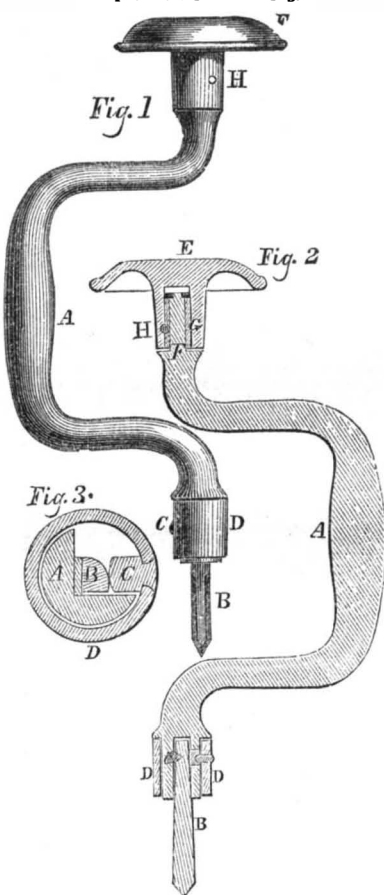

The annexed engravings represent a bit fastening, for which a patent was granted to A. W. Streeter, on the 23rd of last January. The nature of the invention consists in providing the socket of a bitstock having a stationary catch upon one of the sides, with a revolving ring, which has attached to its interior surface a cam or bearer, which, when operated by the ring, presses the shank of the bit or implement inserted within the socket firmly upon the catch, and secures the bit within the socket.

Fig. 1 is a perspective view, fig. 2 a transverse section, and fig. 3 an enlarged cross section. This bit stock is constructed in any of the usual forms with the exception of the end forming the socket, in which is formed a frusto-pyramidal recess or socket to receive the bit, said recess being enlarged sufficiently upon one of its sides to allow of the introduction of the shank of the bit over a stationary catch, which is formed upon the opposite side of the socket. Also a recess opening from the socket to the outer surface of the stock, A, to admit the insertion of the cam, C. Upon the exterior surface of this end of the stock, forming the socket, is placed the ring, D, surrounding the stock, A, and so fitted as to admit of a quarter revolution upon and around said stock. Within this ring, and firmly affixed to its interior surface, is the cam or bearer, C, which being operated

by said ring, is turned from one of the squares or sides of the shank, B, to another side at right angles to the first mentioned side, and opposite to the one in which is formed the notch, accurately fitting upon the catch. E is the stock cap, H its collar, G its recess, and F is the spindle. In order to use this improvement it is necessary to place the cam in the open space shown in fig. 3, on a side of the socket at right angles with the catch, then insert the shank of the bit entering the notch upon the catch, and then, by a quarter revolution of the ring, D, bring the cam upon the side of the shank opposite said notch and catch, when the cam, by pressing upon said shank, B, will firmly secure the shank upon the catch, and consequently confine the same within the socket. These tools are manufactured by Streeter and Bowen, Shelburne Falls, Mass.

## Frauds in Guano.

The Albany *Country Gentleman* gives an account of great frauds in a kind of manure sold under the name of "Chilian guano."—It is sold for \$25 per tun in some places, and \$40 in others, and yet it is almost worthless as a fertilizer. It has been analysed by Prof. Carr, of Albany, and its composition found to be as follows:

Water	- - - - -	4.0
Sand	- - - - -	2.4
Organic Matter	- - - - -	15.3
Sulphate of lime	- - - - -	9.5
Phosphate of lime	- - - - -	24.5
Common salt	- - - - -	6.2
Chalk	- - - - -	37.6
		99.5
Ammonia	- - - - -	1.06

It seems that this kind of guano has been manufactured at Newark, N. J., in great quantities, and is scented with Peruvian guano, for the purpose of deception respecting its real character. This guano is reported to be endorsed with the names of scientific men, which—if the above analysis is correct—is anything but favorable to their reputation. It is stated to be made as follows:—Sugar house scum, pounded fine, 7½ bushels; Mexican guano, 15 bushels; 1½ bushels of common salt; one bushel of plaster; 3 bushels of Peruvian guano, and half a bushel of lime. These ingredients are mixed together, placed in bags, watered, and laid in a heap in layers, with genuine Peruvian guano laid between each. Frauds upon our farmers in relation to manures, seeds, &c., are of the most mean and detestable character; we place them in the same category as the adulteration of food, the sanding of sugar, and such like tricks. The names of the manufacturers of this spurious guano are not given, nor do we know who they are, but their business is certainly an unenviable one.

## Patent Office and Natural Science.

Townsend Glover has been for some time employed by Judge Mason in the Agricultural Department of the Patent Office, in that branch relating to insects that are injurious to vegetation. The object of employing such a distinguished naturalist is, for the investigation of the habits of the insects injurious to crops, and illustrating the same with a view of describing them, with the remedies for their diminution and destruction, and all other information on the subject in the agricultural report. He has recently left for Florida, where he will pass several months studying the insects pernicious or beneficial to rice, tobacco, sugar cane, orange, and the cotton plant, and also to discover the cause and remedy, if practicable, of the white rot in the live oak. Mr. Glover has been engaged during the past year in watching the operations of the rice and cotton insects in the Carolinas, Georgia, and Alabama, the corn and grain insects of the Middle and Northern States, and the insects attacking vines and fruit trees in general, as well as numerous insects beneficial to the farmer.

Diagrams of many of the insects referred to have been engraved and are being printing, and will illustrate the next agricultural report. This is a subject of great interest to our agriculturists, and for which the Com-

missioner of Patents deserves their universal thanks.

## Onions and Tobacco Juice.

Some tobacco steeped for a few hours in water, so as to make a weak solution, is stated to be a perfect cure for the onion worm. Three cents worth of tobacco is sufficient for a bed of onions 20 feet square. The solution should be sprinkled on the onions when they are about three inches high.

## The Iron Manufacture.

It seems that the manufacture of iron is going on with great energy in Pennsylvania. The *Ledger* gives an account of the Crane Works, at Catasauqua, making 566 tons in a week from three furnaces, and other works are doing nearly as well.

## LITERARY NOTICES.

**THE EDINBURGH REVIEW**—This noble old Review for this quarter, has just been issued by its American publishers, Leonard Scott & Co., No. 54 Gold street, this city. It contains an able review of Prof. Johnston's Chemistry of Common Life, Huc's Travels in China etc. An article on the "Autocracy of the Czars," is a complete epitome of Russian history. It is an excellent number.

**THE NATIONAL MAGAZINE**—This magazine for this month contains quite a number of first rate articles, illustrated with quite a number of excellent wood cuts. We like the spirit of this periodical—its high toned morality and ability. It is devoted to literature, art, and religion. Abel Stevens is Editor, and Carlton & Phillips, 200 Mulberry street, this city, its publishers.

**THE NAUTICAL MAGAZINE**—This useful monthly for June, by Griffiths & Bates, this city, contains the conclusion of an excellent article on the *torpedo*, or ship worm, by James Jarvis, of Va., who has devoted great attention to the preservation of ship timber; it also contains a number of other articles equally good on different subjects relating to shipbuilding.

**THE COACHMAKERS' ILLUSTRATED MAGAZINE**—The June number of this useful periodical contains three plates, embracing figures of a "Sporting Wagon," a "Fleming Carriage," and two views of a "Sliding Seat Extension Top," and four figures illustrating McLelland's self-adjusting spring coupling. It also contains a number of wood cuts illustrating different branches of coach making. We perceive that there is quite a powerful excitement among many of the coach makers respecting a dispute relating to the patents of E. C. Everett and G. L. Haussknecht. Published and edited by C. W. Saladee, Columbus, Ohio.

**THE BOOK OF MEN, WOMEN, AND BABIES**—This is a book by Dr. Porter, of this city, published by Lewis & Daventport. It goes in for such nonsensical affairs as Baby Shows, but at the same time it contains much that is exceedingly sensible in the way of advice, and deserves to be widely read.



## Inventors, and Manufacturers

The Tenth Volume of the **SCIENTIFIC AMERICAN** commenced on the 16th of September. It is an ILLUSTRATED PERIODICAL, devoted chiefly to the promulgation of information relating to the various Mechanic and Chemic Arts, Industrial Manufactures, Agriculture, Patents, Inventions, Engineering, Millwork, and all interests which the light of PRACTICAL SCIENCE is calculated to advance.

Its general contents embrace notices of the LATEST AND BEST SCIENTIFIC, MECHANICAL, CHEMICAL, AND AGRICULTURAL DISCOVERIES, —with Editorial comments explaining their application; notices of NEW PROCESSES in all branches of Manufactures; PRACTICAL HINTS on Machinery; information as to STEAM, and all processes to which it is applicable; also Mining, Millwrighting, Dyeing, and all arts involving CHEMICAL SCIENCE; Engineering, Architecture; comprehensive SCIENTIFIC MEMORANDA; Proceedings of Scientific Bodies; Accounts of Exhibitions,—together with news and information upon THOUSANDS OF OTHER SUBJECTS.

Reports of U. S. PATENTS granted are also published every week, including OFFICIAL COPIES of all the PATENT CLAIMS; these Claims are published in the Scientific American in ADVANCES OF ALL OTHER PAPERS.

The CONTRIBUTORS to the Scientific American are among the MOST EMINENT scientific and practical men of the times. The Editorial Department is universally acknowledged to be conducted with GREAT ABILITY, and to be distinguished, not only for the excellence and truthfulness of its discussions, but for the fearlessness with which error is combated and false theories are exploded.

Mechanics, Inventors, Engineers, Chemists, Manufacturers, Agriculturists, and PEOPLE IN EVERY PROFESSION IN LIFE, will find the SCIENTIFIC AMERICAN to be of great value in their respective callings. Its counsels and suggestions will save them HUNDREDS OF DOLLARS annually, besides affording them a continual source of knowledge, the experience of which is beyond pecuniary estimate.

The SCIENTIFIC AMERICAN is published once a week; every number contains eight large quarto pages, forming annually a complete and splendid volume, illustrated with SEVERAL HUNDRED ORIGINAL ENGRAVINGS.

## TERMS! TERMS!! TERMS

One Copy, for One Year	\$5
"    "    Six Months	\$1
Five copies, for Six Months	\$4
Ten Copies for Six Months,	\$8
Ten Copies, for Twelve Months	\$15
Fifteen Copies for Twelve Months	\$22
Twenty Copies for Twelve Months	\$28

Southern, Western, and Canada Money taken at par for Subscriptions, or Post Office Stamps taken at their par value. Letters should be directed (post-paid) to

MUNN & CO.  
123 Fulton street, New York.