

Scientific American

A WEEKLY JOURNAL OF PRACTICAL INFORMATION, ART, SCIENCE, MECHANICS, CHEMISTRY, AND MANUFACTURES.

Vol. XV.—No. 24.
[NEW SERIES.]

NEW YORK, DECEMBER 8, 1866.

\$3 per Annum,
[IN ADVANCE.]

Improved Dead-Stroke Hammer.

The trip hammer has been used almost from time immemorial for heavy forging. It still occupies a prominent place, notwithstanding the introduction of more modern devices, partly because its construction is so simple that it can be made by ordinary mechanics with the most ordinary tools. Cheaply,

of this hammer is analogous to that of the propulsion of an arrow from a bow. A 100 pound hammer will readily forge iron 4½ inches square, running at a speed of 250 strokes per minute, employing only one horse-power to drive it.

Patented in the United States and several foreign countries. For further information address Philip

Trials of Breech-loading Guns in Vienna.

These extensive competitive trials are now drawing to a conclusion. The commission having decided upon the adoption of the American rim-fire cartridge, all needle guns and a great number of other constructions have been set aside in consequence. The number of guns under test has dwindled down from

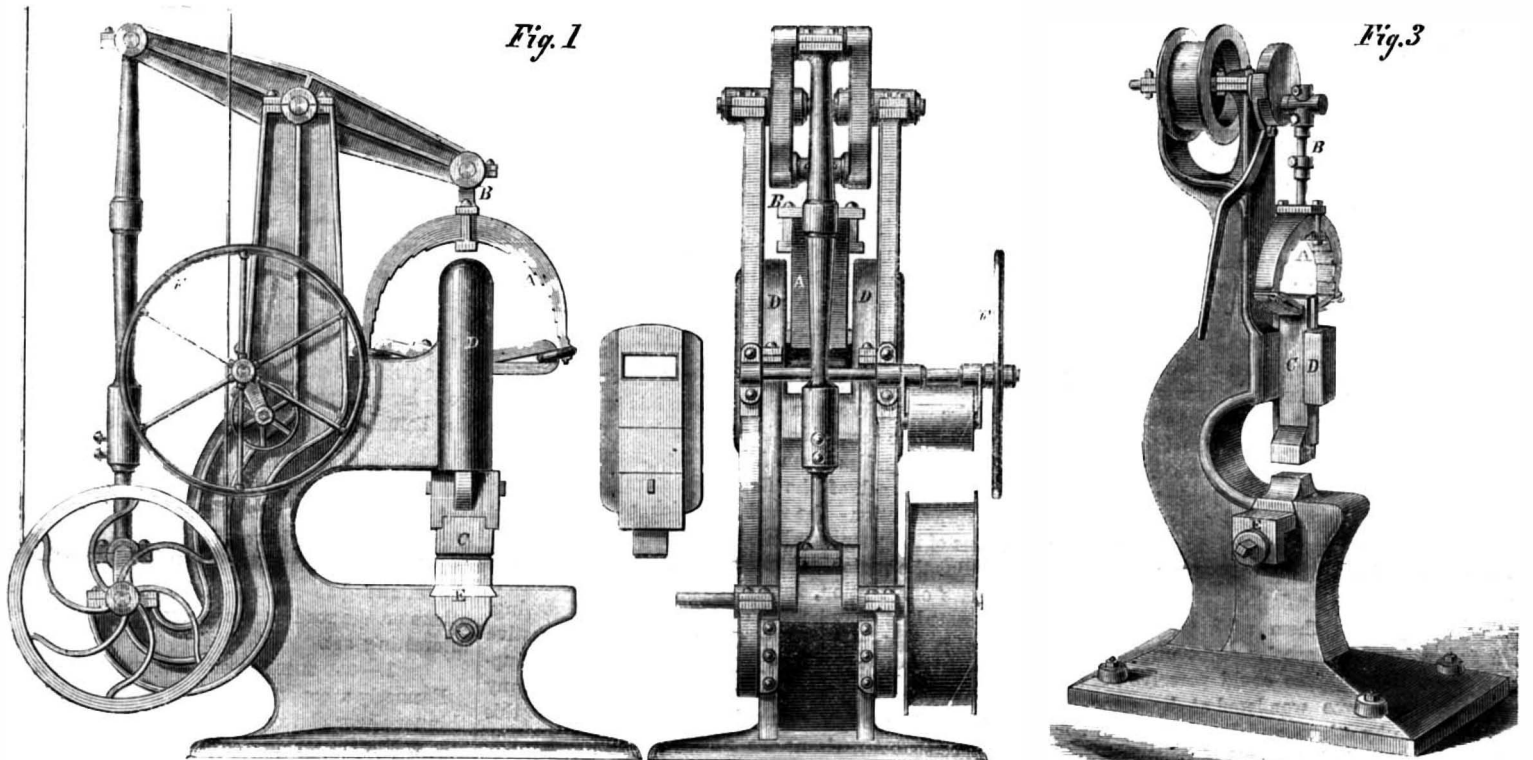

SHAW & JUSTICE'S DEAD-STROKE HAMMER.

however, as it can be built, it is really expensive to keep in operation, as one part or another is continually getting out of order and requiring repairs.

The engravings represent a hammer designed to take the place of the common trip-hammer, and calculated to do work of all kinds for which the trip-hammer or other hammers are now used. They are now made of eight different sizes, varying from 15 to 1,000 pounds, and it is intended to construct them up to 10 tons weight. The engravings show a 15-pound hammer and one of 1,000 pounds. The latter has a walking beam and is calculated for heavy work, as in the forging of blooms, while the smaller size will do the lightest work, readily forging iron one and a quarter inches square.

They are run by a pulley and slack belt, in combination with a tightening pulley operated by a lever. The force of the blow is given by a steel bow spring, A, attached to a crank by the connection, B. The hammer proper, C, is suspended, by a belt and links, to the reflexed ends of the spring, and moves in the guides, D. The bottom die in the anvil block is held by a wedge-shaped gib, E, which is tightened by a screw, preventing the bursting of the block and saving the labor and time of adjusting the bottom die parallel with the upper die, a feature of importance where swaging dies are used. The operation of the hammer can be readily understood by reference to the engravings.

Among the advantages claimed for it, is its ease of working, requiring but a fraction of the power demanded by other hammers; the absence of destructive shocks to the machine, the spring and strap taking up the rebound soon as the blow is delivered; and the enormous force of the hammer, entirely disproportioned to the mere weight. In fact the action

Fig. 2

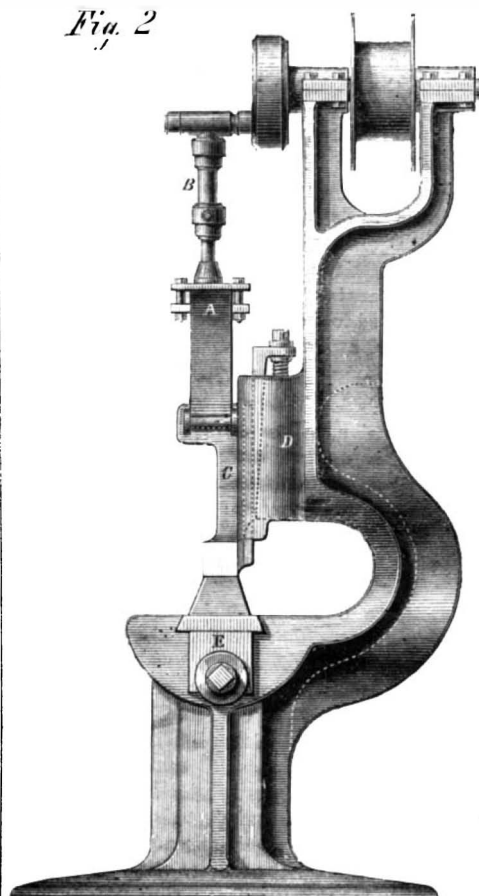

S. Justice, manufacturer, Offices 14 North Fifth street Philadelphia, and 42 Cliff street, New York.

day to day until at present there are only the Remington and the Peabody guns competing with each other with almost equal chances on either side. Upward of 2,000 rounds have been fired from each of the two guns without the slightest deterioration. Cartridges have been filed through at the back, and then fired, to test the chances of an accident from the bursting of the copper shell; but both guns withstood the firing without showing any causes of danger for the soldier. It is still doubtful which of the two guns will ultimately gain adoption by the Austrian war-office, but the decision is expected very soon. Immediately after that, very extensive orders for guns and ammunition will be given out. It is expected that all barrels will be made of steel. The bore will be considerably reduced, and the manufacture of rifles by machinery will be taken into consideration. A novelty of specific Austrian origin is the manufacture of cartridge shells of Bessemer steel instead of copper. The steel is rolled in thin sheets, and its great ductility is taken advantage of to produce the cartridge shells of this material. To prevent oxidation, the steel shell is coated inside and outside with a suitable varnish. These cartridges are said to be much cheaper, and also much stronger, than the copper cartridges, and trials will be made to establish their qualities and value. The Bessemer steel for these cartridges is produced in Austria from Styrian charcoal iron, and is of a very high quality. —Engineering.

THE Quartermaster-General is preparing to establish in his department a museum of the anatomy and diseases of the horse. A great variety of specimens have already been collected and prepared under the superintendence of Dr. Braley, an eminent veterinary surgeon,

THE OIL DISTRICTS OF CANADA.

[For the Scientific American.]

All the world knows somewhat, if not more, respecting the Pennsylvania oil districts. Everybody has heard of the vast developments in and about Pithole, Alleghany, and Petroleum Center. Indeed, we question very much whether the generality of mankind have not a more accurate idea of the *locus in quo* of those odoriferous localities than of many towns of ten times their population. But, for a variety of reasons, the districts referred to in the heading of this article remain, comparatively speaking, unknown to the majority of our countrymen. This ignorance arises partly from the fact that those districts are situated in a distant part of a foreign country, and partly because they are not nearly so productive as those of Pennsylvania; but principally, because the experience of such of our capitalists as have invested their thousands there, has not been of so pleasing a nature as to warrant them in sounding the praises of these districts to the world. And yet it is an undeniable fact that almost the whole territory is exclusively under the control of American operators. It is computed that no less than twelve million dollars' worth of American gold has already been expended in developing the resources under the Canada oil region, and this is in addition to about one-fourth of that sum expended by native capitalists.

The history of these districts (in so far, at least, as it is at present necessary to enter into it) is briefly as follows:—In the summer of the year 1859, an indigent farmer, rejoicing in the classical patronymic of Shaw, resided in the then sparsely-settled and almost unknown township of Enniskillen, in the county of Lambton, Canada West—in fact, had resided there for years, and was remarkable for nothing, except for the extreme difficulty which he occasionally experienced in “making both ends meet.” About the period above alluded to, he began to manifest symptoms of what his neighbors regarded as incipient fitness for the issuing of a commission *de lunotivo inquirendo*—said symptoms consisting of a most decided proclivity on his part for ornamenting his “flat, stale and unprofitable” acres, by covering them with wells. This being an indication of a species of “madness” in which the aforesaid neighbors could perceive no traces of “method,” he was wondered at by some, remonstrated with by others, and laughed at for a fool by all. The equanimity of his disposition, however, was not in the slightest degree disturbed by these things, and his malady began to be regarded as incurable, when a few weeks later, he was observed in the act of inserting in one of the holes a primitive sort of force pump, which he had manufactured with his own hands. The only reply which he vouchsafed to those who inquired the object of this facetious proceeding on his part, was, “Wait a few days, and you will see.” They accordingly waited, and in a few days, sure enough, they did see, with a vengeance. The well in which the pump was placed was situated in a valley, close to the edge of a small creek—now known as “Oil Creek.” One morning, shortly afterward, the well commenced, as it is technically termed, to “flow.” And such a flow! Never, in the most productive region of which Pennsylvania can boast, has such a quantity of crude petroleum been produced at any one well as flowed from Mr. Shaw's well during the ensuing forty-eight hours. We have heard the most conflicting and exaggerated accounts as to the actual quantity—it has been variously estimated at from three to seven millions of barrels. The fact is, we presume, it is neither more nor less than an absolute impossibility to form anything like a close estimate; for, with the exception of about thirty barrels (which was all that the inhabitants could find accommodation for) it all made its escape down the creek.

Such is the somewhat singular history of the first attempt at oil-development in Canada. It would be positively incredible, were it not that we have ample evidence of its veracity as we have of the existence of such a place as Canada. Any person who chooses to take the trouble may, to this day, see unmistakable traces on the trees along the bank of the creek that there must have been a thickness of more than two feet of oil for several miles down

the stream. The whole neighborhood, as might well have been expected, was electrified, and forthwith proceeded to manufacture tanks without number. They kept the matter secret, as long as it was possible to do so, but it was not one of those things which will admit of continued secrecy; and ere long the township of Enniskillen became the resort of shrewd speculators from New England and the Western States. Strange as it may at first sight appear, the subject attracted far more attention in this country than in Canada. Canadians, generally speaking, are not rich, and such of them as have a few thousands to spare, prefer embarking in a legitimate business, and one in which there is at least a tolerable certainty of their realizing a profit. They are too timid to run great risks, and prefer to follow the old beaten track. The field was accordingly left almost entirely open to the enterprising Down-Easter, and the shrewd, calculating Western man—both of whom began to buy up land in great quantities, and to sink wells innumerable. In less than six months from the time of the “great flow,” there were upward of a hundred yielding wells within three miles of it. The houses erected by these parties formed a small village, to which a postal communication was shortly afterward granted; and it is to-day a place of about 3,500 inhabitants, called Oil Springs.

It was soon discovered that the existence of petroleum was by no means confined to the immediate vicinity of the great Shaw well, nor even to the township of Enniskillen. In various other localities it was found in sufficient quantities to warrant pretty extensive operations. Another village shortly afterward sprung up in the county of Kent, about thirty miles from Oil Springs, and is known as Bothwell. It is situated on the main line of the Great Western Railway, and is consequently much more accessible than Oil Springs, which latter is twelve miles from Wyoming (situated on the Sarina Branch of the Great Western) the nearest railway station—the road to which, at certain seasons of the year, is almost impassable.

But the region which has attracted the greatest share of attention, during the last twelve months, is situated midway between Oil Springs and Wyoming, and is distinguished by the somewhat suggestive appellation of Petrolea. There are at present upward of seventy working wells at this place—many of which are producing handsomely. It is to this place that Americans are now directing their footsteps; some for the purpose of sinking wells, others for the purpose of speculating in oil lands. Speculation runs much higher at Petrolea than at either Oil Springs or Bothwell—and, in fact, is almost exclusively confined to the first-named place. But, although the yield at Petrolea is more than considerable, it can no longer be disputed that the oil fever is rapidly dying out. One great drawback is the cheapness of crude oil. A year ago it sold rapidly in great quantities at \$12 to \$14 per barrel, while to day \$2 90 to \$3 35 is the standing figure. Operators in general, confident of a rise, store their stock in huge earth-tanks, and a month ago there were two parties in Petrolea, each of whom was computed to have upward of ten thousand barrels so stored away.

Unquestionably the oil developments of Canada received their death blow upon the occasion of the Fenian invasion, in June last. Up to that time, the region presented a healthy, genial appearance. The result was instantaneous. We have stated that the principal operations are carried on by American capitalists. These latter, alarmed by the tone of the local press, were led to regard a war between the United States and Canada as something very much resembling a certainty. This, of course, would involve a sacrifice, either of their allegiance to their own country or of their Canadian possessions. Almost immediately upon the arrival of the intelligence of the landing of Gen. O'Neil and his followers at Fort Erie, at least half of the wells ceased operations, and the most of these, although their proprietors must be presumed to have been relieved from all anxiety on the subject long ago, have never recommenced. The shock appeared to be one from which they could not recover. Confidence was destroyed, and has never been thoroughly re-established. At the time to which we refer, property de-

preciated in value two hundred per cent within a week. Several leading capitalists, two of whom hailed from New York, immediately sold out at a sacrifice which was perfectly tremendous, and made the best of their way homeward. In fine, for more than a month after the Fenian raid, the inhabitants of Oil Springs, Petrolea, and Bothwell regarded oil speculation in a similar light to that in which Othello regarded his occupation.

All things considered, we place the oleaginous excitement in Canada among the things that were; and we confidently predict that another year or so will see all development in that region at an end. There will necessarily be very heavy losses somewhere, as the soil is almost worthless for farming purposes. Good farm property in the western part of Canada is not worth more than from twenty-five to forty dollars an acre, and a considerable portion of this territory has been purchased at prices varying from four hundred to two thousand dollars an acre. Not a very flattering prospect for extensive landholders, certainly.

Geologists have pretty well established (to their own satisfaction at least) that petroleum can never be found in paying quantities in any portion of Canada, outside of a given boundary, which they have pretty closely defined. This boundary line commences about three miles to the north of Petrolea—thence running in a southerly direction over a tract of ground from ten to twelve miles in width to about five miles south of Oil Springs. Here the course changes to the eastward, and extends in that direction over a tract varying from five to fifteen miles in width to about five miles to the east of Bothwell. There is tolerably good reason for relying upon these assertions on the part of the geologists, for certain it is that while good paying wells have been found a quarter of a mile within the boundary, all experiments outside of it have proved fruitless. J. C. D.

Silver Plating.

A correspondent asks for information about the above subject; we have, of course, no room for a full treatise on this matter, as it would fill a book; the following remarks will, however, place him and others on the road to the successful practice of this interesting art.

1.—OLD METHOD OF SILVER PLATING.

Formerly a copper plate was covered with a much thinner silver plate, and then rolled out together; in this way a very thin coating of silver covered the copper entirely, sometimes on both sides; of such silver-covered copper plates, different objects were manufactured, as teapots, pitchers, goblets, etc. This is still practiced; however, to a very limited extent since the invention of the electro-plating process. The daguerreotype plates are chiefly manufactured in this way.

2.—SILVER PLATING BY FRICTION.

Objects made of copper or brass may be coated in a simple way by a process described by Berzelius in his chemistry, by rubbing them with a chemical mixture consisting of chloride of silver, 1 part; well dried potash, 3 parts; Paris white (very fine chalk), 1 part; common salt, a little more than 1 part. The brass surface is well cleaned, moistened with a little salt water, and then the surface is rubbed with the above mixture till it is silvered. This is the customary way that the thermometer and barometer scales, clock dials, etc., are silvered, and it is well to cover them afterward with a colorless varnish, the process being so very economical, and the silver coating consequently so thin, that when dirty it can stand so much cleaning and polishing afterward without being removed. A later invented method to accomplish the same purpose, and which many operators prefer, is to take 1 part of nitrate of silver and 3 parts of cyanide of potassium, rub these together and add a little water to make them into a paste; rub this with a piece of flannel on the object to be silvered, which, however, before must have been carefully cleaned. This process is peculiarly adapted to copper and brass name-plates attached to apparatus, etc. The film of silver obtained in this way is also very thin, and it is also advisable to cover it with a colorless varnish. When calculating the price of this process after silvering a great number of objects, it is always found to amount to only from 1 to 2 cents per square foot.

3—SILVER PLATING BY A SIMPLE BATH.

This method requires no friction whatever, and is accomplished thus: Make a saturated solution of common salt, dissolve cyanide of silver in it, and filter. A piece of clean copper or brass placed in this solution is soon covered with a silver coating which adheres very strongly.

If the object to be silvered is iron, it must first be coated with copper, as silver will not very well equally deposit on iron. This is simply accomplished by placing the iron object for a sufficient time in a diluted solution of blue vitriol (sulphate of copper) acidulated with sulphuric acid; afterwards wash and clean the object, and when it is well covered with copper, place it in the above described silver bath.

Care must be taken not to touch the cleaned object with the fingers, as the silver will never deposit equally on the thus touched spots.

4.—SILVER PLATING BY ELECTRIC ACTION.

The most important way of silvering is, however, the electro-plating or galvanic process. This is founded on the fact that when an easily oxidizable metal, like zinc, is placed in a properly prepared silvering liquid, it will combine with the acids which hold the silver in solution, and the silver will be precipitated in its metallic state on any object in contact with the zinc, provided the surface of this object is a conductor of electricity. The simplest explanation of this curious fact, is that the action of the acids on the zinc generates electricity which repels the metallic silver from the zinc and carries it to any other metal plunged in the liquid, provided this metal is not acted on by the acid, and is in contact with the zinc, so that it may carry back the electric current to the latter metal. The metal receiving the silver deposit acts as it were like a sieve which lets the ethereal electric current pass through its mass, but retains on its surface the material particles of silver carried on with that current. We do not say that this is the latest and most approved explanation of the phenomenon, which, in reality, is more complex, but it is the simplest reasoning by which beginners, in this branch of study, may satisfactorily account to themselves for the curious results they observe.

In a continuation of this article, we will describe the various processes of electro-plating; first, the simple process without battery, and, second, that with the help of galvanic batteries. V.

AMERICAN INSTITUTE—POLYTECHNIC BRANCH.

The usual weekly meeting was held on Thursday evening, the 22d inst. The President, Prof. Tillman, in the chair.

THE OCEAN CURRENTS.

Columbus, during his first voyage, discovered in the midst of the ocean an immense stream moving with great velocity and superior in its proportions to the largest continental river known. Since the announcement of the existence of this, the Gulf Stream, similar currents have been traced, both in the Pacific and Indian oceans, and now physicists recognize five, one each in the North and South Atlantic and Pacific, the remaining one in the Indian ocean. An inquiry into the causes which produced them was the subject of the interesting remarks of Prof. Grimes, of Philadelphia.

The six continents of the world are arranged in pairs, as a glance at any map will show. Hence, from this and many other points of similarity, it is evident that whatever force caused the one, repeated itself in forming the others. The hypothesis advanced by Prof. Grimes refers the question back to the age when the entire earth was covered with water, at which time six elliptical currents were formed. Five now remain; the sixth one was formed in the North Indian, an ocean which, owing to the elevation of land, no longer exists, but the Caspian and Aral seas, and the large lakes of Asia furnish proof of its former reality. By a simple mechanical problem we can demonstrate why these ellipses were formed. If near the edge of a disk, revolving rapidly on its center, a ball is placed, and caused by any means to pass alternately back and forth on the radius, its motion will not be in a straight line, but it will invariably traverse an ellipse. To make

an application: when the waters in the Gulf of Mexico have become heated by the sun, the tendency will be to pass north until cooled, then to return to the equator; and such would be the only motion were the earth at rest, but the revolution of the earth is a constant force acting upon the current of water and gradually overcoming this northernly motion, and turning it to the east, by the coast of Ireland. Becoming cool, it seeks the warmer regions, and the easting is transferred into a general southernly direction, but, as it nears the coast of Africa, its velocity is lost, and as the earth moves more rapidly than the current, the latter is left behind, or is given an apparent westward motion, till the Gulf of Mexico is again reached and the circle is completed.

During the creation the land appeared on the margin of, and between, the circles; in proof of which the pointing of the three southern continents to the south-east—features first pointed out by Humboldt—the accumulation of lands toward the north, rather than the south, and the direction of the glacial markings during the drift period, these all bear witness to, and are explained by this theory.

At the conclusion of his remarks Prof. Grimes accepted the invitation of the Association, for a further presentation of this subject at some future meeting.

OXIDABILITY OF PETROLEUM.

Dr. Hirsch read an article, which he had prepared in answer to assertions made at a recent meeting, to the effect that petroleum could not be oxidized under any circumstances; could never be made into soap, or undergo a decomposition similar to rancidity.

The mode of purifying hydrocarbons by sulphuric acid, it was shown, was a true process of oxidation, for during the operation the acid loses one atom of oxygen, which is taken up by the oil to form water, while the carbon, formerly belonging to the hydrogen, precipitates, rendering the oil and acid black.

But even without the presence of chemicals, hydrocarbons undergo oxidation, as we see in the popular disinfectant, carbolic acid, formed from benzine by adding two atoms of oxygen. In distilling petroleum, paraffine appears when the temperature is kept high, but if the fires are slackened, air enters the still through the gas escape pipe, and paraffine will be decomposed into lighter hydrocarbons, resulting in permanent gas and naphtha of a very light color, besides water, or oxidized hydrogen. If, when the still is withdrawn from the fire, the manholes are opened at once, the hot vapors will ignite, on contact with the air. The same is true of the pitch, therefore the still is always allowed to cool for a time before making an opening and discharging the pitch.

At common temperatures, petroleum will oxidize in time, and will solidify, forming resins or gums. Light-colored oil, placed in bottles loosely corked, become gradually darkened, showing true oxidation. In bleaching petroleum, by means of boneblack, a black pitch is deposited in the pores, the same that is precipitated by sulphuric acid. The same result being obtained, why not account for it in the same manner? The boneblack acts both mechanically and chemically, for heat is given out. This shows also the condensation of air which is the true cause of rapid oxidation. Spontaneous combustion, then, is possible of all porous combustible bodies; but if petroleum is employed as a lubricator, the small quantities ordinarily brought in contact with porous materials are not sufficient to endanger property. The only reason to account for the aversion of insurance companies to the universal introduction of the oil, for this purpose, is that it would be followed by the use of inferior inflammable oils, from which danger might be expected.

In reply to Dr. Hirsch, Prof. Vander Weyde testified to the change of views held by some of the authorities quoted, caused by later investigations, and brought counter proof to sustain the opposite side of the question. The discussion was continued to a late hour, when the meeting adjourned.

THE daily change in the length of the Britannia Suspension Bridge, owing to temperature, varies from half an inch to three inches.

[For the Scientific American.]

A Self-adjusting Telegraph Instrument Wanted.

A self-adjusting instrument has long been a desideratum in telegraphing. That such an invention will be discovered is a fixed belief among all telegraphers. The necessity of it is never more apparent than on a wet foggy day, particularly when the poles, wires, and insulators have become well saturated with moisture, and the "escapes" along a line are numerous. Let the battery power be ever so excessive, the current in the distance of 100 miles will seldom reach its destination continuously, but will be "everything by fits and starts and nothing long." An observer of human nature, if he entered a large telegraph office on such a day as is mentioned, would be amused and instructed to see its effect on a body of gentlemen discharging their duty as operators. Some will meet their trouble humorously, some angrily, some with epithets not fit for "cars polite," and yet all displaying an intelligence and skill truly marvelous, in every now and then getting their instrument so nicely adjusted, that a few sounds are caught all right—a word or two obtained, and a good guess made for the balance of the message. In thus succeeding a visitor would observe how incessantly the operator screwed and unscrewed the spring of his armature, and sometimes changed the poles of his instrument, because of his *residuum* magnetism; and though he succeeded in freeing it from this saturation, yet how difficult it was after all to get the necessary signals for constructing a message.

It should be observed that rarely, if ever, does a circuit fail to complete its course, but the mischief is that when it reaches its destination it is so attenuated, so inappreciable, that it does not move the armature, and therefore, practically, there is no circuit at all. Now such an instrument is wanted as will reconcile itself to all the vagaries of electricity, even when the current is so "inappreciable," that the armature shall act on the closing and opening of a circuit. Whoever can invent such an instrument will win fame and fortune, and it is more easy to make the discovery than to find out "perpetual motion," on which so many mechanical minds have spent the best part of their existence.

Again, for want of a self-adjusting instrument underground lines cannot be laid down, and thus the country and cities are disfigured with unsightly poles and wires, with kite tails and rags dangling from them.

Underground lines exist in some parts of England and Europe, but it is necessary to have a battery in every office because of the return current. This is very expensive, and the belief is that a self-adjusting instrument will remedy the evil.

There is *genius* enough among operators to invent this "desideratum," but they don't do it because they are thoughtless and spend their leisure time unprofitably. If the money laid out for cigars, etc., was spent in buying a little machinery, chemical apparatus, etc., for practically understanding the nature of the telegraph instrument in all its details, and the character of a battery; if two or three would put their heads together—work together—make a shop of their bedroom, and take advantage of many machine shops in this city, access to which would not be refused them, it would not be long before the "desired thing" would be found, and as is not uncommon, in the pursuit of an object, some other equally important discovery he made. A beginning made in a good course soon becomes fascinating. H.

Circular Skids.

In some of the crowded streets of New York, wherever a cart backs up to the curb to take on or discharge a load, the traffic of the street, railroad cars, and vehicles are arrested, to the great inconvenience of the public.

Mr. Sinclair Tousey, of the American News Company, New York, proposes a very simple remedy, which consists in the use of circular skids, instead of the common parallel skids, for loading. By the use of circular skids the cart may be brought into position parallel with the curb, leaving the center of the street unobstructed, while the loading and unloading may be as readily performed as with straight skids.

MANUFACTURE AND COMBUSTION OF PEAT.

Peats differ in color, weight, degree of decomposition or transformation, in purity, and richness or value for fuel. Grass peat is grayish in color and moss peat of a reddish hue. That formed from shrubs is generally darker. These are the surface hues; as we descend, if the deposit is deep, the peat changes to very dark brown or black. Surface peat is usually light and fibrous. It is neither living vegetation nor perfected peat, and is unfit for fuel. The peat below the surface is soft, pliable, and when moist can be easily molded; it is fine in grain, oily to the touch, and has no perceptible odor. If it shows sand or clay when dried, it is not valuable as a fuel. To be profitable it should not, when consumed, leave more than one-fifth of its weight in ashes. Some very fine specimens do not leave over one-fortieth of ashes.

The author of a little treatise entitled "Peat," published by J. H. Benham, New Haven, Conn., says: "Peat possesses elements and qualities like coal. As manufactured by the present improved machinery, the actual heating power is two-thirds that of coal, while for the generation of steam it is, by its abundant blaze, fully equal to coal. It has qualities peculiarly adapting it to manufacturing purposes. Improvements in machinery for its preparation, to which the best scientific minds in the country are now turned, will, we doubt not, soon enable manufacturers so to condense peat as to make it, with its other excellent qualities, superior to coal for many purposes. It can be prepared and brought to market at a profit, for less than half the present cost of coal."

The deposits of peat fuel have been utilized from time immemorial. The Irish have depended upon them for fuel for many generations. In some countries the turf has been used as a material for constructing habitations, as well as for the furnishing of fuel. In this country peat has been used almost ever since its first settlement, as a fuel. The first settlers discovered, as early as 1690, the value of their peat beds as a means of warming their houses and cooking their victuals. When wood was plenty and easily cut they preferred that, but there are not wanting evidences that our forefathers, in colonial times, knew that peat was a valuable, or at least, a feasible substitute for the plentiful wood pile. We can well recollect when, with team and wagon, we were sent to the adjacent "peat bog" to bring home the results of the summer cutting, and loaded into our wagon the blocks of air-dried peat. They were cut out from the mass with a spade called a "slane" having a side and edge turned at right angles, so that the workman separated at each pressure a complete block. These were built into cob-houses, allowing the air to pass freely through, which dried the turf, until that quality which was the most porous assumed a light brown hue and was as light as cork. The more solid qualities were heavier.

We never burned the peat in a confined air space, as a stove or close grate, but we have seen it used in an open fireplace instead of wood. In these situations it burns as fine as the best walnut. It gives out a genial heat without sparkling or throwing out splinters, and retains fire long after it has ceased to blaze. For this reason, we judge, in our juvenile days the late hours in the evening were enlivened with the glare of burning peat, which held the fire until the next morning.

But lately, since the people have been aroused to the value of their peat beds—a value which we cannot but think has been in some cases overrated—various means have been invented for condensing the turf and for burning it with economy. One means of preparing it for the market, and for economical use as a fuel, is that of treating it as clay for bricks is treated, by grinding it to an almost impalpable pulp, or powder, and then compressing it by mechanical agency, finishing by drying it by artificial means. This, even by the most rapidly working machines, is costly, especially the artificial drying. Another plan is to agglomerate and condense the material by mechanical means and then subject the blocks thus formed to the action of the atmosphere. The result is excellent.

There can be no doubt of the value of peat as a fuel, either for domestic or manufacturing purposes,

when properly prepared and where the place of consumption is near the place of production, and away from the sources of coal supply. Merely cut and dried, however, it still contains about twenty per cent of water, sufficient to greatly lessen its value as a fuel. Disintegration and compression seem to be necessary to rid the substance of this surplus moisture. Baking it, or partially coking it, by expelling the moisture, greatly enhances its value. Even the "grinding" or thorough mixing of the mass aids in the expulsion of the water, and peat so prepared and afterward air dried is greatly improved. The best results however, are obtained by subsequent compression and if possible a thorough after drying.

Peat can be burned as wood on an open hearth, or as coal in an open grate. It can be used under the furnaces of engines adapted for burning either anthracite or bituminous coal, but in neither position do we think it is superior to mineral coal. For manufacturing purposes, when used in combination with iron, it may be less deleterious to the metal than uncoked coal; but we much doubt whether it will ever usurp its place until coal shall become scarce in this country, which will not be in this nor in several succeeding generations.

On the whole, we believe peat to be valuable where it can be prepared and used near the point of production, but notwithstanding the reports we have seen in its favor as a substitute for coal, in heat-producing qualities, as in the running of locomotives, etc., we believe it is far below mineral coal as a fuel. While wood and coal, our ordinary fuels, rule so high in the market, it may be found profitable both to manufacturer, and consumer to enter it as a competitor. It can be said that no fuel now used requires less skill in its management or gives a more genial heat for domestic and household purposes.

THOMAS'S PATENT TUBE CUTTER.

The engraving exhibits a sectional view of a neat, handy, and effective instrument for cutting out boiler tubes from the boiler when defective, and for fitting new tubes to length. A brief description, with reference to the parts, will enable any practical mechanic to understand the device and its mode of operation.

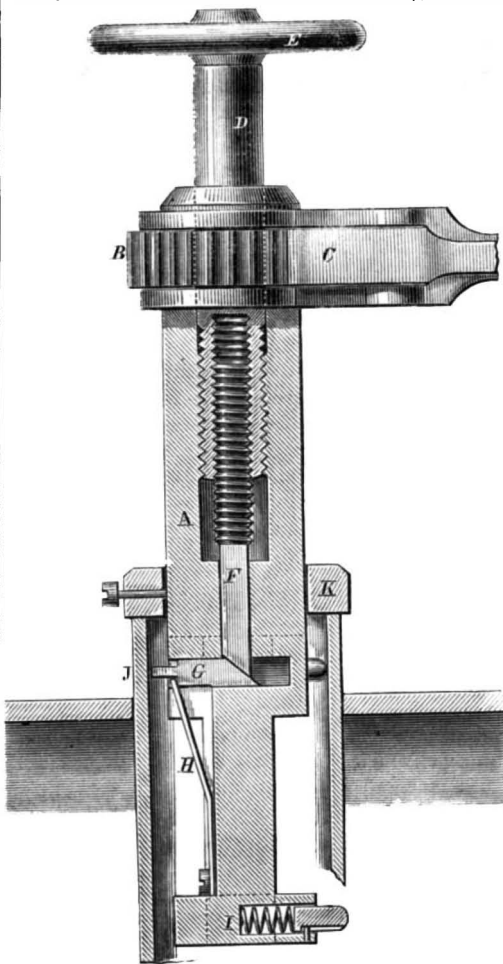

A is a stock, made of wrought or malleable iron, and having at one end a ratchet, B, which is worked by a lever and pawl, C. The stock is bored out

from the ratchet end to the diameter of one inch, and tapped with a thread of twelve to the inch. A plug, D, fitted with a feed wheel, E, and threaded to fit the stock, is inserted. Into the opposite end of this plug is fitted a screw, F, the thread of which is fourteen and a half to the inch. This thread, as well as that of D, is left-handed. The lower portion of the screw, F, is square, the point being wedge-shaped. This part traverses a square hole in the stock to prevent the screw, F, from turning. A cutter, G, is fitted into a transverse slot, and is fed out by the action of the wedge-like end of F, in combination with the corresponding end of the cutter. A spring, H, engages with the shoulder of the cutter and holds it in close contact with F. At the end of the stock is a collar, I, furnished with three spring plugs, disposed at equal distances around its periphery. Similar plugs are placed in that portion carrying the cutter.

The operation of the machine is simple. The stock is placed inside a tube, far enough for the spring plugs nearest the cutter to take on the inside the pipe, J. This steadies and holds firmly the apparatus, and this steadiness is further assured by the movable collar, K, which comes against the end of the tube, and is secured by a set screw. Then, by operating the ratchet lever, the outside stock is rotated, and the hand wheel, E, being held, the difference in the pitch of the screws feeds the cutter out just fast enough to cut the most effectually without breaking the cutter. The inventor says he has cut a pipe one-eighth of an inch thick in nine turns of the cutter, and has cut off a two-inch tube in one minute. The collars carrying the spring plugs can be removed at any time and larger ones substituted, although the same heads will cut tubes from two inches to two and a half in diameter. If more rapid feed than the difference in the threads is desired, it can be obtained by turning the hand wheel. The fact of this instrument cutting from the inside of the tube is greatly in its favor.

Patented through the Scientific American Patent Agency June, 5, 1866, by Nicholas Thomas. For additional particulars address the patentee, Box 2,847, P. O., Chicago, Ill.

THE TRICENNIAL METEORIC SHOWER.

Our foreign advices afford the most satisfactory corroboration of the astronomical calculations which our own beclouded view of the expected meteoric shower only confirmed rather faintly. The display witnessed from the British observatories was truly magnificent. One observer (Mr. G. J. Symons) estimates the total number of meteors visible at seven to eight thousand. Another (T. W. Weare, at Weston-super-Mare), whose report differs from the majority, as to both date and numbers, asserts that from 1:15 to 2:30 A. M., there were visible, in a range of view extending from a point or two south of east to a point or two south of west, say 160 degrees laterally, and 70 degrees vertically, not less than three meteors in every second of time, making 13,500 in one hour and a quarter. At 3:45 they ceased entirely; the earth had passed through the belt of meteoric planets. Prof. Grant, of Glasgow, seems to indicate about 1:18, A. M., as the culmination of the shower. Mr. Symons, and Mr. C. J. Talmage at Leyton, Essex, coincide to a minute (1:12) in fixing the maximum of frequency, and Mr. Hind places it at 1:10. The latter eminent astronomer counted 1,634 meteors from 12 o'clock to 7 $\frac{1}{2}$ minutes after 1, when a sudden increase rendered it impossible to count, and after culminating at 1:10, the number began to decline at 1:20, and diminished steadily until, in the last quarter before 6, A. M., only six meteors were observed. Mr. Symons's maximum was 100 per minute; Mr. Talmage's, 314 in five minutes. Thus the important fact of a well defined point of maximum density in the meteoric shower, is abundantly confirmed.

The tract of sky in which the first meteors appeared, had been equally visible (says one observer) the whole evening, and so continued after the shower had ceased; so that the maximum frequency obtained soon after 1 o'clock, admits of no other explanation than that the star shower, actually, and irrespective of visibility, culminated at about that hour. This was on the 14th, and after daylight, or between seven and eight o'clock, A. M., in our hemi-

sphere; which accounts for the partial disappointment here experienced.

Another and most important scientific datum was confirmed with beautiful precision by the English observations, coinciding with the fainter notices obtained on this side. That is, the entire discharge of meteors (with only three apparent exceptions in the many thousands), radiated from an exact point in the constellation Leo, located in a line between the stars *gamma* and *mu* Leonis, about three degrees from the former and five and a-half degrees from the latter star. The arcs traversed by the meteors increased without exception, according to their distance from this point, while those near the radiant had an extremely short path and train (that is, extremely foreshortened to the eye) with proportionally slow movement, some of the nearest even appearing for an instant as if without motion; the white or yellow light of the head blending visibly with the beautiful emerald green of the train which characterized all these meteors. Some, close to the radiant, are described as little illuminated puff-balls, more or less elongated, or egg-shaped, from the blending of head and train; and one is described as simply a star, that shone out, waxed, waned, and vanished, where it stood. "As clearly as the spokes of a wheel point to the center of the wheel, so did these short-course meteors, of which the trains of two or three were sometimes visible together, point to the spot in the constellation Leo from which they all emanated." At about the culmination of the shower (1:18), Prof. Grant, of Glasgow, saw a whole group of brilliant meteors burst out and diverge like a fan from the radiant point in Leo. Others observed them to fly out simultaneously in every direction from the radiant, like sparks from iron on the anvil. Some, again, darted about in a zig-zag course, but in the same general direction.

The size of the meteors was, in no case, remarkable; the very largest being compared to Venus at her brightest. The trains are described as extremely beautiful, of a greenish (or some say bluish) tint, strikingly phosphorescent in appearance, and leaving a lingering haze of light, but not in themselves remarkably persistent—the longest, according to Mr. Hind, enduring for three seconds. Professor Grant, of Glasgow, gives the maximum duration as five seconds; and a third observer allows it to be possibly ten. But Mr. Symons says that the trains were visible in a two and a-half inch telescope, for two minutes. A singular phenomenon observed by Professor Grant, was an extraordinary blaze of light at the vanishing of a large meteor in Ursa Major, leaving a residue of faint light in the form of a horse-shoe, continuing visible in the heavens for twenty minutes, and expanding in dimensions as it grew fainter, until its extremities included the stars *Epsilon* on one hand, and *Alpha* and *Beta* on the other. This was at 2:42 A. M. In another splendid instance (*Times* report), after the trail had nearly disappeared, together with the rocket-head that had produced it, both were again lit up together. The light of the trains was most brilliant at their midpoint, while that of the meteor itself was brightest just before its extinction.

These stones enter our atmosphere with a velocity, as reckoned by some, of forty miles per second, and are mostly melted and dissipated by the intense frictional heat evolved by their passage through the atmosphere. Many, however, reach the earth; and as every generation has to run the gauntlet of this celestial bombardment (once in thirty-three years), it becomes an interesting question, what may, perhaps, be its future volume and force. But the assurance that He who holds the winds in his fists, and who says to the sea, "Thus far shalt thou come and no farther," wields also the planetary artillery for his own holy purposes of goodness or of judgment, should compose the minds of all who can trust in him; and as for the rest of us, may well "give us pause."

Utilization of Waste Substances.

While considerable attention is being given to gun-cotton and nitro-cum, a somewhat similar substance is gradually making its way as an article of ordinary domestic use, entirely free from danger, and possessing such advantages as are likely to secure its general adoption. In the manufacture of Parkesine, fibrous vegetable matter of any and every kind

—cotton and flax waste, and old rags, being, from their cheapness, the favorite materials—may be employed. These are first dissolved by acids, and they then yield what chemists call pyroxyline. Pyroxyline, however, as its name implies, is highly inflammable, and indeed explosive, like gun-cotton, and this dangerous qualification has to be neutralized. Mr. Parkes effects this by the introduction of either of various chemical ingredients, as iodide of cadmium, tungstate of soda, chloride of zinc, gelatins, several carbonates, sulphates, and phosphates. Collodion (as used by photographers), when evaporated so as to leave a solid residue, has been employed in the production of Parkesine, but it was found by far too expensive. The substances which have given the best results with the pyroxyline are nitrobenzole, aniline, and glacial acetic acid. By the use of various proportions of these substances, all consistencies of Parkesine, from the solid to the fluid form, may be obtained. The applications of Parkesine are, of course as numerous as its forms are various. In the fluid form it is available for waterproofing fabrics, and in this way it is very serviceable. In a plastic state Parkesine is useful in making tubes, etc., and for insulating telegraph wires. Where hardness and toughness are required, these desiderata are arrived at by the admixture of oils prepared with chloride of sulphur, which latter solidifies and makes them (the oils) non-adhesive. Again, by the use of resins, gums, stearin, tar, etc., modified preparations of the invention may be made to suit special applications. Parkesine, indeed, is a most accommodating material, and may be made as hard and brittle as glass, or as fluid and yielding as cream and of every intermediate consistency. It may have elasticity imparted to it to almost any extent or degree, and in this state it is likely to become a dangerous rival to india-rubber and gutta-percha, inasmuch as it will become, if it be not now, far cheaper than those useful articles of commerce, and answer almost all their uses equally well. Vulcanized India-rubber will find a sturdy competitor in Parkesine, for it may be manufactured with less of brittleness, quite as much hardness, and at a lower cost than that tediously manipulated substance. There is no refuse in the manufacture, the chips and cuttings being capable of re-manufacture with the greatest facility. Parkesine will take any color, and may be given any degree of hardness; it may be made to imitate tortoise-shell, marble, malachite, or amber, and can be cut with a saw, turned in the lathe, planed, carved, engraved, stamped between dies, rolled into thick or thin sheets, worked into screws, shaped into moldings or cornices, etc. It is susceptible of a high polish, agreeable to the touch, and not disagreeable in smell. At a temperature of 340 deg. Fah., it is consumed, without flame, being decomposed and passing off as dense smoke, leaving but a dark colored ashy residue behind. It is now being manufactured for a variety of purposes, and is daily becoming more extensively known. —*Mining Journal*.

THE *London Mining Journal* says, "a valuable discovery has just been made by a gentleman, a cheap process for smelting titaniferous iron ore, which has hitherto defied all iron masters and scientific men in the trade. It is well known that titaniferous ore is most valuable, on account of its hardness and tensile strength being five times greater than ordinary iron. This iron will be admirably adapted for plating on iron-clads, and also for rails, on account of its hardness and strength, and the discoverer will be prepared to test this iron against any other iron hitherto discovered for these purposes, or for making steel."

ENGINES for railroads are used in England weighing each 56 tons, and Mr. Fairlie, the eminent locomotive builder, is constructing one of 72 tons weight, intended to be placed in the Paris Exhibition. The boiler is to be double, each barrel 4 feet 4 inches diameter, having together 408 tubes 2 inches diameter and 11 feet long.

ASSOCIATIONS and factories for cheesemaking are springing up in various parts of the country.

THE velocity of the sun has been estimated at 422,000 miles per day.



Manufacture of Pure Acetic Acid and Acetates from Empyreumatic Wood Vinegar.

MESSRS. EDITORS:—I herewith send you the description of a new method for producing pure acetic acid and acetates from wood vinegar, which, full of empyreuma, has long baffled different attempts at producing that result. Of those attempts, only the trials with charring or combustion of the empyreuma recommended themselves on account of their cheapness and simplicity, but the difficulty encountered was, to conduct that combustion without the simultaneous destruction of a part of the acetic acid.

The acetate of lime does not give satisfactory results in this respect, because lime is too weak a basis for the constancy of an acetate, which cannot suffer the heat necessary for the combustion of the empyreuma without undergoing decomposition, which diminishes considerably the resulting quantity of the pure salt.

The acetate of soda behaves similarly. Although it may be exposed to a high temperature without suffering decomposition, the result still leaves room for improvement, as the carbonate of soda, formed by the decomposition of the empyreuma in contact with the soda acetate, is kept mixed with the latter, decomposing it, and combining constantly with fresh quantities of liberated empyreumatic acids. This necessitates an increase of degree and duration of heating when a partial decomposition of acetate of soda can hardly be obviated. From the melted, sirup-thick mass the empyreumatic vapors escape with difficulty only, while the surface of the mass, cooled on stirring, forms hard crusts, which still retain empyreumatic particles.

All the evils referred to may be avoided by employing baryta in place of lime or soda. The acetate of baryta suffers no change at an elevated temperature; it does not melt, and behaves, therefore, perfectly indifferent toward empyreuma. For the production of acetate of baryta, it is best to use powdered native carbonate of baryta (witherite), which is introduced into the wood vinegar, until effervescence ceases, when the still somewhat acidulous solution is neutralized with caustic baryta, or the sulphuret of barium. After clarification by rest, the liquid is evaporated in a shallow pan, the crystals are raked off as fast as formed and left to drain on the inclined sides of the pan.

The dry crystals are heated in a cast-iron pan, about four inches deep, which is so set as to expose its bottom to an even, equalized heat, which has to be kept below red heat. In this pan the crystals are spread about two inches deep, constantly stirred, so as to prevent their burning fast to the bottom, while the heating is continued until empyreumatic vapors cease to escape, and the crystals, placed in water, form a clear, colorless solution.

The crystals fall to powder during roasting, and when sufficiently roasted, as mentioned, are cooled in another pan under constant stirring, which prevents the burning of the mass. This may be caused by the minute particles of carbon remaining in the mass of crystals and originating from the destroyed empyreuma, the carbon becoming pyrophorus. In order to prevent the loss by dusting during the roasting process, an addition to the melting salt of two per cent. of acetate of soda is appropriate, as it melts, preserving the acetate of baryta moist. The solution, as made at first, may, therefore, at once be neutralized with carbonate of soda instead of the caustic baryta or the sulphuret. The roasted mass is next exhausted with water which furnishes, on evaporation, the acetate of baryta, from which pure acetic acid or acetates may be prepared.

JOSEPH HIRSH,

New York City.

Coloring Ivory.

MESSRS. EDITORS:—If some of your readers, who are well posted in the process, would be kind enough to give directions how to dye ivory in various colors, I am certain it would be appreciated by a large number. I have tried all the recipes published in hand-

books, but either they are at fault or I am; for the colors produced are any thing but attractive. Will correspondents please state full particulars, how long the ivory must remain in the dye, etc., etc.

E. P. W.

New York, November, 15, 1866.

Dyeing of Horn.

MESSRS. EDITORS:—A few recipes for the dyeing of horn, especially with reference to the manufacture of buttons, or such other articles as may be exposed to the heat of boiling water, may not be out of place here, especially as practice has proved them to work satisfactorily.

1. **DULL BLACK.**—The buttons are boiled in a saturated solution of sugar of lead, until the color has acquired the desired shade. According to the quality of the horn, this may take a quarter to half an hour. The buttons should then be washed with water, slightly acidulated with vinegar.

2. **IRON BLACK.**—The buttons, after being treated as stated in No. 1, are placed in a cold solution of an alkaline sulphuret. The result is, the buttons possess a bright, metallic luster.

3. **PEARL.**—After undergoing the treatment of No. 1, the buttons are brought into diluted muriatic acid, containing 3 per cent of the strong acid. This weak solution produces, according to the duration of its influence, all shades, from the darkest blackish blue to the lightest white.

4. **SILVER-GRAY.**—The buttons from No. 1 are placed in a solution of nitrate of mercury, saturated at a temperature of 140 degs.—170 degs., Fah. The treatment in this bath should last ten to twenty minutes, which, if cleanliness is observed, will produce most elegant results.

5. **CHOCOLATE BROWN.**—The buttons from No. 4 are boiled for about a quarter of an hour in a concentrated but thin solution of catechu.

6. **CHOCOLATE BROWN, DARK.**—The buttons from No. 5 are placed in a warm bath of bicarbonate of potash, containing 3 per cent of the salt. With the duration of the treatment the color darkens.

7. **CHOCOLATE BROWN.**—The buttons of No. 5 are placed in a warm solution of sugar of lead, saturated at the common temperature. This color looks especially well in knife handles, etc.

8. **BRONZE BROWN.**—The buttons from No. 4 are placed in a solution of aesculine (the pigment of the horse chestnut), and treated and boiled as in No. 5.

9. **BRONZE BROWN.**—The buttons from No. 4 are boiled for quarter of an hour in a concentrated solution of green vitriol, and then in aesculine. The resulting bronze differs materially from the former, possessing great softness.

10. **LIGHT BROWN.**—The buttons from No. 4 are boiled in a solution of galls or pure tannin. This is especially adapted to netty designs, to which it imparts a silky luster.

Upon the sensitive surface, produced by treatment No. 4, a great many combinations of colors may be produced.

JOSEPH HIRSCH.

Changes in Steel by Friction and Heat.

MESSRS. EDITORS:—The "singular quality of steel" alluded to in the SCIENTIFIC AMERICAN of Nov. 3d, is familiar to all saw makers.

When a hand saw is hardened and tempered it is crooked but elastic. Hammering it straight takes from it its elasticity, but not its hardness; for it yet grinds and files hard. Grinding and polishing will destroy the spring nearly as effectually as the hammering, either of which affects soft steel in a manner exactly the reverse.

To restore the elasticity of saws, they are exposed to a degree of heat that will produce a straw color, and if not done too quickly this will be effectual. The color is removed with an acid; the presence or absence of it makes no difference in the elasticity of the saw; that is doubtless due to a certain definite arrangement of the "grain" of the steel.

Heat has power to alter the molecular condition of steel, a fact that can be demonstrated by breaking a rod of soft steel; then harden and break it, again draw the temper and break it once more. The three pieces will be, at the point of fracture, quite dissimilar in appearance. Now if the hardened and the tempered pieces are heated enough to remove all the temper, the grain of the steel will appear as in the first piece.

Saws will lose their spring by long use from friction. We restore it every day, in repairing them, when the original temper is good. I have heard farmers declare that a fractious tempered scythe hung out in the sun during summer would be improved. I have, with others, ridiculed the idea. I am now inclined to think their observations correct.

The "razor question," discussed in your columns some time since, is, I think, susceptible of an explanation from the above facts. The frequent friction the edge is subjected to in honing and stropping, abstracts from it its elasticity, or weakens the cohesion of the particles of steel composing the edge for each other, resulting in a crumbling, tender edge. If so, the effect of dipping the razor in hot water is to restore the toughness and elasticity of the edge, and as a consequence make it retain its sharpness longer. The remarkable changes caused by, or attending different degrees of heat on steel, seem explicable only by admitting "heat to be matter in motion."

WM. CLEMSON.

Middletown, N. Y., Nov. 9, 1866.

Plumbago in Georgia.

MESSRS. EDITORS:—Will you please advise, through your journal, the uses, value, amount of consumption, and best market for plumbago or black lead. We have mineral resources and must develop them, or this poverty-stricken and desolated country is gone up.

THOS. L. WATERMAN.

Marietta, Ga., Nov. 7, 1866.

[Plumbago is used in this country mainly in the manufacture of crucibles, stove polish, and for lining molds for casting iron. It is also used in limited quantities, when of good quality, for the manufacture of black lead pencils. Its value depends altogether upon its quality. That of the Barrowdale, England, mine is used mainly for pencils, as it contains over ninety per cent of carbon. That procured from Ceylon is still more valuable. The manufacture of crucibles and stove polish is restricted to a few concerns in this country, as for the first the demand is limited, the crucibles being used mostly in the steel business, which is not, as yet, very extensively prosecuted in this country. The best method of utilizing a plumbago mine in Georgia, it seems to us, would be to create a demand for the article by starting the steel manufacture.—EDS.]

Welding Mixture.

MESSRS. EDITORS:—Herewith I send you a recipe for using on cast steel in welding and in restoring burnt steel. It is the best preparation that I have ever seen or used. 1½ lbs. of borax, ½ lb. of sal ammoniac, ¼ lb. of prussiate of potash, 1 oz. of rosin, 1 gill of alcohol, 1 gill of water. Pound fine, and boil in an iron kettle slowly until it becomes a thick paste. Use as borax.

WM. A. SWEET.

Syracuse, N. Y., Nov., 12, 1866.

Russian Railroads and the Krupp Guns.

Engineering, under the heading, "In Russia," says:—"There are great lines of railway, extending hundreds and hundreds of miles across the same universal plain, so alike everywhere that a difference of a thousand miles is one of distance and nothing more. These railways are well built and well appointed, and at many of the principal stations, as at Wilna, Pskoff, Tver, and others, the passenger is struck by the magnificence of the buffets, rich with stained glass and oak carvings, while the nearest town—for the railways but seldom run through them—is but a straggling street of miserable log huts. The line from the Prussian frontier is worked by new, well-made, and very powerful wood-burning engines, perhaps one-half of which were made by Borsig, of Berlin, and the rest by various makers, a few by Sharp, of Manchester, others made at Seraing, and at Couillet, in Belgium, and others yet at Stettin. They are nearly all outside-cylinder engines, with four coupled wheels and a bogie, and many of them weigh 36 tons. The trains are very long and heavy, as many as thirty carriages being taken. The highest speed is very fair, perhaps 45 miles an hour; but as brakes are seldom used in stopping, much time is lost in slacking up at stations. The carriages are intersected by passages between the partitions, so as to form separate compartments not only at the ends, but at the sides also. The most remarkable railway carriages to be met with anywhere are those

on the St. Petersburg and Moscow line, and which are of recent French design. They are two stories high, and stand apparently nearly 18 feet from the rails, which are laid to the 6 feet gage. The principal floor is divided, by passages and partitions, into end compartments, interior compartments with windows on one side only, and a central saloon, generally monopolized by Russian officers. From this saloon a staircase ascends to a large apartment above, like the interior of a huge omnibus. It has windows and lounges along the sides, and is furnished with card-tables and wax-lights, and offers every convenience for smoking and sleeping.

"Where are the Krupp guns? Despite Mr. Longdon's reiterated denials, it is repeated here by every one who pretends to know anything of the matter, that all of Krupp's guns, of any considerable caliber, have burst on trial, and are hardly better for the purposes of ordnance than cast iron, albeit that the steel is apparently of excellent quality. It is not indeed a question of quality, but whether cast steel is fit for heavy ordnance. As for enormous orders having been given for steel guns, the report is of a piece with that by which Mr. Sampson, the city editor of the *Times*, was imposed upon two years ago, when he gave out that Captain Blakely had received an order from the Russian Government for £900,000 worth of his guns, whereas hardly any of his guns ever went to Russia."

THE center-rail system, for inclines, has been adopted on the Mont Cenis railway, and is found to work well on inclines as great as 1 in 12. It is claimed that the friction, or adhesion, of the two horizontal wheels on the sides of the central rail, allows a great diminution in the weight of the locomotive, gives control as brakes, over the velocity in descending, prevents the train from leaving the track, and gives greater security in rounding curves.

In the year 1865, Belgium had 365 inhabitants to the square mile, England and Wales had 367, and France 176. If the United States was as densely populated as France, our population would amount to 528,000,000; as England and Wales, 924,000,000, and according to the Belgium density of population, the United States would contain 1,195,000,000 inhabitants, being 110,086,000 more than the entire population of the world in 1866.

NEW INVENTIONS.

The following are some of the most prominent of the patents issued this week, with the names of the patentees:—

TANNING MIXTURE.—IRA WOOD, Woodstock, Vt.—This invention relates to a new mixture for tanning or dressing glove calf, buck-skins, and other hides.

WINDOW-SHADE FIXTURE.—J. W. TAYLOR, Dubuque, Iowa.—This invention consists in the employment of a perforated wheel secured to the end of the shaft of a shade for windows in combination with a lever which is operated by means of a cord passing through an eye arranged on the lower end of the lever.

CAR BELL.—JAMES SWEENEY, New York City.—This invention relates to a car bell which is put up in an inverted position so that the dust and dirt readily discharge therefrom, and the water is not liable to freeze in and to injure it by lodging in the same.

STILL.—B. P. STEBBINS, Cory, Pa.—This invention has for its object to furnish an improved cone still by means of which the steam or spirit vapor may be readily and rapidly condensed, and which shall be simple and cheap in construction.

PERCUSSION TABLE FOR CONCENTRATING AND DRESSING ORES.—HENRY ALDERSON THOMPSON, Grant, Gipp's Land, British Colony of Victoria.—This invention is to provide a table for concentrating and dressing ores, on which the material is kept in a loose state by means of stirrers, thus allowing a more perfect concentration with less loss at one dressing than can be obtained on the plan now generally used by means of several dressings.

CHURN.—G. B. WALLER, Franklin, Ill.—This invention has for its object to furnish an improved churn by means of which the cream may be thoroughly aired while being agitated; and by the use of which the churning may be done in a very short time, and with a small outlay of power.

MACHINE FOR MOLDING CRUCIBLES, ETC.—SAMUEL R. THOMPSON, Portsmouth, N. H.—This invention has for its object to furnish an improved machine by means of which crucibles and other vessels may be molded from any suitable plastic material perfectly and rapidly.

EMBOSSING BRASS TUBES, ETC.—DAVID T. SANFORD.—This invention relates to a machine which is intended to emboss cylindrical pipes or rods of wood, metal, or any other suitable material, the operation of embossing being effected by three or more revolving wheels or knurls which are mounted on pins in the forked ends of shafts that radiate from the center of a hollow spindle and which are so arranged that they can be adjusted toward and from the center.

CARRIAGE TOP.—W. F. RUNDELL, Genoa, N. Y.—This invention relates to the frames for buggy and other carriage tops, and it consists in securing the front bow or section of the frame to the one next adjoining in an extremely novel manner, whereby not only is the frame greatly simplified in construction, but its strength much increased.

CHURN.—J. K. REINER, Line Lexington, Pa.—This invention consists in constructing the body of the churn or cream receptacle of oval form in its transverse sections, the receptacle being placed horizontally on a suitable support and provided with two longitudinal shafts, having curved arms attached which have an oblique position in their transverse section, the arms of one shaft having an opposite oblique position with those of the other, and the two shafts connected by gears at one end, whereby the cream, as the two shafts are rotated, will be forced toward each end of the cream receptacle, and agitated in such a manner as to cause butter to be produced in a short space of time. The invention also consists in having a chamber or butter receptacle attached or applied to the cream receptacle, the butter receptacle having a strainer at its outer end and provided with a slide at its inner end, whereby the latter may be readily separated from the buttermilk.

MODE OF ATTACHING DRAFT POLES TO AXLES.—E. C. SMITH, New Haven, Conn.—This invention relates to a mode of attaching draft poles to axles, whereby a draft pole may be attached to axles of different vehicles. The clips which receive the eyes of the cross bars of draft poles are not placed in the same place on the iron axles of different vehicles, they vary materially, and the object of my invention is to have the eyes of the cross bars attached to the latter in such a manner that they may be adjusted to suit the position of the clips at whatever point they may be placed.

HAY FORK.—W. F. RUNDELL, Genoa, N. Y.—This invention relates to a hay fork for which Letters Patent were granted to this inventor bearing date March 23, 1866. The present invention and improvement consists in a modification of the ferrule, whereby the strength and durability of the fork are very materially increased. The handles of hay forks being invariably constructed of wood and tapered at the end in which the tang of the fork is fitted, are very liable to split and break at said end, as that is the point where they are subjected to the greatest strain.

STRAW AND FODDER CUTTER.—W. D. SCHOOLY, Richmond, Ind.—This invention relates to that class of straw and fodder cutters which are provided with a rotary knife or cutter working over a slanting knife, and it consists in attaching and arranging the rotary knife on its arms, in such a manner that it may, with the greatest facility, be adjusted whenever required to compensate or wear. The invention also consists in a novel construction and arrangement of parts pertaining to the feed mechanism, whereby the same may be readily adjusted to admit of the fodder being cut into pieces of greater or less strength, as may be required, and all the parts pertaining to the feed mechanism rendered strong and durable.

PERPETUAL BRICK KILN.—JOHN McDONALD, New York City.—This invention relates to a useful improvement in that class of brick kilns which are known as perpetual kilns.

TANNING PROCESS.—ALEXANDER HILL, Dubuque, Iowa.—By this process skins may be tanned in a very superior manner and in a very short time.

SIFTING DEVICE.—PAUL CEREDO, Canada East.—This invention relates to a screen or sifting device for separating ashes from cinders and unconsumed coal, and for sifting or separating other substances, and it consists in the employment of a screen box provided with a proper screen and fitted within a suitable case or box so as to work on journals or pivots, and operated through the medium of a cam and spring, the case in which said screen box is placed being provided with discharge apertures so arranged in relation with the screen box as to discharge the part which are separated from each other by the screening process from different parts of the case and into separate receptacles prepared to receive them.

CUTTING AND BAKING CORN AND COTTON STALKS.—HILL and TUTTLE, Eaton, Ohio.—This invention consists in a combination of plows, cutters and a rake applied to a mounted frame, whereby corn and cotton stalks may be cut, plowed up, and raked into suitable piles, convenient for removal from the field.

BURGLAR ALARM.—C. A. BLAKE, Philadelphia, Pa.—The burglar alarm embraced in this invention is extremely simple and in operation must be efficient and certain.

CLASP LOCK FOR BOOKS, PORTFOLIOS, ETC.—LEOPOLD LALL, New York City.—This invention consists in applying a lock to a book clasp in such a manner that when the clasp is closed and the covers of the book secured, so that the book will be in a closed state, the clasp may be locked and rendered incapable of being opened without the aid of a key. The object of the invention is to prevent books being opened and their contents inspected by any except the proper person, and it will prove to be a desirable device for account books in counting houses and other institutions where curious visitors and customers have frequently the opportunity of looking at accounts not designed for their inspection.

SHUTTLE FOR SEWING MACHINES.—GEORGE H. LENNER, Richmond, Va.—One of the objects of this invention is to prevent the twisting of the thread of a rotating shuttle, for which purpose the bobbin is placed at one side of the center of motion of the shuttle and left free to be revolved on its own axis by the pull on its thread in the operation of sewing. Another object is to provide an adjustable tension upon the bobbin thread, which is accomplished by the pressure of a spring whose free end bears against the inner side of the bobbin.

CAR COUPLING.—JOHN H. KAVANAGH, Joliet, Ill.—This invention consists in so constructing the coupling of a car that as the cars approach each other, the link on one car strikes a wing of a trip lever on the other car whereby the coupling of the cars is effected.

WOOD-SAWING MACHINE.—P. A. GERRY, Dover, Me.—This invention has for its object to furnish an improved machine, by means of which wood may be sawed rapidly and conveniently.

DRYING LUMBER.—JAMES W. HANNA, Wabash, Ind.—This invention has for its object to furnish an improved means for drying lumber which will be free from any danger of fire, and which will preserve the lumber from checking.

LUMBER WAGON.—JOSEPH N. BYINGTON, Stockton, Min.—This invention has for its object to furnish a means by which a lumber wagon, used for drawing heavy loads, may be readily changed into a spring wagon for carrying people or light loads.

PORTABLE COMBINED FIRE GRATE AND ANDIRONS.—JOHN H. COATE, West Milton, Ohio.—This invention has for its object to furnish a grate which may be adjusted to radiate more or less heat into the room, and which may be arranged for burning wood, coal, chips, or corn cobs, etc., as may be desired.

GRAIN DRYER.—JOHN R. EVERTSON, Mt. Vernon, Ind.—This invention has for its object to furnish an improved portable apparatus for drying grain, meal, malt, and similar substances, quickly and conveniently.

HAME-TUG BREAST COLLAR.—ADAM McMULLEN, Sterling, Ill.—This invention has for its object to furnish an improved breast collar, so constructed and arranged as to cover the parts of the horse's breast upon which the draft comes, affording an easier and better purchase than the breast collars now in general use.

WASHING MACHINE.—JAMES LAMPHEAR, Panama, N. Y.—This invention consists of a washing machine formed by the combination of the fluted rollers and plain feed roller with each other and with the frame of the machine.

MANUFACTURE OF SUPERPHOSPHATE OF LIME.—A. DE FIGANIERE, Philadelphia, Pa.—This invention has for its object to improve the manufacture of superphosphate of lime, by the more thorough incorporation of the acid with the guano, or other fertilizer, than can be done when the operation is performed by hand labor.

HOE AND SEED PLANTER.—A. T. LARGE, Tomah, Wis.—This invention consists in a combination of a hoe and seed planter, whereby holes may be made in the earth to receive the seed, the seed dropped in the earth and then covered, the work all being performed with the same implement and with great facility and expedition.

MACHINE FOR DRESSING THE FELLES OF WHEELS.—ANDREW P. OLDRAM, Bridgeport, Conn.—This invention relates to a machine for dressing the sides of the felles of wheels, and is more especially designed for operating upon carriage wheels. The object of the invention is to obtain a machine of simple construction which will admit of the work being rapidly and perfectly performed, and capable of being adjusted to suit wheels of different sizes or diameters.

BROOM HEAD.—THOMAS MOORE, Bloomington, Ill.—This invention consists in a broom head formed with elongated sides or ears and hooks, and in combination therewith and with each other of the crescent-shaped tighten, wire ledge on the interior surface of the broom head, the screw by which the tighten is drawn up into the broom head, the bottom of the socket, and the handle.

FEED MOTION FOR DRILLS, ETC.—G. T. CASE, New York City.—This invention relates to an automatic feed motion for drills, boring bars, etc., and particularly for what is known as "Case's expanding drill for enlarging the diameter of oil wells." It consists of a lead screw provided with a nut and worm wheel, to which a slow revolving motion is imparted by a worm which revolves with the feed screw, and which is caused to turn on its own axis by a suitable cam and corresponding cam wheel, in such a manner that the feed screw is caused to advance slowly and continually, and a uniform and automatic feed for the boring bar or other mechanism is obtained.

BUTTER WORKER AND PACKER.—CHARLES F. BARRAGER.—Patented November 23, 1866.—Arranged in connection with the working bowl and packing tub is a pivoted lever with a paddle attached thereto by a universal joint. The lever can be rotated horizontally on its pivoted standard to operate by a plunger upon the butter in the tub.

PRESSING HATS, BONNETS, ETC.—G. L. THOMPSON, New York City.—This invention relates to an improvement in that class of machines in which the operation of pressing hats, bonnets, or other similar articles, is effected by means of steam or other fluid at a suitable pressure acting upon a flexible diaphragm or core applied to one side of the article to be pressed, while the other side is supported by a rigid block or form. By combining with said flexible diaphragm or core a piston which works in a suitable barrel or cylinder, and which can be moved toward and from said flexible core, the pressure of the liquid or fluid can be increased or diminished at pleasure, and the operation of pressing hats, bonnets, or other similar articles, can be effected with the greatest ease and nicety.

SHAFTS FOR SLEIGHS AND CARRIAGES.—GEORGE COFFIN, Boston, Mass.—This invention has for its object to furnish an improved means for detaching the horse from the sleigh or carriage when he becomes unmanageable.

TURNING OR PLANING TOOL.—CHARLES W. BURDICK, Norwich, Conn.—This invention has for its object to furnish an improved tool for turning or planing iron or steel, the holder of which can receive and hold cutters of various shapes, and designed for various uses.

BROOM HEAD.—JAMES C. MCCLELLAND and JAMES GRAHAM, Pittsburgh, Pa.—This invention consists principally in the circular top of the broom head, having a tapering band and short tube through which the handle passes, in the combination of arms with the broom-head cap, and with the binding wire, in forming the lower side edges of the broom-head cap double, and in the combination of the interior ring with the broom head and handle.

EXPANDING MANDREL.—ISRAEL BERTISON, New Britain, Conn.—This invention consists in a tapering mandrel, which is flattened on three or more sides, in combination with three or more segmental wedges, which are fitted on the flattened sides of the mandrel and held in position by a suitable clamp, in such a manner that by moving said edges up or down, the mandrel can be adjusted for different sized holes, and one and the same mandrel can be used for turning a variety of articles.

MACHINE FOR EDGING BUTTON-HOLES.—JOHN T. BRUEN, New York City.—This invention relates to a machine which is intended

to cut out and apply automatically an annular disk of muslin or other textile fabric to the edge of the button-holes in paper collars, cuffs, and other articles of a similar nature, so as to render said button-holes strong and durable.

CARRIAGE.—LOUIS KUTCHER, New York City.—This invention consists in combining the box or top part of a carriage or wheel vehicle with the lower part of the fifth wheel instead of with the upper part thereof, as usual, in such a manner that said box will always remain at right angles to the tongue, and move with the same in either direction independent of the body of the carriage or vehicle, and that the driver is thereby enabled to face in the same direction in which his horses or draft animals pull or move.

INFANTRY ACCOUTERMENTS.—Colonel J. K. MIZNER, Fort McPherson, Nebraska.—Patented November 27, 1866.—The nature of this improvement consists in so arranging the parts of a knapsack as to afford a more convenient mode of packing than has been hitherto attained, while the ration bag or haversack is so attached as to be out of the way in marching, and not so liable to be caught and torn.

MOLD FOR FURNITURE COMPOSITION.—JAY J. WIGGIN, Cincinnati, Ohio.—Patented November 27, 1866.—This invention relates to a mold made up of detachable sections which are held together by screws and clamps. It is employed in the manufacture of the "Egyptian Case-hardened Marble," patented by the same inventor simultaneously herewith.

COMPOSITION FOR FURNITURE AND OTHER PURPOSES.—JAY J. WIGGIN, Cincinnati, Ohio.—Patented November 27, 1866.—The subject of this invention is an artificial substitute for wood, stone, and metal, which has the requisite qualities of hardness, neatness, and durability to adapt it for use in the manufacture of furniture, billiard-table foundations, coffins, floors, and for many other purposes which are generally subserved by the employment of wood, etc. The appellation applied by the inventor to his composition is the "Egyptian Case-hardened Marble."

PLANING MACHINE.—HENRY CLIMMER and JOHN D. RILEY, Cincinnati, Ohio.—Patented November 27, 1866.—This invention relates to an improved combination of devices intended for planing and mortising pieces of furniture which contain both square and turned work, such as bedsteads, etc., in the manufacture of which the material is fed to the machine by hand.



Y. M., of—Your question is rather indefinite but if you desire our opinion as to the anti-rustification you mention we can only say it is highly recommended by practical engineers who have tested it. We are rejoiced from these reports to a favorable opinion.

A. J. H., of Me.—We do not know the address of the company you inquire about. . . . The Avery engine does not develop so much power, "pressure and speed being equal," as the ordinary steam engine. It is used where fuel is not an element of great expense for its cheapness and simplicity. . . . In calculating the power of a double cylinder engine the capacity, etc., of each cylinder must be taken. If indicated the indication should be made at each end of each cylinder. . . . Spiegeleisen will not turn cast-iron to steel in a cupola furnace. The iron may be made very hard by its use, but hardness is not the only, nor distinctive quality of steel. . . . Other things being equal, there is no doubt that the draft of a boiler with upright tubes is greater than one with horizontal tubes.

H. B., of Mo.—The material (mixture of hammer slag and cinder) with which you protect the cast-iron bottom of your puddling furnace is mainly composed of oxide of iron and silicate of iron. It serves as a protector by reason of its non-conducting quality; without it the cast-iron plates would be at once melted. It confines the heat to the iron to be puddled, whereas alone the heat is wanted.

B. G., of N. Y.—The reason that your hair is not so promptly blackened at its ends as near the roots, is probably because at the ends the hair is more dead and dense so that the coloring matter does not penetrate. . . . The sulphur and lead preparation is the least harmful of hair dyes. With care to prevent too much getting on to the scalp, it may safely be used for many years. The coloring matter is sulphide of lead.

BUSINESS NOTICES.

SPECIAL NOTE.—This column is designed for the general interest and instruction of our readers, not for gratuitous replies to questions of a purely business or personal nature. We will publish such inquiries, however, when paid for as advertisements at 50 cents a line, under the head of "Business and Personal Queries," as below:—

H. M., of Pa., wishes to know where the patent needle threader is manufactured.

V. E. Kegan, Roxbury, Mass., wishes to communicate with parties concerned in the manufacture of salt-peter.

L. W. R. Blair, Camden, S. C., wants the best cooking stove.

O. W. Ross, Northfield, Mass., wants 1,000 small pamphlets printed at a cheap rate.

O. H. Strong, Rouseville, Pa., wishes to purchase a good self-regulating wind mill.

Dr. J. B. Williams, 251 Pennsylvania street, Pittsburgh, Pa., desires to communicate with makers of artificial stone.

J. P. Nicholson, West Stockbridge, Mass., desires to communicate with parties owning patents for burning lime with anthracite coal.

Improvement in Screw Plates.

The common screw, or jamb plate, has some objections, known full well to practical workmen, which make the doing of what machinists' apprentices facetiously denominate "circular work," very tedious. The repeated trials of running up and down the bolt, cleaning the dies, and testing the proper size of the thread are trying to the patience. Then, when the dies are worn, it may be necessary not only to recut them on the "hob," but to replace them by new dies, involving much time. The improvement herewith represented is intended to overcome these difficulties.

doing the work well, even when the flax is damp, and leaving the fibers parallel. It is claimed also that this machine leaves less tow on the hackles than any other in use.

The flax is spread on the table, A, the clamp, B, is raised by the lever, C, and the flax pushed under it. The clamp is then brought down upon it and held securely by the lever. At D is a bar extending across the frame, on which the flax rests while the beaters are at work. The table is pushed forward as the work proceeds, until that portion on the apron, E, beyond the clamp is thoroughly dressed, when the flax is reversed and the operation repeated. The

of J. E. E., in No. 20, current volume. That correspondent found that removing the blueing from steel with diluted sulphuric acid would not injure its elasticity. F. L. K. says:—"I desired to coat over with tin some steel hoop-skirt wire tempered in oil. I used sulphuric acid, prepared in the usual way, to brighten the wire. It was easily coated with tin, but about nine-tenths of the wire had lost its elasticity. I dropped a piece about two feet long, on the floor, which broke into six or eight pieces. I used the lime water to remove the acid as J. E. E. did. It may be said that the wire, being thin, the acid penetrated entirely through, which can hardly be the

**ZILLIER'S PATENT SCREW PLATE.**

Fig. 1 shows the center of a plate ready for use. Fig. 2 represents the same portion with the top covering plate removed. The plate itself, at the center, is bored out to receive the disk, A, which has radial slots in which slide dies, B, which are actuated by the spiral, cam-like cuts, equal in number and disposition to the dies. A coiled spring engages in slots in the dies and keeps their outer ends in contact with the cam slides. The top plate, C, has a corresponding plate on the under side, both rigidly secured to the disk, A, so that turning them revolves the disk, and throws the dies in or out according to the direction in which they are rotated. The stock has a scale to which a pointer on the plate, C, is directed. This secures a uniform size to a number of screws or bolts. A thumb nut, D, on a bolt passing through the slot, E, holds the top and bottom plates, and consequently the dies, in any required position. The dies are so arranged and the threads in them so cut, that always the cutting edge alone is presented to the bolt or screw, and there can be consequently no "raising" of the thread by compression, but the thread must be cleanly cut. This device can be used on a lathe to thread bolts, as well as by hand.

It appears to be a convenient tool, not liable to derangement, and easily kept in order. It was patented through the Scientific American Patent Agency, July 24, 1866, by Nicholas Zillier, whom address for further particulars at No. 1,063 Artisan Street, below Richmond, Philadelphia, Pa.

blades of the beaters are curved inward on their edges from each end, to keep the flax from spreading and becoming entangled on the shaft ends. There are two sets of these blades, each five in number, working into one another's interspaces. Those of the upper cylinder beat the flax on the top, and those of the lower act against the under side, each revolving toward the free ends of the flax. It can readily be seen that while these blades thoroughly break the flax, they as certainly clean it from the "shives."

The clamp, B, is hinged at one end, and, by lifting

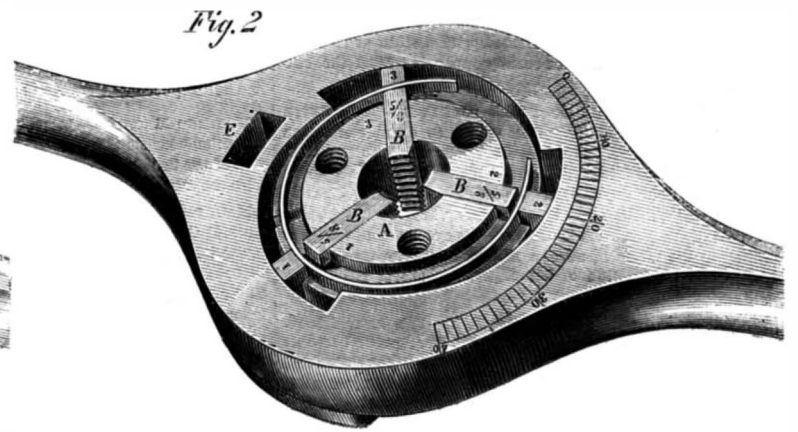
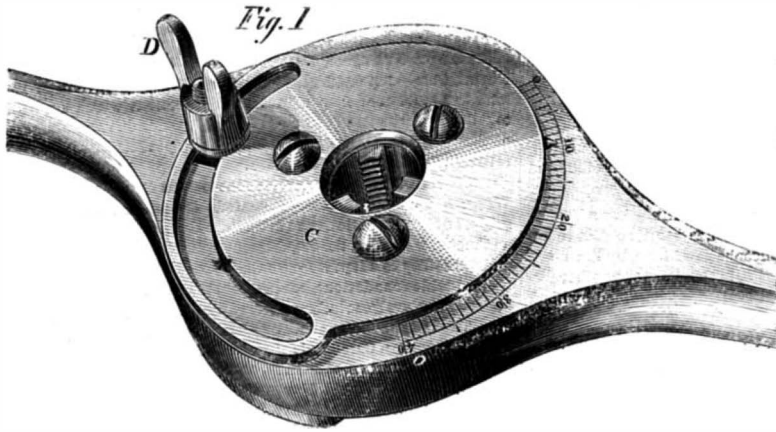
fact, as some of the pieces were as tough after the process as before, although all were from the same coil and received the same treatment."

We think that in coating the wire with tin some of it may have been heated too much and then suddenly cooled, while other pieces may have cooled gradually. The acid and lime water may have had nothing to do with it.—EDS.

Practical Hints.

No. 4. TO PREVENT THE WATER IN GAS METERS, GAS HOLDERS, AND OTHER SIMILAR RESERVOIRS FROM FREEZING.—Formerly alcohol was used for this purpose, as it only freezes at 250 degrees below zero, Fah., consequently all watery liquids containing this substance will freeze at a much lower temperature than pure water, and alcohol is very effective; however, there are two objections; one is, that the price of the alcohol is so high, because of the internal revenue tax; and the most serious objection, that the preventive is only temporary, as the gas passing through the meter causes the alcohol to evaporate still faster than the water, which also disappears, and must be supplied from time to time, as is generally known. Solutions of common salt and other compounds soluble in water, have also been tried in gas meters, but they invariably attacked, in the course of time, the metal of which the meter was made, and were therefore abandoned.

However, we have now a substance which is much cheaper than alcohol, never evaporates, but on the contrary, resists the evaporation of water, does not act injuriously on metals, is soluble in all proportions in water, and only freezes at about 160 degrees below zero, Fah.; this substance is glycerin. The amount to be put in a gas meter depends, of course, on its size, and the degree of cold to which it is exposed in the coldest winter nights. From one-half to one pint of glycerin to a gallon of water will be found sufficient for ordinary circumstances. V.

THE Union Pacific Railway excursion from Philadelphia to Fort Riley, Kansas, and back, was accomplished in a single car, by means of broad-flange wheels, covering the different gages which occur on the intermediate roads. The distance is nearly 1,500 miles each way.

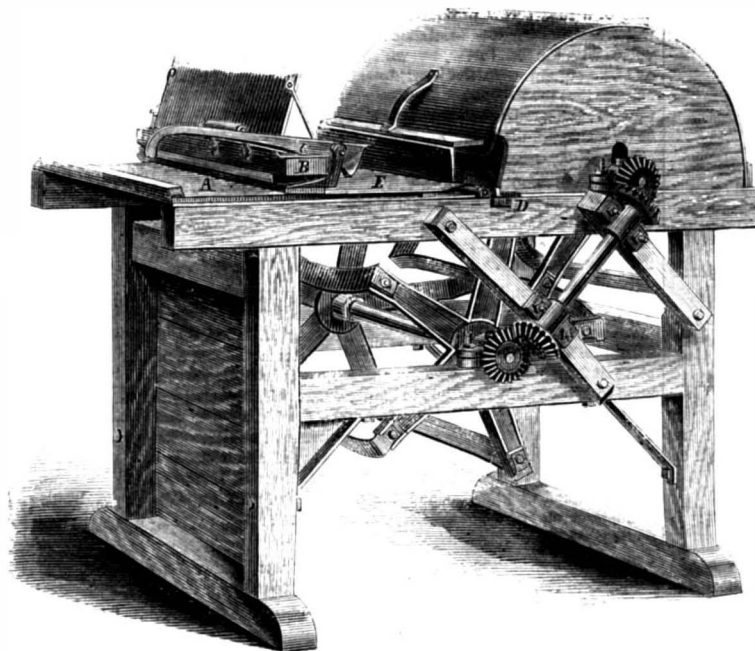
**ABBOTT'S FLAX BREAKER AND DRESSER.****Flax Breaker and Dresser.**

The engraving is a perspective view of an improved machine for dressing flax without previously passing it through a breaker. In the usual way the flax is held in the hand, presenting so small a surface to the action of the beaters, that the outside of the handful is worked too much before the inside is properly dressed; and, if a little damp, the flax becomes knotted and snarled. This machine, the inventor says, breaks and dresses the flax at one operation, and will also dress flax rapidly after having been broken in the ordinary manner. It requires no skilled labor to operate it, and will do twice the amount of work now done by the pulley and blade machines in common use. The flax being presented to the beater blades in a thin sheet, it will dress the top and bottom sides and the middle simultaneously,

the lever, C, is instantly raised to a perpendicular position. Its under surface is provided with a cushion of rubber or other elastic material, which, by means of bars under the table, A, hold the flax securely in place while being dressed. Power is applied to either of the drums.

The patent was secured through the Scientific American Patent Agency, June 12, 1866, by David S. Abbott, Cuba, Allegany county, N. Y., who will sell machines and territorial rights on application.

The Action of Acids on Steel.

A correspondent, F. L. K., of Worcester, Mass., says that his experience with steel differs from that

THE
Scientific American.

MUNN & COMPANY, Editors and Proprietors.

PUBLISHED WEEKLY AT
NO. 37 PARK ROW (PARK BUILDING), NEW YORK.

O. D. MUNN, S. H. WALES, A. E. BEACH.

American and Mexican News Company, Mexico, are Agents for the SCIENTIFIC AMERICAN.

Messrs. Trubner & Co., 60 Paternoster Row, London, are also Agents for the SCIENTIFIC AMERICAN.

"The American News Company," Agents, 121 Nassau street, New York.

Messrs. Simpson Low, Son & Co., Booksellers, 47 Ludgate Hill, London, England, are the Agents to receive European subscriptions or advertisements for the SCIENTIFIC AMERICAN. Orders sent on them will be promptly attended to.

VOL. XV., No. 24 [NEW SERIES.] Twenty-first Year.

NEW YORK, SATURDAY, DEC. 8, 1866.

Contents :

(Illustrated articles are marked with an asterisk.)

*Shaw and Justice's Dead-stroke Hammer.....	383	Plumbago in Georgia.....	388
Trials of Breach-loading Guns in Vienna.....	383	Russian Railroads and the Keupp Gun.....	388
The Oil Wells of Canada.....	384	New Inventions.....	388
Silver Plating.....	384	Notes and Queries.....	389
American Institute—Poly-technic Branch.....	385	Zillier's Patent Screw Plate.....	390
A Self-adjusting Telegraph Instrument Wanted.....	385	*Abbot's Flux Breaker and Dresser.....	390
Circular Skids.....	385	The Action of Acids on Steel.....	390
Manufacture and Combustion of Peat.....	386	Practical Hints.....	390
*Thomas's Patent Tube Cutter.....	386	Important to Advertisers.....	391
The Tricentennial Meteoric Shower.....	386	The Paris Exhibition Building.....	391
Utilization of Waste Substances.....	387	Modern Medicine.....	391
Manufacture of Pure Acetic Acid and Acetates from Empyreumatic Wood Vinegar.....	387	The Steam Ferries of New York.....	391
Coloring Ivory.....	387	Southern Fair.....	392
Dyeing of Horn.....	388	Patent Claims, 392, 393, 394, 395.....	392
Changes in Steel by Friction and Heat.....	388	Advertisements.....	397, 398, 399
		*Stillwell's Stove Tones.....	400
		*Scott's Fastening for Wagon Bows.....	400
		*Spencer's Churn Dasher.....	400
		Prospectus.....	400

IMPORTANT TO ADVERTISERS.

With the enlargement of the SCIENTIFIC AMERICAN on the 1st of January next, it is our purpose to issue an edition of about fifty thousand copies of the first number of the new volume. We intend also to devote a portion of the back outside page to advertisements, for which seventy-five cents per line will be charged. Those who may wish to avail themselves of this rare opportunity to publish their advertisements will do well to correspond with the publishers as early as possible. We can admit but few. First come first served.

THE PARIS EXHIBITION BUILDING.

From the variety of descriptions which have reached us, we condense the following outline of the enormous preparations made by the French Emperor, in the Champs de Mars, for the approaching "World's Congress" of arts, products, and manners.

The monster building is of an oblong form, with rounded corners, coliseum-like, and covers forty acres. It consists, in fact, of eight hollow elliptical structures, one within another, "wheel within wheel," connected by galleries and corridors, and united by one vast iron roof, stretching over all. The inmost area, at the center, is a magnificent garden of trees, flowers, shrubbery, pools, fountains, cascades, statuary, and illustrations of the architecture of all nations, in the form of bowers, cloisters, offices, etc. It has a suspended roof of iron and glass, and occupies an acre and a quarter of ground. The trees in this space—where, six months ago, there was not a green thing—have been transplanted at full size, and the total number here and elsewhere in the grounds, thus transplanted, is eight thousand.

Sixty grand arches open into this garden from the main building around. Between them, and opening likewise into the garden, are located all the *cafés* or refreshment rooms, distributed in the divisions proper to their respective nationalities, and will each present the indigenous articles of food, in the characteristic styles, of their several countries.

The interior area is, of course, open to the lofty roof; likewise the outermost of the eight elliptical structures enveloping it. Two grand transverse ave-

nues—extending to the roof, but not continued across the central garden—divide the whole pile into four quadrant-shaped sections. Twelve intermediate avenues, radiating in like manner from the center, three in each section, again subdivide the whole into sixteen grand national departments, each covering about two and a half acres. Passing from the center, outward, through any of these avenues, the visitor will inspect thirteen successive departments of the civilization of that nationality assigned to either side of the avenue; the first being that of the fine arts, and the second a museum of the history of labor, from the rudest ages. Following any of the elliptical corridors around the building, he will see a single aspect of civilization, as presented in diverse forms and stages by each of the sixteen nationalities, in succession.

Light, ventilation, warming, cleansing, drainage, etc., are munificently provided. For example, the great gallery for machinery is said to be lighted on each side by 260 windows, 520 in all; each of which is about 23 feet high, and 13 feet wide. The underground galleries beneath all parts of the structure, for the various kinds of service and communication, are over three miles in length; the length of drainage is five miles. Air is to be introduced and distributed by means of immense steam pumps.

But the cost of this work is, perhaps, the most impressive illustration of its vastness. The edifice, it is said, will cost \$16,000,000, and the transformation of the grounds \$6,400,000 more. It is built entirely of iron and glass, except the two inner structures, and the grand portal, which are of masonry. Six thousand workmen have wrought on the iron, two thousand five hundred masons on the foundations, fifteen thousand laborers on the grounds, and eleven hundred carters and teamsters, with twenty-eight hundred horses, have conveyed the materials brought in or removed; an army of nearly twenty-five thousand men. And with all this inconceivable force, perhaps the greatest marvel is that it has been so ably handled as to complete the work (so it promises to do) within one year from its commencement, and within eighteen months from the examination of the plans. Of all the trophies of human skill to be exhibited there, the French will be able to point to this dazzling creation with the highest pride.

MODERN MEDICINE.

Professor Paine, of Philadelphia, has recently issued from the press of the University Publishing Society, of that city, a new volume of 950 pages, devoted to the principles and practice of medicine and pathology—a comprehensive and valuable work, based upon observations and experience of twenty-five years' extensive practice. The work embraces modern investigations into the nature and cause of disease, and the improved methods of treatment by recently-discovered therapeutic agents, forming a text book for the student and the profession.

In his introduction, the author slashes into what he denominates the "Old School Practice," a system that condemns everything opposed to the prejudices and inherited opinions of its supporters and advocates. Some old doctors denounce all progress in medicine—they must find a warrant for everything in the doctor-books of olden time, and all new theories and methods of practice are scouted as imposture and quackery. This heathen system of medical priesthood, the author declares, is going out of the old temples consecrated to *Æsculapius*, together with bleeding, blistering, mercury, antimony, and other prominent therapeutic agencies, and bigotry gives way to new, living, theories, and practice. The author condemns blood-letting as a "murderous practice," which declaration calls to mind our friend, the late Dr. Turner, who, with his chrono-thermal system, years ago, led the opposition of regulars in this city against the practice of bleeding, but he died long before he had secured so able a champion of his cause as Prof. Paine. The author of this new treatise also thrusts his scalpel into the epidermis of Homeopathy, and criticises some of the notions put forth by Dr. Jahr, in his manual; for example, that "pulsatilla will cure despair of eternal happiness, with continued prayer and devout aspects." In other words, the *Materia Medica* is made to supply despairing souls with relief from spiritual depression, which the Scriptures and theologians declare

an only be met and satisfied by the divine Spirit Jahr was probably a German idealist, and had more faith in a thin dilution of pasque-flowers, than he had in the divine agency. We cannot look for impartial criticisms in the writing of any school of medicine. Prejudice governs the minds of learned doctors quite as much as it does the leaders of other professions, but mere slaps at the vagaries of Homeopathy do not make the system impotent in the treatment of disease. On the contrary it seems to have gained, step by step, a high rank, and thousands seem to be satisfied with it in preference to other systems. It boasts of its colleges, dispensaries, hospitals, journals, practitioners, and clients, and occupies, in point of numbers, a position second only to the Allopathic school. Prof. Paine belongs evidently to the school of Eclectics, which, like old Potamon, professes to select whatever was good and true from all other systems.

We do not propose to judge between the claims of these rival systems, but we insist that when doctors come to deal with the afflicted bodies of man, and when death stands just outside the door, waiting to claim its victim, it will not do for them to argue with the suffering one the special merits or demerits of different systems of treatment. The patient is entitled to the best known remedy to cure his disease, and any physician that ignores it is unfit to enter the sick chamber.

Dr. John Brown, in his "Horæ Subsecivæ," mentions that some years ago a dyspeptic patient in a state of despair called upon his physician, who advised plain food, making a thorough change, and ended by writing a prescription for some tonic, saying, "Take that, and come back in a fortnight." Ten days afterward the patient returned quite well, blooming, and happy. The doctor was proud of his skill, and asked to see what he had given. The patient replied that he had taken it; "ate the prescription, sir, as you told me." The author adds, "I once told this little story to a Homeopathic friend, adding, 'Perhaps you think the iron in the ink may be credited with the cure?' 'Well,' said my much-believing friend, 'there is no saying; perhaps it may have contributed to the cure.'" A good illustration this of the importance of diet, and of the Homeopath's credulity in the matter of infinitesimal doses. A good illustration, too, of this important principle of therapeutics, that to discover and then to avoid the cause of a disease is a better and a more successful practice than to prescribe remedies for symptoms.

THE STEAM FERRIES OF NEW YORK.

The recent destruction of a New York and Brooklyn ferry boat by fire, at the very beginning of her short trip, with the demonstrated impossibility of escape for most of the passengers on a crowded boat, in such a case, has directed attention to the vast amount of ferry transportation, and to the insecure and reckless manner in which it is carried on. It seems to be taken for granted that a steamboat within a few rods of the shore, as these boats always are, may be got to land in every emergency, by a fair degree of coolness, skill, and courage, in the pilot and engineer. It would seem that this might have been done in the case of the *Idaho*, if the pilot and engineer had stood to their posts but a minute or two, after the danger was realized. But courage and presence of mind in these stations can be secured by no inspection laws. The case of the *Idaho* proves that no reliance can be placed on the proximity of the shore, when a burning or sinking boat may be instantly deserted to drift with the tide. Nothing remains but to insist on a life-preserver just over every passenger's head. How badly the numerous ferries of the metropolitan district are furnished, in this respect, one of our daily cotemporaries has been at the pains to show.

The ferries are no less than 25 in number, and the steamboats in daily use number 61; carrying an estimated average of 208,000 passengers per day, beside thousands of carriages and heavily-laden carts and trucks. The chief concern is the Union Ferry Company to Brooklyn, running four ferries and thirteen boats, and doing nearly as much business as all the others combined. It carries 95,000 passengers per day, and perhaps a dozen life-preservers to each boat, well out of reach. The boats are among the

best of their kind in existence, but the fearful jam of passengers every evening at dusk creates a constant peril, which nothing short of doubling their boats at those hours will remedy. This should be imperatively required. They carry nearly 7,000 per boat, or 25 per cent. more than any other line, and more than twice the average.

Next is the New York and Brooklyn Company, carrying 60,000 passengers, on 11 boats, to the eastern part of Brooklyn. This is the company that lost the *Idaho*. The complaints against its management are chronic, universal, and bitter. No life-preservers reported discoverable.

Seven minor ferries continue the communication of the city with the Long Island shore, eastwardly. These are: the Jackson street ferry to Brooklyn, 2 boats, and 2,000 passengers; Houston street ferry to Brooklyn, Eastern District, formerly Williamsburgh, 3 boats, and 3,000 passengers; Tenth street ferry to Greenpoint, 2 boats, and 2,000 passengers; Twenty-third street ferry to Greenpoint, 1 boat, and 1,000 passengers; James street and Ninety-fourth street lines to Hunter's Point, in connection with the Long Island Railroad, 4 boats, and 3,000 passengers; Sixty-first street ferry to Astoria, 1 boat, and 200 passengers; and the line to Flushing and Harlem, 2 boats, and 2,000 passengers. Of these, the Houston street line is highly spoken of; the boats are supplied with cork life-preservers, and life-ladders. The Flushing and Hunter's Point lines are well conducted.

The Staten Island ferry, west side, has 3 boats, and carries 5,000 passengers, just as it pleases, without life-preservers or common civilities. The north side ferry runs two boats, and 1,500 passengers, in a rather shabby way.

There are four ferries to the New Jersey shore. The chief of these is the New Jersey Ferry Company, with 6 boats, carrying 30,000 passengers per day, from the foot of Cortlandt and Desbrosses streets, to Jersey City. The life-preservers are not visible, but the passengers are kept off the boat by a strong gate, until there is a chance for them to get on safely, and a man is stationed to prevent people from jumping after the boat when it has left. Next is the Hoboken ferry, from Barclay and Christopher streets, 5 boats, and 20,000 passengers per day, well provided with life-boats and life-preservers, within easy reach of the passengers, and with the same arrangements for restraint and protection as the New Jersey Company. Of the New Jersey Central Railroad ferry the same praise is given. Their two boats are the largest in the harbor, and models in every way. The Weehawken ferry, from Forty-second street, runs one boat, and carries daily 1,000 passengers, and many cattle.

Southern Fair.

The first Louisiana Agricultural and Mechanical Fair, just held in New Orleans, is at once a feature and a force in the new era of the South. It has been a brilliant success, and is asserted to have already given a visible impulse to the new spirit of improvement and economy in plantation and domestic management. Mowers, reapers, improved cooking stoves, and other labor-saving and waste-saving implements, now come in for premiums instead of contempt. A remarkable fact developed by the awards at New Orleans, is that the best pianos in this country are made in St. Louis, and the second best in New Orleans. The New York and Boston makers competed in vain for the prize. Preparations are already begun for another fair next November, and to erect permanent buildings for the purpose. The *Picayune* mentions a man who came down the river 150 miles in a skiff, with a basket of vegetables to exhibit, and seemed fuller of enthusiasm for the success of the fair than many who had much more at stake. Over 30,000 people were present at the opening.

THE Selma (Ala.) *Messenger*, states that a comet of considerable brilliancy, was observed on the night of the 10th inst., in the northwest, at an elevation of about 30 degrees above the horizon.

THE great desert of Sahara is in process of transformation into a garden. Every day new oases are produced by the multiplication of artesian wells which supply vast quantities of water.



ISSUED FROM THE U. S. PATENT OFFICE

FOR THE WEEK ENDING NOV. 27, 1866.

Reported Officially for the Scientific American.

Pamphlets containing the Patent Laws and full particulars of the mode of applying for Letters Patent, specifying size of model required, and much other information useful to inventors, may be had gratis by addressing MUNN & Co., Publishers of the SCIENTIFIC AMERICAN, New York.

59,937.—BRIDLE.—George H. Albright and William R. Burns, Lancaster, Pa.

We claim the construction and combination of the gag reins, c c', face pieces, A, passing over the horse's head, one branch thereof connected to the bit by the cased spring, F, when the united branches arise from the single bit, and unitedly connected with an ordinary line and bridle, in the manner and for the purpose specified.

59,938.—PAPER COLLARS AND CUFFS AND THE MANUFACTURE THEREOF.—David A. Alden, Roxbury, Mass.

First, I claim the method herein described of manufacturing flaring paper collars and cuffs, by forming paper directly from the pulp, so corrugated that it may be cut into collars or cuffs with the requisite flare, without subsequent molding, swedging, or stretching, substantially as described.

Second, I also claim, as a new article of manufacture, a flaring paper collar or cuff, in which the flare is produced by the form given to the paper in its manufacture from the pulp, substantially as described.

Third, I also claim, as a new article of manufacture, paper so formed and corrugated in its manufacture from the pulp that it may be cut into flaring collars or cuffs, substantially as described.

59,939.—FAUCET.—Charles E. Allan, Boston, Mass.

I claim an improved combination cock formed by the combination of the plug, B, with the body, A, of the cock, when the passage ways through said plug are formed and arranged substantially in the manner herein shown and described and for the purposes set forth.

59,940.—FORGING APPARATUS.—John Gay Newton Alleyne, Alfreton, England, assignor to Zoheth Sherman Durfee, Pittsburg, Pa.

First, I claim the combination and arrangement of two or more direct-acting steam hammers, each connected with a separate steam cylinder so as to be susceptible of simultaneous, or alternating, or other relative action as may be desired, and also situate relatively to each other so that their strokes converge at a central point at which the iron to be worked is placed, substantially as hereinbefore described.

Second, The combination of two or more horizontal or nearly horizontal direct-action steam hammers, with or without a vertical steam hammer, arranged substantially as hereinbefore described, and connected by links attached to a counter weight for the purpose of producing uniformity of action of the horizontal hammers, and counterbalancing the force of gravity of the vertical hammer, when used in connection therewith.

Third, The combination of two or more horizontal or nearly horizontal direct-action steam hammers, with one vertical or nearly vertical steam hammer, so arranged as to strike a mass of iron placed at the converging point of their stroke, when such horizontal steam hammers are both connected by links, or equivalent device, with the vertical hammer, so as to act alternately therewith and produce regularity and uniformity of action.

Fourth, The use of rollers or wheels, in combination with the hammer blocks of steam hammers, for the purpose of sustaining and guiding in the hammer blocks in their motion in a horizontal or nearly horizontal direction, substantially as hereinbefore described.

59,941.—CHEESE VAT.—Albert G. Bagg, Holland Patent, N. Y.

First, I claim the combination of the pipes, m f J and K, with the vat, P, said pipe and vat being constructed, arranged, combined, and operating substantially as herein described.

Second, The combination of the above with the furnace, A, the heat chamber of said furnace being provided with tiles or bricks, 1 and 2, for the purpose of supporting the bottom of the vat, and distributing the heat evenly through all parts of said heat chamber, as herein described and set forth.

Third, The "fire dog" or grate bar, e, provided with openings, i, when used in connection with a furnace, combined with a cheese vat, as herein described and for the purpose set forth.

59,942.—MANUFACTURE OF SHEET-METAL BOXES.—Alfred Barnes, Williamsburgh, N. Y.

I claim the struck-up flanged sides of the body, A, of the shape herein described for the purpose specified.

59,943.—METHOD OF TEMPERING CLOCK SPRINGS.—Wallace Barnes, Bristol, Conn.

I claim the mode or process in the manufacture of springs for clocks, substantially as described.

59,944.—APPARATUS FOR MAKING PAPER BOXES.—Richard P. Barton, New Haven, Conn.

First, I claim the formation of the recess, F.

Second, The arrangement of the knives, A A A A.

Third, The punches, C C C C, all in combination and constructed for the purposes herein specified.

59,945.—CUSHION AND MATTRESS.—Louis Bauhoef-er, Philadelphia, Pa. Antedated Nov. 3, 1866.

I claim the mattress, A, in combination with the air bag, B, divided into two or more compartments, when the mattress is reduced in thickness in the center, as and for the purpose specified.

59,946.—MEDICINE FOR HOG CHOLERA.—George H. Baugh, Oskaloosa, Iowa.

I claim the compound, substantially as above specified, as a medicine for the cure of hog cholera.

59,947.—STEAM GENERATOR.—F. Baumann, Chicago, Ill.

First, I claim generating steam by the injection of heated water through pipes, c, into a generator, H, in which is placed loose metallic substances, as described.

Second, The combination of a number of heated metallic vessels, with a series of generating pipes, c, and outlet pipes, d, connecting with a common receiver, G, arranged to operate substantially as set forth.

Third, I claim the water jacket, I, arranged in combination with the generators, H, and receivers, G, as shown and described.

Fourth, The combination and arrangement of a receiving and distributing vessel, E, supplied with water from the water jacket, I, with a series of generating vessels, H, all located within the furnace, substantially as set forth.

Fifth, In combination with the heating and distributing vessel, E, generator, H, and receiving vessels, G, I claim the use of a receiving and equalizing chamber, F, arranged to operate substantially as herein described.

Sixth, I claim, in combination with a steam generating furnace, constructed as herein described, the dampers, 1 and 1', arranged to operate as set forth.

59,948.—EXPANDING MANDREL.—Israel Betison, New Britain, Conn.

First, I claim the tapering mandrel, A, flattened on three or more sides, in combination with the segmental wedge, b, fitted on the flattened sides of the mandrel, substantially as and for the purpose described.

Second, I claim the wings, c, provided with screws, d, in combination with the segmental wedges, b, and mandrel, A, constructed and operating substantially as and for the purposes described.

59,949.—BURGLAR ALARM.—Charles A. Blake, Philadelphia, Pa.

I claim the block, A, primer, E, and forked lever, H, or lever, L, when combined and arranged together substantially as and for the purpose described.

59,950.—MACHINE FOR SHARPENING SAWS.—John Borthwick, Philadelphia, Pa.

First, I claim the solid emery ring or rim, of any suitable size, for the purpose of sharpening saws, combined with flange, k, and plate, F, arranged substantially as herein described.

Second, I claim the combination of the hinged re-els, g, constructed as described, with screws, y, y, and bed plate, L, for the purpose as above described.

Third, I claim the combination of the emery ring with the rest, screws, and bed plate, as herein described and set forth.

59,951.—SAW.—Alfred Boynton, Wright Township, Mich., assignor to Eben M. Boynton, Grand Rapids, Mich.

I claim a saw, provided with the teeth, No. 1, and the cleaner teeth, No. 2, arranged and constructed to operate substantially as shown and described.

59,952.—STEAM GENERATOR.—William Branagan, Burlington, Iowa.

I claim the construction of a steam boiler of an elliptical outer shell, A, an elliptical inner shell, B, horizontal transverse communications, g, and a removable portion or portions, G, on the side or sides of the outer shell, all arranged substantially as described and for the purpose set forth.

59,953.—TRAPPING WILD FOWL.—Abel Brear, Saugatuck, Conn.

First, I claim the combination to form a game trap of supports and stretchers, constructed, arranged, and operating substantially as herein specified.

Second, I claim the combination with such trap of a net, D, one or more, substantially as and for the purpose specified.

59,954.—COMBINED COAL HOD AND SIFTER.—Benjamin F. Brown, Portland, Me.

I claim the combination with a hod of the form described, of the sifter, constructed and set forth as and for the purpose specified.

59,955.—SEPARATING GOLD AND SILVER FROM ORES.—Edmund Brown, Chicago, Ill. Antedated October 20, 1866.

First, I claim the application of compressed air for forcing the quartz down into the lead.

Second, I claim the tubes, D D, running down the outside of the kettle, allowing the quartz to become thoroughly heated and disintegrated, the whole combined and arranged for the purpose specified.

59,956.—CENTRIFUGAL MACHINE FOR DRAINING SUGAR.—J. R. Brown, Winchester, Ind.

First, I claim the revolving separator, H, when constructed in the form of the frustum of a cone inverted, and having its outwardly-inclined sides formed of wire gauze or woven wire, and a foraminated plate, so substantially as and for the purpose set forth.

Second, I claim the combination of the distributor, F, E, shaft, D, and separator, H, when respectively constructed and arranged substantially as and for the purpose set forth.

Third, I claim the combination and arrangement of the tray, B, partition, C, outwardly-flaring separator, H, and cover, S, arranged to act as a deflector, substantially as set forth.

59,957.—MACHINE FOR CUTTING AND RE-ENFORCING BUTTON-HOLES.—John T. Bruen and G. M. Jacobs, New York City, assignor to G. M. Jacobs.

First, We claim the suspended die plate, D, in combination with the punches, v w, and main die plate, C, constructed and operating substantially as and for the purpose described.

Second, We claim the feeding toes, a, in combination with the die plates, D B, and punches, v w, constructed and operating substantially as and for the purpose set forth.

Third, We claim the hinged dogs, l, arm, f, and pitman rods, g, in combination with the feeding toes, a, and die plates, B D, constructed and operating substantially as and for the purpose set forth.

Fourth, We claim the pusher bars, b', in combination with the die plates, B D, constructed and operating substantially as and for the purpose described.

Fifth, We claim the hinged dogs, e', and stops, g', in combination with the pusher bars, b', cross head, b, and die plates, B D, constructed and operating substantially as and for the purpose set forth.

Sixth, We claim the roller, c', and apron, d', in combination with the die plates, B D, constructed and operating substantially as and for the purpose described.

59,958.—TURNING AND PLANING TOOL.—Charles W. Burdick, Norwich, Conn.

I claim the combination of the holder, A, shoe, C, cutter, B, and screw, D, when the said holder and shoe are constructed and arranged substantially as herein described and for the purposes set forth.

59,959.—ORNAMENTING PIANOFORTE COVERS, ETC.—J. F. Burgess, Brooklyn, N. Y.

First, I claim applying to india-rubber cloth, or such cloth, having a flocked surface, ornamental figures or designs, in the manner and for the purpose substantially as described.

Second, I claim a pianoforte or table cover composed of an india-rubber cloth or such cloth, with flocked surface, having ornamental figures or designs placed thereon, either in block or bronze or both, substantially as described.

59,960.—ROCK-DRILLING MACHINE.—Charles Burleigh, Fitchburg, Mass.

I claim the annular projection, M, upon the piston bar, E, or an attachment thereto, for the purpose of operating the valve and feeding device of either of them, substantially as set forth.

Second, The stationary rotating device when operated by the movement of the piston bar, substantially as shown and described.

Third, The hollow valve, K, with its chest, L, arranged to operate in line with the axis of the cylinder, substantially as described.

Fourth, The cap, D, consisting of the box, c, and pieces, A and B', constructed and operating substantially as described, in combination with the slide or drill frame, B.

59,961.—SPRING WAGON.—Joseph N. Byington, Stockton, Minn.

I claim, First, Hinging the springs, F, to the bottom, D, of the wagon, and connecting them to the side of the bolsters, A and B, in such a manner that when not in use they may be turned up out of the way, substantially as herein described and for the purpose set forth.

Second, The combination and arrangement of the springs, F, cross bars, G, links, I, bolts, J, and catches, H, with each other, and with the bottom, D, and bolsters, A and B, of the wagon, substantially as herein described and for the purpose set forth.

59,962.—STOP MOTION FOR LOOMS.—Alexander Carnichel and William Barrey (assignors to themselves, Cottrell and Babcock), Westley, R. I.

We claim, First, The combination with a loom of a be-t-shifting motion and positive stop arranged for joint operation, substantially as and for the purpose herein specified.

Second, Arranging a positive stop in such combination that it shall act against the lay of the loom, substantially as and for the purpose herein specified.

Third, The within-described arrangement of such positive stop in combination as specified, in sight and within convenient reach

of the operator, and providing it with a handle, K3, or its equivalent, so that it may be more easily placed by hand in such a position as to allow the loom to be opened freely by hand, all substantially as and for the purpose specified.

59,963.—FEED MOTION FOR DRILLS.—G. F. Case, New York City.

I claim the sleeve, B, which carries the worm, f, and cam wheel, g, in combination with the feed screw, A, nut, D, and worm wheel, h, all constructed and operating substantially as and for the purpose described.

59,964.—ASH SIFTER.—Paul Ceredo (assignor to himself and James H. Springler), Montreal, C. E.

I claim the arrangement of the screen box, B, cam, E, spring, G, spouts, I, J, constructed and operating in the manner and for the purpose herein specified.

59,965.—REINS FOR HORSES.—George T. Chapman, New York City.

I claim the combination of the elastic reins, above described, with the auxiliary reins and with the curb gag and check reins, as constructed and arranged for the purpose described and set forth.

59,966.—PLANING MACHINE.—Henry Climer and John D. Riley, Cincinnati, Ohio.

We claim the two beds, C, C', to receive the material to be planed, operating substantially in the manner and for the purpose set forth.

59,967.—TREE PROTECTOR.—Francis Clymer, Gallion, Ohio.

I claim the cap, A, stake, E, slats, C, and braces, D, in combination with the thatch, K, as and for the purpose set forth.

59,968.—PORTABLE FIRE GRATE AND ANDIRON.—John H. Coate, West Milton, Ohio.

First, I claim the combination of the back plate, L, the side bars, A and B, foot, E, cross bars, F, H, G, C, and part, d2, of the bar, D, with each other, substantially as described and for the purpose set forth.

Second, The combination of the side grates, J and K, cross bars, I, and bar, D, with the back plate, L, side bars, A and B, foot, E, and cross bars, F, H, G, C, substantially as described and for the purpose set forth.

59,969.—CAPSTAN AND WINDLASS.—D. N. B. Coffin, Jr. (assignor to himself and J. D. Spaulding), Boston, Mass.

I claim, first, The employment of the shaft, b, extended from the capstan, in combination with the shafts, d or e, with suitable gears, a, u, f, s and t, substantially as described.

Second, Locking the fulcrum gear of a capstan to the bed plate by means of bolts movable upward from beneath into contact therewith, substantially as described.

Third, The employment of a series of inclines movable in a circle and so applied in combination with the fulcrum gear of a capstan as to lift a d gear from its position of inaction to the proper position to be acted on by gears playing into it, substantially as described.

Fourth, Fastening the cover of a capstan by means of lugs, v, in combination with sockets or grooves in the hub, substantially as described.

Fifth, The arrangement of the cover fastenings in relation to the locking mechanism of the capstan, so that when the cover is rotated to a stop in one direction the bolts will be adjusted for the simple power, and the cover fastened, and when rotated in the opposite direction to a stop the cover will also be fastened and the bolts adjusted for the multiplied power, while in an intermediate position the cover is unfastened and may be removed, substantially as described.

Sixth, Suspending the fulcrum gear to the rotating body of the capstan.

Seventh, The arrangement of the gears, A, Z, pawl wheel, F, barrel, I, friction, L, and chain wheel, P, and the points of disconnection, whereby both barrel, I, and chain wheel, P, are brought under control of the friction mechanism and yet used separately for winding, heaving in, etc., substantially as described.

Eighth, The windlass shaft, N, in combination with the friction band and barrel of a windlass, substantially as described.

Ninth, The partly-circular heads and sockets in combination with the pawls of the windlass, substantially as described.

Tenth, I claim finally a groove formed under the projecting part of a capstan base, substantially as and for the purpose set forth.

59,970.—ATTACHING SHAFTS TO SLEIGHS AND CARRIAGES.—George Coffin, Boston, Mass.

I claim the combination of the wedge-shaped keys, C, and rods, D, with the parts, A and B, of the shafts when said parts are constructed with tenons and sockets, substantially in the manner herein described and for the purpose set forth.

59,971.—HEAT-RADIATING ATTACHMENT TO STOVEPIPES.—Nathaniel E. Cornwall, New York City.

I claim, first, The convex-concave or crescent-shaped pipe, c, arranged and combined with the chambers, b and c, and the pipes, d d d, in the manner and for the purposes set forth.

Second, In connection with the pipe, c, the close chamber, j, constructed substantially as described and for the purposes shown.

Third, The chambers, b and e, connected by pipes, d d d, etc., together with the close chamber, j, constructed and arranged to operate in connection with a stovepipe, in the manner described.

59,972.—HARNES MOTION FOR LOOMS.—George Crompton, Worcester, Mass.

I claim the provision for simultaneous and equal adjustment of all the sheaves of either set, by mounting them in a swinging frame which is controlled and moved by an adjusting screw or other equivalent device, substantially as set forth.

Also, the construction and arrangement as shown and described of the parts by which the heddles are operated to produce the shed.

59,973.—SPINNING MACHINE.—Joseph Crowfoot, Worcester, Mass., assignor to himself, Johathan Gill, Fitchburg, Thomas Gill, Springfield, and Wm. Gill, Cambridge, Mass.

I claim the machine, substantially as described, by which the silver not only can be drawn and twisted but have the twist varied, by means as set forth, or their equivalent.

59,974.—TABLE-LEAF SUPPORT.—Alpheus Cutler, Pittston, Penn.

I claim an adjustable extension leg, or table-leaf supporter, constructed as described and operating as set forth.

59,975.—METHOD OF PREPARING COLORING MATTER FOR BUTTER.—Daniel W. Dake, Brooklyn, N. Y.

I claim, first, The method or process herein described of preparing coloring matter for butter, consisting of pure oil of butter and the coloring matter of anotta, combined as herein described.

Second, I claim as a new composition of matter for coloring butter, pure oil of butter and the coloring matter of anotta, prepared and combined substantially as described.

59,976.—OIL CUP.—Charles F. Davis, New Market, N. H., assignor to J. L. Norris and G. R. Neal, South New Market.

I claim the combination and arrangement of the said insulator with the oil feeder, A, the valve, C, and the valve-operating apparatus, substantially as described.

59,977.—BROOM CLAMP.—Justus Day, Murray, N. Y.

I claim the levers, A and B, in combination with the connecting links or straps, C C', the slots, D D', the chamfered semicircular

notches, E E and F F, the wide notches, K K, the clasp, H, and the rods, G G, operating for the purpose and in the manner specified.

59,978.—MANUFACTURE OF SUPERPHOSPHATE OF LIME.—A. de Figaniere, Philadelphia, Pa.

I claim, first, Making superphosphate of lime by bringing the powdered guano or other suitable fertilizing material in contact with a surface covered or dampened with sulphuric acid, substantially as herein described.

Second, An apparatus for incorporating sulphuric acid with powdered guano, or other suitable fertilizer, formed by the combination of the acid tank, A, the cylinder, C, the hopper, E, and the scraper, F, with each other, substantially as herein shown and described.

59,979.—SURFACE FOR WASHING MACHINE.—George M. Denison, New London, Conn.

I claim the construction of a ribbed or corrugated washing surface of sheet india-rubber folded over the edges of and clamped between strips, i, substantially in the manner herein set forth.

59,980.—ANIMAL TRAP.—S F. Dimock, Spencer, Ohio.

I claim the box, A, door, I, link, J, and tin door, K, as arranged in combination with the pedal, E, in the manner and for the purpose as substantially set forth.

59,981.—ATTACHING LOCKS TO SAFES, VAULTS, ETC.—Thomas Dolan, Albany, N. Y.

I claim a locking mechanism for safes, vaults, etc., consisting of a lock, A, and notched sliding bar, C, applied to the door frame and doors or catch, D, applied to the door, all constructed, arranged, and operating substantially as and for the purpose herein set forth.

59,982.—PIPE COUPLING.—Edward Duffee (assignor to himself and George Appleton), Haverhill, Mass.

I claim the new or improved pipe joint, consisting of the opening, d, and the auxiliary flange, a, the main flange, f, and the socket head, c, arranged and applied to the pipes, A and B, as set forth.

59,983.—SEWING-MACHINE GAGE FOR TUCKING, FELLING, BINDING, ETC.—Mary A. Duffy, New York City.

I claim, first, The several devices of plate holder, B, tucking plate, A, folding plate, E, and tucking gage, D, or their equivalents, in combination with the presser foot of a sewing machine for the purpose of folding and marking or creasing a tuck, substantially as explained.

Second, The combination of plate holder, B, tucking plate, A, felling plate, F, and felling guide, G, or their equivalents, constructed and operating together substantially as and for the various purposes described.

Third, The combination of plate holder, B, with felling plate, F, constructed substantially as and for the purposes described.

59,984.—TOOL FOR SETTING TEMPLE TEETH.—Warren W. Dutcher, Milford, Mass.

I claim the rotary temple tooth setting tool made substantially in the manner and so as to operate as and for the purpose hereinbefore specified.

59,985.—BUTTER WORKER.—Reuben R. Eastman, Granby, Mass.

I claim, first, In a butter press, the combination of the roller, C, and plate, G, with teeth to mesh, substantially as and for the purpose set forth.

Second, The trough, A, in combination with the roller, C, and plate, G, substantially as described.

59,986.—COMPOSITION FOR DESTROYING INSECTS ON TREES AND PLANTS.—Joseph A. Elias, Le Roy, Ohio.

I claim the compositions, Nos. 1 and 2, herein described, consisting of the several ingredients in or about the proportions stated, and applied in the manner as herein specified, and for the purposes set forth.

59,987.—LOOM.—Henry A. Ellis (assignor to himself and Pequot Machine Company), Mystic River, Conn.

I claim the construction of the lever, C, with a slot, d, pin, h, and screw hooks, r, substantially as and for the purposes set forth.

Second, The combination of the slots, d, in levers, C, with the slots, i, in the outer rims of the cams, E, substantially as described.

59,988.—LOZENGE.—Frederick Ernst, New York City.

I claim the deodorizing lozenges as a new article of manufacture, consisting of the ingredients described, for the purpose set forth.

59,989.—GRAIN DRYER.—John R. Everton, Mount Vernon, Ind.

First, I claim the oscillating slide or pan, B, constructed as described in combination with the furnace, A, and with the frame, G, substantially as and for the purpose set forth.

Second, The combination of the cover, F, and hopper, D, constructed as herein described with the slide or pan, B, substantially as and for the purpose set forth.

Third, The combination and arrangement of the discharging spout, E, with the slide or pan, B, substantially as described and for the purpose set forth.

59,990.—POST DRIVER.—D. D. Foley, Washington, D. C.

I claim the fence-post driver composed of a cap, A, and sides, B, substantially as and for the purpose set forth.

59,991.—APPARATUS FOR CARBURETING AIR.—Theodore F. Frank, Buffalo, N. Y.

I claim the combination of the two air-supplying reservoirs, operating alternately and provided with valves, b and f, and pipes, e, with the series of carbureting vessels, D D1 D2, or equivalent, substantially as and for the purpose set forth.

I also claim arranging the series of carbureting vessels, D D1 D2, on different planes and connecting them by suitable pipes and stop cocks, y, z, substantially in the manner and for the purpose specified.

I also claim, in combination with the carbureting vessel, D, the perforated air-discharge pipe, u, provided with stem, v, stuffing, w, and flexible pipe, t, for adjusting the former, substantially as and for the purpose set forth.

I also claim the combination of the air-supplying apparatus and the carbureting apparatus, both constructed as described, with the regulator, b, the whole arranged and operating as described.

59,992.—CURRY COMB.—Francis N. Frost, New Britain, Conn. Antedated Nov. 15, 1866.

I claim in curry combs made of thin plate steel as described, the shank, c, of malleable cast iron and made in the form shown, so as to bear with equal force laterally across the entire breadth of the comb, substantially as described.

59,993.—COOLER FOR PRESERVING BUTTER, MILK AND OTHER ARTICLES.—William Garrard, Fallston, Pa. Antedated Nov. 23, 1866.

I claim a cooler made of any kind of unglazed pottery ware of any size or shape, and so constructed that the articles to be kept cool in a vessel entirely surrounded by water, and thereto air tight and made to combine all the advantages of a more perfect evaporator for the purposes intended as is herein substantially described and set forth.

59,994.—SAWING MACHINE.—P. A. Gerry, Dover, Me.

First, I claim clamping the wood by means of the lever, E,

operating with the arm, O, roller, N, arms, T, and swinging arm, U, arranged and operating as herein specified and described.

Second, Raising and lowering the saw by means of the lever, R, arm, O, roller, N, arm, V, spring, W, and slide box, X, with its guide arm, Y, substantially in the manner and for the purpose represented and described.

59,995.—SPECTACLES.—Samuel Gregg, Boston, Mass.

I claim constructing glasses of spectacles where two distinct lenses or segments of lenses are contained in one glass adapted for seeing near and distant objects, in such manner that the upper edge of the convex lens is adapted for seeing near objects, shall be concentric with the upper edge of the lens adapted for seeing distant objects for the purpose of enlarging the field of vision for the latter lens.

59,996.—BRIDLE.—Michael Haberbusch and Edward Kreckel, Lancaster, Pa.

First, We claim the construction and combination of a tubulated snap hook, C, gum within a sheath, D, formed by the end of a continuous strap, both united and held by a socked head and ring, E, jointly passed through the rings of the bit so that the enclosed gum with its sheath will look into the said ring of the bit in the manner and for the purpose specified.

We also claim the face pieces, G, G', attached to the rings of the bit and severally passed upward through their respective loops, H, I, and forming the throat latch, K, with its biting ring, L, all combined and arranged in the manner specified for the purpose set forth.

59,997.—SEWING MACHINE.—Thomas Hall, Bergen, N. J., assignor to Geo. B. Buell, New York City. Antedated Nov. 23, 1866.

I claim cutting away a portion of the cloth table of a sewing machine or depressing a furrow therein to admit of sewing buckles or other articles upon garments or fabrics, substantially as described.

59,998.—APPARATUS FOR DRYING LUMBER.—James W. Hanna, Wash, Ind., assignor to himself and James H. Osgood, Jr.

First, I claim the combined process of steaming and drying lumber, substantially as herein described and for the purpose set forth.

Second, The combination and arrangement with the kiln of the pipe or pipes, C, for admitting the exhaust steam, the pipe or pipes, E, for admitting the blast of air, and the pipe, F, for introducing the live steam, substantially as herein described and for the purpose set forth.

59,999.—PESSEAIRES.—E. B. Harding, M. D., Northampton, Mass.

First, I claim a pessary constructed with loops, g, h, arranged substantially as and for the purpose set forth.

Second, In combination with a pessary so constructed the levers, A, B, arranged and operating substantially as set forth.

Third, The instrument shown in fig. 6, when constructed and operated in the manner and for the purpose substantially as set forth.

60,000.—EYELETING MACHINE.—Philander Harlow, Hudson, Mass.

First, I claim the combination with the setting die of an eyeletting machine of an eyelet-receiving rod and surrounding sheath or die plate, and mechanism for actuating the same under the arrangement and for operation as herein described, so that the said receiver rod shall constitute the means whereby the eyelet is adjusted to the punch and leather and the leather fed forward to the setting die, substantially as set forth.

Second, In an eyeletting machine, I claim the combination with the eyelet receiver rod, and a rounding sheath or die plate, as described, of the setting die and punch forming the eyelet holes under such an arrangement that by the action of said punch, receiver rod, sheath and setting die, the leather or other material operated on shall be alternately punched, fed forward to the setting die, and stamped with eyelets, substantially as herein shown and described.

Third, In an eyeletting machine as described, I claim the combination with the punch for forming eyelets, of a reciprocating or sliding plate for sustaining the leather under the action of said punch, arranged and operating substantially in the manner and for the purposes set forth.

Fourth, I claim the adjustable presser foot and its actuating mechanism as herein described for producing an intermittent pressure upon the leather or other material operated on by the punch and eyelet-setting die, substantially as and for the purpose set forth.

Fifth, I claim the mechanism for feeding the eyelets as herein described, the same consisting of a hopper and vibrator arm provided with one or more chutes for conducting and holding the eyelets and a wheel or disk in the periphery of which recesses are formed for the reception of the said eyelets, the whole being combined and operating substantially in the manner shown and specified.

Sixth, I claim the combination of the above-described eyelet-feeding mechanism with the eyelet-receiver rod and surrounding sheath, under such an arrangement that by the motion of said vibrating arm the eyelets held in the recessed wheel may be fed to the said receiver rod, substantially as herein shown and described.

Seventh, I claim the combination in an eyeletting machine of mechanism for punching, feeding and holding the material operated on, and for feeding and setting the eyelets to the same, under the arrangement and for operation substantially as herein shown and set forth.

60,001.—METHOD OF EXHIBITING THE GAS OF MINERAL SPRINGS.—J. P. Haskins, Saratoga Springs, N. Y.

I claim the method herein described of exhibiting the gas contained in mineral waters while they are ascending through the same and before reaching the surface.

60,002.—MANUFACTURE OF WROUGHT IRON AND STEEL DIRECT FROM THE ORE.—William Henderson, Glasgow, Scotland.

First, I claim the several improved processes hereinbefore described for manufacturing wrought iron and steel direct from the ores of iron.

Second, The formation of the bottom of the furnace to be used in the working of the above-described processes with the materials and in the manner hereinbefore described.

60,003.—COAL SCUTTLE.—Charles F. Henis, Cincinnati, Ohio.

I claim the coal scuttle constructed with its body, D, fitted upon the shoulder, C, of the corrugated base, B, as and for the purpose set forth.

60,004.—COMB.—Joseph H. Hicks (assignor to himself and George H. Chimcock), Brooklyn, N. Y., assignors to Ignatius Rice, New York City.

I claim a comb having the strip of metal, e, and rivets, i, in combination with each other with the longitudinal groove in the back of the comb, substantially as herein set forth, for the purpose specified.

60,005.—CUT-OFF FOR CISTERN LEADERS.—W. M. Hicks and F. Welker, St. Louis, Mo.

We claim the arrangements herein described for a cut-off for cistern leaders, consisting of a chamber, A, and a revolving and adjustable door, B, set in the side thereof and door being hinged in the middle and when turned down itself serving as a spout, for the purpose and in the manner as described.

60,006.—TANNING.—Alexander Hill, Dubuque, Iowa.

I claim the within mode of treating hides, substantially as specified.

60,007.—PROCESS FOR ORNAMENTS MARBLE.—Asa Hill, Norwich, Conn. Antedated Nov. 14, 1866.

I claim the process of producing figures upon and in marble or other calcareous stones, substantially as herein described.

60,008.—MACHINE FOR CUTTING AND RAKING CORN STALKS.—Thomas M. Hill, and S. D. Tuttle, Eaton, Ohio.

First, We claim the plows and cutters, M M, applied to standards, L, which are secured on the axle, A, of the machine and connected to the sliding thills, E, by chains and rods, I, and connected by chains, m, to the frame, G, all arranged to operate substantially in the manner as and for the purpose herein set forth.

Second, The rake, J, attached to the levers, H H, and connected to the frame, G, by springs, f, f, in combination with the plows and cutters, M M, all arranged substantially as and for the purpose specified.

60,009.—CRUMB REMOVER.—Amelia B. Hoffman, Roxbury, Mass.

I claim the combination of a fan or receiver, A, with a blade or scraper, B, in the manner and for the purpose described.

60,010.—MACHINE FOR MAKING HOOP SKIRTS.—E. R. Hopkins, New York City.

First, I claim a machine in and by which a series of springs such as a c in number, used for the manufacture of hoop skirts by properly feeding them to the machine, can be respectively, but simultaneously, cut to their proper lengths for encircling the frame or other suitable form used for the building or making the skirt upon, substantially as herein described.

Second, Whether combined with the above or not, a marker so arranged as to mark the series of springs whether more or less in number, used for a hoop skirt at such points of their respective lengths as correspond to the points of intersection therewith of the var ou tapes to be used for connecting and binding the series of springs together, substantially as herein described.

Third, The conical or other equivalent shaped feed rollers or drums, B B, so hung and connected together, as to revolve with their surfaces in contact or nearly so with each other and in conjunction, in combination with any suitable knife or cutter blade, when arranged and combined together, substantially in the manner described, and for the purpose specified.

Fourth, In combination with the above, either with or without the knife or cutter blade, of a marker of any suitable form arranged so as to operate substantially in the manner and for the purpose described.

Fifth, The combination with the rollers or drums, B, of the guides, H and I, for the springs passing between the said rollers arranged together, substantially as and for the purpose specified.

Sixth, The raising and lowering the marker, R, used by means of a cam, A, and constructed or formed as to operate upon the marker substantially as described for the purpose set forth.

Seventh, So arranging and connecting the marker used with the driving power or shaft of the machine at the proper times that it will be moved against the springs for the purpose of marking them, and then draw back from the same, substantially as and for the purpose described.

Eighth, The combination with the feed rollers or drums, B B, of any suitable form or frame, such as are now used in the manufacture of hoop skirts or any equivalent for the same, whether a knife or marker or both together are used, when said frame is arranged with regard to the rollers substantially as described and for the purpose specified.

Ninth, A machine in which a series of springs such as are used for the manufacture of hoop skirts can be cut to their respective and proper length according to the portion of the skirt they are to encircle, and mark at such points of their length as are to be intersected by the tapes used for binding and connecting the springs together, and also delivered to and wound about and around any suitable form or frame on which the skirt is to be built or made, when the whole is combined together and arranged so as to operate substantially in the manner described.

Tenth, Providing a frame or form suitable for the manufacture of hoop skirts upon it with a series of spring arms, V, or their equivalents, having studs projecting from them, when such arms with the studs are so arranged as to prevent the hoop skirt when wound upon the form from slipping thereon while at the same time they can be moved or retracted in the manner described.

60,011.—BUNG.—H. Hufendick and E. Spangenberg, St. Louis, Mo.

First, We claim the application of a valve or valves and capillary passages or any equivalent devices to permit the passage of air into a barrel, but prevent the passages of liquor out of the barrel through the bung, substantially as set forth.

Second, The combination of the top plate, B, its projections, b, and recesses, b2, and bottom parts, C and D, and rubber or leather packings, d2, respectively with the upper part of the socket, A, its recesses, a, and projections, a2, shelving, a3, stops, a4, and the lower part of said socket, "a", or their equivalents, as and for the purposes set forth.

Third, The application of the screw, c, and nut, b3, or their equivalents, when operating on the parts described in our second claim, as and for the purposes set forth.

Fourth, The combination of the rider, b4, on B, and the packing, C on C, operated in connection with the pin, c, in the groove, b4, and the screw, c, and nut, b3, to either permit or prevent the passage of air, etc., between the plates, A and C, as set forth.

Fifth, The combination of the plate, C, and holes, c1, valves, c5, nut, d1, plate, D, and rubber or other packing, d2, as and for the purpose set forth.

Sixth, The application of the packing, d2, to produce with the grooves, d1, on D, capillary passages which permit the passage of air, but prevent the passage of fluid "a", as set forth.

Seventh, The application of a key to the parts of our said bung, when operating as and for the purpose set forth.

60,012.—CAR COUPLING.—John H. Kavanagh, Joliet, Ill.

First, I claim the shaft, F, provided with the wing, G, and trip lever, E, connected to the bumper of a car, substantially as herein shown and described and for the purposes set forth.

Second, I claim the lever, H, in combination with the coupling pin, C, substantially as shown and described and for the purposes set forth.

Third, I claim the tube or guide, B, in combination with coupling pin, C, and shaft, F, and trip lever, E, substantially as shown and described.

60,013.—BOILER FLUE BRUSHES.—Robert King, Brooklyn, N. Y., assignor to T. Prosser & Son, N. Y. City.

I claim a helical wire brush in which the wires are arranged to provide unequally from opposite sides of the core or stock, substantially as shown and described.

60,014.—CEMENT PIPE.—Henry Knight, Brooklyn, N. Y.

I claim the combination of a mold, composed of a shell and core, for making a cement article with a pipe by which a heated fluid may be introduced into the hollow portion of such mold for the purpose of heating it, substantially as set forth.

60,015.—SHEEP SHEED.—J. Knupp and H. S. Elliot, New Prospect, Ohio.

We claim the construction and arrangement of a shed, B, in combination with the trough, A, door, L, rail, N, runners, F, for the purpose and in the manner as set forth.

60,016.—CLAMP.—Louis Kutcher, New York City.

I claim attaching the box, F, to the lower part, a, of the fifth wheel, instead of to its upper part, as usual, substantially as and for the purpose set forth.

60,017.—CLAMP LOCK FOR BOOKS, ETC.—Leopold Lall, New York City.

I claim a clamp for books, portfolios, albums, etc., having a lock applied to it and inserted in the binding, substantially as shown and described.

60,018.—WASHING MACHINE.—Jonas J. Humphreys, Panama, N. Y.

I claim the rotating frame, B, provided with one or more rollers, to operate in combination with the rollers, C, B, C, substantially as and for the purposes set forth.

60,019.—HAND SEED PLANTER.—A. T. Large, Tomah, Wis. Antedated Nov. 17, 1866.

I claim the tubes, B, provided with the valves, C C, arranged with the levers, D G, and spring, H, and applied to the handle of a hoe to operate in the manner substantially as and for the purpose herein set forth.

60,020.—FENCE.—Cornelius G. Lazear, Norwalk, Ohio.

First, I claim the panels, A, and posts, D, when respectively constructed as described, and used in combination with the intermediate posts, C, and hooks, C', for securing the panels in position, substantially as set forth.

60,021.—SEWING MACHINE SHUTTLE.—Geo. H. Lender, Richmond, Va.

First, I claim, in rotating shuttles for sewing machines, winding and unwinding the shuttle thread so as to prevent it from being twisted and untwisted during the revolutions of the shuttle, by arranging the bobbin eccentrically to the center of motion of the shuttle, substantially as shown.

60,022.—DIE FOR FORMING THE EYES OF PICK AXES.—H. L. Lowman, New York City.

I claim the combination of a die, A, and punch, B, constructed substantially as described, for simultaneously punching and grinding the points both externally and internally, to the elongated eye of a pick axe, or other tool, with similar elongated eye, the whole operating substantially as set forth.

60,023.—MODE OF HANGING WINDOWS AND DOORS.—G. H. Lupton, Cleveland, Ohio.

First, I claim the link, E, and counterbalance, G, in combination with the rods, D, pins, and window or door, as and for the purpose set forth.

Second, The weather strip, H, groove, c, and sill, M, arranged as set forth, in combination with apparatus for raising the window or door, substantially as set forth.

60,024.—BOOTS AND SHOES.—John C. Mack, Philadelphia, Pa.

First, I claim a boot or shoe having a slit or opening in the center of the upper, in combination with an elastic fabric, extending across said opening, all substantially as and for the purpose described.

Second, In combination with the foregoing, I claim the elastic bands, c, and buttons, d, or their equivalents, the whole being constructed and arranged substantially as and for the purpose specified.

60,025.—DITCHING MACHINE.—J. H. Marshall, Lockport, N. Y., and O. E. Mann, Somerset, N. Y.

First, We claim the triangular lever frame consisting of the parts, K g h, hinged to the frame, A, and connecting with the axis of the wheels, B B, castor wheel, C, scoop, E, in combination with the toothed segment, I, pinion, l, and spring pawl, k, for supporting, raising, and lowering the frame, A, arranged and operating in the manner specified.

Second, We also claim the arrangement of the gearing, d e f, the latter provide l with pawl, n, with the axis, b, ratchet wheel, m, and belt, G, operated by driving wheels, B B, for communicating motion to the endless belt, F, substantially in the manner set forth.

60,026.—HOOK AND EYE.—James B. Martindale, New Castle, Ind.

I claim a hook, formed as described, and an eye having loops, e, and a tongue, d, when respectively constructed and arranged to operate, when combined substantially as and for the purpose set forth.

60,027.—PROCESS OF CURING HOPS.—C. C. Masson, Brookfield, N. Y., assignor to himself and Levi Mason, Clayville, N. Y.

I claim the improvement in the process of curing hops, in the manner and by the means substantially as described.

60,028.—APPARATUS FOR OBTAINING THE MEASURES FOR LADIES' DRESSES.—Curran E. McDonald, Indianapolis, Ind.

I claim the within-described instrument when the same is constructed as aforesaid, in its said several parts, and operated for the purpose and in the manner substantially as set forth.

60,029.—BRICK KILN.—John McDonald, Saratoga Springs, N. Y.

First, I claim the groove or way, G, in the tunnel, A, and the cars, K K, in combination with their running gear, all arranged to operate, substantially as and for the purpose specified.

Second, The combination with the cars, K K, and the supplemental cars, m, tracks, A H I and J, arranged as herein described, and employed to permit the cars to be moved circuitously, in the manner and for the purpose specified.

60,030.—BROOM HEAD.—James C. McLelland and James Graham, Pittsburgh, Pa.

First, We claim forming the lower side edges of the cap, A, double, substantially as herein shown and described, and for the purpose set forth.

Second, The combination of the ring, H, with the cap, A, handle, B, and bolt, C, substantially as herein shown and described, and for the purpose set forth.

60,031.—HAME TUG AND BREAST COLLAR.—A. McMullen, Sterling, Ill.

First, I claim the breast strap, A, made in two parts, a1 and a2, connected by a snap hook and eye, when said parts are constructed in the form and manner substantially as herein shown and described, and for the purpose set forth.

Second, The breast collar, A, in combination with the plates, D and J, and the tug clips, H, substantially as described and for the purposes set forth.

Third, Pivoting the neck strap tugs, K, to the parts a1 and a2, of the collar, A, so that the position of the neck strap on the neck can be changed, when desired, substantially as described and for the purpose set forth.

60,032.—FOOT STOVE.—Melcher Mellinger, Dayton, Ohio.

First, I claim the disk, H, and annular plate, F, provided with the flange, a, and mouth, b, in combination with the air tubes, c, and annular flue, E, constructed, applied, and operating conjointly in the manner and for the purpose specified.

Second, The detachable bottom, A, with its fastening, B, constructed and arranged in combination with the cylindrical body of the stove, so as to form an annular air passage for the lamp, substantially as and for the purposes described.

60,033.—BREACHING HOOK.—George W. Miller, Springfield, Mass.

I claim a breaching hook for the shafts of vehicles, having the spring, C, constructed substantially in the manner and for the purposes described.

60,034.—KNAPSACK.—J. K. Mizner, Detroit, Mich.

First, I claim the straps, D F and H, riveted together and arranged and combined with each other, and with a knapsack, substantially as set forth, for the purpose of affording a reliable support for the weight of a knapsack and its contents.

Second, The manner, as described, of slinging a knapsack by means of straps passing over the shoulders, under the arms, and across the back to meet and connect together, substantially as set forth.

60,035.—CHURN.—Lawrence Mooney, Allegheny City, Pa. and J. S. Greenham, Warren, Pa. Antedated May 14, 1866.

I claim arranging the breakers, e, with relation to the shaft, d, so that they will throw two counter currents of the milk of cream, the reaction of which will clean the milk or cream to flow spirally

ly down and around the shaft, d, and thereby gather the butter as it is formed into two balls or rolls, the whole being constructed, arranged, and operating substantially as herein described and for the purpose set forth.

60,036.—NOZZLE FOR HOSE PIPES.—Robert F. Moore, Manchester, N. H.

I claim, in combination with a hose pipe, or nozzle, a perforated movable cup, made in two parts, and arranged to traverse on the end of a hose pipe, or nozzle, substantially as described, to enable the operator to convert a single stream into a shower or sprinkle, and convert it to a single stream without stopping the flow of water from the nozzle.

60,037.—ROOFING CEMENT.—Solomon B. Moore, Lockport, N. Y.

I claim the combination, and using the materials, as herein specified.

60,038.—BROOM HEAD.—Thomas Moore (assignor to Jackson Hukill), Bloomington, Ill.

I claim the combination of the part, A, with its ears, a2, hooks, D, wires, E, wire F, crescent nut, G, screw, H, socket, A', and handle, C', and keys, I, in the manner as and for the purpose specified.

60,039.—MEDICATED TROCHES.—Caleb H. Needles, Philadelphia, Pa.

I claim the compound camphor troches, prepared substantially as herein set forth and described.

60,040.—MACHINE FOR DRESSING FELLIES OF WAGON WHEELS.—Andrew P. Odholm, Bridgeport, Conn.

First, I claim the slide, D, with adjustable arbor, E, attached, the rotary cutter, D, and the adjustable plate, F, provided with the guide arms, I, arranged so as to rotate as shown, or in any other equivalent way, to admit of being removed or adjusted out of the way of the spokes, by the action of the spokes themselves, in the turning of the wheel, substantially as and for the purpose set forth.

Second, The swinging pendant, K, suspended from the adjustable slide, L, having an arm, I, attached, in connection with the plate, O, on slide, F, and cutter, D, all arranged to operate, substantially in the manner as and for the purpose specified.

60,041.—COMPOSITION FOR MAKING SOAP.—Nelson Orcutt, Binghamton, N. Y.

I claim making soap from untired or unrendered tallow or grease, and the other ingredients named, the ingredients being in the proportions stated.

60,042.—SURFACE CONDENSER.—Frederick Ortleib, Williamsburgh, N. Y.

First, I claim, in hydro-atmospheric condensers, the use of air and water combined, when the same is introduced to the body of the condenser in the form of spray or mist, induced directly downward, in contradistinction to an upward injection, through the condensing tubes, which form said body, substantially as specified.

Second, The combination of the condensing tubes, t, air-discharge pipe, O, and receiving chamber, F, with its delivery pipe, X, said pipes, O and X, being arranged so as to effectually separate the air and water after the same have been injected or passed through the tubes, essentially as herein set forth.

Third, The combination of the upper chamber, H, blast nozzle, or tweezers, T, perforated pipe or pipes, F, and screen, S, with the condensing tubes, t, arranged for action together, substantially as specified.

Fourth, The receiving chamber, F, with its delivery pipe, X, arranged to pass through a stuffing box, W, in combination with the tubes, t, and air pipe, O, suspended from above, essentially as and for the purpose or purposes herein set forth.

Fifth, The combination with devices for producing a spray action of air and water at the top of the condenser and downwardly through the tubes thereof of a water base, B', hollow jacket, A', and circulating pipe, N, substantially as specified.

Sixth, In combination with a surface condenser, the arrangement at or near the top thereof of one or more automatic relief or escape valves, Q, operating essentially as shown and described.

60,043.—APPARATUS FOR DRYING LUMBER.—J. H. Osgood, Boston, Mass., assignor to himself and J. W. Hanna, Wabash, Ind.

I claim the combination of a steam-heating chamber with a hot-air chamber, substantially as and for the purpose set forth.

60,044.—TURNOUT FOR RAILROADS.—Samuel A. Otis, Boston, Mass.

I claim the combination of the device described for turning the car out of the straight line with the fixed points of the dummy switches, as shown and described.

60,045.—SLATE CLEANER.—Abraham W. Overbaugh, New York City.

I claim the plate and tube for moistening the sponge.

60,046.—CORN SHELLER.—Isaac E. Overpeck, Overpeck's Station, Ohio.

I claim the shelling disk, h, and bisected conical tube, c', in combination with discharging spring, m, arranged and operating in the manner and for the purpose specified.

60,047.—ADJUSTABLE SPRING BACK FOR VEHICLES.—Louis E. Page, Pontiac, Mich.

I claim the springs, E E, at the sides, and springs, F F, at the back, when constructed as described and connected to the buggy seat by means of the bar, B, or its equivalent, the plate, G, and azy back, H, in the manner and for the purposes specified.

60,048.—MANUFACTURE OF CUTLERY.—George Parr, Buffalo, N. Y.

I claim a cast metal bolster for cutlery made in two parts, A and B, and having a prong, a', socket, b', and wedge, c, or d for the purpose and substantially as herein described.

60,049.—DEVICE FOR LUBRICATING CARRIAGE AXLES, JOURNALS, ETC.—G. W. Parsons, Harrisburg, Pa.

I claim the screw plug or tube, D, in combination with the plunger, e, with its stem and the cap, F, constructed as and for the purpose herein specified.

60,050.—BRICK MACHINE.—John W. Pease, Belmont, N. Y.

I claim, First, The employment in conjunction with an endless chain of mold boxes, G, of the leveling roller, L, and a pressure roller, N, arranged and operating substantially as described.

Second, The grooved face pressure roller, P, constructed and operating substantially as described for pressing the clay into the mold boxes.

Third, Sustaining the endless chain of mold boxes, G, upon the supporting bars, J and J', by means of offsets, e, on the ends of said boxes, during the filling of the boxes, and also during the discharging of the bricks therefrom.

Fourth, Discharging the bricks from the endless chain of boxes, by means of an inclined plate, K, acting upon the stems, c, of followers, b, substantially as described.

Fifth, Constructing the mold boxes with offsets on their ends which are adapted to form connections for said boxes and also means for sustaining the boxes upon the bars, J, and J', substantially as described.

Sixth, Preventing clay or other substance from getting between mold boxes, which are connected together in the form of a chain, by means of lips, l, substantially as described.

60,051.—BOXES FOR PUTTING UP CAUSTIC ALKALI.—Henry Pemberton, Allegheny City, Pa.

I claim making boxes or cases for inclosing, preserving and protecting the aluminates and hydrates of the alkalies, by means of paper lining, or other suitable fabric, wrapped and cemented together in folds or layers, with silicate of soda or other cement or glue, and externally coated with tar, heavy wax, resin, or other substance capable of resisting the caustic action of such alkalies, and rendering the fabric of which the case or box is made impen-

vious to moisture or air, substantially in the manner and for the purposes hereinbefore described.

Also, the use of a solution of the silicates of soda or potassa, for saturating, coating, or cementing together paper, muslin, pasteboard, or other fabrics for making boxes, cases or wrappings for inclosing and protecting the aluminates and hydrates of the alkalies and similar articles requiring protection from air or moisture.

60,052.—REGULATOR FOR REACTION WATER WHEELS.—Dewey Phillips, Manchester, Vt.

I claim, First, A valve or gate hinged at or near the end of the water way, and a reaction water wheel, O, regulate the opening for the escape of the water in proportion to the centrifugal force resulting from the rotation of the wheel acting upon such valve or gate to close the same, substantially as specified.

Second, The combination and arrangement of the operating lever, B, with the two cross heads or levers, D and E, substantially as described, by which the outer ends of such cross heads are made to approach or recede from each other simultaneously, substantially as and for the purposes set forth.

60,053.—MACHINE FOR MAKING BUTTONS.—L. D. Phillips, New York City. Antedated November 11, 1863.

I claim, First, The general construction and arrangement of the entire machine for forming buttons from plastic materials, the several parts constructed and operating, severally and in combination, substantially as described.

Second, The combination and arrangement of the operating lever, B, with the two cross heads or levers, D and E, substantially as described, by which the outer ends of such cross heads are made to approach or recede from each other simultaneously, substantially as and for the purposes set forth.

Third, The construction and arrangement of the movable jaws in combination with the former or its equivalent for making and shaping the eye of the button, the several parts constructed and operating substantially as described.

Fourth, The construction and arrangement, substantially as described, of the mold to form the button, the same being in two parts, one fixed and the other movable, and the latter shutting over or upon the former, substantially as and for the purposes set forth.

Fifth, The construction and arrangement of the oscillating plate between the mechanism that forms the eye and the movable part of the mold, such plate supporting the former while the eye is being formed, and constituting also a portion of the mold for shaping the button, and by its oscillating motion discharging the buttons as they are formed.

Sixth, The combination of the several parts forming the eye of the button with the parts which mold or shape the button, and their relative motions toward each other, and operating substantially as described, whereby the eye of the button is formed and inserted in the button at the same time the latter is being molded and shaped.

Seventh, The arrangement of the mechanism for feeding the wire to form the eye, arranged and operating substantially as described.

Eighth, The construction of the arm, B, in combination with the pin, S, or their equivalent, for oscillating the plate, I, substantially as and for the purposes set forth.

60,054.—COOKING STOVE.—Samuel G. Piper, Lynn, Mass. Antedated November 22, 1866.

I claim the combination and arrangement of the vessel, B, and the air conduit, C, provided with an air-receiving passage, b, and a register arranged with respect to it, as described, the whole being for application, as explained, to a stove and to the floor of an apartment over that in which the stove may be situated.

60,055.—MORTAR MILL.—Leman B. Pitcher, Salina, N. Y.

I claim the cylinders, A B C and D, with or without any of the attachments which form a part of either of them, made and operated substantially as and for the purposes described.

I also claim the mechanical process of making mortar therewith, substantially in the manner described.

60,056.—MACHINE FOR MAKING NAILS.—Arlon M. Polsey, Boston, Mass., assignor to T. H. Fuller.

I claim a series of rolling dies provided with die grooves having chamferments therein for reception of headed blanks, and other parts constructed substantially as described when arranged with reference to each other, and so as to operate substantially as specified.

60,057.—METHOD OF SINKING TUBULAR WELLS.—Orrin Pratt, Athol, Mass.

I claim so combining with an external tube or case a bori g instrument such as described, so that said instrument will bore a suitable hole for, and carry down with itself, the external tube, which can remain while the borer is withdrawn, and until the tubular well and strainer are introduced and the external tube then withdrawn from the hole, the operation being such substantially as described.

60,058.—CHURN.—J. K. Reiner, Line Lexington, Pa.

I claim, First, The two rotating shafts, C C', provided with curved arms, a a', having an oblique position in their transverse section, and the arms of one shaft having a reverse oblique position to those of the other, substantially as and for the purpose specified.

Second, The butter chamber, D, applied to the cream receptacle, A, and provided with the slide, E, and the strainer or screen, F, substantially as and for the purpose set forth.

60,059.—APPARATUS FOR COOLING BEER.—Henry Reusch, Quincy, Ill.

I claim as my improvement a perpendicular cylinder with double walls, supplied with cold or ice water at the bottom and escaping at the top, in combination with the receiving and distributing troughs at the top, and opening in the bottom of the cylinder for the escape of the beer running down on the inside of the cylinder.

And, in combination with the cylinder above claimed, I claim the pipe, Q, or its equivalent, for supplying air to the interior of the cylinder, near the bottom, to carry off the steam or evaporation from the liquid being cooled.

I also claim the construction and arrangement of the guiding rims, M and N, or flanges, for the purpose set forth.

60,060.—FRUIT PRESS.—Daniel T. Robinson, Boston, Mass.

I claim the improved implement or machine constructed and operating as above described, consisting of the frame, A, spring arms, e, d, g, d, and clamps, D D, or their equivalents.

60,061.—REEL OR SWIF.—A. Rohm and P. Guetlich, Lancaster, N. Y.

We claim the combination of the auxiliary arms, I, and disk, H, with the primary arms, E G, and disk G D, operating substantially as and for the purpose herein set forth.

We also claim, in combination with the above, the slots, I, and joints, b, for the purpose of producing an independent adjustment of the lower arms, as set forth.

We also claim, in combination with the above, the ratchet teeth, g, and collar, k, with spring projection, h, operating in the manner and for the purposes specified.

60,062.—PISTON PACKING.—Frank J. Roth, Newark, Ohio.

I claim, First, The application of expansible packing rings to the circumference of pistons, in such manner that said rings shall be expanded by the pressure of steam upon such portions of them as are exposed beyond the periphery of the piston, substantially as described.

Second, The arrangement of spring plates, g, to recesses formed in circumference of pistons, substantially as described.

Third, The arrangement of springs, c, so as to act upon the ends of the packing rings, b, which are made up of segments, substantially as described.

60,063.—SHOE BRUSH.—E. A. G. Roulstone, Roxbury, Mass.

I claim combining with the handle, d, and brush block, a, a spring for holding the box on the brush block, substantially as described.

60,064.—AXLE BOX.—Henry B. Rowley, Rushville, N. Y.

First, In combination with the journal box, C D, I claim the

axle, A, constructed with a hardened metal collar, B, or collars, b a', on its ends, the hardened or chilled metal collar or collars being made separate from the axle and shrunk on or otherwise fastened to the axle, and said collar or collars conforming in diameter to the chamber or chambers of the journal boxes in which they revolve, all substantially as herein described and for the purposes set forth.

Second, The arrangement of the flexible wipers, e, e, in combination with the journal and journal box, substantially in the manner herein described.

60,065.—HAY FORK.—William F. Rundell, Genoa, N. Y.

I claim the ferrule, C, constructed with a conical part, d, and a cylindrical part, e, in combination with the screw tang, b, of the fork, B, the key, f, and handle, A, to form a new and improved hay fork, substantially as set forth.

60,066.—CARRIAGE TOP.—W. F. Rundell, Genoa, N. Y.

I claim the top frame for carriages, having its front section or bow secured to the section next adjoining, substantially in the manner described and for the purpose specified.

60,067.—MACHINERY FOR EMBOSsing BRASS TUBES.—D. T. Sanford, New York City.

I claim, First, The arrangement of a series of knurls, to which a positive revolving motion is imparted, in combination with a hollow spindle, A, constructed and operating substantially as and for the purpose described.

Second, Making the knurls yielding in a radial direction, by springs, g, substantially as and for the purpose set forth.

Third, The combination, a, and boxes, E, in combination with the shafts, c, the ends of which form the bearings for the knurls, substantially as described, so that said knurls can be adjusted at any desired angle toward the axis of the articles to be embossed, without throwing them out of gear with the driving mechanism.

60,068.—LAMP.—William H. Langster, Chicago, Ill.

I claim, First, The combination of the sleeve, l, on shaft, t, the screw, u, on shaft, h, driven by the belt, s, that carries upon one end the blower, g, with the within described mechanism that supplies the power for operating the blower, when used in a lamp, lantern, or chandelier, in the manner and for the purposes herein set forth.

Second, The placing of the mechanism, c c, on its side, substantially in the manner described.

Third, Attaching the mechanism, c c, with a lamp, lantern, or chandelier, by means of the springs, o o, substantially as described.

60,069.—STRAW CUTTER.—W. D. Schooley, Richmond, Ind.

I claim, First, The vibrating box, O, provided with the pawl, P, and the lever, N, fitted in said box, and provided with the rack, J, for the purpose of admitting of said lever being readily adjusted higher or lower to vary the movement of the feed as occasion may require.

Second, The radius plates, T, provided with the pawls, U, and fitted loosely on the roller shafts, a a', in combination with the ratchets, M M', on said shafts and the adjustable lever, N, substantially as and for the purpose set forth.

Third, The combination of the rod, R, operated from the shaft, E, by the eccentric, Q, the adjustable lever, N, fitted in the vibrating box, O, provided with the pawl, P, the rods, S, radius plates, T, with pawls, U, attached, and the ratchets, M M', all arranged to operate substantially in the manner and for the purpose specified.

60,070.—BLOW PIPE.—Friedrick Shaller, Hudson, N. Y.

I claim, First, The arrangement of the blow pipe, J, and the piston blower, C B, in relation with each other and with the work table, b, and air reservoir, G, substantially as herein set forth for the purpose specified.

Second, The arrangement of the treadle, R, pitman, z, cranks, 5 and s, bent connecting rod, N, and lever, M, in combination with each other and with the spring, T, substantially as herein set forth for the purpose specified.

60,071.—ATTACHING CARRIAGE THILLS.—William C. Sherman, Boston, Mass.

I claim the hook, E, taking a solid bearing on the lower part of the draw bar in combination with spring, G, shoulder, J, and rubber box, O, provided with the pawl, P, the rods, S, radius plates, T, with pawls, U, attached, and the ratchets, M M', all arranged to operate substantially in the manner and for the purpose specified.

60,072.—POLICEMAN'S RATTLE.—Francis P. Smiley, Charles K. Becher, and Isaac Townsend, Philadelphia, Pa.

We claim the application to a policeman's rattle of a jointed handle, constructed and arranged to operate in combination therewith, substantially as and for the purposes described.

60,073.—FLOUR BOLT.—A. R. Smith, Delaware, Ohio.

I claim the reel, F, provided with knocker blocks, or a circular series of projections around it from rib to rib, in combination with a pivoted spring lever, operating substantially as described.

60,074.—CARTRIDGE MACHINE.—Dexter Smith, Springfield, Mass.

First, I claim the disk, P, operated from the shaft, B, by means of the cam, K and O, connected with the ratchet and pawl, g, h, and stop piece, m, or equivalent mechanism, for the purpose of transferring the shells, substantially as herein set forth.

Second, The combination of the cam, H, shaft, D, and mandrel, s, with the cam, Y, and tool, Z, when arranged and operating substantially as and for the purpose as described.

Third, The chuck, O, constructed as described, and used for the purpose of holding the shells, as set forth.

60,075.—ATTACHING DRAFT POLE TO AXLES.—E. C. Smith, Birmingham, Conn.

I claim the bars, G, with the eyes, F, at their rear ends fitted on the iron bar, E, of the cross bar, u, within mortises or notches, D, made therein and provided with the gib or key, H, and screw, I, all arranged substantially as and for the purpose herein set forth.

60,076.—TREATING OILS, ETC.—H. L. Smith, Gambrier, Ohio.

First, I claim for the purpose of rectifying or refining crude petroleum, or the distillates thereof, the herein described process, which is divided into two parts.

Second, I claim the process of treating crude petroleum, or its distillate, in a closed retort, by the introduction of steam, as and for the purpose specified.

Third, I claim the process of treating cold petroleum, or its distillate, by agitation with cold air, as and for the purpose specified.

60,077.—CHURN.—T. K. Smith, Oskaloosa, Iowa.

I claim the spring-board and churn combination, whereby I have made a churn which can be used without a dasher of any kind. In said drawing, blue color denotes metal (tin), and buff denotes wood.

60,078.—TOBACCO-PIPE CASE.—John Speirs, Boston, Mass.

I claim as my invention the combination of the parts, a b and B, arranged and applied together, substantially as described.

I also claim the pipe case, as made of the tubes, e B, and the bowl parts a b, combined and arranged substantially as specified.

I also claim the pipe case, as composed of the bowl parts, a b, the stem holder, B, the cup, c, and the tube, e, arranged together as specified.

I also claim the combination of the clearer, d, with the cup, c, to be applied to the pipe case stem receiver, B, as specified.

60,079.—STILL.—B. P. Stebbins, Corry, Pa.

I claim an improved cone still formed by combining a corrugated cone-shaped partition, B, and an inclined circular flange or apron, C, with each other and with the tank, A, substantially as described and for the purpose set forth.

60,081.—SLIDE VALVE.—Wm. J. Stevens, New York City.

First, I claim the arrangement relatively to each other of the slotted yoke, C, flexible diaphragm, D, roller, b, stop, f, and valve, A, substantially as shown and described.

Second, The arrangement of the flexible diaphragm, D, with the yoke, C, and roller, b, substantially as specified.

Third, The stops, f, in combination with the yoke, C, diaphragm, D, and valve, A, substantially as and for the purpose set forth.

60,082.—FAUCET.—James R. Street, and Stanley M. Davis, Washington, D. C.

We claim the combination and arrangement of the barrel, 7, cap, 5, plunger, 3, spiral spring, 2, elastic bale valve, 4 raised valve seat, a, inlet passage, 6, and exit post, c, all substantially as shown and described.

60,083.—CAR BELL.—James Sweeney, New York City.

I claim the bell, B, having the edge chamfered as described, in combination with the frame, C, and hammer, D, provided with the ears, c c, lug, d, and projections, e, the whole being constructed, arranged, and operated in the manner and for the purpose set forth.

60,084.—GOVERNOR FOR STEAM ENGINES.—Francis Taggart, Brooklyn, N. Y.

I claim a regulator for engines, fitted substantially in the manner specified, so that the pressure from the boiler shall act in the opposite direction to the pressure from the engine, and the difference of pressure produce a movement to regulate the supply of steam, substantially as set forth.

60,085.—SCAFFOLD.—Charles M. Tanner, Mentor, Ohio.

I claim the sliding frames which support the stage or platform, H, in combination with the main frame constructed with recesses, D, guide plate, I, windlass, C, hoisting ropes, E, and E', and additional pairs of framed legs provided with sockets, L, as herein described, and operating as and for the purpose set forth.

60,086.—LAMP BRACKET.—R. S. Tay, Medford, Mass., and Francis T. Fracker, Cambridge, Mass.

We claim a side light in which the lamp ring or support is hinged to and so as to swing up or adjust the hanger plate, substantially as set forth.

60,087.—CURTAIN FIXTURE.—J. W. Taylor, Dubuque, Iowa.

I claim the perforated wheel, e, attached to the roller of a window shade, in combination with the lever, H, when constructed and arranged substantially as herein shown and described and for the purposes set forth.

60,088.—MACHINE FOR PRESSING HATS.—G. L. Thompson, New York City.

I claim the combination of the barrel, G, and movable piston, H, with the flexible or elastic core, F, and die, D, constructed and operating substantially as and for the purpose set forth.

60,089.—TABLE FOR CONCENTRATING ORES.—Henry Alderson Thompson, Grant, Gipps Land, Victoria.

I claim the combination of the frame, A, supports, N, and screws R, with the table, B, stirrers, Q, and stirrer frame, O, substantially as and for the purposes herein shown and described.

60,090.—MACHINE FOR MAKING CRUCIBLES.—Samuel R. Thompson, Portsmouth, N. H.

I claim, First, The combination of the cylinder, B, piston head, D, screw piston rod, E, bevel gear wheels F and G, shaft H, and crank wheel, J, with each other, and with the frame, A, of the machine, substantially as herein described, and for the purpose set forth.

Second, The combination of the case, K, core, L, and cover, M, with each other, the parts being constructed and arranged substantially as herein described, and for the purpose set forth.

Third, The combination of the swinging guide bar, R, the swinging binding bar, T, and the binding and centering screw, U, with each other, with the cover, M, and with the posts, O and P, substantially as described, and for the purpose set forth.

Fourth, The combination of the bow, V, wire, w, and guide rod, W, with each other, and with the cylinders, B and K, substantially as herein described, and for the purpose set forth.

60,091.—MOLDER'S CLAMP.—William W. Tice, California, Ohio.

I claim the molder's clamp, composed of the hook, A B, guard, C, and cam-headed lever, E E', F.

60,092.—CAR COUPLING.—Daniel J. Tittle, Albany, N. Y.

First, The draft bar, c, provided with a head, l, and two hooking shoulders, h h, and pivot, o, in combination with the springs, i and e.

Second, I claim the rack bar, m, and segment, n, in combination with the draft bar, c, as and for the purposes set forth.

60,093.—CARRIAGE.—James D. Van Hovenbergh, Kingston, N. Y.

I claim the wrist and sleeve, or equivalent hinge connection between the side springs and the "third axle," substantially as and for the purpose herein specified.

I also claim the yoke, I, and kingbolt, L, constructed and arranged substantially as described, to connect the forward axle, A, and third axle, D, for the purpose herein set forth.

I also claim the construction of the springs, each composed essentially of the half springs, E and G, with the india-rubber spring cushion, O, between them, substantially as herein specified.

60,094.—CAR BRAKE.—Louis Alexis Felu, Eugene Francois Fosse, and Louis Eugene Alphonse Fosse, Paris, France.

We claim combining with a lever, or its equivalent for operating the brake, and with the frame or wheels of a car, or other similar carriage, the brake blocks, E, and wedges, G, constructed and arranged to operate, in the manner and for the purpose substantially as described.

60,095.—PLOW.—Bruno Volkman (assignor to Frederick Volkman), New York City, N. Y.

First, The plow frame or plow cart, A B C D E F, constructed substantially as described in combination with the plow beam, L, for the purpose set forth.

Second, The small balance beam, e, in combination with the screw chain n, the screw, m', and plow beam L, substantially as described, for the purpose set forth.

Third, The screw tree, I, in combination with the two horizontal frame pieces, d d', and the plow beam, L, substantially as described for the purpose set forth.

Fourth, The cart shaft, G, in combination with the semicircle, D, regulating screw 8, and with the plow frame, A, B, C D E F, substantially in the manner and for the purpose described.

Fifth, The cart axle, D1 D2, in combination with the movable side piece, E, and regulating screw, T, for the purpose of deepening the furrows as required, substantially in the manner described.

60,096.—GRAIN DRILL.—Elijah Wagoner, Westminster, Md.

First, I claim the combination of the drill, A, elastic bars, B B, lever, E, spring, G, and link, D, substantially as and for the purpose herein specified.

Second, In combination with the above parts, I claim the link, D D, and lug a', when formed with the shoulders, a2 d, in the manner and for the purpose set forth.

Third, I claim the stem or shank, i', when formed as a part of the dasher, I, and employed in connection with the spring, G, bars, B B, and stirrup, H, as described.

60,097.—CHURN.—G. B. Waller, Franklin, Ill.

First, I claim the combination of two or more inclined tubes, K, with the dasher shaft, B, substantially as herein shown and described, and for the purpose set forth.

Second, The combination of the inverted cup, J, and two or more inclined tubes, K, with the dasher shaft, B, substantially as herein shown and described, and for the purpose set forth.

Third, The combination and arrangement of the inclined tubes, E, inverted cup, J, dasher shaft, B, shaft, D, and H, gear wheels, F and G, and frame, E, with each other, with the cover, C, and with the body, A, of the churn, substantially as described, and for the purpose set forth.

60,098.—BELLOWS PUMP.—J. M. Wallace, and E. P. Swearingen, Milton, Iowa. Antedated Nov. 11, 1866.

I claim the pump, consisting of a double bellows, with a center board, having a chamber, H, and a valve guarding the openings, J, operated and combined with the pump stalk, substantially as described and represented.

60,099.—GRAPE-VINE PROTECTOR.—John Walter, Princeton, Ill.

I claim a grape-vine protector made and operating substantially as herein shown and described.

60,100.—MACHINE FOR PRESSING TOBACCO.—Wm. H. Watson, Yonkers, N. Y.

First, I claim giving to the tobacco a gradual pressure, substantially as shown, prior to the actual or uniform pressure for the purpose specified.

Second, Retaining the tobacco under a uniform pressure, substantially as shown, for the purpose of giving solidity to the sheet formed.

Third, The use or employment of the side belts, in combination with the main belts, substantially as shown, for the purpose set forth.

Fourth, The use or employment of the chains, in combination with the bolts and springs, for the purpose specified.

Fifth, The use or employment of the main belts, in combination with the chains, for the purpose specified.

Sixth, The use or employment of the side belts, in combination with the chains, for the purpose specified.

60,101.—LOOM.—George L. White, Woonsocket, R. I.

I claim the combination of the stop cam, and the spring bolt, constructed, arranged, and to be applied as specified, and the combination of the same or their equivalent, with the lay and its operative mechanism, substantially as described, the purpose and mode of operation of such mechanism being as herein before explained.

60,102.—MOP WRINGER.—J. F. White, Brattleboro, Vt.

I claim the rectangular frame, A, and yielding roller, C, in combination with the hinged or pivoted frame, E, roller, B, and foot rest, H, when said frame, E, is arranged within the said frame, A, all as herein described, and for the purpose specified.

60,103.—MACHINE FOR DRYING YARN.—Hugh Whitehill, Newburgh, N. Y.

I claim, First, The system of heating pipes, E, connected at both ends by transverse pipes, F, forming a continuous passage for the steam through the entire system, arranged and operating with relation to the revolving slatted cylinder, G, and fan, D, substantially as and for the purpose set forth.

Second, The guard or shield, I, arranged in relation with the opening, B, of the shell or casing, B, substantially as herein set forth, for the purpose specified.

Third, The arrangement and combination of the revolving and slatted cylinder, G, with the casing, A, B, and system of heating pipes, E, substantially as and for the purpose specified.

60,104.—MEASURING FAUCET.—Seba Squire Wiles, Santa Clara, Cal.

I claim, First, The faucet composed of the barrel, A, and the feed and discharge passages, C and D, with the valve, d, operated substantially as described.

I also claim, in combination with the device above claimed, the scale, o, and piston, B, with its rod, c, all arranged to operate substantially as and for the purpose set forth.

60,105.—GRINDING MILL.—George L. Witsil, Philadelphia, Pa.

I claim the roller, D, when constructed with a single helical riblike the thread of a screw, and suspended upon the vertically adjusted shaft, B, when used in combination with the hopper, A, and spirally-ribbed concave, A', said parts being respectively constructed and the whole arranged to operate substantially in the manner and for the purposes set forth.

60,106.—BRECH-LOADING FIRE-ARM.—H. H. Wolcott, Yonkers, N. Y. Antedated November 22, 1866.

First, I claim the lock frames, C, composed of two parts, a, a', hinged to each other at b, and constructed and operating substantially as described.

Second, I claim securing the extremities of the main spring, F, in the manner described within notches, U, S, in the hammer, but and screw, respectively, avoiding any intermediate attachment or bearing point, thus adapting the spring to move freely with the pivoted frame, and causing any deflection of the spring to be equally distributed throughout its entire length.

Third, I also claim the swell, G, on the back part of division, a', of the lock frame, for the purpose of bringing the hammer to half cock in the way substantially as above described.

Fourth, I also claim the projection, 4, of division, a', for keeping the lock frame in place, and preventing its withdrawal when the hammer is at full cock, substantially as above described.

Fifth, in combination with a hinged lock frame, of the construction herein specified, I further claim the shell drawer, e, made with arms, r and k, and operated by the contact of a projection, J, from the guard bow, 1, as explained.

60,107.—HORSE COLLAR.—Christian Wolf, Rantoul, Ill.

First, I claim connecting the upper ends of the side pieces, A, A, of a wooden collar together, by means of a hinge, a, and clamping nuts, c, c, in combination with an interposed block for staying said parts, A, A, laterally, substantially as described.

Second, The leather strap, D, applied to the upper part of the wooden collar, substantially as and for the purpose described.

Third, Connecting the lower ends of the side pieces, A, A, together by means of an adjusting screw, C, substantially as described.

Fourth, Connecting the trace hooks, k, and rings, s, to the wooden sides, A, A, of the collar, by means substantially as described.

Fifth, in combination with the wooden side pieces, A, A, and padding, B, I claim the hinged clamp, a, movable blocks, d, o, g, and the adjusting screw, C, all constructed and operating substantially as described.

60,108.—TANNING.—Ira Wood, Woodstock, Vt.

I claim the tanning mixture, composed of the ingredients mixed together in and about the proportions herein stated, and substantially as and for the purpose described.

I also claim the leather, as a new article of manufacture, produced substantially as herein described.

60,109.—FLUID LENSES.—D. A. Woodward, Baltimore, Md.

First, I claim the method herein described, of bending disks of glass so as to produce a concave or convex lens of spheroidal, parabolic or hyperbolic profile for the purpose set forth.

Second, I claim the use of two or more pieces of plate, or flat-tinted glass, bent to the required curve or profile as herein specified, in combination with the cement and rings, or their equivalents for holding them together, substantially as set forth.

Third, I claim combining with three or more glasses formed into cells, as described, fluids of different index of refraction, that will correct chromatic aberration, substantially as described.

60,110.—STAMP QUARTZ MILL.—William Wright (assignor to John W. Cheever), New York City.

First, I claim the arrangement of the stamps, in the form of a group, in combination with a central feed opening and surrounding screen and delivery receptacle, substantially as and for the purpose herein specified.

Second, in the direct application of steam power to stamping mills or hammers, I claim providing for the adjustment of the steam cylinders and their valves, toward and from the battery, substantially as herein described, whereby the wear of the stamps and the battery may be compensated for, and a uni-

form, or nearly uniform clearance between the pistons and the tops and bottoms of the steam cylinders may be maintained.

Third, I claim in combination with the above provision for the adjustment of the steam cylinders, I claim the attachment of the bedding hopper or hoppers, to the said cylinders, substantially as and for the purpose herein set forth.

60,111.—MARKING DEVICE FOR SEWING MACHINES.—Charles O. Yale, New York City.

First, I claim giving a rotary motion to the pencil while resting on the fabric, substantially as and for the purpose herein set forth.

Second, I claim, in connection with the above, the supporting and guiding parts, E, H, and the pressure spring, I, arranged relatively to each other and to the marking device, G, for joint operation, substantially in the manner and for the purpose herein set forth.

REISSUES.

2,398.—POWER HAMMER.—Philip S. Justice (assignee of Thomas Shaw), Philadelphia, Pa. Patented February 27, 1866.

I claim the combination of a vibratory hammer, with the spring and flexible belt substantially as described.

2,399.—HARVESTER.—Hobart H. Smith, Carlisle, Pa., assignee by mesne assignments of C. M. Lufkin. Patented September 8, 1857.

First, I claim the combination in a two-wheel side-draft machine, of a main frame arranged between the wheels and connected to the main axle with a laterally-projecting hinged cutting apparatus connected to said frame by means of a hinge at its inner or heel end only, in such manner that each end of the cutting apparatus, independently of the other, is free both to fall below and to rise above the plane on which the main carrying wheels are passing, for the purpose specified.

Second, The employment in a two-wheel side-draft machine, of a main frame, which is connected to the main axle, or gear center, and which extends beyond the periphery of the driving wheel at one end only, in combination with a laterally-projecting hinged cutting apparatus, for the purpose specified.

Third, In a two-wheel side-draft machine, a main frame connected at one end to, and vibrating about the main axle or gear center, in combination with a cutting apparatus hinged to the other end of said frame.

Fourth, In a two-wheel side-draft machine, a laterally-projecting cutting apparatus, hinged to one end of a frame which is connected at its other end to, and vibrates about the axle or gear center of said machine.

Fifth, In a two-wheel side-draft machine, a vibrating frame arranged between the wheels, and connected to the main axle or gear center, in combination with a laterally-projecting cutting apparatus, which is hinged at one of its ends to said frame.

2,400.—HARVESTER.—Hobart H. Smith, Carlisle, Pa., assignee by mesne assignments of C. M. Lufkin. Patented September 8, 1857.

First, I claim the combination in a two-wheel side-draft machine, of a main frame, a hinged cutting apparatus, and a draft pole or tongue hinged at a point within the periphery of the driving wheel, for the purpose specified.

Second, The combination in a two-wheel side-draft machine, of a main frame, a tongue hinged to said frame on a line nearly coincident with the axle, and a laterally-projecting hinged cutting apparatus, for the purpose specified.

2,401.—HARVESTER.—Hobart H. Smith, Carlisle, Pa., assignee by mesne assignments of C. M. Lufkin. Patented September 8, 1857.

First, I claim, in a two-wheel side-draft machine, the combination of a main frame arranged between the wheels and a vibrating draw bar, or its equivalent, with a laterally-projecting hinged cutting apparatus, which is free at each end independently of the other, and of the vertical movement of the main axle, to conform to the surface of the ground over which it is drawn.

Second, The employment in a two-wheel side-draft machine, of a draw bar, or its equivalent, connected at one end to and vibrating about a shaft or gear center of said machine, in combination with a main frame, arranged between the wheels, and a laterally-projecting hinged cutting apparatus.

Third, A draw bar, or its equivalent, connected at one end to and vibrating about the main axle or gear center, in combination with a laterally-projecting cutting apparatus hinged to the other end of said bar.

2,402.—HARVESTER.—Hobart H. Smith, Carlisle, Pa., assignee by mesne assignments of C. M. Lufkin. Patented Sept. 8, 1857.

First, I claim the employment in a side-draft machine of a curved slot and set screw, in combination with a vibrating frame, or its equivalent, which adapts a laterally-projecting hinged cutting apparatus to conform to the surface of the ground over which it is drawn, independently of the vertical movements or vibrations of the main axle of the machine, for the purpose specified.

Second, The employment of a curved adjusting way or standard located on the vibrating frame, or its equivalent, for the purpose specified.

Third, The combination of an adjusting lever with a curved standard or way, on which said lever is adjusted or held, for the purpose specified.

Fourth, The combination of a curved way or standard, an adjusting lever, and a means for setting or holding said lever, for the purposes specified.

2,403.—HARVESTER.—Hobart H. Smith, Carlisle, Pa., assignee by mesne assignments of C. M. Lufkin. Patented Sept. 8, 1857.

First, I claim the employment in a two-wheel side-draft machine of a carrying wheel or roller connected to the inner or heel end of a laterally-projecting hinged cutting apparatus, which is free at said end to conform to the surface of the ground over which it is drawn, independently of the vertical movements or vibrations of the main axle of said machine, for the purpose specified.

Second, The employment in a two-wheel side-draft machine of an adjustable wheel or wheels connected to and in combination with a laterally-projecting hinged cutting apparatus, which is free at each end, independently of the other end and of the vertical vibrations of the main axle, to conform to the inequalities in the surface of the ground over which it is drawn, in such a manner that the same may be used both in reaping and mowing, for the purpose specified.

Third, The employment of a rock-shaft lever and an adjusting wheel or wheels, in combination with a hinged cutting apparatus, which projects laterally from the main frame by which it is drawn forward over the ground.

Fourth, A laterally-projecting hinged cutting apparatus, which is free at each end, independently of the other, to conform to inequalities in the surface of the ground over which it is drawn, in combination with a mechanism, whereby the attendant is enabled, by operating a single lever, to raise and lower said cutting apparatus bodily, for the purpose specified.

2,404.—DISTILLING COAL OIL AND OTHER SUBSTANCES.—Herbert W. C. Tweddle, Pittsburgh, Pa. Patented Feb. 4, 1862.

First, I claim distilling hydro-carbon oils, such as petroleum, and other substances under a vacuum or partial vacuum, by the use of steam for producing the vaporization of the article to be distilled.

Second, The use of superheated steam in combination with the employment of a vacuum or partial vacuum, for the distillation of petroleum and other hydro-carbon oils and similar substances.

Third, The combination of a steam vacuum apparatus, constructed substantially as hereinbefore described, with the oil receiver, L and M, for the purpose hereinbefore described.

Fourth, The combination of the vacuum apparatus hereinbefore described, with the steam pipe or pipes in the interior of the still and with the still for the purposes hereinbefore described.

EXTENSIONS.

DUMPING WAGON.—Thomas Castor, Philadelphia, Pa. Letters Patent No. 9,164, dated August 3, 1852.

I claim the arrangement of the body on a fixed roller fulcrum

on the frame of the running gear, in such manner that by a slight amount of force the body can be turned to give its under side, which rests on the roller, either a forward or backward inclination to cause the weight of its load to tend to hold it forward or back, as it is required to carry or dump the same, substantially as herein set forth.

WHIFFLETREE HOOK.—E. A. Palmer and A. J. Simmons, Clayville, N. Y. Letters Patent No. 9,252, dated Sept. 7, 1852.

We claim the head turning upon the shaft to close the hook, the sliding catch to prevent its opening, and the spring within the head acting upon them, the whole combined and operating substantially in the manner specified.

DOOR LOCK.—William Moore, Brooklyn, N. Y., assignor to James Carman, New York City. Letters Patent No. 9,265, dated Sept. 14, 1852.

I claim the tumbler, k, inclosed by the dividing plate, h, to be operated on solely by the key when entered from the inner key-hole, in combination with the revolving check, or its equivalent, and the bolt, for the purposes as described and shown.

MACHINERY FOR BEVELING THE EDGES OF SKELPS OR METALLIC STRIPS, ETC.—Rob. Knight, Cleveland, Ohio. Letters Patent No. 9,274, dated Sept. 21, 1852.

I claim arranging the rollers in the frame, so as to receive a lateral movement, as may be desired, in other words, giving the rollers end play one over the other, as thereby increasing or diminishing the distance between the bosses (according to the width of the plate or strip), and providing suitable means for retaining the same in place.

LATH MACHINE.—H. C. Smith, Cleveland, Ohio. Letters Patent No. 9,286, dated Sept. 28, 1852.

I claim the combination of the method of rotating the log or bolt from which the laths are to be cut, by means of the poppet wheels, J, J', arranged respectively on the shafts, E, E', which forms a part of the mandrel at each end of the log, and the gear wheels, I, I', or the parallel shafts, moving with equal velocity, so as to prevent any wrenching or twisting of the log on its centers, and to hold it firmly up to the knives while being operated upon by them, and the method of clutching and releasing the log by means of the dog, A, hollow bearing, C', for containing the clutch head, G, and hollow shaft, E', for receiving the rod, F, which screws into said clutch, and by which the dog may be driven into the log or the log released, the whole being arranged and operating substantially in the manner and for the purpose set forth.

BEEHIVE.—Lorenzo L. Langstroth, Oxford, Ohio. Letters Patent No. 9,300, dated Oct. 5, 1852.

Reissue No. 1,484, dated May 26, 1863.

I claim, First, Constructing and arranging the movable comb frames of beehives in such a manner that when placed in the hive or case, they have not only their sides and bottoms kept at suitable distances from each other and from the case, substantially in the manner and for the purposes described, but have likewise their tops separated from each other throughout the whole or a portion of their length, substantially in the manner and for the purposes set forth.

Second, Constructing and arranging the movable frames in such a manner that when they are inserted in the hive the distance between them may be regulated at will, substantially in the manner and for the purposes described.

Third, Constructing movable frames and arranging them in the hive, in such a manner that the bees can pass above them into a shallow chamber or space, substantially in the manner and for any or all of the purposes set forth.

Fourth, The shallow chamber, in combination with the top bars of the laterally movable frames, or their equivalents, and with the perforated honey board, upon which to place surplus honey receptacles, substantially as and for the purposes set forth.

Fifth, A movable partition or divider, substantially as described, in combination with movable frames, substantially in the manner and for the purposes described.

Sixth, The use of movable blocks for excluding moths and catching worms, so constructed and arranged as to increase or diminish at will the size of the bee entrance, substantially in the manner and for the purposes set forth.

GRINDING MILL.—Oldin Nichols, Roxbury, Mass. Letters Patent No. 9,330, dated Oct. 12, 1852.

I claim the pointed projections, b, on the front edges of the teeth of the cylinder, E, when used in combination with the teeth, c, c, in the concrete formed with concavities in their front edges, substantially in the manner and for the purpose herein set forth.

GRAIN SEPARATOR.—Peter Geiser, Greencastle, Pa. Letters Patent No. 9,341, dated Oct. 19, 1852.

I claim the method herein described of regulating the blast of winnowing machines by means of a flap on the fan case, arranged and adjusted substantially as herein set forth.

Second, A winnowing machine, substantially as herein shown and described, in which the bottom is divided into three portions, the lowermost being tight and acting merely as a conveyor, the middle one acting both as a conveyor and screen to separate the wheat from the straw and allow it to pass into the winnower, and the upper or third portion acting as a conveyor for the straw and a coarse screen to separate therefrom the heads of unthreshed grain that have been carried over the lower screen, the whole being reciprocating bars moving the straw regularly along the trough and working or shaking the grain and heads so effectually through the screens that none is left to pass off with the straw when it is discharged from the upper end of the trough.

MODE OF COUNTERBALANCING HARNESS IN LOOMS.—James Greenhalgh, Woonsocket Falls, R. I. Letters Patent No. 9,377, dated Nov. 2, 1852.

I claim the construction of the long, double heddles or jacks, D, D, in such a manner and so hanging them on the axle, E, by a short arm, or its equivalent, that in their vibrations neither end of them shall pass beyond a vertical plane passing through the axle, as has been practiced heretofore, so that the weight of the jacks shall be thrown outside of their points of suspension, thus counterbalancing the weight of the harness.

TOOL FOR CUTTING PEGS OUT OF BOOT SOLES.—D. Allen, Adams, Mass. Letters Patent No. 9,340, dated Oct. 19, 1852.

I claim the adjustable float or cutter, C, D, E, connected to a shank, B, by means of the pin or pivot, b, which turns loosely in the bearing or standard, a, so as to permit the float to adjust itself to the proper positions to cut the pegs from the heel to the toe of the boot, in the manner herein set forth.

CONSTRUCTING PLOW.—Albert Gardner and Wm. L. Hunter, deceased, Cincinnati, Ohio. Letters Patent No. 9,363, dated Oct. 26, 1852.

I claim for myself and said Hunter, deceased, bolting the standard, mold board, land side, and share to the block, F, or its equivalent, instead of bolting or fastening the parts to each other as has been practiced heretofore, which block, F, may be connected to the beam by a bolt, K, or otherwise, substantially as described and represented.

SELF-ACTING MULE FOR SPINNING.—Wanton Rouse, Taunton, Mass. Letters Patent No. 9,378, dated Nov. 2, 1852. Reissue No. 233, dated March 15, 1853.

I claim, First, Governing the revolution of the spindles in winding the yarn on the cone, and also in backing off during the progressive stages of the building by means of a cam, B, or any equivalent device of irregular form circumferentially with the said irregularity varying from end to end, the said cam, or equivalent, being caused to operate upon the mechanism which drives the spindles in any way that will produce the results herein set forth.

Second, The mechanism for causing the finger, d, through which the irregular surface of the cam, B, or its equivalent, acts upon the mechanism which drives the spindles in backing off and building on, to traverse the said cam and to be kept close to its

surface, consisting of the screws, e and k, the nut, j, cord or chain, f, lever, G, and stud, h, operating in combination, in the manner substantially as set forth.

MODE OF THROWING SHUTTLES IN LOOMS.—Stephen C. Mendenhall, Richmond, Ind. Letters Patent No. 9,387, dated Nov. 9, 1852.

I claim the combination and arrangement of the spring triggers, f, f, cords, h, h, and treadles, i, i, etc., so that the depression of any one of these treadles shall release the trigger on the forward movement of the lay and allow the picker staff to actuate the shuttle, substantially as set forth.

HAND LOOM.—S. C. Mendenhall, Richmond, Ind., and Obed and Ezra King, Salem, Iowa. Letters Patent No. 9,388, dated Nov. 9, 1852.

First, We claim the combination of nerve, K, operated by lay inclined plane, O, and its guides, M, M, and adjustable pin, W, or their equivalents, combined and operating as described so that we can operate and vary the number of heddles, substantially as and for the purpose set forth.

Second, The combination of the inclined plane, Q, on picker staff, spring, T, and hooks, R, R, for the purpose of lifting the hooks, in the manner and for the purpose specified.

DESIGNS.

2,507.—TOBACCO PIPE.—George C. Britner (assignor to Harvey and Ford), Philadelphia, Pa.

2,508.—COACH LAMP.—James H. Downs (assignor to C. Cowles and Co.), New Haven.

2,509.—HAT ADVERTISING CARRIAGE.—Samuel Jackson, Jr., Roxbury, Mass.

2,510.—BURIAL CASKET.—William L. Lockhart and J. C. Seelye, East Cambridge, Mass.

2,511.—CEMETERY MONUMENT.—Reuben Miller, Lincoln, Ill.

2,512.—HANDLE OF A FORK OR SPOON.—George Sharpe, Philadelphia, Pa.

2,513.—TRADE MARK.—George W. Westbrook, New York City.

MAKE SURE OF IT.—THE PHRENOLOGICAL JOURNAL for December contains fine portraits of Deré, the great French Artist, the King and Queen of Prussia, twelve distinguished American Characters, Miss Kate Bateman, with biographies and sketches of Character. Also, a host of interesting matter, including What is Education? by John Neal, Characters of Shakespeare; Falseness of Society; Thiers, the French Statesman; Ouarang-Outangs, etc. Only 20 cents; \$2 a Year. Now is the time to subscribe. A New Volume begins with the next No. Address FOWLER & WELLS, 289 Broadway, New York.

MOSES G. WILDER, West Meriden, Conn. Draftsman, Machinist, and Manufacturer of all kinds of fine Machinery. Would call attention to his facilities for designing, arranging, or building first-class work. Having the advantages of good tools and good workmen, he is confident of giving satisfaction to any who may favor him with their orders for Power Presses, Foot Presses, Spinning Lathes, and any kind of Special or Automatic Machinery. Some of the best Machinery now running in New England has been made in this shop. Circulars, with references, etc., sent upon application.

NITRO-GLYCERIN.—Parties requiring the above article in quantity—say 100 lbs per day—are invited to correspond with the subscriber, who has devised a new method for its manufacture, reducing the cost as well as the risk to a minimum. GEO. M. MOWER, Y. Tinsville, Pa.

FABRICATION OF VINEGAR by the Quick Process.—Prof. H. DUSSAUCE, Chemist, is ready to furnish the most recent European processes to manufacture vinegar by the slow and quick methods, with and without alcohol, directly from grains; process to purify vinegar; fabrication of wood vinegar and acetic acid. Address New Lebanon, N. Y.

WANTED—Men to Sell, By Sample, Andrews's Gas Generator, price \$1. Can be attached to any lamp. Makes the best gas light in use from Carbonyl oil. Convenient as a candle. Will not blow out. \$30,000 made by Agents selling rights within the last 30 days. Men are coinng money selling it. Address J. C. TILTON, Pittsburgh, Pa.

A MOST INTERESTING NUMBER.—THE ATLANTIC CABLE INSTRUMENTS.

THE TELEGRAPHER, in its issue of Dec. 1, contains an illustration and full description of the transmitting apparatus of the Atlantic Cable. Price nine cents per copy. For sale at 16 Broad Street. Address the Editor, Post-office box 6,077.

TO SOAP MANUFACTURERS.—Plans of Factories, drawings of apparatus, methods of preparing every kind of lyes, and the following soaps:—White and Marbled Castile, Hard, Family, Soft, Transparent, Silicated, Fancy, T-die, etc. Assays, at short notice, of alkalies, greases, oils, soaps. Address Prof. H. DUSSAUCE, Chemist, New Lebanon, N. Y.

IMPORTANT TO STOVE MANUFACTURERS.—The undersigned will sell rights to manufacture his valuable Patent Smoke Consuming Stove for Bituminous Coal. Apply to W. H. GANDEY, Patentee, Lambertville, N. J.

JUST PATENTED—A New Oil Preparation for Leather—Waterproof—the Cheapest and Best in the World. Who will pay cost of procuring Foreign Patents for one-half interest in them? W. K. WYCKOFF, Ispoon, Wis.

IRON CASTINGS COPPERED.—Address S. VANDOREN, Box 58, New Brunswick, N. J.

PETROLEUM—Processes to Distill, Refine, Deodorize Petroleum, with plans of refineries, drawings of apparatus. Preparation of Lubricating oils. Assays of Crude Petroleum. Address Prof. H. DUSSAUCE, Chemist, New Lebanon, N. Y.

IRON PAINT.—THE BEST AND CHEAPEST in market. Hudson River Metallic Paint. Sole Agents, L. G. TILLOTSON & CO., 26 Dey street, New York.

THE Cheapest and Best Wood Mill in the world. Warranted to saw a cord of hard wood in seven minutes, with only one horse. Send for circulars. Address REYNOLDS & TOTMAN, Fredonia, Chautauque county, N. Y.

COAL TAR COLORS.—Prof. H. Dussauce, Chemist, is ready to furnish processes to manufacture colors derived from coal tar and naphthaline, with their applications in dyeing and calico printing. Address, New Lebanon, N. Y.

CIRCULAR SAWS—With EMERSON'S Patent MOVABLE TEETH. These saws cut more and better lumber in the same time, with the same power, than any other saw in the world, with less expenditure of labor and files to keep in order, and never wear smaller. Also, Emerson's Patent Gaging and Sharpening Swage, for spreading the points of saw teeth. Send for descriptive pamphlet, with new price list. AMERICAN SAW COMPANY, 24 5th St., 2 Jacob street, near Ferry street, New York.

MARBLE WORKERS AND SCULPTORS—Your attention is invited to a new and practical work on Monument and Head Stones, edited by Jacob Schumacher, Architect and Carver, Buffalo. It contains 45 plates and 114 original designs, with illustrations, ground plans, and details. Also, a Key, giving amount of marble, time of cutting, carving, and polishing, sent postpaid, on receipt of price, \$10. A. J. BICKNELL, Art Publisher, 282 River street, Troy, N. Y. Circulars sent on receipt of stamp. Local Agent: wanted.

ON HAND AND FOR SALE LOW—TEN ENGINE LATHES—5 1/2, 6, 12, 18 and 24 feet long, 14, 15, 16, 20, 24, and 28 inch swing; Iron Planer, to plane 5 feet by 24 inches; two small Upright Drills (one back geared); one large Upright Drill, back geared; two Upright Hand Drills; Ratchet Drills; Twist Drills, Chucks, and Sockets; Horton's Chucks; Leather and Rubber Belting; Superior Oils. Also, a Woodworth Planer and Mather. WELLS CHASE & GEHRMANN, 68 Howard street, Baltimore, Md.

MESSRS. STEPTOE, McFARLAN & CO., GENTLEMEN.—Inclosed you will please find check for One Thousand Dollars (\$1000), which is in full for the two Engine Lathes last shipped to us. These make, in all, seven of your make, standing side by side in our shop. They are the most complete and well built tools we have seen, and we have tools from several of the best shops east, but none to compare with yours. We shall be glad to order two more this fall yet. BROADRUP & CO., Dayton, Ohio.

LUMBER CONSUMERS AND DEALERS—I can buy Walnut, Whitewood, Ash, Hickory, and Sycamore, west, and in Canada, inspect and ship for consumer's advantage. Have several opportunities for immediate purchase, at low prices. W. F. THOMPSON, Box 1,907, Buffalo, N. Y.

WE WOULD CALL ATTENTION TO WALKER & SNEDE'S Machines, suitable for small fans, working models, and moving articles in show windows when a reciprocating motion is required. Price, boxed, \$10. Address WALKER & SNEDE, Newark, N. J.

PATENTS.—Valuable American and English Patents Manufactured and Sold, for cash, on Commission. Consignments Respectfully Solicited. Address KENYON & CO., 151 Broadway, N. Y. References: Daniel Burtnett, ex-Prest Citizens' Bank, New York; Jacob Miller, Director Citizens' B'k., N. Y.

TO VARNISH MANUFACTURERS.—Processes to prepare every kind of varnishes, viz.—Whit Japan, Painting Wood, Metals, Furniture, Carriages, Varnishes to preserve gold and silver. Address Prof. H. DUSSAUCE, Chemist, New Lebanon, N. Y.

THE CELEBRATED "SCHENCK" WOODWORKING PLANERS, Manufactured by the SCHENCK MACHINE CO., MATTEAWAN, NEW YORK. T. J. B. SCHENCK, Treas. JOHN B. SCHENCK, Pres

WHAT EVERY FARMER IS BOUND TO HAVE.—Late Patented, entirely New Agricultural Machine. It saves two-thirds the labor, runs light as a buggy—no Farmer can farm consistently without one. Rights for sale cheap. For further particulars address Patentee, PRESTON McQUAID, Magnolia, Putnam Co., Ill.

FOR CUTS AND PRICES OF WOOD-WORKING MACHINERY AND MACHINISTS' TOOLS, send us and be particular and say for what purpose tools are wanted, as we are extensively engaged in making both kinds. STEPTOE, McFARLAN & CO., Cincinnati, Ohio.

MANUFACTURERS of machines for the manufacture of Cotton and Woolen goods, are requested to send their address to JOHN W. CORLIES, Davenport, Iowa.

SPOKE LATHES, TENONING AND SPOKE- Polishing Machines, of an approved pattern, manufactured by J. GLEASON, 1080 Germantown Avenue, Philadelphia, Pa.

PACIFIC PATENT AGENCY.—Patents Procured and Sold. Agencies for Manufacturers solicited. JOSEPH H. ATKINSON, San Francisco, Cal.

TO MANUFACTURERS.—To Let—The Ground Floor of building corner 28th street and 1st avenue. Size 75x 60. B. L. SOLOMON & SON, 389 Broadway.

PATTERN Letters & Figures (metallic) for foundrymen, machinists, pattern makers, inventor, etc., to letter patterns to cast from. KNIGHT BROS., Seneca Falls, N. Y.

UNITED STATES CENSUS, BY TOWNS, IN Pocket Form, 174 pages. Price, postpaid, 60c; uncl., \$1. Address A. WOODWORTH & CO., Cambridge, Washington county, N. Y.

MILLED MACHINE SCREWS.—EVERY VARIETY of square or round-head milled and case hardened, set or cap screws. Also, screws made to order. GIFFORD & BAGLEY, No. 12 Central street, Worcester, Mass.

S. GODDARD, No. 7 BEEKMAN STREET, New York, has always on hand all kinds of Manila and Hardware papers—regular sizes, in part as follows: 15x20, 22x32, 30x40, 18x24, 24x36, 36x48, 20x30, 26x38, 40x56. Other sizes made to order at short notice. Issue Manila in sheets and rolls. Wrapping paper of all kinds, and a full assortment of fax and hemp twines. I will give orders special and prompt attention at the lowest market prices, and send samples of papers and twines far or near without charge. S. GODDARD, No. 7 Beekman street, New York.

BARREL MACHINERY.—The American Barrel Machine Company offer for sale their new and improved Machinery for the manufacture of Staves for all descriptions of Casks. They may be seen in operation at the Coopers of Mr. William F. Benzel, No. 650 Washington street, New York; at the Works of the Portland Kerosene Oil Company, Portland, Maine; and at the Works of the Kerosene Oil Company at South Boston, who have adopted them for the manufacture of Merrill's Patent Grooved Barrel. Further references and full information may be obtained by addressing American Barrel Machine Company, No. 151 Devonshire street, Post-office Box 528, Boston, Mass.

NITRO GLYCERIN.—A CARD.—IN REPLY to Col. Shafner's suggestion in his favor of 20th Inst., "Hoping the United States Blasting Oil Co. would not increase the price of Nitro Glycerin above \$1 75 per pound," I would say that, although possessed of a monopoly, our motto is "quick sales and small profits," and we shall at all times supply the trade at the lowest possible price, reserving only a fair manufacturing profit on the article.

When it is known that more than ninety per cent. of the cost of blasting is expended in labor of drilling, and that four-fifths of this drilling can be saved by the use of Nitro Glycerin, the price, whether \$2 or \$5 per pound, is but a trifling consideration to the contractor, miner, or quarryman, but our aim is, and always will be, to furnish it to the public at a price far below that of any kind of blasting material, to say nothing of the very many advantages arising from the use of this valuable compound. ISRAEL HALL, President U. S. Blasting Oil Co., No. 37 Pine street, New York.

CARTRIDGE MACHINERY FOR SALE.—Complete set of Tools and Presses for the Manufacture of Metallic Cartridges, nearly new and in perfect order. Address F. J. HYDEN, Thomaston, Conn.

SHEET AND ROLL BRASS.—German Silver, Brass, and Copper Wire, etc. Especial attention to particular sizes and widths for Machinists and Type Founders. Manufactured by the THOMAS MANUFACTURING COMPANY, Thomaston, Conn.

NEW BRICK MACHINE.—In successful operation since 1854. Common labor, with one brick maker only required. Worked by one man, makes 4,000 per day; by horse, 7,000 to 12,000; by steam, 16,000 to 25,000. Cost from \$100 to \$700.

DRYING TUNNEL, Patented 26th February, 1861, for "drying bricks, tile, pottery, cores for castings, and other manufactures of clay and sand; grain, fruit, vegetables, pea nuts, broom corn, peat, lumber, glue, starch, whitening, sugar, bagasse, gum, leather, hides, fish, meat, saltpeter, alum, and other chemicals." Bricks molded one day are set in the kilns the next, all the year. For further particulars, in a pamphlet (seventh edition enlarged), giving full instructions on brick setting and burning with wood or coal, address, sending twenty cents, FRANCIS H. SMITH, Box 556, Baltimore, Md.

PRANG'S AMERICAN CHROMOS.—Your home is not complete without good pictures; pictures that cultivate the taste and elevate the soul; pictures, the pleasant recollection of which will accompany the child through all his life's wanderings. Next to a masterly painting a good reproduction of a picture in chromo is the most useful and popular. A Chromo print is the result of printing from 15 to 30 plates in oil colors, one over the other, and when done skillfully, will represent the original painting in its minutest details. Our CHICKENS and DUCKINGS, after A. T. Tait, our LANDSCAPES, after A. T. Bricher, and a number of other excellent subjects, which we have the honor to bring before the public this season, have been examined in all Art and Fancy Stores, and in most of the first-class Bookstores throughout the land. The lively interest they create among the Art connoisseurs, and the liberal encouragement we have received by the community at large, give us the pleasant satisfaction that we have not labored in vain to reach the highest standard of European excellence.

L. PRANG & CO., ART PUBLISHERS, BOSTON.

LABORATORY OF INDUSTRIAL CHEMISTRY.—Directed by Professor H. DUSSAUCE, Chemist, U. S. Commissioner to the Universal Exposition, Paris. Professor H. DUSSAUCE, just returned from Europe, brought with him the most recent Chemical Processes, with drawings of apparatus. He is ready to give advice as heretofore on Chemistry applied to arts and manufactures, agriculture, metallurgy. He can furnish processes on the following fabrications: Soaps, Candles, Vinegar, Petroleum, Carbon of Coal Tar, Lead, and Zinc, Dyeing, Bleaching, Calico Printing, Fumigation, Lard, Distillation, Matches, Inks, Varnishes, Oils, Tanning, Perfumery, Refining and Melting of Metals, Chemical Products in General. Address NEW LEBANON, N. Y.

THE HARRISON BOILER—A SAFE STEAM BOILER.—This new Steam Generator combines essential advantages in Absolute Safety from explosion, in first cost and cost of repairs, durability, economy of fuel, facility of cleaning, and transportation, not possessed by any other boiler.

It is formed of a combination of cast-iron hollow spheres—each 8 inches in external diameter, and 2 1/2 inches of an inch thick, connected by curved necks. These spheres are held together by wrought iron bolts with caps at the ends. The form is the strongest known, its strength to resist internal pressure is very great—unweakened as it is by punching or riveting, which lessens the strength of the wrought iron boiler plate about forty per cent. Every boiler is tested by hydraulic pressure at 400 pounds to the square inch. It cannot be burst under any practical or best steam pressure.

Under pressure which might cause rupture in ordinary boilers every joint in this becomes a safety valve. No other steam generator possesses this property of relief under extreme pressure without injury to itself, and thus preventing disaster.

It is not affected by corrosion, which soon destroys the wrought iron boiler. Most explosions occur from this cause. It has economy in fuel equal to the best boilers, arising from the large extent and nearness to the fire of its heating surface, as also from the waved line of this surface which, thoroughly mixing the gases, induces better combustion, and breaking the flame, causes the next to be more effectually absorbed than in the ordinary tubular or cylinder boiler.

It sets up steam quickly, and with little fuel. It produces superheated steam without separate apparatus, and is not liable to priming or foaming.

It is easily transported, and may be taken apart so that no piece need weigh more than eighty pounds. In difficult places of access, the largest boiler may be put through an opening one foot square. It is readily cleaned inside and out. Under ordinary circumstances, it is kept free from permanent deposit by blowing the water entirely out, under full pressure once a week. It requires no special skill in its management. Injured parts can be renewed with great facility, as they are uniform in shape and size. When renewed the entire boiler remains as good as new. The greater part of the boiler will never need renewal, unless unfairly used.

A boiler can be increased to any extent by simply adding to its width, and being the multiplication of a single form, its strength remains the same for all sizes. It has less weight, and takes less than one-half the ground area of the ordinary cylinder boiler, without being increased in height.

Any kind of fuel may be used under this boiler, from the most expensive to refuse coal dust. Drawings and Specifications free of charge. For descriptive Circulars or price address JOSEPH HARRISON, Jr., Harrison Boiler Works, Gray's Ferry Road, Adjoining U. S. Arsenal, Philadelphia.

SMITH'S PATENT FUSIBLE SAFETY VALVE OR PLUG.—These Plugs are in extensive use in England, and are the best application of fusible alloy, for safety from accidents by low water or over pressure; are self-acting, and can not be tampered with. For sale by CHARLES W. COPELAND, No. 171 Broadway, Sole Agent for the United States.

CAN I OBTAIN A PATENT?—FOR ADVICE and instructions address MUNN & CO., 37 Park Row, New York, for TWENTY YEARS Attorneys for American and Foreign Patents. Caveats and Patents quickly prepared. The SCIENTIFIC AMERICAN \$5 a year. 30,000 Patent cases have been prepared by M. & Co.

CHARLES A. SEELY, CONSULTING AND Analytical Chemist, No. 26 Pine street, New York. Assays and Analyses of all kinds. Advice, instruction, Reports, etc., on the useful arts.

CHAMPION ILLINOIS HARVESTER, Patented Oct. 9th, 1866. Undivided half-interest for sale. Address [22 3] C. DENTON, Decatur, Ill.

OLLERS—Olmsted's Improved Spring Top. The spring cannot be set or injured by pressing upon it to expel the oil. Warranted the most substantial oiler in the market. Price for No. 1, Machinist's size, \$3.60 per dozen. The trade generally is supplied. Send for Circular. Address L. H. OLMSTED, Stamford, Conn.

IMPORTANT TO CONSUMERS OF STEAM. 25 per cent of fuel is wasted by using ordinary "wet" steam. Carvalho's Steam Super-Heater is simple and durable, and insures pure steam of any required temperature, low power, or for heating or drying purposes, preventing all priming of boilers. Address HENRY W. BULKLEY, General Agent, 21 6/1 57 Broadway, New York.

PROPOSALS FOR IRON HEAD BLOCKS.

Quartermaster General's Office, Washington, D. C., 815 1866. 1. Sealed Proposals will be received at the Office of the Quartermaster General, Washington, D. C., until November 30th, 1866, for furnishing Cast-iron Head Blocks for National Cemeteries, delivered in quantities about as follows, viz:—At

Table with columns for location and price range for iron head blocks. Locations include Boston, New Haven, Philadelphia, Baltimore, etc. Prices range from \$500 to \$10,000.

2. The head block to be made in accordance with the specifications, and to conform strictly to the samples, both of which may be seen at the Offices of the Depot or Chief Quartermasters at Boston, New York, Philadelphia, Pittsburgh, Baltimore, Washington, Fort Monroe, Richmond, D. C., Raleigh, Newbern, Fayetteville, Charleston, Savannah, Augusta (Ga.), Tallahassee, Mobile, New Orleans, Galveston, Vicksburg, Memphis, Nashville, Chattanooga, Murfreesboro', Louisville, Cairo, Chicago, Jeffersonville, Columbus (Ohio), Cincinnati, Detroit, St. Louis, Fort Leavenworth, Omaha, Little Rock, and San Francisco. (Blus for San Francisco will be received until December 31, 1866.) 3. They will be about nine (9) inches high, round ten (10) to twelve (12) inches long, and from three and a half (3 1/2) to four and a half (4 1/2) inches wide, with a flange around the bottom. They will be hollow, and will have a number cast on the back, and an inscription of the name, rank, regiment, arm, company, or corps, and date of death of the deceased, cast in raised letters on the top. They must be cast of good stove-plate iron, weight not less than twenty (20) lbs. each, and be coated thoroughly by dipping in melted zinc. 4. Separate bids are invited for delivery at each place; and in case the same parties offer to supply more than one locality, it should be stated what reduced price the articles would be furnished in the increased number. 5. Each bid must be accompanied by a good and sufficient guarantee of at least two responsible parties, that the act, if awarded, will be faithfully and promptly executed. (The responsibility of the guarantors must be shown by the official certificate of the clerk of the nearest District Court, or of the United States District Attorney.) 6. The overment reserves to itself the right to reject all bids, if unsatisfactory; and to delay the award not later than the first of January, 1867; and also, in some instances, change the points of delivery of a portion of the head blocks, in which case a reasonable allowance for increased, or deduction for diminished transportation will be made. 7. The time of delivery to be subject to future arrangement, sufficient time being allowed after the lists of names are furnished to the contractor. 8. The articles must conform rigidly to the sample, and will be subject to such inspection, at the point of delivery, as the Chief of the Bureau may direct. 9. The full name and post office address of the bidders should appear in the proposals. 10. Proposals must be plainly endorsed "Proposal for Iron Head Blocks," and be addressed "To the Quartermaster General U. S. A., Washington, D. C."

M. C. MEIGS, Quartermaster General, Brevet Major General, U. S. A.

TO ARCHITECTS. Plans and Specifications for new buildings for the War Department at Washington, D. C.

Architects are invited to prepare plans and specifications, and estimates of cost, for new fire-proof buildings for the War Department, on the site now occupied by the War Department and adjacent vacant ground, in Washington, D. C. The buildings required should have a superficial area as large as the site selected will admit of. Photographs of site, and all other information relating to the subject, will be furnished to Architects desiring to compete for the work, upon application, personally or by letter, to the undersigned. A premium of \$3,000 for the first, of \$2,000 for the second, and of \$1,000 for the third most acceptable plans and specifications received, will be awarded, upon the approval of the Hon. Secretary of War, by the Board of Officers charged with the duty of selecting a site and preparing plans and specifications for the buildings of the War Department, under act of Congress approved July 28, 1860. The plans and specifications must be sent to the office of Brevet Lieut. Col. T. J. Treadwell, Recorder of the Board, Ordnance Office, Winder's Building, Washington, D. C., on or before the 1st day of Feb., 1867. The Board will reserve the right to reject any or all plans submitted, should none be deemed suitable for the purpose, as well as to retain any or all of such plans. By Order of the Board, T. J. TREADWELL, Bvt. Lieut. Col., U. S. A., Recorder.

LECTURES ON CHEMISTRY AND METALLURGY.—Tickets for Prof. SEELY'S Lectures may be procured at his office, No. 35 Pine street, or from Dr. Kingsley, Dean of the Faculty, No. 25 West 27th street.

E. C. TANTER, OF THE LATE FIRM OF J. A. Fay & Co., having bought the Letters, Orders, and Correspondence of the late firm, respectfully solicits orders for Wood-working Machinery. E. C. TANTER, Worcester, Mass.

AGENTS WANTED—To Sell Hodgins's Patent Elastic Paper-Collar Fastening, illustrated in the Scientific American, Aug. 11, 1866. Sample and Circulars sent on receipt of 35 cents. Agent can make \$15 to \$25 per day. Address S. HODGINS & CO., 314 North 3d st., St. Louis, Mo.

ONE PORTABLE ENGINE 35 Horse-power. One " " " 30 " " Stationary " " 18 " " Upright " " 15 " " Also, several Second-hand Engines and Boilers, by C. GAY, 39 Federal street, Boston.

WHO WANTS A NEW RIFLE?—Every way superior to the Needle-Gun. Who wants a splendid Piano, Melodeon, Sewing Machine, Knitting Machine, Washing Machine, Clothes Wringer, or a choice Library of Books, including New Physiology? All these are given as PREMIUMS for Clubs of Subscribers to THE PHRENOLOGICAL JOURNAL for 1867. Send Stamp for Circular, to FOWLER & WELLS, 23 2] No. 389 Broadway, New York.

MACHINISTS.—Every Machinist should have a copy of MCCARTHY'S MECHANICAL SERIES, No. 2, Now Ready—setting of Slide Valve and Link Motion; price 50 cents. No. 1—Manual of Screw Cutting—containing rules for calculating the change gears on a screw cutting lathe, with two gears and with four, also, fractional threads; price 25 cents. Agents wanted in every Shop and State. Sent free by mail on receipt of price. JAMES CAMPBELL, Scientific Bookseller, 18 Tremont-st., Museum Building, Boston.

"GOOD BOOKS FOR ALL."—NEW PHYSIOGONOMY, 1,000 Illustrations, \$5. EDUCATION COMPLETE, embracing Physiology, Memory, and Self-Culture, \$4. WEAVER'S WORKS—Hopes and Helps, Aims and Aids, Ways of Life, \$3. HORACE MANN'S LECTURES, with Portrait, \$3. NEW HAND-BOOK—How to Write, How to Talk, How to Behave, and How to do Business, \$2.50. FAMILY GYMNASIUM, Illustrated, \$1.75. PHYSICAL PERFECTION, \$1.75. LIBRARY OF MEMORISM AND PSYCHOLOGY, \$4. EMPHATIC DIALOGUE, or the New Testament in Greek and English, \$4. SCIENCE OF HUMAN LIFE, by Dr. Graham, \$3.50. All works on Physiology, Psychology, Phrenology, Psychology, Hydropathy, Phonography, and the Natural Sciences. Agents Wanted. Circulars free. FOWLER & WELLS, No. 389 Broadway, N. Y. New Annual of Phrenology for 1867, by return post, 20 cents. "SPECIAL LIST" of Private Medical Works on receipt of stamp.

FOR SALE.—The Right of Henry Asbury & Co.'s Patent Screw Cutting Indicator for the entire United States. A rare opportunity for parties with small Capital. Address HENRY ASBURY & CO., 402 Library street, Philadelphia, Penn.

GOULD MACHINE COMPANY, Of Newark, N. J., and 102 Liberty street, New York. IRON AND WOOD-WORKING MACHINERY, STEAM ENGINES, BOILERS, SAW MILLS, etc.

PORTABLE AND STATIONARY STEAM Engines and Boilers, Circular Saw Mills, Mill Work, Cotton Gins and Cotton Gin Materials, manufactured by the ALBERTSON & DOUGLASS MACHINE CO., New London, Conn. 18 18*

JENKINS'S PATENT COMPRESSION GLOBE VALVE, for Steam, Oil, Water, etc. The bottom of the Valve is provided with an improved, durable, slightly elastic, rubber disk, easily renewed, making the valve perfectly tight, and prevents wear of the valve seat. No grinding. No wearing out. Warranted as represented, or the money returned. 20 10*] NATHANIEL JENKINS, 12 Hawkins-st., Boston, Mass.

RICHARDSON, MERIAM & CO., Manufacturers and Dealers in, DANIEL'S AND EDWARDS' PLANERS, Boring, Matching, Molding, Mortising, and Penoning Machines. Scroll, Cut-off, and Slitting Saws, Saw Mills, Saw Arbors, Spoke and Wood-turning Lathes, and other Wood-working Machinery. Warehouse, 107 Liberty street, New York. Manufacturing, Worcester, Mass. 20 4*

ERICSSON CALORIC ENGINES OF GREATLY IMPROVED CONSTRUCTION.—Ten years of practical working by the thousands of these engines in use, have demonstrated beyond cavil their superiority where less than ten horsepower is required. Portable and Stationary Steam Engines, Grist and Saw Mills, Cotton Gins, Air Pumps, Shunting Pulleys, Gearing Pumps, and General Jobbing. Orders promptly filled for any kind of Machinery. JAMES A. ROBINSON, 104 Duane street, cor Hudson, New York. 1 23 21-D.

LUMBER Can be seasoned in from two to four days, by Bulkley's Patent, at an average cost of \$1 per M. from the green. For circular or information address C. H. BULKLEY, No. 2 Case Building Cleveland, Ohio. 21 4*

WATSON'S MODERN PRACTICE OF AMERICAN MACHINISTS.

JUST READY—THE MODERN PRACTICE OF AMERICAN MACHINISTS AND ENGINEERS, INCLUDING THE

Construction, Application, and Use of Drills, Lathe Tools, Cutters for Boring Cylinders and Hollow work generally, with the most economical speed of the same; the results verified by actual practice at the lathe, the vice, and on the floor; together with workshop management, economy of manufacture, the Steam-engine, Boilers, Gears, Belting, etc., etc. By EGBERT P. WATSON.

Large of the "Scientific American." Illustrated by Eighty-six Engravings. In one volume, 12mo, price \$2.50, by mail free of postage.

CONTENTS: PART I. CHAPTER I.—The Drill and its Office. II.—The Drill and its Office—continued. III.—The Drill and its Office—continued. PART II. LATHE WORK. CHAPTER IV.—Speed of Cutting Tools. V.—Chucking Work in Lathes. VI.—Boring Tools. VII.—Boring Tools—continued. VIII.—Boring Steel Cylinders and Hollow Work. Experiments with Tools needed. Conservation among Mechanics. IX.—Turning Tools. X.—Turning Tools—continued. XI.—Turning Tools—continued. XII.—Turning Tools—continued. XIII.—Turning Tools—continued.

MISCELLANEOUS TOOLS AND PROCESSES. CHAPTER XIV.—Learn to Forge your own Tools. Manual Dexterity. Spare the Centers. XV.—Rough Forging. XVI.—How to use Calipers. XVII.—A Handy Tool. Rimmers. XVIII.—Keying Wheels and Shafts. XIX.—Taps and their Construction. Tapping Holes. Abuse of Files. XX.—Defective Iron Castings. "Burning" Iron Castings. How to Shrink Collars on a Shaft. XXI.—Are Scraped Surfaces Indispensable? Oil Cups. Drilling and Turning Glass. XXII.—Manipulation of Metals.

PART IV. STEAM AND THE STEAM-ENGINE. CHAPTER XXIII.—The Science of Steam Engineering. XXIV.—Piston Speed of Steam-engines. XXV.—How to Set a Slide Valve. To find the length of the Rod.

The above, or any of my Books sent by mail, free of postage, at the publication price. My New Catalogue of Practical and Scientific Books, complete to Oct. 1, 1866, will be sent free of postage to any one who will favor me with his address. HENRY CARY BAIRD, Industrial Publisher, 406 Walnut street, Philadelphia.

INCORUSTATIONS in Steam Boilers prevented by Whann's anti-Incorustation Powder, 11 Wall-st., N. Y.

IMPORTANT TO MANUFACTURERS USING STEAM FOR POWER. KELLEY & LAMB'S Improved Steam Engine Governor, the only Governor that will give the same speed, with high or low pressure of steam, or the Engine being light or heavy loaded—is considered by those who have used it the most equal, and is warranted to give satisfaction. Send for Circular. LAMB, COOK & CO. Proprietors, Slatersville, R. I.

JUDSON'S GOVERNORS. MALLEABLE CAST NGS. SAW GUMMERS. CARRIAGE AND MACHINE BOLTS. BARK MILLS. HOISTING MACHINERY. SORGHUM SUGAR SEPARATORS. STEAM PIPES For warming with escape steam Do. Do. For Boiling Paper Stock. IRON CASTINGS. Address 21 10*] JAMES L. HAVEN & CO., Cincinnati, Ohio

IMPORTANT. MOST VALUABLE MACHINE for all kinds of Irregular and straight work in wood, and the Variety Molding and Planing Machine, indispensable to competition in all branches of wood-working. Our improved guards make it safe to operate. Combination collars for cutters, saving 100 per cent, and feed table and connection, for waned moldings and planing, place it above all others. Evidence of the superiority of these machines is the large numbers we sell, in the different states, and parties laying aside others and purchasing ours, for cutting and shaping irregular forms, sash work, etc. We hear there are manufacturers infringing on some one or more of our nine patents in this machine. We caution the public from purchasing such. All communications must be addressed "Combination Molding and Planing Machine Company, cor. 1st ave. and 24th-st., New York, where all our machines are manufactured, tested before delivery, and warrant d. Send for descriptive pamphlet. Agents solicited. 20 11

TO SPRING MANUFACTURERS. Address JOHN EVANS, 31 Wooster st., New Haven, Conn. for his Patent Improved Machinery for HEADING CARRIAGE SPRINGS.

JOSEPH HIRSH, PH. DR. ANALYTICAL AND CONSULTING CHEMIST. Manufacture of PURE CHEMICALS. Office 33 Courtland tree, New York.

THE BEST POWER HAMMER MADE IS the Dead Stroke Hammer of Shaw & Justice. Sizes suited for manufacturing awl blades or engine shafts; consume but little space, and require but little power.

SHAW & JUSTICE'S POWER HAMMER IS Moderate in Price, is driven with one-tenth the power used by other Hammers, and will not cost the one-hundredth part of what is usually spent in repairs.

\$150 A MONTH. NEW BUSINESS FOR Agents. H. B. SHAW, Alfred, Me.

WHEELER & WILSON, 625 BROADWAY, N. Y.—Lock-stitch Sewing Machine and Buttonhole do. it

TAYLOR, BROTHERS & CO.'S BEST YORK-SHIRE IRON.—This Iron is of a Superior Quality for locomotive and gun parts, cotton and other machinery.

WROUGHT IRON WELDED TUBE OF ALL sizes; Upright Drill Presses; Peace's Improved Gas Pipe Screwing Machines, and all other Tools used by Steam and Gas Fitters.

STEAM BOILER EXPLOSIONS PREVENTED by use of Asiccroft's Low Water Detector. Over 5,000 in use. Send for Circular. JOHN ASICROFT, 50 John st., N. Y.

FOR ENGINE BUILDERS' AND STEAM Fitters' Brass Work, address F. LUNKENHEIMER, Cincinnati Brass Works.

IF YOU WANT ONE of the Latest Improved THOMAS'S PATENT ENGINE LATHES, Send for circular to Thomas Iron Works, Worcester, Mass.

FOR WOODWORTH PATENT PLANING AND MATCHING MACHINES, Patent Siding and Resawing Machine, address J. A. FAY & Co., Cincinnati, O.

ATMOSPHERIC TRIP HAMMERS ARE made by CHAS. MERRILL & SONS, 556 Grand street, New York. They will do more and better in less power and repairs, than any other Hammer.

J. A. FAY & CO., CINCINNATI, OHIO. Patentees and Manufacturers of all kinds of PATENT WOODWORKING MACHINERY

Who are the only manufacturers of J. A. Fay & Co.'s Patent Woodworking Machinery in the United States.

WARREN'S AMERICAN TURBINE is acknowledged the best finished, the simplest constructed, and the greatest water-saving wheel in the market.

R. BALL & CO., SCHOOL STREET, WORCESTER, MASS., Manufacturers of Woodworth's, Daniell's, and Gray & Wood's Planers, Sash Molding, Tenoning, Mortising, Upright and Vertical Shaping, Boring Machines, Scroll Saws, and a variety of other Machines and articles for working wood.

WANTED—AGENTS, \$150 per month, everywhere, male and female, to sell the GENUINE COMMON SENSE FAMILY SEWING MACHINE, the greatest invention of the age.

THE DAVIS BOLT-HEADER.—THIS SIMPLE and durable Bolt-Header has the unqualified approval of over thirty of the first mechanics of our railroad shops; also of Sellers & Co., Philadelphia; Wood, Light & Co., Worcester, and many others.

LENOIR PATENT GAS ENGINES—Without Boiler, Fire, Coals, or Smoke, for hoisting, grinding, sawing, pumping, and all small industries.

COMPLETE SETS OF DRAWING INSTRUMENTS, fine finish, from \$25 per set to \$150 per set, for sale by JAMES W. QUEEN & CO., 224 CHESTNUT STREET, Philadelphia, Pa.

MODELS, PATTERNS, EXPERIMENTAL and other Machinery, Models for the Patent Office, built to order by HOLSKE & KNEELAND, Nos. 226, 230, and 232 Water street, near Jefferson. Refer to SCIENTIFIC AMERICAN Office.

PATENT SHINGLE, STAVE, AND BARREL Machinery, Comprising Shingle Mills, Heading Mills, Stave Cutters, Stave Jointers, Shingle and Heading Jointers, Heading Rounders and Planers, Equalizing and Cut-off Saws. Send for Illustrated List.

ANDREW'S PATENT PUMPS, ENGINES etc.—CENTRIFUGAL PUMPS, from 90 Gals. to 40,000 Gals. per minute capacity.

IRON PLANERS, ENGINE LATHES, DRILLS, and other Machinists' Tools, of Superior Quality, on hand and making. For Sale Low. For Description and Price, address 277 NEW HAVEN MANUFACTURING CO., New Haven, Ct.

"POWER-LOOM WIRE CLOTHS" AND nettings, of all widths, grades, and meshes, and of the most superior quality, made by the CLINTON WIRE CLOTH COMPANY, Clinton, Mass.

OXY-HYDROGEN STEREOPTICONS, OXY-CALCIUM STEREOPTICONS, DISSOLVING LANTERNS, MAGIC LANTERNS, Etc., Etc. A Large Assortment of American, European, and Foreign Photograph Views for the same!

10,000 AGENTS WANTED, IN EVERY TOWN, COUNTY, and STATE, to sell Toplin's Patent Perpetual Lamp Wick. Needs no Trimming. Sample sent for 20c; two for 30c. State and County Rights for Sale.

WOODWORTH PLANERS, BARLETT'S Patent Power Mortise Machine, the best in market. Woodworking Machinery, all of the most approved styles and workmanship.

IMPORTANT TO MANUFACTURERS AND Inventors.—SMITH & GARVIN, No. 3 Hague street, New York, Machinists and Model Makers, are now ready to make proposals for building all kinds of Light Machinery, Manufacturers' Tools, Models, etc.

BULLARD & PARSONS, HARTFORD, CONN., are prepared to furnish Shafting of any size and length, in large or small quantities.

FOR SALE—One New Boring Mill, Swing 9 ft. 2 in. Will do all work required of it for building Engines, etc. Also, very useful for Pulleys. Built from Patterns at Miles's Works, with latest improvements.

GROVER & BAKER'S HIGHEST PREMIUM ELASTIC Stitch Sewing Machines, 495 Broadway, N. Y.

TO ENGINE BUILDERS.—Ross's Celebrated Patent Oil Cups for Cylinders or Engines, Brass and Iron body, Globe and Check Valves, Gage Cocks, Wristlets, etc., on hand and made to order.

TURBINE WATER WHEELS! REYNOLDS'S PATENT SWEEPS THE FIELD! New Improvements; Low Prices; Does not Clog; Has no Complications of Gates or Costly Flume Works; Compact for Shipment; Great Water Saver.

THE ONLY WHEEL THAT EXCELS OVERSHOTS! Gold Medal awarded by American Institute for Superiority. Shafting and Gearing furnished when required.

STATIONARY ENGINES Fitted with BABCOCK & WILCOX'S Improved CUT-OFF LIVE GEAR.

PORTABLE STEAM ENGINES, COMBINING The maximum of efficiency, durability, and economy with the minimum of weight and price.

ALCOTT'S CONCENTRIC LATHES.—FOR Broom, Hoe, and Rake Handles, Chair Rounds, &c., and all other kinds of Woodworking Machinery, for sale by S. C. HILLS, 13 Platt street, New York.

FOR PATENT STAVE AND BARREL Machinery, Shingle Machines, Etc., address J. A. FAY & Co., Cincinnati, Ohio.

MOLDING CUTTERS MADE TO ORDER.—Send for circular to WM. H. BROWN, 17 3/4 eow] 44 Exchange-st., cor. Union, Worcester, Mass.

CLOCKS FOR TOWERS, OFFICES, ETC., also Glass Dials for Illuminating. Address 718 eow] JOHN SHERRY, Oakland Works, Sag Harbor, N. Y.

HARNESS MAKERS AND SADDLERS, send me your address for descriptive circular, showing what I can do for you in the way of an improved Sitching Horse.

THE DRAWING-SCHOOL SET OF INSTRUMENTS.—Mahogany case, lined with velvet, containing pair Needle-point Dividers, with Pen, Pencil, and Extension bar; pair Plain Dividers; Spring Bow Pen, with needle-point; Protractor. Price \$5. Ten per cent. discount on five cases. Twenty per cent. discount on ten cases. T. H. MCALLISTER, Optician, 49 Nassau street, New York (of late firm of McAllister and Bro., Phila.)

MASON'S PATENT FRICTION CLUTCHES, for starting Machinery, especially Heavy Machinery, without sudden shock or jar, are manufactured by VOLNEY W. MASON, Providence, R. I.

WOOD & MANN STEAM ENGINE CO.'S CELEBRATED PORTABLE STEAM ENGINES, from 4 to 35 horse-power. Also, PORTABLE SAW MILLS.

FOR DANIELLS'S PLANING MACHINES, Car Mortising, Boring Machines, Car Tenoning Machines, Gear Planing and Beading Machines, etc., address J. A. FAY & CO., Cincinnati, Ohio.

BUERK'S WATCHMAN'S TIME DETECTOR.—Important for all large Corporations and Manufacturing concerns—capable of controlling with the utmost accuracy the motion of a watchman or patrolman, as the same reaches different stations of his beat. Send for a Circular.

TO BUILDERS.—Patent Rolled Plate Glass for Skylights for sale very low by E. & H. T. ANTHONY & CO., 501 Broadway, Agents of Southbridge Glass Works.

GODDARD'S BURNING MACHINE WORKS Office, No. 3 Bowling Green, New York, manufacture the Patent Steel Ring and Solid Packing BURNING MACHINES, Patent Meezlo Wool-burring Pickers, Shake Willows, Wcoland Waste Dusters, Gessner's Patent Gigs, Etc.

PATENTERS TAKE NOTICE.—Having made large additions to our Works, we can add one or two machines to our list of manufactures. The machines meet by strictly first-class, and well protected. BLYMYER, BATES & DAY Manufacturers of Agricultural Machinery, Mansfield, O.

\$200 A MONTH IS BEING MADE WITH our IMPROVED STENCIL DIES, by Ladies and gentlemen. Send for our free Catalogue containing Samples and Prices. Address S. M. SPENCER & CO., U. S. CO. BLDG., 21 6 eow] Brattleboro, Vt.

COLLINS IRON CO., Manufacturers of Charcoal Pig Iron, at Marquette, Mich. Numbers one and two are a soft "Gray Iron," strong in the Pig, and when "puddled" for Boiler Plate, Sheet Iron, or Merchant Bar, is equal to Swedes, Russia, or Norway Irons.

WOODWORTH PLANER AND MATCHER, 22 inches wide, for \$350 in the works nearly ready. S. C. HILLS, No. 12 Platt street, New York.

\$1,500 PER YEAR, PAID BY SHAW & CLARK, Blidsford, Me., or Chicago, Ill. (11 13 eow]

THOMAS BARRACLOUGH & CO., MANCHESTER, ENGLAND, Makers and Patentees of HECKLING, SPINNING, LAYING, and other Machines, for the Manufacture of ROPE, LINES, CORD, TWINE, FISHING LINES, SPUN YARN, NETS, ETC.

TWENTY-FIVE PER CENT OF THE COST of Fuel saved annually by the use of Hair and Wool Felt as applied and for sale by JOHN ASICROFT, 50 John street, New York. Send for Circular.

PATENT POWER AND FOOT-PUNCHING PRESSES, the best in market, manufactured by N. C. STILES & CO., West Meriden, Conn. Cutting and Stamping Dies made to order. Send for Circulars.

STEAM ENGINES AND BOILERS.—By making the Steam-Engine business a specialty, with Expensive and carefully-prepared Patterns, and all the advantages of Special Machinery and Tools, and division of labor, we are producing a far more perfect, complete, and better a title than can be procured elsewhere, at even much higher prices.

THE STEAM SIPHON PUMP IS THE MOST simple, direct, and effective device for raising water by steam yet discovered. It is an independent lift and force pump, without piston, plunger, valves, or any movable part. It cannot get out of order, or freeze up, and can be used wherever there is a steam boiler, either with high or low pressure. It is an efficient fire engine, and the best bilge pump known.

PRESSURE BLOWERS. PRESSURE BLOWERS—FOR CUPOLA FURNACES, Forges, and all kinds of Iron Works. The blast from this blower is four times as strong as that of ordinary fan blowers, and fully equal in strength to piston blowers, when applied to furnaces for melting iron. They make no noise, and possess very great durability, and are made to run more economically than any other blowing machine. Every blower warranted to give entire satisfaction. Ten sizes, the largest being sufficient to melt sixteen tons of pig iron in two hours. Price varying from \$40 to \$345.

PAN BLOWERS, from No. 1 to No. 45, for STEAMBOILING Iron Mills, Ventilation, etc., manufactured by B. F. STURTEVANT, No. 72 Sudbury street, Boston, Mass.

OIL! OIL!! OIL!!! For Railroads, Steamers, and for machinery and Burning, PEASE'S Improved Engine Oil, and Car Oils, imported and recommended by the highest authority in the United States and Europe. This Oil possesses qualities vitally essential for lubricating and burning, and found in no other oil. It is offered to the public upon the most reliable, thorough, and practical test. Our most skillful engineers and machinists pronounce it superior to and cheaper than any other, and the only oil that is in all cases reliable and will not gum. The Scientific American, after several tests, pronounces it "superior to any other they have used for machinery." For sale only by the inventor and manufacturer, F. S. PEASE, No. 61 and 63 Main street, Buffalo, N. Y.

Improved Stove Tongs.

The engraving gives a view of a simple and handy implement for use about a stove. It is a pair of tongs furnished with double jaws, one side of each being corrugated, the better to seize and hold the rims of wired tin ware. It is made of cast or malleable iron, and can be applied to all the purposes of a cover lifter, tongs, hook, or ordinary

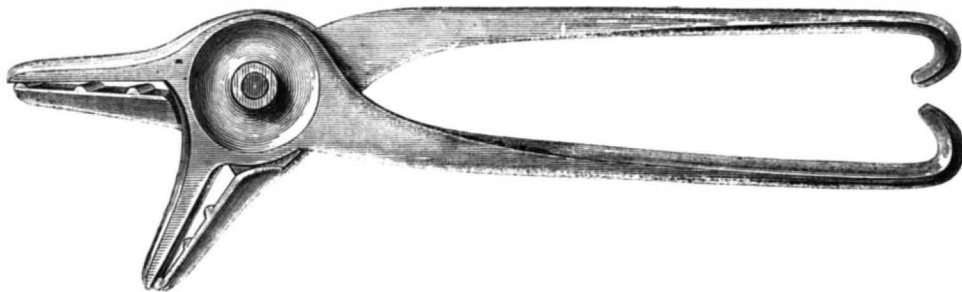

STILLWELL'S STOVE TONGS.

holder. Its efficiency and its operation can be understood without reference to the parts by lettering.

The combination of the two jaws, placed at an angle of forty-five degrees, is a great convenience, as articles of stove furniture in any position may be readily moved and lifted without trouble. It was patented Oct. 2, 1866, by E. R. Stilwell, of Dayton, Ohio, to whom apply for rights or for further information.

SCOTT'S IMPROVED FASTENING FOR WAGON BOWS.

Many of the most valuable improvements, for which patents have been issued, have been those whose apparent insignificance would have caused them to escape the notice of the superficial observer;

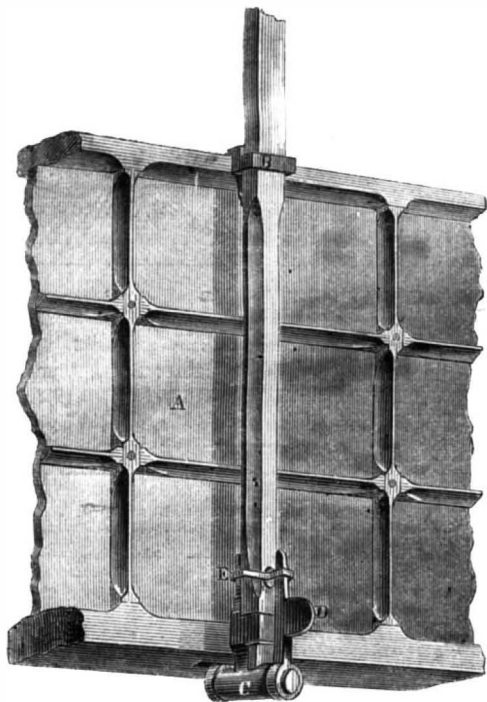

yet, in not a few instances, they have competed, in actual general value and in pecuniary profit, with some of much greater pretensions. Such is the character of that illustrated in the accompanying engraving. It is a new method of attaching the uprights and bows to a wagon frame.

A is a section of the side of a wagon. The staple, B, at the top rail, instead of being permanently fixed to the rail, is secured to the bow at a point corresponding with the height of the top from the bottom rail, and is provided with a flange, fitting over and embracing two sides of the top rail. Of course it can be slipped along to any point desired. At the bottom of the upright is a clasp of metal having a socket, C, which envelopes the shaft of a lever cam, the inner edge of which is sharp, and, when the lever, D, is turned in a vertical position, holds the bow firmly in place. A sliding clasp, E, slips over the end of the lever and secures it.

The upright or bow can be easily disengaged from any part of the rail and secured to any other por-

tion; no holes are required to be bored in the wagon rails, thereby weakening them; if warped by the weather, there is no additional difficulty in moving the bows, as all the iron work goes with them; nothing about the device is liable to break; there is no rattling, and the wagon is greatly strengthened by having the upper and lower rails firmly bound and held together.

Patent issued Oct., 16, 1866, to Amos R. Scott, Bethel, Ohio, whom address for other information relating to the invention.

SPENCER'S CHURN DASHER.

The churn dasher herewith illustrated is intended to facilitate the mechanical and chemical change that takes place in separating the buttery particles of cream from the serum. It appears to have been designed on philosophical principles, and as though it was a decided improvement on the ordinary dasher.

The dasher proper, A, is an inverted, bowl-shaped piston, hollow, and furnished with holes around the periphery near the bottom. Other apertures are formed at the top, countersunk on the upper surface to receive ball valves, which may be marbles or the toy glass balls used by children. These are pre-

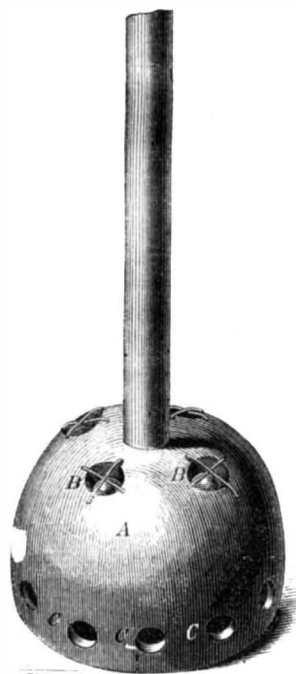

vented from escaping by wires or staples stretched across the holes, as at B.

As the dasher descends into the cream its concavity carries down a quantity of atmospheric air, and as it descends still further the cream is forced laterally out of the lower apertures, C, and, by lifting the valves, through the holes B. When the dasher is raised the valves close, and the tendency is to form a vacuum inside the dasher until it has been raised above the surface of the cream. The effect is to violently agitate the cream and at the same time to mingle the atmosphere with it.

This dasher was patented through the Scientific American Patent Agency, Oct. 23, 1866, by N. H. Spencer, Canandaigua, N. Y., whom address for further information.

NEW PASTE WANTED.—A correspondent writes us for a "combination for pasting paper without acting hygrometrically on the same, viz., not to extend it in pasting, and contract it again in drying."

THE Boston Massachusetts Institute of Technology held their first meeting on the 15th of the present month in their spacious new building, now just finished, a gift from the liberal citizens of Boston and vicinity. Professor Wm. B. Rogers, the President of the Institute, welcomed the members to their new halls in a brief address, making mention of some of the prominent members and benefactors of the Institute who had died since the last meeting. He congratulated them upon their prosperity, the Society of Arts now numbering among its members many of the first scientists of the country, and the School of Practical Industrial Science about one hundred and fifty pupils. This school of practical instruction is rapidly being appreciated by students from all parts of the United States.

THE English railways are assessed for poor rates by the local authorities of the several parishes through which they pass.

THE
Scientific American,
TO BE ENLARGED
For 1867.

This valuable journal enters upon its twenty-second year on the first of January next, at which time the Publishers have determined to considerably enlarge and otherwise improve it. The SCIENTIFIC AMERICAN is the oldest, and, by general consent, the most popular Journal of Science ever published; and, in point of circulation, it is safe to say that it exceeds the aggregate issues of all similar papers in this country and Great Britain combined.

The first number of the SCIENTIFIC AMERICAN, a folio of four pages, appeared in the summer of 1845. Soon after its appearance the form was changed to a quarto of eight pages. In 1859, encouraged by the great success which met their efforts, the Publishers determined to double its size to sixteen pages. But this enlargement has finally proved inadequate to the great demand upon its columns, and, in spite of the greatly enhanced cost of paper and all other materials, the Publishers have decided that their journal must be enlarged, without any increase in the terms of subscription, confident that their generous patrons will appreciate the benefits of the proposed change, and lend their influence to increase its subscription list. It has been the constant aim of the editors of this journal, who are aided by some of the best known scientific writers in the country, to discuss all subjects relating to the Industrial Arts and Sciences in a plain, practical, and attractive manner.

Having access, also, to all the principal Scientific Journals of Europe, the editors have unequalled facilities for gathering up, for the benefit of their readers, a record of all the important Inventions and Discoveries of European Nations.

Avoiding all political and partisan questions, the SCIENTIFIC AMERICAN is universally recognized as the leading exponent of American Industry, in every department. All the latest and best Inventions of the day are described and illustrated by SPLENDID Engravings, prepared expressly for its columns by the first Mechanical Engravers in the country.

It would be impossible within the limits of this Prospectus, to enumerate the great variety of subjects which are discussed and illustrated. A few only can be indicated, such as Steam Engineering, Fire-arms, Mechanics' Tools, Manufacturing Machines, Farm Implements, Hydraulic Engines, Wood-working Machines, Chemical Apparatus, Household Utensils, Curious Inventions, beside all the varied articles designed to lighten the labors of man in the Shop, Factory, Warehouse, and Household.

THE SCIENTIFIC AMERICAN has always been the Advocate of the Rights of American Inventors. Each number contains a weekly list of Claims of Patents, furnished expressly for it by the Patent Office. In this particular, no other journal now published can approach it, as the Publishers, Messrs. MUNN & CO., have long been recognized as the most extensive Solicitors in the world of American and Foreign Patents, their business amounting to more than one-third of all the claims presented at the Patent Office.

With such advantages and facilities, the columns of the SCIENTIFIC AMERICAN are almost exclusive in their value to all who desire to be well informed about the progress of Art, Science, Invention, and Discovery.

Patent Law Decisions, and questions arising under these laws, are fully and freely discussed by an able writer on Patent Law. Correspondents frequently write that a single recipe will repay them the whole cost of a year's subscription.

Published Weekly, two volumes each year, commencing January and July,
Per annum.....\$3 00
Six months..... 1 50
Ten copies for One Year.....25 00

Canada subscriptions, 25 cents extra. Specimen copies sent free. Address

MUNN & CO., Publishers,
No. 37 Park Row, New York City.

Messrs. MUNN & CO. have had twenty years' experience in procuring Patents for New Inventions. Inventors who may have such business to transact can receive free, all needful advice how to proceed.

FROM THE STEAM PRESS OF JOHN A. GRAY & GREEN.