

SCIENTIFIC AMERICAN

A WEEKLY JOURNAL OF PRACTICAL INFORMATION, ART, SCIENCE, MECHANICS, CHEMISTRY, AND MANUFACTURES.

Vol. XXXVI.--No. 8.
[NEW SERIES.]

NEW YORK, FEBRUARY 24, 1877.

[\$3.20 per Annum.
[POSTAGE PREPAID.]

DATES AND THE DATE PALM.

Even those whose knowledge of the customs of the Orient extends no further than a recollection of the contents of that time-honored story book, the "Arabian Nights," are doubtless aware that, since time immemorial, the date has been the chief food staple of the desert-dwellers of the East. The "handful of dates and gourd of water" form the typical meal and daily sustenance of millions of human beings both in Arabia and in North Africa, and to this meager diet ethnologists have ascribed many of the peculiar characteristics of the people who live upon it. Buckle, who finds in the constant consumption of rice among the Hindoos a reason for the inclination to the prodigious and grotesque, the depression of spirits, and the weariness of life manifest in that nation, likewise considers that the morbid temperament of the Arab is a sequence of vegetarianism. He points out that rice contains an unusual amount of starch, namely, between 83 and 85 per cent; and that dates possess precisely the same nutritious substances as rice does, with the single difference that the starch is already converted into sugar. To live, therefore, on such food is not to satisfy hunger; and hunger, like all other cravings, even if partially satisfied, exercises control over the imagination. "This biological fact," says Peschel, "was and still is the origin of the rigid fastings prescribed by religions so widely different, which are made use of by Shamans in every quarter of the world when they wish to enter into communication with invisible powers." Peschel and Buckle, however, are at variance as to the influence of the date diet as affecting a race; and the former remarks that, "while no one will deny that the nature of the food reacts upon the mental powers of man, the temperament evoked by different sorts is different;" yet "we are still far from having ascertained anything

in regard to the permanent effects of daily food, especially as the human stomach has, to a great degree, the power of accommodating itself to various food substances, so that with use even narcotics lose much of their effect." The same author also adds that the date "trains up independent and warlike desert tribes, which have not the most remote mental relationship to the rice-eating Hindoos."

It remains for the reader to reconcile this disagreement of learned doctors according to his own judgment. The evidence of those who subsist on the date is certainly overwhelming in its favor. The Assyrians, tradition says, asserted that it was such a great gift to them that its worth could not be too extravagantly told; for they had found, for the leaves, the fruit, the juices, and the wood of the tree, three hundred and sixty different uses. The Mohammedans adopt the date palm into their religion as an emblem of uprightness, and say that it miraculously sprang into existence, fully grown,

at the command of the Prophet. Palm branches still enter as symbols of rejoicing into Christian religious ceremonies; and throughout Palestine constant reference is found to the date and the palm in the naming of towns. Bethany means "a house of dates." Ancient Palmyra was a "city of palms," and the Hebrew female name Tamar is derived from the word in that language signifying palm. In Africa there is an immense tract of land between Barbary and the great desert named Bilidulgerid, "the land of dates," from the profusion of the trees there growing.

In this country, the date as an article of food is classed

in growth, it shoots up a magnificent stem, to the height sometimes of eighty feet, the summit of which is covered with a graceful crown of pinnated leaves. The trunk is exceedingly rough and spiny; the flower spathes, which appear in the axils of the leaves, are woody, and contain branched spadices with many flowers; more than 11,000 have been counted on a single male spadix. As the flowers are dioecious, it is necessary to impregnate the female blossoms artificially in order to insure a good crop; and to this end the male spadices are cut off when the pollen is ripe and carefully shaken over the female ones. At from six to ten years

of age, the tree bears, and then remains fruitful for upward of 200 years. An excellent idea of the palm in full bearing may be obtained from our illustration, which represents the mode of gathering the dates, of which a single tree will often yield from one to four hundredweight in a season. The fruit varies much in size and quality; and in the oases of the Sahara forty-six varieties have been named.

The utilization of the date palm and its products are very numerous. The stem yields starch, and timber for houses, boats, fences, fuel, etc., as well as an inferior kind of sago. The leaves serve as parasols and umbrellas, and for material for roof covering, baskets, brushes, mats, and innumerable utensils. At their base is a fiber, which is spun into excellent rope. When the heart of the leaf is cut, a thick honey-like juice exudes, which, by fermentation, becomes wine (the "toddy" of India), or vinegar, and is also boiled down into sugar. The young shoots, when cooked, resemble asparagus; and the dates themselves are dried and ground into meal, from which bread is prepared.

Panthers as Seed Distributors.

It is well known that bees carry pollen from flower to flower, and that eggs of marine animals are often car-

ried long distances in the stomachs of aquatic birds. A very curious instance of this kind, showing how vegetable species may be diffused by means which no botanist, however acute, would be likely to think of, is mentioned by Mr. Alfred Smee, who states that, attached to the skin of a panther recently shot in India, were found numerous seeds, each of which had two perfect hooks, manifestly designed to attach themselves to foreign bodies. As the panther moved about it collected the seeds on the skin and carried them about wherever it went; but when it rubbed against the shrubs, it of necessity brushed some off, and thus distributed them. One of the seeds produced a handsome plant, and beautiful clusters of tubular flowers. It was immediately recognized to be the *Martynia diandra*—a plant which, although introduced into England as far back as 1731, has scarcely ever been cultivated, although it has been commented on by botanists and other writers.

The date palm (*Phoenix dactylifera*) is the most important species of the dozen which make up its genus. Though slow

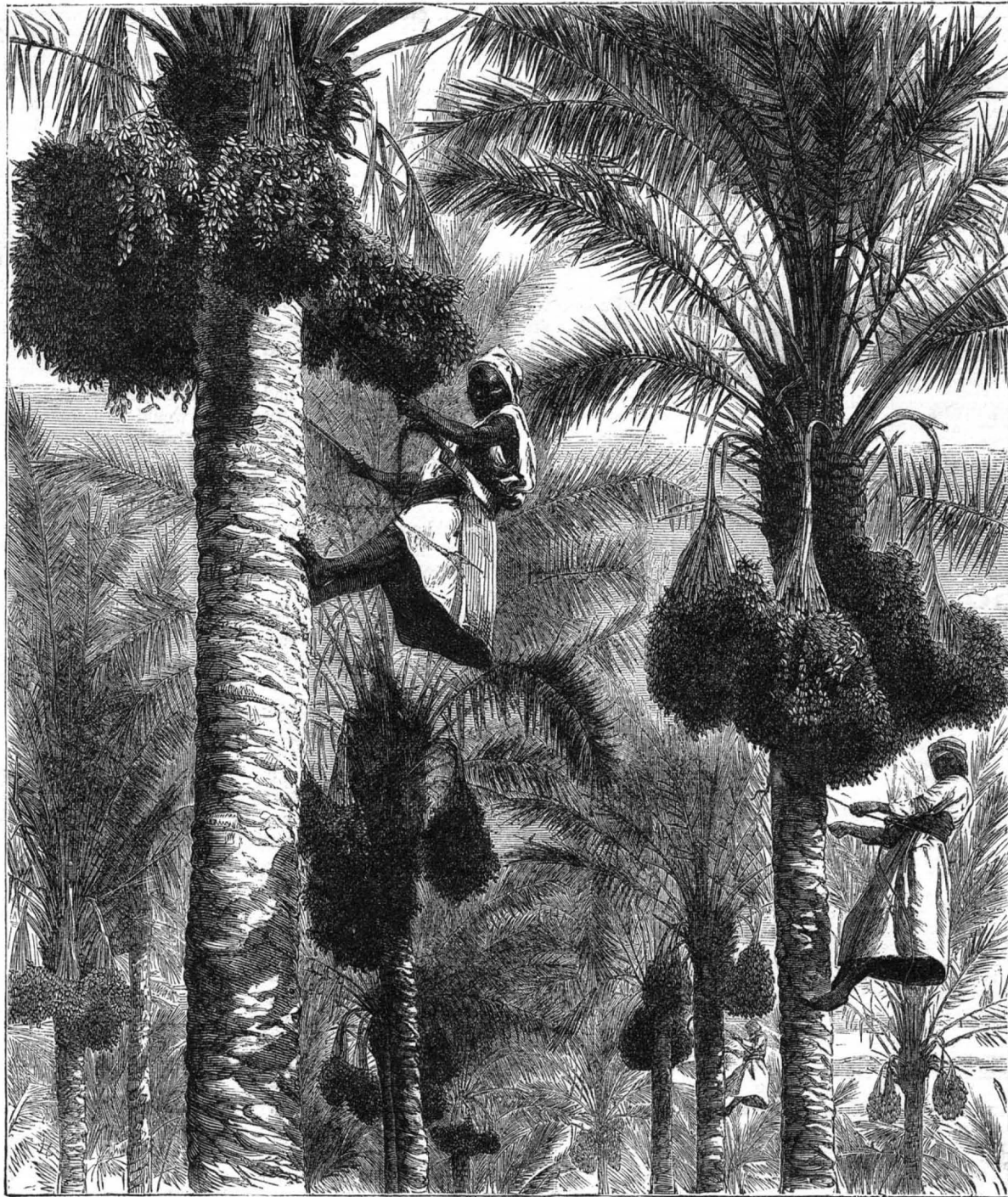

GATHERING DATES IN CEYLON.

Scientific American.

ESTABLISHED 1845.

MUNN & CO., Editors and Proprietors.

PUBLISHED WEEKLY AT
NO. 37 PARK ROW, NEW YORK.

O. D. MUNN.

A. E. BEACH.

TERMS FOR THE SCIENTIFIC AMERICAN.

One copy, one year, postage included. \$3 20
One copy, six months, postage included. 1 60

Clubs.—One extra copy of THE SCIENTIFIC AMERICAN will be supplied gratis for every club of five subscribers at \$3.20 each; additional copies at same proportionate rate. Postage prepaid.

The Scientific American Supplement

is a distinct paper from the SCIENTIFIC AMERICAN. THE SUPPLEMENT is issued weekly; every number contains 16 octavo pages, with handsome cover, uniform in size with SCIENTIFIC AMERICAN. Terms of subscription for SUPPLEMENT, \$5.00 a year, postage paid, to subscribers. Single copies 10 cents. Sold by all news dealers throughout the country.

Combined Rates.—The SCIENTIFIC AMERICAN and SUPPLEMENT will be sent for one year, postage free, on receipt of seven dollars. Both papers to one address or different addresses, as desired.

The safest way to remit is by draft, postal order, or registered letter.

Address MUNN & CO., 37 Park Row, N. Y.

Subscriptions received and single copies of either paper sold by all the news agents.

VOL. XXXVI., No. 8. [NEW SERIES.] Thirty-second Year.

NEW YORK, SATURDAY, FEBRUARY 24, 1877.

Contents.

(Illustrated articles are marked with an asterisk.)

Academy of Sciences, New York. 117	Lead, sea water and..... 119
Answers to correspondents..... 123	Moneyed men..... 122
Arts, lost, in New York..... 113	Mortar, black (10)..... 123
Augers and drills (16)..... 123	New books and publications..... 122
Bain, Alexander..... 121	Ornaments in winter, natural..... 118
Blue glass deception, the..... 121	Papin's steam engine*..... 120
Blue glass science..... 121	Patent decision, a..... 115
Boilers for small engines (2, 14)..... 123	Patent matters in Washington..... 116
Business and personal..... 123	Patent office annual report..... 117
Cafeone..... 114	Patents, American and foreign..... 122
Chromate of lime, acid (18)..... 123	Patents, official list of..... 124
Circle problem, the three (8)..... 123	Planing mill machinery..... 112
Clock collector, a..... 119	Posterity, for—a suggestion..... 112
Coal, burning small (19)..... 123	Railroad, the Wetli mountain*..... 114
Cremation temple, proposed*..... 119	Rock sections for microscopy..... 117
Dark days (11)..... 123	Roofs, leaky slate (1)..... 123
Dates and the date palm*..... 111	Rose bushes, soot for..... 119
Diseases, infectious..... 121	Salicylic acid for the feet..... 115
Dyeing process, a cold (9)..... 123	Sawdust in rough casting..... 111
Engines for boats (12)..... 123	Seed-distributing panthers..... 111
Floors, filling for hardwood (6)..... 123	Self-reliance and success..... 121
Friction at rest (15)..... 123	Snow a fertilizer..... 119
Great plant of Russia, the*..... 116	Something to do..... 121
Glass making, toughened..... 121	Spectroscope prisms (11)..... 123
Greenhouses, tar paint in (3)..... 123	Steam engine, Papin's..... 120
Harness cockeye, improved*..... 118	Steam engine, the Brown..... 120
Heating ranges (17)..... 123	Suicide statistics..... 116
Heating rooms (7)..... 123	Telegraph, the speaking..... 120
Hem-plunger, the*..... 115	Trolling hook, improved*..... 114
Hens, Leghorn..... 114	Watch, position of a (13)..... 123
Ink, purple marking..... 117	Waterproofing, suit for..... 114
Iron trade in England..... 117	White color in animals..... 120
Laboratory manipulations..... 117	Wire, crossing a river on a..... 121
Lathe chuck*..... 118	Wool, purifying..... 114
Lathe, screw-cutting*..... 118	Zinc roofs (4)..... 123

TABLE OF CONTENTS OF
THE SCIENTIFIC AMERICAN SUPPLEMENT,
No. 60,

For the Week ending February 24, 1877.

I. ENGINEERING AND MECHANICS.—Artificial Production of Ice by Steam Power.—The American Roller Skate Rink, Paris, 1 engraving.—The Little Basses Light House, 4 figures.—The Souter Point Electric Light.—On the Minute Measurements of Modern Science, by ALFRED MAYER.—Method of Measuring by Means of the Micrometer Screw furnished with the Contact Level; Method of Electric Contact Applied to Measurements with the Micrometer Screw, 2 engravings.—Abstracts from Report of the Boston Society of Civil Engineers on the Metric System.—New Turret Musical and Chiming Clock for the Bombay University, with 1 page of engravings.—Water Gas and its advantages, by GEO. S. DWIGHT.—Brattice Cloths in Mines.—Eight Horse Power Portable Steam Engine, with dimensions, particulars, and 1 page of engravings.—Clyde Ship Building and Marine Engineering in 1876.—Four Masted Ships.—New Bridges at and near New York city.—The Sutro Tunnel.—Independent Car Wheels.—Passenger Travel, New York city.

II.—TECHNOLOGY.—Design for Iron Stairway, and Iron Grilles, with 3 engravings.—The Process of Micro-photography used in the Army Medical Department.—Direct Positives for Enlarging.—A Monster Barometer.—Architectural Science, Carpentry Queries and Replies.—The Carpet Manufactures of Philadelphia. How the Centre Selvage is Formed, 3 figures.—Glass of the Ancients.—On the Preservation of Meat; a resume of the various methods now practiced.—California Pisciculture.—Saville's System of Distillation, 2 engravings.—New Bromine Still, by W. ARVINE, 1 engraving.—The Phoenix Steam Brewery, New York.—French Cognac Distillation, 1 engraving.—Schwartz' Sugar Refinery, London. General description of the establishment.—Vienna Bread and Coffee.—How Pictorial Crystals are Produced and Exhibited.

III. LESSONS IN MECHANICAL DRAWING. New Series. By Professor C. W. MACCORD; with several engravings.

IV. ELECTRICITY, LIGHT, HEAT, SOUND, ETC.—Magnetic Action of Rotatory Conductors.—The Sensation of Sound.—Sympathetic Vibration of Pendulums.—Protection from Lightning.—Musical Tones, photograph of.

V. MEDICINE, HYGIENE, ETC.—On the Treatment of Typhoid Fevers. By ALFRED L. LOOMIS, M.D.—Hydrophobia Cured by Oxygen.—The efficacy of Lymph, by M. HILLER.—Success of Chloral Hydrate for Scalds and Burns.—Uses of Cyanide of Zinc.—Dr. Brown-Sequard on Nerve Disease.

VI. MISCELLANEOUS.—Geological Notes.—A Geological Congress.—The last Polar Expedition.—Old Men of Science.—Pre-glacial Men.—Post-glacial period, Esthonia.—Northern Pacific Formations.

Terms.—SCIENTIFIC AMERICAN SUPPLEMENT, one year, postpaid, five dollars. One copy of SCIENTIFIC AMERICAN and one copy of SCIENTIFIC AMERICAN SUPPLEMENT, one year, postpaid, seven dollars. CLUBS.—One extra copy of the SUPPLEMENT will be supplied gratis for every club of five SUPPLEMENT subscribers at \$5.00 each.

All the back numbers of the SUPPLEMENT, from the commencement, January 1, 1876, can be had. Price 10 cents each.

NOW READY.—The SCIENTIFIC AMERICAN SUPPLEMENT for 1876. Complete in two large volumes. Over 800 quarto pages; over 2,000 engravings. Embracing History of the Centennial Exhibition. New Illustrated Instructions in Mechanical Drawing. Many valuable papers, etc. Price five dollars for the two volumes, stitched in paper; or six dollars and fifty cents, handsomely bound in stiff covers.

Remit by postal order. Address

MUNN & CO., PUBLISHERS,
37 Park Row, New York.

Single copies of any desired number of the SUPPLEMENT sent to any address on receipt of 10 cents.

PUBLISHERS' NOTICE.

New subscriptions to the SCIENTIFIC AMERICAN and the SCIENTIFIC AMERICAN SUPPLEMENT will, for the present, be entered upon our books to commence with the year, and the back numbers will be sent to each new subscriber unless a request to the contrary accompanies the order.

Instead of a notice being printed on the wrapper, announcing that a subscription is about to end, the time of expiration is now denoted in the printed address each week, so that the subscriber may see when the period for which he has prepaid is about to expire.

FOR POSTERITY—A SUGGESTION.

The Irish gentleman who declined to aid an enterprise for the benefit of posterity, remarking that posterity had never done anything for him, was, after all the sport made of him, no unfair representative of the bulk of mankind. There is talk enough about doing great things for the advantage of future ages, but the real motive is apt to be something very different. To perpetuate their own name or fame, men or nations often set up lasting monuments, and sometimes unintentionally convey thereby to after times a few more or less instructive indications of the artistic or industrial skill of their day and generation. To further their own immediate ends, or to secure some benefit to their immediate descendants, men frequently undertake great material enterprises, and sometimes the work so done remains for ages the source of perennial good. But very rarely, if ever, can it be said that any work of man was undertaken solely, or even chiefly, for the benefit of posterity—more rarely still, for remote posterity.

Hence it happens that we owe far more to accident, to fire, rapine, volcanic outbursts, and the protecting care of desolation, for the knowledge we have of times long past, than to any intentional legacies of art or learning left us by the men of those times. The lost and abandoned tools, weapons, and ornaments of the stone age are all that we have to tell us of the childhood of humanity. Had no fiery disasters ever overtaken the pile-dwellers of the Swiss lakes, we should probably have never heard of such a people.

To the mud and ashes of Vesuvius, rather than to the historians of the Roman Empire, we owe the best of our knowledge of how Roman cities looked and Roman citizens lived eighteen hundred years ago. In the fragments of a *terra cotta* library, buried in the ruins of a royal palace, we find almost our only records of the arts and sciences of ancient Assyria. Under the ash heaps of a forgotten age, in Cyprus, Cesnola finds the only known vestiges of a primitive civilization, reaching far back into the domain of mythology. Thanks to the destroyers of Troy and Mycenæ, and the protective care of temporary oblivion, Schliemann is now able to verify tradition and lay before an astonished and delighted world numerous precious relics of heroic ages hitherto remembered only in song.

Who can estimate the value of these and similar findings to us—the value of the revelations they bring of man's condition in those remote ages? Who can say how many or how few the ages will be ere the time comes when the antiquaries of the future will be rejoicing over equally fragmentary vestiges of the doings and possessions of our day?

On the other hand, who can estimate the value of the knowledge lost beyond hope of recovery, or the checks to human progress experienced, in the repeated wiping out, so to speak, of the higher races and the civilizations they embodied? And who can say that similar disasters may not come again and again to humanity?

Suppose a pestilence peculiarly fatal to the white race should fall upon the world to-day, crippling, perhaps exterminating, the now dominant civilized nations; how long would the material elements of our science and art or general culture remain with power to enlighten the barbarous tribes that would inherit the earth? Human progress has more than once been set back for centuries by such natural or unnatural causes, leaving the sites of once splendid civilizations to be overrun with barbaric hordes knowing nothing of the better times that went before.

Suppose, again, that, by one of those geologic changes so numerous in the history of our unstable globe, the existing continents should sink a thousand feet. Every center of modern civilization would be submerged. The great social and political organizations of humanity would be broken up, and in the wreck of nations that would ensue very little of the glory and culture of the race could survive. The earth is dotted with vestiges of lost and forgotten empires. Can we reasonably assume, in the face of such facts, that the nations of to-day are immortal?

The question is: Shall we continue to trust to chance, as all other civilizations have, for the preservation of the conquests we have made among the forces and secrets of nature; or shall we do something positive for posterity, and leave the ages to come some certain and abiding legacy of our treasures of art and learning?

It may be that human progress will go on and on to the end of time without a break; that in the course of centuries mankind will surpass us in civilization, knowledge and power, as much as we surpass the earliest and rudest men we have yet found traces of: maybe infinitely more.

In such a case, what would not the scholars of, say the year 5000 A.D., or any other future age, be willing to give for a comprehensive picture of humanity as it exists to-day—for a reasonably complete library of our literature, science,

and art? We may safely assume that nothing of the sort will be possible if matters are left to take their natural course. By that time every structure, every machine, every book, every work of art, now in use or stored away in our libraries and galleries of art, will have disappeared, a prey to time, the elements, or the more destructive violence of man.

On the other hand, it may be that, through repeated disasters of one sort or another, mankind, three thousand years hence, will have lost all the knowledge men ever possessed, and be slowly struggling upward for the hundredth time from inherited barbarism. In such a case, what enormous benefits might not accrue to man from a fortunate opening up of the wealth of knowledge we possess!

In any supposable case between these extremes of progress or degradation, a legacy of art and learning, such as we might easily set apart for remote posterity, would certainly be acceptable, perhaps extremely useful. Besides, it might be possible for us to set such a worthy example to those who shall come after us that, come what might, humanity would never be left absolutely void of the means of instruction, nor any worthy human achievement be absolutely lost or forgotten. The experience of these later years has demonstrated the value of such legacies even when unintentional, unselected, and wretchedly fragmentary. It has made clear also how a legacy deliberately made may be indefinitely preserved.

Roughly outlined, the carrying out of such a truly philanthropic enterprise would involve nothing more difficult than—

First. The construction of a practically indestructible treasure chamber in some secure place; and

Second. The preparation of a library well calculated to withstand the corroding tooth of time.

Two kinds of structures would meet the first demand—massive pyramids of covered earth or of solid masonry, or chambers hewn from the heart of some granitic hill. In low latitudes, where glacial action is not to be feared, the pyramidal form might be preferable: in more northern regions the rock-cut chamber would probably be at once cheaper and more durable. In either case, an elevated site should be chosen as a safeguard against submergence.

To secure the permanence of the records would be more difficult. Ordinary books and papers would clearly be unsuitable for long keeping; though for comparatively limited periods they might answer if securely packed in airtight waterproof cases. Nothing liable to spontaneous decay should be admitted. Stereotype plates of metal would be even more open to objection than printed sheets. The noble metals would be too costly, the baser would corrode; and with either the value of the plates as metal would be a standing danger to the deposit. The material basis of the library must be, as nearly as possible, worthless for other uses (to insure them against the natural greed of man), yet such as will hold the records sharply and faithfully under all circumstances. The *terra cotta* tablets of ancient Assyria are instructive in this connection. Possibly plates of artificial stone, or sheets of a *papier-maché*-like preparation of asbestos, might be less bulky and equally durable.

Having determined this point, and dug from the solid rock a chamber for the reception of our legacy, the next step would be the selection of its contents. Obviously the books to be preserved should embrace first of all lexicons and grammars of every known form of speech, since it is impossible to tell which of the dialects of to-day will be the parents of the dominant tongue of any distant future time; while we may be practically certain that some one or more of the languages of to-day will furnish a key to any language that men will ever use. Next in order would come encyclopædias, the most comprehensive and complete that there might be room for. The sacred books of all nations might come next; then the works of the great poets, historians and novelists; after them, the best obtainable records of art, science, the various industries, and so on, with specimens of the best and most typical of our works of art, manufacture, and the like.

The spaces between the various articles should be filled in with some insoluble and neutral substance, to prevent corrosion, or the infiltration of water and consequent damage to the plates. Then, the entrance to the chamber being securely sealed, permanent records should be made in many places and in various ways, setting forth the purpose of the deposit, its exact location, and the nature of its contents. Among such records not the least valuable would be deeply cut polyglot inscriptions on natural cliffs in different parts of the world, observation having shown that such records may remain to challenge human curiosity for ages after all other records of their time have disappeared.

Even a single deposit of this sort might prove of enormous value to the race at some critical period of its history. But the probability is that the good work would not end with one deposit. From age to age this and other nations might repeat the experiment, commemorating in this way important epochs in their history. The fashion once set might easily become a permanent feature of all great national celebrations. The cost would be comparatively small: a penny contribution from each of the visitors to the Philadelphia Exhibition, for example, would have been quite sufficient to provide for a memorial of our first Centennial year that would have carried an imperishable picture of the civilization of the day to the end of—our first millennium, at least; and we may safely infer that, whatever may be the condition of the world at that not very remote epoch, a memorial of that sort would be something worth having.

As we have intimated, the custom might easily become

general, so that in the course of ages the earth would become dotted with such repositories of art and learning. Then, come what might to humanity—whatever might be the ups and downs of nations—whatever moral, social, or intellectual advances mankind might make—whatever lapses or disasters might befall them—it could hardly happen that a knowledge of any considerable period of human history, or the advantage of any worthy human achievement, could ever be permanently blotted out and lost.

It is true that "posterity" has never done anything of the sort for us. It is true that "posterity" may have no valid claim on us for such a legacy. But we might venture to make "posterity" a present! It would not cost us much, and it might turn out to be immensely valuable and useful to some far future age.

THE LOST ARTS IN NEW YORK.

While the objects of ancient art contained in the Castellani collection, recently placed on exhibition in the Metropolitan Museum of Art in this city, are individually of great rarity and archaeological value, they derive additional importance from the fact that, viewed conjunctively as a collection, they represent connected histories of two great industrial arts extending over many centuries. Both in the work of the goldsmith and of the potter, we are enabled to trace progress from the earliest stages up to a period when the greatest skill was attained, and even subsequently into the era of decadence. In both industries, we find that ancient and mediæval workmen possessed knowledge which we do not possess; and among Signor Castellani's treasures may be seen handiwork which is the embodiment of two lost arts, the secrets of which the modern world, with all its infinitely superior wisdom, has not yet rediscovered.

The productions, in the Castellani collection, of precious metal workers dating from prehistoric epochs, the exact dates of which are wholly unknown, and covering the long period ending in the thirteenth century, are represented by the contents of some twenty cases. The first three of these receptacles bear no dates. The ornaments which they contain are of bronze, amber, silver, and glass (the latter having become converted into opalescent silicic acid), and were found in Præneste (modern Palestrina, Italy), and in the territory which was ancient Etruria. Case No. 4 bears date 700 B. C., and here is a rich treasure of primitive Etruscan and Phœnician ornaments of gold, adorned with granulated work. Signor Castellani considers that the workmanship of these objects is so perfect that it is impossible at the present time to explain the process of execution, and very difficult to imitate it. The ornaments are of two kinds—those for ordinary use and those for funeral purposes. The first are massive, and might be worn for years without injury; the others are extremely delicate. All are made of the purest gold, and their decoration evinces the most consummate skill and taste on the part of the artist. There is, for example, a small flask, shaped something like an antique wine jar, and about five inches in height. It is of beaten gold, and is covered with a pattern intended to imitate the similarly shaped designs of variegated glass of the Græco-Phœnician period. This pattern is entirely produced by minute globules of metal soldered to the surface in tiers of zigzag or vandyke patterns. Another specimen is a strip of gold covered with granulated lines and bearing a row of birds in relief. On other ornaments are exquisitely carved heads and flowers, produced apparently by hammering on the reverse of the object, but with a delicacy and precision of touch which is simply marvelous.

The closest students of this ancient handiwork are entirely at a loss to understand how the processes of melting, soldering, and wire drawing, which were employed in the art, were performed. Modern workmen have failed in their attempts exactly to imitate the old ornaments; and it is certain that the secret of the mechanical agents, whereby it was possible to separate and join pieces of gold hardly perceptible to the naked eye, is lost. Signor Castellani has taken great pains to solve the problem, reading all the treatises of mediæval goldsmiths, inquiring of all classes of Italian jewelers, and experimenting with all kinds of chemicals, in the hope of finding the solder wherewith the minute grains were attached to the surface of the metal. At last he found some of the old processes still employed in a remote district, hidden in the recesses of the Apennines, far from the great towns. Bringing away a few workmen, he gave them much more instruction, and at last succeeded, not perhaps in equalling, but certainly in rivalling the ancient productions.

We question whether the Etruscans used fire at all in their soldering, as it would be almost an impossibility to keep the excessively fine tools necessary for the work at a proper heat. Mr. Joshua Rose offers the plausible suggestion that a cold flux was employed, with which the workman followed the lines or dots of his pattern. Then the gold granules were possibly sprinkled over the surface, and adhered only to the solder, the superfluous grains being brushed off after the solder had set.

There is also a fragment of a finely woven fabric, made of threads of pure gold, found on the body of a woman in a tomb at Metapontum. This is without doubt the material to which the Psalmist refers in speaking of "the King's daughter" having "clothing of wrought gold;" and in the Pentateuch there is reference to gold threads being used upon looms.

As we follow the various objects in the twenty cases above mentioned, the decline of the goldworker's art when the use of enamels came into vogue is evidenced. Continuing on to later

periods, the decadence is more marked under the successors of Alexander. In Rome, under the emperors, we find gold used as a mere setting for precious stones, and finally the collection terminates with examples of workmanship of the time of Charlemagne, when the workmen had lost their cunning, and the noble metal had been altogether debased to secondary uses.

The second instance where a lost art is exemplified in Signor Castellani's collection is in the glazing of the Gubbio majolica. We have not space here to review the magnificent series of ancient specimens of pottery in detail; and thus it will suffice to say that, beginning with some of the earliest pieces made by the Arabs when they occupied Sicily, from the twelfth to the sixteenth century, the collection presents examples of all the finest types of later mediæval art. Gubbio, where the peculiar kind of majolica above noted was made, is a small town once in the territory of the dukes of Urbino; and in the sixteenth century it became famous for its pottery. This was attributable to the talent of one man, Giorgio Andreoli, who is reputed to have invented the wonderful luster characteristic of the Gubbio ware. The body of majolica is mere common clay; and after the piece is finished on the wheel, it is dried and burnt in a furnace. After the biscuit thus prepared has been dipped in the glaze, the colors are applied on the soft surface of the latter, and the vitrifying process fuses all into a glossy enamel of the color of the pigment. This is still the common practice; and we mention it merely to show that to his pigment and glaze Andreoli must have added some third substance, which rendered the enamel capable of reflecting white light as blue, red, green, or yellow light—in other words, of giving the object a luster of a color wholly different from the tints of the pigment. He evidently could produce any desired color at will, and the effects gained are indescribably beautiful. The Castellani collection contains 130 superb specimens, which glow like jewels. In one, the scene of the nativity of Christ is provided with the figures in low relief, and the exquisite cerulean lustre is imparted to give the effect of moonlight. The rarest pieces are those of which the luster is a delicate green. Some blaze with yellow, as if of gold; others exhibit the brilliancy of the ruby; while others resemble the interior of the pearl oyster shell. Whether this sheen is produced by polarization of the light in some manner, or whether it is at all analogous to fluorescence, is yet to be decided. The impression of the surface with fine microscopic lines might produce an iridescence, but not separate and clearly defined hues. The ware was intended for ornamental purposes, not for household use; and it was suspended against the rich, dark tapestries of the period with which walls were covered, thus aiding, as it were, in illuminating the apartment with its exquisite radiance.

THE BLUE GLASS DECEPTION.

On September 26, 1871, General A. J. Pleasonton, of Philadelphia, Pa., obtained a patent for "utilizing the natural light of the sun transmitted through clear glass, and the blue or electric (!) solar rays transmitted through blue, purple, or violet colored glass, or its equivalent, in the propagation and growth of plants and animals." In his specification, of which the above constitutes one claim, he states that he has discovered "special and specific efficacy in the use of this combination of the caloric rays of the sun and the electric blue light in stimulating the glands of the body, the nervous system generally, and the secretive organs of man and animals." He also states that he finds that vegetation is vastly improved by the transmitted blue light.

These alleged re-discoveries—for the General only claims to have devised the method of utilizing them—were extensively promulgated through the press early in 1871. Subsequently, in 1876, General Pleasonton published a book on the subject, the volume being appropriately bound in blue and printed in blue ink. Recently public attention has again been called to the subject by a New York daily journal. The peculiar kind of glass in question is known as "pot metal blue," that is, it is stained a bluish violet throughout, and is not clear glass covered with flashings of blue glass. It is used in greenhouses, etc., in connection with clear glass; and in General Pleasonton's graperies it appears that only every eighth row of panes was blue. Some of the results alleged to have been obtained by exposing animals and plants are as follows: Twenty grape vines, in their second year, after being set out under the blue glass, bore 1,200 lbs. of splendid fruit. A very weak Alderney bull calf was in four months developed into a strong and vigorous bull. Heifers when kept under blue glass may safely bear young when 18 months old. A weak child, weighing but 3½ lbs. at birth, weighed at the end of four months 22 lbs.—the light in this instance having come through blue curtains. Two major-generals with rheumatism were cured in three days. A young lady whose hair had come out regained her tresses; and to these must be added various other cures of severe ailments which we have not space here to recapitulate. The above are the alleged facts; and we propose to consider the supposed discovery in the light of previous investigations.

With reference to the theories of electricity, etc., advanced by General Pleasonton to account for his phenomena, their absurdity is so complete that we shall waste no time over them. The important question in the matter, and the only one in which the public is interested, is whether or not blue glass is capable of producing all or any of the results imputed to its use. In order to clear the way for the examination of

the investigations, the records of which we have carefully collected, let us consider first those which General Pleasonton quotes in support of his views. These are (1) Seunebier's researches, which go to show that the blue and violet rays are the most active in determining the decomposition of carbonic acid in plants, and (2) experiments of Dr. Morichini, repeated by Carpa and Ridolfi, proving that violet rays magnetized a small needle. The first statement has been totally disproved. Dr. Von Bezold, in his recent work on color, states that "the chemical processes in plants, as far as they are dependent upon light, are principally caused by the rays of medium and of lower refrangibility. The development of the green color of the chlorophyll, the decomposition of carbonic acid, as well as the formation of starch, etc., in the grains of the chlorophyll, are induced by the red, green, and orange rays." The blue, violet, and ultra violet rays, the same authority goes on to explain, influence "the rapidity of growth, compel the so-called zoöspores to move in certain directions, and alter the positions of leaves, etc. In confirmation of this, we have Sach's experiments in 1872, which show that light, transmitted through the yellow solution of potassium chromate, enables green leaves to decompose over 88 per cent. of carbonic acid; while that passed through blue ammonia copper oxide decomposes less than 8 per cent. This proves the superiority of the yellow ray to decompose carbonic acid; and this fact Professor J. W. Draper discovered a long time ago by the direct use of the spectrum. In still further confirmation, we may cite the investigations of Vogel, Pfeiffer, Selim, and Placentim. The last three have conducted researches in full knowledge of those of General Pleasonton, and their experiments show that yellow rays are more promotive of the evolution of carbon in animals and its absorption in plants than any others in the spectrum, the violet rays having least power in these respects, with the exception of the red rays in the case of animals. The absorption of carbonic acid by plants, and its evolution by animals, we hardly need add, are prime essentials to the growth and health of each. The notion that light possesses a magnetizing power on steel was upset by Niepce de St. Victor in 1861. After removing every source of error, he "found it impossible to make one sewing needle, solarized for a very long time under the rays of light concentrated by a strong lens, attract another suspended by a hair, whether the light was white or colored by being made to pass through a violet-colored glass."

We can proceed further and even show that violet light in some respects hurtful to plants. Cailletet, for example, says in 1868 that "light which was passed through a solution of iodine in carbonic disulphide prevents decomposition altogether." Baudrimont says that "no colored light permits vegetables to go through all the phases of their evolutions. Violet-colored light is positively injurious to plants; they absolutely require white light." This scientist instituted the most elaborate experiments on the subject, ranging over 11 years, from 1850 to 1861; and the result of all his labor may be summed up in the simple statement that no illumination which human ingenuity can devise is so well adapted for promoting natural processes as the pure white light provided by the Creator. So much by way of general denial of the claims of superior efficacy residing in blue light of any kind.

Now we have yet to examine the peculiar variety of blue light here used. Sunlight can, by means of the prism, be split into colored rays, any one of which we may isolate, and so obtain a certain colored light. Similarly we may obtain light of a desired color by the use of a colored glass which will stop out the rays not of the hue required. So that we may obtain violet light from the spectrum or by filtering sunlight through violet glass. When, however, Dr. Von Bezold, as above, asserts that the violet rays have such and such an effect, he means the violet of the spectrum, which has its specific duty to perform in the compound light of which it is a necessary portion. But the violet light of the spectrum and filtered violet sunlight are altogether different things. The first, as our valued contributor Dr. Van der Weyde has very clearly pointed out, is "a homogeneous color containing, besides the luminous, the invisible chemical rays without any caloric rays; while the light colored by passing through violet glass is a mixture of blue rays with the red rays at the other end of the spectrum; and it contains a quantity of the chemical rays belonging to the blue and the caloric rays belonging to the red. In fact, violet glass passes a light identical with sunlight, only much reduced in power, containing but a portion of its caloric, chemical, and luminous agency: being simply deprived of its strongest rays." And this the spectroscopist has clearly demonstrated. Reduced to its simplest terms, then, the necessary conclusion is that the violet glass acts purely as a shade for decreasing the intensity of the solar light. And in the simple fact that it does so serve as a shade lies the sole virtue (if any there be) of the glass. In 1856, Dr. Daubeny made experiments on the germination of seeds, and in his report is this suggestive sentence: "In a south aspect, indeed, light which had passed through the ammonia sulphate of copper (blue solution), and even darkness itself, seemed more favorable than the whole of the spectrum; but this law did not seem to extend to the case of seeds placed in a northern aspect where the total amount of light was less considerable."

In our next issue, we shall review the effects of light and darkness upon the animal organization, and endeavor to account for the curing of diseases and the production of other phenomena which have been erroneously ascribed to the influence of the blue filtered sunlight.

THE WETLI MOUNTAIN RAILROAD AND ITS DISASTROUS TRIAL TRIP.

Among the various means proposed of late years for building lines of railroad on the steep slopes of mountains, that of M. Wetli, of Zurich, Switzerland, has attracted considerable attention from European engineers. We have already laid before our readers the system of central toothed rails used on the Righi and other mountain roads in Europe. In the Wetli system, instead of this rail and the pinion on the vehicle engaging it, there is a drum having a helicoidal thread which engages with triangular rails. This drum is attached to the locomotive. The construction will be readily understood from the illustrations given herewith, which we take from *La Nature*. The thread on the drum is precisely that which would be formed could a rail similar to one of the central angular rails be wrapped around it; so that it always is in contact with the mid rails, and necessarily prevents any bodily sliding or rolling of the vehicles over the regular track when the drum is held motionless. The V-shaped mid rails are securely fastened to horizontal iron ties, which rest on wooden traverses. The angle of the V is 50°; the distance between any two traverses is 2.8 feet.

The locomotive has three coupled axles, on the mid one of which the drum is attached so as to be raised or lowered to engage the rails at the will of the engineer: it being possible to cause it to act on the rails with a pressure of 3.7 tons. The diameter of the drum is 2.14 feet. Its spiral thread is of steel, very solidly attached, and so made as to grip the rails to a distance of 0.6 inch below the level of the track. In order to insure this contact, on the drum axle are two pulleys which run on the exterior road, and of which the diameter determines the depth of the hold of the threads. These pulleys are 3.7 inches in diameter, while the driving wheels are very slightly in excess, to provide for the use of tyres.

M. Wetli's invention, as we have described it, was placed between Woodenswil and Einsiedlen, Switzerland. The difference in altitude between these points is 1,513 feet, the distance 9.6 miles. The grade is from 4 to 5 per cent over the first six miles of the way, and subsequently decreases to 1 per cent. The Wetli railroad was established last October only on the heavy grade, that is, the first six miles

Fig. 2.

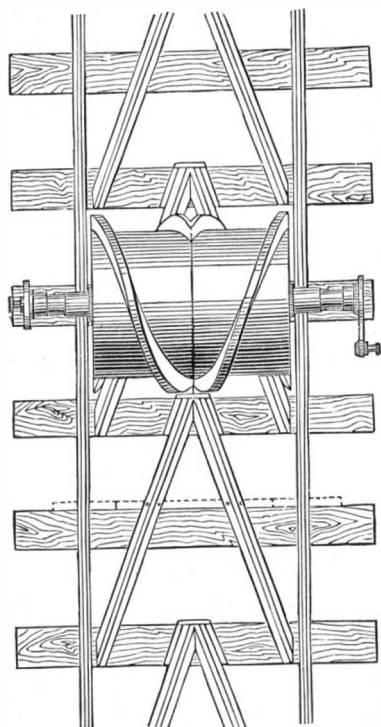
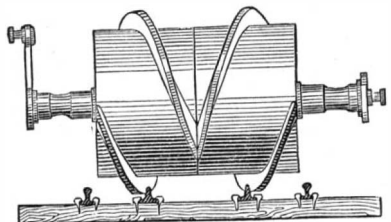

Early in November, trial trips were made which did not prove satisfactory. Sometimes the drum thread gripped the triangular rails properly and acted well; again it would wedge itself upon them, and often would simply roll over their tops without engaging at all. After the first trials, during

which very many of the rails were broken, M. Wetli re-adjusted the drum thread. Finally, he concluded that he had overcome all difficulties in his apparatus; and accordingly a formal trial was arranged on November 30. For about four and a half miles of the ascent the drum worked well; and the hoarfrost, with which the rails were thickly covered, showed good contact. Afterward it worked irregularly; but the station of Schindelleggi, a distance of five miles, was reached without accident, the locomotive dragging a car loaded with 20 tons of rails. It was then attempted to make the descent by the aid of the helicoidal drum; but this jumped the rails, and broke them almost immediately. By the aid of back pressure of steam and brakes, the locomotive was stopped. Then, unfortunately, the engine was

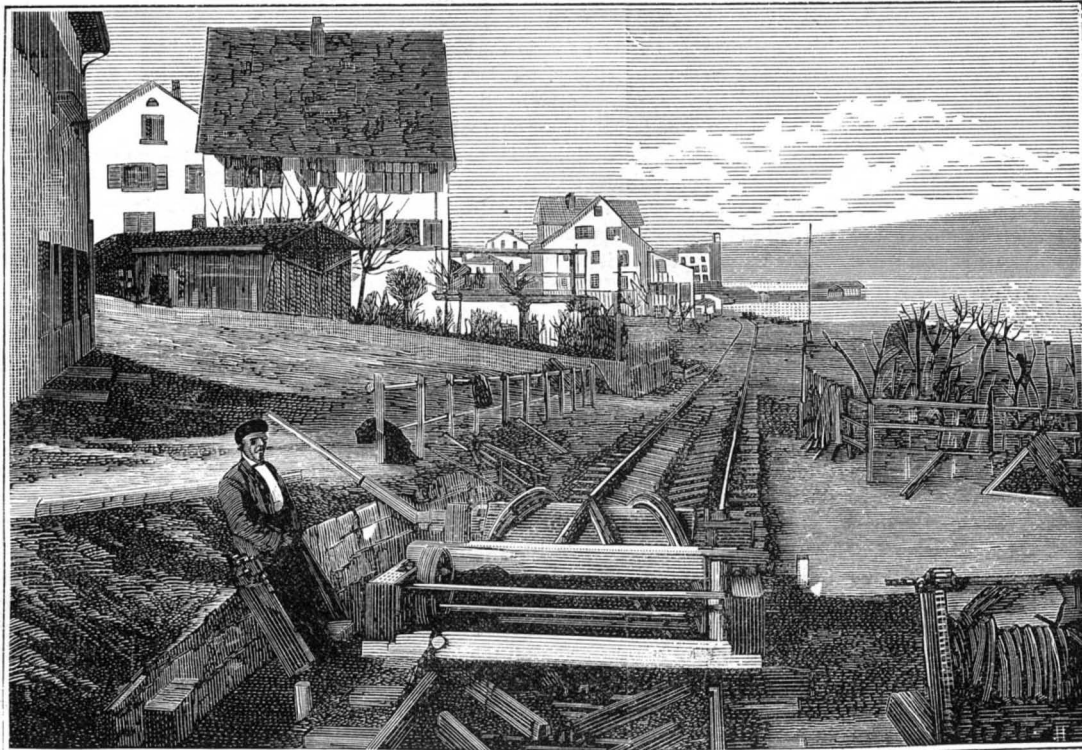

Fig. 1.—THE WETLI MOUNTAIN RAILROAD.

started again; but hardly had the descent been resumed when it was evident that the drum was not holding, and that the speed was accelerating rapidly. Brakes and steam were both found useless, and the engine went tearing over the rails at the rate of a mile a minute. Of the fourteen persons in the vehicles, three were thrown out and killed, and the rest were more or less seriously injured. The heavily loaded car left the track, and tore up both central and side rails until its coupling broke. The engineer, with great intrepidity, clung to his engine, coolly giving signals to open switches so that the locomotive might run upon the level track and so expend its momentum; but the engine left the rails at a sharp curve, destroyed the track for about a hundred feet, and finally stopped a mass of ruins, with its brave engineer mortally wounded. Whether the Wetli system can be made to work as intended by the inventor is regarded as doubtful by the engineers who have examined into the causes of the disaster.

Leghorn Hens.

If a man keeps Leghorns he must have no garden, or he must cover the top of his hen yards. That Leghorns are great layers and active hens, there can be no denying, but they are great flyers. We have built our yard a lath and a half high, says the *Poultry Review*, but what do these saucy things care for that? Although they have the whole outside world to range in, yet the garden seems to have a greater attraction than all the rest. The other day we found it necessary to feed a weak chicken in the garden by itself, so that it might be sure of its share. A few minutes afterwards, on looking out of the window, we discovered the weak chicken in the benyard and two Leghorn hens finishing up its food. We went out, but the two robbers had fled. Going around the corner, we found them rolling in a flower bed. A Leghorn will do as much mischief in a garden in five minutes as anything we know of.

Sawdust in Rough Casting.

Siehr recommends very highly the use of sawdust in mortar as superior even to hair for the prevention of cracking and subsequent peeling off of rough casting under the action of storms and frost. His own house, exposed to prolonged storms on the seacoast, had patches of mortar to be renewed each spring, and after trying without effect a number of substances to prevent it, he found sawdust perfectly satisfactory. It was first thoroughly dried and sifted through an ordinary grain sieve to remove the larger particles. The mortar was made by mixing 1 part cement, 2 lime, 2 sawdust, and 5 sharp sand, the sawdust being first well mixed dry with the cement and sand.

SUITS FOR WATERPROOFING FABRICS.—A German chemist has patented the waterproofing of finely woven fabrics, linen, cotton, etc., by means of suint composition. He adapts his method to securing the suint to wool-washing establishments at a small cost.

Absence of White Color in Animals.

Some very curious physiological facts bearing upon the presence or absence of white colors in the higher animals have lately been adduced by Dr. Ogle. It has been found that a colored or dark pigment in the olfactory region of the nostrils is essential to perfect smell, and this pigment is rarely deficient except when the whole animal is pure white. In these cases the creature is almost without smell or taste. This, Dr. Ogle believes, explains the curious case of the pigs in Virginia adduced by Mr. Darwin, white pigs being poisoned by a poisonous root which does not affect black pigs. Mr. Darwin imputed this to a constitutional difference accompanying the dark color, which rendered what was poisonous to the white colored animals quite innocuous to

the black. Dr. Ogle, however, observes that there is no proof that the black pigs eat the root, and he believes the more probable explanation to be that it is distasteful to them, while the white pigs, being deficient in smell and taste, eat it, and are killed. Analogous facts occur in several distinct families. White sheep are killed in the Tarentino by eating *hypericum criscum*, while black sheep escape; white rhinoceros are said to perish from eating *euphorbia candelabrum*; and white horses are said to suffer from poisonous food where colored ones escape. Now it is very improbable that a constitutional immunity from poisoning by so many distinct plants should, in the case of such widely different animals, be always correlated with the same difference of color; but the facts are readily understood if the senses of smell and taste are dependent on the presence of a pigment which is deficient in wholly white animals. The explanation has, however, been carried a step further by experiments showing that the absorption of odors by

dead matter, such as clothing, is greatly affected by color, black being the most powerful absorbent, then blue, red, yellow, and lastly white. We have here a physical cause for the sense-inferiority of totally white animals which may account for their rarity in nature. For few, if any, wild animals are wholly white. The head, the face, or at least the muzzle or the nose, are generally black. The ears and eyes are also often black; and there is reason to believe that dark pigment is essential to good hearing, as it certainly is to perfect vision. We can therefore understand why white cats with blue eyes are so often deaf—a peculiarity we notice more readily than their deficiency of smell or taste.—*Dr. Wallace, British Association, 1876.*

IMPROVED TROLLING HOOK.

Mr. Henry C. Brush, of Brush's Mills, N. Y., has patented through the Scientific American Patent Agency an improved troller, the novel feature in which consists in attaching a float to the shank of the implement under the revolving blade, the object being to keep the troller near the surface of the water, where the fish may see it more readily, and whereby the liability of catching in weeds and logs is obviated.

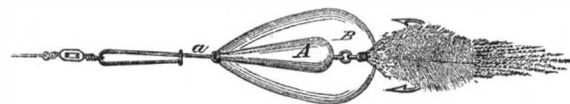

A is a float, attached to the shank, *a*, of the troller. B is the spoon, which is swiveled in the usual manner. The device is very simple, and is claimed to prevent all the annoyance arising from the hook catching in sunken obstructions.

Purification of Wool and Woolen Stuff.

The process, patented some time ago, for the removal of straw, burrs, etc., from wool, by treatment with sulphuric acid, has been modified by Lisc as follows: The stuff is worked for one to two hours in a bath consisting of about 26 gallons sulphuric acid, of 3° to 6°, 1 lb. alum, 1/2 lb. salt, and 750 grains borax. It is then treated in a centrifugal machine, and afterward subjected to a temperature of 212° to 248°. For removal of the acid it is first washed with pure water for 1 1/2 hours, then treated for two hours with fuller's earth, soda, and lime, and finally washed for two hours with fresh water. As sulphuric acid can only be employed with uncolored cloths, or such as have been dyed with indigo, chloride of zinc and chloride of manganese diluted to 6° are substituted with fabrics otherwise dyed.

Caffeone.

Caffeone, the aromatic principle of coffee, may be isolated by distilling 5 or 6 lbs. roasted coffee with water, agitating the aqueous distillate with ether, and afterwards evaporating the ether. It is a brown oil, heavier than water, in which it is only very slightly soluble. An almost imponderable quantity of this essential oil will suffice to aromatize a gallon of water.

THE HEMI-PLUNGER.

The novel form of vessel, to which the above odd name has been given by its inventor, M. Donato Tommasi, of Paris, France, is a combination of a boat wholly submerged with a raft: a connecting link, to borrow the naturalist's expression, between the submerged torpedo boat and the monitor. The advantages which are expected to be realized from this hybrid craft, the inventor describes as follows: "It is evident that a vessel, plunged several yards below the surface of the sea, is no longer influenced by wind or wave. Let the sea be agitated, let there be the most violent tempest, yet the boat which navigates under water will never be wrecked, for the same reason that a fish cannot be drowned. * * * What a beautiful vision, that of traversing the ocean, as a balloon floats through the air, with the same tranquillity, without shocks, without the insupportable rolling and pitching!" etc. The construction of the invention introduced in this glowing manner will be understood from Figs. 1 and 2. A is the plunger cylinder, shown with its side broken away in Fig. 2. In Fig. 1, G is the rudder, H the propeller, and I the tube through which sea water passes to the pump. In Fig. 2, C is the smokestack, M M are compartments in which water may be admitted to increase the weight, and hence the depth of flotation of the plunger, the same being filled or emptied by the pump, P. N is the hold for merchandise, partitioned off from the boiler room as shown.

From the plunger, A, rise two hollow columns, E, to which metallic plates, F, are attached to diminish friction through the water. These support the upper division or platform, B. The second shaft (not lettered), which rises above the platform in Fig. 1, serves to ventilate the plunger. The columns, E, serve as shoots down which merchandise is lowered to the compartments, N; and their upper ends are received in two immense inverted cups attached to the bottom of the part, B. Through these cups pass large screws, which confine the columns so that, by removing the connection, the whole submarine apparatus may in case of necessity be freed from the upper works. On each side of the platform, B, which is of elliptical figure, is a large float, seen in Fig. 3, which, by means of racks and gearing, may be raised or lowered at will. Usually these floats are carried at a height of a yard above the water. In calm weather, this distance is increased, and in storms it is diminished, the object of the floats being to keep the whole vessel on an even plane, and to prevent too violent oscillations. In order to facilitate navigation in shallow water, the columns, E, may be made telescopic, and operated by hydraulic apparatus, so that they may be shortened at will. Any form of engine or propeller may be used.

Besides the advantage of the vessel being unaffected by waves, since its submerged portion travels far below them, the inventor claims that it will meet less resistance from the water than would a vessel of corresponding volume sailing on the surface. It will make faster progress, because it has no waves to mount and descend; and hence it always travels in a nearly right line. The screw being submerged at a great depth will not tend to turn the vessel from her straight path. The platform being easily detachable may serve as a raft in case of injury to the submarine boat. For fast travel, on lakes, rivers, and shallow water generally, M. Tommasi proposes to support his platform on two floats which rest on the surface of the water. No weight, therefore, is thrown on the submarine vessel, which need be constructed with only just enough buoyancy to sustain itself and its engine. In this way, the upper craft has no engine or other load than its cargo; and as it merely rests upon the surface, the inventor thinks that it will skim over the same like an ice boat on ice.

For war purposes, the hemi-plunger is especially adapted, because the vulnerable portions, engines, boiler, rudder, etc., are wholly out of the reach of shot. Guns are mounted on the platform, which thus becomes a circular or elliptical turret, just above the water when the vessel is in fighting trim. Instead of steel armor, M. Tommasi has a new invention which he calls hydro-metallic plating. He reserves the details of this for future publication; but generally the armor consists of tubes in which liquid is forced under a pressure equivalent to the resistance, say, of forged steel. He thinks this will oppose shot as effectually as the solid metal, and will have the additional advantage of superior lightness.

IN-SOLES saturated with salicylic acid have been introduced as a remedy for perspiration of the feet.

Supreme Court Patent Decision.

A United States patent was granted May 23, 1854, to John Myers and Robert G. Eunson for a wood-sawing machine for cutting boards into thin stuff for making picture frame and mirror backs. One of the principal claims was for the employment of two deflecting plates, one on

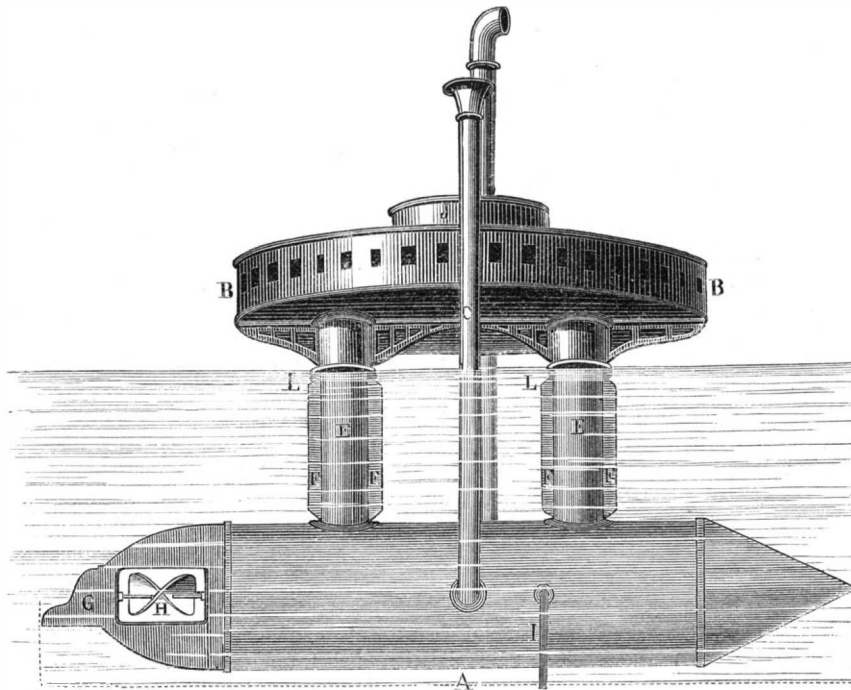

Fig. 1.—TOMMASI'S HEMI-PLUNGER.

each side of the circular saw, by which both sides of the sawed stuff, as fast as it was cut, was slightly deflected so as not to bind upon the saw. Suit was brought by the patentee against Dunbar and Hopper for infringement, and judgment was given in favor of the patentees, in the United States Circuit Court, this city, the damages awarded being \$9,121. The defendants thereupon took an appeal to the Supreme Court of the United States,

in Northern Europe, and in carrying out this commission he repaired to Russia, where he invented the first machine for planing wood. Its mode of operation, whether reciprocating or rotating, it is impossible to ascertain positively, but the conclusion arrived at, after referring to the specifications of his first patent, which was issued in 1791, is that it worked upon the former principle by means closely analogous to the operation of planing by hand. He seems to have made no

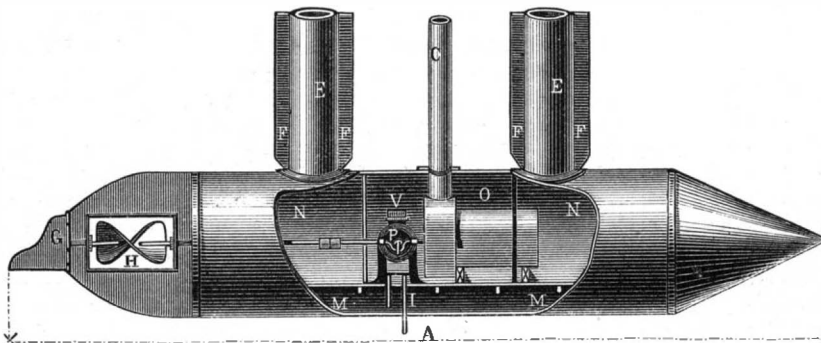

Fig. 2.—THE HEMI-PLUNGER, THE SUBMERGED PORTION.

which tribunal has reversed the finding of the Circuit Court and dismissed the complaint. It was held by the Supreme Court that, inasmuch as the use of a single deflecting plate was old, well known, and in common use, it was simply an exercise of ordinary mechanical skill, and not a patentable invention, to employ a second deflecting plate, although the superiority of the double deflectors, for certain kinds of work, appears to be conceded.

This factory was established in 1794, but was soon found to be too small for the purpose, and another building was occupied. In a lecture before the Society of Arts, in 1853, Professor Willis, referring to the shops of the Bentham's, stated that "there were constructed machines for all general operations in woodwork, including planing, molding, rebating, grooving, mortising, and sawing, both in coarse and fine work, in curved, winding, and transverse directions, and shaping wood in complicated forms; and further, as an example, that all parts of a highly finished window sash are prepared, also all parts of an ornamented carriage wheel were made so that nothing remained to be done by hand but to put the component parts together."

In 1797 the Admiralty consented to the introduction of such of these machines as could be used to advantage in the different dockyards, and they were manufactured under the direction of Jeremy Bentham, and forwarded from time to time to Portsmouth and Plymouth, where they were used with good results, performing all that was claimed for them.

Bentham was joined in 1810 by another genius (formerly in the employ of the brothers) by the name of Brunel, who had invented several valuable machines, among which was one for shaping block shells, which seems to have had Bentham's indorsement. As Inspector General, in 1803, Sir Samuel advised the Admiralty to introduce many of his new machines, and also to permit the use of steam engines; accordingly, the dockyards were fitted with engines for sawing, planing, boring, tenoning, mortising, etc. The labor saved by their use can be inferred from the fact that Brunel, who had assisted in their construction, received as a premium for his inventions the amount saved in the yards by their use in one year, which reached the respectable sum of \$80,000. In the same year the government settled with Jeremy Bentham, after arbitration,

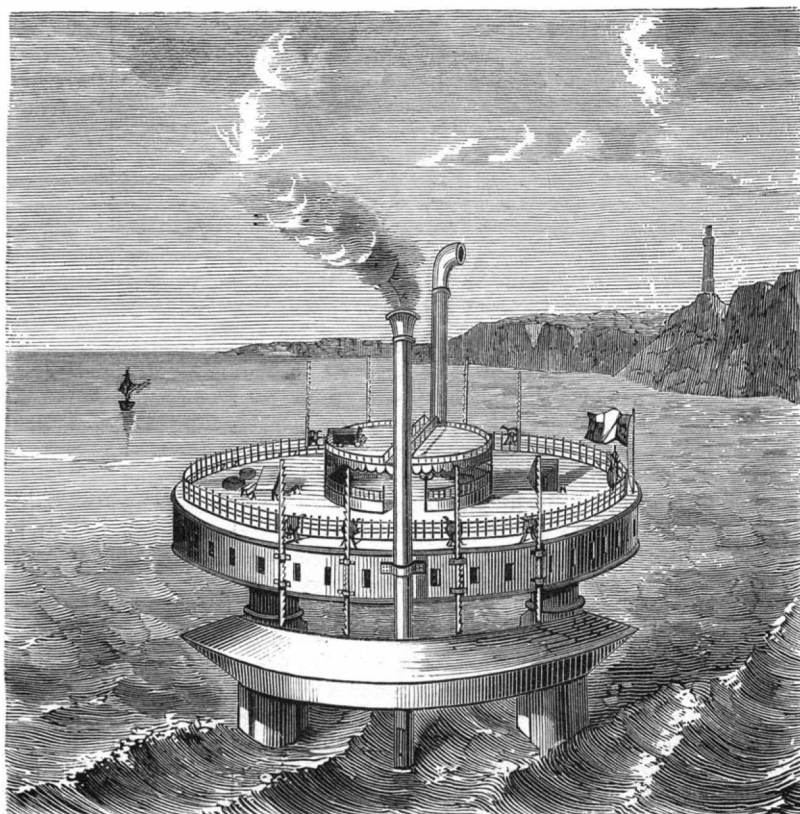

Fig. 3.—THE HEMI-PLUNGER ON A VOYAGE.

Planing Mill Machinery.

The planing machine, next to the saw, is perhaps the most important agent for the conversion and manipulation of wood in use; and before proceeding to consider it, in its present form, says the author of this article, Mr. F. H. Morse, in the *Northwestern Lumberman*, it may not be out of place to notice briefly its origin and history.

The first man to employ power in the operation of smoothing the surface of wood was Sir Samuel Bentham, of London, England, and to him belongs the honor of having discovered the principle upon which all planing machines operate. A brief personal notice of this remarkable inventor will serve to show under what circumstances the planing machine originated. His education was secured at the Westminster school of London, and, as far as can be ascertained from the meager records of his life that have come down to us, was of the most thorough kind, both classical and scientific, that could be obtained at that time (1770). When his education was finished, he was bound to the master shipwright of the Woolwich dockyard, to whom he served an apprenticeship of seven years, acquiring in that time a practical knowledge of the methods of working in both wood and iron then in vogue, and receiving the best scientific instruction that the development of that period afforded. After his term of apprenticeship had expired, he spent about two years in looking up the local peculiarities of other shipyards whose methods of working differed in some respects from those of the Woolwich mechanics.

In 1779 he was ordered by the government to examine into the progress of shipbuilding and to report on the state of the art. He was sent to Russia, where he was employed to examine into the progress of shipbuilding and to report on the state of the art. He was sent to Russia, where he was employed to examine into the progress of shipbuilding and to report on the state of the art. He was sent to Russia, where he was employed to examine into the progress of shipbuilding and to report on the state of the art.

and allowed him for machines furnished the yards and prisons, \$100,000. We learn from testimony given before the arbitrators that "Sir Samuel Bentham prepared a system of machinery for the employment of men without skill, and particularly with a view to utilizing convict labor. In 1793 patents were taken out on these inventions to secure their exclusive use for the prisons." The testimony states that no skill was required in the use of these machines; they were introduced into the dockyards and worked by common laborers. It was claimed that nine tenths of the labor was saved by the use of Bentham's machines, which proves that they were at least effective, which cannot be said in all cases of those of modern manufacture.

The patent of Bentham, issued in 1793, is doubtless one of the most remarkable ones ever issued, both for the importance of the inventions it protected and the clearness with which they and the principles on which they operated are described. Richards, in referring to that section of his patent which relates to rotary tools for woodcutting, quotes the inventor as saying: "The idea of adapting the rotative motion of a tool with more or less advantage, to give all sorts of substances any shape that may be required, is my own, and, as I believe, entirely new."

For those not skilled in nor acquainted with the nature and extent of the various operations in wood conversion which come under the head of shaping with rotary cutters, it will be difficult to convey an idea of the invention here set forth; it includes, indeed, nearly all operations in woodworking, and as an original invention may be said to consist in the discovery of the fact that flat surfaces, or surfaces of any contour, can be properly prepared by the action of rotating tools. It is not to be wondered at that such an operation should not have been sooner discovered, for even at the present time there are few processes in treating material which seem so anomalous as that of planing a flat surface with cutters revolving in a circle of a few inches in diameter.

In reference to planing mouldings, it is said: "If the circumference of a circular cutter be formed in the shape of any moulding, and projecting above the bench no more than necessary, the piece being shoved over the cutter will thus be cut to a moulding corresponding to the cutter—that is, the reverse of it, just as a plane iron cuts the reverse. If a plane cutter, such as that above spoken of for cutting a groove in the breadth of a piece, be made so thick, or, as we might be apt to say now, so broad, or so long, as to cover the whole breadth of the piece, it will present the idea of a roller. This I call a cutting roller; it may be employed in many cases with great advantage to perform the office of a plane."

The cutting roller of Bentham is the present cutter block of England, or the cutting cylinder of America, and after what has been quoted it may be seen that the idea of rotary planing and moulding machines had been fully grasped by Bentham. He goes on as usual to the various conditions which attach to the process of planing, and says further: "if a cutting roller of this sort be placed with its axis horizontal and the bench beneath, it may be made to rise and lower. The bench (machine) may be very readily adjusted, so as to determine the thickness to which a piece will be reduced by being passed under the roller." "To gain time, cutters may be applied to different sides of a piece at once, and such of them as make parallel cuts may be mounted on the same spindle."

These extracts would not be out of place in an explanatory lecture or essay on woodcutting at the present day, and cannot help awakening surprise that they should have been written eighty-three years ago, when there had, so far as we know, been no precedents, nor even suggestions from previous practice.

The foregoing shows that nearly all the fundamental principles, upon which woodcutting by machinery in its present development depends, were familiar to Sir Samuel Bentham, and though his name has been almost forgotten, it may be safely asserted that he gave to the world more useful inventions than any other man of his age. His work shows throughout a constant method and system of reasoning, which point rather to a life of persistent labor than to one of what would ordinarily be called genius. That latter quality he must certainly have possessed in the highest degree, for without it even his knowledge and experience could not have been equal to the work he accomplished. Directed to different ends, his talent and genius would doubtless have secured for him a fame that would live for years, though it does not seem possible that he could have conferred upon the world a greater benefit.

Suicide Statistics.

A curious and suggestive table of statistics has recently appeared in France, which will doubtless prove of much value in the hands of students of psychology and nervous mental ailments. It relates to suicides; and the conditions, etc., of the people who made away with themselves in 1874 in France are taken as the basis of the figures. In that year, 5,617 suicides occurred, the largest number ever known in any one year in the country. Of these, 4,435, or 79 per cent., were committed by men, 1,182, or 21 per cent., by women. In spite of the careful investigations of the police, the ages of 105 people could be determined. The 5,512 others are divided as follows: 16 years, 29; between 16 and 21 years, 193; between 21 and 40 years, 1,477; between 40 and 60 years, 2,214; exceeding the last mentioned age, 1,599. About 36 per cent. of these unfortunates were unmarried, 48 per cent. married, and 16 per cent. widowers. Of those which con-

stituted the last two classes, nearly two thirds had children. More than seven tenths of the suicides were effected by strangulation or drowning. The crime was most frequently committed during spring, when 31 per cent. of the whole number destroyed themselves; during other seasons the percentages were: in summer, 27; in winter, 23; in autumn, 19.

Included in the tables are the results of the judicial inquests, showing the professions and callings of the deceased. About 33 per cent. were farmers, 30 per cent. mechanics, 4 per cent. merchants or business men, 16 per cent. members of the liberal professions, 4 per cent. servants, and 13 per cent. were destitute of any calling. The table even analyzes, in all but 481 people, the motives which caused the fatal act. Thus we are told that 652 killed themselves because of reverses in fortune, 701 through family troubles, 572 through drunkenness, 243 through love, debauchery, etc.; 798 died to avoid physical suffering, 59 to avoid the penalties of capital crimes, 489 for unclassified troubles, and 1,623 were clearly shown to have been afflicted with some mental disease.

Communications.

The Frost Plant of Russia.

To the Editor of the Scientific American:

Mr. Charles Williams, of Wino, Ohio, has written a letter to that veteran botanist, Humphrey Marshall, of Chester county, Pa., on the subject of the abovenamed plant, and my opinion concerning it has been asked for. Seeds of this plant were obtained by citizens of Boston, who had snow brought from the White Mountains and from the coast of Labrador, and who stated that they have "now the most unbounded satisfaction and pleasure of announcing that all signs are favorable to the realization of their fondest hopes." This wonderful plant, it seems, was found amid the perpetual snows of the northern boundaries of Siberia, in 1863, by Count Swinoskoff, the eminent Russian botanist, and it was by him cultivated at St. Petersburg. The account sent me is very vague, and is evidently not from the pen of a botanist. It is stated that it comes forth on the first day of the year, grows to the height of three feet, and flowers on the third day. It continues in bloom for twenty-four hours, then dissolves itself, being of the finest snow; it has a stalk one inch in diameter, and leaves, three in number, $1\frac{1}{2}$ inches wide, covered with infinitesimal frost or snow cones. The flower is of the shape of a star, with petals 3 inches long and $\frac{1}{2}$ inch wide at the broadest part, forming a basketwork of frost. The seeds are like a pin's head. This is about all that can be gleaned from the description, and is by no means satisfactory. Allow me to present my humble views of an analogous discovery of frostwork on December 6, 1856, in a sandy loam in Chester county, Pa., near the Paoli monument. In the *Horticultural Journal* of Philadelphia, then edited by J. Jay Smith (New Series, volume vii., page 73, 1857), an account was published of my observations then. These I have since more fully confirmed. The common dittany (*Cunila Mariana*) is frequently met with in December, with the base of the stem surrounded with shellwork of

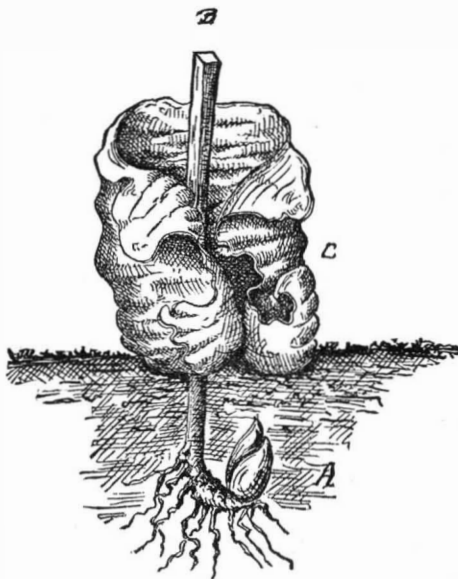

Root-bud and frost-flower of the *Cunila Mariana* (Maryland Dittany). A, the developing or budding root. B, the old stem of the previous year. C, the congealed vapor or hoarfrost, forming the first flower of various shapes.

ice, of a pearly whiteness. Dr. Darlington, in his "*Flora Cestrica*," published in 1853, page 199, under the article *cunila*, observes: "In the beginning of winter, after a rain, very curious ribbons of ice may be observed, attached to the base of the stems, produced, I presume, by the moisture of the earth rising in the dead stems by capillary attraction, and then being gradually forced out horizontally, through a slit, by the process of freezing. The same phenomenon has been observed in other plants. See observations on *helianthemum*, page 27." Had the doctor given a more extended investigation, I fancy he would have agreed with me as to the cause. I found hundreds of diversified specimens. I am not aware that it was after a rain, but I took up a number of the plants, and always found a vigorous scaly root bud, undergoing development at this early season under ground, to produce a new stem the following spring. I came to the conclusion that, as the temperature was below freezing and snow was on the ground, the expanding bud, in close proximity to the surface, gave out sufficient caloric or warmth to generate vapor from the moist soil. This

vapor rising around the stem of the plant, and attracted by it, becomes congealed into what we term hoar-frost, in numerous forms; some like shellwork, others like tulips, with radiated petals, variously contorted, and often as symmetrical as snowflake crystals.

That plants in germinating have the power of generating heat was proved by Mr. Hunter and by Lamarck. Experiments of Hales and Du Hamel show that vegetation is not wholly suspended, however cold it may be; and that there is a regular and gradual progress till the returning warmth of spring gives a greater degree of velocity to the juices, rendering their development more vigorous and apparent. If the crystallization takes place when the air is calm, the crystals will be regularly formed; otherwise, when windy, I have seen them like a shell within a shell, very thin, of a pearly whiteness. Professor Tyndall has shown in a very beautiful manner that ice is but an agglomeration of snow crystals: the transparency of the former being due to the expulsion of the air, entrapped in and causing the whiteness and opacity of the latter. There is a formation called the snow plant of California, which arises to some height, and has been compared to various things, a fountain convoluted and enlarged above, a crystallized small bushy shrub, etc.; but on closer inquiry, I have failed as yet to get any definite ideas to its true character. Some bulbs in the soil might cause such formations by the congelation of vapor deposited successively upon itself, or the stems of the previous year's growth yet remaining, and thus give them a sheathing of frosting.

The shape of a star is common in snow crystals, which we all know assume the most beautiful forms, and which are illustrated in various publications. The eminent botanist Count Swinoskoff should give us some clue as to the genus or character of the plant, the flower of which, we are told, melted away on being touched, and as to the stamens, the diamond seeds like a pin's head, etc. The whole needs further explanation.

I trust those Bostonians who are in such hope will edify the public as to the final result of their experiment. What has that veteran in botany, Dr. Asa Gray, to say about it? Let some one well qualified tell us more about this frost flower of Russia.

J. STAUFFER.

Lancaster, Pa.

Patent Matters in Washington, D. C.

To the Editor of the Scientific American:

From the report of the Commissioner of Patents, just issued, it appears that its surplus revenue for the past year amounts to over one hundred and five thousand dollars, and that there is nearly a million dollars in the United States Treasury to the credit of the Patent Office; and yet, notwithstanding that this enormous amount is lying idle, our pseudo-economists at the Capitol refuse to grant the Office sufficient of its own funds to carry on its business promptly. So much is the work behindhand in some of the departments that, as the Commissioner states in his report, some of the attorneys who require certified copies of papers have been obliged to employ their own clerks to do office copying, and then had to pay the full legal rate of ten cents per hundred words, the same as though the Office had done the work. This style of *economizing*, by making inventors pay two prices for their work, may be "reform" in the eyes of the average Democratic Congressman; but speaking for myself, as one of those who have had to pay twice, I would prefer to dispense with this style of "retrenchment and reform," and therefore ask you, Messrs. Editors, in behalf of the inventors of the United States, to so stir up our legislators that they will allow the Office sufficient of its own funds to do its work properly, and not delay the work of the inventor—work that he has to pay for in advance—and so prevent the discouragement and trouble which these delays always cause.

As the Patent Office has been doing a good business lately, there appears to be some attempt at rivalry at the Capitol, as the following list of applications for extension will show:

LIST OF APPLICANTS FOR EXTENSIONS OF PATENTS NOW BEFORE CONGRESS.

- Reynolds, power loom brake.
- Strong & Ross, scales.
- Wm. & W. H. Lewis, photographic plates.
- T. A. Weston, differential pulley.
- S. S. Hartshorn, buckles.
- H. A. Stone, making cheese.
- N. Whitehall, cultivator.
- J. R. Harrington, carpet lining.
- H. L. Emery, cotton gins.
- J. Stainthorp, moulding candles.
- Walter Hunt's heirs, paper collars.
- A. B. Wilson, sewing machines.
- S. A. Knox, plows.
- Rollin White, firearms.
- Aikin A. Felthousen, sewing machines.
- H. Woodman, stripping cotton cards.
- L. Hall, heel trimmer.
- J. A. Conover, wood splitter.
- J. Dyson, carding engine.
- G. Wellmann, card strippers.
- E. Brady, safety valves.
- Jearum Atkins, harvester rakes.
- John Thomas, re-rolling railroad rails.
- Thomas Mitchell, hair brushes.
- Stephen Hull, harvesters.
- T. R. Crosby, wiring blind slats.
- G. W. Laban, mitre cutting machine.
- T. A. Whitenack, harvesters.
- J. J. Vinton, furnaces.
- A. Fuller, faucets.
- D. Baker, pitcher spouts and lids.
- G. F. Chandler, refining sugar.

G. H. Nott, boiler furnace.
William Hall, lightning rods.
B. F. Rice, paper bag machines.
S. D. Nelson, shovels.
E. T. Russell, car springs.
Hubbell & Conant, steam pumps.
C. A. Chamberlain, shovels.
C. A. Adams, locks.
E. A. Leland, paint can.

In addition to the above, I find the following names as applicants for extensions, but the inventions covered by the patents sought to be extended is not mentioned: S. S. Turner, Arculous Wyckoff, De Witt C. Cummings, Moses Marshall, J. W. Fowler, and Holloway & Graham. Many of the applicants have apparently given up their cases for this session, but they may be only lying back to its close in hopes that in the final rush their "little bills" may slip through easily.

Several bills tinkering at the patent laws are before Congress, and one of these (House Bill, No. 3,370) passed the House on the 30th ult. It has one section that may be made to work great harm to inventors, as it prevents infringers being sued for more than one year's damages previous to notice of infringement being given. By this bill, if it is allowed to become a law, a person will be able to build and use patented machines or processes for years in some out of the way place where the inventor cannot easily find him; and should he be discovered, he can only be sued for one year's damages. There are other sections in this bill which will bear ventilating.

Another bill, introduced into the Senate by Mr. Paddock, provides that all appeals from the Board of Appeals shall be direct to the Supreme Court of the District of Columbia, instead of to the Commissioner as heretofore; and that the fees shall be the same as now paid to the latter official.

Mr. Sampson has introduced into the House a bill changing section 4886 so that it shall read as follows: "SEC. 4886. Any person who has discovered any new or useful art, machine, manufacture or composition of matter, or any new or useful improvement thereof, not known or used by others in this country, and not patented or described in any printed publication in this or any foreign country, before his invention or discovery thereof, and not in public use or on sale for more than two years prior to his application, unless the same is proved to have been abandoned, may, upon payment of the fees required by law, and other due proceedings had, obtain a patent therefor: *Provided, That the manufacture or composition of drugs as a medicine shall not be patentable.*" The change is the addition of the words in italics.

The Smithsonian Institute has sent to Congress a memorial setting forth that the present Institute building is already too small for the vast amount of articles already placed there on exhibition; that at the late Centennial Exposition the Commissioners of various countries presented their entire collection of exhibits to the United States, which had delegated their care to the Smithsonian Institute, and they had no place for them; that the armory building was being fitted up for the reception of the United States Centennial collection, and they therefore asked that a building be erected for the foreign collection, which could be used as a national museum, or otherwise we should have to offend the donors by keeping their valuable gifts stowed away in cellars and other rubbish receptacles.

Mr. Eads, who is now here on the lookout for his pay for his work on the South Pass of the Mississippi's mouth, has received intelligence from the resident engineer at the jetties that the channel through the shoal at the head of the South Pass is now twenty-two feet deep, and that the least width at which twenty feet depth is found is one hundred and ten feet. The principal works to improve this shoal were constructed during the last six months. The low stage and feeble current of the river has delayed their effect until the recent flood from the Ohio reached them, and the problem of deepening the shoal has been fully solved by the rapid scouring away of the obstruction. It is stated that the channel is quite straight and is deepening rapidly. The channel through the jetties at the mouth of the Pass is twenty-one feet deep. The entrance from the sea through the jetties is one thousand feet wide, and through the works at the head of the Pass eight hundred feet.

A recent telegram from Nevada states that the Sutro Tunnel (of which I gave you some particulars in one of my letters) has now progressed a total distance of 15,565 feet and has fairly entered the mineral belt, and will soon help to increase the already vast products of the Comstock lode.

While on the subject of mining, I will state that the amount of quicksilver produced in California has increased so immensely during the last two years that it has attracted the attention of all interested in the article throughout the world. The receipts for the year have been 63,928 and the exports 48,010 flasks. In addition to the receipts there, probably about six thousand flasks were shipped direct from the mines to Nevada, thus bringing up the total production to over 70,000 flasks, a gain in round numbers of from twelve thousand to fifteen thousand flasks over 1875. The exports in that year were 34,844 flasks, or 13,666 less than in 1876.

OCCASIONAL.

TYRIAN PURPLE INK FOR MARKING LINEN.—Von Bele gives the following method for preparing an ink for marking linen and cotton: Neutralize 75 grains of carbonate of ammonia with pure nitric acid, and triturate 45 to 60 grains of carmine with the solution. Mordant the fabric with a mixed solution of acetate of alumina and tin salt, and write upon it, when it is perfectly dry, with the ink.

NEW YORK ACADEMY OF SCIENCES.

On Monday evening, January 29, 1877, a meeting of this Academy was held at the School of Mines, Columbia College, Dr. J. S. Newberry, President, in the chair. Mr. A. A. Julian, A. M., read a paper on the

PREPARATION OF ROCK AND MINERAL SECTIONS FOR MICROSCOPIC STUDY.

The speaker described in detail the various operations, exhibited the different kinds of apparatus employed, showed the operations, and exhibited the finished sections. In some rocks a thin chip can be broken off, others require to be sawn, and for the latter purpose the diamond saw is best. Having obtained the chip, it is first polished on one side, then cemented to a little square of glass, and the other side polished in the same way. The sections must not be too thick, nor too thin; they are usually made from a hundredth to a thousandth of an inch thick. Lathes employed in polishing minerals require to be provided with conical spindles, so that the wear, due to grit and emery dust getting on them, may be readily taken up. The grinding wheel may be either horizontal or vertical; the former has the advantage that the mineral can be held in either hand; with the latter only the right hand can be employed, and that in an awkward and tiresome position. Mr. Julian then referred briefly to the kinds of emery, its preparation by efutration, etc., and cautioned operators against using rouge or tin putty powder in polishing rock sections, although they may be employed in polishing certain minerals and gems. The object of making the rock sections being to study their constituents and determine what minerals enter into their composition, it is important that no foreign substance, liable to adhere to the specimen and to be mistaken for one of its ingredients, be placed on the section while grinding. Lastly, the minerals are mounted on glass, with or without covers, by means of Canada balsam. Square glasses are to be preferred to the long and narrow strips, usually employed, as less liable to break in the center, and more easily revolved on the stage of a microscope.

Mr. L. H. Landy then exhibited, by means of the gas microscope, several beautiful rock sections, both American and German. The same gentleman also showed the effect of passing polarized light through certain crystal sections, the black cross and rainbow-hued rings revolving like so many wheels as the polarizer was turned.

At the conclusion of this brilliant exhibition, Dr. P. T. Austen made some remarks on

LABORATORY MANIPULATIONS.

The points referred to were the apparently unimportant details which often contribute so much to the ease and pleasure of working. First, the use of square pieces of felt, such as are used under beer glasses in saloons, for setting hot beakers and flasks on to prevent chilling and consequent cracking. Second, in crystallizing substances for examination under the microscope; one watch glass is placed upon another with the substance between them, and the upper glass filled with ether, the cold produced by its evaporation hastening the crystallization. Third, removing precipitates and solid matter from flasks, by heating to boiling, and inverting in a vessel of water. Fourth, crystallization by gradual dilution. Fifth, filter paper without ash. In German laboratories it is customary to dissolve out the mineral matter from white filtering paper by washing in dilute hydrochloric and hydrofluoric acids. Sixth, the use of infusorial silica for drying purposes. Being very porous, it will absorb five times its own volume of water. If a filter paper, holding a wet precipitate, be placed upon a layer of this earth, it will become quite dry in a very short space of time. Mr. Austen also remarked that substances retain their heat for several days when placed in cork boxes. To keep a substance air-tight, it may be placed in a flask, the neck painted with a solution of india rubber in chloroform, and a plate of glass laid upon it. The solvent quickly evaporates, leaving a delicate film of rubber, which holds the glass tightly in place.

The next meeting of the Chemical Section will be held February 12; of the Mineralogical Section, February 19.

ANNUAL REPORT OF THE PATENT OFFICE.

The annual report to Congress of the Commissioner of Patents, for the year 1876, has made its appearance.

The amount received on applications for patents, reissues, designs, extensions, caveats, disclaimers, appeals, trade marks, labels, copies, etc., was \$757,987.65. The amount paid for salaries was \$425,930; other expenses, \$226,612. Total payments, \$652,542.

Number of applications for patents during the year 1876.....	21,425
Number of patents issued, including reissues and designs.....	15,595
Number of applications for extension of patents.....	2
Number of patents extended.....	3
Number of caveats filed during the year.....	2,697
Number of patents expired during the year.....	814
Number of patents allowed but not issued for want of final fee.....	3,353
Number of applications for registering of trade marks.....	1,081
Number of trade marks registered.....	959
Number of applications for registering of labels.....	650
Number of labels registered.....	402

Of the patents granted there were to—	
Citizens of the United States.....	16,239
Subjects of Great Britain.....	511
Subjects of France.....	104
Subjects of other foreign governments.....	172
Total.....	17,026

The number of applications for patents was a little less than during the previous year. The Commissioner suggests that Congress should appropriate \$50,000 to promote the printing of the old patents; that additional examiners be

employed, and more clerks, for the purpose of expediting the business of the office; that the price of the *Official Gazette* be reduced, also the fee for trade mark registration; that the library fund be increased; that more space be provided for models, and for the transaction of business.

In respect to the Centennial, the value of new improvements, and the service of the Patent Office in stimulating discovery, the Acting Commissioner speaks as follows:

"The display made at the Exposition by the Patent Office was creditable in every respect, and excited general attention. About 5,000 models of inventions, representing the leading branches of the arts and manufactures, were exhibited in suitable cases, and properly labeled, the various publications of the Office were displayed, its practice fully explained to all inquirers, and copies of the Patent Laws and the Office regulations and forms freely distributed. The knowledge of our patent system thus imparted to foreigners and all others unable to visit Washington has more than repaid the small cost attendant upon the representation. The exhibits were sent from and returned to the Office with scarcely any damage being suffered.

"But the array of models, etc., made by the Patent Office at the Exposition was not needed to illustrate the value of our patent practice. The wisdom of that system was demonstrated in the most practical and triumphant manner in nearly every branch of that munificent enterprise. Not only in the grand display of labor-saving machinery, but in the vast collection of manufactured articles, and even in the department of fine arts, were seen the fruits of that provision in our Constitution giving to Congress the power 'to promote the progress of science and the useful arts by securing for limited times to authors and inventors the exclusive right to their respective writings and discoveries.'

"Whatever persons may do in a 'perfect condition of society' in sharing, without price, the fruits of their labors with others, it must be apparent to the dullest observer that the wonderful growth of the useful arts in this country is due, thus far, to the protection given by our Government to property in inventions—a property as sacred as any other class of property, and whose value is determined by the same general law of supply and demand.

"It may be safely said that two thirds of the manufacturing interests of the country are based upon patents, and the welfare of all such interests are intimately connected with the welfare of the patent system. During the past seven years a larger number of applications for patents were filed and patents granted than during the entire seventy-eight preceding years, reaching back to the enactment of the first patent law. The needs of the Office have advanced in proportion to this sudden and vast increase of work, but have been but partly supplied. Nay, in fact, its already scanty force and accommodations have been actually reduced at a time when most required. If these vast interests, and the future promotion of science and the useful arts are to be encouraged, a liberal recognition must be made of the wants of this Office.

"The Examining Corps, the duties in which are most arduous and exacting, comprises gentlemen of legal, as well as scientific, attainments. It should be re-inforced by more of the same character. They should be relieved, by legislation, of continual embarrassment by reason of meager salaries and fears of removal incident to merely political changes. The Office would then be spared the continual loss of its most experienced and efficient men."

The Iron Trade in England.

The British *Mercantile Gazette* of January 15 states that the situation and prospects of the iron trade have not materially improved in the month of December, but some week or two must elapse yet before trade returns to its regular channels. In the north of England the tone of the market is tolerably cheerful, and prospects, though still vague, are considered encouraging. Makers of pig iron go into the next quarter with a good supply of orders on their books, and merchants and consumers are desirous of buying over the first half of the year. Notwithstanding the great depression which has ruled throughout 1876, there is likely to be a greater production of pig iron by several thousand tons than ever there was before, and the total make must considerably exceed two million tons, which is twice the quantity turned out in Scotland, though in the latter district a greater number of furnaces have been kept in blast. Prices are nominally the same as were quoted last week, but show an upward tendency. The bulk of the mills and forges, foundries, etc., have resumed work, and the finished iron trade is again in full swing. The plate department is well provided with orders, but the rail manufacturers, though rather better off than they were, are still in a poor position. The miscellaneous branches of the iron trade, such as the foundries and tube, wire, and cut-nail manufactures are generally well off for orders, and engineers find plenty to do. The wages agreement in the finished iron trade ends this week, but it is thought that no alteration will be made. In the South Staffordshire iron trade, work has been only partially resumed as yet, and many of the mills and forges will not be started until the quarterly meetings, next week. Orders have rarely been so scarce as they are at this moment, arrears having been pretty generally cleared off before the holidays, and no new ones coming in. Nevertheless, the feeling of the trade is more hopeful than it was a month ago. The number of furnaces in blast in this district is now only 58 out of 153; but should the expected improvement in trade arrive with the quarterly meeting, this number will soon be increased. In the finished iron branch, in which quotations for marked iron contain the basis of \$45 for bars, makers of leading brands of sheets and bars are better off than the manufacturers of cheap iron, who suffer much from competition in the north. Some considerable contracts for girders, bridges, gasometers, etc., are under execution at the works devoted to constructive ironwork; but the merchant iron trade, as a whole, is very dull. Unmarked iron is weak and variable, and to this circumstance may be attributed the reduction, announced this week, in various descriptions of common iron hardware.

IMPROVED LATHE CHUCK.

The annexed engravings represent a new lathe chuck, which may be constructed of any size, which holds tools with great firmness, and which is provided with an improved device for taking up wear and for the separate adjustment of the jaws. The implement is made of the best steel, by special machinery, so that its parts are interchangeable.

Figs. 1 and 2 represent the chuck taken apart so as to exhibit the interior. Figs. 3 and 4 are sectional views. A is a collar which encircles the spindle, and has formed on its outer face a bevel gear wheel, B. C, Fig. 3, is the rear portion of the shell of the chuck inclosing the forward part of the collar, A. Also on said collar, A, is a washer, D, which rests against the shell, C, and a nut, E, which travels on a thread formed on the collar. As it is necessary, as will be explained further on, to turn the entire shell in order to move the jaws, the use of the nut just described is to jam the part, C, and the enlarged portion of the collar, A, tightly together, and so rigidly hold the jaws in any position in which they may be adjusted. Fig. 1 represents the outer face of the chuck with the jaws and their working mechanism. Within the chuck, each jaw has attached to it a screw, E. This enters a bevel wheel, F. As the jaws are incapable of any but radial motion, it follows that, when the chuck is rotated bodily and the bevel wheels engage on the motionless gear wheel, B, the effect of the rotation of said bevel wheels is to cause the jaws to travel toward or from the center of the chuck face. And it will be further clear that this motion must be simultaneous in all the jaws. As the outer portion of the chuck is rigidly secured to the shell, C, by screws, of course when that shell is jammed, as already stated, by the nut, E, it becomes impossible to turn the chuck bodily; and hence the bevel wheels cannot be rotated around the main gear wheel, and consequently the position of the jaws cannot be altered. The above comprises the mechanism proper of the device, that is to say, all that is necessary for moving or clamping the jaws.

There is, however, another feature of considerable importance yet to be described, and that is the device for taking up any play of the jaws due to wear, and which enables each to be adjusted so that the motion of all may be uniform. By referring to Fig. 4, it will be seen that, above the bevel wheel, there is a projection, into the threaded interior of which, as already explained, the jaw screw enters. Surrounding this projection is a sleeve, G, the outer surface of which is threaded to fit a similarly threaded aperture, cut partly in the shell and partly in the face plate. The upper portion of the sleeve is notched to receive a wrench or driver; and beneath the sleeve an armed washer, H, is slipped over the projection. The arms of this washer enter recesses in the face plate. It will be evident that, by turning the sleeve, F, so that the screw works inward, the jaw and all its appendages will be moved bodily in corresponding direction. But its movement is limited by the arms of the washer, G, which, through the narrowness of the recesses, are allowed only just enough play to compensate for slight changes in the jaw. As the above device is applied to every jaw, it follows that any one of them may be nicely adjusted from the outside, so that all are caused to grasp the tool accurately. The spindle, instead of being solid as represented, may be made hollow. Patented to J. H. Vinton, August 18, 1874. For further information, address the manufacturer, Mr. F. Armstrong, Bridgeport, Conn.

SCREW-CUTTING LATHES.

An English lathe, now in use at the Rogers Locomotive Works, Paterson, N. J., contains several novel features. The

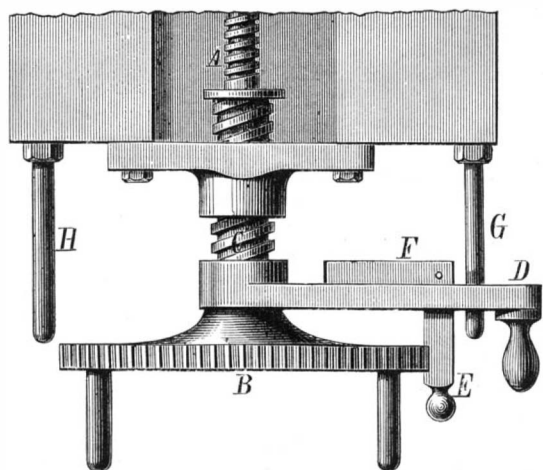

ways are flat on the faces, instead of having raised Vs; and this is a feature of all English lathes, and of those known in this country as the Freeland lathes. A great deal of discussion has at various times taken place as to the relative qualification or merits of these two forms of lathe bed. The advocates of the flat way, with Vs at the edges of the way,

claim superiority on the score of steadiness, increased wearing surface, and strength; while, on behalf of the raised Vs, it is urged that, the Vs being true, the saddle is bound to travel true, because there can be no lost motion on the slides; whereas any lost motion, from want of adjustment of the slides in flat ways, is liable to be reproduced twofold in the work, for the reason that $\frac{1}{10}$ of an inch lateral movement of the slide carriage becomes $\frac{2}{10}$ of an inch in the diameter of the work. Then, again, the most of the wear upon a lathe bed takes place at the part at and near the running center of the lathe, because the saddle is, on account of short jobs, more used in that part than on any other. As a result, when wear has taken place, the saddle, if adjusted to suit the worn part, becomes too tight to travel over the unworn part of the bed; and hence, after the wear has taken place, a proper ad-

justment of the lathe saddle becomes impossible if the job is a long one. In the case of raised Vs, however, the wear simply causes the saddle to fall vertically, so that an amount of wear equal to $\frac{1}{10}$ of an inch would have the same effect as lowering the tool $\frac{1}{10}$ inch, its effect upon the work being almost imperceptible by ordinary measurement. On the other hand, however, V lathes are usually made with either a weight or a spring to keep the saddle down; and as a result, when the cutting tool stands far out from the tool post, the saddle is apt to tip, especially in the case of boring with a lathe tool. In some cases, the raised Vs are accompanied with gibs to secure the saddle; but in many instances the gibs are given too little wearing surface. In the lathe above referred to, there are three ways in one casting, with the slide angles on the outer edges. There are also three separate and independent tail stocks fitting into the two openings between the ways. The running head has one cone pulley connected by suitable gearing to three face plates. The three centers at the running head are stationary. The slide rest saddle spans the three ways, having a V slide which contains three separate slide rests, all connected by a nut to the feed screw, so that all three are operated by the one screw. In addition to this, the two back slide rests have the nuts so attached that they can be moved by means of a separate screw, the object being to facilitate setting the cuts, since it would be a tedious matter to set all three tools to an equal cut, or to their desired respective cuts, without means of operating two of them independently. To set the cut during screw-cutting operations, the ingenious device shown in our engraving is provided. A represents the cross-feed or slide rest screw, which operates the three slide rests. It is fast to the notched wheel, B, and is operated by it in the usual way. C is a short screw which provides journal bearing for the screw, A, by a plain hole. It is screwed on the outside, and the plate in which it fits acts as its nut. It is fast to the handle, D, and is in fact operated by it. The handle or lever is provided with a catch, E, pivoted in the enclosed box, F, which also contains a means of detaining the catch in the notches of the wheel, or of holding it free from the same when it is placed clear. If, then, the lever, D, be moved back and forth the feed screw, A, and hence the three slide rests, will be operated; while, if the catch be placed in one of the notches of the wheel, B, both the screws, A and C, will act to operate the rests. When, therefore, the operator is cutting screws, he sets the catch, E, into one of the notches so soon as the tools are properly adjusted to the work; and then lifting the catch, E, he turns the wheel, B,

so that the catch falls into the next notch, and this puts the cut on. When the tool has taken that cut, and while the latter saddle is traveling back, the catch is placed in the next notch, and so on, the cut for the forward travel always being put on as above while the saddle is traveling back. Thus is insured an exactly equable amount of cut on the whole three rests. When the lever, D, is not in use, the catch is removed from the wheel, B, and is allowed to rest against the pins, G or A, provided for that purpose. For piston rods, or for work such as cutting jack screws, this lathe is very useful. It is obviously, however, a special tool.

Natural Ornaments in Winter.

Now that the hedges are no longer green, and the trees stand black and bare on the landscape, is the time to seek for endless variety and beauty waiting to be admired in its turn. What miniature fairy glens and grottoes are distributed over the hedge banks of our country lanes! Mosses, delicate and beautiful, may be found in the interstices of any old wall, or at the foot of almost any tree or shrub. In the winter time mosses and lichens are found in fruit, and are beautiful objects. A pocket microscope lens is essential for their proper observation; and though the delicate carmine cups of the species known as the cup moss, and the familiar gray and yellow mosaic appearance we see on twigs and branches on our way, are easily recognized, the study of this form of winter vegetation is an inexhaustible one, and is an occupation for a lifetime, if earnestly pursued. We do not however, suggest that every one who endeavors to recognize the different species of moss, lichens, or fungi should necessarily do so through the medium of the microscope; but it will greatly add to the pleasure of making a collection out of doors if there be a good microscope at home, so that when the contents of the basket be turned out, after the winter's walk, there should be interest even in the fragments left, after a little pile of varied bits has been constructed, rivalling the choicest summer bouquet in beauty of form and color. We have seen such a collection formed into a beautiful object by raising a little mound of rough bits of bark in a plate or saucer, and placing on it varieties of fungus of every shade of red, brown, yellow, and gray. They seem to spring forth from a bed of sphagnum or bog moss of brightest emerald green; while a clump of the screw-wal moss in fruit, with its curious little box-like capsules, supports a gray or yellow lichen, which has been gently removed from some

old wall or tree. A bit of stick or a twig, incrusting with a bright orange-colored lichen, supports a trailing branch of delicate green ivy, the most beautiful and adaptable of all winter foliage. Over this little arrangement is placed a bell glass, to preserve it from dust and the effect of a dry atmosphere; and we know how pleasing to the eye is its varied beauty of form and color, lasting thus, a constant source of pleasure, for many a day without renewal.—*Chambers' Journal.*

IMPROVED HARNESS COCKEYE.

We illustrate herewith a very simple little device for attaching traces to the single tree. It forms a secure fastening which may be instantly attached, and which, by its construction, is prevented from wearing out rapidly.

Fig. 1 shows the cockeye attached to the single tree, and Fig. 2 exhibits parts in section, displaying the construction very clearly. The yoke is of the usual pattern. Swiveled to it is a long loop, which is chambered out to receive a spiral spring which acts upon a plunger. The latter is provided with a follower having a semicircular notch, which corresponds in form to the inside of the end of the loop. The follower also has guiding lips which extend over the

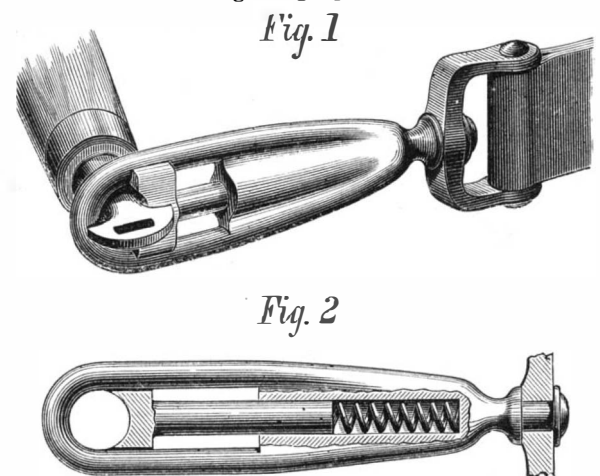

sides of the loop. Through the yielding of the spring, the space between the follower and loop adjusts itself to studs or hooks of any size. Patented December 12, 1876, through the Scientific American Patent Agency. For further particulars, address the inventors, Messrs. F. W. Knapp and C. Schallhorn, Fiddletown, Amador county, Cal.

VINTON'S LATHE CHUCK.

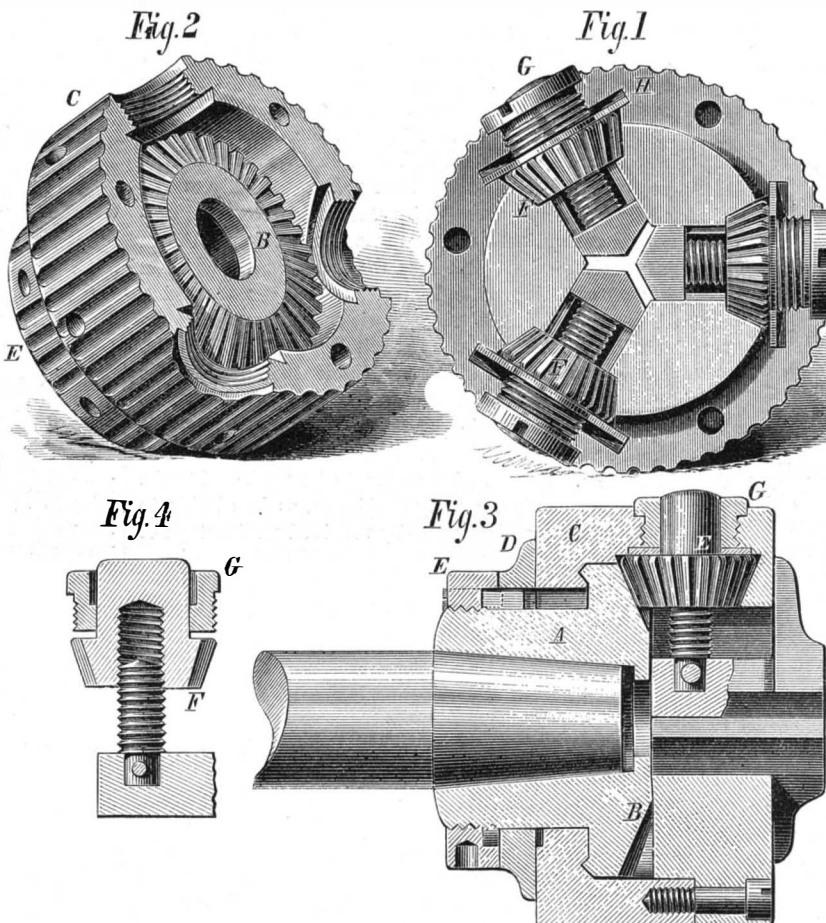

PROPOSED CREMATION TEMPLE.

Cremation, in this country at least, is not popular. For a time, it occupied here some public attention, but only in a sensational way; and the sober discussion of the subject, which followed after its novelty had worn off, led to the general opinion that, while every one might be quite willing to see his dead neighbors cremated, no one would acquiesce

name, etc., of the deceased are recorded, and which is set up in a suitable niche.

The building, which we illustrate both in elevation, Fig. 1, and in plan, Fig. 2, is designed to contain 100,000 urns, and is adapted for a town of 200,000 inhabitants. The architect has certainly exhibited much taste in his design for the building, and has provided every convenience in the in-

Mr. Bonaffon also had an especial fondness for electrical apparatus. His windows were provided with ingenious burglar alarms, his rooms with fire alarms, and he ignited his gas always by electricity. His place of business, his stable, the Continental Hotel where he dined, were all connected with instruments in his room; and he even had perfected arrangements so that he could set at home and send

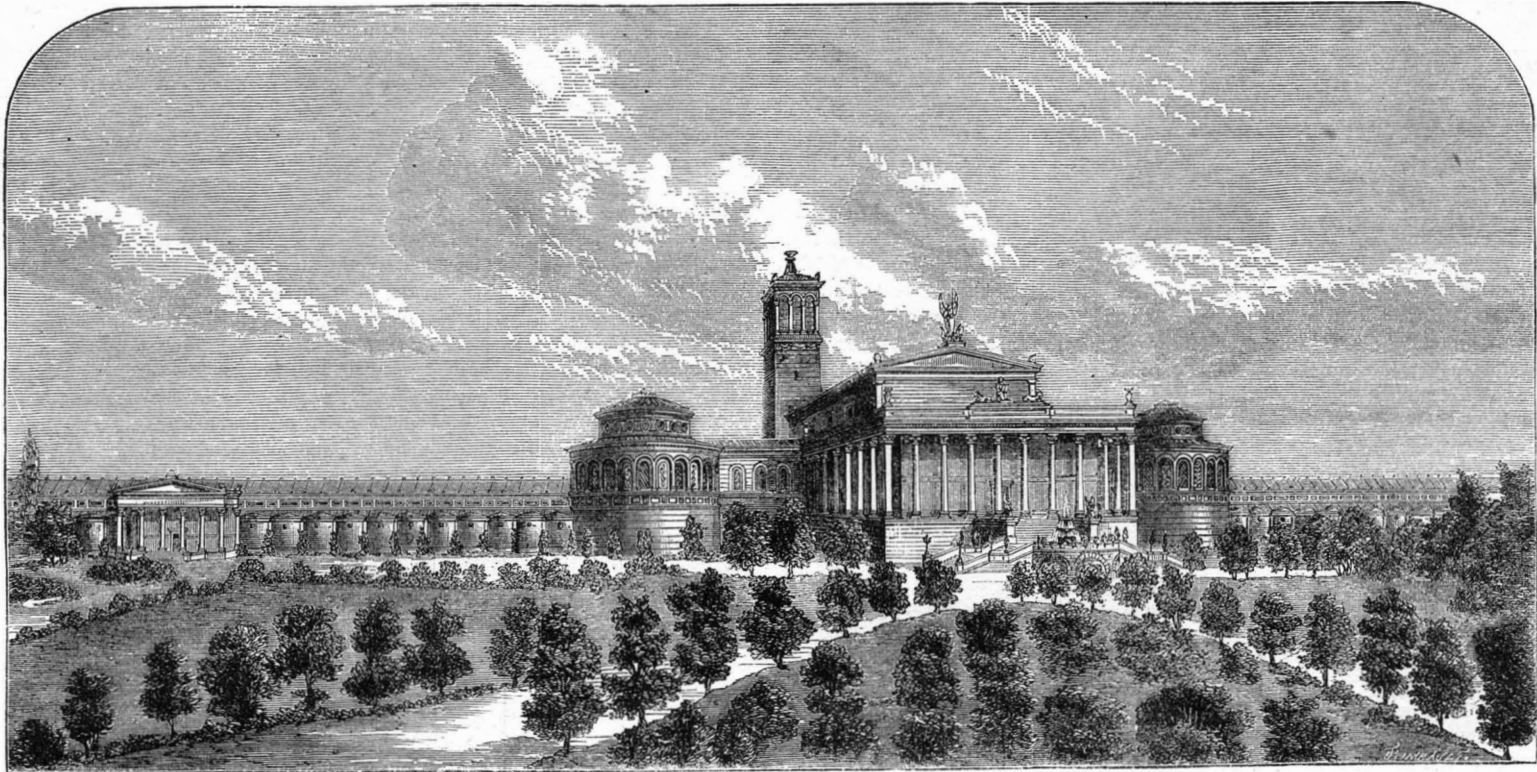

Fig. 1.—DESIGN FOR A CREMATION TEMPLE.

in the disposal of his friends and relatives in so abnormal a manner. Hence, with the single exception of the late revolting exhibition in Pennsylvania, which we alluded to at the time, the dead in this country have continued to be deposited in their hallowed resting places, and have not been packed away, in an incinerated state, in labeled urns. In Europe, however, cremation still finds many warm adherents; and during last summer a congress of the "Friends of Cremation" (a society which, we are informed by *Engineering*, whence we take the annexed engravings, has branches in various parts of the world), was held in Dresden. Before this meeting, a large number of designs for cremation and mortuary buildings were brought in competition, and finally the prize was awarded to Mr. G. Lillenthal, a Berlin architect, for the imposing structure illustrated herewith.

This will be the grand temple of cremation when it is erected—a proceeding to take place in the dim future: when or where not stated. On each side of a central chapel there is a circular memorial hall; and extending so as to inclose the garden of the establishment, on the sides of the halls are wings containing a large number of niches for the reception of funeral urns.

The cremation ceremony is proposed to be as follows: The body, having been brought into the hall, is subjected to the usual medical examination; or when an inquest is necessary, it is removed to offices in another part of the building, where the required investigation can be held. When all is ready, the body, placed on the platform, B, Fig. 2, is raised by a lift into the hall, A, where visitors are gathered, and here the result of the medical examination is declared, and whatever preliminary religious ceremonies that are desired are performed. The body is then transported to the chapel, E, in front of the pulpit, F, where the burial service is performed. The bier is afterward lowered mechanically, and brought to the furnaces, which are arranged in a semicircle and partitioned for the reception of several biers. The ashes are subsequently placed in an urn, on which the

ternal arrangement for carrying on a large business in the cremation line.

How to Rejuvenate an Old Rose Bush.

Never give up a decaying rose bush till you have tried watering it two or three times a week with soot tea. Make the concoction with boiling water, from soot taken from the chimney or stove in which wood is burned. When cold, water the bush with it. When it is used up, pour boiling hot water on the soot a second time. Rose bushes treated in this way will often send out thrifty shoots, the leaves will become large and thick, the blossoms will greatly improve in size and be more richly tinted than before.—*D. H. Jacques.*

A Clock Collector.

One of those odd geniuses, who spend their lives and means in collecting curious and rare articles, lately died.

his own messages to California. Besides the clocks and electric apparatus, there was an immense collection of *bric-a-brac* of every conceivable variety, which was sold at the auction—as is usually the case—at prices much below those paid by its late owner.

Fertilizing Influence of Snow.

Snow is often called the "poor man's manure;" and if it is true that it has any manurial value, the farmer's prospects for the next season are certainly flattering. The body of snow upon the ground in all the Northern and Middle States is very great, and millions of acres of land are covered by it as with a blanket of the whitest wool. It is probable that seldom, perhaps never, has so wide an area of our country been covered as during this month of January, 1877. The question whether snow is capable of affording to lands any of the elements of fertility is one often asked; and in reply, the *Boston Journal of Chemistry* says that it probably is. The atmosphere holds ammonia and some other nitrogenous products, which are without doubt brought to the soil by snow flakes as well as by rain drops.

Experiments both here and abroad would seem to prove the truth of this conclusion.

Rains are not only valuable for the moisture which they supply, but for what they bring to us from the atmosphere. During a thunderstorm nitric acid is produced in considerable quantities; and dissolved in the rain drops to a high degree of attenuation, its effects upon soils are highly salutary, as the nitrogen permeates the entire soil.

Action of Sea Water on Lead.

The *Journal of the Chemical Society* says that freshly cut strips of lead were kept in a bottle of sea water for four days, the bottle being frequently shaken. No trace of lead could be detected in the water; but the bright surface of the strips was coated with an insoluble lead compound. Hence lead pipes may be used in marine aquaria without any fear of injury to their inhabitants.

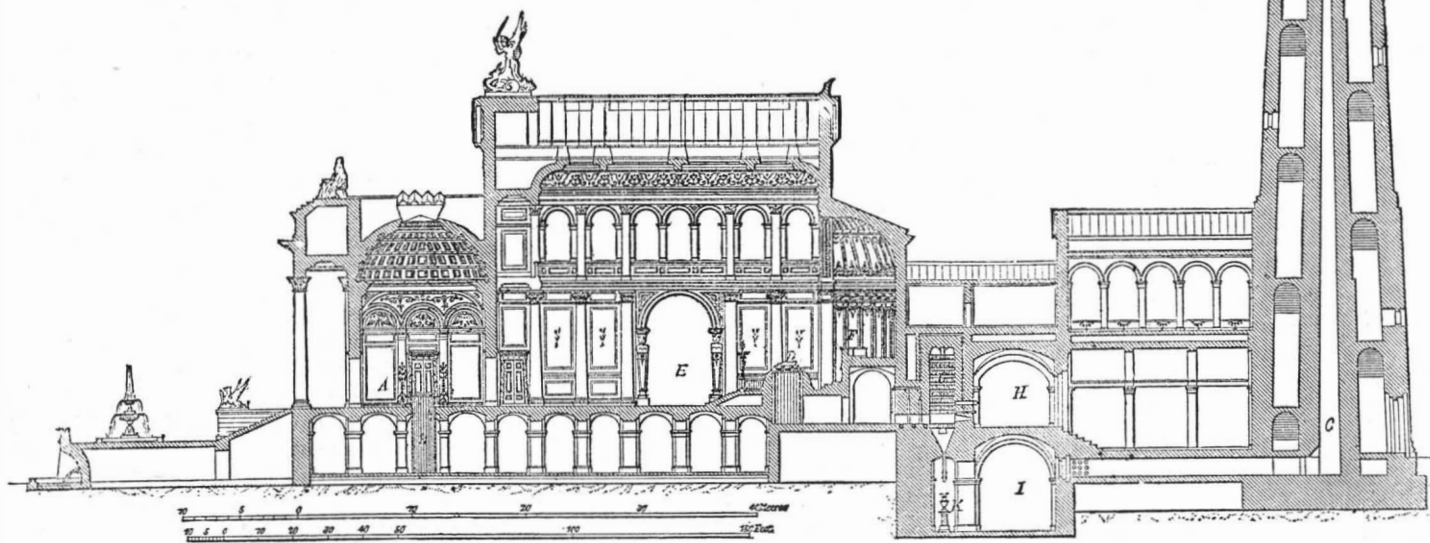

Fig. 2.—SECTION OF A CREMATION TEMPLE.

His name was Sylvester Bonaffon, a retired merchant of Philadelphia. His elaborate collections were sold at auction, and their oddity has attracted general attention. His chief mania was for clocks, which literally covered every portion of available space in his apartments, whether they were placed on chairs, tables, shelves, or hung against the wall. Some of these timepieces were of unique construction. One clock was made to run for 400 days after one winding; another was set in the dashboard of his carriage, and he used to regulate his drives to an exact period by it. In fact, he seems to have utilized his clocks to maintain his reputation for minute punctuality.

PAPIN'S STEAM ENGINE.

BY PROFESSOR CHARLES A. JOY.

It is a matter of history that, as early as 1688, Denis Papin, Professor of Physics and Mathematics at the University of Marburg, proposed to substitute steam for powder in the engine invented by Huyghens, and that in 1695 he published a description of several new inventions, in which steam played an important part. The Elector Carl, of Hesse-Cassel, was anxious to be free from the annoyances and impositions practised upon his boatmen by the authorities at Münden, and he proposed to avoid that city by constructing a canal connecting the Weser with the river that flowed through Cassel. Much of the work was accomplished, and the half finished line of the canal can be traced even at the present day. Papin was authorized to build a powerful steam pump by which the supply of water was to be regulated. A working model of this pump was completed; and the Elector was on the point of visiting the laboratory to witness its operation, when a fearful explosion frightened the workmen, and afforded an opportunity for enemies to intrigue for the expulsion of Papin from the country. The model was preserved for a long time in Cassel; but at the time of the French invasion, it disappeared, and no trace of it has since been found. In writing about his inventions, Papin says, in 1695: "It would occupy too much space for me to describe in what manner this principle could be applied to removing water from mines, throwing bombs, sailing against the wind, and for many other similar purposes; everyone according to his wants can imagine the constructions that could be made. I cannot, however, refrain from remarking how much preferable this power would be to oars for those whose business calls them to the sea." And further on he says: "The steam cylinders could be employed for a great variety of purposes." One of the cylinders, which was to form a part of the pump, was cast at the foundry in Cassel, and after various vicissitudes has finally become the property of the Historical Museum in that city, where it will be preserved, with jealous care, from any further injury. During the recent exhibition of philosophical instruments in London, this remnant of Papin's invention played an important part, it having been generously loaned by the authorities for that occasion.

After the flight of Papin from Germany, the cylinder was used as a receptacle for iron turnings and borings in the royal works; and after the destruction of those works by fire, it came into the possession of Henschel, the founder of one of the most extensive locomotive works in Germany. This man fully appreciated the value of the historical relic; and when I visited him at the works, twenty-five years ago, he pointed out with pride to me the inscription on its side, "Papin's Cylinder," and said that he intended to have it placed upon a solid pedestal near the gate. His grandson has since presented it to the city, and its preservation from destruction or sale is now secured. A copy of the drawing made by Papin of the pump of which this cylinder was to form a part, and which was published in 1695, has recently appeared in Dingley's *Journal*, and I send it to you, hoping that you will have it engraved and perpetuated in your valuable paper. It is a peculiar combination of Savery's invention and Papin's piston engine, suggested for another purpose, and is a decided improvement on Huyghens' powder engine.

A is the boiler for the generation of the steam, provided with a safety valve (an invention of Papin). On opening the stopcock, C, the steam passes through B into the cylinder, D, and by its expansion drives the plunger, E, against the water contained in the cylinder, D, which is thus forced into the chamber, F, compressing strongly the air, which in turn expels the water through the pipe, G, to the height desired. K is a funnel for the fresh supply of water, and at I and H are valves opening upwards and downwards. After the condensation of the steam in D, a renewed supply of water, through K, forces the plunger, E, to the top of the cylinder, ready for the next action of steam. The strokes of such a pump could not be frequent, and it would not compare very favorably with the wonderful machinery exhibited in Philadelphia last summer; but it contains the germ of the idea, and is worthy of all honor. Having often seen it stated that Papin had invented a steamboat, I resolved during a recent visit to Germany to investigate the matter, and especially to search for the correspondence between Papin and Leibnitz in the library at Hanover. It will be borne in mind that two hundred years ago, on December 4, 1676, Leibnitz was appointed to take charge of the library in Hanover, and that he remained in this position until his death in 1716. He bequeathed his manuscripts to the library; and as he had the habit of writing upon all manner of loose scraps of paper, it has cost much labor to assort and classify them.

On making my application to the librarian to be permitted to see the correspondence between Papin and Leibnitz, my request was at once granted; and a table having been assigned me, I was able to examine these precious relics at my leisure. I was also shown a copy of an original treatise on the steam engine by Papin, which contained numerous marginal notes by Leibnitz. In one place, Leibnitz criticized Papin's method for condensing steam, and makes a drawing

on the margin, showing a piston and valve which he thought would be more practical. It is somewhat remarkable that the Germans have not caused a fac-simile of this little volume to be published. After considerable search, I found a copy of the original letter addressed by Papin to Leibnitz in 1707, asking Leibnitz to assist him in obtaining the consent of the Hanoverian Government to navigate the river Weser with a sidewheel steamboat. The letter was dated July 7, 1707, and contained among other interesting passages the following sentence: "The new invention will enable one or two men to accomplish more effect than several hundred oarsmen." It is evident that Leibnitz was deeply impressed by Papin's letter, and he supported the simple and reasonable request contained in it by the following petition addressed to the Councillors of State. This communication from Leibnitz bears two indorsements, one by the clerk of the council, "pro memoria respectfully, in reference to the passage of a ship from the river Fulda into the Weser;" the other is in the handwriting of Leibnitz: "Papin's sidewheel ship." This last indorsement is of great value, as indicating the fact that Papin proposed to apply side wheels for the propulsion of his new invention. The following is a translation of Leibnitz' letter, the original of which I saw in the library:

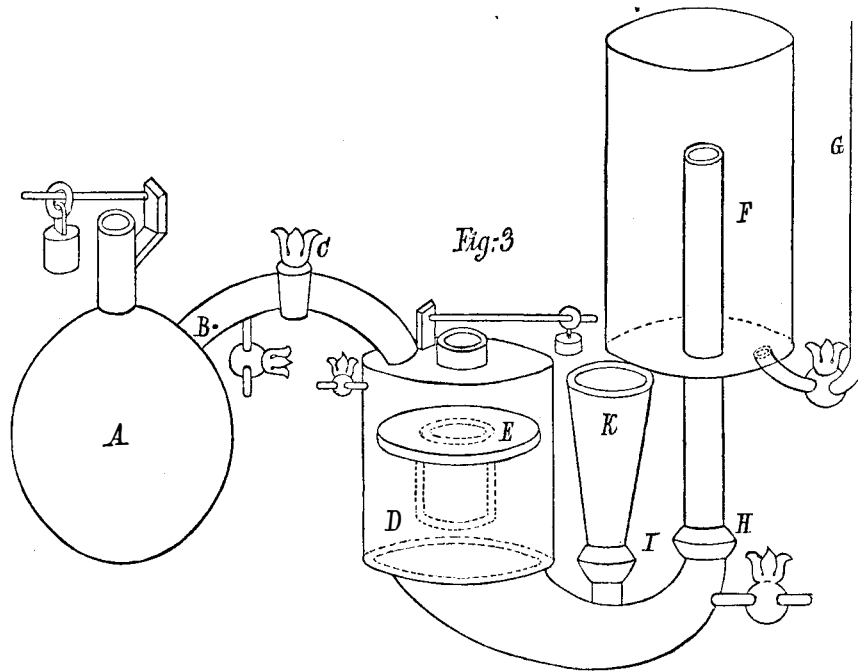

PAPIN'S STEAM ENGINE.

"Dionysius Papin, Councillor and Physician to his royal highness the Elector of Cassel, also Professor of Mathematics at Marburg, is about to dispatch a vessel of singular construction down the river Weser to Bremen. As he learns that all ships coming from Cassel, or any point on the Fulda, are not permitted to enter the Weser, but are required to unload at Münden, and as he anticipates some difficulty, although those vessels have a different object, his own not being intended for freight, he begs most humbly that a gracious order be granted that his ship may be allowed to pass unmolested through the electoral domain, which petition I most humbly support. G. W. LEIBNITZ. Hanover, July 13, 1707."

This letter was returned to Leibnitz with the following indorsement: "The Electoral Councillors have found serious obstacles in the way of granting the above petition, and, without giving their reasons, have directed me to inform you of their decision, and that in consequence the request is not granted by his Electoral Highness. H. REICHE. Hanover, July 25, 1707."

This failure of Papin's petition was the deathblow to his effort to establish steam navigation. A mob of boatmen, who thought they saw in the embryo ship the ruin of their business, attacked the vessel at night and utterly destroyed it. Papin narrowly escaped with his life, and fled to England, where he endured great hardships and poverty, and all traces of him were soon lost, so that it is uncertain in what country he finally died or where he was buried.

This remarkable man was driven out of France on account of his Protestant faith, and found a refuge in Germany; here he was again persecuted on account of the injury that ignorant and jealous people believed his inventions would inflict upon the industries of the country; and when the climax of steam engines for pumping water and propelling ships was reached, the enlightened government of the period "found serious obstacles" in the way of granting him protection, and, without condescending to state what those "objections" were, secretly instigated the mob to make an end of the trouble. It is another instance, unfortunately too often repeated in history, of the mischief men dressed up in a little brief authority can work upon their generation. If Papin had been permitted to navigate the Weser with his ship, and to carry it to London, as was his intention, it is possible that we should have had steamboats one hundred years earlier than they were given to us by Fulton. The plan proposed by Papin was highly impracticable; but a knowledge of what Savery had done in the way of steam machinery, aided by the shrewd suggestions of Leibnitz, combined with the practical assistance of Englishmen, would, no doubt, have enabled him to improve upon his invention until it had obtained sufficient credit to be secure

against the misfortune of being totally forgotten. After the lapse of 100 years from the date of Papin's invention, when the first steamboat was put upon the river Rhine, the vessel was fired into by concealed marksmen on shore, and navigation was more dangerous than it is now on the upper waters of the Missouri in times of Indian hostility. It was only after stationing troops along the banks of the river to protect the boatmen that the government, fortunately more enlightened than in the days of Leibnitz, was able to establish steam navigation on a secure footing.

I have thought it worth while to make this contribution to the history of steam navigation, particularly as I have been able to authenticate a portion of it by reference to original documents.

Columbia College, New York city, January, 1877.

The Speaking Telegraph.

We have heretofore given accounts of the wonderful success of Professor Bell in transmitting the vibrations of the human voice by electrical means over a telegraph wire. He has lately made improvements in his method of transmission, by which he dispenses with the use of the battery, and substitutes the magneto-electric plan of producing the current.

The Boston *Transcript* describes a recent experiment with the new apparatus, by which conversation and singing was successfully carried on between Boston and Malden, a distance of six miles. The telephone, in its present form, consists of a powerful compound permanent magnet, the poles of which are attached ordinary telegraph coils of insulated wire. In front of the poles, surrounded by these coils of wire, is placed a diaphragm of iron. A mouthpiece to converge the sound upon this diaphragm substantially completes the arrangement. As is well known, the motion of steel or iron in front of the poles of a magnet creates a current of electricity in coils surrounding the poles of the magnet, and the duration of this current of electricity coincides with the duration of the motion of the steel or iron moved or vibrated in the proximity of the magnet. When the human voice causes the diaphragm to vibrate, electrical undulations are induced in the coils environing the magnets, precisely analogous to the undulations of the air produced by that voice. These coils are connected with the line wire, which may be of any length, provided the insulation be good. The undulations which are induced in these coils travel through the line wire, and,

passing through the coils of an instrument of precisely similar construction at the distant station, are again resolved into air undulations by this instrument.

The experiments were as follows: Telephones having been connected with the private telegraphic line of the Boston Rubber Shoe Company, conversation was at once commenced. Stationed at the Boston end of the wire, Professor Bell requested Mr. Watson, who was at the Malden end, to speak in loud tones, with a view of enabling the entire company at once to distinguish the sounds.

This was so successful that a smile of mingled pleasure and surprise played on the features of those present. That it, however, might not be supposed that loud speaking was essential to intelligibility, Mr. Bell explained that soft tones could be heard across the wires even more distinctly than loud utterances, even a whisper being audible. In confirmation of this statement, Mr. Watson commenced speaking in turn with each member of the company; and after the efficiency of this method had been proved to the satisfaction of all, he took up a newspaper and informed the assemblage that gold had closed the previous evening at New York at 105½. As there were quite a number of business men present, the effect that this practical demonstration of the value of the telephone produced can scarcely be exaggerated. Other passages from the daily journals were then given, and by this time the desire for conversation having become general, Mr. Watson was plied with questions such as: "Is it thawing or freezing at Malden? Who will be the next President?" etc. It was remarkable that Mr. Watson was able to distinguish between the voices at the Boston end, he calling at least one gentleman by name as soon as the latter commenced speaking.

This went on for some time, until a lady at the Malden end sent the company an invitation to lunch per telephone, and an appropriate response was made by the same medium. At length the Boston company were requested to remain quiet while a lady at the other end conveyed to them the sweet strains of music. The assemblage thereupon listened with rapt attention while a young lady commenced singing "The Last Rose of Summer." The effect was simply charming. The sound of the voice penetrated into the Boston end of the telephone with a distinctness equal to that attainable in the more distant parts of a large concert room, and a unanimous vote of thanks was sent by the handy little instrument which had procured for the assemblage so agreeable an hour.

The superb steam engine built by C. H. Brown & Co., of Fitchburg, Mass., which was illustrated and described on page 1 of our current volume, has been purchased by Messrs. Phineas Jones & Co., and is being erected in their extensive carriage wheel works at Newark, N. J.

Crossing a River on a Wire.

A reporter of the New York *Sun* wanted to realize the sensation of being suspended on a wire 275 feet from the surface of the earth. He applied to the engineer of the Brooklyn bridge for permission to cross the East river on a wire, three quarters of an inch in diameter, which hangs between the two towers. He was refused permission; but he finally saw the president of the company, who granted his request. Arriving at the appointed time, the engineer, Mr. Farrington, said: "Well, sir; whenever you're ready, I am."

"All ready, said I, as bold as brass outside, and as nervous as the Endorian witch on the inside. He walked on and I followed, when, Horror of Horrors—capital H's to both Horrors—instead of leading me to the 'cradle,' which I called a raft, he took me to a little square board held up by two crossed iron arms, called a 'buggy.' It was about three feet square, and depended from the 'traveler,' a three quarter inch wire which crosses the river, and is run from tower to tower over apparatus, by means of a stationary engine. It was too late to back out, but I didn't feel exactly prepared to plunge in. He did.

"He jumped in, and the little buggy swung from side to side, precisely as a swing does when you jump on the board and try to steady it by the ropes. I looked at him, at the scale—that's it; it's exactly like a pair of scales, with one scale—at the deep depths below us, and at myself. I imagined the ticklish thrill which would permeate my body when we started. I fancied the glories of the prospective perspective before me.

"Come, hurry up, please," interrupted Farrington, and with resignation I hurried down. He stood up. I crouched down. Perhaps you think you'd have stood up as he did. You're mistaken. I crouched down and held on tight. Make no mistake. I held on tight and waited for my thrill. It didn't come. Then I stood up, and Farrington gave the word 'Go.' 'Wouldn't you better take a rope along?' said one of the men. 'Yes, I think I would.' What did he want of a rope? He feared I would be nervous. He meant to grapple me in the middle of the river, and tie me in. I knew it. I felt it. But I didn't say a word.

"With a gentle jerk we started—slow, slow, very slow. Farrington stood in front and watched the wire. I stood behind and watched myself. I felt nothing. I wasn't exhilarated. I wasn't scared. I wasn't even timid. I can't look from the top of a house without desiring to jump off, but I looked down from the buggy and hadn't the least desire to jump. Farrington says: 'It's because it's so high up.' Well, we went on without any special sensation till the buggy struck against a stay rope which reaches from one of the cables to the tower. In the effort to free the buggy, Mr. Farrington gave a push which swung us out some little distance and back again, at which a little piece of indigestion seemed to be monarch of my interior, and for a moment I was on the verge of a sensation. Having passed the middle, the ascent was more labored. I waved my handkerchief to the people on the ferryboats. I looked out toward the sea. I looked up at the heavens. I even looked toward Harlem, but, like the buyer in the Bible, I said: 'It is naught, it is naught.'

"In about eight minutes we touched the New York side—all but ten feet. The red flag waved for the engine to stop. There we hung in mid-air 275 feet above the level, swinging to and fro like a drunken buggy, at an angle of forty degrees, and quite uneasy. The rope which was to haul us on was fastened to the iron—blest be the tie that binds—and with a few hearty pulls we were brought so near the New York tower that without difficulty we clambered up. I had made the trip, but I had not felt a feel. From the top of the New York tower I saw much, but the chief point of interest was the innumerable jets of steam which flourish in the air, and fantastically curl off into space.

"Again the steeples, the tower, and the long, narrow, dirty river filled the prospect, and the bright sun of a charming day lightened up the western sky. That was all, except to say 'thanks and good-bye,' and descend the stairs. There were 417 of them stairs, and before I reached the bottom I was dizzy, faint, seasick, and filled with a decoction of tickle, so that I had to shut my eyes and rest from my labors.

"Thus ends the trip which filled my anticipatory imagination as the waters fill the sea, but which resolved itself in realization to a simple, childlike faith in the fixtures on the wire, and in the skill and competence of the man who guided them. **MONSIEUR X.**"

Blue Glass Science.

There is nothing more reassuring in these days, when new "isms" of the scientists are slowly sapping the foundations of cherished beliefs, than to remember that, after all, the much vaunted dicta of Nature are yet opposable by the sound operations of honest common sense. See for example how one of our evening dailies, tossing the dogmas of so-called science contemptuously aside, evolves such profoundly original thoughts as these, to explain the lucid blue glass theory of General Pleasonton: "The blue glass presents an obstruction to the sun's rays which can only be penetrated by one of the seven primary rays—the blue ray; the remaining six rays, travelling with the velocity of 186,000 miles a second, falling upon the blue glass, are suddenly arrested; the impact evolves upon the surface of the glass friction, heat, electricity and magnetism; the heat expands the molecules of the glass, and a current of electricity and magnetism passes through it into the room; this current, falling upon animal

or vegetable life within, stimulates it to unusual vigor. Certainly the results achieved, and abundantly certified to, are marvellous, and sufficient to provoke further experiments and inquiry." Prior to these splendid original discoveries of our contemporary, we ignorantly believed that blue glass only partially sifted out the orange and yellow rays from the spectrum, and that with this exception, it acted merely as a screen to diminish the intensity of all the rays. We also supposed that there was a sharp distinction to be drawn between sunlight after passing through blue glass and the blue spectral ray: that in one case all the colored rays were more or less present, and that in the other but one was. But think of the utter dismay of such pretenders as Helmholtz, Tyndall, and Henry—when they learn that the undulatory theory of light with which they have so long taxed our credulity is overthrown—that of the seven primary rays, six bounce off from blue glass and distribute themselves over the adjoining neighborhood. That the glass is heated by the impact; and as the sun persistently emits more rays, there are more impacts and more heat. The glass gets hotter and hotter; but—mark the scientific acumen here—just as we are wondering whether it will reach the melting point, the pores open. It is the Turkish bath of Nature. Electricity and magnetism, no longer shut out, rush in between the separate molecules. Hand in hand, these great curative powers seek a proper subject. They meet (we learn from a report, also in our contemporary, of Pleasonton's latest triumph) a pig or a young lady whose hair has come out—a heifer, a rooster, or a rheumatic child. Forthwith the pig fattens, hair equal to that produced by the finest *trichopherus* pervades the female scalp, and "unusual vigor" and general happiness prevail. Such is the boon which Pleasonton bestows on humanity, as elucidated by the original genius of our contemporary.

Infectious Disease Propagation.

In view of the alarming prevalence of scarlet fever in many parts of the country, the following hints by the *British Medical Journal* are wholesome warnings: "There are three common ways by means of which infectious diseases may be very widely spread. It is a very usual practice for parents to take children suffering from scarlet fever, measles, etc., to a public dispensary, in order to obtain advice and medicines. It is little less than crime to expose, in the streets of a town and in the crowded waiting room of a dispensary, children afflicted with such complaints. Again, persons who are recovering from infectious disorders borrow books out of the lending departments of public libraries; these books, on their reissue to fresh borrowers, are sources of very great danger. In all libraries, notices should be posted up informing borrowers that no books will be lent out to persons who are suffering from diseases of an infectious character; and that any person so suffering will be prosecuted if he borrow during the time of his illness. Lastly, disease is spread by tract distributors. It is the habit for such well meaning people to call at a house where a person is ill and to leave him a tract. In a week or so the tract is called for again, another left in its place, and the old one is left with another person. It needs not much imagination to know with what result to health such a practice will lead if the first person be in scarlet fever or smallpox."

Dr. Hutton offers "a warning on the reckless manner in which parents allow their healthy children to run into the houses of acquaintances who have members of their families suffering from scarlatina, etc., and states that he has seen the infection thus carried from the patient, and several families attacked."

Toughened Glass Making in Brooklyn.

A *World* reporter has lately visited the works in Brooklyn where the manufacture of the La Bastie toughened glass is now in active progress. The manufacturer states that, in June last, his factory was destroyed by fire, and the introduction of the glass into our markets has for that reason been delayed. Only one kind of goods, lamp chimneys, are now made, and the process is as follows: A workman, having in his hand a pole about eight feet long, with a knob on the end of the size of a lamp burner, fits a chimney on the knob and plunges it into the flame of a furnace. He withdraws it twice or thrice that it may not heat too quickly, turning the pole rapidly the while, and when the glass reaches a red heat quickly shoots it into one of a dozen small baths fixed on a revolving table, and seizes another chimney. A boy keeps the revolving table always in position, and as the chimneys come around to him, having been the proper time in the bath, he takes them out to be dried, sorted, cleaned, and packed. The bath has to be of just the right temperature, as, if it be too hot or too cold, the chimneys are liable to explode. In either case the process of annealing is imperfect. By working the tables at a certain rate, the baths are kept at the right temperature by the immersion of the red hot glass. Oil or tallow is used in the bath. Any greasy substance will do, though tallow has proved most satisfactory.

M. De la Chapelle, the manufacturer, states that he has already sold \$150,000 worth of the chimneys. The toughened chimneys are about 60 per cent dearer than those of ordinary glass. The factory is in Delavan street, Brooklyn, N. Y.

Alexander Bain, Electrician.

This ingenious man, whose inventions in connection with the electric telegraph entitle his name to be held in grateful remembrance, died in January last at the new Home for incurables at Broomhill, Kirkintilloch, near Glasgow, Scot-

land, and on Saturday his remains were interred in the burying ground in the neighborhood of that town known as the Old Aisle Cemetery. Mr. Bain, who was about sixty-six years of age, was a native of Thurso. He was the inventor of the electro-chemical printing telegraph, the electro-magnetic clock, and of perforated paper for automatic transmission of messages, and was author of a number of books and pamphlets relating to these subjects. Sir William Thomson, in his address to the Mathematical Section of the British Association at its meeting in Glasgow last year, said: "In the United States Telegraphic Department of the Great Exhibition at Philadelphia, I saw Edison's automatic telegraph delivering 1,015 words in 57 seconds. This was done by the long neglected electro-chemical method of Bain, long ago condemned in England to the helot work of recording from a relay, and turned adrift as needlessly delicate for that." Mr. Bain was stricken by paralysis, and suffered from complete loss of power in the lower limbs. For some time he had received a pension from the government, obtained for him, we believe, through the instrumentality of Sir William Thomson. Mr. Bain was a widower, and has left a son and daughter, the former of whom is in America, and the latter at present on the Continent. Photographs of him by Mayall were recently presented to the Society of Telegraph Engineers and the American Society of Telegraphers at Philadelphia.—*The Engineer*.

Self-Reliance Necessary to Success.

Self-reliance, conjoined with promptitude in the execution of our undertakings, is indispensable to success. And yet multitudes live a life of vacillation and consequent failure, because they remain undetermined what to do, or, having decided that, have no confidence in themselves. Such persons need to be assured; but this assurance can be obtained in no other way than by their own successes in whatever they may attempt for themselves. If they lean upon others, they not only become dissatisfied with what they achieve, but the success of one achievement, in which they are entitled to but partial credit, is no guaranty to them that, unaided, they will not fail in their very next experiment.

For want of self-reliance and decision of character, thousands are submerged in their first essays to make the voyage of life. Disappointed and chagrined at this, they underestimate their own capacities, and thenceforward, relying on others, they take and keep a subordinate position, from which they rise, when they rise at all, with the utmost difficulty. When a young man attains his majority, it is better for him, as a general rule, to take some independent position of his own, even though the present remuneration be less than he would obtain in the service of others. When at work for himself, in a business which requires and demands foresight, economy, and industry, he will naturally develop the strong points of his character, and become self-reliant.

A glance at the business men of any community will show who have and who have not improved the opportunities of their earlier years. The former transact their business with ease, promptitude, and profit. They rely upon themselves, and execute what they have to do with energy and dispatch. But those who shirked everything in their youth are compelled to rely on their clerks and salesmen for advice, and are never ready to act when occasions of profit arise. Many parents commit a lamentable error in this respect. They lead their children to believe that they can do nothing without the constant assistance of their superiors, and after awhile the child becomes impressed with that idea. Fortunate will it be for him when he emerges from the parental roof, if he can at once acquire the self-reliance which has been kept down at home—otherwise he must necessarily fail in whatever independent enterprise he undertakes; and in such a case, while the misfortune is his own, the fault lies at the door of misjudging parents rather than at his own.

Something to Do.

It is an old trick of despots, and a good one, to employ their subjects. Why? To keep them out of mischief. Employed men are most contented. There is no conspiracy. Men do not sit down and coolly proceed to concoct iniquity so long as there is plenty of pleasant and profitable employment for body and mind. Work drives off discontent, provided there is compensation in proportion to the amount of labor performed. There must be a stimulant. God never intended a man should sweat without eating of the fruits of his labor—reaping a reward—more than he intended the idle man should revel in plenty and grow gouty on luxuries. Industry is a great peacemaker—a mind-your-own-business citizen. Something to do renders the despairing good-natured and hopeful—stops the cry of the hungry, and promotes all virtue. The best men are the most industrious; the most wealthy work the hardest. They always find something to do. Do you ever wonder that men of wealth do not "retire" and enjoy their substance? We know some young men look forward with anticipation to the time of "retiring." It is doubtful if a man should ever retire from business as long as he lives. We think we know men who, were they to abandon business, would be ruined, not pecuniarily, but mentally—their lives would be shortened. God never intended man's mind should become dormant. It is governed by fixed laws. Those laws are imperative in their exactions.

Something to do! "Oh, if I had something to do!" There are young men who sigh for it, yet one thing they can do—that is, seek for a job. Once found, provided it is an honest one, do not hesitate to perform it, even if it does not pay as well as you expected.

Moneyed Men.

The Cleveland *Herald* said, twenty years ago, during a stringency of the times, that moneyed men are the veriest cravens on earth: so timid, that on the least alarm they pull their heads, turtle-like, within their shells, and, snugly housed, hug their glittering treasure until all fear is removed. The consequence is that a few days' disturbance of the monetary atmosphere brings on a perfect dearth of not only the precious metals, but even of paper money, their representative. Moneyed men never adopt the tactics of mutual support; hence, as soon as a shot is fired into the flock, they scatter, each looking out for himself, each distrustful of the other, and each recognizing only the great law of selfishness, which is to take care of number one. Courage has saved many an army, even when ammunition was low; and many a foe has been scattered by one yell of defiance when there was not a cartridge left.

NEW BOOKS AND PUBLICATIONS.

ARCHAEOLOGY, OR THE SCIENCE OF GOVERNMENT. By S. V. Blakeslee. Price \$1.25. New York and San Francisco: A. Roman & Co.

This book is a very metaphysical treatise on theories of government and the duties of citizens to the law, each other, and themselves. Theoretical politics are little in favor with thinking men of this day; and the social difficulties of our age will have to be solved by practical wisdom founded on experience. The people that know that a certain course of legislation has destroyed an empire, and that a contrary policy has developed one, will care little as to whether or not "the will controls the feelings by mediate and indirect force." We are unable to find in this book any attempt to apply the finely worded theories stated to practical use and popular instruction in political science.

GRAPHICAL ANALYSIS OF ROOF TRUSSES, FOR THE USE OF ENGINEERS, ARCHITECTS, AND BUILDERS. By Charles E. Greene, A. M., Professor of Civil Engineering in the University of Michigan. Chicago, Ill.: George H. Frost.

The author of this work truly says that any designer who fairly tries the graphical method will be pleased with the simplicity and directness of the analysis, even for apparently complex forms. The hindrance to the general use of the method is the want of knowledge of the higher mathematics, which are largely used in most treatises on the subject. Professor Greene has avoided this stumbling block, and given us a treatise which may be understood and appreciated by any one of common school education. We therefore give his work a hearty commendation, and we hope that every carpenter and builder may be induced to analyze the stresses which affect the different parts of structures, which he can readily do by carefully reading this volume.

THE HUB: a Journal devoted to the Carriage Building Trades. Published monthly. Subscription price, \$3.00 a year. New York city: The Hub Publishing Company, 323 Pearl street.

This journal is widely known for its accurate and extended information as to carriage building, trimming, lining, painting, etc.; and since its first issue it has maintained its reputation, and given the public an immense amount of instruction in a spirited and practical manner. The illustrations and typography are excellent, and every number shows how extended an area it serves as an authority on the important industry to which it is devoted.

ASSIGNATS AND MANDATS: the Money and the Finances of the French Revolution of 1789. By Stephen D. Dillaye. Price, free by mail, 30 cents. Philadelphia, Pa.: Henry Carey Baird & Co., 810 Walnut street.

Mr. Dillaye differs with the Hon. A. D. White, President of Cornell University, as to the relative merits of money and promises to pay money; and he begins with the assertion that the President's "object is to depreciate American credit, stability, and honor." Further perusal, to ascertain the meaning of this attack on a patriotic and useful member of society, shows us what Mr. Dillaye thinks he means. He talks of credit being the vital element of national power; and from this he argues that the more "credit" a nation has—that is, the deeper it is in debt—the more powerful it becomes. In short, he confuses credit as opposed to discredit with credit as opposed to cash—a grievous blunder, surely. A nation's credit is like a merchant's; it becomes greater only as his debts become smaller; and people trust a government for the same reason as they trust an individual, mainly because every previous obligation has been honorably observed. It is gratifying to know that persons of Mr. Dillaye's way of thinking are few and unimportant, and their number is diminishing daily.

CROTON WATER SUPPLY FOR THE CITY OF NEW YORK: an Address by George B. Butler to the New York Municipal Society. New York city: Published by Order of the Society, 87 Madison avenue.

A review of the whole subject of our water supply, its sources and the area they drain, the geographical features of the district, and the works erected by the city. Mr. Butler maintains that the Croton valley, with proper storage reservoirs, can abundantly supply the whole city; and that no new aqueduct need be constructed in the present condition of the public debt.

EINE KURZE ALLGEMEINE EINLEITUNG ZU DEN AROMATISCHEN NITROVERBINDUNGEN. Von Peter Townsend Austen. Leipzig, Germany: Winter, Publisher.

We are glad to see that an American is able to publish a very useful chemical treatise in Germany, the great head center of chemistry. Dr. Austen, one of our most distinguished young chemists in the field of original research, has produced a work which bears the marks of much patient thought and study. The book is dedicated to the renowned German chemist, Professor A. W. Hofmann.

OUR YOUNG FOLKS' MAGAZINE: a Monthly Journal of Instruction and Amusement. Subscription price, \$1.60 a year. Boston, Mass.: Post Office Box 3090.

A readable little periodical, well calculated to amuse the little ones for whom it is intended.

GLASS FOR THE STUDIO AND DARK ROOM. By Thomas Gaffield. Philadelphia, Pa.: Bencrman & Wilson.

There is much useful information in this little pamphlet, and photographers especially should read it. The matter first appeared in the *Philadelphia Photographer*.

Recent American and Foreign Patents.**NEW AGRICULTURAL INVENTIONS.****IMPROVED GANG PLOW.**

Ezra Peak, Montana, Kan.—This invention is so constructed that it may be easily raised from and lowered to the ground, and adjusted to work at any desired depth in the ground. It is claimed to be of lighter draft than plows constructed in the usual way, also to be simple in construction and inexpensive in manufacture. The wheels, the faces of which are notched to give them a slight up-and-down movement as they are drawn forward, slightly jar the plows, and thus cause them to be easier drawn than when smooth wheels are used. The shaft can be provided with a ratchet wheel and pawl to hold it in any position into which it may be turned; and to it is attached a rope or chain, the other end of which is attached to the forward end of the frame, so that by turning the shaft the plows may be raised from, lowered to, and adjusted to work at any desired depth in the ground.

IMPROVED PLOW.

James Willis Hendley, Cedar Hill, N. C., assignor to David N. Bennett and Samuel T. Wright, of same place.—The objects here are simplicity and cheapness of construction, and such arrangement of parts as will prevent the plow becoming clogged with weeds, etc. The mold-board is welded to the land side, or cast in one piece with it, so that no brace or other connection is required between the mold-board and standard; secondly, the curved beam is attached to the heel of the land-side and supported by a brace, which is bolted to the middle portion of the latter, and arranged in such relation to the mold-board that a space is left between them, into which the trash will fall, and thus be drawn into the furrow and covered.

IMPROVED GRAIN DRILL.

George W. Osborn, Parkville, Mich.—This is an improved attachment for seed drills, for gaging the depth at which the grain shall be deposited in the earth. It consists in an adjustable spring gage bar attached to the shank of each drill tooth, whereby the teeth may be made to enter the ground a greater or less depth. It is claimed to ensure the planting of seeds at equal depth in hard or soft ground, and to diminish the draft.

IMPROVED HORSE HAY RAKE.

Joseph B. Wakeman and John L. Wager, Deposit, N. Y.—The construction of this implement is such that a large space is afforded beneath the rake head for the collection of hay. The pivots of said rake head back are also brought back, so that the teeth may be readily raised to discharge the collected hay. By an ingenious lever arrangement the driver is enabled to hold the rake to its work by the pressure of his foot, and also readily to discharge the hay gathered.

IMPROVED BEE HIVE.

George W. Akins, Bridgeton, Pa.—In this hive, holes are bored in the sides of the compartment for ventilation, and windows are flared for the purpose of inspecting the inside of the hive. A frame is used whenever it is desired to have the honeycomb of any particular shape. It consists of a form of tin or other suitable material, placed on a frame or slide, and having the shape required in the comb. Bees will build inside of the form, leaving about one fourth inch space between the form and the comb. The tin sheet receives a portion of the refuse matter, and can be readily taken out and cleaned. On the 1st of May the bees are driven out into another hive and the frames examined. Three frames are taken out and set in a new box, and three empty frames are put in their place. The old queen must be put with the new colony, and half of the bees must be put in each box and shut up, and put on a stand. The hives are to be opened the next morning. At the next natural swarming time the swarms can be again divided. The hive cannot freeze, and it is proof against mice.

IMPROVED PLOW STOCK.

Robert Weber, New Ulm, Texas.—In this invention, by loosening a nut, the point of draft attachment may be raised and lowered to cause the plow to work deeper or shallower in the ground, or turned to one or the other side, to cause the plow to take or leave land, and may be secured in place when adjusted by again tightening the nut.

IMPROVED COMBINED HAY TEDDER AND SIDE RAKE.

John Huber and Henry Snell, Girard, Ill.—This machine may be used simply for stirring up and turning the hay, or for turning the hay and gathering it into windrows. The shaft of a reel revolves in bearings attached to the side bars of the frame near their rear ends. To the bars of the reel are attached spring teeth, which, as the machine is drawn forward, take hold of the hay, carry it up and over the reel, and drop it to the ground in the rear of the machine. A carrier takes the hay from the teeth, when it has been brought to the top of the reel, carries it over the shaft, and discharges it into a trough, down which it slides, and is deposited in a windrow along one side of the path of the machine.

IMPROVED GRUBBING MACHINE.

Ira Burley, Redwing, Minn.—This invention consists in the combination of wheels and axle, tongue, adjusting bar, adjustable brace, uprights, cross bar, two ropes, and four pulley blocks with each other. To the forward end of the tongue is attached a loop or clevis, to receive an iron pin, to be driven into the ground to keep the machine from moving about while being used. To the pulley block is swiveled a hook, to be hooked into a loop, attached to the forward end of a lever. The rear end of the lever passes through a slot in the upper end of a fulcrum post, and has a notch formed in its lower side to receive a bolt or pin, attached to said post to serve as a fulcrum to said lever. Several notches are formed in the lever to receive the fulcrum bolt, to enable the position of the fulcrum post to be adjusted to regulate the leverage, and as circumstances may require. To the lever is attached a strong clevis, to receive the hook of the chain, that is secured to the stump to be pulled.

IMPROVED SEED PLANTER.

Daniel J. Davis, Red Boiling Springs, Tenn.—In this invention two wheels revolve upon the journals of the axle. Upon the end parts of the axle are attached the rear ends of side bars, the forward ends of which are bolted to the outer sides of the forward ends of the plow beams. The forward ends of the beams are bolted to the ends of the front bar, to the center of which is secured the forward end of the central bar. To the beams are attached the plows for opening furrows to receive the seed as it passes from the conductor spouts. The lower ends of the spouts or tubes pass in through the sides of the plows, so as to conduct the seed into the bottom of the furrows before they have been partially filled by the falling in of the soil. The dropping plate is concealed around its dropping holes, and is provided with a plate that may be adjusted to cover one set of dropping holes to drop the hills twice as far apart as when both sets of holes operate.

IMPROVED ANIMAL TRAP.

Thomas N. Hughes, Muddy Creek, Tenn.—This trap is for animals of all kinds, as rats, mice, and larger animals, as foxes, minks, coons, etc., that are allured by bait, and is automatically set again by the animal caught, to be ready for the next animal attracted by the bait. It is divided by a longitudinal partition into two main sections, in which the working parts are disposed. The entrance at the end of one section has a drop door, which is arranged back of the same, resting, when closed, on side strips in inclined position, and being supported on an upright arm, of a centrally pivoted treadle door, at the bottom of the trap, when the trap is set. The treadle door is only required to swing sufficiently on its pivots to release the drop door from the arm, suitable seats at the under side of the trap, at both sides of the treadle door, preventing the door from swinging farther than necessary. The bait is placed in a grated receptacle, near the treadle door, and entices the animal to pass in, so as to close the drop door when it arrives at the part of the treadle door near the bait. The back end of this section is perforated or grated to admit light, which attracts the frightened animal and induces him to pass toward the light. The top part of the trap may be grated to admit air, and the glass door at the end made to slide, to admit the taking out of the animals for killing them.

NEW MISCELLANEOUS INVENTIONS.**APPARATUS FOR THE HYDRATION OF CHLORINE GAS.**

William Maynard, New York city.—This invention relates to an improved construction of apparatus for the hydration of gases, and more particularly chlorine gas for the manufacture of chlorine water for use in the industrial arts of bleaching, etc. It consists mainly in a case having an inlet for the water above, an inlet for the gas below, and provided with an intermediate water percolating medium; combined with a reservoir located below the level of the case and having a water-sealed communication there-

with, which reservoir receives the hydrated gases, and which water seal prevents the heavy gas in the case from passing out through the bottom inlet. The case for the percolation of water and the absorption of the gas is made of conical shape, with the largest diameter at the bottom, to produce the greatest absorption of the heavy gas when first admitted; while horizontal partitions, or shelves, in said case are provided with upwardly projecting tubes which hold a permanent surface of water on the said partition or shelves. The tubes permit, by their peculiar shape, the water to pass down on one side and the gas up on the opposite side of said tube, while their alternating arrangement in the alternating shelves gives a zigzag and long continued passage to the gas and water in moving in opposite directions through the case.

IMPROVED PROCESS OF PREPARING GAS FUEL.

Martin N. Dially, Terre Haute, Ind.—This inventor saturates wood by immersing it in any hydrocarbon oil for from six to twelve hours, as required by the nature of the wood, so that it may take up the necessary quantity of oil for the required strength of gas. The wood is then immersed in a bath of water, for taking up a quantity of water outside the oil, and is then charged in the retorts, the same as coal, and distilled in the same way. By this process the inventor claims that he produces fixed gas equal to coal gas, much faster, and with less expense, the wood and water furnishing the hydrogen, and the oil furnishing the carbon.

IMPROVED FISHING LINE LEADER.

Welmer T. Jahne and Anthony Moors, Jersey City, N. J.—This consists of a leader made of spring wire, bent into V form, provided with a swivel and eye at its middle part, and with eyes or loops at its ends to receive the line and snells. By this construction the snells and hooks will be kept apart however the line may be thrown, and however they and the leader may be turned about by the tide or current. The device is one well calculated to meet with a favorable reception from fishermen.

IMPROVED ABDOMINAL CORSET.

Christina Lascell, Newark, N. J.—The object of this invention is to furnish an improved abdominal corset, which supports the weight of the abdomen in a perfectly comfortable and easy manner, and throws the strain on the shoulders and hips of the wearer. The corset is adjustable to the varying conditions of the abdomen, does not interfere with the motion and different positions of the body, and is readily put on and taken off. It has adjustable elastic shoulder straps, and opening at the sides by lacings and elastic bands and buttons. The front part of the corset is stiffened by a stay that slides in a pocket to provide for stooping. A central front and lacing admit the front part of the corset to expand. The lower extension part of the corset has short stiffening stays, and it is connected independently of the upper stays by short side lacing and elastic straps to the side or hip parts of the corset. A hernial band extends from the lowermost part of the corset-extension between the legs to the rear, and is attached by adjustable hip straps to the sides of the corset.

IMPROVED FIRE ESCAPE.

John F. Werner, New York city.—The terrible disaster in the Brooklyn theater is serving as a stimulus to induce the invention of devices looking to the prevention of a like occurrence. The present inventor has devised a new fire escape for theaters, concert halls, and other public places of amusement, by which the space at the upper parts of the entrances, halls, or vestibules of the buildings is utilized for the purpose of forming additional passage ways for the persons in the buildings, to be used in case of fire for the more convenient and less dangerous exit of the same. The invention consists, mainly, of a movable floor, suspended by chains, pulleys, and weights, near the ceiling of the entrances, and lowered in case of fire. It is supported on projecting rests of the side walls, at suitable height above the floor. Sliding extensions and swinging stairs and rear sections connect with the ground outside of the door, and with the staircases of the gallery, so as to form separate exits above the regular entrances.

IMPROVED ELECTRO-MAGNETIC DENTAL PLUGGER.

James E. Dexter, New York city.—This invention consists, first, in a magnet having a centrally bored iron core, surrounded by a magnetic coil, which is enveloped by an iron shell that is concentric with the central core, and is attached to a flange formed on the lower end of the said central core. One side of both shell and core are split for the purpose of obviating residual magnetism. The invention also consists in combining a spring yoke, a vibrator, and a spring contact piece, as hereinafter particularly described. The third part of this invention consists in the arrangement of the key for completing the circuit, which is made with an insulating exterior, and is provided with one of the termini of the magnet coil, and bears against the side of the key to insure a constant contact of the surfaces. The various parts of the plugger are combined, so that pressing the key with the finger makes the circuit, and a succession of regular strokes is produced, the force of which may be varied by an adjusting screw.

NEW MECHANICAL AND ENGINEERING INVENTIONS.**IMPROVED COTTON GIN.**

Joseph W. Thorn, Iuka, Miss., assignor to himself and M. W. Beardsley, of same place.—In this machine there is a new construction of the brush drum for simplifying the same, and facilitating the application of the brush wings, so that they can be readily taken off and put on; also, an arrangement of the ribs between the saws for facilitating the separating of the seed from the cotton without breaking and injuring the fiber. There are also ingenious devices for preventing the seed from gathering and clogging at the ends of the saw drum.

IMPROVED SAFETY CHECK FOR ELEVATORS.

Nathan H. Fogg, Boston, Mass.—When the car is suspended normally from the rope, the rubber balls, arranged in sockets near the lower part of the car, are supported on their seats in a state of rest; but the instant that the rope breaks or gets detached from the bolt the action of an aspiral spring throws an actuating plate downward, and levers and ball-carrying rods upward. The balls are thus thrown off their seats and wedged between the inclined sides of the pockets and the guide posts of the elevator so as to stop thereby the car.

IMPROVED COMBINATION LOCK.

Achille Parise, Naples, Italy.—This is a new combination lock for doors, trunks, safes, etc., that admits of a large number of combinations, and may be opened and closed quickly. It consists of sliding tumbler plates, having longitudinal slots and a number of perforations placed at different relative positions to the slots of each tumbler. The trunks are connected by screw set pins attached to face slides, and passing through any one of the perforations, admitting the setting of the tumblers and opening of the lock by outer projections or buttons of the slides to fixed exterior guides.

IMPROVED MACHINE FOR WIRING AND BINDING HATS.

Mari A. Cuming and Judson Knight, New York city.—This is a machine for binding hats, felt skirts, and similar articles, by a uniform and parallel pressure on the rims, and by facilitating the applying and taking off of the articles from the machine, and accomplishing the cutting of the binding or braid and wire in a reliable and improved manner. Pressure rollers attach the binding and the wire, if one is required, in connection with a grooved gage that is supported on a seat of the shaft of the lower pressure roller. The wire is guided by annular recesses or chamferings at the rear circumference of the pressure rollers and the groove of the gage. The gage is so connected to its seat that it may be turned and another guide groove of the same be exposed to face the pressure rollers, so as to adapt the same for a variety of work.

Business and Personal.

The Charge for Insertion under this head is One Dollar a line for each insertion. If the Notice exceeds four lines, One Dollar and a Half per line will be charged.

Manufs. of Scissors address J. W. D. E., Harmony Grove, Ga.

For Sale—36 in. Lathe, \$4.00; 72 in. Lathe, \$4.50; 10 in. Pratt Whiting Shaper, \$2.75; 35 H. P. Loco. Boiler, \$300; 12 in. Lathe, \$35; at Shearman's, 182 N. 3d St., Phila.

Iron Tubing—Wanted, a yearly supply of 1-4 in. light Iron Tubing. Address P. O. box 1250, New York city.

Baxter's Adjustable Wrenches—The best for Farmers, Householders and Mechanics. Greene, Tweed & Co., 18 Park Place, N. Y.

For Sale—Baldwin No. 4 Foot Lathe and fittings; in perfect order. Address P. O. Box 196, Clinton, Mich.

National Steam Pump—Simple, durable, economical. Reduced price. National Iron Works, N. Brunswick, N. J.

Manufs. and dealers in Cotton Gins, Grist Mills, and Rice Hullers and Polishers, address with terms, Y. L. Ridley, Liberty, Texas.

For Sale—Patent Combination Fruit Press, Filter and Funnel. An indispensable article in every household. For circulars, address G. A. Newsam, 118 3d Pl. Brooklyn.

Mill Stone Dressing Diamonds. Simple, effective, and durable. J. Dickinson, 64 Nassau St., N. Y.

Will purchase or introduce, on a reasonable royalty, some good, useful article. Address, with description and full particulars, A. E. Lowison, Boston, Mass.

Mechanical inventors familiar with Envelope Manufacturing. L. J. Henry, 615 Kearny st., San Francisco, Cal.

Set of Mechanical Curves, as illustrated in Sci. Am. Supplement, No. 50, mailed on receipt of \$5.25, by Keuffel & Esser, New York.

Hyatt & Co.'s Varnishes and Japans, as to price, color, purity, and durability, are cheap by comparison with any others extant. 246 Grand st., N. Y. Factory, Newark, N. J. Send for circular and descriptive price list.

Lightning Screw Plates. A perfect thread at one cut adjustable for wear. Frusse & Co., 62 Chatham St., N. Y.

Wire Needle Pointer, W. Crabb, Newark, N. J.

Power & Foot Presses, Ferracute Co., Bridgeton, N. J.

Superior Lace Leather, all sizes, cheap. Hooks and Couplings for flat and round Belts. Send for catalogue. C. W. Arny, 148 North 3d St., Philadelphia, Pa.

F. C. Beach & Co., makers of the Tom Thumb Telegraph and other electrical machines, have removed to 530 Water St., N. Y.

For Best Presses, Dies, and Fruit Can Tools, Bliss & Williams, cor. of Plymouth and Jay Sts., Brooklyn, N. Y.

Water, Gas, and Steam Pipe, Wrought Iron. Send for prices. Bailey, Farrell & Co., Pittsburgh, Pa.

Walrus Leather and supplies for polishing Iron, Steel, and Brass. Greene, Tweed & Co., 18 Park Place, N. Y.

Hydraulic Presses and Jacks, new and second hand. Lathes and Machinery for Polishing and Buffing metals. E. Lyon, 470 Grand St., N. Y.

Solid Emery Vulcanite Wheels—The Solid Original Emery Wheel—other kinds imitations and inferior. Caution—Our name is stamped in full on all our best Standard Belting, Packing, and Hose. Buy that only. The best is the cheapest. New York Belting and Packing Company, 37 and 38 Park Row, New York.

Steel Castings from one lb. to five thousand lbs. Invaluable for strength and durability. Circulars free. Pittsburgh Steel Casting Co., Pittsburgh, Pa.

M. Shaw, Manufacturer of Insulated Wire for galvanic and telegraph purposes, &c., 259 W. 27th St., N. Y.

Shingle, Heading, and Stave Machine. See advertisement of Trevor & Co., Lockport, N. Y.

For Solid Wrought Iron Beams, etc., see advertisement. Address Union Iron Mills, Pittsburgh, Pa., for lithograph, etc.

Articles in Light Metal Work, Fine Castings in Brass, Malleable Iron, &c., Japanning, Tinning, Galvanizing. Welles Specialty Works, Chicago, Ill.

See Boulton's Paneling, Moulding, and Dovetailing Machine at Centennial, B. 8-55. Send for pamphlet and sample of work. B. C. Mach'y Co., Battle Creek, Mich.

Wanted—Novel and practical invention, by a reliable house, for manufacturing. Address Post Office, Box 25, Chillicothe, Ohio.

Chester Steel Castings Co. make castings twice as strong as malleable iron castings, at about the same price. See their advertisement on page 125.

Hand Fire Engines, Lift and Force Pumps for fire and all other purposes. Address Rumsey & Co., Seneca Falls, N. Y., U. S. A.

Notes & Queries

S. J. S. will find good recipes for laundry soaps on pp. 331, 379, vol. 31. For toilet soaps, see p. 289, vol. 28.—B. F. T. will find directions for putting a black finish on brass on p. 362, vol. 25.—J. C. S. will find directions for coloring a meerschaum pipe on p. 90, vol. 36.—A. B. will find a good recipe for Babbitt metal on p. 122, vol. 28.—G. A. D. will find directions for coloring butter with annatto on p. 187, vol. 31.—L. O. J. will find something on iceboats sailing faster than the wind on p. 107, vol. 36.—J. M. L. will find directions for clarifying cotton seed oil on p. 91, vol. 36.—D. V. will find a good recipe for shoe polish on p. 107, vol. 36.—A. B. will find directions for japanning on metal on p. 408, vol. 30.—T. S. D. will find recipes for all kinds of colored fires on p. 203, vol. 34.—G. S. C. can fasten his paper labels to wood with flour paste.—W. R. B. will find directions for dyeing billiard balls on p. 88, vol. 34.—G. W. M. will find directions for making raisins on p. 59, vol. 34.—T. F. T. will find something on burning petroleum in steam boilers on p. 165, vol. 30.—S. B. U. will find some illustrations of lathes for turning spokes, tool handles, etc., on p. 88, vol. 36.—W. E. P. will find a formula for safety valves on p. 330, vol. 32.—A. O. will find directions for removing mildew on p. 138, vol.

27. For mending rubber boots, etc., see p. 203, vol. 30.—W. C. L. will find directions for preserving eggs on p. 306, vol. 34.—R. M. G. will find a recipe for root beer on p. 138, vol. 31.—W. F. H.'s plan for a refrigerator might answer. See p. 251, vol. 31.—J. C. can remove the wool from pelts by steeping the skins in water, and hanging them up till the wool putrefies. Then scrape with a blunt knife. For cleansing wool, see p. 6, vol. 32.—W. H. J. will find a recipe for a cement for marble on p. 344, vol. 32.—T. B. can gild his steel scabbard by following the directions given on p. 106, vol. 34.—A. H. B., J. A. C., W. H. H., J. F. P., D. S., J. N. H., J. P., F. F., M. N., M. C., R. C., K. S. W., T. J., and others, who ask us to recommend books on industrial and scientific subjects, should address the booksellers who advertise in our columns, all of whom are trustworthy firms, for catalogues.

(1) R. H. C. says: We have a slate roof which leaks very much. I have not discovered any defect in the way in which it was put on; it appears to be perfect. The pitch may be too low, and the rain may be driven through by the wind on this account. Is there any wash, paint, or cement that might be used for the purpose of remedying this defect? A. There is an india rubber paint which is used to make leaky roofs tight, but we have not learned of its being applied to slate roofs.

(2) C. C. B. says: I am making a small steam engine. The cylinder has, inside diameter, about 1 inch with 2 1/2 inches stroke. What would be the most suitable material and dimensions for the boiler? A. Make one 10 or 12 inches in diameter and 18 inches high, of 1/2 inch iron. You can carry 60 lbs. steam pressure.

(3) M. C. says: I have had charge of some greenhouses that were erected about four years ago; they are thoroughly heated, and all the pipes have a thick coat of black paint. The houses never gave any satisfaction, no matter how healthy the plants were in the fall. Soon after the fires were lighted both leaves and flowers began to drop, and some plants died. My predecessors attributed it to gas getting into the houses. Upon inquiry I found no gas was there except when the pipes were hot, and that the hotter they were the worse it was. In my opinion, the cause of the trouble was a strong smell of paint from the pipes. Since then I only keep heat enough to save the plants from freezing. A. From your statement there is no doubt that the paint used on the pipes was an imperfectly purified coal tar. Such tar contains a great number of hydrocarbons—naphtha, naphthalen, anthracen, phenol, several organic alkaloïds, hydrosulphuric and hydrocyanic acids, etc., all of which are more or less volatile at the temperature to which they must have been subjected. These exhalations have proved fatal to plant life when in sufficient quantity. We do not know of a better remedy than that of removing the cause. Painting the pipes with a strong solution of washing soda and lime would, in a measure, prevent the escape of the most objectionable constituents into the air, by forming with them compounds non-volatile at any temperature to which they are likely to be subjected in contact with the pipes; but the former would be the surest plan.

(4) C. D. W. asks: The roof of the new Illinois State House, as well as the stylobate cornices and upper portion of the dome, are covered with zinc. It has been on about three years, and I am told is materially affected by oxidation. The theory is that zinc, though subject to oxidization, has the peculiarity that the oxide does not scale off as from iron, but forms a permanent coating impervious to the action of the atmosphere. Some mechanics, however, assert that neither zinc, copper, nor lead will withstand the action of our atmosphere, as bituminous coal strongly impregnated with sulphur is almost the only fuel used. It is claimed by some that the sulphuric acid in the atmosphere tends to corrode zinc so as to make it worthless for roofs or gutter linings. A. Are you sure that the roof and gutters in question are not of galvanized iron, iron coated with zinc? This is the material most commonly used for that purpose at the present time. Zinc has been found to be too brittle for the strain to which it is subjected, in such cases, by the expansion and contraction induced by changes of temperature. A slight oxidation will adhere to the surface, but an acid deposit from the atmosphere will penetrate the coating in points and deteriorate the metal.

(5) N. J. S. says: I have a floor of ash and black walnut which has been oiled with raw linseed oil once. How can I finish it so as to get a hard, smooth finish that will not be scratched by boot heels nor be sticky or retain the dirt as a waxed floor does? A. Oil raises the fiber of black walnut and gives it a rougher surface than when free from it. To polish any wood, it is only necessary to fill the pores well, and then rub it down to a smooth surface. Thus painters prefer to put on a coat of shellac varnish first, before oiling walnut and other hard woods. For fine floors, a thin coat of liquid wax is applied as a finish.

(6) A. J. S. asks: What is the best plan for putting up a cheap dry house of lumber, for drying (by steam) white oak, hickory, and other lumber used in wagon and buggy making? A. Make as tight a house as possible with tongued and grooved siding-boards, floors, roof, etc., and provide a stack of steam pipe containing 1 foot of heating surface to every 50 cubic feet of air contained in the building. Set the steam pipe in compact shape and enclose it with a casing of galvanized sheet iron open at the top; supply cold air from outside of the building by a boxed conduit to the bottom of this stack. The air when heated will rise and diffuse itself into the room, and as it cools will fall to the floor; provide registers in the floor, through which it may escape into other boxed tubes under the floor leading to an upright chimney discharging above the roof. Let a smoke pipe from the boiler enter the chimney and extend up inside the flue far enough to heat the same. The change of air is necessary to dry the lumber. The size of the house of course will depend upon the quantity of material required to be stacked up into it at any one time.

(7) G. asks: 1. How do you calculate the amount of pipe of a given size to warm a room of a given size? A. One square foot of plate or pipe surface is generally taken as sufficient to heat about 70 cubic feet of air in dwellings. 2. What allowance should be

made for doors and windows? A. The said foot of surface will heat, in accordance with varying conditions, from 40 to 100 cubic feet of air, and allowance should be made for extra exposures, to correspond with that scale. A steam pressure of 5 lbs. is sufficient for heating purposes. 3. What is meant by the terms direct and indirect radiation, in giving capacity of steam generators for heating houses? A. Direct radiation is used when the pipes are located in the room, and indirect when they are located in a chamber in the cellar, to warm air which is conducted to the room by air pipes.

(8) D. M. says: After reading L. S. W.'s reply to J. B. C., p. 75 (6), vol. 36, I think the following demonstration will be more acceptable to J. B. C.: Imagine three spheres of which the given circles are great circles, and a plane tangent to the three spheres. Any two of the spheres may be conceived to have been generated by the revolution of two of the circles about the line joining their centers. During such revolution, the lines tangent to the two circles describe a conical surface. We have, therefore, three spheres and three conical surfaces. Now the plane, which is tangent to the three spheres, is also evidently tangent to the three conical surfaces; and therefore the vertices of those conical surfaces are all in the tangent plane. Now those vertices are the points (1), (2), (3). But the same points are also in the plane passing through the centers of the three spheres, which is the same with the plane of the paper on which the figure is drawn. Those points, being in two planes at the same time, must therefore be in the intersection of those planes, that is to say, in a straight line.

(9) C. W. H. asks: Can dyeing or coloring be done in cold water? A. Many of the coal tar colors may be used in this way: For animal fibers—wool, silk, etc.—the affinity of these colors is so great that, in most instances, no mordants are necessary. The baths are usually made slightly acid. With vegetable fibers, however, a fast dye is not assured without mordanting. Some of the finer goods are prepared by treating with steam coagulated albumen (animalizing), gelatin, various tannates, tin salt, alum, and other metallic salts. The following is the usual method of treatment, except with goods intended for very light shades: Pass the goods through a strong decoction of sumac or other tannin solution for an hour, and afterwards for an hour or two through a weak solution of stannate of soda; wring out, dip into a dilute solution of sulphuric acid, and rinse well in water. The goods are then ready to be passed through the color bath, slightly acidulated. For different tints, these baths are worked at different temperatures.

(10) F. W. says: I wish to lay the face tier of a brick wall in black mortar. How can I make the coloring material and mix it? A. Some prefer to use red mortar and afterwards pencil the joints with black. Color the ordinary white mortar with Spanish brown for red mortar, and with ivory black for black, by mixing in enough of the color in a powdered state to give a good deep tone.

(11) H. A. S. asks: 1. How many prisms are required in a spectroscopie to detect mineral elements in presence of all the ash ingredients of organic bodies? A. If we understand you, one 60° prism will answer. 2. What is the best and cheapest form of apparatus to heat such compounds for examination? A. Mix the substance with a little pure hydrochloric acid and glycerin, and introduce into the flame on a coil of platinum wire. 1. Has soup prepared by dissolving meat bones in a Papin's digester ever been known to produce ossification of any of the soft tissues? A. We have never heard of such a result. 2. Has it ever been known to produce a new crop of teeth in toothless persons? A. We have no data as to such a fact.

I have seen a statement that May 19, 1780, was so dark a day that candles were necessary everywhere; and I have heard that another occurred about the year 1820. Has any scientific explanation ever been given of this phenomenon? A. The darkness on the days you mention were the result of solar eclipses. They occurred on days of unusual cloudiness. Perhaps the darkest day in modern history was that caused by the total solar eclipse in the year 1806.

(12) A. B. says: 1. I have built a boat 15 feet long and 4 feet 6 inches wide. How large a boiler and engine do I require to work her to best advantage? She is 22 inches deep from top of rail to top of keel. A. Cylinder, 2 1/2 x 3 inches; boiler, 20 inches in diameter and 3 feet high. Propeller, 18 to 20 inches in diameter, and of 3 feet pitch. 2. How fast ought she to run? A. Probable speed, 5 miles an hour in smooth water.

(13) L. L. asks: 1. Does it make any difference in what position a watch is in when running? A. For watches adjusted to temperature and position, it does not make much difference. 2. When not being carried, what position should it be left in? A. In the case of ordinary watches, we imagine that the wear will be rather more uniform when they are in a vertical position. 3. If a person sleeps in a cold room, would a watch be better under his pillow than on a table or hung up in the same room? A. It is best not to subject them to great changes of temperature.

(14) W. G. says, in reply to C. W. W., who has an engine, of 2 1/2 inches bore and 4 inches stroke, which runs slower with increase of pressure: Having had much experience with small engines and boilers, I will state that I have had the same difficulty when using an upright tubular boiler, and discovered the following to be the cause: The upper portions of the tube superheat the steam to such a degree as to prevent lubrication on the valve and piston surface by condensation, and thereby reduce the speed of engine. Even with increased pressure, this effect will be more appreciable when the area and travel of slide valve are in excess.

(15) J. M. T. asks: Is there friction between two bodies while at rest, or only when one or both are in motion? A. Both when at rest and in motion. Why does a balloon rise in the air? A. See p. 64, vol. 32.

(16) S. J. S. asks: 1. How are augers twisted? A. By special machinery. 2. How are twist drills made, and are they single or double grooved? A. They are double grooved or double twisted, and are cut out in a milling machine.

Can weights, springs, or water from a tank be used to any advantage to run a lathe? A. No.

How much do iron and brass, in rods or bands, expand in length when heated to red heat? A. Iron about 1/4 inch per foot, brass 1/5 inch.

Is the pressure of the air to be added to the weight of water in the bottom of a vessel in estimating the pressure on the bottom? A. No.

Does a watch or clock run faster when just wound up? A. No.

Is it not moisture in the air that makes it heavier, and so affects the barometer? A. Yes.

Is the pressure in a siphon equal throughout, or is it greater in the upper end? A. Equal throughout.

Will it take more power to run two millstones in opposite directions than it will to run one at the same speed, the other being stationary? A. Yes, it will take double the power.

1. How are common screws made? A. In lathes, with tools and dies. 2. How can I make wooden screws perfectly smooth? A. By using keen tools.

What is the simplest way of cutting a square hole in a bar of iron? A. Drill a round hole and square it out.

(17) G. E. C. asks: Could I have a brick range 2 x 3 feet, built on a platform about 1 foot from floor, with two compartments, to be heated with petroleum, the lower one to be used as an oven, the upper one to have a stove top to set cooking utensils on, and have a ventilating pipe run from each compartment of the oil receptacles into the place in the chimney where the stove pipe usually goes, to carry away any gas or smoke? I want the oil receptacles to be arranged to be drawn out, to be filled and trimmed, and I would like four burners to heat an oven 22 inches square, as hot as the same oven could be heated with wood. A. We doubt the propriety or the economy of substituting oil for wood, but something may be done to make the atmosphere of kitchens more endurable in summer, and permanently so in warm climates. A double faced range could be made and set in the center of the thickness of the chimney, with the space above the top of it open to the exterior of the house; a very slight structure, simply having a good floor and roof and open around the sides, and built against the chimney as an extension to the house, would answer for a summer kitchen, while the ordinary kitchen inside the house could be used in winter. The transposition could be made by a pair of iron sliding doors shutting off the kitchen not in use; and these doors could be transferred from one side of the chimney to the other when the change of season required it.

(18) A. X. A. says: In your issue of December 2 is a recipe in which "insoluble acid chromate of lime," and gelatin are to be used; and in a succeeding number of your paper the modes of preparing the insoluble acid are given. I have made the acid according to your directions, but the result of my manipulation of the recipe is a failure. You say: "Take of insoluble acid chromate of lime one part, and of gelatin five parts; but you do not say what further is to be done. Will the acid dissolve the gelatin, or must warm water be added? In my experiment the acid would not dissolve the gelatin, and I had to add considerable warm water before it would do so. A. Dissolve the bichromate of lime in the smallest possible quantity of warm water, and filter; then add the gelatin, previously softened by immersion in cold water. Heat the mixture over a water bath until the gelatin is completely dissolved, stir well, and use while hot. The recipe should have stated that this cement was best suited for glassware. The bichromate of potash or of ammonia will answer nearly as well as the lime salt.

(19) E. C. N. asks: How must a stove be constructed to burn pea coal, for heating outbuildings? Is there any way of constructing a draught below the grate of any common heating stove, sufficiently strong to do without an extra long chimney? A. Use a broad grate to spread the coal out well, so as to avoid the necessity of heaping it up much; make the opening for the draught some distance below the grate, and regulate by the usual slide dampers in the lower and upper doors.

MINERALS, ETC.—Specimens have been received from the following correspondents, and examined, with the result stated:

F. R. R. S.—The substance you send is carbonate of iron. It is held in solution in the water by the large excess of carbonic acid which the water contains. On boiling the water the carbonic acid gas is expelled and the iron salt is precipitated from solution. The removal of this and some other objectionable salts which the water very probably contains, may be removed by the addition of the proper quantity of clear lime water to it—the lime in this instance will combine with the excess of carbonic acid and fall to the bottom together with the carbonate of iron. To determine the precise quantity of lime water requisite, add the reagent (saturated solution) to a small portion (of known volume) of the freshly drawn water, in small quantities at a time, and with constant stirring until no further precipitate forms. Then by a simple operation in proportion the quantity of the reagent necessary for the purification of a given quantity of the well water may be easily determined. An excess of the reagent must be avoided. This impurity would probably prevent the successful working of an injector.

W. S. W. asks: How is the best rosin, used on violin bows, prepared?—W. F. asks: What is a simple method for washing clay for brick and tile making?—E. S. D. asks: What is the best kind of wood to construct a guitar?

COMMUNICATIONS RECEIVED.

The Editor of the SCIENTIFIC AMERICAN acknowledges, with much pleasure, the receipt of original papers and contributions upon the following subjects:

- On Rheumatism. By A. R. E.
 - On Postage Stamps. By E. B.
 - On Boiler Explosions. By G. B. B.
 - On Reaching the North Pole. By J. H. S.
 - On Heating Street Cars. By P. T.
 - On a Hybrid Fruit. By R. S. B.
 - On an Air Vessel. By J. T. R.
- Also inquiries and answers from the following:
E. B. M.—F. F. F.—N. B. H.—B. B.—O. F.—R. V. J.—F. M.—N. B. C.—C. F. E.—W. T.—C. W. C.—T. F.—C. A. S.—S. N. M.—J. R. D.—P. J. D. S.

HINTS TO CORRESPONDENTS.

Correspondents whose inquiries fail to appear should repeat them. If not then published, they may conclude that, for good reasons, the Editor declines them.

Inquiries relating to patents, or to the patentability of inventions, assignments, etc., will not be published here. All such questions, when initials only are given, are thrown into the waste basket, as it would fill half of our paper to print them all; but we generally take pleasure in answering briefly by mail, if the writer's address is given.

Hundreds of inquiries analogous to the following are sent: "Who sells a tool for truing up a crosshead wrist? Who sells tools for refitting steam valves without unscrewing them from the pipes? Who sells spoke-turning lathes? Who makes machinery for freeing wool of burrs and dirt? Where can tungsten, or tungsten steel, be procured, and at what price? Who sells silicate of alumina and silicate of potash?" All such personal inquiries are printed, as will be observed, in the column of "Business and Personal," which is specially set apart for that purpose, subject to the charge mentioned at the head of that column. Almost any desired information can in this way be expeditiously obtained.

OFFICIAL.

INDEX OF INVENTIONS

FOR WHICH

Letters Patent of the United States were Granted in the week Ending

January 16, 1877,

AND EACH BEARING THAT DATE.

[Those marked (r) are reissued patents.]

A complete copy of any patent in the annexed list, including both the specifications and drawings, will be furnished from this office for one dollar. In ordering, please state the number and date of the patent desired, and remit to Munn & Co., 37 Park Row, New York city.

Table listing various inventions such as Abdominal corset, Acoustic telegraph, Advertising card, Air compressor, etc., with corresponding page numbers.

Table listing various inventions such as Hay tedder and side rake, High pressure hot air engine, Hook for drawrods, etc., with corresponding page numbers.

DESIGNS PATENTED.

Table listing various designs such as 9,700, 9,701—CHAINS, 9,702—BRACKETS, etc., with corresponding page numbers.

[A copy of any of the above patents may be had by remitting one dollar to MUNN & CO., 37 Park Row, New York city.]

Advertisements.

Inside Page, each insertion --- 75 cents a line. Back Page, each insertion --- \$1.00 a line. Engravings may head advertisements at the same rate per line, by measurement, as the letter press. Advertisements must be received at publication office as early as Friday morning to appear in next issue.

Water Wheels.

More than four times as many of Jas. Leffel's improved Double Turbine Water Wheels in operation than any other kind. 24 sizes made, ranging from 5 3/4 to 96 in. diam. under heads from 1 to 240 ft. Successful for every purpose. Large new pamphlet, the finest ever published, containing over 30 fine illustrations, sent free to parties interested in water power.

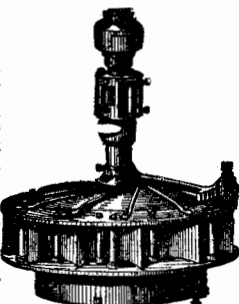

Steel Castings,

From 1-4 to 10,000 lbs. weight. A an invaluable substitute for expensive forgings, or for malleable iron castings requiring great strength. Send for circular and price list to CHESTER STEEL CASTING COMPANY, 150 N. 11th Street, PHILADELPHIA, PA.

GEORGE C. HICKS & CO., Baltimore, Md.

CLAY RETORTS, TILES, FIRE BRICKS, &c. Terra Cotta Pipes of all sizes.

Cheapest Rotary Hand Cornsheller in the U. S. Guaranteed to be the simplest, cheapest, most durable, effective and the best. Buy it. Try it and be convinced. Samples \$1.00. Large profits to agents. Address Harrisburgh Pa., Family Cornsheller Co. Lock Box 9.

Advertisement for A. Fay & Co. Cincinnati, Ohio, Wood Working Machinery. Includes text about various machines and their quality.

Advertisement for Dayton Cam Pump. Includes text about the pump's features and contact information for Smith, Vaile & Co., Dayton, Ohio.

WANTED THE SOLE MANUFACTURE, for England, of one or two Patent Articles in demand by steam users. Advertisers have good manufacturing premises, and a first-class connection among steam users in England and the Continent.

Large advertisement for a New Year's Gift. Features the text 'A \$5 NEW YEAR'S GIFT GIVEN AWAY!' and 'CHRIST IN THE TEMPLE!' with details on how to obtain the gift.

Advertisement for 'A MAN OF A THOUSAND.' Promotes a medicine for various ailments, including lung complaints and general weakness.

Advertisement for 'PRACTICAL TREATISE ON THE PROPERTIES OF CONTINUOUS BRIDGES.' Includes author information and pricing.

Advertisement for 'I HAVE 500 ACRES OF LAND IN SAN JACINTO COUNTY, TEXAS.' Offers land for sale with detailed terms and location information.

Advertisement for 'Wood-Working Machinery,' listing various types of machines and their uses.

Advertisement for '\$290. FOR BEST PIANOS IN THE WORLD' featuring information about piano quality and agents.

Advertisement for 'Brainard Milling Machines' and 'AGENTS TO CONTROL TERRITORY,' including details about machinery and regional agents.

Founded by Mathew Carey, 1785.

BAIRD'S SCIENTIFIC BOOK CATALOGUES

Now Ready, New Revised Editions.

Of our valuable SCIENTIFIC BOOK CATALOGUES, which will be sent by mail gratis, and free of postage, on application.

HENRY CAREY BAIRD & CO., Industrial Publishers, Booksellers & Importers, 810 Walnut Street, Philadelphia.

AIR COMPRESSORS FOR ALL PURPOSES. A SPECIALTY OF HEAVY PRESSURES. THE NORWALK IRON WORKS CO., SOUTH NORWALK, CONN.

OTIS' SAFETY HOISTING Machinery. OTIS BROS. & CO., No. 348 Broadway, New York.

WROUGHT IRON BEAMS & GIRDERS

THE UNION IRON MILLS, Pittsburgh, Pa. Manufacturers of improved wrought iron Beams and Girders (patented). The great fall which has taken place in the prices of iron, and especially in Beams used in the construction of FIRE-PROOF BUILDINGS, induces us to call the special attention of Engineers, Architects and Builders to the undoubted advantages of now erecting Fire Proof structures; and by reference to pages 52 & 54 of our Book of Sections—which will be sent on application to those contemplating the erection of fire proof buildings—THE COST CAN BE ACCURATELY CALCULATED, the cost of Insurance avoided, and the serious losses and interruption to business caused by fire; these and like considerations fully justify any additional first cost. It is believed, that were owners fully aware of the small difference which now exists between the use of Wood and Iron, that in many cases the latter would be adopted. We shall be pleased to furnish estimates for all the Beams complete, for any specific structure, so that the difference in cost may at once be ascertained. Address CARNEGIE, BROS. & CO., Pittsburgh, Pa.

ARSENIC IN THE ARTS.—A Lecture before the Medical Association of Central New York. By S. A. Lattimore, LL.D., Professor of Chemistry in the Rochester University. A popular and important paper. SCIENTIFIC AMERICAN SUPPLEMENT, No. 24. Price, 10 cents. To be had at this office and of all news-dealers.

A NEW DEPARTURE. TRAVELING MEANS WANTED. STAPLE GOODS, NO PEDDLING. Salary \$75 a month. Hotel and traveling expenses paid. S. A. GRANT & CO., manufacturers of ENVELOPES and PAPER, 2, 4, 6, and 8 Home St., CINCINNATI, OHIO.

\$66 a Week in your own town. Terms and \$5 outfit free. H. HALLETT & CO., Portland, Maine.

MESSRS. B. DAMBACHER & CO., Hamburg, Germany, dealers in American Wood-Working Machinery and Tools of all kinds. Messrs. D. & Co., solicit consignments from American manufacturers. Catalogues and descriptive circulars desired, by mail.

MACHINERY OF EVERY DESCRIPTION, COLD ROLLED SHAFTING, HANGERS, PULLEYS, COUPLINGS, BELTING, TA NITE EMERY WHEELS AND GRINDERS, IN STOCK. GEORGE PLACE, 121 Chambers & 103 Reade Sts., New York City.

\$10 to \$500 INVESTED IN WALL ST. Often leads to wealth. A 72 page book explaining everything, and a copy of the Wall Street Review, sent free. JOHN HICKLING & CO., Bankers and Brokers 72 Broadway, New York

WE ENAMEL in FINE JET BLACK every variety of turned wood work parts of machinery, castings, tinware and other metal work ENAMELED JET BLACKS, in wood or metal, made to order. AMERICAN ENAMEL CO. 17 WARREN ST. PROVIDENCE, R. I.

A GIFT By an arrangement with the Publisher we will send every reader of this Paper a sample package of Transfer Pictures free. Send 3c. stamp for postage. They are highly colored, beautiful, and easily transferred to any object. Agents wanted. J. L. PATTER & CO., 122 William St., New York.

Strong Plants delivered free of cost safely per mail at your door. Satisfaction guaranteed. Splendid assortment of ROSES 6 for \$1; 12 for \$2. Send for New Catalogue of Plants. HOOFS, BRO. & THOMAS, Cherry Hill Nurseries, West Chester, Pa.

SHAFTS, PULLEYS, HANGERS, COUPLINGS ETC. In Stock, and for Sale by WILLIAM SELLERS & CO., Philadelphia, and 79 Liberty St., New York. Price lists and pamphlets on application.

WANTED Salesmen to sell light hardware to Dealers. NO PEDDLING. Salary, \$1,200 a year. Hotel and traveling expenses paid. Address DEFIANCE MFG CO., Chicago, Ill.

BARNES Foot Power MACHINERY. 10 INVALUABLE MACHINES for Mechanics and Amateurs. Also Fancy Woods and Designs. Send for 48 page Illustrated Catalogue, Free. W. F. & JOHN BARNES, ROCKFORD, Winnebago Co., Ills.

CELEBRATED FOOT LATHES. Foot Power, Back-gear'd Screw Lathes, Small Hand and Power Planers for Metal, Small Gear Cutters, Slide-rests, Ball Machine for Lathes, Foot Scroll Saws, light and heavy, Foot Circular Saws. Just the articles for Amateurs or Artisans. Highly recommended. Send for illustrated Catalogues. N. H. BALDWIN, Laconia, N. H.

Pond's Tools. Engine Lathes, Planers, Drills, &c. Send for Catalogue. DAVID W. POND, Successor to LUCIUS W. POND, Worcester, Mass.

L. SMITH HOBART, JOHN C. MOSS, D. I. CARSON, President. Superintendent. General Agent.

Photo Engraving Co. MOSS' PROCESS. No. 67 PARK PLACE NEW YORK. An illustration of a large multi-story building with many windows, surrounded by a decorative border.

RELIEF PLATES IN HARD TYPE METAL, For Printing ALL KINDS OF PICTORIAL ILLUSTRATIONS In Books, Newspapers, and Catalogues.

These plates are an excellent substitute for woodcuts, being used in precisely the same way, giving equally good results for much less money.

ELECTROTYPES AND STEREOTYPES are made from them in the usual manner. We offer special advantages to

MANUFACTURERS AND INVENTORS, as our mechanical work is of the best quality and rapidly executed.

Our plates are used satisfactorily in the SCIENTIFIC AMERICAN and the SCIENTIFIC AMERICAN SUPPLEMENT, and by Manufacturers and Publishers in all parts of the country.

"COPY." We work direct only from Prints or properly prepared Pen and Ink Drawings. Any other copy may be furnished, such as Photographs, Pencil Sketches, or the articles themselves, in which cases we have drawings made in the best manner by our own trained draughtsmen. Photographs, taken in the ordinary way, are suitable, and they may be of any size. We make the plates larger or smaller, as desired.

We are glad to have customers prepare their own Pen Drawings, and append one or two DIRECTIONS TO ARTISTS:

The most important requisite in Drawings for our use is that every line shall be perfectly black. The paper or drawing board must be white and smooth. For fine work drawings should be made double the scale of the plate desired. Carefully observing these main points, the artist has the utmost freedom in his choice of styles of drawing. For further information and fine samples of our work, send stamp for current number of our illustrated Quarterly Circular.

WE ALSO PUBLISH,

PRICE, ONE DOLLAR. ART ALBUM. CONTAINING TWELVE BEAUTIFUL PHOTO ENGRAVINGS. Suitable for Framing. Reproduced by the Moss Process from Art Journal Steel Engravings. PUBLISHED BY Photo Engraving Co. No. 67 Park Place.

Please say where you saw this. PHOTO-ENGRAVING CO., 67 Park Place, New York.

THE TRADE ENGINE. Noiseless in operation—Perfect in workmanship—all light parts of Cast Steel. Every Engine indicated, and valve corrected to give the highest attainable results. Warranted superior to any semi-portable Engine in the market! Send for Price List and Circular. HERRMANN & HECHEL-RODE M'FG CO., Dayton, Ohio.

Wood-Working Machinery. Patent Scroll Saws and Band Saws a Specialty. OVER 60 MACHINES IN USE. Medal at Cincinnati Industrial Exposition. Agents in all large cities. CORDESMAN, EGAN & CO., M'f'rs, Cincinnati, O.

containing 192 pages. SEEDS and Plants mailed free. H.A. DREER, SEEDSMAN AND FLORIST, PHILADELPHIA.

\$100. REWARD. \$100. THIS MOUSTACHE produced on a smooth face by the use of DYKKE'S BEARD ELIXIR without injury, or will forfeit \$100. Price by mail in sealed package 25 cents for three 50 cents. A. L. SMITH & CO., Ag'ts, Palestine, Ill.

J. H. Blaisdell's MOULDER, 20 North 4th St., PHILADELPHIA, PA.

Shaping Machines. Have novel device for changing length of stroke while in motion, also, automatic down feed, and quick return. Four sizes. Patented 1868, 1871, 1874. Wood & Light Machine Co. Worcester, Mass. Manufacturers of all kinds of Iron Working Machinery Shafting, Pulleys, &c.

\$12 a day at home. Agents wanted. Outfit and terms free. TRUE & CO., Augusta, Maine.

Lathes, Planers, Shapers, Drills, Gear & Bolt Cutters, &c. E. GOULD, Newark, N.J.

SNYDER'S LITTLE GIANT STEAM ENGINE. The Best One-Horse Power with boiler complete only \$150. POWER ENGINES IN THE COUNTRY. Two-Horse Power, 200. Three-Horse Power, 250. WARD B. SNYDER, 84 Fulton St., New York.

SEE PHOTOGRAPHIC APPARATUS & CHEMICALS complete, with directions \$10. No toy; takes pictures 4x5 1/4 inches. Send for illustrated circular. B. MORGAN, 14 Ann St. New York, P. O. Box 4849.

WANTED! SALESMEN at a salary of \$1200 a year to travel and sell goods to Dealers. NO PEDDLING. Hotel and traveling expenses paid. Address: MONITOR MANUFACTURING CO., Cincinnati, Ohio.

\$39 Each week to Agents. Goods Staple, 10,000 testimonials received. Terms liberal. Particulars free. J. W. WORTH & CO., St. Louis, Mo.

\$55 & \$77 a Week to Agents. \$10 Outfit Free. P. O. VICKERY, Augusta, Maine.

THE COMPOUND STEAM PUMP USES steam expansively, hence economically. Simpler than any other. Only two moving parts in cylinder. No levers, springs, tappets, or reversing valves. Critical examination invited. Address E. & A. Betts, Wilmington, Del.

25 Beautiful Cards, with name, 10 cents, post paid. MILLPORT PRINTING CO., Millport, N. Y.

SPARE THE CROTON AND SAVE THE COST. Driven or Tube Wells furnished to large consumers of Croton and Ridgewood Water. W. M. D. ANDREWS & BRO., 414 Water St., N. Y. who control the patent for Green's American Driven Well

VINEGAR. How made in 10 hours from Cider, Wine or Sorghum without using drugs. Name paper and address F. I. SAGE, Springfield Mass.

AGENTS. 64 page Illustrated Catalogue, Free. Boston Novelty Co., Boston, Mass.

The Toll-Gate! Prize Picture sent free! An ingenious gem! 50 objects to find! Address, with stamp, E. C. ABBEY, Buffalo, N. Y.

\$984 Made by one Agent in 57 days. 13 new articles. Samples free. Address, C. M. LININGTON, Chicago.

LIGHTNING SCREW PLATE. Will make a perfect thread at one cut, and can be adjusted for wear. Send for catalogue to the agents, FRASSE & COMPANY. Dealers in Fine Tools, Files, Steel Wire & Supplies, 62 Chatham Street, New York.

LIST OF ENGRAVINGS.

- 1. THE LETTER WRITER. 2. THE CROSSING SWEEPER. 3. THE ROYAL PRINCESSES. 4. THE SKEIN WINDER. 5. THE SPANISH SISTERS. 6. A REST ON THE HILL. 7. THE FAIR CORRESPONDENT. 8. BARTHAM'S DIRGE. 9. GOING TO SCHOOL. 10. PEEP O'DAY BOY'S CABIN. 11. THE SCANTY MEAL. 12. THE AMAZON.

Printed on heavy toned plate paper, 12x15 inches. Liberal discount to the trade. Sent postpaid on receipt of price.

Advertisements.

Inside Page, each insertion --- 75 cents a line. Back Page, each insertion --- \$1.00 a line. Engravings may head advertisements at the same rate per line, by measurement, as the letter press. Advertisements must be received at publication office as early as Friday morning to appear in next issue.

GUARDIOLA'S COFFEE & SUGAR MACHINERY Coffee, Malt, Corn, Cocoa, and Grain-Drying Machine. Coffee-Hulling and Polishing Machines. Coffee-Washing Machine. Helix Sugar Evaporator.

Messrs. C. ADOLPHE LOW & CO., 42 Cedar Street, Messrs. MUNOZ & ESPRIELLA, 52 Pine Street, New York, are Mr. Guardiola's Agents, and they will give prompt attention to all orders for any of the above machines.

FOUR GRAND PRIZE MEDALS! Awarded Our Exhibit at the Centennial!



Bliss's Illustrated Seed Catalogue and Amateur's Guide to the Flower and Kitchen Garden. 200 pages, including several hundred finely executed engravings, and a beautifully colored lithograph. 35 Cents.

Bliss's Illustrated Gardener's Almanac and Abridged Catalogue. 128 pages. Embraces a monthly calendar of operations, and a price list of all the leading Garden, Field and Flower Seeds, profusely illustrated, with brief directions for their culture. 10 cents.

Bliss's Illustrated Potato Catalogue contains a descriptive list of all the varieties recently introduced, with many other desirable sorts; also much useful information upon their cultivation. 10 cents.

B. K. BLISS & SONS, 84 BARCLAY ST., (P. O. BOX 5712.) NEW YORK. Please state that you saw this advertisement in the SCIENTIFIC AMERICAN

WANTED.—A FIRST-CLASS MOLD MAKER ON Undertakers' Hardware. Address CRANE, BREED & CO., Cincinnati, O.



[ESTABLISHED 1846.]

Munn & Co.'s Patent Offices.

The Oldest Agency for eliciting Patents in the United States.

THIRTY YEARS' EXPERIENCE.

MORE PATENTS have been secured through this agency, at home and abroad, than through any other in the world.

They employ as their assistants a corps of the most experienced men as examiners, specification writers, and draughtsmen, that can be found, many of whom have been selected from the ranks of the Patent Office.

SIXTY THOUSAND inventors have availed themselves of Munn & Co.'s services in examining their inventions and procuring their patents.

MUNN & CO., in connection with the publication of the SCIENTIFIC AMERICAN, continue to examine inventions, confer with inventors, prepare drawings, specifications, and assignments, attend to filing applications in the Patent Office, paying the Government fees, and watch each case, step by step, while pending before the examiner. This is done through their branch office, corner F and 7th Sts., Washington. They also prepare and file caveats, procure design patents, trade marks, and reissues, attend to rejected cases (prepared by the inventor or other attorneys), procure copyrights, attend to interferences, give written opinions on matters of infringement, furnish copies of patents, and, in fact, attend to every branch of patent business, both in this and in foreign countries.

A special notice is made in the SCIENTIFIC AMERICAN of all inventions patented through this agency, with the name and residence of the patentee. Patents are often sold, in part or whole, to persons attracted to the invention by such notice.

Patents obtained in Canada, England, France, Belgium, Germany, Russia, Prussia, Spain, Portugal, the British Colonies, and all other countries where patents are granted, at prices greatly reduced from former rates. Send for pamphlet pertaining specially to foreign patents, which states the cost, time granted, and the requirements for each country.

Copies of Patents.

Persons desiring any patent issued from 1836 to November 26, 1867, can be supplied with official copies at reasonable cost, the price depending upon the extent of drawings and length of specifications.

Any patent issued since November 27, 1867, at which time the Patent Office commenced printing the drawings and specifications, may be had by remitting to this office \$1.

A copy of the claims of any patent issued since 1836 will be furnished for \$1.

When ordering copies, please to remit for the same as above, and state name of patentee, title of invention, and date of patent.

A pamphlet, containing full directions for obtaining United States patents, sent free. A handsomely bound Reference Book, gilt edges, contains 140 pages and many engravings and tables important to every patentee and mechanic, and is a useful handbook of reference for everybody. Price 25 cents, mailed free.

MUNN & CO., Publishers SCIENTIFIC AMERICAN, 37 Park Row, N. Y.

BRANCH OFFICE—Corner of F and 7th Streets, Washington, D. C.

S. EMERSON'S PATENT DAMASCUS TEMPERED SAWS

Patent Planer, Clipper, Lumberman's Clipper, from clipper cross-cut, Universal Adjustable Saw Swage, Band Saws for Saw Mills and re-sawing, and solid saws of all kinds. Are superior to all others. Extra Thin Saws a specialty. Send your full address, plainly written, for Price List and Circular to Emerson, Smith & Co., Beaver Falls, Pa., Successors to Emerson, Ford & Co.

ROOTS' PATENT PORTABLE FORGE.



ADAPTED TO EVERY VARIETY OF WORK.

THE ONLY FORGE WITH FORCE BLAST BLOWER.

THE ONLY EFFECTIVE FORGE MADE.

P. H. & F. M. ROOTS, Manuf'rs, CONNERSVILLE, IND.

S. S. TOWNSEND, Gen'l Ag't, 31 Liberty St., NEW YORK.

First Premium award of All at Centennial, Hand and Self-Inking.

Printing. Save money! Do your own printing. Press for cards, labels, envelopes, etc. Large sizes for large work. Anybody can work them, have good pastime for spare hours, and can make money by taking in small jobs.

MACHINISTS' TOOLS.

NEW AND IMPROVED PATTERNS. Send for new illustrated catalogue.

Lathes, Planers, Drills, &c.

NEW HAVEN MANUFACTURING CO., New Haven, Conn.

HARTFORD

STEAM BOILER

Inspection & Insurance

COMPANY.

W. B. FRANKLIN, V. Pres't. J. M. ALLEN, Pres't. I. B. PIERCE, Sec'y.

ROCK DRILLING MACHINES

AND AIR COMPRESSORS. MANUFACTURED BY BURLEIGH ROCK DRILL CO. FITCHBURG MASS. SEND FOR PAMPHLET.

Niagara Steam Pump Works.

ESTABLISHED 1836. CHARLES B. HARDICK, No. 23 Adams Street, BROOKLYN, N. Y.

NON-COMBUSTIBLE STEAM BOILER AND PIPE COVERING

WITH "AIR SPACE" IMPROVEMENT. Saves 10 to 20 per cent. CHALMERS SPENCE CO., Foot E. 9th St. N. Y.; 122 N. 2d St., St. Louis, Mo.

PATENT COLD ROLLED SHAFTING.

The fact that this shafting has 75 per cent. greater strength, a finer finish, and is truer to gauge, than any other in use, renders it undoubtedly the most economical. We are also the sole manufacturers of the CELEBRATED COLLINS' PAT. COUPLING, and furnish Pulleys, Hangers, etc., of the most approved styles. Price list mailed on application to JONES & LAUGHLINS, Try Street, 2d and 3rd Avenues, Pittsburgh, Pa. 190 S. Canal Street, Chicago, Ill., and Milwaukee, Wis. Stocks of this shafting in store and for sale by FULLER, DANA, & FITZ, Boston, Mass. GEO. PLACE & CO. 121 Chambers St., N. Y.

KNOWLES' STEAM PUMP WORKS,

92 & 94 Liberty St., New York.

Great reduction in prices. Send for catalogue. The "Knowles" has always been the best steam pump made.

PUNCHING PRESSES. Drop Hammers and Dies, for working Metals &c. THE STILES & PARKER PRESS CO., Middletown, Conn.

MACHINERY OF IMPROVED STYLES FOR MAKING SHINGLES, HEADING and STAVES; also GAUGE LATHES for TURNING HANDLES. Sole makers of Law's Pat. Shingle and Heading Sawing Machine. Address TREVOR & CO., Lockport, N. Y.

CHLORIDE OF CALCIUM.

FOR SALE VERY CHEAP. RANSOME, 10 Bush Street, San Francisco, Cal.

PERFECT NEWSPAPER FILE

The Koch Patent File, for preserving newspapers, magazines, and pamphlets, has been recently improved and price reduced. Subscribers to the SCIENTIFIC AMERICAN and SCIENTIFIC AMERICAN SUPPLEMENT can be supplied for the low price of \$1.50 by mail, or \$1.25 at the office of this paper. Heavy board sides; inscription "SCIENTIFIC AMERICAN" in gilt. Necessary for every one who wishes to preserve the paper.

MUNN & CO., Publishers SCIENTIFIC AMERICAN.

To appear end of February.

The United States BUSINESS DIRECTORY FOR 1877.

This Directory contains over 400,000 names of persons in all kinds of business. Arranged alphabetically according to States and classified according to business. It is a valuable aid to the Merchant, Manufacturer, and Mechanic, for correspondence or the distribution of circulars. The edition of 1877 is the third year of issue, and has already received a largely increased patronage from the business public. Price to parties who send their order before the book is issued, \$7.00. GEO. DE COLANGE & CO., Publishers, 8 Bond St., New York.

LOCUTIONIST'S JOURNAL gives choicest standard and new pieces for professional and amateur Readers and Speakers, and interesting articles on appropriate subjects. Just the thing wanted. 10 cts. of any newsdealer or by mail. JESSE HANEY & CO., 119 Nassau Street, New York.

NOYE'S MILL FURNISHING WORKS

are the largest in the United States. They make Burr Millstones, Portable Mills, Smut Machines, Packers, Mill Flcks, Water Wheels, Pulleys and Gearing, specially adapted to flour mills. Send for Catalogue. J. T. NOYE & SON, Buffalo, N. Y.

The HOADLEY PORTABLE STEAM ENGINE. WITH AUTOMATIC CUT-OFF REGULATOR AND BALANCED VALVE. THE BEST & MOST ECONOMICAL ENGINE MADE SEND FOR CIRCULAR. The J.C. HOADLEY CO. LAWRENCE MASS. STATE WHERE YOU SAW THIS.

IMPORTANT FOR ALL CORPORATIONS AND MANF'G CONCERNS.—Buerk's Watchman's Time Detector, capable of accurately controlling the motion of a watchman or patrolman at the different stations of his beat. Send for circular.

J. E. BUERK, P. O. Box 979, Boston, Mass. N. B.—The suit against Imhaeuser & Co., of New York, was decided in my favor, June 10, 1874. Proceedings have been commenced against Imhaeuser & Co. for selling, contrary to the order of the Court. Persons using clocks infringing on my patent, will be dealt with according to law.

ESTABLISHED 1844. JOSEPH C. TODD,

(Formerly of Todd & Rafferty), ENGINEER and MACHINIST. Flax, Hemp, Jute, Rope, Oakum, and Bagging Machinery, Steam Engines, Boilers, etc. Also Agent for the celebrated and improved Rawson & Rittinger Hoisting Engine, I will furnish specifications and estimates for all kinds of machinery. Send for descriptive circular and price. Address J. C. TODD, 10 Barclay St., New York, or Paterson, N. J.

A Cyclopaedia of Mechanics and Engineering.

FOR SALE. The few copies of the Author's Extra Edition of Prof. R. H. Thurston's Report on Machinery and Manufactures at the Great International Exhibition, 1873, with an account of European manufacturing districts. The volume contains over 450 pages, and contains 223 wood-cuts and plates. Please send orders for copies at once. Price, \$4.00. F. T. THURSTON, Civil and Mechanical Engineer, HOBOKEN, N. J.

Tube Cleaners for cleaning Boiler Tubes.

THE NATIONAL STEEL TUBE CLEANER CO. 814 E. 9th St., N. Y.

TO INVENTORS AND MANUFACTURERS

FOLLOWS & BATE, Manchester, England, Hardware and Machinery Merchants, are prepared to buy American Goods for Cash, and to act as Sole Wholesale Agents.

ALCOTT LATHES, for Broom, Rake and Hoe Handles. S. C. HILLS, 78 Chambers St., N. Y.

LeCOUNT'S PATENT Machinists' Tools.

REDUCED PRICES. Set Iron Dogs, 3-8 to 2 in., \$5.00. " Steel " 3-8 to 4 in., 12.00. " " 3-8 to 2 in., 5.30. " " 3-8 to 4 in., 13.00. Iron & Steel Clamps, Die Dogs, Clamp Dogs, Vice Clamps, Expanding Mandrels, &c. Send for latest Price List to C. W. LE COUNT, South Norwalk, Conn.

DAMPER REGULATORS BEST AND LEVERS GAUGE COCKS. MURRILL & KEIZER, 44 HOLLIDAY ST., BALTIMORE.

Brayton Ready Motor

It has no boiler, is safe, economical, started by any one in one minute, occupies small space, and gives an unsurpassed steady, reliable power. Address Penna. Ready Motor Co., 20 N. 4th St., Philadelphia, Pa.

THE TANITE CO.,

STROUDSBURG, PA. EMERY WHEELS AND GRINDERS. GEO. PLACE, 121 Chambers St., New York Agent.

BOLT CUTTERS Schlenker's New Machine Revolving-Die. Send for Catalogue, giving prices and full description. HOWARD IRON WORKS, BUFFALO, N. Y.

STATE, COUNTY AND SHOP RIGHTS for sale of C. Koons' Patent Rat Trap; best out; caught 16 one night. Enclose stamp to owners and manufacturers, J. T. WILHIDE & BRO., York Road, Carroll Co., Md.

\$5 to \$20 per day at home. Samples worth \$5 free. STINSON & CO., Portland, Me.

DUC'S IMPROVED PATENT ELEVATOR BUCKET, FOR BREWERS, FLOUR MILLS, GRAIN ELEVATORS, SUGAR REFINERS, &c.

These buckets are made of the best charcoal stamping iron, and are warranted to outwear six of the "OLD STYLE BUCKETS." The cost is about the same. Address T. F. ROWLAND, Brooklyn, E. D., N. Y.

\$3 WATCHES. Cheapest in the known world. Sample watch and outfit free to Agents. For terms address COULTER & CO., Chicago

BOGARDUS' PATENT UNIVERSAL ECCENTRIC MILLS—For grinding Bones, Ores, Sand, Old Crucibles, Fire Clay, Guanos, Oil Cake, Feed, Corn, Corn and Cob, Tobacco, Smut, Sugar, Salts, Roots, Spices, Coffee, Coconut, Flaxseed, Asbestos, Mica, etc., and whatever cannot be ground by other mills. Also for Paints, Printers' Inks, Paste Blacking, etc. JOHN W. THOMSON, successor to JAMES BOGARDUS, corner of White and Elm Sts. New York.

Working Models

And Experimental Machinery, Metal or Wood, made to order by J. F. WERNER, 82 Center St., N. Y.

EAGLE FOOT LATHES,

With Scroll and Circular Saw Attachments, Slide Rest, Tools, &c.; also Small Engine Lathes, Metal Hand Planers, &c. Neatest designs, superior finish. Low prices. Our new Catalogue describes these and every tool necessary for the Amateur or Artisan. Send for it. WM. L. CHASE & CO., 95 & 97 Liberty St. New York.

Pyrometers. For showing heat of Ovens, Hot Blast Pipes, Boiler Flues, Super-Heated Steam, Oil Stills, &c. HENRY W. BULKLEY, Sole Manufacturer, 149 Broadway, New York.

Prospectus

OF THE SCIENTIFIC AMERICAN For 1877, THE MOST POPULAR SCIENTIFIC PAPER IN THE WORLD.

THIRTY-SECOND YEAR.

VOLUME XXXVI.—NEW SERIES.

The publishers of the SCIENTIFIC AMERICAN beg

to announce that on the sixth day of January, 1877, a new volume was commenced. It will continue to be the aim of the publishers to render the contents of the new volume more attractive and useful than any of its predecessors.

To the Mechanic and Manufacturer.

No person engaged in any of the mechanical pursuits should think of doing without the SCIENTIFIC AMERICAN. Every number contains from six to ten engravings of new machines and inventions which cannot be found in any other publication.

TERMS OF SUBSCRIPTION.

One copy of the SCIENTIFIC AMERICAN will be sent for one year, 52 numbers, POSTAGE PREPAID, to any subscriber in the United States or Canada, on receipt of three dollars and twenty cents by the publishers.

One extra copy of the SCIENTIFIC AMERICAN will be supplied gratis for every club of five subscribers at \$3.20 each; or six copies for \$16.50 without extra copy. Postage free.

The Scientific American Supplement.

A weekly paper, uniform in size with the SCIENTIFIC AMERICAN, but a distinct publication. It contains working drawings of engineering works, and elaborate treatises on every branch of Science and Mechanics, by eminent writers, at home and abroad. An illustrated cover protects the handsomely printed sheets. Price, \$5.00 per annum. Single copies 10 cents.

One copy of the SCIENTIFIC AMERICAN and one copy of the SCIENTIFIC AMERICAN SUPPLEMENT will be sent for one year, postage prepaid, to any subscriber in the United States or Canada, on receipt of seven Dollars by the publishers.

The safest way to remit is by Postal-Order, Draft, or Express. Money carefully placed inside of envelopes, securely sealed, and carefully addressed, seldom goes astray; but it is at the sender's risk. Address all letters and make all orders, drafts, etc., payable to

MUNN & CO.,

37 PARK ROW, NEW YORK.

THE "Scientific American" is printed with CHAS. ENEU JOHNSON & CO.'S INK. Tenth and Lombard Sts., Philadelphia, and 59 Gold St., New York.