

SCIENTIFIC AMERICAN

A WEEKLY JOURNAL OF PRACTICAL INFORMATION, ART, SCIENCE, MECHANICS, CHEMISTRY, AND MANUFACTURES.

Vol. XLI.—No. 7.
[NEW SERIES.]

NEW YORK, AUGUST 16, 1879.

[\$3.20 per Annum.
[POSTAGE PREPAID.]

AMATEUR MECHANICS.

METAL SPINNING.

The operation of spinning metals, although exceedingly simple and capable of being practiced to advantage in almost every shop, and also by the amateur mechanic upon the foot lathe, is not generally understood. One reason for this is that the artisans who follow this branch of mechanics as a business usually conduct it under locked doors, and it is with considerable difficulty that the amateur in search of information on this and kindred subjects can obtain entrance

to one of these establishments. The reason of this secrecy is plain enough, as the "kink" or "wrinkle," or, in plain English, the knowledge required to do the mechanical part of spinning, is so slight that secrecy is the only protection.

The tools required are few. They consist of a lathe; a form or mould on which to shape the article; a tool rest with a series of holes for receiving a pin to keep the tool from slipping, and a few spinning tools or burnishers of different sizes and shapes.

The lathe the amateur is supposed to possess; the tool rest

he may easily make; and the only other addition to the lathe will be a back center of the form shown in Fig. 2. This form of center answers as a step to the work holder, and will bear considerable pressure without undue friction.

The tools required are shown in Figs. 3, 4, and 5. These are simply hard steel burnishers of the form shown, and varying in size, with the size and kind of work to be done. The size given in the engraving is about right for amateur work on the foot lathe. Fig. 3 shows in two views a ball tool. Fig. 4 shows both side and edge views of a curved



TOOLS FOR METAL SPINNING, AND EXAMPLES OF SPINNING.

tool. Fig. 5 shows a plain round burnisher. In some instances it may be necessary to make tools of different forms. The operator will be guided in the selection of his tools by the particular work in hand, and practice will bring new suggestions as to tools and the manner of using them.

The materials generally used in spinning are brass, copper, zinc, britannia metal, and lead. All of these may be worked on the foot lathe, but perhaps the amateur will derive the most satisfaction at first by using britannia metal, as it works easily and does not require annealing. Articles in this metal also present a handsome appearance when done, whether simply polished or plated. Zinc must be spun quite hot. Articles of brass, if of considerable depth, must be annealed when partly done.

The form on which the metal is spun may be either hard or soft wood or metal. A good close-grained pine answers as well as anything for most purposes, and is very readily turned to the required form. It may be attached to the face plate, B, and the disk to be spun may be held against it at first by a hard wood or metal piece, C, as shown in Figs. 6 and 7, which is forced against the disk by the tail center. After the spinning is a little advanced, a cup-shaped holder is applied, as shown in dotted lines in Fig. 7. Sometimes the holder is secured by a bolt that runs through both it and the form or mould, as shown at D, Fig. 8. In some cases a little rosin is applied to the form to increase the friction, but this is rarely necessary. The motion of the lathe should be quite rapid, and the disk should receive a coating of grease (lard or heavy oil) before applying the burnisher. A very strong solution of soap may be used instead of oil. The position of the workman and the manner of holding the tool may be seen in Fig. 1. It will be noticed that the pin in the tool rest serves as a fulcrum for the tool, which must be brought with considerable pressure against the surface of the disk. This pin is moved forward from time to time as the work advances. The movement of the tool may be seen in Figs. 9 and 10, and the shape taken by the metal in front of the tool will also be seen. In swinging the tool toward the form it is moved in the direction of the arrow as shown in Fig. 9, and it is carried back as shown in Fig. 10. This last operation is very essential to the proper fitting of the mould, and it also thickens the metal. Too much should not be attempted at a time. A succession of quick movements, as indicated in Figs. 9 and 10, under a moderate pressure, is much better than to do a great deal of execution at a single stroke. Should the metal tend to vibrate or buckle, a piece of wood may be applied to the back with the left hand as shown in Fig. 8.

The method of spinning a cup or pot without a form is illustrated in Fig. 11. Here the metal is supported by a plain cylindrical mandrel, and is first spun into the form indicated by the dotted lines, and then bringing the burnisher on the return stroke only to the shoulder which forms the larger part of the vessel. For small work on the foot lathe the handles of the tools need not be as long as represented in Fig. 1. The length commonly employed for wood turning tools will answer.

To spin a ring a mandrel like that shown in Fig. 12 will be required. A plain flat ring placed between the shoulders of the mandrel is pressed upon by the roller seen above the mandrel until the ring assumes the desired form. Napkin rings are made in this way. Fig. 13 shows a concave reflector. Fig. 14 represents a simple cup formed of two pieces. Fig. 15 represents a small vase made of three pieces, the smaller end of the upper or conical part and the upper portion of the base piece being soldered in a spherical connecting piece. The two halves of the ball Fig. 16 are made upon the same form. The edges are beveled and soldered together. The pitcher, Fig. 17, is made of five spun pieces, a short cast and turned piece that unites it to its base, and a handle made of square wire. The card receiver, Fig. 18, has a spun top and base, and a cast standard. The vase, Fig. 19, consists of four spun pieces and three legs of square wire, uniting the body with the base. Fig. 20 shows a base for a magnetic needle or other small apparatus. Fig. 21 represents a vase composed of seven spun pieces and two handles of square wire. More complex examples of work done by the process of spinning might be furnished. The ones given are undoubtedly sufficient to enable the amateur to get an idea of the endless variety of articles that may be made by this simple and easily acquired art. M.

A Boy's Promptness and Courage.

Perhaps the most remarkable exhibition of pluck and promptness on record is that of a miner's son recently at Hollis, Ill. It is said that the father, Thomas Harland, lighted a slow match leading to a blast, and signaled to be drawn up the shaft. He struck a projection and was thrown back to the bottom of the shaft, where he lay with a rib broken. Realizing his father's peril, Harland's young son slid down the seventy feet of rope, lacerating his hands terribly, but reaching the bottom in time to tear the match from the fuse and prevent the explosion.

A GENUINE case of spontaneous combustion occurred on the 1st of July in a drug store on Biddle street, St. Louis. The proprietor, in anticipation of the "Glorious Fourth," had prepared four jars of "colored fire," and placed them on the shelves, not dreaming of any trouble from them, but in plain view of several persons present at the time, one jar exploded, shattering the other three, and quicker than can be described a lively conflagration was in progress.

Scientific American.

ESTABLISHED 1845.

MUNN & CO., Editors and Proprietors.

PUBLISHED WEEKLY AT

NO. 37 PARK ROW, NEW YORK.

O. D. MUNN.

A. E. BEACH.

TERMS FOR THE SCIENTIFIC AMERICAN.

One copy, one year, postage included \$3 20
One copy, six months, postage included 1 60

Clubs.—One extra copy of THE SCIENTIFIC AMERICAN will be supplied gratis for every club of five subscribers at \$3.20 each; additional copies at same proportionate rate. Postage prepaid.

Single copies of any desired number of the SUPPLEMENT sent to one address on receipt of 10 Cents.

Remit by postal order. Address

MUNN & CO., 37 Park Row New York.

The Scientific American Supplement

is a distinct paper from THE SCIENTIFIC AMERICAN. THE SUPPLEMENT is issued weekly. Every number contains 16 octavo pages, with handsome cover, uniform in size with SCIENTIFIC AMERICAN. Terms of subscription for SUPPLEMENT, \$5.00 a year, postage paid, to subscribers. Single copies 10 cents. Sold by all news dealers throughout the country.

Combined Rates.—THE SCIENTIFIC AMERICAN and SUPPLEMENT will be sent for one year, postage free, on receipt of seven dollars. Both papers sent by express or freight addresses as desired.

The safest way to remit is by draft, postal order, or registered letter. Address MUNN & CO., 37 Park Row, N. Y.

Scientific American Export Edition.

The SCIENTIFIC AMERICAN Export Edition is a large and splendid periodical, issued once a month. Each number contains about one hundred large quarto pages, profusely illustrated, embracing: (1.) Most of the plates and pages of the four preceding weekly issues of the SCIENTIFIC AMERICAN, with its splendid engravings and valuable information; (2.) Commercial, trade, and manufacturing announcements of leading houses. Terms for Export Edition, \$5.00 a year, sent prepaid to any part of the world. Single copies 50 cents. Manufacturers and others who desire to secure foreign trade may have large, and handsomely displayed announcements published in this edition at a very moderate cost.

The Export Edition has a large guaranteed circulation in all commercial places throughout the world. Address MUNN & CO., 37 Park Row, New York.

VOL. XLI, No. 7. [NEW SERIES.] Thirty-fifth Year.

NEW YORK, SATURDAY, AUGUST 16, 1879.

Contents.

Table listing various articles such as Africans, white; Alpine tunnel, great; Amateur mechanics; American Association; American Institute Exhibition; American manufactures in Cuba; American Philological Association; American tariffs; Australian Exhibition; Boiler preparation; Bridge, suspension; Bronze casting in wax; Canal mowing machine wanted; Cedar posts to preserve; China ware in New Jersey; Churn, improved; Coal, anthracite, effect of exposure; Copper, to amalgamate; Cotton thread, American; Cut-off, new; Danzell, a home-made; Devil's darning needle; Drainage, house; Electrical balance; Electric current regulator; Engine, portable; Feed pump, freaks of; Fire dept. of Topeka, Kansas; Fish, freezing, for winter use; Gold and silver, imitation; Goldbeater's skin; Gold to extract; Holes in hard steel; Horse power test; Industrial distress in England; Ink for greased leather; International Fishery Exhibition; Inventions, agricultural, recent; Inventions, engineering; Inventions, mechanical, recent; Inventions, miscellaneous.

TABLE OF CONTENTS OF

THE SCIENTIFIC AMERICAN SUPPLEMENT

No. 189,

For the Week ending August 16, 1879.

Price 10 cents. For sale by all newsdealers.

Table listing contents of the supplement such as I. PHYSICS—Molecular Physics in High Vacua; II.—ENGINEERING AND MECHANICS—American Engineering; III. AGRICULTURE—International Agricultural Show; IV. GEOGRAPHY AND ARCHEOLOGY—The Eruption of Mount Etna; V. BIOLOGY—The Beginnings of Life.

THE AMERICAN ASSOCIATION FOR THE ADVANCEMENT OF SCIENCE.

The twenty-eighth meeting of the American Association for the Advancement of Science will be held at Saratoga, commencing on Wednesday, August 27. The headquarters of the association will be at the United States Hotel; the general sessions will all be held at the Town Hall. The meeting will occupy about a week, which will be devoted to the usual addresses of the president and the two vice-presidents and the reading of papers on different scientific subjects before the several sections of the meeting to which they are appropriate.

The meetings of the association are a matter of great interest each year to its large membership, and are perhaps entitled to more general public sympathy than they have yet received. In the several cities of the Union where the association has hitherto held its meetings it has been most hospitably entertained, and this was notably the case in Buffalo in 1876, where the presence of Prof. Huxley and a numerous body of eminent foreign men of science, who had come to the United States to attend the Philadelphia Centennial, stimulated the enthusiasm of the citizens. But the association is entitled to a serious hold upon the regard of the people generally, and it will be its own fault, perhaps, if it fails to make a strong impression upon the community at each annual session. It numbers among its members the most eminent men of science in America, a fair representation of the younger students, besides a number of persons from all professions, swelling its membership at the present time to nearly one thousand. In its organization and plan of meeting the American association resembles the British and French associations in spirit, if not always in detail. It is divided into two sections, A and B, the first devoted to mathematics, astronomy, physics, chemistry, and mineralogy, the second to geology, zoology, botany, and anthropology.

The meetings are, of course, devoted more or less to the reading of papers on special subjects, and to encourage all who take an interest in scientific studies the examining committees have always been generous in their judgment. As the result of each meeting a handsome volume is issued, which owes its excellent typographical appearance and arrangement of matter to the long continued labors of the permanent secretary, Professor F. W. Putnam, of Cambridge. The finances of the association are satisfactory, but have been crippled in the past by the attempt to publish too large an annual volume. The papers, which undergo a second sifting before printing, are all worthy of issue by the association, and among them, indeed, are some of the most noteworthy additions to our knowledge, both in physics and biology. But some papers printed by the association would have better found their medium of publication in the proceedings of local scientific bodies or in special serials devoted to their subjects. Of late, while the papers have been read before the association, they have more often been so disposed of, while some authors have still somewhat needlessly occupied space in the Proceedings.

The general aims of the association would be greatly furthered if a plan of evening lectures could be entered upon, at which the public could freely attend during each session. The popularization of knowledge would in this way be assisted and the association benefited, both in reputation and in membership, by identifying itself more boldly than it has yet done with the cause of popular instruction. Some attempts were made in this direction both at Nashville, in 1877, and at St. Louis, in 1878, but no definite action has resulted. We may hope that something may be effected in this direction at Saratoga.

Something of the general spirit of the association may be gathered from the subjects on which it has thought best to appoint special committees in order to further its views upon them in the community. Besides subjects of more local interest, such as a new survey of Niagara Falls, which might be left to Canada and the Legislature of our own State to arrange about, the association has a permanent committee upon weights, measures, and coinage, another to memorialize Congress in relation to meteorological researches, another on the relation of science to the industrial arts, and another on the introduction of science into the public schools. All these subjects are matters of national importance and public interest. That on the relation of science to the industrial arts, of which Prof. Thurston, of the Stevens Institute, is the accomplished chairman, has a most interesting matter to handle. Its purposes are set forth in a letter from Mr. O. Chanute, of New York, and which was read at the St. Louis meeting.

The committee proposes the issuance of a circular inviting communications from leading manufacturers, heads of public works, managers of mines, engineers, agriculturists, or business men, concerning the scientific problems or questions which may have arisen in the pursuit of their avocations and suggestions as to the subjects or points upon which they may think there exists a lack of scientific elucidation. Upon the results of this circular the committee propose to publish annually a list of such points and subjects, and invite papers upon them from members of the association. Further, the committee propose to induce subscriptions by which prizes may be offered for the best papers on the subjects so selected.

The committee on the introduction of science into the public schools certainly yields to none established by the association in interest at this time. Under our present system education is changing and becoming more practical in its effects with every day. The old idea of education seems to have

been that certain things ought to be learned, and we hear, accordingly, that everybody should know how to read, write, and cipher. The new idea seems rather to start with the pupil, and ask what a given brain and sensory power or capacity should be taught in order to develop to the best advantage, both to the individual and to the society to which it belongs. It is owing to this newer way of looking at the educational problem that we find exact knowledge or science coming to be preferred to ancient languages, for instance, or, generally, to metaphysics. At the present time it is needful to insist upon the value of science in general culture. Nothing else leads to firmer and yet less prejudiced thoughts, while the material and moral advancement of the nation must always ultimately depend upon the exactitude of its information. The committee of the association on the teaching of science has a work before it of which we trust it will not be neglectful. In his vice-presidential address at St. Louis, Professor Aug. R. Grote, who was chiefly instrumental in the formation of the committee, says: "The demand has come up from teachers throughout the country that they should be better informed as to the manner in which the sciences may be introduced into the schools and the matter to be taught. It is the duty of this association to furnish the information. If we have not sympathized with this inquiry in the past, let us assist it in the future. It is quite evident that the sooner this association commits itself as a matter of principle to the furtherance of science among the people the more following it will have and the greater influence. And if it does not it will fall behind its peculiar duty and out of the line of advance in human thought. This association must be prepared to demand more time for scientific studies from the public school authorities, and it must show to every one that education is a matter which not only falls properly under its cognizance, but which it is also prepared to take hold of. This association should no longer delay to bring all its forces to bear upon the question of science as applied to education. While it does not do so, it will always seem to shirk a duty and ignore one chief end of its existence."

We may informally point out at the present time some of the directions for improvement in our common school system:

First.—The establishment of primary schools for children between five and nine years of age, where no books are to be used, and object teaching is to be relied on for instruction in the several branches. The hours for tuition to be less than is now the practice in teaching children between these ages.

Second.—The introduction of physical, natural, and social science in the common schools, while the present teaching of grammar, geography, and declamation may be curtailed, and, in part, discontinued. The outlines of mechanics and industrial arts received in the public schools will assist the pupils in their after lives.

Third.—The establishment of a higher grade of schools in which an outline at least of the university course be pursued. The tuition to be by demonstrative lectures, and degrees to be conferred which will carry weight in professional and governmental examinations.

Fourth.—The entirely secular administration of the schools and the teaching of morality without being associated with any system of theology. This reform we seem to clearly owe to the spirit of our republican government and to a national sense of justice.

The time is at hand when our public school system must be extended in its practice, or fail of its legitimate results. The people not only demand better, fuller, and more practically useful tuition, but from an outside point of view it is evident that we need as a nation that liberal thought which only comes from a rounded knowledge. If the association can assist this development through its permanent committee on the introduction of science into the schools it will earn the gratitude of all thinking people in the community.

At its St. Louis meeting last year the American Association elected a limited number of fellows, choosing among its members Mr. Thomas A. Edison, of Menlo Park, N. J., and of world-wide fame as an inventor, for that honor. Its president for the Saratoga meeting is Prof. Geo. A. Barker, of Philadelphia, whose reputation as a physicist and chemist is already extended. The Saratoga meeting will listen to an address from its retiring president, Prof. O. C. Marsh, of Yale College, which will be heard with interest, in addition to addresses from the two vice-presidents of the meeting, Prof. Langley, of Alleghany, and Major J. W. Powell, of Washington. The papers to be presented bid fair to be of more than average interest in many departments, and the most noteworthy will be reported in the SCIENTIFIC AMERICAN.

SANDAL WOOD.

Dr. Berthold Seemann, the eminent botanist, in calling attention to the commercial importance of sandal wood, remarks that "the trade in this fragrant wood has been going on since the dawn of history, and will probably not cease until the connection between sandal trees and idolaters, existing from time immemorial, shall have been broken up by either the one or the other becoming as extinct a race as the Archyopteryx, the Moa, or the Dodo. The religious sentiment of millions of human beings is still intimately associated with this wood. When the Hindoo or Buddhist beholds its smoke curling heavenwards he feels that he has acted up to his religious duties, and that the perfume smelling sweetly in the nostrils of his deity will cover a multitude of sins."

Some of the most ancient records inform us of the promi-

nent part played by the wood in India; and since the introduction of Buddhism into China that country, destitute of sandal trees, has become the principal market for this important production. A piece of wood of the diameter of four to six inches is considered as the most acceptable offering a person can make to the idols of the temples. Large pieces are presented by the rich on particular occasions. The perfume of the sandal wood, which has been held in high esteem throughout tropical Asia for ages, is due to an essential oil residing chiefly in the heart of the tree and near the root, the outer parts of old trunks and young trees being almost destitute of scent. Hence the sandal cutters carefully remove the outer and generally lighter portion of the wood, which they term "sap." The oil is made upon the spot where the trees grow. It is wonderfully strong and penetrating, and is easily extracted, a pound of wood yielding about two drachms. In 1872-73, 10,348 pounds, valued at about \$42,000, were imported into Bombay, from whence most of it was exported to other countries. The oil dissolved in spirits and sweetened with a little oil of rose, forms the handkerchief perfume—"Extrait de bois de santal." From the fact that it mixes favorably with otto of rose it is often used for adulterating that article. Within a few years past the oil has been considerably used in medical practice in the treatment of gonorrhœa. It was once used, too, as a stimulant and sudorific, but is no longer employed for such purposes.

Santal wood is the product of several species of the genus *Santalum*, of the natural order *Santalaceæ*. The genus is composed of about twenty members, spread over Asia, Australia, and Polynesia, and in habit is best compared with the myrtles. The most easterly species of the genus is *Santalum insulare*, found in the Marquesas Islands and Tahiti, where it is known as "eai;" the southernmost, *S. cunninghamii*, is found in New Zealand, and is known there as "mairi;" the northernmost, *S. pyrularium* and *S. freycinetianum*, are natives of the Sandwich Islands, where they are called "lau ala;" and the most westerly, *S. album*, is indigenous to the Indian Peninsula. All the species prefer dry, rocky localities, and, commercially speaking, degenerate in quality when they grow in moist places.

Santalum album and a marked, though inferior, variety known as *Myrtifolium*, grow on the mountains of continental India and the Indian Archipelago; Mysore, Malabar, and Canara being the principal districts. The tree usually attains a height of twenty-five feet, and when it is allowed to exceed these dimensions is generally found rotten at the core. After felling the trees the bark is removed at once, the trunks are cut into billets two feet in length, and these are buried in dry ground for about two months, during which time the white ants eat away all the outer wood without touching the heart. The latter constitutes the sandal wood of commerce. The billets are afterward smoothed and sorted. The deeper the color the stronger the odor, hence merchants often divide sandal into red, yellow, and white sorts. In general, also, the nearer the root the more powerful the perfume; care is therefore taken, by removing the soil, to cut as low down as possible.

The chips and fragments removed in the process of smoothing the billets and squaring their ends, and the smaller sized billets, suit the Arabian market best; and from these is distilled the essential oil, so much esteemed in Turkey. The larger billets are sent to China, which affords the best market for this wood. In 1866 there were received at the various ports of the latter country 5,197 tons. The smaller billets are used in India. The reputation of sandal wood in Europe rests chiefly on its excellence as a material for carving, and it is manufactured into a great variety of elaborately marked card cases, work boxes, card trays, fans, walking-sticks, etc. Dr. Hunter, some years ago, showed that it was admirably adapted for wood engravings. Some blocks yielded upward of 20,000 impressions without wearing out. The best wood for the engraver's purposes is the dark colored, five inches in diameter, grown on rocky soil.

In old English works sandal wood is sometimes called "Sanders wood," but our present form, "sandal" (which is the Arabic name for it), is more correct. The Chinese call the word "tan-heong" (scented tree); on the Malabar coast it is termed "chandana cotta," while the Polynesian species go by the generic name of "ahi," which in Fijian becomes "yasi;" in Eromangan, "nassau;" and in Tanna, "nebissi."

THE SYSTÈME SÉBILLOT.

A French engineer, M. Sébillot, has developed a plan for a ship railway across the Isthmus of Panama, with an alternative scheme involving a ship canal 30 kilometers long from Aspinwall to the mountains, a railway of 33 kilometers over the mountains, and another canal of 10 kilometers on the Panama side, or about 25 miles of canal and 20 of railway.

M. Francis A. Kieffer, of Paris, representing a syndicate of Parisian bankers and speculators interested in this system, arrived in New York July 23. M. Kieffer says that as long ago as 1873 the Colombian Government granted M. Sébillot permission to construct such a ship railway over the mountains of the isthmus.

The plan contemplates a railway with rails fifteen times as heavy as the ordinary T rail, to be laid twelve meters apart. Over this road vessels up to 7,000 tons burden will be transported in immense docks or cars, supported by wheels a foot thick. The driving power will be placed in the docks themselves under the bulge of the vessel, and will be applied directly to the wheels under the dock. M. Kieffer claims that these docks will be capable of a speed of fifteen

to eighteen kilometers (nine to eleven miles) per hour, and that the whole distance from ocean to ocean can be traversed in five hours. The entire cost of construction he estimates at 250,000,000 francs (\$50,000,000), while the ship canal favored by M. De Lesseps will demand a capital of 1,500,000,000 francs (\$300,000,000). He also says that the tariff on vessels passing over this railway need not be higher than \$1.50 per ton, against \$3 per ton by canal, to yield a fair percentage on the capital, and that while seven years must elapse before the canal can be completed, the railway can be in operation at the end of three.

It is reported that M. Deitz Mounin, who was president of the French department in the Paris Exhibition of 1878, is at the head of the syndicate which M. Kieffer represents, and M. Emile Jupy, of the well known Parisian clock manufactory, is its secretary. M. Sébillot was the engineer-in-chief for the Martune Arsenal at Foo Choo, China.

A SANITARY CAPTAIN EADS WANTED.

The success of the jetty system at the mouth of the Mississippi makes that grand river a possible channel for a large part of the commerce of twenty States. What that commerce may amount to when the Mississippi valley harbors a hundred million people, as it is likely to in the near future, it is impossible to estimate. It is enough to foresee that it will surpass anything in the way of river traffic that the world has yet known, provided the sanitary condition of the Lower Mississippi is such as to allow commerce a safe and steady passage that way.

Captain Eads has shown how the Mississippi can be entirely freed from the physical barriers which have hitherto impeded the commercial development of that noble waterway. But, however perfect the channel, commerce will not adopt a route liable to annual interruption by pestilence. Trade cannot brook diversion or delay. No more will it subject itself to liability to interruption. Of greater importance even than thirty feet of water is freedom from sanitary risks. Sand bars are but negatively harmful; pestilence is positive. The Mississippi must be made as healthy as the Hudson before its commercial possibilities will begin to be developed. Sanitary science must complete the work which engineering has begun. The great need of the Mississippi valley, commercially as well as socially, is a sanitary Eads. May he come speedily.

The Scientific American in Italy.

One of our contemporaries says: The English Consul, Colnaghi, reporting from Florence, Italy, states that in steel rails and locomotives, and in Sheffield tools and in machinery (turning lathes, etc.), German enterprise is gradually pushing us out of the Italian market, and also endeavoring to push their goods in Italy, and to this end a newspaper called the SCIENTIFIC AMERICAN, chiefly devoted to the hardware interest, is widely distributed throughout the country.

The English Consul probably intended to say, instead of German, that American enterprise was gradually pushing goods into the foreign markets.

American Institute Exhibition.

Application for space should be forwarded at once to the General Superintendent, room 23, Cooper Union building, New York, and all details arranged through him with as little delay as possible. Persons familiar with the exhibitions annually given by this institute are aware that one of the great troubles with which the exhibitor has to contend is that of insufficient space. As all applications which comply with the rules are considered in the order of their coming, it is therefore evident that better location is secured by the early than by the late applicant. The Exhibition will open on the 17th day of September.

The Toronto Exhibition.

The Industrial Exhibition to be held at Toronto in September next, promises to surpass anything of the kind hitherto attempted in Canada. The Governor-General is patron of the association, and his Excellency, with H. R. H. the Princess Louise, have consented to open the Exhibition. Large additions are being made to the already commodious buildings on the Exhibition grounds. The Exhibition will be opened September 1, and will continue until September 20. The prizes offered aggregate \$20,000.

American Cutlery in Sheffield.

A correspondent of the New York *Herald*, writing from Birmingham, England, says that recently a leading manufacturer in Sheffield showed his workmen an assortment of American made goods, and, taking up a pair of tailor's shears, offered to give the Union £50 if any one of his men, in a month, would produce one pair of shears as good as the American sample.

SUPERVISION has in it three elements—knowledge, counsel, and authority. A knowledge of each teacher's doings is the radical feature of the superintendent's office. Without that knowledge his office is practically vacated. What sort of superintendence is it, when the officer is in ignorance of the very thing he is appointed to superintend? This knowledge should be gained primarily by personal inspection, and secondly by correspondence, and thirdly by proxy.—*Superintendent Schools of Virginia.*

Another Juvenile Prodigy.

The latest addition to the long list of juvenile prodigies, in respect to memory and mathematical accuracy, is reported from Maine. He is, says the *Bangor Commercial*, the son of a former postmaster of that place, and is now ten years of age. He is untaught, save in the art of reading, to which he appears to give more attention than wiser parents would allow. His strong point is memory. He recollects not only everything that he reads, but everything that he does, remembers on what day he did it, where he was at the time, and what were the circumstances that led him to do it. For instance, he will tell where he was on any day within the past two years, and what he was doing. Further, he remembers and can tell everything that his friends have done, providing he has seen them do it, and can tell on what date and on what day of the week they did it.

The first that his friends noticed of his precocity was about a year ago, when they accidentally discovered that he was almost infallible on any date he had ever seen or heard. Walking in company with some relatives in a cemetery it was observed that he would look at a tombstone, read the date of the death recorded, and the exact age of the person buried there, then glance up and tell on what day of the week the dead person was born. This happened on several occasions, and but little attention was paid to it. Finally one of his relatives took pains to look into an old almanac covering some of the dates he had mentioned, and found that the day of the week had been given correctly in every instance. This caused them to ask him questions, when it was discovered that he could almost instantly tell the day of the week on which any date within the last 75 years fell.

In a series of tests made by the *Commercial* writer, the boy gave the day of the week corresponding to a large number of dates between 1812 and 1840, gave it correctly in every instance, and averaged five seconds for each test. The longest time required was eight seconds, the shortest three seconds. His habits are described as "peculiar."

"He never plays with other boys, but is continually busy in reading. Oftentimes he takes an unabridged dictionary and studies it hour after hour, never seeming to consider it anything but a pleasure to do it. In fact he takes no comfort unless busying his brain about something. If there is anything he does not understand he keeps at it till he does understand it, and then it is next to impossible for him to forget it. One would naturally suppose that a child with such unusual powers would gradually fail and fade away, but, singularly enough, he is constantly growing stronger and more healthy."

It is to be hoped that the last assertion is strictly true, and that the precocious youngster will not exhaust his brain power in infancy. The chances, however, are heavily against him. His name is Charles Fuller.

A NEW PISTON ROD PACKING.

We illustrate herewith a novel piston rod packing recently patented by Mr. John Hewitt, of 1323 S. Jefferson avenue, St. Louis, Mo. The invention consists, essentially, of a series of beveled rings placed in the stuffing box and retained by the gland, the rings being beveled on opposite sides. In Fig. 1, in the engraving, the stuffing box is shown in section, and the gland and packing rings are broken away to show their form more clearly. Fig. 2 shows the face of one of the rings, and Figs. 3 and 4 are diametrical sections of internally and externally beveled rings.

The stuffing box, A, is of the usual form, and the gland, B, does not differ materially from those in common use. Its inner edge that comes against the packing is beveled, and it is provided with an oil chamber, *a*. The packing, C, consists of a series of soft metal rings which are triangular in cross section, as shown in Figs. 3 and 4. One half of the rings are beveled upon the inside, the other half upon the outside. These rings alternate in position, as shown in Fig. 1. When the gland is forced against the packing thus arranged, the rings that are beveled on the outside are forced against the piston rod, while the rings that are beveled on the inside are forced against the sides of the stuffing box. In this manner the joint between the rod and the packing and between the packing and stuffing box is made perfectly steam tight. We are informed that this packing will wear a long time without adjusting the gland, and that the wear of the piston rod is less than with other kinds of packing. The oil chamber, *a*, is filled with cotton waste for the purpose of feeding oil to the piston rod.

St. Petersburg as a Seaport.

The canal from Cronstadt to St. Petersburg is progressing so rapidly that Admiral Possiett, who directs the work, assures the Russian Government that in a year's time vessels of small size will be able to pass from the sea to the Neva, and that in the summer of 1881 the canal, the depth of which is fixed at 20 feet, will have been excavated to the extent of 16 feet, enabling a goodly sized craft to reach the capital.

AN IMPROVED CHURN.

We give herewith an engraving of an improved churn recently patented by Mr. Joseph N. Parker, of Titusville, N. J. The dasher consists of two pairs of cross arms fitted horizontally on a short dasher rod and arranged to slide in ways in the side of the churn. The dasher is reciprocated by gearing supported by a frame attached to the side of the churn. The rod that connects the dasher with the crank passes through a slide in the churn cover, and works through a slot in the cover, which is covered by the slide. The crank

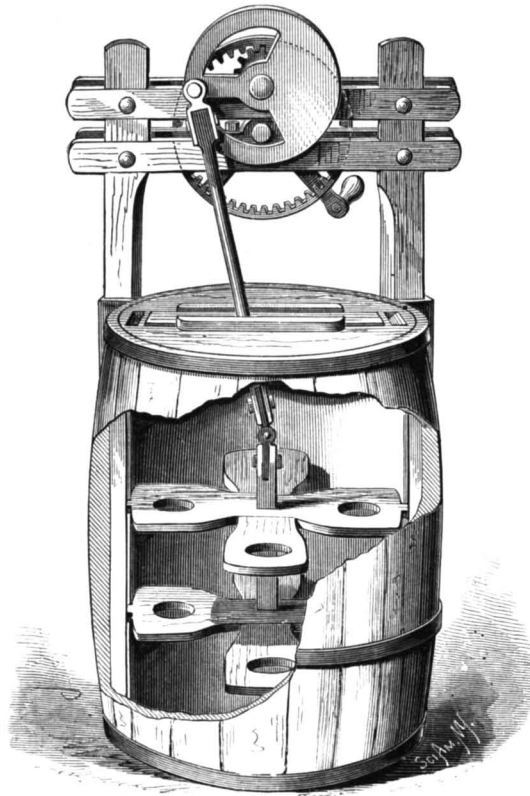
**PARKER'S CHURN.**

is counterbalanced to insure a smooth action of the machinery. When the churn is driven by power a pulley may be placed on the crank shaft; when it is driven by hand a pinion is placed on the crank shaft, and driven by an internal gear wheel supported by the lower cross bar of the frame. The arrangement of the gearing is such that the churn cover may be readily removed without disturbing the frame that supports it. The mechanism is simple, and the inventor claims that it is very efficient.

Value of a Trade Mark.

The value of a trade mark met with a striking exemplification in Louisville, Ky., recently. Milton J. Harvey, of New York, member of the firm of P. Moorman & Co.,

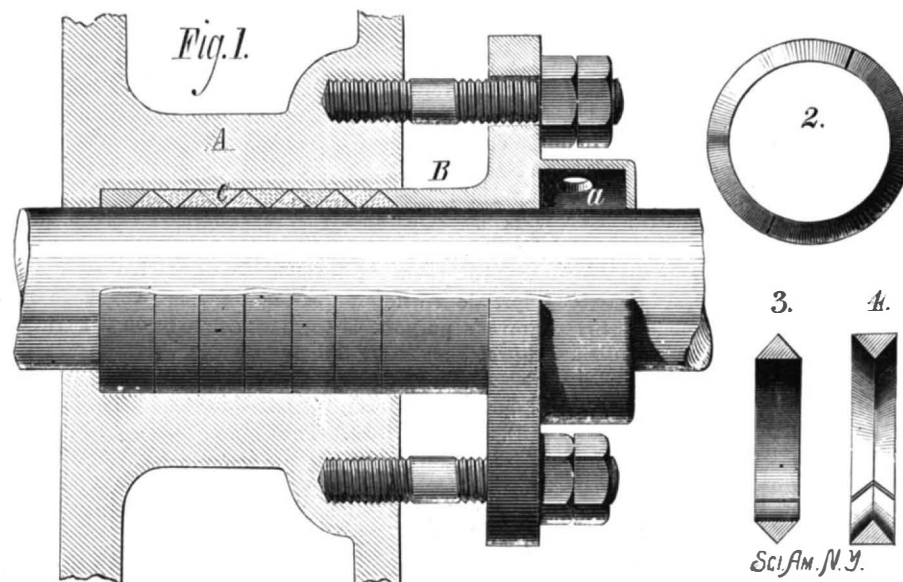
**HEWITT'S PISTON ROD PACKING.**

brought suit in the United States Court to dissolve the firm. The firm have been large whisky operators, the J. H. Cutler brand being a specialty, and the New York, Boston and California markets being their principal centers for operations. This brand, or trade mark, was one of the valuable assets sold by the United States Commissioner. The first bid was for \$5,000, and, after the auctioneer was three hours on the stand and nearly one thousand bids were made, Chas. P. Moorman became the purchaser for \$51,050. This was probably one of the most remarkable trade-mark sales ever made in this country, and shows the value of a peculiar mark by which the manufacturer seeks to distinguish his own productions from those made by other persons. This sale further shows the importance of such a privilege, and also why laws of Great Britain and the United States have been especially framed to protect manufacturers in their rights in this respect, because no honest manufacturer will invent and apply a trade mark to his wares unless

he is convinced that they possess some special excellence, which he wishes thus made known; and it is desirable the public should have the benefit of such direction in the choice of their purchases as is thereby afforded.—*Chicago Journal of Commerce.*

The Electrical Balance.

Mr. Chandler Roberts, at a recent meeting of the Physical Society, gave some results which he had obtained from an examination of certain alloys by means of the induction balance. He had been able to detect a difference of one part in 1,000 in the amount of silver in two shillings of equal weight. He also pointed out that Mathiessen divided alloys into three classes—(1) solidified solutions of one metal in another; (2) solidified solutions of one metal in an allotropic modification of another metal; (3) solidified solutions of allotropic modifications of both metals. For the first class the curve of electric conductivity is a straight line; for the second, a parabolic curve; for the third, a bent line. Mr. Roberts found that the balance gave the characteristic curve for the first class with an alloy of lead and tin, and for the second with an alloy of gold and silver. With a copper-tin alloy, which is a good example of the third class, he found the curve given by the balance to be intermediate between Alfred Risch's curve of density and Mathiessen's curve of conductivity, and considers that the balance is influenced by the density as well as the conductivity of the metal interposed.

ENGINEERING INVENTIONS.

Mr. Thomas L. Lee, of Paducah, Ky., has invented an improvement in chain propellers, which consists in the combination, with an endless chain, of the paddles, each of which is formed of two right-angular plates placed together and secured by bolts passing through their horizontal or base flanges.

Mr. Benjamin S. Benson, of Baltimore, Md., has patented a traction engine and steam plow combined. It is designed mainly to move backward and forward without turning around, but is also provided with means for turning when necessary. This invention cannot be properly described without an engraving.

Mr. James T. Bryant, of Richmond, Va., has invented an improved feed water cleaner, which consists in a strainer case having an inlet and outlet orifice, a vertical chamber containing a strainer of substantially the same diameter as said inlet and outlet orifices, and interposed between the same, in combination with a discharge valve, located below the strainer, and an independent pipe communicating with the space above the strainer.

An improved link motion for steam engines, so constructed that the motion may be readily reversed, and the throw of the valves may be easily regulated to cut off steam at any desired point of the stroke, has been patented by Mr. Daniel S. Stombs, of Stillwater, Minn.

Mr. William P. Lewis, of Oroville, Cal., has patented an improved pneumatic dredging apparatus for clearing out rivers and harbors, and for mining and other purposes. It consists in raising the solid matter by creating a vacuum in the tube, and expelling it from the vacuum chamber by the assistance of the direct action of steam.

An improvement in treenails for ships, etc., has been patented by Mr. Thomas W. Kirby, of Grand Haven, Mich. This invention relates to an improvement in fastening together the strakes of the ship's ceiling, and the fastening of the ceiling to the ship's timbers; the object is to bind the strakes together in a solid ceiling, and thus strengthen the sides of the vessel.

Mr. Henry A. Norton, of Ward City, Nev., has patented an improvement in that class of railroad switches in which the switch rails are actuated by a moving train or devices carried by the locomotive; and it consists in the construction and combination of parts, which cannot be fully described without an engraving.

Messrs. Emory D. Toops and Joseph Braddock, of Waverly, Ohio, have patented an improved ditching machine, by which the soil slice is divided into two equal parts by the central cutter of

the ditching wheel, and carried up and removed from the channels of the latter by the spirally curved wing or clearer, and by it delivered upon a traveling carrier, which consists of an endless belt passing around pulleys or drums, forming the bottom of a trough which projects laterally from the machine.

An improvement in steam engines has been patented by Mr. Henry A. Walker, of Charlotte, N. C. The object of this invention is to provide an improved piston connection with the driving wheel shaft of an engine and cylinders open at the ends, through which the piston rod passes, so that no stuffing boxes will be required, and the loss of power by friction be consequently reduced.

Mr. Oliver W. Barnes, of Fishkill, N. Y., has devised an improvement in elevated railways. The invention consists of a compound girder that is made of different superposed sections of wood, with intermediate layers of elastic material, the sections being firmly bolted together.

RECENT AGRICULTURAL INVENTIONS.

A reversible plow, arranged to swivel upon a vertical axis, and having a right and left mould board, made continuous by a connecting wall arranged in a plane parallel with the line of draught, has been patented by Mr. Lucius S. Edleblute, of Cincinnati, Ohio.

An improvement in horse hay rakes of that form in which the rake teeth project from both sides of an intermittingly rotating shaft, has been patented by Mr. Lucius S. Edleblute, of Cincinnati, Ohio. It consists in peculiar means for controlling the revolution.

An improved hay gatherer has been patented by Mr. Henry Grebe, of Omaha, Neb. It consists in the arrangement of a rake of proper size, provided at each end with a gate, that is pivoted on a post and connected by means of iron bands, ropes, leather belts, or some suitable means, so that when the sweep has arrived at its destination the gates can be swung around on their pivots and the hay or straw pushed off.

An improved sweep for cultivating cotton, which shall be so constructed that the parts subject to wear may be readily ground to keep them sharp, may be readily reversed and exchanged when one edge becomes worn or notched, has been patented by Mr. Charles E. Estes, of Columbus, Ga. It may be moved down to take up the wear, and may be replaced with new ones when worn out at small expense.

An improvement in vertical reciprocating churns has been patented by Mr. Joseph E. Taylor, of Frankfort, Ind. It consists in the construction and attachment to the churn body of the bearing for the crank shaft and the guide for the pitman or rod which connects the dasher staff and crank shaft.

A machine for distributing manure in rows at proper distances apart and in variable quantities, has been patented by Mr. Jephtha M. Chastain, of Gaylesville, Ala. It consists in an ingenious valve motion, which insures the proper discharge of the manure at suitable intervals.

An improved device for attachment to reapers for binding the cut grain into bundles as the gavels are raked from the reaper platform, is the invention of Mr. Daniel Williamson, of Sunbury, Pa. It is so constructed as to receive the gavels, bind them with their own straw, and drop them from the machine. It consists in a series of mechanical devices that cannot be readily described without an engraving.

An improved plow, which is so constructed that it may be readily adjusted to cut a deeper, a shallower, a wider, or a narrower furrow, as may be desired, has been patented by Mr. Amandes Hackman, of Blakesburg, Iowa.

Rotten Wood as a Pest Breeder.

Commenting on the filthy condition of the rotten wood pavements of Memphis, and their alleged influence in causing the outbreak of yellow fever there, the *Baltimore Sun* says that they have been continually denounced as foci of pestilence ever since 1873. The joints between the blocks and the ruts are so deep and so enlarged that they are soon filled in with filth, which in warm, damp weather offers a wide surface for putrefactive action and for the generation of noxious effluvia. The blocks themselves become water-soaked and rotten below the surface, so that when any one is taken out it is found to be no more than a black, pulpy mass of decay, upon which the sun is acting all the time, eliminating malarious gases from it.

The cause of the yellow fever which devastated Norfolk in 1856 was very largely attributed to the decay of wood shavings, which had been used to fill in a wharf. The Memphis pavements must supply a much larger proportion of poisonous malaria to the air than was given out by these decaying shavings at Norfolk. It is a peculiar property of half decayed wood in masses to retain moisture, to continue long in a state of slow fermentation, and to give off malarious effluvia. In country neighborhoods many a case of typhoid fever has been caused by a neglected wood pile near the house, where, upon a gradually accumulated mass of chips and sawdust that is fair enough on the outside, but rotted down to mould at the bottom, all the kitchen slops have been poured. It is a well known fact in sanitary works that hospital gangrene often results from washing the wood in floors of wards with water, and on shipboard new or moist timber is injurious to the health of the sailors. The damp timbers of the United States steamer *Plymouth* retained and were able to revive and propagate the yellow fever germs recently, in spite of the most careful fumigation, disinfection, and refrigeration during a whole winter. The decayed wood of the berth deck of this steamer could not be disinfected, so resolutely did it retain within itself the fever germs.

Memphis is paved with mile after mile of this sort of decayed wood, and every block, exposed to a sweltering sun, may nurse a fatal fever germ. These pavements were laid down from ten to twelve years ago, and are reported by Mr. Niles Meriwether, a civil engineer, as being "almost entirely gone from decay and hard usage, so that their rotten and honeycombed condition makes them so many cesspools and receptacles for the retention of all manner of street filth and noxious gases, and they should therefore be removed as rapidly as possible."

A FEW rubbing posts set up in pastures will save injury to the fences. Cattle will use these conveniences very often, and it is worth all the trouble, says an agricultural writer, to witness the enjoyment of the animals in the use of them.

NEW MAGNETOMETER.

BY GEO. M. HOPKINS.

The instrument represented in Fig. 1 is designed for the measurement of the attractive or repulsive force of magnets; it is more especially designed to measure and indicate the variations in magnetization of the field magnet of a dynamo-electric machine.

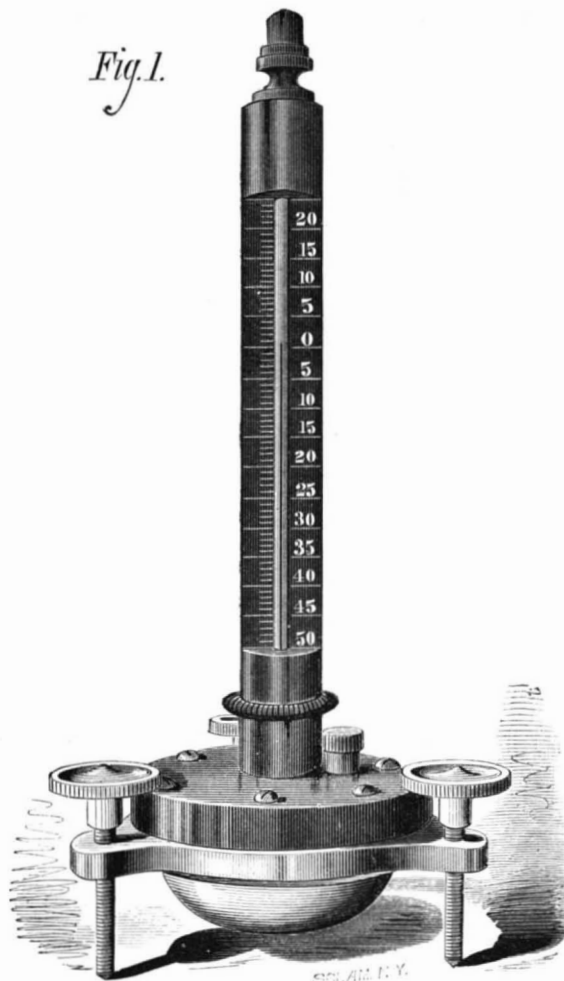

NEW MAGNETOMETER.

The changes in the resistances of the current from the modern dynamo-electric machines effect a corresponding change in the magnetism of the field magnets. An indicator that faithfully shows these fluctuations will give a correct idea of the strength of the current. The instrument illustrated does this, and it may also be used in detecting the location of the greatest magnetic force in an electro or other magnet.

The instrument shown in Fig. 2 is virtually an electrometer, as it indicates the electro-motive force of the dynamo or magneto machine when its helix is included in the elec-

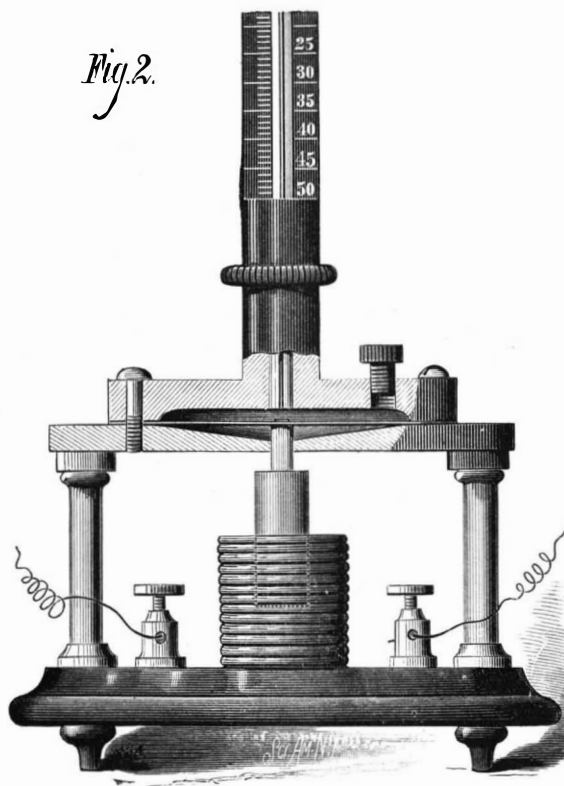

ELECTROMETER.

trical circuit. These instruments are quite simple, and are exactly alike so far as the upper portion is concerned.

The horizontal metallic plate, which in one case is supported by the columns and in the other by three milled screws, is concaved in the middle and supports a steel diaphragm that is held in place by the vulcanite cap secured to the plate by several screws, so as to clamp the diaphragm tightly.

The vulcanite cap is chambered out to receive mercury,

and it has a stuffing box for holding a glass tube of small caliber. A vulcanite screw at the side of the stuffing box serves to adjust the height of the mercury in the tube. The graduations on the scale at the side of the tube represent the number of pounds of attractive force exerted on the instrument. The graduations from 0 upward indicate the degree of upward pressure when the force of repulsion is measured.

A short rod is attached to the middle of the diaphragm, and projects downward through a hole in the base plate to receive in one case (as shown in Fig. 1) a convex soft iron armature, and in the other case (as shown in Fig. 2) a cylindrical armature or core which extends into the helix.

The instrument shown in Fig. 1 may be placed upon any part of the field magnet. The rise and fall of the mercury in the tube, resulting from a deflection of the diaphragm by the action of the magnet, constantly indicates the internal condition of things in the dynamo-machine. By bending the glass tube at right angles near the vulcanite cap the instrument may be applied to the side of the magnet. It may seem that the approach of the armature toward the magnet—thereby diminishing the distance between armature and magnet—would involve an error; but the motion of the diaphragm is very slight, and in a large magnet the variation of .02 of an inch in the distance between the armature and magnet is of no account.

The diameter of the diaphragm is 2 inches; the caliber of the glass tube, .02 inch; therefore a very slight motion of the diaphragm is indicated by a considerable movement of the mercury in the tube.

When the repelling force of a magnet is to be exhibited the soft iron armature is replaced by a permanent magnet.

The instrument shown in Fig. 2 may be placed anywhere in the circuit, and will indicate the strength of the current. An increase in electro-motive force results in the drawing in of the iron core and a consequent deflection of the diaphragm and movement of the mercury column.

Improved Stables for Horse Railways.

The recently completed stables of the Washington and Georgetown Passenger Railroad Company, at Georgetown, D. C., are pronounced unique and perfect by a correspondent of the *Philadelphia Ledger*:

The company employ about 600 horses. Of this number about 330 are stabled at the central stables at Georgetown; the others are domiciled at other smaller stables on the car routes in Washington. At these central stables are the offices of the company, the machinery necessary to build and repair cars, elevate, store, and grind corn, cut hay, bale and press it for the supplementary stables, mix and elevate the feed, etc. Every conceivable operation is effected with ease, speed, and great economy by the ingenious application of steam power.

The offices of the company are on Bridge street, with a frontage of 90 feet. In the rear of these the commodious car house reaches 250 feet to the canal, on a level 34 feet above it. To the left of the car house stands a hospital for horses, wholly complete in itself, and isolated from the smaller stable on the east, and separated from the splendid main stable on the west by the 90 feet width of the car house. These main stables will hold about 300 horses. They are admirably divided into stalls. The floors are laid upon a solid surface, composed of a mixture of cement, gravel, and gas tar, which renders it wholly rat-proof. The story is 23 feet high, and windows everywhere admit abundant air and light. Great open ventilators run through the upper floor to the roof. A graceful and very useful balcony runs the entire length (347 feet) of the property on the canal side, whereon the bedding is sunned and aired. Across a short and wide alley at the southwest corner of the property stands the shoeing shop on the edge of the canal.

From this point an iron bridge spans the canal and enters the third story of the great building constructed on the south side of the canal for the machinery and hay department. The ground level of this building is 34 feet below that of the stables, being also on a level with the canal. The building is 302 feet long by 63 feet wide, and fronts on the canal and Grace street, from both of which stores and supplies are received.

The engine room is located at the northwest angle of this building, and is spacious and convenient. A 35-horse power engine and 40-horse power boiler supply power through long lines of shafting for the various machines employed.

Adjoining is the coal room, with its peculiar method of unloading coal from boats. On the other side is the smith shop.

The whole width of this building, 63 feet by 40 feet, is taken up by the heavy piers upon which the three grain storage bins are erected. Forty-two brick piers, 27 inches square, go down to the bed-rock and reach five feet above ground. Upon these piers are placed immense yellow pine sills, 16 by 12 inches, cross timbered above as base for these storage bins, which rise to the third floor. They contain 15,000 bushels of corn. An immense swinging elevator occupies the canal side of these bins. A single man can project this elevator through the thirty foot high doorway down into a canal boat, and discharge 4,000 bushels of corn in ten hours. From the receiving hopper, after being weighed, the corn is taken by another set of elevators and distributed in the proper bins.

Two hundred feet of this entire building at the east end is for hay storage. It is a room 200 by 63 feet by 45 feet to the eaves, and will contain 1,000 tons. Four hoisting drums

with a spider web of guys and hoist ropes, unload baled or loose hay with magical speed, either from street or boat. The operation is quick and noiseless. A platform twenty feet wide projects from the third floor into the hay room. Here are located the hay cutter, and elevators to carry cut hay into the bin constructed for it on this floor. The second floor of the machinery department contains the latest improved machinery for car construction. Above it on the third floor the cars are painted and prepared for use. The cars come on tracks from the car house over the bridge, and are hoisted and lowered from story to story by means of an immense elevator in the southwest corner of the machinery building.

The milling department, with its paraphernalia of mill bins, scales, shafting, etc., stands on a floor over the storage bins, and is a model. Through the wall of this room a door opens into the cut hay bin; near this, in the floor, a trap door, being raised, discovers a cavernous space, with glimpses of shafts and arms. Into this the cut hay, meal, and bran, are drawn in proportions, motion is given, and, in a few minutes, the bottom falls, the mass is taken by an elevator and thrown into a car on the milling floor, thoroughly prepared for the horses. The whole operation is so simple, so easy, and out of sight, and the feed is mixed so thoroughly, that it is most interesting to witness. The whole of this work has been done under the supervision and direction of the president of the company, Mr. Henry Hurt. How well it has been done a visit will show.

The mechanical portion of the work was designed and constructed by Messrs. Ferrell & Mucklé, of the Enterprise Hydraulic Works, Philadelphia.

Correspondence.

The Devil's Darning Needle.

To the Editor of the Scientific American:

The *Diaperomera femorata* described in a recent number of the SCIENTIFIC AMERICAN, by our distinguished entomologist, Professor Riley, is found in Iowa, but never, so far as known, so abundantly as to materially damage trees or shrubs. It is locally known as the "devil's darning needle." The time of its first appearance in the spring seems to be variable. Evidently quite young individuals, light green in color, and from three eighths to one half inch in length, have been first seen by the writer on July 3 in one case, on June 22 in another, and on May 25 in a third.

A single observation would indicate that the adult individuals may sometimes survive the winter, and may be partially aquatic in habit. About the first week in April, 1878 (the exact date not being recorded), the writer saw an adult male of the species swimming freely in a pool of water situated in a meadow, fully a quarter of a mile from the nearest grove. It swam almost wholly submerged, seeming perfectly at home in the water, and in no way disposed to leave it. The preceding winter was unusually mild.

A precisely similar case in every particular was reported to the writer about five years previously; but he was strongly inclined to doubt the statement until confirmed by his own observation.

Yours truly,

W. J. MCGEE.

Farley, Iowa, July 21, 1879.

Effect of Exposure on Anthracite Coal.

To the Editor of the Scientific American:

"F. G." asks, "Is there any truth in the assertion that anthracite coal loses its heating qualities after being exposed to the air for any length of time?" to which you give a dogmatic No." I have handled, in all capacities, except as a hand laborer underground, for over 41 years, anthracite coal. With this experience, I can assure you that your answer needs modification. Anthracite coal, kept in a reasonably dry atmosphere in the dark, and not subject to violent changes in the temperature, your "No" is correct, as the deterioration would be imperceptible. But change the status. Place anthracite coal in the weather, exposed to storms of rain and snow, and to sunshine, water, heat, and cold, the deterioration is great, not less than ten per cent per annum for the first five years.

WM. LILLY.

Mauch Chunk, Pa.

The Pearl Fisheries of Ohio.

About twenty years ago pearls were discovered in the Little Miami River, Warren County, Ohio, and since then the search for them has been one of the recognized industries of the region. The Cincinnati *Commercial* says that the mussels which furnish the pearls are found in beds anywhere from the banks to the middle of the river, and are generally discovered by the feet of the pearl fisher. About fifty men and boys are engaged in this work. They wade into the river from depths reaching from the knees to the neck.

With their feet they feel the shells, and raise them by their toes to a height where the hands can reach them without stooping so as to bring the head under water. Miniature canoes, tied to the shore and floating out, are used to deposit the shells. When a bushel or more have been collected the fisher goes to the shore, and sitting down on the grass, in some cool shade, he opens the shells with a large knife.

The pearls are found between a slight membrane that lines the shell and the shell itself—a translucent web of texture between a cobweb and a film of mica. Occasionally the pearl is embedded in the shell so firmly that only an expert lapidary could safely detach it. This is rare. The number of

pearls found in a single shell at the Miami fisheries rarely exceeds three, and on an average only one shell out of one hundred and fifty has any pearls at all. It is a common experience to bring to shore bushels of shells with never a pearl. One may work for days with no reward; again, he may make from five to one hundred dollars in a single day. The uncertainty is probably half the fascination of the work to the peculiar class of men and boys who prosecute it.

About a year ago a wealthy banker of Waynesville, Mr. J. H. Harris, began to purchase the pearls, which had previously been bought by New York and European dealers chiefly, and has since made a large and fine collection. Mention is made of one fine specimen, the Everhart pearl, found in the Miami and sold to Messrs. Tiffany & Co., in New York, for \$900. The Tiffanys sold it to a party in France for \$1,000, bought it back for \$1,500, and made a final sale of it for \$2,800.

The season of the pearl fisheries of the Little Miami lasts only from June till October, as it is necessarily dependent upon the warmth of the water. The fisher works about six or seven hours per day, seldom remaining longer than two hours, consecutively, in the water. It would seem as if the work would be very unhealthy, leading to malaria and all its attendant train of low fevers and vital exhaustion, but it was not spoken of particularly in that way.

There are pearls found in other parts of Ohio, but are of the milk-white, owing to the lack of the calcareous deposit that abounds in Warren County. The pearls of the Little Miami region are of a soft, sky-blue, pink, golden tinged, and iron color, with specimens that show a pure type of each, and others that are blendings of all. The colors, of course, are not solid, but exquisite tints and shades, changing with the angle of refracted light. The size ranges from that of a mustard seed to the size of a bullet.

Many of the old Indian mounds that have been opened contain pearls, showing how ancient their existence is. These pearls in the mounds lie as if they had been strung, but they crumble at a touch.

Recently a pearl of the most extraordinary beauty and brilliancy was accidentally found on the Waynesville side of the river by Morton L. Roberts, a little lad of eleven years, the son of Mr. J. A. G. Roberts, of the Adams Express Company, of Cincinnati. Morton was visiting some relatives there, and went down to get mussel shells to border a flower bed for his aunt. There were a quantity of these that had been looked over by fishers and thrown aside, and it was in one of these that the observing eye of the little boy detected the gem that promises to be a very valuable one. It is said to be the largest pearl ever taken from this region, and perfect in its symmetry. It has the brilliancy of the purest and most intense tints of the opal. It seems to rest in an aureole of colors, so delicate, yet so glowing, as to suggest to one a dream of color. The pearl will undoubtedly prove one of very rare value. Its weight is six carats.

Rules of the National Board of Health.

The National Board of Health, which was created by a recent act of Congress, with full authority to take charge of all places in the United States in which infectious and contagious diseases may appear, have issued the following rules and regulations to be enforced during the existence of yellow fever:

Every train leaving an infected city, town, or other place, shall be inspected by a competent medical man, who shall give to the conductor of said train a certificate of the results of his inspection. It shall also be his duty to furnish certificates to each passenger, and no passenger shall be permitted to leave an infected place without such certificate. No person having fever shall be allowed to take passage on such train. All cars leaving such place shall be thoroughly cleansed and fumigated with sulphurous acid gas, by burning 18 ounces of sulphur for every 1,000 cubic feet of space, and closing up the car tight for six hours prior to date of leaving. No upholstered car shall be allowed to leave a dangerously infected place. All baggage shall be thoroughly disinfected at the station before leaving. At a point not less than five miles, and as near this point as possible from the point of departure from a dangerously infected place, there shall be an entire transfer of passengers and baggage to other cars, which cars shall never enter an infected district. This transfer shall be made in the open air, under the supervision of a medical officer, and as far from a habitation as possible, and no person with fever shall be allowed to proceed, but shall return to the point of departure, or be treated in hospital at or near the place of transfer. No sleeping car shall be allowed to leave a dangerously infected place, nor shall any sleeping car approach nearer such place than the point of transfer. Any passenger car leaving such infected place shall be thoroughly ventilated during its passage to the place of transfer, by having the windows of the cars open during such passage.

In cases of suspected infection of a passenger in a sleeping car, such car, including all the upholstery, cushions, curtains, mattresses, etc., shall be thoroughly disinfected, under the supervision of a medical officer, and shall be exposed to the open air for at least 30 days, before being again used.

All freight shall be transferred at a point not exceeding 50 miles from the point of departure, and the cars from which such freight has been transferred shall not proceed further on the road, but shall be returned to the point of departure. The freight cars, after unloading, shall be thoroughly cleansed by scrubbing, fumigation, disinfection, and ventilation.

Mail matter and mail bags should be heated to a temperature of 250° Fah., or should be otherwise disinfected before they are sent from infected places.

At some point, not less than 50 miles from the first transfer station, a second complete transfer of passengers and baggage is desirable, and should be provided for by the authorities of the States through which the lines run. If yellow fever infect a place situated upon a line of railroad, trains of all kinds may be permitted to pass through without stopping, at a speed of not less than 10 miles an hour, provided the National Board of Health has not declared it dangerous to do so, and published, through the local health authorities, a special rule forbidding it; but they shall not take on passengers within one mile of such infected place, and all persons taken on shall first obtain the certificate from the local officers set forth herein. No train having a certificate of such inspection, and no passenger having a proper certificate that he was free from disease and that his baggage was properly disinfected, shall be interfered with by any municipal or other local systems of quarantine.

Fortifying the Treasury.

The work of fortifying the Sub-Treasury Buildings, on Wall, Nassau, and Pine streets, New York city, goes on rapidly. The windows of the basement and first floor are being protected by steel bar gratings one and a half inches in diameter, nine feet long at the lower and eleven feet long at the first floor windows, completely covering the same from casing to casing. Each upright bar is pointed at the top; seventeen uprights are fastened to each of the basement windows and held in place by four cross bars. Five cross bars hold in position twenty-one uprights on each first floor window. The cross bars measure three inches, and are one inch thick. Fifty-two windows in the building are thus protected. Each of the cross bars weighs 100 lb., aggregating 25,000 lb., and the uprights average 15 lb. to the foot, making a total weight of over 100,000 lb. of highly tempered steel, strong enough to resist any attempt at removal. This grating, when complete, will not only give protection from without, but allow the windows to remain open for ventilation. An additional quarter inch steel plate is to be affixed to the present iron shutters, which are to be pierced for rifles. The loopholes are to be protected by coverings of steel. The riflemen, thus protected by the shutters, can sweep the streets from the north, west, and south sides of the edifice, they being concealed in a bullet proof fortification. Besides the loopholes for rifles, arrangements have been perfected for throwing hand grenades at a mob from the windows under the eaves of the roof, without exposing the throwers to any danger from the house tops opposite.

The architect of the Treasury Department has added another novel feature of defense. To repel an attack which might be made on the Treasury Building from the roofs of the Assay Office or the adjoining buildings owned by the government on Pine street, there will be three steel turrets built on the roof of the Treasury, in which will be mounted Gatling guns, which will have a clear sweep of every house top within range. It is expected to have the new fortification finished by the 15th of September. It must be remembered that from \$150,000,000 to \$200,000,000 are constantly in the vaults of the Sub-Treasury; hence the precautions taken by the authorities for the utmost safety of this vast treasure.

The Australian Exhibition.

Mr. O. M. Spencer, United States Consul General at Melbourne, Australia, reports that the relation which exists between the Sydney and Melbourne exhibitors is one of generous rivalry and cordial co-operation. The two cities will soon be connected by railway. There are several lines of steamships now plying regularly between the two places, with low rates for freight. The expense of transferring goods from Sydney to Melbourne will be moderate, including storage. Goods will be received at the latter Exhibition building on the first of June, 1880.

All the usual facilities accorded at previous international fairs in other countries will be liberally afforded at Melbourne. The protection of inventions capable of being patented is fully secured. Should the United States decide not to send out a man-of-war, it is advisable to ship all heavy goods in sailing vessels, via the Cape, not later than February, 1880. Goods from the Pacific slope and parcels of great value and small bulk may be shipped via San Francisco by the Pacific Mail Steamship Company, which runs a monthly line of steamers from San Francisco to Sydney. Show cases, shelving, belting, etc., may be procured in Melbourne at low rates, at the cost of the exhibitors.

A Berlin International Fishery Exhibition.

An international fishery exhibition, to be held in Berlin in April, 1880, promises to bring together displays from all nations. Although the exhibition is limited to a single industry and class of products, considerable variety is given to it by including—besides aquatic animals and fishing gear and craft and machinery used in the manufacture of fishing tackle and nets—models of fishermen's dwellings and costumes, objects and works referring to the history of fisheries, and maps showing the geographical distribution of fish. Exhibitors are to be under no expense except for transportation of exhibits to the Berlin termini and return, and the committee is not indisposed to bear this expense in the case of specially interesting and important objects.

NEW ELECTRIC CURRENT REGULATOR.

In a certain number of applications of electricity, such as the incandescence of platinum wires by the electric current, it is a very important point to maintain the current flowing at a certain strength, above or below which it must not vary appreciably. One of the most effectual means of doing this is to have a resistance in the circuit which can be varied according to the fluctuations in the current strength. M. Hospitalier, a young French engineer, has devised a very simple regulator on this principle.

The apparatus is composed of a resistance bobbin formed of insulated wire wound on in a single layer, and having each turn stripped of its insulating covering for about a centimeter of distance at the same spot. A lever, A B, slightly convex, can be made to touch at any particular part of its length the bared portion of the turn of wire immediately beneath that part. This lever, or "divider," has a joint at A, to which is connected a second lever having an armature, C, fixed near its outer extremity, which armature is placed in front of the electro-magnet, E. One end of the wire of the electro-magnet is connected to one end of the wire on the bobbin, the other end is connected to the metal piece on which the end, F, of the upper lever is swung. The other end of the wire of the bobbin is attached to a terminal on the lever part of the bobbin.

A spring, R, attached to the end, B, of the lever is adjustable by means of the thumbscrew, V, and by its tension draws the end of the lever to which it is attached forward; and the lever, by rocking or rolling on its curved surface, has its upper portion drawn in the reverse direction, that is, it pulls away the armature, C, from the electro-magnet. Under these conditions the lower part of the rocking lever will be in contact with the bare place on the lowest turn of wire on the bobbin, consequently the major portion of the current conveyed by the wires connected to the two terminals on the bobbin flows from the bare spot on the wire, up the lever, and thence through the electro-magnet back to the second terminal. The armature being consequently attracted, the curved lever is made to rock or roll on the bared surfaces of the wires, thus making contact with turns of the wire higher up the bobbin; but when this is so, the current entering the lower terminal has to traverse all the turns up to the turn with which the lever may be in contact, and the current is thus weakened. Hence it is easy to see that when the spring, R, is adjusted to a certain tension, the current flowing will, by pulling the armature, C, pull the lower lever on to such a turn of the wire on the bobbin as will introduce an amount of resistance sufficient to produce equilibrium, and if the current weakens or strengthens the lever will move backward or forward until the resistance adjusted by the decreased or increased number of turns in the circuit again produces equilibrium. To adapt the apparatus for alternating currents the electro-magnet is replaced by a bar of wire, which expands by the heating effect of the currents.

For dynamo-machines the apparatus is arranged to be worked by the machine itself. This is done by connecting the rocking lever to a Watt's governor. Under these conditions the apparatus regulates the velocity of the machine, and not the strength of the current.

It is hardly necessary to call attention to the utility of the invention, but the importance may be well understood when we consider that the apparatus bears the same relation to the regulation of the electric currents as the Watt's and other governors, or to the regulation of the flow of steam in steam engines.—*Telegraph Journal.*

The Fire Department of Topeka, Kansas.

Topeka is a city of about 12,000 inhabitants, situated in a region so new that the first white child born in the county is scarcely more than twenty-five years old; but it now supports three good daily newspapers and at least ten weekly and monthly ones. This is a good showing, but it will surprise no one who knows the character and habits of Kansas people. So says a correspondent of the *Fireman's Journal*, who gives the following interesting particulars:

There are two fire engine houses in the city, one in the main part of the town, and the other in North Topeka, 1½ miles away. They are substantially alike, but I shall speak only of the main one, designated as the "headquarters."

Mr. Wilmarth, the Chief of the Department, has occupied his present position for about eight years, and is a gentleman of intelligence. The present "headquarters" were built under his supervision. The first floor of this building is arranged with places for a steam engine, a Babcock engine, hose-cart, hook and ladder carriage, etc., and stables for the horses, six in number. The second floor contains a place for feed for the horses, a bath and wash room for the "boys," a reading room well supplied with books and newspapers, and sleeping rooms for eight men. Both the first and second floors are kept as clean as a building can well be kept.

This part of the building is surmounted by a tower some 60 feet in height, with machinery for drawing up the hose to be drained and dried. On its top is a station for a watchman, where he is constantly on duty at night, looking out for the first indications of fires.

The fire engines, hose-carts, etc., stand facing the double doors opposite each machine, and the horses stand in the rear, also facing the front of the building, with feed boxes on the sides of their respective stalls. They are kept in their places by short chains, covered with gutta percha, stretched in front of them, and fastened by iron pins, which also secure the horses' halters.

In the front part of the building is an opening through the second floor, some 3 feet square. A pole as smooth as glass is erected on the first floor, and passes up through this aperture into the sleeping room of the firemen. There is also on one side of the building a wooden tube or slide, perfectly smooth on the inside, leading into a room where four other men sleep. At an alarm of fire the boys drop through these places almost instantaneously. The floor at the foot of each of these places is well cushioned to prevent injury to the men as they strike it.

As soon as the watchman on the tower discovers a fire he sounds a shrill whistle located in the end of a tube in the engine room, directly over a bunk where a man sleeps. This man immediately jumps and touches an electric key at the head of his bunk. This sounds a gong, drops the chains in front of the horses—which are always harnessed and bitted—releases the halter straps, and the horses are so trained that each one springs to the place where he belongs at the tongue of the engine or hose-cart. The same touch of the electric key lights the fire in the steam engine; sounds a gong at the head of the bed of the chief at his residence, which is near

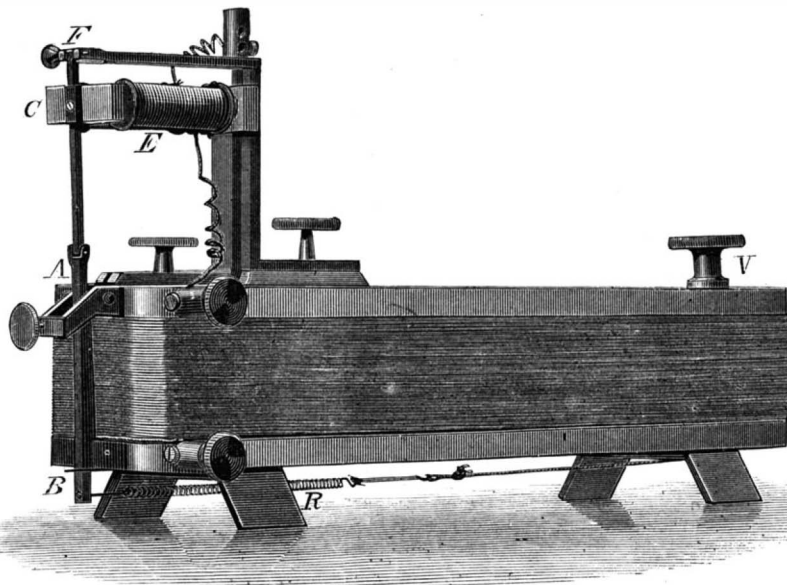
**HOSPITALIER'S ELECTRIC CURRENT REGULATOR.**

by; and also releases the horses, sounds the gong, and lights the fire in the other engine at its house, 1½ miles away. It will be seen that these arrangements are very complete.

Under rules which are strictly enforced no intoxicating liquors are permitted to be brought or used in or about the engine houses; gambling of all kinds is prohibited; loafers and idlers are excluded; no person of questionable character is permitted to be placed on the rolls of the department; and any man "who refuses to pay any just and honorable debt of his own contracting will be liable to discharge." "No person not a member of the department is allowed to sleep at the engine houses, and all firemen who sleep at the engine houses are required to be in bed at 11 P.M."

By enforcing such rules as these, and by strict discipline, this fire department has become an ornament to the city and the pride of her people. T. S. S.

American Manufactures in Cuba.

The British Consul-General at Havana, in a recent report to his government, says that the English are yearly becoming less and less in the commerce of Cuba, and the United States more and more.

"Machinery and hardware, in which we (the British) were once unapproachable, are falling into the hands of our rivals, the only remnant being a limited import of cutlery and large pieces of machinery, such as steam plows, sugar engines, etc.; but even these, from various causes, are now coming from other countries, notably the beautiful machinery from France, such as centrifugal machines, vacuum pans, and those connected with distilling. One of the largest imports from England was the large cane knife or machete; some of these are still imported from England, but the fact cannot be, and is not, disguised from the buyers, that these knives are inferior to those made in the United States and in Germany at equal prices; the only advantage possessed by the English article is superiority of polish, hence the increase of the import from England. Take the English plow; it has no chance against the American, for not only is the latter one third cheaper, but the American manufacturer makes a study of the island of Cuba, and his plow is consequently perfectly adapted to its requirements. So with heavy machinery on sugar estates; the planters find that, as a matter of course, an article whose prime cost is less, which has less freight to pay, and which is made expressly to suit the island, is preferable to the English one, which does not

possess these advantages. In railway plant, also, the Americans are beating us, for the same objection is raised to the English manufacturers; rails, for instance, of the section required here, have to be rolled expressly in England, so that the purchaser has to give his orders four months in advance; whereas in the United States he finds his rails ready for immediate shipment, and cheaper into the bargain."

RECENT MECHANICAL INVENTIONS.

Messrs. A. O. Kaplan and A. Illovy, of Cincinnati, O., have patented an improved device for attachment to wagons, carriages, and other vehicles, which is so constructed that the horse may be instantly detached and the advance of the vehicle checked, preventing the passengers from being injured and the vehicle from being broken.

Mr. Andrew A. Armstrong, of Milford, Pa., has patented an improved sash lock for windows which is simple, convenient, and reliable, and is so constructed that it cannot be unfastened from outside the window, whether the sash be locked when closed or when partly raised.

A caster, in which the frame is made in two parts, the plane of division passing longitudinally through the pivot or stem and transversely across the middle part of the journal, has been patented by Mr. George L. Donovan, of West Meriden, Conn.

An improved machine for applying cane and other flexible seats to the seat frames of chairs, has been patented by Mr. Robert Fitts, of Lunenburg, Mass. It is so constructed that the seat will be drawn taut as it is being applied.

An improvement in wagon brakes has been patented by Mr. O. A. Kenyon, of McGregor, Iowa. The brake is made easily adjustable at several points, and without trouble or expense can always be kept in an effective condition.

An improved wagon brake, which is so constructed that it will be applied by the forward pressure of the load in going down hill, and will be gradually taken off by the draught as the wagon comes to a level, has been patented by Mr. A. M. Van Ness, of Seymour, Ia.

Messrs. George W. Marsland and Arnold Hitchcock, of Pana, Ill., have patented an improved rack for wagons to adapt them for the transportation of hay, grain, fodder, and similar articles, as well as for transporting hogs, sheep, and products of various kinds.

An improved device for holding the brasses for car journal boxes, while being bored, has been patented by Messrs. Richard H. Briggs and James H. Dougherty, of Whistler, Ala. It is so constructed as to hold the brasses securely in place while being bored, and will insure the brasses being bored true, and it may be adjusted for boring brasses for journals of different diameters.

An improvement in that class of wheel hubs in which the spoke tenons are in lateral contact and form a continuous circumferential band, being supported by and clamped between metal flanges that encircle the wooden body of the hub, has been patented by Messrs. John D. Bultz and Joseph L. Baker, of Jacksonborough, Ohio.

An improved machine for plastering walls has been patented by Mr. Gustavus Stevens, of East Tawas, Mich. This invention consists in a receptacle for the mortar, which in shape is the longitudinal segment of a cylinder. It is provided with a hinged leaf or press-plate that moves radially against the mortar, and as the receptacle is moved upwardly against the wall presses the plaster out through a narrow-gauged opening at the bottom.

Mr. William B. Killough, of Larissa, Tex., has patented an improved wrench for holding and turning bolts, pipes, taps, etc. It consists of one fixed and one movable jaw, placed on a shank and pivoted to a sleeve controlled by a screw, and carrying a lever with a cam-face working under the pivoted jaw. The jaws have serrated V-shaped recesses to grasp the larger objects, while projecting from the front there are lips with serrated concave recesses for taking hold of the heads of bolts.

An improved trumpet-guide for carding-machines, patented by Mr. Edward B. Tibbetts, of Holyoke, Mass., consists of a pan provided with a shield and oval tubes or casings placed in front of and under the doffer, so that the shield partially covers the lower calender-roll, and the tubes or casings entirely cover the shaft, the pan catches the litter, and the incasing of the roll and shaft prevents the sliver, when broken, from catching and winding.

An improvement in crozing-machines, patented by Mr. Oscar J. Pennell, of Williamsport, Pa., consists in mounting the cutter-head in a swinging frame, which is vibrated, to cause the cutter-head to act on the staves, by means of a treadle-lever and friction-pulley; and in making the swinging frame adjustable in its bearings to change its radius, for the purpose of enabling the cutter-head to move through the arc of a greater or less circle, and thus adapt it to cut a deeper or shallower croze, as required for staves of larger or smaller barrels or other casks.

A CEMENT peculiarly adapted to stand petroleum or any of its distillates is made by boiling 3 parts of resin with 1 of caustic soda and 5 of water. This forms a resin soap, which is afterward mixed with half its weight of plaster of Paris, zinc white, white lead, or precipitated chalk.

NEW CUT-OFF.

The accompanying engraving represents an improved cut-off for steam engines recently patented by Mr. Thomas E. L. Collins, of Fall River, Mass. The improvement, although especially designed for beam engines, is not confined to this use. The lifters are made in two parts. The fixed portion, A, being attached to the valve rod in the usual way, the adjustable portion, B, is pivoted to the heel of the fixed portion, and is guided and supported by a curved arm that projects downward from the toe of the lifter. Two screws, C, D, pass through the lifter, the screw, C, being swiveled in the adjustable part of the lifter. The screw, D, merely presses against the back of the adjustable portion, giving an additional bearing.

The ordinary cut-off lifters of beam engines are secured to the valve rods by means of set screws and keys; and they can be adjusted only by loosening the set screws and keys and changing the position of the lifters. This operation involves a great deal of labor and requires considerable time, and the engine must be at rest.

The advantages of the improvement above described are apparent. The lifters can be adjusted with great accuracy even while the engine is in full operation, by simply turning the screws, C, D, and the application of the improvement to engines already in use involves no change except in the lifters.

Browning's Stone Varnish.

Respecting the colorless preservative solution by which Cleopatra's Needle has been covered, a correspondent recently wrote to the *Times*: "In operating upon the granite, Mr. Browning first gave it a thorough cleansing, removing all the sooty and greasy matters from the surface, and then indurated it with his invisible preservative solution. The effect has been to give a freshness to the granite as if only just chiseled from the rock, retaining the original color, disclosing the several veins, the white spar shining in the sun's rays like crystals, and exhibiting the polished portions as they formerly existed. The solution soaks well into the pores of the granite, and the best authorities consider that it will have the effect of thoroughly preserving the monolith. Mr. Henry Browning has personally superintended the operations."

COMBINED SAD-IRON AND FLUTING ROLLER.

We give herewith an engraving representing in section and perspective an improved combined sad-iron and fluting roller recently patented by Mr. Carl J. Kramer, of Shreveport, La.

The sad-iron is made hollow, and is open at the top and rear end. It is provided with a door at the rear end, and the inner surface of the bottom is corrugated to facilitate the absorption of heat from the heated iron that is placed in the body of the sad-iron. A concave plate, A, is fitted to the top of the sad-iron to receive the lower fluting roller, B. The fluting roller is hollow, and it is fitted at one end to a hollow movable pivot, C, which conducts the heat from the sad-iron to the fluting roller. The opposite end of the roller, B, revolves on a hollow pivot, D, formed on the rear arm of the handle frame, E.

The upper roller is fitted to a hollow gudgeon, F, which is journaled in the handle frame, and is adapted to a crank by which the fluted rollers are turned. The gudgeon, F, communicates with the passage leading to the lower fluted roll. A movable hollow pivot supports the forward end of the upper roll and communicates with an upward flue, by which the heat escapes. It will be observed that by this arrangement a constant current of highly heated air is made to constantly pass through the rollers.

The part of the handle frame carrying the upper roller is movable, and pressure is applied to it through the spring at the top, the tension of the spring being regulated by the screw, G. This screw is provided with a cam, H, by which it may be raised whenever it becomes necessary to take the pressure from the upper roll.

In this sad-iron either a heated iron, coals, or gas may be

used to heat the smoothing and fluting surfaces. Further information may be obtained by addressing Mr. Carl J. Kramer, care of Mr. E. D. McKellar, Shreveport, La.

MISCELLANEOUS INVENTIONS.

An improvement in grain bag and fastening has been patented by Mr. A. B. Gardner, of East New York, N. Y. The invention consists in bags having inclined slits formed in their upper ends, forming ears and funnel-shaped mouths, and provided with two rows of eyelet holes to receive the fastening cords, and in a peculiar mode of applying a stiffener.

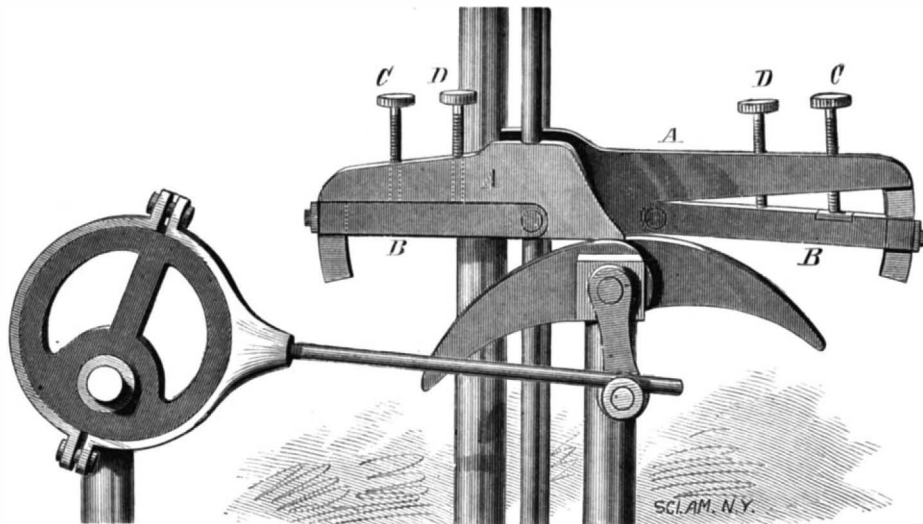
**COLLINS' CUT-OFF FOR BEAM ENGINES.**

A wooden barrel hoop, having a lengthwise groove for the purpose of increasing its flexibility transversely, has been patented by Mr. John Hartsook, of Sparta, Ill.

An improved device for use in setting dough to rise has been patented by Mr. James L. Campbell, of West Elizabeth, Pa. The improvement consists in a covered tray provided with a pan supporting perforated plate and an upwardly convex radiating plate, the latter placed over a bottom hole.

Mr. James L. Campbell, of West Elizabeth, Pa., has invented an improved device for hatching eggs artificially which is so constructed that the burning of the lamp may be regulated automatically, so as to keep the eggs at a uniform temperature. It is also provided with devices by which it is properly ventilated.

Mr. Ferdinand A. Reichardt, of New York city, has patented an improved device for the preservation and use of volatile substances. It is particularly intended for use in connection with nitrite of amyl, iodide of ethyl, and other

A transposing key board for pianos and organs, whereby the music can or may all be written and played in the key of C natural, and yet will sound in any one of the twelve keys to which the finger board has been adjusted, has been patented by Mr. Asa J. Stafford, of Brushton, N. Y.

The combination of a table with a vertically adjustable top or cover that forms, when raised, a canopy and reflector, and when lowered a casing or safe for the table, has been patented by Mr. Daniel J. Davis, of Red Boiling Springs, Tenn.

Mr. Alexander Cunningham, of Augusta, Ohio, has patented an improved cork for milk jars, which consists of an elastic cork having a convex under surface, and provided with a rubber tube, fitted in an aperture in the cork, and with a bail.

Mr. H. W. Schweckendiek, of Baltimore, Md., has patented an improved temporary binder, consisting of hinged covers and a flexible back, and provided with sliding cords and loops for attachment of the sheets, papers, etc.

An improved device for decomposing water for fuel has been patented by Mr. Milton W. Hazelton, of Chicago, Ill. The object of the invention is to atomize water, and force it by and with a current of hot or cold air up through the incandescent coal lying upon the grate of a furnace or boiler, so that the water becomes decomposed and the oxygen combines with the carbon of the solid fuel, while the combustion of the hydrogen will increase the volume of heat and flame.

Mr. Hugh Nelson, of Philadelphia, Pa., has patented an improved adjustable model for shoe patterns, having

sliding pieces with slots which receive the ends of screw studs passed up from a foundation plate, and provided with nuts, by which the slides are held in any desired position. On the foundation plate are graduated pieces under each slide, by which they are set to the different sized patterns.

An improved calendar, patented by Mr. Emanuel J. Trum, of Brooklyn, N. Y., displays two successive months and days of the week in the proper order opposite figures indicating the days of the month.

Mr. Robert F. Hatfield, of Brooklyn, N. Y., has devised an improved machine for drying clothes, so constructed that the clothes will pass through the machine in one direction and the hot air in the other. It will allow the clothes to be attached outside of the drying room.

Mr. John McAnespey, of Philadelphia, Pa., has invented an improved ice cream freezer which is simple, convenient, and effective, freezing the cream quickly and evenly.

An improved blanket for army use, which shall also be adapted for use as an overcoat with a cape or hood, as may

be desired, has been patented by Mr. Charles A. Hodgman, of Tuckahoe, N. Y. It consists in a blanket of woven material or rubber cloth of the required size, nearly square in shape, with a semicircular extension at one side, and fitted with sleeves. The blanket is provided with loops for gathering-strings, whereby, when it is used as a coat, it may be gathered around the neck, with the semicircular portion hanging as a cape, or turned and secured over the head as a hood.

An improved construction of abdominal corsets, by which the corset is made to fit comfortably to the body of the wearer without being liable to rise up in front, as is the case with the abdominal corsets in which the stays or bones run from the top down to the bottom of the corset, has been patented by Mary Ann Day, of Brooklyn, N. Y. The corset has a great degree of

flexibility and sets easily on the body of the wearer, as well in a sitting as in a standing position.

HOLES IN HARD STEEL may be made with nitric acid. To apply it cover the steel plate, at the place where you wish the hole, with a thick layer of melted wax; when cold make a hole in the wax of the size you want the hole in the plate, then put on one or more drops of strong nitric acid, leave it on for some time, wash off with water, and if not eaten through, apply other drops of the same liquid, and continue this until the plate is perforated.—*Ironmonger.*

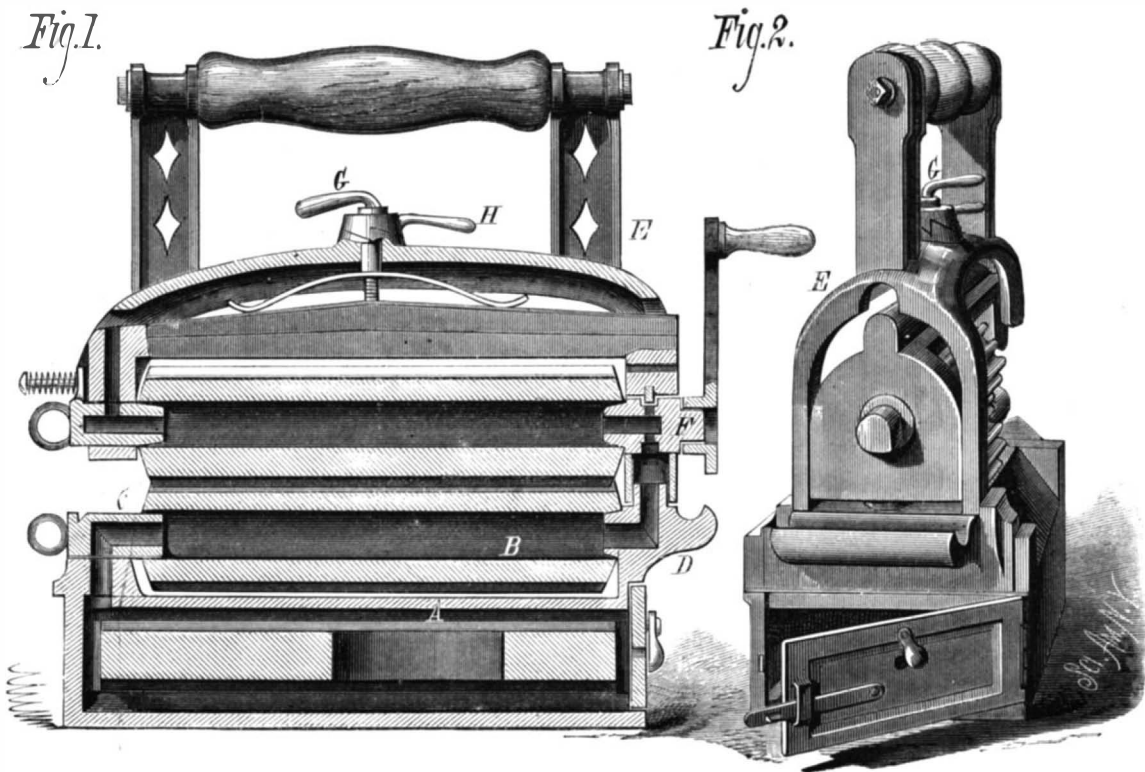
**KRAMER'S COMBINED SAD-IRON AND FLUTING ROLLER.**

volatile substances. The invention consists in a combined casing and plug or piston of novel construction, adapted to the holding and carrying of a number of pearls or capsules containing volatile substances. When desired the pearls may be crushed and the contents liberated by moving the piston.

Mr. John Epting, of Stroudsburg, Pa., has invented an improved floor scrubber, having projecting elastic plates at each end of the metal frame, half inch wide, to protect the washboards of a room, when scrubbing, from being scratched by the frame, and to facilitate the cleaning of the corners.

FAIENCE.

We present herewith an engraving of a group of faience jars and tazza in porcelain and enamel work, designed from Chinese and Japanese originals, by E. Colletot, of Paris.

China Ware in New Jersey.

Last year, at the suggestion of Governor McClellan, of New Jersey, a commissioner was sent to Paris to study the exhibition of ceramics there and purchase a library of works relating to that industry. Mr. W. C. Prime is reported as pronouncing the library thus selected the best of its kind in this country. A slight controversy, which has arisen among the Trenton potters, owing to a fear that the returning commissioner may bring to the company he is connected with more than their share of the knowledge gained by him abroad, has called out the following facts, which are printed in the *Sun*:

There are sixteen great pottery establishments in Trenton. In them are invested between a million and a half and two millions of dollars, and their annual sales amount to nearly the same figures. Their buildings cover large tracts of ground, and give employment to about 3,000 persons. Their grimy, stained buildings seem to be as old as Trenton, but the industry is, in reality, a new one. It is only about twenty-five years ago that the first pottery was established. It is there yet. It made only yellow or Rockingham ware. Other potteries started out to make only yellow ware, but the grades of goods made in Trenton improve every year, and there is now only one yellow ware pottery there. East Liverpool, Ohio, is the great center of yellow ware manufacture. It is nearly as great a pottery center as Trenton. Trenton owes its good fortune, in this respect, to its situation. It has no clay, except some black dirt that is used for the manufacture of the boxes that the crockery is laid in to be "fired." The clay used in Trenton comes from Pennsylvania, New Jersey, and Delaware. The clay near the Amboys, in New Jersey, is the best in the market. A poor man, in South Amboy, borrowed a little money, a few years ago, purchased a lot of ground, and began selling the clay that lies under its surface. He has dug great shafts and tunnels, and is said to have earned a fortune of \$300,000. Trenton's handiness to New York and Philadelphia, and its railroads, canal, and river, are its attractions to the potters. Among the workmen in the potteries are many Englishmen and Irishmen, but Americans are learning to do good work. There are designers and decorators from Minton's great English tile works, and from Tiffany's in New York, employed to decorate the better grades of toilet and table ware.

A little while ago nothing better than cream-colored stone china, and blue stone, and stone porcelain ware was made in Trenton. Now there are establishments that make real china, and others that manufacture a grade of stone china that they claim looks as well and wears better than French china, and is the same in everything except that it is not translucent. This translucent quality is obtained by an intense "firing," and those who do not make "real" china say that this "firing" spoils a large proportion of the goods. Those who do deal in this fine work claim that by "firing" the china just as earthenware is fired—that is, by putting many pieces together where the French put only one piece—there is a tremendous profit at lower prices than the French obtain. The trouble is, however, that the French goods, in standing alone in the firing boxes, receive no blemish, while the American ware, which is stacked up on pegs, in the boxes, bears the marks of the pegs.

Mr. Fisk, of the American Crockery Company, estimates that the growth of the Trenton trade has reduced the importation of foreign ware from 35 to 40 per cent during the past three years. It is said that in one year a great stride has been taken. A market has grown up for fancy goods. People were educated a great deal by the Centennial Exhibition, and, more than all, Americans had ceased to copy from the English, and are relying upon their own originality. Other potters are less cheerful. One young man spent much time and money on a pair of plaques. The principal ornamentation was a wreath containing every garden flower of especial beauty. The copying from nature was almost mirror-like. The potter estimated the cost of the plaques at \$125. He took them to Tiffany and to some one else in New York and asked what they were worth. At one place he was offered \$50; at another \$35. He says that if they had been imported he would have been offered at least \$250 for them. He

gave them to a bride, and found her a more appreciative connoisseur than the New Yorkers.

White Africans.

Major Pinto, the Portuguese explorer, who has just crossed Africa, from Benguela southwestward to Natal, describes a race of white men found by him near the headquarters of the Zambezi. He says:

"I one day noticed that one of the carriers was a white man. He belonged to a race entirely unknown up to the present day. A great white people exist in South Africa. Their name is Cassequer; they are whiter than the Caucasians, and in place of hair have their heads covered with small tufts of very short wool. Their cheek bones are prominent, their eyes like those of the Chinese. The men are extremely robust. When they discharge an arrow at an elephant the shaft is completely buried in the animal's body. They live on roots and the chase, and it is only when these supplies fail them that they hold any relations with the neighboring race, the Ambuelas, from whom they obtain food in exchange for ivory. The Cassequeres are an entirely nomadic race, and never sleep two nights in the same encampment. They are the only people in Africa that do not cook their food in pots. They wander about, in groups of from four to six families, over all the territory lying between the Cuchi and the Cubango. It would seem that from a crossing of the Cassequeres with the negroes of other races sprang those mulattoes of the south, whom the English call Bushmen. The latter are, however, better off than the Cassequeres, and use pots in cooking their food, while their dispositions are good, though quite opposed to civilization."

Cire Perdue—Bronze Casting in Wax.

The series of special loan exhibitions of fine art works, which have been held from time to time under the auspices of the Burlington Fine Arts Club, London, is this year enriched by one of considerable artistic interest—namely, an exhibition of bronze and ivory works of European origin. About 370 bronze works and 166 ivories have been brought together. Among the bronzes are some of the earliest specimens made by Greek, Etruscan, and Roman artists, lent by the Rev. Montagu Taylor. Among them is a mask of a marine deity with ruby eyes, and of a fine quality of finish. For excellence of pose as well as graceful modeling, a winged youth, holding a small dolphin in his left hand, is a striking Roman bronze.

The question of the *modus operandi* in producing these works seems to suggest itself. But on this point the catalogue yields us no information. From time to time the notes to the descriptive entries direct attention to the comparisons which it may be interesting to draw between various versions of similar subjects, as, for instance, between Nos. 180, 148, 138, 133, and 131, all of which are slightly varying editions of a Venus of John of Bologna. Again, No. 172, a fine saltcellar, composed of a kneeling nude male figure supporting a shell on his shoulder, is an artist's model from which others were cast; No. 182 is one of these casts. The difference in quality of texture between these two works should be noted. No. 172 is what would be termed a "cire perdue" model. Now, a little explanation of what "cire perdue" means would add much interest in the casual examination of the collection, and would help to clear up the difficulties which naturally crop up of understanding how it

comes to pass that men chiefly known for their paintings or architectural designs appear in this exhibition as the makers of bronze medals, plaques, or statuettes. A short note placed as a label to one or two of the principal works, such, for instance, as the handsome candlestick designed by Pollajuolo, would help to clear away little misunderstandings on such points. This candlestick, No. 169, is ornamented with delicately worked garlands of flowers and leaves, sharply cut, and as crisp as though they had been produced yesterday. Much of this is due to good preservation. On the other hand, much more is due to the manner in which Pollajuolo's original models in wax were incased in plaster, so that the plaster faultlessly adhered to the wax. As soon as the plaster casing had set, the molten bronze was poured into it, and, melting out the wax model, filled up the impressions made in the plaster. Thus the wax or *cire* was *perdue*, and after the plaster had been broken away, the bronze alone remained as the tangible result of Pollajuolo's model in wax. From this reference to the process of producing certain bronzes it will be readily seen that a clever-fingered artist, without any extraordinary display of skill, might use wax as a vehicle for giving material shape to his designs, and, having made his model in wax, convert it into



FAIENCE JARS AND TAZZA IN PORCELAIN AND ENAMEL.

Unfortunately Major Pinto does not say whether he saw more than one of the white Africans he describes, or whether the account he gives of them is based on observation or on hearsay. His promised book may clear up the matter.

Imitation Gold and Silver.

There have been a great number of alloys resembling gold and silver patented. The last which has come to our knowledge is a patent recently granted in England to one Thomas Meiffier, of Marseilles, France, for the following ingredients:

Gold Alloy.—800 parts of copper, 28 of platinum, and 20 of tungstic acid are melted in a crucible under a flux, and the melted mass poured out into alkaline water, so as to granulate it. It is then melted together with 170 parts of gold.

Silver Alloy.—65 parts of iron and 4 parts of tungsten are melted together and granulated; also 23 parts nickel, 5 of aluminum, and 5 of copper, in a separate crucible, to which is added a piece of sodium, in order to prevent oxidation. The two granulated alloys are then melted together. Both alloys resist the action of sulphureted hydrogen.

EXPANSION OF WROUGHT IRON AND CAST STEEL.—It is important in workshop manipulation to remember that if a piece of cast steel be made red hot and quenched in cold water it will become longer, but if the same operation be performed upon a piece of wrought iron it will become shorter.

bronze by the process alluded to, and so appear on the scene as a bronze work. But the process *cire perdue* does not include all the methods of making a bronze object. Surface work has often to be resorted to, and handicraft other than that of modeling is thereby called into play.—*Iron.*

Incombustible Wood.

The following chemical compound is said to produce the result claimed by M. M. P. Folbarri for rendering wood incombustible, petrifying it, as it were, without producing any change in appearance. Intense heat chars the surface, slowly and without flame, but does not penetrate to any extent, and leaves the fiber intact:

Sulphate of zinc, 55 lb.; American potash, 22 lb.; American alum, 44 lb.; oxide of manganese, 22 lb.; sulphuric acid of 60°, 22 lb.; water, 55 lb.; all of the solids are to be poured into an iron boiler containing the water at a temperature of 45° C., or 113° Fah. As soon as the substances are dissolved the sulphuric acid to be poured in little by little, until all the substances are completely saturated. For the preparation of the wood it should be placed in a suitable apparatus, and arranged in various sizes (according to the purposes for which it is intended) on iron gratings, care being taken that there is a space of about half an inch between every two pieces of wood. The chemical compound is then pumped into the apparatus, and as soon as the vacant spaces are filled up it is boiled for three hours. The wood is then taken out and laid on a wooden grating in the open air, to be rendered solid, after which it is fit for uses of all kinds.

House Drainage.

On this subject Mr. George E. Waring, Jr., in a paper in the *Atlantic Monthly*, says:

Were I called upon to-day to specify the essential features of perfect house-drainage, I should include the following items:

The establishment of a complete circulation in the main line of the soil-pipe and drain, allowing a free movement of atmospheric air through the whole system from end to end, together with as complete a circulation through minor pipes as could conveniently be secured.

The complete separation of the over-flow of every tank or cistern delivering water for the general supply of the house from any soil-pipe or drain containing a foul atmosphere.

The supplementing of every water-trap with a suitable mechanical valve, to prevent the water of the trap from coming in contact with the air of the drain.

The reduction of the size of all waste-pipes, and especially of all traps, to the smallest diameter adequate to their work.

The abolition of all brick or earthen-ware drains within the walls of the house, using in their stead the best quality of iron pipe, with securely calked lead joints.

The substitution, so far as practicable, of wrought-iron pipes for lead pipes, in the case of all minor wastes.

The coating of all iron pipes, both cast and wrought, inside and out, with "American" enamel, a glossy black coating which withstands in the most complete manner the chemical action and changes of temperature to which it is subjected in such use.

The iron pipes should be extended so far beyond the foundation of the house as to obviate the opening of joints by settlement, so common where earthen-ware drains are subjected to a slight movement of the foundation, or of the new filling about it.

The object to be sought is the provision of a permanent drainage channel for the removal of all wastes, offering little asperity for the adhesion of foul matter, swept from end to end by fresh air, absolutely separated by mechanical obstructions from the interior atmosphere of the house, and literally a section of out-of-doors brought for convenience within the walls of the house, open to receive the contents of the various waste-pipes leading to it, but securely closed against the return of its air. I believe that the next step in advance will be the establishment of means by which the whole length of this drainage channel may be thoroughly flushed with clean water at least once in twenty-four hours.

As a prominent detail of house-drainage work, the long-accepted water-closet is being made the object of important modifications. The stereotyped article, the "pan" closet, has little to recommend it beyond the fact of its general adoption. It is faulty in principle, in arrangement, and in construction. While it is cleanly to look at, and lends itself readily to ornamental joinery, it has defects which should drive it out of existence. Deep down in its dark and hidden recesses, where only the ken of the plumber ever reaches, a large and sluggish trap—they call it a "cess-pool" in Scotland—is generally holding the filthiest filth in a state of offensive putrefaction. The iron chamber above this is lined with the foulest smear and slime, constantly producing fetid and dangerous gases. The earthen-ware bowl which surmounts this is set in putty, which yields to corrosion and to the jar of frequent use, until it leaks foul air, often in perceptible quantity. The panful of sealing water soon becomes saturated with foul gases, which exhale thence into the house. The whole apparatus is inclosed in tight-fitting carpentry, which shuts in the leakings and the spatterings and their vapors from the free access of air, boxing up in the interior of the house, and generally in free communication with the spaces between the walls and under the floors, an atmosphere heavy with the products of organic decomposition, and faintly suggestive to the unwonted nostril of the *mus decumanus defunctus*.

In the absence of anything better, I am disposed to go back to the simple "hopper" closet, such as is used in the cheapest work, and to depend on frequent and copious flushing to keep it clean. This closet has the

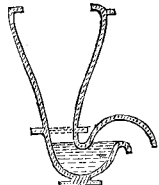

The Hopper Closet.

great advantage that its only trap is in sight at the bottom of its pot. There is no inner "chamber of horrors" concealed by a cleanly exterior. I have recently used a number of these closets supplied with various sorts of apparatus for periodical flushing, and I find that wherever a half-gallon flush can be given every ten or fifteen minutes they are kept perfectly clean. I have no doubt that flushing every twenty minutes, or perhaps at longer intervals, would keep them free from all sanitary objection. This would require a supply of about fifty gallons per diem.

Recent invention has been turned in the direction of the provision of mechanical appliances for separating the trapping water from the air of the soil-pipe or drain. There are several devices which accomplish this purpose—one of them my own, and more than one of them constituting a very great improvement upon, and indeed an absolute step in advance of anything in use five years ago.

Another most important matter of recent development is the through-and-through ventilation of soil-pipes. Formerly the soil-pipe invariably stopped at the highest closet of the house. When the danger of pressure came to be understood, it was considered imperative in all work of the best class to carry a vent-pipe out through the top of the house. As this pipe, from the smallness of its size and from

the irregularities of its course, had but limited capacity of discharge, the necessity was quite generally recognized for carrying up the soil-pipe itself, full-bore, through and above the roof. This was the point reached at the time of my earlier writing. It soon became evident that even this large extension of the pipe afforded no real ventilation. A deep mine shaft cannot be ventilated by simply uncovering its top. No complete frequent change of air can be effected in a soil-pipe by merely opening its upper end. Air must be introduced at the bottom to take the place of that which is discharged at the top. It is now considered imperative in all good work to open the soil-pipe at both ends, or at least to furnish the lower part of the pipe with a sufficient fresh air inlet to effect a thorough ventilation of the whole channel.

American Cotton Thread.

Some time since, in a letter to the English trade journal, *Cotton*, Mr. B. F. Nourse, of Boston, Mass., said in reply to a question as to the fineness of American cotton cloths:

"American manufacturers do not produce the finest qualities of cotton cloths, such as muslins, fine cambrics, etc., not because they cannot (finer thread having been spun here than any ever produced by machinery in England), but because the available markets for such cloths would not sustain a manufacture of sufficient magnitude to be profitable."

To the words in parenthesis *Cotton* took exception and demanded proof. Mr. Nourse's authority for the statement was Mr. Edward Atkinson (an acknowledged authority in textile affairs), who has since written to Mr. Nourse as follows:

"The three-cord No. 550 thread produced by the Willimantic Company, suitable to be used on a sewing machine, was my warrant for this assertion. At the time I made it I also supposed that the same company, in spinning No. 1,100 single yarn on a mule in the open air of their factory, had accomplished finer yarn spinning than had been reached in Great Britain; but I have since learned that this was an error, a much finer number having been spun there. But it was made on a small mule, specially constructed and operated under a glass case. Such excessively fine numbers have, of course, no commercial value. More important is the success of the Willimantic Company in spinning No. 120 for regular commercial uses on a ring spinning frame. This success and our recent progress in fine work in several other mills promised good results, as the work done on the ring frame is cheaper and stronger than that of the mule."

Meantime Mr. Nourse had written for a statement of facts to Mr. William E. Barrows, the treasurer and examiner of the Willimantic Company. From that gentleman's letter of reply Mr. Nourse has condensed the following statement, which he embodies in a long letter to *Cotton*, dated June 6:

"1. Our fine numbers of thread are made for use on sewing machines. They are three and six ply, made from yarn Nos. 300, 400, 500, and 550. The finest numbers are used for pillow lace making, and, judging from the demand, give good satisfaction.

2. The finest number of thread regularly sent to foreign markets by this company is No. 100 six-cord, made from 200 yarn.

3. The finest yarn we have spun on the American ring spinning frame (built by the Lowell Machine Shop, Lowell, Mass.), with the Sawyer spindle, is No. 320. This was experimental, the yarn not used for regular thread. We regularly spin on ring frames No. 120 yarn for No. 60 six-cord sewing cotton.

4. We have no climatic or atmospheric difficulties.

5. We do prefer American machinery. The self-acting mules, built by the Lowell Machine Shop, give less trouble than foreign built mules in the same numbers, 100's to 140's.

6. All our overseers and more than one-third of our work people are Americans—a sufficient guarantee of their intelligence.

7. The most profitable numbers for us to spin are 120's to 140's.

8. See the accompanying certificates of the comparative merit of our sewing cottons from the Expositions at Paris and Philadelphia, and from American and Maryland institutes, and the reports (1876) of M. Louis Chatel.

9. We do not import any machinery for better work or cheaper production. Combers and hand-mules are not yet made in this country, and we are obliged to import these machines.

10. I believe our extra fine numbers—400's, 500's and 550's—are finer threads than ever produced by machinery in England. All of these fine numbers have been tested on power-sewing machines at a speed of eleven hundred stitches per minute, giving satisfaction. Experimentally we have spun No. 1,100 on a handmule of 640 spindles, 60 "stretch, 1 1/4" gauge. Our usual fine work is 140's to 200's on mules, and 80's to 120's on ring frames."

American Tariffs.

It was not anticipated by the most ardent disciple of Cobden that the principles of free trade, which had proved so difficult of comprehension in the British Parliament, would be very quickly followed in other countries, though it was understood that its full benefit could only be realized by international acceptance. It was not, however, thought that in 1879 those principles would be so little understood that they would be rejected by our Transatlantic kinsmen at that then distant time. The belief that this could not

have been the case would have been strengthened if they had had the evidence of the necessity for its adoption which Americans now have with respect to the iron and steel industries. All these years have, however, passed away, and American statesmen are still compelling their countrymen to pay very high bonuses to certain classes of manufacturers. That the high tariffs now imposed on iron manufacturers are simply bonuses to manufacturers will be seen from some of the following figures, and from the fact that the articles so highly taxed do not yield any revenue to the American Exchequer. It appears from the returns of foreign import duties, published by the British Government last month, that the percentage of tax paid by American consumers on the principal sorts of manufactured iron and steel is on an average no less than 71 per cent. On English and Scotch pig iron it is 70 and 60 per cent respectively, and on bar iron, plates, and rails, it ranges from 57 1/2 to 85 per cent. On iron wire it is 85 per cent, on hoops upwards of 100 per cent; on tin and galvanized plates 42 1/2 and 57 1/2 per cent, and on steel and steel rails respectively 65 and 100 per cent. As these enormous taxes do not yet appear to have raised any very strong opposition on the part of the American people, we cannot but admit that there is some reason for the feeling now becoming somewhat prevalent in this country, that the better way to open the eyes of the American people to the necessity for either free trade or reciprocity will be to impose retaliatory duties upon certain American imports. Upon the cheapness of iron and steel many of the American manufactures mainly depend, and yet the Americans allow themselves to be handicapped to the enormous extent shown by the above figures. We cannot do better than conclude this short reference to an important question by quoting one instance as illustration of the tax paid by the American consumer in order to support by bonuses a set of manufacturers who are enabled to enforce the sale of their goods, at prices which have a most injurious effect on other industries. Wood screws, of which even larger quantities are used in America than in this country, are sold in the States at a trade discount of 60 per cent or 8s. in the pound net. The same screws are exported to this country at a discount in Liverpool of 75 per cent or 5s. in the pound net. A tax of 60 per cent on screws is thus paid by the American consumer above their market value. If a duty of upwards of 130 per cent did not prohibit it, our manufacturers would deliver superior screws into American ports at a discount of 75 per cent. Other instances might be cited in support of what has been said, and if a knowledge of these facts does not effect an alteration in American feeling on this subject they will certainly help to strengthen that which is growing in strength in this country.—*The Engineer*.

New Process of Phototypy.

Phototypy is a sort of lithography in which the stone is replaced by a hygroscopic layer of gelatine impressed with an image by the action of light passing through a photographic negative. Now, if we could cut down a lithographic stone, both in its surface dimensions and its height, to make it like a wood block, we should be able to insert it in the text, and take an impression from it simultaneously with that from the type. The difficulties in the way of doing this would be, first, the necessity of wetting the stone previous to each impression; and, secondly, the expense of cutting down lithographic stones, which would entirely lose their value in the process. But what we are on this account prevented from effecting with natural lithographic stones can be managed with an artificial one, provided that the latter possesses a hygroscopic surface from which, after being saturated with water, numerous impressions can be taken without its being necessary to wet it afresh. It became, therefore, necessary to make photo-printing blocks of the requisite size and height to be set up in the form with ordinary type, and possessing so great a hygroscopic quality that the moistening requisite to produce an impression should only be an accidental operation, and not one that is indispensable before each pull.

Now the ordinary process of phototypy was scarcely adapted for this purpose without modification. The plates in this process are made of metal or glass, or even lithographic stone, always larger than the image of which it is required to obtain an impression, and it would be impossible in every case to cut these plates to the size of the printing block. M. Vidal adopted another method for arriving at the same result as that produced by ordinary phototypy. He prepares the artificial lithographic stone and the hygroscopic support separately, and then attaches the one firmly to the other. The image is obtained as in the ordinary carbon process; an impression on carbon tissue is developed on a roughened glass plate coated with some fatty substance. When, by means of hot water, the picture is divested of all the gelatine not acted on by light, it ought to appear with all its half-tones like a good carbon print which is ready to be transferred to its definite support. This is then inclosed in a frame of thick cardboard, beveled outward on the inside, and coated entirely with paraffin or wax; the frame is then filled with the following composition, which is poured into it and over the picture:

Gelatine.....	20 grammes.
Gum-arabic.....	20 "
Glycerine.....	40 "
Water.....	100 cub. centim.
Ammonia.....	5 "
Alum.....	05 gramme.
Salicylic acid.....	2 grammes.
Barium sulphate.....	10 "

The salicylic acid is added as an antiseptic, and the sulphate of barium gives to the layer of gelatine an opalescent appearance. The whole layer should be so deep as to have, after drying in the chloride of calcium box, a thickness of about five millimeters. When the desiccation is complete, the layer above the glass plate is turned out, and will be found to have the image transferred to it. We have now, therefore, a plate of gelatine bearing on it the picture of the exact dimensions required, and beveled downward from the edges, which latter will therefore not take any ink. This plate must then be mounted on a sheet of copper or zinc, which is raised on a wooden support until the height of the image is the same as that of the type with which it is to be printed. The gelatine plate is next saturated with moisture by immersion for a quarter of an hour in a bath composed of,

Glycerine.....	50 grammes.
Water.....	50 cub. centim.
Alum.....	2 grammes.

and the image will appear on its surface in considerable relief, so as to render it particularly well adapted for printing from. The separation of the black parts of the picture from the white parts of the hygroscopic gelatine is very perfect, so that no smudging, such as so often occurs with printing blocks on which the shadows are modeled by fine lines close together, need be feared. The mixture of which the formula is above given is of so hygroscopic a character that repeated wetting is rarely necessary. It must be effected with a sponge dipped in a mixture of half water and half glycerine, after having removed from the plate all trace of ink; but the latter should never be severely washed.

In this way, then, we obtain a carbon print, but with a light colored pigment, so that the degree of inking can be readily determined. Light colored earths in the form of impalpable powders, with a gelatine chosen for its resistant properties, make a very good tissue. The print should not be treated with alum before pouring on the layer of hygroscopic gelatine, otherwise it will not transfer easily. On the contrary, it is better to wash it with water containing a little ammonia, which will facilitate the penetration; the mixture already contains some ammonia, and the transfer of the image to the plate of glycerine and gelatine is thus rendered completely effectual. The alum contained in the first liquid used for moistening increases the hardness of the image, and prevents it from swelling too much.

It is easy to imagine what advantages can be derived from a process of this kind, which enables us to produce, at a moderate cost, plates capable of being inserted among type for the printing press. A number of different blocks obtained by this method can be mounted in the same form with the type of the text, and can be pulled all together in the press. They can be used in cylinder presses also, without any difficulty. Until the contrary is demonstrated, M. Vidal believes that this is the only process by which photographic printing blocks capable of being printed simultaneously with type can be produced.—*Photographic News.*

Freezing Fish for Winter Use.

To equalize the supply of fine fish, several varieties of which are apt to be overabundant in this market in summer and scarce in winter, the fish dealers of New York have erected three large refrigerating houses wherein many tons of frozen fish are stored. The largest of the freezing houses, is located on Front street, and belongs to the members of the Fish Market Association. When there is a greater supply of fish in the market than is likely to be sold during the day the wholesale fish dealers select the best and remove them before daylight from the vessels to the freezing houses, where each fish is cleaned and prepared for the refrigerator. The whole of the Front street house is devoted to the work; the first story from front to rear and the entire width of the building from floor to ceiling being one gigantic refrigerator divided into three sections, each capable of being subdivided into six apartments or boxes. The walls are coated with zinc, a second or inner wall of the same metal separating each apartment—a space of several inches being left between the wall of one subdivision and that of its neighbor, with oblong slits permitting the air from these spaces to pass into the apartments. These spaces are filled with ground ice and rock salt, a mill being used for grinding the mixture together, and at this season of the year it requires over 3,000 lb. of ice and about 14 bushels of salt daily to keep the freezing houses in proper order. The selected fish having been cleaned, are placed in freezing pans covered with ground ice and salt, thus excluding the air while the process of freezing is going on. This work is done on the upper floors of the same building. When frozen stiff the fish are taken to the apartment of the special owner and there laid away in the cold until wanted.

The season for freezing fish, says the reporter of the *Commercial Advertiser*, who furnishes this account, is not yet at its height, as the consumption now nearly equals the supply, and the bluefish have not been caught in such quantities as would pay for preserving. Before September, however, the work will be at its height, and according to the usual statistics of the probable catches, there will then be over 250,000 lb. of frozen fish in the storehouses in this city. The rarest fish will thus be obtainable for the rich man's table in the depth of winter, and sheepshead, salmon, bluefish, Spanish mackerel, and many other kinds, only known to ordinary consumers in the summer season, can then be supplied at rates which will be deemed cheap when the labor and expense of preserving the fish are taken into consideration.

A Congressman's Argument for Repealing the Patent Laws.

A member of Congress arguing in favor of the repeal of the patent laws, and complaining of the universality of inventions and patents, declared that the children of this country are swathed in patent baby clothes; rocked to sleep in patent cradles, danced in patent baby jumpers; take their airings in patent perambulators, amuse themselves with patent "playthings," wear patent bibs, spin patent tops; ride patent hobby horses, and, coming down to business, they prepare their land for crops with patent plows and harrows, sow their seed with patent grain drills, plant their corn with patent corn-planters, cultivate it with patent cultivators; cut their grain with patent harvesters, thrash it with patent separators, have it made into patent flour, by a patent middlings purifier, and finally baked in a patent oven. And thus they go through life, followed by patents, and at death are buried in patent burial-cases. Thus, literally from the cradle to the grave we are harassed and robbed by inventors and patentees. Now, he wanted the patent laws all repealed, that the people might be relieved of this intolerable oppression. That congressman ought at once to remove to China or some of the South Sea Islands not yet visited by the ubiquitous Yankee inventor, where he could live and die and be buried, as his great-grandfather did before him, unvexed by the thousand-and-one changes and improvements offered by the hand of restless invention. Seriously, adds the *Western Manufacturer*, he should remember that none of these patent improvements are ever forced upon him or any body else. Those who choose may wrap their offspring in the traditional "rabbit-skin," and rock them in the half of a hollow log, and "jounce" them upon their knees. Patented improvements are only adopted because they are better, cheaper, and more convenient than the old styles, with which people are already familiar. The fact is, nobody complains of the inventor or his improvements until it is found that a patent stands in the way of their indiscriminate appropriation. Then it is that Congress is appealed to to repeal the patent laws—in other words, to "kill the goose that lays the golden egg." This is a terribly practical age, and the American people are the most practical portion of the human race. They pursue the business of invention as they do any other business, as a means of gaining a livelihood or making money. And that is the secret of the practical nature of their inventions. Take away the stimulus of protection in the property-right and ownership in their inventions, and all that kind of work would be laid aside at once. We would soon find as great a dearth of inventions and improvements as the most conservative could wish.

A Home Made Daniell.

The following method of constructing a voltaic couple, or a home made Daniell cell, may be of interest to the student: Select a small round earthenware jar, such as is used for keeping preserves, and having lined the bottom with gutta-percha, or some suitable cement, to the depth of $\frac{1}{4}$ inch, fix upright in this a rod of zinc, of equal height with the jar, to which a length of copper wire has been attached by passing it through a hole drilled in the upper part of the zinc rod, or by soldering. Make a cylinder of pipe clay, or other porous clay, larger than the zinc rod, and having dried it, make it hot in the fire by degrees, till it attains a red heat. Let this cylinder cool gently, and when cold place it in the jar round the center rod encircling it at a little distance. By moderately heating the end of the cylinder it will, when placed on the gutta percha, make a groove which will fix the tube, and prevent infiltration of the fluids. Line the inside of the jar with a plate of thin copper bent into cylindrical form and having a few holes punched in it, through which may be threaded the extremity of another length of copper wire. On the top of this cylinder place a flat ring of copper pierced with holes, and nearly, but not quite, touching the porous cylinder. This forms the battery. To charge it, the *Electrician* gives a saturated solution of sulphate of copper poured between the copper and the clay tube, and some crystals of the same salt are placed upon the perforated ring so as just to be in contact with the solution. The zinc compartment is then to be filled with a solution of sulphate of zinc, sal ammoniac, or common salt.

A Canal Mowing Machine Wanted.

Canal Superintendent Fish is accredited with the statement that within two weeks after its appearance, in Erie Canal this summer eel grass grew eight feet in length, actual measurement. In July the canal was so full of grass in several localities that the flow of water was seriously impeded. The *Rochester Express* asserts that there seems to be at least half a dozen kinds of eel grass, several of which were entirely unknown to the superintendent, and much more harmful in impeding the progress of canal boats (as well as the flow of water) than the old variety. One new eel grass starts from very slender roots and grows to different lengths. At the end is a dense tuft, through which it is difficult for water to flow. By reason of the different lengths of the stems these tufts form a solid padding from the bottom to the surface of the water. Mr. Fish has had at work clearing out the beds an apparatus consisting of a couple of rudder-like arrangements at the stern of a boat, with sharp sickle-like knives. These rudders are swung backward and forward by two men, and a passage is thus cut through the grass. Mr. Fish says this is the best device as yet found for removing the grass, but hopes that something better may be invented.

Study of Latin and Greek.

At the recent meeting of the American Institute of Instruction, at the White Mountains, Professor J. L. Lincoln read an able paper upon classical teaching and study. Greek and Latin, he said, as languages, must be taught by the tongue and the ear quite as much as by the eye; it must be voiced, and heard, and spoken, by all possible exercises of most practical kind, in union with the reading of the book. Such a method must be carried on from the beginning to the end of a course of instruction in school and college. Thus may our pupils come to master and appropriate the knowledge of these languages, so that the classic writers can be read with ease and satisfaction. The paper touched, also, upon the practice of reading at sight. This, however, can be used only after considerable progress has been made. It is not so much a means of learning, as a test of having learned or not, and also an incentive to further progress. The paper closed with illustrations of the crowning point of the theme—the literary knowledge and culture to be derived from a studious and generous reading of Greek and Latin writers.

In the discussion which followed, Professor Thatcher, of Yale College, thought that should no mental discipline be obtained, the knowledge secured was sufficient to pay for the trouble. If no knowledge is obtained the mental discipline would repay. The utility of studies is not in the knowledge obtained, but in the memorizing power developed.

Professor Louis Soldan, of St. Louis, said the moment Europe went back to the study of the classics a reformation commenced, and scholarship revived. The Scriptures were studied in the ancient tongues, and modern science owes its strength to the classics. The historic growth of our whole educational work is traceable to Latin and Greek. The classics are the basis of all progress in education. Language should be investigated, not only for itself, but for all other purposes.

The Consumption of Smoke.

As our manufacturing works are starting up afresh all over the country, a demand is renewed through the newspapers for some method to prevent the smoke nuisance in our manufacturing towns and cities.

It would seem not to be a difficult problem to solve, and *The Factory and Farm* pertinently inquires if some wise man will inform it why smoke may not be consumed if means are applied to that end. A smoke consumer that will burn the smoke before it leaves the fire bed or pot will reduce the consumption of fuel anywhere up to about one-half. Not alone because the combustion of smoke supplies fuel, but because the burning of the smoke prevents the lodgment of soot on the surfaces where heat is to strike; and less fire will produce greater results because a smoked or sooty surface is a non-conductor of heat, and it requires a fire at its greatest intensity to produce the required amount of heat.

Numerous devices have been studied up to fulfill the requirements, all perhaps with some merit, but none of them, as far as real tests have been made, being successful. So many have been tried and not proved of any real value, that manufacturers despair of being able to secure such a device, and are not in a mood to even try anything more, no matter how full of promise it may be; and yet actual experiment is the only thing that will demonstrate the success or failure of any plan proposed.

If the genius of this country cannot relieve the cities of the everlasting cloud of smoke and reduce the expense for fuel, it would seem there was degeneration and an early limit found to the ability of mechanical skill. The invention of a smoke consuming appliance would not only be a fortune to the inventor, but a blessing to those who dwell in large towns and cities.

A Large Smelting Contract.

The *Leadville Reveille* reports that J. B. Grant & Co., of Leadville, had contracted to smelt the entire product of the Little Pittsburg Consolidated Company, from the middle of July till the first of January next, and adds: "This is, without doubt, the largest transaction in the mineral line ever consummated in this country, and perhaps in the world, the anticipated amount of ore to be furnished being about 150 tons a day, or in the neighborhood of 25,000 tons for the period covered by the contract. In addition to this, Grant & Co. will buy ore of other grades to assist in smelting, so that the amount of ore handled daily will not be far from 200 tons a day." Large additions to the plant of Messrs. Grant & Co. will be required to do this work. The product of the works in June was \$200,000; under the new arrangement it is estimated that the product will range between \$300,000 and \$400,000 a month.

The Children of Rum Drinkers.

Dr. Martin, of the *Salpetrière*, Paris, has made a series of interesting observations on nervous affections among the offspring of alcoholic parents. His results may be summed up as follows: In 83 families in which one or more members showed nervous excitability with a history of alcoholic origin, there were 410 children. Of these, 108—more than a quarter—had convulsions, and in the year 1874, 169 were dead; 241 were still alive, but 83, *i. e.*, more than one-third of the survivors, were epileptic.

Recent Decisions Relating to Patents, Trade Marks, Etc.

BY THE U. S. CIRCUIT COURT—SOUTHERN DISTRICT OF NEW YORK.

The Atlantic Giant Powder Company versus Jasper R. Rand et al.—1. The use of the explosive compound known as "rendrock powder," which contains in 100 parts, by weight, nitro-glycerine, 34.71; nitrate of potash, 52.68; sulphur, 5.84; and woody fiber, charcoal, and resin, in nearly equal proportions, 6.77 parts, is an infringement of reissue patent No. 5,799, granted to the Giant Powder Company, assignee, March 17, 1874, for the combination of nitro-glycerine with infusorial earth, or other equivalent absorbent substance, as a new explosive compound.

2. The owners of reissue No. 5,799 are not deprived of the right to ask for a preliminary injunction to restrain such infringement by the fact that they have prosecuted a suit in equity against the same defendants for an infringement of reissue No. 4,818, of which they were also owners, by the use of the "rendrock powder," have taken testimony to show an infringement of No. 4,818, but not of No. 5,799; have notified the defendants that they need not, until further notice, make proof in the latter case, and subsequently, having successfully prosecuted suits on No. 5,799 in another court, have discontinued the suit on No. 4,818 and prosecuted this on No. 5,799 alone.

3. The reissue patent No. 5,799 does not cover an invention different from that embraced in the original patent No. 78,317, granted to Julius Bandmann, assignee of Alfred Nobel, May 26, 1868. The safety of the compound and its concentration were alike objects of the reissue and of the original patent.

4. The invention claimed in reissue patent No. 5,799 is not described in the French patent taken out by Alfred Nobel, September 18, 1863, nor by the certificate of addition thereto taken out January 19, 1864.

5. Nor is this invention shown in the English patent, dated September 24, 1863, and sealed March 1, 1864, granted to Alfred V. Newton for improvements in the manufacture of gunpowder and powder for blasting purposes upon a communication from abroad by Alfred Nobel.

6. The "rendrock powder" is not described in either of these foreign patents.

7. If Nobel's English patent No. 1,345 be regarded as a patent for the invention found in No. 78,317, and as having been granted more than six months before Nobel's application for No. 78,317, still No. 78,317 was not invalid because it does not appear that the invention covered by it was introduced into public and common use in the United States prior to the application for No. 78,317.

8. Neither the invention claimed in reissue No. 5,799 nor the "rendrock powder" is described in reissue No. 4,818 (division D) of Alfred Nobel's patent No. 50,617 for substitute for gunpowder.

Injunction granted.

BY THE COMMISSIONER OF PATENTS.

Ex parte Thaddeus Davids & Co.—1. The presence in a label of an element which is registrable as a trade mark excludes the whole from registration as a label.

2. A firm name printed in common type or in script type, not being an autograph signature nor the facsimile of an autograph signature, is not registrable as a trade mark.

3. But the name of a firm printed in script type in conjunction with a vignette of the coat of arms of a State is registrable as a trade mark, and the presence of such an element in a label excludes the whole from registration as a label.

Ex parte Wilson.—1. A generic claim may cover several processes as well as several machines; but the applicant must describe at least one of the processes embraced in the generic claim, just as he must describe one of the forms covered by a generic claim for a machine patent.

2. A process claim may be restricted to one of several stages of which a complete process consists. Each of these stages is itself a process, just as each of the elements of an aggregate fact is itself a fact. It is for the applicant to determine whether he will claim the entire process or only one of its subprocesses or several connected subprocesses.

3. The use of the term "shoulder" to designate the enlarged part of the base of the neck of a spinning ring is not unreasonable nor calculated to mislead where the specification and drawings show the part to which it is applied.

Young versus Van Dusen.—1. The construction and use in public of a working machine, whether the inventor has or has not abandoned it, excludes the grant of a patent to a subsequent inventor. An abandonment in such a case inures to the benefit of the public, and not of the subsequent inventor.

2. Abandonment will not be established by mere proof of the want of such a degree of diligence as is necessary to connect a prior conception of an invention with a reduction to practice.

Englemann versus Vester.—A ground for the dissolution of an interference not embraced in the motion before the Examiner of Interferences, but first suggested on the hearing of the application by the Commissioner, will not be considered.

Appleby versus Morgan.—The law aims to secure the grant of the patent to the original and first inventor, and not to him who, although conceded, or admitted, or upon default presumed, to be the original and first inventor, is not such in fact; and this purpose of the law ought not to be unnecessarily thwarted by such an exercise of the discretion vested

in the Commissioner as to substitute presumptions for proofs through the enforcement of forfeitures which can only be reconciled with the law or with justice on grounds of necessity.

The Sun Dance of the Sioux.

A letter received at the Interior Department from Dr. T. Woodbridge, agency physician for the Fort Peck Agency, gives the following graphic description of the annual "sun dance" of the Sioux Nation, which took place near Poplar River, in Montana Territory, in the latter part of May:

I have just witnessed the great Indian festival of the "sun dance," or worship of the sun. Great preparations had been made for it, and everything was on the grandest scale. The city of lodges was moved, and the Indians encamped on a beautiful plain inclosing a hollow square, large enough for the movements of thousands of horsemen. In the center the great pavilion or medicine lodge was erected, 150 feet in diameter, the outside formed of small posts of green poplar and willow, thickly interwoven with green branches. Resting on this and on a rude frame-work within, all around for about twenty feet the space was covered with buffalo skins, forming the "dress circle," with places assigned to the musicians and actors or dancers. In the center was the great medicine pole, fifty feet high. The diameter of the central space, about 100 feet, was open to the broad sunlight.

Only the men occupied the deep circle, where they were feasted during the performance of twenty-eight continuous hours, during which time about forty dogs were immolated and eaten, besides large quantities of buffalo meat, wild-turkey heads, and hot caldrons of other eatables that are nameless. The audience was composed of about 5,000 Indians, but as only the men occupied the circle within, the common people, women, and boys, had to be satisfied by viewing the performances through the wide entrance or through the interstices in the leafy barriers. All had on their holiday attire. The dresses of some of the chiefs, and those acting as directors or priests, were gorgeous.

When all was prepared, amid the waving of banners, music, and loud shouting of the assembled throng, over fifty braves entered—each an Apollo—painted and naked to the waist, except a profusion of ornaments, with headdresses of beautiful feathers, their black, glossy hair reaching down to their lower garments, which were most beautifully and artistically arranged. Each carried in his hand an ornamented whistle, made from the bone of an eagle's wing, which was blown shrilly during the dancing. Each also carried a bouquet composed mostly of the wild sage. Their appearance and reception were grand and imposing.

The first afternoon's performance would have been called wonderful for display of heroism and power to endure and suffer. Many had from fifty to two hundred pieces cut out of the living flesh from their arms and back. The dance was kept up all night with unabated fervor, every performance having something new and startling. But in the morning torture reigned supreme, men dancing with two, three, and four buffalo heads suspended from holes cut in their flesh. One Indian dragged on the ground eight buffalo heads fastened to the flesh of his back, and in the stooping posture he was forced to assume they had lacerated or torn the cuts in his back to the extent of three inches. Others were held by four different cords, two in the breast and two in the back—fastened to four stakes; and still others were fastened to the center pole with ropes which were fastened to the breast and back. Some, in addition to being fastened by the flesh of their breasts, had buffalo heads suspended from the back, and they would be seized by the hanging heads and jerked until one would think their life would be forfeited; others made frantic efforts to break loose, and I often noticed the integument to be stretched three or four inches from the body. Some fell faint and exhausted, and with wild shouts, the din of music, and weird songs, made of it a perfect pandemonium.

The dancers neither took food, sleep, nor water during the festival. Their dancing, their invocations, and their prayers were fervent. They laid their faces on the buffalo heads while praying for success in hunting, and the priest wept and asked the Great Spirit to give them success in the chase and let them have food for their wives and children; also, to give them plenty of horses, to prosper them, and help them to subdue their enemies. The sod was carefully removed in a spot four feet square, and within a white cross was made. This is all they knew, and with no teacher but nature, we must judge them charitably—"Count not impossible that which seems unlike." Their liberality was unbounded. Over 200 horses were given away, besides great quantities of other articles.

The Trade in Time-Pieces.

Galvani's Messenger furnishes the following statistics with regard to the manufacture of clocks and watches. Whether the figures are trustworthy or not, we are not prepared to say. France is placed at the head of the list, and is credited with the production of chronometers, watches, time-pieces, clocks, annually to the value of 65,000,000 francs; then comes Switzerland, with watches, 60,000,000 francs; America, in watches and Dutch clocks, 32,000,000 francs; England, chronometers and watches, 16,000,000 francs; Austria, time-pieces 10,000,000 francs; Germany, in time-pieces and a few thousands of watches, 25,000,000 francs. These figures give a total considerably over 200,000,000 francs for the whole watch and clock making trade of the world. The amount assumes the greater importance

when the fact is remarked that, differing from nearly all other business, the raw material enters so slightly into the prime cost, the principal expenditure being almost exclusively in labor. The approximate number of articles produced is as follows: France, about 1,000,000 pieces annually; Germany turns out more, some 2,000,000, but they are of a much inferior average price. The same may be said of the American manufacture, which provides commerce every year with 700,000 or 800,000 objects. As far as watches are concerned, Switzerland heads the list with an annual production of 1,500,000. France follows with 500,000; the United States produces from 300,000 to 350,000, and England some 200,000, but these are of very superior quality. The enormous total is that 2,500,000 watches and 4,000,000 time-pieces are annually dispersed to the four quarters of the globe.

The Great Alpine Tunnel.

A Swiss journal has recently given some particulars of the present state of the St. Gothard tunnel works. The total length of the tunnel between the two ends at Airolo and at Goeschenen is 14,920 meters, including the approaches of 145 meters. There is, however, a separate curved part of the tunnel on the Airolo side which is 125 meters in length. At the end of May last 3,489 meters of the tunnel from the Goeschenen side had been completed, and 3,633 meters from the Airolo side. This gave a total of 7,122 meters completed from both ends, and this, compared with the length which it was estimated would be completed according to the programme arranged in September, 1875, shows a deficit of 3,389 meters. There is, however, no such great difference between the estimated and achieved lengths in the headings. At the end of May the advanced top headings had reached 6,940 meters from the Goeschenen or northern side, and 6,289 meters from the Airolo or southern side, showing a total length of advanced top heading of 13,229 meters, and only 214 meters less than anticipated in 1875, and leaving 1,548 meters of heading to be made. The meeting from the two ends will not be at the center of the length of the tunnel, but owing to the more rapid advancement from the northern side, it will take place somewhere about 300 meters nearer to the southern side. The present rate of advance of the heading is, on average of both sides, about 238 meters per month. At this rate the meeting of the miners from the two ends will take place soon after the end of January next. The completion work, however, proceeds at a more rapid rate, and it is expected in Switzerland, if the work continues at the present rate, it will be completed for opening in 1894.

Industrial Distress in England.

Press reports from London state that in the middle of July, there were in Burnley 5,795 looms idle out of 33,000, and 307,870 spindles out of 900,000. In the Blackburn district 11,300 looms were idle out of 52,000; 84,000 spindles were working on short time, and 48,000 had stopped altogether. In the Chorley district 1,600 looms, owned by two firms, were working on short time. Nearly twenty other firms were running part of their machinery on short time; several had stopped theirs entirely. In the Bury district both the woolen and cotton trades were very depressed. The average time of working in the woolen manufactories was only four days out of the week, and 406,000 spindles and 3,720 looms were working on short time. In Stockport the prospect, especially in the weaving department, was said to be almost hopeless. It was computed that only 500,000 spindles and 300 looms were working, against 1,195,000 spindles and 7,900 looms five years ago. In Rochdale, it was said, only five mills were working full time; 500 houses there were tenantless. The Manchester *Guardian* gave statistics to show that the condition of trade in the Rossendale district, where the machinery of the factories is adapted for Indian cotton, was even worse. Out of 100 mills only six—and these comparatively insignificant—were working full time; thirty-five were entirely stopped, and the remainder were only running on an average three and a quarter days a week.

American Philological Association.

The eleventh annual meeting of the American Philological Association began at Newport, R. I., July 16. There was a large attendance of college professors and other philologists from all parts of the country. Most of the papers read were as usual far above the level of popular interest. That of Prof. March, of Lafayette College, however, on the "English Dictionary of the Philological Association," should interest every American scholar.

The English Philological Society proposes to publish a great historical dictionary of the English language. For this purpose it has enlisted the services of many readers in England and a few in America. The plan is to make the dictionary cover the whole range of English literature. To Americans have been left the books of the eighteenth century of American literature, and this alone is as yet unread for a dictionary. Prof. March appealed to the members of the society not to allow the great thesaurus, which will be the standard English dictionary for a generation to come, to remain incomplete in the important department of American literature. Printed slips, he said, would be given to those who were willing to undertake the reading of American literary works, with a view to making excerpts and quotations for the dictionary. The society has already made a bargain with the managers of the Clarendon Press of Oxford, and hope to bring out the work in ten years from 1880. The materials already secured amount in weight to two or three tons.

(23) A. A. asks whether a naked iron wire fastened along ceilings and walls, and connected with gas or water pipes, and not insulated, forms as good a ground connection for telephones and call bells as a copper insulated wire connected in the same way. A. Yes, but the iron wire should be at least twice as large as the copper one.

(24) J. E. writes: 1. I wish to cut a flat piece of china or stoneware into several pieces; how can I do it? A. Use a thin disk of copper charged with emery and water. Revolve it in a lathe, and apply to it the china with a gentle pressure. 2. How can I take an electro copy of a round earthenware pitcher? Will the copy have seams? A. Make a mould of plaster of Paris. (It will of course consist of several pieces.) Saturate it with wax or paraffine, cover it with blacklead, and proceed as in electrotyping.

(25) W. T. W. asks (1) how the best kind of razor strops are made, such as are used by barbers. A. Apply to the flesh side of a smooth firm piece of leather a little rouge mixed with a small quantity of tallow. 2. What will prevent or remove the rough edge which sometimes comes on a razor when honing it? A. Strap it on a piece of canvas or on a towel.

(26) A. G. asks: 1. What is the best work on strength of materials, especially with reference to metals and experimental data? A. "Anderson on Strength of Materials," and "Kirkaldy's Experiments on Iron and Steel." 2. Has Professor Thurston, of Stevens Institute, published in book form the results of his experiments on the subject? A. We think not. 3. What is the transverse strength (both permanent injury and breaking weight) of a 5 inch wrought iron pipe, such as is commercially known as 5 inch pipe, fixed at one end, loaded at the other? A. We know of no experiments on the transverse strength of such tubes. 4. What is the reaction of a 2 inch nozzle discharging 560 gallons of water per minute? A. 165 lb. nearly.

(27) C. M. A. writes: A little sidewheel steamer was built here last winter, of the following dimensions: Length, 28 feet; beam, 7 feet; paddle wheels, 4 feet 8 inches diameter, with 5 inch by 10 inch float boards; draught, 1 foot loaded. The engine is by B. W. Payne & Sons, Corning, N. Y.; 3 1/2 inch by 4 inch cylinder, geared by belt to paddle shaft, 1 to 5. The boiler is built up of cast iron rings, in a sheet iron jacket, with 100 lb. pressure; this boat makes 5 1/2 to 6 miles per hour. Is not this rather remarkable performance? From the proportion between the engine and boat, no one thought she would be capable of doing more than two miles an hour. A. It is an extraordinary result for a paddle wheel boat.

(28) M. asks: In ring spinning does the bobbin take up faster when it is full than it does when empty? If it does, then it puts less twist in the yarn each revolution of the traverse motion from the empty to full bobbin. A. The take up is automatic and adjusts itself to the size of the cop.

(29) J. R. P. writes: I am about to try the burning of crude petroleum under a boiler. Have the petroleum stored in a tank at a higher level than the boiler, from whence it flows through a pipe, and being met by a steam jet is forced in the form of spray into the fire box. Is there any danger of an explosion occurring, and if there is danger what is the best means of preventing such an explosion? A. We think there will be no danger of explosion if you keep the supply pipe filled. You might pass the petroleum through a fine wire gauze at or near the outlet.

(30) L. H., Jr., writes: I would like to build a small pleasure boat of the catamaran style to go by steam. I wish to know whether to use a screw or a single paddle wheel same as water velocipedes described in SCIENTIFIC AMERICAN, No. 3, Vol. XXXVI, January 20, 1877. Let me know the dimensions of boat and engine for about 3 or 4 persons. Would a boat of this style be safe in the East River? A. You can use a single water wheel between the two hulls (as was done in Barden's famous cigar steamer), or you may use a screw. Cylinders 18 inches to 20 inches diameter would probably be large enough. It would be safe, if well built and properly managed.

(31) W. H. A. writes: Half a dozen friends wish to spend next winter cruising down the Mississippi river, and in its tributary waters. We are searching for information in regard to the size and kind of steamboat to have built. We want a boat that will run in moderately shallow waters and navigate tolerably small streams. Will a propeller answer? We want a boat with a cabin, and conveniences necessary to render life aboard comfortable and safe. Please give us dimensions for boat, kind and power of engine, and probable cost of vessel complete. A. A screw propeller from 50 to 60 feet long by 10 1/2 to 12 feet beam, and drawing about 3 feet 6 inches water, would probably answer, with engine equal to 10 inch cylinder by 12 inch stroke. Will cost from \$6,000 to \$7,000, according to the finish. A stern wheel boat, 60 feet long by 14 feet beam, and drawing 2 feet to 2 1/2 feet water, would suit and probably cost less money. The propeller would be best for rough water.

(32) C. C. H. writes: I wish to build a suspension bridge over a lake near my place of about 350 feet span. I am a practical mechanic and am tolerably conversant with the different methods of framing suspension work, but have no practical knowledge of the methods of sustaining or supporting such work while in process of building. If you can give me any information regarding such work you will place me under many obligations. The lake I mention is formed by the overflow of a river, and has a bayou for its outlet; practically it has no bottom, and is subject to a perpendicular rise of 18 feet. The banks are bluff, with timber on each side. At low water there is no current; at high water the current averages about 5 1/4 miles per hour; the stream has never been declared navigable. Please give me the name of some book containing methods of estimating the strengths of materials used in building generally. A. Put up your framing to carry the suspension ropes, then fix a drum or sheave on top, and wind your rope from the opposite side of the stream by a windlass. If the weight of your bridge is such as to require a large

rope, you can use three or more small ones, binding them together after they are in place. The best works for your use are probably "Boiler on Bridges" and "Anderson on Strength of Materials."

(33) C. E. F. writes: 1. In SCIENTIFIC AMERICAN, for June 14, 1879, is an article on milk made digestible by lime water. As it is a subject that would interest a great many persons, please state how the lime water is made. What proportion added to the milk? A. See p. 75, (2), current volume SCIENTIFIC AMERICAN. Use a spoonful of the clear lime water to a goblet of milk. 2. Will eating lemons soon after milk curdle it? A. Yes.

(34) F. H. P. asks: What shall I apply to a brick tank lined with cement, so that it will hold crude petroleum without leaking? Will soluble glass answer? Would silicate enamel paint be better? A. We do not know that water glass or "silicate enamel paint" has been used successfully for this purpose. A thick aqueous solution of glue has been found serviceable in similar cases, we believe.

(35) C. W. W. A. asks: 1. What is the best process to put cedar posts through to prevent them from rotting when put in the ground? A. Saturate them as far as possible with warm carbolic acid or dead oil (obtained from the distillation of coal tar). Concentrated aqueous solution of zinc chloride has also been used with very good results. 2. Is green or dry cedar the best for the above purpose? A. Seasoned posts are preferable.

(36) S. W. W. asks: In making hard soap for domestic purposes, what is necessary to prevent its shrinking and twisting after cooling? Our recipe is: 4 lb. strained fat, 12 quarts water, 1 box Babbitt's potash, simmer 10 hours, stir frequently. This makes 24 lb. fine white soap, but after being cut in cakes, and allowed to dry 3 or 4 weeks, it shrinks to about 1-3 original size and weight, and assumes all sorts of irregular shapes. A. Add to the hot soap paste a strong hot solution of salt (say 1 1/2 gallons), collect and press the curds which separate.

(37) J. W. asks how to make aniline colors soluble. A. The aniline colors proper are soluble in warm water or a mixture of water and alcohol or wood naphtha (methyl spirit), also in glycerine.

(38) G. T. S.—A mixture of oxygen and hydrogen is instantly exploded by flame or spark. It would be dangerous to experiment with it in a furnace as you propose. Consult some elementary work on chemistry.

(39) C. S. R. will find the process for reproducing writings, etc. in blue, by chemical means, described on pp. 40 and 230, volume 38, SCIENTIFIC AMERICAN.

COMMUNICATIONS RECEIVED.

- Danger to Blacksmiths. By G. M. A.
On the Course of a Bullet. By W. S.
On Uniform Time. By H. M.
On Changes in the Earth's Polar Axis. By F. M. S.

[OFFICIAL 1

INDEX OF INVENTIONS

FOR WHICH

Letters Patent of the United States were Granted in the Week Ending

July 8, 1879,

AND EACH BEARING THAT DATE.

[Those marked (r) are reissued patents.]

Table listing various inventions and their patent numbers, including items like Annunciators, electrical circuit closer for hotel, Ash receiver, Auger, well, W. W. Jilz (r), Axle box, car, M. M. Barry, Bag holder and truck, G. L. Preece, Bale band tightener, P. N. Johnson, Bale tie, D. F. Agnew, Ball trap, Stock & Morris, Balling iron, E. A. A. Grange, Barrel hoop, J. Hartsook, Bee hive, J. J. Ward, Blackboard, T. Kane, Boiler feed, automatic, S. S. & T. B. Davis, Bolting reel, W. L. Teter, Bone, etc., treatment of, G. H. Smith, Book cover securer, M. Umbdenstock, Book, etc., carrier, M. S. Drake, Boot and shoe heel, J. M. Whiting, Boot and shoe nailing machine, L. R. Blake, Boot and shoe nailing machine, O. R. Chaplin, Bottle stopper, H. Susemihl, Brick drier, G. A. Carlson, Brick machine, C. Stillwell, Bridge gate, draw, A. Stempel, Bridge side truss, J. W. Riley, Brogan, C. E. Tyler (r), Bung, H. Holder, Bung, Jones & Sandford, Bung, self-opening and closing, W. Eaticott, Button, D. S. Cooke, Button and stud, F. P. Barney, Calendar, E. J. Trum, Calendar, rule, and match case, F. Ratcliff, Candlestick, H. Grom, Car brake and coupler, S. Fairman, Car brake and starter, A. White, Car, coal, L. Hetfield, Car wheels, machine for grinding, J. H. Gowan, Carpet sweeper, M. R. Bissell, Carriage body adjuster, J. Clements, Carriage top standard, J. H. Sanderson, Cartridge capper and loader, D. E. Campbell, Caster, furniture, G. L. Donovan, Chair seat press, R. Fitts, Chuck for boring car brasses, Briggs & Dougherty, Chuck, metal drill, G. M. Pratt (r), Churn, H. M. Brown, Churn, J. Knox, Cigar bunch maker, R. A. Bright, Jr., Cigar cutter, C. Du Brul, Cigar cutter and match safe, W. C. Shimoneck, Clevis, C. S. Ellis, Coffee polisher and separator, J. H. Pendleton.

Table listing various inventions and their patent numbers, including items like Coffee roaster and oven, W. B. Hinckley, Coffee roaster and purifier, W. T. & S. E. Brown, Coffin, R. J. Howdon, Coffin handle, R. J. Howdon, Coin roller, P. H. Newbill, Collar and cuffstapener, J. Wehl, Collar, horse, E. J. Blood, Cooking boiler, W. E. Arnold, Core box, A. T. Whitehouse, Cores, combined chaplet and anchor for horizontal, Quinn & Longacre, Corset, abdominal, M. A. Day, Crucibles and other vessels in plumbago suitable for chemical and metallurgical purposes, manufacture of plumbago, S. A. Peto, Cultivator, R. S. Harris, Cutting gauge, J. W. Newkirk, Damper, stovepipe, J. M. Read (r), Dental instrument, S. C. Taylor (r), Dental plugger, C. Schaerr, Dental plugger, J. S. Swartley, Dental polishing and cutting tape, E. T. Starr, Dental vulcanizing flask, A. M. White, Derrick for oil wells, portable, B. F. Asper, Dipper, watering, R. Harrison, Door, sliding, G. R. Kidder (r), Dough tray, J. L. Campbell, Draught equalizer, I. P. Cadman, Draught hook, J. F. Bednar, Drawer handle, W. F. & G. A. Helligmann, Drier, wood, etc., T. A. Dowling, Envelope gumming machine, H. J. Wickham, Envelope machine, H. J. Wickham, Fanning mill, T. M. Bales, Faucet, H. W. Fuller, Fence, N. N. Blake, Fence, B. H. Hargrave, Fence, A. J. Marks, Fence wire stretcher, E. M. Crandal, Filter, tea and coffee, H. C. Rice, Firearm, revolving, Hodges & Hull, Fire kindler, P. Scott, Fire tower, portable, N. Zimmermann, Flue boiler, J. C. Carbine, Forge, portable, A. Burchfield, Friction wheel, T. Hotchkiss (r), Fruit, etc., drier and bleacher, G. W. Hopkins, Frying pan, W. Hodges, Gas, apparatus for manufacturing illuminating, W. B. West, Gas retorts, apparatus for removing coke from, C. F. Dieterich, Gas scrubber and purifier, G. F. North, Gate, W. G. Alexander, Gate, W. H. Bond, Gate, L. C. Brady, Gilding mouldings, etc., J. C. Hofer (r), Glass, plunger for pressing, G. W. Wyman (r), Grain bag and fastening, A. B. Gardner, Grain binder, E. Horton (r), Hair pin, W. Schultz, Hammer, power, L. Brady, Harrow, metallic, N. Beauregard, Harvester, self-binding, M. A. Keller, Hats, caps, and bonnets, making, J. Heimann, Hay rake, horse, F. Hanson, High chair and carriage, F. Chichester, Horseshoe nail maker, G. J. Capewell, Hub, vehicle wheel, Bultz & Baker, Hydrocarbon burner, liquid, H. A. Bradley, Hydrocarbons and water, apparatus for producing power, heat, and light from, J. M. Hunter, Incubator, J. L. Campbell, Inkstand, H. C. Benson, Insulator, telegraphic, B. Taylor, Jewelry, N. Grant, Jewelry, making stock plate for, J. S. Palmer, Journal box, anti-friction, S. P. M. Tasker, Key board, transposing, A. J. Stafford, Key fastener, W. Metcalf, Knitting machine, S. V. Essick et al., Lamp, L. Raphael, Lamp chimney, C. E. Kellogg, Lamp, gas, P. P. Timofeeff, Lamp heater, T. A. Kellett, Lap or carriage robe, T. Goodall, Leather cutting machine, A. Teas, Leather skiving machine, Hadaway & Gott, Letters, figures, and ornaments, compound for forming, J. C. Friedrichs, Lifting jack, P. L. Epler, Lime and cement, manufacture of, J. K. Shinn, Lime, revivifying spent, G. R. Hislop, Loom, J. D. Cottrell, Magneto-electric machine, O. Heikel (r), Marker, land, S. Ryan, Match box, F. S. Dangerfield, Matting, floor, G. Hayes, Matting, wooden floor, G. Hayes, Meats, canning, J. W. Jones, Metallic can, Green & W. Wilson, Jr., Milk cooler, D. W. Hull, Milk cooler, A. E. Turvey, Milliner's and hatter's iron, V. Henry, Millstone feeder, C. Weaver, Mortar mixing machine, C. T. Rowe, Motor, T. Mayhew, Mower, R. Campbell, Nail cleaner and envelope opener, combined finger, C. P. Tener, Napkin holder, W. L. Bundy, Packing box for hardware, R. J. Howdon, Packing casing for oil wells, J. Q. Miller, Paint, distemper, F. Koskul, Paper cutting machines, clamp for, H. Law, Paper stove platform, R. W. Stillwell, Paper, waxing, S. Hammerschlag, Pickling vats, composition for and construction of, J. H. Dreyer, Pictures or signs, manufacture of transparent, C. Quartley, Pillow, bolster, and mattress, T. S. Sperry, Pipe coupling, S. P. M. Tasker, Pipe threading and cutting-off machine, L. W. Stockwell, Pipe wrench, H. Rbyn, Planing machine, wood, Preble & Peoples, Plant extractor, W. James, Planter, horse corn, A. C. Andre, Planter, seed, A. B. Pierson, Planters, check rower attachment for corn, W. L. Phillips, Plow, A. Hackman, Plow and planter, subsoil, L. Kirlin, Plow colters, attaching, F. Gaunt, Pocket book, etc., fastening, J. C. Arms, Pocket, safety, J. M. Hunter, Poke, animal, W. C. Grubb, Potassa, making bitartrate of, E. Muller, Pressing and moulding plastic material, machine for, B. R. Rapp.

Table listing various inventions and their patent numbers, including items like Pressure regulator, J. E. Watts, Pulley block sheave, W. H. McMillan, Pump, double-acting force, P. Breidenbach, Pump, force, J. J. Finney, Pump, steam, W. Craig, Pump, steam, M. Schultz (r), Pyroxyline, treating, W. McCaine, Quilting frame, H. T. Davis, Rail joint, H. W. Cappell, Rail joint, J. Meehan, Railway rail cutting device, J. M. Peterson, Railway signal, W. G. Evans, Railway switch, R. S. Miner, Railway switch, W. L. Potter, Range ventilator, kitchen, D. H. Erdman, Reaper attachment, H. Hoover, Rheostat, electrical, J. Butler, Sash fastener, A. A. Armstrong, Sash fastener, F. S. Dains, Sash fastener, S. Taylor, Saw, circular, T. Tripp, Saw, draw, J. Showalter, Semolina, etc., machine for purifying and assorting, Thompson & Williamson, Sewer gate, automatic, S. S. Tilton, Sewing machine fan attach, J. W. Chambers (r), Sewing machine, straw braid, S. Henshall, Shaft and sleeve coupling, J. F. Appleby, Shawlstrap, A. E. Lyman, Shingle cutting machine, H. T. Davis, Silk cleaning apparatus, W. B. Swift, Skirt elevator, A. A. Campbell, Soap, H. G. Robertson, Sole edge trimming tool, J. F. Cunningham, Spectacle bow hinge, J. S. Spencer, Spinning frame, ring, E. T. Lanphear, Spinning mules, automatic clearer for, S. Mock, Stamp affixing apparatus, M. Simon, Station indicator, J. Butcher, Steam boiler indicator, W. Starkey, Steam boiler, upright, W. Spiegel, Steam engine regulator, P. Gately, Stove pipe thimble, M. McQuire, Tally, grain, C. H. Horton, Telegraph pole, J. B. & J. M. Cornell, Telegraphs, application of the condenser to multiple, Thompson & Selden, Telephone, electric, F. A. Gower, Telephone, pneumatic signal, F. A. Gower, Tether, C. E. Yager, Tool, combination, Benuum & Powers, Torpedo, grave, T. N. Howell, Tube cleaner, boiler, C. H. Kelsey, Tube cutter or trimmer, S. L. Davis, Tug loop, hame, M. S. Bettice, Type writing machine, H. M. Grant, Valve, balance steam, Moore & Pertz, Valve, leather flap, W. L. Crawley, Vehicle wheel sand band, G. C. Hill, Velocipede, S. P. Ruggles, Vent, cask, H. Finck, Ventilator, G. Hayes, Violins, insulating attachment for, O. Bull, Vise, pipe, F. P. Goss, Volatile substances, device for the preservation and use of, F. A. Reichardt, Wagon brake, O. A. Kenyon, Wagon brake, automatic, A. M. Van Ness, Wagon rack, W. T. Burrows, Wagon rack, Marsland & Hitchcock, Wagon running gear, D. Gibbens, Wagon spring seat, J. K. Cadwalader, Waste pipe trap, Scarborough & Bates, Watch and clock pinion, F. Lambert, Watch escapement, V. Bousset, Watches, safety center pinion for, J. A. Smith, Weather strip, Browning & Hay, Whiffletree, spring, J. Hill, Wick tip, mineral, J. T. Shuster, Wind engine, J. Hemp, Window bead fastener, C. F. Hanckel, Window screen, W. H. Hazzard, Wrench, O. R. Weaver, Yarn maker, spotted, Archibald & Holcroft, Yarn, machine for warping, etc., E. G. Gibson.

TRADE MARKS.

Table listing trade marks and their owners, including items like Baking powder, Dunham Manufacturing Company, Boots and shoes, C. H. Fargo & Co., Certain toilet preparations, W. A. L. Knickerbocker, Certain medical compound, C. W. Preston, Cigars, cigarettes, and smoking and chewing tobacco, H. Waldron, Cigars, cigarettes, and smoking and chewing tobacco, Kendall & Clock, Composition for restoring inking rollers of printing presses, R. O. Sweeny, Cotton goods, E. Lyon, Electroplated table ware, W. Rogers, Gloves and mittens, C. Parker, Ground coffee, Basley & McAlvanah, Hams, bacon, etc., F. Link & Son, Laundered shirts, collars, and cuffs, The Wiles Laundering Company (Limited), Mass licorice, A. Y. Stokes & Co., Medicinal preparation, R. W. Robinson & Son, Medicinal teas and pills, Wiener Medizin Company, Medicinal preparation for preventing seasickness, W. Gibbs, Pumps, Mast, Fooks & Co., Saw swages, H. Disston & Sons, Shirts, drawers, and overalls, H. Wallach's Sons, Smoking and chewing tobacco, cigars, cigarettes, and snuff, W. S. Carroll, Smoking and chewing tobacco, cigars, and cigarettes, M. Lindheim.

DESIGNS.

Table listing designs and their owners, including items like Carpet, C. Magee, Cooking ranges, W. Burrows, Die for stamping checks and drafts, W. J. Walker, Fender gas stove, W. T. Symons, Inkstand, C. S. Landers, Oil cloth, C. T. & V. E. Meyer, Spoon and fork handles, G. W. Shiebler, Trimming, J. M. Shanahan, Pepper or salt receptacles, J. W. Hobbs.

English Patents Issued to Americans.

From July 11 to July 15, inclusive.

Table listing English patents issued to Americans, including items like Fire escapes, J. R. Winters et al., Chambersburg, Pa., Hair clippers, C. Carleton, Providence, R. I., Motor engines, W. P. Wood et al., Washington, D. C., Oyster preserving process, D. A. Loring, N. Y. city, Piston packing, S. A. Youse, Sutter Creek, Cal., Railway brakes, O. B. Kendall, Buffalo, N. Y., Spinning tops, J. C. Johnson, Springfield, Vt., Steam boilers, W. H. Brown, Waterbury, Conn., Watermeters, C. H. Bacon, Boston, Mass.

Advertisements.

Inside Page, each insertion --- 75 cents a line. Back Page, each insertion --- \$1.00 a line.

NEW CATALOGUE OF SCIENTIFIC BOOKS JUST PUBLISHED.

Catalogue of Recent Additions to our Stock of PRACTICAL, SCIENTIFIC, and TECHNICAL BOOKS, will be sent free to any one who will forward his address.

RAPID ADDITION! Wonderful Invention! ART of Adding Figures from Left to Right; or from Middle either way; or six columns at one time!

MACHINISTS' TOOLS. Iron Planing Machines A SPECIALTY. C. WHITCOMB & CO., Worcester, Mass.

PARKER'S PATENT SHEAR JOINT FOR SALE. Patented March, 1876, by the Niagara Shear Co. Address L. F. GRANT, Agt., Winsted, Conn.

STATE, COUNTY, AND TOWN RIGHTS FOR THE Draper Acoustic Telephone, or the whole patent for sale. E. W. BEMIS, Spencer, Mass.

THE Bellefonte Water Wheel is the best, cheapest, most powerful, and durable in the market. Send for circular. W.P. Duncan & Co., Bellefonte, Pa.

A GOOD PLAN.—THE MOST PROFITABLE WAY FOR dealing in stocks is by combining many orders and co-operating them as a whole, dividing profits pro rata among the shareholders, according to the market.

FOR SECOND-HAND ENGINES, Address HARRIS IRON WORKS, Titusville, Pa.

MILL CARNEGIE BROS & CO UNION IRON MILLS PITTSBURGH PA. WROUGHT IRON BEAMS CHANNELS TEES & ANGLES

"The 1876 Injector." Simple, Durable, and Reliable. Requires no special valves. Send for illustrated circular. WM. SELLERS & CO., Phila.

AIDS TO DRAWING.—A VALUABLE paper containing: (1) Engravings and Descriptions of the Construction and Use of the PANTAGRAPH, for Accurately and Quickly Copying Drawings, Photographs, Maps, Diagrams, etc., making the Copies larger or smaller or of the same size of the original.

Baker Rotary Pressure Blower. (FORCED BLAST) Warranted superior to any other. WILBRAHAM BROS. 2318 Frankford Ave. PHILADELPHIA

Pond's Tools, Engine Lathes, Planers, Drills, &c. DAVID W. POND, Worcester, Mass.

NEW YORK BELTING AND PACKING COMPY. The Oldest and Largest Manufacturers of the Original SOLID VULCANITE EMERY WHEELS. All other kinds Imitations and Inferior. Our name is stamped in full upon all our standard BELTING, PACKING, and HOSE.

VALVE REFITTING MACHINES. ALL USERS OF GLOBE VALVES SHOULD HAVE ONE. GRISCOM & CO., POTTSVILLE, PENN.

PATENTED ARTICLES, MACHINES, etc., manufactured in France according to the Laws by the Société Anonyme pour l'Exploitation de Brevets, 11 Rue de l'André, Paris, France. References: Mackay Sewing Machine Association, Boston, Mass.

SHEPARD'S CELEBRATED \$50 Screw Cutting Foot Lathe. Foot and Power Lathes, Drill Presses, Scrolls, Circular and Band Saws, Saw Attachments, Chucks, Mandrels, Twist Drills, Dogs, Calipers, etc. Send for catalogue of outfits for amateurs or artisans. H. L. SHEPARD & CO., 331, 333, 335, & 337 West Front Street, Cincinnati, Ohio.

No Sawdust! No Planing! Thin lumber, 1-16 to 1/2 inch thick, cut and seasoned by our recently patented machines, equal if not superior to the sawed and planed wood, being smooth, flat, and in all cases perfectly seasoned.

GEO. W. READ & CO., 186 to 200 Lewis Street, New York.

ELEVATORS HAND POWER AND HYDRAULIC FREIGHT & PASSENGER SHAFTING PULLEYS & HANGERS L.S. GRAVES & SON ROCHESTER N.Y.

FIFTY SIRUP RECIPES FOR HOUSEHOLD purposes, Mineral Waters, etc., to wit: Simple Sirup, (2) Lemon Sirup, Mulberry Sirup, Vanilla Sirup, Vanilla Cream Sirup, (2) Cream Sirup, Ginger Sirup, Orange Sirup, (2) Pineapple Sirup, Nectar Sirup, Sherbet Sirup, Grape Sirup, Banana Sirup, (2) Coffee Sirup, Wild Cherry Sirup, Wintergreen Sirup, (2) Sassafras Sirup, Maple Sirup, (2) Chocolate Sirup, Coffee Cream Sirup, Ambrosia Sirup, Hock and Claret Sirup, Solferino Sirup, Capiscum Sirup, Cherry Sirup, Strawberry Sirup, (2) Raspberry Sirup, Peach Sirup, Blackberry Sirup, Orgeat Sirup, Catawba Sirup, Milk Punch Sirup, Champagne Sirup, Sherry Cobbler Sirup, Excelsior Sirup, Fancy Sirup, Currant Sirup, (2) Golden Sirup, Maidenhair Sirup, Orange Flower Sirup, Cinnamon Syrup. How to make Sirups Frothy. Colognes for the Sick Room, by Geo. Leis. With recipes for the production of preparations that serve as pleasing perfumes, deodorizers, and cosmetic lotions. SUPPLEMENT 77. Price 10 cents.

BLAKE'S STONE AND ORE BREAKER AND CRUSHER. For breaking hard and brittle substances to any size. Endorsed by the leading Mining, Manufacturing, and Railroad corporations in the United States and Foreign Countries. First Premium wherever exhibited, and hundreds of testimonials of the highest character. Indispensable for making best McAdam Roads, Ballasting of Railroads, Crushing the hardest Ores, Stone for Concrete, etc., etc. Prices greatly reduced. Address BLAKE CRUSHER CO., New Haven, Conn.

THE FOSSIL FORESTS OF THE YELLOWSTONE NATIONAL PARK. By W. H. Holmes. A very interesting and valuable paper descriptive of the remarkable "Volcanic Tertiary" formations of the above region, 5,500 feet in thickness. Illustrated by an engraving of the north face of a myrist mountain, 9,400 ft. high, the river bed 6,700 ft. high, showing the position of the multitudes of ancient forest tree trunks of gigantic size, turned into stone and now standing on the cliffs, together with many other interesting geological particulars. Contained in SCIENTIFIC AMERICAN SUPPLEMENT No. 180. Price 10 cents. To be had at this office and of all newdealers.

PATENT COLD ROLLED SHAFTING. The fact that this shafting has 75 per cent. greater strength, a finer finish, and is truer to gauge, than any other in use renders it undoubtedly the most economical. We are also the sole manufacturers of the CELEBRATED COLLINS' PAT. COUPLING, and furnish Pulleys, Hangers, etc., of the most approved styles. Price list mailed on application to JONES & LAUGHLINS, Try Street, 2d and 3d Avenues, Pittsburgh, Pa. 190 S. Canal Street, Chicago, Ill., and Milwaukee, Wis. Stocks of this shafting in store and for sale by FULLER, DANA & FITZ, Boston, Mass. Geo. Place Machinery Agency, 121 Chambers St., N. Y.

FORCE OF WIND. HOW TO ESTIMATE the Necessary Strength of Roofs, Towers, Tall Chimneys, etc., to withstand the Wind. The Solution of all Problems of the kind, with numerous Formulae. Contained in SCIENTIFIC AMERICAN SUPPLEMENT No. 149. Price 10 cents. To be had at this office and of all newdealers.

Shafts, Pulleys, Hangers, Etc. Full assortment in store for immediate delivery. WM. SELLERS & CO., 79 Liberty Street, New York.

BIG PAY to sell our Rubber Printing Stamps. Samples free. Taylor Bros. & Co., Cleveland, O. \$77 a Month and expenses guaranteed to Agents. Oudit free. SHAW & CO., AUGUSTA, MAINE.

J. A. FAY & CO'S WOOD WORKING MACHINERY was awarded at the Paris Exposition over all competitors THE GOLD MEDAL OF HONOR. Also highest award at Phila., Santiago, Australia, and Vienna. It is Original in Design, Simple in Construction, Perfect in Workmanship, Saves labor, Economizes lumber, and increases products of the highest standard of Excellence. Railroad, Furniture, and Agricultural Implement Shops, Planing Mills, etc., equipped at short notice, and the lowest cash prices. Send for Circulars. J. A. FAY & CO., Cincinnati, Ohio, U. S. A. HOW TO REMOVE STAINS AND Spots from Linen, Cotton, Woolens, and Silk. Being a table of Specific Directions, showing how to proceed in removing from each of the above kinds of goods any stains of the following character, to wit: Stains of Sugar, Glue, Blood, Albumen, Grease, Varnish, Oil, Paints, Stearine, Vegetable Colors, Red Wine, Fruit Stains, Red Ink, Alizarine Ink, Iron Rust, Ink made with Galls, Lime, Lye, Alkali Stains, Tannin, Green Nut Stains, Coal Tar Stains, Wagon Grease, Acid Stains, etc. By means of this valuable table of directions any person, by providing himself with a few simple chemicals, and using them as directed, may readily clean any species of the above goods, and if necessary set up a cleaning shop. This is one of the most convenient and valuable papers on the subject ever published. Contained in SUPPLEMENT 158. Price 10 cents.

STEAM PUMPS. HENRY R. WORTHINGTON, 239 Broadway, N. Y. 83 Water St., Boston. THE WORTHINGTON DUPLEX PUMPING ENGINES FOR WATER WORKS—Compound, Condensing or Non-Condensing. Used in over 100 Water-Works Stations. STEAM PUMPS—Duplex and Single Cylinder.

Price list issued Jan. 1, 1879, with a reduction exceeding 30 per cent. WATER METERS. OIL METERS.

OUR SPECIALTY STEAM PUMPS AND BOILER FEEDERS SEND FOR ILLUSTRATED CATALOGUE COPE & MAXWELL MFG CO. HAMILTON OHIO

Special attention is called to the following interesting and highly valuable testimonial to THE HANCOCK INSPIRATOR.

CEREDO, W. VA., July 11, 1879. Messrs. FAIRBANKS, MORSE & CO., Cincinnati, Ohio: GENTLEMEN: I got one of your No. 25 Hancock Inspirators, and it is a good boiler feeder. Before I put it on it took one man to run the pump, one the engine, and a small boy to help fire. Now I have only the engineer, and he needs his pants half-soled. In fact he has not much work to do but entertain the friends when they come around. He wants to know what I am going to do with the surplus fuel that is piling up on him. I have plenty of steam all the time, with one-half less labor and fuel than with my pump. I have a pump for sale, to feed three cylinder boilers, thirty inches in diameter and thirty feet long. I think old Mr. Hancock did a big thing when he signed the Declaration of Independence, and invented the Inspirator. Yours truly, G. W. PARSONS, Ceredo, W. Va.

Illustrated and descriptive circulars sent on application to Hancock Inspirator Co., 52 CENTRAL WHARF, BOSTON, MASS.

PROSPECTUS OF THE Scientific American FOR 1879. The Most Popular Scientific Paper in the World. VOLUME XL.—NEW SERIES.

The publishers of the SCIENTIFIC AMERICAN beg to announce that on the Fourth day of January, 1879, a new volume will be commenced. It will continue to be the aim of the publishers to render the contents of the new volume as, or more, attractive and useful than any of its predecessors. Only \$3.20 a Year including Postage. Weekly. 52 Numbers a Year.

This widely circulated and splendidly illustrated paper is published weekly. Every number contains sixteen pages of useful information, and a large number of original engravings of new inventions and discoveries, representing Engineering Works, Steam Machinery, New Inventions, Novelties in Mechanics, Manufactures, Chemistry, Electricity, Telegraphy, Photography, Architecture, Agriculture, Horticulture, Natural History, etc.

All Classes of Readers find in THE SCIENTIFIC AMERICAN a popular resume of the best scientific information of the day; and it is the aim of the publishers to present it in an attractive form, avoiding as much as possible abstruse terms. To every intelligent mind, this journal affords a constant supply of instructive reading. It is promotive of knowledge and progress in every community where it circulates.

Terms of Subscription.—One copy of THE SCIENTIFIC AMERICAN will be sent for one year—52 numbers—postage prepaid, to any subscriber in the United States or Canada, on receipt of three dollars and twenty cents by the publishers; six months, \$1.60; three months, \$1.00.

Clubs.—One extra copy of THE SCIENTIFIC AMERICAN will be supplied gratis for every club of five subscribers at \$3.20 each; additional copies at same proportionate rate. Postage prepaid. One copy of THE SCIENTIFIC AMERICAN and one copy of THE SCIENTIFIC AMERICAN SUPPLEMENT will be sent for one year, postage prepaid, to any subscriber in the United States or Canada, on receipt of seven dollars by the publishers.

The safest way to remit is by Postal Order, Draft, or Express. Money carefully placed inside of envelopes, securely sealed, and correctly addressed, seldom goes astray, but is at the sender's risk. Address all letters and make all orders, drafts, etc., payable to MUNN & CO., 37 Park Row, New York.

To Foreign Subscribers.—Under the facilities of the Postal Union, the SCIENTIFIC AMERICAN is now sent by post direct from New York, with regularity, to subscribers in Great Britain, India, Australia, and all other British colonies; to France, Austria, Belgium, Germany, Russia, and all other European States; Japan, Brazil, Mexico, and all States of Central and South America. Terms, when sent to foreign countries, Canada excepted, \$4.00, for SCIENTIFIC AMERICAN, 1 year; \$9.00, for both SCIENTIFIC AMERICAN and SUPPLEMENT for 1 year. This includes postage, which we pay. Remit by postal order or draft to order of Munn & Co., 37 Park Row, New York.

