

# SCIENTIFIC AMERICAN

[Entered at the Post Office of New York, N. Y., as Second Class Matter.]

A WEEKLY JOURNAL OF PRACTICAL INFORMATION, ART, SCIENCE, MECHANICS, CHEMISTRY AND MANUFACTURES.

Vol. XLVII.—No. 14.  
[NEW SERIES.]

NEW YORK, SEPTEMBER 30, 1882.

[\$3.20 per Annum,  
[POSTAGE PREPAID.]

## THE NEW PRINCETON TELESCOPE.

The accompanying engraving shows the great telescope of the College of New Jersey, as it stands in Halsted Observatory at Princeton. It ranks fourth in the list of great refractors in use, and is by far the largest belonging to any collegiate institution.

Halsted Observatory was built some fourteen years ago, at a cost of about \$56,000. In making the alterations necessary for the reception of the new telescope some \$5,000 more have been expended. The telescope and its accessories cost \$26,000. This sum was contributed by the friends of the college; the largest donors being Robert Bonner, Esq., and the late R. L. Stuart, who gave respectively \$10,000 and \$6,000.

The telescope was made by Alvan Clark & Sons, of Cambridgeport, Mass.; and all the appointments of the observatory are of the most modern character. The iron dome, under which the telescope is mounted, is 39 feet in diameter. The apparatus for turning the dome and opening the shutter is driven by a four horse power gas engine, which also actuates a small (Edison) dynamo machine for operating the electric lamps used in illuminating the building and furnishing electric currents for various spectroscopic purposes.

The following data respecting the telescope have been kindly furnished by Professor C. A. Young:

The diameter of the object-glass is 23 inches. The radius of the curvature of the crown glass lens, outside surface, is 265.8 inches; inner surface, 81.9 inches. These surfaces are both convex. The flint glass lens (concave on both sides) has for the surface next the crown lens a radius of 73.4 inches. That of the surface next the eye is 223.2 inches. The distance between the lenses is 7.5 inches. The focal length is 30 feet 1 inch. The steel tube of the telescope has a length of 28 feet and a diameter of 33 inches in the middle. The length of the polar axis is 10 feet; diameter at bearings, 8 inches and 6 inches. The diameter of the coarse hour circle is 30 inches; of the fine hour circle, 28 inches. The length of the declination axis is 9 feet; its diameter at bearings, 7½ and 5½ inches. The diameter of the declination circle is 30 inches.

The driving weight of the clockwork weighs 320 pounds, and has a fall of 12 feet. The radius of the sector by which the clockwork drives the telescope is 40 inches. The centrifugal regulator or governor weighs 22 pounds, and revolves once in seven-tenths of a second. The weight is taken off the lower pivot by floating the regulator in mercury. The weight of the telescope and mounting is about seven tons. The height of the center of motion above the floor is 20 feet 9 inches. The declination circle is read from the eye end of the telescope by microscopes 9 feet long.

The telescope is provided with position and double-image micrometers of the best construction. The star spectroscope, by Hilger, of London, was constructed under the supervision of Mr. Cristie, the Astronomer Royal, upon the same plan as that of the instrument for some time in use at Greenwich, but upon an enlarged scale. It is a direct-vision instrument, with three (so-called) half-prisms. It is more than 6 feet long.

and weighs, with its appendages, about 150 pounds. For the present it is expected this telescope will be devoted mainly, though not exclusively, to stellar spectroscopy.

For the purpose of comparison the following facts with regard to other large refracting telescopes will be found of interest. But two instruments excelling the Princeton telescope are now in use, namely, the 25-inch telescope made by Cooke, of England, and owned by Mr. Newhall, of Newcastle-on-Tyne; and the 26-inch equatorial, made by the Clarks, at the Naval Observatory, Washington. The third larger instrument, made by Grubb, of Dublin, and having an aperture of 27 inches, is now in process of mounting at Vienna.

The instrument nearest in size below the Princeton telescope, now in use, is the Strassburg refractor, with an aperture of 19 inches.

There are in process of construction five larger instruments, namely:

The Pulkowa telescope, 30 inches, and the McCormick telescope, 26¼ inches; both by the Clarks. The Henry Brothers, in Paris, are making a 29 inch telescope for the Nice Observatory, and another, of the same size, for the National Observatory at Paris. One of the disks of glass (the crown) for the Lick telescope, to be 36 inches in diameter, has been received by the Clarks, who are waiting for the flint disk before beginning the grinding. This gigantic instrument, when finished, is to be erected on Mount Hamilton, California.

## The Transit of Venus.

A scientific party has lately been sent, under the auspices of the government, to Capetown, South Africa, to observe the transit of Venus, which will occur on December 6. The party consists of Professor Simon Newcomb, U. S. N.; Lieutenant Casey, United States Engineers; Ensign J. H. L. Holcombe, U. S. N.; and Julius Ulke, photographer. The party expect to take the steamer from Southampton to Capetown on October 5, due at the latter port about November 1. At Capetown the party will make its headquarters near the English observatory, and will take artificial observations daily preparatory to the work in connection with the transit.

## The Largest Electroplating Establishment in the World.

Professor Silliman, of Yale College, pronounces the electroplating establishment lately acquired by the Postal Telegraph Company, at Ansonia, Conn., the largest in the world; yet its capacity is soon to be trebled. The works are employed in copper plating the steel wire used in the company's system of telegraphy, and now deposit two tons of pure copper a day. The steel core of the wire gives the required tensile strength, and the copper covering extraordinary conducting power, reducing the electrical resistance to such a degree, the company claim, that San Francisco may be brought, telegraphically, nearer New York than Chicago is now.

When the plant is completed, three three-hundred horse

power engines will drive dynamo machines to supply current for electroplating thirty miles of wire a day, the wire carrying five hundred pounds of copper to the mile. In the process of coating the wire is drawn slowly over spiral coils through vats containing copper in solution, until the proper thickness of deposit is obtained.

The first line of the Postal Telegraph Company will run from New York to Chicago by way of Binghamton, Elmira, Corry, Pa., and Cleveland, Ohio; but there will be no way stations, the company preferring to do what is called "trunk line" service. The lines will be constructed with forty poles to the mile, and are to be completed by December. A line is promised to Boston by the same date.

## The Fastest Trip to Europe.

The Guion Line steamer Alaska, Captain Murray, which sailed from New York September 12, for Queenstown and Liverpool, was signaled passing Fastnet at two o'clock Sept. 19. She made the trip in six days fifteen hours and nineteen minutes.

This is the fastest trip ever made between America and Europe. The next fastest time was made by the Alaska—namely, six days twenty-two hours and ten minutes to Queenstown.

A "SWALLOW'S REST" of remarkable size at Westerly, Rhode Island, has attracted the attention of bird lovers. The birds are mainly the common white-breasted barn swallow, some marten swallows being occasionally seen among them. One observer estimates their number at 3,000,000 nightly in the grove.

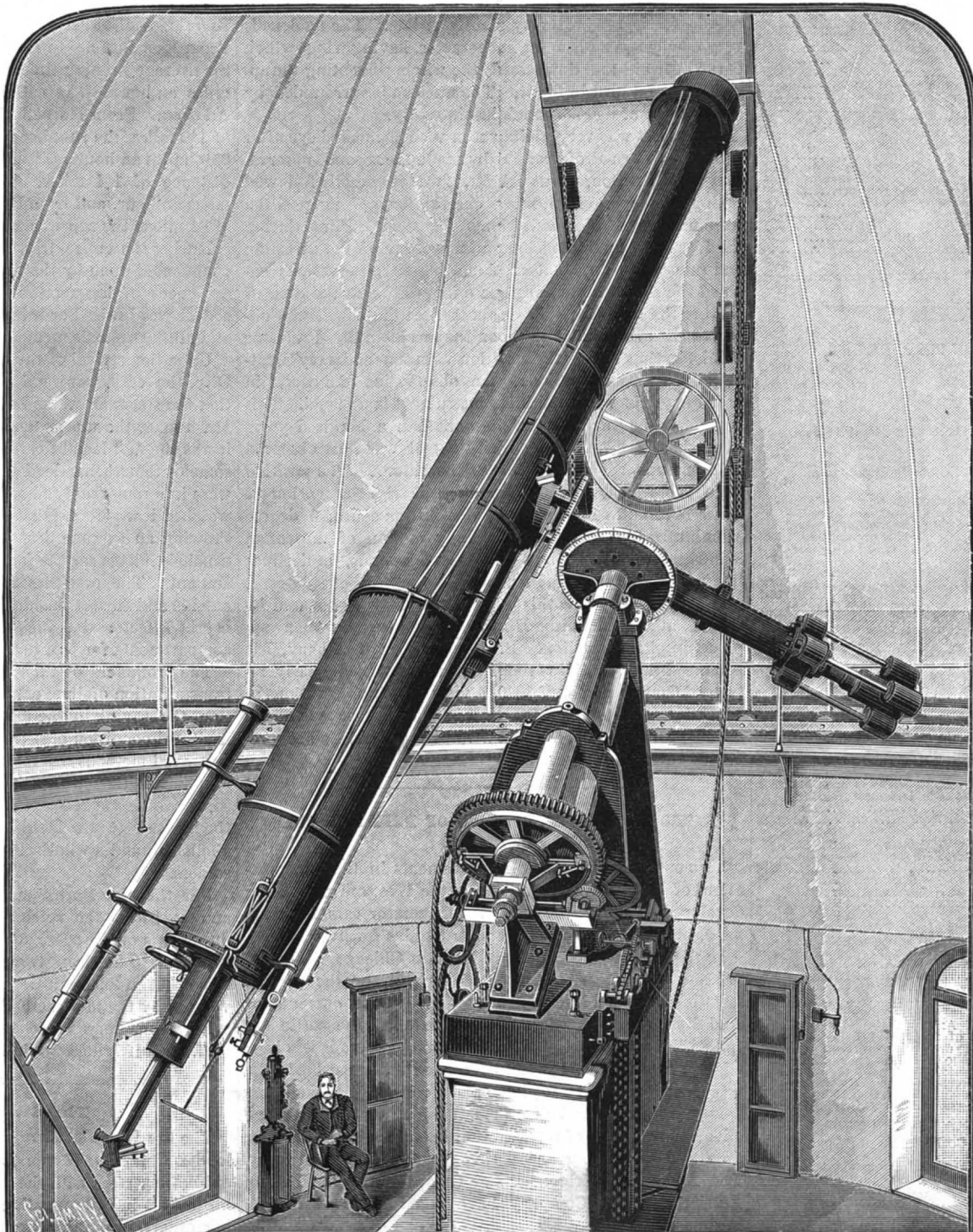

THE PRINCETON TELESCOPE.

Scientific American.

ESTABLISHED 1845.

MUNN & CO., Editors and Proprietors.

PUBLISHED WEEKLY AT

No. 261 BROADWAY, NEW YORK.

O. D. MUNN.

A. E. BEACH.

TERMS FOR THE SCIENTIFIC AMERICAN.

One copy, one year postage included. \$3 20
One copy, six months postage included. 1 60

Clubs.—One extra copy of THE SCIENTIFIC AMERICAN will be supplied gratis for every club of five subscribers at \$3.20 each; additional copies at same proportionate rate. Postage prepaid. Remit by postal order. Address

MUNN & CO., 261 Broadway, corner of Warren street, New York.

The Scientific American Supplement

is a distinct paper from THE SCIENTIFIC AMERICAN. THE SUPPLEMENT is issued weekly. Every number contains 16 octavo pages, uniform in size with SCIENTIFIC AMERICAN. Terms of subscription for SUPPLEMENT, \$5 00 a year, postage paid, to subscribers. Single copies, 10 cents. Sold by all news dealers throughout the country

Combined Rates.—The SCIENTIFIC AMERICAN and SUPPLEMENT will be sent for one year postage free, on receipt of seven dollars. Both papers to one address or different addresses as desired. The safest way to remit is by draft, postal order, or registered letter. Address MUNN & CO., 261 Broadway, corner of Warren street, New York.

Scientific American Export Edition.

The SCIENTIFIC AMERICAN Export Edition is a large and splendid periodical, issued once a month. Each number contains about one hundred large quarto pages, profusely illustrated, embracing: (1.) Most of the plates and pages of the four preceding weekly issues of THE SCIENTIFIC AMERICAN, with its splendid engravings and valuable information; (2.) Commercial, trade, and manufacturing announcements of leading houses. Terms for Export Edition, \$5.00 a year, sent prepaid to any part of the world. Single copies 50 cents. Manufacturers and others who desire to secure foreign trade may have large and handsomely displayed announcements published in this edition at a very moderate cost.

The SCIENTIFIC AMERICAN Export Edition has a large guaranteed circulation in all commercial places throughout the world. Address MUNN & CO., 261 Broadway, corner of Warren street, New York.

NEW YORK, SATURDAY, SEPTEMBER 30, 1882.

Contents.

(Illustrated articles are marked with an asterisk.)

Table listing various articles such as 'Air, oxygen from', 'Albuminoids, digestibility of', 'Autographic printing method', etc., with corresponding page numbers.

TABLE OF CONTENTS OF THE SCIENTIFIC AMERICAN SUPPLEMENT, No. 352, For the Week ending September 30, 1882.

Price 10 cents. For sale by all newsdealers.

Detailed table of contents for the supplement, categorized by I. ENGINEERING AND MECHANICS, II. TECHNOLOGY AND CHEMISTRY, III. ELECTRICITY, ETC., IV. ARCHITECTURE, ART, ETC., V. HYGIENE, MEDICINE, ETC., VI. HORTICULTURE, ETC., VII. GEOLOGY, BOTANY, ETC., VIII. BRITISH ASSOCIATION.

COMETS D AND E 1882.

The fourth comet of the current year was discovered by Professor E. E. Barnard, of Nashville, Tenn., on the morning of Sept. 14, near the star Lambda, in the constellation of the Twins. As observed at the Dudley Observatory on the morning of Sept. 16, its position was right ascension 7 hours 21 minutes 17 seconds; declination north, 15° 16'.

A more remarkable comet (E 1882) was discovered on the morning of Sept. 18. In the clear atmosphere of Colorado and Kansas it was plainly visible to the naked eye, from 3° to 5° southwest from the sun. On the same day this comet was observed in England, at Nice, Italy, and elsewhere.

The comet was easily seen with the naked eye, and exhibited a short tail with a bright head of considerable extent. In the telescope the nucleus showed as a confused mass of bright light, indicating a large comet with plenty of loose material.

Thollon's comet observed at Nice about noon, September 18, 3° west of the sun. The nucleus gives a continuous spectrum, very brilliant and very much extended toward the violet. Both tail and nucleus give the sodium lines extremely brilliant, very sharply divided, and characteristic.

This is the second comet that has shown a sodium spectrum. The displacement of the sodium lines would indicate a rapid movement of the comet toward the earth.

Further observations were made at the Naval Observatory on the morning of September 20, by Prof. Frisby, who describes the comet as a very prominent object, rising about half an hour before the sun and to the southward of it about ten degrees or twelve degrees.

The comet was very plainly seen with the naked eye after sunrise. When Professor Frisby made the second observation of its position, about 6 A.M., it was very easily followed with a telescope. Two more observations of its position were made by Professors Skinner, Boss, and Flint during the forenoon, thus furnishing a knowledge of the direction and rate of its apparent motion.

It is believed that this comet was first discovered by Crulls, at Rio Janeiro, Brazil, September 10, then approaching its perihelion. Professor Boss, of Albany, has advanced the hypothesis that it is an unexpectedly early return of Gould's comet of 1880, a view which observations at Washington, September 21, seem in some degree to confirm.

IMPROVED TRANSPORTATION OF BEEF AND BEEF CATTLE.

Two specially promising improvements in the transportation of beef and beef cattle from the West are now being developed—namely, the use of refrigerator cars for dead meat, and of improved cars and fast trains for live cattle.

In the first case the cattle are killed at Chicago, St. Louis, or other points near the source of supply; and the dressed meat is forwarded in cars kept cool by interior currents of cold dry air, or otherwise. By this method the cattle are spared the discomfort of the long journey; there is less loss; a larger amount of meat can be carried to the car-load; the meat is delivered ripe for immediate consumption and free from the injuries and disorders incident to long carriage alive; and the cost of refrigeration is said to be not greater than that of feeding and caring for live cattle in transit.

Hitherto, owing to the opposition of local butchers and drovers, but little of the refrigerated meat has been brought

to this city. Preparations are making in Washington Market, however, for a large extension of the trade here; and as soon as retail dealers can be sure of a sufficient regular supply, they will doubtless be ready enough to handle it.

Recently a number of Texan capitalists, said to represent a combined live stock and banking interest of \$6,000,000, have been visiting north and east for the purpose of developing a scheme to refrigerate Texan beef for shipment to the larger centers of consumption.

The development of improved live stock transportation is likely to prevent any monopolizing of the meat trade by the butchers of the south and west. As yet this business is only beginning; but the success of experimental trains is such as to hold out a promise of its rapid extension.

One of the younger companies that have undertaken to solve the problem of cattle transportation is the Montgomery Palace Stock Car Company, whose first train-load of cattle to this city arrived from Chicago the forepart of September. The train consisted of twenty cars, carrying 361 steers, weighing when loaded 418,930 pounds.

The average running time from Sarnia, Canada, to East Buffalo, a distance of 193 miles, was 28 miles an hour. From East Buffalo to Hornellsville, a distance of 91 miles, the average running time over the Erie road was only 16 1/2 miles an hour.

During the entire trip, says the World's reporter, it was commented upon by the experts that none of the cattle gave evidences of leg-weariness, there was no "scouring," not a steer was bruised or trampled upon, no prods were used, and all the animals seemed contented.

Upon the arrival of the train at the stock-yards in Jersey City, the cars were unloaded with ease, and it was found that the steers all walked well, and were in good condition. Mr. Truax, the superintendent of the yards, remarked that it was the first load of cattle he had ever seen arrive without some of them being dead and wounded.

The promoters of this and other methods of improved transportation of live cattle claim that the greater expedition, the saving in the matter of shrinkage, and the more healthful condition of the cattle when delivered, make the improved methods as much superior to the old in point of economy as they are on the score of humanity.

For the transportation of beef, from the extreme west and southwest the refrigerator plan offers still greater inducements on the score of humanity, for the cattle are thus subjected to the least travel. The economy of it is as yet somewhat problematical. In any case, the competition developed by the new methods is likely to be advantageous to eastern consumers in an improvement in the quality of our beef, even if it does not lower the price.

The Sweetland Chuck.

The fire which occurred in the premises of Messrs. Sweetland & Co., New Haven, Conn., September 7, fortunately did not interfere with the manufacturing department. The business is in full operation, and customers can rely on having orders promptly executed.



**NATIONAL TELEPHONE ASSOCIATION.**

The fourth convention of the National Telephone Association of the United States met at the Hotel Vendome, Boston, Sept. 5. The attendance was large. The American Bell Telephone Company, of Boston, made every provision for the comfort and entertainment of delegates. Hon. Marshall Jewell, ex-Governor of Connecticut, was chosen president of the association.

At a Nantasket Beach dinner, President Forbes, of the American Bell Company, expressed, in a brief address, the kindly feeling of the parent company toward the various exchanges throughout the country. Gov. Jewell responded for the association, paying handsome and deserved compliments to President Forbes and General Manager Vaile.

Mr. Gardiner G. Hubbard, of the original Bell Telephone Company, and who is the father-in-law of Prof. Graham Bell, the inventor of the telephone, followed in an address, reviewing the history of the development of the telephone. He divided the history of the telephone into epochs. The first was eight years ago, when Professor Bell, rising from a piano where he was seated, declared himself convinced that the sound of the human voice could be carried in tone waves upon electrical wires. Another epoch was later, when one day the professor entered his room and handed him a piece of iron attached to a wire. Placing it to his ear he was amused at hearing articulate sounds. The next was when he stood among others, with the Emperor of Brazil, at the Centennial Exhibition, in Philadelphia. The telephone had been mounted, and was on exhibition. The Emperor, placing the instrument to his ear, started back, exclaiming, "My God, it speaks!" Another epoch was the establishment of the first telephone exchange. Still later and marked periods were when the present management of the American Bell Telephone Company took the control of affairs, and when the Western Union Telegraph Company became identified with its interest.

Out of about 600 exchanges, the whole number of exchanges reporting was only 81, covering about 30,000 telephone subscribers.

Of exchanges having more than 1,000 subscribers, the Metropolitan Telephone and Telegraph Company, of New York City, comes first, with 2,873; the Law Company, of the same city, has 578; Chicago has 2,596; Cincinnati, 2,056; Providence, 1,906; San Francisco, 1,294; Boston, 1,186; Detroit, 1,110; Albany, 1,100; Buffalo, 1,047; Louisville, 1,024; Baltimore, 1,017. The smallest number of subscribers in any exchange reporting is ten.

During the year there has been a general increase in the number of subscribers.

Mr. Babcock, of Evansville, Ind., reported that his exchange had 700 miles of No. 14 wire, and that in building one of the lines, 45 miles long, the lineman got drunk and neglected to put on any insulators, merely tying the wire to the poles. After the wire was up, he could see no difference between its working and that of others that were insulated, and they had built some of their other lines also without insulators, and they had worked well. The exchange now has 400 miles of lines which have been working for a year without insulators. He was not an electrician himself, but those who claimed to be electricians had told him that, although the lines might work in dry weather, he would be unable to do anything with them in wet weather; he had not, however, found that this prediction had come true. On an 81-mile line he has often whispered over it of an evening, and the whisper has been heard distinctly at the other end, although on twenty miles of it there are no insulators. The exchange has two 40-mile lines running parallel, the one insulated and the other not, and no one can tell by the working which one he is on.

**DAIRY INTERESTS OF ITALY.**

In our issue for June 10, 1882, a valuable description of Italian cheeses and the processes of their manufacture was reprinted from the *Journal of the Society of Arts*.

We have since learned that the information given by the *Journal* was drawn entirely from a report on the Dairy Interests of Italy, by Thos. C. T. Crain, U. S. Consul at Milan, to whom all the credit should be given. Mr. Crain's report was printed in the issue of "Commercial Reports" (Department of State, Washington), for August, 1881. In addition to the matter quoted, Mr. Crain gives a considerable amount of information with regard to other dairy interests in Italy, dairy associations, cheese factories, and so on.

The account of butter making is quite interesting. Families having little milk use cylindrical churns, in which the cream is shaken by movement of the churn handle. Factories use large cylindrical churns on trestles, in which are wings turned by machinery. In Pavia, round boxes called "puraggie" are used. Each box has a spoon fastened to an axle which is turned with a crank by two men. Some use a cradle churn, which saves labor and produces equally good butter. In Cremona, an American machine is in general use. It is a horizontally fastened tub, in the interior of which is a reel similar to that used in silk-making. The dairyman of Parma beats the milk with a cream-whipper, and skillfully lets the floating cream, which gathers in the bucket, overflow into a fine edged wooden bowl, and thence into the churn. The temperature of the cream is always kept from 10 degrees to 15 degrees Reaumur (55 degrees to 65 degrees Fahr.).

In churning two men alternately beat the cream with a butter beater joined to a straining frame, raising and covering it by leverage. Butter should begin to form in three-

quarters of an hour. When it is necessary to hasten formation, water is added; where advisable to retard it, ice. If made before the time mentioned, the butter is soft; if after, hard and set. When prepared it is taken from the churn, worked with the hands, formed into blocks, and left to drain. The skimmed milk is used for the ricotta cheese. In Cantanzaro butter is made with the old fashioned churn. The butter is kept by inclosing in small bladders in which it can be conveniently kept and carried about without danger of change.

At Modica, where the butter is delicious, it is not made directly from the cream but from the "ricotta," which is obtained by boiling the "small" milk after extracting the caseine. The butter maker of Sardinia puts the "ricotta" in a bowl of cold water, and shakes and presses it with his fingers. In half an hour a white scum appears on the surface of the water; and by continued movement and pressure of the "ricotta" the scum increases during the succeeding half hour. This scum is the butter of the ricotta.

Mr. Crain finds that dairy associations and the factory system of cheese making have existed since remote times in Savoy, the French Jura, and on the Alpine slopes.

Where land is owned in small plats, as in the mountainous parts of Upper Italy, large dairies are impossible, and cheese making can be carried on only by the factory system. During the past eight or ten years, under the fostering influence of the government, these cheese factories have greatly increased in number and improved in management. They are found everywhere except in Sicily, where a curious custom prevails.

The small producers carry their milk to the large producers; and after their deliveries have amounted to 250 or 350 quarts, they receive that quantity back again at one time. This system of reciprocal loans is said to work well and be beneficial to all, as a large quantity of milk worked at once makes more cheese than the same amount of milk worked in small quantities at different times.

**Damp Houses and How to Remedy Them.**

Damp houses are a fruitful source of discomfort and disease, and yet, as important as their influence is, it is amazing how seldom means are taken by which the evil may be prevented. When a house is said to be "well drained," however true this may be of the plans adopted for carrying away the refuse water of domestic operations, it very rarely means that the site has been drained to prevent damp.

When experienced medical men see house after house built on foundations of deep retentive clay, inefficiently drained, they foretell the certain appearance among the inhabitants of catarrh, rheumatism, scrofula, and a host of other diseases of a similar nature. Where a damp house exists in connection with deficient sewerage, drainage or a cesspool full of decomposing material—an unfortunate conjunction too often met with in country and suburban houses—other and more dangerous diseases, as typhus fever, are induced. The watery mist of fog rising from a damp soil affords an admirable vehicle for the subtle and deadly exhalation of the decomposing drainage matter, by which they are too certainly conveyed to the interior of the house. And, physiologically dependent upon this condition of affairs, a mental as well as a physical depression is induced, which drives those subjected to the temporary relief afforded by the use of ardent spirits and other stimulants. Thus, in this, as well as in other departments of sanitation, the connection between physical and moral disease is easily traced. There can be no doubt as to the increased pecuniary and sanitary value of land suitable for building sites, arising from efficient drainage being carried out. The greater the inducements offered by the healthy condition of a neighborhood, the greater the value of the land for building sites. An excess of moisture in any district inevitably influences the local climate both as regards dryness and temperature.

The most effectual preventive of damp houses is the complete drainage of the site on which they stand. All other remedies are but remedies in name, more especially when the soil is very damp; in such a case lead or slate placed round the bottom courses of the foundation with water-proof cement may prove efficient for the time, but will ultimately become inoperative. The system of drainage for carrying off surplus water from the land is different from that adopted for conveying away domestic refuse water, etc. In the latter it is essential, nay, imperative, that the drains should be water-tight, capable of conveying the water admitted to their interior immediately to its ultimate destination, but incapable of passing any of it to the surrounding soil through which the drains are laid. The former, on the contrary, should be permeable throughout their length; that is, have apertures of sufficient width throughout which the water of the surrounding soil can find its way into the interior of the drain, which should be of such a shape as to facilitate the removal of the water to its destination, preventing its return to the soil.

In laying and forming the drains the following points should be attended to: The first to be observed is the uniformity of slope or level of the bottom of the trenches. The method of accomplishing the perfectly uniform slope of the drains, from their highest point to their outfall, is by the use of level-rods or the spirit-level. Not so with the level-rods, as following description of their uses will show: Three rods are required, two of them two feet long and the third as much more than two feet long as the drain is deep—that is, if the drain is three feet six inches deep, the rod must be five feet six inches long. The rods are strips of wood with cross

pieces nine inches long on the upper end. The two shorter rods are planted upright, one on the ground on a level with the field at the head of the drain, and the other at the lower end, and a person stands at one of them looking over its top, with his eye on a line with the other. A second man then takes the longest rod and holds it upright in the drain, just touching the bottom, and walks along from one end of the drain to the other, keeping it in an upright position. If, while it is moving along, its top always appears on a line with the tops of the other two—as seen by the person looking along the three—the fall of the drain is uniform; but if it rises above this line at any one place, the bottom is too high there, and requires to be reduced; if it falls below the line the bottom is too low, and must be raised. In this way the fall may be rendered perfectly uniform. In cutting drains the best way is to commence with the main drain, and at its lowest point, working gradually up to the highest. An intelligent mason or carpenter may be intrusted to make drains of this sort at very little cost, and we are sure no houseowner who cares for the health of his family will ever regret the investment. —*Builder and Woodworker.*

**Coal in Colorado.**

The Denver (Col.) *Journal of Commerce* reports the existence in Gunnison County, until recently known as the Ute Indian Reservation, of a bed of coal thirty feet thick, covering in one place sixteen hundred acres.

It is situated on a small stream tributary to the Uncompahgre River, about eight miles northwest from the Las Pinas Indian agency, and one hundred and seventy-six miles southwest from the city of Denver. The coal crops out along the mountain side about eighty feet above the plain; where exposed it shows a thickness of thirty feet of solid coal. The *Journal* says that the coal is semibituminous and of a jet black color, and adds:

"It has been analyzed by Professor Wuth, of the city of Pittsburg, Pa., and pronounced by him to be of an excellent quality. It is almost entirely void of sulphur, and will smelt iron without coking. It has been used by the miners in that vicinity for the purpose of dressing their steel drills, and pronounced by them to be superior to charcoal for that purpose. There is no doubt, taking into consideration the thickness of this vein and the extent of the deposit, that it is the largest vein of coal yet christened on this continent. It was discovered about two years ago, when the Indians held possession, by some prospectors, who associated themselves together so as to hold it until such time as the Indians should be removed, and the land thrown open for entry and location, which has now been done."

**Chimney Draught.**

At the closing meeting of the British Association Lord Rayleigh read a paper before the Mechanical Section on the effect of wind on the draught of chimneys, based upon experiments made with tubes and a fan driven by hydraulic power. He stated that a horizontal wind would usually promote a draught, except in cases where the chimney opened out upon a large expanse of wall, and so was indirectly affected. The cure in this case was to carry the chimney higher. When the wind was inclined downward to the chimney at an angle of thirty degrees and upward, there was a down-draught, and the maximum up-draught was produced by wind inclined upward at about the same angle. The simplest thing to prevent wind blowing down a chimney was to erect a T-piece on the top. In that case a vertical or inclined wind favored the draught, and the effect of a wind blowing through the T tube was practically nothing. Mr. Park Harrison suggested as the only real remedy an increase of draught. A member contended that chimneys should be turned upside down, the opening at the fireplace being narrow and the outlet widened. If all the fireplaces in a house could be made to open into a common cloaca, a down-draught would hardly ever occur.

**Suture of Tendon.**

Dr. Yeats recently presented a case to the Manchester Medical Society (*British Medical Journal*) where he had, six weeks after an accident, united with four catgut sutures the divided ends of the tendon of the extensor communis digitorum of the middle finger, at the metacarpo phalangeal joint. The skin wound was united by silver sutures. The operation was done antiseptically. The wound healed in four days; and three weeks afterward the patient had perfect control over his fingers, flexion and extension being perfect. At the end of five months the fingers were as strong and useful as before the operation.

**Lake Constance.**

The shrinkage of Lake Constance, in Switzerland, owing to the extraordinary dryness of the past winter, has brought to light many interesting relics. Among them there are bone and flint implements, harpoons, pottery, many specimens of which are intact, clubs, baskets, arrows, field tools, and animal remains. Among the latter are skeletons of the bear, the bison, and the moor-hen. The discovery also includes a considerable quantity of oats and wheat in a good state of preservation, and a remarkably perfect and artistically executed stag horn harpoon. The relics have all been removed to Frauenfeld, and added to the collection of the local historical and natural history society, which is now the richest in lacustrine objects in the Helvetic Confederation.

**A Great Gas Project.**

The fact that Bradford, Wellsville, Richburg, Bolivar, and all the towns and hamlets on the northern and middle oil fields are not only lighted, but heated by gas, the machine shops, boilers, and hotels being supplied with the same fuel, has attracted the attention of capitalists, and, according to a correspondent of the *Philadelphia Press*, a syndicate is forming to still further utilize the natural gas of the northern belt, which extends from Lake Erie east 200 miles, and from Bloomfield, Ontario county, N. Y., south to near Pittsburg; in other words, nearly 200 miles square. As an evidence that this gas is practically inexhaustible, the fact is stated that one well at Sheffield, Warren county, has been flowing steadily for fifteen years, and another in Westmoreland county nearly as long, and the gas from either would light and heat the city of Philadelphia. It is stated that the gentlemen who are interested in the enterprise are all large capitalists, and are confident of ultimate success in supplying the great cities of the Union with gas, for light and fuel, at much less rates than even electricity can be furnished.

**American Public Health Association.**

The American Public Health Association will hold its tenth annual session at Indianapolis, Ind., October 17 to 20 inclusive. Papers are promised on many subjects of sanitary interest, including the different action of disease in the white and the black races, the removal of excreta, heredity, the work of sanitary associations, vaccination, intermittent fever in New England, and cattle disease. Committees will report on the prevention of venereal diseases, compulsory vaccination, the management of epidemics, cattle diseases, the National Museum of Hygiene, and other matters of popular and professional interest. Two proposed amendments to the constitution will come up for action. Information with respect to contributions, membership, transportation, and so on, may be had of the secretary of the association, Azel Ames, Jr., 12 Pemberton Square, Boston.

**A Rocky Mountain Railway Tunnel.**

The Denver and South Park Division of the Union Pacific Railroad pierces the main range of the Rocky Mountains, 150 miles southwest of Denver, Colorado. The length of the tunnel is 1,700 feet, and its altitude above the sea 11,500 feet. The approaches on either side are described as marvels of engineering skill, laid through scenes unrivaled for grandeur and magnificence. Although the tunnel commences with a sharp curve at its eastern end, so nicely was the engineering done, that when workmen from either side met in the heart of the great snowy range, they found only about one inch variation in the respective bores.

This tunnel, said to be the highest in America or Europe, leads to the new silver region of Gunnison.

**IMPROVED PLOW COLTER.**

The annexed engraving represents an improved plow colter recently patented by Messrs. David Morris and Hugh Speirs, of Bunker Hill, Ill. This plow colter is constructed with a circular blade provided with a hub having a removable metallic bushing inserted in it, and a wooden pin passes through the bushing and is attached to the ends of the

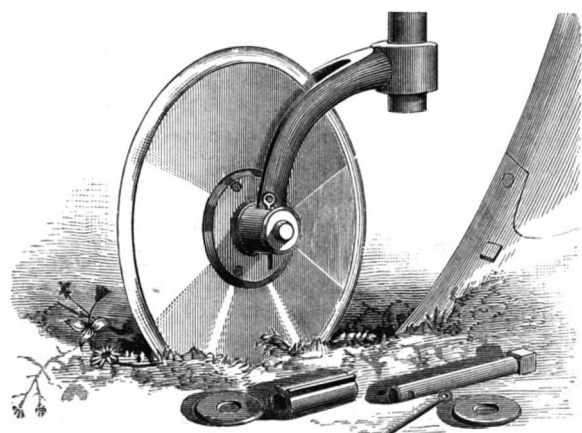
**MORRIS & SPEIRS' PLOW COLTER.**

colter yoke, one of the ends being countersunk to receive the head of the journal, and the other end perforated to receive a pin passed through the opposite end of the journal. Leather washers are inserted between the ends of the hub and bushing and the yoke. By this arrangement the wear is lessened, and the parts subject to wear can be readily and cheaply renewed, and the expense of purchasing the more costly parts of the colter is avoided.

**A Pony Ranch in Texas.**

A Texas paper describes an 8,000 acre ranch in that State entirely devoted to the breeding of ponies for children. The breeding stock consists of seven Shetland stallions and forty-five mares, all thoroughbred, and two hundred small spotted pony mares. These little ponies range over the prairies like sheep, and are described as very gentle.

**COMBINED DRIER AND COOLER.**

We present to our readers an engraving which illustrates a new invention for drying and cooling grain and other material, in one operation, in the most thorough manner, by the joint use of hot metal surfaces and forced currents of hot and cold air. A prominent manufacturer, who has given this method of drying careful study and many experiments, says: "The science of drying is in itself exceedingly simple; but to those who are entirely unacquainted with it, it appears mysterious, for the reason that the medium for carrying off the water, being air, is not visible. All the science there is about it is that the air absorbs moisture as a sponge absorbs water. . . . Heated air will absorb moisture in proportion to the increase of its temperature. A cubic foot of air at 32° will carry off only two grains of water, while at 160° it will carry off sixty grains,

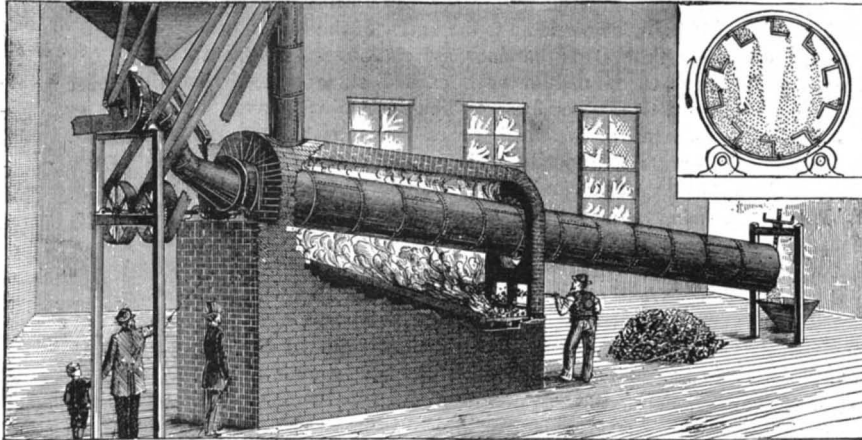
**WORRELL'S COMBINED DRIER AND COOLER.**

hence the necessity of heating the air, which should be as dry as possible, and made to move rapidly, so as to remove the moisture from the surface as it works its way out from the center of the body being dried."

The inventor of the machine herewith illustrated, after ten years of practical experience with three different driers, has devised a machine which appears to carry out the ideas just quoted in the most simple and effectual manner. It is all iron, with no bearings exposed to the heat, simple, and therefore not liable to get out of repair, requires little power, and is economical to operate, as it presents large surfaces, utilizing all the heat.

This machine is virtually a new departure among driers, being constructed so as to cool the material being dried, as well as dry it, in one and the same operation. All persons who have operated drying machines know how much labor and trouble it requires to cool grain (to prevent it from "heating" in bulk) after it has been discharged from the drying machines ordinarily used. In fact this labor is often greater than that required to dry the grain. This very serious objection is entirely overcome in Worrell's combined drier and cooler, and this feature largely increases the value of the machine.

A few words will suffice to explain the engraving, so that any one can easily understand the operation of the drier. The furnace surrounds about one-half of the long drying cylinder, which is slowly rotated by the friction wheels connected by short shafts with the two pulleys seen at the left. The exhaust fan is shown just above these pulleys. The grain or other material being operated upon is fed into the cylinder through the air spout, where it is spread by the troughs, which run the entire length of the case, into a number of thin streams, as represented in the enlarged cross-section of the cylinder. This view gives a good idea of the large amount of metal surface furnished for heating the grain and air; and what a very large surface of grain is presented for the heated currents of air to absorb the moisture from. Owing to the inclination of the case, which can be varied while in motion by screws, the grain gradually passes to the lower or discharge end.

After it has passed through that portion inclosed by the furnace, the cooling part of the process is accomplished by the same current of air which is drawn in at the lower end, which is open. The grain is here discharged into the hopper in a dry and cool condition, suitable for storing in bulk for shipment or immediate consumption. It will be noticed that the grain nowhere comes in contact with the gases of combustion, and consequently it is not tainted and thereby rendered unfit for food.

This machine is adapted for drying and cooling damp or musty grain, seeds, berries, fruit, brewers' grain, tobacco, salt, sugar, and other granular substances. It is peculiarly suited for drying corn for export meal, or new corn, so that it may be graded as old. Elevator owners will notice that this machine may be used without the furnace to cool heated grain.

This invention was patented April 25, 1882. These machines are furnished of any size up to a capacity of 5,000 bushels per day. There is now in operation one of 2,500 bushels capacity at Hannibal, Mo., where it is exhibited to interested parties. Any further particulars may be obtained by addressing the patentee, S. E. Worrell, Hannibal, Mo.

THE largest and oldest chain bridge in the world is said to be that of Kingtung, in China, where it forms a perfect road from the top of one mountain to another.

**Liabilities of Employers for Injuries to Workmen.**

In an action against an employer for the death by injury of a workman, it appeared that the death was caused by the slipping of a plank on which deceased was at work, and which had negligently been placed on some guard rails. The employer was not present at the time, but had left the work in charge of a competent foreman. The work was the building of an iron bridge. The work was in its nature perilous, but the peril was obvious. Ample materials were at hand to secure safety, but the precautions for safety were neglected through the fault of deceased and his fellow-laborers. Held, that defendant was not liable for the death. The servant engaging in hazardous employment assumes its risks, but does not those of the negligence or malfeasance of the master. The master must use diligence, having respect to the nature of the service, to provide the proper materials, appliances, and instrumentalities for doing the work, and also to use due diligence and care in the selection and employment of competent and careful fellow-servants for the particular work or service to be performed.

**Discoveries of Magnetic Iron.**

In sinking an Artesian well on the premises of the St. Paul (Minn.) Harvester Works, magnetic effects were noticed. At the depth of 630 feet a hard stratum was struck, and operations continued to be very difficult for a distance down of 40 feet or more. On analysis the substance of the harder rock proved to be magnetic iron ore, exceedingly rich in quality. A second well has been begun to determine whether the ore deposit underlies any considerable area. There is not a little excitement in the neighbor-

hood, the belief being that St. Paul is destined to be the center of a great iron producing country.

A dispatch from Yankton, Dakota, dated August 22, says that the second Artesian well bored there has developed powerful magnetic properties. It would be interesting to know more of the nature of the rock penetrated. Perhaps there is iron in that place also.

**DROP PRESS BELT PROTECTOR.**

Since drop presses have been run by power with a rope or belt over a moving pulley to raise the drop, there has been wanting some arrangement to keep the belt or rope off from the pulley when the drop is not in use, as when the belt or rope is in contact with the pulley it is continually wearing and heating, which causes the rotting, or rather slow burning of the belt.

This unnecessary friction is accompanied with a continual disagreeable noise. During a considerable portion of the time from one cause and another drops are not in use, either on account of repairs, or for want of work, or waiting for dies to be set, and as it is not usually convenient to take off the belt or rope, it is generally left on until worn out. It will thus be seen that quite a saving can be effected by the use of a device for keeping the belt from the pulley, besides preventing the noise.

In the accompanying illustration is shown a device that will meet all the requirements, and that can be easily made and applied. There are only two steel springs and two shafts with rawhide wheels. The two springs are riveted together in the middle, and the under spring fastened to

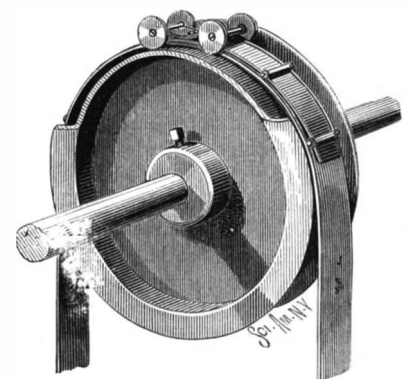
**DROP PRESS BELT PROTECTOR.**

the rope or belt by cross pieces, as shown in the engraving; the wheels and the upper spring are to raise the belt, while the under spring keeps the belt off from the pulley, while suspending it over the moving pulley, and at the same time keeping it ready for use, the same as if in contact with it, and offering no hinderance when it is required to swing the drop for heavy work.

This invention has recently been patented by C. R. Bannibr, of West Cheshire, Conn., from whom further information can be obtained.

A VOLCANO named Sheramino, in the center of Japan, which had been silent for seventy years, broke out in eruption on August 6. A severe earthquake shock was felt in Tokio and Yokohama on August 18.



**New Autographic Printing Method.**

The following method, by Mr. Crocker, of Tasmania, is described in the *Southland Times*:

The basis of operations is common window glass—a most unlikely but perfectly reliable material to withstand the rumble and roll of modern printing machines. A solid ink, composed of beeswax, resin, and lampblack, is made in proportions about which there is no secret. The drawing medium is a common steel pen, with this important adjunct, that it is constantly subjected to the action of a very tiny jet of gas, or an electric spark, which keeps the pen hot. It is inserted in the stick of ink, and its heat at once dissolves a “dip.” The artist now proceeds to sketch on the glass, the fluid ink running as freely as necessary, but the instant it leaves the pen it again becomes solid, and adheres to the glass without blurring or running. As a consequence, shading of any intensity may be executed without risk of forming one big blot. The plate is now ready for an “engraver” whose hand is more potent and swift than that of any of his predecessors. This is hydrofluoric acid, a chemical well known as being about the only “eater” of glass known in practical chemistry. A small portion of this is poured over the face of the glass, and in a very short space of time eats its way downward. The ink, however, defies the acid, and the glass below the sketch therefore remains intact. All that now remains to be done is to mount the slip of glass on a metal block of the same height as printer’s type, where it is secured with a little shellac, and the engraving is ready for the printing press.

**Use the Chloride, not Chlorate.**

It is well known that chlorate of potassium is a very good remedy to gargle the throat, but comparatively few physicians are aware of the fact that it is not this remedy which is so successful in mercurial stomatitis, but chloride of potassium.

Professor Wertheim draws the attention of physicians especially to this fact (*Wiener Med. Blätter*, 15, 1882). He reminds them that the formula of the first is  $KClO_3$ , but that of the second  $KCl$ . He says that the chlorate should never be used, as in concentrated solution it may even prove very harmful; while the chloride is very innocent; a specific in sore throat, and especially in mercurial sore mouth, and very analogous to common salt, which is simply a chloride of sodium, instead of potassium. In America the chlorate is commonly used; no wonder, therefore, says the *Med. and Surg. Reporter*, that it is not found here as efficient as in France and Germany, where they use the chloride.

**PORTABLE ROOF FOR HAY AND GRAIN RICKS.**

The engraving shows an improved portable roof for hay and grain ricks, which can be built up or removed very easily and quickly, and can be folded compactly for storage. The invention consists of a roof formed of two roof sides, held together by novel fastenings.

The rafters are provided at each longitudinal edge with a series of apertures, which receive the upper hooked ends of straps attached to the ends of the inner surfaces of the roof boards, the hooks projecting inward from the upper edges of the boards. The lower ends of the straps or bands project from the lower edges of the boards, which are overlapped, as shown in the engraving, the hooks being passed into the apertures in the rafters, and the lower ends of the straps being passed through staples on the outer surfaces of the boards.

The hooked rods are forced into the hay or other material through the apertures in the rafters, in such a manner that the hooks or barbs catch on the hay or other material, and

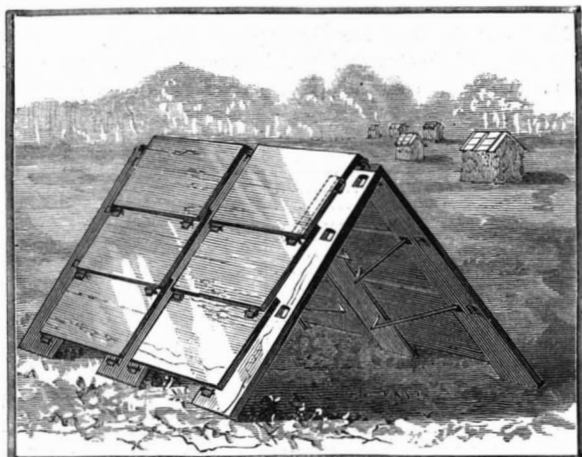

**McEVROY'S PORTABLE ROOF FOR HAY AND GRAIN RICKS.**

the heads rest against the outer surfaces of the roof sections. If desired, this roof can also be supported by posts with suitable framework, by which means a cheap and efficient shelter may be obtained for implements, machinery, or live stock.

The upper board of one side is to be extended over the ridge to protect the same. The entire sides of the roof can be stored away, or the boards can be detached from the rafters, and the detached boards and rafters can then be stored. As no nails, bolts, or screws are required to secure the boards on the rafters, the boards can be attached or removed very easily and rapidly.

This invention has been patented by Mr. Wm. McEvoy, of Equality, Ill.

**BALING PRESS.**

Many devices have been used for obtaining pressure, the most prominent among which are the lever, the common screw, and the hydraulic, none of which develop a progressive power, but, on the contrary, are only enabled to give the same power and movement of platen at the end as at the beginning of the work. In pressing most substances but little power is required in the early part of the operation, but as the pressure is applied the resistance increases, requiring a corresponding increase of power, until at last the resistance becomes so great that no amount of power can wholly overcome it.

With the press herewith illustrated the power increases at every turn of the screw, the platen decreasing in motion in

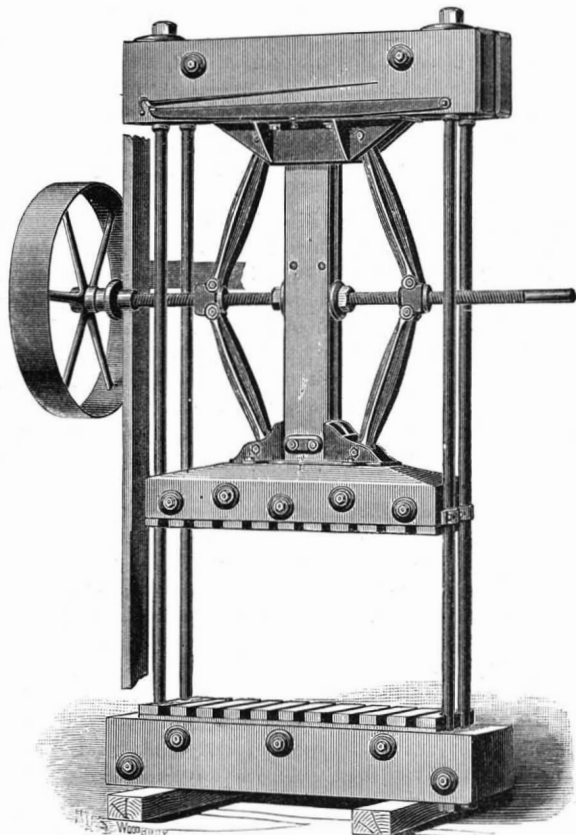

**BOOMER & BOSCHERT'S BALING PRESS.**

the same ratio, so that the increase of resistance and development of power are so nearly equal that the work is easily accomplished from beginning to end.

This press seems well adapted to the purpose of baling goods. It is operated by a belt from the pulley on the end of the screw to a countershaft, on which are pulleys for crossed and open belts, which revolve the screw in either direction, as desired. We are informed that the manufacturers furnish presses of this description for any size of bale, and that they also make them wholly of iron.

Further information can be obtained by addressing the manufacturers, Boomer & Boschert Press Company, Syracuse, N. Y., or 62 Vesey Street, New York city.

**Bottled Beer.**

The following directions for bottling and keeping beer will be of interest to consumers as well as bottlers:

1. In cold weather beer can be drawn from the keg and bottled as soon as it is received, but in warm weather it foams so that it is necessary to keep it several days in a cool cellar, if it has got warm in transport, before tapping.

2. The bottles must be very thoroughly washed each time before filling with warm water and soda, then rinsed repeatedly with cold water until all the soda is washed out, to prevent the beer tasting of soda.

3. Great care must also be devoted to the corks. Those that have been bored or broken must never be used under any circumstances. Whether new or old corks are used they must be soaked in warm soda solution and repeatedly washed with cold water until perfectly cold. It is better, however, not to use corks in beer bottles that have already been used once.

4. In filling the bottles a wooden spigot is used with a piece of rubber tubing attached that reaches to the bottom of the bottle, so as to prevent foaming as far as possible. The bottle is immediately corked, so that the carbonic acid may not escape, and the cork driven down with a small wooden hammer. Great attention must be given to the cleanliness of the rubber tubing and spigot, rinsing them with soda solution before each time of using. [And afterward, too?]

5. The bottled beer should be kept in a cool, dark place, and setting upright is preferable to letting them lie on the side. Every beer has some sediment. When the bottles stand up this sediment becomes attached to the bottom of the bottle, so that if the beer is poured out carefully all except the last glass will be clear and free from turbidity.

6. When drunk beer should always have a temperature of 48° or 50° Fahr. The flavor and effervescence are best at that temperature. If much warmer than 52° any beer will taste flat. Drinks that are too cold injure the stomach. A little practice soon enables a person to judge correctly of the temperature by feeling.

7. In warm weather beer should be used within about eight or ten days after filling. During cold seasons it keeps rather longer—up to two weeks even without injury.—*Gewerbeblatt für Hessen.*

**Rules for Laying Drain Pipes.**

The New York Board of Health require that earthenware drain pipes connecting dwellings with street sewers shall be hard and salt glazed, sound, and cylindrical; at least five-eighths of an inch thick if five inches in diameter, and three quarters of an inch thick if six inches in diameter. Pipe must be connected with hydraulic cement of the best quality. No “tempered” cement can be used. The pipes must be laid with such good alignment that the inspector can see through the entire line from the house to the sewer, and every section must be bedded in cement so as to have a firm bearing, not only at the hub, but along its entire length. The inside of the drain must be freed from all cement which may have oozed through at the joints, and from all other obstructions. Before the drain is covered notice must be sent to the Health Department, by the owner or plumber, that the inspector may visit and examine the work, and the Board of Health will not approve or permit a drain which has not been examined by one of its inspectors and found to be properly constructed.

**The Use of Lime in Coal Mining.**

A series of experiments took place on the 28th of August, says the *St. James Gazette*, in the workings of the Wharfedale Silkstone Collieries, near Sheffield, the object being to test the new method of winning coal by the use of compressed lime instead of blasting powder. The experiments took place in the Parkgate Seam. A hole about three inches in diameter and four feet deep was drilled through the solid coal and cleaned out; a perforated iron tube was then inserted, and the lime cartridge, three inches long, put in. When the lime had been rammed home and the hole made up, a force pump was used to inject water into the bottom of the tube. Simultaneously with the injection of the water the rending process began, and in thirty minutes about ten tons of coal came down almost in an unbroken mass. Of the whole of the fall, not more than six per cent of the coal was small, a much smaller percentage than under the old system. It is predicted by some of the oldest miners that compressed lime will eventually supersede the use of blasting powder and thus revolutionize the system of winning coal.

**NEW MILLSTONE PAINT STAFF.**

This invention is a working or test guide for paint staffs used in dressing millstones. It is designed to facilitate the work of obtaining a perfect running face. The guide is applied to the spindle, so that the weight of the guide and staff is carried upon the spindle, and not upon the face of the stone. By means of this arrangement all inequalities or variations in the surface of the runner can be readily detected.

In using this guide it is hung on the spindle by passing the eye-piece over the spindle and adjusting the slide so that the screw shall bear upon the upper end of the spindle at the center. By turning this screw the guide is slowly raised or lowered, as required, and the weight of the guide and the staff is wholly supported by the screw. The staff may be moved freely around upon the spindle, and by low-

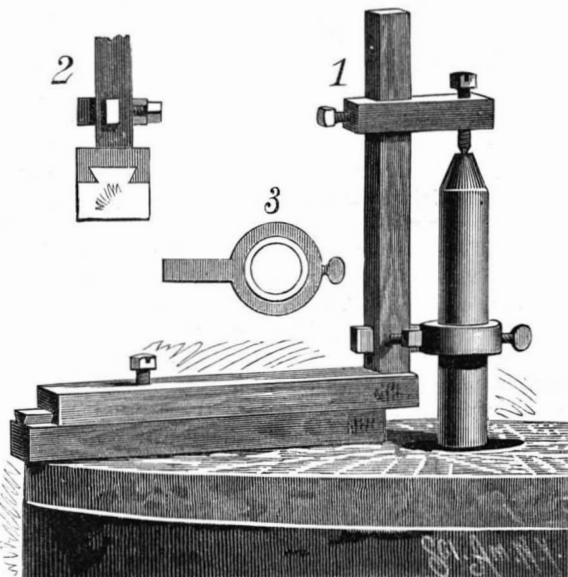

**DAVIS' MILLSTONE PAINT STAFF.**

ering the guide the staff will touch lightly upon the high places of the stone as it passes around. Then, by removing the marked projections with a pick, and repeating the operation until the staff marks the face evenly, the burr will be brought to a perfect face.

With this guide the work of facing a runner is made simple and easy, and there is no liability of making one side higher than the other.

In order to adapt the guide for use with spindles of different sizes, the eye-piece is provided with a collar, held in place by a set screw. These collars are of different diameters for fitting spindles of different sizes.

This invention has recently been patented by Mr. T. E. Davis, of Range, Ohio.

### DECISIONS RELATING TO PATENTS, TRADE MARKS, ETC. United States Circuit Court.—District of New Jersey.

THE BATE REFRIGERATING CO. vs B. W. GILLET  
et al.—FOREIGN PATENT EXTENSIONS.

Nixon, D. J.:

On petition to dissolve injunction.

On the 14th of November, 1881, a decree was entered in the above case, sustaining the validity of complainants' letters patent, and ordering an account and an injunction against the defendants, restraining them from further infringement.

The defendants now file a petition, setting forth that the letters patent for the infringement of which the suit was brought were the letters patent of the United States, numbered 197,314, granted to John J. Bate, of the city of Brooklyn, N. Y., on the 20th of November, 1877, for the term of seventeen years from that date, for "Improvements in the process for preserving meats during transportation and storage." That prior thereto, to wit, on the 9th of January, 1877, letters patent of the Dominion of Canada, No. 6,938, were granted to the said Bate for the same invention or discovery for the term of five years from January 9, 1877; that the said term for the foreign patent expired on the 9th of January, 1882, by reason whereof the letters patent of the United States, No. 197,314, expired at the same time as the said Canadian letters patent, as provided for by Section 4,887 of the Revised Statutes of the United States.

The petition further alleges that the invention or discovery of Bate, having previously been patented by him in the Dominion of Canada, the said letters patent of the United States should have been so limited as to expire with the same time as the foreign Canadian patent; and the granting of the patent in the United States for the term of seventeen years from the 20th of November, 1877, was in direct violation of Section 4,887 of the Revised Statutes, by reason whereof the same were and are null and void.

The prayer of the petition is that the injunction heretofore ordered and issued may be dissolved.

The inventor Bate first took out Canadian letters patent for five years. He afterward procured extensions: first on December 12, 1881, for five years from January 9, 1882; and secondly, on December 13, 1881, for another five years, to be computed from the expiration of the prior extension, to wit, from January 9, 1887.

What effect had these extensions on the life of the United States patent? Under the provisions of Section 4,887, must its term be made to expire with the term of the foreign patent in force when the letters patent were granted, or do these extensions of the foreign patent save the domestic patent from lapsing, when the term ends, which was running at the grant of the domestic patent?

The question is an interesting one, and has already received examination and answer in other circuits.

It first came before the late Justice Clifford, in the First Circuit, in the case of *Henry vs. The Providence Tool Company*, decided in 1878, and reported in XIV. *Off. Gaz.*, 855. In that case, the United States patent had been issued under the act of July 8, 1870, for the full term of seventeen years, although at the time of the grant there was an English patent for the same invention in force, which had been granted to the patentee in Great Britain, for fourteen years from the 15th of November, 1860.

The defendants claimed that the United States patent expired, by operation of law, at the same time with the English patent. The complainant, on the other hand, insisted that the language of the statute extended not only to the term of the foreign patent in force when the United States patent was obtained, but also to the term of any prolongation which the patentee might secure from the foreign government, and that as he had obtained an extension of four years to the original term, the owners of the domestic patent were entitled to add these four years to its life.

Judge Clifford refused to accede to such a construction of the law, but, on the contrary, held: 1. That by the provision of the act of July 8, 1870, Congress never intended to extend the term of the domestic patent beyond the legal term secured to the foreign patentee when the domestic patent was granted. 2. That the prolongation of the English patent for a further term after the expiration of the original, did not save the domestic patent from lapsing under the statute.

He was followed in this construction of the section by Judge Blatchford, of the Second Circuit, in 1879, in the case of *Reissner vs. Sharp*, 16 Blatch. 383. A patent had been granted by the United States on the 20th October, 1874, for seventeen years from that date. It appeared that, under the authority of the patentee, letters patent had been previously obtained in Canada for the same invention, for five years from May 15, 1873. After careful consideration, the learned judge held that the United States patent expired on the 15th of May, 1878, although it appeared that in March, 1878, the Canadian patent had been extended for five years from May 15, 1878, and also for five years from the 15th of May, 1883. There was an attempt made to distinguish the case from *Henry vs. The Providence Tool Co.*, *Supra*. 1. Because the Canadian patent had not expired when the extension was granted; and 2, because the extension, by the terms of the Canadian law, was not a matter of favor, as it was under the English act. But the judge could not perceive that these considerations were of sufficient force to cause any other conclusions as to the plain meaning of the statute than that arrived at by Mr. Justice Clifford.

We are clearly of the opinion that the prayer of the petition should be granted and the injunction be dissolved. Whether the complainant's United States patent is void *ab initio*, because the term was not limited on its face to expire with the same time as the foreign patent, is not properly before the court on this motion. It was a defense to the suit of which the defendants did not choose to avail themselves, and a formal interlocutory decree entered in the case cannot be impeached in and by any such collateral proceeding.

### TRADE MARK DECISIONS.

*Britton vs. Stratton et al.*—U. S. Circuit Court, E. D. Michigan, Fed. Rep. August 1, 1882. The question of the right to the use of trade marks is carefully discussed. The principal question involved was whether the words "Twin Brothers," used as a trade mark in connection with a certain kind of yeast manufactured by the complainant, are a trade mark of such character as entitles the complainant to be protected in his monopoly of them. The point is not free from difficulty. The cases concerning the validity of trade marks are very difficult to reconcile, but the following propositions are stated as settled:

That a court of equity will enjoin unlawful competition in trade by means of simulated label, or of the appropriation of a name; as when the defendant appropriates the name of a hotel conducted by the plaintiff, or imitates his label upon preparations. The ground of interference in this class of cases is fraud, that is the attempt to palm off the goods of the defendant as the goods of the plaintiff. A court of equity will not protect a person in the exclusive use of a word which expresses a falsehood, as if the article bears the word "patented" when in fact it is not patented, or exhibits an untruth as to the place of manufacture or composition of the article. That no one can extend his monopoly of a patented trade mark. By the expiration of the patent the public acquires the right not only to make and sell the article, but to make and sell it under the name used by the patentee. A person cannot by means of a trade mark monopolize the name of the place where the article is manufactured. Nor the ordinary numerals or letters. This proposition, however, has been disputed. Nor can a person monopolize a name expressive of the character or composition of an article. Nor when the words are expressive only of the name and quality of the article, and have acquired that significance in the market.

The complainant claimed that he had bought from the defendant Stratton and his brother the entire right to the use of the trade mark, and asked that the defendants be enjoined from using the name of "Twin Brothers" in connection with the sale of yeast. The defendants insisted that the complainant should not be protected in the use of the trade mark, because in using it he represents that he was the originator of the yeast in question, which was not the fact; and that Twin Brothers is a generic name of a compound made under a discovery of the defendant Stratton. The difficulty is in distinguishing the case where the property has acquired a generic name as indicating the quality of the article rather than its origin or ownership. It is a matter for the court to determine in each case from the testimony as well as from the mark itself, whether the words used as a trade mark have become so well known as to denote to the public the character and quality of the article and not its origin or ownership. Mere words may become valid trade marks when they are merely arbitrary, or are indicative of origin or ownership in the original proprietor. Words which have acquired a significance in the marks as expressive only of the name or quality of an article cannot be appropriated as a trade mark. But if the primary object of the trade mark be to indicate origin or ownership, the mere fact that the article has obtained such a wide sale that the mark has also become indicative of the quality, is not of itself sufficient to debar the owners of protection, or make it the common property of the trade. But if the name be suffered to come into general use without objection from the proprietor, it may become merely generic or indicative of quality.

A trade mark indicative of origin or ownership in the proprietor of a certain business may be sold or assigned by him as an appurtenance of such business, and the assignee may become entitled to the exclusive use of such mark, even as against such proprietor himself. *Held*, That the right to use the words "Twin Brothers" in connection with portraits of the twins had been lawfully assigned to the plaintiff, and that he was entitled to an injunction against one of the twins who had set up a separate establishment and was making use of the trade mark in manufacturing yeast.

The subject of trade marks is also discussed in the case of the *Shaw Stocking Co. vs. Mack et al.*, U. S. Circuit Court, N. D. N. Y., Fed. Rep., August, 1882. The question here was upon infringement by reason of a similitude between the labels used by the defendants and those of the complainant, to which it claimed an exclusive right as a trade mark. The principal question was as to which the complainant had an exclusive right to the number "830" to designate and distinguish those of a particular variety made by it. *Held*, That where numerals constituted one of the most prominent features in complainant's design for a label, and the same numerals were used in a similar design by the defendants, such use upon the same kind of articles is calculated to deceive and is an infringement. It is enough that such a similitude exists as would deceive an ordinary purchaser, not an expert or such as would not be easily detected, if the

original and spurious were seen together. The right to a trade mark is a right depending on use. Complainants had used the numerals in question long enough to convey a precise understanding when such numerals were used alone, and its right to their exclusive use should be upheld. Injunction granted.—*New Jersey Law Journal*.

### Watering Plants in Pots.

Some people attempt to keep pot-plants without giving them any water at all; the result is familiar to every one. Usually, however, the earth in the pot or box is kept soaked and very much in the condition of an ordinary swamp. It is even said that malaria has resulted from living in rooms containing house plants owing to the damp soil. We have ourselves seen dead evergreens pulled out of boxes full of mud. *Neueste Erfindung* gives utterance to the following timely remarks:

Watering plants is one of the most important things in the culture of house plants, and very special care should be devoted to it. Plants ought not to be wet until they need it. It will be evident that they require wetting, if on taking the earth from the pot it crumbles to pieces like dust, a sure sign is to knock on the side of the pot, near the middle, with the finger knuckle. If it gives forth a hollow ring, the plant needs water; if there is a dull sound, there is still moisture enough to sustain the plant. Plants must not be wet more than once or twice a day; on dry, clear days they require more water than on damp, cloudy days. On the other hand the earth must not be allowed to dry out entirely, for that is also very injurious. In wetting them the water must be poured on in such a way that it will run out again through the hole in the bottom of the pot. If the earth gets too dry, it is best to place the pot in water so that the water will saturate the dirt very gradually. They may be watered at any hour of the day, except when the sun is shining on the pot or has just left it; for the earth gets hot when the sun shines on it, and then if cold water is poured on it, it will cool off too rapidly. The best time for watering flowers in summer is the evening, and in winter noon is best. Well water should never be used, but always use either rain water or brook water.

### The Railway Mileage of the United States.

The *Railway Age* compiles from "Poor's Manual" the following table, showing the railway mileage of each State on Jan. 1, 1882, with the numerical rank of the several States in railway enterprise.

1. Illinois.....	3,326	25. South Carolina.....	1,484
2. Pennsylvania.....	6,690	26. Mississippi.....	1,332
3. Ohio.....	6,664	27. Maryland and D. C.....	1,048
4. New York.....	6,279	28. Arkansas.....	1,042
5. Iowa.....	6,113	29. New Hampshire.....	1,026
6. Texas.....	5,344	30. Maine.....	1,022
7. Indiana.....	4,765	31. Louisiana.....	999
8. Michigan.....	4,284	32. New Mexico Ter.....	975
9. Missouri.....	4,211	33. Connecticut.....	959
10. Kansas.....	3,718	34. Vermont.....	916
11. Wisconsin.....	3,442	35. Utah Ter.....	908
12. Minnesota.....	3,391	36. Nevada.....	890
13. Georgia.....	2,581	37. Florida.....	793
14. Nebraska.....	2,310	38. West Virginia.....	712
15. Colorado.....	2,275	39. Oregon.....	689
16. California.....	2,261	40. Arizona Ter.....	557
17. Virginia.....	2,194	41. Wyoming Ter.....	533
18. Tennessee.....	1,974	42. Washington Ter.....	480
19. Massachusetts.....	1,935	43. Delaware.....	273
20. Alabama.....	1,804	44. Indian Ter.....	275
21. New Jersey.....	1,753	45. Idaho Ter.....	265
22. Kentucky.....	1,715	46. Montana Ter.....	232
23. Dakota Ter.....	1,639	47. Rhode Island.....	211
24. North Carolina.....	1,619		
Total miles.....			104,813

### Area of Yacht Sails.

No yacht in the New York yacht fleet is more completely fitted in racing and cruising canvas than the Montauk. The following table gives points of interest:

SAIL.	Yards.	Width in Inches.	Square Feet.
Jib topsail (large).....	360	28	2,343
Flying jib.....	290	14	816
Jib.....	445	14	1,292
Lug foresail.....	665	14	1,675
Mainsail.....	925	14	2,636
Foretopsail.....	170	14	442
Maintopsail.....	180	14	500
Topmast staysail.....	170	28	884
Balloon topmast staysail.....	620	28	3,827
Balloon club topsail.....	135	28	840
Balloon jib.....	390	28	2,700
Spinnaker.....	380	28	2,640
CRUISING SAILS.			
Boom foresail.....	550	14	1,408
Fore staysail.....	280	14	780
Jib.....	225	14	650
Awings, covers, traps, etc.....	700	22	3,675
Totals.....	6,580		26,736

### Isolation in the Paris Maternité.

M. Tarnier, in a letter recently addressed to the Soc. Médic. des Hôpitaux, recalls the very extraordinary results obtained by isolation, the use of antiseptics, and all means proper to ward off contagion. In the new pavilion he has had constructed, in which each chamber can only be entered by a separate door opening outwardly, without any aperture toward the hospital except a single large pane of glass let into the wall, permitting the surveillance of the patients, he has had but 6 deaths in 1,200 cases of labor. Within the past few years even there have been 600 cases without a single death. No statistics ever published have shown such favorable results as these of M. Tarnier.



Correspondence.

Difficulties of Inventors.

To the Editor of the Scientific American:

I have been a reader of your valuable paper for the past four years, and I have watched very closely and with a great deal of interest the different inventions you have illustrated, and more particular, railroad improvements. I saw an article in your issue of September 2, 1882, a list of "railway improvements needed." I feel very much on this subject as a writer of your paper some time ago expressed himself on the article of "car couplings"—no railroad company will adopt any good one until compelled to by law; and it is about the same with any other railroad appliance, or, at least, my experience with railroad companies the past three years proves to me.

In your article of September 2, 1882, you claim among other improvements needed is a machine for clearing the "flangeways" of ice and snow. I have a machine for this purpose, patented 1879. I have shown to six railroad master mechanics the model, and they all agree that the machine will do all I claim for it; besides, I have a full sized one which I have run on the railroad until I am satisfied I can do all I claim, and all railroad men who have seen it work will say the same. To give you some idea of the machine and the work it will do, I will state that I can clear the flanges of any railroad track filled level full of solid ice and snow, and will cut down on the inside of the rails one and three fourths inches deep by ten inches wide, and throw the same on the outside of the track, the same as a man would do with a pick and shovel, and I can do it as fast as any engine can run an ordinary train, and can clear more track of ice and snow in one day than one thousand men can do with picks and shovels. I will back my statement by putting the machine on any railroad, and if I fail to do all I claim I will pay all cost of attaching. I ask no railroad company to buy until I show them what I can do. My experience teaches me that no inventor in ordinary circumstances can reach the proper man to buy or adopt for trial his invention (and most railroad inventions need to be tried to be perfected). You may go to a railroad superintendent in summer and talk to him about an ice cutter for his railroad, and he will answer you about the same as the man who had the leaky roof—when the sun shone he did not need it shingled; and go to one in the winter, when the track is full of ice, and he is busy and has no time to notice you. Besides, he says, our track is filled so travel is stopped, and our men are all idle and nothing to do but use the pick and shovel and clear the track. What show or encouragement has an inventor got to study up any of the "railroad improvements needed" when he cannot get any notice from the railroad companies? If you or some correspondent will state in your paper some way inventors can get good improvements for railroads adopted, then it will be a pleasure to furnish them with the improvements needed; but not so long as the inventor with his machine has to hang around on the outside of a railroad superintendent's door like a beggar at a rich man's gate. INVENTOR.

[It appears from our correspondent's statements that he knows how to invent; but he has not yet acquired the noble art of doing business with railway officials.]

Test for Pepsin.

To the Editor of the Scientific American:

The several American dispensaries differ considerably as regards a good test for pepsin pure. The following is a good test, and is much used:

- R. Pure pepsin..... 0.05 gramme.
- Coagulated albumen..... 10 grammes.
- Muriatic acid..... 0.5 c. c.

Place in a flask and digest on a water bath for six hours at a temperature of 38° to 40° C. (102° F.), shaking vigorously every half hour. At the end of six hours the albumen should be entirely dissolved. GEO. S. WOODS.

New York, September 15, 1882.

On the Essential Oils.

BY DR. AUGUST BELOHOUBEK.

Freshly distilled oil of turpentine contains no oxidized products, and hence no resinous matters, for, owing to their slight volatility, they remain behind in the retort; while an oil that has been kept in open vessels absorbs oxygen from the air and hence contains rosin.

Various observations have forced us to the view that substances composed of carbon, hydrogen, and oxygen mix with other liquids—that is, mutually dissolve each other more easily the more similar they are chemically. The exceptions to this rule are very few.

If we apply this rule of the mutual solvent power of allied substances to the oil of turpentine recently distilled, we can predict that, being a hydrocarbon, it will dissolve easily in other hydrocarbons; and the more readily the more nearly the hydrocarbon series to which they belong are related to each other, and the less they differ in the number of carbon atoms in the molecule.

But how will it be with the old, oxidized, and hence resinous oils which contain but a few per cent of resin. Such resin differs from the oil, C<sub>10</sub>H<sub>16</sub>, in containing one or two atoms more of oxygen, and one or two molecules of water, so that it is tolerably similar to the pure oil and soluble in it; but it differs considerably from other hydrocarbons, especially if they contain but little carbon and comparatively more hydrogen in the molecule, and therefore do not readily mix

with it. This supposition was confirmed by experiment. I selected as a cheap reagent the petroleum ether which boils at about 104° Fah (40° C.), and is a mixture of pentanes, C<sub>5</sub>H<sub>12</sub>, etc. Fresh oil of turpentine mixes in all proportions with this naphtha, and the mixture remains clear, while lumps of rosin separate from the old and oxidized oil.

This experience induced us to extend the experiments to other essential oils similar to turpentine, and it was expected that oil of lemon, of orange-peel, and of juniper would act in the same way toward petroleum ether.

Experiment confirmed this expectation. Not merely the oils named, but many other fresh oils could be distinguished in this way from older oils. viz., the oils of anise, fennel, peppermint, mint, and rosemary. Beside these I also tried old *oleum caryophyllorum*, *carvi*, *macidis*, *cinnamoni*, *salviae*, *serpylli*, and *thymi*, but could not compare the results with those of fresh oils of the same kind because I had none of the latter on hand.

I consider such experiments very useful, and recommend any one who has an opportunity, whether apothecary or oil manufacturer, to test the action of other oils toward petroleum ether and publish his results.

The experiment is performed by dropping one drop of the oil into a dry test tube, and then a drop of naphtha, and observing whether the mixture remains clear or becomes turbid. After we add two, then three and more drops of naphtha, and can be certain whether a white precipitate or a milky turbidity, or even an opalescence results from the presence of a resin.

When old oil of anise was used it did not mix with naphtha, but the fresh oil was miscible in every proportion. Oil of orange gave a turbid mixture; oil of lemon, the resin was deposited on the side of the test tube; oil of fennel only partially dissolves when old; oil of juniper forms white lumps; oil of peppermint becomes turbid; while oil of rosemary scarcely mixes at all. Fresh oil of turpentine, after standing open a week or two, becomes turbid. If alcohol is added to the oils the reaction will not take place.—*Liqueur Fabrikant*.

CHECK REIN HOLDER.

An improvement in check reins, which largely increases the power of the driver over a horse, is shown in the accompanying engraving. A short strap, having suitable branches attached to and extending out from it, is hooked on to the water hook of the back saddle of the harness. The branches extend along each side of the neck of the horse through loops on the ends of short straps attached to and extending backward and downward from the overdraw straps of the

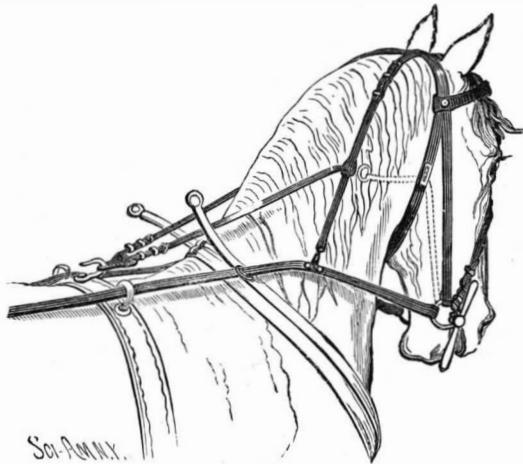

HARDING'S CHECK REIN HOLDER.

bridle. From these loops the branches are carried down to connect with the driving reins in a parbuckle arrangement, by which the tension of the check rein is increased and relaxed in uniformity with that on the driving rein. With this construction the permanent check is dispensed with, and the horse's head is elevated by the assistance which the parbuckle arrangement gives when the reins are drawn.

This improvement has been patented by Mr. Harry T. Harding, of Maitland, Nova Scotia.

The Nicotine in Cigar Smoke.

Kissling has made some experiments in smoking cigars with an aspirator and drawing the smoke through a cooler and five bottles, the first and third being empty, the second filled with alcohol, the fourth with dilute sulphuric acid, and the fifth with caustic soda. In four experiments 50, 42, 132, and 100 cigars were smoked respectively. The percentage of nicotine was 3.75, 3.75, 0.295, and 0.19. In the fifth experiment the tips and ends of those used in the first experiment were used; and in the sixth the cigar stubs left by a smoker were tested for nicotine and were found to contain 2.51 per cent., the cigar having had 2.24 per cent., a very slight increase of nicotine.

The general results were as follows:

The active poisonous constituents of tobacco smoke are carbonic oxide, sulphydric acid, prussic acid, the picoline bases, and nicotine. The three first named are present in tobacco smoke in too small quantities and are too volatile to deserve any consideration in judging of the effect of using tobacco on the system. The picoline bases are present in the smoke in relatively small quantities, so that the poison-

ous qualities may be attributed almost exclusively to the nicotine. The amount of nicotine in smoke depends chiefly on the quantity of nicotine in the tobacco, but the relative amount of nicotine that a cigar gives out in its smoke depends on the size of the unsmoked stump, and stands in an inverse proportion to it.

The quantity of nicotine destroyed by combustion of a cigar is relatively small.

It must be remembered that, although very little carbonic oxide is sucked into the mouth, a considerable quantity is given out at the other end and inhaled through the nostrils. As nicotine is soluble in alcohol it is probable that the use of alcoholic beverages prevents its local accumulation and hastens its removal from the body. [Rum and tobacco are well known as twins.]

Of a similar nature are the experiments of Dr. Troitzsky upon the influence of tobacco smoking on temperature and pulse. He made some six hundred observations on twenty-five persons, grouped according to constitution. The main result was that tobacco smoking has a stronger influence on the pulse than on the temperature. Taking all the classes of persons together, the mean temperature on smoking, as against non-smoking days, showed an increase of in the ratio of 1,008 to 1,000; while the ratio for the pulse was as 1,180 to 1,000.

A Picture from Pompeii.

Mr. E. N. Rolfe, writing from Naples, says: An important painting has been found at Pompeii, and placed in the Naples Museum among the Pompeian frescoes. It represents the judgment of Solomon, and is the first picture on a sacred subject, the first fragment either of Judaism or Christianity, that has been discovered in the buried cities. The picture is 5½ feet long and 19 inches in height, and is surrounded by a black line about an inch in width. The scene is laid upon a terrace in front of a house adorned with creeping plants and shaded with a white awning. On a dais (represented as being about four feet high) sits the King, holding a scepter and robed in white. On each side of him sits a councillor, and behind them six soldiers under arms. The King is represented as leaning over the front of the dais toward a woman in a green robe, who kneels before him with disheveled hair and outstretched hands. In the center of the court is a three-legged table, like a butcher's block, upon which lies an infant, who is held in a recumbent position, in spite of his struggles, by a woman wearing a turban. A soldier in armor, and wearing a helmet with a long red plume, holds the legs of the infant, and is about to cleave it in two with his falchion. A group of spectators completes the picture, which contains in all nineteen figures. The drawing is poor, but the colors are particularly bright, and the preservation is excellent. As a work of art, it is below the average Pompeian standard, but it is full of spirit and drawn with great freedom. The bodies of the figures are dwarfed, and their heads (out of all proportion) large, which gives color to the assertion that it was intended for a caricature directed against the Jews and their religion. This may be so, but my own impression is that the artist was anxious to develop the facial expression, and to do this, exaggerated the heads. There is nothing of the caricature about it in other respects—the agony of the kneeling mother, the attention of the listening king, and the triumph of the second woman, who gloats over the division of the child—are all manifest, and to my mind there is no attempt, intentionally, to burlesque the incident; but this is a matter of opinion.

Compressed Air Locomotives.

At a recent meeting of the British Association a paper was read by Sir F. Bramwell, on "Compressed Air as Applied to Locomotion." He described an improved air tram, running from Doulon to Chautonay, at Nantes, by the side of the river Loire. A car on similar principles has been designed by Sir F. Bramwell for experimental running on the Caledonian Road, London. For the purpose of securing the necessary power to work the car on ascents on the tramway lines there are certain air reservoirs, from which a reserve of highly compressed air may be turned on at a moment's notice. The compressed air is pumped into the reservoirs at the terminal stations. Each car weighs 6½ tons unloaded, and is seated for nineteen passengers inside and fifteen outside. The air is compressed to thirty atmospheres above the ordinary atmospheric pressure. The consumption of fuel required to work a portion of the machinery on the car is about twelve pounds per mile. The system worked admirably at Nantes. The tramway line was 3¾ miles long; the cars were always crowded, and the travelers were thoroughly satisfied with this method of locomotion. The cost per mile per hour was said to compare favorably with horse traction.

Captain Galton believed that some form of tramcar worked by compressed air would ultimately take the place of horse and steam traction because of the great convenience which it would be in a town, especially from the absence of all noise.

Mr. Crampton thought the engine described by Sir F. Bramwell was the best and most simple system he had seen for using compressed air.

Sir John Hawkshaw agreed with those who thought the time would come when compressed air would be applied extensively.

In the SCIENTIFIC AMERICAN of September 9, we gave an engraving of the Hardie compressed air locomotive lately tried in this city.

**IMPROVED SQUARING SHEAR.**

We give an engraving of a new squaring shear recently introduced to the trade by the Niagara Stamping and Tool Company, of Buffalo, N. Y., for the use of tinner, can-makers, and others.

This shear has several new and desirable features. Instead of the usual springs for lifting the treadle, this shear has a very strong and durable weight device, not liable to derangement. On the cross-head carrying the upper knife there is a hold-down or clamp, similar to that of paper cutters, which comes down upon the tin and holds it rigidly to the table before the knife begins to cut, thus preventing the "drawing" of the tin. On the back of the shear is a metallic pan into which the tin cuttings are discharged, and on the top of the cross-head is a shelf to receive patterns, tools, etc., while adjustment is being made. The new gauges attached to these shears allow of adjustment to the smallest fraction of an inch by means of micrometer screws. When once set these gauges are not liable to move accidentally, and are, therefore, much more reliable than ordinary gauges. They fit squaring shears of any make, so that any one having a squaring shear without the patented improved gauges can avail himself of their advantages by ordering them from the manufacturers.

Three sizes of this machine are made: a 22 inch for tinner's use, a 32 inch for stovepipe work, etc., and a 42 inch shears for large work, cornice-makers, etc. The shears can be furnished either plain—that is, with springs and the usual gauges—or with any one or more of the new attachments, and these attachments (except the clamp or hold-down) can at any time be added to the shear.

The Niagara Stamping and Tool Company is largely engaged in the manufacture of presses, dies, and tools for making tinware, fruit cans, etc., and our readers who may be in want of further information in regard to them can obtain it by writing to the company.

**Utah Coal.**

A block of coal, 4 feet wide, 4 feet high, and 10 feet long, weighing 12,900 pounds, was taken on a flat car to the Denver Exposition to be exhibited. It was taken from a coal mine in Utah owned by the Denver and Rio Grande Railroad Company, who are now building a road from Salt Lake City east, to intersect their line to the Rio Grande. This company is at war with the Union Pacific, and rather than patronize or accept a favor from that road they send the coal, which was mined a few hundred miles of Denver, north on the Utah Central to Ogden; thence west, on the Central Pacific, to Lathrop, Cal.; thence south to Yuma, and east to New Mexico, on the Southern Pacific; and thence north, on their own road, to Denver.

**CLAMOND'S INCANDESCENT GAS LAMP.**

Every one is acquainted with the Drummond light, which is obtained through the combustion of a mixture of hydrogen and oxygen that raises a lime or magnesia crayon to a white heat.

Now, Mr. Clamond's new lamp is nothing else than the Drummond light rendered practical. The invention involves two characteristic improvements: (1) a substitution of atmospheric air, which is within reach of every one, for oxygen, which has to be manufactured; and (2) substitution of a wick of woven magnesia for the magnesia or zircon crayon.

For obtaining high temperatures, air may be substituted for oxygen on condition that it be itself raised to a high temperature; and it is by doing this that Mr. Clamond has been enabled to obtain an effect similar to that produced by oxygen in the Drummond light. But it is not so easy as might be supposed to raise to a high temperature, and within a very short circuit, a quantity of air six times greater than that of the illuminating gas. The velocity of such air, which is not much of a conductor of heat, must, in fact, be very great. Mr. Clamond has solved the problem by means of a very simple apparatus, which will be described further along, and which has the effect of putting all portions of the current of air in contact with the sides of a small tube of refractory earth heated externally.

The new burner has a double system of tubing, one for ordinary gas, and the other for air under a pressure of 35 to 40 millimeters of water. We learn that thus far only two types have been constructed—one burning 180 liters of gas, and

giving 4.15 Carcels (equal to 43.3 liters per Carcel), and the other consuming 500 liters of gas, and giving 18 Carcels (equal to 27.7 liters per Carcel).

Leaving aside for the present the production of air under pressure, let us study the operation of the burner, of which, in the accompanying figures, there is given a general view, a view of a burner divested of its jacket, a longitudinal section, and horizontal sections at different heights. A (Fig. 3) is a disk carrying two coupling-tubes designed to receive the ends of the pipes that introduce the air and gas. B is a disk perforated with small holes, and forming a distributor, which serves for distributing the air and gas in suit-

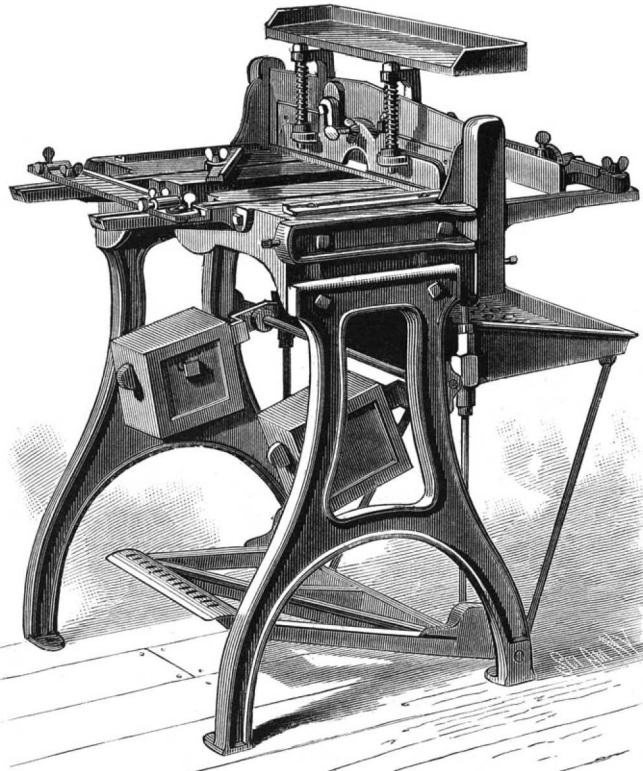

**IMPROVED SQUARING SHEAR.**

able proportions through the burner properly so-called. For this reason it carries no less than five series of holes of variable number.

A certain quantity of gas mixes with a suitable proportion of air, and enters four pendent tubes, K, which are perforated with holes. The mixture burns, and the flame licks the superheater, G, which is thus raised to a very high temperature. Another portion of the gas mixes with a second quantity of air, and enters, through the tube, L, the lower part of the burner, where it inflames. Finally, a third quantity of air enters through the center of the burner at F, traverses the superheater, G, and, by impinging against the sides, rises to a temperature of about 1,000°, and makes its exit through a series of apertures in the refractory piece, H. The combustion of the gas under the action of air at so high a temperature produces a jet of exceedingly hot gas,

wound upon a conical mould that has a double backward and forward rotary motion. The cone, once formed, is taken from the mould and baked so as to give it the requisite solidity. In the lamp it is held by a small platinum wire basket that may be seen in Fig. 2. The magnesian basket thus prepared is capable of furnishing light for about forty hours, after which it must be replaced by another, inasmuch as the diameter of the threads of which it is composed diminishes through the escape of the material in the form of an impalpable powder. The platinum wire support in which this magnesian wick is placed is mounted with a bayonet catch, so that the wick may be removed and replaced with the greatest facility. The present price of these wicks does not exceed twelve centimes, but it will be much lower in the future.

The light produced possesses all the equalities of incandescence, that is to say, perfect steadiness, and a very warm yellowish color, between the whiteness of daylight and the yellow light burning in ordinary gas burners. As the wick burns at the base of the lamp no shadows of the latter are cast. It will be observed that the quality of the gas plays no part in the light produced, since the latter results from the incandescence of the magnesia, and depends only upon the temperature.

We have reserved until now the weak point in Mr. Clamond's system—we refer to the production of air under pressure.

In a factory, shop, or anywhere that a motive power is at one's disposal, the production of such air presents no difficulty; and the economy effected in the gas burned and in the quality of light produced would offset the extra expense attending the purchase of the burners, the double piping, and the putting in of the small blower necessary for the production of air at the low pressure of 40 millimeters of water. The work required for such compression is, in fact, insignificant, for it does not represent 100 kilogrammeters per hour and per focus of 4 Carcel burners. A one horse steam power would serve for more than 2,000 foci. For installations of small extent, then, a small gas motor would be sufficient. In Mr. Clamond's shop, the numerous burners that light it are very readily run by a small Bisschop motor. For installations of less importance, and in which there is no motive

power at disposal, Mr. Clamond has under study a system of blowers and weights which shall operate several hours without any attention having to be paid to them. It will be only necessary to wind up the weight every evening before lighting, by means of a winch. Seeing the small force necessary, such a project is very feasible; for several carbureted gas apparatus employed in country mansions or in places distant from any gas works are already operating by such a process. The use of a small motive power is a drawback that it is not necessary to attach too great importance to; it cannot be compared with that that the manufacture of oxygen would involve.

Finally, we may add that, if some day the distribution of electricity to houses become *un fait accompli*, it will be easy to obtain from the electric current the slight power necessary to actuate the blowing apparatus; and, in such a case, we shall see electricity come to the aid of gas and favor its economic use. Electricity and gas will then once again lend each other mutual support; and this is the best termination that could be desired to the contest now going on between them.

**DESCRIPTION OF FIGURES.**

1. General view of the burner. 2. View of burner divested of its jacket. 3. Longitudinal section of burner. A, B, C, D, horizontal sections of the burner at the points marked by corresponding letters in No. 3. 3. A, disk with air and gas inlets. B, distributor. C, D, E, distributing flues. F, entrance for air to the superheater. G, superheater. H, blow-pipe of refractory clay. K, tubes serving as auxiliary burners for heating the air. L, pipe for leading the gas to the blow-pipe. I, refractory piece for giving a horizontal direction to the gas entering the blow-pipe. M, external jacket perforated with holes. N, platinum

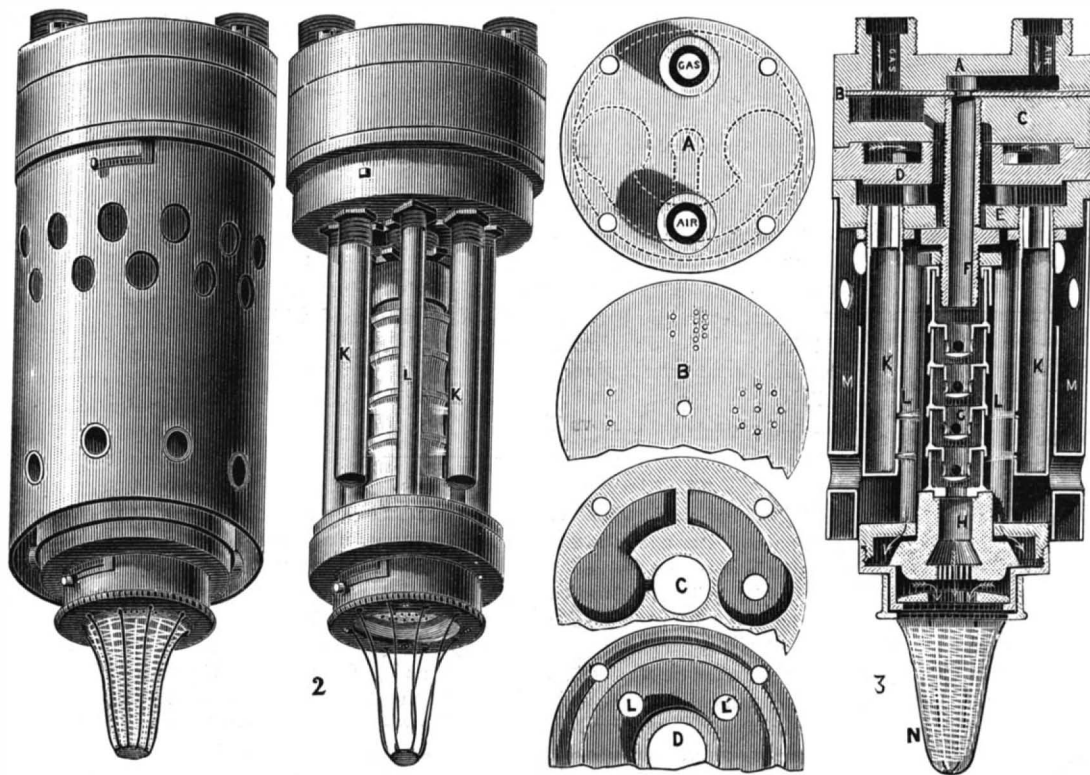

**CLAMOND'S INCANDESCENT GAS LAMP.**

which, coming in contact with a basket of magnesian thread, N, at the bottom of the lamp, raises it to incandescence. This basket was a happy idea of Mr. Clamond's. It is conical in shape and made of a sort of lacework of drawn magnesia. This latter, in powder, is made into a plastic paste with a solution of acetate of magnesia, and drawn out something like vermicelli. The thread, while still soft, is

basket containing the magnesian wick.—*La Nature*.

**DISTINGUISHING SPURIOUS HONEY.**—A solution of 20 parts of honey in 60 parts of water mixed with alcohol gives a heavy white precipitate of dextrine if glucose has been added, while genuine honey, if treated in the same manner, merely becomes milky.



**GALVANI.**

The accompanying portrait of Galvani is taken from the beautiful work by Amédée Guillemin, entitled "L'Electricité et le Magnétisme."

Luigi Galvani was born at Bologna, September 9, 1737. Although it was his own wish in early life to enter the church, his parents educated him for a medical career. In 1762 he was appointed lecturer on anatomy in the University of Bologna, the city in which he practiced. He soon gained repute as a skillful teacher, and, chiefly from his researches on the organs of hearing and genito-urinary tracts of birds, as a comparative anatomist.

His celebrated theory of animal electricity he enunciated in a treatise, "De Viribus Electricitatis in Motu Musculari Commentarius," published in the memoirs of the Institute of Science of Bologna, in 1791, and subsequently in separate form at Modena.

The statement has often been made that Galvani, in 1786, had skinned some frogs to make a broth for his wife, who was in delicate health; that the leg of one of these, on being accidentally touched by a scalpel which had lain near an electrical machine, was thrown into violent convulsions; and that it was thus that his attention was first directed to the relations of animal functions to electricity. From documents in the possession of the Institute of Bologna, however, it appears that Galvani was already engaged in investigating the action of electricity upon the legs of frogs twenty years previous to the publication of his "Commentary." It is in this work that he describes the invention of his metallic arc, which was constructed of two different metals, one of which, when placed in contact with a nerve and the other with the muscle of a frog, caused contraction of the latter. In his view, the motions of the muscle were the result of the union, by means of the arc, of its exterior or negative electrical charge with positive electricity which proceeded along the nerve from its inner substance. Volta, on the other hand, attributed them solely to the effect of electricity having its source in the junction of the two dissimilar metals of the arc, and regarded the muscle and nerve simply as conductors.

After the death of Galvani very little was heard of animal electricity till 1827, when the study of the subject was resumed by Nobili.

On Galvani's refusal, from religious scruples, to take the oath of allegiance to the Cisalpine Republic, on its establishment, he was removed from his professorship. Deprived thus of a means of livelihood, he retired to the house of his brother, where he soon fell into a decline. The government, in consideration of his great scientific fame, eventually, but too late, determined to reinstate him in his chair at the university. He died December 4, 1798.

We should add to the above note that Galvani studied with very great care the electricity of the torpedo, and that it was principally in that study that he found a confirmation of the theoretic ideas that he had conceived from the convulsions of the frog. He believed in the identity of the electric fluid produced by the organs of the torpedo with the fluid secreted by the muscular system of animals. He took much pains to ascertain that the nerves of the electric organs begin in the same manner as those of ordinary muscles. In his opinion, the electric organ of the torpedo was only a muscle enjoying to a high degree properties that are common to all others.

**REGNARD'S TEMPERATURE REGULATOR.**

Those persons who are obliged by the nature of their labors to work in the country, at the seaside, or, in a word, far from towns where there are gas works, experience great difficulty in keeping stoves at a constant temperature. All regulators of any precision that are used in laboratories require the use of illuminating gas, which some mechanism or other lights or puts out at the desired moment.

At one of the recent sessions of the Société de Biologie, Mr. D'Arsonval presented a stove which was capable of operating without gas by utilizing the boiling points of volatile liquids. This leads me to describe a stove that I have made use of for some time past, and which operates very regularly, and with extreme sensitiveness.

Into a water bath there dips an electric thermometer, B, that is to say, a thermometer open at the top, into whose tube runs a very fine platinum wire, A, that may be raised or lowered, or fixed definitely before any degree whatever of the scale. The mercury in the thermometer bulb communicates, through a wire soldered into the glass, with a Leclanché or Daniell pile. Since the upper platinum wire is in connection with the other pole, as soon as the mercury, by dilatation, touches the latter the current will be closed. Interposed in this current there is an electro-magnet, D, whose armature, E,

provided with a long lever, carries a benzine lamp, G. When no current is passing the lamp is placed under the stove; but, as soon as the current begins, the armature of the electro-magnet is attracted and the lamp is removed to a distance. The thermometer, becoming cool almost instantly, causes the mercurial column to leave the platinum wire. As soon as the current is broken the electro-magnet becomes inactive, and a spring, H, draws the lamp back beneath the stove, and so on. The accompanying cut sufficiently explains the mechanism.

It will be seen that the temperature of the stove cannot vary, since, as soon as it rises, the source of heat is removed; and as soon as it lowers the source of heat is replaced. This stove, like another that we have already made known, has the further advantage of being instantly regulated at any desired temperature; to effect which it is only necessary to

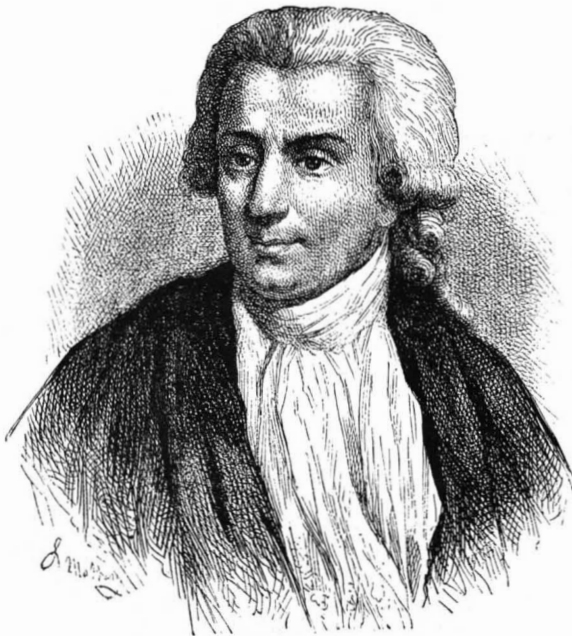

GALVANI.

fix the platinum wire opposite the degree that it is desired to have. After that it will be always at such degree that the current will be closed and the lamp removed from beneath the stove.—Dr. P. Regnard, in *La Nature*.

**Sand for Glassware.**

The sand from which the finest glassware, crown glass, French plate, and the like, is made, is seldom found in large deposits, in accessible places, and in strata free from impurities. Quartz in California, which yields \$5 of gold to the ton, is called in miners' language "pay-rock," and yet the sand itself out of which French plate glass is made is worth \$5 a ton delivered in the city market. A vein of glass sand was discovered over ten years ago near McVeytown, Mifflin Co., Penn., and is now being extensively worked. The sand rock occurs, for the most part, in irregular formation, with an occasional approach toward a stratified

With a force of sixty men, only about fifty feet of rock can be excavated in a year. An analysis of the sand shows almost pure silica, with slight impurities of cobalt, shale, and slate. Under the microscope, beautiful crystals in the sand are seen. The rock in the mine is of a marble white color, with a few tints of yellow and green. The air in the drift is cold and damp, and is kept pure by ventilators running up to the top of the ground. A temperature of about 40° prevails in the mine winter and summer.

The sand is taken out of the mine in small hand-cars by steam power and then dumped into the crusher. The crusher is something like a large coffee-mill, and breaks the sand rock up into coarse pieces, ready for the pulverizer. This consists of two large cast iron wheels, four feet in diameter and over a ton in weight, which roll around, like wagon wheels, in a circular pan. Water is kept constantly pouring into the pan, to help on the process of grinding and to carry the sand along to a sieve, which takes all coarse lumps that have escaped from the ponderous weight of the pulverizing wheels. The sieve is made of brass wire, in the shape of a cylinder, about three feet in length and a foot and a half in diameter, and revolves like a flour-bolting machine. After passing through the sieve, the sand is carried along a trough by the water into the washer. At the lower end of this the sand is forced up a trough by means of spiral conveyers, which act on the principle of the Archimedes screw. Thence the sand is washed down another trough filled with water, at the end of which there is an escape for the impurities. This operation is repeated three times, when the sand passes into another spiral conveyer, and is carried to a large room called the "drainer," where it is distributed over a large surface for draining off the water. The floor of the room is perforated with large holes. From the drainer the sand is carried to the drier, a large receiving chest containing a network of iron pipes through which steam passes. As the sand dries it drops into a funnel-shaped trough, and from that passes into a conveyer, and thence to an elevator. The sand comes from the drier fine and almost as white as flour. The elevator carries it up into a tower to facilitate the work of loading.

The sand is now ready for the market, as much of it as is to be made into fine glassware. That which is intended for ironstone chinaware, however, must go through another process before it is ready for the market. After leaving the drier the sand is put into a large drum made of wrought iron, about six feet in length and three feet in diameter, for the purpose of being repulverized. One ton of the sand and a ton and a half of what are here called "black diamonds," or "Russian pebbles," are put into the drum. Some of these pebbles come from Greenland, and resemble in luster Iceland spar. They are about as large as a hen's egg. Being harder than the sand, they pulverize it by constant friction. A portion of the black diamond is worn off in the process, but when the sand is made into chinaware and burned, it is of the same color throughout. Other pebbles could be used in pulverizing, but the dust that they give off in the process discolors the ware when burnt. The time required for reducing one ton of sand to this fine powder is generally ten hours.

A novelty of the McVeytown sand works is the way in which the water-power is communicated to the machinery at the mine. Steam is used for drying only, and the water of the old Pennsylvania canal, which is over one thousand feet from the works, is used for driving the machinery by a system of wire cables and band wheels. The wheels are set up in three small towers, thus preventing too much slack in the wire cables. Two turbine water-wheels are used at the canals. The sand shipped from this mine amounts to about 25,000 tons a year. Pittsburg, Wheeling, and Ohio cities are the principal markets.—*Glassware Reporter*.

**Earthquakes in Panama.**

The recent earthquake in Mexico has been followed by several less serious yet quite destructive disturbances in the Isthmus of Panama. The more notable occurred September 7 and 8. Traffic on the Panama railroad was suspended owing to damage to the sinking of the track in places and the damage to bridges. A freight building of stone at Aspinwall is reported to be destroyed. One

man was killed and several injured there. No lives were lost at Panama.

Liability to disturbances of this character, or worse, is one of the difficulties which the canal enterprise has to encounter but cannot overcome.

SEVENTY-SIX courses of stone, making 152 vertical feet, have been laid since work recommenced in earnest upon the Washington Monument. Its height is now 302 feet.

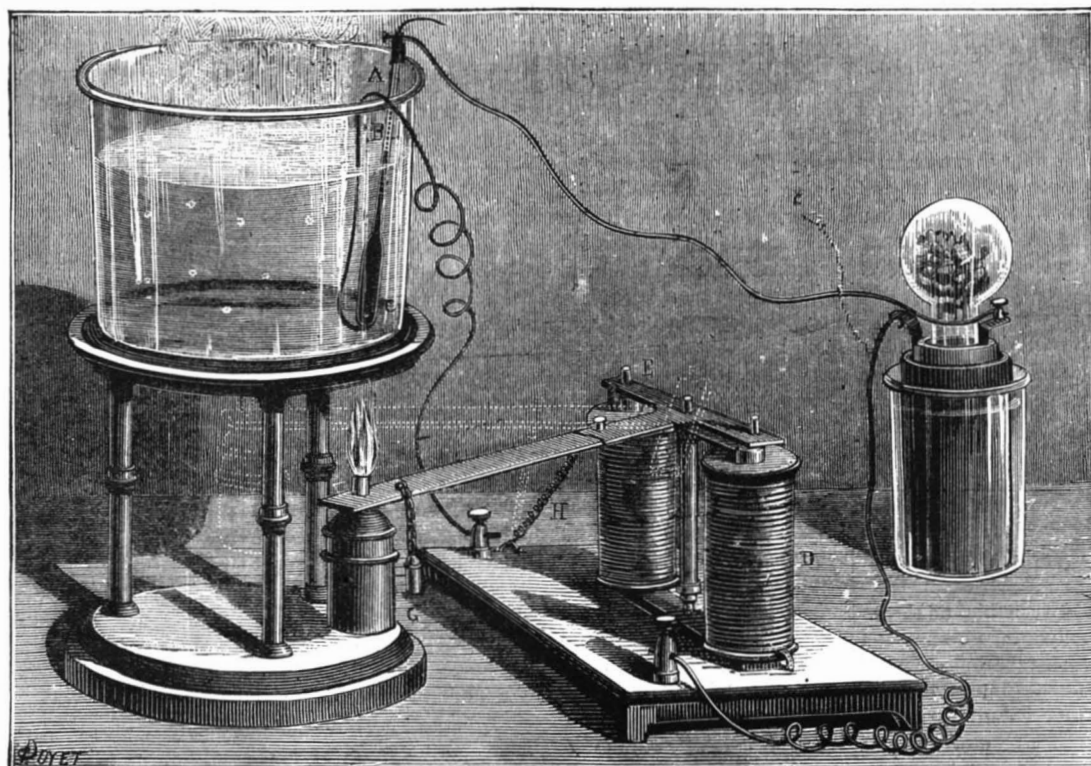

**REGNARD'S TEMPERATURE REGULATOR.**

condition. The rock is hard and dry, yielding with difficulty to the drill, except where water penetrates it, forming crevices. These soft veins, made by the water, are much dreaded by the miners. A mass of this soft rock may fall at any moment and crush or bury the hapless workman.

The sand rock is mined by what is called "drifting," or excavating in a horizontal direction. The drift is made sixteen feet high and twenty feet wide, and extends about 500 feet in different directions from the mouth of the mine.





RECENT INVENTIONS.

Car Coupling.

Mr. Martin V. King, of Bedford, Iowa, has patented a device for coupling cars, that is operated from the top or side of the car, and is so simple that it may be easily repaired without the necessity of taking the car to a repair shop. A loop is formed on one side of the drawhead of a car, and to the opposite side a hook is pivoted, the hooks and loops of the adjacent ends of the cars being adapted to engage with each other. A rod pivoted to the top of the hook extends to the top of the car, and can be locked by means of a latch on the top of the car that engages with ratchet teeth on the rod. The rod is also connected with a transverse crank shaft on the end of the car, and may be raised or lowered to operate the hook and couple or uncouple the cars, either from the side or top of the car. This coupling is shown in the engraving.

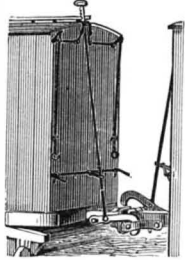

Black's Improved Horse Collar.

The accompanying engraving represents an improved horse collar recently patented by Mr. John Q. Black, of Lone Rock, Wis. The two parts of the collar are secured at the top in the usual manner, and made of a stuffed leather cover, in which the wooden hame is inclosed. Coupling irons, E, adapted to connect the lower ends of the parts, are secured to the hames by a bolt passing through the irons, the cover, and the hames. The tug irons, G, are provided at one end with a T-shaped head, and the opposite end is curved to adapt it to the shape of the collar. The T-heads of the tug irons pass under and are held to the collar by tug plates, F, secured to the hames and collar. By this construction the tug is easily attached to the collar, and automatically assumes the position easiest for the horse, and will change with the change of the draught of the load. The coupling for the lower end of the collar is reliable, durable, and cheap.

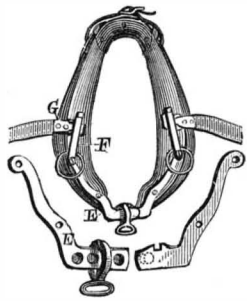

Drier for Fruits, etc.

Mr. Hugh S. Jory, of Salem, Or., has patented an improved apparatus for drying fruits and other substances. The casing of the drier is made of any suitable material, and is formed with a cylindrical middle part and conical ends, and is supported in an upright position by legs secured to its lower end. The lower end has openings to admit dry air, and the upper has damper openings to control the escape of the moist warm air. Within the cylindrical part of the casing is placed a frame formed of skeleton shelves. Each shelf is formed of concentric bands connected by radial bars, and they are connected by upright bars attached to the inner and outer bands, the outer bars being extended and attached near the top of the casing to a collar that surrounds the smoke pipe, and the lower to a collar on a standard at the bottom of the casing, on which the furnace is supported. With this construction the fruit placed on the shelves will be dried quickly, thoroughly, and evenly. The invention is clearly shown in the annexed cut.



THE AUSABLE CHASM.

BY H. C. HOVEY.

This remarkable chasm is as truly a cañon as any in Colorado; but, while my object in paying it a recent visit was mainly in order to study its geological peculiarities, I cannot refrain from mentioning a few of those picturesque features for which the locality is justly celebrated.

The Ausable River rises amid the wildest scenery of the Adirondacks, and running forty-five miles in a northeasterly course empties itself into Lake Champlain, at a point nearly opposite Burlington. The fact that it abruptly emerges from a region of mountains and finishes its course amid a succession of sandy beaches, is supposed to have suggested to the French explorers the name Au-Sable (to the sand). A stage road runs from Port Kent to the Lake View House, near the chasm. The rise in this distance is 300 feet, but it is mostly near the lake, the remainder being a flat, sandy plain, the cultivated portions of which are given up to buckwheat and beans. So narrow and so hidden is the deep channel cut by the Ausable through this champaign country, as not to be visible to one approaching from the east until he is on its very margin. The road to Keesville formerly crossed the chasm at its narrowest place, by a high bridge, concerning which there are several romantic legends that have probably lost nothing in the telling. One of the best authenticated is

the following: After the perilous bridge had been disused and allowed to decay a gale swept it entirely away, with the exception of a single girder. On a dark night a certain clergyman, named Morgan, approached it on horseback. He was returning home after an absence of years, and supposed that the road led, as formerly, over this bridge. On reaching it amid the darkness his horse hesitated, but was spurred onward and carried the traveler safely over; nor did the latter learn of his terrible risk until he was told of it the next morning!

The road now crosses the river by a bridge entirely above the chasm, spanning the rapids near the Rainbow Falls. This fine cataract, said to be 70 feet high with a spread of 150 feet, has been utilized, at very little sacrifice of its wild beauty, by the Montreal Horse Nail Works. The rolling mill, where they roll the best Norway iron into thin bars suitable for their use, is near the Alice Falls, higher up the stream. The wheel-house of the main factory, immediately below the Rainbow Falls, is 115 feet high, three walls being built of stone masonry and the fourth being the wall of native rock. The available fall is 56 feet, with a gain of 3,000 horse power! Through the kindness of the manager I was permitted to go through the entire establishment and see the process of making the twelve sizes of horse-nails, with large and small heads, the body of each nail being soft and uniform, while the points are hardened for driving. On mentioning to the foreman that I was a correspondent of the SCIENTIFIC AMERICAN, he volunteered the remark that once a year he solicited subscriptions from all the men for that periodical, not for a commission, but because those who took it became the best workmen.

A hundred yards below the nail works stands an octagonal building, through which one may reach the stairway of 125 steps, conducting him down into the gorge below. The river here flows through a wide amphitheater, closing around the foaming cataract that is usually spanned by a rainbow when the morning sunlight flashes on its mass of spray. A level floor of sandstone, washed and curiously carved by aqueous erosion, leads down to another cascade known as the Horse-shoe Falls. Rocky buttresses are piled around this amphitheater, and between them we pass, by a sharp turn to the right, known as the Elbow, into the famous Ausable Chasm. The wall opposite to the one along which our narrow pathway lies, shows proof of having been subjected, at some time since its original formation, to immense lateral and upward pressure. The strata exhibit a remarkable anticlinal dip, and suggest the idea of a violent cause for this wonderful rift in the rocks. Yet the causes that have combined to complete what was thus begun are for the most part of a more quiet and gentle sort, and are still at work. The observer notices that the walls are polished for 30 or 40 feet above the summer level of the water, and is assured that in winter and spring a tremendous torrent pours down from the melting snows of the Adirondacks, searching for the weakened seams, prying off detached portions, and polishing what cannot yet be dislodged. Sand is carried along with the flood, and does its part in scouring the rocks, the effect often being visible in concentric grooves and rings cut in the flat floor, and occasionally in smoothing the surface as if by art. These polished spots show the grain of the sandstone, sometimes gnarled like blocks of agate, and again in markings like the squares of a checker-board.

The rhomboidal fracture of the rocks is extraordinary. Each fragment seems to obey the same law as that by which the great columns, from 100 to 200 feet high, are separated from the walls. In transverse chasms, such as the Devil's Slide, Shady and Mystic Gorges, Hyde's Caves, and the Smuggler's Pass, are to be seen numberless blocks, each of which is an almost perfect rhomb, while the cross-cañons themselves lie at an oblique angle with the main chasm. Numerous iron stains and seams of iron stone indicate the possibility of chemical decomposition having much to do with the disintegration of the rocks. Frost has also done its work, and the roots of trees and smaller plants have helped to pry the seams apart. In the path of the torrent I observed numerous granite boulders, one of which must weigh as much as 100 tons. These are signs that the chasm existed in the Glacial Period and was widened and deepened by its action. The whirling of pebbles has pierced the rock in several places with deep wells. I descended into one of these, and remarked the curious fact that it had been bored spirally, as if by an immense screw. This pit was 18 feet deep and about 6 feet in diameter. In another place, and at a much higher level, is to be seen one-half of such a pit of much larger dimensions, the other half having fallen away. A thrifty cedar has found root in the niche thus remaining. Hyde's Cave was measured by me and found to be 60 feet from the entrance to the extremity. Drift-wood lodged within it shows that the winter floods invade the cavity, and have done their work in thus undermining the ledges above.

The path crosses and recrosses the tumultuous flood by means of substantial bridges; and here and there lies along galleries that have been cut out from the face of the rock, or else made by planks supported on iron bars projecting from the wall. There are several small caves besides the one mentioned above, and these are made accessible by stairways. The distance from Rainbow Falls to the Table Rock, where the pathway ends, is one mile by the pedometer, and rather more than that as stated by the guides. Here are the majestic Cathedral Rocks and the Sentinel, columns towering from the water to the height of perhaps 130 feet.

A boat awaits us at Table Rock, capable of seating twelve

persons, in which we are to shoot the rapids and explore the remaining mile or more of the cañon. At one point the walls are said to rise above us to the height of 175 feet, while they stand only 13 feet apart, and the water rushing between is 60 feet deep. The fact that the dip of the sandstone strata is here in the opposite direction to the flow of the stream produces a singular optical illusion, and makes it seem as if our boat were shooting down a far steeper declivity than is really the case. The voyage is quickly made, and we glide out of the chasm into a placid basin, on the margin of which carriages await our coming to convey us back to the hotel.

The rocks cut through by this cañon belong to the Potsdam sandstone that is so splendidly developed in Essex County, and from which the Ausable River has cut nearly its entire channel. Ripple marks abound, showing that the sands were deposited from calm waters shallow in depth, with here and there a beach emerging from the wide Silurian sea. Now and then a lingula, or other shell, is found, a relic of paleozoic life, proving that after the ancient beaches had been somewhat hardened they were liable to submergence. The term sandstone, often applied to brittle and crumbling rocks, must not mislead the reader; for the sandstone of Ausable is solidified into a hard quartzite, which would firmly resist the elements were it not for its jointed structure. Its thin laminations, cut by transverse planes of fracture, constitute one of its important characteristics. There are, indeed, two systems of joints, at nearly right angles with each other; and this explains the tessellated floors, resembling pavements, along which the path extends through so large a part of the chasm. It also explains those striking elevations like the pinnacles and columns of a cathedral, or like the buttresses and battlements of some ruined, moss-grown castle. It is instructive to notice that the main direction of the lines of division run parallel with that of the Adirondack range in the vicinity, showing plainly the relation they bear to the general geological history of the region. At some remote time the Rainbow Falls dashed over the precipice that still frowns above the basin that receives the boat on its emerging from the chasm. By slow retrocession, due to the causes herein described, the falls have worn their way back for the distance of more than two miles. The process is still going on, just as at Niagara Falls, but at what rate cannot now be stated. The action of the flowing water, though modified by freshets and changing seasons, is sufficiently constant to be measured, and it is to be hoped that some local geologist, who is situated so as to note all the elements that should be considered, will obtain the data required for a calculation as to the age of Ausable Chasm.

Wood Finish.

Richness of effect may be gained in decorative woodwork by using woods of different tone, such as amaranth and amboyna, by inlaying and veneering. The Hungarian ash and French walnut afford excellent veneers, especially the burls or gnarls. A few useful notes on the subject are given by a recent American authority. In varnishing, the varnishes used can be toned down to match the wood, or be made to darken it, by the addition of coloring matters. The patented preparations known as "wood fillers" are prepared in different colors for the purpose of preparing the surface of wood previous to the varnishing. They fill up the pores of the wood, rendering the surface hard and smooth. For polishing mahogany, walnut, etc., the following is recommended: Dissolve beeswax by heat in spirits of turpentine until the mixture becomes viscid; then apply by a clean cloth, and rub thoroughly with a flannel or cloth. A common mode of polishing mahogany is by rubbing it first with linseed oil and then by a cloth dipped in very fine brickdust; a good gloss may also be produced by rubbing with linseed oil, and then holding trimmings or shavings of the same material against the work in the lathe. Glass paper, followed by rubbing, also gives a good luster.

There are various means of toning or darkening woods for decorative effect—logwood, lime, brown soft soap, dyed oil, sulphate of iron, nitrate of silver exposed to sun's rays, carbonate of soda, bichromate and permanganate of potash, and other alkaline preparations are used for darkening the wood; the last three are specially recommended. The solution is applied by dissolving one ounce of the alkali in two gills of boiling water, diluted to the required tone. The surface is saturated with a sponge or flannel, and immediately dried with soft rags. The carbonate is used for dark woods. Oil tinged with rose madder may be applied to hard woods like birch, and a red oil is prepared from soaked alkanet root in linseed oil. The grain of yellow pine can be brought out by two or three coats of japan much diluted with turpentine, and afterward oiled and rubbed. To give mahogany the appearance of age, lime water used before oiling is a good plan. In staining wood, the best and most transparent effect is obtained by repeated light coats of the same. For oak stain, a strong solution of oxalic acid is employed; for mahogany, dilute nitrous acid. A primary coat, or a coat of wood-fillers, is advantageous. For mahogany stains the following are given: two ounces of dragon's blood dissolved in one quart of rectified spirits of wine, well shaken; or raw sienna in beer, with burnt sienna to give the required tone; for darker stains boil a half pound of madder and two ounces of logwood chips in one gallon of water, and brush the decoction while hot over the wood. When dry, paint with a solution of two ounces of potash in one quart of water. A solution of permanganate of potash forms a rapid and excellent brown stain.—*Building News.*

## ENGINEERING INVENTIONS.

Mr. Benjamin F. Smith, of Alabaster, Mich., has patented an improved car brake that is operated by running the cars together, the ends of rods placed under each car striking similar rods under other cars to partially rotate turn plates placed under the center of the cars. These plates when rotated draw on ropes that operate the brakes of the car. Devices are provided for shortening the rods so that when the cars are backed the brakes are not operated.

Mr. John H. Smith, of Fairchild, Wis., has patented an improved car coupling in which the coupling pin is temporarily held in an elevated position, by means of sliding support that is pressed forward by a spring placed in a longitudinal slot in the draw head. When the cars come together the coupling-link presses the sliding support back, and the pin drops through the link, coupling the cars.

Mr. Edward B. Meatyard, of Geneva, Wis., has patented an improved car wheel in which the tire is formed with an internal annular web, serving to strengthen it, and to secure it to the body of the wheel. The body of the wheel is composed of two circular disks, centrally apertured, and thickened around the aperture to form a hub. From the hub outward, the disks are curved and formed with radial slots, and at the outer edges are riveted to the web of the tire.

Mr. Arthur Codd, of Bowmanville, Can., has patented improved devices for braking a train of cars from the locomotive. Rods provided with buffers at their outer ends are placed longitudinally under the cars and the tender of the locomotive, these rods being connected by chains and pulleys to the brake bars of the cars. One end of the rod under the tender is attached to the piston of an air or steam cylinder, which when it is moved pushes the rods and operates the brakes of the cars.

An improved compass alidade has been patented by Mr. Franklin J. Drake, of Gasport, N. Y. The alidade is mounted to swing and turn on a standard on the top of the binnacle of a mariner's compass, and is connected by a vertical rod with a pointer-frame on the compass, so that the alidade and the pointers will always be in the same vertical plane, the pointers showing the compass bearings of any object that can be viewed through the alidade.

A device for clearing snow and ice from street railway tracks has been patented by Mr. James M. Elliott, of Columbus, O. It consists in laying connected pipes underneath the rails of the railway, the rails being grooved on their under side to receive the pipes. Steam, hot air, or hot water is conducted through the pipes, heating the rails and melting the snow, etc., from the track.

## METALLURGICAL INVENTION.

Improvements in furnaces for deoxidizing iron ores have been patented by Mr. Israel D. Condit, Jr., of Millburn, N. J. A flue conducts the heat from a puddling furnace or other fire into a distributing chamber extending the whole length of the deoxidizing furnace. From this chamber the heat is distributed by a series of vertical and horizontal flues, in such a manner that the retorts of the furnace will be heated upon all sides, thus heating and deoxidizing the ores evenly.

## MISCELLANEOUS INVENTIONS.

Mr. William S. Plummer, of San Jose, Cal., has patented improvements in devices for heating the drying chambers of fruit evaporators. The products of combustion are made to traverse a winding course, and are thus held in such a position that their heat is absorbed by rising currents of fresh air, which enter from a register below, and pass into the drying chamber placed above the device. Mr. Plummer has also patented improvements in the drying chambers of evaporators, by which the heat from the heating device is divided and so distributed as to heat the chamber evenly in all its parts.

Mr. Nestor R. Alpuche, of Merida, Mexico, has patented a novel centrifugal pump consisting of a tube, having its lower end hinged to a block below the surface of the water, and open to admit the water. Its upper end is attached to a crank wheel, by which it is caused to oscillate, raising and throwing out the water by centrifugal action. A valve is placed in the bottom of the tube to retain the water while the crank is passing its centers.

An improved hand bag frame has been patented by Mr. Henry S. Crans, of Brooklyn, N. Y. The bag frame is of the usual construction, and is provided with a spring fastening at the center of the handles. To the outer end of the stem of the fastening, is hinged a rod that has at its outer end a loop through which the handle of the bag passes. By pressing the rod the fastening and bag are opened.

Improvements in sloop safes for water-closets have been patented by Mr. Joseph B. Frey, of New York city. The safe is of the ordinary shape, and the improvement consists in providing it with a flushing rim, or sprinkler, for washing the surface of the safe with fresh water, removing all objectionable odors. The safe is adapted to be applied as a separate structure to any ordinary bowl.

Mr. Sylvester Huff, of Wabash, Ind., has patented an improved car coupling. At each end of the car an arrow head coupling bar swings vertically, passing through a guide frame on the end of the platform, and is pivoted to a cross piece on the under side of the same. Links attached to each of the coupling bars are connected at their upper ends to bell crank levers, pivoted on the top of the platforms, the inner shank of the levers being provided with handles for raising and lowering the coupling bars.

Mr. Emile M. E. Thorey, of Union Hill, N. J., has patented improvements in cocks, in which the plug is held closely to the socket and yet turns easily. The plug of the cock has the usual opening for the passage of the fluid, and is made hollow. A head provided with a hook on its under side, rests loosely in the top of the plug, and a similar head rests in the bot-

tom of the socket. The heads are connected by a spiral spring, thus holding the plug to the socket in such a manner that it can be easily turned.

Mr. Solomon Kuhlman, of Canton, O., has patented a gauge for regulating the depth to which holes are to be bored by an auger. A clamp holding a gauge rod is so adjusted on the shank of the auger that the lower end of the rod will be from the lower end of the auger a distance equal to the desired depth of the hole to be bored. When the hole has the desired depth the lower end of the gauge comes in contact with the surface of the wood and prevents a further penetration.

Mr. Watson F. Lamb, of Brooklyn, N. Y., has patented improvements in adjustable easels. The standard of the easel is adjustably secured to a pedestal having a cross bar and a roller. The work supporting frame is connected with the cross bar of the standard by a pair of hinged bars, and with the roller by a pair of hinged sliding bars, the bars being slotted longitudinally to receive a rod on which is placed a lever cam that clamps and holds the parts in position.

An apparatus for indicating the time of arrival and departure of trains has been patented by Mr. Joseph C. McKenzie, of Beaver Falls, Pa. A clock dial is provided at its edge with a rim to which adjustable tablets are attached indicating the time of the train. An index hand moved by clock mechanism comes in direct line with the tablets when the trains are due. If the hand has passed the tablet it shows how much the overdue trains are late.

A valve suitable for water tanks has been patented by Mr. Max Miller, of Brooklyn, N. Y. It consists in a spring strip attached to the inner surface of the tank, having a packing layer or disk attached to its inner surface, and covering the spout. A wire attached to the disk projects through the spout. By pressing on the wire the spring strip and disk is raised, and the water flows through the spout.

Improvements in apparatus for hanging, drying, and delivering wall paper from the printing machines have been patented by Mr. William J. Palmer, of Flushing, N. Y. The paper as it comes from the machine is received upon rods, and hangs from them in festoons. The rods are secured to an endless chain or belt, that is moved by suitable devices, and carries the paper through the drying room, and delivers it automatically to a reel to be wound in the usual manner.

A machine for addressing newspapers, etc., has been patented by Mr. Martin M. Morrison, of Kansas City, Mo. Each address is formed upon a separate type block, made of rubber or other elastic material. The blocks are secured separately, side by side, on an endless movable belt. The belt is arranged with such devices that when a type block is pressed down a new block is brought into position for printing.

An improvement in wheel-barrows, by which they are adapted to be easily knocked down for transportation, and are strengthened and made more durable, has been patented by Mr. Stephen L. Rockwell, of Jordan, N. Y. The front and rear legs of the barrow converge at their lower ends and are united to each other by a lap joint and bolt. The corresponding legs on each side of the barrow are further united by a cross piece, and are bolted to the handles and body.

An improved smoking cartridge has been patented by Mr. Edward A. Smith, of St. Albans, Vt. The shell of the cartridge is made of asbestos paper, and is not consumed in smoking and may be refilled. The cartridge filler is provided with wires that pass down into the shell, and after the shell is packed with tobacco are drawn out with the filler, leaving draught passages for air. A split metal collar fits over the end of the cartridge and into the end of the smoking tube, making a tight joint at the end of the tube.

A fire escape, that occupies but little space when not in use and can be quickly made ready for use, has been patented by Mr. Andrew Swanson, of New York city. The escape consists of ladders made of semicircular side bars, connected by rounds that are pivoted at their ends to the side bars, so that the side bars may be closed together. The end of the rounds are formed square at one angle to press against the side bars, and prevent the rounds from passing below a horizontal position.

An apparatus for separating the flat coffee berries from the round has been patented by Mr. Elam Rakestraw, of Cambridgeport, Mass. A reciprocating shoe is provided with two series of screens, one series having round apertures, through which the round berries pass, and the other having slots through which the flat beans pass, the flat and round beans passing into separate chutes. Sieves for separating the different sizes are also provided.

An improved button fastener, consisting of an open hook formed on or secured to a suitable base and a spring tongue also secured to the base. The hook is passed through the cloth or leather, and the eye of the button hooked on the fastener, the spring tongue retaining the button to the fastener. The fastener has been patented by Mr. William S. Spencer, of Sturgis, Mich.

An improved gate latch has been patented by Mr. William H. Marshall, of Oxford, Miss. A latch provided with oppositely projecting side arms slides vertically in a recess in the end post of the gate. The lower face of the latch is recessed to adapt it to engage with a catch secured to the post. Two lugs that project toward each other are formed at the lower edge of the recess, and prevent the gate from being lifted from its hinges by animals.

Therese R. Fischer, of Baltimore, Md., has patented an improved dress form, to be used for fitting and exhibiting dresses. The form is preferably made of willow rings arranged in a horizontal position one above another, and connected by withes to which they are suitably attached. The rings are made of such relative sizes that the figure will have the general shape of a woman's dress. A frame having the form of one end of an ellipse is attached to a lower ring to support the train of the dress.

An improvement in windmills, by which the wind wheel is automatically adjusted according to the force of the wind, has been patented by Mr. Christian B. Harman, of Lanark, Ill. The vane of the wheel

is pivoted to the stock to which the wind wheel is attached, and around which it rotates, and is so attached to the wheel by levers and connecting rods that by the force of the wind it is swung around to carry the wind wheel out of the wind, reducing its speed.

Mr. Hermann Hahn, of Schönberg, Germany, has patented an improved chimney ventilator. An angular cowl is mounted to turn freely on the top of a chimney. Two concentric funnels are attached to the open end of the cowl, in such a manner that the larger ends of the funnels are toward the open end of the cowl. The wind passes in the funnels and produces a suction, causing a strong draught in the chimney. A deflector keeps the open end of the funnels always toward the wind.

Improvements in steam feather renovators have been patented by Mr. Samuel Tate, of Sandusky, O. A steam cylinder adapted to be opened for the admission of feathers, has in its lower part a semi-cylindrical metal partition. The usual steaming and stirring apparatus is in the cylinder, and when the feathers are sufficiently cleaned steam is admitted below the metal partition, heating it and drying the feathers.

Mr. Jonas Hinckley, of Norwalk, O., has patented an improved carpet sweeper. The shaft of the rotary brush is adapted to be raised and lowered in recesses in the side pieces, and is made with pulleys on each end driven by a cross belt from driving pulleys that rest on the carpet. The plane of the driving pulleys is inclined so that the cross belt does not strike in the center to rub or chafe.

An improved method of making flexible bracelets has been patented by Mr. Shubael Cottle, of New York city. A circular spring is made of size sufficient to inclose the wrist. On the outside of this spring is placed a flexible casing, composed of spiral strips of sheet metal which are of a hollow, half-round cross section, wound in spiral convolutions about the spring with their convex sides out. The spiral strips are made ornamental, and the bracelet thus formed is easily expanded to pass over the hand to the wrist.

Mr. Robert M. Skiles, of Davenport, Ia., has patented improvements in evaporators and heaters. The air to be used for evaporating and heating is heated by pipes placed over a furnace, and connected to a pipe extending to the evaporating chamber through which it is drawn by an exhaust fan, and again thrown into the heating chamber to be heated, thus using the same air over and over and saving all the heat and also saving fuel.

A combined chair and child's crib has been patented by Messrs. Joseph B. Welsh and Harry Trudell, of Richmond, Va. The chair has a slat bottom, and upper and lower rails at the sides, and at the forward edge of the bottom is hinged an extension bottom, that folds into the chair and forms the bottom proper. A frame is made similar to the chair frame, only a little smaller, so that it will fold inside the chair frame. This frame is provided with legs, and when folded the legs and chair back together to form one finish. Messrs. Welsh and Trudell have also patented certain novel features of construction, by which reclining chairs are adapted to be converted into couches.

Mr. Moses Cohen, of Hallettsville, Texas, has patented a mechanical fan, adapted to be attached to the ceiling and used in connection with a barber's chair. A swinging bar of metal or wood is secured to the ceiling at some distance forward of the chair; to its lower end are attached fans, and to its upper end a weight to retard the backward motion of the bar. By pulling a cord attached to the bar and passing over pulleys to the chair, the fans are operated.

An improvement in sealing devices for fruit jars has been patented by Mr. Johnston Irvin, of Elk City, Pa. The upper edge of the fruit jar is made wedge shape. The cover of the jar is provided with a wedge shaped annular recess, corresponding with the rim of the fruit jar, and in this recess is placed a rubber packing ring having inclined edges to fit the recess of the cover, and a wedge shaped circular groove to receive the edge of the jar. The cover is held to its place by a screw cap.

A novel spelling toy and puzzle has been patented by Mr. William H. Reiff, of Philadelphia, Pa. Circular disks of different sizes made of cardboard are laid one upon the other, the top disk being the smallest, and the lower one and largest is made square. Upon the faces of the disks next their outer edges are printed the letters of the alphabet. With this device any word containing as many or less letters than the number of disks can be spelled by turning the disks to bring the letters of the words in radial lines.

An improved stump puller has been patented by Mr. Toliver Rice, of Enfield, Ill. Upon a suitable frame is pivoted a lever having a cam head and lifting chain. At the rear end of the frame is a shaft, provided with ratchets and pawls for winding, and holding chains that attach to the end of the cam lever. By this device great leverage is obtained for pulling stumps or for raising any heavy weight.

An improved method of making latch needles for knitting machines has been patented by Mr. Frank B. Woodward, of Hill, N. H., and consists in upsetting the wire from which the needle is made a short distance from the end, to form a lug in which a recess is made to hinge the latch of the needle. Much labor and expense are saved over the old method of reducing the wire to form the lug for the latch.

Messrs. George E. and Charles C. Bauder, of Bonaparte, Ia., have patented improvements in saddles for harness. The improvement consists in hinging the base plate of the water hook to the upper ends of the side pieces of the saddle-tree, so that the side pieces adjust themselves to the back of any sized horse. The housings and pads are secured to the side pieces in the usual manner.

A toy merry-go-round has been patented by Mr. Charles F. Cornelius, of New York city. The toy consists of one or more platforms bearing images of men and beasts, or fantastic figures placed on a box, and adapted to revolve in different directions by mechanism placed in the box, that is operated by a crank secured to a shaft projecting through the side of the box.

## Notes &amp; Queries

## HINTS TO CORRESPONDENTS.

No attention will be paid to communications unless accompanied with the full name and address of the writer.

Names and addresses of correspondents will not be given to inquirers.

We renew our request that correspondents, in referring to former answers or articles, will be kind enough to name the date of the paper and the page, or the number of the question.

Correspondents whose inquiries do not appear after a reasonable time should repeat them. If not then published, they may conclude that, for good reasons, the Editor declines them.

Persons desiring special information which is purely of a personal character, and not of general interest, should remit from \$1 to \$5, according to the subject, as we cannot be expected to spend time and labor to obtain such information without remuneration.

Any numbers of the SCIENTIFIC AMERICAN SUPPLEMENT referred to in these columns may be had at this office. Price 10 cents each.

Correspondents sending samples of minerals, etc., for examination, should be careful to distinctly mark or label their specimens so as to avoid error in their identification.

(1) E. R. asks for the simplest way of melting brass for soldering leaks in copper kettles. A. The brazing of any thin articles made of copper requires much experience. If the copper kettles are such as confectioners use, they are too valuable to be experimented with by new hands. We recommend you to send such to a good coppersmith. If you wish to try it, you may clean the copper around the leaky place by scraping, apply a little pulverized borax to the part, cut some sheet brass in very small pieces or threads, and lay enough upon the spot required to be soldered to close the part; place the part over a small charcoal fire in a forge and blow very gently; look upon the inside where you have placed the solder and see that the borax, in puffing up, does not displace the solder; if it does, put it back with a small stick. Do not be in a hurry, and do not heat any part too hot, or you may burn a hole in the kettle instead of soldering it. Better try on a piece of thin copper first and get a little experience.

(2) D. F. H. writes: A friend says that the fall and head of water are the same. I say that the head is the depth of water in the pond, and the fall is the number of feet from the bottom of pond to the bottom of wheel. Who is right? A. The terms "head and fall" have come to be somewhat mixed. When old millwrights spoke of "head and fall" they meant the whole fall from surface of water in penstock to the surface in wheel pit, the head being from the surface in penstock to the center of gate opening, and the fall from the center of gate opening to surface of water in wheel pit. Now the "head" is defined as the "difference in height from the surface of the water in the wheel pit to the surface in the penstock," and the term "fall" is given the same definition.

(3) N. G. V. asks (1) how to construct a sun dial. I have an iron stand with a solid foot and a fluted column, on top of which is an iron plate a foot 30 inches in diameter. I bought it from an old iron heap. A. Set the plate of your pedestal perfectly level; make a triangular plate or style with one angle equal to the latitude of your place; say for Passaic, 40° 43', and of this shape; set it upon the plate parallel with the meridian. The edge of the style should then correspond with and be parallel with the axis of the earth. Then lay off with a protractor lines radiating from the foot of the style as a center, and from the meridian line the hours as shown in the table. Take your departure from the side of the style if it has any thickness upon the edge.

For XI. and I. hour	9° 55'
" X. and II. hour	20° 36' 30"
" IX. and III. hour	33° 7'
" VIII. and IV. hour	48° 29' 30"
" VII. and V. hour	67° 40'
" VI. and VI. hour	90°
" V. and VII. hour	112° 20'

A. M. P. M.  
The formula is:  $h = \text{hour from noon.}$

$l = \text{latitude of the place.}$

$\alpha = \text{angle required for the hour.}$

$\tan \alpha = \tan h \sin l.$ —So that if you wish to work out the half and quarter hours trigonometrically you may exercise the opportunity. The dial will indicate true time only on four days of the year, viz., on the 15th of April and June, the 1st of September, and 25th December. Its greatest variation from the sun's unequal motion will take place in October and November, amounting to 16 minutes too fast. The other extreme occurs in January and February, amounting to 15 minutes too slow. 2. Will you inform me which works on photography are generally used by newspaper men and law courts? A. Pitman's and Graham's are generally used, we believe.

(4) W. C. R. asks: 1. What kind of glass will be best suited for an object glass of a telescope six inches diameter about, and where can I get it? A. A glass formed of a disk of flint and one of crown cemented together. You can procure it from Feil of Paris, or a reliable local optician. 2. What will they cost in their rough state? A. About \$75. 3. How can I detect impurities in laurel oil, such as is used in the east as a hair dressing? A. Add a small quantity of alcohol to the oil, mix this with a solution of caustic potash in alcohol and a few drops of chloride of iron, after the mixture has cooled pour in a few drops of a solution of chloride of lime, when, if the laurel oil is adulterated with the artificial preparation, a violet color will be developed, otherwise it will not be changed.



Business and Personal.

The Charge for Insertion under this head is One Dollar a line for each insertion; about eight words to a line. Advertisements must be received at publication office as early as Thursday morning to appear in next issue.

Council will receive bids for lighting the streets of Hazleton, Pa., either with oil, gas, or electricity. Address J. E. Giles, Chairman.

BERKLEY SPRINGS, W. VA., Sept. 12, 1882. Messrs. H. W. Johns Mfg Co., 87 Maiden Lane, N. Y.

GENTLEMEN: I am a painter by trade and have been using your paints; find them very good, and recommend them. Will send you an order on receipt of your sample sheets and price list.

Yours respectfully, ROBERT M. ADAMS.

CROSS KEYS, VA., Sept. 11, 1882.

Messrs. H. W. Johns Mfg Co., 87 Maiden Lane, N. Y.

GENTLEMEN: Summer before last I bought some paint of you for our Temperance Hall at this place. I like the paint very much. . . . What will you sell me your Asbestos Roof Paint at? . . .

Yours very respectfully, J. B. WEBB, M.D.

\$25.00 buys a 2 1/2 x 6 engine pump and governor. J. F. Barber, Catskill, N. Y.

Collection of Ornaments.—A book containing over 1,000 different designs, such as Crests, Coats of Arms, Vignettes, Scrolls, Corners, etc., will be mailed free on receipt of \$1. Address Palm & Fechteler, 6 West 14th Street, New York.

For Sale.—New Planer, 27" by 24", with 6 1/4 ft. table with 18" Planer Chuck; weight, 5,000 lb.; price, \$500. New Crank Planer, 18" x 15", with 12" stroke; a good tool; \$350. S. M. York, Cleveland, O.

Tight and Slack Barrel Machinery a specialty. John Greenwood & Co., Rochester, N. Y. See illus. adv. p. 206.

Pure Nickel Anodes, Nickel Salts, and all Polishers' Supplies. Greene, Tweed & Co., New York.

Trevor's Patent Key Seat Cutter. Trevor & Co., Lockport, N. Y. See last or next issue.

See Burgess's Blow Pipe adv., page 221.

American Fruit Drier. Free Pamphlet. See ad., p. 205.

Fire Brick, Tile, and Clay Retorts, all shapes. Bornerg & O'Brien, M'Frs, 23d St., above Race, Phila., Pa.

Peck's Patent Drop Press. See adv., page 206.

For best Portable Forges and Blacksmiths' Hand Blowers, address Buffalo Forge Co., Buffalo, N. Y.

Drop Forgings of Iron or Steel. See adv., page 205.

Brass & Copper in sheets, wire & blanks. See ad. p. 205.

The Chester Steel Castings Co., office 407 Library St., Philadelphia, Pa. can prove by 15,000 Crank Shafts, and 10,000 Gear Wheels, now in use, the superiority of their Castings over all others. Circular and price list free.

The Improved Hydraulic Jacks, Punches, and Tube Expanders. R. Dudgeon, 24 Columbia St., New York.

Diamond Planers. J. Dickinson, 64 Nassau St., N. Y.

Eagle Anvils, 10 cents per pound. Fully warranted.

Hand and Power Bolt Cutters, Screw Plates, Taps in great variety. The Pratt & Whitney Co., Hartford, Ct.

Imperial Mange Cure. Best remedy ever prepared for mange on dogs or horses troubled with scratches. For sale at all gun and ammunition stores. Manufactured by H. Clay Glover, Toms River, N. J. Send for testimonials.

See New American File Co.'s Advertisement, p. 190.

Rubber Hose, Linen Hose, lined and unlined, all sizes. Greene, Tweed & Co., 118 Chambers St., New York.

The Sweetland Chuck. See illus. adv., p. 190.

Steam Pumps. See adv. Smith, Vaile & Co., p. 188.

Knives for Woodworking Machinery. Book binders, and Paper Mills. Taylor, Stiles & Co., Riegelsville, N. J.

Send stamp to Morse Yellow Dock Root Sirup Co., Providence, R. I., for descriptive circular and sets of elegant Advertising Cards.

Bostwick's Giant Riding Saw Machine, adv., page 173.

Draughtsman's Sensitive Paper. T. H. McCollin, Phila., Pa. For Mill Mach'y & Mill Furnishing, see illus. adv. p. 172.

Woodworkg Mach'y. Rollstone Mach. Co. Adv., p. 173.

Drop Forgings. Billings & Spencer Co. See adv., p. 205.

C. B. Rogers & Co., Norwich, Conn., Wood Working Machinery of every kind. See adv., page 205.

Lighting Screw Plates, Labor-saving Tools. p. 206.

Engines, 10 to 50 horse power, complete, with governor, \$50 to \$550. Satisfaction guaranteed. Six hundred in use. For circular address Heald & Morris (Drawer 127), Baldwinsville, N. Y.

Air Pumps for High Pressure, Hand, or Steam Power, at low prices. C. Beseler, 218 Center Street, New York.

Small articles in sheet or cast brass made on contract. Send models for estimates to H. C. Goodrich, 66 to 72 Ogden Place, Chicago, Ill.

Improved Skinner Portable Engines. Erie, Pa.

Combination Roll and Rubber Co., 68 Warren street, N. Y. Wringer Rolls and Moulded Goods Specialties.

Pure Water furnished Cities, Paper Mills, Laundries, Steam Boilers, etc., by the Multifold System of the Newark Filtering Co., 177 Commerce St., Newark, N. J.

Latest Improved Diamond Drills. Send for circular to M. C. Bullock Mfg. Co., 80 to 88 Market St., Chicago, Ill.

First Class Engine Lathes, 20 inch swing, 8 foot bed, now ready. F. C. & A. E. Rowland, New Haven, Conn.

Ice Making Machines and Machines for Cooling Breweries, etc. Pictet Artificial Ice Co. (Limited), 142 Greenwich Street. P. O. Box 3083, New York city.

Jas. F. Hotchkiss, 84 John St., N. Y.: Send me your free book entitled "How to Keep Boilers Clean," containing useful information for steam users & engineers. (Forward above by postal or letter; mention this paper.)

Steel Stamps and Pattern Letters. The best made. J. F. V. Dorman, 21 German St., Baltimore. Catalogue free.

Machinery for Light Manufacturing, on hand and built to order. E. E. Garvin & Co., 139 Center St., N. Y.

For Power & Economy, Alcott's Turbine, Mt. Holly, N. J. Wood-Working Machinery of Improved Design and Workmanship. Cordesman, Egan & Co., Cincinnati, O.

Presses, Dies, Tools for working Sheet Metals, etc. Fruit and other Can Tools. E. W. Bliss, Brooklyn, N. Y.

Supplement Catalogue.—Persons in pursuit of information on any special engineering, mechanical, or scientific subject, can have catalogue of contents of the SCIENTIFIC AMERICAN SUPPLEMENT sent to them free. The SUPPLEMENT contains lengthy articles embracing the whole range of engineering, mechanics, and physical science. Address Munn & Co., Publishers, New York.

Presses & Dies. Ferracate Mach. Co., Bridgeton, N. J.

Presses & Dies (fruit cans) Ayar Mach. Wks., Salem, N. J.

Split Pulleys at low prices, and of same strength and appearance as Whole Pulleys. Yocom & Son's Shafting Works, Drinker St., Philadelphia, Pa.

[OFFICIAL.]

INDEX OF INVENTIONS

FOR WHICH

Letters Patent of the United States were Granted in the Week Ending

September 5, 1882,

AND EACH BEARING THAT DATE.

[Those marked (r) are reissued patents.]

A printed copy of the specification and drawing of any patent in the annexed list, also of any patent issued since 1866, will be furnished from this office for 25 cents. In ordering please state the number and date of the patent desired and remit to Munn & Co., 261 Broadway, corner of Warren Street, New York city. We also furnish copies of patents granted prior to 1866; but at increased cost, as the specifications not being printed, must be copied by hand.

Table listing inventions with names and dates. Includes items like Adding machine, Alarm, Ammonia and bone black, Axle for steam engines, etc.

Table listing inventions with names and dates. Includes items like Chimney top, Cider mill, Clamp, Clothes drier, etc.

Table listing inventions with names and dates. Includes items like Jewelry ring, Jump seat, Key ring, Knitting fabrics, etc.

Sewing machines, clamping device for button-hole, J. F. Snediker..... 263,979  
 Sheller. See Corn sheller.  
 Ship, steam, D. C. Pierce..... 263,805  
 Ship's log, W. G. & G. W. Merrill..... 263,986  
 Shovel. See Steam shovel.  
 Shovel moulds, die for tapering, W. P. T. Jope..... 263,709  
 Show case, F. Sanderson..... 263,970  
 Sink, water, W. J. Granlees..... 263,696  
 Sizing or painting machine, W. H. R. Toye..... 263,996  
 Smoke consumer, Jones & Marshall..... 263,708  
 Smokestack, marine vessel, E. M. Hallock..... 263,898  
 Snap hook, C. H. & M. M. Freer..... 263,693  
 Soda block, J. McCrodden..... 264,044  
 Soda by the ammonia process, manufacture of, E. Solvay..... 263,981  
 Soda, manufacture of, E. Solvay..... 263,821  
 Spindle and bearing therefor, W. G. Morrison..... 263,942  
 Spinning machines, spindle step for, W. A. Delmage..... 263,688  
 Spool for holding wire, O. R. Chaplin..... 263,682  
 Spring. See Bed spring. Wagon spring.  
 Stand boiler and connections, A. P. Creque..... 263,787  
 Starch, manufacturing, E. S. Renwick..... 263,958  
 Steam engine recorder, G. W. Brown..... 263,843  
 Steam generator, for road vehicles or other purposes, F. D. Pierce..... 263,954  
 Steam shovel, Starke & Crowley..... 263,986  
 Steam trap, J. Morehead..... 263,716  
 Still, alcohol, C. J. T. Burcey..... 263,852  
 Stirrup, A. P. Routt..... 263,966  
 Stopper. See Bottle stopper.  
 Stove, gas, J. H. Bean..... 263,671  
 Stove lid, J. A. Horton..... 263,703  
 Stove or furnace, heating, M. C. Hull..... 263,705  
 Stove top, O. F. Evans..... 263,882  
 Straw cutter, O. M. Sackett..... 263,968  
 Street crossing, C. J. Bayer..... 263,754  
 Stretcher, combined elastic and spring, R. H. Shannon..... 263,819  
 Sucker rod elevator, P. Smith..... 263,820  
 Sugar boiler, A. Savoie..... 263,813  
 Sugar compound, grape, T. A. Jebb..... 264,036  
 Sugar, manufacturing grape, T. A. Jebb..... 264,037  
 Sulky. Reed & Shilliam..... 263,810  
 Switch. See Railway switch.  
 Tannic acid, manufacture of, A. Mitscherlich..... 263,797  
 Telegraph, duplex, G. D'Infeville (r)..... 10,193  
 Telegraph system, district, C. E. Buell..... 263,759  
 Telephone exchange, automatic, M. D. Connolly..... 263,862  
 Telephone, mechanical, F. R. Shaw..... 263,973  
 Telephone signaling apparatus, H. B. Lytle..... 263,926  
 Telephone transmitter, L. De Loch-Labye..... 264,028  
 Thrashing machine, R. H. Cox..... 263,865  
 Thrashing machine separator, J. B. Bloom..... 263,875  
 Thread cutter, M. E. Davis..... 263,868  
 Tie. See Bale tie.  
 Tile machine, J. F. Stephenson..... 263,823  
 Tire for traction wheels, N. B. Yingling..... 264,051  
 Tobacco, apparatus for moulding, marking, and finishing, W. R. Montgomery..... 263,940  
 Toe weight, M. H. Houghton..... 263,704  
 Tong, crucible, S. C. Murdoch..... 263,799  
 Tool clamp, W. S. Winterbottom..... 264,017  
 Toy, E. M. Rich..... 263,961  
 Trace carrier, Marshall & Reinhart..... 263,923  
 Trap. See Steam trap.  
 Tube. See Cop-tube.  
 Tubing coupling, E. C. Converse..... 263,863  
 Type and space holder, L. K. Johnson..... 263,707  
 Umbrella, C. B. Sill..... 263,733  
 'alve, balanced slide, W. T. Reaser..... 263,809  
 Valve for engines, reversing, C. N. Leonard..... 263,711  
 Valve gear, H. See..... 263,817, 263,818  
 Valve, lift or check, Sterne & Clerk..... 263,989  
 Vapor burner, H. S. Belden..... 263,840  
 Vehicle wheel, Sperry & Vandenberg..... 263,982  
 Velocipede, J. Church..... 263,857  
 Ventilator. See Barrel ventilator. Car ventilator.  
 Vessel for food and other articles, V. Manuel..... 263,928  
 Vessels, apparatus for loading and unloading, J. W. & J. W. Brown, Jr..... 263,846 to 263,848  
 Vise, J. Dennis..... 263,872  
 Wagon spring, A. H. Cadugan..... 263,853  
 Wash bench and wringer, combined, Camp & Baumgartel..... 264,026  
 Washing machine, H. C. Durborow..... 264,080  
 Washing machine, J. C. Wilson..... 264,014  
 Water closet attachment, S. Edinger..... 263,877  
 Water elevator, automatic, G. W. McKenzie..... 263,713  
 Water elevator bucket, windlass, J. G. Dengler..... 263,871  
 Water governor, H. S. Miller..... 263,796  
 Wheel. See Car wheel. Gear wheel. Vehicle wheel.  
 Wheelbarrow, J. Kelly..... 263,790  
 Windmill, G. W. McKenzie..... 263,714  
 Wire, apparatus for tempering and hardening, E. Clifton..... 263,859  
 Wire coiling machine, H. Schmidt..... 264,046  
 Wool and other fiber, machine for drying, H. W. Church..... 263,683  
 Wool washing machine, F. G. & A. C. Sargent..... 263,727, 263,728  
 Wrench, D. S. Maynard..... 263,794  
 Wringer. See Clothes wringer

DESIGNS.

Burial casket, W. A. Sparks..... 13,286  
 Burial casket, Sparks & Rappleyea..... 13,287  
 Corset, S. H. Rosenberg..... 13,284  
 Corset, I. Strouse..... 13,288  
 Curtain band, G. H. Wright..... 13,289  
 Hame, J. G. Eberhard..... 13,281  
 Ring, J. B. Harrison..... 13,282  
 Whip socket, E. W. Scott..... 13,285  
 Window shade, C. Reinhardt..... 13,283

TRADE MARKS.

Baling presses, Wrenn, Whitehurst & Co..... 9,648  
 Compound extract of roots for the cure of scrofula, ulcers, sores, tumors, boils, and the like, T. Mullin..... 9,646  
 Hair restorative, A. K. McKee..... 9,645  
 Medicated cough drop, J. Dyer..... 9,642  
 Oils and oils for protecting polished metallic surfaces, lubricating and illuminating, De Forest & Driggs..... 9,639  
 Pens, L. Isaacs & Co..... 9,644  
 Perfumery, toilet soaps, tooth powders, and cosmetics, W. Rieger..... 9,647  
 Saws, hand, H. Disston & Sons..... 9,640, 9,641  
 Tobacco, fine-cut chewing, Globe Tobacco Company..... 9,643

English Patents Issued to Americans.

From August 22 to August 25, 1882, inclusive.  
 Ammonia, manufacture of, H. Y. Castner et al, New York city.  
 Batteries, electric secondary, T. A. Edison, Menlo Park, N. J.

Barrel machinery, F. Myers, New York city.  
 Cannon, manufacture of, W. E. Woodbridge, Washington, D. C.  
 Cases for furniture, etc., A. F. Potts, Indianapolis, Ind  
 Caustic soda, recovery of, T. Gibb, Elizabeth, N. J.  
 Dynamo electric machine, T. A. Edison, Menlo Park, N. J.  
 Electric conductors, insulation of, J. M. Hirsch, Chicago Ill.  
 Electric conductors, T. A. Edison, Menlo Park, N. J.  
 Electric lamps (3), T. A. Edison, Menlo Park, N. J.  
 Electricity, storage and generation of, J. S. Williams, Riverton, N. J.  
 Electric signal apparatus, H. W. Southworth, Springfield, Mass.  
 Heating apparatus, W. J. Walsh, New York city.  
 Hydrocarbon furnace, J. Mundell et al., Philadelphia, Pa.  
 Painting and varnishing machine, W. H. Toye, Philadelphia, Pa.  
 Pump, Automatic Boiler and Engine Company, New Haven, Conn.  
 Transom adjuster, G. J. Dickson, New York city.  
 Watch chain, W. C. Edge, Newark, N. J.  
 From August 29 to September 1, 1882, inclusive.  
 Bath, W. W. Rosenfeld, New York city.  
 Dynamo-electric machine, S. Van Choate, New York city.  
 Electric lamp, H. G. Fiske, Springfield, Mass.  
 Filter, W. Maynard, New York city.  
 Knit goods, machine for sewing, etc., C. H. Wilcox, New York city.  
 Looms, J. Dawson, Lewiston, Me.  
 Paper, file, W. R. Clough, Newark, N. J.  
 Paper boxes, manufacture of, E. B. Munson et al., New York city.  
 Pencil case, A. T. Cross, Providence, R. I.  
 Speed accelerating mechanism, L. S. Fithian, Mt. Clair, N. J.  
 Starch, grape sugar, etc., manufacture of, W. T. Jebb, Buffalo, N. Y.  
 Steam heating apparatus, E. F. Osborne, St. Paul, Minn.

Advertisements.

Inside Page, each insertion - - - 75 cents a line.  
 Back Page, each insertion - - - \$1.00 a line.  
 (About eight words to a line.)  
 Engravings may head advertisements at the same rate per line, by measurement, as the letter press. Advertisements must be received at publication office as early as Thursday morning to appear in next issue.

**Saw Mill Operators Have Found VAN DUZEN'S PATENT STEAM JET PUMP**  
 The best and cheapest reliable Steam Pump made. For raising water from Well, Pond, or Stream to boiler supply tank, or to use with hose and nozzle in case of fire, IT HAS NO EQUAL. All brass, no moving parts, no valves. Warranted reliable and satisfactory. TEN SIZES: \$7, \$8.50, \$10.50, etc., and capacities of 300 to 20,000 gallons per hour. Send for "Catalogue No. 49." VAN DUZEN & TIFT, Cincinnati, O.

**A GOOD CHANCE FOR ENGINEERS**  
 and Foundry Proprietors, with some capital, is offered by a man with a number of new, useful, simple, and necessary inventions, to share the inventions with the inventor for the taking out of patents for the same. For particulars, address W. ROSWEL, Box 773, New York City.

**THE COLORS OF FLOWERS.—BY Grant Allen.** A highly interesting and instructive paper, explaining how the special tastes of insects have become the selective agency for developing brilliant colors in flowers that were originally inconspicuous, and explaining how and why certain flowers now green and inconspicuous have reverted to that color. Contained in SCIENTIFIC AMERICAN SUPPLEMENT, No. 326. Price 10 cents. To be had at this office and from all newsdealers.

**THE ONLY PERFECT SEWING MACHINE.**  
 SIMPLEST, LATEST IMPROVED, MOST DURABLE & BEST.  
 BUY IT AND MAKE HOME IF THERE IS NO AGENT NEAR YOU. WRITE DIRECT TO US.  
 NEW HOME SEWING MACHINE CO., 30 UNION SQUARE N.Y. CHICAGO, ILL. ORANGE MASS. OR ATLANTA GA.

**RECENT WONDERS OF ELECTRICITY.**  
 —Two lectures, by W. H. Preece, F.R.S., designed to give young people a clear idea of the manner in which electricity works and how it produces its marvelous effects. Contained in SCIENTIFIC AMERICAN SUPPLEMENT, Nos. 327 and 328. Price 10 cents each, or 20 cents for the two. To be had at this office and from all newsdealers.

**50** Elegant Genuine Chromo Cards, no two alike, with name, 10c. SNOW & CO., Meriden, Ct.  
**WANTED.—PATENTS TO BUY OR MANUFACTURE.** Give full particulars. DuPlaine & Bach, Chicago, Ill.

**MULBERRY TREES FOR SILK.—BY Mrs. V. C. Haven.** Suggestions to those interested in silk culture on the choice of the proper food for silkworms, and in the cultivation of the mulberry tree. Contained in SCIENTIFIC AMERICAN SUPPLEMENT, No. 325. Price 10 cents. To be had at this office and from all newsdealers.

**SAWS** How to straighten and gum all kinds. Address A. E. WILBUR, Schenectady, Otsego Co., N. Y.

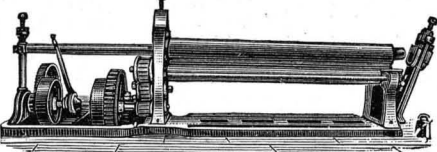

**PATENT BENDING ROLLS.** For Heavy Punches, Shears, Boiler Shop Rolls, Radial Drills, etc., send to HILLES & JONES, Wilmington, Del.

**LOSSES IN THE STEAM CYLINDER.**—A valuable paper, giving, in a series of tables, the results of experiments by Herr Escher on the losses that occur in the steam cylinder through various causes, and throwing much light on some obscure points in the economy of the steam engine. Contained in SCIENTIFIC AMERICAN SUPPLEMENT, No. 327. Price 10 cents. To be had at this office and from all newsdealers.

**\$5**  
 Plays any Tune.

**THE HARMONETTE.** A MUSICAL WONDER, and the best Mechanical Musical Instrument in the World. Novel in construction, elegant in design, powerful and melodious in effect, MUSIC AND MUSICIAN COMBINED. More Reeds and more powerful than \$8 Organettes. THE HARMONETTE plays anything from a simple song to a difficult waltz or operatic selection. Any child can operate it. Music only 4 cents per foot. It is beautifully finished in black walnut, and of handsome shape and design; EXPRESSION SWELL, and many patented improvements. It is as loud as a cabinet organ, and will furnish music for any occasion, and it is a most complete present for any one, old or young. We send the Harmonette, with selection of music, to any address, on receipt of price, \$5. Extra Music can be sent by Mail at any time. This is the most wonderful musical instrument that has ever been invented. Address THE MASSACHUSETTS ORGAN CO., 57 Washington Street, Boston, Mass.

**The most successful Lubricator for Loose Pulleys in use. VAN DUZEN'S PATENT LOOSE PULLEY OILER.** Highly recommended by those who have used them for the past two years. Prices very reasonable. Every user of machinery should have our "Catalogue No. 55" sent free. VAN DUZEN & TIFT, Cincinnati, O.

**RUSSET LEATHER.—A REPORT ON** the manufacture of russet leather, and its adaptability for the military service. By Capt. D. A. Lyle, U.S.A. Description of the mode of tanning by both oak and hemlock. Relative strength. Relative solidity. Relative merits of black and russet leather. Bleaching. Restoring leather. Relative merits of oak and hemlock tanned leather. Harness dressing. Contained in SCIENTIFIC AMERICAN SUPPLEMENT, No. 335. Price 10 cents. To be had at this office and from all newsdealers.

**PROSPECTING MINERAL LANDS A SPECIALTY.** CYLINDRICAL SECTIONS OR CORES OBTAINED THE WHOLE DISTANCE BORED. **ARTESIAN WELLS** BORED ROUND AND STRAIGHT ADMITTING A LARGER PUMP AND CASING IN PROPORTION TO SIZE OF HOLE THAN BY ANY OTHER PROCESS. ESTIMATES GIVEN AND CONTRACTS MADE BY THE **PENNSYLVANIA DIAMOND DRILL CO.** BOX #23 POTTSVILLE PA. MANFRS. OF DIAMOND DRILLS FOR ALL KINDS OF ROCK BORING.

**THE PORTER-ALLEN High Speed Steam Engine.** ADDRESS SOUTHWARK FOUNDRY & MACHINE CO., 430 Washington Ave., Philadelphia, Pa.

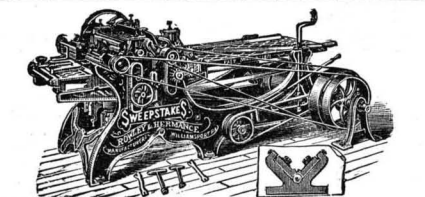

**SWEEPSTAKES, WITH THE ELLIS Patent Journal Box.** The best Planer and Mather ever made. Planing 20 in. wide, 6 in. thick, weight 2,300 lb., \$300; planing 24 in. wide, 6 in. thick, weight 2,600 lb., \$350; Beading, Arbor, and Head, extra, \$20. Sash, Door, and Blind Machinery a specialty. Correspondence solicited. Rowley & Hermance, Williamsport, Pa.

**THE STRONGEST, most complete, and reliable of Engines and Boilers.** Special sizes, 4 to 40 H. P. Others on application. Also Rock Drills, Water Motors, and machinery generally. Geo. W. Tift, Sons & Co., Buffalo, N. Y.

**ON THE CONSERVATION OF SOLAR Energy.—A paper read before the Royal Society, by C. W. Siemens, D.C.L., F.R.S., in which the author explains a new theory to account for the fact that, notwithstanding the enormous loss of heat from the sun which is constantly occurring, the solar temperature has not sensibly diminished for centuries.** Illustrated with one figure. Contained in SCIENTIFIC AMERICAN SUPPLEMENT, No. 329. Price 10 cents. To be had at this office and from all newsdealers.

**HEAVY UNIVERSAL MILLING MACHINE** FOR CIRCULARS AND FURTHER INFORMATION ADDRESS C. E. LIPE, 101 SYRACUSE, N. Y. HORIZONTAL ADJUSTMENT 10 VERTICAL 18 CENTRES SWING 12 TABLE HAS A RAPID CRANK MOVEMENT

**NOTES ON ECONOMIC PLANTS (FROM the last Kew Report).** embracing Cocoa, Cola Nuts, Fodder Plants, India-rubbers, and Tea Plants, and Tea Cultivation. Contained in SCIENTIFIC AMERICAN SUPPLEMENT, No. 325. Price 10 cents. To be had at this office and from all newsdealers.

**WOOD WORKING MACHINERY.** PLANING, MATCHING, MOLDING, MORTISING, TENONING, CARVING, BAND & SCROLL SAWS, UNIVERSAL WORKERS, VARIETY WOOD & CO. **J. A. FAY & CO.** CINCINNATI, O. U.S.A.

**THE TECHNOLOGICAL MUSEUM** Of New South Wales. The Committee of Management of this Museum are solicitous of receiving specimens illustrative of manufacturing processes, embracing all stages, from the raw product to the finished article. The Museum, which is located in the late Sydney International Exhibition Building, occupies an area of over 35,000 square feet, the greater portion of which will shortly be open to the public. The name of the donor with full particulars of each specimen, will be clearly shown on the labels. Exhibits, accompanied by full particulars, may be forwarded, free of freight, through the Agent-General for New South Wales, Westminster Chambers, London, S.W. **CHARLES R. BUCKLAND,** Acting Secretary. SYDNEY, July 13, 1882.

**ELECTRIC LIGHT TELEPHONE & TELEGRAPH SUPPLIES** WALLACE DIAMOND TRADE MARK THE ELECTRICAL SUPPLY CO. 109 LIBERTY ST. NEW YORK

**Horizontal Steam Engines,** For best Automatic Cut-off or Plain Slide Valve of Superior Design, Complete in Every Respect, ADDRESS **LAMBERTVILLE IRON WORKS, LAMBERTVILLE, N. J.**

SEND FOR CIRCULAR AND PRICE LIST OF **COPE & MAXWELL M'F'G CO'S** New and Improved Styles of **STEAM PUMPS AND BOILER FEEDERS** "The Best Made," Address HAMILTON, OHIO.

**WOOD-WORKING MACHINERY.** Universal Wood Workers, Planing, Matching, Moulding, Band and Scroll Sawing Machines, etc. **BENTEL, MARCEDANT & CO., HAMILTON, OHIO, U. S. A.**

**MARTIN'S READY FOR FIRE.** This cut represents the renowned RED JACKET Adjustable Double-acting Lift and Force Pump for general purposes. Highest Prizes awarded wherever exhibited. Thousands now in use throughout the States, giving perfect satisfaction. Fitted for hand and power. Agents wanted everywhere. For particulars, address **CINCINNATI PLUM CO., Cincinnati, Ohio, U. S. A.**

**\$88** A week to Agents. **\$10** OUTFIT FREE. RIDGOUT & CO., 10 BARCLAY ST., New York.

ALL KINDS OF **WOOD WORKING MACHINERY** IRON WORKING TOOLS SPECIAL TOOLS MANUFACTURED BY **H. B. SMITH MACHINE CO.** SMITHVILLE, BUR. CO. N. J. CIRCULARS FREE.

PATENTS.

**MESSRS. MUNN & CO.** in connection with the publication of the SCIENTIFIC AMERICAN, continue to examine Improvements, and to act as Solicitors of Patents for Inventors. In this line of business they have had thirty-five years' experience, and now have unequalled facilities for the preparation of Patent Drawings, Specifications, and the prosecution of Applications for Patents in the United States, Canada, and Foreign Countries. Messrs. Munn & Co. also attend to the preparation of Caveats, Copyrights for Books, Labels, Reissues, Assignments, and Reports on Infringements of Patents. All business intrusted to them is done with special care and promptness, on very reasonable terms. A pamphlet sent free of charge, on application, containing full information about Patents and how to procure them; directions concerning Labels, Copyrights, Designs, Patents, Appeals, Reissues, Infringements, Assignments, Rejected Cases, Hints on the Sale of Patents, etc. We also send, free of charge, a Synopsis of Foreign Patent Laws, showing the cost and method of securing patents in all the principal countries of the world. **MUNN & CO., Solicitors of Patents,** 261 Broadway, New York. BRANCH OFFICE—Corner of F and 7th Streets, Washington, D. C.





**NUT TAPPING MACHINE.**  
**DURELL'S PATENT.**  
 No. 1 Machine, \$100 lb., 7 spindles.  
 " 2 " 1,050 " 7 " "  
 " 3 " 600 " 3 " "  
 Capacity of 7 Spindles, 8,000 per 10 hours.  
 Acknowledged to be an indispensable tool Manufactured by  
**HOWARD BROS.,**  
 Fredonia, N. Y.

Every Machinist, Jeweler, Dentist, Locksmith, Metal Worker, etc., should send blue stamp for descriptive and reference circulars of Burgess' Blow Pipe Pump, as it supersedes the Bellows, Forge, and Mouth Blow Pipe for Brazing, Tempering, Soldering, etc., by saving Time, Labor, and Breath; gives the gentlest flame or hottest blast without exertion. Hundreds have been sold within the last eight years, giving the greatest satisfaction. Price \$10. J. ELLIOTT SLAW, 154 So. 4th St., Phila.

SEND TO LONDON, BERRY & ORTON  
 PHILADELPHIA FOR  
**THE BEST BAND SAW BLADE**

**THE DUPLEX INJECTOR.**

The constantly increasing demand for this Boiler Feeder proves its superiority over other machines now in use. Send for illustrated circular and price list. Manufactured by JAMES JENKINS, Detroit, Mich.

**KEMP'S MANURE SPREADER,**

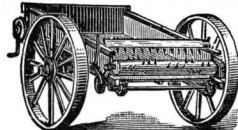

**PULVERIZER and CART COMBINED.**  
 Greatest Agricultural invention of the age. Saves 50 per cent. of labor, and doubles the value of the manure. Spreads evenly all kinds of manure broadcast or in drill, in one-tenth the time required by hand.

Send for Illustrated Catalogue and full particulars to  
**KEMP & BURRILL MFG CO.,** Syracuse, Onondago Co., N. Y.

**RUPTURE**

cured without an operation or the injury trusses inflict by Dr. J. A. SHERMAN'S method. Office, 251 Broadway, New York. His book, with Photographic likenesses of bad cases, before and after cure, mailed for 10c.

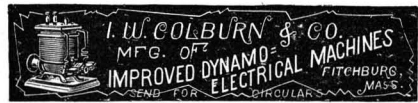

**ERICSSON'S**

**New Caloric Pumping Engine**

FOR DWELLINGS AND COUNTRY SEATS. Simplest, cheapest, and most economical pumping engine for domestic purposes. Any servant girl can operate. Absolutely safe. Send for circulars and price lists.

**DELAMATER IRON WORKS**  
 C. H. DELAMATER & CO., Proprietors,  
 No. 10 Cortlandt Street, New York, N. Y.



**BIBB'S**  
 Celebrated Original  
**BALTIMORE**  
**FIRE-PLACE HEATERS**  
 To warm upper and lower rooms. The handiest, most economical Coal Stoves in the world.  
**B. C. BIBB & SON**  
 Foundry, Office and Salesrooms,  
 39 and 41 Light Street,  
**Baltimore, Md.**  
**MARBLEIZED SLATE MANTELS.**  
 Send for Circulars.

**SPEAKING TELEPHONES.**

**THE AMERICAN BELL TELEPHONE COMPANY,**  
 W. H. FOIBES, W. R. DRIVER, THOS. N. VAIL,  
 President, Treasurer, Gen. Manager.

Alexander Graham Bell's patent of March 7, 1876, owned by this company, covers every form of apparatus, including Microphones or Carbon Telephones, in which the voice of the speaker causes electric undulations corresponding to the words spoken, and which undulations produce similar articulate sounds at the receiver. The Commissioner of Patents and the U. S. Circuit Court have decided this to be the true meaning of his claim; the validity of the patent has been sustained in the Circuit on final hearing in a contested case, and many injunctions and final decrees have been obtained on them. This company also owns and controls all the other telephonic inventions of Bell, Edison, Berliner, Gray, Blake, Phelps, Watson, and others. (Descriptive catalogues forwarded on application.) Telephones for Private Line, Club, and Social systems can be procured directly or through the authorized agents of the company. All telephones obtained except from this company, or its authorized licensees, are infringements, and the makers, sellers, and users will be proceeded against. Information furnished upon application. Address all communications to the  
**AMERICAN BELL TELEPHONE COMPANY,**  
 95 Milk Street, Boston, Mass.



This Tool will be appreciated by every machinist. It is accurately made of the Best Steel, and is of the most approved form. PRICE 50 CENTS.

**WILEY & RUSSELL MFG. CO.,**  
 GREENFIELD, MASS.  
 Makers Lightning Screw Plates, Bolt Cutters, Fine Taps and Dies, etc.

**PATENT QUICK SHAPERS**  
 Adjustable Stroke  
**SHAPERS**  
 Can be Changed while in Motion.  
**E. GOULD & EBERHARDT,**  
 NEWARK, N. J.

**TELEPHONE** Latest, Best, Patented Wire. Illus. Cir's free. Holcomb & Co., Cleveland, O.

\$5 to \$20 per day at home. Samples worth \$5 free. Address STINSON & Co., Portland, Me.



**TOOLS** for Machinists, Carpenters, Amateurs, Jewellers, Model Makers, Blacksmiths, etc. Send for Catalogue, and state what kind of Tools you require. **TALLMAN & McADDEN,** 607 Market St., Philadelphia, Pa.

**CHEAPEST BOOK IN THE WORLD.**

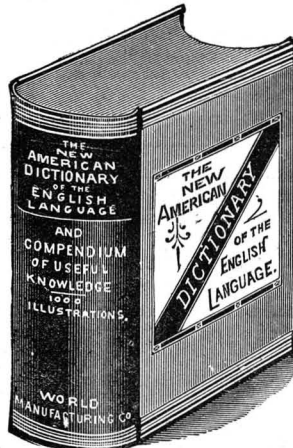

The New American Dictionary Price only \$1.00. Contains 1,000 Engravings and 100 pages more than any other book of the kind ever published. This useful and elegant volume is a Library and Encyclopedia of general knowledge, as well as the best Dictionary in the world, superior both in cloth and gilt. No pocket affair, but a large volume. Contains every useful word in the English language, with its true meaning, spelling and pronunciation, and a vast amount of necessary information upon Science, Mythology, Biography, American History, Insolvent Land and Interest Laws, etc., being a perfect Library of Reference. Webster's Dictionary costs \$9.00 the New American costs only \$1.00.

Read What the Press Says. "We have never seen its equal, or contents."—THE ADVOCATE. "The press ten times the money."—TRIBUNE AND FARMER. "A perfect dictionary and library of reference."—LESLIE'S LITERARY NEWS. We have frequent occasion to use the New American Dictionary in our office and regard it well worth the price.—CHRISTIAN UNION. With the New American Dictionary in the library for reference, many other much more expensive works can be dispensed with, and ignorance of his country, history, business, law, etc. is inexcusable in any man.—SCIENTIFIC AMERICAN. "There's more real worth than in most books at ten times the cost!"—N. Y. WORLD. Price, \$1, postpaid; 2 for \$1.75.

**Extraordinary Offer.** If any person will get up a Club of Ten at \$1.00 each we will send FREE as a premium the American Waterbury Stem Winding Watch. For a Club of 15 we will send free a Solid Silver Hunting Case Watch. For a Club of 30 we send free, a Lady's Solid Gold Hunting Case Watch. For a Club of 50 we will send free, Gents' Solid Gold Hunting Case Watch. Send a Dollar at once for a sample copy. You can easily secure one of these watches in a day or two of during your leisure moments. As to our reliability we can refer to the publisher of this paper, the commercial agencies or any express Co. in this city. Address  
**WORLD MANUFACTURING CO.,**  
 122 NASSAU STREET, NEW YORK.

The New American Dictionary, is an Encyclopaedia of useful knowledge, worth its weight in gold to all classes. It is the most complete, the most useful and entertaining book ever issued. If we could induce every one of our readers to buy one we should feel that we had conferred a benefit on them. When you order the Dictionary, kindly mention that you saw the advertisement in our paper.

Illustrated Catalogue, Photograph and Lecture, 10c. **AUTOMATIC CABINET. Play any Tune.**  
**MAGIC LANTERNS AND VIEWS ORGAN \$5**  
 Magic Lanterns and Slides WANTED. Musical Wonder Catalogue, FREE.  
**HARBACH ORGANINA CO.,** 809 FILBERT STREET, PHILADELPHIA, PA.

**CHARLES CHURCHILL & CO.,**  
 21 Cross Street, Finsbury, London, E. C., England.  
**NEW YORK OFFICE, 495 GREENWICH ST.**

We have been introducing American Machinery and Tools in Great Britain, the British Colonies, and the European Continent since 1862, and are the agents of many of the largest American manufacturers.

Having extensive facilities and connections, we are prepared to introduce new goods, especially in the line of Machinists' and Woodworking Tools and Machinery, and would invite manufacturers to confer with our New York office, where full information will be given.

Geo. Westinghouse, Jr., Ralph Bagaley, H. H. Westinghouse,  
 PRESIDENT. SEC. & TREAS. SUPT.

**THE WESTINGHOUSE ENGINE**

REQUIRES NEITHER  
 Adjustment, Lining, Keying Up,  
 Packing, Oiling, or Wiping,  
 AND

Dispenses Entirely with Skilled Engineers.  
 2 TO 150 HORSE POWER.

Send for Illustrated Circular.

**THE WESTINGHOUSE MACHINE CO.,**  
 92 AND 94 LIBERTY ST., NEW YORK.  
 Works at Pittsburg, Pa.

**"BLAKE'S CHALLENGE" ROCK BREAKER.**

Patented November 18, 1879.

For Macadam Road making, Ballasting of Railroads, Crushing Ores, use of Iron Furnaces, etc. Rapidly superseding our older styles on account of its superior strength, efficiency, and simplicity. Adopted by important Railway and Mining Corporations, Cities, and Towns. First Class Medals of Superiority awarded by American Institute, 1879 and 1880.

**BLAKE CRUSHER CO.,** Sole Makers, New Haven, Conn.

**OUR NEW AMERICAN LEVER WATCH!**

ONLY \$8.



After months of labor and experiment, we have at last brought to perfection a **NEW WATCH.** It is a Key Winding Watch with the celebrated Anchor Lever Movement, Expansion Balance, Fully Jeweled. They are made of the best material, and in the very best manner, so as to insure good time-keeping qualities. The Cases are made of our Celebrated Composition metal known as **ALUMINUM CO.** This metal has a sufficient amount of gold in the composition to give the watch a genuine gold appearance. Indeed it can not be told from a genuine Gold Watch except by the best judges as the metal stands the acid test as well as pure gold. The cases are finely engraved or engine turned and are massive and strong and very handsome making it just the watch for Railroad men, Mechanics and all laboring men who require a good strong watch and an accurate time-keeper. For trading and speculative purposes, it is superior to any watch ever before offered. They can be sold readily for \$15 and \$20 each, and traded so as to realize double those amounts. Farmers as well as Agents can handle these watches to advantage, as they can be readily exchanged for stock or goods. We send the watch free by registered mail, on receipt of \$8.00. Or we will send it C. O. D. on receipt of \$1.00 on a 20 cent balance can be paid at the press office. We also have very fine Aluminum Gold Chains at \$1.00 each Beautiful Medallion Charms 50 cents. We have hundreds of testimonials, but have room for only two.

Hot Springs, Ark. June 3d, 1882.  
 WORLD MANUF'G CO. Gents.—Th. New American Aluminum Gold Watch I ordered of you some time ago was duly received and I am so well pleased with it that I enclose Seven Dollars, P. O. order, on account, for which please forward by express C. O. D. three more of the same style with chains to match. Respectfully,  
 Leavenworth, Kan., Aug. 7th, 1882.  
 WORLD MANUF'G CO. Gents.—The Aluminum Gold American Lever Watch purchased from your firm has proved a good time-keeper, and gives perfect satisfaction. Enclosed find cash for two more, same style. Yours, G. P. ECKERT.  
 Send all orders to **WORLD MANUF'G CO.,** 122 Nassau Street, New York.

It is seldom that we meet with an article that so fully corresponds with its advertised good qualities as does the New American Lever Watch. It has the advantage of being made of that precious metal Aluminum Gold; its works are of the best make, and the general style of the case rank it with the best Watches made anywhere. We recommend it to our readers as a Watch that will give entire satisfaction.

**STEMWINDING** Permutation Lock, No. 125. For any Till, Desk, Drawer, or Closet. Instantly locked; unlocked in a few seconds; constructed upon new and improved principles. Owner may use either 1, 2, 3, or 4 of its 50 numbers. Millions of changes equally possible and easy. Security unrivaled. Simple, durable, nickel plated. Send \$2.50 for sample by mail, or stamp for Illustrated List of Locks, Tills, and Padlocks. **D. K. MILLER LOCK CO.,** Philadelphia, Pa.

AND FINE GRAY IRON ALSO STEEL CASTINGS FROM SPECIAL PATTERNS  
**MALLEABLE** FINE TUNING JAPANNING AND FINISHING  
**THOMAS DEVLIN & CO.,** LEHIGH AVE. & AMERICAN ST. PHILA.  
 40 New No 2 alike Chromo Visting Cards, name on, 10 cents. Warranted best pack sold. Agents Wanted. **L. JONES & CO.,** Nassau, N. Y.

**ROOT'S NEW IRON BLOWER.**

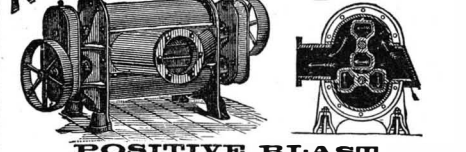

**POSITIVE BLAST.**  
**IRON REVOLVERS, PERFECTLY BALANCED,**  
 Has Fewer Parts than any other Blower.

**P. H. & F. M. ROOTS, Manufacturers,**  
 CONNERSVILLE, IND.

**B. S. TOWNSEND, Gen. Agt.,** 6 Cortland St. 8 Dey St.,  
**COOKE & CO.,** Selling Agts., 6 Cortland Street,  
**JAS. BEGGS & CO.,** Selling Agts. 8 Dey Street,  
**NEW YORK.**  
 SEND FOR PRICED CATALOGUE.



**Proposal to Builders.**

The undersigned, having 55 acres in city of PITTSBURG, PA., on line of Penna. R. R., desires 200 frame dwelling houses built of the following dimensions:

Class	HOUSES.	ROOMS.	Remarks
A	25	3 each	no cellar, with cellar.
B	50	4 " "	" " " "
C	50	5 " "	" " " "
D	25	6 " "	with cellar under half of house.
E	25	7 " "	" " " "
F	25	8 " "	" " " "

Each house to be built separate and of the same design in each class.

PROPOSALS both for designs and buildings are invited. Owner reserving the right to reject any or all. Plans accepted will be paid for at regular rates.

Address **R. M. KENNEDY,**  
 Cor. Second and Wood Sts., Pittsburg, Pa.

**THE RIDER COMPRESSION PUMPING ENGINE**

(Hot Air), for city or country residences where it is required to raise a supply of water, is the most Perfect Pumping Machine in the market. Its marvelous Simplicity, absolute Safety, great Economy and Effectiveness, render it far superior to all others. Can be run by any inexperienced person. Send for catalogue and price list to  
**CAMMEYER & SAYER,**  
 93 Liberty St., New York,  
 and 20 W. Lake St., Chicago, Ill.  
 Please mention this Paper.

**WATCHMAKERS.**

Before buying lathes, see the "Whitcomb," made by AMERICAN WATCH TOOL CO., Waltham, Mass.

**BEATTY'S** ORGANS, 27 stops, \$125. Pianos, \$297.50. Factory running day & night. Catalogue free. Address Daniel F. Beatty, Washington, N. J.



**MACHINISTS' TOOLS.**

NEW AND IMPROVED PATTERNS. Send for new illustrated catalogue.  
**Lathes, Planers, Drills, &c.**  
**NEW HAVEN MANUFACTURING CO.,**  
 New Haven, Conn.

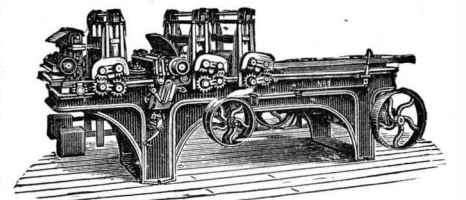

**WITHERBY, RUGG & RICHARDSON,** Manufacturers of Patent Wood Working Machinery of every description. Facilities unsurpassed. Shop formerly occupied by R. Ball & Co., Worcester, Mass. Send for Catalogue.

\$66 a week in your own town. Terms and \$5 outfit free. Address **H. HALLETT & Co.,** Portland, Me.



**FREE** 25 Useful Household Articles. Send 3 cent stamp for postage. Address **E. G. Rideout & Co.,** 10 Barclay St., N. Y.

**DON'T BUILD A HOUSE OF ANY KIND UNTIL YOU** write for prices and sample to the **BODINE ROOFING COMPANY,** Mansfield, Ohio.

**GOLD PENS.**

**PENCILS, HOLDERS, CASES, &c.**  
**The CALLI-GRAPHIC Pen.**  
 A GOLD PEN and RUBBER HOLDER, containing ink for several days' writing. Can be carried in the pocket. Always ready for use. A luxury for persons who care to preserve their individuality in writing.  
**MABIE, TODD & BARD,**  
 180 BROADWAY, NEW YORK.  
 Send for Price-List. JUR. GOODS ARE SOLD BY FIRST-CLASS DEALERS.

**CLARK'S RUBBER WHEELS.**  
 This wheel is unrivaled for durability, simplicity, and cheapness. Adapted for Warehouse and Platform Trucks, Scales, Heavy Casters, and all purposes for which Wheels are used. Circular and Price List free. **GEO. P. CLARK,** Windsor Locks, Ct.



