

# SCIENTIFIC AMERICAN

[Entered at the Post Office of New York, N. Y., as Second Class Matter.]

A WEEKLY JOURNAL OF PRACTICAL INFORMATION, ART, SCIENCE, MECHANICS, CHEMISTRY AND MANUFACTURES.

Vol. XLVII.—No. 19.  
[NEW SERIES.]

NEW YORK, NOVEMBER 4, 1882.

[\$3.20 per Annum.  
[POSTAGE PREPAID.]

## The Transfer of Gold Coin in New York.

The last annual report of President William Dowd, to the Clearing House Association, showed that within the twelve months covered by his review, \$375,000,000 in gold coin was taken through the streets of this city to meet the requirements of the threescore banks included in the association. This \$375,000,000 weighed over 686 tons, coming from the sub-treasury to the clearing house on balances. Of course these balances vary from day to day. During the administration of Assistant Treasurer Acton, the largest debit noted for any one day was on July 3 last, when over \$7,000,000 went out. Prior to the appointment of Mr. Acton the balance on one occasion reached over \$8,500,000, and to pay it 17 tons of gold had to be taken from the sub-treasury vaults and passed over to the clearing house authorities for proper distribution among the creditor banks.

Not the least interesting feature of this immense transfer of gold under the direction of the Clearing House Association is the fact that each and every dollar of the millions is carried through the streets and delivered by one man, or, rather, by one man and his assistants. That man is John C. Barkley, popularly known to every banker, broker, and office boy in the city's financial center as "Honest John Barkley."

Service for the clearing house by no means limits his work. Every dollar shipped to Europe or received from Europe is conveyed to or from the ship on his trucks, and scores and scores of fashionable families are never content to leave the city for summer homes until Barkley has transmitted their silver to safety vaults.

John C. Barkley does not work for nothing, nor for mere pleasure, nor for glory. He has a truck on which he can carry, in gold, \$2,000,000, or 40 shipping kegs. The fee for each keg is \$1, or for the trip out of Wall street to the steamship company's pier, \$40. But this is far from excessive when consideration is given to the responsibilities attending the business.—*N. Y. Times.*

## Progress of Telegraphy.

131,100 miles of poles, 374,368 miles of wires, 12,100 offices, nearly thirty millions of messages transmitted, over seventeen millions of dollars received, over ten millions paid for

expenses, leaving over seven millions of dollars in profits—such are the astonishing returns of the Western Union Telegraph Company for the single year ending June 30, 1882. Enterprise, good management, and the possession of valuable patents have been the basis of this extraordinary success.

## A Test of Potato Seed.

This season's tests of the productiveness of different sizes of potato seed, at the New York State Experiment Station, show the following per acre yield of small plats planted side by side in drills three feet apart and one foot distant in the hill:

Kind of Seed.	Merchantable.	Small.	Total.
Single eyes cut deep.....	152 bush.	39	191
Ordinary cuts.....	127 bush.	75	202
Whole potatoes.....	83 bush.	75	158

Besides the increased return Director Sturtevant notes that the quality from "single eyes cut deep" was "superior," while that from the other seed was "but ordinary."

## TWENTY-TON PORTABLE STEAM CRANE.

The very fine crane which we here illustrate has been erected on the Stobcross Wharf, near Queen's Dock, for the service of Messrs. Henderson Brothers' Anchor Line steamers. For some years four cranes have been in use for loading and discharging these vessels, two of which have a lifting power of five tons, and two of three tons, at a radius of 30 feet. It was found with these cranes that, although quite competent for nearly all the work required, there occasionally were pieces above their lifting capacity, which necessitated removing the steamer to another part of the harbor to get the use of one of the fixed public cranes. In order to obviate this inconvenience the crane we illustrate was constructed by Messrs. George Russell & Co., of Motherwell, near Glasgow. Its leading features are patented by Mr. Russell, of that firm, by whom this special crane has been designed.

Fig. 1 shows an outline of the crane, and the extremely limited space between the edge of quay wall and sheds. The gauge of the wheels is 10 feet center to center, but in order

to clear the eaves of the shed the central post is only 2 feet 6 inches from the center of the outside wheels. In order to distribute the weight equally on the quay wall and grooved rail near the shed, eight supporting wheels are fitted on each side of the carriage.

Fig. 2 is an elevation of a corner of the carriage, showing the wheels and levers for distributing the weight equally. There are on each corner a pair of main levers with fulcrum, A; at each end of these are fulcra, B B, with shorter levers carrying the axle pins of the wheels, C C C. The levers being free to adjust themselves, it will be evident that the pressure at A is equally distributed over the four wheels, notwithstanding any irregularities in the quay surface. The outer wheels bear directly on the granite curb, and the inner in a grooved rail. The carriage is of malleable iron plates, 1½ inches thick, 4 feet deep; the eight wheels on each side being 3 feet, center to center, give a wheel base of 21 feet. The central post is of malleable iron, 2 feet diameter; the jib is 50 feet long, of malleable iron plates of box section, and its radius is variable by steam; the chain barrel is 2 feet 3 inches diameter, screw grooved for the chain, and there are double and single purchase gears.

Continued on p. 290.

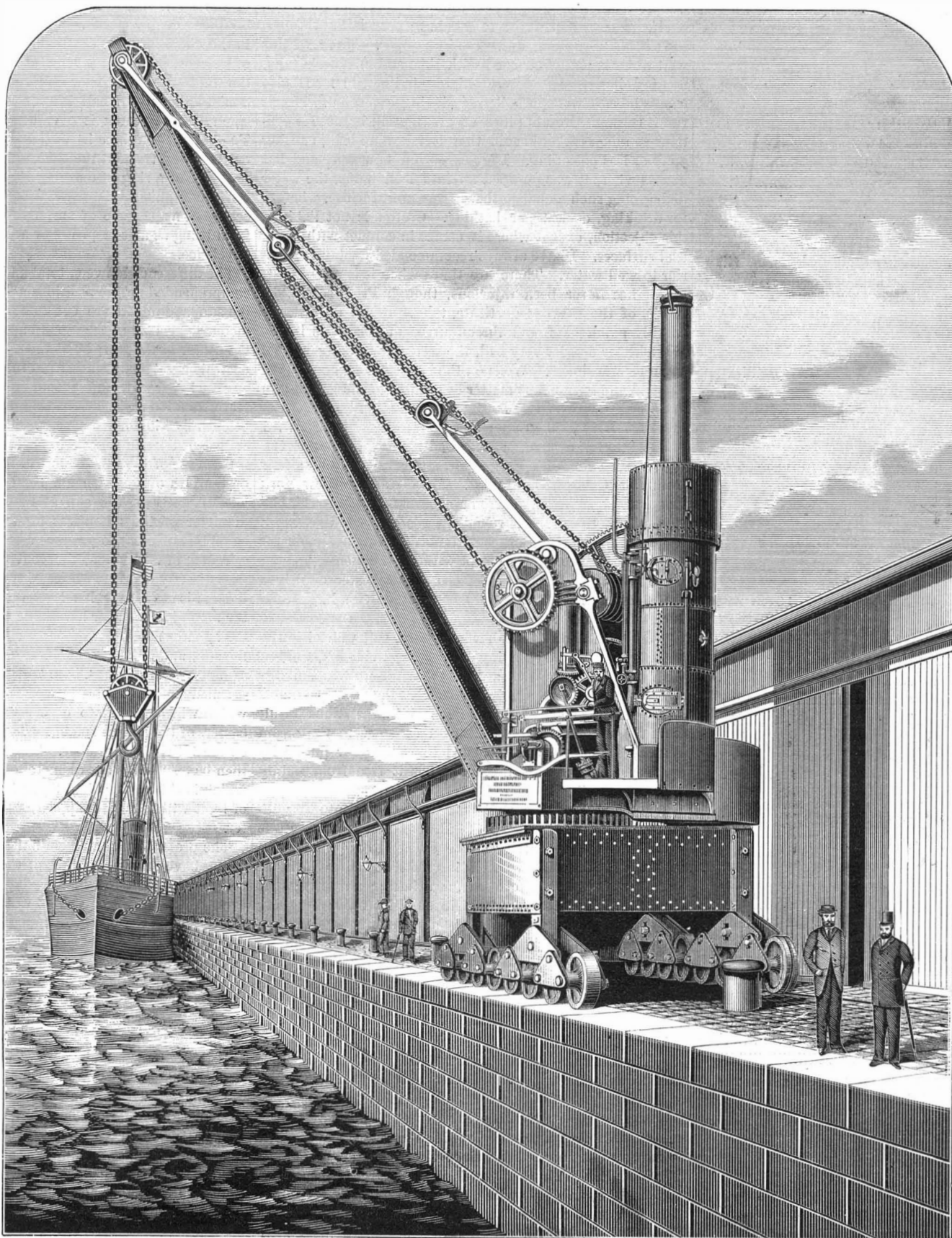

TWENTY-TON PORTABLE STEAM CRANE, GLASGOW HARBOR.

Scientific American.

ESTABLISHED 1845.

MUNN & CO., Editors and Proprietors.

PUBLISHED WEEKLY AT

No. 261 BROADWAY, NEW YORK.

O. D. MUNN.

A. E. BEACH.

TERMS FOR THE SCIENTIFIC AMERICAN.

One copy, one year postage included... \$3 20
One copy, six months postage included... 1 60

Clubs.—One extra copy of THE SCIENTIFIC AMERICAN will be supplied gratis for every club of five subscribers at \$3.20 each: additional copies at same proportionate rate. Postage prepaid.

Remit by postal order. Address

MUNN & CO., 261 Broadway, corner of Warren street, New York.

The Scientific American Supplement

is a distinct paper from the SCIENTIFIC AMERICAN. THE SUPPLEMENT is issued weekly. Every number contains 16 octavo pages, uniform in size with SCIENTIFIC AMERICAN. Terms of subscription for SUPPLEMENT, \$5.00 a year, postage paid, to subscribers. Single copies, 10 cents. Sold by all news dealers throughout the country

Combined Rates.—The SCIENTIFIC AMERICAN and SUPPLEMENT will be sent for one year postage free, on receipt of seven dollars. Both papers to one address or different addresses as desired.

The safest way to remit is by draft, postal order, or registered letter.

Address MUNN & CO., 261 Broadway, corner of Warren street, New York.

Scientific American Export Edition.

The SCIENTIFIC AMERICAN Export Edition is a large and splendid periodical, issued once a month. Each number contains about one hundred large quarto pages, profusely illustrated, embracing: (1.) Most of the plates and pages of the four preceding weekly issues of the SCIENTIFIC AMERICAN, with its splendid engravings and valuable information; (2.) Commercial, trade, and manufacturing announcements of leading houses. Terms for Export Edition, \$5.00 a year, sent prepaid to any part of the world. Single copies 50 cents. Manufacturers and others who desire to secure foreign trade may have large and handsomely displayed announcements published in this edition at a very moderate cost.

The SCIENTIFIC AMERICAN Export Edition has a large guaranteed circulation in all commercial places throughout the world. Address MUNN & CO., 261 Broadway, corner of Warren street, New York.

NEW YORK, SATURDAY, NOVEMBER 4, 1882.

Contents.

(Illustrated articles are marked with an asterisk.)

Table listing various articles such as Belt fastener, new\*, Inventions, recent\*, Coin, gold, transfer of in N. Y., etc., with corresponding page numbers.

TABLE OF CONTENTS OF

THE SCIENTIFIC AMERICAN SUPPLEMENT

No. 357,

For the Week ending November 4, 1882.

Price 10 cents. For sale by all newsdealers.

Table listing sections I through VII, including Engineering and Mechanics, Technology and Chemistry, Electricity, Light, Heat, Sound, etc., Hygiene and Medicine, Natural History, etc., with page numbers.

WELL WATER IN NEW YORK CITY.

The high cost and uncertain supply of Croton water have led to a great multiplication of artesian and driven wells in this city; and the large use of well waters has so affected the revenues of the Board of Public Works as to awaken an active opposition to the wells. The larger part of the water from the artesian and driven wells, certainly on New York Island, is used for cooling and washing purposes by brewers, in laundries and stables, and for steam making and other industrial purposes.

The greater part of the driven wells in the city (including the lately annexed Westchester district) are said to have been sunk within the past three years. To a considerable extent such wells are sunk secretly, to escape examination and possible condemnation by the health officers. The number is put at 1,800, besides fifty artesian wells, and probably as many dug wells.

The work of testing the waters has been going on at the School of Mines during the past four months. Professor E. Waller, who has the work in charge, tells the Tribune that he has analyzed water from about fifty wells, and in most cases he finds it unfit for use. How large a proportion of the fifty wells were deep wells and how many were dug wells he does not say. Of the water examined he says:

"It is generally contaminated with organic substances and extraneous matter, such as appear in drainage, and has an excess of mineral ingredients. Some of these waters resemble tide water, and contain more solids than the ocean itself. The surface drainage gets in by percolating through the earth and running down the iron pipes. Much of this well water is highly charged with lime and magnesia salts, making it very 'hard' and highly indigestible. It also causes incrustations in boilers, inducing explosion. Hotels run it through Croton pipes at great peril, because it contains so much carbonic acid that it takes up lead, causing more or less poisoning. I found eleven tenement and flat houses where it was pumped up into lead tanks, the water undergoing such a change that it was unfit for use, whether for drinking, cooking, or bathing. Croton is not liable to this objection, except where it comes in contact with fresh lead surfaces. I have always recommended Croton as superior to well water. There are times when it is unpleasant, but it has never been injurious, though Professor A. R. Leeds, of the Stevens Institute, takes ground against me on this point. I found three-fourths of the wells in the Westchester district very bad, the water containing a large amount of drainage. Wells on the Harlem Flats contained of solid and extraneous matter 688 grains to the gallon; in West Fifty-sixth street, 56 1/2 grains; in Grand street, near the East River, 50 grains; in the Westchester district, 7 grains (mostly drainage); in Broadway, near Wall street, 20 1/2 grains; in East Forty-eighth street, 22 grains; near Columbia College, 35 1/2 grains. A well at the New York Hospital ran so heavily in iron and other minerals that it had to be abandoned. It destroyed all the pipes and vessels it came in contact with, and could not be made available for use even as waste water, except with great expense."

On the other hand, in defense of the water of driven wells, Mr. C. D. Corwin, who has put down a large number of them, says:

"When these wells are driven, a pure, soft water is guaranteed. Owners can employ an analytical chemist, and test the water, and refuse to accept the work until a suitable water is reached. Clay, through which the pipes pass, acts as a cement to arrest drainage. No incrustations result from the use of this water. A man engaged in the steam laundry business has just opened his boiler for public inspection, after a year's use, and finds it free from scaling and sediment."

The owners of the wells threatened are naturally displeased with the action of the Health Department. It is probable that the matter will be carried to the courts, the argument of the well-owners being that in the majority of instances the water is not used for drinking purposes; that if impure, it is possible to obtain superior water by going deeper; that a large amount of money and numerous industries are involved, and that the Board of Health has been stimulated by the Board of Public Works, for the purpose of compelling the use of Croton water.

FIRE WITHOUT FUELS.

For the past decade or more an English inventor in India, Mr. W. Adams, of Bombay, has been trying to persuade men to make a larger use of direct sunshine in culinary and industrial operations, as a substitute for the solar forces stored in coal and wood. By his plan the use of expensive lenses and curved reflectors, as employed in France in solar engines, is shown to be unnecessary, since flat reflectors of common window glass, plain or silvered, properly arranged, are able to focus the sun's rays with sufficient exactness.

In a communication to the SCIENTIFIC AMERICAN of June 15, 1878, Mr. Adams describes at length his experiments, and figures several of the types of apparatus by which he utilizes the solar rays. By means of large batteries of

comparatively inexpensive reflectors enough sunshine has been concentrated upon boilers to make steam quite rapidly; and in some experiments very high temperatures have been obtained. Mr. Adams' position is that batteries of plain reflectors are cheaper than furnaces, and sunshine vastly cheaper than coal, especially in tropical and other regions where coal is hard to get and the sky is clear of clouds for months at a time. The argument is good, and the practical tests of this sort of solar apparatus have been very promising if not conclusive. Yet for some cause no great progress appears to have been made in the utilization of sun heat in this manner.

In view of these familiar facts it is amusing if not surprising to read in a Washington paper—followed by a column or two of extravagant explanation and expectations—that "The Patent Office has just extended its official wing over one of the most remarkable discoveries of the present century, and one, it is safe to say, which will not only effect a revolution in the present methods of producing and applying heat, but seriously undermine the very structure upon which the at present generally received scientific notion of heat rests. . . . The whole invention simply consists of an arrangement whereby the rays of the sun are reflected from any number of mirrors upon a common focus."

The invention referred to is a complicated device for giving a battery of plane mirrors a motion with the sun (so that the sun's rays will always fall perpendicularly upon the adjustable surfaces of the mirrors), and for utilizing the heat concentrated at the focus of the converging rays. The invention embraces no new discovery; and if it revolutionizes either science or industry, Mr. W. Adams of Bombay will not be the only person surprised.

ANNULAR ECLIPSE OF THE SUN.

On the 10th of November there will be an annular eclipse of the sun, invisible in this country, but visible in the Southern Pacific Ocean. The path of the eclipse lies wholly in the Pacific Ocean, commencing a little east of the Island of Celebes, including several small islands in the vicinity, the southern part of New Guinea, the whole of New Caledonia, and a few small islands scattered along the route. The rest of the track is over a boundless waste of waters. To observers on these islands, and to those who chance to be on the ocean track at the time, the sun will present the appearance of a ring of dazzling light surrounding the moon's intervening disk. An annular eclipse ranks next to a total eclipse as a spectacle of surpassing beauty, though it is far from being as awe-inspiring or as important to the interests of science.

The difference between total and annular eclipses is easily comprehended. The positions and apparent magnitudes of the sun and moon are constantly varying. When, at new moon, the center of the moon happens to pass directly over the center of the sun; if, at the same time, the sun is at or near his greatest distance from the earth, and the moon is at or near her least distance from the earth, the apparent diameter of the moon will exceed that of the sun, and the sun will be entirely hidden from view. There will then be a total eclipse of the sun, visible to observers near the line joining the centers of the sun and moon. These conditions occurred on the 17th of May, when a total solar eclipse took place. The diameter of the sun at that time was 31' 41.6". The diameter of the moon was 31' 43.8", exceeding that of the sun 2.2", sufficient to produce a total eclipse.

When, at new moon, the center of the moon happens to pass directly over the center of the sun; if, at the same time, the sun is at or near his least distance from the earth, and the moon is at or near her greatest distance from the earth, the apparent diameter of the moon will be less than that of the sun, and it is evident that the whole surface of the sun cannot be obscured. There will then be an annular eclipse—called so from the Latin word annulus, meaning a ring—which will be visible to observers near the line joining the centers of the sun and moon. Such a combination will occur on the 10th of November. The diameter of the sun will then be 32' 24.2". The diameter of the moon will be 30' 6.6", which is 2' 17.6" less than that of the sun. A narrow ring of light will therefore appear encircling the darkened center.

The present year numbers but two eclipses on its annals. There have been no eclipses of the moon, and the two solar eclipses are those to which we have referred. But the rare event of the transit of Venus, which will take place on the 6th of December, deserves to be numbered with the solar eclipses, for it is due to a similar cause. The planet obscures as much of the solar disk as she is capable of doing, when she passes like a black point over his disk. If she were as near as the moon she would cause an eclipse of the sun that would last long enough to be of great assistance in the solution of many vexed problems concerning solar physics.

If the eclipses of the year are few in quantity they make up for the deficiency in their excellent quality.

A total solar eclipse, an annular eclipse, and a transit of Venus are seldom the sole records on the annals of a single year. It is much to be regretted that the path of the coming annular eclipse falls upon a portion of the world where there will be few to look upon the superb spectacle when the moon hides the sun's face with the exception of a narrow ring of dazzling light.

DURING 1881 the British Patent Office received 5,751 applications, the largest number recorded for any year.



## CORPULENCE.

Nothing is more common than to hear stout people wish they were thinner, while not a few spare people wish for more adipose tissue. Much of this arises from man's nature not to be satisfied with things as they are; but some of this complaint rests on better grounds. There are certain disadvantages connected with carrying around an excessive quantity of useless fat. It is evident that the labor expended in carrying three hundred pounds of human flesh about from place to place, or lifting it up a flight of stairs, is twice that required to handle 150 pounds. The exertion being greater, the muscles should be stronger, but, unfortunately, they are usually weaker. All this weight must be borne by the same pair of feet, which frequently suffer from the strain, or are crushed by the superincumbent weight. An accumulation of fat about the trunk impedes respiration, and makes exercise almost impossible. For these and similar reasons that will readily occur to the reader, corpulent people are generally anxious to get rid of the excess. This is particularly the case with ladies of fashion, for "too much fat spoils the figure."

In the case of our domestic animals, we have it largely within our own control to say whether they shall be fat or thin. Every farmer knows how to fatten his cattle, and a fat horse is considered an index to the liberality of his feeder. Leaving out of account a few unhealthy individuals, most animals fatten when allowed to eat their fill and take their ease, but soon lose flesh when the feed is limited or bad.

In the human species, the rule fails as often as it holds good. Most lean men are notoriously large eaters, and some are, in addition, excessively lazy. Apparently all the conditions favorable to fattening are present, yet the individual remains spare and thin. Others attain great size on a limited diet of the poorest food. Nothing is more common than to see two individuals, a husband and wife, two brothers, or two sisters, living and working side by side, eating the same food, and drinking the same beverages, apparently taking an equal amount of exercise, yet one will weigh nearly twice as much as the other. The only explanation that has been offered for such cases, if both are in health, is that one is predisposed to *embonpoint*, the other not. No doubt the natural disposition, too, has a great influence; worry, rather than work, consumes the flesh, so that men who take the world easy frequently stay fat on the most limited diet.

The predisposing causes of corpulency, according to Immermann, are as follows: 1. *Heredity*, although it may not show itself until middle life. 2. *Period of life*. Nursing babies and persons over forty are most inclined to be fat. 3. *Sex*; the female is more inclined to be stout than the male. 4. *Physiological constitution*; full-blooded people throw up more fat than most thin-blooded ones, but there is a sort of anæmic condition that also favors corpulence. 5. *Temperament*. 6. *Genital anomalies*; we know that wethers, oxen, and capons, as well as eunuchs, are usually fat. Although the above mentioned causes, which are beyond the control of the individual, favor corpulence, they do not produce it.

That a large number of corpulent persons are anxious to exchange their estate is shown by the large sale that "anti-fat" nostrums have, although their dangerous character is evident from the fact that at least one death has been traced to their use. It is not stated whether the victim, who had taken eighteen bottles of the medicine, had acquired the desired degree of tenuity before her death, but we infer that she had not, as she is spoken of as being "very stout." We conclude that "anti-fat" is not what it pretends to be, notwithstanding its dangerous character, and some authorities say that its chief ingredient is *fucus vesiculosus*, or tangle, a kind of seaweed, also used in some places to fatten hogs. If it really possesses any virtue, which is exceedingly doubtful, it is due to the iodine which it contains.

Many of the persons who complain of their flesh could relieve themselves of part of it by two simple expedients, viz., eating less and taking more exercise. This, however, requires too great a sacrifice on their part; they are like the people who want to get rich or learned without exercising the amount of self-denial necessary to accomplish the desired end.

In early Greece gymnastic exercises had for their express object the prevention of corpulence. A huge padding of fat not only shocked the highly developed æsthetic sensibility of this richly gifted people, but was most justly regarded by them as a hinderance to corporeal robustness.

It is well known that work horses are seldom fat, and persons of active habits avoid excess of flesh. But not only does a quiet life favor corpulence, but corpulence favors quiet, for the fat man finds it impossible to take much exercise.

Before considering the diet most favorable to the cure of corpulence, we must ask whence comes human fat. The views of physiological chemists have undergone much change since the days of Liebig, who considered the carbohydrates (sugar and starch) to be the fat producers. The more recent physiological view regards the greater portion of the fat store as probably a product of the decomposition of the albumen in the food, but some of the fat eaten is deposited in the tissues directly. The magnitude of this store is primarily determined by the amount of food taken, because the store of fat at any time laid up in the animal body is derived from the nutriment assimilated by the organism. It does not follow from our first statement that

if a man lived entirely on albumen he would get fat, because a large portion of the albumen would be consumed in supporting life, and only the residue unconsumed could be laid up as reserve. But if farinaceous food and sugar (carbohydrates) be taken with the albumen, the former protect the latter from burning up, and thus favor the formation of fat, although we have no proof that they can themselves be converted into fat. To make a familiar comparison, a person who receives a very small salary and board will be able to put more money in the savings bank than one who receives a larger compensation for his services, but has to pay his own board. The food which the former receives from his employer cannot be deposited in the bank, but it enables him to preserve intact whatever cash he may get. This protecting influence of the carbohydrates led early chemists to mistake them for fat producers.

Both the quality and quantity of food taken are of importance in the treatment of corpulence. Starvation will reduce the flesh, but it should *never* be resorted to, as it produces weakness in every organ, and leads to the worst results. On the other hand, the quantity of food eaten should be as small as consistent with health and with satisfaction of the natural appetite. As regards the kind of food, the following should only be taken in small quantities: Bread, milk, eggs, potatoes, carrots, rice, buckwheat, sweet soups, sugar, mutton in any form, beef steak, salads with oil, desert dishes, and wine jelly. The following should be almost entirely avoided: Butter, cream, fats, sauces, pork, sweet pastry, confitures, creams, ices, chestnuts and other nuts. For beverages tea and coffee may be taken with little or no milk and sugar, but chocolate and cocoa are to be avoided. Beer and strong alcoholic liquors must be given up, but sour wines diluted with water are permissible.

The first person who ever followed out for a year the strict dietary laid down by his physician was William Banting, who reduced his weight 46 pounds (from 202 pounds to 156 pounds), and his circumference by 12½ inches in that time. This treatment, which was invented by Harvey, has since been known as "Bantingism." The details of his menu may be found in most medical books. Although frequently attempted, it has rarely been found so successful in other cases. There is no doubt, however, that any intelligent person who is willing to impose some restraint on his appetite, and avoid the forbidden foods and drinks mentioned above and take regular exercise, may materially reduce his own weight and bulk.

The waters of certain mineral springs, especially those of a cathartic nature, are sometimes employed with good results. It is generally more successful if taken at the spring, where the customs of the place favor exercise and plain diet. Waters that contain iodides are also recommended, but are of doubtful efficiency.

Another remedy, which seems less rational than any of the above, is recommended in the London journals, namely, the application of external pressure, whereby the dimensions of the body are gradually reduced to normal proportions. Several correspondents of these papers report that they have tried it with success, while no failures have yet been reported. One man, who had tried Bantingism without success, reports that "tight lacing" accomplished the desired result. Another gentleman reports that by the use of an ordinary lady's corset he reduced his circumference 8 inches (from 42 to 34 inches), with great improvement in bodily health. It is probable that tight lacing has a good effect on immoderate eaters, and thus favors leanness and (as some claim) cures dyspepsia, but we are unable to see how it can have any other good effect. Another remarkable fact is that men were the first to make the discovery that tight lacing will cure corpulence, while the other sex, who are supposed to have had more experience in the use of corsets, never found it out. While we do not wish to discredit the statements of so many witnesses, we cannot believe that tight lacing is a universal cure for corpulence, since it is well known that most corpulent women lace, some few of them excessively, and yet they are not cured of their chief infirmity thereby. Perhaps the effect is different on men, for, being unused to tight clothing, the corset proves a constant reminder of the necessity of exercising moderation in eating and drinking, while even the temporary reduction in size makes them more capable of taking active exercise. Since oxygen in the blood is essential to the consumption of the excess of carbon, whatever prevents free breathing should tend to increase corpulence; hence the corsets must not be worn too tight at first. With this restriction, the remedy is safe and worthy of a trial, when other means have failed, or wherever circumstances prevent the observance of Banting's rules. It is certainly safer than anti-fat nostrums.

Whatever course of treatment the man of Falstaffian proportions would adopt, failure is sure to result unless patience and perseverance are abundantly supplied.

In the case of anæmic corpulence, where the number of red blood corpuscles is insufficient to oxidize the elements of the food, the person will have a white, pasty, or doughy look. The cause being different, none of the above modes of treatment are applicable. The general health must be attended to, ferruginous tonics can be tried, and every means should be resorted to for oxygenating the blood. It is probable, even, that exposure to increased atmospheric pressure, as the workmen are in the Hudson River Tunnel, might be beneficial in such cases. Exercise, properly taken, is likewise beneficial. In general, however, such cases had better be referred to a competent physician.

## Some of Herbert Spencer's Impressions.

Discussing the conditions and causes of the immense developments of material civilization, which he has observed in this country, developments of which his previous studies had given him no adequate idea, Mr. Herbert Spencer properly gives a prominent place to the inventiveness which has been "so wisely fostered." "Among us in England," he said, "there are many foolish people who, while thinking that a man who toils with his hands has an equitable claim to the product, and, if he has special skill, may rightly have the advantage of it, also hold that if a man toils with his brain, perhaps for years, and, uniting genius with perseverance, evolves some valuable invention, the public may rightly claim the benefit. The Americans have been more far-seeing. The enormous museum of patents which I saw at Washington is significant of the attention paid to inventors' claims; and the nation profits immensely from having, in this direction (though not in all others), recognized property in mental products. Beyond question, in respect of mechanical appliances, the Americans are ahead of all nations."

Touching the probable issue of the gigantic social, political, and racial problems in process of evolution in the United States, Mr. Spencer said:

"No one can form anything more than vague and general conclusions respecting your future. The factors are too numerous, too vast, too far beyond measure in their quantities and intensities. The world has never before seen social phenomena at all comparable with those presented in the United States. A society spreading over enormous tracts, while still preserving its political continuity, is a new thing. This progressive incorporation of vast bodies of immigrants of various bloods has never occurred on such a scale before. Large empires composed of different peoples have, in previous cases, been formed by conquest and annexation. Then your immense plexus of railways and telegraphs tends to consolidate this vast aggregate of States in a way that no such aggregate has ever before been consolidated. And there are many minor co-operating causes unlike those hitherto known. No one can say how it is all going to work out. That there will come hereafter troubles of various kinds, and very grave ones, seems highly probable; but all nations have had, and will have, their troubles. Already you have triumphed over one great trouble, and may reasonably hope to triumph over others. It may, I think, be reasonably held that both because of its size and the heterogeneity of its components, the American nation will be a long time in evolving its ultimate form; but that its ultimate form will be high. One great result is, I think, tolerably clear. From biological truths it is to be inferred that the eventual mixture of the allied varieties of the Aryan race forming the population will produce a more powerful type of man than has hitherto existed, and a type of man more plastic, more adaptable, more capable of undergoing the modifications needful for complete social life. I think that whatever difficulties they may have to surmount, and whatever tribulations they may have to pass through, the Americans may reasonably look forward to a time when they will have produced a civilization grander than any the world has known."

## Copying Paper.

The following is communicated to the *Polytech. Notizblatt* by E. Dieterich, in regard to the method he employs for making the copying paper which has obtained so good a reputation in Germany. The manufacture may be divided into two parts, viz., the production of the color and the application of the same to the paper. For blue paper, Dieterich uses exclusively the blue color known as "Paris blue," as covering better than any other mineral color. Ten kilogrammes of this color are coarsely powdered, and mixed with 20 kilogrammes of ordinary olive oil; 0.25 kilogramme of glycerine is then added. This mixture is, for a week, exposed in a drying room to a temperature of 40° to 50° C., and then ground as fine as possible in a paint mill. The glycerine softens the hard paint, and tends to make it more easily diffusible. Then Dieterich melted 0.5 kilogramme of yellow wax with 7.5 kilogrammes of ligroine, and added to this 3 kilogrammes of the blue mixture, mixing slowly at a temperature of 30° or 40° C. The mass is now of the consistency of honey. It is applied to the paper with a coarse brush, and afterward evenly divided and polished with a badger's hair brush. The sheets are then dried on a table heated by steam. This is done in a few minutes, and the paper is then ready for shipment. The quantities mentioned will be sufficient for about 1,000 sheets of 50 by 90 centimeters, being a day's work for two girls. For black paper aniline black is used in the same proportion. The operation must be carried on in well ventilated rooms protected from fire, on account of the combustibility of the material and the narcotic effects of the ligroine. The paper is used between two sheets of paper, the upper one receiving the original, the lower one the copy.

## The Mirror Telegraph.

An interesting experiment in heliography, or signaling by sunshine, was successfully made in Egypt during the recent campaign. Colonel Keyser ascended one of the pyramids near Cairo, and by means of a heliographic mirror reflected a ray of sunlight to Alexandria, 120 miles away. At that great distance the signals, appearing like pin points of brightness, were easily ascertained to be a message from Sir Garnet Wolseley to the Khedive.

**TWENTY-TON PORTABLE STEAM CRANE.**

(Continued from first page.)

The engines have a pair of 9 inch cylinders by 13 inch stroke, with steel link motion. The boiler is vertical, with three cross tubes, and a large cylindrical feed water tank is placed above it, through which the heat passes to the chimney; the exhaust steam is also led into it.

Fig. 3 shows a section of the combined ash-box and balance weight; the ashes drop from the fire bars into a conical space terminating in a door at the bottom; when this door is opened the ashes are at once emptied into any convenient receptacle. The crane is moved along the quay by gearing fitted under the carriage, grasping by means of a capped pulley a pitch chain made fast to any of the mooring blocks. The maximum working load is 20 tons at a radius of 30 feet, and 16 tons at 35 feet. Besides ordinary lifts, it is fitted with tipping gear for lifting coal wagons, and will shortly be used for coaling the vessels. The crane weighs 103 tons, and there are about 12 tons of iron ballast in the tank under the boiler, and 35 tons in the land side of the carriage; so that the total weight is 150 tons. Although of such large capacity it is found to work with extreme ease under control of one man.

This is a very favorable example of thoughtful designing, the conditions under which the crane has to work being very exceptional. Messrs. Russell's reputation is an ample guarantee for the quality of the material and workmanship.—*Engineer.*

**WOOL SHEARING.**

The proper way is first to clean all the points, the crutch, and the belly wool, and let this be first taken away by itself. Then the neck should be carefully opened until the wool is posted, and there is a "good face" to the work. The greatest injury to the fleece takes place on the back, and is caused by the operator not raising his hand, so as to keep the points of the shears close down to the skin. This is known as "cutting through," and it takes place when the sheep is being shorn on one side; and in shearing over the back the points of the shears cut nearly or quite through the fleece, from the inside to the out. When the sheep is being shorn on the other or turning out side the shears are again pointed upward, and the cuts on the first and last side overlap each other, forming a sort of Vandyke line, and causing the fleece to part in two halves all along the back. This is soon detected by spreading the fleece on the table, with the cut side uppermost.

No good shearer makes any second cuts; the fact that the wool has been left by the first cut proves that the shears have not been held properly, and the wool thus removed by the second cut entails a great loss on the manufacturer, and lowers the repute of the brand in the market.

Sometimes the fleece is broken into "pieces" by the sheep not being properly held. Sixty or eighty wethers is a fair day's work, and more should not be allowed unless the shearer is a very specially good man. It is well known that the purchaser expects to see the "best side out," and graduates his price accordingly. Of course every fleece is done up by itself, and he who neglects this care cheats himself.

To do up coarse fleeces in fine ones, put in trimmings, or dung, or use unnecessary twine, is undesirable practice, and nothing short of fraud. The fleece should be laid on the table, outside up, in its natural form (see Fig. 1). The folding table should be 8 feet long, 5 feet wide, and 3 feet high. After the fleece is spread, dung, burs, etc., should be carefully removed with a pair of shears. It is then pressed together with the hands, so that it will occupy no more space than it would cover on the skin of the animal. About a quarter of the fleece lengthwise, or from head to tail, represented by 1 in the cut, is then turned or folded in (inverting it) toward the middle. The opposite side (2) is then folded in the same way, leaving the fleece in a long strip, say 18 inches wide. The forward end (3) is then folded toward the breech to a point (represented by dotted lines) corresponding with the point of the shoulder. The breech (4) is next folded toward the head. The fleece now presents an oblong square, represented by Figs. 5 and 6.

The clean fribs are placed in a small compact bunch on the breech, so that they can be subsequently readily separated from the fleece. They do not include trimmings, which should not be done up in the fleeces. The fribs may be laid in at some earlier stage of the folding; but if thrown on top of the fleece, as is very customary, before it is folded at all, they show through, if the latter gets strained apart, as it frequently happens in the process of rolling; and being coarser, and perhaps less white than the fine shoulder wool, they injure the appearance of the fleece.

The fleece is now folded together by turning 5 over on to 6; and the tier carefully sliding it around on the table with

his arms, so that the shoulder should be toward him, it appears as in Fig. 2, ready to go into the wool trough. The wool trough, shown with one of its sides off, should form part of the table, and be 9½ inches wide, and 9 inches deep, and the length 5 feet, the width of the table. Near its back end, and about one-third of its width from side to side, holes are bored for the twine. Two balls of twine are placed in a vessel beneath, the ends passed through the holes, and the

edges of the breech fold, which is not so fine as the shoulder, which sometimes shows by the first method of rolling, are always concealed by the last.

The wool being in the trough the tier steps round to the back end of it, and commences rolling the fleece from the breech to the shoulder. He presses this as tightly as he possibly can without tearing or straining it, to show the inside, and then ties it with the two strings. The fleece is slid out of the end of the trough, when it will be a solid glittering mass of snowy wool, in the shape of Fig. 5.

**The Great Comet.**

The name of our new celestial visitor must, it appears, now be changed from Cruls' comet to Gould's comet. Late advices received at Harvard College Observatory from Dr. B. A. Gould, at Cordova, S. A., show that the honor of the discovery of the great comet belongs to him. It was first seen at his observatory more than a day previous to its discovery by Finlay at the Cape of Good Hope, and five days before it was seen by Dr. Cruls at Rio. Late letters from

the Cape to a prominent English astronomer show that the comet was observed there upon the day of its perihelion passage clear up to the edge of the sun, where it suddenly disappeared. This observation has no parallel in the history of astronomy, and is evidence of the extraordinary brilliancy of the comet. Mr. Chandler, of the Harvard Observatory, has just computed a new orbit, which is of much greater accuracy than any heretofore obtained, and gives unmistakable evidences of periodicity. By means of this a comparison of the observation of Finlay with the position which the present orbit gives for that date has been made, and the variation between the observed and the computed place is less than the diameter of the nucleus of the comet. From this close agreement it is evident that no sensible perturbations attend the very close approach to the sun.

We learn, however, that Professor William R. Brooks, of the Red House Observatory, Phelps, N. Y., on the morning of October 21, while sweeping the heavens in the region of the great comet with his new nine-inch reflecting telescope, discovered a new fragmentary comet, eight degrees east of the great comet. It was a cometary mass, nearly two degrees in length, slightly condensed in the part toward the sun, and resembled in form the celebrated fragment detached from Biela's comet several years ago.

On the following morning the professor was enabled to verify his discovery by a second observation, when it appeared somewhat smaller and fainter, yet unmistakable as to its character.

The comet thus appears to have been in a terrible state of commotion since it left the immediate neighborhood of the sun, and Prof. Brooks believes that this new fragmentary comet was formed of an envelope thrown off during its disturbed condition. We are sorry to say, however, that the great spyglass at Washington, when turned on to the comet a few days later, did not confirm the observation of Prof. Brooks.

Commander Sampson, of the Naval Observatory, observed the comet on the morning of October 25, for the first time, through the great 26-inch equatorial telescope. It has not before had sufficient altitude to be visible in this instrument. With a low-power eye-piece an excellent view was had of the nucleus, which presented an appearance quite different from that seen in the smaller instrument, and showing with considerable distinctness all the appearance which has led to the opinion that the comet was breaking up. In the large instrument the nucleus has a well-defined center, which is quite circular and of considerable apparent diameter. The elongated appearance of the nucleus is due to two masses of nebulous matter, one of which is between the nucleus proper and the sun, and the other on the side toward the tail. Both these masses are somewhat detached from the nucleus—the one in the direction of the tail being the brighter, but neither presenting the condensed sun-like appearance of the nucleus. These luminous portions of the coma are probably the appearances that have been observed for separate portions of the comet; and led to the belief that the comet had "split." The spectroscope this morning showed that the character of the light of the comet had not changed during the past week. It indicates that incandescent carbon vapor is the principal source of light. A search for the small comet reported last Saturday east of the great comet was not successful.

In the season of 1881-82 more than 3,000,000 trees were planted in Great Britain, out of which number Scotland claims about 2,000,000, England 600,000, Ireland 300,000, and Wales 40,000.

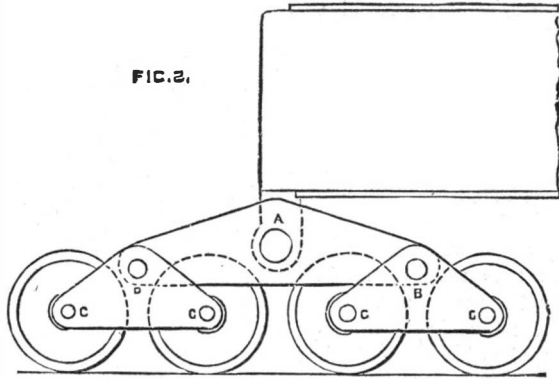

FIG. 2. ONE CORNER OF THE CARRIAGE.

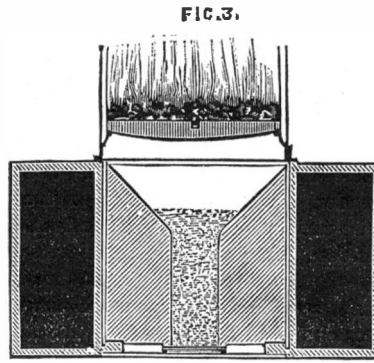

FIG. 3. SECTION OF ASH BOX AND BALANCE WEIGHT.

whole length of the trough, and are fastened in front by being drawn into two saw cuts, as shown.

The tier placing his hands and arms, to the elbow, on each side of the fleece, folded as above, now slides it into

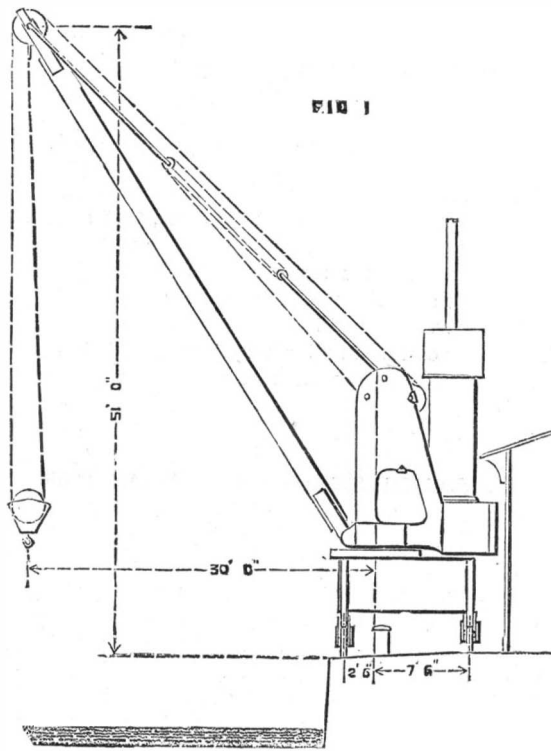

FIG. 1. OUTLINE OF THE CRANE.

the trough. Fig. 3 shows the ordinary, but not the best method. It will bring to the two ends of the done-up fleece the parts most seen in the wool room, the ridge of the back and two lines half way down each side of the sheep. The



Fig. 7.—FIBER.



Fig. 6.—FIBER.

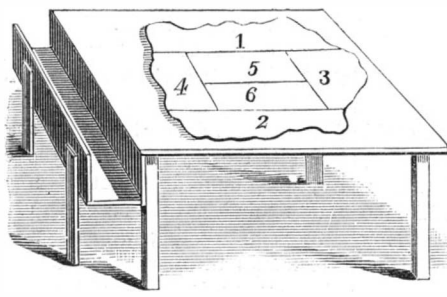

Fig. 1.—FOLDING TABLE.

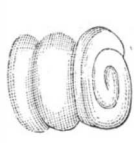

Fig. 5.

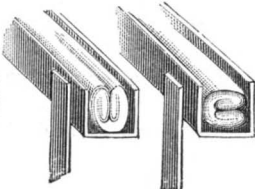

Fig. 4.

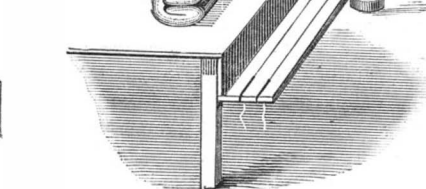

Fig. 2.—WOOL TROUGH.

former is sometimes a little weatherbeaten, and the two lower lines are a little below the choicest wool. Placing it in the trough, as in Fig. 4, rolling would bring both ends of the fleece from the wool between 4 inches and 5 inches from the ridge of the back, the choicest part of the fleece. Besides



**CHATEL'S DIRECT ACTING STEAM COCK.**

The bronze cock shown in the annexed figure consists of a shell, *a*, closed at the top by a hemispherical cap, *K*, with which is cast in a piece the two guides, *c c*, which serve to maintain in a vertical position the conical key, *b*. When the hand wheel, *V*, of the screw, *F*, is revolved, the nut, *d*, which is connected with the key, *b*, by means of the projections, *h*, moves upward or downward and carries along with it the key.

It will be seen from this that the arrangement of this cock allows of the integral section of the pipes being preserved—a first class advantage that is not met with in ordinary cocks; for the section of these, being usually different from that of the conduits, diminishes the pressure of the steam.

As the key of the cock under consideration does not revolve in the shell, it follows that there is no gripping. As for the closing of the cock, that is perfect because of the great surface of contact of the key and its seat.

**PERREAUX'S STEAM TRICYCLE.**

We must go back more than two centuries to find the first idea of a steam carriage, and this is due to Isaac Newton, who proposed it in 1680. His system, which was one of the most rudimentary, was nothing else than an aelopile mounted on wheels. Specimens of it are still to be found as scientific playthings in a few cabinets of physics.

The first tricycle based upon the principle of the steam engine was built by Cugnot, in 1770. To begin with this date, projects have not been wanting, the solutions proposed benefiting each time by the progress of the steam engine applied as a fixed motor. Murdoch in 1784, Symmington in 1786, Read in 1790, Trevethick in 1802, etc., successively proposed apparatus which to-day are forgotten. In 1804, Evans invented the *oruktor amphibolis*, a sort of boat-carriage, the first and last amphibious steam vehicle that has ever been built. We may cite also the steam carriage of Griffiths in 1821, of Gordon in 1822, of Gurney in 1828, of Anderson and James in 1829, and of Hancock in 1833.

The latter was the most fortunate of all inventors of such vehicles, since, in 1835, he had not less than three of them in current service, making the trip by steam on the Paddington route. According to Mr. Thurston, Hancock succeeded in constructing a light steam phaeton for his own use, which ran in the city among horses and carriages, without interfering with or injuring any one, at an ordinary speed of ten miles per hour, and which could be increased to twenty.

The success of locomotives on rails somewhat diminished the ardor of experimenters in this direction, and, in fact, competitions became impossible for steam street carriages.

To-day the question has assumed a transformation. Owing to narrow gauge locomotives and to tramways in the streets, there are no longer any endeavors to build vehicles designed to supplant horses, but there are still endeavors being made to get up a self-propelling vehicle, convenient and easy to maneuver, designed to receive a small number of persons—one or two at the maximum—and capable of operating regularly for a few hours without demanding too great an amount of attention on the part of the one who drives it.

With this object in view, there have been proposed carbonic acid machines, compressed air motors, and electric motors supplied by piles or accumulators. The few experiments that have been tried in this direction have not as yet given very striking results, but the end is far from having been reached.

Other inventors are continuing their researches in regard to thermic motors, and more especially in regard to steam motors. As one of the most curious of these latter we may call attention to the steam tricycle of Mr. L. G. Perreaux, one of our compatriots, whose labors are the more worthy of being better known and encouraged from the fact that the inventor has followed up his idea with remarkable perseverance for fourteen years, and has made considerable sacrifices of time and money to perfect his apparatus. Now that his patents are about to become public property, just on the verge of a success that he had hoped for to indemnify him for his outlays, we deem it of interest to briefly describe Mr. Perreaux's system, which, by a singular coincidence, presents some analogy with that of Sir Thomas Parkins, than which it is older by several years, since it figured in the Universal Exhibition of Paris in 1878 under a less improved form than that possessed by the present model.

Mr. Perreaux's first experiments were made with an ordinary two-wheeled velocipede carrying the boiler behind the seat of the driver, and the motive mechanism under the seat. It is evident that such a type can only serve for experiments and in a few rare cases. It requires a very peculiar ability

on the part of him who maneuvers it, and, for this reason it was, in the experiments, fixed to a whim of four meters radius.

In its present form the apparatus is a tricycle whose fore wheel constitutes the motive and steering one, while the hind wheels support the boiler and the greater part of the weight of the driver. The pedals serve for starting the vehicle; for the motive system, which is of very small

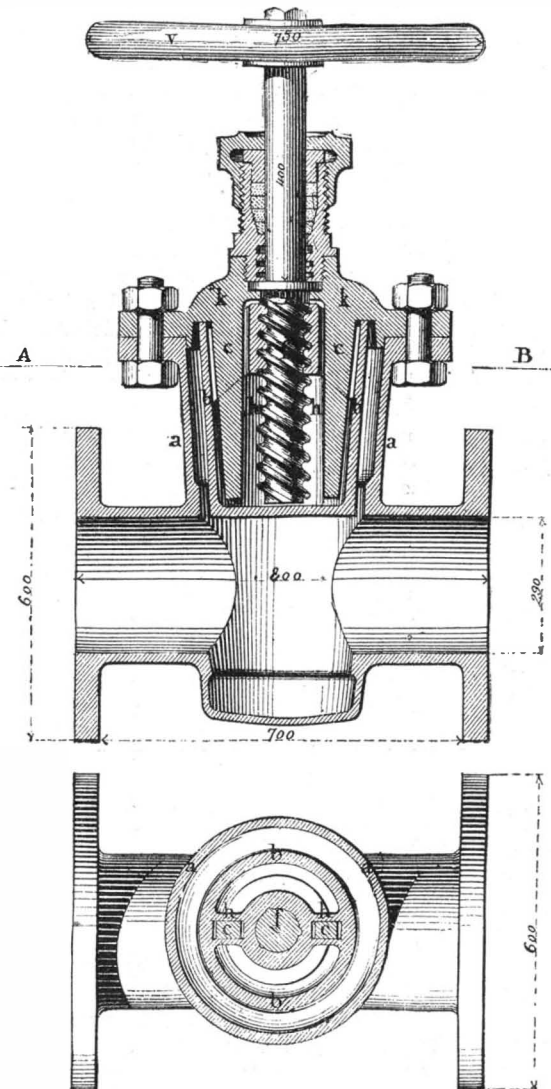

**CHATEL'S DIRECT ACTING STEAM COCK.**

dimensions, would not always do this quickly enough. The boiler, which is tubular, is heated by the vapors of alcohol furnished by a reservoir filled with that fuel, which is itself heated by an alcohol lamp having several wicks. The vaporization of the alcohol which burns under the boiler is regulated by a system of registers, which increases or diminishes the number of lighted wicks, and consequently regulates the production of the boiler according to requirements.

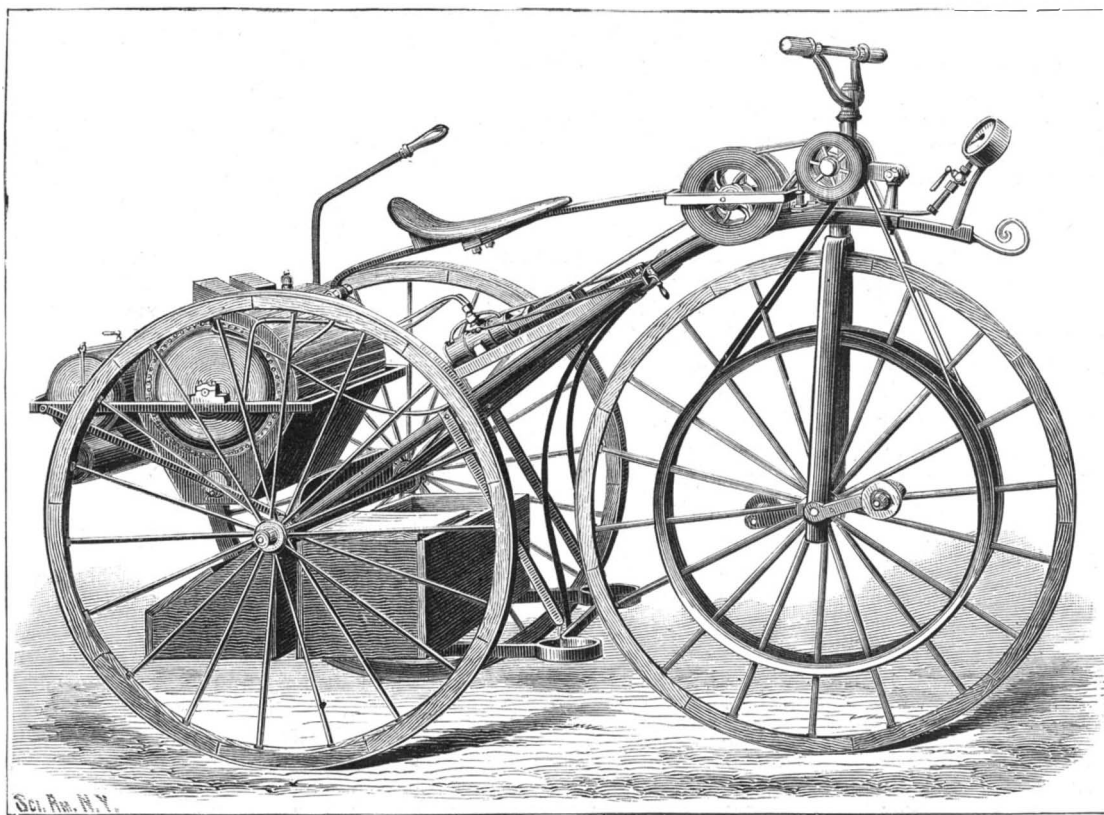

**PERREAUX'S STEAM TRICYCLE.**

The steam produced by the tubular boiler traverses two copper tubes that are wound about the latter and are in direct contact with the flame. There results from this a production of superheated steam which is afterwards sent to the motor. The use of superheated steam permits of a better utilization of it and requires for a given work a much less weight of it, thus diminishing the weight of feed water to be carried on the apparatus. This superheating of the steam

presents no danger, since it is performed on but a very small quantity at a time, and since the pressure never exceeds four atmospheres, as may be ascertained by the pressure-gauge placed in front of the apparatus. The motive system is a small engine having a single cylinder of 22 millimeters in diameter, and a stroke of 40 to 50 millimeters. Mr. Perreux estimates the work produced by his tricycle at 6 kilogrammeters per second, and that produced by his bicycle at 4 kilogrammeters. The escape of steam takes place under the seat, and the feed is effected by means of a small pump that draws water up into a small reservoir whose capacity is calculated for about a three hours' run without renewal. Motion is transmitted from the motor to the fire wheel by means of cords and pulleys. The driver has within reach all the parts, such as cocks, etc., necessary to operate the apparatus, and can, at will, allow himself to go at an ordinary speed of 12 to 15 kilometers per hour, or else aid the running by working the pedals with his feet so as to increase the speed. All the parts of this interesting little machine are constructed with remarkable ability; and in his last model the inventor has taken advantage of his experience in the introduction of numerous modifications and simplifications which we shall advert to after experiments have been tried with them. The question presents so much interest that we shall not fail to be present at such experiments nor to inform our readers of the results obtained.—*La Nature.*

**The Action of Saliva in the Stomach.**

Numerous samples of gastric juice pumped out of the stomachs of healthy persons, at different stages of the digestive process, have shown that during the early stages no hydrochloric acid can be detected even when the fluid is strongly acid. The period at which this acid first makes its appearance varies in different individuals, and, with a mixed diet, seems to depend primarily upon the quantity of food taken. After a light breakfast the hydrochloric acid will be found in three-quarters to one hour, but after a full dinner it does not appear for two hours.

*Industrie Blatter* says that Reinhard von den Velden has been experimenting upon the effect that saliva has on the gastric juice. These experiments showed that when starch paste was mixed with acid gastric juice (free from hydrochloric acid), and fresh saliva added, the mixture at once imparted a light yellow color to an aqueous solution of iodine in iodide of potassium. On the other hand, whenever the juice contained hydrochloric acid the iodine always gave a blue color, no matter how much saliva was added, or how long it was kept in an incubation stove. From this he concludes that there are two separate stages in digestion; that in the first the saliva can act, in the second the pepsine alone acts; the former is an amylaceous digestion, the latter an albuminoid. The latter will, of course, begin as soon as the juices are acid, but only takes place in full force when free hydrochloric acid is present.

**Denver and South Park Railway.**

In announcing the completion of the Gunnison extension of the Denver and South Park division of the Union Pacific the general passenger agent of that company, Mr. J. W. Morse, says that after crossing South Park it enters the Arkansas valley, and leaving it pushes up Chalk Creek canyon to within 600 feet of the summit of the great Saguache range of mountains, and there, far above timber line, at the altitude of eternal snow and ice, it enters a tunnel 1,800 feet in length, and piercing the most rugged of the Rockies. Emerging from the tunnel on the Pacific slope, 11,524 feet above sea level, the enchanting valleys of Quartz Creek and its numerous tributaries, and 150 miles of monster mountains, stretch before the eye—a view of stupendous peaks and rugged canyons unexcelled for grandeur on this or any other continent. Alpine Tunnel, the first to pierce the main range of the Rocky Mountains, is the highest railway tunnel in North America or Europe. The approaches of the Denver and South Park division of the Union Pacific on either side are marvels of engineering skill, laid through scenes unrivaled for grandeur and magnificence. Although the tunnel commences with a sharp curve at its eastern end, so nicely was the engineering done that when the workmen from either side met in the heart of the great Snowy Range they found only about one inch of variation of the respective bores.

THE official returns regarding the army show that the education of the German recruits has been yearly on the increase since 1875. In that year 2.37 per cent of the recruits could neither read nor write. In 1881 it was 1.54.

### The Nutrition of the Heart and the Source of its Muscular Power.

In a lecture that H. Kronecker delivered in Berlin lately, he referred to the seeming paradox that the potash salts, which have long been considered as dangerous, and were known to be powerful cardiac stimulants, are present in the blood in considerable quantity, being conveyed by it through all the organs of the body without injury to them.

He explained this striking phenomenon by assuming that the potash salts were not dissolved in the blood, but were combined with or contained in the blood corpuscles. He proved this by a lecture experiment, in which a frog's heart continued to beat, undisturbed, when unchanged blood was injected into it, but quickly died when blood was sent through it that had been frozen and thawed, so that the corpuscles were bursted and the potash salts dissolved. In conjunction with McGuire he showed, as long ago as 1876, that blood containing these broken corpuscles owed its poisonous properties to the potash salts alone, for it can be freed of the injurious constituents by diffusion (dialysis), and, the other diffusible constituents being without action on the heart, the danger must lie in the potash.

Another curious point which McGuire, working under Kronecker's direction, had demonstrated was, that the corpuscles of the blood do not contribute to the active power of a frog's heart, for the pure serum of the blood has the same action as whole blood.

Blood corpuscles are necessary to sustain respiration, but are not required to nourish muscular tissues. They are, in fact, injurious to this extent, that they favor the production of carbonic acid, and thus place the tissue in a kind of asphyxiated state. The accumulation of carbonic acid quickly reduces the power of a muscle. It is, however, only necessary to pump the carbonic acid out of the blood in order to revivify the heart that it is passing through, without adding oxygen. Hence carbonic acid acts as a direct poison, while blood with carbonic oxide is almost equally as nourishing as the normal blood. Carbonic acid differs from potash salts essentially in this, that it does not kill the heart, but only enfeebles its action for the time being.

After a longer rest the heart produces a weaker pulse, and this is due to the asphyxiating action of the carbonic acid formed in the tissues of the heart itself. Gradually the pulse grows stronger with each beat, and is like ascending the steps of a stair. The phenomenon can be reversed by filling asphyxiated blood into a fresh heart.

Is this due to poison or to the withdrawal of nourishment?

It has been supposed that the development of the heart's energy was due to the consumption of a substance contained in the tissues of the heart itself. But experiments made with the frog-heart manometer, which allows us to compare the action of the most different substances upon the heart, by passing different liquids through it, have proved that the substance of the heart itself is not consumed. When all nutritive matter is washed out of the heart by means of a harmless solution of salt, the power of the heart gradually decreases. If the blood or serum contained in the cavities of the heart are displaced by salt water (0.6 per cent), the pulse sinks very rapidly until it is imperceptible, and soon nothing but peristaltic motions remain, and finally the heart stops, incapable of making the slightest motion in response to the strongest irritation. Then, if oxygenated blood is again thrown into the sleeping organ, a slight twitching begins, and then it beats feebly, until finally the action is as violent as in its fresh condition. If a heart that has been deprived of blood until apparently dead is filled with serum or diluted blood (1 part of blood to 2 of salt water seems to act best), the most beautiful gradations or "steps" can be observed.

The heart is a wonderful piece of mechanism, not merely because of the great force which it displays, or on account of the very perfect system of valves that it possesses, but also because it is able to go to work almost instantly as soon as it is fed, and because it utilizes to the fullest extent, in the most economical manner, the force at its disposal. As soon as the liquid that it is expected to pump is withdrawn it stops work entirely, and does not consume itself doing useless work, but keeps in good condition for a long time.

When the heart works, it always works with its full strength and with suitable velocity; it is not at all affected by changes in the amount of stimulation it receives, and this is essential to its power of moving comparatively heavy burdens with constant uniformity. Under conditions that hasten the decomposition of food (such as heat), the mobility of its parts increases; under external conditions which retard the change (as cold) it moves more slowly.

What is true of the muscles of the heart may safely be assumed to be true for other muscles. Hence we must conclude that Liebig's views were incorrect, although they have long been accepted. In his celebrated "Chemical Letters" he says:

"In animals the unorganized constituents of the blood are converted into organized tissues, and when these break up into disorganized or inorganic bodies, the force stored up in them becomes manifest in a great variety of ways; it resembles the galvanic battery . . . which consumes itself in producing new magnetic, electric, or chemical effects."

This view, Kronecker thinks, must be abandoned as in-

correct, for the frog's heart was able to continue its maximum work for twenty days after it had been freed from all the constituents of the blood. Hence the work done by the muscles is not accomplished by the consumption of their substance or tissues.

The next question is: What substances are able to keep the heart's machinery in motion? Albuminoids, as well as many carbohydrates and fats, have been designated as generators of muscular power.

A series of very careful experiments made by Martins on frogs' hearts proved that none of the non-nitrogenous bodies in blood or muscles are able to nourish the heart, and that none of the albuminoids, except serum albumen, are adapted to this purpose. Neither glycogen nor sugar, white of egg, nor syntonine or peptons, neither myosine nor globulin are able to sustain its action. Von Ott found that milk owed its nutritive power to the serum albumen alone.

Kronecker has further shown that the facts learned from a study of frogs' muscles may be generalized, and very probably they can be applied directly to the whole animal, and also be transferred to the warm-blooded animals, so that serum albumen may be designated as sufficient to sustain the tissues in general.

But the salts dissolved in the serum are by no means unnecessary there. A solution of serum albumen in distilled water stops the heart, for *water acts as a powerful poison to the tissues*. It is only when salt is added in small quantities to water that the tissues can endure it. It has long been known, and numerous experiments prove, that common table salt, in definite quantities, acts in this way. Other salts, in solutions of definite strength, act in a similar manner as preservative agents of the tissues (antiseptics).

It is to be hoped that the experiments now being made regarding the action of certain tissues toward various dilute salt solutions will furnish scientific data on which to explain the therapeutical action of mineral waters.—*Naturforscher*.

### Scientific Hanging.

Dr. G. M. Hammond, of this city, in a recent communication to the *Medical Record*, on the proper method of executing the sentence of death by hanging, cites a number of authorities and cases, all going to show that the practice of jerking the body by the neck with a view to dislocation, is wrong, useless, and barbarous. He says:

In hanging, death takes place either by asphyxia or apoplexy, or both. As Taylor remarks, if the cord is loose or applied too high up on the neck, a small quantity of air may still reach the lungs, and life will be prolonged till the slower death by apoplexy takes place. The main object of the executioner should be to adjust the noose in such a manner as to close the windpipe at once, so as to produce immediate asphyxia. Usually, both apoplexy and asphyxia result if the execution is properly accomplished.

According to Remer, of 83 cases of death by hanging, 9 were by apoplexy, 6 by asphyxia, and in 68 both conditions existed. Of 85 cases collected by Casper, in 9 there was apoplexy, in 14 asphyxia, and in 62 both conditions.

My own experience was somewhat similar to that obtained by other observers, except in the fact that strangulation was not carried to that point at which respiration ceases entirely. My object was more particularly to demonstrate the painlessness of the operation than to show the existence of any new sensations. With the assistance of two medical friends, I was partially strangled in the following manner: After being placed in a sitting position in a chair, a towel was passed around my neck and the ends twisted together. Of course with every twist of the towel very forcible compression was made on the entire circumference of the neck. One of my friends was intrusted with the operation of twisting the towel, while the other was stationed in front of me in order that he might watch my face, and at the same time make the necessary tests of the cessation of sensibility.

My sensations from the first twist of the towel may be briefly stated as follows: I first noticed a sensation of warmth and tingling, beginning in the feet and quickly passing over the entire body; vision partially disappeared, but there was no appearance of any colored lights. My head felt as if about to burst, and there was a confused roaring in the ears, such as is heard when the ear is placed against the opening of a shell. I suffered no loss of consciousness, and was fully able to tell my friend whether I felt any pain from the knife thrusts he was inflicting upon my hand. In one minute and twenty seconds from the commencement of the operation all sensibility was abolished. After a few minutes' rest, a second trial was made in the same manner as before. This was followed by symptoms similar in character to those mentioned in the first attempt, except that sensibility ceased in fifty-five seconds. A stab with a knife sufficiently deep to draw blood was indicative of no sensation whatever.

Taking into consideration my own symptoms, and the accounts of those cases previously described in this paper, it is obvious that the proper and orderly way to execute the law in the case of a person condemned to death by hanging, is not to let him fall or to jerk him into the air, but to stand him on the ground, or on a suitable platform, and to adjust the noose carefully around his neck below the larynx. If he is made to fall through a trap or is lifted suddenly from the ground, this important end can never be assured. The noose is almost certain to become displaced, and hence death is not so sudden as it ought to be. Having arranged the noose properly, the condemned person should be raised

from the place on which he is standing by pulling on the rope, which should pass over a pulley fixed to a beam above, and he should be allowed to hang for thirty minutes. The rope should be soft and flexible, so as to fit closely to the neck. Probably one of cotton or flax would be preferable to the hempen cord usually employed. Carried out in this manner, an execution by hanging will be effectually and mercifully performed. The condemned would undergo no physical or mental suffering from the moment the suspension began, and his life would be taken as speedily and with as much freedom from horrible events as the circumstances of the case would allow. It would be better with persons weighing under one hundred and fifty pounds to attach a weight to the feet, so as to insure a sufficient degree of traction on the cord. It is supposed by many that the dislocation of the neck produces instant death; such, however, is by no means certainly the case. There are instances on record in which the vertebræ of the neck have been dislocated and recovery has taken place. Moreover, even when death does occur, it is no more instantaneous than when asphyxia is accomplished, and there is no greater freedom from convulsions. In some recent cases of hanging there were no convulsions of the limbs, and yet the neck was neither dislocated nor broken.

Of these things we may be positively sure, that from the instant suspension takes place there is no sensibility to pain, and that the convulsions which ensue are no more evidence of pain than are the movements of a decapitated chicken. They are such as always ensue with insensibility when the blood vessels of the neck and the trachea are suddenly closed.

### Fruit Protection.

President William Saunders, in his recent address before the Entomological Society, of Ontario, said:

California has for some years past been shipping fruits from her abundant surplus to all parts of the continent, and her favored climate furnished conditions under which pears, apples, plums, and grapes prospered to an extent unknown elsewhere, and for many years almost free from the insect pests which in other fruit-growing regions levy so heavy a tax on the growers. But this exemption could not be expected to be permanent. The codling moth made its appearance there in 1874, and ever since then has been increasing to an alarming extent, the climate favoring its propagation with a rapidity unknown in less favored districts, so that there are three, and in some instances four broods in a season. They attack the pears and quinces, as well as the apples, and destroy and disfigure a large quantity of fruit.

California fruit growers are also suffering from the phylloxera, pear tree slug, red spider, tussock moth caterpillar, the currant borer, a native tent caterpillar, *Ulisio-campa constricta*, and a number of species of bark lice or scale insects, which attack apple, pear, peach, plum, orange, lemon, fig, and olive trees, being found alike on the bark, foliage, and fruit, and which multiply with amazing rapidity.

Recognizing the vast importance of the fruit crop to the State, the most stringent measures are being enacted for the purpose of subduing these pests. An act was passed by the State Legislature in March, 1881, in the interests of horticulture and viticulture, providing for the appointment of a State Board of Commissioners, one from each of the large fruit growing districts, with almost unlimited powers to restrain, seize, or prohibit the importation of anything and everything likely to aid in distributing these insect pests—any suspected vines, vine cuttings, trees, empty fruit boxes or other material likely to spread insects or contagion, and any willful violation of the quarantine regulations of this Board is considered a misdemeanor and punishable with a fine of from \$25 to \$100.

These commissioners are also charged with the duty of preparing rules to be observed by fruit growers for the extermination of insects, and suitable powers are given them to enforce the carrying out of these rules. In reference to the codling moth, every apple grower is compelled to scrape the rough bark off his apple trees every spring, to collect and burn the scrapings, and apply, after scraping, an alkaline wash—the constituent parts of which are specified—to the tree.

All boxes in which apples, pears, or quinces, have been stored or shipped are required to be dipped in boiling water containing a pound of commercial potash to each twenty-five gallons, for at least two minutes. These measures look to the destruction of the pupa. But, further, bands of cloth or paper of a specified width must be fastened around each apple, pear, and quince tree, before the fifteenth day of May in each year, and examined every seventh day afterwards throughout the season, and all larvæ or pupæ destroyed.

Precautionary and remedial measures are being enforced in reference to many other destructive insects, and any laxity or omission on the part of fruit growers in carrying out the instructions of the commissioners is punishable by fine. The chief officer of the commission is required to visit, examine, and report upon the fruit growing interests in the various sections of the State, appoint resident inspectors for each county to enforce the regulations adopted by the commission, and to experiment on the best methods of subduing insects and diseases destructive to fruits, and disseminate the information so obtained. For the carrying out of these objects an appropriation is made by the State of ten thousand dollars a year.



**Humming Insects.**

An array of mailed forms, including the "shard-borne beetle, with his drowsy hum," demands attention. In no beetle, and, indeed, in no other insect, do we meet the perfection of vocalization seen in the grasshoppers and their relations. And with the beetle we approach more clearly to the region of "hums" and droning, and leave that of specialized sounds, such as we have been metaphorically hearing in the cicadas. To pass from the latter insects to the beetles, bees, flies, and their neighbors, appears to be a transition almost as wide as that between the articulate language or arithmetic of culture and the scanty vocabulary of the savage or the primitive mathematics of the tribe who can count ten as represented on their fingers and toes, but ask in amazement why there should be more things in the world. In the beetles the sound producing organ is comparable to a kind of "rasp" which moves upon an adjoining surface. The site of the organ in question varies in different beetles. In some the rasps are situated on the upper surface of one or two of the tail segments, and are rubbed against the hinder edges of the wing covers. Sometimes the rasp is placed quite at the tip of the tail; and in some well known beetles (such as the weevils) the rasps may be borne on the wing covers and may produce the stridulating sound by rubbing against the edges of the joints of the tail. Among the sounds produced by beetles, the weird noise of the death watch (*Anobium*) stands pre-eminent. The sound produced by these beetles resembles the ticking of a watch, and they may be made to respond by placing a watch close by their habitats. The female death watches are known to tick in response to the sounds of the male insects. The noise is produced apparently by the insect raising itself on its legs and by its striking its chest against the adjoining wood. Thus the simple explanation of an insect call explains away the superstition expressed in Gay's line:

"The solemn death watch click'd the hour she died."

Butterflies and moths are known occasionally to produce sounds, which proceed, in one or two cases at least, from a drum-like membrane analogous to that seen in cicada. Mr. Darwin indeed mentions that one species (*Ageronia feronia*) "makes a noise like that produced by a spring catch, which can be heard at the distance of several yards." Among the bees, wasps, and other so-called *Hymenopterous* insects the production of the humming noise forms a fact of interest in the history of the race. And one or two species possess a power of emitting sounds of more definite nature, which correspond to the "stridulation" of the grasshoppers and their kind. But it is a well known and at the same time interesting fact that bees are known to express emotional variations by aid of their humming sound. "A tired bee," says Sir John Lubbock, "hums on *é*, and therefore vibrates its wings only 330 times in a second." A bee humming on *á* will, on the other hand, increase its vibrations to 440 per second. "This difference," says Sir John, "is probably involuntary, but the change of tone is evidently under the command of the will, and thus offers another point of similarity to a true 'voice.' A bee in pursuit of honey hums continually and contentedly on *á*, but if it is excited or angry it produces a very different note. Thus then," concludes this author, "the sounds of insects do not merely serve to bring the sexes together; they are not merely 'love songs,' but also serve, like any true language, to express the feelings."—*Belgravia*.

**A New Intensifier for Gelatine Plates.**

I have been experimenting during the last three months with (what is to me, at least) a new intensifier, which, as its principal ingredient is platinum, induces the hope of greater permanency than the usual mercurial intensifier, but of that I cannot speak with certainty. The formula stands thus:

**SOLUTION I.**

Chloride of ammonium.....	5 grains.
Bichloride of mercury.....	10 "
Thirty-grain solution of bichloride of platinum.....	1 ounce.
Water.....	20 ounces.

**SOLUTION II.**

Liquor ammonia.....	½ ounce.
Water.....	20 ounces.

Two solutions are given, but it is rarely that more than the first solution is needed.

Immerse the negative to be intensified in No. I. solution and watch carefully the action. Directly the requisite density (a dark-brown color being the result) is reached remove and wash thoroughly. If, however, through extreme weakness or not stopping exactly at the right time, the image begins to bleach, let it continue until nearly white, and then wash and immerse in solution No. II.

For negatives requiring only a small amount of strengthening this process is splendid; and even when carried out so far as to render the use of two solutions necessary, there is no clogging of the shadows or intense yellow films, as is frequently the case with mercury alone. After washing thoroughly and immersing in solution No. II., the change takes place very slowly, the high lights gradually assuming a bluish-black, and the shadows clearing if the negative be an over-exposed one. This clearing of the shadows is very valuable, and, instead of having a thick negative taking hours to print, the result is a negative harmonious from high light to clear shadow. All the changes are slow and under perfect command.

If the negative be in the state best described as *nearly* dense enough, careful washing in the first solution will give

just the requisite density, and then a thorough washing and immersion in—

Ammonia.....	1 drachm.
Water.....	20 ounces.

will yield a result as perfect as possible. After the ammonia solution has done its work the negative does not gather any more density, no matter how long it may be left in. One precaution is, however, necessary during both stages, and that is, the dish must be kept gently rocked, or streaks are likely to form.—*W. T. Wilkinson, in Br. Jour. of Photo.*

**Potato Ivory.**

This new "vegetable ivory" is made from ordinary potatoes—provided they are tolerably sound and fully developed—by purely chemical means. The selected tubers must first be carefully peeled and the "eyes" cut out, all "spongy" and discolored portions being also scrupulously pared away. The peeled tubers should then be allowed to soak for a short time, first in plain then in acidulated water, sulphuric acid being the agent employed, and the mixture should be quite cold before the potatoes are put into it.

The next, and most important part of the process, is that of boiling the vegetables in diluted sulphuric acid for a considerable time, herein lying the gist of the invention, the secret of which is kept rather closely at present, but a short series of well organized experiments would probably enable any of our friends to elucidate the question.

The variety and age of the vegetable itself, the time for which it is subjected to the action of the acid, and especially the strength of the latter, are all matters of great importance to the object in view as affecting the quality of the preparation. As some little guide, however, we may bear in mind the process for "parchmentizing" paper, which is effected in the cold, and also the fact that heat greatly enhances the action of all acids upon organic substances, so that as the potatoes according to our advices have to be "boiled" in the liquid, a comparatively more dilute acid should probably be used.

Treated in this way the entire substance of the potatoes hardens and becomes gradually less pervious. When "done" they are to be taken out and washed in a stream of first warm and afterward cold water, the subsequent drying process being in all instances a slow and gradual one. Potato ivory thus prepared is not very unlike the ordinary "vegetable" kind, but is said to be of a more even "grain," as well as easier to turn, while it is not so liable to split when exposed to the influence of a very dry atmosphere.

Potato ivory is of a creamy white tint, hard, durable, and elastic, it being even adapted, it is stated, for the manufacture of billiard balls. There is no difficulty in dyeing or coloring the material either during the process of preparation or afterward, and altogether it would seem that this new product is one which is capable of an immense number of useful applications. To its other good qualities it adds that of being exceedingly cheap. We should have said before that the sulphuric acid used must be quite free from impurity, even traces of nitric or hydrochloric acid being detrimental.—*Monthly Magazine.*

**Can Plants Assimilate Carbonic Oxide?**

A series of experiments made by Stutzer to settle the question as to whether plants can make the same use of carbon monoxide, CO, that they do of the dioxide, CO<sub>2</sub>, gave a negative answer. L. Just, in a discussion regarding the conditions of the experiments, showed that they did not justify any definite conclusions. The latter, therefore, instituted a series of new experiments in which no India-rubber tubing was used for making the connections. The vegetating vessel consisted of a flask into which the mixture of air and gas entered through a potash apparatus to absorb all the carbonic acid, and as it made its exit it likewise passed through a potash apparatus in which the carbonic acid could be retained and measured. The liquids required to sustain and nourish the plant were admitted and withdrawn through a peculiar form of funnel that closed air tight, so that it was not necessary to open the vessel.

In the experiment it was desired to observe the increase or decrease of dry substance in the plants experimented upon. In each series of experiments comparative measurements were made with atmospheric air that contained the usual quantity of carbonic acid, and with air entirely free from it, also with atmospheric air free from carbonic acid, but mixed with carbonic oxide in quantities gradually increasing from ⅓ per cent up to 80 per cent. These experiments led to the following results:

1. The carbonic oxide furnished to plants exposed to the light was not used by them.
2. Carbonic oxide injures many kinds of plants, but not until the quantity present exceeds 10 per cent of the atmosphere in which they are. The injury is shown by a disturbance of the chlorophyl formation, diminished assimilation, less growth, and the new formation of organs is smaller. If there is 20 per cent of carbonic oxide in the atmosphere, the injury becomes perceptible at the end of three weeks, but is sooner noticeable the higher the percentage of carbonic oxide. After the removal of the carbonic oxide, the plants are able to overcome, in part, the injury they have suffered, provided the action of the gas did not last too long and that there was not too much of it present.
3. The chlorophyl granules do not possess any special power of absorbing carbonic oxide gas.—*Investigations in the Domain of Agric. Physics.*

**Gossamer Spiders.—Autumn Flights.**

A boating party on the Charles River, above Waltham, Mass., encountered, the other day, a cloud of gossamer spiders. One of the party, "W. A. F.," tells a Boston paper that the air seemed to be full of them. The strands were so delicate and so nearly transparent that they could scarcely be seen except against a background, or in looking toward the sunlight, when they appeared like microscopic threads of spun glass. Presently a small spider was seen skimming over the smooth surface of the water at a rapid rate, leaving a triangular wake behind. As the little navigator was not moving his legs, there was evidently some outside force to propel or draw him along. At first this could not be discovered; but, watching closely, it was seen that a thread of gossamer, perhaps ten feet long, was floating in the air, before the almost imperceptible breeze, and that the little fellow, fast to the other end, was drawn along over the surface by his tiny sail. Great numbers of these were noticed. Then others were discovered sailing through the air, with long, glassy streamers stretching out before them. Some seemed to be inclosed in a filmy envelope of the gossamer web, but others were merely attached to a single strand. Occasionally the little aeronauts would be seen ascending or descending their microscopic cordage, the upper ends of which merely floated in the air, while the other ends were attached to the bodies of the little spinners.

Occasionally the floating films would be broken, and leave the spiders on the water. Then they seemed to be able to travel on the surface until they were wet, when they would become, apparently, helpless. Thousands upon thousands of these strange travelers were seen floating in the air or skimming along the surface of the water, on the voyage from Waltham to Newton Lower Falls, and the reeds and rushes along the banks bore a silver fringe of these unsubstantial films, which glistened in the sunlight like threads of silver. Before the return trip was made a brisk breeze had started up and completely cleared the river of the liliputian navigators and aeronauts.

A correspondent, writing from Prattsburg, N. Y., October 15, reports a flight of gossamer spiders on that afternoon, which lasted for over an hour. The wind was blowing from the northwest.

**Food Makes the Man.**

Speaking roughly, say the *Lancet*, about three-fourths, by weight, of the body of man is constituted by the fluid he consumes, and the remaining fourth by the solid material he appropriates. It is therefore no figure of speech to say that food makes the man. We might even put the case in a stronger light and affirm that man *is* his food. It is strictly and literally true, that "A man who drinks beer thinks beer." We make this concession to the teetotalers, and will add that good sound beer is by no means a bad thought factor, whatever may be the intellectual value of the commodity commonly sold and consumed under that name! It cannot obviously be a matter of indifference what a man eats and drinks. He is, in fact, choosing his animal and moral character when he selects his food. It is impossible for him to change his inherited nature, simply because modifications of development occupy more than an individual life, but he can help to make the particular stock to which he belongs more or less beery or fleshy or watery, and so on, by the way he feeds. We know the effect the feeding of animals has on their temper and very natures; how the dog fed on raw meat and chained up so that he cannot work off the superfluous nitrogenized material by exercise becomes a savage beast, while the same creature fed on bread and milk would be tame as a lamb. The same law of results is applicable to man, and every living organism is propagated "in its kind" with a physical and mental likeness. This is the underlying principle of development. Happily the truth is beginning, though slowly and imperfectly, to find a recognition it has long been denied.

**A Monster Steel Spring.**

On the 17th of October, there was made at Pittsburg the largest steel spring in the world. It is the first of a series of eight, destined to act as street car motors. The initial spring was made of open hearth steel, with a carbon percentage of 0.55. The ingot was cast 14x14 inches and 7 feet long. This was rolled down to a bloom 6x4 inches and 24 feet long. To properly heat this bloom, a heating furnace 30 feet in length was built at the Superior Iron and Steel Works, Pittsburg. The next operation, the final rolling, was the most interesting, and was only possible through the use of the Kloman "universal" mill or rolls. These had been devised by the late Andrew Kloman, and have become widely known in connection with the first successful rolling of weldless steel eyebars for structural purpose. By means of hydraulic pressure, acting through a toggle joint, an enormous pressure can be brought to bear upon the metal during its passage between the rolls, while a very quick reversal is also possible. The steel bloom referred to was rolled in this mill, in 30-foot sections, down to a length of 150 feet and 6x½ inches, and finally to a length of 310 feet and a perfectly uniform width of 6 inches and thickness of ¼ inch. Its weight was then 1,700 pounds; and to ship it, the spring was coiled in ten layers around a 4-foot pulley, the latter being given a slow motion as the band emerged from the heating furnace. The process of tempering and final coiling, etc., will be done in Philadelphia by the United States Spring Car Motor Company.

### APPARATUS FOR DETERMINING THE DEGREE OF MOISTURE OF STEAM.

In order to determine the degree of moisture of steam (that is to say, the quantity of water carried over by a given weight of steam) and the pressure of steam in the boiler or the steam chest, Messrs. Boye, of Bergen (Norway) and Müller, of Dresden (Saxony), have constructed an apparatus, the principles of which consist in causing the dilatation of a definite volume of steam, and keeping its temperature constant until it passes from the state of saturation to a superheated condition, and observing the volumes at the beginning and end of the operation. The apparatus is shown in the accompanying cut in section through the axis of the middle, the mercurial pressure-gauge, *d*, and the lever being turned 90 degrees.

A given volume of steam from the boiler is let into the space, *a*, through the cock, *m*, and the piston, *b*, is then raised by means of the hand wheel, *h*, and the threaded shaft, *g* (which is movable in a nut, *f*, fixed on the hollow rod of the piston), so as to dilate the said steam. During this time the temperature of the latter is kept constant in the space, *a*, by means of a jacket, *c*, which surrounds it, and in which constantly circulates fresh steam. When the piston has been raised so far that the steam no longer contains any moisture, or has passed from the saturated to the superheated state, there occurs in the space, *a*, a diminution of pressure that brings about a variation in the level of the mercurial column, *d*, that communicates on the one side with the space, *a*, and on the other with the jacket, *c*.

The travel described by the piston and indicated by the displacement of the crosspiece, *f*, on the scale, *e*, gives the percentage of increase in volume of the space, *a*. The pitch of the screw on the shaft, *g*, is calculated in such a way that every revolution of the latter shall correspond to an increase of one per cent in the original volume of the space, *a*. The circumference of the hand-wheel, *h*, is divided into one hundred parts, so that the index, *i*, permits of estimating a hundredth of a revolution or 0.01 per cent of the volume, *a*.

To prevent cooling of the steam and leakages through the piston, the cover, *k*, is provided with compartments that communicate with the jacket, *c*, and steam is likewise let in over the piston.

The three-way cock, *l*, placed over the mercurial column, *d*, allows the jacket, *c*, and the space, *a*, to be put in communication either singly or jointly with the external air, and the jacket, *c*, and space, *a*, to be connected. This cock serves likewise for moderating the too violent oscillations of the mercurial column. The cock, *m*, has two systems of conduits perpendicular to each other.

The steam is first led through the cock, *m*, in such a way that *a* and *c* communicate with the boiler; then the cock is turned so that the steam shall only circulate in the jacket, *c*. By turning the cock, *m*, 45°, it shuts off the entrance of steam to *a* and *c*. A metallic pressure-gauge is fixed at *n*, on the jacket, *c*, so that the pressure in the boiler and dome or in the jacket may be determined when necessary. An external boiler plate casing, *o*, prevents the cooling of the jacket, *c*. The difference between the moisture of the steam in the boiler and in the steam chest that may be determined by this apparatus indicates whether the steam ports are in a good state.

### Solidified Petroleum.

The authors solidify petroleum, in which state it only burns like tallow. They effect the solidification by mixing crude petroleum (after having undergone the first distillation) with 25 per cent of the purified juice of plants belonging to the family of the *euphorbiaceae*. The two ingredients are put in a boiler fitted with an agitator, and heated together to about 50°, agitating the whole till the mass becomes a uniform milky fluid.

When arrived at this state the mixture is distilled again and refined in the ordinary manner, when it solidifies, and may be used equally well for lighting or as a lubricant.—*MM. Frézon, Dumont, and Francou.*

THE cost of the French squadron of evolution in the Mediterranean is estimated at \$29,000,000. The pay of the officers and crew is \$4,000 a day.

### SANITARY ARRANGEMENTS IN THE RESIDENCE OF MR. CORNELIUS VANDERBILT.

The water supply apparatus in the house of Mr. Cornelius Vanderbilt is marked by its extensive, elegant, and substantial character.

The water supply, the distribution of which we shall first describe, is partly from Fifty-seventh street, on which the house fronts, and partly from Fifty-eighth street, to which the lot extends in the rear. That from the former will be through a 3-inch iron pipe. Just inside the house wall, in the cellar, it will enter a meter, from which a 3-inch brass pipe will run to the pumps and a 2-inch pipe to a distributing reservoir. The tank pump will be run by a hot air

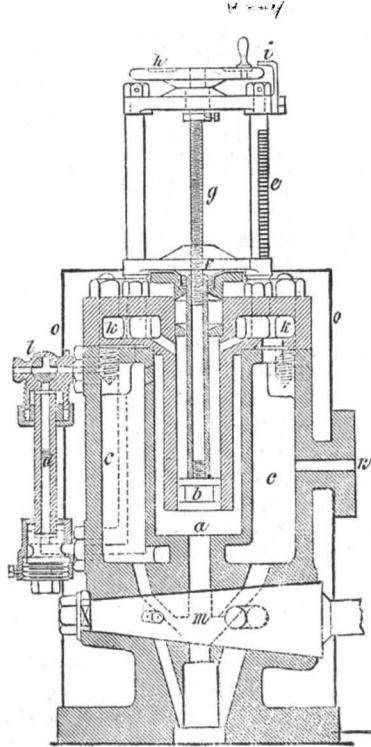

APPARATUS FOR DETERMINING THE DEGREE OF MOISTURE OF STEAM.

engine, and force the water through a 2-inch brass pipe to the tank on the fifth floor just under the roof. A sketch of this tank and its connecting pipes will be seen below on this page. It is a closed tank of about 1,300 gallons capacity below the overflow, made of riveted plates of wrought iron. It rests on wooden beams raised about an inch above the surface of the lead safe, *A*, by small blocks of wood covered with lead. Grooves in the safe converge to an outlet, *B*, to remove the water of condensation. This outlet is connected with a 1½-inch brass pipe, *C*, to be discharged over the lower elevator tank or over a sink. The 2-inch brass supply pipe, *D*, coming up on the other side of the bowling

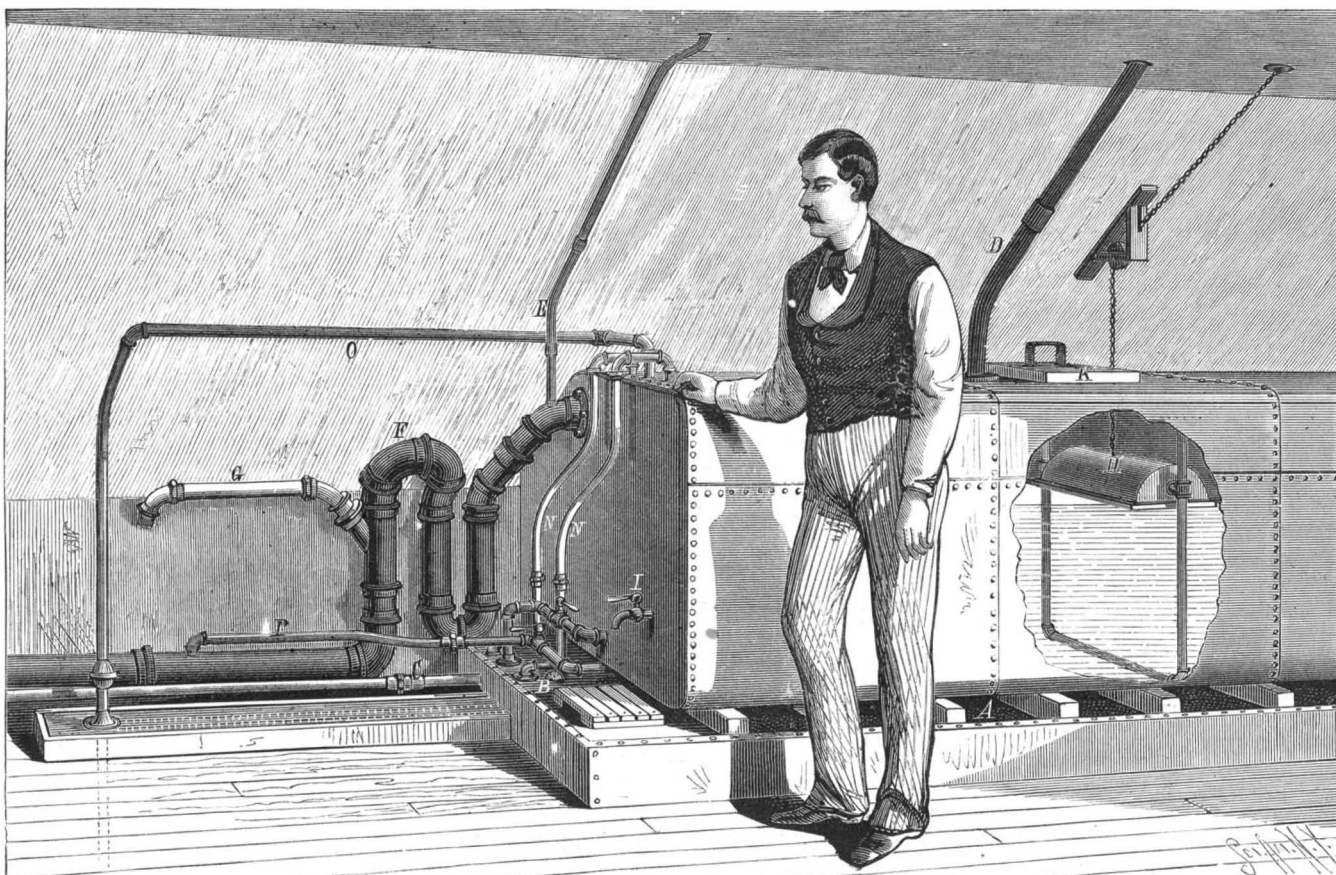

TANKS AND CONNECTING PIPES IN THE RESIDENCE OF MR. CORNELIUS VANDERBILT.

alley which occupies the center of this floor, is carried over the ceiling and down into the tank as shown. A half inch branch, *E*, taken from it above the ceiling, will supply the deep trap on the 4-inch iron overflow, *F*, which is connected with the sewer. The 2-inch iron vent pipe, *G*, runs out through the roof. The side of the tank is broken away to show the copper float, *H*, which slides up and down on the pipe rods, being connected by a brass sash chain, running

over the ceiling in a wooden trough on pulleys and down through a brass pipe to an indicator in the engineer's room. A manhole, at *K*, gives access to the interior of the tank. The down supply from the tank is through the 1¼-inch brass pipe, *L*, passing through the lead-lined and lead-covered trough, *M*, through which the two three-quarter inch relief pipes, *N N*, from the hot water reservoirs, also pass. The lead-lined trough has a waste outlet like safes under fixtures. In all cases horizontal pipes under floors are carried in this way, but the whole amount of such piping is very small, the fixtures above the basement being arranged in tiers, one above another. From the point where the supply pipe, *L*, turns down, a 1¼-inch air pipe, *O*, is returned to the tank, to prevent "air binding." The 1¼ brass pipe, *P*, discharging into the overflow, is for emptying the tank. A self-closing faucet, *R*, is inserted in the end of the tank for drawing water for use on that floor, there being no other tap; beneath it is a wooden rack on which to rest a pail.

Returning to the Fifty-seventh street meter, the distributing reservoir before mentioned will be a vertical iron cylinder about 5 feet high by 15 inches in diameter. The 2-inch supply from the meter will enter the bottom (from which also will be taken a 1-inch sediment pipe), and six distributing pipes leave one side, between a point 4 inches from the bottom and the middle—the upper part to serve as an air cushion. One 1½-inch branch will supply the fixtures of the kitchen which is in the front of the basement, passing on its way to them around the grease traps under the sinks, as will afterward be described. Another 1½-inch branch goes up through the house to the third floor to supply bath room fixtures. The four other branches will be each 1¼ inches in diameter. One will supply the street washers, the fixtures in the front basement, and the steam heating boilers; another the fixtures in the cellar; another the slop sinks; and the last, two fountains.

The supply from Fifty-eighth street is through a 1½-inch lead pipe. This also will pass through a meter, after which it will enter a vertical lead cylinder, 4 inches in diameter, similar to the larger one of iron and for the same purpose. One 1-inch lead branch will supply a fountain and street washer, and a 1½-inch brass pipe the fixtures of the laundry, which is in the rear of the basement. Before reaching any fixtures, this latter branch passes through about one hundred feet of brass pipe in the drying room adjoining the laundry. This is arranged in twelve horizontal lines, one above another, and connected by return bends, like some forms of steam radiators, and has a drip trough below it; it is designed to condense and remove the moisture from the drying room.

These two supplies from the different streets may be connected with each other by opening a stopcock. The two hot water supplies—kitchen and laundry—may also be connected. These will be described in detail after the boilers and ranges are set and connected.

The method of distributing to the bath rooms is as follows: As before stated, these fixtures are arranged one above the other. In a passage way to the bath room on the second floor, three sets of three pipes each come through the

floor beside the wall; one set is for cold water, another for hot water from the kitchen boiler supplied from the tank, and the third from the kitchen boiler supplied from the street pressure. The outside pipes of each set (being, respectively, the street pressure cold and the tank cold; the tank hot and its return circulation; and the street pressure hot and its return circulation) are connected with each other about three feet above the floor, and from the middle of this connection, having a stop cock on each side, the third pipe of each set is taken to supply the bath room fixtures directly opposite, the middle pipes being the distributors (of cold—either tank or street pressure—tank hot and street pressure

hot) to that floor, and going no higher. The two hot water pipes also are connected, so that either source of hot may be drawn from as well as either cold. The same method is repeated on the floor above, but the street pressure pipes (except the boiler circulation pipe, which is extended to the tank for relief) go no higher. All the water supply pipe in the house is of brass, tinned outside and inside, and all in sight above the cellar is nickel plated.



**TRICYCLE ROLLER SKATE.**

The readers of this paper will remember the publication in these columns several years ago of a description and the illustration of an invention similar to the one represented herewith. The former was the subject of a patent in this country, but we believe the invention was not introduced to any successful extent. Recently the invention has been taken up in England, and several of our London contemporaries have spoken of it as a speedy and practical mode of locomotion. A speed of twenty miles an hour on a macadamized level road has been claimed for it. The construction of the skates, and the mode of attaching them to the operator, as well as his position in the act of their use, are so clearly shown in the engraving as to render unnecessary any detailed description.

**GIANT HERRINGS AND HERRING PIKES.**

BY C. F. HOLDER

One of the most remarkable as well as beautiful fish found upon the coast of Southern Florida is the tarpon or megalops. It is comparatively rare, the individual from which the accompanying illustration was made being the only one found during seven years. This was at the extreme southern point of the reef. At rare intervals they are caught on the upper reef and near the mainland. Scientifically it is included in the *Clupeidae* family, that includes our common herrings and the genera *Sardinella*, *Pellona*, *Rogenia*, *Harengula*, *Kowala*, *Pristigaster*, *Clupeonia*, *Spratella*, *Meletta*, *Alausa*, *Engraulis*, *Coilia*, *Odontognathus* or *Gnathobolus*, *Chatoessus*, *Amblogaster*, and *Clupeichthys*.

The appearance of the tarpon is magnificent in the extreme; the immense scales, coated with a secretion that is exact in its resemblance to silver, flash and glisten in the sunlight seemingly bathed in a silvery radiance. They much resemble the ordinary herring, having a long attenuated spine extending from the dorsal fin, and another from the ventral. But it is their great size, perhaps, that is their most striking feature, attaining as they do a maximum length of ten or twelve feet. In the accompanying cut the relative size of one about nine feet long is shown; but nothing save the lavish use of silver could convey an idea of its wondrous appearance.

They are generally harpooned, seldom taking the line, when they make gamy resistance.

Equally striking for their great size are the herring pikes (*Clupeosidae*). The butiru of the West Indies, commonly known as banana fish, ten-pounder, and kakamby, is an interesting illustration; the *Studis*, however, is perhaps the most remarkable for its bulk. It was named by Sir Robert Schomburgk, and its skeleton is one of the most massive known among fishes. The scales are almost solid bone, sculptured in dendritic and mosaic shapes, portions of the skull presenting a similar appearance. Certain species of the genus are found in the Senegal and Niger rivers; the *Studis gigas*, however, is from South America. The hyoid bone is used as a file by the natives of those countries where the genus exists, and is often brought to Europe as a curiosity. The hyoid bones from the Amazon are named *Lingua de Paes*, and those from the Rio Negra de Para are called *Kuare*. As in the tarpon the scales are of great size and beauty. According to Schomburgk, the body is entirely covered with these large scales, round on their posterior edge, and the base of the dorsal and anal fins, thick-

ened and muscular where they leave the line of the body, are scaled upward for two-thirds of their depth, or until the rays are given off with a separate dividing membrane; at their termination succeeds the small caudal extremity, with its very narrow web of rays continued round, appearing, in fact, as if the rayed part of the dorsal and anal fins had been continuous with it, and had formed one large broad extremity formed for powerful sculling. In color this fish is exceedingly brilliant; the head and dorsal part of the body are of a rich umber-brown, becoming paler as it reaches the central lateral line, and thence shading into a brilliant crimson lake, which occupies, also, the basal or scaled part of the dorsal and anal fins; each scale is darker at its base, and has a narrow line of deeper lake near its border. Near the caudal extremity the body and scaled part of the fins are blotched with dark umber-brown, the anal fin showing fourteen streaks of the same color in the direction of the rays. The pectoral and anal fins are gray, having the rays marked irregularly with dull blue. The membranous part of the dorsal, anal, and caudal fins is blackish-gray, the rays being reddish-brown. The *studis* is particularly interesting on account of its manner of breathing; the air bladder, as with *Erythrimus*, serving directly as lungs subsidiary to the gills, the air being inhaled through a connecting passage between the throat and air bladder. By this means the fish could live for a long time out of water.

These fish are plentiful in the Rupununi, Rios Blancos, Negro, and Amazon. In the latter three rivers there are extensive fisheries for supplying the different towns, and great quantities are sent to Para, where it is preferred to the

fish salted on the North American coast, and commands a higher price. When fresh it is excellent, and the belly nearly all fat. They are taken generally with harpoons fastened on a long pole, which is thrown from the canoe, and to which is attached a long line to give the fish play, as they are so strong that they cannot be hauled in to be killed until they are weakened. This is generally performed with a club of hard wood, with which heavy strokes are inflicted upon the skull. The canoes which are used in these fisheries are sometimes very small, with only a fisherman and a boy to steer. After the fish is killed they sink the canoe,



TRICYCLE SKATE.

put it under the fish, and by shoving the canoe backward and forward, throw out as much water as allows it to float, the rest is bailed out with a calabash, and the fish is transported to the place of rendezvous; it is there skinned, and split to an inch thick the whole length of the fish, when a small quantity of salt is sprinkled over it, and it is put at once in the sun to dry, without being allowed to remain in the salt, as is generally done with other fish. In good weather it dries in three days, but it takes longer in the rainy season, when the fish then cured is not nearly so good or white. They are sometimes taken with the hook and line, baited with other fish. The intestines are short, form-

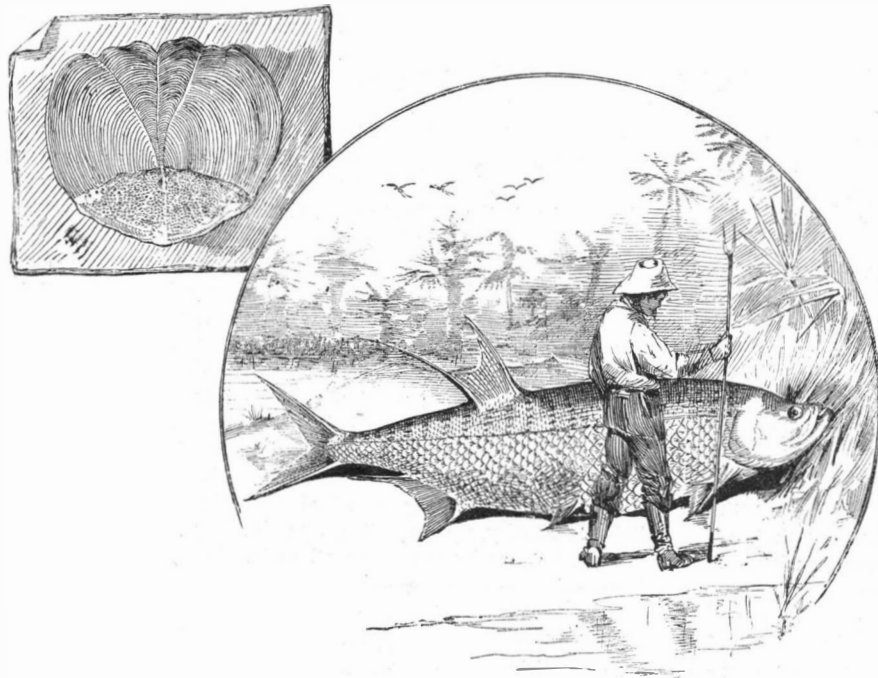

GIANT HERRINGS AND HERRING PIKES.

ing only one flexure, which, together with the stomach, are entirely covered with fat. The liver is large, and not used for food, but would serve for oil, which it appears to contain in large quantities. In the stomach of one opened, several small fish and a quantity of mud were found. It has no air bag, but a curious process like the lungs of birds covers the spine inside, resembling the honeycombed inside of a bone. The roe is large, eggs small, and the membrane which contains them resembles in outward appearance the liver of a hog in size and shape. The young are protected

by the mother for some time after they leave the eggs, just as in the case of the lau-lau (*sturus*), and swim generally over her head. They delight in the *Kirahags*, as those inlets are called which many of the South American rivers form, and where the water is quite currentless. They are sometimes found in water scarcely so deep as to cover them, and the fishermen frequently attempt to drive them on shallow ground, where they fall an easy prey. They are more plentiful in the muddy than in the clear water. The Rupununi is the only river in British Guiana where they are to be found; and as during high floods this river is said to mingle its waters with those of the tributaries of the Rio Branco, they may have entered the latter river. They are occasionally carried by the flood during the inundations to the lower Essequibo, where it is known that they have been taken.

Schomburgk was assured by the inhabitants of the Rio Negro that they have caught some fifteen feet long, and of twelve to thirteen arrobas (410 pounds) weight. A specimen, the skin of which is now in the British Museum, measured, when taken, eight feet one inch in length, and three feet seven inches in girth. The caudal fin was only five inches long and eight inches broad when extended.

Sir William Jardine gives the following account of the capture of these fishes:

"Partly to serve us for economical purposes, but more to satisfy our curiosity of witnessing the Indian manner of hunting the arapaima, this giant of the fresh water fishes, Irai-i, the Carib chieftain at Curassawaka, induced his men to afford us an opportunity. We selected a sunny day, when there was more chance that at the heat of noontide one of these fishes would rise to the surface. Our party was distributed in five small corials, and we proceeded toward the mouth of the small stream Curassawaka, where it enters the Rupununi. Here we remained stationary, one of the corials being put on the watch, and no length of time had elapsed when the signal was given that an arapaima was in sight. All hands were hushed as death. Irai-i and his brother-in-law, Dabaero, who were considered the strongest and best shots, went forward with their corial and approached the fish as nearly as possible, the rest following softly to be within arrow shot. There stood the sinewy Carib, Dabaero, his foot firmly resting upon the bow of the corial, his left hand grasping the large bow of tough *uamaru*, his right the long arrow, upward of six feet in length, and armed with a formidable iron point. His position, although forced to the unpracticed, developed the symmetric forms of his figure, unadorned as it was by any art. Only those who have witnessed the Indian's eye when the bow is strung and he approaches his intended victim, can have any idea of that expression and that fire by which it appears lighted. Irai-i had adopted a similar position, when the crack of the bow string told us that Dabaero had discharged his arrow, and the chief followed his example, but missed, his arrow floating on the water, while the other disappeared with the monster. The corials pulled into the middle of the stream, the eyes of the Indians directed to all points to detect the arrow-feather appearing. Their quick eye saw it above the water, although it was only for a moment; away went all the corials in full chase, and just as it appeared a second time, a second arrow was sent into the fish. All was now excitement, and the yells of the Indian, the rushing of waters, harrowed up by the quick stroke of the paddles, was one of the most enlivening scenes I ever witnessed. Away we went where the experienced hunters expected to see the fish reappear, and scarcely made the tops of the arrows their appearance, when others flew from their strings and pierced the arapaima; down he went again, but the period he remained below the surface was much shorter than previously, a proof that he got fatigued, and when he reappeared he allowed the first corial to come so near that one of the Indians was enabled to give him a stroke with a cutlass; a few more arrows were discharged at him, and he became an easy prey. The question was now how to get him into a corial, as we estimated his length at least six to seven feet, and his weight not less than a hundred and fifty pounds. He was floated into comparatively shallow water, and when one of the corials was got under him, the Indians who were wading in the water shuffled the corial with the fish and water in it to and fro, until the water had got mostly out and the craft commenced to float again; the rest was bailed out, and under the huzza of our Indians, we returned with our prize to Curassawaka, highly delighted with our sport of hunting the arapaima."

**CALIFORNIA WINE.** — The *California*

*Demokrat* says that, notwithstanding the large dimensions which wine culture has attained in California, the American resident of that State has failed as yet to take to wine drinking as a habit. The Napa Valley is filled with luxuriant vineyards, but foreigners remark with surprise that on entering the inns of that section of the State they not only look about in vain to see wine drinkers, but are not always sure of being able to get wine to drink themselves. Strong liquors are still the staple beverages. Grapes are not much in demand, even for table use.

**Effects of Cold on Vegetables.**

While artificial refrigeration is coming into extensive use for the preservation of meats, it is well known that cold, if too intense, is very injurious to vegetables. The farmer knows full well the necessity of protecting his potatoes and apples from frost; the shipper dreads the approach of weather that shall endanger his freight when in transport; the green-grocer rolls his barrels nearer the stove on a cold night; and the buyer carefully examines his purchase to see if they are not "frost-bitten."

Hermann Müller-Thurgau has been investigating the chemical changes that take place in the amylaceous constituents of different vegetables when they are exposed to a low temperature, such as the change of starch into sugar, which gives a sweet taste to frozen vegetables. At the very outset he made the astonishing discovery that the sweetening of the potatoes was in no way related to the *freezing*, but only to the changes of substance due to a low temperature. A further study of the subject revealed a whole series of hitherto unknown facts, a few of which we find given in the *Naturforscher*.

When potatoes are quickly frozen there is no noticeable formation of sugar; but, if they are allowed to freeze very slowly, there is an increase in the quantity of sugar. So far as the actual operation of freezing is concerned, there is no real difference between slow and rapid freezing; in both cases the temperature of the potato must sink to  $-3^{\circ}$  C. ( $27^{\circ}$  Fahr.), before ice begins to form. When congelation has actually begun, it proceeds (in the beginning, at least) very rapidly in both cases. The difference seems to depend chiefly upon the length of time that intervenes between the beginning of the experiment and the first ice formation. In slow freezing a considerable space of time elapses, during which the potatoes are cooled from  $32^{\circ}$  to  $28^{\circ}$  Fahr., without freezing, but in rapid freezing this interval is either lacking or very short. It must be this difference that enables slow freezing to produce a different effect from rapid freezing.

Potatoes are turned sweet not by freezing, but by being cooled for a long time to  $32^{\circ}$  Fahr.

Of the experiments which prove this assertion, only one need be mentioned, as an example. Potatoes that had been cooled to  $28^{\circ}$  or  $30^{\circ}$  Fahr. for two weeks, but *not frozen*, contained as much as 2 per cent of sugar at the end of that time. When frozen potatoes were exposed to the cold for a longer time than that the percentage of sugar did not increase.

The consumption (or respiration) of starch by the protoplasm takes place in two stages, that should be more carefully distinguished from each other than is usually done; first, the conversion of the starch into sugar, and then the destruction of the sugar by the respiration of the protoplasm. The first change is of a chemical nature, dependent upon the presence of a diastase or ferment; the latter is a vital process, chiefly dependent upon the vital energy of the protoplasm. Both changes may take place side by side, and at the same time in a cell which contains starch. They may also take place at different times and in different cells, *i. e.*, the sugar formed by the fermentation of starch in one cell may, under certain circumstances, be used up afterward for respiration in another cell.

Now, it is a fact that when potatoes are kept for a long time in a place where the temperature is  $32^{\circ}$ , the sugar accumulates in them in considerable quantity. In potatoes that were kept for thirty days in a thermostat at  $32^{\circ}$  Fahr., the amount of sugar was found to be as much as  $2\frac{1}{2}$  per cent of the fresh substance, a quantity corresponding to about 12 per cent of the total amount of starch.

There are individual differences in potatoes of the same sort as regards getting sweet; for example, four potatoes that had been cooled to  $32^{\circ}$  for thirty-two days contained respectively 2.5, 2.4, 1.9, and 1.8 per cent of sugar. Yet in five hundred potatoes experimented on there were none that did not contain sugar.

At first the quantity of sugar increases slowly, afterward more rapidly; but when the quantity gets quite large it proceeds more slowly again. A large percentage of water in the potato is favorable to its getting sweet. The decrease in starch corresponds to the increase of sugar.

An accumulation of sugar at the expense of the starch was also observed in a few other parts of plants containing starch, if kept at  $32^{\circ}$  for a long time.

If the conditions above mentioned are really the cause of its getting sweet, we may assume that these relations would not suddenly change when we pass  $32^{\circ}$  Fahr., but that above this point, as the temperature rises, the accumulation of sugar would gradually decrease; and the consumption and production of sugar will approach each other until, at a certain definite temperature, they become equal, the sugar being consumed as fast as it is formed, so that no accumulation can occur. This logical deduction was confirmed by another series of experiments, of which the following may be taken as an example: A potato containing only a trace of sugar was cut in three similar pieces; one was kept at  $32^{\circ}$  Fahr. for thirty days, the second at  $37.5^{\circ}$ , and the third at  $43^{\circ}$  for the same length of time. At the end of the experiment, the first contained 2.54 per cent of sugar, the second 0.76 per cent, and the third 0.37 per cent. Potatoes taken in winter from a heap that was kept at about  $46^{\circ}$  to  $50^{\circ}$  generally contain perceptible quantities of sugar, while those kept in a warmer place contain none or mere traces of it.

Many parts of plants have a different quantitative compo-

sition, the proportions of sugar, starch, and albuminoids changing according to the temperature to which they have been exposed for some time before analysis. This may serve to explain the contradictory statements found in literature.

The accumulation of sugar is not entirely attributable to the respiration being less at  $32^{\circ}$  than at  $68^{\circ}$ ; the conversion of starch into sugar is also greater at low temperatures. A few figures selected from these investigations will show that.

At  $68^{\circ}$  Fahr. a kilo of potatoes exhale about 0.36 gramme of carbonic acid, while at  $32^{\circ}$  they give out only 0.12, a difference of 0.24 gramme. In a month this difference would amount to 7.2 grammes, or 0.72 per cent of the weight of the potato. If the production of sugar were the same in both cases, this difference would correspond to the sugar left in the potato. But it only takes 5 parts of sugar to make 7.2 parts of carbonic acid; hence this difference in respiration would only increase the amount of sugar to the extent of 0.5 per cent, whereas it is generally more than 2 per cent.

The conversion of starch into sugar is accomplished by a diastatic ferment. Numerous observations justify the assumption that this ferment accumulates by long exposure to cold, and hence is more active. The conversion of starch at first increases (owing to the increase of the ferment), and is therefore more energetic than at a higher temperature; afterward, the change of starch into sugar gradually diminishes, owing to the accumulation of sugar. At higher temperatures the changes that take place in the protoplasm are of such a nature that either less ferment is formed, or, what is also quite probable, the ferment is drawn into the rapid decomposition, so that only small quantities are present in a unit of time.

If potatoes which have become sweet at  $32^{\circ}$  are exposed to a higher temperature, the sugar rapidly disappears. (Does it?) One experiment of this series may serve to show this. A potato in which the sugar had increased up to  $2\frac{1}{2}$  per cent by thirty-two days' exposure to a temperature of  $32^{\circ}$  Fahr., contained only 0.4 per cent of sugar after being kept at  $68^{\circ}$  for six days.

The respiration of these sweetened potatoes when exposed to a higher temperature, say  $68^{\circ}$ , is far more energetic than that of potatoes which are not sweet. This rapid respiratory process soon consumes the supply of sugar, and then the respiration sinks to the normal.

The intensity of respiration in potatoes is dependent on the efficiency and activity of the diastatic ferment. At low temperature this produces (as seen above) more sugar than is necessary to cover the loss of protoplasm by respiration. Hence, the accumulated sugar exerts an effect on the amount of respiration, although only a limited one. A potato that was warmed for a long time to  $68^{\circ}$  and then cooled to  $32^{\circ}$ , at first exhibited but a slight amount of respiration. After a few days it increased. Within this time the ferment produced a large store of sugar, which had a favorable effect on the respiration.

The relations are different at higher temperatures; for example, at  $68^{\circ}$ . At this temperature the protoplasm is excited to such activity that it is able to respire all the sugar that is being formed, and could consume a considerably larger quantity if placed at its disposal. The respiration is in fact limited and regulated by the quantity of sugar that the ferment produces for it.

Hence the amount of respiration is different at the same temperatures just according as they have been kept for a long time in a cold place or a warm one. Eudiometric experiments made with leaves that contain starch also agree to a certain extent in this respect. Hereafter, in determining the amount of respiration it will be necessary to take into account what temperatures prevailed before the experiment.

Müller-Thurgau bases the following practical considerations upon these scientific conclusions:

Potatoes may undergo the following changes, according to the degree of cold and its duration: They may be neither sweet nor frozen (not cooled below  $29^{\circ}$  Fahr., and that only for a short time); or frozen but not sweet (when rapidly chilled to  $27^{\circ}$ ); or sweet but not frozen (when cooled to  $29^{\circ}$  or  $41^{\circ}$  for a long time); or both sweet and frozen (when the temperature sinks slowly to below  $27^{\circ}$ ).

Potatoes which have turned sweet have still a considerable nutritive value, and can be made eatable by allowing the sugar to evaporate by keeping them for several days in a warm kitchen. Finally, these sweet potatoes are capable of germination, as shown by careful experiments.

**Boy Inventors.**

The *Christian Advocate* justly considers that a boy's elders are guilty of a foolish act when they snub him because he says or does something which they don't understand. A boy's personality is entitled to as much respect as a man's, so long as he behaves himself. In the following anecdotes wise and foolish elders are exhibited—one class respecting, and the other despising a boy.

Some of the most important inventions have been the work of boys. The invention of the valve motion to the steam engine was made by a mere boy.

Newcomen's engine was in a very incomplete condition, from the fact that there was no way to open or close the valves, except by means of levers operated by hand.

He set up a large engine at one of the mines, and a boy, Humphrey Potter, was hired to work these valve-levers;

although this is not hard work, yet it required his constant attention.

As he was working the levers, he saw that parts of the engine moved in the right direction, and at the same time he had to open or close the valves.

He procured a strong cord, and made one end fast to the proper part of the engine, and the other end to the valve-lever; and the boy then had the satisfaction of seeing the engine move with perfect regularity of motion.

A short time after the foreman came around and saw the boy playing marbles at the door. Looking at the engine he saw the ingenuity of the boy, and also the advantage of so great an invention. The idea suggested by the boy's inventive genius was put in a practical form, and made the steam engine an automatic working machine.

The power loom is the invention of a farmer's boy who had never seen or heard of such a thing.

He whittled one out with his jackknife, and after he had got it all done, he, with great enthusiasm, showed it to his father, who at once kicked it to pieces, saying he would have no boy about him that would spend his time on such foolish things.

The boy was sent to a blacksmith to learn a trade, and his master took a lively interest in him. He made a loom of what was left of the one his father had broken up, and showed it to his master.

The blacksmith saw he had no common boy as an apprentice, and that the invention was a valuable one. He had a loom constructed under the supervision of the boy. It worked to their perfect satisfaction, and the blacksmith furnished the means to manufacture the looms, and the boy received half the profits.

In about a year the blacksmith wrote to the boy's father that he should bring with him a wealthy gentleman who was the inventor of the celebrated power loom.

You may be able to judge of the astonishment at the old home when his son was presented to him as the inventor, who told him that the loom was the same as the model that he had kicked to pieces but a year ago.

Our Patent Office shows many ingenious and useful inventions made by minors and women, and the above list of important inventions made by boys might be largely increased did space permit.

**Electric Lights on the Pennsylvania Railroad.**

A test of electric lamps in car lighting has just been made on the Pennsylvania Railroad between Jersey City and Newark, N. J. The car was lighted by seven incandescent lamps of the Edison make, fed from thirty Faure accumulators, which were placed in two boxes underneath the car, one on each side. The cells were a part of the number brought over from Europe on the steamship Labrador last spring. Each cell was  $11\frac{3}{4}$  inches long,  $5\frac{1}{4}$  inches broad, and 11 inches deep. They were charged in five hours by a small Edison dynamo.

The boxes in which they were placed are 7 feet 6 inches in length and 16 inches wide. From a switch in the closet of the cars the lights can be turned on or extinguished, while each lamp is provided with a switch socket, so that it can be used independently of the other lamps. The wires pass from the batteries along the sides of the cars, crossing over to each other where the lamps are placed.

The lamps in the car gave a steady light of 12 candle power, and when the train was going at full speed did not flicker in the least. When half the lights were turned out there was no appreciable difference in the total light of the car, except that it was softer and more pleasant to read by. The heat from the lamps was about one-fifth of the amount produced by gas. The electricity stored in the accumulators under the car is sufficient to keep all the lights running for sixteen hours, without recharging. The car on the Pennsylvania road is the first that has been lighted in this country, and the light has been in use about two weeks, and has proved satisfactory. It is lighted on the same principle as on the Pullman limited express between London and Brighton, England, where it has been in use for several months.

**Distribution of Wool.**

About twenty-five per cent of the entire production of domestic wool during the census year 1880, came from two States, Ohio and California, the former with 25,000,000 pounds, and the latter with 17,000,000 pounds; in 1870 the product of the former was 20,000,000, and of the latter 11,000,000 pounds. The next States in the order of importance as woolgrowers in 1880, were Michigan, with 12,000,000; New York with 9,000,000; Pennsylvania with 8,000,000; Missouri with 7,000,000, and Wisconsin with 7,000,000. Texas produces nearly as much as the latter State; in 1870 it produced only 1,250,000 pounds. The total product of the Union in 1880 was 155,000,000 pounds, clipped from 35,000,000 sheep.

**Canning Grain.**

A new method of storing grain is proposed, in air-tight cylinders or bins of sheet iron, to be sealed after a partial exhaustion of the air. It is said that wheat, flour, and bread, so stored for seven months, have been found in excellent condition (as might have been expected), and that taking into account the security of the grain against dampness, fermentation, attacks of insects and large vermin, fire and other risks, when sealed up in a partial vacuum, the new plan is more economical than ordinary storage in a granary.



RECENT INVENTIONS.

Novel Window Blind Operator.

The engraving shows a new window blind operator, recently patented by Mr. Bela G. Merrill, of Geneva Lake, Wis. This apparatus is arranged for opening and closing the window blinds by means of a crank, C, attached to the inside of the window jamb. The slats of the blinds are opened and closed by the same mechanism without altering

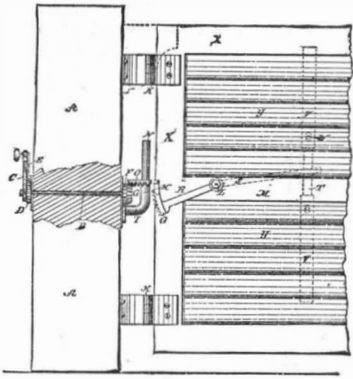

its adjustment, and by the same crank used to open and close the blinds. By turning the crank so as to close the blind, and by continuing the motion of the crank after ward, the toothed arc, Q, will be raised, lifting the segmental wheel, O, out of gear with the bevel pinion, G, allowing the shaft, B, to be turned so as

to open and close the blind slats. By turning the crank in the reverse direction the toothed arc, Q, will be thrown down out of gear, and the segmental wheel, O, will descend into gear, with the pinion, G, again ready for opening the blind. With this device the window blind can be opened and closed without opening the window, and it may be locked securely in any desired position, and by an ingenious connection between the upper and lower slat rods the upper portion of the slats may be opened while the lower slats are closed.

Improved Dog Cart.

The engraving shows an improvement in the class of vehicles known as "dog-carts," the object being to prevent the motion of the animal from affecting the vibratory or rocking movement of the vehicle body or box.

The dog-cart has its body supported by transverse crank-shafts provided in or pivoted to the supporting springs, and which box has one or more spiral or other springs, attached to the front of the box and to the shafts, whereby the box will be rocked or vibrated independently of the movements of the animal. In the dog carts of ordinary construction, the movements of the vehicle-box are governed by the movements of the horse, and these movements are very unpleasant for the occupant of the vehicle, which is jolted and shaken very irregularly. It will be seen that in this improved dog-cart the box is not supported directly by

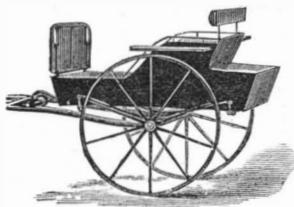

the movements of the horse, and these movements are very unpleasant for the occupant of the vehicle, which is jolted and shaken very irregularly. It will be seen that in this improved dog-cart the box is not supported directly by

the springs, but the crank-shafts are interposed between the springs and the box, and give the box a rocking or vibrating movement forward and backward, and the irregular movement of the animal is counteracted by the springs and the crank-shafts. This invention has been patented by Mr. Edward Bowman, of Santa Cruz, Cal.

New Hand Corn Planter.

The engraving shows an improved hand corn planter recently patented by Messrs. F. B. Preston and W. H. Stapleton. This implement is simple in construction and easily operated. It plants corn in regulated quantities and is positive in its action. In using the planter the operator carries the machine with one hand by the handle at the top and grasps one of the other handles with the other hand ready to operate the seed-dropping slide at the proper time. At each place for a hill the shoe at the bottom is forced into the soil, and the seed-dropping slide is forced downward, pressing back a hinged plate in the shoe and allowing the seed in the space in the shoe to drop into the soil. The planter is then raised and carried forward to the place for the next hill, and at the same time the seed-dropping slide is raised by one of the lower handles to allow the plate in the shoe to close and the seed in the passage leading from the seed box to drop through into the space in the shoe ready to be discharged at the next downward movement of the seed-dropping slide. The seed box is hinged so that the seed-dropping slide may be readily withdrawn when necessary. Further particulars may be obtained by addressing Mr. William H. Stapleton, of Fayette, Mo.



New Belt Fastener.

The accompanying engraving shows a strong, simple, and easily applied belt fastener. The fastener consists of a plate of malleable iron or other metal with clinching points

on one side that are adapted to be driven through the adjoining ends of the belt, and with several slots or passages near its side edges.

The clinching points shown at the bottom of the cut are in double rows and arranged in zigzag or "hit-and-miss" order, and are so formed that when driven through the ends of the belt upon an anvil, they will turn and clinch in different directions.

In case a fastening of unusual strength is required two or more plates may be used with some of the points of the side plates passing through the slots of the center plate, as illustrated at the upper side of the figure. But for ordinary

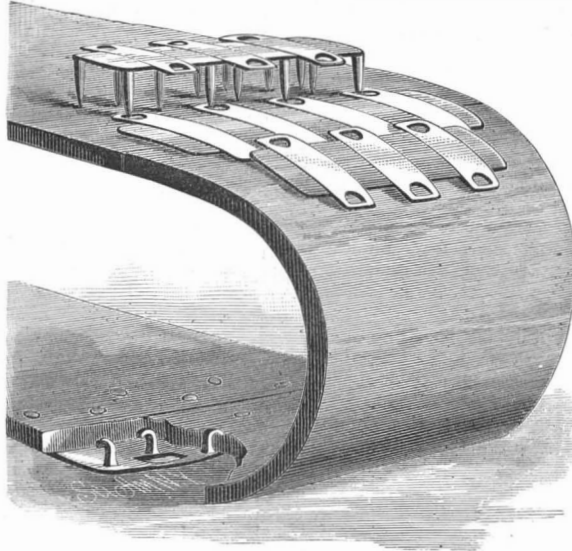

NEW BELT FASTENER.

belts only one fastening plate is intended for making the connection of sufficient strength.

These fastening plates, besides being strong and easily applied, require the use of no other tool than a hammer to adjust them, and they possess the further advantage of holding the parts of the belt parallel, and do not, it is claimed, interfere with the required flexibility of the belt, either when used singly or when two or more of them are used in making the connection, and the points clinching as they do in different directions give them a firm hold on the belt.

Further particulars may be obtained by addressing the Giant Belt Fastener Company, No. 189 Duane street, New York city.

Comparative Economy and Durability.

In a recent discussion touching the relative economy of building certain country bridges before the Society of Civil Engineers, the president, Mr. Ashbel Welch, gave the following useful formula. He said:

The question often arises whether a cheaper bridge that will last a shorter time is more economical than a more costly one that will last a longer time. The same question may arise respecting many other things.

To find the comparative economy of two things of different cost and durability, that will answer the same purpose equally while they last, the following formulæ will be found convenient:

Let C be the cost and assumed real value of one of them, T the time it will last,  $a$  the compound interest on one dollar for that time, at whatever rate money is worth to the party using the thing or costs that party, and L the loss of the thing when done with, which may or may not be equal to C; let R be the real value for the purpose of the other thing, C' its cost, T' its duration,  $a'$  the compound interest for that time, and L' the loss on it; and let V be the value of the thing for that purpose that would last for ever if all circumstances remained constant.

$$\text{Then } V = C + \frac{L}{a}$$

$$R = \frac{a' V}{1 + a'} \text{ that is } R = \left( C + \frac{L}{a} \right) a' \div (1 + a')$$

The difference between R and C' is the advantage or the disadvantage of the thing whose cost is C'.

Suppose a bridge that will last seven years costs \$8,000, and the loss at the end is just the cost, and money costs the parties interested 7 per cent, what would be the equivalent value of a bridge that would last five years, and one that would last for ever?  $8,000 + \frac{8,000}{0.62} = 20,900$ , the value for that place of the bridge that would last for ever, and  $(0.41 \times 20,900) \div (1 + 0.41) = 6,077$ , the value of one that would last five years.

More London Fossils.

Mr. Rowland Ward sends to the London Times a list of the fossils recently discovered at Charing Cross, in the heart of London, when the deep excavations were made for Messrs. Drummond's banking house. The specimens are more than 100 in number. They include bones of the cave lion, tusks and bones of the mammoth, tusks and bones of extinct elephants, remains of extinct Irish deer, remains of red deer, remains of a species allied to the fallow deer, remains of rhinoceros, remains of extinct oxen from the pleistocene gravels, bones of the horse, the sheep, and the shorthorn from recent deposits.

The Geological Survey.

Major Powell, Director of the National Survey, reports that a great part of the past year's work has been in the preparation of statistics relative to the mining industries of the United States. At the beginning of the fiscal year it was resolved to curtail the field work so as to give more attention to the study of the large mass of undeveloped matter which had accumulated. This work consisted in the identification, classification, and description of fossils; the chemical and microscopic examination of rocks, minerals, and ores; the construction of geologic sections; the preparation of charts, diagrams, and other illustrations and the preparation of reports on the various subjects which had occupied the attention of the scientific men of the survey. Experiments were made under the management of the former director, Mr. Clarence King, on the various phenomena connected with rock formation. An examination (chiefly in the laboratory) has been made of the structural geology of the Eureka mining district of Colorado, of the volcanic rocks of the Great Basin, and of Mounts Shasta, Hood, and Rainier.

Another department of the work has been the study of certain lake basins in Utah, Nevada, and California. These lakes are now mostly extinct, Great Salt Lake being one of the few exceptions, and their history, which is now being studied, includes a study of the quaternary climate, which leads in turn to a study of the climate of the arid portion of the United States. Another field of investigation has been the study of glacial formations extending from the Atlantic coast to the middle portion of the great plains in northern latitudes. This investigation also is a research relating to quaternary climate and to the character and origin of the present topographic features of the area involved. Investigations have also been conducted relating to the economic geology of the Ten Mile district, Summit county, Colorado, and of the basaltic mesas at Golden, which will be extended to cover the entire Denver coal basin. Much time has been spent in the preparation of a report on the Leadville district. In Nevada, the Eureka district has been carefully surveyed, and the report has been prepared on the Comstock lode and the Washoe district.

The director says that all of the investigations in economic geology will have a practical value in determining the characteristics of ore deposits, and will advance mining industries by pointing out the best methods of systematic development.

Early in the fiscal year geographical work was commenced in New Mexico and Arizona, preliminary to a geological examination of the country.

Scientific Work on the Jeannette.

In his testimony before the Jeannette Board of Inquiry, at Washington, Lieutenant Danenhower said that during the first year in the ice meteorological observations were taken hourly by specially detailed officers. The instruments used were the barometer, the wet and dry bulb thermometer, the maximum and minimum thermometer, the anemometer, and the black bulb thermometer in a vacuum. Observations were also made upon the state of the clouds and their movements, the direction of the wind, and the general character of the weather and the condition of the ice. The astronomical observations were those of the sun, moon, and stars by artificial horizon for latitude, longitude, and time; and lunar observations and eclipses of Jupiter's satellites for chronometer errors. Soundings were made and the temperature of the sea water ascertained, both at the surface and at various depths, by a Millar-Caselle thermometer. Specimens of the water were examined and its specific gravity determined. The dredge was hauled for specimens of the bottom and of the animal life existing there, and these, with other specimens, were turned over to the naturalist and taxidermist. Bears, seals, and birds were carefully examined, their stomachs especially, to gain all possible knowledge of their habits and of the food obtained by them in the Arctic regions. The soundings were made with an ordinary line, and specimens from the bottom were brought up in a sandcup. A hole was always kept open through the ice for that purpose.

Catalogue of Scientific Periodicals.

Dr. H. C. Bolton, of Trinity College, Hartford, Conn., is preparing for the press his "Catalogue of Scientific Periodicals," which will appear in the octavo series of the Smithsonian Institution. The catalogue is intended to embrace independent journals of pure and applied science, published in all countries from 1665 to 1880.

It does not include the transactions of learned societies, these being found in the admirable "Catalogue of Scientific Serials," by Mr. S. H. Scudder; but it does embrace every branch of applied science, including engineering, architecture, chemical technology, geography, ethnology, agriculture, horticulture, telegraphy, meteorology, etc. More than twenty languages are represented in the work. Printing has begun, and it is hoped that the work will be completed before the close of next year.

Saw Teeth Tipped with Iridium.

Mr. John Holland, whose discoveries and improvements in the working of iridium were noticed not long ago, has now made a circular saw with teeth tipped with that hard and refractory metal. The saw is 12 inches in diameter and is to be used for sawing hard woods.

## ENGINEERING INVENTIONS.

A snow plow provided with means for melting snow, and a tank for receiving the water resulting therefrom, has been patented by Mr. John Flindall, of Chicago, Ill.

An improved car coupling has been patented by Mr. Edmund T. Leonard, of Baltimore, Md. This car coupling is automatic, composed of very few parts, is exceedingly simple in its construction and cheap, and can be applied to passenger or freight or coupled to any car now in use.

Mr. Robert Anderson, of West New Annan, Nova Scotia, has patented an improved car coupling. To a U-shaped hanger suspended from the drawhead is pivoted a hook that is provided with a pivoted latch, against which a spring rests for holding it in position. A ring is hung loosely in the outer end of the hook, and is passed into a similar hook on the opposite drawhead.

Mr. Abraham O. Frick, of Waynesborough, Pa., has patented improvements in traction engines, by which such flexible and elastic connections are provided between the running or traction wheels and the body of the engine and its driving gear as will adapt the engine to pass over rough walls, without producing undue strain upon the working parts.

Messrs. John H. Filcer and James Gilduff, of Mattoon, Ill., have patented an improved spark arrester, applied in connection with the smoke stack of a locomotive. It consists in an arrangement of tubes and deflectors surrounding the smoke stack and calculated to pulverize and extinguish the cinders before they are allowed to escape.

Mr. Frank Sweetland, of Edwardsburg, Mich., has patented an improved device for holding car coupling links to guide them into the drawheads in such a manner that the hands of the operator will not be in danger of being crushed. The invention consists in a plate provided with an aperture and an ordinary coupling link, with its side bars brought together at about the center and held in the aperture of the plate.

An improved snow plow has been patented by Mr. Eric M. Hesselbom, of Rushford, Minn. Knives for separating the snow into two streams are set at the front of the plow. The plates on which the bottom cutters are formed rise by an easy curve and form chutes for conveying the snow upward and outward, and discharging it at the sides of the track. The chutes are jointed and provided with adjusting braces to adapt them to narrow and wide places.

An improved car coupling has been patented by Mr. Charles J. Edwards, of Fairville, Mo. The invention consists of the combination with a drawhead having vertical loops or staples, and properly chambered and slotted, of a T-shaped coupling pin pivoted in the said staples or loops upon the drawhead in such manner that it will be capable of vertical movement, and automatically drop through the coupling link as the link enters the drawhead, and thus couple the cars without the necessity of incurring the danger of going between the cars.

A reversing gear for engines that furnishes a simple substitute for the usual link motion has been patented by Mr. Thomas Moore, of O'Fallon, Ill. Two arms fixed on the crank shaft support the ends of a spiral shaft by which the eccentric is carried, and on one end of which it is fixed and held eccentric to the crank shaft. On the crank shaft is a circular sliding disk that has a threaded aperture for the spiral shaft. The disk is moved to slide on the crank shaft by a lever, and turns the spiral shaft on its own axis, throwing the eccentric as desired.

Messrs. Josiah Austin and Roscoe C. Chamberlain, of East Liberty, O., have patented improvements in car couplings. A screw head, consisting of a rectangular plate, twisted spirally, has its shaft connected with the drawhead of a car, and is adapted to be screwed into the contracted mouth of the opposite drawhead. The revolution of the shaft by the action of the screw is effected against the action of a spring, which, as soon as the head has passed into the opposite drawhead, brings it back to its normal condition, coupling the car. Devices are provided for turning the shaft to uncouple the cars.

Mr. Peter N. Aggergaard, of Danville, D. T., has patented an improved apparatus for drilling wells. The drill is hollow in the upper end and has orifices in its side, and is attached to the lower end of a hollow drill rod. In an opening on one side of the drill is pivoted an auxiliary cutting bit that reams out the drill hole large enough to allow the tubing to settle of its own weight. To the top of the drill rod is attached a flexible hose connected with a force pump that forces water through the drill and rod to wash out the drill cuttings through the tubing. Suitable devices are provided for working the drill.

Improvements in speed regulators for machinery have been patented by Mr. Herbert Cruttenden, of Smeltzerof, Pa. To the outer end of the governing lever that controls the centrifugal governor, is attached a pivoted lever having a weight at its outer end. Above this lever is the belt tightener of the main belt, and on the under side of the arm of the tightener is a projection that, when the tightener falls, presses down the pivoted lever and operates the steam valve to let on more steam. The tightener is so arranged as to fall with increased strain of work on the belt and operates to let on the steam as soon as the work is increased.

An improved device for coupling cars has been patented by Mr. Jacob King, of Geneva, Ind. The drawhead of the car is recessed in its top and end, and in this recess is pivoted an L-shaped coupling hoop, in such a manner that its short arm projects downward, forming the coupling pin. When the cars are run together, the link strikes the pin, swinging it back until the link passes it, when it drops forward and the car is coupled. The device is locked by means of a fork attached to a transverse shaft in the drawhead. The hook is raised to uncouple by a lever projecting from the side of the chain.

## MECHANICAL INVENTIONS.

An improvement in presses for bending or folding blanks of sheet metal into form has been pa-

ented by Mr. John Wagner, of Boston, Mass. The plunger is made of any desired form, and is operated in the usual manner. The die is composed of a base plate, and side and end sections. The base plate is formed with an under cut flange, and the sections are formed at their outer edges with lips that fit under the flange, forming a strong hinge joint, the sections being adapted to a rocking motion to and from the plunger, and when the plunger is pressed down the sections are automatically pressed to it.

An improvement in windmills has been patented by Mr. Edward Stickler, of Neosho Falls, Kan. This invention consists in springs connected with the vanes of a windmill for holding the vanes in position for the wind to act upon them, the arrangement being such that the area of the vanes subject to the wind-pressure will vary according as the wind varies in force, so that power and motion of the wheel will be uniform, although the force of the wind may vary, the power being more or less, according as the power of the spring is greater or less.

Messrs. Andrew Wickey and Albert A. Gehrt, of Quincy, Ill., have patented a hay and cotton press, which is an improvement in hay and cotton presses patented by the same inventors, October 4, 1881. In the former application was described a horizontal press having a follower adapted to be operated by means of a sweep, and an intermediate gearing consisting of a toothed segment and double rack bar, and provided with a sliding head which was adapted to be revolved about a pivot for ejecting the completed bale. The present invention relates to improvements which render the press more complete.

An improved wind engine has been patented by Mr. James E. Jones, of Abilene, Kan. Windmills which are constructed with vertically-rotating wheels have heretofore been provided with broad heavy towers, which are objectionable on account of the great surface they present to the wind in a storm. This inventor constructs the tower of two flat pieces of lumber secured together at the ends by bands and held apart from the center to the ends by intervening blocks. The tower is provided with pivots at the ends, and is to be supported in a vertical position by guys in such manner that the tower may be rotated upon its pivots.

## AGRICULTURAL INVENTIONS.

An improved cotton seed planter, constructed so that it will plant the seed uniformly and in any desired quantity, has been patented by Mr. William C. Hudson, of Yellville, Ark.

Mr. Hugh L. T. Overbey, of Subigna, Ga., has patented an improved fruit gatherer, which consists of an inverted cup-shaped picker device located over the top of the hose chute, on a rod, by which it may be pulled down from over the fruit to press it into the top of the hose and separate it from the branches.

Mr. Edwin S. Frost, of Watkins, N. Y., has patented a grain binding attachment for reapers which may be attached to self-raking reapers to take the grain from behind the knives, and may be put on or off without interfering with the working of the reaper. It may also be used with an endless apron running behind the knives to carry the grain to the binder. The machine has many points of novelty which cannot be clearly described without engravings.

Mr. Emanuel Fleck, of La Grange, Ind., has patented an improved hay rack having the main stay pieces arranged at the inner sides of the bed pieces, to which they are held by loops formed of angle irons or straps attached to the bed pieces and to the cross pieces uniting the bed pieces, so that the sections of the hay rack can slide on the main stay rods, and the racks can thus be shortened or lengthened.

An improved sickle bar for mowing machines, has been patented by Mr. John Laib, of King's Station, Ind. The invention consists of the combination of the cutter-bar provided with the undercut lugs, and cutting blades provided with rectangular openings having lips to fit into the openings of the cutter-bar, and an eye-block fitting on the end of the cutter-bar, and provided with means for adjusting and securing it upon the cutter-bar, thereby fastening the whole series of knives.

A novel machine for assorting cranberries has been patented by Mr. Laurin Leland, of Holliston, Mass. This machine is provided with an endless carrier-belt under the hopper, and with an inclined carrier-belt which carries the flat and imperfect berries upward, the sound berries rolling down this inclined belt upon an inclined platform, at the lower end of which a step or jumping board is provided, upon which the berries drop. The soft berries drop into a receptacle below the jumping-board, and the hard berries jump over a vertical strip into another receptacle.

Mr. Andrew R. Peterson and Frank Wiccox, of Hancock, Minn., have patented an improved machine for shocking bound grain as it is delivered from the harvester. The grainshocker is made with a receiver-frame attached to a pivoted inclined bar kept in place by a pivoted crank arm, and operated from a cam wheel by a slide and connecting rod. The receiver frame is provided with a hinged curved plate operated by a pin and a bent guide rod, and held in place, when closed, by a spring-pressed latch, which is tripped at the proper time by a bent rod. The receiver frame is also provided with a curved hinged arm for holding the bundles in place in the receiver, and is connected with the frame by a connecting rod and pivoted spring pressed crank, so that the hinged arm will be operated by the movements of the receiver frame.

## MISCELLANEOUS INVENTIONS.

Mr. Thomas Penn, of New York City, has patented an improved fire escape of the class in which a flexible chute or conveyer is used for passing persons from the window of a building to the street, the chute being of a close or tubular construction, so that the person passing down through it is under cover, while the flexibility of the device provides for its being bent or inclined to ease the descent of the person through it.

A device to improve the draught in flues of stoves or furnaces has been patented by Mr. Donald M. Bliss, of Westmoreland Point, Can. In a section of

pipe is placed a fan, suitably supported in a horizontal position by a frame, and adapted to be turned in a vertical position in the pipe when not in use. The fan is driven by a shaft that projects through the pipe into a case, and is connected with clockwork of a suitable character for rotating the shaft contained in the case.

A water closet that will retain the water in the bowl to the desired height without a plugvalve or pan has been patented by Mr. Thomas H. Walker, of Kansas City, Mo. A side extension is connected with the bowl by an elbow, on the inner end of which a tilting valve is mounted, that is so connected as to be tilted by raising the pull on the seat, permitting the water to flow through the elbow into the bowl and the waste pipe. When the valve is closed the water in the bowl cannot flow out.

Mr. Thomas J. Brough, of Baltimore, Md., has patented an improved vapor gas apparatus. Hydrocarbon oil passes from a reservoir to the retort of a vaporizer, and after being vaporized and mixed with air, supplied by a pump or bellows, the vapor passes to a gasometer. Suitable devices are provided for regulating the flow of oil to the vaporizer, and for preventing any explosions at the gasometer. This device is especially adapted to supplying gas for steamboats.

A device to attract attention to advertisements in show-windows has been patented by Mr. Orlando S. Trussell, of Rockland, Me. A series of frames carrying advertising cards are moved up and down by bent levers moved by cams operated by clockwork. From a wire agitated by prongs on the fan shaft of the clock are suspended dancing figures. The advertising cards are successively displayed and withdrawn, leaving the dancing figures exposed during the periods of withdrawal.

A button made of two separable parts, and provided with simple and efficient means for attaching the parts, has been patented by Mr. Gabe Felsenthal, of Brownsville, Tenn. The bottom of the button is formed with a sleeve having at its upper end a grooved head in which spring jaws engage that are pivoted on the under side of the top of the button, and on opposite sides of a stud or post that project from the top in the sleeve of the lower part. The ends of the levers extend to the outside of the button, to be operated for detaching the parts.

A portfolio for holding and carrying pictures, and that also serves as an easel for displaying them, has been patented by Mr. Henry T. Thomas, of New Rochelle, N. Y. Three stiff boards are connected to each other by flexible hinges. Two of the boards form a portfolio for holding the pictures, and the third one is hinged to the back of one of the others in such a manner that it serves as a support to hold it in a nearly upright position. When the opposite board is dropped down the device serves as an easel.

An apparatus for reclaiming soda from the spent liquor of pulp mill digesters has been patented by Mr. William L. Longley, of Westbrook, Me. The spent liquor is drawn into trays to a suitable depth and evaporated to a proper consistency, when it is run into a rotating cylinder having axial openings and located immediately behind the fire box of a furnace. The great heat of the furnace passing through the cylinder causes the liquor to be quickly evaporated, and all the inflammable substances are burned out.

A device for removing the hair spring collet from the balance staff of a watch has been patented by Mr. Frank M. Willo, of Springfield, Ill. The device consists of a pair of tweezers having jaws at the outer ends of their prongs, one of which is slotted and made extensible against a spring, and rides over the opposite jaw when the tweezers are closed beneath the collet, and forces the collet off from the balance staff without throwing the hair spring out of truth.

Mr. William W. Bard, of Elizabethtown, Ky., has patented improvements in hay and cotton presses, which permits them to be constructed in a simple and cheap form, and without the cost of expensive fittings. The side pieces and posts of the press are secured together by keys or pins that may be readily detached, and in the ends of the press are followers that are moved back and forth by screws that work in the end pieces of the box, the end pieces being hinged to the sides of the box and retained by cross bars and hooks.

Mr. Joseph B. Warner, of Dighton, Mass., has patented an improved teakettle, in which the bail can be locked in its raised or lowered position. The front bail-ear of the teakettle has an aperture and a downward projecting slot, and the rear ear has an aperture and upward projecting slot. The hooked ends of the bail are squared to correspond with the slots in the ears. When the bail is up the square part passes into the slot of the front ear, and when it is down it is in the slot of the rear ear, locking the bail in either position.

An apparatus for shaping and curling the brims of felt hats has been patented by Mr. Thomas Rowbotham, of Hazel Grove, England. A press is fitted with side-forming plates or blocks, which advance toward the edge, and act in conjunction with an expanding former to impart the required curl to the brim. The former also acts vertically to give to the brim its required set or curvature. While the pressure is on the hat a knife is passed over the brim to remove the superfluous felt.

Messrs. Newell N. and Frank J. Fairchild, of Trenton, Mich., have patented a device for cutting the upper edge of cheese boxes flush with the top of the cheese, so that the cover can rest flat on the cheese. A board has one edge rounded about the same as the sides of the cheese box, and on the rounded edge is secured a device provided with knives that are adapted to cut through the cheese box from each side, the board serving to gauge the knives and carry them around the box.

An ironing board that can be folded compactly and is convenient for use has been patented by Messrs. August O. Tannenber and John R. Barnum, of Newton, Kan. At the corresponding ends of two boards are longitudinal tongues and recesses, the tongues on one board fitting into the recesses of the other, and the boards are hinged to each other at ends of the recesses. The boards are grooved transversely near the outer end of their recessed ends, and when the

boards are separated the edge of a table is passed between the recessed ends, the grooves grasping and holding the edge, the upper board being horizontal and the other inclined as a support. The board is suitably braced, and side pieces are provided for ironing sleeves, etc.

An improved apparatus for inking blocks for hand-block printing has been patented by Mr. James Hutchinson, of Newark, N. J. In a rectangular box are as many separate color boxes as there are separate patterns on the printing block. In each of these boxes rollers dip that are mounted on shafts provided at their ends with friction rollers, on which a frame rests for carrying the printing block. By moving the block over the rollers the distance of one pattern field, each pattern will be provided with its colors.

A box for putting up matches for the trade that can be easily converted into a match-safe has been patented by Mr. Charles W. Chamberlain, of Lanark, Ill. The back of the blank for the box is extended above the box in any desired plain or ornamental shape. The cover of the box is pasted to the back and folded over the ends of the box and secured at the front by the revenue stamps. The matches are placed upright in the box and held by partitions so that they cannot fall. The top of the back has an aperture for suspending the box as a match-safe.

A spinning top, fitted with an explosive cap in such manner that when the top is thrown for spinning the cap shall explode, has been patented by Mr. John O. Beneke, of New Orleans, La. The body of the top is of the usual construction, and a metal pin extending through its center and out at the lower end forms the peg. A head recessed to receive a percussion disk is screwed in the top of the body, and the metal pin held against the disk by means of spiral spring.

An improved meal bolt has been patented by Mr. Robert Wilson, of Greenup, Ky. The case of the bolt is an upright hollow cylinder, the cover of the cylinder having an opening at its center for feeding the meal into the bolt. A disk of bolting material is mounted in the upper part of the cylinder on a horizontal wheel frame attached to a vertical shaft, the bolting disk being oscillated for sifting by a crank and connecting rod, the wheel of the disk striking against buffer springs to prevent the meal from clogging on the bolt.

Mr. George W. Warren, of Bristol, Ind., has patented an improved side spring for vehicles. The spring is formed of two main leaves, placed together like an elliptical spring. One of the leaves is longer than the other, and is bent back over its ends, and the two are held together by a bolt and nut. On the inner sides of these leaves are placed lap leaves. The spring is secured on the under side of the side bar, and the body is suspended from the spring, the weight of the load opening the spring, instead of closing it is the common elliptical spring.

An improvement in the manner of attaching neck yokes to poles by which all rattling is prevented and the yoke is held from twisting on the pole has been patented by Mr. August Kanzler, of Princeton, Ky. The outer end of the pole has a ferrule of such form that a tug of similar shape fitted on it cannot turn on the tip. On the upper side of the tug is an eye through which a staple passes, the shanks of which pass through the neck yoke, and in the staple between the eye and the yoke is placed a block of rubber against which the eye is drawn to prevent rattling.

A cheap and efficient envelope for bottles to protect them from breaking has been patented by Mr. Henry Bell, of Baltimore, Md. Strips of flag as long as the bottle to be covered, are laid side by side, and are sewed to a cross strip near their lower ends, a part of the strips being cut longer than the others to form a bottom. The upper ends of the strips are tied, and the cap thus formed is placed over the bottle from the top, and the long strips are bent across the bottom and cover and protect it. The strips are supported at their center by a band of the flag secured around them.

A railroad rail especially adapted for use in street railroads has been patented by Mr. Jacob Elmer, of Biloxi, Miss. The rail is tubular, the upper part being in the form of a half circle, and the lower part wedge-shaped to fit into a V-shaped groove on the tie, the wedge-shaped part of the opening being divided into two parts by a slit extending the length of the rail. The rails are connected to each other by a sliding bolt that moves in the tubular opening in the rails, one of the rails being slotted to allow a pin by which the bolt is moved to project through the rail.

A new device for exploding torpedoes in oil wells has been patented by Mr. James S. Schoonover, of Titusville, Pa. The exploder consists of a center web having wings leading from it which fit the diameter of the well or casing, all made in one piece. The lower end is made pointed, and the exploder is used by letting it drop into the well, the shape of it being such that the water will not resist its descent, and it drops rapidly and delivers a heavy blow on the torpedo, the wings keeping the point always in the center of the well.

A spring bedstead that can be folded for storage and transportation has been patented by Mr. Edward J. Johnson, of Twinsburg, O. On the lower side rails of the bed are hinged legs that are braced by locking bars, by which they are locked in place and released to be folded. The upper side rails have near their ends longitudinal slots, and the upper ends of hinged end pieces that connect the upper and lower rails have pins that work in the slots, adapting the rails and end pieces to be folded down to compress the springs and hold the bedding in place.

A bucket for wooden pumps, that is adapted to be expanded for fitting the plunger to the pump tube, and for taking up the wear, has been patented by Messrs. Phillip H. and Tobias A. Sprague, of Cornell, Ill. The plunger consists of a metal bottom plate which carries the valve, having an upward circular projection, screw threaded to receive an adjustable flaring ring, to which the pump rod is attached. Between the flaring ring and an inwardly inclined flange on the bottom plate is placed a flexible ring, that is forced outward to fit the pump tube by screwing the adjustable ring and the bottom plate together.



**Business and Personal.**

The Charge for insertion under this head is One Dollar a line for each insertion; about eight words to a line. Advertisements must be received at publication office as early as Thursday morning to appear in next issue.

CAVENDISH, VT., October 21.

H. W. Johns Mfg Co., 87 Maiden Lane. GENTLEMEN: I have just completed painting on my building with paint ordered from you September 1. It gives perfect satisfaction. I find the only misrepresentation to be this: One gallon will cover considerable more than the number of feet given—a good fault. . . My building looks tippity, and all say they are the best colors yet seen in this town. . . My painter says it is the best he ever spread. . . Yours respectfully, E. G. WHITE.

Wanted.—A situation by a practical “nickel plater” who understands polishing, grinding, dipping, and brass finishing. Address W. H. Wright, Indianapolis, Ind.

The Nameless City—the elder and mysterious name of ancient Rome; said to be Valentia. None of Estersbrook's Pens are nameless, each having a designating name as well as number.

Mathematical Instruments of all kinds, Drawing Papers, Tracing Cloth, etc. Send for illustrated catalogue. Keuffel & Esser, 127 Fulton St., New York.

For Sale Cheap—One Boiler Plate Power Punch and Clipper. Inquire of Noble & Hall, Erie, Pa.

The Double Induction Motor and Automatic Battery, Grison's patents, are manufactured and for sale by the Electro Dynamic Co., Philadelphia. This little electric motor, illustrated and described in our editorial, June 24, 1882, is now on exhibition at the American Institute Fair, Alcoa 14, New York. Power from 1,000 to 6,000 ft. lb., according to battery. Weight 2½ lb. The only practical power for driving the family sewing machine, small lathes, dental and surgical instruments, etc. 1,000 stitches per minute on the sewing machine. 7,000 revolutions per minute on dental tools. Apparatus complete for sewing machines, lathes, \$35 and \$40. Dental apparatus, nickel plated, complete, \$50.

Woodworking M'ch'y. Bentel, Margedant & Co., p. 284.

Cope & Maxwell M'g Co.'s Pump adv., page 285.

Steam Hammers, Improved Hydraulic Jacks, and Tube Expanders. R. Dudgeon, 24 Columbia St., New York.

Diamond Engineer, J. Dickson, 64 Nassau St., N.Y.

The Berryman Feed Water Heater and Purifier and Feed Pump. L. B. Davis Patent. See illus. adv., p. 285.

50,000 Emerson's Hand Book of Saws. New Edition. Free. Address Emerson, Smith & Co., Beaver Falls, Pa.

For Pat. Safety Elevators, Hoisting Engines, Friction Clutch Pulleys, Cut-off Coupling, see Frisbie's ad. p. 286.

Gould & Eberhardt's Machinists' Tools. See adv., p. 285.

For Heavy Punches, etc., see illustrated advertisement of Hilles & Jones, on page 286.

Barrel, Key, Hogshead, Stave Mach'y. See adv. p. 285.

Magic Lanterns and Stereopticons of all kinds and prices. Views illustrating every subject for public exhibitions, Sunday schools, colleges, and home entertainment. 116 page illustrated catalogue free. McAllister, Manufacturing Optician, 49 Nassau St., New York.

Vertical Engines, varied capacity. See adv., p. 285.

Lathes, Planers, Drills, with modern improvements. The Pratt & Whitney Co., Hartford, Conn.

Mineral Lands Prospected, Artesian Wells Bored, by Pa. Diamond Drill Co. Box 423. Pottsville, Pa. See p. 286.

C. B. Rogers & Co., Norwich, Conn., Wood Working Machinery of every kind. See adv., page 286.

For best low price Planer and Matcher, and latest improved Sash, Door, and Blind Machinery, Send for catalogue to Rowley & Hearnance, Williamsport, Pa.

The only economical and practical Gas Engine in the market is the new “Otto” Silent, built by Schleicher, Schumm & Co., Philadelphia, Pa. Send for circular.

The Porter-Allen High Speed Steam Engine. South-west Foundry & Mach. Co., 430 Washington Ave., Phila. Pa. 4 to 40 H. P. Steam Engines. See adv. p. 286.

Sheet and cast brass goods, experimental tools, and fine machinery. Estimates given when models are furnished. H. C. Goodrich, 66 to 72 Ogden Place, Chicago.

Drop Forgings. Billings & Spencer Co. See adv., p. 270.

Improved Skinner Portable Engines. Erie, Pa.

Common Sense Dry Kiln. Adapted to drying of all material where kiln, etc., drying houses are used. See p. 270.

Lubricator. See adv., Detroit Lubricator Co., p. 252.

Engines, 10 to 50 horse power, complete, with governor, \$250 to \$550. Satisfaction guaranteed. Nearly seven hundred in use. For circular address Heald & Morris (Drawer 127), Baldwinville, N. Y.

The Sweetland Chuck. See illus. adv., p. 254.

Steam Pumps. See adv. Smith, Vaile & Co., p. 252.

Knives for Woodworking Machinery, Bookbinders, and Paper Mills. Taylor, Stiles & Co., Riegelsville, N. J.

Calcium Light Apparatus and Stereopticons at low prices. C. Beseler, 218 Centre Street, New York.

Bostwick's Giant Riding Saw Machine, adv., page 288.

See New American File Co.'s Advertisement, p. 238.

25/ Lathes of the best design. G. A. Ohl & Co., East Newark, N. J.

Collection of Ornaments.—A book containing over 1,000 different designs, such as Crests, Coats of Arms, Vignettes, Scrolls, Corners, etc., will be mailed free on receipt of \$1. Address Palm & Fechteler, 6 West 14th Street, New York.

Combination Roll and Rubber Co., 68 Warren street, N. Y. Winger Rolls and Moulded Goods Specialties.

Pure Water furnished Cities, Paper Mills, Laundries, Steam Boilers, etc., by the Multifold System of the Newark Filtering Co., 177 Commerce St., Newark, N. J.

Steel Stamps and Pattern Letters. The best made. J. F. W. Dorman, 21 German St., Baltimore. Catalogue free. For Power & Economy, Alcott's Turbine, Mt. Holly, N. J. Presses, Dies, Tools for working Sheet Metals, etc. Fruit and other Can Tools. E. W. Bliss, Brooklyn, N. Y. Presses & Dies (fruit cans) Ayar Mach. Wks., Salem, N. J. Split Pulleys at low prices, and of same strength and appearance as Whole Pulleys. Yocom & Son's Shafting Works, Drinker St., Philadelphia, Pa.

Supplement Catalogue.—Persons in pursuit of information on any special engineering, mechanical, or scientific subject, can have catalogue of contents of the SCIENTIFIC AMERICAN SUPPLEMENT sent to them free. The SUPPLEMENT contains lengthy articles embracing the whole range of engineering, mechanics, and physical science. Address Munn & Co., Publishers, New York.

Machinery for Light Manufacturing, on hand and built to order. E. E. Garvin & Co., 139 Center St., N. Y. Wood-Working Machinery of Improved Design and Workmanship. Cordeman, Egan & Co., Cincinnati, O. Presses & Dies. Ferracute Mach. Co., Bridgeton, N. J.

**Notes & Queries**

**HINTS TO CORRESPONDENTS.**

No attention will be paid to communications unless accompanied with the full name and address of the writer.

Names and addresses of correspondents will not be given to inquirers.

We renew our request that correspondents, in referring to former answers or articles, will be kind enough to name the date of the paper and the page, or the number of the question.

Correspondents whose inquiries do not appear after a reasonable time should repeat them. If not then published, they may conclude that, for good reasons, the Editor declines them.

Persons desiring special information which is purely of a personal character, and not of general interest, should remit from \$1 to \$5, according to the subject, as we cannot be expected to spend time and labor to obtain such information without remuneration.

Any numbers of the SCIENTIFIC AMERICAN SUPPLEMENT referred to in these columns may be had at this office. Price 10 cents each.

Correspondents sending samples of minerals, etc., for examination, should be careful to distinctly mark or label their specimens so as to avoid error in their identification.

(1) B. D. V. R. writes: 1. How can I make a copying ink that can be copied thirty days after writing? A. See, “Inks” SUPPLEMENT, No. 157. 2. How are erasing tablets for lead pencil made? A. They are merely more or less vulcanized gum rubber and moulded into shape. 3. How are aniline leads made? A. See SCIENTIFIC AMERICAN SUPPLEMENT, 186, under “Colored Pencils.” 4. How large should be the reservoirs in the acetate of soda stove described in the SCIENTIFIC AMERICAN, vol. xlvi., No. 3, page 40, to warm a common sized bedroom? How much of each of the soda salts will it require to properly fill the three reservoirs? How long will they require boiling to be melted? A. About 2 ft. 8 in. in height. 1 pound hyposulphite of soda and 10 pounds acetate of soda. Twenty or thirty minutes at a good heat.

(2) L. B. S. asks by what means the crystallized tin used for covering trunks is prepared, how the crystals are produced, and by what the varnishes are colored. A. The crystalline effect may be produced by dipping it into a bath of equal parts muriatic and nitric acids, and 5 parts of water, and quickly rinsing off with hot water. Ordinary transparent colors are mixed with the varnish.

(3) C. B. D. asks: 1. What quantities respectively of nitrate of lead and chloride of sodium must I use to make a saturated solution of chloride of lead in one gallon of water? A. Lead chloride (PbCl<sub>2</sub>) may be prepared by precipitating a solution to contain 65 ounces. If both salts are quite pure, 23½ parts (by weight) of sodium chloride will precipitate 65 parts of lead nitrate, yielding 55½ parts dry lead chloride. Lead chloride is scarcely at all soluble in cold water at 60° Fahr. A gallon of water will not hold more than one-quarter ounce of the substance. It dissolves in hot water readily, but crystallizes out again as the water cools. 2. Is such a solution an efficient disinfectant for water closets? A. When used as a disinfectant in closets, etc., the salt may be mixed with or suspended in water (half a pound to the gallon), but it is better to use the hot solution. Lead chloride is an excellent disinfectant. It absorbs or neutralizes various organic nitrogenous and ammoniacal vapors and sulphureted hydrogen.

(4) E. B. asks: Is there a simple test to determine whether the air of an apartment contains sewer gas? A. Saturate unglazed paper with a solution of one ounce of pure lead acetate in half a pint of rain water; let it partially dry, then expose in the room suspected of containing sewer gas. The presence of the latter in any considerable quantity soon darkens or blackens the test paper.

(5) J. Z. & Co. write: 1. We tried your ebony receipt, “hot solution of logwood and cold solution of sulphate of iron.” But we cannot put fine carvings where there are more or less glued parts on it, in the solution; therefore we would like to know of an ebony stain which could be applied with a small brush. If you know of one please state it. A. Have the work smooth and free from holes. Dissolve in one quart of hot water about one-half ounce of ordinary logwood, and add to it two ounces of sulphate of iron (copperas) previously dissolved in half pint of water; mix well and apply to the wood hot with a brush. Digest two pounds of iron filings with a pint of good vinegar for several days, draw off the liquid, and when the work treated as above is dry, go over the surface again with this liquid. Dry again, sandpaper smooth, oil, and fill in with powdered drop black in the filler. Use a quick drying varnish, and rub down smooth with pumice. 2. Please give us

a receipt to make a good polish to polish walking canes and other hard wood, also wood carvings. State how it shall be used. A. The following process gives the most satisfactory and hardest finished surface: Fill with best clear filler or with shellac; dry by heat; rub down with pumice stone; then put on three coats of clear spirit copal varnish, hardening each in an oven at a temperature as hot as the wood and gum will safely stand. For extra work the two first coats may be rubbed down and the last allowed a flowing coat. For colored grounds alcoholic shellac varnish with any suitable pigment (very finely ground in) can generally be used to advantage.

(6) C. T. E. asks whether and in what rubber can be dissolved. A. Unvulcanized rubber dissolves in bisulphide of carbon or warm naphtha. For common vulcanized rubber we know of no good solvent.

(7) H. M. R. asks: Can you tell me how to prepare a paint which will adhere to my galvanized iron tank and not crack off? A. Heat asphaltum to boiling in a capacious iron vessel for eight hours, then add one-sixth its weight of boiled linseed oil, and one-twentieth its weight of well calcined copperas. Stir well together for half an hour or more; then remove out of doors (away from fire), let it cool a little, and stir in enough oil of turpentine to reduce it to proper consistency for use with the brush.

(8) W. A. H. asks: 1. If such were possible, how far need a body go above the earth before the earth would cease to attract it? A. Theoretically every particle of matter in the universe is attracted by the earth. 2. Is that point above the atmosphere, and what distance? A. At any point within our atmosphere the earth's attraction preponderates. 3. Would a body which would get outside the earth's attraction be attracted by some other planet? A. A body cannot get beyond the earth's attraction. Whether it is attracted most by the earth or some other body will depend upon relative proximity.

(9) C. A. B. asks: 1. Is it unsafe in a dwelling house to have the pipes from hot air furnace near to or in contact with woodwork? A. It is not considered safe to let the hot air pipes touch any wood work; two inches clearance is generally allowed here. Registers on lower floors should have iron or soapstone frames, so as to keep the pipes clear from the floors. The smoke pipe should be at least one foot clear of woodwork. In steam heating apparatus, it is not so necessary to have a clearance around hot air pipes or rings around registers. But the smoke pipe should have nearly the same clearance as in hot air furnaces. 2. Is there any way to remove iron stains from marble without injury to the latter? A. Try oxalic acid. 3. I am making a cane from ebony; how shall I polish it? A. Varnish the cane with shellac and rub down with French polish.

MINERALS, ETC.—Specimens have been received from the following correspondents, and examined, with the results stated:

A. B.—It is chiefly iron sulphide—pyrites.—G. W.—It is galena, a sulphide of lead, and contains silver; if it occurs in any quantity an assay would be advisable.—E. L. D.—The yellow part is iron pyrites—of little or no value; the rest is quartz and limestone.—H. A. I.—It is a common clay slate, not what is sometimes called “blossom.” It cannot be strictly considered as an indication of coal.—J. W. J.—1. Is a mixture of mica albite and quartz, similar to many granites. 2. Are fossil belemnites. 3. Is a crystal of calcite, a carbonate of lime. 4. Fossil crinoid stems.—F. J. F.—No. 1. Galena, lead sulphide. Some of this ore may contain silver. No. 2. Silicious selvaige from lead ore vein.—J. V. McC.—It is sulphide of iron pyrites—of very little value.—C. V. K.—It is a piece of bitumen mixed with some iron pyrites.—Rev. H. C. S.—It is a nodule of partially altered iron pyrites; iron sulphide—not valuable.—E. W.—It is an impure silicious limestone. The bright particles are iron sulphide, of little value.—C. D. P.—It is gypsum-lime sulphate; when properly roasted it yields plaster of Paris.

[OFFICIAL.]

**INDEX OF INVENTIONS FOR WHICH Letters Patent of the United States were Granted in the Week Ending October 17, 1882, AND EACH BEARING THAT DATE.**

[Those marked (r) are reissued patents.]

A printed copy of the specification and drawing of any patent in the annexed list, also of any patent issued since 1866, will be furnished from this office for 25 cents. In ordering please state the number and date of the patent desired and remit to Munn & Co., 261 Broadway, corner of Warren Street, New York city. We also furnish copies of patents granted prior to 1866; but at increased cost, as the specifications not being printed, must be copied by hand.

- Alarm. See Burglar alarm.
- Bar. See Sewing machine needle bar.
- Basins, etc., trap and overflow stop for wash, W. D. Schuyler. . . . . 266,208
- Battery. See Galvanic battery. Secondary battery.
- Bed bottom. S. H. Reeves. . . . . 266,200
- Bed, spring, I. & E. Purcell. . . . . 266,197
- Beehive, J. W. Sillcott. . . . . 266,059
- Binder. See Grain binder.
- Blackboard and support, G. Elsey . . . . . 266,118
- Boat detaching apparatus, Hill & Clark. . . . . 266,150
- Boiler furnace, J. Collis. . . . . 265,945
- Boiler furnace and attachment, R. R. Zell. . . . . 266,249
- Boiler tube, steam, G. S. Strong. . . . . 266,220
- Bolt cleaner, H. C. McKeen. . . . . 266,177
- Book, copying, J. L. O'Connor. . . . . 266,189
- Book covers, protector for the edges of, A. L. Clark. . . . . 266,098
- Book, letter copying, G. C. Lipman. . . . . 266,169
- Book support, F. Schubert . . . . . 266,209
- Boot or shoe sole, device for holding back the channel lip of, G. W. Day. . . . . 266,018
- Boring machine, rock, W. Hasenzahl. . . . . 266,140
- Bottling machine, J. W. Chewning. . . . . 266,095
- Brake. See Car brake.
- Brick for building arches and furnace roofs, W. G. Bell . . . . . 266,010
- Brick, furnace linings, etc., compound for fire, J. Henderson. . . . . 265,961
- Brick machine, Collinge & Serfass. . . . . 266,100
- Bucket, dinner, W. H. Etz. . . . . 266,122
- Bucket elevator, J. Boardman. . . . . 266,082
- Buckle, G. P. Edney. . . . . 266,023
- Buckle, W. A. Fisher. . . . . 266,125
- Buckle, trace, H. J. Butler. . . . . 266,093
- Bung hole reamer, H. F. W. Buecker. . . . . 266,091
- Burglar alarm, Decker & Deming. . . . . 266,252
- Burner. See Vapor burner.
- Bustle, H. W. Moulton. . . . . 266,185
- Buttons to fabrics, connecting, J. B. Secor. . . . . 266,055
- Caloric compound, L. Roth. . . . . 266,205
- Camera attachment, E. R. Higgins. . . . . 266,035
- Can filling machine, V. Barker. . . . . 266,077
- Can jacket, I. Sexton . . . . . 266,211
- Candy making machine, H. Maillard. . . . . 265,970
- Cane and fan, combined, W. H. Fuller. . . . . 265,955
- Car brake, H. Barratt. . . . . 266,260
- Car coupling, N. M. Hale. . . . . 266,138
- Car coupling, Owen & Snider. . . . . 265,977
- Car coupling, Roberts & Duane. . . . . 266,202
- Car, hand, G. S. Sheffield. . . . . 265,987
- Car, stock, G. F. Oehrl. . . . . 266,190
- Car wheel, E. E. Josef . . . . . 265,955
- Car wheel, F. H. Smith. . . . . 266,061
- Carriage top joint, N. L. Fox. . . . . 265,952
- Carriage trimming, J. Irving. . . . . 266,158
- Castings, cements, lead pencils, etc., production of materials for, J. J. Sachs . . . . . 266,053
- Chain, wire, E. G. Burt . . . . . 265,943
- Check row lines, anchor for, J. E. Bering. . . . . 266,250
- Chenille, manufacturing, G. F. Hensel. . . . . 266,147
- Chopper. See Meat and vegetable chopper.
- Chronograph, J. Karr . . . . . 266,162
- Chuck, adjustable bit and drill, G. H. Summers. . . . . 265,990
- Churn, J. H. Dunbar . . . . . 266,252
- Churn, R. Gardner. . . . . 266,128
- Churn, F. P. Stebbins. . . . . 266,219
- Churn dasher, A. J. Blackman. . . . . 266,011
- Cigar machine, G. D. Elges . . . . . 266,024
- Cleaner. See Bolt cleaner.
- Clothes drier, J. H. McCanna. . . . . 266,040
- Club foot apparatus, J. Burns . . . . . 265,942
- Clutch for throttle valves, friction, E. K. Trammell. . . . . 266,224
- Clutch, friction, D. Frisbie. . . . . 265,933
- Clutch, friction, H. James. . . . . 266,159
- Cock, C. H. Goodrich . . . . . 266,132
- Cock, steam gauge, M. D. L. Swank et al. . . . . 265,992
- Collar pad, horse, A. H. Fetty . . . . . 266,255
- Corkscrew, G. W. Griswold. . . . . 266,135
- Corkscrews to bottles, attaching, H. W. Simms. . . . . 266,060
- Corn sheller, E. E. Towns. . . . . 265,998
- Corset, J. D. Banfield . . . . . 266,088
- Corset forming and shaping apparatus, J. A. House. . . . . 265,963
- Cotton cleaning machine, J. F. Cunningham, Sr. . . . . 266,106
- Cotton tie, pivot, J. W. Brown . . . . . 266,085
- Coupling. See Car coupling.
- Cultivator, J. Q. Adams . . . . . 266,066
- Cultivator, W. Evans . . . . . 266,123
- Cultivator, W. H. West. . . . . 266,238
- Cultivator and cotton chopper, M. H. Keys. . . . . 265,988
- Cultivator, wheeled, W. P. Brown. . . . . 266,086
- Cup. See Lubricating cup.
- Curtain fixture, P. Osgood . . . . . 266,191
- Curtain rod holder, R. S. Gould. . . . . 266,028
- Cutlery, manufacture of, G. L. Hart . . . . . 265,959
- Cutter. See Fish cutter.
- Damper, stovepipe, W. E. Quiggle . . . . . 265,982
- Dental plugger, B. Fitts. . . . . 265,950
- Disintegrating machine for jute, etc., F. Luft. . . . . 266,038
- Door, grain, J. Brenzel . . . . . 266,084
- Drawing table, E. C. Cleaves . . . . . 266,099
- Drier. See Clothes drier.
- Drying calico, machine for, F. J. Crowley. . . . . 266,104
- Eaves trough hanger, C. L. Pierpont. . . . . 265,981
- Electric arc light, E. Thomson . . . . . 265,993
- Electric circuits, cut-out for, E. Weston. . . . . 269,241
- Electric conductors, conduit for underground, W. Mackintosh. . . . . 266,171
- Electric machine, dynamo or magneto, E. Weston . . . . . 266,243
- Electrical indicator, E. Weston. . . . . 266,244
- Electrical transmission of power, system for the, E. Weston . . . . . 266,239
- Elevator. See Bucket elevator. Hay elevator. Hydraulic elevator.
- Elevator safety attachment, D. Frisbie. . . . . 265,954
- Elevators, electric safety device for, R. M. Curtis. . . . . 266,107
- End gate, wagon, F. Ball. . . . . 266,076
- Evaporating or concentrating liquids and saturating liquids with gases, apparatus for, F. B. Nichols . . . . . 265,974
- Evaporator, J. C. Henderson . . . . . 266,148
- Fabrics, machine for crimping and preparing elastic, T. H. Ball. . . . . 266,074
- Fan wheel, W. Schmolz. . . . . 265,984
- Feathers, machine for cutting the shafts or stems of, Morris & Westerman. . . . . 266,259
- Feeder for revolving cylinders, E. S. Bennett. . . . . 266,080
- Fence machine, wire, J. Ash . . . . . 266,072
- Fence post, D. W. Copeland. . . . . 266,261
- Fences, metallic post for wire, T. J. Smith . . . . . 265,989
- Fibers of plants, machinery for preparing, P. A. Favier . . . . . 266,124
- File blanks and apparatus therefor, forming teeth upon, W. T. Nicholson. . . . . 265,975
- File blanks, machine for forming teeth upon, W. T. Nicholson . . . . . 265,976
- Firearm, breech-loading, H. R. Granger. . . . . 266,133
- Firearm lock, A. E. Whitmore. . . . . 266,245
- Firearm sight, H. Rowell. . . . . 266,206
- Fire escape, E. J. Moore. . . . . 266,188
- Fire escape, C. F. Spencer . . . . . 266,062
- Fire extinguisher, automatic, O. C. Heath. . . . . 266,142
- Fish cutter, J. B. Grady . . . . . 266,151
- Folding seat for theaters, Underhill & Lake. . . . . 266,226
- Fuel, artificial, G. F. Brott . . . . . 266,038
- Furnace. See Boiler furnace.
- Furnace lining, J. Henderson . . . . . 265,962
- Furnace linings and fire brick, compound for, J. Henderson. . . . . 266,143, 266,146
- Furnace linings and fire brick, manufacture of compounds for, J. Henderson. . . . . 266,144, 266,145
- Gauge. See Railway track gauge.
- Gauge, M. Merz. . . . . 266,042
- Galvanic battery, portable, C. Gibbs . . . . . 266,129
- Gas burners, shield for protecting taper flame of, W. D. Schooley . . . . . 266,210
- Gate. See End gate.
- Gate, E. M. Cass. . . . . 266,094
- Generator. See Steam generator.
- Glass furnaces, water-jacketed eye plate for, S. M. Kane. . . . . 265,967

Glass pot and fore-plate for same, S. M. Kane 265,966
Governor, engine, L. Skinner 266,214
Grain binder, R. Brown 266,087
Rubber binder, C. Wheeler, Jr. 266,001
Grain binders combined needle arm and compressor for, J. L. Owens 265,978
Grain binders, wire twister for, M. M. Hooton 266,153
Grain binding machine, G. Esterly 266,254
Grain mills, etc., feeding apparatus for, Hurt & Strathern 266,157
Grain separator, F. W. Howell 266,258
Grain ventilators, entrance tube for, L. T. Bow 266,083
Grate or fireplace, domestic, C. W. Siemens 266,213
Grinding mill, J. H. Ehle 266,116
Grinding mill, A. Montgomery 266,182
Grinding mill, E. Tush 266,225
Guard. See Railway safety guard.
Hammer, claw, H. D. Morris 266,045
Hammock, invalid, A. Leslie 266,167
Hanger. See Eaves trough hanger.
Harrow tooth fastening, D. C. Hartung 265,960
Harvester rakes, automatic trip for, O. O. Storie 266,063
Harvester, sugar cane and maize, W. C. Dollens 266,020
Hay and stock rack, combined, J. L. Owens 265,979
Hay elevator and stacker, P. F. Chambard 265,944
Hoisting machine, A. Hendey 266,149
Holdback, vehicle, O. V. Price 266,049
Holder. See Curtain rod holder. Lamp shade holder. Spool and thimble holder.
Horse boot, J. E. Watson 266,238
Horse detacher, J. H. Middleton 266,179
Horseshoes, device for forming calks on, W. K. Harrell 266,139
Hub, vehicle, D. May 266,175
Hub, vehicle wheel, T. S. N. Brown 266,251
Hydraulic elevator, Curtis & Wheeler 266,108
Ice creeper, G. Hancock 266,082
Indicator. See Electrical indicator.
Injector for furnaces, air, Davis & Walker 266,109
Inkstand, C. De Roberts 266,111
Joint. See Carriage top joint. Lightning rod joint. Pipe joint.
Knob and rosette attachment, F. J. Harper 266,033
Lamp, electric, E. Weston 266,242
Lamp, electric arc, O. Kartzmark 266,161
Lamp, electric arc, E. Weston 266,240
Lampshade holder, C. Petsch 266,048
Lamps, carbon holder for arc, A. G. Waterhouse 266,236
Lamps, device for suspending arc, A. G. Waterhouse 266,234
Lamps, manufacture of incandescent, electric, J. V. Nichols 266,187
Land roller, R. A. Horning 266,155
Latch, locking, J. Loch 266,170
Lead, preparing peroxide of, A. K. Eaton 266,115
Leather cutting machine, R. S. Allen 266,004
Lifter. See Track lifter.
Light. See Electric arc light.
Lightning rod joint or coupling, C. E. Ball 266,075
Liquids, process of and apparatus for clarifying, C. H. Roekner 266,204
Lock. See Firearm lock. Nut lock.
Locomotive driving gear, W. Crippen 266,103
Loom stop motion, F. O. Tucker 265,997
Loom weft stop motion, Estes & Shorey 265,948
Lubricating cup, automatic, W. R. Michener 266,178
Lubricator, C. W. Sherburne 266,058
Magneto or dynamo electric machine, A. G. Waterhouse 266,235
Meat and vegetable chopper, L. Haas 266,030
Middlings purifiers, etc., feed mechanism for, H. O. Stahley 266,218
Mill. See Grinding mill. Roller mill. Windmill.
Mortising machine, L. Houston 266,156
Mosaic plates, manufacturing, R. W. Eltzner 266,025
Muff, S. A. Cunningham 266,105
Musical instrument, mechanical, O. H. Arno 266,071
Musical instrument, mechanical, G. W. Ingalls 266,086
Musical instruments, stand for supporting, A. Warner 266,231
Nut lock, W. C. Ladd 266,165
Nut lock, W. P. Miller 266,180
Oiler, E. J. Wells 266,237
Organ pipe, W. L. Merrin 266,973
Packing, rod, W. Haas 266,031
Pad. See Collar pad. Truss pad, Pan. See Warming pan.
Pantaloons and trousers, C. H. Ryno 265,983
Paper box basket, C. R. Seabury 265,985
Paris green and fertilizer distributor, B. F. Muschert 266,186
Pattern draught, J. L. Groves 266,137
Pen, fountain, P. E. Wirt 266,247
Pen, stylographic fountain, Sutherland & Brown 266,064
Percolator, J. Berry 266,081
Photographic camera screen, G. F. E. Pearsall 266,980
Pick, miner's, W. H. Sheneman 266,057
Pill, plaster, and lozenge machine, W. C. Francis 266,127
Pipe. See Organ pipe.
Pipe joint, sheet metal, J. Y. Cooper 266,017
Planter check rower, corn, S. R. Allee 266,067
Planter, corn, A. C. Evans 265,949
Planter, cotton seed, T. P. Hopper 266,154
Planter, seed, J. H. Morgan 266,184
Planters, fertilizer attachment and insect exterminator for corn, M. L. Lane 266,037
Planters, self-dropping and check rowing attachment to corn, A. Johnson 265,964
Plow, E. J. Etzler 266,121
Plow, K. Kellogg 266,164
Plow running gear, steam, J. M. Gardner 265,956
Post. See Fence post.
Pot. See Glass pot.
Pressing plastic or other conditioned material
I. to blocks, machine for, G. F. Brot 266,013
Projectile, fine throwing, Lyon & Gordon 265,969
Pump, S. S. Andrews 266,070
Pump, J. P. Ellacott 266,117
Pump, D. E. Washburn 266,232
Pump, beer, J. Fowler 266,126
Pump, rotary, W. N. De Groat 266,019
Pumping engine, steam, W. M. Ferry 266,026
Quarrier and stone shaper, rotary, Crump & Brereton 265,946
Rack. See Hay and stock rack.
Railway apparatus, cable, C. W. Rasmusen 266,198
Railway grips, device for operating cable, A. Grütter 266,029
Railway safety guard, P. F. Given 265,958
Railway signal, J. A. I. Claudon 266,097
Railway signal, J. M. Kelly 266,163
Railway signal, magneto-electric, W. W. Gary 266,027
Railway switch signal, A. H. Baker (r) 10,217
Railway track gauge and level, F. A. Watson 265,999
Razor, E. Heberer 266,034
Reamer, G. R. Valentine 265,998
Reflector, car, C. Robinson 266,203
Refrigerating apparatus, D. D. Johnson 266,160
Regulator. See Watch regulator.
Remedy for corns, bunions, etc., Benkert & Marini 266,079

Roller. See Land roller.
Roller mill, N. W. Holt 266,152
Roofing composition, D. H. Priest 266,196
Rubber, vulcanizing India, H. M. F. J. & A. M. A. De la Tour du Breuil 266,110
Sand paper, manufacture of, C. Baeder 265,940
Sash fastener, J. K. Foss 265,951
Saw, E. C. Atkins 266,006
Sawmill feed mechanism, G. H. Zschech 266,003
Saw set and gummer, combined, E. A. Parks 266,192
Scale for shafting power, J. Emerson 266,120
Scale power, J. Emerson 266,119
Scouring, dyeing, and washing piece goods, apparatus for, Worrall & Kershaw 266,248
Scow, dumping, F. E. Sickels 266,212
Screen. See Photographic camera screen. Window screen.
Screen, N. W. Godfrey 266,130
Secondary batteries, plate for, Maloney & Koyl 266,172
Secondary battery, C. F. Brush 266,090
Secondary battery, A. K. Eaton 266,114
Secondary battery, W. A. Shaw 266,262
Secondary or storage battery element, C. F. Brush 266,089
Separator. See Grain separator. Starch separator.
Sewing machine, buttonhole, D. Mills 266,044, 266,181
Sewing machine buttonhole attachment, J. S. Sackett 266,054
Sewing machine needle bar, R. Rainforth 266,050
Sewing machine shuttle, Choquette & Wallerman 266,096
Sewing machine shuttle, McIntire & Bartholomew 266,041
Sewing machine trimming mechanism, T. Briggs 266,012
Sheep holding device, C. B. Cook 266,016
Sheller. See Corn sheller.
Shingle marking machine, H. E. Marchand 266,173
Ships, bilge water valve for, H. Cordes 266,102
Shirt, P. E. Dubreuil 266,112, 266,113
Signal. See Railway signal. Railway switch signal.
Signaling mechanism, A. & E. F. Webster 266,000
Skate, roller, G. L. Witsil 266,002
Skylight and ventilator, W. Conolly 266,015
Smoker's implement, J. Badger 266,007
Soap, liquid, J. Scharr 266,207
Sodawater receivers and generators, agitator for, J. Matthews 266,039
Sole burnishing machine, M. Dudley 265,947
Sole edge trimmer, Hanson & Dunham 266,257
Spar and sail, H. Tudor 266,065
Spool and thimble holder and thread cutter, combined, A. M. Barrett 266,009
Spring. See Vehicle spring.
Stamp, perforating hand, G. W. Le Vin 266,168
Staple and lock for bag frames, O. Reinchenbach 266,201
Starch separator, P. H. Grimm 266,136
Steam engines, eccentric for, J. W. Thompson 265,994
Steam generator, W. & J. Beesley 266,078
Steam heat and power distributing apparatus, E. F. Osborne 266,046
Stone breaker and crusher, P. W. Gates 265,957
Stove back, W. Schenck (r) 10,318
Stove back lining, W. Allen 266,005
Stove, hay and straw burning, H. Gohrman 266,131
Stove lid and lifter, R. P. Pearson 266,194
Stove, sad iron oil, A. Velguth 266,227
Table. See Drawing table.
Tag, pin, T. W. Searing 265,964
Tanning apparatus, W. Masek 266,176
Tapping mains, device for, G. Richardson 266,052
Telegraph, printing, W. J. McCausland 266,176
Telephone, T. A. Edison 266,021, 266,022
Telephone circuit and apparatus, W. D. McKinney 265,972
Telephone exchange, mechanical, G. F. Shaver 266,056
Telephonic transmitter, G. F. Milliken 266,043
Tie. See Cotton tie.
Toilet implement, combination, A. M. Austin 266,073
Tool, combination, E. A. Parks 266,193
Track lifter and holder, A. C. Phillips 266,195
Trimmer. See Sole edge trimmer.
Truck for moving reapers, O. H. P. Shroyer 265,988
Truss, F. R. Smith 266,215
Truss pad, Norris & Sweet 266,188
Tube. See Boiler tube. Wick tube.
Valve, balanced, Alter & Irvin 266,068
Valve, balanced throttle, Swank & Thornley 265,991
Valve gear, J. Haug 266,141
Valve, steam engine, E. A. Sperry 266,217
Vapor burner, F. M. Campbell 266,014
Vehicle spring, J. G. Parsons 266,047
Vehicle tops, combined fastening and nut lock for, S. H. Raymond 266,199
Velocipede, B. F. Trell 265,996
Wagon running gear, M. Conrad 266,101
Warming pan, E. M. Ames 266,069
Warping machine, W. Bancroft 265,941
Washing machine, J. E. Hobby 266,151
Watch regulator, F. C. Gould 266,256
Water closet cistern, S. F. Sniffen 266,216
Water wheel gates, operating, J. McCoid 265,971
Waterproofing compound or paint, J. A. Titzel 266,228
Wheel. See Car wheel. Fan wheel.
Whip and cane, combined, T. R. Lawhead 266,166
Wick tube for lamp burners, removable, J. Sweeney 266,221
Windmill, D. M. Reed 266,051
Window screen, H. E. Willer 266,246
Wood, preservation of, R. G. Bürstenbinder 266,092

DESIGNS.

Carpet, A. L. Halliday 13,338, 13,339
Carpet, H. Wertz 13,341
Cigar lighter, G. Fuchs 13,337
Coffee-pot, earthenware, D. E. McNicol 13,340

TRADE MARKS.

Cigars, H. R. Kelly & Co 9,731
Cleaning garments, fabrics, silverware, etc., preparation for, Bean & Rabe 9,723
Insect destroying powder, G. N. Milco 9,734
Medical compound, certain, Burroughs, Wellcome & Co 9,725
Medical compounds, certain, Burroughs, Wellcome & Co 9,724
Medicinal bitters, S. R. Adams 9,722
Medicinal food products, compounds, or substances, Reed & Carnrick 9,740
Peaches, Homer & Masheter 9,728
Perfumes, Sharpless & Sons 9,738
Powder to be taken internally, R., F. E., & J. A. Greene 9,727
Prints, labels, showcards, calendars, printed cards and tags, Schumacher & Ettlinger 9,737
Shirts, L. Levi 9,733
Tobacco and cigars and fine-cut chewing tobacco, smoking, C. B. Hull 9,729

Tobacco, chewing and smoking, Salmon, Hancock & Co 9,739
Toilet vinegar, A. & M. Landon 9,732
Tooth and mouth wash, Johnson & Lund 9,730
Whisky, F. J. Crilly 9,726
Wine, port, Morgan Bros 9,735, 9,736

English Patents Issued to Americans.

From September 29 to October 3, 1882, inclusive.
Alloys, decomposing, H. R. Cassel, New York city.
Axle for road vehicles, J. H. Hnyler, Tenafly, N. J.
Bottle stopper, A. Thompson, Brooklyn, N. Y.
Cable for hauling tramways, S. H. Terry, Guthrie, Mo.
Car wheel, G. W. Fairman, New York city.
Corset busks and clasps, Catharine A. Adams, Asheville, N. C.
Dredging bucket, W. H. Wood, New York city.
Electric meter, S. D. Mott, New York city.
Fiber treating machinery, Sanford Universal Fiber Co., New York city.
Furnace lining, C. G. Francklyn, New York city.
Locomotive brake, S. C. Sloan, New York city.
Loom, J. Wade, New York city.
Nut lock, W. Mack et al., Vigo, Ind.
Picture hanger, H. R. Heyl, Philadelphia, Pa.
Power transmission of, J. D. Wright, Worcester, Mass.
Pump, F. M. Root, Connersville, Ind.
Punch, metal, E. A. Bailey et al., Washington, D. C.
Safety hooks for harness traces, W. K. Rairigh, St. Petersburg, Pa.
Steam engine, T. A. Edison, Menlo Park, N. J.
Steam generator, M. M. Monsanto et al., New York city.

Advertisements.

Inside Page, each insertion --- 75 cents a line.
Back Page, each insertion --- \$1.00 a line.
(About eight words to a line.)
Engravings may head advertisements at the same rate per line, by measurement, as the letter press. Advertisements must be received at publication office as early as Thursday morning to appear in next issue.

SUPERIORITY PROVED
THE SIMPLEST & BEST SEWING MACHINE IS THE
LIGHT-RUNNING
NEW HOME
Perfect in every particular. 200,000 sold yearly.
NEW HOME SEWING MACHINE CO.,
30 Union Square, N. Y.
Chicago, Ill., Orange, Mass., or Atlanta, Ga.

MACHINE TOOLS.
We now have in stock, ready for instant delivery, part at our N. Y. Warehouses and a portion at our Works, Manchester, N. H., the following new Machine Tools, which we offer at the below-named exceptional prices, all modern, latest patterns, lathes screw cutting, rod feed, power cross feed, 20 in. and under, with hollow spindle, 14 and 16 ft. x 26 in., with compound rest, viz.:
ENGINE LATHES.
Two 16 ft. x 26 in., \$785 ea.; three 14 ft. x 26 in., \$750 ea.; one 16 ft. x 30 in., compound rest, \$322; two 10 ft. x 20 in., \$419 ea.; two 8 ft. x 20 in., \$425 ea.; one 12 ft. x 18 in., compound rest, \$455; two 12 ft. x 18 in., \$435 ea.; two 10 ft. x 18 in., \$415 ea.; three 8 ft. x 18 in., \$335 ea.; three 6 ft. x 18 in., \$375 ea.; one 7 ft. x 17 in., \$359; one 6 ft. x 17 in., \$350.

DRILL PRESSES.
Two 32 in. back geared and self-feed, \$365 ea.; one 30 in. back geared, \$325; two 28 in. back geared, \$280 ea.; two 24 in., \$185 ea.; three 20 in., \$150 ea.; two 18 in., \$110 ea.
IRON PLANERS.
7 ft. x 32 in. x 25 in., \$775; 4 1/2 ft. x 2 1/2 ft. sq., \$575; 4 ft. x 24 in. sq., \$500.
Heavy Combined Punch and Shear, \$950. 15 in. Shaper, \$450. 6 in. Shaper, \$385. Milling Machine, \$325. 25 in. Radial Drill, \$750. No. 1 7-spindle Durrell Nut Tapper, \$800. No. 2 7-spindle Durrell Nut Tapper, \$850.
In addition, we have an immense assortment of new and second-hand Machine Tools, Engines, Boilers, and Pumps, Woodworking and General Machinery, fully described in our catalogues No. 29, 30, and 31, which we mail free on application, S. C. FORTSMITH & CO.,
Machinists and General Machine Dealers,
Manchester, N. H., and 209 Centre St., N. Y. City.

SCREW PROPULSION.—ABSTRACT OF
lecture by Robert Griffiths. The power actually required for propulsion. Experiments on screws. The cause of the vibration of screws. Proper position of the screw. Protection against fouling. Contained in SCIENTIFIC AMERICAN SUPPLEMENT, No. 349. Price 10 cents. To be had at this office and from all newsdealers.

PATENT EYE AND SPINDLE.
PORTABLE MILLS.
MUNSON BROTHERS,
MANUFACTURERS.
BUHR MILL STONES, MILL MACHINERY,
AND MILL FURNISHINGS.
UTICA N.Y. U.S.A.

LOCOMOTIVES.—PERSPECTIVE AND
detail views of the powerful class of locomotives constructed by the Lehigh Valley Railroad Co., with weights and dimensions. Contained in SCIENTIFIC AMERICAN SUPPLEMENT, No. 347. Price 10 cents. To be had at this office and from all newsdealers.

ROD
HAMMERS
Punching Presses
DIES AND OTHER TOOLS.
SHEET METAL GOODS,
DIE FURNISHINGS, &c.
Stiles & Parker Press Co.,
Middletown, Conn.

SOME CHEMICAL REACTIONS.—
Simple methods by which the chemicals used in photography may be recognized without resort to qualitative analysis, should their labels become illegible. Contained in SCIENTIFIC AMERICAN SUPPLEMENT, No. 348. Price 10 cents. To be had at this office and from all newsdealers.

FEED WATER
PURIFIER
FOR STEAM BOILERS
U.S. & FOREIGN PATENTS

PROFESSORS AYRTON AND PERRY'S
Electric Railway.—With illustrations showing all the details connected with its working, and with portraits and brief biographies of Professors Ayrton and Perry, its inventors. Contained in SCIENTIFIC AMERICAN SUPPLEMENT, No. 345. Price 10 cents. To be had at this office and from all newsdealers.

GET THE BEST AND CHEAPEST.
TRADE MARK.
Silver Finish.
J. A. FAY & CO.,
(Cincinnati, Ohio, U. S. A.)
Exclusive Agents and Importers for the United States, of the
CELEBRATED
PERIN BAND SAW BLADES,
Warranted superior to all others in quality, finish, uniformity of temper, and general durability. One Perin Saw outwears three ordinary saws.

"Perhaps the most judiciously edited magazine in the world."—THE NATION, N. Y., Sept., 1882.

THE CENTURY
For November.

THE CENTURY begins its thirteenth year (the second under the new name) with a November number, of which

140,000 COPIES
have been printed. The issue contains some remarkable literary features, and many striking pictures. Among the contents are:

VENICE, by HENRY JAMES, JR.
A delightful and poetic paper, richly illustrated.

THE BEGINNING OF A NATION,
By EDWARD EGGLESTON. The first of an illustrated series of separate papers, the whole forming a History of Life in the Thirteen Colonies.

VICTOR HUGO, by ALPHONSE DAUDET.
Translated from the original French, which was written expressly for THE CENTURY.

THE CHRISTIAN LEAGUE OF CONNECTICUT.
By WASHINGTON GLADDEN. First paper in a series of great practical value to all Christian workers, showing how a league of churches of various denominations was formed in a Connecticut town, what kinds of work it attempted, and what it did not attempt, and how it spread throughout the whole State. The story is the outcome of much study, and is likely to have important results.

"THE LED-HORSE CLAIM."
Opening chapters of a novelette of mining life, by MARY HALLOCK FOOTE, illustrated by the author.

ENGLAND, by CHARLES DUDLEY WARNER.
An interesting essay on the position of England.

HENRY JAMES, JR., by W. D. HOWELLS.
With a full-page portrait of Mr. JAMES.

A NEW PROFESSION FOR WOMEN.
The training-school for nurses at Bellevue Hospital, with a portrait of Florence Nightingale.

THE LADY, OR THE TIGER?
A droll short story by FRANK R. STOCKTON.

THE OTHER CONTENTS
Include a powerful essay, "Is the Jury System a Failure?" by Albert Stickney, author of "A True Republic;" a finely illustrated paper on the Sculptures of the recently discovered Great Pergamon Altar (mentioned in the Revelation as the throne of Satan); a full-page picture engraved direct from nature; poems by T. W. Higginson, "H. H.," R. W. Gilder, and others; a satire in verse, "Narcissus in Camden;" album verses by Browning and Longfellow not before published; interesting departments, etc., etc.

The subscription price is \$4.00 a year; 35 cents a number. Subscriptions should begin with this number, and to enable new subscribers to commence with the new series under THE CENTURY name, we make the following

SPECIAL OFFER.
A year's subscription from Nov., 1882, and the twelve numbers of the past year, unbound, \$6.00. A subscription and the twelve back numbers bound in two elegant volumes with gilt top, \$7.50.

THE CENTURY CO., NEW-YORK, N. Y.

DEAFENING
FIRE AND VERMIN
PROOF
Sample and Circular Free by mail.
U. S. MINERAL WOOL CO., 22 Courtlandt St., N. Y.

PATENTS.

MESSRS. MUNN & CO., in connection with the publication of the SCIENTIFIC AMERICAN, continue to examine Improvements, and to act as Solicitors of Patents for Inventors.

In this line of business they have had thirty-five years' experience, and now have unequalled facilities for the preparation of Patent Drawings, Specifications, and the prosecution of Applications for Patents in the United States, Canada, and Foreign Countries. Messrs. Munn & Co. also attend to the preparation of Caveats, Copyrights for Books, Labels, Reissues, Assignments, and Reports on Infringements of Patents. All business intrusted to them is done with special care and promptness, on very reasonable terms.

A pamphlet sent free of charge, on application, containing full information about Patents and how to procure them; directions concerning Labels, Copyrights, Designs, Patents, Appeals, Reissues, Infringements, Assignments, Rejected Cases, Hints on the Sale of Patents, etc.

We also send, free of charge, a Synopsis of Foreign Patent Laws, showing the cost and method of securing patents in all the principal countries of the world.

MUNN & CO., Solicitors of Patents,
261 Broadway, New York.
BRANCH OFFICE—Corner of F and 7th Streets, Washington, D. C.



Founded by Mathew Carey, 1785.

# BAIRD'S BOOKS FOR PRACTICAL MEN.

LIST No. 7.

- Taylor.—Statistics of Coal. By R. C. Taylor. Five maps. 8vo. \$10 00
- Templeton.—The Practical Examiner on Steam and the Steam Engine. 12mo. \$1 25
- Thunusian.—The Theory and Practice of the Preparation of Malt and the Fabrication of Beer. Translated from the German, by W. T. Brant. Thoroughly and elaborately edited by A. Schwarz and Dr. A. H. Bauer. 40 illustrations. 8vo. \$15 pp. \$10 00
- Thomas.—The Modern Practice of Photography. By E. W. Thomas. 8vo. \$3 75
- Thompson.—Social Science and National Economy. By Rob't E. Thompson. M.A. 12mo. \$1 50
- Thomson.—Freight Charges Calculator. \$1 25
- Turner's (The) Companion. 12mo. \$1 25
- Turning.—Specimens of Fancy Turning executed on the Hand or Foot Lathe. By an Amateur. 30 illustrations. 4to. \$3 00
- Urbia-Brull.—A Practical Guide for Puddling Iron and Steel. Translated by A. A. Pesquet. 8vo. \$1 00
- Valle.—Galvanized Iron Cornice Worker's Manual. By Charles A. Valle. Illustrated. 4to. \$5 00
- Ville.—On Artificial Manures: their Chemical Selection and Scientific Application to Agriculture. With 31 engravings. 8vo. \$6 00
- Ville.—The School of Chemical Manures; or, Elementary Ideas on the Use of Fertilizing Agents. By A. A. Pesquet. 12mo. \$1 25
- Vogies.—The Architect's and Builder's Pocket Companion and Price Book. By F. W. Vogies. Cloth. \$1 50
- Fuchs. 8vo. \$3 00
- Ware.—The Coachmaker's Illustrated Handbook. Fully illustrated. 8vo. \$3 00
- Ware.—The Sugar Beet. Illustrated. 8vo. \$4 00
- Ware.—A Study of Various Sources of Sugar. 8vo. \$0 50
- Warn.—The Sheet Metal Worker's Instructor and Boiler Maker. By Reuben H. Warn. 32 plates, 37 wood cuts. 8vo. \$3 00
- Watson.—The Modern Practice of American Machinists and Engineers. By Egbert P. Watson. 86 wood cuts. 12mo. \$2 50
- Watson.—A Manual of the Hand Lathe. By Egbert P. Watson. 78 engravings. 12mo. \$1 50
- Watson.—The Theory and Practice of the Art of Weaving by Hand and Power. By John Watson. Plates. 8vo. \$7 50
- Weatherly.—Treatise on the Art of Boiling Sugar, Crystallizing, Lozenge Making, Comfits, Gum Goods, etc. 12mo. \$1 50
- Weinhold.—Introduction to Experimental Physics, Theoretical and Practical. Translated and Edited by Benjamin Loewy, F.R.A.S. Illustrated by 3 colored plates and 404 wood cuts. 8vo. \$6 00
- Wightwick.—Hints to Young Architects. Numerous wood cuts. 8vo. \$2 00
- Will.—Tables for Qualitative Chemical Analysis. Translated by Prof. Charles F. Himes. Third revised edition. 8vo. \$1 50
- Williams.—On Heat and Steam. By Chas. Wye Williams. Illustrated. 8vo. \$3 50
- Wilson.—Cotton Carder's Companion. 12mo. \$1 50
- Wilson.—First Principles of Political Economy. 12mo. \$1 50
- Wilson.—A Treatise on Steam Boilers: their Strength, Construction, and Economical Working. By Robert Wilson. 12mo. Cloth. Illustrated. \$2 50
- Wobler.—Handbook of Mineral Analysis. Edited by Prof. H. B. Nason. 12mo. \$3 00
- Worssam.—On Mechanical Saws. By S. W. Worssam, Jr. 18 large plates. 8vo. \$2 50

The above, or any of our Books, sent free of postage, at the publication prices, to any address in the world.

Our large Catalogue of Practical and Scientific Books—36 pages, 8vo.—together with our various other catalogues, the whole covering every branch of the literature of Science applied to the Arts, sent free, and free of postage, to any one, in any part of the world, who will furnish his address.

HENRY CAREY BAIRD & CO., Industrial Publishers, Booksellers, and Importers, 810 WALNUT STREET, PHILADELPHIA, PA.

**BLEACHING.—A LECTURE, BY DR. P. EBELL,** on peroxide of hydrogen as a means for bleaching, and its availability for technical, medicinal, and surgical purposes. A valuable paper. Contained in SCIENTIFIC AMERICAN SUPPLEMENT, No. 349. Price 10 cents. To be had at this office and from all newsdealers.

**"Moore County Grit" CORN MILLS** AND **Corn Mill Stones,** ALL SIZES. Best in the world. Samples of meal sent on application.

North Carolina Mill Stone Co., WESTMINSTER, MD.

**NEW INVENTIONS FOR SALE.** The advertiser, having become too old to introduce all his inventions himself, will sell some of the best at almost any price. One of the Cooper's Water Riser enables one man to lift 25 feet, each minute, a quantity of water too great to name here. Cost of machine about \$300. Address **JOHN LEE COOPER, Sonoma, Cal.**

**OWNERS OF PATENTS** of Metallic Goods, that wish to place orders for the manufacture of goods, Estimates free. Address **GEO. VAN SANDS, Middletown, Conn.**

**FOR SALE,** at Prince Arthur's Landing, Ontario, a full set of Reducing Machinery. Also two Boilers and Engine, with connections complete. Apply to **THOMAS MARKS & BRO.,** Prince Arthur's Landing, Ontario, Can.

**Automatic Flood Gates** prevent damage by freshets. Inquire of **NATH'L H. HICKLEY, Marston's Mills, Mass.**

Gold, Silver, and Nickel Plater wants Situation. 23 years' experience. Address **S. COWLES, Oakville, Conn.**

**NUT-BEARING TREES.**—BY **JAMES DOUGLASS.** An excellent practical paper. Contained in SCIENTIFIC AMERICAN SUPPLEMENT, No. 348. Price 10 cents. To be had at this office and from all newsdealers.

**CONSUMPTION.** I have a positive remedy for the above disease; by its use thousands of cases of the worst kind and of long standing have been cured. Indeed, so strong is my faith in its efficacy, that I will send TWO BOTTLES FREE, together with a VALUABLE TREATISE on this disease, to any sufferer. Give Express & P. O. address, **D. R. T. A. SLOCUM, 131 Pearl St., N. Y.**

**EMPIRE FORGES** Improved without Belts, Bellows, Crank Pins, Dead Centers, or Back Motion. Send for circular. **EMPIRE PORTABLE FORGE CO., COHOES, N. Y.**

**BUFFALO FORGE CO.** POWER & HAND BLOWERS. BUFFALO, N. Y.

**THE WATER-SOFTENING PROCESS.**—Brief explanation of the Atkins process of softening and purifying hard water in bulk. Contained in SCIENTIFIC AMERICAN SUPPLEMENT, No. 348. Price 10 cents. To be had at this office and from all newsdealers.

**NEW YORK BELTING AND PACKING COMPY.**  
The Oldest and Largest Manufacturers of the Original **SOLID VULCANITE EMEY WHEELS.**

All other kinds Imitations and Inferior. Our name is stamped in full upon all our standard BELTING, PACKING, and HOSE.

Address: **NEW YORK BELTING AND PACKING CO., 29 PARK ROW, NEW YORK.**

John H. Cheever, Treas.

**Special Notice.** Owing to the recent great fire in the "World" Building, our office has been removed as above.

**Patent Rights For Sale.**—The American Patent Rights of Coombe & Co.'s Sail Hank. The hank is extensively used by the British Admiralty and in the Mercantile Marine. Further particulars on application to **COOMBE & CO., 3 Fair View, Frammer, Cheshire, Eng.**

**GREAT WESTERN GUN WORKS,** Pittsburgh, Pa.

Write for Large Illustrated Catalogue. Rifles, Shot Guns, Revolvers, sent c. o. d. for examination.

**RUPTURE**

cured without an operation or the injury trusses inflict by Dr. J. A. SHERMAN'S method. Office, 251 Broadway, New York. His book, with Photographic likenesses of bad cases, before and after cure, mailed for 10c.

**\$66 a week in your own town.** Terms and \$5 outfit free. Address **H. HALLETT & Co., Portland, Me.**

**FIRE BRICK** TILE AND CLAY RETORTS ALL SHAPES. **BORGNER & O'BRIEN,** 23 RD ST. ABOVE RACE, PHILADELPHIA.

**CARDS** Send two 3c. stamps to C. Tollner, Jr., Brooklyn, N. Y., for a new set elegant Chromo Cards and Catalogue of Latest Designs for Fall and Winter.

**\$5 to \$20** per day at home. Samples worth \$5 free. Address **STINSON & Co., Portland, Me.**

**BIBB'S** Celebrated Original **BALTIMORE FIRE-PLACE HEATERS**

The warm upper and lower rooms. The handiest, most economical Coal Stoves in the world.

**B. C. BIBB & SON** Foundry, Office and Sale Rooms, 39 and 41 Light Street, Baltimore, Md. MARBLIZED SLATE MANTELS. Send for Circulars.

**WHAT WILL THE WEATHER BE TO-MORROW**

**Pool's Signal Service Barometer**

OR STORM GLASS AND THERMOMETER COMBINED, WILL TELL YOU!

It will detect and indicate correctly any change in the weather 12 to 48 hours in advance. It will tell what kind of storm is approaching, and from what direction—invaluable to navigators. Farmers can plan their work according to its predictions. Saves 50 times its cost in a single season. Has an accurate thermometer attached, which alone is worth the price of the combination. This great WEATHER INDICATOR is endorsed by the most eminent Physicians, Professors, and Scientific men of the day to be the BEST IN THE WORLD!

The Thermometer and Barometer are put in a nicely finished walnut frame, with silver plated trimmings, etc., making it a beautiful as well as useful ornament. We will send you a simple one, delivered free, to your place, in good order, on receipt of \$1, or six for \$4. Agents are making from \$5 to \$20 daily selling them. A trial will convince you. Order at once. It Sells at SIGHT! Just the thing to sell to farmers, merchants, etc. Invaluable to everybody. U. S. Postage stamps taken in if good order, but money preferred. Agents wanted everywhere. Send for Circular and terms. Address all orders to **OSWEGO THERMOMETER WORKS, (Largest establishment of the kind in the world) Oswego, Oswego Co., N. Y.**

We refer to the Mayor, Postmaster, County Clerk, First and Second National Banks, or any business house in Oswego, N. Y.

Write your Post Office, County and State plainly, and remit by money-order, draft on New York or registered letter, at our risk.

**This will make a Beautiful and Very Useful Present.**

**READ WHAT THE PUBLIC SAY ABOUT IT.** You can rely on it every time. CAPT. CHAS. B. ROGERS, Ship "Twilight," San Francisco. Barometer received in good order, and must say that the instrument gives perfect satisfaction in every respect. It is neatly made and wonderfully cheap at two dollars.

GEO. B. PARSONS, M. C. R. O. Office, Detroit, Mich.

Pool's Barometer has already saved me many times its cost, in foretelling the weather. It is a wonderful curiosity and works to perfection. F. J. ROBERTSON, Milwaukee, Wis.

**BEWARE OF WORTHLESS IMITATIONS.** None genuine without our Trade Mark, and Signature of J. A. POOL, on back of Instrument, as below:

Every instrument warranted Perfect and Reliable. Size 9 1/2 inches long, 3 1/2 wide. If not satisfied on receiving the instrument, return it at once and we will refund your money. Please state where you saw our advertisement.

**WATCHMAKERS.**

Before buying watches, see the "Whitcomb," made by AMERICAN WATCH TOOL CO., Waltham, Mass.

**REMINGTON TYPE-WRITER.** Warranted. Satisfaction guaranteed. Type-Writer Supplies. Send for circulars. Address E. REMINGTON & SONS, Manufacturers, or WYCKOFF, SEAMANS & BENDIS, Sole Agents, 281 and 283 Broadway, New York.

SEND TO LONDON BERRY & ORTON PHILA PA FOR THE BEST BAND SAW BLADE

**ROOFING.**

For steep or flat roofs. Applied by ordinary workmen at one-third the cost of tin. Circulars and samples free. Agents Wanted. T. NEW, 82 John Street, New York.

**ARTISTIC HOMES.**

Just published. 44 Plans, Elevations, and Interiors of QUEEN ANNE and COLONIAL Villas and Cottages, costing from \$700 upward. Inclose 3c. stamp for illustrated circular. Price \$3.50. Agents wanted. A. W. FULLER, Architect, Albany, N. Y.

LARGEST ESTABLISHMENT OF THE KIND IN THE WORLD. MOSS NEW PROCESS SUPERIOR TO ANY OTHER METHOD.

**MOSS ENGRAVING COMPANY**

ENGRAVINGS FOR BOOKS, NEWSPAPERS, CATALOGUES & C. THIRTEEN YEARS PRACTICAL EXPERIENCE.

**ICE MAKING MACHINES,** And Machines for Cooling Breweries, Pork Packing Establishments, Cold Storage Warehouses, Hospitals, etc. SEND FOR ILLUSTRATED AND DESCRIPTIVE CIRCULARS.

**PICTET ARTIFICIAL ICE CO. (Limited),** P. O. Box 3083. 142 Greenwich St., New York City, N. Y.

**TELEPHONE.** SEND FOR NEW CIRCULAR FITCHBURG ACQUSTIC TEL CO. FITCHBURG MASS. NEW METALLIC TELEPHONE.

Agents Wanted Sells Rapidly. Particulars free **C4S \$50** S. M. SPENCER 112 Wash'n St., Boston, Mass.

**\$72 A WEEK.** \$12 a day at home easily made. Costly outfit free. Address **TRUB & Co., Augusta, Me.**

**EVAPORATING FRUIT**

Treatise on improved methods SENT FREE. Wonderful results. Tables of Yields, Prices, Profits, and General Statistics. Address **AMERICAN MANUF'G CO.,** Waynesboro, Pa.

**CLARK'S RUBBER WHEELS.** This Wheel is unrivaled for durability, simplicity, and cheapness. Adapted for Warehouse and Platform Trucks, Scales, Heavy Casters, and all purposes for which Wheels are used. Circular and Price List free. **GEO. P. CLARK, Windsor Locks, Ct.**

**50 ELEGANT NEW STYLE CARDS.** Gift Fringe, Chromo, Fan, Ivy Wreath, Gilt Vase of Roses, etc., no 2 alike, name on 10c. Agent's book of samples, 25c. **GORDON PRYTG CO.,** Northford, Ct.

**50 Elegant Genuine Chromo Cards,** no two alike, with name, 10c. **SNOW & CO., Meriden, Ct.**

**Print Your Own** Cards, Labels, etc. Press \$3. Larger Size \$8. 13 other sizes For business, pleasure, old, or young. Every thing easy by printed instructions. Send two stamps for Catalogue of Presses, Type, Cards, etc., to the factory. **Kelsey & Co., Meriden, Conn.**

**ROOT'S NEW IRON BLOWER.**



**POSITIVE BLAST.**

**IRON REVOLVERS, PERFECTLY BALANCED,** Has Fewer Parts than any other Blower.

**P. H. & F. M. ROOTS, Manufacturers,** CONNERSVILLE, IND.

S. S. TOWNSEND, Gen. Agt., 6 Cortland St., 8 Dey St., COOKE & CO., Selling Agts., 6 Cortland Street, JAS. BEGGS & CO., Selling Agts. 8 Dey Street, NEW YORK.

SEND FOR PRICED CATALOGUE.

**THE SUEZ CANAL.—DESCRIPTION OF** the methods adopted in the construction, with two figures illustrating the dredging machines employed. Contained in SCIENTIFIC AMERICAN SUPPLEMENT, No. 347. Price 10 cents. To be had at this office and from all newsdealers.

**Intelligent Mill Operators in every State in America Use**

**Van Duzen's Patent Steam Jet Pump.** Guaranteed superior to any other Jet Pump for practical service. For raising water from Wells, Ponds, or Streams; or to use with hose and nozzle for Fire Pump, it has no equal. All Brass, no valves, no moving parts. Warranted reliable and satisfactory. Ten Sizes—\$7, \$8.50, \$10.50, etc., and capacities 300 to 20,000 gallons per hour. Send for "Catalogue No. 49." **VAN DUZEN & TIFT, Cincinnati, O.**

"St. Nicholas is above anything we produce in the same line."—LONDON TIMES.

**ST. NICHOLAS FOR YOUNG FOLKS.**

PARENTS who desire entertaining and wholesome reading for their children, and young folks who enjoy accounts of travel and adventure, historical incidents, stories, pictures, household amusement, and harmless fun, will find these in ST. NICHOLAS, which is recognized by the press and public, of both England and America, as THE BEST AND FINEST MAGAZINE for children ever printed. The new volume, which begins with the November number, and opens with a colored frontispiece, will be much the finest ever issued, and the attention of all parents and all reading young folks is invited to the following partial list of attractions:

- "The Tinkham Brothers' Tide-Mill." A new serial story by J. T. TROWBRIDGE, formerly editor of "Our Young Folks," and author of "The Jack Hazard Stories," etc.
- "The Story of Viteau." An historical novelette of girl and boy life in the 13th Century. By FRANK R. STOCKTON, formerly assistant editor of ST. NICHOLAS, author of "Rudder Grange," etc.
- "The Story of Robin Hood." An account of the famous yeoman. By MAURICE THOMPSON, author of "The Witchery of Archery."
- "The Story of the Field of the Cloth-of-Gold." By E. S. BROOKS. To be illustrated with many remarkable pictures.
- "A Brand-New Notion." A capital and novel play. By WILLIAM M. BAKER, author of "His Majesty, Myself," etc.
- "Swept Away." A serial story of the Mississippi floods of 1882. By E. S. ELLIS, formerly editor of "Golden Days."
- "Elizabeth Thompson." A biographical paper regarding this celebrated painter of battle-scenes. Illustrated with pictures prepared for ST. NICHOLAS by MISS THOMPSON.
- "Where was Villiers?" A thrilling story of the Russo-Turkish war. By ARCHIBALD FORBES, War-Correspondent.
- "The Boy at the White-House." An account of the life of "Tad" Lincoln. By NOAH BROOKS, author of "The Boy Emigrants."
- "Comedies for Children." A fine series of juvenile plays. By E. S. BROOKS, author of "The Land of Nod," etc., and including A Christmas Masque: "The False Sir Santa Claus." Prepared expressly for holiday times.
- There will be short stories by LOUISA M. ALCOTT, and many other well-known writers for young folks; papers on home duties and recreations, out-door sports, occupation and instruction for boys and girls, with popular features and departments.
- Price, \$3.00 a year; 25 cents a number. Subscriptions should begin with the November number. The succeeding issue, "The Wonderful Christmas Number," will have, also, a colored frontispiece, and many unusual attractions.
- THE CENTURY CO., New-York, N. Y.

**MALLEABLE** AND FINE GRAY IRON ALSO STEEL CASTINGS FROM SPECIAL PATTERNS. FINE TINNING, JAPANING AND FINISHING. LEHIGH AVE. & AMERICAN ST. PHILA.

**ON THE PROTECTION OF BUILDINGS** from Lightning.—A paper by Capt. J. T. Bucknill, R.E. Illustrated with thirteen figures. Contained in SCIENTIFIC AMERICAN SUPPLEMENT, No. 348. Price 10 cents. To be had at this office and from all newsdealers.

**FARMERS and FARMERS' SONS CAN MAKE \$50 to \$150 PER MONTH** During the Fall and Winter. For particulars, address, **J. C. McCurdy & Co., Philadelphia, Pa.**

**MORPHINE AND WHISKEY**

Habits easily cured with my **DOUBLE CHLORIDE OF GOLD** REMEDIES, 5,000 cures. Books FREE. **LESLIE E. KEELEY, M. D.,** Surgeon C. & A. Railroad, Dwight, Ill.

**GAS AND SUGAR APPARATUS AT THE** Saint Quentin Exhibition. Description and figures of French Gas Apparatus (stationary and portable); of furnace for revivifying animal black; and of apparatus for washing animal black. Contained in SCIENTIFIC AMERICAN SUPPLEMENT, No. 349. Price 10 cents. To be had at this office and from all newsdealers.

**WIRE ROPE—THE HAZARD MANUFACTURING CO. CHARLES PARRISH, PRESIDENT.**

MANUFACTURERS OF **WIRE ROPE, BRIDGE CABLES, SHIP RIGGING,** Tramway Ropes, Champion Barbed Wire, etc. Office and Works: **WILKESBARRE, PA.** Office and Warehouse: **87 LIBERTY ST., NEW YORK.**

Advertisements.

Inside Page, each insertion --- 75 cents a line. Back Page, each insertion --- \$1.00 a line.

Engravings may head advertisements at the same rate per line, by measurement, as the letter press. Advertisements must be received at publication office as early as Thursday morning to appear in next issue.

H.W. JOHNS' ASBESTOS. ASBESTOS STEAM PACKING, ASBESTOS WICK PACKING, ASBESTOS FLAT PACKING, ASBESTOS SHEATHINGS, ASBESTOS GASKETS, ASBESTOS BUILDING FELT. PRICES REDUCED. H. W. JOHNS M'FG CO., 87 Maiden Lane, New York.

NATIONAL TOOL CO., MANUFACTURERS OF MACHINISTS TOOLS. WILLIAMSPORT, PA. PLANERS A SPECIALTY.

The "MONITOR." A NEW LIFTING AND NON-LIFTING INJECTOR. Best Boiler Feeder in the world. GREATEST RANGE yet obtained. Does not Break under Sudden Changes of Steam Pressure. Also Patent EJECTORS OR Water Elevators, For Conveying Water and Liquid. Patent Oilers, Lubricators, etc. NATHAN & DREYFUS, 92 & 94 Liberty St., New York.

Patent Right on Klinkerfues' New Weather Compass for Sale. Apply to BIERNATZKI & CO., Hamburg, Germany.

PATENT COLD ROLLED SHAFTING. The fact that this shafting has 75 per cent. greater strength, a finer finish, and is truer to gauge, than any other in use renders it undoubtedly the most economical. We are also the sole manufacturers of the CELEBRATED COLLINS' PAT. COUPLING, and furnish Pulleys, Hangers, etc., of the most approved styles. Price list mailed on application to JONES & LAUGHLIN, Try Street, 2d and 3d Avenues, Pittsburgh, Pa.

THE BEST THE QUEBER WATCH CASE

I.W. COLBURN & CO. MFG. OF IMPROVED DYNAMO ELECTRICAL MACHINES. FITCHBURG, MASS.

Pyrometers. For showing heat of Boiler Flues, Superheated Steam, Oil Stills, etc. HENRY W. BULKLEY, Sole Manufacturer, 149 Broadway, New York.

CARY & MOEN. STEEL WIRE OF EVERY DESCRIPTION & STEEL SPRINGS. NEW YORK CITY.

WM. A. HARRIS. PROVIDENCE, R. I. (PARK STREET), Six minutes walk West from station. Original and Only builder of the HARRIS-CORLISS ENGINE With Harris' Patented Improvements, from 10 to 1,000 H. P.

DROP FORGINGS OF IRON OR STEEL. BEECHER & PECK, NEW HAVEN CONN.

MACHINISTS' TOOLS. NEW AND IMPROVED PATTERNS. Send for new illustrated catalogue. Lathes, Planers, Drills, &c. NEW HAVEN MANUFACTURING CO., New Haven, Conn.

COLUMBIA Bicycles. Thousands in daily use by doctors, lawyers, ministers, editors, merchants, etc., etc. Send 3c. stamp for elegantly illustrated 36 page catalogue to THE POPE M'FG CO., 597 Washington Street, Boston, Mass.

VOLNEY W. MASON & CO., FRICTION PULLEYS, CLUTCHES, and ELEVATORS, PROVIDENCE, R. I.

SHAFTS PULLEYS HANGERS. At Low Prices. Large Assorted Stock. A. & F. BROWN, 43 Park Place, New York.

ROCK BREAKERS AND ORE CRUSHERS. We manufacture and supply at short notice and lowest rates, Stone and Ore Crushers containing the invention described in Letters Patent, issued to Eli W. Blake, June 15th, 1858, together with New and Valuable IMPROVEMENTS, for which Letters Patent were granted May 11th and July 20th, 1880, to Mr. S. L. Marsden. All Crushers supplied by us are constructed under the superintendence of Mr. Marsden, who, for the past fifteen years, has been connected with the manufacture of Blake Crushers in this country and England. FARREL FOUNDRY AND MACHINE CO., Manuf'rs., Ansonia, Conn. COPELAND & BACON, Agents, New York.

SUPPLIES FROM HYDRANT PRESSURE THE CHEAPEST POWER KNOWN. Invaluable for blowing Church Organs, running Printing Presses, Sewing Machines in Households, Turning Lathes, Scroll Saws, Grindstones, Coffee Mills, Sausage Machines, Feed Cutters, Electric Lights, Elevators, etc. It needs little room, no firing up, fuel, ashes, repairs, engine, explosion, or delay, no extra insurance, no coal bills. Is noiseless, neat, compact, steady; will work at any pressure of water above 15 lb.; at 40 lb. pressure has 4-horse power, and capacity up to 10-horse power. Prices from \$15 to \$300. Send for circular to THE BACKUS WATER MOTOR CO., Newark, N. J.

BOGARDUS' PATENT UNIVERSAL ECCENTRIC MILLS. For grinding Bones, Ores, Sand, Old Crucibles, Fire Clay Gums, Oil Cake, Feed, Corn, Corn and Cob, Tobacco, Snuff, Sugar, Salts, Roots, Spices, Coffee, Coconut, Flaxseed, Asbestos, Mica, etc., and whatever cannot be ground by other mills. Also for Paints, Printers' Inks, Paste Blacking, etc. JOHN W. THOMSON, successor to JAMES BOGARDUS, corner of White and Elm Sts., N. Y.

WATCHMAN'S IMPROVED TIME DETECTOR, with Safety Lock Attachment. Patented 1876, 6-7-80-81. Beware of Infringements. This Instrument is supplied with 12 keys for 12 stations. Invaluable for all concerns employing night watchmen. Send for circulars to E. IMHAUSER, P. O. Box 2875, 212 Broadway, New York.

Sixteen Machinery Wiping Towels will be sent, post-paid, on receipt of \$1. Brown M'fg Co., Providence, R. I.

The Phosphor-Bronze Smelting Co., Limited, 512 Arch Street, Philadelphia, Pa. Trade Mark. "Phosphor-Bronze."

PHOSPHOR-BRONZE Planished Pump Rods, Bolts, Nuts, Valves, Spring Metal, and Wire. Specialties of great durability, strength, and resistance to corrosion for Mining, Marine, and Hydraulic Work. Pamphlets and Particulars on Application. OWNERS OF THE U. S. PHOSPHOR-BRONZE PATENTS. Sole Manufacturers of Phosphor-Bronze in the U. S.

JENKINS PATENT VALVES THE STANDARD MANUFACTURED OF BEST STEEL METAL. JENKINS BROS. 71 JOHN ST. N.Y.

IMPROVED ROTARY BED PLANER BACK KIFE GAUGE LATHE, For all variety of Chair Legs, etc., etc. ROLLSTONE PATENT VARIETY LATHE, Superior to the Waymouth. Pattern Maker's Lathe, Buzz Planers, Band, Jig, and Swing Saws, Wardell Pat. Saw Bench, Rod Machines, Boring Machines, etc., etc. Dealers in Second-hand Iron and Wood Working Machinery, Engines and Boilers, etc., etc. Send stamp for catalogue and address Rollstone Machine Co., 48 Water St., Fitchburg, Mass., U. S. A.

Steam Fitters' & Plumbers' Supplies. STURTEVANT'S FAN BLOWERS. JOHN S. URQUHART, Successor to ALBERT BRIDGES, 46 Cortland Street, New York.

UPRIGHT DRILLS AN EXCLUSIVE SPECIALTY SEND FOR ILLUSTRATED PRICE LIST H. BICKFORD. CINCINNATI, OHIO.

MACHINERY of every description. 121 Chambers and 103 Reade Sts., New York. THE GEORGE PLACE MACHINERY COMPANY.

WITHERBY, RUGG & RICHARDSON, Manufacturers of Patent Wood Working Machinery of every description. Facilities unsurpassed. Shop formerly occupied by R. Bail & Co., Worcester, Mass. Send for Catalogue.

NUT TAPPING MACHINE. DURRELL'S PATENT. No. 1 Machine, 900 lb., 7 spin dies. No. 2 " " 600 " " 3 Capacity of 7 Spin Dies, 8,000 per 10 hours. Acknowledged to be an indispensable tool Manufactured by HOWARD BROS., Fredonia, N. Y.

JOHN ROLLAND, 19 W. 4th St., Cincinnati, O. Manufacturer of all styles of Best Quality Gold Pens, Pen and Pencil Cases, Gold Toothpicks, etc. Our pens received the highest award at Philadelphia Exposition "for great elasticity and general excellence." See judges' report, published by Lippincott & Co. For sale by the trade. Illustrated lists mailed free.

MARTIN'S READY FOR FIRE. This cut represents the renowned RED JACKET Adjustable Double-acting Lift and Force Pump for general purposes. Highest Prizes awarded wherever exhibited. Thousands now in use throughout the States, giving perfect satisfaction. Fitted for hand and power. Agents wanted everywhere. For particulars, address CINCINNATI PUMP CO., Cincinnati, Ohio, U. S. A.

ERICSSON'S New Caloric Pumping Engine FOR DWELLINGS AND COUNTRY SEATS. Simplest, cheapest, and most economical pumping engine for domestic purposes. Any servant can operate. A absolutely safe. Send for circulars and price lists. DELAMATER IRON WORKS C. H. DELAMATER & CO., Proprietors, No. 10 Cortlandt Street, New York, N. Y.

The Eclipse Engine Furnishes steam power for all Agricultural purposes, Driving Saw Mills, and for every use where a first-class and economical Engine is required. Eleven first-class premiums awarded, including Centennial, 1876. Refer to No. 7, issue of 77, No. 14, issue of 78, of SCIENTIFIC AMERICAN, for Editorial Illustrations. FRICK & CO., Waynesboro, Franklin Co., Pa.

Established EAGLE ANVILS. 1843. Solid CAST STEEL Face and Horn. Are Fully Warranted. Retail Price, 10 cts. per lb.

TOOPE'S PATENT Asbestos Lined Removable Covering, Made of Felt and Asbestos. For use on STEAM BOILERS and PIPES, Refrigerators, Meat Cars, Ice Houses, and HOT and COLD WATER PIPES. Easily applied by any one. Address CHALMERS' PATENT CO., 23 John St., New York.

MAGIC LANTERNS And STEREOPTICONS, all prices. Views illustrating every subject for PUBLIC EXHIBITIONS, etc. A profitable business for a man with small capital. Also Lanterns for home amusement. 116-page catalogue free. McALLISTER, Mfg. Optician, 49 Nassau St., N. Y.

THE RIDER COMPRESSION PUMPING ENGINE (Hot Air), for city or country residences where it is required to raise a supply of water, is the most Perfect Pumping Machine in the market. Its marvelous Simplicity, absolute Safety, great Economy and Effectiveness, render it far superior to all others. Can be run by any inexperienced person. Send for catalogue and price list to CAMMEYER & SAYER, 38 Liberty St., New York, and 20 W. Lake St., Chicago, Ill. Please mention this Paper.

Leffel Water Wheels, With recent improvements. Prices Greatly Reduced. 8000 in successful operation. FINE NEW PAMPHLET FOR 1879. Sent free to those interested. James Leffel & Co., Springfield, O. 110 Liberty St., N. Y. City.

T. M. NAGLE, ERIE, PA., Manufacturer of Portable, Stationary, and Agricultural STEAM ENGINES.

OUR 10-HORSE Spark-Arresting Threshing Engine has cut 10,000 feet pine lumber in ten hours. Will burn wood six feet long, coal, straw, and corn stalks. Send for Price List and Catalogue "A" 2. Box 1207. B. W. PAYNE & SONS, Corning, N. Y.

TOOLS FOR Machinists, Carpenters, Amateurs, Jewellers, Model Makers, Blacksmiths, etc. Send for Catalogue, and state what kind of Tools you require. TALLMAN & McFADDEN, 607 Market St., Philadelphia, Pa.

KORTING UNIVERSAL INJECTOR FOR BOILER FEEDING. Operated by one handle. WILL LIFT HOT WATER. POSITIVE ACTION GUARANTEED UNDER ALL CONDITIONS. NO ADJUSTMENT FOR VARYING STEAM PRESSURE. WILL LIFT WATER 25 FEET. SEND FOR DESCRIPTIVE CIRCULAR. OFFICES AND WAREHOUSES: PHILADA., 12TH & THOMPSON STS. NEW YORK, 109 LIBERTY ST. BOSTON, 7 OLIVER ST. CHICAGO, 84 MARKET ST. AUGUSTA, GA., 1028 FENWICK ST. ST. LOUIS, MO., 709 MARKET ST. DENVER, COL., 194 FIFTEENTH ST. SAN FRANCISCO, 2 CALIFORNIA ST. RICHMOND, VA., 1419 MAIN ST.

HARTFORD STEAM BOILER Inspection & Insurance COMPANY. W. B. FRANKLIN, V. Pres't. J. M. ALLEN, Pres't. J. B. PIERCE, Sec'y.

TIGHT & SLACK BARREL MACHINERY A SPECIALTY JOHN GREENWOOD & CO. ROCHESTER N. Y.

Stevens' Roller Mills, FOR GRADUAL REDUCTION OF GRAIN. Manufactured exclusively by THE JOHN T. NOYE MFG. CO., Buffalo, N. Y.

THE SEIBERT CYLINDER OIL CUP CO., Sole Manufacturers of Oil Cups for Locomotives, Marine and Stationary Engine Cylinders, under the Seibert and Gates Patents, with Sight Feed. TAKE NOTICE. The "Sight Feed" is owned exclusively by this company. See Judge Lowell's decision in the United States Circuit Court, District of Massachusetts, Feb. 23, '82. All parties are hereby notified to desist the use, manufacture, or sale of same, as we shall vigorously pursue and prosecute all infringers. THE SEIBERT CYLINDER OIL CUP CO., 53 Oliver Street, Boston, Mass.

ROCK DRILLS & AIR COMPRESSORS. INGERSOLL ROCK DRILL CO., 1 PARK PLACE, NEW YORK.

SPEAKING TELEPHONES. THE AMERICAN BELL TELEPHONE COMPANY, W. H. FORBES, President. W. R. DRIVER, Treasurer. THEO. N. VAIL, Gen. Manager. Alexander Graham Bell's patent of March 7, 1876, owned by this company, covers every form of apparatus, including Microphones or Carbon Telephones, in which the voice of the speaker causes electric undulations corresponding to the words spoken, and which articulations produce similar articulate sounds at the receiver. The Commissioner of Patents and the U. S. Circuit Court have decided this to be the true meaning of his claim; the validity of the patent has been sustained in the Circuit on final hearing in a contested case, and many injunctions and final decrees have been obtained on them. This company also owns and controls all the other telephonic inventions of Bell, Edison, Berliner, Gray, Blake, Phelps, Watson, and others. (Descriptive catalogues forwarded on application.) Telephones for Private Line, Club, and Social systems can be procured directly or through the authorized agents of the company. All telephones obtained except from this company, or its authorized licensees, are infringements, and the makers, sellers, and users will be proceeded against. Information furnished upon application. Address all communications to the AMERICAN BELL TELEPHONE COMPANY, 95 Milk Street, Boston, Mass.

PAT. KEY SEAT CUTTER WILL CUT 100 SEATS 4 1/2 x 3/8 INCH PER DAY. OTHER SIZES IN PROPORTION. See Sci. Am. VOL. 45, No. 5, 181. TREVOR & Co. LOCKPORT, N.Y.

"LAFARGE" PORTLAND CEMENT. "BURHAM" English PORTLAND CEMENT. "KENE" CEMENT (Coarse and Superfine). These celebrated makes of imported cements for sale by JAMES BRAND, 85 Beekman St., New York.

COE BRASS MFG. CO. BRASS TORRINGTON - CONN. WIRE AND COPPER MATERIALS FOR METALLIC AND IN SHEETS. AMMUNITION A SPECIALTY. BLANKS

Steel Castings From 1/4 to 15,000 lb. weight, true to pattern, of unequalled strength, toughness, and durability. 20,000 Crank Shafts and 15,000 Gear Wheels of this steel now running prove its superiority over other Steel Castings. Send for circular and price list. CHESTER STEEL CASTINGS CO., 407 Liberty St., Philadelphia, Pa.

CATALOGUES FREE TO ANY ADDRESS TOOLS OF ALL KINDS GOODNOW & WIGHTMAN BOSTON

PRINTING INKS. THE "Scientific American" is printed with CHAS. T. JENNE JOHNSON & CO.'S INK. Tenth and Lombard Sts. Phila., and 47 Rose St., opp. Duane St., N. Y.