

# SCIENTIFIC AMERICAN

[Entered at the Post Office of New York, N. Y., as Second Class Matter.]

A WEEKLY JOURNAL OF PRACTICAL INFORMATION, ART, SCIENCE, MECHANICS, CHEMISTRY, AND MANUFACTURES.

Vol. LIII.—No. 6.  
[NEW SERIES.]

NEW YORK, AUGUST 8, 1885.

[\$3.20 per Annum.  
[POSTAGE PREPAID.]

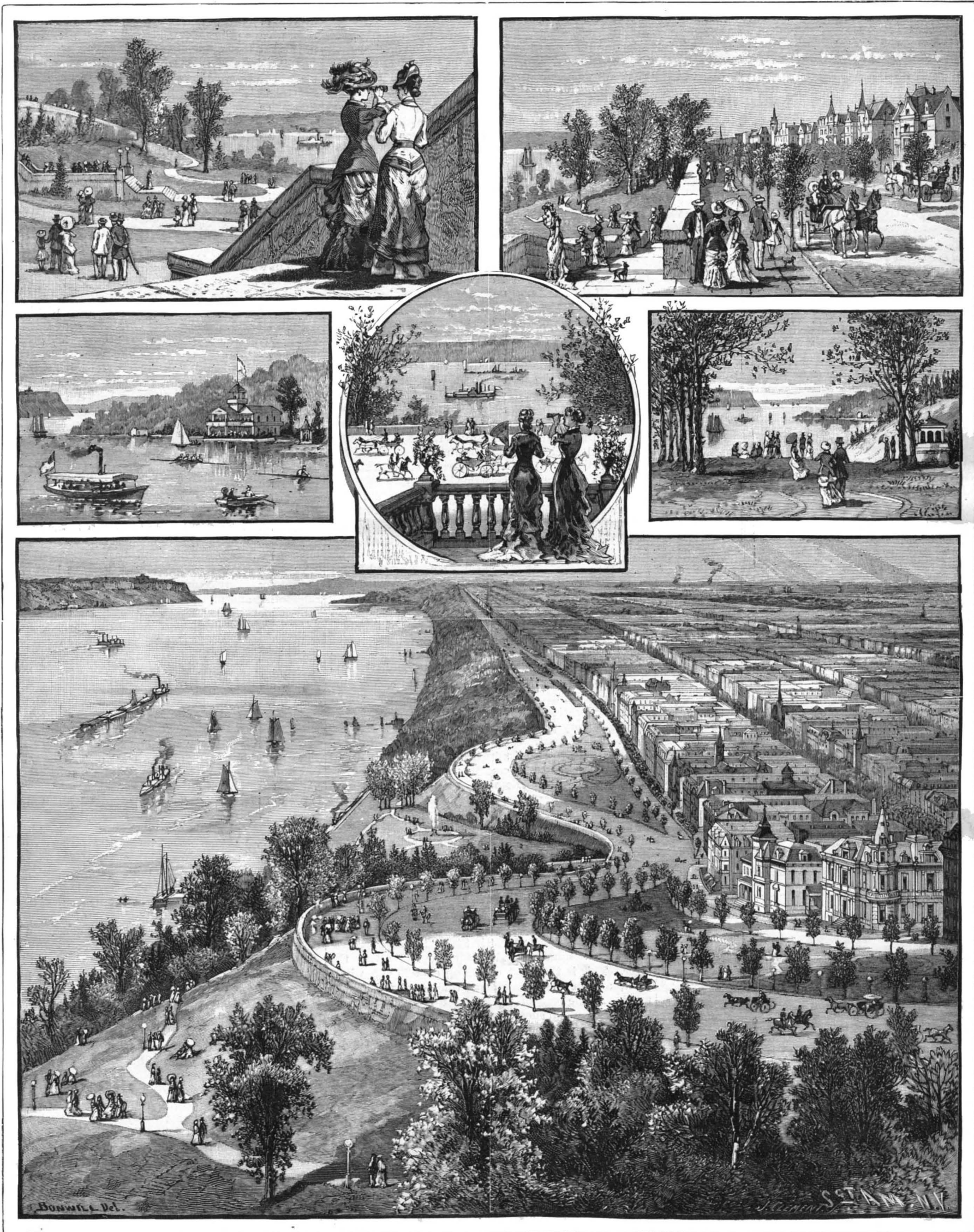

RIVERSIDE PARK, NEW YORK.—THE BURIAL PLACE OF GENERAL GRANT.—[See page 80.]

Scientific American.

ESTABLISHED 1845.

MUNN & CO., Editors and Proprietors.

PUBLISHED WEEKLY AT

No. 361 BROADWAY, NEW YORK.

O. D. MUNN.

A. E. BEACH.

TERMS FOR THE SCIENTIFIC AMERICAN.

One copy, one year, postage included.....\$3 20
One copy, six months, postage included..... 1 60

Clubs.—One extra copy of THE SCIENTIFIC AMERICAN will be supplied gratis for every club of five subscribers at \$3.20 each; additional copies at same proportionate rate. Postage prepaid.

Remit by postal order. Address

MUNN & CO., 361 Broadway, corner of Franklin Street, New York.

The Scientific American Supplement

is a distinct paper from the SCIENTIFIC AMERICAN. THE SUPPLEMENT is issued weekly. Every number contains 16 octavo pages, uniform in size with SCIENTIFIC AMERICAN. Terms of subscription for SUPPLEMENT, \$5.00 a year, postage paid, to subscribers. Single copies, 10 cents. Sold by all newsdealers throughout the country.

Combined Rates.—The SCIENTIFIC AMERICAN and SUPPLEMENT will be sent for one year, postage free, on receipt of seven dollars. Both papers to one address or different addresses as desired.

The safest way to remit is by draft, postal order, or registered letter. Address MUNN & CO., 361 Broadway, corner of Franklin Street, New York.

Scientific American Export Edition.

The SCIENTIFIC AMERICAN Export Edition is a large and splendid periodical, issued once a month. Each number contains about one hundred large quarto pages, profusely illustrated, embracing: (1) Most of the plates and pages of the four preceding weekly issues of the SCIENTIFIC AMERICAN, with its splendid engravings and valuable information; (2) Commercial, trade, and manufacturing announcements of leading houses. Terms for Export Edition, \$5.00 a year, sent prepaid to any part of the world. Single copies, 50 cents.

The SCIENTIFIC AMERICAN Export Edition has a large guaranteed circulation in all commercial places throughout the world. Address MUNN & CO., 361 Broadway, corner of Franklin Street, New York.

NEW YORK, SATURDAY, AUGUST 8, 1885.

Contents.

(Illustrated articles are marked with an asterisk.)

Table listing various articles such as Analgesia, Atomizer, Barometers, Bolt, door improved, British ship Rodney, Burial place of General Grant, Business and personal, Charts for great circle sailing, Cocoon, cellulose, Corks, Engineering as a profession, Engine, horizontal, 50 horse, Exposition, new, at New Orleans, Fever, hay, and its cure, Firearms, accelerating, Fish and oyster hatching, Frames, bronze, Gulf Stream, the, Invention, progress of, Inventions, agricultural, Inventions, engineering, Inventions, miscellaneous, Iron business, the, Italians, why they sing, Ladder, improved, Lamp, safety, an early, Lantern, magic, Light and heat, New experiments, Light house construction, Metals, oxidation and bronzing, Museum, locomotive, New books and publications, Notes and queries, Optical illusion, a curious, Oyster pest, a new, Patents, decisions relating to, Perfumes, homeopathic, Planets, aspects of for August, Riverside Park, New York, Roofs, tin, repairing, Samuel Ireneus Prime, D.D., Siren, electric, Weber's, Stamps, device for handling, Sunstroke, or thermic fever, Surgery for pianoforte players, Whale, right, of the North Atlantic, Why they sing.

TABLE OF CONTENTS OF

THE SCIENTIFIC AMERICAN SUPPLEMENT

No. 501,

For the Week Ending August 8, 1885.

Price 10 cents. For sale by all newsdealers.

Table listing contents of the supplement: I. CHEMISTRY AND METALLURGY.—A New Chlorimeter, Electrolytic Refining of Copper, Essential Oils.—Distillation of same from flowers. II. ENGINEERING AND MECHANICS.—Improvements in Velocipedes.—1 engraving, An Agricultural Mitrailleuse.—1 figure, Range of Guns, The Empress Bridge over the Sutlej.—7 figures, The Dawson Gas Apparatus.—2 figures. III. NAVIGATION, ETC.—Charts for Great Circle Sailing.—Showing at once the great circle track, the compass bearing at each point, and the distance; also the "composite" course touching any given latitude.—By R. A. PROCTOR.—6 illustrations. IV. TECHNOLOGY.—Reins for Three Horses Abreast.—1 figure, Japanese Technical Apparatus, Direct Photo-typography and Photo-lithography by the Chrom-Albumen Process.—4 figures, A New Singer's Sewing Machine Factory near Glasgow.—With engraving, Care and Use of the Microscope Lenses.—By WM. WALES. V. ELECTRICITY, HEAT, ETC.—A New System of Telephonic Communication.—Numerous figures, Kendall's Electric Generator.—1 figure, On the Conversion of Heat into Useful Work.—Lecture delivered by WM. ANDERSON before the Society of Arts, London.—With table giving properties of fuels, and several figures illustrating different burners, furnaces, etc. VI. ART, ETC.—The Unveiling of the Darwin Statue, South Kensington. VII. BOTANY, ETC.—How to Form a Herbarium.—3 figures, The Coloring Matter of Flowers and Fruits. VIII. HYGIENE, ETC.—Sanatory Precautions in the Dwelling.—By E. DWIGHT KENDALL.

RIVERSIDE PARK.—THE BURIAL PLACE OF GEN. GRANT.

In preparing for General Grant's obsequies, the first question was naturally where he should be buried. A diversity of opinion prevailed, many preferring that national ground should be chosen for his last resting place, as he belonged in a peculiar manner to the nation at large; but his family thought fitting that New York, as the city which had been his home during the last few years, and had witnessed the heroic struggle of the past winter and spring, would be the most suitable place for his burial. The choice, indeed, was sanctioned by General Grant himself, who stated, but a short time before his death, that he selected New York as his burial place, "because the people of that city befriended me in my need."

The city authorities were prompt in offering the use of any of the city parks which the family might select, and for several days Central Park was uppermost in mind, and seemed likely to be the spot honored by their choice. Colonel Grant, upon whom devolves the principal arrangements for the funeral, was several times in consultation with Mayor Grace, and in company with several gentlemen of the city corporation visited the park, and examined various sites which had been proposed. A number of objections, however, conspired to make Central Park seem undesirable, and Mayor Grace suggested that Riverside Park should be selected, as it possessed many advantages, and would in all respects be a suitable site. The final decision rested with Mrs. Grant, and as her acquiescence was early telegraphed to Mayor Grace, Riverside Park was announced as the spot selected for the resting place of the hero.

The park thus chosen for so distinguished a trust is little known outside of New York, and indeed in the city itself there are many who are entirely unacquainted with its beauties. From 72d Street to 129th a high bluff extends along the Hudson River, its sides sometimes precipitous, and again falling in gentle slopes toward the river. It is but a narrow strip of ground, and as yet, with the exception of the broad macadamized drive and the heavy stone parapet toward the river, it is almost entirely unimproved, but it possesses the elements of great beauty, and is destined in time to become one of the loveliest spots on the whole island. Three miles of river frontage gives to the park a living feature, whose charm and naturalness can be disturbed by no future growth of the metropolis, and fully entitles it to the name of Riverside.

Just now it is in a state of transition; the old order of things is passing away, and the new has not yet taken its place. Three generations of homesteads are built side by side, facing the winding stream, and bringing the memories of the past into contact with modern progress. Here and there stands an old Dutch farmhouse, square and comfortable, and surrounded with its gardens and orchards, while a little further along and one comes upon the mansion of a less remote period, with its prim colonnade and heavy, dignified aspect. Several lovely spots have been selected as the site of modern villas, which tell of what is coming, and hint unmistakably that their neighbors are decidedly old-fashioned, and will soon be seen no more.

The park is fortunate in possessing together with its charming location many noble old trees, whose heavy foliage is very graceful and attractive. These, too, speak of the past. Occasionally one sees a few old apple or pear trees mixed with the other timber, and recalling pictures of former homesteads; or the remnants of an avenue of Lombardy poplars or aged elms tell of more pretentious country seats. It is a great advantage in choosing this quiet, unadorned spot, which must forever remain inviolate, that its development will shape itself to be a fitting environment for the sacred dust which it receives. It cannot fail to be dominated by the memory of the hero who is to rest there, and to become consecrated to him in a manner that could never have been the case with Central Park.

Following the road to the north, the ground gradually rises until at 124th Street it has an elevation of one hundred and thirty-five feet above the river. This is the most charming spot in the whole park, and has been chosen as the site of the monument. At the base of the hill, the river spreads out into the beautiful sheet of water known as the Tappan Zee. Its surface is always alive with all kinds of river craft, and its surrounding shores abound with associations of the Revolution. The past and the present are both here; it is a fitting place to lay a hero. On the opposite shore, the trap rock of the Palisades rises from the river and makes a graceful outline against the horizon.

But a short distance above the park are Fort Lee and Fort Washington. Just beyond the commanding knoll stands the Claremont House, which was the home of the eccentric Lord Courtney in the days before the Revolution. The wooden figure-head of George III. is still one of the curiosities of the neighborhood; but the house is near enough the site of the monument to be an obstruction, and is therefore to be removed. To the east the view is also commanding, and on clear days the boats on Long Island Sound

can be distinctly seen. Twenty acres of land are to be devoted to the monument.

Though Riverside Park is so comparatively unknown, it is by no means inaccessible. The Boulevard, a broad, shady avenue, which promises in time to become one of the most fashionable in the city, leads from the Circle on 59th Street, at the southwest corner of Central Park, almost directly to the monument site, where numerous other pleasant drives connect the locality with the surrounding parks. Our illustrations show some of the features of Riverside. The lower portion of the picture is a view from the bluff at 90th Street looking toward the north. The central and upper cuts represent different views in the park as one approaches Claremont. Various boat houses occupy the water's edge along the park domain, as represented in the cut at the left. The small engraving on the right gives a glimpse of Claremont taken a few steps in front of the spot chosen for the tomb.

It is admitted that Riverside is the most suitable place in the city, and though its selection has not given general satisfaction, we believe that time will justify the choice. It would be difficult to find a more beautiful spot, and almost impossible to select one which would become more thoroughly consecrated to the memory of General Grant.

CHARTS FOR GREAT CIRCLE SAILING.

We publish in this week's issue of the SUPPLEMENT an illustrated article by Prof. Richard A. Proctor, on charts for great circle sailing, which is a very interesting development of the law of least force. The chart brought forward by Prof. Proctor is a stereographic projection—one in which each point on the sphere is projected on a tangent plane by a line joining the point and the outer end of the tangential diameter; and since it gives the entire globe, except a small area within the Antarctic Circle, on one sheet, it is well adapted for plotting a great circle course. By the method given in connection with the chart, a seaman may lay down without any difficulty the shortest track between two ports, that is, the arc of a great circle joining those ports, or the shortest distance between any point reached during the journey and any desired haven, and can calculate the distance. Ordinarily, vessels follow what is called the rhumb course, or that in which the same compass bearing, apart from magnetic variation, is maintained throughout the journey, but a great saving of distance is effected by sailing on the arc of a great circle; thus the distance from Melbourne to Cape Town is 6,154 miles on the rhumb course, but is 587 miles shorter on a great circle. It is the purpose of Prof. Proctor's article to make this more advantageous course practically attainable.

The advantages of great circle sailing have been known for many years, but hitherto the difficulties of calculating and plotting the course have been so great that it never came into more than exceptional use. The gnomonic projection suggested by Mr. Hugh Godfray, for charts to be used in great circle and composite sailing, was some advance, but the area represented on one chart being of necessity limited, it was impossible to lay down a ship's course of any extent on one chart, and the process of calculation was too complicated. The chart and methods suggested by Prof. Proctor are very simple, and may be readily grasped by navigators of even small mathematical knowledge. They promise to bring great circle sailing into general use, and by the notable saving of time effected, to be a valuable contribution to the progress of an age which is prone to rank speed among its greatest attainments.

BRONZE FRAMES.

Many productions of artistic articles are made under personal or trade secrets, and the methods are not made patent. Even where the methods are not guarded and controlled by legal act they may be confined in practice to a limited number of expert workmen. There is no exclusive right to the employment of bronze as a means of ornamentation, but in its uses as a decorative material few are experts.

Ever since the Exhibition at Philadelphia in 1876, there has been manifested great interest in the possibilities of bronze as a means of ornamentation. It was shown there that the appearance of hard steel and crude iron could be produced by treatments of bronze; in short, that bronze powders might be so managed by acids and heat as to assume all the metallic tints that could be possible in the solid metal. Of course, any mechanic can understand that such a disintegrated material as iron could not be spread into layering leaves like gold or like nearly pure silver; it was not capable of the extreme tenuity of fiber that could make it plastic in thin foils. So steel, although capable of greater tenuity, could not be beaten or rolled into films so requisitely thin as to make a tenuous sheet capable of being spread over even a plane surface. But much of this imitation of the hard metals must, by the present demands of fashion, be made on alto rilievo work, projections that would seem to require very flexible material to meet the requirement. This material is in the form of a very fine powder or dust, but being actual metal is capable of being bur-

nished. Very fine effects are produced by different colored bronzes, or bronze powders, but finer effects are produced by their treatment after being "laid."

The steel, and iron, and rusty iron, and copper, and brass, and the bronzes are all produced on picture frames and other ornamental objects by careful preparation of bronze powders, by acids, and heat, aided somewhat by some other materials and by tasty workmanship. These metallic powders are not attached to the object to be ornamented by ordinary "tacky" size as is gold leaf, but are laid on by means of an alcoholized solution that softens temporarily the whitening coating that is put on the wood mouldings of picture frames, mirror frames, and other articles to give a smooth, hard surface for the reception of gold leaf.

The bronze powders, whatever be the color they have been made to assume by calorific and acidulous treatment, may be applied so thinly as to be partially transparent, and so very attractive effects are produced by the use of a colored varnish or wash to the surface of the article before applying the powder. Thus different shades of one color may be produced by mixing with the softening alcoholic solution that prepares the surface for the reception of the powder, certain proportions of ivory black, burnt umber, or other volatile pigments which dry readily but leave their stain. In an attempt to imitate in bronze powder the appearance of rusty iron, the actual oxide of iron was found to be the very best pigment. This was made in the usual way by steeping soft iron—horse shoe nails—in acetic acid—vinegar—and mixing it with a little alcohol. This was washed over the surface of the frame or moulding, the bronze powder applied in different thicknesses to produce different tints, and was ready for burnishing within two hours.

Except plain and distinctive color, the most pleasing effects of bronzing are produced by the manipulations of the artist workman. He must be an artist to properly do his work. Chippers of stone may be employed to reproduce in marble the sculptor's clay model; but the decorator is himself the artist and the worker. He lays the powder in solution on the surface, thick or thin, as the work or his taste demands, employing the softest of camel's hair brushes. Where the original tint is to remain, the surface is wiped with silk floss or a rabbit's foot. But where prominences should show boldly, the protuberances are carefully burnished with queerly shaped implements of agate, flint, or of hardened steel or bloodstone. All these hand tools are ground to curves, angles, and edges to fit the sinuosities of the work; and they require practice in their use as well as taste in working, because much of the raised ornamental work on which they are employed is only a paste of glue and plaster of Paris.

#### National Fish and Oyster Hatching.

An officer in the service of the U. S. Fish Commission at stations on Chesapeake Bay reports obtaining 500,000 eggs from five Spanish mackerel on July 14, and that great success has been reached in hatching the eggs at the several stations, the temperature of the water being such at present that the eggs are hatched in from twenty to twenty-six hours. Included in the work of the Fish Commission there is also an oyster breeding farm at the mouth of the Potomac River, where ponds have been created to rear oysters hatched artificially. The oysters are taken indiscriminately, male and female, opened, the eggs expressed from the ovaries of the one and brought in contact with the spermatozoa of the other. Development begins immediately, and the oysters are swimming about freely in the rearing tanks in twenty-four to thirty hours. This is the height of the oyster spawning season in that locality. Ample material is found in the oysters of the bay and those reared in small ponds. These ponds are provided with collectors of various forms, on which the spat or young oyster attaches itself. When about five months old they are removed from the collectors, which have been coated with mortar to enable the delicate young oysters to be more easily detached. It is essential they should be separated, as they gather in such numbers as to smother each other. The experiments have been directed to making a certainty of obtaining the annual catch of spat, with which to plant oyster beds, independently of the ordinary and natural elements and influences. The French have developed oyster raising largely by depending on the natural oyster to fix the spat. Our Fish Commissioners are carrying the experiments to the earlier stage, and produce the oyster artificially as fish are produced. The oyster itself, when first hatched, is only one five-hundredth of an inch in diameter, which makes it an exceedingly difficult animal to handle. The difficulty here has been to confine them to limited waters and to give a sufficient change of water to keep them in healthy condition. The Commissioners expect by their experiments to be able to repopulate at small cost beds which have been exhausted. The spawn can be transported in great number at small cost. The present transplanting when grown to an inch in diameter is quite costly.

The oyster experiments will be continued at Wood's Holl to a later period of the year than on the Chesapeake.

The oysters in Buzzard's Bay and vicinity spawn considerably later. This is the rendezvous, also, of our vessels engaged in deep sea researches. The Albatross, having refitted after a winter cruise in the Gulf of Mexico, has visited the Banks of Newfoundland and the Georges, engaged in bottom dredging.

Several sea salmon, weighing eight to twelve pounds, were taken recently in the Chesapeake waters. One of nine and a half pounds was secured by the Commission twenty miles south of Washington in the Potomac, and was fresh run, beautiful, true salmon. It has been preserved in alcohol at the Smithsonian Institution. The spring run leads to the hope that that valuable fish has been permanently established in the Chesapeake Bay and its tributaries, hundreds of miles south of its old haunts.

#### Cocoon Cellulose as a Lining for Ships.

The long standing rivalry between heavy ordnance and armor plates is likely to be disposed of in a manner little expected, as a means appears to have been discovered whereby the effects of shot and shell, and even torpedoes, will be effectually neutralized. For some time past naval architects have ceased to rely solely upon armor for the protection of ships, for, notwithstanding the enormous thickness to which armor plates had attained, they were found to be no match for the artillery that was brought to bear upon them. Steel plates and compound plates were next tried, but to no avail. As a further increase in the thickness of plates, whether of iron or steel or both combined, was impracticable, owing to the overweighting of vessels with armor, shipbuilders tried the expedient of supplying a second line of defense in the coal bunkers, which were constructed along the sides of ships, especially those parts where the machinery and magazines are located. They certainly, to some extent, furnished that second line without overburdening the vessel, for coals nave to be carried under any circumstances.

But a far more effective protection appears now to have been supplied by the invention of a composition which, besides being efficacious as a protector, possesses the merit of being light—a desideratum much wanted by naval constructors. This composition is a preparation obtained from cocoon cellulose, which has the remarkable property, when penetrated by shot and shell, or even after the explosion of a torpedo, of closing up as rapidly as it has been in preventing the influx of water into the ship's hold. The very appropriate name of "coffer dam" has been given to the preparation, which, besides being very light, is highly elastic and tenacious. Some important experiments have lately been made with the composition before a French commission at Toulon, which, if everything that is reported concerning them is true, prove the preparation to be destined to solve the armor plate controversy. The commission submitted the composition to a threefold test against shot, shell, and torpedo. The target was a coffer dam made of a mixture of 14 parts of pulverized cellulose and 1 part of cellulose in fiber. This composition was compressed to a felt-like mass, of which 1 cubic foot weighed about eight pounds. A layer of beams  $4\frac{1}{2}$  inches thick represented the side of the ship, behind which there was a layer of coffer dam 2 feet thick. Against this target a  $7\frac{1}{2}$  inch solid shot was fired, which penetrated it, taking with it not quite one-fifth cubic foot of composition, a very small quantity, considering the size of the shot. But as soon as the shot had passed through the target the cellulose composition closed up again, and so firmly that a strong man was unable to force his arm through the opening made. A box filled with water was then fixed against the aperture, the contents of which ought to have acted in the same way as if the coffer dam had been washed away by the sea. It was observed that a few drops of water began to percolate after the lapse of from 10 to 15 minutes; and even after the composition had become well saturated with water, only between 3 and 5 pints of water escaped per minute, which could be easily intercepted by pails. As soon as the cellulose had become thoroughly soaked and grown denser, it offered greater resistance to the percolation of water, which finally almost ceased to flow. The experiments with shell gave similar results, the breach made closing automatically. It was also found that the coffer dam was proof against fire. A special experiment was made in which red hot coals were placed upon a mass of coffer dam, and covered with the same composition, the result being that the fire went out. The experiments with torpedoes were not so decisive as those with shot or shell. A chest was anchored out at sea, one side of which was lined with coffer dam, a torpedo attached to it, and exploded. The chest floated for a few seconds, and then sank. When fetched up by a diver, it was found that the lid had been blown off, but that the coffer dam composition was little injured. The above experiments appear to prove that the material in question possesses the property of automatically closing a leak caused by shot or shell, and of protecting a ship to a certain extent against fire. Whether its use will render ships unsinkable remains to be

shown, but we understand that in order to investigate this point thoroughly further experiments on a larger scale are to be undertaken by the Toulon commission.

#### Animals as Barometers.

I do not know of any surer way of predicting the changes in the weather, says a correspondent of the Cincinnati *Enquirer*, than by observing the habits of the snail. They do not drink, but imbibe moisture during a rain and exude it afterward. This animal is never seen abroad except before a rain, when you will see it climbing the bark of trees and getting on the leaves. The tree snail, as it is called, two days before rain will climb up the stems of plants, and if the rain is going to be a hard and long one, then they get on the sheltered side of a leaf, but if a short rain, on the outside. Then there are other species that before a rain are yellow; after it, blue. Others indicate rain by holes and protuberances, which before a rain rise as large tubercles. These will begin to show themselves ten days before a rain. At the end of each tubercle is a pore which opens when the rain comes, to absorb and draw in the moisture. In other snails deep indentations, beginning at the head between the horns and ending with the jointure of the tail, appear a few days before a storm.

Every farmer knows when swallows fly low that rain is coming; sailors, when the sea gulls fly toward the land, when the stormy petrel appears, or Mother Carey's chickens, as they are called, predict foul weather.

Take the ants: have you never noticed the activity they display before a storm—hurry, scurry, rushing hither and yon, as if they were letter carriers making six trips a day, or expressmen behind time? Dogs grow sleepy and dull, and like to lie before a fire as rain approaches; chickens pick up pebbles, fowls roll in the dust, flies sting and bite more viciously, frogs croak more clamorously, gnats assemble under trees, and horses display restlessness.

When you see a swan flying against the wind, spiders crowding on a wall, toads coming out of their holes in unusual numbers of an evening, worms, slugs, and snails appearing, robin redbreasts pecking at our windows, pigeons coming to the dovecote earlier than usual, peacocks squalling at night, mice squeaking, or geese washing, you can put them down as rain signs. Nearly all the animals have some way of telling the weather in advance. It may be that the altered condition of the atmosphere with regard to electricity, which generally accompanies changes of the weather, makes them feel disagreeable or pleasant. The fact that a cat licks herself before a storm is urged by some naturalists as proof of the special influences of electricity. Man is not so sensitive. Yet many feel listless before a storm, to say nothing of aggravated headaches, toothaches, rheumatic pains, and last, but not least, corns.

#### The British Ship Rodney.

The steel armor plated barrette ship Rodney, ten guns, 9,600 tons, 7,000 horse power, lately returned to Chatham Dockyard after a successful series of trials of her engines. The official trial, which took place recently, was of the most satisfactory character. With a natural draught the following results were obtained: Mean indicated horse power, starboard, 4,222; port, 4,040; collective, 8,262; steam in the boilers, 89 lb.; vacuum in condensers, starboard, 28.5 in.; port, 28 in.; revolutions per minute, starboard, 94; port, 93; mean pressure in cylinders, starboard, high, 45.61; low, 11.74; port, high, 43.44; low, 11.50. With forced draught and inclosed stokeholes, the following results were obtained: Mean indicated horse power, starboard, 5,598.55; port, 5,558.21; collectively, 11,156.76; steam in the boilers, 90 lb.; vacuum in condensers, starboard, 27.5; port, 28; revolutions, starboard, 104; port, 103; mean pressure in cylinders, starboard, high, 59.75; low, 12.83; port, high, 60.10; low, 12.78. The rate of speed attained was beyond that anticipated, over 17 knots per hour being made, notwithstanding the fact that the vessel's bottom was foul through having been in the basin at Chatham so long. The machinery worked with smoothness and regularity, the boilers generating an ample supply of steam, and no hitch occurred.

#### A New Oyster Pest.

In the vicinity of Stratford, and elsewhere along the Connecticut shore of Long Island Sound, it is said that a new and very destructive pest has made its appearance, to the alarm of the oystermen. It resembles an insect, and mainly attacks the "seed oysters," *i. e.*, those from one to two years old. It builds on top of the oyster shell a cluster of brown coll-like cells, which accumulate so rapidly that the young bivalve is soon smothered. According to Mr. Henry C. Rowe, an experienced oyster grower, nine-tenths of the many thousands of bushels of seed oysters planted this year have been thus destroyed. Others dispute this and seem to think there is no ground of alarm. The matter has been taken in hand by the Connecticut Shell Fish Commission, by whom the evil will be investigated.

### A CURIOUS OPTICAL ILLUSION.

Which is the tallest of the three persons figured in the annexed engraving? If we trust to our eyes, we shall certainly say it is No. 3. But if we take a pair of compasses and measure, we shall find that we have been deceived by an optical illusion. It is No. 1 that is the tallest, and it exceeds No. 3 by about 0.08 inch.

The explanation of the phenomenon is very simple. Placed in the middle of the well calculated vanishing lines, the three silhouettes are not in perspective. Our eye is accustomed to see objects diminish in proportion to their distance, and, seeming to see No. 3 rise, concludes therefrom that it is really taller than the figures in the foreground.

The origin of the engraving is no less curious than the engraving itself. It serves as an advertisement for an English soap manufacturer, who prints his name in vanishing perspective between each of the decreasing lines, and places the cut thus formed in a large number of English and American newspapers. The soap merchant completes this curious advertisement by giving a name to the three figures. No. 1 is Lord Churchill, No. 2 is Salisbury, and No. 3 is Gladstone.—*La Nature*.

### WEBER'S ELECTRIC SIREN.

The demonstration of the origin of tones and the determination of the number of vibrations that corresponds to each of them are of the highest importance for the study of the relations that exist between the different ones, from an acoustical point of view, as well as from that of the theory of music. Such study has been made either by acoustical or by optical methods, and the results are no longer subject to any doubt.

An apparatus intended for verifying such results will, then, have scarcely any value unless it gives something new. The siren which we now propose to describe differs from all analogous apparatus, in that the medium set in vibration and the mode of setting it in vibration are new, and that the cause and effect are at an arbitrary distance. Like other sirens, it gives at will one or several tones, and the interval between these may be fixed in advance. In its simplest form it consists essentially of the following parts: Of a toothed wheel, (Fig. 1), which revolves around an axis, A, and against the perimeter of which rests a spring, one of the extremities of which is fixed and communicates with a wire, while the other alternately touches a tooth and a hollow filled with an insulating substance. The wire connected with the spring runs to one of the poles of a pile. The other pole communicates with a telephone, T. The electric circuit is then closed in starting from the pile, to pass through the telephone to the axle, A, the wheel, and the spring to the other pole of the pile. If the wheel is revolving, the circuit will consequently be closed or open according as the spring is bearing against a tooth or an insulating hollow.

In the telephone there will be an identical series of attractions and freeings of the vibrating disk, whence will result a tone. The pitch of the latter, and the corresponding number of vibrations, will be directly proportional, then, to the number of teeth in the wheel, and to the velocity of the axle's revolution. The intensity of the tone, the amplitude of the vibrations of the telephone disk, is a function of the intensity of the electric current, and variable from one telephone to another.

The *timbre*, or the number, the pitch, and the intensity of the tones that are added to the principal one,

They all have the same diameter, 1.5 inches, and are all at an equal distance apart, say one-eighth inch. The number of teeth varies from one wheel to another, it being 24 in the first, 27 in the second, 30 in the third, and so on—each of the following having a number that

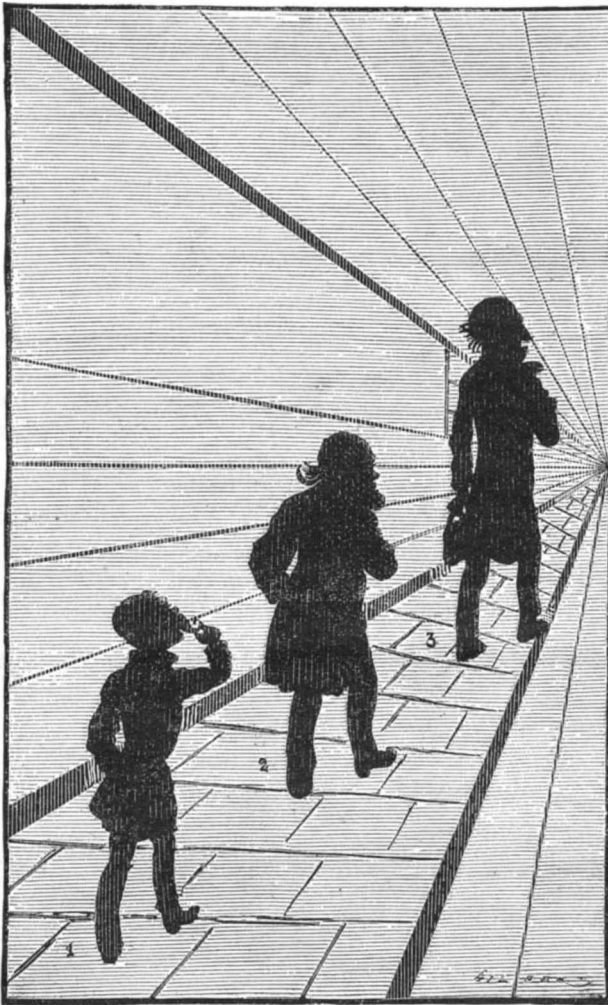

AN OPTICAL ILLUSION.

corresponds to the successive tones of the same scale up to the fiftieth. The space between the wheels and that between their teeth is filled in with a very hard insulating mass. The surface of the cylinder thus formed is carefully turned so as to have it very smooth. The surface of the teeth alone is visible, and each coincides with the surface of the cylinder. A crosspiece that joins the supports in which the cylinder revolves carries the fifteen springs. Each of these latter runs in

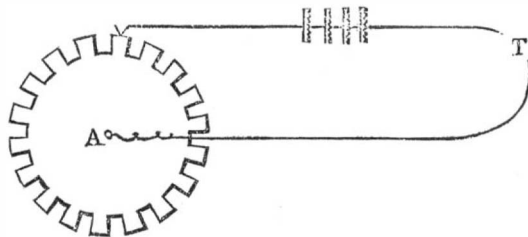

Fig. 1.

the plane of the corresponding wheel, and consequently bears alternately against a tooth and a hollow of it. A number of wires equal to that of the springs establishes a communication of the latter with the same number of binding screws arranged upon the board

terminal being connected with the pile. The most convenient arrangement of the pile is this: The number of elements is equal to that of the wheels, or one of the multiples thereof, and their negative poles communicate and connect with a wire from the telephone. The positive pole of each element (or of each series of elements), on the contrary, is connected with a binding screw, and by the latter with one of the springs corresponding to one of the wheels.

In certain cases, especially if the resistance in the circuit is great, it is advantageous to use induced currents for the telephone. To this end, we place near the siren and pile an induction coil whose primary bobbin is in the same circuit with the battery and siren, while the secondary one is connected only with the telephone.

For counting the number of vibrations that correspond to a certain tone in a given time, the axis of the siren carries an endless screw with which gears a 150-toothed wheel. The same axle that carries this wheel carries still another one, placed higher, upon which are traced two radii. Alongside of this latter, at the same height and nearly touching it, there is fixed a small disk, which is provided with a mark. In order to determine the number of revolutions of the axle of the siren, the process is as follows: The desired tone being produced, the index radius of the upper wheel will pass before the mark on the fixed disk. At this moment there is set in motion a seconds pendulum or the hands of a chronometer. Just at the moment the upper wheel is passing with its index radius before the mark for the second or third time, the hands are stopped. The chronometer tells the time that it takes the upper wheel to make one or two revolutions, or the time that it takes the axle of the siren to make 150 or twice that number. In this way, and with the number of the teeth of the siren wheel, we have all that is necessary for calculating the number of vibrations that corresponds to the tone.

The axle of the siren may be revolved by any motor whatever. In the engraving, Fig. 2, the motor shown coupled with the siren is an electro-dynamic one, constructed by Mr. Hipp according to an American model.—*Condensed from La Lumiere Electrique*.

### Corks.

Corks are divided into four classes according to their thickness:

1. Thick corks, having more than 31 millimeters in diameter.
2. Ordinary or commercial, from 25 to 40 millimeters.
3. Bastard corks, from 23 to 25; and
4. Thin cork, less than 23 millimeters.

Each class is again divided by the French and Spanish merchants, according to their quality and to the fineness of the cork.

In the cork tree plantations of Lot et Garonne, Catalonia, and the Mediterranean region generally, a forest kept in good condition and worked for ten years will yield two-thirds of good ordinary corks, and one-third of thick and thin cork, the whole being of the average price of 60 francs per cwt.

A cork of good quality should be white, tawny, or pink, with a close, fine grain, and free from cracks. Wet plantations give a soft, flabby description of product.

The powder of cork is met with in trade under the name of *liegine*, and is used in place of lycopodium for healing skin cuts, etc. The waste resulting from the manufacture of bottle corks is made useful by being mixed with plaster, etc., for partitions, filling walls, and other purposes. It also produces an excellent kind of charcoal, which is said to be good for gunpowder manufacture.

Linoleum is a composition of cork powder and linseed oil. Sometimes cork powder is found highly adulterated with sawdust and clay. Cork leather is made from India rubber and cork powder; it is much used for waterproof articles.

Catalonia and Algeria possess the cork oak in great quantity, and it is successfully cultivated in Corsica, in the French departments of Var, Lot et Garonne, and elsewhere. It grows about 200 years, and attains some 30 to 40 feet in height as an average, though trees as high as 65 feet are met with here and there.

The virgin cork is the suberous bark; it has little commercial value, being only used for marine buoys, fishing net floats, ornamental flower pots and ferneries, and for making Spanish black. The bark reaches its proper thickness in about eight years, but a tree is not unbarked until it is twenty or thirty years old. A young tree will give six to eleven pounds of cork, while an old tree will yield 250 to 350 pounds.

The manufacture of corks for bottles dates from the seventeenth century; machinery is now largely used for this purpose, by means of which one man can turn out about 5,000 to 6,000 corks a day.

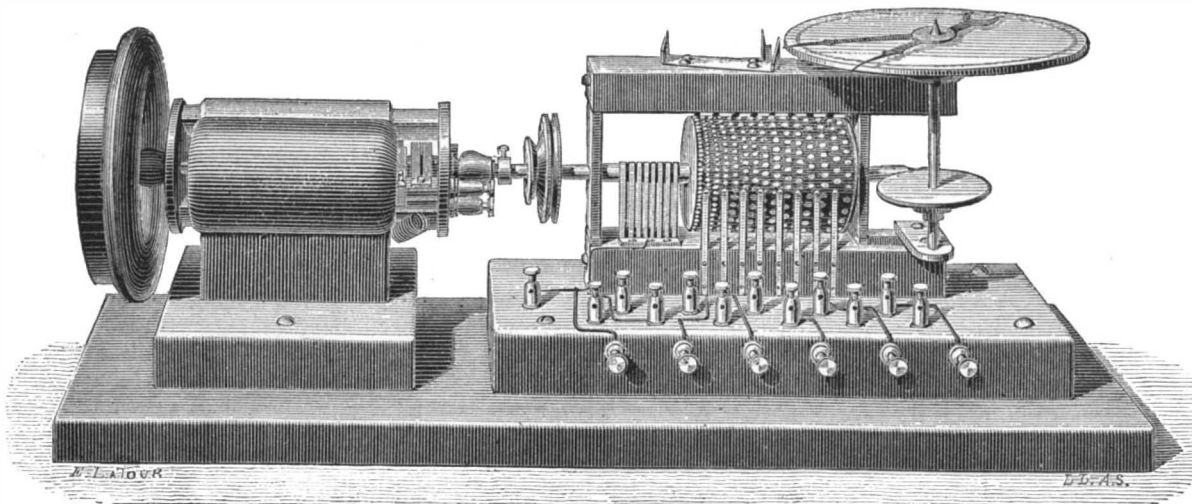

Fig. 2.—WEBER'S ELECTRIC SIREN.

depends upon the constancy of the pile, upon the perfection of the wheel, and upon the quality of the telephone.

The siren, as Dr. Weber actually constructs it, consists of fifteen toothed wheels fixed upon the same axle,

that carries the whole. A brush spring causes the current to enter the axis of the cylinder. This bears against the latter, and also communicates with the sixteenth binding screw. It is at this latter that ends one of the wires coming from the telephone—the other ex-

**DEVICE FOR HANDLING STAMPS.**

Mr. Gerard W. Schimmel, of Amsterdam, Holland, has patented a device for picking up and placing or fastening stamps or labels of various kinds having adhesive backs. The India rubber base of the stamp fastener is secured to a plate provided with an upright handle, and having projecting from its under side and penetrating the rubber base any number of strong, sharp pointed pins. The pins, in their normal position, project but slightly beyond the face of the rub-

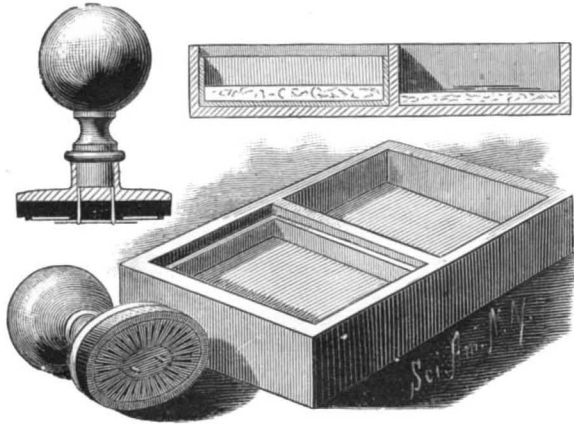

**SCHIMMEL'S DEVICE FOR HANDLING STAMPS.**

ber. In using the device the stamps are placed detached and dry, with their faces uppermost, in the compartment of the case, having a cushion on its bottom to prevent injury of the pins of the fastener. The fastener is then pressed down on one of the stamps, which will cause the rubber base to yield slightly and the points of the pins to penetrate the stamp, which may then be lifted and transferred by the fastener to a dampened cushion contained within a cup in the second compartment of the case. The back of the stamp is thus dampened. The fastener carrying the stamp is then pressed down on the surface designed to receive the stamp and quickly raised, leaving the stamp fastened as required. The several operations of picking up the stamps, dampening and sticking them may be done with the greatest rapidity.

**BURGESS' IMPROVED ATOMIZER.**

The accompanying illustration represents a new form of atomizer of extreme simplicity and superior durability. The metal cap and tube are made in one piece, and nickel plated, the former having a thread cut upon the inside, which screws down securely upon a corresponding thread blown in the neck of the bottle, the connection being made airtight by a soft rubber washer placed on the inside of the cap. The tubes are three-sixteenths of an inch in diameter and five and a half inches long, and are made in three forms to give

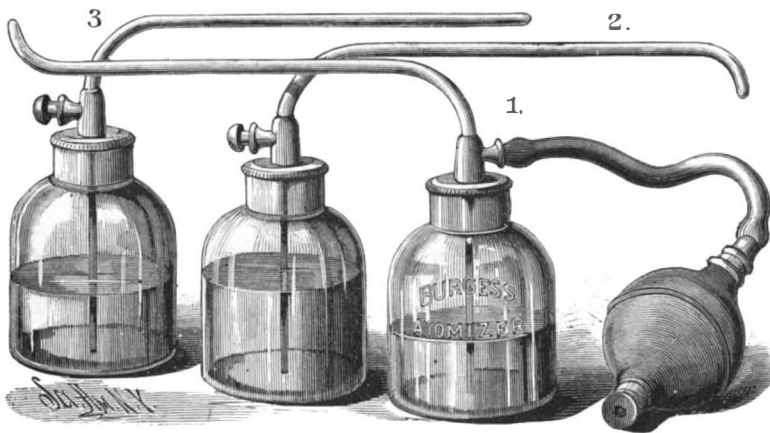

**BURGESS' IMPROVED ATOMIZER.**

either a straight, upward, and downward spray, as shown in the engraving. The bottles are round and have a capacity of three ounces. Each atomizer is accompanied by a wire by means of which the small opening in the end of the tube can easily be kept free.

The spray is produced by forcing the air partly into the bottle and partly into the upper end of the tube; the pressure of air within the vessel causes the liquid to ascend, and coming in contact with the air current is carried out of the contracted end of the tube in the form of a fine spray.

The black gum bulb used is not so easily soiled and possesses much greater durability than the white bulb usually furnished. It is made with a neck at each end, which allows the nipple and valves to be securely fastened and adjusted, thereby giving a *continuous spray*. For all atomizing purposes, especially for treatment of throat and nose, this spray is superior.

This atomizer is manufactured by Messrs. Shaw & Geary, 55 North 7th St., Philadelphia, Pa.

INOCULATION for yellow fever is reported to have resulted fatally with three patients who were experimented upon at Vera Cruz.

**The Progress of Invention.**

An exchange truthfully says that, like many other human activities, the patenting of new inventions "breaks out in spots." An example of this is found in the recent rapid issue of patents and applications for patents in a very few lines of invention. The first class to be mentioned, which, indeed, is the one that would be guessed by every intelligent reader of the newspapers of the day, is mechanism for the practical use of electricity. A new principle, such as that of converting sound waves to electrical waves on a wire, as exemplified in the telephone, brings after it numerous devices for its practical application. Every great invention is thus followed by a numerous train of subsidiary patents, usually dependent upon it, as all the varieties of the sewing machine with their many "attachments" were dependent upon the device of a needle with the eye in the point. So the telephone, with its improved transmitters, receivers, switchboards, and devices for "shunting," occupies a large share of the attention of the patent examiners. Another impulse has been given to inventive talent by one of the whims of fashionable life. Four years ago the number of recent patents on two wheeled vehicles might have been counted on one's fingers. In October, 1880, two patents of this sort were taken out, followed by others, and now the examiner in that line of conveyance is kept busy looking into the merits of new styles of village carts, with their paraphernalia. For several years past only a small number of applications for fire escapes have been received, but latterly such applications have been coming in rapidly.

It is proper to note in this connection that the Patent Office is getting its work along very well for this time of year, and to add the fact that new cases are acted upon very much sooner after the filing than they were a few months ago; but there is still too much delay in the examination of cases, and there always must be till the examining force in the Office is increased.

**Homeopathic Perfumes.**

The odoriferous molecule of musk must be incomprehensibly small, when we are told the particles one grain of musk had, in a radius of ninety feet, disengaged in one day. No microscopical power has yet been conceived to enable the human eye to see one of these atoms; yet the organs of smell have the sensitiveness to detect them. We cannot imagine their smallness, as it is stated that the same grain of musk undergoes absolutely no diminution in weight. A single drop of the oil of thyme, ground down with a piece of sugar and a little alcohol, will communicate its odor to twenty-five gallons of water. Haller kept for forty years papers perfumed with one grain of ambergris. After this time the odor was as strong as ever. Bordenave has evaluated a molecule of camphor sensible to the smell to 2,262,584,000th of a grain. Boyle has observed that one drachm of assafetida exposed to the open air had lost in six days the eighth part of one grain, from which Keill concludes that in one minute it had lost one 69,120th of a grain.

**Accelerating Firearms.**

A system of accelerating firearms has been devised by Mr. J. H. Stewart, of San Francisco, which is stated to accomplish very satisfactory results. The powder is fired in front, and becomes completely ignited only when the projectile is once in motion. Tests made at Benicia, Cal., with a rifle constructed on this principle showed, it is stated, a maximum velocity of 2,596 feet per second, and gave a penetration of three-quarters inch in rolled iron, where a Springfield field rifle, under similar conditions, made but a slight dent. In general, the penetration is twice the caliber.

**IMPROVED DOOR BOLT.**

The engraving shows a simple, inexpensive, and effective bolt, which, while fastening the door, will hold it closely to its casing without regard to variations in the size of the door or casing caused by changes in temperature or weather. Fig. 1 is a perspective view of the bolt, Fig. 2 is a face view of the catch, Fig. 3 is an edge view of the door with the spring case in section, and Fig. 4 is a horizontal sectional elevation of the door, jamb, and bolt. The bar fits loosely in a bearing formed on a plate secured to the face of the door, and is formed with a lever handle projecting from near its forward end, which is adapted to enter the eye of the catch.

In a box-like chamber placed at the forward end of the plate is a U-shaped spring which presses against a cam or eccentric lug fixed to the bolt bar about at a right angle with its handle, as shown in Fig. 3. After the end of the bar has entered the eye of the catch, the pressure of this spring against the end or toe of the lug will force the door closely against the casing; the

bolt bar is locked in position by the contact point of the lug passing beyond a line through the center of the bar. The spring yields more or less to the pressure of the lug should the wood of the door or casing shrink or swell, and hence the door will always be closed tightly. To unbolt the door it is only necessary to swing the handle so as to withdraw the lug from the spring chamber, when the bar may be moved back. To better resist the strain, the catch plate is made of a dovetail shape, and is let into the side of the rabbet of the casing.

This device, patented by Mr. John F. Taylor, of

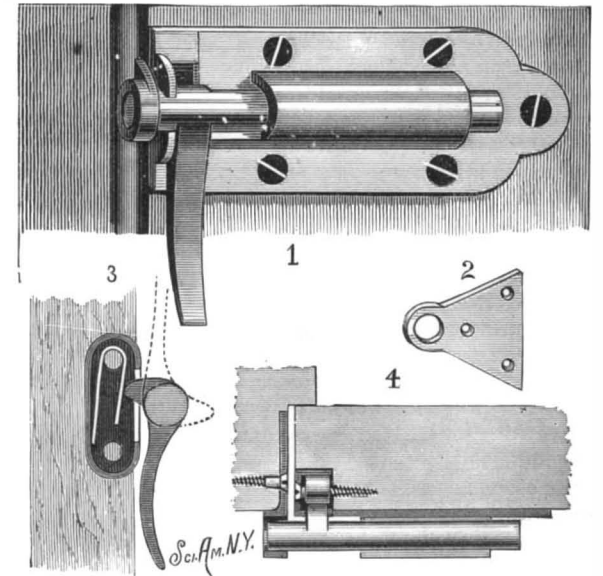

**TAYLOR'S IMPROVED DOOR BOLT.**

West Park, N. Y., is applicable to doors, sash, blinds, or other objects requiring a fastening such as the bolt affords.

**MAGIC LANTERN.**

On the inside of each end of the front, and on the inside of each end of the box, is a concave reflector; these are so placed as to concentrate the light upon the picture at the center of the back of the box. In a tube, F, projecting inward from the front, between the mirrors, is arranged a sliding tube, G, holding a convex lens, H. This tube is moved for focusing by means of a rod, J, extending up to the top of the back of the box. In the box two lamps or other lights—such as calcium or electric—are placed between the mirrors at each end as shown in Fig. 1. Above each light is placed a detachable funnel. The top of the box is curved and the under side is polished to reflect the rays of light. In the top is a ventilating opening provided with a hood to permit the hot air to escape; the supply of air is admitted through the perforated bottom. The pictures are held in a sliding apparatus moving between two longitudinal grooves (Fig. 2) secured on the outside of the back of the box, and having two apertures, which can be closed by hinged doors. The pictures are held in place by closing the doors, and can be shifted to appear in an opening in the back of the box. The light from the lamps is reflected by the mirrors upon the picture, and from the same through the lens upon a screen or wall. By means of a mirror, T, on a door, S, hinged to the front of the box below or at either side of the tube, the light can be reflected upon any desired surface. Any opaque object, such as a photograph, chromo, or drawing, can easily be reflected upon the screen in any desired size, all parts being clear and distinct. The pictures do not

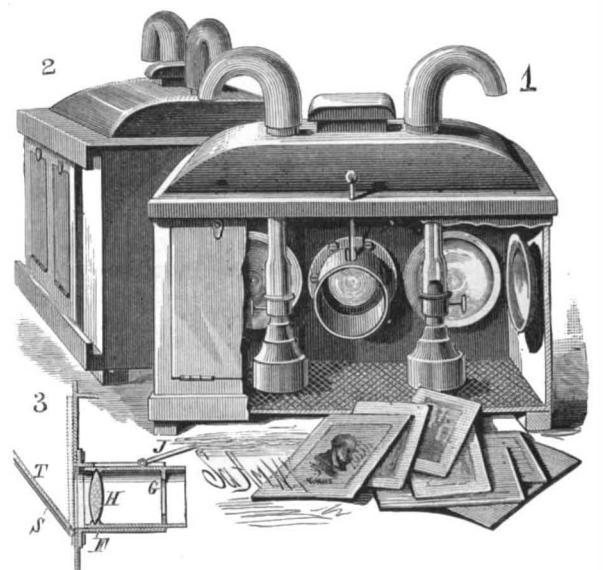

**DAVENPORT'S MAGIC LANTERN.**

become heated sufficiently to injure them, and may remain in the apparatus for hours without being destroyed.

This invention has been patented by Messrs. Henry and George Davenport, of Somerville, 22d ward, Philadelphia, Pa.

**Hay Fever and Its Cure.**

Hay fever people will be glad to see the nature and treatment of their complaint described in simple terms, readily understood by every one who comprehends the author's meaning:

These unhappy individuals, according to Dr. Sajous, of Philadelphia, possess, "as a result of heredity or of diseases implicating markedly the nervous system, nerve centers which have become abnormally sensitive, and are therefore inordinately influenced by the external elements to which they respond."

As a result of local disease the nasal mucous membrane becomes hyperæsthetic, and transmits to the abnormally sensitive nerve centers the impressions made by the "external irritants" (pollen, etc.), which results in a paroxysm of "hay fever."

These are the three conditions necessary for a paroxysm, and when one is absent, as is the case with the external irritants a portion of the year, and all the year in certain regions, it will not take place. Hence to cure the disease is to render the hyperæsthetic nasal membrane oblivious to the annual visitation of the external cause. The writer maintains that this can be done by cauterizing the hyperæsthetic portions of the nasal membrane, which he has accomplished with pleasing and permanent results by means of the galvano-cautery or acids.

He describes these hyperæsthetic areas as consisting of three—posterior, middle, and anterior. The posterior area is implicated when reflex asthma is the most prominent symptom; the anterior, when the head symptoms alone are present; the middle is the starting point of all the symptoms combined.

He recommends that abnormal conditions of the nasal cavities, such as hypertrophies, polypi, exostoses, etc., be eradicated before using the superficial cauterization. The best results are obtained by instituting treatment six weeks at least before the onset of a paroxysm, though it may be conducted during a paroxysm, resulting sometimes in an arrest of it or a beneficial modification. Immunity depends on the thoroughness with which the treatment is conducted.

It would seem, says the *Medical Record*, from the perusal of Dr. Sajous's monograph on the subject, that the hay fever might become unknown, provided its victims would put their hyperæsthetic nasal membranes under the treatment of an adept in rhinology. The banishment of hay fever from the list of diseases would be a boon to all except the hotel keepers of those resorts where, since the "external irritant" does not lurk in the atmosphere, the cause is removed and a cure is effected.

With the mechanism of the disease still in mind there remains one other method, which will be as much superior to that advanced by Dr. Sajous as his is better than the now prevailing method of changing abode, namely, that of finding a remedy which will act directly upon the abnormally sensitive nerve centers. We commend this to investigators.

**Repairing Tin Roofs.**

A correspondent communicates to the *American Artisan* his method of finding and mending the leaky places in painted tin roofs, which seems very practical. "My way is to start at the bottom of the roof, with a piece of chalk in one hand and a thin knife in the other. I examine the seams in one tier of sheets, and if I find a place that looks as if it might leak, I try it with the knife, and if it requires soldering, I mark the place with chalk. In this way I go over each tier of sheets, and look at every inch of the seams.

Of course, it is no little labor to go over a roof in this way. It often takes considerable trouble to get on to a roof; but the workman who hesitates about doing this work thoroughly belongs to the same class as the 'other fellow' who was on the roof before and did not stop the leaks.

The tools to be used other than the regular soldering tools are a hoe shaped scraper, which can be made out of an old file, and a piece of grindstone to sharpen the scraper with, so as always to have a sharp cutting edge. After having scraped clean a number of leaks, tin the places by using ordinary soldering acid, so that every scratch made in the tin will be well tinned, and not left to rust through. Then wipe off the acid with a wet cloth. The leaky seam is now as bright and clean to solder with the use of rosin as when the roof was new.

The reason for using rosin instead of acid to solder with, is on account of the curious way solder has of acting when acid is used. With rosin the solder can be piled on very evenly, and if the scraper is only as wide as the space on which solder is required on each side of the crack in the seam, then all the soldered places will present an even and orderly appearance.

The objection to this way of repairing a roof is that the unequal expansion and contraction is apt to break open the solder. I have noticed on old roofs where the solder has been piled over a nail head, that the nail had worked up through the solder so it could be pulled out with the fingers. To overcome this difficulty, cut some pieces of tin, say three-quarters of an inch wide, and give them a slight bend in the locker, so the edges will not be apt to spring in soldering. These pieces

are to be cut to proper lengths and soldered over the cracks, and as very little solder is required they expand and contract the same as the roof, and consequently will not crack off.

Another way to repair a roof, is to cut some pieces of cloth, three-quarters of an inch wide, and run them through thick paint, which can be done by soldering a wire on the bottom of the paint dish before the paint is put in; putting the strip of cloth through the wire loop and pulling it through the paint, cutting off the desired lengths with a pair of shears. The seam in the roof should first be painted, then the strip of cloth can be made to lie down nicely by the use of a small flat paint brush. I have made at the rate of three dollars per hundred patches repairing roofs in this way."

**IMPROVED LADDER.**

The accompanying engraving represents an adjustable ladder patented by Mr. Robert Furlong, of Sausalito, Cal., for house or orchard use, and which is adapted to support a platform when desired. Two pairs of side bars are pivoted to each other in pairs a short distance above their centers. The bars of one pair are united by a series of cross bars, and the other bars by cross bars at the top and crossed braces and a cross bar near the lower ends. The bars are inclined toward each other from their lower to their upper ends, and are widest at the pivots. A strap joining the lower cross bars prevents the ladder from spreading, and serves to hold the sections at the desired inclin-

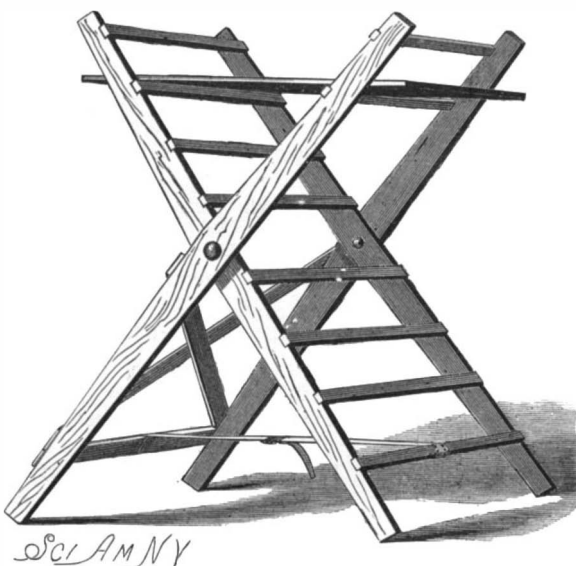
**FURLONG'S IMPROVED LADDER.**

ation. When necessary, a platform can be placed on the upper rungs, or the ladder can be used without the platform. The ladder is strong, folds up compactly, and can be quickly placed in position.

**Analgesia.**

The chief fact in connection with this subject is that almost any irritation of the larynx and upper end of the trachea is said to have the power of depriving the animal of the capacity to feel pain, the whole of the other functions of the nervous system remaining intact. The most powerful agents with which to effect the irritation are carbonic acid and chloroform. Brown-Sequard has continued his experiments on monkeys, and also on his own person. It is difficult to apply the necessary measures to the human being. Some success was obtained by getting an individual to inhale pure air during two-thirds of each inspiration, and then finishing up with chloroform or carbonic acid, which had to be immediately expelled. Sometimes an analgesic effect was produced, but the experiment had to be prolonged for many minutes. On the whole, the results did not seem to be very satisfactory. In monkeys the irritation can be effectually carried out, and then the analgesia is most marked, and lasts many days. It is said that there was insensibility to the existence of wounds for as long as ten days.—*Lancet*.

**Why the Italians Sing.**

C. H. Von Klein, M.D., gives the following in a paper read before the thirty-ninth annual session of the Ohio State Medical Society, at Dayton, June 5, 1885:

Through the kindness and under the auspices of the late Dr. Bordini, of Rome, the author had made the examination of the throats of thirty-two Italians, thirteen of whom were professional singers. The Italians appear to have natural organs of voice for music. He found the throat very roomy, the tonsils almost level with the fauces, the uvula extending only one-eighth of an inch from the soft palate, the posterior nares very large, the larynx thickly lined with a smooth mucous membrane, the trachea enormous. Another peculiarity was, the author found it very seldom necessary to use a tongue depressor. They seem to place their tongue down to the mylohyoid muscles, forming it into a concave shape. This accomplishment is necessary for a singer, and can be effected only by long and tedious training.

**DECISIONS RELATING TO PATENTS.**

**U. S. Circuit Court.—Northern District of New York.**  
GAGE v. KELLOGG *et al.*

METHOD AND APPARATUS FOR TREATING SEEDS.

Coxe, J.:

There cannot be in the same patent a claim for a machine and a claim for the process of using that machine.

Reissued letters patent No. 8,615, dated March 1, 1879, and granted to William B. Fisher for an improvement in seed steaming apparatus, expands the claims in the original patent, and is void.

**U. S. Circuit Court.—Southern District of New York.**  
TOMKINSON v. WILLETS MANUFACTURING COMPANY.  
DESIGN PATENT FOR A VEGETABLE DISH.

Coxe, J.:

When a decree has been entered by consent in a prior suit declaring a patent valid, and that complainant is the sole owner thereof, such decree will be considered binding, as to all questions determined thereby, in a second suit between the same parties.

It is not necessary that a design patent should be copied in every particular to constitute an infringement. It is sufficient if the resemblance is such that an ordinary purchaser would be deceived, although the infringer has deviated slightly in details or has omitted something which an expert could discover.

**U. S. Circuit Court.—Southern District of New York.**  
HOLMES ELECTRIC PROTECTIVE COMPANY v. METROPOLITAN BURGLAR ALARM COMPANY.

Wheeler, J.:

It is only a patent for an invention that has been previously actually patented in a foreign country that is limited by the foreign patent. The description of the invention in the foreign patent might affect the validity of the domestic one, and might not, but would not limit it. (Rev. Stat., sec. 4,887.)

**Light and Heat.—New Experiments.**

A remarkable observation of M. Felix Lucas upon the radiation of incandescent carbon has been communicated to the Academie des Sciences. The author begins by recounting how with inoxidizable metals heated in air the radiations, at first obscure, become more and more luminous as the temperature is raised. Thus, according to M. Pouillet, a temperature of 525° C. corresponds to a just visible red; and that of 1,500° C. to brilliant white. An analogous phenomenon is observed if carbon is heated, being previously placed in a vacuum to prevent combustion. When sufficiently heated, the carbon becomes a veritable lamp, thus showing the existence of a relationship between the temperature and the brightness of the radiations from the body.

With a view to determine this relationship in precise terms, M. Lucas prepared an arrangement of apparatus whereby he could heat *in vacuo* (by the current from a De Meritens machine) some specimens of ordinary arc-lamp carbon, 5 mm. in diameter, manufactured by M. Carre. He obtained formulæ by which he was able to calculate the temperature of the carbon corresponding to any observed intensity of current and illuminating value. By this means he was able to trace how the illuminating power increased with the heat from the first visible glow at 1,000° C., valued at only 3 carcels, rapidly up to over 300 carcels, and then slower, until, at a temperature of 4,500° C., the luminous radiations were equal to 413 carcels. Up to this point, therefore, although the heat had been only increased in the ratio 1:4.5, the luminous intensity was increased in the ratio 3:413. Now, however, a curious phenomenon appeared. An increase of temperature from 4,500° to 4,750° C. only increased the light from 413 to 420 carcels; and a further increase of temperature to 5,000° C. actually had the effect of lowering the light to 413 carcels, or the same intensity as that produced at a temperature 500° lower. It is noteworthy, as contrasted with this, that the increase of temperature from 3,125° to 3,520°, or only 395°, doubled the light emitted from the carbon. Thus, after a certain point, increase of temperature has a lessened effect in developing light, until, beyond the maximum of 4,750°, heat ceases to provoke more luminous radiations, and even reduces their visual value. Consequently, in stating this most striking conclusion, M. Lucas expresses the opinion that it is probable that calorific radiations, at first obscure, then successively luminous from red up to white, finish by passing beyond the violet end of the spectrum, and thus cease to be visible. Heat may, therefore, be invisible because of its intensity as because of its feebleness.

**A Locomotive Museum.**

The Chicago division of the Brotherhood of Locomotive Engineers is making a collection of railway appliances and historical works pertaining to locomotive management, to be placed on exhibition in Scientific Hall, for the purpose of more fully instructing members in the working and management of locomotive engines. The hall will be fitted up with proper appliances for showing the working of each article on exhibition.

## ASPECTS OF THE PLANETS FOR AUGUST.

## VENUS

is evening star, and takes the first rank on the planetary annals of August, for two reasons. She has entered upon her period of visibility, and she figures as chief actor in the incidents that diversify the month. She will be the most interesting star in the heavens, from the present time until the end of the year, the distance between the queen of the stars and the sun increasing all the time as she moves on her eastward course until the 8th of December, when, reaching her eastern elongation, she commences to retrace her steps toward the sun. Therefore, one of the most charming pages of planetary lore, written in characters of gold, on the blue vault that encircles the earth, is unfolded on moonless nights for the observation of the student of the stars.

Unfortunately, our sister planet does not take on the most favorable aspect, on account of her increasing southern declination. It is well known that the farther south the sun is, the shorter is the path he describes in the heavens, and, consequently, the shorter the day. For the same reason when Venus is far to the south of the equator, her path in the heavens follows the same law, and her stay above the horizon is correspondingly lessened. The result is that though the distance between Venus and the sun is constantly increasing, she sets only about an hour after the sun, through August, September, and the first part of October. On the 1st of November, she sets two hours after the sun, and on the 1st of December she shines with bewitching grace for three hours after the disappearance of the sun. As however, the twilight shortens with the shortening days, and her brilliancy and size increase with her approach to the earth, she will be more easily visible and far more beautiful as the autumnal months fulfill their course.

There is only a difference of ten minutes on the 1st of the month in the time of setting of Venus and Jupiter. On the 6th the former overtakes the latter, the conjunction taking place at 2 o'clock in the morning, Venus being 26' south. The planets will be below the horizon when at their nearest point, but they will be near enough together on the evenings of the 5th and 6th, to form a lovely picture in the glowing twilight. On the evening of the 6th the planets will have changed places, Venus being on the east.

On the 8th, at 10 o'clock in the evening, Venus is in conjunction with Mercury, being at the time 3° 42' north. It will be remembered that, on the 17th of July, the same planets were in conjunction. They were then both moving eastward, and Mercury, the swift-footed, overtook and passed his fair rival in the race. He has since reached his eastern limit, and, retracing his steps, again meets and passes Venus as he draws nearer to the sun. Hence the two conjunctions with so short a space of time.

On the 24th, Venus, still traveling eastward, encounters a third planet. Uranus is the fellow actor in the scene. They meet at 9 o'clock in the morning, Venus being 13' north. The fair evening star then proceeds unmolested in her course without meeting a brother planet for the rest of the year.

Venus, not contented with paying her respects to Jupiter, Mercury, and Uranus, draws near on the 19th to Beta Virginus, a star of the 3d magnitude in Virgo, the planet being at the time 24' north.

The right ascension of Venus on the 1st is 10 h. 24 m.; her declination is 11° 35' north; her diameter is 11'6"; and she is in the constellation Leo.

Venus sets on the 1st a few minutes after 8 o'clock in the evening; on the 31st she sets at half past 7 o'clock.

## JUPITER

is evening star. We award to him the second rank, as this is the last month he will hold the place of evening star during the present year. Before the month closes, his bright presence will be missed among the starry throng, for he will be eclipsed in the sun's rays. He must therefore be left to pursue his invisible course, while his belts, spots, and clouds will be hidden from terrestrial telescopes. He does not bid goodbye to the earthly domain without mingling in the events of the month.

On the 4th, at 4 o'clock in the afternoon, he is in conjunction with Mercury, being 2° 32' north. Bright eyed observers may be fortunate enough to pick up the largest and the smallest of the planets in near vicinity, for mercury should be visible about this time to the naked eye, and Venus follows closely on the track of both. The conjunction of Jupiter and Venus on the 6th has already been described.

On the 27th, at 6 o'clock in the morning, Jupiter is in conjunction with Mercury for the second time in the month, being then 6° 1' north. The explanation is the same as in the case of Venus. For Mercury having arrived at his eastern goal, on retracing his steps, overtakes the more stately and slower moving planet.

The right ascension of Jupiter on the 1st is 10 h. 41 m.; his declination is 9° 25' north; his diameter is 30"; and he is in the constellation Leo.

Jupiter sets on the 1st about a quarter after 8 o'clock in the evening; on the 31st he sets about half past 6 o'clock.

## MERCURY

is evening star, and is a near neighbor to Venus and Jupiter during the month, making one conjunction with the former and two conjunctions with the latter planet, as has been stated.

On the 6th, at 3 o'clock in the morning, he reaches his greatest eastern elongation, being 27° 23' east of the sun. He is then so situated as to be visible to the naked eye, although not under the most favorable conditions. He is indeed at his maximum distance from the sun, but like Venus, is moving too rapidly southward to present his best aspect. Southern observers will enjoy a fine view of the fiery little planet at the time of his elongation. Observers who succeed in finding Venus and Jupiter, will find Mercury on the evening of the 6th, a little east, and about 3° south of the larger planets. They all set not far from 8 o'clock.

The right ascension of Mercury on the 1st is 10 h. 31 m.; his declination is 8° 23' north; his diameter is 7", and he is in the constellation Leo.

Mercury sets on the 1st a few minutes after 8 o'clock in the evening; on the 31st he sets soon after 6 o'clock.

## URANUS

is evening star. Venus overtakes and passes him on the 24th, as he travels westward, approaching conjunction with the sun.

The right ascension of Uranus on the 1st is 12 h. 1 m.; his declination is 0° 35' north; his diameter is 3'4"; and he is in the constellation Virgo.

Uranus sets on the 1st about 9 o'clock in the evening; on the 31st he sets soon after 7 o'clock.

## SATURN

is morning star, and is by far the most interesting of the three planets that precede the sun. He rises on the 1st about 2 o'clock, and at the close of the month makes his appearance soon after midnight, and is a lovely object to reward the gaze of the observer in the small hours in the morning. The mysterious rings are now open to their widest extent, the planet is drawing near perihelion, and is also approaching the earth. By the last of September Saturn will be above the horizon at half past 10 o'clock, and will not only be delightful to behold with the naked eye, but will afford a rare opportunity for telescopic research.

On the 5th, at 3 o'clock in the afternoon, Saturn is in close conjunction with Mu Geminorum, a star of the 3d magnitude in Gemini, passing 4' south.

On the 6th, at 3 o'clock in the afternoon, he overtakes Mars. The planets are in conjunction, Saturn being 1° 20' south.

The right ascension of Saturn on the 1st is 6 h. 14 m.; his declination is 22° 30' north; his diameter is 16"; and he is in the constellation Gemini.

Saturn rises on the 1st 10 minutes before 2 o'clock in the morning; on the 31st he rises a few minutes after midnight.

## MARS

is morning star. Besides being in conjunction with Saturn on the 6th, he also is in conjunction with Mu Geminorum, being at the time 1° 16' north. Thus, Mars, the star, and Saturn are almost in line, the star almost touching Saturn. The double conjunction is invisible as it occurs at 3 o'clock in the afternoon, but though the actors in the scene will have changed places on the morning of the 7th, they will still be near enough to make an interesting celestial picture that will amply repay an early riser for making the required effort. A small telescope or opera glass will aid the observer, who will find the planets in favorable position at 3 o'clock in the eastern sky.

The right ascension of Mars on the 1st is 6 h. 1 m.; his declination is 23° 49' north; his diameter is 4'8"; and he is in the constellation Gemini.

Mars rises on the 1st about half-past 1 o'clock in the morning; on the 31st he rises about 1 o'clock.

## NEPTUNE

is morning star. On the 18th, at 4 o'clock in the morning, he reaches quadrature with the sun on his western side, and thenceforth he is nearer to the earth than he is to the sun, that is, he appears to be.

The month closes with Neptune, Saturn, and Mars on the western side of the sun as morning stars, and with Mercury, Jupiter, and Uranus, and Venus on his eastern side as evening stars.

The right ascension of Neptune on the 1st is 3 h. 34 m.; his declination is 17° 27' north; his diameter is 2'5"; and he is in the constellation Taurus.

Neptune sets on the 1st at half past 11 o'clock in the evening; on the 31st he sets at half past 9 o'clock.

## THE MOON.

The August moon falls on the 25th, at 25 minutes after midnight. The moon is in conjunction with Neptune on the 4th at 3 h. 49 m. P.M., being at the time 2° 45' south. On the 7th, at 9 h. 5 m. A.M., she is in conjunction with Saturn, being 4° 13' south. Also on the 7th, 43 minutes later at 9 h. 48 m. A.M., she is in conjunction with Mars, being 5° 33' south. The conjunction is invisible, but the waning moon will be near the two planets on the morning of the 7th. On the 11th, at 9 h. 2 m. P.M., the new moon of the 10th

is in conjunction with Jupiter, being 2° 31' south. On the 12th, at 3 h. 36 m. A.M., the moon is in conjunction with Mercury, being 1° 55' north. On the same day, the 12th, but nearly four hours later at 7 h. 12 m. A.M., she is in conjunction with Venus, being 2° 13' south. The crescent moon and evening star, though not near each other, will be fair to see on the evening of the 12th. On the 13th, at 5 h. 49 m. A.M., the moon is in close conjunction with Uranus, being 17' north. On the 31st, our satellite again commences her round. She is in conjunction with Neptune for the second time during the month at 10 h. 6 m. P.M., being 2° 52' south.

## AUGUST

presents a full chapter of planetary incidents. There is an unusual stir among the members of the sun's family of worlds. The fairest of the stars pays her respects to her august brother Jupiter, to the swift-footed Mercury, and to the slow moving Uranus, while she fills out her portion of planetary work by a close conjunction with Beta Virginus. The prince of planets pays his court twice to the smallest of his brethren, who at least can outrun him in the race if he can do nothing else. The ring-girdled planet and the god of war meet and change places on the celestial road, and both planets pay their respects to the small star Mu Geminorum, at nearly the same time, the approach in Saturn's case being an appulse, for 4' of arc is in celestial mathematics a small space to intervene between two visible heavenly bodies. As the month passes, the light of Jupiter grows dim and fades away, Venus slowly advances to easy visibility and will soon put on her queenly apparel, Saturn is superb with his wide open rings and the beaming light he borrows from a nearer approach to the sun, while the day of Martian importance nears the dawn.

## Oxidation and Bronzing of Metals.

In the National Armory, Springfield, all the metallic parts of small arms, except those requiring to be case-hardened, and those colored in tempering, are oxidized by immersion in melted niter mixed with a few pounds of peroxide of manganese. A cast iron pot or vessel, built into a furnace, contains the mixture heated to such a point that a pinch of sawdust thrown on to the surface takes fire. The objects to be treated are suspended from hooks above, and are lowered into the fluid, when they are moved about until they attain the desired color. They are then lifted out and left suspended until the niter has dropped off and they have cooled to the temperature of boiling water, when they are washed and finally dipped in a bath of sperm oil. All articles that are likely to be injured by distortion are dipped vertically, and the mixture is allowed to penetrate the inside of the rifle barrels. The result is the formation of a coating of magnetic oxide of iron which has a very fine color, and withstands the action of moisture. It is necessary that the niter should be refined. The crude salt of commerce does not give a satisfactory color or uniform results. The best effect is gained when the metallic surface is smooth and free from the markings of the polishing material, but not highly polished. A smooth polished surface of cast iron treated with niter is given a good bronze color. There is no danger of explosion from the process if the objects be clean, and even if the pot of niter be upset on the fire nothing worse occurs than the evolution of a suffocating gas. The process has been worked out by Lieutenant-Colonel A. R. Buffinton.

## Light House Construction.

A tapering round tower of cast iron, weighing 200 tons, rises from the floor of the Colwell Iron Works foundry to the roof. It is the shell of the iron light tower to be erected on the Delaware Breakwater. For three months a large force of workmen have been casting the 150 plates that compose the shell. This novel and expeditious method of constructing lighthouses has but recently been put in operation by the United States Lighthouse Board. This shell sets the light 80 feet above water, and has a circumference of 66 feet at the base and 54 at the top. The lighthouse is all made, tested, and inspected at the works, and on arrival at its concrete foundations will receive an interior lining of brick. This new variety of lighthouses can be built very rapidly and at comparatively small cost.

## Samuel Ireneus Prime, D.D.

Rev. Dr. Prime, the well known senior editor of the *New York Observer*, died on Saturday, July 18, at Manchester, Vt., from a stroke of paralysis. Dr. Prime was born in 1812 and graduated at Williams College 17 years later, after which he took the theological course at Princeton. Dr. Prime was a charming, easy writer, who carried his readers along with him in a most delightful and familiar way. He was a conspicuous figure in the religious and charitable world, a pleasant, easy talker, with the ability of making a stirring and interesting impromptu address at a moment's notice, genial and kindly in his ways, with jolly, sparkling eyes. Dr. Prime will long be missed by a large circle of friends and admirers.

**SURGERY FOR PIANO-FORTE PLAYERS.**

The most earnest advocates admit that evolution is an extremely slow process: that it produces wonderful results, but that its operations occupy a corresponding amount of time. Certain it is, that the process is not keeping pace with the requirements of modern times, and that the artificial development of the human faculties has of late taken precedence over the natural results of time.

Helmholtz, after making an exhaustive study of the human eye, declared that should he receive an optical instrument of man's making which contained so many defects as the eye, he should be justified in returning it to the manufacturers. But it is these very defects which have stimulated man's ingenuity to find a remedy. So completely has the science of optics come to his assistance, that with the help of the lens in microscope and telescope, he is possessed of an organ capable at once of studying the infinitesimal world represented by a drop of water or of penetrating the immensity of a solar system. Yet no progress, except, perhaps, in the power of discrimination, is being made with the living instrument, for the eye of the present school child is probably much inferior in strength and capacity to that of his pioneer grandfather at an equal age.

In other directions, however, man may be improving. His hands, from their constant use of sensitive instruments and their employment in painstaking investigations, have probably gained a nicety and delicacy of touch which were quite unknown to earlier generations. But even here, the progress has not been sufficient to satisfy his wants, and the anatomy of the hand is undergoing a number of modifications due to special treatment or to surgical science. The delicate manipulations of the chemist and physicist or the effective touch of the artist are by no means natural; they result only from the most careful training. In music, whether in using the keys of an instrument, or in working the strings directly, as in zither or harp, every student remembers the weary practice which has gained him his present proficiency. No amount of devotion, however, seems to have succeeded in overcoming the obstinate weakness of the third or ring finger. Innumerable exercises and daily fingering of the keyboard have left that member but slightly stronger at the end than in the beginning. When, for instance, the middle and little finger are pressed upon the keys to produce a continuous sound, it is almost impossible to bring the ring finger into intermittent use with a strength sufficient to produce any equality in the tones. The reason is very simple, but rather curious. The extensor communis digitorum muscle, which moves the ring finger, is connected by lateral or

accessory tendons with the muscles of the neighboring digits, and when these are held down, the accessory tendons prevent the free action of the muscular fibers of the third finger, and hence the clumsy result. These accessory tendons are sometimes found in both hands, often only in one, which in this case is usually the right hand. Occasionally, the extensor muscle of the ring finger splits at the point of departure of the accessory tendons, and when reunited leaves a button hole appearance, and now and then these tendons are en-

ing liberty at the expense of power in any other direction. The operation does not decrease in the least the ordinary functions of the extensor muscle. Since it can be performed by a surgeon of any competence, it promises in time to become a part of every conservatory course.

As the downwardly projecting point on the helix of the ear is considered by evolutionists to be the remnant of a once pointed ear, so it is not unreasonable to suspect that the unnecessary tendon may be the last traces of a former webbed formation of hand and foot. That its occurrence is not constant is an undoubted proof of its rudimentary nature. It is quite possible that future students of music will hear with wonder of a binding tendon quite unknown in their own experience.

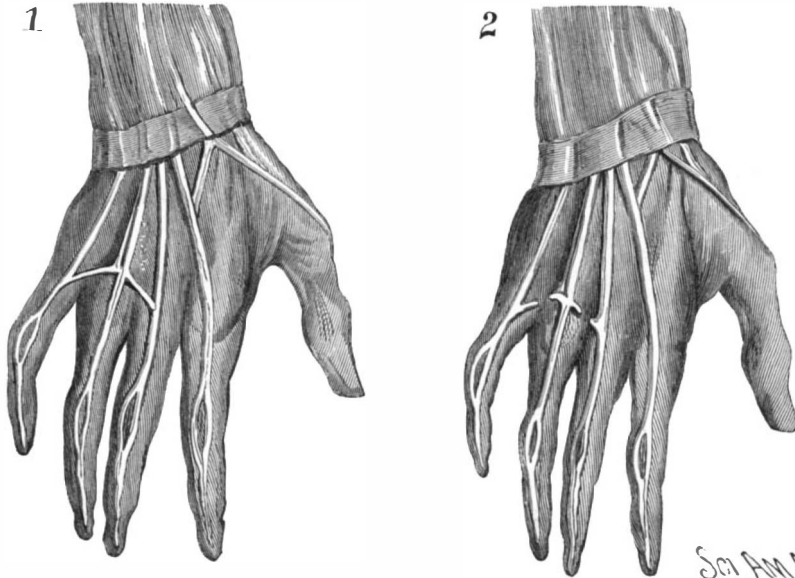

**SURGERY FOR PIANO-FORTE PLAYERS.**

tirely absent. The possibility of removing this restriction in the use of the ring finger by dividing the accessory tendons suggested itself many years ago, but it is only of late years that the operation has become at all common. Dr. Forbes, the Demonstrator of Anatomy at Jefferson College, and Mr. Zeckwer, the Director of the Philadelphia Musical Academy, have both been much interested in the subject, and have done much to make the operation popular.\* By this division of the accessory tendons, the liberation of the ring finger was complete. After such an operation, which is often performed on both hands at one sitting, and without the loss of perhaps more than half a drachm of blood, the finger could be elevated an inch higher above the plane of the hand, and could be used with delightful freedom. There was an entire absence of the sense of exertion which was formerly so painful. Out of fourteen operations which have been performed by Dr. Forbes, all were entirely successful, and in none did any unpleasant results follow. Nor is this result-

\* The illustrations show respectively the muscular system of the right hand in its natural condition and after the operation has been performed.

**FIFTY HORSE HORIZONTAL ENGINE.**

The engine we illustrate is one of a type made by the Societe Lyonnaise, Paris. It has been fixed in the Hotel du Credit, Lyonnais, Paris, for driving the dynamo electric machines which provide currents for the Brush lamps, by which this establishment is lighted.

The distribution of the steam is effected by means of the eccentric, E, and two Farcot valves, T T', on the one spindle, F, guided by the slide, D. On the back of the valves slide two cut-off valves, t t', the movement of which is determined by the governor through the medium of two half cams. On the axes of these cams are fixed two helicoidal pinions, movable by the two screws and the hand wheel, G.

By this means the position of the cams is adjustable, and thereby the cut-off, through a range of from one-fifteenth to one-half the stroke. The arrangement secures very short steam ports. The governor is of the Buss type, driven by gearing, and steadied by an air cushion in the cylinder, H. The engine is fitted with an injection condenser, the double acting air pump of which is actuated by a bell crank lever, and the rod worked from the crank. The bell crank lever also operates the feed pump. The cylinder and its ends are steam jacketed. The condensed water cocks in the cylinder are both moved by one lever, L, and the pipes from them converge in a cock, R. The engine, in case of need, can be worked without the condenser, by closing the admission thereto of the exhaust by the valve shown attached to the condenser, and allowing it to pass into the air. Our information is taken from the *Annales Industrielles*.

VELOCIPEDES of every kind have been expelled from the streets of Berlin by an ordinance of the police, the legality of which has been upheld by the Prussian Court of Common Pleas.

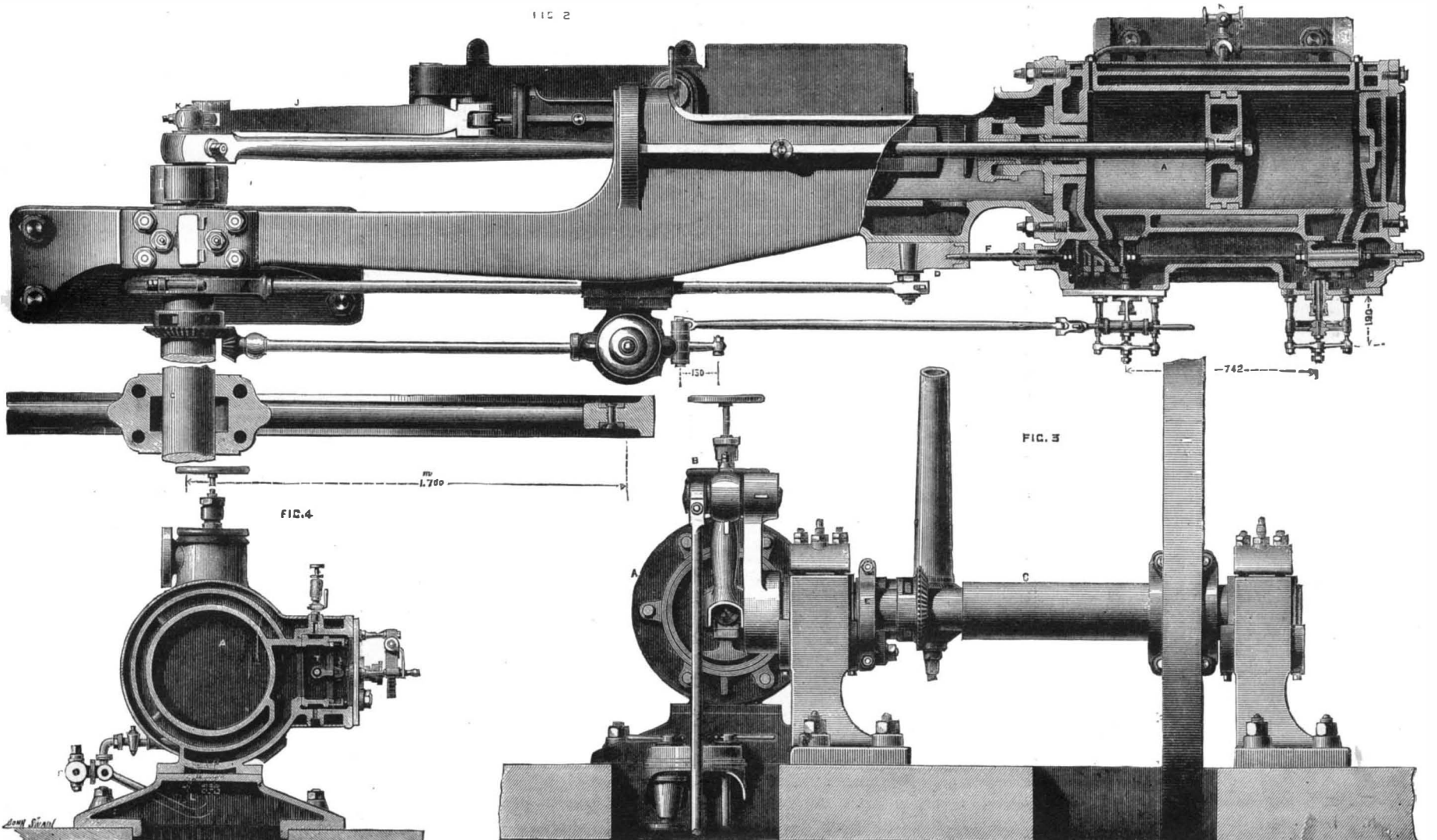

**A FRENCH 50-HORSE POWER HORIZONTAL CONDENSING ENGINE.**



## THE RIGHT WHALE OF THE NORTH ATLANTIC.

As every one knows, right whales were once very common in the Gulf of Gascony, the dwellers along which, in France as well as in Spain, appear to have been the first Europeans to raise the fishery of these monsters of the deep to the rank of a great industry. Upon the coast of Cantabria are still to be seen the ruins of the towers where watchers were stationed to give notice of the approach of the numerous whales that visited these shores during winter, and the remains of the furnaces where the fat was melted. Official documents and royal edicts of the 12th and 13th centuries speak of the whale fishery as an already ancient industry. The majority of the cities of the Spanish coast—Fontarabie, Guetaria, Motrice, etc.—have figures of whales or of fishing implements on their coat of arms.

The Basques were soon no longer content to fish for whales on their coasts, where they were becoming scarcer and scarcer, but pursued them into the English Channel and North Sea, and as far as to Iceland. Later on, at the close of the 14th century, they did not hesitate to sail out upon the broad sea toward the quarter where Cabot, a hundred years afterward, discovered Newfoundland, and where they found the cetacean very abundant during the summer months. Their success made rivals for them, and

perpetuated for a long time, which is still found repeated in many books, and which has been committed not only concerning the right whales of the North Atlantic, but also the various species of true whales distributed through the different oceans. The same causes have everywhere produced the same effects—the almost entire disappearance of the large, utilizable cetaceans. No longer than thirty years ago the whaling industry still occupied whole fleets; and the Americans, who had almost the entire monopoly of it, repeated with pride that their whaling vessels, placed in a line in sight of one another, would occupy more than half of a great circle of the globe. In 1856 they still had 655 ships on the sea, but to-day the industry is almost completely abandoned for lack of whales. Fishing is no longer done except by a few rare ships from the ports of Scotland, that go out to the Polar Sea for seals, and fish for whales incidentally. In the large seas of the temperate zones, the South Atlantic, the Pacific, and the Indian Ocean, where fifty years ago a load of oil was obtained in a very short time, the whale is now so rare that it may almost be said that there is none. It has been said that the whales of these seas fled toward the poles in order to escape man; but it is now well ascertained that the different species of right whales are quartered in spaces in which they accomplish, according to the season, periodical naviga-

two species of right whales—one at the north and the other at the south. They knew besides that these animals never frequented the same waters, and that the northerly limit of the one was the southerly limit of the other.

If representatives of the southern species remained, they must have been very rare, for one could traverse and retrace the North Atlantic without meeting a single one of them. The case is cited of a right whale stranded upon Re Island, in February, 1680, and in 1783 a whaleman harpooned one between this island and Newfoundland. Cod fishermen have spoken much of whales in the vicinity of this island, but science has not pronounced upon it. The whale of the Basques was regarded as extinct, when, on the 14th of January, 1854, a specimen accompanied by a calf showed itself opposite Saint Sebastian. The mother succeeded in escaping, but the calf was captured. Its external form and a study of its skeleton convinced Eschricht that it belonged to a peculiar species differing completely from *B. mysticetus*—hence the appellation *B. biscayensis*, introduced by him into the nomenclature.

Five Balenidæ, either stranded or captured upon the Atlantic coast of the United States between 1862 and 1883, and considered at first by Prof. Cope as belonging to a new species (*B. cisarctica*), have been found to differ in no wise from the Saint Sebastian specimen.

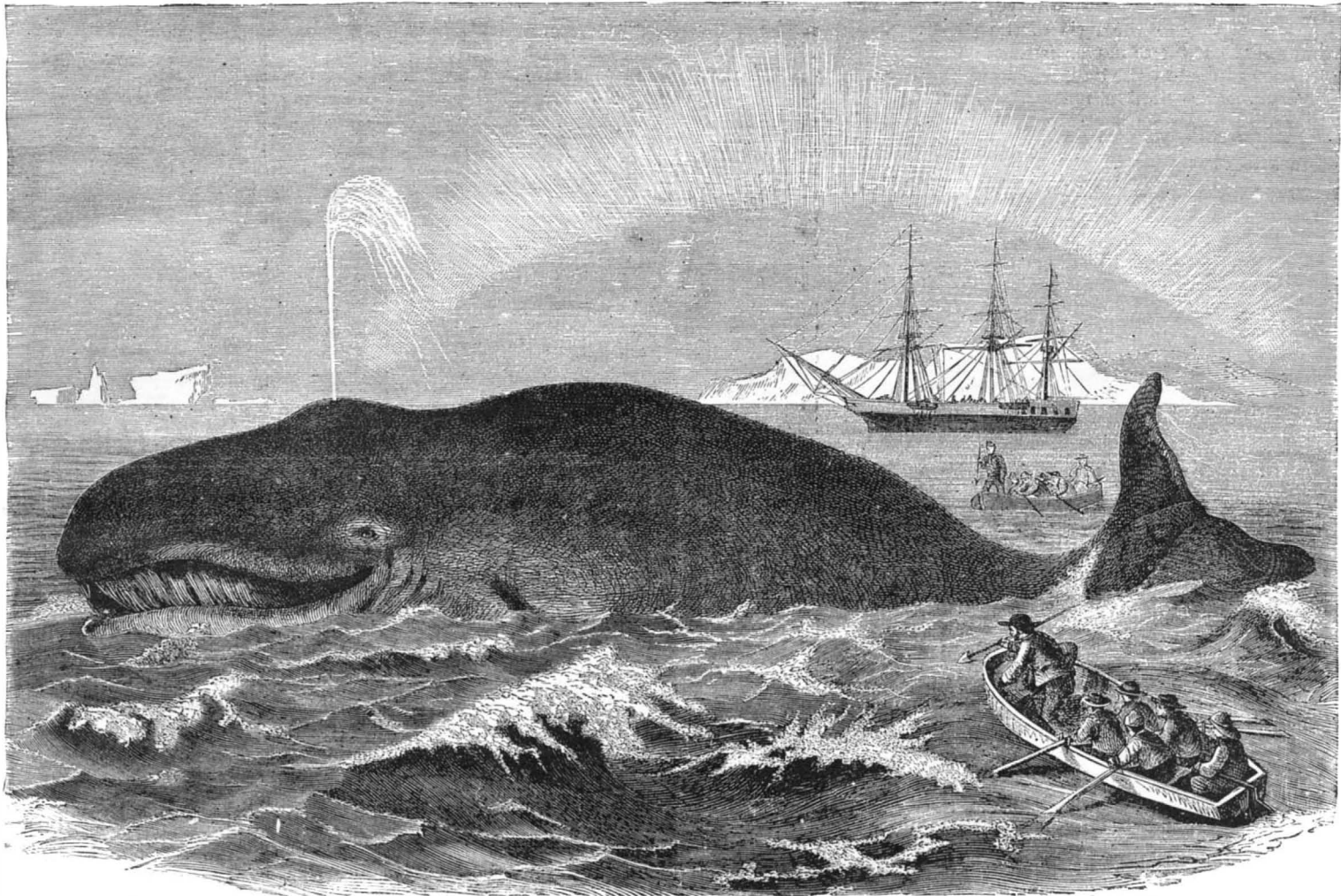

THE RIGHT WHALE OF THE NORTH ATLANTIC.

in 1578 there were, on this part of the ocean, three hundred ships—French, Spanish, Portuguese, and English.

Fishing upon the high sea is scarcely applicable to any but the sperm and true whales—those whose back is even, finless, and without a hump—the “right whales” of fishermen (*Balæna*, L.; *Eubalæna*, Gray; *Leibalæna*, Eschricht). The other cetaceans, the “finbacks” and “humpbacks” of fishermen, and *Balenoptera* and *Megaptera* of naturalists, almost always sink when killed, and are thus lost to the captors unless they are driven into a bay, where the carcass, upon making its appearance on the surface in a few days, can be towed to the shore and cut up. It is very probable, then, that the cetaceans that the old Basques fished for were sperm and right whales, and especially the latter, which were much commoner than the former in temperate or cold water.

As a consequence of the war against it, the whale became more and more rare. In the 17th century the seas in the vicinity of the pole, where navigators in search of a northeast passage to India had sighted a large number of the animals, which were remarkable for their gigantic size, became the scene of the fishery. A century later, the scene shifted to Baffin's Bay. Did these whales and those that were formerly fished for in the temperate part of the Atlantic belong to the same species? Upon the authority of Cuvier, when cetology was scarcely beginning to get out of its swaddling clothes, zoologists answered in the affirmative, and the reason that whales were no longer found in the temperate zone was because they had taken refuge amid the ice of the poles in order to hide themselves from pursuit! This is a gross error, which was

tions that are necessitated by need of food and the parturition of the females, and which their organization does not permit them to leave. If no more of them are found, it is simply because they have been destroyed. Moreover, the frosts of the poles have proved no more of a barrier to whalers than the heat of the tropics; every corner of the globe has been explored whither ships could venture, even at the risk of a thousand dangers. Just as soon as a new field was made known as productive, everybody flocked thither, and it was soon exhausted—a result that is explainable without recourse to the theory of flights or migrations *en masse*.

While regarding the polar whale (*Balæna mysticetus*, L.) as the same as was formerly fished for in the temperate North Atlantic, naturalists (Cuvier among them) catalogued, under the name of *B. glacialis*, another species which differed from *B. mysticetus* in its much smaller size, its slenderer body, its much smaller head, and its shorter mouth plates (“whale bone”), and which inhabited the shores of Iceland and Norway. The Icelanders called it *sletbak*, the Dutch, *nordkaper*, and the French, *sarde*—a name that the Basques gave to the whale of the Gulf of Gascony. It is astonishing that this name did not attract the attention of naturalists, and that they did not ask whether the *sletbak* of the Icelanders, the *nordkaper* of the Dutch, and the *sarde* of the Basques was the same animal. A discussion of the old fishery narratives and of documents derived from the Dutch and Norsemen answers yes. A Norse MS. of the 12th century, the *Royal Mirror*, teaches us that the Icelanders fished in the entire North Atlantic, and they perfectly distinguished

The cetaceans that were called *φαλαίνας* by the Greeks and *balæna* by the Romans were doubtless large balenoptera that entered the Mediterranean, and perhaps also sperm whales (which are sometimes met therein), and not right whales, since these do not seem to have ever frequented this sea, at least regularly. At all events, their presence there had never been authentically announced since historic times until February 9, 1877, when, to the great joy of cetologists, a female was captured in the Bay of Taranto. The length of this was about forty feet. Its relatively slender form, the small size of its head (one-fifth the length of its body), and the shortness of its mouth plates (numbering 240 on each side, the largest of which was only 30 inches, its falcate pectorals, and its black color separated it widely from *B. mysticetus*. Its stomach was entirely empty, and it appeared to have suffered from a long fast. In consequence of this peculiarity, and from its resemblance to the whales of the southern hemisphere, Prof. Capellini, of Bologna, believed that it came from this latter region. To him it was, perhaps, a representative of the Indian Ocean species, one nearly unknown to naturalists, and one that no European museum had the remains of.

Among other objections to this manner of viewing it, there is one that is very important, viz., it has been well proved that the right whale never passes from one coast of the equator to the other, this being for it like a circle of insuperable flames, and that, except in very rare cases, it even keeps outside of the tropics. It was more natural to see in the Taranto whale a North Atlantic species that had strayed into the Mediterranean, and this was proved by a comparison with the Saint

Sebastian calf and other skeletons, and by a very complete study by Prof. F. Gasco. According to the latter, the animal could not have been more than three or four years old, judging by its size, and in admitting that the female of *B. biscayensis* (as shown by several examples) was fifty feet in length. A female of this size, taken by the harpoon off the coast of New Jersey, was towed to New York in the spring of 1882. This also had a wholly black body. From the figure of it given in the *Bulletin* of the American Museum of Natural History (May 1, 1883), it appears to have been more massive than the Taranto specimen. This relative heaviness is perhaps attributable to a difference of age between the two individuals. In short, compared with known examples, it does not exceed the limits of individual variation. Thus the whale of the Basques (*sarde, nordkaper, sletbak, balena biscayensis*, Esch., *B. cisarctica*, Cope) still exists, although represented, it is true, by a small number of individuals. It inhabits the North Atlantic, and in winter frequents the coasts of Europe, and in summer those of North America, where probably the females are delivered. Iceland is its northerly limit. It appears nearly certain that its migrations take place entirely in the course of the Gulf Stream.

For some time past the number of individuals has sufficiently increased on the coasts of South Carolina and Georgia to make it an object to fit out vessels for capturing them, and the operations of these have given results that are satisfactory to the eyes of the promoters, but deplorable to those of naturalists. As its resurrection has been nipped in the bud, will not the species for ever disappear?—*H. Jouan, in Science et Nature.*

#### Engineering as a Profession.\*

A recent writer on political economy says: "The tournament of the world has changed its fields and its weapons. Men no longer strive with lance for a lady's favors. They struggle with matter to change its forms and add to its value. He who can render industry more varied or more efficient, who can turn any element or gift of nature to novel use, is the winner of the prize."

The same writer says further: "Society will not dispense with professional men, although they do not stand so far above the level as in generations ago. We will call upon lawyers when we get into strife over property, and they are necessary to the social structure which protects the person. While sickness comes, doctors will maintain their calling. So long as there is a soul that longs for immortality, clergymen will be welcome in home and pulpit. But with expanding industries, with developing science, new professions have gained favor. Commerce has its spheres in which high training and strong intellects are needed and are well rewarded. So has the varied mechanism of this age. In the professions hundreds are starving in this country in the foolish pride of a decayed caste. In the walks of production, wealth invites every man who will bring brains and industry, which will win skill."

It is of one of these new professions, engineering, that I would speak, and I claim for it a rank as a learned profession equal to that of law or medicine, and second only to that of divinity.

Such a claim, for engineering to rank as a learned profession, worthy of all the honors that have been paid to the older professions, may seem to you, who are students or practitioners in that profession, as an unnecessary statement of a truism—one which needs no proof; you already accept it as almost an axiom. But it is not thus accepted by the world at large. In a recent conversation with a lawyer on this subject, he held that it was impossible that engineering could be of equal rank with the three learned professions of the olden time, since all its work tended only to the material advancement of the race; it benefited civilization only by the increase of wealth which it brought; it was of the earth earthy; in fact, a servant of Mammon; while the other professions were on a higher plane, preserving the life and the morals, and dealing with the intellect and with the immortal part of man. So Charles Dudley Warner, in the *North American Review* for September, 1884, writes of the "Demand of the Industrial Spirit" (of which spirit we must admit that the engineering profession is the handmaiden) as denying the higher wants of the soul, as "demanding a radical revision of the college curriculum, and that the ancient stamp of scholarship shall be put upon industrial and commercial pursuits." He says: "The last demand of the industrial spirit is that all education shall be lowered to its material aims; for lowered it will be, if all distinction is removed in academic honor between an education for the sake of the mind itself and an education dependent on and limited to material and practical aims. The danger in this is no less to science than to literature and philosophy. It is the greatest of all to the tone of modern life."

Such criticisms as these of the modern tendency of

educational methods to fit men for the practical duties of life make it necessary for us to be able to give a reason for our belief that such a tendency is not a degrading one, and that one of the results of such a tendency, that of placing engineering on the high plane of a learned profession, is not a danger to the tone of modern life, but one of its best safeguards, and is a real and important step in the advancement of civilization.

Let us first consider the requirements of the three professions which have hitherto appropriated the distinction "learned," and compare them with the requirements of the profession of engineering. But first we notice that the requirements of the three older professions are not now the same as they formerly were, but are becoming broader and more severe as the general public becomes better educated. In olden times, it might be sufficient for a lawyer to own a few books, to have a knowledge of the forms of law, and to have the ability to browbeat a witness and befog the judge; the doctor needed to be expert with the lance and with the leech, to have a wise expression of countenance like that of the owl, and be faithful in adherence to tradition regardless of the consequence; the minister should be a man of lordly mien, to be able to exercise proper authority and command the respect of his parishioners, and to have the grace of charity and general kindness of manner, so as to make him always a welcome guest in their homes.

In modern times, however, the requirements have greatly expanded. It is necessary for a lawyer, in counsel, to have such intelligence and such honesty as will enable him to advise a client when to avoid as well as when to seek litigation; in advocacy, to have all the powers given by a thorough knowledge of logic and rhetoric, the quickness of perception, the eloquence, and the profound knowledge of the law, which are needed in combat against similar powers arrayed on the other side. In medicine, a doctor must know when to withhold as well as when to give medicine, how to save a leg as well as how to take one off; and he must keep familiar with all the most recent discoveries of medical science, and know how to make proper application of them. In divinity the minister must keep abreast of his flock in intelligence; must be well versed in history, literature, and science, as well as theology, to enable him to meet every new argument against his own beliefs which may be drawn from any branch of human knowledge. These three professions now all ask for the most liberal general culture, including not only a classical education, but a knowledge of the universe of learning, of all that is known or to be known of nature and humanity.

Let us compare these requirements with those of an engineer who should rank as a member of a learned profession. He should be a man of broad, general culture. No branch of education should be looked on by him with contempt, and his culture should be a broader one than that given by the old college curriculum. The "demand of the industrial spirit" is a noble one. It is for a higher and broader education than that of Oxford and Cambridge. All the culture that the Greek and Latin tongues may give, all that history, literature, music, and the fine arts may give, must not be slighted. Do the classics give a man stronger reasoning powers? Does literature give him the graces of speech and the power of the pen to mould human thought? Do the fine arts give him the sense of the beautiful? All these are of benefit to the engineer; but to these he must add, as more important to his professional success, the knowledge of human nature and of finance, gained only in the school of business experience; and of the higher mathematics, which he must use as easily as a mechanic does his two-foot rule; of the sciences which reveal to us the secrets of nature—geology, mineralogy, physics, chemistry, and their allies; and to all these he must add a sound body with a sound mind, a familiarity with the powers and the limitations of the mechanical trades, and a certain amount of personal manual dexterity.

So vast, indeed, is the field of knowledge which the profession of engineering requires as its foundation, that no one man can be expected to encompass the whole of it. As the jack-of-all-trades is generally master of none, so the engineer who attempts to become educated in all branches of even the groundwork of an engineering education, not to speak of the branches of the profession itself, is apt to prove a failure. Hence the necessity not only of specializing the profession of engineering into the branches of military, naval, civil, mechanical, mining, electrical, sanitary, and the like, but also of making a discrimination as to the branches of general education which should be acquired as preliminary to an entrance into the general study of engineering, and of its special branches. Hence the specializing of schools of engineering, Rensselaer devoting itself chiefly to civil engineering, Columbia to mining, Stevens to mechanical engineering.

So much for the requirements of the engineering profession so far as education is concerned. Let us now consider its requirements in actual work.

The work of the engineer has been defined as the overcoming of the resistances of nature, and the best

engineer is he who effectually overcomes these resistances with the least expenditure of time, labor, and money. The successful engineer must love his work for its own sake, and not for its emoluments. He must have the same professional pride that a good lawyer or doctor has, and be ready to sacrifice his money, fame, or even life itself, if duty should demand it. The responsibility thrown upon an engineer is sometimes one whose extent cannot be measured by a money standard. His mistakes may be more serious than those which hurt only the pockets of the lawyer's client, or those which the doctor buries six feet underground. Think of the mistake of the Ashtabula Bridge, the engineer of which committed suicide; of the Tay Bridge, the disaster to which is said to have broken the heart of its builder. And as to financial responsibility, how many millions of dollars have been lost by engineering mistakes? See the abandoned mines and mills in our gold and silver districts, the silent blast furnaces and rolling mills built in the wrong locations, the waste of money and of life in the Hudson River Tunnel and in the Panama Canal.

No higher trusts are assumed by any other profession than by that of engineering. It behooves that profession, therefore, as much as any other, to be sensitive of its honor. Shall a judge be corrupt, or a lawyer defraud his client? No more should an engineer either give or take a bribe, or do aught to bring dishonor on himself, or to demoralize his associates. In manners he should be beyond reproach, but in integrity beyond suspicion.

In its rewards the profession of an engineer is not behind any other. If statistics could be brought to bear, I have no doubt that professional engineers could be found, on an average, to be reaping greater financial rewards than the average of doctors, lawyers, and ministers of the same number of years in practice. Mr. Roberts, in his "Government Revenue," estimates that of physicians only one-third earn over \$2,000 per year, one-fifth earn between \$1,000 and \$1,500, the next one-fifth will strive for \$1,000, and one-fourth will get only \$600, \$500, or less. Of lawyers he says the annual earnings of less than one-fourth are \$2,000 per year, one-tenth in addition receive \$1,000 a year. "No calculation can bring the number getting \$1,000 a year from their profession to one-half of those on the rolls as in active practice. One-fourth do not earn \$500 annually from legal business." I have no doubt that the engineering profession would show a much better record than this if statistics could be obtained.

In the reward of public fame and honor, no profession stands higher than that of the engineer. If a list of the benefactors of mankind since the time of Archimedes should be made, the engineers of the world would be conspicuous in it, both in the number of their names and in the grandeur of their achievements.

There is one grand distinction between the professions of law, medicine, and divinity and that of engineering. The former are the professions of conservatism, the latter is the one of progress. The object of the profession of medicine is the conservation of life; that of law, the conservation of morals and the rights of property; that of divinity, the conservation of belief. Engineering, however, is essentially progress. Its history is one of continual advancement. It is like science itself, so far in fact that many of the advancements in civilization greatly credited to science, pure and simple, are really the achievements of engineering, an applied science, of which pure science is but the handmaid. In this connection I may quote from Prof. Thurston's paper on the "Mission of Science," and you will note that the word "engineering" might be used wherever he uses the word "science":

"A century ago, with the birth of the steam engine, later with the introduction of the product of the printing press into the daily life of the world, with the operation of the electric telegraph and the introduction of the railroad, began the real progress of science, and we are now seeing but the beginning of her awe-inspiring career. She has taught us to drive 10,000 tons across the seas by the might of over 12,000 horse power engines. She has taught us to send printed messages across the continent; she has shown us how to drive railroad trains faster than birds can fly, yet the mission of science has made but the veriest beginning. It still remains to her to perfect and systematize a thousand new industries, to invent as yet unimagined new arts, to bring the laborer worthy of his hire all that he needs and all that he can desire for his own comfort and for the care and comfort of his family, to adjust the power of production to that of consumption, and both to the working capacity of the world, so that the now seeming natural conflict between labor and capital shall no longer have even an appearance of existence."

Probably similar thoughts were in my own mind three years ago when, writing from the Electrical Exhibition in London, I mentioned the possibilities of future achievements of one branch of engineering, the electrical. I said: "These currents of electricity shall furnish power to drive our railway cars, our road vehicles, and our steamboats; shall furnish energy to run our sewing machines, to raise our water, to light and warm our houses, and cook our food. They shall sepa-

\* Extract from an address to the Alumni Association of the Stevens Institute of Technology, by Wm. Kent, M.E., President of the association, delivered June 18, 1885.—*Van Nostrand's Engineering Magazine* for August.

rate the ore from the dross, shall reduce and fuse the ore into metal, and shall gild and refine not only our metals, but our whole civilization. And when this is done—when man has subdued unto himself all the forces of nature and forced them to do his work, will he work any fewer hours or less hard? Will he take any more rest, or any more pleasure, or will he be the same overworked, nervous, ambitious, and dyspeptic creature that he is now? Will electricity solve the labor problem? Ah! these are questions apparently beyond the reach of our present philosophy, but they are questions which the future is bringing to us with terrible rapidity. It is wise to look them in the face."

I have thus given you briefly some of my views on the requirements of the engineering profession, of the work it is called upon to do, and of some of its future possibilities. I hope you see, as I do, that the profession is not altogether of the earth earthy, that it is not altogether a profession whose end is simply the increase of wealth of a favored few, but that it is a profession charged with as weighty responsibilities and duties to the human race as any other; that it is the profession to which the world must look for nearly all future advances in civilization, whether these come through the engineering of war, civilizing barbarians by the means of modern artillery, through sanitary engineering, at the same time preserving the health and benefiting the morals of mankind, or through inventions which shall so increase the wealth of the human race at large that the primal curse of labor may be to a great extent removed, and the race have more time than it now has for the cultivation of its intellectual, moral, and spiritual nature.

#### The Iron Business.

The present condition of the iron industries, though by no means all that could be desired, may fairly be looked upon as satisfactory. If circumstantial evidence goes for anything, the recent amicable settlement of labor difficulties in the Pittsburg district and the West indicates a better feeling among manufacturers, if not an actual revival of a long stagnant industry. Owing to the almost deplorable condition of the market during the past year, the manufacturers found themselves paying rates for labor unwarranted by the scale of profits, and they determined, when the scale of wages should be adjusted on the 1st of June for the present year, to insist upon a reduction. The result was a general strike of the men and the shutting down of the mills. Later on the demands of the men for last year's scale were acceded to with some trifling changes, and the whole district blossomed once more into life.

Considering the reiterated complaints of the manufacturers, based upon facts and figures, that there was no profit in iron making at the old rates, there was something strange in their sudden acquiescence, and for a time it looked as though only those mills having large contracts unfilled would fire up. But it very soon became apparent that this was not the case.

The whole iron making community of Pittsburg and the West seemed, of a sudden, to see signs ahead that warranted them in paying rates which, but a short time before, they had refused to consider seriously. It is possible that besides the chances of a good market in the autumn, they saw a means of reducing the cost of manufacture by the use of natural gas, a fuel which is now used throughout the Pittsburg district in lieu of coal.

However that may be, the iron mills are now actively engaged in turning out iron to meet the expected demand.

The present condition of the market, though this, of course, is not to be taken as an index to what is to be three months hence, may be looked upon as unusual, if not extraordinary. The quality of iron reaching the market is not up to the mark, and far in excess of the demand, and yet there is a ready sale at good figures for the best grades, and not enough of the latter to go round.

The bugaboo concerning cheap Southern iron, which for a time created not a little consternation among Western and Eastern ironmakers, has at last disappeared, and those enthusiastic persons who have been writing to the press about the cheapness of iron manufactured in the South, and naming ridiculously low figures at which it could, with a profit, be placed on Northern markets, may now turn their attention to other and more promising themes.

The American Institute of Mining Engineers performed a valuable service when, through their president, Mr. J. C. Bayles, they made a searching investigation into the facts concerning iron manufacture in the South.

Before the meeting of the society at Chattanooga Mr. Bayles said: "When the red fossil ores of Alabama were first in demand, they were taken off the Red Mountain outcrop, and of course gave strength and encouraged the statement that vast quantities of ore were in sight and required no mining. They panned out 50 per cent virgin iron, though giving no trouble whatever in mining. In estimating the cost of producing iron from these ores, it was assumed that two tons of ore to the ton of iron would be needed, and that the ore at

furnace would not cost more than sixty cents per ton. But of this surface ore the quantity is comparatively limited. To secure a supply, mining below the surface is necessary, and as we go deeper we find that the ore becomes harder and more difficult to mine, as well as leaner in iron, averaging only about forty per cent. When operations began, a good miner could easily mine eight to ten tons of the soft surface ore a day without explosives, but it requires a good hand to mine four tons of the hard ore in a day, even with a liberal use of forty per cent dynamite. Consequently, instead of making a ton of iron with two tons of ore, costing one dollar and twenty cents, it requires two and two-fifths tons of ore, costing about two dollars and forty cents per ton of iron.

"For furnaces so situated that a railroad haul is necessary, twenty-five cents per ton must be added, bringing the cost of ore up to about three dollars per ton of iron, or one dollar and eighty cents more than the original estimates. There is plenty of ore in Red Mountain, but it is not all available. Its quality varies as much as its quantity. Much of it is so silicious as to have no present value. According to the best information I can gain, the red fossil ores used at all the coke furnaces in Alabama carry an average of seventeen per cent silica, and the percentage increases as greater depths are reached. The surface ore contains but little lime, while the hard ore contains from fifteen to thirty per cent. In this variation is found the explanation of much of the difficulty experienced by furnace managers in Alabama. The greatest care is necessary to keep the surface ore and the hard ore separate, and the burden must be changed frequently. Hence limesets and scaffolds are very common, and the time lost by reason of these almost unavoidable accidents would turn a Northern furnace manager's hair gray in a very brief period.

"Taking into consideration the quality of the red fossil ores of Alabama, the most favorable of this district, the quality of coal for coking, the inconveniently placed location of limestone, and the troublesome labor questions, I have the best and most intelligent as well as the most conservative local authority for calculating the cost of iron making at the point where the natural advantages seem to be greatest, as follows, per ton of pig iron: 2 3-5 tons of ore at \$1.25, \$3.25; 2 tons of coke at \$2.50, \$5.00; 1 ton of limestone, 85 cents; salaries and labor, \$2.50; interest and expenses, 50 cents; repairs and replacement, 50 cents. To this is added the average cost of getting to market, which is estimated at \$4, making the total cost about \$16. Mr. Bayles could see nothing in these figures to discourage iron makers or alarm producers of other sections. The hope of the South is a large local consumption of iron. Most of its pig iron product now pays freight to Northern rolling mills and foundries, and such part of it as is needed for Southern use pays a second transportation charge when returned in manufactured forms. In this respect Southern industrial development has not been uniform. Its permanent prosperity will be found in rolling mills, machine shops, foundries, and manufacturing industries to consume pig iron and convert it into a form which will bear transportation better than the raw material."

The increased and increasing demand for steel is resulting in changing many iron mills into steel works, and the new process for steel making (the Clapp-Griffiths), unless its virtues are greatly exaggerated, makes the presence of phosphorus in American ores no hindrance in steel manufacture. This process is pneumatic, and in more than one particular resembles the Bessemer, but it differs from that in the construction and management of the converter and the position of the tuyeres; the latter being in the sides instead of the bottom of the vessel.

With the prospects of a good trade in the immediate future, mills and shops engaged in all kinds of manufacture are showing a disposition to renew or improve their plants, and the result is already seen in the increased activity in the iron and steel works, the only class of iron manufacture remaining abnormally dull being that engaged in supplying the railway trades.

#### The New Exposition at New Orleans.

The buildings and plant of the World's Cotton Centennial Exposition at New Orleans have been bought by a stock company for \$175,000, the amount of indebtedness attached to the late enterprise. The new Board of Managers are to reopen in the fall again, under the title of the North, Central, and South American Exposition, the display to be opened to the public November 10, and close not later than March 31. The plans and regulations are similar to those of the last exposition, and the display is intended to cover the same class of exhibits. The entry book for exhibitors is to be opened August 1 and closed November 5, so there need be no delay in opening at the appointed time with everything in order from the start. The company to manage the new exposition is organized under the laws of Louisiana, with a capital stock of \$500,000, and it is said will not ask or expect aid from the government.

#### Sunstroke, or Thermic Fever.

No error can be fraught with more dangerous consequences than that of failing to discriminate between heat exhaustion and true sunstroke. The former is comparatively a mild affection, which does not differ in symptoms from any other form of acute exhaustion. It is characterized by dilated pupils, a cold, pale, and perspiring skin, a quick but feeble pulse, with great general prostration, and a tendency to syncope. Recovery ensues within twenty-four hours under rest and the administration of stimulants.

True sunstroke, or *coup-de-soleil*, is a far more terrible affection. It is characterized by contracted pupils, a hot, dry, and flushed skin, rapid, and forcible pulse, throbbing carotids, labored or stertorous breathing, with profound coma, or delirium and convulsions ending in coma. In the fulminant cases that have been observed, the unfortunate persons have dropped dead as if struck a mortal blow by an unseen hand. Contrary to the popular opinion, it is not necessary that the patient should have been exposed to the direct rays of the sun. For as was noticed by many distinguished observers, and practically demonstrated by Dr. H. C. Wood, Jr.,\* in his experiments on animals, excessive heat and heat alone is the essential factor in this disease. Many of the worst cases have occurred at night, in houses, in tents, and in narrow defiles, where the sun never entered, but where the atmosphere was hot and stifling. It is, therefore, a true fever, and, as suggested by Dr. Wood, should be designated thermic fever, as expressive of its exciting cause.

The treatment, which must be instituted promptly, can be summed up in three words: reduce the temperature. It is the extraordinary high temperature which is burning up the patient, and which, unless speedily reduced, will cause death by paralysis of the heart. He should therefore be at once removed to a shady place in the fresh air, his head slightly elevated, and his whole body, especially his head and chest, kept deluged with ice water. An icecap, in addition, should be applied to the back of his head, until his temperature and pulse have fallen. Aconite internally will also probably be found beneficial in controlling the circulation. Morphine, hypodermatically, has been found to be of great value in cases characterized by restlessness and convulsions. If the attack has come on shortly after a meal there can be no doubt of the propriety of at once unloading the stomach by an emetic. If the patient is insensible, apomorphia, gr. one-tenth, may be given hypodermatically. The Australian physicians produce emesis in these cases by the rectal injection of twenty grains of ipecac. They have always noticed an abatement of the symptoms as soon as vomiting began.—*Medical Bulletin*.

#### An Early Safety Lamp.

The first attempt toward a safe light of which there is any record was one made in the year 1760, by Mr. Carlisle Spedding, of Whitehaven, Eng. He invented the machine known as the steel mill, which consisted of a spur and pinion wheel, geared about 6 to 1, fixed in a wooden frame on the same shaft as the pinion, being a steel disk about 6 inches in diameter. The disk was made to revolve rapidly, while the player, as the person who worked it was called, held a piece of chalk flint against its sharp edge. This produced a rapid succession of sparks, giving a light—though but a feeble one—for the miner to work by.

When firedamp was known to exist, the players were instructed to be careful not to work it too rapidly, so that the coruscations might be of the lowest temperature possible. At the time of its introduction, the machine was considered perfectly safe, but such was not the case, for in spite of every precaution, explosions of firedamp were known to be the result of its use. It was rarely used in working places, but frequently in exploring and traveling in old workings. The color of sparks emitted by the mill afforded some test as to the quantity of firedamp present. The sparks were of a dull red where but a small percentage of firedamp was present, but they were of a very bright red color where the gas was of a strong explosive mixture.

As each machine required a separate person to work it, the expense of maintaining a large number of steel mills was necessarily very heavy, and their cost would be sure to militate against their general adoption. It is said that at one time the workings in Hebburn Colliery were entirely lighted by the steel mills, of which they had over fifty at work.

#### The Gulf Stream.

From his observations during the past three months, Captain Pillsbury finds that the strength of current of the Gulf Stream is invariably on the Florida instead of the Bahama side of the stream. He has found the temperature of the stream to range from 42 degrees to 81 degrees. The greatest velocity of the stream at the surface is about 4½ knots, but the fluctuations are frequent and great.

\*Thermic Fever, or Sunstroke. By H. C. Wood, Jr., M.D. J. B. Lippincott & Co., Philadelphia. Boylston Prize Essay.

**ENGINEERING INVENTIONS.**

A car coupling has been patented by Mr. Joseph T. Hammick, of Rhinebeck, N. Y. It is simple in construction, and is designed for coupling cars without going between them, and so that cars can be uncoupled from the top or either side, making a device calculated to be strong and durable, and yet one which can be easily operated.

A gearing for reverse shafts has been patented by Mr. William F. Cowden, of Cumberland, Md. This invention covers an improvement in gearing, and is especially intended for driving shafts of twin propellers, although it is also capable of use as a substitute for a cog belt and like gearing in mills, workshops, etc., where it is desired to drive two shafts in opposite directions.

A rail chair has been patented by Mr. Timothy L. Beaman, of Knoxville, Tenn. It is formed of two sections, each having an inwardly and an outwardly projecting base flange, an inward projection above the base, with other special features, whereby the cross ties or sleepers may be laid at any desired depth below the surface of the street without increasing the width or depth of the rail.

A refrigerator car and a refrigerator system for cars are the subjects of two patents which have issued to Mr. David Hennessy, of New York city. This invention contemplates the use of an ice machine instead of ice and the circulation of cold brine or other suitable cooling liquid through all or any of the cars of a train, the whole forming a traveling cooling plant, to be used in carrying meat and other perishable articles from place to place; the brine is forced by a pump from the ice machine through all the cars as desired and returned to a brine tank, and a fresh water condenser is used in combination with the motor that works the refrigerating apparatus.

**AGRICULTURAL INVENTIONS.**

A potato digger has been patented by Messrs. Hans and Jacob Nelson, of Waupaca, Wis. Combined with a frame and plow is a wheel journaled in the rear of the plow with toothed arms projecting from it and inclined upward from the plane of the wheel, with means for revolving the wheel by the forward movement of the machine, thus digging the potatoes and separating them from the soil.

A pulverizer and cultivator has been patented by Messrs. John R. Silas, Asa Chambers, and William J. Davis, of Cleburne, Texas: This invention covers special novelties in the construction and combination of parts, for pulverizing the soil in an improved manner, and with less expenditure of power in draught, and so the land can be plowed close up to plants growing in rows, but which are not regularly in line with one another.

**MISCELLANEOUS INVENTIONS.**

A spoke setting machine has been patented by Mr. Charles P. Lewis, of Sweet Springs, W. Va. This invention covers a special construction to enable spokes to be rapidly driven into the hub by unskilled labor, and so that every spoke shall have precisely the same slant or dish.

A gate has been patented by Mr. John F. Hopgood, of Morganfield, Ky. This invention covers a special arrangement of parts and details to simplify the construction of a gate which can be opened from either side by a pedestrian or a person in a vehicle by pulling on a rope or wire.

A folding umbrella has been patented by Mr. Samuel J. Wilson, of Wellsborough, Pa. The ribs are formed in sections, the smaller outer one adapted to slide into a larger inner one, and the stick has a hinge at or near its middle, so the umbrella can be folded in about half the usual length of an umbrella.

An oil drip pan for sewing machines has been patented by Mr. William Connolly, of South Norwalk, Conn. Combined with the machine table is a compound drip pan, with an upper trough or pan having drainage outlets and a subjacent detachable pan, there being a perforated strainer between the machine and the lower detachable pan.

A supporting attachment for pants, overalls, and drawers, has been patented by Mr. Isidor Stark, of New York city. Combined with the body and waistband of the pants, which have suspending loops and eyes, is a curtain having button holes in line with the loops and eyes, so the curtain can be used to suspend the pants, overalls, etc.

A lamp has been patented by Mr. Fritz S. Svenson, of Lund, Sweden. This invention covers a special construction and combination of parts for a lamp which can be lighted, extinguished, or cleaned without requiring the removal of the lamp chimney and globe, so these parts are not so liable to be broken, and the lamp can be easily handled.

A minnow bucket has been patented by Mr. William W. Hough, of Mound City, Ill. It consists of a perforated bucket with an annular float, a spring operated cover hinged to the top of the float over its central opening, and an outer impermeable bucket, the bucket being simple in construction, floating easily, and yet strong and durable.

A sewer gas excluder has been patented by Lydia N. Jackson, of New York city. It consists in a rubber cap and two crossed pivoted levers held therein, having hooks at their inner ends and finger plates at their outer ends, the inner ends of the levers being drawn together by a spring and passed into the apertures of the overflow grating to hold the cap in place.

A journal box has been patented by Messrs. Simon and Willis Shuffelbarger, of Eddville, Ill. Combined with an axle having an annular groove are box sections with cavities and anti-friction rollers in the groove and cavities, a split steel spring band surrounding the rollers, the rollers being thus held securely in place to reduce wear and make the box more durable.

A hand truck has been patented by Mr. John C. Dean, of Indianapolis, Ind. Its side bars are formed of tubes, round or oval in cross section, united by a series of transverse tubes, with their ends split and

held in opposite directions to form curved tongues, which fit against the inner sides of the tubes, each held by a rivet passed through the tubes and the tongues.

A pin tag has been patented by Mr. James J. Murphy, of New York city. It has an inflexible base, on which is an outside card or paperticket, and a pin or wire fastening arranged to project through the base, secured thereto by an under bridge portion, and upper bent over portions, the device making a finer and more durable pin tag than those heretofore in use.

A package for whitewash has been patented by Mr. Charles F. Crockett, of Mount Vernon, N. Y. The box or package has triangular corner pieces to form compartments at its upper corners, so that in putting up whitewash for the market the buyer may at the same time be supplied, in the same package, with a suitable quantity of glue and coloring matter to use therewith.

A mixed paint has been patented by Mr. William H. Van Keuren, of Winona, Minn. This invention consists in the production, as a new article of manufacture, of paint powder from the "pipe stone" of Minnesota and Dakota, or from fused pipe stone, making an article which has certain general proportions of silica, alumina, oxide of iron, potassa, soda, and carbonate of lime.

A screw bolt lock has been patented by Mr. Gayger D. Tolman, of Shawano, Wis. A screw bolt has a longitudinal screw threaded aperture, its lower end having a smooth inclined shoulder, in combination with a screw having a portion smooth and tapered to correspond with the inclined portion, making a device for locking screw bolts so they will not turn.

A sofa bed has been patented by Mr. George W. Robbins, of Los Angeles, Cal. Cleats project beyond the rear sides of the main frame, the back frame is jointed to the main frame, and an auxiliary frame with longitudinal bar is hinged to the lower edge of the back frame, all so constructed and fitted as to make what may be convertibly used as either a sofa or a bed.

A hot air fireplace has been patented by Mr. Doyel Pearson, of Memphis, Tenn. The fire box has a forwardly-inclined back plate with side flanges, and with ribs, while there are tubular grate bars and a partition in combination with special inlet and outlet, so that fire places can be more largely utilized for heating rooms, and the heated air can be more efficiently directed.

A water gate has been patented by Mr. Daniel T. Hoppood, of Morganfield, Ky. This invention consists in a hinged gate and a horizontally-pivoted fender at the up-stream side, so made that the fender will be opened by the gate as the latter is opened by the rising of the water, to prevent the opening of water gates by live stock and keep the animals from entering adjacent lands.

A grinding mill has been patented by Messrs. Alphonso L. and William T. Anderson, of Tolland, Conn. Combined with the shafts, stones, frame, etc., is a nut within the frame, constructed to slide but not rotate therein, a screw passing through an apertured arm and the nut, elastic washer, etc., in order to provide for the separating of the stones should a hard substance pass between them.

A ratchet driving mechanism has been patented by Mr. Daniel H. McCoy, of Smithville, N. J. It is so made that the pawls of the driving clutch shall act more positively to drive or operate the connected machine, preventing noisy rattling of the pawls, so that a machine, or such device as a bicycle, may be run freely in either direction without effect on the ratchet driving mechanism.

A vehicle spring has been patented by Mr. John A. Birkmer, of New Lexington, Ohio. It is a compound spring with single upper spring widened at its mid length and with narrowed outer portions having eyes, in combination with sectional elliptical lower springs, so connected and arranged as to give to the vehicle a soft and easy motion, and form an even and steady riding spring.

A machine for spinning and twisting has been patented by Mr. Leedham Binns, of Philadelphia, Pa. This invention relates to cap spinning frames, and covers a tube made to engage with the bobbin and arranged around the whirl tube, upon which it is fitted to slide, so that a bobbin of considerable length can be used, and a steady and smooth rising and falling motion is secured for it.

An escapement for watches has been patented by Messrs. Gerson Kricheski and Abraham Edmonds, of New York city. This invention consists principally of a curved or circular detent or locking piece for the escapement wheel, which piece has a circular movement for releasing the teeth of the escapement wheel, with specially devised means for rotating the escapement detent.

A double grinding paint mill has been patented by Mr. John A. Berrill, of Waterville, N. Y. The frame of the upper mill rests upon the hopper of the lower mill, and has downwardly projecting lugs and hand screws, whereby the upper mill will be supported by and securely connected with the lower mill, with other novel features to promote convenience and economy of space.

A velocipede has been patented by Mr. Adam Rugally, of New York city. Combined with the frame are a driving shaft and wheels with ratchet wheels and pinions on the shaft disks mounted rigidly on the shaft, pins engaging with the ratchet wheels, rocking levers with curved racks engaging with the pinions, and there being springs for pulling the rear ends of the levers upward.

A combination table has been patented by Messrs. George D. Overin and Otto Meyers, of New York city. It has an upper sliding frame and preferably a hinged top, and combined with the main frame a sink, bread tray, rolling pin compartment, and bread and chopping board, having also a sliding ironing board adapted to be drawn out for use and shoved within the table when not in use.

A faucet or valve has been patented by Mr. Joseph Darling, of Karns City, Pa. Combined with

the valve body is a hollow divided plug having radial slots, the stem having radial lugs fitted into said slots, with other special features, so that the plug can easily be kept tight, and the seats of the turning plug are not subjected to wear from gritty particles in the fluid passing through.

A fireplace attachment has been patented by Mr. Thomas W. Dickinson, of Sharon, Pa. It consists of a metallic or fireproof flexible curtain with its roller supported in brackets detachably connected by hooks and slots to the mantel or fireplace front, which can be so operated as to serve as a blower to regulate the draught, and to answer the purpose of a summer front.

A box fastener has been patented by Mr. Charles R. Nelson, of New York city. Combined with a clamp plate having an aperture in one end, is a plate adapted to be secured on the box, and having an internally threaded tubular projection, which is passed through the aperture in the clamp plate, and a screw for holding the clamp plate on the projection, making a device for rapidly fastening and unfastening covers.

A vehicle seat has been patented by Mr. Francis W. Coleman, of Rodney, Miss. It consists in a flexible tension surface of canvas leather, or other analogous material, combined with and attached to horizontal end frames journaled in uprights, with other novel features, to make a seat which will be soft, elastic, and cool, or the invention may also be used in making lounges, bed bottoms, chairs, etc.

A side bar vehicle has been patented by Mr. Elisha Dupue, of Skinner's Eddy, Pa. This invention covers certain novel features in the parts or gearing which give an elastic support to the body and connect it with the axles, and the axles and head block together, being applicable to both high and low vehicles, and dispensing with the usual perches, perch plates, and bolts, and wooden spring bar.

A door check has been patented by Mr. Christian A. Schmidt, of Hoboken, N. J. Combined with a spring bolt is a slide with wedged prongs adapted to act on pins or projections on the bolt, thereby withdrawing the bolt more or less and regulating its throw, the device being adapted to hold doors in certain positions, but permitting them to pass if sufficient pressure is brought to bear.

A gate latch has been patented by Mr. Samuel B. Elzey, of Morrisville, Mo. The construction is such that when the gate is swung against the post the projecting end of a bolt strikes the bottom edge of a latch and raises it, the latch afterward dropping in front of the bolt and unlocking the gate; to open the gate a handle is pressed down which withdraws the bolt, the bolt resuming its position by the action of a spring when the pressure on the handle is removed.

A cover for pots has been patented by Isabella Ann Lyon, of Boston, Mass. Combined with the cover is a hinged piece closing an opening therein, and having along its swinging outer edge a downwardly projecting perforated piece, and along its side edges strips with flanges, to prevent the hinged piece from swinging out too far, to facilitate drawing off the water from vegetables without removing them from the pot.

A shutter worker has been patented by Mr. John Dierks, of Harlan, Iowa. A hinge with one leaf has an externally toothed socket or eye, the teeth being directly in the surface of the socket, while a spindle has a screw thread or worm engaging the toothed socket or eye of the leaf, so a shutter or blind can be opened and closed by turning a handle in the spindle, and the blind will be retained in any position, more or less opened.

A chemical fire extinguisher has been patented by Mr. Joseph A. DeMaulec, of Paris, France. The alkaline containing vessel has fixed around the outside of its collar a funnel which serves as a seat to hold the spherical acid containing vessel superposed thereon, a novel arrangement permitting the acid receiver to serve for an indefinite time, and to fulfill the double object of an acid receiver and of a stopper for the apparatus.

A carbonaceous antiseptic dressing has been patented by Mr. Aron F. Westerlund, of Stockholm, Sweden. The invention consists in a carbon wool obtained by soaking vegetable matters in mixtures of water and phosphoric acid, or boracic acid, or phosphates or borates, then drying the material and carbonizing it, the product being suitable to use as an insulator for electric lamps, for keeping vegetable substances, disinfection, and keeping wounds clean.

**NEW BOOKS AND PUBLICATIONS.**

**THE MANUAL OF PHONOGRAPHY.** By Benn Pitman and Jerome B. Howard. Cincinnati: Phonographic Institute, 1885.

This little volume of about 150 pages is a revised edition of the Manual of Phonography by Benn Pitman, which first appeared in 1855. It has since run through several editions, and has been the standard text book in America. The present edition contains many improvements, and is quite abreast of phonographic progress. The main part of the book is devoted to the correspondence style of phonography, and an effort has been made to provide a system of sufficient simplicity to induce its adoption in ordinary business and social communications. The subject has been logically developed, following closely phonetic principles, and introducing as little empiricism as possible. As something less than two hundred words, by their frequent repetition, make up more than half the vocabulary of ordinary speech and correspondence, abbreviated forms for these have been introduced, and constitute a desirable feature of the book. The authors state that the system presented permits from two to three times the speed of ordinary longhand. The contents also include a number of well selected exercises, and a brief introduction to the reporting style, indicating the contractions necessary to enable one to keep pace with a rapid speaker. The volume is compact and well made, the phonographic characters being particularly clear and intelligible—that is, when one is initiated.

**Business and Personal.**

The charge for insertion under this head is One Dollar a line for each insertion; about eight words to a line. Advertisements must be received at publication office as early as Thursday morning to appear in next issue.

H. Clay Scott, Minneapolis, Minnesota, writes that the notice in our issue July 4, of his Indestructible Asbeston Wick and Burners, has flooded him with letters for circulars, agencies, and burners. A meritorious article like this will always sell.

Providence Steam Engine Co., Providence, R. I., are sole builders of the "Improved Greene Engine."

Steamboats supplied with Pumps for every service by Valley Machine Works, Easthampton, Mass.

Billings' Drop Forged Lathe Dogs, 12 sizes— $\frac{3}{4}$  to 4 inches. Billings & Spencer Co., Hartford, Conn.

One 20 x 48 Corliss Engine, in good order, for sale by Henry I. Snell, 135 North Third Street, Philadelphia, Pa.

Cotton Factory, complete equipment, for sale. Address W. W. Jennings, Harrisburg, Pa.

Astronomical Telescopes, from 6' to largest size. Observatory Domes, all sizes. Warner & Swasey, Cleveland, O.

Peerless Leather Belting. Best in the world for swift running and electric machines. Arny & Son, Phila.

"How to Keep Boilers Clean." Send your address for free 88 page book. Jas. C. Hotchkiss, 85 John St., N. Y.

The most complete catalogue of Scientific and Mechanical Books ever published will be sent free on application to Munn & Co., 361 Broadway, N. Y.

Shafting, Couplings, Hangers, Pulleys, Edison Shafting Mfg. Co., 86 Goerck St., N. Y. Send for catalogue and prices.

Air Compressors, Rock Drills. Jas. Clayton, B'klyn., N. Y.

Iron Planer, Lathe, Drill, and other machine tools of modern design. New Haven Mfg. Co., New Haven, Conn.

Wanted.—Patented articles or machinery to manufacture and introduce. Lexington Mfg. Co., Lexington, Ky.

Mills, Engines, and Boilers for all purposes and of every description. Send for circulars. Newell Universal Mill Co., 10 Barclay Street, N. Y.

Presses & Dies, Ferracite Mach. Co., Bridgeton, N. J. For Power & Economy, Alcott's Turbine, Mt. Holly, N. J.

Send for Monthly Machinery List to the George Place Machinery Company, 121 Chambers and 103 Reade Streets, New York.

If an invention has not been patented in the United States for more than one year, it may still be patented in Canada. Cost for Canadian patent, \$40. Various other foreign patents may also be obtained. For instructions address Munn & Co., SCIENTIFIC AMERICAN patent agency, 361 Broadway, New York.

Guild & Garrison's Steam Pump Works, Brooklyn, N. Y. Steam Pumping Machinery of every description. Send for catalogue.

For Sale.—Patent on Exercising Bars described in SCIENTIFIC AMERICAN of June 2, 1883. Address Geo. Worthington, 57 Second St., Baltimore, Md.

Machinery for Light Manufacturing, on hand and built to order. E. E. Garvin & Co., 139 Center St., N. Y.

Nickel Plating.—Sole manufacturers cast nickel anodes, pure nickel salts, polishing compositions, etc. Complete outfit for plating, etc. Hanson, Van Winkle & Co. Newark, N. J., and 92 and 94 Liberty St., New York.

For Steam and Power Pumping Machinery of Single and Duplex Pattern, embracing boiler feed, fire and low pressure pumps, independent condensing outfits, vacuum, hydraulic, artesian, and deep well pumps, air compressors, address Geo. F. Blake Mfg. Co., 44 Washington St., Boston; 97 Liberty St., N. Y. Send for catalogue.

Supplement Catalogue.—Persons in pursuit of information of any special engineering, mechanical, or scientific subject, can have catalogue of contents of the SCIENTIFIC AMERICAN SUPPLEMENT sent to them free. The SUPPLEMENT contains lengthy articles embracing the whole range of engineering, mechanics, and physical science. Address Munn & Co., Publishers, New York.

*Knots, Ties, and Splices.* By J. T. Burgess. A Handbook for Seafarers and all who use Cordage. 12mo., cloth, illustrated. London, 1884. Sent, postage prepaid, on receipt of 75 cts., by Munn & Co., New York.

Send for catalogue of Scientific Books for sale by Munn & Co., 361 Broadway, N. Y. Free on application.

Mineral Lands Prospected, Artesian Wells Bored, by Pa. Diamond Drill Co. Box 423, Pottsville, Pa. See p. 46.

C. B. Rogers & Co., Norwich, Conn., Wood Working Machinery of every kind. See adv., page 62.

If you want Engines, Boilers, or Machinery of any kind, send your address to Henry I. Snell, 135 North Third Street, Philadelphia, Pa.

We are sole manufacturers of the Fibrous Asbestos Removable Pipe and Boiler Coverings. We make pure asbestos goods of all kinds. The Chalmers-Spence Co., 419 East 8th Street, New York.

Curtis Pressure Regulator and Steam Trap. See p. 12.

The Crescent Boiler Compound has no equal. Crescent Mfg. Co., Cleveland, O.

Steam Hammers, Improved Hydraulic Jacks, and Tube Expanders. R. Dudgeon, 24 Columbia St., New York.

Emerson's *Best Book of Saws free. Reduced prices for 1885.* 50,000 Sawyers and Lumbermen. Address Emerson, Smith & Co., Limited, Beaver Falls, Pa.

Hoisting Engines, Friction Clutch Pulleys, Cut-off Couplings. D. Frisbie & Co., Philadelphia, Pa.

Barrel, Keg, Hogshead, StaveMach'y. See adv. p. 76.

For best low price Planer and Matcher, and latest improved Sash, Door, and Blind Machinery, send for catalogue to Rowley & Hermance, Williamsport, Pa.

Patent Elevators with Automatic Hatch Covers. Circular free. Tubbs & Humphreys, Cohoes, N. Y.

Nervous, Debilitated Men. You are allowed a free trial of thirty days of the use of Dr. Dye's Celebrated Voltaic Belt with Electric Suspensory Appliances, for the speedy relief and permanent cure of Nervous Debility, loss of Vitality and Manhood, and all kindred troubles. Also for many other diseases. Complete restoration to health, vigor, and manhood guaranteed. No risk is incurred. Illustrated pamphlet, with full information, terms, etc., mailed free by addressing

Voltaic Belt Co., Marshall, Mich.

Split Pulleys at low prices, and of same strength and appearance as Whole Pulleys. Yocom & Son's Shafting Works, Drinker St., Philadelphia, Pa.

Notes & Queries

HINTS TO CORRESPONDENTS.

**Names and Address** must accompany all letters, or no attention will be paid thereto. This is for our information, and not for publication. **References** to former articles or answers should give date of paper and page or number of question. **Inquiries** not answered in reasonable time should be repeated; correspondents will bear in mind that some answers require not a little research, and, though we endeavor to reply to all, either by letter or in this department, each must take his turn. **Special Information** requests on matters of personal rather than general interest, and requests for **Prompt Answers by Letter**, should be accompanied with remittance of \$1 to \$5, according to the subject, as we cannot be expected to perform such service without remuneration. **Scientific American Supplements** referred to may be had at the office. Price 10 cents each. **Minerals** sent for examination should be distinctly marked or labeled.

(1) T. E. M. writes: Having occasion to use the following:  
 R. Sodii borat. . . . . 3 ss.  
 Sodii bicarb. . . . . 3 ss.  
 Acid carbol. . . . . 3 ii.  
 Glycerine. . . . . 3 ii.  
 Aque ad. . . . . 3 viii. M.

I was astonished at the bottle bursting with great force. No effervescence occurs until the glycerine is added, when it equals a Seidlitz powder solution. The same preparation I have long used in about one-eighth or one-tenth the above proportions to the same amount of water, in which no such reaction occurs, and this strength was prepared for the purpose of diluting when used. Will you please explain the cause of the effervescence? It will not occur if either the borax or soda is left out, but only when both are used, and only when the glycerine is added, and in proportion to the quantity of glycerine. A. Messrs. Senior and Lowe reported to the Pharm. Journ. and Trans., 1878, the result of experiments made with a view of determining the cause of the effervescence alluded to. A solution of borax (or other acid borates) to which a little litmus was added turned deep blue, but on the addition of some glycerine changed to the characteristic wine red produced by free boric acid. When sodium monoborate was used instead of borax, no red color was developed. They conclude that the glycerine separates the borate into free boric acid and a more basic borate, the former causing the evolution of the carbonic dioxide. Mannite, levulose, and dextrose are said to act in a similar manner to glycerine. Carbonic dioxide may be liberated from a bicarbonate by boiling with borax. The subject is treated in the *Druggists Circular* for June, 1873, and July, 1883. The same question came up at the March meeting of the Kings County Pharmaceutical Society, and is referred to on page 103, *Weekly Drug News*, March 14, 1885.

(2) R. B. R. asks (1) a receipt for a strong glue or cement used in sticking the ends of the cylindrical small wooden boxes for pills and ointment, made use of in medical dispensaries. A. An excellent liquid glue is prepared as follows: Soak 8 ounces of best glue in 1/2 pint of water in a wide mouth bottle, and melt by heating the bottle in a water bath. Then add slowly 2 1/2 ounces of nitric acid, stirring constantly. Effervescence takes place under escape of nitrous acid gas. When all the acid has been added, the liquid is allowed to cool. Keep it well corked, and it will be ready for use at any moment. 2. Treatises with information regarding the machinery for matches, etc.? A. There is "A Practical Treatise on the Fabrication of Matches, Gun Cotton, etc.," by H. Dussauce, costing \$3.00. There is also an excellent article on the manufacture of matches contained in the recent *Encyclopedia of Industrial Arts*, two numbers, 75 cents each. 3. I am perfectly deficient in the sense of smelling. Is this a natural defect or arising from some disorder in the system? Will you kindly propose any remedy for the cure? A. This is a question for a physician to decide. The nerves of smell are deadened according to your statement, but whether they are destroyed we cannot venture to express an opinion.

(3) G. H. F. writes: 1. What is the method of refining kerosene oil? A. The different grades are separated by distillation, the lighter products coming over first, while the heavier ones come over later on, leaving a residue of coke in the retort. 2. How may any one test a sample of oil? I have tested by gently heating a quantity in a cup and watching the temperature as shown by thermometer with bulb immersed, applying a match to see at what temperature it would take fire. A. The method adopted by you is the process generally employed for testing kerosene, and is what is known as the flashing test. The degree at which the oil burns is known as the burning test. In Massachusetts there are specially appointed inspectors who examine the oil used for illuminating purposes. The Massachusetts law of 1869 fixes the flashing point of safe oil at 100° F., and igniting point at 110° F.

(4) J. M.—Wood engravings are made by first coating the wood with a white wash, and then drawing in free hand with pencil or brush directly on the wood the design which is wanted. The block is then cut, an electropenis made, from which the printing is made.—Lithography is described in answer to query 13, *SCIENTIFIC AMERICAN* for May 9, 1885.—Photo-engraving processes are numerous, and most of the best ones are described in the various issues of the *SCIENTIFIC AMERICAN SUPPLEMENT*. See catalogue of subjects.

(5) C. G.—Both zinc sulphate and iron sulphate are soluble in water. A saturated solution is one in which it is impossible to dissolve any more of the sulphate. In other words, use as little water as possible in making your solution.

(6) A. S. desires to know the method of preparing an insoluble cement from bichromate of potash and glue. A. In order to render glue insoluble in water, even hot water, it is only necessary, when dissolving the glue for use to add a little potassium bi-

chromate to the water and expose the glued part to the light. The proportion of bichromate will vary with circumstances; but for most purposes, about one-fiftieth of the amount of glue will suffice.

(7) E. B. writes: I am getting up a collection of different kinds of wood with the bark on. Can you tell me of any receipt to keep it in good condition, and also keep worms and bugs from destroying both wood and bark? A. As you say you do not wish to use varnish or shellac, which is usually employed, dipping the wood in a solution of corrosive sublimate would probably be best, as it is an excellent antiseptic and on account of its poisonous qualities. Solutions of chloride of zinc can likewise be used. Camphor and like substances protect by driving insects away, but they are of doubtful utility.

INDEX OF INVENTIONS

For which Letters Patent of the United States were Granted,

July 21, 1885,

AND EACH BEARING THAT DATE.

[See note at end of list about copies of these patents.]

Aerated beverages, apparatus for filling and siruping, J. McEwen	322,738
Aeriform fluids, apparatus for mixing, Walworth & Seyter	322,661
Agricultural machines, tooth securing device for, C. E. Stonesifer	322,597
Air motor, A. M. Koniakowsky	322,616
Airtight vessels, device for closing, A. Evans	322,433
Alarm, See Railway alarm.	
Ammoniacal gas, apparatus for producing, C. B. Lee	322,458
Animal trap, M. B. Marshall	322,736
Automatic sprinkler, F. B. Comins	322,685
Axle box, E. P. Curtiss	322,584
Bags, etc., holder for, A. N. Barnes	322,408
Bale tie, F. B. Griswold	322,442
Baling press, C. Smith	322,651
Bark press, J. Daigneau	322,687
Barrel, keg, or similar article, L. M. Reed	322,641
Bed bottom, J. H. Brown	322,577
Bed pan, C. C. Thompson	322,503
Bed, sofa, G. W. Robbins	322,643
Bed, wardrobe, Wirts & Scholle	322,880
Bedstead, adjustable double, A. T. Schlichting	322,645
Beer into siphons, etc., apparatus to prevent frothing when filling, F. Heyman	322,719
Beer into siphons, etc., preventing frothing when filling, F. Heyman	322,720
Beer kegs, apparatus for supplying and regulating the pressure of carbonic acid gas in, Baumeister & Bartsch	322,410
Bell circuits, indicator for electric, Leipner & Brotherhood	322,619
Bench clamp, H. C. Fenton	322,434
Berth, ship's, C. A. Milligan	322,466
Billiard table, N. H. Ganser	322,436
Blind, Venetian, W. H. Lang	322,732
Block and switch signal, L. E. Wimer	322,877
Board, See Bosom board.	
Boiler, See Steam boiler.	
Bolt lock, screw, G. D. Tolman	322,657
Book finishing machine, F. W. Davenport	322,526
Boot or shoe, T. P. Mitchell	322,487
Bosom board, J. A. Emmert	322,703
Bosom fold machine, G. E. Norris	322,551
Bottle stopper, L. Ehrlich	322,702
Bottles, cleaning, R. Robinson	322,644
Bottling machine, J. A. Brown	322,576
Box fastening, W. S. Thayer	322,868
Brake, See Car brake. Wagon brake.	
Bran duster, A. Heine	322,715
Breastpin, H. P. Pruim	322,640
Brick moulds, machine for sanding, Judson & Hancock	322,455
Bricks, appliance for laying, M. Raymond	322,563
Bricks, building blocks, etc., made of purified ashes and lime, E. L. Ransome	322,559
Bridge, draw, W. D. Bullock	322,787
Bridge, draw, J. Groves	322,708
Buckle, back band, F. Millett	322,624
Buggy boot, D. Buckler et al.	322,518
Bung and faucet for ale and beer barrels, combined, Reilly & King	322,853
Burial case, P. T. Cregan	322,424
Burial caskets, device for securing lids to, R. Otto	322,471
Burner, See Hay and straw burner. Hydrocarbon burner. Vapor burner.	
Bustle, E. B. Cady	322,678
Button attaching instrument, J. F. Thayer	322,655
Button fastener setting instrument, F. H. Richards	322,483
Cable, elastic tubular, P. Sorgue	322,493
Cable roads, conduit for, J. Warner	322,766
Calimine compound, W. K. Powers	322,851
Can, See Oil can.	
Candlestick, J. C. Schlarbaum	322,753
Car brake, J. M. T. Daudelin	322,585
Car brake, C. S. Hart	322,597
Car brake, C. L. Sledge	322,490
Car brake clamp, C. A. Fuller	322,536
Car coupling, J. Barry	322,672
Car coupling, A. L. Eriar	322,814
Car coupling, H. Field, Jr.	322,591
Car coupling, I. A. Whitman	322,512
Car step, Race & Guernsey	322,749
Car wheel and axle, J. H. Black	322,575
Car wheels, making, W. Pelz	322,635
Cars, head rest for railway, C. Munagle	322,843
Carbonaceous antiseptic dressing, A. F. Westerland	322,664
Carpet stretcher and tack driver combined, C. F. Crockett	322,799
Carriage brake, child's, G. W. & A. A. Hodges	322,721
Carriage seat, J. Pariseau, Jr.	322,555
Carrier, See Shear carrier.	
Cartridge shell, Knight & Docker	322,730
Case, See Burial case. Watch case.	
Caster, S. M. Michelson (r)	10,627
Ceiling, fireproof, P. B. Wight	322,873
Centrifugal machine, W. H. Tolhurst	322,762
Chain, drive, C. E. Alden	322,405
Chain, drive, C. H. Eggleston	322,431
Chain, drive, W. Stephens	322,653
Chair, See Sewing chair.	
Check for horses, driving, E. L. Metcalf	322,627

Child's chair, F. F. Parker	322,472
Chuck, drill, F. De Forest	322,807
Chuck, lathe, E. Pement	322,636
Churn, C. Hanna	322,445
Churn, J. G. Harris	322,712
Churn, J. C. Moody	322,742
Churn, K. A. Rodger	322,854
Circuit breaker, sparkless, L. H. Speller	322,494
Clamp, See Bench clamp. Car brake clamp. Skate clamp.	
Clasp, See Shoe clasp.	
Cleaner, See Seed cleaner.	
Clipping horses, etc., machine for, J. C. Wilson, Sr.	322,668
Clutch or loose pulley device, J. W. Corey	322,423
Clock and indicator, combined gauge, S. Macfarlane	322,837
Coffee roaster and cleaner, Schmitt & Huber	322,646
Coffin, D. B. Hiser	322,604
Coil, neutralizing, Jackson & Chambers	322,725
Collar fastener, M. F. Maddox	322,462
Collar or cuff, C. H. Denison	322,697
Collar or cuff, E. Kipper	322,729
Condenser, J. Klingel	322,615
Cooker, steam, D. M. Armstrong	322,774
Cooking utensil, R. H. & E. A. Everett	322,532
Cooling and refrigerating apparatus, F. G. Johnson	322,826
Corn sheller, Barnard & Cornwall	322,777
Corn sheller, E. C. Fisher	322,535
Corset, M. P. Bray	322,677
Corset, J. M. St. Claire	322,497
Coupling, See Car coupling. Pipe coupling. Shaft coupling. Spring coupling. Thill coupling.	
Cradle, grain, W. B. Smith	322,885
Cultivator plant shield, D. Cramer	322,524
Cultivator running gear, F. G. Bright	322,411
Cut-off valve, C. Harmon	322,711
Cutter, See Sod cutter.	
Damper, automatic, S. P. Smith	322,492
Damper for shafts, E. F. Kittoe	322,832
Derrick, D. Sharp	322,756
Ditching machine, P. Ahlund	322,771
Ditching machine, Titus & Morrall	322,656
Door check, J. H. Shaw	322,648
Door check, T. G. Williamson	322,513
Door check, pneumatic, G. Vincent	322,763
Door hanger, S. Shreffler, Jr.	322,488
Door opener, electric, T. A. Casey	322,681
Door spring, J. H. Shaw	322,649
Draught equalizer, A. Sellers	322,647
Draught regulator, automatic, M. H. Smith	322,491
Drill, See Grain drill. Rock drill.	
Drum, heating, J. P. Lydon	322,549
Egg packer, H. Handy	322,444
Electric indicating apparatus, M. W. Grovesteen	322,818
Electric lights, holder for incandescent, O. A. Moses	322,744
Electric switch, E. B. Nicolaus	322,745
Electric switch, F. Schaefer	322,857
Electric signal apparatus, M. W. & M. F. Parrish	322,474
Electrical synchronous movements, effecting, P. B. Delany	322,690, 322,691
Electrically maintaining synchronous movements, P. B. Delany	322,692
Elevators, automatic safety guard for, F. P. Hinds	322,452
Embalming device, J. Jackson	322,541
Embalming table, adjustable, G. P. Gaston	322,437
Embroidering machine, J. Sobotka	322,860
Embroidering machines, device for securing the needles in, W. H. Farmer	322,704
Embroidery, imitation bead, E. Cornely	322,582
End gate, wagon, S. G. Travis	322,506
Engine, See Gas engine. Pumping engine. Wind engine.	
Excavating machine, Scherff & Wolf	322,858
Expansion joint, P. Koch	322,457
Eye-glass, J. J. Bausch	322,673
Eye-glasses, A. C. Lord	322,461
Fabrics, machine for forming raised ornaments by threads on, R. Guerrand	322,537
Fan attachment, C. E. Eaton	322,530
Feed water purifier and heater, J. P. Warner	322,767
Fence machine, G. W. Homsher	322,822
Fence machine, wire, S. Watson	322,872
File, paper, R. H. Welch	322,663
Filter, hydrant, G. W. Shawk	322,486
Finger ring, adjustable, F. N. Foster	322,435
Firearm, breech-loading, W. S. Teall	322,568
Fire escape, G. W. Kern	322,613
Fire escape, portable, W. H. Bechtel	322,778
Fire extinguisher, chemical, J. A. De Mauler	322,587
Fire extinguisher, hand, G. I. Chapin	322,683
Fire extinguisher holder, E. C. Nelson	322,468
Fireplace, hot air, D. Pearson	322,634
Fishing rods, joint ferrule for, W. H. Reed	322,750
Floor cloth, waterproof cloth, etc., figured fabric or material for, Hebblewhite & Holt	322,601
Flouring mill rolls, adjusting device for, I. H. Eisenberg	322,432
Folding machine, J. G. Northrup	322,552
Foot rest, J. S. Clark	322,792
Furnace, See Roasting furnace.	
Furnace door arch, R. R. Zell	322,883
Gauge, See Saw table gauge.	
Garment and carrying device attached thereto, Myers & Rogers	322,844
Gas engine, J. F. Place	322,477
Gas engine, C. Shelburne	322,650
Gas, etc., heating burner for, H. B. Chess	322,791
Gas, method of and apparatus for generating, Isbell & Taylor	322,608
Gas regulator, T. Angell	322,572
Gate, See End gate. Hatch gate. Water gate.	
Gate, Carpenter & Dudley	322,419
Gate, W. A. Preston	322,852
Gate hanger, J. S. Pringle	322,556
Gear, reversing, H. D. Coleman	322,797
Gear wheel, J. C. Wilson, Sr.	322,667
Gearing for reverse shafts, W. F. Cowden	322,798
Glass surfaces and signs, decoration of silvered, R. Stern	322,864
Governor, steam engine, J. Kelly	322,456
Grain and seed separators, recleaner for, A. Miller	322,465
Grain binder, J. E. Giles	322,439
Grain binder, C. M. Young	322,770
Grain drill, H. R. Wolfe	322,669
Grain separator, I. Hess	322,820
Gridiron, C. M. Cooke	322,686
Grinding mill, A. L. & W. T. Anderson	322,773
Guard, See Railway switch safety guard.	
Gusset, armhole, W. Sachs	322,855
Hanger, See Gate hanger.	
Harmonica holder, W. H. Dawley	322,586
Harrow, F. A. Johnson	322,827
Harvesting machine, corn, Lewis & Allen	322,459
Hatch gate, elevator, C. T. Schulze	322,488
Hay and straw burner, H. W. McClure	322,737
Hay gatherer, J. H. Poage	322,639
Hay loader, J. H. Lux et al.	322,836

Hay loading and unloading apparatus, K. E. Lathrop	322,618
Hay tedder, J. F. Winchell	322,878
Heel blanks, applying top lifts to, F. F. Raymond, 2d.	322,561
Heel machine, J. Tingley	322,761
Heel nailing machine, F. F. Raymond, 2d.	322,560
Hoist, miner's, H. S. Bailey	322,516
Holder, See Sash holder.	
Holder for legal blanks, C. R. Smead	322,758
Hook, See Whiffletree hook.	
Hook, A. B. Robinson	322,484
Hoopskirt, I. H. Day	322,806
Horseshoe, C. Sheather	322,564
Horseshoe, W. Somerville, Sr.	322,652
Horseshoe, expanding, C. C. Allen	322,671
Horseshoe nail, J. C. Kearns	322,542
Horseshoe pad, M. S. Starkweather	322,861
Hub, vehicle, P. P. Smith	322,759
Hub, vehicle, F. W. Starr	322,863
Hydraulic testing machine, U. Cummings	322,800
Hydrocarbon burner, H. A. Bradley	322,676
Ice machine, A. R. Kenney	322,829
Ice machine, J. M. W. Neff	322,550
Indicator, See Time and interest indicator. Valve indicator.	
Induction disturbances, apparatus for suppressing, Jackson & Chambers	322,724
Induction, neutralizing, Jackson & Chambers	322,728
Induction neutralizing coil, Jackson & Chambers	322,727
Induction, suppressing, Jackson & Chambers	322,726
Injector and injector nozzle, O. Westphal	322,768
Insecticide, A. Muller	322,630
Iron and steel, compound for purifying, W. H. Purdy	322,557
Iron and steel, purifying, W. H. Purdy	322,558
Iron, utilizing the waste cuttings of tinned, J. H. Kolb	322,833
Joint, See Expansion joint. Rail joint. Toggle joint.	
Kerite compounds, manufacturing of crude, A. G. Day	322,804
"Kerite," making the compound termed, A. G. Day	322,802
"Kerite," vulcanized product termed, A. G. Day	322,803
Knife, See Oilcloth knife.	
Knitting machine needle, G. E. Jones	322,454
Ladder, extensible, T. R. Park	322,632
Ladder, folding, T. S. Diston	322,699
Ladder, step, C. E. Bronson	322,414
Lamp and holder, sealing wax, Hoyt & Nichols	322,539
Lamp burner, H. W. Hayden	322,599
Lamp burner, H. D. Place	322,850
Lamp extinguisher, automatic, W. S. Burgess	322,579
Lamp, incandescent electric, P. K. Stern	322,498
Lamp, miner's safety, Wolf & Friemann	322,514
Lamp, multiple incandescent electric, W. Stanley	322,496
Lamps, apparatus for suspending arc, J. Young	322,515
Lantern, E. K. Haynes	322,448
Latch, gate, S. B. Elzey	322,589
Laundry reel, B. R. Hawley	322,538
Lead, apparatus for the manufacture of white, H. G. Blyth	322,782
Leather blacking machine, J. Hodkinson	322,606
Leather, glazed kid, T. R. Clark	322,521
Lifter, See Stove lifter.	
Lock, See Bolt lock. Mortise lock. Seal lock.	
Lubricator, P. Barclay	322,407
Mail crane, J. H. Harden	322,709
Match boxes, machine for making, Newton & Beecher	322,470
Match splint machine, Flewelling & Harris	322,708
Mattress machine, Mears & Jennings	322,740
Metal working machine, compound, E. A. Oliver	322,547
Meter, See Oscillating meter.	
Mill, See Grinding mill. Windmill.	
Mortise lock, L. Tighe	322,605
Motion, device for converting, R. Campbell	322,679
Motion, device for converting, T. C. Fleming	322,815
Motor, See Air motor. Sewing machine or other motor. Water motor.	
Motor, Cloud & Vogt	322,794
Musical instrument, mechanical, R. W. Pain	322,554
Musical instrument, mechanical, I. T. Stanley	322,566
Nail, See Horseshoe nail.	
Nail machine, M. B. Brown	322,413
Neck and ear protector, combined, I. B. Kleinert	322,614
Nipple protector, C. Ware	322,508
Nut, cap headed screw, C. D. Thatcher	322,867
Nut lock, F. L. Miller	322,628
Nut lock, D. S. Troy	322,869
Oil and water, separator for mingled, H. H. Garrett	322,817
Oil cabinet, H. Kroemmelbein	322,834
Oil can, H. B. Hart	322,447
Oil can, A. Tufts	322,569
Oilcloth knife, A. S. Seaman	322,755
Oil previously used in mechanical operations, process of and apparatus for reclaiming, Cromwell & Coy	322,425
Oiler, car axle, Menely & Gibbons	322,625
Ore feeder, J. Hendy	322,716
Organ reed, A. Newell	322,469
Organ stop-action, reed, J. A. Warren	322,509
Oscillating meter, E. Tatham	322,500
Oyster dredge, E. Watts	322,511
Pad, See Horseshoe pad.	
Paint, mixed, W. H. Van Keuren	322,659
Pan, See Bed pan.	
Paper and other fibrous material for journal bearings, beltings, etc., treatment of, H. W. Morrow	322,629
Paper pulp, treating vegetable substances for making, Young & Pettigrew	322,882
Paper stock, apparatus for bleaching	

Press. See Baling press. Bark press. Tobacco press. Pressure regulator, fluid, Cabell & Abney..... 322,519 Printing machine, P. Jackson..... 322,609 Printing machine chromatic attachment, W. H. Goding..... 322,441 Printing press feeding attachment, E. Yates..... 322,670 Protector. See Neck and ear protector. Nipple protector. Puller. See Stump puller. Pulverizer and cultivator, J. R. Chambers et al..... 322,420 Pump bucket, chain, W. B. Wilcox..... 322,874 Pump valve, P. T. Coffield..... 322,795 Punch, duplex ticket, M. M. Welch..... 322,632 Pumping engine, steam, J. C. Born..... 322,784 Quilts or comforts, filling for bed, M. H. Marcus..... 322,735 Rail joint, R. V. Jones..... 322,828 Railway alarm, E. L. Edmonds..... 322,430 Railway and car, etc., parabolic, M. Geber..... 322,594 Railway bumping post, E. W. Ellis..... 322,812 Railway crossing, J. Daly..... 322,801 Railway electric, E. M. Bentley..... 322,517 Railway electric, E. W. Siemens..... 322,859 Railway rail, F. W. Brooks..... 322,412 Railway switch safety guard, M. F. Bonzano..... 322,783 Ratchet driving mechanism, D. H. McCoy..... 322,622 Reel. See Laundry reel. Refrigerator building, J. F. Hanrahan..... 322,446 Regulator. See Draught regulator. Gas regulator. Pressure regulator. Ring. See Finger ring. Roaster. See Coffee roaster. Roasting furnace, Black & Larkin..... 322,780 Rock drill, I. Reese..... 322,642 Roller. See Shade roller. Roofing machine for double seaming tin, E. L. Osborn..... 322,848 Rope fastener, T. Taylor..... 322,501 Rotary shears, G. O. Gilmer..... 322,440 Sash cord fastener, G. W. Graves..... 322,707 Sash fastener, W. S. Cunningham..... 322,426 Sash fastener, J. Paillet..... 322,553 Sash holder, F. P. Catlin..... 322,520 Saw, drag, R. Gurney..... 322,596 Saw, drag, J. J. Parker..... 322,473 Saw table gauge, M. B. Banowitz..... 322,775 Sawing machine, circular, C. Trier..... 322,658 Sawing machine, screw, D. W. Perry..... 322,748 Scale, weighing, A. Turnbull..... 322,870 Scow, dumping, G. D. Barney..... 322,409 Screw cutting machine, L. Wilkinson..... 322,575 Seythe snath fastener, D. T. Chambers..... 322,682 Seal lock, car door, J. A. Kirby..... 322,830 Seed cleaner and huller, R. B. Hutchcraft..... 322,824 Seed, removing fiber from cotton, F. Montgomery Seeding machine, G. W. Miskimen..... 322,841 Separator. See Grain separator. Wheat, oats, and cockle separator. Sewing chair, C. G. Little..... 322,547 Sewing machine, A. Faulkner..... 322,533 Sewing machine, S. W. Wardwell, Jr..... 322,571 Sewing machine, buttonhole, P. Diehl..... 322,423 Sewing machine buttonhole attachment, Egge & Sjoberg..... 322,811 Sewing machine oil drip pan, W. Connolly..... 322,522 Sewing machine or other motor, C. W. & W. C. Collyer..... 322,422 Shade roller, S. Hartshorn..... 322,713 Shaft and pulley bearing, W. E. Crist..... 322,525 Shaft casing, W. F. Hutchinson..... 322,540 Shaft coupling, H. Tabor..... 322,866 Shaft, flexible, J. C. Wilson, Sr..... 322,666 Shafts, ball and roller bearing for, D. H. Rice..... 322,482 Sheaf carrier, Berger & Harris..... 322,779 Shears. See Rotary shears. Sheller. See Corn sheller. Ship's log, registering, J. & G. H. Bliss (r)..... 10,625 Shirt, S. Thal..... 322,502 Shirts, attaching bosoms to, M. Hermann..... 322,717 Shoe clasp, S. A. Chapman..... 322,789 Shutter worker, J. Dierks..... 322,588 Signal. See Block and switch signal. Skate clamp, T. C. Merz..... 322,464 Skate, roller, J. T. & C. T. Jones..... 322,611 Skate, roller, Kramer & Snider..... 322,617 Skate, roller, H. Ogborn..... 322,846 Skate, roller, J. H. Thompson..... 322,504 Snap, harness, J. Gibbons..... 322,438 Snap hook, T. Beecher..... 322,674 Snow plow, E. Payne..... 322,849 Sod cutter and pulverizer, J. R. Phillips..... 322,638 Sole nailing machine, F. F. Raymond, 2d..... 322,562 Speed governor, E. Penney..... 322,637 Spigot, measuring, J. W. Witt..... 322,876 Spinning and twisting machine, L. Binns..... 322,675 Spinning and twisting machine, spindle and bolster for, J. J. Sumner..... 322,654 Spring. See Door spring. Vehicle spring. Spring coupling, T. D. Lines..... 322,734 Spring heads, die and punch for making clips for carriage, A. Kronenbitter..... 322,544 Spring heads, ear piece for forming, A. Kronenbitter..... 322,545 Sprinkler. See Automatic sprinkler. Stalls, device for releasing animals from, Heistand & Swade..... 322,603 Stamps, apparatus for affixing, V. I. H. Bundsen..... 322,578 Stamps, box and pad for canceling, J. A. Fife..... 322,534 Steam boiler, T. Drummond..... 322,701 Steam boiler, J. C. McNeil..... 322,623 Steam boiler, B. N. Payne..... 322,475 Steam engine link, S. T. Bryant..... 322,415 Stoker, mechanical, J. Hodgkinson..... 322,605 Stone lifter, D. English..... 322,813 Stone sawing machine, J. G. Hofer..... 322,821 Stopper. See Bottle stopper. Stove, T. Burkhard..... 322,580 Stove, C. Lancaster..... 322,731 Stove, gas, T. Fletcher..... 322,592 Stove or furnace regulating device, S. W. Jackson..... 322,610 Stove oven, gas, oil, and vapor, R. M. Cain..... 322,418 Stump puller, F. Blazier..... 322,781 Superphosphate, manufacture of, F. Dibben..... 322,638 Suspend attachment, T. O. Potter..... 322,479 Suspenders, T. O. Potter..... 322,478 Syringe, M. Hart..... 322,598 Table. See Billiard table. Embalming table. Tag, pin, J. J. Murphy..... 322,631 Tank, C. Olsen..... 322,746 Target trap, A. H. Hebbard..... 322,714 Telegraph for synchronous telegraphy, printing, Delany & Calahan..... 322,693 Telegraph, quadruplex, L. O. McPherson..... 322,739 Telegraphs, receiving apparatus for synchronous, P. B. Delany..... 322,688 Telegraphy, printing device for synchronous, P. B. Delany..... 322,689 Telegraphy, relay for synchronous multiplex, P. B. Delany..... 322,808 Telegraphy, synchronous, P. B. Delany..... 322,427 Telephone offices, signal call for, A. H. Low..... 322,835 Telephone receiver, J. E. Fuller..... 322,884

Thermostat, electric, C. E. Kells, Jr..... 322,612 Thermostat for fire alarms, J. J. Byrne..... 322,417 Thill coupling, T. P. Randall..... 322,481 Thill coupling, F. M. Waters..... 322,510 Tie. See Bale tie. Time and interest indicator, R. T. Sitterley..... 322,757 Tobacco press, J. C. Barkley..... 322,776 Toggle joint, F. L. Ellis..... 322,531 Toy bowling alley, circular, P. Burkel..... 322,416 Toy, educational, E. Schueller..... 322,754 Track, P. D. Wagner..... 322,660 Tramway switches, device for operating, W. F. Shorey..... 322,487 Trap. See Animal trap. Target trap. Treadle and rod, combined foot, Cleves & Ryan..... 322,793 Tree protectors, constructing oil troughs for, A. G. Cook..... 322,593 Tremolo, fan, J. A. Hendrick..... 322,450 Tricycle, D. M. Babcock..... 322,406 Truck, H. A. Stevens..... 322,499 Truck, barrel, J. E. Hunter..... 322,823 Truck, car, W. H. Montz..... 322,741 Tugs, roll for harness loop, J. Wagner..... 322,570 Tumbling barrel, D. McCance..... 322,621 Type writing machine, P. T. Dodge..... 322,810 Type writing machine, C. Spiro..... 322,495 Umbrella display, F. R. Hazelton..... 322,600 Underground conduit, D. H. Dorsett..... 322,529 Valve indicator, A. L. Ide..... 322,723 Valve, lock, F. Engelhard..... 322,590 Vapor burner, oil, F. Marquart..... 322,620 Vault cover or grating, illuminating, T. Hyatt (r)..... 10,626 Vegetable washer, J. S. Dodge..... 322,429 Vehicle seat, F. W. Coleman..... 322,684 Vehicle spring, J. A. Birkimer..... 322,574 Velocipede, J. Knous..... 322,543 Velocipede, E. G. Latta..... 322,733 Ventilating apparatus for rocking chairs, J. Fernie..... 322,705 Vibrations of forks, reeds, etc., regulating the, P. B. Delany..... 322,694 Vibrations of reeds, actuating and correcting the, P. B. Delany..... 322,696 Vibrations of forks, reeds, etc., actuating and correcting the, P. B. Delany..... 322,809 Vibrations of reeds and forks, mechanically correcting the, P. B. Delany..... 322,695 Vulcanizable compound or crude kerite, A. G. Day..... 322,805 Wagon brake, G. P. Card..... 322,788 Wagon loading and unloading device, A. M. Woolfolk..... 322,581 Wall paper, hanging-up and carrying-off machine for, J. Waldron..... 322,871 Wall paper, etc., manufacture of, S. E. Trout..... 322,507 Wall paper manufacturers' use, hanging-up and carrying-off machine for, J. Waldron..... 322,765 Washer. See Vegetable washer. Washing machine, G. Harzreaves..... 322,710 Washing machine, A. J. Mercer..... 322,840 Watch case, W. Carpenter..... 322,680 Watch case, E. F. Heffernan..... 322,449 Water closet, F. J. Merz..... 322,625 Water gate, D. T. Hoppood..... 322,607 Water motor, C. P. Bradway..... 322,785 Water purifying compound, A. & C. Melzer..... 322,839 Water service, purifying and aerating apparatus for, J. Howes..... 322,722 Water wheel, R. A. Wingo..... 322,879 Water wheel turbine, W. Waddell..... 322,764 Wheat scouring and cleaning machine, F. Dorsey..... 322,700 Wheat, oats, and cockle separator, J. Lucas..... 322,548 Wheel. See Car wheel. Gear wheel. Water wheel. Wheel or pulley, G. P. Clark..... 322,581 Whiffletree hook, J. R. Davis..... 322,527 Whitewash package, C. F. Crockett..... 322,583 Wind engine, P. T. Coffield..... 322,796 Winding yarn or thread on to spools or bobbins, machinery for, Hill & Brown..... 322,451 Windmill, Manvel & Williams..... 322,463 Windmill, F. W. Starr..... 322,862 Wire machine, barb, C. Skinner..... 322,489 Wire machine, barbed, G. H. Lasar..... 322,546 Wire stretcher, E. Long..... 322,460 Wood bending machine, C. E. Sargent..... 322,856 Wood preserving apparatus, Hansen & Smith..... 322,819 Wrapper, sample package, S. G. Howe..... 322,453

DESIGNS.

Catalogue cover, J. De Yough..... 16,173 Door hanger, J. S. Buhner..... 16,179 Mould for jelly, etc., A. Joyce..... 16,174 Quilting pattern for skirts, W. Koch..... 16,175 Rug, A. Petzold..... 16,177, 16,178

TRADE MARKS.

Boots and shoes, rubber, leather, and canvas, Goodyear Boot and Shoe Company..... 12,419 Cigars, J. P. Wallace et al..... 12,434 Drawing materials and instruments, certain named, E. J. Soltmann..... 12,439 Dress shields, A. H. Brinkmann..... 12,434 Flour, wheat, Steelton Flouring Mill Company..... 12,433 Food for infants, Fairchild Bros. & Foster..... 12,418 Hats, caps, and bonnets, C. Tress..... 12,425 Herbal remedies, S. & J. M. Kilmer..... 12,422 Perfumery and perfumed preparations for the toilet, C. A. & C. P. Gosnell..... 12,420 Razors, razor guards, razor strops, and shaving cream, A. V. Brokhahe..... 12,417 Sirup and sugar, maple, D. M. Hazen..... 12,436 Shoe and garment clasp, J. C. Hammond, Jr..... 12,421 Snuff, P. Lorillard & Co..... 12,423 Soap, laundry, Oberne, Hosick & Co..... 24,431 Soap, laundry and toilet, S. Strunz..... 12,438 Spectacle and eyeglass frames, certain, Morgan & Heady Optical Manufacturing Company..... 12,430 Spectacles and eyeglasses, H. Hirschberg..... 12,437 Tobacco, all kinds of fine-cut chewing, J. Schriber & Co..... 12,432 Tobacco, chewing and smoking, J. G. Dill..... 12,427 Varnishes and japans, T. T. Lines..... 12,429 Velvets, Wimpheimer & Bro..... 12,426 Worsted, Tittel & Kruger..... 12,424

A printed copy of the specification and drawing of any patent in the foregoing list, also of any patent issued since 1866, will be furnished from this office for 25 cents. In ordering please state the number and date of the patent desired, and remit to Munn & Co., 361 Broadway, New York. We also furnish copies of patents granted prior to 1866; but at increased cost, as the specifications, not being printed, must be copied by hand. Canadian Patents may now be obtained by the inventors for any of the inventions named in the foregoing list, at a cost of \$40 each. For full instruction address Munn & Co., 361 Broadway, New York. Other foreign patents may also be obtained.

Advertisements. Inside Page, each insertion - - - 75 cents a line. Back Page, each insertion - - - \$1.00 a line. (About eight words to a line.) Engravings may head advertisements at the same rate per line, by measurement, as the letter press. Advertisements must be received at publication office as early as Thursday morning to appear in next issue.

DO NOT FORGET THAT The Travelers OF HARTFORD, CONN., IS THE Largest Accident Company in the World.

THAT IT IS THE ONLY LARGE ONE IN AMERICA.

That it is also a LIFE COMPANY, with Larger Assets in proportion to its Liabilities than any other Successful Company.

That it pays for Losses by Death and Disabling Injury \$4,000 A DAY.

That it has Paid to Life and Accident Policy-holders since 1864 \$11,000,000.

That ONE IN NINE of all insured under its Accident Policies have received fatal or disabling injuries.

That its Policies are all NON-FORFEITABLE: An Accident Policy-holder may change his occupation, a Life Policy-holder may let his premiums lapse (after three years), and each still receive an equitable proportionate insurance.

That it pays ALL CLAIMS, Life and Accident, Without Discount, and immediately upon receipt of satisfactory proofs.

That its Rates are as low as will PERMANENTLY Secure Full Payment of Face Value of Policies.

Assets, \$8,055,000. Surplus, \$2,089,000.

AGENTS EVERYWHERE.

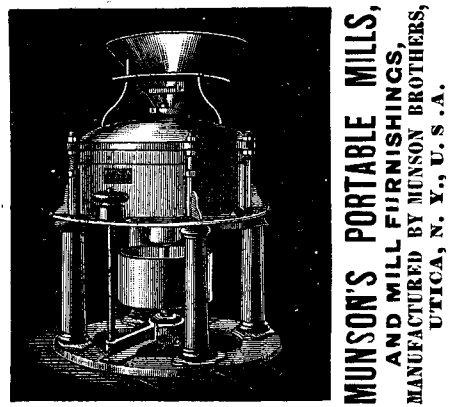

MUNSON'S PORTABLE MILLS, AND MILL FURNISHINGS, MANUFACTURED BY MUNSON BROTHERS, Utica, N. Y., U. S. A.



Woodworking Machinery. For Planing Mills, Furniture and Chair Factories, Car and Agricultural Works, Carriage and Buggy Shops, and General Wood Workers. Manufactured by The Egan Company, Cincinnati, O., U. S. A. Full assortment of Port Saw Blades.

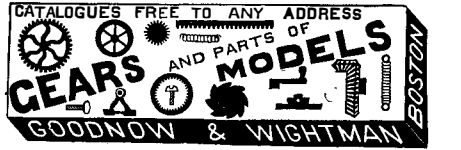

ARCHITECTURAL PERSPECTIVE for Beginners, with 11 plates of Practical Examples. Quarto, cloth. By F. A. Wright. This book will be sent to any address, postage prepaid, on receipt of price by MUNN & Co., New York. Price \$3.00.

NEW BOOKS. Wrinkles in Electric Lighting. By Vincent Stephen. Written for engineers in charge of Electric Light Machinery. With illustrations. 8vo, cloth, \$1.00 Domestic Electricity for Amateurs. Translated from the French of E. Hospitalier, with additions by C. J. Wharton. Illustrating and describing all the more recent electrical devices. 229 pages with 170 illustrations. 8vo, cloth, \$3.00 Soaps and Candles, Lubricants and Glycerine. A treatise on their manufacture, by Wm. Lant Carpenter. 344 pages, with 87 illustrations. 8vo, cloth, \$4.00 Catalogue, 128 pages, and circulars free. E. & P. N. SPON, 35 MURRAY ST., NEW YORK.

FOR SALE on royalty. A new and useful household article (tin), large profits. L. K. Gibbs, Detroit, Mich.

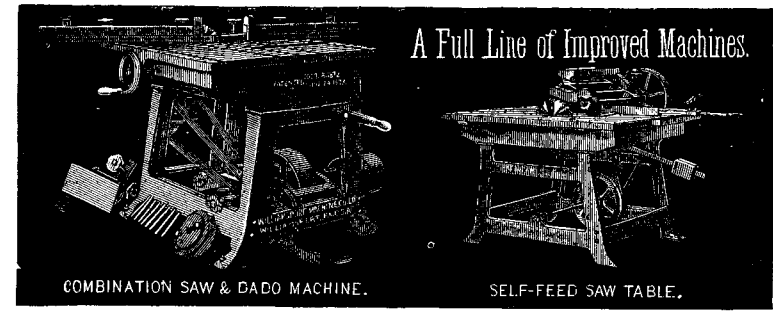

A Full Line of Improved Machines. COMBINATION SAW & DADO MACHINE. SELF-FEED SAW TABLE.

Woodworking Machinery. Williamsport Machine Co. (Ltd.), 110 W. 3d St., Williamsport, Pa., U. S. A.

SPECIAL NOTICE. Napier's Patent Governor or Speed Regulator. Messrs. Napier Brothers, Engineers, Glasgow, Scotland, wish to dispose of their United States Patent of November 11, 1884, for their Speed Regulator and Governor, which has been so successful in Great Britain.

Apply to Messrs. NAPIER BROTHERS, Hyde Park Street, Glasgow, Scotland.

Telegraph and Electrical SUPPLIES. Medical Batteries, Inventors' Models, Experimental Work, and fine brass castings. Send for catalogue C. E. JONES & BRO. Cincinnati, O. It is important to us that you mention this paper.

CAR BUILDERS CAN SECURE EXTREMELY valuable U. S. monopoly by addressing R. HUDSON, Gildersome Foundry, Leeds, England.

CAMERA ATTACHMENT.—DESCRIPTION, with illustration, of an effective camera attachment to support paper photo-negatives, for use on photographic tours. Contained in SCIENTIFIC AMERICAN SUPPLEMENT, No. 460. Price 10 cents. To be had at this office and from all newsdealers.

Defeats Thieves, Burglars, Fire. Doors and Windows Closed or Open. ELECTRIC Alarm MATTING. This Protection Unexcelled. Few Mats under Carpets (Invisible). Address Applegate MFG. CO., Camden, N. J.; Phila., 628 Chestnut St.

NICKEL PLATING & POLISHING MATERIALS. ZUCKER & LEVETT CHEMICAL CO. NEW YORK U.S.A. NICKEL & ELECTRO PLATING OUTFITS.

Rubber Stamps. Best made. Immense catalogue free to agents G. A. HARPER Mfg Co., Cleveland, O. FREE TRIAL.—NERVITA speedily cures all effects of youthful errors. Nervous Debility. Involuntary Losses. Lost Manhood, and kindred affections. Dr. A. G. OLLIN CO., 180 E. Washington St., Chicago.

FRICITION CLUTCH Pulleys and Cut-off Couplings. JAS. HUNTER & SON, North Adams, Mass.

TO GAS CONTRACTORS. The city of Lexington, Ky., solicits bids for the construction of Gas Works, to be owned by the city, and also bids for Gas (bigger to name kind of Gas) to be furnished to consumers and to street lamps of the city, the lamps to burn from sunset to sunrise, every night in the year. Bids to be on both propositions. The city of Lexington contains twenty-five thousand inhabitants, and will require five hundred street lamps, averaging two hundred feet apart. The bids must be for first-class work and best material. All bids must be accompanied by sufficient bond to insure a faithful performance of contract. The city reserves the right to reject any or all bids. For information, etc., address the chairman.

JOHN BOYD, Chairman, Gas Committee. W. S. MCCHESENEY, M. KAUFMAN.

COUNTERSINK and DRILL COMBINED.



The Countersink following the Drill, the job is finished at one operation, saving the adjusting of tools and work twice. Made by Wiley & Russell Mfg. Co., Greenfield, Mass.

THE CITY OF SEDALIA, MISSOURI, will entertain propositions for making such improvements in her present system of Water Works as may be deemed necessary. The city will also entertain propositions for the purchase of the works. Sedalia has 15,000 to 18,000 inhabitants; present Water Revenue about \$10,000; this can be largely increased by laying additional mains and improving the quality of water. The source of supply is a creek 2 1/2 miles from the city, 153 feet below the highest point of elevation of mains. There are about 13 miles of mains. Communications to be addressed to JAS. W. SNYDER, City Register, Sedalia, Mo.

PERFECT NEWSPAPER FILE

The Koch Patent File, for preserving newspapers, magazines, and pamphlets, has been recently improved and price reduced. Subscribers to the SCIENTIFIC AMERICAN and SCIENTIFIC AMERICAN SUPPLEMENT can be supplied for the low price of \$1.50 by mail, or \$1.25 at the office of this paper. Heavy board sides; inscription "SCIENTIFIC AMERICAN," in gilt. Necessary for every one who wishes to preserve the paper. Address MUNN & CO., Publishers SCIENTIFIC AMERICAN.

POWER AND LIGHT. Electricity for all Manufacturing Purposes. Motors, Dynamos, Batteries, and Lamps. ELECTRO DYNAMIC CO., 323 Carter St., Philadelphia. W. W. GRISSOM, Consulting Electrical Engineer. Consultation by letter at reasonable rates.

MR. JOSEPH DENTON, 98 Godwin Street, PATERSON, NEW JERSEY,

HAS PATENTED A NEW SHEDDING MACHINE, Or dobbie, for shaft work in silk, cotton, or woolen goods...

FOOT OR POWER LATHES FOR WOOD OR METAL. All sizes. Catalogues free. Lathes on trial.

STEWART'S PATENT COMBINED EFFED WATER HEATER, LIME EXTRACTOR, AND WATER CATCHER.

The most complete and reliable Heater in the market. Automatic in its action. The only Heater that acts as a Water Catcher.

MILLER'S half round packing especially for Steam Hammers. Sizes: 3/8, 1/2, 5/8, 3/4, 1, to 3 in.

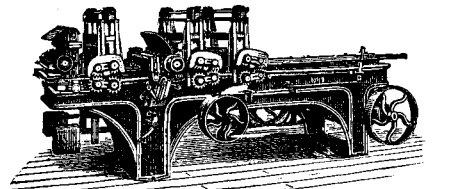

WITHERBY, RUGG & RICHARDSON. Manufacturers of Patent Wood Working Machinery of every description.

GUSTAV SCHWARZ, COMMISSION AGENT, RICA, RUSSIA. Acts as representative for reliable American Business for the entire Empire of Russia.

PATENT GOLD ROLLED SHAFTING. The fact that this shafting has 75 per cent. greater strength, a finer finish, and is truer to gauge...

EVAPORATING FRUIT. Full treat se on improved methods, yields, profits, prices and general statistics. FREE.

THE COPYING PAD.—HOW TO MAKE and how to use; with an engraving. Practical directions how to prepare the gelatine pad, and also the aniline ink by which the copies are made...

DEAFNESS its CAUSES and CURE, by one Treated by most of the noted specialists of the day with no benefit. Cured himself in three months, and since then hundreds of others by same process.

WEAK NERVOUS MEN. Perfect restoration to full manhood, health and vigor without Stomach Drugging, assured to all who suffer from nervous and physical debility, exhausted vitality, premature decline, Diseases of the Kidneys, Prostate Gland, Bladder, &c., by the Marston Bolus.

THE SCIENCE OF LIFE. KNOW THYSELF. A GREAT MEDICAL WORK ON MANHOOD. Exhausted Vitality, Nervous and Physical Debility. Premature Decline in Man, and the untold miseries flesh is heir to.

ROOFING for Buildings of every description. Durable, Light, Easily Applied, Inexpensive. BUILDING PAPER—Sackett's Waterproof Sheathing. Clean to Handle, Impervious to Moisture, Water, and Gases.

NEW YORK BELTING AND PACKING COMPY.

The Oldest and Largest Manufacturers of the Original SOLID VULCANITE Emery Wheels. All other kinds Imitations and Inferior. Our name is stamped in full upon all our standard BELTING, PACKING, and HOSE.

MINING AND HOISTING Machinery; also, Stationary Engines, Boilers, and Ventilating Fans. Estimates made and contracts taken for constructing all kinds of Mining Machinery.

PYROMETERS GAUNTLETT'S, HOBSON'S, and STEINER'S PRESSURE GAUGES Hot-Well THERMOMETERS ANEMOMETERS SAFETY LAMPS BAROMETERS SALINOMETERS Mining and Meteorological Instruments of every description.

JAMES W. QUEEN & CO. 924 Chestnut St. Philadelphia List and Description of our Ten Catalogues sent free on application.

BOILER EXPLOSIONS—A PAPER BY J. L. Lowery, discussing the causes of boiler explosions and the prevailing erroneous opinions regarding them.

INJECTORS For all kinds of STEAM BOILERS. RUF MFG. CO., PHILBERT ST., Philadelphia, Pa., U. S. A.

CONSTRUCTION OF STABLES.—A paper by A. W. Wright, describing a model stable just finished for the North Chicago City Railway.

SHAFTING, PULLEYS, HANGERS. Pat. Steel Shafting. PATENT FRICTION CLUTCH, Internal Clamp Couplings. Send for Illustrated Circular and discount sheet.

ROCK BREAKERS AND ORE CRUSHERS. We manufacture and supply at short notice and lowest rates, Stone and Ore Crushers containing the invention described in Letter Patent issued to Eli W. Blake June 15th, 1858...

The New Catalogue of Valuable Papers contained in SCIENTIFIC AMERICAN SUPPLEMENT, sent free of charge to any address.

DILLON NUT LOCK CO., 185 W. Pearl St., Cin'ti, O. ENTIRELY NEW The only nut lock based on Mechanical Principles. Can be used anywhere a jam or nut lock is needed.

BEFORE YOU BUY A BICYCLE Of any kind, send stamp to A. W. GUMP, Dayton, Ohio, for large Illustrated Price List of New and SECOND-HAND MACHINES.

BOGARDUS' PATENT UNIVERSAL ECCENTRIC MILLS—For grinding Bones, Ores, Sand, Old Crucibles, Fire Clay, Guanos, Oil Cake, Feed, Corn, and Cob, Tobacco, Snuff, Sugar, Salts, Roots, Spices, Coffee, Coconut, Flaxseed, Asbestos, Mica, etc.

AIR MOISTENER. By my system any humidity even to saturation can be uniformly maintained in any sized room. Used in more than 100 factories.

How to QUICK AT FIGURES. Price 21.—All dealers.—Circular free.—The Woodbury Company, Boston, Mass.

ECONOMIC MOTOR CO.'S GAS ENGINES. Best in principle, workmanship, and materials. An unequalled small motor adapted to all uses.

ROOFING for Buildings of every description. Durable, Light, Easily Applied, Inexpensive. BUILDING PAPER—Sackett's Waterproof Sheathing.

Scientific American BOOK LIST

To Readers of the Scientific American: By arrangements with the principal publishers, we are now enabled to supply standard books of every description at regular prices.

The subjoined List pertains chiefly to Scientific Works; but we can furnish books on any desired subject, on receipt of author's name and title.

All remittances and all books sent will be at the purchaser's risk.

On receipt of the price, the books ordered will be sent by mail, unless other directions are given. Those who desire to have their packages registered should send the registration fee.

The safest way to remit money is by postal order or bank check to order of MUNN & Co.

A catalogue furnished on application. Address MUNN & CO., 361 Broadway, New York, Publishers of the "Scientific American"

Fitzgerald.—THE BOSTON MACHINIST. Being a complete School for the Apprentice as well as the advanced Machinist, with a Treatise on Screws and Gear Cutting. Sixth edition. 18mo. cloth. \$1.75

Flammarion.—WONDERS OF THE HEAVENS. By Camille Flammarion. 12mo. 48 illustrations. \$1.25

Flint.—MUSCULAR POWER: The Source of. By Dr. Austin Flint, Jr. The Human Subject under Conditions of Rest and of Muscular Exercise. 8vo. cloth. \$1.00

Fordyce Barker.—SEA-SICKNESS. By Dr. Fordyce Barker. With Prescriptions Therefor. \$1.75

Forney.—CAR-BUILDER'S DICTIONARY. By M. N. Forney. A Vocabulary of Terms on American Railway Cars. \$2.00

Forney.—LOCOMOTIVE: a Catechism on. By M. N. Forney. With 19 plates and 227 engravings. \$2.50

Fourier.—THE ANALYTICAL THEORY OF HEAT. By Joseph Fourier. Translated with notes by Alex. Freeman, M.A. 8vo. cloth. \$4.50

Fownes.—CHEMISTRY. By Professor George Fownes. English (12th) edition. 2 vols. crown 8vo. cloth. \$7.00

Frankel-Hutter.—STARCH, GLUCOSE, STARCH SUGAR, AND DEXTRINE. By Julius Frankel and Robert Hutter. A Practical Treatise on the Manufacture in Europe and this Country. 8vo. 344 pages, with illustrations of machinery. \$3.50

Frazar.—BOAT SAILING. By Douglas Frazar. On the Management of small Boats and Yachts. 16mo. cloth. \$1.00

Fresenius.—MANUAL OF QUALITATIVE CHEMICAL ANALYSIS. By C. Fresenius. 8vo. cloth. Ninth edition. \$5.00

Fuller.—ARTISTIC HOMES IN CITY AND COUNTRY: A Selection of Sketches prepared in the routine of Office Work and now amplified and enlarged. By A. W. Fuller. \$3.50

Fur, Fin, and Feather.—Containing all the Game Laws of each State in the Union. 8vo. paper. \$1.50

Ganot.—NATURAL PHILOSOPHY FOR GENERAL READERS AND YOUNG PERSONS. Translated and edited from Ganot's "Cours Elementaire de Physique." By E. Atkinson, Ph.D., F.C.S. With frontispiece and 404 woodcuts. 12mo. cloth. \$3.00

Ganot.—PHYSICS: EXPERIMENTAL AND APPLIED. 923 pages, with 4 colored plates and 820 woodcuts, covering the most important facts and general laws of all branches of Physics. \$5.00

Gee.—SILVERSMITH'S HANDBOOK. By Geo. E. Gee. Gives Particulars of Alloying and Working, Solders, Imitation Alloys, etc. \$1.75

Gee.—THE PRACTICAL GOLD WORKER. OR GOLDSMITH'S AND JEWELER'S INSTRUCTOR. By Geo. E. Gee. Giving details of Alloying, Melting, Reducing, Coloring, Refining, etc., with system of mixing alloys and solders. \$1.75

Gillespie.—SURVEYING. By W. M. Gillespie. A Practical Treatise. With many engravings. \$2.60

Gillmore.—CEMENTS. By Major Gen. Q. A. Gillmore. A Practical Treatise on Limes, Hydraulic Cements, and Mortars. \$4.00

Gladstone.—THE LIFE OF MICHAEL FARADAY. By J. H. Gladstone. \$1.90

Goodeve.—A TEXT-BOOK ON THE STEAM ENGINE. 143 illustrations. Fifth edition. 12mo. cloth. \$2.00

Goodeve.—MECHANISM: The Elements of. By Prof. T. M. Goodeve. 12mo. cloth. Illustrated. \$2.50

Gordon.—A PHYSICAL TREATISE ON ELECTRICITY AND MAGNETISM. By J. E. H. Gordon, B.A. Camb., Member of the International Congress of Electricians, Paris, 1881, Manager of the Electric Light Department of the Telegraph Construction and Maintenance Company. Second edition, revised, rearranged, and enlarged. Two volumes, 8vo. With about 312 full page and other illustrations. Cloth. \$10.00

Gordon.—A PRACTICAL TREATISE ON ELECTRIC LIGHTING. By J. E. H. Gordon, author "A Physical Treatise on Electricity and Magnetism." Member of the Paris Congress of Electricians. With twenty-three full page plates and numerous illustrations in the text. 8vo. cloth. \$4.50

Gore.—ELECTRO-METALLURGY. By G. Gore. For scientific students and practical workers. \$2.25

Gosse.—EVENINGS AT THE MICROSCOPE; or, Researches among the Minuter Organs and Forms of Animal Life. By P. H. Gosse. Thick 12mo. cloth. \$1.50

Gould.—CARPENTERS' AND BUILDERS' ASSISTANT AND WOOD-WORKERS' GUIDE. The Work is intended to combine the Knowledge the Workman requires to construct any Design in Carpentry by an easy System of Lines, reducing the Science of Construction to an Agreeable and Pleasant Occupation, rather than an unpleasant Task. By L. D. Gould, Architect and Practical Builder. Revised and enlarged edition. Cloth, 8vo. \$2.50

Advertisements.

Inside Page, each insertion - - - 75 cents a line. Back Page, each insertion - - - \$1.00 a line.

(About eight words to a line.)

Engravings may head advertisements at the same rate per line, by measurement, as the letter press. Advertisements must be received at publication office as early as Thursday morning to appear in next issue.

TO INVENTORS AND MANUFACTURERS

The Fifty-fourth Annual Exhibition OF THE AMERICAN INSTITUTE OF THE CITY OF NEW YORK Will open September 30, 1885. Heavy machinery will be received as early as September 14th, other goods September 21st. Intending exhibitors must make early application to secure proper space and classification. For blanks and information, address GENERAL SUPERINTENDENT, AMERICAN INSTITUTE, N. Y. CITY.

STATIONARY STEAM ENGINES ESPECIALLY adapted to Electric Lighting Purposes. Treating of the development of Steam Engines; the principles of Construction and Economy; with descriptions of Moderate Speed and High Speed Engines. By Robert H. Thurston A.M., C.E., with many handsomely executed illustrations. 12mo, cloth, \$1.50. Address, MUNN & CO., 361 Broadway, New York.

NATIONAL TOOL CO., MANUFACTURERS OF MACHINISTS TOOLS. WILLIAMSPORT PA. PLANERS A SPECIALTY.

WM. A. HARRIS, Providence, R. I. (Park St.), Six minutes' walk West from station. Original and Only Builder of the HARRIS-CORLISS ENGINE, With Harris Pat. Improvements, from 10 to 1,000 H. P. Send for copy Engineer's and Steam User's Manual. By J. W. Hill, M.E. Price \$1.25.

Wood Working Machinery. Universal Saw Benches, Buzz Planers, Turning Lathes for Pattern, Cabinet, and Wood Working Shops, Single and Double Rotary Bed Surfacers, Stretching Machines, Blind Slat Planers, etc. HERBERT BAKER, Foundry and Machine Works, Toledo, Ohio.

RADIATORS FOR STEAM OR HOT WATER HEATING SEND FOR DESCRIPTIVE CATALOGUE OF THE BUNDY MANUFACTURED BY A.A. GRIFFING IRON CO. 650 COMMUNIPAW AV. JERSEY CITY, N. J.

SPECIAL NOTICE. IRON WORKING MACHINERY. Beaudry & Cunningham, of Boston, Mass. have been awarded the Medal of the First Class at the World's Exposition, at New Orleans, La., for the best Power Hammer. Send for circular "A." P. O. Box 1218. Beaudry & Cunningham, 70 Kilby St., Boston, Mass.; 49 Dey St., New York.

POINTERS for Users of Steam Pumps. Van Duzen's Patent Steam Pump Can Pump Sundry or Impure Water Liquids. Efficient. Has no moving parts, consequently no wear, no repairs, no trouble. Purchasers assume no risks, as we guarantee every Pump. Above comparison with Jet Pumps, Ejectors, etc., made of Iron. Demand this Pump of your dealer and take no cheap substitute. We make Ten Sizes. Prices from \$7 to \$75. Capacities from 100 to 20,000 gallons per hour. State for what purpose wanted and send for Catalogue of "Pumps." VAN DUZEN & TIFT, Cincinnati, O.

THE MANUFACTURE OF CRUCIBLE Cast Steel.—A paper read before the Steel and Iron Institute by Henry Seeborn. A presentation of the facts connected with the old-fashioned method of converting bar iron into steel and then melting it in clay pots to form ingots of cast steel. Contained in SCIENTIFIC AMERICAN SUPPLEMENT, No. 464. Price 10 cents. To be had at this office and from all newsdealers.

WESTON DYNAMO-ELECTRIC MACHINE The undersigned, sole agents for the above machine for

ELECTROPLATING AND ELECTROTYPING, refer to all the principal Stove Manufacturers, Nickel and Silver Platers in the country. Over 1,500 now in use. Are also manufacturers of Pure Nickel Anodes, Nickel Salts, Polishing Compositions of all kinds, and every variety of supplies for Nickel, Silver, and Gold Plating; also, Bronze and Brass Solutions. Complete outfits for plating. Estimates and catalogues furnished upon application.

HANSON VANWINKLE & Co. SOLE AGENTS NEWARK, N. J. New York Office, 92 and 94 Liberty St.

PATENTS.

MESSRS. MUNN & CO., in connection with the publication of the SCIENTIFIC AMERICAN, continue to examine improvements, and to act as Solicitors of Patents for Inventors.

In this line of business they have had forty years' experience, and now have unequalled facilities for the preparation of Patent Drawings, Specifications, and the prosecution of Applications for Patents in the United States, Canada, and Foreign Countries. Messrs Munn & Co. also attend to the preparation of Caveats, Copyrights for Books, Labels, Reissues, Assignments, and Reports on Infringements of Patents. All business entrusted to them is done with special care and promptness, on very reasonable terms.

A pamphlet sent free of charge, on application, containing full information about Patents and how to procure them; directions concerning Labels, Copyrights, Designs, Patents, Appeals, Reissues, Infringements, Assignments, Rejected Cases, Hints on the Sale of Patents, etc.

We also send, free of charge, a Synopsis of Foreign Patent Laws, showing the cost and method of securing patents in all the principal countries of the world.

MUNN & CO., Solicitors of Patents, 361 Broadway, New York. BRANCH OFFICE—Corner of F and 7th Streets, Washington, D. C.

RUBBER BELTING, PACKING, HOSE, AND ALL OTHER KINDS OF RUBBER GOODS,

FOR MECHANICAL AND MANUFACTURING PURPOSES. The Largest and Most Extensive Manufacturers in America. THE GUTTA PERCHA AND RUBBER MFG. CO., New York, Chicago, San Francisco, Toronto.

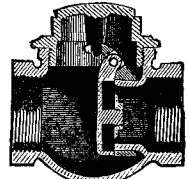

BURNHAM'S SELF-ADJUSTING SWING CHECK VALVE.

Users of Check Valves will please note the advantages these Valves possess over all others. The most important claim is, that as the Jenkins Disk wears, the yoke that passes around the seat moves away from the seat in proportion to the wear of the Disk, thus causing a uniform wear of the Disk until said Disk is completely worn out.

JENKINS BROS., 71 John Street, New York. Send for Price List "A." 79 Kilby St., Boston.

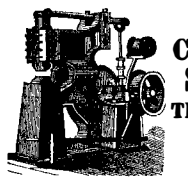

"VULCAN" Cushioned Hammer.

Steel Helve, Rubber Cushions, TRUESQUARE, ELASTIC BLOW Full Line of Sizes. W. P. DUNCAN & CO., Bellefonte, Pa., U. S. A.

SWIMMING.—DESCRIPTION OF THE method of teaching swimming employed in France; with 6 illustrations. Contained in SCIENTIFIC AMERICAN SUPPLEMENT, No. 462. Price 10 cents. To be had at this office and from all newsdealers.

Standard Thermometers

Accurate, Legible, Sizes of Dials 5 and 8 inches. For sale by THE TRADE. Manufactured and Warranted by the Standard Thermometer Co., Peabody, Mass. General Agents, FAIRBANKS' SCALE HOUSES In all the principal cities of the U. S. and Canada.

STRAW FUEL on the Prairie. Mode of burning baled straw. Wanted partner with cash to procure patent. One-half interest given. CHAS. W. JEFFERSON, Rugby, Tenn.

BURSTED BOILERS DO NOT BOCCUR. WHERE PROVIDENT PROPRIETORS KEEP THEIR BOILERS PERFECTLY CLEAN BY USING VAN DUZEN'S MECHANICAL BOILER CLEANER MANUFACTURED BY E.W. VAN DUZEN, CINCINNATI, O.

Aluminum Bronze, Aluminum Silver, Aluminum Brass,

AND SILICON BRONZE, FURNISHED IN INGOTS, CASTINGS, RODS, OR WIRE.

Our Malleable Castings can be made of over 100,000 pounds tensile strength, with extraordinary power to withstand corrosive influences, and unrivaled beauty of color. Send for pamphlet. THE COWLES ELECTRIC SMELTING AND ALUMINUM CO., CLEVELAND, O.

H.W. JOHNS' ASBESTOS Roofing, Building Felt, Steam Packings, Boiler Coverings, Fire Proof Paints, Cements, Etc. Samples and Descriptive Price Lists Free. H. W. JOHNS MFG CO., 87 MAIDEN LANE, N. Y. 175 Randolph St., Chicago; 170 N. 4th St., Philadelphia.

Syracuse Malleable Iron Works

The Seibert Cylinder Oil Cup Co.,

Manufacturers of Oil Cups for Locomotive, Marine, and Stationary Engine Cylinders, under the Seibert and Gates Patents, with Sight Feed. TAKE NOTICE. The "Sight Feed" is owned exclusively by this Company. See Judge Lowell's decision in the United States Circuit Court, District of Massachusetts, Feb. 23, '82. All parties, except those duly licensed by us, are hereby notified to desist the use, manufacture, or sale of infringing Cups, as we shall vigorously pursue all infringers. The Seibert Cylinder Oil Cup Co. 35 Oliver Street, Boston, Mass.

CARY & MOEN STEEL WIRE OF EVERY DESCRIPTION & STEEL SPRINGS. NEW YORK CITY. 234 W. 29 ST.

ENGINEER'S POCKET BOOK. BY Charles H. Haswell, Civil, Marine, and Mechanical Engineer. Giving Tables, Rules, and Formulas pertaining to Mechanics, Mathematics, and Physics, Architecture, Masonry, Steam Vessels, Mills, Limes, Mortars, Cements, etc. 900 pages, leather, pocket-book form. Price \$4. This valuable work will be sent on receipt of price by MUNN & CO., New York.

THE PUSEY & JONES CO. BUILDERS OF ALL DESCRIPTION OF MACHINERY USED BY MANUFACTURERS OF PAPER. Wilmington, Delaware.

OTTO GAS ENGINE OVER 10,000 IN USE WORKS WITHOUT ENGINEER OR BOILER. STEAM COAL OR ASH. STARTS AT ONCE AND IS FREE OF DANGER FIRE OR EXPLOSION. 1 1/2 TO 25 HORSE POWER. SCHLEICHER SCHUMM & CO. 47 DEY ST. NEW YORK. 214 RANDOLPH CHICAGO 334 WALNUT ST. PHILADELPHIA

THE AMERICAN BELL TELEPHONE CO. 95 MILK ST., BOSTON, MASS.

This Company owns the Letters Patent granted to Alexander Graham Bell, March 7th, 1876, No. 174,465, and January 30th, 1877, No. 186,787.

The transmission of Speech by all known forms of Electric Speaking Telephones infringes the right secured to this Company by the above patents, and renders each individual user of telephones not furnished by it or its licensees responsible for such unlawful use, and all the consequences thereof, and liable to suit therefor.

PATENT JACKET KETTLES, Plain or Porcelain Lined. Tested to 100 lb. pressure. Send for Lists. JAMES C. HAND & CO., 614 and 616 Market St., Philadelphia, Pa.

TELESCOPES Spectacles, Barometers, Thermometers, & Photographic Optics for Amateurs. Opera Glasses, Microscopes. W. H. WALMSLEY & CO., successors to R. & J. Beck, Philadelphia. Illustrated Price List free to any address.

TIGHT & SLACK BARREL MACHINERY A SPECIALTY JOHN GREENWOOD & CO. ROCHESTER N. Y.

Leffel Water Wheels, With Important Improvements. 11,000 IN SUCCESSFUL OPERATION. FINE NEW PAMPHLET FOR 1885 Sent free to those interested. JAMES LEFFEL & CO., Springfield, Ohio. 110 Liberty St., N. Y. City.

The Scientific American. THE MOST POPULAR SCIENTIFIC PAPER IN THE WORLD.

Published Weekly, \$3.20 a Year; \$1.60 Six Months. This unrivaled periodical, now in its forty-first year, continues to maintain its high reputation for excellence, and enjoys the largest circulation ever attained by any scientific publication.

Every number contains sixteen large pages, beautifully printed, elegantly illustrated; it presents in popular style a descriptive record of the most novel, interesting, and important advances in Science, Arts, and Manufactures. It shows the progress of the World in respect to New Discoveries and Improvements, embracing Machinery, Mechanical Works, Engineering in all branches, Chemistry, Metallurgy, Electricity, Light, Heat, Architecture, Domestic Economy, Agriculture, Natural History, etc. It abounds with fresh and interesting subjects for discussion, thought, or experiment; furnishes hundreds of useful suggestions for business. It promotes Industry, Progress, Thrift, and Intelligence in every community where it circulates.

The SCIENTIFIC AMERICAN should have a place in every Dwelling, Shop, Office, School, or Library. Workmen, Foremen, Engineers, Superintendents, Directors, Presidents, Officials, Merchants, Farmers, Teachers, Lawyers, Physicians, Clergymen, people in every walk and profession in life, will derive benefit from a regular reading of THE SCIENTIFIC AMERICAN.

Terms for the United States and Canada, \$3.20 a year; \$1.60 six months. Specimen copies free. Remit by Postal Order or Check. MUNN & CO., Publishers, 361 Broadway, New York.

THE Scientific American Supplement.

THE SCIENTIFIC AMERICAN SUPPLEMENT is a separate and distinct publication from THE SCIENTIFIC AMERICAN, but is uniform therewith in size, every number containing sixteen large pages. THE SCIENTIFIC AMERICAN SUPPLEMENT is published weekly, and includes a very wide range of contents. It presents the most recent papers by eminent writers in all the principal departments of Science and the Useful Arts, embracing Biology, Geology, Mineralogy, Natural History, Geography, Archaeology, Astronomy, Chemistry, Electricity, Light, Heat, Mechanical Engineering, Steam and Railway Engineering, Mining, Ship Building, Marine Engineering, Photography, Technology, Manufacturing Industries, Sanitary Engineering, Agriculture, Horticulture, Domestic Economy, Biography, Medicine, etc. A vast amount of fresh and valuable information pertaining to these and allied subjects is given, the whole profusely illustrated with engravings.

The most important Engineering Works, Mechanisms, and Manufactures at home and abroad are represented and described in the SUPPLEMENT.

Price for the SUPPLEMENT for the United States and Canada, \$5.00 a year, or one copy of the SCIENTIFIC AMERICAN and one copy of the SUPPLEMENT, both mailed for one year for \$7.00. Address and remit by postal order or check. MUNN & CO., 361 Broadway, N. Y., Publishers SCIENTIFIC AMERICAN.

To Foreign Subscribers.—Under the facilities of the Postal Union, the SCIENTIFIC AMERICAN is now sent by post direct from New York, with regularity, to subscribers in Great Britain, India, Australia, and all other British colonies; to France, Austria, Belgium, Germany, Russia, and all other European States; Japan, Brazil, Mexico, and all States of Central and South America. Terms, when sent to foreign countries, Canada excepted, \$4, gold, for SCIENTIFIC AMERICAN, one year; \$9, gold, for both SCIENTIFIC AMERICAN and SUPPLEMENT for one year. This includes postage, which we pay. Remit by postal order or draft to order of MUNN & CO., 361 Broadway, New York.

PRINTING INKS. THE "Scientific American" is printed with CHAS. TENEU JOHNSON & CO.'S INK. Tenth and Lombard Sts. Phila., and 47 Rose St., opp. Duane St., N. Y.