

TT 520

.B38

Copy 1

TT 520
.B38
Copy 1

TT 520

.B3B

Copy 1

SEWING-MAKING AND TAILORING MADE EASY.

Entered according to Act of Congress, in the year 1890, by

A. E. BEARRIE,

In the office of the Librarian of Congress, at Washington, D. C.

AGENTS WANTED. — We want both Ladies and Gentlemen in all parts of the United States to represent our business.

WRITE FOR TERMS.

All mail should be addressed to A. E. BEARRIE, 1220 Olive St., St. Louis, Mo.

A. E. BEARRIE,
MANAGER.

THE
PERFECT DRESS FITTER.

OFFICE,

1220 OLIVE STREET,

ST. LOUIS, MO.

COMPLETE INSTRUCTIONS IN THE ART OF
CUTTING ALL KINDS OF GARMENTS.

COPYRIGHTED IN 1890.

TO THE PUBLIC.

— 4 —

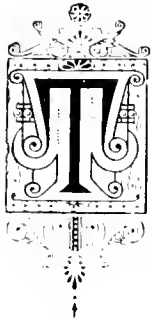

HERE are thousands and thousands of dollars annually spent in this country for the cutting and making of garments, thereby making a great expense upon every household that should not exist, but the expense, time required to learn, and the intricacies of the systems of cutting heretofore in use, have placed it so far beyond the reach of families that the knowledge, to be efficient in the art of cutting, has been almost out of the question.

As it costs many dollars to learn anything of it at all and months of time and study.

Then it could not easily be done; new calculations must be made for every different garment, and it kept the party who learned it in a constant study in order to cut with any accuracy whatever.

The art through these disadvantages has only been learned by those who wished to make the art of garment cutting a profession. Very few ladies outside of those making it a profession thoroughly understand garment cutting. In fact but very few know anything of it at all.

While the ladies are not to blame on account of the disadvantages they must go through in order to be enabled to do cutting.

Yet this should not be so. Every lady, young or old, should understand as well how to cut and make garments as she should all other domestic duties. She should understand as well how to cut herself a dress as she should know how to prepare a meal of victuals or any other duty allotted to woman, and yet we find but very few informed upon this most necessary part of her duties. Even if she should not wish to make the garments herself, she should at least know how they were cut and how they were made.

If every lady understood the cutting and making of garments she could save more in her home every year than upon most any other duty of the household.

Seeing this great necessity for some simple method of garment cutting for to be used in the family, the inventor, after years of practical experience and study, finally produced "The Perfect Dress Fitter," which he feels assured will meet this great public necessity.

His aim has been to make it so simple and yet so perfect, that any lady could with but very little instruction be enabled to cut any article of wearing apparel worn by themselves or members of their families.

And judging from the way the "Fitter" has been received wherever it has been placed before the public, he feels well satisfied that his plan is a success even beyond his own expectations. No lady has ever

used it that has not praised both its simplicity and the perfectness of its work.

We are in receipt daily of testimonial letters from all parts of the country. We have never sold one that has not given perfect satisfaction.

There are many systems of cutting in use, but all more or less imperfect in their work, and these cutting but very few garments, most of them, but one basque, and that in many cases only to the waist line.

Our system covers the entire field of cutting. We cut not only one garment but every garment worn by ladies, gentlemen and children. No matter what it is our system cuts it.

It is based upon the finest scientific principles known, which are used in all mechanical work, and therefore basing our work upon the only correct methods of measurements and calculations which are used by all classes of mechanics we have been able to produce a correct scientific work.

And it requires but a few moments for us to prove that what we say is true.

We do not insist by any means that every one shall learn our work, but there are a great many ladies idling away hour after hour of time who could, if they knew how to cut and fit the garments for the family, save a great expense upon the household and turn their idle hours into pleasure and profit, and there is no reason why it should not be done when it can be accomplished so easily.

We would like for every lady or gentleman who has an opportunity of seeing our work to have it fully explained to them and thoroughly examine it in every particular. You will always find our agents ladies and gentlemen in every sense of the word. We employ no others and they will always be found willing to explain the work fully to you in every way. And should you after a careful examination of our system, conclude to learn it, you will find our employes very efficient teachers, as we never send one out who is not competent in every way both to explain the work and teach it, though it requires but very little teaching, as you will find by carefully examining it that it is so simple and the directions so plain for its use that any one can by first carefully reading the directions be enabled to cut any garment they may wish without any teaching whatever.

All we ask is a fair square trial of our work, knowing that if you will honestly investigate it that it will fully meet with your approval.

With these few remarks we remain,

Yours truly,

A. E. BEARRIE & CO.

TO APPLY THE FITTER.

The first thing to be done is to take the Measures.

THE MEASUREMENTS.

We take five measures, viz. :

Chest.

Waist.

Length of Waist.

Elbow.

Length of Arm.

THE CHEST MEASURE is taken tight just above the bust and high up under the arms.

THE WAIST MEASURE is taken straight around the waist as tight as the party wishes to wear the dress you are cutting for.

THE LENGTH OF WAIST is taken from the center of back at neck where the collar should be attached to the dress straight down the back to the waist, being careful

that the measure is even with the hips at the side.

THE ELBOW AND LENGTH OF ARM is taken with arm hanging loosely at the side, commencing at the same point as for length of waist measure, straight across to shoulder point down the arm to elbow point and wrist joint.

CARE must be used in taking measures.

SPECIAL.

All upper garments are laid out by chest measure. The entire garment is laid off by rule corresponding with chest measure, backs, front and sleeves. Accompanying draft No. 1 will be found directions for applying special measures. Under each draft will be directions telling you what rule to use to lay the garment off by, etc.

IN COMMENCING TO DRAFT.

First make your base lines to work from by drawing your pencil around the outside of the square. Then follow the directions For Applying the Rule, governing yourself by the special directions accompanying whatever diagram you are laying off. Next follow directions For Applying the Scroll to connect the points and form the draft. Next lay off your seams following the

directions On the Seams. When the garment is all drafted follow your special directions for Changing the Size of Waist (if any change be necessary); when that is done your garment is completed. Then by reading Our Basting Directions carefully the garment can be easily and properly put together.

HOW TO APPLY THE RULE.

There are four distinct points or places where the end of the rule must be placed and measurements made from.

THE FIRST

Is the top of the side base line, where we commence measuring to get the length of garments and the points to strike the lines across from to get the width on.

THE SECOND

Is where we lay our rule on the cross lines to get the points for width of garments, which start from the side base line wherever they occur on the diagram we are laying off.

THE THIRD IS FROM THE



In making measurements with our rule, which is five spaces in length, we measure all points given on the diagram we are laying off. By first getting the points straight down the side base line until we reach the end of the rule. Then at the end of the rule or the 5th space we mark a V as shown upon the diagram. Then we move the rule down its full length, placing the end of the rule at the point of the V we have just marked and commence measuring from that point again, just the same as if we were measuring from the starting point. The 5V occurs on all lines where the rule is not long enough to reach the number we require on the diagram, and by simply marking the V at the end and moving the rule down if on base line or out if on cross lines, we can get any number of spaces we require.

The V always occurs on the diagram just as many times as it is necessary to move the rule to get all the points required.

Wherever you see the 5V on the diagram mark the V at the end of rule and move your rule down its full length and measure again from that point just the same as if the rule had not been moved from the starting point.

THE FOURTH

Place we commence measuring from is the

waist line. Length of waist vary on different persons of the same chest measure. And the only way the measure can be made correct is with the tape-line.

THE SPECIAL DIRECTIONS

Accompanying Diagram No. 1, first pattern in the book, fully explain this and tell you plainly how to make the waist line correct.

WHEN IT IS CORRECTED

Place the end of the rule upon the corrected waist line and measure again from that point, in the same way that you have been instructed to measure from the base lines and the 5V.

TO EXPLAIN THIS FULLY.

On the backs of Diagram No. 1, first pattern in the book, we place the rule at the top on side base line and get the following points for length. First point is B, then 1B, then 2, then 2F, then 3B, then 4E. Then we come to the 5V. Now just mark V at the end of rule and then move the rule down its full length, placing the end of the rule on the point of the V. Now mark points again same as you did above. Next point is 2A, which is waist-line, mark it and then follow the directions on changing waist line (if any change is necessary). And then place the end of the rule at the point where the corrected waist line is marked (as explained in the special directions with first diagram), and commence measuring your points again. Next point is 1F, next is 2, and next or last point is 2B. When all the points are marked on the base line, strike the lines across wherever they occur on the diagram and then take your rule and get all points upon the cross lines. When that is done take your scroll and apply it, connecting the points as directed in the directions for Applying the Scroll. And then mark off your seams and your diagram is completed.

IN LAYING OFF THE SEAMS

Be careful and follow directions for seams closely.

HOW TO APPLY THE SCROLL.

The scroll has a large and a small end. The large end is used in making the curves on Ladies' and Gentlemen's garments, and the small end for making the curves on Children's garments.

We have two hands upon the scroll. And we also have hands upon our diagrams to simplify its use.

Whatever way the hand upon the diagram points, let the hand upon the scroll point in the same direction. If the curve is an inward curve the hand will be placed upon the outside of the line to be drawn, and in laying the scroll on to connect the points and make the line you must also place it upon the outside of the points you are connecting, being careful that the hands on the diagram and the hand on the scroll point in the same direction. If there is

simply a hand connect two points at one time. If the hand has a star upon the wrist connect three points. When the curve to be made is an outward curve, the hand will occur inside of the draft, and in laying down the curve to form the line you must also have it inside of the points to be connected and the hands on the scroll and on the diagram must be pointing in the same direction.

SPECIAL CURVES,

such as Front neck Curve, Arms Eye Curve, Darts, Front hem Curve, Side under arm on front and Side back curve are marked on the scroll so that it can be applied with ease. Where lines occur without any hands (except it be the special curves just explained) they are straight lines and must be connected with the square.

THE SEAMS.

Seams are of different widths, some are marked with the rule and some are marked with the tape line. But each diagram has the amount printed upon it that is allowed for seams wherever seams are to be taken. All seams that are made with the rule are laid off when you are first making the draft, excepting the shoulder seams, which are all marked on the diagram telling you just what letter to measure to for width of seam. When all seams are marked off con-

nect the points with the tools in the same manner that you did the outline, being careful to keep the seam the same width apart at all places. When drafts are all completed and seams marked off, then follow directions for changing size of waist (if any change is necessary). Forms of the same chest measure vary in size of waist same as in length of waist and can only be correctly made by the tape-line.

DIRECTIONS FOR BASTING.

IN CENTER BACK SEAM.

Begin at waist line and baste up.

IN BASTING SIDE BACK SEAMS.

Hold the backs to you, making the seams come out even without clipping on the ends. If necessary stretch the side back from about two and one-half to three inches down from the top to make them come out even.

IN BASTING SIDE SEAMS.

Baste the left side seam first, and then pin the right side seam up to the top, beginning at waist line, making it come out same as the left side seam, and then begin at top and baste down to waist line, holding the back towards you.

IN SIDE UNDER ARM SEAMS.

Hold the side backs towards you, basting same as for side back seams.

IN UNDER ARM DARTS AND FRONT DARTS.

Begin at waist line and baste up, after having the darts basted together, cut open through the center.

IN HEM.

Run a basting thread on hem line and leave open to do fitting, pinning to fit the form.

IN ALL SEAMS BELOW WAIST.

Begin at waist and baste down.

IN SHOULDER SEAMS.

Begin at shoulder point and baste to neck on the left shoulder, stretching the front so that it will come out even with the back piece.

Pin the right shoulder seam, stretching the front seam as for left shoulder, and then begin at neck basting to shoulder point. After having done your fitting, all seams should be trimmed down to just what is needed for the whalebones. All seams should be pressed open with a hot iron before putting in whale bones.

IN BASTING SLEEVES.

Begin at the top and baste down to waist.

IN PUTTING THE SLEEVES IN.

Place the back seam at about one-half inch below the side from seam in arm's eye. Baste over the top of sleeve, holding the sleeve towards you, sew in the right sleeve first, pin the left sleeve, being careful that you get both sleeves in exactly alike.

There should be a basting thread run around the top of the upper sleeve portion to make it full over the shoulder.

BEFORE FITTING.

Clip all seams at waist and for an inch above and below waist, making several clips. Be careful not to clip them too close.

LADIES' PLAIN BASQUE.

FOR MEDIUM FIGURES.

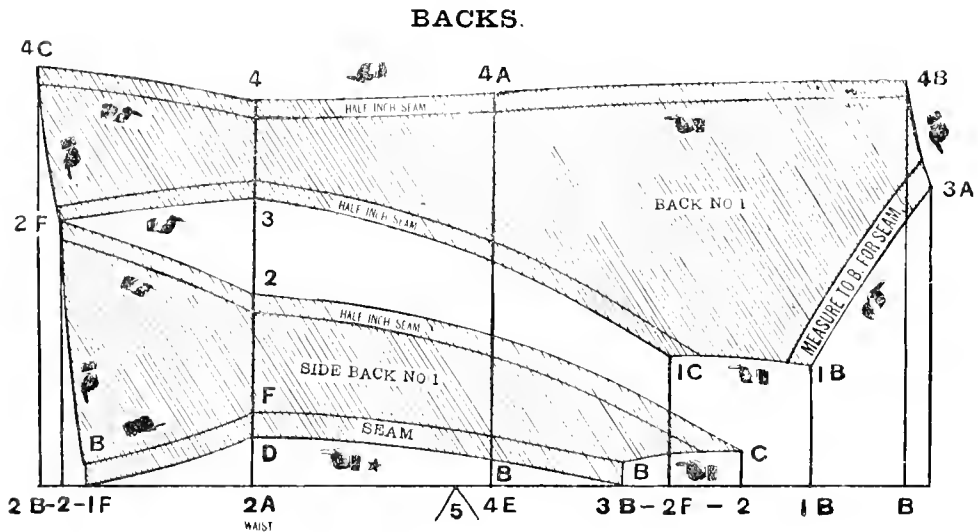

TO LAY OFF BACKS.

Make base lines first. Then suppose we are cutting for a lady whose measures are:

- Chest 33.
- Waist 23.
- Length of Waist $15\frac{1}{2}$.
- Elbow $19\frac{1}{2}$.
- Length of Arm 29.

Add one inch to last two measures amount required for seams, which makes the elbow measure $20\frac{1}{2}$ and the length of arm 30 inches. Take rule 33 which corresponds with chest measure and then follow directions for applying the rule, marking all points down base line to point 2A inclusive which is waist line. Now take tape line and measure from the first point marked or the letter B down $15\frac{1}{2}$ inches on base line the length of waist we want, and mark it, and then by measuring the difference between point 2A (original waist line), and the waist line point marked with the tape line, we find it is necessary to make the

waist $\frac{1}{4}$ of an inch shorter than original waist line or point 2A which we marked with rule.

Now shorten point 4E one-half as much as you did the waist line, or $\frac{3}{8}$ of an inch.

Now place the end of rule at the corrected waist line (according to directions on points to measure from), and mark the points for skirt. Now strike lines across from base line points wherever they occur on the diagram, and then get all points on them for width of garment. Then take scroll and connect points according to hands on draft following special directions on (Applying the Scroll).

Then lay off all seams as they are marked on diagram inside of the lines just drawn and use scroll in the same manner to connect your points for the seam lines. Read carefully directions for seams before laying them off.

Next is

LADIES' PLAIN BASQUE.

FOR MEDIUM FIGURES.

FRONT.

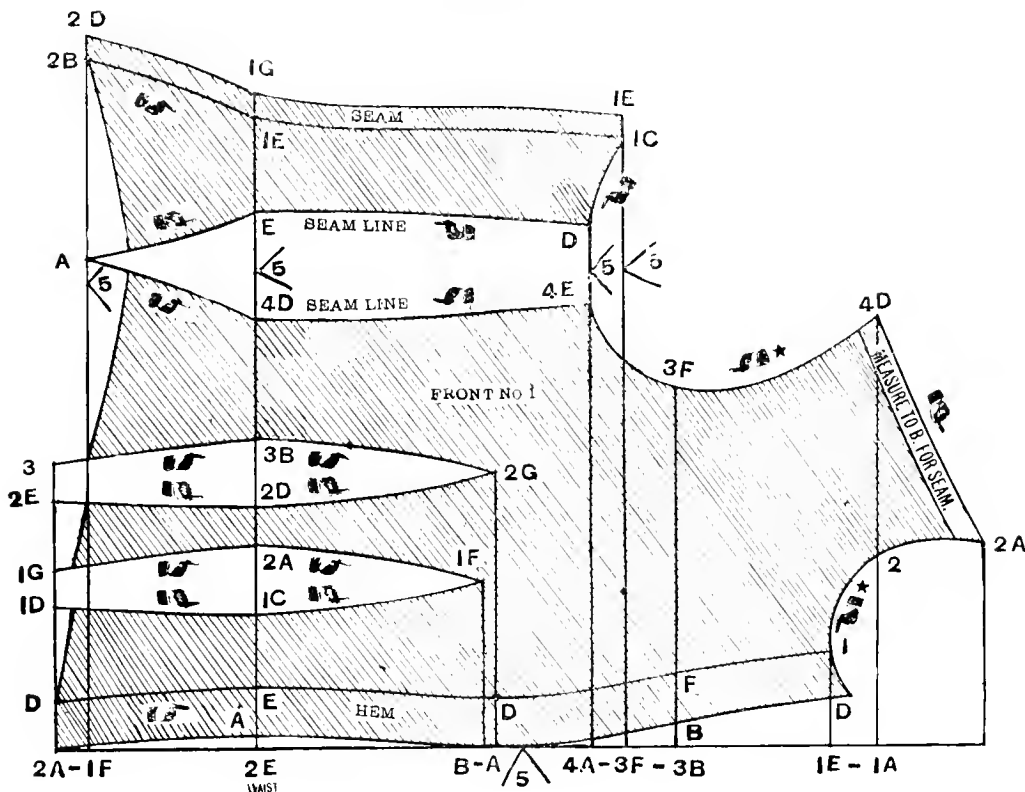

TO LAY OFF FRONT.

Proceed in the same manner as for laying off backs. When waist line point 2E is reached, mark it. And as out waist lines are made to be placed together, we must shorten the waist on Front $\frac{3}{4}$ of an inch, same as we did on backs, to make front come even again with waist line on backs. You do not measure down with tape-line as you did on backs. Simply measure up $\frac{3}{4}$ of an inch from waist line point 2E and mark it. Then shorten points at top of

darts A and B one-half as much or $\frac{3}{8}$ of an inch. Then place your rule upon the corrected waist line and finish getting your points for length. Then strike the cross lines and get all points for width on them. Then take the scroll and connect all points shown on diagram by following the directions for Applying the Scroll, excepting the points that form the large or under arm dart. Do not draw those lines until we test size of waist.

TO TEST SIZE OF WAIST.

There are two fronts and two each of the back pieces, so we have one-half of the pattern.

Having but one-half of the pattern, to correct our size of waist (if any correction be necessary) we take one-half of the actual waist measure which with the waist measure (23) we are drafting to would be $11\frac{1}{2}$ inches. By measuring the goods across the pattern on waist line, leaving out all seams, hems and darts, we find it measures $11\frac{1}{4}$ inches, which is too large, as we only want the measure to be $11\frac{1}{2}$ inches or one-fourth of an inch smaller. Now, to make it one-fourth of an inch smaller we simply move

points 4D and E on waist line, which form the large or under arm dart, one-fourth of an inch apart.

Move point E one-eighth of an inch or one-half the amount of the change and point 4D one-eighth of an inch, which makes one-fourth of an inch. By moving apart the two points one-half the amount of change required on each side, it keeps the garment in proportion, wherein if it were all changed on one side it would throw the garment all out of shape. Now draw your lines for under arm dart and your diagram is completed.

Next is

UPPER SLEEVE.

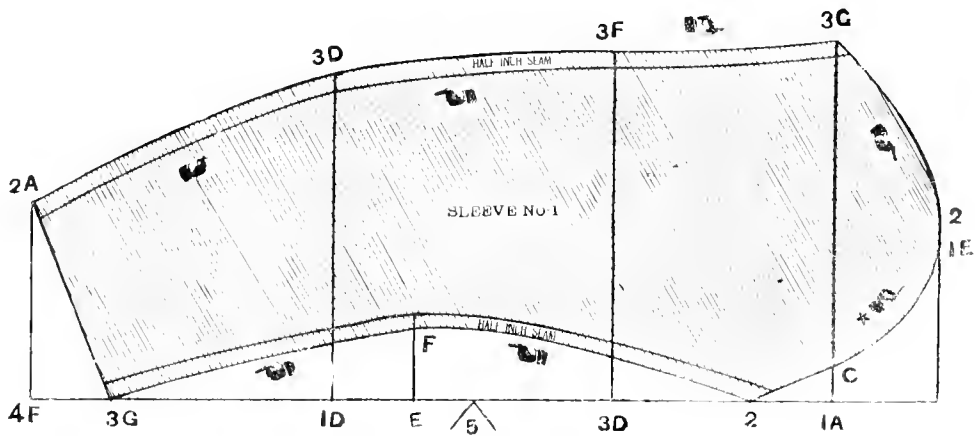

TO LAY OFF UPPER SLEEVE.

Lay off sleeve same plan as on backs and front, marking all points down to the bottom of base line. Then to get proper length of sleeve measure, on back from seam line at top of neck at center of back to seam line point at shoulder point at arm's eye. We find the measure to be $71\frac{1}{4}$ inches. Now place the $71\frac{1}{4}$ at the top of base line or top of sleeve and make a point at $20\frac{1}{2}$ inches down on base line, which is elbow measure, and then at 30, which is length of arm measure. Point E being elbow point, we next measure the difference between elbow point just marked and original elbow point E and find it to be one-

eighth of an inch. The original elbow point would be one-eighth of an inch too long, consequently we shorten the elbow point one-eighth of an inch. When elbow point is shortened we must also shorten point 1D the same amount. Then when we come to length of arm by measuring the difference between point 30, marked with tape line and point 4F, which is length of arm point marked with rule, we find the difference to be one-half of an inch. So we must shorten the bottom point one-half an inch. Whenever bottom point is shortened we must also shorten point 3G the same amount.

Next is

UNDER SLEEVE.

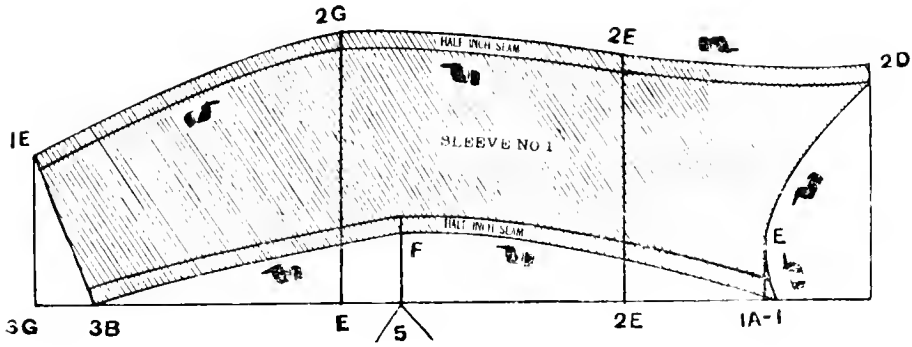

TO LAY OFF UNDER SLEEVE.

Proceed same as in laying off Upper sleeve. When all points are marked down together same as waist lines, point 5V must also be shortened one-eighth of an inch, bottom base line, then shorten point 1E, which is elbow point, one-eighth of an inch same as on upper sleeve. As elbow points must come same as they were on upper sleeve, must also be shortened one-half an inch length of arm points.

COLLAR.

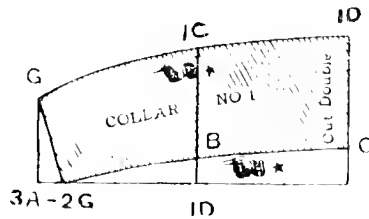

TO LAY OFF COLLAR.

Lay off collar in the same manner you did backs and fronts, making it the proper length with tape line to fit the neck.

THE CHANGES.

Two ladies of the same chest measurement may vary in size of waist, L. of waist, L. of arm, etc.

We will suppose, for instance, the measures had been :

Chest 33.

Waist 24 $\frac{1}{2}$.

L. of Waist 17.

Elbow 20.

L. of Arm 30.

By adding the one inch for seams to last two measures it makes them 21 elbow and 31 L. of arm.

In that case we would have to lengthen waist line five-eighths of an inch in place of shortening it. Which is done in the same manner as to shorten it, only you move your waist line point down in place of up. If waist line is lengthened, you must also lengthen point 4E one-half as much as you do waist line.

When you come to front, you must also lengthen the waist line the same amount as you do on backs and the top of darts one-half as much as you do waist line and always in the same direction.

On size of waist, if the measure had been 24 $\frac{1}{2}$, we want the one-half of pattern to measure 12 $\frac{1}{4}$ or one-half inch longer, as one-half of the pattern did measure 11 $\frac{3}{4}$ inches. To make the change move the two points 4D and E, one-half inch closer together, moving each point in one-fourth of an inch, which would throw in one-half inch more goods at waist line, 11 $\frac{3}{4}$ original measure and one-half would be 12 $\frac{1}{4}$. The measure we want, twice 12 $\frac{1}{4}$ would be 24 $\frac{1}{2}$, the waist measure we are drafting to.

If elbow measure had been 21 and the length of arm 31, it would have been necessary to lengthen elbow point three-eighths of an inch, and L. of arm one-half an inch. As original rule points would not have been long enough.

Always remember in shortening or lengthening elbow point E, you must shorten or lengthen (as the case may be) point 4D the same amount and where point 4F bottom of sleeve is lengthened or shortened you must always lengthen or shorten point 3G the same amount. When you come to under sleeve portion lengthen or shorten, as the case may require, elbow point E and the 5V, and also points 3G and 3B the same amount that you do the same points on upper sleeve, and in the same direction.

Under each garment will be given the necessary measures for laying it off, all points that may require changes and all directions necessary. Read them carefully before attempting to cut the garment.

The garments do not generally need changing; but in case they do, to fit them to tape measurement, we give all points on all garments that may have to be changed.

DRAFTS 1 AND 2

Are so designed that any one wishing to use a plain back and French bias front can use back and side, back of No. 1 and front of No. 2. Or if one wishes to reverse and use the backs of No. 2 and plain front of No. 1 they can do so. Any sleeve desired may be cut with any draft.

THE SHADING OR FINE CROSS LINES

Show just what amount of the diagram is made up into the garment, or in other words, represents the cloth.

LADIES' BASQUE, FRENCH BLAS.

BACKS.

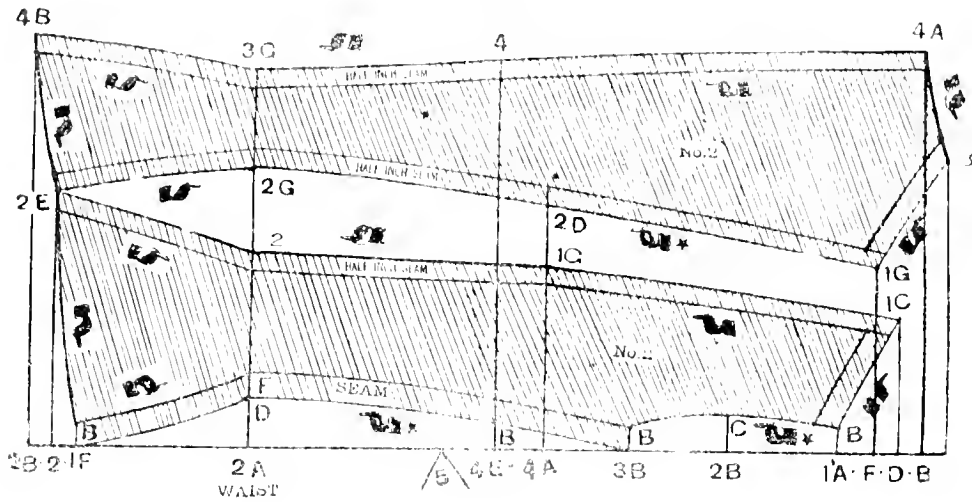

Take chest, waist, length of waist, elbow, and length of arm. Use rule corresponding with chest measure. Measure down from letter B to get length of waist. If any change be necessary, 2A being waist line point, lengthen or shorten it, as the case may require. Points 1E and 1A must be changed one-half as much as waist line and in the same direction.

UNDER ARM GORE.

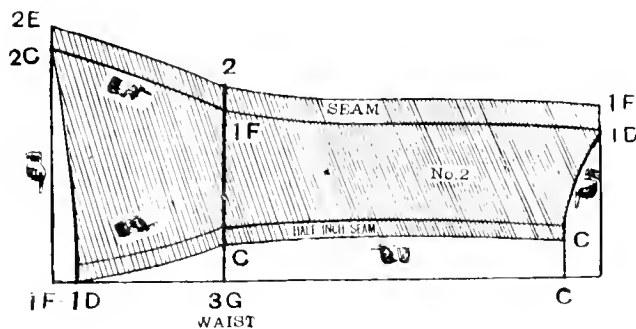

Under arm gore is laid off by same rule. If waist on backs is lengthened or shortened, Point 3G being waist line point, must be lengthened or shortened same amount.

LADIES' BASQUE FRENCH BIAS.

FRONT.

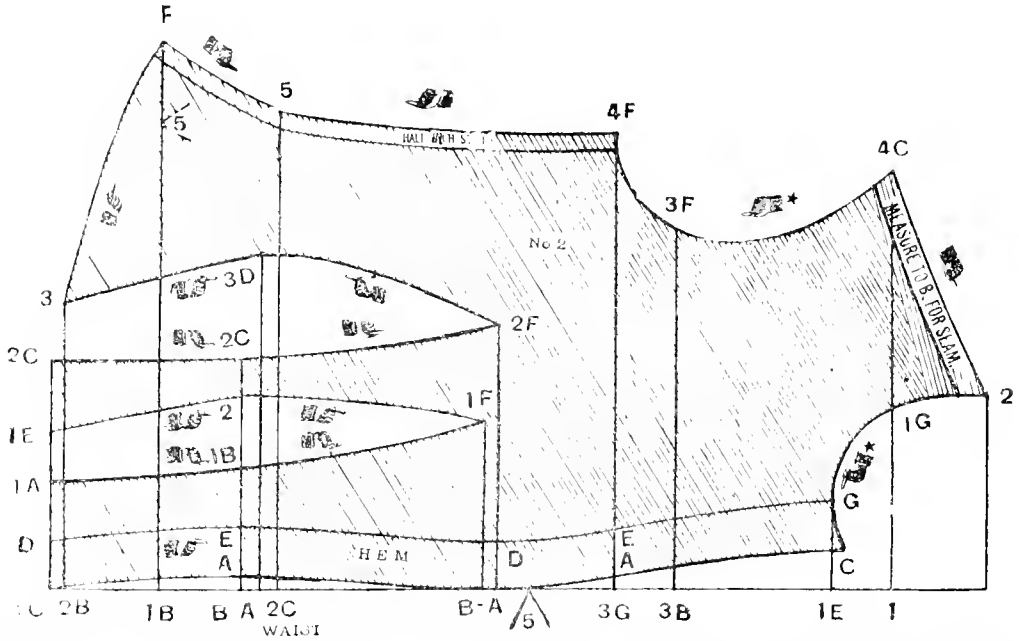

Use same rule. If waist lines have been lengthened or shortened, lengthen or shorten point 2C, which is waist line, same amount as on backs and under arm gore and top of darts A and B one-half as much in the same direction. When seams are all laid off test size of waist. If change be necessary, move point C on waist line on under arm gore, and point 5 on waist line on front next to under arm gore one-half the amount of change required, in the same manner that change was made on Diagram No. 1 in under arm dart. If the waist needs to be larger the points are moved towards each other. If smaller, they are moved apart.

LEG OF MUTTON SLEEVE.

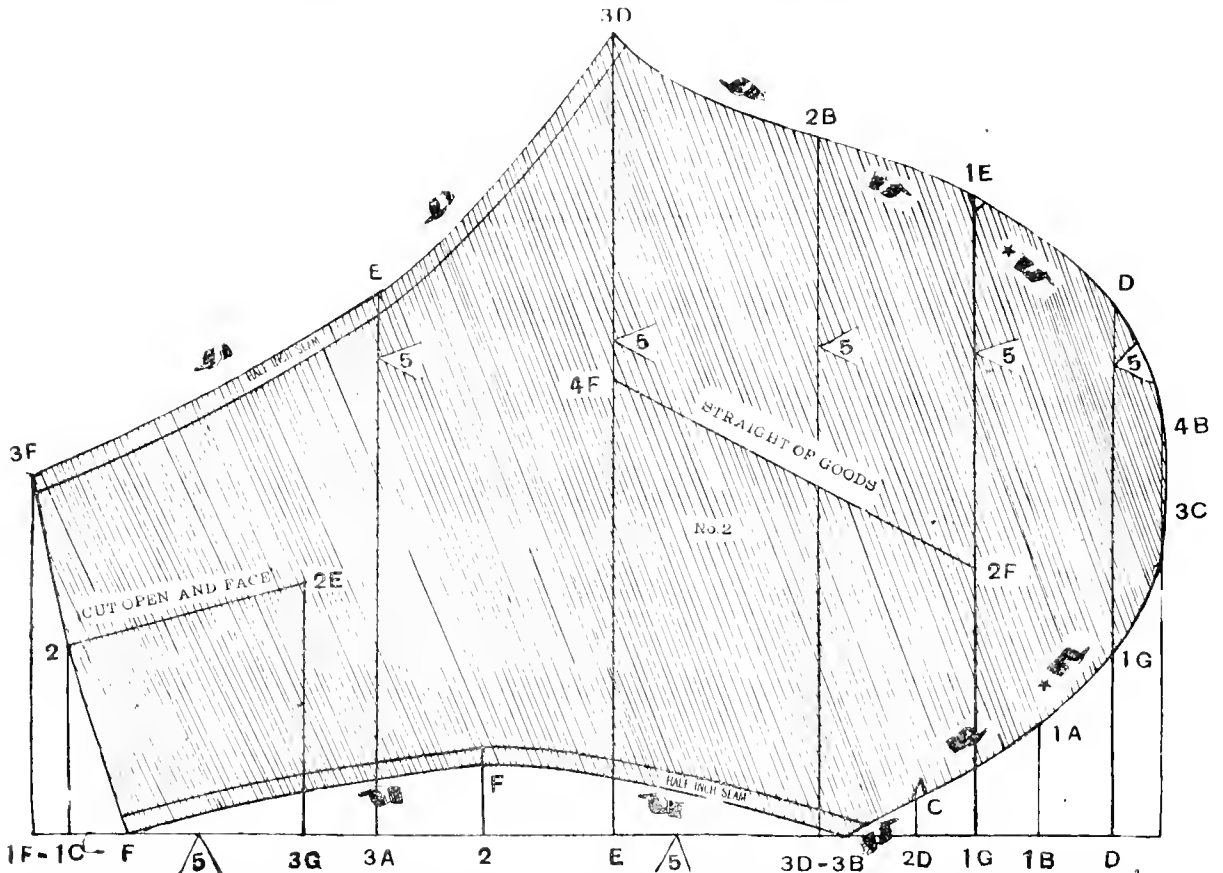

Use rule corresponding with chest measure. Point 2 is elbow line. If it be changed change point E same amount. If bottom point be changed change points 10 - F - 3G and 3A same amount and in the same directions.

LADIES' MORNING DRESSING WAIST.

GATHERED SLEEVE.

UPPER SLEEVE.

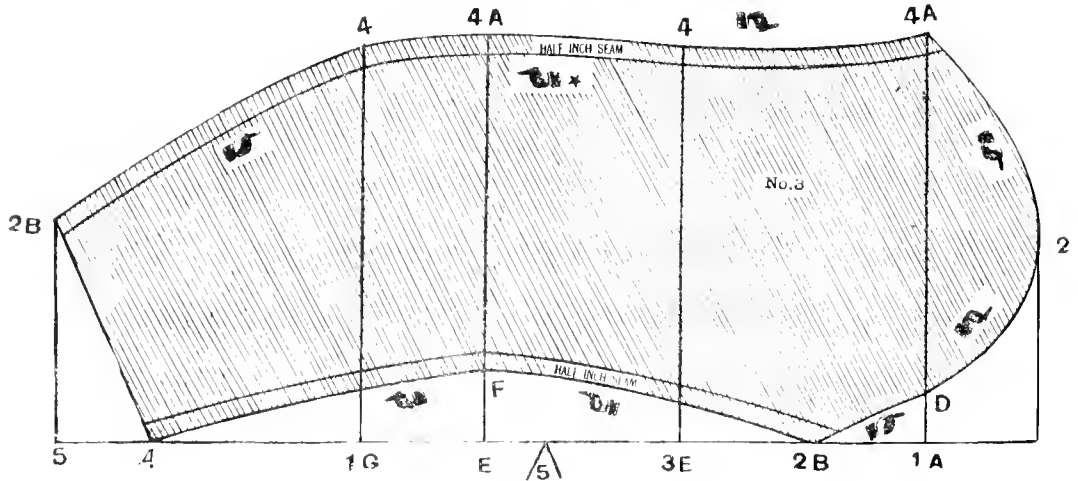

Use same rule, lengthen or shorten, to tape measurement; point E is elbow point; 1G must be changed same amount as elbow and in same direction; point 5 is L. of arm point, and point 1 must be changed same amount as point 5, if any change is made. Gather to fit notches between points 2E and 2F on under sleeve.

UNDER SLEEVE

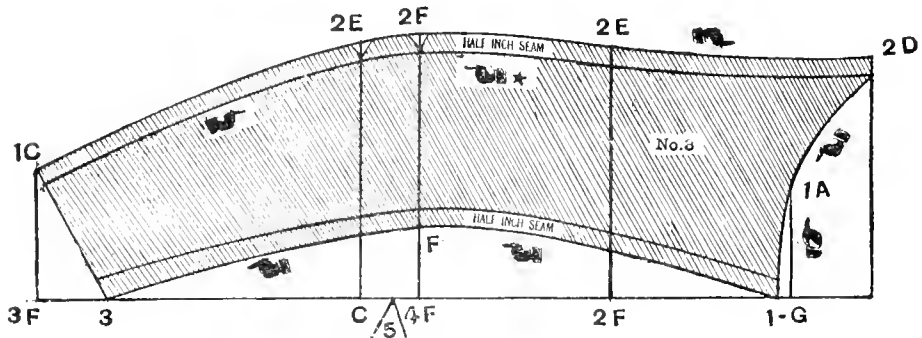

To lay off under sleeve use same rule; points C and 4F must be changed same amount as points E and 1G on upper sleeve, and points 3 and 3F must be changed same amount as points 4 and 5.

LADIES' PLAIN BASQUE.

BACKS.

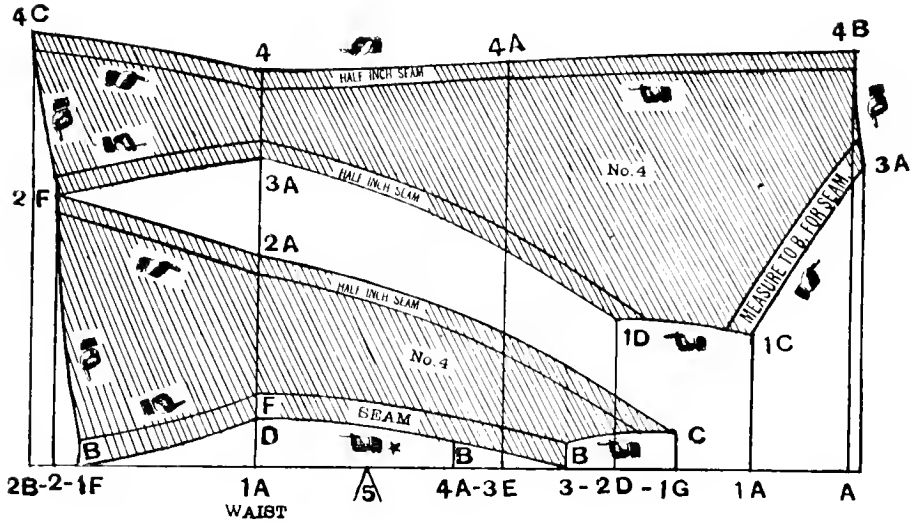

Take chest, waist, L. of waist, elbow and length of arm, measure down from point A to get length of waist, 1A, marked waist, is waist line point. Change to fit tape line measure. If waist is changed, change point 4A one-half the amount.

FRONT.

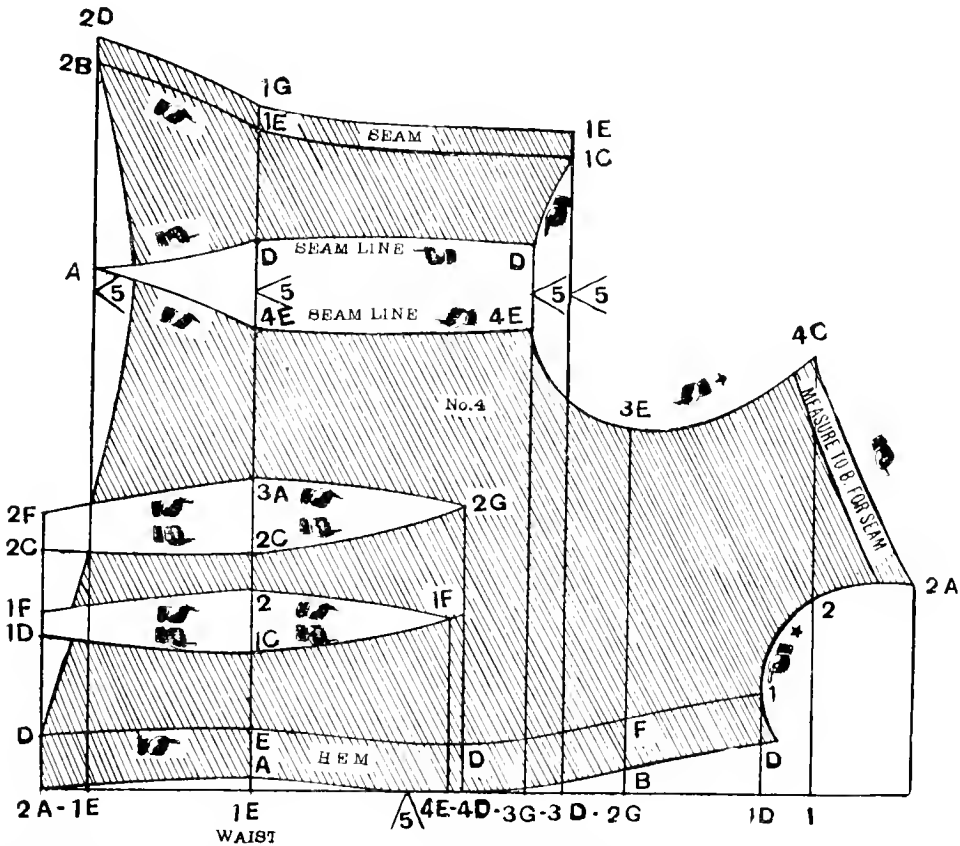

To lay off front use same rule. If waist on back has been changed, change waist line point 1E same amount and top of darts 1E and 1D one-half as much. If any change is necessary in size of waist, regulate it at under arm dart, moving points 1E and D, in or out, as the change may require.

LADIES' PLAIN BASQUE.

GATHERED SLEEVE.

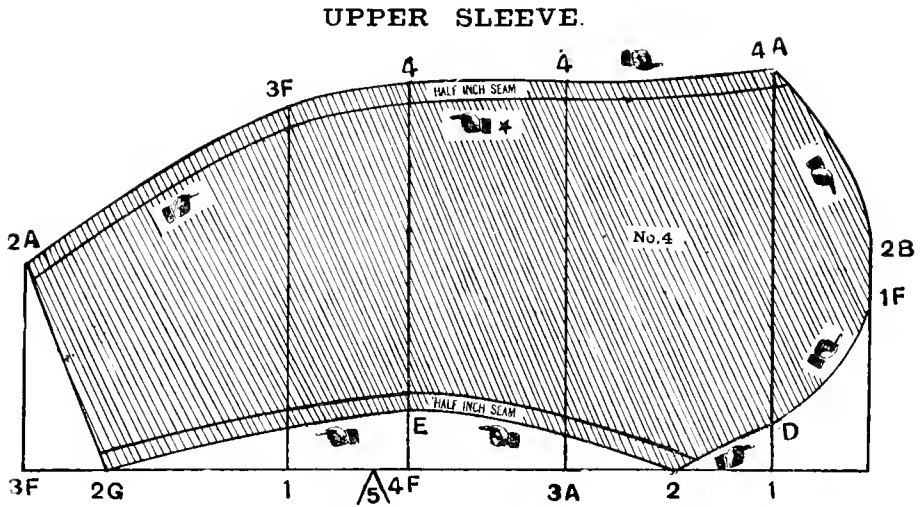

Use same rule. Point 1F is elbow and point 1 is to be changed same amount with it. (If change be made) 3F is L. of arm point. If it is changed, change 2G same amount. Gather to fit notches on under sleeve between points 2D and 2E.

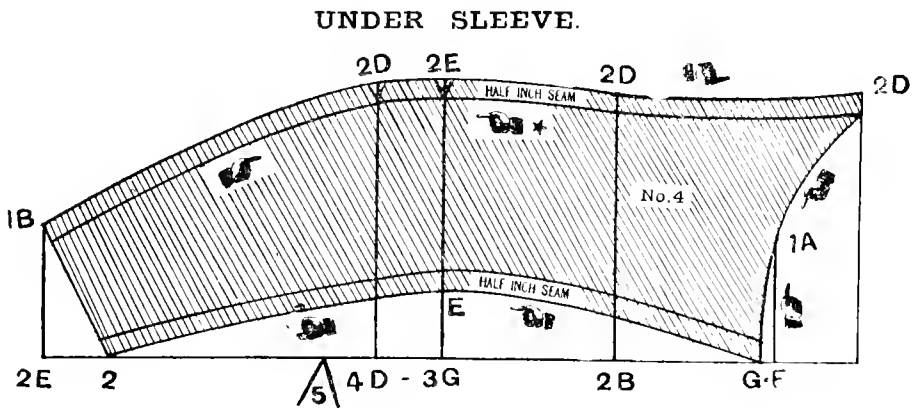

Use same rule. If points 4F and 1 are changed on upper sleeve, change points 4D and 3G same amount, and 2E and 2 same amount as L. of arm measures 3F and 2G.

LADIES' BASQUE.

FOR STOUT FIGURES.

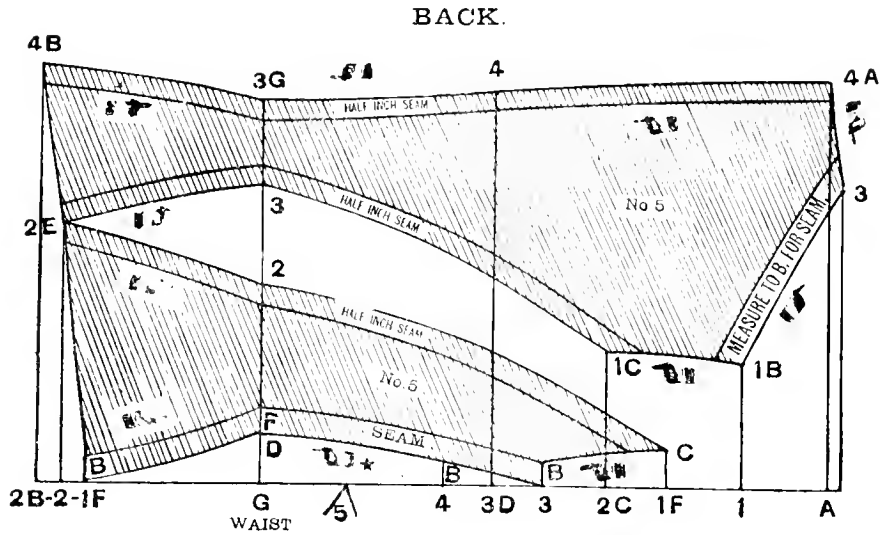

Take chest, waist, L. waist, elbow, L. of arm. Use rule corresponding with chest. Measure from point A to get L. of waist, change G waist line point to fit tape measurement and point 4 one-half as much.

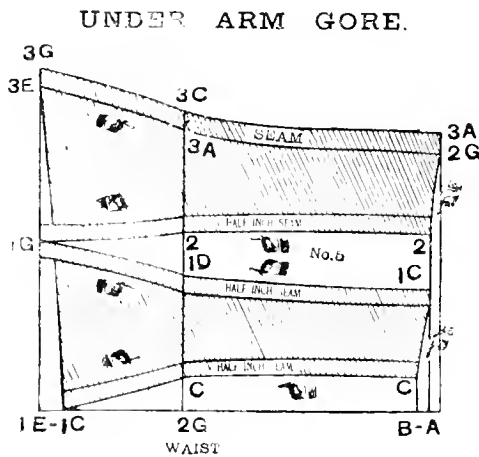

Use same rule. If waist line was changed on backs, change waist line point 2G same amount.

FRONT.

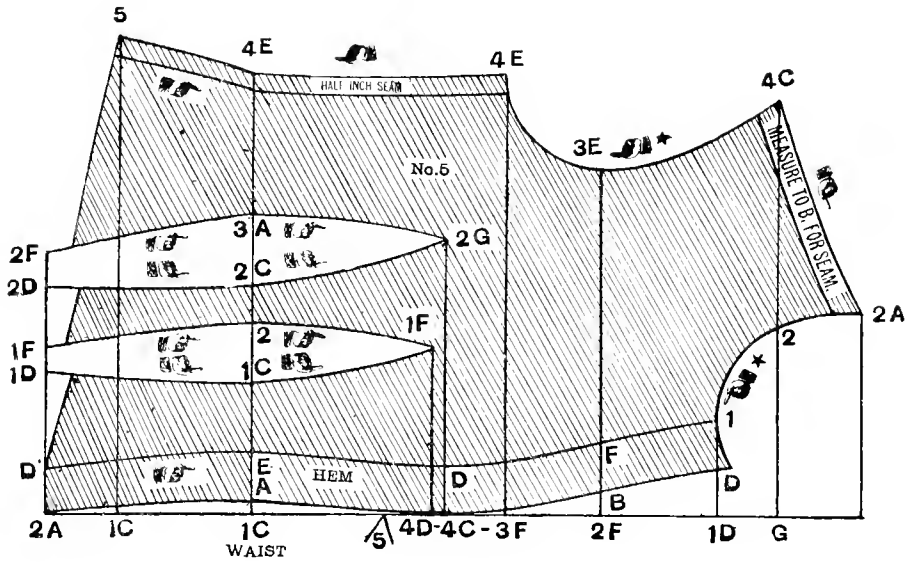

Use same rule if waist lines have been changed on backs and under arm gore. Change waist line point 1C same amount and points 4D and 4C at top of darts one-half as much. If size of waist needs changing, let out or take, as the case may require, point 2G on under arm gore next to front and point 4E on front next to under arm gore. Change them same as change is made in under arm dart.

UPPER SLEEVE.

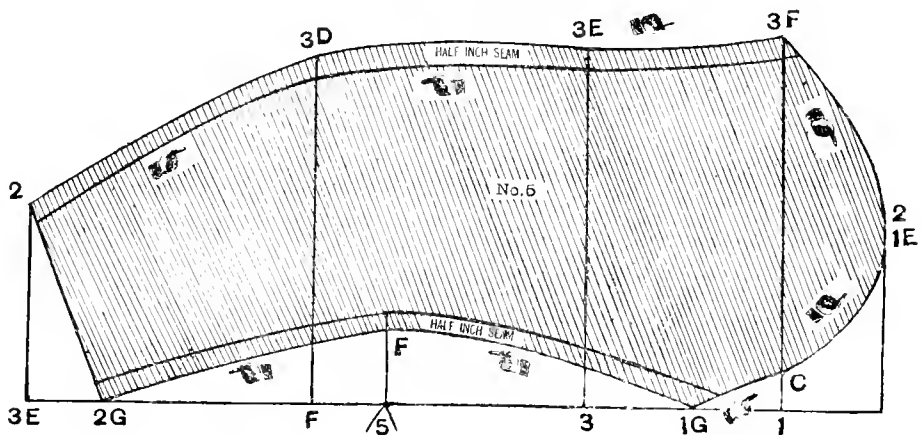

Lay off by same rule; 5V is elbow. If changed, change point F same amount. 3E is L. of arm point. If changed, change 2G same amount.

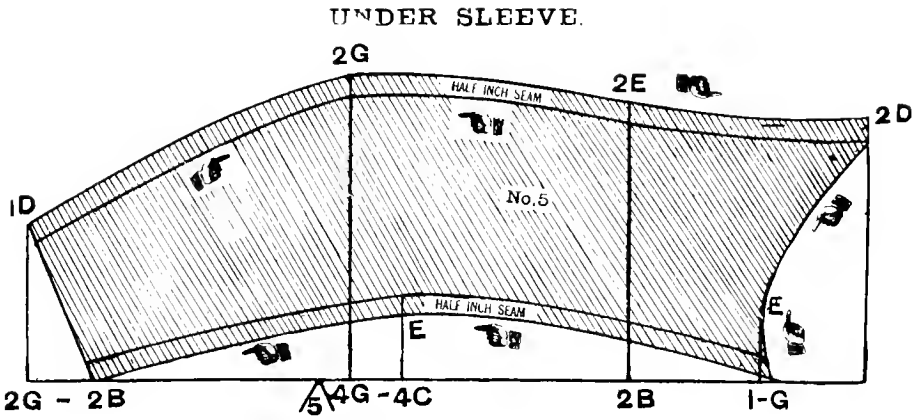

Use same rule. If 5V and F have been changed on upper, change 1G and 4C elbow points same amount, and also 2G and 2B same as 3E and 2G on upper sleeve.

LADIES' TEA GOWN.

Take chest, waist L., waist, elbow, L. of arm and length of skirt. L. of skirt is taken from waist (on person you are cutting for) down to the floor. Use rule corresponding with chest. Measure down from A for L. of waist. 2 is waist line point. Change to fit. If changed, change point 4D one-half the amount. If skirt length point 2A is changed, change point 1F and 1D same amount and point 3E one-half as much.

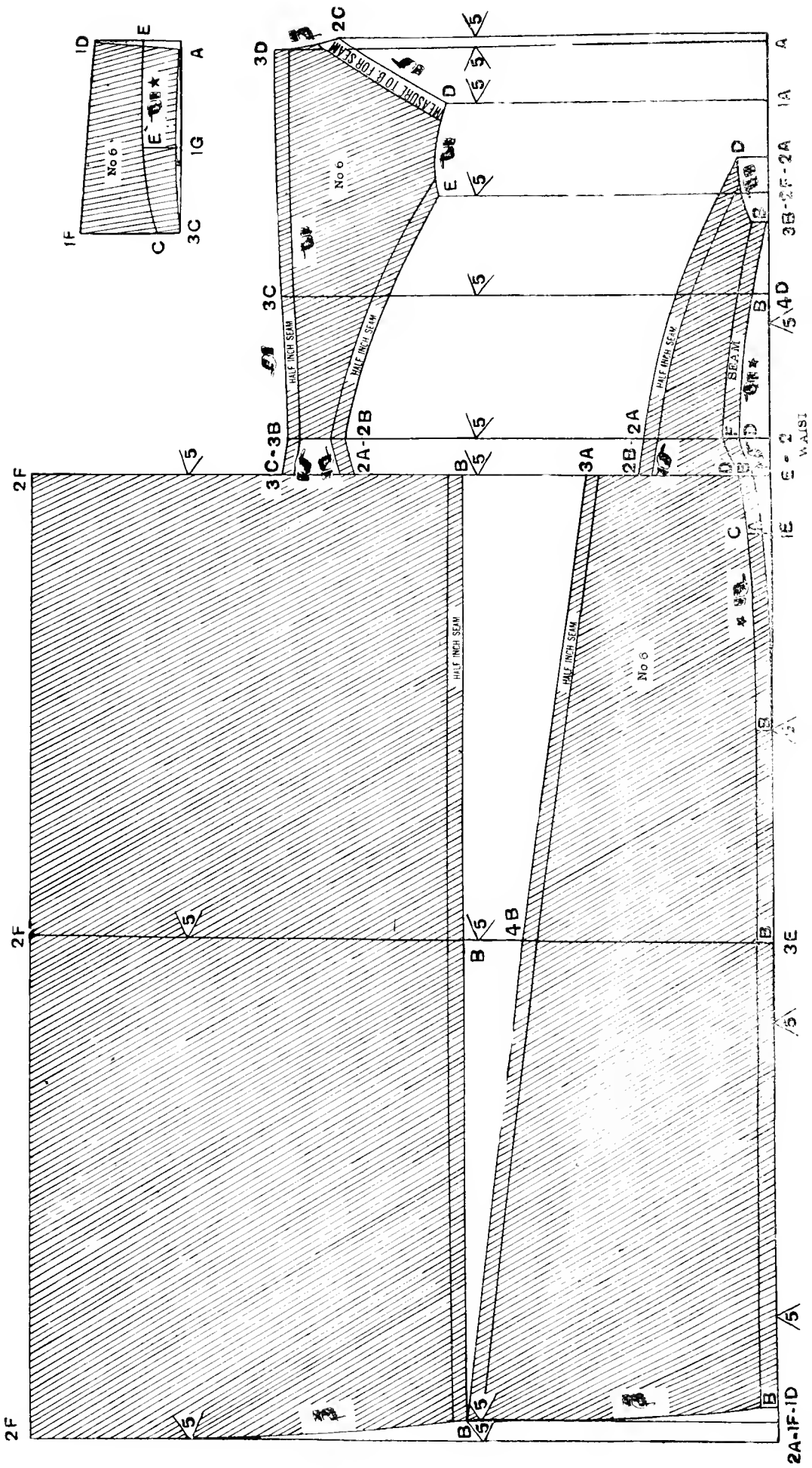

LADIES' TEA GOWN.

FRONT.

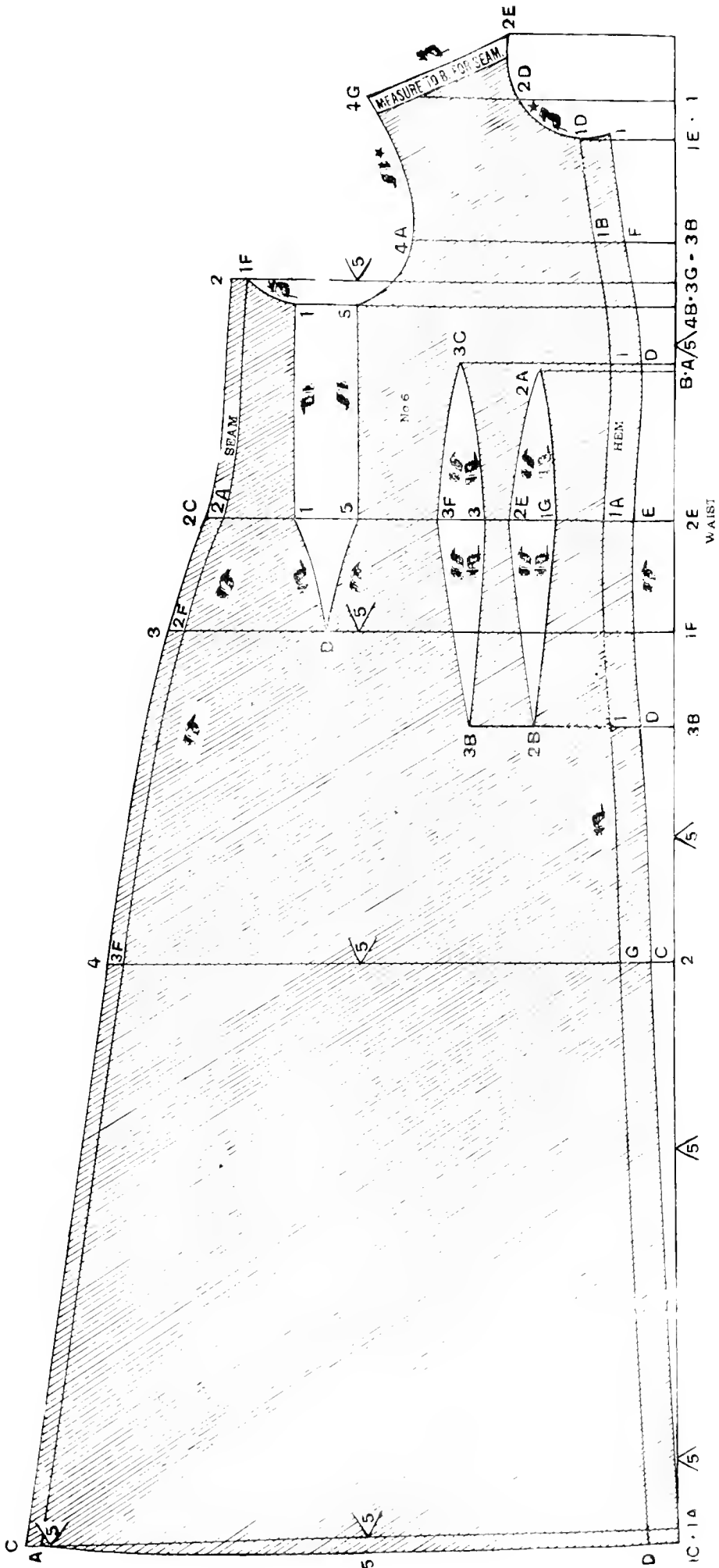

Use same rule. If waist has been changed on backs, change waist line point 2E same amount and A and B top of darts one-half as much. If length of skirt has been changed, change 1C and 1A same amount as you did points 2A, 1F and 1D. On backs always remember to change them in the same direction, and move point 2 up or down, as the case may require, one-half the amount of change. Regulate size of waist in under arm dart at points 5 and 1 on waist line.

LADIES' TEA GOWN.

UPPER SLEEVE.

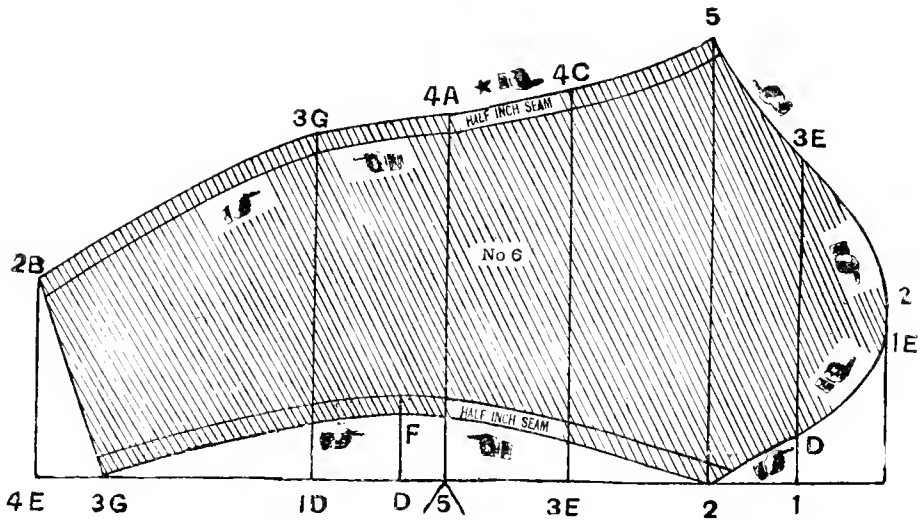

Use same rule. D is elbow. If changed, change and 1D same amount. 4E is L. of arm measure. If necessary to change, change 3G same amount.

UNDER SLEEVE.

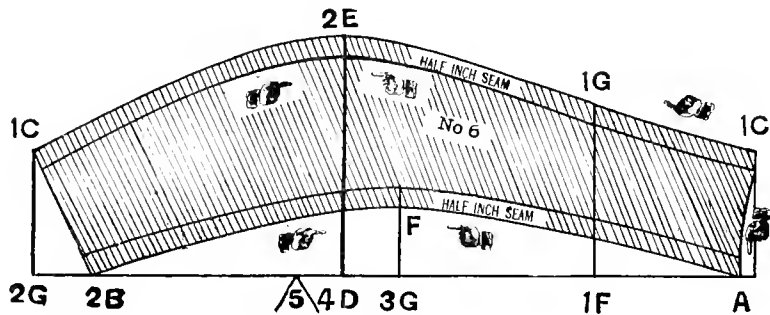

Lay off by same rule. Lengthen or shorten points 1D and 3G same amount as D elbow point on upper sleeve, and 2G and 2B same amount as points 4E and 3G.

LADIES' SKIRT.

FOR STOUT FIGURES.

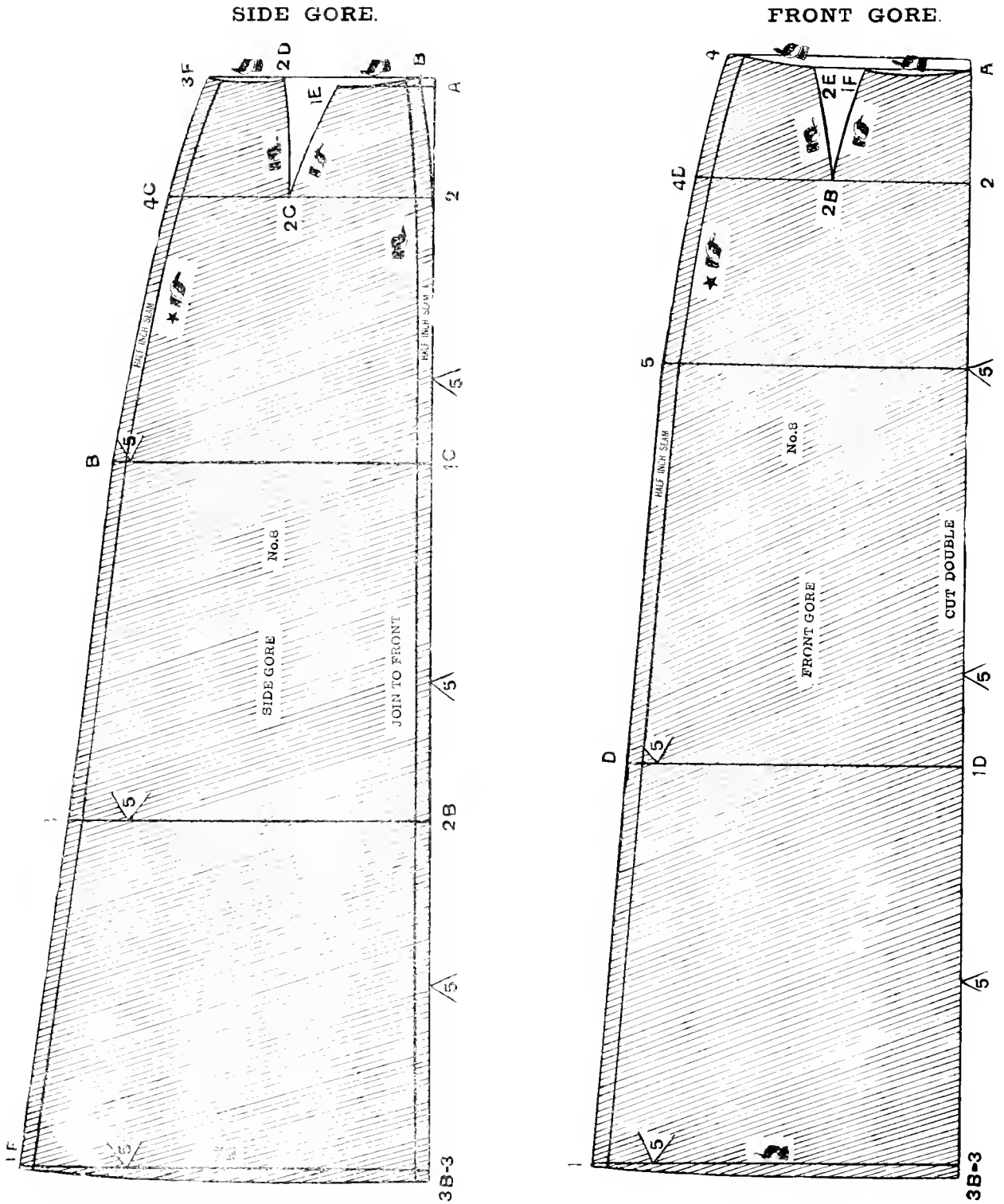

Use rule corresponding with waist measure. Follow the same rule as in cutting No. 7 skirt. Take L. of skirt measure same way and if changes are necessary they are made exactly the same as on No. 7.

LADIES' SKIRT YOKE.

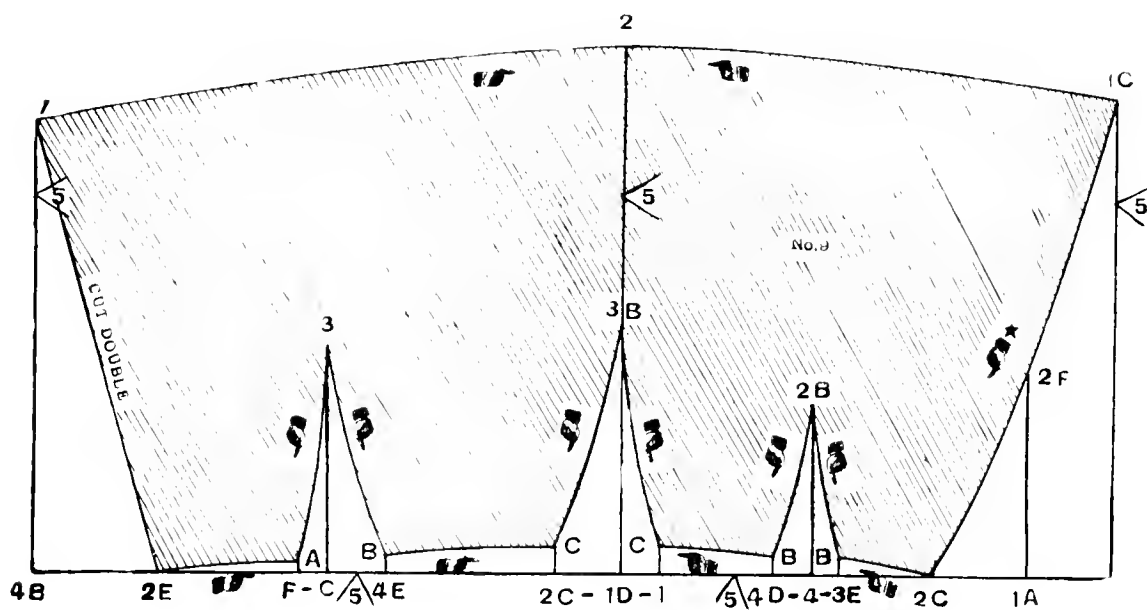

Take waist measure and use rule corresponding therewith. It can be cut as deep as one wishes.

FULL WAIST FOR LADIES OR MISSES.

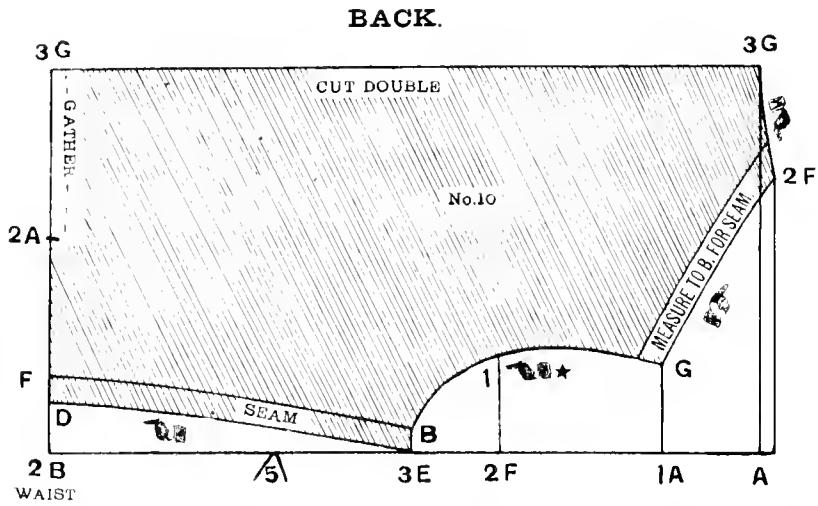

Take chest, waist, L. of waist, elbow and L. of arm, measure down from A and regulate 2B waist point to tape measurement.

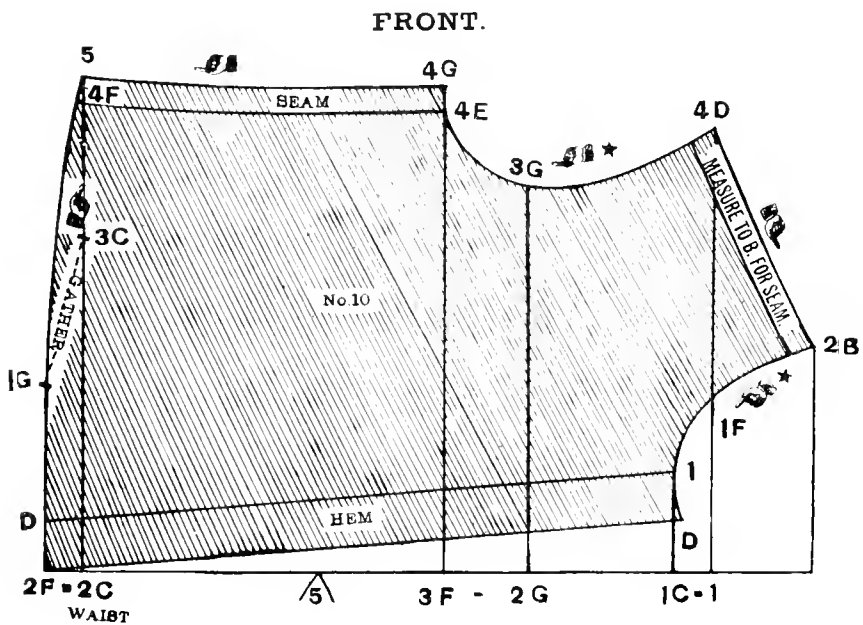

To lay off front use same rule. If waist has been changed on back, change same amount on front.

Cut waistband, which is a straight piece of goods, about two inches wide to exact waist measure and gather fronts between points 1G and 3C and backs between points 2A and 3G, to fit waistband.

FULL WAIST FOR LADIES OR MISSES.

COLLAR.

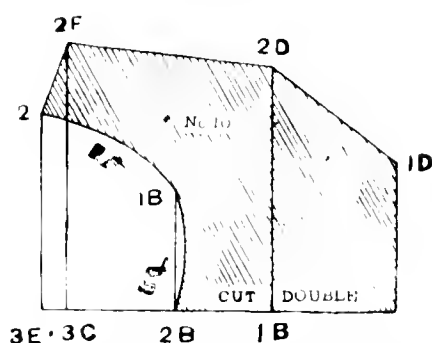

Lay off collar by same rule. Regulate size of neck by tape line.

UPPER SLEEVE.

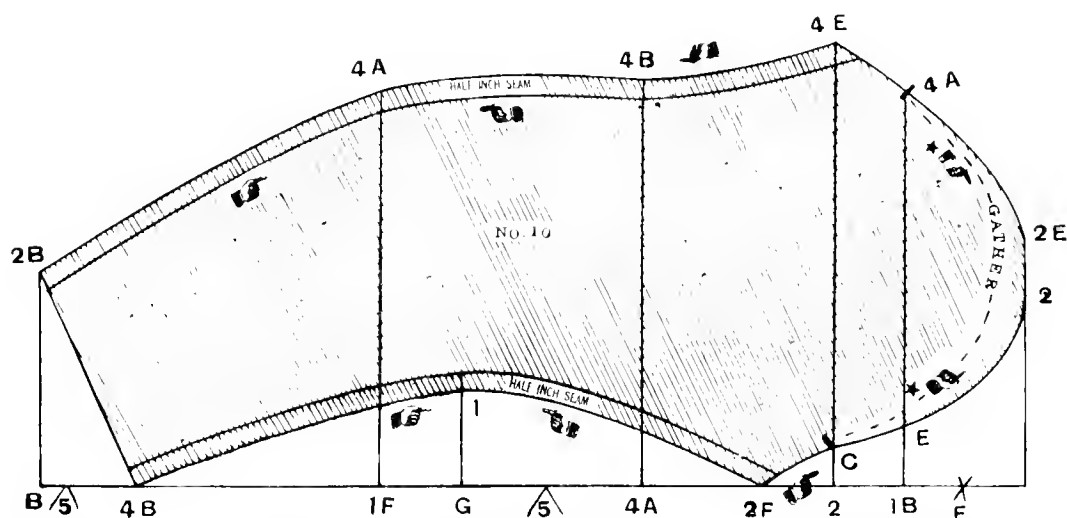

Use same rule. Measure down from E point where the X is for elbow and L. of arm measures. G is elbow point. If necessary to change, change 1F same amount. If point B, L. of arm, has to be changed, change 4B point same amount. Gather around top of sleeve from point C on cross line at point 2 to point 4A on cross line at point 1B.

UNDER SLEEVE.

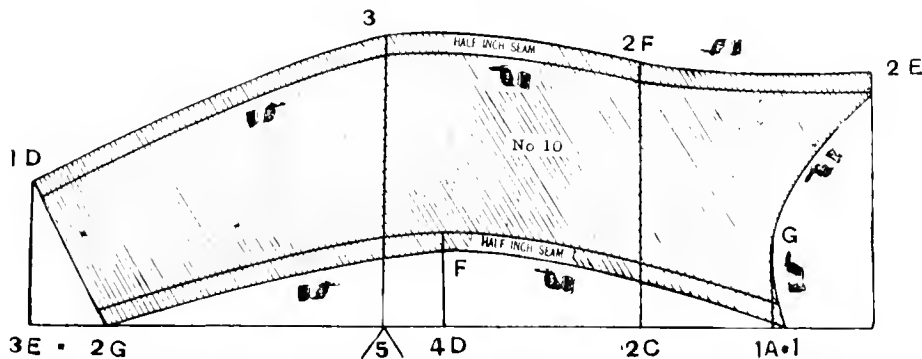

To lay off under sleeve use same rule. If elbow has been changed on upper sleeve change 4D and 5V same amount, and L. of arm points 3E and 2G same amount as L. of arm points on upper sleeve.

MISSES' BASQUE.

OPEN IN FRONT.

BACKS.

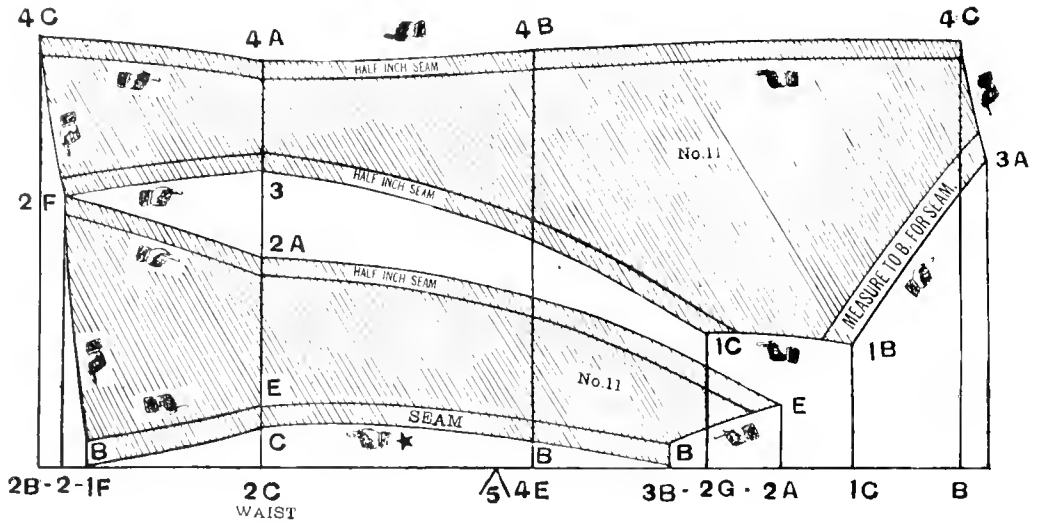

Take chest, waist, L. of waist, elbow and length of arm. Measure from B to get length of waist, change 2C' waist line point to fit, and 1E point one-half the amount.

FRONT.

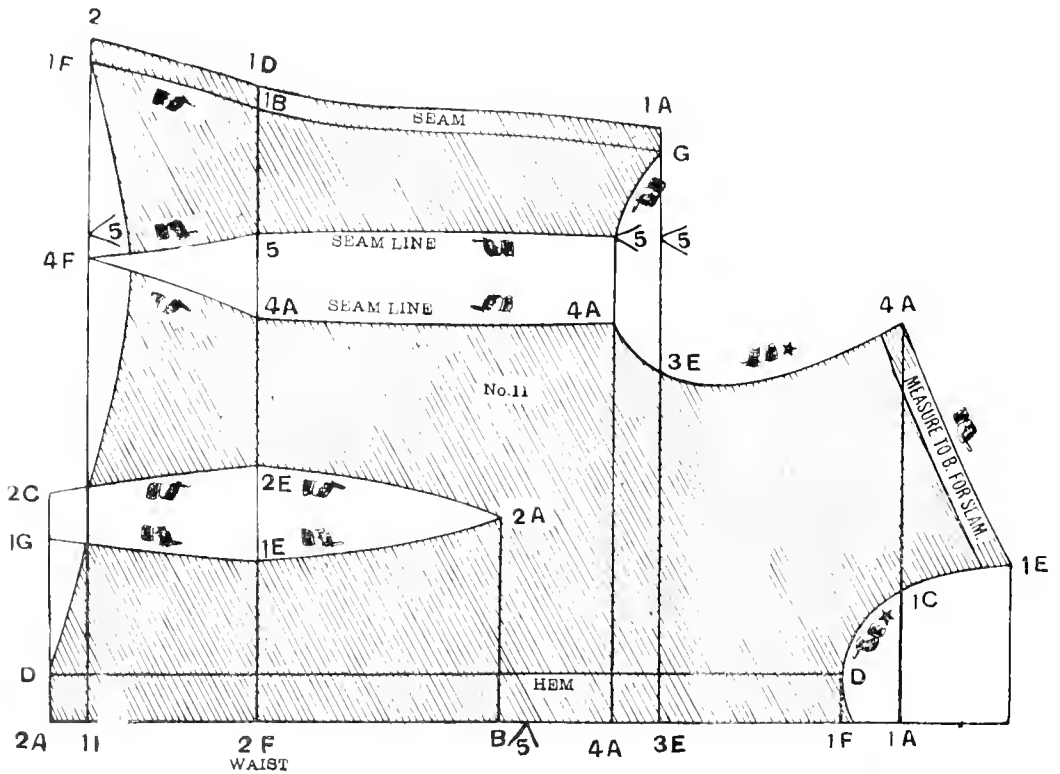

Use same rule. If waist has been changed on back, change 2F waist line point same amount and B top of dart point one-half the amount. Regulate size of waist at under arm dart, same as other basques.

MISSES' BASQUE.

UPPER SLEEVE.

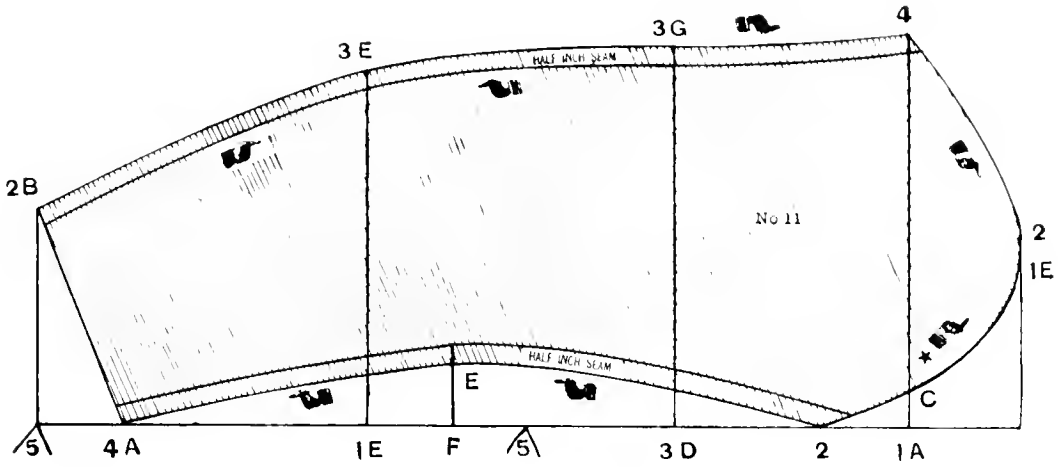

Use same rule. F is elbow point. If changed, change 1E same amount. 5V is L. of arm point. If changed, change 4A same amount.

UNDER SLEEVE.

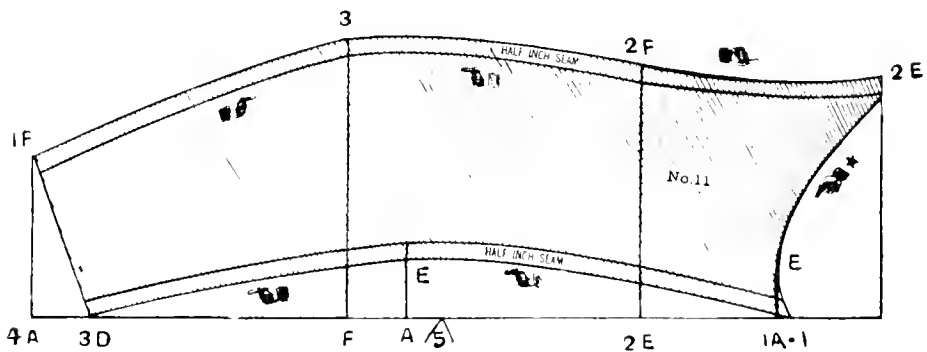

Use same rule. If elbow points and length of arm points have been changed on upper sleeve, change them same amount on under sleeve.

MISSES' BASQUE.

OPEN IN BACK.

BACKS.

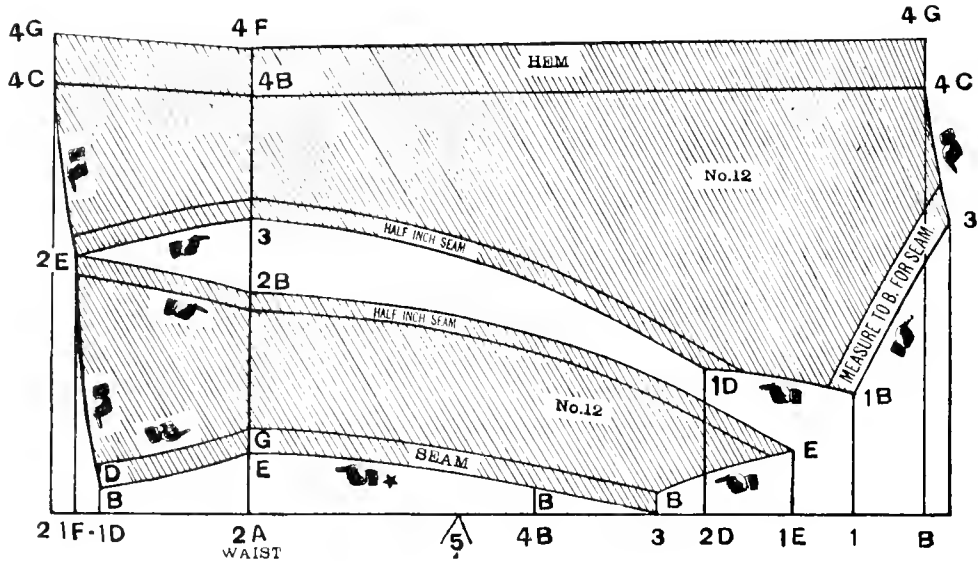

Take chest, waist, L. of waist, elbow and length of arm. Measure from B to test length of waist. 2A is waist line. Change to fit. If changed, change 4B one-half the amount.

FRONT.

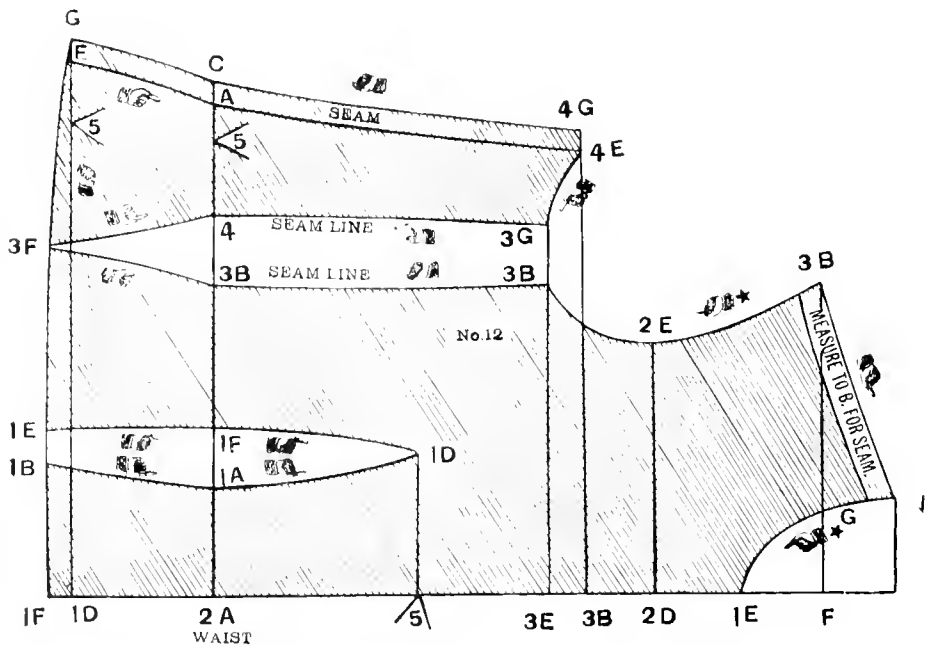

Use same rule. If waist has been changed on back, change waist line point 2A same amount. Top of dart point 5V one-half as much. Regulate size of waist at under arm dart same as in other basques.

MISSES' BASQUE.

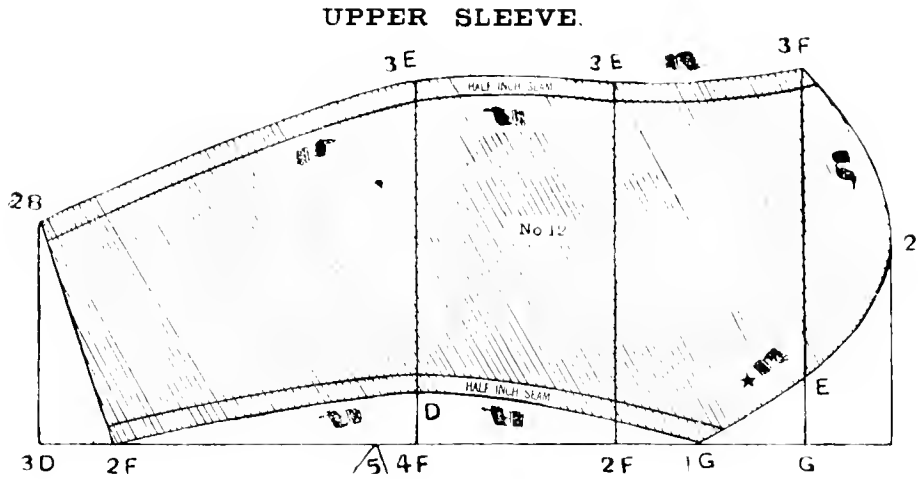

Lay off by same rule; regulate elbow and L. of arm measures same as on other sleeves. 4F is elbow point, 3D L. of arm. Change 2F same amount as 3D.

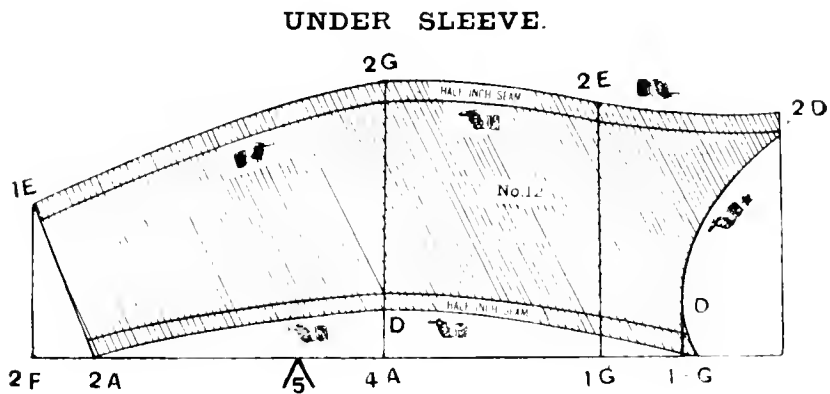

Lay off by same rule. If changes have been made on upper sleeve, change elbow point 4A and L. of arm points 2F and 2A same amount.

CHILD'S WAIST.

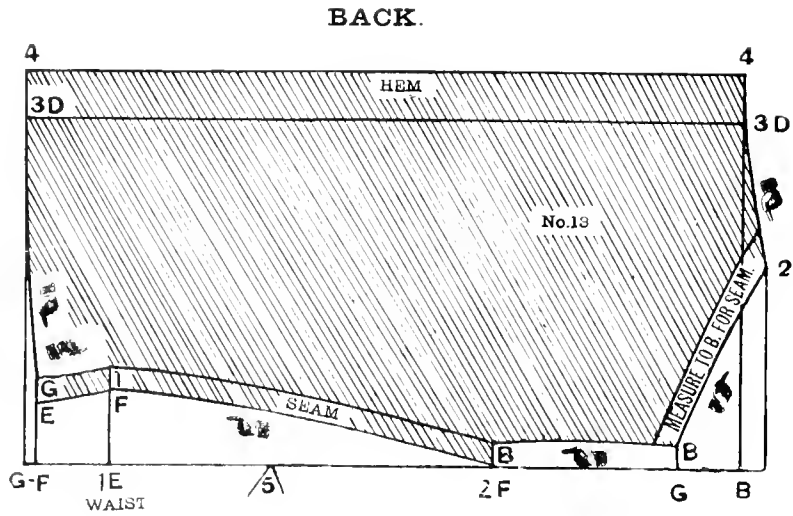

Take chest, waist, L. of waist, elbow and L. of arm. Measure from B for length of waist, change 1E waist line point to fit tape measurement.

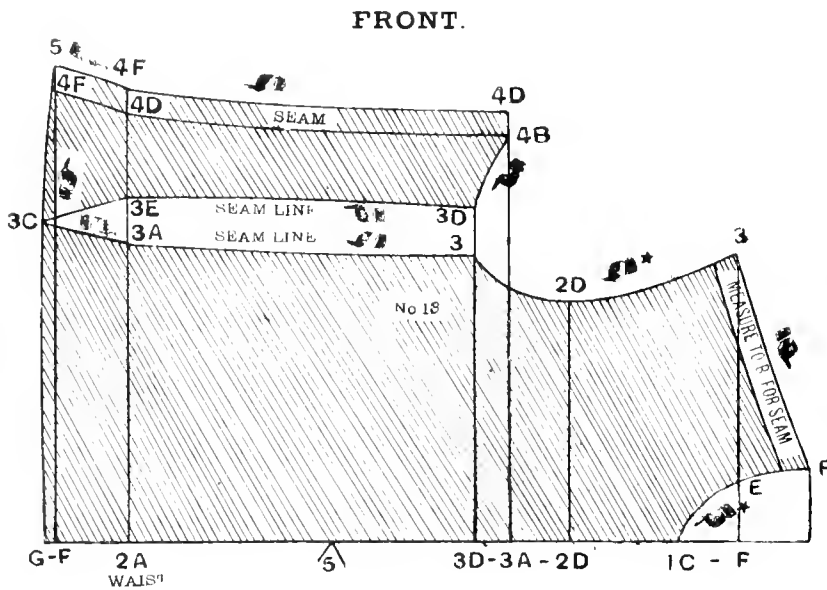

Use same rule. If waist has been changed, change 2A waist line point same amount.

CHILD'S APRON.

FRONT.

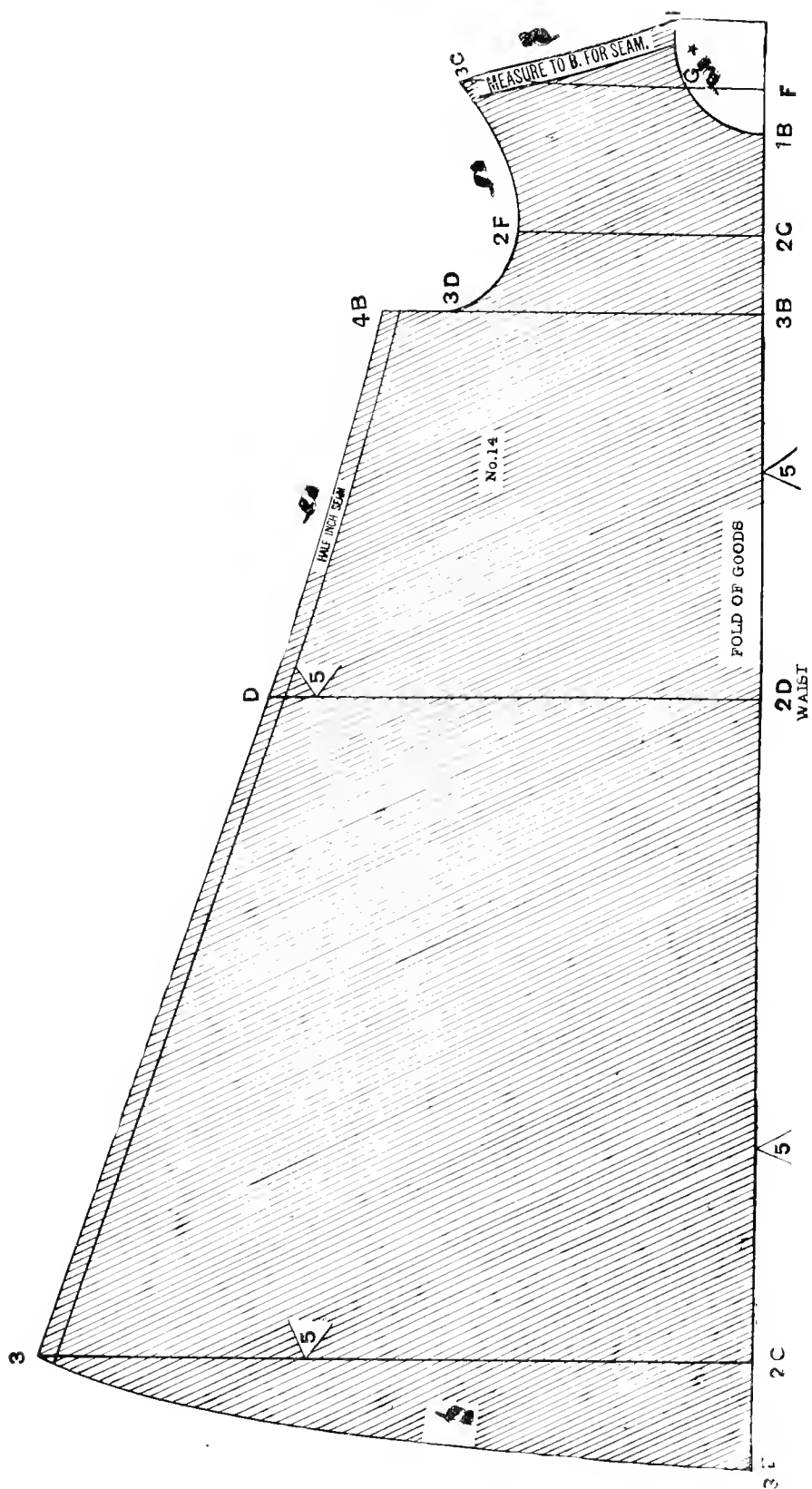

To lay off front use same rule. If waist has been changed on back change 2D waist line point same amount. If length points have been changed on back, change 3E and 2C same amount.

CHILD'S APRON.

UPPER SLEEVE.

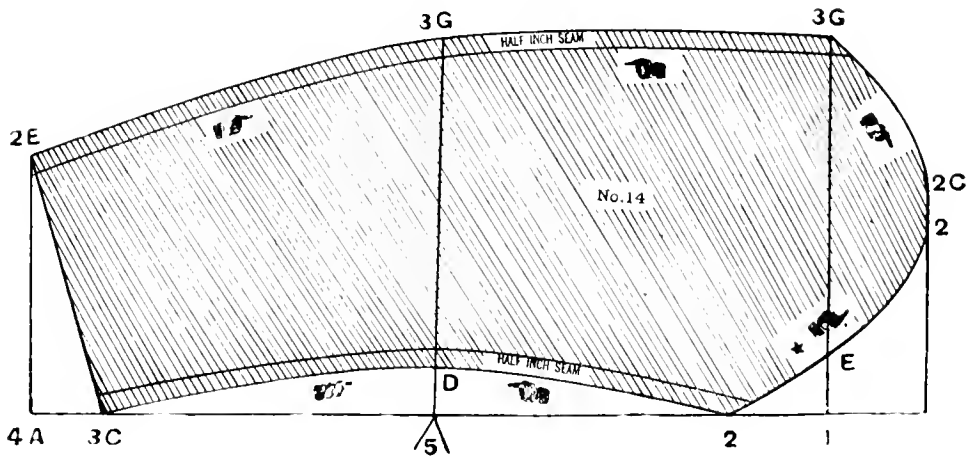

Use same rule. 5V is elbow. Change to fit tape measurement if necessary and length of arm point 4A to L. of arm tape measurement. Change 3C point same amount.

UNDER SLEEVE.

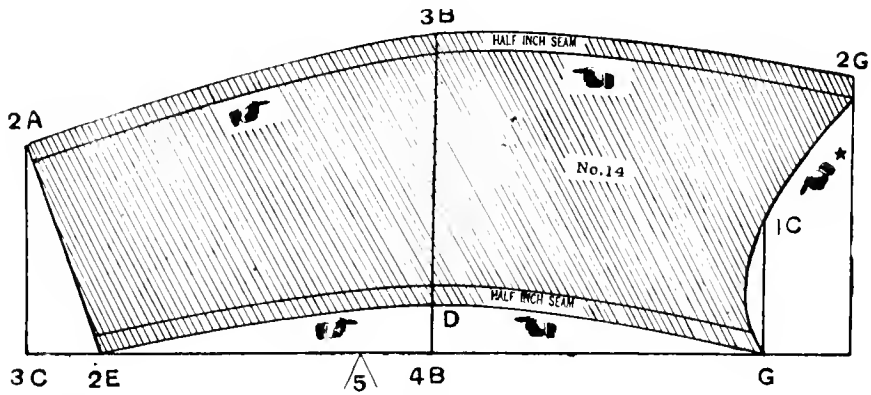

Use same rule and make changes as directed on other sleeves. 4B is elbow and 3C and 2E L. of arm points.

COLLAR.

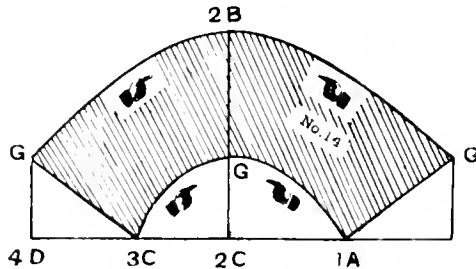

Use same rule. Regulate to fit size of neck by tape line.

LADIES' CHEMISE.

Take chest, L. of waist and full length in back. Use rule corresponding with chest measure. Regulate L. of waist by measuring down from point B. Change waist line E to fit. For full length, measure from point B and change 2E to tape measurement, changing 1G same amount and point 4C one-half the amount.

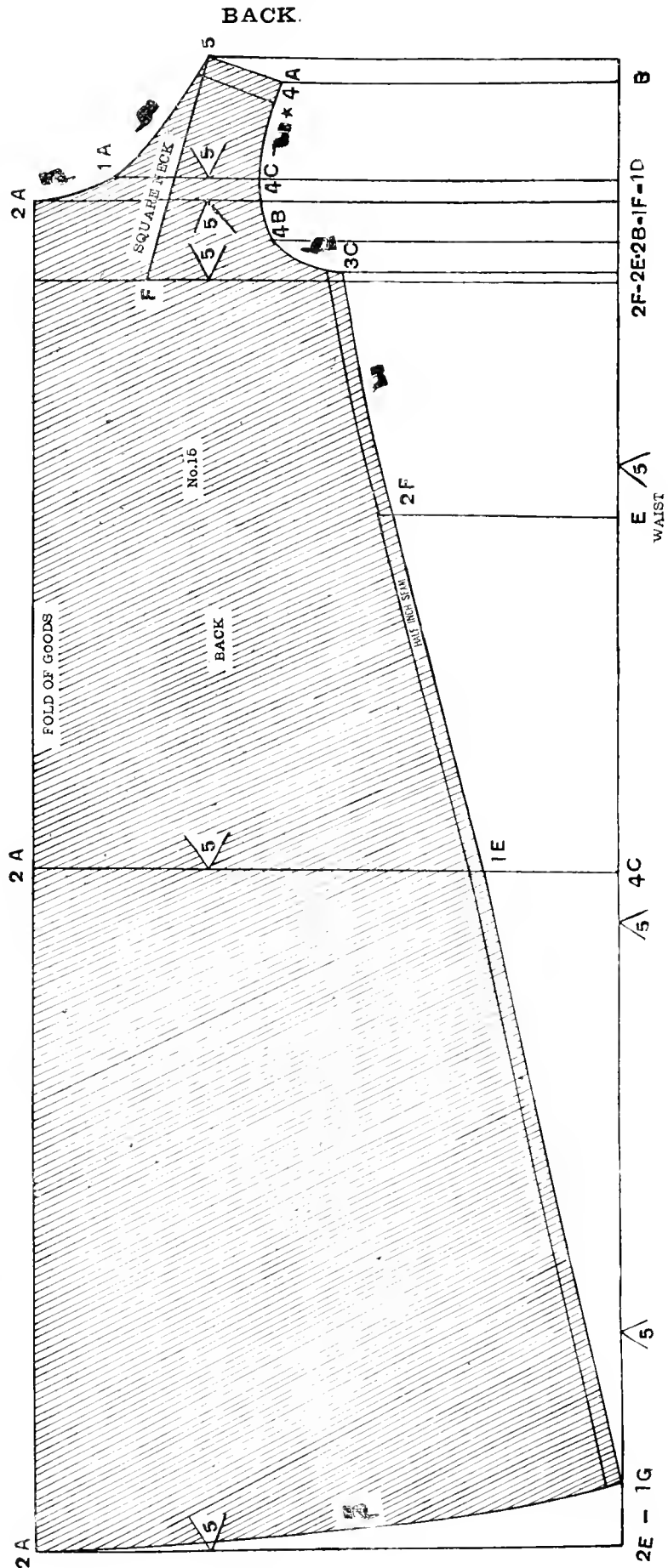

FRONT.

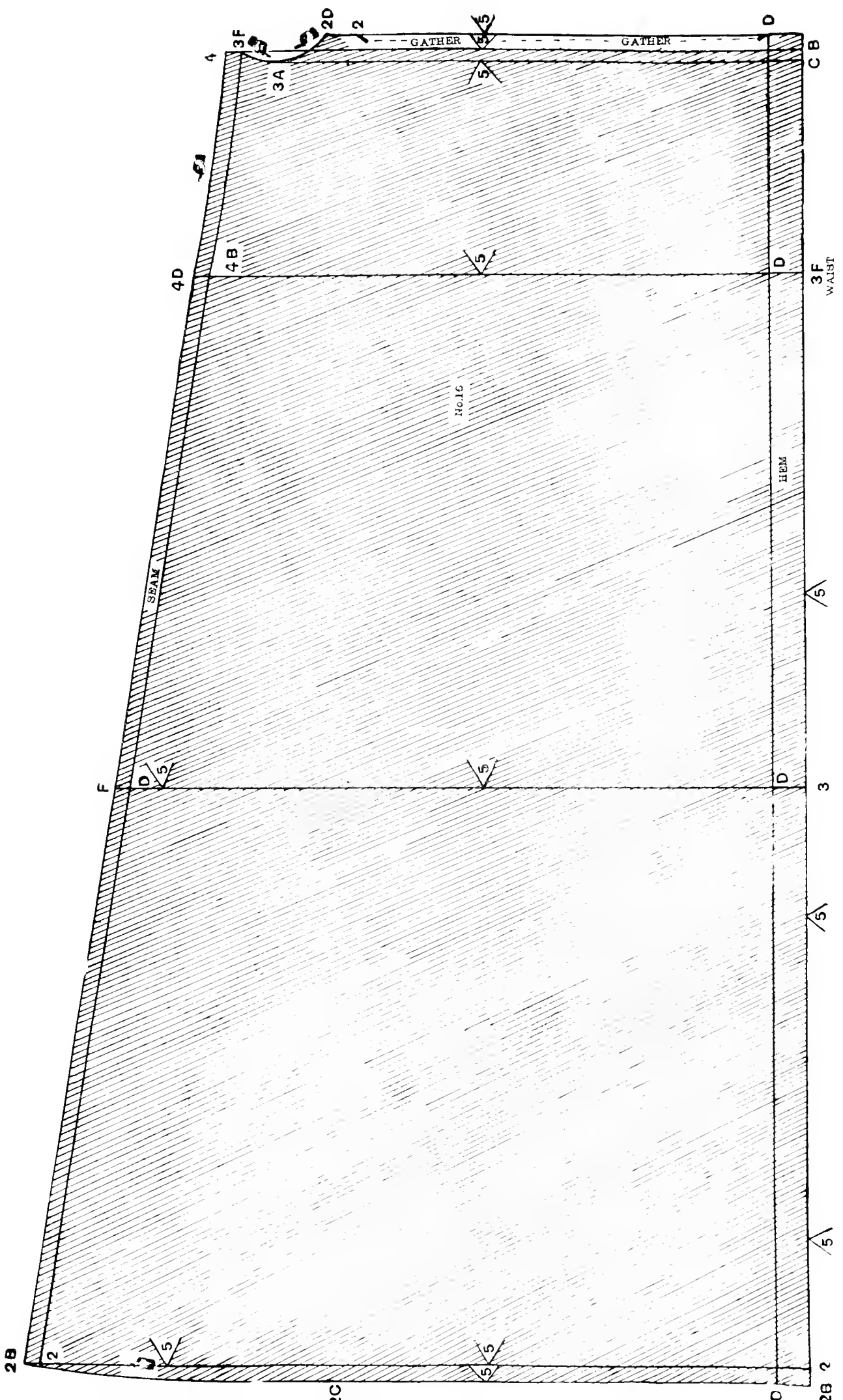

LADIES' MOTHER HUBBARD NIGHT DRESS.

SLEEVE.

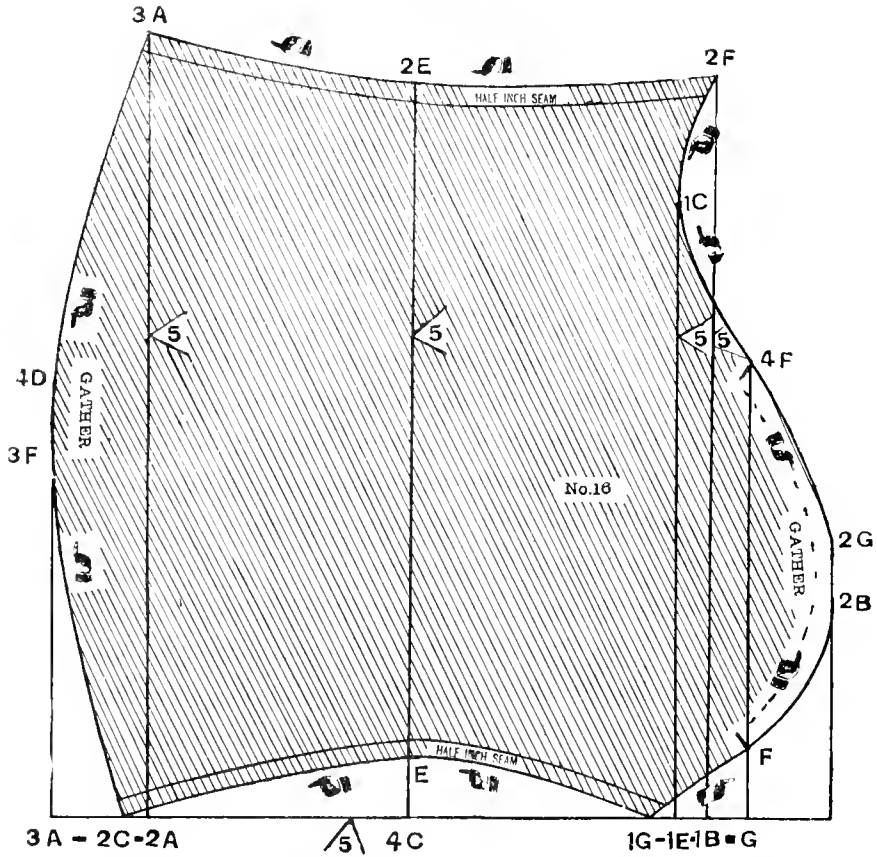

Use same rule. Gather sleeves at points marked gather. 1C is elbow. Change to fit. Make length whatever you desire. If you change point 3A, change 2C and 2A the same amount.

YOKE.

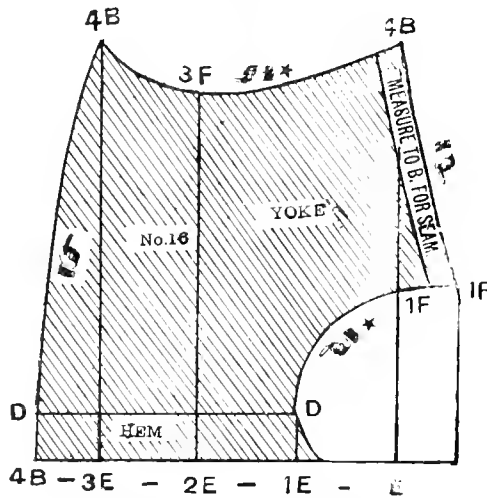

Lay off by same rule.

COLLAR.

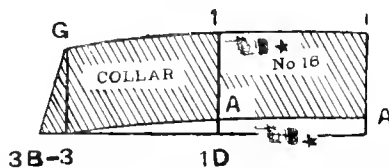

Lay off by same rule. Fit to size of neck with tape.

LADIES' DRAWERS.

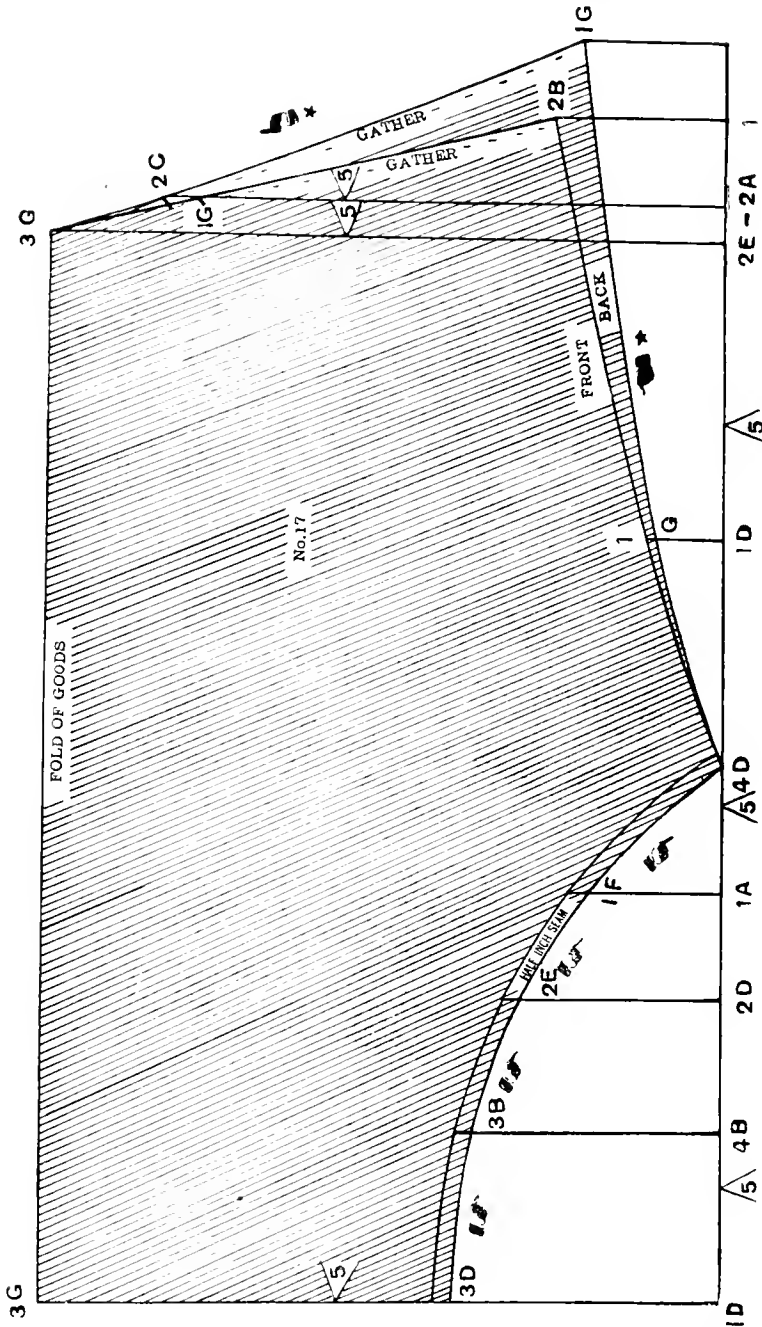

Take waist and length desired. Use rule corresponding with waist measure. If yoke is used, cut off two and one-half inches from top of pattern. Cut on the outside line for backs and then turn away the goods and cut on the inside line for fronts.

YOKE.

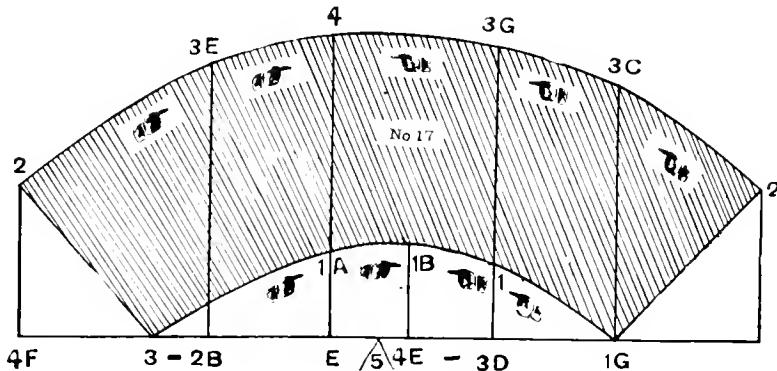

Lay off by same rule.

MISSES' DRAWERS.

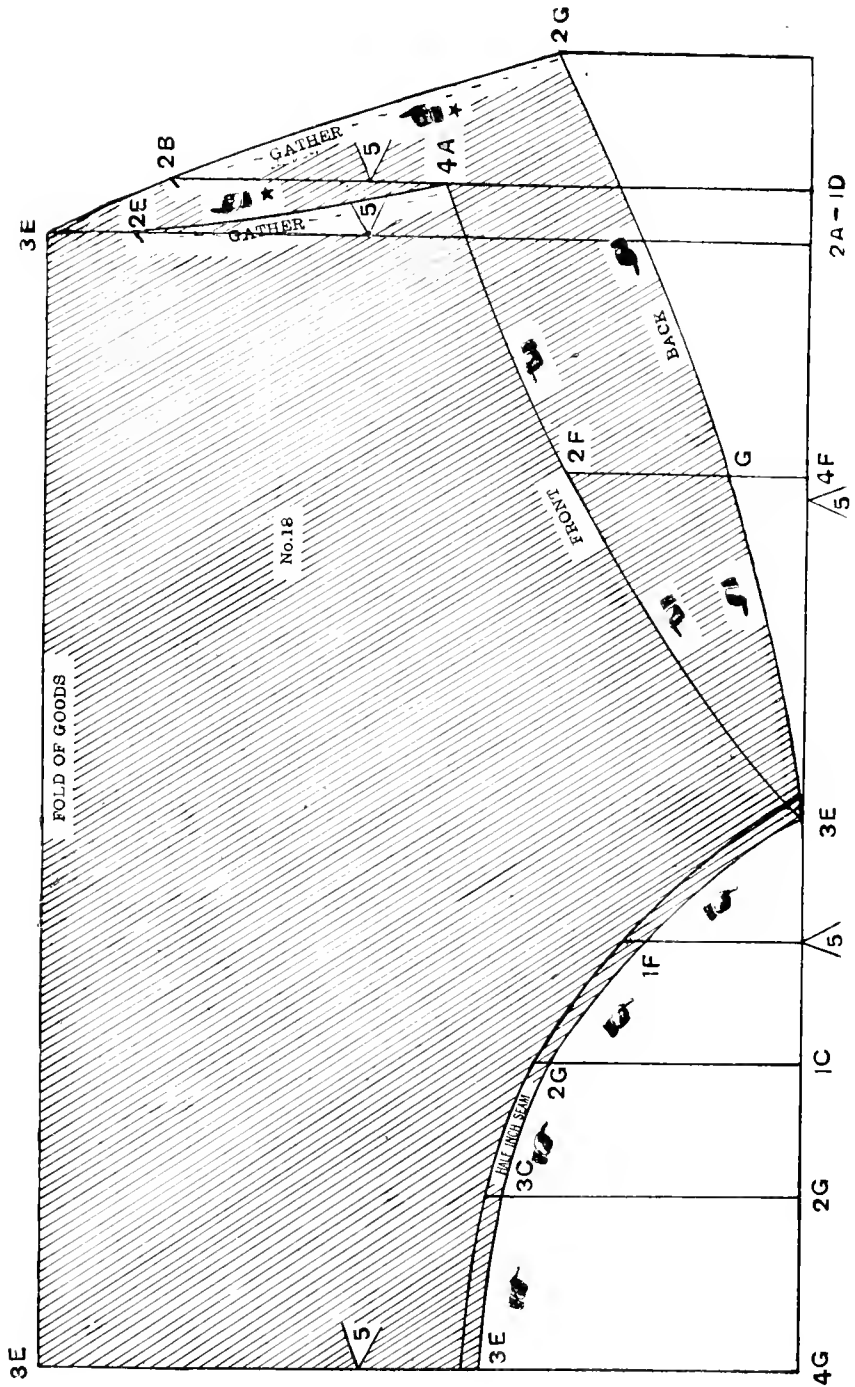

Take waist and length desired. Follow same rule as for No. 17. Make a band exact size of waist and gather goods into it. Cut by outside line for backs and inside line for fronts.

GENTS' SACK COAT.

UPPER SLEEVE.

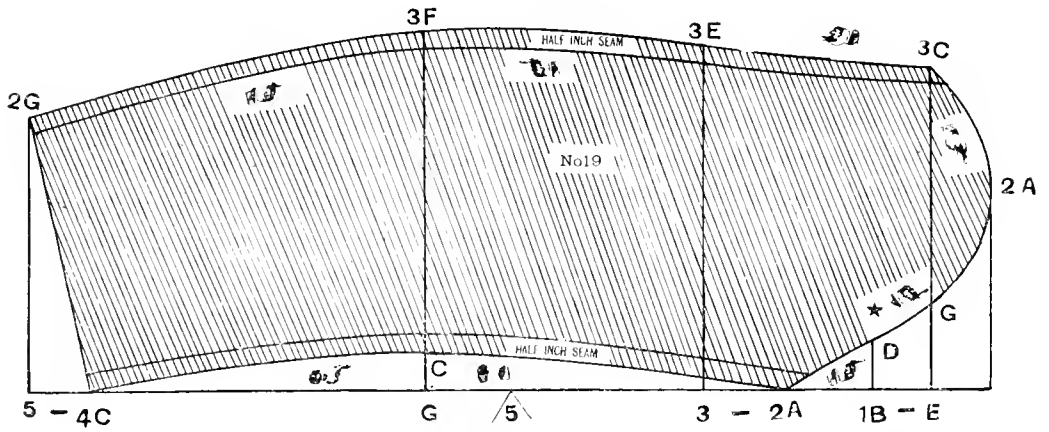

Use same rule. Regulate length same as on other sleeves.

UNDER SLEEVE.

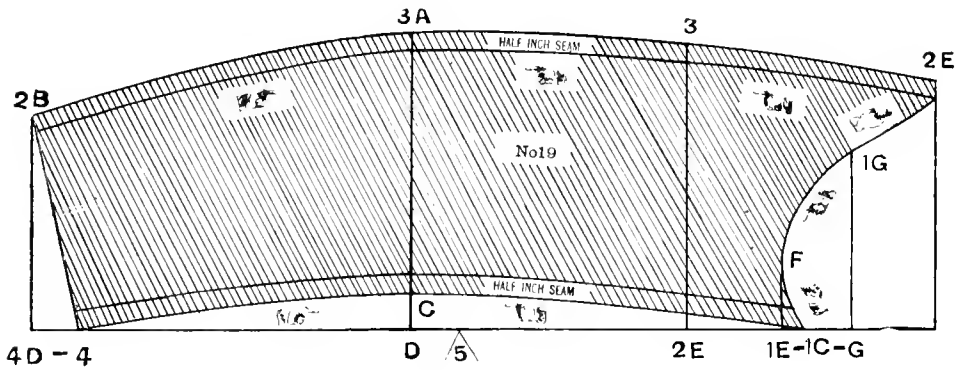

Use same rule. If any changes are made on upper sleeve, make same changes on under sleeve.

COLLAR.

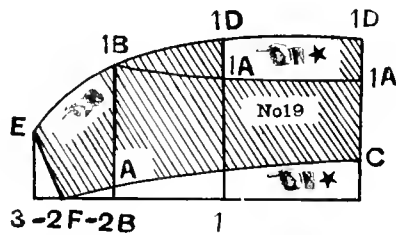

Lay off by same rule. Fit to neck by tape measure.

GENTS' VEST.

BACK.

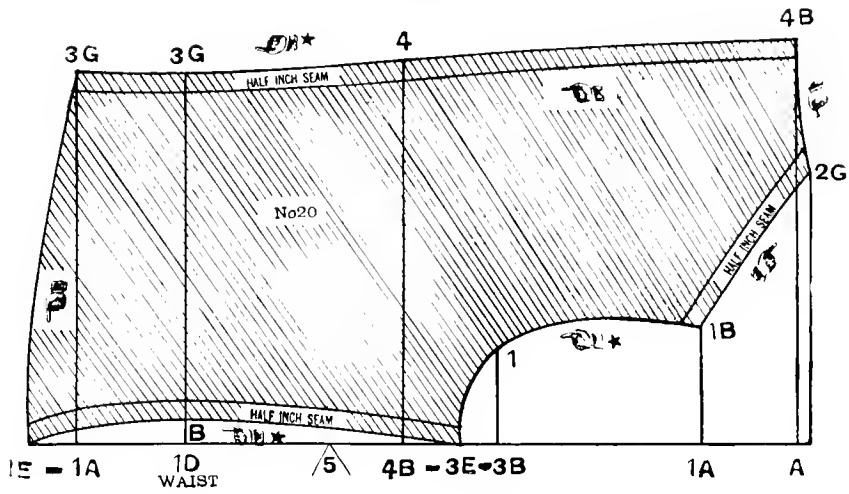

Take chest and length of waist; regulate length of waist with tape.

FRONT.

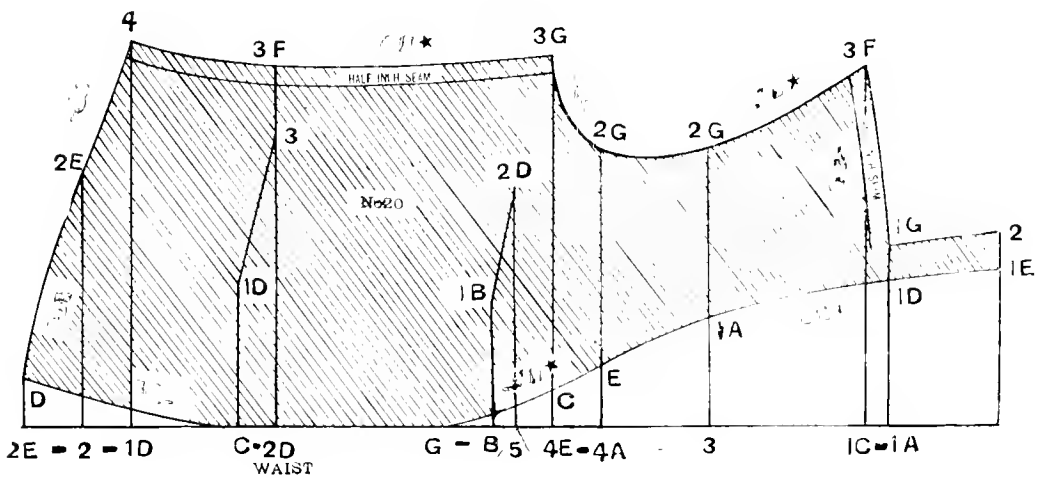

Use same rule. If waist has been changed on back change waist on front same amount.

GENTS' PANTS.

If knee measure has been changed on back, change point 4D same amount, and point 1G one-half as much. Length points must be changed same as on back, to change size of waist. If the waist is too small, let out point 1 on front one-half the amount of change. If the waist must be made smaller, take in goods in darts on back pieces one-half the amount on each side. Waist band is a straight piece of goods, 2 inches wide.

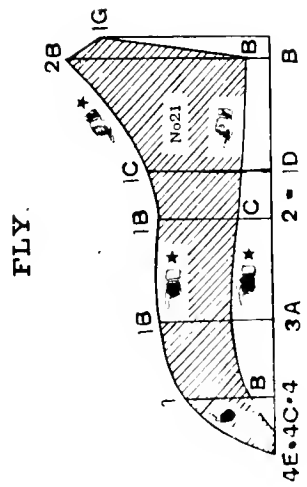
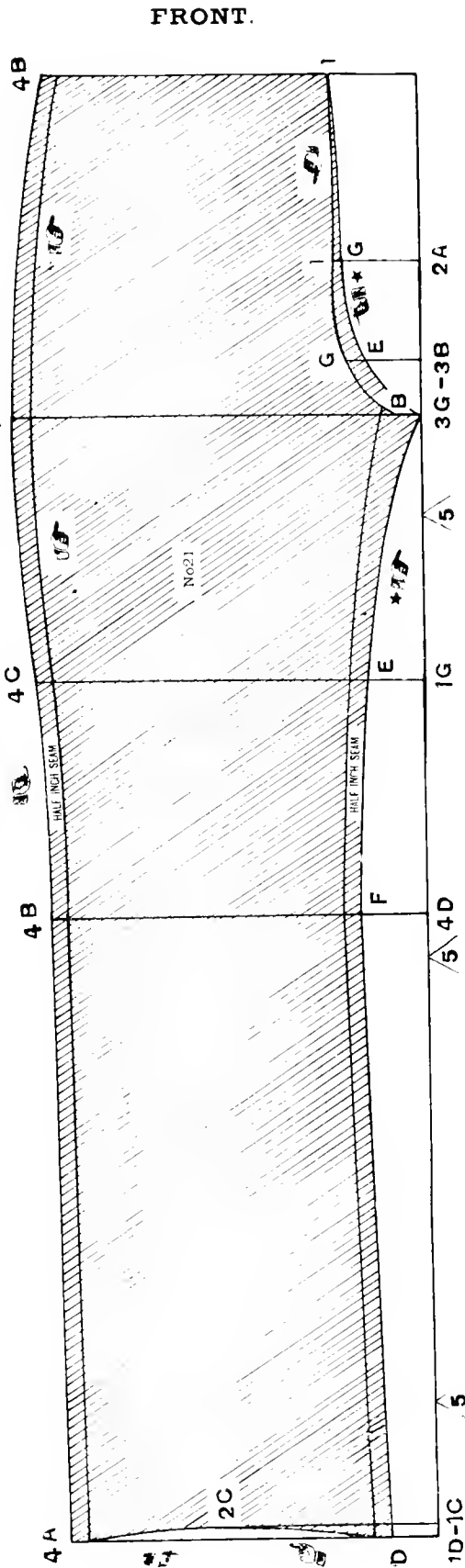

Use same rule.

GENTS' DRESSING GOWN.

Take chest, L. of waist, full length in back, elbow and length of arm. Length of arm measure is taken to knuckle joint. Use rule corresponding with chest measure; regulate waist length and full length same as on other garments. If waist is changed, change 5V point 1-2 the amount, and change 5V point where line is nearest bottom 1-2 as much as length point.

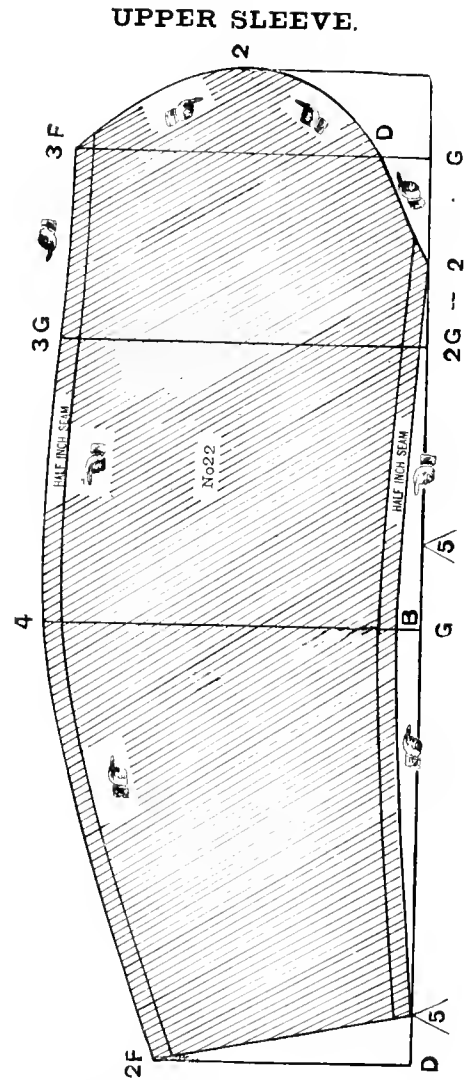
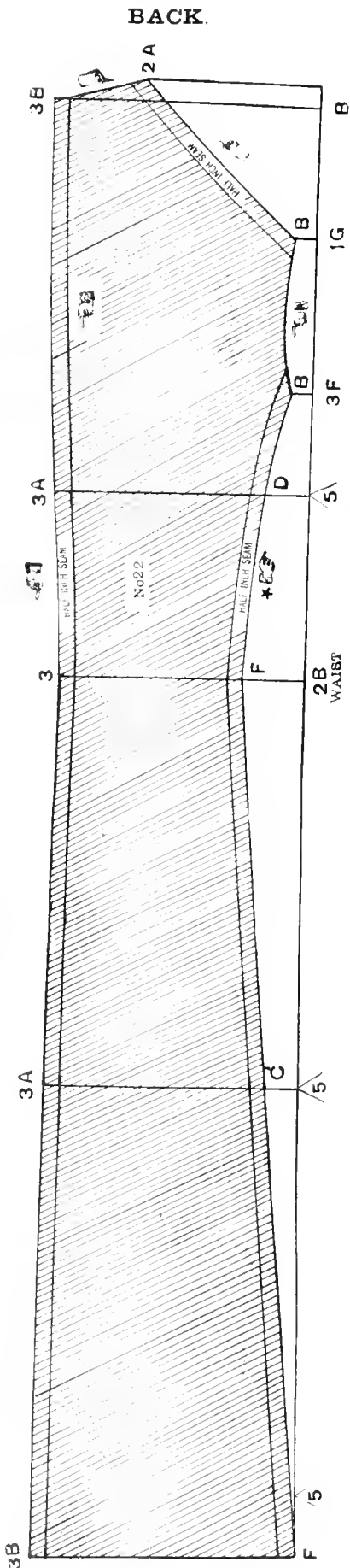

Use same rule. Test length same as on other sleeves.

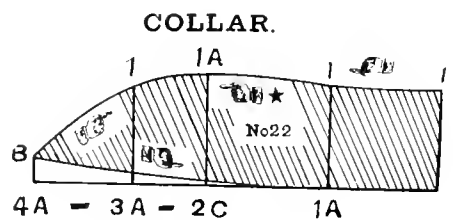

Use same rule.

UNDER SLEEVE

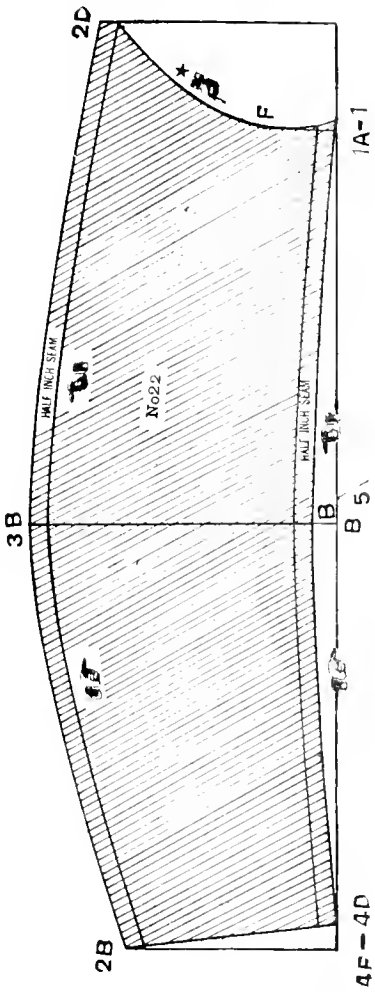

FRONT

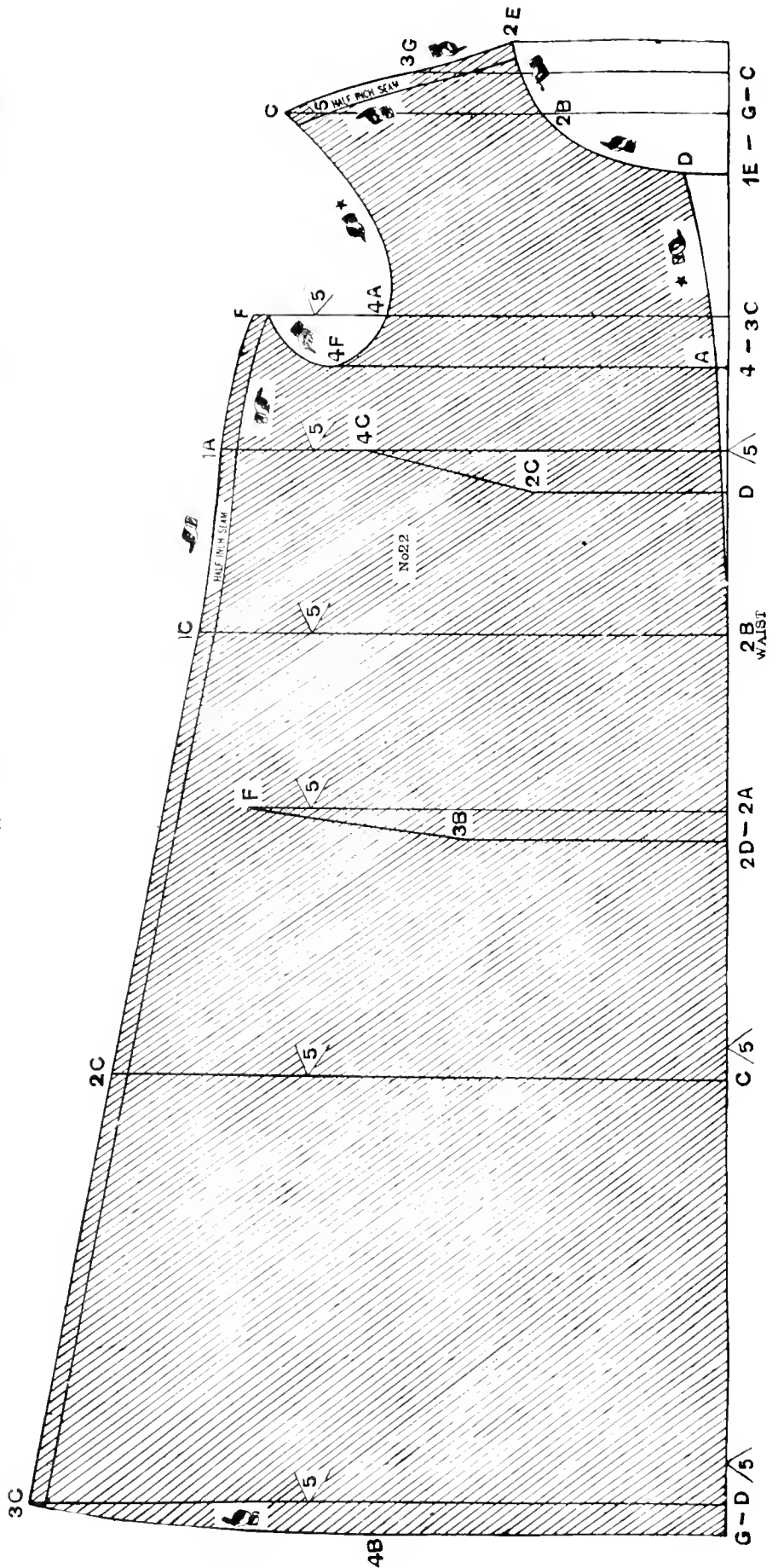

Use same rule. Make changes according to upper sleeve.

Lay off front with same rule. If waist has been changed on back, change same amount on front. If bottom point has been changed, change G and D same amount and point C nearest to bottom one-half as much.

WAIST BAND.

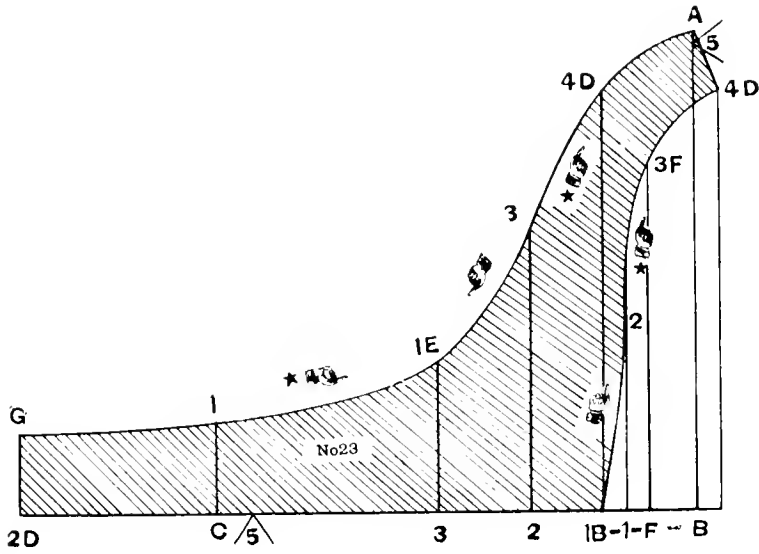

TO LAY OFF DRAWERS.

Take hip measure and in seam measure. Use rule corresponding with hip measure. Take length measure on in seam from Fork to Ankle. To test length measure from point B down change bottom point 2C to tape measurement and knee line at F point half the amount. If waist is to be made longer let out point E on cross line 1C. If smaller take up goods in Dart half the amount on each side. Shorten or lengthen the waist band as is required at point 2D to fit the tape measurement for waist.

Use same rule. Change waist line and bottom points same as on back.

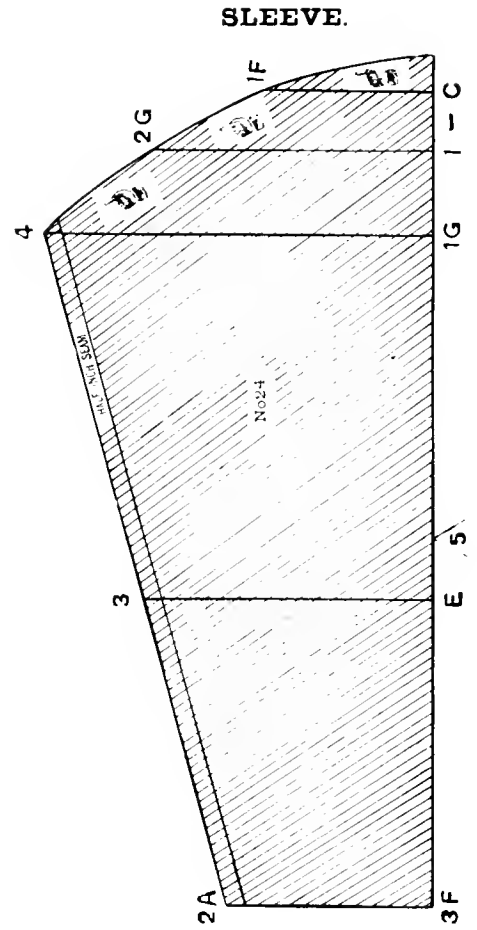
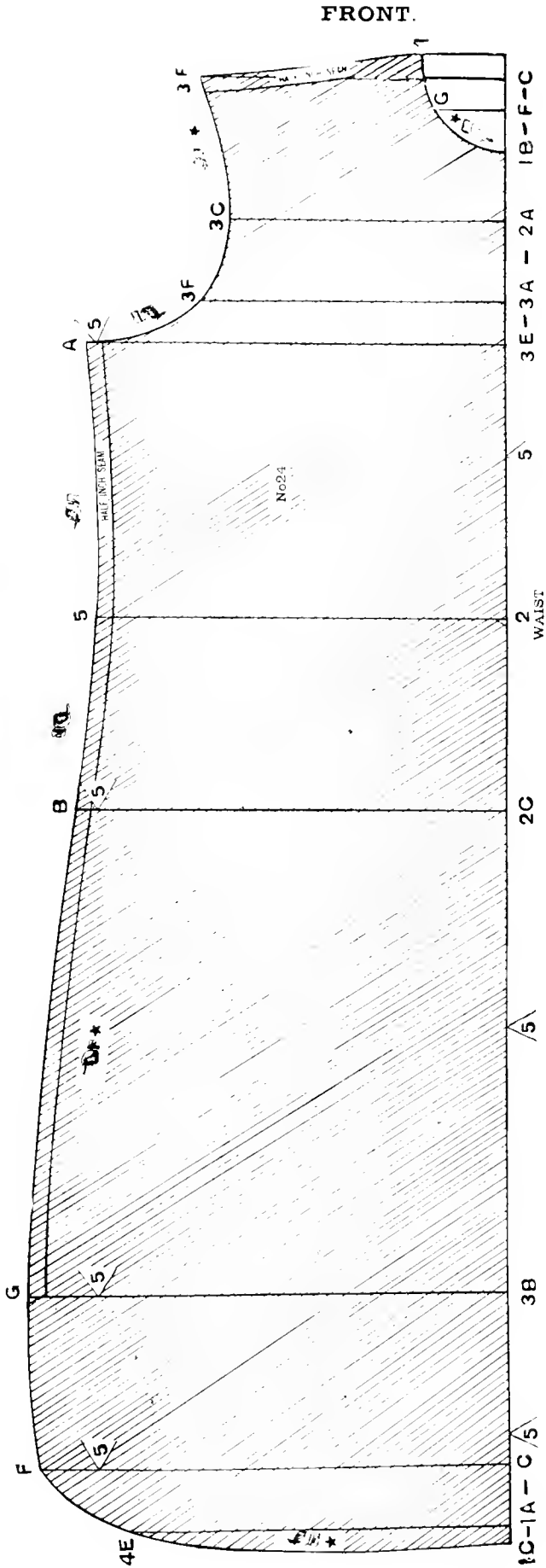

Lay off by same rule. Add one inch to L. of arm measure (which is taken wrist joint), for making up; E. is elbow point.

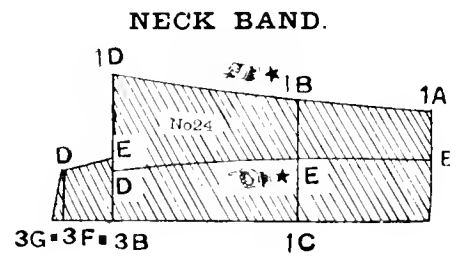

Lay off by same rule. Neck band should be 2 inches longer than measure to allow for making up.

GENTS' AND BOYS' SACK SHIRT.

Take chest, L. of waist, sleeve, full length, and neck. Use rule corresponding with chest. Regulate waist length and full length same as on No. 24, and sleeve in the same manner. Neck band should be cut one inch larger than neck measure. In putting the band on, if neck needs cutting out, trim it off on front. If any changes are made on back in L. of waist and full length, be sure and make them the same on front.

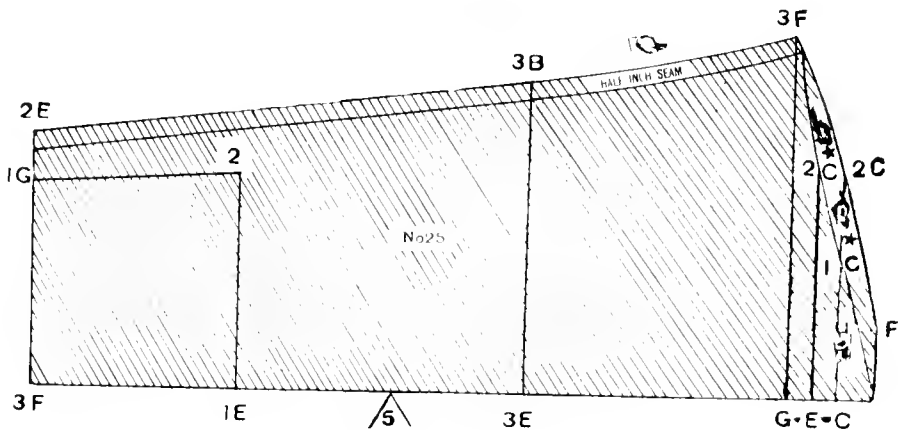
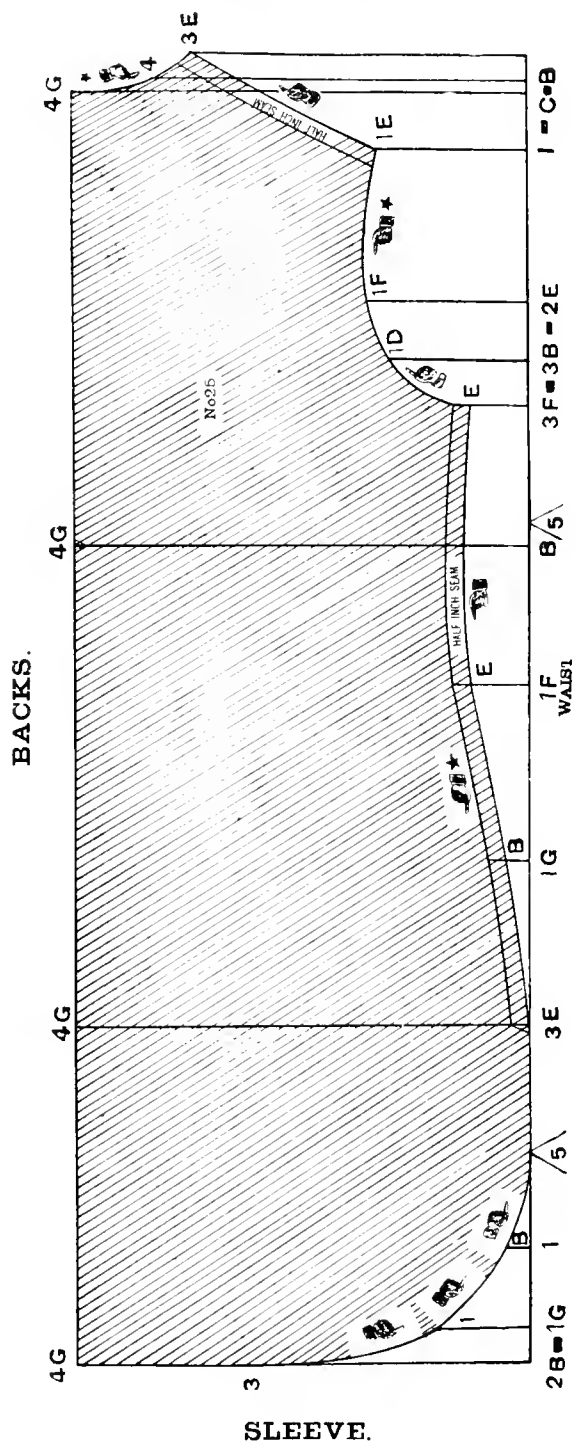

Use same rule.

GENTS' AND BOYS' SACK SHIRTS.

FRONT.

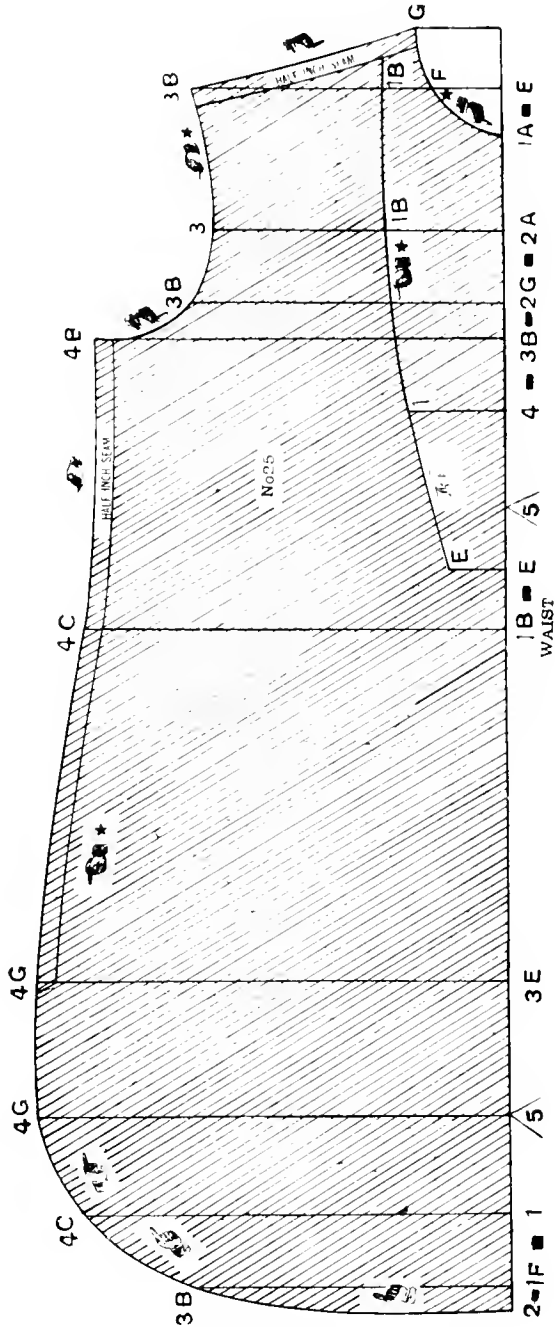

Lay off by same rule.

NECK BAND.

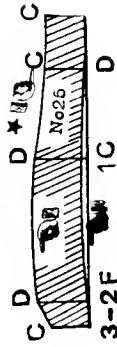

Use same rule.

BOSOM.

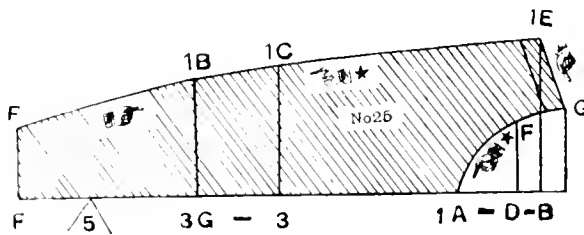

Lay off by same rule.

GENTS' AND BOYS' YOKE SHIRT.

SLEEVE.

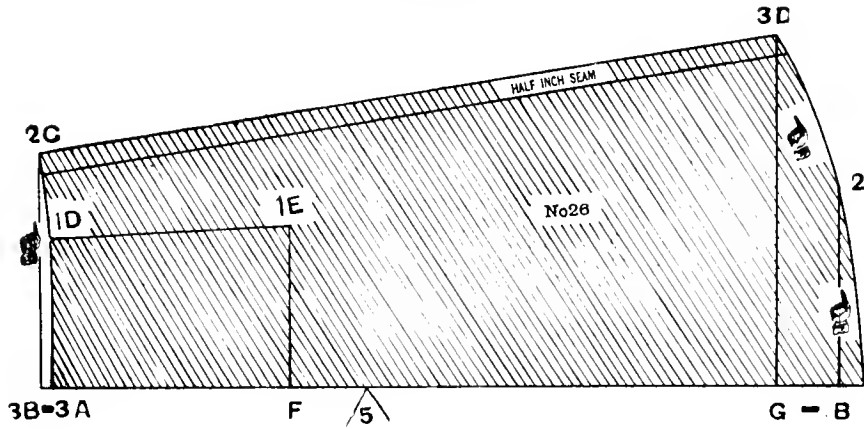

Use same rule.

BOSOM.

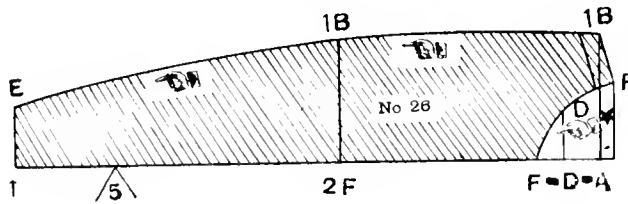

Use same rule.

COLLAR.

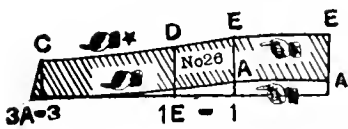

Use same rule.

YOKE.

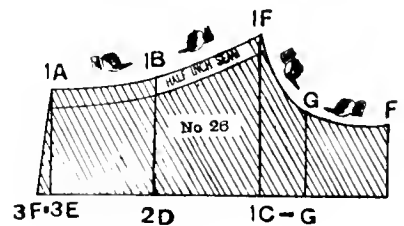

Use same rule.

BOYS' SACK COAT.

UPPER SLEEVE.

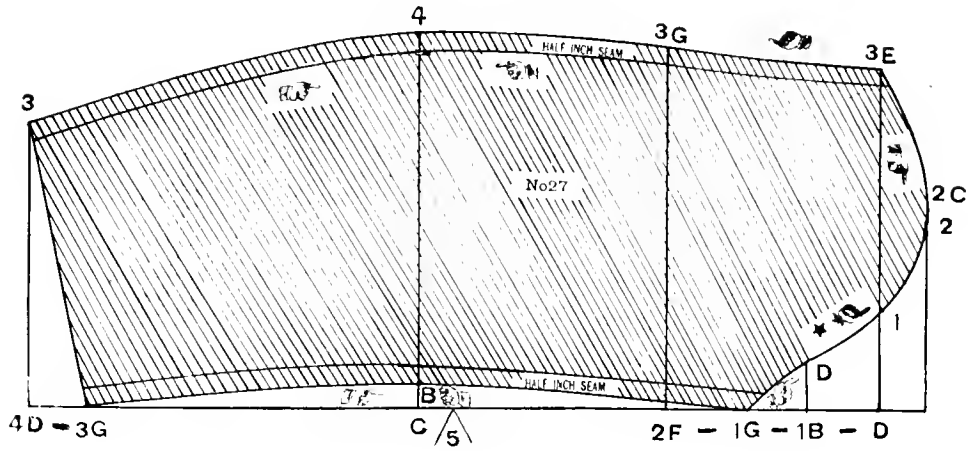

Lay off by same rule, regulate length same as other sleeves.

UNDER SLEEVE.

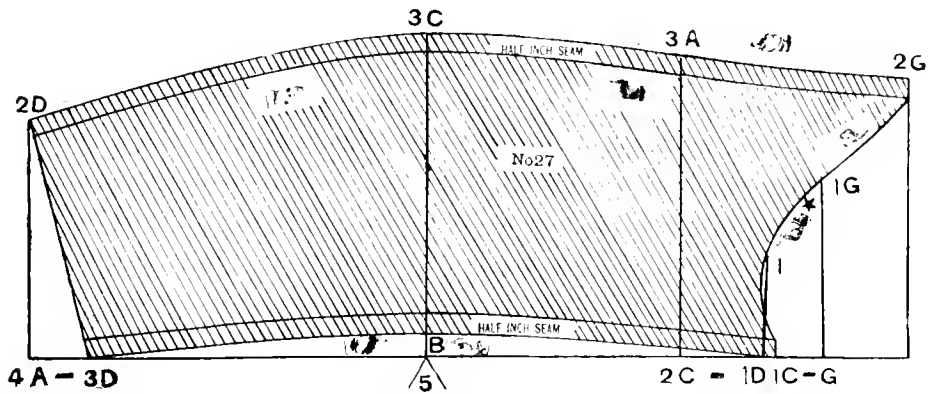

Lay off by same rule. If any changes are made on upper sleeve, make same changes on under sleeve.

COLLAR.

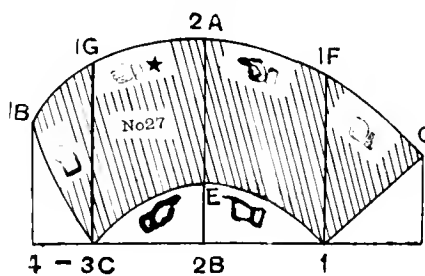

Lay off by same rule, test to tape line measurement for size.

BOYS' VEST.

BACK.

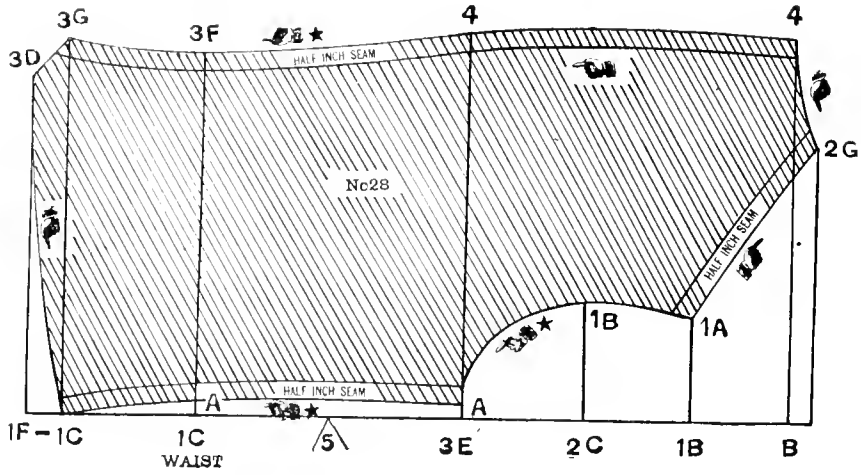

Take chest, L. of waist and full length; use rule corresponding with chest, regulate length of waist and full length same as on Gents' Vest.

FRONT.

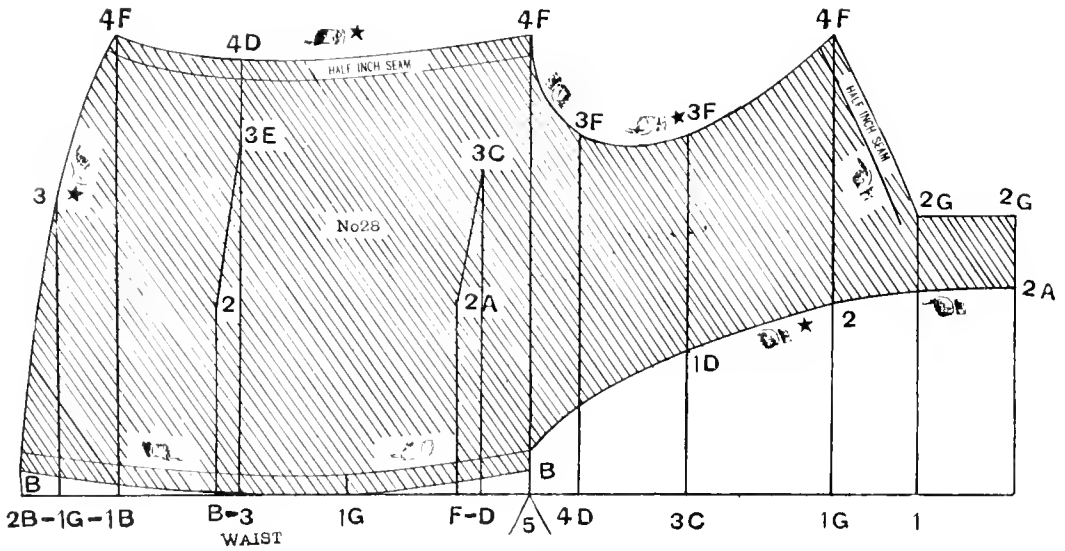

Lay off by same rule, follow same directions as for Gents' Vest. Cut off half inch on left front.

BOYS' WAIST.

BACK.

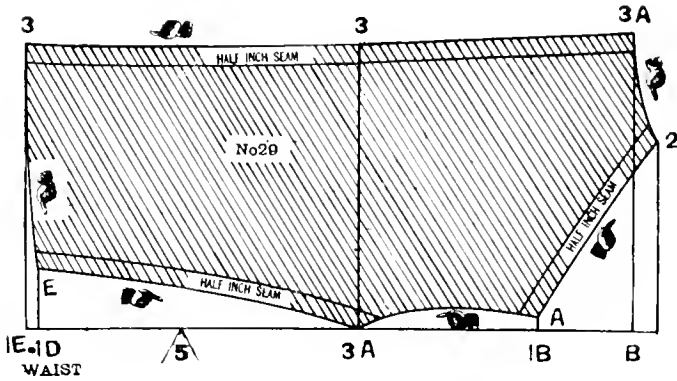

To lay off boys' waist, take chest, L. of waist, elbow and length of arm. Locate waist length from point B. If ID waist be changed, change IE same amount. Make same change on front.

FRONT.

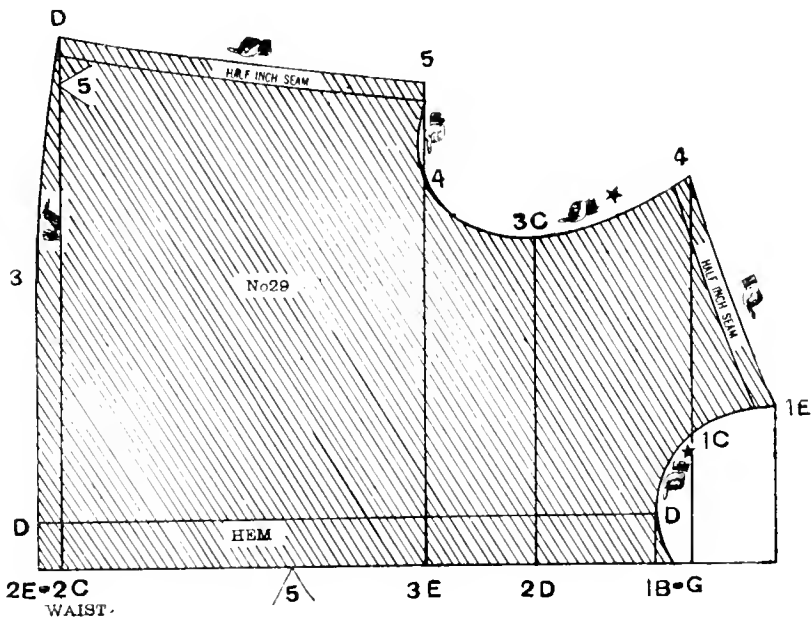

Lay off by same rule. Waist band is a straight piece of goods. Gather the goods into waist band.

UPPER SLEEVE.

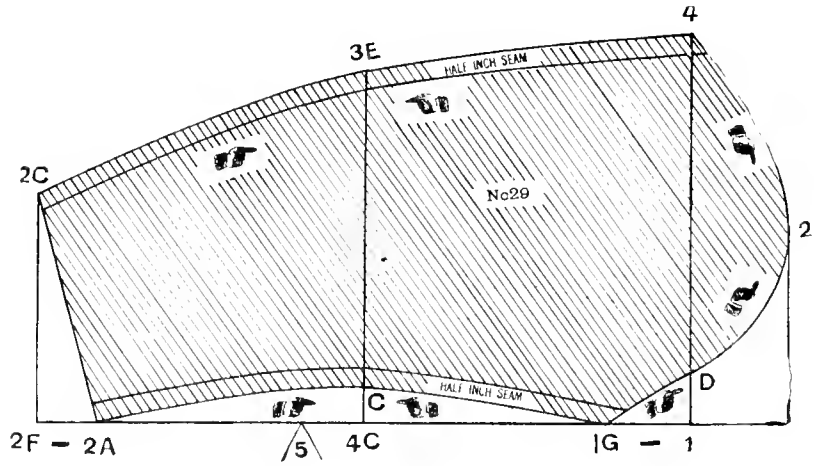

Lay off by same rule. Regulate length same as on other sleeves.

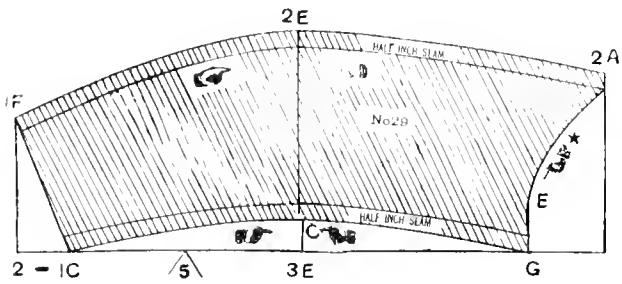

Lay off by same rule, regulating according to upper sleeve.

BOYS' PANTS.

BACK.

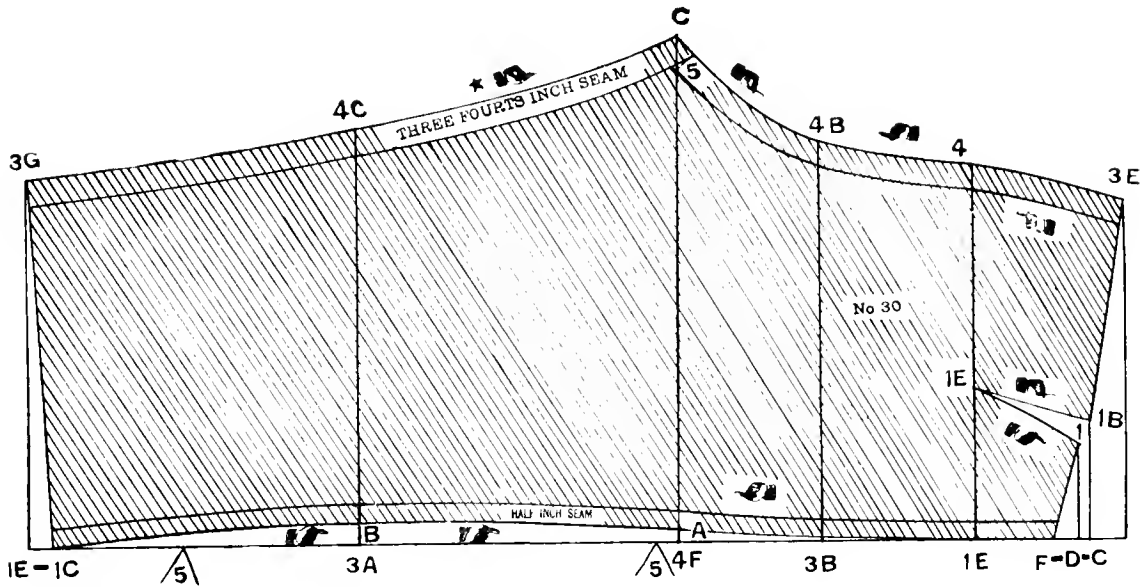

To lay off pants, take hip, waist, L. of knee and full length measure. Use rule corresponding with hip measure and make same changes (if any changes are necessary) same as in gents' pants. 3A point is knee line and 1E is full length point.

FRONT.

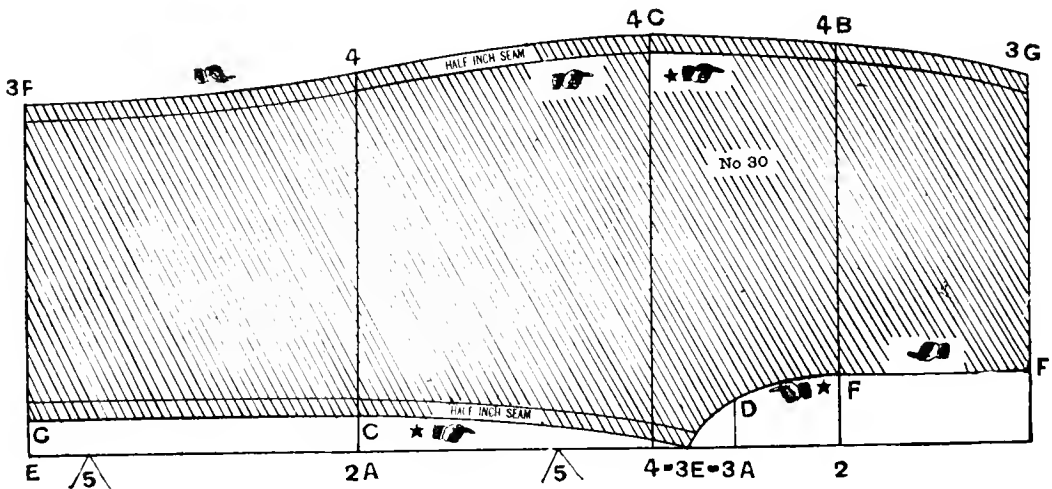

Lay off by same rule. If any changes be made on back make same changes on front. To make waist larger let out point F on top one-half the amount; if to make smaller change in dart on back.

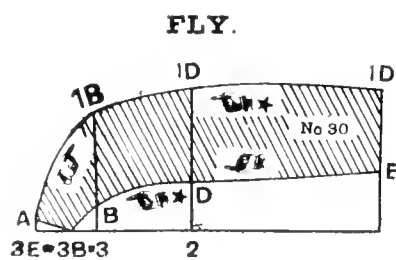

Lay off by same rule. Waist band is a straight piece of goods about $1\frac{1}{2}$ inches wide.

TT 520
.B38
Copy 1

place our system of Fitting before the public. It is a very rare
nents for good workers.

Those who are out of employment or others wishing to change
their business will find our work a very pleasant, easy and profitable
business.

WRITE FOR TERMS.

Let

72 inches wide.

OFFICE,
1220 OLIVE STREET,
ST. LOUIS, MO.

TT 520
.B38
Copy 1

LIBRARY OF CONGRESS



0 014 061 876 7

Hollinger Corp.
pH 8.5