



AMERICAN
GARMENT CUTTER

MEN'S GARMENTS





Class _____

Book P. 4

Copyright N^o 1004

COPYRIGHT DEPOSIT.

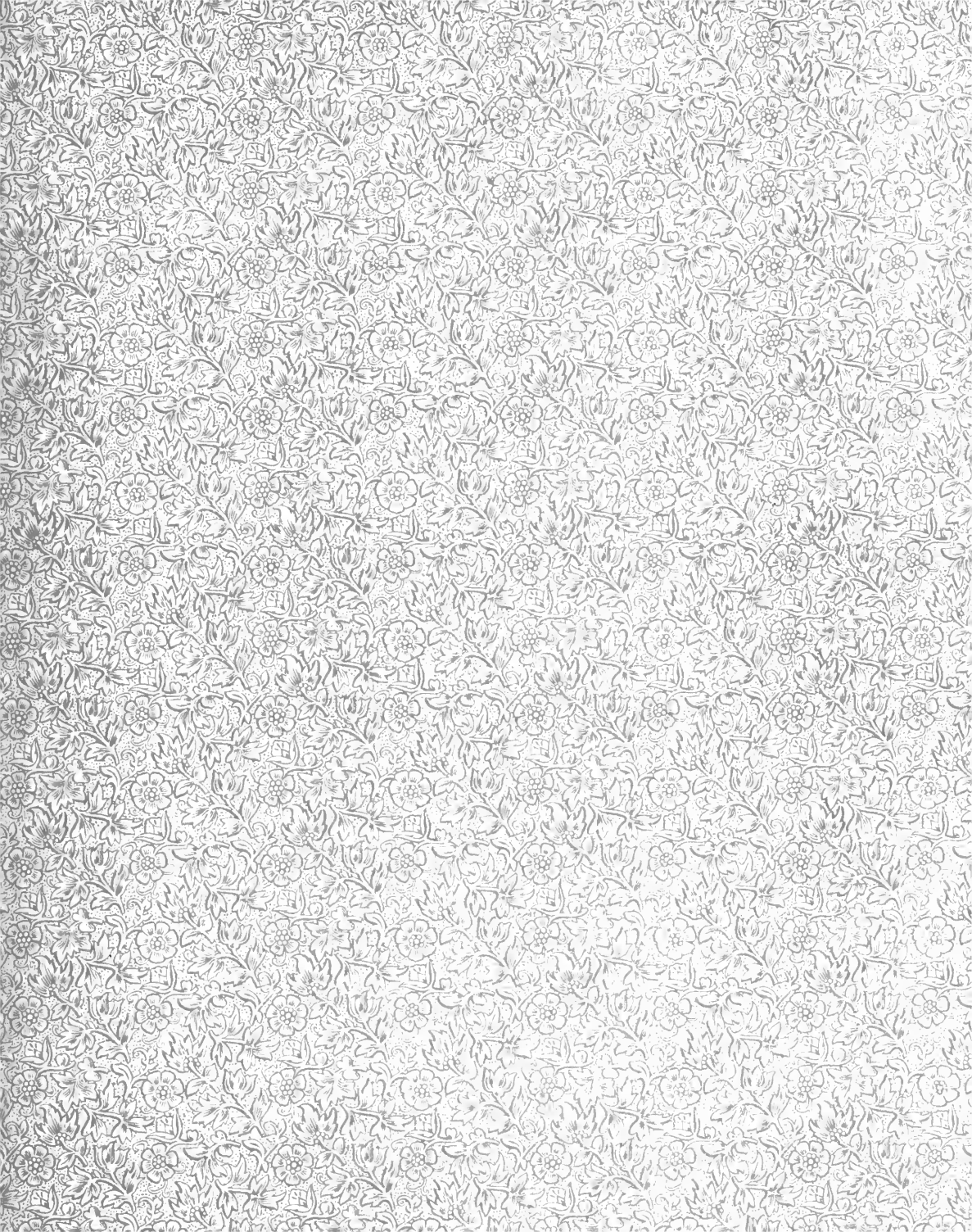

Handwritten text along the left margin, likely bleed-through from the reverse side of the page. The text is illegible due to its orientation and fading.

THE
American Garment Cutter

A Complete, Practical, Up-to-date Treatise
on the Cutting of

Men's Garments

According to the Latest and Most Approved Method

Joseph T. ...



Published by
AMERICAN FASHION COMPANY
New York, London, Paris, Berlin

build of a man, and to be reproduced as nearly perfect as is possible to human ingenuity is what has been sought in this work. The author has so far succeeded that of the many who have studied, either by direct instruction or by the aid of this publication, not one has failed to enjoy the fullest confidence of their clientage. Particularly is this system of value where cutting has to be done without "try-on" and at no time can a garment be spoiled. The perfect points being the fundamental object of this method.

PREFACE

In placing this work before the Cutting Fraternity, we feel confident that we have placed before them something that is useful and practical. Unlike any other work of its kind, its construction is simple and easy to understand. It has been our aim to eliminate all discussion of an anatomical nature, for we do not pretend to teach anatomy, nor do we try to convince the student of something we are not convinced of ourselves. We do claim that our work is absolutely practical, and correct, its measures are simple, and applied on the pattern exactly as taken and they cover any and all points that have heretofore confused the cutter. There will be no need for the cutter to mark on the book "R. B." for round back or "O. E." for over erect or any other sign by which to know the shape of his customer, for his measurements will show all such points. We feel certain that any cutter following the instructions of the AMERICAN GARMENT CUTTER will be satisfied with the results obtained.

THE AUTHOR.

THE MEASURING OF THE HUMAN BODY

The fact that in order to perfectly fit the human body, it requires perfect measurements, cannot be too often urged upon the cutter, and not only that, but it requires much tact on the part of the cutter to get his customer to forget that he is being measured. A fact, well known among cutters is, that ninety-nine out of one hundred men will pose, unconsciously perhaps, while being measured. It is common to see a man standing erect, with shoulders thrown back and chest expanded, and if you were to ask him to stand naturally, he would be indignant and answer, "Why, of course this is my natural position," but if after the garment is completed he stoops forward, his chest sunken in, his back rounded, it will then be necessary for the cutter to either make a big alteration or a new garment; so it will readily be seen that the cutter who can make his customer forget that he is being measured, has the best chance of success.

HOW TO MEASURE

Before measuring it is well to see that the sides of the Vest are not too loose; if necessary, pin up both sides of the Vest, but see that the center seam of the back is in the right place.

Use the ordinary division square. Place square under the arm with the long end down and parallel with the body. (See Fig. 1.) The short end to be close, but not tight, under the arm; make a chalk mark on top of it in front, and, still holding the square in the same position, make a mark on the side of the back, and remove.

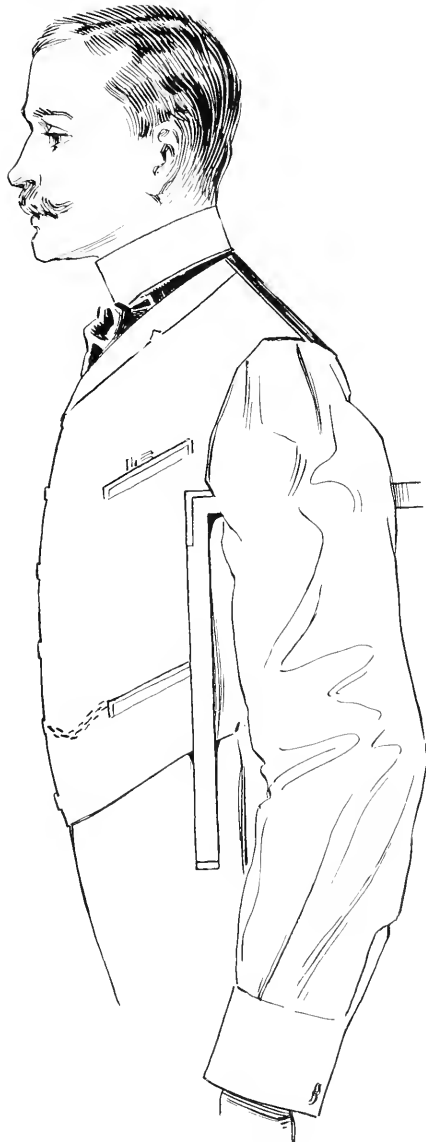

FIGURE 1

HOW TO MEASURE—Continued

Now place the short end of the square under the arm with the long end upward (see Fig. 2), still keeping the inner edge of it close, but not tight, at the front scye; mark at the outer edge of it across the first line, so that it leaves a cross mark at the front scye (see Fig. 3). Now place the square under the other arm and mark the same way at front and side of the back.



FIGURE 2

HOW TO MEASURE—Continued

The cross mark shown on the front in Figure 3 shows where the line of scye depth and blade line cross.

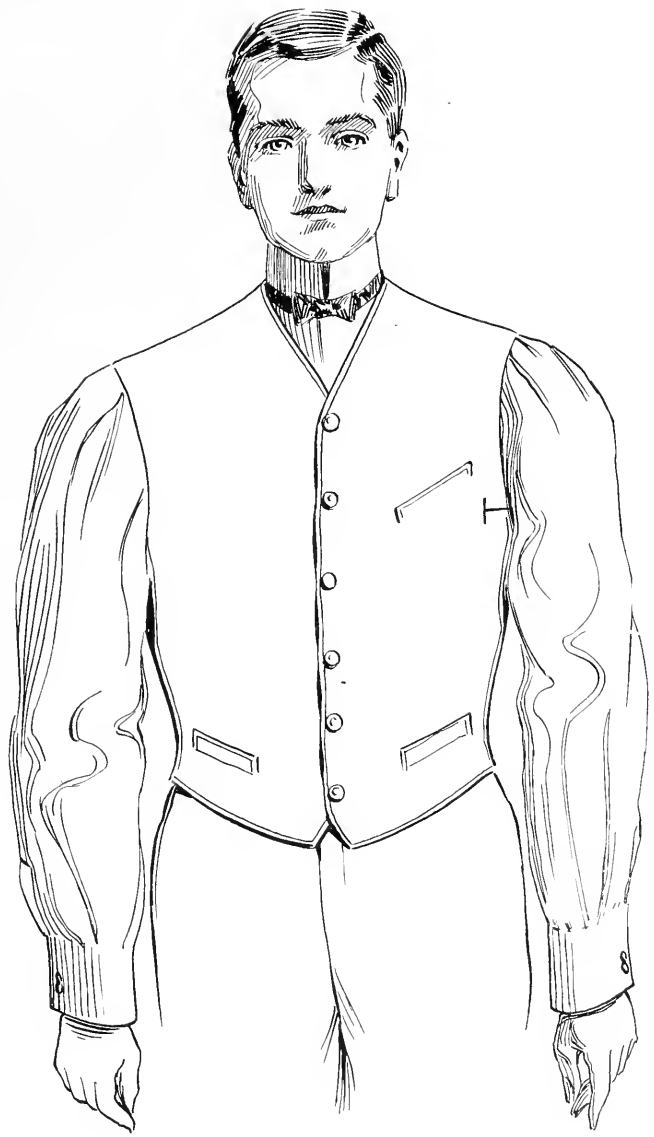

FIGURE 3

HOW TO MEASURE—Continued

Place the long end of the square across both marks on the back and mark across the center seam (see Fig. 4); this gives the scye depth. Now find the socket bone, or from above the collar button at the back, measure to the scye depth, divide in half and mark across the center seam.

To get the waist length, put the tape line around the waist just above the hip bone, and mark across center seam of back. measure 6 inches down for the hip. It is easily understood that no matter where the hip may be, as long as you go down the same distance for the draft, as the measure, you must be right.

We will now proceed to measure.

First from the socket bone to the scye depth; on to the waist line; on to the full length. Now place the tape line to the back collar button (Figure 4) and measure to cross line on front (Fig. 3) for strap measure; then from line half way between socket bone and scye depth, to the same cross line on front for over-shoulder measure.

Then from front cross line (Fig. 3) under arm and over the blade bone to the center seam of back for blade measure.

Then breast, not tight; waist, and hip.

In taking the breast measure be sure that your tape string is over the most prominent part of the blade bone.

THE VEST

If measured for a suit all that is needed is the opening and full length measure.

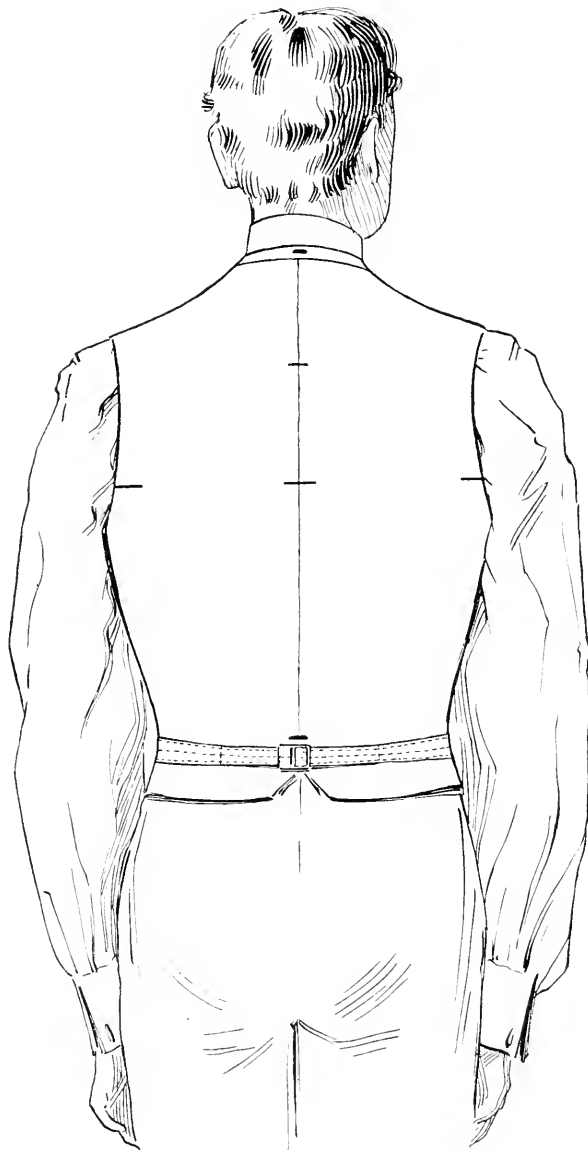

FIGURE 4

HOW TO MEASURE—Continued

TROUSERS

Measure the outside seam from the hip bone to the top of heel.

For the inseam have the trousers well drawn up and measure from the crotch to the top of heel, then the waist, hip, seat, thigh, knee and bottom.

THE SQUARE

The square used for these diagrams is a plain division square, understood by most cutters, but for the benefit of those who do not understand it, we herewith give an explanation of the divisions of same.

The long end of the square is divided into $\frac{1}{2}$, $\frac{2}{3}$, $\frac{1}{3}$, $\frac{1}{2}$, $\frac{1}{4}$ the short end is divided into $\frac{1}{2}$, $\frac{1}{4}$, $\frac{1}{8}$, $\frac{1}{16}$ and $\frac{1}{32}$. Should you try to find $\frac{1}{8}$ of any size, say 36, 40 or 48, look at the short end of the square marked $\frac{1}{8}$, and there you will find the number you want, 18 for 36, 20 for 40, or 24 for 48. Should you want $\frac{1}{2}$ of any size, look at the same short end of square marked $\frac{1}{2}$, or if you want $\frac{1}{6}$, $\frac{1}{3}$ or $\frac{1}{12}$ look at the long end for the mark $\frac{1}{3}$, $\frac{1}{6}$ or $\frac{1}{12}$ and you will find it.

In drawing for square lines be sure that you hold your square on the one line firmly, while drawing the right angle, for one line off will spoil the whole draft.

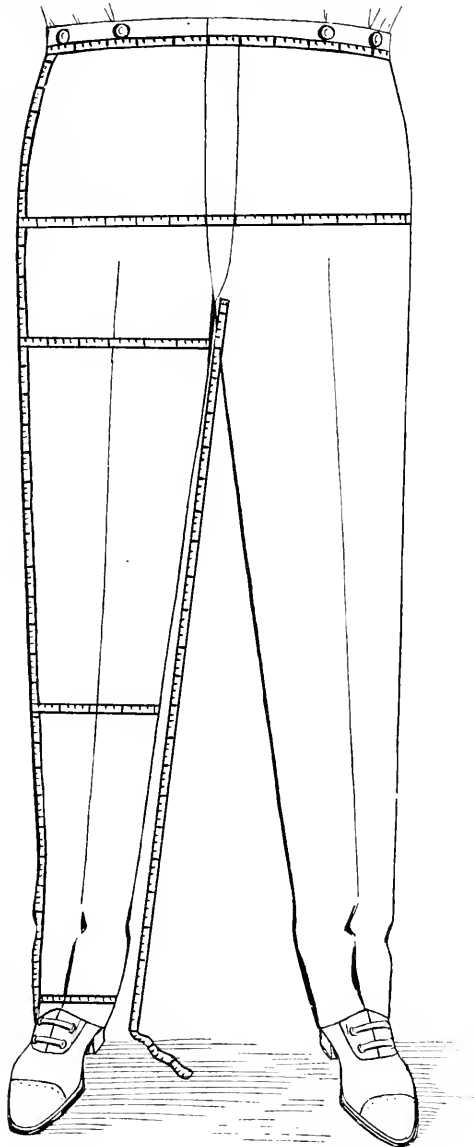

FIGURE 5

22

LESSON I.

SINGLE BREASTED SACK COAT

We will now begin with our first lesson, the ground work.

This is to be a single breasted sack coat.

The measures are as follows

Seye depth,	9½ inches	Blade,	13 inches
Natural waist,	17 inches	Breast,	38 inches
Full length,	30 inches	Waist,	34 inches
Strap,	12¾ inches	Seat,	39 inches
	Over shoulder,	14½ inches	

Square lines A—N and A—F.

A to B is seye depth, 9½ inches; B to C is ¾ inch; this ¾ inch allowance is for the three seams that we lose—¼ inch at the center seam of the back, and ¼ inch each at the back and front shoulders.

A to D is waist length, 17 inches. D to E is 6 inches always, same as measure. F is full length plus ¼ inch.

Square out from B, C, D, E and F. G is half way between A and B.

At D go in ½ inch in all sack coats except on box or straight back coats.

Draw a line from the ½ inch line, point up to G and down to F.

From the line just drawn at B to H is ½ of full breast—19 inches.

H to I is 3½ inches; square down from I.

J is half way between the inner line at B and H.

K to L is 3½ inches always. Square down from K.

Now apply the blade measure from the line inside of B to wherever it comes; in this case the blade measure is 13 inches and comes even with the lower line, but let it be understood that the blade line is independent of the line squared down from K, and may be ¼ inch, ½ inch, or 1 inch in or out of that line, according to measure. (*See diagrams 8 and 9.*)

Square up from where the blade line comes, and make no allowance for seams, as in placing the square in front of the arm seye you have already made allowance, the width of the square being 1½ inches, which makes just five seams.

K to L is ¼ the distance from A to B.

The seye depth in this case being 9½ inches, make the distance from K to L, 19 on 6th division of the square.

Square up from L.

LESSON I.—Continued

P is half way between the line inside of B and K.

P to Q is $1\frac{1}{4}$ inches. Square up from Q. From r to R is $\frac{1}{4}$ breast always. From R to S is $1\frac{1}{2}$ inches.

Square out from S. S to T is about $\frac{3}{4}$ inch, more or less, according to the style of shoulder. From P to back line is about $\frac{3}{4}$ inch, more or less, according to style and taste. However, in cases where a full or straight back is wanted, cut the back wide, say from P to back line 1 inch. Square down.

A to U is $\frac{3}{4}$ inch more than $\frac{1}{2}$ breast.

Square up from U.

U to V is $\frac{5}{8}$ inch.

Draw a line from midway between U and V to T. Shape the back.

M is half way between K and L.

Measure back from A to V, apply same to K and up to N, which is strap measure— $12\frac{3}{4}$ inches; add $\frac{1}{4}$ inch to it, making 13 inches.

Draw a line from N to G. Square forward from N. N to 14 is $\frac{1}{4}$ breast. 14 to 13 is $1\frac{1}{2}$ inches. N to O is $\frac{1}{2}$ breast.

Place the square at O and M and square forward.

Draw a line from 13 to 1.

From Z to 2 is $\frac{1}{2}$ waist, 17 on half division of the square. From 2 to 3 is $1\frac{1}{4}$ inches. From 3 back to 4 is $3\frac{1}{2}$ inches.

Shape front through 1 and 3 down.

Note that in placing point R $\frac{1}{4}$ breast from the lower line always, you get the proper slope of the shoulder. For if the scye depth is short, it will give a square and narrow shoulder, and if long, a sloping wide shoulder. However, in case of a sloping shouldered man wanting his shoulders padded heavily, you may make the distance from R to S $1\frac{3}{4}$ or 2 inches, according to the amount of padding wanted.

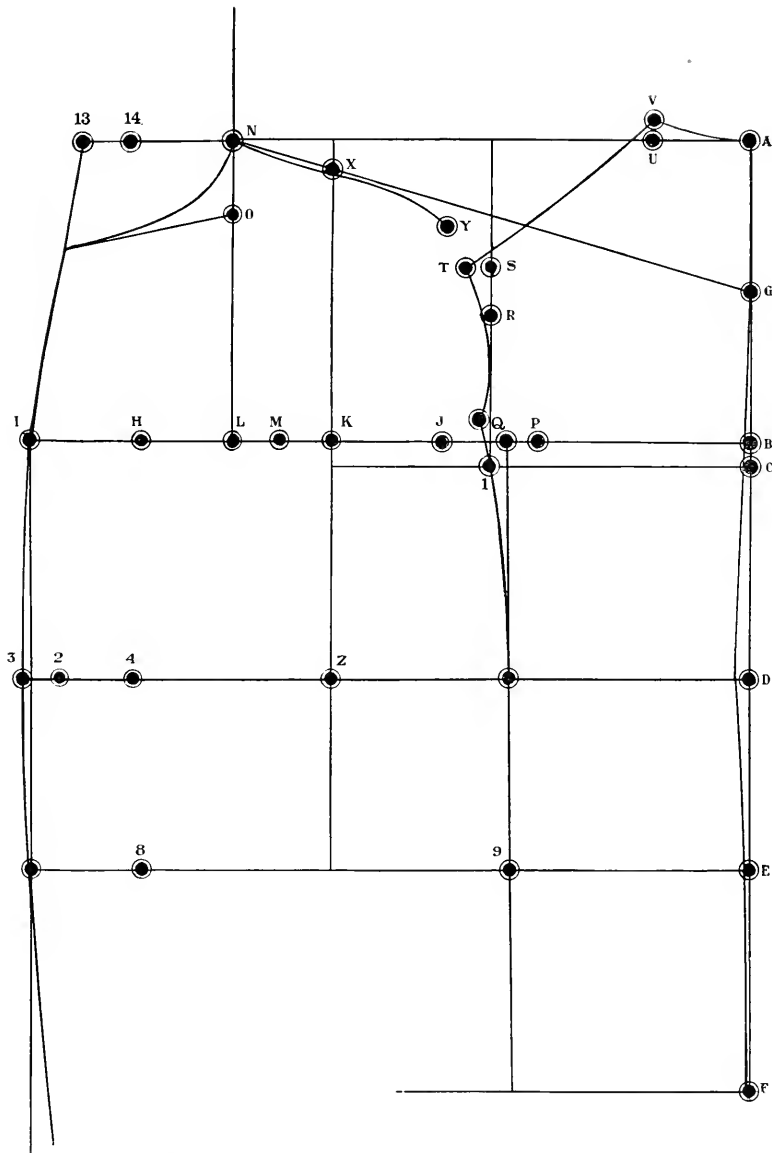

DIAGRAM 2

LESSON I.—Continued

Measure back from 9 to E, apply to 8 and back to 10, seat measure, plus $\frac{1}{2}$ inch.

Measure back 7 to D, apply to 4 and back to 6, waist measure, plus 1 inch; draw a line from 6 to 10.

Between front and back at Q take out $\frac{1}{2}$ inch, the amount of cloth it would take for seams if you were to cut an underarm fish. Shape the side of the front.

Sweep from 12 to 15, pivoting at N.

Straighten out the bottom of forepart.

The height of the pocket is $\frac{2}{3}$ of the sleeve length, measured on the inseam. For instance, if the sleeve length be 18 inches, look for 18 at the long end of the square, marked "2 Thirds"; 12 inches from the armseye, and mark the pocket parallel with the bottom of the front; make line Z—K the center of it, and mark $\frac{1}{6}$ of the breast each side of it.

For a one or a four button sack, mark the last button $1\frac{1}{4}$ inches above the pocket.

For a three button sack mark the last button opposite to the ticket pocket or $3\frac{1}{2}$ inches above the side pockets.

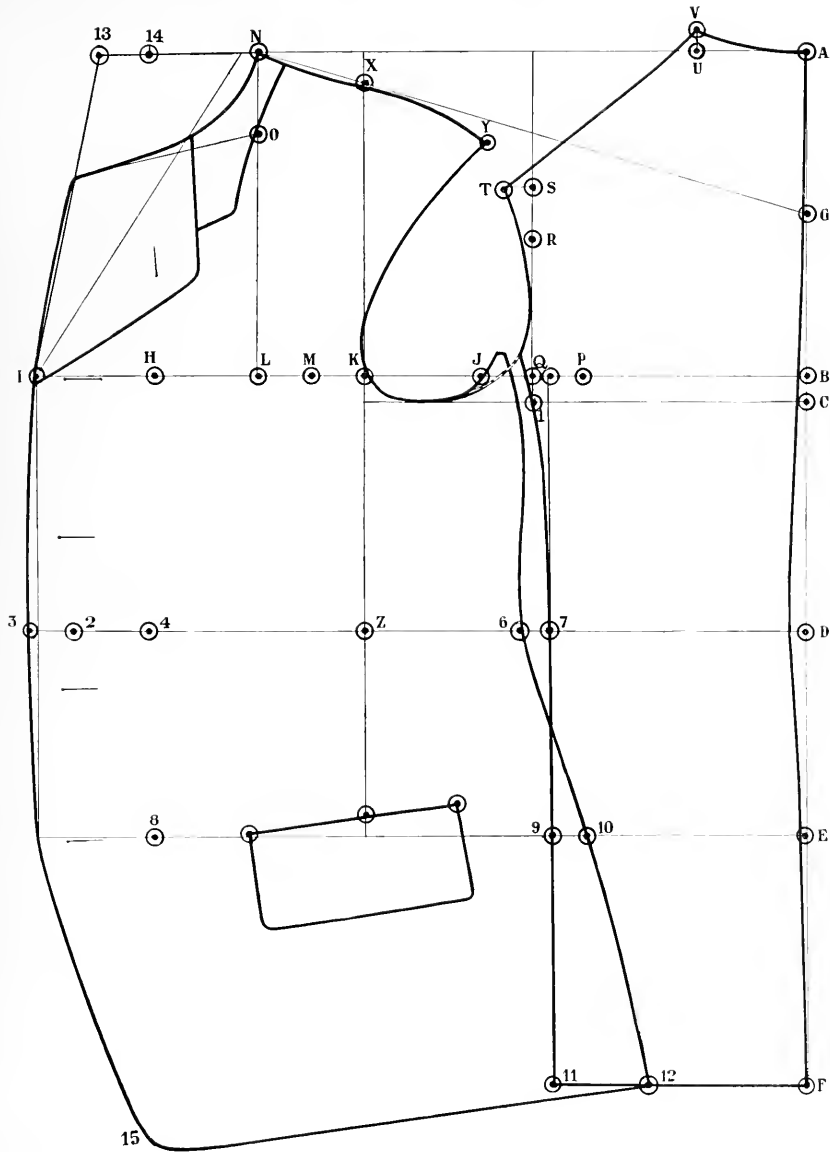

DIAGRAM 3

LESSON I.—Continued

Cut the back out, and place point V on point X, measure over shoulder from G through X to K, swing the back until you get the proper measurement with $\frac{1}{2}$ inch allowance, mark at X; sweep from point X to Y, pivoting at M. Reshape shoulder and finish.

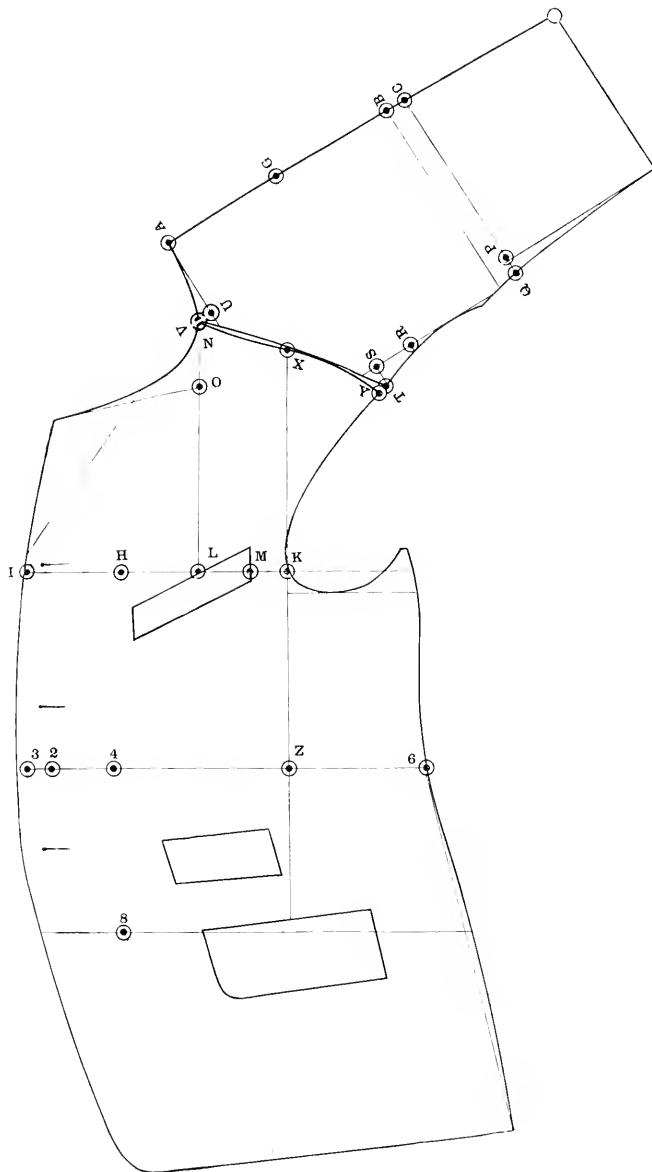

DIAGRAM 4
HOW TO GET THE OVER-SHOULDER MEASURE.

ACTUAL MEASUREMENTS WILL SHOW FIGURE

A question often asked by the student is, "How are we to know a stooping from an erect figure?"

The answer is, "The measurements will show;" on diagram 5 is a draft of a normal figure; that is, the distance from A to B is the same as L to N, which shows that the back and front are of the same height and normal.

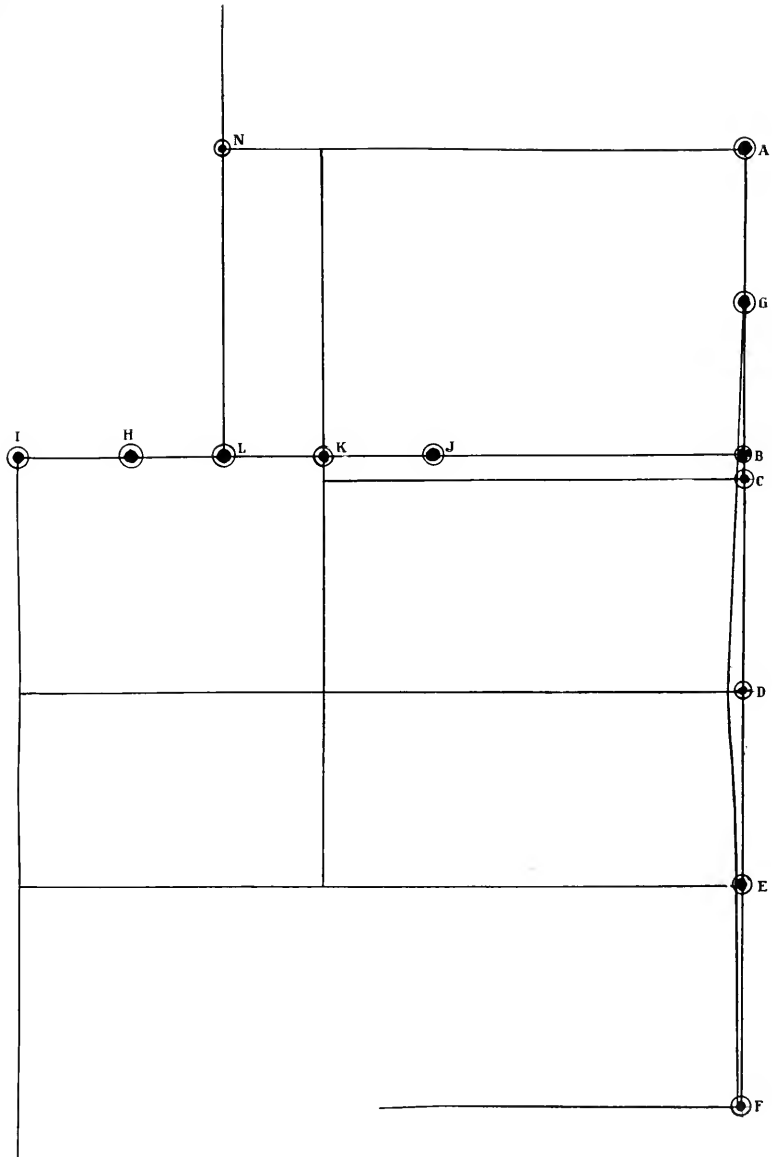

DIAGRAM 5

ACTUAL MEASUREMENTS WILL SHOW FIGURE**Continued**

On diagram 6 we have an erect figure where the distance from L to N is greater than from A to B, which shows that the person is flat in the back and full on the front shoulder, and leans backwards.

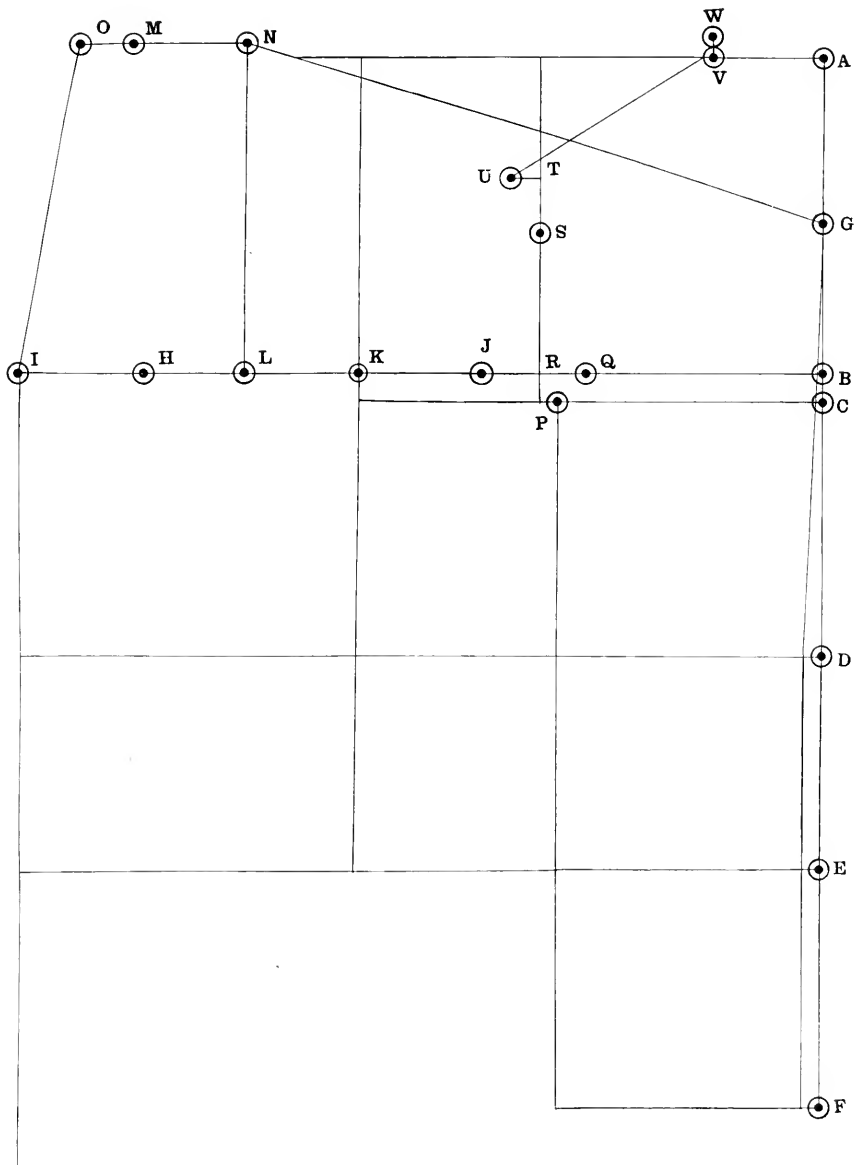

DIAGRAM 6

ACTUAL MEASUREMENTS WILL SHOW FIGURE
Continued

On diagram 7 we have the stooping figure where the distance from A to B is greater than L to N, showing that the person is round shouldered and stoops forward; but the blade also plays an important part in the make-up of a person; for instance, on a normal figure the width of a front across the breast from K to I is $\frac{1}{4}$ of breast measure. (*See diagram 8.*)

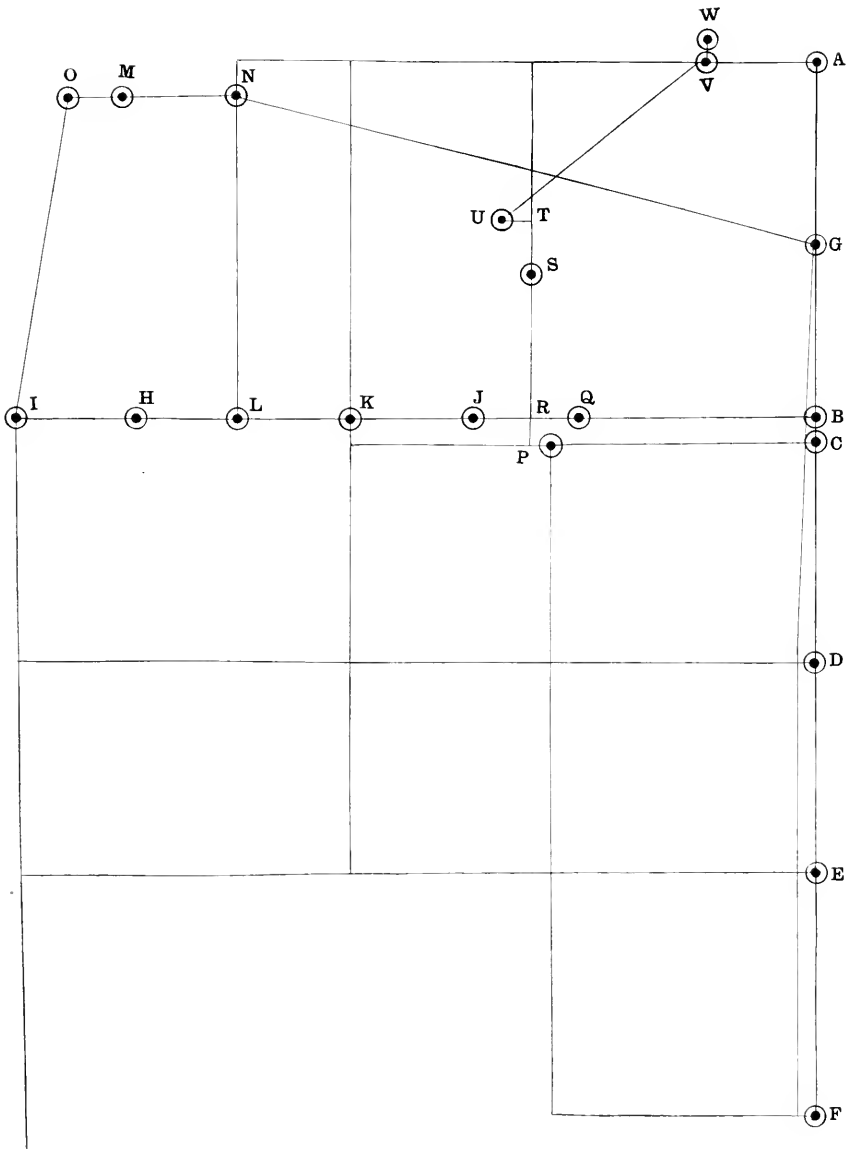

DIAGRAM 7

These measures are the same as on previous draft, Diagram 7, except that the blade measure is $\frac{1}{2}$ inch smaller, that is $12\frac{1}{2}$ instead of 13 inches, causing the back to decrease from B to P, while the front, from K to I, is increased to 10 instead of $9\frac{1}{2}$ inches, thus showing a full breast and flat back.

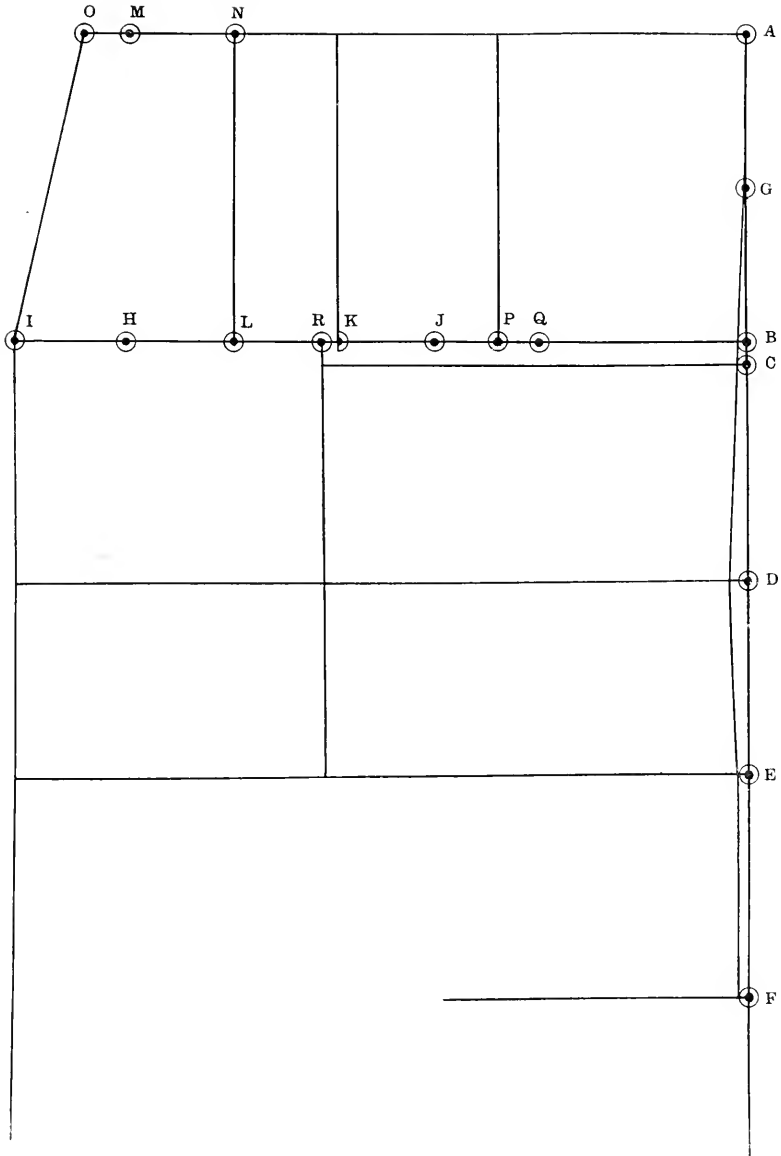

DIAGRAM E

FULL BACK—FLAT BREAST

These measures are the same as on Diagram 5, except that the blade measure is increased to $13\frac{1}{2}$ inches, causing the back from B to P to increase, while the breast from K to I has decreased to 9 inches, showing that the back is round while the breast is flat.

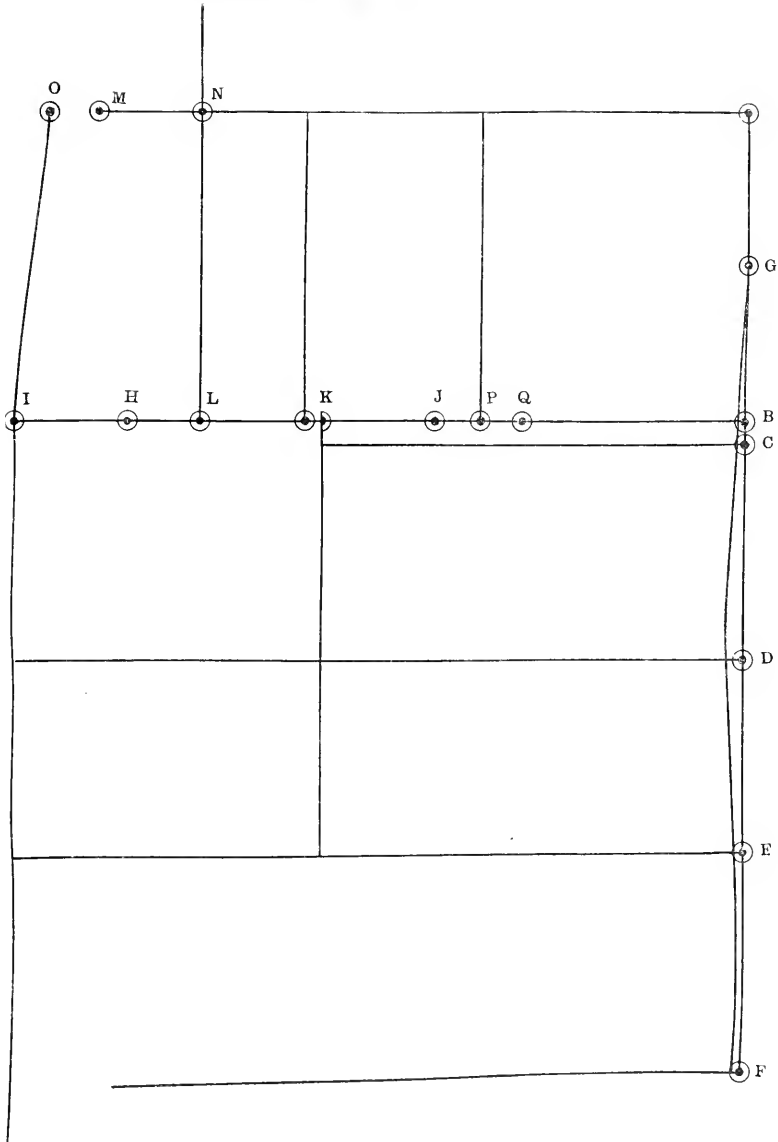

DIAGRAM 9

THREE BUTTON SACK

The measurements by which this draft is produced are as follows:

Depth of scye,	9 inches	Over shoulder,	13½ inches
Waist length,	17 inches	Blade,	12½ inches
Seat,	23 inches	Breast,	36 inches
Full length,	30 inches	Waist,	32 inches
Strap,	12 inches	Seat,	37 inches

Square lines A—U and A—F.

A to B is 9 inches; B to C is $\frac{3}{4}$ inch; A to D is 17 inches; A to E is 23 inches; A to F is 30 inches.

Square out from B, C, D, E and F.

G is half way between A and B. At D go in $\frac{1}{2}$ inch. Draw a line from G to D and square down.

From line just made at B to H is half of full breast—18 inches. H to I is $3\frac{1}{2}$ inches. Square down from I. J is half way between B and H. J to K is $3\frac{1}{2}$ inches. Square down from K.

Apply blade measure from B to K—12½ inches. Square up from K. K to L is $\frac{1}{2}$ the distance from A to B. Square up from L. P is half way between B and K, P to Q is 14 inches. Square up from Q.

Q to R is $\frac{1}{2}$ breast, R to S is $1\frac{1}{2}$ inches, S to T is $\frac{3}{4}$ inch, A to U is $\frac{3}{4}$ inch more than $\frac{1}{2}$ breast. Square up from U. U to V is $\frac{5}{8}$ inch. Draw a line from U to T. Shape the back

Measure back A to V, apply to K and up to N, strap measure plus $\frac{1}{4}$ inch—12¼ inches.

Draw a line from N to G. Square forward from N. N to 13 is $1\frac{1}{2}$ inches more than one-sixth breast. Draw a line from 13 to I. N to O is $\frac{1}{4}$ breast. M is half way between K and L. Square forward from O by K. Sweep from N to Y, pivoting at M. N to Y is $\frac{1}{4}$ inch less than V to T. Shape gorge, shoulder and armseye.

Z to 5 is $\frac{1}{2}$ waist, 5 to 3 is $1\frac{1}{4}$ inches, 3 to 2 is $3\frac{1}{2}$ inches.

Measure back 7 to D and 2 to 6, waist measure, plus 1 inch—17 inches.

Measure 9 to E and 8 to 10, seat measure plus $\frac{1}{2}$ inch—19 inches.

Shape the side of the front, taking out $\frac{1}{2}$ inch between front and back at Q.

Sweep from 12 to 15, pivoting at N. Finish front as represented. Cut out the back. Place point V on point N. Get over shoulder measure from G through X to K plus $\frac{1}{4}$ inch—13¾ inches.

THE COLLAR

Draw a line from lapel crease through N to 18. N to 18 is the same as A to V. Square down from 18. 18 to 19 is $1\frac{1}{4}$ inches, 18 to 17 is $1\frac{3}{4}$ inches. Shape collar as represented.

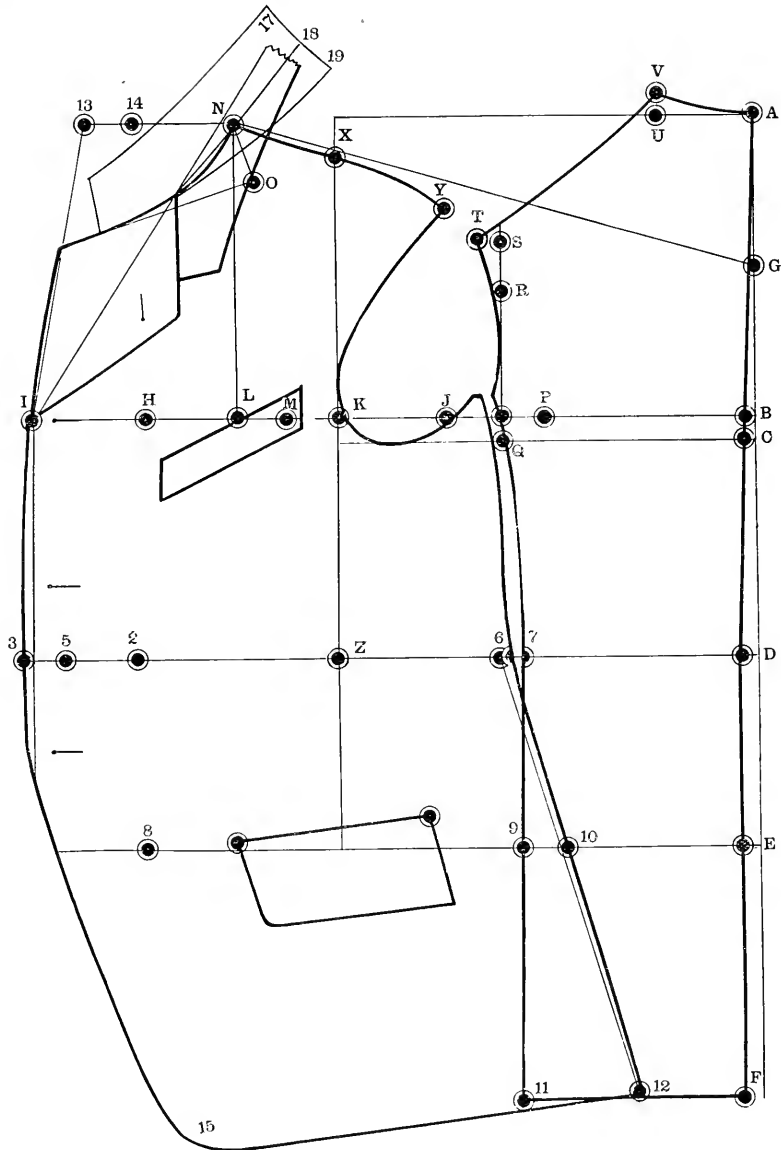

THREE BUTTON SACK

STRAIGHT FRONT SACK—STRAIGHT BACK

The measurements by which this draft is produced are as follows:

Scye depth,	9½ inches	Blade,	13 inches
Natural waist,	17 inches	Breast,	38 inches
Full length,	30 inches	Waist,	34 inches
Strap,	12¾ inches	Seat,	39 inches
Over shoulder,	14½ inches		

Square lines A—U and A—F.

A to B is 9½ inches; B to C is ¾ inch; A to D is 17 inches; D to E is 6 inches; A to F is 30 inches.

Square out from B, C, D, E and F. G is half way between A and B. B to H is half of full breast, 19 inches; H to I is 3½ inches. J is half way between B and H, J to K is 3½ inches. Square down from I and K.

Apply the blade measure from B to K, 13 inches, and square up.

K to L is ¼ the distance from A to B, in this case 19 on the 6th division. Square up from L. P is half way between B and K, P to Q is 1¼ inches. Square up from Q. From O to R is ¼ breast, R to S is 1½ inches. Square out from S. S to T is ¾ inch. A to U is ¾ inch more than ¼ breast. Square up from U. U to V is ⅔ of an inch. Draw a line from U to T.

Shape the back.

Measure distance A to V, apply to K and up to N, strap measure plus ¼ inch, 13 inches.

Draw a line from N to G. Square forward from N. N to 8 is ¼ breast measure plus 1½ inches. Draw a line from 8 to I. N to 19 is ¼ breast measure. M is half way between K and L. Square out from 19 by M.

W to X is half waist, X to Y is 1¼ inches, Y back to Z is 3½ inches. Shape front edge

From front edge to 10 is 3½ inches. Measure back 4 to E, apply to 10 and back to 1, seat measure plus 1 inch. 1 to 3 is 1¾ inches. Square up from 3 to establish 13. Draw a line from 13 through 1 to 11.

Between back and front at Q take out ½ inch. Shape side of front. Sweep from 9 to 20, pivoting at M. N to 20 is ¼ inch less than V to T. Shape gorge, shoulder and armseye. Sweep from 11 to 12, pivoting at N. Cut out back and place point V on point N.

Measure over shoulder from G through 9 to K, 14½, plus ¼ inch—14¾ inches. Mark at 9, where the back laps over the front shoulder and sweep from there to 20, pivoting at M.

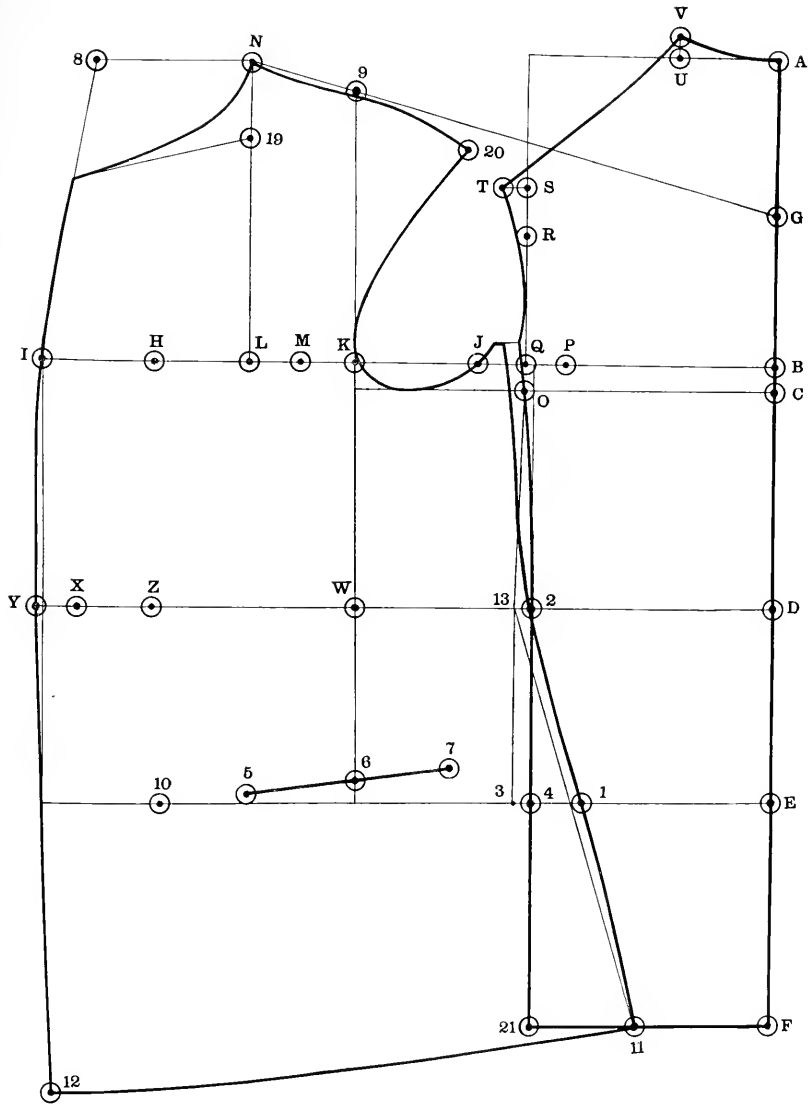

STRAIGHT FRONT SACK—STRAIGHT BACK

FOUR BUTTON MILITARY SACK

With or without Exaggerated Shoulders. The dotted lines show exaggeration

The measurements are the same as on previous draft.

Square lines A—F and A—U.

A to B is $9\frac{1}{2}$ inches; B to C is $\frac{3}{4}$ inch; A to D is 17 inches; A to E is 23 inches; A to F is 30 inches.

Square out from B, C, D, E and F. G is half way between A and B.

At D go in $\frac{1}{2}$ inch, square down and draw a line up to G.

From line inside of B to H is half of full breast, 19 inches. H to I is $3\frac{1}{2}$ inches. J is half way between B and H. J to K is $3\frac{1}{2}$ inches. Square down from I and K.

Apply the blade measure from B to K, 13 inches. Square up from K.

K to L is $\frac{1}{2}$ the distance from A to B, 19 on 6th division. Square up from L. P is half way between B and K, P to Q is $1\frac{1}{4}$ inches. Square up from Q. Q to R is $\frac{1}{4}$ breast, R to S is $1\frac{1}{2}$ inches. Square out from S. S to T is $\frac{3}{4}$ inch. From P to back line 7 is $\frac{3}{4}$ inch. Square down to 11. From A to U is $\frac{3}{4}$ inch more than $\frac{1}{4}$ breast. Square up from U. From U to V is $\frac{1}{2}$ inch.

Draw a line from U to T; shape the back.

Measure distance A to V; apply to K and up to N, strap measure $12\frac{1}{2}$ plus $\frac{1}{4}$ inch— $12\frac{3}{4}$ inches.

Draw a line from N to G. Square forward from N. N to 11 is $\frac{1}{4}$ breast, 11 to 13 is $1\frac{1}{2}$ inches. Draw a line from 13 to L. M is half way between K and L.

Sweep from X to Y, pivoting at M. N to Y is $\frac{1}{4}$ inch less than V to T. N to O is $\frac{1}{4}$ breast. Square forward from O by M. Shape gorge, shoulder and armseye.

Z to 2 is half waist, 2 to 3 is $1\frac{1}{4}$ inches, 3 back to 4 is $3\frac{1}{2}$ inches. Shape front edge. 8 is $3\frac{1}{2}$ inches back from the edge.

Measure back 9 to E; apply to 8 and back to 10, $10\frac{1}{2}$ inches; add $\frac{1}{2}$ inch—20 inches.

10 to 9 is $1\frac{3}{4}$ inches, square up from 9 to get 6, draw a line from 6 through 10 to 12.

Shape the side of forepart and take out $\frac{1}{2}$ inch under arm fish.

Sweep from 12 to 15, pivoting at N. Cut out the back and apply point V to N; swing until you get shoulder measure, plus $\frac{1}{4}$ inch.

For broad shoulders and narrow collar, proceed as follows: After the back is cut, add $\frac{1}{4}$ or $\frac{3}{8}$ inch at A—A', and the same at N. Add $\frac{1}{4}$ or $\frac{3}{8}$ inch at T, raising the shoulder for padding and increasing the back as per broken lines. Increase the shoulder at Y as much as is necessary.

Diagram on page 43 shows a very good way to cut a concave shoulder.

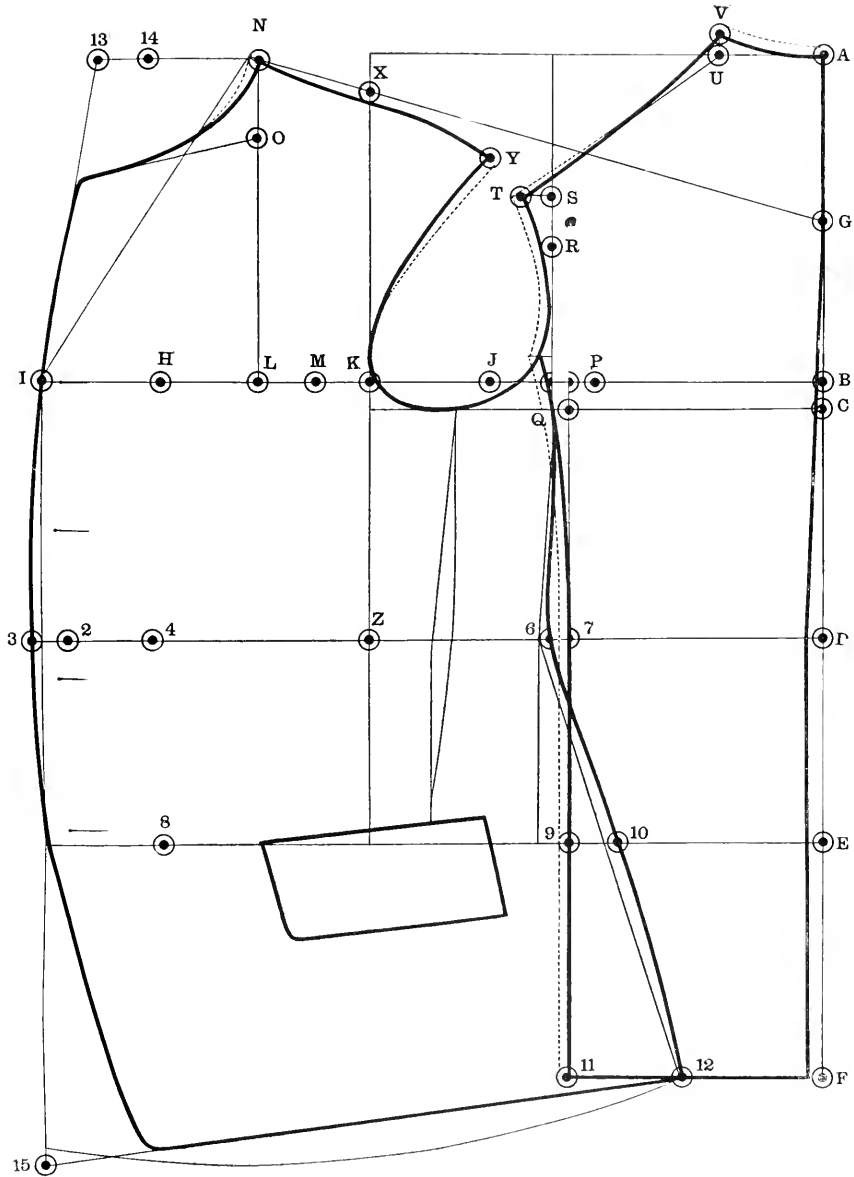

FOUR BUTTON MILITARY SACK

With or without exaggerated shoulder. The dotted lines are exaggerated.

HOW TO CUT A CONCAVE SHOULDER.

The trouble that cutters usually experience in trying to get concave shoulders is that they fail to make provision for the stretching of it, and thus lose the original position of the shoulder point. A good test of this is: take the fronts of any ordinary coat and stretch the hollow of the gorge, the shoulder and the armseye, then lay the original pattern upon it and see the result.

The following diagram shows a very good way to get a concave shoulder:

After the pattern has been cut according to measurements, double your front over, say $\frac{1}{2}$ inch, as from E to F, the result will be to bring the shoulder point over as from solid line A to broken line B, and from solid line C to broken line D. Stretch the hollow of the gorge, the shoulder and armseye as marked on diagram.

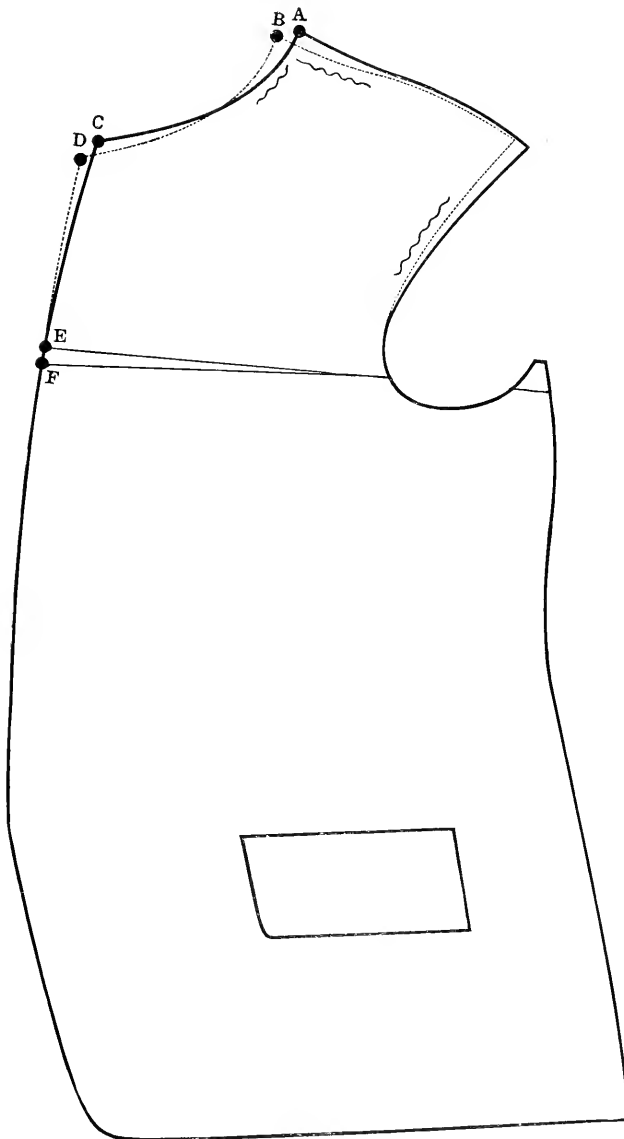

"HOW TO CUT A CONCAVE SHOULDER"

THREE BUTTON DOUBLE BREASTED SACK

The measurements by which this draft is produced are as follows:

Sceve depth,	9½ inches	Over shoulder,	14¼ inches
Waist length,	17 inches	Blade,	13 inches
Seat,	23 inches	Breast,	38 inches
Full length,	30 inches	Waist,	34 inches
Strap,	12½ inches	Seat,	39 inches

Square lines A—U and A—F.

A to B is 9½ inches; B to C is ¾ inch; A to D is 17 inches; A to E is 23 inches; A to F is 30 inches.

Square out from B, C, D, E and F; G is half way between A and B.

At D go in ½ inch, draw line up to G and down to F.

From line inside of B to H is ½ full breast. H to I is 2½ inches, I to J is 3¼ inches.

Square down from I and J. K is half way between B and H. K to L is 3½ inches.

Square down from L. Apply blade measure from B to L, 13 inches. Square up from L. L to M is ¼ the distance from A to B. Square up from M.

P is half way between B and L. P to Q is 1¼ inches. Square up from Q. Q to R is ¼ breast, R to S is 1½ inches, S to T is ¾ inch. P to back line is 1 inch. Square down for back.

A to U is ¼ breast measure plus ¾ inch, U to V is ½ inch. Draw a line from V to T. Shape back.

Measure distance A to V, apply to L and N for strap measure plus ¼ inch—12¾ inches

Draw a line from N to G to get W. Sweep from W to X, pivoting at O. N to X is ¼ inch less than V to T. N to 14 is ½ breast measure. Square forward from 14 by O.

Shape gorge, shoulder and armseye.

Y to Z is half waist measure, Z to 2 is 3½ inches, 2 back to 3 is 5¾ inches.

Measure distance 4 to D, and 3 to 1, waist measure plus 1 inch.

Measure distance 6 to E and 5 to 7, seat measure plus ½ inch.

Square out from N. N to 12 is ½ inch more than ¼ breast measure. 12 to 11 is 3½ inches; draw a line from 12 to I and from 11 to J. Shape front.

Sweep from 8 to 9, pivoting at N, extend line I—Z up and take out V.

Cut out back and place point V on point N.

Get over shoulder measure from G through W to L, 14¼ plus ¼ inch, 14½ inches.

Sweep to X and reshape shoulder.

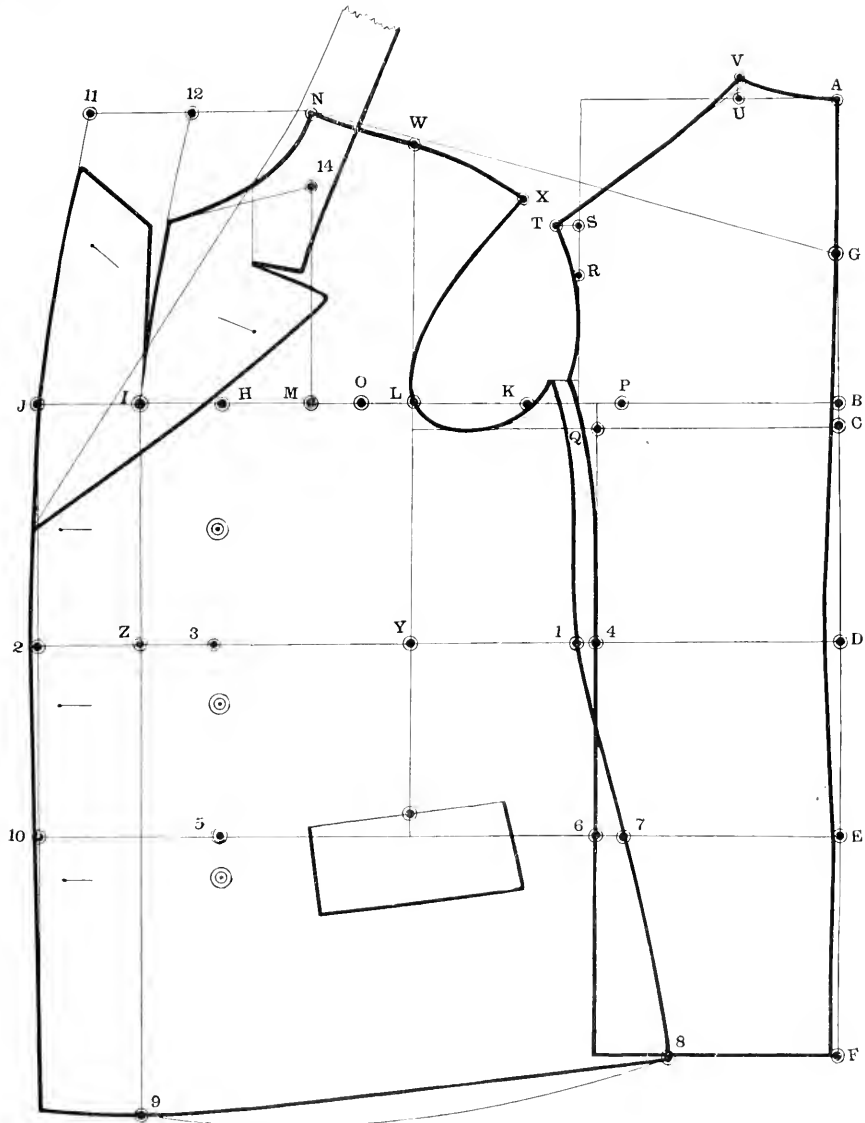

THREE BUTTON DOUBLE-BREASTED SACK

FOUR BUTTON SACK

For Stout Figure

The measurements by which this draft is produced are as follows:

Seye depth,	9 $\frac{1}{2}$ inches	Strap,	13 inches
Waist length,	17 inches	Over shoulder,	15 inches
Seat,	23 inches	Blade,	13 $\frac{1}{2}$ inches
Full length,	30 inches	Breast,	40 inches
	Waist,		40 inches

Square lines A—U and A—F.

A to B is 9 $\frac{1}{2}$ inches; B to C is $\frac{3}{4}$ inch; A to D is 17 inches; A to E is 23 inches; A to F is 30 inches.

Square out from B, C, D, E and F. G is half way between A and B.

At D go in $\frac{1}{2}$ inch, square down to F and draw a line up to G.

From the line just made inside of B to H is half of full breast, 20 inches. H to I is 3 $\frac{1}{2}$ inches.

J is half way between B and H, J to K is 3 $\frac{1}{2}$ inches. Square down from I and K.

Apply blade measure from the line inside of B to K 13 $\frac{1}{2}$ inches. From K to L is $\frac{1}{4}$ the distance from A to B, in this case 19 on the 6th division. Square up from L. P is half way between B and K. P to O is 1 $\frac{1}{4}$ inches. Square up from O. Square down for back. From I to R is $\frac{1}{4}$ breast, R to S is 1 $\frac{1}{2}$ inches. Square out from S. S to T is $\frac{3}{4}$ inch.

A to U is $\frac{3}{4}$ inch more than $\frac{1}{2}$ breast. Square up from U, U to V is $\frac{3}{8}$ inch. Draw a line from U to T. Shape back.

Measure distance A to V, apply to K and up to N, strap measure, 13 plus $\frac{1}{4}$ inch—13 $\frac{1}{4}$ inches.

Draw a line from N to G. Square forward from N. N to 26 is $\frac{1}{4}$ breast, 26 to 25 is 1 $\frac{1}{2}$ inches. Draw a line from 25 to I.

M is half way between K and L; N to O is $\frac{1}{8}$ breast. Square out from O by M. Sweep from X to Y, pivoting at M. N to Y is $\frac{1}{4}$ inch less than V to T.

Shape gorge, shoulder and armseye.

Z to 2 is $\frac{1}{4}$ waist, 2 to 3 is 14 inches; 3 back to 4 is 3 $\frac{1}{2}$ inches. Square down from 3.

Measure back from 7 to line inside of D, apply to 4 and back to 6, waist measure plus $\frac{1}{2}$ inch; square down from 6 to get 9; 9 to 10 is 1 $\frac{1}{2}$ inches; draw a line from 6 through 10 to 12. Shape the side of front.

Sweep from 12 forward, pivoting at N. Shape front edge and bottom. From K to 16 is $\frac{2}{3}$ the sleeve length.

Measure distance from 16 to bottom of forepart; mark the same distance from bottom of forepart to 18 and to 17; draw a line from 17 to 18. 16 to 17 and 16 to 18 are $\frac{1}{4}$ breast each; the under arm cut is from half way between O and K to half way between 16 and 18; cut open the under arm seam. Cut the pocket to 17. Take out a one inch V from 17 to bottom of forepart as marked. (See Diagram Page 49.)

THE COLLAR

Draw a line from 24 through N to 20; N to 20 is the same as A to V.

Square down from 20. 20 to 21 is 1 $\frac{1}{4}$ inches, 20 to 22 is 2 inches. The width of collar in front at 23 is 1 $\frac{3}{4}$ inches. Shape as represented.

Cut out back and place point V on point N; get over shoulder measure from G through N to K, 15 inches plus $\frac{1}{4}$ inch, 15 $\frac{1}{4}$ inches.

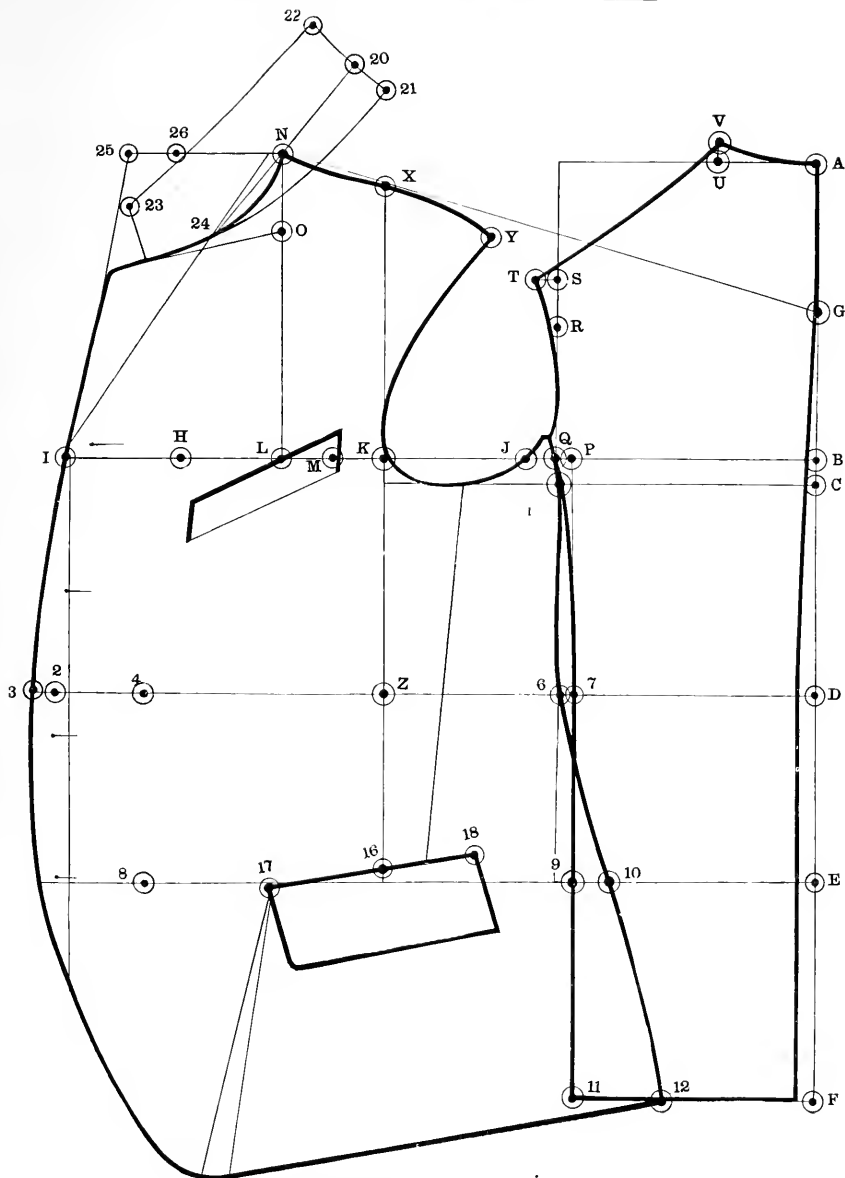

FOUR BUTTON SACK FOR STOUT FIGURE

FOUR BUTTON SACK For Corpulent Figure

The measurements by which this draft is produced are as follows:

Seye depth,	9½ inches	Over shoulder,	15½ inches
Waist length,	17½ inches	Blade,	13½ inches
Full length,	31 inches	Breast,	40 inches
Strap,	13½ inches	Waist,	42 inches

Square lines A—F and A—V.

A to B is 9½ inches; B to C is ¾ inch; A to D is 17½ inches; A to E is 23½ inches; A to F is 31 inches.

Square out from B, C, D, E and F. G is half way between A and B.

D to inner line is ½ inch. Square down from inner line and draw line up to G. From the line just made at B to H is half of full breast. K is half way between B and H, K to 9 is 3½ inches.

Square up and down from 9. O is half way between B and 9. O to P is 1¼ inches. Square up from P.

P to Q is ¼ breast; Q to R is 1½ inches. Square out from R. R to S is ¾ inch.

A to V is ¾ inch more than ¼ breast. Square up from V. V to U is ½ inch. Draw a line from V to S and shape back.

For every inch that the waist is larger than the breast advance ¼ inch from 9 to L; in this case, where the breast measure is 40 and the waist 42 inches advance the blade ½ inch from 9 to L. Square up and down from L.

L to M is ½ the distance from A to B. Square up from M. H to J is the same as 9 to L—½ inch, J to I is 3½ inches.

Measure distance A to U, apply to L and up to N, 13½ inches plus ¼ inch—13¾ inches. Draw a line from N to G. N to 8 is ¼ breast, plus 1½ inches. Draw a line from 8 to L. N to 19 is ¼ breast measure, 17 is half way between L and M, Square forward from 19 by 17.

W to X is ½ waist. X to Y is 1¼ inches, Y back to Z is 3½ inches. Square down from Y.

Measure back 2 to D and Z to 3, ½ waist measure plus ½ inch. Square down from 3 to 4. From 4 to 1 is 1½ inches. Draw a line from 3 through 1 to 11. Shape the side of front. Sweep from 11 to 12 pivoting at N. Sweep from 16 to 20, pivoting at 17. Shape front, gorge, shoulder and armseye.

From 1 to 15 is ¾ of sleeve length. Measure distance from 15 to bottom of front. Mark same distance from bottom to 13 and 14. Draw a line from 13 to 14. From 15 to 14 and 13 are ¼ breast measure each. 23 is half way between P and 9. Between 23 and 22 take out the ½ inch that has been added from 9 to L, cut the pocket to 14 and take out 1 inch V to bottom of front.

Cut out the back and place point U on point N. Get over shoulder measure with ¼ inch allowance from G through 16 to L. Sweep to 20.

Finish as represented. See next page.

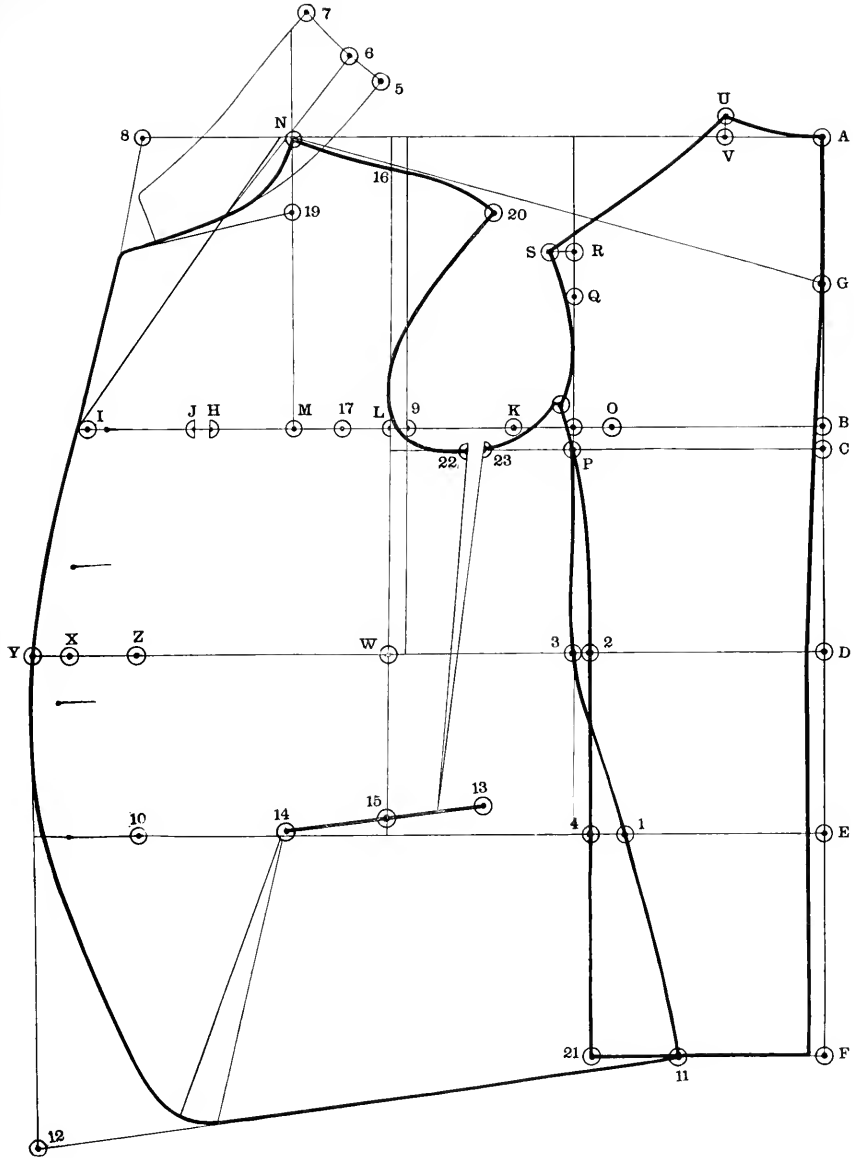

FOUR BUTTON SACK FOR CORPULENT FIGURE

After the front is cut out and the V taken out as from 17 to the bottom of front, reshape the bottom as shown on Diagram 10, following:—

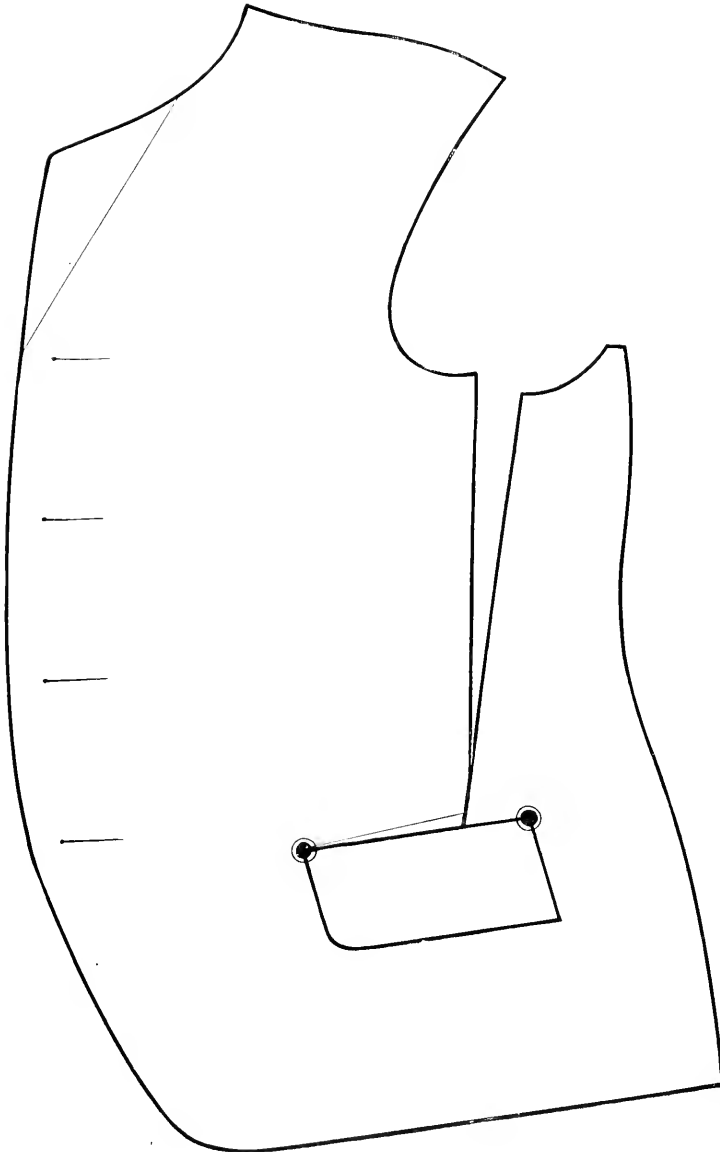

DIAGRAM 10.

THREE BUTTON CUTAWAY FROCK.

The measurements by which this draft is produced are as follows:

Scye depth,	9 inches	Over shoulder,	13½ inches
Natural waist,	16½ inches	Blade,	12½ inches
Fashionable waist,	18½ inches	Breast,	36 inches
Full length,	36 inches	Waist,	32 inches
Strap,	12 inches	Seat,	37 inches

Square lines A—E and A—U.

A to B is 9 inches; B to C is ¾ inch; A to D is 16½ inches; A to E is 18½ inches; A to F is 36 inches.

Square out from B, C, D, E and F. G is half way between A and B.

B to H is half of full breast, 18 inches. H to I is 2½ inches. I to J is 1 inch. K is half way between B and H, 9 inches. K to L is 3½ inches. Square down from I and L.

Apply the blade measure from B to L, 12½ inches. L to M is ⅓ the distance from A to B, 18 on 6th division.

Square up from L and M. O is half way between B and L. O to P is 1¼ inches. Square up from P; P to Q is ¼ breast, Q to R is 1½ inches; Q to T the same.

Square out from R. R to S is ¾ inch. A to U is ¾ inch more than ½ breast. Square up from U. U to V is ⅝ inch. Draw a line from U to S.

E to 1 is ¼ inch more than ½ breast. F to 21 is the same as E to 1. Shape back. Measure back A to V, apply to L and up to N, strap measure 12 plus ¼ inch, 12¼ inches. Draw a line from N to G. Square forward from N. N to 14 is ¼ breast, 14 to 13 is 1½ inches. Draw a line from 13 to J. Sweep from 18 to 20, pivoting at 17.

N to 20 is ¼ inch less than V to S. N to 12 is ½ breast measure. Square forward from 12 by 17. Shape gorge, shoulder and armseve.

From 2 to 3 is 1¼ inches in this case. The waist suppression is as follows: Where the waist measures the same as the breast, or more, take out 1¼ inches between 2 and 3, never less; and for every inch the waist is smaller than the breast take out ⅝ inch in addition to 1¼ inches; in this case, where the waist is 4 inches smaller than the breast, 4 eighths and 1¼ make 1¾ inches.

From 3 to 6 is ¼ waist measure. From W to X is ½ waist measure, X to Y is 1¼ inches. Y back to Z is 3¾ inches.

Measure waist 2 to D and Z to 3, and take out balance between 6 and 7, in this case ½ inch, or ¼ inch for every inch the waist is smaller than the breast.

However, when the waist is as large as the breast and there is nothing left to take out between 6 and 7, take ½ inch out, and omit taking a fish out at the waist, and three inches from Y to Z is enough for a stout person.

Draw a line from K to 6 and K to 7, and shape front and side body. Sweep from 1 to 1, pivoting at T. Sweep from 4 to 8, pivoting at a point 1 inch back from N. Draw a line from 8 to waist line at 7. Draw a line from waist line to 4.

THE SKIRT

Square down from 3 to 9. 3 to 9 is 9 inches. 9 to 10 is 1½ inches. Draw a line from 1 through 10 to 11. 4 to 11 is ½ inch more than 1 to 21. 8 to 15 is the same as 4 to 11. Draw a line from 15 to 11.

Shape top of skirt dropping it ¼ inch at 8, round the skirt ⅝ inch over 10. Cut out the back and place point V on point N; get over shoulder measure from G through 18 to L, sweep to 20 and reshape shoulder.

THE COLLAR

Draw a line from 1 inch above J through N to 24. N to 24 is the same as A to V. Square down from 24. 24 to 25 is 1¼ inches. 24 to 23 is 1¾ inches. Shape collar.

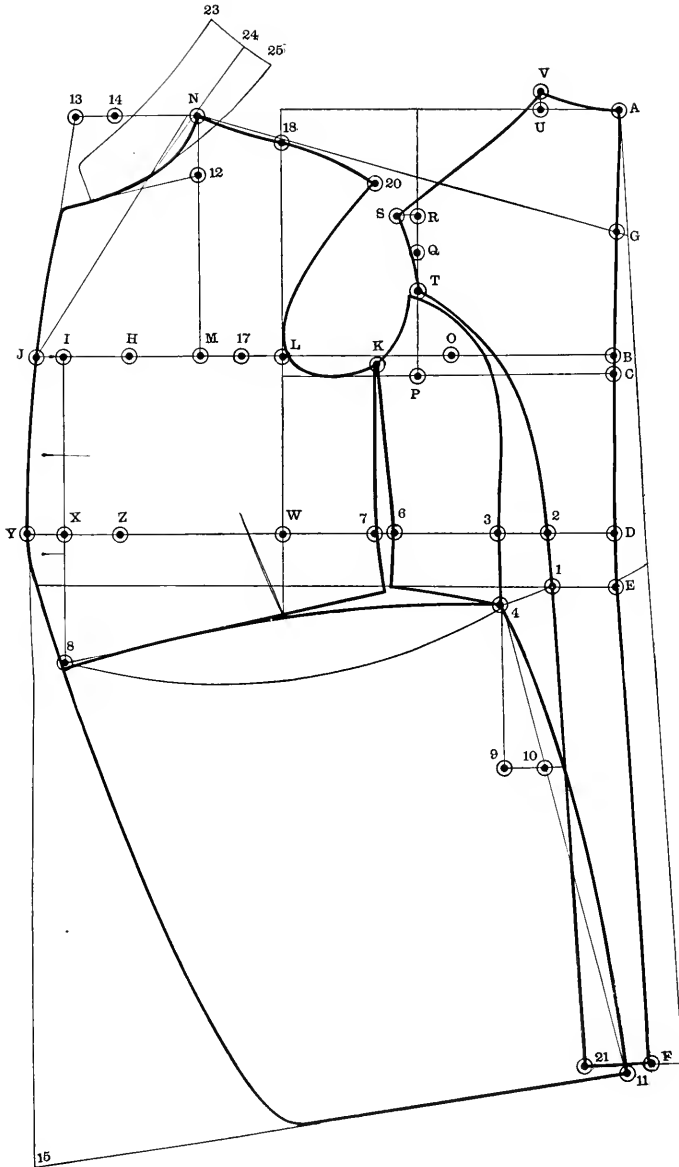

THREE BUTTON CUTAWAY FROCK

ONE BUTTON CUTAWAY FROCK

The measurements by which this draft is produced are as follows:

Scye depth,	9 inches	Over shoulder,	13½ inches
Natural Waist,	16½ inches	Blade,	12½ inches
Fashionable waist,	18½ inches	Breast,	36 inches
Full length,	36 inches	Waist,	32 inches
Strap,	12 inches	Seat,	37 inches

Square lines A—E and A—U.

A to B is 9 inches; B to C is ¾ inch; A to D is 16½ inches; A to E is 18½ inches; A to F is 36 inches.

Square out from B, C, D, E and F. G is half way between A and B.

B to H is half of full breast, 18 inches. H to I is 2½ inches. I to J is 1 inch

K is half way between B and H, 9 inches. K to L is 3½ inches. Square down from I and L.

Apply the blade measure from B to L, 12½ inches.

L to M is ¼ the distance from A to B, 18 on 6th division.

Square up from L and M. O is half way between B and L. O to P is 1¼ inches; square up from P. P to Q is ¼ breast. Q to R is 1½ inches. Q to T the same.

Square out from R; R to S is ¾ inch. A to U is ¾ inch more than ¼ breast measure. Square up from U; U to V is ¾ inch. Draw a line from U to S. E to I is ¼ inch more than ¼ breast. F to 2I is the same as E to I. Shape back.

Measure back A to V, apply to L and up to N, strap measure 12 plus ¼ inch, 12½ inches.

Draw a line from N to G. Square forward from N. N to 14 is ¼ breast. 14 to 13 is 1½ inches. Draw a line from 13 to J. Sweep from 18 to 20, pivoting at 17. N to 20 is ¼ inch less than V to S. N to 12 is ¼ breast. Square forward from 12 by 17. Shape gorge, shoulder, and armseye. From 2 to 3 is 1¾ inches.

From 3 to 6 is ¼ waist. From W to X is ½ waist. X to Y is 1¼ inches. Y back to Z is 3½ inches.

Measure waist, 2 to D and Z to 3 and take out balance between 6 and 7, in this case ¼ inch, or ¼ inch for every inch the waist is smaller than the breast.

Draw a line from K to 6 and K to 7, and shape front and side body.

Sweep from 1 to 4, pivoting at T.

Sweep from 4 to 8, pivoting at 1 inch back from N.

Draw a line from 8 to fashionable waist line. Draw a line from waist line to 4. Shape the side body reducing it ¼ inch at T and ¼ inch at blade line.

THE SKIRT

Square down from 3 to 9. 3 to 9 is 9 inches. 9 to 10 is 1½ inches. Draw a line from 4 through 10 to 11. 4 to 11 is ¼ inch more than 1 to 21. 8 to 15 is the same as 4 to 11. Draw a line from 15 to 11.

Shape top of skirt dropping it ¼ inch at 8, and rounding it ¾ inch over 10.

Cut out the back and place point V on point N.

Measure over shoulder from G through 18 to L, adding ¼ inch and reshape shoulder.

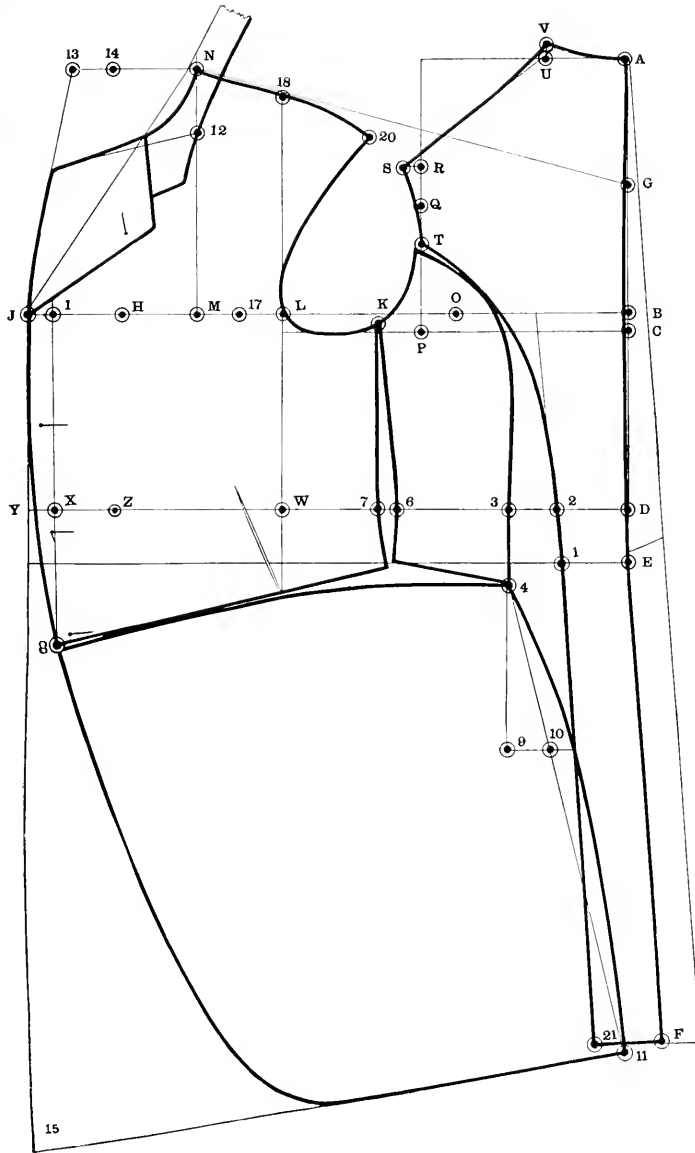

ONE BUTTON CUTAWAY FROCK

ENGLISH WALKING COAT

The measurements by which this draft is produced are as follows:

Scye depth,	10 inches	Over shoulder,	14 $\frac{3}{4}$ inches
Natural waist,	17 inches	Blade,	13 $\frac{1}{2}$ inches
Fashionable waist,	19 inches	Breast,	40 inches
Full length,	38 inches	Waist,	36 inches
Strap,	13 $\frac{1}{4}$ inches	Seat,	41 inches

Square lines A—E and A—U.

A to B is 10 inches; B to C is $\frac{3}{4}$ inch; A to D is 17 inches; A to E is 19 inches; A to F is 38 inches.

Square out from B, C, D, E and F. G is half way between A and B.

B to H is half of full breast measure, 20 inches. H to I is 2 $\frac{1}{2}$ inches; I to J is 1 inch. K is half way between B and H, 10 inches. K to L is 3 $\frac{1}{2}$ inches. Square down from I and L. Apply blade measure from B to L, 13 $\frac{1}{2}$ inches.

L to M is $\frac{1}{3}$ the distance from A to B, 20 on 6th division. Square up from L and M. O is half way between B and L. O to P is 1 $\frac{1}{4}$ inches. Square up from P. P to Q is $\frac{1}{4}$ breast. Q to R is 1 $\frac{1}{2}$ inches. Q to T is the same. Square out from R. R to S is $\frac{3}{4}$ inch. A to U is $\frac{3}{4}$ inch more than $\frac{1}{2}$ breast. Square up from U. U to V is $\frac{5}{8}$ inch. Draw a line from U to S.

E to 1 is $\frac{1}{4}$ inch more than $\frac{1}{2}$ breast, F to 21 is the same as E to 1. Shape back

Measure back A to V, apply to L and up to N, strap measure 13 $\frac{1}{4}$ plus $\frac{1}{4}$ inch, 13 $\frac{1}{2}$ inches

Draw a line from N to G. Square forward from N. N to 23 is $\frac{1}{2}$ breast. 23 to 22 is 1 $\frac{1}{2}$ inches. Draw a line from 22 to J.

Sweep from 18 to 20, pivoting at 17. N to 20 is $\frac{1}{4}$ inch less than V to S. N to 19 is $\frac{1}{8}$ breast measure. Square forward from 19 by 17. Shape gorge, shoulder, and armseye.

From 2 to 3 is 1 $\frac{3}{4}$ inches.

From 3 to 6 is $\frac{1}{4}$ waist. From W to X is $\frac{1}{2}$ waist. X to Y is 1 $\frac{1}{4}$ inches, Y back to Z is 3 $\frac{1}{2}$ inches.

Measure waist, 2 to D and Z to 3 and take out balance, $\frac{1}{2}$ inch, between 6 and 7, or $\frac{1}{3}$ inch for every inch the waist is smaller than the breast.

Draw a line from K to 6 and K to 7, and shape front and side body. Sweep from 1 to 4, pivoting at T. Sweep from 4 to 8, pivoting at a point 1 inch back from N. Draw a line from 8 to fashionable waist line. Draw a line from waist line to 4. Shape the side body reducing it $\frac{1}{4}$ inch at T and $\frac{1}{4}$ inch at blade line.

THE SKIRT

Square down from 3 to 9. 3 to 9 is 9 inches; 9 to 10 is 1 $\frac{1}{2}$ inches. Draw a line from 4 through 10 to 11. 4 to 11 is $\frac{1}{4}$ inch more than 1 to 21. 8 to 12 is the same as 4 to 11. Draw a line from 12 to 11.

Shape top of skirt dropping it $\frac{1}{4}$ inch at 8, and rounding it $\frac{2}{2}$ inch over 10.

Cut out the back and place point V on point N. Measure over shoulder from G through 18 to L and add $\frac{1}{4}$ inch. Finish as represented.

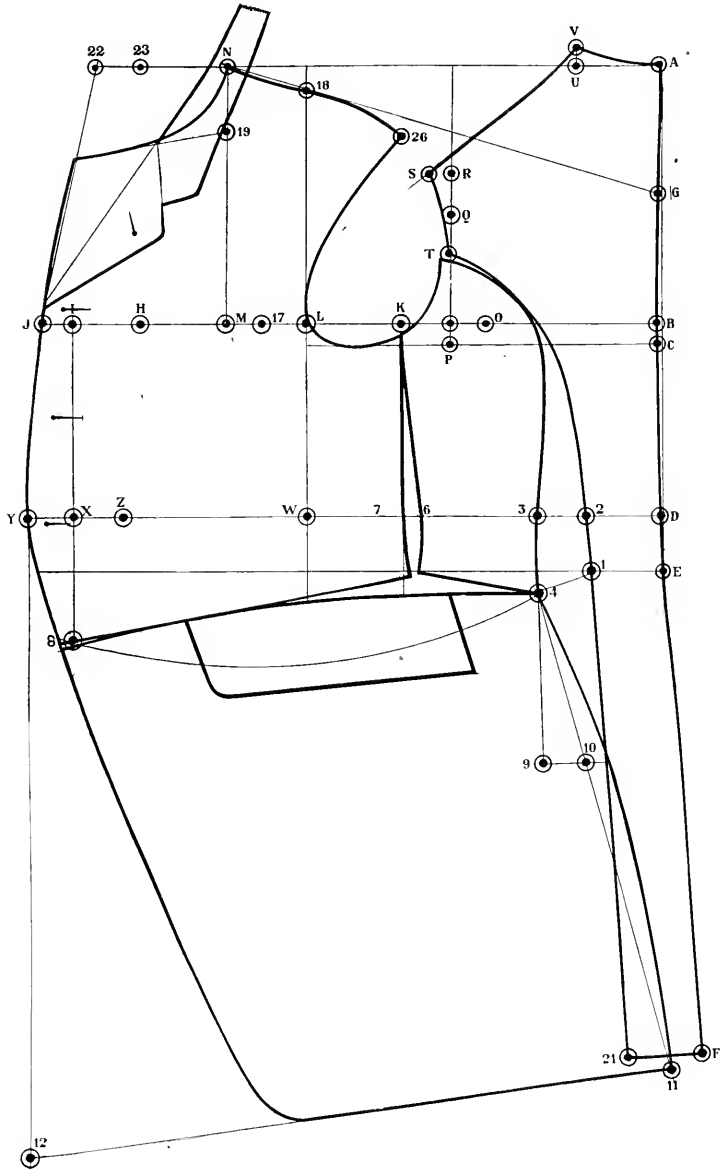

ENGLISH WALKING COAT

THREE BUTTON FROCK

For Stout Figure

The measurements by which this draft is produced are as follows:

Scye depth,	9½ inches	Strap,	13¼ inches
Natural waist,	17 inches	Over shoulder,	15¼ inches
Fashionable waist,	19 inches	Blade,	13½ inches
Full length,	38 inches	Breast,	40 inches
	Waist,		40 inches

Square lines A—E and A—U.

A to B is 9½ inches; B to C is ¾ inch; A to D is 17 inches; A to E is 19 inches; A to F is 38 inches.

Square out from B, C, D, E and F. G is half way between A and B.

B to H is half of full breast, 20 inches. H to I is 2½ inches. I to J is 1 inch. K is half way between B and H. K to L is 3½ inches. Square down from L. Apply blade measure from B to L or wherever it comes to.

Square up from blade; from L to M is ¼ the distance from A to B. Square up from M.

O is half way between B and L. O to P is 1¼ inches. Square up from P. P to Q is ¼ breast. Q to R is 1½ inches. Q to T the same. Square out from R. R to S is ¾ inch: A to U is ¾ inch more than ¼ breast.

Square up from U. U to V is ⅝ inch. Draw a line from U to S. E to I is ¼ inch more than ¼ breast. F to T is the same as E to I. Shape back.

From 2 to 3 is 1¼ inches; 3 to 6 is ¼ waist.

Measure back A to V, apply to L and up to N, strap measure plus ¼ inch, 13½ inches.

Draw a line from N to G. Square forward from N. N to 14 is ¼ breast. 14 to 13 is 1½ inches. Draw a line from 13 to J.

17 is half way between L and M. Sweep from 18 to 20, pivoting at 17. N to 20 is ¼ inch less than V to S.

N to 19 is ⅙ breast; square out from 19 by 17. Shape gorge, shoulder, and armseye. Shape side body, reducing it ¼ inch at T and ⅓ inch at blade line. From W to X is ½ waist. X to Y is 1¼ inches. Y to Z is 3½ inches.

Square down from Y. Measure waist 2 to D and Z to 3. There being nothing to take out in this case between 6 and 7, omit taking out a fish, and instead take out ½ inch between 6 and 7.

Sweep from 1 to 4, pivoting at T. Sweep from 4 to 8, pivoting at 1 inch back from N.

Draw a line from where sweep crosses line 8 to side of front. From front edge to 27 is ¼ waist. Take out ¼ inch V at 27.

Draw a line from 4 through 27 and 8; note the V at 27 is to be taken out only when the waist is as large or larger than the breast.

THE SKIRT

Square down from 3 to 9; 3 to 9 is 9 inches; 9 to 10 is 1½ inches.

Draw a line from 4 through 10 to 11. 4 to 11 is the same as 1 to 21. 8 to 12 is the same as 4 to 11.

Draw a line from 12 to 11. Shape top of skirt reducing it ¼ inch at 8 and rounding it ⅝ inch over 10.

Cut out the back and place point V on point N. Measure over shoulder from G through 18 to L and add ¼ inch, 15½ inches.

Sweep from wherever the back reached on front and reshape shoulder.

THE COLLAR

Draw a line from 1 inch above J through N to 25. N to 25 is the same as A to V.

25 to 26 is 1¼ inches; 25 to 24 is 2 inches; shape as represented.

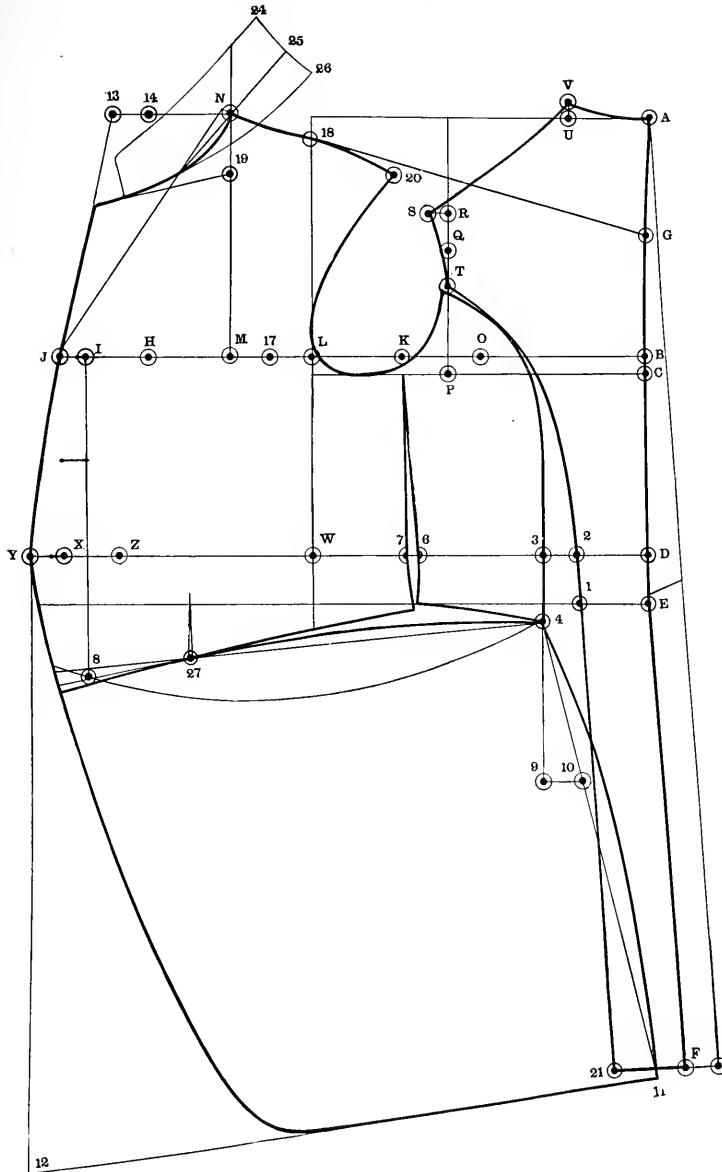

THREE BUTTON FROCK FOR STOUT FIGURE

THREE BUTTON FROCK

For Corpulent Figure

The measurements by which this draft is produced are as follows:

Sceve depth,	9½ inches	Strap,	13½ inches
Natural waist,	17 inches	Over shoulder,	15½ inches
Fashionable waist,	19 inches	Blade,	13½ inches
Full length,	38 inches	Breast,	40 inches
	Waist,	42 inches	

Square lines A—V and A—E.

A to B is 9½ inches; B to C is ¾ inch; A to D is 17 inches; A to E is 19 inches; A to 11 is 38 inches.

Square out from B, C, D, E and 11. G is half way between A and B.

B to 25 is half of full breast, 20 inches. H is half way between B and 25. H to J is 3½ inches.

For every inch that the waist is larger than the breast, advance ¼ inch at J. In this case, where the waist is 2 inches larger than the breast, advance from J to L ½ inch, also advance the same ½ inch from 25 to 24. From 24 to 5 is 2½ inches; from 5 to I is 1 inch. Square down from 5.

Apply blade measure from B to J, 13½ inches; and to L, ½ inch. Square up from L. L to M is ⅓ the distance from A to B, 19 on 6th division.

O is half way between B and J. O to P is 1¼ inches; square up from P. P to Q is ¼ breast; Q to R is 1½ inches; Q to T the same. Square out from R. R to S is ¾ inch.

A to V is ¾ inch more than ⅓ breast. Square up from V. V to U is ⅝ inch. Draw a line from V to S. E to 11 is ¼ inch more than ⅓ breast. 11 to 21 is the same as E to 1. Shape back.

Measure back A to U, apply to L and up to N, strap measure plus ¼ inch, 13½ inches. Draw a line from N to G. Square forward from N. N to 23 is ¼ breast. 23 to 22 is 1½ inches. Draw a line from 22 to 1.

Sweep from 26 to 20, pivoting at 17. N to 20 is ¼ inch less than U to S. N to 15 is ⅝ breast. Square out from 15 by 17. Shape gorge, shoulder and armscye.

From W to X is ½ waist. X to Y is 1¼ inches. Y back to Z is 3½ inches. From 2 to 3 is 1¼ inches.

Shape side body, reducing ¼ inch at T, and ¼ inch at blade line. 3 to 6 is ¼ waist. 6 to 7 is ½ inch, or measure back 2 to D and Z to 3 for waist measure.

From H to K take out the half inch increase from J to L.

Draw lines from H to 6 and from K to 7. Sweep from 1 to 4, pivoting at T. Sweep from 4 to 18, pivoting at a point 1 inch back from N.

Draw a line from side of front to where sweep crosses line at 18. From front edge to 19 is ⅓ waist. Take out ⅓ inch V at 19. Draw a line from 4 through 19 to front edge, and from waist line to 4.

THE SKIRT

Square down from 3 to 9. 3 to 9 is 9 inches, 9 to 10 is 1½ inches. Draw a line from 4 through 10 to F. From 4 to F is the same as 1 to 21.

Shape top of skirt, dropping it ¼ inch at 18. From 18 to 12 is the same as 4 to F. Draw a line from 12 to F. Finish skirt, rounding it ⅝ inch over 10.

Cut out back, place point U on point N. Measure over shoulder from G through 26 to L, 15½ plus ¼ inch, 15¾ inches. Sweep to 20 and reshape shoulder.

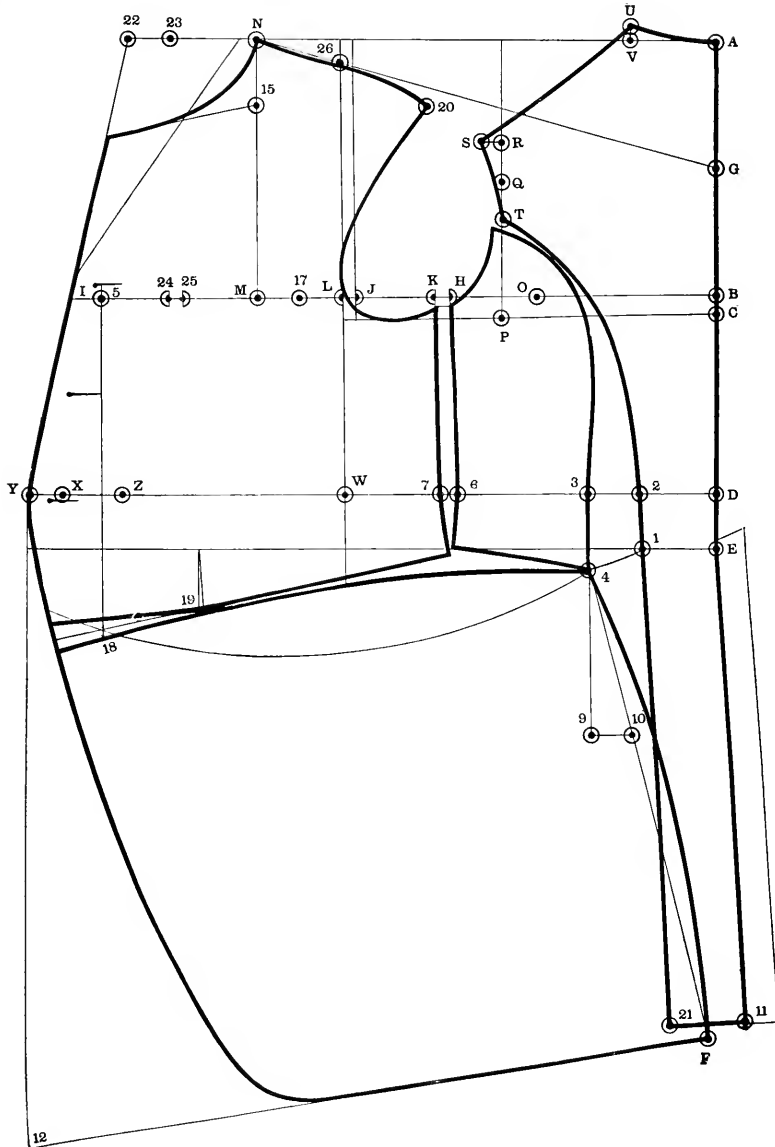

THREE BUTTON FROCK FOR CORPULENT FIGURE

SINGLE BREASTED FROCK, STRAIGHT FRONT

The measurements by which this draft is produced are as follows:

Scye depth,	9 inches	Over shoulder,	13½ inches
Natural Waist,	16½ inches	Blade,	12½ inches
Fashionable waist,	18½ inches	Breast,	36 inches
Full length,	40 inches	Waist,	32 inches
Strap,	12 inches	Seat,	37 inches

Square lines A—E and A—U.

A to B is 9 inches; B to C is $\frac{3}{4}$ inch; A to D is 16½ inches; A to E is 18½ inches; A to F is 40 inches.

Square out from B, C, D, E and F. G is half way between A and B.

B to H is half of full breast—18 inches. H to I is 2½ inches; I to J is 1 inch. K is half way between B and H—9 inches. K to L is 3½ inches. Square down from I and L.

Apply the blade measure from B to L—12½ inches. Square up from L. L to M is $\frac{1}{3}$ the distance from A to B—18 on 6th division. Square up from M.

O is half way between B and L. O to P is 1¼ inches; square up from P. P to Q is $\frac{1}{4}$ breast; Q to R is 1½ inches; Q to T the same. Square out from R; R to S is $\frac{3}{8}$ inch. A to U is $\frac{3}{4}$ inch more than $\frac{1}{8}$ breast. Square up from U; U to V is $\frac{5}{8}$ inch. Draw a line from U to S. E to 1 is $\frac{1}{4}$ inch more than $\frac{1}{2}$ breast. F to 21 is the same as E to 1. Shape back.

Measure back A to V, apply to L and up to N, strap measure, 12 plus $\frac{1}{4}$ inch—12½ inches. Draw a line from N to G. Square forward from N.

N to 14 is $\frac{1}{8}$ breast, 14 to 13 is 1½ inches.

Draw a line from 13 to J.

17 is half way between L and M. Sweep from 18 to 20, pivoting at 17.

N to 20 is $\frac{1}{4}$ inch less than V to S. Place square at K and 18 and square forward. Shape gorge, shoulder, and armseye.

From 2 to 3 is 1¾ inches in this case. From 3 to 6 is $\frac{1}{4}$ waist. From W to X is $\frac{1}{2}$ waist; X to Y is 1½ inches; Y back to Z is 3½ inches. Measure waist 2 to D and Z to 3 and take out balance between 6 and 7, in this case $\frac{1}{2}$ inch.

Draw lines from K to 6 and K to 7 and shape front and side body.

Sweep from 1 to 4, pivoting at T. Sweep from 4 to 8, pivoting at a point 1 inch back from N. Shape the bottom of front.

THE SKIRT

Draw a line from 8 to 4. Square down from 4. 4 to 9 is 9 inches; 9 to 10 is 1½ inches. Draw a line from 4 through 10 to 11. 4 to 11 is $\frac{1}{4}$ inch more than 1 to 21. 8 to 12 is the same as 4 to 11. Draw a line from 12 to 11. Round the skirt $\frac{5}{8}$ inch over 10.

Finish as represented.

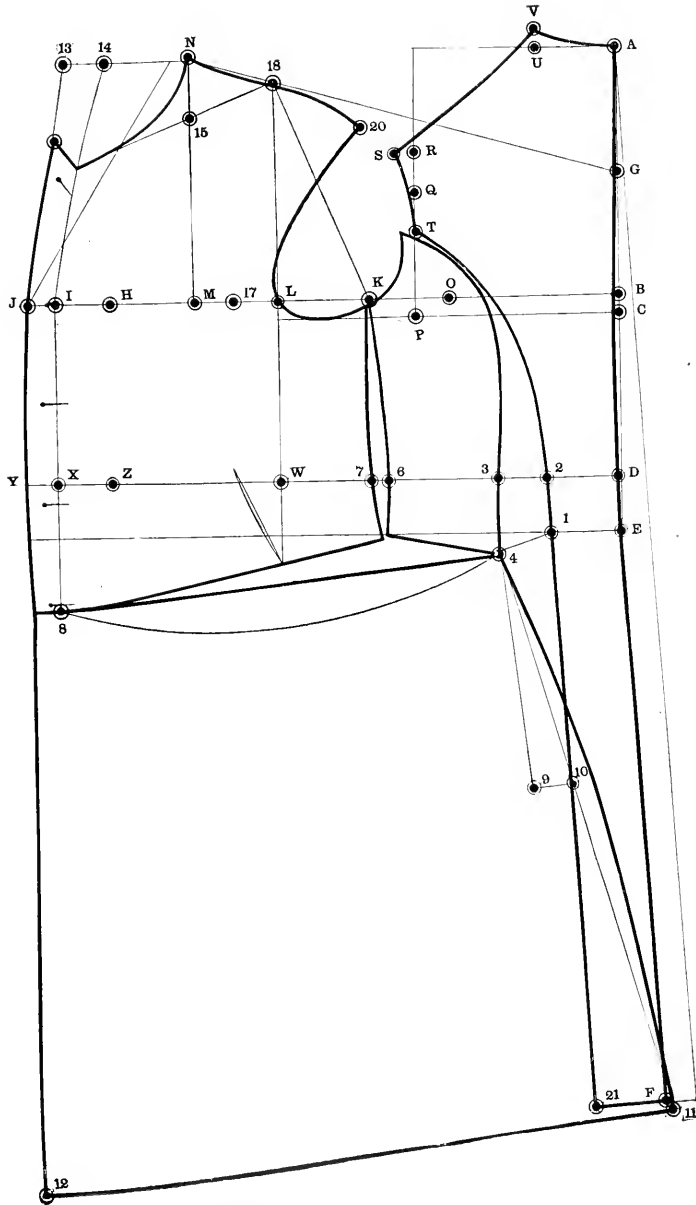

SINGLE BREASTED FROCK, STRAIGHT FRONT

THREE BUTTON DOUBLE BREASTED FROCK

The measurements by which this draft is produced are as follows:

Scye depth,	10 inches	Strap,	13 $\frac{1}{4}$ inches
Natural waist,	17 inches	Over shoulder,	15 inches
Fashionable waist,	19 inches	Blade,	13 $\frac{1}{2}$ inches
Full length,	42 inches	Breast,	40 inches
		Waist,	36 inches

Square lines A—V and A—E.

From A to B is the scye depth, 10 inches; from B to C is $\frac{3}{4}$ inch; from A to D is natural waist, 17 inches; A to E is fashionable waist, 19 inches; A to F is full length, 42 inches.

Square out from B, C, D, E and F. G is half way between A and B.

From B to H is half of full breast, 20 inches; H to I is 2 $\frac{1}{2}$ inches. Square down from I. K is half way between B and H; from K to L is 3 $\frac{1}{2}$ inches; square down from L to get W.

Apply the blade measure from B to L, 13 $\frac{1}{2}$ inches. Square up from L.

From L to M is $\frac{1}{3}$ the distance from A to B. Square up from M.

O is half way between B and L. From O to P is 1 $\frac{1}{4}$ inches. Square up from P.

From P to Q is $\frac{1}{4}$ breast. From Q to R is 1 $\frac{1}{2}$ inches. From Q to T is the same.

Square out from R. From R to S is $\frac{3}{4}$ inch.

From A to V is $\frac{3}{4}$ inch more than $\frac{1}{2}$ breast. Square up from V. V to U is $\frac{5}{8}$ inch. Draw a line from U to S.

From E to I is $\frac{1}{4}$ inch more than $\frac{1}{2}$ breast. From F to 21 is the same as from E to I.

Shape the back as represented.

Measure distance from A to U, apply same to L and up to N, strap measure plus $\frac{1}{4}$ inch, 13 $\frac{1}{2}$ inches.

Draw a line from N to G to get 18. Square forward from N. From N to 22 is $\frac{1}{2}$ inch more than $\frac{1}{2}$ breast. Draw a line from 22 to I.

17 is half way between L and M. Sweep from 18 to 20, pivoting at 17; from N to 20 is $\frac{1}{4}$ inch less than from U to S. Place the square at K and 18 and square forward for gorge.

Shape the gorge, shoulder and armseye. From W to X is $\frac{1}{2}$ waist; X to Y is $\frac{1}{4}$ inch. Y back to Z is 2 $\frac{1}{2}$ inches.

From 2 to 3 is 1 $\frac{3}{4}$ inches; from 3 to 6 is $\frac{1}{2}$ waist. Measure waist from 2 to D, apply same to Z and back to 3, and take out balance between 6 and 7.

Sweep from 1 to 4, pivoting at T; sweep from 4 to 8, pivoting at a point 1 inch back from N.

Shape the side body, reducing it $\frac{1}{4}$ inch at T, and $\frac{1}{4}$ inch at blade line, and finish bottom of front as represented.

THE SKIRT

Draw a line from 8 to 4, square down from 4 to 9, square down from 8 by the waist line.

From 4 to 9 is 9 inches; square out from 9. From 9 to 10 is 1 $\frac{1}{2}$ inches. Draw a line from 4 through 10 to 11. From 4 to 11 is the same as from 1 to 21. From 8 to 12 is the same as from 4 to 11. Draw a line from 12 to 11 and round the skirt $\frac{5}{8}$ inch at 10.

THE REVER

Draw a line parallel with X—I, make the width of the rever 2 $\frac{1}{2}$ inches at the waist, 3 $\frac{1}{2}$ inches at J and 2 $\frac{3}{4}$ inches at 19.

THE COLLAR

Draw a line from the lapel crease through N to 24. From N to 24 is the same as from A to U. Square down from 24. From 24 to 25 is 1 $\frac{1}{2}$ inches. From 24 to 23 is 2 inches. Make the width of the collar at the notch 1 $\frac{3}{4}$ inches.

Finish as represented.

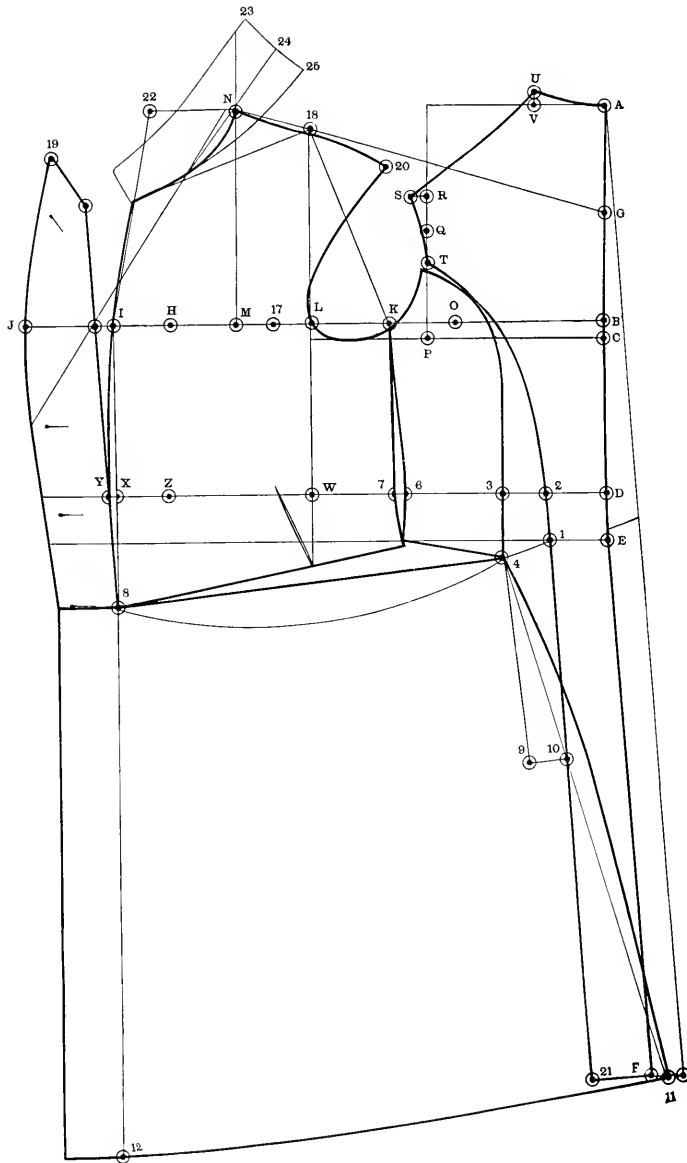

THREE BUTTON DOUBLE BREASTED FROCK

THREE BUTTON DOUBLE BREASTED FROCK For Stout Figure

The measurements by which this draft is produced are as follows:

Seye depth,	9 $\frac{1}{2}$ inches	Strap,	13 $\frac{1}{4}$ inches
Natural waist,	17 inches	Over shoulder,	15 $\frac{1}{4}$ inches
Fashionable waist	19 inches	Blade,	13 $\frac{1}{2}$ inches
Full length,	42 inches	Breast,	40 inches
	Waist,	40 inches	

Square lines A—V and A—E.

A to B is 9 $\frac{1}{2}$ inches; B to C is $\frac{3}{4}$ inch; A to D is 17 inches; A to E is 10 inches; A to F is 42 inches.

Square out from B, C, D, E and F. G is half way between A and B.

B to H is half of full breast, 20 inches. H to I is 2 $\frac{1}{2}$ inches.

K is half way between B and H. K to L is 3 $\frac{1}{2}$ inches. Square down from I and L.

Apply blade measure from B to L. Square up from L.

L to M is $\frac{1}{4}$ the distance from A to B, 10 on 6th division. Square up from M.

O is half way between B and L. O to P is 1 $\frac{1}{4}$ inches. Square up from P.

P to Q is $\frac{1}{4}$ breast. Q to R is 1 $\frac{1}{4}$ inches. Q to T is the same.

Square out from R. R to S is $\frac{3}{4}$ inch.

A to V is $\frac{3}{4}$ inch more than $\frac{1}{2}$ breast. Square up from V. V to U is $\frac{5}{8}$ inch. Draw a line from V to S.

E to I is $\frac{1}{4}$ inch more than $\frac{1}{2}$ breast. I to 21 is the same as E to I. Shape the back.

Measure back A to U, apply to L and up to N, strap measure 13 $\frac{1}{4}$ plus $\frac{1}{4}$ inch, 13 $\frac{3}{4}$ inches.

Draw a line from N to G. Square forward from N.

N to 22 is $\frac{1}{4}$ inch more than $\frac{1}{2}$ breast. Draw a line from 22 to I. 17 is half way between L and M. Sweep from 18 to 20, pivoting at 17.

N to 20 is $\frac{1}{4}$ inch less than from U to S.

Shape shoulder and armseye.

Place a square on K and 18, square forward for gorge. 2 to 3 is 1 $\frac{1}{4}$ inches. 3 to 6 is $\frac{1}{4}$ waist. W to X is $\frac{1}{2}$ waist. X to Y is $\frac{1}{4}$ inch; Y back to Z is 2 $\frac{1}{2}$ inches.

Measure waist from 2 to D and from Z to 3.

There being nothing left to take out, omit the fish and take out $\frac{1}{2}$ inch instead between 6 and 7.

Shape the side body, reducing it $\frac{1}{4}$ inch at T and $\frac{1}{4}$ inch at blade line.

Sweep from 1 to 4, pivoting at T.

Sweep from 4 to 13, pivoting at 1 inch back from N. Draw a line from 13 to side of front and shape bottom of side body.

From 8 to 14 is 1 inch less than $\frac{1}{2}$ waist. Take out $\frac{1}{4}$ inch V at 14. Draw a line from 1 through 14 to 8.

THE REVER

Draw a line parallel with N—I, make the width of the rever 2 $\frac{1}{2}$ inches at 8, 3 $\frac{1}{2}$ inches at J, and 2 $\frac{1}{4}$ inches at 10.

THE SKIRT

Square down from 4. 4 to 9 is 9 inches. 9 to 10 is 1 $\frac{1}{2}$ inches. Draw a line from 4 through 10 to 11. 4 to 11 is the same as 1 to 21.

Square down front of skirt by waist line. 8 to 12 is the same as 4 to 11.

Draw a line from 12 to 14. Round the skirt $\frac{3}{8}$ inch at 10. Cut out the back.

Place point U on point N. Get over-shoulder measure from G through 18 to L, plus $\frac{1}{4}$ inch, 15 $\frac{1}{4}$ inches. Sweep to 20 and reshape shoulder.

THE COLLAR

Draw a line from crease through N to 24. N to 21 is the same as A to U.

24 to 27 is 1 $\frac{1}{4}$ inches. 24 to 23 is 2 inches. Shape collar as represented.

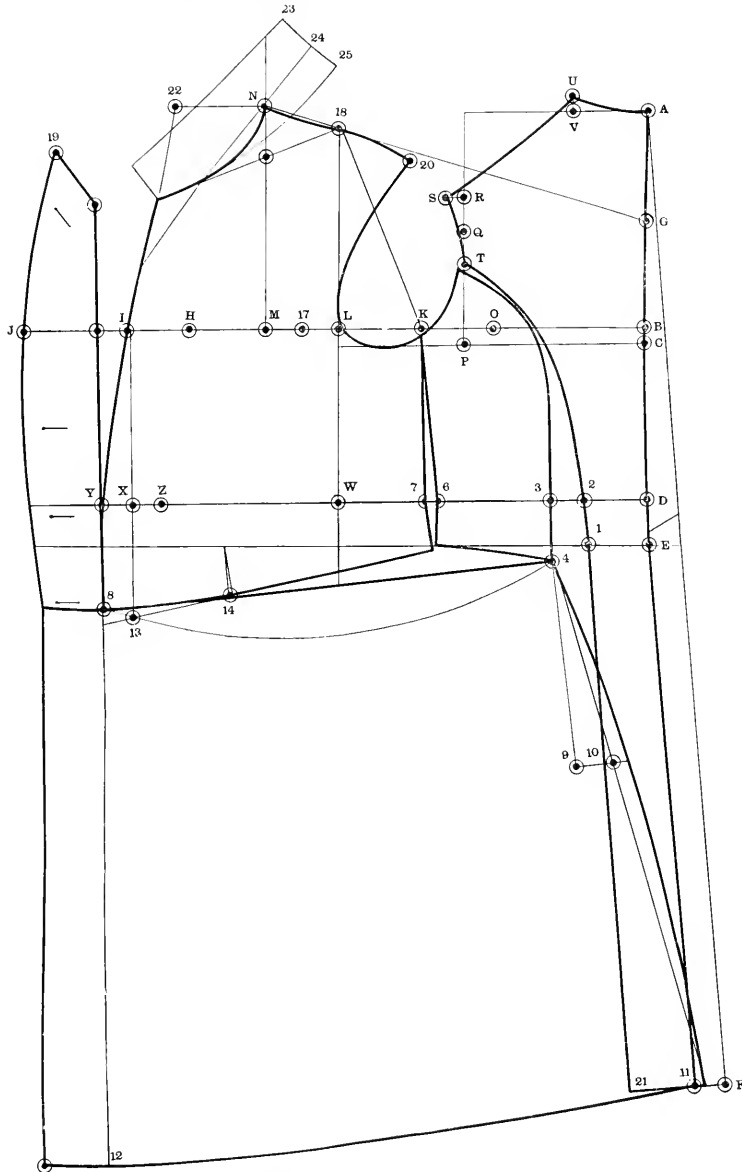

DOUBLE BREASTED FROCK FOR STOUT FIGURE

THREE BUTTON DOUBLE BREASTED FROCK For Corpulent Figure

The measurements by which this draft is produced are as follows:

Seye depth,	9½ inches	Strap,	13¼ inches
Natural waist,	17 inches	Over shoulder,	15¼ inches
Fashionable waist	19 inches	Blade,	13½ inches
Full length,	42 inches	Breast,	40 inches
	Waist,	42 inches	

Square lines A—V and A—E.

A to B is 9½ inches; B to C is ¾ inch; A to D is natural waist, 17 inches; A to E is fashionable waist, 19 inches; A to F is full length. Square out from B, C, D, E and F. G is half way between A and B. B to 22 is half of full breast, 20 inches. K is half way between B and 22. K to 26 is 3¼ inches. Square down from 26.

For every inch that the waist is larger than the breast advance ¼ inch from 26 to L. In this case, where the waist is two inches larger than the breast, the distance between 26 and L is ½ inch. Square down from L.

Advance the same, ½ inch, from 22 to 21. From 21 to I is 2½ inches. Square down from I. Apply blade measure from B to 26, 13½ inches. Add ½ inch to L and square up. L to M is ¼ the distance from A to B. Square up from M.

O is half way between B and 26. O to P is 1¼ inches. Square up from P.

P to Q is ¼ breast. Q to R is 1½ inches. Q to T is the same.

Square out from R. R to S is ¾ inch.

A to V is ¾ inch more than ¼ breast. Square up from V. V to U is ½ inch. Draw a line from V to S. E to 1 is ¼ inch more than ¼ breast. Shape back.

2 to 3 is 1¼ inches. 3 to 6 is ¼ waist.

Measure back A to U, apply to L and up to N, strap measure 13¼ plus ¼ inch, 13½ inches.

Draw a line from N to G. Square forward from N. N to 32 is ½ inch more than ¼ breast. Draw a line from 32 to I. 17 is half way between L and M. Sweep from 18 to 20, pivoting at 17. N to 20 is ¼ inch less than from U to S.

Place a square on K and 18, square forward for gorge. Shape gorge, shoulder and armseye. W to X is ½ waist. X to Y is ¼ inch. Y back to Z is 2½ inches.

Measure waist from 2 to D and from Z to 3.

There being nothing left to take out, omit the fish and take out ½ inch instead between 6 and 7. Shape the side body, reducing it ¼ inch at T and ¼ inch at blade line.

Sweep from 1 to 4, pivoting at T. Sweep from 4 to 14, pivoting at a point 1 inch back from N. Draw a line from 14 to the side of front.

8 to 13 is 1 inch less than ¼ waist. Cut out ¼ inch V at 13.

Draw a line from 4 through 13 to 8. Shape the bottom of side body.

Between the front and side body at K take out the ½ inch that has been advanced between 26 and L.

THE REVER

Draw a line parallel with I—N.

Make the width of the rever 2¾ inches at 8; 3½ inches at J; and 2¾ inches from X to 19.

THE SKIRT

Square down from 4 to 9. From 4 to 9 is 9 inches. From 9 to 10 is 1½ inches.

Draw a line from 4 through 10 to 11. 4 to 11 is ¼ inch more than from E to F. 8 to 12 is the same as from 4 to 11. Square down front of skirt by waist line.

Draw a line from 12 to 11 and finish skirt, rounding it ½ inch at 10.

THE COLLAR

Draw a line from 31 through N to 28. N to 28 is the same as A to U. Square down from 28. 28 to 29 is 1¼ inches. 28 to 27 is 2 inches. Finish collar as represented.

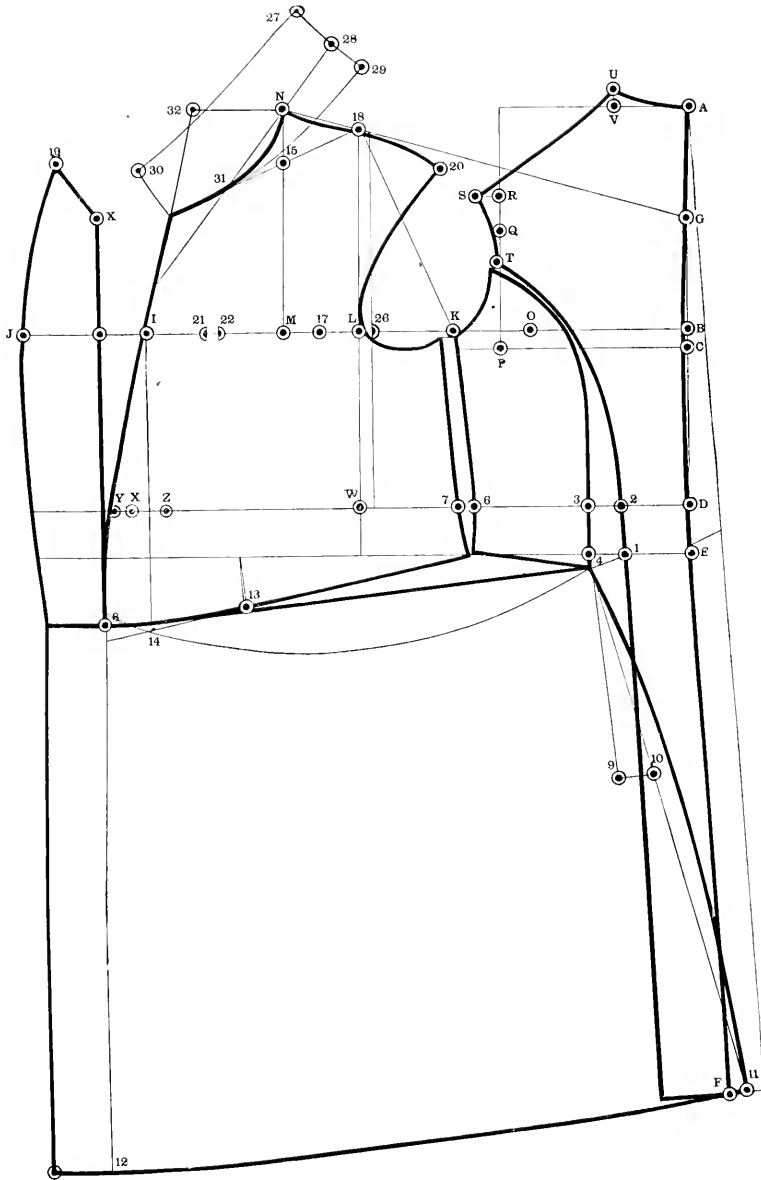

DOUBLE BREASTED FROCK FOR CORPULENT FIGURE

TUXEDO COAT

The measurements by which this draft is produced are as follows:

Scye depth,	9 $\frac{3}{4}$ inches	Over shoulder,	14 $\frac{3}{4}$ inches
Waist,	17 inches	Blade,	13 $\frac{1}{4}$ inches
Full length,	30 inches	Breast,	39 inches
Strap,	13 inches	Waist,	35 inches
		Hip,	40 inches

Square lines A—F and A—U.

From A to B is 9 $\frac{3}{4}$ inches; from B to C is $\frac{3}{4}$ inch; from A to D is 17 inches; from A to E is 23 inches; to F is 30 inches.

Square out from B, C, D, E and F. G is half way between A and B.

At D go in $\frac{1}{2}$ inch, draw a line up to G and down to E.

From the line inside of B to H is half of full breast, 19 $\frac{1}{2}$ inches. H to I is 2 $\frac{1}{2}$ inches.

Square down from I.

J is half way between B and H. From J to K is 3 $\frac{1}{2}$ inches. Square down from K.

Apply the blade measure from B to K, 13 $\frac{1}{4}$ inches. Square up from K.

From K to L is $\frac{1}{2}$ the distance from A to B.

Square up from L. M is half way between K and L.

P is half way between B and K; P to Q is 1 $\frac{1}{4}$ inches; square up from Q.

From Q to R is $\frac{1}{4}$ breast; from R to S is 1 $\frac{1}{2}$ inches; square out from S. S to T is $\frac{3}{4}$ inch.

From A to U is $\frac{3}{4}$ inch more than $\frac{1}{2}$ breast. Square up from U; U to V is $\frac{3}{8}$ inch. Draw a line from V to T.

Shape back.

Measure distance A to V, apply to K and up to N, strap measure plus $\frac{1}{4}$ inch, 13 $\frac{1}{4}$ inches.

Draw a line from N to G to get X; square forward from N.

Place the square at J and X and square forward through O for gorge.

Sweep from X to Y, pivoting at M. From X to Y is $\frac{1}{4}$ inch less than from V to T.

Shape the gorge shoulder and armseye.

From Z to 3 is 1 $\frac{1}{4}$ inches more than $\frac{1}{2}$ waist; from 3 back to 2 is 3 $\frac{1}{2}$ inches. Square down from 2 to get 8.

Measure hip from 9 to E and from 8 to 10, 20 plus $\frac{1}{2}$ inch, 20 $\frac{1}{2}$ inches.

Measure waist from 7 to the line inside of D and 2 to 6, 17 $\frac{1}{2}$ plus 1 inch, 18 $\frac{1}{2}$ inches.

Shape the side of front, reducing it $\frac{1}{2}$ inch at Q. Sweep from 12 to 15 pivoting at N.

THE COLLAR

The break of the roll is 1 $\frac{1}{4}$ inches above the pocket. Draw a line from the break to a point $\frac{1}{2}$ inch outside of N to 24. From N to 24 is the same distance as from A to V. Square down from 24. 24 to 25 is 1 $\frac{1}{4}$ inches. From 24 to 23 is 1 $\frac{3}{4}$ inches. Draw a line from 23 to 3 and finish as represented.

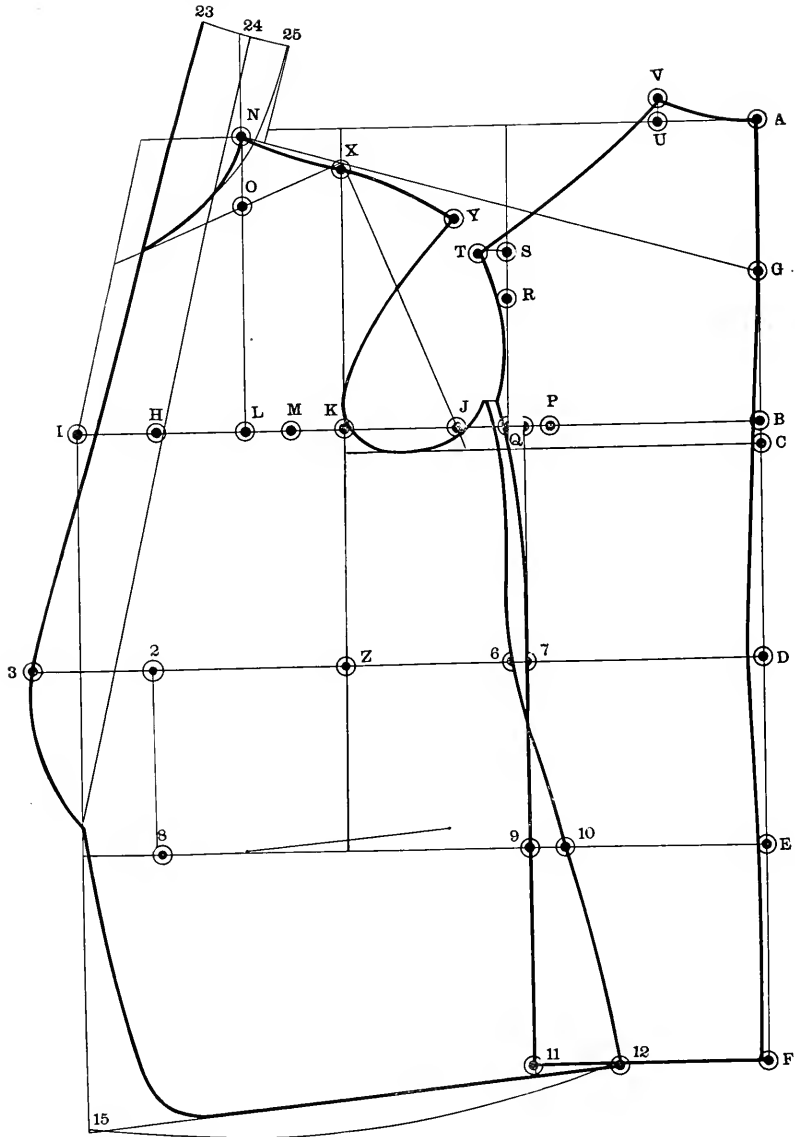

TUXEDO COAT, SHAWL COLLAR

TUXEDO COAT, PEAKED LAPEL

The measurements by which this draft is produced are as follows:

Scye depth,	9½ inches	Over shoulder,	14½ inches
Waist length,	17 inches	Blade,	13 inches
Seat,	23 inches	Breast,	38 inches
Full length,	30 inches	Waist,	34 inches
Strap,	12¾ inches	Seat,	39 inches

Square lines A—U and A—F.

A to B is the scye depth, 9½ inches; B to C is ¾ inch; A to D is 17 inches; A to E is 23 inches; A to F is full length, 30 inches.

Square out from B, C, D, E and F. G is half way between A and B.

At D go in ½ inch. Draw a line up to G and down to F.

From the line inside of B to H is half of full breast, 19 inches. H to I is 2½ inches; square down from I.

J is half way between B and H. J to K is 3½ inches; square down from K.

Apply the blade measure from B to K 13 inches. Square up from K.

From K to L is ½ the distance from A to B. Square up from L. M is half way between K and L.

P is half way between B and K. P to Q is 1¼ inches. Square up from Q.

From r to R is ¼ breast; from R to S is 1½ inches. Square out from S. S to T is ¾ inch.

From A to U is ¾ inch more than ¼ breast. Square up from U. From U to V is ¾ inch. Draw a line from V to T. Shape the back.

Measure distance A to V, apply same to K and up to N, strap measure plus ¼ inch, 13 inches.

Draw a line from N to G to get X. Square forward from X. From X to W is ½ inch more than ¼ breast. Draw a line from W to L.

From X to O is ¼ breast. Draw a line from X through O for gorge.

Sweep from X to Y, pivoting at M. From X to Y is ¼ inch less than from V to T. Shape the gorge, shoulder and armseye.

From Z to 2 is ¼ inch more than ½ waist. From 2 back to 3 is 2½ inches. 8 is 2½ inches back from front edge.

Measure back 9 to E, apply to 8 and back to 10, seat measure plus ½ inch.

Measure 7 to line inside of D, apply to 3 and back to 6, waist measure plus 1 inch, 18 inches. Shape the side of forepart reducing it ½ inch at Q.

Sweep from 12 forward, pivoting at N. Finish as represented.

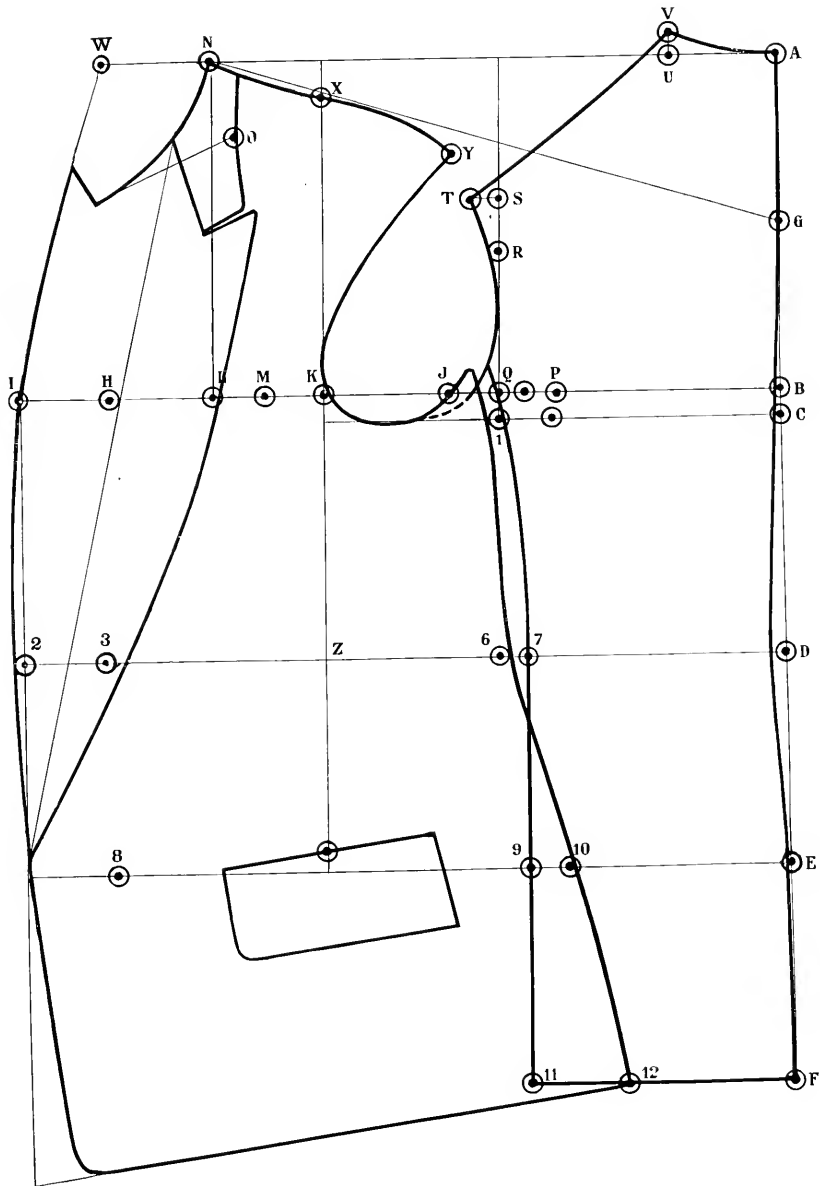

TUXEDO COAT, PEAKED LAPEL

FULL DRESS COAT, SHAWL COLLAR

The measurements by which this draft is produced are as follows:

Sye depth,	9 inches	Strap,	12 inches
Natural waist,	16½ inches	Over shoulder,	13½ inches
Fashionable waist,	18½ inches	Blade,	12½ inches
Full length,	40 inches	Breast,	36 inches
Waist,	32 inches		

Square lines A—U and A—E.

From A to B is the sye depth, 9 inches; from B to C is $\frac{3}{4}$ inch; from A to D is natural waist, 16½ inches; A to E, fashionable waist, is 18½ inches; A to F, full length, is 40 inches.

Square out from B, C, D, E and F. G is half way between A and B.

From B to H is half of full breast, 18 inches. From H to I is 1½ inches.

K is half way between B and H. K to L is 3½ inches. Square down from L.

Apply the blade measure from B to L, 12½ inches. Square up from L.

O is half way between B and L. From O to P is 1¼ inches. Square up from P.

From P to Q is $\frac{1}{4}$ breast. Q to R is 1½ inches. Q to T is the same. From E to I is $\frac{1}{4}$ inch more than $\frac{1}{8}$ breast. F to T is the same as E to I. Draw a line from I to T. From A to U is $\frac{3}{4}$ inch more than $\frac{1}{4}$ breast. Square up from U. U to V is $\frac{3}{8}$ inch. Draw a line from U to S. Finish as represented.

From L to M is $\frac{1}{3}$ the distance from A to B. 17 is half way between L and M. Square up from M.

Measure distance A to V, apply same to L and up to N, strap measure 12, plus $\frac{1}{4}$ inch, 12¼ inches.

Draw a line from N to G to get 18. Sweep from 18 to 20, pivoting at 17. Square forward from N. From N to 24 is $\frac{1}{2}$ inch less than $\frac{1}{6}$ breast. Draw a line from 24 to 1.

From N to 19 is $\frac{1}{4}$ breast. Draw a line from 18 through 19 for gorge. From N to 20 is $\frac{1}{4}$ inch less than from V to S. Shape the gorge, shoulder and armseye.

From 2 to 3 is 1¼ inches. From 3 to 6 is $\frac{1}{4}$ waist. From W to X is 2¼ inches less than $\frac{1}{2}$ waist. X to Y is 1¼ inches.

Measure waist from 2 to D and X to 3 and take out balance between 6 and 7.

Sweep from 1 to 4, pivoting at T. Sweep from 4 to 16, pivoting at a point 1 inch back from N. From 16 to 8 is $\frac{3}{8}$ inch. Draw lines from K to 6 and K to 7.

Shape the side body, reducing it $\frac{1}{4}$ inch at T and $\frac{1}{4}$ inch at blade line.

Shape bottom of front from 8 to waist line.

THE SKIRT

Square down from 3 to 9. From 3 to 9 is 6 inches. Square out from 9. 9 to 10 is 1½ inches. Draw a line from 4 through 10 to 11. From 4 to 11 is the same as from 1 to 21. Shape the top of skirt. From 16 to 13 is 1¼ inches. From 13 to 14 is $\frac{1}{3}$ the distance from 16 to 4. From 11 to 12 is the same as from 13 to 14. Draw a line from 14 to 12.

Finish the skirt, rounding it $\frac{3}{8}$ inch at 10.

THE REVER AND COLLAR

Draw a straight line from 24 through I to the waist. Make the width of the rever at the waist 1¾ inches and 2 inches from I to J. Draw the shawl crease through X to 25.

From X to 25 is the same as from A to V. Square down from 25. 25 to 26 is 1¼ inches. From 25 to 15 is 1¾ inches. Draw a line from 15 to J and shape as represented.

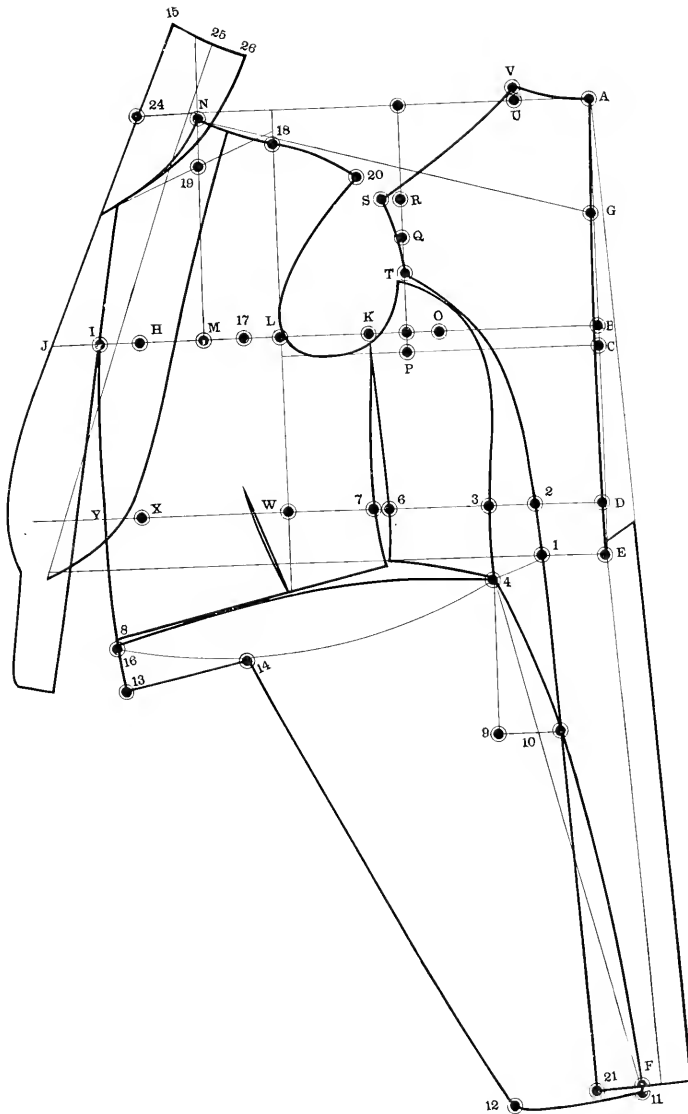

FULL DRESS COAT, SHAWL COLLAR

FULL DRESS COAT, PEAKED LAPEL

The measurements by which this draft is produced are as follows:

Seye depth,	$9\frac{1}{2}$ inches	Strap,	$12\frac{1}{2}$ inches
Natural waist,	$16\frac{1}{2}$ inches	Over shoulder,	$14\frac{1}{4}$ inches
Fashionable waist,	$18\frac{1}{2}$ inches	Blade,	13 inches
Full length,	40 inches	Breast,	38 inches
Waist,	34 inches		

Square lines A—C and A—E.

A to B is seye depth, $9\frac{1}{2}$ inches; B to C is $\frac{3}{4}$ inch; A to D is natural waist, $16\frac{1}{2}$ inches; A to E is fashionable waist, $18\frac{1}{2}$ inches; A to F is full length, 40 inches.

Square out from B, C, D, E and F. G is half way between A and B.

B to H is half of full breast, 19 inches. H to I is $1\frac{1}{2}$ inches.

K is half way between B and H; K to L is $3\frac{1}{2}$ inches. Square down from L.

Apply the blade measure from B to L, 13 inches. Square up from L. L to M is $\frac{3}{4}$ the distance from A to B. N is half way between L and M. O is half way between B and L. O to P is $1\frac{1}{4}$ inches.

Square up from P. P to Q is $\frac{1}{4}$ of breast measure. Q to R is $1\frac{1}{2}$ inches. Q to T the same.

Square out from R; R to S is $\frac{3}{4}$ inch.

A to U is $\frac{3}{4}$ inch more than $\frac{1}{4}$ of breast measure. Square up from U. U to V is $\frac{5}{8}$ inch. Draw a line from U to S.

E to T is $\frac{1}{4}$ inch more than $\frac{1}{4}$ breast measure, F to 21 is the same as E to T. Draw a line from T to 21. Shape the back.

Measure back A to V, apply to L and up to N, strap measure plus $\frac{1}{4}$ inch, $12\frac{3}{4}$ inches.

Draw a line from N to G; square forward from N. N to 24 is $\frac{1}{2}$ inch less than $\frac{1}{4}$ of breast measure; draw a line from 24 to L. N to 19 is $\frac{1}{4}$ of breast measure.

Draw a line from 18 through 19 for gorge.

Sweep from 18 to 20, pivoting at 17; N to 20 is $\frac{1}{4}$ inch less than V to S.

Shape gorge, shoulder and armseye.

From 2 to 3 is $1\frac{3}{4}$ inches. 3 to 6 is $\frac{1}{4}$ of waist measure.

From W to X is $2\frac{1}{4}$ inches less than $\frac{1}{2}$ of waist measure. X to front edge is 1 inch.

Draw a line from 24 through 1 and 8.

Measure back 2 to D and X to 3. Take out balance between 6 and 7.

Shape the side body, reducing it $\frac{1}{4}$ inch at T and $\frac{1}{4}$ inch at blade line.

Sweep from 1 to 4, pivoting at T.

Sweep from 4 to 16, pivoting at a point 1 inch back from N.

From 16 to 8 is $\frac{3}{4}$ inch. Draw a line from 8 to the side of forepart.

THE REVER

Draw a line parallel with 1—8.

Make the width of the rever $1\frac{3}{4}$ inches at 8, $2\frac{1}{2}$ inches at J and $2\frac{1}{4}$ inches at 15.

THE SKIRT

Square down from 3 to 9. 3 to 9 is 9 inches. Square out from 9. 9 to 10 is $1\frac{1}{2}$ inches.

Draw a line from 1 through 10 to 11. From 1 to 11 is the same as from 1 to 21. Shape the top of skirt.

From 16 to 13 is $1\frac{3}{4}$ inches.

From 13 to 14 is $\frac{1}{4}$ the distance from 16 to 4. 11 to 12 is the same as 13 to 14.

Draw a line from 14 to 12.

Finish skirt, rounding it $\frac{1}{2}$ inch at 10. Cut out the back, and place point V on point N.

Get the over-shoulder measure from G through 18 to L, plus $\frac{1}{4}$ inch, $14\frac{1}{2}$ inches. Re-shape shoulder.

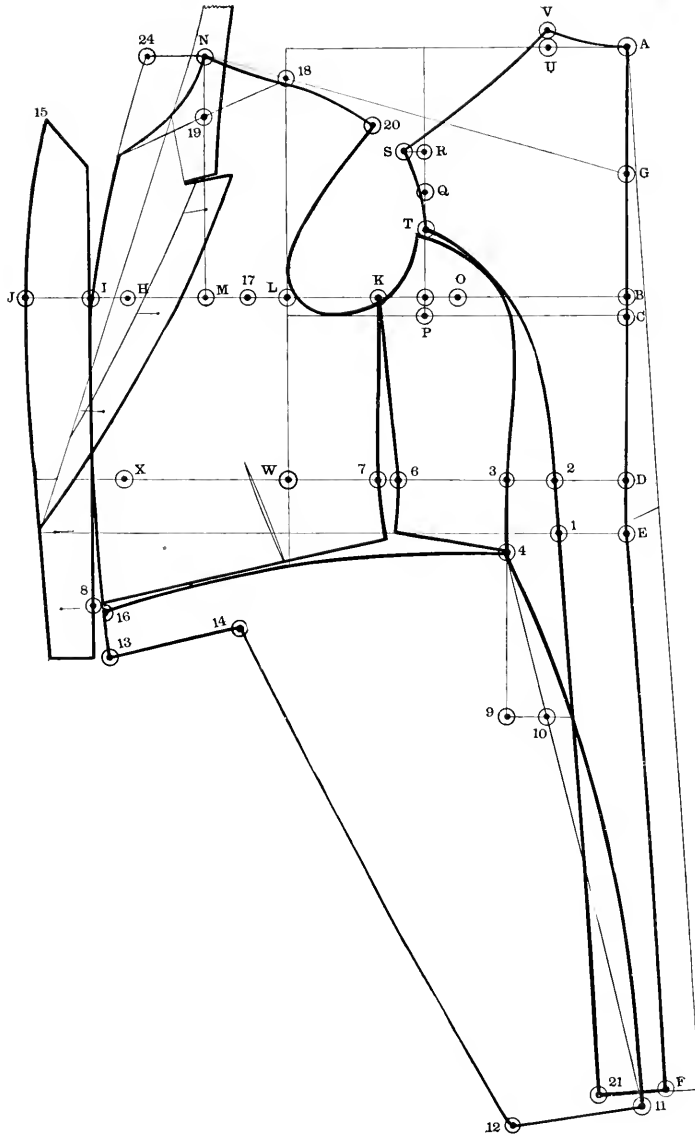

FULL DRESS COAT

A FEW WORDS IN REGARD TO WAIST SUPPRESSION

In order to get the proper amount of blade pocket, or roundness over the blade bone, we herewith place 3 different diagrams for 3 different figures, namely, the normal, the flat back and the round blade to show how the waist suppression changes the blade fullness.

DIAGRAM A

The measurements of this draft are:

Blade,	13 inches
Breast,	38 inches
Waist,	34 inches

This blade is considered normal for the breast measure as it leaves the distance from L to J $9\frac{1}{2}$ inches, or $\frac{1}{4}$ breast. The distance from 2 to 3 is $1\frac{3}{4}$ inches.

Cut out the back and place point O to side body and point I to 4, and the distance from 28 to 29 over-lapped is $\frac{3}{4}$ inch.

FULL BREAST—FLAT BACK

DIAGRAM B

Blade,	12½ inches
Breast,	38 inches
Waist,	34 inches

The distance from 27 to J is 10 inches, showing the person to be full breasted with flat back, in which case proceed as follows:

From 2 to 5 is 1¾ inches; from 27 to L is ½ inch; take out ½ of that distance, ¼ inch, and place it from 5 to 3.

The distance from 6 to 7 will be ¾ inch; cut out the back and place point T to side body and point I to 4, and the distance from 28 to 29 over-lapped is a little less than ½ inch, thus showing a small blade pocket.

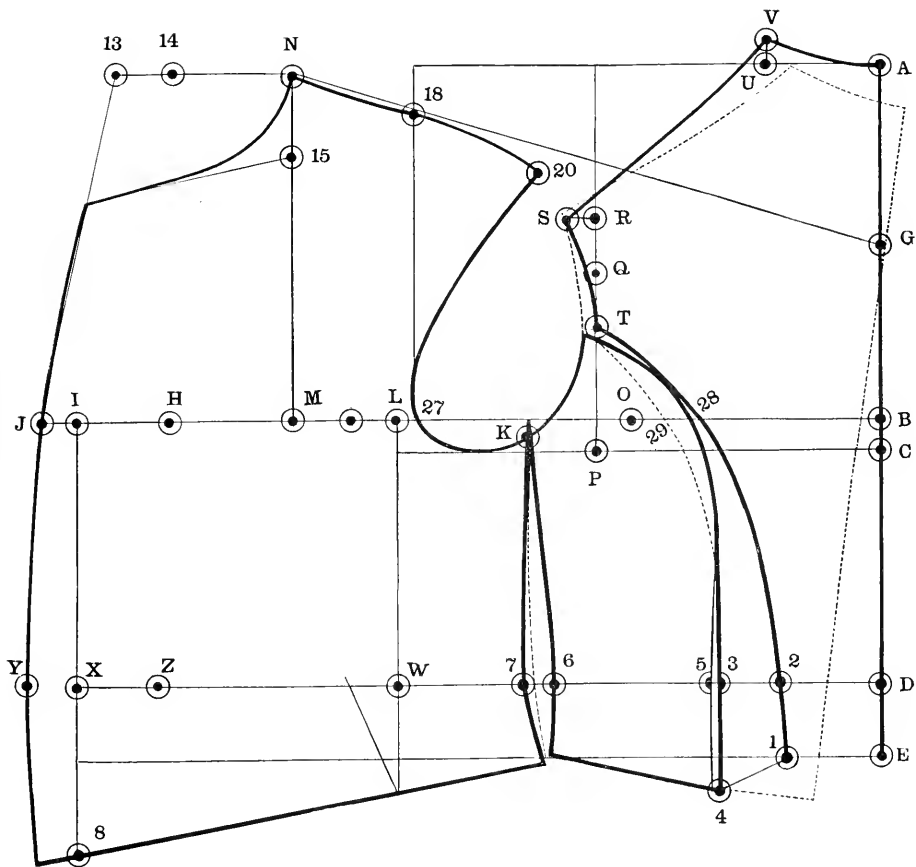

DIAGRAM B
FULL BREAST, FLAT BACK

FULL BACK—FLAT BREAST

DIAGRAM C

Blade measure from B to 26 is $13\frac{1}{2}$ inches.

Breast, 38 inches

Waist, 34 inches

The distance from 26 to J is 9 inches, showing the person to be full backed and flat breasted.

Proceed as follows:

From 2 to 3 is $1\frac{3}{4}$ inches.

From L to 26 is $\frac{1}{2}$ inch.

Take $\frac{1}{4}$ inch off from 3 to 5, which is $\frac{1}{2}$ the distance from L to 26, and take out balance of waist between 6 and 7.

Cut out the back and place point T to sidebody and point I to 4 and the distance from 28 to 29 over-lapped is $\frac{3}{4}$ inch, showing a large blade pocket.

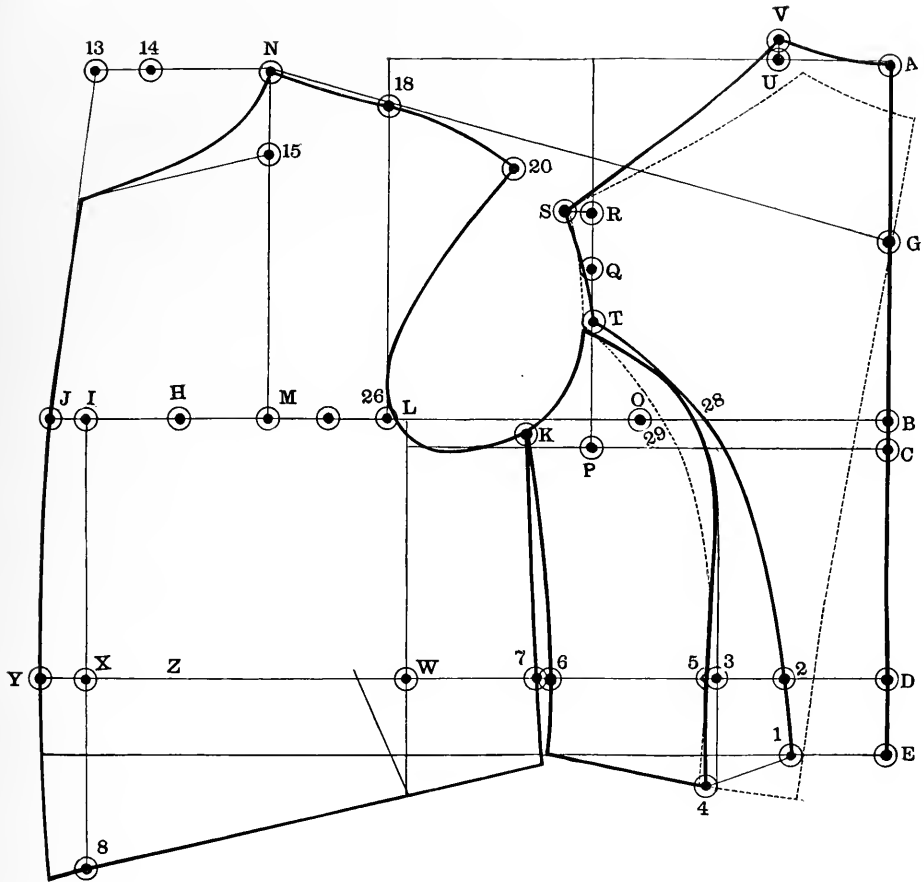

DIAGRAM C
FULL BACK, FLAT BREAST

CHESTERFIELD OVERCOAT

The measurements by which this draft is produced are as follows:

Scye depth,	9½ inches	Over shoulder,	14½ inches
Waist length,	17 inches	Blade,	13 inches
Full length,	42 inches	Breast,	38 inches
Strap,	12¾ inches	Waist,	34 inches
		Hip,	39 inches

Add 3 inches to the breast and waist measures and ¾ inch over short measures.

Square lines A—U and A—F.

From A to B is 10½ inches; B to C is ¾ inch; from A to D is 17 inches; A to E is 23 inches; A to F, full length, is 42 inches. G is half way between A and B.

Square out from B, C, D, E and F.

From B to H is half of full breast, 20½ inches.

H to 4 is 2½ inches; 4 to I is 2 inches. Square down from 4 and I.

J is half way between B and H. J to K is 3½ inches. Square down from K.

Apply the blade measure from B to K, 13 plus ¾ inch, 13¾ inches. Square up from K.

From K to L is ¼ the distance from A to B. Square up from L. M is half way between K and L.

P is half way between B and K. P to Q is 1½ inches. Square up from Q.

From Q to R is ¼ breast. R to S is 1½ inches. Square out from S. S to T is ¾ inch. From A to U is ¾ inch more than ¼ breast. Square up from U.

U to V is ¾ inch. Draw a line from V to T. Shape the back.

Measure distance from A to V, apply same to K and up to N, strap measure 12¾ plus 1 inch, 13¾ inches.

Draw a line from N to G to get X.

Square forward from N. From N to 14 is ¼ breast. 14 to 13 is 2½ inches. Draw a line from 13 to 1.

From N to O is ¼ breast. Square forward from O by M.

Sweep from N to Y, pivoting at M. From N to Y is ¼ inch less than from V to T. Shape the gorge, shoulder and armscye.

From Z to 5 is ½ waist. From 5 to 3 is 2¼ inches. From 3 back to 2 is 4½ inches. 8 is 4½-inches back from the front edge. Shape the front.

Measure back from 10 to E, apply same to 8 and back to 10, seat measure, 21 plus ½ inch, 21½ inches. From 10 to 9 is 1¾ inches. Square up from 9 to 6. Draw a line from 6 through 10 to 12.

Shape the side of front reducing it ¼ inch at Q. Sweep from 11 to 12, pivoting at J.

Sweep from 12 to 15, pivoting at X.

THE COLLAR

Draw a line from the lapel crease through N to 21. N to 21 is the same distance as from A to V. Square down from 21. From 21 to 22 is 1¼ inches. 21 to 20 is 2¼ inches. Finish as represented.

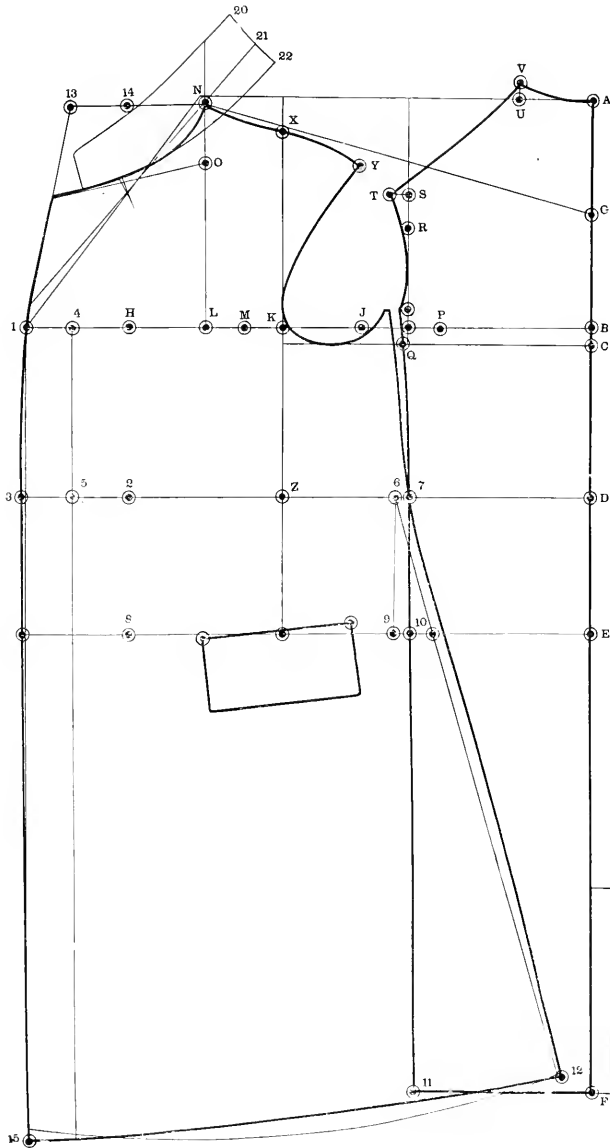

CHESTERFIELD OVERCOAT

TOP COAT

The measurements by which this draft is produced are as follows:

Scye depth,	9½ inches	Over shoulder,	14¾ inches
Waist length,	17 inches	Blade,	13¼ inches
Full length,	35 inches	Breast,	39 inches
Strap,	13 inches	Waist,	35 inches

Add 3 inches to the breast and waist measures and ¾ inch to the short measures.

Square lines A—U and A—F.

From A to B is 10½ inches; B to C is ¾ inch; A to D is 17 inches; A to E is 23 inches; A to F is 35 inches.

G is half way between A and B.

Square out from B, C, D, E and F.

From B to H is half of full breast, 21 inches.

H to I is 4½ inches. Square down from I. J is half way between B and H. J to K is 3½ inches. Square down from K.

Apply the blade measure from B to K, 13¼ plus ¾ inch, 14 inches; square up from K.

From K to L is ½ the distance from A to B. Square up from L.

P is half way between B and K. P to Q is 1½ inches.

Square up from Q. Q to R is ¼ breast. R to S is 1½ inches. Square out from S. S to T is ¾ inch.

A to U is ¾ inch more than ¼ breast. Square up from U. U to W is ½ inch. Draw a line from W to T.

Shape the back.

Measure distance A to W, apply same to K and up to M, strap measure 13 plus 1 inch, 14 inches.

Draw a line from M to G to get 22.

Square forward from M. M to 12 is ¼ breast; 12 to 11 is 2½ inches. Draw a line from 11 to I.

From M to N is ½ breast. O is half way between K and L. Square forward from N by O.

Sweep from 22 to O, pivoting at O. From M to O is ¼ inch less than W to T. Shape the gorge, shoulder and armseye.

V is where the armseye crosses line B. Square down from V to X; from V to X is 12 inches.

Square out from X. From X to Z is 3 inches.

From X to Y is ½ inch. Draw lines from V through Y and from V through Z.

From V to J is as much extra back as you wish to add to a box coat, from ½ inch to 1½ inches. Reshape back as from broken to solid lines.

From V to 2 is the same length as from J to 1. Sweep from 2 to 7, pivoting at M.

From 10 to 9 is ½ waist; from 9 to 8 is 2¼ inches. Finish the front.

THE COLLAR

Draw a line from lapel crease through M to 14. M to 14 is the same as from A to W. Square down from 14. 14 to 15 is 1¼ inches. 14 to 13 is 2¼ inches. Finish as represented.

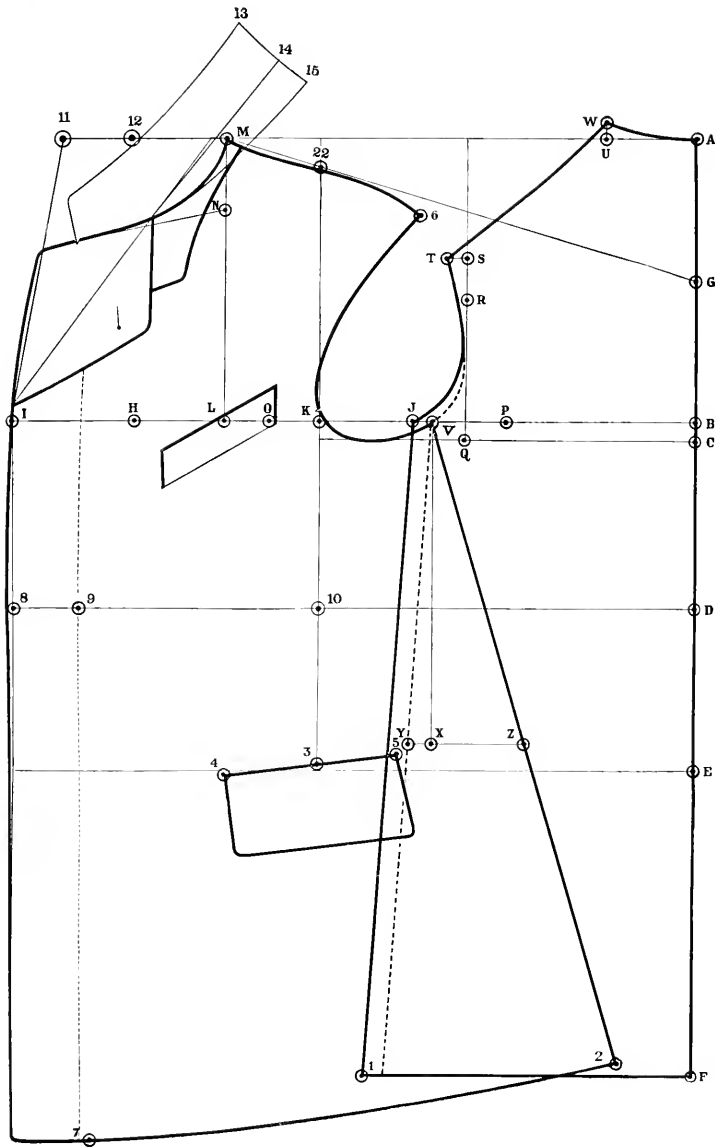

TOP COAT

FULL BOX OVERCOAT

The measurements by which this draft is produced are as follows:

Seye depth,	9½ inches	Over shoulder,	14½ inches
Waist length,	17 inches	Blade,	13 inches
Full length,	50 inches	Breast,	38 inches
Strap,	12¾ inches	Waist,	32-36 inches

Add 3 inches to breast and waist measures, and ¾ inch over all short measures. Square lines A—U and A—F.

A to B is 10¼ inches; B to C is ¾ inch; A to D is 17 inches; A to F is 50 inches. Square out from B, C, D and F; G is half way between A and B.

B to H is half of full breast, 20½ inches.

H to I is 2½ inches; I to J is 2 inches.

Square down from I and J.

W is half way between B and H; W to K is 3½ inches; square down from K.

Apply the blade measure from B to K, plus ¾ inch, 13¾ inches.

Square up from K; K to L is ½ the distance from A to B, 20½ on 6th division.

P is half way between B and K.

P to Q is 1½ inches.

Square up from Q; Q to R is ¼ breast. R to S is 1½ inches.

Square out from S; S to T is ¾ inch.

A to U is ¾ inch more than ¼ breast. Square up from U.

U to V is ¾ inch. Draw a line from V to T.

Measure back A to V, apply to K and up to O, strap measure plus 1 inch, 13¾ inches.

Draw a line from O to G. Square forward from O.

O to 12 is ¼ breast. 12 to 11 is 2½ inches. Draw a line from 11 to J.

M is half way between L and K. Sweep from 5 to 6, pivoting at M.

From O to 6 is ¼ inch less than V to T.

From O to X is ¼ breast. Square forward from X by M.

Shape gorge, shoulder and armseye.

4 is where the armseye crosses line B. Square down from 4 to X.

4 to X is 12 inches. Square out from X.

X to Z is 3½ inches. X to Y is ¾ inch.

Draw a line from 4 through Z to 2. Draw a line from 4 through Y to the bottom.

From 4 to W is as much extra back as you want to allow for a box coat, from ½ inch to 1¼ inches.

Draw a line from W to 1. Reshape back as represented.

10 to 9 is ½ waist. 9 to 8 is 2¼ inches. Shape the front.

Sweep from 1 to 2, pivoting at 4.

Sweep from 2 to 7, pivoting at O.

Shape bottom of front.

Cut out back and place point V on point O.

Get over-shoulder measure from G through 5 to K, 14½ inches, plus 1 inch, 15½ inches.

Reshape shoulder.

THE COLLAR

Draw a line from lapel crease through O to 14. O to 14 is the same as A to V. Square down from 14. 14 to 15 is 1¼ inches. 14 to 13 is 2¼ inches.

Shape collar as represented.

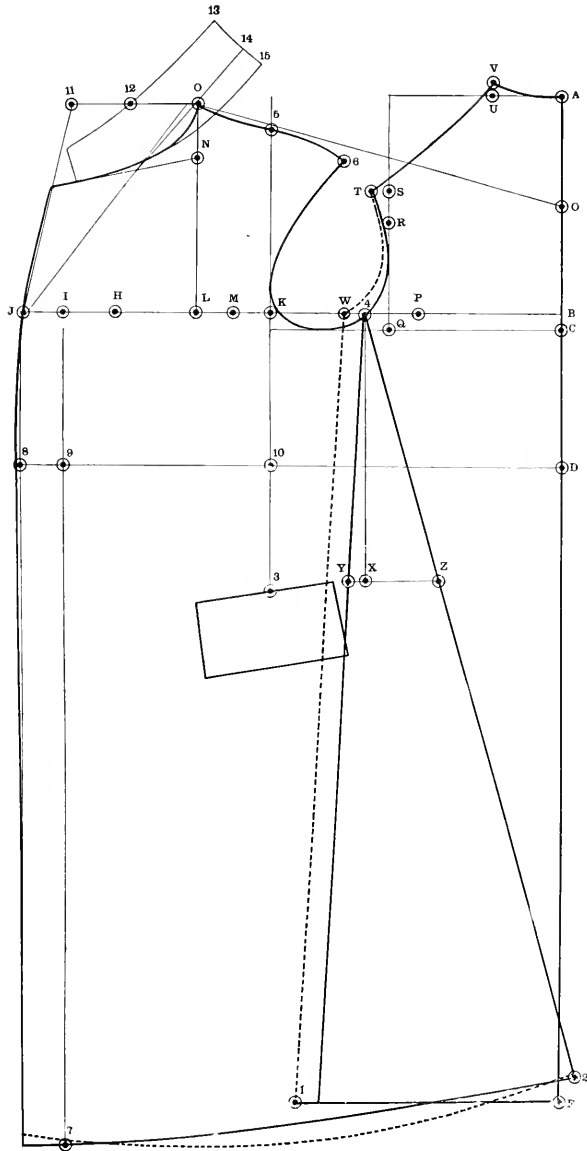

FULL BOX OVERCOAT

INVERNESS

The measurements by which this draft is produced are as follows:

Scye depth,	9 $\frac{1}{2}$ inches	Over shoulder,	14 $\frac{1}{2}$ inches
Waist length,	17 inches	Blade,	13 inches
Full length,	50 inches	Breast,	38 inches
Strap,	12 $\frac{3}{4}$ inches	Waist,	32-36 inches

Add 3 inches to breast and waist measure and $\frac{3}{4}$ inch to all short measures.

Square lines A—E and A—V.

A to B is 10 $\frac{1}{4}$ inches; B to C is $\frac{3}{4}$ inch; A to D is 17 $\frac{1}{2}$ inches; A to E is 50 inches.

Square out from B, C, D and E. F is half way between A and B.

B to G is half of full breast, 20 $\frac{1}{2}$ inches.

G to H is 4 $\frac{1}{2}$ inches. Square down from H.

I is half way between B and G. I to J is 3 $\frac{1}{2}$ inches. Square down from J.

Apply blade measure from B to J plus $\frac{3}{4}$ inch, 13 $\frac{3}{4}$ inches. Square up from J. J to K is $\frac{1}{2}$ the distance from A to B. Square up from K. L is half way between J and K.

P is half way between B and J. P to Q is 1 $\frac{1}{2}$ inches.

Square up from Q.

From Q to U is 1 inch. Q to R is $\frac{1}{4}$ breast measure.

R to S is 1 $\frac{1}{2}$ inches. Square out from S. S to T is $\frac{3}{4}$ inch.

A to V is $\frac{3}{4}$ inch more than 1 breast. Square up from V.

V to W is $\frac{5}{8}$ inch. Draw a line from V to T.

Square down from U to X. U to X is 12 inches.

Square out from X. X to Z is 3 $\frac{1}{2}$ inches.

X to Y is $\frac{3}{4}$ inch. Draw a line from U through Y to 10. Draw a line from U through Z to 11. From U to 11 is the same as from U to 10.

Shape back from A to W and from W through R to U.

Measure distance A to W, apply to J and up to M, strap measure plus 1 inch, 13 $\frac{3}{4}$ inches.

Draw a line from M to F. Square forward from M.

M to O is $\frac{1}{4}$ breast; O to 17 is 2 $\frac{1}{2}$ inches. Draw a line from 17 to H.

M to N is $\frac{1}{4}$ breast. Square forward from N by L. M to 1 is the same distance as from W to 36.

J to 6 is $\frac{1}{8}$ of the breast. Square out from 6.

From 7 to 8 is $\frac{1}{4}$ waist. 8 to 9 is 2 $\frac{1}{2}$ inches. Shape the front.

Sweep from 11 to 12, pivoting at M. Shape gorge, shoulder and armseye.

THE CAPE

Place a sheet of paper under the pattern and trace out as follows:

From 1 to M, around the gorge, to crease of lapel. Back from H is 2 $\frac{1}{4}$ inches and 9 to 8 is the same.

Measure the inside sleeve length from J to 4.

Sweep from 4 to 5, pivoting at M. Sweep from 4 to 3, pivoting at M. Extend line 1 through 2 and B to 3.

Finish as represented.

Nick the back at line 6.

THE COLLAR

Draw a line from H through M to 13. M to 13 is the same as A to W.

Square down from 13. From 13 to 15 is 1 $\frac{1}{4}$ inches.

From 13 to 14 is 2 inches.

Make the width of the collar at 16 two inches.

Draw a line from 14 to 16 and finish as represented.

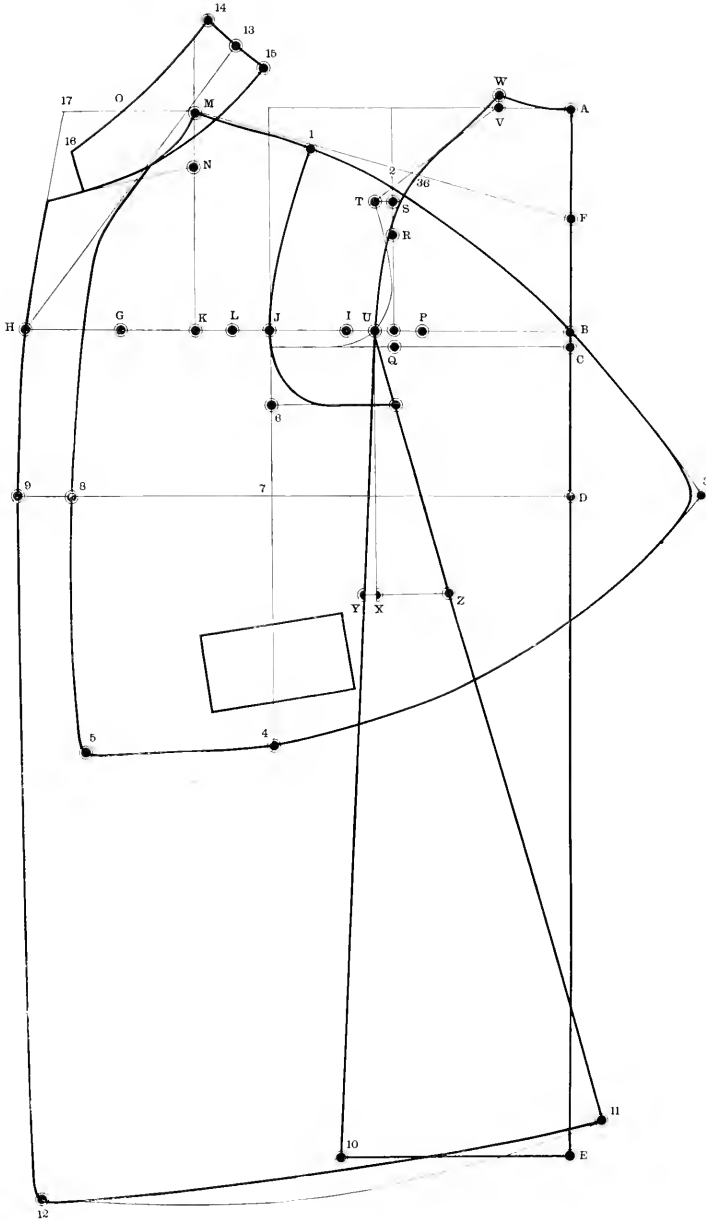

DOUBLE BREASTED ULSTER

The measurements by which this draft is produced are as follows:

Depth of seye,	10 inches	Over shoulder,	15 inches
Waist length,	17½ inches	Blade,	13½ inches
Full length,	48 inches	Breast,	40 inches
Strap,	13¼ inches	Waist,	36 inches
	Seat,	41 inches	

Add 3 inches over breast and waist and $\frac{3}{4}$ inch over all short measures.

Square lines A—U and A—F.

A to B is $10\frac{3}{4}$ inches; B to C is $\frac{3}{4}$ inch; A to D is $17\frac{1}{2}$ inches; D to E is 6 inches; A to F is full length, 48 inches.

Square out from B, C, D, E and F. G is half way between A and B.

B to H is half of full breast measure, $21\frac{1}{2}$ inches.

H to 4 is $2\frac{1}{2}$ inches. 4 to I is $4\frac{1}{2}$ inches.

Square down from 4 and I. J is half way between B and H. J to K is $3\frac{1}{2}$ inches. Square down from K.

Apply the blade measure from B to K, $13\frac{1}{2}$ plus $\frac{3}{4}$ inch, $14\frac{1}{4}$ inches.

Square up from K. K to L is $\frac{1}{3}$ the distance from A to B.

Square up from L. M is half way between K and L.

P is half way between B and K. P to Q is $1\frac{1}{2}$ inches. Square up and down from Q.

A to U is $\frac{3}{4}$ inch more than $\frac{1}{2}$ breast.

Square up from U. U to V is $\frac{5}{8}$ inch. Q to R is $\frac{1}{4}$ breast. R to S is $1\frac{1}{2}$ inches. Square out from S. S to T is $\frac{3}{4}$ inch.

Draw a line from U to T. Shape the back.

Measure distance A to V, apply to K and up to X, strap measure plus 1 inch, $14\frac{1}{4}$ inches.

Draw a line from X to G to get N. Square forward from N.

N to 14 is $\frac{1}{4}$ breast. 14 to 13 is 5 inches. Draw a line from 13 to L. N to O is $\frac{1}{8}$ breast.

Square forward from O by M. Sweep from X to Y, pivoting at M. N to Y is $\frac{1}{4}$ inch less than V to T.

Shape the gorge, shoulder and armseye.

Z to 5 is $\frac{1}{2}$ waist measure. 5 to 3 is $4\frac{3}{4}$ inches. 3 to 2 is 7 inches.

From front edge to 8 is the same as from 3 to 2.

Measure back 10 to E, apply to 8 and back to 10, seat measure, 44 inches.

10 to 9 is $1\frac{3}{4}$ inches. Square up from 9 to 6.

Draw a line from 6 through 10 to 12. Shape the side of the front.

From 6 to 12 is the same as from 7 to 11.

Sweep from 12 to 15, pivoting at X.

Between front and back at Q take out $\frac{1}{4}$ inch.

Extend line from 4—5 up and take out V as indicated.

THE COLLAR

Draw a line from lapel crease to $\frac{1}{2}$ inch beyond X.

Extend line O—N to 21.

From X to 21 is the same as from A to V.

Square down from 21 to 22. From 21 to 22 is $5\frac{1}{2}$ inches. From 21 to 20 is $1\frac{1}{4}$ inches.

Draw a line from 21 down to V as marked. Shape the collar stand from 20 as indicated.

Cut out the back. Place point V on point X.

Get over-shoulder measure from G through X to K, 15 plus 1 inch, 16 inches.

Reshape shoulder.

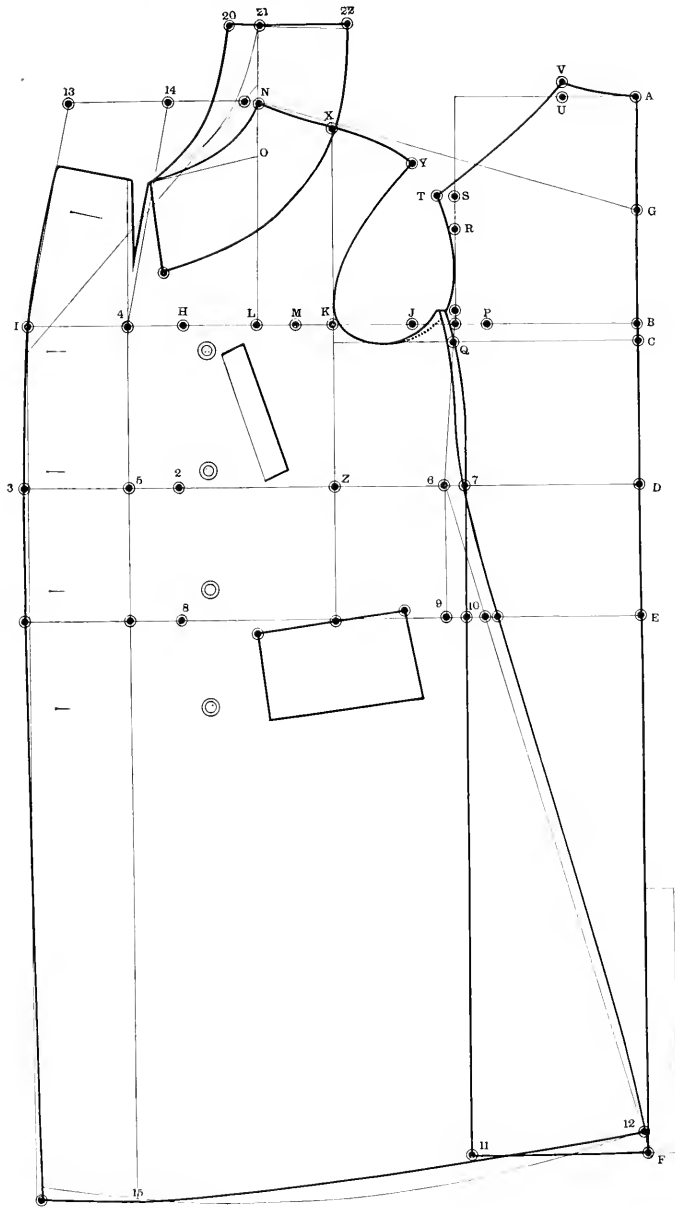

DOUBLE BREASTED ULSTER

SINGLE BREASTED FROCK OVERCOAT

The measurements by which this draft is produced are as follows:

Syce depth,	9 $\frac{3}{4}$ inches	Strap,	13 inches
Natural waist,	17 $\frac{1}{2}$ inches	Over shoulder,	14 $\frac{3}{4}$ inches
Fashionable waist,	19 $\frac{1}{2}$ inches	Blade,	13 $\frac{1}{4}$ inches
Full length,	50 inches	Breast,	39 inches
Waist,	35 inches		

Add three inches to the breast and waist measures, and $\frac{3}{4}$ inch over all short measures.

Square lines A—E and A—U.

A to B is 10 $\frac{1}{2}$ inches; B to C is $\frac{3}{4}$ inch; A to D is 17 $\frac{1}{2}$ inches; A to E is 19 $\frac{1}{2}$ inches; A to F is 50 inches.

Square out from B, C, D, E and F. G is half way between A and B.

B to H is half of full breast, 21 inches. H to I is 2 $\frac{1}{2}$ inches. I to J is 2 inches.

K is half way between B and H. K to L is 3 $\frac{1}{2}$ inches.

Square down from I and L.

Apply the blade measure from B to L, 13 $\frac{1}{4}$ plus $\frac{3}{4}$ inch, 14 inches.

Square up from L.

L to M is $\frac{1}{4}$ the distance from A to B, 21 on 6th division.

Square up from M. O is half way between B and L. O to P is 1 $\frac{1}{4}$ inches. Square up from P. P to Q is $\frac{1}{4}$ breast measure. Q to R is 1 $\frac{1}{2}$ inches. Q to T is the same.

Square out from R. R to S is $\frac{3}{4}$ inch. A to U is $\frac{3}{4}$ inch more than $\frac{1}{4}$ breast measure.

Square up from U. U to V is $\frac{2}{4}$ inch. Draw a line from U to S.

E to I is $\frac{1}{4}$ inch more than $\frac{1}{4}$ breast measure. F to 21 is the same as E to I.

Draw a line from I to 21 and shape back.

Measure back A to V, apply to L and up to N, strap measure, plus 1 inch, 14 inches.

Draw a line from N to G.

Square forward from N. N to 14 is $\frac{1}{4}$ breast measure. 14 to 13 is 2 $\frac{1}{2}$ inches.

Draw a line from 13 to J. 17 is half way between L and M.

Sweep from 18 to 20, pivoting at 17.

N to 15 is $\frac{1}{4}$ breast measure, square forward from 15 by 17.

N to 20 is $\frac{1}{4}$ inch less than V to S. Shape gorge, shoulder and armsyce.

From 2 to 3 is 1 $\frac{3}{4}$ inches. 3 to 6 is $\frac{1}{4}$ waist measure. W to X is $\frac{1}{2}$ waist measure.

X to Y is 2 $\frac{1}{4}$ inches. Y back to Z is 4 $\frac{1}{2}$ inches.

Measure waist 2 to D and Z to 3; take out balance between 6 and 7.

Sweep from 1 to 4, pivoting at T. Sweep from 4 to 8, pivoting at 1 inch back from N.

Draw a line from 8 to the side of front.

Shape the side body, reducing it $\frac{1}{4}$ inch at T and $\frac{1}{4}$ inch at blade line.

THE SKIRT

Draw a line from 8 to 4. Draw a line from point 5 to waist line at 16 and square down to 9. 16 to 9 is 9 inches. Square out from 9. 9 to 10 is 1 $\frac{1}{2}$ inches. Draw a line from 16 through 10 to 11. 16 to 11 is the same as 1 to 21. 8 to 12 is the same as 16 to 11.

Square down from 8 by waist line. Square down the front of the skirt by the waist line.

Shape bottom of skirt. Round the skirt $\frac{2}{4}$ inch at 10.

Cut out the back. Place point V on point N.

Get the over-shoulder measure from G through 18 to L, plus 1 inch, 15 $\frac{3}{4}$ inches.

THE COLLAR

Draw a line from the lapel crease through N to 23. N to 23 is the same as A to V. Square down from 23. 23 to 22 is 1 $\frac{1}{4}$ inches. 23 to 24 is 2 $\frac{1}{4}$ inches.

At the notch make the collar 2 inches wide. Finish as represented.

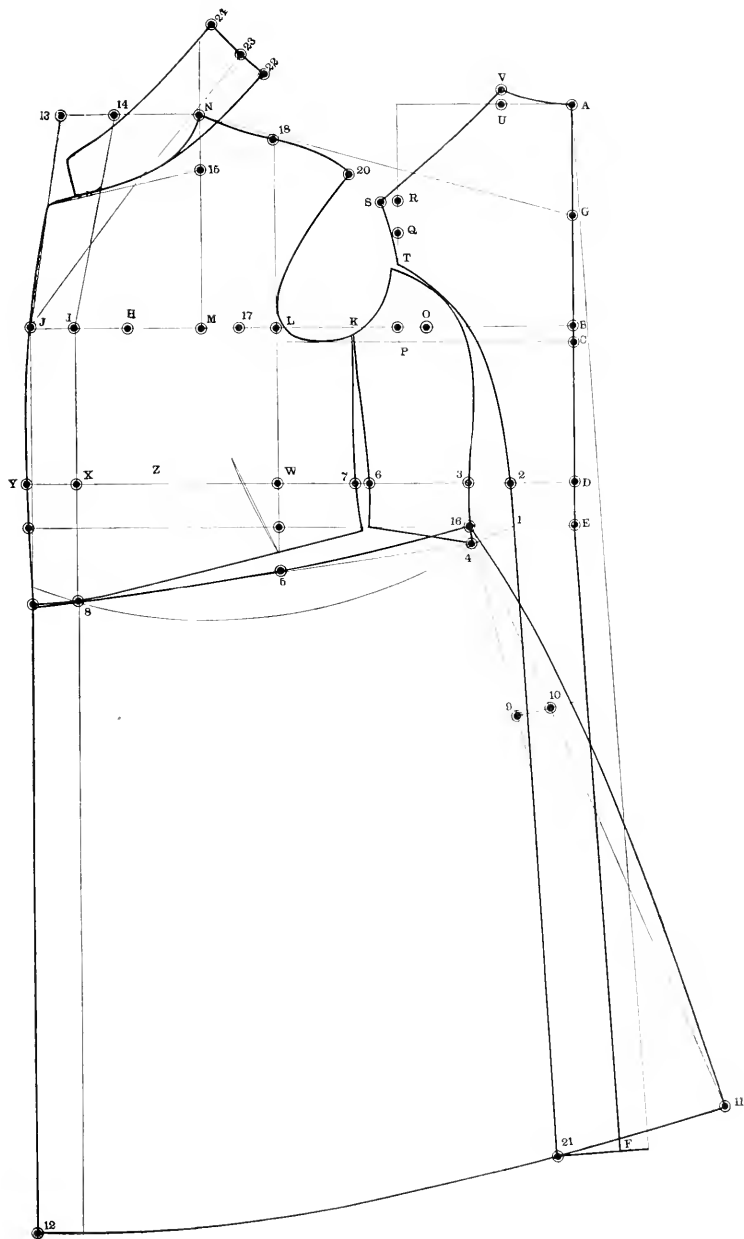

SINGLE BREASTED FROCK OVERCOAT
OR SINGLE BREASTED SURTOUT

DOUBLE BREASTED FROCK OVERCOAT

The measurements by which this draft is produced are as follows:

Seye depth,	9 $\frac{3}{4}$ inches	Strap,	13 inches
Natural waist,	17 $\frac{1}{2}$ inches	Over shoulder,	14 $\frac{3}{4}$ inches
Fashionable waist,	19 $\frac{1}{2}$ inches	Blade,	13 $\frac{1}{4}$ inches
Full length,	50 inches	Breast,	39 inches
	Waist,	35 inches	

(Add 3 inches to the breast and waist measures and $\frac{3}{4}$ inch over all short measures.)

Square lines A—E and A—U.

A to B is 10 $\frac{1}{2}$ inches; B to C is $\frac{3}{4}$ inch; A to D is 17 $\frac{1}{2}$ inches; A to E is 19 $\frac{1}{2}$ inches; A to F is 50 inches.

Square out from B, C, D, E and F. G is half way between A and B.

B to H is half of full breast measure, 21 inches. H to I is 2 $\frac{1}{2}$ inches.

K is half way between B and H. K to L is 3 $\frac{1}{2}$ inches. Square down from I and L.

Apply the blade measure from B to L, 13 $\frac{1}{4}$ inches, plus $\frac{3}{4}$ inch, 14 inches. Square up from L. L to M is $\frac{1}{4}$ the distance from A to B. Square up from M.

O is half way between B and L. O to P is 1 $\frac{1}{4}$ inches. Square up from P.

P to Q is $\frac{1}{4}$ breast. Q to R is 1 $\frac{1}{2}$ inches. Q to T is the same. Square out from R. R to S is $\frac{3}{4}$ inch.

A to U is $\frac{3}{4}$ inch more than $\frac{1}{2}$ breast. Square up from U. U to V is $\frac{3}{8}$ inch. Draw a line from U to S.

E to 1 is $\frac{1}{4}$ inch more than $\frac{1}{2}$ breast. F to 21 is the same as E to 1.

Draw a line from 1 to 21 and shape back.

Measure back A to V, apply to E and up to X, strap measure plus 1 inch, 14 inches.

Draw a line from N to G. Square forward from N.

X to 13 is $\frac{1}{2}$ inch more than $\frac{1}{4}$ breast. Draw a line from 13 to 1.

17 is half way between L and M. Sweep from 18 to 20, pivoting at 17.

Place the square at K and 18 and square forward through 15 for gorge.

X to 20 is $\frac{1}{4}$ inch less than V to S. Shape gorge, shoulder and armseye.

From 2 to 3 is 1 $\frac{3}{4}$ inches. From 3 to 6 is $\frac{1}{4}$ waist.

From W to X is $\frac{1}{2}$ waist measure. X to Y is $\frac{1}{4}$ inch. Y back to Z is 2 $\frac{1}{2}$ inches.

Measure waist 2 to D and Z to 3 and take out balance between 6 and 7.

Sweep from 1 to 4, pivoting at T. Sweep from 4 to 8, pivoting at 1 inch back from X.

Draw a line from 8 to the side of front.

Shape the side body, reducing it $\frac{1}{4}$ inch at T and $\frac{1}{4}$ inch at blade line.

THE SKIRT

Draw a line from 8 to 4. Draw a line from point 16 to waist line at 4 and square down to 9. 4 to 9 is 9 inches. Square out from 9. 9 to 10 is 1 $\frac{1}{2}$ inches. Draw a line from 4 through 10 to 11. 4 to 11 is the same as 1 to 21. 8 to 12 is the same as 4 to 11. Square down from 8 by waist line. Finish skirt rounding it $\frac{3}{8}$ inch at 10.

THE REVER

Draw a line parallel with N—F. Make the width of the rever 2 $\frac{3}{4}$ inches at the waist line, 1 inches at J, and 3 inches at 19. Square down the front of the skirt by the waist line. Cut out the back. Place point Y on point X. Get over-shoulder measure from G through 18 to E, over-shoulder measure plus 1 inch, 15 $\frac{3}{4}$ inches.

THE COLLAR

Draw a line from the lapel crease through N to 23. N to 23 is the same as A to V. Square down from 23. 23 to 22 is 1 $\frac{1}{4}$ inches. 23 to 24 is 2 $\frac{1}{4}$ inches. At 25 make the collar 2 $\frac{1}{4}$ inches wide. Finish as represented.

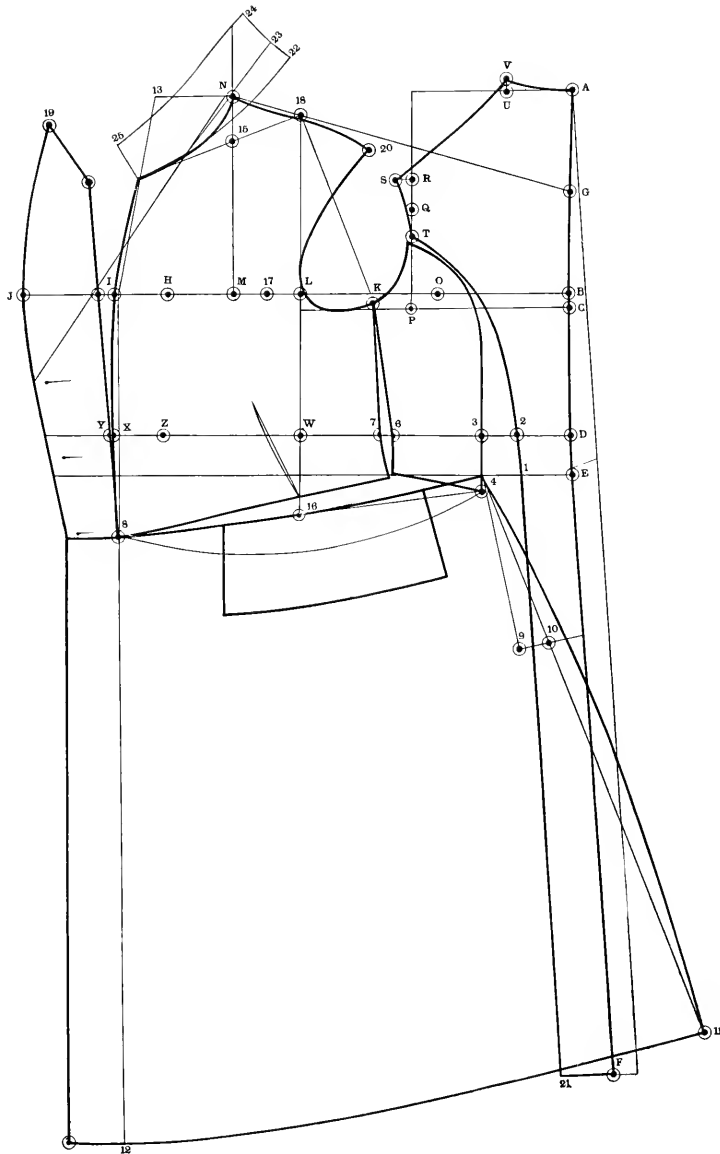

DOUBLE BREASTED FROCK OVERCOAT, OR
DOUBLE BREASTED SURTOUT

SINGLE BREASTED PALETOT

The measurements by which this draft is produced are as follows:

Scye depth,	9½ inches	Strap,	13 inches
Natural Waist,	18 inches	Over shoulder,	14¾ inches
Fashionable Waist,	20 inches	Blade,	13¼ inches
Full length,	50 inches	Breast,	39 inches
	Waist,	35 inches	

Add 3 inches to the breast and waist measures and ¾ inch over all short measures.

Square lines A—U and A—E.

A to B is 10¼ inches; B to C is ¾ inch; A to D is 18 inches; A to E is 20 inches; A to F is 50 inches.

Square out from B, C, D, E and F. G is half way between A and B.

B to H is half of full breast, 21 inches. H to I is 2½ inches. I to J is 2 inches. Square down from I and J.

K is half way between B and H. K to L is 3½ inches. Square down from L.

Apply the blade measure from B to L. 13¼ plus ¾ inch, 14 inches. Square up from L.

L to M is ¼ the distance from A to B. Square up from M.

N is half way between B and L. N to O is 1½ inches. Square up from O. O to P is ¼ breast. P to Q is 1½ inches. P to S is the same.

Square out from Q. Q to R is ¾ inch.

E to T is ½ inch more than ¼ breast measure.

Square down from T.

A to U is ¾ inch more than ¼ breast measure. Square up from U. U to W is ⅝ inch.

Draw a line from U to R. Shape the back.

Measure back A to W, apply to L and up to X, strap measure plus 1 inch, 14 inches.

Draw a line from X to G. Square forward from X. X to 23 is ¼ breast measure. 23 to 22 is 2½ inches.

Draw a line from 22 to J. 18 is half way between L and M. Sweep from 24 to Z, pivoting at 18.

X to Z is ¼ inch less than W to R.

X to Y is ⅓ breast. Square forward from Y by 18. Shape gorge, shoulder and arm-scye.

From 14 to 6 is 1½ inches. Square down from K.

Shape the side body, reducing it ¼ inch at S and ¼ inch at blade line.

Sweep from T to 5, pivoting at S.

Sweep from 5 to 20, pivoting at 1 inch back from X.

From 1 to 2 is ½ waist measure. From 2 to 3 is 2½ inches. 3 back to 4 is 4½ inches. Measure waist 14 to D and 4 to 6, take out balance between 7 and 8.

From 20 to 21 is ¾ inch. Draw a line from 21 through the side of front to 9. Square down from 9. 9 to 10 is 9 inches. Square out from 10. 10 to 11 is 1½ inches. Draw a line from 9 through 11 to 13.

9 to 13 is the same as E to F.

Sweep from 13 to 19, pivoting at X. Finish skirt rounding ¾ inch from 11 to 12.

Cut out the back.

Place point W on point X.

Get over shoulder measure from G through 24 to L. 14¾ plus 1 inch, 15¾ inches.

Sweep to Z and reshape shoulder.

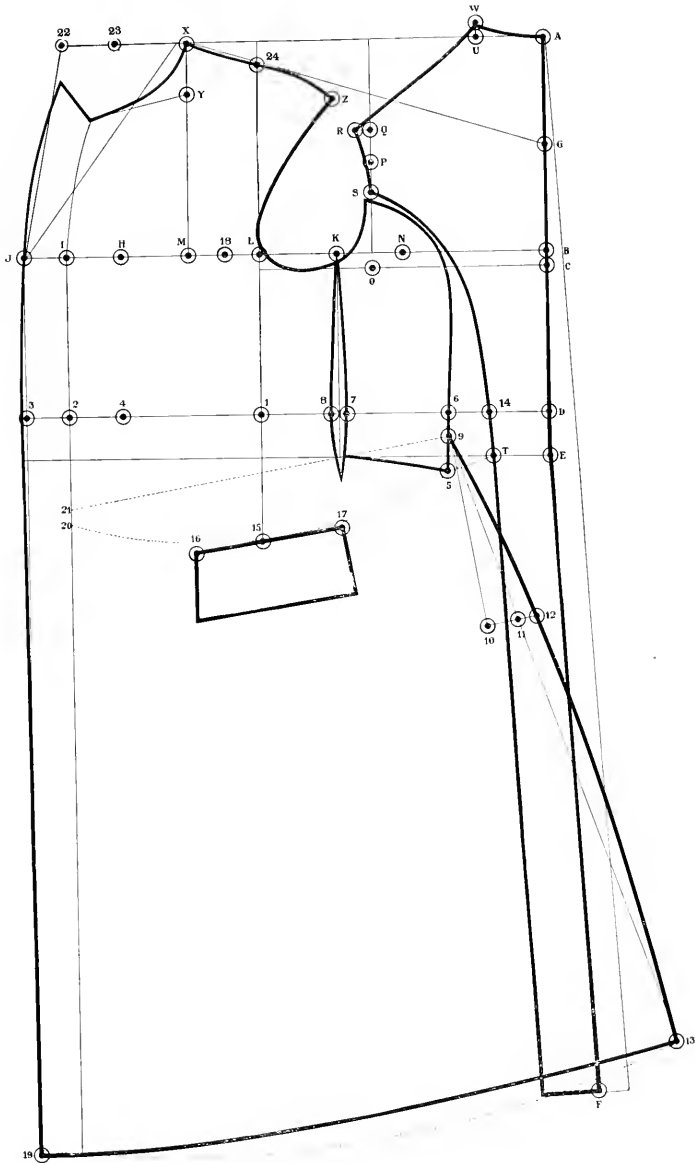

SINGLE BREASTED PALETOT

SINGLE BREASTED PADDOCK

The measurements by which this draft is produced are as follows:

Sceye depth,	9 inches	Over Shoulder,	13½ inches
Natural Waist,	17 inches	Blade,	12½ inches
Fashionable waist,	19 inches	Breast,	36 inches
Full length,	50 inches	Waist,	32 inches
Strap,	12 inches	Seat,	37 inches

(Add 3 inches to the breast and waist measures and ¾ inch over all short measures.)

Square lines A—V and A—G.

A to B is 9¾ inches; B to C is ¾ inch; A to D is 17½ inches; A to E is 19 inches; A to G is 50 inches.

Square out from B, C, D, E and G. H is half way between A and B.

From D to F is 6 inches always. Square out from F. From D to Y is ½ inch.

Draw a line from Y to H. From the line just made at B to I is half of the full breast measure, 19½ inches. I to J is 2½ inches. J to K is 2 inches. Square down from J and K.

L is half way between B and I. L to M is 3½ inches. Square down from M.

Apply the blade measure from the line inside of B to M, 12½ plus ¾ inch, 13¼ inches. Square up from M.

M to N is ½ the distance from A to B, 19½ on 6th division. Square up from N.

P is half way between B and M. P to Q is 1½ inches. Square up from Q. Q to R is ¼ breast. R to S is 1½ inches. R to T is the same. Square out from S. S to U is ¾ inch.

A to V is ¾ inch more than ¼ breast. V to W is ½ of an inch. Draw a line from V to U. Y to X is ¼ breast. Square down from X. Shape the back.

Measure back A to W apply to M and up to Z, strap measure plus 1 inch, 13 inches.

Z to 3 is ½ breast measure. Square forward from 3 by O.

Draw a line from Z to H. Square forward from Z. Z to 26 is ¼ breast measure.

26 to 25 is 2½ inches. Draw a line from 25 to K.

O is half way between M and N. Sweep from 1 to 2, pivoting at O.

Z to 2 is ¼ inch less than W to U.

Shape gorge, shoulder, and armseye.

From 4 to 5 is ½ waist measure. 5 to 6 is 2¼ inches. 6 back to 7 is 4½ inches. Shape the front edge.

From 8 to 9 is 4½ inches.

Measure back 12 to F and 9 to 13, seat measure 20 plus 1 inch, 21 inches.

From X to 11 is 1¼ inches. Draw a line from 11 through 13 to 14.

Measure waist X to Y and 7 to 11, take out balance between 16 and 17.

Shape the side of the front, reducing it ¼ inch at P and rounding ⅔ of an inch over the line 13 and 14.

From 11 to fashionable waist is ⅔ of an inch more than X to fashionable waist.

Sweep from 27 to 14, pivoting at T. Sweep from 14 to 15, pivoting at Z. Shape the bottom.

Cut out back, place point W on point Z.

Get over shoulder measure from H through 1 to M, 13½ plus 1 inch—14½ inches.

Sweep to 2 and reshape shoulder.

THE COLLAR

Draw a line from 23 through to 20. Z to 20 is the same as A to W. Square down from

20. 20 to 21 is 1¼ inches. 20 to 22 is 2¼ inches.

Shape as represented.

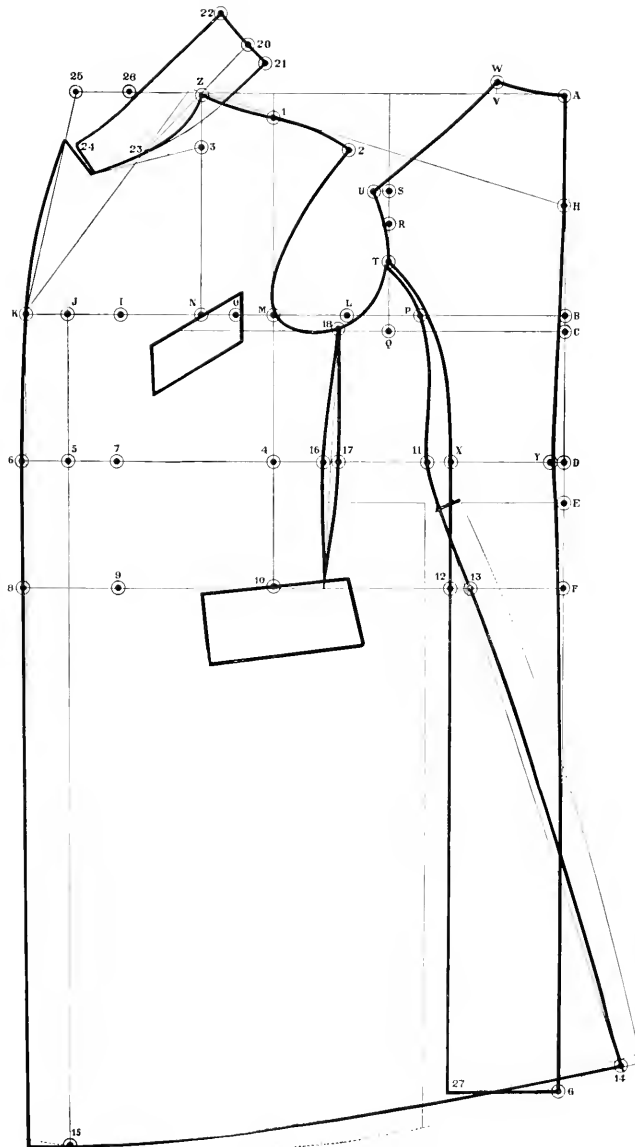

SINGLE BREASTED PADDOCK

DOUBLE BREASTED PADDOCK

The measurements by which this draft is produced are as follows:

Scye depth,	9½ inches	Over shoulder,	14¼ inches
Natural waist,	17½ inches	Blade with allowance,	13 inches
Fashionable waist,	19½ inches	Breast,	38 inches
Full length,	50 inches	Waist,	34 inches
Strap,	12½ inches	Hip,	40 inches

Add ¾ inches to the breast, waist and hip, and ¼ inch over scye depth, strap, over shoulder and blade.

Square lines A—V and A—G.

A to B is 10¼ inches; B to C is ¾ inch; A to D is 17½ inches; E fashionable waist; F hip; and G full length.

Square out from B, C, D, E, F and G. H is half way between A and B.

D to inner line is ½ inch.

Draw a line from the ½ inch to H and down.

From line inside of B to I is ½ of full breast, 20½ inches. I to J is 2½ inches. J to K is 4 inches. Square down from J and K.

L is half way between B and I

L to M is 3½ inches. Square down from M.

Apply the blade measure from B to M, 13 plus ¾ inches, 13¾ inches.

M to N is ½ the distance from A to B.

Square up from N and up and down from M.

P is half way between B and M. P to Q is 1¼ inches. Square up from Q. Q to R is ¼ breast. R to S is 1½ inches. R to T is the same. Square out from S.

S to U is ¾ inch.

A to V is ¼ breast plus ¾ inch. V to W is ¾ inch. Draw a line from V to U.

From D to X is ¼ breast.

Square down from X.

Finish back as represented.

Measure distance A to W; apply to M and Z, strap measure plus 1 inch, 13½ inches.

Draw a line from Z to H. Square forward from Z. Z to 25 is ¼ breast. 25 to 24 is 4½ inches. O is half way between M and N.

Sweep from 1 to 2, pivoting at O.

Z to 2 is ¼ inch less than W to U.

Z to 3 is ¼ breast.

Draw a line from 1 through 3 for gorge. Shape gorge, shoulder and armscye.

From 4 to 5 is ½ waist; 5 to 6 is 4¼ inches; 6 to 7 is 6½ inches. Draw lines from 25 to J and 24 to K.

Extend line J—5 up and take out V.

Shape front edge and lapel. 8 to 9 is 6½ inches.

Square down from L. From X to 11 is 1¼ inches. Measure waist from X to line inside of D, apply to 7 and back to 11. Take out balance between 16 and 17.

Measure back 12 to F and 9 to 13, hip measure plus 1 inch.

Draw a line from 11 through 13 to 14 and shape side.

Sweep from 14 to 15, pivoting at Z.

Finish as represented.

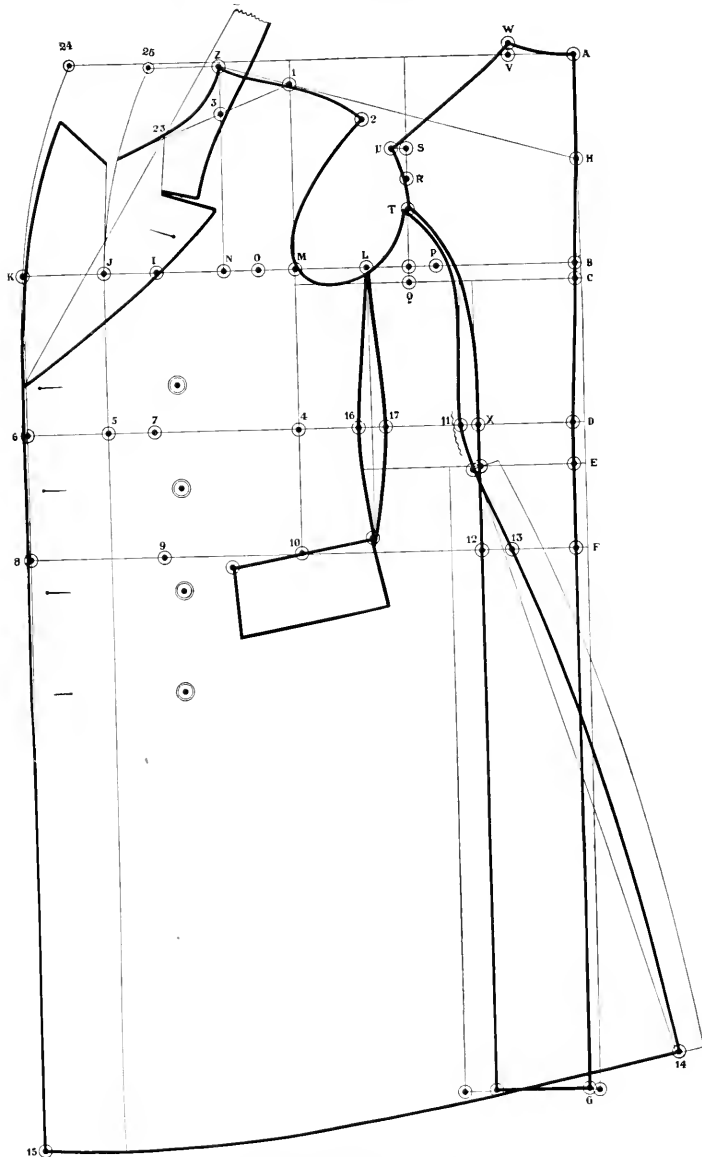

DOUBLE BREASTED PADDOCK

MEASURING A HUNCHBACK

In measuring this figure all the measures are taken the same as for any other person, except that after the scye depth is located place a square or a ruler at the back and let the upper end come opposite to where the collar ought to begin. See figure 6.

Line B is the scye depth.

Letter A is the height of the neck.

Take the measure as from A to B, then begin to measure the scye depth as from C to B.

The difference in the length in A—B and C—B is changed in the draft.

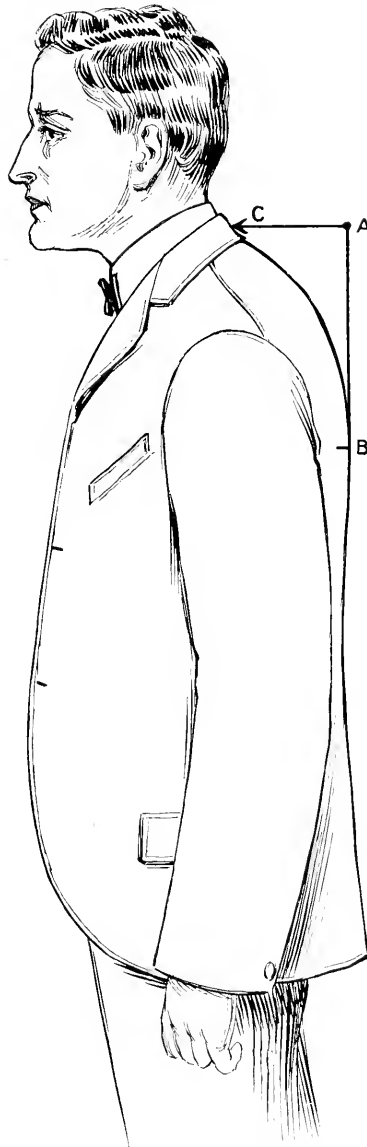

HOW TO MEASURE A HUNCHBACK

STRAIGHT FRONT SACK FOR HUNCHBACK

The measurements by which this draft is produced are as follows:

Height of neck,	$8\frac{1}{2}$ inches	Over shoulder,	$13\frac{1}{4}$ inches
Scye depth,	$9\frac{1}{4}$ inches	Blade,	$13\frac{1}{2}$ inches
Waist length,	17 inches	Breast,	38 inches
Full length,	30 inches	Waist,	36 inches
Strap,	$11\frac{1}{4}$ inches	Seat,	38 inches

Square lines A—U and A—F.

A to B is height of neck, $8\frac{1}{2}$ inches; B to C is $\frac{3}{4}$ inch; A to D is 17 inches; A to E is 23 inches; A to F is full length, 30 inches.

Square out from B, C, D, E and F. G is half way between A and B.

At D go in $\frac{1}{2}$ inch. Draw a line from G to D and square down. From the line just made at B to H is half of full breast, 19 inches. H to I is $3\frac{1}{2}$ inches. Square down from I.

J is half way between B and H. J to K is $3\frac{1}{2}$ inches.

Square down from K.

Apply the blade measure from line inside of B to W, $13\frac{1}{2}$ inches.

Square up from W.

W to L is $\frac{1}{2}$ the measure of depth of scye, $18\frac{1}{2}$ on 6th division.

M is half way between W and L. P is half way between B and W.

P to Q is $1\frac{1}{4}$ inches. Square up from Q. Q to R is $\frac{1}{4}$ breast.

R to S is $1\frac{1}{2}$ inches. Square out from S. S to T is $\frac{3}{4}$ inch.

A to U is $\frac{3}{4}$ inch more than $\frac{1}{2}$ breast measure.

Square up from U. U to V is $\frac{1}{2}$ inch. Draw a line from U to T.

Shape back as represented.

Measure distance A to V, apply to W and up to N, strap measure $11\frac{1}{4}$ plus $\frac{1}{4}$ inch, $11\frac{1}{2}$ inches.

Draw a line from N to G.

Sweep from N to Y, pivoting at M. N to Y is $\frac{1}{4}$ inch less than V to T. N to O is $\frac{1}{8}$ breast measure.

Square forward from O by M.

Square forward from N. N to 13 is $\frac{1}{6}$ breast. 13 to 14 is $1\frac{1}{2}$ inches.

Draw a line from 14 to 1. Shape the gorge, shoulder, and armseye.

From Z to 5 is $\frac{1}{2}$ waist measure. 5 to 3 is $1\frac{1}{4}$ inches. 3 to 2 is $3\frac{1}{2}$ inches.

8 is $3\frac{1}{2}$ inches from the front edge.

Measure back 7 to D and 2 to 6, waist measure plus 1 inch.

Measure 9 to E and 8 to 10, seat measure plus 1 inch.

Shape side of front, reducing one half inch between back and front at Q, sweep from 12 forward, pivoting by N; finish bottom.

The scye depth as from C to B on figure is $9\frac{1}{4}$ inches.

Cut the back from G to R, and open it from G to 15 until the measure from B to 16 is $9\frac{1}{4}$ inches.

Cut out the back and place point V on point N.

Get over-shoulder measure from G through N to W, $13\frac{1}{4}$ plus $\frac{1}{4}$, $13\frac{1}{2}$ inches.

Finish as represented.

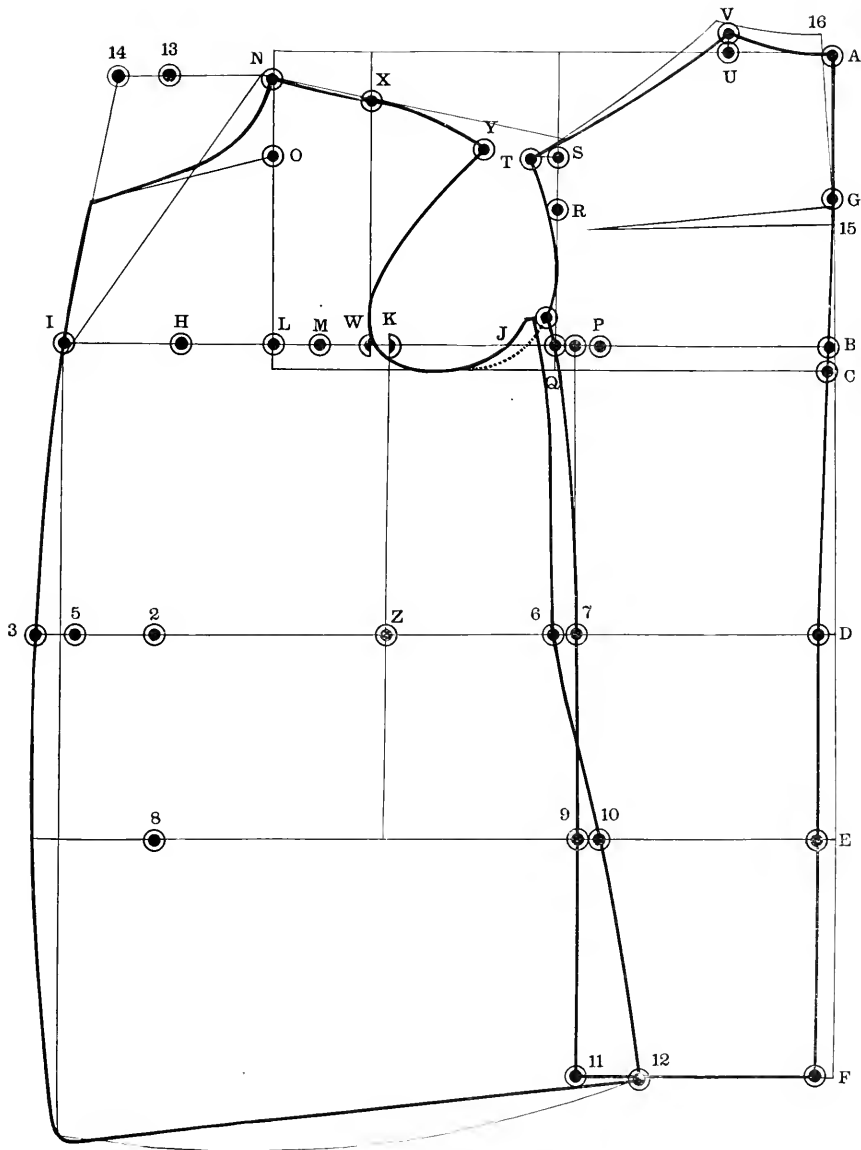

STRAIGHT FRONT SACK FOR HUNCHBACK

CASSOCK COAT

The measurements by which this draft is produced are as follows:

Scye depth,	9 $\frac{1}{2}$ inches	Strap,	12 $\frac{3}{4}$ inches
Natural waist,	17 $\frac{1}{2}$ inches	Over shoulder,	14 $\frac{1}{2}$ inches
Fashionable waist,	19 $\frac{1}{2}$ inches	Blade,	13 inches
Full length,	52 inches	Breast,	38 inches
	Waist,	34 inches	

Square lines A—U and A—E.

A to B is 9 $\frac{1}{2}$ inches, B to C is $\frac{3}{4}$ inch; A to D is 17 $\frac{1}{2}$ inches; A to E is 19 $\frac{1}{2}$ inches; A to F is 52 inches.

Square out from B, C, D, E and F. G is half way between A and B.

B to H is half of full breast, 19 inches. H to I is 2 $\frac{1}{2}$ inches. I to J is 1 inch.

K is half way between B and H. K to L is 3 $\frac{1}{2}$ inches. Square down from I and L.

Apply the blade measure from B to L 13 inches. Square up from L.

L to M is $\frac{1}{4}$ the distance from A to B. Square up from M.

O is half way between B and L. O to P is 1 $\frac{1}{4}$ inches. Square up from P. P to Q is $\frac{1}{4}$ breast.

Q to R is 1 $\frac{1}{2}$ inches. Q to T is the same.

Square out from R. R to S is $\frac{3}{4}$ inch.

A to U is $\frac{3}{4}$ inch more than $\frac{1}{2}$ breast measure. Square up from U. U to V is $\frac{5}{8}$ inch.

Draw a line from U to S.

E to 1 is $\frac{3}{4}$ inch more than $\frac{1}{2}$ breast measure. F to 21 is $\frac{1}{2}$ breast measure.

Draw a line from 1 to 21. Shape back as represented.

Measure distance A to V, apply to L and up to N, strap measure plus $\frac{1}{4}$ inch, 13 inches.

Draw a line from N to G. Square forward from N. N to 14 is $\frac{1}{4}$ breast. From 14 to 13 is 1 $\frac{1}{2}$ inches. Draw a line from 13 to J.

5 is half way between L and M. Sweep from 18 to 20, pivoting at 5. From N to 20 is $\frac{1}{4}$ inch less than from V to S.

N to 15 is $\frac{1}{8}$ breast. Square forward from 15 by 5.

Shape gorge, shoulder, and armseye.

From 2 to 3 is 1 $\frac{3}{4}$ inches. From 3 to 6 is $\frac{1}{2}$ waist.

From W to X is $\frac{1}{2}$ waist. From X to Y is 1 $\frac{1}{2}$ inches. Y back to Z is 3 $\frac{1}{2}$ inches.

Measure waist 2 to D, apply to Z and back to 3 for waist measure; take out balance between 6 and 7.

Sweep from 1 to 4, pivoting at T. Sweep from 4 to 8, pivoting at a point 1 inch back from X.

From 8 to 17 is $\frac{1}{2}$ inch. Draw a line from 17 through 33 to 16.

Square down from 16. From 16 to 9 is 9 inches. From 9 to 10 is 1 $\frac{1}{2}$ inches. Draw a line from 16 through 10 to 11.

From 16 to 11 is the same as from E to F.

Square down from front of skirt by waist line.

From 8 to 12 is the same as from 16 to 11. Shape the bottom of skirt.

Cut out the back and place point V on point N, get over shoulder measure from G through 18 to L plus $\frac{1}{4}$ inch, 14 $\frac{3}{4}$ inches.

THE COLLAR

Draw a line from the top of lapel through N to 23. From N to 23 is the same as from A to V. From 23 to 22 is 1 inch. From 24 to 23 is $\frac{1}{2}$ inch.

Finish collar, making the width of same in front 1 $\frac{1}{2}$ inches.

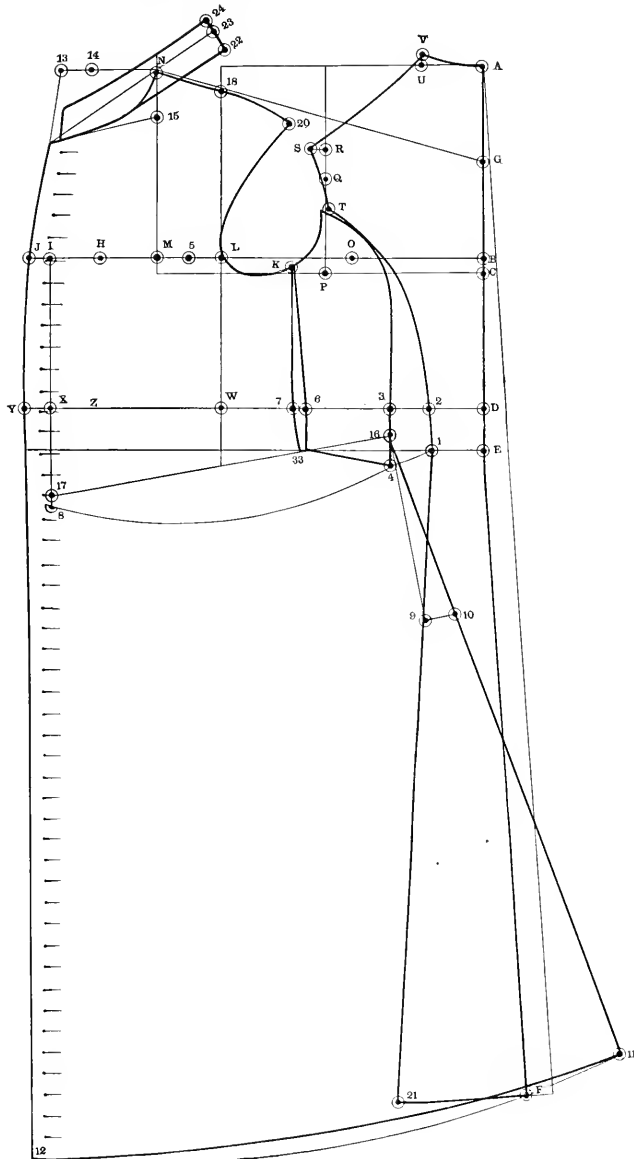

CASSOCK

THE SLEEVE

Measure the arm scye.

If for a sack coat without an underarm seam, add $\frac{1}{2}$ inch to the measurement; for instance, if the armseye measures 18 inches, make the sleeve $18\frac{1}{2}$ inches; but if there is an underarm seam, then cut it according to measure.

Square lines A—L and A—F.

A to B is $1\frac{1}{2}$ inches always.

B to D is $\frac{1}{4}$ of the armseye.

D to C is 1 inch.

C to E is $\frac{1}{3}$ of the armseye.

Square out from B and D.

From C to H find $\frac{1}{2}$ of the arm scye.

H to I is $\frac{1}{2}$ inch.

Square down from I.

H to J is 1 inch.

Draw a line from E to J.

A to K is $\frac{1}{4}$ of the armseye.

K to L is $\frac{1}{4}$ of the armseye.

Draw a line from C to K.

From D to O and F to Q is $1\frac{1}{4}$ inches.

From B to P and F to R are $1\frac{1}{4}$ inches.

Shape the sleeve from O through C through L to H.

Shape the undersleeve from C through P to J.

D to F is the inside length of the sleeve plus $\frac{1}{4}$ of an inch.

Square out from F.

From the line just made to N is $1\frac{3}{4}$ inches.

M is half way between I and N.

Measure width of sleeve from F to N.

Add 1 inch for seams.

Draw lines from H to M and from J to M.

Finish as represented.

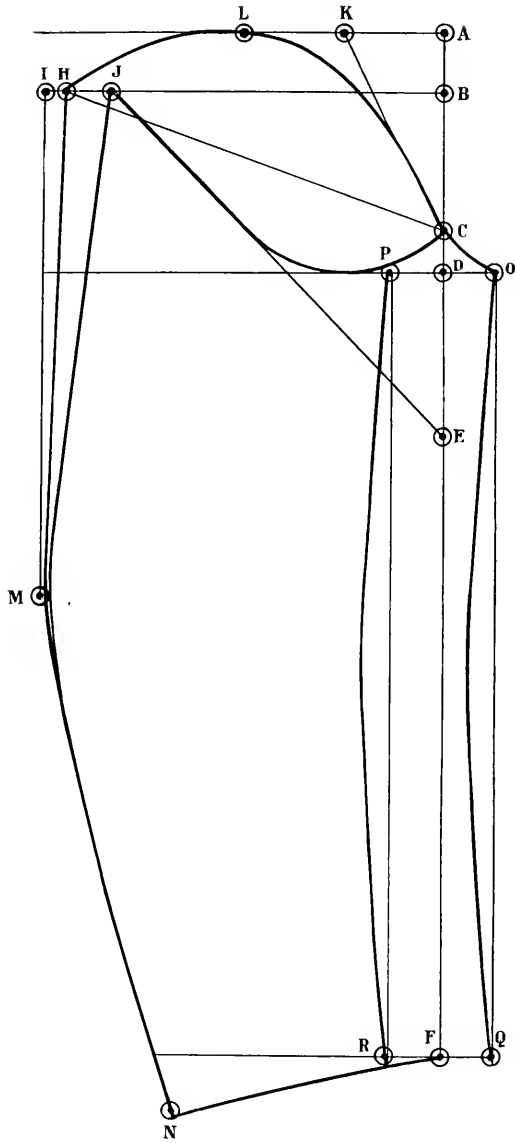

SLEEVE

HALF AND HALF SLEEVE

Measure the arm scye.

If for a sack coat without an underarm seam, add $\frac{1}{2}$ inch to the measurement. For instance, if the armscye measure is 18 inches, make the sleeve 18 $\frac{1}{2}$ inches, but if there is an underarm seam, then cut it according to measure.

Square lines A—L and A—F.

A to B is 1 $\frac{1}{2}$ inches always. B to D is $\frac{1}{4}$ of the armscye.

D to C is 1 inch always. C to E is $\frac{1}{3}$ of the armscye.

Square out from B and D.

From C to H is $\frac{1}{2}$ of the armscye.

H to I is $\frac{1}{2}$ inch.

H to J is 1 inch.

Square down from L.

A to K is $\frac{1}{2}$ of the armscye.

K to L is $\frac{1}{4}$ of the armscye.

Draw a line from C to K.

Draw a line from E to J.

From D to F is the sleeve length.

F to Q is 1 $\frac{3}{4}$ inches.

Square out from Q.

From F to N is the width of the sleeve plus 1 inch for seams.

M is half way between I and N.

Shape the upper sleeve from H to M and the undersleeve from J to M.

Shape the upper sleeve from H through L to C.

And the undersleeve from J to C.

Finish as represented, hollowing the sleeve $\frac{3}{8}$ inch at the front seam.

SLEEVE FOR BOX OVERCOAT

Measure the armseye before the back is cut out without extra addition to the back, and then measure the addition that the back makes. For instance, if the armseye measures 20 inches without the addition, cut the sleeve 20, and add the difference of the addition of the back, to the undersleeve.

Square lines A—L and A—F.

A to B is $1\frac{1}{2}$ inches always.

B to D is $\frac{1}{4}$ of the armseye.

D to C is 1 inch always.

C to E is $\frac{1}{3}$ of the armseye.

Square out from D and B.

From C to H is $\frac{1}{2}$ of the armseye.

H to I is $\frac{1}{2}$ inch. I to J is 1 inch.

Square down from I.

A to K is $\frac{1}{4}$ of the armseye.

K to L is $\frac{1}{4}$ of the armseye.

Draw a line from C to K.

Draw a line from E to J.

From D to F is the length of the sleeve

Square out from F.

From the line just made to N is $1\frac{3}{8}$ inches.

From F to N is the width of the sleeve plus 1 inch for seam.

M is half way between I and N. From D to P and F to R is $1\frac{1}{4}$ inches.

From D to O and F to Q is $1\frac{1}{4}$ inches in each case.

Shape the upper and under sleeve, hollowing them $\frac{1}{2}$ inch at front seam.

From J to I add the increase that the back has made, say $\frac{1}{2}$ inch.

Shape the under sleeve from I to M and from I through P to C.

Finish as represented.

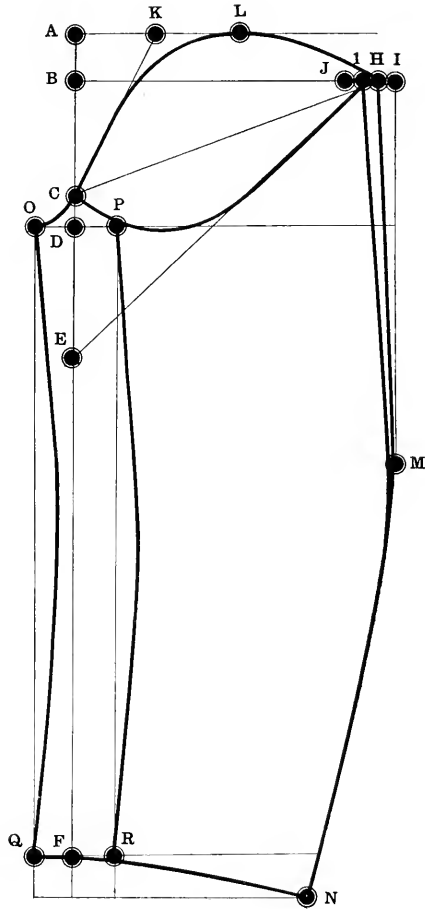

SLEEVE FOR BOX OVERCOAT

SINGLE BREASTED VEST, NO COLLAR

The measurements by which this draft is produced are as follows:

Scye depth,	9 inches	Breast,	36 inches
Waist length,	17 inches	Waist,	32 inches
Strap,	12 inches	To opening,	12½ inches
Blade,	12½ inches	Full length,	25½ inches

The blade measure in all vests should be cut $\frac{1}{2}$ inch smaller than in the coat, the vest having but three seams, while the coat has five, therefore $\frac{1}{2}$ inch less.

Square line A—O and A—D.

A to B is 9 inches; A to C is 17 inches; C to D is $3\frac{1}{2}$ inches.

Square out from B and C.

C to U is $\frac{5}{8}$ inch.

Draw a line from U to E. From the line just made at B to F, half of full breast, is 18 inches.

From F to G is 2 inches. Square down from G.

H is half way between B and F. H to I is 3 inches.

Square down from I.

Apply the blade measure from B to I, $\frac{1}{2}$ inch less than the blade measure 12 inches.

Square up from I. I to J is $\frac{1}{2}$ the distance from A to B.

Square up from J.

M is half way between B and I. M to N is $\frac{1}{2}$ inch. Square up from N.

A to O is $\frac{3}{4}$ inch more than $\frac{1}{4}$ breast. Square up from O. O to P is $\frac{1}{2}$ inch.

Measure distance A to P, apply to I and up to K, 12 inches net.

Draw a line from K to E to get Q. Draw a line from O to Q.

K to R is $\frac{1}{4}$ inch less than P to Q.

Shape the back shoulder and armseye, dropping the armseye $\frac{1}{2}$ inch below Y and $\frac{1}{2}$ inch inside of line I.

From S to T is $\frac{1}{2}$ the waist measure.

Square forward from K.

K to 2 is $\frac{1}{2}$ inch more than $\frac{1}{4}$ breast.

Draw a line from 2 to G.

K to L is $\frac{3}{4}$ inch.

K to V is the same as A to P.

Measure the opening from V, 12 plus $\frac{3}{4}$ inch, and to Z $25\frac{1}{2}$ plus $1\frac{1}{2}$ inches, for make-up, $26\frac{3}{4}$ inches.

From T to X is 1 inch more than $\frac{1}{2}$ waist; from U to W is the same.

Y is half way between B and G.

Finish as represented.

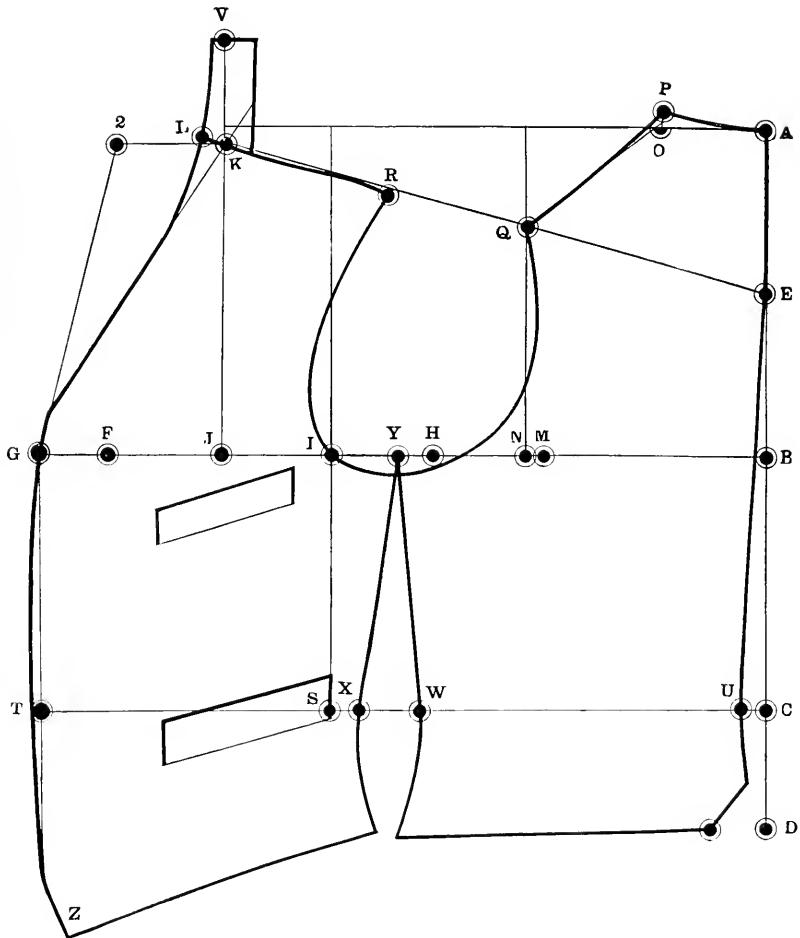

SINGLE BREASTED VEST—NO COLLAR

SINGLE BREASTED VEST WITH NOTCH COLLAR

The measurements by which this draft is produced are as follows:

Scye depth,	9 inches	Breast,	36 inches
Waist length,	17 inches	Waist,	32 inches
Strap,	12 inches	To opening,	12½ inches
Blade,	12½ inches	Full length,	25½ inches

The blade measure in all vests should be cut $\frac{1}{2}$ inch smaller than in coat, the vest having but three seams while the coat has five, therefore $\frac{1}{2}$ inch less.

Square line A—O and A—D.

A to B is 9 inches; A to C is 17 inches; C to D is $3\frac{1}{2}$ inches.

Square out from B and C.

C to U is $\frac{5}{8}$ inch.

Draw a line from U to E.

From line just made at B to F is half of full breast, 18 inches.

From F to G is 2 inches.

Square down from G.

H is half way between B and F.

H to I is 3 inches.

Square down from I.

Apply the blade measure from B to I, $\frac{1}{2}$ inch less than the blade measure, 12 inches.

Square up from I.

I to J is $\frac{1}{3}$ the distance from A to B.

Square up from J.

M is half way between B and I.

M to N is $\frac{1}{2}$ inch.

Square up from N.

A to O is $\frac{3}{4}$ inch more than $\frac{1}{4}$ breast.

Square up from O.

O to P is $\frac{1}{2}$ inch.

Measure distance A to P, apply to I and up to K, 12 inches net.

Draw a line from K to E to get Q. Draw a line from O to Q.

K to R is $\frac{1}{4}$ inch less than P to Q.

Shape the back, shoulder and armseye, dropping the armseye $\frac{1}{2}$ inch below and $\frac{1}{2}$ inch inside of line L.

From S to T is $\frac{1}{2}$ waist.

Square forward from K. K to V is $\frac{1}{2}$ inch more than $\frac{1}{6}$ breast. Draw a line from V to G. K to L is $\frac{3}{4}$ inch.

Measure the opening from A to P and K to G, 12 plus $\frac{3}{4}$ inch for opening; and to Z $25\frac{1}{2}$ plus $1\frac{1}{4}$ inches for make-up, $26\frac{3}{4}$ inches.

From T to X is 1 inch more than $\frac{1}{2}$ waist.

From U to W is 1 inch more than $\frac{1}{2}$ waist.

Y is half way between B and G.

Finish as represented.

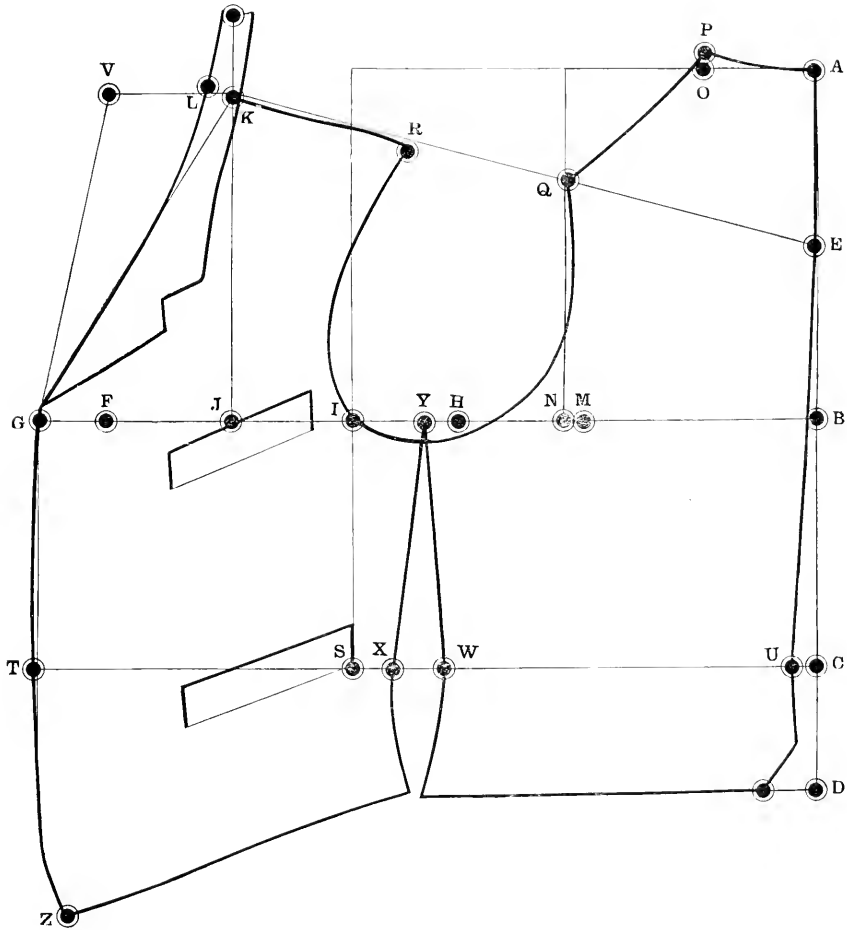

SINGLE BREASTED VEST, WITH NOTCH COLLAR

SINGLE BREASTED VEST WITH NOTCH COLLAR For Stout Figure

The measurements by which this draft is produced are as follows:

Scye depth,	9½ inches	Breast,	40 inches
Waist length,	17 inches	Waist,	40 inches
Strap,	13 inches	To opening,	12½ inches
Blade,	13½ inches	Full length,	27 inches

Square lines A—O and A—D.

A to B is scye depth 9½ inches; A to C is 17 inches; C to D is 3½ inches.

Square out from B and C.

E is half way between A and B.

From C to U is ½ inch. Draw a line from U to E.

From line just made at B to F is half of full breast, 20 inches.

F to G is 2 inches. H is half way between B and F. H to I is 3 inches. Square down from I to get S.

From S to T is ½ waist. Square down from T.

Apply the blade measure from B to I, less ½ inch, 13 inches.

Square up from I. I to J is ¼ the distance from A to B. Square up from J.

M is half way between B and I. M to N is ½ inch. Square up from N.

A to O is ¾ inch more than ⅓ breast. Square up from O. O to P is ½ inch.

Measure distance A to P, apply to I and up to K, strap measure net.

Draw a line from K to E to get Q. Draw a line from O to Q.

From K to R is ¼ inch less than P to Q.

Shape the back, shoulder and armseye, dropping the armseye ½ inch below Y and ½ inch inside of I.

Square forward from K. K to V is ½ inch more than ¼ breast.

Draw a line from V to G. K to L is ¾ inch.

Measure distance A to P, apply to K and G, opening plus ¾ inch.

Down to Z full length plus 1¼ inches.

From T to X is 1 inch more than ½ waist.

From U to W is 1 inch more than ½ waist.

Y is half way between B and G.

Shape the front and bottom of vest.

The pocket is 5 inches from and parallel with bottom of front.

Cut the pocket open and crease over ½ inch as from 1 to 2.

See diagram 7.

Front of corpulent man's vest after "X" has been taken out at the pocket.
See Diagram 7.

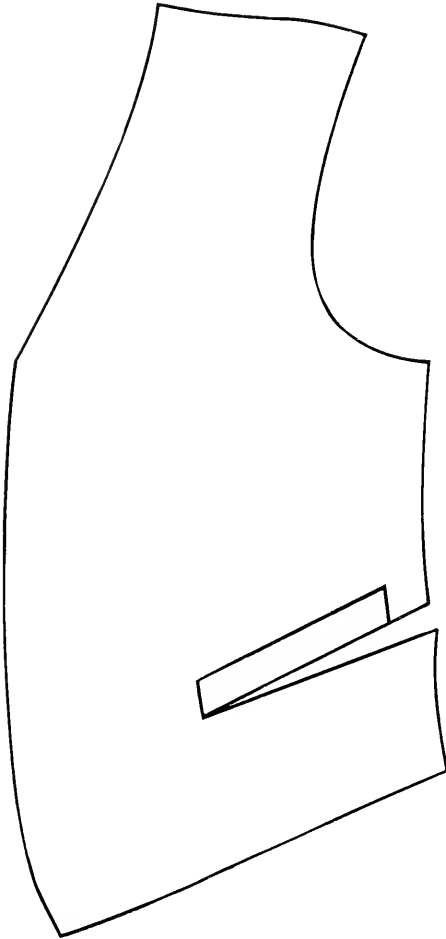

DIAGRAM 7

SINGLE BREASTED VEST, NOTCH COLLAR

For Corpulent Figure

The measurements by which this draft is produced are as follows:

Depth of scye,	$9\frac{1}{2}$ inches	Breast,	40 inches
Waist length,	$17\frac{1}{2}$ inches	Waist,	42 inches
Strap,	13 inches	To opening,	14 inches
Blade,	$13\frac{1}{2}$ inches	Full length,	28 inches

Square lines A—D and A—S.

A to B is $9\frac{1}{2}$ inches; A to C is $17\frac{1}{2}$ inches; C to D is $3\frac{1}{2}$ inches.

Square out from B and C; E is half way between A and B.

C to F is $\frac{1}{2}$ inch.

Draw a line from E to F.

From line just made at B to G is half of full breast, 20 inches.

J is half way between B and G. J to K is 3 inches. Square down from K.

For every inch that the waist is larger than the breast advance $\frac{1}{4}$ from K to L; in this case the waist being 2 inches larger than the breast the distance from K to L is $\frac{1}{2}$ inch.

Square down from L, apply the blade measure from B to K 13 inches, advance the extra half inch from K to L.

L to M is $\frac{1}{3}$ the distance from A to B. Square up from M.

G to H is the same as K to L, $\frac{1}{2}$ inch. H to I is 2 inches.

Q is half way between B and K. Q to R is $\frac{1}{2}$ inch.

Square up from R. A to S is $\frac{3}{4}$ inch more than $\frac{1}{2}$ breast.

S to T is $\frac{1}{2}$ inch.

Measure distance A to T, apply to L and up to N, strap measure, 13 inches net.

Draw a line from N to E to get U.

Draw a line from S to U.

N to 3 is $\frac{1}{4}$ inch less than T to U.

Shape back, shoulder, and armseye, dropping the armseye $\frac{1}{2}$ inch below V and $\frac{1}{2}$ inch inside of line L.

From W to X is $\frac{1}{2}$ waist. Square down from X.

Square forward from N. N to P is $\frac{1}{2}$ inch more than $\frac{1}{4}$ breast. N to O is $\frac{3}{4}$ inch.

Shape the front.

At V take out $\frac{1}{2}$ inch that has been advanced from G to H.

From X to 3 is 1 inch more than $\frac{1}{2}$ waist. From X to Y is the same.

Measure distance A to T, apply to N and down to I, opening, plus $\frac{3}{4}$ inch.

Down to Z, full length, 28 inches plus $1\frac{1}{4}$ inch, $29\frac{1}{4}$ inches.

Finish sides and bottom.

The pocket is 5 inches above and parallel with bottom of front.

Cut in the pocket and double over $\frac{1}{2}$ inch between 1 and 2. See diagram 7.

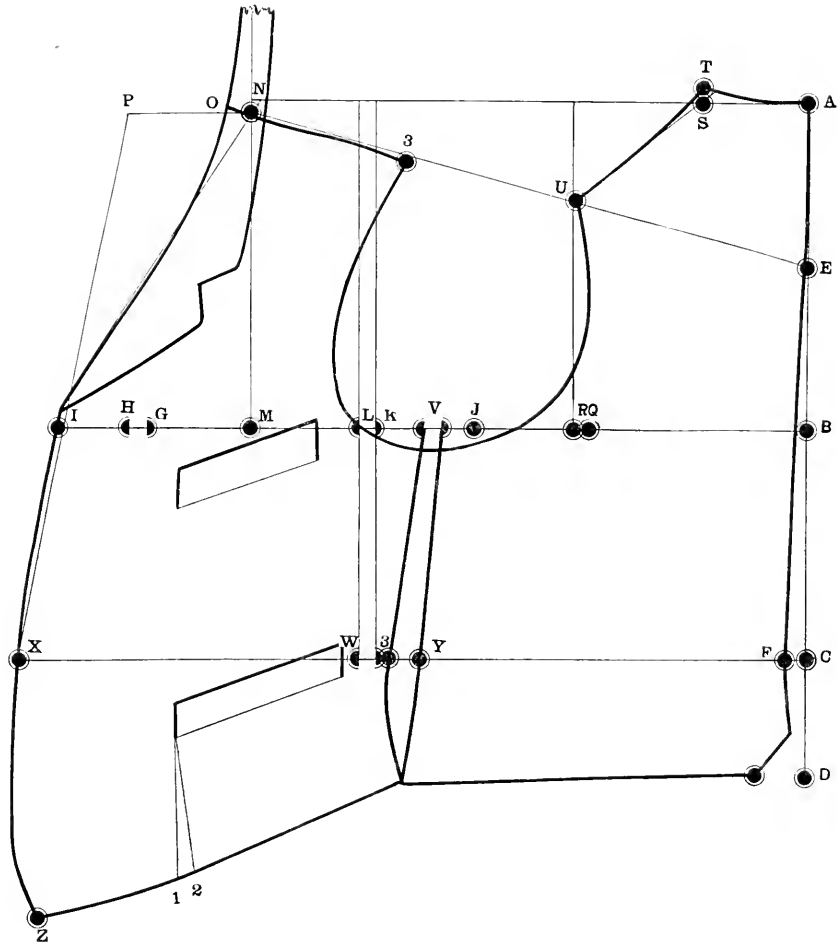

SINGLE BREASTED VEST WITH NOTCH COLLAR
FOR CORPULENT FIGURE

FULL DRESS VEST, SHAWL COLLAR

The measurements by which this draft is produced are as follows:

Scye depth,	9½ inches	Blade,	13 inches
Waist length,	17 inches	Breast,	38 inches
Strap,	12¾ inches	Waist,	34 inches
	Full length,	26 inches	

Square lines A—O and A—D.

A to B is scye depth, 9½ inches; A to C is 17 inches; C to D is 3½ inches.

E is half way between A and B. Square out from B and C.

C to U is ½ inch. Draw a line from E to U.

From the line just made at B to F is half of full breast, 19 inches.

F to G is 2 inches. Square down from G.

H is half way between B and F; H to I is 3 inches; square down from I.

Apply the blade measure from B to I, 13 less ½ inch, 12½ inches.

I to J is ¼ the distance from A to B. Square up from J.

M is half way between B and I. M to N is ½ inch. Square up from N.

A to O is ¾ inch more than ¼ breast. Square up from O. O to P is ½ inch.

Measure distance from A to P, apply to I and up to K, strap measure, 12¾ inches.

Draw a line from K to E to get Q. Draw a line from O to Q.

From K to R is ¼ inch less than P to Q.

Shape the back, shoulder and armseye, dropping the armseye ½ inch at Y and ½ inch inside of line I.

Square forward from K.

From K to V is ½ inch more than ¼ of breast measure. Draw a line from V to G.

From K to L is ¾ inch. From S to T is ½ waist measure. Square down from T.

Measure back A to P, apply to K and down to T for opening and down to Z, for full length plus 1¼ inches.

Draw a line from K to Z.

Shape gorge and front edge.

From S to X is 1 inch.

U to W is 1 inch more than ½ waist.

Y is half way between B and G.

Finish as represented.

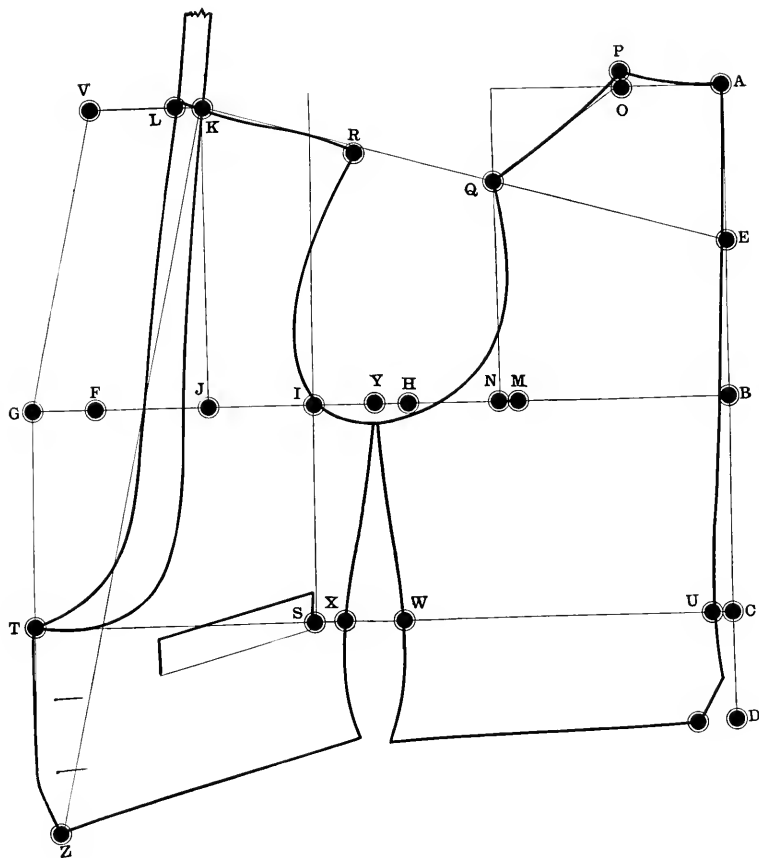

SINGLE BREASTED FULL DRESS VEST
SHAWL COLLAR

DOUBLE BREASTED FULL DRESS VEST, SHAWL COLLAR

Scye depth,	9½ inches	Blade,	13 inches
Waist length,	17 inches	Breast,	38 inches
Strap,	12¾ inches	Waist,	34 inches
	Full length,	26 inches	

Square lines A—C and A—N.

A to B is scye depth, 9½ inches; A to C is 17 inches; C to 2 is 3½ inches. D is half way between A and B.

Square out from B and C.

C to V is ¾ inch. Draw a line from V to D.

From the line just made at B to E is half of full breast, 19 inches. From E to F is 1½ inches.

G is half way between B and E. G to H is 3 inches. Square down from H.

Apply the blade measure from the line inside of B to H, 12½ inches. Square up from H.

H to I is ¼ the distance from A to B. Square up from I.

K is half way between B and H. K to L is ½ inch. Square up from L.

A to N is ¾ inch more than ½ breast. Square up from N. N to O is ½ inch.

Measure distance A to O, apply to H and up to J, strap measure 12¾ inches.

Draw a line from J to D to get M. Draw a line from N to M.

From J to P is ¼ inch less than O to M.

Shape the back, shoulder and armseye, dropping the armseye ½ inch below W and ½ inch inside of line H.

From Q to R is ½ inch less than ½ waist.

Draw a line from F through R to S.

From R to T is 3¼ inches. From S to U is 2 inches.

Draw a line from T to U.

Square out from J. From J to I is ¼ breast. From J to Z is ¾ inch.

Draw a line from J to S.

Shape the gorge and the front edge.

From Q to X is 1 inch. From A to Y is 1 inch more than ½ waist.

W is half way between B and F.

Shape the sides and finish bottom as represented.

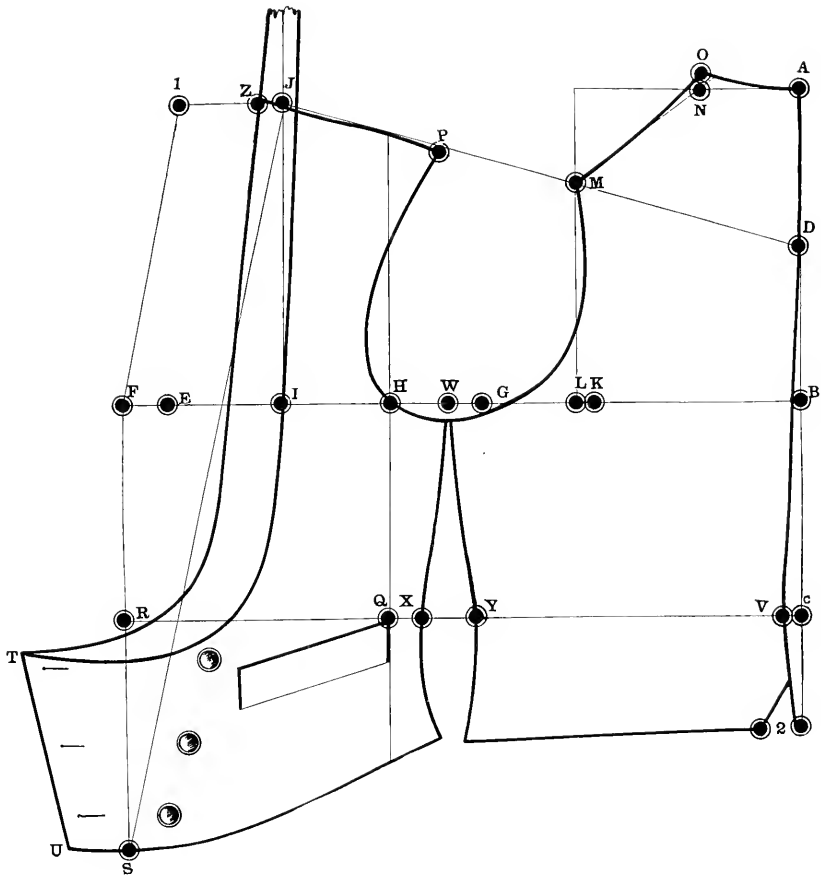

DOUBLE BREASTED FULL DRESS VEST
SHAWL COLLAR

DOUBLE BREASTED VEST, NO COLLAR

The measurements by which this draft is produced are as follows:

Seye depth,	$9\frac{1}{2}$ inches	Breast,	38 inches
Waist length,	17 inches	Waist,	34 inches
Strap,	$12\frac{3}{4}$ inches	To opening,	$12\frac{1}{2}$ inches
Blade,	13 inches	Full length,	26 inches

Square lines A—C and A—N.

A to D is seve depth, $9\frac{1}{2}$ inches; A to B is waist length, 17 inches; B to C is $3\frac{1}{2}$ inches.

Square out from D and B. 3 is half way between A and D.

B to V is $\frac{5}{8}$ of an inch. Draw a line from 3 to V.

From the line just made at D to E is half of full breast 19 inches.

E to F is $1\frac{1}{2}$ inches. G is half way between D and E. G to H is 3 inches. Square down from H.

Apply blade measure from D to H, $12\frac{1}{2}$ inches.

Square up from H. H to I is $\frac{1}{4}$ the distance from A to D. Square up from I.

K is half way between D and H. K to L is $\frac{1}{2}$ inch. Square up from L.

A to N is $\frac{3}{4}$ inch more than $\frac{1}{2}$ breast. Square up from N. N to O is $\frac{1}{2}$ inch.

Measure distance A to O, apply to H and up to J, strap measure, $12\frac{3}{4}$ inches.

Draw a line from J to 3 to get M. Draw a line from N to M.

J to P is $\frac{1}{4}$ inch less than O to M.

Shape back, shoulder and armseye.

Square forward from J. J to 2 is $\frac{1}{4}$ breast. J to L is $\frac{3}{4}$ inch.

Q to R is $\frac{1}{2}$ inch less than $\frac{1}{2}$ waist.

R to T is $3\frac{1}{2}$ inches.

Draw a line from 2 to F.

Draw a line from F through R to S.

The distance from S to U is $2\frac{1}{4}$ inches.

Draw a line from U through T.

Measure distance A to O, apply to J and down to opening, $12\frac{1}{2}$ inches plus $\frac{3}{4}$ inch, $13\frac{1}{4}$ inches, down to S is 26 plus $1\frac{1}{4}$ inches, 27 $\frac{1}{4}$ inches.

From Q to X is 1 inch.

V to Y is 1 inch more than $\frac{1}{2}$ waist.

Draw a line from J through opening and finish as represented.

DOUBLE BREASTED VEST, PEAKED LAPEL

The measurements by which this draft is produced are as follows:

Scye depth,	$9\frac{1}{2}$ inches	Breast,	38 inches
Waist length,	17 inches	Waist,	34 inches
Strap,	$12\frac{3}{4}$ inches	To opening,	$12\frac{1}{2}$ inches
Blade,	13 inches	Full length,	26 inches

Square lines A—C and A—N.

A to D is scye depth, $9\frac{1}{2}$ inches; A to B is waist, 17 inches; B to C is $3\frac{1}{2}$ inches.

Square out from D and B. 3 is half way between A and D.

B to V is $\frac{5}{8}$ of an inch. Draw a line from 3 to V. From the line just made at D to E is half of full breast, 19 inches.

E to F is $12\frac{3}{4}$ inches.

G is half way between D and E.

G to H is 3 inches. Square down from H.

Apply blade measure from D to H, $12\frac{1}{2}$ inches.

Square up from H. H to I is $\frac{1}{4}$ the distance from A to D. Square up from I.

K is half way between B and H. K to L is $\frac{1}{2}$ inch. Square up from L.

A to N is $\frac{3}{4}$ inch more than $\frac{1}{4}$ breast. Square up from N. N to O is $\frac{1}{2}$ inch.

Measure distance A to O, apply to H and up to J, strap measure, $12\frac{3}{4}$ inches.

Draw a line from J to 3 to get M. Draw a line N to M.

J to P is $\frac{1}{4}$ inch less than O to M.

Shape back, shoulder and armseye.

Square forward from J. J to 2 is $\frac{1}{4}$ breast. Draw a line from 2 to F. J to Z is $\frac{3}{4}$ inch.

Q to R is $\frac{1}{4}$ inch less than $\frac{1}{2}$ waist.

Draw a line from F through R to S.

Shape front.

THE REVER

Draw a straight line parallel with F—R.

Make the width of the rever from R to T, $3\frac{1}{2}$ inches, and from U to S $2\frac{1}{4}$ inches.

Draw a line from U to T, measure the distance A to O, apply to J and down to opening $12\frac{1}{2}$ inches plus $\frac{3}{4}$ inch, $13\frac{1}{4}$ inches, then down to S, 26 inches plus $1\frac{1}{4}$ inches, $27\frac{1}{4}$ inches.

From Q to X is 1 inch.

V to Y is 1 inch more than $\frac{1}{2}$ waist.

Draw a line from J through opening and finish as represented.

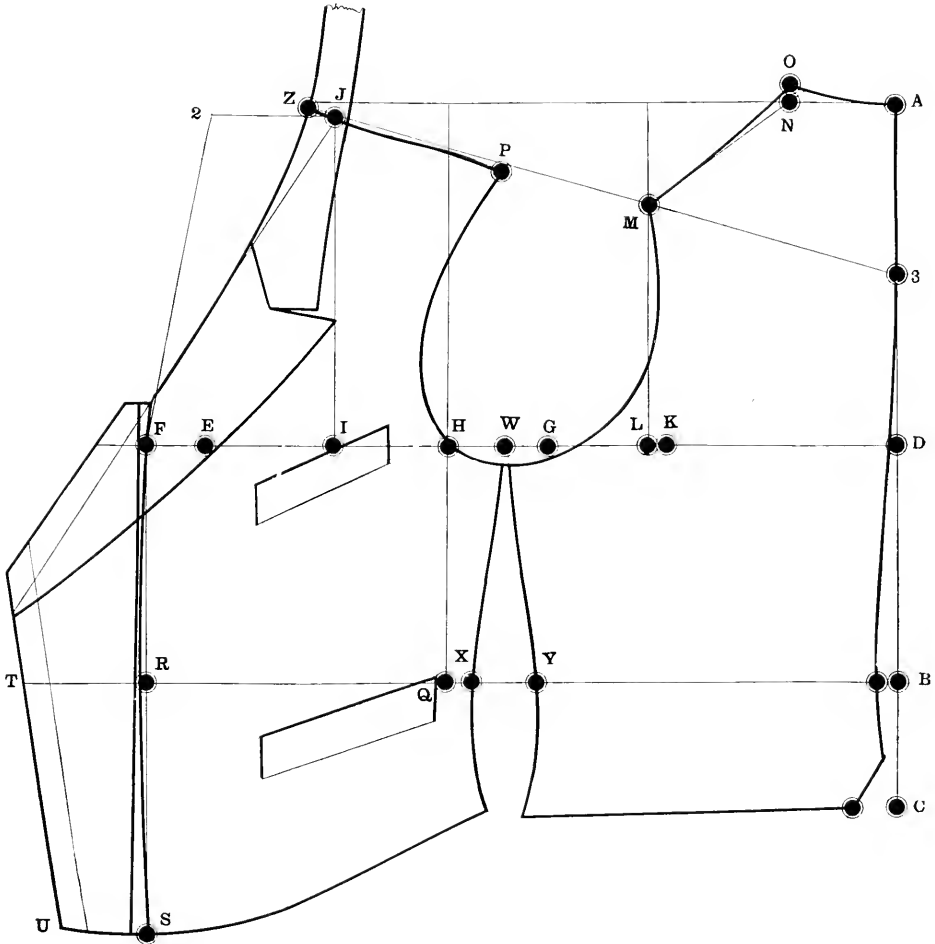

DOUBLE BREASTED VEST, PEAKED LAPEL

CLERICAL VEST, BUTTONED ON THE SIDE

The measurements by which this draft is produced are as follows:

Scye depth,	$9\frac{1}{2}$ inches	Breast,	38 inches
Waist length,	17 inches	Waist,	34 inches
Strap,	$12\frac{3}{4}$ inches	Full length,	26 inches
Blade,	13 inches		

Square lines A—O and A—D.

A to B is scye depth, $9\frac{1}{2}$ inches; A to C is waist, 17 inches; C to D is $3\frac{1}{2}$ inches. E is half way between A and B.

Square out from B and C.

C to U is $\frac{5}{8}$ inch. Draw a line from E to U.

From the line just made at B to F is half of full breast, 19 inches.

F to G is $1\frac{3}{4}$ inches. Square down from G.

H is half way between B and F. H to I is 3 inches. Square down from I.

Apply blade measure from line inside of B to I, $12\frac{1}{2}$ inches. Square up from I.

I to J is $\frac{1}{3}$ the distance from A to B. Square up from J.

M is half way between B and I. M to N is $\frac{1}{2}$ inch.

A to O is $\frac{3}{4}$ inch more than $\frac{1}{8}$ breast. Square up from O. O to P is $\frac{1}{2}$ inch.

Measure distance A to P, apply to I and up to K, strap measure, $12\frac{3}{4}$ inches.

Draw a line from K to E to get Q.

Draw a line from O to Q. From K to R is $\frac{1}{4}$ inch less than from P to Q.

K to 2 is $\frac{1}{8}$ breast. Square forward from 2 by 3.

Shape gorge, shoulder and armseye, dropping the armseye $\frac{1}{2}$ inch at Y and $\frac{1}{2}$ inch inside of line I.

K to L is $\frac{1}{4}$ inch more than $\frac{1}{8}$ breast. Draw a line from L to G.

From S to T is $\frac{1}{4}$ inch less than $\frac{1}{2}$ waist. S to X is 1 inch.

From U to W is 1 inch more than $\frac{1}{2}$ waist.

Measure back A to P, apply to K and down to Z, full length, 26 inches plus $1\frac{1}{4}$ inches. $27\frac{1}{4}$ inches.

After the vest is cut, an extra piece of cloth is cut as per dotted line for a button stand, and is to be sewed on to the back on the right side, to be buttoned over from the left side. The buttonholes are to be on the front, and the buttons on the extra piece. These vests are usually cut with a standing collar to come about $\frac{1}{2}$ inch apart in front.

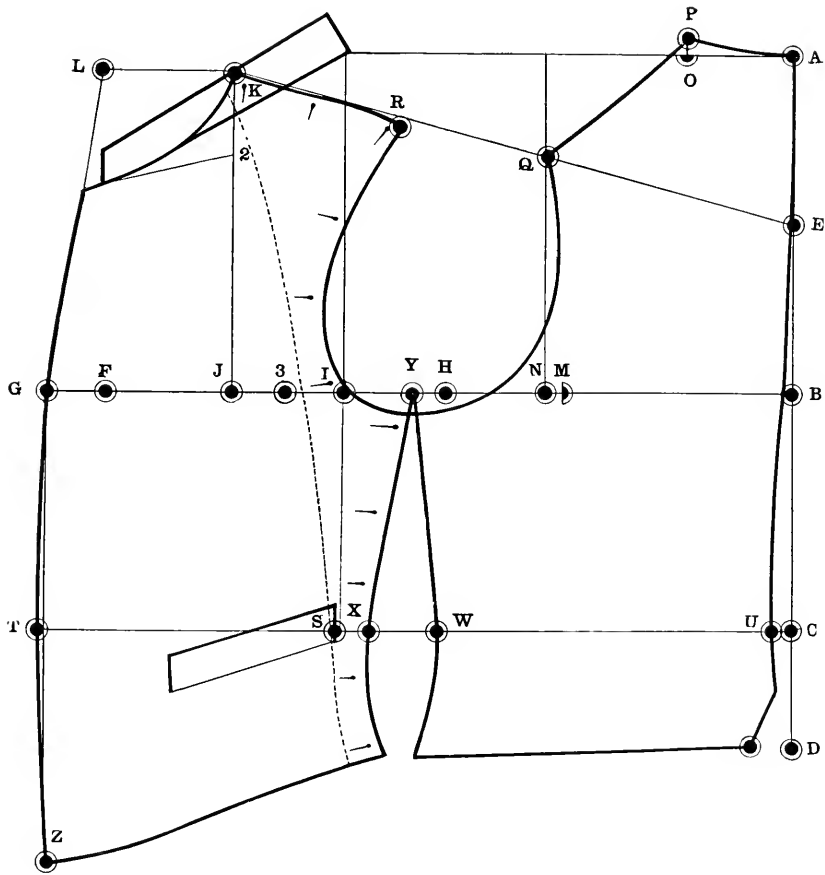

CLERICAL VEST

TROUSERS

The measurements by which these drafts are produced are as follows:

Outside length,	42 inches	Seat,	38 inches
Inside length,	32 inches	Knee,	18½ inches
Waist,	33 inches	Bottom,	16 inches

Square lines A—B and A—J.

A to B is the outside length, 42 inches.

B to C is inside length, 32 inches.

D is 2 inches more than half way between B and C.

Square out lines B, C and D.

C to E is $\frac{1}{2}$ seat measure. E to F is $\frac{1}{8}$ seat measure. G is half way between C and F.

B to H is the same as C to G.

Draw a line from H through G to I.

Square up from E to establish J.

Draw lines $\frac{1}{4}$ inch in and $\frac{1}{4}$ inch out from E to J.

F back to Z is $\frac{5}{8}$ inch; E to V is $\frac{1}{8}$ seat.

H to M is $\frac{1}{4}$ of the bottom. H to L is $\frac{1}{2}$ inch less than from $\frac{1}{4}$ bottom.

P to O and P to N are $\frac{1}{4}$ knee each.

Draw a line from M through O to Z. Draw a line from L to N and up to C.

J to K is $\frac{1}{2}$ waist; finish forepart as represented, hollowing the bottom 1 inch at H.

THE BACK PART

Extend lines L—M, N—O, C—Z, and G—I.

From I to X is $\frac{3}{8}$ of an inch less than $\frac{1}{8}$ seat.

Sweep from K to Y, pivoting at L. Sweep from C to W, pivoting at N.

From X to Y is 2 inches more than $\frac{1}{2}$ waist.

From C to W is $1\frac{1}{2}$ inches. From F to U is $1\frac{1}{2}$ inches.

Draw lines from X to Y, from X to V and from Y to W.

M to T is $\frac{1}{2}$ inch more than $\frac{1}{2}$ bottom. From L to S is the same.

From O to R is $\frac{1}{2}$ inch. From N to Q is the same.

Finish back part, taking out $\frac{3}{4}$ inch V and dropping $\frac{3}{8}$ inch below U.

These trousers may also be cut by a thigh measure.

The thigh measure is to be taken close, but not tight on the undress side. If, for instance, the thigh measure is 23 inches, and using the same measurements as in the last draft, proceed as follows:

From C to E is $\frac{1}{2}$ the seat measure.

From C to Z is $\frac{1}{2}$ the thigh measure, $11\frac{1}{2}$ inches.

From Z to F is $\frac{3}{8}$ of an inch.

G is half way between C and F.

Square up from E.

And make the rest of the diagram as the last.

It will readily be seen how the line I—H is thrown either forward or backward, according to the thigh measure.

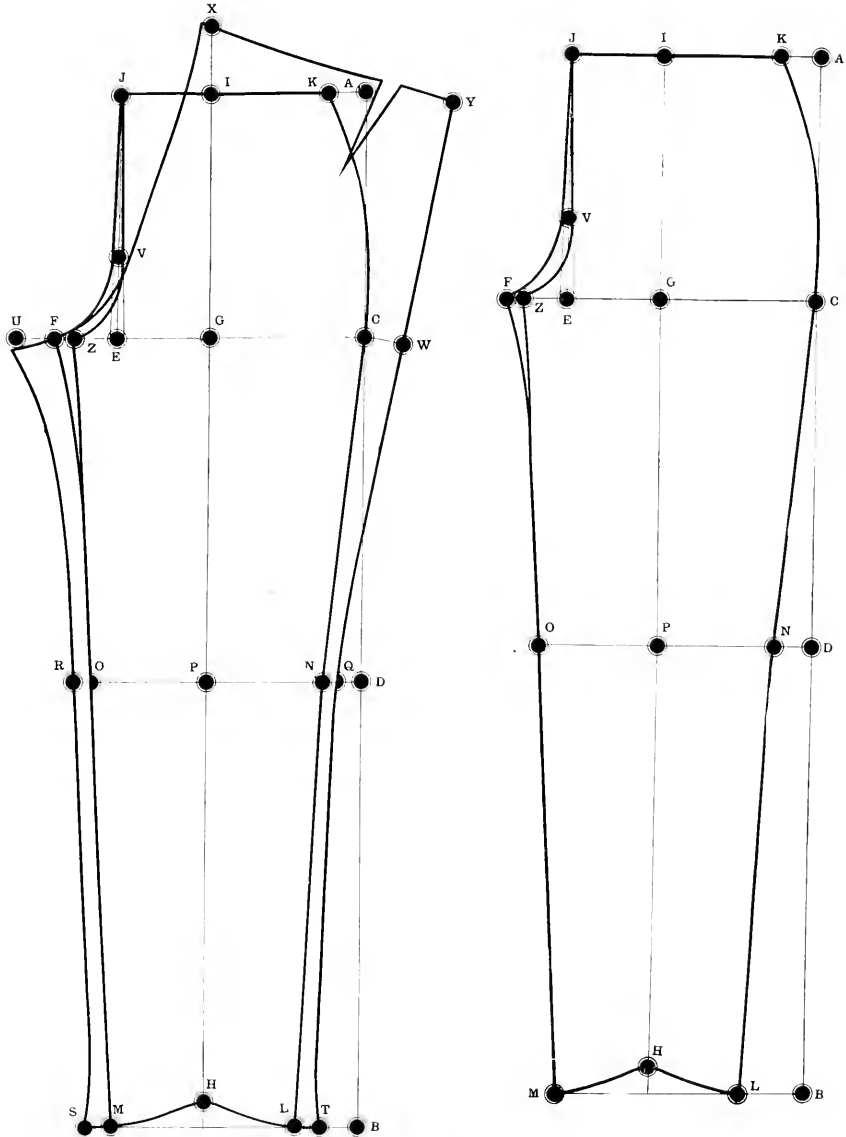

TROUSERS

PEG TOP TROUSERS

The measurements by which this draft is produced are as follows:

Outside length,	42 inches	Seat,	40 inches
Inside length,	32 inches	Thigh,	26½ inches
Waist,	34 inches	Bottom,	16 inches

The knee measure may be taken or may be left out, as desired.

Square lines A—B and A—J.

A to B is the outside length, 42 inches.

B to C is inside length, 32 inches.

D is 2 inches more than half way between B and C.

Square out from B, C and D.

C to E is half of seat measure; E to F is $\frac{1}{4}$ of seat measure.

G is half way between C and F; B to H is the same as C to G.

Draw a line from H through G to I.

Square up from E to establish J.

Draw lines $\frac{1}{4}$ inch in and $\frac{1}{4}$ inch out from E to J.

E to V is $\frac{1}{4}$ of seat measure.

H to M is $\frac{1}{4}$ of the bottom; H to L is $\frac{1}{2}$ inch less than $\frac{1}{4}$ of bottom.

Draw a line from M to Z to establish O.

Draw a line from L to C to establish N.

Z is $\frac{2}{3}$ of an inch back from F; from Z to 3 is $\frac{1}{2}$ of the thigh, 13½ inches.

J to K is $\frac{1}{2}$ waist. Finish forepart as represented.

THE BACK PART

Extend lines M—L, O—N, C—Z, J—K and G—I.

I to X is $\frac{3}{4}$ inch less than $\frac{1}{4}$ of seat measure; X to Y is $\frac{1}{2}$ waist, plus 1 inch.

3 to W is 1½ inches; F to U is 1½ inches.

From M to T is $\frac{1}{2}$ inch more than $\frac{1}{2}$ of bottom; from L to S is the same.

O to R is $\frac{1}{2}$ inch; N to Q is the same.

Finish back part, dropping $\frac{3}{8}$ inch at U.

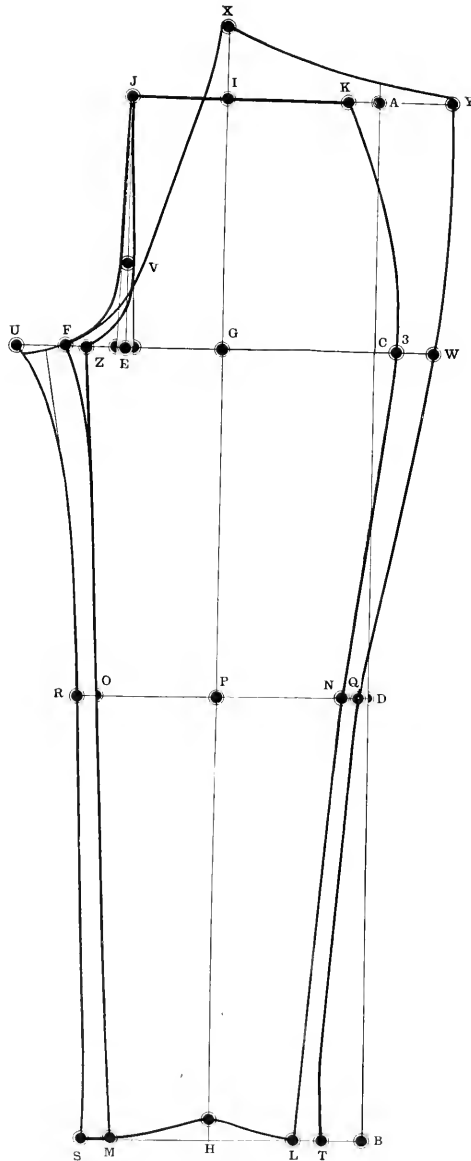

PEG TOP TROUSERS

SPRING BOTTOM TROUSERS

The measurements by which this draft is produced are as follows:

Outside length,	43 inches	Knee,	19 inches
Inside length,	32 inches	Bottom,	19 inches
Waist,	38 inches	Hip,	40 inches
Seat,	40 inches		

When a person is inclined to be corpulent it is best to take a hip measure about three inches below the waist.

A to B is outside length, 43 inches.

B to C is inside length, 32 inches.

D is 2 inches more than half way between B and C.

A to 3 is 3 inches.

Square out from 3, C, D and B.

From C to E is $\frac{1}{2}$ seat. E to F is $\frac{1}{3}$ seat. G is half way between C and F.

B to H is the same as C to G. Draw a line from H through G to I.

In the Spring-bottom trousers the forepart must be small at the bottom.

From H to M is $4\frac{1}{2}$ inches. H to L is 4 inches.

P to O is $\frac{1}{4}$ of the knee and P to N is the same.

Draw lines from L to N and from M to O. Extend line from O to Z and from N to C.

Square up from E to get 2.

From 2 to K is $\frac{1}{2}$ waist.

However, the distance between K and A must never be less than 1 inch.

In this case, where the waist is only 2 inches smaller than the seat, the distance from K to A would be $\frac{1}{2}$ inch. We will therefore make it one inch and measure waist from K to 1, $9\frac{1}{2}$ inches.

From 2 to J is the same distance as from 1 to 2.

Shape the side from K to C.

From 3 to 4 is $\frac{1}{4}$ inch more than $\frac{1}{2}$ hip.

Draw a line from J to K, and finish as represented.

THE BACK PART

Extend lines L—M, N—O, C—Z and G—I.

Sweep from C to W, pivoting at N. Sweep from K to Y, pivoting at L.

I to X is $\frac{3}{8}$ inch less than $\frac{1}{4}$ seat.

Z to W is $1\frac{1}{2}$ inches. F to U is $1\frac{1}{2}$ inches.

L to S is $\frac{1}{2}$ inch more than $\frac{1}{2}$ bottom. M to T is the same.

N to Q is $\frac{1}{2}$ inch. O to R is the same.

From X to Y is 2 inches more than $\frac{1}{2}$ waist.

Draw lines from X to V, from X to Y, and from Y to W.

Finish back part, taking out $\frac{1}{2}$ inch V at the waist and dropping $\frac{3}{8}$ inch at U.

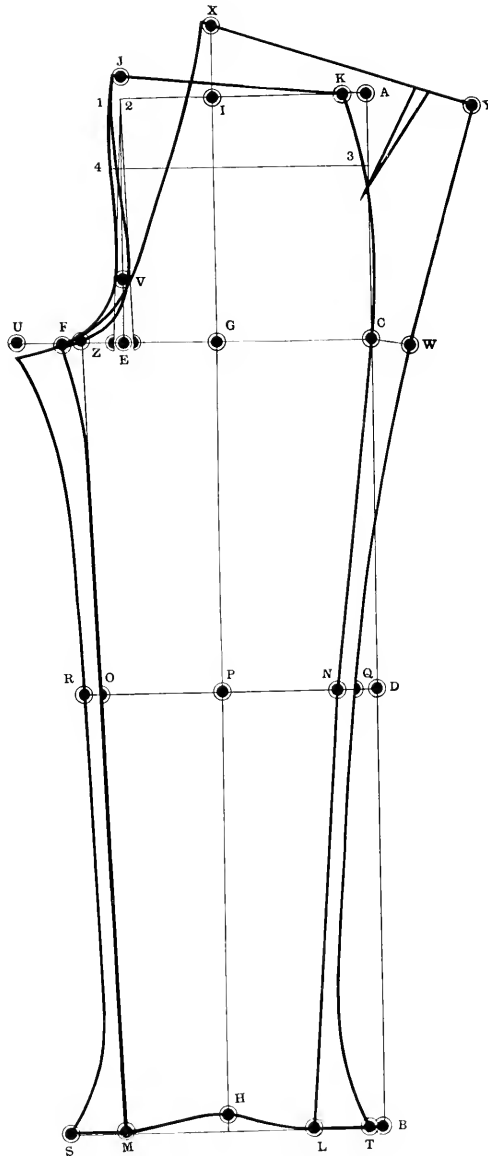

SPRING BOTTOM TROUSERS

TROUSERS FOR CORPULENT FIGURE

The measurements by which this draft is produced are as follows:

Outside length,	43 inches	Seat,	42 inches
Inside length,	32 inches	Knee,	20 inches
Waist,	42 inches	Bottom,	17 inches
Hip,	44 inches		

Square lines A—2 and A—B.

A to B is outside length, 43 inches; B to C is inside length, 32 inches.

D is 2 inches more than half way between B and C.

A to 3 is 3 inches.

Square out from 3, C, D and B.

C to E is $\frac{1}{2}$ seat. E to F is $\frac{1}{4}$ seat.

G is half way between C and F.

B to H is the same as C to G.

Draw a line from H through G to L.

H to M is $\frac{1}{4}$ bottom. H to L is $\frac{1}{2}$ inch less than $\frac{1}{4}$ bottom.

P to O and P to N are $\frac{1}{4}$ knee each.

Draw lines from M to O and from L to N.

Extend lines from O to Z and from N to C.

Square up from E.

At E go $\frac{1}{4}$ inch out and $\frac{1}{4}$ inch in; draw lines up to 2.

From 2 to K is $\frac{1}{2}$ waist. But the distance from A to K must be no less than 1 inch. We will therefore make the distance from A to K 1 inch and measure from K to 1 half of the waist.

From 2 to J is the same distance as from 2 to 1.

Shape the side from K to C.

From 3 to 4 is $\frac{1}{4}$ inch more than $\frac{1}{2}$ hip.

Draw a line from J to K and shape the front through 1 and 4 to F.

Finish forepart, hollowing 1 inch at H.

THE BACK PART

Extend lines M—L, O—N, C—F and G—L.

L to X is $\frac{3}{4}$ inch less than $\frac{1}{6}$ seat.

Sweep from C to W, pivoting at N. Sweep from K to Y, pivoting at L.

From X to Y is 1 inch more than $\frac{1}{2}$ waist.

From C to W is $1\frac{1}{2}$ inches. From F to U is $1\frac{1}{2}$ inches.

Draw lines from X to V, from X to Y and from Y to W.

L to S is $\frac{1}{2}$ inch more than $\frac{1}{2}$ bottom. M to T is the same.

N to O and O to R are $\frac{1}{2}$ inch each.

Finish back part as represented, dropping it $\frac{3}{4}$ inch at U.

In trousers where the waist is as large as the seat it is not necessary to take the V out at the waist.

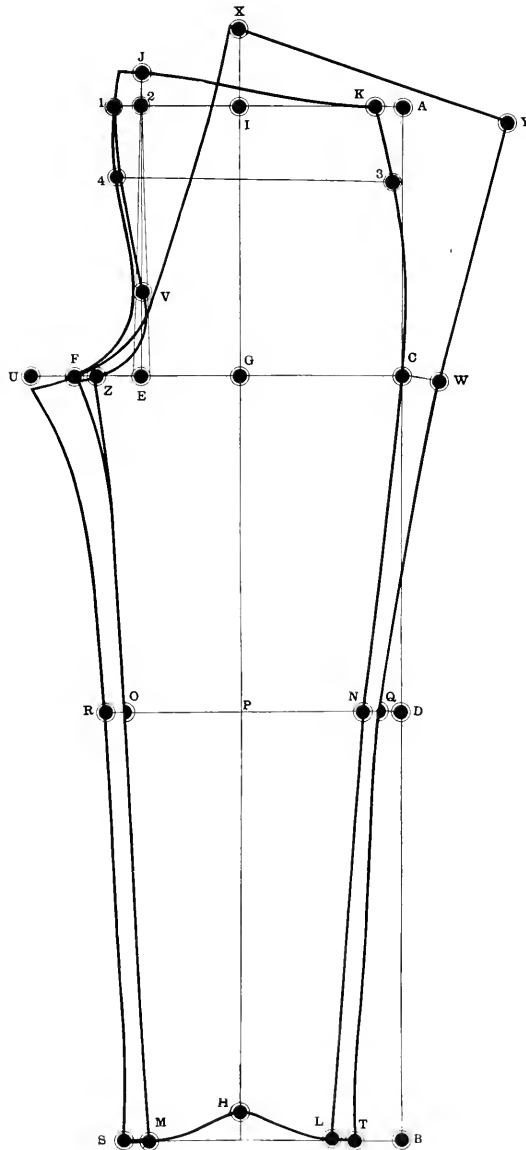

CORPULENT MAN'S TROUSERS

TROUSERS FOR A BOW-LEGGED PERSON.

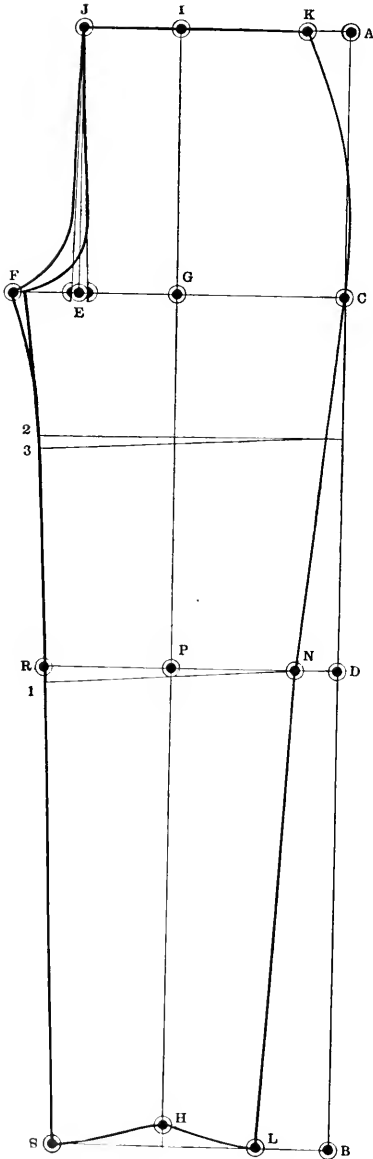

After the measures have been taken as usual, ascertain the amount that the legs are bowed, by having the person stand with both feet together. Draft your forepart accordingly. If the bow be two inches, cut in the forepart as from R to N and at 2.

From R to 1 is $\frac{1}{2}$ inch.

From 2 to 3 is $\frac{1}{2}$ inch.

Pin the pattern over figure 2 on the figure 3 and letter R to figure 1, after which place them on a clean sheet of paper. (See Diagram II.) Straighten out the inseam and measure the length from F to M so that you get the proper length. Now cut the back part accordingly. (See Diagram III.) If the bow be 1 inch, then it is not necessary to cut it in two places, $\frac{1}{2}$ inch between 2 and 3 will be sufficient.

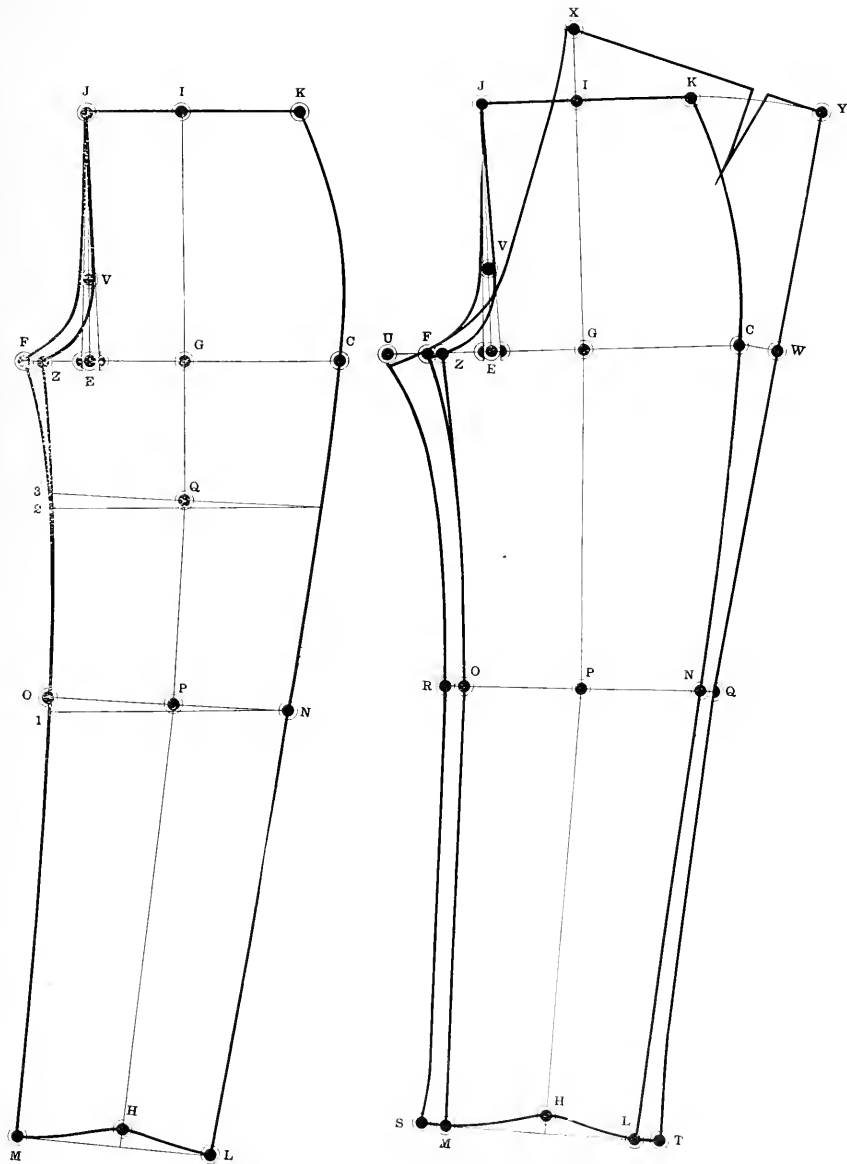

II

AFTER BEING SHORTENED IN SEAM

III

FINISHED

TROUSERS FOR KNOCK-KNEED PERSON

These trousers are cut just opposite to the trousers for a bow legged man. They are cut open as from N to O. From N to I is $\frac{1}{2}$ inch or as much more as may be necessary. Lap the pattern over as from N to I and cut the back part accordingly.

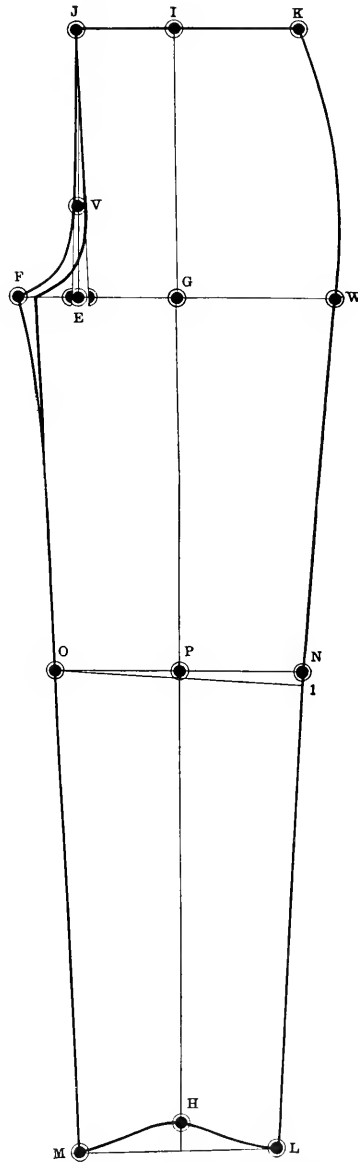

TROUSERS FOR KNOCK-KNEED MAN

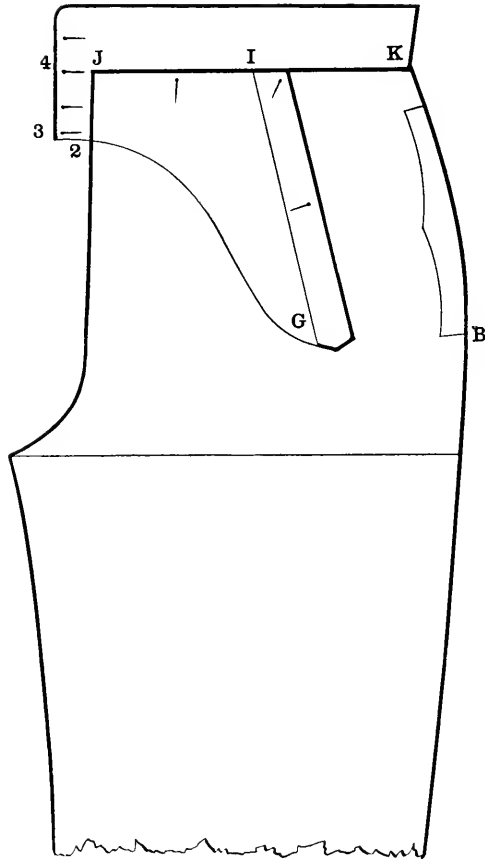

NARROW FALLS

The pattern for the trousers having been cut, proceed as follows:

I is half way between J and K.

B to G is the same distance as from I to K.

From I to G is 8 inches, or 1 inch below the pocket as from B.

Add 1 inch from 2 to 3 and J to 4.

The waist-band for these trousers is cut separately. A welt is sewed on as from I to G and the fly that is added is sewed underneath part of the forepart marked B—K.

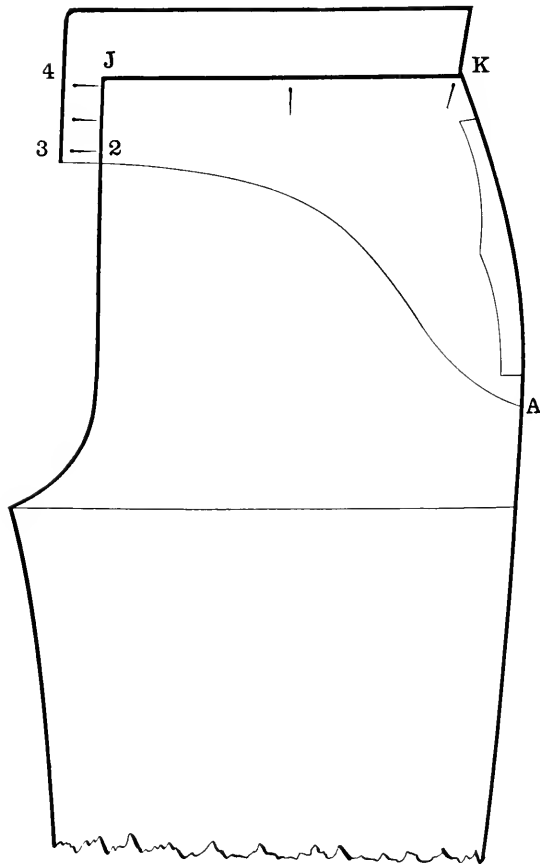

BROAD FALLS

After the forepart has been cut out, proceed as follows:
 Lay the pattern on the paper and mark as from K to J, to 2, and to A.
 From K to A is 8 inches, or A is 1 inch below the pocket.
 From J to 2 is 2 inches.
 From J to 4 and 2 to 3 is 1 inch for buttons and button-holes.
 The waist-band may be added to the piece or may be cut separately.

RIDING BREECHES WITH EXTENSION

The measurements by which this draft is produced are as follows:

Outside length,	35½ inches	Knee,	16½ inches
Inside length,	25 inches	Small of knee,	13½ inches
To knee,	22 inches	Calf,	15 inches
Waist,	35 inches	Ankle,	12 inches
Seat,	40 inches		

Square lines A—E and A—J.

A to B is 22 plus 1¼ inches. 23¼ inches. B to C is 2½ inches; C to D is 4 inches; A to E is 36¾ inches.

E to F is inseam, 26¼ inches.

Square out from F, B, C, D and E.

F to G is ½ seat. G to H is ¼ inch more than ½ seat measure.

H to S is ⅝ inch. Square up and down from G to establish 7 and J.

Draw a line from S through L to M.

Square down from M.

From M to N is ½ inch more than ⅓ of small of knee.

Square down from N.

P to Q is ½ inch more than ¼ calf.

O to R is ½ inch more than ¼ ankle.

Draw a line from F to N; F to T is 1 inch.

J to W is ½ waist. Shape side seam, and finish as represented.

THE BACK PART

Extend lines I—U, Y—Z, B—L, 8—5, 9—6 and E—7.

R to 7 is ½ inch; Q to 6 is ½ inch; M to 5 is ½ inch.

H to Z is 2 inches; T to Y is 2 inches; G to 11 is ⅓ seat.

U to V is 4 inches; V to X is ½ waist plus 1 inch.

Draw a line from V to 11.

Draw a line from Z to 5.

Measure ankle R to O and 7 to 10, 12 inches, and 2 inches for the V and seams.

Q to P and 6 to 9 calf, plus ½ inch.

M to N and 5 to 8, small of knee plus ½ inch. 1 is half way between O and R.

Square up from 1 to 2.

1 to 3 and 1 to 4 are ½ inch each.

Cut out V on back part.

Finish as represented.

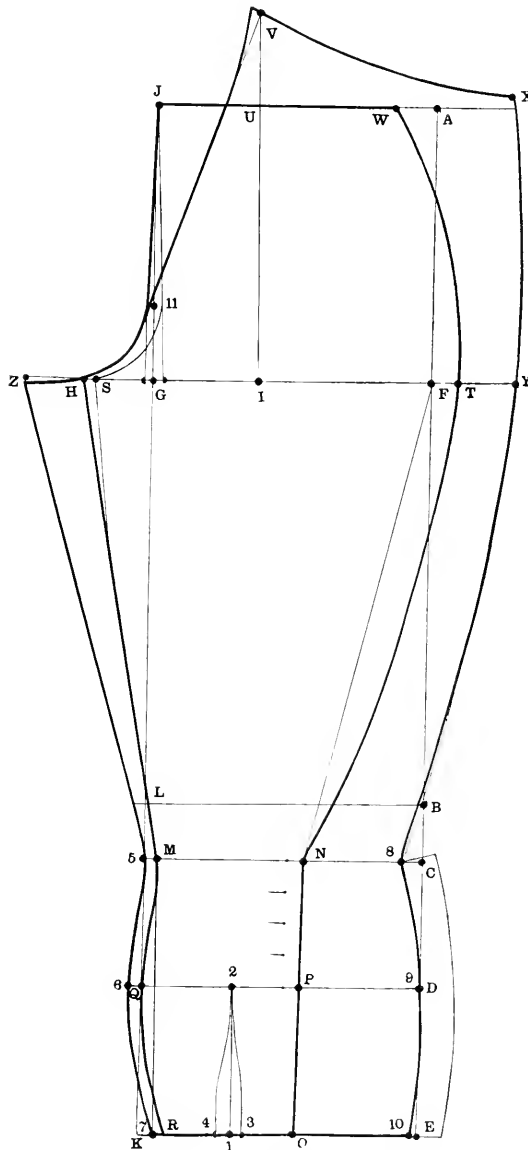

RIDING BREECHES WITH EXTENSION

GOLF OR BICYCLE TROUSERS.

Outside length to the knee,	24 inches	Waist,	34 inches
Full length,	31 inches	Seat,	40 inches
Inseam,	21 inches	Knee,	21 inches
	Ankle,		12½ inches

Square lines A—B and A—J.

A to B is full length. B to C is inseam. A to 14 is length to knee. 14 to D is 1¼ inches.

Square out from C, 14, D and B.

C to E is ½ seat.

E to F is ¼ inch more than ⅓ seat. G is half way between C and F.

B to H is the same as C to G.

Draw a line from H through G to I.

P to N and P to O are ¼ knee each.

Draw a line from X to C and from O to Z.

3 is half way between 4 and H. 2 is half way between T and H.

From 2 to L is ⅓ bottom. From 2 to 5 is ¼ inch more than ⅓ ankle.

From 3 to M is ⅓ ankle. From 3 to 6 is ¼ inch more than ⅓ ankle.

Shape the bottom of forepart from O to M, from P to 6 and 5 and from N to L.

Take out a V between 6 and 5 as marked.

Square up from E to J.

Mark ¼ inch in and ¼ inch out from E to J.

J to K is ½ waist.

C to 1 is 1 inch.

Finish forepart as represented.

THE BACK PART

Extend lines L—M, N—O, C—Z and I—K.

Draw a line from G and from I to X; I to X is ⅓ seat.

Draw a line from X to V.

X to Y is 1 inch more than ½ waist.

I to W is 1½ inches.

F to U is 1½ inches.

O to R and N to Q are ½ inch each.

M to S and L to T are ½ inch each.

Cut out V from back part as P—5—6 and finish back part as represented, dropping it ¾ inch at U.

The cuff is 12½ inches wide; allow 1¼ inches for make-up and 5 inches deep, to be finished with 5 buttons.

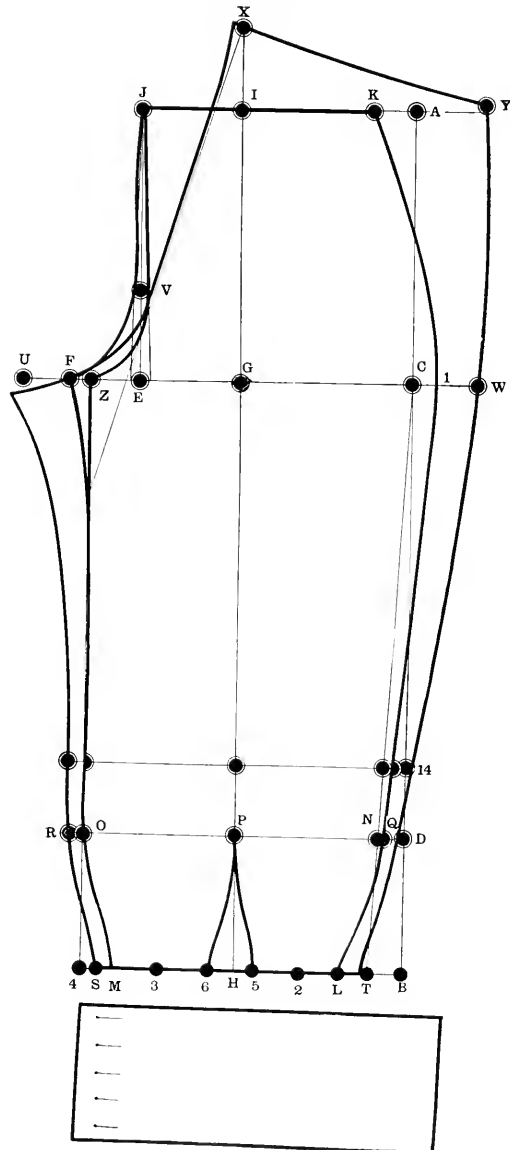

BICYCLE OR GOLF TROUSERS

MILITARY CAPE

Square lines A—B—C.

Place the back of an overcoat pattern of the size required to touch line A—B.

Place the forepart to touch line A—C with the shoulder touching at M—P.

Mark around the back at D—E—M and the front at P—U around the gorge and front edge.

From E to F is 1 inch.

From P to T is $1\frac{1}{4}$ inches.

From U to S is 1 inch.

From T to N is 1 inch.

Draw lines from S to N and from F to N.

Sweep from B to C, pivoting at S.

Flatten the bottom and hollow shoulder as represented.

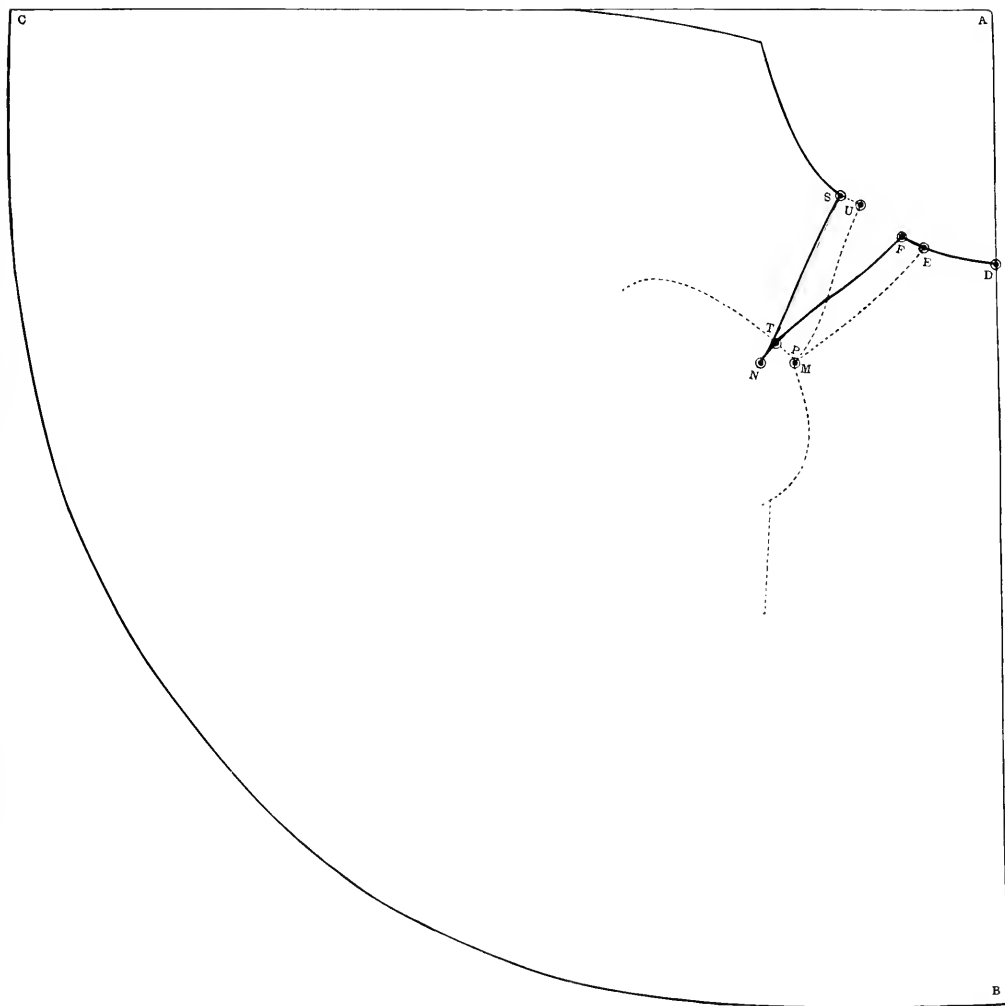

MILITARY CAPE

SHOULDER CAPE.

Draw a line and place the back of an overcoat pattern of the size required, the center seam to touch at A—C.

B is the breast line.

Mark around the back as at A—H—D.

From B to D is $\frac{1}{2}$ breast.

From D to E is $\frac{1}{4}$ breast.

Draw a line from H through E to I.

From I to J is 1 inch.

From F to G is $\frac{1}{2}$ inch.

Shape the back from G through H through E to J.

From A to C is the length required. From G to J is 3 inches more than from A to C.

Finish the bottom as represented.

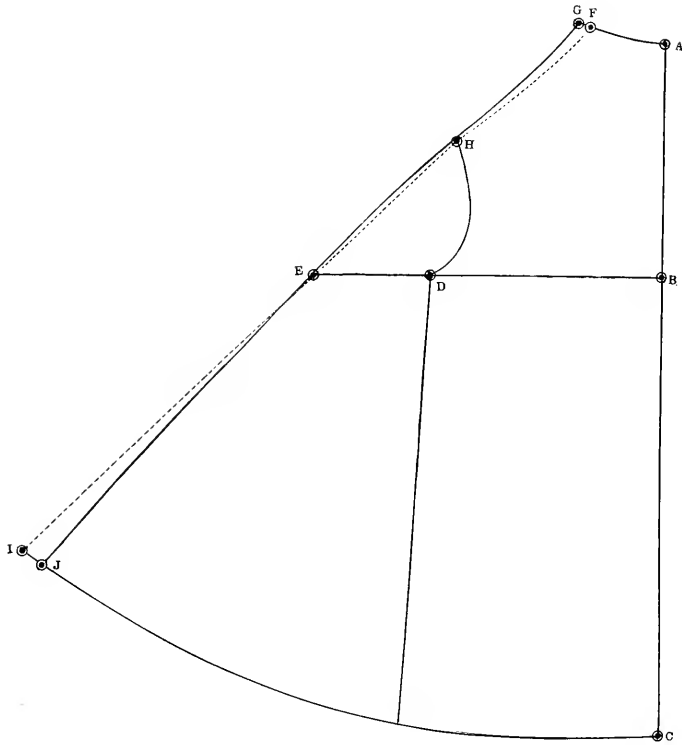

SHOULDER CAPE

THE SHOULDER CAPE—Continued

THE FOREPART

Place the forepart of an overcoat pattern of the size required on a sheet of paper and mark around it as per dotted lines. M—X is the breast line.

From X to K is $4\frac{1}{2}$ inches, or the addition to the breast of a single breasted overcoat.

From K to L is $\frac{1}{2}$ breast.

From L to M is $\frac{1}{4}$ breast.

From R to S is $\frac{1}{2}$ inch.

From N to Q is $\frac{1}{4}$ breast.

From N to O is 1 inch.

Sweep from O to P, pivoting at Q.

From N to P is 1 inch. Draw lines from O to Q and from P to Q.

Draw a straight line from P through M to U.

From U to V is 1 inch.

Draw a line from V to M. Shape the shoulder from S to O, and the side from P to Y, rounding it $\frac{1}{4}$ inch over M.

From X to Y is 2 inches. From Z to W is the same.

From S to T is 1 inch.

From S to O and from P to V is the same as from G to J on the back part.

Sweep from V to W, pivoting at T.

Finish as represented.

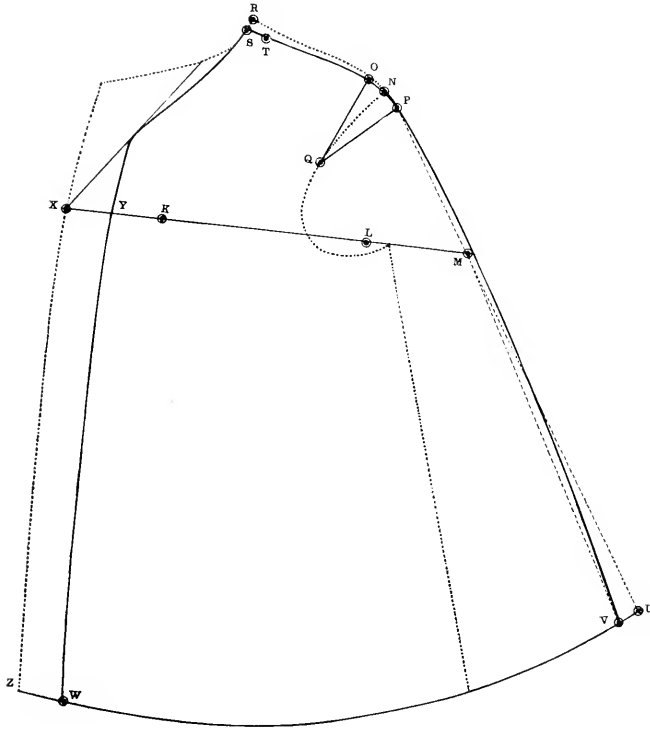

THE SHOULDER CAPE

A FEW REMARKS ABOUT MAKING COATS.

THE CANVAS.—The canvas and hair cloth should always be cut on the bias.

SACK COATS

SACK COATS.—In sewing up the side seams hold the back easy over the blade, straight to about 3 inches below the waist, and a trifle short over the hip.

THE SHOULDERS.—The front shoulder may be slightly stretched from the middle of it, to the shoulder point and the back held easy over the same parts, but never stretch it for a stout person.

THE EDGES.—Always dip the stay tape in water and press before using it. When basting stay tape on the front edge, hold it short over the breast, and work the front edge in, so that the roundness of the breast is pressed in to the middle of the front and the edge becomes straight. For a stout person, hold the stay tape short over the most prominent rounding, which is over the waist. In all straight front coats, such as over coats, double breasted sacks, or straight front sacks, the front edges must be worked in until they are straight.

THE SLEEVES.—In sewing up the front seams always begin at the top, and, basting on the upper sleeve, keep both upper and under sleeves even for about 3 inches; from there down hold the upper sleeve a little short to about 3 inches from the bottom, and from there down hold them even. When sewing up the back seam, begin also on top, and basting on the upper sleeve, keep them both even to the elbow, over the roundness of the elbow hold the upper sleeve easy, and from there down even.

Before basting in the sleeves straighten out the armseye, and take a linen thread, draw in the back part of the armseye from the shoulder seam to about $1\frac{1}{2}$ inches below the side seam, and press the fullness away so as to leave a pocket over the blade bone.

When basting in the sleeve, begin with the right one and placing the seam of the sleeve to the nick of the back hold it even to about 1 inch beyond the shoulder seam, from there on full the sleeve in until the front nick of the sleeve reaches the nick of the front; from there hold the sleeve even until you reach the part of the armseye that is drawn in with the linen thread and full the under sleeve in over it.

THE COLLAR.—Collars are to be put in easy in the hollow of the gorge for normal or slim persons. A concave shoulder needs a longer collar than a normal shoulder. A stout person needs a shorter collar than a normal person. In either case, don't stretch the collar stand.

FROCKS

In basting the side body to the front, always begin and keep them even at the armseye and hold the side body a little short at the waist.

THE SKIRT.

After the side seam and fish are sewed and pressed open, baste a piece of stay tape to the bottom, or the waist seam of the side body, so as to prevent it from stretching, after which baste the skirt on, beginning at the side, hold the skirt and side body even to the side seam; from there on for about 4 inches hold the skirt full, and from there on even to the front.

In sewing the back to the side body, begin at the armseye and keep both back and side body even to about 4 inches from the waist; from there down full the back in about $\frac{1}{4}$ or $\frac{3}{8}$ inch; *don't stretch the side body* until after the back is sewed on to it, and then only just enough to make the back seam straight. Shrink in the side body half way.

THE PLEATS.

The proper way to make the pleats is to put a baste in $\frac{1}{4}$ inch or a seam back from the mark stitch, and press the roundness of the skirt in until the pleat is straight, press it open as if it were a seam. Pull the baste out and it is ready to be joined to the back.

The shoulder, collar and sleeves are the same as in the sack coats.

In double breasted frocks or dress coats all the seams are joined the same as the single breasted coats, except that the rever is held short over the breast and the bell shape skirt needs but little fullness at the waist.

VESTS.

All vests cut by this system need no collar stand, as the stand is cut on the vest.

THE EDGES.—All the front edges are to be made straight with the stay tape, i. e., they are to be worked in until the edge is straight and the fullness pressed in to the middle of the front.

THE SHOULDERS.—The shoulders ought to be stretched slightly and the back held full over them. The collar, if there be one, should be held easy to about 3 inches from the shoulder and from there held short to about 2 inches from the front edge.

Double breasted vests, with or without collar, or dress vests with low openings should have stay tape laid around the opening and held short so as to prevent the edge sticking away from the shirt front.

Double breasted vests, and double breasted coats must have more breast worked in them than single breasted vests or coats.

TROUSERS.

Avoid stretching trousers, except the inseam of the back part from the knee to the crotch, and that only $\frac{1}{2}$ inch. Any stretching on the forepart is sure to spoil them. Let the notches come together evenly; hold the forepart easy over the knee and the back part hold easy over the calf.

Peg top trousers should have the roundness from over the hip pressed in to the back. Let the fore part be held easy over the back part from the hip to the knee. Waist bands should be held a little short over the fore part, easy in hollow of the waist and even from there back.

The right fly should be held easy in the hollow of the crotch. Let all the shaping be done by shrinking. *Do not stretch.*

INDEX

INTRODUCTION	3
PREFACE	5
THE MEASUREMENT OF THE HUMAN BODY	7
HOW TO MEASURE	8
VEST MEASUREMENTS	14
TROUSERS MEASUREMENTS	16
THE SQUARE	16
SINGLE BREASTED SACK COAT	18
ACTUAL MEASUREMENTS WILL SHOW FIGURE	26
THREE BUTTON SACK	36
STRAIGHT FRONT SACK—STRAIGHT BACK	38
FOUR BUTTON MILITARY SACK WITH OR WITHOUT EXAGGERATED SHOULDER	40
HOW TO CUT A CONCAVE SHOULDER	42
THREE BUTTON DOUBLE BREASTED SACK	44
FOUR BUTTON SACK (FOR STOUT FIGURE)	46
FOUR BUTTON SACK (FOR CORPULENT FIGURE)	48
THREE BUTTON CUTAWAY FROCK	52
ONE BUTTON CUTAWAY FROCK	54
ENGLISH WALKING COAT	56
THREE BUTTON FROCK (FOR STOUT FIGURE)	58
THREE BUTTON FROCK (FOR CORPULENT FIGURE)	60
SINGLE BREASTED FROCK (STRAIGHT FRONT)	62
THREE BUTTON DOUBLE BREASTED FROCK	64
THREE BUTTON DOUBLE BREASTED FROCK (FOR STOUT FIGURE)	65
THREE BUTTON DOUBLE BREASTED FROCK (FOR CORPULENT FIGURE)	68
TUXEDO COAT	70
TUXEDO COAT (PEAKED LAPEL)	72
FULL DRESS COAT (PEAKED LAPEL)	76
FULL DRESS COAT (SHAWL COLLAR)	74
A FEW WORDS IN REGARD TO WAIST SUPPRESSION	78
FULL BREAST—FLAT BACK	80
CHESTERFIELD OVERCOAT	84
TOP COAT	88
FULL BOX OVERCOAT	88
INVERNESS	90
DOUBLE BREASTED ULSTER	92
SINGLE BREASTED FROCK OVERCOAT	94
DOUBLE BREASTED FROCK OVERCOAT	96
SINGLE BREASTED PALETOT	98
SINGLE BREASTED PADDOCK	100
DOUBLE BREASTED PADDOCK	102
MEASURING A HUNCHBACK	104
STRAIGHT FRONT SACK FOR HUNCHBACK	106
CASSOCK COAT	108
THE SLEEVE	110
HALF AND HALF SLEEVE	112
SLEEVE FOR BOX OVERCOAT	114
SINGLE BREASTED VEST (NO COLLAR)	116
SINGLE BREASTED VEST WITH NOTCH COLLAR	118
SINGLE BREASTED VEST, NOTCH COLLAR (FOR STOUT FIGURE)	120
SINGLE BREASTED VEST, NOTCH COLLAR (FOR CORPULENT FIGURE)	124
FULL DRESS VEST (SHAWL COLLAR)	126
DOUBLE BREASTED FULL DRESS VEST (SHAWL COLLAR)	128
DOUBLE BREASTED VEST (NO COLLAR)	130
DOUBLE BREASTED VEST, (PEAKED LAPEL)	132
CLERICAL VEST (BUTTONED ON SIDE)	134
TROUSERS	136
PEG TOP TROUSERS	138
SPRING BOTTOM TROUSERS	140
TROUSERS FOR CORPULENT FIGURE	142
TROUSERS FOR BOW-LEGGED PERSON	144
TROUSERS FOR KNOCK-KNEED PERSON	146
NARROW FALLS	148
BROAD FALLS	149
RIDING BREECHES WITH EXTENSION	150
GOLF OR BICYCLE TROUSERS	152
MILITARY CAPE	154
SHOULDER CAPE	156
A FEW REMARKS ABOUT MAKING COATS	160



Publishers of

AMERICAN GENTLEMAN
Men's Fashions.
\$7.50 A YEAR

WITH
EDITION DE LUXE
Magnificent Art Plates of
Men's Fashions
\$15.00

**AMERICAN ALBUM OF
FUR NOVELTIES**
The Authority on Fur Fashions
\$20.00 A YEAR

LES PARISIENNES
The Acknowledged Authority on
"Tailor Made" Styles
\$20.00 A YEAR

AMERICAN CLOAK ALBUM
Cloaks, Suits, Etc.
\$50.00 A YEAR

AMERICAN SKIRT ALBUM
\$25.00 A YEAR

SHIRTWAIST SUITS
120 Designs Yearly
\$25.00 A YEAR

AMERICAN WAIST ALBUM
for Manufacturers
\$25.00 A YEAR

**AMERICAN GARMENT
CUTTER**
Men's Garments
CLOTH BOUND, COMPLETE \$15.00

**AMERICAN GARMENT
CUTTER**
Women's Garments
CLOTH BOUND, COMPLETE \$25.00

**AMERICAN GARMENT
CUTTER**
Women's Skirts
CLOTH BOUND, COMPLETE \$10.00

**AMERICAN GARMENT
CUTTER**
For Furriers
CLOTH BOUND, COMPLETE \$25.00

PICTORIAL REVIEW
Three Magazines in One
Literary, Fashion, Home
\$1.00 PER YEAR

**GARMENT CUTTING AND
DESIGNING SCHOOL**
The Simplest and Most Popular
System Taught

PATTERN DEPARTMENT
Patterns Unequaled in Style
and Fit, Cut to Order

TYPOGRAPHICAL DEPT.
For Catalogues and
Advertising Specialties

**ENGRAVING
and
ELECTROTYPING**

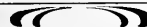

Cable Addresses:

ANNELT NEW YORK
ANNELT, LONDON
ANNELT PARIS
MODEANNELT BERLIN
A B C CODE USED

Telephone 3791 | GRAMERCY
3792

WM. P. ANNELT, PRES. & TREAS.
CHAS. W. NELSON, 1ST VICE-PRES.
WM. O. FREYER, 2ND VICE-PRES.
LEON LEWIN, SECRETARY

American Fashion Co.

[INCORPORATED]

ESTABLISHED 1890

Designers and Publishers of



Fashions



853 Broadway

Corner of 14th Street

NEW YORK

CHICAGO: 158-164 STATE STREET

European Branches:

PARIS: 14 Rue Taibout

BERLIN: Leipziger Strasse 90

LONDON: 203 Regent Street

AMERICAN GENTLEMAN

Is the Leading High-Class Practical
Tailors' Journal of the World

SUBSCRIPTION \$7.50 PER ANNUM

: : : WHICH INCLUDES : : :

EIGHT LARGE JOURNALS cram full of the best and latest sartorial ideas and news, profusely illustrated with fashion designs; drafts and diagrams of all garment illustrated on plates; Style Chats with the Leaders in the Trade, etc.

SIX LARGE PANORAMAS of styles, 22x28 inches.

TWENTY-FOUR TWO-FIGURE PLATES, 12½x18, all exquisitely printed in colors on royal plate paper, showing the very latest styles in Men's Garments.

The Edition de Luxe

of the AMERICAN GENTLEMAN is the acme of fashion publications. Magnificently embossed and printed in colors on the finest steel plate paper.

The **Edition de Luxe** is a production to be proud of. There are 32 of these plates issued annually, and they are works of art, suitable for the very highest class of tailors.

Subscription, including the Regular Edition of the American Gentleman with its plates, \$15.00 per annum.

PUBLISHERS
AMERICAN FASHION COMPANY

853 BROADWAY, NEW YORK

BRANCHES AT

CHICAGO: 158-164 STATE STREET

PARIS: 14 Rue Taibout

LONDON: 203 Regent Street

BERLIN: 90 Leipziger Strasse

*PATTERNS OF ALL KINDS CUT TO ORDER PROMPTLY
LEARN CUTTING AT THE AMERICAN CUTTING SCHOOL*

Les Parisiennes

Album de Luxe
"Genre Tailleur"

Les Parisiennes is the leading Fashion Journal of the world devoted to the Creation of Styles for Ladies' Tailors. It is the only journal of its kind maintaining offices, each with an able staff of designers and artists, in Paris, Berlin, London and New York.

Les Parisiennes is a well-edited trade journal devoted to the interests of Ladies' Tailors. It gives all the latest news, fashion chat, etc., of interest in the world of Women's Fashion.

Published Monthly
Except December and June.

Subscription Price
For One Year (10 numbers) \$20.00.

: : : PUBLISHERS : : :

American Fashion Company

853 BROADWAY, NEW YORK

Branches at
PARIS
14 Rue Talbot

BERLIN
90 Leipziger StraÙe

LONDON
203 Regent Street

CHICAGO
158-164 State Street

PATTERNS OF ALL KINDS CUT TO ORDER PROMPTLY
LEARN CUTTING AT THE AMERICAN CUTTING SCHOOL

American Album of Fur Novelties

Thirteenth Year

The One Standard Authority for Furriers

THE DESIGNS ARE ORIGINAL

::: THE MODELS AUTHENTIC

THE DIAGRAMS CORRECT :::

An absolutely correct guide to Coming Fashions and Chronicle of Fur Trade News. Published nine times a year (monthly, from March to November).

Subscription \$20.00 a Year

Including large Artistic Season's Show Card, 22x28, magnificently printed in colors on plate paper, and 72 Exquisite Fashion Plates, 12x17, together with nine journals replete with Fur Trade News, Items, Chats with Leaders in the Trade, etc., all profusely illustrated.

*** PUBLISHERS ***

American Fashion Company

853 Broadway, New York.

BRANCHES AT

CHICAGO
153-164 State Street

BERLIN
90 Leipziger Strasse

LONDON
203 Regent Street

PARIS
14 Rue Taitbout

*PATTERNS OF ALL KINDS CUT TO ORDER PROMPTLY
LEARN CUTTING AT THE AMERICAN CUTTING SCHOOL*

The American Garment Cutter



For
Women

The Newest, Most Complete
and Up-to-Date Work on
Cutting and Designing

Women's Garments.

THE "AMERICAN GARMENT CUTTER" for Women is the most complete as well as the most up-to-date work of its kind ever published. It contains everything pertaining to the cutting of garments for all sizes and shapes, with illustrations fully explaining the workings of the system, so that anybody can see at a glance the simplicity of it. In it you will find not only how to cut all styles of garments but also how to make them up. It is the result of years of practical experience put on paper, and we are sure that in subscribing for it you will find it the best investment that you have ever made.

The diagrams will be of the same practical and superior kind as shown in "LES PARISIENNES" and on which we have received many very complimentary letters.

It teaches how to make up all styles of garments.

The work is elaborately and substantially bound in cloth and gilt, making a very handsome volume of nearly 200 pages.

Price \$25.00 for Complete Work.

The American Garment Cutter

(Women's Skirts)

Being the skirt section of the above work, and containing concise and complete instructions for cutting and drafting all styles of skirts, such as circular skirts, 5 to 19 different gored skirts, flounce skirts, flare skirts, riding habits, divided riding skirts, etc., etc. A most complete manual of the art of skirt cutting.

Send for Illustrated Prospectus with Specimen Pages.

Price \$10.00

PUBLISHERS

American Fashion Company,

853 Broadway, New York.

American Garment Cutter

FOR FURRIERS

The only work of the kind that is thoroughly up-to-date and thoroughly practical.

A Most Complete Text = Book

Containing instructions for the cutting and drafting of all kinds of Fur Garments, accompanied by concise drafts and diagrams of different kinds of Jackets, Ulsters, Dolmans, Newmarkets, Capes, Neckpieces of all sorts.
. Gentlemen's Fur Lined Coats, etc., etc.

A Complete Working Manual for the Practical Furrier

A large quarto volume of over one hundred pages, handsomely bound in cloth and gold

Price for the Complete Work \$25.00

Send for Illustrated Prospectus and Specimen Pages.

American Fashion Company,

PUBLISHERS

853 Broadway, New York.

158 164 State Street, Chicago.

14 Rue Taitbout, Paris.

90 Leipziger Strasse, Berlin.

41 Cheapside, London, E. C.

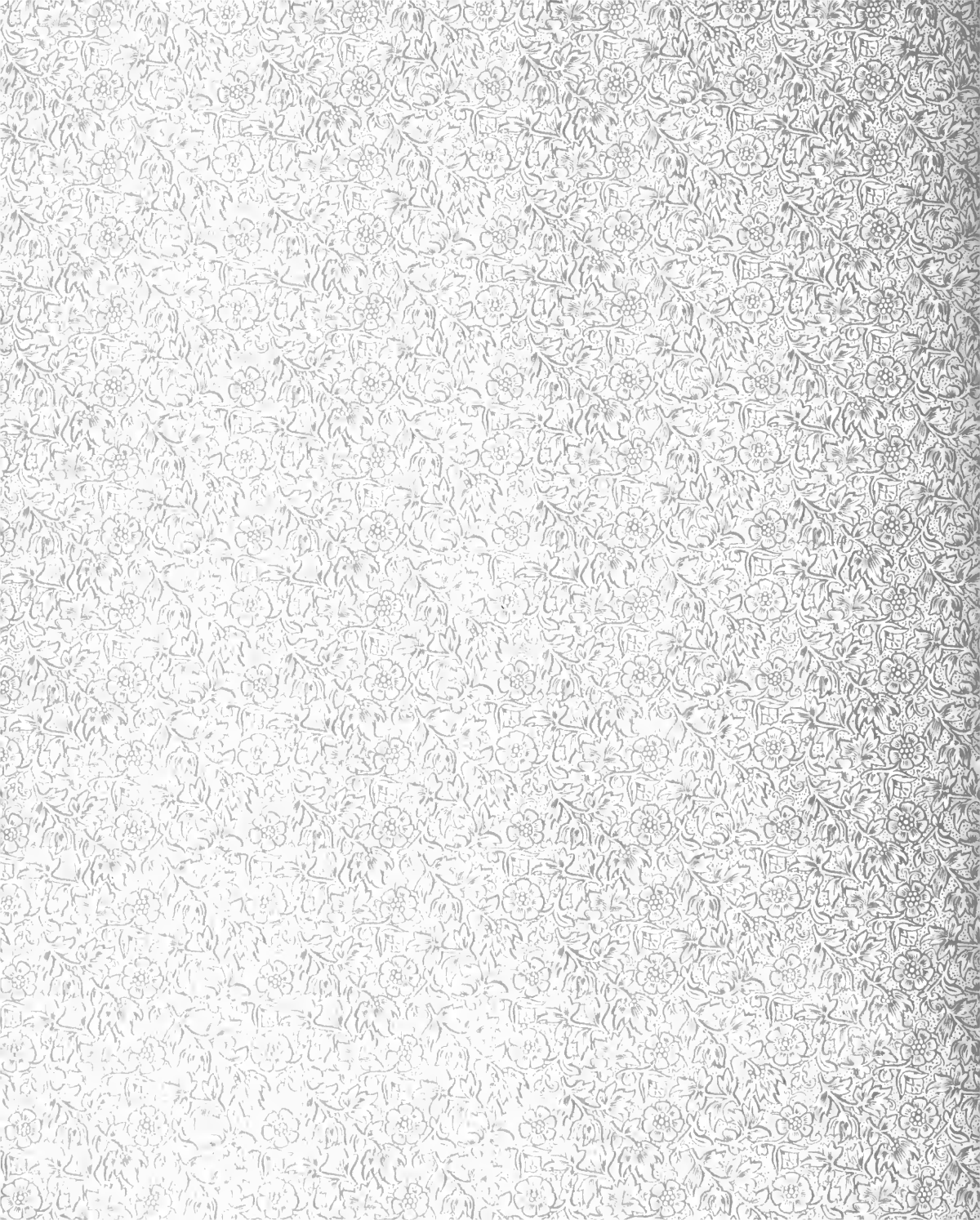

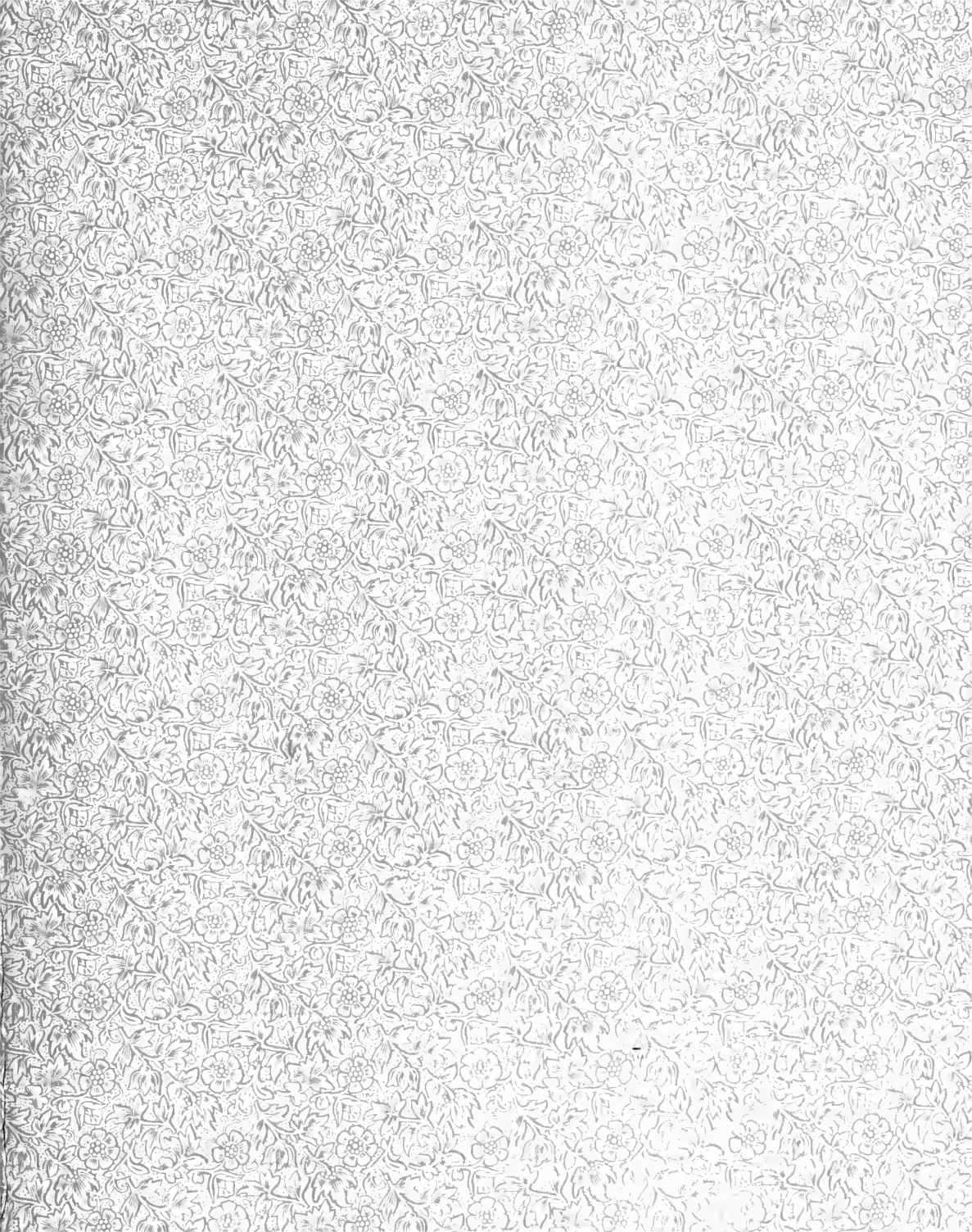

LIBRARY OF CONGRESS



0 014 082 916 A

