

# International Cutting System



Class TT590

Book G5

Copyright N<sup>o</sup> \_\_\_\_\_

**COPYRIGHT DEPOSIT.**

# The International Cutting School's System of Cutting

By L. GIBSON  
New York — Chicago

First Edition, 1909, One Thousand Copies

Second Edition, 1911, One Thousand Copies

Third Edition, 1913, One Thousand Copies

## COATS (PART ONE)



Entered according to Act of Congress (Act of March 4, 1909), in the year 1913  
by L. Gibson, in the office of the Librarian of Congress, Washington, D. C.

ALL FOREIGN RIGHTS RESERVED

(Printed in the United States)

T T590  
95

## Preface to Second Edition

Give to the world Knowledge, and knowledge presented simply, acceptably. The Greatest Thing in the World. It is not the fault of the masses of human beings that they go through life ignorant of the great work that the students of the world have done for them. Knowledge is not presented properly. It should be and it could be given to the people in such shape as would make it easier to read than to stop.

The greatest task that any man could undertake is the presentation to his fellow-men of knowledge, simply, attractively, and put before the millions of readers at frequent intervals, in relatively small installments, always with a beginning and an end satisfying to the mind. If you want a well-fed, well-developed body you give to that body a certain limited amount of well-prepared food at very frequent intervals. To have well-fed, well-developed brains in this world you must give to those brains at frequent intervals well-prepared mental food. That is the big task that some man or some organization of men will one day carry out.

The education of children is a great and important work. The education of Growing Men will one day be greater and more important. The great task of our day is Distribution; the problem of production has been solved. Our fertile earth and the fertile brains of men have produced food enough for body and for mind. There are bodies and brains with food and knowledge close by, as there are deserts that stretch beside the Mediterranean Sea.

You will see the real beginning of civilization when the average man shall know as much as is now known to the few, when the earth shall be a great republic of knowledge and every human brain a thinking dynamo contributing its share to the sum total of human power—which is human thought. That is the Idea carried out in this work by THE AUTHOR.

13-21875

\$10<sup>00</sup>

## Contents

---

	Section.	Page.		Section.	Page.
The Study Habit.....	1	5	Chesterfield Corpulent .....	3	5
The Right Way to Read.....	1	6	Box Overcoat .....	3	6
How to Study.....	1	7	D. B. Frock Overcoat.....	3	9
Measuring .....	1	7	D. B. Ulster.....	3	10
How to Draft.....	1	12	Inverness with Cape.....	3	12
The Sack as a Basis.....	1	13	Shoulder Cape .....	3	14
Proportion Sack .....	1	14	Cape, Half Circle.....	3	14
Remarks on the System.....	1	17	Cape, Three-Quarter Circle.....	3	15
Chesty Coat .....	1	18	Circular Cape .....	3	15
S. B. Sack.....	1	20	Table of Proportions, How to Make.....	3	16
D. B. Sack.....	1	21	Tables of Proportions .....	3	18
Long Roll Sack.....	1	22	Making Up .....	3	20
Exaggerated Sack .....	1	24	Vest, Measuring .....	4	1
Norfolk with Belt.....	1	26	Vest, Normal .....	4	3
Norfolk Yoked .....	1	27	Vest, Dress .....	4	6
Norfolk Pleated .....	1	28	Vest, D. B.'s.....	4	7
Tuxedo Peak .....	1	30	Vest, with Coat Collar.....	4	8
Tuxedo Shawl .....	1	32	Vest, Corpulent .....	4	10
Disproportion Sack .....	1	34	Vest, Clerical .....	4	11
Tall and Slim.....	1	37	Vest, Cassock .....	4	12
Short and Stout—1st Degree.....	1	38	Table of Proportion.....	4	14
Corpulent Sack—2nd Degree.....	1	41	Trousers Cutting.....	5	2
Corpulent Sack—3rd Degree.....	1	42	Measurements of Trousers.....	5	3
Military Blouse .....	1	45	Construction Lines .....	5	4
Collars .....	1	47	Openness and Close of Legs.....	5	6
Cutaway, Frock .....	2	1	Cutting the Cloth.....	5	7
Cutaway, Stout—1st Degree.....	2	2	Trousers, Normal .....	5	8
Cutaway, Corpulent—2nd Degree.....	2	5	Trousers, Wide Hips.....	5	10
Dress Without Rever.....	2	6	Trousers, Bow Leg.....	5	11
Dress With Rever.....	2	8	Trousers, Peg .....	5	12
Dress, Stout—1st Degree.....	2	10	Trousers, Corpulent .....	5	14
Dress, Corpulent—2nd Degree.....	2	11	Corpulent, Narrow Hips.....	5	15
D. B. Frock.....	2	12	Riding Breeches .....	5	16
S. B. Frock .....	2	14	Tables of Proportions.....	5	18
D. B. Stout—2nd Degree.....	2	17	The Principle of Grading.....	6	2
D. B. Corpulent—3rd Degree.....	2	18	Cutaways .....	6	3
Military Frock .....	2	21	Frocks .....	6	4
Clerical Frock .....	2	22	Skirts .....	6	6
Knight Templar Frock.....	2	23	Sleeves .....	6	7
Cassock .....	2	25	Sacks .....	6	8
Sleeves .....	2	28	Vests .....	6	10
Raglan Coat .....	3	1	Trousers .....	6	13
Chesterfield .....	3	2	Tables of Proportions.....	6	14
Chesterfield D. B.....	3	3	Lay-Outs .....	7	4
			Block Patterns, How to Use.....	8	4

## Preface to Third Edition

Any attempt to teach the principle of garment cutting must presume that certain causes will produce certain effects, and that the relation between these causes and effects has been reduced to general rules. In this treatise an effort has been made to select the known facts and working theories that constitute the science of garment cutting today.

In preparing these textbooks, it has been our constant endeavor to view the matter from the student's standpoint, and try to anticipate everything that would cause him trouble. The utmost pains have been taken to avoid and correct any and all ambiguous expressions—both those due to faulty rhetoric and those due to insufficiency of statement or explanation. As the best way to make a statement, explanation, or description clear is to give a picture or a diagram in connection with it, illustrations have been used almost without limit.

Formerly it was our practice to send to each student entitled to receive them a set of volumes printed and bound especially for the Course for which the student enrolled. In consequence of the vast increase in the enrollment, this plan became no longer practicable, and we therefore concluded to issue a single set of volumes, comprising all our textbooks under the general title of I. C. S. Reference Library. The students receive such volumes of this Library as contain the instruction to which they are entitled. Under this plan some volumes contain one or more Papers not included in the particular Course for which the student enrolled, but in no case are any subjects omitted that form a part of such Course. This plan is particularly advantageous to those students who enroll for more than one Course, since they no longer receive volumes that are in some cases practically duplicates of those they already have. This arrangement also renders it much easier to revise a volume and keep each subject up to date.

Each volume in the Library contains, in addition to the text proper, the Examination Questions.

The method of numbering pages and articles is such that each part is complete in itself; hence in order to make the indexes intelligible, it was necessary to give each part a number. This number is placed at the top of each page, on the headline, opposite the page number, and to distinguish it from the page number it is preceded by a section mark (§). Consequently, a reference, such as § 2, page 8, can be readily found by looking along the inside edges of the headlines until § 2 is found, and then through § 2 until page 8 is found.

## The Study Habit

The difference between men who succeed in life and men who fail lies primarily in seeing and seizing opportunity. We are living in an age of multitudinous opportunities. They stare us in the face every day; they most plead with us to put out our hands and grasp them; they come laden with the most tempting rewards. But each opportunity, as it passes, returns no more; another may come, better or worse, but not the same one. Yet, however many and of whatever value, only he who is trained can see and seize them. It depends upon himself, and himself alone. Education fits a man to appreciate and to make the most of his opportunities. We stand on the threshold of unmeasured possibilities; every industry is demanding clear brains, skilled hands, and men of disciplined minds. Wherever there is a possibility of cheapening production by new methods, of producing two articles where only one is now available, of quickening transportation, of simplifying processes, of adopting natural forces to mechanical ends, of saving time or strength to the worker—*there is an opportunity.* Thought is observation, reflection, conclusion. To teach men to think quickly, correctly, and consecutively, is the mission of education. The man who puts no thought into his work is only a mechanical device for carrying out some other man's thinking; the difference between the human machine and the mental machine being that the one feels and the other does not.

But education is not the mere process of gathering knowledge; a man may be taught a great many things and yet be uneducated. The brain can be stuffed just as the stomach, but if the mind food or the body food is not digested, it is wasted. Education when properly understood is the development of our powers, so directing and strengthening and disciplining them that they can achieve the ends for which they were created. Life's opportunities are entirely missed and its possibilities are unrealized by the man who has neglected the training of his intellectual abilities.

Too often we think and speak of "Educational Institutions" as if they were the only means of education. Education is the product of *Habit* rather than of institutions, for a man may live within the best educational institutions for a lifetime and unless he has cultivated the *Study Habit*, he will not profit by his advantage.

The study habit may be considered the beginning of character building; it forms a sound foundation for all future achievements. The two most striking features of the growth of any habit, whether good or bad—regularity and repetition—point the way to the man who determines to form the study habit. We venture to make a few practical suggestions, such as has been tried successfully by thousands of men who now hold envied position in the world. They may act as guide-

posts to the man who desires earnestly to make life a success and yet does not know the way.

I. Launch yourself upon the task with as much impetus as you can command. In doing so bring all your nature into play—your mind, imagination, heart, and conscience. Make a solemn vow to yourself that you *will* do it; pledge yourself upon your honor to keep that pledge; write your determination upon a piece of paper and sign it as a binding bond, and if tempted to falter read the obligation and remind yourself that your manhood is at stake.

II. Decide upon the course of study you wish to pursue. This should be done with the utmost care after having estimated your powers to determine along what line you are likely to reach the best result. Usually the thing to which we turn naturally is the one we will be able to do the best.

III. Obtain the very best textbooks available on the subject selected. There are three kinds of textbooks: The first are written for professors and advanced students, in which all elementary knowledge is taken for granted; the second are written for students in schools and colleges, on the assumption that the teacher will conduct the class work and explain the difficulties as they arise; the third are planned and written for home study; they are adapted to the student who is studying without the aid of a personal instructor; they take no previous knowledge for granted, leading the student from the elementary to the advanced principles by regular, easy stages; they are arranged in short lessons to fit the needs of the student who can give only a little time each day to study; they are intensely practical, and they give the student exactly the information he needs in order to advance himself. It is this last named type of textbooks you should obtain, and the only textbooks that fully meet all the requirements are those printed for International Cutting Schools students.

IV. Set aside a definite time for study, and keep your books and papers always in one place; in this way you will waste no time in setting to work and you will find it more difficult to excuse yourself for not doing the required amount of study.

V. Never allow an exception to your rule. Let your friends know your study hour and hold it as sacred. Put your conscience before the door as sentry and regard any theft of your time as seriously as you would regard a theft of your money. In point of fact, it amounts to the same thing. To make this easier you can set apart another time for outside engagements or pleasures—say one evening a week. When you have made such an arrangement, stick to it as if the destiny of an empire depends on your fidelity.

VI. If you study at night, allow a few minutes before going to work the next morning for review. You will make some brief notes for this purpose. Such a plan will fix the subject firmly in the mind and give you something definite to think about during the spare moments of the day. It is not difficult to rise one-quarter or one-half hour earlier; if you persist in it for a week the *Habit* will be acquired.

VII. Whatever you gain from your textbooks, put to a practical test as quickly and as often as possible. In this way you will also form the *Habit* of passing readily from knowing to doing, and, becoming convinced of the value of knowledge, you will be eager to gather more.

VIII. By way of encouragement, you must remember that it is only the first steps in the formation of a *Habit* that are difficult. To study will be more tedious the first week than the second, and the second more irksome than the third; but the regular repetition will soon make the effort normal, and it will grow to be a delight to turn the attention to serious mental work.

In order to avoid unnecessary difficulties, the following hints deserve attention.

There are certain physical conditions which make study irksome and almost impossible. Students sometimes find themselves incapable of close attention to a printed page or a mechanical drawing—the effort brings weariness, headache, nervousness. They make the error of believing themselves unfitted for mental work. The fault does not lie in their mental powers at all—it is generally physical.

If you suffer from such feelings, have your eyes examined by the most skillful eye specialist you can reach. A large percentage of men today have defective sight; their ordinary work does not reveal the fact, but as soon as they begin to study under artificial light they are aware of a handicap. If it is necessary to wear glasses do not purchase them at the nearest store; have them made under a doctor's orders and according to his specifications.

Always keep the air fresh in the room where you study; open a window whenever possible, if but an inch. Air affects not only the lungs but the brain. In using the evening for study, observe two or three simple rules:

Do not eat heartily at supper. Stop after eating a reasonable amount and before you are conscious of a feeling of fullness. Then, after your studies are finished, enough nourishment may be taken, if it is felt necessary, to keep the stomach active during the early hours of sleep.

Avoid sitting so near a lamp that the heat is felt upon your head. If drowsiness threatens to put a stop to the work, a part of the work should be done standing. The change of position will insure a redistribution of the blood. Five minutes of physical exercise will effect the same result to a larger degree, and study may be resumed with comparative ease.

Any student who follows the foregoing advice is sure to succeed; and he will be better fitted morally, physically, intellectually, and financially to cope with the problems and difficulties of life.

## The Right Way to Read

"Principles and Maxims for the Reading of Books." One should read in a critical, that is to say, a searching, testing spirit. Our spirit ought, no doubt, to be respectful to the author of the book, if he happens to be a well informed man; but respect is not the same thing as submission.

Books that aim to give information, to supply facts, or to show the relations between facts, books that do this or that try to change the reader's mind, may safely

be read in a searching, testing, critical spirit. That the only way to read them is to be temporarily submissive.

Anybody who looks back over his reading years, and picks out the fiction and the poetry that has really counted in his life, will find that in most cases he read them in his least critical spirit. They laid their spell upon him so strongly that his critical faculty was inhibited. Nor, if he is wise, will he be sorry that he once read them in this way.



## How to Study

The *Instructions* are divided into sections by suitable headings, and are further subdivided into lessons, each of which has a number. Study section by section, taking each lesson consecutively. Do not skip about the paper, reading here and there, but start at the beginning and go through it in the proper order.

**Beginning the Study of a New Subject.**—The greatest difficulties encountered when beginning the study of a new subject are the strangeness of the terms used, the inability of the student to comprehend the usefulness of certain operations, and the feeling of helplessness that takes hold of him. Anyone studying a subject that is entirely new to him will encounter these difficulties.

**Study Thoroughly.**—You must not expect to understand all that you study when going through a paper for the first time. The best way is to study a few pages, then if you do not understand certain statements or illustrations, it will be better for you to pass on further into the subject, rather than to spend too much time on these points, as it is very likely you will find applications of them later on in the paper that will clear up the matter. Carefully study each section, noting the various statements, drawings, etc. Having finished one section, take up the next, and study it with the same care and in the same manner as you studied the preceding one.

**Do Not Study Too Much at a Time.**—Do not try to study too much at a time, nor attempt to study longer than an hour or an hour and a half at a sitting. If you study longer than that, your mind will become confused, and you will be unable to reason clearly.

**Make Haste Slowly.**—By "making haste slowly" you will accomplish much more in a given time than by hurrying through the subject before obtaining a perfect understanding of it; because, unless you really understand the subject, you will meet with difficulties further on in the course, and will then be obliged to stop and review some of the earlier papers.

**Devote a Certain Amount of Time Each Day to Study.**—If you will follow the instructions here outlined, you cannot fail. If possible, it would be well for you to devote a certain amount of time each day to the prosecution of your studies. Even though you may not be able to devote more than half an hour, the progress you will make will be surprising, providing you do not allow the program you have outlined to be interrupted. For instance, suppose you decide that you can devote one hour a day to study; then, if you will allow no deviation from this program and will follow the method we have outlined in the preceding paragraphs, your progress will be rapid and thorough, and satisfactory both to yourself and to us.

## Measuring

**1. The Coat Measures.**—Should always be taken in the same order, a plan which, particularly in the case of beginners, tends materially to obviate confusion and mistakes.

The order found most convenient can be set out as follows:

Inside sleeve	17¾ inches
Breast	36 inches
Waist	32 inches
Hip or seat	37 inches
Strap or first over	12 inches
Over shoulder	17 inches
Blade (with 1¼ in. for seams added)	12½ inches
Depth of scye	9 inches
Natural waist	16¾ inches
Fashion waist	18¾ inches
Full length, style of garment.	
Height	5 ft. 6 inches

### Measurements of Coat

**2. The Method of Measuring** used is the result of long experience, and as this is for the guidance of students it is very minutely described.

In the first place, a cutter should have confidence in himself, as the show of nervousness or lack of method will create an unfavorable impression on the customer.

A lack of method to proceed is usually the cause of the confusion; hence a cutter should follow the suggestions and the rotations as explained, which will result in his becoming methodical and expert, and free from all confusion.

While measuring no stops should be made, nor no familiarity displayed toward the customer.

**3. Measuring Coat.**—When ready to take the measures for the coat, have someone to put down the measures; otherwise have paper and pencil ready, and do it yourself. A loose sheet of paper should be used, so

that notes for the cutter can be put down, afterwards to be transcribed in the measure book.

The measures should be taken over the vest always. Before removing the coat of the customer it is best to ascertain how the length of the coat he has on suits, as it gives you a good idea of what the customer wants; measure the coat he has on for length, deducting  $1\frac{1}{4}$  inches from the top edge of the collar; then request him to remove his coat.

When the coat is off, observe if the vest fits close enough to take the measures over; otherwise pin it in under the arms the amount of the surplus; equal amount on each side; also at the waist line if taking measures for a frock.

4. Place the Square under the arm on the "Left" side of the customer, for the reason that the person is more normal on the left side; also that it is more convenient, because you are then applying all the measures with the right hand, the left hand doing nothing but holding the tape line in position (unless you should be a left-handed person. Place the square with the short arm extending upwards and the long arm horizontally under the arm and close against the front of the arm; mark with the chalk in front of the square. (See Fig. 1.)

5. Tip the square outward and down, keeping the long arm in the same position (horizontal); then mark on top or upper side of the square in front, crossing the first chalk line; also make a mark back of the arm above the square. (See Figs. 2 and 3.)

6. Remove the square and place the long arm across the back horizontally and make a cross mark for the depth of scye, or bottom of armhole, in the center of the back. (See Fig. 4.) If not sure of being able to do it correctly, place the long arm of the square under the right arm and mark back of the arm, the same as on the left side; then replace the square across the back and mark for depth of scye. (See Fig. 5.) This mark should be in the center of the back, regardless of where the vest seams run.

7. **Waist.**—Place the square at waist line above the hip bones, from the back, the short arm of the square resting on the hip bones, and extending forward; the location is found by the feeling of your hand; then mark the waist line. It can also be done with a tape-line. (See Fig. 5.)

Make a cross mark for the height of neck,  $1\frac{1}{4}$  inches down from the top edge of where the coat collar should be when finished. (See Fig. 5.)

8. **The First Measure.**—Place the square under the left arm with the long arm of the square extending downwards towards the hand; keeping the square close up, and held in position by the right hand on the short arm of the square. Find the length of sleeve by measuring to the root of the thumb and deduct 1 inch, in the following manner:

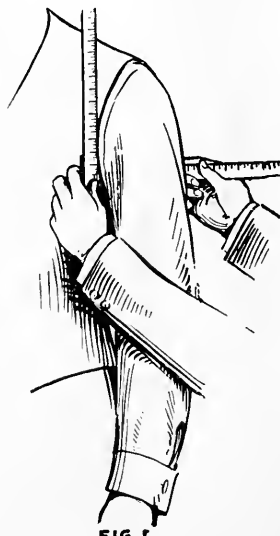

FIG. 1

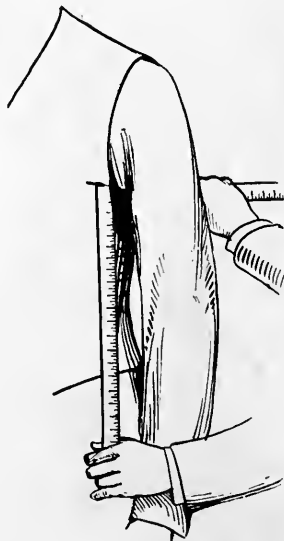

FIG. 2



FIG. 3

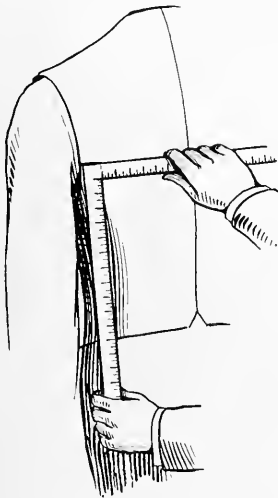

FIG. 4

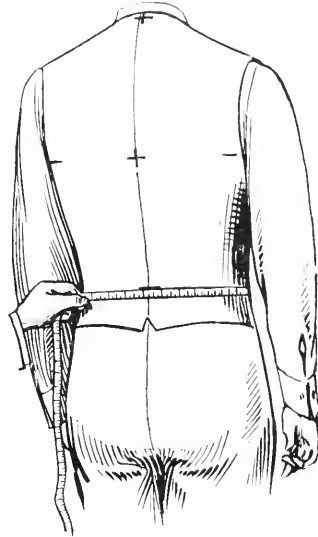

FIG. 5

Hold the square in position with the right hand; with the left hand take hold over the customer's closed hand and see that the arm is at full length. Extend your index finger at the root of his thumb and note the length, say 19 inches; deduct 1 inch and call out 18 inches, the inside sleeve length, and the first measure.

9. **Body Measures** should be taken closely, as there is a decided tendency with beginners to take them too easy. If the vest and trousers worn are at all easy fitting, it will form into one or more folds under the tape while the measures are being taken. The student need not be troubled by this fact, as he is supposed to be taking the actual measures of the body, not the measures of the garment covering it.

10. **Strap Measure.**—Place the end of the tape-line at the cross-mark in front of the arm, "or place the 10-inch mark of the tape-line on the cross mark; a better hold on the tape with the left hand can be obtained. (See Fig. 6.) When calling out the numbers deduct 10 inches from the amount, as for example, strap length would show 22 inches; call out 12 inches."

11. **The Tape** should be held firmly in position with the left hand; with the right hand bring it over the shoulder in as near a straight line as possible to the nape of the neck or socket bone, the cross mark made on the back. This is called the Strap, or first-over measure, and should be 12 inches.

12. **The Over-Shoulder Measure.**—Keep the tape-line in position in front, and with the right hand move it to the center of shoulder, and bring it in a straight line over the shoulder to the mark at depth of scye in the center of back. (See Fig. 7.) This is called the Over-Shoulder, or Second-Over, measure, and should be 17 inches (deducting the 10 inches, if starting from 10 inches).

13. **The Blade Measure.**—Place the tape-line under the arm, and from the cross-mark in front, measure under the arm in a straight line over the blade to the center of the back. (See Fig. 8.) This is called the Blade measure, and should be  $12\frac{1}{2}$  inches in this case; this will include  $1\frac{1}{4}$  inches, the width of the square from in front of the arm, which also will allow for five seams for making up.

14. **The Length Measure.**—Place the end of the tape-line at the neck point mark, and measure down to depth of scye, or armhole mark, 9 inches; continue to waist line,  $16\frac{3}{4}$  inches, and to full length desired. (See Fig. 9.)

The measures should be called out as you pass them; as 9,  $16\frac{3}{4}$ , and 30 inches.

15. **The Breast Measure** is taken from in front of the customer; with the tape-line in the right hand, holding it about 18 inches from the end, pass it around under his left arm, meeting the left hand behind; carry the tape around to the front, and taking hold of both ends with the right hand, holding it close, while running the left hand under the tape behind and raise it over the blades in a horizontal line; then take the end of the tape in the left hand and bring the two together across the breast; not too high nor too low, and as medium closeness; 36 inches.

16. **The Waist Measure** is taken from the front, in exactly the same manner as the breast measure, over the smallest part, or the mark made on the back; 32 inches.

This is the **only** measure which should be taken fairly snug or close, as there is always a lot of loose cloth, also articles of various kinds in the pockets of the vest.

17. **The Seat Measure** is taken from in front, over the largest part of the hip or seat; while holding the tape in front, bring the left hand around the hip and adjust the tape over the largest part, at the same time pushing up any article in the hip pockets from under the tape line. The customer should stand with heels and toes together while this measure is taken.



FIG. 6

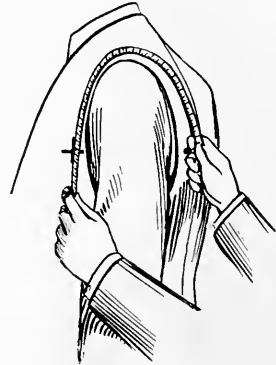

FIG. 7

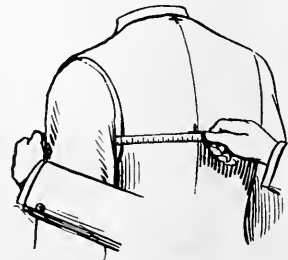

FIG. 8

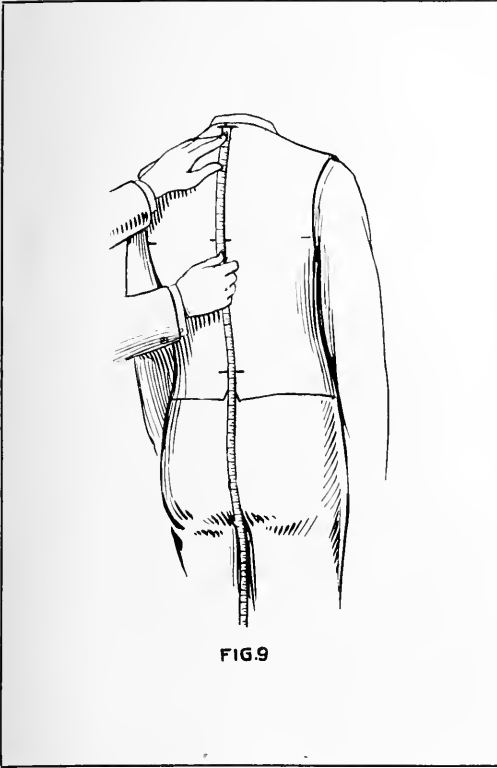

FIG. 9

18. **Supplementary Measures** can be taken when the person is extreme in some particulars; such as heavy muscles around the shoulder or arm. A circular measure is then taken around the arm; when extra high, or low shoulders, measure from front of arm mark over the shoulder to the back of arm mark on a line where the sleeve seam would run.

19. **Other Measures**, as in frock coats, from a line drawn vertically in front of the arm and down to the waist; measure from side to the front of waist and from side to the back of the waist; likewise further down, back over the seat.

20. **The Vest Measures.**—The same measures are used for the vest as for the coat, with the addition of the **opening**, or to the top button, and the full length in front. Sometimes a measure is taken to the side opposite the hip from nape of neck. For vest measures

see under Vests (Part 4). For trousers measures see under Trousers (Part 5.)

21. **This completes** the measures for the coat, which are the same for all coats, including overcoats, and you so announce to the customers; also remove the pins and brush off the chalkmarks, which should not be made too heavy in case it is forgotten to brush them off.

22. **The Height.**—The height of the customer should now be measured; have a place convenient for such a purpose. The actual measuring can in most cases be dispensed with by asking the customer about his height; most everyone knows his own height.

**The height should in no case be omitted.** When the **Breast, Height and Attitude** is obtained, no cutter can fail in coming within a quarter of an inch of the actual measures of any person (excepting actual deformities).

23. **The Attitude** or standing and form of the customer should now be noted, such as stooping, sloping, square shoulders or erect. For convenience they can be divided into two degrees, of one-quarter and one-half inch. It can be done while taking the measures by calling out "S. T. one-half" for stooping, or "S. L. one-quarter" for sloping, and so on; or the cutter can mark it on the paper himself. Also note whether the shoulders are even. Call out the **low side** as "right one-half inch." Do the same with trousers. See under the section of Trousers.

24. **Style.**—Next find out the style of coat desired on the fashion plate, if not previously selected, noting any particulars wanted in the cut deviating from the style; otherwise this is left to the cutter.

25. **Note to Cutters.**—The foregoing minute description of taking measures may seem superfluous to an experienced cutter. It is nevertheless a fact that the greatest trouble in cutting arises from careless or inadequate measures, so that in applying them to the draft the cutter is afraid of using them, rendering them thereby of no value. However, by using this system as it is explained, the miss of a measure would not seriously affect the production of a well-fitting garment.

## How to Draft

The few necessary articles needed for drafting are a tape line, a square, some chalk and a piece of cloth to draft on, besides the paper.

**26. The Paper** should be unrolled from right to left over a piece of cloth, a yard and a half of moleskin is the best; it presents an even and firm surface and does not shift under the chalk. White paper and a drafting lead can be used.

It is not always possible to get the right kind of paper; for that reason and also that it has a tendency to produce a heavy hand on the draftsman, therefore it is better to use the regular tailor's paper of any color desired, and chalk.

**27. The Chalk.**—The shaping and use of the chalk may seem a small matter to some; it is nevertheless important. First shave down the heavy ends till almost a sharp edge; this prevents a lump forming at each end when sharpening and using, and also allowing it to follow close to the ruler. Then sharpen one of the thin edges. Never sharpen but one side. A piece of sandpaper stretched on a knocked-down cigar box makes a fine finish edge on the chalk.

**28. Palming** of the chalk is a practice which should be studiously avoided; by palming it the oil in the chalk, together with the moisture of the hand, causes the oil to appear and prevents the chalk from marking properly. The chalk should be held between the thumb and the first and second fingers, leaving the other fingers to assist in placing the square, etc. When unable to do so lay it down or put it in the apron pocket.

**29. The Square.**—The understanding of the square is really very simple. The square is nothing but a ready-reckoner, assisting a person in finding a given division or number at the instant. Each arm of the square is divided into six parts, or subdivisions, all commencing and counting from the corner.

The first figure in each division is 12, indicating a 24-inch breast (as only one-half of the coat is drafted), and the last one is 24, but falls on the 12 of the next higher division, which should be a 48 breast.

**The Long Arm.**—Commencing at the corner is the "24ths," and it ends at the first inch.

**The "12ths."** Counting from the corner, the first figure 12, is at the one inch, and the last one at the two inches.

**The "6ths."** The first figure is at two inches, and the last at four inches, which would mean that from the corner to the two inches marked 12 would be one-sixth of 24 breast. From the corner to 18 would be one-sixth of 36 breast.

**The "3rds."** The first figure is at four inches, and the last at eight inches, which would mean that from the corner to, say 20, would be one-third of 40 breast.

**The "2 Thirds"** commences at eight inches and ends at sixteen inches, but can be extended to the end of the square.

The full inches to the end of the square are divided into one-sixth part of an inch. The whole long arm of the square is divided into sixths of inches; no eighths are found on this side.

It should be understood that in reading the square, where a number is omitted, it is because of there not being room for all of them to show, although the between numbers are marked always, for example, one-third of 37 breast would be between 18 and 19 on "3rds." In like manner a half size is located as  $37\frac{1}{2}$  breast.

**30. The Short Arm.**—Commencing at the corner is the "32nds," which end at  $\frac{3}{4}$  inch.

The "16ths" begin at  $\frac{3}{4}$  inch and end at  $1\frac{1}{2}$  inch.

The "8ths." The first figure is at  $1\frac{1}{2}$  inches and the last at 3 inches.

The "4ths" start at the 3 inches and end at the 6 inches length, and contain all the numbers.

The "Halves" extend the length of the arm from the 6 inches point, and each number is here marked.

On the inner edge of the square on both arms the full inches are indicated.

The whole short arm of the square is divided into one-eighths inches; no 6ths are found on this side.

**31. The numbers** on all of these divisions are equal to one-half the full breast size dealt with, because all patterns are cut from the center of the back to the center of the front, which is only one-half of the man measured. In cutting, however, we cut the cloth double, which gives us the two sides.

Therefore, when the breast size is, for example, 36, only one-half of that quantity, or 18 inches, is used; the breast size and all divisions of that breast size will also be 18. Therefore the numbers on these divisions cover the range of sizes from 24 to 48 breast.

To illustrate further, one-half of a 40 breast is 20 on all of the divisions, and whatever divisions are to be used will be 20 of that particular division. The one-half of a 44 breast is 22, and so on all the way through the different sizes.

The **reverse** side of the square contains plain inches, so when inches are mentioned they are always obtained on the **reverse** side by turning over the square.

Before attempting to do any actual drafting become familiar with the square and go through such exercises as finding different sizes on all divisions.

**32. In using the divisions** in the text to follow they will always be referred to as 1/12ths, 1/6ths, 1/3ds, 2/3ds, 1/8ths, 1/4ths and 1/2 breast. When a **total quantity** instead of a division is used they will be spelled out, as one-fourth, one-half, etc. In this way the student will be able to know the difference between the division of the square and any part of a quantity as a whole.

**33. The Use of the Square.**—When drafting always keep it in the **left** hand, holding it by the **long arm**. The **right** hand should never let go of the chalk, and only assist in placing the square.

Always keep **within** the square; do not let the ends of the square come against the body. In most cases when a point is located all that is required is to either slide or roll the square in that direction.

Always try to mark at the corner of the square, so as to have the chalk move **with** the square.

Stand up close to the cutting table, and have it high enough to avoid bending over too much.

**34. Up Measures.**—One thing to always keep in mind is that all **up** measures are obtained on the **long arm** of the square, and all horizontal or lateral measures are found on the **short arm**; so that when the measure calls for an eighth or a twelfth it is easy to remember on which end of the square to look for it.

## The Sack Coat as a Basis

**35.** In selecting the style of a sack coat for the first illustration of the working of the system, the usual rule of presenting a frock coat first has been reversed, for the reason that a sack coat is by far the easiest of coats for a beginner to start with. As the system becomes more familiar to him and the hand gets more used to drafting, it will insure quicker results by commencing with the sack.

The system can be explained as well for a sack as any other coat.

With the object of affording the student early encouragement, while at the same time rendering him familiar with the plan for producing the various lines and points embodied in the system, the divisions used in the first draft are supplied from the breast measure, or **proportional**, taken in the ordinary way, and fully described in the previous remarks on measurements.

As the system thus worked is extremely simple (there being no confusing shifting of the position of the back, etc.) the student, by a careful study of the instructions for drafting, will soon be qualified to draft accurately and expeditiously the diagrams illustrated.

The subsequent diagrams will be worked by proportions and actual measures, as described in the articles on measures, while for uniformity and consequent simplicity (features which have been carefully considered in all stages of this work) the same lines and quantities will be used as introduced in the first draft.

In addition to acquiring a knowledge of the location of the points, the student should observe the formation of the various curves or outlines of the pattern, as attention to such details contributes greatly to obviate mistakes in the making up of the garment.

**36. The Letters** in this work are arranged in alphabetical order, and by following the rotation adopted no confusion, or overlooking any points, can be possible, thereby acquiring accuracy and efficiency. Also no letters or figures are used twice on any garment; furthermore, that each letter or figure occupies the same position (or nearly so) throughout the system.

The system has been laid out for study, and many lines have been introduced, but each line makes some point easier of comprehension.

It is the easiest thing in the world to leave out and make incomplete, but to give just the points and lines needed is not so small a task. Here the student will find that each line and point carries an idea that requires that much less mental effort on his part.

# Proportion Sack

## Diagram 1

To render the student familiar with the working of the system, all points in this, the first draft are, unless otherwise specified, found by division of the breast measure.

NOTE—A rule which should always be observed by cutters and students is to read through a description before commencing drafting it, the first time especially.

37. The measures are taken over the Vest always.

Inside sleeves  $17\frac{3}{4}$  inches. Natural waist  $16\frac{3}{4}$  inches.  
 Breast 36 inches. Full length 30 inches.  
 Waist 32 inches. Height 5 feet 6 inches.  
 Hip or seat 37 inches.

### TO DRAFT.

- 1 Place the corner of the square at point A, with the *long arm* downward, and about  $1\frac{1}{2}$  inches from the edge of the paper. (See Diagram 1.)
- 2 A to B is  $\frac{1}{3}$  breast on "3RDS" and  $3\frac{1}{2}$  inches ( $9\frac{1}{2}$ ).
- 3 That is from A find 18 on "3RDS" and make a small mark; turn the square over and place the corner on the mark and measure down  $3\frac{1}{2}$  inches to B.
- 4 Move the corner of the square up to A—the distance from A to B should be  $9\frac{1}{2}$  inches.
- 5 The two quantities, the *division* from A and the *fixed* quantity of  $3\frac{1}{2}$  inches, gives the depth of scye, or the distance from the top of the backpart to the breast line, for all sizes. (Not including the collar.)
- 6 The *division* from A gives the relative increase and decrease according to the breast size dealt with, while the *fixed* quantity checks it from increasing or decreasing too rapidly.
- 7 It is called the arm-scye and is pronounced like arms-eye from which it no doubt derived its name.
- 8 Place the corner of the square at point A with the *inches side up* and mark length to C ( $16\frac{3}{4}$  inches) called natural waist.
- 9 The natural waist length should be one-fourth the man's height and  $\frac{1}{4}$  inch added for curvature of the back.
- Place corner of square on point C with the *division side up* and mark to D— $\frac{1}{3}$  of breast—18 on "3RDS" (6 inches) for 36 breast establishing the seat or hip line.
- 10 A to E is the full length of the Coat, use the tape line or use the square, mark the length (24) and add the balance.
- 11 Place the square, corner on A and find point F halfway between A and B—used for obtaining height of front shoulder, and also locate the back notch for sleeve.
- 12 Square out from A, B, C, D, E and F using the long arm of the square.
- 13 Mark all the letters with the chalk whenever a line or measure is completed. Then read the next sentence and look on the diagram.
- 14 Follow the rotation of the letters or figures as set down in the text.
- 15 C to G is  $\frac{1}{2}$  inch, draw line F to G and down to E.
- 16 From the line just drawn inside of B measure to H.
- 17 Place 18 inches or half the breast measure on the line inside of B and measure to H, the corner of the square.
- 18 Move the square forward  $2\frac{1}{4}$  in. and mark point I.
- 19 The  $2\frac{1}{4}$  inches are for seams and make-up.
- 20 Place corner of square on inside line of B with the *short arm* across and measure  $\frac{1}{2}$  breast—18 on "HALVES" to point 2.
- 21 It being a cross measure is found on the *short arm*.
- 22 Turn over the square, keeping hold on the *long arm*, and place corner of square on point K.
- 23  $3\frac{1}{2}$  inches from 2 and square up from K—the front of armhole ( $12\frac{1}{2}$  inches).
- 24 This is the *normal* blade measure and includes  $1\frac{1}{4}$  inches allowance for seams.
- 25 While the square is in position find point L.
- 26 L is halfway between B and K—( $6\frac{1}{4}$  inches).
- 27 Place corner of square on point M,  $1\frac{1}{4}$  inches from L—the width of back.
- 28 Square up to O and down to N, mark letters.
- 29 P is  $\frac{1}{2}$  inch back from O-N line; mark P.
- 30 A to Q is  $\frac{1}{12}$  breast—18 on "12THS." Find 18 on division of "12THS"; place 18 on A and mark at end of square as at Q ( $1\frac{1}{2}$ ).
- 31 Turn over the square and move to R.
- 32 Q to R is  $1\frac{1}{2}$  inches; square up to S.
- 33 R to S is  $\frac{5}{8}$  inch—width of back at the neck.
- 34 K to T is  $1\frac{1}{2}$  inches, and T to U is  $\frac{1}{12}$  breast, 18 on "12THS," same as A to R.
- 35 Draw a line from S to U—this gives the height for the back shoulder.



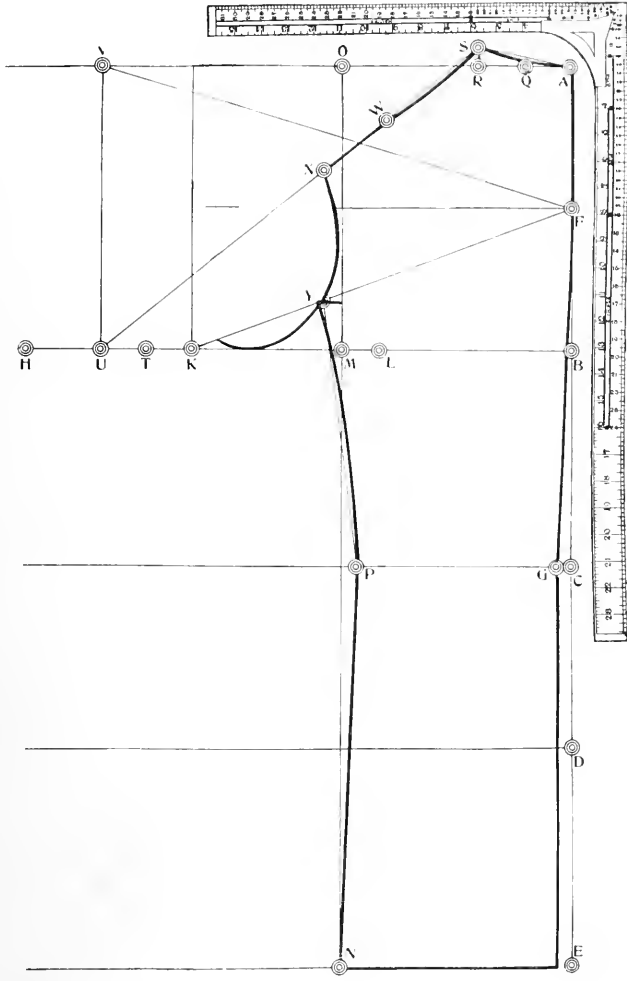

DIAGRAM 1

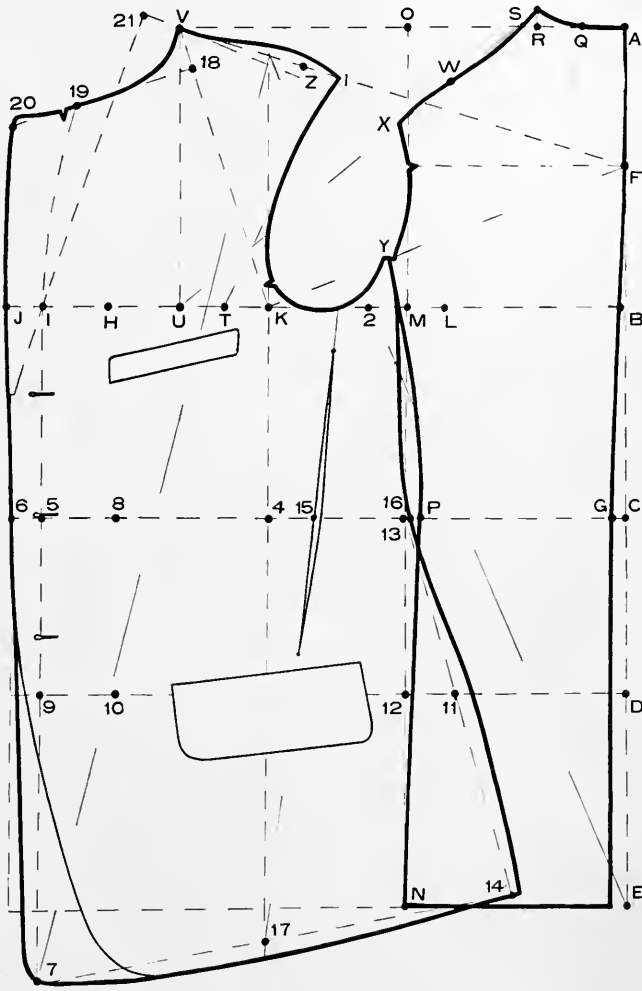

DIAGRAM 2 — PROPORTION SACK

- 36 Draw a line from F to V—this gives the height of the front shoulder.
- 37 Draw a line from F to K locating Y, the height of sideseam at Y.
- 38 X is  $\frac{1}{2}$  inch on the S-U line, or style width of back.
- 39 Y is  $\frac{1}{2}$  inch from the M-O line always.
- 40 Draw a guide line from Y to P and P to N with the square.
- 41 Shape the back from A to S from S to X hollow  $\frac{1}{8}$  inch between S and W; from X through Y to bottom of armhole.
- 42 From Y to P curve slightly to P.
- 43 From P to N in a straight line.
- 44 In shaping at Y a  $\frac{1}{4}$  inch should be added for a scam beyond Y.
- 45 This completes the Back and Diagram 1.

## Proportion Sack

### Diagram 2

- 46 Place corner of square on X and measure to S.
- 47 Place corner of square on Y and measure to point 1  $\frac{3}{8}$  inch less than S to X, the width of shoulder.
- 48 Draw a guide line from Point 1 to T.
- 49 Shape arm-scye and shoulder rounding  $\frac{1}{2}$  in. over Z.
- 50 Square down from K through 4 to 17.
- 51 Place corner of square on 4, measure to 5,  $\frac{1}{2}$  waist—16 on "HALVES"—center of waist. Square down from 5 to 7.
- 52 For spring over the hip go out from 12 to 11— $1\frac{1}{4}$  in.
- 53 Draw a line from 13 through 11 to 14.
- 54 Y to 14 is the length from Y to N.
- 55 Shape the sideseam of the forepart from Y, touching the back over the breast-line and halfway between P and 13.
- 56 Going out  $\frac{5}{8}$  inch over 11 to a  $\frac{1}{4}$  inch of 14.
- 57 Z to 7 is the length from Z to E, and 1 in. from line K.
- 58 The 1 inch is taken up in making the front edge.
- 59 Draw a line from 14 to 7 and shape bottom.
- 60 Place corner of square on V, long arm on K, find  $\frac{1}{12}$  breast on "12THS" and mark as at 18.
- 61 Move the square down to 18 and square to 19.
- 62 18 to 19 is  $\frac{1}{4}$  breast on "4THS" ( $4\frac{1}{2}$  inches).
- 63 Draw a line from 19 to I and 5.
- 64 19 to 20 is  $2\frac{1}{4}$  inches—or style—notch  $\frac{1}{2}$  in. from 19.
- 65 I to J is  $1\frac{1}{4}$  inches, 5 to 6 is 1 inch.
- 66 Go in a  $\frac{1}{2}$  inch at 7 and draw a line to 6.
- 67 Shape from V the gorge or neck hole and front.  
This completes Diagram 2.

## Remarks on the System

40. The lines A and B constitute the normal balance, and is used as a check or proof.

Any measures or attitude deviating from it would indicate disproportion in the parts they differ.

The height and width is combined as explained in the depth of scye measure and the normal line is established from A to V.

41. The strap or first over measure should not go above or below the line A-V for a normal figure. When S is established as directed, and point F half way between 4 or A (if normal); lines drawn from S to U and F to V will be correct height of shoulders always.

It should be noted that point S is not obtained by  $\frac{1}{6}$  or  $\frac{1}{8}$  and a fraction. Some persons will make a mistake and think because  $\frac{1}{6}$  of 36 is 3 inches, and  $\frac{1}{8}$  and  $\frac{3}{4}$  inch is 3 inches; and that  $\frac{1}{12}$  and  $1\frac{1}{2}$  inches also is 3 inches; that it is the same; (We have had that handed to us many times).

Certainly it is the same on a 36 breast size; but it ends right then and there is no more sameness.

By using the division of  $\frac{1}{12}$ ; when this amount (from A to R) is placed at K, the correct strap length will be at point V; with all allowances added if the person is normal; or in other words, *this is normal* strap length always for all sizes.

If a 6th were used or an 8th it is evident it cannot be the same. On a 48 breast the strap would vary  $\frac{3}{4}$  inch.

When the strap length comes above point V it indicates an erect form; or the measures are taken wrong.

It is as sure a check as can be.

42. Likewise the over shoulder measure is correct provided point A or 4 is established as explained.

The high shoulder or low shoulder is regulated by the depth of scye and front shoulder point from point 4; or A (if height corresponds to width).

The breast line is never changed, the measures are really applied from the breast line up.

The breast line and A-V line form the balance or frame; if attitude is stooping point V will be below the line and point A will rise above the normal line.

The lower part of the coat is never disturbed by attitude; all changes are made on the line A-V.

Consequently the sleeves will hang correct every time, because a sleeve, or rather the arm) hangs straight down always; no matter what attitude.

Therefore if the breast line is always horizontal (the way the measures were taken) the sleeve must fit correctly every time.

43. For erect or stooping attitude there can therefore be only a  $\frac{1}{4}$  or  $\frac{1}{2}$  inch more or less spring changes from the normal; for erect more, and for stooping less.

Measures can be applied when measuring and when drafting; or a near enough quantity added or reduced if no measure is taken.

The stationary breast line enables us to easily determine the run of bottom; by a sweep from E to 7; from the *center of body* on line K.

Line E is the extreme back width and line 7 is the extreme front width. All three of them are fixed points, fashion cannot change them; therefore, by adding  $\frac{5}{8}$  below 17 gives a continuous even run to the bottom; the same distance from the floor *every time*.

All measures and system points are applied from fixed or stationary points.

Therefore, style can have no effect on the system insofar as displacing any of the points.

If there is one solid (stationary) and correct point, other points obtained from it will also be correct; but never from movable points.

All coats are finished to the *front center*, then additions for D, B, or style are put on. A further study in the disproportions of the coat should be gone over carefully, until the principle it works on becomes clear.

When the system points are obtained correctly there is not such a great variation in the different points as some cutters seem to imagine.

44. The shoulder point can in no possible instance rise more than  $\frac{1}{2}$  inch above line A-V, and that is extreme; and half the distance back from line U-V.

It cannot possibly go more than  $\frac{3}{8}$  inch below the line, and the same amount forward. The back height can in no instance go more than a  $\frac{1}{4}$  inch below the line, nor  $\frac{1}{2}$  inch above the line.

This means for attitude after the normal *width* and *height* line has been established. For example: A person 5 feet 9 inches, 42 breast, stooping  $\frac{1}{2}$  inch, low shoulders or sloping  $\frac{1}{4}$  inch, establish the depth of scye from 4 to B by the breast measure (42); from B up apply the depth of scye of the height (39 breast); A is

half way between the two and is the normal *depth of scye*.

Line 4 forms the normal front height.

45. When the *actual* depth of scye measure is applied it will be found as follows: Scye plus  $\frac{1}{2}$  inch, sloping shoulders plus  $\frac{1}{4}$  inch, stooping plus  $\frac{1}{2}$  inch total measure; with allowance of  $\frac{1}{2}$  inch for make-up.

The front shoulder will be (a  $\frac{1}{4}$  inch below for normal) in this instance the sloping shoulders add a  $\frac{1}{4}$  inch to the strap length, thereby rising line A-V a  $\frac{1}{4}$  inch. The measure will therefore fall on the line A-V *as drawn*, but a  $\frac{1}{4}$  inch forward.

The height of shoulders are taken from the highest point S to U, or line 4, and from F (half way between 4 and B) to point V *normal*. This will give the correct height of the shoulders.

It should also be remembered that if a person stoops  $\frac{1}{2}$  inch in the back, the point V will only lower *half* as much, and advance half as much. This can easily be verified by placing the normal shoulders together, and by raising the collar  $\frac{1}{2}$  inch in back it will be found to be a  $\frac{1}{4}$  inch at point V.

## Chesty Coat

### Diagram 3

46. Draw a line from  $1\frac{1}{4}$  inches back of point V through the corner of the pocket.

Draw a line from the breastline to the notch.

Cut in from the notch to the breastline, down to the pocket and up to V; leave pattern together at V.

Open at the breastline  $\frac{3}{4}$  to 1 inch and fold pleat below the pocket; this will open  $\frac{1}{2}$  inch at the notch.

Re-shape by the new position as shown.

The  $\frac{1}{2}$ -inch opening should be worked in between the two bars marked 6 inches apart.

Add a  $\frac{1}{4}$  inch over the blade for the back and  $\frac{3}{4}$  inch for flare. Take out  $\frac{1}{2}$  inch in the under arm cut.

Add  $\frac{1}{2}$  inch flare to the back part.

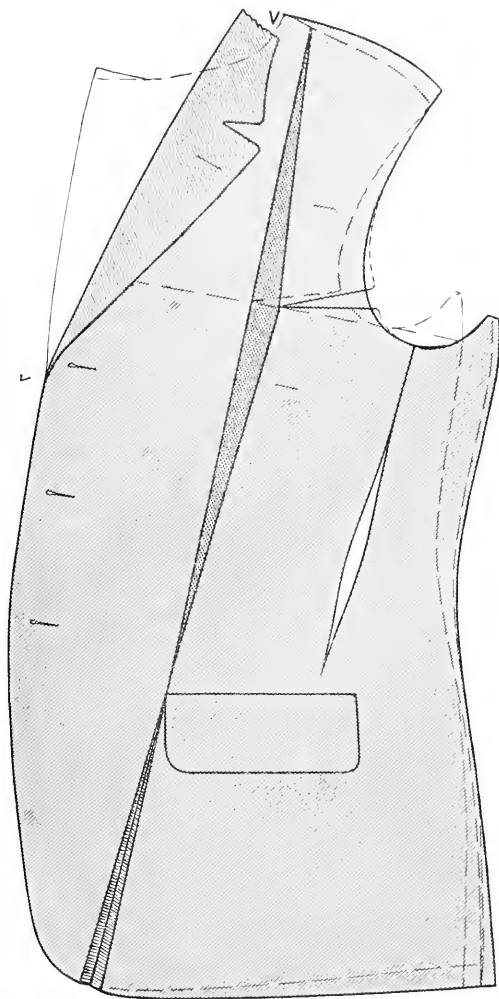

DIAGRAM 3 — CHESTY COAT

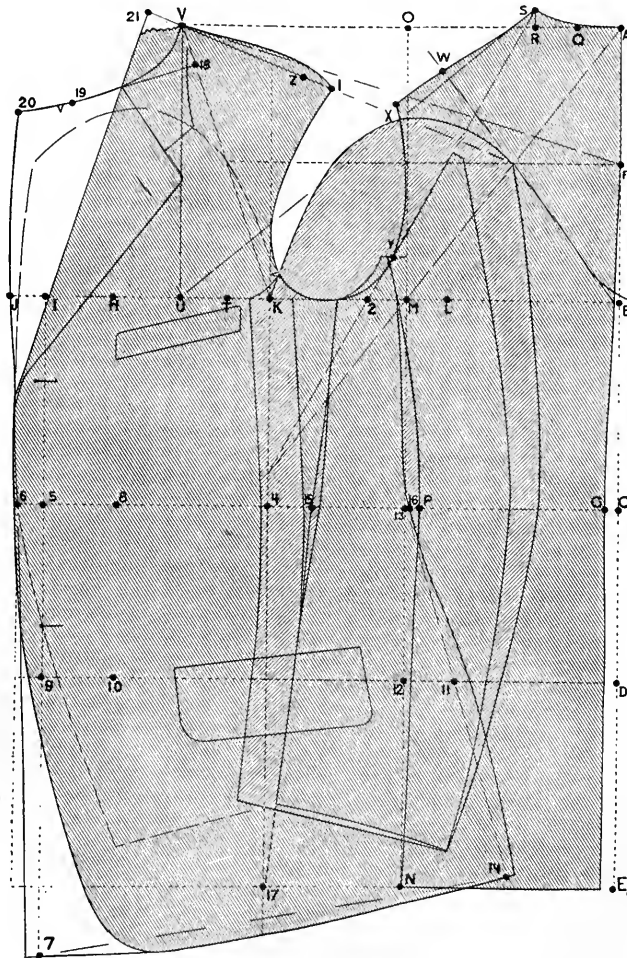

DIAGRAM 4—SINGLE BREASTED SACK

# Single Breasted Sack

## Diagram 4

38. The measures are taken over the Vest always.  
 Inside sleeve 17 $\frac{3}{4}$  inches. Blade (with 1 $\frac{1}{4}$  inches for  
 Breast 36 inches. seams added) 12 $\frac{1}{2}$  inches.  
 Waist 32 inches. Depth of scye 9 inches.  
 Hip or seat 37 inches. Natural waist 16 $\frac{3}{4}$  inches.  
 Strap 12 inches. Full length 30 inches.  
 Over shoulder 17 inches. Height 5 feet 6 inches.  
 Form and Attitude, normal. Sizes 33 to 42 breasts.

### TO DRAFT.

- 1 Square both ways from A
- 2 A to B is  $\frac{1}{3}$  breast on "3RDS" and 3 $\frac{1}{2}$  inches (9 $\frac{1}{2}$ ).
- 3 This is the proportional, and includes all allowances.
- 4 A to C is one-fourth height, and  $\frac{1}{4}$  inch for curve of Back (16 $\frac{3}{4}$ ).
- 5 C to D is  $\frac{1}{3}$  breast, on "3RDS" (6) Seatline.
- 6 Added to the natural waist gives correct length.
- 7 A to E is the Full Length of Back.
- 8 F is half between B and A, for front shoulder height.
- 9 Square out from A, B, C, D, E and F.
- 10 C to G is  $\frac{1}{2}$  inch, draw line F to G and down to E.
- 11 From the line just drawn inside of B measure<sup>6</sup> to H.
- 12 B to H is half the full breast measure (18).
- 13 H to I is 2 $\frac{1}{4}$  inches—center of breast.
- 14 B to K is blade (with 1 $\frac{1}{4}$  inches for seams) (12 $\frac{1}{2}$ ).
- 15 Square up from K—front of armhole.
- 16 L is half way between B and K.
- 17 L to M is 1 $\frac{1}{4}$  inches—width of Back.
- 18 Square up to O and down to N.
- 19 P is  $\frac{1}{2}$  inch from line O-M; draw line to N.
- 20 A to Q is  $\frac{1}{12}$  breast—on "12THS," and
- 21 Q to R is 1 $\frac{1}{2}$  inches; square up to S,  $\frac{5}{8}$  inch.
- 22 K to T is 1 $\frac{1}{2}$  inches; T to U is  $\frac{1}{12}$  breast.
- 23 Square up from U to V, locating the shoulder point.
- 24 V is located on lines from K and A.
- 25 Draw lines from S to U, and F to V.
- 26 This gives the proportional height of shoulders.
- 27 Rise at X  $\frac{1}{2}$  inch, and lower at point I the same.
- 28 X is  $\frac{1}{2}$  inch on the S-U line—or Style.
- 29 Y is  $\frac{1}{2}$  inch from the O-N line, and  $\frac{1}{12}$  up from M.
- 30 Draw guide line from Y to P.
- 31 From B up apply depth of scye measure and  $\frac{1}{2}$  in. (9 $\frac{1}{2}$ ) to A, in normal attitude will meet line A.
- 32 The  $\frac{1}{2}$  inch is for fulness held in over the blade.
- 33 Shape the Back as shown; draw line from B to W.
- 34 Apply strap measure, and 1 inch A to R, placing the amount at K, and measure up, locating V (13 in.).
- 35 When attitude is normal will meet line A-V.
- 36 Apply over shoulder measure and 1 in. from B to W, placing the amount at K, and measure up, locating Z (18 inches).
- 37 When attitude is normal will meet line F-V.
- 38 Z is 1 $\frac{1}{4}$  inches from line K.
- 39 Draw a line from V through Z to point I.
- 40 V to point I is  $\frac{3}{8}$  inch less than S to X.
- 41 Draw a guide line from point I to T.
- 42 Shape arm-syce and shoulder rounding  $\frac{1}{2}$  in. over Z.
- 43 B to 2 is  $\frac{1}{2}$  breast on "HALVES"; 2 to K is 3 $\frac{1}{2}$  inches.
- 44 This is normal blade and independent of the actual blade, and comes even with K in normal sizes.
- 45 Square down from K through 4 to 17.
- 46 4 to 5 is  $\frac{1}{2}$  waist—on "HALVES"—center of waist.
- 47 Square down from 5 to 7. The measure from B to 2, K, 4 and 5, is used only to obtain the front center of the waist and to check the blade measure.
- 48 5 to 8 is 2 $\frac{1}{2}$  inches, 9 to 10 is the same.
- 49 These 2 $\frac{1}{2}$  inches are for seams and make-up.
- 50 Apply hip measure and  $\frac{3}{4}$  inch for 3 seams; width of Back from 12 to D and 10 to 11.
- 51 11 to 12 is 1 $\frac{3}{4}$  inches; square up, locating 13.
- 52 (Proportional hip spring 12 to 11 is 1 $\frac{3}{4}$  inches.)
- 53 Draw a line from 13 through 11 to 14.
- 54 Measure waist and 1 $\frac{1}{2}$  inches P to G and 8 to 16.
- 55 Y to 14 is the length from Y to N.
- 56 Shape side seam of forepart from Y to 16, going out  $\frac{5}{8}$  inch over 11 to 14—or Style.
- 57 Draw line 15 and take out a  $\frac{1}{4}$  inch or more.
- 58 (Reduce  $\frac{1}{2}$  in. from Y to 16 when no underarm cut.)
- 59 Z to 7 is length from Z to E and 1 inch, from line K.
- 60 The 1 inch is taken up in making the front edge.
- 61 Draw line 14 to 7; shape bottom; lower  $\frac{3}{8}$  at 17.
- 62 V to 18 is  $\frac{1}{12}$  breast; square forward from 18 by K.
- 63 18 to 19 is  $\frac{1}{4}$  breast; draw line from 19 to I and 5.
- 64 The coat is now completed to the front center; any addition is for overlap, either single or double breasted.
- 65 19 to 20 is 2 $\frac{1}{4}$  inches; notch  $\frac{1}{2}$  inch from 19.
- 66 I to J is 1 $\frac{1}{4}$  inches; 5 to 6 is 1 inch; square down.
- 67 Go in  $\frac{1}{2}$  inch at 7; draw line from 6 and shape front.
- 68 V to 21 is 1 $\frac{1}{4}$  inches; draw line to end of roll.
- 69 The pocket is 2, 3 sleeve length and  $\frac{1}{2}$  inch from K.
- 70 (For double-breasted add 2 $\frac{1}{4}$  inches to the front.)
- 71 All coats are drafted a straight front *always*; then the style is put on; such as 2, 3 or 4 buttons; the cut-away in front, and the width and style of lapel.
- 72 To place the pocket: lay corner of square on K, find the inside sleeve length (17 $\frac{3}{8}$ ) on the 2 "3RDS," add a  $\frac{1}{2}$  inch for the slant; about 12 $\frac{3}{4}$  inches down from K.
- 73 The width is 3 $\frac{1}{4}$  inches on each side of the line K, running even with the bottom.

## Double Breasted Sack

39. All points are obtained as usual in Sack Coats. From center or front line 19-I and 5 to front edge 26-J and 6 is 3 $\frac{1}{2}$  inches. Peak lapel for style. The lower button is 1 inch below the pocket.

The buttons are placed as far back from the center line as the end of the holes (or eyes) are in front of it.

A *I'* should be taken out in the gorge. The length of the roll is to suit or measure. A collar must be cut for each coat *always*.

## Long Roll Sack

### Diagram 5

47. The measures are taken over the Vest always.
- |               |                          |  |
|---------------|--------------------------|--|
| Inside sleeve | 17 $\frac{3}{4}$ inches. | Blade (with 1 $\frac{1}{4}$ inches for |
| Breast        | 36 inches.               | seams added) 12 $\frac{1}{2}$ inches.  |
| Waist         | 32 inches.               | Depth of scye 9 inches.                |
| Hip or seat   | 37 inches.               | Natural waist 16 $\frac{3}{4}$ inches. |
| Strap         | 12 inches.               | Full length 30 inches.                 |
| Over shoulder | 17 inches.               | Height 5 feet 6 inches.                |

Form and attitude, normal. Sizes, 33 to 42 breast.

#### TO DRAFT.

- 1 Square both ways from A.
- 2 A to B is  $\frac{1}{3}$  breast on "3RDS" and 3 $\frac{1}{2}$  inches (9 $\frac{1}{2}$ ).
- 3 This is the proportional and includes all allowances.
- 4 A to C is one-fourth height, and  $\frac{1}{4}$  inch for curve of Back. (16 $\frac{3}{4}$ ).
- 5 C to D is  $\frac{1}{3}$  breast, on "3RDS." seatline (6).
- 6 Added to the natural waist gives correct length.
- 7 A to E is the Full Length of Back.
- 8 F is half between B and A, for front shoulder height.
- 9 Square out from A, B, C, D, E and F.
- 10 C to G is  $\frac{1}{2}$  inch, draw line F to G and down to E.
- 11 From the line just drawn inside of B measure to H.
- 12 B to H is half the full breast measure (18).
- 13 H to I is 2 $\frac{1}{4}$  inches—center of breast.
- 14 B to K is blade (with 1 $\frac{1}{4}$  inches for seams). (12 $\frac{1}{2}$ ).
- 15 Square up from K—front of armhole.
- 16 L is half-way between B and K.
- 17 L to M is 1 $\frac{1}{4}$  inches—width of Back.
- 18 Square up to O, and down to N.
- 19 P is  $\frac{1}{2}$  inch from Line O-M; draw line to N.
- 20 A to Q is  $\frac{1}{12}$  breast—on "12THS" and
- 21 Q to R is 1 $\frac{1}{2}$  inches; square up to S,  $\frac{5}{8}$  inch.
- 22 K to T is 1 $\frac{1}{2}$  inches; T to U is  $\frac{1}{12}$  breast.
- 23 Square up from U to V, locating the shoulder point.
- 24 V is located on lines from K and A.
- 25 Draw lines from S to U, and F to V.
- 26 This gives the proportional height of shoulders.
- 27 Rise at X  $\frac{1}{2}$  inch, and lower at point 1 the same.
- 28 X is  $\frac{1}{2}$  inch on the S-U line—or Style.
- 29 Y is  $\frac{1}{2}$  inch from the O-N line, and  $\frac{1}{12}$  up from M.
- 30 Draw guide line from Y to P.
- 31 From B up apply depth of scye measure and  $\frac{1}{2}$  inch to A, in normal attitude will meet line A.
- 32 The  $\frac{1}{2}$  inch is for fullness held in over the blade.
- 33 Shape the Back as shown; draw line from B to W.
- 34 Apply strap measure, and 1 inch A to R and K to V (13) in normal attitude will meet line A-V.
- 35 Apply over shoulder measure and 1 inch (18) B to W and K to Z; when normal, meet line F-V.
- 36 Z is 1 $\frac{1}{4}$  inches from line K.
- 37 Draw a line from V through Z to point 1.
- 38 V to point 1 is  $\frac{3}{8}$  inch less than S to X.
- 39 Draw a guide line from point 1 to T.
- 40 Shape arm-scye and shoulder rounding  $\frac{1}{2}$  in. over Z.
- 41 B to 2 is  $\frac{1}{2}$  breast on "HALVES"; 2 to K is 3 $\frac{1}{2}$  inches.
- 42 This is normal blade and independent of the actual blade, and comes even with K in normal sizes.
- 43 Square down from K through 4 to 17.
- 44 4 to 5 is  $\frac{1}{2}$  waist—on "HALVES"—center of waist.
- 45 Square down from 5 to 7. The measure from B to 2, K, 4 and 5, is used only to obtain the front center of the waist and to check the blade measure.
- 46 5 to 8 is 2 $\frac{1}{2}$  inches, 9 to 10 is the same.
- 47 These 2 $\frac{1}{2}$  inches are for seams and make-up.
- 48 Apply hip measure and  $\frac{3}{4}$  inch for 3 seams; width of Back from 12 to D and 10 to 11.
- 49 11 to 12 is 1 $\frac{3}{4}$  inches; square up, locating 13.
- 50 (Proportional hip spring 12 to 11 is 1 $\frac{3}{4}$  inches.)
- 51 Draw a line from 13 through 11 to 14.
- 52 Measure waist and 1 $\frac{1}{2}$  inches P to G and 8 to 16.
- 53 Y to 14 is the length from Y to N.
- 54 Shape side seam of forepart from Y to 16, going out  $\frac{5}{8}$  inch over 11 to 14—or style.
- 55 (Reduce  $\frac{1}{2}$  in. from Y to 16 when no underarm cut.)
- 56 Z to 7 is length from Z to E and 1 inch, from line K.
- 57 The 1 inch is taken up in making the front edge.
- 58 Draw line 14 to 7; shape bottom; lower  $\frac{5}{8}$  at 17.
- 59 V to 18 is  $\frac{1}{12}$  breast; square forward from 18 by K.
- 60 18 to 19 is  $\frac{1}{4}$  breast; draw line from 19 to I and 5.
- 61 19 to 20 is 2 $\frac{1}{4}$  inches; notch  $\frac{1}{2}$  inch from 19.
- 62 5 to 6 is 1 inch, square down.
- 63 Place buttonholes as desired and shape front.
- 64 V to 21 is 1 $\frac{1}{4}$  inches; draw a line to end of Roll.
- 65 From the crease and gorge lines to 19 is the opening 2 inches.
- 66 Draw a rounding line  $\frac{1}{2}$  inch over the breast.
- 67 From 19 draw a straight line to end of Roll.
- 68 Back of 19 add 2 seams and draw parallel line.
- 69 19 to 20 is the width to the notch.
- 70 20 to 26 is 1 $\frac{3}{4}$  inches or width desired.
- 71 Make the inside of the lapel either curved or straight.
- 72 Shape as represented and cut out the V.
- 73 The end of the cut runs off the break line.
- 74 This will produce a prominent curved roll.
- 75 The forepart is cut along the break line.
- 76 Finished with patch pockets and no underarm cut.
- 77 The pocket is  $\frac{2}{3}$  sleeve length and  $\frac{1}{2}$  inch from K.



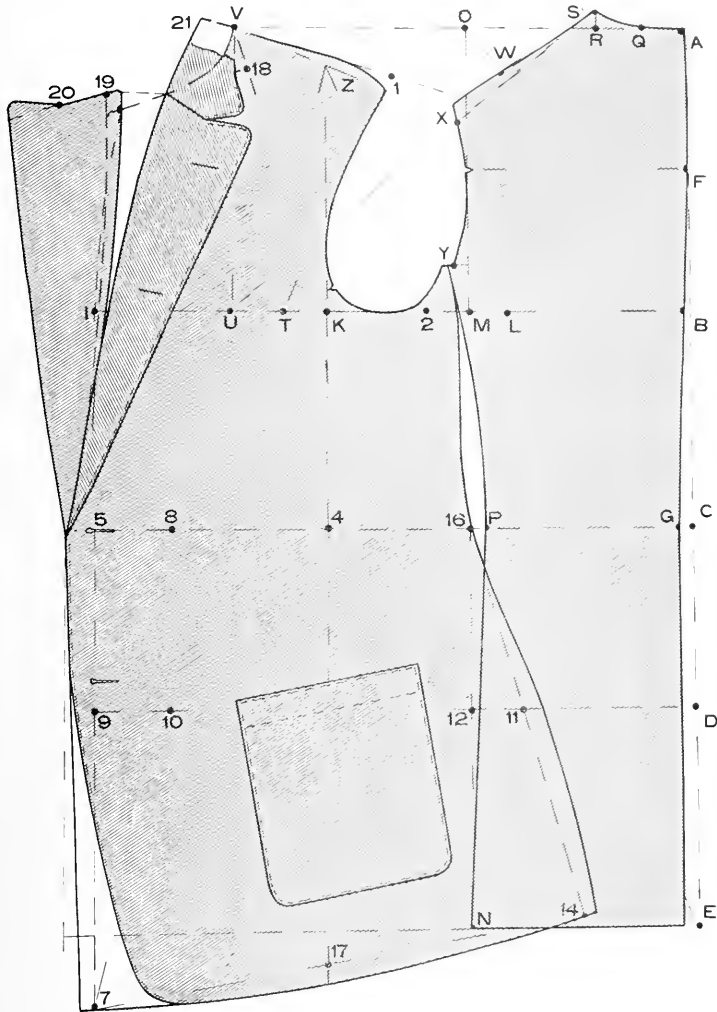

DIAGRAM 5—LONG ROLL SACK

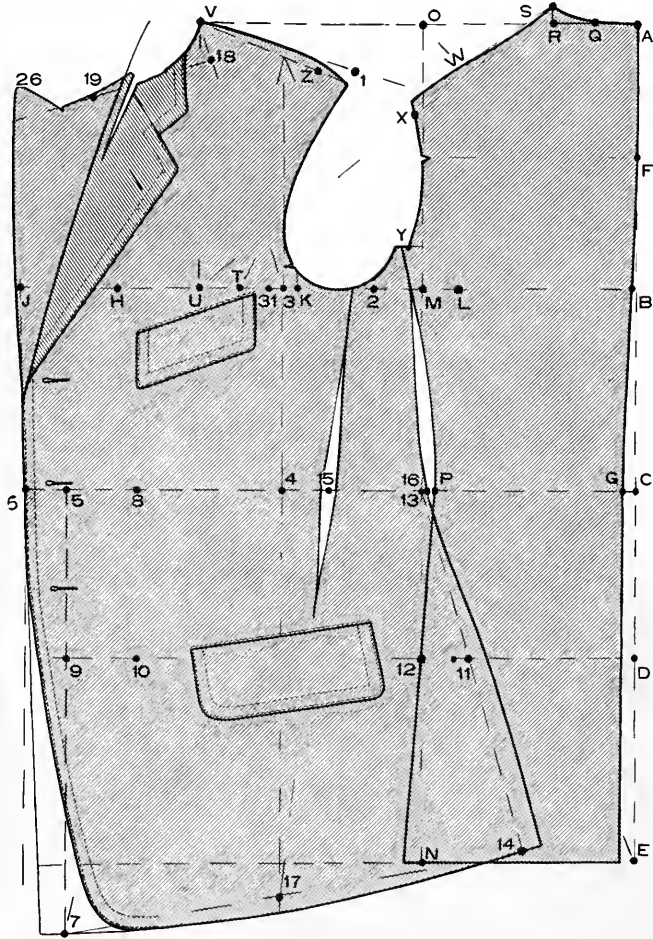

DIAGRAM 6—EXAGGERATED SACK

## Exaggerated Sack

### Diagram 6

48. The measures are taken over the Vest always.

Inside sleeve	17 $\frac{3}{4}$ inches	Blade (with 1 $\frac{1}{4}$ inches for
Breast	36 inches.	seams added) 12 $\frac{1}{2}$ inches.
Waist	32 inches.	Depth of scye 9 inches.
Hip or seat	37 inches.	Natural waist 16 $\frac{3}{4}$ inches.
Strap	12 inches.	Full length 30 inches.
Over shoulder	17 inches.	Height 5 feet 6 inches.
Exaggerated	2 inches.	
Form and Attitude	normal.	Sizes, 33 to 42 breasts.

#### TO DRAFT.

- Square both ways from A.
- A to B is  $\frac{1}{3}$  breast on "3RDS" and 3 $\frac{1}{2}$  inches (9 $\frac{1}{2}$ ).
- This is the proportional, and includes all allowances.
- A to C is one-fourth height, and  $\frac{1}{4}$  inch for curve of Back. (16 $\frac{3}{4}$ ).
- C to D is  $\frac{1}{3}$  breast, on "3RDS" (6) Seatline.
- Added to the natural waist gives correct length.
- A to E is the Full Length of Back.
- F is half between B and A, for front shoulder height.
- Square out from A, B, C, D, E and F.
- C to G is  $\frac{1}{2}$  inch, draw line F to G and down to E.
- From the line just drawn inside of B measure to H.
- B to H is half the full breast measure. (19) Exagg.
- H to I is 2 $\frac{1}{4}$  inches—center of breast.
- B to K is blade (with 1 $\frac{1}{4}$  inches for seams).
- Square up from K.
- K to 31 is 1 inch—half exaggeration.
- 3 is half-way between K and 31; square up.
- L is half-way between B and 3.
- L to M is 1 $\frac{1}{4}$  inches—width of Back.
- Square up to O, and down to N,  $\frac{1}{2}$  inch flare.
- P is  $\frac{1}{2}$  inch from line O-M; draw line to N.
- A to Q is  $\frac{1}{12}$  breast—on "12THS," and
- Q to R is  $\frac{1}{2}$  inches; square up to S,  $\frac{5}{8}$  inch.
- 3 to T is 1 $\frac{1}{2}$  inches; T to U is  $\frac{1}{12}$  breast.
- Square up from U to V, locating the shoulder point.
- V is located on lines from K and A.
- Draw lines from S to U, and F to V.
- This gives the proportional height of shoulders.
- Rise at X  $\frac{1}{2}$  inch, and lower at point 1 the same.
- X is  $\frac{1}{2}$  inch on the S-U line—or Style.
- Y is  $\frac{1}{2}$  inch from the O-N line, and 1/12 up from M.
- Draw guide line from Y to P.
- From B up apply depth of scye measure and  $\frac{1}{2}$  inch to A, in normal attitude will meet line A. (9 $\frac{1}{2}$ ).
- The  $\frac{1}{2}$  inch is for fullness held in over the blade.
- Shape the Back as shown; draw line from B to W.
- Apply strap measure, and 1 inch A to R and 3 to V. (13) in normal attitude will meet line A-V.
- Apply over shoulder measure and 1 inch (18) B to W and 3 to Z; when normal, meet line F-V.
- Z is 1 $\frac{1}{4}$  inches from line K.
- Draw a line from V through Z to point 1.
- V to point 1 is  $\frac{3}{8}$  inch less than S to X.
- Draw a guide line from point 1 to T.
- Shape arm-scye and shoulder rounding  $\frac{1}{2}$  in. over Z.
- A continuous rounding to V for length over chest.
- B to 2 is  $\frac{1}{2}$  breast, and  $\frac{1}{2}$  inch exaggeration.
- 2 to K is 3 $\frac{1}{2}$  inches.
- This is normal blade and independent of the actual blade, and comes even with K in normal sizes.
- Square down from K through 4 to 17.
- 4 to 5 is  $\frac{1}{2}$  waist—on "HALVES"—center of waist.
- Square down from 5 to 7. The measure from B to 2, K, 4 and 5, is used only to obtain the front center of the waist and to check the blade measure.
- 5 to 8 is 2 $\frac{1}{2}$  inches, 9 to 10 is the same.
- These 2 $\frac{1}{2}$  inches are for seams and make-up.
- Apply hip measure and  $\frac{3}{4}$  inch for 3 seams; width of Back from 12 to D and 10 to 11 and  $\frac{1}{2}$  inch exaggeration.
- Measure normal back width at 12, not the flare.
- 11 to 12 is 1 $\frac{3}{4}$  inches; square up, locating 13.
- (Proportional hip spring 12 to 11 is 1 $\frac{3}{4}$  inches.)
- Draw a line from 13 through 11 to 14.
- Measure waist and 1 $\frac{1}{2}$  inches P to G and 8 to 16.
- Y to 14 is the length from Y to N.
- Shape side seam of forepart from Y to 16, going out  $\frac{5}{8}$  inch over 11 to 14; add  $\frac{1}{4}$  inch for flare.
- Draw line 15 and take out a  $\frac{1}{4}$  inch or more.
- (Reduce  $\frac{1}{2}$  in. from Y to 16 when no underarm cut.)
- Z to 7 is length from Z to E and 1 inch, from line K.
- The 1 inch is taken up in making the front edge.
- Draw line 14 to 7; shape bottom; lower  $\frac{5}{8}$  at 17.
- V to 18 is  $\frac{1}{12}$  breast; square forward from 18 by K.
- 18 to 19 is  $\frac{1}{4}$  breast; draw line from 19 to I and 5.
- 19 to 20 is 2 $\frac{1}{4}$  inches; notch  $\frac{1}{2}$  inch from 19.
- I to J is 1 $\frac{1}{2}$  inches; 5 to 6 is 1 inch; square down.
- Go in  $\frac{1}{2}$  inch at 7; draw line from 6 and shape front.
- V to 21 is 1 $\frac{1}{4}$  inches; draw line to end of roll.
- The first button is 10 inches down from the notch; the last is 7 $\frac{1}{2}$  inches from the first.
- The pocket is  $\frac{2}{3}$  sleeve length and  $\frac{1}{2}$  inch from K.
- And 6 $\frac{1}{2}$  inches running even with the bottom line.
- (For double-breasted add 2 $\frac{1}{4}$  inches to the front.)
- All coats at point Y should be cut with  $\frac{1}{4}$  inch step for a seam. The forepart is cut *straight* across.

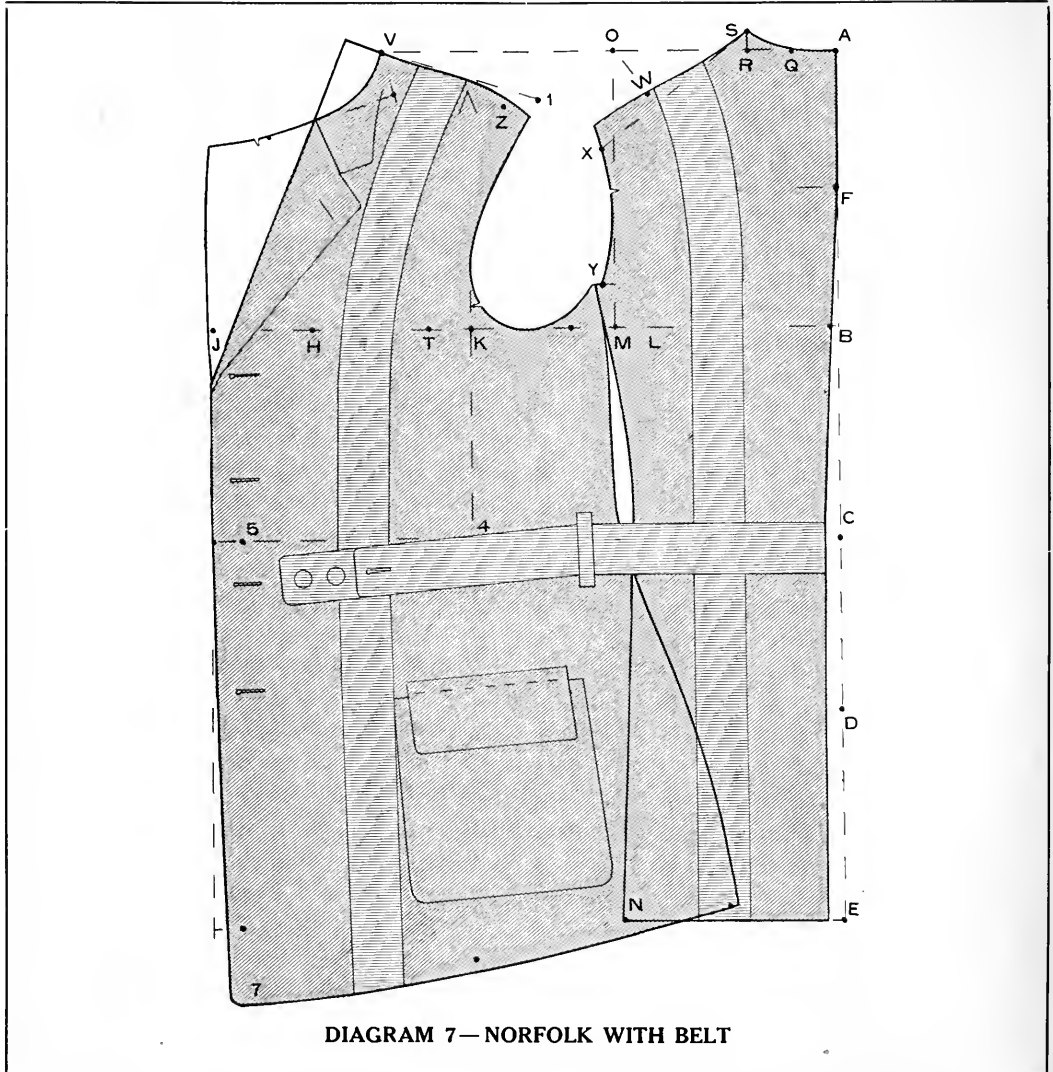

DIAGRAM 7—NORFOLK WITH BELT

49. This coat is cut in the same manner as a sack coat; the pleats are cut separate and laid on the coat, or they can be cut as explained in the Norfolk Pleated.

The pleat pieces are cut twice as wide as the pleats, and in cutting the cloth must match the material of the coat.

The front pleat is about  $1\frac{1}{4}$  inches from the shoulder point; the pocket is moved back a  $\frac{1}{2}$  inch to allow the pleat to pass.

The back pleat is the same distance from the armhole as the front pleat.

The center of the pleat at the bottom is at  $\frac{1}{2}$  the back width.

The belt is cut twice as wide as made up, and is cut across on the cloth the full width of the goods.

It is considered more stylish to cut the belt lengthwise, and first-class houses are doing it now. If a belt is

cut lengthwise it should be the waist width and 12 inches. No under-arm cut, but the full width of blade is used.

A  $\frac{1}{4}$  inch is added to front to give chest room.

The outside breast pocket is inserted in the left breast, the opening being under the breast pleat and lengthwise. Usually finished with patch pocket.

The Norfolks are now being used to a great extent and by all classes of people and made up in all kinds of manners. The general features of "Norfolks" should be of what is termed a bold character. They should be cut roomy. The stitching of the edges and pleats should be extra wide. All the pockets should be strongly tacked, and are best lined with waterproof material. The lining is often of flannel, or some such absorbent material.

When no lining is put in, the seams are taped. The material should be a rough make of cheviot or Bannockburn tweed. The buttons are of buffalo horn.

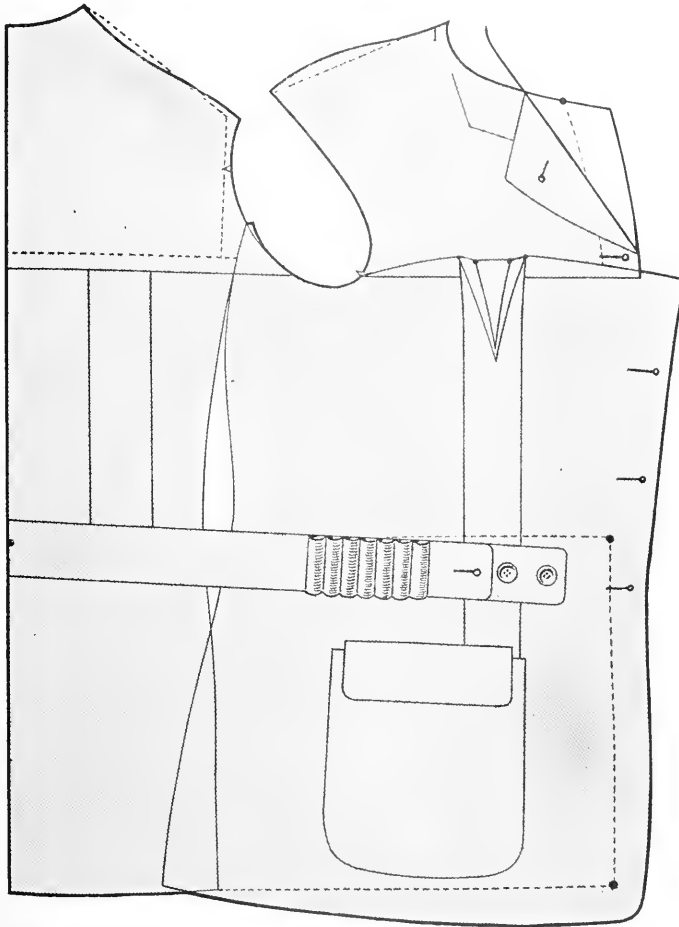

DIAGRAM 8 — NORFOLK YOKED

50. Norfolk coats are frequently finished with yoked shoulders—that is, the shoulders are finished plain, the same as in ordinary sack coats, while a seam is run across the back and forepart about level with the bottom of the scye, upon which the lower part of the garment is pleated in to any desired style.

The yoke is by many considered to impart improved style; it certainly is of considerable advantage in allowing additional ease over the chest.

This diagram has an inverted pleat in back and front, extending from waist line up to the yoke line. The

amount of material taken up by the breast pleat, or V, must be allowed on to the front edge, starting from the bottom button and gradually increased to the desired amount at the top.

The belt is 2 inches wide, or the same width as the body pleat. It is perhaps advisable to have the belt sewn to the waist of the coat, from the back to within about 3 inches of the front. By this method the fullness can be distributed in a slight manner and without loss of comfort and style. The lower button should be above the belt. The pockets should be well stayed and of good size.

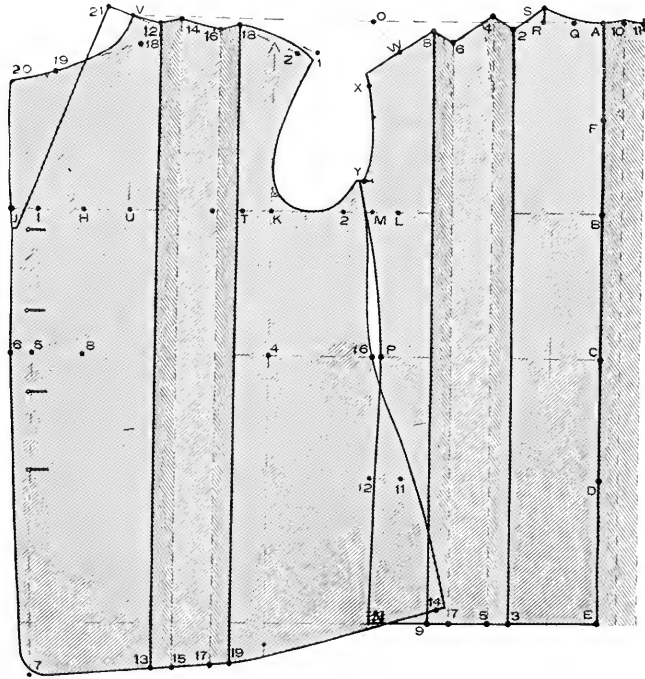

DIAGRAM 9 — NORFOLK PLEATED

## Norfolk Pleated

### Diagram 9

51. The measures are taken over the Vest always.

Inside sleeve	17 $\frac{3}{4}$ inches.	Blade (with 1 $\frac{1}{4}$ inches for
Breast	36 inches.	seams added) 12 $\frac{1}{2}$ inches.
Waist	32 inches.	Depth of scye 9 inches.
Hip or seat	37 inches.	Natural waist 16 $\frac{3}{4}$ inches.
Strap	12 inches.	Full length 30 inches.
Over-shoulder	17 inches.	Height 5 feet 6 inches.

Form and attitude, normal.      Sizes 33 to 42 breasts.

#### TO DRAFT.

- 1 Inverted pleat, 2 inches wide.
- 2 Square from A 2 inches from edge of paper.
- 3 A to B is  $\frac{1}{3}$  breast on "3RDS" and 3 $\frac{1}{2}$  inches (9 $\frac{1}{2}$ ).
- 4 This is the proportional and includes all allowances.
- 5 A to C is one-fourth height and  $\frac{1}{4}$  inches for length.
- 6 C to D is  $\frac{1}{3}$  breast on "3RDS" (6), Seatline.
- 7 Added to the natural waist gives correct length.
- 8 A to E is full length.
- 9 Square out from A, B, C, D, E and F.
- 10 A to Q is  $\frac{1}{12}$  breast—on "12THS", and
- 11 Q to R is 1 $\frac{1}{2}$  inches; square up to S,  $\frac{5}{8}$  inch.
- 12 R to 2 is 1 $\frac{1}{2}$  inches; square down to 3.
- 13 2 to 4 is  $\frac{1}{2}$  pleat (1 inch) 3 to 5 the same.
- 14 Draw folding line of pleat from 4 to 5.
- 15 4 to 6 and 5 to 7, width of pleat, 2 inches.
- 16 Draw folding line of pleat from 6 to 7.
- 17 6 to 8 and 7 to 9 each  $\frac{1}{2}$  pleat (1 inch).
- 18 Draw folding line of pleat from 8 to 9.
- 19 A back to 10 is 1 inch; 10 to 11 is the same.
- 20 Draw folding lines 10 to 11—center of Back.
- 21 Line 11 is the crease edge of the material.
- 22 Trace lines 11, 12, A, 2, 4, 6 and 8.
- 23 Fold 10 on A, 11 on 10 and 4 on 2 and 6 on 8.
- 24 B to K is blade (with 1 $\frac{1}{4}$  inches for seams) (12 $\frac{1}{2}$ ).
- 25 Square up from K—front of armhole.
- 26 L is half way between B and K.
- 27 L to M is 1 $\frac{1}{4}$  inches—width of Back.
- 28 Square up to O and down to N.
- 29 P is  $\frac{1}{2}$  inch from line O-M; draw line to N.
- 30 K to T is 1 $\frac{1}{2}$  inches; T to U is  $\frac{1}{12}$  breast.
- 31 Square up from U to V, locating the shoulder point.
- 32 Draw lines S to U and F to V.
- 33 This gives the proportional height of shoulders.
- 34 Rise at X  $\frac{1}{2}$  inch, and lower at point I the same.
- 35 X is  $\frac{1}{2}$  inch on S-U line—or Style.
- 36 Y is  $\frac{1}{2}$  inch from the O-M line, and  $\frac{1}{12}$  up from M.
- 37 Draw guide line from Y to P.
- 38 From B up apply actual depth of scye measure and  $\frac{1}{2}$  inch to A; in normal attitude will meet line A.
- 39 The  $\frac{1}{2}$  inch is for fullness held in over the blade.
- 40 Shape the back as shown; draw a line from B to W.
- 41 Apply strap measure and 1 inch A to R and K to V.
- 42 In normal attitude will meet line A-V (13).
- 43 Apply over shoulder measure and 1 inch B to W and K to Z.
- 44 (18) When normal will meet line F-V.
- 45 Z is 1 $\frac{1}{4}$  inches from line K.
- 46 Draw a line from V through Z to point 1.
- 47 V to point 1 is  $\frac{3}{8}$  inch less than S to X.
- 48 Draw a guide line from point 1 to T.
- 49 Shape arm-scye and shoulder rounding  $\frac{1}{2}$  in. over Z.
- 50 V back to 12 is 1 $\frac{1}{2}$  inches.
- 51 Draw folding line to 13.
- 52 12 to 14 is 1 inch, 13 to 15 is the same.
- 53 Draw folding line 14 to 15.
- 54 14 to 16 is the width of pleat.
- 55 15 to 17 is the same.
- 56 Draw folding line 16 to 17.
- 57 16 to 18 is half width of pleat (1 inch).
- 58 17 to 19 the same, draw folding line.
- 59 Trace lines 12, 14, 16 and 18.
- 60 Fold 14 on 12 and 16 on 18.
- 61 Reduce  $\frac{1}{4}$  inch inside of 16 when no underarm cut.
- 62 B to H is  $\frac{1}{2}$  full breast measure (18).
- 63 H to I is 2 $\frac{1}{4}$  inches.
- 64 B to 2 is  $\frac{1}{2}$  breast on "HALVES"; 2 to K is 3 $\frac{1}{2}$  inches.
- 65 This is the normal blade and independent of the actual blade, and comes even with K in normal sizes.
- 66 Square down from K through 4 to 17.
- 67 4 to 5 is half waist—on "HALVES"—center of waist.
- 68 Square down from 5 to 7.
- 69 The measure from B to 2, K, 4 and 5 is only used to obtain the front center of the waist and to check the blade measure.
- 70 5 to 8 is 2 $\frac{1}{2}$  inches; 9 to 10 is the same.
- 71 These 2 $\frac{1}{2}$  inches are for seams and make-up.
- 72 (Proportional hip spring 12 to 11 is 1 $\frac{3}{4}$  inches.)
- 73 Measure hip and  $\frac{3}{4}$  inch for 3 seams, width of Back from 12 to D and 10 to 11.
- 74 11 to 12 is 1 $\frac{3}{4}$  inches; square up, locating 13.
- 75 Draw a line from 13 through 11 to 14.
- 76 Measure waist and 1 $\frac{1}{2}$  inches, P to G and 8 to 16.
- 77 Y to 14 is the length from Y to N.
- 78 Shape sideseam of forepart from Y through 16, going out  $\frac{5}{8}$  inch over 11 to 14—or Style.
- 79 Z to 7 is the length from Z to E and 1 in. from line K.
- 80 Draw line 14 to 7; shape bottom; lower  $\frac{5}{8}$  at 17.
- 81 V to 18 is  $\frac{1}{12}$  breast; square forward from 18 by K.
- 82 18 to 19 is  $\frac{1}{4}$  breast; draw line from 19 to 1 and 5.
- 83 19 to 20 is 2 $\frac{1}{4}$  inches; notch  $\frac{1}{2}$  inch from 19.
- 84 I to J is 1 $\frac{1}{4}$  inches; 5 to 6 is 1 inch; square down.
- 85 Go in  $\frac{1}{2}$  inch at 7; draw line from 6 and shape front.
- 86 V to 21 is 1 $\frac{1}{4}$  inches; draw line to end of roll.

## Tuxedo Peak

### Diagram 10

52. The measures are taken over the Vest always.

Inside sleeve	17 $\frac{3}{4}$ inches.	Blade (with $1\frac{1}{4}$ inches for
Breast	36 inches.	seams added) 12 $\frac{1}{2}$ inches.
Waist	32 inches.	Depth of scye 9 inches.
Hip or seat	37 inches.	Natural waist 16 $\frac{3}{4}$ inches.
Strap	12 inches.	Full length 30 inches.
Over shoulder	17 inches.	Height 5 feet 6 inches.

Form and attitude, normal. Sizes, 33 to 42 breast.

#### TO DRAFT.

- 1 Square both ways from A.
- 2 A to B is  $1/3$  breast on "3RDS" and  $3\frac{1}{2}$  inches ( $9\frac{1}{2}$ ).
- 3 This is the proportional, and includes all allowances.
- 4 A to C is one-fourth height, and  $1/4$  inch for curve of Back.
- 5 C to D is  $1/3$  breast, on "3RDS" (6) Seatline.
- 6 Added to the natural waist gives correct length.
- 7 A to E is the Full Length of Back.
- 8 F is half between B and A, for front shoulder height.
- 9 Square out from A, B, C, D, E and F.
- 10 C to G is  $1/2$  inch, draw line F to G and down to E.
- 11 From the line just drawn inside of B measure to H.
- 12 B to H is half the full breast measure. (18).
- 13 H to I is  $2\frac{1}{4}$  inches—center of breast.
- 14 B to K is blade (with  $1\frac{1}{4}$  inches for seams). ( $12\frac{1}{2}$ ).
- 15 Square up from K—front of armhole.
- 16 L is half-way between B and K.
- 17 L to M is  $1\frac{1}{4}$  inches—width of Back.
- 18 Square up to O, and down to N.
- 19 P is  $1/2$  inch from Line O-M; draw line to N.
- 20 A to Q is  $1/12$  breast—on "12THS," and
- 21 Q to R is  $1\frac{1}{2}$  inches; square up to S,  $5/8$  inches.
- 22 K to T is  $1\frac{1}{2}$  inches; T to U is  $1/12$  breast.
- 23 Square up from U to V, locating the shoulder point.
- 24 V is located on lines from K and A.
- 25 Draw lines from S to U, and F to V.
- 26 This gives the proportional height of shoulders.
- 27 Rise at X  $1/2$  inch, and lower at point I the same.
- 28 X is  $1/2$  inch on the S-U line—or Style.
- 29 Y is  $1/2$  inch from the O-N line, and  $1/12$  up from M.
- 30 Draw guide line from Y to P.
- 31 From B up apply depth of scye measure and  $1/2$  inch ( $9\frac{1}{2}$ ) to A, in normal attitude will meet line A.
- 32 The  $1/2$  inch is for fullness held in over the blade.
- 33 Shape the Back as shown; draw line from B to W.
- 34 Apply strap measure, and 1 inch A to R and K to V (13) in normal attitude will meet line A-V.
- 35 Apply over shoulder measure and 1 inch (18) B to W and K to Z; when normal, meet line F-V.
- 36 Z is  $1\frac{1}{4}$  inches from line K.
- 37 Draw a line from V through Z to point 1.
- 38 V to point 1 is  $3/8$  inch less than S to X.
- 39 Draw a guide line from point 1 to T.
- 40 Shape arm-scye and shoulder rounding  $1/2$  in. over Z
- 41 Z to 2 is  $1/2$  breast on "HALVES"; 2 to K is  $3\frac{1}{2}$  inches.
- 42 This is normal blade and independent of the actual blade, and comes even with K in normal sizes.
- 43 Square down from K through 4 to 17.
- 44 4 to 5 is  $1/2$  waist—on "HALVES"—center of waist.
- 45 Square down from 5 to 7. The measure from B to 2, K, 4 and 5, is used only to obtain the front center of the waist and to check the blade measure.
- 46 5 to 8 is  $2\frac{1}{2}$  inches, 9 to 10 is the same.
- 47 These  $2\frac{1}{2}$  inches are for seams and make-up.
- 48 Apply hip measure and  $3/4$  inch for 3 seams; width of Back from 12 to D and 10 to 11. ( $19\frac{1}{4}$ ).
- 49 11 to 12 is  $1\frac{3}{4}$  inches; square up, locating 13.
- 50 (Proportional hip spring 12 to 11 is  $1\frac{3}{4}$  inches.)
- 51 Draw a line from 13 through 11 to 14.
- 52 Measure waist and  $1\frac{1}{2}$  inches P to G and 8 to 16.
- 53 Y to 14 is the length from Y to N.
- 54 Shape side seam of forepart from Y to 16, going out  $5/8$  inch over 11 to 14—or style.
- 55 (Reduce  $1/2$  in. from Y to 16 when no underarm cut.)
- 56 Z to 7 is length from Z to E and 1 inch, from line K.
- 57 The 1 inch is taken up in making the front edge.
- 58 Draw line 14 to 7; shape bottom; lower  $5/8$  at 17.
- 59 V to 18 is  $1/12$  breast; and  $1/2$  in. square from 18 by K.
- 60 18 to 19 is  $1/4$  breast; less  $1/2$  inch.
- 61 Draw line from 19 to I and 5.
- 62 The end of the roll can be  $1\frac{1}{2}$  inches below the natural waist line, corresponding to the fashion waist length on Dress Coat; or the second button on the Vest;  $2\frac{1}{2}$  inches below the natural waist line.
- 63 V to 21 is  $1\frac{1}{4}$  inches; draw a line to end of roll, rounding  $1/2$  inch over the breast.
- 64 Square forward from crease line the amount of opening (2 inches) as to 19; draw a straight line to end of roll.
- 65 This forms the finished crease line.
- 66 From line 19 on gorge line to 20 is the distance from the break-line to the notch.
- 67 Draw a line from 19 through 20 to 26.
- 68 20 to 26 is 2 inches; rise from 26— $1\frac{1}{2}$  inches.
- 69 To 19 add 2 seams and draw parallel line.
- 70 Shape the lapel as shown on diagram; either straight or curved line from 19 down.
- 71 The forepart is cut in the crease line and ends in a curved line under the lapel.
- 72 The pocket is  $2/3$  sleeve length and  $1/2$  inch from K, and finished with a welt  $1\frac{3}{4}$  inches wide.
- 73 Go in  $1\frac{1}{2}$  inches at 7; draw line from 5 and shape front.



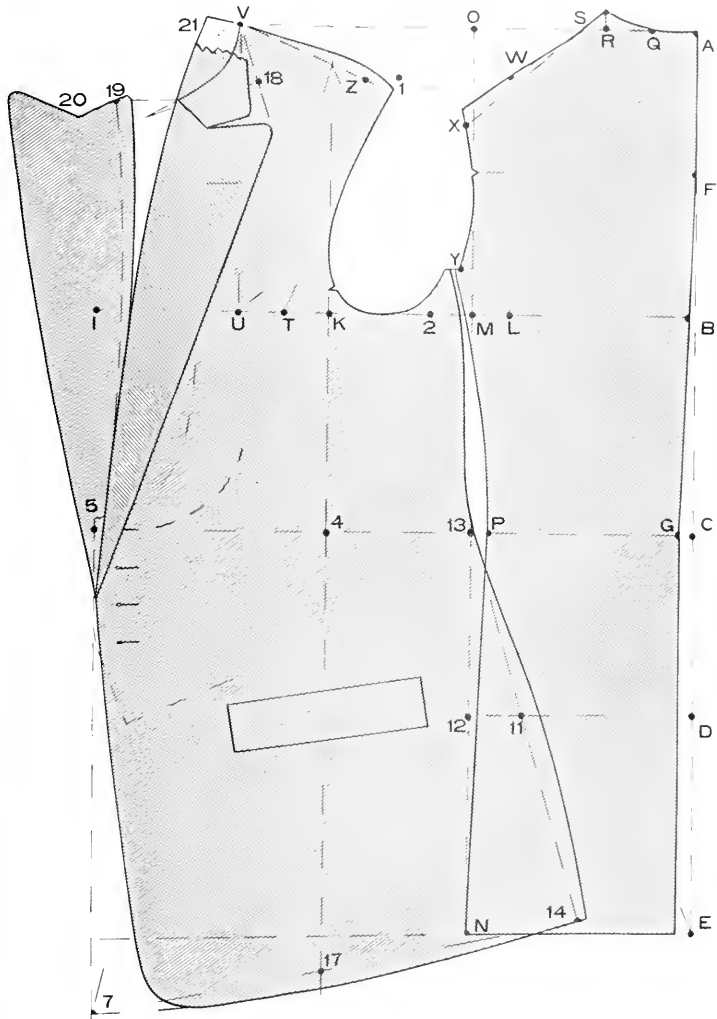

DIAGRAM 10 — TUXEDO PEAK

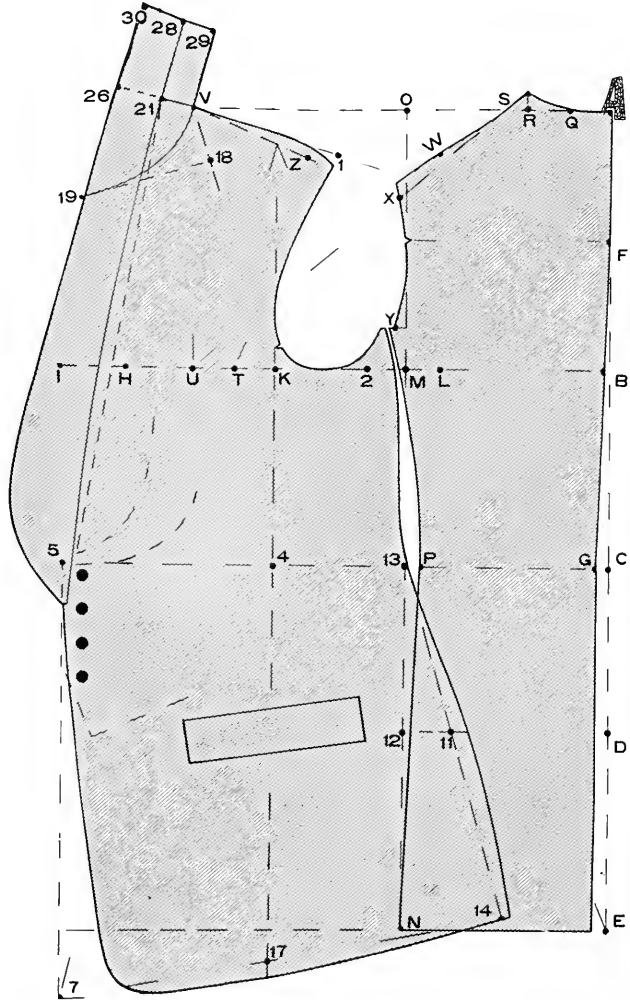

DIAGRAM 11 — TUXEDO SHAWL

## Tuxedo Shawl

### Diagram 11

53. The measures are taken over the Vest always.

Inside sleeve	17 $\frac{3}{4}$ inches.	Blade (with 1 $\frac{1}{4}$ inches for
Breast	36 inches.	seams added) 12 $\frac{1}{2}$ inches.
Waist	32 inches.	Depth of scye 9 inches.
Hip or seat	37 inches.	Natural waist 16 $\frac{3}{4}$ inches.
Strap	12 inches.	Full length 30 inches.
Over shoulder	17 inches.	Height 5 feet 6 inches.

Form and attitude, normal. Sizes, 33 to 42 breast.

#### TO DRAFT.

- 1 Square both ways from A.
- 2 A to B is  $\frac{1}{3}$  breast on "3RDS" and 3 $\frac{1}{2}$  inches (9 $\frac{1}{2}$ ).
- 3 This is the proportional, and includes all allowances.
- 4 A to C is one-fourth height, and  $\frac{1}{4}$  inch for curve of Back (16 $\frac{3}{4}$ ).
- 5 C to D is  $\frac{1}{3}$  breast, on "3RDS" (6) seatline.
- 6 Added to the natural waist gives correct length.
- 7 A to E is the Full Length of Back.
- 8 F is half between B and A, for front shoulder height.
- 9 Square out from A, B, C, D, E and F.
- 10 C to G is  $\frac{1}{2}$  inch, draw line F to G and down to E.
- 11 From the line just drawn inside of B measure to H.
- 12 B to H is half the full breast measure.
- 13 H to I is 2 $\frac{1}{4}$  inches—center of breast.
- 14 B to K is blade (with 1 $\frac{1}{4}$  inches for seams).
- 15 Square up from K—front of armhole.
- 16 L is half-way between B and K.
- 17 L to M is 1 $\frac{1}{4}$  inches—width of Back.
- 18 Square up to O, and down to N.
- 19 P is  $\frac{1}{2}$  inch from line O-M; draw line to N.
- 20 A to Q is  $\frac{1}{12}$  breast—on "12THS," and
- 21 Q to R is 1 $\frac{1}{2}$  inches; square up to S,  $\frac{5}{8}$  inch.
- 22 K to T is 1 $\frac{1}{2}$  inches; T to U is  $\frac{1}{12}$  breast.
- 23 Square up from U to V, locating the shoulder point.
- 24 V is located on lines from K and A.
- 25 Draw lines from S to U, and F to V.
- 26 This gives the proportional height of shoulders.
- 27 Rise at X  $\frac{1}{2}$  inch, and lower at point I the same.
- 28 X is  $\frac{1}{2}$  inch on the S-U line—or Style.
- 29 Y is  $\frac{1}{2}$  inch from the O-N line, and  $\frac{1}{12}$  up from M.
- 30 Draw guide line from Y to P.
- 31 From B up apply depth of scye measure and  $\frac{1}{2}$  inch (9 $\frac{1}{2}$ ) to A, in normal attitude will meet line A.
- 32 The  $\frac{1}{2}$  inch is for fullness held in over the blade.
- 33 Shape the Back as shown; draw line from B to W.
- 34 Apply strap measure, and 1 inch A to R and K to V (13) in normal attitude will meet line A-V.
- 35 Apply over shoulder measure and 1 inch (18) B to W and K to Z; when normal, meet line F-V.
- 36 Z is 1 $\frac{1}{4}$  inches from line K.
- 37 Draw a line from V through Z to point 1.
- 38 V to point 1 is  $\frac{3}{8}$  inch less than S to X.
- 39 Draw a guide line from point 1 to T.
- 40 Shape arm-scye and shoulder rounding  $\frac{1}{2}$  in. over Z.
- 41 B to 2 is  $\frac{1}{2}$  breast on "HALVES"; 2 to K is 3 $\frac{1}{2}$  inches.
- 42 This is normal blade and independent of the actual blade, and comes even with K in normal sizes.
- 43 Square down from K through 4 to 17.
- 44 4 to 5 is  $\frac{1}{2}$  waist—on "HALVES"—center of waist.
- 45 Square down from 5 to 7. The measure from B to 2, K, 4 and 5, is used only to obtain the front center of the waist and to check the blade measure.
- 46 5 to 8 is 2 $\frac{1}{2}$  inches, 9 to 10 is the same.
- 47 These 2 $\frac{1}{2}$  inches are for seams and make-up.
- 48 Apply hip measure and  $\frac{3}{4}$  inch for 3 seams; width of Back from 12 to D and 10 to 11 (19 $\frac{1}{4}$ ).
- 49 11 to 12 is 1 $\frac{3}{4}$  inches; square up, locating 13.
- 50 (Proportional hip spring 12 to 11 is 1 $\frac{3}{4}$  inches.)
- 51 Draw a line from 13 through 11 to 14.
- 52 Measure waist and 1 $\frac{1}{2}$  inches P to G and 8 to 16.
- 53 Y to 14 is the length from Y to N.
- 54 Shape side seam of forepart from Y to 16, going out  $\frac{5}{8}$  inch over 11 to 14—or Style.
- 55 (Reduce  $\frac{1}{2}$  in. from Y to 16 when no underarm cut.)
- 56 Z to 7 is length from Z to E and 1 inch, from line K.
- 57 The 1 inch is taken up in making the front edge.
- 58 Draw line 14 to 7; shape bottom; lower  $\frac{5}{8}$  at 17.
- 59 V to 18 is  $\frac{1}{12}$  breast, plus  $\frac{1}{2}$  inch.
- 60 Square forward from 18 by K.
- 61 18 to 19 is  $\frac{1}{4}$  breast; draw line from 19 to I and 5.
- 62 I to J is  $\frac{3}{4}$  inch, 5 to 6 is 1 $\frac{3}{4}$  inches.
- 63 Go in 1 $\frac{1}{2}$  at 7; draw line from 5 and shape front.
- 64 V to 21 is 1 $\frac{1}{4}$  inches; draw line to end of roll rounding  $\frac{1}{2}$  inch over breast.
- 65 The end of the roll can be 1 $\frac{1}{2}$  inches below the natural waist line, corresponding to the fashion waist length on Dress Coat, or the second button on the Vest, 2 $\frac{1}{2}$  in. below the natural waist line.
- 67 The pocket is  $\frac{2}{3}$  sleeve length and  $\frac{1}{2}$  inch from K and finished with a welt 1 $\frac{3}{4}$  inches wide.
- 68 The Collar—21 to 28 equal A to R.
- 69 28 to 29 is  $\frac{5}{8}$  inch.
- 70 Square from 21 through 29 for stand, 1 $\frac{1}{4}$  inches.
- 71 29 to 30 is 1 $\frac{3}{4}$  inches—21 to 26 is the same.
- 72 Draw line from 26 through 6 and shape as shown.

## Disproportion Sack

### Diagram 12

54. The measures are taken over the Vest always.

Inside sleeve	17 $\frac{3}{4}$ inches.	Stooping	$\frac{1}{2}$ inch.
Breast	36 inches.	Blade (with 1 $\frac{1}{4}$ inches for	
Waist	32 inches.	seams added)	12 $\frac{1}{2}$ inches.
Hip or seat	37 inches.	Depth of scye	9 $\frac{1}{2}$ inches.
Strap	11 $\frac{3}{4}$ inches.	Natural waist	17 inches.
Over shoulder	17 inches.	Full length	30 inches.
		Height 5 feet	6 inches.

Supplementary measures:

Front waist 8 $\frac{1}{2}$  inches. Back waist 7 $\frac{1}{2}$  inches.

In breast sizes ranging from 33 to 42 breasts.

This is a form frequently met with and is considered very hard to fit.

In taking the measures extend the square downward from in front of the arm and mark *back* of the square, at the waist-line. Measure from this line to center of waist in front; and to center of back; which added together should be half the waist measure

This form may be described as—Head erect, dip neck or round back, blade normal, waist forward, seat normal; appearing what is commonly called sway-back.

It is common to those who do not preform muscular work, people of sedentary habits, and persons subjected to prolonged standing on their feet, including a great majority of city people, in addition to other abnormalities.

#### TO DRAFT.

- 1 Square both ways from A.
- 2 A to B is 1/3 breast on "3RDS" and 3 $\frac{1}{2}$  inches (9 $\frac{1}{2}$ ).
- 3 This is the proportional and includes all allowances.
- 4 A to C is one-fourth height and  $\frac{1}{4}$  inch for curve of back.
- 5 C to D is 1/3 breast—on "3RDS" (6) Seatline.
- 6 Added to the natural waist gives correct length.
- 7 A to E is the Full Length of Back.
- 8 F is half normal A to B, for front shoulder height.
- 9 Square out from A, B, C, D, E, F, 3, 4 and 5.
- 10 C to G is  $\frac{1}{2}$  inch, draw line F to G and down to E.
- 11 From the line just drawn inside of B measure to H.
- 12 B to H is half the full breast measure (18).
- 13 H to I is 2 $\frac{1}{4}$  inches—center of breast.
- 14 B to K is blade with 1 $\frac{1}{4}$  inches for seams (12 $\frac{1}{2}$ ).
- 15 Square up from K—front of armhole.
- 16 L is half-way between B and K.
- 17 L to M is 1 $\frac{1}{4}$  inches—width of Back.
- 18 Square up to O, and down to N.
- 19 P is  $\frac{1}{2}$  inch from line O-M; draw line to N.
- 20 A to Q is 1/12 breast—on "12THS" and
- 21 Q to R is 1 $\frac{1}{2}$  inches; square up to S,  $\frac{5}{8}$  inch.
- 22 K to T is 1 $\frac{1}{2}$  inches; T to U is 1/12 breast.
- 23 Square up from U to V—locating the shoulder point.
- 24 Draw lines from S to U and F to V.
- 25 This gives the proportional height of shoulders.
- 26 Rise at X  $\frac{1}{2}$  inch and lower at point 1 the same.
- 27 X is  $\frac{1}{2}$  inch on the S-U line—or Style.
- 28 Y is  $\frac{1}{2}$  inch from the O-M line, and 1/12 up from M.
- 29 Draw guide line from Y to P and P to N.
- 30 From B up apply actual depth of scye and  $\frac{1}{2}$  in. (10).  
When attitude is normal will meet line A.
- 31 The  $\frac{1}{2}$  inch if for fullness held in over the blade.
- 32 Lay square on 5, O and F, and square lines O, 5, F.
- 33 Obtain point S from 5 and shape 5, S to X.
- 34 Shape the Back as shown; draw line from B to W.
- 35 Apply strap measure and 1 inch, A to R and K to V (12 $\frac{3}{4}$ ); when normal meet line A-V.
- 36 Advance V from line U-V, as much as below line A.
- 37 Apply over shoulder measure and 1 inch B to W and K to Z (18); when normal will meet line F-V.
- 38 Z is 1 $\frac{1}{4}$  inches from line K.
- 39 Draw a line from V through Z to point 1.
- 40 V to point 1 is  $\frac{3}{8}$  inch less than S to X.
- 41 Draw a guide line from point 1 to T.
- 42 Shape arm-scye and shoulder rounding  $\frac{1}{2}$  in. over Z.
- 43 B to 2 is  $\frac{1}{2}$  breast on "HALVES"; 2 to K is 3 $\frac{1}{2}$  inches.
- 44 This is normal blade and independent of the actual blade and comes even with K in normal sizes.
- 45 Square down from K through 4 to 17.
- 46 4 to 5, apply the front waist measure (8 $\frac{1}{2}$  inches).
- 47 Square down from 5 to 7. The measure from B to 2, K, 4 and 5 is only used to obtain the front center of the waist and to check the blade measure.
- 48 5 to 8 is 2 $\frac{1}{2}$  inches, 9 to 10 is the same.
- 49 Apply hip measure and  $\frac{3}{4}$  inch for 3 seams; width of Back from 12 to D and from 10 to 11 (19 $\frac{1}{4}$ ).
- 50 11 to 12 is 1 $\frac{3}{4}$  inches, square up, locating 13.
- 51 (Proportional hip spring 12 to 11 is 1 $\frac{3}{4}$  inches.)
- 52 Draw a line from 13 through 11 to 14.
- 53 Apply waist measure and 1 $\frac{1}{2}$  in., P to G and 8 to 16.
- 54 Y to 14 is the length from Y to N.
- 55 Shape sideseam of forepart from Y to 16 going out  $\frac{5}{8}$  inch over 11 to 14—to Style.
- 56 Draw line 15 and take out a  $\frac{3}{4}$  to  $\frac{1}{2}$  inch.
- 57 Z to 7 is length from Z to E and 1 inch, from line K.
- 58 The 1 inch is taken up in making the front edge.
- 59 Draw line 14 to 7; shape bottom, lower  $\frac{3}{8}$  at 17.
- 60 V to 18 is 1/12 breast; square forward from 18 by K.
- 61 18 to 19 is  $\frac{1}{4}$  breast; draw line from 19 to 1 and 5.
- 62 19 to 20 is 2 $\frac{1}{4}$  inches, or Style; notch  $\frac{1}{2}$  in. from 19.
- 63 I to J is 1 $\frac{1}{4}$  inches; 5 to 6 is 1 inch; square down.
- 64 Go in  $\frac{1}{2}$  inch at 7, draw line from 6 and shape front.
- 65 V to 21 is 1 $\frac{1}{4}$  inches; draw a line to end of roll.
- 66 The pocket is 2/3 sleeve length and  $\frac{1}{2}$  inch from K.
- 67 (For double breasted add 2 $\frac{1}{4}$  inches to the front.)

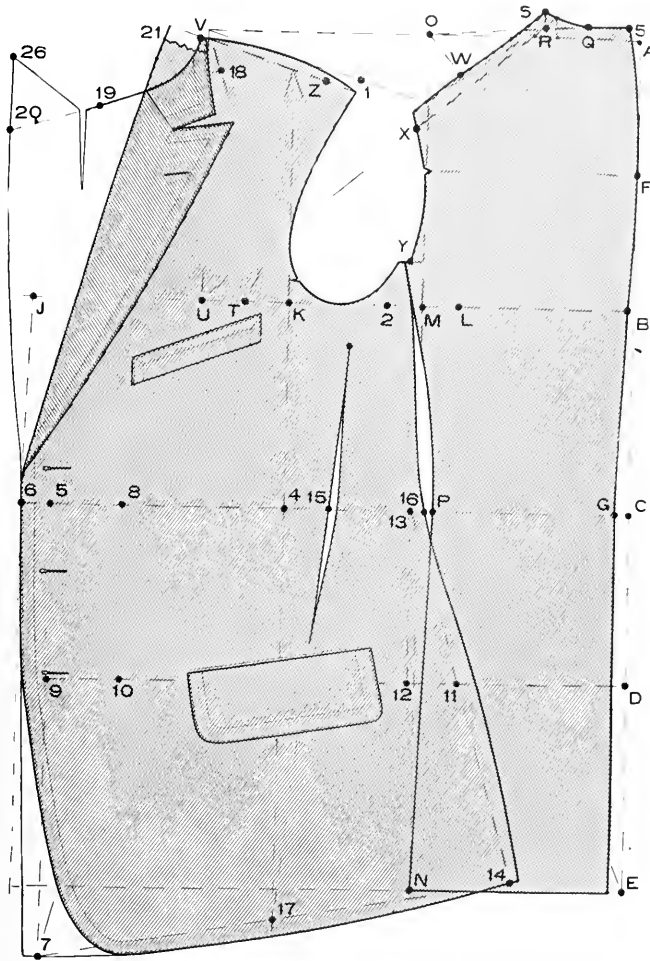

DIAGRAM 12 — DISPROPORTION SACK

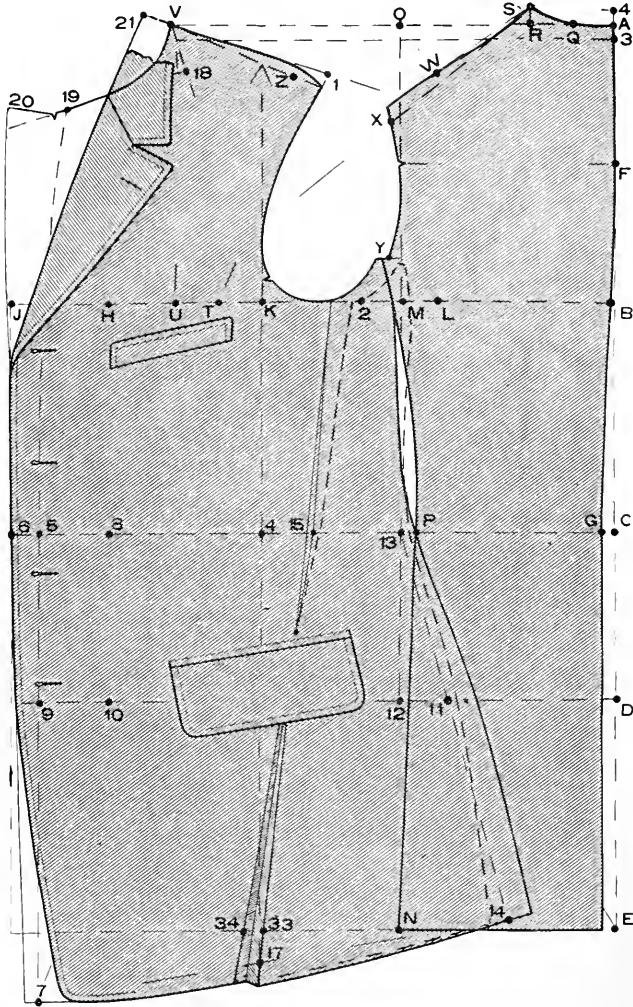

DIAGRAM 13 — TALL AND SLIM

## Tall and Slim

### Diagram 13

55. The measures are taken over the Vest always.

Inside sleeve	19¼ inches.	Blade (with 1¼ inches for
Breast	36 inches.	seams added) 12½ inches.
Waist	31 inches.	Depth of scye 9½ inches.
Hip or seat	38 inches.	Natural waist 18¾ inches.
Strap	12½ inches.	Full length 33 inches.
Over shoulder	17¾ inches.	Height 6 feet 0 inches.

Form and Attitude normal. Sizes, 33 to 38 breasts.

#### TO DRAFT.

- 1 Square both ways from 3.
- 2 3 to B is 1/3 breast on "3RDS" and 3½ inches (9½).
- 3 B to 4 is 1/3 breast on "3RDS" of height, and 3½ inches (10½).
- 4 A is half way between 3 and 4.
- 5 This is the proportional and includes all allowances.
- 6 A to C is one-fourth height, and ¼ inch, for length.
- 7 C to D is 1/3 breast, on "3RDS" (6) Seatline.
- 8 Added to the natural waist gives correct length.
- 9 A to E is the Full Length of Back (33).
- 10 F is half between A and B, for front shoulder height.
- 11 Square out from A, B, C, D, E, F and 3.
- 12 C to G is ½ inch; draw line F to G and down to E.
- 13 From the line just drawn inside of B measure to H.
- 14 B to H is half the full breast measure (18).
- 15 H to I is 2¼ inches—center of breast.
- 16 B to K is blade (with 1¼ inches for seams) (12½).
- 17 Square up from K—front of armhole.
- 18 L is half way between B and K.
- 19 L to M is 1¼ inches—width of Back.
- 20 Square up to O, and down to N.
- 21 P is ½ inch from line O-M; draw line to N.
- 22 A to Q is 1/12 breast—on "12THS" and
- 23 Q to R is 1½ inches; square up to S. ⅝ inch.
- 24 K to T is 1½ inches; T to U is 1/12 breast.
- 25 Square up to V from U—locating the shoulder point.
- 26 V is located on lines from K and A through line 3.
- 27 Draw lines from S to U and F to V.
- 28 This gives the proportional height of shoulders.
- 29 Rise at X ½ inch and lower at point 1 the same.
- 30 X is ½ inch on the S-U line—or Style.
- 31 Y is ½ inch from the O-M line and 1/12 up from M.
- 32 Draw guide line from Y to P and P to N.
- 33 From B up apply depth of scye measure, and ½ in. to A in normal attitude, will meet line A (10).
- 34 The ½ inch is for fulness held in over the blade.
- 35 Shape the Back as shown; draw line from B to W.
- 36 Apply strap measure and 1 inch, A to R and K to V (13½), in normal attitude will meet line A-V.
- 37 Apply over shoulder measure and 1 inch B to W and K to Z; when normal will meet line F-V (18¾).
- 38 Z is 1¼ inches from line K.
- 39 Draw a line from V through Z to point 1.
- 40 V to point 1 is ⅜ inch less than S to X.
- 41 Draw a line from point 1 to T.
- 42 Shape arm-scye and shoulder rounding ½ in. over Z.
- 43 B to 2 is ½ breast on "HALVES"; 2 to K is 3½ inches.
- 44 This is normal blade and independent of the actual blade and comes even with K in normal sizes.
- 45 Square down from K through 4 to 17.
- 46 4 to 5 is ½ waist—on "HALVES"—center of waist.
- 47 Square down from 5 to 7. The measure from B to 2, K, 4 and 5 is only used to obtain the front center of the waist and to check the blade measure.
- 48 5 to 8 is 2½ inches. 9 to 10 the same.
- 49 Apply hip measure and ¾ inch for 3 seams; width of Back from 12 to D and from 10 to 11 (add ⅜ inch).
- 50 11 to 12 is 1¾ inches, square up, locating 13.
- 51 Proportional hip spring 12 to 11 is 1¾ inches.)
- 52 Draw a line from 13 through 11 to 14.
- 53 Measure waist and 1½ inches P to G and 8 to 16.
- 54 Y to 14 is the length from Y to N.
- 55 Shape sideseam of forepart from Y to 16 going out ⅝ inch over 11 to 14—to Style.
- 56 Draw line 15 and take out a ¼ inch; pleat at 33.
- 57 (Reduce ½ in. from Y to 16 when no underarm cut.)
- 58 Z to 7 is length from Z to E and 1 in. from line K.
- 59 The 1 inch is taken up in making the front edge.
- 60 Draw line 14 to 7; shape bottom, lower ⅝ at 17.
- 61 V to 18 is 1/12 breast; square forward from 18 by K.
- 62 18 to 19 is ¼ breast; draw line from 19 to I and 5.
- 63 19 to 20 is 2¼ inches, or Style; notch ½ in. from 19.
- 64 1 to J is 1¼ inches; 5 to 6 is 1 inch; square down.
- 65 Go in ½ inch at 7; draw line from 6 and shape front.
- 66 V to 21 is 1¼ inches; draw a line to end of roll.
- 67 The pocket is 2/3 sleeve length and ½ inch from K.
- 68 (For double breasted add 2¼ inches to the front.)

## Short and Stout

### Diagram 14

56. The measures are taken over the Vest always.

Inside sleeve	17 $\frac{3}{4}$ inches.	Blade (with 1 $\frac{1}{4}$ inches for
Breast	42 inches.	seams added) 13 $\frac{3}{4}$ inches.
Waist	40 inches.	Depth of scye 9 $\frac{1}{4}$ inches.
Hip or seat	43 inches.	Natural waist 16 $\frac{3}{4}$ inches.
Strap	13 $\frac{3}{4}$ inches.	Full length 30 inches.
Over shoulder	18 $\frac{3}{4}$ inches.	Height 5 feet 6 inches.

Corpulent, 1 degree.  
Form and Attitude, erect                      Sizes, 36 to 46 breast.

#### TO DRAFT.

- 1 Square both ways from 6.
- 2 6 to B is  $\frac{1}{3}$  breast on "3RDS" and 3 $\frac{1}{2}$  inches (10 $\frac{1}{2}$ ).
- 3 B to 7 is  $\frac{1}{3}$  breast of height, and 3 $\frac{1}{2}$  inches (9 $\frac{1}{2}$ ).
- 4 A is half way between 7 and 6.
- 5 This is the proportional and includes all allowances.
- 6 A to C is one-fourth height, and  $\frac{1}{4}$  inch; for length
- 7 C to D is  $\frac{1}{3}$  breast—on "3RDS" (7) seatline.
- 8 Added to the natural waist gives correct length.
- 9 A to E is the Full Length of Back.
- 10 F is half between 6 and B, for front shoulder height.
- 11 Square out from A, B, C, D, E, F and 6.
- 12 C to G is  $\frac{1}{2}$  inch; draw line F to G and down to E.
- 13 From the line just drawn inside of B measure to H.
- 14 B to H is half the full breast measure (21).
- 15 H to I is 2 $\frac{1}{4}$  inches—center of breast.
- 16 R to K is blade (with 1 $\frac{1}{4}$  inches for seams, 13 $\frac{3}{4}$ ).
- 17 Square up from K—front of armhole.
- 18 L is halfway between B and K.
- 19 L to M is 1 $\frac{1}{4}$  inches—width of back.
- 20 Square up to O, and down to N.
- 21 P is  $\frac{1}{2}$  inch from line O-M; draw line to N
- 22 A to Q is  $\frac{1}{12}$  breast—"12RUS" and
- 23 Q to R is 1 $\frac{1}{2}$  inches; square up to S,  $\frac{5}{8}$  inch.
- 24 K to T is 1 $\frac{1}{2}$  inches; T to U is  $\frac{1}{12}$  breast.
- 25 Square up to V from U—locating the shoulder point.
- 26 V is located on lines from K and 6.
- 27 Draw lines from S to U and F to V.
- 28 This give the proportional height of shoulders.
- 29 Rise at X  $\frac{1}{2}$  inch and lower at point 1 the same.
- 30 X is  $\frac{1}{2}$  inch on the S-U line—or Style.
- 31 Y is  $\frac{1}{2}$  inch from the O-M line, and  $\frac{1}{12}$  up from M.
- 32 Draw guide line from Y to P and P to N.
- 33 From B up apply depth of scye measure, and  $\frac{1}{2}$  inch to 8 (9 $\frac{3}{4}$ ); in normal attitude, will meet line A.
- 34 The  $\frac{1}{2}$  inch is for fullness held in over the blade.
- 35 Obtain point S from 8 and shape 8, S to X.
- 36 Shape the Back as shown; draw line from B to W.
- 37 Apply strap measure and 1 inch, A to R and K to V (14 $\frac{3}{4}$ ); when attitude is normal will meet line 6-K.
- 38 Go back from K-V line  $\frac{1}{2}$  as much as above line V-6.
- 39 Apply over shoulder measure and 1 inch (19 $\frac{3}{4}$ ) B to W and K to Z; when normal will meet line F-V.
- 40 Z is 1 $\frac{1}{4}$  inches from line K.
- 41 Draw a line from V through Z to point 1.
- 42 V to point 1 is  $\frac{3}{8}$  inch less than S to X.
- 43 Draw a guide line from point 1 to T.
- 44 Shape arm-scye and shoulder rounding  $\frac{1}{2}$  in. over Z.
- 45 B to 2 is  $\frac{1}{2}$  breast on "HALVES"; 2 to K is 3 $\frac{1}{2}$  inches.
- 46 This is normal blade and independent of the actual blade and comes even with K in normal sizes.
- 47 Square down from K through 4 to 17.
- 48 4 to 5 is  $\frac{1}{2}$  waist on "HALVES"—center of waist.
- 49 Square down from 5 to 7. The measure from B to 2, K, 4 and 5 is only used to obtain the front center of the waist and to check the blade measure.
- 50 5 to 8 is 2 inches, 9 to 10 is the same.
- 51 These 2 inches are for seams and make-up.
- 52 Corpulency: Measure the waist first and obtain the hip spring from it. This rule applies where the waist is even, or more, than the breast.
- 53 Measure waist and 1 $\frac{1}{4}$  inches P to G and 8 to 16.
- 54 Square down from 16 to 12; 12 to 11 is 1 $\frac{3}{4}$  inches.
- 55 (Proportional hip spring, 12 to 11 is 1 $\frac{3}{4}$  inches.)
- 56 Draw a line from 16 through 11 to 14.
- 57 Y to 14 is the length from Y to N.
- 58 Shape sideseam of forepart from Y to 16, going out  $\frac{5}{8}$  inch over 11 to 14—or Style.
- 59 Z to 7 is length from Z to E and 1 inch, from line K.
- 60 The 1 inch is taken up in making the front edge.
- 61 Draw line 14 to 7, shape the bottom; lower  $\frac{5}{8}$  at 17.
- 62 Measure hip and  $\frac{3}{4}$  inch for 3 seams; width of back from 12 to D, and from 10 to 11.
- 63 Open at 2 the amount of seat surplus and fold 33 on 34.
- 64 By cutting to pocket and front of pocket.
- 65 V to 18 is  $\frac{1}{12}$  breast; square forward from 18 by K.
- 66 18 to 19 is  $\frac{1}{4}$  breast; draw line from 19 to I and 5.
- 67 19 to 20 is 2 $\frac{1}{4}$  inches, or Style; notch  $\frac{1}{2}$  in. from 19.
- 68 I to J is 1 $\frac{1}{4}$  inches; 5 to 6 is 1 inch; square down.
- 69 Go in  $\frac{1}{2}$  inch at 7, draw line from 6 and shape front.
- 70 V to 21 is 1 $\frac{1}{4}$  inches; draw line to end of roll.
- 71 The pocket as usual; draw line from K to 33.
- 72 One button; go in 1 inch between waist and seatline.
- 73 For chesty coats or curved lapel cut a V in gorge.



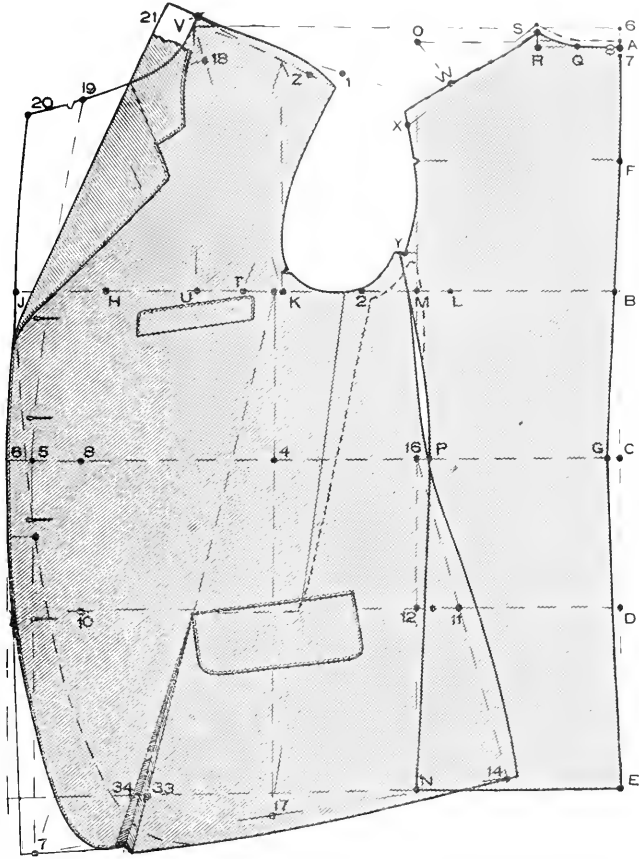

DIAGRAM 14 SHORT AND STOUT

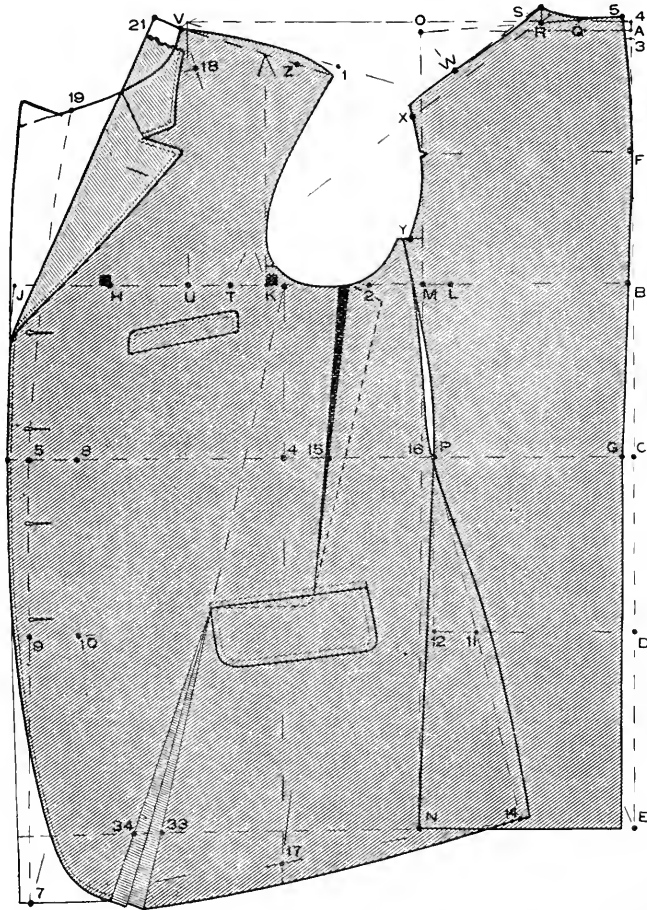

DIAGRAM 15 — CORPULENT 2 DEGREE

## Corpulent Sack

### Diagram 15

57. The measures are taken over the Vest always.

Inside sleeve	18¾ inches.	Blade (with 1¼ inches for
Breast	44 inches.	seams added) 14½ inches.
Waist	44 inches.	Depth of scye 10½ inches.
Hip or seat	45 inches.	Natural waist 17¾ inches.
Strap	13½ inches.	Full length 32 inches.
Over shoulder	19½ inches.	Height 5 feet 10 inches.
Corpulent 2 degrees.		

Form and Attitude, stooping. Sizes, 42 to 52 breast.

#### TO DRAFT.

- 1 Square both ways from 4.
- 2 4 to B is 1/3 breast on "3RDS" and 3½ inches (10⅞).
- 3 B to 3 is 1/3 breast on "3RDS" of height, and 3½ inches (10⅞); A is half way between 3 and 4.
- 4 This is the proportional and includes all allowances.
- 5 A to C is one-fourth height, and ¼ inch; for length.
- 6 C to D is 1/3 breast—on "3RDS" (7¼) Seat line.
- 7 Added to the natural waist gives correct length.
- 8 A to E is the Full Length of Back (32).
- 9 F is half between 4 and B, for front shoulder height.
- 10 Square out from A, B, C, D, E, F, 3 and 4.
- 11 C to G is ½ inch; draw line F to G and down to E.
- 12 From the line just drawn inside of B measure to H.
- 13 B to H is half the full breast measure (22).
- 14 H to I is 2¼ inches—center of breast.
- 15 B to K is blade (with 1¼ inches for seams) (14½).
- 16 Square up from K—front of armhole.
- 17 L is half way between B and K.
- 18 L to M is 1¼ inches—width of Back.
- 19 Square up to O, and down to N.
- 20 P is ½ inch from line O-N; draw line to N.
- 21 A to Q is 1/12 breast—on "12THS" and
- 22 Q to R is 1½ inches; square up to S, ⅝ inch.
- 23 Advance upper part from K 1/16 inch each size above 4 inches less than breast, to straighten the front run; take it out in the underarm cut as shown by shaded part on diagram.
- 24 K to T is 1½ inches; T to U is 1/12 breast.
- 25 Square up to V from U—locating the shoulder point.
- 26 V is located on lines from U and 4.
- 27 Draw lines from S to U and F to V.
- 28 This gives the proportional height of shoulders.
- 29 Rise at X ½ inch and lower at point 1 the same.
- 30 X is ½ inch on the S-U line—or Style.
- 31 Y is ½ inch from the O-N line, and 1/12 up from M.
- 32 Draw guide lines from Y to P and P to N.
- 33 From B up apply depth of scye measure, and ½ inch to 5 (11); when normal attitude, will meet line A.
- 34 The ½ inch is for fullness held in over the blade.
- 35 Lay square on 5, O and F, and square lines O, 5 and F.
- 36 Obtain point S from 5 and shape 5, S to X.
- 37 Shape the Back as shown; draw line from B to W.
- 38 Apply strap measure and 1 inch, A to R and K to V (14½); when attitude is normal will meet line 4-V.
- 39 Advance V from line U-V as much as below line 4.
- 40 Apply over shoulder measure and 1 inch B to W and K to Z (20½); when normal will meet line F-V.
- 41 Z is 1¼ inches from line K.
- 42 Draw a line from V through Z to point 1.
- 43 V to point 1 is ⅜ inch less than S to X.
- 44 Draw a guide line from point 1 to T.
- 45 Shape arm-scye and shoulder rounding ½ in. over Z.
- 46 B to 2 is ½ breast on "HALVES"; 2 to K is 3½ in.
- 47 This is normal blade and independent of the actual blade and comes even with K in normal sizes.
- 48 Square down from K through 4 to 17.
- 49 4 to 5 is ½ waist on "HALVES"—center of waist.
- 50 Square down from 5 to 7. The measure from B to 2, K, 4 and 5 is only used to obtain the front center of the waist and to check the blade measure.
- 51 5 to 8 is 2 inches, 9 to 10 is the same.
- 52 These 2 inches are for seams and make-up.
- 53 Corpulency: Measure the waist first and obtain the hip spring from it. This rule applies where the waist is even, or more, than the breast.
- 54 Measure waist and 1¼ inches P to G and 8 to 16.
- 55 Square down from 16 to 12; 12 to 11 is 1¾ inches.
- 56 (Proportional hip spring, 12 to 11 is 1¾ inches.)
- 57 Draw a line from 16 through 11 to 14.
- 58 Y to 14 is the length from Y to N.
- 59 Shape sidescam of forepart from Y to 16, going out ⅝ inch over 11 to 14—or Style.
- 60 Z to 7 is length from Z to E and 1 inch, from line K.
- 61 The 1 inch is taken up in making the front edge.
- 62 Draw line 14 to 7, shape the bottom; lower ⅝ at 17.
- 63 Measure hip and ¾ inch for 3 seams; width of Back from 12 to D, and from 10 to 11.
- 64 Draw line 15 and take out the shaded part.
- 65 Open at 2 the amount of seat surplus and fold 33 on 34 by cutting to pocket and front of pocket.
- 66 V to 18 is 1/12 breast; square forward from 18 by K.
- 67 18 to 19 is ¼ breast; draw line from 19 to I and 5.
- 68 Advance at 1 the amount from K, shaded part.
- 69 19 to 20 is 2¼ inches, or Style; notch ¼ in. from 19.
- 70 I to J is 1¼ inches; 5 to 6 is 1 inch; square down.
- 71 Go in ½ inch at 7, draw line from 6 and shape front.
- 72 V to 21 is 1¼ inches; draw line to end of roll.
- 73 The pocket as usual; draw line from K to 33
- 74 One button. Go in 1 inch between waist and seatline.

# Corpulent Sack

## Diagram 16

58. The measures are taken over the Vest always.

Inside sleeve	18 $\frac{3}{4}$ inches.	Blade (with 1 $\frac{1}{4}$ inches for
Breast	52 inches.	seams added) 16 $\frac{1}{2}$ inches.
Waist	56 $\frac{1}{2}$ inches.	Depth of scye 10 $\frac{7}{8}$ inches.
Hip or seat	53 inches.	Natural waist 17 $\frac{3}{4}$ inches.
Strap	15 $\frac{3}{8}$ inches.	Full length 32 inches.
Over shoulder	22 inches.	Height 5 feet 10 inches.

Corpulent 3 degrees.

Form and Attitude, normal. Sizes, 42 to 52 breast.

### TO DRAFT.

- 1 Square both ways from 4.
- 2 4 to B is  $\frac{1}{3}$  breast on "3RDS" and 3 $\frac{1}{2}$  inches (12 $\frac{1}{8}$ ).
- 3 B to 3 is  $\frac{1}{3}$  breast of height, and 3 $\frac{1}{2}$  inches (9 $\frac{1}{2}$ ).
- 4 A is half way between 3 and 4.
- 5 This is the proportional and includes all allowances.
- 6 A to C is one-fourth height, and  $\frac{1}{4}$  inch; for curve of Back.
- 7 C to D is  $\frac{1}{3}$  breast on "3RDS" (8 $\frac{5}{8}$ ) Seatline.
- 8 Added to the natural waist gives correct length.
- 9 A to E is the Full Length of Back.
- 10 F is half between 4 and B, for front shoulder height.
- 11 Square out from A, B, C, D, E, F, 3 and 4.
- 12 C to G is  $\frac{1}{2}$  inch; draw line F to G and down to E.
- 13 From the line just drawn inside of B measure to H.
- 14 B to H is half the full breast measure (26).
- 15 H to I is 2 $\frac{1}{4}$  inches—center of breast.
- 16 B to K is blade (with 1 $\frac{1}{4}$  inches for seams) (16 $\frac{1}{2}$ ).
- 17 Square up from K—front of armhole.
- 18 L is half way between B and K.
- 19 L to M is 1 $\frac{1}{4}$  inches—width of Back.
- 20 Square up to O, and down to P.
- 21 P is  $\frac{1}{2}$  inch from line O-M; draw line to N.
- 22 4 to Q is  $\frac{1}{12}$  breast—on "12THS" and
- 23 Q to R is 1 $\frac{1}{2}$  inches; square up to S,  $\frac{5}{8}$  inch.
- 24 Advance upper part from K  $\frac{1}{16}$  inch each size above 4 inches less than breast, to straighten the front run; take it out in the underarm cut as shown by shaded part on diagram.
- 25 K to T is 1 $\frac{1}{2}$  inches; T to U is  $\frac{1}{12}$  breast.
- 26 Square up to V from U—locating the shoulder point.
- 27 V is located on lines from U and 4.
- 28 Draw lines from s to U and F to V.
- 29 This gives the proportional height of shoulders.
- 30 Rise at X  $\frac{1}{2}$  inch and lower at point 1 the same.
- 31 X is  $\frac{1}{2}$  inch on the S-U line—or Style.
- 32 Y is  $\frac{1}{2}$  in. from the O-M line, and  $\frac{1}{12}$  up from M.
- 33 Draw guide lines from Y to P and P to N.
- 34 From B up apply depth of scye measure, and  $\frac{1}{2}$  inch to A (11 $\frac{3}{8}$ ); when normal attitude, will meet line A.
- 35 The  $\frac{1}{2}$  inch for fullness held in over the blade.
- 36 Obtain point S from half s-s, and shape A, S to X.
- 37 Shape the Back as shown; draw line from B to W.
- 38 Apply strap measure and 1 inch, A to R and K to V (16 $\frac{3}{8}$ ); when attitude is normal will meet line 4-V.
- 39 Apply over shoulder measure and 1 inch B to W and K to Z (23); when normal will meet line F-V.
- 40 Z is 1 $\frac{1}{4}$  inches from line K.
- 41 Draw a line from V through Z to point 1.
- 42 V to point 1 is  $\frac{3}{8}$  inch less than S to X.
- 43 Draw a guide line from point 1 to T.
- 44 Shape arm-scye and shoulder rounding  $\frac{1}{2}$  in. over Z.
- 45 B to 2 is  $\frac{1}{2}$  breast on "HALVES"; 2 to K is 3 $\frac{1}{2}$  inches.
- 46 This is normal blade and independent of the actual blade and comes even with K in normal sizes.
- 47 Square down from K through 4 to 17.
- 48 4 to 5 is  $\frac{1}{2}$  waist on "HALVES"—center of waist.
- 49 Square down from 5 to 7. The measure from B to 2, K, 4 and 5 is only used to obtain the front center of the waist and to check the blade measure.
- 50 5 to 8 is 2 inches, 9 to 10 is the same.
- 51 These 2 inches are for seams and make-up.
- 52 Copulency: Measure the waist first and obtain the hip spring from it. This rule applies where the waist is even, or more, than the breast.
- 53 Measure waist and 1 $\frac{1}{4}$  inches P to G and 8 to 16.
- 54 Square down from 16 to 12; 12 to 11 is 1 $\frac{3}{4}$  inches.
- 55 (Proportional hip spring; 12 to 11 is 1 $\frac{3}{4}$  inches.)
- 56 Draw a line from 16 through 11 to 14.
- 57 Y to 14 is the length from Y to N.
- 58 Shape sideseam of forepart from Y to 16 going out  $\frac{5}{8}$  inch over 11 to 14—or Style.
- 59 Z to 7 is length from Z to E and 1 inch, from line K.
- 60 The 1 inch is taken up in making the front edge.
- 61 Draw line 14 to 7, shape the bottom; lower  $\frac{5}{8}$  at 17.
- 62 Measure hip and  $\frac{3}{4}$  inch for 3 seams; width of back from 12 to D, and from 10 to 11.
- 63 Draw line 15 and take out the shaded part.
- 64 Open at 2 the amount of seat surplus and fold 33 on 34 by cutting to pocket and front of pocket.
- 65 V to 18 is  $\frac{1}{12}$  breast; square forward from 18 by K.
- 66 18 to 19 is  $\frac{1}{4}$  breast; draw line from 19 to I and 5.
- 67 Advance at 1 the amount from K, shaded part.
- 68 19 to 20 is 2 $\frac{3}{4}$  inches, or Style; notch  $\frac{1}{2}$  in. from 19.
- 69 I to J is 1 $\frac{1}{4}$  inches; 5 to 6 is 1 inch; square down.
- 70 Go in  $\frac{1}{2}$  inch at 7, draw line from 6 and shape front.
- 71 V to 21 is 1 $\frac{1}{4}$  inches; draw line to end of roll.
- 72 The pocket as usual; draw line from K to 33.
- 73 One Button. Go in 1 inch between waist and seatline.

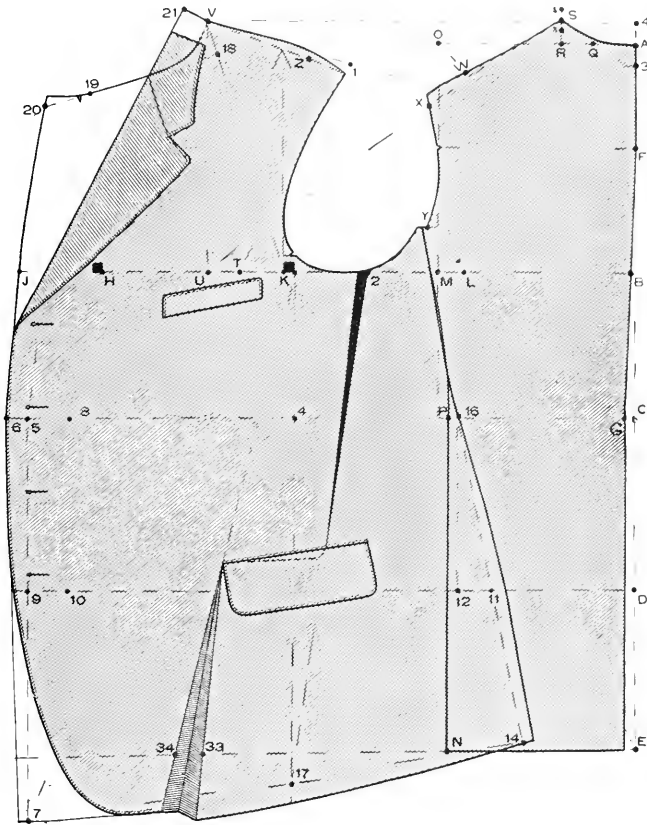

DIAGRAM 16 — CORPULENT 3 DEGREE

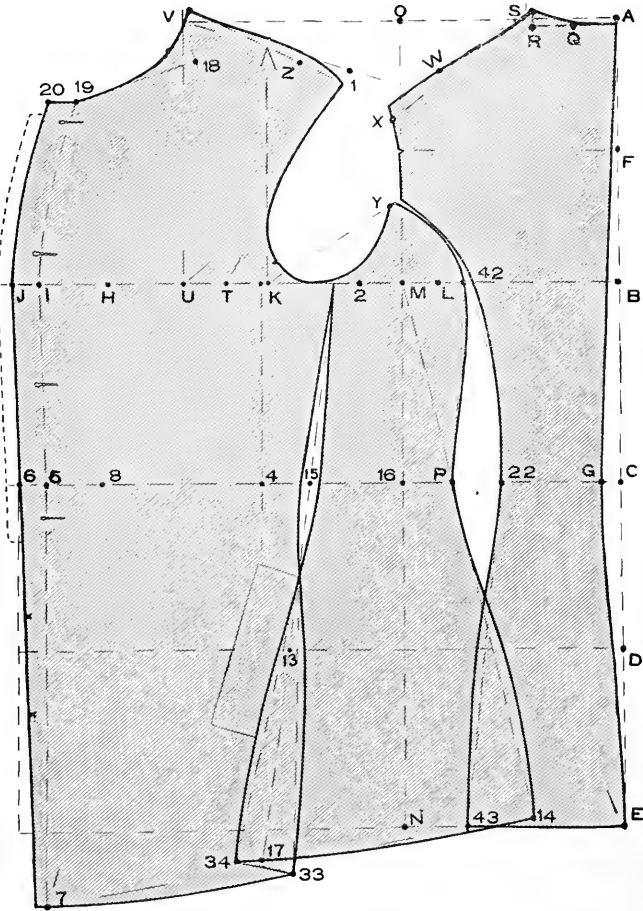

DIAGRAM 17 — MILITARY BLOUSE

# Military Blouse

## Diagram 17

59. The measures are taken over the Vest always.  
 Inside sleeve  $17\frac{3}{4}$  inches. Blade (with  $1\frac{1}{4}$  inches for  
 Breast 36 inches. seams added)  $12\frac{1}{4}$  in.  
 Waist 31 inches. Depth of scye  $8\frac{3}{4}$  inches.  
 Hip or seat 37 inches. Natural waist  $16\frac{1}{2}$  inches.  
 Strap  $12\frac{1}{2}$  inches. Full length 29 inches.  
 Over shoulder 17 inches. Height 5 feet 6 inches.  
 Form and attitude, erect. Sizes, 33 to 42 breasts.

### TO DRAFT.

- 1 Square both ways from A or 4.
- 2 4 to B is  $\frac{1}{3}$  breast on "3RDS" and  $3\frac{1}{2}$  inches ( $9\frac{1}{2}$ ).
- 3 B to 3 is  $\frac{1}{3}$  breast of height and  $3\frac{1}{2}$  inches.
- 4 A is half way between 3 and 4.
- 5 This is the proportional, and includes all allowances.
- 6 A to C is one-fourth height and  $\frac{1}{4}$  inch for curve of Back ( $16\frac{3}{4}$ ).
- 7 C to D is  $\frac{1}{3}$  breast, on "3RDS" (6) seat line.
- 8 Added to the natural waist gives correct length.
- 9 A to E is the Full Length of Back (29).
- 10 F is half between B and 4 for front shoulder height.
- 11 Square out from A, B, C, D, E, F, 3 and 4.
- 12 C to G is  $\frac{3}{4}$  inch; draw line A to G and down to E.
- 13 From the line just drawn inside of B measure to H.
- 14 B to H is half the full breast measure (18).
- 15 H to I is  $2\frac{1}{2}$  inches, center of breast.
- 16 B to K is blade (with  $1\frac{1}{4}$  inches for seams) ( $12\frac{1}{4}$ ).
- 17 Square up from K—front of armhole.
- 18 L is half way between B and K.
- 19 L to M is  $1\frac{1}{4}$  inches—width of Back.
- 20 Square up to O and down to N, locating 16.
- 21 A to Q is  $\frac{1}{12}$  breast—on "12THS"—and
- 22 Q to R is  $1\frac{1}{2}$  inches; square up to S,  $\frac{5}{8}$  inch.
- 23 K to T is  $1\frac{1}{2}$  inches; T to U is 1-12 breast.
- 24 Square up from U to V, locating the shoulder point.
- 25 V is located on lines from K and 4.
- 26 Draw lines from S to U, and F to V.
- 27 This gives the proportional height of shoulders.
- 28 Rise at X  $\frac{3}{4}$  inch and lower at point 1 the same.
- 29 X is  $\frac{3}{4}$  inch on the S-U line.
- 30 Y is  $\frac{1}{2}$  inch from the O-N line, and  $\frac{1}{6}$  up from M.
- 31 From B up apply depth of scye measure and  $\frac{1}{2}$  inch ( $9\frac{1}{4}$ ) to A in normal attitude will meet line A.
- 32 The  $\frac{1}{2}$  inch is for fullness held in over the blade.
- 33 Obtain point S from A and shape A S to X.
- 34 Shape the Back as shown; draw line from B to W.
- 35 Apply strap measure, and 1 inch A to R and K to V ( $13\frac{1}{2}$ ) in normal attitude will meet line 4-V.
- 36 Go back from K-V line as much as above line V-4, or  $\frac{1}{2}$  as much from line U.
- 37 Apply over shoulder measure and 1 inch (18) B to W and K to Z; when normal, meet line F-V.
- 38 Z is  $1\frac{1}{4}$  inches from line K.
- 39 Draw a line from V through Z to point 1.
- 40 V to point 1 is  $\frac{3}{8}$  inch less than S to X.
- 41 Draw a guide line from point 1 to T.

- 42 Shape arm-scye and shoulder rounding  $\frac{1}{2}$  in. over Z.
- 43 B to 2 is  $\frac{1}{2}$  breast on "HALVES"; 2 to K is  $3\frac{1}{2}$  inches.
- 44 This is normal blade and independent of the actual blade, and comes even with K in normal sizes.
- 45 Square down from K through 4 to 17.
- 46 4 to 5 is  $\frac{1}{2}$  waist—on "HALVES"—center of waist.
- 47 Square down from 5 to 7. The measure from B to 2, K, 4 and 5 is used only to obtain the front center of the waist and to check the blade measure.
- 48 5 to 8 is 2 inches, 9 to 10 is the same.
- 49 These 2 inches are for seams and make-up.
- 50 M to 42 is  $\frac{1}{8}$  breast; N to 43 is the same.
- 51 22 is half way between G and 16.
- 52 P is half way between 16 and 22.
- 53 Draw a line from M through P to 14.
- 54 Shape the Back and side seam.
- 55 Apply waist measure net 22 to G and 8 to P.
- 56 Draw line 15 and take out the surplus ( $\frac{3}{4}$ ) half on each side of 15.
- 57 Add a  $\frac{1}{4}$  inch on each side of 13.
- 58 Draw lines from 15 through 13, locating 33 and 34.
- 59 Shape the underarm cut from 44.
- 60 14 to 42 equal to 14 to 43.
- 61 Z to 34 equals Z to 14.
- 62 Z to 7 equals Z to E from line K.
- 63 Shape bottom 14 to 34 and 33 to 7.
- 64 V to 18 is  $\frac{1}{12}$  breast; square forward from 18 by K.
- 65 18 to 19 is  $\frac{1}{4}$  breast; draw line from 19 to 1 and 5.
- 66 19 to 20 and I to J are 1 inch.
- 67 Shape the gorge and front. Add a  $\frac{1}{2}$ -inch stand.
- 68 In shaping the gorge for erect, the curve must fall into the normal,  $\frac{3}{4}$  inch from junction U-18 line.
- 69 The opening for the sword is half on each side of seat line and 6 inches long, finished with a loose facing or flap.
- 70 4 buttons, about  $4\frac{3}{4}$  inches apart, and 2 hooks below.

## Collars

60. It is surprising how indifferent the cutters usually are about the collar, as if it was of little consequence how it is cut, either long or short, or round, or straight, so long as it has the appearance of a collar; or else let the journeyman fashion it himself from the cloth furnished him by the cutter.

It should be patent that if a long collar is correct, a short collar will not do, and vice versa. That there is such a thing as a correct collar, or that it can be cut to be exactly like the balance of the coat, seems to have escaped their observation. As a rule, only in wholesale clothing is an *attempt* made to cut them to fit. We say *attempt* advisedly, because from experience the so-called first-class houses do not cut them exactly as they ought to go in or on the coat; and why not?

We will proceed to show and prove that it can be done.

### Collars—Diagram 18

61. Place the first button; or the end of the roll as desired.

Place the square with  $1\frac{1}{4}$  inches mark on point V and the long arm of the square at the end of the roll.

The corner of the square thereby establishes point A. Mark from V through A to end of roll. Do not make the mistake and go out from point V  $1\frac{1}{4}$  inches and then draw the crease line.

Point A is as much a point in this case as point V.

Measure the width of back from A to R with the square in 36 size 3 inches; move the square up 3 inches and let the corner rest on Point B.

Mark down to C  $\frac{5}{8}$  inch while the square is lying on point B and the crease line. Move the corner of the square down to point C and the long arm touching point A and mark from C to A. This is the collar break line.

While the square is in this position (corner on C and arm on A) mark down to D  $1\frac{1}{4}$  inches. This is for the stand of the collar. Pull the square up and mark a line parallel with C-A from D past V.

Square up from D through C to E. C to E is width desired. Square from B. At the notch of the coat rise a  $\frac{1}{4}$  inch to the collar and make the collar  $\frac{1}{2}$  inch longer from the notch out. For a seam collar add a  $\frac{1}{4}$  inch more.

The leaf is width desired; shape from E. Shape from D, allowing an  $\frac{1}{8}$  inch opposite V, which, when stretched, will disappear, striking the gorge at the break line, and continue to the end of the collar. This completes the collar. When the end of the collar is brought back to the notch of the coat, the difference from where the collar break line is to the coat break line is the amount of fullness that particular collar needs according to the length of roll. The outside leaf of the collar is not stretched at all; the underside or stand is stretched until it has the same length as the outside.

This collar can now be put on, shaped before or after putting on, and the top collar put on without an iron put on the under collar.

The coat will hug the linen collar clear around to the break line and not appear as if the coat hung on the collar button by the hanger, like some of them do.

### Collars—Diagram 19

62. Shows the different lengths of roll, all obtained as previously explained. The longer the roll the shorter the outside length, as shown by the circle and dash line. The amount of fullness and length of the collar regulates itself every time.

### Military Collar—Diagram 20

63. Measure the length of the collar on the coat, or make it 1 inch more than the linen collar. Example: Linen collar, 15; coat collar, 16 inches. Draw a line from A to E the full length of collar (16).

E to F is  $1\frac{3}{4}$  inches, or width desired.

Sweep from E to C and E to D, half the length of the collar (8 inches); pivot at A. This is the lower edge of the collar.

Sweep from F to G and F to B.

Draw lines from A through B to D and G to C for run of slant in front.

This is the stand of the collar, and for a military standing collar is complete.

64. **Double Collar.**—For a double collar cut another piece for the leaf the width desired ( $2\frac{3}{4}$  inches in this case).

The two are sewed together at the top edge, G-F-B, with raw edges and 3-ply of canvas in the stand.

The leaf has a spread of about  $\frac{3}{8}$  inch opposite C and D, or to suit. The broken lines represent the leaf.

The top collar, represented by the dot and dash lines, is cut after the under collar, allowing  $\frac{3}{8}$  inch more for the leaf and even amount for width of stand.

The circle cut has the advantage over other methods in that it hugs the collar very close at the top edge, which is exactly what is wanted for all standing collars.

The collar is put on without any extra fullness.

### Ulster or Storm Collar—Diagram 21

65. Read first description for cutting collars on the coat collar, and follow it always.

V to 21 is  $1\frac{1}{4}$  inches; draw a line to end of roll, establishing 27.

Draw a line from 27 through V to 28.

V to 28 equals A to R.

28 to 29 is  $\frac{5}{8}$  inch; square from V through 29 to 31,  $1\frac{1}{4}$  inches for stand.

V to 32 is  $1\frac{1}{4}$  inches; draw line from 31 through 32 to 27.

Square out to 30 by 21-29 for width desired (4 inches in this case).

The leaf is about  $2\frac{1}{4}$  inches wide; allow  $\frac{1}{2}$  inch to length for working in.

From break line to end of collar reduce a  $\frac{1}{4}$  inch.

### Fur Collar—Diagram 22

66. Read description first on coat collar.

V to 21 is  $1\frac{1}{4}$  inches; draw a line to end of roll, establishing 27.

Draw a line from 27 through V to 28.

V to 28 equals A to R.

28 to 29 is  $\frac{5}{8}$  inch; square from V through 29 to 31,  $1\frac{1}{4}$  inches for stand.

V to 32 is  $1\frac{1}{4}$  inches; draw a line from 31 through 32 to 27.

Square out to 30 by 21-29 the width desired (4  $\frac{3}{4}$  inches in this case).

Shape as represented and cut out the collar. Place the collar as cut in position as shown in

### Diagram 23

67. Square out from 32 through V to 33.

Sweep from 33 to 34 and from 33 to 35  $1\frac{1}{2}$  inches; pivot at V.

Cut the pattern from 33 to 32; lay on another piece of paper and open as from 34 to 35; pivot at V.

### Diagram 24

68. Represents the complete collar. The broken lines show the stand, as bent over, in which a piece must be stoted to give circumference to the stand.

The stand can be cut with less stand, if desired.



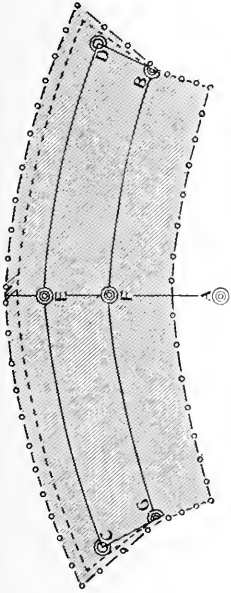

DIAGRAM 20

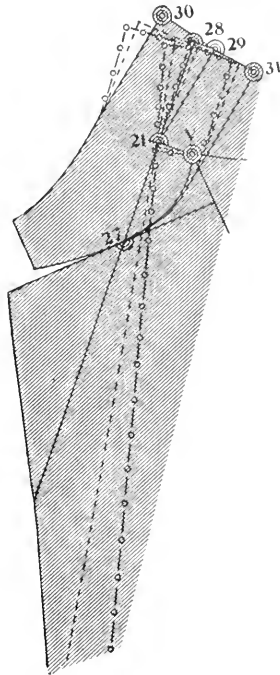

DIAGRAM 19 - COLLARS

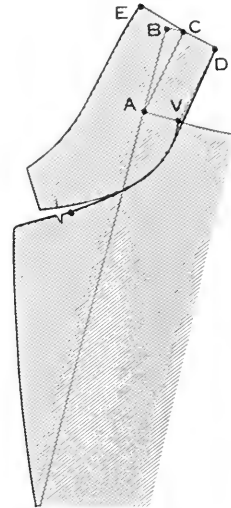

DIAGRAM 18 - COLLAR

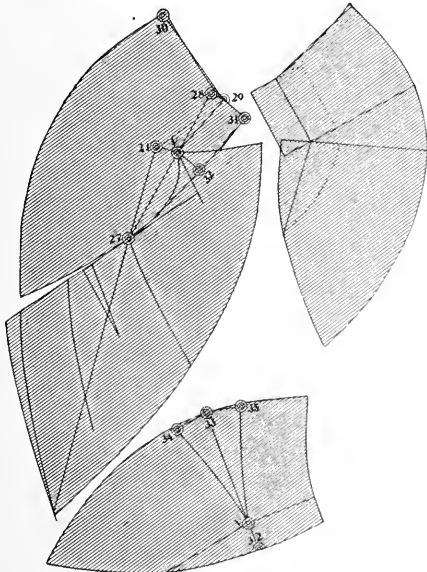

DIAGRAM 22, 23, 24 - FUR COLLAR

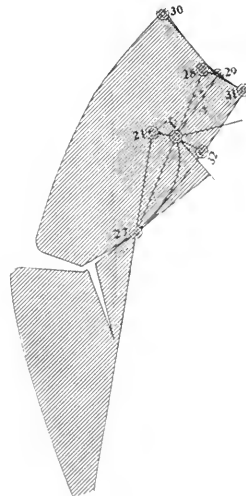

DIAGRAM 21 - ULSTER

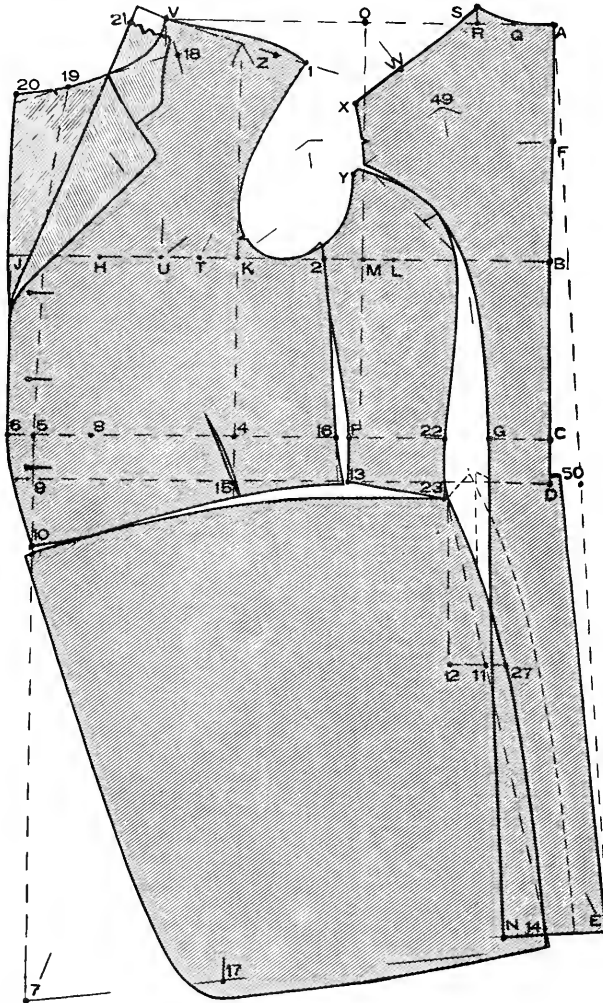

DIAGRAM 25 — CUTAWAY FROCK

## PART TWO

## Cutaway Frock

## Diagram 25

1. The measures are taken over the Vest always.

Inside sleeve	17 $\frac{3}{4}$ inches.	Blade (with 1 $\frac{1}{4}$ inches for Breast	36 inches.	seams added)	12 $\frac{1}{2}$ inches.
Waist	32 inches.	Depth of scye	9 inches.		
Hip or seat	37 inches.	Natural waist	16 $\frac{1}{2}$ inches.		
Strap	12 inches.	Fashion waist	18 $\frac{3}{4}$ inches.		
Over shoulder	17 inches.	Full length	37 inches.		
		Height	5 feet 6 inches.		

Form and Attitude, normal. Sizes 33 to 42 breasts.

## TO DRAFT.

- 1 Square both ways from A.
- 2 A to B is  $\frac{1}{3}$  breast on "3RDS" and 3 $\frac{1}{2}$  inches (9 $\frac{1}{2}$ ).
- 3 This is the proportional, and includes all allowances.
- 4 A to C is one-fourth height, and  $\frac{1}{4}$  inch for length.
- 5 A to D is the fashion waist; one-fourth height and  $\frac{1}{2}$  inches (18 $\frac{3}{4}$ ).
- 6 D to 50 is 1 $\frac{1}{4}$  inches, line from A through 50 to E.
- 7 A to E is the Full Length of Back.
- 8 F is half between A and B, for front shoulder height.
- 9 Square out from A, B, C, D, E and F.
- 10 B to H is half the full breast measure (18).
- 11 H to I is 2 $\frac{1}{4}$  inches, center of breast.
- 12 B to K is blade (with 1 $\frac{1}{4}$  inches for seams).
- 13 Square up from K—front of armhole.
- 14 L is half way between B and K.
- 15 L to M is 1 $\frac{1}{4}$  inches—width of Back.
- 16 Square up to O and down to P.
- 17 P is  $\frac{1}{2}$  inch from line O-M; square down to 13.
- 18 A to Q is  $\frac{1}{12}$  breast—on "12THS," and
- 19 Q to R is 1 $\frac{1}{2}$  inches; square up to S,  $\frac{5}{8}$  inch.
- 20 K to T is 1 $\frac{1}{2}$  inches; T to U is  $\frac{1}{12}$  breast.
- 21 Square up from U to V—locating the shoulder point.
- 22 V is located on lines from U and A.
- 23 Draw lines from S to U, F to V and A to K.
- 24 This gives the proportional height of shoulders.
- 25 Rise at X  $\frac{1}{2}$  inch, and lower at point 1 the same.
- 26 X is  $\frac{1}{2}$  inch on the S-U line—or Style.
- 27 Y is  $\frac{1}{2}$  inch from the O-M line.
- 28 Draw guide line from X to Y.
- 29 From B up apply depth of scye measure and  $\frac{1}{2}$  inch to A; in normal attitude will meet line A (9 $\frac{1}{2}$ ).
- 30 The  $\frac{1}{2}$  inch is for fullness held in over the blade.
- 31 C to G is  $\frac{1}{16}$  breast and 1 $\frac{1}{4}$  inches.
- 32 E to N is the same width as 50 to G, and  $\frac{1}{2}$  inch.
- 33 Draw a line from G to N and from
- 34 49 to G for width of Back over breast-line.
- 35 49 is on F-V and A-K lines.
- 36 Blade fullness is  $\frac{5}{8}$  inch over the rounding.
- 37 Shape the back as shown; draw line from B to W.
- 38 Apply strap measure and 1 inch A to R and K to V; in normal attitude will meet line A-V (13).
- 39 Apply over shoulder measure and 1 inch B to W and K to Z; when normal, meet line F-V (18).
- 40 Z is 1 $\frac{1}{4}$  inches from line K.
- 41 Draw a line from V through Z to point 1.
- 42 V to point 1 is  $\frac{3}{8}$  inch less than S to X.
- 43 Draw a guide line from point 1 to T.
- 44 Shape arm-scye and shoulder, rounding  $\frac{1}{2}$  in. over Z.
- 45 B to 2 is  $\frac{1}{2}$  breast on "HALVES"; 2 to K is 3 $\frac{1}{2}$  inches.
- 46 This is normal blade and independent of the actual blade, and comes even with K in normal sizes.
- 47 Square down from K through 4 to 17.
- 48 4 to 5 is  $\frac{1}{2}$  waist—on "HALVES"—center of waist.
- 49 Square down from 5 to 7. The measure from B to 2, K, 4 and 5 is used only to obtain the front center of waist, and to check the blade measure.
- 50 5 to 8 is 2 $\frac{1}{4}$  inches; 9 to 10 is  $\frac{1}{6}$  breast.
- 51 These 2 $\frac{1}{4}$  inches are for seams and make-up.
- 52 G to 22 is 1 $\frac{3}{4}$  inches, or 1 $\frac{1}{4}$  inches in all sizes to allow for blade fullness and  $\frac{1}{8}$  inch for every inch the waist is smaller than the breast.
- 53 Square up, and down to 23; 23 is  $\frac{5}{8}$  inch below the fashion waist; or sweep from the Back by Y.
- 54 Measure waist net G to C, P to 22, and 8 to 16.
- 55 Shape side body, reducing  $\frac{1}{4}$  inch near Y,  $\frac{3}{8}$  inch at breast line and from 2 to 13 and 16, and 23 to 13.
- 56 V to 18 is  $\frac{1}{12}$  breast; square forward from 18 by K.
- 57 18 to 19 is  $\frac{1}{4}$  breast; draw line from 19 to I and 5.
- 58 19 to 20 is 2 $\frac{1}{4}$  inches; notch  $\frac{1}{2}$  inch from 19.
- 59 I to J is 1 $\frac{1}{4}$  inches; 5 to 6 is 1 inch.
- 60 Draw a line from 13 to 10 and shape forepart.
- 61 Skirt—square both ways from 23.
- 62 23 to 12 is  $\frac{1}{3}$  breast, and  $\frac{1}{2}$  inch.
- 63 12 to 11 is 1 $\frac{1}{2}$  inches; 11 to 27 is  $\frac{3}{4}$  inch.
- 64 Draw a line from 23 through 11 and 14.
- 65 14 is natural waist, and 1 inch from 23.
- 66 23 to bottom is  $\frac{1}{4}$  inch more than D to E.
- 67 Lay square on 27-14 and mark for run of bottom.
- 68 Shape skirt through 27 to bottom.
- 69 Z to 7 is length from Z to E and 1 inch from line K.
- 70 Draw line 14 to 7; shape bottom; lower 1 inch at 17.
- 72 Take out a fish  $\frac{1}{8}$  inch,  $\frac{1}{6}$  up from 15.
- 73 Go out  $\frac{1}{2}$  from D and line parallel to 50-E.
- 74 Reduce  $\frac{1}{8}$  inch at B from A to C.
- 75 Shape front run of skirt.

# Cutaway Stout

## Diagram 26

2. The measures are taken over the Vest always.

Inside sleeve	18 $\frac{3}{4}$ inches.	Blade (with 1 $\frac{1}{4}$ inches for
Breast	42 inches.	seams added) 14 inches.
Waist	40 $\frac{1}{2}$ inches.	Depth of scye
Hip or seat	43 inches.	Natural waist
Strap	13 $\frac{1}{2}$ inches.	Fashion waist
Over shoulder	19 inches.	Full length
Stout, 1 degree.		Height
Form and Attitude, normal.		5 feet 10 inches.

Sizes 40 to 46 breasts.

### TO DRAFT.

- 1 Square both ways from A or 4.
- 2 4 to B is  $\frac{1}{3}$  breast on "3RDS" and 3 $\frac{1}{2}$  inches.
- 3 B to 3 is  $\frac{1}{3}$  breast of height, and 3 $\frac{1}{2}$  inches.
- 4 A is half way between 4 and 3.
- 5 This is the proportional, and includes all allowances.
- 6 A to C is one-fourth height, and  $\frac{1}{4}$  inch for length.
- 7 A to D is the fashion waist; one-fourth height and 1 $\frac{1}{2}$  inches (19 $\frac{1}{2}$ ).
- 8 D to 50 is 1 $\frac{1}{4}$  inches, line from A through 50 to E.
- 9 A to E is the Full Length of Back.
- 10 F is half between 4 and B, for front shoulder height.
- 11 Square out from A, B, C, D, E, F, 3 and 4.
- 12 B to H is half the full breast measure (21).
- 13 H to I is 2 $\frac{1}{4}$  inches—center of Breast.
- 14 B to K is blade (with 1 $\frac{1}{4}$  inches for seams) (14).
- 15 Square up from K—front of armhole.
- 16 L is half way between B and K.
- 17 L to M is 1 $\frac{1}{4}$  inches—width of Back.
- 18 Square up to O, and down to P.
- 19 P is  $\frac{1}{2}$  inch from line O-M; square down to 13.
- 20 A to Q is  $\frac{1}{12}$  breast—on "12THS," and
- 21 Q to R is 1 $\frac{1}{2}$  inches; square up to S  $\frac{5}{8}$  inch.
- 22 K to T is 1 $\frac{1}{2}$  inches; T to U is  $\frac{1}{12}$  breast.
- 23 Square up from U to V—locating the shoulder point.
- 24 V is located on lines from U and A.
- 25 Draw lines from S to U, F to V, and A to K.
- 26 This gives the proportional height of shoulders.
- 27 Rise at X  $\frac{1}{2}$  inch, and lower at point 1 the same.
- 28 X is  $\frac{1}{2}$  inch on the S-U line—or Style.
- 29 Y is  $\frac{1}{2}$  inch from the O-M line.
- 30 Draw guide line from X to Y.
- 31 From B up apply depth of scye measure and  $\frac{1}{2}$  inch to A; in normal attitude will meet line A (10 $\frac{3}{8}$ ).
- 32 The  $\frac{1}{2}$  inch is for fullness held in over the blade.
- 33 C to G is  $\frac{1}{16}$  breast and 1 $\frac{1}{4}$  inches.
- 34 E to N is the same width as 50 to G, and  $\frac{1}{2}$  inch.
- 35 Draw a line from G to N and from
- 36 49 to G for width of Back over breast line.
- 37 49 is on F-V and A-K lines.
- 38 Blade fullness is  $\frac{5}{8}$  inch over the rounding.
- 39 Shape the Back as shown; draw line from B to W.
- 40 Apply strap measure and 1 inch A to R and K to V; in normal attitude will meet line 4-V (14 $\frac{1}{2}$ ).
- 41 Apply over shoulder measure and 1 inch B to W and K to Z; when normal, meet line F-V (20).
- 42 Z is 1 $\frac{1}{4}$  inches from line K.
- 43 Draw a line from V through Z to point 1.
- 44 V to point 1 is  $\frac{3}{8}$  inch less than S to X.
- 45 Draw a guide line from point 1 to T.
- 46 Shape arm-scye and shoulder rounding  $\frac{1}{2}$  in. over Z.
- 47 B to 2 is  $\frac{1}{2}$  breast on "HALVES"; 2 to K is 3 $\frac{1}{2}$  inches.
- 48 This is normal blade and independent of the actual blade, and comes even with K in normal sizes.
- 49 Square down from K through 4 to 17.
- 50 4 to 5 is  $\frac{1}{2}$  waist—on "HALVES"—center of waist.
- 51 Square down from 5 to 7. The measure from B to 2, K, 4 and 5 is used only to obtain the front center of waist, and to check the blade measure.
- 52 5 to 8 is 2 $\frac{1}{4}$  inches; 9 to 10 is  $\frac{1}{6}$  breast.
- 53 These 2 $\frac{1}{4}$  inches are for seams and make-up.
- 54 G to 22 is 1 $\frac{1}{2}$  inches, or 1 $\frac{1}{4}$  inches in all sizes to allow for blade fullness and  $\frac{1}{8}$  inch for every inch the waist is smaller than the breast.
- 55 Square up and down to 23; 23 is  $\frac{5}{8}$  inch below the fashion waist; or sweep from the Back by Y.
- 56 Measure waist net G to C, P to 22, and 8 to 16.
- 57 Shape side body by reducing  $\frac{1}{4}$  inch near Y,  $\frac{3}{8}$  in. at breast line and from 2 to 13 and 16, and 23 to 13.
- 58 V to 18 is  $\frac{1}{12}$  breast; square forward from 18 by K.
- 59 18 to 19 is  $\frac{1}{4}$  breast; draw line from 19 to I and 5.
- 60 19 to 20 is 2 $\frac{1}{2}$  inches; notch  $\frac{3}{4}$  inch from 19.
- 61 1 to J is 1 $\frac{1}{2}$  inches; 5 to 6 is 1 inch.
- 62 Draw a line from 13 to 10 and shape front.
- 63 10 to 35 is  $\frac{1}{2}$  inch; draw line from 13 to 35.
- 64 Lay square on 13-36-H and take out a V at 36.
- 65 Shape forepart from 13 through 36 to 10.
- 66 Advance 23 the amount of V and seams.
- 67 Skirt—Square both ways from 23.
- 68 23 to 12 is  $\frac{1}{3}$  breast, and  $\frac{1}{2}$  inch.
- 69 12 to 11 is 1 $\frac{1}{2}$  inches; 11 to 27 is  $\frac{3}{4}$  inch.
- 70 Draw a line from 23 through 11 and 14.
- 71 14 is natural waist, and 1 inch from 23.
- 72 23 to bottom is  $\frac{1}{4}$  inch more than D to E.
- 73 Lay square on 27-14 and mark for run of bottom.
- 74 Shape skirt through 27 to bottom.
- 75 Z to 7 is length from Z to E and 1 inch from line K.
- 76 Draw line 14 to 7; shape bottom; lower 1 inch at 17.
- 79 Go out  $\frac{1}{2}$  inch from D and line parallel to 50-E.
- 80 Reduce  $\frac{1}{8}$  inch at B from A to C.
- 81 Shape front run of skirt.

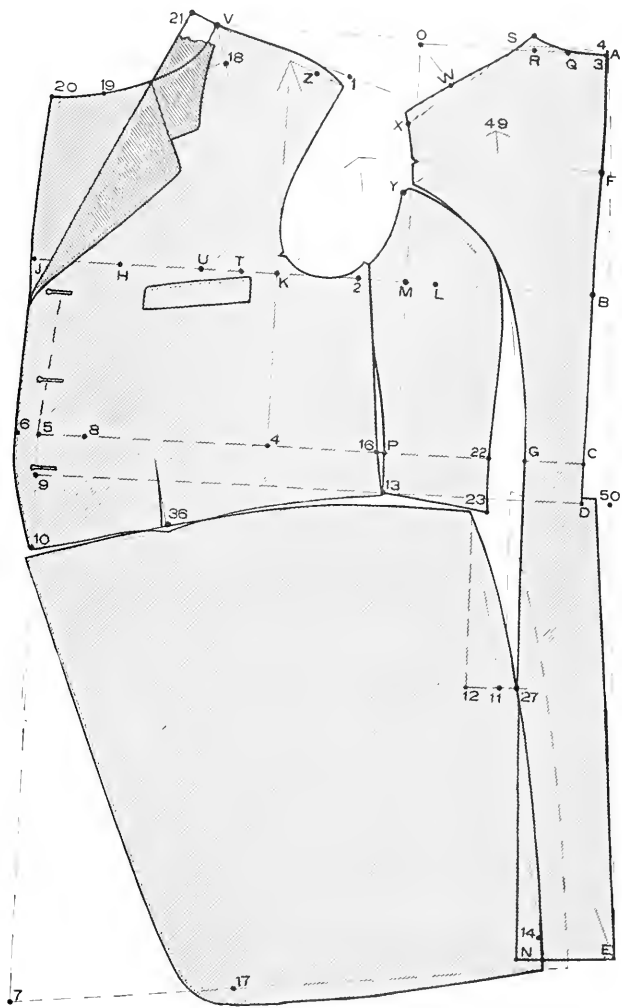

DIAGRAM 26 CUTAWAY STOUT

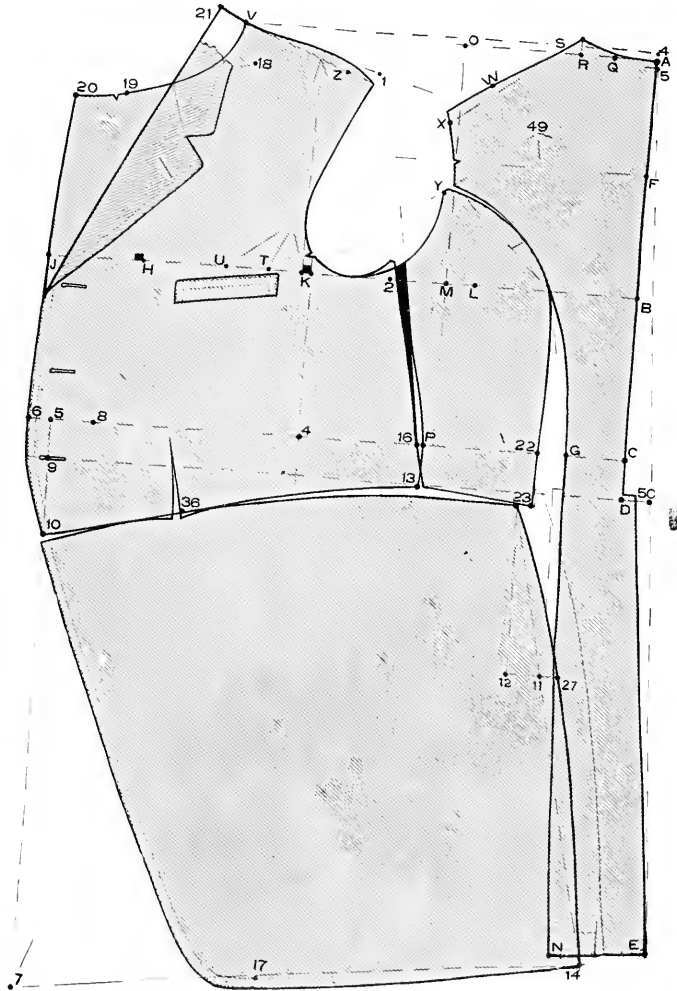

DIAGRAM 27 — CUTAWAY CORPUENT

# Cutaway Corpulent

## Diagram 27

3. The measures are taken over the Vest always.

Inside sleeve	19 inches.	Blade (with $1\frac{1}{4}$ inches for
Breast	45 inches.	seams added) $14\frac{1}{4}$ inches.
Waist	$45\frac{1}{2}$ inches.	Depth of scye $10\frac{1}{4}$ inches.
Hip or seat	46 inches.	Natural waist 18 inches.
Strap	14 inches.	Fashion waist $19\frac{1}{4}$ inches.
Over shoulder	$19\frac{3}{4}$ inches.	Full length $39\frac{1}{2}$ inches.
Corpulent	2 degrees	Height 5 feet 11 inches.
Form and Attitude,	normal.	Sizes 40 to 48 breasts.

### TO DRAFT.

- 1 Square both ways from A or 4.
- 2 4 to B is  $\frac{1}{3}$  breast on "3RDS" and  $3\frac{1}{2}$  inches (11).
- 3 B to 3 is  $\frac{1}{3}$  breast of height, and  $3\frac{1}{2}$  inches ( $10\frac{1}{4}$ ).
- 4 A is half way between 3 and 4 ( $10\frac{1}{4}$ ).
- 5 This is the proportional, and includes all allowances.
- 6 A to C is one-fourth height, and  $\frac{1}{4}$  inch for length.
- 7 A to D is the fashion waist; one-fourth height and  $\frac{1}{2}$  inches ( $19\frac{1}{4}$ ).
- 8 D to 50 is  $1\frac{1}{4}$  inches, line from A through 50 to E.
- 9 A to E is the Full Length of Back.
- 10 F is half between 4 and B, for front shoulder height.
- 11 Square out from A, B, C, D, E, F, 3 and 4.
- 12 B to H is half the full breast measure ( $22\frac{1}{2}$ ).
- 13 H to I is  $2\frac{1}{4}$  inches—center of Breast.
- 14 B to K is blade (with  $1\frac{1}{4}$  inches for seams) ( $14\frac{1}{2}$ ).
- 15 Square up from K—front of armhole.
- 16 L is half way between B and K.
- 17 L to M is  $1\frac{1}{4}$  inches—width of Back.
- 18 Square up to O, and down to P.
- 19 P is  $\frac{1}{2}$  inch from line O-M; square down to 13.
- 20 A to Q is  $\frac{1}{12}$  breast—on "12THS," and
- 21 Q to R is  $1\frac{1}{2}$  inches; square up to S,  $\frac{5}{8}$  inch.
- 22 Advance from K,  $\frac{1}{16}$  inch each size above 4 inches less than breast; to straighten the front run, take it out in the underarm cut as shown by shaded part.
- 23 K to T is  $1\frac{1}{2}$  inches; T to U is  $\frac{1}{12}$  breast.
- 24 Square up from U to V—locating the shoulder point.
- 25 V is located on lines from U and 4.
- 26 Draw lines from S to U, F to V, and A to K.
- 27 This gives the proportional height of shoulders.
- 28 Rise at X  $\frac{1}{2}$  inch, and lower at point 1 the same.
- 29 X is  $\frac{1}{2}$  inch on the S-U line—or Style.
- 30 Y is  $\frac{1}{2}$  inch from the O-M line.
- 31 Draw guide line from X to Y.
- 32 From B up apply depth of scye measure and  $\frac{1}{2}$  inch to A; in normal attitude will meet line A ( $10\frac{3}{4}$ ).
- 33 The  $\frac{1}{2}$  inch is for fullness held in over the blade.
- 34 C to G is  $\frac{1}{16}$  breast and  $1\frac{1}{4}$  inches.
- 35 E to N is the same width as 50 to G, and  $\frac{1}{2}$  inch.
- 36 Draw a line from G to N and from

- 37 49 to G for width of Back over breast line.
- 38 49 is on F-V and A-K lines.
- 39 Blade fullness is  $\frac{5}{8}$  inch over the rounding.
- 40 Shape the Back as shown; draw line from B to W.
- 41 Apply strap measure and 1 inch A to R and K to V; in normal attitude will meet line 4-V (15).
- 42 Apply over shoulder measure and 1 inch B to W and K to Z; when normal, meet line F-V ( $20\frac{3}{4}$ ).
- 43 Z is  $1\frac{1}{4}$  inches from line K.
- 44 Draw a line from V through Z to point 1.
- 45 V to point 1 is  $\frac{3}{8}$  inch less than S to X.
- 46 Draw a guide line from point 1 to T.
- 47 Shape arm-scye and shoulder rounding  $\frac{1}{2}$  in. over Z.
- 48 B to 2 is  $\frac{1}{2}$  breast on "HALVES"; 2 to K is  $3\frac{1}{2}$  inches.
- 49 This is normal blade and independent of the actual blade, and comes even with K in normal sizes.
- 50 Square down from K through 4 to 17.
- 51 4 to 5 is  $\frac{1}{2}$  waist—on "HALVES"—center of waist.
- 52 Square down from 5 to 7. The measure from B to 2, K, 4 and 5 is used only to obtain the front center of the waist, and to check the blade measure.
- 53 5 to 8 is 2 inches; 9 to 10 is  $\frac{1}{6}$  breast.
- 54 These 2 inches are for seams and make-up.
- 55 G to 22 is  $1\frac{1}{4}$  inches, or  $1\frac{1}{4}$  inches in all sizes to allow for blade fullness and  $\frac{1}{8}$  inch for every inch the waist is smaller than the breast.
- 56 Square up and down to 23; 23 is  $\frac{3}{8}$  inch below the fashion waist; or sweep from the Back by Y.
- 57 Measure waist net G to C, P to 22, and 8 to 16.
- 58 Shape side body reducing  $\frac{1}{4}$  inch near Y,  $\frac{3}{8}$  inch at breast line and from 2 to 13 and 16, and 23 to 13.
- 59 V to 18 is  $\frac{1}{12}$  breast; square forward from 18 by K.
- 60 18 to 19 is  $\frac{1}{4}$  breast; draw line from 19 to I and 5.
- 61 Advance at I the amount from K, shaded part.
- 62 19 to 20 is  $2\frac{1}{4}$  inches; notch  $\frac{1}{2}$  inch from 19.
- 63 I to J is  $1\frac{1}{2}$  inches; 5 to 6 is 1 inch.
- 64 Draw a line from 13 to 10 and shape front.
- 65 Lay square on 13-36-H and take out a V at 36.
- 66 Advance 23 the amount of I' and seams.
- 67 Skirt—Square both ways from 23.
- 68 23 to 12 is  $\frac{1}{3}$  breast, and  $\frac{1}{2}$  inch.
- 69 12 to 11 is  $1\frac{1}{2}$  inches; 11 to 27 is  $3\frac{1}{2}$  inch.
- 70 Draw line from 23 through 11 and 14.
- 71 14 is natural waist, and 1 inch from 23.
- 72 23 to bottom is  $\frac{1}{4}$  inch more than D to E.
- 73 Lay "square" on 27-14 and mark for run of bottom.
- 74 Shape skirt through 27 to bottom.
- 75 Z to 7 is length from Z to E and 1 inch from line K.
- 76 Draw line 14 to 7; shape bottom; lower 1 inch at 17.
- 79 Go out  $\frac{1}{2}$  from D and line parallel to 50-E.
- 80 Reduce  $\frac{1}{8}$  inch at B from A to C.
- 81 Shape front run of skirt.

# Full Dress Rever On

## Diagram 28

4. The measures are taken over the Vest always.

Inside sleeve	17 $\frac{3}{4}$ inches.	Blade (with 1 $\frac{1}{4}$ inches for
Breast	36 inches.	seams added) 12 $\frac{1}{2}$ inches
Waist	32 inches.	Depth of scye 9 inches.
Hip or seat	37 inches.	Natural waist 16 $\frac{3}{4}$ inches.
Strap	12 inches.	Fashion waist 18 $\frac{3}{4}$ inches.
Over shoulder	17 inches.	Full length 39 inches.

Height 5 feet 6 inches.

Form and Attitude, normal. Sizes, 33 to 42 breasts.

### TO DRAFT.

- 1 Square both ways from A.
- 2 A to B is  $\frac{1}{3}$  breast on "3RDS" and 3 $\frac{1}{2}$  inches (9 $\frac{1}{2}$ ).
- 3 B to A is  $\frac{1}{3}$  breast of height, and 3 $\frac{1}{2}$  inches.
- 4 A is half way between 3 and 4.
- 5 This is the proportional, and includes all allowances.
- 6 A to C is one-fourth height, and  $\frac{1}{4}$  inch for length.
- 7 A to D is the fashion waist; one-fourth height and  $\frac{1}{2}$  inches (18 $\frac{3}{4}$ ).
- 8 D to 50 is 1 $\frac{1}{4}$  inches, line from A through 50 to E.
- 9 A to E is the Full Length of Back.
- 10 F is half between A and B, for front shoulder height.
- 11 Square out from A, B, C, D, E and F.
- 12 B to H is half the full breast measure (18).
- 13 H to I is 2 $\frac{3}{4}$  inches, center of Breast.
- 14 B to K is blade (with 1 $\frac{1}{4}$  inches for seams) (12 $\frac{1}{2}$ ).
- 15 Square up from K—front of armhole.
- 16 L is half way between B and K.
- 17 L to M is 1 $\frac{1}{4}$  inches—width of Back.
- 18 Square up from O, and down to P.
- 19 P is  $\frac{1}{2}$  inch from line O-M. Square down to 13.
- 20 A to Q is  $\frac{1}{12}$  breast—on "12THS," and
- 21 Q to R is 1 $\frac{1}{2}$  inches. Square up to S,  $\frac{5}{8}$  inch.
- 22 K to T is  $\frac{1}{2}$  inches; T to U is  $\frac{1}{12}$  breast.
- 23 Square up from U to V—locating the shoulder point.
- 24 V is located on lines from U to A.
- 25 Draw lines from S to U, F to V and A to K.
- 26 This gives the proportional height of shoulders.
- 27 Rise at X  $\frac{1}{2}$  inch, and lower at point I the same.
- 28 X is  $\frac{1}{2}$  inch on the S-U line—or Style.
- 29 Y is  $\frac{1}{2}$  inch from the O-M Line.
- 30 Draw guide line from X to Y.
- 31 From B up apply depth of scye measure and  $\frac{1}{2}$  inch to A, in normal attitude will meet line A (9 $\frac{1}{2}$ ).
- 32 The  $\frac{1}{2}$  inch is for fullness held in over the blade.
- 33 C to G is  $\frac{1}{16}$  breast and 1 $\frac{1}{4}$  inches.
- 34 E to N is the same width as 50 to G, and  $\frac{1}{2}$  inch.
- 35 Draw a line from G to N and from
- 36 49 to G for width of Back over breast-line.
- 37 49 is on F-V and A-K lines.
- 38 Blade fullness is  $\frac{5}{8}$  inch over the rounding.
- 39 Shape the Back as shown; draw line from B to W.
- 40 Apply strap measure and 1 inch A to R and K to V in normal attitude will meet line A-V (13).
- 41 Apply over shoulder measure and 1 inch B to W and K to Z; when normal, meet line F-V (18).
- 42 Z is 1 $\frac{1}{4}$  inches from line K.
- 43 Draw a line from V through Z to point 1.
- 44 V to point 1 is  $\frac{3}{8}$  inch less than S to X.
- 45 Draw a guide line from point 1 to T.
- 46 Shape arm-scye and shoulder rounding  $\frac{1}{2}$  in. over Z.
- 47 B to 2 is  $\frac{1}{2}$  breast on "HALVES"; 2 to K is 3 $\frac{1}{2}$  inches.
- 48 This is normal blade and independent of the actual blade, and comes even with K in normal sizes.
- 49 Square down from K through 4 to 17.
- 50 4 to 5 is  $\frac{1}{2}$  waist—on "HALVES"—center of waist.
- 51 Square down from 5 to 7. The measure from B to 2, K, 4 and 5 is used only to obtain the front center of the waist, and to check the blade measure.
- 52 5 to 8 is 2 $\frac{1}{4}$  inches (8 to 6, 1 $\frac{1}{8}$  dress); 9 to 10 is  $\frac{1}{6}$  breast.
- 53 G to 22 is 1 $\frac{3}{4}$  inches, or 1 $\frac{1}{4}$  inches in all sizes to allow for blade fullness and  $\frac{1}{8}$  inch for every inch the waist is smaller than the breast.
- 54 Square up, and down to 23; 23 is  $\frac{5}{8}$  inch below the fashion waist; or sweep from the Back by Y.
- 55 Measure waist net G to C, P to 22, and 8 to 16.
- 56 Shape side body, reducing  $\frac{1}{4}$  inch near Y,  $\frac{3}{8}$  inch at breast line and from 2 to 13 and 16, and 23 to 13.
- 57 V to 18 is  $\frac{1}{12}$  breast plus  $\frac{1}{2}$  inch, square forward from 18 by K.
- 58 18 to 19 is  $\frac{1}{4}$  breast.
- 59 Draw line from 19 to I and 6 through 24.
- 60 V to 21 is 1 $\frac{1}{4}$  inches; draw line to end of Roll.
- 61 Rounding  $\frac{1}{2}$  inch over the breast.
- 62 Square from 19 to 20— $\frac{1}{2}$  inches or more.
- 63 20 to 26 is 2 $\frac{1}{2}$  inches; I to J is 2 $\frac{1}{4}$  inches.
- 64 Draw line from 13 to 10.
- 65 10 to 24 is 2 $\frac{1}{4}$  inches.
- 66 24 to 35 is  $\frac{1}{2}$  inches; 35 to 25 is the same.
- 67 Square across from the break line to 19, the amount of the opening  $\frac{1}{2}$  inches.
- 68 Draw a straight line to junction of break and front line; connect 19 and 20.
- 69 The opening is cut in the break line and on the 19 line—ending off from the straight line.
- 70 Skirt—Square both ways from 23.
- 71 23 to 12 is  $\frac{1}{3}$  breast, and  $\frac{1}{2}$  inch.
- 72 12 to 11 is  $\frac{1}{2}$  inches; 11 to 27 is  $\frac{3}{4}$  inch.
- 73 Draw a line from 23 through 11 and 14.
- 74 14 is natural waist, and 1 inch from 23.
- 75 23 to bottom is  $\frac{1}{4}$  inch more than D to E.
- 76 Lay "square" on 27-14 and mark for run of bottom.
- 77 Shape skirt through 27 to bottom.
- 78 Z to 7 is length from Z to E and 1 inch from line K.
- 79 Draw line 14 to 7; shape bottom; lower 1 inch at 17.
- 81 Take out a fish  $\frac{1}{8}$  inch,  $\frac{1}{6}$  up from 15.
- 82 Go out  $\frac{1}{2}$  from D and line parallel to 50-E.
- 83 Reduce  $\frac{1}{8}$  inch at B from A to C.
- 84 24 to 36 is  $\frac{1}{4}$  the width from 24 to 23 and 1 inch.
- 85 14 to 33 equal 24 to 36 and 1 inch.
- 86 Shape front run of skirt.



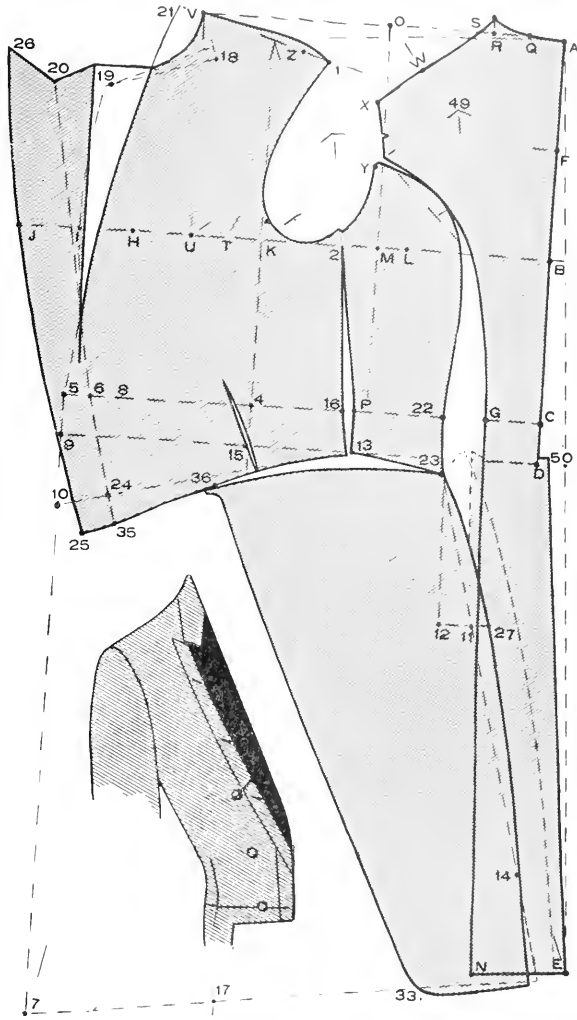

DIAGRAM 28 - DRESS WITHOUT REVER

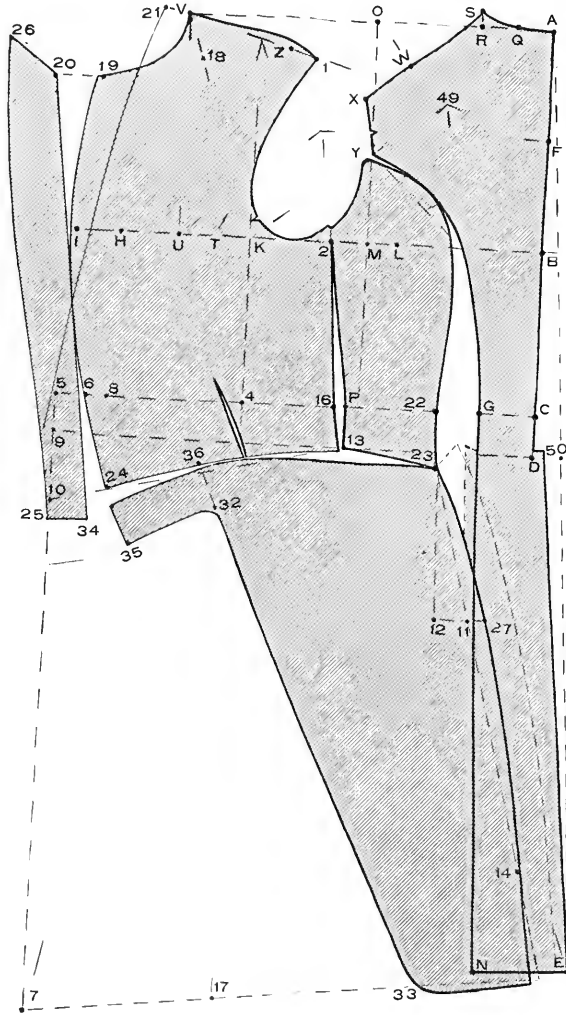

DIAGRAM 29 -- DRESS WITH REVER

# Full Dress

## Diagram 29

5. The measures are taken over the Vest always.

Inside sleeve	17 $\frac{3}{4}$ inches.	Blade (with 1 $\frac{1}{4}$ inches for
Breast	36 inches.	seams added) 12 $\frac{1}{2}$ inches.
Waist	32 inches.	Depth of scye
Hip or seat	37 inches.	Natural waist
Strap	12 inches.	Fashion waist
Over shoulder	17 inches.	Full length
		Height

Form and Attitude, normal. Sizes, 33 to 42 breasts.

### TO DRAFT.

- 1 Square both ways from A or 4.
- 2 4 to B is  $\frac{1}{3}$  breast on "3RDS" and 3 $\frac{1}{2}$  inches (9 $\frac{1}{2}$ ).
- 3 B to 3 is  $\frac{1}{3}$  breast of height, and 3 $\frac{1}{2}$  inches.
- 4 A is half way between 3 and 4.
- 5 This is the proportional, and includes all allowances.
- 6 A to C is one-fourth height, and  $\frac{1}{4}$  inch for length.
- 7 A to D is the fashion waist; one-fourth height and 1 $\frac{1}{2}$  inches (18 $\frac{1}{4}$ ).
- 8 D to 50 is 1 $\frac{1}{4}$  inches, line from A through 50 to E.
- 9 A to E is the Full Length of Back.
- 10 F is half between A and B, for front shoulder height.
- 11 Square out from A, B, C, D, E, F, 3 and 4.
- 12 B to H is half the full breast measure.
- 13 H to I is 2 $\frac{1}{4}$  inches, center of Breast.
- 14 B to K is blade (with 1 $\frac{1}{4}$  inches for seams (12 $\frac{1}{2}$ )).
- 15 Square up from K—front of armhole.
- 16 L is half way between B and K.
- 17 L to M is 1 $\frac{1}{4}$  inches—width of Back.
- 18 Square up to O, and down to P.
- 19 P is  $\frac{1}{2}$  inch from line O-M. Square down to 13.
- 20 A to Q is  $\frac{1}{12}$  breast—on "12THS," and
- 21 Q to R is 1 $\frac{1}{2}$  inches. Square up to S,  $\frac{5}{8}$  inch.
- 22 K to T is 1 $\frac{1}{2}$  inches; T to U is  $\frac{1}{12}$  breast.
- 23 Square up from U to V—locating the shoulder point.
- 24 V is located on lines from U and A.
- 25 Draw lines from S to U, F to V and A to K.
- 26 This gives the proportional height of shoulders.
- 27 Rise at X  $\frac{1}{2}$  inch, and lower at point 1 the same.
- 28 X is  $\frac{1}{2}$  inch on the S-U line—or Style.
- 29 Y is  $\frac{1}{2}$  inch from the O-M Line.
- 30 Draw guide line from X to Y.
- 31 From B up apply depth of scye measure and  $\frac{1}{2}$  inch (9 $\frac{1}{2}$ ) to A, in normal attitude will meet line A.
- 32 The  $\frac{1}{2}$  inch is for fullness held in over the blade.
- 33 C to G is  $\frac{1}{16}$  breast and 1 $\frac{1}{4}$  inches.
- 34 E to N is the same width as 50 to G, and  $\frac{1}{2}$  inch.
- 35 Draw a line from G to N and from.
- 36 49 to G for width of Back over breast line.
- 37 49 is on F-V and A-K lines.
- 38 Blade fullness is  $\frac{5}{8}$  inch over the rounding.
- 39 Shape the Back as shown; draw line from B to W.
- 40 Apply strap measure and 1 inch A to R and K to V in normal attitude will meet line A-V (13).

- 41 Apply over shoulder measure and 1 inch B to W and K to Z; when normal, meet line F V (18).
- 42 Z is 1 $\frac{1}{4}$  inches from line K.
- 43 Draw a line from V through Z to point 1.
- 44 V to point 1 is  $\frac{3}{8}$  inch less than S to X.
- 45 Draw a guide line from point 1 to T.
- 46 Shape arm-scye and shoulder rounding  $\frac{1}{2}$  in. over Z.
- 47 B to 2 is  $\frac{1}{2}$  breast on "HALVES"; 2 to K is 3 $\frac{1}{2}$  inches.
- 48 This is normal blade and independent of the actual blade, and comes even with K in normal sizes.
- 49 Square down from K through 4 to 17.
- 50 4 to 5 is  $\frac{1}{2}$  waist—on "HALVES"—center of waist.
- 51 Square down from 5 to 7. The measure from B to 2, K, 4 and 5 is used only to obtain the front center of waist, and to check the blade measure..
- 52 5 to 8 is 2 $\frac{1}{4}$  inches (8 to 6, 1 $\frac{1}{8}$  dress); 9 to 10 is 1, 6 breast.
- 53 G to 22 is 1 $\frac{3}{4}$  inches, or 1 $\frac{1}{4}$  inches in all sizes to allow for blade fullness and  $\frac{1}{8}$  inch for every inch the waist is smaller than the breast.
- 54 Square up and down to 23; 23 is  $\frac{5}{8}$  inch below the fashion waist; or sweep from the Back by Y.
- 55 Measure waist net G to C, P to 22 and 8 to 16.
- 56 Shape side body reducing  $\frac{1}{4}$  inch near Y,  $\frac{3}{8}$  inch at breast line and from 2 to 13 and 16, and 23 to 13.
- 57 V to 18 is 1 12 breast; square forward from 18 by K.
- 58 18 to 19 is  $\frac{1}{4}$  breast; draw line from 19 to I.
- 59 Add a  $\frac{1}{4}$  inch rounding over the breast.
- 60 Draw a line from 13 to 10—10 to 24 is 2 $\frac{1}{4}$  inches.
- 61 Shape gorge and front through 6—24 to 35.
- 62 24 to 35 is 1 $\frac{3}{8}$  inches; the opening  $\frac{3}{4}$  inch.
- 63 Rever—19 to 20 is 2 inches; draw a straight line.
- 64 Parallel with the front; get length to 34.
- 65 34 to 25 is 1 $\frac{3}{4}$  inches.
- 66 Draw a line from K through 20 to 26.
- 67 20 to 26 is 2 $\frac{1}{2}$  inches; I to J is 2 $\frac{1}{4}$  inches.
- 68 Shape lapel through 26—J to 25.
- 69 Skirt—square both ways from 23.
- 70 23 to 12 is 1, 3 breast, and  $\frac{1}{2}$  inch.
- 71 12 to 11 is 1 $\frac{1}{2}$  inches; 11 to 27 is  $\frac{3}{4}$  inch.
- 72 Draw a line from 23 through 11 and 14.
- 73 14 is natural waist, and 1 inch from 23.
- 74 23 to bottom is  $\frac{1}{4}$  inch more than D to E.
- 75 Lay "square" on 27-14 and mark for run of bottom.
- 76 Shape skirt through 27 to bottom.
- 77 Z to 7 is length from Z to E and 1 inch from line K.
- 78 Draw line 14 to 7; shape bottom; lower 1 inch at 17.
- 80 Take out a fish  $\frac{1}{8}$  inch, 1, 6 up from 15.
- 81 Go out  $\frac{1}{2}$  from D and line parallel to 50-E.
- 82 Reduce  $\frac{1}{8}$  inch at B from A to C.
- 83 24 to 36 is  $\frac{1}{4}$  the width from 24 to 23 and 1 inch.
- 84 14 to 33 equal 24 to 36 and 1 inch.
- 85 Shape front run of skirt.

# Full Dress Stout

## Diagram 30

6. The measures are taken over the Vest always.

Inside sleeve	18 $\frac{3}{4}$ inches.	Blade (with 1 $\frac{1}{4}$ inches for Breast	42 inches. seams added)	14 inches.
Waist	40 $\frac{1}{2}$ inches.	Depth of scye	9 $\frac{3}{4}$ inches.	
Hip or seat	43 inches	Natural waist	17 $\frac{1}{2}$ inches	
Strap	13 $\frac{1}{4}$ inches.	Fashion waist	19 inches.	
Over shoulder	19 inches.	Full length	42 inches.	
Stout	1 degree.	Height	5 feet 10 inches	

Form and Attitude, normal. Sizes, 40 to 48 breasts.

### TO DRAFT.

- Square both ways from 4.
- 4 to B is 1/ breast on "3RDS" and 3 $\frac{1}{2}$  inches (10 $\frac{5}{8}$ ).
- B to 3 is 1/3 breast of height, and 3 $\frac{1}{2}$  inches (10 $\frac{5}{8}$ ).
- A is half way between 3 and 4.
- This is the proportional, and includes all allowances.
- A to C is one-fourth height, and  $\frac{1}{4}$  inch for length.
- A to D is the fashion waist; one fourth height and 1 $\frac{1}{2}$  inches (19).
- D to 50 is 1 $\frac{1}{4}$  inches, line from A through 50 to E.
- A to E is the Full Length of Back.
- F is half between 4 and B, for front shoulder height.
- Square out from A, B, C, D, E, F, 3 and 4.
- B to H is half the full breast measure.
- H to I is 2 $\frac{1}{4}$  inches, center of Breast.
- B to K is blade (with 1 $\frac{1}{4}$  inches for seams) (14).
- Square up from K—front of armhole.
- L is half way between B and K.
- L to M is 1 $\frac{1}{4}$  inches—width of Back.
- Square up to O and down to P.
- P is  $\frac{1}{2}$  inch from Line O-M. Square down to 13.
- A to Q is 1/12 breast—on "12RHS," and
- Q to R is 1 $\frac{1}{2}$  inches. Square up to S,  $\frac{5}{8}$  inch.
- K to T is 1 $\frac{1}{2}$  inches; T to U is 1/12 breast.
- Square up from U to V—locating the shoulder point.
- V is located on lines from U and 4.
- Draw lines from S to U, F to V and A to K.
- This gives the proportional height of shoulders.
- Rise at X  $\frac{1}{2}$  inch, and lower at point 1 the same.
- X is  $\frac{1}{2}$  inch on the S-U line—or Style.
- Y is  $\frac{1}{2}$  inch from the O-M Line.
- Draw guide line from X to Y.
- From B up apply depth of scye measure and  $\frac{1}{2}$  inch to A, in normal attitude will meet line A (10 $\frac{1}{4}$ ).
- The  $\frac{1}{2}$  inch is for fullness held in over the blade.
- C to G is 1/16 breast and 1 $\frac{1}{4}$  inches.
- E to N is the same width as 50 to G, and 1 inch.
- Draw a line from G to N and from
- 49 to G for width of Back over breast-line.
- 49 is on F-V and A-K lines.
- Blade fullness is  $\frac{5}{8}$  inch over rounding.
- Shape the Back as shown; draw line from B to W.
- Apply strap measure and 1 inch A to R and K to V. in normal attitude will meet line 4-V (14 $\frac{1}{4}$ ).
- Apply over shoulder measure and 1 inch B to W and K to Z; when normal meet line F-V (20).
- Z is 1 $\frac{1}{4}$  inches from line K.
- Draw a line from V through Z to point 1.
- V to point 1 is  $\frac{3}{8}$  inch less than S to X.
- Draw a guide line from point 1 to T.
- Shape arm-scye and shoulder rounding  $\frac{1}{2}$  in. over Z.
- B to 2 is  $\frac{1}{2}$  breast on "HALVES"; 2 to K is 3 $\frac{1}{2}$  inches.
- This is normal blade and independent of the actual blade, and comes even with K in normal sizes.
- Square down from K through 4 to 17.
- 4 to 5 is  $\frac{1}{2}$  waist—on "HALVES"—center of waist.
- Square down from 5 to 7. The measure from B to 2, K, 4 and 5 is used only to obtain the front center of the waist, and to check the blade measure.
- 5 to 8 is 2 $\frac{3}{4}$  inches (8 to 6, 1 $\frac{1}{8}$  dress); 9 to 10 is 1/6 breast.
- G to 22 is 1 $\frac{1}{4}$  inches, or 1 $\frac{1}{4}$  inches in all sizes to allow for blade fullness and  $\frac{1}{8}$  inch for every inch the waist is smaller than the breast.
- Square up, and down to 23; 23 is  $\frac{5}{8}$  inch below the fashion waist; or sweep from the Back by Y.
- Measure waist net G to C, P to 22, and 8 to 16.
- Shape side body reducing  $\frac{1}{4}$  inch near Y,  $\frac{3}{8}$  inch at breast line and from 2 to 13 and 16, and 23 to 13.
- V to 18 is 1/12 breast; square forward from 18 by K.
- 18 to 19 is  $\frac{1}{4}$  breast.
- Draw a line from 13 to 10.
- 10 to 24 is 2 $\frac{1}{4}$  inches.
- Draw line from 19 through 1-6 to 35;  $\frac{3}{4}$  beyond 24.
- V to 21 is 1 $\frac{1}{4}$  inches; draw line to end of Roll.
- Rounding a  $\frac{1}{2}$  inch over the breast.
- Square from 19 to 20, 1 $\frac{1}{2}$  inches or more.
- Draw straight line with the forepart.
- Square across from the break-line to 19, the amount of the opening (1 $\frac{1}{2}$ ).
- Draw a straight line to junction of break-line.
- Connect 19 and 20.
- The opening is cut in the break-line and on the 19 line, ending off from the straight line.
- 24 to 35 is 1 $\frac{1}{2}$  inches; 35 to 25 is the same.
- Shape the gorge and front through 6-24 to 35.
- Draw a line from K through 20 to 26.
- 20 to 26 is 2 $\frac{1}{2}$  inches; I to J is 2 $\frac{1}{4}$  inches.
- Shape lapel through 26—J to 25.
- Lay square on 13-36-11 and take out a V at 36.
- Advance 23 the amount of V and seams.
- Skirt—Square both ways from 23.
- 23 to 12 is 1/3 breast, and  $\frac{1}{2}$  inch.
- 12 to 11 is 1 $\frac{1}{2}$  inches; 11 to 27 is  $\frac{3}{4}$  inch.
- Draw a line from 23 through 11 and 14.
- 14 is natural waist, and 1 inch from 23.
- 23 to bottom is  $\frac{1}{4}$  inch more than D to E.
- Lay "square" on 27-14 and mark for run of bottom.
- Shape skirt through 27 to bottom.
- Z to 7 is length from Z to E and 1 inch from line K.
- Draw line 14 to 7; shape bottom; lower 1 inch at 17.
- Go out  $\frac{1}{2}$  from D and line parallel to 50-E.
- Reduce  $\frac{1}{8}$  inch at B from A to C.
- 24 to 36 is  $\frac{1}{4}$  the width from 24 to 23 and 1 inch.
- 14 to 33 equal 24 to 36 and 1 inch.
- Shape front run of skirt.

### Full Dress Corpulent

The corpulent dress coat is cut the same as the stout; only it is advisable to cut the skirt with a strap below line 10-13 and also a loose rever, so assist in working the fullness over the corpulency.

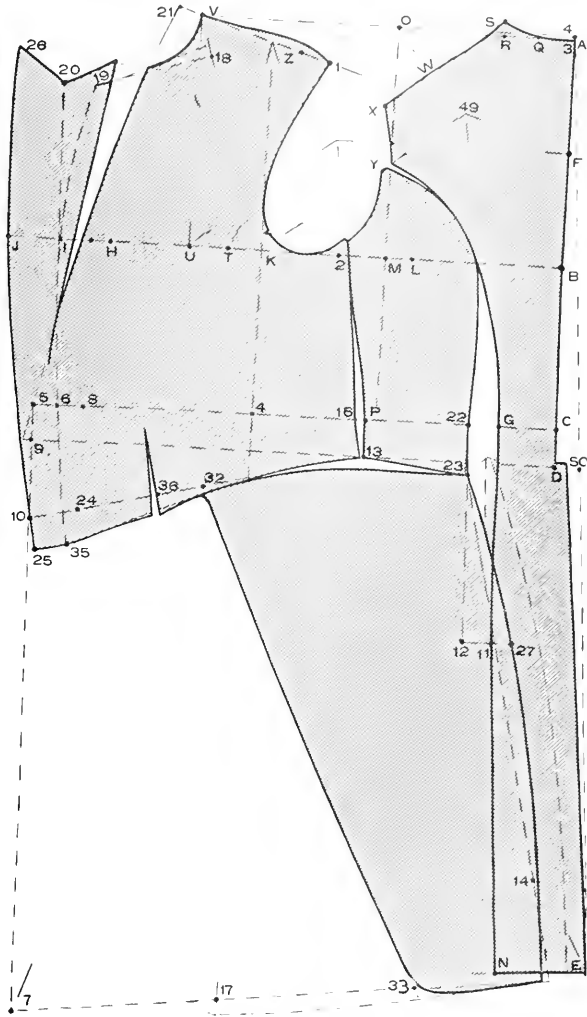

DIAGRAM 30 -- FULL DRESS STOUT

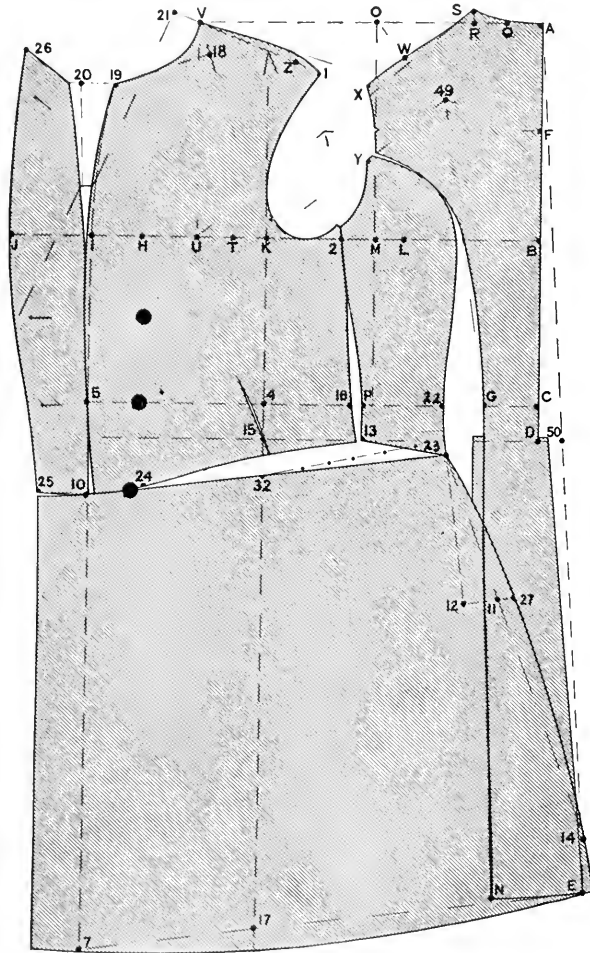

DIAGRAM 31 — DOUBLE-BREASTED FROCK

## Double-Breasted Frock

Diagram 31

7. The measures are taken over the Vest always.

Inside sleeve	17 $\frac{3}{4}$ inches	Blade (with 1 $\frac{1}{4}$ inches for	
Breast	36 inches	seams added)	12 $\frac{1}{2}$ inches
Waist	32 inches	Depth of scye	9 inches
Hip or seat	37 inches	Natural waist	16 $\frac{3}{4}$ inches
Strap	12 inches	Fashion waist	18 $\frac{1}{4}$ inches
Over shoulder	17 inches	Full length	38 inches
		Height	5 feet 6 inches

Form and Attitude, normal. Sizes, 33 to 42 breasts.

### TO DRAFT.

- 1 Square both ways from A.
- 2 A to B is  $\frac{1}{3}$  breast on "3rds" and 3 $\frac{1}{2}$  inches (9 $\frac{1}{2}$ ).
- 3 This is the proportional, and includes all allowances.
- 4 A to C is one-fourth height, and  $\frac{1}{4}$  inch for length.
- 5 A to D is the fashion waist; one-fourth height and 1 $\frac{1}{2}$  inches (18 $\frac{3}{4}$ ).
- 6 D to 50 is 1 $\frac{1}{4}$  inches, line from A through 50 to E.
- 7 A to E is the Full Length of Back.
- 8 F is half between A and B, for front shoulder height.
- 9 Square out from A, B, C, D, E and F.
- 10 B to H is half the full breast measure (18).
- 11 H to I is 2 $\frac{1}{4}$  inches, center of Breast.
- 12 B to K is blade (with 1 $\frac{1}{4}$  inches for seams) (12 $\frac{1}{2}$ ).
- 13 Square up from K—front of armhole.
- 14 L is half way between B and K.
- 15 L to M is 1 $\frac{1}{4}$  inches—width of Back.
- 16 Square up to O, and down to P.
- 17 P is  $\frac{1}{2}$  inch from line O-M. Square down to 13.
- 18 A to Q is  $\frac{1}{12}$  breast—on "12rds," and
- 19 Q to R is 1 $\frac{1}{2}$  inches. Square up to S,  $\frac{5}{8}$  inch.
- 20 K to T is 1 $\frac{1}{2}$  inches; T to U is  $\frac{1}{12}$  breast.
- 21 Square up from U to V—locating the shoulder point.
- 22 V is located on lines from U and A.
- 23 Draw lines from S to U, F to V, and A to K.
- 24 This gives the proportional height of shoulders.
- 25 Rise at X  $\frac{1}{2}$  inch, and lower at point J the same.
- 26 X is  $\frac{1}{2}$  inch on the S-U line—or Style.
- 27 Y is  $\frac{1}{2}$  inch from the O-M line.
- 28 Draw guide line from X to Y.
- 29 From B up apply depth of scye measure and  $\frac{1}{2}$  inch (9 $\frac{1}{2}$ ) to A. in normal attitude will meet line A.
- 30 The  $\frac{1}{2}$  inch is for fullness held in over the blade.
- 31 C to G is  $\frac{1}{16}$  breast and 1 $\frac{1}{4}$  inches.
- 32 E to N is the same width as 50 to G, and  $\frac{1}{2}$  inch.
- 33 Draw a line from G to N, and from
- 34 49 to G for width of Back over breast-line.
- 35 49 is on F-V and A-K lines.
- 36 Blade fullness is  $\frac{5}{8}$  inch over the rounding.
- 37 Shape the Back as shown; draw line from B to W.
- 38 Apply strap measure and 1 inch A to R and K to V in normal attitude will meet A-V (13).
- 39 Apply over shoulder measure and 1 inch B to W and K to Z; when normal, meet line F-V (18).
- 40 Z is 1 $\frac{1}{4}$  inches from line K.
- 41 Draw a line from V through Z to point 1.
- 42 V to point 1 is  $\frac{3}{8}$  inch less than S to X.
- 43 Draw a guide line from point 1 to T.
- 44 Shape arm-scye and shoulder rounding  $\frac{1}{2}$  in. over Z.
- 45 B to 2 is  $\frac{1}{2}$  breast on "HALVES"; 2 to K is 3 $\frac{1}{2}$  inches.
- 46 This is normal blade and independent of the actual blade, and comes even with K in normal sizes.
- 47 Square down from K through 4 to 17.
- 48 4 to 5 is  $\frac{1}{2}$  waist—on "HALVES"—center waist.
- 49 Square down from 5 to 7. The measure from B to 2, K, 4 and 5 is used only to obtain the front center of the waist, and to check the blade measure.
- 50 5 to 8 is 2 $\frac{1}{4}$  inches; 9 to 10 is  $\frac{1}{6}$  breast.
- 51 These 2 $\frac{1}{4}$  inches are for seams and make-up.
- 52 G to 22 is 1 $\frac{3}{4}$  inches, or 1 $\frac{1}{4}$  inches in all sizes to allow for blade fullness and  $\frac{1}{8}$  inch for each inch the waist is smaller than the breast.
- 53 Square up, and down to 23; 23 is  $\frac{5}{8}$  inch below the fashion waist; or sweep from the Back by Y.
- 54 Measure waist net G to C, P to 22, and 8 to 16.
- 55 Shape side body reducing  $\frac{1}{4}$  inch near Y,  $\frac{3}{8}$  inch at breast line and from 2 to 13 and 16, and 23 to 13.
- 56 V to 18 is  $\frac{1}{12}$  breast; square forward from 18 by K.
- 57 18 to 19 is  $\frac{1}{4}$  breast; draw line from 19 to I and 5.
- 58 Add  $\frac{1}{4}$  inch rounding over the breast.
- 59 Rever—19 to 20 is 1 $\frac{1}{2}$  inches, or draw a straight line through 5-9; straighten  $\frac{1}{2}$  inch at 20.
- 60 10 to 24 is 2 $\frac{1}{4}$  inches; 10 to 25 the same; sweep by 20.
- 61 Draw a line from 13 to 24—Shape from 13 to 25.
- 62 Draw a line from K through 20 to 26.
- 63 20 to 26 is 2 $\frac{1}{2}$  inches; I to J is 3 $\frac{1}{4}$  inches.
- 64 Shape lapel through 26—J to 25.
- 65 Square both ways from 23 for a close skirt.
- 66 Draw a line from 23 to 24; square down to 12.
- 67 Flare—At 23 go up  $\frac{3}{8}$  inch and square down by 32.
- 68 23 to 12 is  $\frac{1}{3}$  breast, and  $\frac{1}{2}$  inch.
- 69 12 to 11 is 1 $\frac{1}{2}$  inches; 11 to 27 is  $\frac{3}{4}$  inch.
- 70 Draw a line from 23 through 11 and 14.
- 71 14 is natural waist, and 1 inch from 23.
- 72 23 to bottom is  $\frac{1}{4}$  inch more than D to E.
- 73 Lay "square" on 27-14 and mark for run of bottom.
- 74 Shape skirt through 27 to bottom.
- 75 Z to 7 is length from Z to E and 1 inch from line K.
- 76 Draw line 14 to 7; shape bottom; lower 1 inch at 17.
- 77 Square down the front edge to 7, by the waist line.
- 78 Take out a fish  $\frac{1}{8}$  inch,  $\frac{1}{6}$  up from 15.
- 79 Go out  $\frac{1}{2}$  from D and line parallel to 50-E.
- 80 Reduce  $\frac{1}{8}$  inch at B from A to C.

# Single-Breasted Frock

## Diagram 32

8. The measures are taken over the Vest always.

Inside sleeve	17 $\frac{3}{4}$ inches	Blade (with 1 $\frac{1}{4}$ inches for	
Breast	36 inches	seams added)	12 $\frac{1}{2}$ inches
Waist	32 inches	Depth of scye	9 inches
Hip or seat	37 inches	Natural waist	16 $\frac{3}{4}$ inches
Strap	12 inches	Fashion waist	18 $\frac{1}{4}$ inches
Over shoulder	17 inches	Full length	38 inches
		Height	5 feet 6 inches

Form and Attitude, normal. Sizes, 33 to 42 breasts.

### TO DRAFT.

- 1 Square both ways from A.
- 2 A to B is  $1/3$  breast on "3KDS" and  $3\frac{1}{2}$  inches ( $9\frac{1}{2}$ ).
- 3 This is the proportional, and includes all allowances.
- 4 A to C is one-fourth height, and  $1/4$  inch for length.
- 5 A to D is the fashion waist; one-fourth height and  $1\frac{1}{2}$  inches ( $18\frac{1}{4}$ ).
- 6 D to 50 is  $1\frac{1}{4}$  inches, line from A through 50 to E.
- 7 A to E is the Full Length of Back.
- 8 F is half between A and B, for front shoulder height.
- 9 Square out from A, B, C, D, E and F.
- 10 B to H is half the full breast measure (18).
- 11 H to I is  $2\frac{1}{4}$  inches, center of Breast.
- 12 B to K is blade (with  $1\frac{1}{4}$  inches for seams) ( $12\frac{1}{2}$ ).
- 13 Square up from K—front of armhole.
- 14 L is half way between B and K.
- 15 L to M is  $1\frac{1}{4}$  inches—width of Back.
- 16 Square up to O, and down to P.
- 17 P is  $1/2$  inch from line O-M. Square down to 13.
- 18 A to Q is  $1/12$  breast—on "12THS," and
- 19 Q to R is  $1\frac{1}{2}$  inches. Square up to S,  $5/8$  inch.
- 20 K to T is  $1\frac{1}{2}$  inches; T to U is  $1/12$  breast.
- 21 Square up from U to V—locating the shoulder point.
- 22 V is located on lines from U and A.
- 23 Draw lines from S to U, F to V, and A to K.
- 24 This gives the proportional height of shoulders.
- 25 Rise at X  $1/2$  inch, and lower at point 1 the same.
- 26 X is  $1/2$  inch on the S-U line—or Style.
- 27 Y is  $1/2$  inch from the O-M line.
- 28 Draw guide line from X to Y.
- 29 From B up apply depth of scye measure and  $1/2$  inch ( $9\frac{1}{2}$ ) to A, in normal attitude will meet line A.
- 30 The  $1/2$  inch is for fullness held in over the blade.
- 31 C to G is  $1/16$  breast and  $1\frac{1}{4}$  inches.
- 32 E to N is the same width as 50 to G, and  $1/2$  inch.
- 33 Draw a line from G to N and from
- 34 49 to G for width of Back over breast-line.
- 35 49 is on F-V and A-K lines.
- 36 Blade fullness is  $5/8$  inch over the rounding.
- 37 Shape the Back as shown; draw line from B to W.
- 38 Apply strap measure and 1 inch A to R and K to V in normal attitude will meet line A-V (13).
- 39 Apply over shoulder measure and 1 inch B to W and K to Z; when normal, meet line F-V (18).
- 40 Z is  $1\frac{1}{4}$  inches from line K.
- 41 Draw a line from V through Z to point 1.
- 42 V to point 1 is  $3/8$  inch less than S to X.
- 43 Draw a guide line from point 1 to T.
- 44 Shape arm-scye and shoulder rounding  $1/2$  inch over Z.
- 45 B to 2 is  $1/2$  breast on "HALVES"; 2 to K is  $3\frac{1}{2}$  inches.
- 46 This is normal blade and independent of the actual blade, and comes even with K in normal sizes.
- 47 Square down from K through 4 to 17.
- 48 4 to 5 is  $1/2$  waist—on "HALVES"—center of waist.
- 49 Square down from 5 to 7. The measure from B to 2, K, 4 and 5 is used only to obtain the front center of the waist, and to check the blade measure.
- 50 5 to 8 is  $2\frac{1}{4}$  inches; 9 to 10 is  $1/6$  breast.
- 51 These  $2\frac{1}{4}$  inches are for seams and make-up.
- 52 G to 22 is  $1\frac{1}{4}$  inches, or  $1\frac{1}{4}$  inches in all sizes to allow for blade fullness and  $1/8$  inch for every inch the waist is smaller than the breast.
- 53 Square up, and down to 23; 23 is  $5/8$  inch below the fashion waist; or sweep from the Back by Y.
- 54 Measure waist net G to C, P to 22, and 8 to 16.
- 55 Shape side body reducing  $1/4$  inch near Y,  $3/8$  inch at breast line and from 2 to 13 and 16, and 23 to 13.
- 56 V to 18 is  $1/12$  breast; square forward from 18 by K.
- 57 18 to 19 is  $1/4$  breast; draw line from 19 to I and 5.
- 58 10 to 24 is  $2\frac{1}{4}$  inches.
- 59 Draw a line from 13 to 24. Shape from 13 to 25.
- 60 Draw a line from K through 20 to 26.
- 61 20 to 26 is  $2\frac{1}{2}$  inches; I to J is  $1\frac{1}{2}$ , 5 to 6  $1\frac{1}{4}$  inches.
- 62 Shape lapel through 26—J to 25.
- 63 Square both ways from 23 for close Skirt. Go up from 32 a  $1/2$  inch for medium Skirt.
- 64 Draw a line from 23 to 24; square down to 12.
- 65 *Flare*—At 23 go up  $5/8$  inch and square down by 32.
- 66 23 to 12 is  $1/3$  breast, and  $1/2$  inch.
- 67 12 to 11 is  $1\frac{1}{2}$  inches; 11 to 27 is  $3/4$  inch.
- 68 Draw a line from 23 through 11 and 14.
- 69 14 is natural waist, and 1 inch from 23.
- 70 23 to bottom is  $1/4$  inch more than D to E.
- 71 Lay "square" on 27-14 and mark for run of bottom.
- 72 Shape skirt through 27 to bottom.
- 73 Z to 7 is length from Z to E and 1 inch from line K.
- 74 Draw line 14 to 7; shape bottom; lower 1 inch at 17.
- 75 Square down the front edge to 7, by the waist line.
- 76 Take out a fish  $1/8$  inch,  $1/6$  up from 15.
- 77 Go out  $1/2$  from D and line parallel to 50-E.
- 78 Reduce  $1/8$  inch at B from A to C.



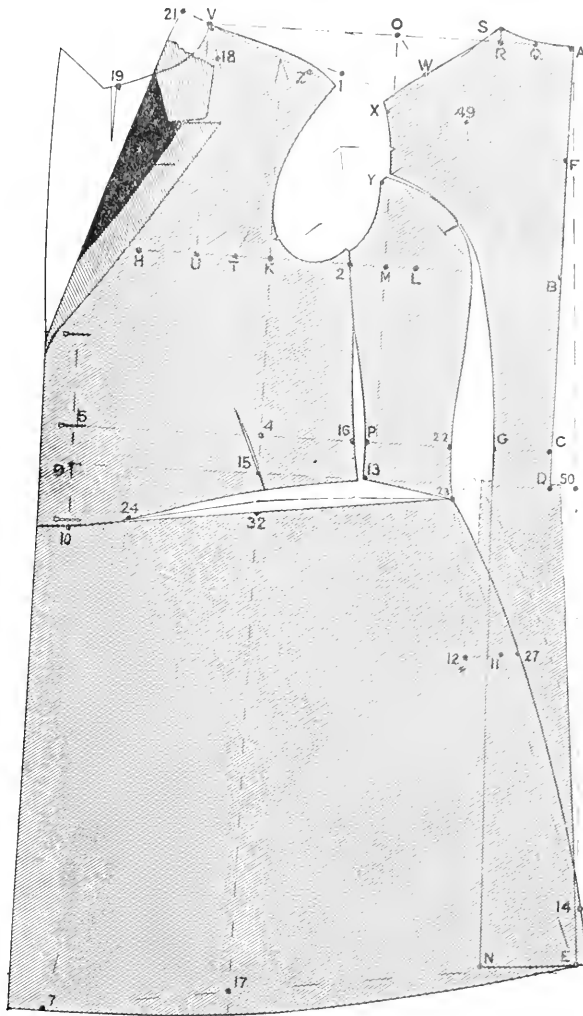

DIAGRAM 32 — SINGLE-BREADED FROCK

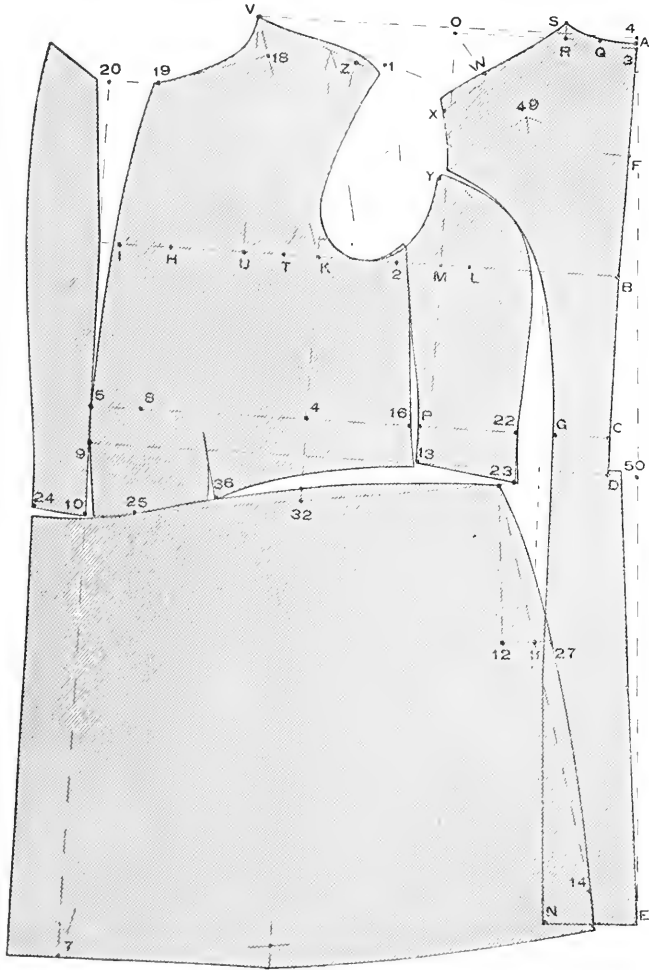

DIAGRAM 33 — DOUBLE-BREADED FROCK, STOUT

# Double-Breasted Frock Stout

## Diagram 33

9. The measures are taken over the Vest always.

Inside sleeve	18¾ inches.	Blade (with 1¼ inches for	
Breast	42 inches.	seams added)	14 inches.
Waist	40½ inches.	Depth of scye	9¾ inches.
Hip or seat	43 inches.	Natural Waist	17½ inches.
Strap	13¾ inches.	Fashion waist	19 inches.
Over shoulder	19 inches.	Full length	41 inches.
Corpulent	1 degree.	Height	5 ft. 10 inches.

Form and Attitude, normal. Sizes, 40 to 48 breasts.

### TO DRAFT.

- 1 Square both ways from 4.
- 2 4 to B is 1/3 breast on "3RDS" and 3½ inches (10⅝).
- 3 B to 3 is 1/3 breast of height, and 3½ inches (10⅝).
- 4 A is half way between 3 and 4.
- 5 This is the proportional, and includes all allowances.
- 6 A to C is one-fourth height, and ¼ inch for length.
- 7 A to D is the fashion waist; one-fourth height and 1½ inches (19).
- 8 D to 50 is 1¼ inches, line from A through 50 to E.
- 9 A to E is the Full Length of Back.
- 10 F is half between 4 and B, for front shoulder height.
- 11 Square out from A, B, C, D, E, F, 3 and 4.
- 12 B to H is half the full breast measure.
- 13 H to I is 2¼ inches, center of Breast.
- 14 B to K is blade (with 1¼ inches for seams) (14).
- 15 Square up from K—front of armhole.
- 16 L is half way between B and K.
- 17 L to M is 1¼ inches—width of Back.
- 18 Square up to O, and down to P.
- 19 P is ½ inch from line O-M. Square down to 13.
- 20 A to Q is 1/12 breast—on "12RHS," and
- 21 Q to R is 1½ inches. Square up to S, ⅝ inch.
- 22 (Corp.)—Advance from K, 1/16 inch each size above 4 inches less than breast; to straighten the front run, take is out in the underarm cut as shown by shaded part.
- 23 K to T is 1½ inches; T to U is 1/12 breast.
- 24 Square up from U to V—locating the shoulder point.
- 25 V is located on lines from K and 4 through line U.
- 26 Draw lines from S to U, F to V and A to K.
- 27 This gives the proportional height of shoulders.
- 28 Rise at X ½ inch, and lower at point 1 the same.
- 29 X is ½ inch on the S-U line—or style.
- 30 Y is ½ inch from the O-M line.
- 31 Draw guide line from X to Y.
- 32 From B up apply depth of scye measure and ½ inch to A, in normal attitude will meet line A.
- 33 The ½ inch is for fullness held in over the blade.
- 34 C to G is 1/16 breast and 1¼ inches.
- 35 E to N is the same width as 50 to G, and ½ inch.
- 36 Draw a line from G to N and from
- 37 49 to G for width of Back over breast line.
- 38 49 is on F-V and A-K lines.
- 39 Blade fullness is ⅝ inch over the rounding.
- 40 Shape the Back as shown; draw line from B to W.
- 41 Apply strap measure and 1 inch A to R and K to V in normal attitude will meet line 4-V (14¼).
- 42 Apply over shoulder measure and 1 inch B to W and K to Z; when normal, meet line F-V (20).
- 43 Z is 1¼ inches from line K.
- 44 Draw a line from V through Z to point 1.
- 45 V to point 1 is ⅜ inch less than S to X.
- 46 Draw a guide line from point 1 to T.
- 47 Shape arm-scye and shoulder rounding ½ in. over Z.
- 48 B to 2 is ½ breast on "HALVES"; 2 to K is 3½ inches.
- 49 This is normal blade and independent of the actual blade, and comes even with K in normal sizes.
- 50 Square down from K through 4 to 17.
- 51 4 to 5 is ½ waist—on "HALVES"—center of waist.
- 52 Square down from 5 to 7. The measure from B to 2, K, 4 and 5 is used only to obtain the front center of the waist, and to check the blade measure.
- 53 5 to 8 is 2¼ inches; 9 to 10 is 1.6 breast.
- 54 These 2¼ inches are for seams and makeup.
- 55 G to 22 is 1½ inches, or 1¼ inches in all sizes to allow for blade fullness and ⅝ inch for every inch the waist is smaller than the breast.
- 56 Square up, and down to 23; 23 is ⅝ inch below the fashion waist; or sweep from the Back by Y.
- 57 Measure waist net G to C, P to 22, and 8 to 16.
- 58 Shape side body reducing ¼ inch near Y, ⅜ inch at breast line and from 2 to 13 and 16, and 23 to 13.
- 59 V to 18 is 1/12 breast and ½ inch; square forward.
- 60 18 to 19 is ¼ breast; draw line from 19 to I and 5.
- 61 (Corp.)—Advance at I the amount from K to 3.
- 62 Add ¼ inch rounding over the breast.
- 63 Rever—19 to 20 is 2 inches, or draw a straight line through 5-9; straighten ½ inch at 20.
- 64 10 to 24 is 2¼ in.; 10 to 25 the same; sweep by 20.
- 65 Draw a line from 13 to 24—Shape from 13 to 25.
- 66 Draw a line from K through 20 to 26.
- 67 20 to 26 is 2½ inches; I to J is 3¼ inches.
- 68 Shape lapel through 26—J to 25.
- 69 (Corp.)—10 to 35 is ½ in.; draw line from 13 to 25.
- 70 Lay square on 13-36-H and take out a V at 36.
- 71 Advance 23 the amount of V and seams.
- 72 Skirt—Square both ways from 23 for a close skirt, or go up from 32 a 1½ inch for medium skirt.
- 73 Draw a line from 23 to 24; square down to 12.
- 74 Flare—At 23 go up ⅝ inch and square down by 32.
- 75 23 to 12 is 1/3 breast, and ½ inch.
- 76 12 to 11 is 1½ inches; 11 to 27 is ¾ inch.
- 77 Draw a line from 23 through 11 and 14.
- 78 14 is natural waist, and 1 inch from 23.
- 79 23 to bottom is ¼ inch more than D to E.
- 80 Lay "square" on 27-14 and mark for run of bottom.
- 81 Shape skirt through 27 to bottom.
- 82 Z to 7 is length from Z to E and 1 inch from line K.
- 83 Draw line 14 to 7; shape bottom: lower 1 inch at 17.
- 84 Square down the front edge to 7, by the waist line.
- 85 Go out ½ from D and line parallel to 50-E.
- 86 Reduce ⅝ inch at B from A to C.
- 87 The opening at 25 is equal to the opening at 10.
- 88 Take out ¼ inch in the V at 36.

# Corpulent Frock

## Diagram 34

10. The measures are taken over the Vest always.

Inside sleeve	19 $\frac{3}{4}$ inches	Blade (with 1 $\frac{1}{4}$ inches for	
Breast	48 inches	seams added)	15 $\frac{1}{2}$ inches
Waist	50 $\frac{1}{2}$ inches	Depth of scye	10 $\frac{1}{2}$ inches
Hip or seat	49 inches	Natural waist	18 inches
Strap	14 $\frac{3}{4}$ inches	Fashion waist	19 $\frac{3}{4}$ inches
Over shoulder	20 $\frac{3}{4}$ inches	Full length	41 inches
Corpulent	3 degrees	Height	6 feet

Form and Attitude, normal. Sizes, 44 to 52 breasts.

### TO DRAFT.

- 1 Square both ways from 4.
- 2 4 to B is 1/3 breast on "3RDS" and 3 $\frac{1}{2}$  inches (11).
- 3 B to 3 is 1/3 breast of height, and 3 $\frac{1}{2}$  inches.
- 4 A is half way between 3 and 4.
- 5 This is the proportional, and includes all allowances.
- 6 A to C is one-fourth height, and  $\frac{1}{4}$  inch for length.
- 7 A to D is the fashion waist; one-fourth height and 1 $\frac{1}{2}$  inches (19 $\frac{3}{4}$ ).
- 8 D to 50 is 1 $\frac{1}{4}$  inches, line from A through 50 to E.
- 9 A to E is the Full length of Back (41).
- 10 F is half between 4 and B, for front shoulder height.
- 11 Square out from A, B, C, D, E, F, 3 and 4.
- 12 B to H is half the full breast measure (24).
- 13 H to I is 2 $\frac{1}{4}$  inches, center of Breast.
- 14 B to K is blade (with 1 $\frac{1}{4}$  inches for seams) (15 $\frac{1}{2}$ ).
- 15 Square up from K—front of armhole.
- 16 L is half way between B and K.
- 17 L to M is 1 $\frac{1}{4}$  inches—width of Back.
- 18 Square up to O, and down to P.
- 19 P is  $\frac{1}{2}$  inch from Line O-M. Square down to 13.
- 20 A to Q is 1/12 breast—on "12RDS," and
- 21 Q to R is 1 $\frac{1}{2}$  inches. Square up to S,  $\frac{5}{8}$  inch.
- 22 Advance from K, 1/16 inch each size above 4 inches less than breast; to straighten the front run, take it out in the underarm cut as shown by shaded part.
- 23 K to T is 1 $\frac{1}{2}$  inches; T to U is 1/12 breast.
- 24 Square up from U to V—locating the shoulder point.
- 25 V is located on lines from U and 4.
- 26 Draw lines from S to U, F to V, and A to K.
- 27 This gives the proportional height of shoulders.
- 28 Rise at X  $\frac{1}{2}$  inch, and lower at point I the same.
- 29 X is  $\frac{1}{2}$  inch on the S-U line—or Style.
- 30 Y is  $\frac{1}{2}$  inch from the O-M line.
- 31 Draw guide line from X to Y.
- 32 From B up apply depth of scye measure and  $\frac{1}{2}$  inch (11) to A, in normal attitude will meet line A.
- 33 The  $\frac{1}{2}$  inch is for fullness held in over the blade.
- 34 C to G is 1/16 breast and 1 $\frac{1}{4}$  inches.
- 35 E to N is the same width as 50 to G, and  $\frac{1}{2}$  inch.
- 36 Draw a line from G to N and from
- 37 49 to G for width of Back over breast-line.
- 38 49 is on F-V and A-K lines.
- 39 Blade fullness is  $\frac{5}{8}$  inch over the rounding.
- 40 Shape the Back as shown; draw line from B to W.
- 41 Apply strap measure and 1 inch A to R and K to V (15 $\frac{3}{4}$ ) in normal attitude will meet line 4-V.
- 42 Apply over shoulder measure and 1 inch B to W and K to Z; when normal, meet line F-V (21 $\frac{3}{4}$ ).
- 43 Z is 1 $\frac{1}{4}$  inches from line K.
- 44 Draw a line from V through Z to point I.
- 45 V to point I is  $\frac{3}{8}$  inch less than S to X.
- 46 Draw a guide line from point 1 to T.
- 47 Shape arm-scye and shoulder rounding  $\frac{1}{2}$  inch over Z.
- 48 B to 2 is  $\frac{1}{2}$  breast on "HALVES"; 2 to K is 3 $\frac{1}{2}$  inches.
- 49 This is normal blade and independent of the actual blade, and comes even with K in normal sizes.
- 50 Square down from K through 4 to 17.
- 51 4 to 5 is  $\frac{1}{2}$  waist—on "HALVES"—center of waist.
- 52 Square down from 5 to 7. The measure from B to 2, K, 4 and 5 is used only to obtain the front center of the waist, and to check the blade measure.
- 53 5 to 8 is 2 inches; 9 to 10 is 1/6 breast.
- 54 These 2 inches are for seams and make-up.
- 55 G to 22 is 1 $\frac{1}{4}$  inches, or 1 $\frac{1}{4}$  inches in all sizes to allow for blade fullness and  $\frac{1}{8}$  inch for every inch the waist is smaller than the breast.
- 56 Square up, and down to 23; 23 is  $\frac{5}{8}$  inch below the fashion waist; or sweep from the Back by Y.
- 57 Measure waist net G to C, P to 22, and 8 to 16.
- 58 Shape side body reducing  $\frac{1}{4}$  inch near Y,  $\frac{3}{8}$  inch at breast line and from 2 to 13 and 16, and 23 to 13.
- 59 V to 18 is 1/12 breast; square forward from 18 by K.
- 60 18 to 19 is  $\frac{1}{4}$  breast; draw line from 19 to I and 5.
- 61 Advance at 1 the amount from K to 3.
- 62 Add  $\frac{1}{4}$  inch rounding over the breast.
- 63 Take out the shaded part under the arm.
- 64 Rever—19 to 20 is 3 $\frac{1}{2}$  inches, or draw a straight line through 5-9; straighten  $\frac{1}{2}$  inch at 20.
- 65 10 to 24 is 2 $\frac{3}{4}$  inches; 10 to 25 the same; sweep by 20.
- 66 Draw a line from 13 to 24. Shape from 13 to 25.
- 67 Draw a line from K through 20 to 26.
- 68 20 to 26 is 2 $\frac{3}{4}$  inches; I to J is 3 $\frac{1}{2}$  inches.
- 69 Shape lapel through 26—J to 25.
- 70 10 to 35 is  $\frac{1}{2}$  inch; draw line from 13 to 35.
- 71 Lay square on 13-36-H and take out a V at 36.
- 72 Advance 23 the amount of V and seams at 36.
- 73 For a close skirt rise at 32 a  $\frac{1}{2}$  inch.
- 74 Draw a line from 23 to 24; square down to 12.
- 75 Flare—At 23 go up  $\frac{5}{8}$  inch and square down by 32.
- 76 23 to 12 is 1/3 breast, and  $\frac{1}{2}$  inch.
- 77 12 to 11 is 1 $\frac{1}{2}$  inches; 11 to 27 is  $\frac{3}{4}$  inch.
- 78 Draw a line from 23 through 11 and 14.
- 79 14 is natural waist, and 1 inch from 23.
- 80 23 to bottom is  $\frac{1}{4}$  inch more than D to E.
- 81 Lay "square" on 27-14 and mark for run of bottom.
- 82 Shape skirt through 27 to bottom.
- 83 Z to 7 is length from Z to E and 1 inch from line K.
- 84 Draw line 14 to 7; shape bottom; lower 1 inch at 17.
- 85 Square down the front edge to 7, by the waist line.
- 87 Go out  $\frac{1}{2}$  from D and line parallel to 50-E.
- 88 Reduce  $\frac{1}{8}$  inch at B from A to C.

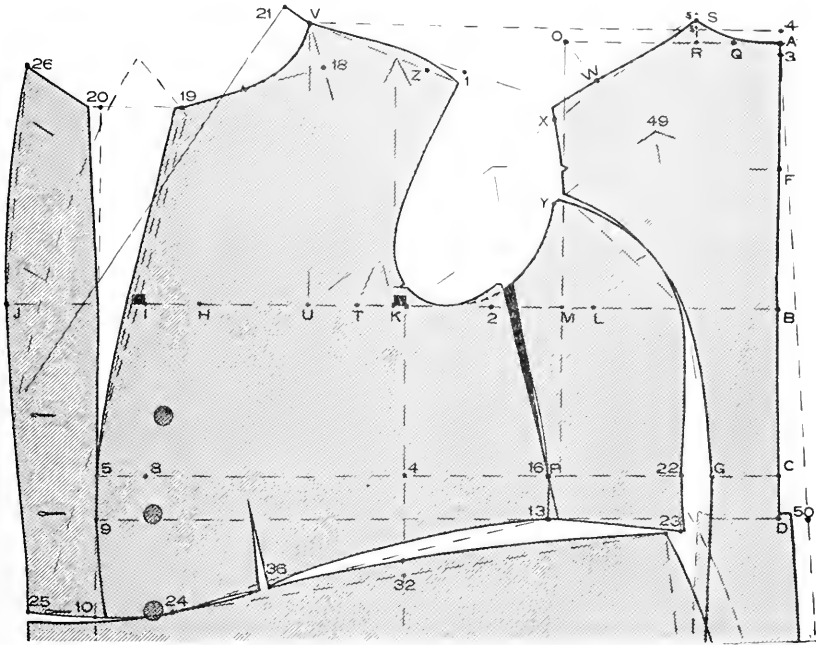

DIAGRAM 34 — DOUBLE-BREASTED FROCK, CORPULENT

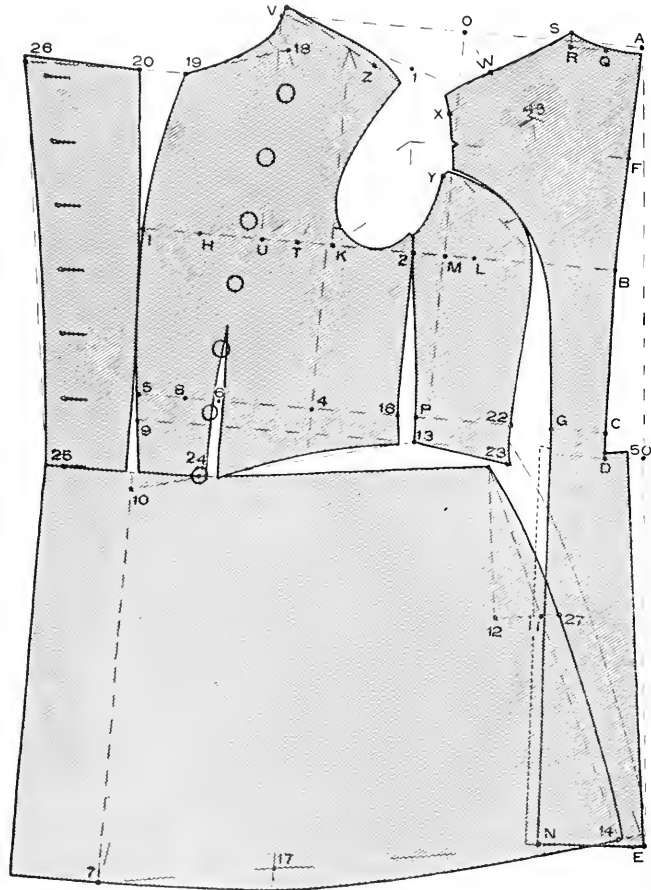

DIAGRAM 35 — MILITARY FROCK

# Military Frock

## Diagram 35

11. The measures are taken over the Vest always.

Inside sleeve	17¾ inches.	Blade (with 1¼ inches for
Breast	36 inches.	seams added) 12¼ in.
Waist	31 inches.	Depth of scye 8¾ inches.
Hip or seat	37 inches.	Natural waist 16½ inches
Strap	12½ inches.	Fashion waist 17½ inches.
Over shoulder	17 inches.	Full length 34 inches.
Normal erect	1 degree.	Height 5 ft. 6 inches.

Form and Attitude, erect. Sizes, 33 to 42 breasts.

### TO DRAFT.

- 1 Square both ways A or 4.
- 2 4 to B is 1/3 breast on "3RDS" and 3½ inches (9¼).
- 3 B to 3 is 1/3 breast of height, and 3½ inches.
- 4 A is half way between 3 and 4.
- 5 This is the proportional, and includes all allowances.
- 6 A to C is one-fourth height, and ¼ inch of curve of Back (16¾).
- 7 A to D is the fashion waist; one-fourth height and 1 inch (17½).
- 8 D to 50 is 1¾ inches, line from A through 50 to E.
- 9 A to E is the Full Length of Back (34).
- 10 F is half between 4 and B, for front shoulder height.
- 11 Square out from A, B, C, D, E, F, 3 and 4.
- 12 B to H is half the full breast measure (18).
- 13 H to I is 2½ inches, center of Breast.
- 14 B to K is blade (with 1¼ inches for seams) (12¼).
- 15 Square up from K—front of armhole.
- 16 L is half way between B and K.
- 17 L to M is 1¼ inches—width of Back.
- 18 Square up to O, and down to P.
- 19 P is ½ inch from Line O-M. Square down to 13.
- 20 A to Q is 1/12 breast—on "12THIS," and
- 21 Q to R is 1½ inches. Square up to S, ⅝ inch.
- 23 K to T is 1½ inches; T to U is 1/12 breast.
- 24 Square up from U to V—locating the shoulder point.
- 25 V is located on lines from U and 4.
- 26 Draw lines from S to U, F to V, and A to K.
- 27 This gives the proportional height of shoulders.
- 28 Rise at X ¾ inch, and lower at point 1 the same.
- 29 X is ¾ inch on the S-U Line—or Style.
- 30 Y is ½ inch from the O-M Line.
- 31 Draw guide line from X to Y.
- 32 From B up apply depth of scye measure and ½ inch (9¼) to A, in normal attitude will meet line A.
- 33 The ½ inch is for fullness held in over the blade.
- 34 C to G is 1/16 breast and 1¼ inches.
- 35 E to N is the same width as 50 to G, and ½ inch.
- 36 Draw a line from G to N and from
- 37 49 to G for width of Back over breast-line.
- 38 49 is on F-V and A-K lines.
- 39 Blade fullness is ⅝ inch over the rounding.
- 40 Obtain point S from A and shape A, S to X.
- 41 Shape the Back as shown; draw line from B to W.
- 42 Apply strap measure and 1 inch A to R and K to V (13¾) in normal attitude will meet line 4-V.
- 43 Go back from K-V line as much as above line V-4, or ½ as much from line U.
- 44 Apply over shoulder measure and 1 inch B to W and K to Z; when normal, meet line F-V (18).
- 45 Z is 1¼ inches from line K.
- 46 Draw a line from V through Z to point 1.
- 47 V to point 1 is ¼ inch less than S to X.
- 48 Draw a guide line from point 1 to T.
- 49 Shape arm-scye and shoulder rounding ½ in. over Z.
- 50 B to 2 is ½ breast on "HALVES"; 2 to K is 3½ inches.
- 51 This is normal blade and independent of the actual blade, and comes even with K in normal sizes.
- 52 Square down from K through 4 to 17.
- 53 4 to 5 is ½ waist—on "HALVES"—center of waist.
- 54 Square down from 5 to 7. The measure from B to 2, K, 4 and 5 is used only to obtain the front center of the waist, and to check the blade measure.
- 55 5 to 8 is 2 inches; 9 to 10 is 1/6 breast.
- 56 These 2 inches are for seams and make-up.
- 57 G to 22 is 1¾ inches, or 1¼ inches in all sizes to allow for blade fullness and ¼ inch for every inch the waist is smaller than the breast.
- 58 Square up, and down to 23; 23 is ½ inch below the fashion waist; or sweep from the Back by Y.
- 59 Measure waist net G to C, P to 22, and 8 to 16.
- 60 Shape side body reducing ¼ inch near Y, ⅜ inch at breast line and from 2 to 13 and 16, and 23 to 13.
- 61 V to 18 is 1, 12 breast; square forward from 18 by K.
- 62 18 to 19 is ¼ breast; draw line from 19 to I and 5.
- 63 Add ¼ inch rounding over the breast.
- 64 Rever—19 to 20 is 2 inches, draw a straight line through 5; straighten ½ inch at 20.
- 65 10 to 24 is 2¾ inches; 10 to 25 the same and 1 inch.
- 66 Draw a line from 13 to 10. Shape from 13.
- 67 Draw a line from 19 through 20 to 26.
- 68 20 to 26 is 5 inches; rise at 26 a ½ inch.
- 69 Shape Lapel through 26—J to 25.
- 70 Draw a line from center of breast through 6.
- 71 Take out a ¼ inch on each side; square down.
- 72 The I' extends up half way between breast and waist line.
- 73 Square forward by line 6 through 24 to 25.
- 74 Take off ⅜ inch of Lapel and ⅜ inch of forepart for opening above point 10.
- 75 The inside line of Lapel should be rounded ½ inch less than the forepart rounding.
- 76 In shaping the gorge for erect, the curve must come out to the original or normal curve, which is ¾ inch from the junction of lines U and 18.
- 77 The suppression at 16—P is ¾ inch with springs added to forepart to produce hip fullness.
- 78 Advance 23 the amount of P and seams (1 in.).
- 79 The opening of skirt below 13 is 1 inch; square down by 23.
- 80 23 to 12 is 1/3 breast, and ½ inch.
- 81 12 to 11 is 2 inches; 11 to 27 is ¾ inch.
- 82 Draw a line from 23 through 11 and 14.
- 83 14 is natural waist, and 1 inch from 23.
- 84 23 to bottom is ¼ inch more than D to E.

- 85 Lay "square" on 27-14 and mark for run of bottom.  
 86 Shape skirt through 27 to bottom.  
 87 Z to 7 is length from Z to E and 1 inch from line K.  
 88 Draw line 14 to 7; shape bottom; lower 1 inch at 17.  
 89 Square down the front edge to 7, by the waist line.  
 91 Go out  $\frac{1}{2}$  from D and line parallel to 50-E.  
 92 Reduce  $\frac{1}{4}$  inch at B from A to C.
- 93 The bars for the shoulder epaulette are placed even with a line drawn from point V to the back notch, and is 1 inch from edge of gorge and armhole.  
 94 The buttons are placed 1 inch from edge of Lapel.  
 95 Full information regarding other details is furnished by the government upon request.  
 96 Hooks to hold the belt are inserted in the waist seam and one in front seam.

## Cassock

### Diagram 36

12. The measures are taken over the Vest always.
- |               |                         |                                      |
|---------------|-------------------------|--------------------------------------|
| Inside sleeve | 17 $\frac{3}{4}$ inches | Blade (with $\frac{1}{4}$ inches for |
| Breast        | 36 inches               | seams added) 12 $\frac{1}{2}$ inches |
| Waist         | 32 inches               | Depth of scye                        |
| Hip or seat   | 37 inches               | Natural waist                        |
| Strap         | 12 inches               | Fashion waist                        |
| Over shoulder | 17 inches               | Full length                          |
|               |                         | Height                               |
- 5 feet 6 inches
- Form and Attitude, normal. Sizes, 33 to 42 breasts.
- TO DRAFT.
- 1 Square both ways from A.
  - 2 A to B is  $\frac{1}{3}$  breast on "3RDS" and  $3\frac{1}{2}$  inches ( $9\frac{1}{2}$ ).
  - 3 This is the proportional, and includes all allowances.
  - 4 A to C is one-fourth height, and  $\frac{1}{4}$  inch for length.
  - 5 A to D is the fashion waist; one-fourth height and  $1\frac{1}{2}$  inches ( $18\frac{1}{4}$ ).
  - 6 D to 50 is 3 inches for box pleat.
  - 7 A to E is the Full Length of Back, 58 inches.
  - 8 F is half between A and B, for front shoulder height.
  - 9 Square out from A, B, C, D, E and F.
  - 10 B to H is half the full breast measure (18).
  - 11 H to I is  $2\frac{1}{4}$  inches, center of breast.
  - 12 B to K is blade (with  $\frac{1}{4}$  inches for seams) ( $12\frac{1}{2}$ ).
  - 13 Square up from K—front of armhole.
  - 14 L is half way between B and K.
  - 15 L to M is  $\frac{1}{4}$  inches—width of Back.
  - 16 Square up to O, and down to P.
  - 17 P is  $\frac{1}{2}$  inch from Line O-M. Square down to 13.
  - 18 A to Q is  $\frac{1}{12}$  breast—on "12TUS," and
  - 19 Q to R is  $1\frac{1}{2}$  inches. Square up to S,  $\frac{5}{8}$  inch.
  - 20 K to T is  $1\frac{1}{2}$  inches; T to U is  $\frac{1}{12}$  breast.
  - 21 Square up from U to V—locating the shoulder point.
  - 22 V is located on lines from U and A.
  - 23 Draw lines from S to U and F to V.
  - 24 This gives the proportional height of shoulders.
  - 25 Rise at X  $\frac{1}{2}$  inch, and lower at point 1 the same.
  - 26 X is  $\frac{1}{2}$  inch on the S-U Line—or Style.
  - 27 Y is  $\frac{1}{2}$  inch from the O-M Line, and  $\frac{1}{6}$  up from M.
  - 28 Draw guide line from X to Y.
  - 29 From B up apply depth of scye measure and  $\frac{1}{2}$  inch ( $9\frac{1}{2}$ ) to A in normal attitude will meet line A.
  - 30 The  $\frac{1}{2}$  inch is for fullness held in over the blade.
  - 31 C to G is  $\frac{1}{16}$  breast and 2 inches.
  - 32 E to N is  $\frac{1}{2}$  breast, or  $\frac{1}{6}$  length of 58.
  - 33 E to 45 is the same. Draw lines.
  - 34 Add 3 inches for box pleat to D-45.
  - 35 Draw line from 46 to N, add 2 inches for pleat.
  - 36 Shape the Back as shown; draw line from B to W.
  - 37 Apply strap measure and 1 inch A to R and K to V (13) in normal attitude will meet line A-V.
  - 38 Apply over shoulder measure and 1 inch B to W and K to Z; when normal, meet line F-V (18).
  - 39 Z is  $\frac{1}{4}$  inches from line K.
  - 40 Draw a line from V through Z to point 1.
  - 41 V to point 1 is  $\frac{3}{8}$  inch less than S to X.
  - 42 Draw a guide line from point 1 to T.
  - 43 Shape arm-scye and shoulder rounding  $\frac{1}{2}$  inch over Z.
  - 44 B to 2 is  $\frac{1}{2}$  breast on "HALVES"; 2 to K is  $3\frac{1}{2}$  inches.
  - 45 This is normal blade and independent of the actual blade, and comes even with K in normal sizes.
  - 46 Square down from K through 4 to 17.
  - 47 4 to 5 is  $\frac{1}{2}$  waist—on "HALVES"—center of waist.
  - 48 Square down from 5 to 7. The measure from B to 2, K, 4 and 5 is used only to obtain the front center of waist, and to check the blade measure.
  - 49 5 to 8 is  $2\frac{1}{4}$  inches, 9 to 10 is  $\frac{1}{6}$  breast.
  - 50 These  $2\frac{1}{4}$  inches are for seams and make-up.
  - 51 G to 22 is  $1\frac{1}{4}$  inches.
  - 52 Square up, and down to 23; 23 is  $\frac{5}{8}$  inch below the fashion waist; or sweep from the Back by Y.
  - 53 Measure waist net G to C, P to 22, and 8 to 16.
  - 54 Shape side body reducing  $\frac{1}{4}$  inch near Y,  $\frac{3}{8}$  inch at breast line and from 2 to 13 and 16, and 23 to 13.
  - 55 V to 18 is  $\frac{1}{12}$  breast; square forward from 18 by K.
  - 56 18 to 19 is  $\frac{1}{4}$  breast; draw line from 19 to I and 5.
  - 57 Draw a line from 10 through 13 to 47.
  - 58 Square down from 47 to 12; 12 to 11 is  $1\frac{1}{2}$  inches.
  - 59 11 to 27 is  $\frac{3}{4}$  inch.
  - 60 Draw line from 47 through 27 to 48.
  - 61 47 to 48 is a  $\frac{1}{2}$  inch more than 46 to N.
  - 62 This is provided no height measure is at hand.
  - 63 Z to 7 equal Z to E on line K and 1 inch.
  - 64 Measure width of Bottom from N to 45 and
  - 65 from 7 to 48, total 58 inches, or  $\frac{7}{8}$  of height.
  - 66 19 to 20 is 1 inch, I to J is  $\frac{1}{4}$  inches.
  - 67 5 to 6 is 1 inch; finish front.
  - 68 A standing collar, cut as military, reaching to within a  $\frac{1}{2}$  inch of 19.
  - 69 Pleat pockets are inserted, 10 inches down to the X.
  - 70 The skirt is slightly curved at 32 in order to distribute the hip fullness more on the side.
  - 71 If no seam is cut across, trace the sidebody.
  - 72 Buttons  $1\frac{3}{4}$  inches apart, 33 in number.
  - 73 One for every year of the Lord.



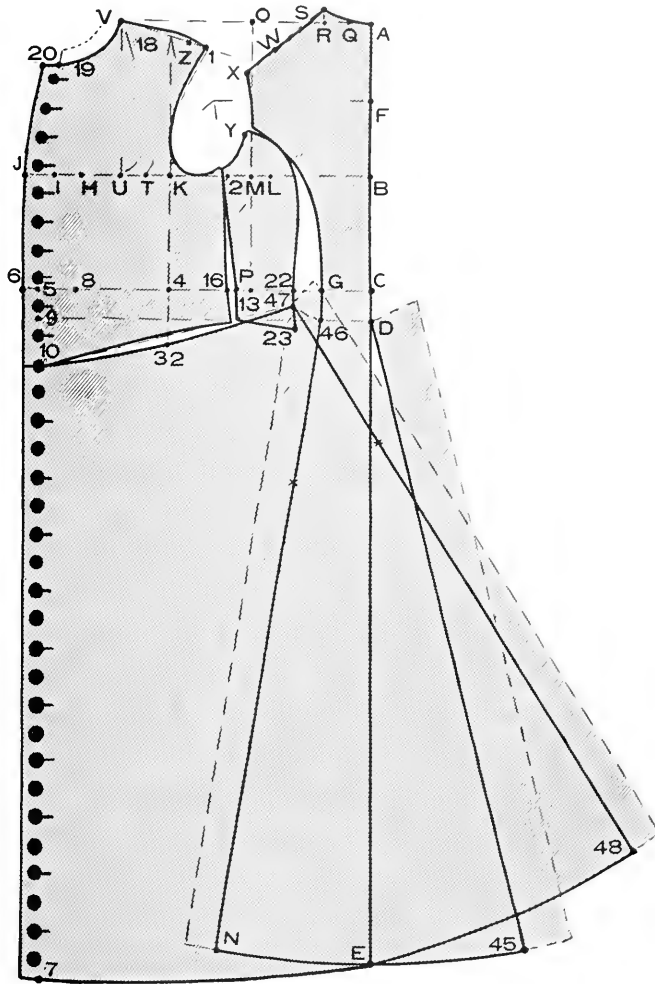

DIAGRAM 36 — CASSOCK

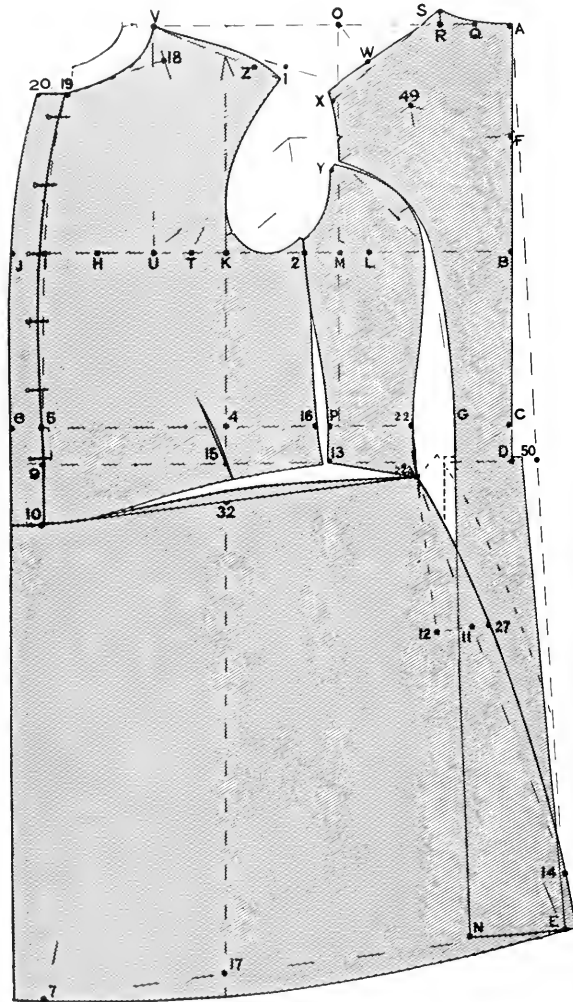

DIAGRAM 37 — CLERICAL FROCK

# Clerical Frock

## Diagram 37

13. The measures are taken over the Vest always.

Inside sleeve	17 $\frac{3}{4}$ inches	Blade (with 1 $\frac{1}{4}$ inches for
Breast	36 inches	seams added) 12 $\frac{1}{2}$ inches
Waist	32 inches	Depth of scye
Hip or seat	37 inches	Natural waist
Strap	12 inches	Fashion waist
Over shoulder	17 inches	Full length
		Height

Form and Attitude, normal. Sizes, 33 to 42 breasts.

### TO DRAFT.

- 1 Square both ways from A or 4.
- 2 4 to B is  $\frac{1}{3}$  breast on "3RDS" and 3 $\frac{1}{2}$  inches (9 $\frac{1}{2}$ ).
- 3 B to 3 is  $\frac{1}{3}$  breast of height, and 3 $\frac{1}{2}$  inches.
- 4 A is half way between 3 and 4.
- 5 This is the proportional, and includes all allowances.
- 6 A to C is one-fourth height, and  $\frac{1}{4}$  inch for length.
- 7 A to D is the fashion waist; one-fourth height and 1 $\frac{1}{2}$  inches (18 $\frac{1}{4}$ ).
- 8 D to 50 is 1 $\frac{1}{4}$  inches, line from A through 50 to E.
- 9 A to E is the Full Length of Back.
- 10 F is half between 4 and B, for front shoulder height.
- 11 Square out from A, B, C, D, E and F.
- 12 B to H is half the full breast measure.
- 13 H to I is 2 $\frac{1}{4}$  inches, center of breast (18).
- 14 B to K is blade (with 1 $\frac{1}{4}$  inches for seams) (12 $\frac{1}{2}$ ).
- 15 Square up from K—front of armhole.
- 16 L is half way between B and K.
- 17 L to M is 1 $\frac{1}{4}$  inches—width of Back.
- 18 Square up to O, and down to P.
- 19 P is  $\frac{1}{2}$  inch from line O-M. Square down to 13.
- 20 A to Q is  $\frac{1}{12}$  breast—on "12TINS," and
- 21 Q to R is 1 $\frac{1}{2}$  inches. Square up to S,  $\frac{5}{8}$  inch.
- 22 K to T is 1 $\frac{1}{2}$  inches; T to U is  $\frac{1}{12}$  breast.
- 23 Square up from U to V—locating the shoulder point.
- 24 V is located on lines from U and A.
- 25 Draw lines from S to U, F to V, and A to K.
- 26 This gives the proportional height of shoulders.
- 27 Rise at X  $\frac{1}{2}$  inch, and lower at point 1 the same.
- 28 X is  $\frac{1}{2}$  inch on the S-U line—or Style.
- 29 Y is  $\frac{1}{2}$  inch from the O-M line.
- 30 Draw guide line from X to Y.
- 31 From B up apply depth of scye measure and  $\frac{1}{2}$  inch (19 $\frac{1}{2}$ ) to A, in normal attitude will meet line A.
- 32 The  $\frac{1}{2}$  inch is for fullness held in over the blade.
- 33 C to G is  $\frac{1}{16}$  breast and 1 $\frac{1}{4}$  inches.
- 34 E to N is the same width as 50 to G, and  $\frac{1}{2}$  inch.
- 35 Draw a line from G to N and from
- 36 49 to G for width of Back over breast-line.
- 37 49 is on F-V and A-K lines.
- 38 Blade fullness is  $\frac{5}{8}$  inch over the rounding.
- 39 Shape the Back as shown; draw line from B to W.
- 40 Apply strap measure and 1 inch A to R and K to V (13), in normal attitude will meet line A-V.
- 41 Apply over shoulder measure and 1 inch B to W and K to Z; when normal, meet line F-V (18).
- 42 Z is 1 $\frac{1}{4}$  inches from line K.

- 43 Draw a line from V through Z to point 1.
- 44 V to point 1 is  $\frac{3}{8}$  inch less than S to X.
- 45 Draw a guide line from point 1 to T.
- 46 Shape arm-syce and shoulder rounding  $\frac{1}{2}$  inch over Z.
- 47 B to 2 is  $\frac{1}{2}$  breast on "HALVES"; 2 to K is 3 $\frac{1}{2}$  inches.
- 48 This is normal blade and independent of the actual blade, and comes even with K in normal sizes.
- 49 Square down from K through 4 to 17.
- 50 4 to 5 is  $\frac{1}{2}$  waist—on "HALVES"—center of waist.
- 51 Square down from 5 to 7. The measure from 4 to 2, K, 4 and 5 is used only to obtain the front center of the waist, and to check the blade measure.
- 52 5 to 8 is 2 $\frac{1}{4}$  inches; 9 to 10 is 1, 6 breast.
- 53 These 2 $\frac{1}{4}$  inches are for seams and make-up.
- 54 G to 22 is 1 $\frac{3}{4}$  inches, or 1 $\frac{1}{4}$  inches in all sizes to allow for blade fullness and  $\frac{1}{8}$  inch for every inch the waist is smaller than the breast.
- 55 Square up, and down to 23; 23 is  $\frac{5}{8}$  inch below the fashion waist; or sweep from the Back by Y.
- 56 Measure waist net G to C, P to 22, and 8 to 16.
- 57 Shape side body reducing  $\frac{1}{4}$  inch near Y,  $\frac{3}{8}$  inch at breast line and from 2 to 13 and 16, and 23 to 13.
- 58 V to 18 is  $\frac{1}{12}$  breast; square forward from 18 by K.
- 59 18 to 19 is  $\frac{1}{4}$  breast; draw line from 19 to 1 and 5.
- 60 19 to 20 is 1 $\frac{1}{4}$  inches; 1 to J is the same.
- 61 5 to 6 is 1 $\frac{1}{4}$  inches; square down.
- 62 Shape the front and fore part from 13 to 10.
- 63 The front is finished with 7 holes to the waist.
- 64 The collar is cut on the military style (see collars) and is 1 inch high finished, and a  $\frac{1}{2}$  inch back from 19.
- 65 Making an opening of 1 $\frac{1}{2}$  inches in the collar.
- 66 For medium full skirt, rise at 32 a  $\frac{1}{2}$  inch and square down by 23.
- 67 23 to 12 is 1, 3 breast, and  $\frac{1}{2}$  inch.
- 68 12 to 11 is 1 $\frac{1}{2}$  inches; 11 to 27 is  $\frac{3}{4}$  inch.
- 69 Draw a line from 23 through 11 and 14.
- 70 14 is natural waist, and 1 inch from 23.
- 71 23 to bottom is  $\frac{1}{4}$  inch more than D to E.
- 72 Lay "square" on 27-14 and mark for run of bottom.
- 73 Shape skirt through 27 to bottom.
- 74 Z to 7 is length from Z to E and 1 inch from line K.
- 75 Draw line 14 to 7; shape bottom; lower 1 inch at 17.
- 76 Square down the front edge to 7, by the waist line.
- 77 Take out a fish  $\frac{3}{8}$  inch, 1, 6 up from 15.
- 78 Go out  $\frac{1}{2}$  from D and line parallel to 50-E.
- 79 Reduce  $\frac{3}{8}$  inch at B from A to C.

## Knight Templar Coat

12. This coat is drafted the same as a Frock Coat.
- 1 With a medium flare skirt.
- 2 The front is finished like a clerical, with 1 $\frac{1}{2}$  inches stand for buttons in front and 11 holes.
- 3 The collar is the same as a military.
- 4 The skirt has a side edge or sash, about  $\frac{2}{3}$  the length down, and a button at each end.

## Sleeves

14. **The Sleeve.**—The sleeve forms a much more important part of coat cutting than is generally accorded it by most cutters. If the coat is otherwise well cut, an improperly cut sleeve, or badly balanced in the *hang*, will pull the coat and distort it from its proper position.

### SLEEVE IN COAT.

15. **The Test.**—Diagram 3. A study of this diagram will clearly indicate its proper position and the relation it holds to the coat, as drafted, or when attached to the coat, and *prove* every point and line. The same result is obtained if drafted without the coat.

16. **The Top Sleeve.**—The intersecting lines at G are obtained from three directions—by the *proportional* lines B to O and A through M to K; the *actual* measure from C to G. The *height* is established by the lines G-V and O-M. The front run should end at B, not at C.

17. **The Rule** that all lines should be drawn to *stationary* or fixed points, never to *movable* points, holds throughout this system, whether Coats, Vests or Trousers. Nearly all sleeves are drawn to C from J, producing too much cloth opposite C, necessitating a cutting by the journeyman from the sleeve or the armhole. By reversing the top sleeve the location of the notch proves itself—

that it is exactly  $\frac{3}{4}$  inch. In half-and-half sleeve a seam is added between C and the notch, which brings the *run* to its natural position.

18. **Undersleeve.**—The undersleeve has caused more trouble and worry than most any other part of the garment. The *run* of the undersleeve should be on a line drawn from point S through Y continued to C. It certainly should follow the armhole, because there is where it must come to when sewed onto the coat. If a sleeve *run* is away from Y when drafted, it will pull on the coat when sewed in, causing *breaks* and wrinkles on the coat back of the arm. This brings the location of R to  $\frac{1}{8}$  sleeve from G. A to J is also  $\frac{1}{8}$  sleeve.

19. **Proof.**—Reversing the sleeve, laying point R of the undersleeve to G, the *run* should follow the line from B to O, keeping breast line even.

20. **The Elbow.**—The elbow of the sleeve should be on the waist line of the coat; the width should be  $\frac{1}{4}$  breast and  $4\frac{1}{4}$  inches from N to I. The  $\frac{3}{4}$  breast should meet point 13, or the M-O line. The width of the top sleeve, when reversed, should meet point 6 on front and run through point J on breast line. The cuff of the undersleeve should meet line 44-17. 44 is half way between B and M.

## Sleeve—Diagram 38

- 1 The front notch on the coat is  $\frac{3}{4}$  inch up from the breast line *always*.
  - 2 The back notch is on line F *always*.
  - 3 Measure from the front notch over the shoulder to the back notch for the upper sleeve.
  - 4  $9\frac{1}{2}$  inches for a 36 breast.
  - 5 21. **Measure** the under sleeve from front notch under the arm to the back notch over all the seams.
  - 6  $8\frac{1}{2}$  inches for a 36 breast.
  - 7 Always follow the edge of the pattern with the tape line in measuring for sleeve size.
  - 8 On Overcoats do not measure fullness or drapery.
  - 9 Inside sleeve length,  $17\frac{3}{4}$  inches; cuff width,  $12\frac{1}{2}$  inches.
  - 10 Upper sleeve,  $9\frac{1}{2}$  inches; under sleeve,  $8\frac{1}{2}$  inches.
  - 11 Total, 18 inches—the drafting size for the sleeve.
  - 12 The length of inside sleeve is one-fourth height and  $1\frac{1}{4}$  inches.
  - 13 The outside length should read 7-19 $\frac{1}{2}$ -31; that is, 7 inches for width of back, 19 $\frac{1}{2}$  to the elbow, and 31 inches full length.
  - 14 The outside sleeve measure is taken to 1 inch beyond the wrist bone while the arm is in a bent position, the elbow even height with the shoulder, and the hand about 7 inches in front of the face. To this length seams must be added.
  - 15 Mark the measures on the sleeve paper before drafting.
- TO DRAFT.
- 16 Cut off a piece of paper large enough for a pair of sleeves and fold it with a sharp crease.
  - 17 Place fold edge away from you, and draw a line about  $1\frac{1}{2}$  inches from edge of fold as from A to E.
  - 18 22. **The Top Sleeve.**—Square from A back to G.
  - 19 A to B is F to B on Coat—half depth of scye ( $4\frac{3}{4}$ ).
  - 20 B to C is  $\frac{3}{4}$  inch *always*—the front notch.
  - 21 B to D is the inside sleeve length ( $17\frac{3}{4}$ ).
  - 22 D to E is  $1\frac{1}{2}$  inches—back length of cuff.
  - 23 F is half way between A and E—the elbow.
  - 24 Square out from A, B, C, D, E and F.
  - 25 C diagonally to G is the upper sleeve measure ( $9\frac{1}{2}$ ).
  - 26 Square down from G to H.
  - 27 A to J is  $\frac{1}{8}$  sleeve; draw a line from J to B.
  - 28 B to K is  $\frac{1}{3}$  drafting size—on “3RDS” (6).
  - 29 Draw a line from G to K, locating L.
  - 30 G to L is height of sleeve to M, or M is  $\frac{1}{12}$  sleeve from line A.
  - 31 Shape the upper sleeve from G to M and J to B.
  - 32 F to N is  $\frac{1}{2}$  inch; H to I is the same.
  - 33 The distance from N to I is the width of the sleeve over elbow— $\frac{1}{4}$  breast and  $4\frac{1}{4}$  inches *always* for all normal sizes.
  - 34 D to P is  $\frac{3}{4}$  inch. Shape from B through N to P.

- 35 P to Q is  $\frac{1}{2}$  width of sleeve cuff, including seams ( $6\frac{3}{4}$ ).
- 36 Draw a line from P to Q.
- 37 To make the seams come even over the elbow and to prevent folds running diagonally from head of sleeve to elbow, which will happen to all sleeves where the upper sleeve meets the under sleeve at or near the elbow—
- 38 Go out  $\frac{1}{2}$  inch from I to O for upper sleeve.
- 39 Go in  $\frac{1}{2}$  inch from I to H for under sleeve.
- 40 Draw guide line from G to O and O to Q.
- 41 Shape, and finish top sleeve as represented.
- 42 **23. The Under Sleeve.**—G to R is  $\frac{1}{8}$  sleeve.
- 43 Draw line from R to K.
- 44 Shape under-arm curve from R to front notch at C.
- 45 Allow two seams or  $\frac{1}{2}$  inch back of R and shape through H to Q.
- 46 This is called the half-and-half sleeve, because they are cut of equal size, or in half.
- 47 If it is desired to change the seams, especially the front seam, so as to bring it more in under the arm and not to show in front, proceed as explained in the next paragraph.
- 48 **24. To Change the Inseam.**—Allow  $\frac{3}{4}$  inch more on the upper sleeve and take off the same amount of under sleeve, from line B, N, P, as follows:
- 49 From B to S, N to T and P to U is  $\frac{3}{4}$  inch for the upper sleeve; draw guide line and shape.
- 50 From B to V, N to W and P to X is  $\frac{3}{4}$  inch for the under sleeve; draw guide line and shape.
- 51 **25. The Pattern** is cut through both papers after the upper sleeve; also the notch at C.
- 52 The under layer becomes the top sleeve; use it to shape by, from V to X, and to get the length.
- 53 Turn the paper around, place the now upper sleeve even with Q and get the length to two seams back of R.
- 54 The length will always be about  $\frac{1}{4}$  inch above line A.
- 55 Shape the run of seam through elbow.
- 56 Cut out the under sleeve and compare with top sleeve.
- 57 **26. The Seams.**—Both the front and side seams always should run *straight* as far up as the cuff reaches.
- 58 The run of the top sleeve at the hand should be straight from Q to P, to fit the shirt cuff; the under sleeve is hollowed from Q to X.
- 59 **27. Narrow Shoulders.**—To fit the sleeve to narrow shoulders, rise at M a  $\frac{1}{4}$  inch, or the amount the shoulders are less than normal, and shape gradually from G through M to B.

**Overcoat Sleeve—Diagram 39**

- 60 The upper sleeve,  $10\frac{1}{2}$  inches for a 36 breast.
- 61 The under sleeve,  $9\frac{1}{2}$  inches. Total, 20 inches.
- 62 Length,  $\frac{1}{2}$  inch; cuff,  $1\frac{1}{2}$  inches more than undercoat.

- 63 The sleeve for an Overcoat is measured and drafted the same way as for an Undercoat from measures.
- 65 **28. Overcoat Sleeve.**—Diagram represents an Undercoat sleeve and an Overcoat sleeve made from an Undercoat sleeve.
- 66 Draw a line from B through G and add 1 inch.
- 67 Lines B and G must be same height as B-F on Overcoat.
- 68 Add  $\frac{3}{4}$  inch to width at hand, and shape side seam.
- 69 Shape top rounding from G to B; add  $\frac{1}{2}$  inch to length.
- 70 Add the same amount to under sleeve.

**Box Undersleeve—Diagram 40**

- 71 **29. Box Under Sleeve.**—(Dia.)—First make the regular undef sleeve and cut it out; place it on another piece of paper and mark all around it as indicated on the diagram by the letters R, V, X and Q.
- 72 Mark at B the amount of drapery, 1 inch or more.
- 73 Pivot the pattern at X and swing it over to B.
- 74 Shape from B to X; the broken line shows the position.
- 75 Remove the pattern and fill in the scye about a  $\frac{1}{4}$  inch.
- 76 The shaded part represents the box sleeve.
- 77 The top sleeve is the same as regular Overcoat sleeve.

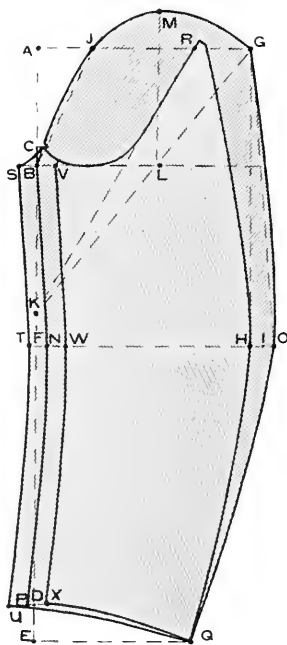

Diagram 38 — Sleeves

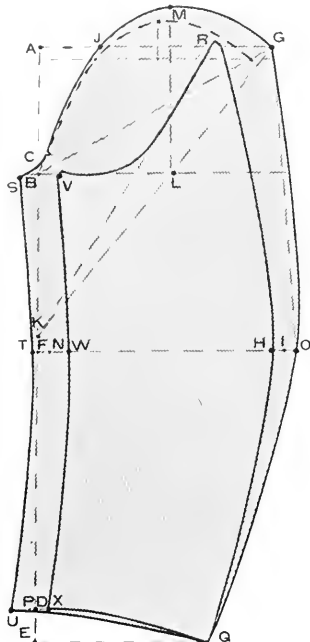

Diagram 39 Overcoat Sleeve

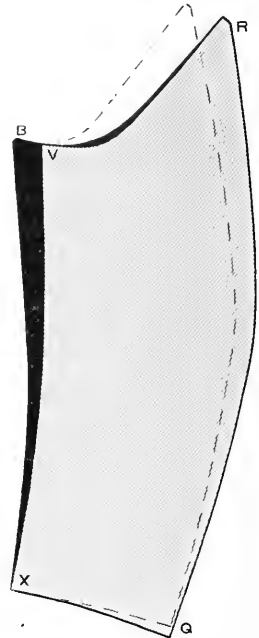

Diagram 40 Box Undersleeve

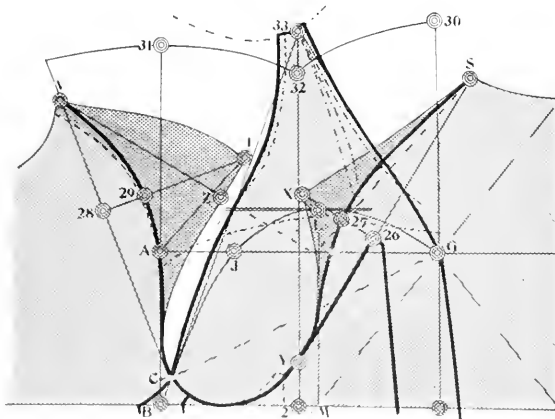

Diagram 41 — Raglan Coat with Sleeve

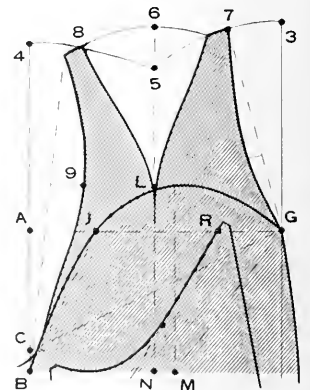

Diagram 42 — Raglan Sleeve

## PART THREE

**Raglan Coat****Diagram 41**

- 78 **30. The Raglan Coat** is drafted the same as other Overcoats, either the Box or Chesterfield effect, as desired.
- 79 To prepare for the sleeves, proceed as follows:
- 80 The front notch is always  $\frac{3}{4}$  inch up from the breast line.
- 81 The back notch is always on line F, for drafting purposes.
- 82 Draw a straight line from S to Y, or the inside run of the armhole.
- 83 Square out from this line from 26 to X.
- 84 26 to 27 is  $1\frac{1}{4}$  inches.
- 85 Shape from S through 27 to Y. See diagram.
- 86 Draw a line from V to the front of armhole.
- 87 Square by this line from 28 to point 1.
- 88 28 to 29 is  $1\frac{1}{4}$  inches.
- 89 Shape from V through 29 to the notch.
- 90 Move the seam down in the gorge  $\frac{1}{2}$  inch or more from V and re-shape to 29.
- 91 The shaded part represents the cut-off.
- 92 **31. Measure for Sleeve.**—From front notch over the shoulder through point 1 to the back notch, for the upper sleeve:
- 93  $10\frac{1}{2}$  inches for a 36 breast Overcoat.
- 94 **32. Measure under sleeve** from front notch under the arm to back notch, including seams:
- 95  $9\frac{1}{2}$  inches for a 36 breast Overcoat.
- 96 In measuring armhole for sleeve always follow the edge of the pattern, not including fullness or drapery.
- 97 If a Box Coat, draft under sleeve as shown in "Box Under Sleeve."
- 98 Measure the distance from the back notch in a straight line to S— $7\frac{3}{4}$  inches.
- 99 Measure the distance from the front notch in a straight line to V— $10\frac{1}{4}$  inches.

**Raglan Sleeve****Diagram 41**

## TO DRAFT.

Upper sleeve,  $10\frac{1}{2}$  inches.Under sleeve,  $9\frac{1}{2}$  inches.Depth of scye, B to F,  $5\frac{1}{4}$  inches.Front length,  $10\frac{1}{4}$  inches.Back length,  $7\frac{3}{4}$  inches.Inside length,  $18\frac{3}{4}$  inches.

- 100 Diagram Represents the sleeve without any shoulder seam, the position as drafted in the coat and the principle on which it is based, namely: To obtain the required length over the shoulder.
- 101 The broken lines represent the pieces as cut off from the coat and placed in position to get the length; or, in other words, the width across the shoulder from V to Z, less two seams.
- This style of sleeve is not used much at present, because it is nearly impossible to get the square shoulder effect desired at the present date.

**Diagram 42**

- 102 **34.** Represents the same sleeve drafted separately.
- 103 Finish the Raglan sleeve the same as an ordinary Overcoat sleeve; then proceed as follows:
- 104 Extend the lines A and G upwards to 4 and 3.
- 105 Apply the back length,  $7\frac{3}{4}$  inches, from G to 3 and sweep forward to 5.
- 106 3 to 7 is 2 inches; draw a line from 7 to G.
- 107 Apply the front length,  $10\frac{1}{4}$  inches, and  $1\frac{1}{4}$  inches ( $11\frac{1}{2}$ ), from C to 4 and sweep back to 5.
- 108 4 to 8 is 2 inches.
- 109 Square up from N through 5 to 6.
- 110 In normal N is half way between B and G line.
- 111 In *stooping* forms this line would be moved forward, and in *erect* forms would be farther back.
- 112 Draw a line across the top of sleeve at L.
- 113 Measure the width across the shoulders from V through Z.
- 114 Apply this amount to the line drawn on top of sleeve at L to 6, less  $\frac{1}{2}$  inch for two seams.
- 115 **35. The Test.**—A sweep forward from 6 should meet 8.
- 116 It will be noted it gives *three* ways to test the accuracy of the measures, or check them—
- 117 *First*, by the length from C to 4 to 5.
- 118 *Second*, by the length from G to 3 to 5.
- 119 *Third*, by the shoulder width to 6.
- 120 Sweep forward from 8, pivot at N; mark off  $\frac{3}{4}$  inch on sweep line from 8 for two seams, and draw a line to B.
- 121 Add  $\frac{3}{4}$  inch to 7 for two seams (and the  $\frac{1}{2}$  inch lowered from point V); draw a line to L.
- 122 Draw a line from 8 to L, and shape.
- 123 9 is  $1\frac{1}{4}$  inches from the straight line.
- 124 Make a notch  $\frac{1}{2}$  inch up from 9 and at 29.
- 125 The shoulder back notch is on line W, and the sleeve notch is squared in from the straight line to 7. The curved line is  $\frac{1}{2}$  inch in.
- 126 Shape back sleeve from 7 to G and front sleeve through 9 to B.
- 127 This completes the diagram. The shaded part represents the sleeve.
- 128 The shaded part on the Coat can be left on for the try-on, if desired. Medium wadding is provided for.
- The Split Raglan Sleeve**
- 129 **36. Split Sleeve.**—If it is desired to split the sleeve mark center line half way between P-Q and N-1 and at line N.
- 130 Allow a seam or more on each side and shape as shown on diagram.

# Chesterfield

## Diagram 43

1. The measures are taken over Vest always.

Inside Sleeve	17 $\frac{3}{4}$ inches.	Blade (with 1 $\frac{1}{4}$ inches for
Breast	36 inches.	seams added) 12 $\frac{1}{2}$ inches.
Waist	32 inches.	Depth of scye 9 inches
Hip or seat	37 inches.	Natural waist 16 $\frac{3}{4}$ inches.
Strap	12 inches.	Full length 37 inches.
Over shoulder	17 inches.	Height 5 ft. 6 inches.

Form and attitude, normal. Sizes, 33 to 42 breasts.

In drafting overcoats, the same measures are used as taken over the vest for an undercoat.

In applying the measures, obtain all points the same as for an undercoat, then add 1 inch which gives the allowance for the overcoat as follows:

A to B is 1/3 breast and 3 $\frac{1}{2}$  inches 9 $\frac{1}{2}$  proportional; or actual depth of scye and  $\frac{1}{2}$  inch for an undercoat; then add 1 inch for the overcoat, making it 10 $\frac{1}{2}$  inches.

To apply strap and oversoulder measure from A to R and 3 to V and from the X above B to W and from 3 to Z, use it as an undercoat measure, as strap 12 and 1 inch for seams; oversoulder 17 and 1 inch for making up below the X belong to the overcoat.

The old idea of adding 3 or 4 sizes to an undercoat is certainly illigical and very unscientific; it simply produces a larger undercoat but does not make an overcoat.

Why add  $\frac{3}{4}$  inch to blade and only  $\frac{1}{2}$  inch to the depth of scye; which leaves only  $\frac{1}{2}$  inch addition to the strap, and  $\frac{3}{4}$  inch addition to the oversoulder/

To test—draft an undercoat and lay inside the overcoat, try that on your system and the same on this; the result will show for itself.

### TO DRAFT.

- 1 Square both ways from A.
- 2 A to B is 1/3 breast and 3 $\frac{1}{2}$  inches. . . . . Add 1 inch.
- 3 B to A is 1/3 breast of *height*, and 3 $\frac{1}{2}$  inches (10 $\frac{1}{2}$ ).
- 4 This is the proportional, and includes all allowances.
- 5 A to C is natural waist (16 $\frac{3}{4}$ ) . . . . . Add 1 inch.
- 6 C to D is 1/3 breast, on "3RDS"; (6) seatline.
- 7 Added to the natural waist gives correct length.
- 8 A to E is the Full Length of Back.
- 9 F is half between B and A. . . . . Add  $\frac{1}{2}$  inch.
- 10 Square out from A, B, C, D, E and F.
- 11 C to G is  $\frac{1}{2}$  inch; draw line F to G and down to E.
- 12 From the line just drawn inside of B measure to H.
- 13 B to H is half the full breast measure (18).
- 14 H to I is 2 $\frac{1}{2}$  inches, center of breast. . . . . Add 1 inch.
- 15 B to K is blade, with seams. . . . . Add 1 inch.
- 16 Square up from K to 3 is —. . . . . Add 1 inch.
- 17 L is half way between B and K.
- 18 L to M is 1 $\frac{1}{4}$  inches—width of Back.
- 19 Square up to O, and down to N. . . . . Add 1 inch.
- 20 P is  $\frac{1}{2}$  inch from Line O-M; draw line to N.
- 21 A to Q is 1/12 breast—on "12THS," and
- 22 Q to R is 1 $\frac{1}{2}$  inches; square up to S,  $\frac{5}{8}$  inch.
- 23 K to T is 1 $\frac{3}{4}$  inches; T to U is 1/12 breast.
- 24 Square up from U to V, locating the shoulder point.

- 25 V is located on line from U and A.
- 26 Draw lines from S to U, and F to V.
- 27 This gives the proportional height of shoulders.
- 28 Rise at X  $\frac{1}{2}$  inch, and lower at point 1 the same.
- 29 X is  $\frac{1}{2}$  inch on the S-U line—or Style.
- 30 Y is  $\frac{1}{2}$  inch from the O-N line, and 1/12 up from M, 31 plus  $\frac{1}{4}$  inch; draw guide line from Y to P.
- 32 From B up apply depth of scye measure and  $\frac{1}{2}$  inch (10 $\frac{1}{2}$ ) to A, in normal attitude will meet line A.
- 33 The  $\frac{1}{2}$  inch is for fullness held in over the blade.
- 34 Shape the Back as shown; draw line from B to W.
- 35 Apply strap measure, and 1 inch A to R and 3 to V in normal attitude will meet line A-V.
- 36 Apply over shoulder measure and 1 inch B to W and 3 to Z; when normal, meet line F-V.
- 37 Z is 1 $\frac{1}{4}$  inches from line K.
- 38 Draw a line from V through Z to point 1.
- 39 V to point 1 is  $\frac{1}{2}$  inch less than S to X.
- 40 Draw a guide line from point 1 to T.
- 41 Shape arm-scye and shoulder rounding  $\frac{1}{2}$  inch over Z.
- 42 B to 2 is  $\frac{1}{2}$  breast on "HALVES"; 2 to K is 3 $\frac{1}{2}$  inches.
- 43 This is normal blade and independent of the actual blade.
- 44 Square down from K through 4 to 17.
- 45 4 to 5 is  $\frac{1}{2}$  waist—on "HALVES". . . . . Add 1 inch.
- 46 Square down from 5 to 7. The measure from B to 2, K, 4 and 5 is used only to obtain the front center of the waist and to check the blade measure.
- 47 5 to 8 is 2 $\frac{1}{2}$  inches, 9 to 10 is the same.
- 48 These 2 $\frac{1}{2}$  inches are for seams and make-up.
- 49 Apply hip measure and  $\frac{3}{4}$  inch, width of Back from 12 to D and 10 to 11. . . . . Add 1 inch.
- 50 11 to 12 is 1 $\frac{3}{4}$  inches; square up, locating 13.
- 51 (Proportional hip spring 12 to 11 is 1 $\frac{3}{4}$  inches.)
- 52 Draw a line from 13 through 11 to 14. . . . . Add 1 inch.
- 53 Measure waist and 1 $\frac{1}{2}$  inches P to G and 8 to 16. Add 1 inch.
- 54 Y to 14 is the length from Y to N.
- 55 Shape side seam of forepart from Y to 16, going out  $\frac{5}{8}$  inch over 11 to 14—or Style.
- 56 (Reduce  $\frac{1}{2}$  in. from Y to 16 when no underarm cut.)
- 57 Z to 7 is length from Z to E and 1 inch, from line K.
- 58 The 1 inch is taken up in making the front edge.
- 59 Draw line 14 to 7; shape bottom; lower 1 inch at 17.
- 60 V to 18 is 1/12 breast; square forward from 18 by 3.
- 61 18 to 19 is  $\frac{1}{4}$  breast. . . . . Add 1 inch.
- 62 Draw a line from 19 to I and 5.
- 63 19 to 20 is 2 $\frac{1}{2}$  inches; notch,  $\frac{1}{2}$  inch from 19.
- 64 1 to J is 2 $\frac{1}{2}$  inches; 5 to 6 is the same.
- 65 Go in  $\frac{1}{2}$  inch at 7; draw line from 6 and shape front.
- 66 V to 21 is 1 $\frac{1}{4}$  inches; draw line to end of roll.
- 67 The pocket is 2/3 sleeve length and  $\frac{1}{2}$  inch from K.
- 68 (For double-breasted add 2 inches to the front.)
- 69 In applying seat measure to Overcoats or any coat with flare skirt, the normal lines should be used, not the flares.



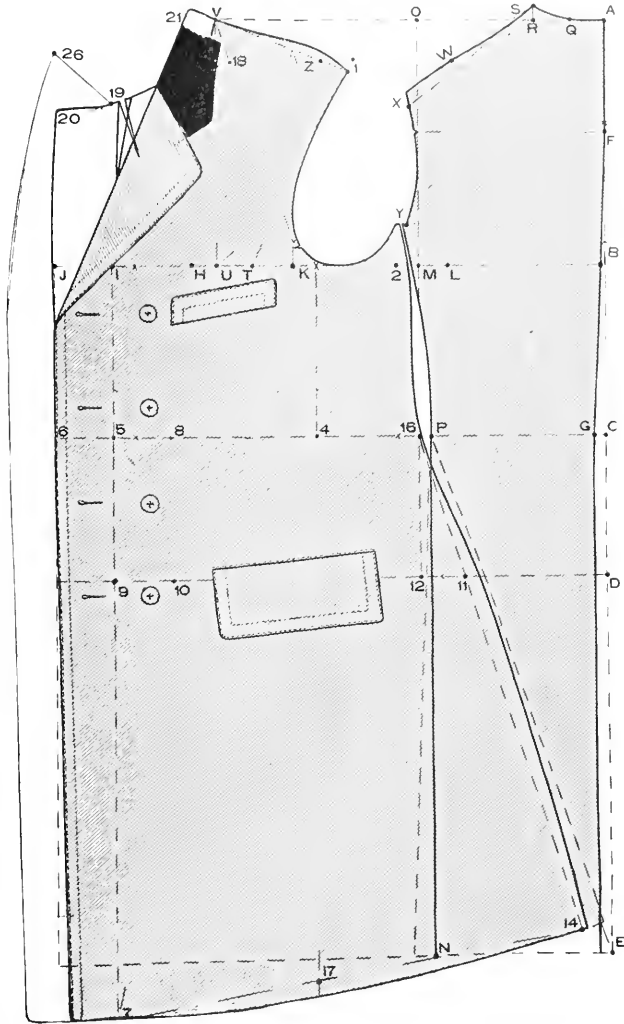

DIAGRAM 43 - CHESTERFIELD

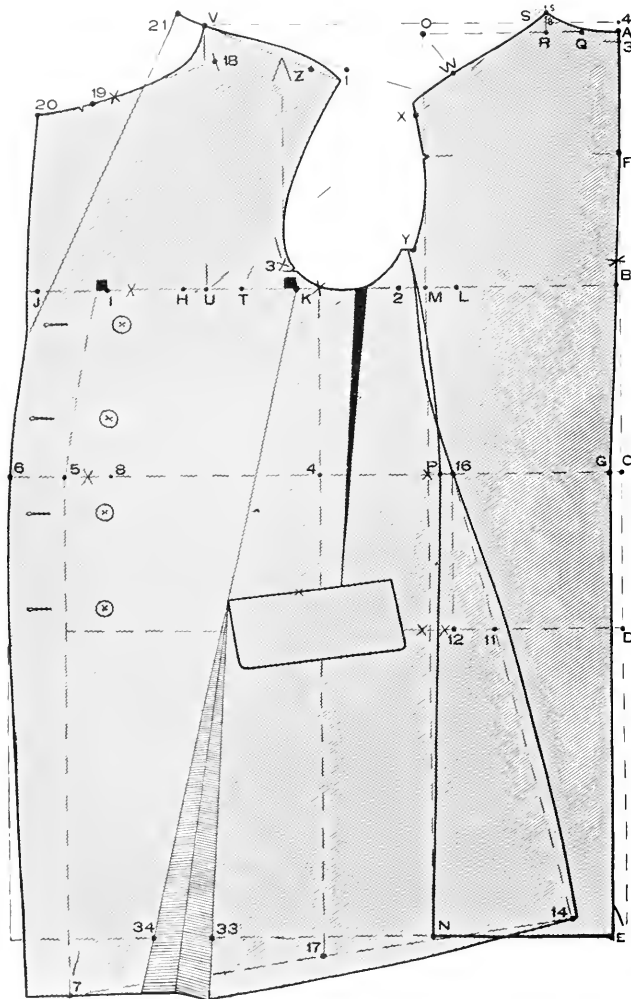

DIAGRAM 44 — CHESTERFIELD CORPULENT

## Chesterfield Corpulent

### Diagram 44

2. The measures are taken over the Vest always

Inside sleeve	19 $\frac{3}{4}$ inches.	Corpulent	3 degree
Breast	48 inches.	Blade (with 1 $\frac{1}{4}$ inches for	
Waist	50 $\frac{1}{2}$ inches.	seams added)	15 $\frac{1}{2}$ in.
Hip or seat	49 inches.	Depth of scye	10 $\frac{1}{2}$ inches.
Strap	14 $\frac{3}{4}$ inches.	Natural waist	18 $\frac{3}{4}$ inches.
Over shoulder	20 $\frac{3}{4}$ inches.	Full length	42 inches.
		Height	6 feet.

Form and attitude, normal. Sizes 42 to 52 breasts.

#### TO DRAFT.

- Square both ways from 4.
- 4 to B is  $\frac{1}{3}$  breast and 3 $\frac{1}{2}$  inches.....Add 1 inch
- B to 3 is  $\frac{1}{3}$  breast of height, and 3 $\frac{1}{2}$  inches.
- A is half way between 3 and 4.
- This is the proportional, and includes all allowances.
- A to C is natural waist (18 $\frac{3}{4}$ ).....Add 1 inch
- C to D is  $\frac{1}{3}$  breast, on "3RDS"; (8) seat-line.
- Added to the natural waist gives correct length.
- A to E is the Full Length of Back.
- F is half between B and 4.....Add  $\frac{1}{2}$  inch
- Square out from A, B, C, D, E, F, 3 and 4.
- C to G is  $\frac{1}{2}$  inch; draw line F to G and down to E.
- From the line just drawn inside of B measure to H.
- B to H is half the full breast measure (24).
- H to I is 2 $\frac{1}{2}$  inches, center of breast....Add 1 inch.
- B to K is blade, with seams.....Add 1 inch.
- Square up from K to 3.....Add 1 inch.
- L is half way between B and K.
- L to M is 1 $\frac{1}{4}$  inches, width of Back.
- Square up to O, and down to N.....Add 1 inch
- P is  $\frac{1}{2}$  inch from Line O-M; draw line to N.
- A to Q is  $\frac{1}{12}$  breast—on "12THS," and
- Q to R is 1 $\frac{1}{2}$  inches; square up to S,  $\frac{5}{8}$  inch.
- Point S is half way between upper and lower s.
- Advance from K,  $\frac{1}{16}$  inch each size above 4 inches less than breast. To straighten the front run, take it out in the underarm cut as shown by shaded part.
- K to T is 1 $\frac{3}{4}$  inches; T to U is  $\frac{1}{12}$  breast.
- Square up from U to V, locating the shoulder point.
- V is located on lines from U and 4.
- Draw lines from S to U, and F to V.
- This gives the proportional height of shoulders.
- Rise at X  $\frac{1}{2}$  inch, and lower at point I the same.
- X is  $\frac{1}{2}$  inch on the S-U line—or Style.
- Y is  $\frac{1}{2}$  inch from the O-N line, and 1-12 up from M, plus  $\frac{1}{4}$  inch.
- Draw guide line from Y to P.
- From B up apply depth of scye measure and  $\frac{1}{2}$  inch to A, in normal attitude will meet line A.
- The  $\frac{1}{2}$  inch is for fullness held in over the blade.
- Shape the Back as shown; draw line from B to W.
- Apply strap measure, and 1 inch A to K and 3 to V in normal attitude will meet line 4-V.
- Apply over shoulder measure and 1 inch B to W and 3 to Z; when normal, meet line F-V.
- Z is 1 $\frac{1}{4}$  inches from line K.
- Draw a line from V through Z to point 1.
- V to point 1 is  $\frac{1}{2}$  inch less than S to N.
- Draw a guide line from point 1 to T.
- Shape arm-scye and shoulder rounding  $\frac{1}{2}$  inch over Z.
- B to 2 is  $\frac{1}{2}$  breast on "HALVES"; 2 to K is 3 $\frac{1}{2}$  inches.
- This is normal blade and independent of the actual blade.
- Square down from K through 4 to 17.
- 4 to 5 is  $\frac{1}{2}$  waist—on "HALVES".....Add 1 inch
- Square down from 5 to 7. The measure from B to 2, K, 4 and 5 is used only to obtain the front center of the waist and to check the blade measure.
- 5 to 8 is 2 inches, 9 to 10 is the same.
- These 2 inches are for seams and make-up.
- In corpulency, measure the waist first and obtain the hip spring from it. This rule applies where the waist is even, or more, than the breast.
- Measure waist and 1 $\frac{1}{4}$  inches P to G and 8 to 16. ....Add 1 inch
- Square down from 16 to 12; 12 to 11 is 1 $\frac{1}{4}$  inches.
- (Proportional hip spring 12 to 11 is 1 $\frac{3}{4}$  inches.)
- Draw a line from 16 through 11 to 14....Add 1 inch.
- Y to 14 is the length from Y to N.
- Shape side seam of forepart from Y to 16, going out  $\frac{5}{8}$  inch over 11 to 14—or Style.
- (Reduce  $\frac{1}{2}$  inch from Y to 16 when no underarm cut.)
- Z to 7 is length from Z to E and 1 inch, from line K.
- The 1 inch is taken up in making the front edge.
- Draw line 14 to 7; shape bottom; lower 1 inch at 17.
- Measure hip and  $\frac{3}{4}$  inch; width of Back from 12 to D, and from 10 to 11.....Add 1 inch
- Draw line 15 and take out the shaded part.
- Open at 2 the amount of seat surplus and fold 33 on 34 by cutting to pocket and to front of pocket.
- The surplus 2 $\frac{1}{4}$  inches opens the pocket  $\frac{5}{8}$  inch.
- V to 18 is  $\frac{1}{12}$  breast; square forward from 18 by 3
- 18 to 19 is  $\frac{1}{4}$  breast.....Add 1 inch
- Draw line from 19 to I and 5.
- Advance at I the amount from K to 3.
- 19 to 20 is 2 $\frac{1}{2}$  inches notch  $\frac{1}{2}$  inch from 19.
- I to J is 2 $\frac{1}{2}$  inches, 5 to 6 is the same.
- Go in  $\frac{1}{2}$  inch at 7; draw line from 6 and shape front.
- V to 21 is 1 $\frac{1}{4}$  inches; draw line to end of roll.
- The pocket is  $\frac{2}{3}$  sleeve length and  $\frac{1}{2}$  inch from K.
- (For double-breasted add 2 $\frac{1}{4}$  inches to the front.)
- The buttons are 4 inches from the edge.

## Box Overcoat

### Diagram 45

3. The measures are taken over the Vest always.

Inside sleeve	17 $\frac{3}{4}$ inches.	Blade (with 1 $\frac{1}{4}$ inches for
Breast	36 inches.	seams added) 12 $\frac{1}{2}$ in.
Waist	32 inches.	Depth of scye 9 inches.
Hip or seat	37 inches.	Natural waist 16 $\frac{3}{4}$ inches.
Strap	12 inches.	Full length 38 inches.
Over shoulder	17 inches.	Height 5 feet 6 inches.

Form and attitude, normal. Sizes 33 to 48 breasts.

#### To DRAFT.

- 1 Square both ways from A.
- 2 A to B is  $\frac{1}{3}$  breast and 3 $\frac{1}{2}$  inches. . . . . Add 1 inch
- 3 B to A is  $\frac{1}{3}$  breast of height, and 3 $\frac{1}{2}$  inches (10 $\frac{1}{2}$ ).
- 4 This is the proportional, and includes all allowances.
- 5 A to C is natural waist (16 $\frac{3}{4}$ ). . . . . Add 1 inch
- 6 C to D is  $\frac{1}{3}$  breast, on "3rds" (6) seat-line.
- 7 Added to the natural waist gives correct length.
- 8 A to E is the Full Length of Back.
- 9 F is half between B and A. . . . . Add  $\frac{1}{2}$  inch
- 10 Square out from A, B, C, D, E and F.
- 11 B to H is half the full breast measure (18).
- 12 H to I is 2 $\frac{1}{2}$  inches, center of breast. . . . . Add 1 inch
- 13 B to K is blade, with seams. . . . . Add 1 inch
- 14 Square up from K to 3. . . . . Add 1 inch
- 15 L is half way between B and K.
- 16 L to M is 1 $\frac{1}{4}$  inches—width of Back.
- 17 Square up to O and down to P.
- 18 A to Q is  $\frac{1}{12}$  breast—on "12rds"—and
- 19 Q to R is 1 $\frac{1}{2}$  inches; square up to S,  $\frac{5}{8}$  inch.
- 20 K to T is 1 $\frac{3}{4}$  inches; T to U is  $\frac{1}{12}$  breast.
- 21 Square up from U to V, locating the shoulder point.
- 22 V is located on lines from U and A.
- 23 Draw lines from S to U, and F to V.
- 24 This gives the proportional height of shoulders.
- 25 Rise at X  $\frac{1}{2}$  inch, and lower at point 1 the same.
- 26 X is  $\frac{1}{2}$  inch on the S-U line—or Style.
- 27 Y is  $\frac{1}{2}$  inch from the O-N line, and  $\frac{1}{12}$  up from M.
- 28 P to 12 is 2 inches.
- 29 P to 11 is 3 inches.
- 30 Draw lines from Y through 12 to N, and Y through 11 to 14.
- 31 If drapery is wanted, add to Y 1 inch and draw parallel line to N, from X.
- 32 From B up apply depth of scye measure and  $\frac{1}{2}$  inch (10 $\frac{1}{2}$ ) to A in normal attitude will meet line A.
- 33 The  $\frac{1}{2}$  inch is for fullness held in over the blade.
- 34 Shape the Back as shown; draw line from B to W.
- 35 Apply strap measure, and 1 inch A to R and 3 to V (13) in normal attitude will meet line A-V.
- 36 Apply over shoulder measure and 1 inch (18) B to W and 3 to Z; when normal, meet line F-V.
- 37 Z is 1 $\frac{1}{4}$  inches from line K.
- 38 Draw a line from V through Z to point 1.
- 39 V to point 1 is  $\frac{1}{2}$  inch less than S to X.
- 40 Draw a guide line from point 1 to T.
- 41 Shape arm-scye and shoulder rounding  $\frac{1}{2}$  in. over Z.
- 42 B to 2 is  $\frac{1}{2}$  breast on "HALVES"; 2 to K is 3 $\frac{1}{2}$  inches.
- 43 This is normal blade and independent of the actual blade.
- 44 Square down from K through 4 to 17.
- 45 4 to 5 is  $\frac{1}{2}$  waist—on "HALVES". . . . . Add 1 inch
- 46 Square down from 5 to 7. The measure from B to 2, K, 4 and 5 is used only to obtain the front center of the waist and to check the blade measure.
- 49 Z to 7 is length from Z to E and 1 inch, from line K.
- 50 The 1 inch is taken up in making the front edge.
- 51 Draw line 14 to 7; shape bottom; lower 1 inch at 17.
- 52 V to 18 is  $\frac{1}{12}$  breast; square forward from 18 by K.
- 53 18 to 19 is  $\frac{1}{4}$  breast. . . . . Add 1 inch
- 54 Draw a line from 19 to I and 5.
- 55 19 to 20 is 2 $\frac{1}{2}$  inches; notch  $\frac{1}{2}$  inch from 19.
- 56 1 to J is 2 $\frac{1}{2}$  inches; 5 to 6 is the same.
- 57 Go in  $\frac{1}{2}$  inch at 7; draw line from 6 and shape front.
- 58 V to 21 is 1 $\frac{1}{4}$  inches; draw line to end of roll.
- 59 The pocket is  $\frac{2}{3}$  sleeve length and  $\frac{1}{2}$  inch from K.
- 60 (For double-breasted add 2 $\frac{1}{4}$  inches to the front.)

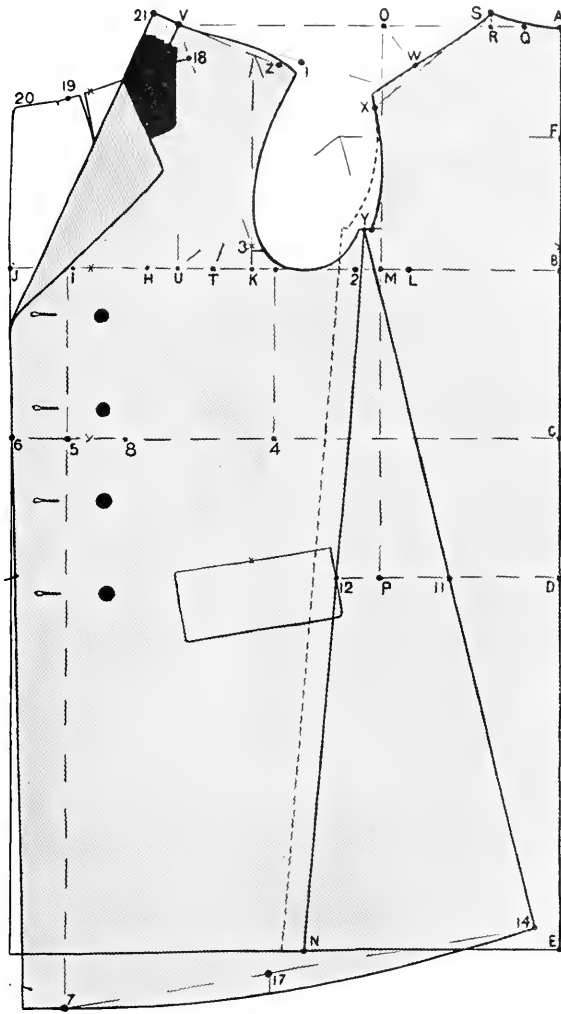

DIAGRAM 45 — BOX OVERCOAT

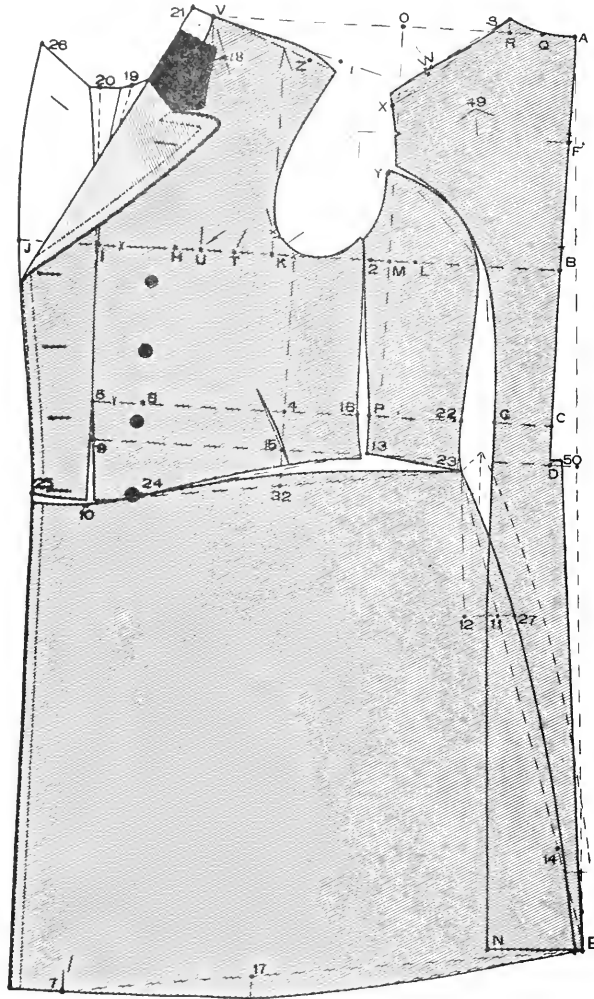

DIAGRAM 46 - FROCK OVERCOAT

# Frock Overcoat

## Diagram 46

4. The measures are taken over the Vest always.

Inside sleeve	17 $\frac{3}{4}$ inches.	Blade (with 1 $\frac{1}{4}$ inches for
Breast	36 inches.	seams added) 12 $\frac{1}{2}$ in.
Waist	32 inches.	Depth of scye
Hip or seat	37 inches.	Natural waist
Strap	12 inches.	Fashion waist
Over shoulder	17 inches.	Full length
		Height

Form and attitude, normal. Sizes, 33 to 42 breasts.

### TO DRAFT.

- 1 Square both ways from A.
- 2 A to B is  $\frac{1}{3}$  breast and 3 $\frac{1}{2}$  inches. . . . . Add 1 inch
- 3 B to A is  $\frac{1}{3}$  breast of *height*, and 3 $\frac{1}{2}$  inches.
- 4 A is half way between — and —.
- 5 This is the proportional, and includes all allowances.
- 6 A to C is natural waist (16 $\frac{3}{4}$ ). . . . . Add 1 inch
- 7 A to D is the fashion waist; one-fourth height and 1 $\frac{1}{2}$  inches (18 $\frac{1}{4}$ ). . . . . Add 1 inch
- 8 D to 50 is 1 $\frac{1}{4}$  inches, line from A through 50 to E.
- 9 A to E is the Full Length of Back.
- 10 F is half between A and B. . . . . Add  $\frac{1}{2}$  inch
- 11 Square out from A, B, C, D, E and F.
- 12 B to H is half the full breast measure.
- 13 H to I is 2 $\frac{1}{2}$  inches, center of breast. . . . . Add 1 inch
- 14 B to K is blade (with seams). . . . . Add 1 inch
- 15 Square up from K to 3. . . . . Add 1 inch
- 16 L is half way between B and K.
- 17 L to M is 1 $\frac{1}{4}$  inches—width of Back.
- 18 Square up to O, and down to P.
- 19 P is  $\frac{1}{2}$  inch from Line O-M. Square down to 13.
- 20 A to Q is  $\frac{1}{12}$  breast—on "12THS"—and
- 21 O to R is 1 $\frac{1}{2}$  inches. Square up to S,  $\frac{5}{8}$  inch.
- 22 K to T is 1 $\frac{3}{4}$  inches; T to U is  $\frac{1}{12}$  breast.
- 23 Square up from U to V, locating the shoulder point.
- 24 V is located on lines from U to A.
- 25 Draw lines from S to U, F to V, and A to K.
- 26 This gives the proportional height of shoulders.
- 27 Rise at X  $\frac{1}{2}$  inch, and lower at point 1 the same.
- 28 X is  $\frac{1}{2}$  inch on the S-U line—or Style.
- 29 Y is  $\frac{1}{2}$  inch from the O-M line.
- 30 Draw guide line from X to Y.
- 31 From B up apply depth of scye measure and  $\frac{1}{2}$  inch to A in normal attitude will meet line A.
- 32 The  $\frac{1}{2}$  inch is for fullness held in over the blade.
- 33 C to G is  $\frac{1}{16}$  breast and 1 $\frac{1}{2}$  inches.
- 34 E to N is the same width as 50 to G, and  $\frac{1}{2}$  inch.
- 35 Draw line from G to N and from
- 36 49 to G for width of Back over breast line.
- 37 49 is on F-V and A-K lines.
- 38 Blade fullness is  $\frac{5}{8}$  inch over the rounding.
- 39 Shape the Back as shown; draw line from B to W.
- 40 Apply strap measure and 1 inch A to R and 3 to V (13) in normal attitude will meet line A-V.
- 41 Apply over shoulder measure and 1 inch B to W and 3 to Z; when normal, meet line F-V (18).
- 42 Z is 1 $\frac{1}{4}$  inches from line K.
- 43 Draw a line from V through Z to point 1.
- 44 V to point 1 is  $\frac{1}{2}$  inch less than S to X.
- 45 Draw a guide line from point 1 to F.
- 46 Shape arm-seye and shoulder rounding  $\frac{1}{2}$  in. over Z.
- 47 B to 2 is  $\frac{1}{2}$  breast on "HALVES"; 2 to K is 3 $\frac{1}{2}$  inches.
- 48 This is normal blade and independent of the actual blade.
- 49 Square down from K through 4 to 17.
- 50 4 to 5 is  $\frac{1}{2}$  waist—on "HALVES". . . . . Add in inch.
- 51 Square down from 5 to 7. The measure from B to 2, K, 4 and 5 is used only to obtain the front center of the waist, and to check the blade measure.
- 52 5 to 8 is 2 $\frac{1}{4}$  inches; 9 to 10 is 1.6 breast.
- 53 These 2 $\frac{1}{4}$  inches are for seams and make-up.
- 54 G to 22 is 1 $\frac{3}{4}$  inches, or 1 $\frac{1}{4}$  inches in all sizes, to allow for blade fullness and  $\frac{1}{8}$  inch for every inch the waist is smaller than the breast.
- 55 Square up, and down to 23; 23 is  $\frac{5}{8}$  inch below the fashion waist, or sweep from the Back by Y.
- 56 Measure waist net G to C, P to 22, and 8 to 16. . . . . Add 1 inch
- 57 Shape side body reducing  $\frac{1}{4}$  inch near Y,  $\frac{3}{8}$  inch at breast line and from 2 to 13 and 16, and 23 to 13.
- 58 A  $\frac{1}{4}$  inch should be added to 22 for ease.
- 59 V to 18 is 1  $\frac{1}{2}$  breast; square forward from 18 by K.
- 60 18 to 19 is  $\frac{1}{4}$  breast; draw line from 19 to 1 and 5.
- 61 Add  $\frac{1}{4}$  inch rounding over the breast.
- 62 Rever—19 to 20 is 1 $\frac{1}{2}$  inches, or draw a straight line through 5-9; straighten  $\frac{1}{2}$  inch at 20.
- 63 10 to 24 is 2 $\frac{1}{2}$  ins.; 10 to 25 the same; sweep by 20.
- 64 Draw a line from 13 to 24; shape from 13 to 25.
- 65 The opening at 10 and 25 should be the same.
- 66 Draw a line from K through 20 to 26.
- 67 20 to 26 is 2 $\frac{3}{4}$  inches; 1 to J is 3 $\frac{1}{2}$  inches.
- 68 Shape lapel through 26—J to 25.
- 69 Skirt—For a medium full skirt rise at 32 a  $\frac{1}{2}$  inch and square down by 23.
- 70 Draw a line from 23 to 24; square down to 12.
- 71 Flare—At 23 go up  $\frac{5}{8}$  inch and square down by 32.
- 72 23 to 12 is 1  $\frac{1}{3}$  breast and  $\frac{1}{2}$  inch.
- 73 12 to 11 is 1 $\frac{1}{2}$  inches; 11 to 27 is  $\frac{3}{4}$  inch.
- 74 Draw a line from 23 through 11 and 14.
- 75 14 is natural waist, and 1 inch from 23.
- 76 23 to bottom is  $\frac{1}{4}$  inch more than D to E.
- 77 Lay "square" on 27-14 and mark for run of bottom.
- 78 Shape skirt through 27 to bottom.
- 79 Z to 7 is length from Z to E and 1 inch from line K.
- 80 Draw line 14 to 7; shape bottom; lower 1 inch at 17.
- 81 Square down the front edge to 7, by the waist line.
- 82 Take out a fish  $\frac{1}{8}$  inch, 1.6 up from 15.
- 83 Go out  $\frac{1}{2}$  from D and line parallel to 50-E.
- 84 Reduce  $\frac{1}{8}$  inch at B from A to C.
- 85 A Frock Overcoat should always be worn over a Frock Coat; never over a Sack Coat.

# Ulster

## Diagram 47

5. The measures are taken over the Vest always.

Inside sleeve	17 $\frac{3}{4}$ inches.	Blade (with 1 $\frac{1}{4}$ inches for
Breast	36 inches.	seams added) 12 $\frac{1}{2}$ in.
Waist	32 inches.	Depth of scye 9 inches.
Hip or seat	37 inches.	Natural waist 16 $\frac{3}{4}$ inches.
Strap	12 inches.	Full length 50 inches.
Over shoulder	17 inches.	Height 5 feet 6 inches.

Form and attitude, normal. Sizes, 33 to 42 breasts

### TO DRAFT.

- 1 Square both ways from A.
- 2 A to B is 1/3 breast and 3 $\frac{1}{2}$  inches. . . . . Add 1 inch
- 3 B to A is 1/3 breast of height and 3 $\frac{1}{2}$  inches (10 $\frac{1}{2}$ ).
- 4 A is half way between — and —.
- 5 This is the proportional and includes all allowances.
- 6 A to C is natural waist (16 $\frac{3}{4}$ ). . . . . Add 1 inch
- 7 C to D is 1/3 breast, on "3RDS" (6) seat line.
- 8 Added to the natural waist gives correct length.
- 9 A to E is the Full Length of Back (50).
- 10 F is half between B and A. . . . . Add  $\frac{1}{2}$  inch
- 11 Square out from A, B, C, D, E and F.
- 12 C to G is  $\frac{1}{2}$  inch; draw line F to G and down to E.
- 13 From the line just drawn inside of B measure to H.
- 14 B to H is half the full breast measure (18).
- 15 H to I is 2 $\frac{1}{2}$  inches, center of breast. . . . . Add 1 inch
- 16 B to K is blade (with seams). . . . . Add 1 inch
- 17 Square up from K to 3. . . . . Add 1 inch
- 18 L is half way between B and K.
- 19 L to M is 1 $\frac{1}{4}$  inches, width of Back.
- 20 Square up to O, and down to N. . . . . Add 1 inch
- 21 P is  $\frac{1}{2}$  inch from Line O-M; draw line to X.
- 22 A to Q is 1/12 breast—on "12RNS"—and
- 23 Q to R is 1 $\frac{1}{2}$  inches; square up to S,  $\frac{5}{8}$  inch.
- 24 K to T is 1 $\frac{3}{4}$  inches; T to U is 1/12 breast.
- 25 Square up from U to V, locating the shoulder point.
- 26 V is located on lines from U and A.
- 27 Draw lines from S to U, and F to V.
- 28 This gives the proportional height of shoulders.
- 29 Rise at X  $\frac{1}{2}$  inch, and lower at point 1 the same.
- 30 X is  $\frac{1}{2}$  inch on the S-U line—or Style.
- 31 Y is  $\frac{1}{2}$  inch from the O-N line, and 12 up from M, plus  $\frac{1}{4}$  inch.
- 32 Draw guide line from Y to P.
- 33 From B up apply depth of scye measure and  $\frac{1}{2}$  inch (10 $\frac{1}{2}$ ) to A in normal attitude will meet line A.
- 34 The  $\frac{1}{2}$  inch is for fullness held in over the blade.
- 35 Shape the Back as shown; draw line from B to W.
- 36 Apply strap measure, and 1 inch A to R and 3 to V (13) in normal attitude will meet line A-V.
- 37 Apply over shoulder measure and 1 inch (18) B to W and 3 to Z; when normal, meet line F-V.
- 38 Z is 1 $\frac{1}{4}$  inches from line K.
- 39 Draw a line from V through Z to point 1.
- 40 Y to point 1 is  $\frac{1}{2}$  inch less than S to X.
- 41 Draw a guide line from point 1 to T.
- 42 Shape arm-scye and shoulder rounding  $\frac{1}{2}$  in. over Z.
- 43 B to 2 is  $\frac{1}{2}$  breast on "HALVES"; 2 to K is 3 $\frac{1}{2}$  inches.
- 44 This is normal blade and independent of the actual blade.
- 45 Square down from K through 4 to 17.
- 46 4 to 5 is  $\frac{1}{2}$  waist—on "HALVES". . . . . Add 1 inch
- 47 Square down from 5 to 7. The measure from B to 2, K, 4 and 5 is used only to obtain the front center of the waist and to check the blade measure.
- 48 5 to 8 is 2 $\frac{1}{2}$  inches, 9 to 10 is the same.
- 49 These 2 $\frac{1}{2}$  inches are for seams and make-up.
- 50 Apply hip measure and  $\frac{3}{4}$  inch for 3 seams; width of Back from 12 to D and 10 to 11. . . . . Add 1 inch
- 51 11 to 12 is 1 $\frac{3}{4}$  inches; square up, locating 13.
- 52 (Proportional hip spring 12 to 11 is 1 $\frac{3}{4}$  inches.)
- 53 Draw a line from 13 through 11 to 14. . . . . Add 1 inch
- 54 Measure waist and 1 $\frac{1}{2}$  inches P to G and 8 to 16. . . . . Add 1 inch
- 55 Y to 14 is the length from Y to N.
- 56 Shape side seam of forepart from Y to 16, going out  $\frac{5}{8}$  inch over 11 to 14—or Style.
- 57 (Reduce  $\frac{1}{2}$  in. from Y to 16 when no underarm cut.)
- 58 Z to 7 is length from Z to E and 1 inch, from line K.
- 59 The 1 inch is taken up in making the front edge.
- 60 Draw line 14 to 7; shape bottom; lower 1 inch at 17.
- 61 V to 18 is 1/12 breast plus  $\frac{1}{2}$  inch; square forward.
- 62 18 to 19 is  $\frac{1}{4}$  breast. . . . . Add 1 inch
- 63 19 to 20 is 2 inches; add a seam in P.
- 64 20 to 26 is 3 $\frac{1}{2}$  inches by 2.
- 65 I to J and 5 to 6 is 4 inches.
- 66 Go in  $\frac{1}{2}$  inch at 7; draw line from 6 and shape front.
- 67 The pocket is 2/3 sleeve length and  $\frac{1}{2}$  inch from K.
- 68 The collar is either a Prussian style or double stand.



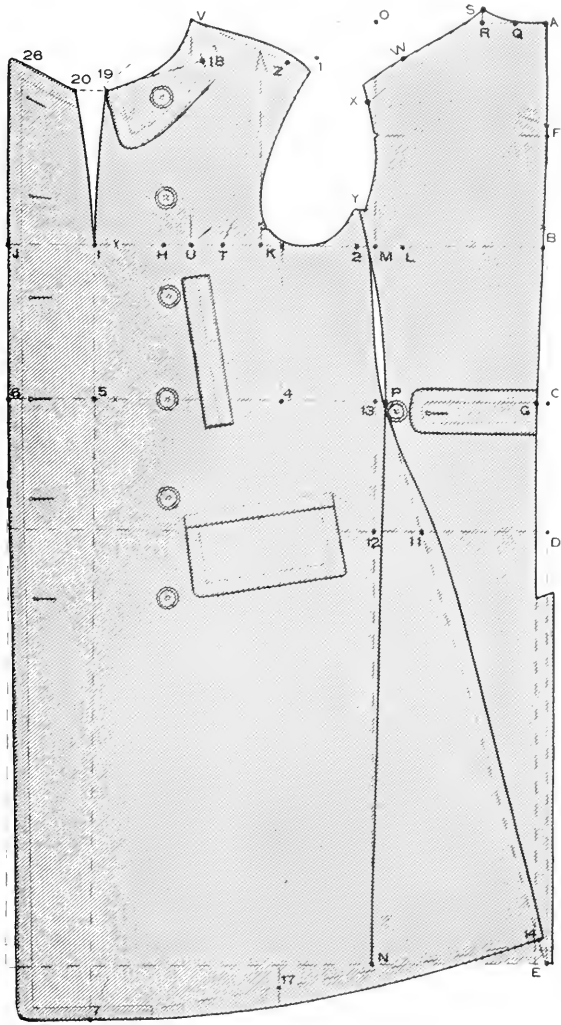

DIAGRAM 47 — DOUBLE-BREADED ULSTER

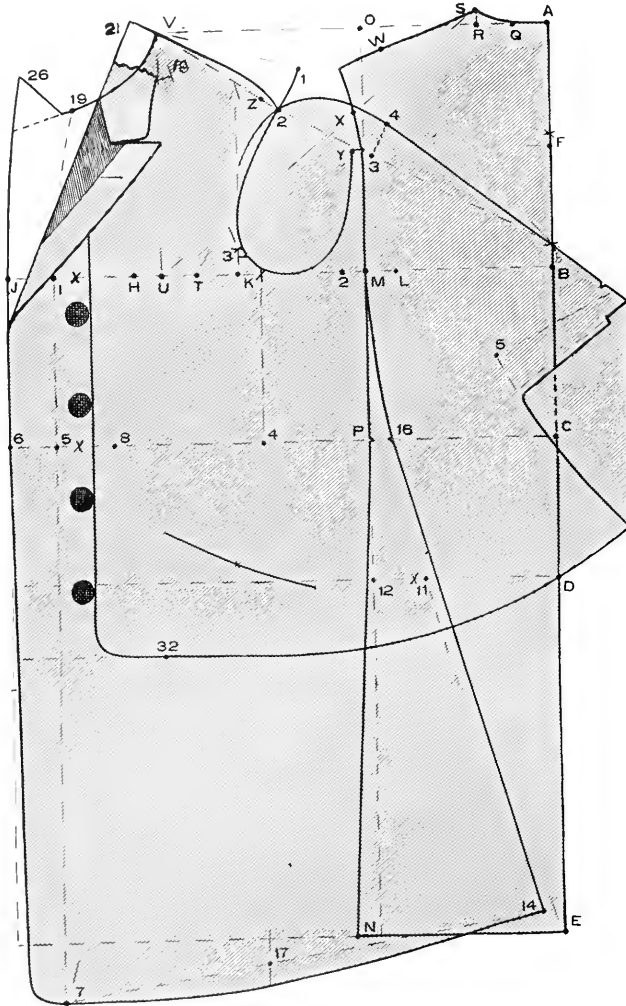

DIAGRAM 48 — INVERNESS WITH CAPE

## Inverness With Cape

Diagram 48

6. The measures are taken over the Vest always.  
 Inside sleeve 17¾ inches. Blade (with 1¼ inches for  
 Breast 36 inches. seams added) 12½ in.  
 Waist 32 inches. Depth of scye 9 inches.  
 Hip or seat 37 inches. Natural waist 16¾ inches.  
 Strap 12 inches. Full length 40 inches.  
 Over shoulder 17 inches. Height 5 feet 6 inches.  
 Form and attitude, normal. Sizes 33 to 42 breasts.

### TO DRAFT.

- 1 Square both ways from A or 4.
- 2 4 to B is 1/3 breast and 3½ inches. . . . . Add 1 inch
- 3 B to 3 is 1/3 of height and 3½ inches (10½).
- 4 A is half way between 3 and 4.
- 5 This is the proportional, and includes all allowances.
- 6 A to C is natural waist (16¾) . . . . . Add 1 inch
- 7 C to D is 1/3 breast, on "3RDS"; (6) seat line.
- 8 Added to the natural waist gives correct length.
- 9 A to E is the Full Length of Back.
- 10 F is half between B and 4. . . . . Add ½ inch
- 11 Square out from A, B, C, D, E, F, 3 and 4.
- 14 B to H is half the full breast measure (18).
- 15 H to I is 2½ inches, center of breast. . . . . Add 1 inch
- 16 B to K is blade (with seams) . . . . . Add 1 inch
- 17 Square up from K to 3. . . . . Add 1 inch
- 18 L is half way between B and K.
- 19 L to M is 1¼ inches, width of Back.
- 20 Square up to O, and down to N. . . . . Add 1 inch
- 21 A to Q is 1/12 breast—on "12THS"—and
- 22 Q to R is 1½ inches; square up to S, ⅝ inch.
- 23 K to T is 1¾ inches; T to U is 1/12 breast.
- 24 Square up from U to V, locating the shoulder point.
- 25 V is located on lines from U and A.
- 26 Draw lines from S to U, and F to V.
- 27 This gives the proportional height of shoulders.
- 28 Rise at X 2 inches and lower at point 1 the same.
- 29 X is 1 inch on the S-U line—or Style.
- 30 Y is ½ inch from the O-N and ½ inch below notch.
- 31 From B up apply depth of scye measure and ½ inch to A in normal attitude will meet line A (10½).
- 32 The ½ inch is for fullness held in over the blade.
- 33 Shape the Back as shown; draw line from B to W.
- 34 Apply strap measure and 1 inch A to R and 3 to V in normal attitude will meet line A-V.
- 35 Apply over shoulder measure and 1 inch B to W and 3 to Z; when normal, meet line F-V.
- 36 Z is 1¼ inches from line K.
- 37 Draw a line from V through Z to point 1.
- 38 V to point 1 is ⅜ inch less than S to X.
- 39 Draw a guide line from point 1 to T.

- 40 Shape arm-scye and shoulder rounding ½ in. over Z.
- 41 B to 2 is ½ breast on "HALVES"; 2 to K is 3½ inches.
- 42 This is normal blade and independent of the actual blade.
- 43 Square down from K through 4 to 17.
- 44 4 to 5 is ½ waist—on "HALVES". . . . . Add 1 inch
- 45 Square down from 5 to 7. The measure from B to 2, K, 4 and 5 is used only to obtain the front center of the waist and to check the blade measure.
- 46 5 to 8 is 2½ inches, 9 to 10 is the same.
- 47 These 2½ inches are for seams and make-up.
- 48 Apply hip measure and ¾ inch for 3 seams; width of Back from 12 to D and 10 to 11. . . . . Add 1 inch
- 49 11 to 12 is 1¾ inches; square up, locating 10.
- 50 (Proportional hip spring 12 to 11 is 1¾ inches.)
- 51 Y to 14 is the length from Y to N.
- 52 Shape side seam of forepart from Y to 16 and 14.
- 53 Z to 7 is length from Z to E and 1 inch, from line K.
- 54 The 1 inch is taken up in making the front edge.
- 55 Draw line 14 to 7; shape bottom; lower 1 inch at 17.
- 56 V to 18 is 1/12 breast, plus ½ inch; square from 18 by K.
- 57 18 to 19 is ¼ breast. . . . . Add 1 inch
- 58 Draw a line from 19 to 1 and 5.
- 59 19 to 20 is 2½ inches; notch ½ inch from 19.
- 60 1 to J is 2 inches; 5 to 6 is 2 inches; square down.
- 61 Go in ½ inch at 7; draw line from 6 and shape front.
- 62 The side seams are notched at the waistline.
- 63 The opening of front is made to measure.
- 64 The pocket is 2/3 sleeve length and ½ inch from K.
- 65 (For double-breasted add 3 inches to the front.)

### To Form the Wing or Cape

- 66 Draw shoulder seam of the cape even with the forepart, from V to 2 and from V to 19.
- 67 Draw a line from 2 through B to 5.
- 68 2 to 3 is ¼ breast (4½).
- 69 3 to 4 is 1½ inches.
- 70 Shape side seam of wing through points 4 and 2.
- 71 The curve may be continued to the front shoulder, as shown on the diagram.
- 72 The front edge of the wing is curved from the back of the break, or crease line.
- 73 V to 32 in a direct line down is length desired (27).
- 74 Sweep from 32 to 5; pivot at 2; finish to front.
- 75 2 to notch on the wing in a straight line is the same as X to the notch on side seam.
- 76 The front of cape is about 3½ inches from edge.
- 77 The buttons, 3 inches; finished with hooks or buttons under collar.

## Shoulder Cape

### Diagram 49

Breast, 36 inches. Length, 27½ inches.

- 1 9. Square both ways from A.
- 2 A to B is 1/3 breast and 3½ inches. . . . . Add 1 inch
- 3 A to C is ¼ height and ¼ inch. . . . . Add 1 inch
- 4 A to E is the full length (27½).
- 5 Square out from B, C and E.
- 6 B to H is half full breast (18). . . . . Add 1 inch
- 7 A to Q is 1/12 breast—on "12rns" and
- 8 Q to R is 1½ inches; square up to S 5/8 inch.
- 9 A to O is half breast (10). . . . . Add 1 inch
- 10 Square down to X, 1/6 breast (3).
- 11 Draw lines from S to X and X through K to Y.
- 12 Shape from A to S, X to K.  
This completes the back part.
- 13 10. A to F is 1/6 and 5/8 inch.
- 14 E to D is 2 inches.
- 15 Sweep from D to Y; pivot at S.
- 16 Shape the Back from E to Y.
- 17 Shape front shoulder from R to X and gorge to F.
- 18 F is 1 inch from line A, or to measure.
- 19 B to J is 1¾ inches; square down.
- 20 This finishes the front for hooks and eyes.
- 21 To F and J add 1½ inches for buttons.
- 22 The broken lines show the position of the overcoat, and also prove the correct position of the cape.
- 23 If the front cape is laid to the front, point J will fall on point I.
- 24 It clears the shoulder, head and sleeve and brings the seams squarely on top of the shoulder.
- 25 For shorter capes proceed the same way.
- 26 For longer capes keep on line I from K down.

## Cape—Half Circle

### Diagram 50

- 1 11. Square both ways from A.
- 2 Place the pattern (Overcoat) in position.
- 3 The back against line A-E and the front against line A-B.
- 4 The shoulders to meet at X.
- 5 Draw a line from A through G to F.
- 6 Measure length desired from C to E.
- 7 G to F is 2 inches more than C to E.
- 8 D to B is 1 inch less than C to E.
- 9 Reduce 1 inch from the front. This will leave a 1½-inch stand beyond the front center of an Overcoat, or hook and eye line. (See shoulder cape.)
- 10 Sweep both ways from F; pivot at G and finish.

## Cape—Three-Quarter Circle

### Diagram 51

- 1 12. Draw line O-P and place the forepart pattern (Overcoat) in position.
- 2 Place back with the shoulder seam in a closing position and mark all around the upper part of the coat.
- 3 Draw a line through the shoulder to Q.
- 4 Measure length desired from R to S.
- 5 T to Q is 2 inches more than R to S.
- 6 N to P is 1 inch less than R to S.
- 7 Reduce 1 inch from the front. This will leave 1½-inch stand beyond the front center of an Overcoat and is the hook and eye line.
- 8 Sweep both ways from Q; pivot at T and finish as represented.

## Cape—Circular

### Diagram 52

- 1 13. Draw line H-I and place the pattern (Overcoat) in position.
- 2 The back against the line drawn and the shoulders to meet at J.
- 3 Draw a line from K through J to L.
- 4 Measure length desired from M to H.
- 5 J to L is 2 inches more than M to H.
- 6 N to I is 1 inch less than M to H.
- 7 Reduce 1 inch from the front. This will leave 1½-inch stand beyond the front center of an Overcoat, and is the hook and eye line.
- 8 Sweep both ways from L; pivot at J and finish.

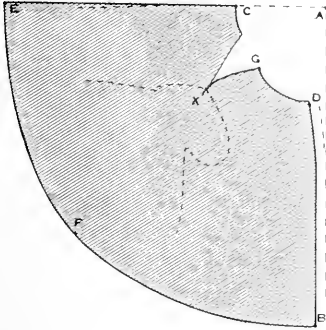

DIAGRAM 50 — CAPE HALF CIRCLE

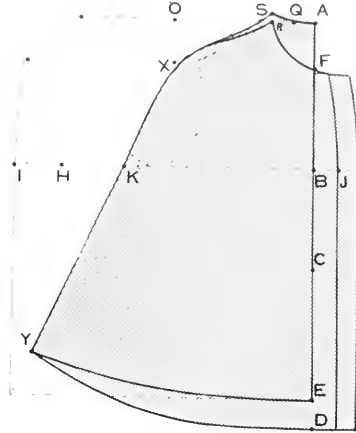

DIAGRAM 49 — SHOULDER CAPE

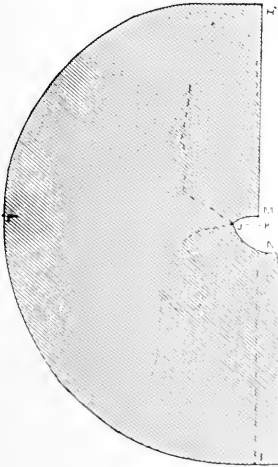

DIAGRAM 52 — CAPE CIRCULAR

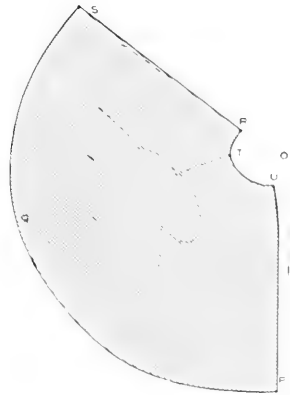

DIAGRAM 51 — CAPE THREE-QUARTER CIRCLE

## Tables of Proportions

14. Tables of proportions are to most people great mysteries in the makeup; but if taken hold of and dissected to see the inside of them, they will be found to be really very simple, like anything else, once in the right direction.

In the first place, it is impossible to make a table of proportion that will fit the majority of people in the United States, because there is too much difference in the people in the different parts of the country.

15. Persons who have had a chance to observe know that the average breast sizes of the people in New York city will be 37 breast, or between 35 and 38. In Chicago they will average 38 breast.

In the middle West or mountain district the average will be 39 breast, and on the Pacific coast the average is 40 breast.

The stature also is very variable. Again, it is known the Southern people grow very tall and usually slim.

Arguments perhaps will be advanced to show that wholesale houses must have such tables. Today the ready-to-wear houses take the orders first before anything but standard sizes are made up; consequently each locality orders what is needed in the way of sizes. It is now possible to order six suits or less from a manufacturer.

It brings us square up to the question: Why not make a table of proportions to fit the locality? Why, of course, yes.

TABLE 1.

16. There are several ways of making tables of proportions. By trying to follow near to what the tailors are wont to consider their ideal of standard; not that it is any better, but perhaps will be more readily understood.

First determine what the "standard of height" shall be; this done, write Line 1. (If this don't suit, change it.)

17. In this case it has been decided that 6 feet shall be the limit of height, and then gradually down again.

Next place the breast sizes under each figure of height—Line 2. It has also been decided that 38 breast shall be the "Single Standard" of measurement. (The double standard of monetary units are not in vogue now.)

Draw two vertical black lines on each side of 38.

It has further been decided that there shall be 4 inches difference in the breast and waist.

It will be argued that 4 inches is all right for 38 and under; but not for a 50 breast—all right, change it by proceeding as follows:

Take  $\frac{1}{2}$  of the last figure of the breast, starting with 38, and make line 3.

Of 38, the last figure is 8, half of it is 4; half the last figure of 39 is  $4\frac{1}{2}$ ; half of the last figure of 40 is 5. Well, just increase  $\frac{1}{2}$  inch for each size, then there is no figuring.

Deduct the 4 inches difference in waist and breast decided on, make line 4; 38 size, 4 from 4 leaves 0, or increase a  $\frac{1}{2}$  inch each size; the result is line 5.

Place the waist sizes of 4 inches difference under each breast size starting from single standard column, making line 6.

Add lines 5 and 6, the result is line 7; or a gradually increasing waist size.

How simple and correct it is, too.

In other words, above the standard column each size increases  $1\frac{1}{2}$  inches; below it follows the 4 inches decided on.

Next take the stouts and the corpulents.

The "Single Standard" was decided on in heights and widths.

The "Standard" heights, the "Standard" breasts, and the "Standard" waists have been obtained; use them.

In order to increase the waist circumference, it has been decided to deduct only 3 inches from the breast sizes.

For the purpose of further emphasizing the stoutness, one size less in height is adopted; thus—

By moving the breast size one column to the left, and place 39 in the "Standard" column, instead of 38; leaving the height as it is; write line 8.

Deduct the 3 inches from 39 and it leaves 36 waist for a 5 ft. 8 inches stout.

18. The standard above has been accepted, therefore add  $1\frac{1}{2}$  inches increase to each waist size above 36, and deduct 3 inches even below the column; the result is line 9.

The waist sizes for the stouts or 1st degree of corpulency.

Next take the corpulent and continue the same as the last; deducting only 2 inches for a 2nd degree of corpulency.

Place 40 in the column this time and write line 10. Deduct the 2 inches from 40, leaves 38 waist.

Add  $1\frac{1}{2}$  inches increase to each waist size above 38 and deduct 2 inches even below 40 breast.

The result is line 11; the waist size for the corpulent in 2nd degree.

19. A corpulent in 3rd degree, or 1 inch difference.

Place the next highest breast size in the "Standard" column, this time 41, and write line 12.

Deduct 1 inch difference. Leaves 40. Add  $1\frac{1}{2}$  inches increase to each waist size above 40, and deduct 1 inch even below 41 breast. The result is line 13.

Lines 14, 15, 16 and 17 are the depth of scye, obtained as explained in the system.

TABLE 2.

20. Gives the same figures with the front shoulder and over shoulder measures for the normals and the depth of scye for the stouts.

When the depth of scye is established correctly from height and width, it will give the strap and over shoulder measures without any table of calculations.

This table can also be used for combining any height and width in the table. For example, 36 breast corpulent and 5 ft. 10 inches; find depth of scye.

Advance the same distance from each column along the scye line, which will bring it to  $9\frac{7}{8}$  under the 5 ft. 7 inches, which is correct.

**Table No. 1**

Line	5 ft.										5 ft.									
1 Height, 5 ft. and inches	3	4	5	6	7	8	9	9½	10	10½	11	11½	6 ft.	11½	11	10½	10	9½		
2 Breast	33	34	35	36	37	38	39	40	41	42	43	44	45	46	47	48	49	50		
3 ½ last figure						4	4½	5	5½	6	6½	7	7½	8	8½	9	9½	10		
4 4 inches deducted						4	4	4	4	4	4	4	4	4	4	4	4	4		
5 Balance added to waist						0	½	1	1½	2	2½	3	3½	4	4½	5	5½	6		
6 4-in. waist added	29	30	31	32	33	34	35	36	37	38	39	40	41	42	43	44	45	46		
7 Total—Waist	29	30	31	32	33	34	35½	37	38½	40	41½	43	44½	46	47½	49	50½	52		
8 Breast	34	35	36	37	38	39	40	41	42	43	44	45	46	47	48	49	50	51		
3 inches deducted						3														
9 Waist	31	32	33	34	35	36	37½	39	40½	42	43½	45	46½	48	49½	51	52½	54		
10 Breast	35	36	37	38	39	40	41	42	43	44	45	46	47	48	49	50	51	52		
2 inches deducted						2														
11 Waist	33	34	35	36	37	38	39½	41	42½	44	45½	47	48½	50	51½	53	54½	56		
12 Breast	36	37	38	39	40	41	42	43	44	45	46	47	48	49	50	51	52	53		
1 inch deducted						1														
13 Waist	35	36	37	38	39	40	41½	43	44½	46	47½	49	50½	52	53½	55	56½	58		
14 Depth of Scye	9	9½	9¾	9½	9¾	9¾	10	10½	10¾	10¾	10½	10½	10½	10¾	10¾	10¾	10¾	11		
15 Stout—1st Degree	9	9¼	9¾	9¾	9¾	10	10½	10¾	10¾	10½	10½	10¾	10¾	10¾	10¾	11	11	11		
16 Corpulent—2d Degree	9¼	9¾	9¾	9¾	9¾	10	10½	10¾	10¾	10½	10½	10¾	10¾	10¾	11	11	11½	11½		
17 Corpulent—3d Degree	9¼	9¾	9¾	9¾	9¾	10½	10¾	10¾	10½	10½	10¾	10¾	11	11½	11½	11½	11½	11½		

**Table No. 2**

	5 ft.										5 ft.									
Heights, 5 ft. and inches	3	4	5	6	7	8	9	9½	10	10½	11	11½	6 ft.	11½	11	10½	10	9½		
Breasts	33	34	35	36	37	38	39	40	41	42	43	44	45	46	47	48	49	50		
Waists, 4 in.	29	30	31	32	33	34	35½	37	38½	40	41½	43	44½	46	47½	49	50½	52		
Depth of Scye	9	9½	9¾	9½	9¾	9¾	10	10½	10¾	10¾	10½	10½	10½	10¾	10¾	10¾	10¾	11		
Front of Shoulder	12½	12¾	12¾	13	13¼	13¾	13¾	14	14¼	14¾	14¾	15	15½	15¾	15¾	15¾	15¾	16		
Over Shoulder	17	17¼	17¾	18	18¼	18¾	19	19¼	19¾	19¾	20	20¼	20¾	20¾	21	21¼	21½	21¾		
Breasts—1st Degree	34	35	36	37	38	39	40	41	42	43	44	45	46	47	48	49	50	51		
Waists, 3 in.	31	32	33	34	35	36	37½	39	40½	42	43½	45	46½	48	49½	51	52½	54		
Depth of Scye	9½	9¼	9¾	9¾	9¾	10	10½	10¾	10¾	10½	10½	10¾	10¾	10¾	10¾	11	11	11		
Breasts—2d Degree	35	36	37	38	39	40	41	42	43	44	45	46	47	48	49	50	51	52		
Waists, 2 in.	33	34	35	36	37	38	39½	41	42¼	44	45½	47	48½	50	51½	53	54½	56		
Depth of Scye	9½	9¼	9¾	9¾	9¾	10	10½	10¾	10¾	10½	10½	10¾	10¾	10¾	11	11	11½	11½		
Breasts—3d Degree	36	37	38	39	40	41	42	43	44	45	46	47	48	49	50	51	52	53		
Waists, 1 in.	35	36	37	38	39	40	41½	43	44½	46	47½	49	50½	52	53½	55	56½	58		
Depth of Scye	9¼	9¾	9¾	9¾	9¾	10½	10¾	10¾	10½	10½	10¾	10¾	10¾	11	11	11½	11½	11½		

## Vests

### Table No. 3

Height	Breast	Waist	Scye	Strap	Over Shoulder	Blade	Opening	Length	Side Length
5 ft. 3 in.....	33	29	9	12¼	17	11¾	11¼	23¾	21¼
5 ft. 4 in.....	34	30	9½	12¾	17¾	12	11½	24¼	21½
5 ft. 5 in.....	35	31	9¾	12½	17¾	12¼	11¾	24¾	21¾
5 ft. 6 in.....	36	32	9½	12¾	18	12½	12	25	22
5 ft. 7 in.....	37	33	9¾	13	18¼	12¾	12¼	25¾	22¼
5 ft. 8 in.....	38	34	9¾	13¼	18½	13	12½	25¾	22½
5 ft. 9 in.....	39	35½	10	13½	19	13¼	12¾	26	22¾
5 ft. 9½ in.....	40	37	10½	13¾	19¼	13½	13	26½	23
5 ft. 10 in.....	41	38½	10¾	14	19½	13¾	13¼	26¾	23¼
5 ft. 10½ in.....	42	40	10¾	14¼	19¾	14	13½	27¼	23½
5 ft. 11 in.....	43	41½	10½	14¾	20	14¼	13¾	27¾	23¾
5 ft. 11½ in.....	44	43	10½	14½	20¼	14½	14	28	24
<hr/>									
5 ft. 3 in.....	36	35	9¾	12¾	18	12½	12	24½	21¾
5 ft. 4 in.....	37	36	9¾	13	18¼	12¾	12¼	25	22
5 ft. 5 in.....	38	37	9¾	13¼	18¾	13	12½	25¾	22¼
5 ft. 6 in.....	39	38	9¾	13½	19	13¼	12¾	25¾	22½
5 ft. 7 in.....	40	39	9¾	13¾	19¼	13½	13	26¼	22¾
5 ft. 8 in.....	41	40	10¾	14	19½	13¾	13¼	26¾	23
5 ft. 9 in.....	42	41½	10¾	14¼	19¾	14	13½	27¼	23¼
5 ft. 9½ in.....	43	43	10¾	14¾	20	14¼	13¾	27¾	23½
<hr/>									
5 ft. 10 in.....	44	44½	10½	14¾	20¼	14½	14	28	23¾
5 ft. 10½ in.....	45	46	10¾	14¾	20½	14¾	14¼	28¾	24
5 ft. 11 in.....	46	47½	10¾	15	20¾	15	14½	28¾	24¼
5 ft. 11½ in.....	47	49	10¾	15¾	21	15¼	14¾	29¼	24½
6 ft. in.....	48	50½	11¾	15¼	21¼	15½	15	29½	24¾
5 ft. 11½ in.....	49	52	11	15½	21½	15¾	15¼	29¾	25
5 ft. 11 in.....	50	53½	11	15¾	21¾	16	15½	30	25¼
5 ft. 10½ in.....	51	55	11¾	16	22	16¼	15¾	30¾	25½
5 ft. 10 in.....	52	56½	11¾	16¼	22¼	16½	16	30¾	25¾

To Scye has been added ½ inch. To Strap ¾ inch. To Over-Shoulder 1 inch. To Blade 1¼ inches. Lengths are net.



## Making Up

To the practical tailor the assertion will seem an almost superfluous one, that the making up or putting together of the garment is of the greatest importance. It may be necessary to state that the most thoughtful and accurate work of the cutter may be, and often is, completely neutralized by the carelessness or incompetence of the workman, hence, in any work on cutting the importance of accurate making up should be continuously impressed upon the student, and such information as it is possible to impart in print should be freely and fully placed at his disposal.

Convinced of this fact, and as concisely as the subject permits, is here given a few general rules for the making of the coats, while *detailed* instruction pertaining to particular garments will be taken up in successive papers.

### Closing of Shoulder Seams.

Perhaps different systems require different treatments in the making up. However, the following rules must be observed in order to insure success with this system:

Never under any circumstances should the forepart from the bottom of seye up be stretched or shrunk in any way whatever with an iron; such as stretching the gorge and the shoulder seam near the shoulder point must not be done.

If the shoulder seam is stretched it will advance the shoulder point; consequently, it will not be where the cutter has intended it to be. If the gorge is stretched it will lengthen the strap or first over measure, and also hollow the gorge away from the neck.

In sewing on the back shoulder seam to the forepart, the amount of extra length allowed to the backpart,  $\frac{3}{8}$  inch in normal,  $\frac{1}{2}$  inch for stooping, and about even for erects, should be filled on just below the collar and sewed in. When pressing, open the seam, or in pressing off care should be taken to keep the shoulder forward. The fullness will then throw the shoulder forward as if a hinge or joint were inserted just below the collar, and prevent the coat from sliding backwards over the shoulder heads.

The canvas should be cut with a piece inserted in the shoulder to create a slight spring over the shoulder head; no stretching or cutting of the canvas from the seye up over the shoulder must be done; only the haircloth is slit in front of the seye and a piece inserted in the shoulder, the same as in the canvas.

If the shoulder seam has been stretched no amount of long collar can prevent the coat from appearing to fall off the shoulder and to pull away from the neck over the gorge, instead of the shoulder coming forward and fol-

lowing the natural movement of the arm and shoulder without causing a break in the front canvas.

### Making the Collar.

In cutting the collar, as has been explained under Collars, it may not be amiss to again call attention to a few points. When the collar is cut as explained in the text by raising  $\frac{1}{4}$  inch and lengthening  $\frac{1}{2}$  inch beyond point 19, the collar around the break edge will always have the same length, no matter what the length of the roll is, which it should have to fit the same size of coat and neck. Collars cut in any other way will not have this important feature.

### Putting on Collar.

Assuming that the under collar has been correctly cut, it will require much less stretching than many journeymen consider necessary. The leaf or fall edge should not be stretched at all, and the underside or stand should be stretched only enough to give it the same length as the fall piece. The collar will then give just the right amount of fullness to be put on for all lengths of roll. The fullness is started from about  $\frac{1}{2}$  inch back of the shoulder seams to about  $1\frac{1}{2}$  inches in front of the shoulder seams.

As a rule for length of rolls in front, rise  $\frac{1}{8}$  inch more at the end of the collar above point 19 for a roll to second button; for a roll to third button, or long roll, raise  $\frac{1}{4}$  inch more at the end of the collar, gradually, to nothing at the break line.

### Putting in Sleeves.

The pitching of the sleeves, or, in other words, the position of the fore and hind arm notches of the sleeve and coat, is of great importance, and should never be left to the discretion of the workman. In this system the forearm notch is located three-quarters of an inch above the bottom of the seye, the same as on the coat, and the hindarm notch at the top of the sideseam as cut. The backnotch on the coat is placed halfway of the depth of seye, as explained under the Coats. If such has been done, the notches must go together both in front and back, and the sleeves will always hang correctly, no matter what the attitude of the customer, because all arms hang straight down, and by cutting the breast line on a floor level all the changes for attitude are done on the top construction line A-V, and therefore in no way interfere with the hang of the sleeve.

The three foregoing rules should be observed and followed. In addition, it may be stated that no "bridle" is necessary to be put on, nor should the front edge be held in too much. In all other respects the coat requires no special instruction and can be given to any coat-maker.

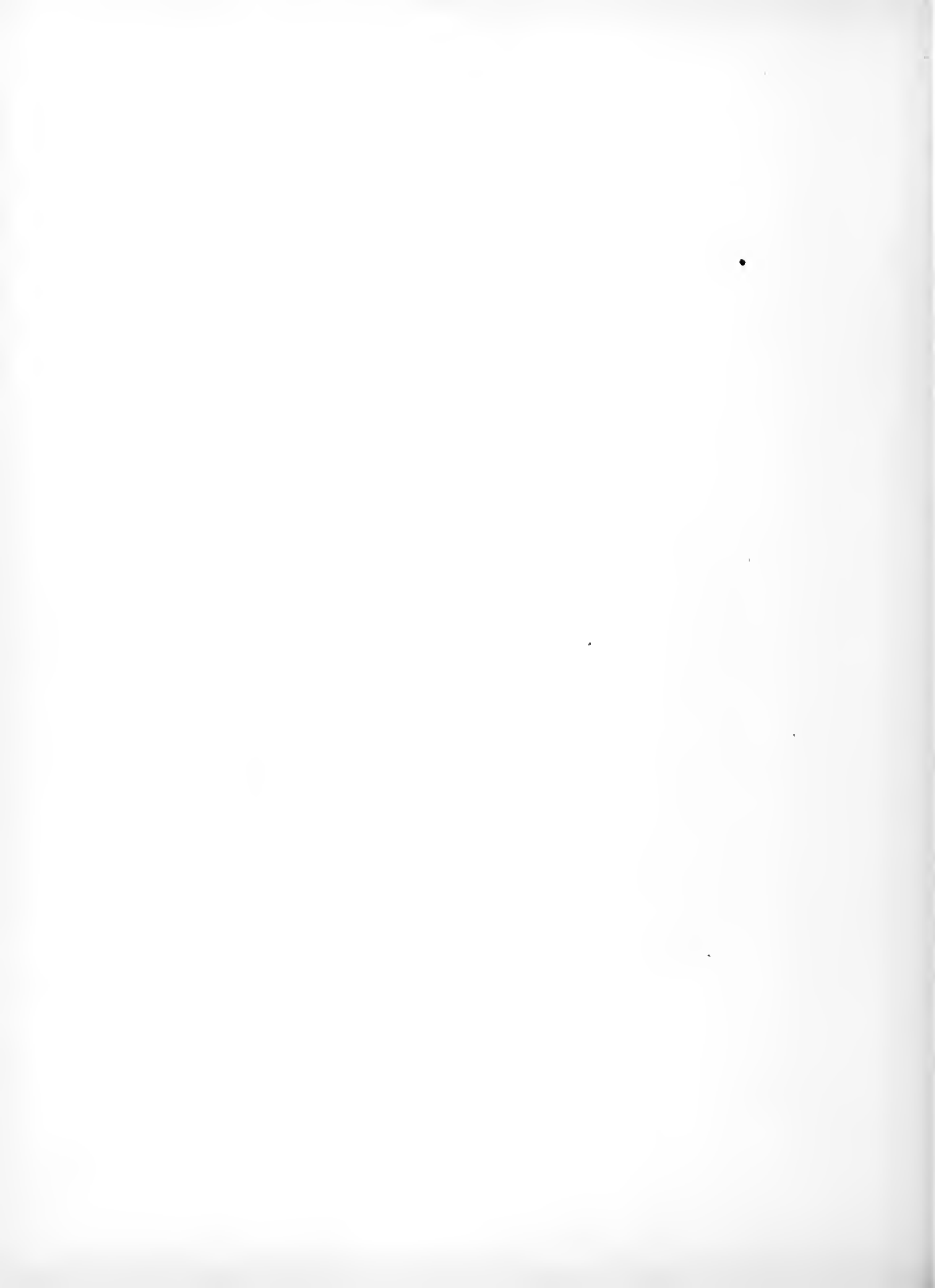



DIAGRAM 2



DIAGRAM 1

1. Suit lay: Cloth,  $3\frac{1}{4}$  yards. By reversing forepart of trousers, under sleeve and the Vest will lay to a 43 breast size.

2. Suit lay: Shows also a Coat and Vest lay. (See the dotted lines across.)

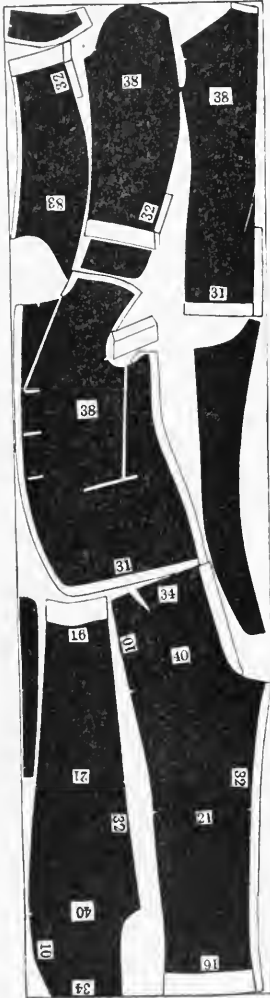

DIAGRAM 3



DIAGRAM 4

3. Coat and trousers lay: Amount of cloth, 3 yards.  
 4. Suit lay: For a 36 size, cloth required,  $2\frac{7}{8}$  yards.

## International Cutting Schools

# VESTS

## PART FOUR

Copyrighted, 1913

1. The measures for the vest are the same as for the coat; depth of scye and length to waist; the strap, over shoulder and blade; breast and waist; in addition to the opening and the full length.

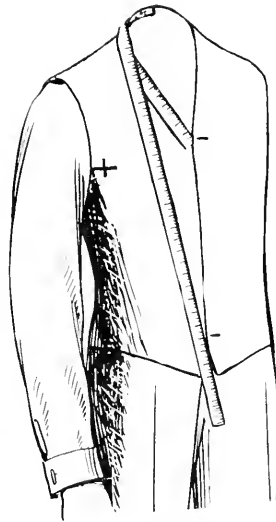

FIG. 10

Place the end of tapeline on back of neck, bring the tape over the shoulder to the first button or the opening.

Then from the neck point in a *straight* line over the front to the center of the length desired. (See Fig. 10.)

Sometimes a measure is taken to the side of the vest over the hip; from the nape of neck in a *straight* line.

The opening measures may be taken for D. B.'s and for dress vest, to get the exact opening desired.

For other particulars see under measures for the coat

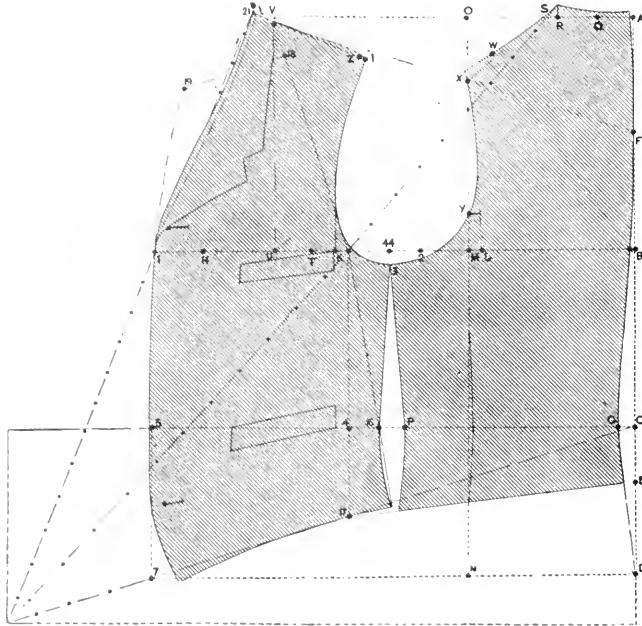

DIAGRAM 53 VEST NORMAL

## Vest Normal

Diagram 53

3. The measures are taken under the Vest always.

Breast	36 inches.	Blade (with $1\frac{1}{4}$ inches for
Waist	32 inches.	seams added) $12\frac{1}{2}$ in.
Strap	12 inches.	Depth of scye 9 inches.
Over shoulder	17 inches.	Natural waist $16\frac{3}{4}$ inches.
Opening	12 inches.	Full length 25 inches.
		Height 5 feet 6 inches.

Form and attitude, normal. Sizes, 33 to 42 breasts.

### TO DRAFT.

- 1 Square both ways from A or 4.
- 2 4 to B is  $\frac{1}{3}$  breast on "3RDS" and  $3\frac{1}{2}$  inches ( $9\frac{1}{2}$ ).
- 3 B to 3 is  $\frac{1}{3}$  breast of height and  $3\frac{1}{2}$  inches.
- 4 A is half way between 3 and 4.
- 5 This is the proportional, and includes all allowances.
- 6 A to C is one-fourth height, and  $\frac{1}{4}$  inch for length.
- 7 C to D is  $\frac{1}{3}$  breast—on "3RDS"—(6) seat line.
- 8 Added to the natural waist gives correct length.
- 9 A to E is the Full Length of Back—19 inches.
- 10 F is half between B and A for front shoulder height.
- 11 Square out from A, B, C, D, E, F, 3 and 4.
- 12 C to G is  $\frac{3}{4}$  inch; draw line F to G and down to D.
- 13 From the line just drawn inside of B measure to H.
- 14 B to H is half the full breast measure (18).
- 15 H to I is 2 inches, center of breast.
- 16 B to K is blade (with  $1\frac{1}{4}$  inches for seams) ( $12\frac{1}{2}$ ).
- 17 Square up from K—front of armhole.
- 18 L is half way between B and K.
- 19 L to M is  $\frac{1}{2}$  inch—width of back.
- 20 Square up to O, and down to N.
- 21 A to Q is  $\frac{1}{12}$  breast—on "12THS"—and
- 22 Q to R is  $1\frac{1}{2}$  inches; square up to S,  $\frac{1}{2}$  inch.
- 23 K to T is 1 inch; T to U is  $\frac{1}{12}$  breast.
- 24 Square up from U to V, locating the shoulder point.
- 25 V is located on lines from U and A.
- 26 Draw lines from S to U and F to V.
- 27 This gives the proportional height of shoulders.
- 28 Rise at X  $\frac{1}{2}$  inch and lower at point 1 the same.
- 29 Y is  $\frac{1}{12}$  up from M on line O-M.
- 30 From B up apply depth of scye measure and  $\frac{1}{2}$  inch ( $9\frac{1}{2}$ ) to A in normal attitude will meet line A.
- 31 The  $\frac{1}{2}$  inch is for fullness held in over the blade.
- 32 Add  $\frac{1}{4}$  inch above A to nothing at S; no outlet.
- 33 Shape the back as shown; draw line from B to W.
- 34 Apply strap measure, and  $\frac{3}{4}$  inch A to R and K to V in normal attitude will meet line A-V, less  $\frac{1}{4}$  inch.
- 35 Apply over shoulder measure and  $\frac{3}{4}$  inch B to W and K to Z; when normal, meet line F-V.
- 36 Z is  $1\frac{1}{4}$  inches from line K.
- 37 Draw a line from V through Z to point 1.
- 38 V to point 1 is  $\frac{3}{4}$  inch less than S to X.
- 39 Draw a guide line from point 1 to T.
- 40 Shape arm-scye and shoulder rounding  $\frac{1}{4}$  in. over Z.
- 41 B to 2 is  $\frac{1}{2}$  breast on "HALVES"; 2 to K is 3 inches.
- 42 This is normal blade and independent of the actual.
- 43 Square down from K through 4 to 17.
- 44 4 to 5 is  $\frac{1}{2}$  waist—on "HALVES"—center of waist.
- 45 Square down from 5 to 7. The measure from B to 2, K, 4 and 5 is used only to obtain the front center of the waist and to check the blade measure.
- 46 2 to 44 is 1 inch; square down to 3,  $\frac{1}{2}$  inch.
- 47 G to P is  $\frac{1}{2}$  waist and  $\frac{3}{4}$  inch.
- 48 4 to 16 is  $1\frac{1}{4}$  inches.
- 49 Draw straight lines from 3 to P and 3 to 16.
- 50 For spring over hip draw line K through 16.
- 51 From P down add  $\frac{1}{4}$  inch for spring.
- 52 For small waist take out a fish on line N.
- 53 Apply length and  $1\frac{1}{4}$  inches, A to R and V to 7 ( $26\frac{1}{4}$ ).
- 54 Apply opening and  $\frac{3}{4}$  inch, A to R and V to J ( $12\frac{3}{4}$ ).
- 55 Draw lines from C to 7 and E to 17.
- 56 V to 21 is 1 inch; when no collar,  $\frac{3}{4}$  inch.
- 47 Draw line from 21 to first button and finish as represented.
- 58 The line D is a feature of this system, and when obtained as explained above is a reliable guide for the front length of the Vest.
- 59 It agrees with all sizes and all heights.
- 60 The dot and dash lines indicate  $56\frac{1}{2}$  inches waist.
- 61 Note how the system works for all sizes and through solid points.
- 62 The depth of scye is on the height and width system also, and in many cases is more reliable than measures.
- 63 The V-18-19 lines give normal or military height.

# Dress Vest

## Diagram 54

4. The measures are taken over the Vest always.
- |               |            |                                       |
|---------------|------------|---------------------------------------|
| Breast        | 36 inches. | Blade (with $1\frac{1}{4}$ inches for |
| Waist         | 32 inches. | seams added) $12\frac{1}{2}$ in.      |
| Strap         | 12 inches. | Depth of scye 9 inches.               |
| Over shoulder | 17 inches. | Natural waist $16\frac{3}{4}$ inches. |
| Opening       | 19 inches. | Full length 25 inches.                |
|               |            | Height 5 feet 6 inches.               |
- Form and attitude, normal. Sizes, 33 to 42 breasts.

### TO DRAFT.

- 1 Square both ways from A or 4.
- 2 4 to B is  $\frac{1}{3}$  breast on "3RDS" and  $3\frac{1}{2}$  inches ( $9\frac{1}{2}$ ).
- 3 B to 3 is  $\frac{1}{3}$  breast of height and  $3\frac{1}{2}$  inches.
- 4 A is half way between 3 and 4.
- 5 This is the proportional, and includes all allowances.
- 6 A to C is one-fourth height, and  $\frac{1}{4}$  inch for length.
- 7 C to D is  $\frac{1}{3}$  breast—on "3RDS"—(6) seat line.
- 8 Added to the natural waist gives correct length.
- 9 A to E is the Full Length of Back.
- 10 F is half between B and A for front shoulder height.
- 11 Square out from A, B, C, D, E, F, 3 and 4.
- 12 C to G is  $\frac{3}{4}$  inch; draw line F to G and down to D.
- 13 From the line just drawn inside of B measure to H.
- 14 B to H is half the full breast measure (18).
- 15 H to I is 2 inches, center of breast.
- 16 B to K is blade (with  $1\frac{1}{4}$  inches for seams) ( $12\frac{1}{2}$ ).
- 17 Square up from K—front of armhole.
- 18 L is half way between B and K.
- 19 L to M is  $\frac{1}{2}$  inch—width of Back.
- 20 Square up to O, and down to N.
- 21 A to Q is  $\frac{1}{12}$  breast—on "12THS"—and
- 22 Q to R is  $1\frac{1}{2}$  inches; square up to S,  $\frac{1}{2}$  inch.
- 23 K to T is 1 inch; T to U is  $\frac{1}{12}$  breast.
- 24 Square up from U to V, locating the shoulder point.
- 25 V is located on lines from U and A.
- 26 Draw lines from S to U, and F to V.
- 27 This gives the proportional height of shoulders.
- 28 Rise at X  $\frac{1}{2}$  inch, and lower at point 1 the same.
- 29 Y is  $\frac{1}{12}$  up from M on line O-M.
- 30 From B up apply depth of scye measure and  $\frac{1}{2}$  inch ( $9\frac{1}{2}$ ) to A in normal attitude will meet line A.
- 31 The  $\frac{1}{2}$  inch is for fullness held in over the blade.
- 32 Add  $\frac{1}{4}$  inch above A to nothing at S; no outlet.
- 33 Shape the Back as shown; draw line from B to W.
- 34 Apply strap measure, and  $\frac{3}{4}$  inch A to R and K to V in normal attitude will meet line 4-V, less  $\frac{3}{4}$  inch.
- 35 Apply over shoulder measure and  $\frac{3}{4}$  inch B to W and K to Z, when normal, meet line F-V.
- 36 Z is  $1\frac{1}{4}$  inches from line K.
- 37 Draw a line from V through Z to point 1.
- 38 V to point 1 is  $\frac{3}{4}$  inch less than S to X.
- 39 Draw a guide line from point 1 to T.
- 40 Shape arm-scye and shoulder rounding  $\frac{1}{4}$  in. over Z.
- 41 B to 2 is  $\frac{1}{2}$  breast on "HALVES"; 2 to K is 3 inches.
- 42 This is normal blade and independent of the actual.
- 43 Square from K through 4 to 17.
- 44 4 to 5 is  $\frac{1}{2}$  waist—on "HALVES"—center of waist.
- 45 Square down from 5 to 7. The measure from B to 2, K, 4 and 5 is used only to obtain the front center of the waist and to check the blade measure.
- 46 2 to 44 is 1 inch; square down to 3;  $\frac{1}{2}$  inch.
- 47 G to P is  $\frac{1}{2}$  waist and  $\frac{3}{4}$  inch.
- 48 4 to 16 is  $1\frac{1}{4}$  inches.
- 49 Draw *straight* lines from 3 to P, and 3 to 16.
- 50 For spring over hip draw line K through 16.
- 51 From P down add  $\frac{1}{4}$  inch for spring.
- 52 Apply length and  $1\frac{1}{4}$  inches, A to R and V to 7 ( $26\frac{1}{4}$ ).
- 53 Apply opening and  $\frac{3}{4}$  inch, A to R and V to 5 (20).
- 54 Draw lines from C to 7 and E to 17.
- 55 I to J is 3 inches always; when made up will cover the dress shirt about 1 inch on each side.
- 56 V to 21 is 1 inch; draw guide line through J.
- 57 Shape from 21, rounding slightly to J.
- 58 The opening is usually about a  $\frac{1}{2}$  inch above waist.
- 59 Shape bottom as shown, or otherwise.
- 60 Add a  $\frac{1}{2}$  inch to the *right* side for a stand.
- 61 The collar is full 2 inches wide over largest part.
- 62 The double-breasted is made by reducing a  $\frac{1}{2}$  inch from 5 and 7, which makes the center line.
- 63 7 to 9 is  $\frac{3}{4}$  inch; 5 to 12 is 2 inches.
- 64 9 to 10 and 12 to 13 are each  $\frac{3}{4}$  inch.



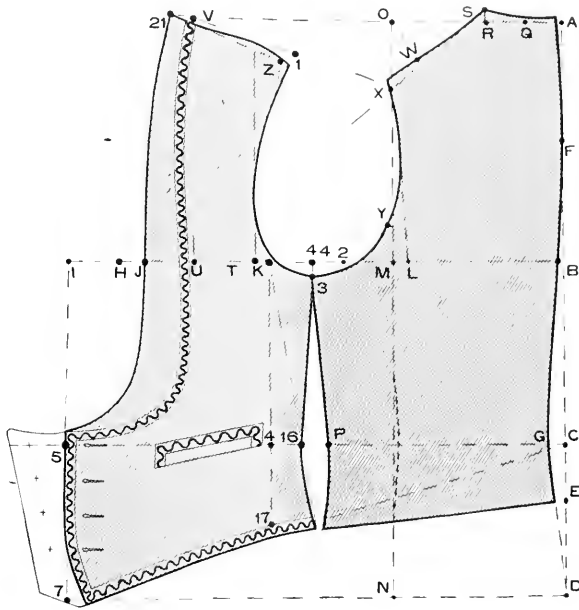

DIAGRAM 54 - DRESS VEST

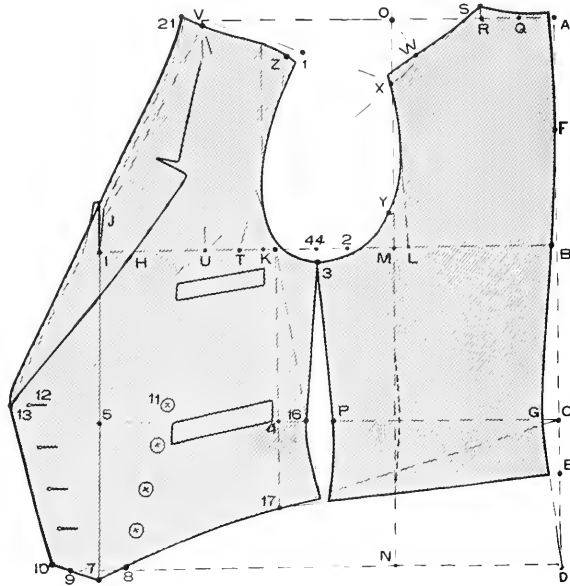

DIAGRAM 55 — DOUBLE-BREASTED VESTS

## Double-Breasted Vests

### Diagram 55

5. The measures are taken over the Vest always.

Breast	36 inches.	Blade (with $1\frac{1}{4}$ inches for
Waist	32 inches.	seams added) $12\frac{1}{2}$ in.
Strap	12 inches.	Depth of scye 9 inches.
Over shoulder	17 inches.	Natural waist $16\frac{3}{4}$ inches.
Opening	$11\frac{1}{4}$ inches.	Full length 25 inches.
		Height 5 feet 6 inches.

Form and attitude, normal. Sizes, 33 to 42 breasts.

#### TO DRAFT.

- Square both ways from A of 4.
- 4 to B is  $\frac{1}{3}$  breast on "3RDS" and  $3\frac{1}{2}$  inches ( $9\frac{1}{2}$ ).
- B to 3 is  $\frac{1}{3}$  breast of height and  $3\frac{1}{2}$  inches.
- A is half way between 3 and 4.
- This is the proportional, and includes all allowances.
- A to C is one-fourth height, and  $\frac{1}{4}$  inch for length.
- C to D is  $\frac{1}{3}$  breast—on "3RDS"—(6) seat line.
- Added to the natural waist gives correct length.
- A to E is the Full Length of Back—19 inches.
- F is half between B and A for front shoulder height.
- Square out from A, B, C, D, E, F, 3 and 4.
- C to G is  $\frac{3}{4}$  inch; draw line F to G and down to D.
- From the line just drawn inside of B measure to H.
- B to H is half the full breast measure (18).
- H to I is  $1\frac{1}{2}$  inches, center of breast.
- B to K is blade (with  $1\frac{1}{4}$  inches for seams) ( $12\frac{1}{2}$ ).
- Square up from K—front of armhole.
- L is half way between B and K.
- L to M is  $\frac{1}{2}$  inch—width of back.
- Square up to O, and down to N.
- A to Q is  $\frac{1}{12}$  breast—on "12THS"—and
- Q to R is  $1\frac{1}{2}$  inches; square up to S,  $\frac{1}{2}$  inch.
- K to T is 1 inch; T to U is  $\frac{1}{12}$  breast.
- Square up from U to V, locating the shoulder point.
- V is located on lines from U and A.
- Draw lines from S to U and F to V.
- This gives the proportional height of shoulders.
- Rise at X  $\frac{1}{2}$  inch and lower at point 1 the same.
- Y is  $\frac{1}{12}$  up from M on line O-M.
- From B up apply depth of scye measure and  $\frac{1}{2}$  inch ( $9\frac{1}{2}$ ) to A in normal attitude will meet line A.
- The  $\frac{1}{2}$  inch is for fullness held in over the blade.
- Add  $\frac{1}{4}$  inch above A to nothing at S; no outlet.
- Shape the back as shown; draw line from B to W.
- Apply strap measure, and  $\frac{3}{4}$  inch A to R and K to V in normal attitude will meet line 4-V, less  $\frac{1}{4}$  inch.
- Apply over shoulder measure, and  $\frac{3}{4}$  inch B to W and K to Z, when normal, meet line F-V.
- Z is  $1\frac{1}{4}$  inches from line K.
- Draw a line from V through Z to point 1.
- V to point 1 is  $\frac{3}{4}$  inch less than S to X.
- Draw a guide line from point 1 to T.
- Shape arm-scye and shoulder rounding  $\frac{1}{4}$  in. over Z.
- B to 2 is  $\frac{1}{2}$  breast on "HALVES"; 2 to K is 3 inches.
- This is normal blade and independent of the actual.
- Square down from K through 4 to 17.
- 4 to 5 is half waist, less  $\frac{1}{2}$  inch.
- Square down from 5 to 7.
- The measure from B to 2, K, 4 and 5 is used only to obtain the front center of the waist and to check the blade measure.
- 2 to 44 is 1 inch; square down to 3,  $\frac{1}{2}$  inch.
- G to P is  $\frac{1}{2}$  waist and  $\frac{3}{4}$  of an inch.
- 4 to 16 is  $1\frac{1}{4}$  inches; draw a straight line from 50 3 to P and 3 to 16.
- For correct spring over the hip, draw line from K through 16.
- From P down add  $\frac{1}{4}$  for spring.
- For small waist take out a fish on line N.
- Apply length and  $1\frac{1}{4}$  inches, A to R and V to 7 ( $26\frac{1}{4}$ ).
- Apply opening and  $\frac{3}{4}$  inch, A to R and V to J (12).
- Draw lines from C to 7 and E to 17.
- V to 21 is  $\frac{3}{4}$  inch.
- 7 to 8 is  $1\frac{1}{4}$  inches; 7 to 9 is the same.
- 5 to 11 is  $2\frac{1}{4}$  inches; 5 to 12 is the same.
- 9 to 10 is  $\frac{3}{4}$  inch; 12 to 13 is the same.
- Draw a line from V through J to 13.
- For collar Vest take out a  $\frac{1}{4}$  V at J.
- Shape from 21 through 13 to bottom.
- This completes the collar Vest.

### No-Collar Vest

- For a No-Collar Vest add a  $\frac{1}{4}$  inch to 21; no V is taken out over the breast.
- For double breasts, when there is no seam in the front, it is best to take out a V at the pocket to hold in the bottom.

# Vest, Frock Lapel

## Diagram 56

7. The measures are taken over the Vest always.

Breast	36 inches.	Blade (with $1\frac{1}{4}$ inches for
Waist	32 inches.	seams added) $12\frac{1}{2}$ in.
Strap	12 inches.	Depth of scye 9 inches.
Over shoulder	17 inches.	Natural waist $16\frac{3}{4}$ inches.
Opening	$11\frac{3}{4}$ inches.	Full length 25 inches.
		Height 5 feet 6 inches.

Form and attitude, normal. Sizes, 33 to 42 breasts.

### To DRAFT.

- 1 Square both ways from A or 4.
- 2 4 to B is  $\frac{1}{3}$  breast on "3RDS" and  $3\frac{1}{2}$  inches ( $9\frac{1}{2}$ ).
- 3 B to 3 is  $\frac{1}{3}$  breast of height and  $3\frac{1}{2}$  inches.
- 4 A is half way between 3 and 4.
- 5 This is the proportional, and includes all allowances.
- 6 A to C is one-fourth height, and  $\frac{1}{4}$  inch for length.
- 7 C to D is  $\frac{1}{3}$  breast—on "3RDS"—(6) seat line.
- 8 Added to the natural waist gives correct length.
- 9 A to E is the Full Length of Back, 19 inches
- 10 F is half between B and A, for front shoulder height.
- 11 Square out from A, B, C, D, E, F, 3 and 4.
- 12 C to G is  $\frac{3}{4}$  inch; draw line F to G and down to D.
- 13 From the line just drawn inside of B measure to H.
- 14 B to H is half the full breast measure (18).
- 15 H to I is  $1\frac{1}{2}$  inches, center of breast.
- 16 B to K is blade (with  $1\frac{1}{4}$  inches for seams) ( $12\frac{1}{2}$ ).
- 17 Square up from K—front of armhole.
- 18 L is half way between B and K.
- 19 L to M is  $\frac{1}{2}$  inch—width of back.
- 20 Square up to O, and down to N.
- 21 A to Q is  $\frac{1}{12}$  breast—on "12THS"—and
- 22 Q to R is  $1\frac{1}{2}$  inches; square up to S,  $\frac{1}{2}$  inch.
- 23 K to T is 1 inch; T to U is  $\frac{1}{12}$  breast.
- 24 Square up from U to V, locating the shoulder point.
- 25 V is located on lines from U and 4.
- 26 Draw lines from S to U, and F to V.
- 27 This gives the proportional height of shoulders.
- 28 Rise at X  $\frac{1}{2}$  inch, and lower at point 1 the same.
- 29 Y is  $\frac{1}{12}$  up from M on line O-M.
- 30 From B up apply depth of scye measure and  $\frac{1}{2}$  inch ( $9\frac{1}{2}$ ) to A in normal attitude will meet line A.
- 31 The  $\frac{1}{2}$  inch is for fullness held in over the blade.
- 32 Add  $\frac{1}{4}$  inch above A to nothing at S; no outlet.
- 33 Shape the back as shown; draw line from B to W.
- 34 Apply strap measure, and  $\frac{3}{4}$  inch A to R and K to V in normal attitude will meet line 4-V, less  $\frac{1}{4}$  inch.
- 35 Apply over shoulder measure and  $\frac{3}{4}$  inch B to W and K to Z, when normal, meet line F-V.
- 36 Z is  $1\frac{1}{4}$  inches from line K.
- 37 Draw a line from V through Z to point 1.
- 38 V to point 1 is  $\frac{3}{4}$  inch less than S to X.
- 39 Draw a guide line from point 1 to T.
- 40 Shape arm-scye and shoulder rounding  $\frac{3}{4}$  in. over Z.
- 41 B to 2 is  $\frac{1}{2}$  breast on "HALVES"; 2 to K is 3 inches.
- 42 This is normal blade and independent of the actual.
- 43 Square down from K through 4 to 17.
- 44 4 to 5 is half waist, less  $\frac{1}{2}$  inch.
- 45 Square down from 5 to 7.
- 46 The measure from B to 2, K, 4 and 5 is only used to obtain the front center of the waist and to check the blade measure.
- 47 2 to 44 is 1 inch; square down  $\frac{1}{2}$  inch to 3.
- 48 G to P is  $\frac{1}{2}$  waist and  $\frac{3}{4}$  of an inch.
- 49 4 to 16 is  $1\frac{1}{4}$  inches; draw a straight line from 3 to P and 3 to 16.
- 50 For correct spring over the hip, draw line from K through 16.
- 51 From P down add  $\frac{1}{4}$  inch for spring.
- 52 For small waist take out a fish at line N.
- 53 Apply length and  $1\frac{1}{4}$  inches, A to R and V to 7 ( $26\frac{3}{4}$ ).
- 54 Apply opening and  $\frac{3}{4}$  inch, A to R and V to J ( $12\frac{1}{2}$ ).
- 55 Draw a line from C to 7 and E to 17.
- 56 V to 18 is  $\frac{1}{12}$  breast, plus  $\frac{1}{2}$  inch.
- 57 Square forward from 18 by K.
- 58 18 to 19 is  $\frac{1}{4}$  breast, plus  $\frac{3}{4}$  inch.
- 59 Draw a line from 2 through 19 to 20.
- 60 19 to 20 is  $1\frac{3}{4}$ .
- 61 7 to 8 is  $1\frac{1}{4}$  inches; 7 to 9 is the same.
- 62 5 to 11 is  $2\frac{1}{4}$  inches; 5 to 12 is the same.
- 63 9 to 10 is  $\frac{3}{4}$  inch; 12 to 13 is the same.
- 64 The collar is drafted like a Coat collar, only 1-inch stand; the leaf is  $1\frac{3}{8}$  inches.
- 65 The turn-over is  $1\frac{1}{2}$  inches.

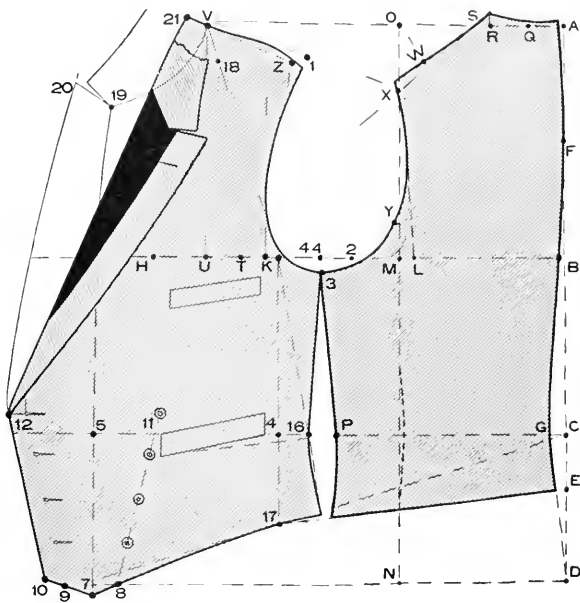

DIAGRAM 56 — VEST WITH FROCK LAPEL

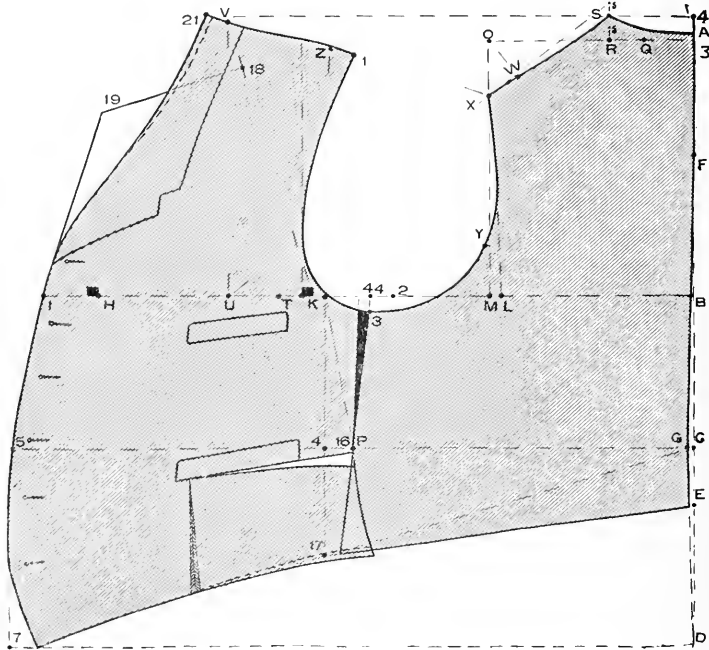

DIAGRAM 57 — CORPULENT VEST

## Corpulent Vest

Diagram 57

8. The measures are taken over the Vest always.

Breast	52 inches.	Blade (with $1\frac{1}{4}$ inches for
Waist	$56\frac{1}{2}$ inches.	seams added) $16\frac{1}{2}$ in.
Strap	$15\frac{1}{2}$ inches.	Depth of scye $10\frac{1}{2}$ inche
Over shoulder	22 inches.	Natural waist $17\frac{3}{4}$ inches.
Opening	16 inches.	Full length 31 inches.
		Height 5 ft. 10 inches.

Form and attitude, corpulent. Sizes, 42 to 52 breasts.

### TO DRAFT.

- 1 Square both ways from 4.
- 2 4 to B is  $\frac{1}{3}$  breast on "3RDS" and  $3\frac{1}{2}$  inches ( $12\frac{1}{4}$ ).
- 3 B to 3 is  $\frac{1}{3}$  breast of height, and  $3\frac{1}{2}$  inches.
- 4 A is half way between 3 and 4.
- 5 This is the proportional, and includes all allowances.
- 6 A to C is one-fourth height, and  $\frac{1}{4}$  inch for length.
- 7 C to D is  $\frac{1}{3}$  breast, on "3RDS" ( $8\frac{5}{8}$ ) seat line.
- 8 Added to the normal waist gives correct length.
- 9 A to E is the Full Length of Back ( $20\frac{3}{4}$ ).
- 10 F is half between B and 4, for front shoulder height.
- 11 Square out from A, B, C, D, E, F, 3 and 4.
- 12 C to G is  $\frac{3}{4}$  inch, draw line F to G and down to D.
- 13 From the line just drawn inside of B measure to H.
- 14 B to H is half the full breast measure (26).
- 15 H to I is 2 inches, center of breast.
- 16 B to K is blade (with  $1\frac{1}{4}$  inches for seam) ( $16\frac{1}{2}$ ).
- 17 Square up from B—front of armhole.
- 18 L is half way between B and K.
- 19 L to M is  $\frac{1}{2}$  inch—width of Back.
- 20 Square up to O.
- 21 A to Q is  $\frac{1}{12}$  breast—on "12THS," and
- 22 Q to R is  $1\frac{1}{2}$  inches; square up to S,  $\frac{1}{2}$  inch.
- 23 Advance from K,  $\frac{1}{16}$  inch each size above 4 inches less than breast; to straighten the front run, take it out under the arm as shown by the shaded part.
- 24 K to T is 1 inch; T to U is  $\frac{1}{12}$  breast.
- 25 Square up from U to V, locating the shoulder point.
- 26 V is located on lines from U and 4.
- 27 Draw lines from upper small S to U, and F to V.
- 28 This gives the proportional height of shoulders.
- 29 Rise at X  $\frac{1}{2}$  inch, and lower at point 1 the same.
- 30 Y is  $\frac{1}{4}$  inch from the O-N line, and  $\frac{1}{12}$  up from M.
- 31 From B up apply depth of scye measure and  $\frac{1}{2}$  inch (11) to A, in normal attitude will meet line A.
- 32 The  $\frac{1}{2}$  inch is for fullness held in over the blade.
- 33 Obtain point S from half s-s and shape 5, S to X.
- 34 Shape the Back as shown; draw line from B to W.
- 35 Apply strap measure, and  $\frac{3}{4}$  inch A to R and K to V ( $16\frac{3}{4}$ ) in normal attitude will meet line A-V.
- 36 Add  $\frac{1}{4}$  inch above A to nothing at S; no outlet.
- 37 Apply over shoulder measure and  $\frac{3}{4}$  inch B to W and K to Z; when normal, meet line F-V ( $22\frac{3}{4}$ ).
- 38 Z is  $1\frac{1}{4}$  inches from line K.
- 39 Draw a line from V through Z to point 1.
- 40 V to point 1 is  $\frac{3}{4}$  inch less than S to X
- 41 Draw a guide line from point 1 to T.
- 42 Shape arm-scye and shoulder rounding  $\frac{1}{4}$  in. over Z.
- 43 B to 2 is  $\frac{1}{2}$  breast on "HALVES"; 2 to K is 3 inches.
- 44 This is normal blade and independent of the actual.
- 45 Square down from K through 4 to 17.
- 46 4 to 5 is  $\frac{1}{2}$  waist—on "HALVES"—center of waist.
- 47 Square down from 5 to 7. The measure from B to 2, K, 4 and 5, is used only to obtain the front center of the waist and to check the blade measure.
- 48 2 to 44 is 1 inch; square down to 3; a  $\frac{5}{8}$  inch.
- 49 From G go out  $\frac{1}{16}$  inch for every size above 4 inches less than breast ( $\frac{1}{2}$ ).
- 50 G to P is  $\frac{1}{2}$  waist and  $\frac{3}{4}$  inch.
- 51 4 to 16 is  $1\frac{1}{4}$  inches.
- 52 Draw straight lines from 3 to P and 3 to 16.
- 53 For spring over hip draw line K through 16.
- 54 From P down add a  $\frac{1}{4}$  inch for spring.
- 55 Advance at I the amount from K (shaded part).
- 56 Draw a line from Z to 7 and E to 17.
- 57 V to 18 is  $\frac{1}{12}$  breast; square forward from 18 by K.
- 58 18 to 19 is  $\frac{1}{4}$  breast; draw line from 19 to I and 5.
- 59 Apply length and  $1\frac{1}{4}$  inches, A to R and V to 7 ( $32\frac{1}{4}$ ).
- 60 Apply opening and  $\frac{3}{4}$  inch, A to R and V to J ( $16\frac{3}{4}$ ).
- 61 V to 21 is 1 inch; when no collar  $\frac{3}{4}$  inch.
- 62 Draw line from 21 to first button and finish as rep.
- 63 Take out a V in the pocket of  $\frac{1}{16}$  for extra sizes.

## Clerical Vest

### Diagram 58

9. The measures are taken over the Vest always.

Breast	36 inches.	Blade (with $1\frac{1}{4}$ inches for
Waist	32 inches.	seams added) $12\frac{1}{2}$ in.
Strap	12 inches.	Depth of scye 9 inches.
Over shoulder	17 inches.	Natural waist $16\frac{3}{4}$ inches.
Height	5 feet 6 inches.	Full length 25 inches.

Form and attitude, normal. Sizes, 33 to 42 breasts.

#### TO DRAFT.

- 1 Square both ways from A or 4.
- 2 4 to B is  $\frac{1}{3}$  breasts on "3RDS" and  $3\frac{1}{2}$  inches ( $9\frac{1}{2}$ ).
- 3 B to 3 is  $\frac{1}{3}$  breast of height, and  $3\frac{1}{2}$  inches.
- 4 A is half way between 3 and 4.
- 5 This is the proportional, and includes all allowances.
- 6 A to C is one-fourth height, and  $\frac{1}{4}$  inch for length.
- 7 C to D is  $\frac{1}{3}$  breast, on "3RDS" (6) seat line.
- 8 Added to the natural waist gives correct length.
- 9 A to E is the Full Length of Back.
- 10 F is half between B and A, for front shoulder height.
- 11 Square out from A, B, C, D, E, F, 3 and 4.
- 12 C to G is  $\frac{3}{4}$  inch, draw line F to G and down to D.
- 13 From the line just drawn inside of B measure to H.
- 14 B to H is half the full breast measure (18).
- 15 H to I is 2 inches, center of breast.
- 16 B to K is blade (with  $1\frac{1}{4}$  inches for seams) ( $12\frac{1}{2}$ ).
- 17 Square up from K—front of armhole.
- 18 L is half way between B and K.
- 19 L to M is  $\frac{1}{2}$  inch—width of Back.
- 20 Square up to O, and down to N.
- 21 A to Q is  $\frac{1}{12}$  breast—on "12THS," and
- 22 Q to R is  $1\frac{1}{2}$  inches; square up to S,  $\frac{1}{2}$  inch.
- 23 K to T is 1 inch; T to U is  $\frac{1}{12}$  breast.
- 24 Square up from U to V, locating the shoulder point.
- 25 V is located on lines from U and A.
- 26 Draw lines from S to U, and F to V.
- 27 This gives the proportional height of shoulders.
- 28 Rise at X  $\frac{1}{2}$  inch, and lower at point 1 the same.
- 29 Y is  $\frac{1}{2}$  inch from the O-N line, and  $\frac{1}{12}$  up from M.
- 30 From B up apply depth of scye measure and  $\frac{1}{2}$  inch ( $9\frac{1}{2}$ ) to A, in normal attitude will meet line A.
- 31 The  $\frac{1}{2}$  inch is for fullness held in over the blade.
- 32 Shape the Back as shown; draw line from B to W.
- 33 Apply strap measure, and  $\frac{3}{4}$  inch A to R and K to V in normal attitude will meet line A-V less  $\frac{1}{4}$  inch.
- 34 Apply over shoulder measure and ( $\frac{3}{4}$  inch) B to W and K to Z; when normal, meet line F-V.
- 35 Z is  $1\frac{1}{4}$  inches from line K.
- 36 Draw a line from V through Z to point 1.
- 37 V to point 1 is  $\frac{3}{4}$  inch less than S to X.
- 38 Draw a guide line from point 1 to T.
- 39 Shape arm-scye and shoulder rounding  $\frac{1}{4}$  in. over Z.
- 40 B to 2 is  $\frac{1}{2}$  breast on "HALVES"; 2 to K is 3 inches.
- 41 This is normal blade and independent of the actual.
- 42 Square down from K through 4 to 17.
- 43 4 to 5 is  $\frac{1}{2}$  waist—on "HALVES"—center of waist.
- 44 Square down from 5 to 7. The measure from B to 2, K, 4 and 5, is used only to obtain the front center of the waist and to check the blade measure.
- 45 2 to 44 is 1 inch; square down to 3;  $\frac{1}{2}$  inch.
- 46 G to P  $\frac{1}{2}$  waist and  $\frac{3}{4}$  inch; 4 to 16 is  $1\frac{1}{4}$  inches.
- 47 Draw straight lines from 3 to P, and 3 to 16.
- 48 For spring over hip draw line K through 16.
- 49 From P down add  $\frac{1}{4}$  inch for spring.
- 50 Apply length and  $1\frac{1}{4}$  inches, A to R and V to 7 ( $26\frac{1}{4}$ ).
- 51 Draw lines from C to 7 and E to 17.
- 52 V to 18 is  $\frac{1}{12}$  breast; square forward from 18 by K.
- 53 18 to 19 is  $\frac{1}{4}$  breast less  $\frac{1}{4}$  inch.
- 54 Shape the gorge and front; also bottom.
- 55 Leave a button stand in front  $\frac{3}{4}$  inch wide.
- 56 All clerical and military collars should be cut as in the diagram on military collar.
- 57 Cut vest collar  $\frac{1}{2}$  inch larger than linen collar.



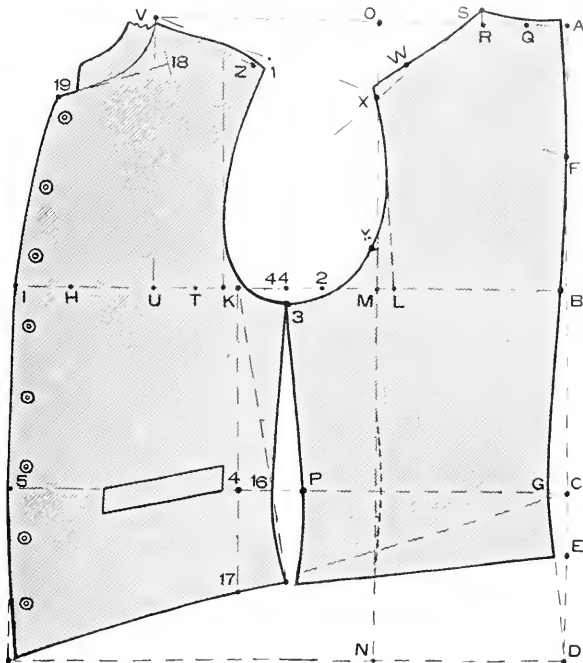

DIAGRAM 58 — CLERICAL VEST



DIAGRAM 59 — CASSOCK VEST

- 1 10. Draft a Vest or use a model forepart.
- 2 21 to V is  $3\frac{1}{4}$  inch; mark all around the "left" forepart from V, and at breast and waist lines.
- 3 I to J is a  $\frac{1}{4}$  inch; 5 to 6 is the same.
- 4 Draw a straight line through J and 6 to 7.
- 5 Reverse the forepart and lap it a  $\frac{1}{4}$  inch at J and 6.
- 6 Mark all around the "right" forepart and remove.
- 7 Add a seam in the V at 19 and breast.
- 8 V to 26 is  $1\frac{1}{4}$  inches.
- 9 From side seam to 17 is  $\frac{3}{4}$  inch.
- 10 Shape from 26 to 17, touching front of scye at 3.
- 11 A  $1\frac{1}{2}$  inch is taken out on each side, the fill in at 7.
- 12 Shape bottom as shown on diagram.
13. 11. **The Button Piece**, or under side.—Mark around the top and back of "right" forepart.
- 14 26 to 20 is 2 inches; 17 to 18 is  $1\frac{3}{4}$  inches. Shape as represented.
- 15 12. **The Collar**.—The collar has an opening of 2 inches in front, when finished, and is buttoned about 1 inch back of point V on the right side.
- 16 When made with a seam in the center, no V's are taken out. Finish as represented.

# The International Cutting School's System of Cutting

By L. GIBSON  
New York — Chicago

First Edition, 1909, One Thousand Copies

Second Edition, 1911, One Thousand Copies

Third Edition, 1913, One Thousand Copies

## TROUSERS (PART FIVE)



Entered according to Act of Congress (Act of March 4, 1909), in the year 1913  
by L. Gibson, in the office of the Librarian of Congress, Washington, D. C.

ALL FOREIGN RIGHTS RESERVED

---

(Printed in the United States)

## Trousers

1. The question of masculine nether garments is of far greater importance, not merely from a sociological, but from a political point of view, than most people would be willing to believe.

Indeed, the fashion in this respect constitutes an interesting corollary in the history of national enlightenment, progress and development.

Thus the absence of clothing for the nether limbs denotes the barbarism of the ages which preceded the crusades. The breeches made of chain armor and steel plate (uncomfortable they must have been) followed next, and are associated in our minds with feudalism, tournaments and the medieval age.

The hose and trunks of the sixteenth and seventeenth centuries demonstrated that the fine arts, the sciences, and, in one word, the elegancies of the mind had supplanted might and rule by the superiority of brute force.

The knee breeches and silk stockings of the eighteenth century may be looked upon as in keeping with an age of courtliness and dignity. The trousers, alas, are characteristic of a period when men have no longer time nor inclination to devote to the cultivation of that "politesse du coeur" which contributes so much to sweeten human intercourse.

There is but one court in Europe, namely, that of St. James, where one may see men who wear neither trousers nor breeches, but who, "sans culottes" in the truest sense, content themselves with kilts, namely, the Scottish chieftains and the officers of the various highland regiments.

The trousers or pantaloons came in fashion in the year 1801, mainly as the result of drink.

Old-world royalty and its blue-blooded associates in those days ate, and especially drank, heavily, and were consequently afflicted with gout and other maladies of a character to swell the legs.

Knee breeches and stockings, so dear, not only to the early presidents of the United States and to the signers of the Declaration of Independence, but likewise to the old Puritan element of America, were scarcely suitable to swollen limbs, even if they belonged to the anointed; and the result was that George IV, as prince regent, his brothers, the Dukes of York, Clarence, Cumberland and Sussex; the French princes, who afterwards reigned as Louis XVIII, Charles X, and Louis Phillipe, also King Fredeirik William III of Prussia, and many other equally illustrious personages, adopted the modern form of pantaloons, which was at the time a source of no end of ridicule and entertainment to caricaturists.

It was not until the fourth decade of the nineteenth century, when heavy drinking by the classes went out of fashion, that an endeavor was made to revive the knee breeches as articles of masculine attire.

The custom of wearing trousers, however, had meanwhile become so universal that it was found impossible to do away with them, save by the enactment of sumptuary laws, such as Peter the Great was wont to enforce in Russia, but which would not have been tolerated in any country farther west.

People, forgetful of the royal origin of trousers, insisted that they were a symbol of equality and democracy, and that they had a leveling tendency.

They declared that the trousers constituted a perpetual and most effectual rebuke to the man who would like to raise himself above his fellows by reason of shape.

### Trouser Cutting

2. The art of trouser cutting is very often underestimated. The fact remains that in the opinion of most experienced and practical cutters no garment that the tailor is called upon to produce is so perplexing and truly difficult as a simple pair of trousers.

3. The difficulty in trouser cutting is that of providing for the different positions assumed by the wearer in standing, sitting and walking.

That it is possible, and quite easy, to cut a pair of trousers that will fit in either one of the above mentioned positions is true; but to cut a pair of trousers to fit equally as well in all three positions is of course impossible; hence the difficulty for the cutter to know how much he must allot for each when cutting *one* pair to fit all three positions, which ordinary trousers must do.

Perhaps no trousers are in all positions perfect, but it is almost unnecessary to add that some are greatly superior to the majority, while just a few in their adaptable fitting qualities and general style or "hang" are worthy of the trade and a credit to those constituting it.

4. Much confusion and valuable time has been lost in accepting old theories as absolute facts and trying to evolve new systems on the foundations of the old ones, or to accept the theories of others that no improvement could possibly be made.

Before entering into further explanations it will be best to make a diagram, then the different points can be more readily taken up. We will therefore proceed with the

### Measurements of Trousers

5. The method of measuring used is the result of long experience, and as this is for the guidance of students it is very minutely described. In the first place, a cutter should have confidence in himself, as the show of nervousness or lack of method will create an unfavorable impression on the customer.

A lack of method to proceed is usually the cause of the confusion, hence a cutter should follow the suggestions and the rotations as explained, which will result in

his becoming methodical and expert and free from all confusion. While measuring, no stops should be made, nor any familiarity displayed toward the customer.

**6. Measuring Trousers.**—When ready to take the measures for the trousers, have someone to put down the measures; otherwise have paper and pencil ready and do it yourself. A loose sheet of paper should be used, so that notes for the cutter can be put down, and afterwards transcribe it in the book. A footstool should be used and placed before the customer with an invitation to "Please step up on this footstool." Always stand on the right-hand side of the customer and take all the lengths and leg measures on the right leg.

**7. The First Measure.**—The outside length is taken from point D, which should be the top of the hip bone *always* (not from top of trousers), to point B, the sole of the shoe, near the front of the heel (see Fig. 1). If the customer should be very fleshy, and it is hard for you to locate the top of the hip bone, have the customer locate it for you.

**8. The Second Measure** is the inside length and is taken from close up in the fork or crotch point C to E, the sole of the shoe, near the front of the heel.

When taking this measure, the trousers should be pulled up close *in front*—not on the sides—by taking hold of the top of the fly. Take the end of the tape between the index and second finger of the *left* hand and place it snug up in the center of the fork or crotch, from the front; with the *right* hand measure the length to the sole. If for any reason you are in doubt of the result, take it the second time, and if too much at variance, even a third time; the two nearest of the three must be the correct ones. Sometimes a measuring devise is used and, if not too sharp, is a help.

Beginners sometimes take the leg length too short. To guard against this serious defect, measure from the fork point C down to the ground and deduct 1 inch from the quantity obtained. Thus: Ground length, 33; deduct 1 inch, leaves 32, which gives the length of the trouser leg.

It is important to have the length measure correct, as it will make the trousers hang smoothly and possibly save an alteration.

Many customers are averse to having them changed after they are made, being under the impression that it spoils the fit.

**9. The Third Measure** is the waist. Standing in front of the customer, raise the vest in front and with the tape in the right hand follow the waistband around to the back, meeting it with the left hand; carry the tape to the front, and with the thumb of the left hand resting on the first inch, the thumb outward, carry the tape past with the right hand in a medium close measure, taking care that it is up above the hip bone, but on the trousers. (See Fig. 1, point D.) Call out the figures or mark it down.

**10. The Fourth Measure.**—Stout or corpulent is taken over the corpulent part, or the stomach, about 4 inches down from the waistband. This measure is used only when stout.

**11. The Fifth Measure.**—Seat or hip is taken over the largest part of the seat opposite X.

Before taking this measure, place both your hands, one on each side, on the hips of the customer and press gently, requesting the customer to "Please put your heels and toes together."

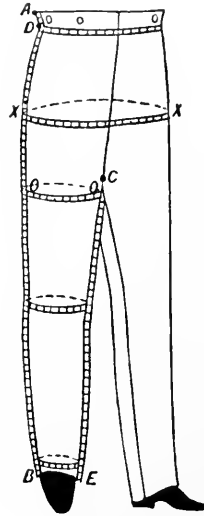

Fig. 1

This is a part which should never be overlooked, as otherwise the measure will be too loose. Take this measure in the same manner as described in the waist measure.

While holding both ends of the tape in front with the right hand, with the left hand adjust the tape behind over the largest part of the seat; push up the contents of the hip pockets.

This measure should be taken, like all others, a *medium close*, and on the level with the floor. Call out the measure.

While the customer is standing in the closed position, heels and toes together and *erect*, take hold of the trousers with both hands on the sides, opposite the knees, and pull outward to see if the customer is bowlegged. If so, the amount can easily be determined by the eye as 1 inch,  $1\frac{1}{2}$  or 2 inches or more—the opening between the knees.

Call out or mark down the amount, but only in inches or as " $1\frac{1}{2}$  inches *straight*." Do not call out bowleg.

Remember, the eye must take it in quickly before the customer spreads his legs; if he does, it must be gone

over again if there is the least tendency to bow leg. When this is done, tell the customer, "Now you may stand as you please."

12. **The Sixth Measure** is the thigh. The thigh is taken right below the trunk or body on the right leg, close up to the fork or crotch, and is taken close or actual measure of the thigh (marked O, Fig. 1).

It is used only in extremely large or extremely small thighs. It can also be used to gain an idea how large a peg is desired by measuring the peg or amount of width opposite thigh.

13. **The Seventh Measure** is the knee, taken around the knee, the width desired by the customer, or the style.

Always get the customer's idea about the knee and bottom measures—whether he desires a close, medium or loose width—and follow as near style as possible.

14. **The Eighth Measure** is the bottom, taken over the shoe from just above the sole on the heel to in front, the tape meeting in front over the instep the width desired, or style.

15. Breeches are measured for the same as trousers (including the length of leg seam).

In addition it is necessary to take the length to knee, to small knee and to calf, as also the size of the leg over the drawers, at the knee—the small knee—and the calf.

16. This completes the measurements of the trousers and you announce to the customer: "That is all; thank you."

In studying the above measurements, the first point to notice is the order in which the various measures are obtained; the second, that all length measures, side and leg seams, are entered first, and all width measures, waist, seat, knee and bottom, in the order named.

Great care should be taken to secure accurate measurements, as the result—good, bad and indifferent—is greatly dependent on them.

While taking the measures the eye should have observed any peculiarities about the customer regarding the trousers, such as right dress; if so, call out or mark "R. D."

Sometimes very wide over the hip, curving considerably opposite the hip joint, attention will be drawn to it by the great difference between the waist and seat measure—as much as 8 inches difference—while the normal should be about 4 inches and, as stoutness increases, less.

Such will be designated "curved hips." A note should be made of it on the measure blank.

The hips may be "narrow," usually on stout or fat men, indicated by small seat measure compared to the waist and corpulent measures.

It may be a small seat or what is commonly called "Flat" seat, which is generally accompanied by "Prominent Dress," where the customer carries himself forward at that particular point.

The dress also varies much either higher or lower. This should be distinguished from "full" or "large dress."

Sometimes the hip bone comes straight up and very wide at point A. Note should be made of these divergencies and taken care of in drafting.

Find out the style of pockets whether side or top, and how many hip pockets.

If peg top is wanted, in what degree, as  $\frac{1}{2}$  peg or full peg, etc. Cuffs, belt loops, or flaps. Sometimes a person wishes a very low "Rise" or height of waist. If so, mark down low waist or Rise; but the outside length must be taken from the top of the hip bone always.

A large person may call for a "High Waist" or Rise. Such must be written down, but the measures taken as usual from the hip bone. Toe-out or slew-footed should also be noted.

17. **Construction Lines.**—In the matter of construction lines different systems use different lines as construction lines. It is obvious that every system must have some fixed points to go out from. There has been much difference of opinion as to which would be the best and most appropriate, the side, or center, or front line. As most practical men will admit that they may be placed at the sides or the center of the draft with equally good results, provided that the working of the system be arranged to produce an outline of the garment agreeing with that of the figure and in harmony with the form of the individual for which it is cut.

18. **Accuracy and Simplicity.**—These are the two distinctive feature of this system. Accuracy in that it can be used with equal success on tall and slim and short and stouts; and relied on to give the correct amount in every instance.

Simplicity in that it can be applied with a common tailor's square, and all complicated calculations and rules are reduced to simple working methods, easy to use and still conforming to all anatomical and scientific measurements and calculations.

It was our intention to cite proof in the support of our statements from the numerous investigators. But as this system was worked out without consulting any of these authorities it has since been compared with them and it stands the test of any of them and we think far surpasses all of them.

Therefore, it would only be a waste of space and the reader's time to bring them out.

19. The majority of cutters of experience will certainly agree that the center line system has by far the most followers, provided, however, that this center line is a center line and placed in the center. Lots of systems have what they term a center line but in fact is not a center line.

The definition of a center line must be that it is in the center. It is naturally inferred that if a line is drawn down the center of the forepart it should be placed

where the center of the leg, or, as at present, where the center crease would be.

Equally it would be expected that the center line of the Back part would be where the crease is.

If such be the case, it can be called a center line system. This, however, implies also that the Back seam or seat seam should be in the middle or center of the Back. There is where it will be when finished. Therefore, there is where it should be when cutting it; if it is not there, it will get there just the same when finished; then is when the trouble commences.

**20. The Center Line,** therefore, has many advantages over side or front line systems. It is then only a matter of distributing the right quantity on each side of the center line, and in doing so, the best results will be obtained by following nature's divisions.

That rule has been adopted in this system.

This brings us to the consideration of the "Rise" or height of waist.

The quantity given,  $1/3$  seat and  $3\frac{1}{2}$  inches, will be found to correspond with all scientific measurements.

Man is the most perfect mechanism and he certainly grows by proportion as understood by the tailors; hence, it is only a question of finding the divisions by which he increases or decreases in the different parts.

Some systems use  $1/2$  seat and a fraction for the heights. It has been found that  $1/3$  and  $3\frac{1}{2}$  inches is the correct one.

**21. The Rise.**—It is well known that an actual measure of the "Rise" cannot always be used, as some persons differ in the height of the waist. True, the actual measure will give the actual height and in some cases must be followed in preference to the proportional heights; but it also must be admitted that it is sometimes difficult to get a correct height by measure; further, it has been proven that this part of the human body changes the least in length or height.

The seat line will be found to correspond with scientific measurements; the fork also will be found to agree with this method.

In fact every measure and every division and proportion used in this system, be it trousers, coat, or vest, are based on common sense and experience, as well as on scientific or basic principles.

The "Rise" as a rule is governed by the wearer and does not matter much as long as suspenders are worn; but when a belt is substituted, the "Rise" must in all cases come over the hip bone.

**22. Seat Angle.**—The correct location of the seat line from points J to T and the *height above* the forepart is of great importance, as the degree of angle given not only provides room for the insertion of the trunk of the body, but also forms the degree of length in the back when standing to provide for the changed positions assumed when *sitting* and *walking*.

If the seat line is what is termed *too straight*, that is

drawn nearer to point K; providing points U and J are retained in the position as on normal trousers; the body room, or what is termed the diameter of the trousers, is decreased. They will be too close from the fork point of underside upwards to the round of the seat, and the fork will appear—as it actually is—too tight.

Some systems advocate increasing the fork to counterbalance it; but that does not give the same ease and fit.

Trousers cut that way will hang smooth when standing perfectly straight, but as soon as any movements take place the defect is shown at once.

If on the other hand the seat line is excessively crooked or brought nearer to the side seam from the center line, the seat room (or diameter) will be excessive and the trousers when on will appear full about the fork, while on the back of the thighs and the top of the leg seams a quantity of surplus material will be formed, most unsightly in appearance and unnecessary for the provision of ease in either sitting or walking.

As has previously been stated that the height above the forepart is necessary at the back of the seat, to provide length of the seat when sitting, it may be stated that the extent of the length may by way of experiment be measured, for if a measure be taken from the fork point of the under side upwards to the waistband when the figure is standing, it will be found about 3 inches less than the measure between the same points when the figure is seated.

The division used in this system as applied to normals and to corpulents has been found to work satisfactory in all sizes.

In other words, when the person sits down, the height in back should be on a horizontal line with the rise in front, and no excessive *draw* from the knees up, and with no excessive surplus of cloth in the lap, and sufficient ease over the seat.

**23. Size of the Fork.**—The size of the fork (as the effect of the change of the seat angle just mentioned may explain) is *not*, as many cutters imagine, the quantity measured between the points J and I and J and U.

This quantity in systems of cutting is merely a matter of convenience dependent upon the amount of the seat angle or slope and the position of the bottom of the leg seams.

The system here given would fit equally as well the forepart advanced until point I and Q were even with point U and V, and the same amount of slope maintained on the seat line.

The actual size of the fork is the distance across from the front of the forepart to the back or seat seam opposite the seat line B-2; when the forepart and back are laid in position, with the fork line running horizontally and points I and U touching. This accounts for the fact that a comparatively crooked seat admits of a small fork, and a straight seat of a larger fork than the average.

24. **Openness and Closeness of Legs.**—The correct "hang" of the legs of the trousers at leg and side seams is dependent principally upon what is termed the openness of legs.

A trouser correctly cut in this respect will, if held up by the side seams (as trousers are usually tested), stand apart at the bottoms the same amount as the legs are divided when the figure is standing in the ordinary position.

If the trousers have been cut too open, that is, with a smaller amount than is necessary from *N* to *Q* and outwards to *V*, they will, when held up as previously described, stand apart at the bottom *more* than the natural separation of the legs, and when on will be forced *inwards* and *upwards* by the legs, with the result that bulging and folds will appear at the *top* of the leg seams, while at the *bottom* the leg seam will appear short, as though the measure taken was insufficient.

If the trousers have been cut too close, that is, with an excess of material on both top and under sides from the points *Q* and *V* upwards, the defects will be the opposite of those just described.

The legs of the trousers will touch from fork to bottom when the trousers are held up by the side seams, and when on, will press inwards upon the outside of the legs, which will force the trousers outwards and upwards, producing surplus length in diagonal folds at the side seams.

The consideration of these facts will enable the student to realize why riding trousers—in which the legs are carried open or apart—require a more *open* style of cut than those intended for gentlemen who insist upon a clean fit at fork and leg seams when the feet are kept close together at the bottom.

## Points in Good Fitting Trousers

25. **Standing.**—There should be no folds between the legs from the feet upwards to the fork.

The side seams should hang fair from the hips without bulge or break.

The horizontal fold below the seat should not be excessive nor fall downwards to the fork.

There should be no strain on the back buttons, and the seat line should touch the hollow of the waist.

No pressure should be felt at the fork, bringing the dress into undue prominence, and channeling at the seat seam.

There should be no pressure at the top fly buttons, or fold between the front suspender buttons.

26. **Sitting.**—There should be no undue strain upon the ball, or round of the seat, to the knees.

The bottoms should not work upwards from the shoes more than about one inch.

The length of seat should not work downward, causing a strain upon the back buttons.

The top of the trousers in front should not uncomfortably press upon the stomach.

The amount of material in the lap, and under the knee should not be excessive.

27. **Walking.**—The trousers should not cling to the knee, and strain towards the fork.

They should not ride upwards from the heel.

There should be no "flopping" at the bottom of the legs seams.

Assuming that the trousers have been properly made the above is the result of:

First—The proper adjustment of the seat angle.

Second—The correct size and form of fork.

Third—The required slope or "Openness" of legs.

Fourth—The accurate height of "Rise."



### Cutting the Cloth

- 56 When cutting the cloth leave outlets down the inside leg seam and seat seam of the under sides, also a turn-up, of from 2 to 3 inches, at the bottom of both top and under sides.
- 57 Make notches at the bottom, knee and seat lines of both top and under sides, to prevent twisting in the making up.
- 58 Previous to cutting always see that the nap or pile of the cloth (if any) is running downward.
- 59 32. **Checked Material.**—The pattern should be laid on the cloth so that the lines match at side seam at least; inside seam should also match.

### To Draft

Always read the description through before commencing to draft it.

The measures needed for a pair of trousers are as follows: (For measuring see measures for trousers).

First measure is "Outside length."

Second measure is "Inside length."

Third measure is "The Waist."

Fourth measure is "The Corpulency."

Fifth measure is "The Seat" or Hip.

Sixth measure is "The Thigh."

Seventh measure is "The Knee."

Eighth measure is "The Bottom."

When no corpulency, the fourth measure can be left out.

In studying these measurements the first points to notice is the order in which they are obtained.

28. **Seat.**—The trousers are always drafted by the seat measure.

The divisions used are units of the seat measure. Only half of the trousers are drafted because the cloth is always cut on the double. For example, seat, 40 inches, would therefore be 20, which will be used on all divisions in the draft. Mark all letters on the draft as you proceed.

## Trousers Normal

### Diagrams 60 and 61

Outside length	43 $\frac{3}{4}$ inches.	Thigh (actual)	21 inches.
Inside length	32 $\frac{1}{2}$ inches.	Knee	20 inches.
Waist	36 inches.	Bottom	16 inches.
Seat or hip	40 inches.		

#### TO DRAFT. The Forepart.

- 1 A to B is  $\frac{1}{3}$  seat on "3RDS" and
  - 2 B to C is  $3\frac{1}{2}$  inches ( $10\frac{1}{4}$ ).
  - 3 This is the proportional, and includes all allowances.
  - 4 From C to A is the actual "Rise" as measured.
  - 5 C to E is the inside length, and  $\frac{1}{4}$  inch for a seam.
  - 6 D is half way between E and C, and 2 inches up.
  - 7 Square out from A, B, C, D and E.
  - 8 C to H is  $\frac{1}{2}$  seat—on "HALVES."
  - 9 H to I is  $\frac{1}{8}$  seat—on "8THS."
  - 10 Go out  $\frac{1}{2}$  inch from I, and in  $\frac{1}{4}$  inch from I, making  $\frac{3}{4}$  inch; this is for the dress side.
  - 11 Square up from H, locating 2 on line B.
  - 12 H to J is  $\frac{1}{2}$  inch (for 2 seams), square up to K.
  - 13 Draw a guide line from K to H for run of dress.
  - 14 L is half way between C and I.
  - 15 Go in  $\frac{1}{8}$  inch for every size less than 40 seat, and out  $\frac{1}{8}$  inch for every size more; from L.
  - 16 Square up and down from L, locating O, M and N.
  - 17 N to P is  $\frac{1}{4}$  bottom less  $\frac{1}{4}$  inch; N to Q is the same.
  - 18 Draw a *straight* line from I to Q, locating R.
  - 19 M to G is  $\frac{1}{4}$  knee on "4THS"; M to R is the same.
  - 20 Draw lines C, G, P and I to R.
  - 21 Normal waist is 4 inches less than seat.
  - 22 A to S is  $1\frac{1}{2}$  inches. This is normal.
  - 23 H to the curve of front fork is  $\frac{1}{12}$  seat by A.
  - 24 Shape the fork K to I outer corner; and
  - 25 *Dress side* from K to  $\frac{1}{8}$  inch above I; inner corner.
  - 26 The largest dress hollow ( $\frac{5}{8}$  inch) is opposite H.
  - 27 The seams from I should be *straight*  $7\frac{1}{2}$  inches down.
  - 28 For "Prominent dress," allow  $\frac{1}{4}$  inch more on fork curve, as shown by the broken lines.
  - 29 Shape the side seam from S; the broken line shows a high hip bone.
  - 30 Trace out the "Dress" and center line.  
This completes the Forepart. Cut out the pattern.
- The Backpart.
- 31 The white part represents the forepart.
  - 32 Extend lines O, B, L, M and N.
  - 33 Add  $\frac{1}{4}$  inch to length of Backpart from N.
  - 34 O to T is  $\frac{1}{6}$  seat—on "6THS."
  - 35 Draw a straight line from T to J.
  - 36 From the forepart fork to U is  $\frac{1}{16}$  seat.
  - 37 Measure seat and  $1\frac{3}{4}$  inches 2 to B, and 11 to F.
  - 38 R to X is  $\frac{1}{2}$  inch for seams; G to Y is the same.
  - 39 P to V is  $\frac{1}{2}$  inch more than  $\frac{1}{2}$  bottom.
  - 40 Q to W is the same; draw lines Y to W and X to V.
  - 41 Draw a line from Y through F to Z.
  - 42 Y to Z is the length from S to G, or sweep.
  - 43 Draw a line from Z to T.
  - 44 Z to 10 is  $\frac{1}{8}$  seat; draw a line to L.
  - 45 Apply waist measure and  $2\frac{1}{4}$  inches from K to S and T to Z; take out a  $\frac{1}{2}$  inch *V* at 10.
  - 46 The *V* extend down  $\frac{1}{6}$  of seat measure.
  - 47 J to the curve of back fork is  $\frac{1}{24}$  seat by A.
  - 48 U is  $\frac{1}{4}$  inch below line C-I.
  - 49 Shape seat seam through corner of forepart to U.
  - 50 Shape outside and inside seams and mark notches.
  - 51 In no case should A to S exceed  $1\frac{3}{4}$  inches.
  - 52 Hollow outside seam slightly from F to T.
  - 53 Notch at knee and seat or fork line ( $\frac{3}{8}$  inch below on backpart).
  - 54 The notch for the fly is 1 inch from the point of forepart; if placed too high up it causes a draw and disfigures the fly.
  - 55 30. **Calves.**—If calf is needed place it on the outside seam, nothing on the inside, and  $\frac{1}{3}$  the distance down from the knee to bottom.

## Trousers—Wide Hips

### Diagram 63

This diagram represents the wide hip and the small or flat seat; such persons measure more around the seat than they really are, proportional from front to rear.

If the trousers are cut regular they will be too deep from front to rear, and too narrow from side to side.

This also accounts for why some cutters get from 7 to 9 inches difference in the waist and seat measure.

The trousers are drafted 1 size less in the seat division from C to I and U; the difference is added to the sides opposite C, in this way retaining the full width as originally measured.

L is half way between C and I.

On all sizes below 40 go in from L  $\frac{1}{8}$  inch for every size.

Point L must be retained in the same position or half way between C and I; because point T depends on L.

For flat seat draw line from T to J, finish as ordinary trousers.

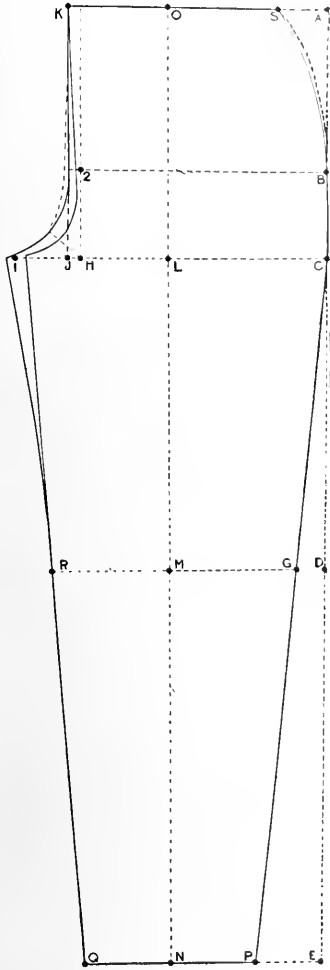

DIAGRAM 60

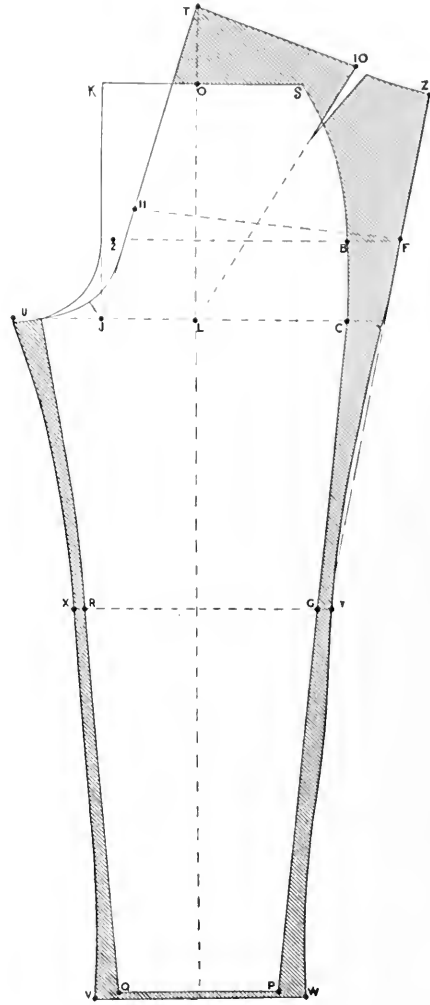

DIAGRAM 61

TROUSERS NORMAL

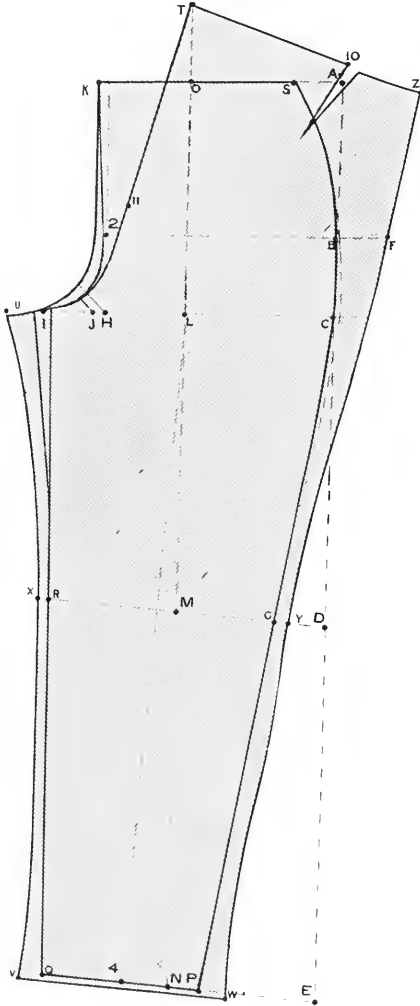

DIAGRAM 62  
BOW-LEG TROUSERS

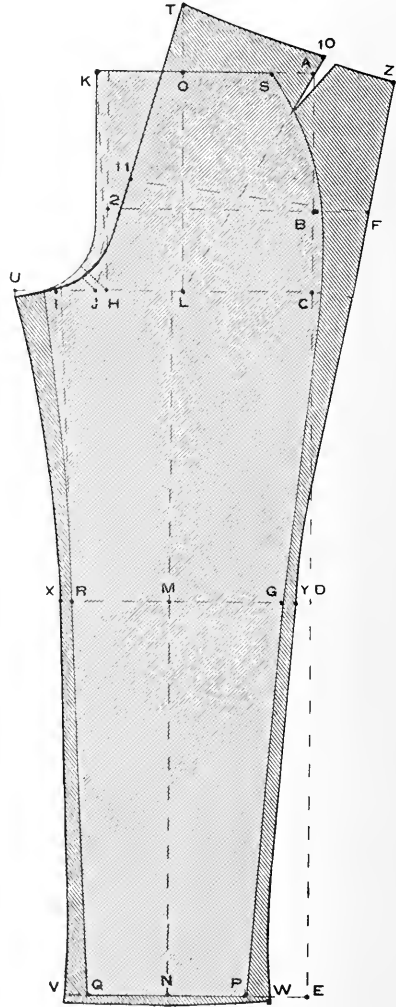

DIAGRAM 63  
WIDE HIPS, SMALL SEAT

## Trousers—Bow-Leg

Diagram 62

Outside length	42 $\frac{3}{4}$ inches.	Seat or hip	40 inches.
Inside length	32 $\frac{1}{2}$ inches.	Thigh (actual)	21 inches.
Waist	36 inches.	Knee	21 inches.
Bowleg	2 inches	Bottom	16 inches.

### To DRAFT. The Forepart.

- 1 A to B is  $\frac{1}{3}$  seat on "3RDS" and
- 2 B to C is  $3\frac{1}{2}$  inches.
- 3 This is the proportional and includes all allowances.
- 4 From C to A is the actual "Rise" as measured.
- 5 C to E is the inside length, and  $\frac{1}{4}$  inch for a seam.
- 6 D is half way between E and C, and 2 inches up.
- 7 Square out from A, B, C, D and E.
- 8 C to H is  $\frac{1}{2}$  seat—on "HALVES."
- 9 H to I is  $\frac{1}{8}$  seat—on "8THS."
- 10 Go *out*  $\frac{1}{2}$  inch from I and *in*  $\frac{1}{4}$  inch from I, making  $\frac{3}{4}$  inch; this is for the dress side.
- 11 Square up from H, locating 2 on line B.
- 12 H to J is  $\frac{1}{2}$  inch (for 2 seams) square up to K.
- 13 Draw a guide line from K to H for run of dress.
- 14 L is half way between C and I.
- 15 Go *in*  $\frac{1}{8}$  inch for every size less than 40 seat, and *out*  $\frac{1}{8}$  inch for every size more; from L.
- 16 Square up and down from L, locating O, M and N
- 17 N to 4 is 2 inches, the full amount of Bow leg.
- 18 Draw a line from 4 to L.—The center line.
- 19 4 to P is  $\frac{1}{4}$  bottom less  $\frac{1}{4}$  inch; 4 to Q is the same.
- 20 Draw a *straight* line from I to Q; this locates R.
- 21 Measure  $\frac{1}{2}$  width of knee from R to G.
- 22 Draw lines from C to G and P.
- 23 Normal waist is 4 inches less than seat.
- 24 A to S is  $1\frac{1}{2}$  inches. This is normal.
- 25 H to the curve of front fork is  $\frac{1}{12}$  seat by A.
- 26 Shape the fork K to I, outer corner; and
- 27 *Dress side* from K to  $\frac{1}{8}$  inch above I; inner corner.
- 28 The largest dress hollow ( $\frac{3}{8}$  inch) should be opposite H.
- 29 The seams from I should be *straight*  $7\frac{1}{2}$  inches down.
- 30 For "Prominent Dress," allow  $\frac{1}{4}$  inch more on fork; curve as shown by the broken lines.
- 31 Shape side seam from S; the broken line shows a high hip bone.
- 32 This completes the Forepart. Cut out the pattern.

### The Backpart.

- 34 Extend lines O, B, L, M and N.
- 35 Add  $\frac{1}{4}$  inch to length of Backpart from N.
- 36 O to T is  $\frac{1}{6}$  seat—on "6THS."
- 37 Draw a straight line from T to J.

- 38 From forepart fork to U is  $\frac{1}{16}$  seat.
- 39 Measure seat and  $1\frac{3}{4}$  inches 2 to B, and H to F.
- 40 R to X is  $\frac{1}{2}$  inch for seams; G to Y is the same.
- 41 P to V is  $\frac{1}{2}$  inch more than  $\frac{1}{2}$  bottom.
- 42 Q to W is the same; draw lines Y to W and X to V.
- 43 Draw a line from Y through F to Z.
- 44 Y to Z is the length from S to G, or sweep.
- 45 Draw a line from Z to T.
- 46 Z to 10 is  $\frac{1}{8}$  seat; draw a line to L.
- 47 Apply waist measure and  $2\frac{1}{4}$  inches from K to S and T to Z; take out a  $\frac{1}{2}$  inch *V* at 10.
- 48 The *V* extends down  $\frac{1}{6}$  of seat measure.
- 49 J to the curve of back fork is  $\frac{1}{24}$  seat, by A.
- 50 U is  $\frac{1}{4}$  inch below line C-I.
- 51 Shape seat seam through corner of forepart to U.
- 52 Shape outside and inside seams and mark notches.
- 53 In no case should A to S exceed  $1\frac{3}{4}$  inches.
- 54 If narrow trousers, a calf should be put on.
- 55 Notch knee and bottom and they will hang correct without extra manipulations; trace the center line through front and backpart.
- 56 This will absolutely cure any case of bow legs.
- 57 **34. Curved Hips.**—Bow legs are usually accompanied by curved hips, i. e., they are wide from side to side and very shallow from front to rear.
- 58 In such cases the seat measure will be too large, producing too deep a fork.
- 59 Draft the pattern by one size less, and add to the side at C a  $\frac{1}{4}$  inch on front and backpart.
- 60 **35. Flat Seat.**—So-called, if treated as described under curved hips, will produce a clean fit.
- 61 When a person is otherwise normal built (not curved hips) take off  $\frac{1}{4}$  to  $\frac{1}{2}$  inch on seat seam opposite 11; draw a line from T to H and reshape to U.
- 62 **36. Slew Footed.**—Or toe-out. Establish the center line and width of bottom; add to V on backpart  $\frac{1}{2}$  inch, or the amount over the instep the crease line is off; shape from the knee down; deduct from W the same amount.
- 63 The forepart will follow the new backpart, notch the bottom, and they will fall right when finished.
- 64 **37. Knock-Knee.**—For Knock-Knees, the process of the bow leg is reversed.
- 65 **38. Spring Bottom.**—Or Bell bottom. The forepart should be cut narrow at the bottom so as to facilitate shrinking in front, and should not exceed 7 inches in width; the extra width is added to the backpart, and should not extend up over 4 or 5 inches.

# Peg Top

Diagram 64

Outside length 42 $\frac{3}{4}$  inches. Thigh (actual) 21 inches.  
 Inside length 32 $\frac{1}{2}$  inches. Knee 21 $\frac{1}{2}$  inches.  
 Waist 34 inches. Bottom 16 inches.  
 Seat or hip 40 inches.

TO DRAFT. The Forepart.

- 1 First draft a normal trouser, then add the peg.
- 2 A to B is  $\frac{1}{3}$  seat on "3RDS" and
- 3 B to C is 3 $\frac{1}{2}$  inches (10 $\frac{1}{4}$ ).
- 4 This is the proportional, and includes all allowances.
- 5 From C to A is the actual "Rise" as measured.
- 6 C to E is the inside length, and  $\frac{1}{4}$  inch for a seam.
- 7 D is half way between E and C, and 2 inches up.
- 8 Square out from A, B, C, D and E.
- 9 C to H is  $\frac{1}{2}$  seat—on "HALVES."
- 10 H to I is  $\frac{1}{8}$  seat—on "8THS."
- 11 G *o out*  $\frac{1}{2}$  inch from I, and *in*  $\frac{1}{4}$  inch from I, making  $\frac{3}{4}$  inch; this is for the dress side.
- 12 Square up from H, locating 2 on line B.
- 13 H to J is  $\frac{1}{2}$  inch (for 2 seams), square up to K.
- 14 Draw a guide line from K to H for run of dress.
- 15 L is half way between C and I.
- 16 Go *in*  $\frac{1}{8}$  inch for every size less than 40 seat, and *out*  $\frac{1}{8}$  inch for every size more; from L.
- 17 Square up and down from L, locating O, M and N.
- 18 N to P is  $\frac{1}{4}$  bottom less  $\frac{1}{4}$  inch; N to Q is the same.
- 19 Draw a *straight* line from I to Q, locating R.
- 20 Draw lines, C, G, P and I to R.
- 21 Normal waist is 4 inches less than seat.
- 22 A to S is 1 $\frac{1}{2}$  inches. This is normal.
- 23 H to the curve of front fork is  $\frac{1}{12}$  seat, by A.
- 24 Shape the fork K to I outer corner; and
- 25 *Dress side* from K to  $\frac{1}{8}$  inch above I; inner corner.
- 26 The largest dress hollow ( $\frac{5}{8}$  inch) is opposite H.
- 27 The seams from I should be *straight* 7 $\frac{1}{2}$  inches down.
- 28 For "Prominent dress," allow  $\frac{1}{4}$  inch more on fork curve, as shown by the broken lines.
- 29 Shape the side seam from S; the broken line shows a high hip bone.
- 30 This completes the forepart, as represented by the thin solid lines.
- 31 The dot and dash lines is the half Peg.

- 32 The heavy solid lines is the full Peg
- 33 In this case all measures are figured for the normal and the Peg added.

The Backpart.

- 35 Extend lines O, B, L, M and N.
- 36 Add  $\frac{1}{4}$  inch to length of Backpart from N.
- 37 O to T is  $\frac{1}{6}$  seat—on "6THS."
- 38 Draw a straight line from T to J.
- 39 From normal forepart fork to U is  $\frac{1}{16}$  seat.
- 40 Measure seat and 1 $\frac{3}{4}$  inches 2 to B, and 11 to F.
- 41 R to X is  $\frac{1}{2}$  inch for seams; G to Y is the same.
- 42 P to V is  $\frac{1}{2}$  inch more than  $\frac{1}{2}$  bottom.
- 43 Q to W is the same; draw lines Y to W and X to V.
- 44 Draw a line from Y through F to Z.
- 45 Y to Z is the length from S to G, or sweep.
- 46 Draw a line from Z to T.
- 47 Z to 10 is  $\frac{1}{8}$  seat; draw a line to L.
- 48 Apply waist measure and 2 $\frac{1}{4}$  inches from K to S and T to Z; take out a  $\frac{1}{2}$  inch V at 10.
- 49 The V extends down  $\frac{1}{6}$  of seat measure.
- 50 J to the curve of back fork is  $\frac{1}{24}$  seat.
- 51 U is  $\frac{1}{4}$  inch below C-I.
- 52 Shape seat seam through corner of forepart to U.
- 53 Shape outside and inside seams and mark notches.
- 54 In no case should A to S exceed 1 $\frac{3}{4}$  inches.
- 55 This completes the backpart, as represented by the thin, solid lines; trace through the center line and mark crease in that line.
- 56 The dot and dash lines is the half peg.
- 57 The heavy, solid lines is the full peg.
- 58 Below is the addition for all peg sizes, to be added to the normal trousers.
- 59 The first column of figures represents the forepart, the second the backpart.
- 60 40. For example half peg. Add to seat line of the forepart 1 inch, and to the backpart 1 inch.
- 61 Add to fork; forepart  $\frac{1}{8}$  inch, to backpart  $\frac{1}{4}$  inch.
- 62 Add to knee forepart 1 inch; backpart 2 inches.
- 63 Lower the waist a  $\frac{1}{2}$  inch.
- 64 The same way for a full peg, etc.

No. 0	No. 1	No. 2	No. 3	No. 4	No. 5
Normal.	Slightly Peg.	Half Peg.	Full Peg.	Extreme Peg.	Extra Large.
Add to seat line	$\frac{1}{2}$ and $\frac{1}{2}$ inch	1 and 1 inch	1 $\frac{1}{2}$ and 2 inches	2 and 3 inches	2 $\frac{1}{2}$ and 4 inches
Add to fork	0 and $\frac{1}{4}$ inch	$\frac{1}{8}$ and $\frac{1}{4}$ inch	$\frac{1}{4}$ and $\frac{3}{8}$ inch	$\frac{1}{4}$ and $\frac{1}{2}$ inch	$\frac{3}{8}$ and $\frac{3}{4}$ inch
Add to knee	$\frac{1}{2}$ and 1 inch	1 and 2 inches	1 $\frac{1}{2}$ and 3 inches	2 and 4 inches	3 and 5 inches
Lower the "Rise"	$\frac{1}{4}$ inch	$\frac{1}{2}$ inch	$\frac{3}{4}$ inch	1 inch	1 $\frac{1}{4}$ inches

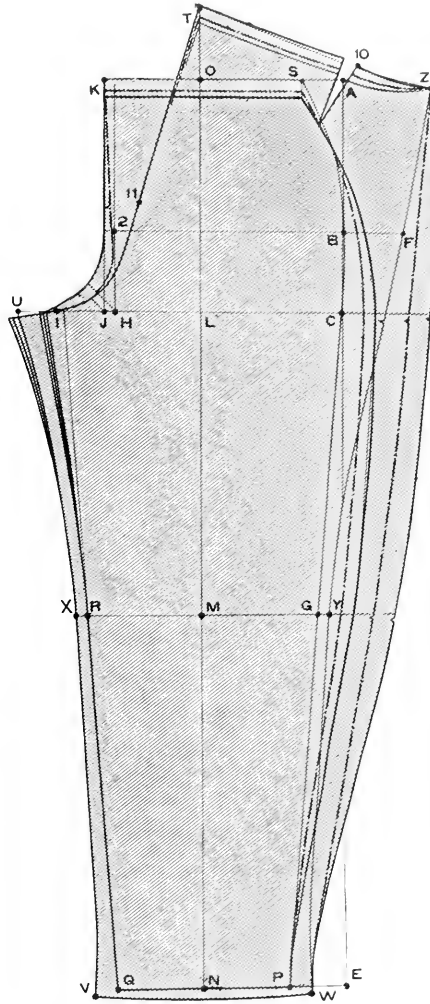

DIAGRAM 64 — PEG TROUSERS

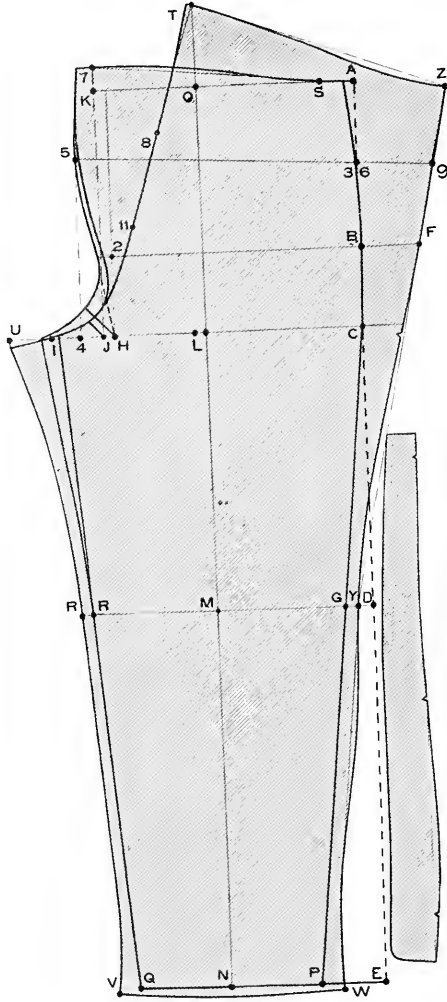

DIAGRAM 65 — CORPULENT TROUSERS



## Corpulent Trousers

Diagram 65

Outside length	43 inches.	Seat or hip	44 inches.
Inside length	31½ inches.	Thigh (actual)	23 inches.
Waist	46 inches.	Knee	23½ inches.
Corpulency	48 inches.	Bottom	17 inches.

To DRAFT. The Forepart.

- 1 A to B is  $\frac{1}{3}$  seat on "3RDS," and
- 2 B to C is  $3\frac{1}{2}$  inches ( $10\frac{7}{8}$ ).
- 3 This is the proportional, and includes all allowances.
- 4 From C to A is the actual "Rise" as measured.
- 5 C to E is the inside length, and  $\frac{1}{4}$  inch for a seam.
- 6 D is half way between E and C, and 2 inches up.
- 7 3 is  $\frac{1}{3}$  of A and B, or "Rise."
- 8 Square out from A, B, C, D, E and 3.
- 9 C to H is  $\frac{1}{2}$  seat—"HALVES."
- 10 H to I is  $\frac{1}{8}$  seat—"8THS."
- 11 Go *out*  $\frac{1}{2}$  inch from 1 and *in*  $\frac{1}{4}$  inch from 1, making  $\frac{3}{4}$  inch; this is for the dress side.
- 12 Square up from H, locating 2 on line B.
- 13 H to J is  $\frac{1}{2}$  inch (for 2 seams), square up to K.
- 14 L is half way between C and I.
- 15 Go *in*  $\frac{1}{8}$  inch for every size less than 40 seat, and *out*  $\frac{1}{8}$  inch for every size more, from L.
- 16 Square up and down from L, locating O, M and N.
- 17 N to P is  $\frac{1}{4}$  bottom less  $\frac{1}{4}$  inch; N to Q is the same.
- 18 Draw a *straight* line from I to Q, locating R.
- 19 M to G is  $\frac{1}{4}$  knee on "4THS"; M to R is the same.
- 20 Draw lines C, G, P and I to R.
- 21 J to 4 is  $\frac{1}{4}$  inch for every inch difference between seat and corpulency.
- 22 Square up from 4, locating 5.
- 23 K to 7 is one and one-half times as much as J to 4; square back from 7.
- 24 7 forward is  $\frac{1}{8}$  inch for every inch over normal.
- 25 Normal waist is 4 inches less than seat.
- 26 Draw a line from 5 to H for run of fly.
- 27 5 to 6 is  $\frac{1}{2}$  corpulency and  $\frac{1}{2}$  inch for 2 seams.
- 28 A to S is  $1\frac{1}{2}$  inches. This is normal.
- 29 S to A is  $\frac{1}{8}$  inch for every inch more than normal.
- 30 Draw a line from S to 7, and shape the top.
- 31 H to the curve of front fork is  $\frac{1}{12}$  seat by A.
- 32 Shape the fork from K to I outer corner; and
- 33 Dress side from K to  $\frac{1}{8}$  inch above I; inner corner.
- 34 The largest dress hollow ( $\frac{3}{8}$  inch) should be opposite H.
- 35 The seams from I should be *straight*  $7\frac{1}{2}$  inches down.

- 36 Shape the side seam from S.
- 37 This completes the forepart. Cut out the pattern.

The Backpart.

- 39 Extend lines O, B, L, M, N and 3.
- 40 Add  $\frac{1}{4}$  inch to length of backpart from N.
- 41 O to T is  $\frac{1}{6}$  seat—on "6THS."
- 42 Draw a straight line from T to J.
- 43 From forepart fork to U is  $\frac{1}{16}$  seat—on "16THS."
- 44 Measure seat and  $1\frac{1}{4}$  inches 2 to B, and 11 to F.
- 45 R to X is  $\frac{1}{2}$  inch for seams; G to Y is the same.
- 46 P to V is  $\frac{1}{2}$  inch more than  $\frac{1}{2}$  bottom.
- 47 Q to W is the same; draw lines Y to W and X to V.
- 48 Draw a line from Y through F to Z.
- 49 Y to Z is the length from S to G, or sweep.
- 50 Draw a line from Z to T.
- 51 Corpulency—From 5 to 6, and 8 to 9, and I inch.
- 52 Apply waist measure and 1 inch from K to S, and T to Z; no *V* is taken out.
- 53 Add  $\frac{1}{2}$  the surplus waist to S and T.
- 54 J to the curve of backfork is  $\frac{1}{24}$  seat by A.
- 55 U is  $\frac{1}{4}$  inch below line C-I.
- 56 Shape seat seam through corner of forepart to U.
- 57 Shape outside and inside seams and mark notches.
- 58 If more ease or fullness is required over the seat, a *V* must be taken out, and the difference added to T and Z.
- 59 A waistband should be cut for corpulents, and the forepart held in *on top* over the stomach; *not in front*.
- 60 If the person is built narrow over the hip and deep from front to back (as most corpulents are) it is best to increase the stride or fork from J to I and U by one size.

### Corpulent Trousers—Narrow Hips

The process as described and shown on the diagram for wide hips, is reversed for corpulents.

The trousers are cut one size more from J to I and U. L is established as usual; then go out  $\frac{1}{8}$  inch for every size above 40 seat.

Corpulent people are built more close in the hips; because the hips are contracted from holding up the large stomach.

The legs also spread out at the bottom, for the same reason, requiring a longer inseam.

Finish the top as described on corpulent.

# Riding Breeches

## Diagram 66

- 1 In measuring for Riding Breeches have the customer pull up the trousers in the front, not by the sides, then pin, or tie a string around the leg just above knee, so as to hold the trousers in position while the length measures are taken.
  - 2 Make a chalk mark opposite the upper part of the knee cap (or large knee).
  - 3 Mark below the knee joint (small knee or garter).
  - 4 Mark the largest part of the calf, and about 1 inch above the anklebone, or about  $4\frac{1}{2}$  inches less than trouser length.
  - 5 Now take the measures.
  - 6 The outside length can be taken to opposite the lower chalk mark—or the rise can be obtained by proportion, and the length from regular trousers.
  - 7 Measures of the circumferences of the leg should be taken over the underwear.
  - 8 In measuring over the knee, hold your tape line close, then bend the knee as in a sitting position. It will make a difference of 1 inch.
  - 9 The measure over the calf should be taken when leg is in a bent position.
  - 10 The other measures are taken in the ordinary way. The measures are as follows:
 

11 Outside length ( $42\frac{3}{4}$ ).....	$38\frac{1}{2}$ inches.
12 Inside length ( $32\frac{1}{2}$ ) to knee (large knee)	$14\frac{1}{4}$ inches.
13 Inside length to garter (small knee)....	$17\frac{1}{4}$ inches.
14 Inside length to Calf.....	$20\frac{1}{4}$ inches.
15 Full length .....	$24\frac{1}{4}$ inches.

The circumference measures are:

16 Large knee (or bent knee).....	$14\frac{3}{4}$ inches.	
17 Garter (or small knee) (close).....	$12\frac{1}{2}$ inches.	
18 Calf (bent position) .....	$14\frac{1}{2}$ inches.	
19 Bottom (or ankle) .....	$9\frac{1}{2}$ inches.	
20 Waist .....	35 inches.    Seat .....	40 inches.
  - 21 Add 2 inches to all length measures which will be taken up when in a sitting position.
  - 22 Square both ways from A.
  - 23 A to C is  $\frac{1}{3}$  seat, plus  $3\frac{1}{2}$  inches.
  - 24 A to B is the outside length— $38\frac{1}{2}$  inches.
  - 25 B to C is the inside length— $27\frac{1}{2}$  inches.
  - 26 C to D is 2 inches—more than  $14\frac{1}{4}$  inches.
  - 27 D to E is 3 inches— $19\frac{1}{4}$  inches.
  - 28 E to F is 4 inches— $23\frac{1}{4}$  inches.
  - 29 F to B is 5 inches— $28\frac{1}{4}$  inches.
  - 30 C to G is  $\frac{1}{6}$  seat.
  - 31 Square out from A, B, C, D, E, F and G.
  - 32 C to H is  $\frac{1}{2}$  seat—20 on "HALVES."
  - 33 H to I is  $\frac{1}{8}$  seat plus  $\frac{1}{2}$  inch—for stride.
  - 34 I to J is 1 inch—for dress.
  - 35 H to K is  $\frac{1}{2}$  inch, square up to L and from H through 2.
  - 36 M is half way between C and I.
  - 37 Square up to N and down to O.
  - 38 B to P is  $\frac{1}{8}$  seat. E to Q is the same.
  - 39 Draw a line from P through Q establishing R and S.
  - 40 C to T is  $1\frac{1}{2}$  inches.
  - 41 L to U is  $\frac{1}{2}$  waist, lower  $\frac{1}{2}$  inch at L in front.
  - 42 Shape the outside seam.
  - 43 S to 3 is  $\frac{1}{3}$  large knee ( $14\frac{3}{4}$  inches) plus 1 inch.
  - 44 Q to 4 is  $\frac{1}{3}$  garter ( $12\frac{1}{2}$  inches) plus 1 inch.
  - 45 R to 5 is  $\frac{1}{3}$  calf ( $14\frac{1}{2}$  inches) plus 1 inch.
  - 46 Draw a line from 3 to I and J.
  - 47 Shape the fork and inside seams through 3-4-5 to O. This completes the forepart.
- The Backpart.
- 48 Extend lines A, B, C, D, E, F and N to X.
  - 49 3 to 6 is  $\frac{1}{2}$  inch; 4 to 7, 5 to 8 and O to 9 is the same.
  - 50 J to V is  $\frac{1}{16}$  seat plus  $\frac{1}{2}$  inch.
  - 51 6 to 10 is  $\frac{2}{3}$  large knee plus  $\frac{1}{2}$  inch.
  - 52 7 to 11 is  $\frac{2}{3}$  garter (small) plus  $\frac{3}{8}$  inch.
  - 53 8 to 12 is  $\frac{2}{3}$  calf plus  $\frac{1}{2}$  inch.
  - 54 9 to 13 is ankle plus 3 inches, take out 2 inch V.
  - 55 The V is in the center of back part.
  - 56 N to X is  $\frac{1}{6}$  seat, K to 4 is  $1\frac{1}{2}$  inches.
  - 57 Draw a line from X to 4.
  - 58 Apply waist measure plus 1 inch L to U and X to W,  $\frac{3}{4}$  inch above W and 1 inch above X.
  - 59 T to 14 is 2 inches.
  - 60 Shape side seam from W through 14, 10, 11, 12 to 13. Notch at 14 and hold in the back to W.
  - 61 Shape seat seam from above X to V.
  - 62 From 7 to 10 take out a fish 1 inch in the center tapering to 7 and 10—under the knee.
  - 63 Take out  $\frac{1}{2}$  inch of top side opposite knee; providing a strapping covers it, and must be *stoted*.
  - 64 **In Making.**—The forpart is held in  $\frac{1}{2}$  inch between Q and S, and 3 and 4, the amount of the fish and seams, and shrunk out to form the knee.
  - 65 The *calves* are shrunk back until the seams are straight.
  - 66 **The Reinforcement.**—Start half way between seat and knee and extend about 1 inch below small knee, and about half way in on the back part, nothing on the forepart.
  - 67 The top button is  $\frac{3}{4}$  inch from knee line.
  - 68 Finish with a Small Falls, or a fly.

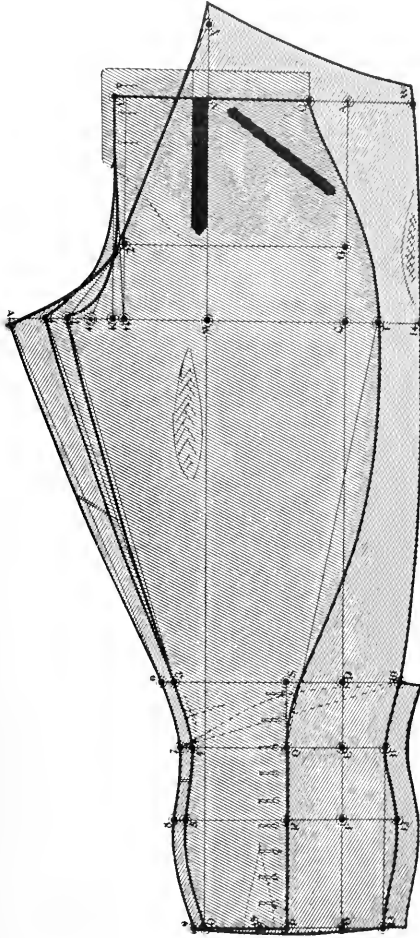

DIAGRAM 66 — RIDING BREECHES

**Table No. 4**

	5 ft.												
Height .....	3	4	5	6	7	8	9	9½	10	10½	11	11½	6 ft.
Breast .....	33	34	35	36	37	38	39	40	41	42	43	44	45
Waist .....	29½	30	31	32	33	34	35½	37	38½	40	41½	43	44½
Seat .....	34	35	36	37	38	39	40	41	42	43	44	45	46
Rise .....	9¼	9¾	9½	9⅝	9⅞	10	10¼	10⅜	10½	10⅝	10⅞	11	11¼
Length .....	29½	30	30½	31	31½	32	32½	32¾	33	33¼	33½	33¾	34
Knee .....	17	17½	18	18½	19	19½	20	20½	21	21½	22	22½	23
Bottom .....	14¾	15	15¼	15½	15¾	16	16¼	16½	16¾	17	17¼	17½	17¾

**Table No. 5**

**TROUSERS — STOUT — 1st DEGREE**

	5 ft.											5 ft.	
Height .....	4	5	6	7	8	9	9½	10	10½	11	11½	6 ft.	11½
Breast .....	35	36	37	38	39	40	41	42	43	44	45	46	47
Waist .....	32	33	34	35	36	37½	39	40½	42	43½	45	46½	48
Seat .....	36	37	38	39	40	41	42	43	44	45	46	47	48
Rise .....	9½	9⅝	9⅞	10	10¼	10⅜	10½	10⅝	10⅞	11	11¼	11⅝	11⅞
Length .....	30	30½	31	31½	32	32½	32¾	33	33¼	33½	33¾	34	33¾
Knee .....	18	18½	19	19½	20	20½	21	21½	22	22½	23	23½	24
Bottom .....	15	15¼	15½	15¾	16	16¼	16½	16¾	17	17¼	17½	17¾	18

**Table No. 6**

**TROUSERS — CORPULENT — 2d DEGREE**

	5 ft.											5 ft.	
Height .....	5	6	7	8	9	9½	10	10½	11	11½	6 ft.	11½	11
Breast .....	37	38	39	40	41	42	43	44	45	46	47	48	49
Waist .....	35	36	37	38	39½	41	42½	44	45½	47	48½	50	51½
Seat .....	38	39	40	41	42	43	44	45	46	47	48	49	50
Rise .....	9⅞	10	10¼	10⅜	11½	10⅝	10⅞	11	11¼	11⅝	11⅞	11⅞	11⅞
Length .....	30½	31	31½	32	32½	32¾	33	33¼	33½	33¾	34	33¾	33½
Knee .....	18½	19	19½	20	20½	21	21½	22	22½	23	23½	24	24½
Bottom .....	15¼	15½	15¾	16	16¼	16½	16¾	17	17¼	17½	17¾	18	18¼

**Table No. 7**

**TROUSERS — CORPULENT — 3d DEGREE**

	5 ft.											5 ft.	
Height .....	6	7	8	9	9½	10	10½	11	11½	6 ft.	11½	11	10½
Breast .....	39	40	41	42	43	44	45	46	47	48	49	50	51
Waist .....	38	39	40	41½	43	44½	46	47½	49	50½	52	53¼	55
Seat .....	40	41	42	43	44	45	46	47	48	49	50	51	52
Rise .....	10¼	10⅜	10½	10⅝	10⅞	11	11¼	11⅝	11½	11⅝	11⅞	12	12¼
Length .....	31	31½	32	32½	32¾	33	33¼	33½	33¾	34	33¾	33½	33¼
Knee .....	19	19½	20	20½	21	21½	22	22½	23	23½	24	24½	25
Bottom .....	15½	15¾	16	16¼	16½	16¾	17	17¼	17½	17¾	18	18¼	18½

# The International Cutting School's System of Cutting

By L. GIBSON  
New York — Chicago

First Edition, 1909, One Thousand Copies      Second Edition, 1911, One Thousand Copies  
Third Edition, 1913, One Thousand Copies

## GRADING (PART SIX)



Entered according to Act of Congress (Act of March 4, 1909), in the year 1913  
by L. Gibson, in the office of the Librarian of Congress, Washington, D. C.

ALL FOREIGN RIGHTS RESERVED

---

(Printed in the United States)

# Complete Grading System

---

## The Principle of Grading

1. The principle of a system of grading is the carrying out of the different proportions from one size to another.

To those who are now using this system, it will be very easy. But this principle will be equally applicable to any system of cutting, so that all the patterns will have the same merits as the model, or the same faults.

If you are cutting a different system it will be good exercise, as well as testing your system, to draft two patterns by your system, the largest and the smallest, and grade one of them to the size of the other and see if they come out even; which they should.

Do not make yourself believe that spacing between 2 patterns is grading; that would be only spacing; there would be no graduation in that.

The fact is that there is not a system of grading published in the United States today but this one.

The idea of parallel grading, as it was called, has been given up long ago even by the man who made it.

A system, if correct in its proportions, should come out even with the grading points for all sizes.

This system does that. Try and see if yours does.

In grading the different types of form, it is better to grade each separately, such as Normals, Fat Men, Slims, Youths and Boys.

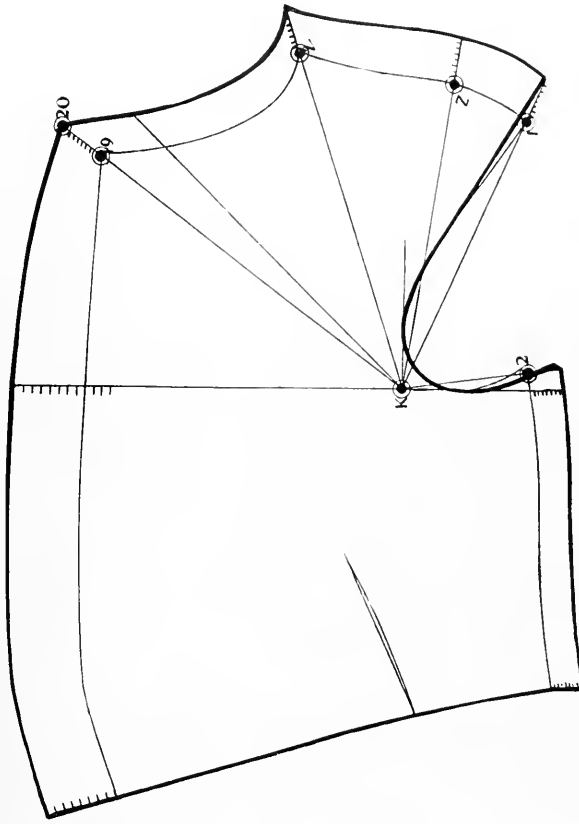

DIAGRAM 68 — CUTAWAYS

50 5. The Forepart Cutaway.—All points are the same, as the frock forepart.

51 The line through the notch is to regulate the height and is 1/6 inch for every size.

52 Point 20 is where the two lines meet.

53 The bottom length is the same continued forward.

See next page for details.

## Frock and Cutaways

- 1 For the normal sizes, that is 33 to 44, it is best to use a 36 size model.
- 2 A model to be used for grading should be cut very accurately and allowances made for the different classes of work and the make up; such as Custom Tailoring, Custom Order and Wholesale.
- 3 With a model of the class you wish to make, proceed as follows:
  - 4 To establish the breast-line
  - 5 Lay the model pattern in position; the Back against a straight line drawn vertically.
  - 6 The sidebody  $1\frac{3}{4}$  inches from the back at the waist and touching the back over the rounding above the breast line.
  - 7 The forepart against the sidebody at breast line and a  $\frac{1}{4}$  inch apart at the bottom.
  - 8 Square across for the breast line.

### Diagram 69

- 9 **2. The Back.**—Mark all around the model.
- 10 From B, which is the grading point, draw radiating lines through A, R, X, Y and L.
- 11 The increase from A, R and X is  $\frac{1}{6}$  inch every size.
- 12 Square up from breast line at L to Y.
- 13 L to M is  $\frac{1}{8}$  inch for every size. Square up to N.
- 14 From X advance the same amount (1 inch) and square up. This is to regulate the width of shoulder.
- 15 The waist line increases  $\frac{1}{32}$  inch for every size, or  $\frac{1}{4}$  inch.
- 16 Place the model over the breast line B on B.
- 17 Move up on line R to size 44, keeping breast line even.
- 18 Mark from R to A and R to X.
- 19 Place model pattern B on B; move forward on the B-Y line, keeping the back even until the new point at the waist.
- 20 Mark the back from breast to waist line.
- 21 The new position is shown by the broken lines.
- 22 Now let the back touch at point N and breast line, and mark the run over the blade.
- 23 Draw a new grading line through X.
- 24 Shape X to N.
- 25 The length remains the same at the bottom.

- 26 The full length from A to Bottom of skirt increases a  $\frac{1}{2}$  inch for every size.
- 27 Divide the spaces in halves, or by the "Square."
- 28 In taking off the patterns from the model chart shape by the size larger.

### Diagram 70

- 29 **3. The Side Body.**—Mark all around the model, mark the breast line.
  - 30 Square up from M to O—top of side body.
  - 31 M to U is  $\frac{1}{16}$  inch for every size. Square up.
  - 32 Draw lines from D through O and T.
  - 33 The increase over breast line is  $\frac{3}{4}$  inch from 36 to 44.
  - 34 Shape the large size by the model, placing O to top, keeping the breast line parallel and mark backwards.
  - 35 Place model D on D and swing up till the lines meet above the blade.
  - 36 Move forward over the breast line and shape the side parallel with the model.
  - 37 Place model O on O, keeping breast line even, and mark for run of scye.
  - 38 Where the two lines intersect at T draw a line through first and last from a point as far back of T as K is from 2 on forepart.
  - 39 The waist line is straight across, connect with back corner. This completes the side body.

### Diagram 71

- 40 **4. The Forepart Frock.**—Mark all around the model, the breast line, and point K.
  - 41 Square up from K by the breast line.
  - 42 Draw radiating lines K through 19, V, Z, 1 and 2.
  - 43 The increase, 19 and V is  $\frac{1}{6}$  inch for every size.
  - 44 The increase, point 1 is  $\frac{1}{8}$  inch for every size.
  - 45 From 2 to B on Back there is an increase of 2 inches all told, as the increase over breast line on Back is a  $\frac{1}{4}$  inch, and to the side body  $\frac{3}{4}$  inch, making 1 inch; there remains for the forepart 1 inch to increase.
  - 46 From 2 therefore is  $\frac{1}{8}$  inch increase for every size.
  - 47 The front increases a  $\frac{1}{4}$  inch for every size.
  - 48 The depth in front is  $\frac{1}{24}$  inch for every size.
  - 49 Shape outside lines by the model and space off.



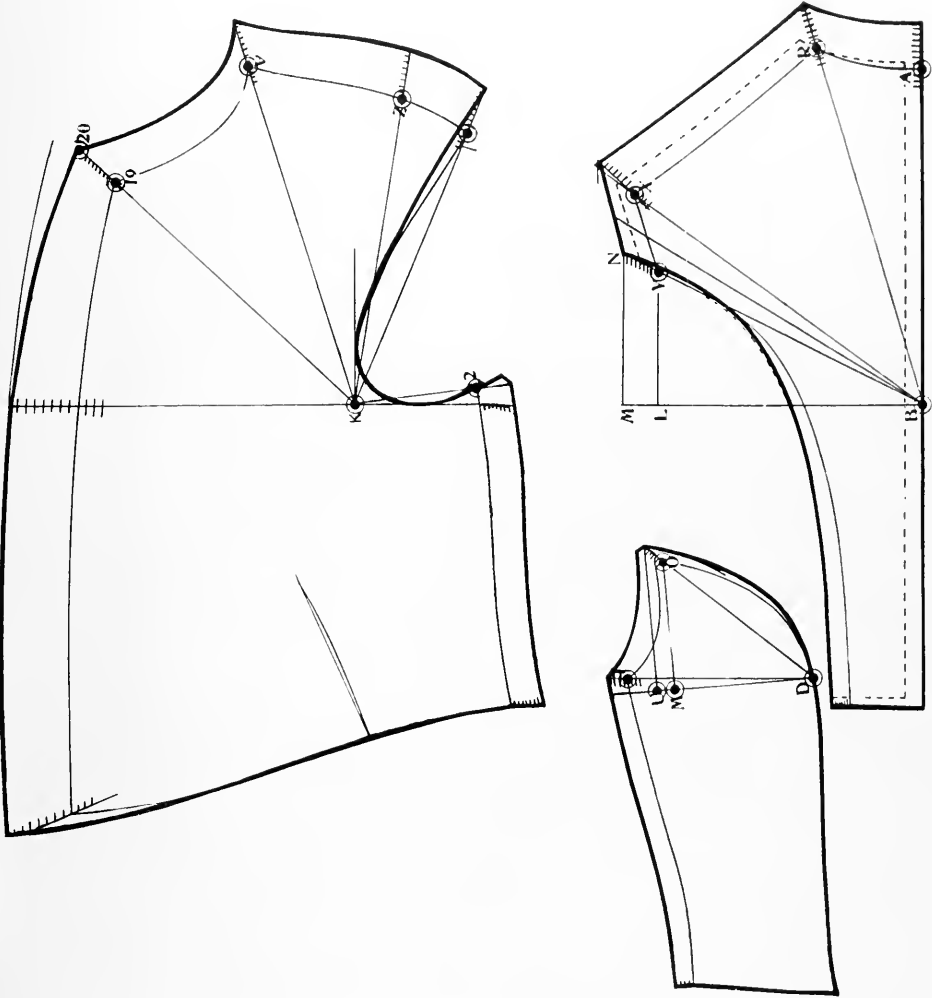

DIAGRAMS 69-70-71 — FROCKS

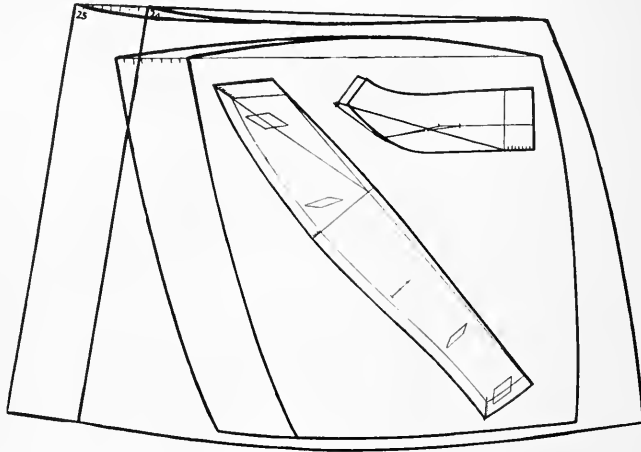

DIAGRAMS 72-73-74 — SKIRTS AND COLLARS

**Diagram 72**

- 54 6. **The Lapel.**—Draw lines through the top corner and through inside lower corner from the breast line.
- 55 The increase at top is  $\frac{1}{8}$  inch for every size.
- 56 The increase of lower length is  $\frac{1}{24}$  every size.
- 57 The increase over breast is  $\frac{1}{16}$  inch for every size.
- 58 Shape by the model. Draw grading line through lower corner; space buttonholes as shown.

**Diagram 73**

- 59 7. **The Collar.**—The collar increases  $\frac{1}{8}$  inch for every size in the back, and  $\frac{3}{4}$  inch from 33 to 44 in the front; on a line drawn from the 36 size in back through the front corner.
- 60 The width increases a  $\frac{1}{4}$  inch from 33 to 44 sizes.

**Diagram 74**

- 61 8. **The Skirt.**—Mark all around the model.
- 62 Draw a line from 23 through 24 to 25.
- 63 The increase of the side body and forepart has been 4 inches; therefore, 24 to 25 is 4 inches or a  $\frac{1}{2}$  inch for every size.
- 64 The lapel is not included, there will be that much less fullness on the skirt, which is right.
- 65 For increase of length see length of the Back.

**Diagram 74**

- 66 9. **The Cutaway Skirt.**—Is graded the same way; only  $3\frac{3}{4}$  inches, as the lapel increase is not included.

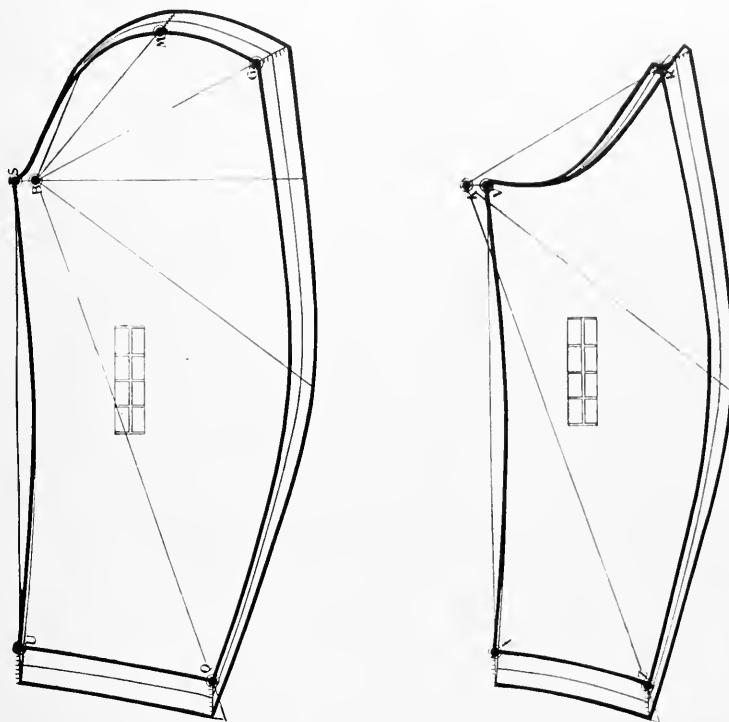

DIAGRAMS 75-76 — SLEEVES

**Diagram 75**

- 67 **10. Top Sleeve.**—If the pattern is a half-and-half establish point B on breast line or the point as at S.  
 68 In this case point B is  $\frac{3}{4}$  inch back of S.  
 69 Laying the corners Q together, the upper on under sleeve will show how much the seam is shifted.  
 70 Mark all around the model, and point B.  
 71 From B draw radiating lines J, M, G and Q.  
 72 The increase at G is  $\frac{1}{6}$  inch for every size.  
 73 At M  $\frac{1}{8}$  inch (J  $\frac{2}{3}$  of an inch all told).  
 74 The length from S-U is  $\frac{1}{6}$  inch for every size.  
 75 Shape outside lines by the model: space elbow and Q.

**Diagram 76**

- 76 **11. Under Sleeve.**—Mark all around the model.  
 77 Draw a line from V to X and square out to K.  
 78 K is  $\frac{3}{4}$  inch from V or half-and-half sleeve.  
 79 From K draw radiating lines R and Z.  
 80 The increase at R is  $\frac{1}{6}$  inch for every size.  
 81 The length from V-X is  $\frac{1}{6}$  inch for every size.  
 82 Shape outside lines by the model; space elbow and Q.  
 83 The advantages of taking 4 sizes between is found by dividing in halves for every size.  
 84 In taking off patterns always shape by the next largest.

## Sack Coats

### Diagrams 77-78

- 85 Sizes 4 year to 48 breast. The diagram shows a pattern up to a 48 breast; but it is not advisable to go higher than a 42 or 44 breast, because the height of the person will not follow.
- 86 It should be understood a 36 breast corresponds to a 5 feet 6 inches in height; to be normal to this style of grading would bring the height up to 6 feet 6 inches.
- 87 We know that people do not grow that high; as a rule the height is usually limited to 6 feet. (See table of proportions and how to make one yourself to fit the locality.)
- 88 The Stouts run from 36 to 44.
- 89 The corpulents from 40 to over 50 breast size.
- 90 For corpulent coat see under Part 1 corpulent Sack, 52 breast, 56½ waist, which will show the increase and decrease on point A, S, X and V.
- 91 For sizes below 36 proceed as explained in this Dia.
- 92 **12. Normal Size.**—Lay the pattern in position, the back against a straight line, the forepart touching the back at the breast line and a vertical line in front.
- 93 Square across for the breast line. Mark point K.
- Diagram 77**
- 94 **13. The Back.**—Mark all around the model.
- 95 Mark breast line and point B; remove the pattern.
- 96 From B draw radiating lines through A, S, X, L, P, N and E, through Y as far back as K is from Y.
- 97 The *increase* and *decrease* from A, S and X is 1/6 inch for every size (X on the corner).
- 98 Square up from breast line L to X.
- 99 L to M is ⅛ inch *increase* for every size.
- 100 Square up to O.
- 101 This is to regulate the width of shoulder.
- 102 Draw a new grading line through outer corner.
- 103 N, P, Y lines are parallel with L.
- 104 E increases 1/6 inch for every size.
- 105 This is for all sizes down to 33 breast.
- 106 All sizes below 33 breast are called ages instead of breast size; for example, 33 breast is 18 year; the next called 17 year and so on down to 4 year.
- 107 Each year of age represents a ¾ inch size instead of 1 inch.

- 108 Therefore 4 years is drafted by 22½ inches; 5 years by 23¾ inches, etc.
- 109 Boys sizes are short and small in the back.
- 110 Change them to erect forms by reducing size 33 two points at A and S and 2 points over the blade; a ¼ inch at L and a ¼ inch on the forepart, as shown by the shaded part on the Back.
- 111 The breast sizes now being ¾ inch below 33.
- 112 The blade therefore is ½ breast and 3 inches.
- 113 From the new 33 or 18 years to 4 years is 14 sizes, amounting to 15/16 of an inch (3/16 inch for every 2 sizes) to be divided into 14 sizes.
- 114 The *decrease* from E is a ½ inch for every size.
- 115 The 36 is 29, and the 4 year is 18½ inches long.
- 116 Shape by the model, keeping parallel with the breast line.
- 117 Divide the spaces in halves until the required sizes are obtained. This completes the Back.

### Diagram 78

- 118 **14. The Forepart.**—Mark all around the model.
- 119 Square up from K by the breast line.
- 120 From K draw radiating lines through 20, 19, V, Z, 1, Y, 15 and 11.
- 121 The *increase* and *decrease* from 20, 19 and V is 1/6 inch for every size. Point 1 is ⅛ inch.
- 122 The front *increases* a ¼ inch for every size.
- 123 Y, L and 11 *increases* ⅛ inch for every size.
- 124 The length *increases* 1/6 inch for every size.
- 125 This is for all sizes down to 33 breast.
- 126 Size 33 in front has a ½ inch added that was lost over the blade, bringing the new 33 to size 35.
- 127 From 33 decrease 1/6 inch for every size (2½ inches for 14 sizes) over the breast.
- 128 At L from 33 reduce a ¼ inch for small blade.
- 129 The balance 14 sizes decrease 3/16 inch for every 2 sizes (15/16 inch) over blade.
- 130 The front and side lines run parallel with front and L.
- 131 The line from K to 11 is to govern the spring on the smaller sizes.
- 132 Shape outside lines by the model; mark divisions.
- 133 Draw new grading line through 20 to 26.
- 134 In taking off a pattern always shape by the next size.

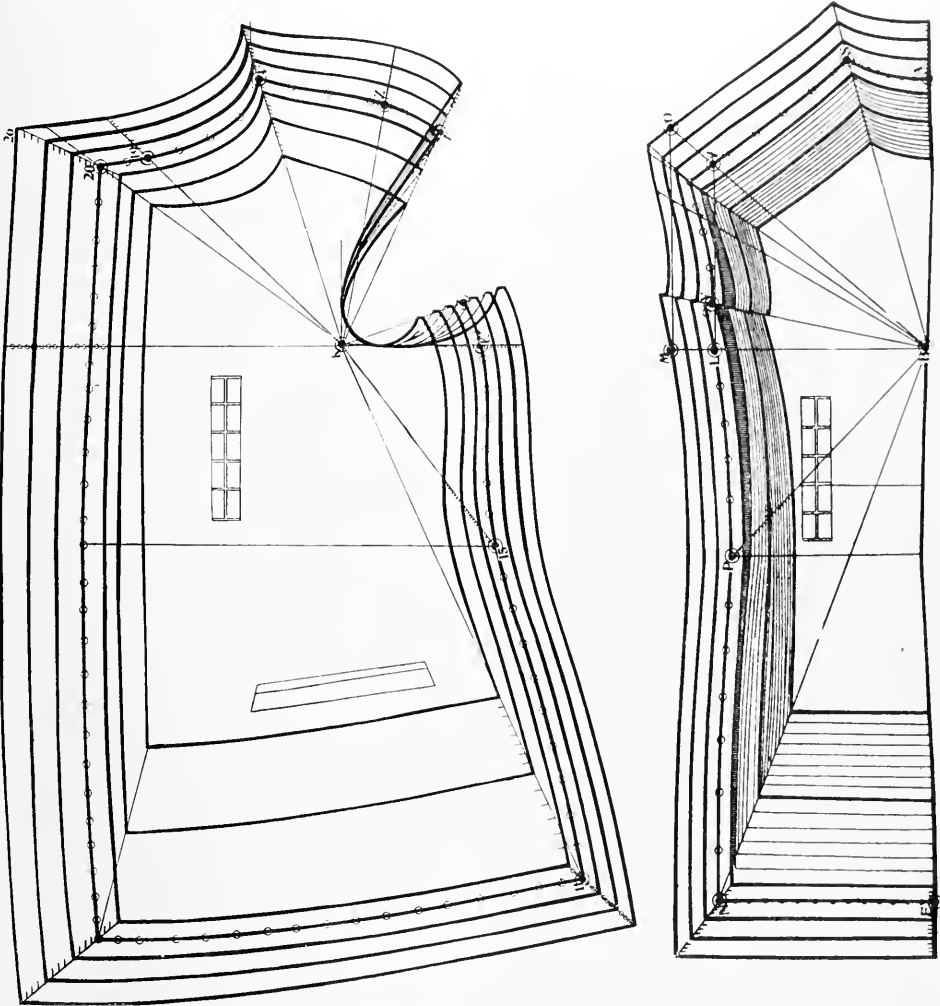

DIAGRAMS 77-78 — SACKS

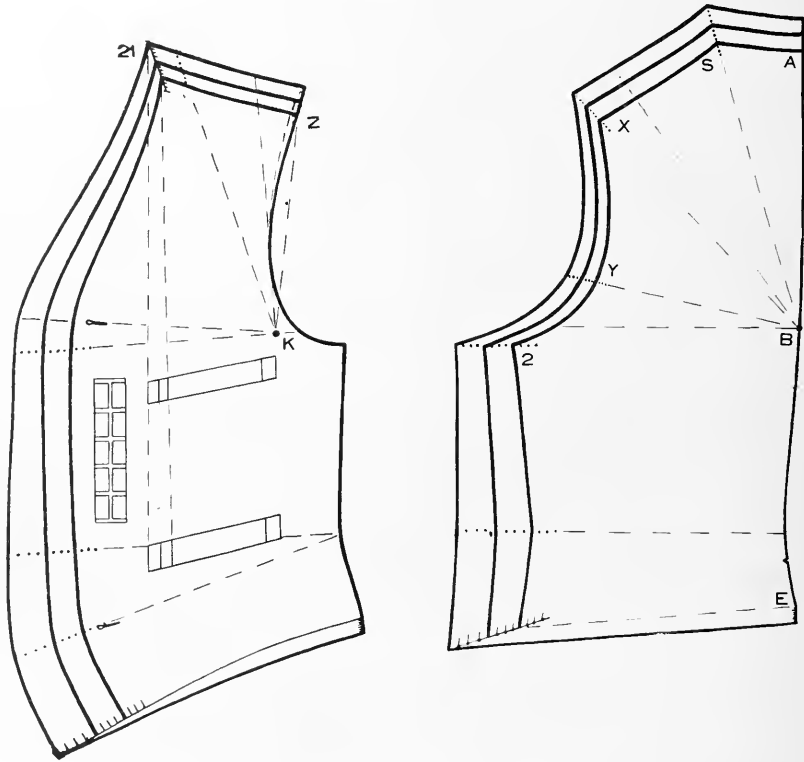

DIAGRAMS 79-80 -- VESTS

## Vests

- 135 Sizes 33 to 44.—Lay the patterns in position.  
 136 The back against a straight line, the forepart touching the back at breast line and a  $\frac{1}{4}$  inch from a straight line in front, opposite breast line.  
 137 For a 4 inches difference breast and waist, keep an opening of 1 inch between front and back at the waist line.  
 138 Square across, establishing the breast line.

### Diagram 79

- 139 **15. The Back.**—Mark all around the model.  
 140 Mark the breast line and remove the pattern.  
 141 From B draw radiating lines A, S and X.  
 142 The *increase* and *decrease* from A, S and X is  $\frac{1}{6}$  inch for every size.  
 143 The increase at 2 is  $\frac{1}{4}$  inch for every size.  
 144 The same at the waist.  
 145 E increases a  $\frac{1}{2}$  inch from 36 to 44 (parallel).  
 146 Below 33 the same sizes as in the Sack Coat.  
 147 Draw grading lines through 2 and the bottom.  
 148 Shape by the model. Divide the spaces in halves.  
 149 Draw check lines through Y ( $\frac{1}{8}$  inch) and over shoulder.

### Diagram 80

- 150 **16. The Forepart.**—Mark all around the model.  
 151 Mark the breast line and remove the pattern.  
 152 K is  $\frac{1}{2}$  inch from the front of armhole.

- 153 Square up from K by the breast line.  
 154 From K draw radiating lines V and Z.  
 155 21 is parallel with point V line.  
 156 The *increase* and *decrease* from 21 and V is  $\frac{1}{6}$  inch for every size; through Z  $\frac{1}{8}$  inch.  
 157 The front increases  $\frac{1}{4}$  inch for every size.  
 158 The front length increases  $\frac{1}{6}$  inch for every size.  
 159 The side length is a  $\frac{1}{2}$  inch from 36 to 44.  
 160 The first button on a 36 is 1 inch above breast line.  
 161 Draw line from K through first button.  
 162 The lower button is  $3\frac{1}{2}$  inches up or half way between waist line and bottom; draw grading line.  
 163 The back end of the top pocket is flush with the armhole, and  $\frac{3}{4}$  inch from the breast line.  
 164 The front dip is  $\frac{1}{2}$  inch; the length is 4 inches.  
 165 Draw line from 21 through front end of top pocket for front run of lower pocket.  
 166 The top of front, and the bottom of back end of pocket rest on the waist line.  
 167 The length is  $4\frac{3}{4}$  inches, the width  $\frac{7}{8}$  inch.  
 168 The front end increases  $\frac{1}{8}$  inch for every size.  
 169 The back *advances* half that much.  
 170 The top pocket the same; welt  $\frac{3}{4}$  inch wide.  
 171 Divide the spaces with this "Square" the required sizes.  
 172 The vest grade can be continued up to 52 breast, provided the necessary changes are made in waist size.

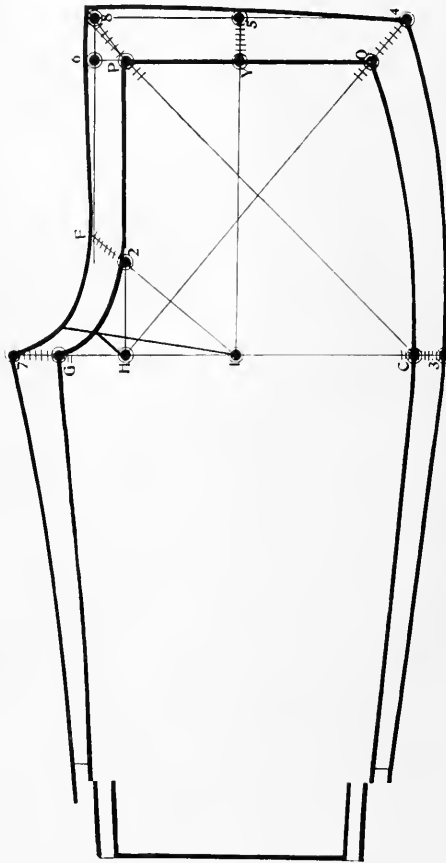

DIAGRAM 81 — TROUSERS

### Diagram 81

Trousers sizes 34 to 45 seat.

- 173 17. **The Forepart.**—Draw a line across from C to G.  
 174 I is half way between C and G.  
 175 Mark through the pattern at I.  
 176 Mark all around the pattern and remove.  
 177 Square up from I through Y.  
 178 Y to 5 is  $\frac{1}{6}$  inch for every size.  
 179 Square both ways from 5 locating 4 and 8.  
 180 H to 2 is  $\frac{1}{6}$  seat.

- 181 Draw a line from I through 2.  
 182 2 to F is  $\frac{1}{6}$  inch for every size.  
 183 Draw lines H through Q, and C through P.  
 184 C to 3 is  $\frac{1}{8}$  inch for every size (1 inch).  
 185 G to 7 is  $\frac{3}{16}$  inch for every size ( $1\frac{1}{2}$  inches).  
 186 P to 6 is 1 inch ( $\frac{1}{8}$ ), square up to 8.  
 187 Rise above 8, the amount C-P is in front of 8.  
 188 To bottom add  $\frac{1}{16}$  inch for every size ( $\frac{1}{2}$  inch).  
 189 Make the length the same (33 inches), or draw grading lines from I.  
 190 Shape by the model, divide the spaces in halves.



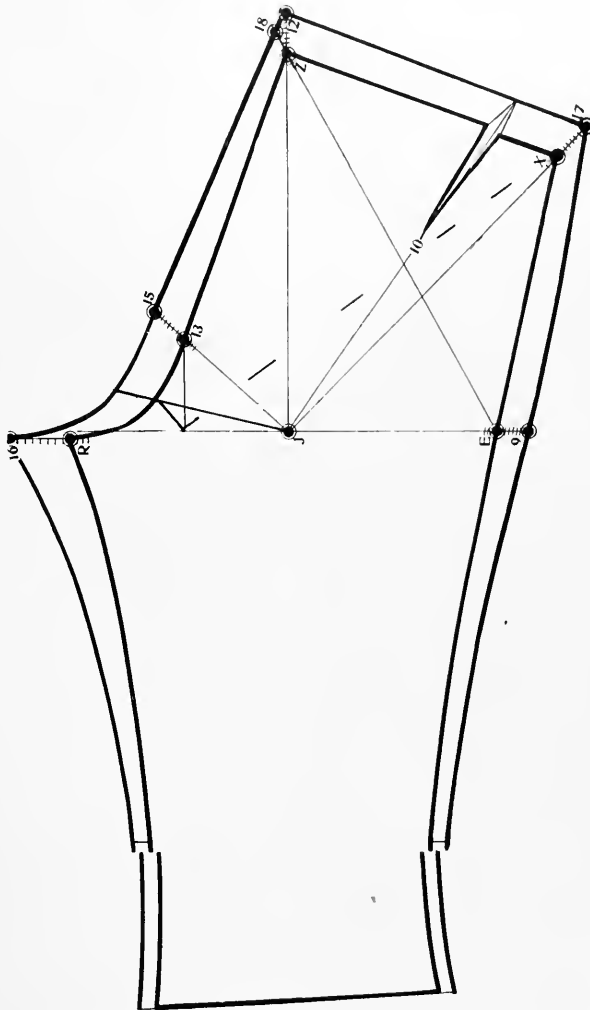

DIAGRAM 82 — TROUSERS

### Diagram 82

- 191 **18. The Backpart.**—Lay forepart on back part in natural position, with C about 1 inch from E; mark through at I, establishing J.
- 192 Draw a line across from E to R.
- 193 Mark all around the pattern and remove it.
- 194 Square up to 13,  $\frac{1}{6}$  seat.
- 195 From J draw radiating lines 13, Z, 10 and X.

- 196 The increase from 13, Z and X is  $\frac{1}{6}$  inch.
- 197 Draw a line from E through Z to 18.
- 198 Z to 18 is  $\frac{1}{12}$  for every size ( $\frac{1}{6}$  on division).
- 199 E to 9 is  $\frac{1}{8}$  inch for every size (1 inch).
- 200 At bottom go out  $\frac{1}{16}$  for every size (or style).
- 201 Shape outside lines by the model, and divide by halves.
- 202 In taking off a pattern shape by the next size.
- 203 The waist band increases  $\frac{1}{2}$  inch for every size.



# BLOCK PATTERNS

## AND A CORRECT WAY TO USE THEM

We do not believe there is a cutter today but who will admit, that the use of a "Block Pattern" is an advantage and a saving of time. The only two questions to enter his mind is: First, how to get such a pattern, and, second, how to use it. The first question we will answer by saying that we have the only system in the world from which patterns can be cut according to the system and which will correspond to the grading points. No other system will do so! The second question is how to use them correctly. No books published today gives a practical way of using patterns. For the lack of knowing how the cutter does not feel inclined to invest in Block Patterns.

A "Block Pattern" is a normal pattern, cut on scientific principles. There is such a Pattern. We will prove to any interested party that we have such a pattern. We have so far printed two editions of 1,000 copies each of our system and they are all gone but eight copies. We have cutters using our system in every large city with exception of a few cities. And not one dissatisfied customer. To mention system to a cutter is like waving a red bandana to a bull; but when it comes to patterns we are down amongst them, and results speak.

Our Patterns are cut as close as a pencil mark will allow and each with the utmost care, so that sleeves and collar, etc., fit together accurately. In using such a pattern a cutter can cut a suit; that is, draft the paper pattern in from 10 to 15 minutes; apply all short measures and make all changes, still the fitting points and the outlines will remain as accurately as the block pattern. The balance of the time a cutter can certainly put in to better advantages than to be drawing perpendicular and horizontal lines and curves on the paper. Yet you retain the model pattern for use again.

An explanation on how to use them follows: To use Block Patterns on drafting paper is not difficult and only a few general rules are necessary. To use them direct on the cloth requires some practice, but it can be done equally as well. We will give an illustration of how they are used in the second instance.

Here is a measure taken from a live customer reading as follows: Length of coat 35 inches, sleeves 35 inches, breast 38, waist 35 inches (here use the short measures if you have them). The trousers:

Outside 15, inside 31 inches, waist 33, thigh 22, seat 40, knee  $21\frac{1}{2}$ , bottoms 16. Height 6 feet, weight 155 pounds, shoulders regular, neck medium long, chest regular, hollow waist, hips medium broad, collar size 15. Measures taken over heavy underwear, form fitting back. Suppose this measure was taken in the store, a description of the attitude, etc., of the customer will not be amiss, in addition to the measures. It will bring the whole form before your mind's eye when drafting.

Take an ordinary Block Pattern of the size required, and before drafting make these memorandums. The height being 6 feet indicate too tall for the size of pattern. Lengthen front and back shoulder of the coat  $\frac{1}{4}$ -inch. Widen the shoulders of front and back  $\frac{1}{4}$ -inch. Add to spring over the hip  $\frac{1}{4}$ -inch; then either enlarge the sleeve head  $\frac{1}{4}$ -inch or use a 39 sleeve. For trousers, he has indicated a full peg; would therefore use a 40 No. 1, a full peg. The measure shows a rise of 11 inches. The normal rise of a 40 seat is  $10\frac{1}{4}$  inches, but as this man wants a full peg or No. 1; the size 40, of which has a rise of  $9\frac{1}{2}$  inches, will therefore change this measure to  $9\frac{3}{4}$  inches on account of his height; the other measures remain as taken.

After receiving the goods, shake it thoroughly so that it will lay naturally; smooth it out. If it is a cut, or length, see that the tag end is at your right side, then the nap, if any, will run towards the left. Lay the patterns in position, as shown in the diagram. The sleeves may be reversed if necessary. The rule of laying patterns is to place the larger pieces first and to commence at the left end.

To use: Commence with the forepart of trousers, mark from halfway up the fly to top of waist band, along the top of forepart and the side at waist, now lower the pattern  $\frac{1}{4}$  inch (in this case), making the rise  $9\frac{3}{4}$ . Then mark from inside knee up to fork and through curve of fork, mark past the seat notch and notch it, now mark the knee notches at the 32 inches long knee mark. The measure calls for a  $21\frac{1}{2}$ -inch knee, and the pattern being  $25\frac{1}{2}$  inches; reduce  $\frac{1}{2}$  inch on fore part and  $\frac{1}{2}$  inch on back part; swing the pattern out of the way and mark the reduction of  $\frac{1}{2}$ -inch on the outside seam at knee, bring the pattern

back in position. Now get the length 34 inches by moving the pattern down 2 inches, noting the notches at the knee, thereby avoiding the use of the tape line. The bottom wanted 16 inches, the pattern also being 16 inches. Now shape by the pattern from bottom to knee on the inside, then from bottom to new knee mark, from knee to hip notch. The waist wanted 33 inches, the pattern being 34 inches; reduce  $\frac{1}{4}$ -inch for every inch on the side seam of the waist, using the pattern to shape by, also shape part way of the dress, then add the turn-up, whether cuffs or otherwise. This completes the forepart of the trousers.

The back part: Place in position; mark the amount of turn-up, the width of bottom and a few inches up, move up the pattern; at the knee the length required, 31 inches, mark the notches at the 32 length notch, so as to have them in the same place as the forepart. Mark seat, and inside seam to knee; mark the hip notch, and past it. Now raise the rise  $\frac{1}{4}$ -inch and mark along the top; reduce  $\frac{1}{4}$ -inch on side seam at waist to 33 from 34 waist. Shape outside seam by the pattern, reducing  $\frac{1}{2}$ -inch at the knee. Bring the pattern back in original position, shape from the bottom up to the knee on both sides. This completes the trousers with the exception of shaping the outlet on the inside seam, also mark the outlet over seat seam by the hand. Never change the seat seam on back part nor the front line on forepart.

The coat: Place the forepart in position, mark along the bottom and rise the amount of turn-up  $1\frac{1}{4}$  inch; now move the pattern up until the desired length is obtained (in this case 35 inches); the pattern being 31 inches. Mark along the front from the waist down. (The pattern being a straight front sack.) Now mark the armhole, the notches and top of side seam, add the  $\frac{1}{4}$ -inch over the hip; move the whole pattern out horizontally, the  $\frac{1}{4}$ -inch and shape from hip down, then connect top of side seam with the line at the hip, using the pattern to shape by. Shape the outlet on side seam

by the model always. Bring the pattern back in original position and mark the pockets and under-arm cut. Now mark to top of the shoulder  $\frac{1}{4}$ -inch higher and also  $\frac{1}{4}$ -inch wider, move the pattern up and shape the shoulder, armhole and the gorge as far as the collar notch; remove the block and finish the lapel and front by the style shaper, or if the block is style, finish with it, marking the buttonholes, also lower the lower pocket and lower buttonhole to correspond to the height. The pocket being 2-3 the inside sleeve length down from armseye. This completes the forepart.

Place the facing as indicated by the diagram. Lay the coat back in position, if a center vent is wanted, allow cloth for the vent; also see that the stripes will come out even spaced in center seam when finished; mark along the bottom and allow for turn-up  $1\frac{1}{4}$ -inch, move up the pattern until the desired length is gained, less the  $\frac{1}{4}$ -inch to be lengthened at the top of back for height. Now mark inside seam from top of shoulder down, taking off  $\frac{1}{4}$ -inch at the waist if the goods are striped to balance the fill in in the center of back. In this case raise the shoulder and back  $\frac{1}{4}$ -inch, as indicated on the memorandum slip, and finish, allowing outlet at the top of the back.

Place the two sleeves in position; if necessary, reverse the lay of both if there is no nap; see that the upper and lower points of the inseam of the top sleeve run even with a stripe. Allow  $2\frac{1}{2}$  inches for a turn-up, then mark from elbow down on both seams; move the pattern up until the right length is obtained, keeping even with the stripes, then mark the upper half of the sleeve; connect the upper and lower marks, following a straight line so that the original hollowness on inseam is maintained; also the same width over the elbow. The outlet for the turn-up and vent is shaped by the pattern. This completes the top sleeve.

*This Coupon when properly filled out and accompanied by 25 cents, will be good for one Pattern of any size, either Coat, Vest or Trousers, described in this circular.*

*Style.....Size.....Customer's Height.....Breast.....Seat.....*

*Other Measures.....*

*Firm Name .....*

*Address .....*

.....

Place undersleeve in position; it is not necessary for the stripes to run exactly true; mark the upper half, get the length and finish bottom in the same manner as the top sleeve, allowing an outlet on inside seam.

Place the top collar, if nap on the goods, so the nap will run downward in the center of back.

The breast pocket welt nearly always is taken out of the armseye. The lower flaps can be taken either above or below the sleeve, other fittings have their places. In all cases shape outlets by the model, except the top of shoulder. This lay can be closed up or extended to suit any sizes, except very large ones, and for a lay with fittings cannot be surpassed; scores of cutters have adopted it since we first introduced it. We claim originality of it.

Whether the changes are made on the cloth as described or a pattern is cut, the process of laying and marking is the same. To start, would advise drafting a pattern first, making the necessary changes by the same process as here described.

To prove the merits of the patterns, we will make this extraordinary offer: To anyone sending or bringing us the coupon attached hereto and 25 cents, we will cut one pattern, choice of any one printed in this circular, be it coat, vest or trousers.

In ordering trousers, state what number desired, from 1 to 6 or corpulent. In all cases give height of customer.

It is surprising so many merchants and cutters hesitate about investing in patterns. A merchant thinking nothing of expending \$50 on a store fixture, which really brings him no returns. Whereas, it is the good fitting garment that brings the trade; that, and nothing else; hence a cutter is paid high salary to bring customers, through his cutting.

One satisfied customer pays for a set of patterns. Why not invest \$50 in a selection of patterns. Our patterns are used all through the country, from New York to San Francisco, and in all class of trade, in wholesale, mail order and merchant tailoring; something very few pattern makers can say. But ours can stand the test.

In ordering a set state what class of trade it is to be used for, as they are cut differently.

Trousers run in 6 different styles, from Nos. 1 to 6. No. 1 is normal, No. 2 is slightly peg, No. 3 is half peg, No. 4 is full peg, No. 5 is extreme peg and No. 6 is extra large peg. For example, a 40 seat, No. 6, is 29½ inches knee and actual 51 inches over the seat,

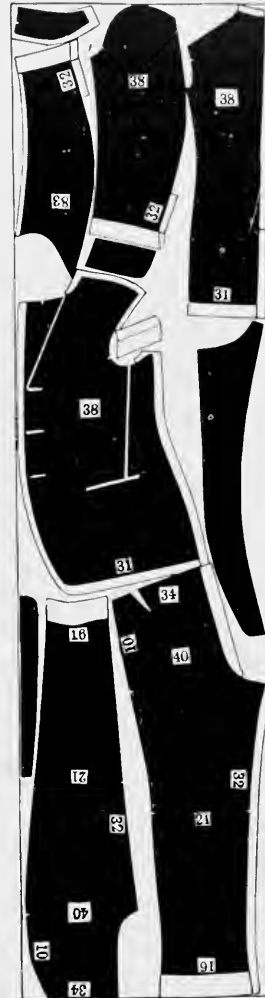

16 bottom, 34 waist. When over 45 seat is ordered, we take it for granted it is a corpulent, unless otherwise specified. For example, a 53 seat will call for a 56½ waist.

To anyone ordering \$50 worth of patterns we will give personal instruction FREE how to use them, either on paper or direct to cloth.

In trying one of these patterns (they can be safely made up without try-on) there will perhaps be less changes than if the garment was tried on.

# THE I. C. S. PATTERNS

We will call your attention to the superiority over other Patterns, and a few reasons therefor.

(1) Ours are cut from a system based on scientific principles, and the ONLY SYSTEM IN THE WORLD from which patterns can be cut directly and will correspond to grading points. Their balance is correct.

(2) They are models of the highest attainment in the art of cutting, and contain features not found in any other patterns.

(3) Their fitting points are perfect and need never be changed. The sleeves have 2 notches which always fit.

(4) They are marked to breast and heights, no others have these very important features. For example: 44 br. is marked to heights from 6 ft. 2, to 5 ft. 4 inches.

(5) The breast and waist lines are marked, as also are the short measures.

(6) They are made of "flexible fibre paper" unbreakable 300 lb. weight (sample free).

(7) A whole set of coats, vests and trousers, can be rolled and carried in a suit box, or suit case without injury.

(8) We also furnish with each full set of patterns, "style shapers" free of charge. By the use of "style shapers" a block pattern never gets out of style; therefore, the investment is only once.

(9) They can be hung up or rolled up and occupy but little space. One peg will hold a full set.

The waist measure on coats are cut 4 inches less than breast, except the corpulents. Seat measure to each breast measure is 1 inch more than breast. Waist measure is 6 inches less than seat measure on trousers; all trouser patterns are marked to the seat size.

Lengths of all garments are usually cut to proportional heights, except the trousers which are all cut 32 inches long. Each Vest pattern is cut without a collar, but a collar is included giving the collar shape an opening.

All short measures can be accurately applied because ours is an absolutely non-swinging system.

Special patterns are cut from light-weight manilla or pattern paper. No tissue paper patterns sold.

Measures for all coats, vests and overcoats are taken over the vest.

**IMPORTANT**—Give breast, waist and seat measures, etc., height of customer and attitude—**IMPORTANT**.

## PRICES OF SINGLE PATTERNS

SPECIAL OR BLOCK (Any Size)			
Inverness and Cape .....	\$2.00	Vest .....	\$ .50
Newmarket .....	2.00	Trousers .....	.75
Overcoat (Frock or Ulster) .....	2.00	Riding Breeches .....	1.00
Raglan .....	2.00	Cycle or Golf .....	1.00
Overcoat (Box or Chesterfield) .....	1.25	Shoulder Cape .....	1.00
Undercoat (Frock or Cutaway) .....	1.50	Spanish or Military Cape .....	1.00
Undercoat (Sack) .....	1.00	Hood .....	.75
Coat, Vest and Trousers .....	1.50	Livery, Uniform, Clerical and Unusual Patterns at special rates.	

## PRICES OF BLOCKS IN SETS

(Sizes 33 to 43 inches inclusive. 11 Patterns.)			
Inverness and Capes .....	\$15.00	D. B. Sack Shapers .....	\$3.00
Newmarkets .....	15.00	D. B. Overcoat Shapers .....	3.50
Overcoats (Frocks or Ulsters) .....	15.00	Vests (Normal or Corpulent) .....	5.00
Raglans .....	15.00	Trousers (34 to 44 seat, No. 1 and 2) .....	7.50
Overcoats (Box or Chesterfields) .....	10.00	Trousers, Peg (34 to 44 seat, No. 3 half, No. 4 Full Peg) .....	7.50
Undercoats (Frocks, Dress or Cutaways) .....	10.00	Trousers, Extreme Peg (34 to 44 seat, No. 5 & 6) .....	7.50
Undercoats (other styles) .....	9.00	Trousers, Corpulent (45 to 53 seat) .....	7.50
Stouts (36 to 43 breast) .....	9.00	A discount of 25 per cent. is allowed on all pattern orders, on amounts exceeding \$50. net.	
Corpulents (45 to 52 breast) .....	9.00		

THE I. C. S. PATTERNS CAN BE OBTAINED ONLY FROM THIS OFFICE DIRECT

Remittances must accompany all orders for Patterns.

Address all orders to

51 W. 28th Street  
New York

**International Cutting Schools**

54 W. Lake Street  
Chicago

## INTERNATIONAL CUTTING SCHOOLS

### DIAGRAM

The measures are taken over the Vest always.

Inside sleeve	inches	Blade (with $1\frac{1}{4}$ inches for	
Breast	inches	seams added)	inches
Waist	inches	Depth of scye	inches
Hip or seat	inches	Natural waist	inches
Strap	inches	Fashion waist	inches
Over shoulder	inches	Full length	inches
	inches	Height	ft. inches
Form and Attitude.		sizes	to breasts

### To Draft.

- 1 Square both ways from A.
- 2 — to B is  $1/3$  breast on "THIRDS" and  $3\frac{1}{2}$  inches.
- 3 B to — is  $1/3$  breast of height, and  $3\frac{1}{2}$  inches.
- 4 A is half-way between — and —.
- 5 This is the proportional, and includes all allowances.
- 6 A to C is one-fourth height, and  $1/4$  inch for curve of Back.
- 7 C to D is  $1/3$  breast, on "THIRDS" (also Vest). Seat.
- 8 Added to the natural waist gives correct length.
- 9 A to E is the Full Length of Back.
- 10 F is half between B and A, for front shoulder height.
- 11 Square out from A, B, C, D, E, F, 3, 4, 5, 6, 7.
- 12 C to G is  $1/2$  inch, draw line F to G and down to E D.
- 13 From the line just drawn inside of B measure to H.
- 14 B to H is half the full breast measure.
- 15 H to I is  $2\frac{1}{4}$  inches (Vest 2 inches), center of breast.
- 16 B to K is blade (with  $1\frac{1}{4}$  inches for seams).
- 17 Square up from K—front of armhole.
- 18 (Exagg.)—K to 31 is 1 inch—half exaggeration.
- 19 (Exagg.)—3 is half-way between K and 31; square up from 3.
- 20 L is half-way between B and K.
- 21 L to M is  $1\frac{1}{4}$  inches (Vest  $1/2$  inch)—width of Back.
- 22 Square up to O, and down to N.
- 23 P is  $1/2$  inch from Line O-M; draw line to N.
- 24 A to Q is  $1/12$  breast—on "TWELFTHS," and
- 25 Q to R is  $1\frac{1}{2}$  inches; square up to S,  $3/8$  inch.
- 26 K to T is  $1\frac{1}{2}$  inches (Vest 1 inch); T to U is  $1/12$ .
- 27 Square up from U to V, locating the shoulder point.
- 28 V is located on lines from K and — through line —.
- 29 Draw lines from S to U, and F to V.
- 30 This gives the proportional height of shoulders.
- 31 Rise at X  $1/2$  inch, and lower at point 1 the same.
- 32 X is  $1/2$  inch on the S-U line—or Style.
- 33 Y is  $1/2$  inch from the O-N line, and  $1/12$  up from M.
- 34 Draw guide line from Y to P.
- 35 From B up apply depth of scye measure and  $1/2$  inch to —, in normal attitude will meet line A.
- 36 The  $1/2$  inch is for fullness held in over the blade.
- 37 (Stoop)—Lay square on 5, O and F, and square line O, 5, F.
- 38 Obtain point S from 5 and shape 5, S to X.
- 39 Shape the Back as shown; draw line from B to W.
- 40 Apply strap measure, and 1 inch A to R and K to V in normal attitude will meet line F-V. (Vest  $3/4$  in.)
- 41 (Stooping)—Advance V from line K-V as much as below line 4.
- 42 (Erect)—Go back from K-V line as much as above line V—.
- 43 Apply over shoulder measure and 1 inch (Vest  $3/4$  inch) B to W and K to Z; when normal, meet line F-V.
- 44 Z is  $1\frac{1}{4}$  inches from line K.
- 45 Draw a line from V through Z to point 1.
- 46 V to point 1 is  $3/8$  inch less than S to X. (Vest  $3/4$  in.)
- 47 Draw a guide line from point 1 to T.
- 48 Shape arms-eye and shoulder rounding  $1/2$  in. over Z.
- 49 B to 2 is  $1/2$  breast on "HALVES"; 2 to K is  $3\frac{1}{2}$  inches.

### SACK

### PART 1

- 50 This is normal blade and independent of the actual blade, and comes even with K in normal sizes. (Vest 3 inches.)
- 51 Square down from K through 4 to 17.
- 52 4 to 5 is  $1/2$  waist—on "HALVES"—center of waist.
- 53 Square down from 5 to 7. The measure from B to 2, K, 4 and 5, is used only to obtain the front center of the waist and to check the blade measure.
- 54 5 to 8 is  $2\frac{1}{2}$  inches, 9 to 10 is the same. (Corp.: 2 in.)
- 55 These  $2\frac{1}{2}$  inches are for seams and make-up.
- 56 In corpulency, measure the waist first and obtain the hip spring from it. This rule applies where the waist is even, or more, than the breast.
- 57 (Corp.)—Measure waist and  $1\frac{1}{2}$  inches P to G and 8 to 16.
- 58 Square down from 16 to 12; 12 to 11 is  $1\frac{3}{4}$  inches.
- 59 Apply hip measure and  $3/4$  inch for 3 seams; width of Back from 12 to D and 10 to 11. (Faxag,  $1/2$  in.)
- 60 11 to 12 is  $1\frac{3}{4}$  inches; square up, locating 13.
- 61 (Proportional hip spring 12 to 11 is  $1\frac{3}{4}$  inches.)
- 62 Draw a line from 13 through 11 to 14.
- 63 Measure waist and  $1\frac{1}{2}$  inches P to G and 8 to 16.
- 64 Y to 14 is the length from Y to N.
- 65 Shape side seam of forepart from Y to 16, going out  $5/8$  inch over 11 to 14—or style.
- 66 Draw line 15 and take out a  $1/4$  inch or more.
- 67 (Reduce  $1/2$  in. from Y to 16 when no underarm cut.)
- 68 Z to 7 is length from Z to E and 1 inch, from line K.
- 69 The 1 inch is taken up in making the front edge.
- 70 Draw line 14 to 7; shape bottom; lower  $5/8$  at 17.
- 71 (Corp.)—Measure hip and  $3/4$  inch for 3 seams; width of Back from 12 to D, and from 10 to 11.
- 72 (Corp.)—Draw line 15 and take out the shaded part.
- 73 Open at 2 the amount of seat surplus and fold 33 on 34 by cutting to the pocket and to the front of pocket.
- 74 V to 18 is  $1/12$  breast; square forward from 18 by K.
- 75 18 to 19 is  $1/4$  breast; draw line from 19 to 1 and 5.
- 76 (Corp.)—Advance at 1 the amount from K to 3.
- 77 19 to 20 is  $2\frac{1}{4}$  inches; notch  $1/2$  inch from 19.
- 78 I to J is  $1\frac{1}{4}$  inches; 5 to 6 is 1 inch; square down.
- 79 Go in  $1/2$  inch at 7; draw line from 6 and shape front.
- 80 V to 21 is  $1\frac{1}{4}$  inches; draw line to end of roll.
- 81 (One Bottom)—Go in 1 inch between waist and seat line.
- 82 The pocket is  $2/3$  sleeve length and  $1/2$  inch from K.
- 83 (For double-breasted add  $2\frac{1}{4}$  inches to the front.)
- 84 I to J is  $1/2$  inch; 5 to 6 is  $1\frac{3}{4}$ ; 6 to 25 is  $1\frac{1}{2}$  inches.
- 85 2 to 44 is 1 inch; square down to 3;  $1/2$  inch.
- 86 G to P  $1/2$  waist and  $3/4$  inch; 4 to 16 is  $1\frac{1}{4}$  inches.
- 87 Draw straight lines from 3 to P, and 3 to 16.
- 88 For correct spring over hip draw line from K through 16.
- 89 Draw line from G to D. From P add  $1/4$  inch for spring.
- 90 Apply length and  $1\frac{1}{4}$  inches, A to R and V to 7.
- 91 Apply Opening and  $3/4$  inch, A to R and V to J.
- 92 Draw lines from C to 7 and E to 17.
- 93 V to 21 in 1 inch; when no collar  $3/4$  inch.
- 94 Draw line from 21 to first button and finish as rep.
- 95 (Corp.)—Open pocket  $1/16$  for every inch more than normal.
- 96 (Dress)—J to I and 6 to 5 is  $1/2$  inch; draw line 1 to 7.
- 97 J to B is 3 inches. Opening  $1/2$  inch above waist line.
- 98 7 to 8 is  $1\frac{1}{4}$  inches; 7 to 9 is the same.
- 99 5 to 11 is  $2\frac{1}{2}$  inches; 5 to 12 is the same.
- 100 9 to 10 is  $3/4$  inch; 12 to 13 is the same.
- 101 (Clerical)—For vest to button in front, leave a stand  $3/4$  inch.
- 102 (Cleri.)—Reduce a seam at 19 dotted line; and shape the bottom.

## INTERNATIONAL CUTTING SCHOOLS

## DIAGRAM

The measures are taken over the Vest always.

Inside sleeve	inches	Blade (with $1\frac{1}{4}$ inches for	
Breast	inches	seams added)	inches
Waist	inches	Depth of scye	inches
Hip or seat	inches	Natural waist	inches
Strap	inches	Fashion waist	inches
Over shoulder	inches	Full length	inches
	inches	Height	ft. inches
Form and Attitude.		sizes	to breasts

## To Draft.

- 1 Square both ways from A.
- 2 — to B is  $\frac{1}{3}$  breast on "THIRDS" and  $3\frac{1}{2}$  inches.
- 3 B to — is  $\frac{1}{3}$  breast of height, and  $3\frac{1}{2}$  inches.
- 4 A is half-way between — and —.
- 5 This is the proportional, and includes all allowances.
- 6 A to C is one-fourth height, and  $\frac{1}{4}$  inch for curve of Back.
- 7 C to D is  $\frac{1}{3}$  breast, on "THIRDS" (also Vest). Seat.
- 8 Added to the natural waist gives correct length.
- 9 A to E is the Full Length of Back.
- 10 F is half between B and A, for front shoulder height.
- 11 Square out from A, B, C, D, E, F, 3, 4, 5, 6, 7.
- 12 C to G is  $\frac{1}{2}$  inch, draw line F to G and down to E D.
- 13 From the line just drawn inside of B measure to H.
- 14 B to H is half the full breast measure.
- 15 H to I is  $2\frac{1}{4}$  inches (Vest 2 inches), center of breast.
- 16 B to K is blade (with  $1\frac{1}{4}$  inches for seams).
- 17 Square up from K—front of armhole.
- 18 (Exagg.)—K to 31 is 1 inch—half exaggeration.
- 19 (Exagg.)—3 is half-way between K and 31; square up from 3.
- 20 L is half-way between B and K.
- 21 L to M is  $1\frac{1}{4}$  inches (Vest  $\frac{1}{2}$  inch)—width of Back.
- 22 Square up to O, and down to N.
- 23 P is  $\frac{1}{2}$  inch from Line O-M; draw line to N.
- 24 A to Q is  $\frac{1}{12}$  breast—on "TWELFTHS," and
- 25 Q to R is  $1\frac{1}{2}$  inches; square up to S,  $\frac{5}{8}$  inch.
- 26 K to T is  $1\frac{1}{2}$  inches (Vest 1 inch); T to U is  $1/12$ .
- 27 Square up from U to V, locating the shoulder point.
- 28 V is located on lines from K and — through line —.
- 29 Draw lines from S to U, and F to V.
- 30 This gives the proportional height of shoulders.
- 31 Rise at X  $\frac{1}{2}$  inch, and lower at point 1 the same.
- 32 X is  $\frac{1}{2}$  inch on the S-U line—or Style.
- 33 Y is  $\frac{1}{2}$  inch from the O-N line, and  $1/12$  up from M.
- 34 Draw guide line from Y to P.
- 35 From B up apply depth of scye measure and  $\frac{1}{2}$  inch to —, in normal attitude will meet line A.
- 36 The  $\frac{1}{2}$  inch is for fullness held in over the blade.
- 37 (Stoop)—Lay square on 5, O and F, and square line O, 5, F.
- 38 Obtain point S from 5 and shape 5, S to X.
- 39 Shape the Back as shown; draw line from B to W.
- 40 Apply strap measure, and 1 inch A to R and K to V in normal attitude will meet line F-V. (Vest  $\frac{3}{4}$  in.)
- 41 Stopping—Advance V from line K-V as much as below line 4.
- 42 (Erect)—Go back from K-V line as much as above line V—.
- 43 Apply over shoulder measure and 1 inch (Vest  $\frac{3}{4}$  inch) B to W and K to Z; when normal, meet line F-V.
- 44 Z is  $1\frac{1}{4}$  inches from line K.
- 45 Draw a line from V through Z to point 1.
- 46 V to point 1 is  $\frac{3}{8}$  inch less than S to X. (Vest  $\frac{3}{4}$  in.)
- 47 Draw a guide line from point 1 to T.
- 48 Shape arms-eye and shoulder rounding  $\frac{1}{2}$  in. over Z.
- 49 B to 2 is  $\frac{1}{2}$  breast on "HALVES"; 2 to K is  $3\frac{1}{2}$  inches.

## SACK

## PART I

- 50 This is normal blade and independent of the actual blade, and comes even with K in normal sizes. (Vest 3 inches.)
- 51 Square down from K through 4 to 17.
- 52 4 to 5 is  $\frac{1}{2}$  waist—on "HALVES"—center of waist.
- 53 Square down from 5 to 7. The measure from B to 2, K, 4 and 5, is used only to obtain the front center of the waist and to check the blade measure.
- 54 5 to 8 is  $2\frac{1}{2}$  inches, 9 to 10 is the same. (Corp.: 2 in.)
- 55 These  $2\frac{1}{2}$  inches are for seams and make-up.
- 56 In corpulency, measure the waist first and obtain the hip spring from it. This rule applies where the waist is even, or more, than the breast.
- 57 (Corp.)—Measure waist and  $1\frac{1}{2}$  inches P to G and 8 to 16.
- 58 Square down from 16 to 12; 12 to 11 is  $1\frac{3}{4}$  inches.
- 59 Apply hip measure and  $\frac{3}{4}$  inch for 3 seams; width of Back from 12 to D and 10 to 11. (Exag.  $\frac{1}{2}$  in.).
- 60 11 to 12 is  $1\frac{3}{4}$  inches; square up, locating 13.
- 61 (Proportional hip spring 12 to 11 is  $1\frac{3}{4}$  inches.)
- 62 Draw a line from 13 through 11 to 14.
- 63 Measure waist and  $1\frac{1}{2}$  inches P to G and 8 to 16.
- 64 Y to 14 is the length from Y to N.
- 65 Shape side seam of forepart from Y to 16, going out  $\frac{5}{8}$  inch over 11 to 14—or style.
- 66 Draw line 15 and take out a  $\frac{1}{4}$  inch or more.
- 67 (Reduce  $\frac{1}{2}$  in. from Y to 16 when no underarm cut.)
- 68 Z to 7 is length from Z to E and 1 inch, from line K.
- 69 The 1 inch is taken up in making the front edge.
- 70 Draw line 14 to 7; shape bottom; lower  $\frac{5}{8}$  at 17.
- 71 (Corp.)—Measure hip and  $\frac{3}{4}$  inch for 3 seams; width of Back from 12 to D, and from 10 to 11.
- 72 (Corp.)—Draw line 15 and take out the shaded part.
- 73 Open at 2 the amount of seat surplus and fold 33 on 34 by cutting to the pocket and to the front of pocket.
- 74 V to 18 is  $1/12$  breast; square forward from 18 by K.
- 75 18 to 19 is  $\frac{1}{4}$  breast; draw line from 19 to 1 and 5.
- 76 (Corp.)—Advance at 1 the amount from K to 3.
- 77 19 to 20 is  $2\frac{1}{4}$  inches; notch  $\frac{1}{2}$  inch from 19.
- 78 I to J is  $1\frac{1}{4}$  inches; 5 to 6 is 1 inch; square down.
- 79 Go in  $\frac{1}{2}$  inch at 7; draw line from 6 and shape front.
- 80 V to 21 is  $1\frac{1}{4}$  inches; draw line to end of roll.
- 81 (One Bottom)—Go in 1 inch between waist and seat line.
- 82 The pocket is  $2/3$  sleeve length and  $\frac{1}{2}$  inch from K.
- 83 (For double-breasted add  $2\frac{1}{4}$  inches to the front.)
- 84 I to J is  $\frac{1}{2}$  inch; 5 to 6 is  $1\frac{3}{4}$ ; 6 to 25 is  $1\frac{1}{2}$  inches.
- 85 2 to 44 is 1 inch; square down to 3;  $\frac{1}{2}$  inch.
- 86 G to P  $\frac{1}{2}$  waist and  $\frac{3}{4}$  inch; 4 to 16 is  $1\frac{1}{4}$  inches.
- 87 Draw straight lines from 3 to P, and 3 to 16.
- 88 For correct spring over hip draw line from K through 16.
- 89 Draw line from G to D. From P add  $\frac{1}{4}$  inch for spring.
- 90 Apply length and  $1\frac{1}{4}$  inches, A to R and V to 7.
- 91 Apply Opening and  $\frac{3}{4}$  inch, A to R and V to J.
- 92 Draw lines from C to 7 and E to 17.
- 93 V to 21 in 1 inch; when no collar  $\frac{3}{4}$  inch.
- 94 Draw line from 21 to first button and finish as rep.
- 95 (Corp.)—Open pocket  $1/16$  for every inch more than normal.
- 96 (Dress)—J to I and 6 to 5 is  $\frac{1}{2}$  inch; draw line I to 7.
- 97 J to B is 3 inches. Opening  $\frac{1}{2}$  inch above waist line.
- 98 7 to 8 is  $1\frac{1}{4}$  inches; 7 to 9 is the same.
- 99 5 to 11 is  $2\frac{1}{2}$  inches; 5 to 12 is the same.
- 100 9 to 10 is  $3\frac{1}{4}$  inch; 12 to 13 is the same.
- 101 (Clerical)—For vest to button in front, leave a stand  $\frac{3}{4}$  inch.
- 102 (Cleri.)—Reduce a seam at 19 dotted line; and shape the bottom.



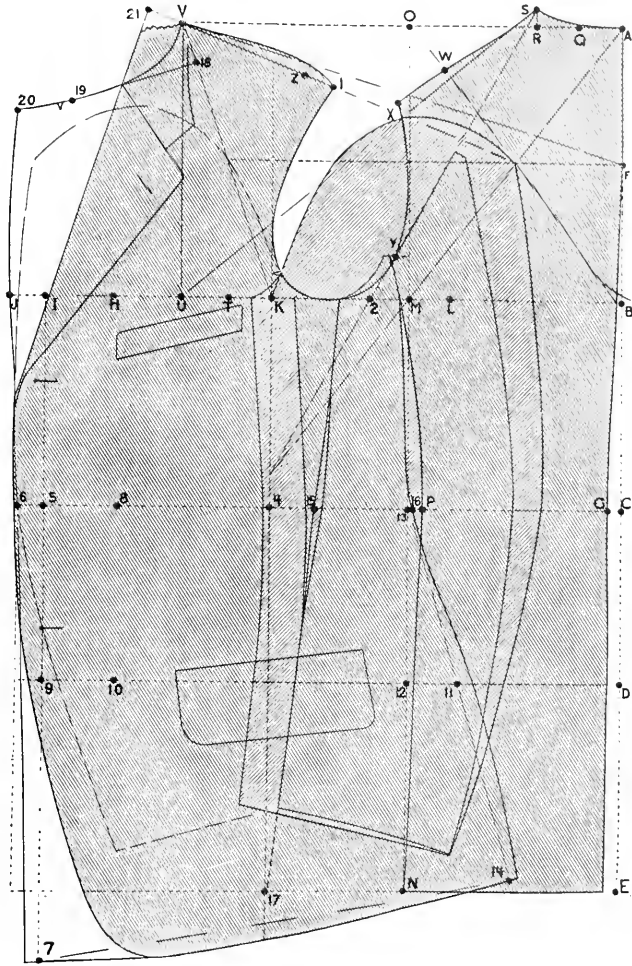

SACK AND SLEEVES

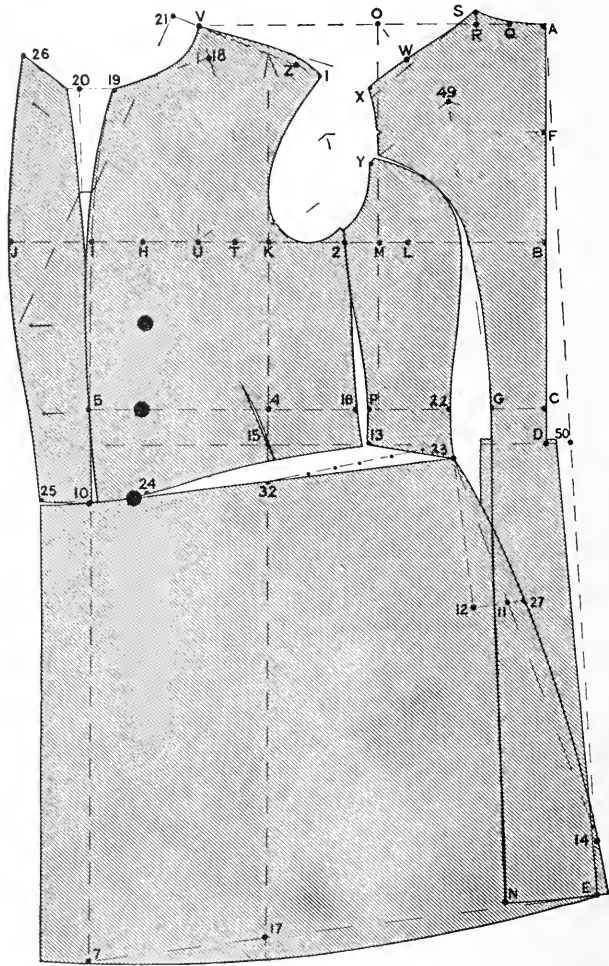

D. B. FROCK

INTERNATIONAL CUTTING SCHOOLS

DIAGRAM

FROCK

PART 2

The measures are taken over the Vest always.

Inside sleeve	inches	Blade (with 1¼ inches for	
Breast	inches	seams added)	inches
Waist	inches	Depth of scye	inches
Hip or seat	inches	Natural waist	inches
Strap	inches	Fashion waist	inches
Over shoulder	inches	Full length	inches
		Height	ft. inches
Form and Attitude.		sizes to	breasts

To Draft.

- 1 Square both ways from A.
- 2 — to B is 1/3 breast on "THIRDS" and 3½ inches.
- 3 B to — is 1/3 breast of height, and 3½ inches.
- 4 A is half-way between — and —.
- 5 This is the proportional, and includes all allowances.
- 6 A to C is one-fourth height, and ¼ inch for curve of Back.
- 7 A to D is the fashion waist; one-fourth height and 1½ inches.
- 8 D to 50 is 1¼ inches, line from A through 50 to E.
- 9 A to E is the Full Length of Back.
- 10 F is half between A and B, for front shoulder height.
- 11 Square out from A, B, C, D, E, F, 3, 4, 5, 6, 7.
- 12 B to H is half the full breast measure.
- 13 H to I is 2¼ inches, center of Breast.
- 14 B to K is blade (with 1¼ inches for seams).
- 15 Square up from K—front of armhole.
- 16 L is half-way between B and K.
- 17 L to M is 1¼ inches—width of Back.
- 18 Square up to O, and down to P.
- 19 P is ½ inch from Line O-M. Square down to 13.
- 20 A to Q is 1/12 breast—on "TWELFTHS," and
- 21 Q to R is 1½ inches. Square up to S, ¾ inch.
- 22 (Corp.)—Advance from K, 1/16 inch each size above 4 inches less than breast; to straighten the front run, take it out in the underarm cut as shown by shaded part.
- 23 K to T is 1½ inches; T to U is 1/12 breast.
- 24 Square up from U to V—locating the shoulder point.
- 25 V is located on lines from K and — through line —.
- 26 Draw lines from S to U, F to V, and A to K.
- 27 This gives the proportional height of shoulders.
- 28 Rise at X ½ inch, and lower at point 1 the same.
- 29 X is ½ inch on the S-U Line—or Style.
- 30 Y is ½ inch from the O-M Line.
- 31 Draw guide line from X to Y.
- 32 From B up apply depth of scye measure and ½ inch to—, in normal attitude will meet line A.
- 33 The ½ inch is for fullness held in over the blade.
- 34 C to G is 1/16 breast and 1¼ inches.
- 35 E to N is the same width as 50 to G, and ½ inch.
- 36 Draw a line from G to N and from
- 37 49 to G for width of Back over breast-line.
- 38 49 in on S-U and A-K lines.
- 39 Blade fullness is ⅝ inch over the rounding.
- 40 (Stooping)—Lay square on 5, O and F, and square lines O, 5, F.
- 41 Obtain point S from 5 and shape 5, S to X.
- 42 Shape the Back as shown; draw line from B to W.
- 43 Apply strap measure and 1 inch A to R and K to V in normal attitude will meet line F-V.
- 44 (Stooping)—Advance V from line K-V as much as below line 4.
- 45 (Erect)—Go back from K-V line as much as above line V—.
- 46 Apply over shoulder measure and 1 inch B to W and K to Z; when normal, meet line F-V.

- 47 Z is 1¼ inches from line K.
- 48 Draw a line from V through Z to point 1.
- 49 V to point 1 is ¾ inch less than S to X.
- 50 Draw a guide line from point 1 to T.
- 51 Shape arms-eye and shoulder rounding ½ in. over Z.
- 52 B to 2 is ½ breast on "HALVES"; 2 to K is 3½ inches.
- 53 This is normal blade and independent of the actual blade, and comes even with K in normal sizes.
- 54 Square down from K through 4 to 17—center of body.
- 55 4 to 5 is ½ waist—on "HALVES"—center of waist.
- 56 Square down from 5 to 7. The measure from B to 2, K, 4 and 5 is used only to obtain the front center of the waist, and to check the blade measure.
- 57 5 to 8 is 2¼ inches (8 to 6, 1½ dress); 9 to 10 is 1/6 breast.
- 58 These 2¼ inches are for seams and make-up.
- 59 G to 22 is 1¼ inches, or 1¼ inches in all sizes to allow for blade fullness and ⅛ inch for every inch the waist is smaller than the breast.
- 60 Square up, and down to 23; 23 is ⅝ inch below the fashion waist; or sweep from the Back by Y.
- 61 Measure waist net G to C, P to 22, and 8 to 16.
- 62 Shape side body reducing ¼ inch near Y, ⅜ inch at breast line and from 2 to 13 and 16, and 23 to 13.
- 63 V to 18 is 1/12 breast; square forward from 18 by K.
- 64 18 to 19 is ¼ breast; draw line from 19 to I and 5.
- 65 (Corp.)—Advance at I the amount from K to 3.
- 66 Add ¼ inch rounding over the breast.
- 67 (Cutaway)—19 to 20 is 2¼ inches; notch ½ inch from 19.
- 68 (Cutaway)—I to J is 1¼ inches; 5 to 6 is 1 inch; square down.
- 69 Rever—19 to 20 is 1½ inches, or draw a straight line through 5-9; straighten ½ inch at 20.
- 70 10 to 24 is 2¼ ins.; 10 to 25 the same; sweep by 20.
- 71 Draw a line from 13 to 24—Shape from 13 to 25.
- 72 (Cutaway, Dress)—Draw a line from 13 to 10.
- 73 (Dress)—24 to 35 is 1½ ins.; 35 to 25 is the same.
- 74 (Dress)—Shape the gorge and front through 6-24 to 35.
- 75 Draw a line from K through 20 to 26.
- 76 20 to 26 is 2¼ inches; I to J is 3¼ inches.
- 77 Shape lapel through 26—J to 25.
- 78 (Corp.)—10 to 35 is ½ in.; draw line from 13 to 35.
- 79 (Corp.)—Lay square on 13-36-H and take out a V at 36.
- 80 (Corp.)—Advance 23 the amount of V and seams.
- 81 Skirt (Cutaways and Dress)—Square both ways from 23.
- 82 Draw a line from 23 to 24; square down to 12.
- 83 Flare—At 23 go up ⅝ inch and square down by 32.
- 84 23 to 12 is 1/3 breast, and ½ inch.
- 85 12 to 11 is 1½ inches; 11 to 27 is ¾ inch.
- 86 Draw a line from 23 through 11 and 14.
- 87 14 is natural waist, and 1 inch from 23.
- 88 23 to bottom is ¼ inch more than D to E.
- 89 Lay "square" on 27-14 and mark for run of bottom.
- 90 Shape skirt through 27 to bottom.
- 91 Z to 7 is length from Z to E and 1 inch from line K.
- 92 Draw line 14 to 7; shape bottom; lower 1 inch at 17.
- 93 Square down the front edge to 7, by the waist line.
- 94 Take out a fish ⅝ inch, 1/6 up from 15.
- 95 Go out ½ from D and line parallel to 50-E.
- 96 Reduce ⅝ inch at B from A to C.
- 97 (Dress)—24 to 36 is ¼ the width from 24 to 23.
- 98 (Dress)—14 to 33 equal 24 to 36 and 1 inch.
- 99 (Dress)—Shape front run of skirt (cutaway).

## INTERNATIONAL CUTTING SCHOOLS

### DIAGRAM

### TROUSERS

### PART 5

Outside length	inches	Seat or hip	inches
Inside length	inches	Thigh	inches
Waist	inches	Knee	inches
Corpulency	inches	Bottom	inches

To Draft. The Forepart.

- No. 1 A to B is 1/3 seat on THIRDS and
- 2 B to C is 3 1/2 inches.
- 3 This is the proportional, and includes all allowances.
- 4 From B to A is the actual "rise" as measured.
- 5 C to E is the inside length, and 1/4 inch for a seam.
- 6 D is half-way between E and C, and 2 inches up.
- 7 3 is 1/3 of A and B, or "rise."
- 8 Square out from A, B, C, D, E and 3.
- 9 C to H is 1/2 seat—on "HALVES."
- 10 H to I is 1/8 seat—on "EIGHTHS."
- 11 Go out 1/2 inch from I, and in 1/4 inch from I, making 3/4 inch; this is for the dress side.
- 12 Square up from H, locating 2 on line B.
- 13 H to J is 1/2 inch (for 2 seams), square up to K.
- 14 Draw a guide line from K to H for run of dress.
- 15 L is half-way between C and I.
- 16 Go in 1/8 inch for every size less than 40 seat, and out 1/8 inch for every size more; from L.
- 17 Square up and down from L, locating O, M and N.
- 18 N to P is 1/4 bottom less 1/4 inch; N to Q is the same.
- 19 Draw a *straight* line from I to Q, locating R.
- 20 M to G is 1/4 knee on "FOURTHS;" M to R is the same.
- 21 Draw lines, C, G, P and I to R.
- 22 J to 4 is 1/4 inch for every inch difference between seat and corp; square up from 4, locating 5.
- 23 K to 7 is the same as J to 4, square back from 7.
- 24 7 forward is 1/8 inch for every inch over normal.
- 25 Normal waist is 4 inches less than seat.
- 26 Draw a line from 5 to H for run of fly.
- 27 5 to 6 is 1/2 corpulency, and 1/2 inch for 2 seams.
- 28 A to S is 1 1/2 inches. This is normal.
- 29 S to A is 1/8 inch for every inch more than normal.
- 30 Draw a line from S to 7, and shape the top.
- 31 H to the curve of front fork is 1, 12 seat.

- 32 Shape the fork from K to I outer corner; and
- 33 Dress side from K to 1/8 inch above I; inner corner.
- 34 The largest dress hollow (5/8 inch) is opposite H.
- 35 The seams from I should be *straight* 7 1/2 inches down.
- 36 "Prominent dress," allow 1/4 inch more on fork curve, as shown by the broken lines.
- 37 Shape the side seam from S; the broken line show high hip-bone.
- 38 This completes the Forepart. Cut out the pattern.

The Backpart.

- 1 The white line represents the forepart.
- 2 Extend lines O, B, L, M, N and 3.
- 3 Add 1/4 inch to length of Backpart from N.
- 4 O to T is 1/6 seat—on "SIXTHS."
- 5 Draw a straight line from T to J.
- 6 From forepart fork to U is 1/16 seat.
- 7 Measure seat and 1 3/4 inches 2 to B, and 11 to F.
- 8 R to X is 1/2 inch for seams; G to Y is the same.
- 9 P to V is 1/2 inch more than 1/2 bottom.
- 10 Q to W is the same; draw lines Y to W and X to V.
- 11 Draw a line from Y through F to Z.
- 12 Y to Z is the length from S to G, or sweep.
- 13 Draw a line from Z to T.
- 14 Z to 10 is 1/8 seat; draw a line to L.
- 15 Corpulency—From 5 to 6 and 8 to 9, and 1 inch.
- 16 Apply waist measure and 2 1/4 inches from K to S and T to Z; take out a 1/2 inch I' at 10.
- 17 The I' extend down 1/6 of seat measure.
- 18 (Corp.)—Add 1/2 the surplus to S and T; no I' is taken out.
- 19 J to the curve of Backford is 1/24 seat by A.
- 20 U is 1/4 inch below line C-I.
- 21 Shape seat seam through corner of forepart to U.
- 22 Shape outside and inside seams and mark notches.
- 23 In no case should A to S exceed 1 3/4 inches.
- 24 Bow Leg—N to 45 is 2 inches—the amount of bow.
- 25 Draw a line from 45 to L. The center line.
- 26 Draw straight line from I to Q; this locates R.
- 27 Measure 1/2 width of knee from R to G.
- 28 Notch Knee and Bottom on straight lines across.

	No. 0 Normal.	No. 1 Slightly Peg.	No. 2 Half Peg.	No. 3 Full Peg.	No. 4 Extreme Peg.	No. 5 Extra Large.
Add to seat line	1/2 and 1/2 inch	1 and 1 inch	1 1/2 and 2 inches	2 and 3 inches	2 1/2 and 4 inches	
Add to fork	0 and 1/4 inch	1/8 and 1/4 inch	1/4 and 3/8 inch	1/4 and 1/2 inch	3/8 and 3/4 inch	
Add to knee	1/2 and 1 inch	1 and 2 inches	1 1/2 and 3 inches	2 and 4 inches	3 and 5 inches	
Lower the "rise"	1/4 inch	1/2 inch	3/4 inch	1 inch	1 1/4 inches	

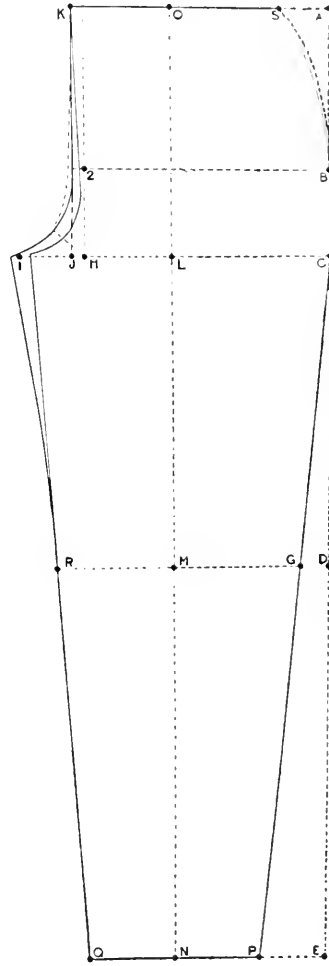
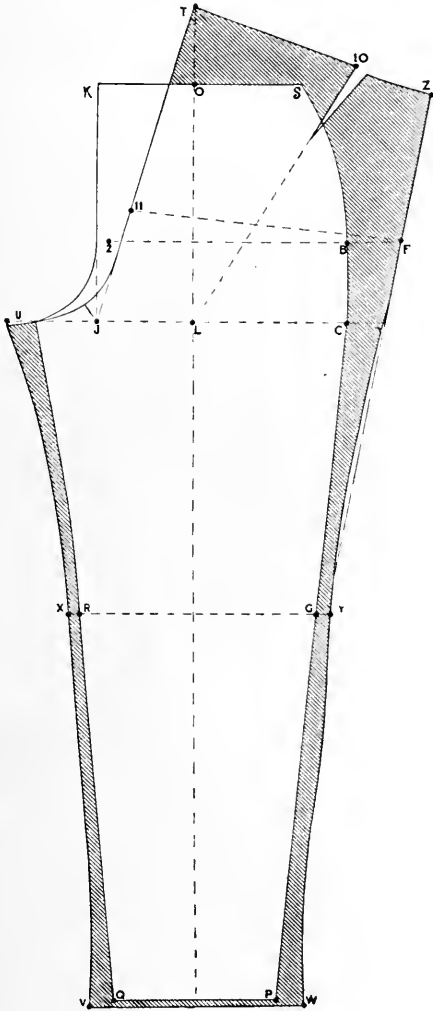

TROUSERS—DIAGRAMS 1 AND 2

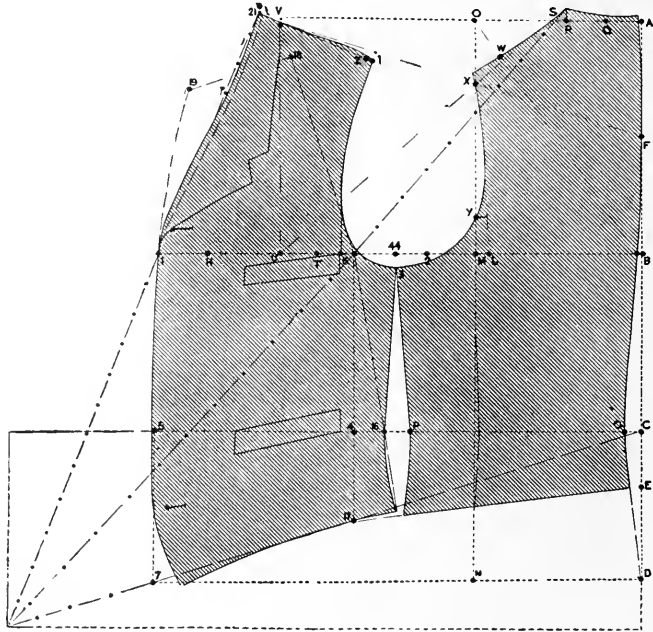

S. B. VEST

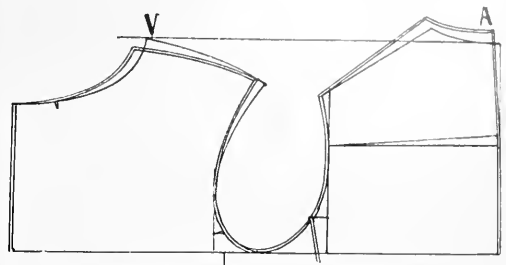

איינעכוינען - א פולע בעק  
 B צו K און A אינטיש מער  
 הויכט אויף ביי A אינטיש  
 לאנט אראב ביי V אינטיש  
 נעמט ארום ביי V אינטיש  
 זעט דעם Dia XXII פירדזש 35

איינעכוינען א פלאכע ברוסט, א פולע בעק

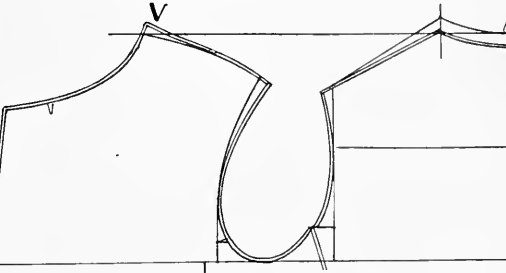

שלאנק - פעסט נעבויט  
 B צו K און A אינטיש וועניגער  
 לאנט אראב ביי A אינטיש  
 הויכט אויף ביי V אינטיש  
 זעט דעם Dia VIII פירדזש 19

שלאנק, פעסט נעבויט, א פולע ברוסט

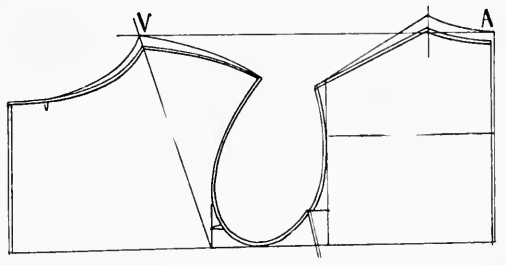

הויכע אקסלען  
 א קורצע האלז  
 לאנט אראב ביי A אינטיש  
 לאנט אראב ביי V אינטיש  
 אויף לוי צו K

הויכע שאולדערס, א קורצע האלז

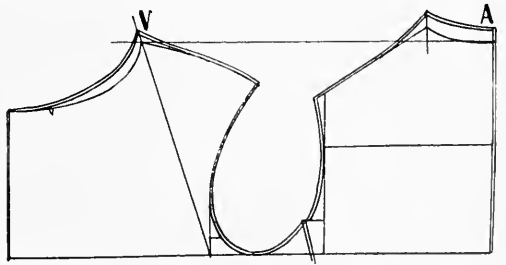

אראבעלאזענע אקסלען  
 א לאנגע האלז  
 הויכט אויף ביי A אינטיש  
 הויכט אויף ביי V אינטיש  
 אויף לוי פון K  
 מאכט טשענישעס פאר די קאמבי  
 נאציאנען פון די "פארמס"

אראבעלאזענע אקסלען א לאנגע האלז

פראפארציאנעלער דאק.

שייפט די וויסענע סעימ פון דעם פארענטהאלט פון Y דורך 16, ארויס  
 געקענדיג 5 אינטיס איבערן 11 צו 11.  
 ציהט א לוינ פון 11 צו 7 און שייפט דעם באטטאם.  
 V צו 1 און 1 צוועלפטעל ברעסט—אויפן לוינ צו K.  
 גלייבט אויס פאראויסצו פון 14 ביי K  
 14 צו 19 און 1/2 ברעסט; ציהט א לוינ פון 19 צו 1 און 5.  
 19 צו 20 און 1/2 ברעסט (2%).  
 I צו 1 און 14 אינטיס 5 צו 6 און 1 אינטיס גלייבט אויס ארונטער.  
 געהט אריין א האלבען אינטיס ביי 7 און ציהט א לוינ צו 6.  
 שייפט די נאָדדוּס, די האַזן און די פראנט.  
 דער פאקעט איז די לוינג פון כרויו—18 אויף 2, דריטער און א 1/2  
 אינטיס (12%) ארונטער פון K, און 3/4 אינטיסעס אויף יעדען וויט,  
 לויפענדיג גלייך מיט דער באטטאם לוינ.  
 V צו 21 און 14 אינטיס; ציהט א לוינ צום ערשטען באטטאָהאַל  
 ווי וך צו בענצען מיט די מאַסען א. ה. ו. ו. זעהט לעסכאן 2.  
 פארן געשטעל אָדער שאַנד זעהט די פאַרמס אין בייט  
 לויט עס פאָדערט זיך.

ס ל ו י ו ב

דער פראנט איינטיג אויפן קאָוט איז שטענדיג 1 אינטיס ארויף.  
 די מאַס פון דעם פראנט איינטיג איבערן שאַנדער צו דעם בעק  
 איינטיג פירן אויבערשטען טהייל סליוו—9% אינטיסעס פיר 30  
 ברעסט.  
 די מאַס אונטערן סליוו פון איינטיג צו איינטיג צו צוואַסען מיט די  
 סעימס—1/2 אינטיסעס, באטטאָל 1 אינטיסעס.  
 די נעגט פון איינטיג כרויו 18 אינטיסעס.  
 צו צוויבענען—לוינט אויף דעם פייערען מיט א שאַרפען קלייטש.  
 גלייבט אויס ביידע וועגען פון A צו E.  
 A צו 2 און B צו 1 אויפן קאָוט—1/2 טיעף פון אַרסלאָף.  
 B צו 1 און C צו 1 אינטיס—דער פראנט איינטיג.  
 B צו 1 און איינטיג כרויו—14 אינטיסעס.  
 D צו 1 און E צו 1 אינטיסעס.  
 F און די האַלבע וועג צווישען A און E.  
 גלייבט אויס פון A, B, C, D, E און F.  
 C צו 1 און דער אויבערשטער כרויו—9% אינטיסעס.  
 גלייבט אויס ארונטער פון G צו H  
 A צו 1 און 1/2 סליוו; ציהט א לוינ פון J צו B.  
 B צו 1 און 1/2 סליוו M און 14 אינטיסעס ארויפצו פון A לוינ.  
 שייפט דעם אויבערשטען טהייל סליוו פון G דורך M און J צו B  
 צו F און N און 1/2 אינטיס; H צו O און די זעלבע.  
 D צו 1 און P אינטיס; P צו 1 און 1/2 אינטיסעס—אָדער סליוו  
 ביי O נעגט ארויס א 1/2 אינטיס פארן אויבערשטען טהייל סליוו און  
 געהט אריין א 1/2 אינטיס פארן אויבערשטען טהייל סליוו. פון  
 נישט דעם אויבערשטען טהייל סליוו ווי פארענטשטעמט.  
 G צו 1 און 1/2 סליוו; ציהט א לוינ פון R צו K.  
 S, U, T און 1/2 אינטיס; ארויס פארן אויבערשטען טהייל סליוו.  
 W, V און 1/2 אינטיס אריין פארן אויבערשטען טהייל סליוו.  
 שנייטט אויס ביידע פייערעס נאָרן אויבערשטען טהייל סליוו.  
 שייפט דעם אונטערשטען טהייל סליוו נאָרן אויבערשטען טהייל סליוו.

די מאַס ווערט שטענדיג גענומען ארום דער וועסט.  
 איינטיג סליוו..... 18 אינטיסעס.  
 ברעסט..... 36 אינטיסעס.  
 ווייסט..... 39 אינטיסעס.  
 היפ אָדער סיט..... 37 אינטיסעס.  
 נאטורליכע ווייסט 16% אינטיסעס.  
 די פולע לוינג..... 30 אינטיסעס.  
 די הויך..... 5 פוס 6 אינטיסעס.  
 גלייבט אויס ביידע וועגען פון A.  
 A צו B און 1/2 ברעסט און 3/4 אינטיסעס (9 1/2 אינטיסעס).  
 A צו 1 און 1/2 הויך און 1/2 אינטיס (16 1/2 אינטיסעס)  
 C צו D און 1/2 ברעסט—אויף "דריטלאָף"—(22%) סיט.  
 A צו E און די פולע לוינג (30 אינטיסעס).  
 F און א האַלבע וועג צווישען A און B—איינטיג פארן סליוו.  
 גלייבט אויס פון A, B, C, D, E און F.  
 C צו G און 1/2 אינטיס; גלייבט ארונטער צו E בינט צוואַסען F און G  
 G—F לוינ איז שטענדיג דער סענטער פון די בעק.  
 B צו H און 18 אינטיסעס—האַלב די מאַס פון דער ברעסט.  
 H צו 1 און 2 1/2 אינטיסעס—דער סענטער פון ברעסט.  
 B צו K און כרויו מיט 14 אינטיס פאַר סימס (12% אינטיסעס)  
 גלייבט אויס ארויפצו פון K—דער פראנט פון אַרסלאָף.  
 L און האַלבע וועג צווישען B און K.  
 L צו 1 און 14 אינטיסעס—די נאטורליכע ברייט פון די בעק.  
 גלייבט אויס ארויפצו O און ארונטער צו N.  
 P און א 1/2 אינטיס פון O—N לוינ; ציהט א לוינ צו N.  
 A צו Q און איין צוועלפטעל פון ברעסט—אויף צוועלפטלאָף (18).  
 Q צו R און 1 1/2 אינטיסעס—גלייבט אויס ארויף צו S.  
 R צו 1 און 1/2 אינטיסעס.  
 K צו T און 1 1/2 אינטיסעס און  
 T צו U און איין צוועלפטעל ברעסט—אויף "צווערפטלאָך" (18)  
 גלייבט אויס ארויפצו פון U אַפּשטעלענדיג זיך און V—דער שאַנדער  
 פאַנט.  
 ציהט לוינס פון S צו U, F צו K און V צו V.  
 הויבט אויף דעם שאַנדער סעימ א 1/2 אינטיס ביי X; לאַזט ארויף  
 טער א 1/2 אינטיס ביי פאַנט 1.  
 X און 1/2 אינטיס אויף U-S לוינ—סטיל לוינ ברייט פון די בעק.  
 Y און 1/2 אינטיסעס פון O—M לוינ; ציהט א נידרליין צו P.  
 שייפט די בעק פון A צו S, פון S צו X, פון X דורך Y צום באטטאם  
 פון אַרסלאָף; און פון Y צו P—דייאַנרעס I  
 צו V פאַנט 1 און 1/2 אינטיס וועניגער ווי S צו X.  
 ציהט א נידרליין פון פאַנט 1 צו T.  
 שייפט—די אַרס לאַך און דעם שאַנדער ארויבערשטענדיג 1/2 אינטיס  
 איבערן Z.  
 פון B צו 2 און א 1/2 ברעסט—אויף "האַלבע" (18) און  
 2 צו K און שטענדיג 3/4 אינטיסעס. דאָס איז דער נאטורליכער ברייך.  
 גלייבט אויס ארונטער פון K דורך 7 צו 17—דער סענטער פון קערפער  
 4 צו 5 און 1/2 ווייסט—אויף האַלבע (18). דער סענטער פון ווייסט.  
 גלייבט אויס ארונטער פון 5 צו 7.  
 7 און 3 אינטיסעס אונטערן לוינ E.  
 12 צו 11 און 1 1/2 אינטיסעס; ציהט א לוינ פון 13 דורך 11 צו 14.  
 Y צו 14 און די לוינג פון Y צו N, דרעהט אויס ביי Y.





LIBRARY OF CONGRESS

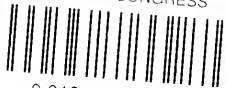

0 013 514 776 A