



797 Davis

REFERENCE

9017 <sup>120</sup>

Harper's Boating Book  
for boys.

797

D

9017

THE CENTRAL CHILDREN'S ROOM  
DONNELL LIBRARY CENTER  
20 WEST 53 STREET  
NEW YORK, N.Y. 10019.

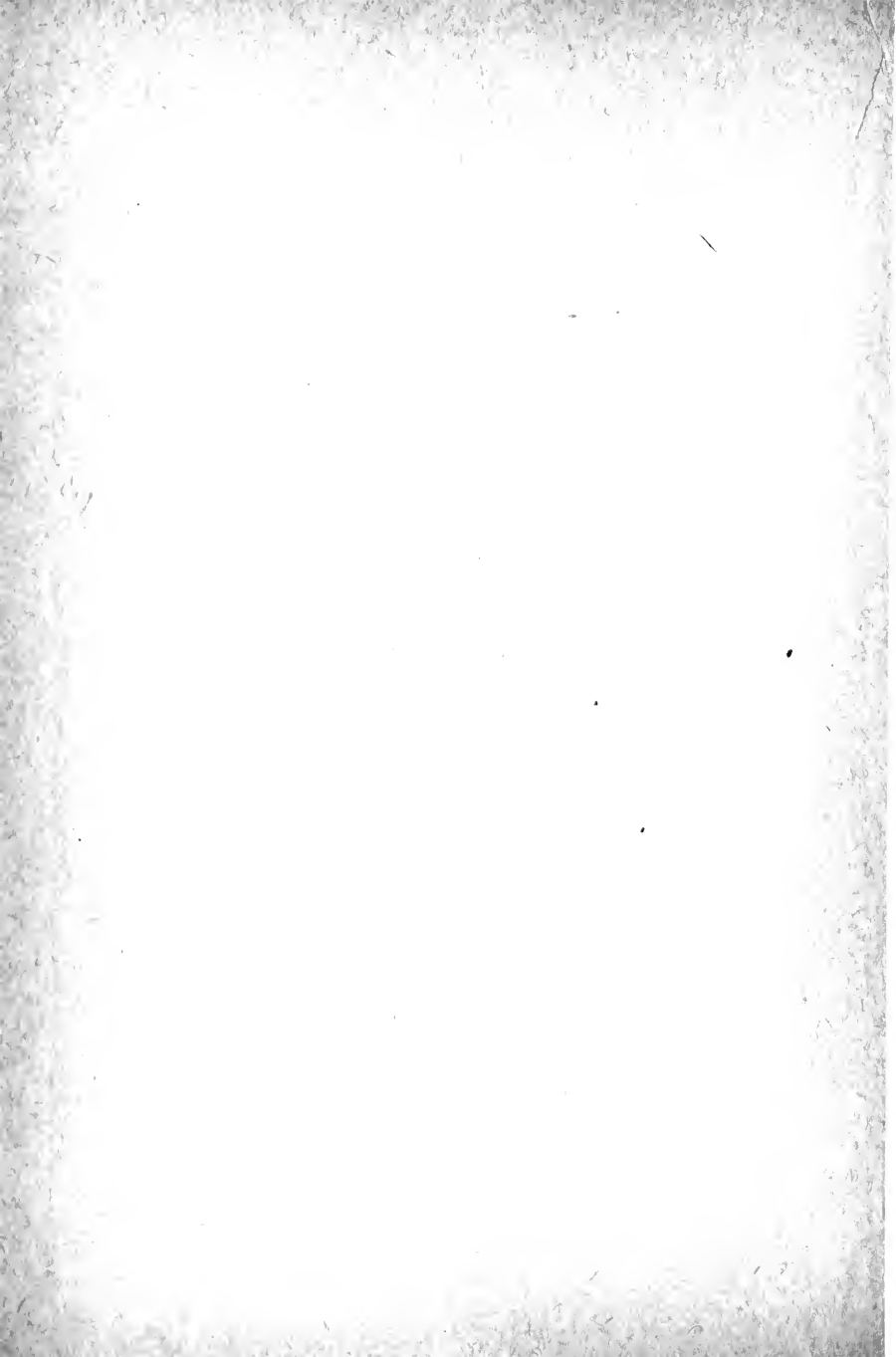



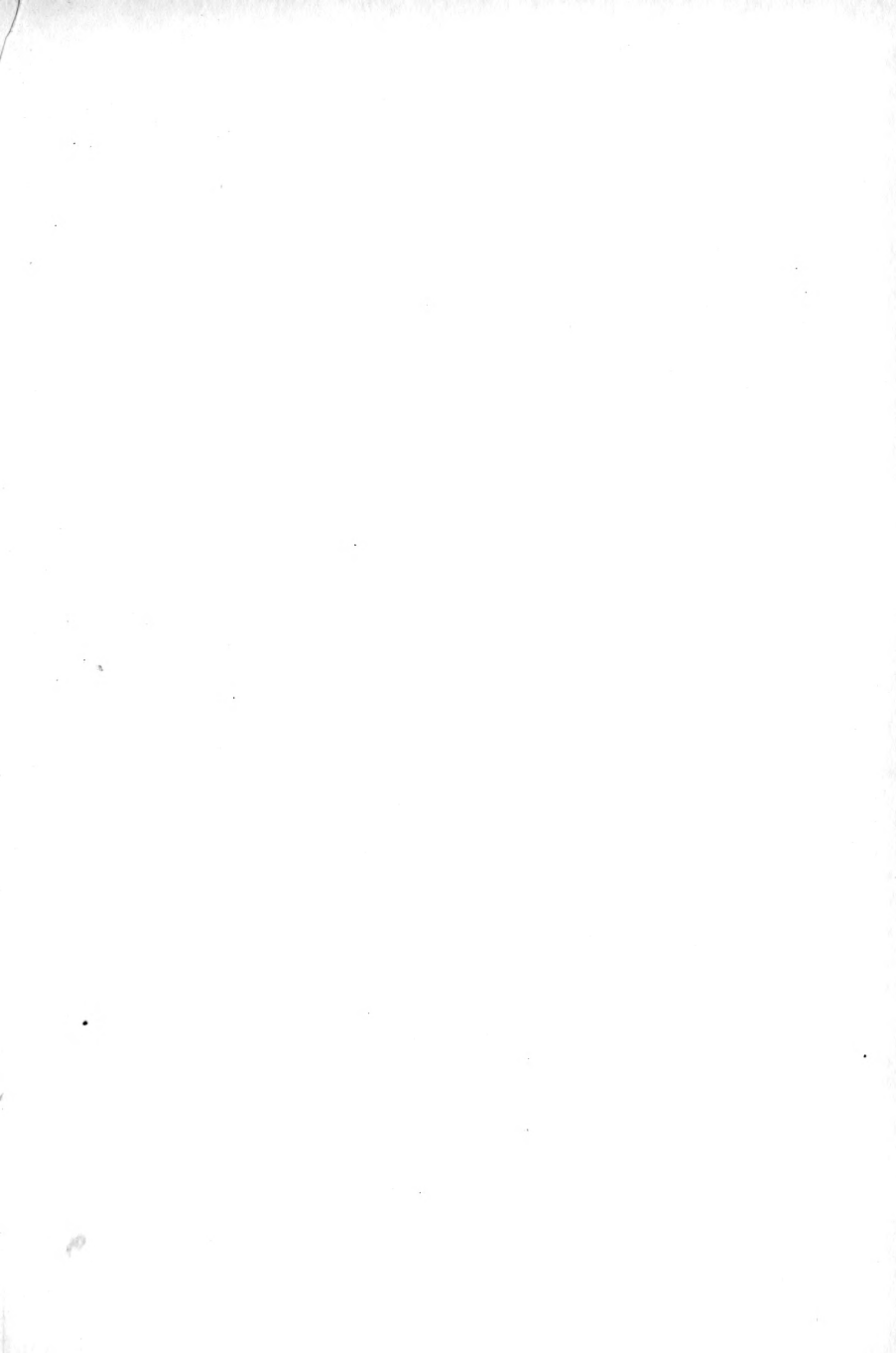



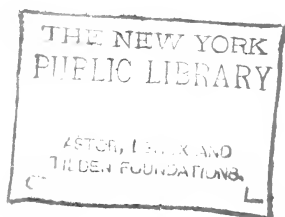

THE NEW YORK  
PUBLIC LIBRARY

ASTOR, LENOX AND  
TILDEN FOUNDATIONS

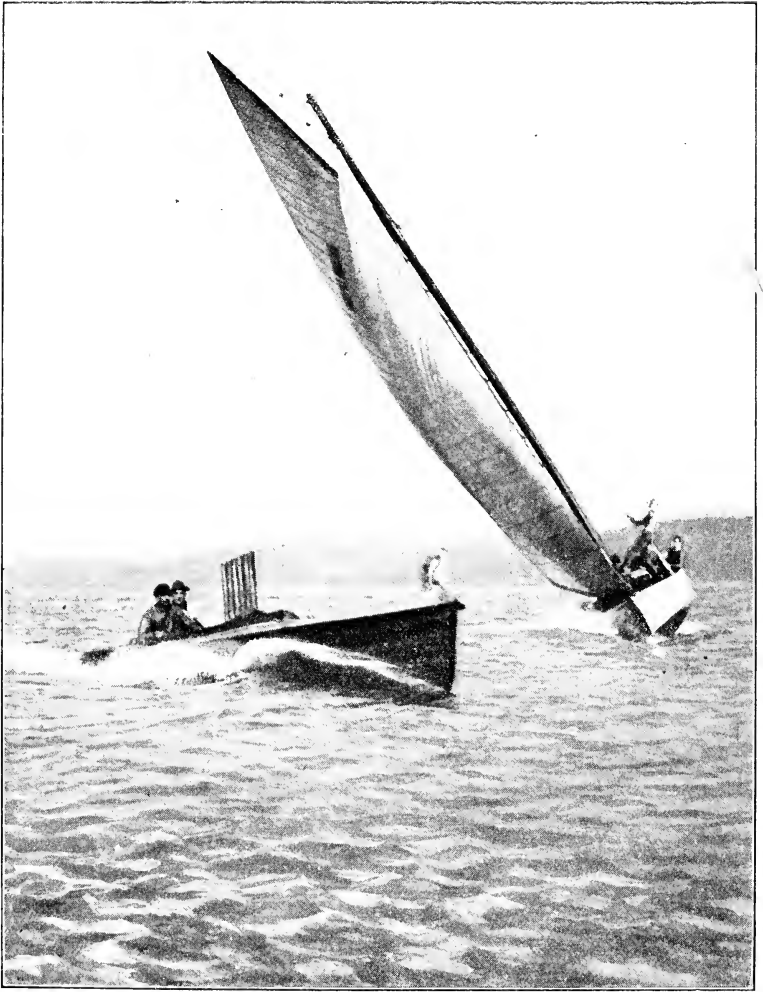

# HARPER'S BOATING BOOK FOR BOYS

A GUIDE TO MOTOR BOATING, SAILING  
CANOEING AND ROWING

CONSULTING EDITOR  
CHARLES G. DAVIS  
EDITORIAL STAFF OF "MOTOR BOAT"

WITH MANY ORIGINAL  
ILLUSTRATIONS



HARPER & BROTHERS PUBLISHERS  
NEW YORK AND LONDON  
MCMXII

THE NEW YORK  
PUBLIC LIBRARY

9017

ASTOR, LENOX AND  
TILDEN FOUNDATIONS.

C

L

## Harper's Practical Books for Boys

A SERIES OF NEW HANDY-BOOKS FOR BOYS

### HARPER'S CAMPING AND SCOUTING

An Outdoor Book for American Boys. Consulting Editors, George Bird Grinnell, Editor "Forest and Stream"; Dr. Eugene L. Swan, Director Pine Island Camp, etc.

### HARPER'S ELECTRICITY BOOK FOR BOYS

Written and Illustrated by Joseph H. Adams. With a General Chapter by Joseph B. Baker, and a Dictionary of Electrical Terms.

### HARPER'S HOW TO UNDERSTAND ELECTRICAL WORK

By William H. Onken, Jr., and Joseph B. Baker.

### HARPER'S OUTDOOR BOOK FOR BOYS

By Joseph H. Adams and others

### HARPER'S INDOOR BOOK FOR BOYS

By Joseph H. Adams and others.

### HARPER'S MACHINERY BOOK FOR BOYS

By Joseph H. Adams.

### HARPER'S HANDY BOOK FOR GIRLS

Edited by Anna Parmly Paret.

### THE STORY OF GREAT INVENTIONS

By Elmer Ellsworth Burns.

*Each volume fully illustrated from photographs, drawings, and diagrams. Uniform in size and appearance. Crown 8 1/2" x 5 1/2" x 1 1/2", each, except "The Story of Great Inventions," which is 8 1/2" x 5 1/2" x 1 1/2".*

HARPER & BROTHERS, PUBLISHERS, NEW YORK

COPYRIGHT 1912 BY HARPER & BROTHERS  
PRINTED IN THE UNITED STATES OF AMERICA  
PUBLISHED MAY, 1912

797  
D

# CONTENTS

INTRODUCTION . . . . .	PAGE ix
------------------------	------------

## Part I

### FIRST AID TO BOATING

CHAPTER I.—SWIMMING COMES FIRST . . . . .	3
THE FRIENDLY WATER	THE BREAST STROKE
CONFIDENCE	FLOATING—DIVING
UNDER WATER	THE SIDE STROKE
ON THE SURFACE	FANCY SWIMMING

## Part II

### HOW TO MAKE PLAY BOATS

CHAPTER II.—MODEL YACHTS . . . . .	19
<i>By Charles Ledyard Norton</i>	
THE PLAN	BALLAST AND KEEL
SIZE OF THE BOAT	SPARS AND RIGGING
ACCURATE DRAWING	SAILS
THE HULL	DECK FITTINGS
CUTTING AWAY THE WOOD	SEAMANSHIP
FINISHING THE HULL	A SELF-ACTING HELM
SOME RULES FOR NAVIGATION	

CHAPTER III.—SUGGESTIONS FOR SLOOP MODELING. . . . .	37
<i>By H. Percy Ashton</i>	

THE FIN-KEEL	PAINT AND VARNISH
DECK AND SPARS	FLAGS

# CONTENTS

	PAGE
CHAPTER IV.—HOW TO MAKE A TOY STEAMBOAT . . .	42
By <i>Victor Smedley</i>	
THE MOTOR-POWER	THE HULL
	THE CABIN
CHAPTER V.—A BOAT WITH A SCREW PROPELLER . . .	48
By <i>F. Chasemore</i>	
MAKING THE MACHINERY	THE PROPELLER
	POWER
CHAPTER VI.—PADDLE-WHEELS FOR A SMALL BOAT . . .	54
By <i>C. F. Post</i>	
APPLICABLE TO ANY BOAT	ASSEMBLING THE PARTS
HUBS AND SPOKES	COST
PADDLES	HAND-POWER
	ANOTHER WAY TO MAKE WHEELS

## Part III

### HOW TO MAKE REAL BOATS

By *Joseph H. Adams*

CHAPTER VII.—BOATS WHICH BOYS CAN BUILD . . .	65
PUNT AND SCOW	A CENTER-BOARD SHARPY
A SHARPY	A PROA
A ROWING DORY OF THE OLD TYPE	A SWALLOW
A SAILING SHARPY	A POWER-BOAT
CHAPTER VIII.—CATAMARANS . . . . .	93
A ROWING CATAMARAN	A SAILING CATAMARAN
	A SIDE-WHEEL CATAMARAN
CHAPTER IX.—HOUSE-BOATS AND RAFTS . . . . .	103
A HOUSE-PUNT	A HOUSE-RAFT
	A FLOAT



# CONTENTS

## Part IV

PAGE

### SAIL-BOATS AND SAILING

#### CHAPTER X.—BUYING A SAIL-BOAT . . . . . 125

SOME GENERAL CONSIDERATIONS	A THOROUGH TRIAL
IS THE BOAT SOUND?	DIFFERING MODELS
OVERHAULING THE BOTTOM	THE CAT-BOAT RIG
MAST, SAILS, AND RIGGING	KEEL AND CENTERBOARD
	RACING TYPES

#### CHAPTER XI.—FIRST LESSONS WITH TILLER AND SHEET . . 136

*By Dudley D. F. Parker*

SOME BASIC PRINCIPLES	HANDLING TILLER AND SHEET
THE TILLER	TOGETHER
TENDING SHEET	LUFFING ABOUT
JIBING	GENERAL HINTS
	MAKING DOCK

#### CHAPTER XII.—SECOND LESSONS, WITH DIAGRAMS . . 153

*By Lieut. Worth G. Ross, U. S. R. M.*

THE HELM	CARE OF THE SHEETS
CLOSE-HAULED	BEFORE THE WIND
TACKING	WEARING
REEFING	GETTING UNDER WAY
ANCHORING	SOME PRACTICAL ADVICE

#### CHAPTER XIII.—FITTING OUT A BOAT . . . . . 161

*By W. J. Henderson*

THE SPRING HOUSECLEANING	SETTING UP THE RIGGING
WORK ON THE MAST	BENDING ON THE MAINSAIL
	DECK AND HULL

# CONTENTS

	PAGE
CHAPTER XIV.—SAILS FOR OPEN BOATS . . . . .	169
<i>By Lieut. Worth G. Ross, U. S. R. M.</i>	
SPRIT-SAIL RIG	SCHOONER RIG
CAT RIG	SHARPIES
BALANCE LUG	LEG-OF-MUTTON RIG
SLOOP RIG	THE SLIDING-GUNTER
MIZZEN RIG	LATEEN-SAILS
CHAPTER XV.—RIGS AND MAKESHIFTS OF THE SMALL BOAT . . . . .	177
<i>By Dudley D. F. Parker</i>	
TO MAKE THE SAIL SET FLAT	THE FORE-AND-AFT SAIL
A SHORTER MAST	RIGGING A JIB
A YARD	BLOCKS
CENTERBOARD AND KEEL	
CHAPTER XVI.—A RACING CAT-BOAT AND ITS CARE . . .	190
OVERHAULING THE BOAT	JIBING AROUND THE MARK
CLEANSING THE BOTTOM	RUNNING TO IT
TRAINING THE CREW AT THE START	RIGHTING A CAPSIZED BOAT
DISTRIBUTION OF WEIGHT	WINTER QUARTERS
CHAPTER XVII.—MARLIN-SPIKE SEAMANSHIP . . . . .	204
SPLICES	BENDS
KNOTS	HITCHES

## Part V

### MOTOR-BOATS AND MOTOR-BOATING

*By Charles G. Davis*

CHAPTER XVIII.—SIMPLE TYPES OF BOATS FOR MOTORS. . . . .	219
PUNT	DORY
SKIFF	ROUND-BOTTOMED BOATS
SKIPJACK	RESISTANCE OF THE WATER
CHAPTER XIX.—GASOLENE ENGINES . . . . .	229
GENERAL DESCRIPTION	THE JUMP-SPARK ENGINE
THE MAKE-AND-BREAK SYSTEM	THE COIL
CARBURETER AND OTHER PARTS	

# CONTENTS

	PAGE
CHAPTER XX.—HOW THE ENGINE WORKS . . . . .	235
TRANSMISSION OF POWER	ACCESSORIES
THREE VITAL POINTS	TWO-CYCLE AND FOUR-CYCLE ENGINES
	IGNITION
CHAPTER XXI.—INSTALLING THE ENGINE . . . . .	243
ENGINE-BED	SHAFT COUPLINGS
STUFFING-BOX AND SHAFT-LOG	PROPELLER
SHAFT-HANGER	EXHAUST-PIPING
LINING UP THE SHAFT	WATER-INTAKE
CHAPTER XXII.—GASOLENE-TANKS AND CARBURETERS. . . . .	257
FITTING IN THE TANK	THE CARBURETER
FEED-PIPES	HOW TO START THE MOTOR
CHAPTER XXIII.—IGNITION AND OILING . . . . .	265
JUMP-SPARK MOTORS	LUBRICATION OR OILING
CELLS AND WIRES	GREASE-CUPS
	REVERSE GEAR
CHAPTER XXIV.—RUNNING THE ENGINE . . . . .	275
FILLING THE GASOLENE-TANK	IN CASE OF DIFFICULTY
HOW TO TELL GASOLENE	TESTS OF THE IGNITION SYSTEM
FILLING THE GREASE-CUPS	PRACTICAL HINTS
TO START THE ENGINE	HOW TO WIRE UP DRY BATTERIES
CHAPTER XXV.—THE HYDROPLANE . . . . .	287
THE SIMPLEST MODEL THE FASTEST	PLACING THE ENGINE
BUILDING A HYDROPLANE	THE RUDDER
CHAPTER XXVI.—SIGN-BOARDS AND LAMP-POSTS OF THE WATER . . . . .	294
THE ARRANGEMENT OF BUOYS	NUN, CAN, SPAR, AND OTHER BUOYS
	LIGHT-SHIPS AND BEACONS
CHAPTER XXVII.—RULES OF THE ROAD . . . . .	300
TWO BOATS MEETING END ON	TWO BOATS CROSSING
TWO BOATS PASSING	A GOOD LOOKOUT



## INTRODUCTION

NATURE made it inevitable that Americans and Canadians should be water-loving peoples. To say nothing of the descent of the earlier newcomers from maritime nations, the vast stretches of American coast-line with the many sheltered harbors, and the innumerable lakes and rivers of the continent, made it natural that the canoes of the Indians should be followed by a multiplication of improving boat-types down to the incredibly swift racing motor-boat of to-day. The story is illustrated in the waters about New York, both in the variety of craft in the neighborhood of the Hudson's mouth, and in the change which this great Indian water-route has witnessed from paddle to gasoline, from stately processions of birch-bark canoes to tip-tilted hydro-planes rushing over racing courses at the rate of thirty-five miles or more an hour.

Now, since this is a book of the present and future, not of the past, the modern motor-boat naturally has a prominent place. But the motor-boat does not represent the first stage of boating. The first step is to learn to be at home *in* the water as well as *on* it. Learn to swim.

In accordance with the plan of *Harper's Practical Books*, which is to explain how to do things one's self, the subject of boating is introduced by instructions how to make model

## INTRODUCTION

---

---

boats and other craft, an amusement which will also convey very valuable knowledge.

Next comes the making of boats for actual use. All this will lead to an understanding of types and actual construction, which will always prove of value.

From boat-building the reader advances to boat-sailing, an art which involves manifold practical considerations: the choice of a boat, its outfit and care, the management of helm, sheet, and sails, and a study of different types and models. These helpful and comprehensive chapters on sailing and sail-boats will afford useful hints even to Corinthians who pride themselves on their experience.

In the important part of the book devoted to motor-boats and their outfit and management the aim has been to afford a working A B C of motor-boating. It is a subject which has suffered in much of its literature from the two extremes of mere superficial description on the one hand, and purely technical treatment on the other. The aim of the writer, an expert of the widest experience, has been to make clear every step and every difficulty which will be met with in actual practice. The engine, its installation, and the many matters in connection with mechanism, carbureters, batteries, wiring, gasolene, ignition, and the unexpected questions which arise in running are taken up carefully and thoroughly, and the result is a *vade mecum* for owners of motor-boats which will be invaluable, even though these owners have attained man's estate, and motor-boating has become a matter of actual usefulness, not of amusement.

Canoeing obviously requires less written explanation,

## INTRODUCTION

---

and, therefore, the part devoted to this subject is limited to a little practical advice, in addition to instructions in building a simple canoe.

In the part devoted to rowing a former 'varsity oarsman explains how to row and how to organize a boat club and build a house. The closing chapters have a peculiar interest. They afford a complete history of our oldest college race—that between Harvard and Yale—which shows the evolution of rowing methods; and there is also an account of the Poughkeepsie race, and a glance at amateur rowing elsewhere.

A dictionary of technical terms has been added with particular reference to motor-boating.

The keynote of *Harper's Practical Books* is usefulness. It would have been possible to fill many chapters with descriptions of boating oddities and toys; but the remarkable appreciation which the public has shown of a series of books which aim straight at the mark indicates that *Harper's Boating Book* will afford a measure of usefulness which has not been provided in other books on the subject.

It seems proper to call attention to the thorough illustration of the subjects treated, with diagrams, plans, and pictures, and particularly to the careful drawings which Mr. Davis himself has made to accompany his explanations of the equipment and management of the motor-boat.





Part I

FIRST AID TO BOATING



# BOATING BOOK FOR BOYS

## Chapter I

### SWIMMING COMES FIRST

**L**EARN to be at home *in* the water before you go *on* the water. That knowledge should precede the use of boats. It is a knowledge to be fully gained only by actual experience under proper supervision, whether in swimming-tanks which are to be found in so many schools, colleges, clubs, Y. M. C. A. buildings, and elsewhere, or in public baths, or better, out-of-doors. In summer camps for boys and girls swimming is one of the very first features of the programme. Naturally it must be learned by practice, but here are some simple suggestions from experts which will be found to be immensely helpful.

#### The Friendly Water

The very first thing needful in learning how to swim is to realize that water is a friendly vehicle. It will carry us along, floating idly as a cloud in a summer sky or gently rocking as in a hammock, if only we will allow it to do so

## BOATING BOOK FOR BOYS

---

---

and do not hurt ourselves by struggling and fighting with it. We must have confidence in the water, trust it, approach it in a friendly spirit. That spirit of trust and friendliness can be obtained only by practical experience. How?

Choose the edge of a bay or river—salt water preferred, for it floats one more easily—where there is little tide and you can go along breast-deep for many yards, with no fear of straggling off into depth and danger.

Throw yourself into the water and try to stay down. Dig your fingers and toes into the sandy bottom and notice how the water is always trying to lift you to the top. Play in the water. It is beautiful. Open your eyes and look about. You are in a realm of magic. The sun, pouring its golden rays through the water, is revealing a new world full of strange and glorious colors. It is easy to duck your head under the surface of a bath-tub or wash-basin, is it not? It is equally easy to plunge headlong into a clear stream when you know you can stand up on your feet and breathe clear of the water at will, just as you can in a bath-tub.

Play in the water. Plunge under and splash about in it, again and again. Get used to living in the new wet world. After a while, as you plunge along beneath the surface, try the breast stroke—that is, simply pull yourself ahead by waving your hands and arms backward. You'll enjoy the fun. Keep trying it, over and over. After a while you will find that your head rises above the surface almost without any effort on your part. When that time comes—lo! you have actually learned to swim.

## SWIMMING COMES FIRST

---

### Confidence

The natural tendency of the human body is to float, and if you let it alone it will do so. Lie down gently in the water on your back. Throw out your chest, and let your arms lie flat against your sides. Let your head be all immersed except your nose and mouth. You will find that your feet will sink very slowly, until your body assumes a nearly perpendicular position; and then, if you keep your head and shoulders thrown back and your chest thrown out, your body will, nine times out of ten, remain floating in that position. Now raise your arms above your head and you will instantly sink. If you happen to be one of those happy mortals whose feet do not sink, you can float by the hour. If your feet show a tendency to sink, the gentlest kind of paddle with them will keep them afloat. Your head will not sink as long as your chest is thrown out. The reason why I mentioned raising your arms over your head is this: half the young beginners I have ever seen are constantly going under water because they try to stay too far above the surface. Be content with having your head out when you swim on your breast; don't try to get your shoulders out too. The more of your body you keep under water the greater will be your tendency to float. If you go under water altogether and keep still, you will come to the surface in spite of yourself.

One of the best places in the world to learn to swim is a shallow and rapid stream. The clear water, with the bottom plainly visible, within easy reach of the hand, gives the young swimmer confidence, while the current bears him along.

## BOATING BOOK FOR BOYS

---

Go into such a stream with a friend to hold up your chin. Lie down and strike out. You will sink at first, but you must not mind that. In the shallow water no harm can come to you. Let your friend tow you down-stream by the chin. It will not be long before you have confidence enough not to care whether he holds you or not. The victory is pretty nearly won then. Before long you will find the current carrying you a yard or two before you sink. Soon it will be five or six yards. Then you will suddenly awake to a consciousness that you are swimming. After that you will not care whether you sink or not. When you have reached that stage your troubles, so far as keeping afloat is concerned, are over. Confidence is the secret of swimming. Some people say: "Oh, I'm not a bit afraid of going under, but that doesn't help me; I can't swim a stroke." They may not be afraid, but they enter the water confident that they are going to sink, and they do. As soon as a boy learns that he can keep afloat for two or three strokes he acquires the necessary confidence in the water, and away he goes—a swimmer.

### Under Water

The swimmer usually enters the water with a dive; so let us consider diving. Stand with the feet together, and the body bent slightly forward. Place the hands together over your head, and plunge in head-first. As soon as you are under water separate your hands and extend them in front of the head. They will thus meet any obstacle you may happen to encounter under water, and protect your

## SWIMMING COMES FIRST

---

---

head. Keep your feet close together and your legs straight in diving; and whatever other bad habit you may acquire, I beg of you never to draw your knees up in front of you just as you are about to strike the water. It is absurd and ungraceful.

If you want to go directly to the bottom when you dive, keep your body perfectly straight, and enter the water almost perpendicularly. As soon as your hands strike the bottom, bend your body forward at the waist, double up your legs in front of you, and your feet will come down to the bottom. Then rise to a standing posture, place your arms flat against your sides, and spring upward from both feet, straightening your legs immediately. In water of moderate depth this will send you well out. If you are in deep water, raise your hands above your head; put them together, palms outward, the back of the fingers touching; then sweep them downward and outward with all your force. Don't use your legs at all, but keep them straight up and down. Repeat the stroke till you reach the surface, which you will do speedily.

If you wish to plunge in and come to the surface immediately, begin your dive in the same way as before, but strike the water at a greater angle. I need not tell you not to strike it flat on your breast, because after you do that once you will be careful. As soon as your head is under water throw it backward and upward, at the same time bending your back all you can; in short, perform that graceful feat known to all boys as "bending the crab." You will find that thus you will merely skim under the surface of the water, even if you dive from a height of five or six feet.

## BOATING BOOK FOR BOYS

---

---

When you dive you do not always want to come up immediately, so you must learn to swim under water. In order to remain under water for any length of time you must learn how to hold your breath. Stand straight up and throw out your chest; then take two or three long breaths, drawing the lungs quite full of air and expelling every bit of it; after doing this, draw the lungs about half full, so that there is no strain upon them from their having too much air nor too little, and then dive. The lungs have been provided with clean, fresh air, every bit of foul air having been blown out, and when you have hit the exact point at which there is no strain, you will be astonished to find how much longer you can hold your breath by this method than by going at it haphazard. I have known several swimmers who could not stay under water over thirty seconds learn to remain immersed a minute and a half.

Always keep your eyes open under water. It is dangerous to do otherwise; you might swim head-first against a rock, stun yourself, and be drowned. Your eyes will speedily become accustomed to the water, and it will do them no harm, not even in the ocean. Do not dive with your eyes open, as their impact with the surface might hurt them, but open them as soon as they are under.

To swim about under water keep your head down. Strike out just as you would on the surface, but turn the palms of the hands up as they pass backward, so as to keep forcing yourself downward. If you don't, you will rise to the surface in spite of yourself.



## SWIMMING COMES FIRST

---

### Swimming on the Surface

Now let me give you a hint or two about swimming on the surface. A good swimmer needs strong shoulders; so use Indian clubs. Then go to work to acquire a full sweeping stroke. The greatest fault among young swimmers is that they end the stroke just at the point where it ought to be most powerful; that is, when the arm is extended at right angles to the body. Don't stop there, but, keeping your arms stretched out at full length and the palms of the hands perpendicular, sweep the stroke backward with all your power till your hands nearly touch your sides. Then turn the hands so that the palms are parallel with the bottom, bring them in under your breast, shoot them out ahead of you as far as you can, and repeat the stroke. In this way you will get all possible power into your breast stroke, and will make fine headway. The best way of using the legs is the old-fashioned method of the frog, which needs no description.

The side stroke is the best for speed. Lie on your right side, keeping your head down so that the water just touches your nose and mouth. Stretch the right arm out in front of you, with the palm of the hand downward; then sweep it downward and backward. While it is coming back, throw the left arm forward above the water. Bring the hand down just in front of your face and sweep it backward. The arms should move alternately, and the legs should be driven out behind at each stroke. When you become tired of swimming on the right side, turn over and swim on your left.

## BOATING BOOK FOR BOYS

---

In learning to swim on your back study the different ways of swimming with the arms alone, the legs alone, or both together. You will find you can get along very fast by folding your arms and then drawing your legs up under you, kicking outward and backward, first with the left and then with the right. When you become tired of that, let the legs rest and propel yourself with your arms. The best stroke is like rowing: lift the hands out of the water, and carrying them forward as far as you can, drive them backward just under the surface, with the palms perpendicular.

You should learn to undress in the water, so that you may save your life if you ever fall overboard from a boat. Practise the following method in some old clothes: Swim with your right hand and left foot, while you take off your right shoe with your left hand; get the other shoe off in a similar manner. Always take your shoes off first, as they are the greatest obstacles to swimming. Next turn over on your back and swim with your legs while you take off your coat and waistcoat. You'll get a few mouthfuls of water while trying this, but don't mind that. Now roll up your shirt - sleeves to the shoulder. Turn over on your breast, and roll up the legs of your trousers as far as you can, swimming with one hand and one foot while you do it. You have not much more than a bathing-suit on now, and can swim a long time.

It is not likely that as a beginner you will ever attempt to save life; but when you do you must be cool about it. Try to get behind the drowning person and seize him by the collar; then lie on your back, keeping him also on his back, and swim toward the shore. By swimming on your

## SWIMMING COMES FIRST

---

---

back behind him and partly under him, you can keep clear of his struggles, and see that his face is above the surface. This is the method approved by many professional swimmers.

Here are some practical explanations of the simpler water methods from Mr. "Gus" Sundstrom, a former champion long-distance swimmer.

### The Breast Stroke

The first thing to master is the breast stroke.

This is the stroke which frogs use, and always have used, and it seems to be the natural way of swimming. Imitate a frog as closely as you can, and you will need no better teacher. But a frog's legs and feet form one straight line, and his fingers are fastened together so as to form a very fine paddle. Hold your fingers close together when you strike out, so as to imitate the webbed feet of a duck; and when you draw up your legs for a fresh kick, be careful to straighten out your feet, so as to avoid the resistance of the water against your insteps. In kicking out, strike the soles of your feet against the water, as though you were pushing yourself up in bed. Spread your legs far apart as you kick, and then, when they are fully extended, comes an important point in swimming. Do not jerk them up for another kick, as ignorant swimmers do, but draw them tight together, as though your legs were a pair of shears with which you wanted to cut the water. By thus closing your legs on the water you will add almost as much to your speed as by the first kick.

## BOATING BOOK FOR BOYS

---

Kick out as your arms are being extended for a stroke, and draw up your legs while making the stroke. That is the moment at which to get your breath, as the water is then smooth in front of you, and less apt to get into your mouth. It is well to accustom yourself to breathe only at every third stroke, as it will help you very much in rough water. It is important to draw the breath in quickly, and so breathing through the mouth, which ought not to be practised in other exercises, is good in swimming.

### Floating

When you have learned to swim on the breast correctly and strongly, learn to float. Begin by taking in a deep breath, and then draw up your knees and place your hands upon them, squatting in the water. At first you will sink, but by and by you will float in that position, with the eyes just above the level of the water. That will accustom you to holding the breath. Then swim ahead with the ordinary breast stroke, and, while well under way, suddenly give a reverse stroke with the hands. This will throw you upon your back, and by working the hands with a corkscrew motion you will keep afloat. If you are alone, you may swallow a good deal of water in learning unless you keep your mouth shut; if you have any one to support you, it is very simple. Do not try to raise the head and keep the ears out of the water, as you cannot float in that position. Lie perfectly flat and straight, and in a natural position, as though stretched upon your back in bed. In swimming upon the back the legs do most of the work.

## SWIMMING COMES FIRST

---

Kick out with them as in the breast stroke, and paddle with your hands at the same time to keep afloat. When you become expert you can learn to swim very rapidly on the back by stretching your hands straight out above the head, lifting your arms from the water to do so, and then bringing them down to your sides with a long, powerful sweep through the water.

### Diving

You will perhaps learn more about diving by watching a good diver than by many lines of printed instruction. Do not try to dive from a height at once, but begin about a foot from the surface of the water. Keep the feet together, and stretch the arms straight out before you, with the hands together and the palms downward. The hands should always strike the water first, to save the face from striking against any dangerous object in the water. When you first start, have some one hold your ankles. Then fall simply forward, without any jump, and let the friend who holds your ankles give them a slight toss, so as to send you down head-first and prevent you from striking upon the stomach. Draw a big breath while you are in the air. Close the eyes as you dive, but open them as soon as your head is under water. Accustom yourself early to being under water with your eyes open. It is very necessary, and will not hurt the eyes. You will soon learn the knack of diving, and accustom yourself gradually to different heights. Use your outstretched hands as a rudder. Keep them pointed downward as long as you wish to go down, and let them start upward when you want to rise.

### Side-stroke

First for the side-stroke underhand. You lie in the water upon the left side, half of your head being under water, and your face turned round toward the right shoulder. The left hand shoots out above the head, under water all the time, while the right arm is extended along the body. For the first stroke bring the left hand down with a powerful sweep until the fingers are just above the left knee; at the same time shoot out the right hand, and bring it back to the original position with a shorter sweep. The arms are thus made to work alternately, and while the right arm is being pushed ahead, the legs kick out, catching the water on the insteps. This stroke, which permits of very fast swimming, should be practised on either side.

The best stroke known for long and rapid swimming is the overhand side-stroke. The position is the same as in the underhand, and the principle is the same, with one exception. While swimming on the left side, instead of pushing the right hand ahead under water, and making but a short stroke with it, it is lifted out of the water and thrown far ahead, not touching the water again until it is fully stretched out. It is then brought down to the body with a long and very powerful sweep. There is a stroke known as the "porpoise stroke," in which the swimmer reaches around with his right arm as far as possible back of his head, so as to get a longer sweep. The power of the stroke may be increased, but the swimmer is fully half of the time under water, and that way of swimming is very exhausting.

## SWIMMING COMES FIRST

---

---

### Fancy Swimming

Any one who has mastered the strokes already spoken of is a thorough swimmer, and for practical purposes needs nothing more. With the ability to dive from a height, float, and swim strongly, he can always take care of himself. But there are endless feats in fancy swimming that all boys long to master. In diving alone there are innumerable variations. There is the farmer's dive, in which you jump with the legs doubled up, and strike the water with the shins. The efforts to keep from turning a somersault are very comical; and there are all the amusing dives that can be made from a spring-board. Practise a little until you learn to take advantage of the springiness of the board, and then watch good divers. You will soon learn all that they know if you are not afraid to try—somersaults in the air, long and high diving, and all. The backward somersault is easiest to learn, but in practising never fail to hold the hands so that they will strike the water before the head does.

But "fetching"—that is, going a long distance under water—is good practice, and a few words about it may be of interest. Take a regular dive, without any upward jump, but sharp into the water head-first, and with a good start forward. Allow your body to go down about three feet under water, and then swim straight ahead with the breast stroke. Do not make the movements too quickly, because, instead of making you go farther, it will cause you to lose breath much more rapidly, and diminish the length of your "fetch." Keep your eyes open, and use your

## BOATING BOOK FOR BOYS

---

---

hands as a rudder to keep you from rising or from sinking too far. After a few trials you will know instinctively how to keep at the right depth, and then your expertness will depend upon your ability to hold your breath.

The various special and racing strokes, the "crawl," "overhand," "truncheon," etc., are not necessary for our immediate purpose. We may add that when one has learned to swim well, it is desirable to practise "rescue" work under supervision, swimming with one's clothes on, which has been described on a preceding page, and up-setting and regaining boats or canoes.



Part II

HOW TO MAKE PLAY BOATS



## Chapter II

### MODEL YACHTS

**W**HEREVER there are boys and water, model yachts of some kind are sure to be found. There is a good deal of fun to be had with chips and nutshells, with pins or matches for masts, scraps of paper for sails, and a gutter or a puddle to represent the ocean. But boys can generally have access to a brook or a pond, and as nautical tastes generally go with more or less mechanical ingenuity, boys who have tools—a jack-knife, by the way, is a whole chest of tools in skilled hands—are sure to go farther, and construct more complete vessels.

Very elaborate model yachts, embodying the latest ideas of yacht designers, are built by members of the American Model Yacht and Brooklyn clubs, and the members of several other model yacht clubs in this country and Canada.

There is skill and science in the building and sailing of model yachts, and the best sailor is sure to win in a race if he has a reasonably good boat. We will save time, trouble, and labor by giving certain directions as to shaping the hull and fitting spars and sails to the best advantage.

#### The Plan

No vessel, large or small, can be successfully built without a drawn plan. In the case of large vessels this is made

on a reduced scale, with painstaking accuracy, so that the measurements will bear enlarging to the full size; but with a model yacht the drawings may be made of the full size, and, as it were, on the frame itself.

It is easier to reduce a plan than to enlarge it: so the one given herewith represents a boat thirty-six inches long, as that is probably as large as any one will wish to build. The proportions of length, breadth, and depth here given are not intended to show the best possible shape for a model yacht. Some good judges will say that there is not enough beam for the length, and others that there is too much beam for the length. These are questions which have never been settled—perhaps never will be settled. At all events, we will tell how to plan one boat. If you want greater depth and less beam, it is only necessary to change the plan according to your own ideas.

### Size of the Boat

For convenience, then, let us say that the boat is to be thirty-six inches long, ten inches wide, and eight inches deep. If you are a good carpenter you can buy a piece of pine timber in the rough and plane it down to the above dimensions; but it is better to have a skilled workman do this, so as to begin with every angle true and square. The wood must be as nearly perfect as possible, free from knots and cracks, straight-grained, and well-seasoned throughout.

The smoothly planed sides will receive pencil marks as well as paper, but pieces of card-board should be glued

## MODEL YACHTS

upon the ends where the grain is such that accurate drawing is impossible. (See Fig. 1.)

While the glue is drying mark off each of the four long sides into six-inch spaces, measuring always from the same

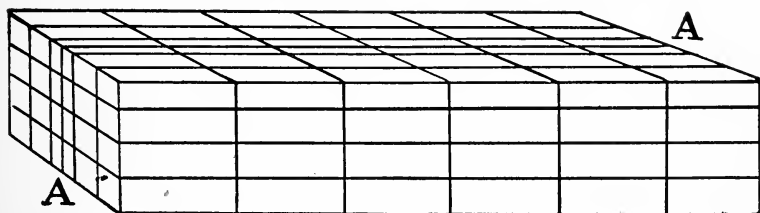

*Fig. 1*

end of the block and marking the divisions with a notch deep enough to prevent mistakes. With a sharp lead-pencil draw straight lines from notch to notch across all four sides. By the time this is done the glue should be dry enough to permit marking on the cardboard.

Draw a central line from end to end of the ten-inch sides, and continue it across the ends. (See A A, Fig. 1.)

### Accurate Drawing

These lines must be very accurately drawn, so that if the block were sawn in two, following them, it would be exactly divided in half lengthwise. When drawn they should be scored with a marker, so that they cannot be rubbed off. Next mark off the ends in two-inch squares, and draw lines as shown in Fig. 1, dividing the four sides of the block into parallelograms of two inches by six inches, and two-inch squares on the ends.

## BOATING BOOK FOR BOYS

---

In Fig. 2, A represents a side of the block, B the top or deck, C the stern, and D the bow. The long curved line near the upper edge of A is known as the "sheer line." It shows the curve of the deck from bow to stern. To draw it, take a straight, slender strip of wood, drive two wire nails into the block; say at *a* and *a*, and resting the strip upon them, bend it downward till the curve is sufficient, when a third nail may be set above the middle of the strip to hold it, and the line drawn with a pencil. By setting the nails exactly opposite on the other side of the block the sheer line may be repeated there. The line of the keel is straight for almost the whole length of the block, and the lines for bow and stern can be drawn by measurement to correspond on the opposite sides; or, if desired, paper patterns may be cut, and used for guides on either side. The shaded portions of Fig. 2 show the lead keel and the rudder, which are made and attached afterward. If there is any choice between the two broad sides of the block, select that which is freest from defects for the bottom of the boat, as the upper, or deck, side will be for the most part cut away. Draw the outlines of the deck (B, Fig. 2) by bending a slender piece of wood as in the case of the sheer line. To secure absolute accuracy it is best to double a piece of paper and cut out a half-breadth plan, with the doubled edge on the central line.

When opened and laid on the block, the deck outline may be accurately traced along the edge of the pattern. Draw also an inner line, half an inch from the outer one, as a guide in making the hold.

Draw the after sections on the cardboard at one end

# MODEL YACHTS

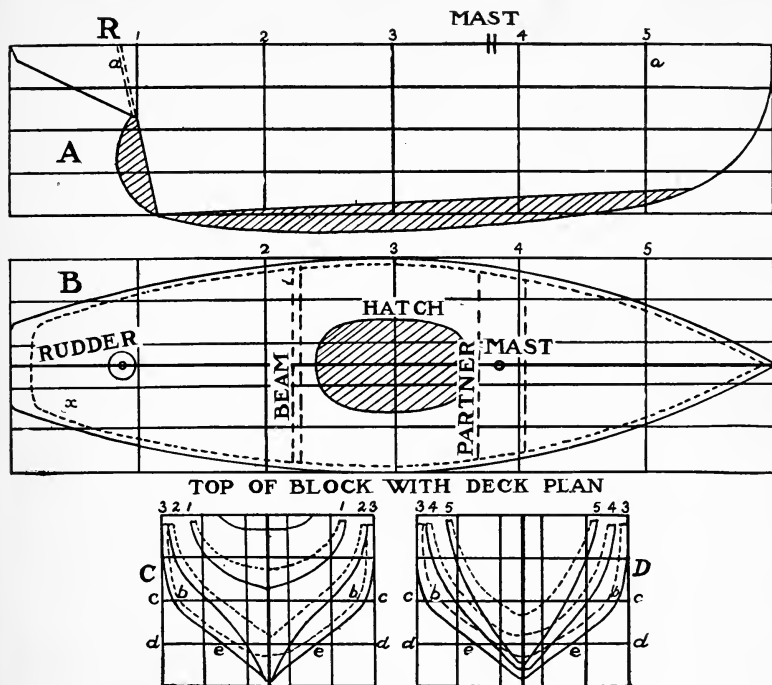

Fig. 2

END OF BLOCK

C, After sections; D, Fore sections

of the block (C, Fig. 2) and the fore sections on the other end (D, Fig. 2), as indicated; the midship section (3) need not be drawn on both, except for convenience. The dotted line shows the inner surface of the hold.

## Scoping Out the Hull

Now comes an operation which will render the trimming and scooping comparatively easy, and will define within

## BOATING BOOK FOR BOYS

---

the block the exact shape of hull and hold. Take a straight brad-awl, and beginning with the midship section (3), measure the distance from *b* to *c* carefully from the point of the awl. To mark the space on the awl, wind a small rubber elastic band around it, or drive it through a small bit of solid rubber—anything, in fact, that will not slip too easily up and down the awl, and can still be moved readily if desired. Bore a hole at *c* perpendicularly to the surface of the block; of course, the end of the hole will mark the point *b* within the block. Bore a corresponding hole on the opposite side of the block without changing the position of the marker. Next slip the marker up on the awl to correspond with the distance *d*, *e*, and bore holes at *d* and *d*, and so on, boring holes at all the intersections of lines where the thickness of wood is not too great. Where the awl is too short, the hole may be finished by means of a steel knitting-needle filed to a wedge-like point, and held with a pair of pliers or a hand-vice. When all the holes are made it is evident that the outside of the hull will be defined within the block. In the same way bore holes in the deck plan, defining the inside of the hold, making all measurements on the end cards.

### Cutting Away the Wood

In cutting away the wood it is easy to cut too deep if the awl marks are not plainly to be seen. To prevent this, procure a supply of bird-shot of a size to fit tight in the awl holes. Press a shot into each hole, and drive it home with the square end of the knitting-needle. This done, there



## MODEL YACHTS

---

will be two systems of holes, with a leaden shot at the bottom of each. The sides of the holes will have been blackened by the passage of the shot, and the cutting may be done with a free hand until the shot are reached.

Scoop out the hold first, as the block in its original shape will be better on the bench for working. A few holes bored nearly to the bottom of the hold with an auger will greatly help work with the gouge. Do not remove the wood from the overhang of the stern until after the hole is made for the rudder post (R), and then cut away all round it, leaving solid wood up to the deck-level for a rudder-case. This will prevent leakage at the rudder-head. The inside of the hold need not be smoothed. It will be concealed by the deck, and to sand-paper the tool marks to a cabinet finish is a mere waste of time. If convenient, put the block in water when the hold is finished to see if it balances. If not, trim away carefully on the heavier side until it floats nearly true. No matter about the trim fore and aft at this stage of the work.

In trimming the outside, the profile of bow and stern and the line of the keel should first be cut away across the whole width of the block. This may be freely done with saw, plane, and shave. With a fine saw cut carefully down at the numbered points in A (Fig. 2) as far as the sheer line. Do this on both sides. Next, the large masses of wood at bow and stern may be sawed off on lines not quite touching the side curves.

If the model is placed in a vise for trimming, the inside should be strengthened by cross-pieces to resist pressure from the outside. Trim away the outside with chisel, gouge, or

## BOATING BOOK FOR BOYS

---

knife until the shot are all removed, and then finish carefully with sand-paper and rasp, until the whole model is fair, round, and smooth. The last thing to be done is to trim the gunwales down to the sheer-line, using the saw-cuts already made as guides for the drawing-knife or spoke-shave.

### Finishing the Hull

The thickness of the sides of the model has been given as half an inch, but skilled workmen may reduce this to a quarter of an inch, or even less. Near the ends and along the bottom greater thickness is required for strength. Model yachts may be built in several different ways, but the hollowed block is the simplest. When the hull is shaped, bore a quarter-inch hole for the rudder head, running up through the solid wood of the stern, on the line of the stern-post (R, Fig. 2). This done, the overhang may be lightened by cutting away the extra wood, leaving, say, half an inch of thickness to serve as a rudder-case.

Cross-pieces half an inch thick are now set in place to strengthen the deck, at the mast-step, and elsewhere if needed (see dotted lines on deck plan, Fig. 2), a hole is bored to receive the foot of the mast, and then the whole interior is painted with white lead and allowed to dry before the deck is finally in place. As the wet paint is out of the way, however, work may go on.

The deck is made of quarter-inch or eighth-inch pine, bass-wood, white-wood, or cedar—the lighter the better. Lay it on the work-bench with one or two blocks under it to bend it to the sheer of the gunwale, and turning the

## MODEL YACHTS

model upside down, mark the shape with a lead-pencil, trim it out nearly to the line, fasten it in position with a few fine wire nails, and finish trimming the edges. Bore holes for the mast, rudder, and hatchway (if one is required), and make also a small hole, say at X (see deck plan, Fig. 2), where any leakage may be poured out in case of need. A hatchway large enough for a hand and arm is very convenient should anything go wrong below-decks. Paint the under side of the deck, and leave it to dry with the rest of the inside paint.

### Ballast and Keel

It is now necessary to set the ship afloat again to get her in trim for the lead keel. Probably she will require four or five pounds of ballast. This may be laid inside in small pieces till the proper immersion is secured and the required weight ascertained. The mold is simply a trough about half an inch wide and an inch and a half deep in the middle. It is best made by cutting a half-inch board to something like the shape indicated in A, Fig. 3. Set wooden pegs in the edge at three-inch intervals as indicated, and then nail other boards against its sides (B, Fig. 3). Pour in the proper amount of melted

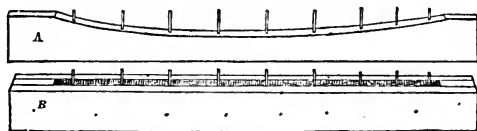
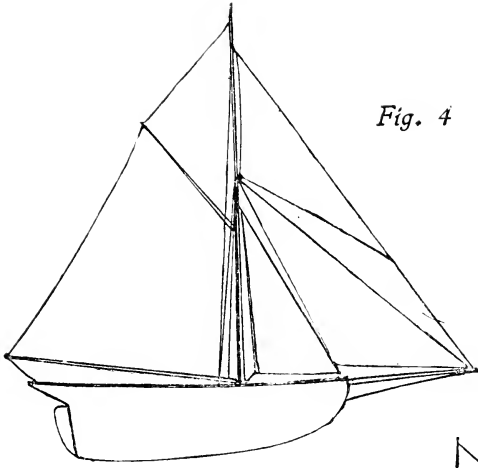

*Fig. 3*

lead, and when it has cooled it will be found that the pegs have left holes in the metal, which can be easily reamed out and countersunk, so that the keel can be fastened to the bottom of the model by means of brass screws. Before fastening it in place, smooth away all imperfections in casting, and shape the lead so as to correspond with the general line of the model. It is not intended here to indicate the exact lines that will give the best results, but if these are followed, the model will not be far out of the way, and any variations may be corrected by inside ballast as may be needed. The best form of ballast is shot in half-pound bags. Fasten the deck to gunwales and beams with small, flat-headed, brass-wire nails driven at intervals of about one inch. The model is now ready for paint and varnish.

### Spars and Rigging

While the paint is drying, work may begin on spars, sails, and rigging. The cutter or sloop rig is, upon the whole, the best for model yachts, as it is for their larger kindred. The spars required for such a craft are lower mast, topmast, boom, gaff, and bowsprit. Spruce is the best material for a solid mast, but bamboo is preferred by many builders. The diameter of the lower mast should be at least one-sixtieth the length of the boat: about five-eighths of an inch for a three-foot model. The lengths and proportions of the spars and the shape of the sails may be nearly enough judged from Figs. 4 and 5, which are from photographs of American and English model yachts.



*Fig. 4*

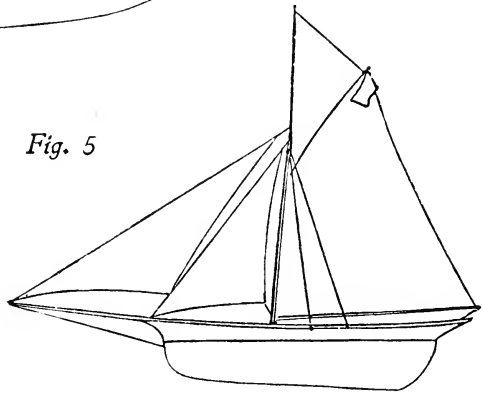

*Fig. 5*

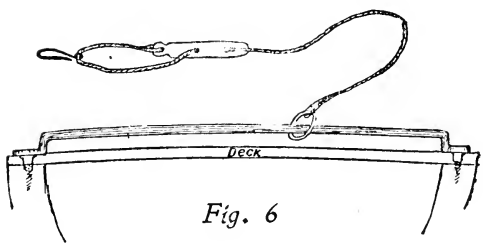

*Fig. 6*

SPARS, SAILS, AND DECK FITTINGS

## BOATING BOOK FOR BOYS

---

The Englishman (Fig. 5), it will be noticed, carries no jib-topsail. Her length is five feet, and her beam only six inches, or one in ten—a marked contrast to our American models; and we may note here that center-boards have been ruled out of model-yacht club races in England in loyal support of the position taken by owners of larger craft. She is steered without a rudder by trimming sails and shifting ballast.

### Sails

Light muslin or cotton sheeting is the best material for sails. Soak it in cold water overnight, and dry without wringing. Then iron it smooth and mark the shape of the sails with a pencil, having first cut out paper patterns to serve as guides. The sails of a "single-sticker" are mainsail, gaff-topsail, stay-sail, jib, jib-topsail. The forward edge of the sail is called the "luff," and the after edge the "leech." The material should be cut so that the selvage will form the leech of mainsail and gaff-topsail, and the luff of all the head-sails. The other edges are turned over and stitched on a sewing-machine, with narrow tape in addition to the hem if desired. The "set" of the sail is improved by cutting the foot on a slight curve, and in that case the tape should be sewed on straight across, not following the curve. Eyelet-holes are made at all the corners of all the sails, and along such edges as have to be laced to a spar or a stay. It is proper to say that some experts hold that the foot of the mainsail should not be laced to the boom. Small brass curtain-rings are sewn to the edges of such sails as are to be hoisted and lowered.

## MODEL YACHTS

---

The head-sails are best set "flying," provided with rings or loops at the corners—that is, so that they can be hooked to the proper points of attachment on masthead, bowsprit, and tack.

The bowsprit is a trifle more difficult. A brass screw-eye large enough to receive it is set in the cutwater. Six or eight inches from this, in exact line with the middle of the boat, is a step for the heel of the bowsprit—namely, two cleats screwed to the deck far enough apart for the squared heel of the bowsprit to rest between them. At this point the deck should be reinforced underneath, unless it is thick enough to withstand the strain. An easily removable pin made of brass wire passes through the heel of the bowsprit and through both the cleats.

### Deck Fittings

Two other deck fittings are required—namely, the travelers, which are made of spring brass wire about an eighth of an inch in diameter, and bent to the shape indicated in Fig. 6. They may be made long enough to reach clear across the deck, and be screwed to the gunwales. If preferred, however, they may be shorter, and screwed through the deck to a beam or partner. Before fastening it down, pass it through a small, strong brass ring to which the jib or main-sheets may be attached.

In Fig. 6, too, are shown the hook and the "fiddle," the latter being a piece of bone or hard-wood pierced with small holes, through which a line passes in and out as shown, and by means of which standing or running rigging can be lengthened or shortened as required.

## BOATING BOOK FOR BOYS

---

The main-sheet traveler is set a little forward of the rudder, and the stay-sail traveler a little forward of the mast. To the rings on each are made fast the "sheets," or lines that regulate the position of the sails. The jib-sheet and jib-topsail sheet are made fast to bowsprit and mast, as may be seen in Figs. 4 and 5. This is one of the particulars in which the rig of a model must needs differ from that of a real vessel, where there are always men to tend the jib-sheets, whereas in a model they must tend themselves.

The necessary standing rigging may be limited to shrouds (namely, stout lines running from the head of the lower mast to the gunwales nearly opposite the mast), and a stay from the head of the lower mast to the head of the stem. This may be attached to the "gammoning," or screw-eye through which the bowsprit runs. Other stays, according to the number of jibs, may be required between topmast and bowsprit. The bowsprit itself should be strengthened by a bobstay underneath, and bowsprit shrouds at the sides, unless it is heavy enough to bear any possible strain by itself. All these stays should have hooks, so that they can readily be unfastened or adjusted as to length. Where fiddles are undesirable, the line may be passed through an eye and then around a cleat.

The best line for standing and running rigging is linen fish-line, which may be had of any size. For lashings use strong linen thread.

### Seamanship

It is very easy to make a model yacht that will sail close-hauled but will not run before the wind; but to make one



## MODEL YACHTS

---

that will go in any given direction calls for science. In order to tell how to sail a model yacht on different winds, it seems necessary to define two terms—namely, 1, the center of lateral resistance of the hull; and, 2, the center of effort of the sails. If you attempt to pull a boat side-wise through the water by a line attached to her side, she will sheer one way or the other, according as the line is near the bow or the stern. The point where she can be towed squarely broadside on is the center of lateral resistance. The center of effort of the sails is that point where they would all balance if they were cut out of stiff cardboard and held up against the wind.

Now it is necessary to have these two centers nearly in the same line, one above the other. The first may be nearly enough found by towing sidewise as suggested. The second may be fixed by cutting out a small general pattern of the sail plan in cardboard and balancing it, say, on the flat head of a nail or some such object. This will give the center of effort, and by measurement you can place it in the actual sails.

In making the original plans for sails and hull these centers should be kept in mind, and the aim of the builder should be to prevent their falling very far apart. If they do not come out right, one or the other must be shifted. Deepening the keel toward the stern moves the center of lateral resistance aft, and the reverse moves it forward. So also does shifting ballast in either direction. Increasing the area of head-sails moves the center of effort forward, and the contrary if the after-sails are enlarged. In this way the two centers can probably be brought together. If

not, it may become necessary to insert a false keel between the lead keel and the wooden keel. This is easily done by planing out a wedge-shaped piece of wood of the same thickness as the keel, but deeper toward bow or stern as may be required. Holes are burned or bored through it to correspond with the screw holes in the lead keel.

### A Self-acting Helm

In sailing, as soon as the model heels over under the pressure of the wind the center of effort moves aft, and she tends to come up into the wind and lose headway. To counteract this a self-acting helm is necessary. (See Figs. 7 and 8.) A B is a brass tiller with a screw-thread

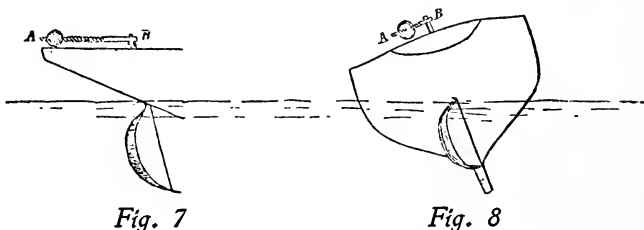

turned on it. It extends *aft* from the rudder-head. It carries a leaden ball weighing from two to four ounces or more, as may prove necessary, and is fitted to run on the tiller-screw. When the model heels over, as in Fig. 8, the leaden ball will tend to swing toward the lower or lee side: in sea language, the helm will put itself a-weather, and the tendency to luff will be corrected. By moving the leaden ball in or out, the strength of the helm can be increased or

## MODEL YACHTS

---

lessened. The same result is gained by weighting the after-part of the rudder with lead. (See shaded portion of rudders in Figs. 7 and 8.) Sometimes a model yacht is fitted with a set of several loaded rudders of different weights and sizes which are easily unshipped, and are used according to wind or course. There are in use very ingenious and effective contrivances through which the main-sheet is attached to the tiller, and so steers the boat, but they are too complicated to describe here.

### Some Rules for Navigation

No rules can be laid down which will cover every case, or which will meet the habits of every boat, for boats are just as full of notions as people are, and their humors have always to be taken into the account. With a boat whose centers are nearly in line, the following rules should hold good:

1. *To sail to windward.*—Trim the main-sheet well in, and let head-sails be rather slack. Set the lead ball rather near the rudder-head. Some experiments will probably be necessary before you will learn the proper relations of sheet and helm. Keep on trying till she sails steadily on either tack. Shift ballast if necessary.

2. *Reaching.*—Give her more helm—that is, move the ball farther out on the tiller; slack the main-sheet till the boom can swing out about fifteen degrees. Probably no change will be needed in the head-sails.

3. *Quartering off the wind.*—Slack away the main-sheet still farther, and give her still more helm.

## BOATING BOOK FOR BOYS

---

4. *Down the wind.*—Guy out the boom at right angles with the hull, and move the leaden ball out to the very end of the tiller.

These directions, as has been said, may not work in all cases. Every boat has fancies of its own, particularly about the jib-sheets. Nothing but experiment will show what treatment each requires. Considerable changes are often found necessary before a boat can be made to sail in a way that will fully satisfy expert sailormen.

One item in the model yachtman's equipment has not been mentioned—namely, the line with which he captures or rescues his boat when she runs away or comes to grief. This is a fishing-line with a sinker attached. It is a good plan to cover the sinker with cloth, so that it will not damage hull or spars if it chances to hit them. The sinker may weigh three ounces or so, and the line should be as long as the owner can manage. The sinker is thrown so that the line will fall across some part of the rigging or hull, and the weight of the sinker will enable the owner to pull the boat ashore.

The method described in this chapter of hollowing out a solid piece of wood is probably the best for boys. A second method is to saw out some planks in the middle, glue them together, and pare them down. Experts make their models by timbering and planking as in the case of real boats.

## Chapter III

### SUGGESTIONS FOR SLOOP MODELING

WITH the assistance of a few practical designs, drawn on a scale, the correct form of the newest sloop yachts in America can be easily shown to you in a way that will help any boy if he wants to build a model. They are

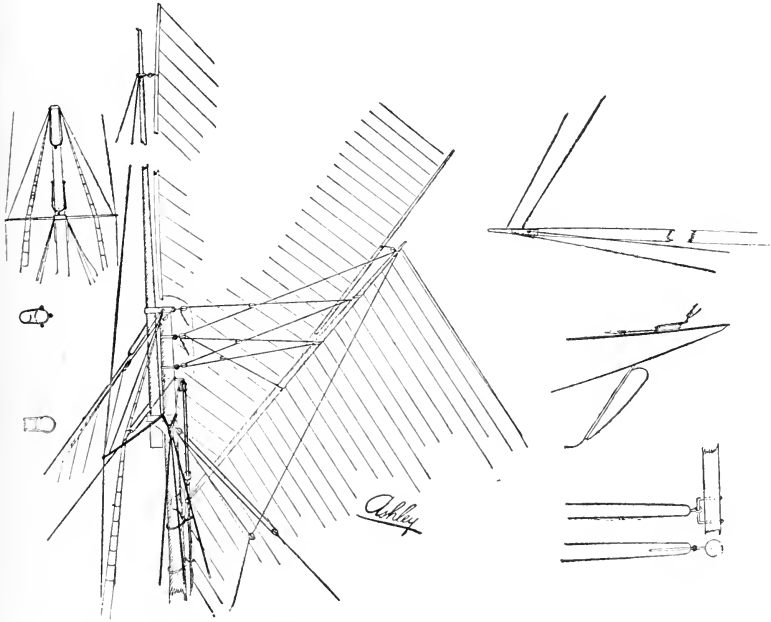

HINTS ABOUT RIGGING, ROPES, BLOCKS, STAYS, AND SHROUDS

## BOATING BOOK FOR BOYS

divided into two classes, known as the regular and fin (keel). Look carefully at the plan of sail area and hull, and mark out your block, which should be of soft and well-seasoned pine free from knots. Take a fine rule and measure each part of the design; for instance, if the deck is two and one-half inches, multiplied by ten it would give your model twenty-five inches for deck, or ten times the size of your draft. This is the way a yacht-builder constructs the vessel from the designer's plans.

### The Fin-keel

The easiest model to make and the fastest is the fin-keel. Take your block of wood and shape it into a form resembling a cigar; cut this in two lengthwise; be sure and have all your wetting surface take a slight outward curve; bring the stern down to a knife-edge (see side view of hull, Fig. 1), and give it a broad sweep on deck; put but a slight curve in the deck

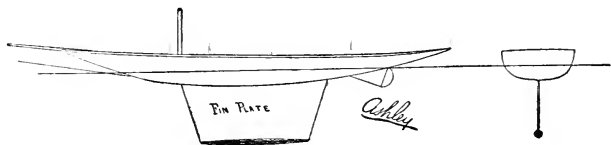

Fig. 1

THE "FIN-KEEL" MODEL. SIDE AND END SECTIONS

fore and aft; saw a slight slit in the bottom and center of your boat lengthwise, and insert a brass plate (same shape as shown in design); it should be composed of one-sixteenth of an inch brass. Mold your lead bulb in white plaster-of-Paris. This is done in the following way: Make a wooden

## SUGGESTIONS FOR SLOOP MODELING

---

form of a half-section, coat it lightly with lard, and rub smooth; take a small wooden box, and fill it with wet plaster-of-Paris; even off the surface, and press the form to be molded even with the surface, taking care to have the rounded part downward; leave it in this state for about two days, and upon removing the wood it will be found that the result is a perfect fac-simile of the pattern, except it is the reverse; pour in your melted lead and allow it to cool for three hours. Two casts will make a perfect bulb for the fin. These casts should be riveted on each side of the fin. Now pass the fin up through the slit previously made in bottom of hull; bore holes in the upper part of the fin plate, and rivet a block on each side from the inside of the hull. This will keep it in place. Screw the blocks to the hull.

### Deck and Spars

Now put on your deck, and after that tack on a very slight strip over it, following the outer edges of the deck. The mast-hole is a little aft of one-third of the deck measurement. Put in a piece of brass tubing for the mast-step, and a smaller piece for the rudder-sleeve. Before putting on the deck put four slats across to form deck beams. The deck should be about one-eighth of an inch thick. Make your spars of pine. The boom and gaff should taper slightly at each end. Use only pine and brass in your construction, and do not attempt to use any but marine glue, as any other kind will give way when brought in contact with water.

### Paint and Varnish

When the hull is finished paint below the water-line a light green, add a little varnish with the paint; above the water-line it can be painted either white or black, but it will be found that the latter color is the more practical. Give the deck and spars two coats of varnish. The sails should be of the lightest muslin. Mark with a soft lead-pencil the lines that are shown in the design (Fig. 2), which will serve to show how the clothes are laid on a yacht's sails. If you wish wire rigging, buy a coil of three-ply picture wire, and when heated red-hot drop in cool water. This takes the temper out of it, and makes it easy to divide. To take the kinks out of it run it back and forth over a soft piece of pine. A very good substitute for thimbles used on a yacht can be obtained by using the old eyelets on a laced shoe.

### Flags

Every yacht has its own private flag, and also a club flag. When racing, the club flag is carried at tip of the topmast, and the private flag is fastened on the mainsail leech, just below the gaff. If two or more models are racing, a number should be printed in black on a small piece of white cloth, say one and a half by three inches, and pinned on each side of mainsail, about four inches above the boom and two inches away from the mast. In case a race is arranged, ascertain in which direction the wind blows, and race di-



## SUGGESTIONS FOR SLOOP MODELING

---

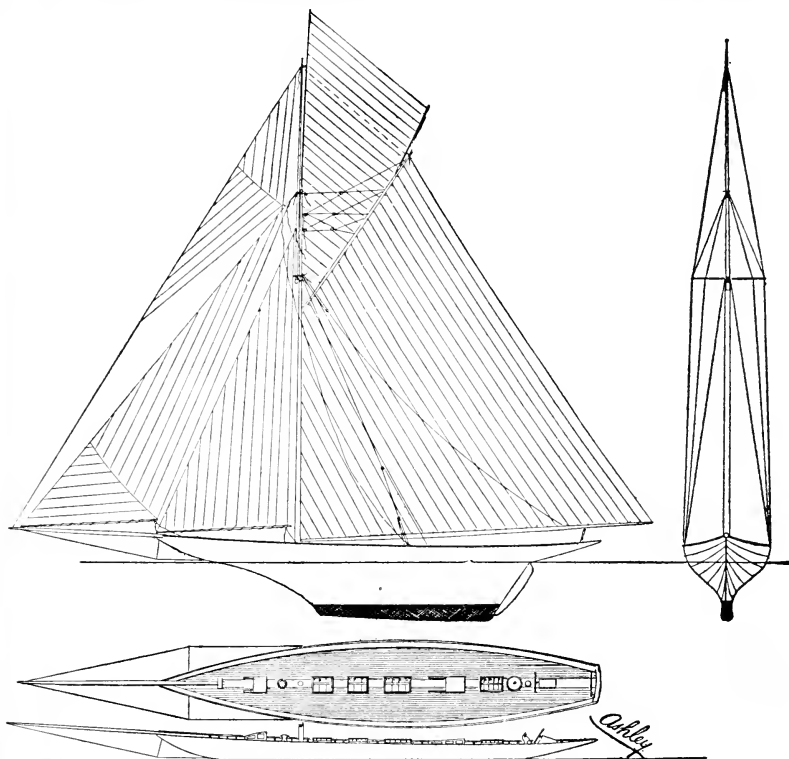

*Fig. 2*

SAILS, SHEER PLAN, CROSS-SECTION, AND DECK VIEWS OF THE KEEL BOAT

rectly against it, so as to return with a free wind. The other way is to make a triangular course. September and the first part of October is the very best time in the year to sail miniature yachts.

## Chapter IV

### HOW TO MAKE A TOY STEAMBOAT

ROBERT FULTON could not have been more proud and delighted with his first successful steamboat than was the writer when, as a boy, he succeeded in making a toy craft that would run itself. (Fig. 1).

#### The Motor-power

The drawings and diagrams that are here given explain how to make a small boat, the motor-power being a thin

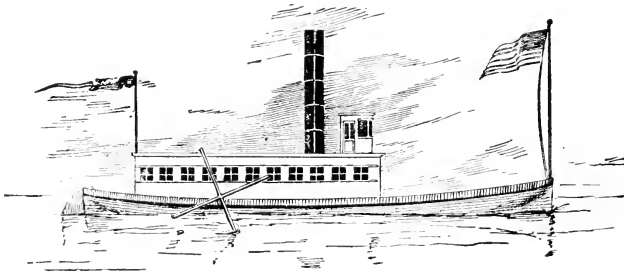

*Fig. 1*

THE TOY STEAMBOAT "ROBERT FULTON"

band of elastic, one end of which is attached to the center of the paddle-wheel axle, the other end being tied to the

## HOW TO MAKE A TOY STEAMBOAT

---

flag-staff in the bow of the boat. A piece of string a few inches longer than the elastic when the latter is stretched out to its full length is also attached to the axle about midway between the elastic and one of the paddle-wheels.

Do not tie the string on until you have turned the paddle-wheels around backward until the elastic is stretched to its utmost. When you let go the paddle-wheels the elastic will unwind; in doing this it will wind the string on the axle; so to start the boat you simply have to draw the string out to its full length.

### The Hull

The hull is made from a piece of soft wood about a foot long and an inch thick, shaped as shown in the diagrams. (Fig. 2). The boat is flat-bottomed, and is not hollow, the wood being sufficiently buoyant. The paddle-wheels are made of shingle or cigar-box wood about three and a half inches long and one inch wide, with an incision cut in the center the same width as the thickness of the board; four of these will be necessary to make the two wheels. They are joined together by the axle, which should be about the thickness of a lead-pencil and half an inch longer than the width of the boat, to prevent the wheels catching on the sides of the boat as they revolve.

To fasten the paddle-wheels on the axle, drive a small finishing nail through one section of the paddle at the incision into the end of the axle, as shown in Fig. 2; then fit the sections together, and the paddle-wheels are complete. The axle is kept in place by pieces of wire, or pins

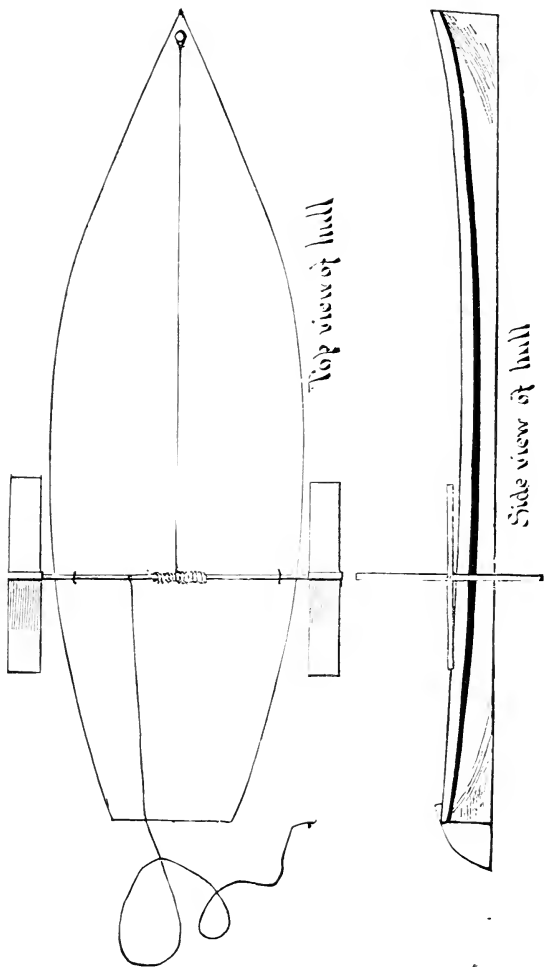

Top view of hull

Side view of hull

Fig. 2

WORKING PLANS

## HOW TO MAKE A TOY STEAMBOAT

---

with their heads filed off, bent like a horseshoe, and placed over the axle and driven into the boat. The cabin is made of white cardboard, measuring, when extended out before being bent, about twenty inches; the sides are seven inches long and one and a half inches high. Upon this windows are painted in black. If you have no black paint, ink will do nearly as well. White spaces must be left to represent the sash. In the back of the cabin a small hole is punched through the cardboard for the winding-up cord to pass through. The dotted lines in the cut show where to bend the cardboard to form the four sides of the cabin. The pilot-house is bent in only one place to form the back, the front curving round in a half circle. (Fig. 3.)

### The Cabin

After having fastened the sides of the cabin to the hull, place the boat upside down on a sheet of cardboard, and with a pencil go around the cabin; lift off the boat, and you will have a pattern for the roof. Cut around the outlines, leaving a quarter of an inch between your scissors and the outline. When you fasten on the roof it will project beyond the sides of the cabin, and this will improve the appearance of your boat. The smoke-stack is made of the same material as the cabin, blackened to give it the appearance of being made of iron. To make it circular, roll it around a lead-pencil. The pieces are fastened together by pasting a strip of writing-paper half an inch wide over the joint, half on each side. Fasten the flag-staff securely in place by boring a hole with a gimlet in the bow

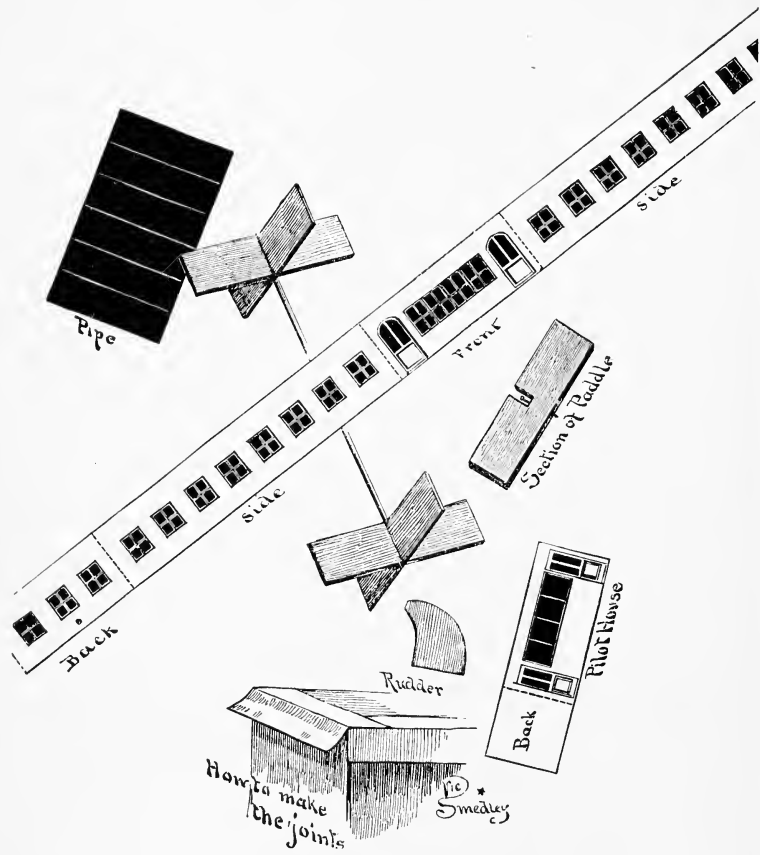

Fig. 3

WORKING PLANS

## HOW TO MAKE A TOY STEAMBOAT

---

of the boat, and then the vessel will be ready to be launched with appropriate ceremonies.

The boilers will never burst, and when the steam gives out it is only necessary to pull the string to procure a new supply that will send the little paddle-wheels whirling with renewed vigor, to the great delight of everybody.

## Chapter V

### A BOAT WITH A SCREW PROPELLER

TO make a model steamboat that will go is the ambition of many boys, but the high price of engine and boiler prevents them from doing so. The instructions here given will enable any boy to make for himself, by the exercise of a little ingenuity, at a very trifling cost, the machinery for a model screw steamboat which may be fitted into any craft, the rigging of which may have been wrecked off the dangerous coast of the duck-pond.

First you must procure your boat; but if you should wish to make it yourself, remember that it must be very light and hollowed out as thin as possible. Let it be twenty-four inches long, four inches wide at midships, and three and a half inches deep. The stern-post should be about an inch and a half within the stern, raking, and two and a half inches high, as marked in Fig. 1. Fasten a strip of lead one-eighth of an inch thick along the bottom of the keel. The bows should be sharp, and the boat should have a clean run aft. When it is finished paint it, and when dry put it into water, and mark on the stern-post the height that the water comes. Now you must bore a hole in the stern-post right through into the boat in the direction of the top of the stem. This



## A BOAT WITH A SCREW PROPELLER

must be done with a red-hot wire; the hole is to be three-eighths of an inch across.

### Making the Machinery

The next thing to do is to get a brass tube from the gas-fitter's, or get a tinman to make you one of tin, three-eighths of an inch inside measurement. This tube must

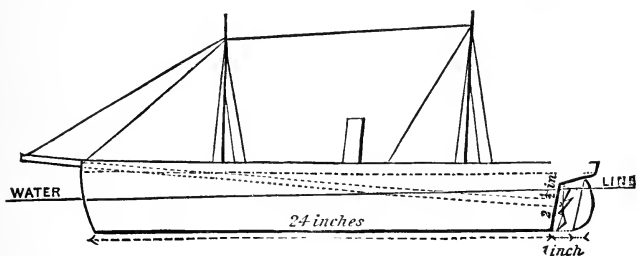

Fig. 1

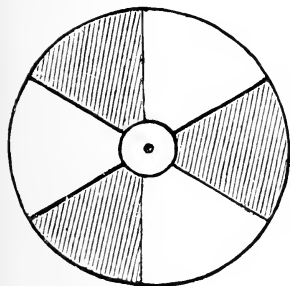

Fig. 3

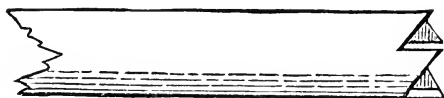

Fig. 2

be long enough to reach from the stern-post to three and a half inches beyond the top of the stem. Four inches from one end of this tube solder a strip half an inch wide and one and three-quarters inches long, bending the mid-

dle of it half round the tube, and bending the ends outward; punch a hole in each end of this strip; in this end of the tube cut four teeth like saw-teeth one-eighth of an inch deep, like Fig. 2.

Put this tube in the boat thus: push the end without the tin strip through the hole in the stern-post from the inside of the boat, so that the tube is flush with the wood, and fasten the other end by driving tacks through the holes in the tin strip into the boat. Put some putty round the tube, where it goes through the wood, to keep the water out. Now make the deck of board one-eighth of an inch thick, plane it, and fix it in its place by pins, leaving a gunwale of half an inch all round. Stop up with putty, and mark with a pencil the boards on the deck.

Bore a hole near the stern a sixteenth of an inch wide right through the deck and boat, coming out under the counter one inch from the stern-post. This is the rudder-hole. To make the rudder get a piece of brass wire one-sixteenth of an inch, and six inches long; cut your rudder out of tin, and solder it on to the wire so that the heel of the rudder is flush with one end of the wire. Now push the other end up through the hole in the counter, and bend it down to the deck; this will form the tiller, and by pressing tightly onto the deck will keep the rudder firm and in its place for steering.

Two inches abaft the middle of the deck cut a hole three-quarters of an inch in diameter for the chimney, which is a tube of tin three-quarters of an inch in diameter and four inches long. Bore two more holes in the deck, three-eighths of an inch in diameter, one half-way between the stem and

## A BOAT WITH A SCREW PROPELLER

---

the chimney, the other half-way between the rudder and the chimney; these are for masts, which are made of wood, and should stand about nine inches above deck; put a pin into the lower end of each mast, and cut the head off, leaving about half an inch of the pin projecting; put the masts in their places, and the pins will keep them firm by being pushed into the bottom of the boat.

### The Propeller

Make the propeller out of a circular piece of stout tin two inches in diameter, cut as in Fig. 3. The dark parts are to be cut away. The projections are to be three-quarters of an inch long. Punch a hole one-sixteenth of an inch in the center, and fix a piece of brass wire one-sixteenth of an inch, two inches long, in the hole, to form an axle for the propeller. Twist each of the fans of the screw out of the plane of the circle about a quarter of an inch, in the manner of the sails of a wind-mill, as in Fig. 4. Now make two little wooden plugs three-quarters of an inch long, and half an inch wide at one end, tapering to a quarter of an inch at the other. Bore a hole through each from end to end one-sixteenth of an inch wide. Take the propeller, and put a glass head that will fit easily on the wire, and push the wire through one of the wooden plugs from the large end; bend the wire into a loop at the small end.

### Power

Now take another piece of wire two and a half inches long, and make a similar loop at one end, and put the other

## BOATING BOOK FOR BOYS

end through the other little plug from the small end, and bend the wire into a handle (Fig. 5). Now the only thing we want is the power. This is a strip of strong elastic about three and a half feet long and a quarter of an inch wide;

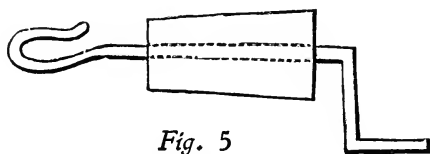

*Fig. 5*

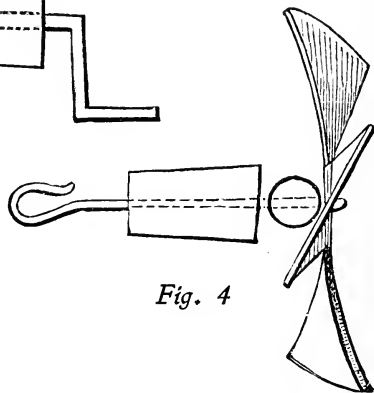

*Fig. 4*

tie the ends together to make a band—a large, stout elastic ring will do, or two smaller rings looped together. Fasten a string to the elastic, and pass the string through the tube in the boat from the stern end; hook the loop on the propeller wire into the elastic, and push the wooden plug into the tube so that the screw is clear of the rudder; draw the elastic by the string through the other end of the tube, and hook the wire in the other plug into it; take off the string, and push the plug into its place. You must cut the plug away so that the handle can catch in the teeth cut in the tube. Now the boat is ready for use.

To use it wind up the elastic by the handle at the end

## A BOAT WITH A SCREW PROPELLER

of the tube, holding the screw firmly with the other hand. As soon as wound up enough set the rudder and put the boat into the water; release the screw, and the boat will go until the elastic is quite unwound. The distance it will travel will be regulated by the extent to which the elastic is wound up.

## Chapter VI

### PADDLE-WHEELS FOR A SMALL BOAT

SEVERAL years ago, while staying with friends who lived in New Jersey, on the banks of one of the prettiest rivers in the State, I conceived the idea of making for myself a side-wheel paddle-boat; and going to work with what I had on hand, succeeded so well in my undertaking that I wish to let my young friends enjoy the same privilege. I give a working sketch for a boat of three-foot beam and under, so that my readers may follow measurements and have one for themselves. (Fig. 1).

#### Applicable to Any Boat

A particularly good feature of this contrivance is that the whole machinery may be applied to any boat, and may

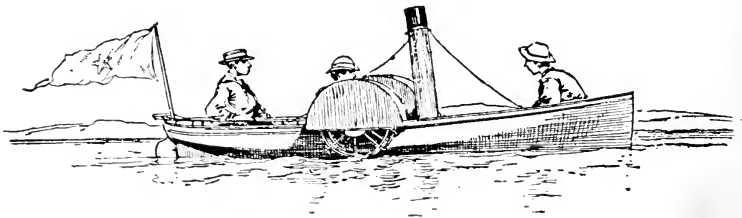

*Fig. 1*

## PADDLE-WHEELS FOR A SMALL BOAT

be taken off and put on at will, and without doing either boat or wheel any damage. Any boy with some mechanical ability, and at very little expense, can make and run his own paddle-boat, and if he derives as much pleasure from the making and working of it as I did, he will be amply repaid for all his trouble.

### Hubs and Spokes

The first thing to do is to go to the carpenter and get six strips of pine one inch thick by two inches wide, and

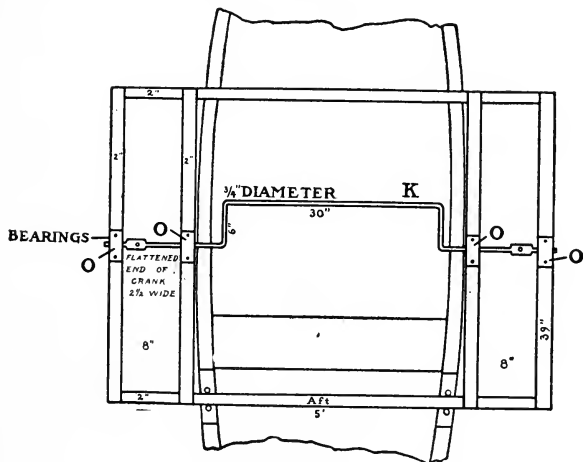

*Fig. 2*

SHOWING FRAME IN WHICH THE WHEELS ARE TO WORK

K, crank; O, O, bearings. (See also O, Fig. 5).  
The frame is resting upon a section of a boat

make a frame (Fig. 2), fastening together with two-inch screws—galvanized screws are preferred in every case, as

## BOATING BOOK FOR BOYS

they do not rust. Then cut four pieces of three-quarter or one-inch stuff, circular-shaped, eight inches in diameter (Figs. 3, A, and 6, A) for the hubs of the wheels, and fasten with one-and-three-quarter-inch or two-inch screws the

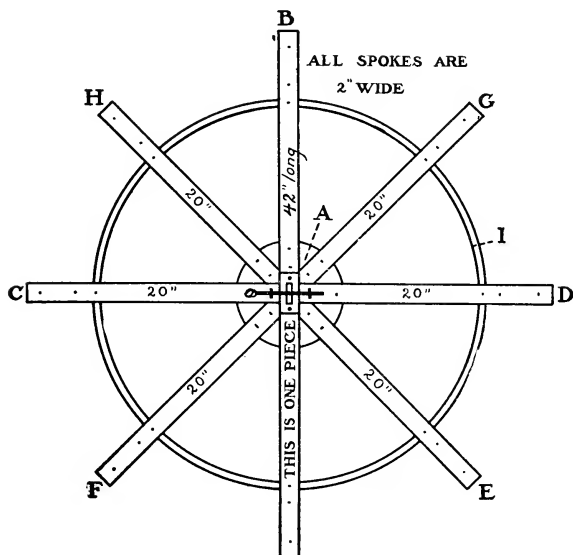

*Fig. 3*

SHOWING CONSTRUCTION OF WHEEL AND SIZES OF PIECES

spokes, B, C, D, E, F, G, and H (Figs. 3 and 6, for lengths and shape of ends), strengthening with an ordinary thirty-inch hoop (I, Fig. 3).

### Paddles

Now make the paddles (J, Fig. 4) of one-inch pine, five inches square, and fasten with two-inch screws, being care-



## PADDLE-WHEELS FOR A SMALL BOAT

ful to have the circular pieces, A, on the outside of the wheels (see Fig. 4). Now the wheels are all ready for the crank (K, Fig. 2) and crank plates (L, Fig. 6). Have the blacksmith make the crank of iron bar three-quarters of an inch in diameter in the same shape as shown in K (Fig. 2), with ends flattened to fit the plate L, which should be fastened to spoke B (Fig. 6) and kept in place by iron pin N, run through staples or screw-eyes in spokes C and D (Fig. 6). Be careful to screw this plate and pin on the inside of the outside spokes of each wheel (see L and N,

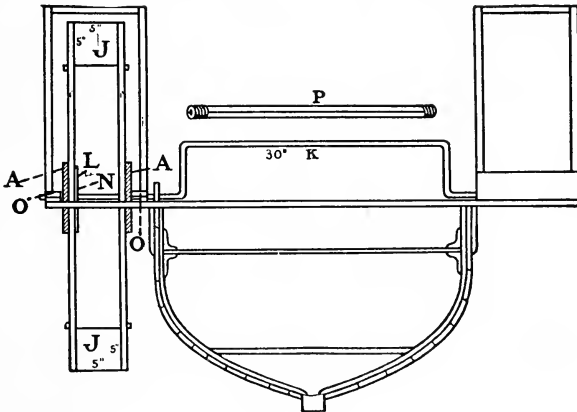

*Fig. 4*

SHOWING ON LEFT-HAND SIDE A SECTION OF THE WHEEL IN PADDLE-BOX  
AND ON THE OTHER SIDE THE PADDLE-BOX WITHOUT A WHEEL; THE  
WHOLE IN POSITION ON THE BOAT

K, crank; P, wooden handle to be fixed around the center part of the crank

Fig. 4), thereby making crank and wheels as one article and to work together; the better the crank fits the plates the more steady will it be and easily worked.

## Assembling the Parts

Now we fasten all this to the frame by bearings, each one made of two strips of wood one inch thick by four inches long, with a one-inch hole bored through between layers; then, unscrewing the pieces, screw the bottom piece to the frame, lift the wheels and crank, and place the ends on the bearing, screwing the top one over the axle to the bottom one (see O, Fig. 5).

We now have the machinery ready for working. Let us turn to the paddle-boxes (see Fig. 5). These are made like the arch frames used by builders as guides in making

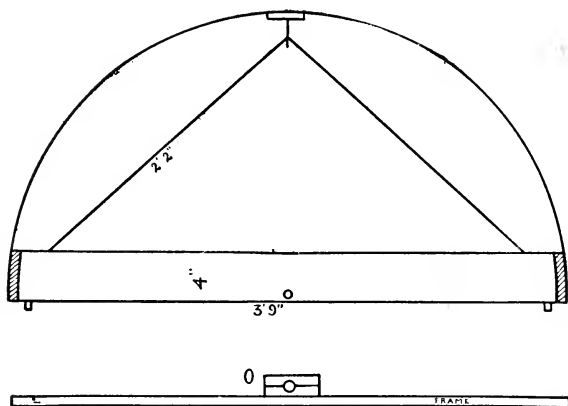

*Fig. 5*  
 SHOWING CONSTRUCTION OF PADDLE-BOX  
 O, crank-bearing fastened to frame, as shown in Fig. 2

brick archways, but not so heavy. They should be covered either with common unbleached muslin and painted or with thin oil-cloth such as is used for covering tables

## PADDLE-WHEELS FOR A SMALL BOAT

and shelves, and which can be bought for a very small sum. The later material is much the better. Fasten these boxes to the frames, and the paddle-box is ready.

All this work may be done at the house or barn, and afterward fixed on the boat, that part of the frame (Fig. 2) marked "Aft" being placed between the after-rowlocks;

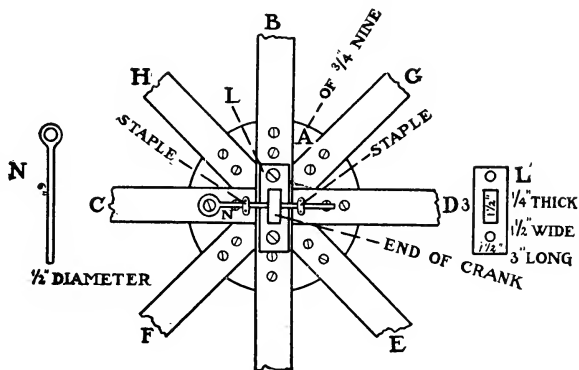

*Fig. 6*

SHOWING CONSTRUCTION OF WHEEL, BUT ON A LARGER SCALE THAN IN FIG. 3  
L, crank-plate; N, iron pin

this will bring the wheels in the right place on ordinary boats, and the crank will be in about the right position for working.

### Cost

The whole make-up should cost less than ten dollars, the principal expense being for crank, pin, plate, lumber, and screws, all of which should not cost above three dollars. The rest is to be done by yourself; and the more carefully it is made, the more satisfactory will it prove.

## Hand-power

The propelling power will be "hand-power"—that is, you will work the wheels by pulling the crank as you sit on the seat of the boat facing the bow. The movement is something like rowing. As it would be uncomfortable to take hold of the bare iron crank, a covering should be made for it. This may be done by whittling two pieces of wood (Fig. 4, P) half round, grooving the flat side of each so

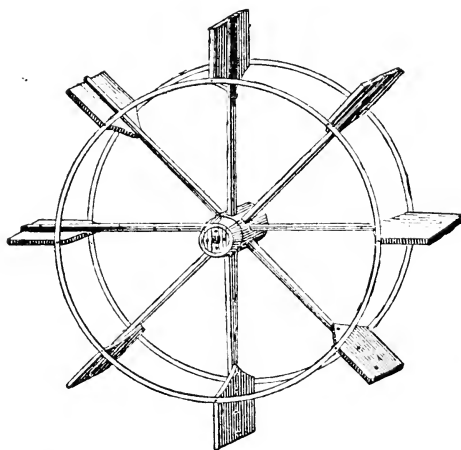

*Fig. 7*

WHEEL MADE FROM A CARRIAGE-WHEEL  
S, hub plate, with square hole to receive the end of the crank

that the two will fit on to the crank K (Fig. 4), and fastening with stout cord, which, if wound neatly from end to end, will make a nice soft handle. A more steamer-like

## PADDLE-WHEELS FOR A SMALL BOAT

effect may be obtained by putting up a piece of stove-pipe or leader about four feet long. The whole apparatus may be taken off and put on by two boys at any time, and the boat need not be disfigured by nails or screws, as the frame can be easily tied to the gunwale of the boat.

### **Another Way to Make Wheels**

Get the blacksmith or wheelwright to give or sell you a pair of old wheels without tire or rim. Then cut off each spoke the same length, so as to make the circumference of the wheel, when all are cut, forty-two inches. Plane down the side of the spoke which strikes the water first, and fasten the paddles of one-inch stuff with galvanized screws, as in Fig. 7. This time have the crank ends squared, and the round plate screwed in the end of the hub, and make boxes the same as for other wheels.



Part III

HOW TO MAKE REAL BOATS





## Chapter VII

### BOATS WHICH BOYS CAN BUILD

OF all the things that a boy is interested in there is nothing more fascinating than boats, whether they are to row, paddle, or sail in, and, as many of the simple kinds are quite within the ability of a boy to make, he can take a great deal of pleasure in their construction.

For the sea-shore and salt waterways the boats should be heavily constructed, and as this is usually beyond the average boy's ability, the sea-going dorys, surf-boats, and heavy sail-boats will be omitted, and those described and illustrated will be for use in fresh water, or on small enclosed salt waterways where the wind and tide are moderate.

In making a boat it is not only necessary to have it float, but to construct it in such a manner that the joints will keep closed and the boards will not rip off if run on a snag or against a rocky shore.

These are essential points in the proper construction of boats, and they might as well be learned by the amateur boat-builder when he is young, instead of constructing something for fun and having to learn the right way all over again when he is older and more serious work begins.

In this chapter a few of the simpler forms of boats are shown, and the warning must be given at the start that the

young shipwright should use the greatest care in constructing a boat, not only for the natural pride they will take in making a good one, but for the still more important reason that the safety of all on board is dependent upon his skill and conscientious work.

### Punt and Scow

A punt with a flat bottom is about the easiest and safest boat for a boy to make and own, for it is straight in construction and difficult to upset if not overloaded. As both ends are the same it can be rowed or poled forward or backward, and the overhanging ends allow plenty of seating room.

The punt shown in Fig. 4 is fifteen feet long, nineteen inches deep, and four feet wide. The ends cut under twenty inches, and at one end a skag and rudder can be arranged as shown in Fig. 2.

The sides are made of two boards, one of six and the other of a twelve-inch width, and the added thickness of the bottom boards make the total depth of the sides nineteen inches. The wider boards are the lower ones, and they are fastened together near both ends and at the middle with battens as shown in Fig. 4. The middle battens are six inches wide, and into the upper ends of them the row-lock pins are driven. The bottom planking should not be more than four or five inches wide, and it is securely nailed to the edges of the sides and to an inner keel-strip running the entire length of the bottom as shown in Fig. 3.

The wood should be very dry so that it will not shrink

Fig. 1

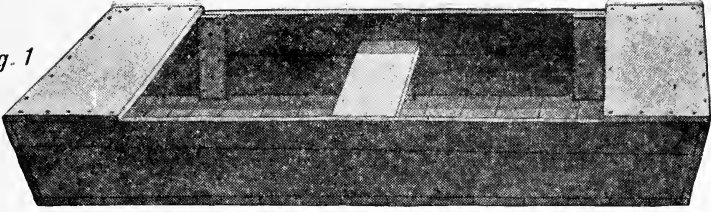

Fig. 4

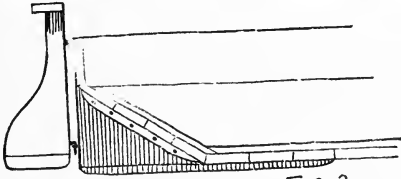
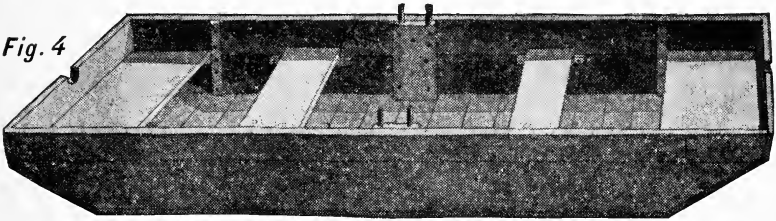

FIG 2

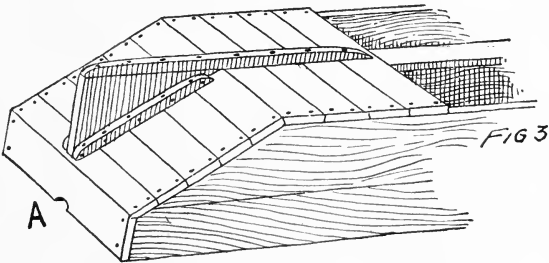

FIG 3

PUNT AND SCOW

afterwards and open the seams. Along the edges, and before the planking is laid or nailed on, smear white-lead, and lay one or two thicknesses of lamp-wicking on the lead, so that when the ends of the planking are driven down it makes a water-tight joint. Where the planks butt up against the other planking, the joints are to be generously smeared with white-lead and laid with a string of the lamp-wicking. Begin at one end and work towards the other, having first attached the end planks. Fig. 3 A.

The method of attaching the skag is also shown in Fig. 3, and if the punt shows a tendency to swing around in the water and not mind the oars or rudder, a keel three inches wide may be attached on the bottom of the punt to run from the forward end of the straight bottom back to the end of the skag.

The bottom planking is to be attached at both sides and to the inner keel-strip with galvanized nails. Do not use ordinary nails as they will rust in a short time, and the only ones that are of use are the regular galvanized boat nails that can be had at most hardware stores, and always at a ship-chandler's or from a boat-builder.

A rudder can be made and hung at one end of the boat as shown in Fig. 2.

A scow (Fig. 1) will be found the easiest of all boats to construct, but at the same time the hardest to row, since both the ends are blunt and vertical. A scow is for use in shallow water and is poled generally instead of being rowed. It is built in a similar manner to the punt, but the ends are not cut under. A good size to make the scow for general use will be fourteen feet long, eighteen inches deep, and four

## BOATS WHICH BOYS CAN BUILD

---

feet wide. It may be provided with two or three seats, and when complete both the punt and scow should receive two or three good coats of paint.

### A Sharpy

It is not a difficult matter to make a sharpy like the one shown in Fig. 5, but care must be taken in its construction to insure good unions and tight joints.

Cedar, white-wood, pine, or cypress are the best woods of which to build small boats, and wide boards can be had at almost any lumber-yard. White cedar is somewhat more difficult to get than the other woods, but if possible it should be used.

To make this sharpy the proper size for a boy's use, obtain two boards fifteen or sixteen inches wide, fourteen feet long, and seven-eighths of an inch thick, planed on both sides and as free from knots as possible. If the boards cannot be had fifteen inches wide, then batten two boards together with strips just as plain board doors are made. Before they are fastened, however, smear the joint edges with white-lead and embed a string of lamp-wicking through the middle. Use plenty of white-lead, and after the boards are pressed together and fastened the surplus lead can be scraped from both sides of the joint and saved for other joints.

From a piece of hard-wood cut a stem eighteen inches long and four inches wide, with bevelled planes, as shown in Fig. 6. A section or end view of this post will appear like Fig. 6 A. Against the cut-in sides of this post the bow

## BOATING BOOK FOR BOYS

---

---

ends of the side boards are to be attached with screws or galvanized boat nails.

The long side boards are to be cut at bow and stern as shown at Fig. 7 A and B. The bow recedes three inches and the stern is cut under thirty-four inches. Attach the bow ends of the boards to the stem-piece or post so that the top of the sides will be seven-eighths of an inch below the flat top of the post. If properly done you will then have a V-shaped affair resembling a snow-plough, which must be bent and formed in the shape of a boat.

From a board seven-eighths of an inch thick cut a spreader ten inches wide, forty-eight inches long at one side, and forty-two inches at the other, as shown in Fig. 8. Arrange this between the boards about midway from bow to stern, so that the bottom of the spreader is flush with the bottom of the sides; then draw in the rear ends of the boards and tie them temporarily with a piece of rope.

Drive a nail into the edge of each board near the end, to prevent the rope slipping off, for if it should do so the boards would fly apart and might break away from the stem-piece.

In order to draw in the ends to the proper position, insert a short stick between the ropes and twist it around until the rope is wound up; then if the end is not in far enough, slip another rope around the ends of the boards, and after releasing the first rope insert the stick and continue the twisting until the ends of the side boards are twenty-one inches apart. Before this bending process is begun, it would be well to pour a kettleful of boiling water over each side board to limber them, for dry boards are

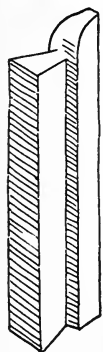
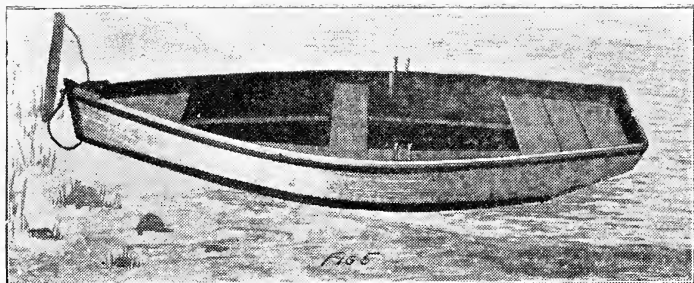

FIG 6



A



B

FIG 7



FIG 8

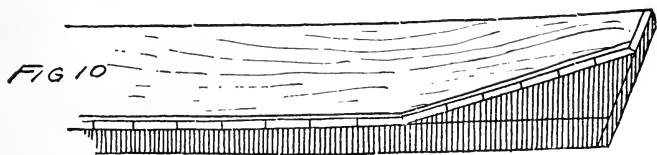

FIG 10

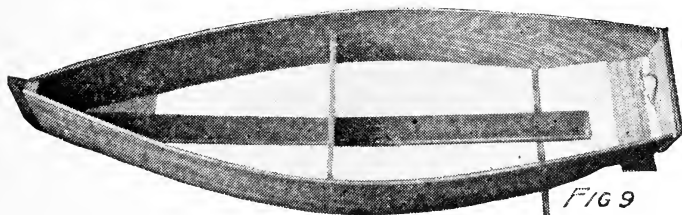

FIG 9

A SHARPY

stiff and will not bend easily without checking or cracking. If it is possible to steam the boards they will yield still better to the bending process.

The stern-plank is cut in the same shape as the spreader, but it is curved or crowned at the top, where it is twenty-three inches long, while at the bottom it measures twenty inches. It is six inches wide at the ends and nine inches at the middle, and is attached to the ends of the sides with boat nails while the tension-rope is still in place.

An inner keel is then cut six inches wide and pointed at the bow end, where it is attached to the lower edges of the sides at the bow and flush with them. The planking or bottom boards should fit snugly to it and to the edges of the sides.

A lap six inches long and seven-eighths of an inch deep is cut in the bottom of the spreader at the middle. In this the inner keel will fit, and after the first two or three bottom boards are nailed on at the bow end the frame of the sharpie will appear as shown in Fig. 9. The spreader and stern-plank will give the sides a flare which will have a tendency also to curve the bottom of the boat slightly from bow to stern. The bottom planks are four inches wide, of clear wood, and must not have tongue and grooved edges, but should be plain so that the white-lead and lamp-wicking will make a tight joint when the planks are driven up snug to each other.

Drive all nails carefully so as not to split the planking or sides, and as a precaution a small bit or gimlet should be used to make the start for the nail-hole.

A seat ten inches wide is fastened at the middle of the boat, over the spreader, and seats may also be arranged



at the bow and stern, where they rest on cleats that are screwed fast to the sides.

A short keel or skag is fastened to the under side of the sharpy and extends from about under the middle seat aft to the stern-post. A V-shaped piece is let in where the stern is cut under as shown in Fig. 10. This keel prevents the sharpy from turning about quickly and serves to steady her when rowing, as well as making a deeper stern-post to which a rudder may be hung as shown in Fig. 2. Six inches to the rear of the middle seat plates of wood six inches wide are attached to the sides of the sharpy, as shown in the illustration (Fig. 5), and on the tops of these oarlocks or pins are inserted after the usual fashion.

At the outside of the sides and an inch below the top edge a gunwale-strip is made fast, and with a ring in the bow for a painter and a pair of oars the sharpy is ready for use.

Of course it should be thoroughly painted. Three or four successive coats of paint should be applied to a boat the first time it is painted, and before using, it should be launched, half filled with water, and allowed to stand for a few days so that the joints will swell and close properly. A mast six or eight feet high and a leg-of-mutton sail will enable a boy to sail before the wind in a quiet breeze, but rough-weather sailing should not be attempted in this style of open boat.

### A Rowing Dory of the Old Type

A dory (Fig. 11), is somewhat similar to a sharpy but has higher sides and a narrower bottom, therefore it draws more water than a wide, flat-bottomed sharpy.

## BOATING BOOK FOR BOYS

A boy can make a dory from twelve to sixteen feet long, but a fourteen-foot dory will be quite large enough to hold from four to six boys comfortably and safely. The sides should be twenty-four inches high and the bottom twenty-four inches across amidships.

The bottom is made from four six-inch planks battened across as shown in Fig. 12. The joints are leaded before

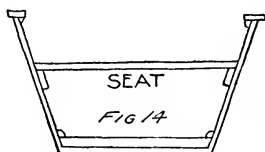
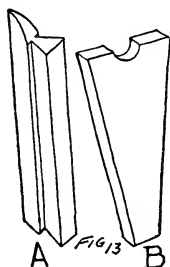
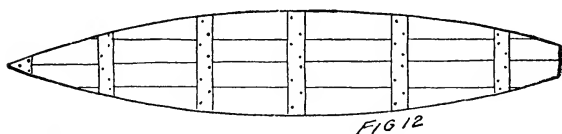
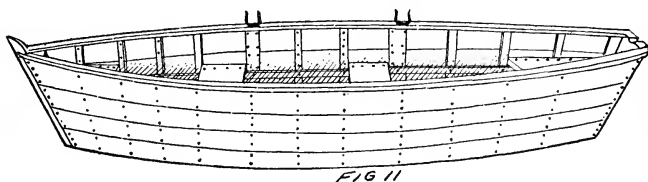

the boards are brought together, and the fastenings are of galvanized nails clinched at the inside. The battens, of course, are on the inside, but the nail-heads are on the outside or bottom of the boat.

A stem and stern-piece (Fig. 13 A and B) are cut from

## BOATS WHICH BOYS CAN BUILD

---

---

hard-wood, and to these the wooden sides are made fast at both ends. The bow and stern of a dory have more of a rake than those of a sharpy as may be seen in Fig. 11. The top of the bow extends out beyond the bottom at least from fifteen to twenty inches, while the stern overhangs the keel about twelve inches. The sides flare out nine inches at both sides amidships, so that the total width of beam is forty-two inches for a dory fourteen feet long.

Planks sixteen feet long are necessary with which to make this dory, for when they are sprung out at the sides they take up on the length. They can be six inches wide, and are made fast to ribs along the inside of the boat and attached with galvanized boat nails.

In Fig. 14 an amidships section of the dory is shown and the position of the seat is located. Along the top of the sides, to cap them and the upper ends of the ribs, rails two inches wide and three-quarters of an inch thick are made fast with boat nails. These rails should be of hard-wood, and they should be sprung into place and securely fastened.

A dory of this description makes an ideal fishing-boat where the water is rough, since it can be rowed either forward or backward.

### A Sailing Sharpy

A rowing sharpy can be converted into a sail-boat by partially decking it over, making a mast-step, and providing it with a lee-board if a centre-board cannot be arranged in the middle of the hull. Fig. 18.

The half-deck will keep out the water that might splash



FIG 18

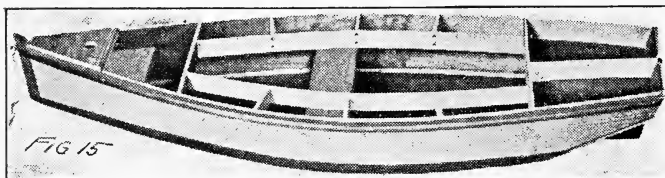

FIG 15

A SAILING SHARPY

## BOATS WHICH BOYS CAN BUILD

---

over the sides or come over the bow and stern, and the row-boat features need not be altered nor the seats removed, as the rib and brace work for the deck can easily be fitted and fastened over the seats, and so give additional strength to the deck.

Just behind the front seat and at the forward edge of the back seat cross-ribs are made fast to the sides of the sharply. Between these, and eight inches from the sides of the boat, additional braces are sprung into place and securely attached at the ends, and provided with short cross-braces as shown in Fig. 15. The deck planking is nailed to these ribs and the seats under them give a substantial support to both the ribs and deck. The opening or cockpit will be six feet long and varying in width, as the side decks are eight inches wide and follow the line of the boat's sides. Amidships it should measure about twenty-eight inches.

The braces and ribs are made of three-quarter-inch spruce boards five or six inches wide, and to bend them in the segment of a circle (as they will have to be for the side-ribs) pour hot water over two of them and place the ends on boxes with heavy stones at the middle to bend them down to the required curve. Allow them to remain in this position for several hours to dry in the sun; they may then be cut and fitted to the boat. The decking is done with narrow strips of pine, cypress, or cedar one inch and a half wide and three-quarters of an inch in thickness. They are bent to conform to the side lines of the boat, and if they are fitted nicely and leaded the deck should be water-tight after it receives varnish or paint.

If straight boards are employed in place of the narrow

## BOATING BOOK FOR BOYS

---

planking the deck can be covered with canvas and first given a coat of oil, then several successive thin coats of paint. The canvas should be tacked down over the outer edge of the boat and to the inner edge of the cockpit. A gunwale-strip an inch square is to be nailed along the top edge on both sides of the boat, and one inch below the top of the deck nail a guard rail along each side.

To finish the cockpit arrange a combing in place to project four inches above the deck, and make the boards fast to the inner side of the ribs with screws as shown in the illustration of the hull of sailing sharpy. Fig. 15.

Ten inches back from the bow-post bore a hole two inches and a half in diameter so that a mast will fit securely in place. The hole should extend through the deck and front seat, and a step-block with a hole in it to receive the foot of the mast must be nailed fast to the bottom of the boat. The hole in this block is oblong, and the foot of the mast should be cut on two sides so as to fit in the block as shown in Fig. 16.

Spruce or clear pine sticks are to be dressed and planed for the mast and boom, the mast measuring fourteen feet high by two inches and a half at the base, and the boom thirteen feet long by two inches in diameter, both tapering near the end.

The rudder is eighteen inches long, including the post, and ten inches high. It is fastened to a post of hard-wood three inches wide and seven-eighths of an inch thick. At the top of this an iron strap is fastened to hold the tiller as shown in Fig. 17 A. The rudder is hung to the stern of the boat with pins and sockets, as shown in Fig. 17 B, so that if it becomes necessary the rudder may be unshipped by lifting it out

## BOATS WHICH BOYS CAN BUILD

---

of the sockets or eyes. The rudder is fastened to the post with galvanized-iron pins ten inches long and three-eighths of an inch in diameter driven through snug holes bored in the wood as shown by the dotted lines in Fig. 17 B.

It is impossible to hold a boat on the wind without a centre-board, but as this sharpy has none a lee-board will be required to keep her from drifting leeward. Fig. 18.

This board can be made five feet long, thirty inches wide, and hung over the lee side when running on the wind, where ropes and cleats will hold it in place. The board may be made of three planks banded together at the rear end with a batten, and at the forward end it is strapped across with bands of iron as shown in Fig. 18.

With a sail of twilled or heavy unbleached muslin this boat may be driven through the water at five or six miles an hour, and two boys can have a great deal of fun out of her. Care should be exercised in handling the boat; and be sure to reef the sail in case of a strong breeze.

### A Centre-board Sharpy

When making a sharpy to sail in, a trunk and centre-board should be built when the keel is laid so that the cumbersome and unhandy lee-board may be done away with. The centre-board is housed in the trunk, through which it can be raised or lowered as occasion requires.

The arrangement of the trunk in the boat is shown in Fig. 19, and it is located so that the front of the trunk is three feet from the bow. For a centre-board one inch and a quarter in thickness the trunk should be one inch and

## BOATING BOOK FOR BOYS

---

three-quarters wide between sides, five feet long, and eighteen inches high. It is made of tongue-and-grooved boards one inch and one-eighth in thickness, and these are attached by stout screws to posts one inch and three-quarters square at bow and stern. The trunk is mounted on the keel, set in white-lead, and securely fastened with screws. A slot is cut in the keel the same size as the inside opening of the trunk—that is, two inches wide and about five feet long. The bottom planking is butted against the sides of the trunk at the middle of the boat as shown in Fig. 20.

An inner keel is laid over the bottom planking through the centre of the boat from stem to stern, and where it fits around the trunk it is cut out. Both the inner and outer keels are six inches wide and the exposed edges are bevelled with a plane. A sectional or end view of the trunk and its location in the keels is shown in Fig. 20, where the shading and lettering will designate each part.

The centre-board is four feet and nine inches long, thirty inches wide at the back, and twenty-four inches at the front. It is attached to the trunk with a hard-wood pin located near the forward lower end, and when it is drawn up it will appear as shown in Fig. 21 A, but when lowered it will look like Fig. 21 B.

The centre-board is made of hard-wood, several boards of which are pinned together with galvanized-iron rods three-eighths of an inch in diameter and driven through from edge to edge of the boards in snug holes made with a long bit or auger. The rods are riveted at both ends over washers to prevent the boards from working apart.

It would be better to let a boat-builder or carpenter make



## BOATS WHICH BOYS CAN BUILD

---

and stern. There are various forms of the half-rater, but the one shown in Fig. 24 is easy to construct and requires less careful fitting and joining than the hulls with pointed bows and long, overhanging sterns.

In general construction this hull is similar to the punt, and when putting it together the description for the building of the punt must be borne in mind.

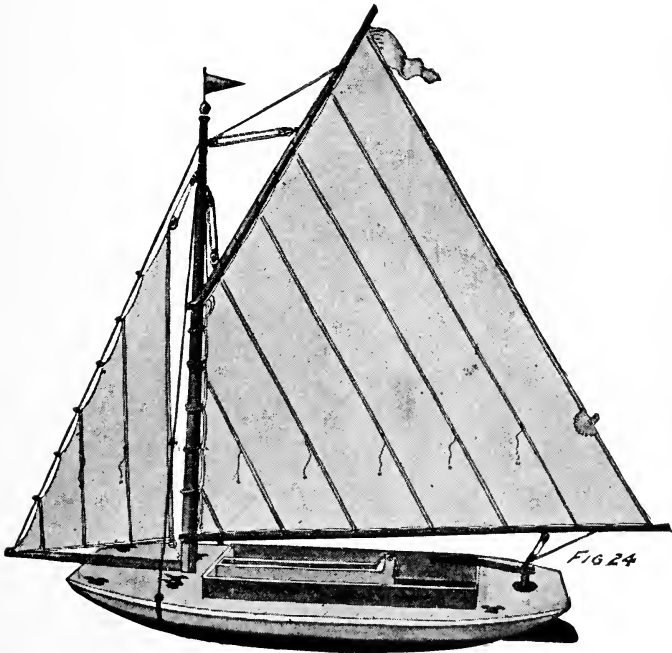

Obtain two clear cedar planks sixteen feet long and from fourteen to sixteen inches wide. Four feet from either end begin to round the lower edges of these side boards. Cut two spreaders five feet and six inches long and make them

fast four feet from the ends of the sides as shown at Fig. 25. Between these spreaders attach an inner keel in the forward end of which an opening has been made. The keel is of hard-wood eight inches wide and the opening is three inches and a half in width and four feet and eight inches long.

A centre-board trunk is made and fitted into this opening as described for the sailing sharpy. Then braces are fastened between the sides and trunk as shown at Fig. 26.

Two bevelled hard-wood bow and stern pieces are cut as shown at Fig. 27. The ends of the boards are sprung in and attached to the ends of these pieces, and between them and the spreaders two more boards are fastened as indicated by the lines of nail-heads in Fig. 26. At the bow just ahead of the forward long cross-piece or spreader step the mast, and at the stern make the rudder-post trunk, taking care to use plenty of white-lead and lamp-wick so as to render the joints water-tight. Put a line of braces through the middle of the frame, then begin at the bow and plank the bottom with boards not more than three or four inches wide.

With the planking on and the braces, spreaders, and trunk in position the frame will appear as shown in Fig. 28. The deck planking is of strips seven-eighths of an inch thick and three inches wide. Begin at the middle of the boat by laying down a strip six inches wide by one inch and a quarter in thickness. Drive the deck planking close to this and smear the points with white-lead in which the lamp-wicking is embedded. Make all the fastenings with galvanized boat nails and drive the heads well into the wood with a nail-punch so they can be puttied and covered from the action of the water. An outer flat keel is laid along the bottom

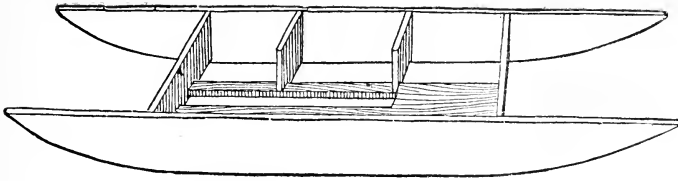

FIG 25

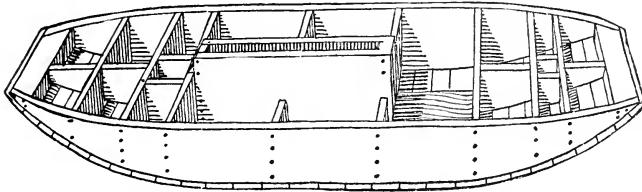

FIG 26

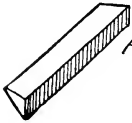

FIG 27

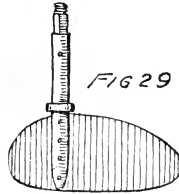

FIG 29

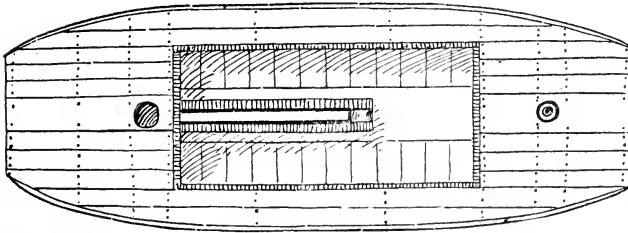

FIG 28

A LARK

of the hull from the forward part of the cockpit or about under the mast. This leads aft to where the stern begins to round up and there it is stopped.

This keel is attached with galvanized or brass screws, and a generous number are driven through the keel into the bottom edges of the centre-board trunk.

The rudder is made from galvanized sheet-iron as shown at Fig. 29, and is let into a one-and-a-quarter-inch round iron rudder-post and riveted fast. Just above the rudder-blade a collar of iron is welded to the post and this bears against the bottom of the boat. To prevent the rudder from dropping down a pin is passed through a hole in the post close to the deck and a large washer made fast to the deck will prevent the pin from chafing the wood.

Have the top of the post made with a square shank so that a tiller may fit over it and be held in position by a nut.

The rudder-blade should be twenty-six inches long and twelve inches wide.

The mast is fifteen feet long, cut from a four-inch spruce stick with draw-knife and plane. The boom is fifteen feet long, cut from a two-and-one-half-inch spruce stick, and the gaff is eleven feet long.

Extending out from the mast and attached to the deck is a short bowsprit five feet and six inches long. This is of two-by-three-inch spruce with the sharp corners rounded off beyond the end of the boat.

A wire forestay and two shrouds lead from mast-head to bowsprit and to both sides of the boat as shown in Fig. 24.

The main-sheet is seven feet on the mast, ten feet on the gaff, fourteen feet at the foot or on the boom, and eighteen

## BOATS WHICH BOYS CAN BUILD

---

feet on the leach. The jib is eleven feet on the forestay, five feet at the foot, and ten feet on the leach. The blocks are all of galvanized iron or wood, and three-eighth-inch Manila-rope should be used for the halyards and sheets.

This swallow will ride well on the water, and if properly rigged it should be a very speedy boat.

### A Power-boat

A novel feature for the propulsion of a flat-bottom boat or punt is shown in Fig. 30. Two small paddle-wheels attached to one shaft are hung out over the stern, and by means of a sprocket on the shaft connected to another and larger one on the seat frame the wheels are turned by the boys who mount the seats and work the pedals.

The punt is fifteen feet long on the deck line and six feet wide. The side boards are twelve inches wide, and with the thickness of the deck and bottom planking it will make the total depth about fourteen inches. Through the middle a strengthening rib is run the same size and thickness as the outer sides as shown in Fig. 31. This gives an additional rib to nail the sheathing boards to and also an anchorage to which the uprights forming the seat frame can be made fast with bolts.

The outriggers that suspend the wheels are of spruce two inches thick and three inches wide. They are bolted to the deck and at the outer end U-notches are cut for the axle of the wheels to fit into and capped with iron straps such as shown in Fig. 32. A blacksmith will make these for you from strap-iron an eighth of an inch thick and two inches

## BOATING BOOK FOR BOYS

wide. They should be bolted on when the wheels are in position, for they not only have to support the weight of the wheels but also stand the action of the water against them.

The wheels are each twenty-four inches in diameter and

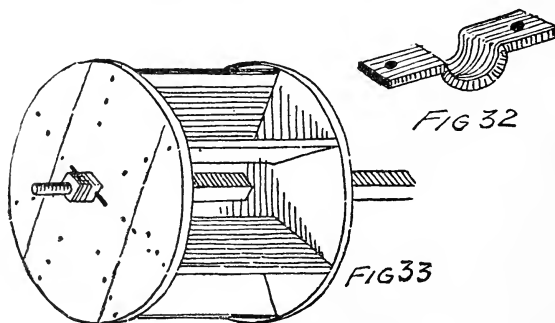
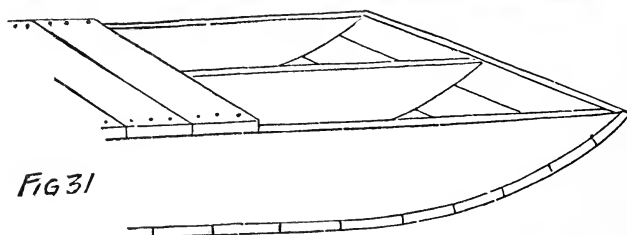
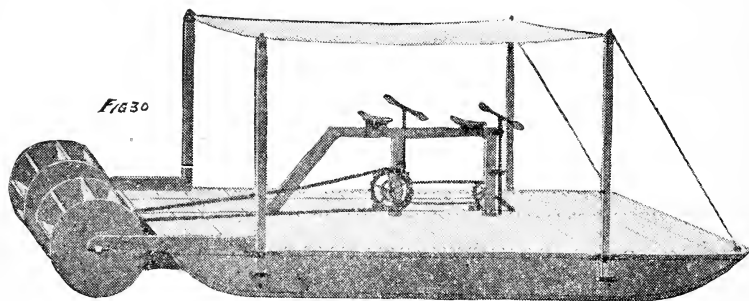

## BOATS WHICH BOYS CAN BUILD

---

two feet long, and are made from wood seven-eighths of an inch in thickness. Seven blades eight inches wide are screwed fast to the sides or held in place with long, galvanized boat nails.

The axle is of spruce two inches square, and the wheel sides are provided with square holes through which the axle is driven as shown in Fig. 33. The ends of the axle are banded with iron, or copper wire may be wound round them to prevent their splitting. Into the ends half-inch round iron pins are driven which revolve in the bearings.

The seat-frame is thirty inches high and made from spruce rails three inches wide and one inch and a half in thickness. On the middle upright a large and small gear wheel are arranged on an axle with the cranks and pedals, and on the front post a small wheel is attached so that tandem power may be used on the paddle-wheels or one boy alone can work the boat. A rod and handle-bars may be arranged for the rear boy to grasp, and with a socket and set-screw it can be raised or lowered at will.

The forward bars have a cross-piece of iron at the foot of the vertical rod. This is two feet long, and from the ends of it running aft wires connect with the ends of a tiller for operating the rudder.

The rudder is hung between the wheels on a skag which is the rear extension of a short keel that should be nailed fast to hold the punt steady on the water.

Four canopy poles may be arranged to fit into sockets at the sides, and an awning six by ten feet can be supported over the machinery of the boat to keep off sun and rain.

This is a genuine boy-power boat, and as the wheels are

## BOATING BOOK FOR BOYS

---

substantially large and strong it can be driven over the water at quite a good speed. While it takes two boys to properly run it, that is not the boat's capacity, for she will easily carry from four to six boys, their lunch-baskets, or a one-day camping outfit for a visit up the river or lake.



## Chapter VIII

### CATAMARANS

#### A Rowing Catamaran

FOR safety on the water, as nearly as safety can be assured, there is nothing to compare with a catamaran, for they are practically "non-capsizable," and if not damaged to the leaking-point one or the other of the two boats will float and hold up several persons. Fig. 1 gives a good idea for a rowing catamaran that any boy can make from some boards and light timbers. It is provided with a seat and oar-locks so that the occupant may be seated above the water far enough to row easily.

The boats are fourteen feet long, eighteen inches wide, and fourteen inches deep, including the bottom and deck.

Pine, white-wood, cedar, or cypress, three-quarters of an inch thick and planed on both sides, will be necessary from which to construct the boats. At the bow the ends of the sides are attached to a stern-piece of hard-wood as shown in Fig. 2. Having poured boiling water on the forward ends, they may be drawn around a spreader sixteen inches long and twelve inches wide provided with two U-cuts as shown in Fig. 3. These are placed at the bottom, so that any water may be run to one end of a boat where it can be pumped out.

## BOATING BOOK FOR BOYS

---

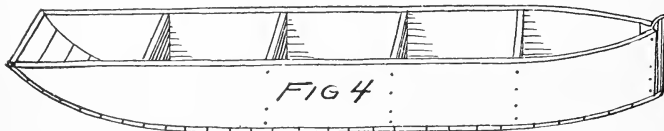
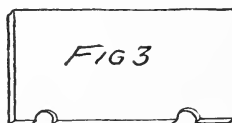
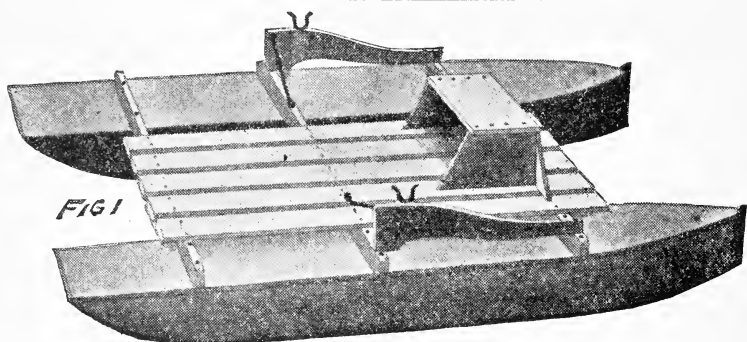

The first spreader is placed three feet from the bow, and three or four more of them should be fastened between the sides as shown in Fig. 4, the last one being three feet from the stern where the sides begin to curve up to the upper edge of the stern and to the deck.

The bottom is of three-inch pine or white-wood boards seven-eighths of an inch thick and well leaded in the joints and along the edges where the bottom and top boards join

## CATAMARANS

---

the sides. Before the top or deck is placed on, the interior of the boats should have two or three good coats of paint.

Three cross-stringers of spruce two and one-half by four inches and six feet long are securely attached to the boats, and on these the deck of four-inch boards is made fast as the illustration will show. Between the middle and forward stringer, at the ends, two boards are attached on which the row-locks may be fastened. These boards are eight or nine inches wide and cut away at the front so that they are not more than two or three inches wide.

The high ends are braced with round iron braces as shown in the illustration, and where the oar-locks are mounted a short plate of wood is screwed fast to the inside of each piece.

Near the front cross-piece a seat is built and braced with a board. With another boy at the stern sitting on the deck this catamaran will be well balanced and will prove very seaworthy, as well as a light boat to row.

### A Sailing Catamaran

It is almost impossible to upset a sailing catamaran even in a gale, and for boys a boat of this kind affords a great deal of comparatively safe pleasure.

A catamaran is about the easiest sort of a boat to make, and no matter in what locality one lives there is always material at hand from which to make one as the wood is similar to that used for house construction.

Fig. 5 shows a side elevation of a safe catamaran, and in Fig. 6 the deck plan is shown. In Fig. 7 an elevation view

## BOATING BOOK FOR BOYS

of the stern shows the arrangement of the boats, deck timbers, and rudders.

The boats are fifteen feet long, eighteen inches wide at the middle, and two feet deep uniformly from bow to stern except for a short distance at the bow where the keel rounds up.

They are in the form of a V, and at the ends the angle becomes more acute, so that at the stem and stern the lines are vertical.

Four feet from both ends the deck line begins to curve as shown in Fig. 6, and in Fig. 8 the cross-braces are shown. They are cut in at the bottom to slip over the keel and to them the sheathing planks are made fast.

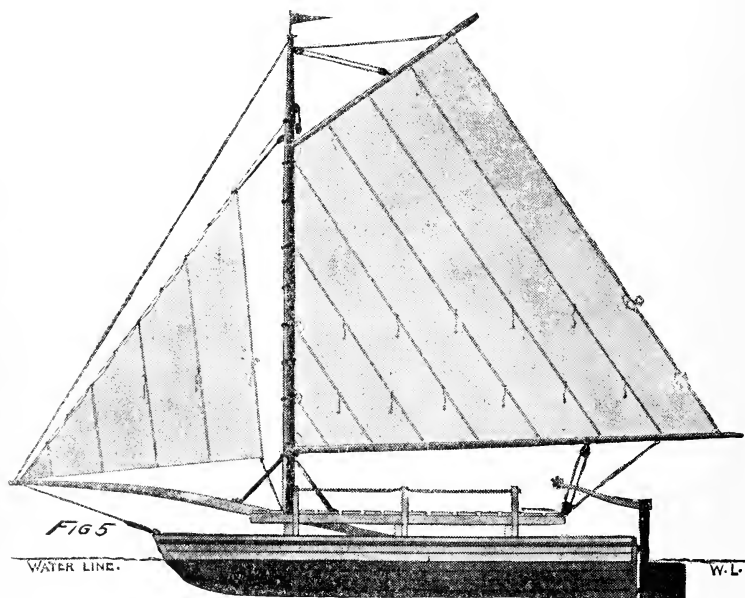

## CATAMARANS

---

In Fig. 8 the curved stem-piece and one side of planking is shown, and it indicates also where the curved stem-piece is joined to the keel, which extends in a straight line to the stern of the boats.

The keel is of hard-wood one inch and a quarter thick and six inches wide. The cross-braces or spreaders are of pine or other soft wood seven-eighths of an inch thick and made up of three pieces of wood with the grain running vertically.

The sheathing is of pine, cedar, or cypress three-quarters of an inch thick, planed on both sides, and three or four inches wide. Each board should be given a priming coat of paint before it is nailed to the braces, and where the planks are edged together white-lead and lamp-wick should be employed for calking. Galvanized boat nails are to be used for all the fastenings, but screws may be employed where it is necessary to have a very secure joint.

The cross-pieces that fasten the boats together are bolted fast by means of long bolts that pass through the timbers and deck and into stout pieces of wood that are nailed fast to the upper part of the spreaders as shown at A in Fig. 8. The boats are decked over with the three-quarter-inch planking, and to insure an absolutely tight deck the wood may be treated to a thick coat of paint and covered with canvas which is pressed down well into the paint and the edges tacked down over the sides of the boats. The canvas is then given a coat or two of paint and allowed to dry thoroughly, after which it can be sand-papered and finished with the desired shade of paint.

Three spruce timbers eight feet long, three inches thick, and six inches wide are bored with holes at the ends where

## BOATING BOOK FOR BOYS

---

the bolts pass through them and into the boats. Running parallel to the boats three timbers are laid across the brace-timbers and on top of these the deck planking is nailed. These pieces are two and one-half by four inches, and ten feet long, and are bolted down with long slim bolts.

The decking is formed of slats three-quarters of an inch thick and four inches wide nailed down to these stringers. Spaces half an inch wide are left between each one.

The bowsprit is of three-by-four-inch spruce left with its square corners for half its length but dressed round at the outer end. It is caught under the middle cross-brace where the end is bolted, and extending over the front piece it projects four or five feet beyond the bow ends of the boats. With wire-cable the bowsprit end is stayed to the bow of each boat, where turn-buckles can be caught into eyes in the stem-posts.

The mast is of spruce dressed from a four-inch spruce stick and slightly tapered at the top. It is fifteen feet long and stepped at the middle of the front cross-piece and on top of the bowsprit where it is held in place with a collar and iron braces as shown in the illustration. Fig. 5.

Standing rigging of wire-cable stays the mast from the top to both ends of the front cross-piece as indicated by the dotted line in Fig. 7.

Three short posts are made fast to the cross-pieces close to the decking, and holes bored in the tops of them will hold a safety-rope around the deck.

The rudder-posts are of hard-wood one inch and a quarter thick and two inches and a half in width. They are three

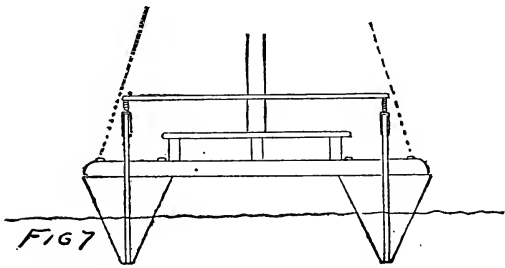
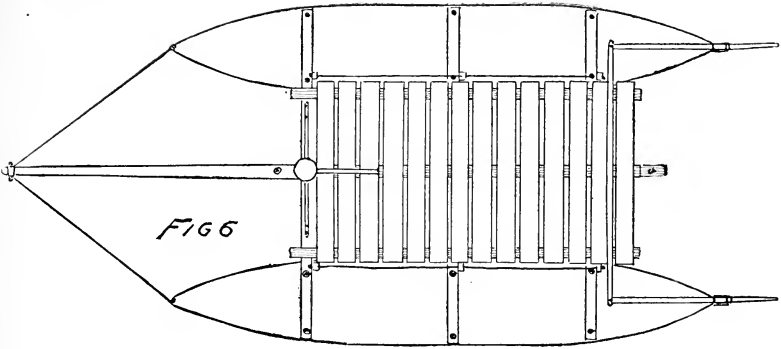

FIG 9

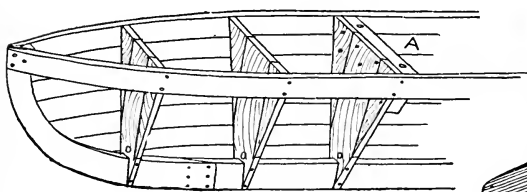

FIG 8

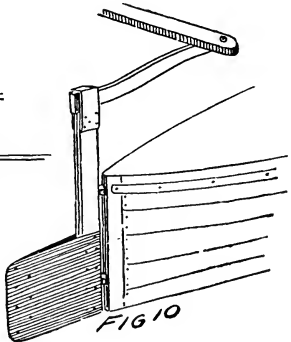

FIG 10

A SAILING CATAMARAN

## BOATING BOOK FOR BOYS

---

feet long and to the upper end of each a strap of metal is arranged to receive the tiller as shown in Fig. 9.

The tillers are of hard-wood three feet long and their inner ends are connected with a hard-wood stick by means of which the steering is done and both rudders operated at the same time.

The rudders, made from two sheets of galvanized iron, are riveted fast to the rudder-posts and are twelve inches high and fifteen inches long. Pins on the posts fit into eyes attached to the stern-post of the boats, and in Fig. 10 the arrangement of rudders, tillers, and connecting-rod is shown.

The main-sail is of twilled cotton that can be had at a dry-goods store for about ten cents a yard, and a rib should be sewed through the middle of each breadth to strengthen the cloth. The sail is nine feet and six inches on the mast, six feet on the gaff, thirteen feet on the boom, and fifteen feet on the leach. The jib, also of twilled cotton, is eleven feet and six inches on the forestay, eight feet across the foot, and eight feet and six inches on the leach. The blocks can be of galvanized iron but patent sheave-wood blocks are preferable.

For the halyards Manila-rope three-eighths of an inch in diameter will be the right size, and a half-inch anchor-rope will be stout enough, since a catamaran does not tug as heavily on an anchor as does a boat.

The wood-work of the boat and deck should be painted and the spars varnished. A pretty effect will be to paint the boat a rich olive green, with buff decks, and all the cross-pieces and deck planking in ivory white.

The ordinary sailing rules will apply to the handling of a



## CATAMARANS

---

catamaran. With these wedge-shaped boats you can sail quite close to the wind, but if round-bottomed and shallower boats are used they will have to be provided with centre-boards.

### A Side-wheel Catamaran

The rowing catamaran can easily be converted into a side-wheel boat by removing the middle slat of the deck and making an opening through which a chain will lead to a cog or sprocket wheel on an axle.

At the outer side of each boat, between the middle and rear cross-braces, fasten two pieces of wood two inches wide and three inches high. Six or eight inches from the rear end make two U-cuts for a five-eighth-inch axle to fit into. At a blacksmith's obtain two old carriage or buggy wheels, and cut the spokes so that they will be fourteen inches long from the hub. Dress one side of each spoke flat, so that a paddle may be attached to it with screws. The paddles are of hardwood, eight inches wide at the outer end, six at the inner end, and six inches deep.

Have a blacksmith heat the ends of an axle and pound them square, then slip one hub over the iron, and with hardwood wedges make it fast. The other wheel can be slipped on when the axle is in place and attached in a similar manner. It would be best to remove the old iron boxes from the hubs, so that a few screws can be driven through the hub and into the wedges to help in holding them securely in place.

In Fig. 11, which is a stern view of the rowing catamaran, one of the paddle-wheels is shown in place, and it also shows the location of the axle, the sprocket-wheel, and the chain

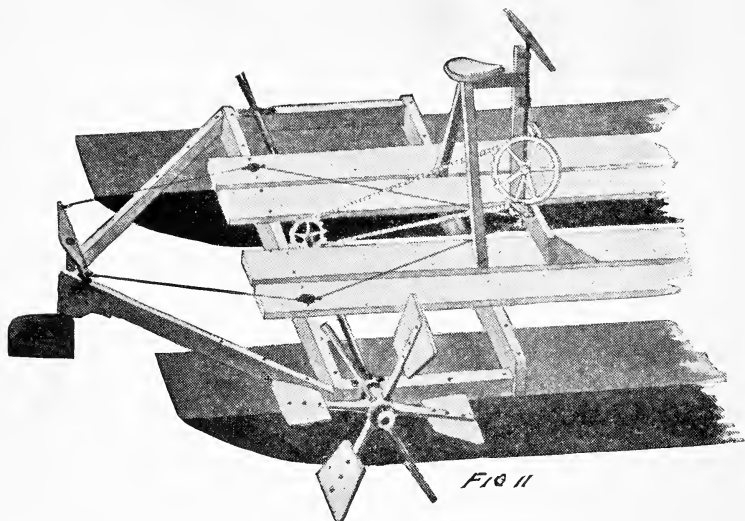

that leads to the large sprocket-wheel by means of which the axle is turned.

An old bicycle chain and sprockets, together with the axle, cranks, and pedals, can be arranged on a frame, so that a saddle may be mounted the proper distance above the pedals. This arrangement is clearly shown in the illustration, which shows also the outrigger timbers at the stern, to which a sheet-iron rudder may be made fast. It is operated by a handle and bar, which turns the rudder by means of flexible wire-rope run through two deck-pulleys at the outer rear ends of the deck planking. The iron rod is held in place to the forward upright of the seat-frame with metal straps. At its lower end a wooden wheel having a groove is made fast, around which a wrap or two of the wire-cable is taken to hold the rudder steady.

## Chapter IX

### HOUSE-BOATS AND RAFTS

#### A House-punt

A HOUSE-PUNT of very simple construction is shown in Fig. 1. The punt is from sixteen to twenty-four feet long according to the size desired, but for a party of four boys it should be twenty-four feet long, eight feet wide, and two feet deep with a cabin eight feet high.

The sides and middle rib should be of pine, spruce, or white-wood one inch and a quarter thick, free from sappy places and knots. If the boards cannot be had as long as twenty-four feet nor as wide as two feet, use two boards twelve inches wide and make one joint at the middle of the lower board and two in the upper board as shown in the drawing of the side elevation (Fig. 2). Six inches down from the top at either end and thirty inches in at the bottom cut the sides as shown so that the punt will have a shovel-nose at both ends and can be poled or sailed in either direction. Make a third or middle rib the same size as the side board. This is to be placed at the middle of the punt so as to receive the sheathing and deck planking. The arrangement of this middle rib and the side boards is shown in Fig. 3 and at A in Fig. 3. A batten is shown to which

the upper and lower boards of a side are nailed fast. If the two boards are used it will be necessary to arrange these battens along the inside of each side about eighteen inches apart. They should be of tough wood five or six inches wide, an inch and a quarter thick, and two feet long.

Galvanized boat nails should be used, and when driven in from the outside they should be clinched at the inside. Good boat nails are of malleable iron stiff enough to go through hard-wood but ductile enough to be turned over at the ends with a light hammer and quick, sharp blows.

The sheathing and deck planking should be not less than four inches and not more than six inches in width, and before it is put on it should be well sun-dried to take out all moisture. It should then be given two good coats of paint on both sides to make it water-proof.

Lay the sides and middle rib bottom up and begin to sheath from one end. Lumber sixteen feet long should be used, and this, when cut in half, will make two pieces from each length. If matched boards are used smear the edges with white-lead before the boards are driven together, but if straight-edge lumber is employed it will be necessary to lead and wick the joints. This is done by taking a piece of round iron one-quarter of an inch in diameter and eight inches long and bending it as shown at Fig. 4 A. Lay this on the flat edge of each board at the middle and heat the iron so as to form a groove as shown at Fig. 4 B. The wood, having been beaten in, forms a gully in which a string of lamp-wick can be laid as shown in Fig. 4 C. The groove must not be cut with a chisel for then its effect would be lost. The object of this treatment is that when the punt is in the water the

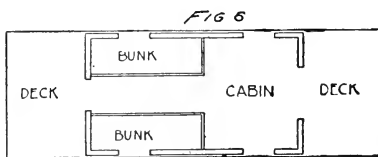
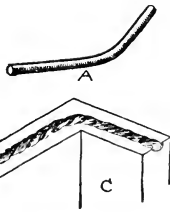
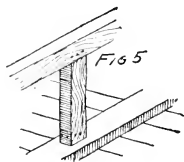
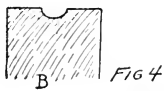
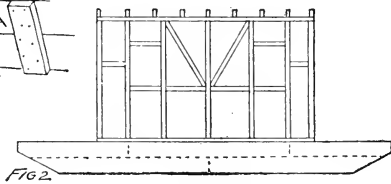
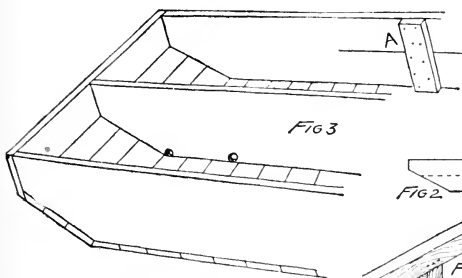
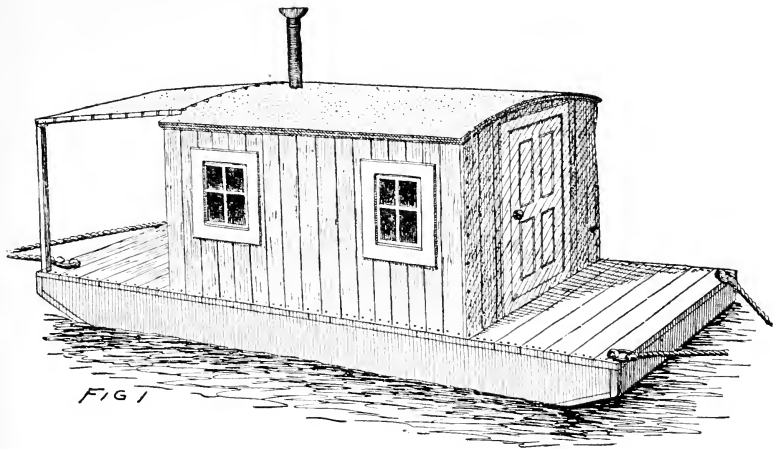

A HOUSE-PUNT

## BOATING BOOK FOR BOYS

---

joint swells forcing out the wood against the lamp-wick and making a water-tight joint. The edges of the wood and the wicking must be well smeared with white-lead in order to properly calk the joint.

Between the middle rib and each side an inner keel should be arranged so that each plank can be nailed fast to it. This will act as an additional brace to hold the sheathing planks in place and make the bottom more rigid. This inner keel should extend from end to end of the punt, and short pieces may be laid inside the bevelled ends to lend added strength.

At each end a spruce plank eight inches wide is made fast with long boat nails, first leading all the joints to make them water-tight. The deck planks are laid on the same as the sheathing, and to brace them from underneath, in the space between the middle rib and the sides, two-by-three-inch spruce rails are propped on short sticks which are nailed to the inner keel and to the rails as shown at Fig. 5. These under props should be arranged about eighteen inches apart, the entire length of the punt. Groove the upper edges of the end and side planks with the iron, then lay the lamp-wicking in, lead, and nail down the planking, taking care to put the nails in straight and true. When the punt is finished give it several good coats of copper paint on the bottom and sides and several coats of good marine paint on the deck.

To construct the cabin lay down the sill-joist of two-by-three-inch spruce, making the plan fourteen feet long and seven feet and eight inches wide (Fig. 6). To this nail the uprights and bracing timbers, forming the sides and ends as shown in the drawings of the side and end elevation

## HOUSE-BOATS AND RAFTS

---

(Fig. 7). The door spaces at the ends should be three feet wide and seven feet high, so that when trimmed and the doors hung the actual size will be two feet and eight inches wide by six feet and ten inches high.

The window openings are two feet wide by two feet and six inches high, and between all the uprights braces are nailed fast to prevent the frame from racking. The arrangement of framing timbers is quite clearly shown in the drawings, and in the deck plan (Fig. 6) the arrangement of the bunks is indicated. Across the top of the framework one-and-a-half-by-six-inch beams are laid having their upper edge crowned as shown in the end elevation (Fig. 7). Over these the roofing boards are laid lengthwise, and on top of them canvas is drawn and tacked down all around the edges with copper tacks.

The roofing boards may be of three-quarter-inch stuff planed on both sides and from two to four inches wide, whichever is the easiest to obtain. The boards should extend over the ends and sides for two or three inches so that a finishing moulding can be made fast under the boards. Give the top of the boards two good coats of paint, then stretch oiled canvas over the top and tack it fast. Several coats of paint will finish the canvas and make it hard enough to walk on, for in pleasant weather this upper deck will make a pleasant place to spend many hours under the shade of a canopy. The cabin sheathing is of narrow matched boards planed on both sides and as free from knots and sappy places as it is possible to get them. The boards must be thoroughly sun-dried before they are laid on and nailed fast, and it would be well also to paint the matched edges so that moist-

## BOATING BOOK FOR BOYS

---

ure may not get in and swell them. The inside and outside of the cabin is to be painted to protect the wood from moisture, and if painted a light tint of any color, or white, it will be cooler in summer when the sun is shining than if coated with a dark color. Dark colors absorb light and heat while light ones reflect or shed them.

The window-sashes should be arranged on hinges so that they may be swung in and back against the inside of the cabin and hooked. Or, by cutting away a part of the upright, the sash may be arranged to slide. Wire screening may be tacked over the window-frame at the outer side to keep out flies and mosquitoes, and screen doors can be made also for the front and rear doorways—to swing in, as the wooden doors swing out.

Over the rear deck a canopy is arranged on poles. This is similar to a tent fly for camping, and will shed the sun and rain from the deck when the cook is preparing meals.

A small cook-stove may be arranged inside the cabin, but if it is not convenient to carry coal in a box on the deck an oil-stove will answer every purpose.

Two bunks may be built in on each side, one above the other, and four wire springs may be arranged to rest on battens driven across the bunks at the head and foot. A small hatch should be cut in the rear deck and another one through the cabin floor so that a few things may be stored in the hold. The aft hatch should be provided with a suction-pump so that any water that leaks in can be readily pumped out.

Rings, cleats, and ropes should be provided for the punt, and two anchors would be better than one, especially when



## HOUSE-BOATS AND RAFTS

---

near the shore or in shallow water, to hold the punt from swinging, which it is sure to do if there is any wind or waves. Always anchor it so that the wind is blowing on one end and not broadside as it is a strain on the anchors and ropes to hold a boat broadside on.

By erecting a spar fifteen or twenty feet high and four or five inches in diameter, a square-sail can be rigged on yard-arms so that the house-punt can be sailed before the wind. A long oar will be necessary to steer with, or a portable rudder may be made and hung to the stern with pins and ropes.

A house-punt of this description will be a very great source of enjoyment to several boys in the summer-time, and in the winter when not in use the punt can be hauled out on shore, the windows boarded up, and old canvas drawn over the decks to protect them from the sun.

### A House-raft

Almost any boy can build a fairly good boat, even if it is a flat-bottomed sharpie. But to build a raft of the proper size, and on it a house that may be comfortably occupied, will require the aid of a good carpenter who understands construction, and under whose direction several boys can work to good advantage.

For a party of four or five young fellows, a very convenient and commodious house-raft at anchor is shown in Fig. 8. The raft is about thirty-eight feet long and twelve feet wide, while the house is twenty-three feet long and twelve feet wide by nine feet high from raft deck to top of house.

## BOATING BOOK FOR BOYS

---

These dimensions will, if necessary, permit the raft to be taken through any canal, and without mast and deck-rails it will pass under the road bridges that span the canals.

If the house-raft is to be used on canals only, it will be better not to have the mast, and the deck-rail may be arranged so that it can be removed quickly before passing under a low bridge.

The mast is for use on lakes, bays, or rivers only, where a large square-sail can be hoisted on a yard-arm, and by means of which the raft may be made to sail before the wind slowly, so that its position may be changed from time to time.

The construction of a house-raft is quite simple, and will not require the services of a boat-builder, as the carpenter can build both the raft and the house on it. To begin with, it will be necessary to obtain four straight logs thirty-eight feet long, as sound as possible, and not wind-racked. Two of these logs are to be laid with the butt end at the stern, and the other two with butts at the bow, thus giving equal spaces between each along the entire length of the raft.

Across the ends of these logs nail a temporary strip to keep them the proper distance apart; then at right angles lay four-by-twelve-inch timbers on edge about two feet apart, and spike them securely to the logs. This part of the work should be done in shallow water, where the logs can be near enough to shore for the workers to stand on bottom.

When laying these cross-timbers it is always well to place the first ones about five feet apart, and stand a straight timber across from one to the other parallel to the logs, so that as each succeeding timber is laid it can be levelled by either

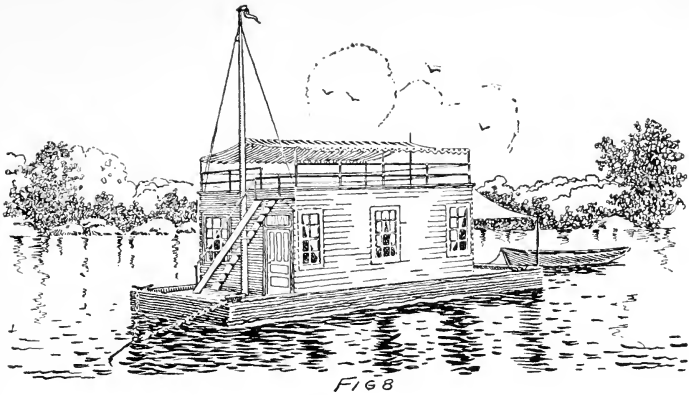

Fig 8

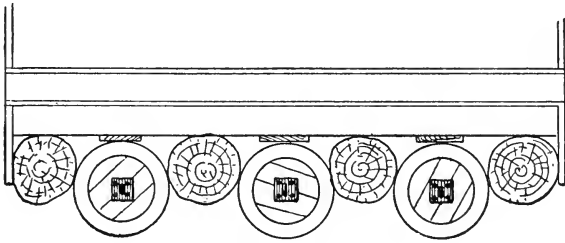

Fig. 9

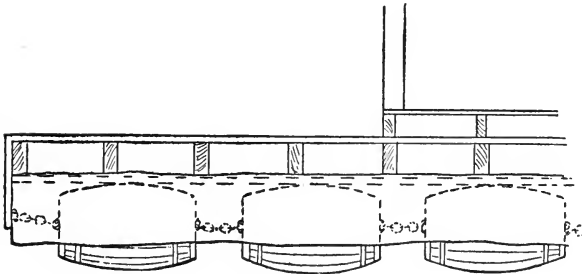

Fig. 10

A HOUSE-RAFT

## BOATING BOOK FOR BOYS

---

cutting slightly into the log or building up the bearing, as it may require.

Having timbered the logs the entire length, begin to plank or deck the raft with one-inch-and-a-quarter spruce boards six inches wide, laying the strips from bow to stern.

Fig. 9 will show the position of the logs with cross-timbers above, on top of which the planking may be seen. To the under side of the cross-beams and midway between the logs, planks should be fastened that will run the entire length of the raft. These are to form a bearing against which the upper bilge of the barrels will rest. Fig. 9 shows the heads of three barrels, each the end one of a number that are chained together and run all along under the raft to give it sufficient buoyancy to counteract the displacement that would be caused by the weight of the house and occupants.

Fig. 10 is a side view of those same barrels, showing the position they occupy and the distance from one to the other. Oil-barrels are the best for this purpose, and after being well bunged they should be treated to several good coats of copper paint before being drawn under the raft. It would be well to leave a gallon of oil in each barrel, as it keeps the glue sizing in good condition, and prevents it from yielding to the dampness caused by the water, the pressure of which might in time find its way through small cracks or openings.

A few yards of wrought-iron chain sufficiently heavy for the purpose can be obtained and cut into short lengths, and each end should be fitted with an eye-plate with four holes in it, which plates are to be fastened to the ends of the barrels with short, fat screws, having first thoroughly smeared the back of each with white-lead. The barrels should be

## HOUSE-BOATS AND RAFTS

---

arranged about one foot apart, and if the logs are from twenty-four to thirty inches in diameter at the butt end there should be just enough space to accommodate the three rows of barrels between the four logs as shown in Fig. 9.

Across the logs at the bow and stern attach the planking, to extend down a foot below the water-line, and with short uprights against which to nail, fasten weather-boards along the sides of the raft to cover the logs and come up flush with the deck line.

Seven feet in from the ends of the raft lay cross-stringers, three by six inches, at distances of eighteen inches apart, on which to place the floor of the house. This flooring may be of narrow spruce boards, planed on one side and having matched edges.

The uprights for the house construction are placed on the flooring beams and sills, and securely pinned to them, and the cross-beams at top of house should be placed the same distance apart as the floor beams to sustain the weight above, as the top of the house or upper deck will be the open-air living-room. The side elevation (Fig. 11) shows the position of windows that will be placed on both sides of the house, and another illustration (Fig. 12 A and B) shows both front and rear elevations of the house, as well as the location of companionway and deck-rails.

The deck plan (Fig. 13) shows the arrangement of the house and how it is divided into the several compartments.

In the front, the dining and living saloon is a room measuring about eight feet in width and eleven feet in length. At one end a couch is placed which, if necessary, can be used as a bed; and close to it are two large windows—one overlook-

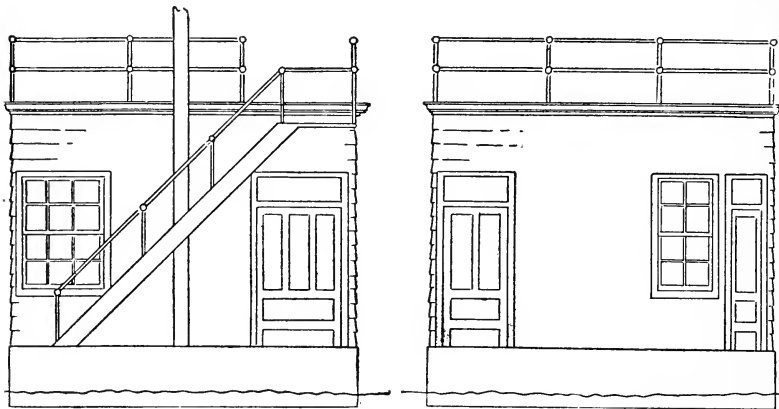
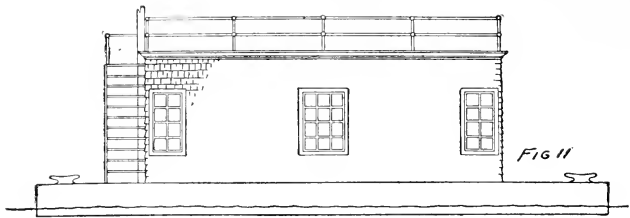

A

Fig. 12

B

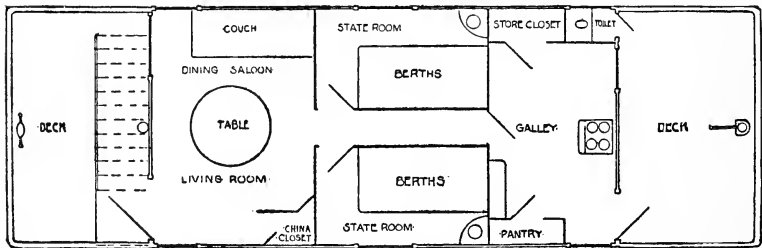

Fig. 13

DETAILS OF A HOUSE-RAFT

## HOUSE-BOATS AND RAFTS

---

---

ing the fore-deck, the other giving a view from the side of the house. At the other end of the room a neat china-cupboard is built into the corner, and in the opposite corner the front door and a window are placed. One of the illustrations is an interior view of this cabin, showing how comfortable and attractive it can be made to appear. As it is a sort of general mess-room and living-cabin, it can be decorated and kept as such in a ship-shape manner.

Fishing-rods, guns, and nets against the wall will take up little space, while in the locker under the cupboard a variety of sporting paraphernalia can be stored.

Leading aft from this saloon, a passageway opens into the galley, a room six feet and six inches wide by eleven feet long, where all the cooking-utensils and stores are kept.

This galley should be painted a light gray or ivory white, with several coats of paint mixed for outside use, so the wood-work can all be wiped down with a damp cloth when necessary. White is always the best color for a kitchen or galley, and it has the appearance of cleanliness that no other color will give; it will be found to keep a room much cooler also, and for that reason it is recommended. A rug or rag carpet will be an acceptable covering for the floor, which should be treated to several coats of yellow-ochre paint.

Between the dining-saloon and the galley two state-rooms are placed, so the passageway runs between them, and from which the doors open that lead into them. These rooms are each about eight feet and six inches long by nearly five feet wide, and two berths, each three feet wide, are built in the rooms. Both rooms have large windows, and spaces for

## BOATING BOOK FOR BOYS

---

corner wash-stands; and as the doors open against the ends of the berths, there is no lost space nor wasted room.

Rows of hooks will accommodate clothing, and the lower berth should be at least twenty-two inches up from the floor to allow room to slide a trunk or two under it. These rooms can be ceiled and papered, or painted, as a matter of choice, but a few coats of varnish will render the wood-work in good shape and proof against dampness.

All the windows and doors in this boat can be of stock sizes, so that the cost of special sizes can be avoided. The sheathing may be of cedar shingles or of clapboards, as the cost is about the same. The clapboards should be painted, and will look better than shingles, although a very artistic effect is had by staining the shingles and painting the door and window casings in shades to match, preferably in the brown and olive-green shades.

The flooring of the upper deck should be of regular flooring boards with matched edges and planed on one side. Over this flooring canvas should be stretched and tacked, and afterwards given two or three coats of oil and varnish to make it water-proof, and finally treated to a coat or two of lead-colored paint. The seams should all be well laid down, and fastened with copper or tinned tacks, driven about two inches apart. It would be well to give the boards two good thick coats of paint before the canvas is applied, so that when the oil soaks through the canvas it will soften the paint somewhat, and help to hold the canvas in its proper place.

Leading from the fore-deck to the upper deck a stair or companionway is built, and anchored securely in place to the front of the house. The platform at the head of the



## HOUSE-BOATS AND RAFTS

---

staircase is braced over the front doorway by means of two iron rods that act as brackets, and which are screwed securely both to the under side of the platform and to the door-casing. This can be an open stairway composed of two side ways and eleven treads, the ends of the treads being anchored in grooves cut in the ways, and securely fastened with screws.

The rail around the deck is of common iron gas-pipe held in place by sockets and uprights. If the piping cannot be had, then hickory or hard-wood poles one inch and a half in diameter may be employed and held in place by uprights three inches wide and thirty inches high, through which two holes have been bored to receive the poles.

Around the fore and after decks a stringer three by six inches can be spiked down, and to the sides near the bow and stern large cleats should be bolted fast, by which the raft can be moored. Amidships at the bow a large post may be fastened, around which to attach a tow-line if necessary, and at the stern a rudder is arranged, with the post projecting up through the deck for a distance of a foot or eighteen inches. A mortise should be cut in the top of this post, into which the end of a tiller can be inserted when steering the craft, either when in tow or under sail.

A mast twenty-five or thirty feet long can be stepped amidships against the front of the house, and strapped fast to the upper deck with a horseshoe band. A step-block can be fastened to the deck into which the tenoned end of the mast will fit.

A yard-arm about twenty feet long, or longer if desired, can be arranged to hoist nearly to the top of the mast, and from which a large square-sail may be rigged so the lower corners

will fasten to outriggers four or five feet long that can be temporarily braced at the sides of the boat when sail is set. This pole affords a good place from which to fly club or college colors, and from which to suspend lines of colored and Japanese lanterns to illuminate at night. This mast should be six inches in diameter at the base, and gradually taper near the top, and if a sail is to be used frequently, it would be a good plan to bobstay and shroud the stick with some standing rigging, so as to relieve it from the entire strain of a large sail.

The top of the house affords a living-room twenty-three feet long and twelve feet wide, and in that space a number of chairs, a table, hammocks, and benches can be accommodated.

For lake, river, and bay use this deck can be covered by a large awning, supported at the centre by a ridge-pole, and at the sides by upright posts that hold a stout wire in place, over which the striped awning canvas is caught. Drop-curtains at the sides will be convenient to ward off the bright sunlight, and this deck-room will be found the most delightful place to spend the pleasant days and evenings.

Along the inland waterways a raft of this description is a most desirable craft, as it can be towed from place to place, and for pleasure purposes its value cannot be overestimated, as it is a base for hunting and fishing as well as a retreat from village life; and the pleasure and comfort that can be had from a raft like this can well be appreciated when once tried.

To build a house-raft on these plans is not a difficult nor an expensive piece of work, and outside of the cost of the lumber, timber, barrels, and logs the amount is limited, unless

## HOUSE-BOATS AND RAFTS

---

finish is contemplated. With materials at hand and the help of three or four good workers, it should not require more than a week to construct this raft and house, and if fitted and painted in the manner described the cost should not exceed from two hundred to three hundred dollars, including all labor and material, according to the locality in which it is constructed.

### A Float

In the spring, when every one who owns a boat of any sort is painting and repairing his craft, boat-houses, and floats, a few suggestions in regard to the floats will be found of practical value.

My chum and I own two canoes and a row-boat. The first year we built a boat-house, which exhausted our funds, and we were obliged to wait till the next spring before we could consider the expense of making a float. Most floats are constructed of spars on logs, with a mooring on top.

As we prepared to make the float ourselves, we wanted to find the easiest and cheapest way of doing so. The spars were costly, and, besides, are clumsy, and for a float of adequate size they would have to be so large that we could not move them alone.

As we lived in the city we could not get logs, or, if we could, we should have had a big bill for cartage. It was while we were painting the boat-house one afternoon that we saw an empty barrel go floating by. My chum said he had an idea that we could make a float after all. We went to one of the grocery stores and got four new flour-barrels, with the heads, at a cost of twenty-five cents apiece.

## BOATING BOOK FOR BOYS

We took them, two by two, over to the boat-house, and then went to a near-by lumber-yard and got three two-by-three sixteen-foot joists, which cost us fifty-five cents, and one hundred square feet of boards such as are sold at thirty dollars a thousand feet. Some nails and our tools, and we were ready to begin work.

First we laid two barrels end to end about two feet apart; then about twelve feet from them we laid the other two in the same way. Then we took two of the joists and laid them on each side of the barrels on edge. Taking the other, we cut it in two pieces six feet long, which left a waste space of four feet in length. We then nailed the two sixteen-foot pieces and the two six-foot pieces together in the form of a rectangle as in Fig. 14.

Then, having propped the barrels to keep them in place,

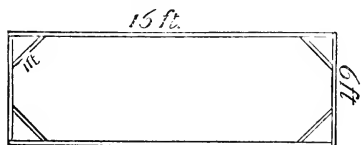

**Fig. 14**



A (end view)

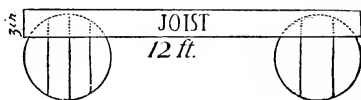

**Fig. 15**

B (side view)



**Fig. 16**

## HOUSE-BOATS AND RAFTS

---

we lifted this hollow rectangle onto them so that it rested on their sides as in Fig. 15. Cutting the four-foot joists into four one-foot pieces, we utilized them as corner braces.

Next we fastened the barrels to the frame, and, after painting them with a coat of thick paint to fill the cracks, we launched the craft. Then we covered the frame with the boards, laying them crosswise. A ring-bolt in each corner and a roller in the middle, and an old hose-pipe tacked around the edges, completed the float as shown in Fig. 16.

This we found was a most excellent float, and, above all, it was light, could be hauled out on the bank easily, or stored during the winter.

As it rose and fell with the tide there was no trouble in launching the boats at any time, whereas with a dock the pleasures of launching at low-water are too well known to be described.

Below is a table of expenditures:

Barrels, at 25 cents each.....	\$1.00
Joists " \$20 per M.....	.55
Boards " 30 " .....	3.00
Nails " 4 cents a pound.....	.20
Paint " 20 cents a can .....	.20
Rings " 20 cents each.....	.80
Total.....	\$5.75

While the prices of these articles, particularly the lumber, have risen somewhat, the cost of this float will remain extremely small.



Part IV

SAIL-BOATS AND SAILING





## Chapter X

### BUYING A SAIL-BOAT

THE first question to be decided is whether you will sail for pleasure or merely for sport—that is, whether you intend to enjoy sailing for its own sake, or only for the fun of racing and winning races. It is possible to have both forms of enjoyment with a single boat, but not until the owner is a good sailor. The beginner, who alone needs hints on boat-buying, will have a great deal more enjoyment, as well as less worry and disappointment, if he resolves to think as little as possible about racing until he has well-proved confidence in himself as a sailor. Consequently he should first avoid the most common blunder of beginners, which is to buy a boat simply because it is fast. The temptation will be great, but the risks are greater.

#### Some General Considerations

It is always best, in learning to sail, to buy a boat at second-hand. Such a one can generally be had at about half the price of a new boat, and, if it proves to be too large or too small or too “crank” or too heavy for the owner’s taste or strength, it can be sold at about cost, whereas a new boat must generally be disposed of at a sacrifice. It may be accepted as a rule that a boy’s first boat, like his

first horse, never entirely suits: it is merely a means of finding out exactly what is wanted.

Next to buying a racing boat, a boy's most common blunder is in selecting too large a craft. He thinks it will be nice to have room enough for his whole family or a party of friends, but the truth, humiliating though it be, is that the fewer people a sail-boat will hold the less will be the probability of accident. Guests in a sail-boat like guests anywhere else (except in church), must talk to their entertainer, and no one who is learning to sail, or even learning the ways of a new boat, dare have his attention diverted from his work. Even at sea, among old sailors, there is the rule, "Do not talk to the man at the wheel." In a boat full of people, too, the owner is always disturbed by a sense of responsibility for his friends' safety. A boat which will hold only two people besides the owner is large enough for any beginner.

Never buy a boat at second-hand merely because it looks like a beauty as it lies on the water. Graceful "lines" are desirable, but they will not prevent a boat being rotten or "crank" or oversparred or sprung at the center-board or too slight of frame. A boat at second-hand has as many possible weak points as a horse that has been used a great deal; and, as in the case of the horse, they are often concealed from the casual observer by faultless outward appearance.

### Is the Boat Sound?

After finding a boat which is small enough and is not unpleasing to the eye, the first duty is to examine closely

## BUYING A SAIL-BOAT

---

to see if it is rotten anywhere. This is not always easy, for paint and putty can be made to hide almost all rotten places, and the less sound a boat is the more carefully it is likely to be painted—if for sale. For this reason it usually is best to look at a shabby boat rather than one newly painted. If signs of rot appear inside, on either the planking or the framing, do not consider that boat any farther, no matter how cheap it may be or at how little cost the owner says the damaged parts can be repaired. Give up, also, any boat which shows a fine line of water-soaked wood at the joints of the center-board trunk. Look carefully to the “step” of the mast—the socket in the bottom in which the foot of the mast rests; this, if rotten, may be repaired at little cost; but the sum must be mentally added to the price of the boat.

### Overhaul the Bottom

If satisfied that the inside is sound, have the boat hauled out of the water, or at least high enough ashore to be “heeled over” to either side, so that the outside of the planking may be examined. Unless recently painted, some parts of the bottom will be bare, and a little scraping with a knife will show whether the wood is sound. Look closely at the ends of the planking where they join the stem and stern; many planks, sound elsewhere, are so rotten at these parts that fibres may be rubbed from them with the finger. Do not buy a boat which is in this condition. One rotten board is proof presumptive of more; a broken or splintered board, however, is a fault that may be corrected, though the cost must be added to the price.

Very light framework should be avoided; boats made very light, for special purposes, are often good for a year or two, but after that they strain rapidly, and are unsafe for steady use by an amateur, for they have a way of suddenly leaking badly in rough weather.

### Masts, Sails, and Rigging

If the mast is rotten at the bottom, you must consider the expense of a new one, which for a small boat is trifling. As new sails are costly, examine sails carefully. Many which are in daily use are so rotten that holes may be punched in them by vigorous use of the finger. As sails are held together principally by the leech-rope—the cord that passes entirely around the edge of the sail—test this rope by rubbing with thumb and forefinger to see if it is rotten, and test in the same way the thread with which it is sewed to the canvas.

All the rigging and the appliances in which it works must be carefully looked to; rope is cheap, and old halyards, lifts, falls, sheets, etc., can be replaced at little cost, but the weak and dangerous parts of a boat's rig are generally the "throats," "collars," or whatever else they may be called, of the spars, the fastenings of the "blocks"—pulleys through which the cordage runs—and the cleats to which any of the rigging is made fast. Dozens of serious accidents occur through cleats breaking away while the strain is upon them. Cleats and blocks are generally fastened too tightly, and in such cases are sure, sooner or later, to strain loose and break away, and always just when the result would be most dangerous.

## BUYING A SAIL-BOAT

---

### A Thorough Trial

When you have found a boat which is sound in all particulars, take it out on the water and try it thoroughly, to see how you are likely to agree. Old sailors insist that every boat has a "way of her own," and that no two boats, built exactly alike, will act alike; and old sailors ought to know. If you find the sail is all you can manage in a light breeze, you do not want that boat; it may be perfection itself for a stronger boy, but at present you are not that person. If it is hard to steer, requiring the full sweep of the tiller to change its course, leave it to somebody more experienced in stubborn boats, for this is a fault that can be remedied only by an expert, and experts' services are costly. If she "heels over" to the outer edge of the deck in light wind, she has not "bearings" enough for a beginner; this may be corrected by plenty of ballast—which usually consists of sand-bags—properly placed; but beginners should avoid the necessity of handling ballast while under sail, or of having any one do it for them; it will be better, therefore, to have a boat with greater bearings.

While on the water, test the center-board freely. If it is difficult to raise or lower, avoid that boat as you would the small-pox. There are some fine boats with bad center-boards or trunks, but their owners do not allow their own boys to sail them.

In buying a boat you will always find the seller quite willing and anxious to show you how it will sail. There is no harm in letting him do this as long as he likes; but no matter how well the boat acts in his hands, do not for-

## BOATING BOOK FOR BOYS

---

get that he will not be the sailor after you become owner. Men have been called very hard names for what they said regarding boats they were selling, but no man can sell his seamanship with his boat.

After you have looked among boats according to the suggestions given above, you will come to the conclusion that there are not many really good boats in existence. You will not be entirely wrong, but you will have gained an amount of knowledge that will be worth far more than it has cost in time—and temper.

When you have money enough to buy a boat, and feel as if you could not possibly wait another day, a good way to obtain proper patience is to ask a lot of boating men, successively, what model of craft you should select. By the time you have heard what they say in favor of their own particular models, and against all others, and learned that the special favorite of one very good sailor is the special detestation of another sailor equally good, you will wonder whether all boats are not very bad—or very good. Further observation, however, will teach you that men who like to be on the water select their boats according to the special uses to which they are to be put, or the waters in which they sail; if you follow their example in this respect you are not likely to make a mistake.

### Differing Models

In many localities there is but one model of sail-boat, but between Maine and Florida there are to be found at least a dozen distinct styles, each of which is entirely satis-

## BUYING A SAIL-BOAT

---

---

factory to the people who use it, probably because it is the outgrowth of their necessities. Boys seem to imagine that small sail-boats are built only for pleasure-sailing, but the truth is that most of them were designed for working purposes and are built accordingly. If you happen to live in a town where there is but one model in use, you must be content with the local fashion, unless you are rich enough to order a new boat, of different model, from elsewhere. There are many towns on Long Island Sound where nothing can be had but the sharpie—a craft almost as simple in shape as a box, but very fast in a “free” wind, and quite likely to upset in any other, if a novice is at the helm. On the New England coast, where the water is quite deep, even inshore, there are bays on which only deep yawls are seen. On the Jersey coast are hundreds of sail-boats called “sneak-boxes” which look like a deep spoon covered by a narrow one, while in and about New York the broad, shallow cat-boat is the favorite. These four distinct models are the types of which almost all others are mere variations. Recently there has come into use a graceful combination of canoe and rowboat model, with one or two masts and several sails, and it answers nicely the demands of persons who sail only in the mildest breezes, but it is not to be recommended to boys who are ambitious to handle sail-boats in all weathers.

Any of the other models named are safe enough for a careful beginner, though the sharpie should be placed at the foot of the list, and any of them can be bought in or near New York or any other large sea-coast city. On the lakes and other interior waters the buyer must generally

choose between the cat-boat and yawl models. The cat-boat has an evil reputation for upsetting; the fault being always with the crew instead of the boat. Nevertheless, a beginner would do well to learn sailing in some other craft. A boy's trouble with a cat-boat is generally that the sail—there being but one—is very large, and although there are appliances for "reefing," or shortening, sail, they are not always easy to handle at times when reefing is desirable. A yawl-rigged boat has the canvas so divided between the two masts that a learner may begin with as little as he likes, and in a sudden squall, when carrying all sail, can drop his mainsail and be perfectly safe, while still carrying enough canvas to make headway, and even speed.

### The Cat-Boat Rig

To the cat-boat rig, with its large single sail, the amateur is sure to come sooner or later, but in his first season it is better for him to try the yawl, not only for safety, but for convenience. The breezes of summer, late spring, and early autumn have a provoking way of disappearing suddenly; this is annoying enough to the veteran sailor, but it is worse to the novice, for it is not pleasant to sit in the hot sun, on smooth water, and wonder how you ever will get home again. Patience and endurance are sufficiently taxed in learning sailing without the extra strain of being becalmed just as you were intending to go about and scud for home and supper, or to meet an appointment at school or baseball. A cat-boat *can* be rowed ashore, but the work is terribly hard, even for two boys; but the yawl, dory,



## BUYING A SAIL-BOAT

---

or boat of that class is practically a heavy rowboat. The cat-boat is useless except when there is wind, but the yawl is always available as a rowboat, as well as for fishing or duck-shooting. The yawl, too, can be used in narrow streams, where a boat propelled only by sail is sometimes useless.

### Keel and Center-Board

Every American who sails for pleasure must at some time—probably many times—take part in the yet unsettled fight as to the relative merits of keel and center-board, but it is not necessary that a boy should give himself any uneasiness about this while learning to sail. He will find a center-board boat the pleasanter to begin with, for with a given amount of wind it does not “heel over” as much as a keel boat, and it is during the “heeling” process that amateurs are most frightened. The center-board, however, requires attention which compels the beginner to have an assistant on board, while the keel always takes care of itself, besides leaving the inside of the boat free and clear. Keel boats are charged with some very bad habits; if, in running ashore or over a just submerged stone, log, or stump, the keel happens to ground, the boat is likely to tip sidewise so quickly that the crew is in the water before knowing what has happened; to step from a small keel boat to the shore or a float or pier is also often productive of a ducking.

For very shallow water, such as is most common in American bays and rivers, the broad center-board cat-boat is the only sailing craft practicable. The small hull, rigged

with jib and mainsail instead of a single large sail, is sure to capture the eye and heart of a boy, but the learner would do well to admire such a rig from a distance. It certainly is pretty: nothing but a sloop-yacht, which it closely resembles, can be prettier; but no boy should trust himself to handle a boat with a jib until he has mastered the single sail. This caution does not apply to the jib of the two-masted yawl above alluded to, for in this it is balanced to some extent by a small sail aft, and, besides, is not as large, in proportion to the mainsail, as in the sloop rig.

To recapitulate: the first thing to think of in determining a model is safety; the next is comfort and convenience. The safest of all the boats named is the sneak-box, but it is not a pretty craft, nor is it easy to find except on part of the Jersey coast. The most risky in unaccustomed hands is the sharpie. The cat-boat is steadiest under the wind—that is, she lies over least to windward, and is also the most roomy. The yawl is not as pretty as the cat-boat, but is far better as an “all-around” boat.

If the reader happens to live on inland waters, where there are no sail-boats of any kind—and there are hundreds of such places—he will have to put rigging and keel, center-board or lee-board, on such rowboat as he can find with beam and bearings enough to carry sail. In such case he cannot do better than consult Lieutenant Ross’s chapter, “Sails for Open Boats.” After rigging his boat, he should not attempt to sail until he has carefully read the same author’s “At the Helm.” On the coast, or wherever sailing is common, a boy can always get instruction and suggestion from men and boys accustomed to boats, but the

## BUYING A SAIL-BOAT

---

boy who cannot take any one aboard as teacher cannot too carefully read all the printed instructions within reach. Confidence will come quickly after experience, but haste and recklessness are nowhere more out of place than in a sail-boat.

### Racing Types

This chapter does not include the fast modern racing types, since it is intended for beginners. These boats have what is termed the canoe hull and the fin-keel, which means that a weight of lead is suspended below the actual keel, as in the case of the big racing yachts, or they have the semi-fin-keel, which is a compromise between the fin-keel and the plain-keel boat. These fast boats, built by Herreshoff and other leading boat builders, may be seen at their best in harbors such as Marblehead, which is a great boating center, and elsewhere, and they are assuredly most picturesque and fast. But they are more expensive than the older types, and it is a more delicate matter to select and to "tune them up" and to sail them. Before entering upon this field a boy should be thoroughly at home in a sail-boat, and he should have the best expert advice in the selection of the boat and in its management.

## Chapter XI

### FIRST LESSON WITH TILLER AND SHEET

**M**ANY consider the sailing of the small cat-boat a most simple matter, and are thoroughly convinced that they have mastered its handling if they have been able to take out a small boat in a light wind without any disastrous results, while, in fact, they may not have caught hold of the first underlying principles of sailing. It is this large class that furnish the long list of boating accidents that appear in the papers almost every day during the summer months. They may have acquired a sufficient smattering to be able to handle the boat under ordinary conditions, but when something a little out of the ordinary happens they are totally at loss.

#### Some Basic Principles

Before proceeding to a discussion of the subject proper, perhaps it will be advisable to explain the fundamental principles of the action of the wind on the sail, and its relation to the boat's course, and also the action of the rudder. To begin with, there are two "centers" that we must consider in our cat-boat, and it is the relation that these centers bear to each other that determines the be-

## LESSON WITH TILLER AND SHEET

---

---

havior of our boat. They are the "center of effort" and the "center of lateral resistance." The center of effort is the center point of the sail area, hence the point at which the whole force of the wind may be supposed to act. The center of resistance is the center of the lateral area of the immersed boat, or, in other words, the center of the side area of the under-water body of the boat. If a perpendicular be dropped through this center, it may be considered as the pivot around which the boat swings. If a force is applied forward of this point the boat's bow swings off; if aft, the stern then swings off. As the wind is the force in question, and the point of application of this force the center of effort, we can readily see by the relative positions of these points whether our boat will have a strong or a small tendency to drive its bow up into the wind. As the sail area of the cat-boat is collected in one large sail, the center of this sail is pretty well aft, and consequently a good bit back of the center of resistance, and so we have a very strong tendency of the boat to send its head into the wind. To counteract this the use of the rudder becomes necessary, and hence is accountable for the great pull noticed on the tiller of the cat-boat. As the rudder plays such an important part in the sailing of a cat-boat, the first thing to master in learning to sail is the proper use of the tiller.

### The Tiller

Now, to start, take your seat next to the tiller, to windward, facing the bow, with your hand on the tiller near the end. The first thing you will notice is that when you pull

the stick toward you the boat's bow falls away from the wind. The next thing noticed is that if you let go of the tiller the boat's head will come up into the wind. This is the usual way of bringing a boat into the wind (luffing), because, with the exception of light winds, if the rudder is used to bring the boat's head into the wind it very frequently does it so rapidly as to kill the headway. As has been stated, the boat is kept on a straight course by a constant use of the rudder, and this may be easily acquired by practice.

In your first lessons in sailing it will be necessary to take some one along to manage the sail, and you must devote your whole attention to the steering. A very good way to train yourself to steer a straight course is to take some fixed object on shore and head the boat for it, altering the rudder from time to time, as may be necessary to keep the boat's head pointed toward it. After this step has been thoroughly mastered you may advance to "going about"—that is, putting the boat on the other tack. When you want to go about call out, "Hard-a-lee" (this is the signal to the sheet-tender to be ready), and let go the tiller. The tendency of the sail to bring the boat's head up into the wind will swing her around until the sail flaps, and when this point is reached put her over the rest of the way by pushing the tiller away from you, at the same time changing your seat to the other, now the windward, side. Several days should be taken in practice with steering, until you feel that you have thoroughly mastered these two lessons. This will perhaps be a sufficient preliminary drill with the rudder, and you may now hand the tiller over to your

## LESSON WITH TILLER AND SHEET

---

companion, and in the next practice spin take charge of the sheet. It is better to take the two up separately as described, for when the handling of the tiller and sheet are combined later on, you have had a certain amount of practice with each.

### Tending Sheet

In the first lessons in tending sheet your station had better be in the cockpit, just forward of the steersman, and after you are accustomed to handling it you can then try the deck aft of the cockpit. This is the position of the sheet-tender in racing, and, in fact, is the only place where his movements are entirely unhampered, and he is out of the way of the steersman.

As to the position to take when hauling in or paying out the rope, the one shown in the sketch will be found very convenient for the rapid handling of a long rope, such as the sheet of a cat-boat is. (Fig. 1.) The feet should be placed



*Fig. 1*

## BOATING BOOK FOR BOYS

---

well apart and the knees bent. The rope is hauled in with a rapid, steady, "hand-over-hand" motion, and allowed to fall in a loose coil between the feet. When it is desired, the rope is paid out with a "hand-over-hand" motion in the opposite direction. Under no circumstances let the rope slide through your hands in paying out, and never loose your grip on it.

Of course this position has to be modified when a man has to attend to sheet and tiller at the same time, but the "hand-over-hand" motion should always be retained. Always strive to have your sheet run in or out smoothly, and avoid jerks wherever possible. When you are tending sheet the course of the boat does not concern you; it is your duty simply to see that the sail is kept full. This can be seen by watching the sail along the mast, especially the region marked A in sketch, Fig. 2. At this part of the sail a little bagging is caused by topping up the peak, and if the sail is not drawing properly it is first made manifest by a tendency to flap here. If this is noticed, the sail is out too far, and you should haul it in until this disappears. When going about on the command "Hard-a-lee" of the steersman, trim the sheet in with a steady pull until the boom is nearly amidships as the boat is rounding up, so as to keep the sail full as long as possible, and then pay the rope out smoothly until the sail is trimmed properly for the altered course of the boat.

There are two reasons for trimming the sheet in when going about—first, it keeps the sail full for a longer time, and in that way sends the boat about quicker and with but little loss of headway; and, secondly, should the boom



## LESSON WITH TILLER AND SHEET

---



*Fig. 3*

but the sail just swings over. The delicate part of this movement is to break the force of the shock that is caused by the sheet checking the sail on the other side. To accomplish this when the wind begins to spill out of the sail the sheet must be hauled in rapidly as the sail swings in-board, so that when the boom is amidships there is no slack, and paid out rapidly as the sail fills on the other side, whilst

doing so introducing a sufficient pull on the rope to gradually check the boom. This and the management of the rudder can only be successfully acquired by observation and practice. One other point to be borne in mind is to raise the center-board when about to jibe, as no neat jibe can be made with the board down.

### Handling Tiller and Sheet Together

Sufficient practice has been had in the use of the tiller and sheet separately, and on the next lesson you may try them both together. No new ideas will be introduced, but it will consist principally in becoming familiar with the many little makeshifts that render it possible to handle both the tiller and sheet of a fair-sized boat together.

The first point perhaps is the matter of cleats for the sheet-rope, a most convenient arrangement of which is shown in the sketch, Fig. 4. The cleats on the coaming should be placed just about opposite the tiller-head, and it is also very desirable to have a cleat attached to the traveler. Fig. 4 A.

When sailing a boat single-handed it is customary to handle the tiller by standing to leeward and placing the hip against it, as shown in the photograph of the cabin cat-boat, Fig. 3. In this manner both hands are left free to handle the sheet; or if the sheet be given a twist around one of the cleats to ease the strain, the other hand may be used to help steer. As to the matter of catching the sheet around a cleat to make it easier to hold, never fasten it in such a way that it cannot be loosened at a moment's notice. The

## LESSON WITH TILLER AND SHEET

proper manner is to give it a single turn and hold it with one hand, so that it may be easily thrown off or let slide over the cleat when necessary. This position may be seen in the photograph of the boat coming head on, Fig. 5. She is pulling rather hard, and the steersman has found difficulty in holding both tiller and sheet, so he is sitting on the tiller

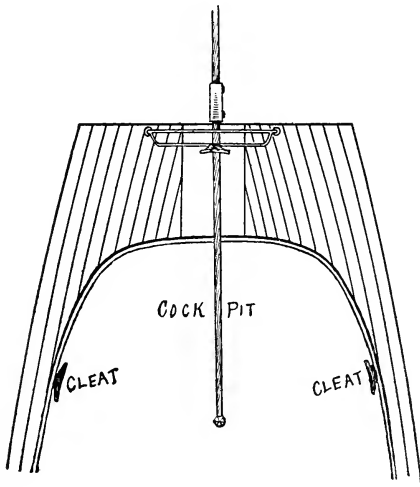

*Fig. 4*

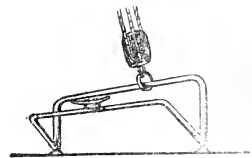

*Fig. 4 A*

and steadying it with the right hand, and has given the sheet, which is held in the left, a single turn around the cleat on the coaming on the leeward side, in this manner having the boat under perfect control.

### Luffing About

The illustration, Fig. 6, will illustrate two points—luffing about and trimming in the sheet. "Luffing about" is a

## BOATING BOOK FOR BOYS

---

very simple movement. You are to leeward, leaning against the tiller, and when ready to luff about you step away from it, so it is free to swing, at the same time hauling in the sail as the boat rounds up, while the sail is flapping



*Fig. 5*

changing your place to the other side of the tiller, and swinging the boat around the rest of the way by means of the rudder. The photograph will give a clear idea of the movement when you start to round up and haul in the sheet,

## LESSON WITH TILLER AND SHEET

---



*Fig. 6*

Before going about always be sure you have some board down. It will often be found necessary when sailing with a strong wind abeam to luff the boat up a little so as to be able to trim the sheet in. This luffing is done in the same manner as when you swing up (or luff) to go about, only the boat's motion up into the wind is checked when the desired alteration in the trim of the sail is made, and then the head is thrown off again by means of the rudder.

## BOATING BOOK FOR BOYS

---

The jibe will not be described, as it is most advisable to have an instructor for this manœuver. Of course, when the wind is light, the rudder and sheet may be held in the manner most suitable to the individual. The foregoing hints are only intended as aids when it is a breezy day and the tiller and sheet prove a little difficult to manage together.

### General Hints

A few general hints will not be out of place here. When putting off from a dock see that the tiller is shipped and the sheet free; then step up to the bow and pull your boat up to the end of the dock, until it lies sideways, and then, pushing against the dock, walk aft along the deck, in this manner giving the boat a good start in a line parallel to the dock.

As soon as the boat is well under way and clear of the dock, take the tiller and trim in the sail. Of course it is not always possible to get off in this manner, as your boat may be inshore of another boat, and in this case it will be necessary to give your boat a shove straight backward, directing her with the rudder (which will act all right when the boat is going stern foremost), until astern of the obstructing boat, and then swing her head off with the rudder, and fill the sail.

### Making Dock

Making a dock will not be as simple, on account of the necessity of killing the greater part of the boat's way before touching the dock. In general, this is done by ap-

## LESSON WITH TILLER AND SHEET

proaching at an acute angle to the line you purpose to make the dock on, and rounding up abruptly by putting the rudder hard over and letting the sheet run to spill the wind out of the sail. This abrupt turn serves to kill nearly all the headway, and should leave only enough for the boat to carry up to the dock. The remaining headway is checked by going up in the bow and "fending off" in the manner shown in the sketch, Fig. 7. The abruptness of the turn, and the



*Fig. 7*

## BOATING BOOK FOR BOYS

amount of room allowed for rounding up, will vary according to the wind, and can only be acquired by practice. At first there will be just as much liability of your killing the headway too soon, and having to get an oar out to pole

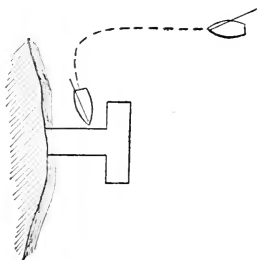

MAKING DOCK WITH WIND ABEAM

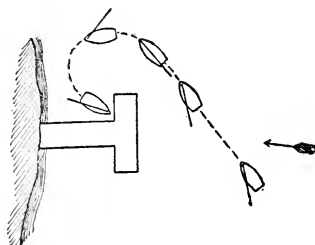

MAKING DOCK BY JIBING

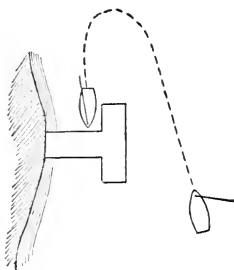

MAKING DOCK BEFORE THE WIND

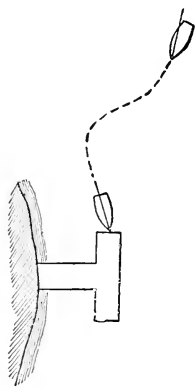

MAKING DOCK CLOSE HAULED

*Fig. 8*



## LESSON WITH TILLER AND SHEET

up, as there is of not killing it sufficiently. In the latter case, if you see the boat after rounding up has too much momentum for you to check easily by standing in the bow,

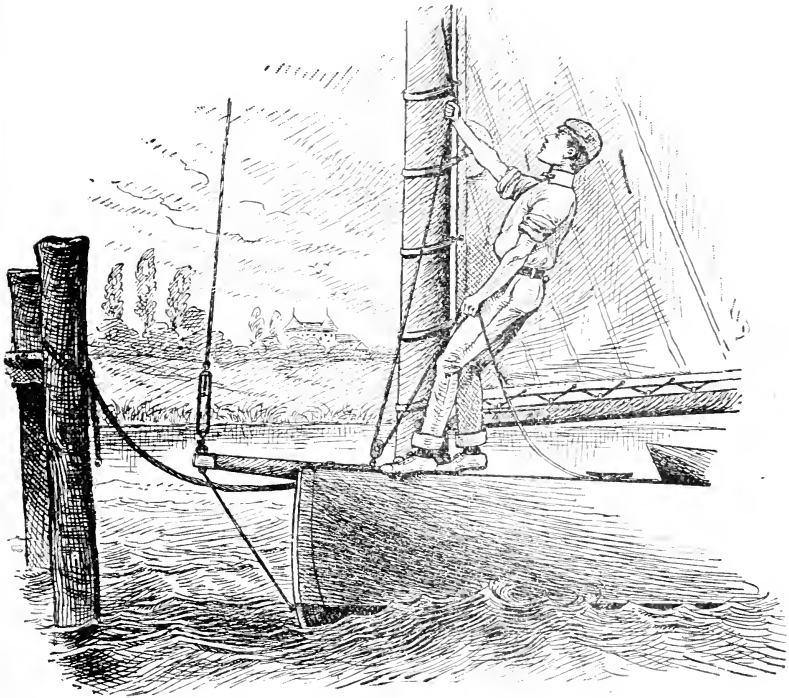

*Fig. 9*

drop the center-board and weigh on it. The dragging of the board on the bottom will form a most effective brake.

It is a bad thing to get into this practice, because, though most docks are in comparatively shallow water and it will act all right, it may be necessary to make a deep-water

## BOATING BOOK FOR BOYS

---

dock sometimes, or a mooring-buoy, and, of course, the board cannot in this case be used in the above manner.

The diagrams, Fig. 8, show the ordinary conditions under which a dock has to be made, and they are sufficiently clear without further explanations. If you intend to leave the boat at the dock for any time, always unship the tiller, and it is also advisable to hoist the boom up by means of the topping-lift or to drop the peak, thus causing the sail to bag and preventing an excessive swinging of the boom in the wind. Another hint about leaving a boat at a dock with sail up: always tie her with a very short painter, so as to prevent swinging.

A little difficulty is experienced at times in "topping up" the peak or tauting the halyards. This may be easily overcome in the manner shown in the sketch, Fig. 9. The halyard is grasped in the manner shown, and the body swung back. Great power can be obtained in this way, and a large sail can be topped up by such means.

## Chapter XII

### SECOND LESSON, WITH DIAGRAMS

WHILE boat sailing cannot be taught by precept alone, an intelligent knowledge of the theory of the art will enable any one, with a little additional practice, to handle a boat with skill, freedom, and perfect safety. The limits of so brief an article will not admit of minute instructions bearing on every situation likely to arise, yet the few practical hints and details that follow will, if carefully noted, be found of service to the youthful mariner. The latter will understand that the principles of true seamanship apply with equal force to all boats of whatever size, build, or rig. These remarks will in great part have reference to the sloop—a simple type of craft, with a single mast, mainsail, and jib.

#### Helm

This is a term applied to the steering gear, including the rudder and tiller (or wheel). When a boat carries a *weather helm*, her head has a tendency to come up “into the wind,” or nearer the direction from which the wind blows, necessitating an action of the rudder to keep her on her course. This troublesome habit is generally caused by too much after-sail or a faulty stowage of the ballast. To carry a

*lee helm*, or an inclination to fall off or away from the wind (the opposite of that just described), is even a worse trait, and should be counteracted, if a smaller jib, a shorter bowsprit, or a larger mainsail will remedy a defect due to too much head-sail.

When the helm is "put to starboard" or "port" (to right or left), the tiller handle is moved in the direction named, but the boat's head is carried the contrary way by the operation of the rudder. Fig. 1 will illustrate this point, the arrows denoting the course the vessel will take with each helm. When the boat is pressed backward through the water (or has what is called *stern-board*), the action of the rudder is reversed.

### The Care of the Sheets

Sheets are ropes that confine and trim the jib and mainsail when set. They usually lead along the deck to the helmsman, and in squally or threatening weather should never be so tied or made fast that they cannot be eased or cast off at a moment's warning. It has been truly said that the main-sheet is the key to the whole science of boat sailing, and for that reason great care should be exercised in its proper management. No good boat will capsize unless the sails are hampered by the sheets. A skilled boatman will take advantage of every change of the wind, however small, to trim the sheets so that the sails will stand full and receive the most favorable pressure.

### Close-hauled, or By the Wind

This is the situation a boat is in when she is pointing as near the direction or "eye" of the wind (with the sheets

## SECOND LESSON, WITH DIAGRAMS

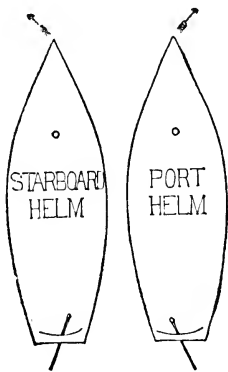

*Fig. 1*

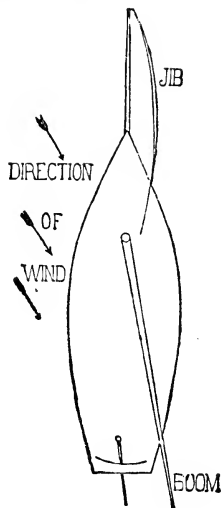

*Fig. 2*

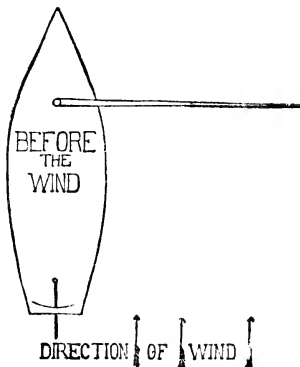

*Fig. 3*

trimmed flat aft) as will insure her progress through the water (Fig. 2). The boom is kept at a small angle with the keel, as shown in the cut. A well-balanced craft will sail within five points ( $56^{\circ} 15'$ ) of the wind. If the boat gets too close, an experienced eye will detect a ripple along the forward edge of the mainsail, owing to the fact that the

## BOATING BOOK FOR BOYS

---

wind is pressing the opposite side of the canvas. When the sail "shakes" in this way, the helm should be put up by moving the tiller slightly toward the side upon which the wind blows, allowing the boat to go off a trifle, so that the sails will stand full. To keep a craft up to her work, without letting her shake or fall off, is one of the surest signs of a good helmsman, and many a race has been won, or bad weather saved, by skilful management in "beating to windward." A boat's sails can be trimmed flatter aft in smooth water than in rough, as it is impossible to sail so near the wind with a lumpy head-sea against you; neither will she lie so close after reefing.

### Before the Wind

When the sails receive the direct force of the wind from astern the boat is said to be "running before it," or "scudding" (Fig. 3). With a sea on, and the boat first rising on top of the wave and then burying her bowsprit under at the next moment, this will be found the most difficult situation for steering. Great care should be taken not to let the main-boom *jibe*—that is, allowing it to swing around on the opposite side by the sail getting aback (the pressure coming on the forward surface) either by a shift of wind or bad steering, which would easily happen to a heedless yachtsman. Such a manœuver might carry away your mast in a jiffy.

### Tacking

The process of putting a vessel about by working her up against the wind, so that the latter will act on the op-

## SECOND LESSON, WITH DIAGRAMS

posite side (Fig. 4). When the gear is all clear, the sails full, and plenty of headway, give the order, "*Ready about!*" then put the helm down by pressing the tiller end *a-lee* (in an opposite direction to that from which the wind blows), and as the boat starts into the wind, "*Ease off the jib-sheet!*"

When nearly head to the wind the jib is borne out to leeward and held aback to assist in sending the bows around. As the craft gets past the direction of the wind, and the mainsail begins to fill, pass the word to "*Let draw!*" and at once trim down the jib-sheet. If the boat gets sternway (goes stern foremost), the helm has to be shifted. Pushing the main-boom over to windward as soon as the jib-sheets are let go will aid a sluggish craft in this maneuver.

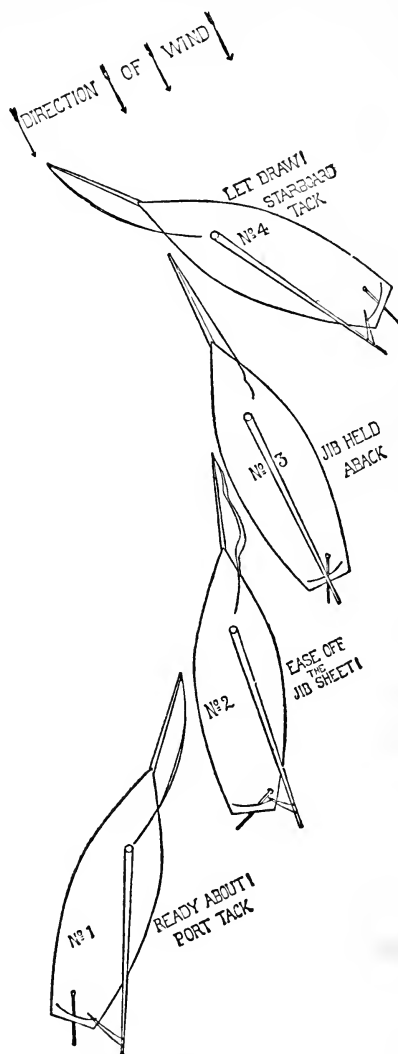

Fig. 4

### Jibing, or Wearing

This is a delicate evolution, and should only be adopted, unless by the most experienced, in light summer winds (Fig. 5). When the boat will not go about by turning to windward, the helm is put up, and she is allowed to go off before the wind. With the latter pretty well on the quarter, haul the main-boom rapidly amidships, and as the helm is

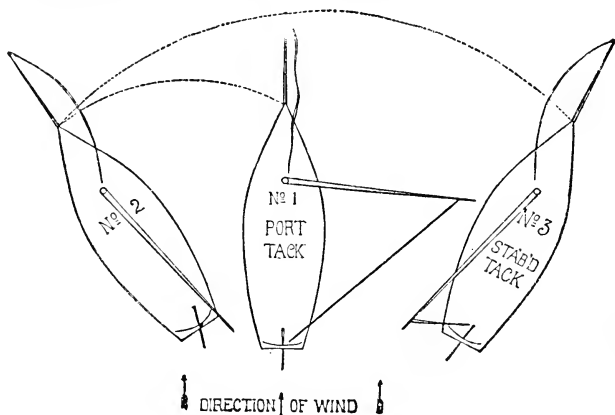

Fig. 5

gradually shifted the sail will take on the other tack, and the main-sheet may be slackened. If the boom is carelessly allowed to jibe, it will whip round with force enough to part the sheets or snap the mast. It is a good plan before jibing to settle or lower the peak of the sail.

### Reefing and Furling

As soon as the boat begins to wet, it is a safe plan to reef, and always before bad weather sets in. Bring the boat



## SECOND LESSON, WITH DIAGRAMS

---

to the wind by putting the helm down. In reefing a jib lower away on the halyards so as to tie the reef-points beneath it, lash the outer clew to the bowsprit, and shift the sheets. To shorten a mainsail lower it a trifle below the boom in order to get at the reef band; stretch the foot out by means of the reef pennant, make fast the tack, and pass the points last (tying with a square knot) either around the boom, or foot of sail, or to a jack-stay on the boom, according as the boat is rigged. The boat is kept hove-to (stationary), head to the sea, by securing the tiller a-lee. In shaking out a reef (the boat being brought to the wind), first undo the points, then cast off the tack, and lastly the reef pennant. Always keep to windward of the sail.

### Getting Under Way

Hoist the main-sail and loose the jib; heave away on the cable until it is *short*. If in a tideway, cast the boat's head in the direction you want to go, by means of the rudder; break out the anchor and set the jib. If there is no tideway, cast the boat's head with the sails.

### Anchoring

On the approach of a thunder-shower it is advisable to go quickly to a harbor. If caught in a gale of wind, however, on a bad shore, often the safest plan is to anchor at once, if you can find a good place. Let the boat come to the wind, haul down the jib, and as soon as she has sternway let go the anchor, and pay out considerable cable be-

## BOATING BOOK FOR BOYS

---

---

fore checking it; then veer away as much more as will hold her. Furl the mainsail and make everything snug.

### Some Practical Advice

Be particular about the sails being properly set; get the wind out of a sail if you want to manage it. Do not sit on the gunwale, stand on the thwarts, or let go the tiller. If caught in a hard squall, put the helm down at once, let fly the sheet, and lower the sail. Do not overload a boat; keep weights amidships; a laden vessel carries her way (progress through the water) longer than a light one. Endeavor always to maintain steerage-way, and do not put the helm down suddenly or too far over. Abstain from all reckless exploits; the best sailor is the one who shows the greatest caution. Be cool in emergencies. Keep the hal-yards and sheets clear. Do not attempt to navigate strange waters without a chart and compass. *Learn to swim* before sailing, and never play pranks in an open boat.

## Chapter XIII

### FITTING OUT A BOAT

A GOOD many boys who could raise enough money to buy small pleasure craft are deterred from doing so by the expense of keeping them. The truth is, however, that an industrious and self-reliant boy can keep a boat himself, and need only in rare circumstances have recourse to a builder. One young friend of mine who bought a very able yawl-rigged sharpie for \$150, because her owner was afraid of her, told me that it had cost him \$100 for her keep during his first season with her. This included expenditures for fitting out and laying up, new sand-bags, changing the gear of the jib, and one or two other minor things. Now, if this young man had been really fond of working about his own boat he could have done the whole of this himself, except making the iron traveler for his jib. It is not always agreeable, of course, to paint, hammer, and scrape on your own boat when other fellows send theirs to a yard to be done up by a builder; but a boy of independence ought not to mind it, especially when he remembers that by doing his own work he earns his boat.

#### The Spring House-cleaning

For the sake of convenience let us suppose that your boat is a small sloop, because whatever hints I offer for such a

## BOATING BOOK FOR BOYS

---

craft will answer equally well for a yawl, a cat-boat, a sharpie, or any other small craft. Last fall you took advantage of a very high tide and hauled your boat on the beach. Then, with the aid of rollers and a friend or two, you hauled her high and dry. Perhaps you were lucky enough to have a horse; but if you didn't, you had a heavy block and rope, and you made one end of the rope fast to the bow, hitched the block to a tree, put your muscle on the other, and up she came. Then you took off the canvas and running rigging, and went ahead till your little boat showed only a bare mast, with the shrouds, and her bowsprit. After that you covered her deck and cabin with heavy tarpaulin, lashed securely to keep out snow and rain.

Now the sun is on this side of the equator, the days are balmy, and the water looks inviting. So you go down to the yacht and say to yourself, "It's about time to begin fitting out." And as you look her over you shake your head. Her sides and deck are dull, dingy, and mottled, and the mast looks as if it had never had a coat of varnish since it was made. But don't be discouraged. True enough, there's a good bit of work ahead of you, but it is work that you can take a pride in, and when it is done it will give you a great deal of pleasure.

If you knew your business when you laid the boat up, you left a line rove through a block at the masthead. What for? To hoist yourself up with when you go to work. Before you go aloft, however, you would better go below. I suppose your little ship carries lead ballast stowed away under her flooring, or at any rate she has pig-iron. When you took them out in the fall, of course you marked them

## FITTING OUT A BOAT

---

so that you now know just where each one belongs. Before putting them in place, you clean out the hold thoroughly. Then give it three coats of red lead. If you cannot afford red lead, use whitewash. You should also paint or white-wash the ballast before replacing it. Your friends who patronize the high-priced builders may laugh at you for using whitewash, but pay no attention to them. The bilges of your boat will be sweet and clean.

### Work on the Mast

You next turn your attention to the mast, and the first thing you do is to make a boatswain's chair. This is very simple. Take a slab of wood, and bore two holes in each end. Then stretch two pieces of rope, about six feet long, over the board by running the ends through the holes and knotting them. Take one of the ends of your masthead gant-line, as it is called, and take a couple of half-hitches around the slings of your chair, as shown in Fig. 1. You must take care to keep it evenly balanced. You will soon learn how. When you are ready to begin scraping the mast get some one to hoist you up to the masthead. Make the hauling part of your gant-line fast where you can reach it (under the slings of your chair will do), and you can lower yourself as you scrape down the mast. A sailor's jack-knife is a good thing to scrape spars with, but any instrument that will scrape off the black will do. If the mast is exceedingly dirty and rough, a smoothing-plane is sometimes employed, but my advice to you is to avoid it. You cannot use a plane without weakening your mast a little.

## BOATING BOOK FOR BOYS

---

Patience and a piece of glass are much better than a plane. After your mast, boom, and gaff are scraped, go over them with sand-paper, and rub them smooth. Use very coarse paper to begin with, and very fine for finishing.

Now put on two coats of good spar varnish. Take my advice and buy a good article. There are several excellent brands in the market, and you can get one of them by going to a reputable dealer. When these two coats are

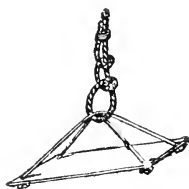

*Fig. 1*

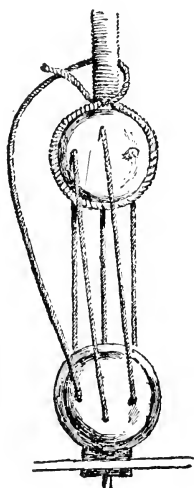

*Fig. 2*

thoroughly dry, go over the spars once more with fine sand-paper, and then give them another coat of varnish. No crack racer just out of a yard will show a prettier polish than yours. Do not forget to scrape and varnish the hoops that hold the hoist of your mainsail to the mast. Then go

## FITTING OUT A BOAT

---

over all the wooden blocks of your boat. Scrape, sand-paper, and varnish them. It will be a tedious job, but you will be delighted with the results.

### Setting Up the Rigging

Now you are ready to set up your rigging. If you have taken the shrouds off, you must now put them on again. Each one has a collar to go over the masthead and rest on the lower cap. The starboard shrouds go on first, and the port shrouds over them. The forestay goes over all, and rests on the bolt to which the main halyard-block is attached. If your shrouds are set up by means of turn-buckles, you will not need any instruction as to how it is done. To "set up," by the way, means to make taut. If they are set up by old-fashioned lanyards and dead-eyes, see Fig. 2, which will show you how the lanyards are rove. The ends should be neatly half-hitched and seized down to the shroud with small stuff, tarred over. As a rule, however, you will have none of this work to do, for it is customary to lay up sloops without stripping them of shrouds and forestay. Ordinarily your first business after scraping and varnishing spars will be to get the topmast aloft. The topmast is hoisted by means of a heel-rope rove through a block at the mainmast-head. As soon as your topmast-head is through the upper cap make fast the heel-rope, go aloft, and put on the iron band to which are attached the topmast stay and the topmast shrouds. Hoist away the topmast and ship the fid which holds it in place. Then you are ready to set up the stay and shrouds belonging to this

spar. This is so simple a piece of work that you need only examine the rig of your boat to see how it is done.

The next step is to get the gaff and boom aboard, ship them, and reeve the running rigging which belongs to them. As different styles and sizes of craft have different arrangements of running gear, it is impossible for me to give explicit directions in this matter. I advise you, however, to go in for simplicity in rig, for every extra line means so much more trouble. Bear one thing always in mind: the hauling part of the throat-halyards of a mainsail should always come down on the port side, and of the peak-halyards on the starboard side. The jib-halyards also come down on the starboard side.

### Bending on the Mainsail

You are now ready to bend on the mainsail, and this is the way to do it. Get the sail on deck, and stretch it along with the luff (the side which belongs next to the mast) forward and the head up. Begin by fastening the throat to the gaff, according to whatever plan it has been done before on your yacht. Hoist the gaff a foot or so clear of the boom. Stretch the head of the sail along the gaff, and make the peak fast, hauling it out taut so that the head of the sail lies flat against the gaff. Now make fast the head of the sail either by lacing or by robands (small ropes) passed through the jack-stay on the under side of the spar. Robands and jack-stay are the only proper fitting for a yacht. As soon as the head of the sail is bent, make fast the luff to the uppermost mast-hoop; hoist away, and make fast



## FITTING OUT A BOAT

---

---

to the second, and so on, till all are fastened. Now make fast the tack at the jaws of the boom. Then haul out the clew good and taut, and make that fast. Now bend the foot of the sail to a neat wire jack-rope run through screw-eyes on top of the boom, and your mainsail is ready. Lower it, furl it, and hoist it well above the deck out of your way. Next bend on the jib. Unless your yacht is pretty large this is a very simple matter. Get the sail out on the bowsprit, and make fast the tack. Hook on the halyards and hoist a little at a time, so that you can hook the hanks on the forestay as the sail goes up. After your hanks are hooked and sheets bent on, lower away and furl.

### Deck and Hull

So far I have said nothing to you about your hull. I have omitted it for this reason: it is customary to complete all the work on the hull before reeving running rigging and bending on canvas. In a large yacht that is well enough; but in a little craft of which you are taking care yourself, I think you will find it profitable to leave at least the deck until the last, because you will not mar its handsome fresh appearance by tramping over it while working on rigging and sails. You might do the cleaning of it before going to work on these things, but my advice is to leave the varnishing till the last thing. It will have plenty of time to harden while you are getting your cabin fittings in shape. Another reason for doing the deck and hull painting early is that the boat may be launched before the running rigging and canvas are taken in hand.

## BOATING BOOK FOR BOYS

---

The first thing to do with the deck is to get the dingy varnish of last year off it. Don't paint your deck white or gray or green. Leave that sort of thing to the fishermen. Have a "bright" deck, with a bit of brass-work somewhere to set it off, if it's only a couple of brass cleats. Here are directions for cleaning the old varnish off: Dissolve from five to six pounds of soda in boiling-hot water, add a bucketful of unslacked lime, and spread the mixture on the deck after sundown. Before sunrise the next morning scrub the deck with a hard broom, and rinse it thoroughly. You may have to repeat this operation twice or three times, but when you are through your deck will look as if it were new. Now proceed with your varnishing and the painting of your hull. I presume that you have carefully examined the hull to see whether it needs calking anywhere. Paint it above the water-line with the best white lead, unless you prefer to have your boat black. White is prettier for a small craft, and, strange as it may seem, much easier to keep clean. Moreover, if your paint gets scratched anywhere, you cannot put on a daub of black without its showing, by reason of the dullness which comes over black when it is old, so that the glistening new spot stands out plainly. This is not the case with white paint. The hull below the water-line should be coated with first-class metallic paint.

## Chapter XIV

### SAILS FOR OPEN BOATS

**S**MALL open boats are designed, in a greater or less degree, to be impelled on the water by oars, and are distinguished by different names according to their use, size, and model. Among such are life-boats, launches, dingies, gigs, jolly-boats, pinnaces, yawls, barges, feluccas, sharpies, whale-boats, long-boats, cutters, dories, canoes, punts, bateaux, skiffs, etc. Many of these craft are provided with light, portable sails and masts that can be readily rigged up when occasion requires. Boats, therefore, that are not specially intended for sailing purposes are usually equipped with a handy suit of sails, care being taken to choose a style that is likely to insure speed and weatherly qualities, though often local prejudices and the "custom" of the waters prevail as to the kind of rig.

All sails have either three or four sides. The former of these are sometimes spread by a stay, as a jib, or by a yard, as lateen sails, or by a mast, as leg-of-mutton sails, in which cases the foremost edge is attached throughout its whole length to the stay, yard, or mast. The latter, or those of four sides, are extended by yards or by gaffs and booms, as the principal sails of a ship or schooner. They

all acquire their names from the mast, yard, or stay upon which they are extended or made fast. The accompanying cut (Fig. 1), showing jib and mainsail, will aid the reader in learning the names of the different parts. The upper edge, A, is called the head; B, the leach; C, the foot; D, the luff; the corner, *e*, is called the peak; *f*, the nock; *g*, the clew; *h*, the tack; the dotted rows are the reef points; O, the boom; R, the gaff; S, the stay.

### Spritsail Rig

These sails have four sides (Fig. 2). The luffs are secured to the mast by lacings, or pieces of rope-yarn, rove through holes made in the sails about three feet apart, and the heads are raised and extended by sprits (small, tough poles) that cross the sail diagonally from the mast to the peak. The lower end of the sprit has a blunt point, which rests in a rope becket or loop that encircles the mast like a slip-knot, and can be fixed in position without slipping. If there is any tendency, however, for the becket to slide, a little wetting will prevent it. One advantage of the spritsail is that it can easily be brailed up alongside of the mast, with a line leading through a block on the mast and through the clew and around the sail. Pieces of cord are sewn in the seam across the sail, near the foot, for reefing points.

### Cat Rig

Purely an American idea, and for narrow and crowded waters, bays, and harbors is unsurpassed (Fig. 3). The mast

## SAILS FOR OPEN BOATS

is stepped right in the bows of the boat, and carries one sail (secured to mast-hoops), with a boom and gaff. These boats work with great quickness, are easily managed by one person, and have few equals in going into the "eye" of the wind.

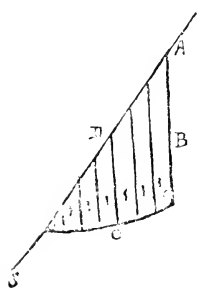

*Fig. 1*

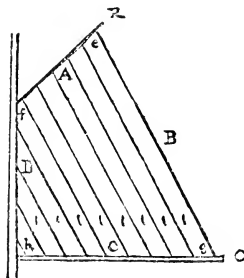

*Fig. 3*

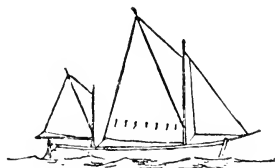
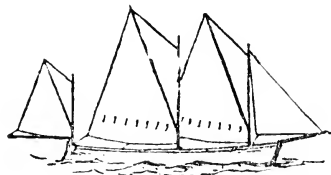

*Fig. 2*

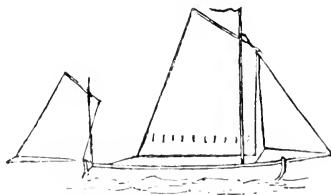
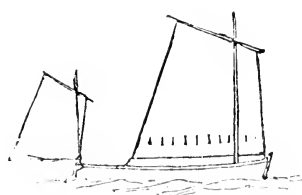

*Fig. 4*

### Balance Lug

These sails are four-sided, secured to a yard which hangs obliquely to and is balanced on the mast, part of the sail being in front and part behind (Fig. 4). The boom and the yard are of about equal lengths. The tack of a lug-sail is usually a loop on the boom, caught into a hook on the mast near its heel, and is made fast before the sail is set. When a boom is not used, as is often the case with a single sail, the tack of the lug is secured to the weather-bow. While this is a popular rig and has many good sailing points, it suffers an inconvenience on account of the yard having to be shifted to leeward of the mast in tacking, termed "dipping the lug."

### Sloop Rig

Undoubtedly the handsomest of all rigs, though it is not so convenient for single-handed sailing, two people being required to sail them properly (Fig. 5). For small boats the sails consist of mainsail and jib, and sometimes a top-sail, the former secured to a gaff, and with or without a boom, as preferred. The bowsprit is an adjustable one. For cutters and small yachts this style of rig is the most common, and is well adapted for racing craft, as a great spread of canvas can be carried.

### Mizzen Rig

Quite a small sail, as is shown in a number of the drawings, secured to a mast stepped in the stern of the boat,

## SAILS FOR OPEN BOATS

---

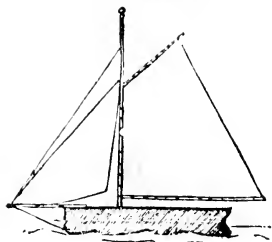

*Fig. 5*

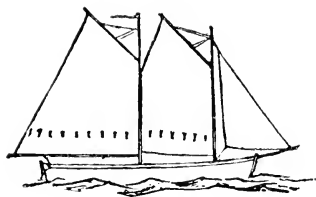

*Fig. 6*

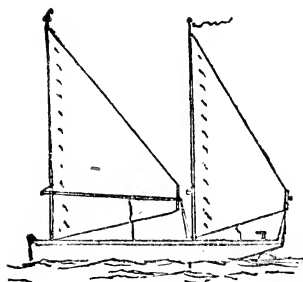

*Fig. 7*

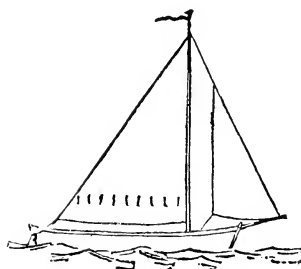

*Fig. 8*

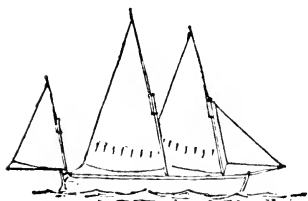

*Fig. 9*

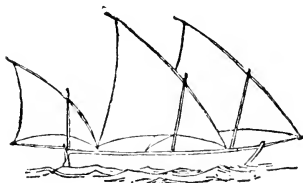

*Fig. 10*

near the rudder-head, and may be either a lug, or a spritsail, or a fore-and-aft sail (Figs. 2, 4, 9). Where the waters are likely to be lumpy and the winds gusty and strong, the main and mizzen rig will be found the most useful (the mainsail

## BOATING BOOK FOR BOYS

---

being a balance lug or other sail), and is undoubtedly the best for single-handed work in open waters. The mizzen is of great help in beating to windward, and should set as flat as possible; and whenever it is necessary for any reason to lower the mainsail, the mizzen will keep the boat head to wind and sea.

### Schooner Rig

A rig very common for long open boats (Fig. 6). It consists of two masts and temporary bowsprit for the jib. Both the mainsail and the foresail are extended by gaffs instead of sprits. The mainsail usually has a boom, while the foresail is often without one, though this is optional. The jib can be dispensed with by stepping the bowsprit in the bows of the boat.

### Sharpies

These craft are long, flat-bottomed, draw only a few inches of water, and are best suited for shallow sounds and bays (Fig. 7). In smooth waters, sailing on the wind, they are unquestionably among the swiftest boats afloat. The best specimens are to be found along the North Carolina coast. They have long masts, with one or two sails of peculiar shape, which are made as nearly flat as possible by being extended near the foot by sprits, as shown in the illustration. On the after-part of the sail is a small yard, or *club*, to which the sprit is made fast. The reefing is done along the luff, the reef bands running parallel to the mast.



## SAILS FOR OPEN BOATS

---

### Leg-of-mutton Rig

A very safe, simple, and handy rig for boys (Fig. 8). The sail is triangular, like a jib, and the peak is hauled almost to the masthead, with one halyard. It is specially adapted to smooth-water sailing for small boats and in light winds where reefing is not likely to become necessary. One or two masts can be used, and booms rigged if desired.

### The Sliding-gunter

The principle of this rig is that the yard to which the sail is laced slides up and down on the mast, two iron hoops or travelers forming the connection (Fig. 9). It is not a favorite sail in going before the wind, on account of its narrow head, but has advantages when close-hauled, and is preferable to a leg-of-mutton rig for sea work and in reefing.

### Lateen Sails

These sails are common on the Mediterranean, and are familiar to all who have seen pictures of the East (Fig. 10). The sail is triangular, and is bent to a long tapering yard, sometimes twice the length of the boat, which hoists to a strong short mast that rakes forward.

There is a variety of odd and original rigs for small boats which are not in common use. Those mentioned are the simplest forms, and have stood satisfactory trial by boatmen generally in various parts of the world. A rig with a single sail is always the handiest and safest when one has

## BOATING BOOK FOR BOYS

---

to "work ship" unassisted. A properly fitted center-board will add to the sailing qualities of an open boat, and when it can be put in without taking up too much space or being in the way of the oarsmen, it should be done. The ballast should be inside and easily removable; bags of sand are the most convenient. When about to fit out a craft, remember that a smaller amount of canvas in one piece is more effective than a larger amount divided up.

## Chapter XV

### RIGS AND MAKESHIFTS OF THE SMALL BOAT

WHILE a boy may not have occasion or the good fortune to handle or own a large boat, he is almost certain, if he lives near water, to have something to do with a bateau, skiff, or small boat of some character. Or perchance he may own a rowboat of the St. Lawrence-skiff variety, and may wish to put a sail on it. Now there is nothing more clumsy and dangerous than a badly rigged small boat. By badly rigged is not meant only the boat whose spars are imperfect, or other things connected with her rig radically wrong, but also the boat that carries a rig that may be perfectly suitable for another class, but is entirely out of place in one of this size. A thing to be avoided in all small boats is unnecessary rigging; too many halyards and sheet-ropes are in the way, and where the rigging is on a very small scale are very apt to get tangled or out of order when most wanted. So it may readily be seen that, for instance, the jib-and-mainsail rig of a twenty-five-foot boat, with its accompanying number of sheets, stays, and halyards, would be totally out of place in a fourteen-foot bateau. The whole attention of the natives or "shell-backs" in or near our fishing villages has been devoted to the originating of makeshifts for the avoidance of everything that

## BOATING BOOK FOR BOYS

---

makes the construction and handling of a boat more difficult. Their idea seems to have been that anything that could be accomplished without the aid of mechanical means, simply by the use of a little extra muscle, had better be done that way.

It might be said that in the small boat are seen the various rigs, in their simplicity, whose principles have been



ST. LAWRENCE SKIFF WITH FORE-  
AND-AFT SAIL



A DUCK-BOAT TYPE

elaborated and altered to meet the different conditions required. Taking them in order of simplicity, we first come to the "leg-o'-mutton" rig. Here only two spars are used, and no halyards. In No. 1 (Fig. 1) the boom has no jaws, and is held in place at the mast by catching the projecting end in a sling, and by poking the other end through a cringle in the leech. The only lacing required is to fasten

## RIGS AND MAKESHIFTS

the sail to the mast, the sail only being fastened to the boom (more properly sprit) at the points mentioned. If it is found to bag, the remedy is to shorten the sling until the sail sets flatly. This can never be entirely accomplished, as the sail, being supported by the boom only at the extreme outer end and the mast at the other, is very apt to stretch in a stiff breeze.

### To Make the Sail Set Flat

Advancing a step, we come to the remedy of this trouble (No. 2, Fig. 1). It is the introduction of jaws at the mast, instead of the rope sling. The tendency to bag is removed, as the sail is fastened at frequent intervals by

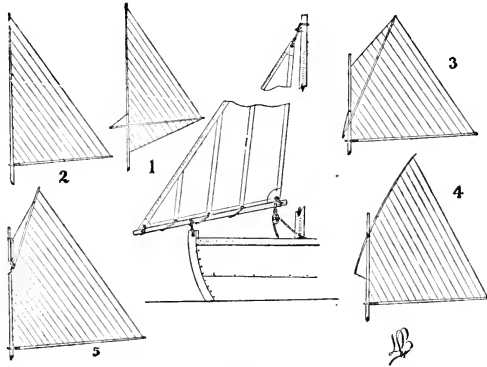

*Fig. 1*

lacing to the boom, along which it may be kept stretched tightly. Also the tendency of the boom to slide forward is effaced as it butts up against the mast. In this method a much lighter spar can be used, as the strain is made to

come more or less throughout its whole length, while in the first-mentioned it comes wholly at the ends. The principal objection against the "leg-o'-mutton" rig in general is the great length of mast required. This is one of its most serious drawbacks, and the other is the inability to reef the sail. Of course, modifications of this rig have been made, introducing halyards and supplying reef points, but a discussion of that is beyond the scope of this paper, such modifications being rarely seen on a small boat.

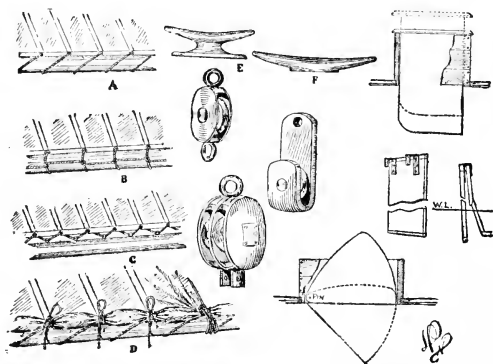

*Fig. 2*

As mention has been made of lacing a sail to spars, perhaps it would be just as well to digress a little here, and speak of three well-known methods of lacing. The first, A, (Fig. 2), is the simplest and about as effective as any. The sail is fastened to the boom by an "over-and-over" lacing. In B the sail is held by a series of "half-hitches," and in the third, or C, the lacing runs through eyes screwed into the boom.

### A Shorter Mast

The next step in rendering the rig more compact is to shorten the mast. This can only be done at the cost of an increase in the complexity of the rigging. A new spar is introduced, and the sail is cut down from a triangle to an area having four sides. Some means had to be found to support the upper edge, and a study of the last three sail plans will show some of the methods in use (Fig. 1). Nos. 3 and 4 are nearly equal, as far as simplicity goes, though Fig. 3 is simpler on account of the absence of lacings on the upper edge. This is commonly known as the "spritsail," and, taking all things into consideration, it seems to be the most efficient and handiest of all the rigs. Of course, it is not as efficient in some respects as the sail in Fig. 5, the same trouble being experienced on the top edge as in the "leg-o'-mutton"—bagging—but it possesses the advantage of greater simplicity. If we examine this rig we will readily see that it is any large fore-and-aft sail reduced to its simplest form. We find, instead of the gaff and the two hal-yards to hold the sail up, all this is replaced by the simple device of the pole (sprit), one end of which is stuck in a cringle in the upper corner of the sail, and the other caught in a sling. The sail does not move on the mast, and is laced to it. The boom has jaws at the mast, and the sail is laced on, or sometimes the device shown in No. 1 is resorted to, though the former method will be found to make this sail set better. There are no reef points, and the only way to reef is to drop the peak by removing the sprit. Of course, it must be understood that this rig is not at all

practicable in a boat of any size, but in any of about the size of a rowboat it will be found to be most convenient.

### A Yard

In the next device (No. 4) we approach nearer to the regular "fore-and-aft" sail. There can be seen the introduction of a yard to which the upper edge of the sail is laced, as to the ordinary gaff. No halyards are used, and the yard is lashed to the mast, and held at the proper angle to keep the sail flat by a rope fastening its lower extremity to the mast. The only objection to this rig is that the yard has a tendency to give and to permit the sail to bag. This rig is frequently seen on duck-boats. There is no method of reefing except dropping the yard, unless reef points are introduced.

### The Fore-and-aft Sail

Taking a step further we come to the "fore-and-aft" sail proper, No. 5 (Fig. 1). Here we find the introduction of a gaff, which might be looked upon as the shortening of the yard in the preceding rig. There are jaws on both boom and gaff, and the sail is movable on the mast, being usually held on by loops, the gaff moving up and down. To take the place of the lashings in the preceding rigs, ropes (halyards) fastened to this spar and passing through blocks at the mast-head and so down have been introduced. Because of the ability to hoist and lower the sail, reefing is accomplished by a row, or rows, of little ropes (reef points), by which it is tied down, thus reducing it to almost any size desired ac-



## RIGS AND MAKESHIFTS

---

---

cordova to the number of reefs tied in. Most small sails of this character have at least one row, and some two, though the small cat-boat usually has three. In a previous chapter a description of how to tie a reef in the sail of a larger boat was given. The principle is the same in all-sized sails, and perhaps it will only be necessary to add here that the reef points are not tied around the boom but around the part of the sail taken in by the reef (D, Fig. 2). The stop at the outer cringle, however, is tied around the boom. A simple means of reefing, which may be used in all the rigs except the first, is by rows of holes of the same character as the leech cringle; and after pulling the sail down to the proper distance (most sails laced to the mast can, with a little care, be moved), hold the reef in by a single lacing through them, in the same manner as the sail is laced on in A (Fig. 2). A stop at the leech is required, as in the preceding method.

### Rigging a Jib

Many combinations are made with the jib. There seems to be about only one common way of rigging a jib for a small boat. A pretty clear idea may be gained from the sketch (Fig. 1). As may be seen, no stay is used, the sail usually being bound with a rope, which gives it sufficient strength; no halyard is used either, the jib being lashed to the mast and lowered and hoisted when it is stepped or unstepped. The lower edge is laced to a boom, which is secured to the bow with a lashing about four inches long, a third of its length projecting. The sheet-rope is fastened to the inner extremity. The most common combination

is the jib and spritsail, generally known as the "skiff rig" (see sketch). It is quite often used with one of the "leg-o'-mutton" sails. The most general use of the "leg-o'-mutton" types, however, is either two together, as in the sharpie rig, or separately as the only sail in the boat.

### The Spars

Perhaps a few words on the spars would be in place here. First taking the stick itself; it should always be a straight-grained piece of wood, as free from knots as possible, and well seasoned. The several spars require different degrees of tapering. The aim of the taper is to reduce weight, by concentrating the greatest amount of material at the point most strained, and removing the surplus. The mast should leave little taper, except in the "leg-o'-mutton"—where it is tapered very much toward the head—and ought to be nearly the same size throughout its whole length, the thickest part, if any, from a short distance above the deck or brace to a few inches below. It should have a slight taper at the head and a pretty good-sized one at the heel where it enters the step. The boom should have a slight gradual taper, the thickest part being between a quarter and a third of the distance from the mast to the end of the spar, and the mast end much heavier than the other. The making of the jaws has been described in a previous chapter. The thickest part of the gaff should be about a third of the distance from the mast. The sprit should be about the same thickness throughout its entire length. In the yard rig the thickest part of the yard should be in about

## RIGS AND MAKESHIFTS

the same relative position to the mast as it is in the gaff.

Turning now to the rigging of the boat; the only one of the rigs requiring halyards is the fore-and-aft sail No. 5 (Fig. 1). The method of threading can readily be understood from a study of the sketch. No. 5 (Fig. 3) is only practicable for

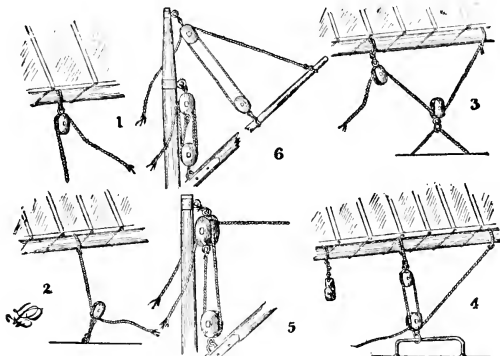

Fig. 3

a small boat, but No. 6 is more suitable for a larger one. About the only other thing requiring mention in the rigging are the different methods of reeving the sheet-rope. No. 1 and No. 2 are the simplest, the only difference between them being the positions of the fastened ends. In the first the end is secured to the boat, and in the second it is fastened to the boom. The device shown in the third sketch is a trifle more complicated. The fourth one is the most intricate of all, but has the least drag on the sheet, as every time the rope passes over a wheel in a block by so much is the pull diminished. This rig requires the introduction of a double

## BOATING BOOK FOR BOYS

---

block on the traveler, and perhaps a snatch-block to ease the pull when close-hauled.

### Blocks

As blocks have been mentioned, perhaps it would be as well to say that small galvanized-iron blocks can be procured at very little cost, and will accomplish all that is required of them. Of course, if the boat's owner is inclined to spend more money, wooden blocks will make the rigging neater and run easier. Travelers are used to fasten sheet-ropes to the boat, and may be made in two ways, out of either iron or rope. The iron traveler in this case is an iron rod carrying a ring to which the block is attached, bent down at the ends, which are threaded and fastened with nuts through the stern. The rope traveler is a strong cotton rope, the ends fastened on each side of the boat, and the rope passing through a ring on the lower side of the block. In the rigging may be also included the cleats for belaying the halyards and sheets. For the halyards, and for purposes where it is desirable to fasten the rope securely and for some time, a cleat shaped like E (Fig. 2) is best; but if it is desired to fasten the rope temporarily, or to use it as a means of breaking the pull on the rope, the jam-cleat F is the most efficient, a turn or two causing the rope to jam. Leaving the rigging, we will turn to the boat proper.

### Center-board and Keel

There are three methods of keeping a boat from making leeway (going sideways)—by a center-board, lee-board, or

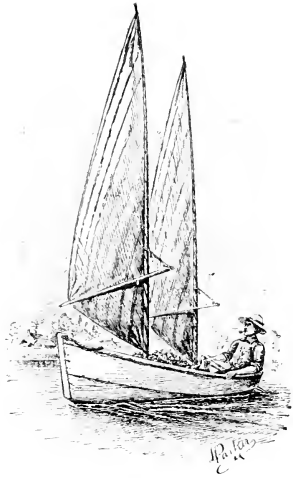

A SHARPIE-RIGGED OYSTER-BOAT



SKIFF-RIGGED BATEAU

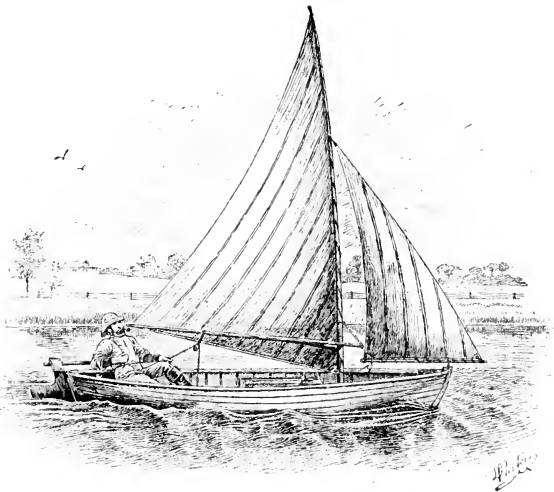

A DOUBLE-END CLAM-BOAT

## BOATING BOOK FOR BOYS

---

keel. The last is impracticable for a small boat, and will not be considered. There are two varieties of center-boards in use—the ordinary drop pattern, as used in the larger boats, and the dagger. The drop is generally triangular in shape, held in place by a pin at the lower corner of the trunk passing through the apex. The dagger is only a board or board shaving a projecting cap on the top, so that it will not fall through the trunk, and is lifted entirely clear when not wanted. The drop pattern is a little more convenient, but somewhat difficult to make. The drop is just as efficient, and can never get out of order, while easily replaced if broken. It is the one most used by the “natives.” The only danger of this board, and one that must be always borne in mind when sailing in waters where bars abound, is that it cannot raise up when it strikes an obstruction as the drop will, and, if you are not watchful, may upset your boat. The lee-board seems only a miserable apology at the best, and is only pardonable when you do not desire to cut a hole in your boat’s bottom to build a trunk. The only practicable method is to make a movable board with clamps that fit over the gunwale, and move it to the lee side as the boat’s course changes. In a previous chapter there has been described how to make a rudder with tiller and yoke-line attachments, and it will be unnecessary to go into details here. The yoke-lines are sometimes the only way of steering in some types of boats, as, for example, the St. Lawrence skiffs. In the sea skiffs and river bateaux there is an extremely simple means of steering by an oar. It is held in two places, either in a lock or groove cut in the stern-board or under the lee counter.

## RIGS AND MAKESHIFTS

---

The stern oar is used in much the same manner as a rudder, but the lee oar is kept out of the water most of the time, only being immersed when the boat begins to fetch up, and taken out as soon as this tendency is corrected. The reason of this is that the oar, being rested against the gunwale, projects over the side at quite an angle from the fore-and-aft, and hence, if kept in all the time, it would throw the boat's head off.

There is quite an extensive use of the jib in this class of boats. The jib can be made to exert quite an influence on the boat's speed, and if the sails are nearly balanced the boat can be held on a straight course by proper trimming. It is only by experience that the trim of the jib can be learned, as it depends on the balancing of the sails, on how close you are sailing, and on the strength of the wind. When going about let slack the jib-sheet just before the boat begins to round up, trimming it again when on the other tack. If the jib is out too far it has a tendency to flap; and if too flat, there is a tendency of the boat's head to fall off the wind.

## Chapter XVI

### A RACING CAT-BOAT AND ITS CARE

THE popular idea that a racing cat-boat is an expensive luxury has doubtless arisen from the cost entailed upon those who keep a racing boat, and either cannot or will not themselves attend to the labor connected with keeping such a craft in the best of condition. Many boat owners after entering for a race put their boats in the hands of boat-builders to be gotten into condition.

To these men are usually intrusted, besides getting the boat into condition, the procuring and training of the crew; and if the race is important, the command of that, too. Most likely the crew will be composed of rivermen, amply compensated for their services, and an amateur or two, one of whom, perhaps, is the owner. Of course all this costs, the builder having to be paid for his labor of getting the boat ready, and if he wins the race he naturally expects something extra.

There are some owners, however, who attend to all these matters personally, and their expenses are reduced to a very low figure.

A few words may be added about the care of the sail. Suppose that the boat has been thoroughly overhauled and renovated as described in Chapter XIII. It may be added



## A RACING CAT-BOAT AND ITS CARE

---

that a sail should never be rolled up when wet. Nothing will rot and mildew it more quickly. If you are compelled to put the boat up for the night when the sail is damp, tie a few stops around it at intervals, and allow it to hang loosely between them, just using a sufficient number to prevent the sail from thrashing about in case of a strong wind during the night. As soon as possible after a rain hoist the sail and let it dry. The quickest way to dry a sail is to hoist it to the full extent along the mast and drop the peak, and raise the boom quite high with the toppen lift. This will cause the sail to bag greatly, and the wind shaking it will soon dry the moisture out.

### Cleaning the Bottom

Your boat has been in the water for some time, and you have entered it for a race. The first thing to do in this case is to examine its bottom. This may be effected by selecting a shelving beach and running your boat as far up as possible at high water, having previously removed all extra weights. Secure two guy-ropes to the masthead, and drive stakes on each side of the boat about twenty feet off. Fasten the ropes to these stakes, so when the tide goes out they will hold the boat on an even keel, and on the receding of the tide it will be an easy matter to examine the under body of the boat.

If the bottom is so foul as to require repainting, construct ways and haul out, scraping and painting as in the beginning of the season. If the bottom should need only a slight cleaning and polishing, slacken one of the guy-ropes

## BOATING BOOK FOR BOYS

---

so that the boat will rest on its side, and scrub clean with water and a stiff brush, polishing with cloths. After this side is finished pull the boat up to an even keel, and slack away the other rope so it will rest on the other side, thus permitting you to get at the rest of the under-water body.

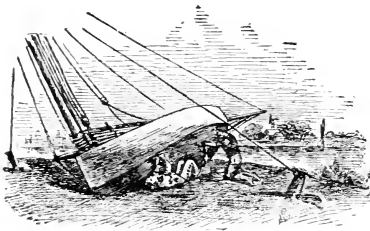

METHOD OF SCRAPING BOTTOM

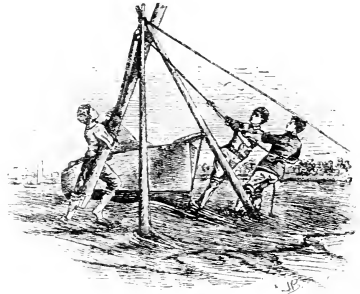

STEPPING MAST WITH SHEARS

If you are so fortunate as to possess a racing sail and spars, unship the old ones and ship the racing sails and spar. If you have not, your boat is about ready. Remove all extra weights (except ballast), and if movable ballast is permitted take it aboard. Examine all your rigging carefully, and do not omit to go over it again just before starting in the race. All this should be finished the day before the race.

### Training the Crew

Ranking almost equal in importance to the condition of the boat is the training of the crew. The length of time required before the race to get the crew in condition will, of course, depend upon the knowledge of the individuals.

## A RACING CAT-BOAT AND ITS CARE

---

If the members have a fair idea of their business, a few hours before the race will be sufficient; but if they do not, the sooner the training commences the better. For a racing crew to be handy, every man in it must know his especial part in all the manœuvres, and when a manœuver is ordered he must do it quickly and with the least confusion possible, and not try in an excess of zeal to attempt to do more than his part, unless so ordered. Above all, every man must obey implicitly and without question any order of the captain, for no boat can be handled properly by its crew when anybody but the captain is permitted to give orders. As to the number of the crew, the average cat-boat of, let us say, eighteen or twenty feet will require a helmsman, usually captain, sheet-tender, center-board tender, and a man to look after the halyards. If your boat is so small as not to have so many men allotted to it, the center-board and halyards may be tended by one man. If, on the contrary, more than the requisite number are allowed, take the extra men, if the day is windy, as ballast only, or if movable ballast is permitted, as shifters.

Do not divide the work up into small parcels and give each one a little to do; it creates too much moving about when under way, a thing not in the least desirable. You might, however, have an understanding with them as to what they are to do in an emergency, such as taking in or shaking out a reef. Here a slight digression on taking in a reef when under way may be pardoned. When under way drop the sail so that the desired reef points are about in a line with the boom, and when they are in the right position let the boat come up into the wind so that the boom will

be inboard. Then order the crew to spread along the boom, and when the bowman has fastened the desired cringle at the jaws of the boom, have them catch hold of the sail, stretch it along the boom, the sheet-tender making fast the cringle on the leach (outer edge) to the boom. As soon as this is accomplished tie the reef in. When all the reef points are tied, let the boat's head fall off and continue on course, as the peak and throat may be properly hoisted, especially when you are strongly manned, nearly as well under way as when in the wind. This operation, so long on paper, may, with a well-trained crew, be accomplished almost in the time it takes to read this. Shaking out a reef is a very easy matter, and will need no mention. The whole aim in the training of a racing crew may be summed up as follows: Every man to know his part and do it when required. The first thing after explaining clearly to each man his particular station is to get the crew accustomed to the boat. A good way to do this is to take a spin at every opportunity with them over the course, making a careful note yourself of the bearings of the different marks by objects on shore, so that you will not lose valuable time in the race in finding them. Do not allow any lagging in these spins, for it is liable to lead to a blunder in the race, but maintain the same discipline as you would at that time.

### At the Start

The hour of the race is at hand. Your crew is aboard, and after a careful examination of the running rigging, blocks, mast-hoops, sail and its lacings, you set out for the

A FLYING START

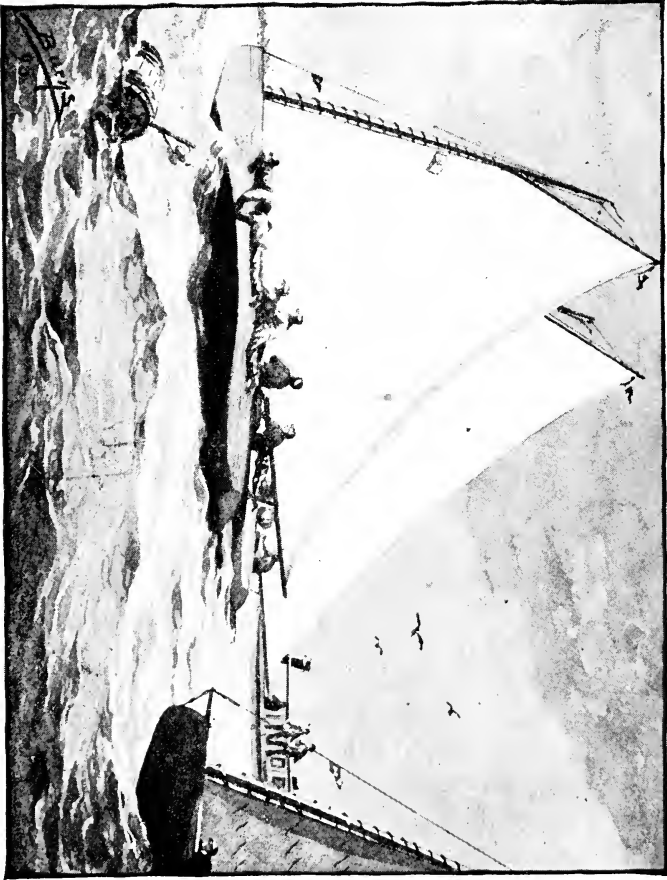

## BOATING BOOK FOR BOYS

---

starting-point. Arriving there, procure your racing number, and after fastening it upon the sail, take your boat out and cruise around in the vicinity of the starting-line, using this opportunity to practise your crew in tacking, jibing, and other evolutions likely to be encountered during a race. Upon hearing the preparatory gun, it is best to get near the line. If you feel confident that you have your boat well in hand, you might manœuvre for a flying start, but if you are a little uncertain, it is best to secure a good position, and let your sail flap in the wind close as the boat lies stationary close to the line.

If the first leg is close-hauled or a thrash to windward, it is advantageous to get away as near the front as possible, as the boats slower in starting usually get off in a bunch and cut up each other's wind. If the start is off the wind this is not so important. A flying start is very desirable, but it requires careful calculation and handling to bring your boat to the line at the right moment; and if by some mistake you should cross a few seconds before the gun, you would lose lots of valuable time in recrossing again. In a one-gun start the importance of getting off quickly is greater than in a two-gun. Bang! goes the starting gun. You are over the line, close-hauled most likely, on the starboard tack (on account of having right of way). Do not make the common mistake of hauling your boom in nearly amidships and jamming your boat up into the wind; it will not pay. It increases the drift, and your boat will not "foot" it as fast as one that is allowed a little more leeway. Again, do not let your boat sag off too far or a heavy gust may cause a "knockdown," with the consequent loss of

## A RACING CAT-BOAT AND ITS CARE

---

much ground. Always be ready to luff and take advantage of any little gust of wind, and it is astonishing the amount of windward gain a clever sailor makes in this way. This does not mean to luff so much at every puff as to dump the wind out of your sail, or attempt to sail so close to the wind as not to get its full power.

The amount of sail carried should be proportionate to the wind; it is a great mistake to oversail a boat so that it wallows through the seas, necessitating luffing or dumping out the wind in the squalls and lowering of the peak when running before the wind. The angle of heel at which your boat sails best can only be determined by experiment, and it is a great blunder to carry sail so as to heel her to a greater one. When sailing close-hauled or to windward, all obstructions that may catch the wind should be placed below deck if possible, or if it should be necessary to have the crew up to windward, let them lie close to the deck. (See sketch of start.)

### Distributing Weight

As to the distribution of weight, aim to have your boat sail on the proper water-line at all times; do not allow your crew, when beating to windward, to pile aft, so as to escape spray, and so lift the bow out; at the same time do not get your bow too deeply in. When ready to go about (go on other tack), give the order "hard alee," and let go the tiller, the unbalanced action of the wind on the sail will bring the boat up into the wind with a sweeping curve, and then use the rudder to put her on the other tack.

In this way you will go about easily, and will not lose

headway, as is the case when the tiller is jammed over at the beginning. Immediately on hearing the order "hard alee," the crew should stand ready to shift the ballast, and as the boat rounds up should change it rapidly, so as to have it to windward when the sail fills on the other tack. A manœuver of the same character should be executed when luffing around a mark.

Always be sure before going about that you have plenty of board down. We will suppose that you have luffed around the first mark, and the next leg is a run with the wind aft of abeam. This will not be particularly exacting, the only points to keep in mind being to have your water-line on proper trim, a full sail, and a straight course.

### Jibing Around the Mark

The second mark will have to be jibed around. This is a manœuver your crew cannot be too well drilled in. Give yourself plenty of room, and do not attempt to shave too closely. I witnessed last summer the capsizing of a boat resulting from this desire.

The mark was a buoy placed near a heavy stake, and the helmsman of the boat, wishing to make a close shave, steered too near it, and in passing fouled his sheet-rope on the stake before jibing; the result was the boat became unmanageable, and its momentum carrying it around jibed the sail over, causing an upset. As you near the mark have the man forward stand by the peak-halyard, ready to let go if anything happens wrong. As you are about to turn, have the board raised and come around with an easy sweep; but



## A RACING CAT-BOAT AND ITS CARE

not so rapidly that the sheet-tender cannot haul all the sheet-rope in. The sheet should be brought in with a steady pull, and allowed to run out evenly. If any amount

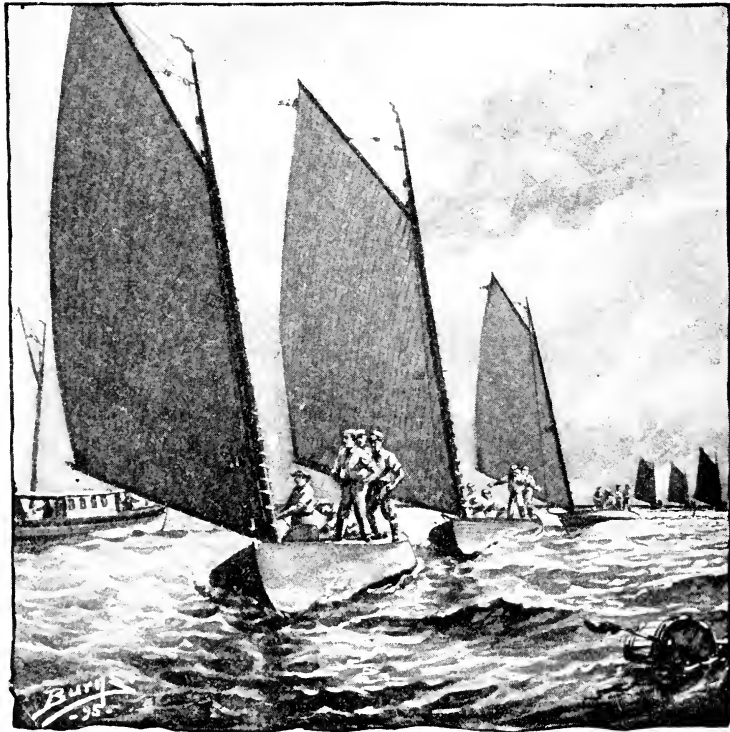

FINISHING BEFORE THE WIND

of slack is given as the sail goes over, the wind on catching on the other side, if it does not capsize the boat or carry away something, will bring her head up into the wind with

such force that it will be some seconds before you can overcome it with the rudder.

### Running Free

The remaining leg of our course we will suppose to be nearly free. When running this way the board should be kept up and all the weight in the boat aft, as a boat under the great pressure exerted by the wind when running this



PEAK LOWERED TO AVOID "GOOSE-WING"

way has a tendency to dig its nose under. It is not necessary for your crew to lie down now, and you may allow them to stand and stretch themselves, as whatever wind they will catch will help the boat instead of retarding, as in the other cases. (See sketch of finish.) The only thing to be looked out for when running free, or nearly so, is a "goose-wing." This happens when the wind is so strong as to cause the boom to jump up parallel to the mast and the sail wrap around it. If when running before the wind

## A RACING CAT-BOAT AND ITS CARE

---

you find your boom is jumping too much, lowering the peak a little will lessen the pressure on the sail and stop it.

It is impossible to prophesy the result of the race, but I can say that it depends equally on your boat and your management, with the training of the crew a close second.

### Righting a Capsized Boat

A few hints on how to right a capsized boat may not be out of place here. If you should happen to be near some boat that has capsized you will, doubtless, feel it your duty to assist the unfortunate. It is not a difficult matter to right a boat when you go about it in the proper way.

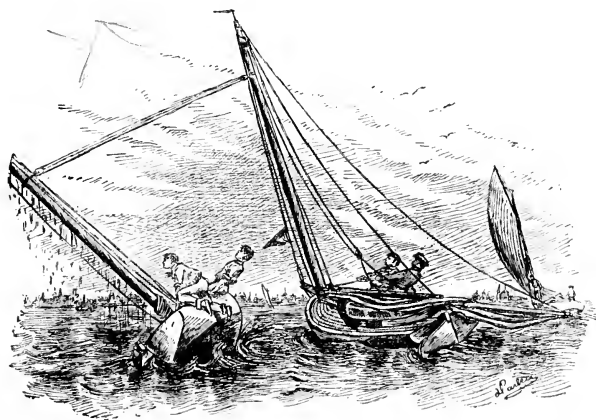

RIGHTING A CAPSIZED BOAT

Run your boat alongside of the capsized one's mast and strip its sail off, unfastening the throat and peak-blocks, unreeving the sheet-rope, and cutting the lashings of the

sail to the mast-hoops. (Be careful that the sail does not sink.) Put your boat in a position alongside the bottom of the upturned boat, and unfasten your throat-halyard block from the gaff. Fasten this to the mast of the capsized boat, as shown in sketch. It will then be an easy matter to pull the boat up to an even keel, when she may be pumped out.

### Winter Quarters

We will suppose the autumn to have arrived and you are ready to put your boat in winter quarters. After removing ballast, mast, sail, spars, etc., construct ways as shown in the sketch of winter quarters. They consist principally of two skids, on which the boat is run and hauled out, but if you care for the condition of the boat's bottom, a cradle had better be made following the idea shown in sketch. Pull the boat out to the end of the skids, and if it is desirable to get it farther away from the water, lay beams in front of the skids, and pull the boat on them. When free of the skids take them up and lay them in front of the beams, repeating this operation until the boat is at the distance desired. After removing everything, cover the deck and cockpit with canvas. The sail should be sprinkled with salt and a little lime—not too much or it will cause rotting, the lime being used to bleach the sail only. This should be rolled up and packed away in a dry place, and the mast and spars should also be under shelter, but not where there is too great heat.

We have followed the fortunes of our boat from the beginning of the season until the end. We have confined

## A RACING CAT-BOAT AND ITS CARE

---

ourselves to the mere mention of some points on which whole volumes could be written. It is the purpose of this chapter to treat this subject in only the broadest fashion, and simply to give general hints for the use of the beginner in one of the most manly of sports.

## Chapter XVII

### MARLIN-SPIKE SEAMANSHIP

**R**OPEs may be joined to one another either by knotting or by splicing. If the rope belongs to the running rigging (such as halyards, sheets, etc.) of the vessel, it will be necessary to put a splice in it, as a knot would refuse to render (pass) through the swallow (opening) in the block. There are three kinds of splices in general use—namely, the long, the short, and the eye-splice. When joining running rigging a long splice is always employed, as it does not increase the diameter of the rope, and when neatly made cannot easily be detected. The short splice is very bulging, but it can be made quickly and is employed in all cases where the rope does not pass through blocks. The eye-splice is used for making a permanent loop in the end of a rope, such, for instance, as is seen in the hawsers by which steamboats are temporarily made fast to a dock, the loop or eye being thrown over the spile on the pier. Let us first consider the making of the latter splice.

#### Splices

**THE EYE-SPLICE** (Fig. 1).—Open the end of the rope and lay the strands 1, 2, 3 upon the standing part as shown in

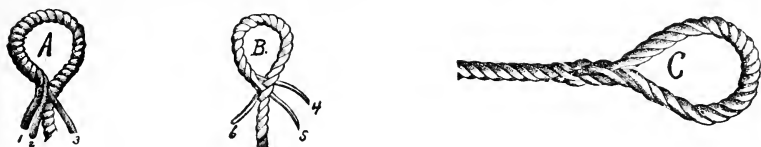

FIG. 1. THE EYE-SPLICE

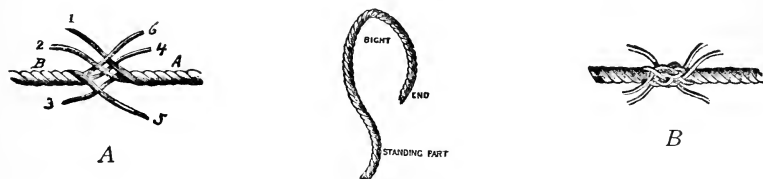

FIG. 2. THE SHORT SPLICE

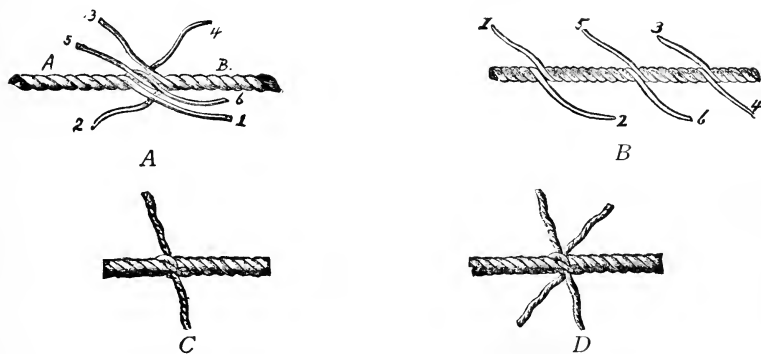

FIG. 3. THE LONG SPLICE

A in Fig. 1; now push strand 4 through the rope as shown in B; next thrust strand 5 over the part through which the former was passed, and last push the strand 6 through on the opposite side. Repeat this once, then cut off the remaining ends, and the splice will appear as in C.

THE SHORT SPLICE (Fig. 2).—Hold the rope B (Fig. 2 A)

## BOATING BOOK FOR BOYS

---

in the left hand; pass the strand 4 over 1, and having thrust it through under 3, pull it taut; take strand 5 and pass it over 2 and under 1; pass strand 6 over the first strand next to it and under the second. Shift the rope around and treat the other side in the same way, and the result will be as shown in Fig. 2 B. This single tucking of the ends is not sufficient for strength, so repeat the operation once, then cut off the ends of the strands.

**THE LONG SPLICE** (Fig. 3).—Unlay (untwist) the two ends to be joined some two or three feet, and place the ends together in the same manner as explained for the short splice. Now take the strand 1 and unlay it as far back as A, and in the groove left in the rope wind the strand 2; unlay the strand 3 and in its place lay-up (wind) the strand 4. At this stage the rope will represent the appearance of Fig. 3 B. The middle strands, 5 and 6, will now be knotted with a simple overhand knot Fig. 3 C, care being observed that the knot is formed to follow the lay (form) of the rope. Next divide these two strands equally as shown in Fig. 3 D, and tuck them into the rope on the same principle as explained for the short and eye splice. The remaining strands will be treated in the same manner, after which stretch the rope well and cut off the ends.

### Knots

**REEF KNOT** (Fig. 4).—This commonly used knot is also known as a flat knot and square knot, and is one of the most valuable of the many employed. As its name implies, it is used to tie the reef points of a sail, the stops (short



lengths of rope) used to secure the jib to the bowsprit when the sail is lowered, etc. Should a person find it necessary in order to affect an escape from a burning building to fashion a line by tearing sheets into lengths and tying them together, this knot should be employed, for it will not slip and the bulge where the strips are tied will afford good hold for the hands. In order to make the knot, simply tie an overhand knot, then pass the ends so that they shall take the same lay (form) as the crossed parts beneath. Should the ends be passed (crossed) wrong, an Old Granny knot (Fig. 5) will be the result, and this knot will capsize (pull out of shape) and slip as soon as a strain is put upon it.

**BOWLINE KNOT** (Fig. 6).—Take the end (1) of the rope in the right hand and the standing part (2) in the left hand; lay the end over the standing part and turn the left wrist so that the standing part forms a loop (4) enclosing the end; now lead the end back of the standing part and above the loop and bring the end down through the loop again as shown. A bowline of this kind, sometimes called a single bowline, is employed in a variety of ways. Seamen sit in the bight (3) of this shape to be hoisted aloft under certain circumstances, and two towing hawsers are often made fast to each other by two bowlines, the bight of one being passed through the bight of the other.

**BOWLINE ON A BIGHT** (Fig. 7).—Double the rope, and take the double end (1) in the right hand, the standing part (2) of the rope in left hand; lay the end over the standing part, and by turning the left wrist form a loop (3), having the end inside; now pull up enough of the end (1) to dip under the bight (4), bringing the end towards the right and dipping it

under the bight, then passing it up to the left over the loop and hauling taut. This knot is employed in the same way as explained for the single bowline, and it may also be stated that it affords much amusement as a puzzle, for if the standing part (2) is held and the knot presented to be untied, only those familiar with the way in which it is made will be apt to discover the secret of dipping the end (1) back and undoing the knot by handling it in a reverse manner to that described for its manufacture.

**RUNNING BOWLINE** (Fig. 8).—The only difference between this knot and the one described under the head of “Bowline” is that the end (1) of the rope is taken around the standing part (2), and then a single bowline (3) is tied on its own part. As will be understood by reference to the diagram, this forms a slipknot or lasso, and in fact it is employed for the same purposes as the latter. When a shark is hooked by sailors the great fish is hauled up until his head is out of water, then a running bowline is made around the hook-line and allowed to fall down over the fins, when it is hauled taut and the strain taken off the hook and line, so that the danger of the fish escaping may be greatly lessened, for the line is apt to break from the thrashing of the creature or the hook pull out.

**WALL KNOT** (Fig. 9).—Unlay the end of the rope and whip (tie) it where shown, and form a bight of strand 1, and hold it down at the side represented by 2; pass the end of 3 around 1, and the end of 4 around 3 and through the bight of 1, then the knot will appear as shown in Fig. 10; now haul the parts taut and the knot will be formed.

**CROWNED WALL KNOT** (Fig. 11).—Over the top of the



Fig. 4



Fig. 5



Fig. 6



Fig. 7



Fig. 8

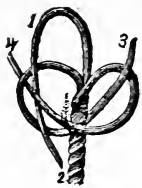

Fig. 9



Fig. 11



Fig. 10



Fig. 12



Fig. 13



Fig. 14



Fig. 15



Fig. 16



Fig. 17



Fig. 18



Fig. 19



Fig. 20



Fig. 21



Fig. 22



Fig. 23



Fig. 24

KNOTS

knot lay the strand 1, then lay strand 2 over 1, and strand 3 over 2, and pass it through the bight of 1; now haul taut the parts and the knot will take the shape shown in Fig. 12.

**DOUBLE WALL AND DOUBLE CROWN KNOT** (Fig. 13).—This is made by allowing the strands to follow their respective parts round, first walling, then crowning, as shown in the diagram. This formation is also used as a Stopper Knot and a Man Rope Knot, although a proper Stopper Knot is shown in Fig. 14. It is a very beautiful knot when nicely made, and as a fancy knot is common on yachts and naval vessels.

**MATTHEW WALKER KNOT** (Fig 15).—As its name implies, this knot is named after the man who invented it. It is exceedingly simple and easy to make, and is in common use on board of all vessels. Unlay the strands for a short distance, and pass the end 1 around the rope and through its own bight; next the strand 2 underneath and through the bight of 1, also its own bight; last the strand 3 underneath and through the bights of 1 and 2. When hauled taut the knot will appear as in Fig. 16.

**DIAMOND KNOT** (Fig. 17).—Unlay the strands as for a Matthew Walker Knot, and form three bights and then take strand 1 over 2 and through the bight of 3; take strand 2 over 3 and through the bight of 1; take strand 3 over 1 and through the bight of 2, then haul the parts taut, and lay up (arrange) the strands of the rope again, and the knot will then appear as in Fig. 18. What is known as a Double Diamond Knot (Fig. 19) may be made by leading the strands through two single bights, having the ends come out at the top of the knot, then leading the last strand

## MARLIN-SPIKE SEAMANSHIP

---

---

through two double bights; last lay the strands up as previously explained, and the knot will show as in Fig. 19.

**TURK'S HEAD KNOT** (Fig. 20).—This is purely an ornamental knot, and is used to beautify yoke lines for a rowing boat, man ropes, ridge ropes, gangway ropes, etc. The material used in the construction of this knot is regulated according to the character of the article to be decorated, ranging from twine to signal halyard stuff (line). To make this knot, form a clove hitch, and bring the bight of 1 (Fig. 21) under the bight of 2, then take the end up through it, make another cross with the bights, and take the end down. Fig. 22 represents a Turk's Head of two lays, but it may have any number of lays, it being necessary only to follow the lead around according to the formation desired.

**ROPE YARN KNOT** (Fig. 23).—It is to be explained that a rope yarn is simply one of the several parts which make a strand of rope. When a strand is untwisted, its parts become rope yarns. These yarns are used for a number of purposes, such as for rough seizings, etc. When a considerable length of rope yarn is required, it is necessary to knot it smoothly, and this is effected in the following manner: Split in halves the two ends of the rope yarns, and crotch and tie the two opposite ends, then jam the tie and cut off the remaining ends.

**LARK'S HEAD KNOT** (Fig. 24).—This knot is used on the same principle as explained for the Slippery Hitch; when it is desired to undo it quickly, simply pull out the wooden toggle 1. The making of the knot will be fully understood by consulting the diagram.

Ropes are temporarily fastened to one another, or to a

spar, hook, ring-bolt, etc., by bends and by hitches. These are all more or less simple, and a little practice and patience is all that is necessary for the young reader to become expert in their manufacture. Let us first consider the bends in general use.

### Bends

**COMMON BEND** (Fig. 25).—This is also known as a single bend, and is used for making one rope fast to another in a hurry. Make a bight with one rope, and hold it in the left hand; pass the end of the other rope 1 through the bight 2, then back round the two parts 3, over the rope 4, under the rope 5, and over the short end of the loop. If the end 1 is taken around once more and through the bight again, as shown in Fig. 26, the bend will stand a greater strain and be less liable to jam. The bend shown in Fig. 26 is known as a double bend.

**CARRICK BEND** (Fig. 27).—This, like the common bend, is used for bending hawsers together, but is a trifle more difficult to make. Make a bight with the end of one rope; pass the end of the other rope through the bight and over the standing part of the first rope where marked 1, then under the end 2, and again through the bight and over the standing part 3.

**FISHERMAN'S BEND** (Fig. 28).—First pass the rope twice round the spar or ring, which act is understood by sailors as "taking two round turns," next take a half hitch round the standing part, then thrust the end under the two turns, and last half hitch the end round the standing part A. When hauled taut the bend will appear as shown in Fig. 29.

## MARLIN-SPIKE SEAMANSHIP

SHEET BEND (Fig. 30).—Pass the end 1 through the eye; take two turns round, observing in each case that the end passes under the standing part 2. The greater the strain,



Fig. 25



Fig. 26



Fig. 27



Fig. 28



Fig. 29



Fig. 30



Fig. 31



Fig. 32



Fig. 33

the more the standing part binds the two turns, and insures them from slipping.

### Hitches

TWO HALF HITCHES (Fig. 31).—This is an exceedingly simple way of fastening a rope, and it has the double advantage of being proof against jamming. Take a turn around the object to which it is desired to fasten; bring the end 1 on top of the standing part 2, then pass it under and bring it up through the bight; repeat this process, haul taut,

and the result will show as in Fig. 32. In case the hitch is to be subjected to a great strain, lash the end of the rope to the standing part where marked 3 in Fig. 32.

**CLOVE HITCH** (Fig. 33).—This is another very useful hitch, but is only employed when the strain upon it is temporary. It is in general use for bending a heaving-line (small rope) to a hawser so that a coil of the former may be thrown from a vessel to the dock and, after it is caught, the hawser pulled ashore.

**SLIPPERY HITCH** (Fig. 34).—This hitch is simply a turn around a spar or other object or through an eye, the end carried across the standing part, and a loop put through the bight, the end 1 being allowed to hang out. When it is desired to separate the hitch, pull out the loop by hauling on the end 1.

**BLACKWALL HITCH** (Fig. 35).—This is used in hoisting. Simply take a turn around the back of the hook, crossing the parts of the rope in front as shown. When a strain is put on the standing part of the rope, the underneath part is jammed and slipping prevented.

**TIMBER HITCH** (Fig. 36).—A hitch employed in towing spars and logs, as it will not slip. Pass the end 1 of the rope around the spar and lead it up and around the standing part 2, then pass two or three turns with the end around its own part as shown in the illustration.

**ROLLING HITCH** (Fig. 37).—A very good method of clapping (fastening) a tail-block. Take a hitch with the tail 1; take another hitch over the first; pass the end under the standing part 2, and twist the remainder of the tail round the rope, following the lay. A tail-block, being portable, is



convenient to make fast anywhere about decks or the rigging, and a rope being rove through this block, a purchase, called a "whip," is created.

MAGNUS HITCH (Fig. 38).—Some people confuse this hitch with the rolling hitch just described, but a comparison of the two will explain the difference between them. With the end of the rope 1 pass two turns over the spar; carry the end in front of the standing part 2; pass it again under



Fig. 34



Fig. 35

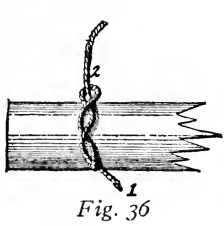

Fig. 36



Fig. 37

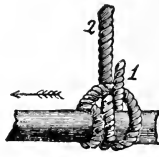

Fig. 38



Fig. 39



Fig. 40



Fig. 41



Fig. 42

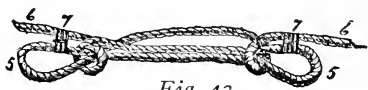

Fig. 43



Fig. 44

the spar and bring it up through the bight. The value of this hitch is its insurance against slipping in the direction represented by the arrow.

CATSPA W HITCH (Fig. 39).—Like the Blackwall Hitch, this one is used for making a rope fast to a hook for hoist-

## BOATING BOOK FOR BOYS

---

ing purposes. Seize the bight of the rope in your two hands, and by turning the wrists form the two loops, then hang these loops on the hook as in Fig. 40.

**SHEEPSHANK HITCH** (Fig. 41).—A quick way of shortening a rope without cutting it is to convert a portion of it into a shape known as a sheepshank. Gather up the spare rope and lay it in parallel lines as shown. These parallel lines may be represented by any number, according to the quantity of spare rope and the length of the sheepshank. In the accompanying diagrams we show the smallest sheepshank that can be made, consisting of three parallel lines. After forming the rope as shown in Fig. 41, take a half hitch with the standing part 1 round the bight 4, and repeat this at the other extremity with the standing part 2 and the bight 3. The result will be as shown in Fig. 42. If it is desired to make this hitch doubly secure, put a seizing (fastening) 7 on the loops 5 and standing parts 6 (Fig. 43).

**MARLING HITCH** (Fig. 44).—Employed to make a running binding which can be put on and removed quickly.

Part V

MOTOR-BOATS AND MOTOR-BOATING



## Chapter XVIII

### SIMPLE TYPES OF BOATS FOR MOTORS

BOATS are attractive enough in themselves to interest any boy, but when they are equipped with a motor the interest multiplies many times. This gives a boat the power of propelling itself, and that is what boys of to-day want. Many of them have fathers who own automobiles, and a boy soon learns how a motor runs and what makes it run by watching the older people start their motors and occasionally take them apart. There are a great many boys of to-day who can run gasolene-motors quite as well as some older people, but there are also many boys who have not had the opportunity to run or to experiment with a motor.

Since a boy must have the boat before the motor, let us consider boats first and see what kind of a boat is best suited to the conditions. Afterward we will consider the motor for it. Let us first get somewhat acquainted with the different kinds of boats. All dogs are in general spoken of as dogs, but there are many different breeds of dogs—St. Bernards and fox-terriers and greyhounds. Any boy can tell one from the other. Boats are just the same, and we will classify a few for those boys whose experience has

not brought them into contact with boats enough to tell one from the other.

### Punt

The simplest and most easily built of all is the square-ended punt or scow (Fig. 1) which in shape is nothing but a long, narrow, shallow box, square at both ends, with the side planks deeper in the middle and narrower at the ends, to

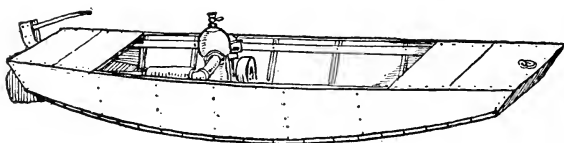

*Fig. 1*

make it easier for the water to crowd down under the boat and rise up again at the stern as the boat passes over it.

There are hundreds of just such boats used on the Mississippi River and its tributaries by men who fish for the pearl oysters. Some of them are quite fast. Almost any boy can build such a boat\* about sixteen feet long, which, with a one or two horse-power motor, will make about six miles an hour. Such boats are very safe, being "stiff," as sailors say, and not apt to tip and spill one over the side into the water.

Most of the boats are built so that one wide board forms each side, and the bottom is put on crosswise, just as if one were making a box. You will be surprised at the amount of fun to be had with such a boat on smooth rivers and lakes.

\*For instructions in building punts and other boats see Chapter vii.

## SIMPLE TYPES OF BOATS

---

### Skiff

For more exposed bays and rivers where waves are apt to be encountered the skiff model is better. This boat is a little more difficult to build, but any bright boy can make one. The only difference is that the front end, or bow, is drawn in to a point like a wedge (Fig. 2). The bottom is put on like the bottom of the punt, or it can be put on in boards running lengthwise from bow to "after end," or stern—"fore and aft," as sailors say—by fitting in oak

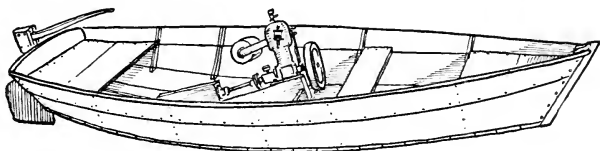

*Fig. 2*

cross-pieces to nail the boards to. A skiff looks much more like a real boat than a punt does. Among yachtsmen this handy and serviceable skiff used to be looked down upon as "cheap," but that is all the more of a recommendation. It is a boat any boy can save up money enough to build. The materials will cost about a dollar a foot. To have one built generally costs about three dollars a foot; the man's wages making up the difference.

### Skipjack

The only objection to these two flat-bottomed types is the fact that they slap or pound the water when there are any waves, but this can be overcome in two ways without abandoning flat planks, and without going into the difficult

## BOATING BOOK FOR BOYS

---

round-bottomed boat construction, which is too intricate for most boys, and for most men, too, for that matter.

One of these ways is to build what is called a "skipjack" (Fig. 3), sometimes known as the "diamond-bottomed boat,"

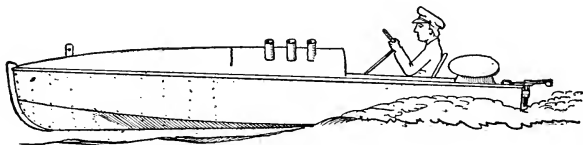

*Fig. 3*

and also as a "deadrise boat," and the other way is to build a dory. The "skipjack," as we shall call this first type, has a flat bottom like a skiff, only while each side is flat in itself, they come together in a wide open V-shape so that the wedge-shaped bow does not pound the water, but cuts it apart. This kind of a boat is good for all speeds. The fastest boats of the day are constructed on this model, as at the extreme speeds up to which motor-boats are driven the water becomes almost a solid substance causing the boats to crowd up and slide over the top of it, and the sliding necessitates a form of bottom so flat that the boat will not roll over, but will slide and stay right side up. This is the way all hydroplanes run. Hydro, meaning water, tells us what they are—water-planes or flat planes sliding over the water's surface. The modern high-speed gasoline-engine is so light for the power it develops that it is now possible to get two hundred horse-power into a twenty-foot boat, whereas formerly only eight or ten horse-power was possible. The impetus which this enormous amount of power gives a



## SIMPLE TYPES OF BOATS

---

boat through the medium of its propeller is sufficient to lift the bow up out of the water, and the boat skitters over the surface like a flat stone skimmed by a boy over the surface of a pond. The fastest boat of 1911, the *Sand Burr II*, owned at Atlantic City, is twenty feet long, with a one hundred horse-power motor, and at full speed it is lifted out of the water until only about seven or eight feet of the after end touches the water. In this position she rushes hither and thither with her high-speed motor humming like a bumble-bee. No round-bottomed boat could stand right side up if she were driven at such a speed, and boats flat, or nearly flat-bottomed in their after part, have to be used.

### Dory

The other way in which the flat-planked construction can be used to produce a good, seaworthy boat is in building what is called a dory (Fig. 4). For slow speeds and for use in

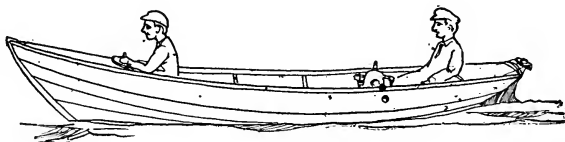

*Fig. 4*

rough water the dory, long used by the hardy fishermen in the Newfoundland bank fisheries, has proved itself to be the safest kind of small boat.

Here the bottom is flat, but much smaller, and made pointed at each end. Both the ends and the sides flare out

considerably—the sides are built up much higher than a skiff, and the ends are considerably higher than the middle of the boat, so that they ride dry and safely over big waves.

The original dories built to row were narrow and had almost flat sides, but as these are rather cramped when a motor is installed the sides are now rounded out more, which greatly increases the buoyancy and makes a more comfortable boat to move about in.

### Round-bottomed Boats

The average boy will hardly be likely to try to build for himself anything more difficult than the dory. That is the connecting link, as it were, between the simple construction and the more complex round-bottomed boats. To build a regular round-bottomed launch calls for a lot of patience and no small amount of knowledge and skill. It is an art in itself.

Round-bottomed boats are more comfortable to ride in, as there is less flat surface and no hard corners for a wave to hit. The round-sided boat takes the shock more gradually and naturally. It is the ambition of every boy to own a real round-bottomed boat.

One would suppose after all the years that boats have been built some standard would have been reached as to the best size and shape, but such is not the case. Every little while some one evolves what to him is a new idea in a boat's shape, though as a fact it may have been tried out a hundred years before.

## SIMPLE TYPES OF BOATS

---

New inventions in the propelling power are largely responsible for the ever-changing type of motor-boats. When steam was the only motive power the weights to be carried in engine, boiler, water, and fuel made it impossible to build a small fast boat equipped with the outfits then on the market, and there were not enough people willing to pay the necessary price for a specially designed light outfit.

Conditions were greatly improved only a few years ago when the naphtha-motor was invented with its small, compact power-plant. To-day, by the use of the more powerful and compact gasolene-motor, many times the power can be gotten into the same space, and naturally all this changed the shapes and proportions of the boats.

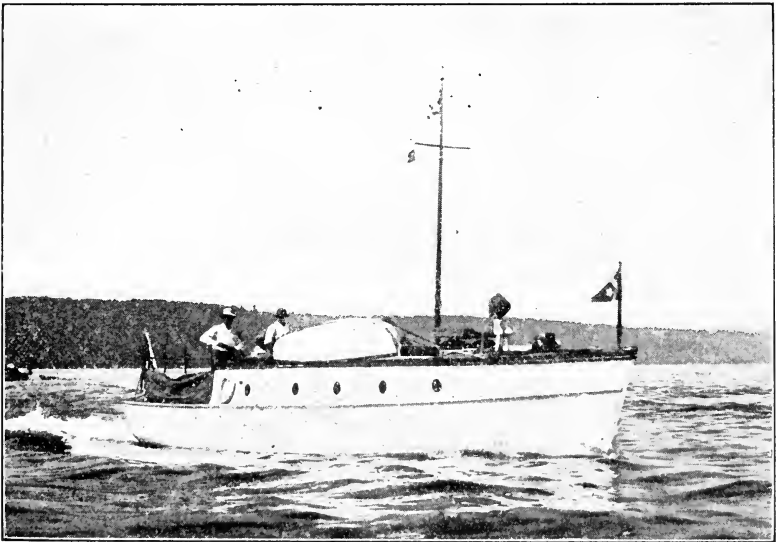

A RAISED-DECK CRUISER

## BOATING BOOK FOR BOYS

---

The principles that underlie the actions and movements of all boats in the water have always remained the same just as the rules of addition and subtraction have remained the same. The same laws of gravitation that have ruled the world heretofore are still at work on boats. The rounder a boat's shape is, the more apt she is to roll; the flatter it is, the less apt to roll. The narrower it is, the easier it will upset; and the wider it is, the more stable it becomes. As boats are made smaller they need more stability, since the weight of a man does not decrease, but stays the same.

Don't expect a boat built like a plank on edge to float upright in the water. It will try to turn over on its side. On the other hand, don't make a boat so wide and flat that it cannot be dragged over the water easily.

### Resistance of the Water

The resistance boats have to overcome in going through the water are the friction of the water along their sides and the cleaving and pushing aside of the water met by the bow. Hydroplanes are so built that they crowd up on the surface of the water and skitter along at a high rate of speed, reducing the friction of the water by crowding a film of air under the boat between it and the water. Ordinary round-bottomed launches do not do this. They have to wedge the water apart and let it close up behind them, and when they go so fast that the water begins to drag after them trying to fill up the hole they leave behind, they are going as fast as they are supposed to be able to go. Sometimes this drag is due to a poorly shaped boat, one where

## SIMPLE TYPES OF BOATS

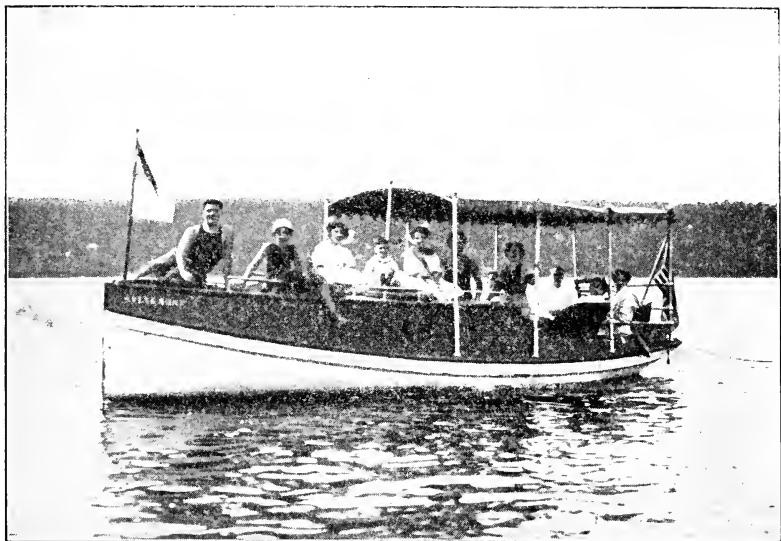

A FAMILY CRUISER

the stern end is rounded in so abruptly that the water does not have an easy curve to flow into at the stern. Boats which are crowded in this manner raise the bows up and drag their sterns down low. The force that makes the boat go is the push of the propeller against the water. The propeller-blades are set at an angle just like the thread on a screw, but whereas the latter will advance one thread ahead into wood for every complete turn, the propeller, turning in water instead of wood, does not go ahead the full pitch of the propeller-blades, because the water gives way to a certain extent. It "slips," so to speak, and this loss is called the "slip" of the propeller. Suppose, for example, the angle of a certain boat's propeller is such that if it

## BOATING BOOK FOR BOYS

---

followed that angle of advance for one complete revolution the propeller would go ahead two feet. It would have a pitch of two feet. But if the boat advances eighteen inches, then there is six inches lost in slip, or, as it would be termed, a 25% slip, six being 25% of twenty-four.

## Chapter XIX

### THE GASOLENE-ENGINE

#### General Description

**A** GASOLENE-ENGINE is in itself as simple as engines can be made. On the outside you see the iron casting like a big piece of round pipe standing up on end as shown by letter A in the illustration of a make-and-break motor (Fig. 1).<sup>\*</sup> That is the cylinder, and the bottom of it, B, is called the "base," the top of it, A, the "head."

Through this casting near the base goes the shaft (F), with a big, heavy fly-wheel (E) on one end and a place to add on more shafting at the other (F). All the rest of the wheels and oil-cans and faucets you see are the fittings. C is the by-pass where the gasolene vapor ascends from the base up past the piston.

Some engines have the heads and sides of the cylinders all cast in one piece, as shown in the accompanying illustration; but others have the heads bolted on separately. If you were to take off this head and look inside you would only see a polished, smooth surface like the inside of a gun-barrel. If you turn the fly-wheel over you will see the top

<sup>\*</sup> If any of these terms are not clear, consult the Dictionary of Technical Terms in the Appendix.

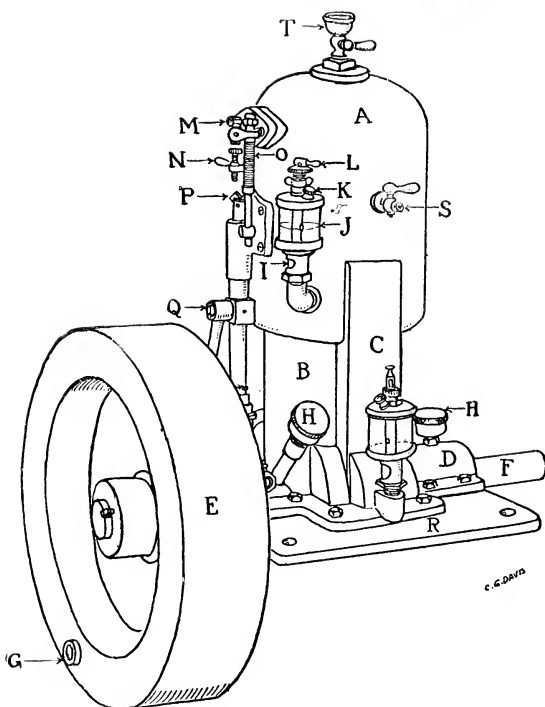

Fig. 1

of the piston slide up and down like the plunger of a pump. This piston takes the pressure as the gases expand upon being ignited. It is shaped like a tin-can upside down, and looking in from the top you see the bottom of the can-shaped piston. Across the inside of this piston there is a steel pin on which is hinged the steel arm which reaches down and grasps the shaft just where it is bent in a U, thus forming a crank by which the shaft and the fly-wheel are turned.



## THE GASOLENE-ENGINE

---

This steel arm is called the connecting-rod. The piston, connecting rod, shaft, and fly-wheel are the principal moving parts of an engine, and all, except the fly-wheel, are out of sight inside the engine.

Another moving part is a small steel shaft that is worked up and down by an eccentric on the shaft just behind the fly-wheel. This works not only the sparker (M), but also another rod (Q), which acts as a pump-plunger to pump the circulating water that keeps the head of the engine cool.

### The Make-and-break System

The make-and-break system of ignition is shown on this engine. As the rod is pushed up the trigger (P) hits against the time-adjusting screw (N) and is pulled away from the rod so that the spring (O) snaps the ignition points apart inside the cylinder and makes an electrical spark. By turning the handle of the screw (N) the trigger (P) can be released at different times so as to make the spark earlier or later during the stroke of the piston.

D shows the after bearing. There is another one between the fly-wheel and the engine where the shaft turns, and this is kept lubricated by the grease-cups (H H). The forward one is generally screwed to the end of a piece of pipe, to make it easier to get at, since the revolving fly-wheel is rather close to it.

J is an oil-cup, I the little glass window, or sight-feed, as it is called, through which one can see if oil is being fed or not. K is the refilling hole, and L, the handle, which, when

raised perpendicularly, opens the valve to let oil pass. When laid down horizontally, L shuts off the oil supply.

S is a relief-cock. By opening it some of the compression is relieved, making it easier to turn over the engine. T acts in the same way and also serves as a cup to prime the motor in starting.

G is the handle for turning the fly-wheel. It has a spring which pulls it back into the rim of the fly-wheel when it is released. Be careful to see that it does go back. Sometimes it sticks, and this handle may catch your clothes.

### The Jump-spark System

The difference between the make-and-break engine and the jump-spark engine is shown in the accompanying second illustration (Fig. 2). Here there is no small shaft jumping up and down on the front of the engine. Instead there is a bevel gear (b) which, in well-made engines, is encased in metal covers so that nothing can fall in between the teeth of the gears and break them. This bevel gear rotates a little rod on the top of which is the timer. This is a wheel or finger revolving in the rubber cup-like box (W). At the proper time, in relation to the stroke of the piston, this timer comes in contact with a metal point that sticks through this rubber box. To this point on the outside the electric wire is made fast so that the electricity, at the second of contact, has a complete circuit to flow around. The action is like turning on a faucet in a house which starts the water flowing in the pipes.

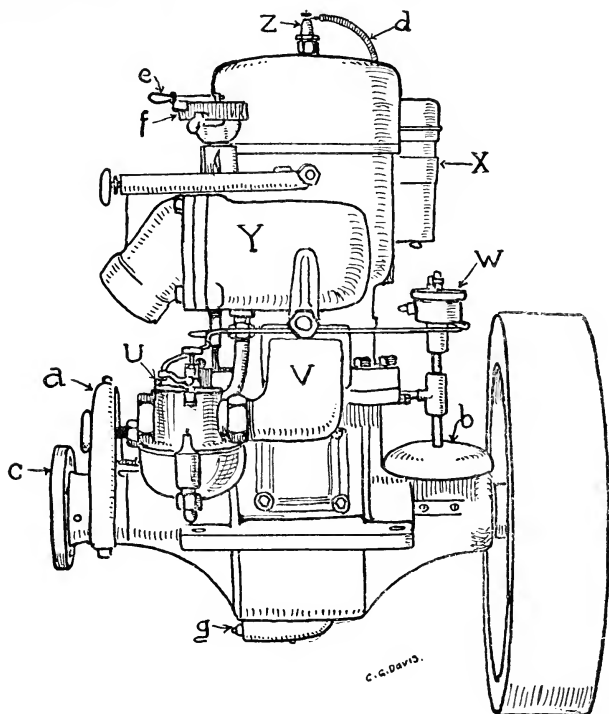

Fig. 2

### The Coil

X is the coil which magnifies the power of the electricity from a low pressure to a high pressure or high tension, as it is technically called. To hold and carry this high tension current of electricity from the coil to the spark-plug (Z), a larger wire is used (d), with more insulation around it. It is more strongly made, just as a fire hose is much stronger than a garden hose.

### Carbureter and Other Parts

Both make-and-break and jump-spark motors use a carbureter (U). The pipe which carries the gases into the engine is called the intake port (V).

To enable the person running the engine easily to reach and adjust the time of the spark and thus either advance or retard it, a handle (e) is fitted to a ratchet (f), which is bolted onto the top of the cylinder-head, and the timer connected to this by means of rods.

Where a chain or a gear-driven pump is used instead of a plunger-pump, the chain or gears are sometimes encased as shown at a. A flange coupling is shown at c. The plug for draining oil out of the base of the engine at g. Water-jacketed exhausts are becoming very popular, since they do away with a red-hot exhaust-pipe, on which one is apt to burn his hands. Y shows such a water-jacketed exhaust.

## Chapter XX

### HOW THE ENGINE WORKS

AS regards the transmission of power to the shafts the gasolene-engine is very similar to the sewing-machine or grindstone. The axle of the wheel has metal bearings or supports, like those of a grindstone, and there is a bent kink in the shaft by which it is turned. When once started the heavy grindstone acts like the engine's fly-wheel. With the muscles of your arm you push the crank that turns the grindstone, but in a motor this push is much quicker and stronger. The engine is built of cast iron, heavy enough so that a gas, when ignited, can suddenly expand and push the piston down. The piston is shaped like a can upside down, with an arm that extends down to the crank. This piston fits snugly up into the engine itself. As the fly-wheel turns around, the crank, or kink in the shaft, causes this piston, or can-shaped affair, to go up and down in the engine cylinder, and every time it comes up near the top it is kicked back again by the explosion of the gas.

#### Three Vital Points

Three things are of vital importance in a gasolene-engine. First, there must be sufficient air mixed with the gas vapor

## BOATING BOOK FOR BOYS

---

to make a high explosive. Secondly, there must be a hot electric spark to ignite this mixture; and thirdly, there must be proper lubrication to prevent the metal wearing on metal from getting hot and expanding so as to bind. Don't expect an engine to run without any of these three things—they will not do it. While this is the A B C of gas-engines it stands to reason that with an outfit of this kind one must use brains. Even a door-knob is apt to come loose, and that has only one screw, so why shouldn't things happen on a motor-boat, where the engine, by the time it is ready to run, contains a line of shafting to be turned, three lines of pipings, gasolene, water, and exhaust to be kept tight, and all the delicate wiring of the electrical outfit to

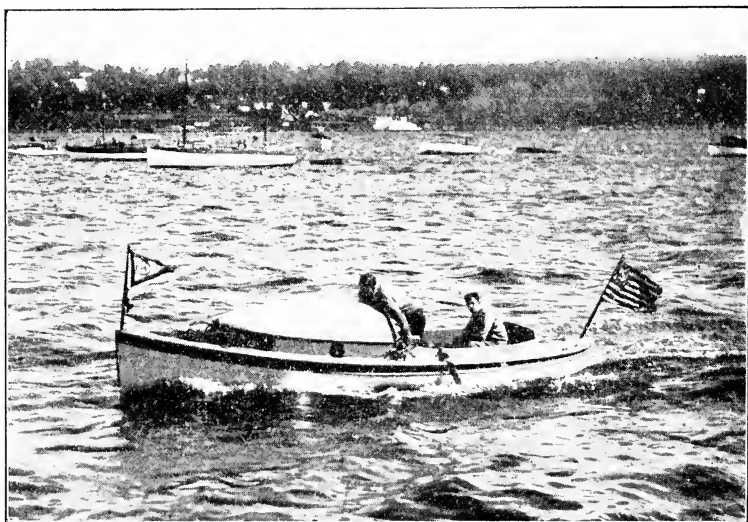

A DOUBLE-ENDED MODEL

be kept in order? Even a door-bell will not ring if one of the wires comes loose from the dry batteries. No one of these in itself is particularly intricate, but all of them help to swell the sum total of parts to be kept in mind. The exhaust-pipe, for instance, if well set up in the beginning, may never have to be touched again. The gasolene-pipe likewise, if care is exercised in straining the gasolene when it is put in, may never give trouble; but, unfortunately, care is the one ingredient often left out, and then we have trouble. Just as some lead-pencils are better than others, so some gasolene-engines are made of better proportions, or of a better grade of metal, or have better workmanship than others. You can't expect to get a hundred-dollar article for twenty-five dollars. But you do get a fair engine very cheaply to-day compared to the cost a few years ago.

### Accessories

What is of more importance, the engines of to-day are generally fitted with everything in the way of accessories best suited to that motor. Engine manufacturers have found it pays them to sell a more complete plant than formerly. When gasolene-engines were first put on the market it was like buying a pair of trousers at one store, a waist-coat at another, and a coat at another. That is to say, you might be able to match the goods, and you might not. But now you buy the whole outfit at one place, and the results to both engine manufacturer and buyer are more satisfactory. There is one prominent company which built up a reputation for its engines just because they insisted on

## BOATING BOOK FOR BOYS

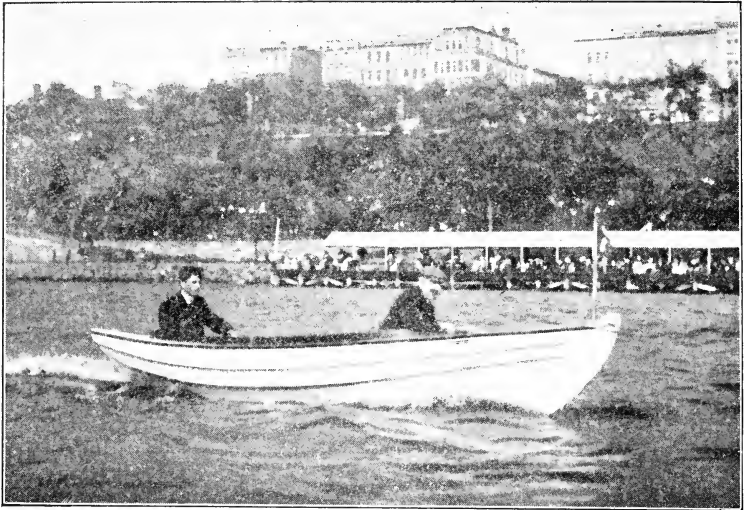

A POWER-DORY IN THE HUDSON RIVER OFF THE COLUMBIA YACHT CLUB

supplying the carbureter to mix the gas and an ignition outfit to discharge it which they knew to be best suited to their motor. They made a reputation for themselves, while other engines, perhaps just as good, were being sold without these important parts, and, as few owners were able to get the right accessories, the reputation of those engines suffered. It is the outfit as a whole that counts.

### Two-cycle and Four-cycle Engines

Gasolene-engines are divided into two kinds: two-cycle and four-cycle. The two-cycle are generally in the smaller-sized engines, and the four-cycle are more common in en-



## HOW THE ENGINE WORKS

---

gines of greater horse-power. The term *cycle* is somewhat confusing, since most people think of it as a circle and imagine that the fly-wheel makes two or four circles. This is not the case. If we used the terms two-stroke and four-stroke engines, as they do in England, this popular error would not have existed.

The two-cycle engine sucks in a charge of gas through holes called "ports" in the sides of the cylinder when the piston is at or near the bottom of its stroke, and compresses the gas against the top of the cylinder as the piston comes up. Then the spark-plug explodes it when the piston is away up and the burnt gases, as it goes down again, escape through a hole low down in the side of the cylinder, and a new charge comes in. All this happens while the fly-wheel is making one revolution.

The four-cycle engine sucks in a charge of gas when the piston goes down, compresses or squeezes it together on the up-stroke, explodes it when the piston is away up, and allows it to expand and keep pushing the piston during its whole down-stroke. Then an exhaust-port opens and all the burnt gases are blown out as the piston rises again. This requires two revolutions of the fly-wheel—two down and two up motions of the piston. The disadvantages of the four-cycle engine in very small sizes are apparent, since a heavy fly-wheel is needed to keep the engine working during the revolution when there is no push.

The two-cycle engine uncovers its ports as the piston slides up and down, but the four-cycle has a separate shaft, called a cam-shaft, turned by gear-wheels from the main shaft, which by means of cams and push-rods automatically

opens and closes the inlet and outlet valves as required. The two-cycle motor has its base all enclosed, since there is pressure maintained in the base. The gases are squeezed from the base as the piston descends. They are forced up around the piston through a small passageway leading from the base up into the cylinder above the piston to the top of the cylinder, and they are ready to be ignited after being again squeezed on the up-stroke.

This compression and explosion of the gases generates so much heat that the cylinder-heads of marine gas-engines are cast double, with a space between the two thicknesses of metal where water can circulate and cool them off. (See A in Fig. 1). This is easy because there is always plenty of water available around a boat. On land it is customary to use air-cooled motors, in which the head of the cylinder is cast with many thin ribs to increase the cooling surface and permit as much radiation of this heat as is possible. (Fig. 3). The appearance of a marine engine is shown in Fig. 2. A two-cycle engine explodes its charge much oftener than a four-cycle one, and the concussion is not so heavy. Hence, for small boats the two-cycle is generally preferred.

### Ignition

The ignition, or means of exploding the gas, also is provided for in two ways: one is called the "make-and-break" (Fig. 4); the other the "jump-spark" ignition (Fig. 5). In both cases the electricity is led in through the head of the cylinder by insulated plugs. In the make-and-break system a low power of electricity is used and a movable arm

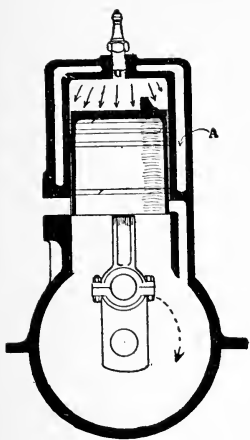

Fig. 1

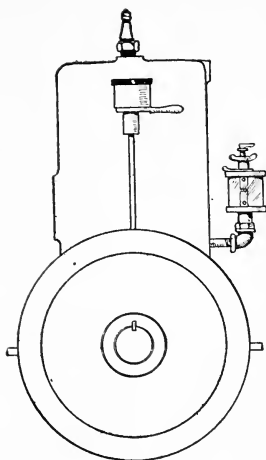

Fig. 2

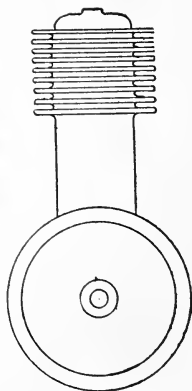
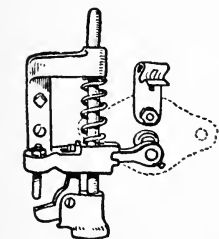

Fig. 3



OUTSIDE



INSIDE

Fig. 4

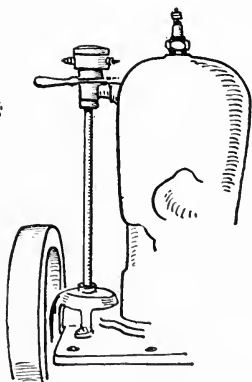

Fig. 5



Fig. 6

## BOATING BOOK FOR BOYS

---

geared to a shaft on the outside of the cylinder. When the piston is up, ready to be pushed down, this arm snaps away from the plug which has the electricity, and as it breaks the electric current it produces a spark that ignites the gasolene vapor inside the cylinder.

In the jump-spark system there are two small wires whose points almost touch each other in the end of the spark-plug (Fig. 6) inside the cylinder. The current of electricity is intensified by means of a spark-coil (Fig. 3. See page 266), and when, at the proper second, a contact is made in the circuit outside the motor by the commutator, the electricity is turned on, and as it rushes along the wires and comes to this break in the plug—the “spark-gap,” as it is called—it jumps from point to point and makes a hot spark which ignites the gasolene vapor.

Without going into all the little details of construction of each engine these are the principal features of the gasolene-engine.

To get a clear idea of all the various parts that one must know in order to understand how motors are installed, or put into a boat, let us see how we would put a two or three horse-power, single-cylinder, two-stroke engine into a skiff.

## Chapter XXI

### INSTALLING THE ENGINE

#### Engine-Bed

THE first step in installing the motor is to build a bed or foundation to which the motor may be bolted. This must hold it up clear of the bottom boards so that the fly-wheel will be free to revolve.

As this varies with different makes of motors, some being wider than others, some having larger fly-wheels, etc., we must obtain the exact dimensions of the motor we are to fit into our skiff, and besides this we must have the diameter of the propeller-wheel that is to be used, in order to know how the shaft line will run. Many engine makers sell the whole outfit complete—shaft, propeller, batteries, etc.

Knowing the diameter of the fly-wheel and the propeller-wheel, we must determine the proper place for the shaft-hole in the bottom of the boat. Stretch a piece of fish-cord to represent the center line of the shaft (Fig. 1), and bore a small augur-hole where it goes through the bottom. Some motors have the base or bottom of the engine foundation right at the level of the shaft-line, others an inch or so below it. Suppose the base is one-half inch below. The first thing

to do is to make a stout floor or brace of about one-and-a-half-inch oak to go across the boat from side to side, high enough to hold the fly-wheel off the floor. When this is fitted to the floor, cut two pieces to run fore and aft, or lengthwise, of the boat just far enough apart to receive the bolts in the bed or base of the motor. These should be notched about two inches into the cross-floor to steady the ends. They should be cut with a slant like that of the fish-line which represents the angle of the shaft-line (Fig. 2 and Fig. 3). Let these pieces run as far aft as they will, to distribute the strain and weight of the motor over as large an area as possible. Between these two, to brace them apart, aft of the engine fit another cross-piece. Fasten all these pieces to the bottom boards of the skiff with large galvanized-iron wire nails, or bolts driven up through the bottom planking of the skiff. To this bed the engine is bolted with lag-screws.

### Stuffing-box and Shaft-Log

There must be some sort of a water-tight arrangement where the propeller-shaft goes out through the boat's bottom. This is called the stuffing-box (Figs. 9 and 10). It is a brass casting that the shaft goes through, with a hole bored out larger than the shaft, so that lamp-wicking or hemp packing dipped in oil and graphite can be tucked in around the shaft and squeezed up around it tightly enough to keep out the water, while the graphite and oil allow the shaft to turn freely against the packing. By boring a hole through a block of wood big enough at its end to have this stuffing-box bolted to it over the hole, and by fitting

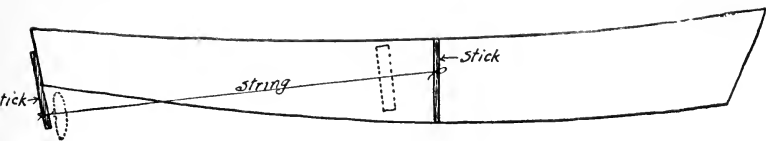

Fig. 1

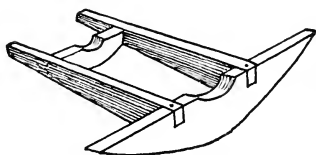

Fig. 2

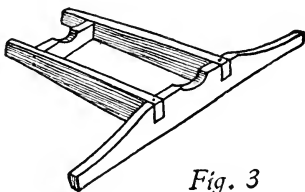

Fig. 3

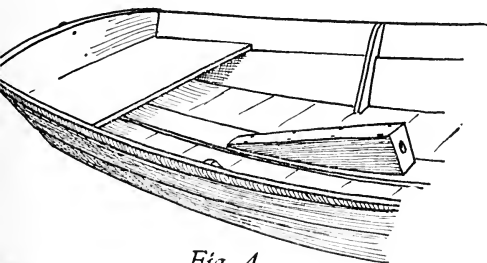

Fig. 4

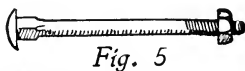

Fig. 5

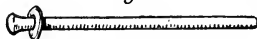

Fig. 6

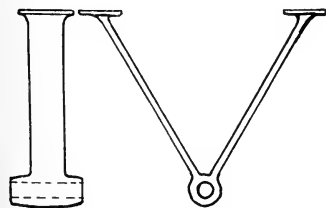

Fig. 7

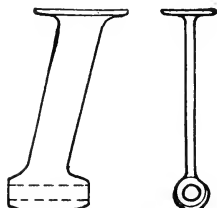

Fig. 8

this block, which is called the shaft-log, accurately to the inner bottom of the skiff so that the fish-line previously referred to will pass exactly through the center of the hole, we have a water-tight place for the shaft to go out (Fig. 4).

Be careful to make a close fit between this shaft-log and the bottom boards of the boat. Before you bolt the shaft-log down, paint the wood with thick white lead-paint. Lay a piece of muslin in this, paint that, and then lay the shaft-log down and bolt it fast with long carriage-bolts (Fig. 5). If you can't get carriage-bolts long enough take some round iron rods and rivet the ends over iron "clinch" rings made for that purpose. They are different from a common flat washer in that they are thicker and tapered thin at the edges. The inside of the hole is beveled out to let the iron rod swell and form a head that will not pull through. (Fig. 6).

### Shaft-Hanger

If the after end of the shaft near the propeller were not held firmly it would wobble about. To hold it we need what is called a shaft-hanger (Fig. 7 and Fig. 8). This is a brace with a bearing for the shaft to turn in. The bearings are brass castings with the shaft-hole lined with babbitt metal, which is the only metal that can stand the heat generated by the rapidly revolving shaft without getting so hot as to expand and bind the shaft. In large ships they formerly used a kind of very hard, oily wood called *lignum-vitæ*. It will be necessary to buy the shaft-hanger, unless you wish to exercise your ingenuity and make one with the aid of a plumber, who must melt and run in the babbitt



## INSTALLING THE ENGINE

---

metal. If, however, one wishes to fit a piece of wood outside, similar to the shaft-log inside, a stern-bearing can be used such as some engine makers supply with the motor as part of the outfit. The stern-bearing is a brass casting much like a stuffing-box, except that the bearing has no part to screw up in order to make it water-tight. It is simply a bearing lined inside with babbitt metal. A great many boats do not have both the stuffing-box and stern-bearing. Instead they have only a stuffing-box (Fig. 10), and that answers both purposes by being placed on the outside. The disadvantage of this is that if the packing around the shaft wears so that it begins to leak one cannot tighten it up from the inside. It will be necessary to haul the stern of the boat out to get at the stuffing-box in order to tighten it up with a monkey-wrench.

If a floating log should be hit by the propeller with sufficient force to bend the shaft this stuffing-box would soon become worn and a bad leak would be caused. It requires some neat carpenter work to fit this deadwood piece for the stuffing-box, and there is a much simpler way of accomplishing the same result at but little if any more cost, and certainly in much less time. This is by buying a metal shaft-log, as it is called—a flat casting (Fig. 9) that can be screwed flat into the surface of the boards with the stuffing-box in one piece. Amateurs will find this an easy way to overcome a difficulty. Shaft-hangers too can be purchased which are adjustable to any desired depth, either in a single strut (Fig. 8) or of the double or V type with two legs (Fig. 7).

Lining Up the Shaft

When the stuffing-box is all fitted run the propeller-shaft through it up to the motor's shaft and see how the two meet. They should be in perfect line, one with the other. To see if they are, lay a straight edge along the joint and

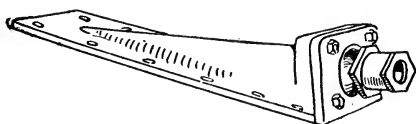

Fig. 9

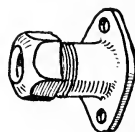

Fig. 10

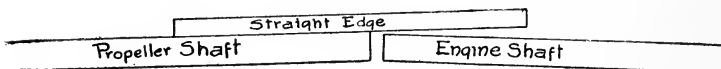

Fig. 11 .

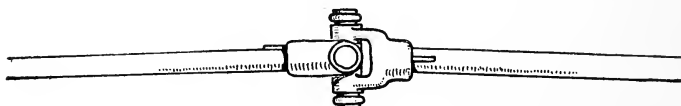

Fig. 12

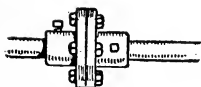

Fig. 13



Fig. 14



Fig. 15

see that it fits flat on top, on both sides, and underneath (Fig. 11). Never pull the shaft out of a true line to force it into the coupling on the engine-shaft. In running ma-

## INSTALLING THE ENGINE

---

chinery one must be particular about such things. The two shafts must be exactly in line.

If the bottom of the boat is so flat that it will tip the engine at too great an angle to line it up true with the propeller-shaft, a universal joint (Fig. 12) can be used to unite the two shafts and permit the engine to be set nearly if not quite level while the shaft slants down.

### Shaft-Couplings

Two kinds of couplings may be used for shafts—the flanged and the sleeve coupling. The flanged coupling (Fig. 13) consists of two round, flat discs that are either keyed or set by set-screws to the ends of the shafts, and the faces when brought together are bolted to each other.

The sleeve coupling (Fig. 14) is like a short, heavy piece of pipe split in two. These halves clamp down over the two ends and are bolted to each other. Some are made so that they take a larger shaft at one end than at the other. When this is the case they are called reducing couplings (Fig. 15), and they are employed when the engine-shaft is larger than the propeller-shaft, which is often the case.

### Propellers

The engine makers, by actual test of motors of different horse-powers, have found out just which propeller gives the best results. A beginner, therefore, should adopt their selection of the propeller best adapted to a given motor.

It will be time enough to experiment with propellers

## BOATING BOOK FOR BOYS

after one has learned something by actual experience. There are a great many different kinds of propellers, wheels or screws as they are variously called, some good, some poor, and some intended for a special kind of work. But

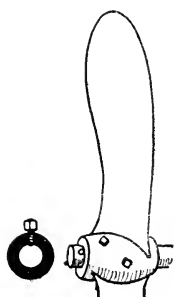

*Fig. 16*

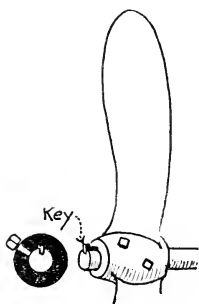

*Fig. 17*

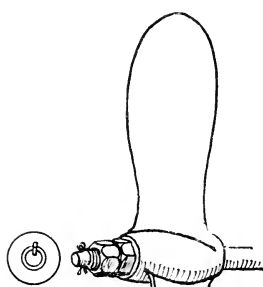

*Fig. 18*

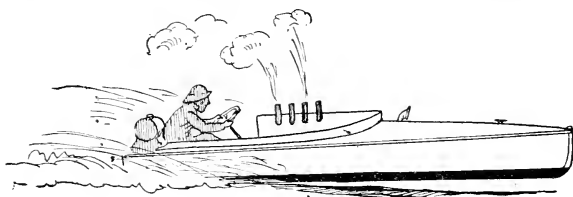

*Fig. 19*

until one has learned to distinguish a true propeller from an expanding pitch it is better to use what the maker sends.

As in any other wheel, the central part of a propeller is called the hub. The fan-like projections are called the blades. According to the work there may be two, three, or four blades.

A tug-boat, with a big, heavy, slow-moving hull intended

## INSTALLING THE ENGINE

---

---

to pull other heavy vessels, generally has four large, wide blades, while a light racing hull designed for speed has only two or three blades of a much smaller area.

The diameter of a propeller is its distance from tip to tip across the wheel. The pitch is a little more difficult to explain. It is the distance the blades are supposed to advance in one complete revolution. Look at an ordinary wood screw, the pitch there is the distance from one thread or edge of the screw to the next. A slow-going working boat has a propeller that does not go ahead very far, while a racer's does. The former is termed a low-pitched wheel, while the latter is a high-pitched one.

The way the propellers are fastened to the shafts varies in outfits of varying prices. The cheaper ones merely slide upon the shaft, and are kept from sliding around by a couple of set-screws which are fastened down hard against the shaft (Fig. 16). It is generally necessary to file a slight dent in the shaft to make these screws hold. A far better way is to cut a slot, or "key-way," in both shaft and propeller-hub (Fig. 17). This stops the propeller from slipping around on the shaft; but a better way is to taper the end of the shaft and have a tapered hole in the propeller with a key-way cut in both, and a nut screwed on the end of the shaft to prevent the propeller from slipping back. A second nut called a lock-nut is sometimes screwed up against the first one to prevent it from working loose, or a split or cotter pin is put through a small hole bored through the shaft to answer the same purpose (Fig. 18).

### Exhaust-Piping

We now have the engine connected to the propeller-shaft. The next task is to pipe the exhaust. On high-speed racing boats the noise and smoke shoot straight out into the air through a short length of pipe which may be high enough to blow the smoke overhead, or the pipe may lead to one side (Fig. 19). As this pipe becomes very hot, it must be of fairly heavy iron and of large enough diameter to carry off all the burnt gases. There is not much comfort in one of these noisy boats. It is necessary to shout in order to be heard, and the smoke and oil spatters all over the face and clothes.

All this can be overcome by running the exhaust through a muffler or silencer (Fig. 20), which deadens the sound, and from the muffler out through the stern or side of the boat.

Where the exhaust-pipe comes out of the motor its heat would burn all the paint off if it were left bare, and, therefore, most of the engines are fitted with what are called water-jacketed elbows or manifolds (Fig. 21). Around the cylinder-head, where it is doubled and kept cool by being filled with water, holes are now provided to let some of this water run out around the exhaust-pipe, which is a special double casting. This water cools the inner pipe, through which the hot exhaust, or used-up gases, are passing out. When these gases cool they condense, or become smaller, and if cooled enough the exhaust can be made to come out so quietly that it is not objectionable. Besides cooling the pipe from the outside with water it is a good

## INSTALLING THE ENGINE

plan to turn some water into the exhaust-pipe. The intense heat, of course, almost immediately turns it into steam; but the sharp, noisy crack and bang of the exhaust, like a cannon's report, is completely stopped by the water.

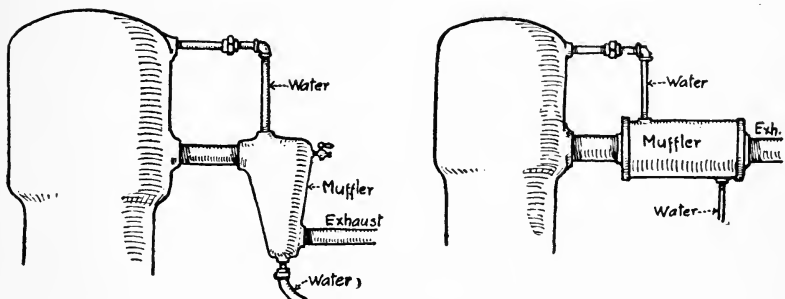

*Fig. 20*

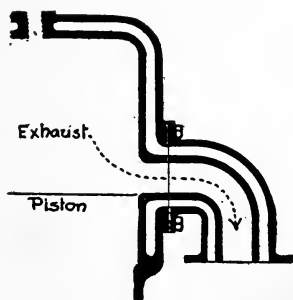

*Fig. 21*

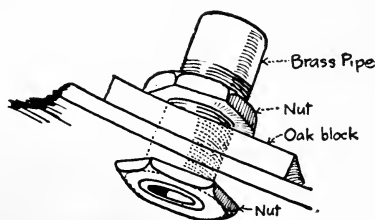

*Fig. 22*

To cut threads on a one-and-a-half-inch pipe for a three-horse-power motor is a task that should be left to a plumber or pipe-fitter. He has the necessary tools and cutters, and from him one can probably buy all the necessary elbows and unions to connect up the pipes. For the circulating water

brass piping is generally used, and this can be arranged at the same time, although this part is sometimes connected up with rubber hose clamped tightly to short brass nipples over which it fits. For the motor a one-half-inch brass pipe is large enough. When a pipe runs out through the side or bottom of a boat it is a good plan to fit an oak block on the inside to strengthen it. Set it in white lead to make it water-tight, and screw or rivet it fast to the planks. Have a thread cut on the pipe long enough not only to screw through the wood, but to take a thin, flat nut on the inside and outside (Fig. 22). These will keep the pipe from shaking loose with the vibration.

### Water-Intake

You will find on the motor a water-pump gear driven from the crank-shaft of the engine. Some use a regular plunger-pump (Fig. 23) to suck the water in from outside the hull of the boat and force it to flow all around the cylinder in the water-jacket and out overboard again. Others use a round, flat pump consisting of two gear-wheels (Fig. 24), and still others use various makes of centrifugal pumps (Fig. 25); but all are for the same purpose. Those pumps get their supply of water from a pipe which goes through the bottom of the boat well down under water, so that when the boat rolls the pipe will not come out and suck air instead of water (Fig. 26). This also can be either a brass pipe or a rubber hose. Common iron pipe is apt to rust through and cause a leak which might sink the boat. In fresh water iron might last several years, but for



## INSTALLING THE ENGINE

salt water use brass by all means or else the hose. Use lock-nuts on the intake as previously described for the exhaust. If the boat is a fast one, it is a good plan to fasten some sort of a scoop (Fig. 27) to supply water to the pipe, as without something of this sort the water is apt to shoot past the end of the pipe so fast that but little of it will be sucked in by the pump, and without water the engine will soon run hot and give you trouble.

The suction into this pipe may draw sea-weed, mud, or

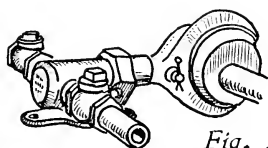

Plunger Pump

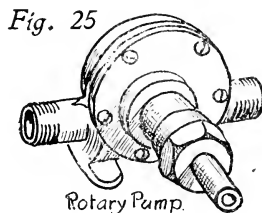

Rotary Pump.

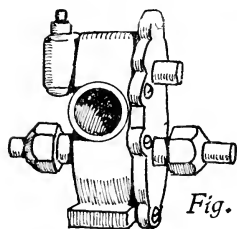

Gear Pump

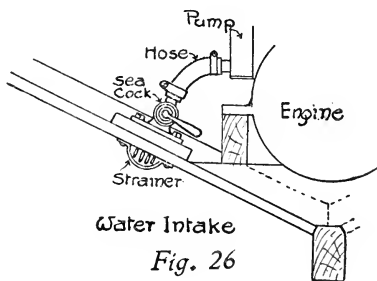

Fig. 26

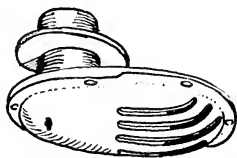

Fig. 28



Fig. 27

## BOATING BOOK FOR BOYS

---

any floating object, choke up the pipe, and shut off the water supply. To prevent this a brass sieve or screen (Fig. 28) is generally fitted over the end. Sometimes when a small boat is aground at the shore this pipe becomes clogged up with mud; but this generally washes off after the boat has been running a short time. The intake-pipe, being well below water, would, if the pipe to the engine ever became broken, leak so as to sink the boat, and as a safeguard against such an accident this pipe generally has a valve or sea-cock which can be turned so as completely to shut off all water. In leaving the boat over night this cock should always be closed.

While it might seem best to run all pipes as straight as possible from the motor to the outside through the planking, yet when one considers what happens when the shaking of the motor begins, one can see that something is apt to give way. Therefore, a turn in the pipe is advisable, for this allows movement to take place without breaking anything. Since all pipes expand when hot and contract as they cool, that is another reason why they should be allowed to swing.

## Chapter XXII

### GASOLENE-TANKS AND CARBURETERS

**E**NGINE makers do not generally supply the tanks to hold the gasolene, because these are usually made to fit the shape of the boat in the bow (Fig. 1). This is the most out-of-the-way place to put it on a small boat, and since the bow is the higher, gasolene will readily flow down to the engine.

#### Fitting in the Tank

Make a framework of thin strips of wood of the size desired for the tank, shaped to fit up in the bow. The bottom of the tank must be no lower than the carbureter on the engine. Take this pattern to a tinsmith and have him make a tank out of fairly heavy copper with a screw-plate of about two inches in diameter for the hole in the top through which the tank is to be filled, and a plate fitted for a quarter-inch brass pipe for the outlet about a quarter of an inch above the bottom in the after end or else in the bottom near the after end. In the center of the screw-plate on top have a small pinhole drilled to let air into the tank as the gasolene is used out of it. More than one man has had his engine stop, and has worked over it for a long time trying to find out why it stopped, only to find that it was

because the air could not get in to fill up the space left by the receding gasolene in the tank. Square or shaped tanks, as this kind is called, should have a compartment built like a box in the bow to hold them, with a floor of pine boards on which the tank may rest firmly. Punch all the nail-heads well into the wood, or one may rub a hole through the tank and cause a bad leak. After the tank is in this box-like compartment push some flat, smooth boards in alongside of it to hold it from shifting as the boat rolls, or it might break the pipes.

Many people use galvanized sheet-iron tanks. If there is room in the boat one can buy a pressed-steel tank shaped just like the hot-water boiler beside the kitchen range at home, only smaller (Fig. 2). These tanks are the least likely of all to leak. Large tanks have partitions, or "swash plates," inside to prevent the whole bulk of oil from surging back and forth as the boat rolls. A smarter effect is obtained by selecting a cylindrical tank and placing it aft, behind the stern seat (Fig. 3). The tank must be raised so that it will be above the carbureter, which can be done by setting it in two pieces of boards cut saddle-shaped to receive it. All the small, fast racers have adopted this arrangement for carrying their tanks. It prevents any leakage of gasolene into the boat, and can be readily inspected, and all the pipe connections can be looked after.

In large yachts, where the gasolene-tanks are below the floor, and even in some of the small racers, where the gasolene is carried low in the boat, a small "feed tank" is placed up above the motor. The gasolene is made to flow up into this feed tank by an air-pump, like a bicycle or auto

# GASOLENE-TANKS AND CARBURETERS

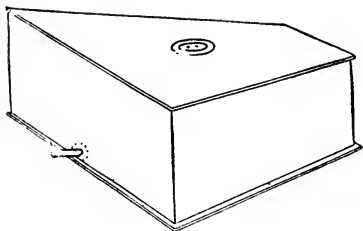

Fig. 1

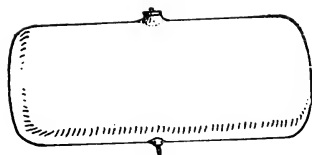

Fig. 2

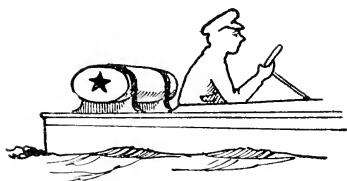

Fig. 3

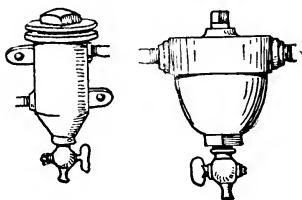
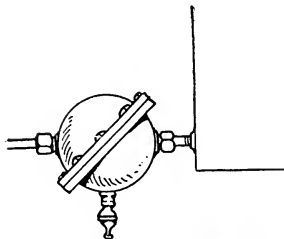

Fig. 4



Fig. 5

tire pump. It does not take much air pressure to make the gasolene flow up into the feed tank, and from there it flows down to the carbureter itself.

## Feed Pipes

To carry the gasolene from the tank to the carbureter on the engine all kinds of pipes are used, and all kinds of troubles experienced as a result. Some cheap outfits are piped with an iron pipe, but it is not the best. Some use

## BOATING BOOK FOR BOYS

---

brass pipes, some block tin, some tin-lined lead pipes, but copper pipes are the cleanest and least likely to get choked up. Gasolene is a very thin fluid, and it will leak through a pipe which will hold water securely. It is also lighter than water, so that any water which gets into a tank of gasolene will sink to the bottom. More or less dirt always gets into a tank, and even in a clean tank a thick yellow gum is generated from impurities in the gasolene, which clogs up the pipe and causes the engine to stop. All this makes it advisable to have a sort of trap or separator (Fig. 4), to catch this dirt before it can reach the small pipe. These separators should be connected up close to the tank, so as to catch the dirt as soon as it comes out. They can be opened occasionally and the dirt removed. A boat will run sometimes for days and not give any trouble, and then on some windy day when there is a great deal of motion the gasolene in the tank is shaken up so violently as to stir up all the scale, dirt, and gum, and unless there is a separator to catch it this dirt chokes off the supply of fuel. The only precaution taken where there is no separator is to fit a piece of very fine wire gauze into the ends of the pipe, so that no dirt can get back onto the small needle valve in the carbureter.

The brass nipple which screws up into the tank, if the outlet is in the bottom, should extend up about a quarter or an eighth of an inch, so that dirt cannot get into it. It should not be flush with the bottom. A separator is usually designed to be connected to a nipple coming out of the after end of the tank, with a stop-cock between. The gasolene comes in at the top of the separator, goes down and comes

## GASOLENE-TANKS AND CARBURETERS

up through a fine wire-gauze screen, and flows out the other side at the top, leaving any dirt to settle and go out at the opening in the bottom. These separators also hold the water and by opening a small "pet-cock," like a little faucet, this water can be drained off. One can see the water lying in bubbles in the gasolene very much as heavier oils lie in water.

To this separator connect the annealed copper feed-pipe with a union, and have all such joints sweated and brazed or soldered, for gasolene will go through most screw joints. The best thing to stop it is to dip the threads into shellac before screwing them together. That makes an oil-tight joint, but not so good a one as a soldered joint. The difference between a hard copper pipe and annealed copper pipe is that the latter is soft, and it can be bent without breaking it, so that it can be led along in the boat's lockers or under the seats, where it will not be trodden upon and crushed flat, and, also, using one piece only, it can be bent to lead to the carbureter. If brass pipe is used there must be several joints in order to make the turns.

Have another union (Fig. 5) at the carbureter, so that if the pipe gets stopped up you can disconnect it at each end and clean it out.

### **The Carbureter**

There have been many references to the carbureter (Fig. 6), and now we will explain it in detail. It is a part of the motor; a rather formidable-looking brass contrivance whose whole duty is to receive the gasolene as a liquid and to mix it with air in order to make a high explosive gas.

This mixture is led through pipes into the base of the engine. In four-cycle engines it is led up to the top of the cylinders above the piston, but in a small, three-horse-power, two-cycle engine it goes into the base and is sucked out, at each revolution, into the top through what is called the "by-pass."

The carbureter is generally furnished to the buyer with the motor, though many engine manufacturers give a choice of several different makes. The kind of carbureter which a man has grown accustomed to is apt to be the best

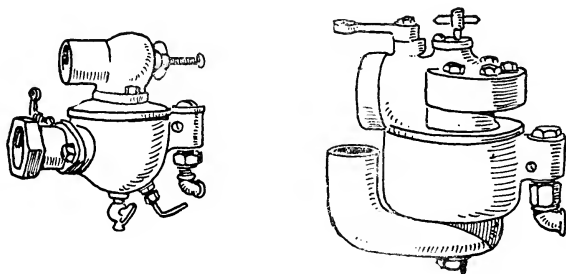

*Fig. 6*

in his opinion, and all makes of carbureter are sold and used. The principal trouble with them all is that many of those who use them do not understand them, and will not take the trouble to study up the actions that take place at different points of adjustment in the carbureter.

The gasolene enters the carbureter through a very small hole, which is called the needle valve, and as the piston of the engine goes up it creates a suction like that in any pump. This sucks a supply of air from the carbureter, since that is the only inlet to the engine-base open at that



time, and as this air has to come through a regular reservoir of gasolene it becomes mixed with the fumes and forms an explosive gas. One part of gasolene to four parts of air makes a weak explosive mixture; one to eight a violent explosive; and one to thirty-three will not explode. Sometimes there is too little air admitted and the engine sucks up a charge of gasolene vapor that is "too rich" a mixture, and when one tries to start the motor this gas has not enough air mixed with it to be explosive. On the other hand, the reverse may be the case. There may be too much air and not enough gasolene. Then the mixture is "too lean" or "too poor" to explode. When the air is warm and dry it mixes with the gasolene far better than on a cold, wet, or foggy day when the air is charged with water, and for that reason many makers of engines arrange the pipe of the carbureter so that it draws in the hot air from around or near the exhaust pipe.

### How to Start the Moter

To start the motor when it has stood unused for some time, so that it would require considerable cranking of the engine by hand in order to suck up and compress an explosive charge from the base, it is customary to have a little cock, or "priming cup" (Fig. 7), in the top or side of the cylinder-head through which some gasolene can be put directly into the head of the cylinder. Keep a "squirt can" full of gasolene in the locker for this purpose. Some people drain a little gasolene from their carbureter into a tin can or cup

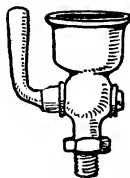

Fig. 7

## BOATING BOOK FOR BOYS

---

---

and try to pour it into the tiny priming cup, with the result that in getting a thimbleful into the engine they spill more than half.

By rocking the fly-wheel enough to move the piston up and down an inch or so, after opening the pet-cock, this gasolene in the priming cup is sucked into the cylinder-head. Rock the fly-wheel a couple of times to mix this gasolene, and then throw the wheel clear around. If the gasolene is properly mixed, the engine will start and sparks will shoot up through the priming cup, which should be closed, of course, before one begins to crank.

Sometimes the carbureter gets too much gasolene, and becomes "flooded." In this case turn off the feed-pipe from the tank and drain out the carbureter. Sometimes the base of the engine is also flooded. Shut off the supply of gasolene by screwing the needle valve down tight, open the pet-cocks, and turn the fly-wheel over by hand several times. A "back fire"—when the motor explodes the charge in the base and spits out fire through the carbureter—is caused when the mixture is so weak and has so little gasolene that it is slow to ignite and burns so long that it is still burning when the fresh charge is coming up through the by-pass. Then the fresh charge is ignited and it blows back through the by-pass into the base. It is a sign that the engine is not getting enough gasolene.

## Chapter XXIII

### IGNITION AND OILING

**T**HERE are two ways to fire the charges of explosive gas in the cylinder-head by an electric spark. In the "make-and-break" system the spark is obtained by means of a movable arm or point of metal which touches another point inside the cylinder, and when the spark is needed this movable arm is suddenly tripped on the outside by a push-rod worked from the main shaft of the engine. As the push-rod snaps it away from the other point, breaking the flow or current of electricity, it produces a spark or flash of flame which fires the charge. The action is like that when one snaps the two wires from a dry battery together to see whether it is a "live" battery or a "dead" one. If it is alive—that is, capable of giving out electricity—it will make a spark as the two wires snap apart. It is also sometimes referred to as a "wipe" or "touch" spark to distinguish it from the "jump" spark.

#### Jump-spark Motors

The "jump-spark" motors do not have an arm to trip. Instead they have a revolving shaft which is turned by the engine shaft, and on top of this is a flat, round rubber box

called the "timer" (Fig. 1), because there is a finger on the shaft which revolves with it, and every time it passes a certain spot in this box it touches metal and makes an electrical contact.

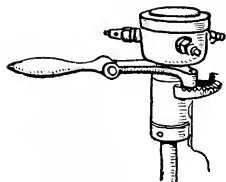

*Fig. 1*

In this way it turns on the electricity to the spark-plug for a second, and in jumping this small gap between the two fine wire points on the end of the spark-plug (Fig. 6, see page 241), which is screwed down into the cylinder, it produces a bright spark as the electricity jumps from one point to the other, and this ignites the gasolene vapor.

To distinguish one from the other, think of the first one, or "make-and-break," as a stream of water flowing naturally through a small pipe, and think of the second, or "jump spark," as a stream with a pump behind it forcing it through swiftly. The first is termed a low-tension and the second a high-tension current of electricity. In the case of a "make-and-break" motor there are about six dry cells or dry batteries (Fig. 6), a spark-coil, or primary coil as it is called (Fig. 3), a switch (Fig. 4), and some insulated wire.

### Cells and Wires

These cells should be fitted into a box to keep them from rolling about and breaking the wire connections. Cut short lengths of wire or buy the regular connections made for this purpose (Fig. 5), and couple one cell to another. Lay bare the end of the wire for about three-quarters of an inch, and turn it around or thrust it through the small

## IGNITION AND OILING

---

hole in the center or carbon post of one cell and the side or zinc post of the next cell. Put the spark-coil under a seat or in a locker where it will not get wet, for water will ruin it. Attach a wire to the last zinc or side post of the cells, and run it under the seat along the side of the boat, high enough up to keep it as dry as possible until it reaches the engine. Then pass it down and attach it to one of the nuts which hold the base of the engine (Fig. 6). This is the ground wire. The other wire should lead to one end of the coil. In going through the primary coil the electricity is increased in force and it is carried out by a wire from the other end; or it may be on the same end, but through a different post. From this outlet the second wire goes to the arm which causes the "make-and-break" spark; but at a convenient spot this wire should be cut and the ends attached to a switch, so that the current can be cut off when not in use. (Fig. 4.)

In the case of a "jump-spark" motor the batteries are wired together just the same, but the induction-coil is different. It has a "vibrator," or "buzzer," as some call it, on one end, and it has another post to take a third wire.

One wire, called the ground wire, leads from the side post of the dry cell to a screw on the handle of the timer-lever. A switch to throw off the current should be put somewhere along this wire. The other wire, from the center post of the cells, leads to a screw at one end of the coil-box. From the other screw on the same end of the coil a wire should be run to the screw on the side of the timer-box. These primary wires are the usual small insulated wires, but a larger, heavy secondary wire should

## BOATING BOOK FOR BOYS

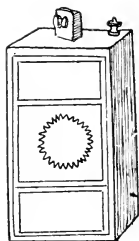
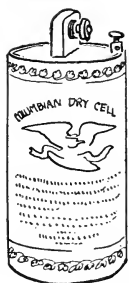

*Fig. 2*

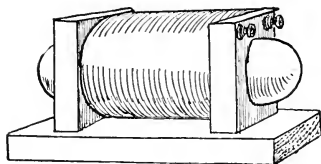

*Fig. 3*

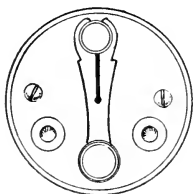

*Fig. 4*

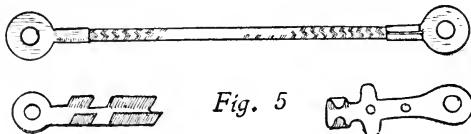

*Fig. 5*

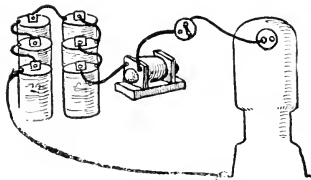

*Fig. 6*



*Fig. 7*



*Fig. 8*

lead from the spark-plug to a screw at the side of the coil-box. This may be regarded as the high-pressure wire. It carries a great deal of electricity, as you are apt to find out if you touch it. In this arrangement the timer is

## IGNITION AND OILING

---

geared in such a way that every time the piston comes up to the top of the cylinder its revolving finger makes a contact with the metal and a current of electricity races through the wires. The vibrator begins to buzz, and a hot spark jumps across the points of the spark-plug as long as this finger touches the metal contact point in the timer-box. This is only a fraction of a second when the engine is running.

If the vibrator does not buzz there is no spark, and it may be necessary to turn the screw which adjusts the movement of the vibrator. As one changes the adjustment of this screw a humming begins and grows louder, but the action of the engine, after a little practice, will show when the adjustment of the vibrator is the best.

### Lubrication or Oiling

Any piece of machinery where two pieces of metal are rubbed together will get hot unless the points of contact are oiled, and a gasolene-engine is no exception to this rule. In the cylinder the piston slides up and down four hundred or more times a minute, and in a very hot place at that. On our little motor there is a grease-cup on each end of the crank-skaft bearings, and one where the main shaft of the engine revolves in babbited bearings, and another in the base of the engine. On a small brass pipe screwed into the side of the cylinder is a good-sized glass oil-cup to oil the inner wall of the cylinder where the piston slides. The grease-cups (Fig. 7) have a top which screws up and down. Unscrew and remove the top, and

## BOATING BOOK FOR BOYS

---

with a flat, thin stick fill both the cup and the top with grease. Every time you turn the top down a thread of the screw you squeeze some of this heavy grease down through a small pipe, and if the bearing gets so warm that it needs oil it will melt enough of this grease to make it flow around and lubricate the bearing. The oil-cup (Fig. 8) is to be filled with a thinner oil by pouring this into the filling hole, which has a little flat cover that slides sideways. When the engine is running, the oil-cup can be closed by turning down the little hinged lever handle on the top of the oil-cup. Then refill it and open the feed-lever again. Don't forget to see that these levers are up every time the engine is running and closed when it is stopped. The oil used in the cylinder must be of good quality. If it is not it will develop hard particles of carbon as it is used up by the heat. One would not think these bits of carbon capable of doing much harm, but when they get between the piston and the cylinder wall, and are rubbed up and down over four hundred times a minute, they are likely to scratch the smooth steel surface, and this causes more friction and heat.

The base of the motor is made to act as an oil reservoir or tank. This should have enough oil put into it so that every time the connecting rod (the arm that comes from the piston to the crank-shaft) comes down it splashes into this oil and gives the interior a little oil bath.

It is a common custom now to pour some lubricating oil into the gasolene-tank along with the gasolene, and let it work through to the motor with the latter. The proper mixture is not over a pint of lubricating oil to every five



## IGNITION AND OILING

gallons of gasolene. Pour the oil into the gasolene and stir it up well. Mix the compound thoroughly before you pour it into the gasolene-tank. Then it will stay mixed and will not settle.

### Grease-cups

The grease-cups act automatically. The grease will not run unless the turning of the shaft causes heat, which will thin the grease. But with oil-cups one has to be continually on the watch to see that they are open when the engine is running and closed when it is not. So many people have forgotten to close or open these cups, and so many engines have been scratched up inside as a result, that engine-makers, particularly in the larger sizes of motors, have adopted the force-feed system of lubrication as being safer. This feeds oil when the engine runs, and stops

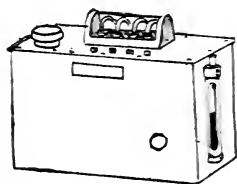

*Fig. 9*

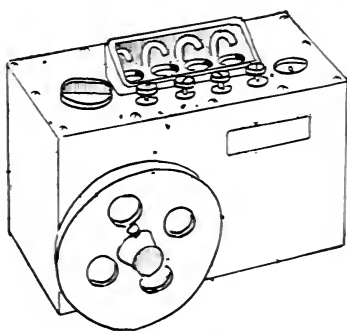

*Fig. 10*

feeding oil when the engine stops (Fig. 9). It consists of a reservoir of oil generally attached to the back of the motor, and there is a leather belt from a pulley on the shaft

to a pulley on the oiler which pumps a supply of oil into four, six, eight, or ten pipes that run to the various parts of the engine which need oiling (Fig. 10). Little glass windows permit one to watch each of the lines of pipes, and to see the oil dropping. In some cases, where the belt cannot be used, the oiler pump is worked by a ratchet-arm.

### Reverse-gear

Most small single-cylinder engines have the propeller-shaft fastened direct to the engine (Fig. 11). A reverse-gear (Fig. 13) takes more room than some of the small, cheap boats will allow. It is a very convenient and valuable addition when it can be used, since with it the engine alone can be started with the propeller standing still, and when that is running and the boat is headed out clear of the float and of other boats, you take the steering rope or wheel in one hand and with the other throw in the lever of the reverse-gear so that it turns the propeller, and the boat will be driven ahead. In case of emergency, when another boat comes unexpectedly in the way, one can push the lever to the other side and instantly reverse the propeller so that it will back up and stop the boat.

It is possible to reverse the motor itself without a reverse-gear, if one becomes expert enough to do so, but it requires considerable practice. This can be done by pulling out the switch and, when the engine slows down, throwing in the switch with the spark so advanced that it will fire the charge when the piston is coming up. This kicks it back again and makes the engine reverse. This should

## IGNITION AND OILING

---

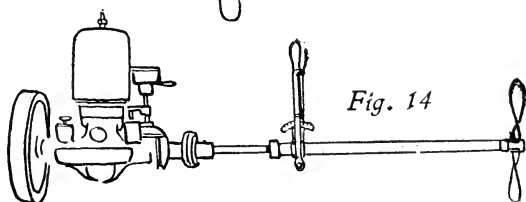
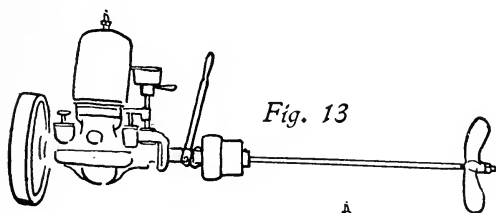
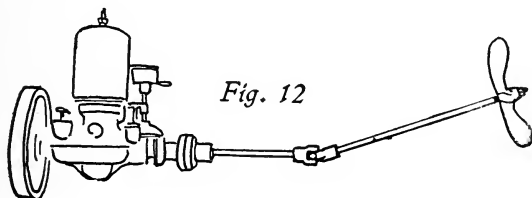
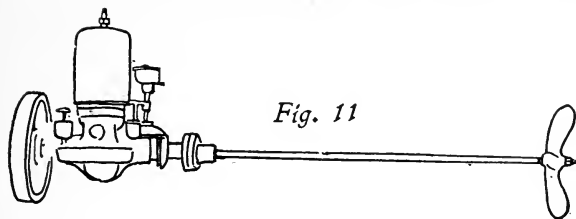

be practised where one has plenty of room. Don't rely on making a landing in this way until you are sure you can catch the engine just right, or you may bump something very hard. Even if you have not room in your small skiff for a regular reverse-gear, which is now made small enough for almost any boat, there is still another way of having

## BOATING BOOK FOR BOYS

---

a positive control over the propeller. You can put in what is called a reversing-propeller (Fig. 14). This has a solid shaft inside of a hollow pipe. The inner shaft is coupled to the engine and does the turning, while the outer one, by means of gears or a spiral slot working on a pin in the blades of the propeller, turns the blades and pushes the boat ahead, or merely turns around, cutting edgeways through the water so that the boat stands still or backs up. The blades are swiveled into the hub so that they can turn as required.

In the reverse-gears (Fig. 13) the engine-shaft and the propeller-shaft do not meet. One is fastened into one end of the reverse-gear, the other into the opposite end. In going ahead the whole case revolves. In stopping the engine-shaft alone revolves idly in the gear-case, and in reversing the outer shell is clamped fast with a friction band to hold it solid while gear-wheels inside are thrown against each other in such a way that while the engine is still turning over in the same direction the propeller-shaft is made to revolve in the opposite direction. In high-speed boats the engine is often set level and the shaft slanted at any angle desired. This is done by having a knuckle-joint attachment (Fig. 12) between the engine and the propeller-shaft.

## Chapter XXIV

### RUNNING THE ENGINE

**N**EARLY every engine-maker sends with the engine a book of instructions telling just how to start the engine after it is placed in the boat and bolted down, piped, and wired. But there are many little things which one must learn by experience.

Let us proceed with the engine just as we would if the boat were in the water ready to start. At this point every one, very naturally, is impatient for a trial run. Don't forget one thing—first, last, and all the time keep your mind on the fact that you are in a boat, and that the safety and success of the cruise depends upon yourself. You must use your head and think of everything that will be needed before you start. If you are a mile from the dock when you need an anchor or an oar, it will do you no good to know that they are on that dock. Take along enough lubricating oil and also the tools that belong with the engine.

#### Filling the Gasolene-tank

Fill the gasolene-tank first. This is the fuel which makes the engine go, and, since it has to flow into the carbureter through a little pin-hole (the needle-valve), see that no dirt

goes into the tank along with the gasolene. Have a perfectly clean funnel, which can be bought fitted with a very fine copper gauze strainer to catch any dirt. Even then it is safer to put a piece of chamois skin over the top of the funnel, and to sift the gasolene through that. If chamois skin is not available, use a clean piece of linen or cotton cloth. Gasolene will go through a chamois skin while water will not. You can see if there is any water by the bubbles which will be left on the chamois after the gasolene has sifted through. Water will cause trouble. Naturally an engine will not run on it.

The man who sells the gasolene generally brings it in five-gallon cans. Before you pour it in, fill a pint measure full of cylinder-oil, pour it into the gasolene, and with a clean stick stir the whole mixture well together. The gasolene will cut the oil into such fine particles that they cannot be seen; but in the cylinder of the engine, when the gasolene is burned up, this oil is spread in a thin film all over the piston, making it slippery.

### How to Tell Gasolene

It is puzzling sometimes to know whether one is getting gasolene or kerosene. They look alike and smell so nearly alike that some people cannot tell the difference. One way is to take a little in your hand and rub it with one finger. If it is kerosene it will not evaporate as quickly as gasolene, and it will feel greasy and oily, whereas gasolene is clear like water and evaporates completely. There is a little glass instrument like a thermometer with a scale

## RUNNING THE ENGINE

---

marked on it, and by inserting this in the can the weight or specific gravity of the liquid can be measured. These hydrometers are supposed to be used at a temperature of 60° F. When a liquid is heated its weight becomes less. If it is colder it becomes heavier. In order to secure accurate measurement of a liquid some of these hydrometers have a thermometer in them which shows the temperature of the liquid as well as its specific gravity.

Gasolene evaporates very quickly when warm, but very slowly in cold weather. It is not the gasolene in its liquid or oil form that explodes, but the gas or vapor from it when mixed with just the right amount of air. For this reason, when filling the tank, or at any time when gasolene is exposed, it is essential to be very careful that no one strikes matches or smokes or has any light. Don't spill the gasolene over the tank and into the bottom of the boat, for it will make an explosive gas which is particularly dangerous, because, like the fire-damp in a coal-mine, it does not rise, but settles down in the boat. Most gases rise, but this does not. Therefore, be careful to see that there are no leaks in tank or piping. Open up all the hatches or openings and let the wind blow through the boat to carry off all the gas it can.

In spite of all precautions water sometimes gets into the gasolene-tank. Often this is due to the sweat which forms in the tank in warm weather as the moisture in the air condenses on the side of the tank. The water is heavier than the gasolene and sinks to the bottom. By opening the little valve in the bottom of the separator this water and dirt can be drawn off and thrown away. Keep a clean stick

of wood or an iron rod to measure the height of the gasoline in the tank. Never use a dirty stick, and do not wash a stick off in the water and then thrust it into the gasoline. The water is almost as likely to stop the engine as the dirt.

### Filling the Grease-cups

Every boy knows that the farmer puts axle-grease on the axles of his wagon to make them turn easily. For the same reason you must put some grease on the two bearings where the shaft turns in the engine-bed. "Albany grease," which is a thick, brown paste like vaseline or soft, brown soap in appearance, is used for this purpose. Unscrew the cap on the brass grease-cup and fill both the inside of the cover and the cup itself, using a thin, flat piece of wood to dig the grease out of the can.

As the steel engine-shaft revolves in the bronze or babbitt-metal bearing the constant rubbing produces heat. Before the metals get very warm this Albany grease begins to melt and run in between the two, making them slip easily and keeping them cool.

### Oil in the Base

The engine-maker usually explains how much oil it requires in the base to fill the engine so that the crank, as it swings around, will dip into it and splash the oil around, thus lubricating the moving parts.

The crank should dip about half an inch into the oil. If there is too much oil it will get upon the sparking-points and prevent the proper ignition of the gas. Under the



## RUNNING THE ENGINE

---

---

motor a cock or a plug is generally fitted to permit the drawing-off of this oil when it gets too deep. In installing the motor see that a place is cut in the engine-bed large enough to put one's hand in to open this cock or plug hole. Sometimes it is almost impossible to pour the oil from a can into a funnel so that it will go into the base, and even if it could be poured in when the boat is running and rolling, much of it would be spilled. It is best to have one of the syringe-like squirt-guns called oil-guns. You can put the nozzle of this into a can of oil and suck it full by pulling the handle back, and then squirt it all, or as much as may be wanted, into the base or an oil-cup without spilling a drop.

### To Start the Engine

Give each of the grease-cups a half-turn, and open the cock at the gasolene-tank to let gasolene run back to the carbureter. Give the needle-valve on the carbureter a half-turn, and open the cocks in the circulating water-pipe line, not forgetting the sea-cock where the pipe comes through the bottom of the boat. Turn on the switch, and, with the sparking device set so it does not fire the charge until the fly-wheel has passed the center, rock the fly-wheel back and forth so that the piston, as it goes up and down inside the engine, acts as a pump to suck in a charge of gasolene, and then quickly turn the fly-wheel a couple of times all the way round. With a make-and-break engine one can hear the points of the igniter inside the engine snap together. With a jump-spark motor one hears a buzzing

## BOATING BOOK FOR BOYS

---

every time the electric contact is made by the timer. Don't let this buzzing sound continue. This only uses up the batteries unnecessarily. Turn the fly-wheel just a little and it will stop.

Remember that there are two things necessary to make an engine run. One is a mixture of gasolene and air, which is explosive; the other is a spark to ignite it. Of these two the former is the harder to get right the first time. After that the adjustment will be very small, and the ignition is the thing to be looked after. A beginner is more apt to feed too much gasolene to the carbureter than too little. If this is done, the mixture will be too heavily charged with gasolene vapor to ignite. If, after rocking the wheel several times and then turning the fly-wheel over a couple of turns, you do not succeed in starting the engine, close the needle-valve on the carbureter, open the relief or pet cock on the side or top of the engine, throw off the switch, and turn the fly-wheel over a few times. You can tell by the rich smell of gasolene which comes out of the pet-cock if there is too much gasolene. After pumping some of this over-rich gas out this way, close the cock, throw in the switch, and try to start again. After a few attempts you should be rewarded for your efforts by a bang like a shot, followed by action. When the gasolene is used up after the engine has run a few minutes, the engine "sneezes." It seems to explode in the lower part, and blows out through the carbureter. That is a sign that more gasolene is needed. In this case turn on the needle-valve a little, until the engine runs smoothly.

## RUNNING THE ENGINE

---

### In Case of Difficulty

If the engine is very hard to turn over by hand, open the relief-cock in the top. This will make it easier by breaking up the compression and relieving the vacuum by admitting air. The relief-cock can be shut as soon as the engine starts and spits fire through the pet-cock. Another way is to put some gasolene in an oil-can and fill the priming-cup from it. Let the gasolene run into the engine and turn the fly-wheel until this charge explodes. The start thus given will run the engine until it sucks up a new charge from the crank-case, and then it will continue to run. If, after priming the engine in this way and turning the fly-wheel over several times with the relief-cock open, the engine does not explode the charge, it is a pretty sure sign that it is flooded, provided the ignition is all right. This means that everything must be drained out through the cock or plug in the bottom of the engine-base. Don't forget to refill the base with lubricating oil afterward.

When you have once found the point at which the needle-valve makes the engine run the best, leave it alone. Occasionally, however, a change in the weather will require more or less air to be let in through the air-intake pipe on the carbureter. Where this intake pipe draws its air from the open such adjustment will be needed more than if it sucks in its air from a pipe around the outside of the exhaust-pipe, where the air is heated and dry. This dry air takes up more of the gas vapor and makes a better mixture than when cold or damp air is drawn directly into the carbureter. This mixing of the gasolene and the air requires care and

## BOATING BOOK FOR BOYS

---

thought. To get the most out of the least gasoline, and to make it last longest, are points which one can experiment on for some time. With the proper mixture and care, it will be surprising to find how little gasoline will run the engine. One-half of a pint an hour for each horse-power of the engine is the usual amount allowed by the manufacturers. A two-horse-power engine will use up a pint an hour; a four-horse-power a quart, and so on.

If the gasoline seems to feed all right and yet there is no explosion in the cylinder-head of the engine, look over the electric outfit, the trigger, as it were, that should fire off the charge. Perhaps the spark does not get inside the cylinder. Disconnect the wire to the igniter and wipe it across the iron part of the engine, and you will see by the sparks that snap off from it, or their absence, if the electricity is there or not. If it does not spark it shows that there is a loose wire somewhere and the flow of electricity is broken. Perhaps the batteries are at fault. Look for a loose wire first, and, if that is not the trouble, test each battery by disconnecting each and touch one of the parts with a screw-driver or piece of wire held against the other. A spark will show itself unless the battery is dead. If it is, throw it out and put in a new one. For testing batteries there is a little instrument like a watch with a small wire attached, called an amp-meter. By touching one leg of this instrument to one post of the dry battery and the end of the wire to the other, one can read on the dial how many volts there are, or what the pressure of the cell indicates. If it is less than one and one-quarter, throw it away. It should be between two and two and one-half volts. By touching the other

## RUNNING THE ENGINE

---

---

leg of the instrument in the same way, the amperage, or flow of the battery, can be tested. This should not be less than six amperes. The letters V and A over the legs indicate volts and amperes. It is a good plan to have two sets of batteries always wired up in order to switch from one to the other at intervals, and let one rest awhile. By this means they will last much longer than if one is used all the time.

If the batteries are all right, but still there is trouble, it may be that the points of the sparker inside the cylinder-head have become so spattered with oil that the points, when they separate and should make a spark, are bridged by this oil so that the electricity runs across the oil bridge and does not make a spark at all. Wipe off the points and put the sparking apparatus back into the cylinder. After some little use the points may become pitted. In that case, clean their ends with a fine file, so that they become bright and smooth. This pitting is caused by the electric current, which carries little tiny particles of metal with it as it jumps across from one piece of metal to the other on the contact points. These particles are so exceedingly small that they cannot be seen until after some time when they have accumulated in a little pile. They cause irregular firing, and must be filed off. This accumulation can be prevented by occasionally reversing the flow of electricity, which is done by changing over the wires to the opposite terminals on the dry cells. This will cause the electricity to carry back the particles again, and therefore build up the point they have been tearing down.

### Tests of the Ignition System

If the engine uses a spark-plug and the jump-spark system of ignition, as many of the small engines do, test out that system by first seeing if the batteries are giving out any current. Turn the fly-wheel over until the timer makes a contact, and see if the vibrators on the coil buzz. If they don't, go over the batteries and all the wire connections to see if there is a loose wire. Water cannot flow through a pipe if there is a break somewhere in the line, and this is the case with electricity. Perhaps the ground wire from the coil to the engine is broken. If the wires are all right, examine the switch, the timer, and the contact-points on the vibrator. If there is no trouble with them, there may be a break in the primary or first winding of the coil, which it is almost impossible for an amateur to remedy, or the coil may be wet. Get another coil and you can soon see if that is the trouble or not. If, however, the buzzer does work it is certain that all these parts are in good order, and that the trouble lies somewhere in the spark-plug or the high-tension wire. Take out the spark-plug, lay it down on the top of the engine with the wire still attached, and turn the fly-wheel until the timer again makes a contact and the electricity is sent flowing through the wires. If everything is in working order the spark will be easily seen as it snaps and cracks across the points of the spark-plug. If there is no spark it shows there is a leak somewhere, or that the points of the spark-plug are either dirty, which makes it harder for the electricity to jump across, or that the points are bent too far apart. They should only be about

## RUNNING THE ENGINE

---

one-sixteenth of an inch apart. Very often the porcelain insulation becomes cracked and the electricity escapes through this crack to the metal of the cylinder-head. If the plug has mica rings for insulation, they sometimes become so dirty that the electricity escapes through them. We are trying to force a tiny stream of electricity down through the plug with force enough to make it jump across from point to point inside the engine, and any break in the insulation will let the electricity leak, like a leak in a hose. It has to go through with considerable force because the spark has to be strong enough not only to jump the gap, but to do so in an atmosphere of gas that has been squeezed up or compressed with a pressure of many pounds.

### Practical Hints

Try a new spark-plug if you cannot make a spark through the old one. Sometimes a wire will break inside of the insulated covering on account of the continual shaking due to the vibration of the engine.

A drop of water on the point of a spark-plug will prevent it from sparking, and one sometimes is at a loss to know how it could get on the plug when the engine is all inclosed. But in merely standing overnight the condensation will produce sweat inside that wets the plug.

Many small boats used by fishermen go out in all kinds of weather with only the dry cells to supply the electricity to ignite the engine, but it is a safer plan to have some sort of machine aboard that can make its own electricity. This is what the dynamo and magneto do. The first few sparks are made by the dry cells, and then, as soon as the

## BOATING BOOK FOR BOYS

---

engine is running, a switch throws off the dry cells and throws on the current which is being made by the magneto.

These magnetos will make the electricity as fast as it is needed for the engine, and will not run down as a dry cell will do.

There are a number of parts in a gasoline-engine, all simple in themselves, but all necessary for successful running. Study them all, from the carbureter to the switch, and learn all about them, so that when anything happens—if a wire shakes loose, for instance—you will know how to fix it. Some people run their engines year after year with no trouble at all, and others have trouble all the time. It is more the fault of the man running the engine than it is the engine itself.

### How to Wire Up Dry Batteries

The wiring of a set of batteries makes a great difference in their life. The best way to secure long life is to have ten of them. Put five in each row and connect them from carbon to zinc, carbon to zinc, along the row. Then have another row of five wired the same way. Across the ends of these two sets of batteries connect one wire to both the carbon terminals and another to both zinc posts. If the batteries are wired this way the drain on each cell is very small. This is the most economical way.

Another method is to wire up two sets of cells as described, only, instead of having one wire from both zinc terminals, run one from each to a double-throw switch. Then you can use one set of five cells for an hour and switch over to the other set. There must be two separate wires from the carbon posts as well.



## Chapter XXV

### THE HYDROPLANE

“HYDRO” means water, and “plane” a flat surface. Hydroplane is a term for a flat surface which will glide over the water. If you slap water hard with your hand when it is open and flat you seem to be hitting a hard substance. When a hydroplane, driven at high speed, hits the water the impact is like a solid blow. The part of the bottom of the boat which rests on the water must be quite flat or the hull will roll dangerously.

Some hydroplanes are simply flat-bottomed skiffs like the *Gunfire, Jr.* They are called monoplanes—meaning one plane—since the whole length of the bottom forms one surface.

Where there is a jog or step in the bottom (as in the case of *The Bug*) there are two flat surfaces, one forward and one aft. Such a boat is called a biplane, meaning two planes. Some boats have three planes (*Breeze I*, for instance), some four, five, six, or more; but anything over two planes is simply referred to as a hydroplane, and the number of planes is not specified.

In the old days of the sail-boat the skip-jack model was rather looked down upon as a poor man’s boat. It was so simple, having only straight pieces of wood for the frames,



"EDITH II." A TWENTY-FOOT RUNABOUT

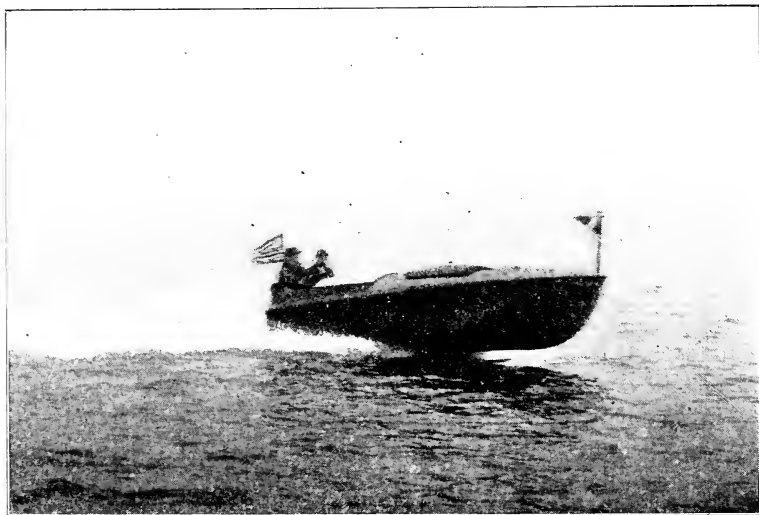

"THE BUG"

## THE HYDROPLANE

---

---

that anybody could build one. It was only one step up from box-making. People used to think the more complicated a boat was, and the more difficult she was to construct, the better she would be as a racing sail-boat.

### The Simplest Model the Fastest

Now the fastest motor-boat that can be built is the simplest, and the simplest is the old skip-jack style of hull modified a little as to beam or width in proportion to its length.

If a boy can learn to run a high-speed gasolene-engine, there is no reason why he cannot have a very fast hydroplane. In 1910 the last day's race at Peoria, Ill., was won by a boy in his own home-made boat. She was called the *Pippin*, an ordinary flat-bottomed skiff 18½ feet long, 3 feet 2 inches wide, drawing only 6 inches of water, with a 10-horse-power, two-cylinder, two-cycle Elk motor making about 1000 revolutions. The boats had to go six times around a five-mile triangular course. There were hundreds of people watching that race, and every time the little *Pippin* came around her boyish skipper, Edwin W. Lenck, was cheered to the echo. When that little craft came down the home stretch in the lead the spectators went wild with joy.

### Building a Hydroplane

Now, the task of building a small, fast hydroplane 17 feet 6 inches long and 4 feet wide is very much like building a skiff. The keel is a perfectly straight stick of oak

## BOATING BOOK FOR BOYS

---

3 inches wide by 1 inch thick. The stem is at right angles to this, and is riveted to an oak knee which is riveted to the keel. The transom of 1-inch cedar is also kneed to the keel. Then a temporary mold is braced on the keel in the middle, and the side planks, of  $\frac{1}{2}$ -inch cedar, are shaped and bent around it. The forward ends are screwed fast to the rabbet or notch cut in the stem and screwed at their after ends to a piece of 1-inch by 2-inch oak, also fastened either by copper rivets or screws to the transom. As the cedar sides are too thin to nail the bottom to, bend a thin strip of oak 2 inches by 1 inch along the lower edge, rivet it fast flush with the lower edge, and plane the two off smooth. Put frames of oak  $\frac{3}{4}$  inch thick and 2 inches deep across on top of the keel, and notch them into the underside of the oak strip on the side planks. They will be perfectly flat from the stern half-way up to the bow. From this point they can be made in two pieces, as they form a V-shape, and they should overlap each other at the keel plank. Then bend the  $\frac{3}{4}$ -inch cedar bottom-boards lengthwise of the boat over the floors, using brass screws  $1\frac{3}{4}$  inch No. 10 to fasten them, just setting the heads in flush. The deck is  $\wedge$  shaped and built just like a house's roof, covered with muslin, and painted. The edges, where the canvas laps over, are covered with a half-round oak molding.

### Placing the Engine

To get speed, place the engine well aft—run its shaft forward to a gear ( $1\frac{1}{2}$  to 1). This, with an engine that makes about 800 revolutions, will turn the propeller 1200

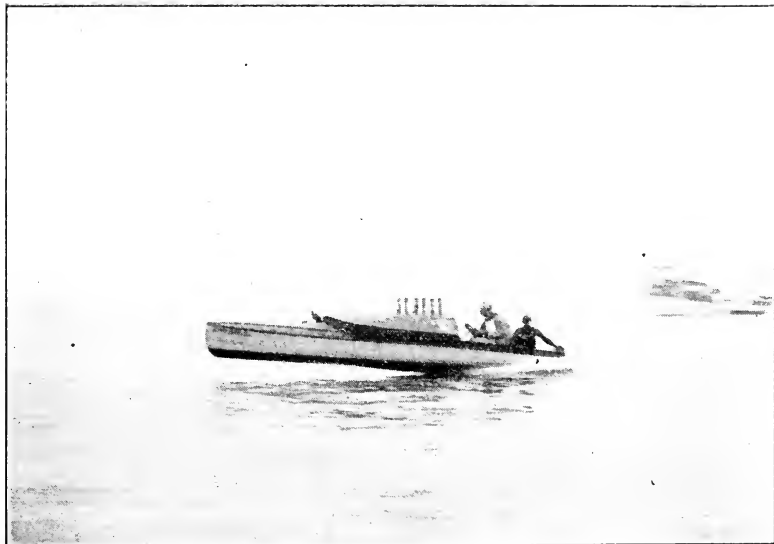

"SANDBURR II." BEST RACING TYPE OF 1911

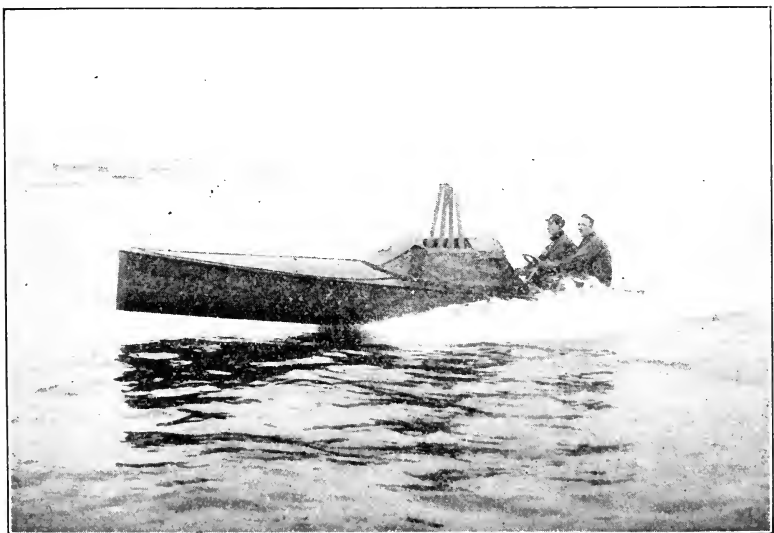

"GUNFIRE, JR." A MONOPLANE

revolutions a minute. The propeller-shaft comes aft from a metal gear-box, and the gear should run in oil at a very easy angle. The shaft should go out through the keel-plank through one of those metal ball-and-socket-joint style of stuffing-boxes aft to the propeller. The size of the propeller and its pitch will depend on the power of the engine. The engine-makers will tell you what pitch of wheel to use to give the best results with their engine.

The strut which steadies the shaft should be aft of the propeller, since anything in front of it breaks the water at high speed so that the propeller sucks in air and "cavitates," as they call it, which means "making a hole." This cavitation is one of the most difficult things to overcome in high-speed boats. The propeller kicks the water away from under the hull so fast, while the boat in front of the propeller prevents the continuous flow of water, that air is sucked down instead of water. This air spoils the push of the propeller, which needs solid water to work in.

### The Rudder

Make the rudder out of metal, and don't be afraid to make it strong. The strain on it is terrific. *Sandburr II*, a little 20-footer from Atlantic City, was the most successful planer of 1910. She was nothing but a skip-jack with a 60-horse-power Emerson motor installed well aft, the shaft running forward to gears that increased the revolutions of the propeller shaft from 900 turns of the engine to 1800 at the propeller.

*The Bug*, another diminutive hydro which made quite a

## THE HYDROPLANE

sensation by defeating the big 185-foot steam yacht *Helenita* in a match race from Huntington to New London, is only 16 feet long with a 60-horse-power engine. Her propeller-shaft also runs forward, and is geared so as to increase the speed of the propeller-shaft. Instead of gear-wheels boxed in a metal case and running in oil, as *Sandburr II's* do, her gear-wheels are geared by a sprocket chain kept well covered with graphite, just as a bicycle-chain is fitted, only, of course, the chain is much heavier and stronger.

*The Bug* is a stumpy little skip-jack with two metal plates forming planes, the plates being corrugated like the metal on a scrubbing-board such as a washerwoman uses. A great many of these little flyers have been built of late.

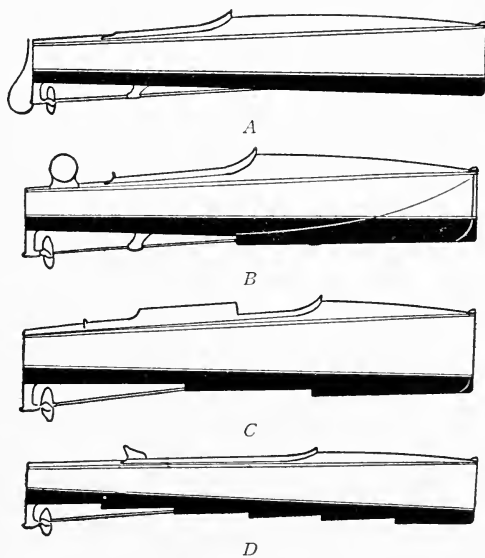

A. Monoplane—bottom all one plane. B. Biplane—bottom in two planes with one jog on step. C. Two-step Hydroplane. D. "Multi-step" Hydroplane.

## Chapter XXVI

### SIGN-BOARDS AND LAMP-POSTS OF THE WATER

THERE are many who do not know the difference between a can-buoy and a nun-buoy, nor do they realize that every buoy has a specific meaning and value for men who follow the sea. On the sea-coast there are many places too shallow for a boat of any size, but there are deep channels which are marked out by the government with buoys like a row of lamp-posts along a street. Sea-captains, familiar with these buoys, can tell what each one means just as people on shore can tell a drug-store at night by the colored lights, and a police station by its green lights.

#### The Arrangement of Buoys

Buoys are laid out according to a regular rule. A boat coming in from sea should have all the red buoys on the right side of the boat, and all the black buoys on the left. What confuses most amateur sailors is that they generally start from the land and so imagine the buoys are laid out for the guidance of boats going out rather than for those coming in. This is not the case. Take an important waterway like New York harbor for instance. The first real channel mark to be seen is a light-ship. There is one at



## SIGN-BOARDS AND LAMP-POSTS

---

the outer end of Gedney's Channel, and one off the end of the Sandy Hook Channel. Gedney's Channel is the main steamship channel now since it has been dredged deeper. This channel is marked by big iron can-buoys lighted by acetylene lights at night. Those that are tapered on top are called nun-buoys, and have even numbers, 2, 4, 6, 8, etc. They are in a row along the right-hand side of the channel. The cylindrical buoys are shaped just like a tin can, are called can-buoys, and have odd numbers, such as 1, 3, 5, 7, 9, etc. They are in a row on the left-hand side, so that on a dark day—even if the ship's captain cannot see the color of the buoys, as is often the case when they stand out like black silhouettes against a setting sun—he can tell, by the shape of the cans, which are to be passed on the right-hand side, or starboard side, of his ship, and which on the left-hand side, or port side. All the buoys are numbered beginning out at sea with number 1. Where the main channel branches off into secondary channels, spar-buoys are used. These are huge round sticks as large as telegraph-poles, with only ten or fifteen feet sticking up out of water. They look small until one gets close to them. These are painted red and black, and are numbered.

Nun, can, and spar buoys are like lamp-posts. The nun-buoys are like lamp-posts on the wide, important avenues; the can-buoys are the lamp-posts of less important avenues, and the spar-buoys the lamp-posts on common, every-day streets. That is the way they are graded.

But there are many other buoys which all mean something to one acquainted with the customs of the sea. If you were going down-town and saw a red flag in the middle

## BOATING BOOK FOR BOYS

---

of the street you would know there was some sort of danger to look out for. A buoy painted with red and black stripes running horizontally around the buoy shows that there is a rock or some other obstruction under water, and that you are to keep away from it and pass either side of it. A spar-buoy painted with vertical stripes of white and black means just the opposite. It means that there is danger, and the only way to avoid it is to go close to that buoy. There may be shoal water a little way from the buoy on either side. The buoy marks the middle of the channel.

Bell-buoys and whistling-buoys are generally located at important turning-points in channels. The bell has several clappers which clang as the buoy moves in the waves, while whistling-buoys give a mournful sort of wail or a deep grunt as the air is blown through the whistle by the rising and falling of the buoy in the waves. The latter are nicknamed "grunter" buoys, since they grunt more than they whistle. These buoys are placed out at sea to enable sailors to locate the beginning of a channel, or on the outer end of reefs that extend well out from shore, or over sunken rocks.

Gas-buoys are often placed in exposed positions where a lighthouse could not be kept, or where the expense of maintaining a lightship is not warranted. These buoys burn acetylene or compressed gas, and are charged to last for months. Most of them burn night and day, though the government is now perfecting and using in some places lights which are automatically shut off at daybreak, and are lighted up at night or on very dark days.

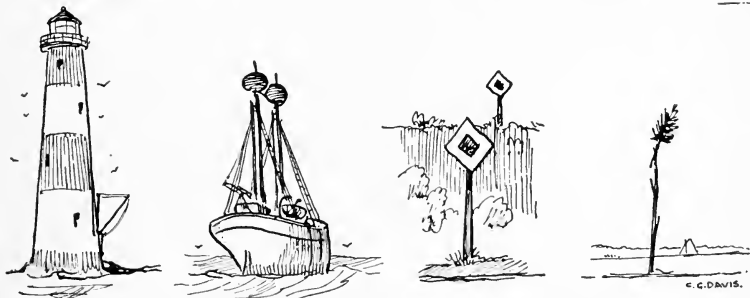
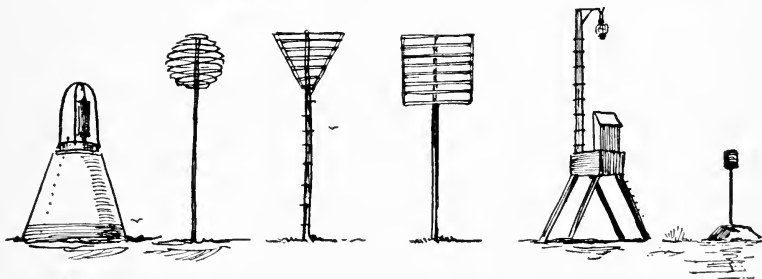
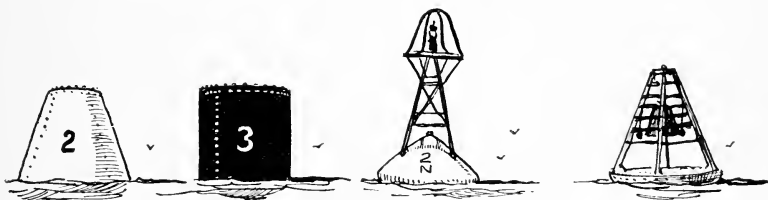

c. c. DAVIS.

SIGN-BOARDS AND LAMP-POSTS OF THE WATER

### Lightships and Beacons

In very dangerous localities, such as Nantucket Shoals, lightships are anchored to show the deep-water channels across a shallow stretch of water. On headlands and islands lighthouses serve to show a sailor what land it is by a system of flashes at different intervals, by a steady white light, or by alternate red and white flashes. In some localities the light is made to show white over the deep water, and a red sector throws a red light over the shallow part. As long as the sailor can see a white light he knows he is out of danger. When he sees the light red he knows that he must avoid danger by keeping over farther until the light shows white again.

In some places where buoys cannot be used a big, round ball is set on an iron pole (a "perch and ball" in sailor's language), and this is painted red or black according to the side on which it is to be passed. Sometimes a cone, or a square box made of slats of iron and wood, is placed on the top of the pole.

In going up rivers one finds beacons built up on tripods of wood painted red or black, on which at night lanterns are hung. Where there is much ice these are sometimes made of stone or built like a plow to rip the ice as it comes drifting against it.

On small rivers it is customary to use range marks of various kinds on the shore. Sometimes these are diamond-shaped frames of white-painted boards set up on posts so that one shows up behind the other, and directly over it, when you are in the channel. If they are not directly in

## SIGN-BOARDS AND LAMP-POSTS

---

line it is certain that one is out of the center of the channel and likely to run aground. Some of these frames have a black center like a bull's-eye in a target to make it easier to distinguish them from surrounding objects. At night lanterns are shown on these range marks. In some of the shallow bays one will see small cedar-trees lashed to the top of poles which have been thrust into the mud. This is the way that bay-men mark out channels where the government does not provide buoys. In many localities, where a small boat is likely to go, local boatmen set up empty kegs or cans on iron rods driven into the rocks which are to be avoided. A novice may be confused by the oyster-stakes, shad-poles, and other things used by local fishermen to mark out their oyster-beds, or to hold their shad-nets; but one will generally see so many around he will know that they are the property of fishermen, and not intended as a mark for navigating. In large harbors there is sometimes a large white spar-buoy with a little black anchor painted upon it. That is to show how far up vessels can anchor without obstructing river navigation or occupying too much of the bay.

The character of the range marks may vary in different localities throughout the country, but by learning what they mean the novice will soon be able to look out for them, and to sail his boat accordingly without running on a rock or into the mud.

## Chapter XXVII

### RULES OF THE ROAD

**I**F there is only one boat on the water it has everything its own way. Suppose another boat is put afloat. As these two sail about there will come a time when they will meet; then there is a question of how they will pass each other. On land, in the United States, we keep to the right. On the water the same rule holds, and if all would observe this rule there would be no collisions.

If you are sailing at night certain lights show how other boats are going. On the right hand or starboard side of your launch, as you stand looking forward, you should have a green lantern hooked on the outside of the coaming, and on the left or port-hand side a red lantern. These are the colors by which another boat can distinguish the course of your boat. Besides these two, which are called the side-lights, and differ from ordinary lanterns in that the glass allows the light to shine only ahead and to the side, boats are supposed to carry a white light forward, on the deck or on a low flag-pole, which shines all around the forward half of a circle, and another at the stern. This stern-light should show on all sides. By studying this arrangement of lights you will see that it is possible to determine how any boat is heading, and you can lay your course accordingly.

## RULES OF THE ROAD

---

If you are overtaking another boat you can see the white stern light. If you are coming at right angles you can see the low white light forward, a red or a green side-light about amidships, and the high white stern-light. If you are coming head on at another boat you can see all the four lights, the two white lights being in a line one above the other. When they shift so that one is not directly below the other you can understand which way it has turned by remembering that the lower of the two white lights is the one on the bow.

To enable the beginner better to remember how he should turn out when meeting another boat the rules have been put into verse as follows:

### Two Boats Meeting End On, or Nearly End On

Meeting steamers do not dread  
When you see three lights ahead!  
Port your helm and show your red.

The tiller is always considered the helm. Your steering-wheel may be rigged so that the wheel turns either way. To port your helm means to turn it in such a way that the tiller is pulled over to the port or left-hand side, as you stand looking forward in the boat. The boat, of course, turns out the opposite way, to the right or starboard.

### Two Boats Passing

Green to green, or red to red,  
Perfect safety—go ahead.

Which means, if you see a green light on your right-hand side—the side your green light is on—that the other boat is

## BOATING BOOK FOR BOYS

---

---

passing well clear of you, and red to red, of course, the same way on the left.

### Two Boats Crossing

This is the real position of danger. The boat that has the other on her own starboard (or right-hand side) must keep out of the way of the other.

If to starboard red appear,  
'Tis your duty to keep clear;  
Act as judgment says is proper—  
Port or starboard, back or stop her;  
But when on your port is seen  
A steamer with a light of green,  
There's not so much for you to do—  
The green light must keep clear of you.

### A Good Lookout

All ships must keep a good lookout, and stop or go astern, if necessary.

Both in safety and in doubt  
Always keep a good lookout;  
Should there not be room to turn,  
Stop your boat and go astern.

In the daytime steamers and motor-boats are supposed to show how they are about to steer by blowing a whistle. At all times power-boats must keep clear of sailing-boats. The steamer which blows first tells how it will pass you, and you should repeat the signal.

One blast means: I am directing my course to starboard. That is, she is turning out to her right.



## RULES OF THE ROAD

---

Two blasts mean: I am directing my course to port. She is turning out to her left.

Three blasts mean: My engines are full-speed astern.

If an approaching boat blows one blast, never answer with two; that is what is called "cross signal," and is liable to cause collision. If you cannot turn out as the approaching steamer has signaled, or if you do not understand the signal, four short blasts of the whistle will explain. This is the danger signal, and both boats should stop until new signals are given and returned on each side.

If you are caught out in a fog where unseen boats are around, you blow a blast of about four to six seconds' duration at frequent intervals on the whistle, siren, or fog-horn. It is not safe to run at full speed in foggy weather, and a good lookout for other boats should be kept. If there are sail-boats around in the fog, you can tell which way they are going, because they blow different signals according to their tacks. If they are on the starboard tack, that is, if their right-hand side is toward the wind, they blow one blast at about a minute's interval; if on the port tack, or the left-hand side is toward the wind, they blow two short blasts; if they are running before the wind and have the wind blowing on their sterns they blow three blasts.

Thus there is a regular language of the sea which sailors understand, as you will if you note these hints and gain a little experience. From this it will be seen that a boat, even a small boat, should be equipped with the proper lights and a horn. The laws vary in different States, usually requiring life-preservers and other features. But even if you

## BOATING BOOK FOR BOYS

---

---

are doing only harbor cruising, you should have a horn, in the absence of a regular power whistle. And life-preservers are never out of place. It will be well to acquaint yourself exactly with the requirements of the law, and also to err on the side of safety.

Part VI

CANOES AND CANOEING



## Chapter XXVIII

### HOW TO BUILD A CANVAS CANOE

**S**ELECT some situation where, if the canoe is built in the open air, it can be removed to shelter in case of rain. Procure two strips of pine,  $12\frac{3}{4}$  feet long and 2 inches by  $\frac{3}{4}$  inch; a bunch of pine strips,  $1\frac{1}{4}$  by  $\frac{1}{2}$  inch (which should be in length about 13 feet); and one piece of spruce 12 feet long and 2 inches by  $1\frac{1}{8}$  inches, which is the keel proper.

First saw your mid-section out of pine (Fig. 1), and make your stem and stern-post join the keel (Fig. 2). Nail on the two sections at each end of the cockpit. Now put on the two sheer planks (the strips 2 inches by  $\frac{3}{4}$  inch), and bend from the inside the ribs (barrel hoops). There should be six inches space between ribs; clinch on with galvanized wrought-iron nails the lighter pine strips, which act as planking. The space between them should be four inches. This will bring all your planking on the outside of the ribs. Be sure to have the protruding lines (after the canvas is put on) run fore and aft, and do not forget that the planking is brought down to a fine point at the stem and stern-post and is securely clinched (Fig. 3 shows the cross sections).

## BOATING BOOK FOR BOYS

Put in your deck beams at each end of the cockpit—they are 1 inch square (spruce)—and on them lay the cockpit combing of 2-inch by  $\frac{3}{8}$ -inch pine, putting in braces of triangular-shaped light pine, the same material as combing, having

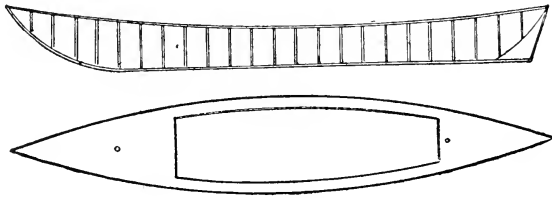

DECK AND SIDE

*Fig. 1*



THE STEM

*Fig. 2*



CROSS SECTIONS

*Fig. 3*

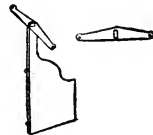

THE RUDDER

*Fig. 5*

each touch the rib, and nail securely. Make from pine one board to receive the foremast, with mast-hole (it should be 7 inches wide by  $\frac{3}{4}$  thick) fit flush with the gunwale strips. Aft of the cockpit fix a similar board, and make the mast-

## HOW TO BUILD A CANVAS CANOE

holes exactly alike, so that in case of a hard blow you can shift the smaller sail forward.

The mast steps go underneath the mast-hole, and are fastened securely to the keel. After all the ribs are securely fastened turn your boat bottom upward and lay on the canvas. Buy only a medium-weight sail duck; second-hand will do, provided it is firm; in fact, weather-beaten canvas is preferable, as it has a smoother and more pliable surface. To insure its setting firmly and smoothly four gores should be made along the upper edge on each side and firmly sewed from the inside (do not cut, but lap over the canvas). Sponge the canvas off on both sides with water, and in a damp state tack it on along the gunwale, letting the stem and stern-post protrude half an inch. Don't be afraid to put the galvanized tacks too near together, for if you do not use plenty of tacks there

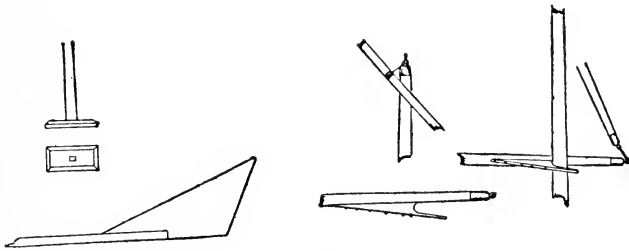

*Fig. 4*

is considerable risk of a leak. Now turn your boat right side up, and when the canvas is perfectly dry it will tighten and set with a firm surface.

It is a great help to have the canoe in the sun when dry-

ing. Before tacking on your deck canvas, give the inside and the outside of the hull and canvas a liberal coat of the following: Three-quarters boiled oil to one-quarter raw oil, with some patent drier. This compound acts as a filler for the canvas and insures it being water-tight. When you are sure it is perfectly dry apply two coats of brown ready-mixed paint for the inside and two of dark green for the outside. Add patent drier to the mixed paint, with a little spar varnish for the finishing coat. Before applying the last coat of paint add a gunwale-waring strip of 1-inch spruce, first rounding the outer surface, and a spruce keel of 1 inch by  $\frac{5}{8}$ . The keel and waring strips are put on after the canvas has been painted, and should receive two coats of filler and one of spar varnish, which give a bright finish and add to the looks of your canoe.

In case you wish only to have a paddling canoe, leave off the deck and bulkheads, but retain the two deck beams at each end of the cockpit; their edges can be rounded. A good spruce paddle, double, seven feet long and jointed, can be bought for a few dollars. The sails are made of unbleached muslin, one yard wide. The larger sail measures: gaff,  $7\frac{1}{4}$  feet; boom, 6 feet; and leach,  $6\frac{1}{2}$ . The smaller is: hoist, 5 feet; boom,  $3\frac{3}{4}$  feet. The foremast is short, and is surmounted by a pin of iron surrounded by an iron collar. An iron ring is lashed to the gaff, and is hooked *over the pin on the mast*. The *jaw* is lashed on the boom, as is shown in Fig. 4. This is a handy sail, and the only drawback is that it cannot be reefed; but then you must consider there is no halyard to foul.



## HOW TO BUILD A CANVAS CANOE

The smaller sail is the regulation leg-of-mutton shape, and can be shifted forward in case of a strong wind. When

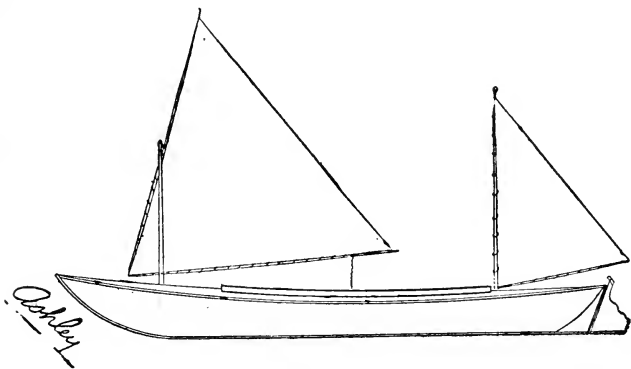

Fig. 6

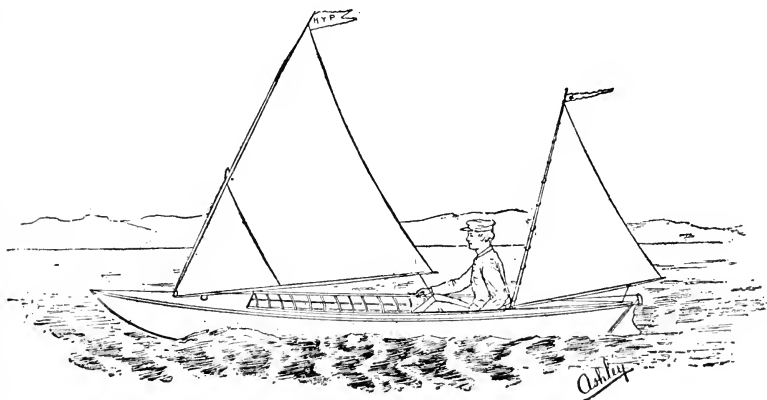

Fig. 7

your boat has been completed, lash in the forward and aft ends two good-sized varnish-cans with the corks squarely

## BOATING BOOK FOR BOYS

---

---

driven home. They are more than handy in case you have an upset, for they will sustain the weight of two people. They should receive several coats of paint to keep them from rusting. Get a plank 9 feet long by 14 inches wide and  $\frac{1}{2}$  inch thick, and shape for bottom board. This should receive two coats of the filling-in composition. Make and hang the rudder (Fig. 5), and your canoe is complete (Figs. 6 and 7).

## Chapter XXIX

### HOW TO USE A CANOE

**B**EARING in mind the many varieties of nomenclature that we now have in the out-of-door world, such as aircraft, icecraft, water-craft, plaincraft, etc., I shall use two generic terms—woodcraft and campercraft, or campercraft—because we shall here consider two conditions.

First, there is the boy living in an organized camp having meals cooked and served for him, with a boathouse, a dock for landing, a place for housing his canoe, a cabin, bungalow, or tent with a cot or bunk ready to tumble in at night—a constant and ready shelter from sudden storm.

Secondly, there is the boy who makes trips away from the main camp where he will choose his own camping-place, erect a tent or lean-to, build a fire, cook, and cut wood. He must know on these trips how to equip a canoe, how to pack and care for it, how to paddle, how to land and launch these frail and silent Indian craft, and how to police camps.

If he is going on a hike or tramp he, of course, will be fitted out very differently than for a canoe trip. He must know how to care for his feet, what sort of shoes and socks to wear, and what to take. The arrangement of a blanket

for transportation on a hike is very different from that on a canoe trip.

### Canoes and Their Cost

Canoes are made of various materials. The kind of voyage intended will determine the variety of canoe. Any canoe under sixteen feet is a dangerous affair, and should be used only by an expert. Its short length does not permit of sufficient beam for any stability.

The canvas-covered canoe is the one most frequently used, and with care in landing and a lookout for nails in hauling over dams, stumps, and sharp sticks on beaches, such a canoe should last for years. The canoes manufactured by the Old Town Canoe Company of Old Town, Maine, or by the Racine Boat Company of Racine, Wisconsin, are good examples. A sixteen-foot canoe costs about \$35. The wooden canoe is made of cedar, usually with oak ribs and combings. If it is to be used as a sailing canoe it is generally decked over, having a small cockpit. This naturally increases its safety in rough water. These canoes cost from \$65 to \$150, according to nickel fittings.

In the Canadian rivers, lakes, and some parts of Maine, where a few Indians live, there will still appear the frail, graceful, birch-bark canoe. They are light and easy to paddle when not going against the wind. I have purchased an eighteen-foot canoe for \$15 and sold it at \$10 when I came out of the woods.

A birch-bark canoe is easily injured, and the seams need attention every night on landing if the paddling is done in a river where sandy shallows or rocks scrape the bottom.

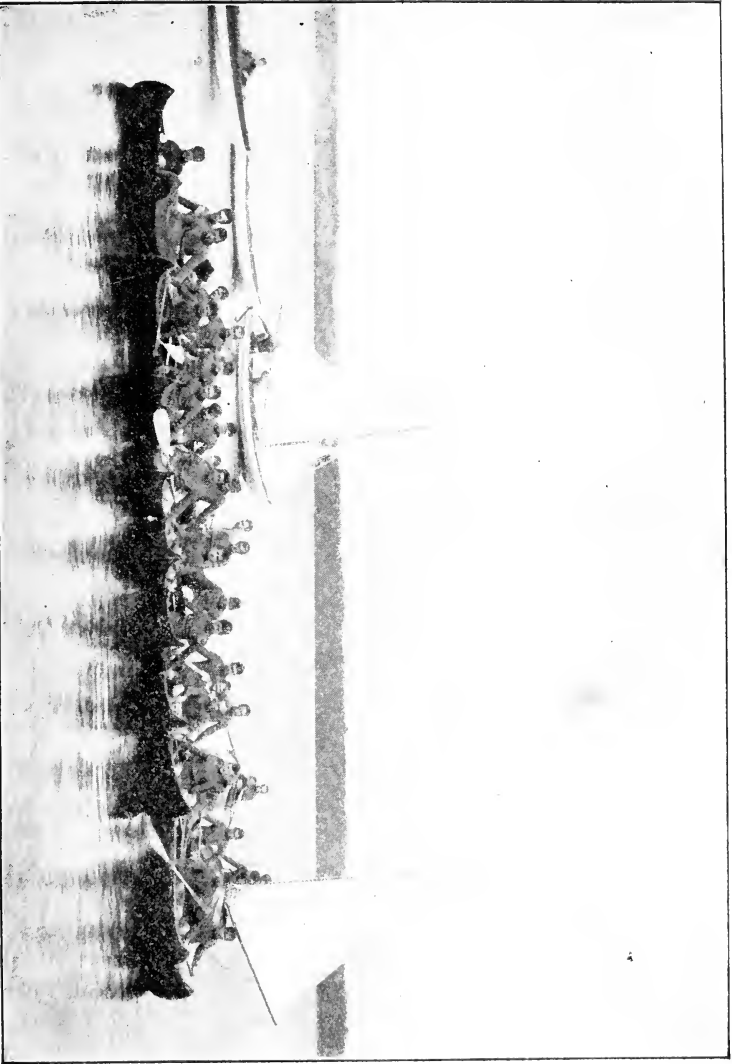

W. H. Langley

A CANOE PARADE IN A BOYS' ORGANIZED CAMP

### Repairing a Canoe

To mend a tear or rip in a canvas or bark canoe, or tighten up the seams, there is a gumlike substance that can be purchased at any outfitter's which when heated forms a waxlike covering over the opening which is watertight. The Indians melt a little pitch and rosin in an iron pot and smear it on with a stick. I have camped with Indians who carry a small pot full for that purpose tucked up in the bow of the canoe. Adhesive tape will also mend a canoe, and surgeon's plaster will answer this purpose. Beeswax will stop leaks.

### How to Paddle

To paddle a canoe needs a little practice and understanding of its ways. Never push out from shore and then attempt to jump in, as you might do in a rowboat. Have the canoe afloat beside a rock, if possible, or let the bow merely touch the sand; then step lightly in—do not jump—and if two are going, the sternman sits or kneels down, steadying the canoe by holding to a branch or rock, or, if he desires to steady the boat by his paddle, always reverse ends, and let the handle bear the weight. The blade is very easily cracked by pushing against stones or sand. A broken paddle a hundred miles from home may be a severe handicap.

The bowman now steps in and sits down at once, and if the sternman has not floated the canoe, he assists him in so doing, using the handle of his paddle in pushing out.

## HOW TO USE A CANOE

---

In loading a canoe always be careful to ballast it "by the stern." The heavier man must always paddle stern.

In paddling, the sternman steers. This is accomplished by twisting the paddle, as it is drawn back in the stroke, until by a sweeping, circular motion outward the blade is parallel to the boat. This is in straightaway paddling to keep the boat in a direct path. Of course, in turning the canoe's head in another direction the motion is reversed. In steering it is very rarely advisable to change the paddle from side to side. This marks a novice at once. Two canoeists adapt themselves very readily to each other's strokes after a short time. If things do not go smoothly for the first mile do not be discouraged, for the second one is sure to go better. Canoeists drop into a regular stride with a sweeping, steady motion, just as a pedestrian does in walking. The novice will make the mistake of beginning his day by paddling as though his life depended on covering a certain distance in a given time. He will soon tire or get a very painful shoulder which corresponds to the neuritis, with which violin-players become affected at times. Begin slowly and paddle comfortably. It is good form to keep the arms as straight as can readily be done. This will depend somewhat on the length of arms and the position of the paddler. At the end of the stroke the upper arm should always be straight. In rough water use short, snappy strokes, recovering as quickly as possible. Bear in mind that a canoe usually upsets while the paddle is *out* of water. The bad name that canoes have as to "tippiness" is undeserved if any sort of care and judgment is exercised in their management. In fifteen years' experi-

## BOATING BOOK FOR BOYS

---

ence with these boats on lakes and rivers of all sizes, as well as on the ocean, I have never had a spill, and have seen but two. One occurred at a small Maine lake on a perfectly calm, still day. A young man was reading in one end of the canoe and dropped his book, forgot that he was in a canoe, reached suddenly for it, and got a swim. The second was more serious. Two young men went fishing in a seventeen-foot canoe on a rough day and lay broadside to the waves. A steamer's wash made a sea that no canoe could stand. They swam to within fifty feet of shore, holding to the canoe, then released their hold, tried to swim in, and one never reached the shore. Had he retained his hold on the canoe he would have been saved. It is a good general rule to make, *never* to abandon a capsized boat or canoe until help comes or the feet can touch bottom. A boy can retain his hold on a boat almost indefinitely if the water is not too cold, while but few boys can swim more than one-half mile, particularly if frightened.

### Equipment

Paddles should be six feet long for a boy five feet and eight inches or over in height; and five feet and six inches to five feet and eight inches for a boy under that. The bowman always has the shorter paddle. They should always be varnished, since this makes them shed water better and keep longer. The best ones are spruce or maple. Be sure that the wood is seasoned. The Canadian Indians use hard wood (oak or ash) paddles as they pole a great deal. They are strong but clumsy and heavy. Bird's-eye maple



## HOW TO USE A CANOE

---

makes beautiful paddles, but they are more expensive. Double-ended paddles are only for fancy work around a boat-club dock, and no real woodsman ever uses one. The cost of paddles is as follows:

First quality—spruce or maple . . .	\$1.50
Second quality—spruce or maple . . .	\$1.00
Bird's-eye maple, selected . . . . .	\$2.50-\$3.00

Back rests and folding-slat canoe chairs are comfortable for a passenger, but they are not needed for a trip where boys do their own paddling. They cost from \$1 to \$2.50.

For sailing a canoe a lateen sail is used with lee boards over the side. The outfit would cost approximately:

Mast and step . . . . .	\$1.50
Lee boards . . . . .	6.00
Sail (50 feet area) . . . . .	8.50
	<hr/>
	\$16.00

Sponson canoes have air chambers along both sides, making it impossible to sink, and difficult to capsize. They will support three adults sitting on the rail without capsizing.

They are, however, not so easy to paddle, and much heavier.

### Loading

Put your axe, fire-irons, collapsible stove, and other heavy articles in the middle of the canoe. They keep the ballast, and act as stringers on which to place weight. Roll or fold the tent as tightly as strength can do it; lay it lengthwise

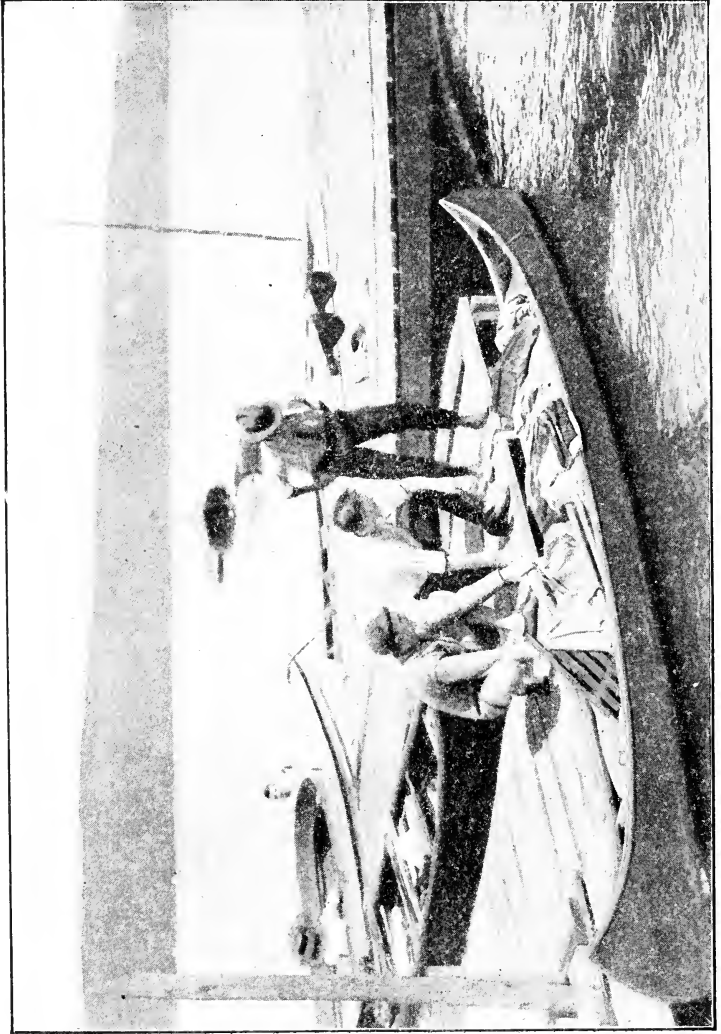

PREPARING FOR A CANOE TRIP

## HOW TO USE A CANOE

---

---

fore and aft. Put your cooking dishes in a small box, and slip it under the seat in the bow. This will keep them together and not get smut all over the other things, including your fine cedar flooring. The best thing that I have ever found for carrying dishes, knives, forks, spoons, is a tin cake-box. These boxes can be purchased in any department store for at least twenty-five cents, and are watertight, compact, convenient, and make excellent receptacles. The square kind about  $1\frac{1}{2}$  feet long are best. In such a box also put such odds and ends as mustard, pepper and salt, bread, crackers, cheese, and any food that water or sun will spoil. The lid will shut tightly and has a clasp. Put it under your stern seat.

Reserve the small 6 or 7 inch decked-over places in the bow and stern for the sweater, coat, or shirt. This will keep them dry until you need them. The feet will often tire in an all-day grind, and paddling in stocking-feet is often a relief.

### Rough Water

In rough water keep the paddle moving in the water as much as possible, and minimize the amount of time that it is in the air. Keep the boat ends on to the waves either going to windward or running before them. In whirlpools and rapids let the bowman paddle and the sternman keep his paddle in the water to act as a rudder, ready at any moment to swing to avoid a rock or hidden danger. In going up a rapid rocky stream use a pole and push up; do not attempt to paddle. If a steamer passes near, even on a still day, point the canoe's nose toward the waves raised.

## BOATING BOOK FOR BOYS

---

A well-ballasted canoe is always safer than one lightly loaded, and is more buoyant the lower the centre of gravity is placed. In other words, a canoe with its occupant sitting or kneeling in the bottom is much safer than one with the crew sitting on the seats or thwarts. If alone, put a weight in the bow and paddle from the centre of the canoe. With a man and a sack or two of flour and camp duffle resting in the middle, besides the paddlers in either end of a seventeen-foot canoe, an almost unbelievable amount of heavy sea will be weathered. I have seen Big Thunder, chief of the Old Town Indians, in a birch-bark canoe outside Mt. Desert Island in a blow riding the waves like a sea-gull. So be light of foot, steady of hand, strong of arm, and wary in judgment in your canoe. It will carry you silently and swiftly "along the listening woodland"—the very embodiment of its savage maker.

Part VII  
ROWING



## Chapter XXX

### A BOYS' BOAT CLUB

**I**F a boy of fourteen, or even of a younger age, should come to me and ask what form of exercise he should pursue in order to become strong and healthy, I should certainly say, take up rowing. Then if he were to ask me how he should learn to row, I should advise him to join a boat club. Then if he were to say that he was too young to join a boat club, I should tell him to form a boat club of boys.

But how is this to be done? It is to answer that question that this chapter is written.

I have been rowing ever since I was thirteen years old. When I went to college (and I presume most of my boy readers hope to go to college some day), I found that the knowledge of rowing that I had acquired enabled me to row in my freshman crew as captain and stroke, and in two university crews, in one of which I was stroke.

There are two kinds of boys whom I hope this chapter will reach: First, boys who go to a preparatory school where there are baseball clubs, foot-ball clubs, and possibly rowing clubs. Most of these boys will probably go to college. Second, boys who do not attend such a school, but go to public or private schools, and feel the need of some sort of organized work in athletics. If my readers

## BOATING BOOK FOR BOYS

---

belong to the former class, I may be able to tell them how they can improve their club. If they belong to the latter class, I hope to be able to tell them how to form a boat club, build a boat-house, buy a boat, choose their officers, and learn to row.

Now let me say one word about who should be asked to join this club. Don't reject a boy because he is thin and weakly. Before he has been long in training he may become one of the best boys at the oars the club has. In my next chapter, on training and the manner of rowing, I will show you how this can be accomplished. A case occurs to me that I will here speak of. Mr. Metcalfe was, some years ago, one of the foremost members of the Columbia College crew. When he was in his freshman year, he was thin, lank, and weak, and the captain hesitated about letting him row. But by constant work at the oars, and by careful observance of the rules of training, he was one of the best men on the university crew that I coached, and most of his strength came from following the rules I propose to give to you.

Perhaps I had better confine myself in this chapter to the boat-house and boat, and tell you what kind of boys you should choose, and how they should be governed and trained in another chapter.

### The Boat-house

First you must have a boat-house. This is necessary. You cannot keep your boat in the water overnight, and you cannot store away your oars and rudders and do your training unless you have a boat-house. The plan that



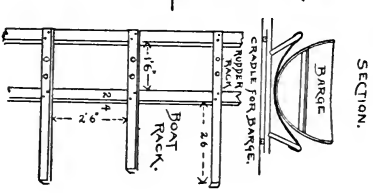
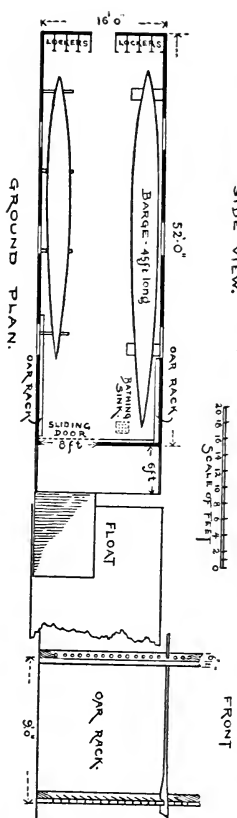
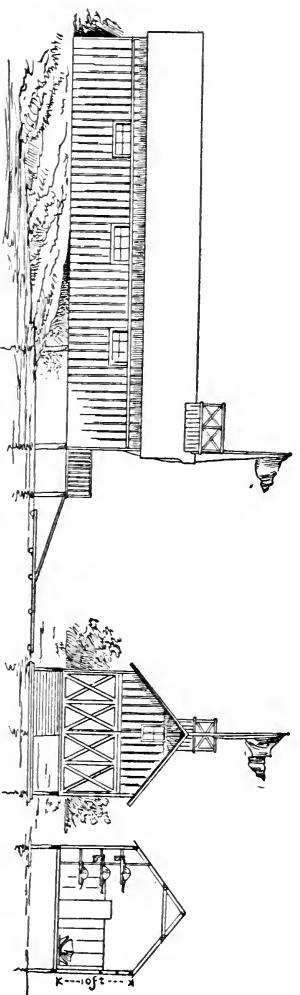

PLANS FOR A BOAT-HOUSE  
*Fig. 1*

## BOATING BOOK FOR BOYS

---

accompanies this chapter will show you what kind of a boat-house you should build, how it should be arranged, and what sort of a boat you should row in.

The boat-house should be built close to the water's edge, and from the platform that extends from the front of the house there should be an incline leading to a float. Possibly you may be able to build the float yourselves by making a raft of logs on the water, each log fastened to the other, and the top covered with a flooring of planks. The boat-house shown in the plan (Fig. 1) is exactly the right size to accommodate your boat or boats. You will see that the artist has made in his picture a boat rack, with room on it for a number of boats, for all boat clubs as they grow in size add to their number of boats. The rack should be built at the beginning, as it costs little, and when you buy gigs and shells, as you probably will if your club grows, it will be a necessity.

The barge also has two cradles, which are shown in this picture. The barge is a delicate boat, and without these cradles it would not last very long. It should never be allowed to rest on anything but the water and the canvas bottoms of these cradles. More barges have been ruined by the neglect of this rule than would equip a dozen such clubs as you may form.

The oar rack is also a necessity, because were an oar left on the floor, where it is likely to be stepped on, the chances are that you would find your bill for new oars a large item of your expenses. The blade of the oar is very delicately made, and a careless footstep might ruin its usefulness.

## A BOYS' BOAT CLUB

---

The boat-house should be kept clean and in ship-shape. This is very important, as your boat and oars and all the furnishings of the boat and house will last much longer if they are attended to properly.

The house will cost you almost whatever you may care to spend. In such a matter it is easy to make your house cost double the original amount set aside for the purpose, by the addition of little fixtures that will add to its beauty, but not particularly to its utility. Such a house as I have planned can be built in New York for from five hundred to eight hundred dollars. In the country, or in smaller cities, where both lumber and work are cheaper, it can be built for much less money. A friend of mine once built a house of this size on Lake Champlain for one hundred dollars, and he hired a carpenter to do all the work, too. But this was a number of years ago, and the cost of wages and material has increased greatly.

Of course you can save some expense by painting the house yourselves. The paint would not cost much, and any intelligent boy can do the work with little practice.

### The Boat

Now as to the boat. You should buy a good boat from a good builder. The first boat you buy should be either a six-oared or a four-oared barge. A six-oared barge is the most useful boat for a boys' club. The best way to get such a boat is to buy it from a recognized dealer, and secure the standard size. It should be forty-five feet in length, and it will cost you from three hundred to three

## BOATING BOOK FOR BOYS

---

hundred and fifty dollars. These figures should include everything—rowlocks, oars, sliding seat, and stationary seat.

It is extremely necessary that you should have both stationary and sliding seats. When you begin your practice, you must use the stationary seats altogether. After I had spent several months rowing on a sliding seat, I was forced to unlearn all I had learned, because I had not mastered the first principles of the art on a stationary seat. I have seen many college men who started in on sliding seats, and were afterward obliged to go back and begin over again on stationary seats. When I come to tell you what kind of a stroke you should row, you will see that there is an excellent reason for this piece of advice.

If you do not think that you can afford at first to have a new boat built for you, you can easily buy a second-hand one from an established boat club in any large city. There are always several of such craft in the market.

One word more. Do not think that because you are boys you should have a small boat and small oars. Buy both of the regulation size.

## Chapter XXXI

### HOW TO TRAIN A BOYS' BOAT CLUB

#### Organization

**I**N my previous chapter I gave you a few simple suggestions as to your boat-house and boat. Now I will tell you how to select your members, organize your club, choose your officers, and train your crew in the best way to develop your muscles, broaden your chests, and improve your general health. A boy who does plenty of rowing at school and in college, provided he rows in the proper manner, stores up a reserve fund of vitality and strength that will be of great use to him all through his life.

Your club should be thoroughly organized before any work is done. The best way to do this is to take the constitution and by-laws of any first-class rowing club, and model one after that. Here is the preamble of one of the best clubs in New York City, and you could not do better than adopt it as it is without a change:

*“Whereas, The intents and purposes of this club are to promote physical culture, and more especially to encourage the manly art and exercise of rowing, and believing that such object can be attained only by active co-operation and enforcement of regular order, be it therefore*

*“Resolved, That we, the undersigned, do hereby pledge ourselves to support and be governed by the following constitution and by-laws, endorsing the same by our individual signatures.”*

A list of the officers and the definition of their duties can be obtained from any rowing club, and I need not mention them in detail in this article, but I want to say a few words to you about your selection of a captain. He should not be too hastily elected; popularity should not be his sole qualification. If possible, he should be the most conscientious, hard-working, level-headed, and determined boy in the club. He should be able to govern his fellow-members, and enforce the constitution and by-laws. He may not know anything about rowing, but if he has the above characteristics he will soon learn. Many crews have captains who are popular but careless. It must be understood at the outset that he has entire control, and he should allow no one to dictate to him in the boat or on the shore. I know of a university crew that was ruined by two or three "kickers" and fault-finders. Such members discourage the other boys, do much harm, and positively no good. They either should be quieted or turned out of the club.

### Training

Now as to the training. If possible, the first work the club does should begin during the winter months, and in a gymnasium. This is preparatory work, and will save many disappointments when the rowing months come. If you have no gymnasium in your neighborhood, you could rent a room, and fit it up with some of the regular gymnasium fixtures, the most important of which are pulley weights. Excellent directions for their use accompany all such appliances as are of standard make. Be sure to

## HOW TO TRAIN A BOYS' BOAT CLUB

---

have your room well ventilated, as plenty of fresh air is of the utmost importance during in-door exercise. In your gymnasium work do not make the mistake that many would-be oarsmen make, of developing only those muscles that they think they will require in rowing, but develop the whole body symmetrically, strengthening all muscles alike, and not one at the expense of another. Some boys are weak in certain sets of muscles, or have some physical defects, such as hollow chests. Of course in these cases special attention should be paid to strengthening these weaknesses. But even then keep in mind the great importance of uniform muscular exercise.

Among your fixtures you should have a stationary seat four or five inches above the floor. A "stretcher" should be placed a short distance away from this—a little less than the average length of a boy's legs—and on this "stretcher" two toe straps, such as are used on old-fashioned skates, should be fastened. Then each boy should take his turn on the seat, placing his toes in the straps, and gently sway his body backward and forward, just as an oarsman swings his body in a racing boat. This exercise is very valuable in imparting the proper way of holding the back in the boat. The swing should be made entirely from the hips, bending the back as little as possible. A boy who is very stiff at the hips will, if this exercise is practised patiently, be able in a short time to get his "reach" in the proper way. The "reach," I may explain, is the movement made when the body is swung forward from the hips and the arms are extended just before dipping the oar into the water.

In some college gymnasiums there are rowing tanks, in which

## BOATING BOOK FOR BOYS

---

the boat is stationary, but there is room on both sides of it for the oars to work. In such a tank the crew practise during the winter months.\* But for all practical purposes at first, the stationary seat and stretcher will be all that is necessary.

Running is another exercise of great value, and it should be out-of-doors when the weather permits. Start with very short distances and at an easy gait, and work up gradually until you can run a mile or two. This exercise should be stopped when you begin to row; but when such days come that you are unable to row, you should take a run. The more out-of-door work of any kind a boy does, the stronger he will grow. After such violent exercise take a shower-bath, or, if you cannot do that, take a bucket of cold water and a sponge and give yourself a thorough dousing, after which have your body rubbed with a rough towel until it glows.

The old idea of a very limited diet for boys or men in training has long been exploded, and each year the college crews are given a more liberal bill of fare. The thinner a boy is, the greater variety of food he should have. Growing boys especially should have a great variety, and should only eschew rich pastry and other indigestible articles. When you are in training, you should eat nothing between meals, and have the meals at regular intervals. Do not get into the coffee or tea habit. For two weeks before a race the bill of fare should be more carefully considered, and nothing but plain and wholesome food should be eaten. Accustom yourself to get along without ice-water. It does much

\*Most of the colleges have discarded the tanks and substituted rowing machines.



## HOW TO TRAIN A BOYS' BOAT CLUB

harm even to those who do not row. Do not gulp the water, but sip it, and you will find that it quenches your thirst much more quickly. If you have any aspirations to become oarsmen, you might as well give them up if you use alcohol or tobacco in any form. A cigarette will do your lungs incalculable injury.

## Chapter XXXII

### HOW TO ROW

**I**N this chapter I will tell you how to utilize some of the information I have given in my former chapters in a practical way in your boat. We will suppose that you are ready to take your first row. Before you do this, you must select your "stroke" oarsman, who pulls the last oar in the stern of the boat, and sits facing the coxswain. The stroke oar should be the most experienced oarsman in the club, as he sets the stroke for all the other boys to follow. If he rows fast, so must they; if he slows up, they must slow up too. You should arrange where the other boys are to sit, and you should place the heaviest boys in the middle of the boat. The coxswain should be the lightest boy you can trust to handle the rudder ropes and steer the boat.

Now you are ready to put the boat in the water. Lift it carefully out of its cradles, carry it to the end of the float, and place it in the water. Then put the oars in the rowlocks. When you step in the boat, be careful to step on the keelson; never step on the bottom of your barge. As soon as the boat is shoved off, the coxswain gives the orders under direction of the captain. The first order the captain gives is somewhat in the following manner: "Go ahead!" he says. Then the coxswain calls out, "Ready,

## HOW TO ROW

---

---

all!" and the crew place their oars in the water preparatory to beginning a stroke. "Row!" calls the coxswain, and the stroke is begun. When the captain wants the boys to stop rowing, he directs the coxswain, who gives the order, "Way, all!" When he wants the boat stopped, he orders, "Hold, all!" and the crew put their oars deep into the water, and hold them in that position until the boat comes to a standstill. When he wants the boat turned to the "port," for instance, the order is: "Port, hold! Starboard, pull!" and the barge moves in the desired direction. When he wants the boat to go backward, the proper order is, "Stern, all!" and the crew back water with their oars.

### The Stroke

In describing a stroke which you should use, I will not give the exact stroke of any college, but such a one as will enable you to easily catch the stroke of the college you may attend from the foundation you have acquired from my directions. While you are learning the principles of the stroke, which will take you a week or longer, the whole crew should not row together, though you should all sit in the boat. You should row in pairs, such as "bow" and "two," who pulls an oar on the opposite side of the boat from the "bow" oar. For a month at least you should use stationary seats.

Take hold of your oars with a hand's-breadth between your hands. Commence by reaching forward toward the stern of the boat with both body and arms and putting the blade of the oar in the water, being careful to swing for-

## BOATING BOOK FOR BOYS

---

---

ward from the hips without bending the middle of the back any more than possible. In the swing forward toward the stern great care should be taken that the last part of this movement should be very slowly and firmly made. The back should be fairly straight, and the shoulders should be down and back, as is shown in Fig. 1, and not up and forward, as in Fig. 2.

In dropping the oars into the water, the lower part of the blades should be turned slightly toward the bow of the boat. They should not be dropped in straight up and down. Drop your blades into the water by raising your hands when you are at full reach. You are at "full reach" when your arms are extended and your body is swung for-



*Fig. 1*

GOOD FULL REACH



*Fig. 2*

BAD FULL REACH

ward. Be sure that the blade is entirely under water, but do not put it down too deep. The upper edge should be covered but that is all. Swing back slightly past the perpendicular, at the same time bringing in the hands until they just touch the body. At this point the body should be held firmly, as in Fig. 3, without settling down, as is shown in Fig. 4. The commencement of the stroke should be hard, and the pull through the water should be strong and firm, not jerky. As the hands come in, the elbows should not

## HOW TO ROW

---

---

be spread out, neither should they be very close to the side; they should be between the two. When you have brought your hands in close to the body, immediately drop them to raise the blade from the water, and do not, at first, turn

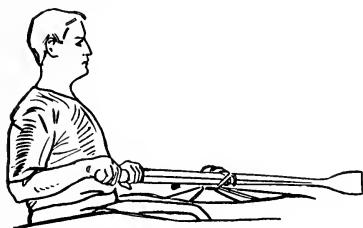

*Fig. 3*  
GOOD FINISH

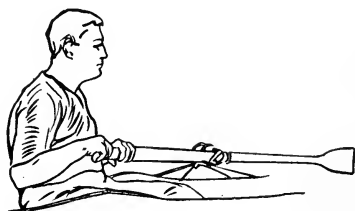

*Fig. 4*  
BAD FINISH

your hands to “feather” your oar until they are dropped. Later you can somewhat merge the two movements. Start your hands and your body together as you swing toward the stern of the boat, which movement is called the “recover,” but “shoot” your hands away from your body very quickly until your arms are straight. The blade should always clear the water on the recover by three or four inches, and should be kept at a uniform distance from the water. When you “feather” your oar, you should chiefly use your hand nearest the rowlock, the oar turning a little in your other hand. In your forward and backward swings be sure to keep your body directly over the keel of the boat, and do not lean either to one side or the other.

### Sliding Seats

After you have learned to row this stroke on stationary seats, use sliding seats. The points that I have given you

## BOATING BOOK FOR BOYS

---

above can be used when you row on your sliding seats without change. But I want to caution you not to start your slides toward the bow of the boat before you begin to pull on your oars. Never push your stretcher before your oar is under water and you are pulling on it. On the recover, the slide, hands, and body should start together. During the first part of the recover, the slide should move rapidly, and during the last part correspondingly slowly. You can add to the speed of your boat by pushing against the stretcher hard when you are using the slide.

I would advise you to select some experienced person as a "coach," who will go with you when you row, and see that you follow all of these directions precisely as they are given. By that means you will be sooner able to correct your faults and perfect your style of rowing.

When you first begin to row as a crew, you should take short rows, gradually increasing the distance and your speed.

When you come in from a row, take a souse bath and a brisk rubdown. I want to caution you not to row before you have learned to swim; but when you are practising hard you should not stay long in the water when you do go swimming.

## Chapter XXXIII

### THE HARVARD-YALE RACE<sup>1</sup>

1852-1885

THE year 1912 brings the sixtieth anniversary of the first meeting between Harvard and Yale as rivals in sport. Their race in 1852 initiated a series of varied athletic contests, in which nearly all our better-known colleges have at one time or another taken part. Out of that race grew all American college boating. To it must be ascribed, indirectly, the credit of the physical development which many graduates trace back to the boating of their college days. For Harvard and Yale, by inaugurating races and other contests between students from different institutions of learning, furnished a needed stimulus to care of the body as well as of the mind, and hastened the recognition of physical education as an essential part of the college curriculum. If the benefits of college boating were limited to the six or eight representative oarsmen, the value of boating might well be questioned. But such is not the case. The fact that a picked crew is to be sent out to do battle against a rival does assuredly help to draw hard-reading men from their sedentary life to the

<sup>1</sup>By the courtesy of the *Outing Magazine*.

## BOATING BOOK FOR BOYS

---

---

gymnasium and the river. Without these annual races boating at Harvard and Yale would languish, and perhaps utterly perish. The years which have passed since these colleges were first pitted against each other on the water has brought a marked improvement in the physical welfare of the average college student, and in this, as I have indicated, the Harvard-Yale race has been no unimportant factor.

As regards equipment and methods, it is more than improbable that any changes which the future may bring will be as sweeping as those included in the records of the first thirty-three years of these contests. There will be no transition comparable to that from the clumsy barge, three and a half feet wide, rowed on the gunwale, to the slender shell of recent years. There will be no such series of changes as were presented by the early scratch-races on Lake Winnipiseogee, the turning races at Worcester, with their uproarious accompaniments, the intercollegiate regattas at Springfield and Saratoga, culminating in 1875 in the beautiful spectacle of thirteen six-oared crews ready at the starting-line, and finally, the eight-oared contests which began between Harvard and Yale in 1876, and between Cornell and the field in 1895 at Poughkeepsie. The conditions of both races have been well tried, and nothing better has been found.

But the experience and general perfection of methods represented in the college races of to-day are derived from much vain groping in the dark, from beginnings and experiments which seem laughable enough in the light of our present wisdom, and from many costly blunders. Many an



old oarsman feels even now a dull ache at his heart as he remembers how the result of some hard-fought race betrayed his faith in a new "rig," a new stroke, or a new system of training. There may still be graduates who recall the fifty and sixty strokes to the minute, pulled by the men of the early days, and they may be inclined to regard the sliding seats and slower stroke of to-day as signs of degeneracy. *Consule Planco*, "when Wilbur Bacon pulled stroke of Yale," or, "when Harvard sent forth the Crowninshields, Watson, the McBurneys, and the Lorings," "then, indeed, there was a race of giants upon the earth." Well, the race endures, and the men who represent the two universities at New London, year by year, sustain the traditions of their predecessors. No Harvard or Yale graduate will admit that his interest in the race has waned. He may care little for other victories, except in football, but he never fails to watch the wires when the decisive news is expected from New London. No one but a Harvard or a Yale man can fully understand the force of this feeling. Properly directed it is a stimulus to open and honorable emulation. Left uncontrolled it has led in the past to recriminations and ruptures which, I have faith to believe, have occurred for the last time.

Boating began at both Harvard and Yale about 1844, but received little attention from the majority of the students until after the first Harvard-Yale race, in 1852. The challenge came from Yale, and was accepted by the Oneida Club of Harvard. The date of the race was August 3d, and upon August 10th, according to the fashion of those leisurely times, the *New York Tribune* published a report

## BOATING BOOK FOR BOYS

---

sent by a correspondent at Center Harbor, N. H. This account was as follows:

The students of the Yale and Harvard boat-clubs met each other in the depot hall at Concord, where mutual introductions took place, and they proceeded together to Weirs. Here the "Lady of the Lake" was in waiting to convey them to Center Harbor, where they arrived after a delightful trip of an hour and a half, just in time for a splendid dinner at the Center House. Some idea of the immense capacity of these boats may be gained from the fact that the captain requested the passengers not to seat themselves all on one side of the boat. . . . The students have free passage in her to any part of the lake; and indeed their whole trip, as we understand, was free, the expenses being defrayed principally, we understand, by the Boston and Montreal Railroad Company. . . . The Yale boats arrived on Monday, which was mostly spent in fishing and practising for the regatta on Tuesday. The boats are: From Harvard, the *Oneida*, 38 feet long, 8 oars; from Yale, the *Undine*, 30 feet long, 8 oars; the *Shawmut*, 38 feet long, 8 oars; the *Atlanta*, 20 feet long, 4 oars.

There is but one boat-club in existence at Harvard at present, which accounts for their sending but one boat. The crew have evidently had considerable practice—somewhat more than the boats at Yale. The *Oneida* is quite a model for fleetness and beauty. The first regatta was run on Tuesday at eleven in the morning. The shore was lined with a numerous and excited throng, and the betting ran quite high. At the third blast of the bugle, the boats shot forward almost with the speed of race-horses, while the band on the shore struck up a lively tune. The sight was perfectly enchanting, scarce a breeze ruffled the water, and the whole crowd were anxiously bending their gaze upon the boats, which were flying over the water with all the speed which the vigorous and rapid strokes of the young oarsmen could produce. Meanwhile, the little parties who were out in skiffs were urging on the oarsmen with encouraging shouts as they rushed by them. The distance to be run was about a mile and a half, to a boat anchored off upon the lake. The *Oneida* ran the distance in seven minutes, the *Shawmut* being about two lengths behind, while the *Undine* and *Atlanta* pressed closely after.

This was what was denominated the scrub-race, being merely a trial of the strength of the respective crews and no prize being awarded.

The grand regatta came off this afternoon at four o'clock. The boats (with the exception of the *Atlanta*, which was not allowed to compete

## THE HARVARD-YALE RACE—1852-1885

---

for the prize on account of its inequality in size and number of oarsmen) started at the distance of about two miles from shore and ran directly for the wharf. A large boat, with the band on board, was stationed midway upon the lake and [the boat?] played some very fine airs for the benefit of the lookers-on, for it evidently attracted no attention from the oarsmen, who were altogether too busily occupied.

The result of the race was the same with that of the first, the distance between the boats being almost exactly the same.

A fine pair of black-walnut oars, tastefully ornamented with silver, was presented to the *Oncida*, with an appropriate speech, by the Chairman of the Deciding Committee.

The first move toward an intercollegiate regatta was made by Harvard in 1858. Yale, Brown, and Trinity responded to her call; but the drowning of the Yale stroke, Mr. George E. Dunham, at Springfield, July 17, 1858, caused the abandonment of the race. The first regatta in which more than two colleges participated was not rowed until the following year, and the second and the last general regatta, for a period of ten years, was held in 1860. The experience of the Brown crew was not calculated to encourage other entries. Then the war, and certain restrictions imposed by the faculties of Harvard and Yale, made the boating record a blank until 1864. In 1865 Yale's time, first announced as 17m. 42½s., was afterward, according to the *Harvard Book*, "declared by both judges and referee to be a mistake." In this publication the Yale time is given as 18m. 42½s. The author of *Yale Boating* claims the faster time. In the Citizens' regatta, on the same course, a day later, the time of the Yale crew was 19m. 5½s. In 1869 Harvard, after sending her four best oarsmen to England, won an unexpected victory from Yale at Worcester. Two of the Worcester crew afterward took the places of

## BOATING BOOK FOR BOYS

---

the men originally selected to meet Oxford. An unfortunate foul in 1870 caused an angry and protracted discussion, which was taken up by the daily press. This was the last of racing at Worcester. The advantage of the landlocked Quinsigamond course was its freedom from rough water. Its disadvantages were the necessity of a turning race, with the chance of fouls at the stake, and comparative inaccessibility. In the opinion of Yale the general sentiment of the good people of Worcester was strongly in favor of Harvard. In the opinion of Worcester's sedate citizens, the uproar which annually began at the Bay State House, and drove sleep from almost the entire city, finally became too dear a price to pay for the visits of either Harvard or Yale oarsmen and their friends.

So a new era was inaugurated. Yale positively refused to row at Worcester. The New London course was examined, and the report was favorable. But in April, 1871, Harvard, Brown, Amherst, and Bowdoin organized the "Rowing Association of American Colleges," for the management of an annual regatta on a three-mile straight-away course, and Springfield was selected for the first race. Yale neither participated nor consented to Harvard's acceptance of her challenge, which named Springfield and the intercollegiate regatta as the place and time. Harvard's second acceptance came too late, and 1871 was the only year since 1863 when Harvard and Yale failed to meet. Harvard's unexpected defeat by the Amherst Agricultural crew proved a text for much newspaper moralizing as to the superiority of "brawny country boys" over "pampered city youths," and others of the smaller colleges were

## THE HARVARD-YALE RACE—1852-1885

---

encouraged to enter the competition. When, in 1872, Harvard was defeated by Amherst and Yale was the last of the six crews, the boating-fever broke out at almost every college which could possibly equip six oarsmen. Eleven crews entered in 1873, the year of the famous "diagonal line finish." The flags, first given to Harvard, were afterward recalled, and the race was awarded to Yale. The referee's decision is final. But those who care to review this curious controversy will find in the *Harvard Book* an explanatory diagram and various proofs and arguments which will appear convincing until the reader turns to the evidence and the special pleading set forth in *Yale Boating*.

The crooked Springfield course presented peculiar difficulties to both judges and spectators, as is vividly suggested by the following account of the race of 1873, written for the New York *Tribune*, by Bret Harte:

The great race was coming. It came with a faint tumult, increasing along the opposite side into the roars of "Rah!" and yells of "Yale!" like the bore of the Hoogly River—and then, after straining our eyes to the uttermost, a chip, a toothpick, drifted into sight on the broad surface of the river. At this remarkably and utterly novel sight we all went into convulsions. We were positive it was Harvard. We would wager our very existence it was Yale. If there was anything we were certain of it was Amherst; and then the toothpick changed into a shadow, and we held our breath; and then into a centipede, and our pulses beat violently; and then into a mechanical log, and we screamed of course it was Harvard. And then, suddenly, without warning on shore, and here at our very feet dashed a boat the very realization of the dream of to-day—light, graceful, beautifully handled, rapidly and palpably shooting ahead of its competition on the opposite side. There was no mistake about it this time. Here was the magenta color, and a "Rah!" arose from our side that must have been heard at Cambridge—and then Yale on the other side, Yale the indistinguishable, Yale the unsuspected—won!

## BOATING BOOK FOR BOYS

---

The dispute of 1873 put a greater strain upon the relations of Harvard and Yale. A new race of oarsmen had come forward in 1872, headed on the Yale side by Robert J. Cook and at Harvard by Richard H. Dana, 3rd. The rivalry was intense, and when, at Saratoga, in 1874, Harvard was fouled by Yale, there was an outpouring of the spirit at the lake and an outbreak of hostilities in the town, in the presence of which no one would have dared to predict such harmony as now attends the meeting of Harvard and Yale at New London. But the succeeding years brought satisfaction to both sides. In 1875 Harvard defeated Yale, and in the first of the eight-oared races at Springfield, in 1876, Yale was easily victorious over Harvard. In the four intercollegiate regattas engaged in by both Harvard and Yale, Harvard took second place once and third place three times, while Yale was sixth in 1872, first in 1873, ninth after the foul of 1874, and sixth in 1875.

The race of 1875 at Saratoga was the first in which the plan of rowing in "lanes" marked out by flags was adopted, and in consequence there was a total absence of fouls. It may be because this race was the first which I had seen that it appeared to me an extraordinarily beautiful spectacle; but I still think that the sight of thirteen six-oared crews in line was sufficient warrant for certain descriptive extravagances. The newspapers that year, as at the two preceding regattas, devoted pages to detailed accounts of the training, stroke, boats, and even the personal peculiarities of the oarsmen. The crowds of summer visitors in the grand-stand and on the shore were merely the background for the kaleidoscopic ribbons of the intent, excited, uproarious mob which

represented thirteen colleges. What bitter memories could resist the wild celebration which followed the race? Harvard and Yale joined in congratulating victorious Cornell, marched together in a tumultuous procession, and mingled in a fraternal embrace.

But this reconciliation really meant the end of the unwieldy Intercollegiate Rowing Association. Frequent postponements on account of rough water had shown the uncertainty of the Saratoga course, the only one available for a race with so many participants. Now that Harvard and Yale were able to arrive at a clear understanding, the advisability of returning to an independent contest was conceded on both sides. Yale withdrew from the association, and challenged Harvard to a four-mile eight-oared race. The challenge was accepted. Harvard alumni decided that a crew should be sent once more to an intercollegiate regatta, and, as a point of honor, Harvard was represented by a six-oared crew in the Saratoga race of 1876, as well as by an eight-oar in the contest with Yale at Springfield. Harvard rowed a separate race against Columbia in 1877, but the day of general intercollegiate races was ended for both universities, and their one distinctive race has remained a dual contest, with two exceptions—1897, when both took part in the Poughkeepsie regatta which was won by Cornell, and 1898, when Cornell won against Harvard and Yale at New London.

The improvement in the boats used in the Harvard-Yale races amounts to a revolution. The first boat owned at Harvard was the *Oneida*, built for a race between two clubs

## BOATING BOOK FOR BOYS

---

of Boston mechanics, and purchased in 1844 by members of the class of 1846. She was a type of all the club-boats down to 1855. According to the *Harvard Book* the *Oneida* was "thirty-seven feet long, lap-streak built, heavy, quite

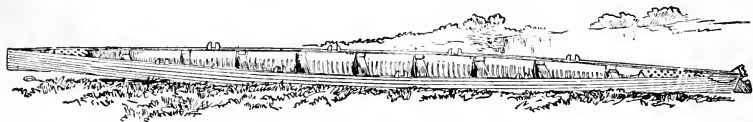

### THE "ONEIDA," THE FIRST HARVARD RACING-BOAT

Bought in 1846 and used for thirteen years

(By the courtesy of the "Outing Magazine.")

low in the water, with no shear, and with a straight stem. Her width was about three feet and a half in the widest part, and she tapered gradually toward bow and stern. She was floored half-way up to the gunwale with wooden strips, and had a hard-wood grating in each end. These gratings were kept unpainted and oiled; and, although used by the bow-oar sometimes to walk on in using his boat-hook and in setting and striking colors, they were the principal vanity of the boat. Many a hard day's work have members of her crew done in sandpapering and polishing these gratings when things were to be made shipshape for some special occasion! The boat had plain, flat, wooden thole-pins fitted into the gunwale. Her oars were of white ash, and ranged from thirteen feet six inches long in the waist to twelve feet at bow and stern. A plain bar of hard wood served for stretcher, and each seat had a red-baize-covered cushion. The tiller-ropes were stout, covered with canvas, and finished at the end with a knot known as a 'Turk's head.'



The captain's gig of a man-of-war will give a very good idea of her general fittings."

Such was the first boat entered by Harvard in a race against Yale. The *Oneida* was used continuously for thirteen years by Harvard students, and tradition has it that she was never beaten in a race. The boats entered by Yale in the race of 1852, the *Halcyon*, or *Shawmut*, and the *Undine*, were of a similar pattern. In the race of 1855 the Harvard eight-oared barge was slightly outrigged with wooden pieces spiked to the gunwale; but the crack Harvard boat was supposed to be the *Y. Y.*, a four-oar from St. John, fairly outrigged and furnished with oars of spruce instead of ash. The Yale boats, spoken of as much superior, had "bent wooden outriggers, braced like those of a wherry, running from the bottom of the boat across the gunwale."

This was the first appearance here of outriggers, although they were used in the Oxford-Cambridge races after 1846. Oddly enough, the boat most deficient in these appointments won the race. Soon after, Harvard obtained from St. John an eight-oar, built especially for racing, fifty-one feet long, a lap-streak, fairly outrigged, without a rudder, and decked over with canvas fore-and-aft. This, the first university, as distinguished from club-boat owned by Harvard, was never used against Yale. Meantime, the use of outriggers and spoon-oars was becoming more general at both colleges, thanks to the influence of English boat-builders and the St. John oarsmen. In the fall of 1857 James Mackay, an English resident of Brooklyn, built for Harvard the first six-oared shell ever constructed in this country. The *Harvard* was forty feet long, "made short in order to turn a

## BOATING BOOK FOR BOYS

---

stake easily," twenty-six inches wide amidships, and carrying iron outriggers, although the oars were not kept in place by wires. The material was white pine, and the boat weighed one hundred and fifty pounds. The *Harvard* was shorter, wider, and higher out of water than the modern racing-shell, but the general plan of construction was similar to that now followed. The new shell was tested in local races. "The fight between the *Merrimac* and wooden frigates was not more decisive, and lap-streak boats were henceforth useless for racing."

In 1859 Yale appeared at Worcester with a new shell, built by Mackay, and with spoon-oars. The Yale shell, built of Spanish cedar, was forty-five feet long, twenty-four inches wide, eight inches deep. With her crew she drew four and a half inches of water. Each boat weighed one hundred and fifty pounds. The Yale shell, which was rigged for a coxswain, although said at the time to be the fastest racing-boat in America, was afterward pronounced unsatisfactory by a member of the crew. "The stroke was on the port side, the outriggers were shaky and short, and the spoon-oars were but ten feet long, the length of single sculls." This boat was received only three days before the race by a crew which had practised in a lap-streak without a coxswain, with oars thirteen and a half feet long, and the stroke on the starboard side. In consequence of the shortness of the oars the Yale crew was forced to increase their stroke from thirty-eight to forty-five, and, in a final spurt, to sixty. The Harvard crew rowed without coxswain or rudder. Under these conditions the first race between the shells was pulled. As the record shows, Harvard won the

regular university race on July 26th, by sixty seconds, to be beaten by two seconds in the "Citizens' regatta" on the following day. This was Harvard's first defeat by Yale.

The result was significant. The two lap-streaks entered in the first race were easily left behind, and the time made indicated a remarkable advance, in so far as the records of those years may be trusted. Yale's time, 19m. 14s., was the best ever made, except that of the Harvard crew, 19m. 11s., in a Beacon cup regatta at Boston—a comparison which may be accepted for what it is worth, since both courses and times were unreliable. Thus the superiority of the shell was clearly demonstrated. And another important outcome of these two races was Harvard's adoption of "a rudder connected with the bow-oarsman's feet by wires." In the "Citizens' regatta" Harvard drew the side more exposed to the high wind, which blew across the course, "some of the gusts being so strong that twice on one side the crew were obliged to hold water to get the boat's head around." Little importance is attached to the influence of the wind by Yale writers in view of Harvard's fast time; but the circumstance is mentioned here simply as the cause of a new departure in steering. Something had been done in this direction with the Harvard *Undine*, a four-oared boat, two years before; but the plan of a rudder worked by the bow-oarsman was not adopted until the "Citizens' regatta" proved that a shell could not be satisfactorily steered by the oars. Although new boats were built for the Cambridge oarsmen the pine shell *Harvard* was used in 1860, winning three races, among them the race against Yale and Brown. In 1865 the *Harvard* was broken

up and her pieces preserved as relics. The oarsmen of those days cherished a personal regard for their boats which, I think, no longer exists. The lap-streaks used in the "irregular" races, and the first shells, were named, a custom long since abandoned, and after a service, in some cases of several years, the parting from these old boats was like a parting from old friends.

Yale introduced the use of sliding-seats in 1870. A correspondent, writing from Worcester, naively described the Harvard men as having "seats some eighteen inches long, running fore-and-aft, polished smoothly, and coated with grease, upon which they slide. The Yale men have seats so mounted that they slide themselves." Notwithstanding Yale's new device Harvard reached the turning-stake first, but was disabled at that point by a foul. Yale's time was slow—a fact due, probably, to delay at the stake. When sliding-seats were first used in the Oxford-Cambridge race, in 1873, the time was astonishingly fast. Harvard adopted the sliding-seat in 1872, and was defeated by Amherst, rowing with stationary seats; but Yale discarded the new invention in that year only to be the last of six crews. There was, therefore, some apparent reason for the earnest discussion, pro and con, which preceded the universal adoption of sliding-seats.

From 1873 on the changes in the rig of six-oared shells were only trifling modifications of tolerably well-determined standards. In 1876 "the Yale eight-oar was built by Keast & Collins, of New Haven, after the model of one built for Yale by Clasper, of Oxford (England), while the Harvard boat was the work of Fearon, of Yonkers. These

were the first eight-oared shells that ever competed in America." Paper boats built by Waters, of Troy, were favored for a time. The average length of these boats was fifty-eight feet. In 1882 Yale appeared with a boat sixty-seven feet long, so rigged that the men sat together in pairs. The temporary substitution of paper for wood as the material for racing-shells, which began in 1868, and the introduction of swivel row-locks were peculiarly interesting experiments, although only the latter proved permanent.

Closely connected with the changes in boats is the development of boating methods, understanding by this phrase, training and styles of rowing. When the Harvard-Yale races began, such a thing as systematic physical education was unknown at our colleges. Dr. Sargent's scientific methods and his refinements in apparatus were not dreamed of. It was years afterward when Amherst became the pioneer in even and wholesome education of the body, and years after that when Cornell made general physical development an essential part of her curriculum. In 1852 the Harvard crew only rowed a few times before the race, "for fear of blistering their hands." The Rev. James Whiton, of the Yale crew, wrote, in a subsequent account: "As to training, as now practised, there had been none—only that some care was taken of diet on the day of the race, such as to abstain from pastry and from summer fruit, and to eat meat in preference. One of the Yale clubs thought it was a smart thing when they turned out on Tuesday morning, an hour before sunrise, took their boat into a secluded cove, and rubbed her bottom with black-lead." In

## BOATING BOOK FOR BOYS

---

1855 the Harvard men "had all rowed during the spring-time, and had the same general style." The Yale crews "rowed with short, jerky strokes, more than sixty [?] to the minute."

Up to 1864 the Harvard University crew had been beaten but twice—by the Union Club crew in Boston, 1857, and at Worcester in 1859. The Harvard men had the advantages of studying the St. John oarsmen, and they were near the water. "Yale never saw good rowing except at Springfield and Worcester." Nevertheless, the Yale crew of 1859 was put through a severe course of training. Winter gymnasium work was taken up at both colleges after the second race. Among rowing-men Yale's short, choppy stroke and Harvard's long swing soon became proverbial.

Training then, and for many years afterward, was largely guided by the crude empiricism of retired prize-fighters—"physic first, sweat and work down, no liquid, plenty of raw meat, and work it into 'em." An intelligent knowledge of the subject on the part of medical men, or amateur athletes of experience, was almost entirely wanting.

The experiences of the Yale crews of 1864 and 1865 were forcible illustrations of old-school training. Mr. Edmund Coffin, a member of the Yale crew for three years, refers, in *Yale Boating*, to the training of those years as "more severe than any other college crews have ever had in this country. I believe the old and time-worn stories of raw beef, and the other things accompanying it, were facts with us; that training lasted about two months in its severity before the race. On week-days we rose about six, walked and ran before breakfast on an absolutely empty stomach,

between three and five miles, running more than half the distance, and a part of that at full speed, often carrying small weights in our hands. Most of this running-exercise was taken in heavy flannels, for the purpose of melting off any possible fatty substance. After that we breakfasted, attended recitation for an hour, rowed about four miles, attended a second recitation, dined, rowed again the same distance, and had a third recitation in the afternoon. All the rowing was at full speed, much of it over the course on time. The bill-of-fare consisted of beef and mutton, with occasional chicken, toasted bread, boiled rice, and weak tea, no wine or beer, and very rarely vegetables." Such a system as this resulted in light crews, for one of its chief objects was "to get the men down."

In 1864 a professional trainer was first employed—Mr. William Wood—who was with the Yale oarsmen for four weeks before the race. In the same year "the Harvard men appeared with bare backs; and, as they had practised all the season thus stripped, presented a rich mahogany color, while the Yale crews, who had rowed in shirts, were milk-white by contrast. The *New York Sun*, in its account of the race, attributed the hue of Harvard's oarsmen to the use of some artificial coloring matter." It was at this race that the magenta and crimson became popularly confounded as the Harvard colors. Magenta was the color of the class of 1866, which furnished the entire university crew in 1865. The crew of the preceding year, unable to find crimson handkerchiefs at Worcester, substituted magenta perforce, although the color was called "red" in the programmes. Perhaps Worcester was the first town ever literally "painted

## BOATING BOOK FOR BOYS

---

red." In 1865 the shops contained nothing but magenta, and its use caused an erroneous impression, officially corrected some ten years later by a formal return to crimson. Yale's stroke in these two races was quick and jerky, the arms doing more than their share of the work. Harvard, pulling only thirty-six and thirty-seven to the minute, was severely criticized by the New York *Tribune*, which remarked editorially, in 1865, "No crew pulling less than forty to the minute has any right to expect to win a race."

But a change was at hand. Under Mr. Wilbur R. Bacon's splendid discipline Yale had been victorious for two years. Harvard was stimulated to new efforts, directed by Mr. William Blaikie and other veteran oarsmen. For the first time at Cambridge the rowing-men entered upon regular work in the autumn. On alternate days they ran five or six miles. The old-school training was radically changed. "Instead of training off flesh the maxim was, keep all the flesh you can, and do the prescribed work." A far more liberal diet was adopted and continued up to the race; and, as the result, a heavy, "beefy" crew, well trained, won the race of 1866. A close study was made of English rowing, improved rowing-weights were obtained, and on them the candidates for the crew pulled a thousand strokes daily throughout the winter, meantime applying the principles of the "English stroke." This meant more use of the back and legs, and a firm catch at the beginning of the stroke. Yale, although pulling a slower and longer stroke, still relied mainly on arm-work. In the race Harvard quickened up to forty-three; but Harvard's half-minute victory was considered due to her new style of rowing. Six years later



Mr. Robert J. Cook imported and modified an "English stroke," which won success for Yale.

In 1868, a year distinguished for the sign-stealing, howling, and other nocturnal disturbances at Worcester, the styles of the two crews were described as follows: "Yale is dropping the rigid-arm stroke. The men reach well over their toes and come back with a strong, steady pull, finishing up with something very like a jerk, then recovering more slowly than the Harvards. Their backs are much more bent, and they do not seem to get so firm a hold. They row with oars rather longer, thus making up for less strokes. Harvard's stroke makes the men reach even farther forward, and row with perfectly straight backs, almost raising themselves off the seat at every stroke, giving the stretcher a most wicked kick at the beginning, and finishing up gracefully with their arms."

Thus the successive stages of rowing may be traced from exclusive use of the arms, at first, to use of the back and arms, then of the back and legs, with as little employment of the arms as possible, and finally to the principle of assigning to all the muscles of the body their fitting proportion of the work, but with the back and legs always the important factors.

Of the slighter modifications introduced from year to year it is impossible and unnecessary to speak. The adoption of sliding-seats caused a slower stroke. The traditional "straight back" and "catch on the beginning" of Harvard date back to 1866 or 1867. After the time of Mr. Wilbur R. Bacon there was no radical new departure in rowing at Yale until Mr. Robert J. Cook spent the winter of 1872-73

## BOATING BOOK FOR BOYS

---

in England studying English rowing and gaining information of infinite value, which was practically applied in 1873. Newspaper ridicule of the "English stroke" was changed by the result of the race which was heralded as a "victory for Cook and for the slow stroke of thirty to thirty-two a minute with full use of the back and loins." Of this race The *Harvard Book* says: "Physically the Yale crew were not remarkably strong, but their captain had been able, by great perseverance and labor, to infuse into his crew the principles he had learned in England, and also his own energy and spirit. A great deal is seen in the newspapers about the English style, as if it were a peculiar and well-defined style. The fact is the English rowing-men have very different styles. When Harvard's four-oared crew were in England, in 1869, their style was preferred by the London watermen to Oxford's, as more like their own. The longer the race the slower should be the stroke, and what has been called the English stroke by the newspapers is simply the long stroke which is rather peculiar to Oxford and Cambridge, and to them only, when rowing over the Putney course of four and a quarter miles. Since the introduction here of straight-away races, where there is no change or let-up like that allowed in turning a stake, the crew cannot live to row a quick stroke even in a three-mile race. This fact gives color to the statements that the present [1875] style of rowing has been adopted from England." In 1882 Yale changed to a short, jerky stroke, pulled principally with the arms, the bodies swinging very little from the perpendicular. I believe Mr. Cook promptly predicted defeat on first seeing this remarkable style of

rowing, and his prediction proved correct both in 1882 and 1883. In 1884 the Yale crew returned to the old stroke, and after their victory Mr. Cook remarked, "We are now back to where we were in 1873," and he expressed a sincere hope that the "donkey-engine stroke" would not be seen again.

At Harvard there was a new departure in 1877, which may be roughly termed a change from the "Loring stroke" to the stroke taught by Messrs. Watson and Bancroft. This stroke was begun with the body well forward, and the successive motions were: "first, the swing up, with a hard catch on the beginning; second, the slide with the legs, the arms still rigid; third, the arm pull, bringing the oar-handle to the chest; fourth, after the oar-blade is lifted from the water, a quick, outward shoot of the hands; fifth, the slide back by doubling the legs, and, last, the downward swing of the body."

As to training, the prize-fighter school made its influence felt into the seventies. In 1871 the Brown oarsmen were limited to nine swallows of water daily, and in 1873 the Dartmouth giants were taken out directly after a hearty supper for a six-mile pull at full speed, on the old principle of "working food into 'em." Very naturally, four of the six were made sick, much to the surprise of John Biglin, their trainer. Fortunately, such ignorant and dangerous "training" as this has passed away. The best resources of science and experience are applied to the physical care of college oarsmen. With a physician, a trained specialist, at hand to decide whether or not the candidate is fitted to compete for boating honors, the old argument of the dangerous over-

exertion, and so on, of rowing rarely finds support. It is acknowledged that there are men with tendencies to heart troubles, let us say, who should never enter a racing-boat, just as there are men forbidden by inherited appetites to touch a drop of wine. But the first condition of participation in competitive college athletics to-day is a competent physical examination.

All this is of comparatively recent date, and yet, if we had such an American record as Dr. Morgan's *University Oars*, I think we should find very few instances of permanent injury, even among our earlier and poorly cared-for oarsmen. Let us gather a few names from such records as there are at hand. In the race of 1852 Mr. Benjamin K. Phelps, afterward district attorney of New York, and Mr. George W. Smalley, the London correspondent of the *Tribune* for many years, were members of Yale's second crew, together with two future clergymen. Professor Alexander Agassiz was the bow-oar of Harvard's second crew in 1855, and he continued to row "on the Varsity" in 1856, 1857, and 1858. In the last year Professor Agassiz occupied the bow, President Emeritus Charles W. Eliot the waist, and the stroke was the veteran B. W. Crowninshield—his fourth year in the Harvard crew. I regret to find in the records of that unsophisticated time that this crew rowed and won a race at Boston for a purse of \$75, and another for a purse of \$100. According to the fine distinctions of these suspicious latter days President Eliot lost rank as an amateur oarsman. As the race of 1858 was abandoned, President Eliot never enjoyed an opportunity of rowing against Yale. Mr. Caspar Crowninshield, who made his

début in 1858, rowed for three years, and was followed by Mr. F. Crowninshield in 1865—the third Harvard stroke furnished by the family. He, like Mr. William Blaikie, Dr. C. H. McBurney, and R. S. Peabody, the architect, was a member of the famous boating-class of 1866. The names of Richard Waite, William P. Bacon, Charles H. Owen, Hamilton Wallis, and S. C. Pierson are distinguished in Yale's earlier boating annals, and "Wilbur Bacon's crew" has become a tradition.

On the battle-field, as well as on the river, college oarsmen have made a record of courage and endurance. A member of the Yale crew of 1859 writes, "Within five years after the race every one of the Yale seven, and all but one of the Harvard six, held their commands as United States army officers." Mr. Brayton Ives, Yale's bow-oar in 1860, won the rank of Colonel in the Union army, and, according to a class history, was "in command of the troops who escorted General Grant to the conference with General Lee, which resulted in the surrender of the rebel army." In after years Mr. Ives was elected president of the New York Stock Exchange and president of the University Club in New York. Mr. A. P. Loring, a member of the Harvard crews of 1866, 1867, and 1868, pulled stroke of the four beaten by Oxford in 1869. Mr. Robert C. Watson rowed on the Harvard crew in 1867 and 1868, and his valuable counsel later to Harvard oarsmen showed that his enthusiastic interest in boating remained unabated.

Mr. William A. Copp entered the Yale crew of 1866, and rowed for four years, only to be beaten every year. Yale had just won a race when he began to row, but she won no

## BOATING BOOK FOR BOYS

---

other until he was a graduate of four years' standing. I know nothing regarding Mr. Copp's personality, but I am filled with admiration at his courage in coming up, year after year, only to face defeat. So the roll might be prolonged, McCook, Bone, Day, Adee, Kennedy, Kellogg, Thompson, representing a few of Yale's more persistent oarsmen, and Lyman, Simmons, Goodwin, Dana, Otis, and the Bacons serving the same end for Harvard. In this history there are two names which deserve conspicuous recognition—those of Robert J. Cook and William A. Bancroft. The author of the article on boating, in the *History of Yale College*, alludes to the fact that the class of '76 furnished for four years a captain of the university crew, and says: "This was Robert Johnston Cook, whose five years' practice of rowing at Yale, and quiet persistence in his determination to follow what seemed to him the best attainable methods of that art—spite of ridicule, abuses, and slander—resulted in a personal triumph and vindication quite unprecedented in the annals of American college-boating. It is simply a fact to say that no other collegian ever did so much to develop skill in rowing at Yale."

Mr. Bancroft, in 1876, pulled stroke of the Harvard six at Saratoga, and of the eight-oared crew at Springfield. He continued as stroke of the Harvard crew for three years more, winning three out of the four eight-oared races with Yale. Very few men have worked more faithfully in the cause of Harvard boating, or studied styles of rowing more carefully, than Mr. Bancroft. There are other oarsmen, among them the members of Yale's splendid crew of 1876, and of Harvard's victorious crews of 1877, 1878, and 1879,

whose work should be recognized, but I can only single out a few, and I am confident that the memories of many of my readers will supply the deficiencies.

Since the Harvard-Yale University race to 1885 forms my subject I have passed over the class and single-scutt races and the intercollegiate and other contests, like those with outside clubs and professional crews. In the earlier years of college-rowing, races with professionals, like the Ward and Biglin crews, were of common occurrence, and judges or referees at regular college regattas were sometimes selected from the same class. Harvard never employed a professional trainer in those years, although Yale crews, from 1864 to 1870, were under the care of "professionals."

The undergraduates themselves have an important though very different part in forming the character of these races. Nothing tended to lower college-boating in the eyes of outsiders so much as the disputes and recriminations which accompanied some Harvard-Yale races in their earlier years. Of these quarrels this article has taken little account, although in some boating records to which I have referred this acrimonious spirit has been preserved in permanent form. These issues are past, and it is the hope of all graduates that the newspapers will never again be filled with the squabbles of Harvard and Yale. The undergraduates of to-day have to sustain the dignity of their colleges and atone for some errors of their predecessors. This I think they are doing. This race is, or should be, a test of the picked men from the two colleges, pitted against

## BOATING BOOK FOR BOYS

---

each other under conditions which each side should desire to make equal. In methods of training and styles of rowing each crew may well endeavor to surpass the other. But anything which savors of a professional spirit must be discountenanced.

To visit New London for the race is a very different thing from a visit to New London for itself. The old order has not wholly passed away, and contrasts of new and old face the lingering visitor on every side. The old mill stands in its mossy, shaded ravine as it stood in colonial days, and beside it the Winthrop mansion rears a front still stately, although insulted by the changes upon which it looks. Up on the hill the crumbling stones of an ancient God's acre preserve, in quaint phrase and eccentric rhyme, the memories of departed worthies, some of whom worshiped in a rude meeting-house hard by, while sentinels watched for the approach of prowling Pequots. The meeting-house has vanished as entirely as the Pequot. The modern church has usurped its place. But, just as the name of the Mohegans is preserved by a few descendants to the northward, so the earlier life of this seaport town is embalmed in its buildings scattered here and there, the old side by side with the new. Legends of Indian stratagem and Revolutionary warfare and tales of the stirring days when New London's wharves were lined with whalers and merchant-vessels are represented by the odd old buildings which the passer-by scans askance. Outside the town the contrast continues. Ancient gambrel-roofed cottages look down from the hills upon Newport-like villas and velvet lawns, and a stone dwelling which might pass for the tower of the Master of



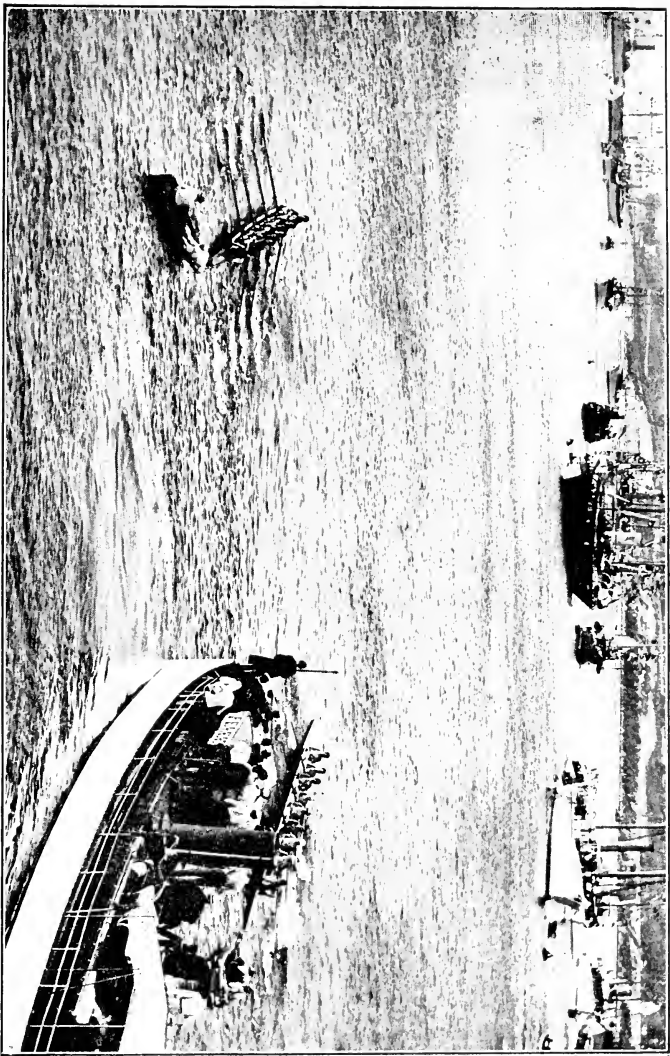

PREPARING FOR THE START, NEW LONDON

## BOATING BOOK FOR BOYS

---

---

Ravenswood stands within rifle-shot of a beach called "the Coney Island of Connecticut."

But this is not the New London of the boat-race excursionist. For him there waits the brilliant spectacle of a great race which can be seen under favorable conditions. On the eventful day he finds himself four miles up the river, eagerly scanning the red-roofed cottage across the water, or the boat-house farther up, below Yale's quarters on the point, until at last he sees stalwart student-oarsmen appearing on the floats, while the sunlight glistens on the polished shells raised in air for a moment, then tenderly lowered to the water. Now the two boats shoot across the river, welcomed lustily by the gaily beribboned throng which fills the long line of observation-cars.

Suddenly the cheers die away. The crews are in line. Behind them are sixty years of rivalry. Before them the silvery pathway of the Thames leads on past the navy-yard, past Mamacoke headland, to a wilderness of masts, and the grand-stand on the point, while the Groton Monument on the one side and the spires of New London on the other seem to mark the finish-line. And now, even while we are wondering at the beauty of the scene, a pistol cracks, and the roar of a thousand voices from the moving train breaks the silence of suspense. The crews are off, striving desperately for the vantage of the start, then settling down into their steady stroke. What can be better than this? Here before us are the best men of our two greatest colleges. For nearly a year they have led lives of ascetic self-denial. They have given up their pleasures; they have resigned their very wills to the con-

trol of others; they have exercised aching muscles in gymnasiums, on the running-path, in long, hard rows, for months—and for what? All for this, for the twenty thrilling minutes of a race, which shall either proclaim their year's work naught or return them, crowned with laurels, to their college, to meet there such a triumph as awaited the victors in the Grecian games. Is it not magnificent, the sight of the splendid rivalry before us? Not one of these bronzed, sturdy giants needs the stimulus of the cheers wafted across from the shore. Each will put forth all that is in him, although his eyes grow blind and his heart break in the effort.

And now we see the eight broad backs in one boat rising and falling more and more quickly. Keen eyes on shore detect the spurt, and there is a note of fierceness in the yells hurled at the lagging crew. Now the latter quickens, and so the race goes on. Likely enough we can tell its outcome by the time the two-mile flag is reached. Then for two miles more we shall hear an exultant, frenzied cheering, mingled with the sullen shouts of the defeated. Now the noise redoubles. The excited crowd at the grand-stand have joined the chorus, and the yachts send back their cheers. Down close to the point, past the gaily decorated yachts, flash the two boats, and the roar of cannon tells the end of the race.

## Chapter XXXIV

### THE HARVARD-YALE RACE

1885-1912

IN 1885 the writer was a member of the Columbia University crew that journeyed to New London to row against the Harvard eight. We were quartered next door to Yale, and, not having any regular race on with the dark blue, we had a number of practice starts and brushes with them. These tests showed the two crews to be about even.

When Harvard arrived both Yale and Columbia were greatly surprised at the entirely new and unorthodox style of the Cambridge men. They sat very high in the boat; the torso swing had been shortened; but the slide had been lengthened, thus evening up matters. The conventional hard catch on the beginning was entirely wanting. Smiles were seen on Yale and Columbia faces, and Harvard was put down for a double defeat. But on closer inspection, the crimson men showed that they were perfectly together in every way. The lack of the initial hard catch was made up for by the vigorous heave which was begun after the stroke had commenced, and which was carried through to the very finish. And this was accomplished synchronously,

## THE HARVARD-YALE RACE—1885-1912

---

in perfect unison—a difficult feat in this style of rowing, which is the stroke of single-scullers. The watermanship was as nearly perfect as we ever saw, and the boat traveled on an absolutely even keel at all times, despite the fact that the seats were so high. The rigging had been exceptionally well done, the four oars on each side always being parallel.

Columbia's race with Harvard came several days earlier than the date of the meeting between Yale and Harvard.

In an appallingly few strokes after the starting-pistol had been fired Harvard's rudder went out of our side vision like a flash. It seemed as though we were actually anchored. Harvard flew away from us. Spurt as we might, we could make no impression on their ever-increasing lead. When we returned crestfallen to the float at Gale's Ferry, the Yale men greeted us with ridicule, and remarked that the result was on account of "the stage-fright which you inexperienced New-Yorkers had over you."

Yale's turn came. Harvard went away from them even faster than she had left us; and the dark blue was a minute and a quarter behind at the finish—one of the greatest differences in time in New London records.

But Harvard could not repeat. Although the next year she had seven of the original crew in the boat, she had lost that rare, good oar, Captain J. J. Storrow; and he had been in a most important seat—number seven.

In 1886 both Yale and Columbia, the latter coached by the writer, won from the crimson.

The loss of Storrow, and the inability of the Cambridge men to execute this difficult stroke as perfectly in unison

## BOATING BOOK FOR BOYS

---

as they had done the year before, were the chief causes of their downfall.

Thereafter, as will be seen by the record, Yale had a long string of fifteen winnings, interrupted only by two Harvard victories, thus more than balancing the great majority which Harvard had before piled up.

Storrow's phenomenal 1885 crew, which brought a new style as a model for Harvard rowing-men, really put a setback to her rowing, as, to a great extent, it counteracted the good old orthodox principles which Bancroft had won with, and which he had instilled into Harvard boating.

Several men of the "1885 school" tried in succeeding years to turn out a winning boat. And Messrs. Watson and Peabody, working together, coached a couple of years on former principles, but the change to the old style was too radical; the rowing-men in college could not "unlearn" their accustomed stroke.

There were two breaks in Yale's winning streak. The first came in 1891, when Henry Keyes developed the Harvard crew; and the second was in 1899, when Mumford and E. C. Storrow coached the crimson.

Meanwhile "Bob" Cook and his pupil-protégés stuck to the well-defined old Yale style; and to their great work is due the consistently good rowing of the dark blue during a long period. For over a decade Mr. Cook continued to guide Yale, assisted by the able coaching of Dr. John Rogers, Jr., Alfred Cowles, Frederick Allen, and Edson M. Gallaudet.

Then followed a half-dozen years during which Gallaudet and Allen were the head coaches—the former having charge during the first half of the period.

John Kennedy, the professional, had for years been assisting Cook and his followers in rigging the boats. He gradually took over more and more of the coaching until 1902, when he was made head coach. This position he held until the end of the season of 1911, when he retired.

Harvard made a decided departure in 1896 by inviting Mr. R. C. Lehman, the famous British coach, to come here and teach the English stroke. He drilled the crimson candidates during the autumn of 1896, and returned from England early in 1897 to coach until the end of the season.

That year Harvard rowed with Cornell and Yale at Poughkeepsie.

A number of days before the race Mr. Lehman, rowing at stroke, with one of the Harvard crew at bow, took the writer out in a pair-oared gig to demonstrate the English style which he was teaching to Harvard. The writer was surprised to see the extremely long swing toward the bow which the stroke entailed, and feared that the tax on the abdominal muscles during the recover would be too great for our boys. When this was told to Mr. Lehman, he replied, "We never have any trouble in England with this long swing past the perpendicular." But conditions which obtain in England are entirely different from those which exist here. There, almost without exception, the men who eventually "make" the Oxford and Cambridge boats start rowing as mere school-boys. They use the long swing during all of their preparatory boating, developing the abdominal muscles; and thus they become inured to the strain of this position. Here, except in rare instances, our college oarsmen have absolutely no experience before their fresh-

## BOATING BOOK FOR BOYS

---

man year; hence they have not these developed abdominal muscles essential for the recover from the long swing toward the bow. This is precisely wherein Harvard failed. In every other essential the crimson rowing was beautiful. Cornell and Yale fought it out, the former winning by ten seconds, while the Cambridge men were decisively beaten.

The next year these three universities raced at New London, each using the style of stroke that it had rowed at Poughkeepsie, and the result was identically the same.

In 1904 Frederick Colson, the ex-Cornell coxswain-captain and former assistant coach, went to Cambridge for one year to teach Cornell's stroke. This also was an unsuccessful move.

The year following, James Wray, the professional single-sculler, was engaged by one of the boat clubs at Harvard, and was so successful that a little later he was made 'Varsity coach. He began by teaching all of his pupils to scull, and he still keeps this up. Through his good work the crimson has beaten Yale five times in the last six races, the last four wins having been in succession. Harvard has again struck her gait and is once more on top.

After the disappointments of the last few years, Yale has again made a radical change, and the pendulum of her rowing policy has once more swung back to the amateur graduate-coach system.

James O. Rogers, '98, captain of the '97 foot-ball eleven, afterward head foot-ball coach, and who rowed number four on the Yale 'Varsity eight at Henley in 1896, has been made



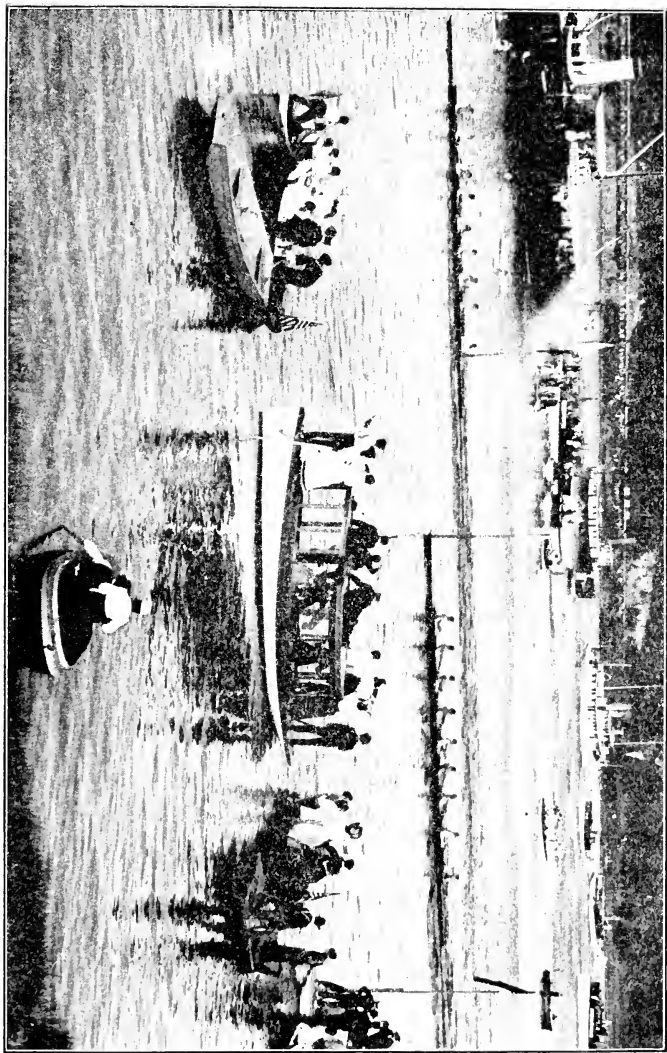

A FINISH AT NEW LONDON

## BOATING BOOK FOR BOYS

---

---

head rowing-coach. He was a pupil of Cook, and has coached several freshman crews.

And in this connection it is interesting to note that Yale is now the only university, with the sole exception of Princeton, whose rowing is under the guidance of an amateur coach.

In the chapter on "Yale Boating," prepared by "Karl Kron" for the *History of Yale College*, there is a résumé of the Harvard-Yale races, republished by the author in the *Boat-race Bulletin*, of which he was the editor from 1878 to 1883. His record has been followed from 1852 to 1883, with some slight changes and additions.

### THE RECORD OF HARVARD-YALE RACES

#### FIRST PERIOD—1852-60—IRREGULAR RACES

1. 1852, August 3.—Lake Winnipiseogee, Center Harbor, N. H., 2 miles straight pull to windward in eight-oared barges, class of '53. *Oneida*, of Harvard, defeated *Halcyon*, of Yale, by two lengths; time about 10m.

2. 1855, July 21.—Connecticut River, Springfield, 1½ miles downstream and return, in barges. *Iris* (eight-oared) and *Y. Y.* (four-oared), of Harvard; *Nereid* and *Nautilus* (both six-oared), of Yale. Allowing eleven seconds' handicap per oar for the smaller craft, the times of the boats in the order named were 22m.; 22m. 3s.; 23m. 38s.; 24m. 38s.

3. 1859, July 26.—Lake Quinsigamond, Worcester, Mass., 1½ miles up the lake and return. Harvard shell, 19m. 18s.; Yale shell, 20m. 18s.; Harvard lap-streak, *Avon*, 21m. 13s.; Brown lap-streak, *Atlanta*, 24m. 40s.

4. 1859, July 27.—Same course and same shell-crews, in "Citizens' regatta." Yale, 19m. 14s.; Harvard, 19m. 16s.

5. 1860, July 24.—Same course. Harvard, 18m. 53s.; Yale, 19m. 5s.; Brown, 21m. 15s.

# THE HARVARD-YALE RACE—1885-1912

## SECOND PERIOD—1864-70—UNIVERSITY RACES—SAME COURSE

- 1864, July 29.—Yale, 19m. 1s., won by 42½s.  
1865, July 28.—Yale, 17m. 42½s., won by 26½s.  
1866, July 27.—Harvard, 18m. 43s., won by 27s.  
1867, July 19.—Harvard, 18m. 13s., won by 72½s.  
1868, July 24.—Harvard, 17m. 48½s., won by 50s.  
1869, July 23.—Harvard, 18m. 2s., won by 9s.  
1870, July 22.—Harvard, 20m. 30s., won by foul:

## THIRD PERIOD—1871-75—UNIVERSITY RACES

1. 1871, July 21.—Three colleges. Massachusetts Agricultural defeated Harvard 37s. (16m. 46½s. to 17m. 23½s.), and Brown 61s. (17m. 47½s.); Harvard defeated Brown 24s.
2. 1872, July 24.—Six colleges. Amherst defeated Harvard 24s. (16m. 33s. to 16m. 57s.); Agricultural, 37s. (17m. 10s.); Bowdoin, 58s. (17m. 31s.); Williams, 86s. (17m. 50s.); Yale, 100s. (18m. 13s.); Harvard defeated Yale 76s.
3. 1873, July 17.—Eleven colleges. Yale defeated Wesleyan 10s. (16m. 59s. to 17m. 9s.); Harvard, 37½s. (17m. 36½s.); Amherst, 41s. (17m. 40s.); Dartmouth, 68s. (18m. 7s.); Columbia, 77s. (18m. 16s.); Massachusetts Agricultural, 87½s. (18m. 26½s.); Cornell, 93s. (18m. 32s.); Bowdoin, 110½s. (18m. 49½s.); Trinity, 154s. (19m. 33s.); Williams, 166s. (19m. 45s.).
4. 1874, July 18.—Nine colleges. Columbia defeated Wesleyan 8s. (16m. 42s. to 16m. 50s.); Harvard, 12s. (16m. 54s.); Williams, 26s. (17m. 8s.); Cornell, 49s. (17m. 31s.); Dartmouth, 78s. (18m.); Trinity, 101s. (18m. 23.); Princeton, 116s. (18m. 38s.); Yale fouled and withdrew.
5. 1875, July 14.—Thirteen colleges. Cornell defeated Columbia 11s. (16m. 53½s. to 17m. 4½s.); Harvard, 11½s. (17m. 5s.); Dartmouth, 17s. (17m. 10½s.); Wesleyan, 20s. (17m. 13½s.); Yale, 21s. (17m. 14½s.); Amherst, 36s. (17m. 29½s.); Brown, 40s. (17m. 33½s.); Williams, 50s. (17m. 43½s.); Bowdoin, 57s. (17m. 15½s.); Hamilton, time not taken; Union, time not taken; Princeton, withdrew; Harvard, defeated Yale 9½s.
6. 1876, July 19.—Six colleges. Cornell defeated Harvard 4s. (17m. 1½s. to 17m. 5½s.); Columbia, 7s. (17m. 8¼s.); Union, 26s. (17m. 27½s.); Wesleyan, 57s. (17m. 58½s.); Princeton, 69s. (18m. 10s.).

## BOATING BOOK FOR BOYS

### FOURTH PERIOD—EIGHT-OARED RACES—FOUR MILES

1. 1876, June 20.—Yale, 22m. 2s.; Harvard, 22m. 31s.
2. 1877, June 30.—Harvard, 24m. 36s.; Yale, 24m. 43s.
3. 1878, June 28.—Harvard, 20m. 44s.; Yale, 21m. 29s.
4. 1879, June 27.—Harvard, 22m. 15s.; Yale, 23m. 48s.
5. 1880, July 1.—Yale, 24m. 27s.; Harvard, 25m. 9s.
6. 1881, July 1.—Yale, 22m. 13s.; Harvard, 22m. 19s.
7. 1882, June 30.—Harvard, 20m. 47s.; Yale, 20m. 50s.
8. 1883, June 30.—Harvard, 25m. 46½s.; Yale, 26m. 49s.
9. 1884, June 30.—Yale, 20m. 31s.; Harvard, 20m. 48s.

### FROM 1885-1912

10. 1885, June 26.—Harvard, 25m. 15½s.; Yale, 26m. 30s.
11. 1886, July 2.—Yale, 20m. 41¼s.; Harvard, 21m. 5s.
12. 1887, July 1.—Yale, 22m. 56s.; Harvard, 23m. 10¾s.
13. 1888, June 29.—Yale, 20m. 10s.; Harvard, 21m. 24½s.
14. 1889, June 29.—Yale, 21m. 30s.; Harvard, 21m. 55s.
15. 1890, June 27.—Yale 21m. 29s.; Harvard, 21m. 40s.
16. 1891, June 26.—Harvard, 21m. 23s.; Yale, 21m. 57s.
17. 1892, July 1.—Yale, 20m. 48s.; Harvard, 21m. 42½s.
18. 1893, June 3.—Yale, 25m. 1½s.; Harvard, 25m. 15s.
19. 1894, June 28.—Yale, 22m. 47s.; Harvard, 24m. 40s.
20. 1895, June 28.—Yale, 21m. 30s.; Harvard, 22m. 5s.
21. 1899, June 29.—Harvard, 20m. 52½s.; Yale, 21m. 13s.
22. 1900, June 28.—Yale, 21m. 12¾s.; Harvard, 21m. 37¾s.
23. 1901, June 27.—Yale, 23m. 37s.; Harvard, 23m. 45s.
24. 1902, June 26.—Yale, 20m. 20s.; Harvard, 20m. 33s.
25. 1903, June 25.—Yale, 20m. 19¾s.; Harvard, 20m. 20¾s.
26. 1904, June 30.—Yale, 21m. 40½s.; Harvard, 22m. 10s.
27. 1905, June 29.—Yale, 22m. 33s.; Harvard, 22m. 36s.
28. 1906, June 28.—Harvard, 23m. 2s.; Yale, 23m. 11s.
29. 1907, June 27.—Yale, 21m. 10s.; Harvard, 21m. 13s.
30. 1908, June 25.—Harvard, 24m. 10s.; Yale, 27m. 45s.
31. 1909, July 1.—Harvard, 21m. 50s.; Yale, 22m. 10s.
32. 1910, June 30.—Harvard, 20m. 46½s.; Yale, 21m. 4s.
33. 1911, June 30.—Harvard, 22m. 44s.; Yale, 23m. 41½s.

The fastest time for the New London four-mile course is 20m. 10s., made by Yale in 1888.

## THE HARVARD-YALE RACE—1885-1912

---

In 1896 there was no Harvard-Yale race. Yale went to England to row in the Henley Regatta, where she was beaten; and Harvard took part in the Intercollegiate Regatta at Poughkeepsie on June 26th, where she was second to Cornell, beating Pennsylvania and Columbia. Time: Cornell, 19m. 59s.; Harvard, 20m. 8s.

In 1897, on June 25th, Harvard, Yale, and Cornell rowed at Poughkeepsie. Cornell won; Yale was second. Time: Cornell, 20m. 34s.; Yale, 20m. 44s.; Harvard, 21m.

In 1898 Harvard, Yale, and Cornell rowed at New London. Cornell won; Yale was second. Time: Cornell, 23m. 48s.; Yale, 24m. 2s.; Harvard, 24m. 35s.

Harvard and Yale have rowed forty-five dual races, beginning in 1852 on Lake Winnipiseogee. Of these Yale has won twenty-three and Harvard twenty-two. And this of itself is an eloquent demonstration of the equality of the efficiency of their respective methods during all these years, for in environment and number of students they are closely similar. The record of Oxford and Cambridge is not nearly so even.

## Chapter XXXV

### INTERCOLLEGIATE ROWING AT POUGHKEEPSIE

THE Intercollegiate Rowing Association has held regattas on the Hudson, at Poughkeepsie, since 1895, when Columbia won. Wisconsin, Syracuse, Pennsylvania, Cornell, and Columbia take part in these races each year. All are coached by professionals—Columbia by James C. Rice; Cornell by Charles E. Courtney; Pennsylvania by Ellis F. Ward; Syracuse by James A. Ten Eyck; and Wisconsin by Harry Vail.

Princeton has re-entered the sport after an absence of over a quarter of a century. This was made possible by the beautiful artificial lake which was made for the New Jersey college by Andrew Carnegie, and which bears his name.

As yet the faculty allows the students to row no races away from home; but the best 'Varsity crews in the country go to Princeton, on invitation, to row with her men. Dr. J. Duncan Spaeth, professor in the university, is the coach, and is doing remarkably good work.

The United States Naval Academy has had 'Varsity crews for a number of years. The midshipmen usually row on their home water—the Severn River, where they meet

## ROWING AT POUGHKEEPSIE

---

---

some of the leading 'Varsity crews in early spring races. The Annapolis men are coached by Richard Glendon.

University rowing is rapidly growing in the West; Washington, California, and Leland Stanford now have a 'Varsity race each year.

While the score of Harvard and Yale is within one race of being even, the record of the Intercollegiate Rowing Association, since its inception at Poughkeepsie in 1895, is more one-sided—Cornell having won twelve of the eighteen 'Varsity races rowed. (And also she holds the record for four miles, which is 18m. 53 $\frac{1}{2}$ s., made in 1901.) This is due to several things. In the first place, this university is particularly fortunate in having a very large number of candidates turn out for the boats each year. Secondly, no rowing university in the world has had one and the same coach so many years successively. And this fact has enabled Charles E. Courtney, the Cornell rowing teacher, gradually to build up a definite system; while our other colleges have often changed coaches, with consequent radical alterations in methods and style. This Cornell system which Courtney has developed is unique.

Briefly, it is as follows: 1. Absolute control by Courtney, with no interference whatever. 2. No captain. Cornell has not had a crew captain for a number of years. The coxswain gives the necessary orders, and, of course, the stroke-man has more or less discretion as to the management of the boat while he is actually in it; but everything else is in the hands of the coach. 3. As nearly perfect mechanical fittings of the boat in every detail as is possible; and this "rigging" is infinitely more important than

## BOATING BOOK FOR BOYS

---

most people—even rowing-men—realize. 4. No alcohol in any form. Courtney allows no ale or stimulant of any kind at the training-table, or anywhere else. 5. High moral effect on the men in every way possible. 6. No gymnasium exercise whatever—only rowing. Cornell even goes so far as to cut out the old-established custom of running to improve the “wind,” Courtney’s theory being that it is more conducive to the development of speed to use all the extra energy which the men have directly in the boat, thus getting much more rowing practice, experience, and smoothness. In this way the rowing muscles only are developed, avoiding the condition known as “muscle-boundness.” A man who does much gymnasium work develops opposing muscles on different sides of the bones. This, while it gives good general development, is apt to bring on “muscle-boundness,” which prevents the man from getting a good reach easily, which is so essential to smoothness and speed in the boat.

During the last few years Yale, Pennsylvania, and Cornell have gone to Henley without success; and Harvard has also traveled to England to meet Cambridge, and has been defeated. The tale would undoubtedly be different were the best English crew to meet us here or on neutral waters.

Many improvements have been made in the last quarter of a century in the boats, oars, and mechanical fittings.

The paper shell had a comparatively short life. It was found from experience that both single shells and crew-boats made of wood were much faster. The porosity of the Spanish cedar gives the much-needed “life”—buoyancy,



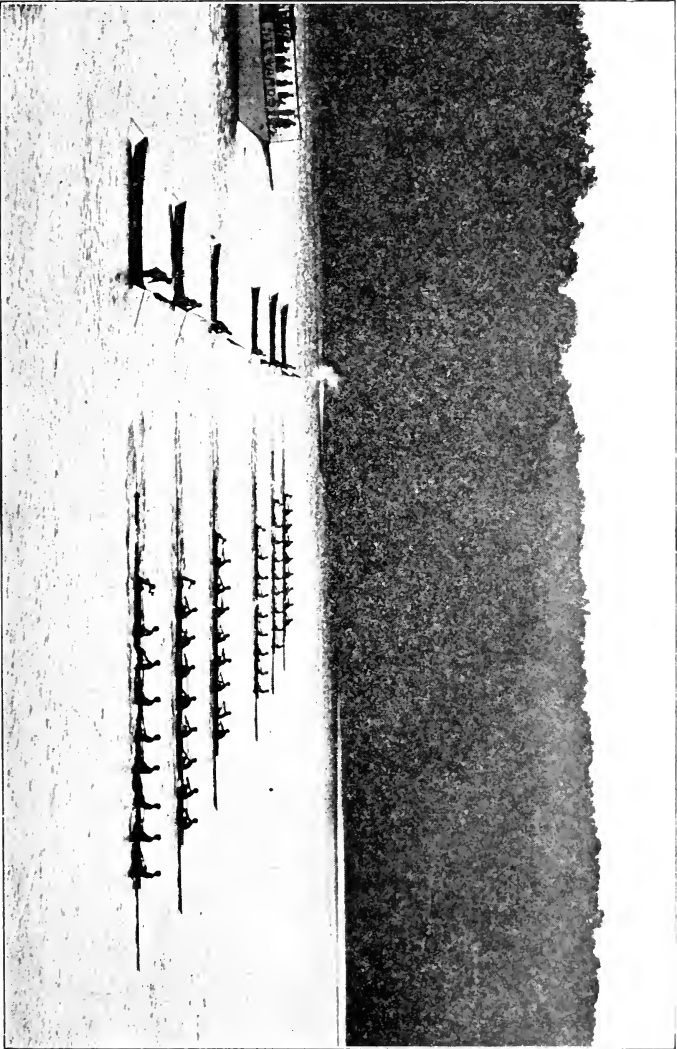

A START AT POUGHKEEPSIE

## BOATING BOOK FOR BOYS

---

which is essential to speed. Aluminum was also tried by Cornell as a material for boat-building, but the expansion and contraction from heat and cold were too great, and it was abandoned. Briefly, the other improvements have been: the perfection of the swivel row-lock; the addition of roller wheels to the sliding-seat; the decided incline of the slide; the fin on the bottom of the boat, to keep it from heading up into the wind (and this has even been made so as to be raised and lowered like a centerboard in a sailing-boat); and the bulkheads in the cockpit of the boat, with swinging gates, which allow all water which may be shipped to go astern at each stroke, without returning, so that the coxswain may either pump or dip it out.

One of the greatest steps forward has been in the "rigging." The only fixed points affecting a man in a boat are the stretcher and the pin of the row-lock. Upon the relative position of the former to the latter, for each individual, a vast amount depends. It is obvious that if a man's stretcher is moved toward the stern, his blade will go farther toward the bow and less toward the stern; and, conversely, if the stretcher is moved toward the bow, the blade goes less toward the bow and farther astern. The great desideratum is not only properly to divide the stroke fore-and-aft of the pin of the row-lock; but also to have the oars on each side of the boat parallel. To accomplish this, the stretchers must be properly placed.

Cornell, as well as some of the other universities, has a machine placed on the floor with a sliding-seat. On either side is an outrigger and row-lock. A line is drawn on the

## ROWING AT POUGHKEEPSIE

---

---

floor at right angles to the side of the machine, passing directly under the pin of the row-lock. The proper fore-and-aft division of the stroke is marked out on the floor. The men in turn are put on the sliding-seat and row with the oar. The stretcher is moved back and forth, until the end of the blade describes as nearly as possible the desired arc of a circle. The distance from the pin to the stretcher is measured, and this is the measure for the man's stretcher in the boat. But this is only one—the most important, perhaps—of the many details of rigging.

The actual stroke, as rowed to-day by Harvard, Yale, Cornell, Columbia and one or two other colleges differs very slightly in its component parts from that used years ago, which is described in Part I; but its execution has been much improved. A most noticeable change is in the smoothness, one part being run into the next without the semblance of a pause or hitch. The amalgamated whole is one continuous wheel-like motion. Courtney once naively answered, when asked something about the beginning of Cornell's stroke, "There is no beginning; it's always going." Furthermore, at the beginning of the heave the torsos and the slides start together; and, on the recover, hands, torsos, and slides commence to move at the same time; but, of course, the hands travel the fastest. These are decided innovations of late years. Also the very fast slide during the first part of the recover, with the extremely slow slide during the last part, just before the full reach is attained, has been much perfected of late. This not only eliminates the check of the boat between strokes, but it gives a most excellent breathing period.

## Chapter XXXVI

### AMERICAN AMATEUR ROWING

IN addition to the college rowing, which we have described, there is great interest in many centers, both here and in Canada, in amateur oarsmanship.

The regatta of the National Association of Amateur Oarsmen, which is held annually, decides the championships of America in the various classes. There is no fixed course, the regattas being held at the various rowing-centers successively. The course is one and one quarter miles straight-away, which is the distance of almost all of the amateur non-collegiate races.

Other important regattas are the American Henley, held each spring at Philadelphia, on the Schuylkill course (as is the case in the English Henley, college crews enter and meet the amateur boat clubs); the Harlem Regatta, held in New York; the People's Regatta, held in Philadelphia; the New England Rowing Association Regatta, usually rowed at Boston; the Hudson River Rowing Association Regatta; the Long Island Rowing Association Regatta; the Middle States Rowing Association Regatta; the Schuylkill Navy Regatta, and the Central States Rowing Association Regatta.

The Canadians are enthusiastic oarsmen, Toronto being

## AMERICAN AMATEUR ROWING

---

a great boating focus, with its large and active Argonaut Rowing Club. The Royal Canadian Henley, which always has many entries from the United States, is an annual fixture.

We are following in England's footsteps by encouraging more and more school-boy rowing. Boston and Philadelphia are especially active in fostering the sport in preparatory schools.

For many years the writer has studied the physical effects of rowing from three viewpoints: that of personal experience in the boat; that of a coach; and that of a physician. And he is convinced that more benefit is derived from this sport, with less chance of injury, than from any other form of athletics. The great authority, Dr. Dudley A. Sargent, Harvard's physical director, asserts that college rowing leads to long life and that the men who take part in it marry younger and have more children than do other athletes.

Some years ago there arose in the British press a great discussion as to whether rowing was injurious. This extended to the medical profession, with the result that a prominent surgeon, himself an old Oxford oar, undertook the task of an exhaustive search of the post-collegiate lives of all the men who had rowed in the university races covering a period of forty years. The results of the investigation were as follows:

Benefited by rowing.....	115
Uninjured.....	162
Injured.....	17

[*University Oars*, by John Ed. Morgan, M. A., Oxon., F. R. C. P.]

The last figure undoubtedly would have been reduced, and the first correspondingly increased, had there been in those days the system requiring the thorough physical examination of all college athletes which now obtains.

There are several reasons for these great records of the good of rowing. In the first place, in few other forms of athletics is the action of the heart accelerated so gradually. In the four-mile contests the men are coached to conserve their energy in the beginning, so that they may distribute it throughout the long course, while in foot-ball and short running, for instance, the heart is pushed from the normal, slow beat of complete bodily quietude to the highest possible rate by extremely sudden and violent exertion; and the pressure is as suddenly taken off. One of our most noted sprinters developed fainting periods after leaving college as a direct result of this.

Also, the long training, gradually begun, slowly strengthens the heart for the increased work. Furthermore, it entails a six months' period of enforced self-denial, abstemiousness, and clean living—and most of the coaches allow no alcohol whatever now.

Happily all this occurs at just the age when the character and life habits are being moulded, and it shows to the good in the after-college record of the great majority of university rowing-men.

The injuries from accident or from strain in a well-trained crew are not to be compared with those of foot-ball or other sports, while the benefits are infinitely greater.

In the enumeration and description of action of the muscles used in rowing in *Exercise and Training*, by C. H.

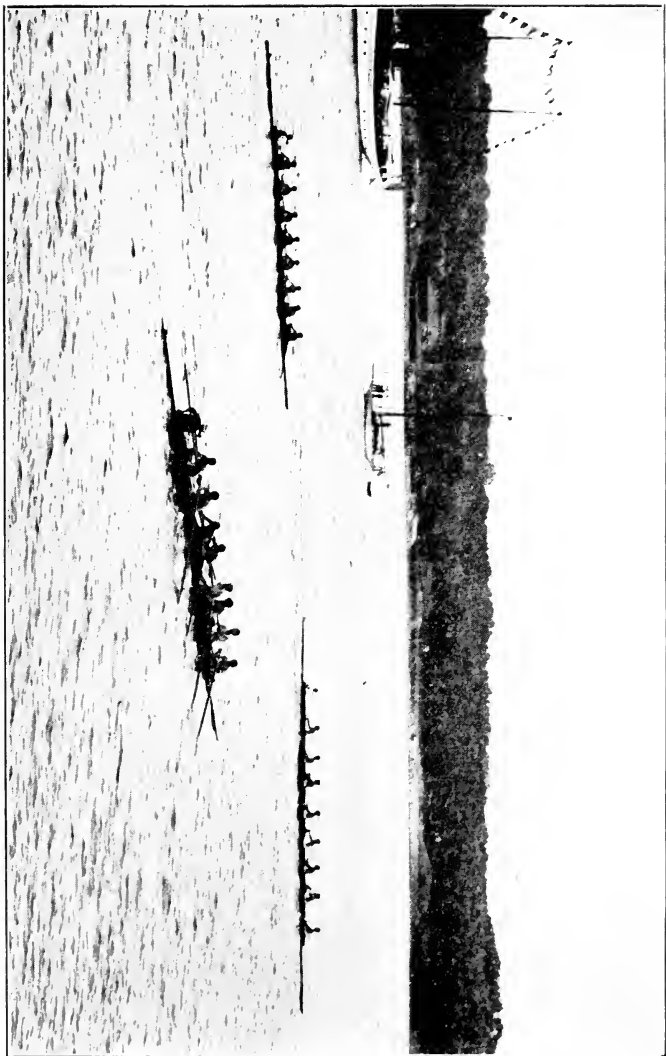

AFTER THE FINISH AT POUCHKEEPSIE

## BOATING BOOK FOR BOYS

---

---

Ralfe, M.A., M.D., Cantab., F.R.C.P., he shows the great number of muscles used in this sport, how evenly the work is distributed over the body, and consequently the excellent general physical development this exercise brings. Much depends, however, on the style of rowing. A man who rows with a comparatively straight spine and with the shoulders back is undoubtedly much more benefited than he who handles his sweep with a bent back, the shoulders forward, and the chest contracted.

Oarsmen should not stop rowing abruptly after leaving college, or after a series of years of club-boating; they should continue the exercise in a modified degree. Especially is this true of those whose business is of a sedentary nature. Lungs which have been greatly developed by rowing or any other exercise should not suddenly be forced into comparative idleness, for the unused parts of such lungs are in danger of disease, especially the apices, which are behind the collar-bone on either side. These, when not often "aired out," so to speak, become vulnerable points for tubercular infection. Also athletes who suddenly stop exercise, and who are apt to become obese, often develop fatty heart.

So, as you get on in years, don't stop exercising. Row if possible. If this is not convenient, brisk walking or any exercise accompanied by deep breathing, with the mouth closed, will keep the lungs in healthy condition and the tissues of the heart in good muscular tone and free from fat.



## APPENDIX

### DICTIONARY OF MECHANICAL AND ELECTRICAL TERMS

This list has been extended to include many terms not directly mentioned in this book, in order to make clear subjects closely associated with the matters which are treated.

#### A

**Acceleration.** The rate of change in velocity.

The increase or decrease of motion when acted upon by the electric current.

**Acid.** A compound of hydrogen capable of uniting with a base to form salts.

Sour, resembling vinegar.

A sharp, biting fluid.

**Adherence.** The attraction between surfaces of iron due to electro-magnetic action. The term is used in connection with electric brakes—electro-magnetic adherence.

**Adjustment.** Any change in an apparatus rendering it more efficient and correct in its work.

**Alive, or "Live."** A term applied to a wire or circuit that is charged with electricity. A "live" wire.

**Alligator.** A form of wrench having two fixed jaws (one or both being provided with teeth) for turning pipe or round rods.

**Alloy.** Any mixture of two or more metals making a scientific compound. For example: copper and zinc to form brass; copper, tin, and zinc to form bronze; copper, nickel, and zinc to form German-silver.

**Alternating Current.** (*See* Current, Alternating.)

**Alternating Current-power.** Electrical distribution employing the alternating current from dynamos or converters.

**Alternation.** A change in the direction of a current; to and fro. Alternations may take place with a frequency ranging from 500 to 10,000 or more vibrations per second.

**Alternator.** An electric generator-dynamo supplying an alternating current.

**Amalgam.** A combination of mercury with any other metal.

**Ampere.** The practical unit of electric-current strength. It is the measure of the current produced by an electro-motive force of one volt through a resistance of one ohm.

**Ampere-currents.** The currents theoretically assumed to be the cause of magnetism.

**Annealing.** The process of softening yellow metals by heating them to a cherry redness, then allowing them to cool gradually in the air.

Electric annealing is done by passing a current through the body to be annealed, and heating it to redness; then allowing it to cool gradually.

**Anode.** The positive terminal in

a broken, metallic, or true conducting circuit.

The terminal connected to the carbon-plate of a battery, or to its equivalent in any other form of electric generator, such as a dynamo or a voltaic pile.

The copper, nickel, gold, or silver plates hung in an electro-plating bath, and from which the metal is supplied to fill the deficiency made by the electro-deposition of metal on the kathode or negative object in the bath.

**Arc.** A term applied to an electric current flowing from carbon to carbon, or from metals separated by a short gap, as in the arc street-lamps.

The original arc was produced by two vertical rods, through which the current passed up and down. When not in action the upper ends touched, but as the current flowed the ends were separated, so that the current, passing up one carbon across the gap and down the other, formed the segment of a circle in jumping from one tip to the other.

An arc of electric flame is of brilliant and dazzling whiteness. The voltaic arc is the source of the most intense heat and light yet produced by man. The light is due principally to the incandescence of the ends of carbon-pencils, when a current of sufficient strength is passing through them and jumping over the gap. Undoubtedly the transferred carbon particles have much to do with its formation. The conductivity of the intervening air and the intense heating to which it is subjected, together with its coefficient of resistance, are other factors in the brilliant light produced.

**Armature.** A body of iron or other material susceptible to magnetization, and which is placed on or near the poles of a magnet.

That part of an electric mechanism which by magnetism is drawn to or repelled from a magnet.

The core of a dynamo or motor which revolves within the field magnets, and which is the active principle in the generation of current by mechanical means, or in the distribution of power through electrical influence. Armatures are sometimes made of steel, and are permanent magnets. These are used in magneto-generators, telegraph instruments, and other apparatus.

**Atmospheric Electricity.** (See Electricity, Atmospheric.)

**Attraction.** The tendency to approach and adhere or cohere which is shown in all forms of matter. It includes gravitation, cohesion, adhesion, chemical affinity, electro-magnetic and dynamic attraction.

**Automatic Cut-out.** An electro-magnetic switch introduced into a circuit, so as to break the circuit of the latter should it become overloaded with current; it also acts in the event of a mechanical interruption.

**Axle.** A bar, or shaft, that supports wheels or pulleys. It may be either fixed or movable.

### B

**Babbitt.** A soft alloy of metals chiefly employed for bushings and bearings.

**Barometer.** An apparatus for measuring the pressure exerted by the atmosphere. It consists of a glass tube 31 inches long, closed at one end, filled with mercury, and then inverted, with its open end immersed in a cistern of mercury. The column of mercury falls to a height proportional to the pressure of the atmosphere. At the sea-level it ranges from 30 to 31 inches.

**Batten.** A strip of wood grooved longitudinally, in which electric

light or power wires are set. The grooved strip is screwed to the wall, the wires being laid in the grooves, and then covered with a thin wooden strip fastened on with small nails.

**Battery.** A combination of parts, or elements, for the production of electrical action.

A number of cells connected parallel or in series for the generation of electricity. Under this heading there are at least one hundred different kinds. Nowadays the dynamo is the cheap and efficient generator of electricity.

**Battery Cell, Elements of.** The plates of zinc and carbon, or of zinc and copper, in a cell are called elements. The plate unattacked by the solution, such as the carbon or copper, is the negative element, while the one attacked and corroded by the electrolyte is the positive.

**Battery, Dry.** A form of open circuit cell in which the electrolyte is made practically solid, so that the cell may be placed in any position. A zinc cup is filled with the electrolyte and a carbon-rod placed in the middle, care being taken to avoid contact between cup and carbon at the bottom of the cell. The gelatinous chemical mass is then packed in closely about the carbon, so as to nearly fill the cup. A capping of asphaltum, wax, or other non-conducting and sealing material is placed over the electrolyte, and this hardens about the carbon and around the top inner edge of the zinc cup. The latter becomes the positive pole, the carbon the negative. Binding-posts, or connections, may be attached to the zinc and carbon to facilitate connections.

**Battery, Galvanic.** The old name for a voltaic battery.

**Battery, Gravity.** A battery in which the separation of fluids is obtained through their difference in

specific gravity—for example, the bluestone cell. The sulphate of copper solution, being the more dense, goes to the bottom, while the zinc solution stays at the top. In its action the acid at the top corrodes the zinc, while at the bottom the solution is decomposed and deposits metallic copper on the thin copper plates.

**Battery, Leclanché.** An open circuit battery consisting of a jar, a porous cup, and the carbon and zinc elements, the electrolyte of which is a solution of ammonium chloride (sal-ammoniac). The carbon plate is placed in the porous cup, and packed in with a mixture of powdered manganese binoxide and graphite, to serve as a depolarizer. A half-saturated solution of sal-ammoniac is placed in the outer jar, and a rod of zinc suspended in it. Another form of the battery is to omit the porous cup and use twice the bulk of carbon, both elements being suspended in the one solution of sal-ammoniac; this form of battery is used for open-circuit work only, such as bells, buzzers, and annunciators. It is not adapted for lights, power, or plating purposes.

**Battery Mud.** A deposit of mud-like character which forms at the bottom of gravity batteries, and which consists of metallic copper precipitated by the zinc. It only occurs where wasteful action has taken place.

**Battery, Plunge.** A battery in a cabinet or frame, so arranged that the active plates can be removed or raised out of the solutions. This is usually accomplished by having the plates attached to a movable frame which, by means of a ratchet-shaft and chains, can be raised or lowered. Its object is to prevent the corrosion of the plates when not in use.

## BOATING BOOK FOR BOYS

**Battery, Primary.** A voltaic cell or battery generating electric energy by direct consumption of material. The ordinary voltaic cell, or galvanic battery, is a primary battery.

**Battery, Secondary.** A storage-battery, an accumulator.

**Battery Solution.** The active excitant liquid, or electrolyte, placed within a cell to corrode the positive element. Also called Electropoison.

**Bearing.** The support, or rest, on which axles, shafts, and pinions turn. A journal-box.

**Becket.** A fixture on the bottom of a pulley-block through which an end of rope is spliced.

**Bevel.** Any inclination of two surfaces other than ninety degrees.

**Bevel Square.** An adjustable instrument for measuring angles.

**Bore.** The inside diameter of a cylinder.

**Braze.** To join by the use of hard solder and intense heat.

**Break.** A point where an electric conductor is broken, as by a switch or a cut-out.

**Buoy, Electric.** A buoy to indicate dangerous channels in harbors and to mark wrecks and reefs. It is provided with an electric light at night, and with a gong or an electric horn by day.

**Burr.** A small washer used principally with rivets.

A roughness left on metal after casting or cutting.

A roughening tool.

**Bushing.** The box in a wooden or metal wheel.

A metal cylinder, or cone, fitted inside a hole, in order to reduce its diameter.

A threaded metal cylinder fitted in pipe connections.

**Buzzer.** An electric alarm, or call, produced by the rapid vibration of an armature acted upon by electro-magnetism. The sound is

magnified by inclosing the mechanism in a resonant box.

An apparatus resembling an electric bell *minus* the bell and clapper. The buzzer is used in places where the loud ring of a bell would be a nuisance.

### C

**C.** An abbreviation for centigrade when speaking of thermal temperature. In chemistry the centigrade scale is used extensively, but in air temperatures the Fahrenheit scale is universally employed.

**Caliper.** An instrument for the measurement of diameters.

**Cam.** A modified form of eccentric fixed upon a revolving shaft. It is used to convert rotary into reciprocating motion.

**Can.** Any inclination from the vertical or horizontal. A slope or set to one side.

**Capacity.** A term used when speaking of the carrying power of a wire or circuit. The capacity of a wire, rod, bar, or other conductor is sufficient so long as the current does not heat it. Directly electric heat is generated, we speak of the conductor as being overloaded or having its capacity overtaxed.

**Carbon.** One of the elements in graphitic form used as an electric-current conductor. It is the only substance which conducts electricity, and which cannot be melted with comparative ease by increase of current. It exists in three modifications—charcoal, graphite, and the diamond. In its graphitic form it is used as an electro-current conductor, as in batteries and arc-light electrodes, and as filaments in incandescent lamps. In arc-lamp use the carbons are usually electroplated on the outside with a film of copper which acts as a better conductor.

## APPENDIX

**Cell, Standard.** Meaning the same as battery. The vessel, including its contents, in which electricity is generated.

**Cell Storage.** Two plates of metal, or compounds of metal, whose chemical relations are changed by the passage of an electric current from one plate to the other through an electrolyte in which they are immersed.

**Cements, Electrical.** Cements of a non-conducting nature, such as marine glue and sticky compounds, used in electrical work.

**Centrifugal Force.** A diametric revolving force which throws a body away from its axis of rotation. A merry-go-round is a simple example of this force. The more rapidly the platform revolves the greater the tendency for those on it to be thrown off and out from the center. The high velocity attained by the armatures in motors and dynamos would throw the wires out of place and cause them to rub against the surfaces of the field-magnets. Consequently, wire bands or binders are necessary to keep the coils of wire from spreading under the influence of the centrifugal force.

**Centripetal.** Force, whose impulsion is toward a center.

**Charge.** The quantity of electricity that is present on the surface of a body or conductor.

The component chemical parts that are employed to excite the elements of a cell in generating electric current.

**Channel-iron.** Strip-iron turned up at both edges, so as to form a channel or trough.

**Chemical Change.** When bodies unite so as to satisfy affinity, or to bring about the freeing of thermal or other energy, the union is usually accompanied by sensible heat or light. Sulphuric acid added to wa-

ter produces heat; a match in burning produces light. Another form of chemical change is decomposition or separation (the reverse of combination), such as takes place in the voltaic-battery, the electro-plating bath, and other forms of electrolysis. This is not accompanied by heat or light, but by the evolution of electricity.

**Chock.** A block, or wedge, used to prevent or limit motion.

**Circuit.** A conducting-path for electric currents. Properly speaking, a complete circuit has the ends joined, and includes a source of current, an apparatus, and other elements introduced in the path. When the circuit is complete it is called active. The term circuit is also applied to portions of a true circuit—as, an internal or external circuit.

**Circuit-breaker.** Any apparatus for opening and closing a circuit, such as switches, automatic cut-outs, lightning-arresters, and the like.

A ratchet-wheel engaged with a spring, or wire, which rests against the teeth. The current passes through the wire, the wheel, and axle. The wheel is revolved by a crank, and as the ratchets pass the spring, or wire, an instantaneous make-and-break occurs. The speed of the wheel regulates the frequency of the interruptions.

**Circuit, Open.** A circuit in which a switch has been opened to prevent the continuous flow of current, such as an electric-bell circuit, which normally remains open, and which is active only when the push-button is pressed, thereby closing the circuit and operating the bell. An open-circuit battery is one that remains inactive when the circuit is open.

**Close Nipple.** A threaded piece of pipe less than two inches in length. It is employed in water, steam, and gas pipe fittings.

## BOATING BOOK FOR BOYS

**Clutch.** A device for coupling shafting. A friction-clutch is composed of metal arms and shoes which impinge upon a collar or rim on a revolving shaft or pulley, allowing the speed to be picked up gradually.

**Code, Cipher.** A set of disconnected words which, in accordance with a prearranged key, stand for whole sentences and phrases. Commercially the system is used as a short-cut—ten words perhaps meaning what otherwise it would take forty or fifty words to express. It is used extensively in telegraphy, both as an abbreviated message and as a means for securing secrecy.

**Coil.** A strand of wire wound in circular form about a spool, a soft-iron core, or in layers, as a coil of rope.

An electro-magnetic generator.

A helix. (*See also* Induction, Resistance, Magnetizing.)

**Coil, Induction.** A coil in which the electro-motive force of a portion of a circuit is, by induction, made to produce higher or lower electro-motive forces in an adjacent circuit, or in a circuit a part of which adjoins the original circuit. There are three principal parts to all induction-coils—the core, the primary coil, and the secondary coil. The core is a mass of soft iron, cast or wrought, but preferably divided—for example, a bundle of rods or bars. The primary coil of comparatively larger wire is wound about this core, each layer being properly insulated and varnished, or coated with melted paraffine, to bind the wires. The secondary coil is of fine wire, and is wound about the primary coil. A great many turns of the fine wire are necessary, and care must be taken to properly insulate each layer and shellac the wires. The primary must be well

insulated from the secondary coil, so as to prevent sparking, which would destroy the insulation. A make-and-break is operated by the primary coil, and is constructed upon the general form of an electric bell or buzzer movement. Extra currents which interfere with the action of an induction-coil are avoided by the use of a condenser. (*See also* Condenser.) The induction-coil produces a rapid succession of sparks which may spring across a gap of thirty or forty inches, according to the size of the coil. Induction-coils are used extensively in electric work, especially in telephone transmitters, wireless telegraphy, electric welding, and in the alternating-current system.

**Compass.** An apparatus for indicating the directive force of the earth upon the magnetic needle. It consists of a case covered with glass, in which a magnetized needle, normally pointing to the north, is balanced on a point at the center. Under the needle a card is arranged on which the degrees or points of the compass are inscribed. A valuable instrument in electrical work, magnetism, etc.

In mechanics an instrument consisting of two legs joined at the top. It is used for marking and measuring, and for describing circles.

**Compass, Mariners'.** A compass in which the needle is attached to a card that rotates in pointing to the north. A mark, called the "lubber's mark," is made upon the case, and this is in line with the ship's keel, so that a glance at the card will indicate the direction in which the ship is headed.

**Concentric.** Having a common center. Spheres or circles are concentric.

**Condenser.** An apparatus separate from the cylinder, in which the

## APPENDIX

exhaust steam is condensed by the action of cold water or air.

**Conductance.** The conducting power of a mass of material, varying according to its shape and dimensions. The cylindrical or round conductor is the best type for the conveyance of electric currents.

**Conductor.** Anything which permits the passage of electric current. The term conductor is a relative one, and, excepting a vacuum, there is probably no substance that has not some conductive power. Metals, beginning with silver, are the best conductors, liquids next, glass the worst. The ether, or air, is a conductor of sound and electric vibratory disturbances, but not in the same sense as the ground. The air conducts frictional electricity, while the ground acts as a conductor for the galvanic current, or "current electricity." By this last term is meant electricity which flows continually, instead of discharging all at once with an accompanying spark or flash.

**Connect.** The act of bringing two ends of wire together, either temporarily or permanently. Bringing one end of a conductor into contact with another so as to establish an electric connection.

**Contact.** The electrical union of two conductors, whether temporary or permanent. It may be established by touching the ends or terminals of a circuit through the agency of a push-button, a telegraph-key, an electric switch, etc.

**Controller.** The lever or handle on the switch-board of a resistance-coil, by means of which electric current is let or in kept out of a circuit.

**Cotter-pin.** A wedge-shaped piece of metal used for fastening together parts of a machine or for securing a nut against working off.

**Counter-shaft.** An intermediate shaft that receives power from a main line and transmits it to a machine.

**Countersink.** To form (by drilling, turning, or chiseling) a depression for the head of a screw or bolt. A tool with beveled cutting edges.

**Couple.** The combination of two electrodes and a liquid, the electrodes being immersed in the latter, and being acted on differentially by the liquid. This combination constitutes a source of electro-motive force, and, consequently, of current, and is called the galvanic or voltaic cell or battery.

**Crank.** The bent portion of a shaft, or axle, or an arm keyed at right angles to the end of a shaft. It is used for converting rotary into reciprocating motion, or vice versa.

**Crank-pin.** The cylindrical piece that forms the handle, or to which the connecting-rod is attached, at the end of a crank, or between the arms of a double crank.

**Creeping.** A phenomenon met with in solution batteries. The electrolyte creeps up the sides of the containing jar and evaporates, leaving a deposit of salts. Still more solution creeps up through the salts until it gets clear to the top and runs over. To prevent this the tops of the jars should be brushed with hot paraffine for a distance of two inches from the upper edge. The salts will not form on paraffine. Oil is sometimes poured on the top of the battery solution, but this affects the elements if it touches them, and makes their surfaces non-conducting.

**Current, Alternating.** A current flowing alternately in opposite directions. It is a succession of currents, each of short duration and of direction opposite to that of its predecessor. Abbreviation, A-C.

**Current, Constant.** An unvary-

ing current. A constant-current system is one in which the current is uniformly maintained—for example, in electric light, power, and heat plants.

**Current, Continuous.** A current of one direction only, or the reverse of an alternating current.

**Current, Make-and-break.** A current which is continually broken or interrupted and started again. The term is applied only where the interruptions occur in rapid succession, as in the action of an induction-coil or pole-changer.

The alternating current.

**Current, Oscillating.** A current periodically alternating.

**Current - reverser.** A switch or other contrivance for reversing the direction of a current in a conductor.

**Currents, Positive.** (See Positive Currents.)

**Cut-in.** To electrically connect a piece of mechanism or a conductor with a circuit.

**Cut-out.** The reverse of the cut-in. To remove from a circuit any conducting device. The cut-out may be so arranged as to leave the circuit complete in some other way.

An appliance for removing a piece of apparatus from a circuit so that no more current shall pass through the former.

**Cut-out, Automatic.** A safety device for automatically cutting out a circuit to prevent accident or the burning-out of an apparatus, due to an overload of current. It is worked by an electro-magnet and spring. An overload of current causes a magnet of high resistance to draw an armature toward it, and this, in turn, releases the spring of the cut-out device. Sometimes a strip or wire of fusible metal is employed which is in circuit with a switch. The excess of current fuses the metal, and the broken cir-

cuit releases a spring-jack, which, in turn, breaks the circuit.

## D

**Dead-point or Center.** Either of two points in the orbit of a crank at which the crank-axle, crank-pin, and connecting-rod lie in a straight line.

**Deflection.** In magnetism, the movement of the needle out of the plane. It is due to disturbance, or to the needle's attraction toward a mass of iron or steel or another magnet.

**Density, Electric.** The relative quantity of electricity, as a charge, upon a unit area of surface. It may be positive or negative.

Surface density, as the charge of a Leyden-jar.

**Deposit, Electrolytic.** The metal or other substances precipitated by the action of a battery or other current-generator, as in the plating processes.

**Die.** A metal block, or plate (often one of a pair), used for shaping, impressing, or cutting objects. A tool for cutting external threads on nuts, couplings, or pipe-fittings.

**Dielectric.** Any substance through which electrostatic induction is allowed to occur, such as glass or rubber. It is a non-conductor for all electric currents.

**Differential Gearing.** A train of toothed wheels (usually an epicyclic train) so arranged as to constitute a differential motion.

**Discharge.** The eruptive discharge from a Leyden-jar or accumulator of a volume of electricity stored within it.

The abstraction of a charge from a conductor by connecting it to the earth or to another conductor.

**Disconnect.** To break an electric circuit or open it so as to stop the



## APPENDIX

flow of current; to remove a part of a circuit or a piece of apparatus from a circuit.

**Disk.** A flat circular plate.

**Dowel.** A pin of wood or metal fitting into holes in the abutting portions of two pieces. Being partly in one piece and partly in the other, the dowel serves to hold the pieces in their proper relative position.

**Dynamic Electricity.** Electricity in motion or flowing, as distinguished from static or frictional electricity.

Electricity of relatively low potential or electro-motive force in large quantity or amperage.

**Dynamo.** An apparatus consisting of a core and field-magnets, properly wound with insulated wire, which, when put into operation by revolving the core or armature at high speed, develops electric current; a mechanical generator of electricity.

### E

**Eccentric.** A disk, or wheel, so arranged upon a shaft that the center of the disk and that of the shaft do not coincide. Used for operating valves in steam-engines. The motion is that of a crank.

**Efflorescence.** The dry salts on a jar or vessel containing liquid that collects above the water or evaporation line. This is due to creeping.

**Ejector.** A jet-pump for expelling water from boilers, vats, or tanks.

**Elasticity.** A property in some bodies and forces through which they recover their former figure, shape, or dimensions when the external pressure or stress is removed. Water has no elasticity. Air is very elastic; steam has a great volume of elasticity; while electricity is undoubtedly the most elastic of all in its motion through air, water, and other conducting mediums.

**Elbow.** A short, angular pipe-fitting in the shape of an L. Used in joining pipes.

**Electric.** Pertaining to electricity; anything connected with the use of electricity. It has been a much-abused word, and its meaning has been garbled by the impostor, the crook, and the "business thief" in foisting on the public wares in which there was no electrical property whatever. "Electric" tooth-brushes, combs, corsets, belts, and the like may contain a few bits of magnetized steel, but they possess no active therapeutic value.

**Electricity.** One of the hidden and mysterious powers of nature, which man has brought under control to serve his ends, and which manifests itself mainly through attraction and repulsion; the most powerful and yet the most docile force known to man, coming from nowhere and without form, weight, or color, invisible and inaudible; an energy which fills the universe and which is the active principle in heat, light, magnetism, chemical affinity, and mechanical motion.

**Electricity, Atmospheric.** The electric currents of the atmosphere, variable but never absent. They include lightning, frictional electricity, the Aurora Borealis, the electric waves used in wireless telegraphy, etc. Benjamin Franklin indicated the method of drawing electricity from the clouds. In June, 1752, he flew a kite, and by its moistened cord drew an electric current from the clouds so that sparks were visible on a brass key at the ground end of the cord. Later, when a fine wire was substituted for the cord, and a kite was flown in a thunder-storm, the electric spark was vivid. This experiment confirmed his hypothesis that lightning was identical with the disruptive discharges of electricity.

## BOATING BOOK FOR BOYS

**Electricity, Voltaic.** Electricity of low potential difference and large current intensity.

Electricity produced by a voltaic battery or dynamo as opposed to static electricity, which is frictional and practically uncontrollable for commercial purposes.

**Electrolysis.** The separation of a chemical compound into its constituent parts by the action of an electric current.

**Epicyle.** A circle which rolls on the circumference of another circle, either externally or internally.

**Exhaust.** Pertaining to air, gas, or steam that is released from the cylinder of an engine after performing its work.

**Exhaust Draught.** A forced draught produced by drawing air through a furnace or fire-box instead of forcing it in.

**Exhaust-pipe.** The pipe that conveys the expended steam from the cylinder to the atmosphere or to the condenser.

**Exhaust-port.** The opening in the cylinder, or valve, by which the used steam escapes.

### F

**F.** The sign commonly employed to designate Fahrenheit. Thus, 30° F. means 30 degrees Fahrenheit, or 30 degrees above zero.

**Flange.** A plate with a rim that fits on a pipe end.

A projecting edge on a wheel. Its use is to hold the latter in position, as on a metal track.

**Flexible Shaft.** A shaft made of two spirals usually running in opposite directions, and revolving within a sheath, or case, the latter being well lubricated to prevent friction.

**Flow.** The volume of a current or stream escaping through a con-

ductor, such as a wire, rod, or pipe.

**Force.** Any change in the condition of matter with respect to motion or rest. Force is measured by the acceleration or change of motion that it can impart to a body of a unit mass in a unit of time. For instance, ten pounds pressure of steam will be indicated on a gauge made for measuring steam. That pressure of steam, with the proper volume behind it, is capable of instantly producing a given part of a horse-power. In the same way ten volts of electro-motive force is capable of pushing a current so as to exert a certain friction of horse-power.

**Force, Electro-magnetic.** The force of attraction or repulsion exerted by the electro-magnet. It is also known as electric force in the electro-magnetic system.

**Fulcrum.** The support on or against which a lever rests.

**Full Load.** A complete load. The greatest load a machine or secondary battery will carry permanently. The full capacity of a motor running at its registered speed for its horse-power.

**Fuse, Electric.** A fuse for igniting an explosive charge by electricity. It is made by bringing the terminals or ends of wires close together, so that they will spark when a current passes through them. Or a thin piece of highly resistant wire may be embedded in an explosive and brought to white heat by current.

**Fuse-block.** An insulator having a safety-fuse made fast to it.

**Fuse-box.** A box containing a safety-fuse, generally of porcelain, enameled iron, or some other non-conductor.

**Fuse-links.** Links composed of strips or plates of fusible metal serving the purpose of safety-fuses.

## APPENDIX

### G

**Galvanic.** Voltaic. Relating to current electricity or the electrochemical relations of metals.

**Galvanometer.** An instrument for measuring current strength.

A magnetic needle influenced by the passage of a current through a wire or coil located near it.

**Gate-valve.** A valve whose entrance is arranged to close with a gate, operated by a lever or screw, and through which fluids or gases can pass in a straight line.

**Gear.** Moving mechanical parts provided with teeth or sprockets which engage one another for the transmission of power. When a change in direction is desired a beveled gear is used.

**Generator.** An apparatus for maintaining an electric current, such as a dynamo, a Faradic machine, a battery, etc.

**Gland.** A stuffing-box through which a piston-rod can pass without the escape of steam, water, or gases.

**Globe-valve.** A valve with a round or spherical body, through which steam is admitted when the plug is removed from the seat.

**Gutta-percha.** Caoutchouc treated with sulphur to harden it; sometimes called vulcanized rubber or vulcanite. It is a product obtained from tropical trees, and when properly treated it is a valuable insulator in electrical work, particularly in submarine cables, since it offers great resistance to the destructive agencies of the ocean's depths.

### H

**Hand-hole.** A small orifice in a boiler through which the hand may be passed in order to make minor repairs and adjustments.

**Heat.** One of the force agents of

nature. It is recognized in its effects through expansion, fusion, evaporation, and generation of energy.

**Horse-power, Electric.** Meaning the same as in mechanics. Referred to when speaking of the working capacity of a motor or the power required to drive a dynamo.

**Hydrometer.** An instrument employed to determine the amount of moisture in the atmosphere.

An instrument for determining through flotation the density or specific gravity of liquids and fluids. It consists of a weighted glass bulb or hollow metallic cylinder with a long stem on which the Baumé scale is marked. Dropping it into a liquid it floats in a vertical position, and sinks to a level consistent with the gravity of the fluid.

### I

**Igniter.** A mechanical hand apparatus, in which a battery, induction-coil, and vibrator are located, and whose spark, jumping across a gap at the end of a rod, ignites or lights a gas flame, blasting-powder, or dynamite.

**I-H-P.** An abbreviation for indicated horse-power.

**Impulse.** The motion produced by the sudden or momentary action of a force upon a body. An electro-magnetic impulse is the action produced by the electro-magnetic waves in magnetizing a mass of soft iron and attracting to it another mass of iron or steel.

**Injector.** An apparatus by which steam or any gas under pressure is made to carry with it a current of another fluid, such as water, oil, or air, and deliver the latter in a stream of reduced diameter against the original pressure.

**Installation.** The entire apparatus, building, and appurtenances of

## BOATING BOOK FOR BOYS

a technical or manufacturing plant or power-house. An electric-light installation would mean the machinery, street-lines, lamps, etc.

**Insulation.** The dielectric or non-conducting materials which are used to prevent the leakage of electricity. The covering for magnet wires, and overhead conduits for power lines and electric lighting.

**Insulator Varnish.** A varnish composed of insulating material, such as gums, shellac, or diluted rubber. Shellac dissolved in alcohol is perhaps the best. It is easy to make and dries quickly, making an insulating surface practical for almost every ordinary use.

**Intensity.** The intensity or strength of a current is its amperage. The strength of a magnetic field, its power to attract or magnetize.

### J

**Joint.** The point where two or more electric conductors join.

**Journals.** The boxes or bearings in which axles or spindles revolve.

**Jumper.** A short circuit-shunt employed temporarily around an apparatus, lamp, or motor to cut off the current.

**Jump-spark.** A disruptive spark excited between two conducting surfaces in distinction from a spark excited by a rubbing contact.

### K

**Kathode.** The terminal of an electric circuit whence an electrolyzing current passes from a solution. It is the terminal connected to the zinc pole of a battery or the article on which the electro-deposit is made.

**Key.** A pin, or wedge, used to secure a crank, pulley, or coupling upon a shaft. It is usually embedded partly in the shaft and partly

in the crank or wheel—or it may lock through friction alone.

**Keyway.** A channel cut in a shaft or hub in which a key is placed to lock two parts of machinery together.

### L

**Lag-screw.** A heavy screw with a square, octagon, or hexagonal head, and which can be turned with a wrench.

**Level.** An instrument for ascertaining horizontal planes or lines.

**Leyden-jar.** A type of static condenser. Its usual form is a glass jar. Tin-foil is pasted about its inner and outer surfaces covering about half the wall. The balance of the glass is painted with shellac or insulating varnish. The mouth is closed with a cork stopper, and through its center a brass rod is passed which, by a short chain, is connected with the interior coating of the jar. The top of the rod is provided with a brass knob or ball, and from this last the spark is drawn.

**Lightning.** The electro-static discharge of clouds floating in the atmosphere. It is the highest form of frictional electricity, uncontrollable and very dangerous, since the strength of a single flash may run into hundreds of thousands of volts.

**Litharge.** Yellow-lead. A chemical form of metallic lead.

**Local Action.** In a battery, the loss of current due to impurities in the zinc. The currents may circulate in exceedingly minute circles, but they waste zinc and chemicals and contribute nothing to the efficiency of the battery.

In a dynamo, the loss of energy through the formation of eddy currents in its core or armature, in the pole pieces, or in other conducting bodies.

## APPENDIX

### M

**Magnet, Field.** The electro or permanent magnet in a dynamo or motor, used to produce the area of electric energy.

**Magnet, Horseshoe.** A magnet of U shape with the poles or ends brought closer together than the other parts of the limbs. A soft iron bar is placed across the poles when not in use, as this serves to conserve the magnetism.

**Make and Break, Automatic.** An apparatus which enables the armature of a magnet to make and break its circuit automatically.

**Muffler.** A metallic box having perforated disks or cylinders. Used to deaden the noise of exhaust steam or gases.

A cylindrical case having disk diaphragms and filled with asbestos. Used to deaden sound and to prevent fire escaping from the exhaust-pipes of gas-engines.

### N

**Needle.** A term applied to a bar-magnet poised horizontally upon a vertical point.

A magnetic needle, or the magnet in a mariners' compass.

**Negative.** Opposed to positive.

**Negative Electricity.** The kind of electricity with which a piece of amber is charged by friction with flannel.

In a galvanic battery or cell the surface of the zinc is charged with negative electricity. Negative electricity, according to the theory of some scientists, really means a deficiency of electricity.

**Negative Element.** The plate not dissolved by the solution in a voltaic cell; the one which is positively charged.

The carbon, platinum, or copper plate or pole in a battery.

**Non-conductor.** A material or substance offering very high resistance to the passage of the electric current.

**North Pole.** The north-seeking pole of a magnet.

The pole of a magnet which tends to point to the north, and whence lines of force are assumed to issue on their course to the other pole of the magnet.

**Nut.** A small block of metal having an internal screw thread, which engages a similar thread on a bolt, pipe, or tube.

### O

**Offset.** An abrupt bend in an object (such as a rod) by which one part is turned aside out of line but nearly parallel with the rest. The part thus bent aside.

**Ohm.** The practical unit of resistance. A legal ohm is the resistance of a column of mercury one square millimeter in cross-sectional area and 106.24 centimeters in length.

**Ohm, True.** The true ohm is the resistance of a column of mercury 106.24 centimeters long and one square millimeter in cross-sectional area. An ohm may be measured by a No. 30 copper wire nine feet and nine inches long. If larger size wire is used the piece must be proportionately longer, since the resistance is less.

### P

**Periphery.** The outer surface or circumference.

The distance around.

**Pinion.** A cog-wheel with a small number of teeth or leaves adapted to engage with a larger wheel or rack.

**Piston.** A disk attached to a rod and fitting closely in the bore of a cylinder. The piston receives the pressure of the steam or expanding

gas, and by its reciprocal motion communicates power to the crank-shaft.

**Pitman.** A rod that connects a rotary with a reciprocating part. A connecting-rod usually working in a vertical position.

**Pivot-bearing.** A conical-shaped bearing turning on a plate or a collar of steel balls to reduce friction.

**Plug.** A piece of metal, with a handle, used to make electric connections by being inserted between two slightly separated plates or blocks of metal.

A wedge of metal, slightly tapered, and used to thrust between two conductors to close or complete a circuit.

**Polarity, Electric.** The disposition in a paramagnetic body to be influenced by electric waves and lines of force. The otherwise non-magnetic body or mass becomes magnetic to attract or repulse when influenced by electricity, but ceases to retain the phenomena after the electric influence is removed. A piece of soft-iron wire, a nail, or a short rod of iron will become electro-polarized when a current of electricity is sent through a coil of insulated wire so wound that one end will be N, the other S. So soon as the circuit is broken the polarity ceases.

**Polarization.** The depriving of a voltaic cell of its proper electro-motive force. This may be brought about through the solution becoming spent, or in the event of the acid being saturated with zinc, and so failing to act on the metallic zinc.

Counter electro-motive force due to the accumulation of hydrogen on the negative plate.

**Poles.** The terminals of an open electric circuit at which there necessarily exists a potential difference.

The terminals of an open magnetic

circuit, or the ends of a magnetized mass of iron.

**Porous Cup or Cell.** A cup or cell made of pipe-clay or of unglazed earthenware through which a current of electricity can pass when wet or in a liquid. Porous cups are used in cells and batteries to keep two liquids apart, and yet permit electrolysis and electrolytic conduction.

**Positive Currents.** Currents which deflect the needle to the left.

**Positive Electricity.** The current that flows from the active element, the zinc in a battery, to the carbon. The negative electricity flows from the carbon to the zinc.

**Positive Electrode.** The electrode which is connected with the positive pole of a source of electric energy.

**Positive Pole.** The N pole in a magnet or magnetic needle. So called because it seeks the north or negative pole of the earth.

**Positive Wire, or Conductor.** The wire, or conductor, connected with the positive pole of any apparatus which produces electro-motive force.

### Q

**Quantity, Electro-magnetic.** The electro-magnetic current measured by its intensity for a second of time.

**Quick-break.** A break affected in an electric current by the employment of a quick-break switch.

### R

**Ratchet.** A wheel bearing teeth on its periphery to engage with a pawl, thereby preventing backward motion.

**Reciprocating.** Motion to and fro or alternating.

**Resistance.** That quality of an electric conductor in virtue of which it opposes the passage of an electric

## APPENDIX

current, causing the disappearance or modification of electro-motive force, and converting electric energy into heat energy.

**Resistance, Electrolytic.** The resistance of an electrolyte to the passage of a current decomposing it. It is almost entirely due to electrolysis, and is intensified by counterelectro-motive force. When a current of a voltage so low as not to decompose an electrolyte is passed through the latter, the resistance appears very high and sometimes almost infinite. If the voltage is increased until the electrolyte is decomposed the resistance suddenly drops to a point lower than the true resistance.

**Resistance, Internal.** The resistance of a battery or generator in an electric circuit, as distinguished from the resistance of the rest of the circuit.

### S

**Safety Fuse.** A device to prevent overheating of any portion of a circuit by excessive current. It generally consists of a strip of fusible metal which, if the current attains too great strength, melts and opens the circuit.

**Salt.** A chemical compound containing two atoms or radicals which saturate each other. One is electro-positive, the other electro-negative.

Salts are decomposed by electrolysis, and in separating they combine to form new molecules.

**Saturated.** A liquid is said to be saturated when it has dissolved all the salts it will take up.

**Series.** Arranged in succession. When incandescent lamps are installed so that the current goes in and out of one lamp, and so on to the next and the succeeding ones, they are said to be arranged in series. It takes high E-M-F and

current, or amperage, to operate such lamps.

Series batteries are arranged with the zinc pole of one connected to the carbon pole of the next.

**Shackle.** A ring, clasp, brace, or fastening to hold parts together.

**Shellac.** A resin gum, gathered from certain Asiatic trees. It is soluble in alcohol, and is used extensively in electric work as an insulator.

**Shroud.** A chain or brace used to guy or stay.

A band of metal encircling anything to hold it in place or together.

**Siphon.** A pipe or tube bent into two branches and used for drawing liquids from one level to a lower level over an intermediate elevation.

**Snatch-block.** A pulley-block with one side partly open, so that a rope can be passed in and over the pulley without the necessity of reeving it in from one end.

**Solution.** A fluid composed of dissolved salts; a mixture of liquids and fluids.

**Spark-coil.** A coil for producing a spark from a source of comparatively low electro-motive force. The induction-coil is an example.

**Spark, Electric.** The phenomenon observed when a disruptive charge leaves an accumulator or induction-coil and passes through an air gap.

**Spark-gap.** The space left between the ends of an electric resonator across which the spark springs.

**Sparking.** The production of sparks at the commutator, between the bars and the brushes of dynamos and motors. They are minute voltaic arcs, and should not be allowed to occur, as they cut away the metal and score the surface of the commutator.

**Specific Gravity.** The relative

## BOATING BOOK FOR BOYS

weight or density of a body as compared with a standard. Water is usually taken as a standard for solids and liquids, and air for gases.

**Spent Acid.** Acid which has become exhausted. In a battery the acid becomes spent from combination with zinc; it also loses its depolarizing power.

**Spring-contact.** A spring connected to one lead of an electric circuit. It is arranged to press against another spring or contact, which it opens or closes by the introduction of a plug or wedge.

**Steam-separator.** A mechanical device for separating heavy and light steam. The heavy steam falls from the baffle-plate and condenses while the lighter passes on to the engine.

**Steam-trap.** An apparatus designed to catch the water from condensing steam and return it to the boiler before it has time to enter the cylinder.

**Stoke.** To supply with fuel, as to stoke a fire.

**Strength of Current.** Amperage; the quantity of current in a circuit.

**Stroke.** In an engine or motor the stroke is one of a series of recurring movements in which the connection-rod is carried to and fro for its full swing by the crank or eccentric.

**Stuffing-box.** A mechanical contrivance to hold the packing about piston-rods or eccentrics, thereby preventing the escape of steam, water, or gases.

**Switch.** A device for opening and closing an electric circuit. Made in a great variety of forms, such as push-button, telegraph-key, knife switch, automatic switch, lever switch, rheostat, etc.

### T

**Tape, Insulating.** Prepared tape used in covering the bared ends of wires or joints.

**Throttle.** To obstruct or shut off. A damper or valve employed to regulate the flow of steam, gas, or fluid through a pipe.

**Throw.** The travel or extent of reciprocating motion in a crank or eccentric.

**Turbine.** A rotating wheel or cylinder propelled by water or steam and designed for the purpose of developing power.

A windmill of the modern feather-blade type.

### U

**Unit.** The single standard of force, light, heat, magnetism, attraction, repulsion, resistance, etc.

**Universal Joint.** A joint that permits both connected parts to be turned in any direction.

A coupling for connecting two shafts so as to permit of angular motion in nearly all directions.

### V

**Vacuum.** A space from which the air has been exhausted to a very high degree. In the theoretical vacuum the exhaustion is supposed to be perfect.

**Valve.** A gate or ball contrivance which opens and closes a passage and so controls the flow or supply of gases and liquids.

**Vibrator, Electro-magnetic.** The make-and-break mechanism used on induction-coils, or other similar apparatus, in which, through alternate attractions, an arm or spring is kept in motion.

**Volt.** The practical unit of electric-motive force; the volume and pressure of an electric current.

**Voltage.** Electric-motive force expressed in volts—as, a voltage of 100 volts.

**Vulcanite.** Vulcanized rubber. Valuable for its insulating properties and inductive capability.



## APPENDIX

### W

**Watt.** The practical unit of electrical activity; the rate of work or rate of energy. It is a unit of energy or of work represented by a current of one ampere urged on by one volt of electro-motive force.

The volt-ampere.

The standard of electrical power or work. It takes 746 electric watts to equal one horse-power.

**Winch.** A small windlass fixed on a truck or the mast of a crane. It is usually provided with one or two cranks and handles. A winch is sometimes rigged to be operated by steam-power.

**Windlass.** A horizontal drum upon which a rope winds for hoisting objects.

**Wire, Flexible.** A cord of fine wire strands laid together and insulated so that it may be easily bent or wrapped.

**Wiring.** Installing wires so as to

form a circuit for the conveyance of current for light, heat, and power.

**Withe.** A band made of iron for binding, as the withes on the spars and masts of a ship.

### Y

**Yoke.** A joining or connecting piece, such as a clip, a tie-beam, or a strap.

In electrical work, a piece of soft iron which connects the ends of two portions of a core on which wire coils are wound. It is located at the ends farthest from the poles.

The soft-iron bar placed across the ends of a horseshoe magnet to retain its magnetism.

### Z

**Zinc-battery.** A battery which decomposes zinc in an electrolyte, thereby producing a current.

**Zinc Currents.** Negative currents.

THE END

THE UNIVERSITY OF CHICAGO  
LIBRARY  
540 EAST 57TH STREET  
CHICAGO, ILL. 60637  
TEL: 773-936-3000  
WWW.CHICAGO.EDU









