



**A POPULAR AND**  
**PRACTICAL TREATISE**  
**ON**  
**MASONRY AND STONE-CUTTING.**

LONDON:  
PRINTED BY S. AND R. BENTLEY, DORSET STREET.

*S.H. 1828.*

# A POPULAR

AND

## PRACTICAL TREATISE

ON

# MASONRY

AND

## STONE-CUTTING:

Containing the Construction of

PROFILES OF ARCHES,  
HEMISPHERIC NICHES,  
HEMISPHERIC DOMES,  
CYLINDRIC GROINS,



VERTICAL CONIC VAULTS,  
CYLINDRO-CYLINDRIC ARCHES,  
RIGHT ARCHES,  
OBLIQUE ARCHES,

AND GOTHIC CEILINGS:

ESSENTIAL FOR THE ENGINEER, ARCHITECT, BUILDER, AND STONE-MASON;

THE ARTICLES BEING PRECEDED BY THE REQUISITE  
INFORMATION IN PLANE AND SOLID GEOMETRY.

---

BY PETER NICHOLSON, ESQ.

ARCHITECT AND ENGINEER.

AUTHOR OF THE "ARCHITECTURAL DICTIONARY," "THE CARPENTER'S  
GUIDE," AND OTHER WORKS ON MATHEMATICAL SUBJECTS.



---

LONDON:

THOMAS HURST, EDWARD CHANCE, & CO.

ST. PAUL'S CHURCH YARD.

1828.

*800.*



## P R E F A C E.

---

IT is rather surprising that, notwithstanding the great number of public edifices executed in stone, and the numerous Treatises which have been furnished on the art of Carpentry in this and other countries, no work on the principles of Masonry has yet appeared in this country, except an attempt on Stone-cutting by General Vallancey, published in London in 1766. The General, though he has not avowed it, has copied the diagrams and references from a very able work on the subject by *De la Rue*; and though this English publication was originally intended to consist of five parts, only one has been given to the public; and that too without inserting the most valuable precepts and observations which are to be found in the original. And it is still more surprising, when it is considered that no department in the art of building affords so great a scope for ingenuity, nor stands in need of so great a fund of Geometry, as Stone-cutting.

To be able to direct the operations of Masonry, taken in the full extent of the Art, requires the most profound mathematical researches, and a greater combination of scientific and practical knowledge than all the other executive branches in the range of architectural science.

It was not the intention of the Author in this undertaking to give a complete Treatise on Masonry, nor even on Stone-cutting, as such a production would far exceed the prescribed limits; but to produce such a Work as he hopes will be found of the most essential service in the art, in regard both to the methods employed and the examples adduced; most of those in the French publications being such as the English workman would never meet with in the course of his practice.

As this art requires a considerable knowledge both of *Plane* and *Solid* Geometry, such Problems have been introduced in practical Geometry as respect the positions of lines and points; and in Solid Geometry are shown the properties arising from the intersection of lines and planes with each other; and also the construction of trehedrals under various circumstances. To enable the workman to construct the plans and elevations of the various forms of arches or vaults, as much of *descriptive* Geometry and Projection has also been introduced, as will be found necessary to conduct him through the most difficult undertakings.

The several branches are so arranged, that those subjects which are subsequent, are made to depend on those which have preceded them ; and as the most obvious methods are not always the most eligible for practice, there are given in several instances, for the more ready comprehension of the student, the methods which are best calculated to explain the principle ; and from these, others are deduced, more convenient and expeditious for practice.

The Author has availed himself of the useful precepts and observations which are to be met with in the most valuable French productions on the Art of Stone-cutting ; but, excepting in one or two instances, he has neither followed their methods, nor adopted their examples, for the reason alluded to ; and farther, he thinks it necessary to observe, that this Treatise contains several constructions, and many methods which are nowhere else to be found.

The examples which have been chosen are not numerous, nor are they subjects of mere curiosity, but those of elegance and utility in the construction of mansions, bridges, and other public works.

To conclude : the following Work is the first and only one in English, on the Art of Stone-cutting ; and such a



publication has been long and eagerly sought after. The Author indulges the hope, from the experience he has had in treating other subjects intimately connected with the present, that the contents of the Work will be found to be interesting, the instructions and diagrams easily understood, and therefore that the performance will not disappoint his reader.

# CONTENTS.

---

## CHAPTER I.

PRACTICAL GEOMETRY, ADAPTED TO MASONRY AND STONE-CUTTING.

### SECTION I.

*On the position of Lines and Points.—p. 1.*

### SECTION II.

*On the species, nature, and construction of Curve Lines.—p. 5.*

### SECTION III.

*Of the positions of Lines and Planes, and the properties arising from their intersections.—p. 10.*

### SECTION IV.

*Of the right sections of Arches or Vaults.—p. 11.*

### SECTION V.

*On the nature and construction of Trehedrals.—p. 15.*

### SECTION VI.

*On the projection of a Straight Line bent upon a cylindric surface, and the method of drawing a Tangent to such a projection.—p. 20.*

## CHAPTER II.

THE GEOMETRY OF PLANS AND ELEVATIONS, ADAPTED TO THE CONSTRUCTION  
OF ARCHES AND VAULTS.

## SECTION I.

*Preliminary principles of Projection.—p. 22.*

## SECTION II.

*On the developements of the Surfaces of Solids.—p. 32.*

## CHAPTER III.

CONSTRUCTION OF THE MOULDS FOR HORIZONTAL CYLINDRETIC VAULTS, EITHER  
TERMINATING RIGHTLY OR OBLIQUELY, UPON PLANE OR CYLINDRICAL  
WALLS, WITH THE JOINTS OF THE COURSES EITHER IN THE DIRECTION OF  
THE VAULT, PERPENDICULAR TO THE FACES, OR IN SPIRAL COURSES.

## SECTION I.

*Definitions of Masonry, Walls, Vaults, &c.—p. 35.*

## SECTION II.

*On oblique Arches.—p. 39.*

## SECTION III.

*A circular Arch in a circular Wall.—p. 60.*

## SECTION IV.

*A conic Arch in a cylindric Wall.—p. 62.*

## CHAPTER IV.

CONSTRUCTION OF THE MOULDS FOR SPHERICAL NICHEs, BOTH WITH RA-  
DIATING AND HORIZONTAL JOINTS, IN STRAIGHT WALLS.—P. 66.

## SECTION I.

*Examples of Niches, with radiating joints, in straight walls, as in  
Plate XXIV.—p. 67.*

## SECTION II.

*Examples of Niches in straight walls with horizontal courses, as in  
Plate XXVII.—p. 69.*

## CHAPTER V.

CONSTRUCTION OF THE MOULDS, AND FORMATION OF THE STONES, FOR  
DOMES UPON CIRCULAR PLANES, AS IN PLATE XXX.

*On the Construction of Spherical Domes.*—p. 72.

## CHAPTER VI.

CONSTRUCTION OF CIRCULAR ROOFS, OF WHICH THE EXTERIOR AND INTERIOR  
SURFACES ARE CONICAL AND CENTRIC WITH EACH OTHER.—P. 85.

## CHAPTER VII.

CONSTRUCTION OF THE MOULDS, AND FORMATION OF THE STONES, FOR  
RECTANGULAR GROINED VAULTS.

*Construction of Groined Vaults, with Cylindretic Surfaces.*—p. 87.

## CHAPTER VIII.

CONSTRUCTION OF THE STONES FOR GOTHIC VAULTS, IN RECTANGULAR  
COMPARTMENTS UPON THE PLAN.

*Groined Arches, springing from Polygonal Pillars.*—p. 91.

## CHAPTER IX.

THE MANNER OF FINDING THE SECTIONS OF RAKING MOULDINGS.—P. 95.

## CHAPTER X.

CONSTRUCTION OF A LINTEL, OR AN ARCHITRAVE, IN THREE OR MORE  
PARTS, OVER AN OPENING, AND THE STEPS OF A STAIR, OVER AN  
AREA.—P. 97.

## CHAPTER XI.

OF WATERLOO BRIDGE.—P. 99.



A

# PRACTICAL TREATISE,

&c. &c.

---

## CHAPTER I.

### PRACTICAL GEOMETRY, ADAPTED TO MASONRY AND STONE-CUTTING.

#### SECTION I.

##### ON THE POSITION OF LINES AND POINTS.

As the construction of every complex object in nature consists of certain combinations of the simple operations of geometry; and as positions cannot be understood without angles and parallel lines, it will be necessary to treat of the practical part of this science, at least as far as the operations of the positions of lines and points are concerned, in order to render the constructions and the language of geometry familiar to the student in their applications to the principles of Masonry.

#### PROBLEM I.

From a given point in a given straight line to draw a perpendicular.

*Plate I.* Let  $AB$ , *fig. 1*, be a given straight line, and  $c$  the given point. In  $AB$  take two equal distances,  $cd$  and  $ce$ . From  $d$  as a centre, with any radius greater than  $cd$  or  $ce$ , describe an arc at  $f$ , and with the same radius, from the point  $e$ , describe another arc intersecting the former at  $f$ , and draw  $fc$ , and  $fc$  is the perpendicular required.

B

## PROBLEM II.

From the one extremity of a straight line to draw a perpendicular.

*Fig. 2.* Let  $AB$  be the given straight line, and let it be required to draw a perpendicular from the extremity  $B$ . On one side of the line  $AB$  take any convenient point  $c$ ; and from  $c$ , as a centre, with any radius that will cut the line, describe an arc  $dBe$ , intersecting  $AB$  in the point  $d$ ; through  $c$  draw the diameter,  $de$ , and join  $eB$ , and  $eB$  is the perpendicular required.

## PROBLEM III.

From a given point out of a straight line to let fall a perpendicular.

*Fig. 3.* Let  $AB$  be the given straight line, and  $c$  the given point; it is required to draw a straight line from  $c$  perpendicular to  $AB$ . From  $c$ , as a centre, with any distance that will cut the line  $AB$ , describe an arc intersecting  $AB$  in the points  $d$  and  $e$ ; from  $d$ , as a centre, with any radius greater than the half of  $de$ , describe an arc, and from  $e$ , with the same radius, describe another arc intersecting the former in  $f$ , and draw  $fc$ , and  $fc$  is the perpendicular required.

The criterion of the truth of the method of *fig. 2.* is that of the angle in a semicircle being a right angle.

## PROBLEM IV.

At a given point in a given straight line to make an angle equal to a given angle.

*Fig. 4.* Let  $CBA$  be the given angle, and  $LF$  the given straight line. Let it be required to draw a straight line, at the point  $L$ , to make an angle with the line  $LF$ , equal to the angle  $CBA$ . From the point  $B$ , with any radius, describe an arc meeting  $BA$  in  $h$ , and  $BC$  in  $g$ ; and from the point  $L$ , with the same radius, describe an arc  $ik$ , meeting  $LF$  in  $i$ . Make  $ik$  equal to  $gh$ , and through  $k$  draw the straight line  $LD$ , and  $FLD$  is the angle required.

## PROBLEM V.

Through a given point  $f$  to draw a straight line parallel to a given straight line  $AB$ .

*Fig. 5.* Let  $f$  be the given point, and  $AB$  the given straight line. Draw any straight line  $fe$ , meeting  $AB$  in  $e$ , and draw  $gh$ , making the angle  $hgB$  equal to  $feB$ . Make  $gh$  equal to  $ef$ . Through the points  $f$  and  $h$  draw the line  $CD$ , and  $CD$  is parallel to  $AB$ , as required.

## PROBLEM VI.

To draw a straight line parallel to a given straight line at a given distance from the given straight line.

*Fig. 6.* Let  $AB$  be the given straight line; it is required to draw a straight line at a given distance from  $BC$ . In  $AB$  take any two points  $e$  and  $f$ ; from  $e$ , with the given distance, describe an arc  $gh$ ; and from  $f$ , with the same distance, describe another arc  $ik$ . Draw the line  $CD$  to touch the arcs  $gh$  and  $ik$ , and  $CD$  is parallel to  $AB$ , as required.

## PROBLEM VII.

To bisect a given straight line  $AB$  by a perpendicular.

*Fig. 7.* From the point  $A$  as a centre, with any radius greater than the half of  $AB$ , describe an arc  $cd$ ; and from  $B$ , with the same radius, describe another arc intersecting the former at  $c$  and  $d$ , and draw  $cd$ , intersecting  $AB$  in  $e$ ; then  $AB$  is divided in  $e$ , as required.

## PROBLEM VIII.

Upon a given straight line to describe an equilateral triangle.

*Fig. 8.* Let  $AB$  be the given straight line. From the point  $A$ , with the radius  $AB$ , describe an arc, and from the point  $B$ , with the radius  $BA$ , describe another arc, intersecting the former in  $C$ , and draw the straight lines  $CA$  and  $CB$ ; then  $ABC$  is the equilateral triangle required.

## PROBLEM IX.

Upon a given straight line to describe a triangle, of which the sides shall be equal to three given straight lines, provided that any one of the three given lines be less than the sum of the other two.

*Fig. 9.* Let the three given straight lines be  $A$ ,  $B$ ,  $C$ , and let  $DF$  be the straight line on which the triangle is required to be described. Make  $DF$  equal to the given straight line  $A$ . From  $D$ , with the radius of the line  $B$ , describe an arc, and from  $F$ , with the radius of the line  $C$ , describe another arc, meeting the arc described from  $D$  in the point  $E$ . Draw  $ED$  and  $EF$ , then  $DEF$  is the triangle required.

## PROBLEM X.

Given the base and height of the segment of a circle to find the centre of the circle, and thence to describe the arc.



*Fig. 10.* Let  $AC$  be the base bisect,  $AC$  in  $D$  by the perpendicular  $BE$ ; make  $DB$  equal to the height, and join the points  $A$  and  $B$ . Make the angle  $BAE$  equal to  $ABE$ , and the point  $E$  is the centre required.

From the point  $E$ , with the radius  $EA$  or  $EB$ , describe the arc  $ABC$ ; then  $ABC$  is the arc required.

N.B. The centre must also have been found by bisecting  $AB$  by a perpendicular, which would have met  $BE$  in the point  $E$ .

#### PROBLEM XI.

Given two converging lines through a given point in one of them, to draw a third straight line, so that the angles on the same side of the line thus drawn, made by this line and each of the first two given lines, may be equal to each other.

*Fig. 11.* Let the two converging lines be  $AC$  and  $BD$ , and let  $A$  be the given point. Draw  $AE$  parallel to  $BD$ ; bisect the angle  $CAE$  by the straight line  $AB$ ; then will the angles  $CAB$  and  $DBA$  be equal to one another.

For, suppose  $AE$  to be produced from  $A$  to  $F$ , and suppose  $AC$  and  $BD$  to be produced to meet in some point  $G$ , then  $AC$  would have been a line falling upon the two parallel straight lines  $AF$  and  $BD$ , and consequently making the angle at  $G$  equal to the  $A$  angle  $FAC$ ; and since the three angles of every triangle are equal to two right angles, and since the angles  $FAC$ ,  $CAB$ ,  $BAE$ , are also equal to two right angles, and since  $FAC$  is equal to the vertical angle of the triangle, the angle  $CAE$  is equal to the sum of the angles at the base; and therefore, since  $CAB$  is half the sum, the angle  $ABD$  must be equal to the other half.

#### PROBLEM XII.

Given two converging lines to describe the arc of a circle through a given point in one of them, without having recourse to a centre, so that the point of convergency may be in the centre of the arc.

*Fig. 12.* Let  $AB$  and  $EF$  be the two converging lines, and  $A$  the given point through which the arc is to pass. Draw  $AE$ , making the angles  $BAE$  and  $FEA$ , equal to each other. Bisect  $AE$  by the perpendicular  $CD$ , and draw  $Ah$ , making the angles  $BAh$  and  $DhA$  equal to one another; then  $Ah$  is the chord of the arc, and  $nh$  is the versed sine. Suppose now that the three points  $A$ ,  $h$ ,  $E$ , are transferred to  $A$ ,  $B$ ,  $C$ , *fig. 13.* Join  $BA$  and  $BC$ . Produce  $BA$  to  $d$ , and  $BC$  to  $e$ . Make the edge of a slip of wood to the angle  $dBe$ . Move the edge  $dBe$  of the slip of

wood so that the point B may be upon A; then move this slip again, so that while the part  $Bd$  of the edge of the slip is sliding upon the pin at A, and the part  $Be$  upon the pin at C, a pencil held to the angle B, will describe a curve; then this curve will be the arc required.

#### PROBLEM XIII.

Given two straight lines to find a third proportional.

*Fig. 14.* From any point A, draw any two straight lines BA, AC, at any angle. Make AB, equal to one of the given straight lines, and AC equal to the other; and in AB make  $Ad$  equal to AC. Join BC and draw  $de$  parallel to BC, meeting AC in  $e$ ; then  $Ae$  is the third proportional required.

Or if  $Ae$  be equal to one of the given straight lines, and  $Ad$  equal to the other. Make AC equal to  $Ad$ . Join  $de$  and draw CB parallel to  $ed$ , then AB is the third proportional.

#### PROBLEM XIV.

Given a straight line, any how divided, to divide another in the same proportion.

*Fig. 15.* Draw the lines BA, AC as in the preceding problem, and let AB be the given divided line,  $d$  and  $e$  being the points of division, and let AC be the line to be divided. Join BC and draw  $eg$  and  $df$  parallel to BC, meeting AC in  $f$  and  $g$ ; then AC is divided in  $f$  and  $g$ , in the same proportion as AB is divided in the points  $d$  and  $e$ .

#### PROBLEM XV.

Given three straight lines to find a fourth proportional.

*Fig. 15.* The angle BAC being made as before; let  $Ae$  be equal to one of the given lines,  $Ad$  equal to a second, and  $af$  equal to the third. Join  $df$  and draw  $eg$  parallel to  $df$ ; then  $Ag$  is the fourth proportional.

### SECTION II.

#### ON THE SPECIES, NATURE, AND CONSTRUCTION OF CURVE LINES.

THE geometrical orders of lines employed in architecture in the construction of arches, are circular and elliptic, and occasionally parabolic, hyperbolic, cycloidal, and catenarian curves.

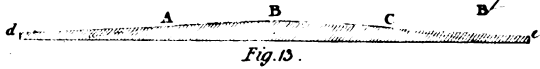
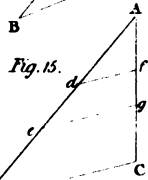
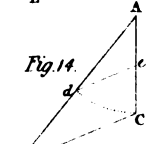
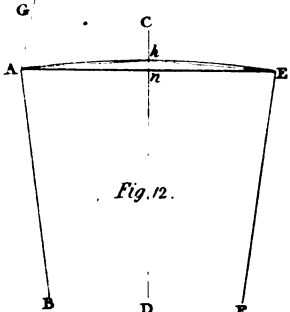
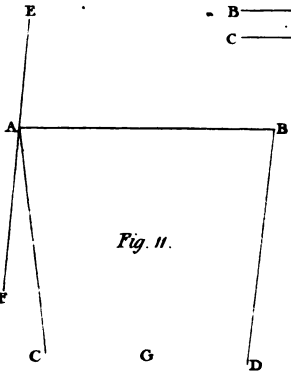
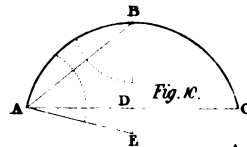
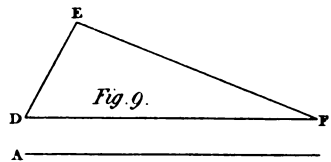
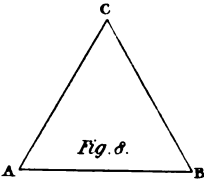
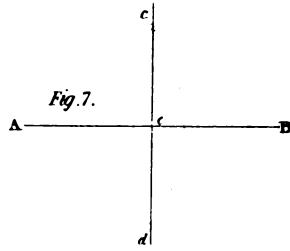
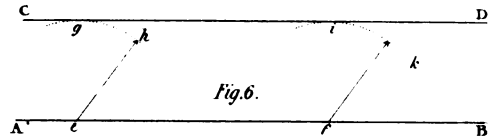
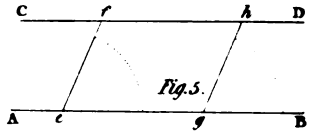
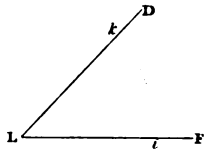
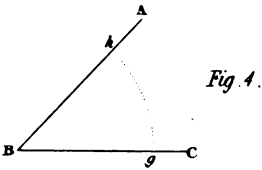
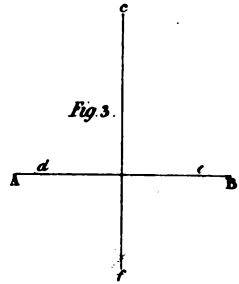
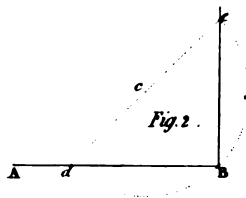
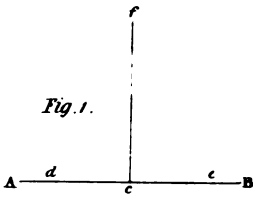
In houses, the chief lines employed in the construction of arches and vaults, are circular and elliptic curves, generally a semi, and sometimes less, but seldom or never greater. When a circular or elliptic arc is adopted, one of the axes of the curve is most frequently situated upon the springing line; but is sometimes placed so as to be parallel to it. The most usual portions of circular or elliptic curves are the semi; and in the pointed style of architecture, parabolic and hyperbolic curves are very frequently employed.

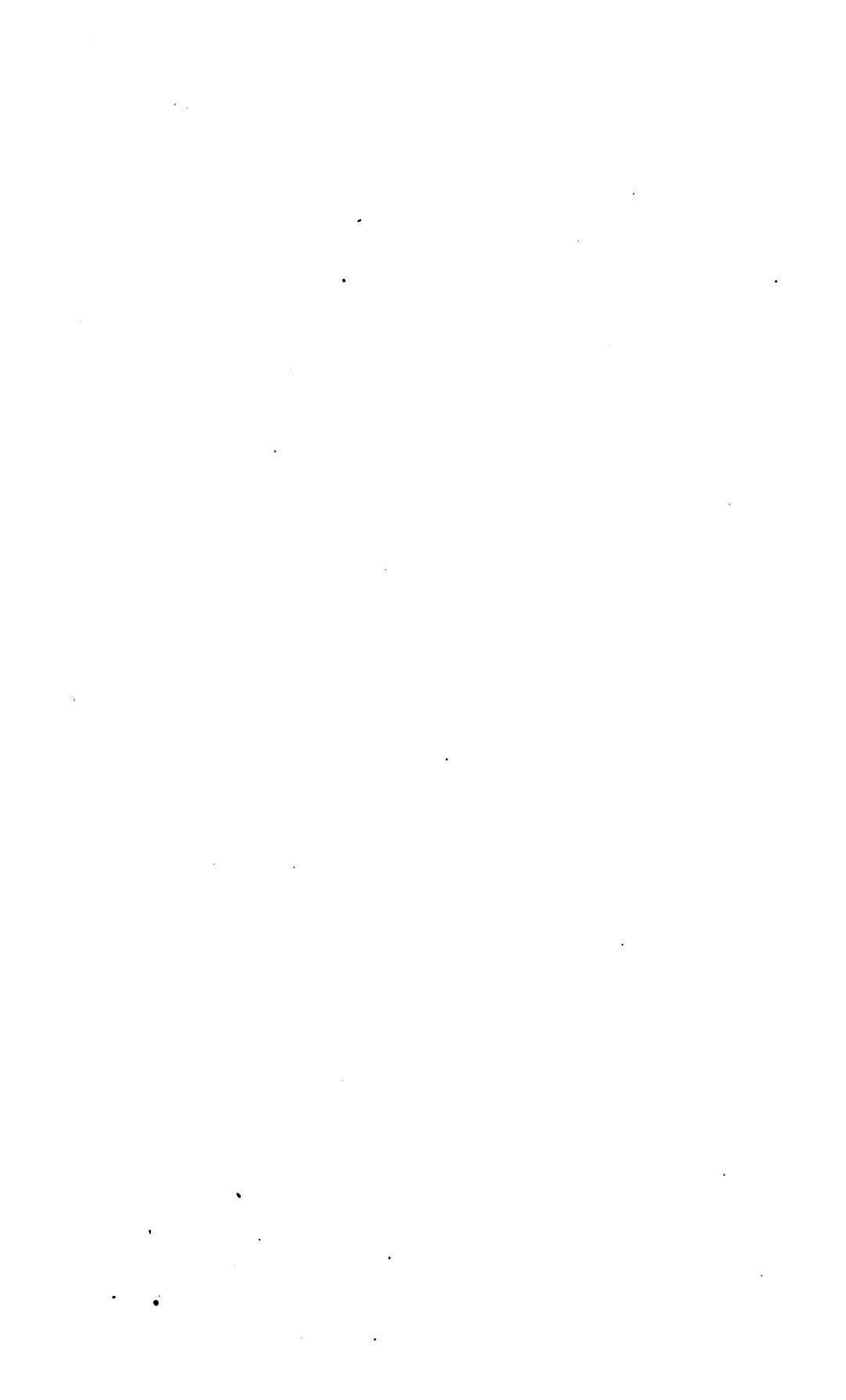
In bridge building, besides circular and elliptic curves which are the most often used in the construction of stone arches, cycloidal curves may also be introduced. In chain bridges, or bridges of suspension, not only the circular and parabolic curves, but that of the catenarian may be employed. The suspending chains necessarily assume the form of catenarian curves; but the road-way may be any curve line whatever; but as all curves are nearly circular at the vortex, it will be better to employ those in the construction of works which are susceptible of the most easy calculation.

Among the numerous orders of curve lines, the parabolic affords the most easy means of computing its ordinates and tangents, which will be found necessary in ascertaining the rise and inclination of the road-way in all points of the curve, from either extreme to the centre of the bridge.

The base of an arc is that upon which the arc is supposed to stand; and the highest point of an arc is that in which a straight line parallel to the base would meet the curve, without the possibility of coming within the area included by the curve and its base, and this point is called the summit of the arc.

As the curves employed in building are generally symmetrical, therefore they are equal and similar on each side





of the summit, and their areas are equal and similar on each side of the perpendicular from the middle of the base.

#### PROBLEM I.

To describe a semi-ellipse upon the transverse axis.

*Plate II.* Let  $Aa$ , *fig. 1*, be the axis major, and let  $BC$  bisecting  $Aa$  perpendicularly in the point  $C$ , be the semi-conjugate axis.

Upon the straight edge  $mi$  of a rule, mark the point  $m$  at or near one of its ends, and the point  $l$  at a distance; from  $m$  equal to  $BC$ , the semi-conjugate axis; and the point  $k$  at a distance from  $m$ , equal to  $AC$  or  $Ca$  the semi-transverse axis; the distance  $kl$  being equal to the difference of the two axes. To find any point in the curve, place the point  $k$  in the line  $BC$  produced, and the point  $l$  in the axis  $Aa$ ; and mark the paper or plane on which the figure is to be described at the point  $m$ . Proceed in this manner until a sufficient number of points are found, and draw a curve through them, and the curve will be the semi-ellipse required.

#### PROBLEM II.

Upon a given double ordinate to describe the segment of an ellipse, to a given abscissa, and to a given semi-axis in that abscissa.

*Figs. 2 and 3.* Let  $Mm$  be the double ordinate,  $PH$  the abscissa, and  $HC$  the semi-axis.

Through the centre  $C$ , draw  $Kk$  parallel to  $Mm$ . From either extremity  $m$  of the double ordinate as a centre with the distance  $HC$  of the given semi-axis, as radius describe an arc intersecting  $Kk$  in  $r$ . Draw  $mr$  intersecting  $HC$  in  $q$ , or produce  $mr$ , and  $HC$  to meet in  $q$ ; then  $mq$ , *fig. 2* will be the semi-transverse, and  $mr$  the semi-conjugate, and in *fig. 3* the contrary will take place,  $mr$  will be the semi-transverse, and  $mq$  the semi-conjugate; the two axes being thus found, the curve may be described as in the immediately preceding problem.

#### PROBLEM III.

Given two conjugate diameters to find any number of points in the curve, and thence to describe it.

*Figs. 4 and 5.* Let  $Aa$ ,  $Bb$ , be the conjugate diameters. Draw  $AD$  parallel to  $BC$ , and  $BD$  parallel to  $CA$ . Divide  $AD$  and  $AC$  each into the same number of equal parts. Through the points of division in  $AC$  draw straight lines from  $b$ , and through the points of division in  $AD$  draw other straight lines to the point  $B$ , meeting those drawn from  $b$  in the

points  $f, g, h$ . Draw a curve line through the points  $A, f, g, h, B$  which will be one quarter of the whole figure. The other three will of course be found in the same manner.

#### PROBLEM IV.

To draw a normal, or a line perpendicular to the curve of an ellipse at a given point in the curve.

*Fig. 6.* Let the curve be  $ABa$ , and let  $Aa$  be the transverse axis, and  $CB$  the semi-conjugate, and let it be required to draw a line from the point  $n$  perpendicular to the curve. With  $AC$  the semi-axis major as a radius; from the point  $B$  describe an arc, intersecting  $Aa$  in the foci,  $f, f'$ . From the points  $f', f$ , and through the point  $n$ , draw  $f'd$  and  $fe$ , and bisect the angle  $e n d$ , and the bisecting line  $nN$  will be perpendicular to the curve as required.

#### PROBLEM V.

To draw a tangent to the curve of an ellipse at a given point.

*Fig. 6.* Let  $m$  be the given point. Draw  $fm$ , and produce  $fm$  to  $g$ , and join the points  $f', m$ . Bisect the angle  $f'mg$ , and the bisecting line  $Tt$  will be the tangent required.

#### PROBLEM VI.

The curve of an ellipse being given to find the two axes.

*Fig. 7.* Let  $AMNnm$  be the given curve within the figure; draw any two parallel lines  $Mm, Nn$ . Bisect  $Mm$  in  $o$ , and  $Nn$  in  $p$ , and draw the straight  $Aopa$ . Bisect  $Aa$  in  $C$ , from  $C$  as a centre, with any radius that will cut the curve: describe the arc  $rr'$ , intersecting the curve in the points  $r, r'$ , and draw the straight line  $rr'$ . Bisect  $rr'$  in  $h$ , and through the points  $h$  and  $C$  draw the line  $de$ , then  $de$  is the axis major; and a line drawn through the point  $C$  at right angles to  $de$ , to meet the curve on each side of  $C$  will be the axis minor.

#### PROBLEM VII.

With a given abscissa and ordinate to describe a parabola.

*Fig. 8.* Let  $AB$  be the abscissa, and  $BC$  the ordinate. Draw  $CD$  parallel to  $BA$ , and  $AD$  parallel to  $BC$ . Divide  $CD$  and  $CB$  each into the same number of equal parts. From the points 1, 2, 3 in  $CD$  draw lines to  $A$ , and from the points 1, 2, 3 in  $CB$ , draw lines parallel to  $BA$ , meeting the former lines to  $A$  in the points  $f, g, h$ . Draw the curve  $CfghA$ , which will be one half of the parabola, the other half will be

found in the same manner. The radius of curvature at the point A, is half the parameter.

#### PROBLEM VIII.

The curve of a parabola being given to find the parameter.

*Fig. 8.* Let CAN be the curve of the parabola. Bisect BC in the point 2, and draw A2 and 2d perpendicular to A2, meeting AB produced in d; then Bd is one fourth part of the parameter.

For AB : B2 :: B2 : Bd, now let AB = a, BC = b, then B2 =  $\frac{1}{2}b$ , hence  $a : \frac{1}{2}b :: \frac{1}{2}b : \frac{1}{4}p$ ; whence  $ap = b^2$  or  $p = \frac{b^2}{a}$ .

#### PROBLEM IX.

To draw a tangent to any point M, in the curve of a parabola.

*Fig. 8.* Draw the ordinate PM, and produce PA to q. Make Aq equal to AP, and draw the straight line qM; then qM will be the tangent required.

For the subtangent of the curve is double to the abscissa.

#### PROBLEM X.

To form the curve of a parabola by means of tangents.

*Fig. 9.* Let AC be the double ordinate. Draw DB bisecting AC, and make DB equal to the abscissa. Produce DB to E, and make BE equal to BD. Draw the two straight lines EA and EC. Divide AE and EC each in the same proportion, or into the same number of equal parts at the points 1, 2, 3, &c. in each line. Draw the straight lines 1-1, 2-2, 3-3, &c. and their intersections will circumscribe the curve of the parabola as required.

*Scholium.* Small portions of the curves of conic sections, near to the vertices, may be described with compasses so as not to be perceptible; and thus, not only in the parabola, but in the ellipse; and, in the hyperbola, the radius of curvature at the vertices is half the parameter, which passes through the focus. In the parabola, the parameter is a third proportional to the abscissa and ordinate; and in the ellipse and hyperbola, the parameter is a third proportional to the transverse and conjugate axis; and therefore may be easily found by lines or by calculation on large works, such as bridges, &c.



## SECTION III.

## OF THE POSITIONS OF LINES AND PLANES, AND THE PROPERTIES ARISING FROM THEIR INTERSECTIONS.

A plane is a surface in which a straight line may coincide in all directions.

A straight line is in a plane when it has two points in common with that plane.

Two straight lines which cut each other in space, or would intersect, if produced are in the same plane; and two lines that are parallel, are also in the same plane.

Three points given in space, and not in a straight, are necessary and sufficient for determining the position of a plane. Hence two planes which have three points common, coincide with each other.

The intersection of two planes is a straight line.

*Plate III.* When two planes ABCD, ABFE, *fig. 1*, intersect, they form between them a certain angle, which is called the inclination of the two planes, and which is measured by the angle contained by two lines; one drawn in each of the planes perpendicular to their line of common section.

Thus, if the line AF, in the plane ABFE, be perpendicular to AB, and the line AD, in the plane ABCD, be perpendicular also to AB, then the angle FAD is the measure of the inclination of the planes ABFE, ABCD. When the angle FAD is a right angle, the two planes are perpendicular.

*Fig. 2.* A line AB, is perpendicular to a plane PQ when the line AB is perpendicular to any line BC in the plane PQ, which passes through the point B, where the line meets the plane. The point B is called the foot of the perpendicular.

A line AB, *fig. 3*, is parallel to a plane PQ, when the line AB is parallel to another straight line CD, in the plane PQ.

If a straight line have one of its intermediate points in common with a plane, the whole line will be in the plane.

Fig. 1.

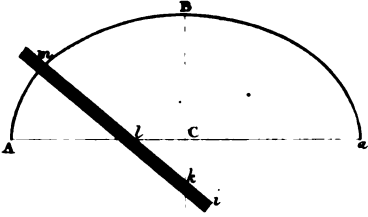


Fig. 2.

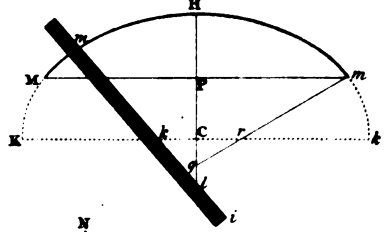


Fig. 3.

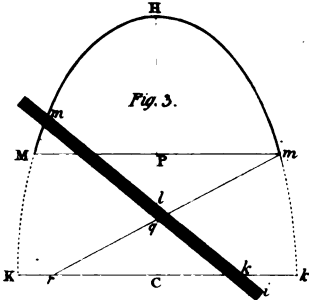


Fig. 6.

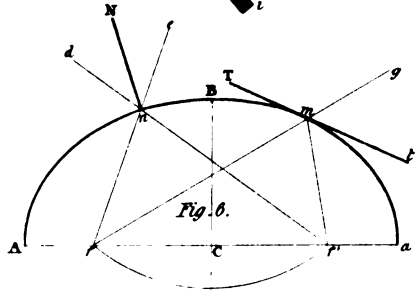


Fig. 4.

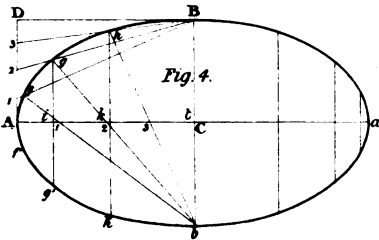


Fig. 5.

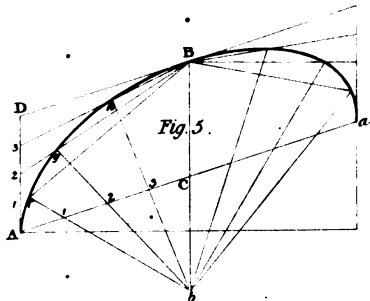


Fig. 7.

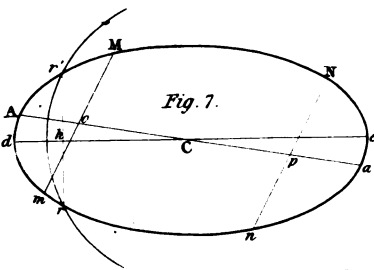


Fig. 8.

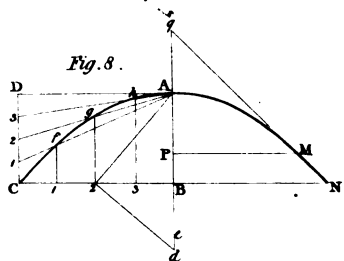
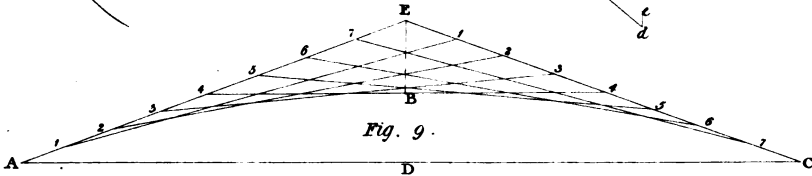
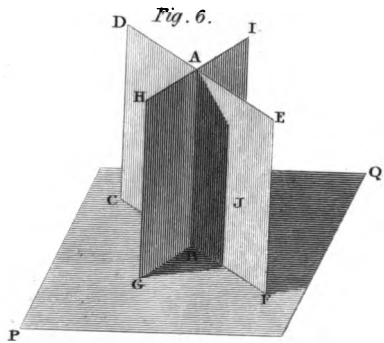
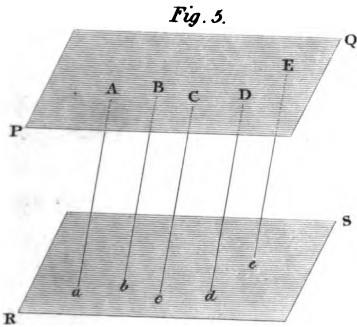
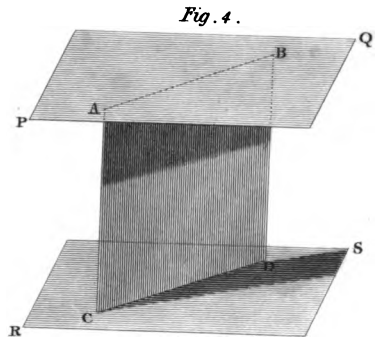
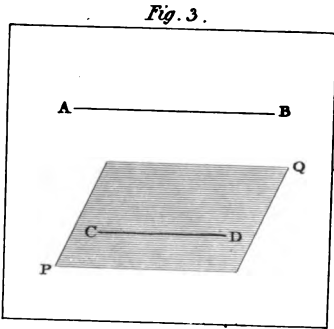
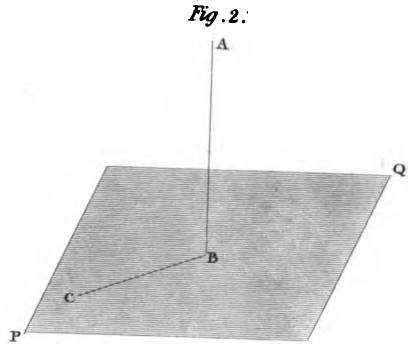
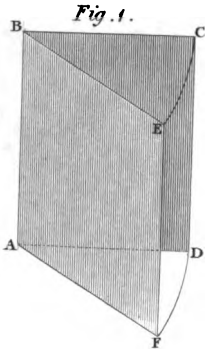
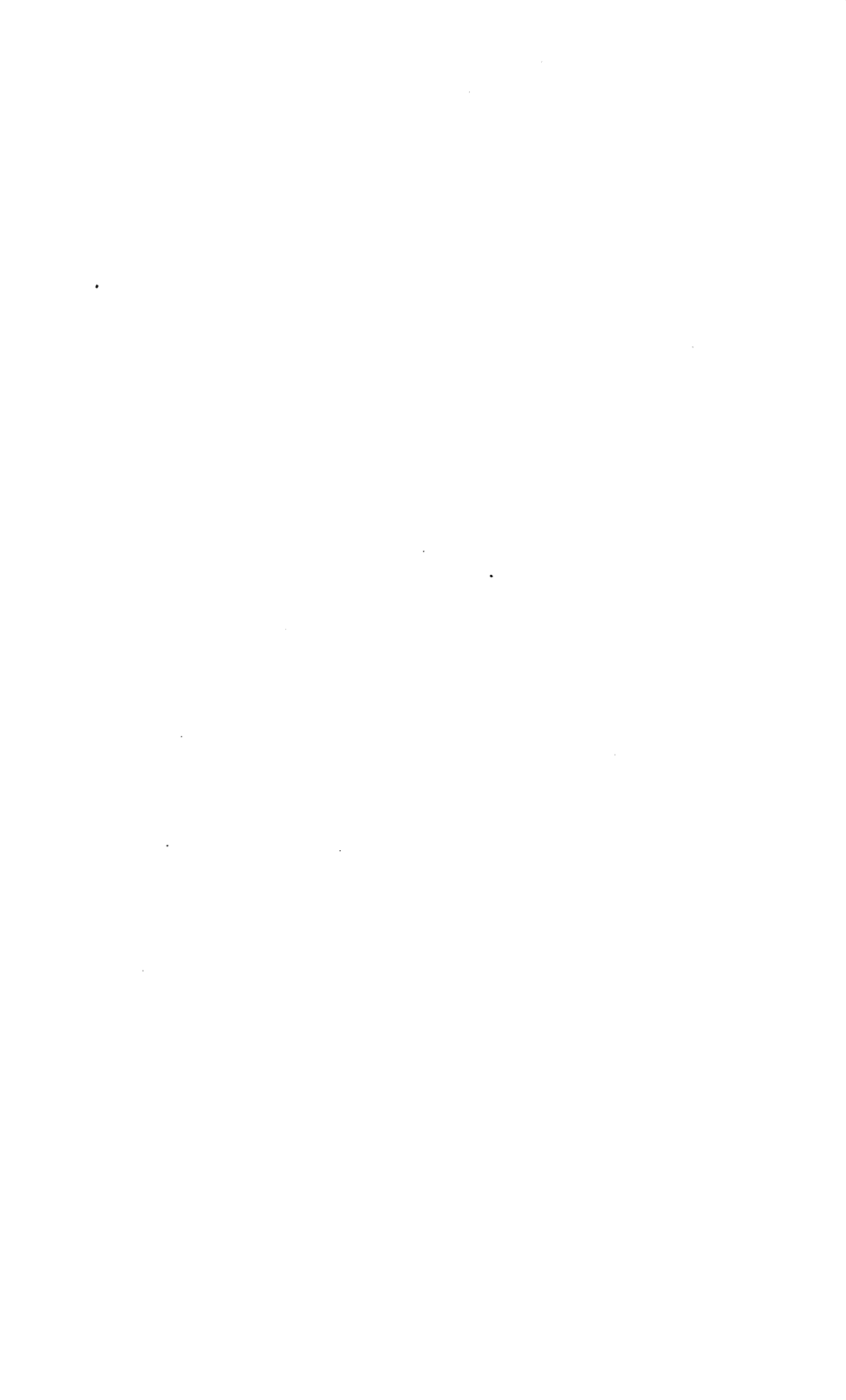


Fig. 9.









Two planes are parallel to one another when they cannot intersect in any direction.

The intersections of two parallel planes with a third are parallel. Thus in *fig. 4*, the lines *AB*, *CD* comprehended by the parallel plane *PQ*, *RS* are parallel.

Any number of parallel lines comprised between two parallel planes, are all equal. Thus the parallel lines *Aa*, *Bb*, *Cc*, . . . . , comprised by the parallel planes *PQ*, *RS* are all equal.

If two planes *CDEF*, *GHIJ*, *fig. 6*, are perpendicular to a third plane *PQ*, their intersection *AB* will be perpendicular to the third plane *PQ*.

If two straight lines be cut by several parallel planes, these straight lines will be divided in the same proportion.

---

#### SECTION IV.

##### OF THE RIGHT SECTIONS OF ARCHES OR VAULTS.

###### PROBLEM I.

To describe the arc of a circle which shall have a given tangent at a given point, and which shall touch another given arc.

*Plate IV.* Let *Bk*, *fig. 1*, be one of the given arcs, and *lau* the other, and let it be required to describe the arc of a circle, which shall touch the arc *Bk*, in the point *k*, and the arc *lau* in some point to be found; let *g* be the centre of the arc *Bk*.

Draw *gk*, and make *kp* equal to the radius of the circle *lau*. Draw a straight line from *p* to *q*, the centre of the arc *lau*, and bisect *pq*, by a perpendicular, meeting *kg* in *m*. Join the points *m*, *q*, and prolong *mq* to *l*. It is manifest that *mk* and *ml* are equal; therefore, from *m* with the radius *mk* or *ml* describe an arc *kl*; then *kl* will be the arc required.

###### PROBLEM II.

To describe an oval, representing an ellipse, to any given dimensions of length and breadth, given in position.

Let *Aa*, *Bb*, *fig. 2*, be the two given lines bisecting each other in *C*; *Aa* being equal to the length, and *Bb* to the breadth.

Find a third proportional to this semi-axis  $Ca$ ,  $CB$ ,\* and make  $ah$  equal to the third proportional; also find a third proportional to  $CB$ ,  $Ca$ ,† and make  $Bg$  equal to the third proportional.

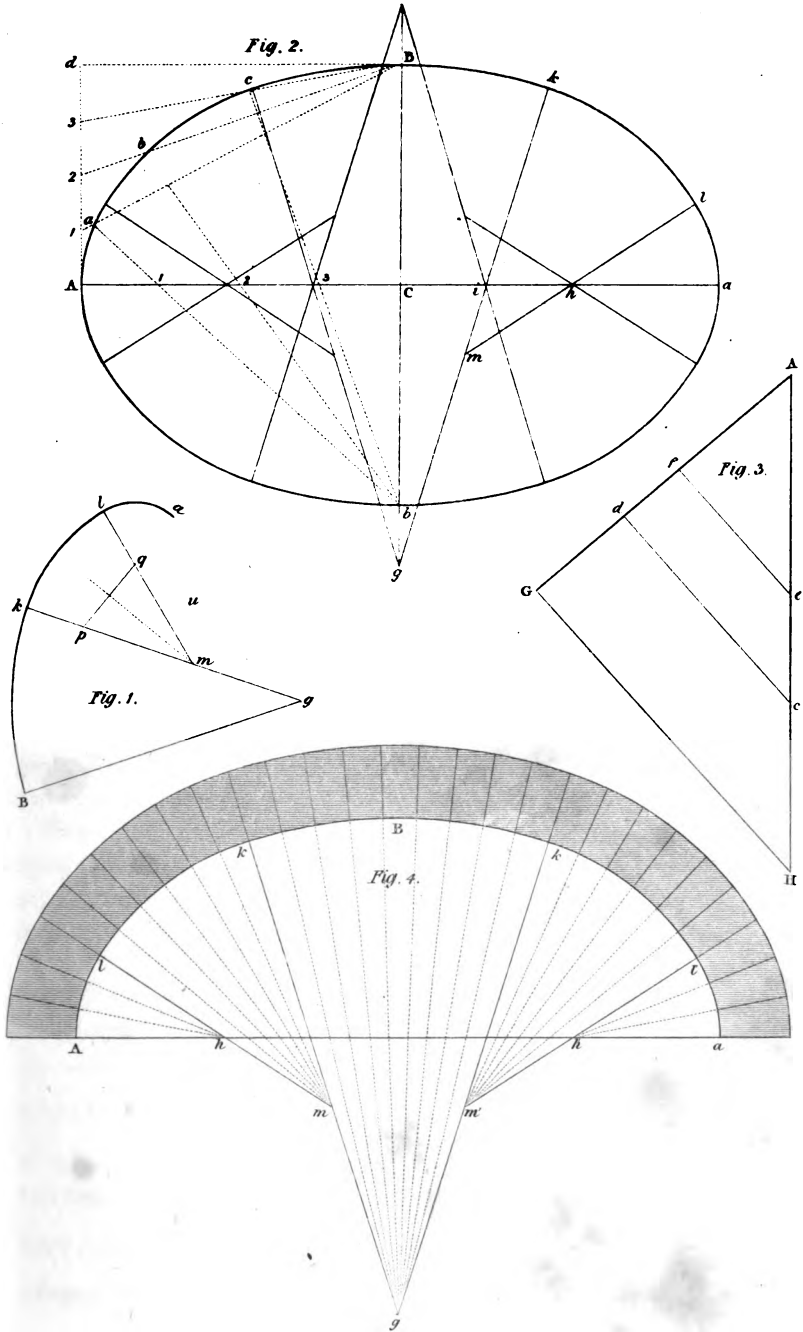
Make the angle  $Bgk$  equal to about  $15^\circ$ , and let  $gk$  meet  $Aa$  in the point  $i$ . From  $g$  with the radius  $gB$ , describe an arc  $Bk$ ,‡ and from  $h$  with the radius  $ha$ , describe an arc  $la$ . Describe the arc  $kl$  by the pre-

\* Thus in *fig. 3*, draw the two lines  $GA$ ,  $AH$  making any angle with each other; make  $ac$  equal to  $aC$ , *fig. 2*, and  $Ad$  equal to  $CB$ , *fig. 2*, and make  $Ae$  equal to  $Ad$ . Join  $cd$ , and draw  $ef$  parallel to  $cd$ ; then  $af$  is the third proportional.

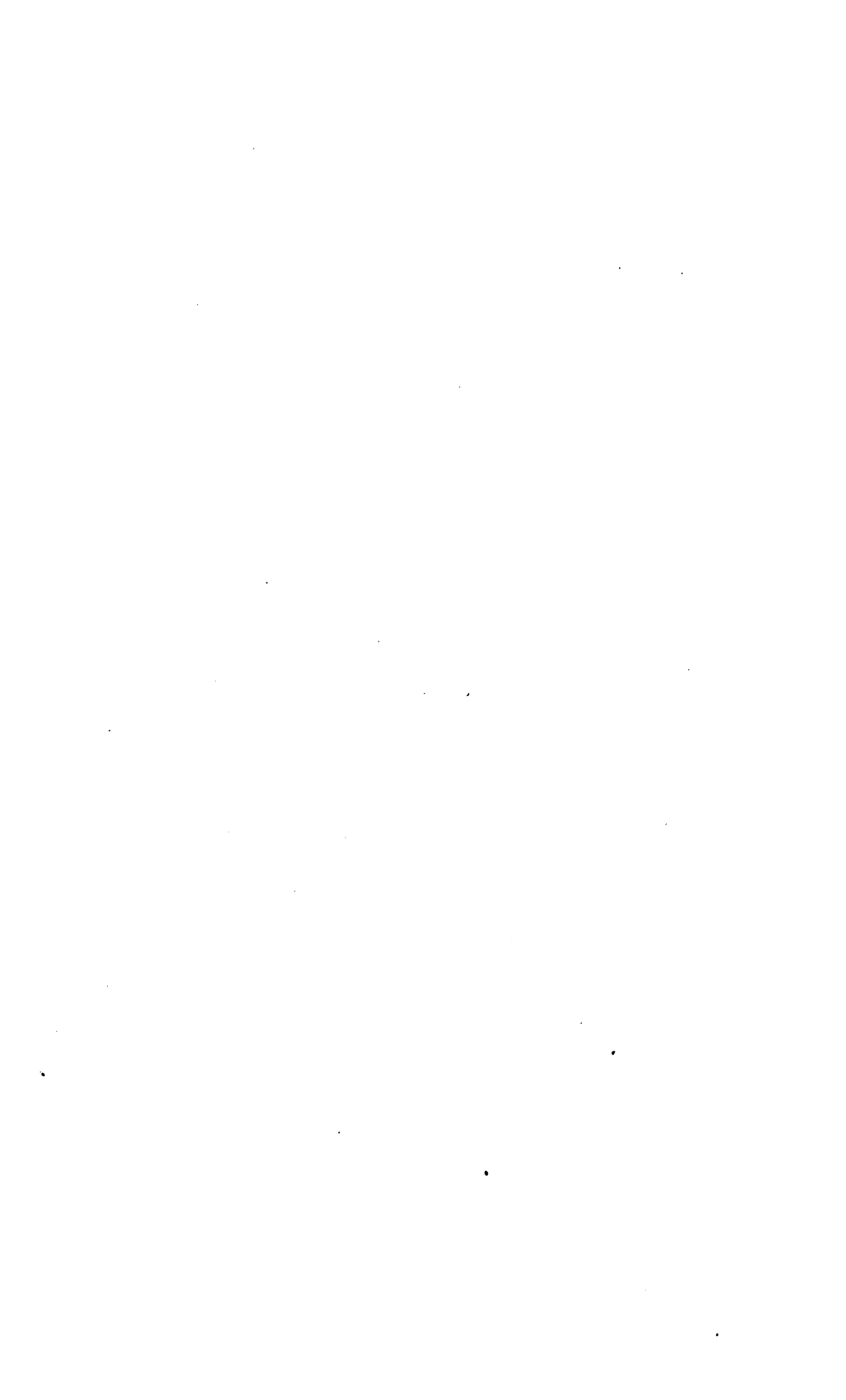
† That is in *fig. 3*, make  $Ac$  equal to  $AG$ , or  $aC$  *fig. 2*, and  $Ad$  equal to  $CB$  or  $Cb$ , *fig. 2*, and make  $AG$  equal to  $Ac$  and join  $cd$ . Draw  $GH$  parallel to  $dc$ ; then  $AH$  is the third proportional.

‡ Mathematicians have demonstrated that in all the conic sections, the radius of curvature is equal to the cube of the normal, divided by one-fourth of the square of the parameter, and that this radius at either extremity of the axis major, is half the parameter, which passes through the focus; and, moreover, that the radius of curvature at either extremity of the axis minor, is half the parameter to this axis. Now the focal semi-parameter is a third proportional to the semi-axis major and the semi-axis minor, and the parameter of the axis minor is a third proportional to the semi-axis minor and the semi-axis major. These parameters are found geometrically, as in *fig. 3*, or they may easily be found by calculations, by finding the normal from this formula. Thus, if  $n$  represent the normal,  $a$  the semi-axis major, and  $b$  the semi-axis minor,  $x$  the abscissa from the centre, and  $y$  the ordinate as usual, then  $n = \frac{b}{a}$

$\sqrt{\{a^4 - (a^2 - b^2)x^2\}}$  and if  $R$  represent the radius of curvature, then  $R = \frac{n^3}{\frac{1}{4}p^2}$ ; by making  $x = 0$  the expression for the value of the normal would become simply  $b$  or  $n = b$ ; therefore the radius of curvature at either extremity of axis minor would be  $\frac{b^3}{\frac{1}{4}p^2}$ ; and if  $x = a$  we should then have  $n = \frac{b^3}{a}$ ; but  $a : b :: b : \frac{1}{2}p$ , hence  $\frac{1}{2}p = \frac{b^2}{a}$ , or  $\frac{1}{4}p^2 = \frac{b^4}{a^2}$  whence  $R = \frac{a^2}{b}$ ; therefore the radius of curvature at either extremity of the axis minor, is a third proportional to the semi-axis major and the semi-axis minor. Again, if  $x = a$ , the equation  $n = \frac{b}{a^2} \sqrt{\{a^4 - (a^2 - b^2)x^2\}}$







ceding problem to touch the arc  $Bk$  in  $k$ , and to touch the arc  $al$  at  $l$ , and thus one quarter of the oval will be completed; the other three will be found by placing the centres in their proper positions.

Three or more points  $a, b, c$  might easily have been found in the curve. Thus draw  $Ad$  parallel to  $Bb$ , and  $Bd$  parallel to  $CA$ . Divide  $Ad$  into four equal parts, and divide  $AC$  also into four equal parts at 1, 2, 3. From  $b$  and through 1, 2, 3 in  $CA$ , draw  $ba, bb, bc$ , and from the points 1, 2, 3 in  $Ad$ , draw lines towards  $B$ , to intersect the former in  $a, b, c$ , so that we may find the radius of curvature upon the sides, and at the two ends, by finding the centre of a circle passing through three points at each extremity, the extremity being the middle point.

*Fig. 4* exhibits the use of this method of describing an oval, in finding the direction of the joints of arches, so as to agree with the normals drawn from the several divisions of the inner arc. The arcs are marked the same as in figure 2.

### PROBLEM III.

To describe a Gothic isosceles arch to any width, height, and to a given vertical angle.

*Plate V.* Let  $AB$ , *fig. 1*, be the span or width of the arch,  $mC$  perpendicular to  $AB$ , from the middle point  $m$  the height, and  $eCf$  the vertical angle given by the tangents  $Ce$  and  $Cf$ , making equal angles with the line of height  $mC$ .

In this example, the points  $e$  and  $f$ , the lower extremities of the tangents, are regulated by erecting  $Ae$  and  $Bf$ , each perpendicular to  $AB$ , and making each equal to  $\frac{3}{4}$  of the height line  $mC$ .

From the point  $A$ , towards  $B$ , make  $Ak$  equal to  $Ae$  or  $Bf$ , that is, equal to  $\frac{3}{4}$  of  $mC$ ; and from the point  $C$ , the vortex of the arch, draw  $Ci$  perpendicular to  $Ce$ . In  $Ci$  take  $Cl$ , equal to  $Ak$ , and join  $kl$ ; bisect  $kl$  by a perpendicular,  $di$  meeting  $Ci$  in the point  $i$ ; join  $ik$ , and produce  $ik$  to  $q$ .

From the point  $i$ , with the radius  $iC$ , describe an arc  $Cg$ , meeting the line  $iq$  in the point  $g$ , and from the point  $k$ , with the radius  $kg$ , describe

would become  $n = \frac{b^2}{a}$ ; hence  $R = \frac{n^3}{\frac{1}{4}p^2} = \frac{b^2}{a}$ , hence the radius of curvature at either extremity of the axis major, is a third proportional to the semi-axis major and the semi-axis minor; the geometrical magnitude for  $R$  when equal to  $\frac{a^2}{b}$ , and when equal to  $\frac{b^2}{a}$ , have been found by the construction of figure 3.

an arc  $gA$ , and  $AgC$  will be one-half of the intrados of the Gothic arch required.

Produce  $Cm$  to meet  $ki$  in the point  $n$ , and in  $AB$  make  $mu$  equal to  $mk$ . Join  $nu$ , and prolong  $nu$  to  $t$  and  $un$  to  $o$ . Make  $no$  equal to  $ni$ . From the centre  $o$ , with the radius  $oC$ , describe the arc  $Ch$ , meeting  $ut$  in the point  $h$ , and from  $u$ , with the radius  $uh$ , describe the arc  $hB$ , and  $BhC$  will be the other half of the intrados.

Upon  $AB$ , prolonged both ways to  $p$  and  $s$ , make  $Ap$  and  $Bs$  each equal to the length of each one of the arch stones, in a direction of the radius.

From the point  $k$ , as a centre with the radius  $kp$ , describe the arc  $pq$ ; and from the point  $i$ , with the radius  $iq$ , describe the arc  $qr$ , and  $pqr$  will be half of the extrados of the arch.

In the same manner will be found  $str$ , the other half of the extrados.

The arch-stones are divided upon the dotted line in the middle into equal parts, and the joint lines are drawn by the centres of the intrados and extrados of the arch.

#### REMARK.

When the height of the arch is equal to, or greater than half the span, and when it is not necessary that the vertical angle should be given, the curves of the intrados and extrados on the one side may be described from the same centre, as also those of the other side from another centre.

The most easy Gothic arch to describe is that of which the height of the intrados is such as to be the perpendicular of an equilateral triangle, described upon the spanning line as a base, such is *fig. 2*, and these centres are the points to which the radiating joints must tend.

Gothic arches seldom exceed in height the perpendicular of the equilateral triangle inscribed in the intrados of the aperture; but when the arch is surmounted, and the height less than the perpendicular of the equilateral triangle made upon the base, draw a straight line from one extremity of the base to the vertex, and bisect this line by a perpendicular. From the point where the perpendicular meets the base of the arch, and with a radius equal to the distance between this point and the extremity of the base joined to the vertex, describe an arc between the two points, joined by the straight line, and the curve which forms one side of the intrados will be complete. In the same manner will be found the curve on the other side, see *fig. 3*, so that by only two centres the whole of the intrados will be formed.

The curves of all kinds of Gothic arches whatever may be described by means of conic parabola, to a given vertical angle, and to any given

dimensions. Thus in *fig. 4*, let *Ce*, *Cf*, be the two tangents and *Ae*, and *Bf* the heights of their extremities. Divide *Ae* and *eC* each into the same number of equal parts by the points 1, 2, 3, in each of these lines. Draw lines from the corresponding points 1-1, 2-2, 3-3, &c. ; and the intersections will form the curve of one side of the intrados, as we have already seen. The curve on the other side will be formed in the same manner.

Join *BC*, and bisect it in *g* and join *gt*, intersecting the curve in *l*. Draw *hk* parallel to *CB*, meeting *gf* in *k*. Make *li* equal to *lk*, and *ih* joined is a tangent at *h*. Hence, *hm* perpendicular to *hi*, is the joint.

## SECTION V.

ON THE NATURE AND CONSTRUCTION OF TRE-  
HEDRALS.

## DEFINITIONS.

Every stone bounded by six quadrilateral planes or faces forms a solid, of which the surfaces terminate on eight points, every three surfaces in one point. Every three planes thus terminating is termed a *solid angle* or *trehedral*.

The angles formed by the intersections of the faces with one another, or the three plane angles, are called sides of the trehedral, and the angles of inclination are called, by way of distinction from the other, simply *angles*.

The three sides, as well as the three angles, are each called a *part*; so that the whole trehedral consists of six parts; and if any three of these parts be given, the remaining three can be found.

Therefore, in bodies constructed of stone, which are intended to have their solid angles to consist of three plane angles, the construction of such bodies may be reduced to the consideration of the trehedral.

As to the remaining surface of the solid which incloses the solid, completely making a fourth side to the trehedral,

it may be of any form whatever, regular or irregular, or consisting of many surfaces: it or they have nothing to do in the construction.

The parts of the trehedral, which may be obtained from three given parts, are the very same as three parts found in a spherical triangle from three given parts. This is, in fact, the same as spherical trigonometry.

We shall not, however, enter into any operose analytical investigations, but treat the subject in the most simple manner, according to the rules of solid geometry; and only those trehedrals, which have two of their planes at a right angle with each other, (though there are many cases in which the oblique trehedral would be necessary); as the bounds prescribed for this work will not admit of such an extension of the principles.

If the trehedral have two of its planes perpendicular to each other, it is called a *right angled trehedral*; each of the two faces thus forming a right angle, is called a *leg*, and the remaining side joining each leg, is called the *hypotenuse*.

#### PROBLEM I.

Given two legs of a right angled trehedral to find the hypotenuse.

*Plate VI., figs. 1, 2, 3, 4.* Let  $PON$  and  $POR$  be the given legs. Draw  $PR$  perpendicular to  $OP$ , and  $PQ$  perpendicular to  $ON$ . From  $O$ , as a centre with the radius  $OR$ , describe an arc intersecting  $PQ$  in  $Q$ , and join  $OQ$ , and  $QON$  is the hypotenuse required.

*Demonstration.*—Suppose the triangle  $POR$  revolved upon  $OP$ , until  $PR$  become perpendicular to the plane of the triangle  $OPN$ , then the plane of the triangle  $OPR$  will be perpendicular to the plane of the triangle  $OPN$ .

Again, suppose the triangle  $ONQ$  to revolve upon  $ON$ , and let  $PQ$ , or  $PQ$  produced intersect  $ON$  in  $m$ , then  $mQ$  will always be in a plane passing through  $Pm$ , and the plane described by  $mQ$  will be perpendicular to the plane  $mOP$ ; and as  $PR$  is, by supposition, also perpendi-





cular to the plane  $mOP$ , therefore  $PR$  and  $mQ$  being thus situated in the same plane will meet, except they are parallel.

Let  $mQ$  therefore be revolved until the straight line  $mQ$  fall upon the point  $R$ ; let  $Q$  then be supposed to coincide with  $R$ ; then because  $Q$ , by supposition, coincides with  $R$ , and the point  $O$  is common to the straight lines  $OQ$  and  $OR$ , therefore the straight lines  $OQ$  and  $OR$  having two common points will coincide, and therefore  $mOQ$  will be the hypotenuse required.

#### PROBLEM II.

Given the hypotenuse, and one of the legs to find the other leg.

*Figs. 1, 2, 3, 4.* Let  $NOQ$  be the given hypotenuse and  $NOP$  the given leg, and let these two parts be attached to each other by the straight line  $ON$ .

In  $ON$  take any point  $m$ , and through  $m$  draw  $PQ$  perpendicular to  $ON$ . Draw  $PR$  perpendicular to  $OP$ . From the point  $O$ , with the radius  $OQ$ , describe an arc  $QR$  and join  $OR$ ; then will  $POR$  be the other leg, as required.

These four diagrams show the various positions in which the data may be placed: every one will frequently occur in practice.

#### PROBLEM III.

Given the two legs of a right-angled trehedral to find one of the angles at the hypotenuse.

*Figs. 5, 6.* Let the two given legs be  $PON$  and  $POR$ . In  $OP$  take any point  $P$ , and draw  $PN$  perpendicular to  $ON$ , and  $PR$  perpendicular to  $PO$ , and  $PK$  parallel to  $ON$ . Make  $PK$  equal to  $PR$ , and join  $NK$ ; then  $PNK$  will be the angle at the hypotenuse.

In *fig. 5*, the two legs lie upon separate parts; and in *fig. 6*, one of the legs lies upon the other.

*Fig. 7* exhibits the same principle applied in finding a series of bevels or angles made by the hypotenuse and a leg. Thus let the two legs be  $PON$  and  $POR$ . From any point  $m$  in  $OP$  draw  $mR$  perpendicular to  $OP$ . On  $Om$ , as a diameter, describe the semicircle  $Oqm$ , intersecting  $ON$  in  $q$ , and join  $qm$ . Make  $mr$  equal to  $mq$ , and join  $rR$ ; then  $PrR$  will be the angle required.

#### PROBLEM IV.

Given one of the legs and the inclination of the hypotenuse to that leg, to find the other leg.



*Figs. 8 and 9.* Let  $NOP$  be the given leg. In  $ON$  take any point  $m$ , and draw  $mi$  perpendicular to  $ON$ . Make  $imp$ , equal to the angle which the leg  $NOP$  makes with the hypotenuse. Through any point  $i$ , in  $mi$ , draw  $Pp$  parallel to  $ON$ , and  $PQ$ , perpendicular to  $OP$ . Make  $PQ$ , equal to  $ip$ , and join  $OQ$ , and  $QOP$  will be the other leg.

#### PROBLEM V.

Given one of the legs and the angle which the hypotenuse forms with that leg to find the hypotenuse.

*Fig. 10 and 11.* In  $NO$ , take any point  $m$ , and draw  $mn$  perpendicular to  $ON$ . Make  $nmp$  equal to the angle which the hypotenuse makes with the leg  $NOP$ . From the point  $m$  as a centre with any radius,  $mn$  describe an arc  $np$ . Draw  $pP$ ,  $nQ$  parallel to  $NO$ , and  $PQ$  perpendicular to  $NO$ , and join  $OQ$ ; then  $NOQ$  is the hypotenuse required.

#### *General applications of the Trehedral to Tangent Planes.*

##### EXAMPLE I.

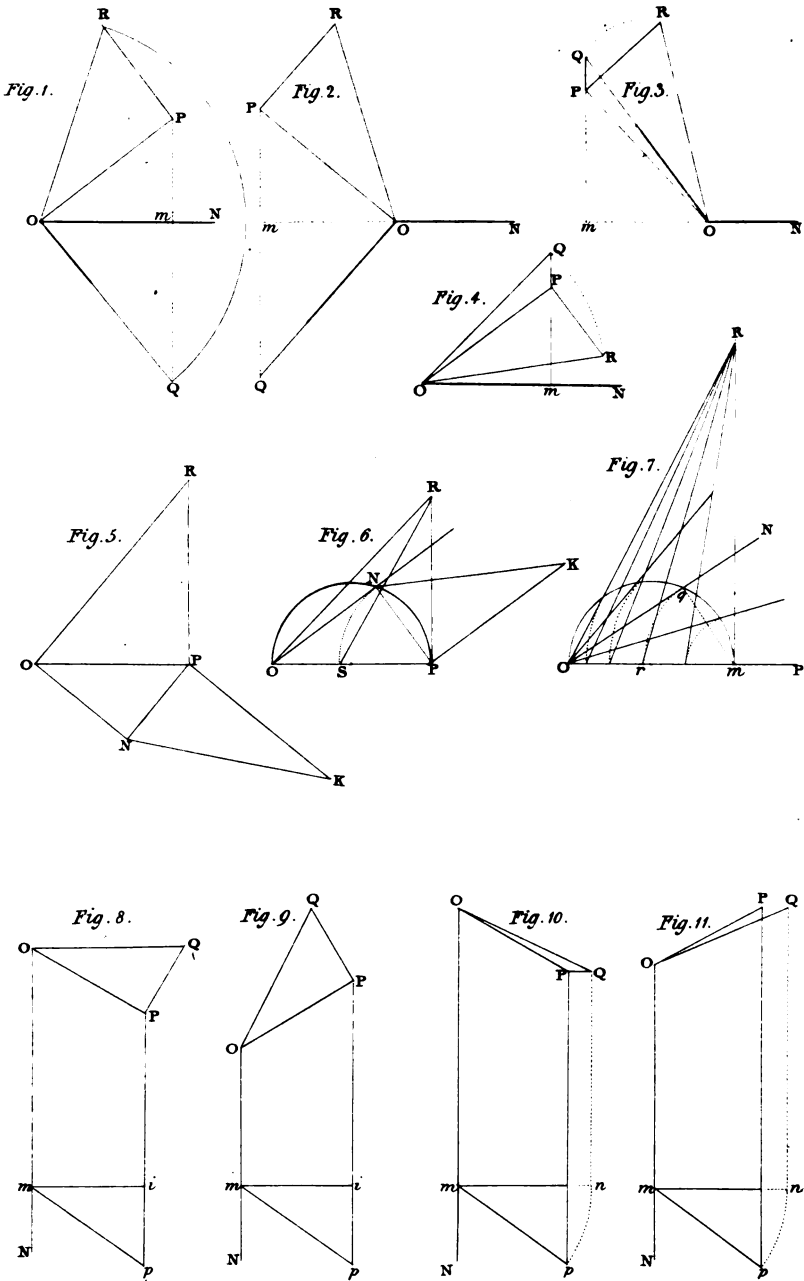
Given the inclination and seat of the axis of an oblique cylinder or cylindroid, to find the angle which a tangent makes at any point in the circumference of the base, with the plane of the base.

*Figs. 1, 3, Plate VII.* Let  $AEBO$  be the base of the cylinder or cylindroid,  $CB$  the seat of the axis, and let  $BCD$  be the angle of inclination, and let  $O$  be the point where the tangent plane touches the curved surface of the solid.

Draw  $ON$  a tangent line at the point  $O$  in the base, and draw  $OP$  parallel to  $CB$ . Make the angle  $POR$  equal to  $BCD$ , and draw  $PR$  perpendicular to  $PO$ .

Then, if the triangle  $POR$  be conceived to be revolved round the line  $PO$  as an axis, until its plane become perpendicular to the plane of the circle  $AEBC$ , the straight  $OR$  will, in this position, coincide with the cylindrical surface, and a plane touching the cylinder or cylindroid at  $O$ , will pass through the lines  $ON$  and  $OR$ . Here will now be given the two legs  $POR$  and  $PON$  of a right angled trehedral to find the angle which the hypotenuse makes with the base. Draw  $PQ$  perpendicular to  $ON$ , intersecting it in  $m$ , and draw  $PS$  perpendicular to  $PQ$ . Make  $PS$  equal to  $PR$ , and join  $mS$ ; then  $PmS$  is the angle required.

The hypotenuse will be easily constructed at the same time, thus—





make  $mQ$ , equal to  $mS$ , and join  $OQ$ , then  $NOQ$  will be the hypotenuse required.

In *fig. 1*, the method of finding the angle which the tangent plane makes with the base and the hypotenuse is exhibited at four different points. In the two first points  $O$  from  $A$  in the first quadrant, the tangent planes make an acute angle at each point  $O$ ; but in the second quadrant, they make an obtuse angle at each point  $O$ .

*Fig. 2* is the second position of the construction from the point  $A$ , for finding the angle which the tangent plane makes with the base, and for finding the hypotenuse enlarged; in order to show a more convenient method by not only requiring less space, but less labour. It may be thus described, the two given legs being  $P'O'R'$  and  $P'O'N'$ .

Draw  $P'm'$  perpendicular to  $O'N'$ , meeting  $ON$  in  $m'$ . In  $P'O'$ , make  $P'v'$  equal to  $P'm'$ , and draw the straight line  $v'R'$ , then  $P'v'R'$  will be the inclination of the tangent plane at the point  $O$ .

Again in  $O'P'$ , make  $O't'$  equal to  $O'm'$ , and draw  $t'u'$  parallel to  $PR'$ . From  $O'$ , with the radius  $O'R'$ , describe an arc meeting  $t'u'$  in  $u'$ , and draw the straight line  $O'u'$ ; then  $t'O'u'$  is the hypotenuse.

For since  $P'S'$  is equal to  $PR'$ , and  $P'v'$  equal to  $P'm'$ , and the angles  $m'P'S'$ , and  $v'P'R'$ , are right angles; therefore the triangle  $v'P'R'$ , is equal to the triangle  $m'P'S'$ , and the remaining angles of the one, equal to the remaining angles of the other, each to each; hence the angle  $P'v'R'$  is equal to the angle  $P'm'S'$ .

Again, because  $O't'$  is equal to  $O'm'$ , and  $O'Q'$  is equal to  $O'R'$ , and  $O'u'$  is also equal to  $O'R'$ ; therefore  $O'u'$  is equal to  $O'Q'$ , and since the angles  $O't'u'$  and  $O'm'Q'$  are each a right angle, therefore the two right angled triangles have their hypotenuses equal to each other, and have also one leg in each, equal to each other; therefore the remaining side of the one triangle is equal to the remaining side of the other, and therefore also the angles which are opposite to the equal sides are equal; hence the angle  $P'O'u'$  is equal to  $N'O'Q'$ .

By considering this construction by the transposition of the triangles, the whole of the angles which the tangent planes make at a series of points  $O$  in figures 1 and 3, and their hypotenuses may be all found in one diagram, as in figure 4.

Thus, in *fig. 4*, if the angles  $ACO$ ,  $ACO'$ ,  $ACO''$ ,  $ACO'''$ , be respectively equal to  $ACO$ ,  $ACO'$ ,  $ACO''$ ,  $ACO'''$ , *fig. 1*, and in *fig. 4*, the semicircle  $AO'B$  be described, and if  $CD$  be drawn perpendicular to  $AB$ , and the angles  $CAD$ ,  $CBD$ , be made equal to  $BCD$ , *fig. 1*; then each half of *fig. 4*, being constructed as in *fig. 2*; the angles at  $m$ ,  $m'$ ,

$m''$ ,  $m'''$ , will be respectively equal to the angles  $PmS$ ,  $P'm'S'$ ,  $Q''m''S''$ ,  $Q''m'''S'''$ , in *fig. 1*.

Also, in *fig. 4*, the angles  $CAE$ ,  $CAG$ ,  $CAh$ ,  $CBi$ ,  $CBk$ ,  $CBF$  will be the hypotenuses at the point  $A$ ,  $O$ ,  $O'$ ,  $O''$ ,  $O'''$ ,  $B$  in *fig. 1*.

We may here observe, *fig. 1*, that the angles which the tangent planes make with the plane of the base in the first quadrant are acute; and those in the second quadrant are obtuse; and those in the second quadrant are the supplements of the angles  $PmS$ ; and, moreover, that all the angles which constitute the hypotenuses of the trehedral, are all acute, whether in the first quadrant or second quadrant of the semi-circle  $AOB$ .

---

## SECTION VI.

### ON THE PROJECTION OF A STRAIGHT LINE BENT UPON A CYLINDRIC SURFACE, AND THE METHOD OF DRAWING A TANGENT TO SUCH A PROJECTION.

#### PROBLEM I.

Given the developement of the surface of the semi-cylinder, and a straight line in that developement, to find the projection of the straight on a plane passing through the axis of the cylinder, supposing the developement to encase the semi-cylindric surface.

*Fig. 5.* Let  $ABC$  be the developement of the cylindric surface,  $BC$  being the developement of the semi-circumference, and let  $AC$  be the straight line given.

Produce  $CB$  to  $D$ , making  $BD$  equal to the diameter of the cylinder. On  $BD$ , as a diameter, describe the semicircle  $BED$ , and divide the semicircular arc  $BED$ , into any number of equal parts, at 1, 2, 3, &c.; and its developement  $BC$  into the same number of equal parts, at the points  $f, g, h$ , &c. Draw the straight lines  $fk, gl, hm$ , &c. parallel to  $BA$ , meeting  $AC$  at the points  $k, l, m$ , &c.; also parallel to  $BA$ , draw the straight lines  $1o, 2p, 3q$ , &c. and draw  $ko, lp, mq$ , &c. parallel to  $CD$ ; and the points  $o, p, q$ , &c. are the projections or seats of the points  $k, l, m$ , &c. in the developement of the straight line  $AC$ .

The projection of a screw is found by this method:  $BD$  may be considered as the diameter of the cylinder from which the screw is formed;

and the angle  $BAC$ , the inclination of the thread with a straight line on the surface; or  $BCA$  the inclination of the thread with the end of the cylinder. The same principle also applies to the delineations of the hand-rails of stairs, and in the construction of bevel bridges, of which we shall treat in a subsequent part of this work.

#### PROBLEM II.

Given the entire projection of a helix or screw, in the surface of a semi-cylinder, and the projection of a circle in that surface perpendicular to the axis, upon the plane passing through the axis, to draw a tangent to the curve at a given point.

*Fig. 6.* Let  $BPK$  be the projection of the helix or screw, and  $BA$  the projection of the circumference of a circle, and since this circle is in a plane perpendicular to the plane of projection, it will be projected into a straight line  $AB$ , equal to the diameter of the cylinder.

On  $AB$  as a diameter, describe the semicircle  $A\tau B$ , and draw  $P\tau$  perpendicular to, and intersecting  $AB$  in  $q$ , join the points  $e$ ,  $r$ , and produce  $er$  to  $f$ .

Produce  $AB$  to  $C$ , so that  $BC$  may be equal to the semicircular arc  $B\tau A$ . Draw  $CD$  perpendicular to  $BC$ , and make  $CD$  equal to  $AK$ , and draw the straight line  $BD$ ; then  $BD$  will be the development of the curve line  $BPK$ .

Draw  $Pu$  parallel to  $AC$ , meeting  $BD$  in  $u$ , and draw  $ut$  perpendicular to  $BC$ . Draw  $rg$  perpendicular to  $er$ , and make  $rg$  equal to  $Bt$ . Draw  $gn$  perpendicular to  $AC$ , meeting  $BC$  in  $n$ , and draw the straight line  $nP$ ; then  $nP$  will touch the curve at the point  $P$ .

Or the tangent may be drawn independent of  $BCD$  thus: Draw  $P\tau$  perpendicular to  $AB$ , and  $rg$  a tangent at  $r$ . Make  $rg$  equal to the development of  $\tau B$ , and draw  $gn$  perpendicular to  $BC'$ , meeting  $BC$  in  $n$ , and join  $nP$ , which is the tangent required.

## CHAPTER II.

THE GEOMETRY OF PLANS AND ELEVATIONS, ADAPTED  
TO THE CONSTRUCTION OF ARCHES AND VAULTS.

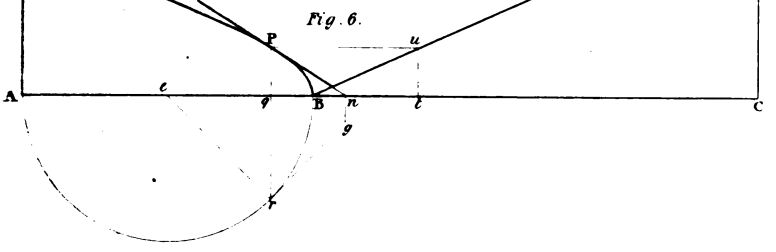
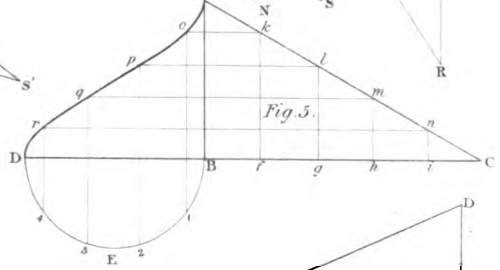
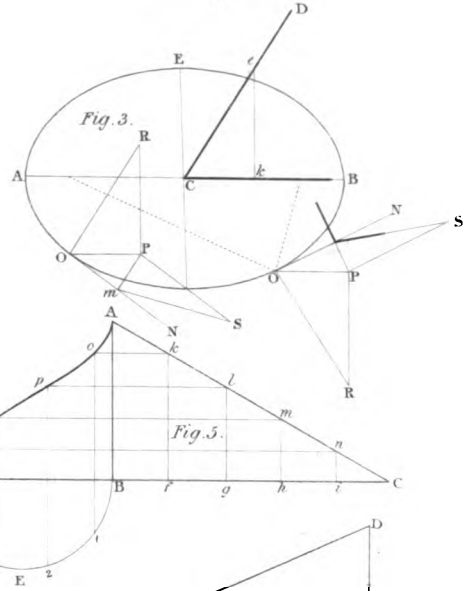
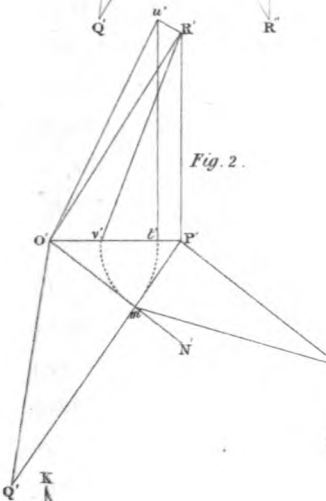
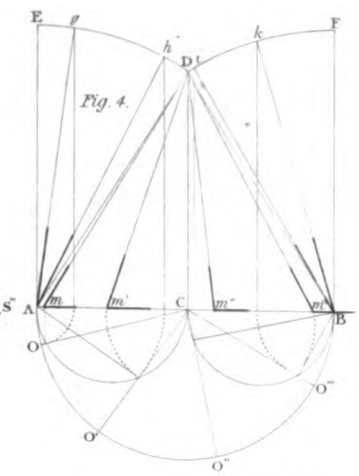
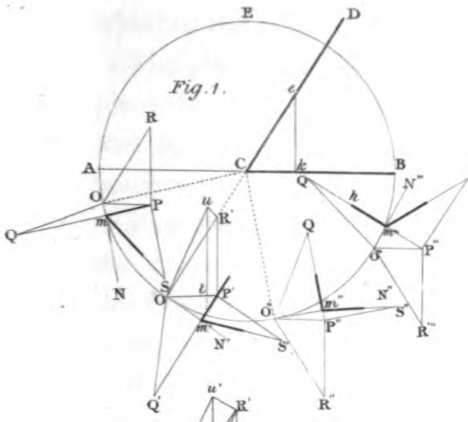
## SECTION I.

## PRELIMINARY PRINCIPLES OF PROJECTION.

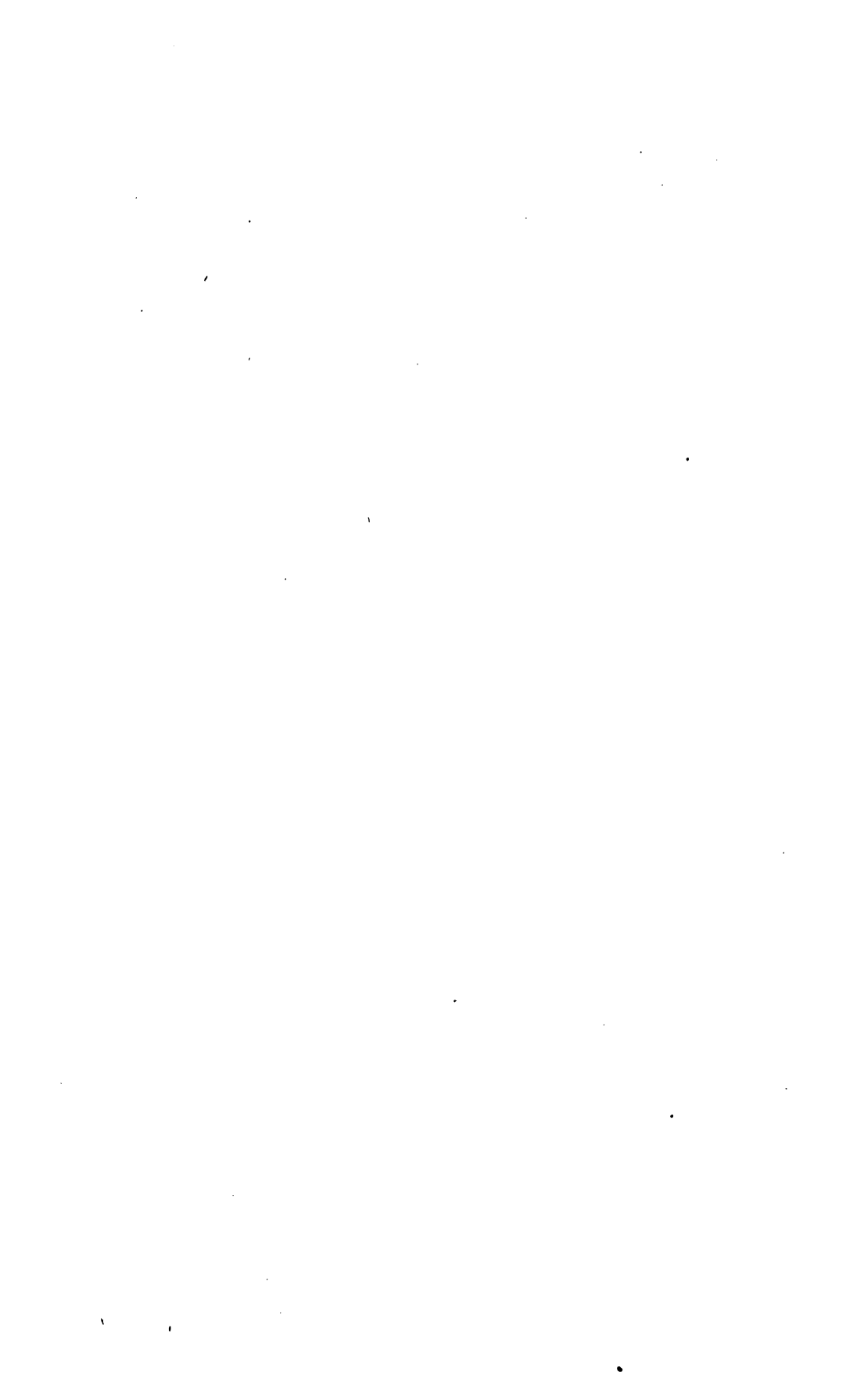
IF from a point  $A'$ , *fig. 1* in space, a perpendicular  $A'a$  be let fall to any plane  $PQ$  whatever, the foot  $a$  of this perpendicular is called the *projection* of the point  $A'$  upon the plane  $PQ$ .

If through different points  $A', B', C', D' \dots$  *figs. 2, 3, 4*, of any line  $A'B'C'D' \dots$  whatever in space, perpendiculars  $A'a, B'b, C'c, D'd, \dots$  be let fall upon any plane  $PQ$  whatever, and if through  $a, b, c, d, \dots$  the projections of the points  $A', B', C', D', \dots$  in the plane  $PQ$  a line be drawn, the line thus drawn will be the projection of the line  $A'B'C'D' \dots$  given in space.

If the line  $A'B'C'D' \dots$  *fig. 3*, be straight, the projection  $abcd \dots$  will also be a straight line; and if the line  $A'B'C'D' \dots$  *fig. 2*, be a curve not in plane perpendicular to the plane  $PQ$ , the curve  $abcd \dots$  which is the projection of the curve  $A'B'C'D' \dots$  in space, will be of the same species with the original curve, of which it is the projection. Hence, in this case, if the original curve  $A'B'C'D' \dots$  be an ellipse, a parabola, hyperbola, &c., the projection  $abcd \dots$  will be an ellipse, a parabola, an hy-







perbola, &c. The circle and the ellipse being of the same species, the projected curve may be a circle or ellipse, whether the original be a circle or ellipse, as in *fig. 4*.

The plane in which the projection of any point, line, or plane figure is situated, is called the plane of projection, and the point or line to be projected is called the primitive.

The projection of a curve will be a straight line when the curve to be projected is in a plane perpendicular to the plane of projection. Hence the projection of a plane curve is a straight line.

If a curve be situated in a plane which is parallel to the plane of projection, the projection of the curve will be another curve equal and similar to the curve of which it is the projection.

The projection upon a plane of any curve of double curvature whatever is always a curve line.

In order to fix the position and form of any line whatever in space, the position of the line is given to each of two planes which are perpendicular to each other; the one is called the horizontal plane and the other the vertical plane; the projection of the line in question is made on each of these two planes, and the two projections are called the two projections of the line to be projected.

Thus we see in *fig. 5*, where the parallelogram UVWX represents the horizontal plane, and the parallelogram UVYZ represents the vertical plane, the projection *ab* of the line A'B' in space upon the horizontal plane UVWX, is called the horizontal projection, and the projection AB of the same line upon the vertical plane UVYZ, is called the *vertical projection*.

The two planes, upon which we project any line whatever, are called the planes of projection.

The intersection  $UV$  of the two planes of projection, is called the ground line.

When we have two projections  $ab$ ,  $AB$  of any line  $A'B'$  in space, the line  $A'B'$  will be determined by erecting to the planes of projection the perpendiculars  $aA'$ ,  $bB'$ . . . . ,  $AA'$ ,  $BB'$ . . . . through the projections  $a$ ,  $b$ , . . . . ;  $A$ ,  $B$ , . . . . of the original points  $A'$ ,  $B'$ , . . . . of the line in question. For the perpendiculars  $aA'$ ,  $AA'$  erected from the projections  $a$ ,  $A$  of the same point  $A'$  will intersect each other in space in a point  $A'$ , which will be one of these in the line in question. It is clear that the other points must be found in the same manner as this which has now been done.

When we have obtained the two projections of a line in space, whether immediately from the line itself, or by any other means whatever, we must abandon this line in order to consider its two projections only. Since, when we design a working drawing, we operate only upon the two projections of this line that we have brought together upon one plane, and we no longer see any thing in space.

However, to conceive that which we design, it is absolutely necessary to carry by thought the operations into space from their projections. This is the most difficult part that a beginner has to surmount, particularly when he has to consider at the same time a great number of lines in various positions in space.

The perpendicular  $A'a$ , *fig. 5*, let fall from any point  $A'$  whatever in space upon the plane  $XV$  of projection, is called the projectant of the point  $A'$  upon this plane. Moreover, the perpendicular distance between the point  $A'$  and the horizontal plane  $XV$ , is called the projectant upon the horizontal plane, or simply the horizontal projectant; and the perpendicular distance  $A'A$  between the original point  $A'$  and the vertical plane  $UY$ , is called

the projectant upon the vertical plane, or simply the vertical projection.

We shall remark, so as to prevent any mistake, that the horizontal projectant  $A'a$ , is the perpendicular let fall from the original point upon the horizontal plane, and that the vertical projectant is the perpendicular let fall from that point upon the vertical plane. Hence the horizontal projectant is parallel to the vertical plane, and is equal to the distance between the original point and the horizontal plane; and the vertical projectant is parallel to the horizontal plane, and is equal to the distance between the original point and the vertical plane.

We may remark, that if through  $a$ , *fig. 6*, the horizontal projection of the point  $A'$  we draw a perpendicular  $aa$  to  $UV$  the ground line, this perpendicular  $aa$  will be equal to the measure of the vertical projectant  $A'A$ ; consequently the distance of the point  $A'$  to the vertical plane is equal to the distance between  $a$ , its horizontal projection, and  $UV$  the ground line measured in a perpendicular to  $UV$ . In like manner, if through  $A$ , the vertical projection of the point  $A'$ , we draw a perpendicular  $Aa$  to  $UV$  the ground line, this perpendicular  $Aa$  will be equal to the measure of the horizontal projectant  $Aa$ ; consequently, the distance of this point  $A'$  to the horizontal plane, is equal to the distance between  $A$  its vertical projection, and  $UV$  the ground line measured in a perpendicular to  $UV$ .

To these very important remarks we shall add one which is not less so. Two perpendiculars,  $aa$ , *fig. 6*,  $Aa$ , being let fall from the projections  $a$ ,  $A$  to the same point  $A'$ , upon the ground line  $UV$ , will meet each other in the same point  $a$ , of the said ground line  $UV$ .

If we now wished the two projections of a point  $A'$ , *fig. 6*, or of any line  $A'B'$  whatever be upon one or the same plane, it is sufficient to imagine the vertical

plane UVYZ to turn round the ground-line UV, in such a manner as to be the prolongation of the horizontal plane UVWX; for it is clear that this plane will carry with it the vertical projection A or AB of the point, or of the line in question. Moreover we see, and it is very important that the lines Aa, Bb, perpendicular to the ground-line UV will not cease to be so in the motion of the plane UVYZ; and as the corresponding lines aa, bb, are also perpendiculars to the ground-line UV, it follows that the lines aa', bb', will be the respective prolongation of the lines aa, bb.

Hence it results, when we consider objects upon a single plane, the projections *a*, A of a point A' in space are necessarily upon the same perpendicular Aa to the ground-line UV.

It is necessary to call to mind that the distance Aa measures the distance from the point in space to the horizontal plane, (the point A being the vertical projection of this point,) and that the line aa measures the distance from the same point in space to the vertical plane.

It follows, that if the point in space be upon the horizontal plane, its distance with regard to this last-named plane will be zero or nothing, and the vertical Aa will be zero also. Moreover, the vertical projection of this point will be upon the ground-line at the foot a of the perpendicular aa let fall upon the ground-line, from the horizontal projection *a* of this point.

Again, if the point in space be upon the vertical plane, its distance, in respect of this plane, will be zero, the horizontal aa will be zero, and the horizontal projection of the point in question will be the foot a of the perpendicular Aa let fall upon the ground-line from the vertical projection A of this point.

In general, we suppose that the vertical projection of

a point is above the ground-line, and that the horizontal projection is below; but from what has been said, it is evident that if the point in space be situated below the horizontal line, its vertical projection will be below the ground-line; for the distance from this point to the horizontal plane, cannot be taken from the base-line to the top, but from the top to the base with respect to its plane.

So if the point in space be situated behind the vertical plane, its horizontal projection will be above the ground-line; from which we conclude—

1st. If the point in question be situated above the horizontal plane, and before the vertical plane, its vertical projection will be above and its horizontal projection below the ground-line.

2nd. If the point be situated before the vertical plane, and below the horizontal plane, the two projections will be below the ground-line.

3rd. If the point be situated above the horizontal plane, but behind the vertical plane, the two projections will be above the ground-line.

4th. Lastly. If the point be situated above the horizontal plane, and behind the vertical plane, the vertical projection will be below, and the horizontal projection above, the ground-line.

The reciprocals of these propositions are also true.

If a line be parallel to one of the planes of projection, its projection upon the other plane will be parallel to the ground-line. Thus, for example, if a line be parallel to a horizontal plane, its vertical projection will be parallel to the ground line; and if it is parallel to the vertical plane, its horizontal projection will be parallel to the ground-line.

Reciprocally, if one of the projections of a line be parallel to the ground line, this line will be parallel to the plane of

the other projection. Thus, for example, if the vertical projection of a line be parallel to the ground-line, this line will be parallel to the horizontal plane, and *vice versa*.

If a line be at any time parallel to the two planes of projection, the two projections of this line will be parallel to the ground-line; and reciprocally, if the two projections of a line be parallel to the ground-line, the line itself will be at the same time parallel to the two planes of projection.

If a line be perpendicular to one of the planes of projection, its projection upon this plane will only be a point, and its projection upon the other plane will be perpendicular to the ground-line. Thus, for example, if the line in question be perpendicular to the horizontal plane, its horizontal projection will be only a point, and its vertical projection will be perpendicular to the ground-line.

Reciprocally, if one of the projections of a straight line be a point, and the projection of the other perpendicular to the ground-line, this line will be perpendicular to the plane of projection upon which its projection is a point. Thus the line will be perpendicular to the horizontal plane, if its projection be the given point in the horizontal plane.

If a line be perpendicular to the ground-line, the two projections will also be perpendicular to this line. The reciprocal is not true; that is to say, that the two projections of a line may be perpendicular to the ground-line, without having the same line perpendicular to the ground-line.

If a line be situated in one of the planes of projection, its projection upon the other will be upon the ground-line. Thus, if a line be situated upon a horizontal plane, its vertical projection will be upon the ground-line; and if this line were given upon the vertical plane, its horizontal projection would be upon the ground-line.

Reciprocally, if one of the projections of a line be upon the ground-line, this line will be upon the plane of the

other projection. Thus, for example, if it be the vertical projection of the line in question which is upon the ground, this line will be upon the horizontal plane; if on the contrary, it were upon the horizontal projection of this line which was upon the ground-line, this line would be upon the vertical plane.

If a line be at any time upon the two planes of projection, the two projections of this line would be upon the ground-line, and the line in question would coincide with this ground-line. Reciprocally, if the two projections of a line were upon the ground-line, the line itself would be upon the ground-line.

If two lines in space are parallel, their projections upon each plane of projection are also parallel. Reciprocally, if the projections of two lines are parallel on each plane of projection, the two lines will be parallel to one another in space.

If any two lines whatever in space cut each other, the projections of their point of intersection will be upon the same perpendicular line to the ground-line, and upon the points of intersection of the projections of these lines. Reciprocally, if the projections of any two lines whatever cut each other in the two planes of projection, in such a manner that their points of intersection are upon the same perpendicular to the ground-line, these two lines in question will cut each other in space.

The position of a plane is determined in space when we know the intersections of this plane with the planes of projection.

The intersections AB, AC, of the plane in question, with the planes of projection, are called the *traces* of this plane.

The trace situated in the horizontal plane is called the *horizontal trace*, and the trace situated in the vertical plane is called the *vertical trace*.



A very important remark is, that the two traces of a plane intersect each other upon the ground-line.

If a plane be parallel to one of the planes of projection, this plane will have only one trace, which will be parallel to the ground-line, and situated in the other plane of projection. Reciprocally, if a plane has a trace parallel to the ground-line, this plane will be parallel to the plane of projection which does not contain this trace. Thus :—

1st. If a plane be parallel to the horizontal plane, this plane will not have a horizontal trace, and its vertical trace will be parallel to the ground-line. Likewise, if a plane be parallel to the vertical plane, this plane will not have a vertical trace, and its horizontal trace will be parallel to the ground-line.

2d. If a plane has only one trace, and this trace parallel to the ground-line, let it be in the vertical plane; then the plane will be parallel to the horizontal plane. So if the trace of the plane be in the horizontal plane, and parallel to the ground-line, the plane will be parallel to the vertical plane.

If one of the traces of a plane be perpendicular to the ground-line, and the other trace in any position whatever, this plane will be perpendicular to the plane of projection in which the second trace is in. Thus, if it be a horizontal trace which is perpendicular to the ground-line, the plane will be perpendicular to the vertical plan of projection; and if, on the contrary, the vertical trace be that which is perpendicular to the ground-line, then the plane will be perpendicular to the horizontal plane.

Reciprocally, if a plane be perpendicular to one of the planes of projection without being parallel to the other, its trace upon the plane of projection to which it is perpendicular will be to any position whatever, and the other trace will be perpendicular to the ground-line. Thus, for exam-

ple, if the plane be perpendicular to the vertical plane, the vertical trace will be in any position whatever, and its horizontal trace will be perpendicular to the ground-line. The reverse will also be true, if the plane be perpendicular to the horizontal plane.

If a plane be perpendicular to the two planes of projection, its two traces will be perpendicular to the ground-line. Reciprocally, if the two traces of a plane are in the same straight line perpendicular to the ground-line, this plane will be perpendicular to both the planes of projection.

If the two traces of a plane are parallel to the ground-line, this plane will be also parallel to the ground-line. Reciprocally, if a plane be parallel to the ground-line, its two traces will be parallel to the ground-line.

When a plane is not parallel to either of the planes of projection, and one of its traces is parallel to the ground-line, the other trace is also necessarily parallel to the ground-line.

If two planes are parallel, their traces in each of the planes of projection will also be parallel. Reciprocally, if on each plane of projection the traces of the two planes are parallel, the planes will also be parallel.

If a line be perpendicular to a plane, the projections of this line will be in each plane of projection, perpendicular to the respective traces in this plane. Reciprocally, if the projections of a line are respectively perpendicular to the traces of a plane, the line will be perpendicular to the plane.

If a line be situated in a given plane by its traces, this line can only intersect the planes of projection upon the traces of the plane which contains it. Moreover, the line in question can only meet the plane of projection in its own projection. Whence it follows, that the points of meeting of the right line, and the planes of projection are respec-

tively upon the intersections of this right line, and the traces of the plane which contains it.

If a right line, situated in a given plane by its traces, is parallel to the horizontal plane, its horizontal projection will be parallel to the horizontal trace of the given plane, and its vertical projection will be parallel to the ground-line. Likewise, if the right line situated in a given plane by its traces is parallel to the vertical plane, its vertical projection will be parallel to the vertical line of the plane which contains it, and its horizontal projection will be parallel to the ground-line.

Reciprocally, if a line be situated in a given plane by its traces, and that, for example, let its horizontal projection be parallel to the horizontal trace of the given plane, this line will be parallel to the horizontal plane, and its vertical projection will be parallel to the ground-line. Likewise, if the vertical projection of the line in question be parallel to the vertical trace of the given plane, this line will be parallel to the vertical plane, and its horizontal projection will be parallel to the ground-line.

---

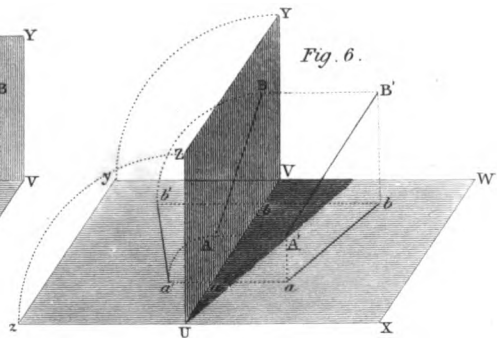
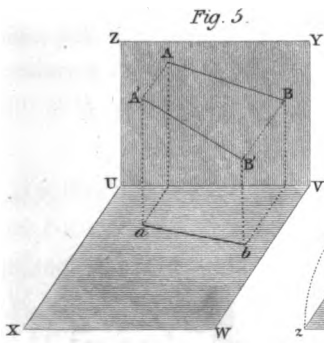
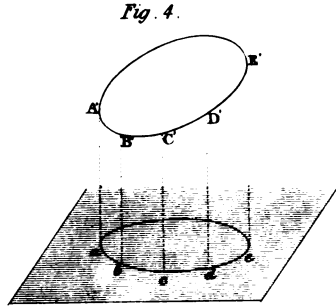
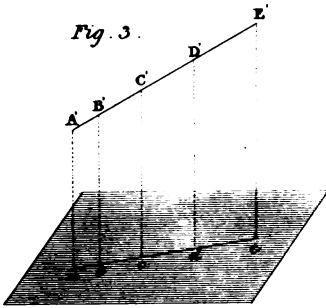
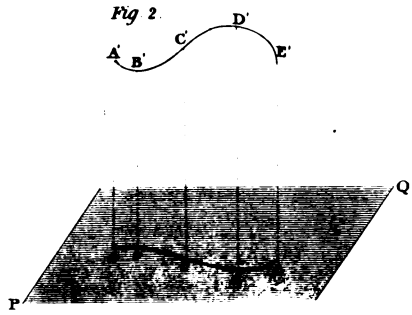
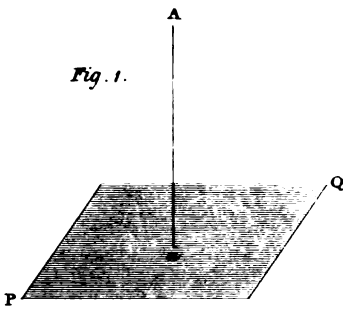
## SECTION II.

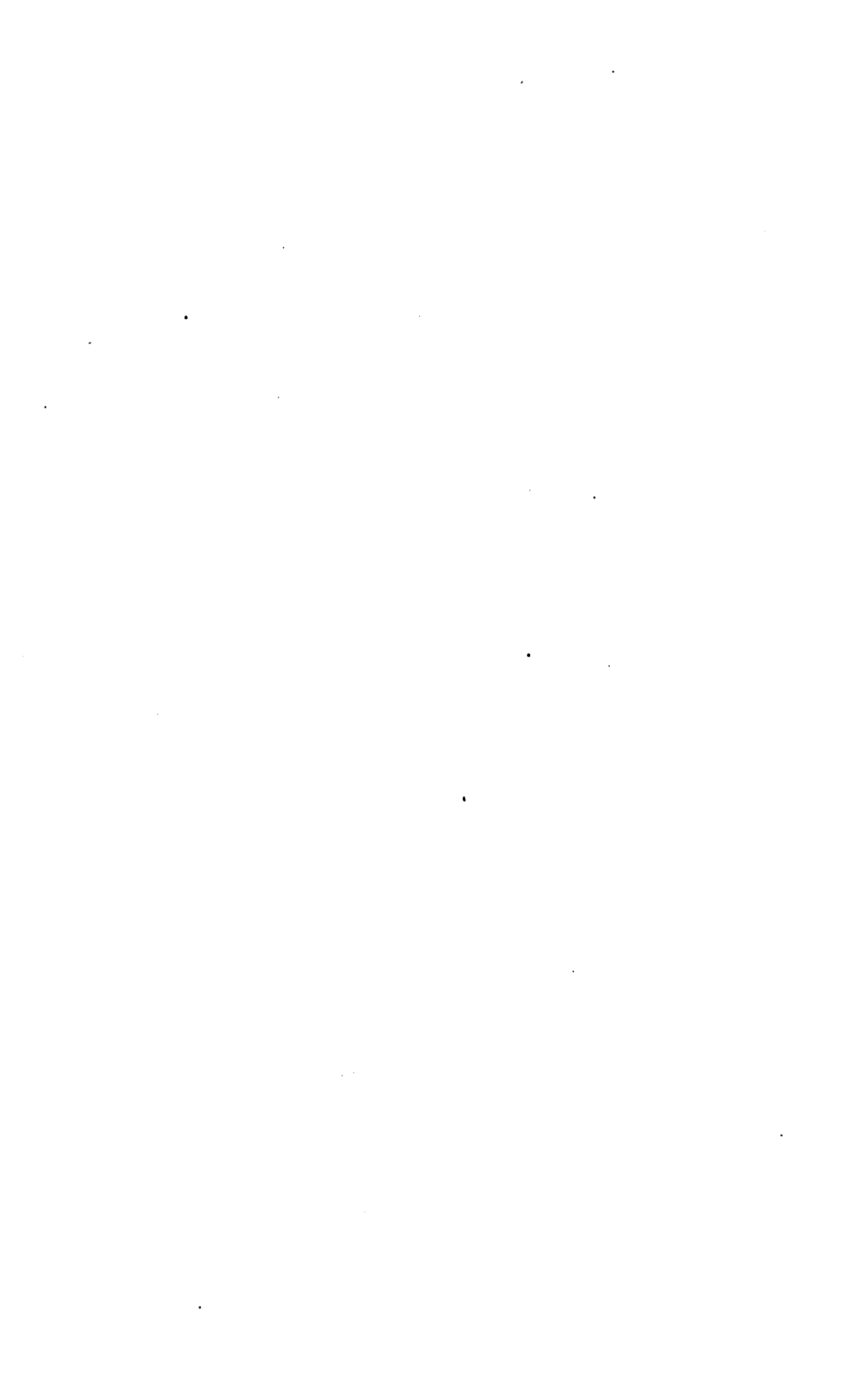
### ON THE DEVELOPEMENTS OF THE SURFACES OF SOLIDS.

#### PROBLEM I.

To find the development of the surface of a right semi-cylinder.

*Fig. 1.* Let ACDE be the plane passing through the axis. On AC, as a diameter, describe the semicircular arc ABC. Produce CA to P, and make AF equal to the development of the arc ABC. Draw FG parallel to AE, and EG parallel to AF; then AFGE is the development required.





## PROBLEM II.

To find the developement of that part of a semi-cylinder contained between two perpendicular surfaces.

*Figs. 2, 3, 4.* Let ACDE be a portion of a plane passing through the axis of the cylinder, CD and AE, being sections of the surface, and let DE and GF be the insisting lines of the perpendicular surface; also let AC be perpendicular to AE and CD. On AC, as a diameter, describe the semi-circular arc ABC. Produce CA to H, and make AH equal to the developement of the arc ABC. Divide the arc ABC, and its developement, each into the same number of equal parts at the points 1, 2, 3.

Through the points 1, 2, 3, &c. in the semi-circular arc, and in its developement, draw straight lines parallel to AE, and let the parallel lines through 1, 2, 3, in the arc A, B, C, meet FG in *p, q, r, &c.* and AC in *k, l, m, &c.* Transfer the distances *kp, lq, mr, &c.* to the developement upon the lines *1a, 2b, 3c, &c.* Through the points F, *a, b, c, &c.* draw the curve line Fc1. In the same manner draw the curve line EK; then FEKI will be the developement required.

## PROBLEM III.

To find the developement of the half surface of a right cone, terminated by a plane passing through the axis.

*Fig. 5.* Let ACE be the section of the cone passing along the axes AE; and CE the straight lines which terminate the conic surface, or the two lines which are common to the section CAE and the conic surface; and let AC be the line of common section of the axial plane, and the base of the cone.

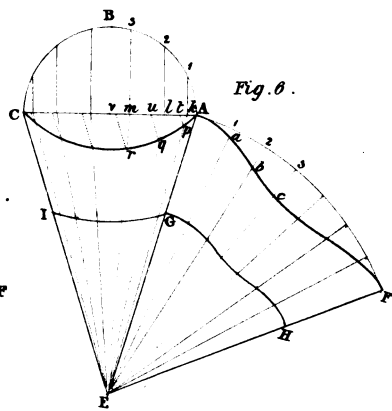
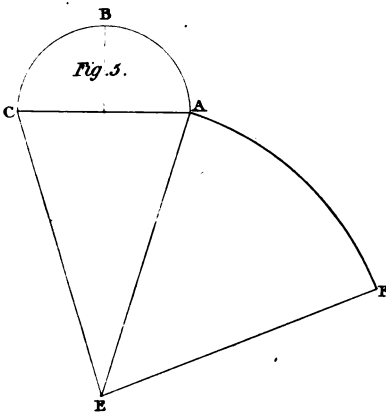
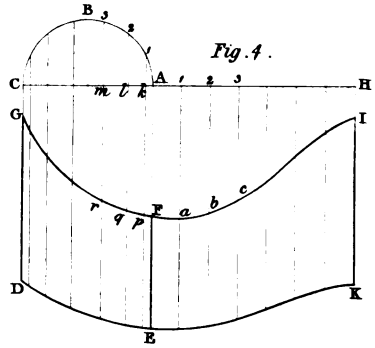
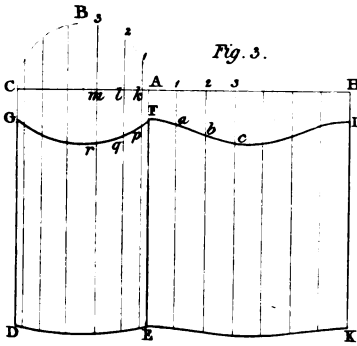
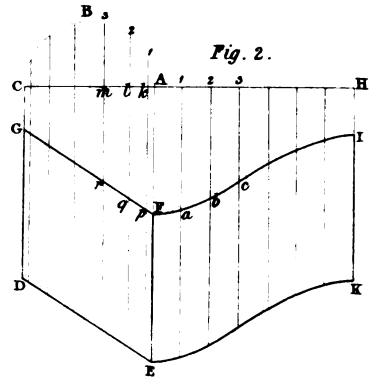
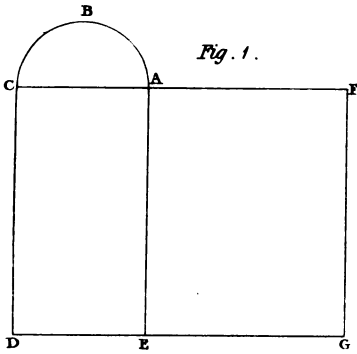
On AC as a diameter describe a semi-circle ABC. From E, with the radius EA, describe the arc AF, and make the arc AF equal to the semi-circular arc ABC, and join EF; then the sector AEF, is the developement of the portion of the conic surface required.

## PROBLEM IV.

To find the developement of that portion of a conic surface contained by a plane passing along the axes, and two surfaces perpendicular to that plane.

*Fig. 6.* Let ACE be the section of the cone along the axis, and let AC and GI be the insisting lines of the perpendicular surfaces. Find the developement AEF as in the preceding problem. Divide the semi-circular arc ABC, and the sectorial arc AF, each into the same number of equal parts at the points 1, 2, 3, &c. From the points 1, 2, 3, &c.

in the semi-circular arc draw straight lines  $1k, 2l, 3m, \&c.$  perpendicular to  $AC$ . From the points  $k, l, m, \&c.$  draw straight lines  $kE, lE, mE, \&c.$  intersecting the curve  $AC$  in  $p, q, r, \&c.$  Draw the straight lines  $pt, qu, rv, \&c.$  parallel to one side,  $EC$  meeting  $AC$  in the points  $t, u, v, \&c.$  Also from the points  $1, 2, 3,$  in the sectorial arc  $AF$ , draw the straight lines  $1E, 2E, 3E, \&c.$  Transfer the distances  $pt, qu, rv, \&c.$  to  $1a, 2b, 3c, \&c.$ ; then through the points  $A, a, b, c, \&c.$  draw the curve  $AcF$ , and  $AcF$  is one of the edges of the developement, and by drawing the other edge, the entire developement,  $AGHF$ , will be found.







## CHAPTER III.

CONSTRUCTION OF THE MOULDS FOR HORIZONTAL CYLINDRETIC VAULTS, EITHER TERMINATING RIGHTLY OR OBLIQUELY, UPON PLANE OR CYLINDRICAL WALLS, WITH THE JOINTS OF THE COURSES EITHER IN THE DIRECTION OF THE VAULT, PERPENDICULAR TO THE FACES, OR IN SPIRAL COURSES.

## SECTION I.

DEFINITIONS OF MASONRY, WALLS, VAULTS, &c.

STONE-CUTTING is the art of reducing stones to such forms that when united together they shall form a determinate whole.

In preparing stones for walls, of which their surfaces are intended to be perpendicular to the horizon, nothing more is necessary than to reduce the stone to its dimensions, so that each of its eight solid angles may be contained by three plane right angles.

Moreover, in working the stones of common straight right cylindretic vaults, where the planes of the sides of the joints terminate upon the intrados or extrados of the arch or vault, in straight lines parallel ruler lines of the cylindretic surface, there can be no difficulty; for if one of the beds of the stone be formed to a plane surface, and if this side be figured to the mould, and the opposite ends squared,

and, lastly, the face or vertical moulds applied upon the ends thus squared, and their figures drawn, these figures will be the two ends of a prism, consisting of equal and similar figures, and will be similarly situated; and therefore we have only to form this prism, in order to form the arch-stone required.

But the formation of the stones in the angles of vaults, and in the courses of spheretical niches and domes, are much more difficult, and require more consideration. In such constructions various methods may be employed, and some of these, in particular instances, with great advantage, both in the saving of workmanship and material, as we shall have occasion to show. In general, however, previous to the reducing of a stone to its ultimate form for such a situation, it will be found convenient to reduce the stone to such a figure as will include the more complex figure of the stone required, so that any surface of the preparatory figure may either include a surface or arris of the stone required to be formed, or be a tangent to their surface.

Surfaces are brought to form by means of straight and curved edges, always applied in a plane perpendicular to the arris-lines, so that, when a surface is thoroughly formed, the edge of application may have all its points in contact with the surface in its whole intended breadth.

A wall, in masonry, is a mass of stones or other material, either joined together with or without cement, so as to have its surfaces such that a plumb-line, descending from any point in either face, will not fall without the solid.

One of the faces of a wall is generally regulated by the other, and the regulating surface is called the principal face.

The line of intersection of the principal face of a wall, and a horizontal plane on a level with the ground, or as

nearly so as circumstances will permit, is called *the base-line*.

A horizontal section of a wall, through the base-line, is called *the seat of the wall*.

The other side of the seat of a wall, opposite to the base-line, is called *the rear-line*.

In exterior walls the outer surface is always the principal face, and the base and rear-lines are generally so situated, that normals drawn to the base-line, between the base and rear-lines, are all equal to one another. This uniformity most frequently takes place also in partition or division walls; but, in some instances, on account of a room being circular or elliptical, while the other faces are plane or curved surfaces, this equality of the normals cannot subsist.

If a wall be cut by a plane perpendicular to the base-line, or if the base-line be a curve perpendicular to a tangent through the point of contact, such a section is called a *right section*.

Hence, according to this definition, since the base-line is always in a horizontal plane, every straight line and every tangent to a base-line, when it is a curve, will be a horizontal line, therefore the right section must be in a vertical plane.

Walls are denominated according to the figure of their base-line. When the base-line is straight, the wall is said to be straight. Hence, if the figure of the base be an arc or the whole circumference of a circle, or a portion or the entire curve of an ellipse, the wall is said to be circular or elliptical. Other forms seldom occur in building.

Walls are more strictly defined by the joint consideration of the figures of their bases and right section.

When the base and the right section of a wall are each a straight line, and all the horizontal sections straight lines,

the face of the wall is called a ruler surface, and if all the right sections have the same inclination, the wall is called a straight inclined wall; if they are all vertical, the wall is called an erect straight wall, or a vertical straight wall. If the right sections vary their inclination, the wall is called a *winding wall*.

When the base line is the circumference or any arc of a circle, and the right section a straight line perpendicular to the horizon, the wall is said to be cylindric. If the right sections of a wall be all equally inclined to the horizon, the wall is said to be conic; and thus a wall takes also the name by which its surface is called; hence a straight wall, which has its right sections either vertical or at the same inclination, is called a *plane wall*.

A wall in tallus, or a *battering wall*, is that of which the vertical section of the principal face is a straight line not perpendicular to the horizon. This vertical section is called the *tallus-line*.

The horizontal distance between the foot of the tallus-line and the plumb-line, passing through its upper extremity, is called the *quantity of batter*; and the plumb line, from the top of the tallus-line to the level of its foot, is called *the vertical of the batter*.

The interstices between the stones, for the insertion of cement or mortar, in order to connect the stones into one solid mass, are called *joints*, and the surfaces of the stones between which the mortar is inserted, are called *the sides of the joints*.

When the sides of the joints are everywhere perpendicular to the face of a wall, and terminate in horizontal planes upon that face, such joints are called *coursing joints*; and the row of stones between every two coursing joints, is called a *course of stones*.

An *arch* or *vault*, in masonry, is a mass of stones sus-

pended over a hollow, and supported by one or more walls at its extremities, the surface opposed to the hollow being concave, and such that a vertical line, descending from any point in the curved surface, may not meet the curved surface in another point.

The concave surface under the arch or vault, is called *the intrados* of that arch or vault; and if the upper surface be convex, this convex surface is called *the extrados*.

Those joints which terminate upon the intrados in horizontal lines, are called *coursing joints*, and the coursing joints will either be straight, circular, or elliptic, accordingly as the horizontal sections of the intrados are straight, circular, or elliptic.

Whether in walling or in vaulting, the joints of the stones should always be perpendicular to the face of the wall, or to intrados of the arch, and the joints between the stones should either be in planes perpendicular to the horizon, or in surfaces which terminate upon the face of the wall or intrados of a vault in horizontal planes; these positions being necessary to the strength, solidity, and durability of the work.

Walls and vaults being of various forms; viz. straight, circular, and elliptic, depending on the plan of the work; hence the construction will depend upon the simple figure or upon the complex figure when combined in two.

---

## SECTION II.

### ON OBLIQUE ARCHES.

#### PROBLEM I.

To execute an oblique cylindroidic arch, intersecting each side of the wall in a semi-circle, the imposts of the arch being given.

Let *fig. 1*, *Plate X.* be the elevation, and in *fig. 2*, let ABCD, EFGH, be the two impostes which are equal and similar parallelograms, having the sides AB, FE one of each in a straight line, and the sides DC and GH in a straight line.

Join GC, and on GC as a diameter, describe the semi-circle GIC, which, if conceived to be turned upon the line DC as an axis, until its plane become perpendicular to the seat BCGF of the soffit of the arch, it will be placed in its due position. Divide the semi-circular arc CIG, into as many equal parts as the ring-stones are to be in number. We shall here suppose there are to be nine ring-stones. From the points of division, 1, 2, 3, &c. draw ordinates perpendicular to GC, meeting GC in the points *p*, *q*, *r*, &c. Perpendicular to CB, the jamb line of the impost, draw the lines, *p1*, *q2*, *r3*, &c.; from the point C as a centre, with the chord of one-ninth part of the semi-circular arc, CIG', describe an arc intersecting *p1* CB at 1; from the point 1, with the same radius describe an arc intersecting the line *q2*, in the point 2; from the point 2 as a centre with the same radius, describe an arc intersecting the line *r3*, in the point 3; and so on. Join the point C and 1; 1 and 2, 2 and 3, &c. and thus form the entire edge CKL, of the development of the semi-circular arc CIG.

Through the points 1, 2, 3, &c. in CKL, draw the lines 1 $\beta$ , 2 $\gamma$ , 3 $\delta$ , &c. parallel to CB, and make 1 $\beta$ , 2 $\gamma$ , 3 $\delta$ , &c. each equal to CB; and join B $\beta$ ,  $\beta\gamma$ ,  $\gamma\delta$ , &c.; then CB $\beta$ 1 is the soffit of the first ring-stone; 1 $\beta\gamma$ 2, is the soffit of the second ring-stone; 2 $\gamma\delta$ 3, the soffit of the third ring-stone, and so on.

Perpendicular to GF draw FJ; produce CB to J; and parallel to CJ, draw *ps*, *qt*, *ru*, &c. Intersecting FJ in the points *v*, *w*, *x*, &c., make *vs*, *wt*, *xu*, &c. respectively equal to *p1*, *q2*, *r3*, &c. Join J and *s*, *s* and *t*, *t* and *u*, &c.; and complete the polygonal line JuF. Through the points *s*, *t*, *u*, &c. draw the joint lines *sy*, *tz*, *u $\theta$* , radiating to the point *o*; then will the angles of inclination of the beds and soffits be NJ*s*, *ysJ*, the first ring-stone; *yst*, *zts*, for the second ring-stone; *ztu*,  *$\theta$ ut* for the third ringstone; and so on.

From any point B in EC, *fig. 3*, make the angle CBA equal to the angle ABC, of the impost *fig. 2*. Prolong CB to E. From B as a centre, with any radius describe the semi-circular arc CDE; and on BC as a diameter, describe another semi-circular arc CgB. Divide the semi-circular arc CDE, in the points 1, 2, 3, &c. into nine equal parts, equal to the number of ring-stones, and draw the radials 1B, 2B, 3B, &c. intersecting the semi-circular arc CgB in the points *f*, *g*, *h*, &c. Draw CA perpendicular to BC; and in BA as a diameter, describe the same circular

arc  $BCA$ . From the point  $B$ , with the radii  $Bf, Bg, Bh$ , &c. describe the arcs  $fi, gk, hl$ , &c. meeting the semi-circular arc  $BCA$ , in the points  $i, k, l$ , &c. and draw the straight lines  $Bi, Bk, Bl$ , &c. Then,  $ABC$  being the angle of the impost,  $ABi$  will be the angle of the joints at the junction of the first and second ring-stones;  $ABk$  the angle of the joints at the junction of the second and third ring-stones;  $ABl$  will be the angle of the joints at the junction of the third and fourth ring-stones, &c.

To apply the moulds for cutting any one of the ring-stones, or to form the solid angles made by the face, the two beds and the soffit of the stone, which being done will form that ring-stone.—For instance, let it be required to form the third ring-stone:—We have given the plain angle  $2\gamma\delta$ , figure 2, which is a side, and the plane angle  $ABk$ , fig. 3, another adjacent side; also the angle  $ztu$ , which is the inclination of these two sides, to construct the solid angle. This can be easily done by working the bed of the stone corresponding to the joint  $2\gamma$  on the soffit, fig. 2; then work the narrow side of the stone, from which the soffit is to be formed, first as a plane surface, making an angle  $ztu$ , with the bed first wrought; place the surface of the mould  $abcd$ , fig. 4, upon the narrow side of the stone, which is to form the soffit, so that the edge  $ab$  may be upon the arris of the stone; then by the edge  $bc$ , draw a line: again upon the wrought side which is intended for the bed, apply the angle  $ABk$ , fig. 3, so that the line  $AB$  may be upon the arris, and the point  $B$  upon the same point that  $b$  was applied; then by the leg  $Bk$ , which is supposed to be upon the surface of the bed, draw a line; we have only to cut away the superfluous stone on the outside of the two lines on the bed and on the soffit; and thus we shall form a complete trehedral; the plane soffit of the stone being gauged to its breadth, and the mould  $2ed3$ , fig. 1, being applied upon the last wrought side, so that the points  $d, e$ , may be upon the points of the stone to which  $b$  and  $c$  were applied; then drawing a line by the edge  $d3$ , and cutting away the superfluous stone between the two lines on the front, and on the plane of the soffit, will form the upper bed of the stone.

This will be made sufficiently evident by a development of the soffit, the two beds, and the front of the ring-stone. Make an equal and similar parallelogram  $abcd$ , fig. 4, to that of  $2\gamma\delta3$ , fig. 2. Make the angles  $abe, dcg$ , fig. 4, respectively equal to the angles  $ABk, ABl$ , fig. 3; then  $bc$  being equal to  $de$ , fig. 1, apply the mould  $2de3$ , so that the points  $d, e$  may be upon  $bc$ , fig. 4, and draw the front of the stone  $bcki$ , fig. 4, and similarly draw  $adml$ . Make  $be$  equal to  $bi$ ,  $cg$  equal to  $ck$ , and draw  $ef$  and  $gh$  parallel to  $ba$  or  $cd$ , and this will complete the development.

A complete model of the stone will instantly be formed, by revolving



the four sides *abef*, *bcki*, *cdhg*, *dalm*, upon the four lines *ba*, *bc*, *cd*, *da* as axes, until *e* coincide with *i*, *k* with *g*, *h* with *m*, and *l* with *f*.

We have here made use of the development of the intrados in the construction of the solid angles, as being easily comprehended. The ring-stones might, however, have been formed by the angle of the joints, which is one side of a trehedral; one of the angles of the face mould, which is the other adjacent side; and the inclination of these two sides; so that we shall have here also two sides and the contained angle, to construct the solid angle of the trehedral. As an example, let it again be required to construct the third ring-stone. To find the angle which the face of the third ring-stone makes with the bed in the second joint: we have here given the two legs *ABC*, *CB2*, *fig. 3*, of a right-angled trehedral, to find the angle which the hypotenuse makes with the side *CB2*: this being found, will be the inclination of the face-mould, *2de3*, *fig. 1*. and *ABk*, *fig. 3*. Therefore, in this case work the bed of the stone first, then the face, to the angle of inclination thus found. Upon the arris apply the leg *AB* of the joint-mould *ABk*, *fig. 3*, so that the side *Bk* may be upon the bed, and draw a straight line on the bed by the edge *Bk*; next apply the mould *2de3*, so that the arc *d2* may be upon the arris, and the point *d* upon the same point of the arris to which the point *B* was applied, and the chord *de* upon the face; then draw a line on the face of the stone, by the leg *de*; and work off the superfluous stone, and the face will be exhibited. *Fig. 5*, shows the stone as wrought.

From what has been said, it is evident that if one of the solid angles of a ring-stone be formed of an oblique arch in a straight wall, the remaining solid angle may be formed without the use of the trehedral. Thus, for instance, suppose the solid angle which is formed be made by the surface of the soffit, the bed, and the face of the arch—we have only to guage the soffit to its breadth, and apply the head-mould upon the face of the stone; then by working off the superfluous stone between these lines, another solid angle will be formed by the surface of the soffit, the upper bed of the stone, and the face of the arch.

And since the angle of the joints is the same in the lower and upper beds of any two ring-stones that come in contact with each other, the same angle of the joints will do for both, so that in fact, if this be carried from one ring-stone to another, the arch may be executed without any joint mould.

This mode would, however, not only be inconvenient, but liable to very great inaccuracy. It would be inconvenient, as it is necessary to work one stone before another, so that only one workman could be employed in the construction of the arch. It would be liable to inaccuracy when the

number of ring-stones are many, for then any small error would be liable to be multiplied or transmitted from one stone to another. Besides, it is satisfactory to have a mould to apply, in order to examine the work in its progress.

What has been now observed, with regard to the oblique arch in a straight wall, and with respect to the angle on the edges of the point, will apply to every arch of which the intrados is a cylindric or cylindroidic surface.

In the construction of any object it is always desirable to have two different methods, as one may always be a proof or check to the other. Besides, though these methods may be equally true in principle, one of them may be often liable to greater inaccuracy in its construction than the other.

#### PROBLEM II.

To construct the moulds for a cylindretic oblique arch terminating upon the face of a wall in a plane at oblique angles to the springing plane of the vault, so that the coursing joints may be in planes parallel to the ruller lines of the intrados of the vault.

Let the vertical plane of projection be perpendicular to the axis of the intrados, and it will therefore be also perpendicular to all the joints of which their planes are parallel to the axis: hence

The vertical projection of the intrados will be a curve equal and similar to the curve of the right section of the intrados.

The vertical projections of the coursing joints will be radiant straight lines, intersecting the curve lined projection of the intrados.

The vertical projections of all the joints which are in vertical planes parallel to the axis, will be straight lines perpendicular to the ground line.

The vertical projection of all the joints *m*, horizontal planes, will be straight lines parallel to the ground-line.

Moreover the vertical projections of the intersections of planes which are parallel to the axis will be points.

The horizontal projections of the planes of the coursing joints, and of all the intersections of the planes of all joints which are parallel to the axis, will be straight lines perpendicular to the ground-line.

And because the axis of the archant is perpendicular to the vertical plane, the vertical projections of the intrados, and of the joints which are parallel to the axis, will have the same position to one another, as the curve and other lines in the right section which are formed by the joints in planes parallel to the axis.

All sections which are perpendicular to the horizon, will have straight lines for their horizontal projections.

The length of any inclined line will be to the length of its projection, as the radius is to the cosine of the line's inclination to the plane of projection.

We shall suppose that the stones which constitute the intrados of the archant, have not fewer than three, nor more than four, of their faces that intersect the intrados. The stones which form the face of the archant, when they do not reach the rear of the vault, have three of their faces which intersect the intrados, and three at least which intersect the face.

We shall call all these surfaces which intersect the intrados, or face of the archant, *the retreating sides of joints of the stones*; and the surface of any stone which forms a part of the intrados, the *douelle* of the stone.

When the stones do not reach from the front to the rear of the intrados of an archant, they are arranged in rows, in such a manner, that the stones which constitute any one of the rows, have as many of their retreating sides as there are stones in the row, in one continued surface, and the opposite retreating sides of all the stones in another continued surface, while the heads form a portion of the intrados extending from front to rear of the vault, and the remaining retreating sides of the stones either come in contact, or are connected together by mortar.

Every such row of stones is called *a course of vaulting*.

One course may be joined to another by bringing their adjacent continued surfaces in contact; but they are generally cemented with mortar, which is called *the coursing joint*, and as this cementing substance should be as thin as possible, and of an equal thickness, we shall suppose that the coursing joints intersect the intrados in lines, extending from front to rear of the vault, we shall call these lines the *coursing lines of the intrados*.

In this example, as the vertical projection of the intrados, and of the joints which are in planes parallel to the axis, are identical in all respects to the lines of the right section, the dimensions between every two corresponding points being equal in both, we may therefore substitute at once the right section for the vertical projection, placing the right section upon the ground-line UV.

*Plate XI.* Let No. 1 be the right section placed in the situation of the vertical plane projection upon the ground-line UV, the curve-line COC' being the vertical projection of the intrados, AD, BF, CH, the projections of the vertical projection coursing joints, meeting the projection of the intrados in the points A, B, C. Of these radiant lines CH is the projection of the springing. The line BF meets the line FG parallel, and EF perpendicular to the ground-line UV. The extrados

Fig. 1.

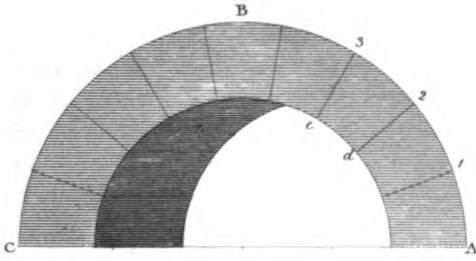


Fig. 5.

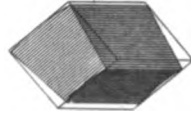


Fig. 2.

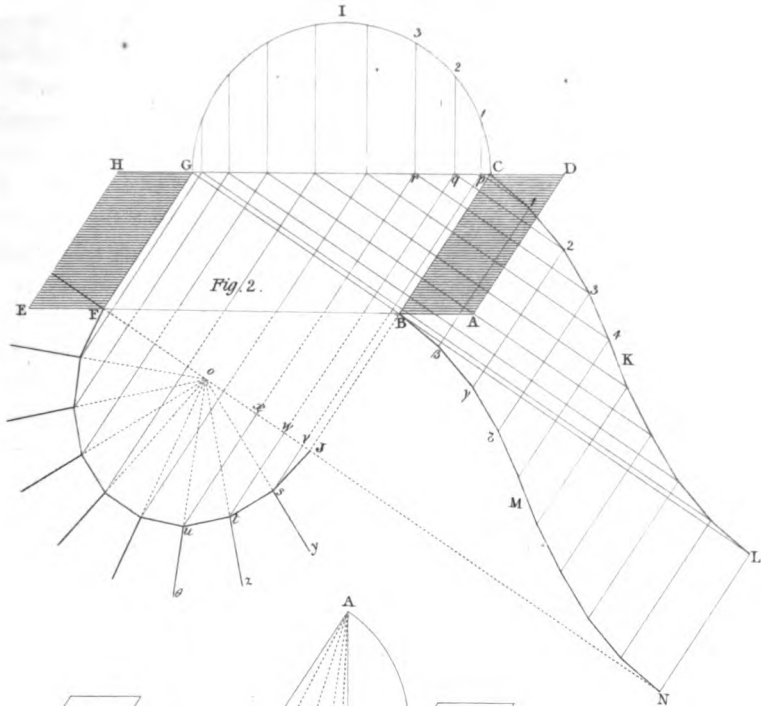


Fig. 3.

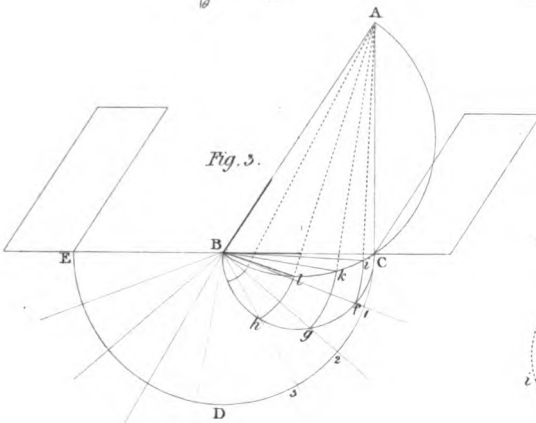
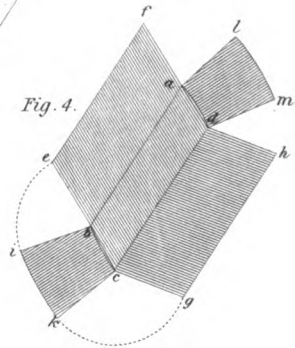


Fig. 4.





ZEDY of this section is a straight line parallel to the ground-line. As this right section of this vault is symmetrical, we shall only describe one half, the other will be understood by the same rules.

Let  $rs$ , No. 2, be the trace of the vertical face of the wall on the horizontal plane of projection, making a given angle with the ground-line  $UV$ , and let  $uv$  and  $rs$ , be the traces of the inclined face of the wall; the inclination of this face being given by a right section of the wall.

Let  $\Gamma\Delta\Pi$ , No. 3, be the right section of the wall, of which  $\Delta\Pi$ , the base, is equal to the shortest distance between the two traces  $uv$  and  $rs$ , No. 2, of the faces of the wall. The line  $\Pi\Gamma$  of this section, is the section of the vertical face, and  $\Lambda\Delta$ , that of the inclined face of the wall.

This section  $\Gamma\Delta\Pi$ , No. 3, is so situated, that the base line  $\Delta\Pi$  is perpendicular to the traces  $uv$ ,  $rs$ , of the faces of the wall, No. 2, the point  $\Pi$  being in the line  $rs$  or  $sr$  prolonged, therefore the point  $\Lambda$  in the line  $uv$ , or in  $vu$  prolonged, and  $\Pi\Gamma'$  being perpendicular to  $\Delta\Pi$  will be in the same straight line with the horizontal trace  $rs$  of the vertical face of the wall.

In order to obtain the projection of the intersection of the intrados and of the joints which are in planes parallel to the axis of the intrados with the inclined face of the wall; we must find the projection of every line in this inclined face made by the intersection of a horizontal plane passing through every point in the right section which is formed by every two lines in its construction.

For this purpose it will be necessary to find the horizontal projection of every point of the lines where the intersections of the planes parallel to the axis meet the inclined face of the wall. To proceed:—

Take all the heights of the points of the right section, and apply them respectively from the point  $\Pi$  in the line  $\Pi\Gamma$  No. 3; through these points draw lines parallel to  $\Delta\Pi$ , so that each line may meet the sloping line  $\Lambda\Delta$ . From each of the points in the line  $\Lambda\Delta$  draw lines parallel to the horizontal trace  $uv$ , No. 2, and lines being drawn from the corresponding points of the right section will give the points required by the intersection of the two systems of parallel lines.

Thus to find the horizontal projection of the intersection of any particular line which is parallel to the axis with the inclined face of the wall, this line being given by its intersecting point in the right section, No. 1; this point being the intersection of one of the coursing lines, viz. the first  $A$  from the middle of the section, No. 1.

Draw  $Aa$  perpendicular to the ground-line, and transfer the height  $KA$  of the point  $A$ , No. 1, upon the line  $\Pi\Gamma'$ , No. 3, from  $\Pi$  to  $1$ . Draw  $1-2$  parallel to  $\Pi A$ ,  $\Lambda A$  meeting  $PQ$  in  $2$ . From  $2$  draw  $2a$  parallel

to either of the horizontal traces  $uv$ , or  $rs$ , No. 2, and the point  $a$  (No. 2) is the horizontal projection of the extremity of the coursing line of the intrados which passes through the point  $A$  of the right section.

In the same manner may be found the projections  $b$  and  $c$  of the intersections of the coursing joints of the intrados, with the face of the archant, and also those of the intersections of the planes parallel to the axis: the projections of these points being exhibited by Italic letters corresponding to these of the Roman in the right section.

To find the developement of the intrados or soffit of the arch.

Parallel to the ground-line in No. 2, draw the regulating line  $\delta\epsilon$  in the horizontal plane of projection, intersecting the projections  $aa'$ ,  $bb'$ ,  $cc'$ , &c. of the coursing joint-lines in the points  $a$ ,  $\beta$ ,  $\gamma$ , &c.

In any convenient situation, No. 4, draw the line  $VW$ , and in  $VW$  take any convenient point  $o$ . In  $oV$  make  $oa$  equal to  $OA$ , No. 1, the half-chord of the arc of the section of the key-course; and in No. 4, make  $a\beta$ ,  $\beta\gamma$ , &c. equal to the succeeding chords  $AB$ ,  $BC$ , &c. No. 1, of the sections of the courses in intrados.

Through the points  $a$ ,  $\beta$ ,  $\gamma$ , No. 4, draw the lines  $aa'$ ,  $bb'$ ,  $cc'$ , perpendicular to  $VW$ , and make  $aa$ ,  $\beta b$ ,  $\gamma c$ , respectively equal to  $aa$ ,  $\beta b$ ,  $\gamma c$ , No. 2, as also  $aa'$ ,  $\beta b'$ ,  $\gamma c'$ , No. 4, equal to  $aa'$ ,  $\beta b'$ ,  $\gamma c'$ , No. 2. In No. 4, join  $ab$ ,  $bc$ , on the one side, and  $a'b'$ ,  $b'c'$ , on the other; then  $aa'b'b$ ,  $bb'c'c$ , will be the chord-planes of the soffits of the courses of the stones on each side of the key-course. The figures of the chord-planes of the right-hand side of the arch being found in the same manner, will give the entire developement of the intrados by joining the corresponding ends of the chord plane of the key-course.

Through any convenient point  $V$ , No. 4, in the line  $VW$ , draw  $ac'$  perpendicular to  $VW$ , and prolong  $WV$  to  $D$ . Make  $VD$  equal to  $AD$ , No. 1, and through  $D$ , No. 4, draw  $dd'$  parallel to  $ac$ . In  $ac$ , No. 4, make  $Va$ ,  $Va'$ , respectively equal to  $aa$ ,  $aa'$ , No. 2, and make  $Dd$ ,  $Dd'$ , No. 4, respectively equal to  $ld$ ,  $ld'$ , No. 2. Join  $ad$ ,  $ad'$ , then will  $aa'd'd$ , No. 4, be the side or figure of the coursing joint corresponding with the line  $AD$ , No. 1. In the same manner the remaining figures  $bb'f'f$ ,  $cc'h'h$ , will be found, as also the remaining figures of the coursing-joints on the right-hand side.

Then the figures of the moulds for the course of stones, of which the right section is a figure equal and similar to  $ABFED$ , No. 1, are No. 1, and  $aa'bb$ ,  $aa'd'd$ ,  $bb'f'f$ , No. 4. All the stones are wrought to the form of right prisms before the heads in the front and rear of the

arch are formed, then the moulds of the upper and lower beds are applied, and their figures are drawn upon the surfaces of the coursing-joints, so as to give the intersections of the coursing-joints with the face of the arch.

In the course of stones, on the left hand next to the key-course  $aa'bb'$ , No. 4, is the chord-figure of the intrados,  $aa'd'd'$ , No. 4, the upper bed, and  $bb'f'f'$  the lower bed.

To find any point in the oblique face of the arch. Let the point to be found be the point corresponding to the point A.

The place of the point A in the oblique line  $\Lambda\Delta$ , No. 3, is at the point 2, and its place upon the projection No. 2, is at  $a$ . Draw  $\Lambda Y$  perpendicular  $\Lambda v$ , or to  $uv$ , and in  $\Lambda Y$  make  $\Lambda 2$ , equal to  $\Lambda 2$  in  $\Lambda\Delta$ . From the point 2, in  $\Lambda Y$ , draw  $2p$  parallel to  $uv$ , and draw  $ap$  perpendicular to  $uv$ , and the point  $p$  will in the curve of the oblique face of the arch.

In the same manner will be found the points  $i, q$ , &c. in the curve of the oblique face of the arch, as also all other points, by first finding their projections as at No. 2, and the heights of these points upon the oblique line  $\Lambda\Delta$ , No. 3, and then transferring the points thus found upon the perpendicular  $\Lambda Y$ . Through the points found in the perpendicular  $\Lambda Y$ , draw lines parallel to  $uv$ , to intersect with lines drawn perpendicular to  $uv$  from the projections of the points to be found in No. 2, and the points of intersection of every two lines, will be the points in the oblique face of the arch, corresponding to those in the section, No. 1.

The curve thus found in the oblique face of the arch will be an oblique curve; therefore the line  $uv$  will not be an axis, but a diameter.

To find the direction of any joint in the oblique face of the arch, the plane of the joint being perpendicular to the springing plane of the arch.

Suppose, for instance, the plane passing through  $LT$  in the elevation No. 1, perpendicular to  $UV$ . Find the projection  $t$  and  $l$  in the horizontal plane of projection of the points represented by  $T$  and  $L$  in the vertical plane of projection, and find the point  $i$  in the curve of the oblique face of the arch, corresponding to the point  $T$  in the vertical plane of projection; then joining the points  $l$  and  $i$ , the straight line  $li$  will be the position of the joint in a plane perpendicular to the springing plane of the intrados of the arch.

*Plate XII.* The diagram in this plate exhibits the construction of an arch of the same species as that in the preceding plate; but here the



figure of the curve in the oblique face of the arch, is a given symmetrical figure, and therefore the right section of the arch is an oblique curve, which is exactly the reverse of that in the immediately preceding plate.

### PROBLEM III.

To construct an oblique arch for a canal with a cylindrical intrados, so that the sides of the coursing joints may be in planes which intersect each other in straight lines perpendicular to the two faces of the arch, and parallel to the horizon, and that the planes of the coursing joints may make equal angles with each other:—

*Plate XIII.* Let  $ABCD$  be the plane of the arch;  $AD$  and  $BC$  being the plans of the faces, and  $AB$ ,  $DC$ , the plans of the springing lines of the intrados of the arch parallel to the line of direction of the canal.

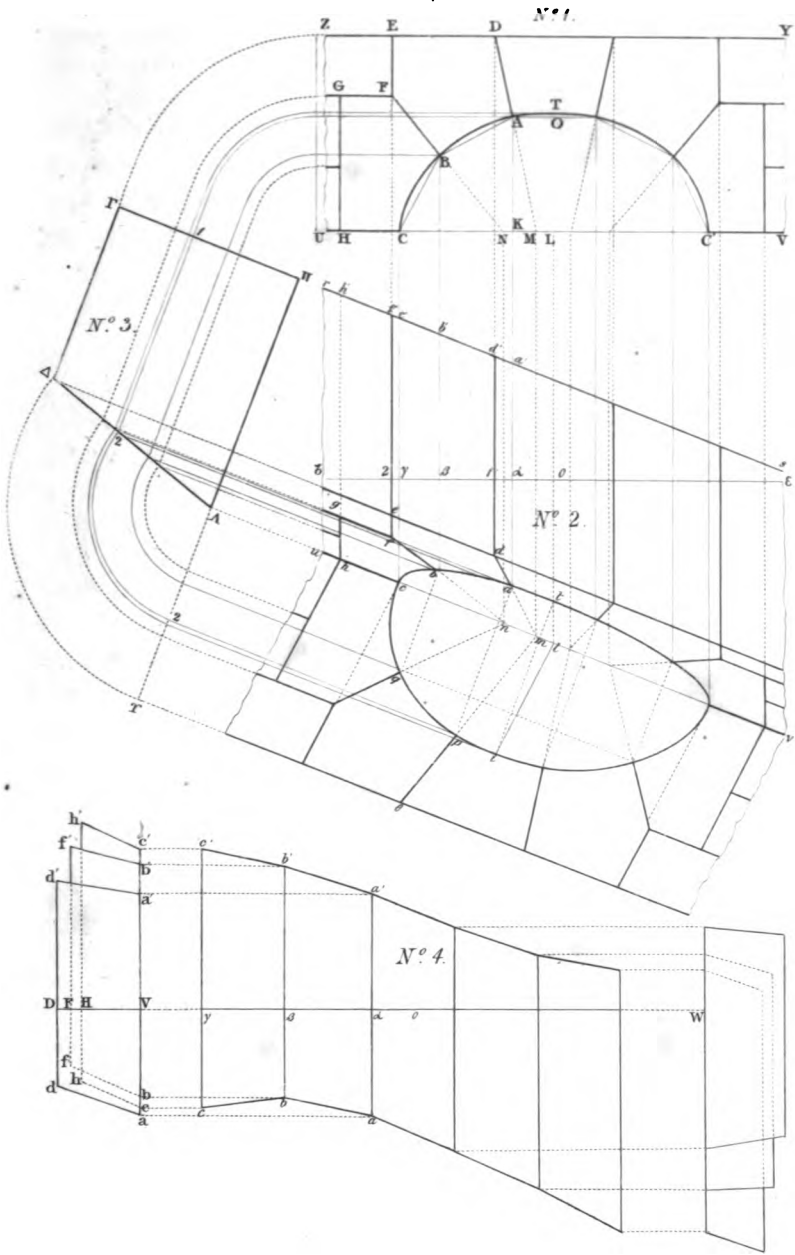
Find the middle point  $e$  of the parallelogram  $ABCD$ , and draw  $ef$  perpendicular to  $AD$  or  $BC$ . Through any convenient point  $f$  in  $ef$  draw  $GH$  perpendicular to  $ef$ , and from the point  $f$  with a radius equal to half of  $AD$  or  $BC$ , describe the semi-circumference  $ikl$  meeting  $GH$  in  $i$  and  $l$ . Divide the circumference  $ikl$  from  $i$  into as many equal parts as the coursing joints are intended to be in number: for example, let it be divided into nine equal parts,  $i1$ ,  $12$ ,  $23$ , &c. Draw the tangent  $QR$  parallel to  $GH$ , and from  $f$ , and through the points  $1$ ,  $2$ ,  $3$ , &c. of division, draw the straight lines,  $fm$ ,  $fn$ ,  $fo$ ,  $fp$ , &c. meeting  $QR$  in the points  $m$ ,  $n$ ,  $o$ ,  $p$ .

Through  $e$  draw  $st$  parallel to  $AB$  or  $DC$ , and draw  $ms$ ,  $nu$ ,  $ow$ ,  $py$ , perpendicular to  $GH$ , meeting  $st$  in the points  $s$ ,  $u$ ,  $w$ ,  $y$ . Make  $ez$ ,  $ex$ ,  $ev$ ,  $et$ , equal respectively to  $ey$ ,  $ew$ ,  $eu$ ,  $et$ . Prolong  $CD$  to meet  $ef$  in  $\gamma$ , and prolong  $fe$  and  $AB$  to meet each other in the point  $\beta$ ; then with the two diameters  $st$  and  $\beta\gamma$  describe the ellipse  $s\beta t\gamma$ , and with the two diameters  $uv$  and  $\beta\gamma$  describe the ellipse  $u\beta v\gamma$ , and so on; then the portions of these curves comprised between the lines  $AD$  and  $BC$ , will be the plans of the coursing joints.

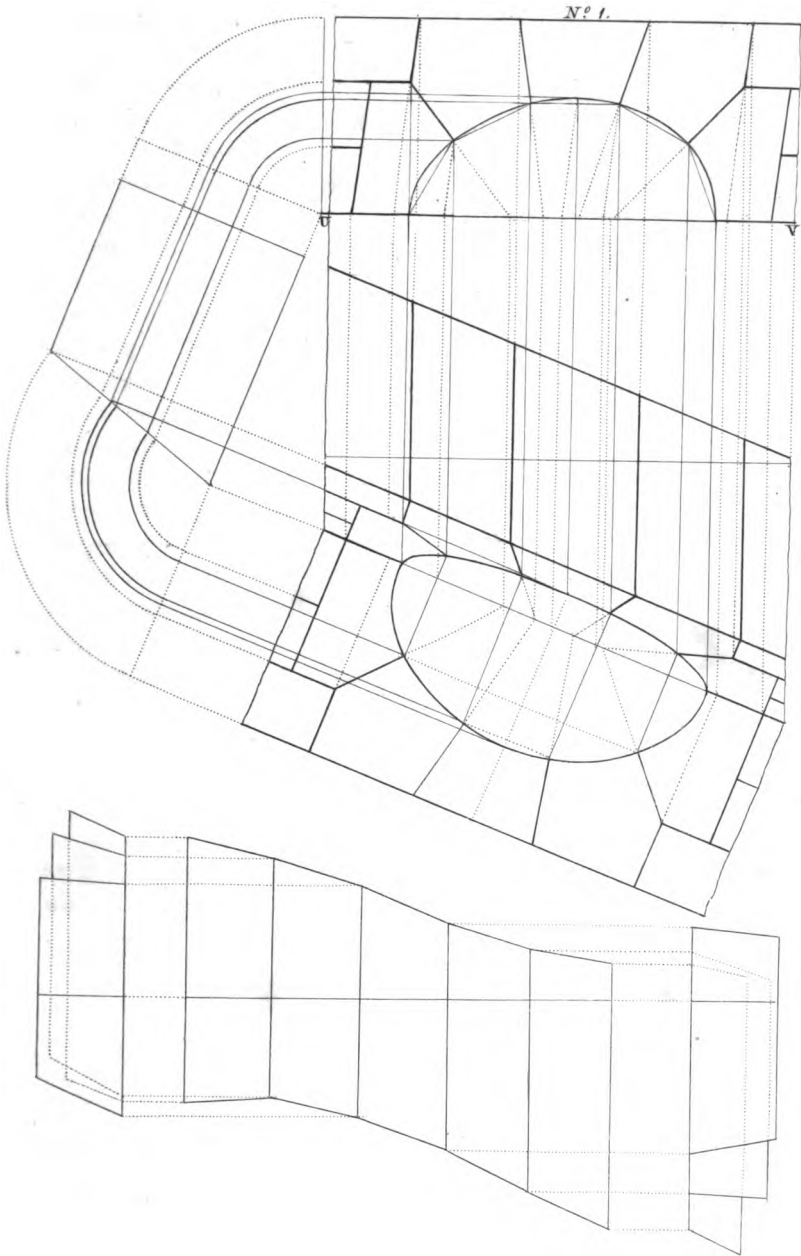
The method which has now been shown for finding the joint lines of the intrados of the arch is quite satisfactory as to the principle, since it exhibits the plans of the complete sections of the cylinder by the cutting planes of the joints to the several angles of inclination. We shall show how the joint lines of the intrados themselves may be found, as depending upon the plans of the joints.

To find the plane curves for the joints of the intrados:

Having found the conjugate diameter  $\beta\gamma$ , and the semi-conjugate  $es$ ,







1) ? Nikolson delin.



as also the semi-conjugate diameters  $eu, ew, ey$ , plate XIV, as has been shown in the immediately preceding plate, proceed in the following manner. Draw  $st, uv, wx, yz$ , perpendicular to  $es$ , and make  $st, uv, wx, yz$ , each equal to the radius of the semi-circle  $ikl$ . Join  $et, ev, ex, ez$ . Draw  $ss', uu', ww', yy'$ , perpendicular to  $\beta\gamma$  or  $\beta f$ ; and from the point  $e$  as a centre, with the radii  $et, ev, ex, ez$ , describe the arcs  $ts', vu', xw', zy'$ . Join  $es', eu', ew', ey'$ .

With the diameters  $es', eu', ew', ey'$ , and with their common conjugate  $\beta\gamma$ , describe the semi-ellipses  $\beta s'\gamma, \beta u'\gamma, \beta w'\gamma, \beta y'\gamma$ , &c. then the portions of these curves contained between the lines BC and AD will be the curve lines of the joints required.

In order to describe the curve lines of the joints of the intrados, the conjugate diameters of the plans must be found. The operation by the following method is very convenient in finding the plans of the joint-lines of the intrados, but it does not afford the means of finding the joint-lines themselves, and therefore is but of little use in the construction of the moulds.

Let ABCD, *fig. 2, plate XIII*, be the plan, which is a parallelogram as before. Divide AB into any number of equal parts, as, for example, into four, at the points 1, 2, 3, and draw the lines  $1a, 2\beta, 3\gamma$ , parallel to BC or AD, meeting DC in the points  $a, \beta, \gamma$ , and let  $hg$  be the ground-line of the elevation; then AD,  $1a, 2\beta, 3\gamma, BC$ , are the plans of semi-circular sections of the intrados, and are each parallel to the ground-line  $hg$ , the elevations of these plans will be semi-circles.

These elevations being described, let  $efg$  be the elevation to the plan BC,  $klm$  the elevation to the plan  $2\beta$  in the middle, between the plans BC and AD of the semi-circular sections of the cylinder. Let  $c$  be the centre of the semi-circular arc  $klm$ , and divide the semi-circular arc  $klm$  into as many equal parts as there are intended to be courses in the arch; for example, let the number of courses be nine, and therefore the semi-circular arc  $klm$  must be divided into nine equal parts, in the points 1, 2, 3, &c.

From the centre 1, 2, 3, &c. and through the points of division  $c$ , draw lines which will be the elevations of the joints, and let  $pt$  be one of these lines, intersecting the five semi-circles in the points  $p, q, r, s, t$ . Draw the lines  $pu, qv, rw, sx, ty$ , perpendicular to the ground-line  $hg$ , intersecting the plans AD,  $1a, 2\beta, 3\gamma, BC$ , in the points  $u, v, w, x, y$ , and the line  $uvwxy$  being drawn, will be the correct plan of the joint required.

In the same manner the plans of the remaining joints may be found.

In the Supplement to the Encyclopedia Britannica, article Stone Masonry, (page 569, Plate CXVIII. fig. 28. T. Tredgold delin.) a method in order to effect the finding of the plan here shown, is there intended to be accomplished; whence the following description and diagram are verbally copied.

“ When a road crosses a canal in an oblique direction, the bridge is often made oblique. When the angle does not vary more than 10 or 12 degrees from a right angle, the arch-stones may be formed as already described; but in cases of greater obliquity, a different principle of construction is necessary. These cases should, however, be avoided whenever it is possible; as however solid the construction of an oblique arch may be in reality, it has neither the apparent solidity nor fitness which ought to characterise a useful and pleasing object.

“ An oblique arch may be constructed on the principle of its being a right arch of a larger span, as is shown in *fig. 2, plate VI*; or in *fig. 1, plate XV*, of this work.

“ Let ABCD be the plan, and EFGH the corresponding points in the elevation: in this elevation the dotted lines show the parts which would not be seen.

“ The joints of the arch are supposed to be divided upon the middle section, and therefore drawn to the mean centre K, which corresponds to the point I on the plan.

“ Divide AD into any number of equal parts, as at 1, 2, 3, &c. and transferring these points to the elevation, describe the arch belonging to each point, and also draw the parallel lines 11, 22, &c. on the plan.

“ To find the mould for the arris of any joint, as *a*, draw *ab* parallel to the base line EF: and from *a*, as a centre, transfer the distances of the points, where the arches cut the joint, to the line *ab*. Then let fall perpendiculars from the points in the line *ab*, to the lines 11, 22, &c. in the plan, whence we find *a, m, n, o, p*, in the curve of the mould for the arris of the joint *a*. The mould for any other joint may be found in the same manner. The ends of the arch-stones will be square to the joints; and *pode* will be the mould for one end, and *acdf* the mould for the other end. It will be of some advantage in working the arch-stones to observe, that the arch-stone being in its place, the soffit should be every where perfectly straight, in a direction parallel to the horizon.”

Whoever is the author of this article on stone-masonry

Fig. 1.

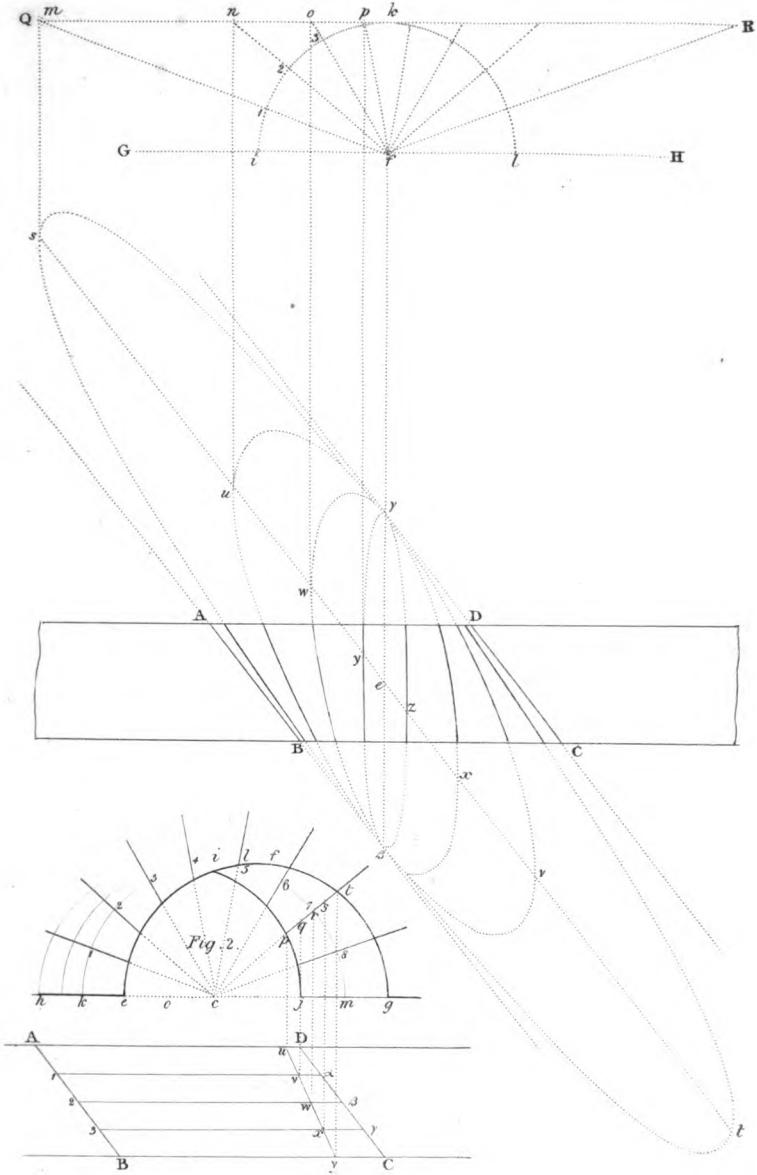
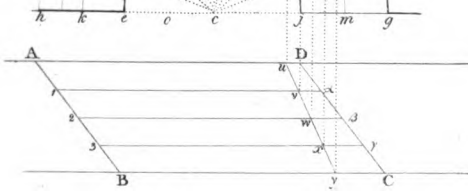
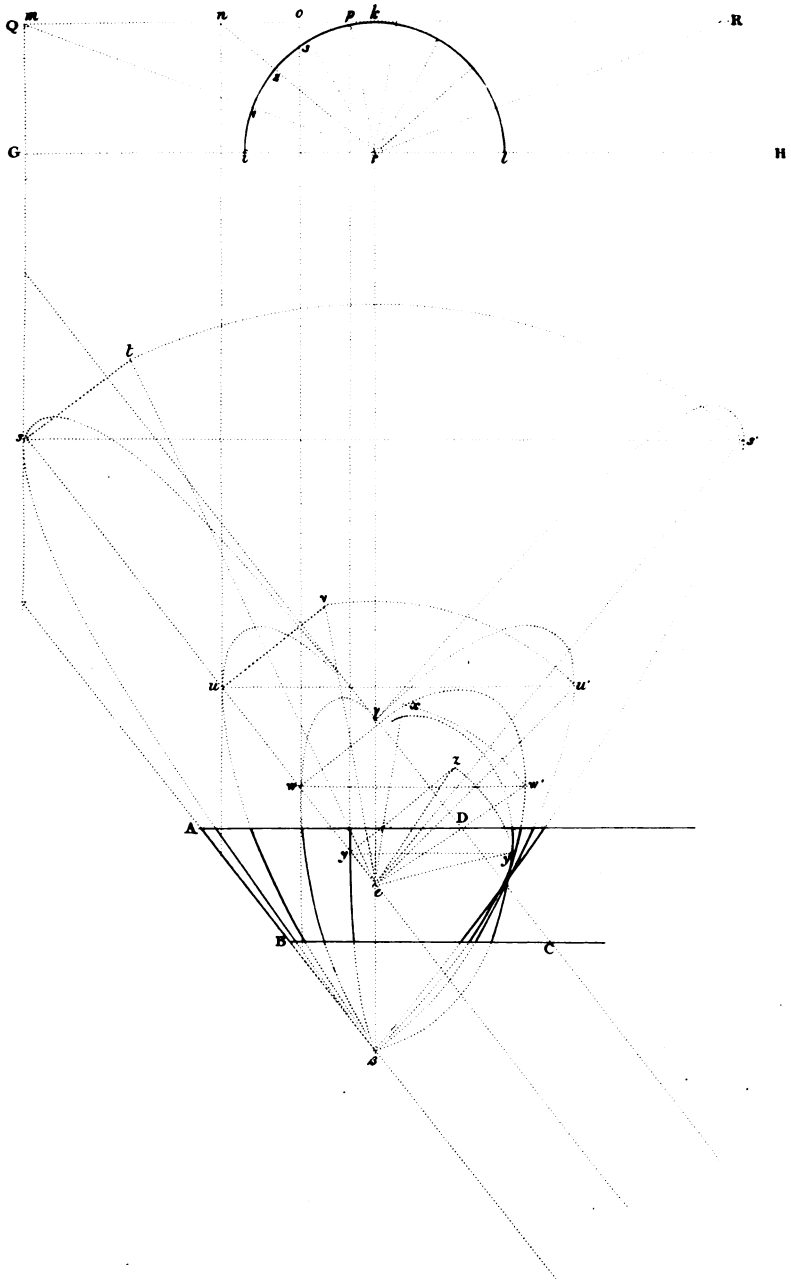


Fig. 2.











just now quoted from the work alluded to, he is chargeable with a description and representation which will lead the reader to an erroneous construction of finding the plans, or the arrises of the joints as he calls them. We will defy the writer, or even Mr. Tredgold who affixes his name as draughtsman to the plate, to demonstrate the truth of the method there described.

After all, this method only divides the curve of the middle section, which is parallel to the front and rear faces, into equal parts, and the plane passing through the semi-circular arc into straight lines perpendicular to the curve; but in order to have the surfaces which form the sides of the joints in the front and rear faces perpendicular to the curve, and at the same time perpendicular to each face, proceed according to the following method, *fig. 2, plate XV.*

Let *lad* be the plan of one pier, and *yef* the plan of the other pier, *ad* and *cf* being the plans or horizontal sections of the springing lines of the intrados; also, let *LF* be the ground-line parallel to the planes of the front and rear elevations. Describe the five semi-circles in the elevation as before, *ABC* being that in the front, *DEF* that in the rear, and *GHI* that belonging to the middle section.

Divide the semi-circular arc *GHI* into the number of equal parts required, and let the points of division be 1, 2, 3, &c. Through the points 1, 2, 3, &c. draw the straight lines *1o*, *2s*, *3U*, &c. radiating to the centre of the semi-circular arc *ABC'* intersecting the curve *ABC* in the points *N*, *R*, *T*, and the lines *NO*, *RS*, *TU*, will be the joint lines of the face, and will be perpendicular to the curve line *ABC*.

In the straight line *ac*, which is the plan of the face of the arc, take a part *zn* for the joint in the direction *NO* of the elevation, and let the lines *1N*, *2R*, *3T*, intersect the semi-circular arc between the parallel sections *ABC* and *DEF* in the points *α*, *β*, *γ*, &c. Let the points *u* and *v* be in the straight line *ac*. Make *nu* and *uv* respectively equal to *Na*, *a1*, and draw *uw* and *vx* perpendicular to *zv*.

Divide *ad* into as many equal parts as the thickness of the arch is divided into equal parts by the planes of the semi-circular arcs which are parallel to the planes of the front and rear faces; that is, divide *ad* into four equal parts, and let *ak*, *ag*, be two of those parts in succession, and

draw  $kn$  and  $gx$  parallel to  $ac$ ; then,  $n$ ,  $w$ ,  $x$ , will be three points in the curve, which is the intersection of the plane of the curving joint and the cylindric surface, forming the intrados; and thus we might find as many points as we please, by increasing the number of equi-distant sections. This gives the first joint next in succession to the springing AD.

In the same manner all the other coursing joints will be found as at No. 2, No. 3, No. 4, &c.

#### Observations on the preceding methods:—

The most simple construction of an oblique arch with a cylindrical intrados, is that where the sides of the coursing joints are in planes intersecting the intrados perpendicularly in straight lines, as in the first example; but when the arch is very oblique, the coursing joints intersect the planes of the two vertical faces in very oblique angles.

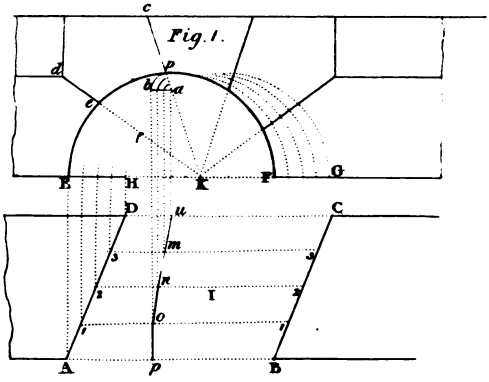
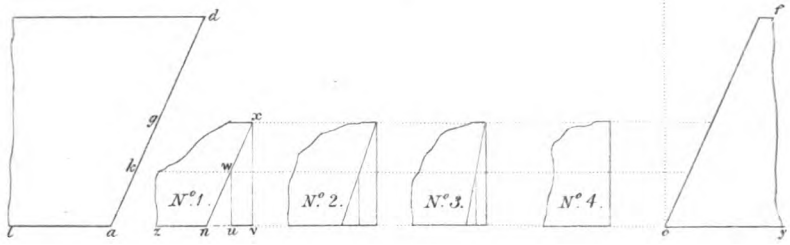
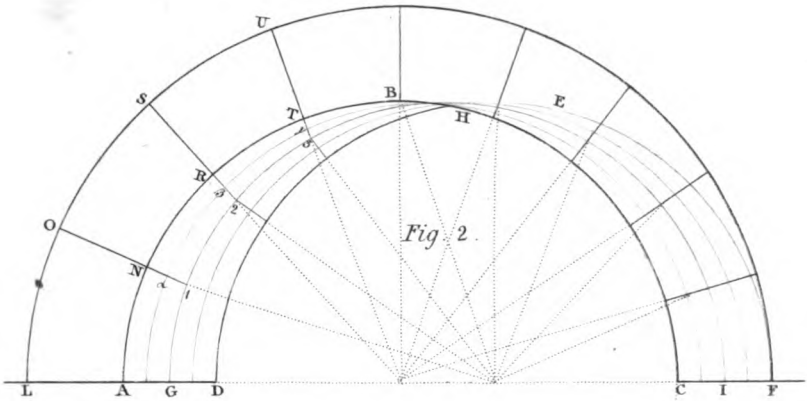
It has been shown that when the sides of the coursing joints are in planes perpendicular to the front and rear faces, these planes cut the intrados very obliquely, except at the middle section, or in the best method in the curve of the front and rear. It therefore appears, that in an oblique arch, in order that the surfaces of the coursing joints may intersect both the intrados, and the face of the arch perpendicularly, the sides of the coursing joints cannot be in planes.

In order that every arch may be the strongest possible, a straight line passing through any point of the surface of a joint perpendicularly to the intrados, ought to have all its intermediate points between the point through which it passes; and the intrados, in the surface of the side of the coursing joint; and in order that the stones may be reduced to their form in the easiest manner possible, the surfaces should be uniform; and the forms of the stones should be similar solids, and the solids similarly situated.

To obtain these desirable objects will not be possible where the faces of the arch are plane surfaces; however, even in this case, the joints may be so formed by uniform helical surfaces, that they will intersect the intrados perpendicularly in every point, and the faces of the arch perpendicularly in two points of the curve.

This mode of executing a bridge renders the construction much stronger than when the joints of it are parallel to the horizon. Since in this last case, the angles of the beds and the faces are so acute upon one side, that the points of the ring-stones are very liable to be broken, or even to be fractured in large masses.

For, though the gravitating force acts perpendicularly to the horizon; yet, notwithstanding, when one body presses upon the surface of another,





the faces act upon each other in straight lines perpendicularly to their surfaces. Hence a right-angled solid will resist equally upon all points of its surface.

From this consideration, we are induced to give a preference to the construction with spiral joints, though attended with greater difficulty in the execution.

#### PROBLEM IV.

To execute a bridge upon an oblique plan, with spiral joints rising nearly perpendicular to the plane of the sides.

*Fig. 1, plate XVI, is the plan of a bevel bridge; fig. 2, the elevation of the same, as the two faces of the obtuse angle are shown; the joints of the intrados descend from the face of the arch in such a manner, that supposing the lines  $ab, a'b', a''b''$ , *fig. 1*, to be the joints of the intrados, meeting the curve of the intersection of the face of the arch and intrados in the points  $b, b', b''$ , &c. then the joints  $ba, b'a', b''a''$ , &c. are as nearly perpendicular to the curve  $bb'b''b'''$  as possible for the construction to admit of, supposing the joints to be all parallel to each other. By making the joints of the intrados all parallel to each other, all the intermediate arch-stones will have the same section when cut by a plane at right angles to the arris-line of the bed and intrados of the arch; therefore, if the intermediate arch-stones are equal in length, the upper and lower beds must be the same winding surfaces, and consequently must all coincide with each other, and all the end-joints must be equal and similar surfaces, and thus all the arch-stones may be equal and similar bodies.*

The most considerable obliquity of the joints in the intrados is at those two parts of the curve where it meets the horizon. The obliquity of the intradosal joints, at the crown of the arch, is considerably less than at the horizon; but in the middle of that portion of the curve, between the crown and the horizon on each side, the intradosal joints are exactly perpendicular to the horizon.

Had it not been for these deviations, the execution of this arch would have been extremely easy, and very few constructive lines would have been necessary.

This arch, however, might be executed so that all the intradosal joints would be perpendicular to the curve-line of the face and intrados; but this position would have caused such a diversity in the form of the stones as to increase the labour in a very great degree, and, consequently, to render the execution very expensive; and not only so, but as the joints would have been out of a parallel, their effect would have been very un-



sightly. A succession of equal figures, similarly formed, has a most imposing effect on the eye of the spectator. The laws of perspective produce on the imagination a most fascinating variety, the figure only varying by imperceptible degrees, which yet in the remote parts produces a great change.

There is still another method in which the greater part of the difficulty may be removed without impairing the strength of the arch; this manner is to form the ring-stones so that the joints in the intrados may be perpendicular to the curve forming its edge; the intermediate portion of the intrados to be filled in with arch-stones, which have their soffit-joints parallel to the horizon. This disposition of the joints might not be so pleasant to the eye, but, if well executed, it could not be disagreeable.

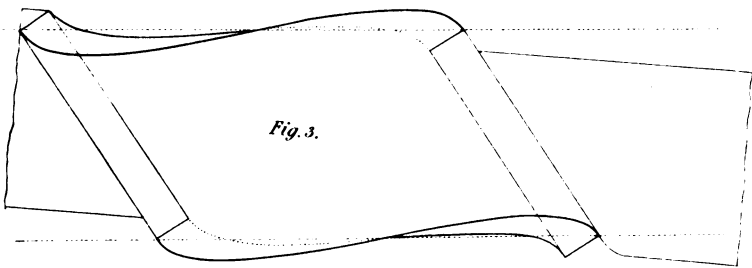
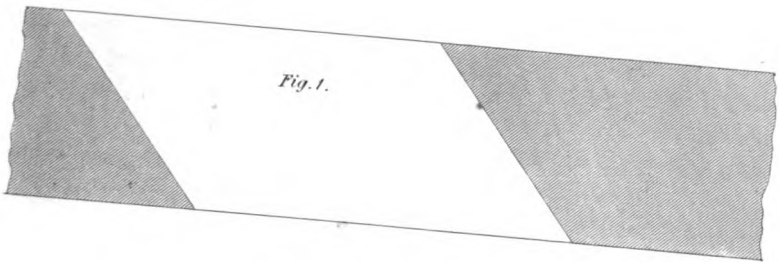
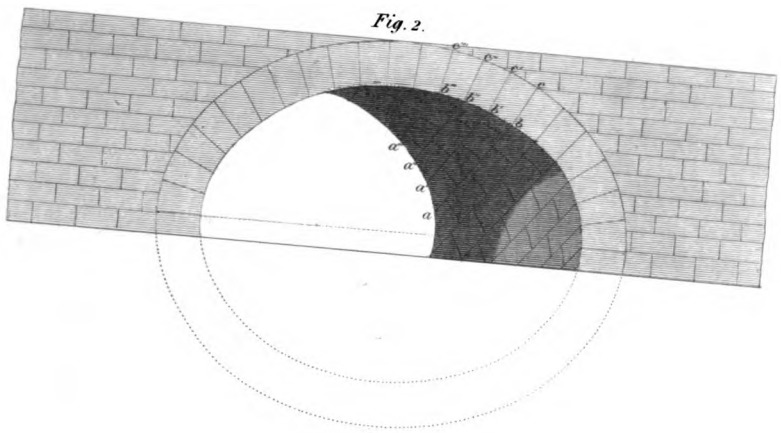
If the ends were made to form spirals, as in *fig. 3*, and a wall erected above the arch, as this wall could only be made to coincide in three points at most with the face of the arch, no regular form of work could be introduced so as to connect the wall to the ring-stones.

To form the developement of the intrados of the oblique arch, with spiral or winding joints, and thence to find the plan of the developement or intrados.

Let AC, *plate XVII*, be the inner diameter of the face of the ring-stones; upon AC describe the semi-circular arc ABC, and find its developement upon the straight line AD. Draw the straight lines AG and DI perpendicular to AD.

In AG take any point M, and draw ML, making the angle AML equal to the angle of the bevel of the bridge, meeting CH in the point L. Draw La perpendicular to AG, meeting AG in *a*. Prolong La to meet DI in Q, and draw ON parallel to LM, so that the distance between LM and ON may comprise the breadth of the bridge. Let ON meet CH in O, and AG in N; then will LMNO be the plan of the bridge. Find the developement MPQSRN upon the straight line AG, the curve MPQ being the developement of the arc insisting on ML, and NRS the developement of the curve line upon NO.

Draw MQ, and divide MQ into as many equal parts as there are intended to be arch-stones, which we shall here suppose to be fifteen; hence there will be a ring-stone in the middle, and the number of ring-stones will be equal on each side of the middle one; let P be the middle point of the line MQ, and let *a, b, c, &c.* be the points of division on one side of P, and *a', b', c', &c.* the points of division on the other side.





Through the middle point P draw the straight line WX. Through the points  $a, b, c$ , &c. draw the lines  $do, ep, f'q$ , &c. parallel to WX, meeting the curve MQ in the points  $k, l, m$ , &c. and the curve NS in the points  $o, p, q$ , &c.; also through the points  $a', b', c'$ , &c. draw the lines  $d'o', e'p', f'q'$ , &c. parallel to WX, meeting the curve MQ in the points  $k', l', m'$ , &c., and the curve NS in the points  $o', p', q'$ , &c.; then  $ao, lp, mq$ , &c.; also  $a'o', l'p', m'q'$ , &c. will be the joint lines on the intrados of the arch; the heading joints are marked on the developement at right angles to these joints. The curves on the plan are projected by means of Problem 1, Ch. I. Sec. VI.

Thus,  $dgr$  is the seat of the developement  $do$ ;  $ehs$  the seat of the developement  $ep$ , &c.

Now as all the intermediate arch-stones are equal and similar, it will only be necessary to show how one of the stones may be formed. For this purpose, let  $uvwx$  be the developement of the soffit. Draw  $vy$  parallel to MN or QS. Run a straight draught  $vy$  diagonally upon the intrados of the stone, making an angle  $uyv$  with the edge  $uy$ , or  $ux$ , of the soffit. Draw  $ua$  and  $v\beta$  perpendicular to  $vy$ .

Make two moulds Z,Z to the arc ABC, so that their chords may be equal; then cut two draughts  $ua$  and  $v\beta w$  so as to coincide with the convex edges of the two moulds Z,Z, while the straight edges of the two moulds Z,Z are out of winding.

That is, apply the moulds Z,Z at the same time; the one upon the line  $ua$ , and the other upon the line  $v\beta w$ ; and sink a cavity or draught under each line; so that, after one or more trials, the convex edge may coincide with the bottom of each draught; and that the point marked upon each circular edge may coincide with the bottom of the draught  $vy$ ; and that the two chord-lines of each circular mould may be in the same plane, that is in workman's terms out of winding or out of twist.

The remaining superfluous part may be worked off as directed by two straight edges, and thus the cylindric surface of the soffit of the stone will be formed.

The longitudinal spiral joints may be formed by means of the bevel at  $\gamma$ , where it is applied to the section of one of the arch-stones: but before the heading joints and beds are wrought, a pliable or flexible mould  $uvwx$  must be made, and bent to the convexity of the surface, so that the line  $vy$  may coincide with the bottom of the straight draught first wrought.

In applying the mould  $\gamma$ , the curved edge must be laid along the line  $ua$  or  $v\beta w$ ; and in directions parallel to these lines; and several draughts

must be wrought on the spiral bed, so as to coincide with the straight edge and the angular with the line  $vm$ , or  $ux$ .

Having shown the developement of the intrados and its projection, it will be proper to show how the curves are projected, and more particularly as it will not only show the application of Problem 1, Ch. I, Section VI, but also the positions of the sections of the cylinder, in order to find the proper moulds.

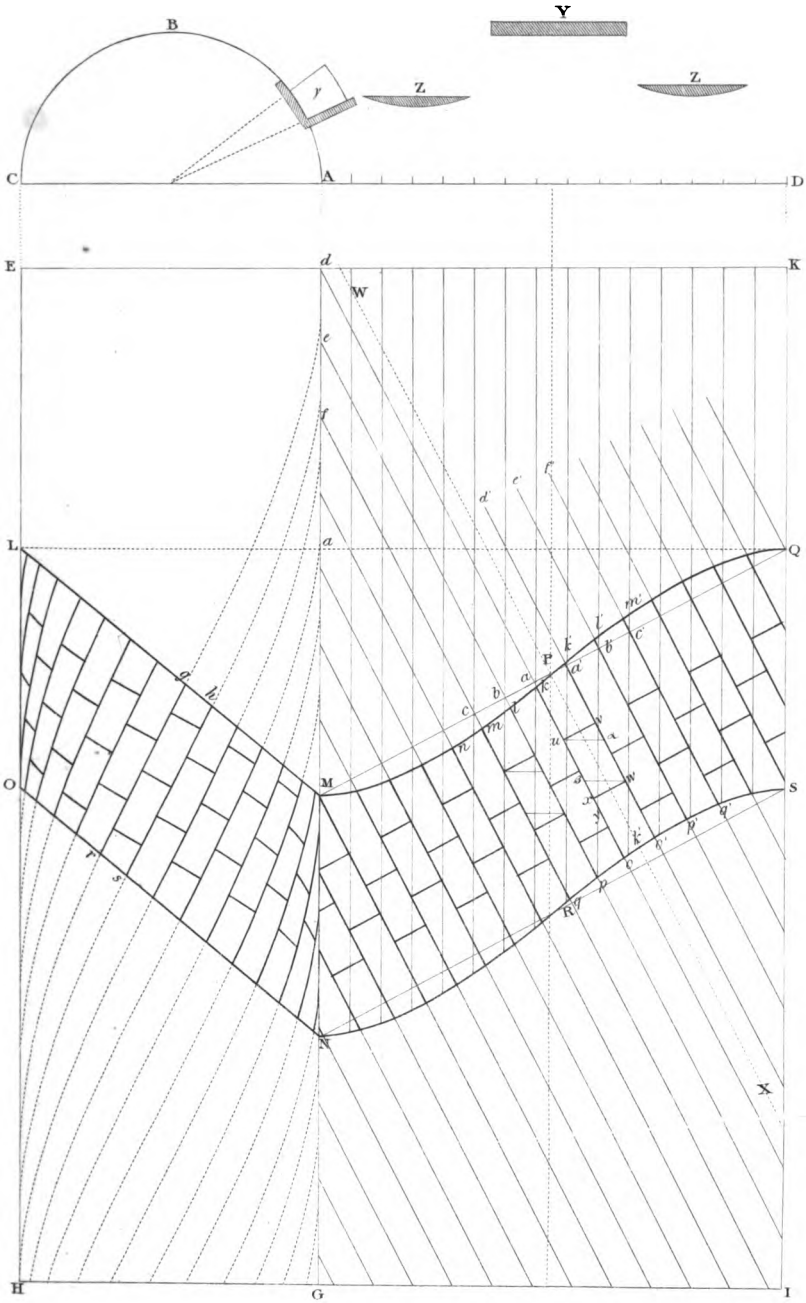
Let the line  $AF$ , *Plate XVIII*, the edge of the triangle  $AEF$ , be the developement of one of the longitudinal joints, and let  $HG$  at right angles  $AF$  be the developement of one of the lines of direction of the heading joints; then, as the projection of all the longitudinal lines is equal and similar, and the projection of the heading joints is equal and similar, one curve of each being obtained, and a mould formed thereto, each series of curves may be drawn by means of its proper mould.

Divide the arc  $ABC$  into any number of equal parts at the points 1, 2, 3, &c., and the straight line  $AF$  into the same number of equal parts at the points 1, 2, 3, &c.; but it will be most convenient to divide each into as many equal parts as the ring-stones are in number, which in this example are fifteen. From the points 1, 2, 3, &c. of division in the straight line  $AF$ , draw  $1a$ ,  $2b$ ,  $3c$ , &c. perpendicular to  $AE$ , and through the points 1, 2, 3, &c. in the arc  $CB$ , draw lines  $1a$ ,  $2b$ ,  $3c$ , &c., parallel to  $CD$ , and through the points  $a$ ,  $b$ ,  $c$ , &c. draw a curve, which is the projection of a cylindric spiral, and is the plan of one of the longitudinal joints required. In the same manner, dividing  $HG$  into the same number of equal parts as the arc  $ABC$ , and drawing lines as before from the divisions of the arc, and from the divisions of the straight line  $HG$ , to intersect each other respectively in the points  $a$ ,  $b$ ,  $c$ , &c. we shall have the curve of direction of the heading joints. In order to find the direction of the curve in the middle, it will be necessary to show the manner of finding a tangent in the middle of the curve. For this purpose,

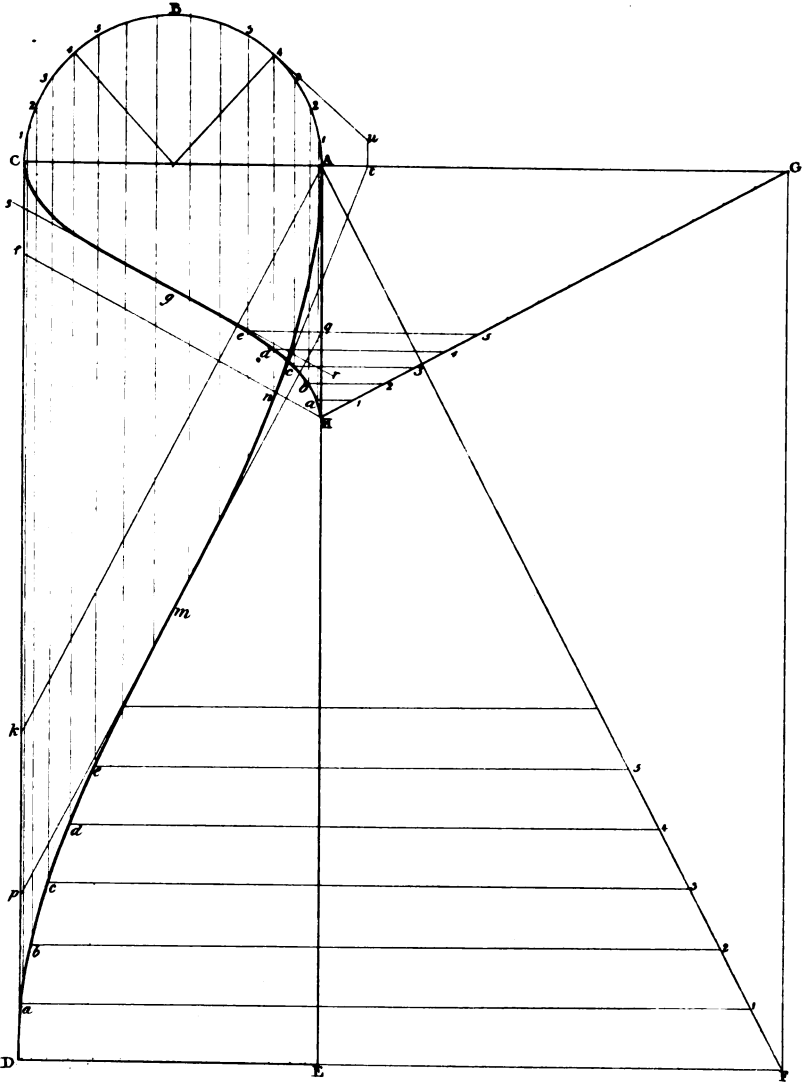
Make the angle  $EAk$  equal to  $EAF$ , and let the point  $m$  be the middle of the curve  $DmA$ . Through the point  $m$  draw  $pq$  parallel to  $kA$ , and  $pq$  will be the tangent required.

In like manner, make the angle  $AHf$  equal to  $AHG$ , and let  $g$  be the middle point of the curve  $HgC$ ; through  $g$  draw  $rs$  parallel to  $Hf$ , and  $rs$  will be a tangent to the curve  $HgC$ .

It is here evident from the tangents, that if these two curves had in-











tersected each other in the middle, they would have been at right angles to each other; they are, however, still the projections of two straight lines bent upon the cylindric surface.

To draw a tangent to the point  $n$ . Draw  $n4$  parallel to  $EA$ , meeting the curve  $AB$  in  $4$ . Draw  $4u$  perpendicular to the radical line, and make  $4u$  equal to the developement of the arc  $4A$ . Draw  $ut$  perpendicular to  $AG$ , and join  $tn$ , which is the tangent required.

To find the curvature of a stone along the two edges of the longitudinal joints, and along the heading joints of the intrados. In *fig. 1, plate XIX*, which is a developement of the intrados,  $abcd$  is the developement of the intrados of an arch-stone, it is required to find the curvature along  $bc$ , and  $ad$ , also in the direction  $ab$ ,  $dc$  at the ends.

In *fig. 2*, make  $OA$  equal to the radius of the cylinder, and through  $A$  draw  $BE$  perpendicular to  $AO$ . Make the angle  $BOA$  equal to the complement of the angle which the joints in the developement of the intrados make with the springing lines, that is equal to the angle  $DAE$ , *fig. 1*. Make  $OC$ , *fig. 2*, equal to  $OB$ , and draw  $OD$  perpendicular to  $BC$ . Make  $OD$  equal to  $OA$ . Then with the transverse axis  $BC$ , and semi-conjugate  $OD$ , describe the semi-elliptic arc or curve  $CDB$ ; then the portion of the elliptic arc on each side of the point  $D$  will be the curvature in *fig. 1*, along the longitudinal edge  $bc$  or  $da$  of the soffit of a stone.

Again, produce  $DO$  to  $E$ , and make  $OE$  equal to  $OD$ . In  $OB$ , take  $OG$ , equal to  $OA$ , the radius of the circular end of the cylinder; then with the transverse axis  $DE$ , and the semi-conjugate  $OG$ , describe the semi-elliptic arc  $DGE$ , and the small portion of this arc on each side of the point  $G$  has the same curvature as  $ab$  or  $dc$ , *fig. 1*. Therefore, the stone being wrought hollow, as directed in the description of the preceding plate, then the mould shown at  $D$  is that for working the longitudinal joints, or those which terminate on the soffit in the lines  $ad$  and  $bc$ . In like manner, the mould  $G$  is that for working the heading joints which terminate upon the soffit in the lines  $ab$ ,  $dc$ , &c. It will hardly be necessary to remind the reader, that the convex edge of the squares at  $D$  and  $G$  is to be applied upon the hollow soffit already wrought. The curvature of these moulds may be shown by calculation thus: let  $R$  be the radius of curvature,  $a =$  the semi-transverse axis, and  $b =$  the semi-conjugate; then  $b : a :: a : R = \frac{a^2}{b}$ .

As for example to this formula, let the radius of the cylindric intrados, or  $b = 13$  feet, and the semi-transverse axis, or  $a = 28$  feet

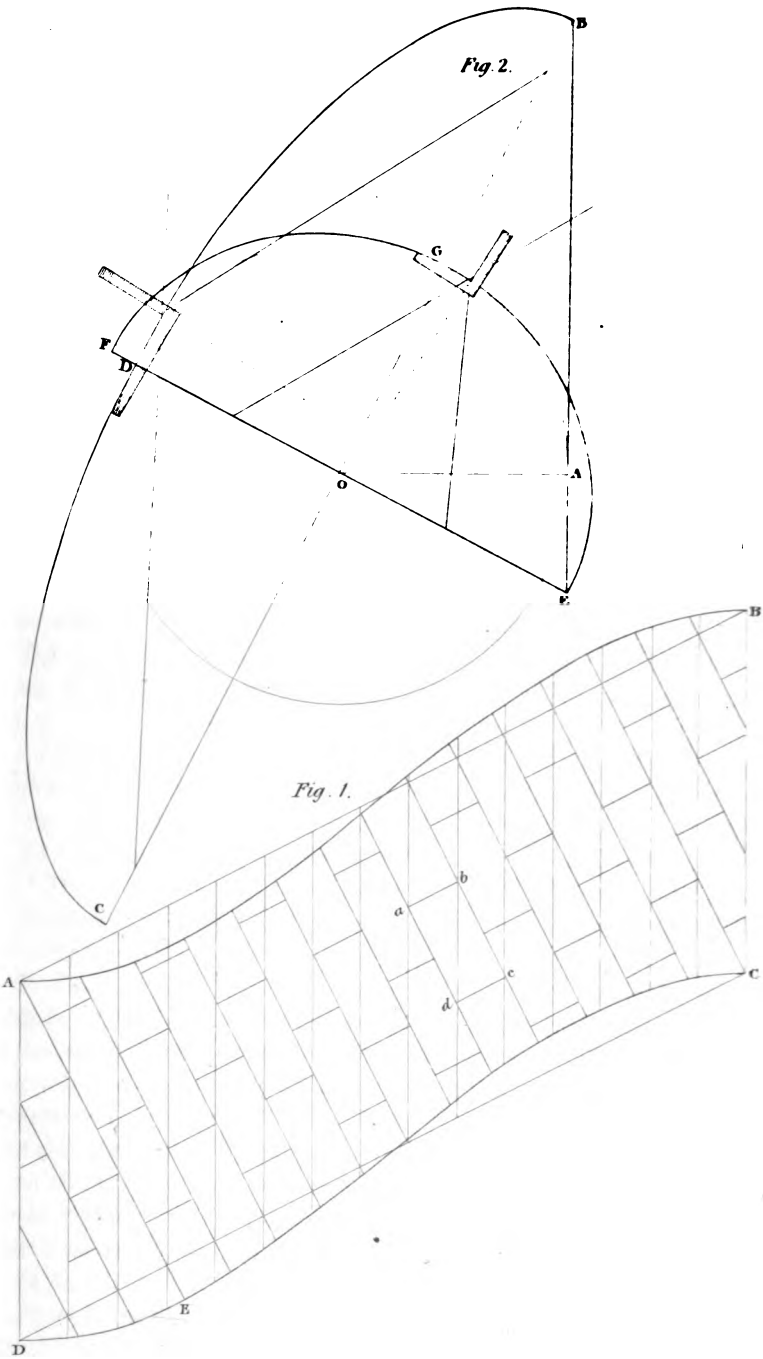
$$\begin{array}{r}
 28 \\
 28 \\
 \hline
 224 \\
 56 \\
 \hline
 13 \overline{)784} (60 \text{ feet 4 inches nearly} \\
 \underline{78} \\
 4 \\
 \underline{12} \\
 \hline
 )48(
 \end{array}$$

To find the angle of the joints of the face of the arch, and intrados of the oblique arch with spiral joints.

Let the semi-circular arc  $ABC$ , *Plate XX*, be a section of the intrados at right angles to the axis of the cylinder. Draw  $CD$  and  $AE$  perpendicular to the diameter  $AC$ . Draw  $AD$ , making an angle with  $CD$ , equal to the inclination which the plane of the face of the arch makes with the vertical plane which is parallel to the axis of the cylinder, and which passes through the springing line of the arch.

Find the edge  $DfG$  of the developement and face of the arch, or draw the curve  $DfG$  with a mould made from the developement before shown. Draw the face of the ring-stones  $AKD$ . Let it now be required to find the fourth joint from the point  $D$ . Make  $Df$  equal to the portion  $D4$  of the intrados  $AKD$ . Draw  $fl$  the developement of a part of the longitudinal spiral joint corresponding to the point  $4$  of the elliptic arc  $AKD$ . Draw the line  $st$  a tangent to the curve at  $f$ . To do this, we shall again repeat the process of which the principle has already been taught, viz. On  $CD$ , as a diameter, describe the semi-circle  $CqD$ , and draw  $fq$ , intersecting  $CD$  perpendicularly. Draw  $qr$  a tangent to the semi-circular arc at the point  $q$ , and make  $qr$  equal to the developement of the portion  $qD$  of the semi-circular arc. Draw  $rt$  perpendicular to  $CD$ , meeting  $CD$ , or  $CD$  produced in the point  $t$ . Through  $f$  draw the straight line  $ts$ , and  $ts$  will be a tangent to the curve at the point. By this means we have the angles which the spiral joints in the intrados make at the point  $4$  with the elliptic curve  $AKD$ .

To find the angle made by the normal and the curve, in *fig. 2*.





In *fig. 2* draw the straight line *ab*, and make *ab* equal to the radius of curvature of the elliptic arc AKD at the point 4. This radius would be near enough to make it the half of the half sum of the semi-parameters of the two axes.

But if greater nicety is required, let the radius of curvature be denoted by *r*, the semi-transverse axis OD or OA be denoted by *a*, and the semi-conjugate, which is the radius of the semi-circular arc ABC, be denoted by *b*, and let the distance *Op* be denoted by *x*; then will

$$r = \left\{ \frac{a^2 - (a^2 - b^2) \frac{x^2}{a^2}}{a \cdot b} \right\}^{\frac{1}{2}}$$

which will be exact to the number of figures found in the operation here indicated.

Having thus found the radius of curvature, either mechanically or by calculation, make *ab*, *fig. 2*, equal to that radius. From the point *a* as a centre, with the distance *ab*, describe the arc *bc*; and draw the straight line *bd* a tangent to the curve.

To find the angle made by a tangent plane to the cylindrical surface at the point 4, *fig. 1*, and the plane of the face of the arch.

Draw the straight line *4u* a tangent to the elliptic curve AKD at the point 4, and draw *4v* parallel to AD. Transfer the angle *u4v* to *abc*, *fig. 3*.

In *fig. 3*, at the point *b*, in the straight line *bc*, make the angle *cbd* equal to the angle DOP, *fig. 1*, which the axis makes with the plane of the face of the arch. Again in *fig. 3*, draw *ef* perpendicular to *ab*, intersecting *ab* in the point *a*. Draw *cd* perpendicular to *cb*, and *ce* perpendicular to *cf*. Make *ce* equal to *cd*, and join *ea*; then will the angle *eaf* be the inclination of the curved surface of the cylindrical intrados, and the face of the ring-stones.

We have now ascertained two sides, and the contained angle of a trehedral; in order to find the remaining parts, the third side of this trehedral is the angle of the joints of the intrados and face of the arch, by applying the proper curved moulds to the angular point; it is, however, rather unfavourable to our purpose, that the angle *abd*, *fig. 2*, is a right angle, and that the angles *lft* and *lfs*, *fig. 1*, differ but in a very small degree from right angles. As from this circumstance the principle cannot be made evident, we shall therefore suppose, that these angles have at least a certain degree of obliquity.

In *figs. 4* and *5*, let ABC equal to angle *lft*, *fig. 1*, and ABD, *figs. 4* and *5*, equal to the angle *abd*, *fig. 2*: thus, in *figs. 4* and *5*, draw *De*, intersecting AB in *f*, or producing *De* to meet AB in *f*. At the point *f* in the

straight line  $ef$  in *fig. 5*, make the angle  $efg$  equal to the angle  $eac$ , *fig. 3*; or in *fig. 4*, make the angle  $efg$  equal to the supplement of the angle  $eaf$ . In *figs. 4* and *5*, draw  $ek$  perpendicular to  $BC$ , meeting  $BC$  in  $i$ , or  $BC$  produced in  $i$ . Draw  $eg$  perpendicular to  $ef$ , and  $eh$  to  $eK$ . Make  $eh$  equal to  $eg$ , and join  $hi$ . Make  $iK$  equal to  $ih$ , and join  $BK$ ; then will the angle  $CBK$  be the angle of the joints of the intrados and face of the arch.

When each of the given sides is a right angle, then the remaining side of the trehedral will be the same as the contained angle; that is, the angle of the joints of the intrados and face of the arch, will be the same as the angle  $eaf$ , *fig. 3*. In this case, no lines are necessary in order to discover the angle of the joints.

In order to apply the angle  $CBK$ , one of the lines which applies to the face must be straight, and the curved edge shown by the bevel at  $D$  of the preceding plate must be so applied, that the other leg of the bevel may be a tangent to the curve at the angular point  $B$ , and this will complete what is necessary in the construction of an oblique arch with spiral joints.

---

### SECTION III.

#### A CIRCULAR ARCH IN A CIRCULAR WALL.

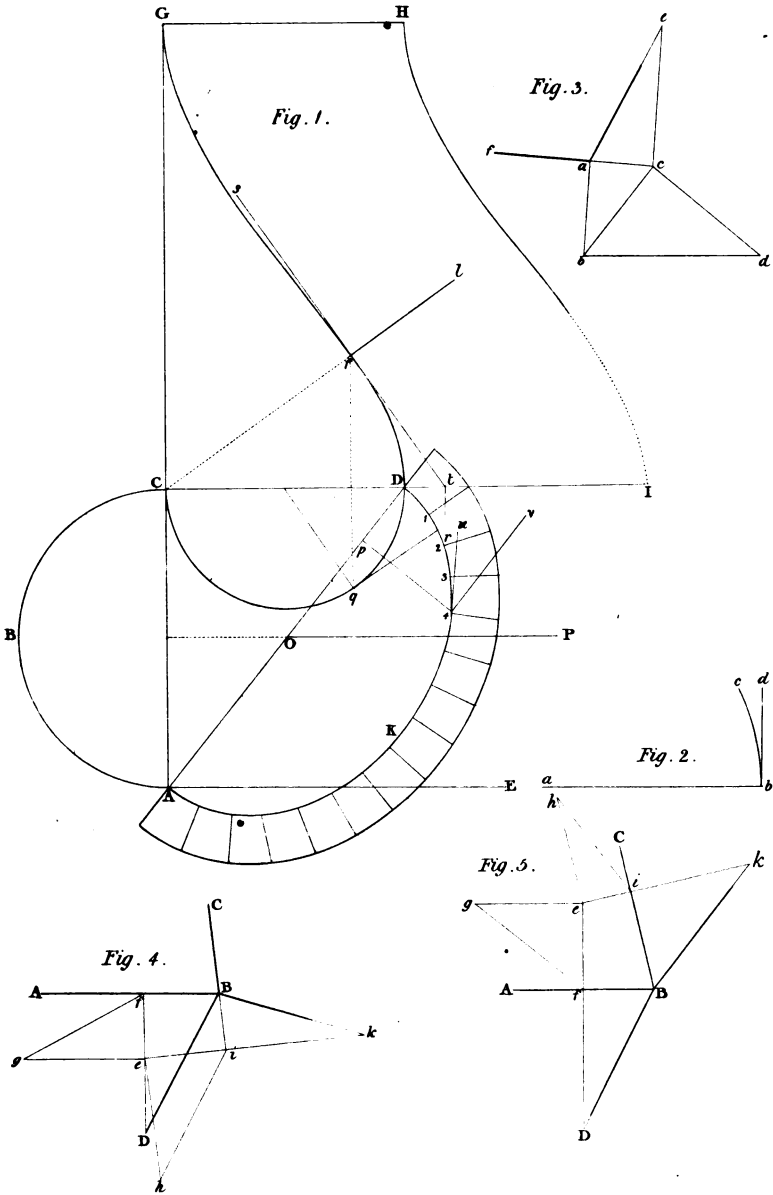
##### PROBLEM I.

To execute a semi-cylindric arch in a cylindric wall, supposing the axes of the two cylinders to intersect each other. Given the two diameters of the wall, and the diameter of the cylindric arch, and the number of arch-stones.

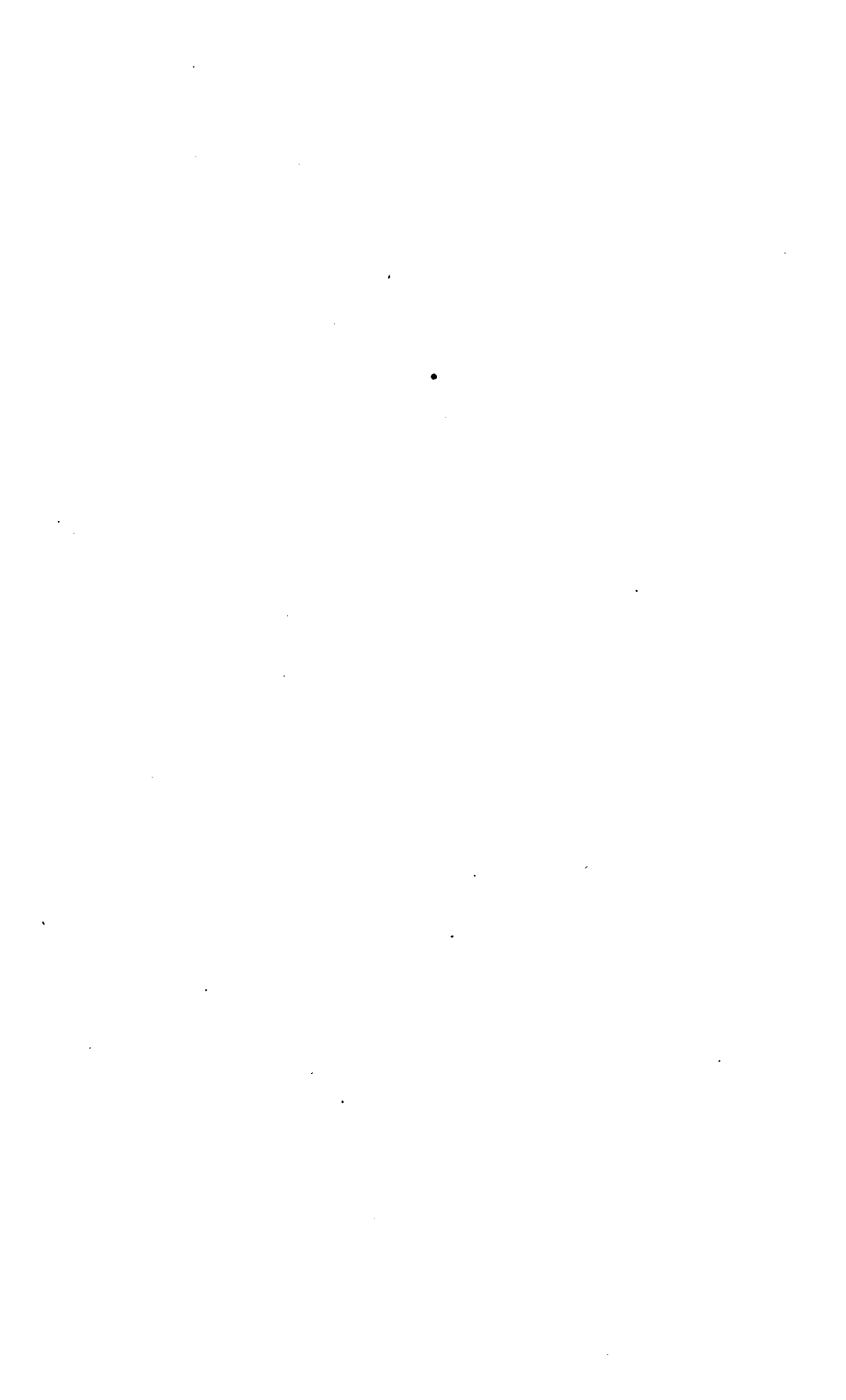
*Fig. 1, plate XXI.* From any point  $o$  with the radius of the inner circle of the wall describe the circle  $ABC$ , or as much of it as may be necessary; and from the same point  $o$ , with the radius of the exterior face of the wall describe the circle  $DEF$ , or as much of it as may be found convenient.

Apply the chord  $AB$  equal to the width of the arch, and draw  $DA$  and  $EB$  perpendicular to  $AB$  or  $DE$ ; then  $ABED$  will be the plan of the cylindric arch.

Draw  $op$  perpendicular to  $AB$ , and draw  $tv$  perpendicular to  $op$ . From the point  $p$  as a centre, with the radius of the intrados of the arch describe the semi-circular arc,  $qrs$ ; and from the same point  $p$ , with the radius of the extrados, describe the semi-circular arc  $tuv$ . Divide the arc  $qrs$  into as many equal parts as the arch-stones are intended to be in num-







ber, that is, here into nine equal parts. From the centre  $p$ , draw lines through the points of division to meet the curve  $tuv$ ; and these lines will be the elevation of the joints; and the joints, together with the intradosal and extradosal arcs, will complete the elevation of the arch.

Find the developement, *fig. 2*, as in *fig. 3*, *plate IX*, and the parallel equi-distant lines to the same number as the joints in the elevation, will be the joints of the soffits of the stones; and the surfaces comprehended by the parallel lines, and the edges of the developements, will be the moulds for shaping the soffits of the stones.

In *fig. 3*. Let  $AB$  be equal to the diameter of the external cylinder. Draw  $AC$  and  $BD$  each perpendicular to  $AB$ . Bisect  $AB$  in  $p$ , from which describe the intradosal and extradosal arcs, and draw the joints as in *fig. 1*. Produce the joints to meet  $AC$  or  $BD$ , in the point  $e, f, g$ , &c.; then it is evident that since every section of a cylinder is an ellipse, the lines  $pA, pe, pf, pg$ , &c. are the semi-transverse axis of the curves, which form the joints in the face of the arch, and that these curves have a common semi-conjugate axis equal to half the diameter of the cylinder.

Therefore, upon any indefinite straight line  $pQ$ , *fig. 4*, set off the semi-axis  $pA, pe, pf, pg$ , &c. and draw  $pB$  perpendicular to  $pQ$ . From  $p$ , with the radius  $pA$ , describe an arc  $AB$ . On the semi-axes  $pe$  and  $pB$ , describe the quadrantal curve of an ellipse; in the same manner describe the quadrantal curves  $fB, gB$ , &c. Make  $pq$  equal to  $pq$ , *fig. 3*, and in *fig. 4* draw  $qt$  parallel to  $pB$ , intersect the curves  $AB, eB, fB$ , &c. in the points  $i, k, l$ , &c.; then  $him, hkn, hlo$ , &c. are the bevels to be applied in forming the angles of the joints: viz. the bevel  $him$  is that of the impost, the straight side  $hi$  being applied upon the soffit or intrados; and the curved part  $im$  horizontally to the curve of the exterior side of the wall: the point  $k$ , of the bevil  $hkn$ , *fig. 4*, applies to the point  $k$ , *fig. 3*, so that  $kh$  may coincide with the joint upon the intrados, and the curved edge  $kn$ , *fig. 4*, upon the face  $kn$ , *fig. 3*; and so on.

As to the angles which the beds of the stones make with the intrados, they are all equal, and may be found from the elevation  $svyx$ , *fig. 1*; which is the same as a section of one of the arch-stones perpendicular to any one of the joints on the soffits.

The faces of the stones must be wrought by a straight edge, by perpendicular lines. The first thing to be done is to work one of the beds; secondly, work the intrados—at first as a plane surface at an angle  $sxy$ , or  $xsv$ , *fig. 1*; then gauge off the bed of the soffit, and work the other bed of the stone by the angle  $vsx$  or  $yxv$ ; then apply the proper soffit, 1, 2, or 3, *fig. 2*; and lastly, the two moulds in *fig. 4*.

## SECTION IV.

## A CONIC ARCH IN A CYLINDRIC WALL.

## PROBLEM I.

To execute a semi-conic arch in a cylindric wall, supposing the vertex of the cone to meet the axis of the cylinder. Given the interior and exterior diameters of the wall, the length of the axis of the cone, and the diameter of its base.

## EXAMPLE I.

From the point  $o$ , *plate XXII*, with the radius of the interior surface of the wall describe the arc  $ABC$ , and from the same point  $o$ , with the radius of the exterior surface, describe the arc  $DEF$ , and the area between the arcs  $ABC$  and  $DEF$  will contain the plan of the wall.

Draw any line  $op$ , and make  $op$  equal to the length of the axis of the cone. Through  $p$  draw  $tv$  perpendicular to  $op$ . From  $p$  as a centre, with the radius of the base of the cone, describe the semi-circle  $qrs$  meeting  $tv$  in the points  $q$  and  $s$ . Divide the arc  $qrs$  into as many equal parts as the arch-stones are to be in number, that is, in this example, into nine equal parts. Through the points of division draw the joint lines, which will of course radiate from the centre  $p$ . The extradosal line  $tuv$  is here described, as we here suppose the cone to be of an equal thickness, and consequently the axis of the exterior cone longer than that of the interior.

From the points 1, 2, 3, &c. where the lower ends of the joints of the arch-stones meet the intradosal arc, draw lines perpendicular to  $tv$ , meeting  $tv$  in the points  $i, k, l, m$ , &c. From these points draw lines to the vertex of the cone at  $o$ , meeting the arc  $DE$  of plan of the wall under the arch, in the points  $a, b, c, d$ , &c. Draw the lines  $ae, bf, cg, dh$ , &c., parallel to the chord  $DE$ , to meet  $op$  in the points  $e, f, g, h$ , &c. and let  $DE$  meet  $op$  in  $w$ . In *fig. 2*, draw the straight line  $AB$ , in which take the point  $p$  near the middle of it, and make  $pA, pB$ , each equal to the radius of the exterior surface of the cylindric wall. Through the points  $A$  and  $B$  draw  $fg, fg$ , perpendicular to  $AB$ .

From the point  $p$  as a centre, with any radius, describe a semi-circular

Fig. 1.

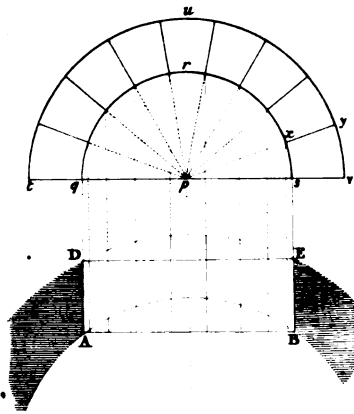


Fig. 2.

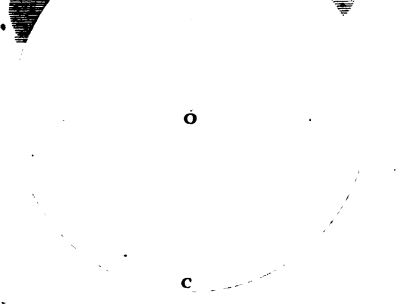
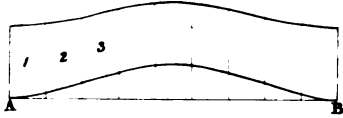


Fig. 4.

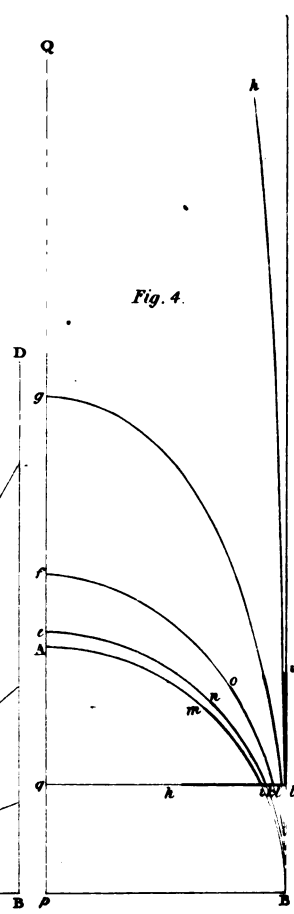
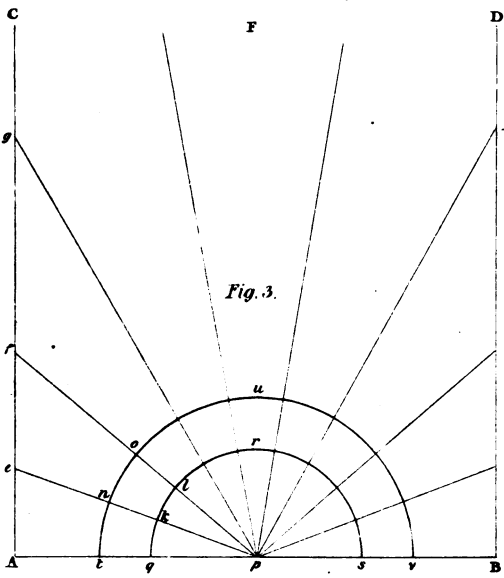


Fig. 3.





arc, and divide it into nine equal parts as before. Through the points of division draw the radiating lines to meet  $fg$  in the points  $e, f, g, \&c.$  From  $fig. 1$  transfer the distances  $Em, ae, bf, cg, \&c.$  to  $pq, pr, ps, pt, \&c.$  on each side of the point  $p$ . Draw the perpendiculars  $rk, sl, tm, \&c.$  to  $AB$ , which will intersect with the radials  $pe, pf, pg, \&c.$  in the points  $k, l, m, \&c.$ ; through the points  $k, l, m, \&c.$  on each side draw a curve, and this curve will be the elevation of the intrados of the arch.

*Fig. 3* exhibits another method by which the heights of the points  $k, l, m$ , might have been found. This method is as follows:—Upon a straight line  $ab$ , and from the point  $a$  make  $ab', ac, ad, ae, \&c.$  and  $af$  respectively equal to  $oi, ok, ol, \&c. fig. 1$ . In *fig. 3*, draw the straight lines  $bg, ch, di, ek, fo$ , perpendicular to  $ab$ . Make  $bg, ch, di, ek$ , respectively equal to the heights  $i1, k2, l3, m4$ . Draw the straight lines  $ag, ah, ai, ak$ , intersecting  $fo$  in the points  $l, m, n, o$ .

In *fig. 2*, make  $rk, sl, tm, un$ , respectively equal to  $fl, fm, fn, fo, fig. 2$ ; and thus the points  $k, l, m, \&c.$  are found by a different method, which is more accurate for ascertaining the points near the top, as the radials and the perpendiculars intersect more and more obliquely as they approach the summit.

In some line  $pQ, fig. 4$ , make  $pA, pe, pf, pg, \&c.$  equal to  $pA, pe, pf, pg, \&c. fig. 2$ . Draw  $pB$  perpendicular to  $pQ$ . From  $p$  with the radius  $pA$ , describe the arc  $AB$ . With the several semi-axes  $pe, pB; pf, pB; pg, pB, \&c.$  describe the quadrantal elliptic curves  $eB, foB, \&c.$  Draw  $Bu$  parallel to  $AQ$ . Make the angle  $Bpt$  equal to the angle  $PEop, fig. 1$ ; and let  $i, k, l, \&c.$  be the points where  $pt$  intersects the curves  $AB, eB, fB, \&c.$  Then the bevels of the joints are  $him, hkn, hlo, \&c.$

Now, if  $EBCF, fig. 1$ , be the developement of the intrados, with the joints drawn on it, we shall have the soffits of the stones.

In *fig. 5*, draw  $ab$  and  $ac$  at a right angle with each other. Make  $ab$  equal to the radius of the base of the cone, and  $ac$  equal to the length of its axis. Join  $bc$ . From  $a$ , with the radius  $ab$ , describe an arc,  $dbe$ . Make  $bd$ , equal to the chord of the intrados of one of the arch-stones. Produce  $be$  to any point  $f$ , and draw  $fg$  perpendicular to  $ab$ , meeting  $ab$  in  $g$ . Draw  $gi$  perpendicular to  $bc$ , and  $gh$  parallel to  $bc$ . Make  $gh$  equal to  $gf$ , and join  $hi$ ; then  $hig$  is the angle which the soffits of the stones, when wrought as planes, make with the beds.

#### EXAMPLE II.

To construct an arch in a cylindric wall, of which arch the intrados is a uniform conic surface, so that the axes of

conic and cylindric surfaces may meet or intersect each other.

In *fig. 1*, which is the plan and elevation of the arch, the elevation being above, and the plan below as usual, let  $AD$  be considered as the ground-line, and  $ABD$  the elevation of the base of the cone, which base is supposed to be a tangent plane to the surface of the wall; let  $bd$ , parallel to the ground-line  $AD$ , be the half plan of the base of the cone;  $a'b'c'hgf$  the plan of the cylindric face of the wall; and  $d'rmkl$  the plan of the intersections of the conic and the intermediate cylindric surfaces which terminate the interior of the aperture of the arch.

First, to find the elevation of the intersections of the cylindric face of the wall and the conic surface of the intrados. Having divided the semi-circular arc  $DBA$ , into the equal parts  $D1', 1'2', 2'3', \&c.$  at the points  $1', 2', 3', \&c.$ , draw the connecting lines  $Dd, 1'1, 2'2, 3'3, \&c.$  meeting  $bd$  in the points in  $d, 1, 2, 3, \&c.$  Draw  $bc$  perpendicular to  $bd$ , and make  $bc$  equal to the axis of the conic surface.

Draw the straight lines  $dc, 1c, 2c, \&c.$  meeting the plan of the face of the wall in the points  $f, g, h$ , and draw the connecting lines  $fF, gG, hH, \&c.$  intersecting the lines  $FC, GC, HC, \&c.$  in the points  $F, G, H, \&c.$  A sufficient number of points being found in the same manner, through these points draw the curve  $EBF$ , and the curve  $EBF$  will be the elevation of the line of intersection of the conic and cylindrical surfaces required.

To find the elevation of the intersection of the conic surface with the intermediate concentric cylindric surface. Let the arc  $d'rk$  be the plan of this concentric cylindric surface, having the same centre as the arc  $a'b'f$ , which is the plan of the cylindric surface of the wall; and let the straight lines  $dc, 1c, 2c, \&c.$  meet the arc  $d'rk$  in the points  $k, l, m, \&c.$ ; then, if connectants be drawn from the points  $k, l, m$ , to the elevation to meet the radial lines, we shall thus obtain the elevations  $K, L, M$ , of the corresponding points. Let us now suppose that a sufficient number of points are thus found, and the curve  $IJK$  drawn through these points; then  $IJK$  will be the elevation of the intersection of the conic and cylindric surfaces required.

Let us now construct a mould for one of the joints, suppose for the second joint  $UX$ , in the elevation. Draw the connectants  $Uu, Vv, Ww, Xx$ , meeting the line  $db$  prolonged in the points  $u, v, w, x'$ , and prolong the connectants  $Uu, Vv, Ww, \&c.$  to meet the plan of the exterior cylindric surface of the wall, in the points  $a', b', c'$ ; and the connectant  $Xx$  to meet

Fig. 1.

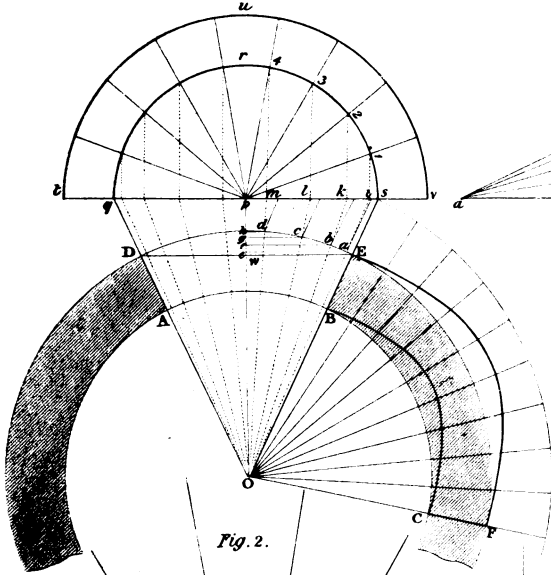


Fig. 3.

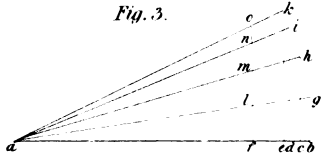


Fig. 2.

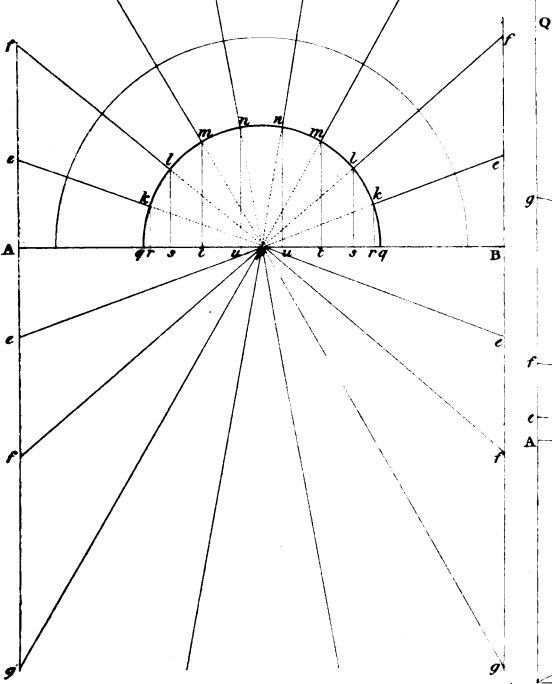


Fig. 5.

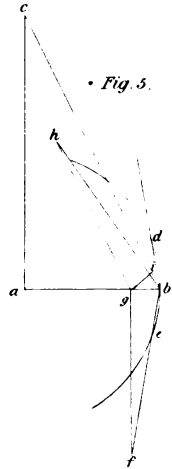
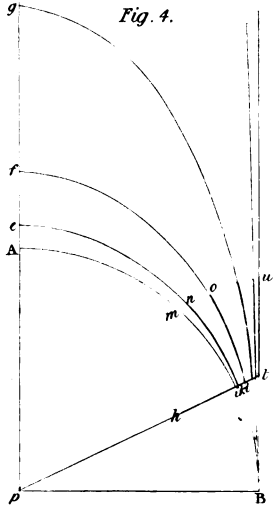


Fig. 4.







the plan of the intermediate cylindric surface in the point  $d'$ , and the plan  $est$  of the inner cylindric surface on the point  $e$ .

Suppose No. 1, No. 2, No. 3, No. 4, to be the figures of the moulds of the first, second, third, and fourth joints from the springing-line; and as it is proposed to find the figure of the joint, No. 2, draw the straight line  $ux$ , No. 2, and in  $ux$  take  $uv, vm, nx$ , respectively equal to  $UV, VW, WX$ , in the elevation, *fig. 1*. Draw in No. 2,  $ua, vb, vc, xe$ , perpendicular to  $ux$ , and make  $ua, vb, vc, xd, xe$ , respectively equal to  $ua', vb', vc', xd', xe'$ , on the plan, *fig. 1*. Through the points  $a, b, c$ , No. 2, draw a portion of an ellipse, and we shall have the edge of the joint that meets the surface of the wall. Draw the straight line  $cd$ , No. 2, and this straight line will be the intersection of the joint and the conic surface; the portion  $de$ , No. 2, will be the section of the inner cylindric surface.

The remaining lines of the figure of the mould will be found in the same manner, and thus we shall have the complete figure, No. 2, of the mould.

*Fig. 2*, exhibits the developement of the soffit of the horizontal cylindric surface next to the aperture, upon the supposition that the face of the ring-stones are first wrought in horizontal lines from the curve  $EBF$ , to meet the inner horizontal cylindric surface, and afterwards reduced to the conic form. The breadth of the stones in this developement are not equal, but increase from each extreme to the middle.

The mould for the springing-stone is the same as the plan of the jamb.

It will be necessary to work the arch-stones into prisms, of which the ends are the sections of the stones in the right section of the arch, viz. the same as the compartments adjacent to the curve in the elevation. The prisms being formed, draw the figure of the soffit of the stone upon the surface intended for the same. Then apply the joint-mould upon each face of the stone intended for the joint, and draw the figure of the joints; then reduce the end of the stone which is to form a part of the face of the arch in such a manner that when the arch-stone is placed in the position which it is to occupy, or in a similar situation, a straight edge, applied in a horizontal position, may have all its points in contact with the surface of the face of the stone now formed. The face being thus formed, the conic surface must also be formed by means of a straight edge, in such a manner that all points of the straight edge must coincide with the surface when the straight edge is directed to the centre of the cone.

## CHAPTER IV.

## CONSTRUCTION OF THE MOULDS FOR SPHERICAL NICHES, BOTH WITH RADIATING AND HORIZONTAL JOINTS, IN STRAIGHT WALLS.

WHEN niches are small, the spherical heads are generally constructed with radiating joints meeting in a straight line, which passes through the centre of the sphere perpendicularly to the surface of the wall, when the wall is straight; but when it is erected upon a circular plan, the line of common intersection of all the planes of the joints is a horizontal line tending to the axis of the cylindric wall.

Niches of large dimensions will be more conveniently constructed in horizontal courses, than with joints which meet in the centre of the spheric head; since in the latter, the length and breadth of the stones are always proportional to the diameter or radius of the sphere, and therefore when the diameter is great, the stones would be difficult to procure.

The construction of niches depend also upon the nature and position of the surface from which they are recessed; viz. a spherical niche may be made in a straight wall, either vertical or inclined; or it may be constructed in a circular wall, or a spherical surface, such as a dome.

This subject, therefore, naturally divides itself under several heads or branches; the principal are, a spherical niche in a straight wall, with radiating joints; a spherical niche in a straight wall, in horizontal courses; a spherical niche in a circular wall, with radiating joints; a spherical niche in a circular wall, in horizontal courses; and, a spherical niche in a spherical surface or dome.

Fig. 1.

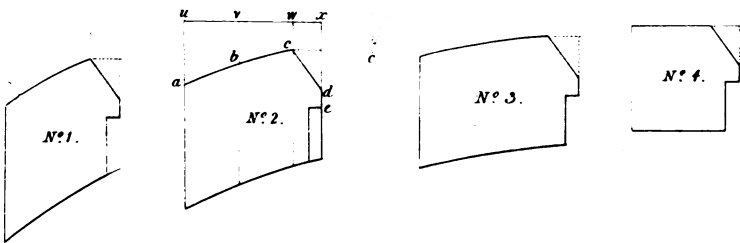
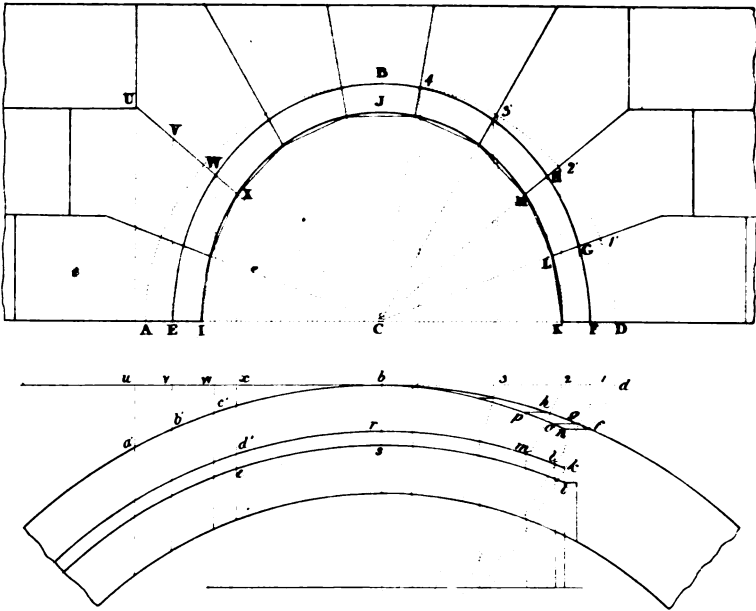
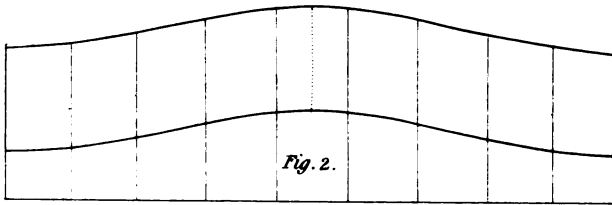
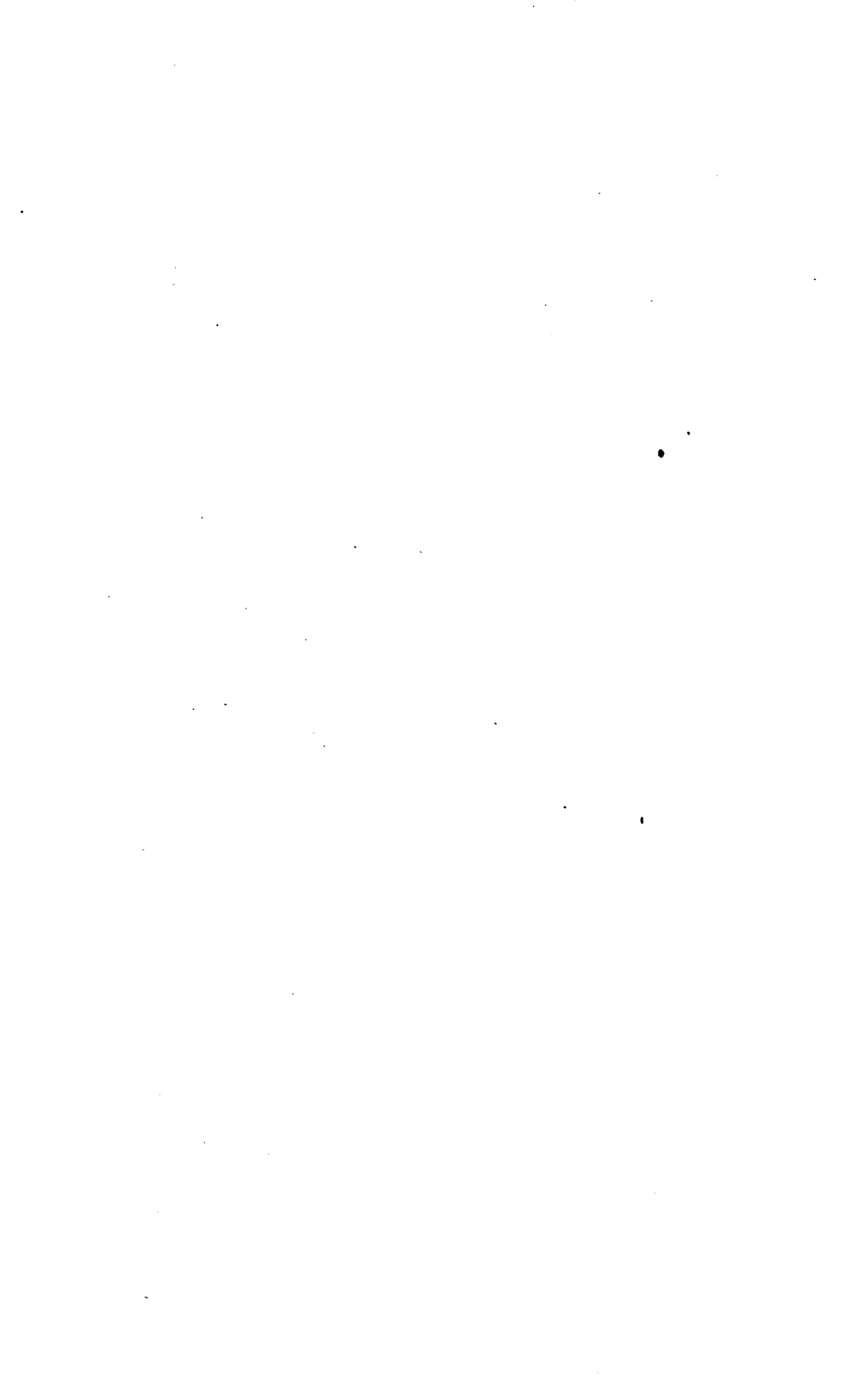
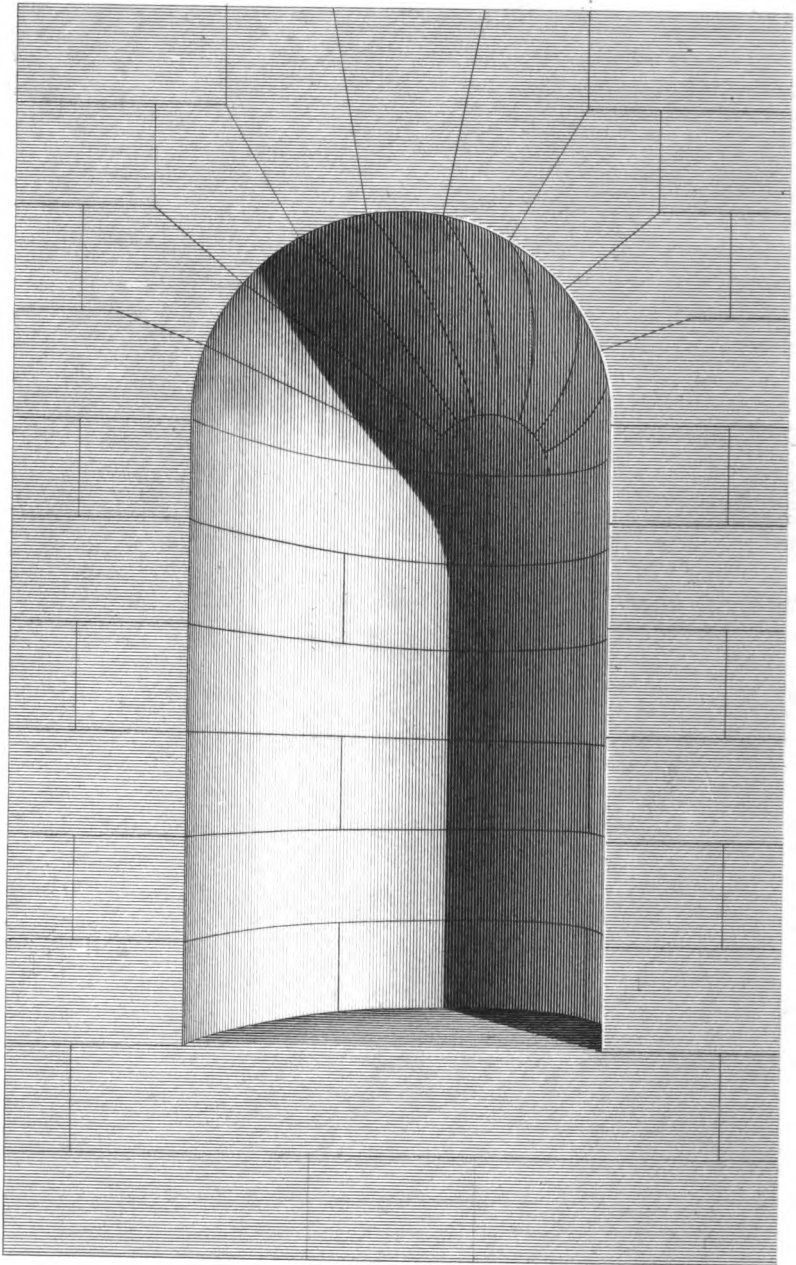


Fig. 2.









## SECTION I.

## EXAMPLES OF NICHES, WITH RADIATING JOINTS, IN STRAIGHT WALLS, AS IN PLATE XXIV.

NICHES of very small dimensions will be easily constructed in two equal cubical stones, hollowed out to the spherical surface, with one vertical joint; the portion of the spherical surface, formed by both stones, being one fourth of the entire surface of the sphere.

*Fig. 1, plate XXV.*, is the elevation, *fig. 2*, the plan, and *fig. 3*, the vertical section perpendicular to the face of the straight wall of such a niche.

The first operation is to square the stone; viz. to bring the head of each stone to a plane surface, then the vertical joints and the upper and lower beds to plane surfaces at right angles with the surface which forms the head.

The two stones as hollowed out are shown at Nos. 3 and 4. To show how they are wrought, we will commence with one of the stones after being brought to the cubical form. Let this stone be No. 3. In the solid angle of the stone formed by the head, the vertical joint and the lower bed meeting in the point *p*, apply the quadrantal mould, No. 2, upon each side, so that the angular point of the two radiants may coincide with the point *p*, and one of the radiants upon the arris of the stone which joins the point *p*; then if the face of the quadrantal mould coincide with the surface of the stone, the other radiant line will also coincide, because the angle of the mould, and all the angles of the faces of the stone, are right angles.

By this means we obtain by drawing round the curved edge of the mould, the three quadrantal arcs *abc*, *agh*, and *cih*. The superfluous stone being cut away, the spherical surface will be formed by trial of the mould, No. 2.

*Fig. 1, plate XXVI.*, is the elevation, and *fig. 2*, the plan of a niche in a straight wall.

The elevation, *fig. 1*, not only shows the number of stones which must be odd, and the number of radiating joints which must in consequence be one less than the number of stones, but also the thickness of these stones, and the moulds for forming the heads and opposite sides.



The head of the niche being spherical, makes it a surface of revolution. It follows therefore, that the sections through the joints are equal and similar figures; hence, if all the joints were of one length, one mould would be sufficient for the whole; but since in this example, they are of different lengths, every two joint moulds will have a common part; and thus if the mould for the longest joint be found, each of the other moulds will only be a part of the mould thus found.

In order to ascertain the mould for each joint, the longest being AD, *fig. 1*, extending from the centre to the extremity of the stone upon one side of the plan, the next longest is AF, extending from the centre to the extremity of the keystone, and the shortest AG.

Upon PQ, *fig. 1*, make AF equal to AF'', and AG equal to AG'. Perpendicular to PQ draw Dd, Ff, Gg, meeting the front line RS of the plan *fig. 2*, in the points *d, f, g*, intersecting the back line of the stone in the points *m, n, o*: then will *hikedm* be the mould for the first stone raised upon the plan, *hikefn* the mould for the joint on each side of the keystone, *hikego* the mould for the first stone above the springing line. These moulds are shown separately at I, II, III, and identified by similar letters.

Nos. 1, 2, 3, exhibit the first, second, and third stones of the niche as if wrought to the form of the spherical surface; No. 3 being the keystone; therefore the two remaining stones are wrought in a reverse order to the stones exhibited at No. 1, and No. II.

The first part of the operation is to work the stones into a wedge-like form, so that the right sections of these stones may correspond to the figures formed by the radiations of the joints to the centre A, *fig. 1*, and by the horizontal and vertical joints of the stones adjacent to those which form the niche; for this purpose, two moulds for each head will be necessary, viz. one whole mould must be made for each stone, and one mould for the part within the circle, which will apply to every stone, in order to form the extent of the part within the recess: thus a mould formed to the sectoral frustrum EE'K'K in the elevation, *fig. 1*, will apply alike to all stones as will be shown presently.

The next thing is to form the moulds K'KDSG', K''K'G'TF'' and K''K''F''F'' of the heads, the application of these moulds is as follows:—

Having wrought the under bed, the head and back of each stone, and having formed a draught next to the edge of the bed, upon the side which is to lie upon the cylindrical part in the centre, at a right angle with the head, apply the mould K'KDSG', *fig. 1*, upon the head of the stone, No. 1, so that the straight edge KD may be close upon the bed of the stone, and draw by the other edges of the mould; thus applied the

Fig. 3.

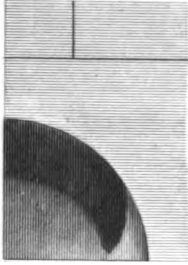
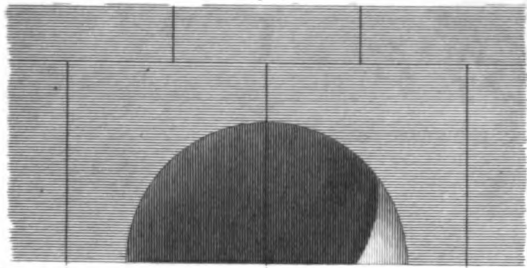


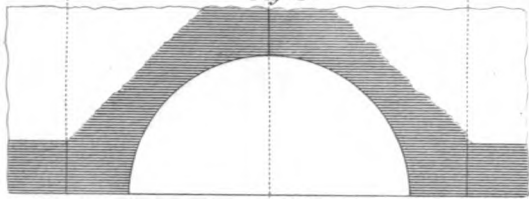
Fig. 1.



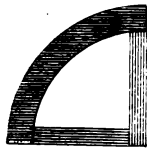
N<sup>o</sup> 1.



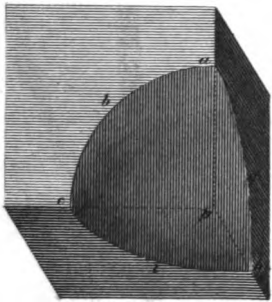
Fig. 2.



N<sup>o</sup> 2.



N<sup>o</sup> 3.



N<sup>o</sup> 4.

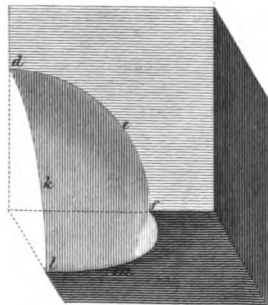




Fig. 1.

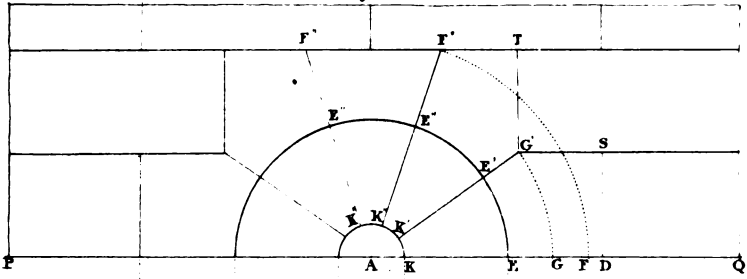
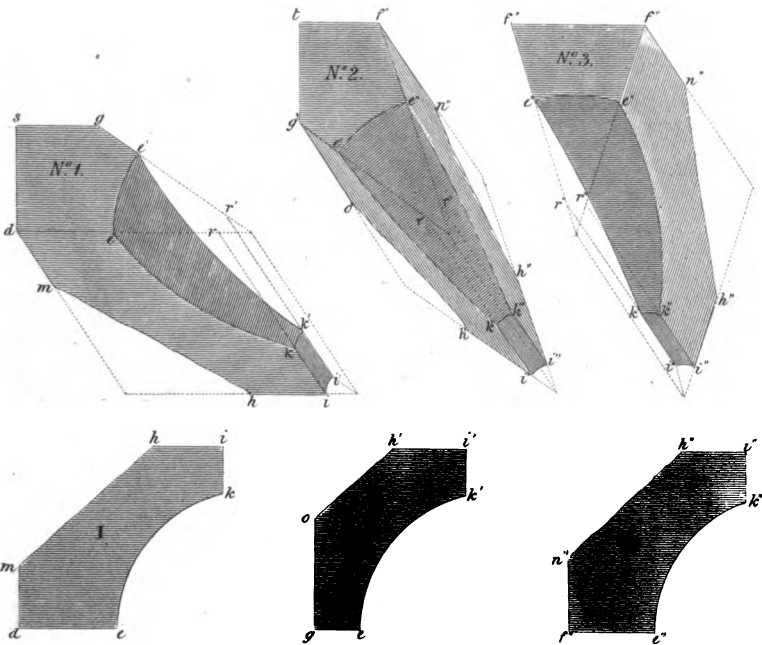
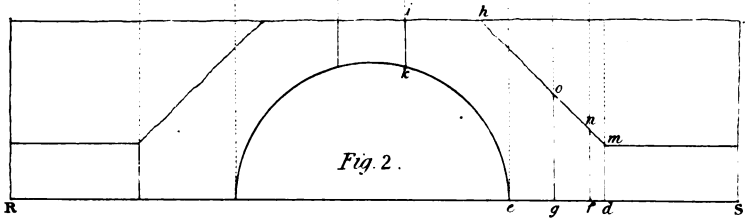
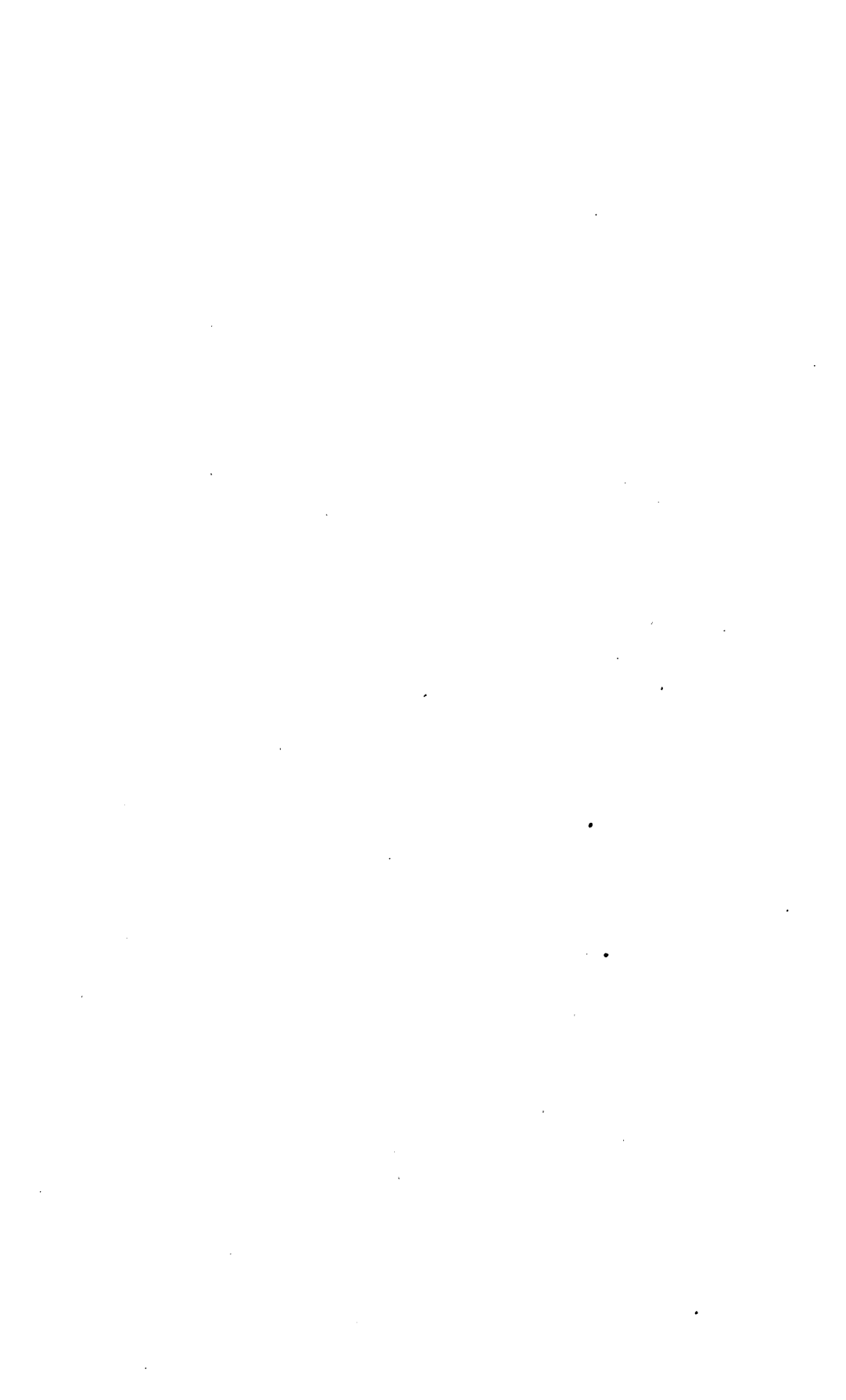


Fig. 2.







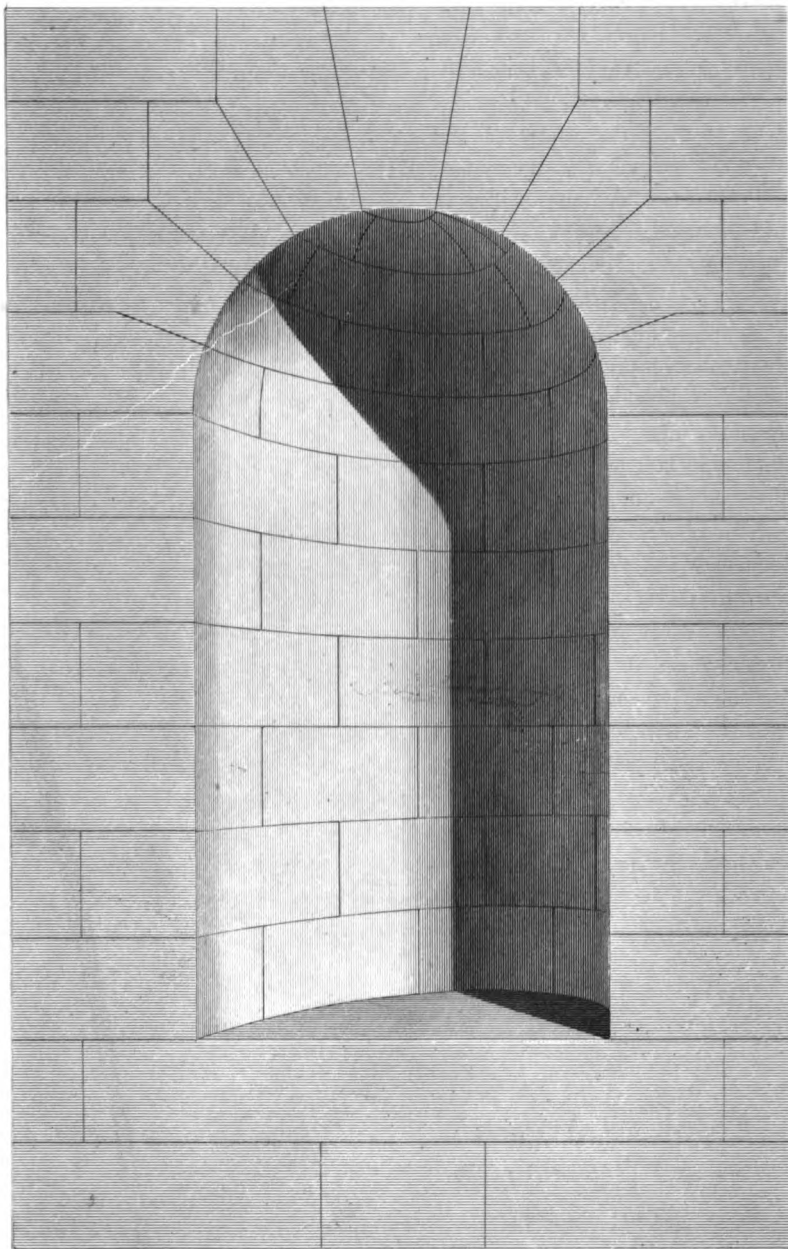


figure *r'rdsg*; and, in the same line *rd*, close to the bed, apply the mould K'KEE', *fig. 1*, and by the other edges of this mould draw the figure *r'ree'*. Apply the mould K'KDSG', to the opposite, or parallel side of the stone, close to the bed, and draw a similar and equal figure as was done by the same mould when it was applied to the head; this done, work the upper bed of the stone.

Proceed in like manner with the stones exhibited at No. 2 and No. 3, and similarly with the stones on the left-hand side of the arch; the stones No. 1 and No. 2, answering to those on the right hand of the key-stone.

In order to show the application of the moulds marked I. II. III. at the bottom of the plate, taken from the plan, *fig. 2*; the mould I. applies to the under bed of the stone, No. 1; the next mould II. applies upon the upper bed of No. 1, and upon the under bed of No. 2; and the mould III. applies upon the upper bed of No. 2, and upon each side of the keystone, No. 3.

As every arch has both a right and left-hand side, and as every joint is formed by the surfaces of two stones, every mould has four applications, one on each of the four stones.

In order to render these applications of the moulds I. II. III. as clear as possible, the corresponding situations of the points marked upon each stone by each respective mould, are marked by similar letters to those on the moulds I. II. III. or their correspondents on the plan, *fig. 2*, viz. on the under bed of the stone, No. 1, will be found the letters *h, i, k, e, d, m*, as in the mould I.; upon the under bed of No. 2, will be found *h', i', k', e', g', o'*; as also upon the upper bed, of No. 1, *i', k', e', g'*, and upon the right hand side of the keystone, No. 3, will be found the letters *h'', i'', k'', e'', f'', n''*, as also similar letters upon the upper bed, No. 2, to those of the mould III.

---

## SECTION II.

### *Examples of Niches in straight Walls with horizontal Courses, as in Plate XXVII.*

*Plate XXVIII.* Let *fig. 1* represent a niche with horizontal courses, No. 1 being the elevation, exhibiting three arch-stones on each side of the key-stone, and No. 2 the plan, consisting of two stones, making together a semicircle, each being one quadrant.



The heads of the stones in the wall, on the right-hand side of the arch, which also form a portion of the concave surface, are ABCDE, FDCGHI, HGKLM, and the key-stone LKKL. Round each of these figures circumscribe a rectangle, so that two sides may be parallel and two perpendicular to the horizon: thus round the head of the stone ABCDE circumscribe the rectangle ANOE', round the figure FDCGHI, the head of the second stone, circumscribe the rectangle PQRI, &c.

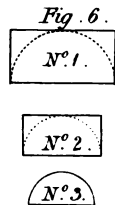
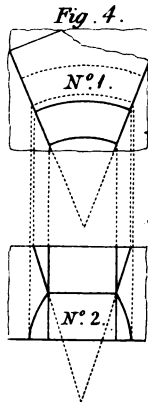
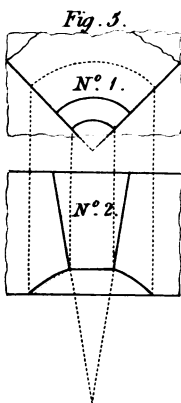
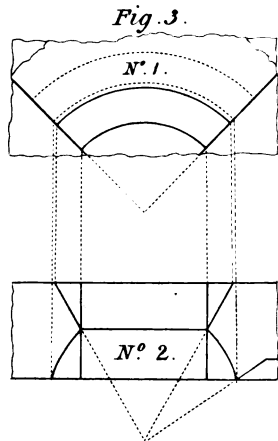
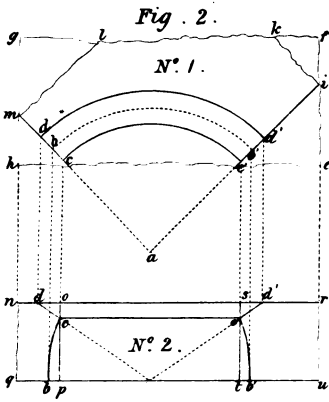
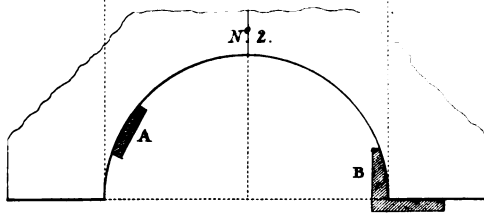
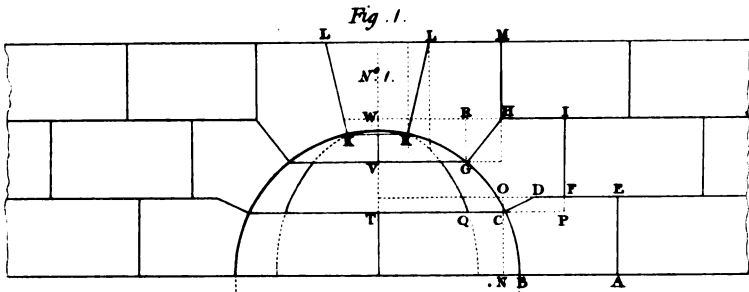
Draw the straight lines  $am$ , and  $ai$ , *fig. 2*, No. 1, forming a right angle with each other; from the point  $a$  as a centre, with the radius  $TC$ , *fig. 1*, describe the arc  $cc'$ , meeting the lines  $am$  and  $ai$  in the points  $c, c'$ .

Let the quadrangular figure  $hgfe$ , No. 1, be considered as the upper bed of a stone, which, as well as the lower bed, is wrought smooth, these two surfaces being parallel planes at a distance from each other equal to the line  $AE$  or  $NO$ , *fig. 1*. Moreover, let  $mcc'ikl$  be considered as a mould made to the figure before described and laid flat on the upper bed of the stone in its true position, the points  $c, c'$  of the mould being brought as near to the side  $he$  as will just leave a sufficient quantity of stone, in order to work it complete. By the edges of the mould thus placed draw the curve  $cc'$ , the straight lines  $cm$  and  $c'i$ , and the rough edges  $ik$  and  $ml$ .

Perpendicular to the upper bed, and along the arc  $cc'$ , cut the stone so as to form a surface perpendicular to the upper bed, and the surface thus formed will necessarily be cylindric; through each of the straight lines  $cm$  and  $c'i$ , cut a surface perpendicular to the said upper bed, and these surfaces will be the planes of the vertical joints, and will be at a right angle with each other; then with a guage, of which the head is made to the cylindric surface, and which is set to the distance  $OD$ , *fig. 1*, No. 1, draw the curve line  $dd'$  on the upper bed of the stone. Upon the lower bed of the stone, with the guage set to the distance  $NB$ , draw the arc  $bb'$ .

The thickness of the stone is exhibited at No. 2, *fig. 2*, the upper bed being represented by the line  $nr$ , and the lower bed by the line  $qu$ , so that  $nr$  and  $qu$  are parallel lines, the distance between them being equal to the thickness of the stone, *viz.* equal to  $AE$ , *fig. 1*, No. 1. Lastly, with a plane or common guage set to the distance  $NC$ , *fig. 1*, No. 1, draw the line  $cc$  on the cylindric surface, *fig. 2*, No. 1.

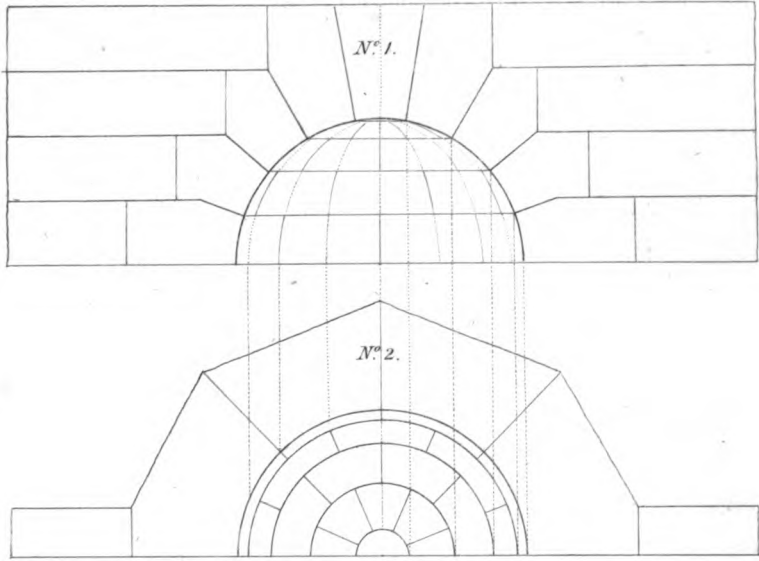
Now, in *fig. 2*, the line  $dd'$ , No. 2, represents the arc  $dd'$ , No. 1;  $cc'$ , No. 2, represents the arc  $cc'$ , No. 1; and  $bb'$ , No. 2, represents the arc  $bb'$ , No. 1: so that the stone must be cut away between the line  $dd'$  on the upper bed, and  $cc'$  on the cylindric surface, by means of a straight edge, so as to form a conic surface; this may be done by setting a bevel



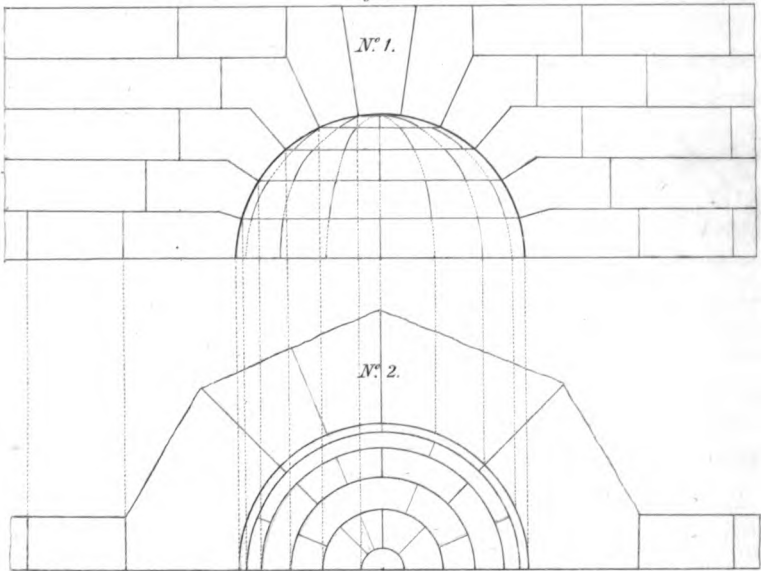




*Fig. 1.*



*Fig. 2.*



to the angle EDC, *fig. 1*, No. 1. The conic surface thus formed will be one side of the joint within the spheric surface.

Again, cut away the stone between the line *cc'* on the cylindric surface, and the arc *bb'* before drawn on the lower bed by means of the curved bevel shown at A, *fig. 1*, No. 2, so as to form a spherical surface. This may be done in the most complete manner, by applying the straight side of the curved bevel B, *fig. 1*, No. 2, to the under bed of the stone, so as to be perpendicular to the curve; then, if the curved edge coincide at all points, the surface between these lines will be spherical, and will form that portion of the head of the Niche which is contained on the stone.

In the same manner all the other stones may be cut to the form required.

*Fig. 3* exhibits the stone in the middle of the second course, and *fig. 4*, the stone on the left of the same course in the angle, which last stone is only half of the stone represented by *fig. 3*.

*Fig. 5* exhibits the left-hand stone of the third course, and *fig. 6*, the keystone, which is wrought into the frustrum of a cone to a given height in order to agree with the circular courses; and to prevent any tendency of the keystone from coming out of its place, the upper part is cut into the frustrum of a pyramid.

*Plate XXIX, fig. 1*, represents a spheric headed niche in a straight wall with four arch-stones on each side of the keystone, and therefore, also, with four horizontal courses; and as the joints are broken, if we begin the first course with four whole stones, as exhibited on the plan, No. 2, the next course will consist of three whole stones and two half stones in one in each angle. As the stones are here in this example projected on the plan as well as on the elevation, the elevation, No. 1, not only exhibits the number of courses, but the number of stones also in each course.

*Fig. 1* represents a spheric headed niche in four courses besides the keystone.

It may be observed once for all, that the greater the dimensions of a niche, the greater must also be the number of courses in the height.

The principles for cutting the stones of these niches, is the same as has already been explained for *Plate XXVIII*.

## CHAPTER V.

CONSTRUCTION OF THE MOULDS, AND FORMATION OF THE STONES, FOR DOMES UPON CIRCULAR PLANES, AS IN PLATE XXX.

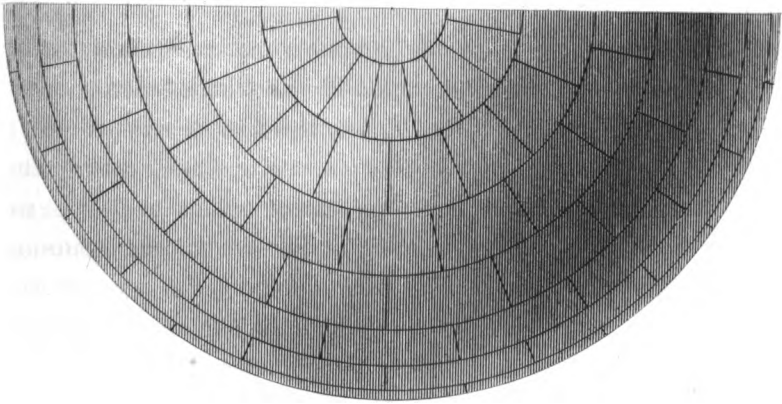
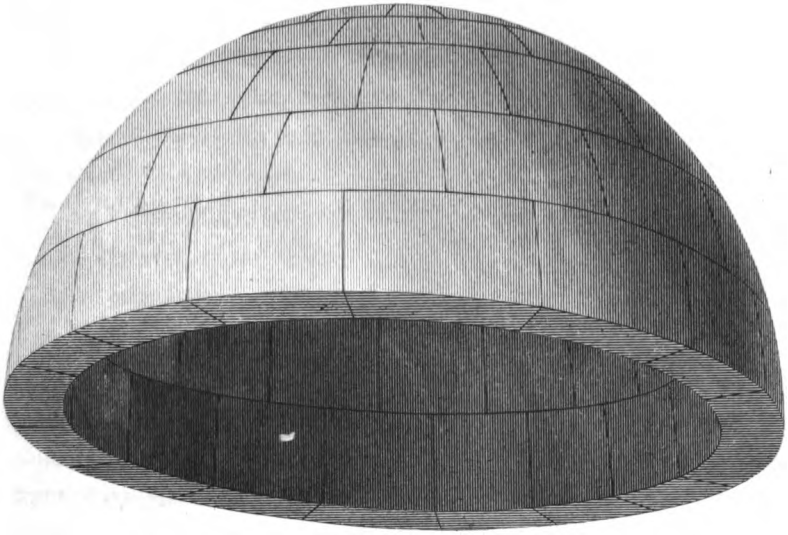
## ON THE CONSTRUCTION OF SPHERICAL DOMES.

SINCE walls and vaults are generally built in horizontal courses, the sides of the coursing joints in spherical domes are the surfaces of right cones, having one common vortex in the centre of the spheric surface, and one common axis; hence the conic surfaces will terminate upon the spheric surface in horizontal circles: again, because the joints between any two stones of any course are in vertical planes passing through the centre of the spheric surface, the planes passing through all the joints between every two stones of every course will intersect each other in one common vertical straight line, passing through the centre of the spheric surface.

The line in which all the planes which pass through the vertical joints intersect, is called the axis of the dome.

Because a straight line drawn through the centre of a spheric surface, perpendicular to any plane cutting the spheric surface, will intersect the cutting plane in the centre of the circle of which the circumference is the common section of the plane and spheric surface, the axis of the dome will intersect all the circles parallel to the horizon in their centre.

The circumference of the horizontal circle, which passes through the centre of the spheric surface, is called *the equa-*







*torial circumference*, and any portion of this circumference is called an *equatorial arc*.

The circumferences of circles, which are parallel to the equatorial circle, are called *parallels of altitude*, and any portions of these circumferences are called *arcs of the parallels of altitude*.

The intersection of the axis, and the spheric surface, is called *the pole of the dome*.

The arcs between the pole and the base of the dome, of the circles formed on the spheric surface by the planes which pass along the axis, are called *meridians*, and any portions of these meridians are called *meridional arcs*.

The conical surfaces of the coursing-joints terminate upon the spheric surface of the dome in the parallels of altitude, and the surfaces of the vertical joints terminate in the meridional arcs.

Hence in domes, where the extrados and intrados are concentric spheric surfaces, two apparent sides of each stone contained by two meridional arcs, and the arcs of two parallel circles are spheric rectangles, the two sides which form the vertical joints are equal and similar frustrums of circular sectors, and the other two sides forming the beds are frustrums of sectors of conic surfaces.

In the execution of domes, since the courses are placed upon conical beds which terminate upon the curved surfaces in the circumferences of horizontal circles, they are comprised between horizontal planes, and therefore may be said to be horizontal. Hence the general principle of forming the stones of a niche constructed in horizontal courses may likewise be applied in the construction of domes.

Each of the stones of a course is first formed into six such faces as will be most convenient for drawing the lines which form the arrises between the real faces. Two of

these preparatory faces are formed into uniform concentric cylindric surfaces, passing through the most extreme points of the axial section of the course in which the stone is intended to be placed, the axis of the dome being the common axis of the two cylindric surfaces of every course.

Two of the other surfaces are so formed as to be in plans perpendicular to the axis of the dome, and to pass through the most extreme points of the axial or right section of the course, as was the case with the two cylindric surfaces.

The extreme distance of the two remaining surfaces depends upon the number of stones in the course. These surfaces are in planes passing through the axis, and are therefore perpendicular to the other two planes. As these planes, which pass through the axis, form the vertical joints, they remain permanent, and undergo no alteration except in the boundary, which is reduced to the figure of the axial section of the course.

In order to find the terminating lines of the last and permanent faces, draw the figure of the section of the course upon one of the two vertical joints in its proper position, then two of the corners of the mould will be in the two cylindric surfaces, one point in the one, and the other in the other, and the two remaining corners of the mould will be in the two surfaces which are perpendicular to the axis, one point of the mould being in the one plane surface, and the other point in the other plane surface.

Draw a line on each of the cylindric surfaces through the point where the axial section meets the surface parallel to one of the circular edges, and the line thus drawn on each of the cylindric surfaces will be the arc of a circle in a plane perpendicular to the axis of the two cylindric surfaces, and will be equal and similar to each of the edges of the cylindric surface to which it is parallel; but in the first course of a hemispheric dome, there will be no intermediate line on

the convex side, since the circular arc terminating the lower edge, will also be the arris line of the convex spheric surface and the lower bed of the stone, which, in this course, is a plane surface.

In all the intermediate courses of the dome between the summit and the first course, the line drawn on the convex cylindrical surface will be the arris line between the convex spheric surface, and the convex conic surface which forms the lower bed of the stone; and in all the courses from the base to the summit, the line drawn on concave cylindrical surface will be the arris line between the concave conic surface forming the upper bed, and the concave spheric surface of the stone, which concave surface will form a portion of the interior surface of the dome.

On the upper plane surface of each stone to be wrought for the first course, draw a line parallel to one of the circular edges; but in each of the stones for the intermediate courses between the first course and the key-stone at the summit, draw a line on each of the planes which are perpendicular to the axis parallel to either of the edges of the face upon which the line is made through the common point in the vertical plane of the joint and the horizontal plane, then the line drawn on the top of every stone will be the arris line between the convex spheric, and the concave conic surfaces to be formed, and the line drawn on the under side of any stone in each of the intermediate courses will be the arris between the convex conic and the concave spheric surfaces to be formed; that is between the surfaces which will form the lower bed and a portion of the interior surface of the dome.

Draw the form of the section of the course upon the plane of the other joint, so that the corners of the quadrilateral figure thus drawn, may agree with the four lines drawn on the two cylindrical, and on the two parallel plane surfaces.

Lastly, reduce the stone to its ultimate figure by cutting away the parts between every two adjacent lines which are to form the arrises between every two adjacent surfaces, until each surface acquire its desired form.

Each of the spherical surfaces must be tried with a circular edged rule, in such a manner that the plane of curve must in every application be perpendicular to each of the arris lines, the mould for the convex spheric surface being concave on the trying edge which must be a portion of the convex side of the section, *fig. 1*, and the mould for the concave side convex on the trying edge, and a portion of the concave arc forming the inside of the section.

The two conical surfaces of the beds, and the two plane surfaces of the vertical joints, must be each tried with a straight edge, in such a manner that the trying edge must always be so placed as to be in a plane perpendicular to each of the circular terminating arcs; so that the surfaces between these arcs must always be prominent until the trying edge coincide with the two circular edges, and every intermediate point of the trying edge with the surface.

*Plate XXXI, fig. 1.* Let *Abcdef . . . Y*, be the exterior curve of the section divided into the equal parts *Ab, bc, cd, &c.* at the points *b, c, &c.* so that each of the chords *Ab, bc, cd, &c.* may be equal to the breadth of the stones in each of the circular courses; also let *ghijkl . . . X*, be the inner curve of the section, divided likewise into the equal arcs *gh, hi, ij, &c.* by the radiating lines *bî, ci, &c.*; hence *Abhg* is a right section of the first course; and, therefore, the figure of the joint at each end of every stone in the first course; likewise *bcih* is the right section of the second course; and, therefore, the figure of the joint at each end of every stone in the second course.

Since the entire exterior curve of the axial section of the dome is divided into equal parts alike from the base on each side of the section; and since the exterior and interior sides of the section are each a semi-circular arc, and described from the same centre; and since the dividing

lines  $bh$ ,  $ci$ , &c. radiate to this centre, all the sections of the courses, and the boundaries of the vertical joints will be equal and similar figures; and, therefore, a mould made to the figure of the section of any course will serve for the vertical joints of all the stones.

*Fig. 2* exhibits one-fourth part of the plan of the convex side of the dome, showing the number of courses, and the number of stones in each quarter-course, there being three stones of equal length in each quarter-course.

In the first or bottom course,  $mno p$  is the plan of the convex side of one of the stones, and  $m'n'o'p'$  the plan of the concave side of the same stone; and, in the second course,  $qrst$  is the plan of the convex side of one of the stones, and  $q'r's't'$  is the plan of the concave side of the same stone; so that in the first course  $mn'o'p'$  is the figure of the top and bottom of one of the ring-stones,  $po$  is the intermediate line on the top, and  $m'n'$  that on the bottom, and so on for the remaining stones.

All the stones of any course being equal and similar solids, and alike situated, the same mould which serves to execute any stone of any one course will serve to execute every stone of that course; but every course must have a different set of moulds from those of another, except the figures of the vertical joints, which will be all found by one mould, as has been already observed.

The reader, who has a competent knowledge of the construction of niches in horizontal courses, will not be at any great loss to understand the construction of domes; or if the construction of domes is well understood, he cannot be at any loss to comprehend the construction of niches; however, as there are many observations respecting the construction of domes that do not apply to niches, particularly as the dome in the present article has two apparent sides, in order to prevent the reader from wasting his time in referring to both articles, we shall here conduct him through the formation of one of the stones in the first two courses, the figure of the stones in the remaining courses being found in a similar manner.

In *fig. 1* draw  $AD$  perpendicular to the ground-line  $AY$ , and through  $A$  draw  $BC$  also perpendicular to the ground-line  $AY$ . Now  $AB$  as well as  $Ag$  being upon the ground-line, therefore to complete the rectangle  $ABCD$ , so as to circumscribe the section  $Abhg$ , and to have two vertical and two horizontal sides, draw through the point  $b$  the remaining side  $DC$  parallel to  $AY$ .

The rectangle  $ABCD$  is the section of a circular course of stone, or that of a ring contained by two vertical concentric uniform cylindric surfaces and by two horizontal plane rings, the radius of the concave cylin-

dric surface being  $\alpha B$ , and the radius of the convex cylindric surface being  $\alpha A$ , and the height of the ring being  $AD$  or  $BC$ .

Make a mould to the plan of one of the stones in the first course, that is, to  $mno p$ , *fig. 2*.

From any point  $y$ , *fig. 3*, with a radius  $zm$ , *fig. 2*, or the radius  $\alpha A$ , *fig. 1*, describe the arc  $mn$ . Make the arc  $mn$ , *fig. 3*, equal to the arc  $mn$ , *fig. 2*, and draw the lines  $mu$  and  $nv$  radiating to the point  $y$ . Again, from the centre  $y$ , and with the radius  $\alpha B$ , *fig. 1*, describe the arc  $vu$ .

Make a face-mould to  $mnuv$ , and this mould will serve for drawing the figure of the two horizontal surfaces of each stone in the first or bottom.

To cut one of the stones in the first course to the required form:— Reduce the stone from one of the sides till the surface becomes a plane. Apply the mould made to the figure  $mnuv$  on this surface, which is one of the two horizontal faces, and having drawn the figure of the mould, reduce the stone so as to form three of the arris lines of the faces, which are to be vertical, and these arrises will be square to the face already wrought. On each of the three arrises thus formed, set the height of the stone from the plane surface already made; reduce the substance till the surface becomes a plane parallel to that first formed.

Apply then the face mould  $mnuv$ , upon the plane surface last wrought, so that three points of the mould may join the corresponding points in the meeting of the three arrises, and having drawn the figure of the mould upon the second formed face, run a draught on the outside of each line upon each of the intermediate surfaces from each of the parallel faces. So that there will be four draughts receding from the face first formed, and four receding from the face last formed, and that upon the whole, including the two draughts upon each side of each of the four perpendicular arrises, there will be sixteen in all.

The two draughts along the edges of the convex cylindric surface to be formed, must be tried with a concave circular rule, made to the form of the arc  $mn$ , *fig. 2*, and the two draughts along the edges of the concave cylindric surface, must be tried with a convex circular rule made to the form of the arc  $po$ , *fig. 2*. Moreover, the two draughts which are made along each of the edges of each opposite intermediate plane surface, must be tried with a straight edge.

Having regularly formed the draughts, so that the circular and straight edges of each of the three rules may coincide in all points with the bottom surface of each respective draught, and with the arris line at each

extremity, the workman may then cut away the superfluous parts of the stone, as far as he can discern to be just prominent, or something raised above the four draughts, bordering the four edges of each of these surfaces.

The rough part of the operation being done, each of the four intermediate faces may be brought to a smooth surface and to the required form, by means of a common square ; the face of coincidence of the stock, or thick leg, being applied upon one of the two parallel faces, and the thin leg, called the blade, to the surface of the stone, in the act of reducing, until it has acquired the figure desired, or the two cylindrical surfaces may also be tried by means of circular edged rules, the edge of each rule being placed so as to be parallel to one of the parallel faces ; a concave circular edge being applied upon the convex side, and a convex circular edge upon the concave side.

The six faces which contain the solid being thus formed, we shall now proceed to find the upper arris :—for this purpose apply the mould made to the form *mnop*, *fig. 2*, upon the top of the stone drawn by the means of the mould *mnvu*, *fig. 3*.

Suppose *mnvu*, *fig. 3*, to be the figure drawn on the top of the stone itself, by means of the mould made to *mnvu* ; and *mnop*, *fig. 3*, to be the mould made from *mnop*, *fig. 2*. Lay the edge *mn*, *fig. 2*, upon the edge *mn*, *fig. 3*, on the top of the stone, so that the equal circular arcs may coincide in all their points ; and draw the line *op* along the concave edge of the mould, and *op* will be the arris line of the spherical and conical surfaces which are yet to be formed.

Let the rectangle *mn'n'm'*, *fig. 4*, be the elevation of the convex cylindrical surface of the same stone, projected on a plane parallel to each of the chords of the circular arcs, and to one of the straight arrises of this surface ; the straight line *mn* representing the upper circular edge, *nm*, *nn'* the two vertical arrises ; so that the convex spherical surface is terminated at the top by the arc *op*, and at the bottom by the arc *n'm'*.

Let the rectangle *nmn'n'*, *fig. 5*, be the elevation of the concave cylindrical face projected on a plane, parallel to one of the chords of one of the circular boundaries, and to one of the straight-lined boundaries of this face ; then the upper and lower planes will be projected into the parallel lines *nm*, *n'm'*. Therefore all the lines of each of these three planes will be projected upon the lines *nm*, *n'm'*, and as the rectilinear figure formed by the two chords and the two straight lines is parallel to the plane of projection, it will be projected into an equal and similar figure ; there-



fore the projected figure is a rectangle, and the sides  $nm$ ,  $n'm'$  are equal to each other, and to the chords of the two circular arcs; and the lines  $m'm$ ,  $nn'$  are each equal to the height of the hollow cylinder, or equal to the distance between the parallel planes.

Hence the concave surface will be projected also into a rectangle, and the middle of the chords of the arcs terminating the parallel edges of the concave surface upon the middle of the chords of the arcs, terminating two of the opposite edges of the convex surface, as also the two opposite parallel straight-lined sides in the height of the solid, will be projected into straight lines equi-distant from the projections of the corresponding lines in the height of the solid on the convex side.

Therefore, the straight lines  $nn'$ ,  $mm'$ ,  $vv'$ ,  $uu'$ , are all equal to the height of the hollow cylindrical solid, or equal to the distance between the parallel planes and the distance between the lines  $nn'$ ,  $vv'$ , equal to the distance between the lines  $mm'$ ,  $uu'$ .

To form the common termination between the upper conical and the lower spherical surfaces, let  $vv'$ ,  $u'u$ , represent the concave cylindrical surface; and, therefore  $vv'$ ,  $uu'$ , will represent the opposite circular arcs, which terminate two of the sides of this concavity. Upon this surface draw the line  $v''u''$ , parallel to the circular edge  $vu$ , on the top at the distance  $hC$ , fig. 1, and the line  $v''u''$  will be the arris now required between the concave conic surface at the top, and the concave spheric surface. These two surfaces being as yet to be formed.

To form the remaining and common termination of the concave spherical surface, and the lower or level bed of the stone:—Draw a circular arc on the level surface, underneath parallel to the circular, to the circular edge on the lower edge of the concave cylindrical surface, and this line will be the remaining arris required.

The two cylindrical surfaces, and the upper plane surface, are entirely cut away; but the intermediate line drawn on the top, and that drawn on each cylindrical surface, remain, as well as the outer edge of the lower-bed.

To form the intermediate faces of the stone, into the two upper and lower conical beds, and into the two apparent concave and convex spherical surfaces:—Reduce each side of the solid as near to the required surface as possible, so that all the intermediate parts between the arrises or lines drawn on the former faces, may be prominent.

Suppose then, that we proceed to finish the stone required to be formed, in the following order: first, by proceeding with the convex spherical surface; secondly, the upper concave conical surface; thirdly and lastly, the concave spherical surface. Having approached as nearly

to the required surfaces as can be done with safety, the upper conical concave surface will be reduced to its ultimate form by cutting away the substance carefully, so that the surface between the two arris lines may at last coincide with all the points of a straight edge applied perpendicularly to the two arrises.

The convex spherical face will be formed ultimately by cutting the substance of the stone carefully, so that the surface between the arris-line on the top, and the circular convex arris-line on the outside of the lower bed, may at last agree with all the points of the circular concave edge of the rule made to a portion of the arc *Abcd*, *fig. 1*, of the section of the dome. This circular-edged rule must be frequently applied; and in each application the plane of the arc must be perpendicular to the surface, gradually approaching to its required sphericity.

To form the concave surface of the upper bed of the stone, reduce the solid by carefully cutting parts away, so as at length the surface between the upper arris and the intermediate line drawn on the inside formerly concave, may coincide with all the points of a straight edge applied perpendicularly to the upper arris-line from any point of this arris.

The concave spherical surface will be formed in the same manner as the convex spherical surface already supposed to be formed, with this difference, that the circular edge which proves the sphericity, by trial must be convex instead of being concave. This convex surface lies between the lower arris, terminating the upper conic bed, and the inner arris of the lower bed.

As to the lower bed it is already formed, being part of the plane surface, formerly one of the ends of the hollow cylinder, in a plane perpendicular to the common axis; and as to the ends forming the vertical joints, they were at first formed in making the hollow cylindrical solid; so that one of the stones in the lower course is now finished.

One of the stones in the second course being first formed into the frustrum of a cylindric wedge, as was done with the stone formed for the first course, the several faces which contain this solid are as follow:—*qrxw*, *fig. 3*, represents the plane truncated sector forming the top, *st* being the arris-line between the spheric surface on the convex side of *st*, and the conic surface in the concave side of *st*; *qrr'q'*, *fig. 6*, the convex cylindric surface, *q''r''* the arris between the convex spheric and the convex conic surfaces, and *rqqr'*, *fig. 7*, the concave cylindric surface; *x''w''*, the arris between the concave spheric surface underneath and the concave conic surface above, the arris-line being drawn upon the lower plane

surface, we shall thus have the arris-lines between the spheric and conic surfaces.

The solid being cut as before directed between the arris-lines until the surfaces are duly formed, we shall have also one of the stones in the second course completely prepared for setting.

Perhaps for preparing the stones for the first and second courses, as also the stones near the summit, no better method can be followed than that which we have employed in preparing a stone in each of the two lower courses, yet as the saving of an expensive material and labour is a desirable object, we shall here show how the waste of stone and the labour of the workman may in a considerable degree be prevented.

### *Plate XXXII. Another Method.*

Let *fig. 1* be a section of the dome, and *fig. 2*, a plan of the same, showing the convex side. Now as the saving of material will be principally in the stones which constitute the intermediate courses, we shall select, for an example, the fifth stone from the bottom and from the summit. The section of this stone is *abcd*, *fig. 1*.

Draw *de* parallel, and *ae* perpendicular to the base of the dome. Then instead of first working the sides of the stone, so that the section may be a rectangle, of which two sides are parallel and two perpendicular to the horizon; let it be wrought into the form *abcde*, so that the part *de* may be parallel to the horizon.

Let the section *abcde* be transferred to No. 1, at *abcde*, and let *fghi*, No. 1, be the section of the rough stone, out of which the coursing-stone of the dome is to be wrought; the sides of the section of the rough stone having two parallel and two perpendicular faces to the lower bed of the stone. The wrought stone must be selected sufficiently large, so that, when it is reduced to the intended form, all the spherical and conical surfaces must be entire, and thus the arrises will also be entire.

The first operation is to reduce the stone by taking away a triangular prism from the top; the section of which prism is represented by *khi*, No. 1, so that the surface, of which the section is *de*, may be a plane surface.

No. 2 is an orthographical projection of the stone, of which the section is *lfghkl*, after being thus reduced, *qrst* representing the plane surface, of which the section is *kl*, No. 1, is parallel to the plane of projection. On the plane surface *qrst*, No. 2, apply a mould *xuvw*, so that the radius of the curved edge *uv*, may be equal to the line *dx*, *fig. 1*, *dx* being parallel to the

Fig. 1.

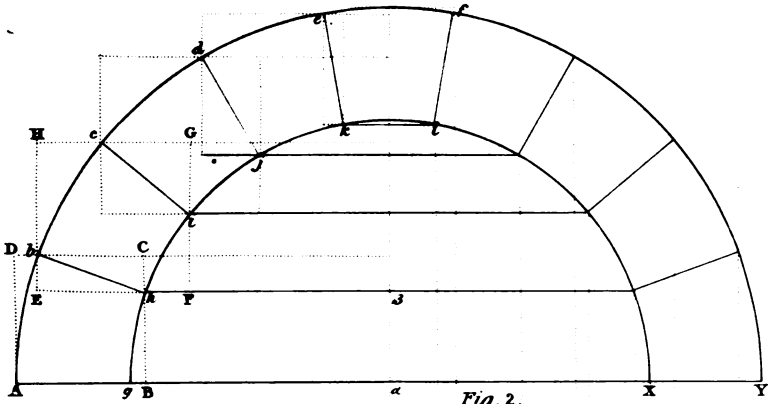


Fig. 2.

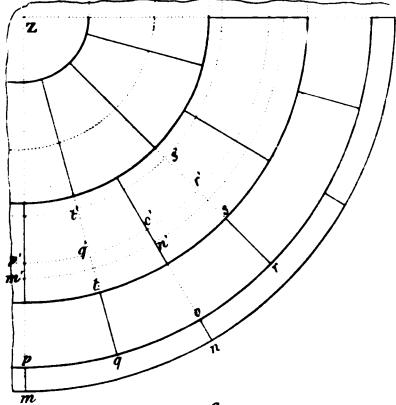


Fig. 4.

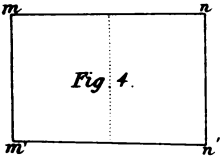


Fig. 5.

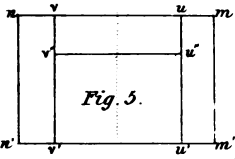


Fig. 3.

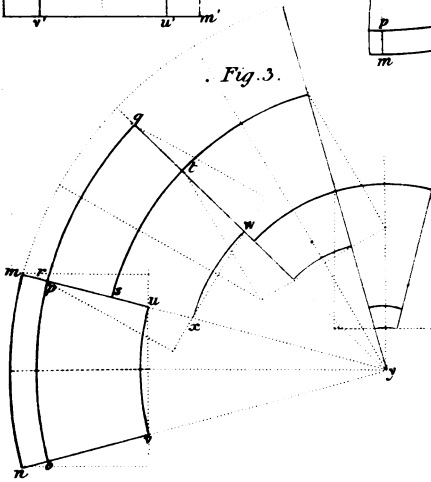


Fig. 6.

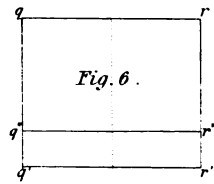
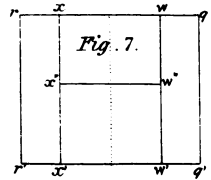


Fig. 7.





base, meeting the axis in  $x$ , and that  $vu$  and  $wx$  may be straight lines tending to the centre of the arc  $ux$ ; and that the chord of the arc  $ux$  may be equal to the length of the chord of the upper arris of the stone. Draw lines along  $vw$ ,  $ut$ , and  $wx$ , of the mould, and let  $vw$  be the line drawn by the curved edge  $vw$  of the mould,  $wv$  the line drawn by the straight edge  $wv$  of the mould, and  $xw$  the line drawn by the straight edge  $xw$  of the mould.

Take the mould away, and there will remain the three lines, viz. the arc  $vw$ , and the straight lines  $vu$  and  $wx$ , which radiate to the centre. Then  $vw$  is the upper arris of the stone, and the straight lines  $vu$  and  $wx$ , as in the planes of the meeting joints of the two adjacent stones in the same course to that which is now in the act of working.

The second operation is to work the spherical surface by means of the bevel  $edc$ , *fig. 1*, in such a manner, that while the point  $d$  is upon any point of the arc  $vw$ , No. 2, the straight edge  $de$  may coincide with the plane surface  $xuvn$ , No. 2, and the curved edge  $dc$  may coincide with the spherical surface required to be formed, and lastly, that the plane of the bevel  $cde$  may be perpendicular to the arris line  $vw$ .

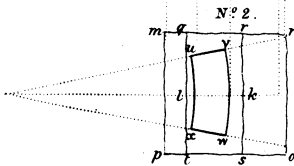
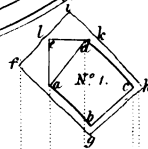
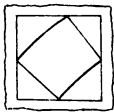
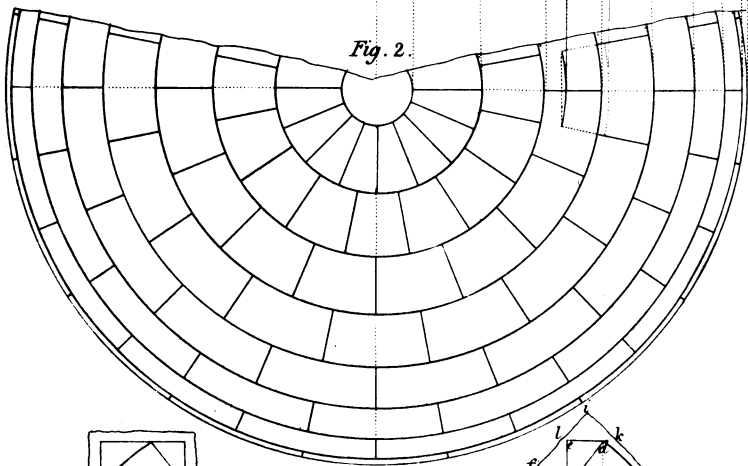
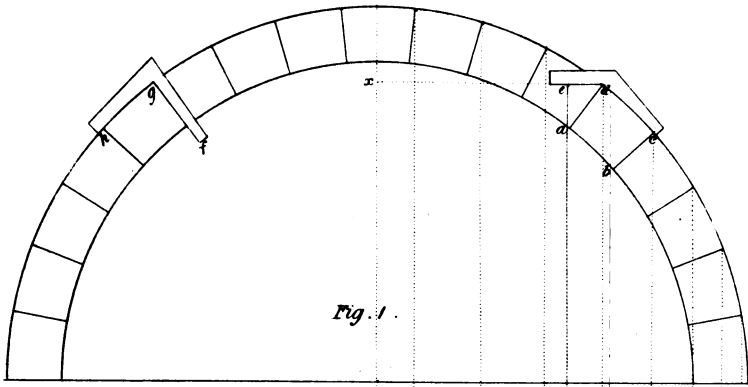
The third operation is to find the vertical joints of the stone: these will be formed by means of a common square, of which the right angle is contained by two straight lines, so that when the vortex of the angle of the square is upon any point of the line  $vw$  or  $ux$ , No. 2, the inner face of application of the third part must be upon the plane surface  $tuvn$ , and the edge of application of the thin part upon the vertical joint, and that both edges of application may be perpendicular to the line  $vw$  or  $ux$ .

The fourth operation is to form the conical upper bed of the stone by means of the bevel  $fgh$ , *fig. 1*, so that when this conic surface is wrought to the required form, and the vortex  $g$  of the angle is applied upon any point of the curve  $uv$ , No. 2, the curved edge  $gh$  may then coincide with the spherical surface, and the straight edge  $gf$  with the conical bed thus formed, the edges  $gf$  and  $gh$  being perpendicular to the arris  $ux$ .

Thus four sides of the stone are now formed, viz. the convex spherical surface, the concave conical surface, and the two vertical joints of the stone. By gauging the spherical surface to its breadth, the under or convex conical surface may be formed by means of the same bevel  $fgh$ , *fig. 1*, and gauging the sides of the stone which form the joints, viz. the concave and convex conic surfaces which form the upper and lower beds, and the two vertical joints from the spherical convex surface, we shall now be enabled to form the concave spherical surface by means of a slip of wood, of which one edge is formed to the curve of the inside of the

section, No. 1, and thus we have formed a stone of the fifth course as required to be done. In the same manner the stones of every course may be formed.

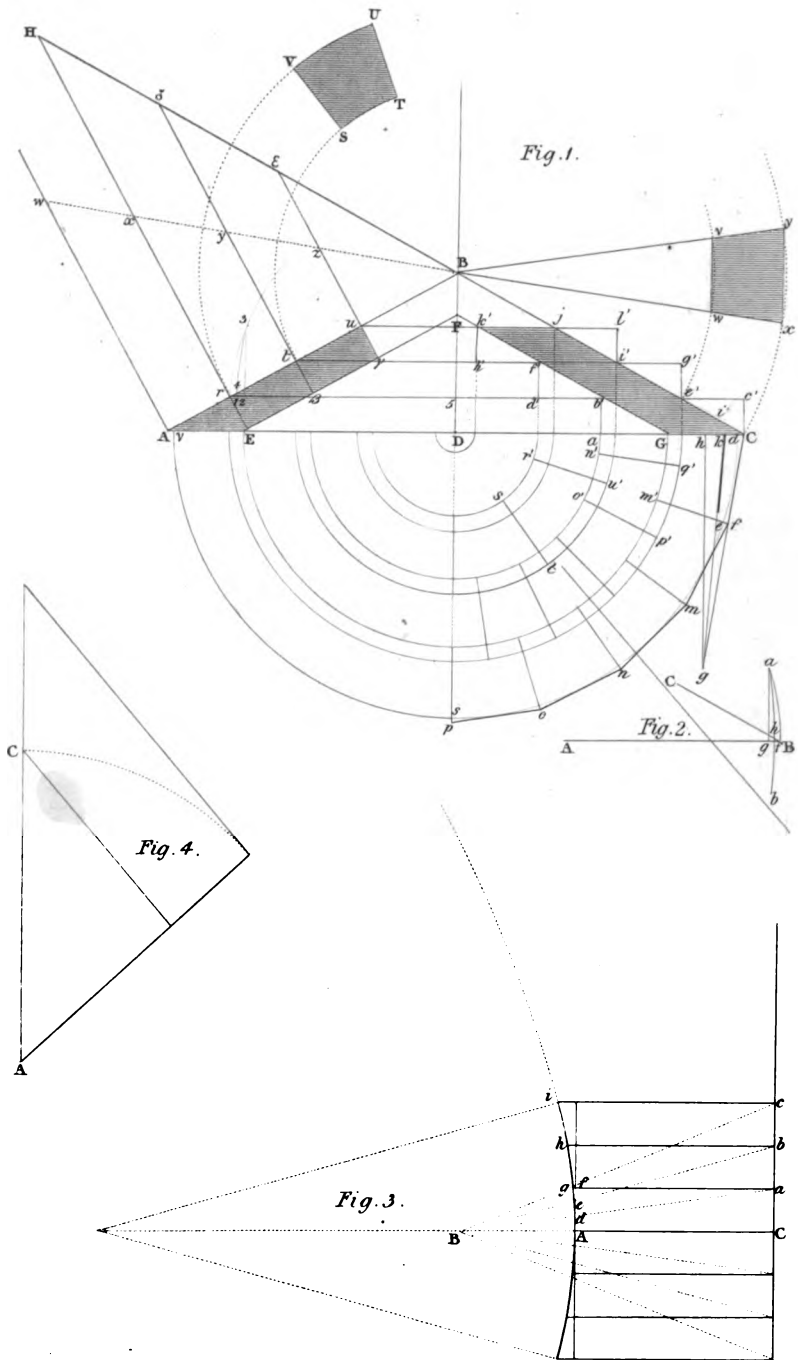
This method will neither require so much stone as the former or first method, nor yet the quantity of workmanship; but it requires greater care in the execution. This last method is that which the author used in the construction of the dome of the Hunterian Museum at Glasgow.











## CHAPTER VI.

CONSTRUCTION OF CIRCULAR ROOFS, OF WHICH THE  
EXTERIOR AND INTERIOR SURFACES ARE CONICAL  
AND CONCENTRIC WITH EACH OTHER.

## PROBLEM.

To execute a vault, of which both the extrados and intrados are conic surfaces, having a common vertical axis, the solid being equally thick between the conic surfaces, so that in the joint lines those of beds may be horizontal, and those of the headings in vertical planes passing along the axis.

The easiest method of executing this, is to form the beds so that when built they will unite in horizontal planes, and the headings in vertical planes.

Let  $ABC$ , *fig. 1*, be a section of the exterior surface, and  $EFG$  a section of the interior surface; the lines  $AB$  and  $EF$  being parallel, as also the lines  $CB$  and  $GF$ .

In order for the easy application of the bevels, it will be convenient to work the exterior faces of the stones first as plane surfaces; then form the joints by means of a face mould, and the angles which the joints make with the planes of the faces by means of the bevels, and lastly, run a draught upon each end of the face first wrought according to the proper curve of the cone.

Let  $dsv$  be the exterior line of the plan,  $D$  being the centre of all the circles which form the seats of the joint lines in the plan. Divide the semi-circular arc  $dsv$  into as many equal parts as the number of vertical joints in the semi-circumference.

Let there be five stones, for instance, in each quadrant; therefore, if  $ds$  and  $sv$  be quadrants, divide  $ds$  into five equal parts, and let  $de$  be the first part. Through the point  $e$ , draw the radius  $fD$ . Bisect the arc  $de$  in  $\theta$ , and draw  $Cf$  a tangent to the semi-circular arc  $dsv$  at the point  $\theta$ .

Bisect each of the arcs between the points of division in the quadrantal arc  $ds$ , and the tangents being drawn at each point of bisection, will form the polygonal base  $Cfmnop$ .

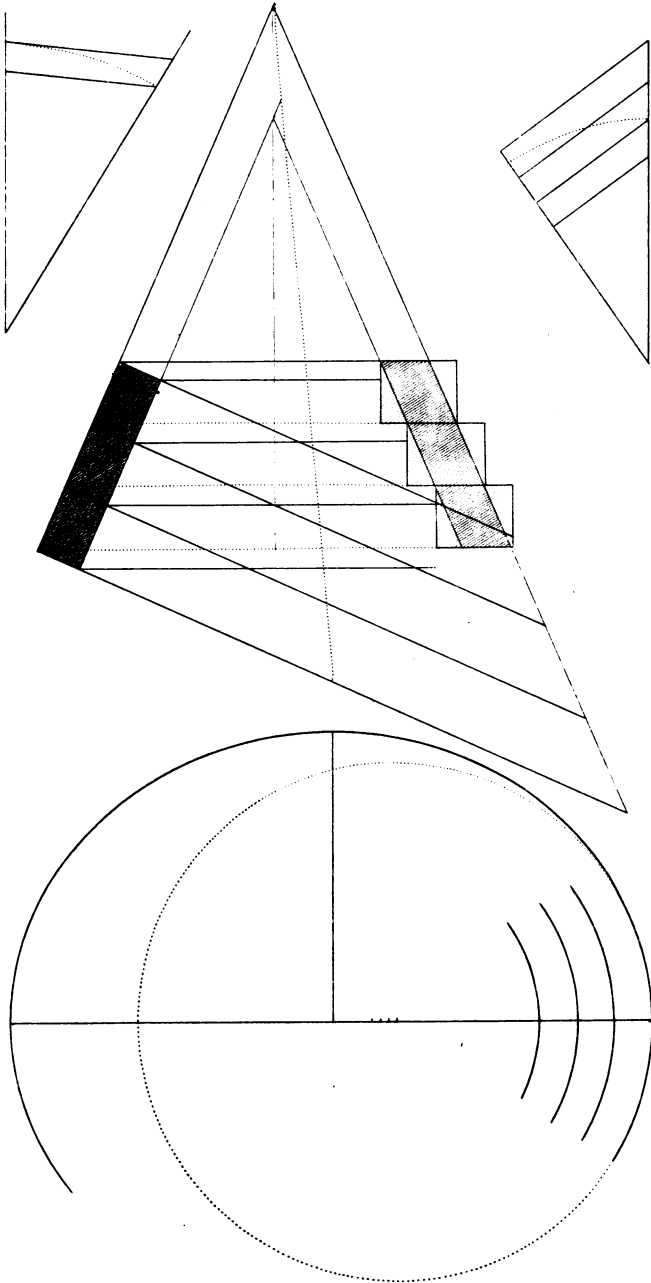
To form the angle of the mitre at the meeting of two heading joints. In  $Cf$ , or  $Cf$  produced, take any point  $g$ , and draw  $gh$  perpendicular to the diameter  $AC$ , meeting  $AC$  in the point  $h$ . Draw  $hi$  perpendicular to  $CB$ , meeting  $CB$  in the point  $i$ . In  $DC$  make  $hk$  equal to  $hi$  and join  $kg$ ; then will the angle  $Dkg$  be the bevel of the mitre.

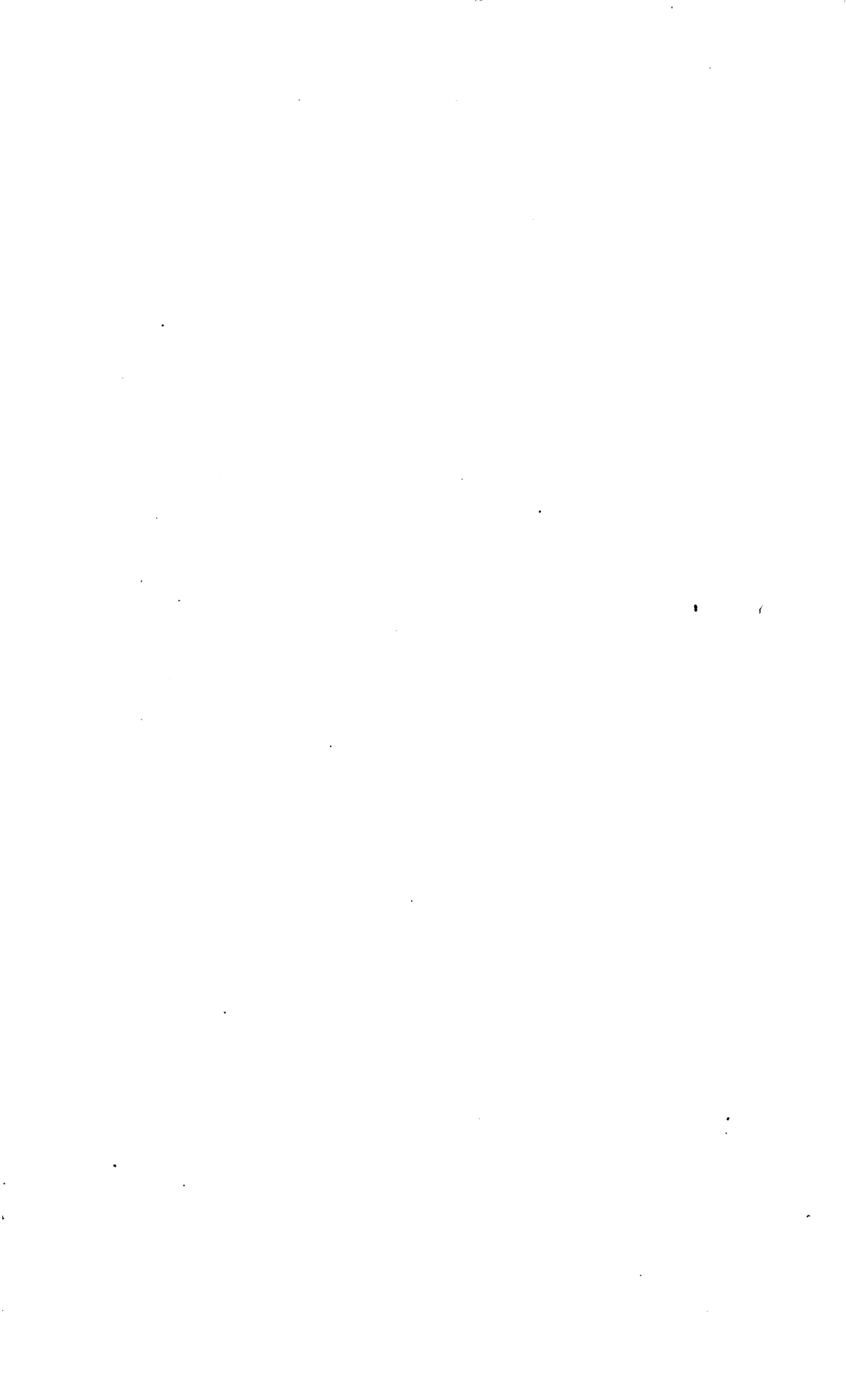
The sections of each of the stones as they rise, being  $debb'G'$ ,  $e'f'f'b'$ ,  $i'j'k'f'$ , the dimensions of the stones will be found as follows. Through the points  $e'$ ,  $i'$ ,  $j'$ , draw the straight lines  $d'c'$ ,  $h'g'$ ,  $k'l'$ , intersecting the inner line  $GF$  in the points  $b'$ ,  $f'$ ,  $k'$ . Through  $b'$ ,  $f'$ ,  $k'$ , draw the lines  $ab'$ ,  $d'f'$ ,  $kk'$ , perpendicular to  $AC$ . Also through the points  $e'$ ,  $i'$ ,  $j'$ , draw  $e'g'$ ,  $i'l'$ , as also  $Cc$ , which will complete the sections of the stones. The other side,  $AEFB$  of the section, exhibits the sections of the stones perpendicular to the intrados and extrados of the lines; the sections of the stones being  $AEr$ ,  $E\beta tr$ ,  $\beta\gamma ut$ , and the sections of the joints  $Er$ ,  $\beta t$ ,  $\gamma u$ . To find the curve of the stone at any section as  $Er$  at the point  $r$ . With the horizontal radius  $5r$ , *fig. 1*, and from the centre  $5$ , describe an arc  $r3$ . From the point  $3$ , draw  $32$  perpendicular to  $5r$ , meeting  $5r$  in  $2$ . In  $2r$  make  $2l$  equal to the nearest distance between the point  $2$  and the line  $AB$ . From some point found in the line  $5r$ , describe an arc  $l3$ , and the arc  $l3$  will be the curvature of the top of the stone at the joint. This is shown at *fig. 2*.

*Figs. 3 and 4* exhibit another method of finding the curve at the joint, by means of the radius of curvature.

#### PLATE XXXIV.

The construction exhibited in this plate being similar to the foregoing, and may therefore be understood from the description now given. Only one particular which we shall observe is, that in the curve of the joints in the former case they are portions of the hyperbolic arcs, and in the latter case they are portions of elliptic arcs.





## CHAPTER VII.

CONSTRUCTION OF THE MOULDS, AND FORMATION OF  
THE STONES, FOR RECTANGULAR GROUND VAULTS.

## CONSTRUCTION OF GROINED VAULTS, WITH CYLINDRETIC SURFACES.

A CYLINDRETIC surface is every surface which may be generated by a straight line moving parallel to itself, and intersecting a given curve line.

Since, in good masonry, the sides of the joints of any course of a vault are made to terminate upon the intrados, in a horizontal plane perpendicularly to the intrados, if the intrados be a cylindric surface, of which the sides are straight lines parallel to the horizon, the sides of the coursing joints will be in planes intersecting the intrados, perpendicularly in straight lines, and the course will form one prismatic solid; hence all the right sections will be equal and similar figures, and will be in vertical planes.

The stones of a groin, which have any difficulty in their construction, are those at the meeting of two adjacent sides, and it is only the formation of these which we shall describe.

In order to form the stone of any course, circumscribe a rectangle round each corresponding right section of the course, so that the sides of the rectangle may each pass through the point of meeting of every two sides of the section of the course, and that two of these sides may be parallel, and two perpendicular to the horizon, as was



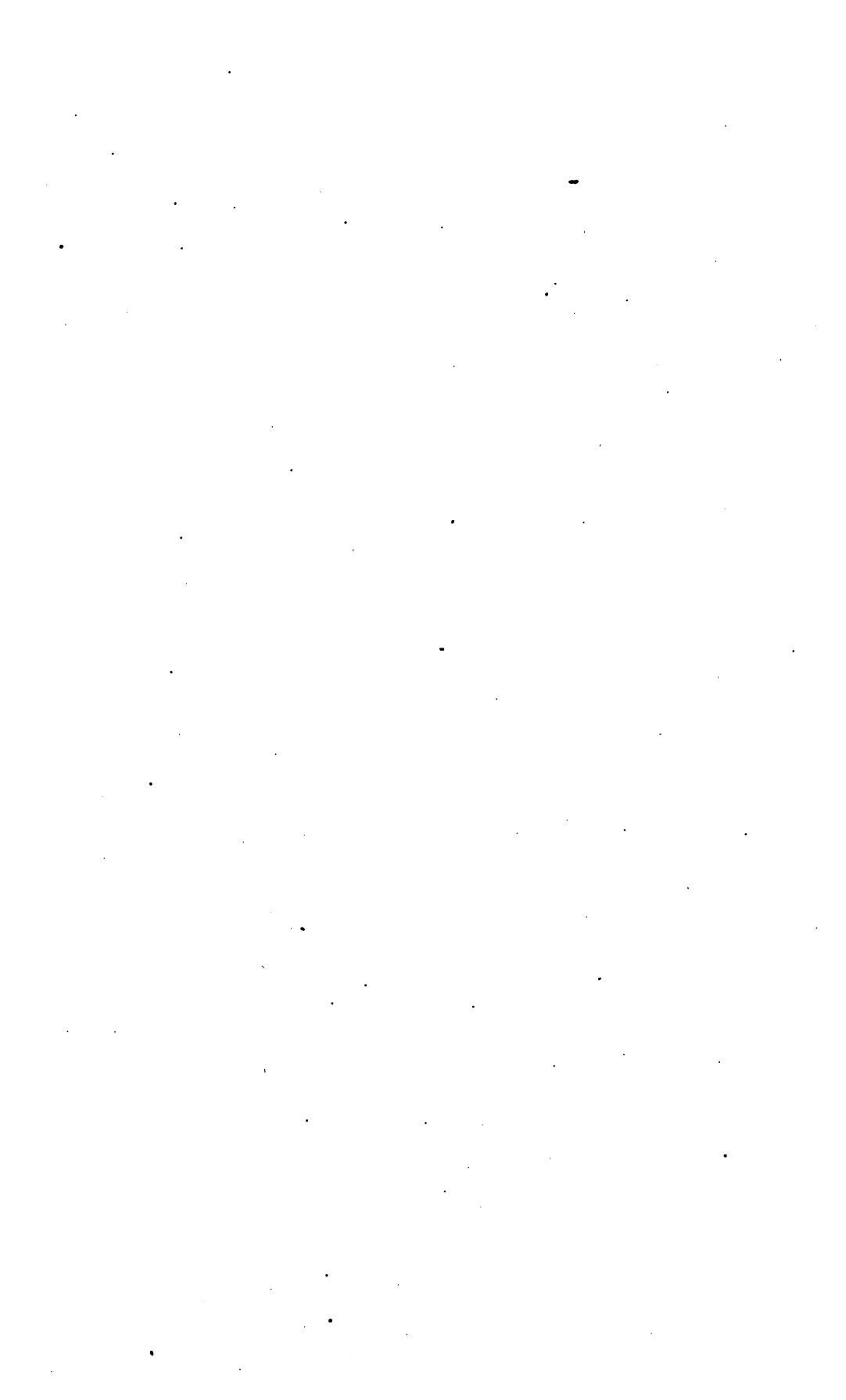
done in respect of the execution of niches in horizontal courses, and in the formation of the stones of a dome.

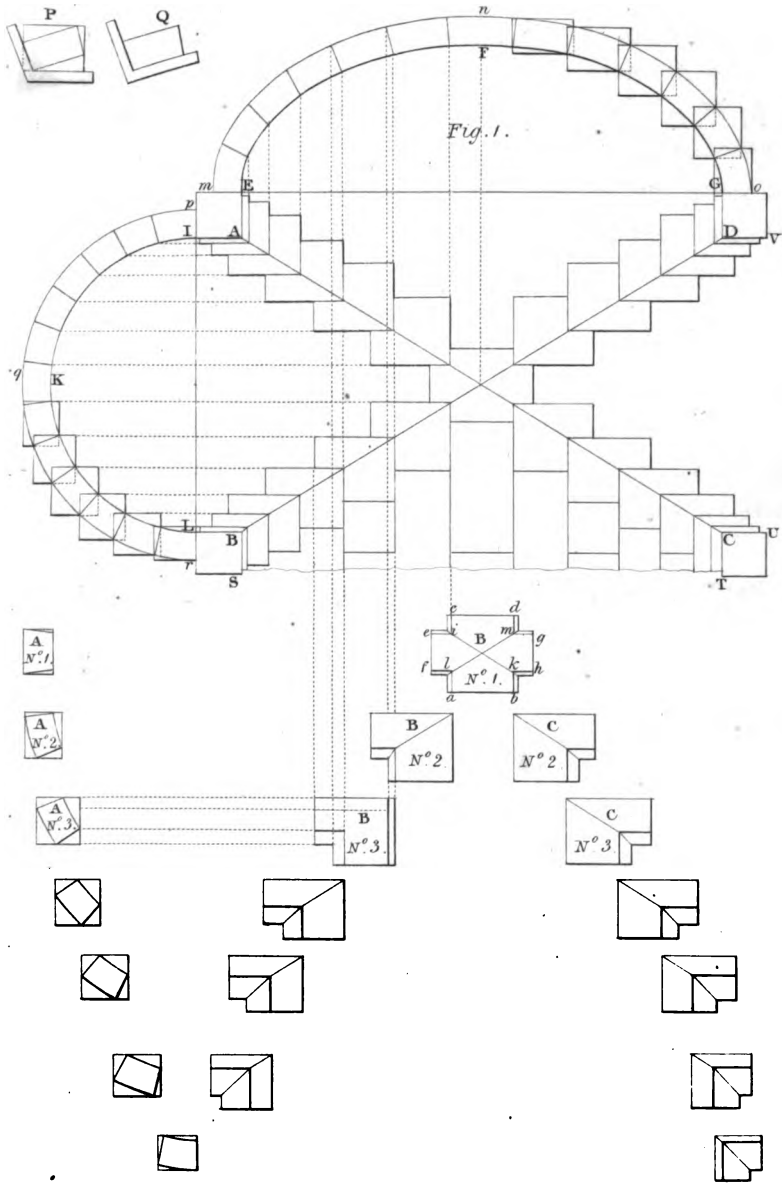
In the first place, the stone must be squared in such a manner, that every two faces which meet each other may form a right angle, and that two of the faces may be parallel and six perpendicular to the horizon, and that only two of the six faces which are perpendicular to the horizon may form a receding angle; and, moreover, that the figure of the two faces which are parallel to the horizon may be formed to the plan of the stone, as formed by the rectangular planes.

The two vertical faces which form a right angle with each other, but which do not join in consequence of the two vertical faces which form the receding angle coming between them, are those two faces in the plane of the vertical joints.

The figures of these faces must be made to the rectangle, circumscribing each respective section.

The next operation is to gauge two lines on the upper level surface, so as to form the return arris between the upper bed and the convex cylindretic surface on each side of the groin; this operation being done, gauge two lines on the lower level surface, so as to form the return arris between the lower bed and the concave cylindretic surface on each side of the groin. These two lines will thus form a right angle, which being drawn, gauge a line upon each of the vertical sides which form the internal right angle, and these lines will be the arris of the stone on each side of the groin between the upper bed of the stone and the concave cylindretic surface; and, lastly, gauge a line upon each of the vertical surfaces which are opposite to those forming the internal angle, so that each of the two lines thus drawn may form the arrises between the convex surface and the lower bed.





The arrises of the stone being thus drawn, it must be reduced to such surfaces, that each of the lines may be the arris of every two adjacent surfaces.

The two beds of the stone are plane surfaces, and are therefore formed by means of a straight edge. The other cylindretic surfaces are brought to form by means of a curved edge made to the place where the stone is to be set. It is evident that when the curve varies, a mould must be made to every stone.

*Fig. 1, plate XXV*, is the plan of a ground vault with its vertical right sections upon each side of it. In the plan *A, B, C, D*, exhibit the springing points of the groins, *AC* and *BD* are the plans of the groins, or intersections of the cylindretic surfaces. These plans of the surfaces of the stones in the intrados, which form the ground angles, are exhibited along the lines *AC, BD*.

*IKL* is a section of the intrados, and *pqr* a section of the extrados, the intrados and extrados being concentric semi-circular arcs; *EFG* and *mno* are sections of the intrados and extrados of the other vault, being each a surbated semi-elliptic arc, equal in height respectively to the semi-circular arcs of the other vault.

These two sections of each vault exhibit the section of each course of stone, with the circumscribing rectangle. These stones are exhibited separately at No. 1, No. 2, No. 3, &c.

No. 1 is that over the centre of the section of the semi-circular vault; No. 2, that next to the stone over the centre; No. 3, the second stone from that over the centre, and so on.

No. 1, *A*, is a section of the course, or of a stone over the centre of one of the semi-circular branches of the groined vault, showing the circumscribing rectangle; and No. 1, *B*, is the underside of the same stone, forming a part of the intrados of the vault. This exhibits the stone as if squared with the portions of the plans of the groins, which are to be wrought on this stone, as also the plans of the intersections of the joints with the upper surface or intrados.

Having wrought a concave draught along the lines *ab, cd* to the middle of the intrados *EFG* of the section of the elliptic vault, the intermediate surface between *ab* and *cd* may be formed by means of a straight edge applied parallel to *ac* or *bd*, and having wrought the concave draught along the lines *ef, gh*, so that the points *e, f, g, h* may remain, while the

intermediate is sunk, and so that the draught thus sunk, may have the same curve as the intrados line *IKL* of the semi-circular branch. The intermediate part may be formed by means of a straight edge applied parallel to *eg* or *fh*, and thus the two cylindretic surfaces crossing each other will form the groins *ik*, *lm*, which belong to the central stone, and which are a portion of the whole groins resting on the springing points.

These arrises being formed by the intersection of the cylindretic surfaces, which meet each other at very obtuse angles, ought to be done with care, otherwise the beauty of the intersections would be destroyed.

No. 2, 3, &c. require a similar description to that of No. 1, and therefore will be sufficiently understood from that now given.

*P* and *Q* exhibit the manner of forming one of the stones agreeable to the section of one of the elliptic branches of the groined vault after having squared the stone, this stone being supposed to be the second from that over the centre.

It is worthy of notice, that except the stone in the summit of the groined vault, any four stones equally distant from the centre of the ground ceiling, though reduced by the same moulds to the same number of similar surfaces, and though every two corresponding similar surfaces meet each other; yet nevertheless any one of the four stones can only fit one of the four situations; so that the same moulds will serve for the formation of four stones equally distant from the summit.





## CHAPTER VIII.

CONSTRUCTION OF THE STONES FOR GOTHIC VAULTS,  
IN RECTANGULAR COMPARTMENTS UPON THE PLAN.GROINED ARCHES SPRINGING FROM POLYGONAL  
PILLARS.

To execute a ribbed-groined ceiling in severies, upon a rectangular plan, so that the ribs may spring from points in the quadrantal arc of a circle, of which the centres are in the angular points of the plan, and to terminate in a horizontal ridge parallel to the sides of the severies, and in a vertical plane, bisecting each side of the plan.

Let  $STVW$ , *Plate XXXVI. fig. 1*, be a portion of the plan consisting of two severies  $STUX$ ,  $XUVW$ , the points  $S$ ,  $T$ ,  $U$ ,  $V$ ,  $W$ ,  $X$ , being the points into which the axes of the pillars are projected.

Bisect  $VW$  by the perpendicular  $rL$ , and bisect  $VU$  by the perpendicular  $pL$ . Draw the straight lines  $uq$ ,  $vL$ ,  $wm$ ,  $xn$ ,  $yo$ , radiating from  $V$  to meet the ridge lines  $rL$  and  $Lp$  in the points  $r$ ,  $q$ ,  $L$ ,  $m$ ,  $n$ ,  $o$ , and the arc  $tz$  described from  $v$  in the points  $u$ ,  $v$ ,  $w$ ,  $x$ ,  $y$ , and these lines will be the plans of the ribs for one quarter of a severy.

Suppose now the rib over  $tr$  to be given, and let this rib be *fig. 2*, which is here made double. The half  $abc$  is the rib which stands upon  $rt$ , the curve  $bc$ , *fig. 2*, and the plans  $tr$ ,  $uq$ ,  $vL$ ,  $wm$ ,  $xn$ ,  $yo$ ,  $zp$ , *fig. 1*, of the ribs are given by the architect in the plan and sections of the work: it is the workman's province to find the curvature of the ribs, and the formation of the stones for the ceiling.

For this purpose we shall suppose that the chords which are formed by the joints in the intrados upon the meeting of the rib over  $tr$  to be equal; therefore divide the curve  $bc$ , *fig. 2*, into equal parts, so as to admit of vault stones of a convenient size.

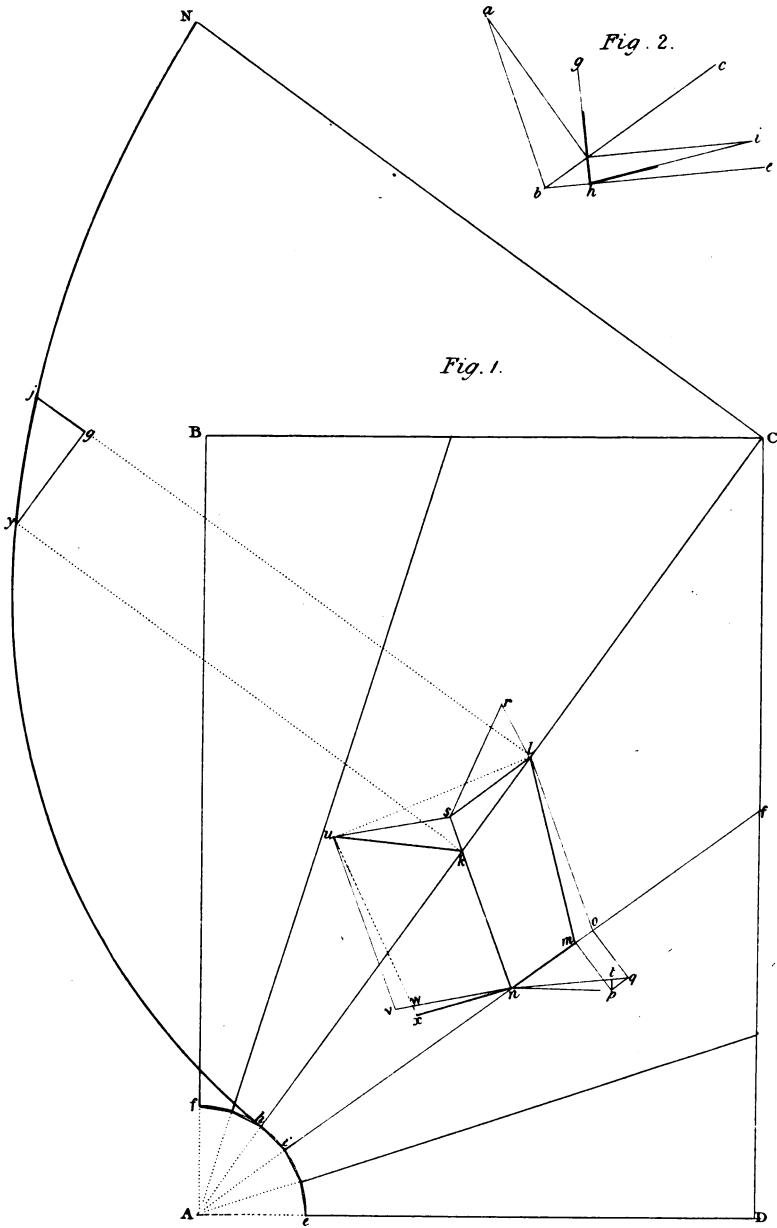


From the points 1, 2, 3, &c. *fig. 2*, in the arc *bc*, draw lines perpendicular to *ab* the base of the rib. Transfer the parts of the line *ab* to *rt*, *fig. 1*, and let A be one of the points representing *c*, *fig. 2*. In *fig. 1*, draw *ut* and produce *ut*, and *Lr* to meet each other in the point 2. Draw the straight line AB radiating to the point 2, to meet the plan *uq* in B. Join *uv* and produce *vu*, and *Lr* to meet in 3, and draw the straight line BC radiating from 3, to meet the plan *vL* in C. Join *vw*, and produce *vw* and *Lp* to meet each other in H. Draw CD radiating to the point H, to meet *wm* in D. Join *wx* and produce *wx*, and *Lp* to meet each other in I, and draw DE radiating to the point I, to meet *xn* in E. Find the points F and G in the same manner as each of the points B, C, D, E, have been found, and the compound line ABCDEFG will be the line of joints corresponding to the point 5, *fig. 2*. Find the lines corresponding to the other joints in the same manner. Transfer the divisions in the line *uq* to the base line of *fig. 3*, and draw lines perpendicular to the base as ordinates. Transfer the ordinates of *fig. 2* to their corresponding ordinate in *fig. 3*, and draw the curves which will complete the inner edge of the rib, *fig. 3*. In the same manner find the curve of the ribs, *figs. 4, 5, 6, &c.* which stand over the lines *vL, wm, xn, &c.*

*Fig. 7* exhibits a part of the plan of a groin-ceiling, consisting of two severies when the plans of the piers are squares, of which the angular points terminate in the sides of the plan of each severy, and then we have only to find the diagonal ribs and those upon the narrow side of the severy. It must, however, be observed, both in *figs. 1* and *7*, that only one of the curves which belong to arches of the two sides of a severy can be given, the other must be found in the same manner as the curves of the intermediate ribs. In *fig. 7* the plan of the joints has only two points of convergence, which are found by producing the side of the square which forms the plan of the pillars, and the plan of the ridge-lines, till they meet each other.

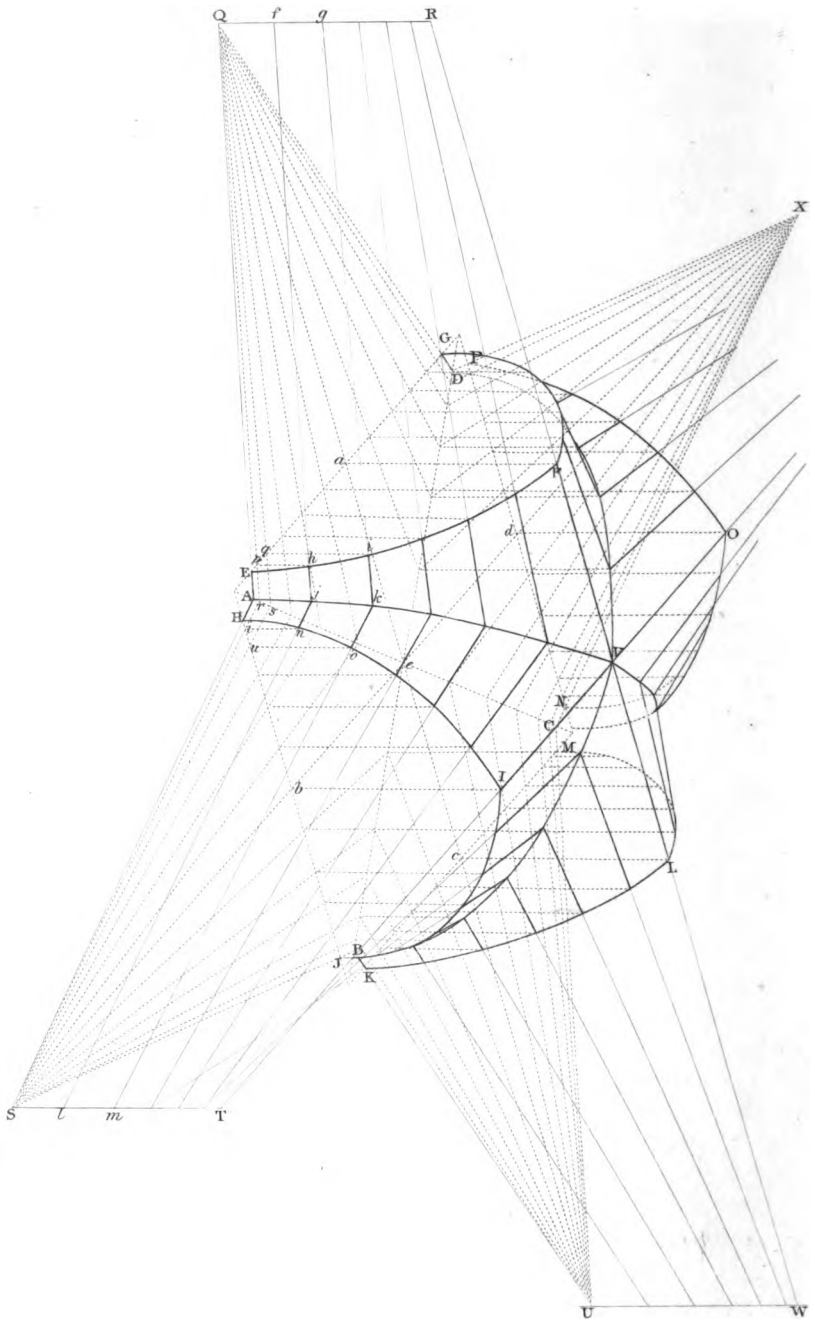
We shall now proceed towards the formation of the stones of the vaulting.

Let ABCD be the plan of one quarter of a severy, and let *hC* and *if* be the seats of two adjacent ribs, and let *hyjzC* be the rib which stands upon *hC*, and let *klmn* be the plan of the soffit of a stone. Perpendicular to *hC* draw *ky* and *lj*, and draw *yg* parallel to *hC*. Produce *nk* to *s* and *nm* to *o*. Draw *lo* and *ls* respectively parallel to *sn* and *nm*. Draw *lr* perpendicular to *ls*; make *lr* equal to *gi*, and join *sr*. Draw *lu* perpendicular to *sn*; and from *s*, with the radius *sr*, describe an arc meeting *lu* in the point *u*. Draw *uv* and *nv* respectively parallel to *sn* and *su*.









Perpendicular to  $no$  draw  $oq$  and  $mp$ . Make  $oq$  and  $mp$  each equal to  $gi$ , and join  $np$  and  $nq$ . Draw  $pt$  perpendicular to  $nq$ , meeting  $nq$  in the point  $t$ . To form the winding surface of the intrados, first work the soffit as a plane surface; on the plane surface describe the *figs. usnv*. Make  $nv$  equal to  $nt$ .

In *fig. 2* make the angle  $abc$  equal to  $sno$ , *fig. 1*, and make the angle  $cbe$ , *fig. 2*, equal to  $onq$ . By problem 3, page 17, having the two legs  $cba$ ,  $cbe$  of a right-angled trehedral, find the angle  $ghi$ , which the hypotenuse makes with the leg  $cbe$ . Secondly, form the bed of the stone to make an angle at the arris-line  $nv$  with the surface  $usnv$ , equal to the angle  $ghi$ , *fig. 2*. Draw  $wx$  upon the end of the stone thus formed perpendicular to  $nv$ , and make  $wx$  equal to  $tp$ , and on the end of the stone draw  $nx$ . Join  $ku$ ; then the four points  $n$ ,  $k$ ,  $u$ ,  $x$ , are the four angular points of the soffit of the stone. The other end of the stone will be formed in a similar manner.

### On the nature and construction of Gothic ceilings.

Let  $A, B, C, D$ , *Plate XXXVIII*, be the springing points,  $AC$  and  $BD$  the plans of the groins disposed in the vertices of the angle of a rectangle, their plans bisecting each other in the point  $e$ ; also let  $QU$  and  $SX$ , passing through the point  $e$ , and bisecting the angles  $AeB$ ,  $BeC$ ,  $CeD$ ,  $DeA$ , be the plans of the ridges of the gothic arches, and let  $AE, AH, BJ, BK, CM, CN, DP, DG$ , be the springing lines of the gothic ceiling.

Moreover, let the four straight lines  $EG, HJ, KM, NP$ , at right angles to  $QU$  and  $SX$ , be the plans of four right sections to each wing of the groined vault; and let the springing-lines  $AE, DG, AH, JB$ , &c. be such as to meet respectively in the points  $Q, S$ , &c.

To construct the ribs which are at right angles to the ridge-lines, and of which their plans are  $EG, HJ$ , &c. Let us suppose that the given rib is  $EFG$ , standing upon  $EG$  as its plan. Prolong  $AE$  and  $DG$  to meet each other in the point  $Q$ . Divide the half curve  $EF$  of the arch into as many equal parts as the number of courses is intended to be in the ceiling on each side of the ridge-line of the intrados of the arch; let us suppose that this number is six, and that  $h$  is the first point of division from the bottom point  $E$  of the rib, the succession of parts being  $Eh, hi$ , &c. From the points  $h, i$ , &c. draw the straight lines  $hp, iq$ , &c. perpendicular to  $EG$ , meeting  $EG$  in the points  $p, q$ , &c. Through the joints  $p, q$ , &c. draw from the point  $Q$  the lines  $Qr, Qs$ , &c., meeting  $AC$ , the plan of the groin in the points  $r, s$ , &c., and perpendicularly to  $AC$  draw the straight lines  $rj, sk$ , &c. Make  $rj, sk$ , &c., each respectively equal to  $ph, qi$ , &c. through the points  $A, j, k$ , &c., draw

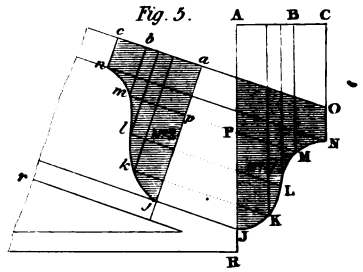
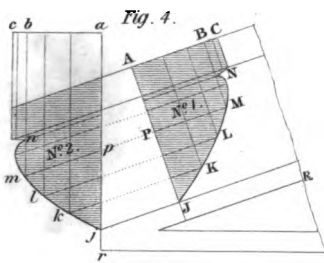
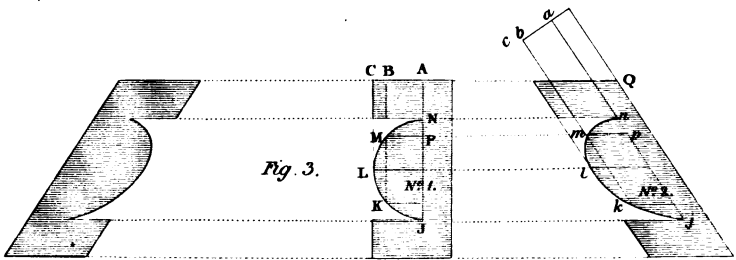
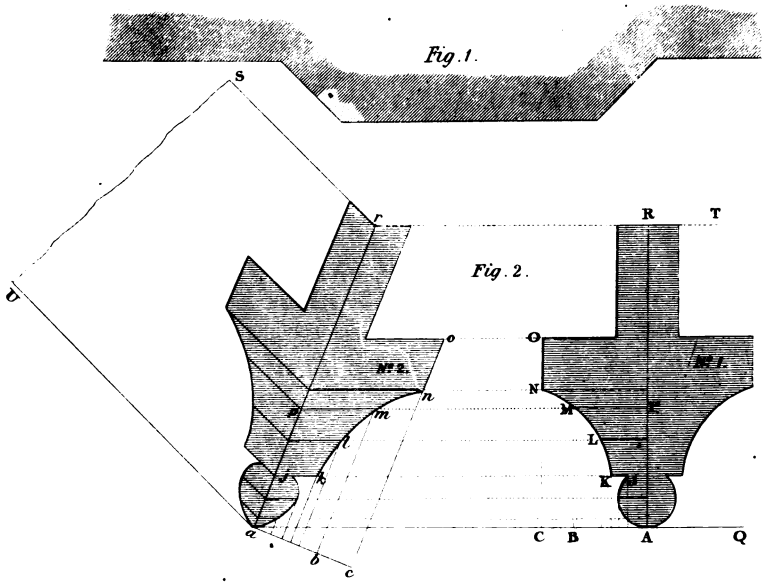
the curve  $AjkV$  for one-half of the curve of the groin rib, the other half is symmetrical, and therefore the same curve in a reversed order.

To find the rib  $HIJ$ . Prolong  $AH$  and  $BJ$  to meet each other in the point  $S$ , and draw the lines  $rS$ ,  $sS$ , &c. intersecting  $HJ$  in the points  $t$ ,  $u$ , &c. Draw  $tn$ ,  $uo$ , &c. perpendicular to  $HJ$ , and make  $tn$ ,  $uo$ , &c. respectively equal to  $ph$ ,  $qi$ , &c. Through the points  $H$ ,  $n$ ,  $o$ , &c. draw the curve  $HI$ , and  $HI$  will be the curve of one-half of the arch over the line  $HJ$  for the plan.

Hence we see that the lines  $jh$ ,  $ki$ , &c. prolonged will meet the line  $QR$  perpendicular to the plane  $ABCD$  in the points  $f$ ,  $g$ , &c. at the same heights  $Qf$ ,  $Qg$ , &c. as  $ph$ ,  $pi$ , &c. of the heights of the ordinates of the given rib. Since both sides are symmetrical, one description will serve each of them.







## CHAPTER IX.

THE MANNER OF FINDING THE SECTIONS OF RAKING  
MOULDINGS.

To find the raking mouldings of a canted bow-window, with munion and transoms.

Let the plan of the window be *fig. 1, Plate XXXIX*, consisting of three sides, the middle one being parallel to the walls, and the other two at an angle of 135 degrees each, with the middle face of the window.

Also, let  $UaQ$ , *fig. 2*, be a horizontal section of one of the angles, No. 1 being a right section of one of the munion, the same as the right section of the transom sill or lintel, and let  $ar$ , No. 2, be the line of mitre corresponding to  $AR$ , No. 1,  $AR$  being perpendicular to  $aQ$ .

In order to find the right section, No. 2, of the angular munion. In the curves of the given section, No. 1, draw lines through a sufficient number of points perpendicular to  $aQ$ , and draw  $ac$  perpendicular to  $ar$ ; transfer the points  $B C$  from  $A$ , No. 1, made by the perpendiculars to No. 2; from  $a$  to  $c$  upon  $ac$ , and from  $a$  to  $b$  through the points in  $ac$  draw lines parallel to  $ar$ , to intersect the corresponding lines parallel to  $Qa$  from the assumed points  $K, L, M, N$ , in the curves, No. 1, and through these points trace the curves which will form one side of the section, No. 2; repeat the same operation on the other side, and we shall have the complete section required.

*Fig. 3* exhibits the same species of lines applied to an architrave, or mouldings run round the two jambs and soffit of a window or door parallel to the face of the wall, the soffit being level, and the jambs splayed: the middle section, No. 1, is that which is given, being a right section of the moulding on the soffit.

*Fig. 4*, No. 1, is the right section of the raking moulding on a pediment, which if supposed to be given, the section No. 2 may be found as that at No. 2, from No. 1, *fig. 2*; but in this case No. 2 is generally that which is given, and the section No. 1 is traced therefrom.

In all these cases of raking mouldings, draw  $ac$  perpendicular to  $ar$  the line of mitre. To find any point  $m$ , take the point  $M$  in the section No. 1, and draw  $MB$  perpendicular to  $AC$ , *figs.* 2, 3, 4, meeting  $AC$  in  $B$ , and draw  $Mm$  parallel to  $Rr$ . Make  $ab$  equal to  $AB$ , and draw  $bm$  parallel to  $ar$ , and  $m$  will be a point in the curve. In the same manner will be found the points  $j, k, l, n$ , No. 2, from the points  $J, K, L, N$ , No. 1; and hence the section No. 2 may be traced from No. 1.

Fig. 1.

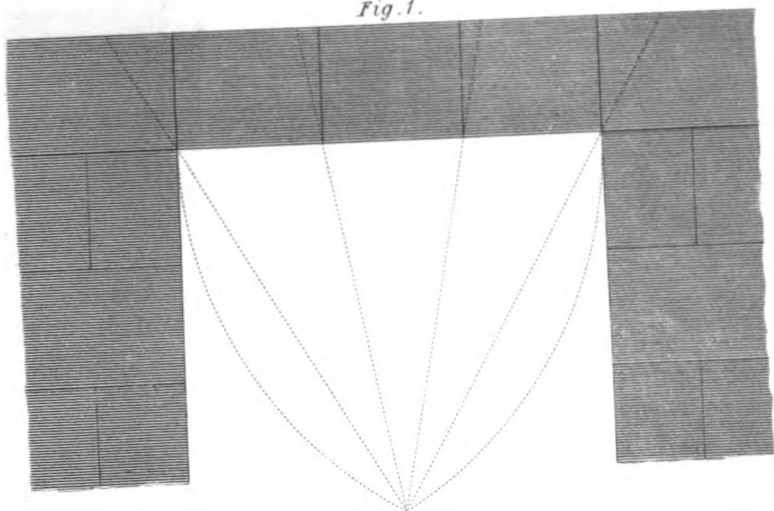


Fig. 2.

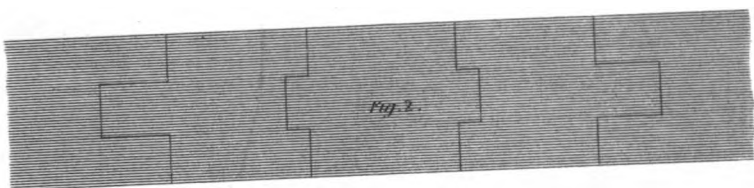
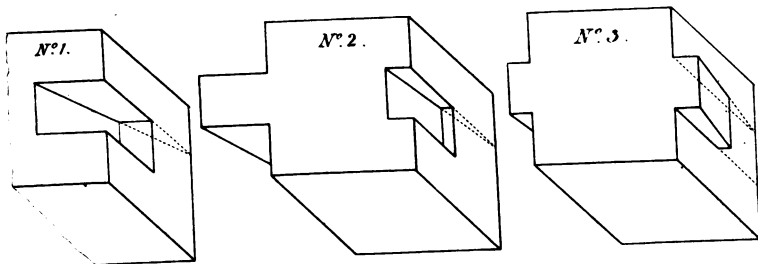
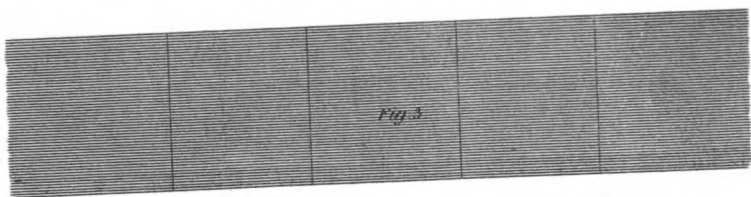


Fig. 3.





## CHAPTER X.

## CONSTRUCTION OF A LINTEL, OR AN ARCHITRAVE, IN THREE OR MORE PARTS, OVER AN OPENING, AND THE STEPS OF A STAIR OVER AN AREA.

ON the method of building a lintel, or architrave, with several stones, so that the soffit and top of the lintel, or architrave, may be level; and that the connecting joints of the course may appear to be vertical in the front and rear of the lintel, or architrave.

A lintel, or architrave, is frequently formed in several stones, from the difficulty of procuring one of sufficient length. The method of doing this is founded upon the principle of arching, the arch being concealed within the thickness of the stones.

*Fig. 1, plate XL,* represents the upper part of an aperture, linteled as specified in the contents of this chapter; the centre of the radiating joints being the vertex of an equilateral triangle.

*Fig. 2* represents the top of the lintel, exhibiting the thickness of the radiating joints, and the thickness of the square joints on each side of the concealed arch.

*Fig. 3* represents the soffit of the lintel, exhibiting the joint lines perpendicular to the two edges, as the radiating as well as the vertical joints, all terminate in these lines.

No. 1. exhibits the first abutment-stone over the pier; No. 2, the first stone of the lintel; No. 3, the second stone, which forms the key; the two remaining stones are the same as the first stone of the lintel, and the abutment-stone being placed in reverse order.

The three stones here exhibited, show the manner of indenting the stones so as to form a series of wedges; and in order to regulate the soffit, the radiations are stopped at half their height.

No. 1, *plate XLI*, exhibits the method of constructing an architrave over columns when the stone is not of sufficient length to reach the two columns. No. 2, Plan of the upper horizontal side of the architrave exhibiting a chain-bar of wrought-iron, with collars let in flush with the top bed, the sockets being filled with melted lead round the collars.

In the plan and elevation, the same letters express different sides of the same parts; thus in the elevation, No. 1, the letter *A* is written upon the part expressing the vertical face of the stone, over the angular column; and *A* on the plan, No. 2, expresses the horizontal side or bed of the same stone. The letter *B*, on the elevation No. 1, represents the vertical face of the middle stone of the architrave; and *B*, on the plan, represents the bed of the middle stone. The letter *C*, on the elevation, represents the vertical face of the stone over the second column; and *C* represents the upper horizontal surface or bed. The stones *A* and *C* serve as abutments to the middle stone *B*, which is let in in the manner of a keystone, and therefore acts as a wedge. In order to lessen the effect of the pressure of the inclined sides from forcing the columns to a greater distance, the joint *lmnop* has two horizontal ledges, *mn*, *op*, which will prevent the middle part from descending.

*D* exhibits a stone in the act of setting, and is let down by means of a lewis; *efg* represents a brick arch over the architrave, in order to discharge the weight from above, and is resisted by the abutments *x*, *r*. The lateral pressure of the brick arch, and of the stone *B*, is entirely counteracted by means of the chain-bar, of which the top is represented in No. 2.

No. 4 exhibits a section of the work, *z* being a section of the arch in the middle, and *y* shows the void between. The right section through the middle of the arch at *f*, between the columns, is the same as shown at *yz*.

No. 3 exhibits the manner of cutting the joints of the stones over the column *v* and *w*, being the steps of the socket and *uuu* the square part of the joint.

On the construction of stairs over an area to an entrance door.

Stairs of this description, which consist of one flight, must either be supported upon a solid foundation raised from the ground; or, if over a hollow, the steps must be supported upon a brick arch, or otherwise, by working the soffits in the form of a concave curve.





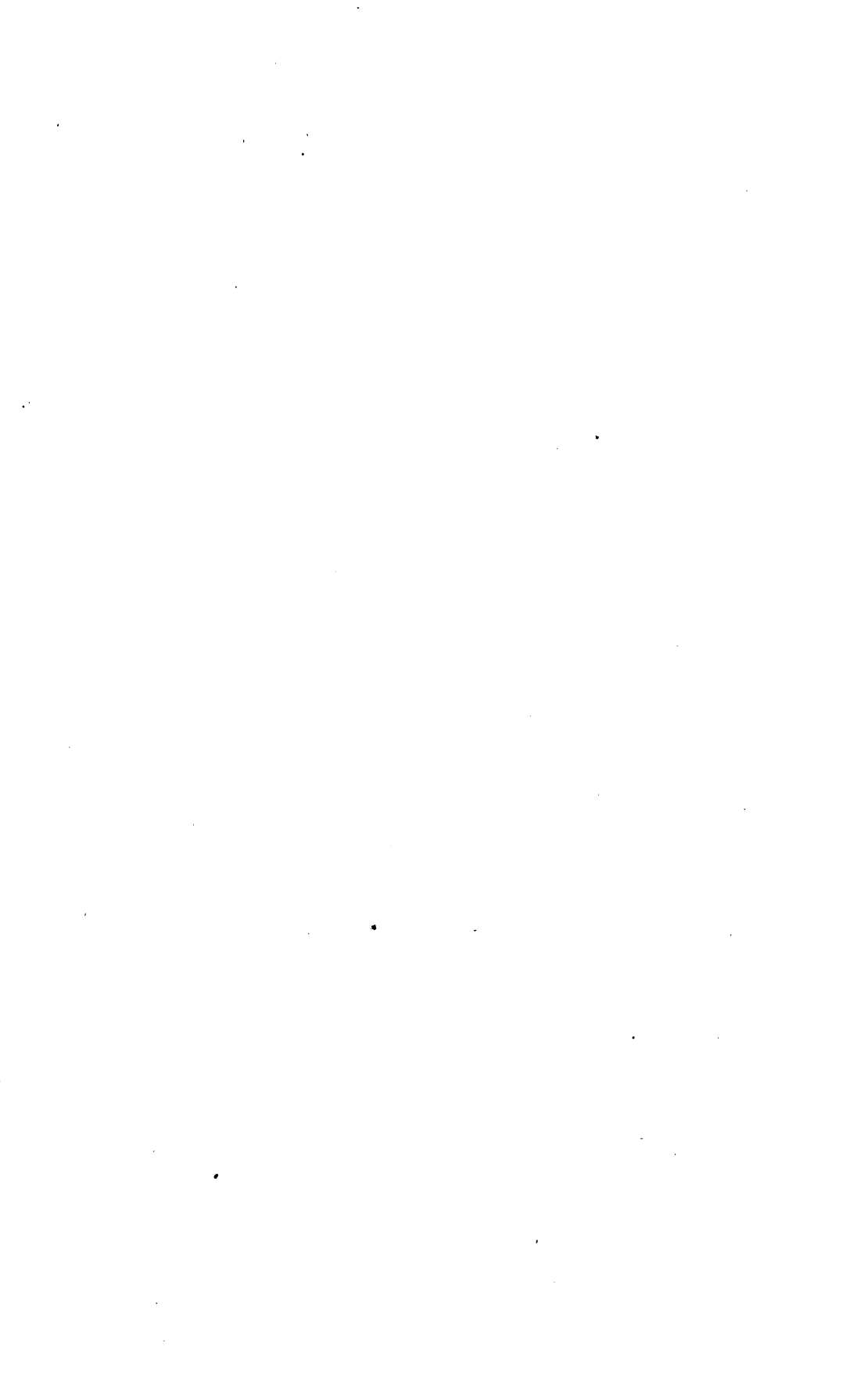




Fig. 4.

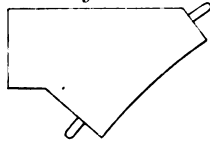


Fig. 1.

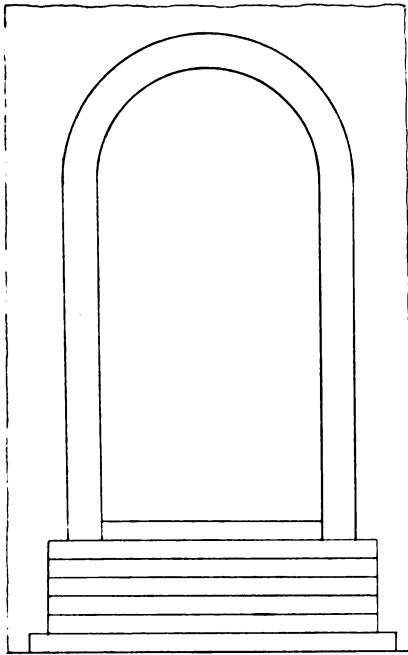


Fig. 2.

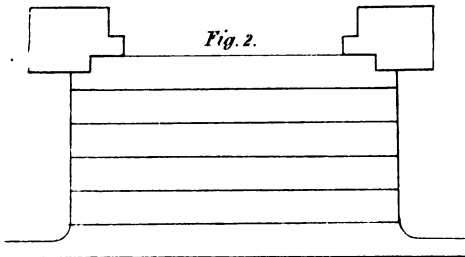
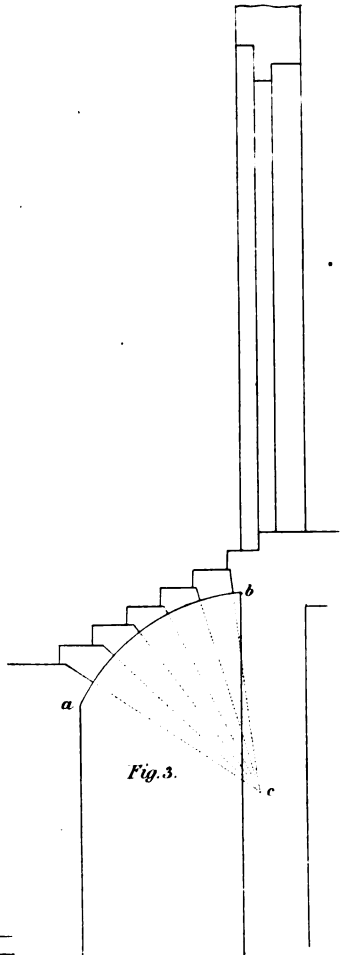


Fig. 3.



Since the joints should always be perpendicular to the curve, they must all tend to the centre of the circle which forms the soffit ; and since the steps should rest firmly upon one another, they ought to rest upon a horizontal surface. To accomplish these ends, every joint between two steps ought to consist of two surfaces, one horizontal, and the other part a plane, radiating to the axis of the cylinder, of which the soffit of the steps is the curved surface.

*Fig. 2, plate XLII,* is the plan ; *fig. 1,* the elevation of a door-way with steps, and *fig. 3,* a section of the same ; *ab* is the curve-line, representing a section of the soffits. The joints are here drawn to the centre *c* of the arc *ab*.

In this case, where there are no brick arches below, the joints should be plugged. *Fig. 4* exhibits a section of the steps, showing the plugs, one in each end perpendicular to the surface of the joint.

## CHAPTER XI.

### OF WATERLOO BRIDGE.

*Plate XLIII.* exhibits a longitudinal section of one of the arches, the adjacent piers, and part of the next adjacent arches, with the elevation of one of the trusses forming the centre. This elegant structure was built under the direction of Mr. John Rennie, civil engineer. The curve of equilibrium passes through the middle of the length of the arch stones, or very nearly so. The hollows over the piers are raised to the level of the summits of the arches by parallel brick walls, and connected with blocks of stone from wall to wall, for supporting the road-way.

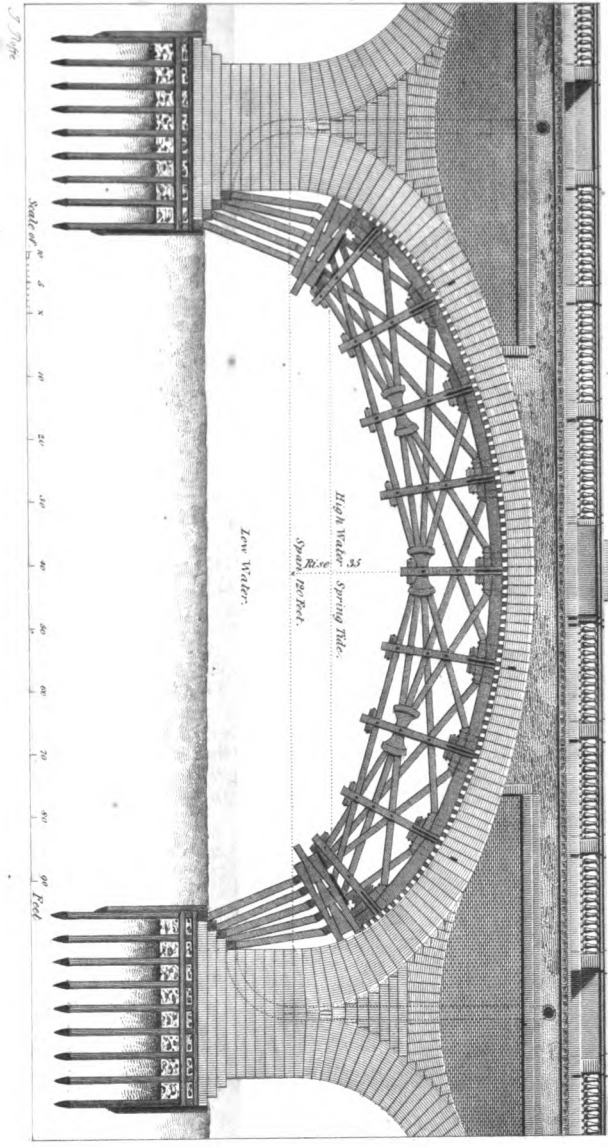
The centering was composed of eight trusses.

This plate is given with a view of showing the construction of masonry as generally applied to bridge building. The geometrical principle of constructing arches, and drawing the joint lines so as to be perpendicular to the curve, is sufficiently explained in the second section of this work.

#### ERRATA.

Insert Plate viii. in page 22, line 6 from the top after fig. 1; Plate ix. page 32, in line 27, after fig. 1; Plate xxiii. page 64, in line 3, after fig. 1; Plate xxxiii. page 85, in line 15, after A B C; xxxv. page 89, line 10, instead of xxv. and Plate xxxvii. page 92, in line 33, after A B C D.

In page 15, line 8, *Instead of t in gt, write f*; in page 22, line 19, *insert a between the words in plane*; in page 25, line 22, *for a in A a, write a*; in page 32, line 28, *instead of P, at the end of the line, write F*; in page 40, line 6, in DC *write G, in place of D*; in page 41, line 13, *after x t u, insert fig. 2*; and in line 36, in A B i, *instead of i, write l*; in page 49, line 33, *for 1, 2, 3, write c; and for c before the last word, write 1, 2, 3*; in page 50, line 31, *instead of a, after the word find, write u*; in page 51, line 16, *after plan, insert fig. 2*; in page 63, line 24, *for P E o p, write P o E*; and in line 32, *after bd, write b e*; in page 76, line 28, in bi *write h in place of i*; in page 87, line 3, *instead of ground, write groined*; in page 92, line 34, in h y z C, *for x write N*; and in line 38, in gi, *write j instead of i*; in page 93, line 1, in gi, *write j for i*; and in page 96, line 5, in a r, *write j for r*.





A

# GLOSSARY

OF

## TECHNICAL TERMS USED IN THIS TREATISE.

---

A.

*Abscissa*, a right line which bisects all the ordinates of a curve.

*Acute*, any sharp edge.

*Acute angle*, an angle less than a right angle.

*Angle*, the space contained between two right lines which meet each other in a point, but which are not both in the same right line.

*Angle of the joint lines*, the angle made on either of the beds of a stone comprised between the face of an arch and the intrados.

*Arc*, any small portion of a curve ; but in a circle, an arc is any portion of the circumference.

*Arch*, in masonry, a mass of wedge-formed stones, supported at the extremities by abutments, and supporting each other by their mutual pressure.

*Arch-stone*, one of the stones of an arch.

*Architrave*, the lowest part of an entablature, and that which rests upon the columns.

*Arris*, the line in which two surfaces meet.

*Axal plane*, a plane passing along the axis. In domes, all the axal planes are perpendicular to the horizon.

*Axal section*, the section of a body through its axis.

*Axis of a curve*, a right line which bisects all the ordinates.

*Axis of a cone*, a right line passing from the vertex to the centre of the base.

*Axis of a cylinder*, a right line passing through the solid from the centre of one of the circular ends to the centre of the other.

*Axis of a dome*, a right line perpendicular to the horizon, passing through the centre of its base.



## B.

*Base*, the lower line of a figure, or the lowest face of a solid.

*Base line*, the line upon which a figure is supposed to stand.

*Base of a cone*, the circular end opposite the vertex.

*Base of a cylinder*, either of the two circular ends.

*Base of a prism*, either of the parallel ends.

*Base of a pyramid*, the figure which is joined at the vertices of its angles to the summit by straight lines separating every two of the sides.

*Battering wall*, a wall of which the upper part of the surface falls within the base.

*Beds of a stone in walling*, those horizontal faces which form the sides of the joints.

*Bevel bridge*, a bridge in which the axes of the cylindretic surface is not at right angles to the face.

*Bisect*, to divide any thing into two equal parts.

*Bridge upon an oblique plan*, see *bevel bridge*.

## C.

*Canted*, a prismatic body.

*Canted bow window*, a window which has three or more upright faces.

*Catenarian curve*, the form of the iron chain which supports the roadway in suspension bridges.

*Centre*, a mould for supporting an arch in its progress of building.

*Centre of a figure*, the point, through which a straight line may be drawn in any direction which will divide the figure into two equal parts.

*Centre of a circle*, the point from which all right lines being drawn, to points in the line surrounding the figure, are equal.

*Centre of an ellipse*, the point through which any diameter must pass.

*Chord*, a straight line drawn from any point of an arc to any other point of that arc.

*Circle*, a plane figure of which its boundary is every where at an equal distance from a point within its surface, called its centre.

*Circular arc*, any portion of the circumference of a circle.

*Circular arch*, an arch of which the profile is a portion of the circumference of a circle, not exceeding the half.

*Circular roofs*, all roofs upon a circular plan are so called.

*Circular course*, a course or row of stones in a circular wall.

*Circular edges*, those edges of a stone where two surfaces meet in the arc of a circle.

*Circular plan*, a plan of which the exterior or interior edges are the circumferences of circles of any portions of them.

*Circular wall*, a wall built upon a circular plan.

*Circumference*, the curve line which bounds the area of a circle.

*Close curve*, that which encloses a space.

*Common axis*, an axis which equally belongs to two or several things, as the axis of a spherical dome belongs to all the vertical great circles of the sphere.

*Common section*, when two or more lines or surfaces all meet in the same line or point, the line or point is called the common section.

*Common vertex*, is the point in which two or more plain angles or surfaces meet each other.

*Concave surface*, that in which, if any two points whatever be taken, and if a straight line stretched out between them cannot meet the surface in any intermediate point, the side of the surface on which the line is extended is called the *concave surface*, and the other is the *convex surface*.

*Concentric circles*, are those that have the same centre.

*Concentric conical surfaces*, are those which have the same axis.

*Concentric cylindrical surfaces*, are those that have the same axis.

*Concentric spherical surfaces*, are those that have the same centre.

*Conic arch*, the arch of a circular headed aperture, applied over splayed jambs as in doors and windows.

*Conic parabola*, that parabola which is one of the three conic sections.

*Conic sections*, are the plane figures made by cutting a cone, which do not include the triangle nor the circle. These three sections are the ellipse, parabola, and hyperbola.

*Conic surface*, is the surface of a piece of masonry presenting the whole or a portion of the surface of a cone. In the construction of domes and tapering buildings upon a circular plan, the beds of every joint are frequently conic surfaces.

*Conic wall*, a battering wall built upon a circular plan, of which wall the line of batter is a straight line.

*Conjugate diameter*, is the term applied to the least axis of an ellipse, being the shortest of all the diameters of this curve.

*Construction*, a drawing or building performed by certain rules, and is the result of the operations by which it was made to exist.

*Convex surface*, see *concave surface*.

*Convex conical face*, the convex surface of a cone.

*Convex cylindrical face*, the convex surface of a cylinder.

*Course of stones*, a row of stones generally placed on a level bed. The stones round the face and intrados of an arch, are also called a course of stones.

*Coursing joint*, the joint between two courses of stones.

*Coursing joint lines*, the edges of the coursing joints in the face of the work.

*Curved edge*, a mould with one of its edges curved, in order to draw a curve line on the surface of a stone, or to ascertain its concavity or convexity.

*Curve line*, a concave or convex line.

*Curve lined joints*, those joints which meet curved surfaces.

*Curved surface*, is that which is concave or convex, see *concave*.

*Cylindretic oblique arch*, an arch of which the axis of the surface is not perpendicular to the face.

*Cylindrical intrados*, is the intrados of an arch, of which the surface is that of a cylinder, or a portion of a cylindrical surface.

*Cylindrical spiral*, a spiral on the surface of a cylinder.

*Cylindrical surface*, is the whole or a portion of the surface of a cylinder.

*Cylindrical wall*, a vertical wall on a circular plan.

*Cylindroidic wall*, a wall of which the surface is the whole or a portion of the surface of a cylindroid.

#### D.

*Design*, a scheme or drawing, of something intended to be constructed of stone or other material, as, *the design of a house, the design of a bridge, &c.*

*Developable surface*, such as can be extended upon a plane, the surfaces of prisms, cylinders, and cones are developable surfaces.

*Development*, the extension of a surface upon a plane, so that every point of the surface may coincide with the plane.

*Diagram*, any scheme or geometrical construction of a proposition.

*Dimensions*, such measures of extension as will be sufficient to ascertain the superficies or solidity of a body, or to construct a surface or solid.

*Double curvature*, a curve of which its parts cannot be brought into one plane.

*Double ordinate*, two equal ordinates of a curve in a right line, separated by another right line called *the abscissa*.

*Douelle*, the surface of a stone, intended to be that which is to form a portion of the intrados of an arch.

*Draught*, a groove, or rebat, sunk in a stone for the purpose of directing its reduction to the required surface.

#### E.

*Ellipse*, a close curve which may be divided into two equal and similar

parts by a diameter drawn in any direction : moreover the semi-ellipse, terminated by either axis, may be divided into two symmetrical parts.

*Elliptic arc*, any small portion of the curve of an ellipse.

*Equatorial circumference of a dome*, the circumference at the base of a hemispheric dome.

*Equilateral triangle*, one having three equal sides.

*Exterior cylindric surface*, the curved surface of a cylinder, whether solid or hollow.

*Extrados*, the outer surface of an arch.

*Extradosal arc*, the outer curve of the section of an arch.

## F.

*Focus* is one of the two points to which a string may be fixed, so as to describe the curve of an ellipse.

*Foot*, an extension containing twelve inches.

*Figure*, any area enclosed on all sides.

*Figures of the faces of a stone*, the two beds, the face or faces, and the vertical joint or joints.

## G.

*Geometry*, the science which explains, and the art which shows, the construction of lines, angles, plane figures, and solids.

*Geometrical elevation*, an orthographical projection of an object of which the surfaces are plane figures, either parallel or perpendicular to the plane of projection.

*Gothic arch*, an arch of which the two sides of the intrados meet in a point or line at the summit.

*Gothic isosceles arch*, a pointed symmetrical arch, of which the springing lines are in the same level.

*Ground line*, the straight line upon which the vertical plane of projection is placed.

## H.

*Heading*, the vertical side of a stone perpendicular to the face.

*Heading joint*, the thin stratum of mortar comprised between the vertical surfaces of two adjacent stones.

*Helix*, a spiral winding round the surface of a cylinder.

*Horizontal joint*, the same as the bed.

*Horizontal plane of projection*, the plane which contains the plan of an object, or its horizontal projection.

*Horizontal projection of an object*, the same as the plan of the object.

*Horizontal trace*, the intersection of any plane, and the horizontal plane of projection.

*Hyperbola*, an open curve being one of the three conic sections of which the curve will ever meet a certain right line.

*Hypotenuse*, the longest side of a right angled triangle.

## I.

*Inclination*, the angle contained between a line and a plane, or between two planes.

*Irregular*, a term expressing the inequality of the sides and angles of a body.

*Intersection*, the point on which two lines meet or cut each other ; the line in which two surfaces cut or meet each other.

*Intrados*, the inner curve of an arch.

*Intradosal curve*, the inner curve of the profile of an arch.

*Intradosal joints*, those joints which are seen in the intrados of an arch.

## J.

*Joints of a stone*, the mortar comprehended between the adjacent sides of two stones and the face of the work.

## K.

*Key course*, the horizontal range of stones in the summit of a vault, in which the course is placed.

*Key-stone*, the stone which appears in the front and in the summit of an arch.

## L.

*Leg of a right-angled triangle*, one of the three sides which contain the right angle.

*Leg of a trihedral angle*, is either of the two planes of a right trihedral angle, which contains the right angle.

*Line in space*, any line of which the projection is required, but not in the plane of projection.

*Line of batter*, the line of section made by a plane and the surface of a battering wall, the plane being perpendicular both to the surface of the wall and to the horizon.

*Lintel*, the stone which extends over the aperture of a door or window.

## M.

*Masonry*, the art of constructing buildings of stone.

*Meridians*, are the curves on the surface of a dome made in vertical planes.

*Meridional arc*, a portion of the meridional curve of a dome.

*Meridional joint*, the vertical joint of a vault of which the horizontal sections are all circles.

## N.

*Normal*, a right line perpendicular to a curve.

## O.

*Oblique angles*, adjacent angles of which their line of separation is not perpendicular to the base.

*Oblique arch*, a cylindretic arch of which the axis is not perpendicular to the face.

*Oblique bridge*, a bridge which crosses a river, and of which the faces of the arch are not perpendicular to the direction of the stream.

*Oblique cylinder*, a cylinder of which the axis is not perpendicular to the circular ends.

*Oblique cylindroid*, a cylindroid in which the axis is not perpendicular to the two bases.

*Oblique plan*, a parallelogrammatic plan of which the sides are not at right angles.

*Oblique trehedral*, a trehedral of which the angles contained by any two of its faces are not a right angle.

*Open curve*, that which does not enclose an area.

*Ordinate*, a right line comprised between a curve and its abscissa, and is parallel to a tangent at the extremity of this abscissa.

## P.

*Parabola*, an open curve, being one of the three conic sections, of which both of its branches may be extended infinitely without ever meeting.

*Parallel right lines*, are those which can never meet.

*Parallelogram*, a quadrilateral figure of which the opposite sides are equal and parallel.

*Parallels*, the same as parallel right lines.

*Parameter*, the ordinate of a conic section, which passes through the focus perpendicular to the axis.

*Perpendicular*, a right line perpendicular to another right line or to a surface.

*Perpendicular surface*, a surface perpendicular to a right line, or to a plane.

*Plane*, a surface in which all the points of a right line will coincide.

*Plane angles*, those drawn upon a plane surface.

*Plane curve*, that which has all its parts in one plane.

*Plane wall*, a wall of which the surface is a plane.

*Plane of projection*, the plane on which an object is to be represented.

*Pole of a dome*, the summit or upper extremity of the axis.

*Position*, the situation in which one thing is placed in respect of another.

*Prism*, a solid bounded on the sides by parallelograms, and on the two remaining faces, by polygonal figures in parallel planes.

*Problem*, a proposition which proposes something to be done.

*Projectant*, the distance of a point from its projection.

*Projection*, the art of finding the representation of a point, line, surface, or solid.

*Proportion*, the parts of two things so that the whole of the one may be to any one of its parts as the whole of the other is to its corresponding part.

## Q.

*Quadrant*, the fourth part of a circle.

*Quantity of batter*, the angular distance between the plumb-line and the line of batter.

## R.

*Radius*, a right line, of which if one end be fixed in a certain point, the other, if moved round, may be made to coincide with all the points of another line, or with the points of a surface.

*Radius of a circle*, is any right line drawn from the centre to the circumference.

*Radius of a cylinder*, the radius of the circle which is the profile of the cylinder.

*Radius of a sphere*, the right line extending from the centre to the surface.

*Radius of curvature*, the radius of a circle which has the same curvature as the curve at the point to which this radius belongs.

*Radiating joints*, those joints which tend to a centre.

*Raking mouldings*, moulding which run in an inclined position.

*Rear line*, a line on the back part of any thing.

*Regulating line*, a line which fixes the position of other lines.

*Retreating sides of the joints*, those which recede from the surface.

*Right angle*, an angle of ninety degrees.

*Right arch*, an arch of which the intrados is perpendicular to the face.

*Right cone*, that of which its axis is perpendicular to the base.

*Right section*, the section of a body at right angles to the axis.

*Right trehedral*, a trehedral having one of its angles a right angle.

*Ring-stones*, the stones which appear in the face and intrados of an arch.

*Ruler surface*, a curved surface on which two parallel straight lines may be drawn through any two given points.

## S.

*Section*, the figure, formed by cutting a solid by a plane.

*Segment*, the part of a surface or solid containing the upper extremity or summit.

*Segment of a circle*, a portion of the circle contained by an arc and its chord.

*Segment of an ellipse*, a portion of an ellipse contained by a part of the curve and its chord.

*Segment of a cylinder*, a portion cut off by a plane parallel to the axis.

*Semi-axis major*, the longest diameter of an ellipse.

*Semi-axis minor*, the shortest diameter of an ellipse.

*Semi-parameter*, half the parameter, or the focal ordinate.

*Semi-cylinder*, the half of a cylinder contained by the curved surface and a plane passing along the axis.

*Semi-cylindric surface*, the whole or a portion of the surface of a cylinder.

*Severies*, the compartments of grained ceilings.

*Similar figures or bodies*, those which are of the same shape.

*Soffit*, the under surface of any part of a ceiling.

*Soffit joints*, those joints which appear on the under surface.

*Solid*, any body whatever.

*Solid angles*, angles in which three or more surfaces all meet in one point.

*Solid geometry*, the consideration of the properties and construction of solids.

*Solid of revolution*, that which may be generated round an axis.

*Spherical dome*, a dome having a spherical surface.

*Spherical niche*, a niche of which the surface of the head is spherical.

*Spherical triangle*, a triangle of which the surface is spherical.



*Spiral curves*, those consisting of one or more revolutions.

*Spiral joints*, those joints which run in a spiral line.

*Spiral surface*, a ruler surface, of which the direction of the straight lines tend to an axis, such are the soffits of winding stairs.

*Splayed*, a bevelled jamb.

*Springing plane of an arch [or vault]*, the plane from which the first arch-stones rise.

*Squaring a stone*, is the form to which it is made in order to apply the moulds, so as to obtain its ultimate form as inserted in the building.

*Stone-cutting*, the art of reducing stones to their intended form.

*Straight edge*, a rule with a straight edge for trying a surface.

*Straight vaults*, those which have their axis straight.

*Straight walls*, those which have plane surfaces.

*Surface of revolution*, such as may be generated round an axis.

*Surmounted arch*, an arch or vault of greater height than half its width.

#### T.

*Talus line*, the battering line of a wall.

*Tangent*, a straight line which touches a curve without being able to cut it.

*Tangent plane*, a plane which touches a curved surface without being able to cut it.

*Third proportional*, the fourth term of four proportionals, when the two middle terms are equal ; it is called a third proportional.

*Traces of a plane*, the intersections of an oblique plane with the horizontal and vertical planes of projection.

*Transverse axis*, the longest diameter of an ellipse.

*Trehedral*, a solid angle consisting of three plane angles.

*Triangle*, a figure consisting of three equal sides.

*Trying edge*, the edge of a rule for trying a given surface.

#### U.

*Uniform conic surface*, the surface of a right cone.

*Uniform cylindrical surface*, the surface of a right cylinder.

*Upper bed of a stone*, the side of the stone which comes in contact with that above it.

#### V.

*Vault*, a concave ceiling.

*Vertex*, the summit of any thing.

*Vertex of a cone*, the point in which the surface ends.

*Vertical angle*, the opposite angle.

*Vertical of a batter*, the perpendicular distance.

*Vertical plane*, a plane perpendicular to the horizon.

*Vertical plane of projection*, the plane on which the elevation is made.

*Vertical projectant*, the distance of a point from its projection, in the horizontal plane of projection.

*Vertical projection*, the elevation of an object.

*Vertical trace*, the trace of a plane in the vertical plane of projection.

*Vertical wall*, an upright wall.

## W.

*Wall in tallus*, a battering wall.

*Winding joints*, spiral joints.

THE END.

LONDON

PRINTED BY S. AND R. BENTLEY, DORSET STREET.



## DIRECTIONS TO THE BINDER.

<table style="width: 100%; border-collapse: collapse;"> <tr> <td style="width: 15%;">Plate 1</td> <td style="width: 35%;">to face</td> <td style="width: 10%;"></td> <td style="width: 10%;">page</td> <td style="width: 30%; text-align: right;">6</td> </tr> <tr> <td>2</td> <td>—</td> <td></td> <td></td> <td style="text-align: right;">10</td> </tr> <tr> <td>3</td> <td>to face the back of</td> <td></td> <td></td> <td></td> </tr> <tr> <td></td> <td>plate 2.</td> <td></td> <td></td> <td></td> </tr> <tr> <td>4</td> <td>to face</td> <td>—</td> <td></td> <td style="text-align: right;">12</td> </tr> <tr> <td>5</td> <td>—</td> <td></td> <td></td> <td style="text-align: right;">16</td> </tr> <tr> <td>6</td> <td>—</td> <td></td> <td></td> <td style="text-align: right;">18</td> </tr> <tr> <td>7</td> <td>—</td> <td></td> <td></td> <td style="text-align: right;">22</td> </tr> <tr> <td>8</td> <td>—</td> <td></td> <td></td> <td style="text-align: right;">32</td> </tr> <tr> <td>9</td> <td>—</td> <td></td> <td></td> <td style="text-align: right;">34</td> </tr> <tr> <td>10</td> <td>—</td> <td></td> <td></td> <td style="text-align: right;">44</td> </tr> <tr> <td>11</td> <td>—</td> <td></td> <td></td> <td style="text-align: right;">48</td> </tr> <tr> <td>12</td> <td>to face the back of</td> <td></td> <td></td> <td></td> </tr> <tr> <td></td> <td>plate 11.</td> <td></td> <td></td> <td></td> </tr> <tr> <td>13</td> <td>to face</td> <td>—</td> <td></td> <td style="text-align: right;">50</td> </tr> <tr> <td>14</td> <td>to face the back of</td> <td></td> <td></td> <td></td> </tr> <tr> <td></td> <td>plate 13.</td> <td></td> <td></td> <td></td> </tr> <tr> <td>15</td> <td>to face</td> <td>—</td> <td></td> <td style="text-align: right;">52</td> </tr> <tr> <td>16</td> <td>—</td> <td></td> <td></td> <td style="text-align: right;">54</td> </tr> <tr> <td>17</td> <td>—</td> <td></td> <td></td> <td style="text-align: right;">56</td> </tr> <tr> <td>18</td> <td>to face the back of</td> <td></td> <td></td> <td></td> </tr> <tr> <td></td> <td>plate 17.</td> <td></td> <td></td> <td></td> </tr> <tr> <td>19</td> <td>to face</td> <td>—</td> <td></td> <td style="text-align: right;">58</td> </tr> <tr> <td>20</td> <td>—</td> <td></td> <td></td> <td style="text-align: right;">60</td> </tr> <tr> <td>21</td> <td>—</td> <td></td> <td></td> <td style="text-align: right;">62</td> </tr> </table>	Plate 1	to face		page	6	2	—			10	3	to face the back of					plate 2.				4	to face	—		12	5	—			16	6	—			18	7	—			22	8	—			32	9	—			34	10	—			44	11	—			48	12	to face the back of					plate 11.				13	to face	—		50	14	to face the back of					plate 13.				15	to face	—		52	16	—			54	17	—			56	18	to face the back of					plate 17.				19	to face	—		58	20	—			60	21	—			62	<table style="width: 100%; border-collapse: collapse;"> <tr> <td style="width: 15%;">Plate 22</td> <td style="width: 35%;">to face</td> <td style="width: 10%;"></td> <td style="width: 10%;">page</td> <td style="width: 30%; text-align: right;">64</td> </tr> <tr> <td>23</td> <td>—</td> <td></td> <td></td> <td style="text-align: right;">66</td> </tr> <tr> <td>24</td> <td>—</td> <td></td> <td></td> <td style="text-align: right;">67</td> </tr> <tr> <td>25</td> <td>—</td> <td></td> <td></td> <td style="text-align: right;">68</td> </tr> <tr> <td>26</td> <td>to face the back of</td> <td></td> <td></td> <td></td> </tr> <tr> <td></td> <td>plate 25.</td> <td></td> <td></td> <td></td> </tr> <tr> <td>27</td> <td>to face</td> <td>—</td> <td></td> <td style="text-align: right;">69</td> </tr> <tr> <td>28</td> <td>—</td> <td></td> <td></td> <td style="text-align: right;">70</td> </tr> <tr> <td>29</td> <td>—</td> <td></td> <td></td> <td style="text-align: right;">71</td> </tr> <tr> <td>30</td> <td>—</td> <td></td> <td></td> <td style="text-align: right;">72</td> </tr> <tr> <td>31</td> <td>—</td> <td></td> <td></td> <td style="text-align: right;">82</td> </tr> <tr> <td>32</td> <td>—</td> <td></td> <td></td> <td style="text-align: right;">84</td> </tr> <tr> <td>33</td> <td>—</td> <td></td> <td></td> <td style="text-align: right;">85</td> </tr> <tr> <td>34</td> <td>—</td> <td></td> <td></td> <td style="text-align: right;">86</td> </tr> <tr> <td>35</td> <td>—</td> <td></td> <td></td> <td style="text-align: right;">89</td> </tr> <tr> <td>36</td> <td>—</td> <td></td> <td></td> <td style="text-align: right;">91</td> </tr> <tr> <td>37</td> <td>—</td> <td></td> <td></td> <td style="text-align: right;">92</td> </tr> <tr> <td>38</td> <td>—</td> <td></td> <td></td> <td style="text-align: right;">93</td> </tr> <tr> <td>39</td> <td>—</td> <td></td> <td></td> <td style="text-align: right;">95</td> </tr> <tr> <td>40</td> <td>—</td> <td></td> <td></td> <td style="text-align: right;">96</td> </tr> <tr> <td>41</td> <td>—</td> <td></td> <td></td> <td style="text-align: right;">98</td> </tr> <tr> <td>42</td> <td>—</td> <td></td> <td></td> <td style="text-align: right;">99</td> </tr> <tr> <td>43</td> <td>—</td> <td></td> <td></td> <td style="text-align: right;">100</td> </tr> </table>	Plate 22	to face		page	64	23	—			66	24	—			67	25	—			68	26	to face the back of					plate 25.				27	to face	—		69	28	—			70	29	—			71	30	—			72	31	—			82	32	—			84	33	—			85	34	—			86	35	—			89	36	—			91	37	—			92	38	—			93	39	—			95	40	—			96	41	—			98	42	—			99	43	—			100
Plate 1	to face		page	6																																																																																																																																																																																																																																													
2	—			10																																																																																																																																																																																																																																													
3	to face the back of																																																																																																																																																																																																																																																
	plate 2.																																																																																																																																																																																																																																																
4	to face	—		12																																																																																																																																																																																																																																													
5	—			16																																																																																																																																																																																																																																													
6	—			18																																																																																																																																																																																																																																													
7	—			22																																																																																																																																																																																																																																													
8	—			32																																																																																																																																																																																																																																													
9	—			34																																																																																																																																																																																																																																													
10	—			44																																																																																																																																																																																																																																													
11	—			48																																																																																																																																																																																																																																													
12	to face the back of																																																																																																																																																																																																																																																
	plate 11.																																																																																																																																																																																																																																																
13	to face	—		50																																																																																																																																																																																																																																													
14	to face the back of																																																																																																																																																																																																																																																
	plate 13.																																																																																																																																																																																																																																																
15	to face	—		52																																																																																																																																																																																																																																													
16	—			54																																																																																																																																																																																																																																													
17	—			56																																																																																																																																																																																																																																													
18	to face the back of																																																																																																																																																																																																																																																
	plate 17.																																																																																																																																																																																																																																																
19	to face	—		58																																																																																																																																																																																																																																													
20	—			60																																																																																																																																																																																																																																													
21	—			62																																																																																																																																																																																																																																													
Plate 22	to face		page	64																																																																																																																																																																																																																																													
23	—			66																																																																																																																																																																																																																																													
24	—			67																																																																																																																																																																																																																																													
25	—			68																																																																																																																																																																																																																																													
26	to face the back of																																																																																																																																																																																																																																																
	plate 25.																																																																																																																																																																																																																																																
27	to face	—		69																																																																																																																																																																																																																																													
28	—			70																																																																																																																																																																																																																																													
29	—			71																																																																																																																																																																																																																																													
30	—			72																																																																																																																																																																																																																																													
31	—			82																																																																																																																																																																																																																																													
32	—			84																																																																																																																																																																																																																																													
33	—			85																																																																																																																																																																																																																																													
34	—			86																																																																																																																																																																																																																																													
35	—			89																																																																																																																																																																																																																																													
36	—			91																																																																																																																																																																																																																																													
37	—			92																																																																																																																																																																																																																																													
38	—			93																																																																																																																																																																																																																																													
39	—			95																																																																																																																																																																																																																																													
40	—			96																																																																																																																																																																																																																																													
41	—			98																																																																																																																																																																																																																																													
42	—			99																																																																																																																																																																																																																																													
43	—			100																																																																																																																																																																																																																																													

